



**FY 87 ENERGY SURVEY**  
**OF**  
**DESIGNATED U.S. ARMY GARRISON**  
**HONSHU BUILDINGS 1 & 8**  
**TOKYO, JAPAN**  
**ENERGY ENGINEERING**  
**ANALYSIS PROGRAM**

**US ARMY CONTRACT NO. DACA79-87-C-0060**  
**PRE-FINAL SUBMITTAL**

19971016 203

**PREPARED BY:**

**CEDRIC D.O. CHONG & ASSOCIATES**  
**25-9 SOBUDAI, I-CHOME SAGAMIHARA CITY**  
**KANAGAWA 228, JAPAN**

**DISTRIBUTION STATEMENT A**  
Approved for public release  
Distribution Unlimited

**SEPTEMBER 9, 1988**

**DTC QUALITY INSPECTED 2**



DEPARTMENT OF THE ARMY  
CONSTRUCTION ENGINEERING RESEARCH LABORATORIES, CORPS OF ENGINEERS  
P.O. BOX 9005  
CHAMPAIGN, ILLINOIS 61826-9005

REPLY TO  
ATTENTION OF: TR-I Library

17 Sep 1997

Based on SOW, these Energy Studies are unclassified/unlimited.  
Distribution A. Approved for public release.

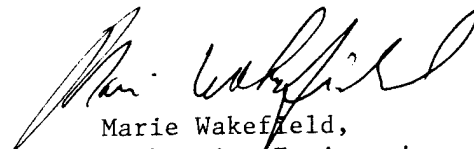
  
Marie Wakefield,  
Librarian Engineering

## EXECUTIVE SUMMARY

I. Introduction/Background: This study includes a complete energy audit and analysis for Buildings 1 and 8 at the Akasaka Press Center, Tokyo, Japan. Building 1 is a six story, 54,200 square foot building which contains administrative offices on the first through third floor, and bachelors' enlisted quarters and officers' quarters on the fourth through sixth floor. Building 8 is a four story, 91,000 square foot building which houses the offices, printing, and press operations of the newspaper, "Pacific Stars and Stripes".

II. Present Energy Consumption and Costs: Present energy consumption and costs for FY87 for Buildings 8 and 1, based on utility records and based on an exchange rate of 163.1 yen per U. S. dollar for FY87 are summarized as follows:

Total Energy Costs: The energy costs for Building 8 totaled \$230,388 in FY87. A breakdown of the utility costs is shown in Figure E-1. Approximately 86% of the cost for energy was for electricity, while fuel oil accounted for 13% and coal gas for the remaining 1%. The energy costs for Building 1 totaled \$118,630 in FY87. A breakdown of the utility costs is shown in Figure E-2. Electricity represented approximately 77% of the total energy cost, while fuel oil accounted for the remaining 23%.

A summary of the total energy costs for both buildings is shown in Figure E-3. Total annual energy cost for the buildings amounted to \$344,018 in FY87.

FIG. E-1: ENERGY COSTS FOR BUILDING 8

ENERGY COSTS FOR BLDG 8

ELECTRICITY: \$36.75/MBTU  
\$0.1110/KWH

FUEL OIL: \$4.69/MBTU  
\$0.65/GAL.

COAL GAS: \$11.68/MBTU  
\$11.68/1000 CF

ELECTRICAL RATE SCHEDULE  
(INCLUSIVE OF DISCOUNTS)

DEMAND: \$8.70 /KW

SUMMER ENERGY CHARGE  
(JUNE THRU SEPT):

\$19.28/MBTU  
\$0.0658/KWH

OTHER THAN SUMMER CHARGE:

\$16.82/MBTU  
\$0.0574/KWH

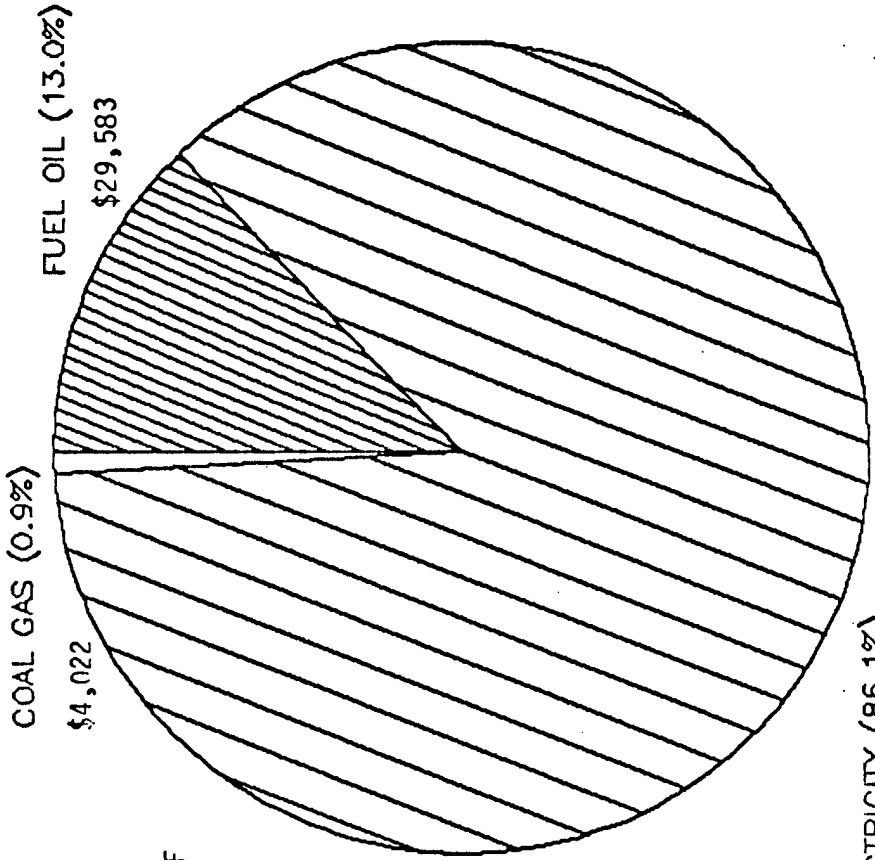

10<sup>6</sup> BTU  
KWH 3413 BTU (JUST)  
KWH 1 KWH  
0.0658 \$

TOTAL ANNUAL ENERGY COST: \$230,388

NOTE: BUILDING LOCATED  
NOT TO BE APPLIED TO  
OTHER BUILDINGS OF THE  
FACILITY. ENERGY COSTS  
ARE BASED ON 1974 DATA.

FIG. E-2: FUEL ENERGY COSTS FOR BUILDING 1

ENERGY COSTS FOR BLDG 1

ELECTRICITY: \$44.24/MBTU  
\$0.1510/KWH

FUEL OIL: \$4.69/MBTU  
\$0.65/GAL.

ELECTRICAL RATE SCHEDULE  
(INCLUSIVE OF DISCOUNTS)

DEMAND: \$8.75/KW

SUMMER ENERGY CHARGE  
(JUNE THRU SEPT):

\$31.23/MBTU  
\$0.1066/KWH

OTHER THAN SUMMER CHARGE:

\$27.69/MBTU  
\$0.0945/KWH

ELECTRICITY (76.6%)

\$90,872

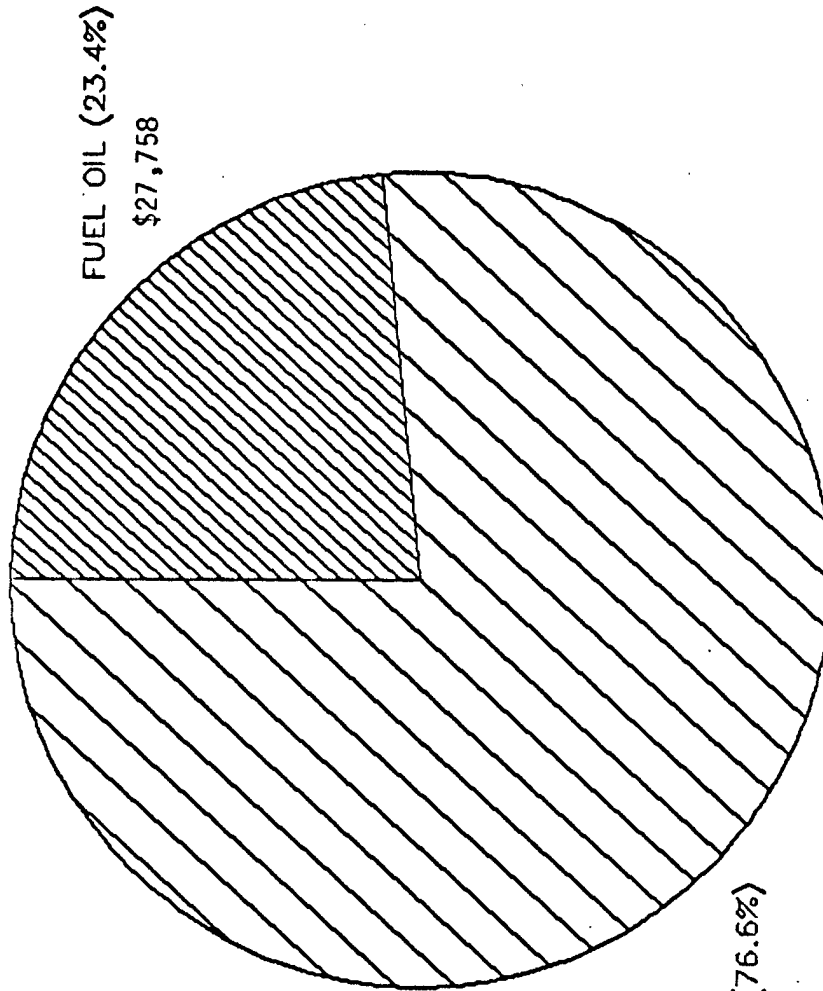

TOTAL ANNUAL ENERGY: \$118,630

FIG. E-3: FY87 ENERGY COST FOR BUILDING 1 & 8

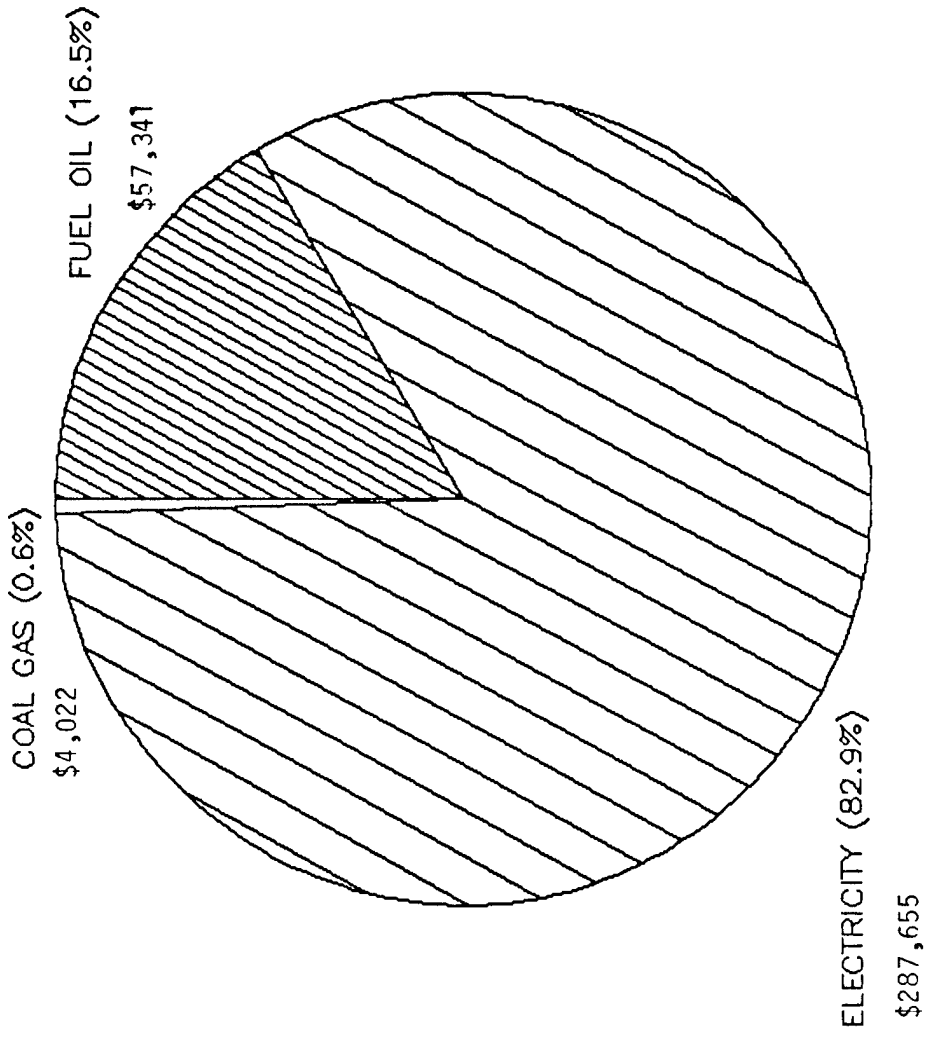

TOTAL ANNUAL ENERGY COST: \$349,018

Total annual energy consumption in Building 8 is shown in Figure E-4. The total annual energy consumption for the building of 12,539 MBtu is categorized as follows: 48% is for electricity, 50% is for fuel oil, and 2% is for coal gas. A more detailed breakdown of current electrical consumption, fuel oil consumption, and coal gas consumption is included in Figures E-5, E-6, and E-7, respectively.

Total annual energy consumption for Building 1 is also shown in Figure E-8. The total annual energy consumption of 7,976 MBtu is comprised of 74% for fuel oil and 26% for electricity. A breakdown of current electrical consumption and fuel oil consumption for Building 1 are also included in Figures E-9 and E-10, respectively.

Overall annual energy consumption of the facilities totaled 20,515 MBtu as shown in Figure E-11.

Total maintenance, operation and repair costs for Building 8 amounted to \$104,459 in FY87 as shown in Figure E-12. Approximately 68.0% of the costs were for operation of the boiler plant, 10% of the cost was for boiler maintenance and repair, while the remaining 22% was for upkeep of the air conditioning systems.

Total maintenance, operation and repair costs for Building 1 amounted to \$101,077 in FY87 and is included in Figure E-13. Approximately 70.3% of the cost was for operation of the boiler plant, 6.5% was for boiler maintenance and repair, and the remaining 23.3% was for upkeep of the air conditioning systems. Total maintenance, operation and repair costs for upkeep of the hvac equipment for Buildings 8 and 1 totaled \$205,536 in FY87.

*Vertical handwritten notes on the right margin:*  
Total Annual Energy Consumption for Building 8 is 12,539 MBtu.  
Total Annual Energy Consumption for Building 1 is 7,976 MBtu.  
Overall Annual Energy Consumption of the facilities is 20,515 MBtu.  
Total maintenance, operation and repair costs for Building 8 are \$104,459.  
Total maintenance, operation and repair costs for Building 1 are \$101,077.  
Total maintenance, operation and repair costs for hvac equipment for Buildings 8 and 1 are \$205,536.

FIG. E-4: PRESENT ANNUAL ENERGY CONSUMPTION FOR BUILDING 8 (FY87)

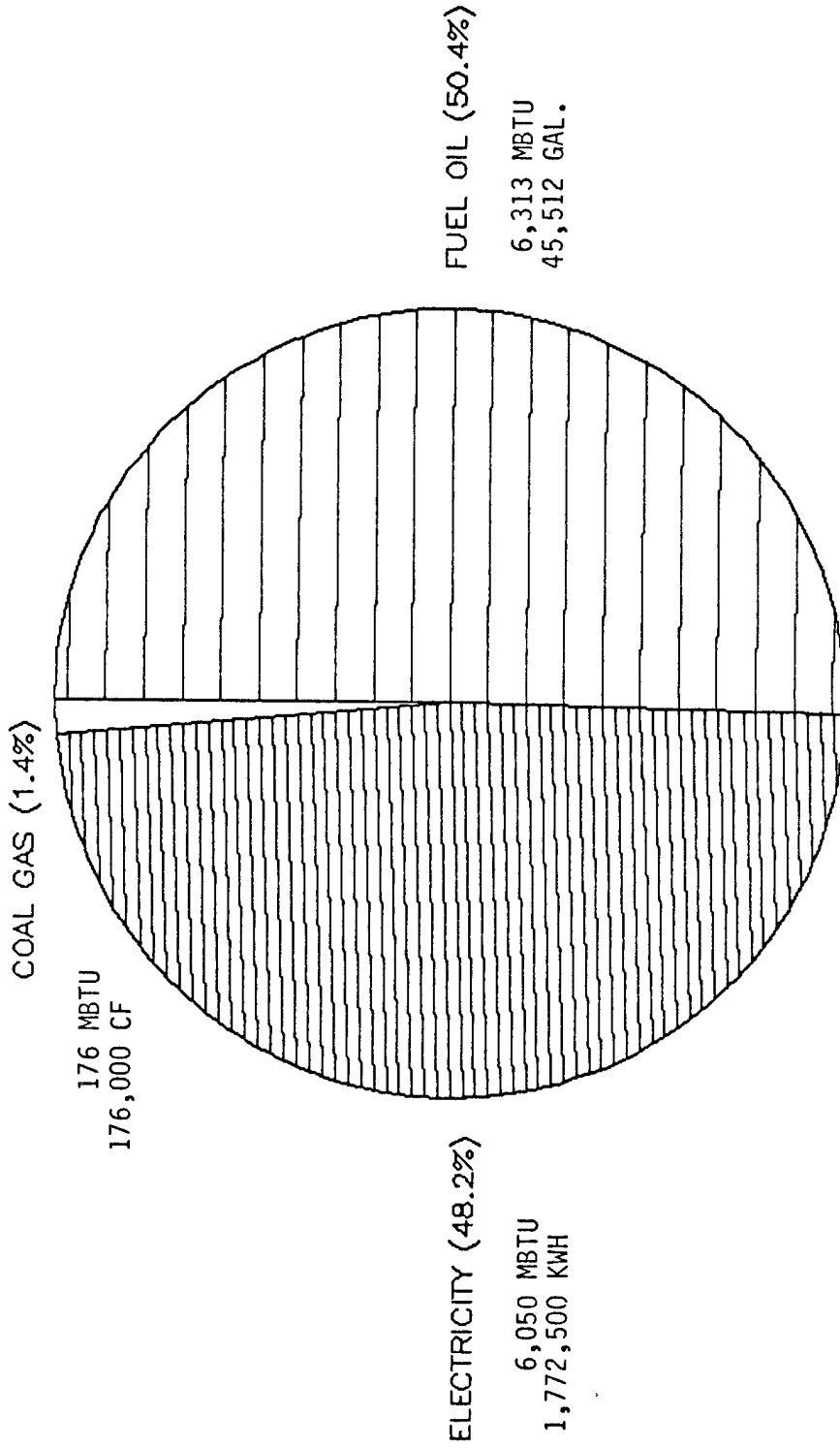

TOTAL ANNUAL ENERGY CONSUMPTION: 12,539 MBTU



FIG. E-5: BREAKDOWN OF PRESENT ELECTRICAL ENERGY CONSUMPTION FOR BUILDING 8 (FY87)

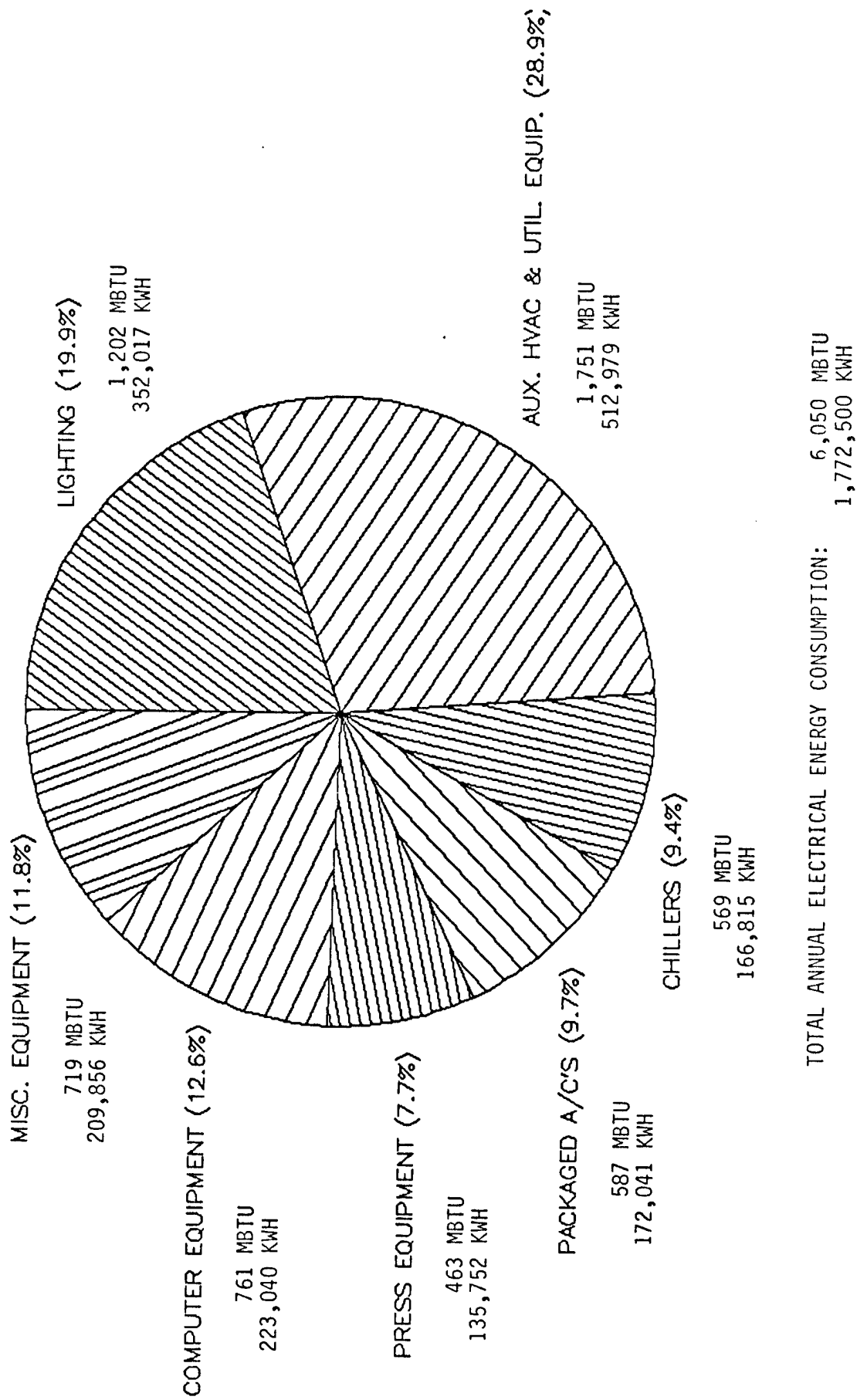

FIG. E-6: BREAKDOWN OF PRESENT FUEL OIL CONSUMPTION FOR BUILDING 8 (FY87)

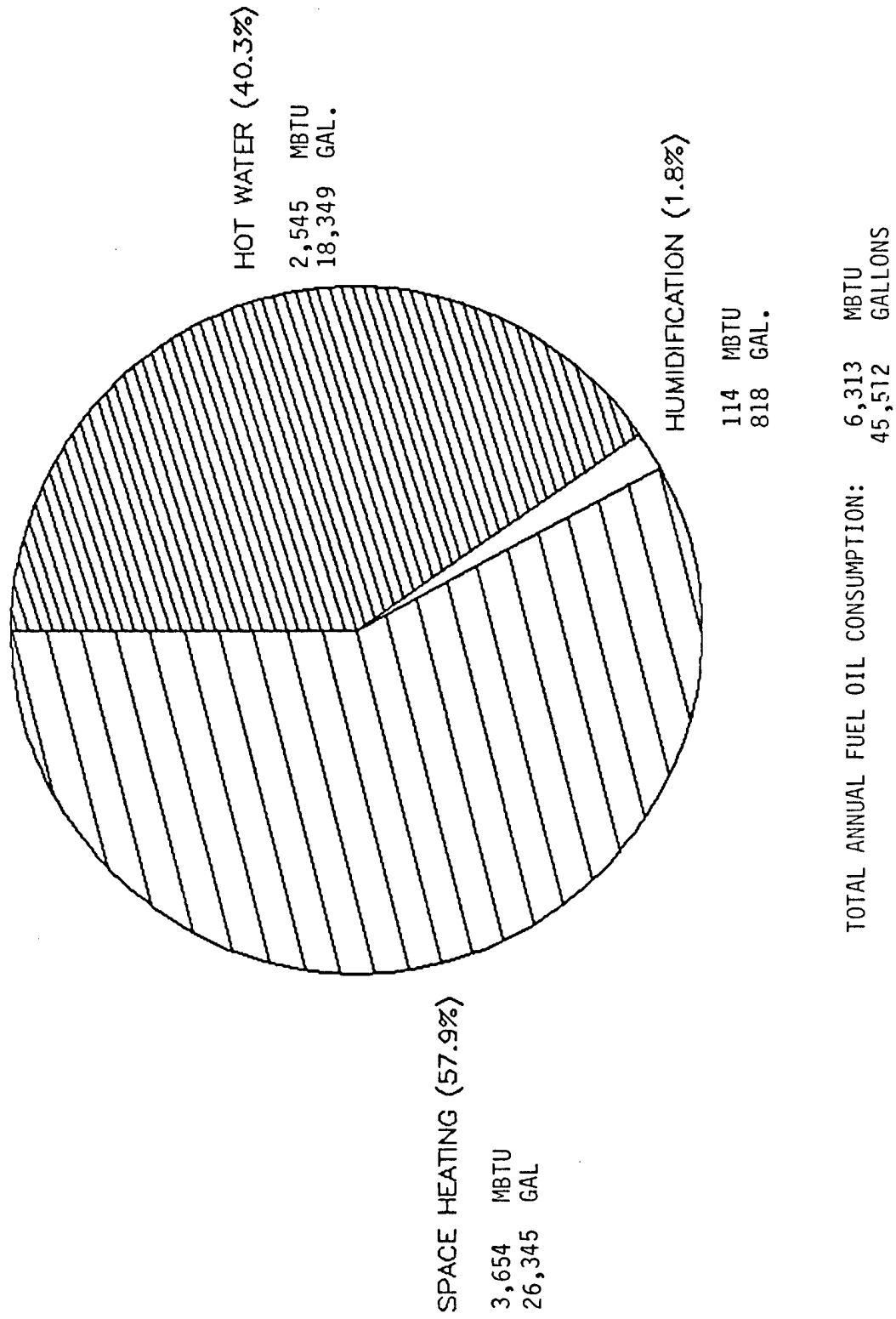
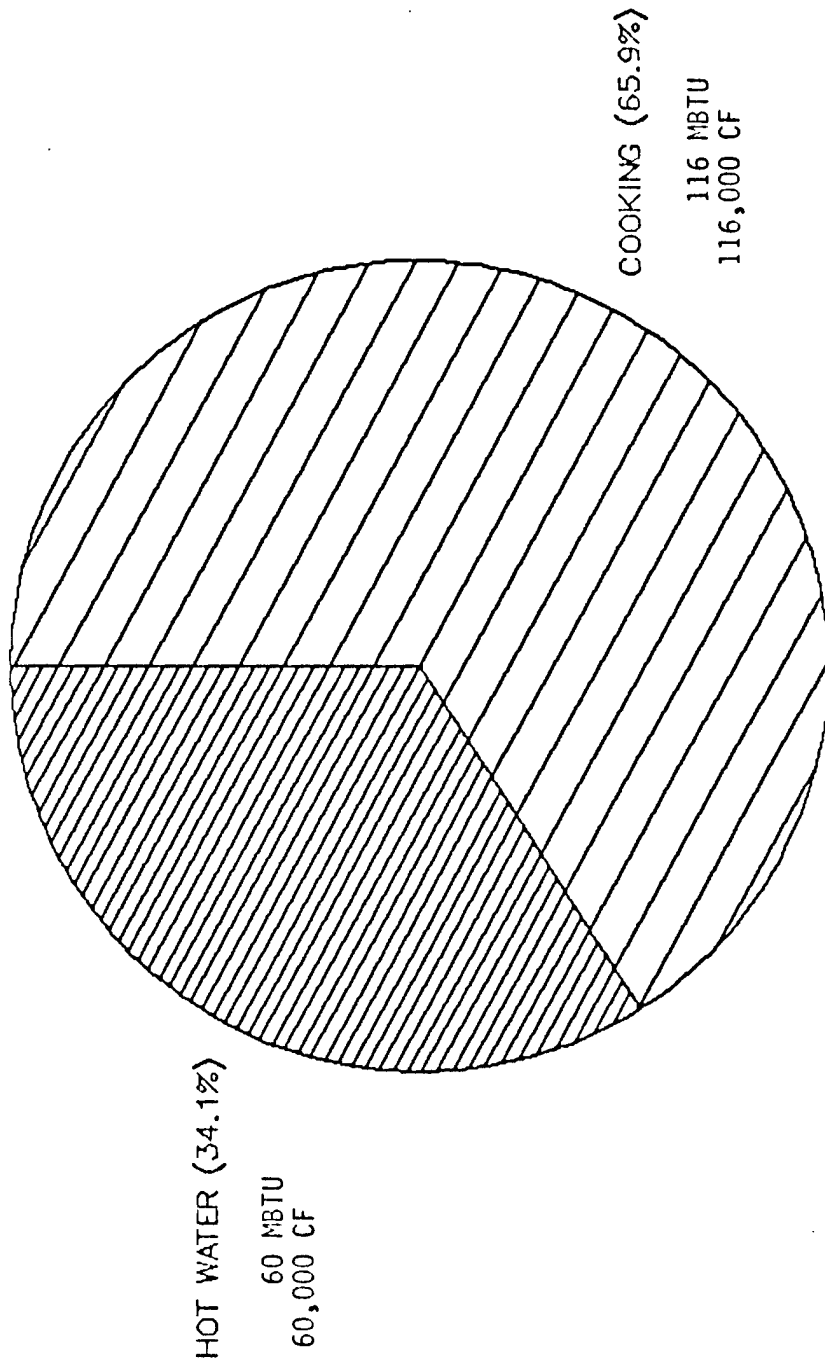
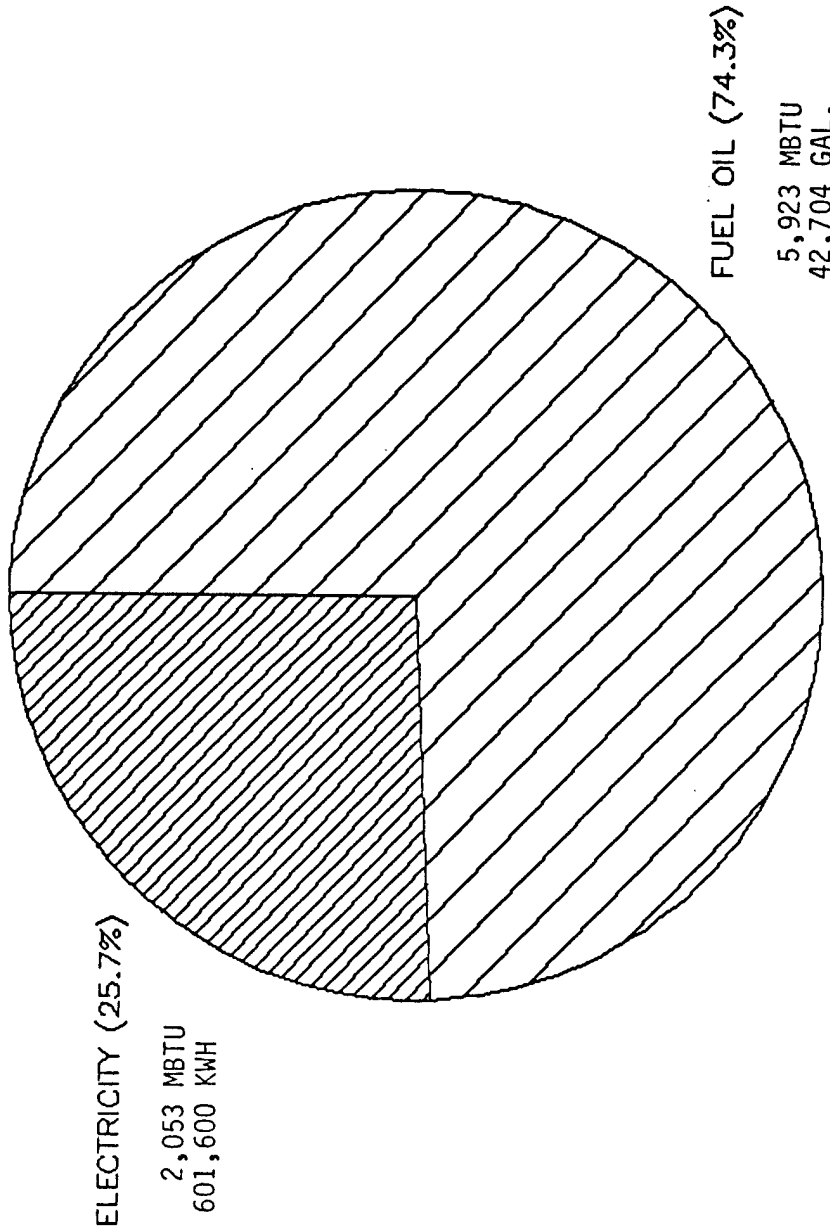

FIG. E-7: BREAKDOWN OF PRESENT ANNUAL COAL GAS CONSUMPTION FOR BUILDING 8 (FY87)



TOTAL ANNUAL COAL GAS CONSUMPTION: 176 MBTU  
176,000 CUBIC FEET

FIG. E-8: PRESENT ANNUAL ENERGY CONSUMPTION FOR BUILDING 1 (FY87)



TOTAL ANNUAL ENERGY CONSUMPTION: 7,976 MBTU

FIG. E-9: BREAKDOWN OF PRESENT FUEL OIL CONSUMPTION FOR BUILDING 1 (FY87)

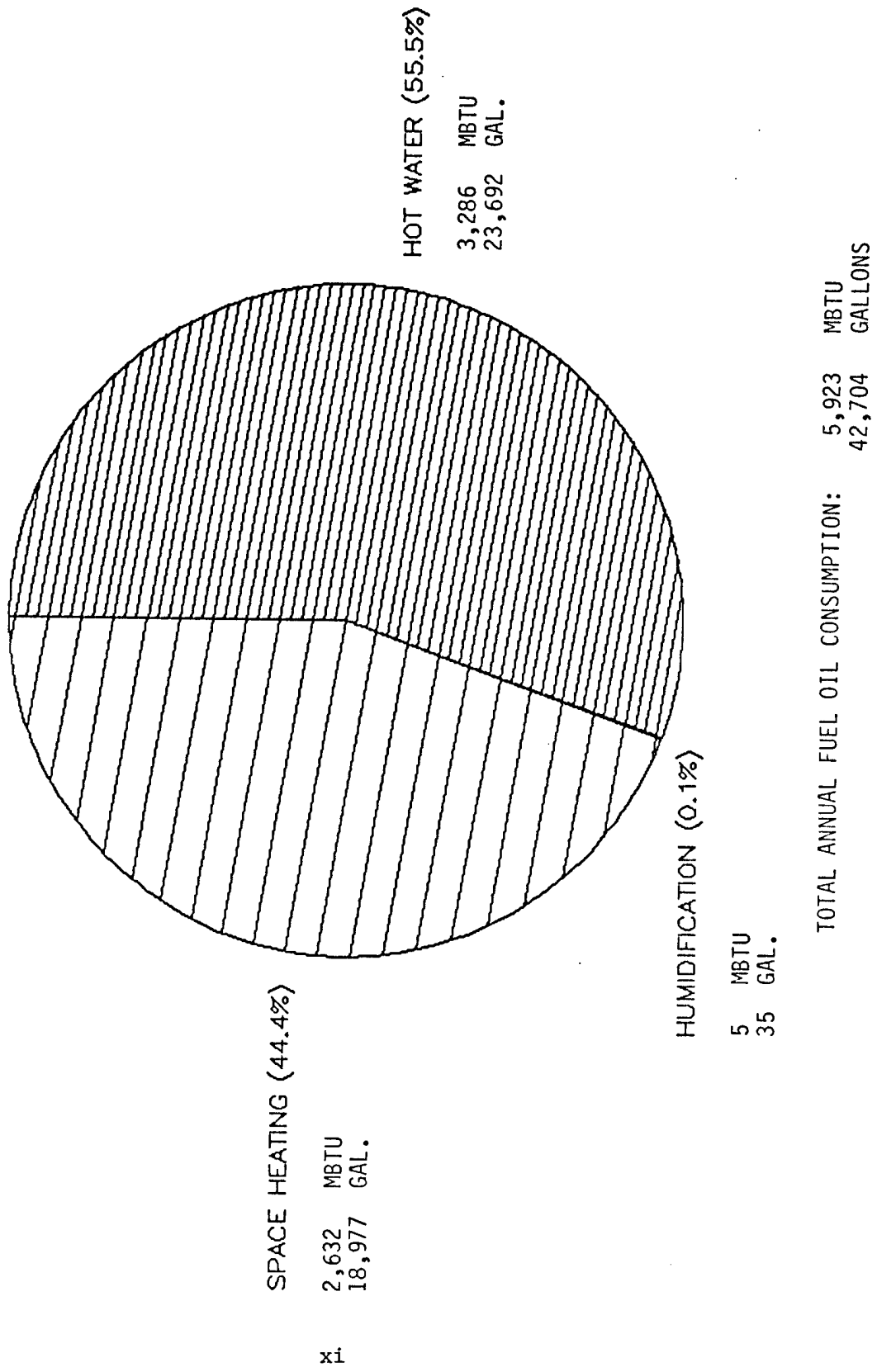

FIG. E-10: BREAKDOWN OF PRESENT ELECTRICAL ENERGY CONSUMPTION FOR BUILDING 1 (FY87)

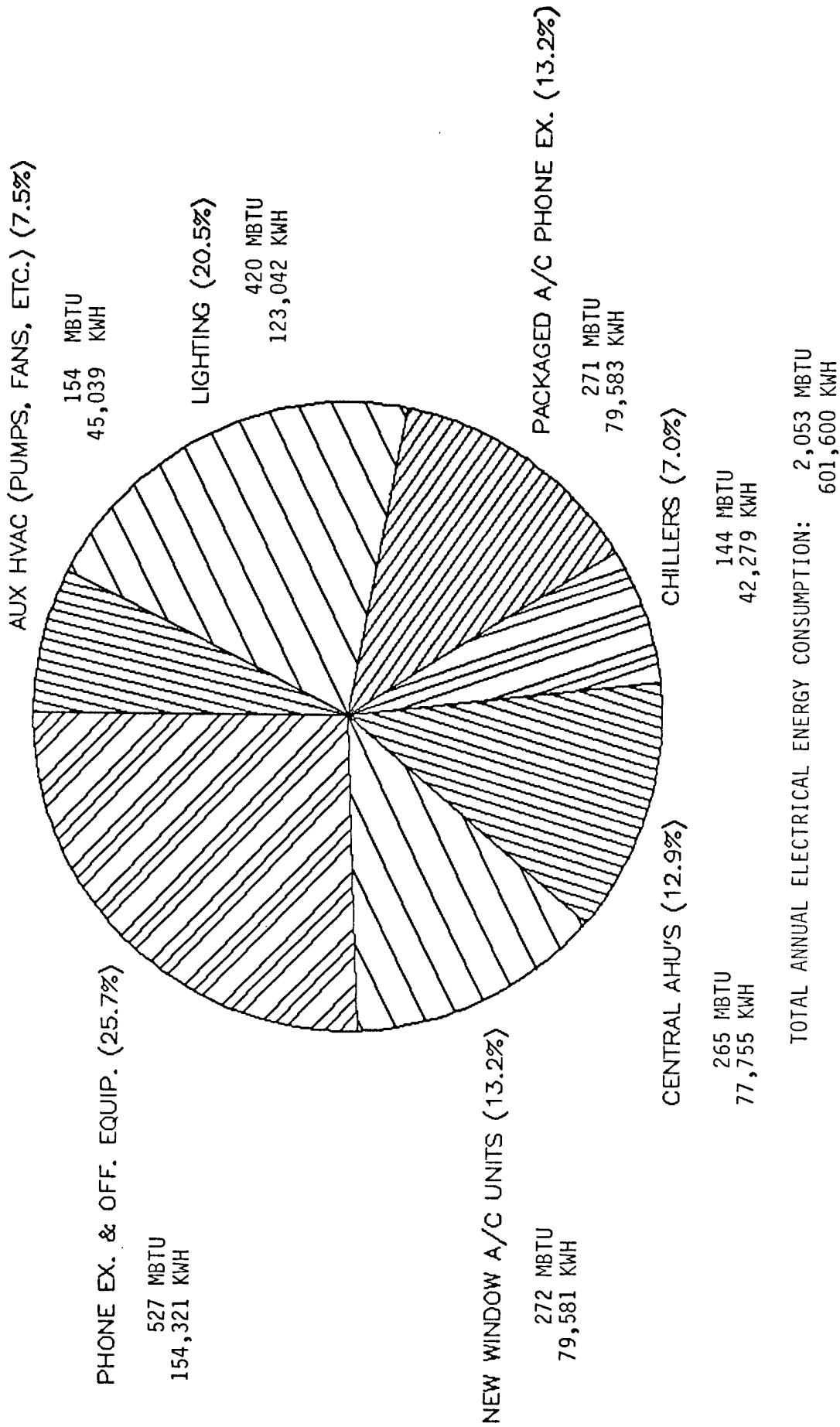
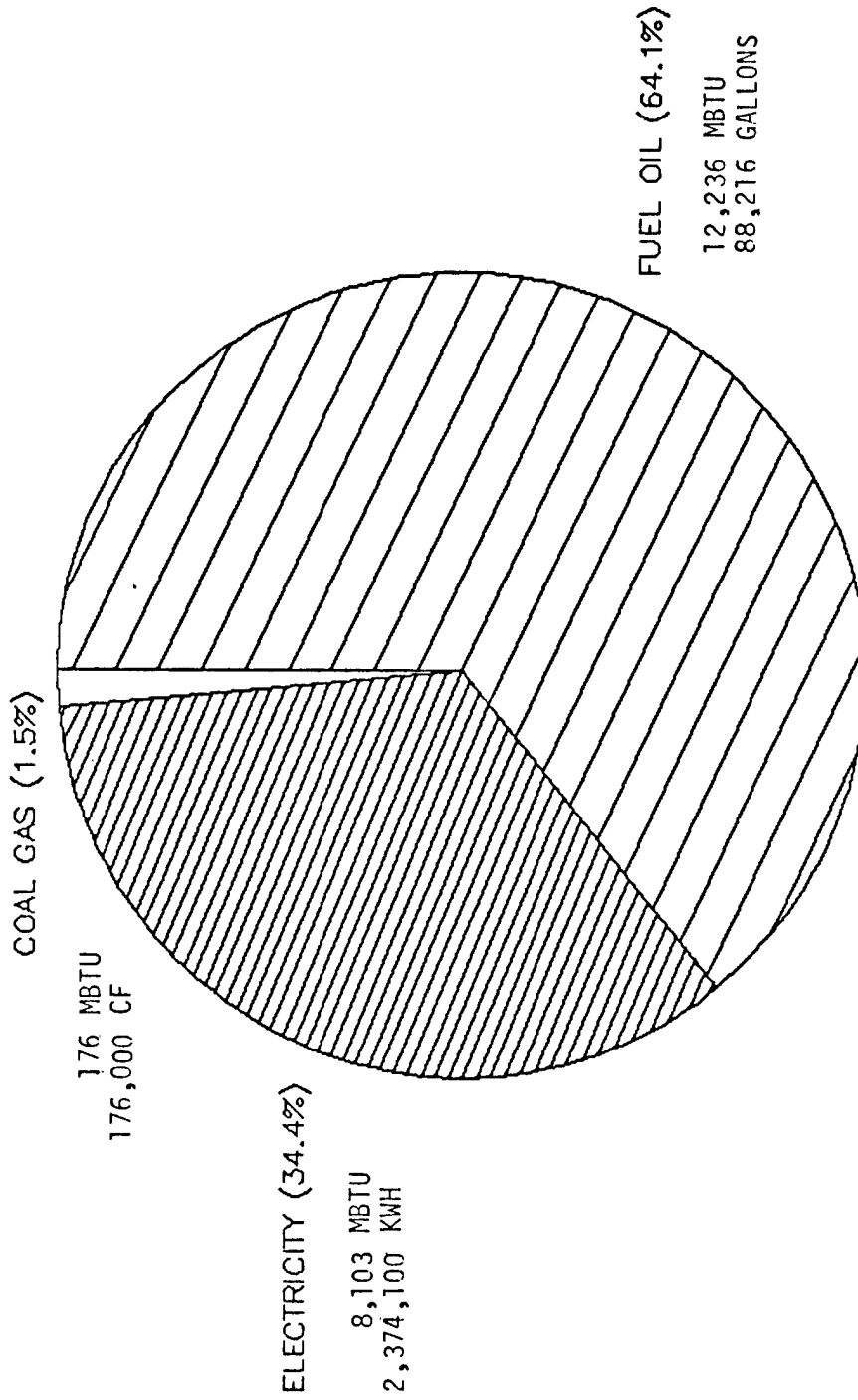

FIG. E-11 : PRESENT ANNUAL ENERGY CONSUMPTION FOR BUILDING 1 & 8 (FY87)



TOTAL ANNUAL ENERGY CONSUMPTION: 20,515 MBTU

FIG. E-12: FY 87 O&M COSTS FOR BLDG 8

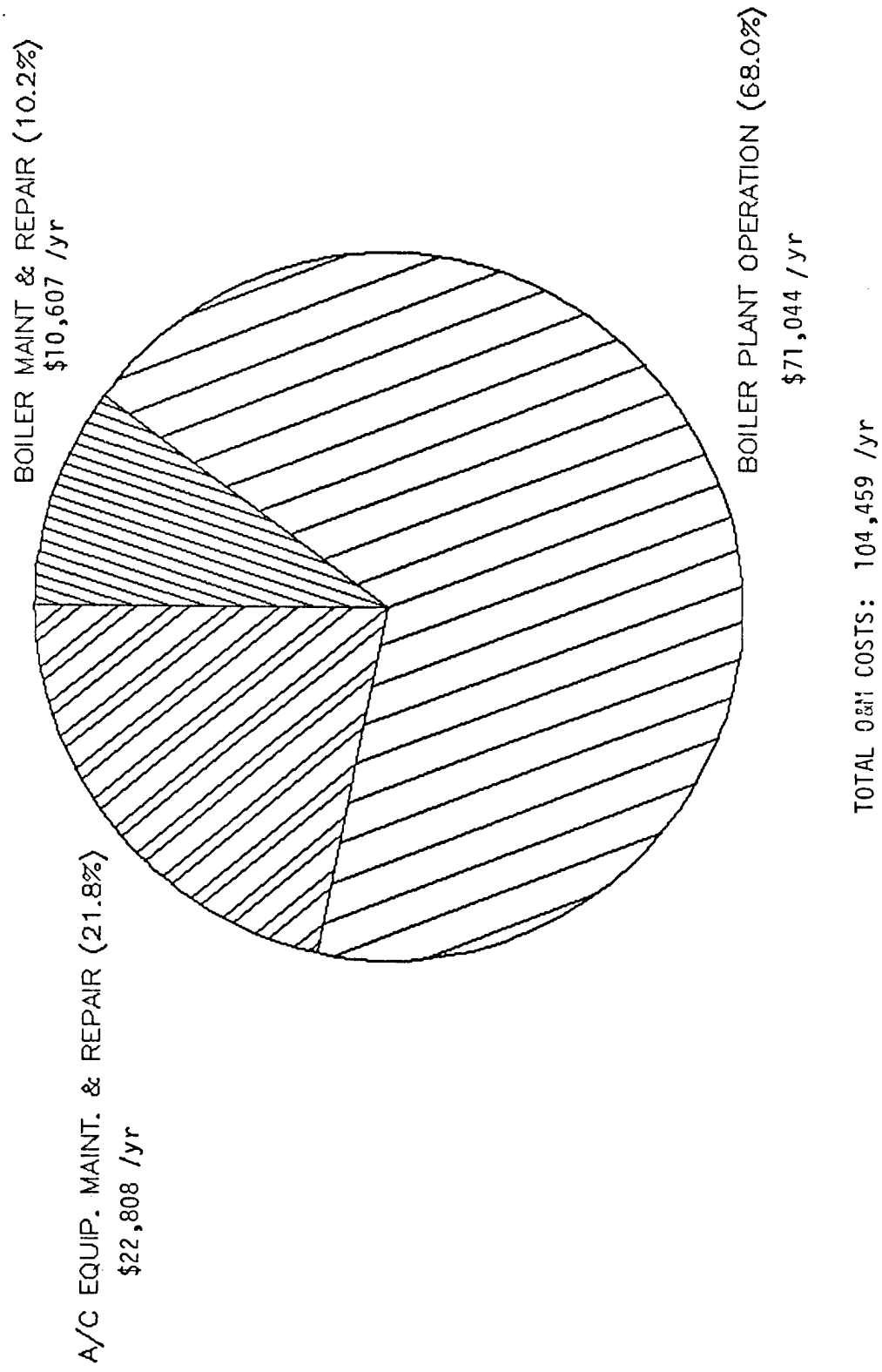
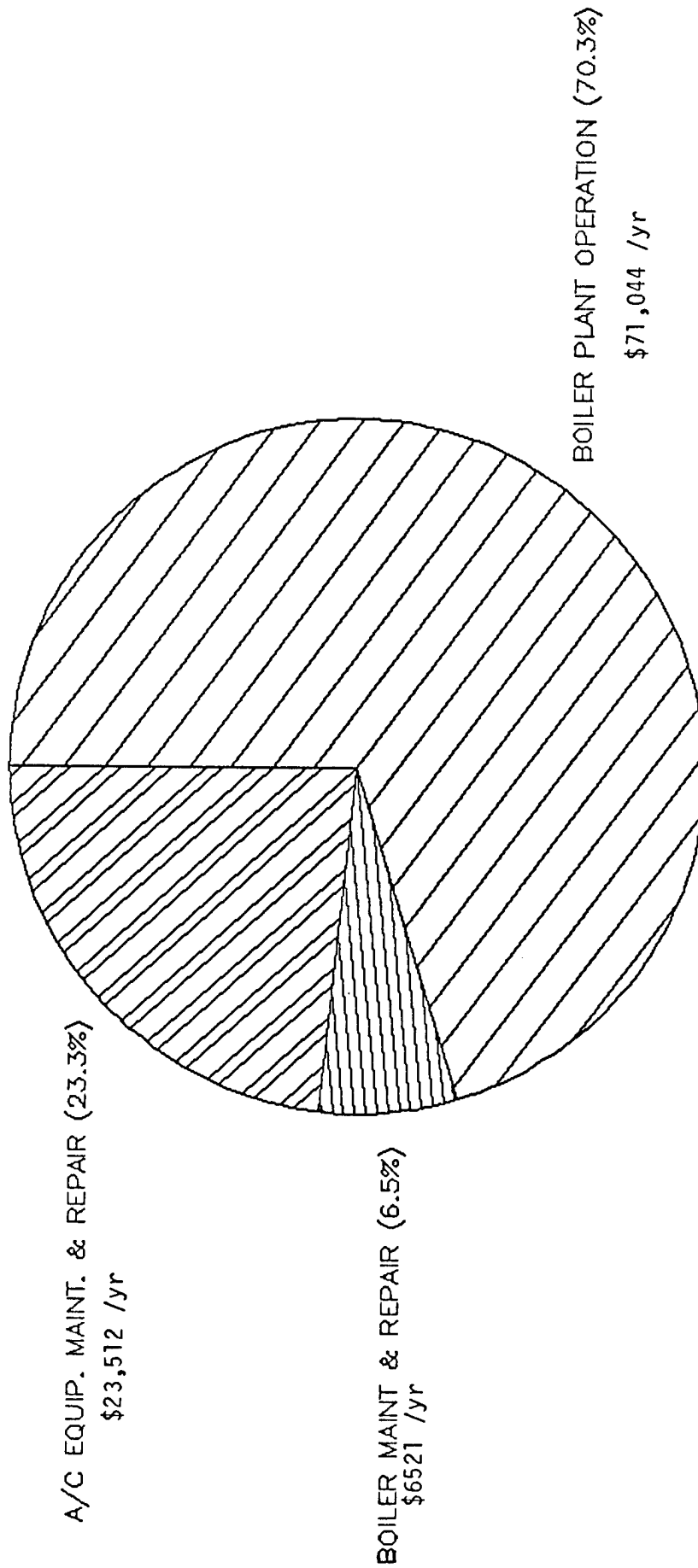



FIG. E-13: FY 87 O&M COSTS FOR BLDG 1



TOTAL O&M COSTS: \$101,077 /yr

### III. Energy Conservation Opportunity (ECO) Analysis and Recommendations:

All reasonable energy conservation opportunities were analyzed for feasibility of reducing energy costs. A summary of the analysis is included in Table E-1 for Building 8 and in Table E-2 for Building 1. No cost ECO's identified in the study which should be implemented are listed in Table E-3 and are summarized as follows:

- 1) Outside air for air handlers "A" and "B" in Building 8 and for the central air handlers in Building 1 should be reduced to 10 cfm per person. The amount of outside air used by air handler "D" which operates as a 100% outside air system should also be reduced by closing off the diffusers to the linotype area which is no longer utilized.
- 2) Room thermostats for the central hvac systems in both buildings should be adjusted from 75 degrees F. to 68 degrees F. for heating and from 75 degrees F. to 78 degrees F. for cooling to comply with Architectural and Engineering Instructions, Design Criteria, dated 13 March 1987.
- 3) Excess air for the boiler plant at Building 8 should be reduced by increasing the concentration of carbon dioxide in the flue gas from 10 to 12 percent.
- 4) Steam pressure for the boiler plant at Building 8 should be lowered from 30 to 15 psig to reduce heating losses.

Recommended ECO's identified in the study included in Table E-4 which require funding to be implemented are summarized as follows:

- 1) Time clocks should be installed to shutdown the restroom fans in

TABLE E-1 : SUMMARY OF FEASIBLE ECO'S FOR BLDG 8

DESCRIPTION	ANNUAL FUEL OIL SAVINGS		ANNUAL ELECTRICAL SAVINGS		ANNUAL ELECTRICAL DEMAND SAVINGS		TOTAL ENERGY SAVINGS		ECC PAYBACK	SIR	
	MBTU	\$	MBTU	\$	MBTU	\$	MBTU	\$			
1. Reduce Outside Air - Short Term	885	4150	34	1105	--	--	919	5255	0	INF.	
2. Lower T-Stats	1042	4485	108	3515	--	--	1150	8000	0	INF.	
3. Reduce Boiler Excess Air	562	2634	--	--	--	--	562	2634	0	INF.	
4. Reduce Steam Pressure	67.5	317	--	--	--	--	67.5	317	0	INF.	
5. Shed Loads During Peak	--	--	--	--	90	9396	90	9396	0	INF.	
6. Shutdown Restroom Fans	--	--	30	964	--	--	30	2100	2.2	4.4	
7. New Boiler - Entire Load	2135	10005	--	--	--	--	2135	15530	5	2.39	
8. New Boiler w/ O2 Trim	2445	11458	--	--	--	--	2445	16983	5	2.29	
9. Install Timeclock on HX and Pump	103.7	486	12.21	397	--	--	115.91	883	4100	5	2.22
10. Operate Exist Generators	-3235	-15161	811	15636	216	22500	-2208	17798	99000	5.6	1.62
11. Boiler O2 Control - Entire Load	310	1453	--	--	--	--	310	1453	10000	7	1.59
12. Consolidated HVAC Plant	2374	11126	265	8813	--	--	2639	145287	1E+06	7	1.53
13. Install Economizer on Computer/Composing Rm ACUs	--	--	138	4499	--	--	138	4499	30000	7	1.44
14. Automated Light Controls	--	--	100.6	3272	--	--	100.6	3272	22000	7	1.43
15. Economizer/Air Preheat - Entire Load	310	1453	--	--	--	--	310	1453	14300	10	1.11
16. Replace Chiller	--	--	337	6514	208	21715	545	28229	264000	9	1.03
17. Install Solar Heaters	26.91	126/PNL	--	--	--	--	26.91	126/PNL	2100/PN	17	0.98
18. New 100 KW Cogenerator	-1276	-5981	1657	28711	100	10440	481	23463	237000	10	0.96
19. New 60 KW Cogenerator	-1036	-4854	1292	22788	60	6264	316	16621	172000	10	0.93
20. New Generator	-1238	-5801	371	7160	100	10440	-767	9623	95000	10	0.92
21. Heat Recovery on Dishwashe	21.2	483	--	--	--	--	21.2(Gas)	483	7200	15	0.77
22. Install Air Curtain	53	452	1.71	56	--	--	98.24	508	7500	15	0.73
23. New 30 KW Cogenerator	565	-2648	646	11394	30	3132	1241	8089	110000	14	0.7
24. Modify Ductwork to Reduce Outside Air	999	4680	316	10296	--	--	1315	14976	327000	22	0.63
25. Recover Heat from Refrigerant Gas	141.2	662	-2.8	-91	--	--	138.4	571	16000	28	0.6
26. Add Bldg Insulation	550.5	2580	15.75	512	--	--	566.25	3092	94000	30	0.52
27. Install Vestibule	53.12	249	12.45	405	--	--	65.57	654	66000	24	0.5
28. New Boiler - Space Heating	522	2449	--	--	--	--	522	2449	56000	23	0.48
29. Boiler Oxygen Control - Space Heat	82	386	--	--	--	--	82	386	10000	26	0.42
30. Modulate HW by O.A. Temp	55	256	--	--	--	--	55	256	7000	27	0.4
31. Add Pipe Insulation	.0957/LF	.45/LF	.0028/LF	.090/LF	--	--	.960/LF	.54/LF	21.84/L	40	0.39
32. Change to VAV	999	4680	764	24859	--	--	1763	29539	806000	27	0.36
33. Economizer/Air Preheat - Space Heat	82	386	--	--	--	--	82	386	13000	34	0.32
34. Install Solar Film	--	--	29.41	956	--	--	29.41	956	42000	44	0.29
35. Install Economizer, Central AC	--	--	22	715	--	--	22	715	26000	36	0.27
36. Recover Heat From Blowdown	30	140	--	--	--	--	30	140	7500	54	0.2
37. Replace Lights	56.92	267	66.5	2164	--	--	66.5	2164	143000	66	0.19
38. Install Storm Windows	--	--	4.2	137	--	--	61.12	404	36000	89	0.17
39. Add Duct Insulation	.0028/SF	.0013/SF	.0003/SF	.011/SF	--	--	.0031/SF	.0284/SF	2.65/SF	110	0.04

THE COSTS SHOWN ARE APPROXIMATE AND SHOULD BE CHECKED AGAINST THE ACTUAL COSTS. THE COSTS ARE NOT TO BE USED FOR BIDDING PURPOSES. THE COSTS ARE NOT TO BE USED FOR BIDDING PURPOSES. THE COSTS ARE NOT TO BE USED FOR BIDDING PURPOSES.

TABLE E-2: SUMMARY OF FEASIBLE ECO'S FOR BLDG 1

DESCRIPTION	ANNUAL FUEL OIL SAVINGS		ANNUAL ELECTRICAL SAVINGS		TOTAL ENERGY SAVINGS		EGG	PAYBACK	S.I.R.
	MBTU	\$	MBTU	\$	MBTU	\$			
1. Reduce Outside Air	692	3245	11.1	492	703.1	3737	0	0	INFINITE
2. Lower T-Stats	922	4322	47.3	2093	969.3	6415	0	0	INFINITE
3. Shutdown Restroom Fans	--	--	14	617	14	617	1400	2.3	4.25
4. Install Economizer on Tel Exchange ACU	--	--	90	3992	90	3992	15000	3.8	2.57
5. Consolidate Bldg 1 Loads to Bldg 8 Central Plant	1057	4954	15.8	699	1072.8	88955	512000	6	1.81
6. Heat Recovery on Tel. Exchange ACU	345	2100	-2.8	-128	342.2	1972	15000	7.6	1.5
7. Automated Light Controls	--	--	90	3986	90	3986	32000	8	1.2
8. Reduce Excess Air with Oxygen Monitor	95.7	449	--	--	95.7	449	5400	12	0.91
9. Add Building Insulation	953	4468	--	--	953	4468	89000	20	0.82
10. Recover Heat from Refrigerant Gas	350	1638	-2.8	-123	347.2	1515	22000	15	0.76
11. Install Solar Film	--	--	42.6	1883	42.6	1883	51000	27	0.47
12. Install Storm Windows	130	609	6.1	270	136.1	879	39000	44	0.34
13. Change to VAV	--	--	341	15077	341	15077	680000	45	0.21
14. Economizer on Central AC	--	--	32	1413	32	1413	81000	57	0.17
15. Recover Waste Heat From Blowdown	14.5	68	--	--	14.5	68	7500	110	0.15
16. Replace Lighting	--	--	6.5	289	6.5	289	90000	311	0.03

THESE ARE COST A  
 WITH THESE ECOS  
 STAYS IN ENERGY ARE LOW  
 COST AND INCLUDE THE  
 COST OF MAINTENANCE

TABLE E-3 SUMMARY OF RECOMMENDED NO COST ECO'S

	FUEL SAVINGS		ELECTRICAL SAVINGS		TOTAL SAVINGS	
	MBTU/YR	\$/YR	MBTU/YR	\$/YR	MBTU/YR	\$/YR
<b>BLDG 1</b>						
1. Reduce Outside Air	692	3245	11	492	703	3737
2. Adjust T-Stats	922	4322	47	2093	969	6415
SUBTOTAL	1614	7567	58	2585	1672	10152
<b>BLDG 8</b>						
1. Reduce Outside Air	885	4150	34	1105	919	5255
2. Adjust T-Stats	1042	4885	108	3515	1150	8400
3. Reduce Boiler Excess Air	562	2634			562	2634
4. Reduce Steam Pressure	68	317			68	317
SUBTOTAL	2557	11986	142	4620	2699	16606
<b>TOTAL SAVINGS FOR BUILDINGS 1 &amp; 8</b>						
	4171	19553	200	7205	4371	26758

TABLE E-4 SUMMARY OF RECOMMENDED ECO'S REQUIRING FUNDING

PROJECT TITLE	ANNUAL ENERGY SAVINGS		ANNUAL ENERGY COST SAVINGS \$/YR	ANNUAL OPERATIONAL/ MAINTENANCE SAVINGS \$/YR	TOTAL ANNUAL SAVINGS \$/YR	ESTIMATED CONSTRUCTION COST \$/YR	PAYBACK YEARS	SIR	POSSIBLE SOURCES OF FUNDING	
	FUEL OIL MBTU/YR	ELECTRICITY MBTU/YR								
1. Shutdown restroom fans, Bldgs 1 & 8*	0	44	1581	0	1581	3500	2.2	3.9	PECIP	
2. Install Economizer, Bldg 1, Telephone Exchange ACU	0	90	3992	0	3992	15000	3.8	2.6	PECIP	
3. New 125 hp boiler w/ Oxygen trim	2445	0	11458	5525	16983	76000	4.5	5	2.3	OMA
4. Install timeclock on boiler, Bldg 8	104	12	883	0	883	4100	4.5	2.2	OMA	
5. Install switchgear to operate exist generators	-3235	811	17798	0	17798	99000	5.6	1.6	OMA	
6. Consolidate hvac plants/replace AHU's	2274	265	19939	125348	145287	1000000	6.7	1.5	MCA	
7. Install economizer Bldg 8 computer room/composing room ACU's	0	138	4499	0	4499	30000	6.7	1.4	OMA	
8. New 250 ton centrifugal chiller	0	337	28229	0	28229	264000	2.4	1.03	OMA	
TOTAL	1826	1559	88379	130872	219252	1491600				

REMARKS: SEE ATTACHED SHEETS FOR FUNDING AND PAYBACK CALCULATIONS. THE TOTAL FUNDING REQUIRED FOR THESE ECO'S IS \$1,491,600. MEAN COVER PAGE 6.8

\*ECO's for shutdown of restroom fans for Bldgs 1 & 8 combined to qualify for PECIP funding.

both buildings after working hours.

- 2) Economizer cycles should be installed on the air conditioners serving the telephone exchange in Building 1 and the computer/composing areas in Building 8.
- 3) A time clock should be installed to shut down the hot water return pump and close the stem valve to the hot water heat exchanger in Building 8 after work hours.
- 4) Automatic switchgear should be installed to operate the existing emergency generators as peak demand sharing units during the summer months to reduce the peak demand charge for electricity.
- 5) The central plant at Building 1 should be eliminated and the heating and cooling loads consolidated into the central plant at Building 8. This would eliminate the need for maintenance, operation and repair of the boiler plant at Building 1 and the maintenance and repair of the separate air conditioning systems. Existing air handlers at both buildings should be replaced and the duct systems for AHU's "C" and "D" at Building 8 converted to 100% recirculation systems. All steam heating coils at Building 8 should also be converted to a hydronic heating system. These changes would allow the buildings to be heated and cooled by a central dual pipe hot water/chilled water system and eliminate the need for steam. This would further reduce the labor required for 24 hour operation of the boiler plant at Building 8. Reduction of the outside air used for air handlers "C" and "D" would also reduce the peak heating and cooling loads so that the capacity of the existing boiler and chilled water plant at Building 8 would be adequate to heat and cool both buildings.

- 6) One of the existing 80 hp boilers at Building 8 should be replaced with a new fully modulating oxygen trim central boiler. The existing boilers are relatively inefficient and are near the end of their useful lives. The other remaining boiler should serve as back-up to the new boiler. The new boiler would provide all of the heating for space and domestic water heating for the buildings.
- 7) The existing centrifugal chiller should be replaced with a new 250 ton centrifugal chiller because it is also near the end of its' useful life. The new chiller should be provided with demand limiting control to reduce its' capacity during the summer peak demand hours when the printing presses are also in operation.

IV. Projected Energy Consumption and Costs After Implementation of ECO's:

Impact of the implementation of the ECO's in present energy consumption and costs are summarized in Figures E-14 and E-15. No cost/low cost ECO's would generate a total savings of 4,171 MBtu per year or 30,072 gallons in fuel oil and 200 MBtu per year or 58,599 kwh in electricity, for a total annual energy savings of \$26,758. This would amount to a 21% reduction in energy consumption over present energy use and an 8% reduction in energy costs.

Implementation of all recommended ECO's requiring funding would reduce energy consumption by an additional 1,826 MBtu per year or 13,165 gallons in fuel oil, 1,559 MBtu per year or 456,703 kwh in electricity, and 424 kw in electrical demand, for a total annual energy cost savings of \$88,379. This would amount to an additional 17 percent reduction over present energy use and a 25% reduction in present energy costs.



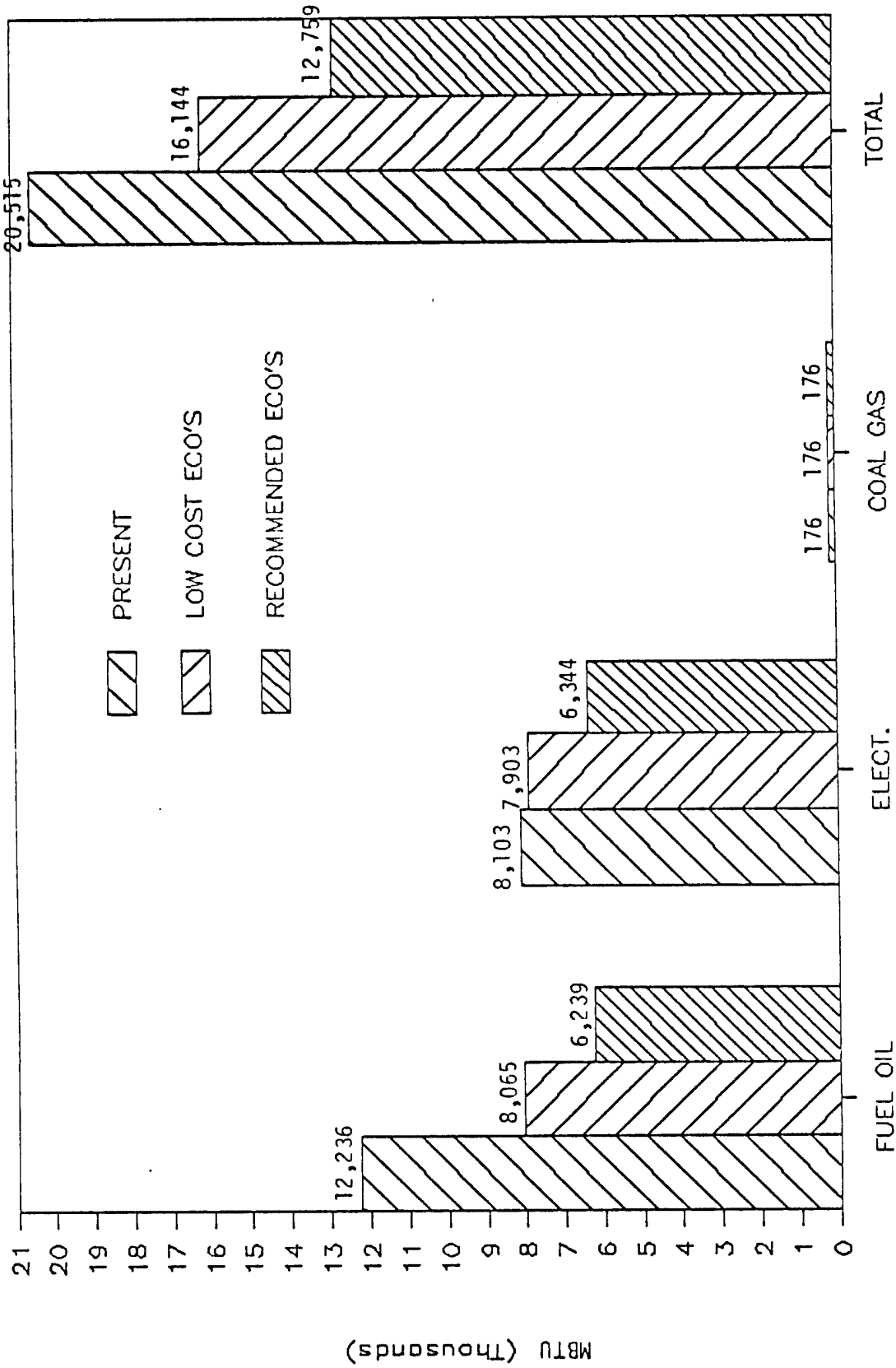

FIG. E-14: PROJECTED ANNUAL ENERGY USE FOR BUILDINGS 1 & 8

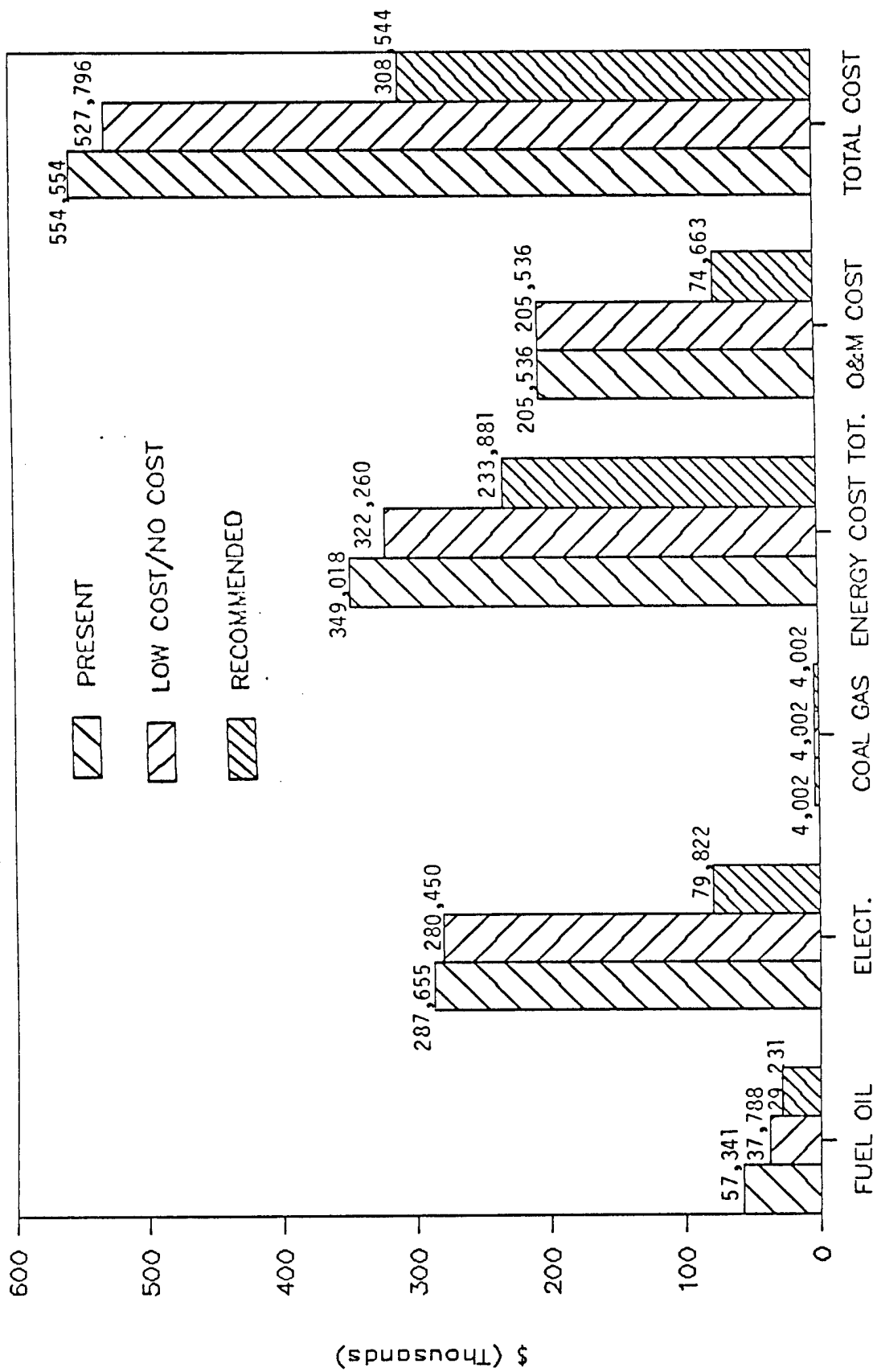

FIG. E-15: PROJECTED ANNUAL ENERGY, OPERATING & MAINTENANCE COSTS FOR BUILDINGS 1 & 8

An additional savings of \$130,873 or a 64% reduction in avoided operating and maintenance cost would also be realized.

Combined energy savings of all ECO's would result in an overall reduction in energy usage of 38% and an overall reduction in energy costs of 33%. Total cost savings for implementation of all recommended ECO's is estimated at \$115,137 per year in energy costs, and \$130,873 in maintenance, operation and repair costs, for a total of \$246,010 per year. This represents an overall cost reduction of 44% over the current utility, operating, and maintenance costs for the facilities.

PERHAPS THE % REDUCTIONS BY BUILDING WOULD ALSO BE USEFUL. AS THE NARRATIVE AND THE ECOS ARE GIVEN BY BUILDING, IT WOULD SEEM LOGICAL TO PRESENT THE RESULTS BY BUILDING, PROVIDE THE INFORMATION.

CHANGES WILL NEED TO BE MADE TO BOTH EXECUTIVE SUMMARIES

## EXECUTIVE SUMMARY

I. Introduction/Background: This study includes a complete energy audit and analysis for Buildings 1 and 8 at the Akasaka Press Center, Tokyo, Japan. Building 1 is a six story, 54,200 square foot building which contains administrative offices on the first through third floor, and bachelors' enlisted quarters and officers' quarters on the fourth through sixth floor. Building 8 is a four story, 91,000 square foot building which houses the offices, printing, and press operations of the newspaper, "Pacific Stars and Stripes".

II. Present Energy Consumption and Costs: Present energy consumption and costs for FY87 for Buildings 8 and 1, based on utility records and based on an exchange rate of 163.1 yen per U. S. dollar for FY87 are summarized as follows:

Total Energy Costs: The energy costs for Building 8 totaled \$230,388 in FY87. A breakdown of the utility costs is shown in Figure E-1. Approximately 86% of the cost for energy was for electricity, while fuel oil accounted for 13% and coal gas for the remaining 1%. The energy costs for Building 1 totaled \$118,630 in FY87. A breakdown of the utility costs is shown in Figure E-2. Electricity represented approximately 77% of the total energy cost, while fuel oil accounted for the remaining 23%.

A summary of the total energy costs for both buildings is shown in Figure E-3. Total annual energy cost for the buildings amounted to \$344,018 in FY87.

FIG. E-1: ENERGY COSTS FOR BUILDING 8

ENERGY COSTS FOR BLDG 8

ELECTRICITY: \$36.75/MBTU  
\$0.1110/KWH

FUEL OIL: \$4.69/MBTU  
\$0.65/GAL.

COAL GAS: \$11.68/MBTU  
\$11.68/1000 CF

ELECTRICAL RATE SCHEDULE  
(INCLUSIVE OF DISCOUNTS)

DEMAND: \$8.70

SUMMER ENERGY CHARGE  
(JUNE THRU SEPT):

\$19.28/MBTU  
\$0.0658/KWH

OTHER THAN SUMMER CHARGE:

\$16.82/MBTU  
\$0.0574/KWH

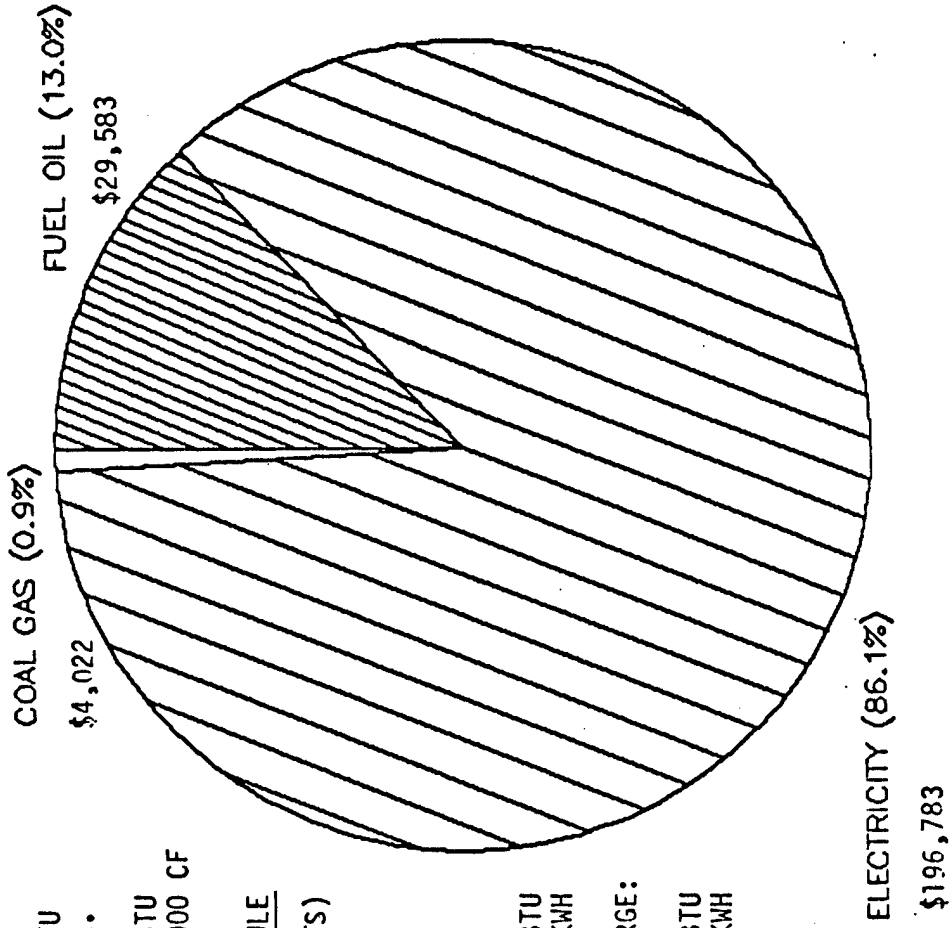

TOTAL ANNUAL ENERGY COST: \$230,388

FIG. E-2: ENERGY COSTS FOR BUILDING 1

ENERGY COSTS FOR BLDG 1

ELECTRICITY: \$44.24/MBTU  
\$0.1510/KWH

FUEL OIL: \$4.69/MBTU  
\$0.65/GAL.

ELECTRICAL RATE SCHEDULE  
(INCLUSIVE OF DISCOUNTS)

DEMAND: \$8.75/KW

SUMMER ENERGY CHARGE  
(JUNE THRU SEPT):

\$31.23/MBTU  
\$0.1066/KWH

OTHER THAN SUMMER CHARGE:

\$27.69/MBTU  
\$0.0945/KWH

ELECTRICITY (76.6%)

\$90,872

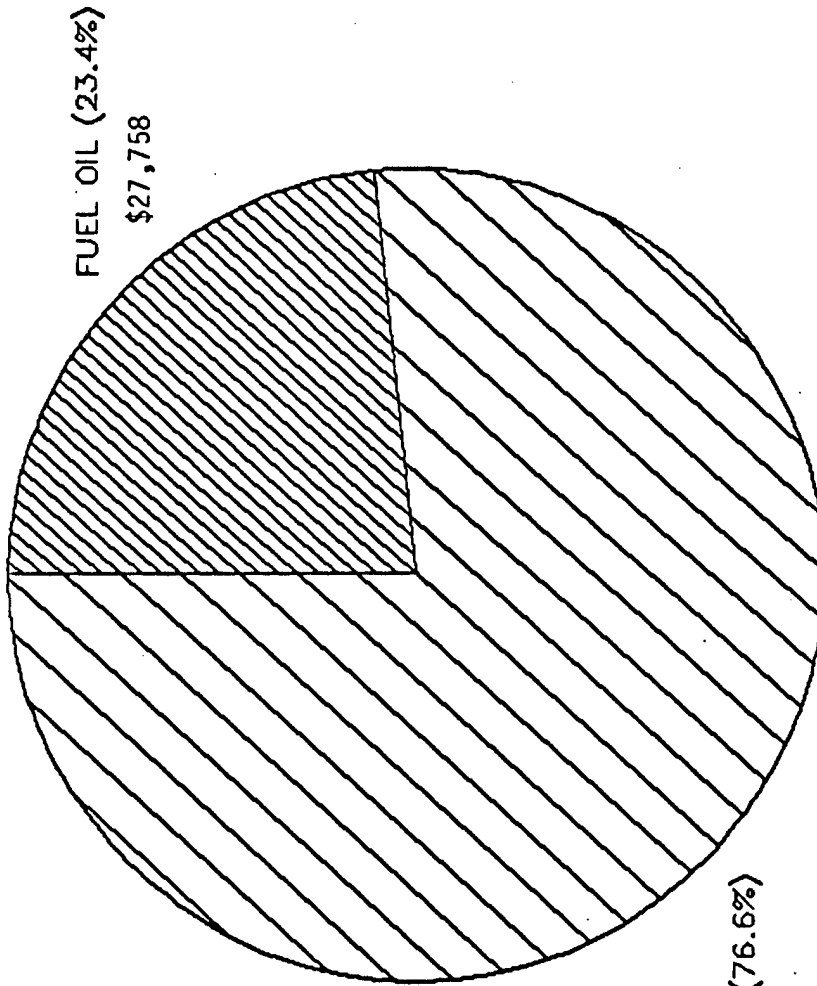

TOTAL ANNUAL ENERGY: \$118,630

FIG. E-3: FY87 ENERGY COST FOR BUILDING 1 & 8

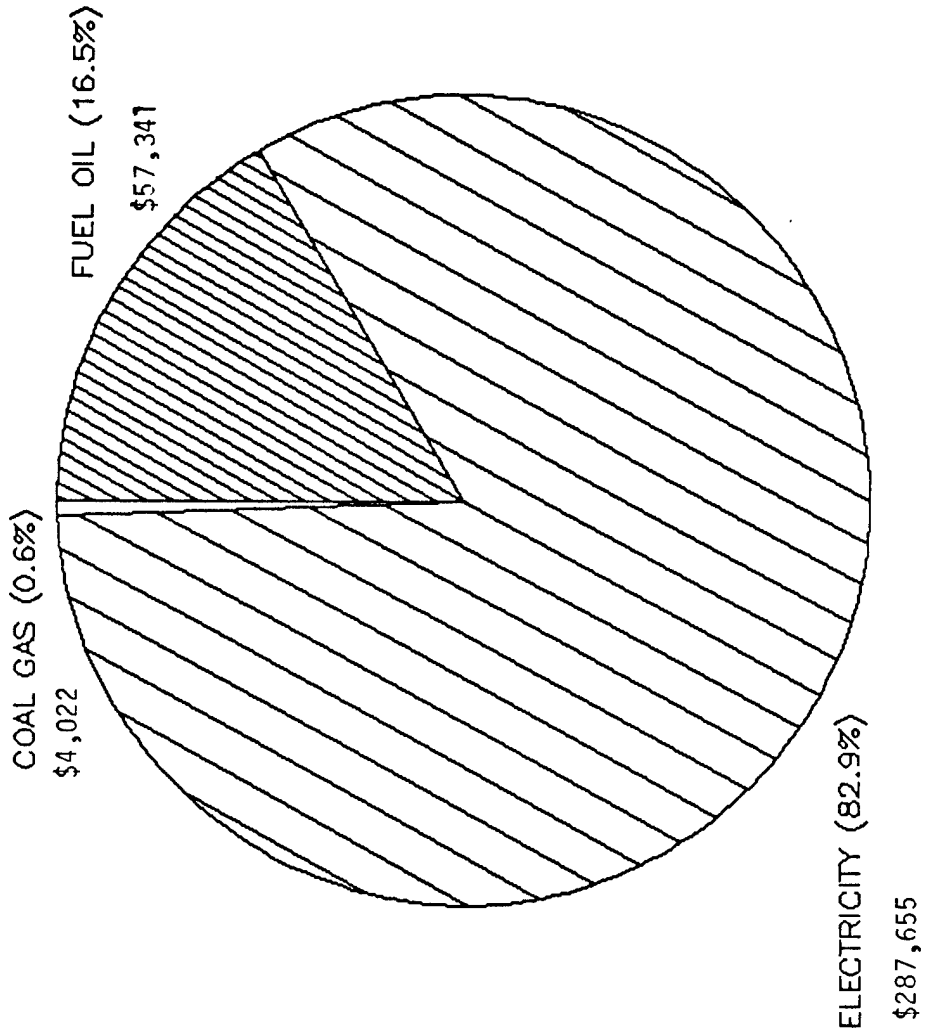

TOTAL ANNUAL ENERGY COST: \$349,018

Total annual energy consumption in Building 8 is shown in Figure E-4. The total annual energy consumption for the building of 12,539 MBtu is categorized as follows: 48% is for electricity, 50% is for fuel oil, and 2% is for coal gas. A more detailed breakdown of current electrical consumption, fuel oil consumption, and coal gas consumption is included in Figures E-5, E-6, and E-7, respectively.

Total annual energy consumption for Building 1 is also shown in Figure E-8. The total annual energy consumption of 7,976 MBtu is comprised of 74% for fuel oil and 26% for electricity. A breakdown of current electrical consumption and fuel oil consumption for Building 1 are also included in Figures E-9 and E-10, respectively.

Overall annual energy consumption of the facilities totaled 20,515 MBtu as shown in Figure E-11.

Total maintenance, operation and repair costs for Building 8 amounted to \$104,459 in FY87 as shown in Figure E-12. Approximately 68.0% of the costs were for operation of the boiler plant, 10% of the cost was for boiler maintenance and repair, while the remaining 22% was for upkeep of the air conditioning systems.

Total maintenance, operation and repair costs for Building 1 amounted to \$101,077 in FY87 and is included in Figure E-13. Approximately 70.3% of the cost was for operation of the boiler plant, 6.5% was for boiler maintenance and repair, and the remaining 23.3% was for upkeep of the air conditioning systems. Total maintenance, operation and repair costs for upkeep of the hvac equipment for Buildings 8 and 1 totaled \$205,536 in FY87.



FIG. E-4: PRESENT ANNUAL ENERGY CONSUMPTION FOR BUILDING 8 (FY87)

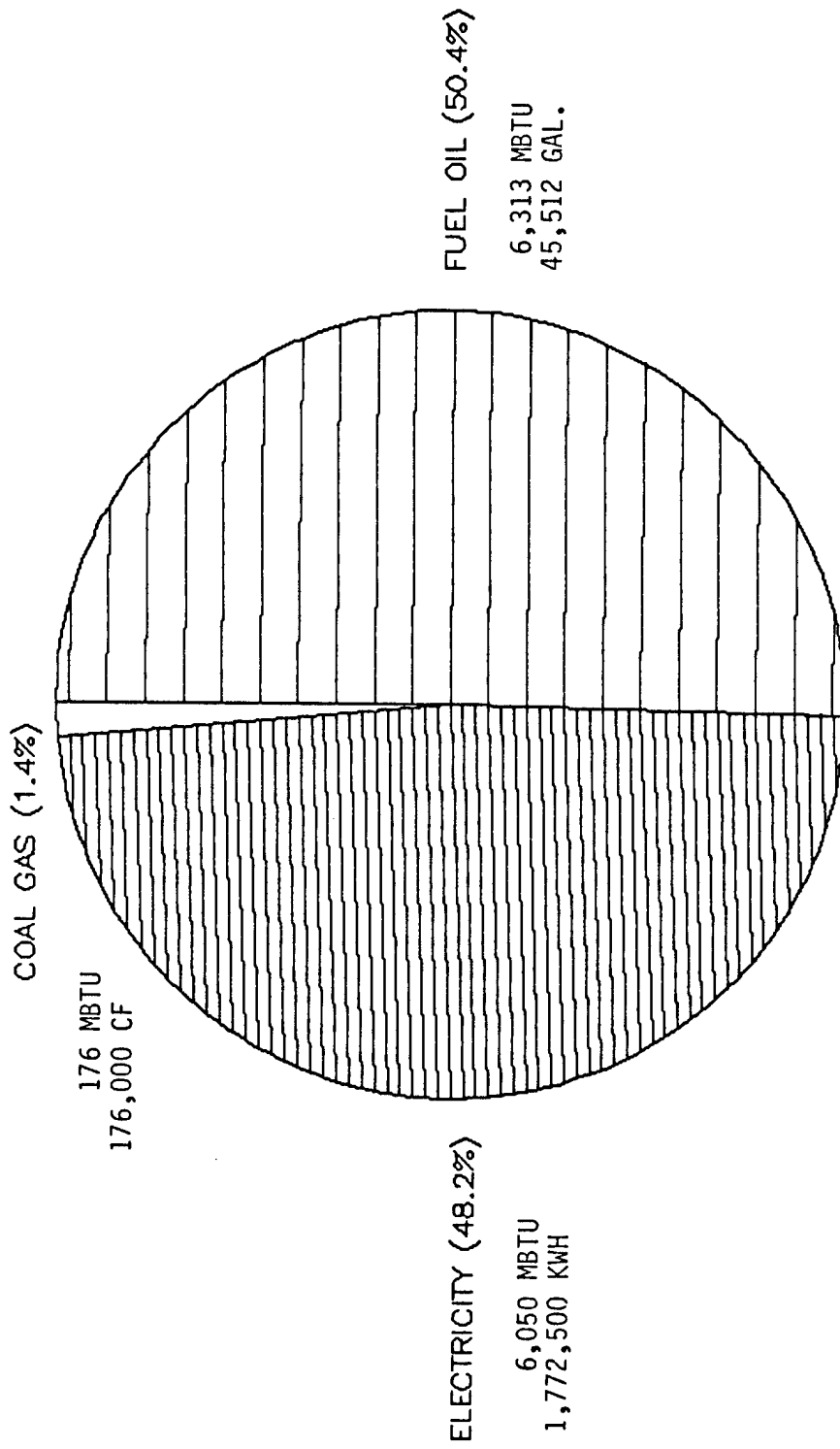

TOTAL ANNUAL ENERGY CONSUMPTION: 12,539 MBTU

FIG. E-5: BREAKDOWN OF PRESENT ELECTRICAL ENERGY CONSUMPTION FOR BUILDING 8 (FY87)

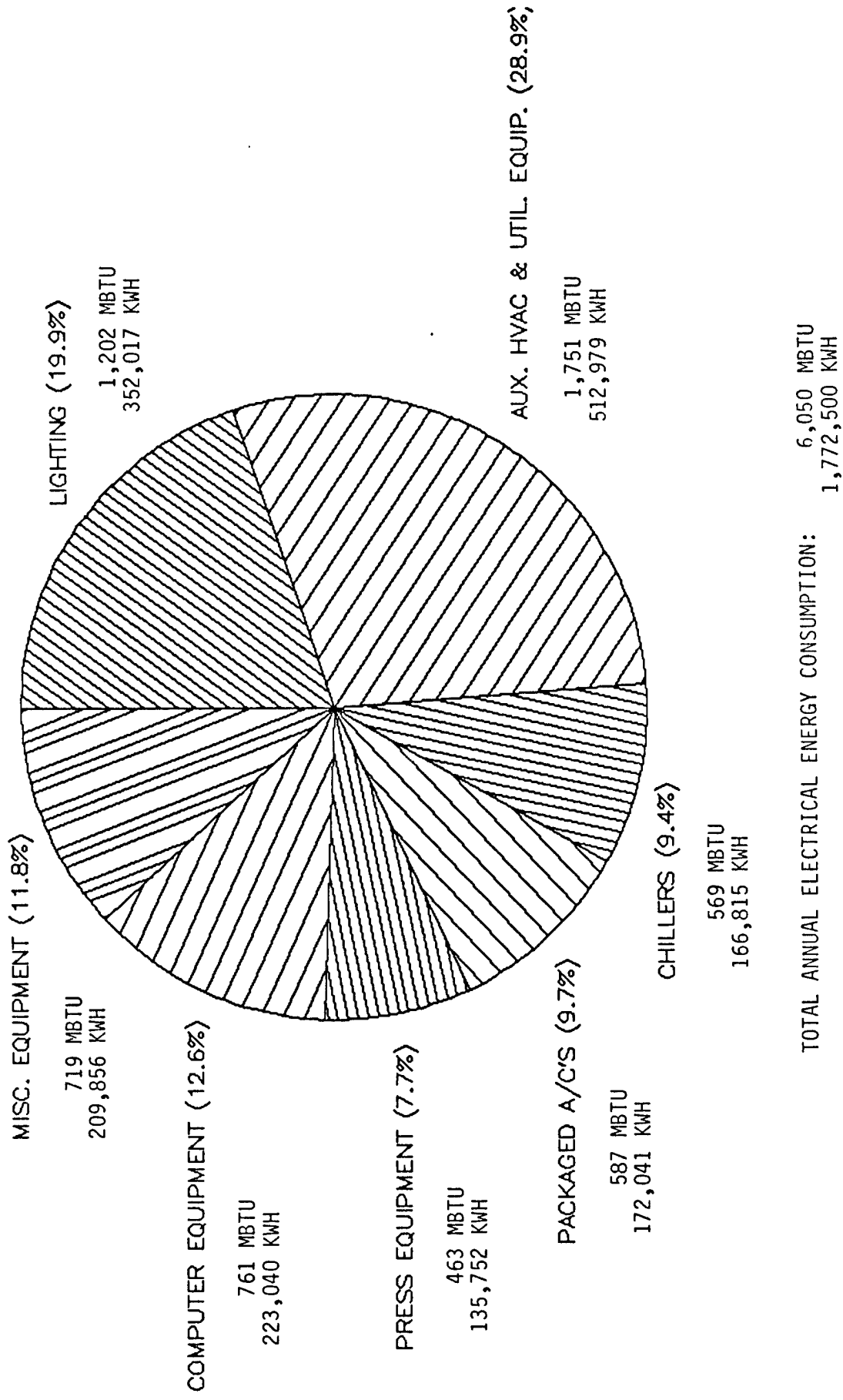

FIG. E-6: BREAKDOWN OF PRESENT FUEL OIL CONSUMPTION FOR BUILDING 8 (FY87)

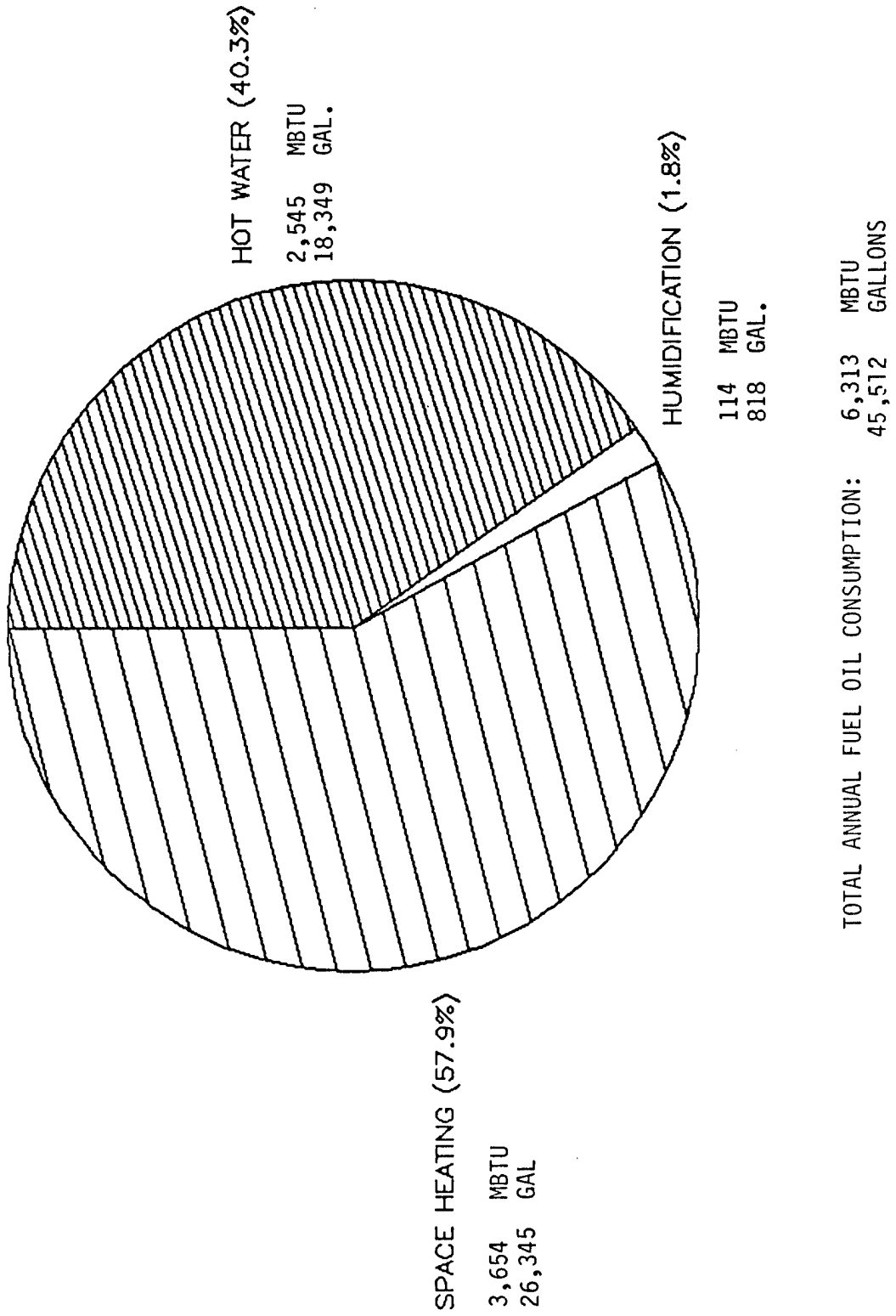
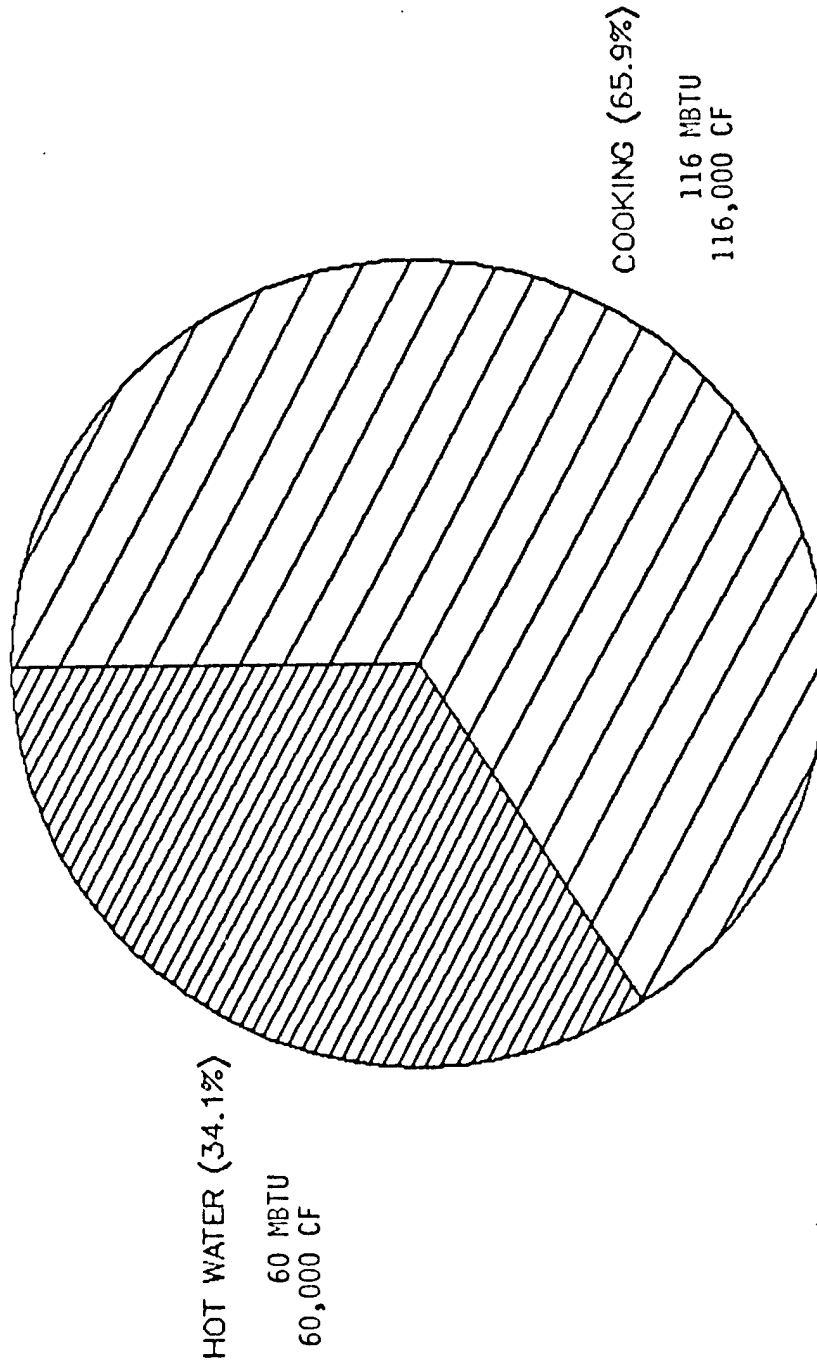
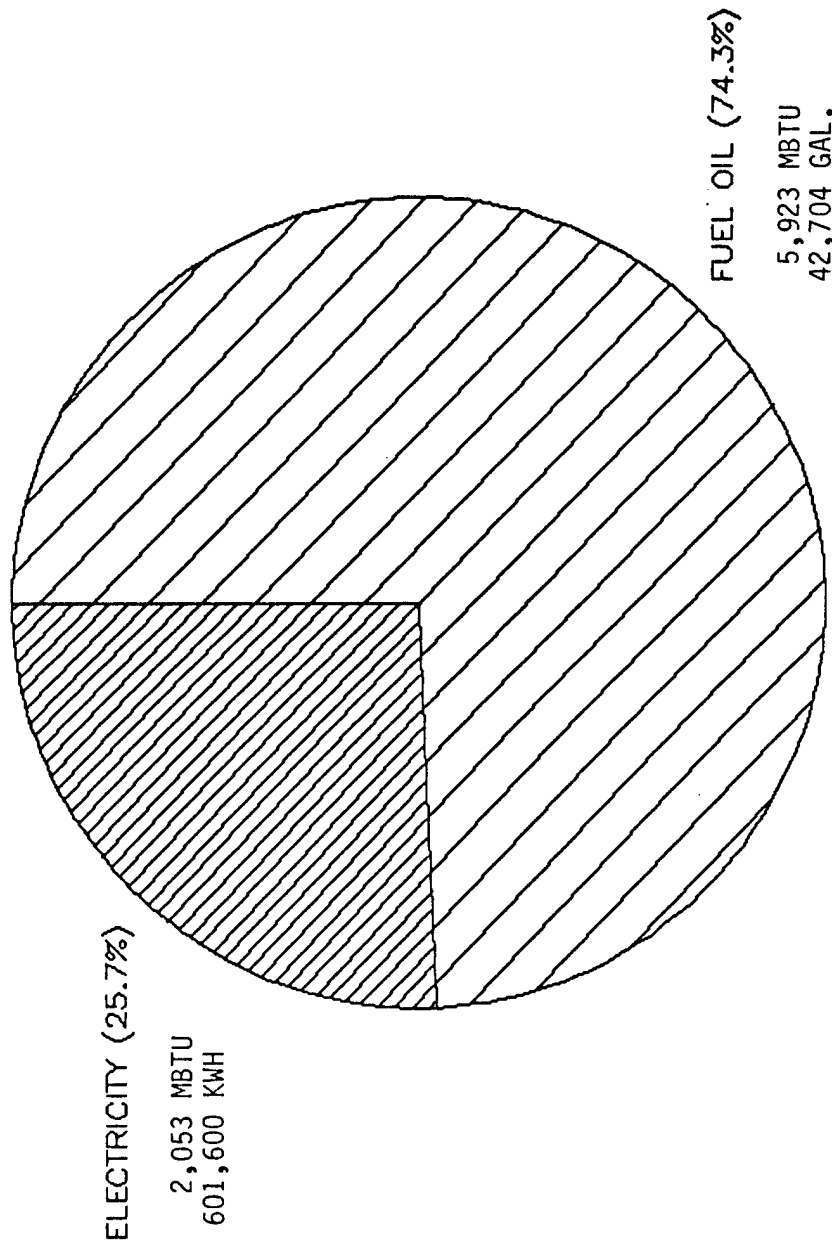

FIG. E-7: BREAKDOWN OF PRESENT ANNUAL COAL GAS CONSUMPTION FOR BUILDING 8 (FY87)



TOTAL ANNUAL COAL GAS CONSUMPTION: 176 MBTU  
176,000 CUBIC FEET

FIG. E-8: PRESENT ANNUAL ENERGY CONSUMPTION FOR BUILDING 1 (FY87)



TOTAL ANNUAL ENERGY CONSUMPTION: 7,976 MBTU

FIG. E-9: BREAKDOWN OF PRESENT FUEL OIL CONSUMPTION FOR BUILDING 1 (FY87)

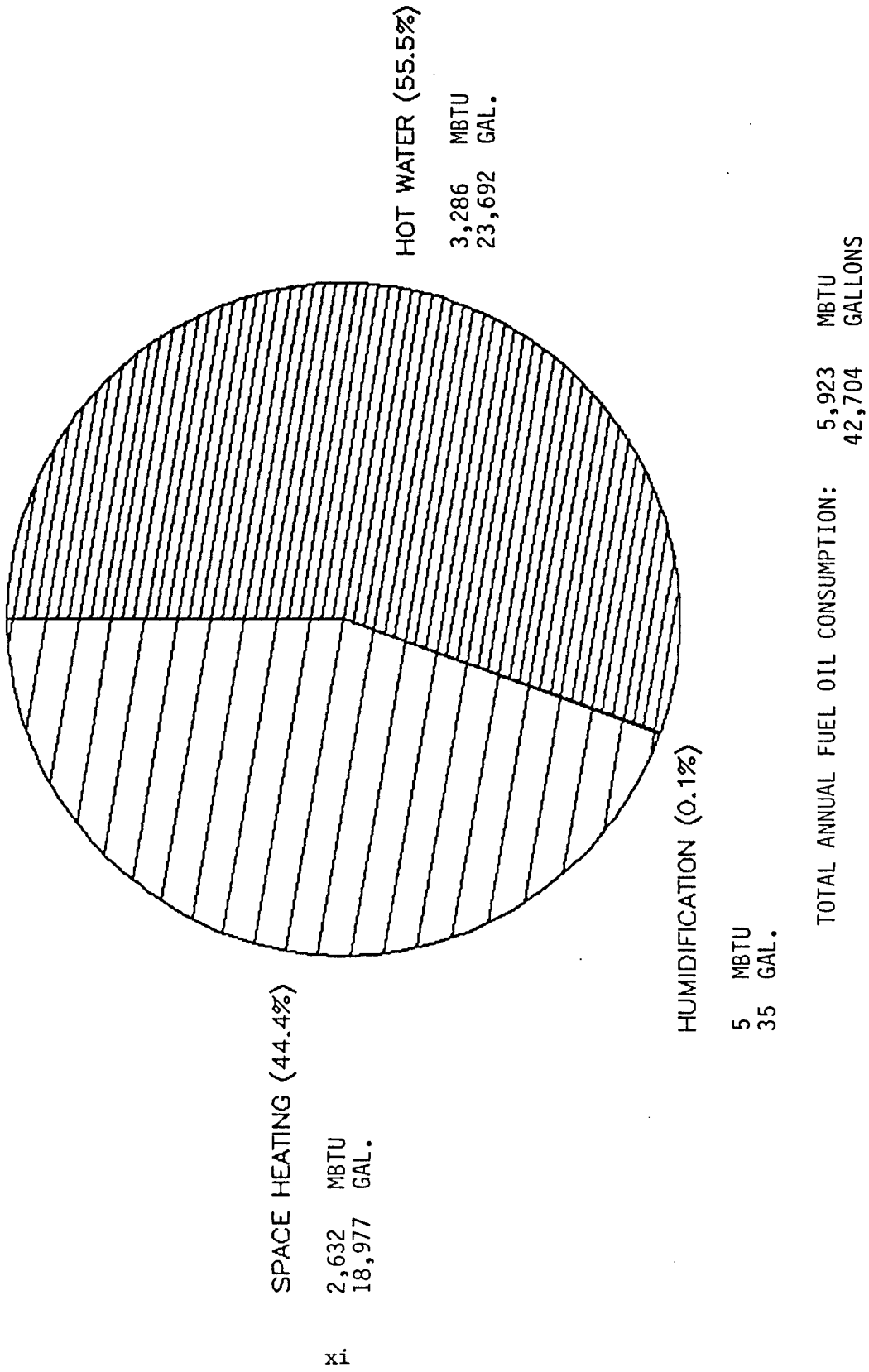

FIG. E-10: BREAKDOWN OF PRESENT ELECTRICAL ENERGY CONSUMPTION FOR BUILDING 1 (FY87)

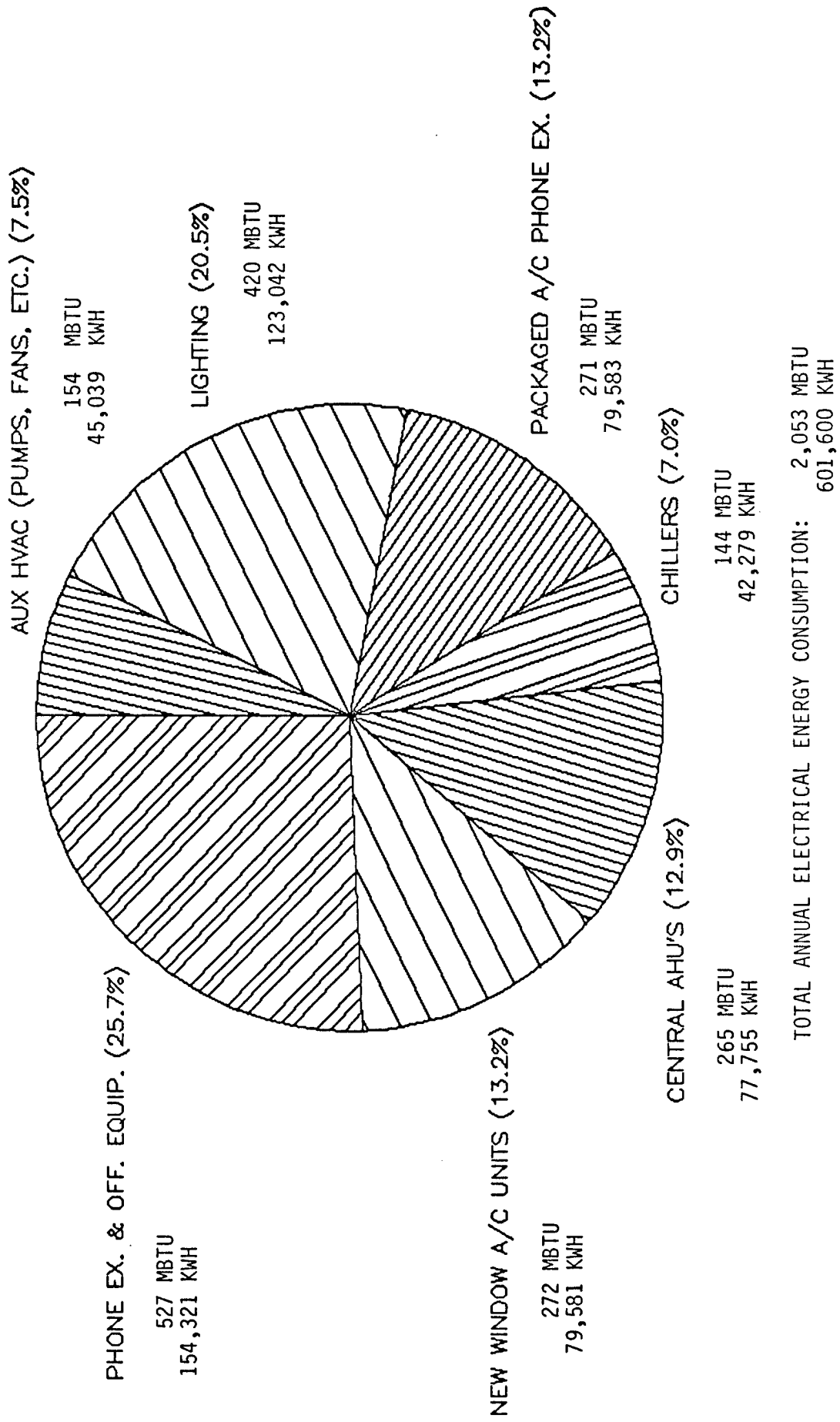
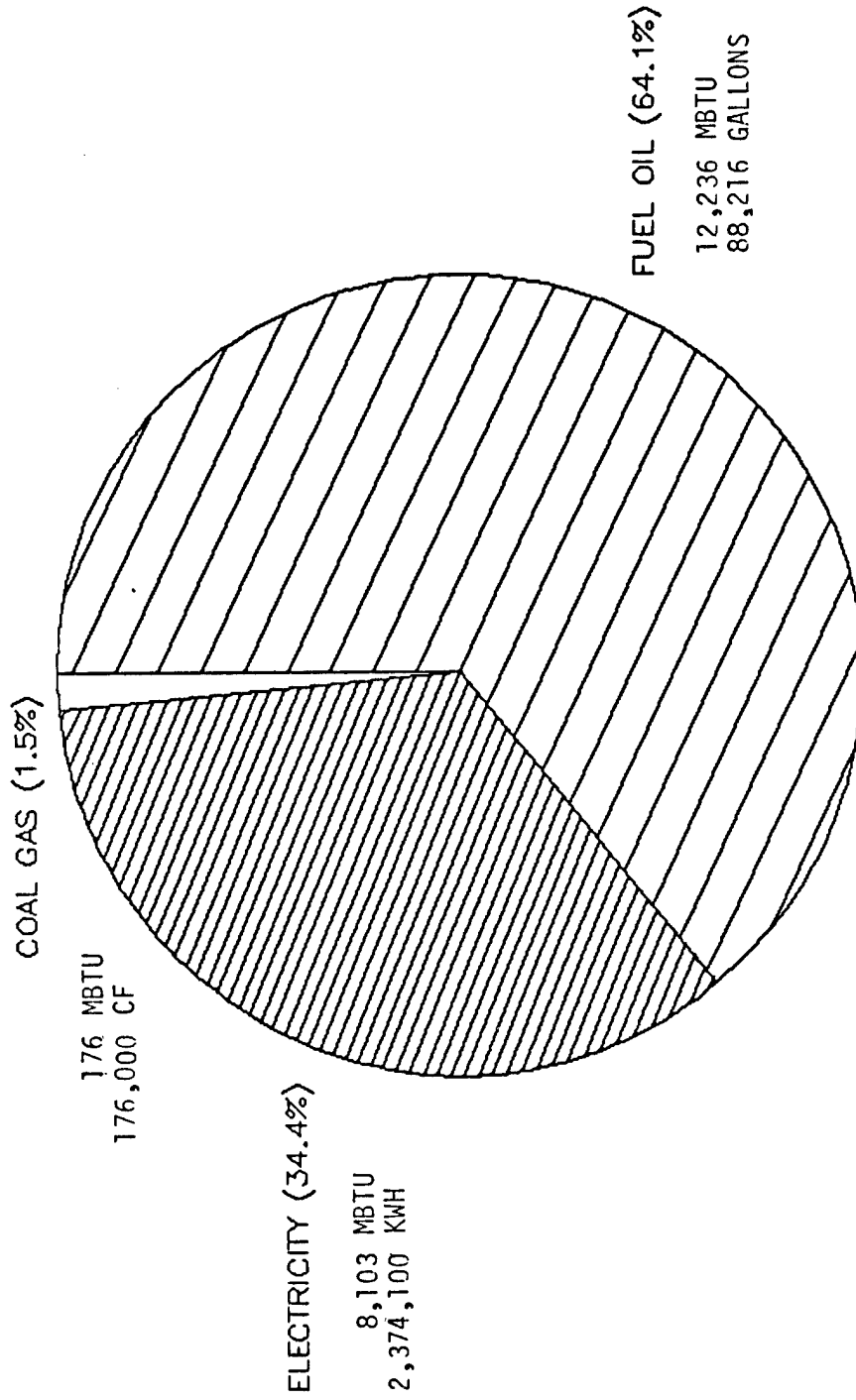

FIG. E-11 : PRESENT ANNUAL ENERGY CONSUMPTION FOR BUILDING 1 & 8 (FY87)



TOTAL ANNUAL ENERGY CONSUMPTION: 20,515 MBTU



FIG. E-12: FY 87 O&M COSTS FOR BLDG 8

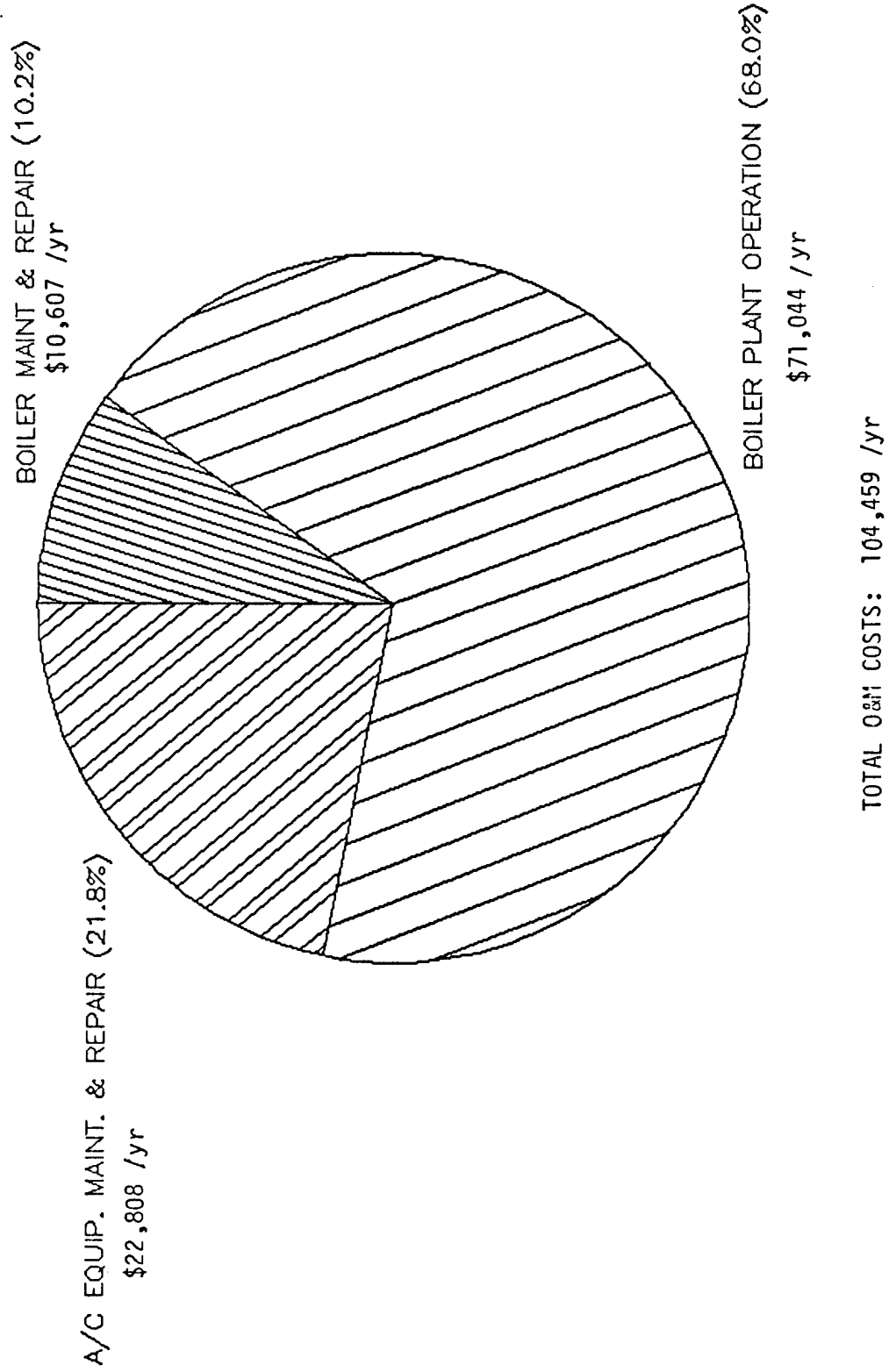
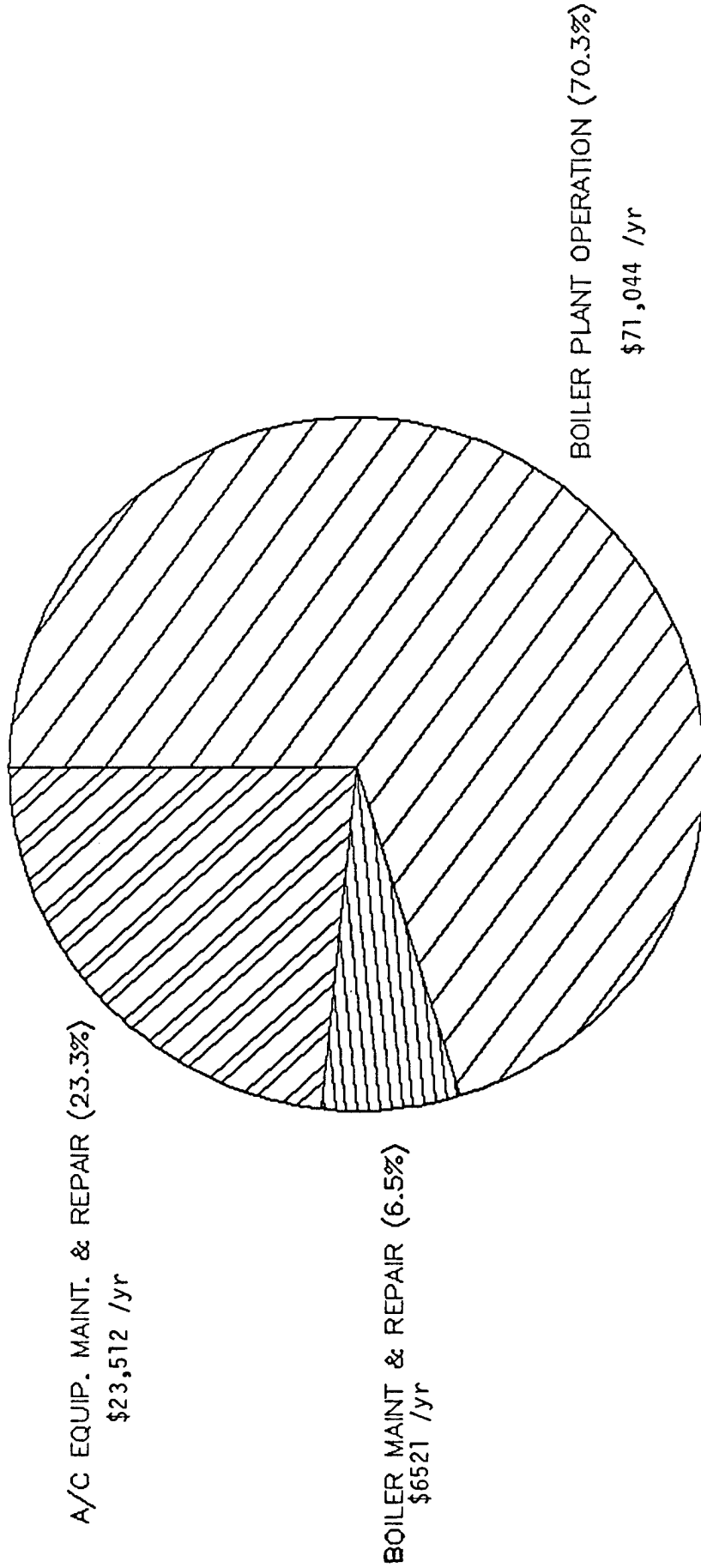

FIG. E-13: FY 87 O&M COSTS FOR BLDG 1



TOTAL O&M COSTS: \$101,077 /yr

### III. Energy Conservation Opportunity (ECO) Analysis and Recommendations:

All reasonable energy conservation opportunities were analyzed for feasibility of reducing energy costs. A summary of the analysis is included in Table E-1 for Building 8 and in Table E-2 for Building 1. No cost ECO's identified in the study which should be implemented are listed in Table E-3 and are summarized as follows:

- 1) Outside air for air handlers "A" and "B" in Building 8 and for the central air handlers in Building 1 should be reduced to 10 cfm per person. The amount of outside air used by air handler "D" which operates as a 100% outside air system should also be reduced by closing off the diffusers to the linotype area which is no longer utilized.
- 2) Room thermostats for the central hvac systems in both buildings should be adjusted from 75 degrees F. to 68 degrees F. for heating and from 75 degrees F. to 78 degrees F. for cooling to comply with Architectural and Engineering Instructions, Design Criteria, dated 13 March 1987.
- 3) Excess air for the boiler plant at Building 8 should be reduced by increasing the concentration of carbon dioxide in the flue gas from 10 to 12 percent.
- 4) Steam pressure for the boiler plant at Building 8 should be lowered from 30 to 15 psig to reduce heating losses.

Recommended ECO's identified in the study included in Table E-4 which require funding to be implemented are summarized as follows:

- 1) Time clocks should be installed to shutdown the restroom fans in

TABLE E-1 : SUMMARY OF FEASIBLE ECO'S FOR BLDG 8

DESCRIPTION	ANNUAL FUEL OIL SAVINGS		ANNUAL ELECTRICAL SAVINGS		ANNUAL ELECTRICAL DEMAND SAVINGS		TOTAL ENERGY SAVINGS		ECC	PAYBACK	SIR	
	MBTU	\$	MBTU	\$	MBTU	\$	MBTU	\$				
1. Reduce Outside Air - Short Term	885	4150	34	1105	--	--	919	5255	0	0	INF.	
2. Lower T-Stats	1042	4485	108	3515	--	--	1150	8000	0	0	INF.	
3. Reduce Boiler Excess Air	562	2634	--	--	--	--	562	2634	0	0	INF.	
4. Reduce Steam Pressure	67.5	317	--	--	--	--	67.5	317	0	0	INF.	
5. Shed Loads During Peak	--	--	--	--	90	9396	90	9396	0	0	INF.	
6. Shutdown Restroom Fans	--	--	30	964	--	--	30	2100	2100	2.2	4.4	
7. New Boiler - Entire Load	2135	10005	--	--	--	--	2135	15330	66000	5	2.39	
8. New Boiler w/ O2 Trim	2445	11458	--	--	--	--	2445	16983	76000	5	2.29	
9. Install Timeclock on HX and Pump	103.7	486	12.21	397	--	--	115.91	883	4100	5	2.22	
10. Operate Exist Generators	-3235	-15161	811	15636	216	22500	-2208	17798	99000	5.6	1.62	
11. Boiler O2 Control - Entire Load	310	1453	--	--	--	--	310	1453	10000	7	1.59	
12. Consolidated HVAC Plant	2374	11126	265	8813	--	--	2639	145287	1E+06	7	1.53	
13. Install Economizer on Computer/Composing Rm ACUs	--	--	138	4499	--	--	138	4499	30000	7	1.44	
14. Automated Light Controls	--	--	100.6	3272	--	--	100.6	3272	22000	7	1.43	
15. Economizer/Air Preheat - Entire Load	310	1453	--	--	--	--	310	1453	14300	10	1.11	
16. Replace Chiller	--	--	337	6514	208	21715	545	28229	264000	9	1.03	
17. Install Solar Heaters	26.91	126/PNL	--	--	--	--	26.91	126/PNL	2100/PN	17	0.98	
18. New 100 KW Cogenerator	-1276	-5981	1657	28711	100	10440	481	23463	237000	10	0.96	
19. New 60 KW Cogenerator	-1036	-4854	1292	22788	60	6264	316	16621	172000	10	0.93	
20. New Generator	-1238	-5801	371	7160	100	10440	-767	9623	95000	10	0.92	
21. Heat Recovery on Dishwashe	21.2	483	--	--	--	--	21.2	(Gas)	483	7200	15	0.77
22. Install Air Curtain	53	452	1.71	556	--	--	98.24	508	7500	15	0.73	
23. New 30 KW Cogenerator	565	-2648	646	11394	30	3132	1241	8089	110000	14	0.7	
24. Modify Ductwork to Reduce Outside Air	999	4680	316	10296	--	--	1315	14976	327000	22	0.63	
25. Recover Heat from Refrigerant Gas	141.2	662	-2.8	-91	--	--	138.4	571	16000	28	0.6	
26. Add Bldg Insulation	550.5	2580	15.75	512	--	--	566.25	3092	94000	30	0.52	
27. Install Vestibule	53.12	249	12.45	405	--	--	65.57	654	66000	24	0.5	
28. New Boiler - Space Heating	522	2449	--	--	--	--	522	2449	56000	23	0.48	
29. Boiler Oxygen Control - Space Heat	82	386	--	--	--	--	82	386	10000	26	0.42	
30. Modulate HW by O.A. Temp	55	256	--	--	--	--	55	256	7000	27	0.4	
31. Add Pipe Insulation	.0957/LF.	.45/LF	.0028/LF	.090/LF	--	--	.960/LF	.54/LF	21.84/L	40	0.39	
32. Change to VAV	999	4680	764	24859	--	--	1763	29539	806000	27	0.36	
33. Economizer/Air Preheat - Space Heat	82	386	--	--	--	--	82	386	13000	34	0.32	
34. Install Solar Film	--	--	29.41	956	--	--	29.41	956	42000	44	0.29	
35. Install Economizer, Central AC	--	--	22	715	--	--	22	715	26000	36	0.27	
36. Recover Heat From Blowdown	30	140	--	--	--	--	30	140	7500	54	0.2	
37. Replace Lights	56.92	267	66.5	2164	--	--	66.5	2164	143000	66	0.19	
38. Install Storm Windows	--	--	4.2	137	--	--	61.12	404	36000	89	0.17	
39. Add Duct Insulation	.0028/SF.	.0013/SF	.0003/SF	.011/SF	--	--	.0031/SF	.0284/SF	2.65/SF	110	0.04	

TABLE E-2: SUMMARY OF FEASIBLE ECO'S FOR BLDG 1

DESCRIPTION	ANNUAL FUEL OIL SAVINGS		ANNUAL ELECTRICAL SAVINGS		TOTAL ENERGY SAVINGS		ECC	PAYBACK	S. I. R.
	MBTU	\$	MBTU	\$	MBTU	\$			
1. Reduce Outside Air	692	3245	11.1	492	703.1	3737	0	0	INFINITE
2. Lower T-Stats	922	4322	47.3	2093	969.3	6415	0	0	INFINITE
3. Shutdown Restroom Fans	--	--	14	617	14	617	1400	2.3	4.25
4. Install Economizer on Tel Exchange ACU	--	--	90	3992	90	3992	15000	3.8	2.57
5. Consolidate Bldg 1 Loads to Bldg 8 Central Plant	1057	4954	15.8	699	1072.8	88955	512000	6	1.81
6. Heat Recovery on Tel. Exchange ACU	345	2100	-2.8	-128	342.2	1972	15000	7.6	1.5
7. Automated Light Controls	--	--	90	3986	90	3986	32000	8	1.2
8. Reduce Excess Air with Oxygen Monitor	95.7	449	--	--	95.7	449	5400	12	0.91
9. Add Building Insulation	953	4468	--	--	953	4468	89000	20	0.82
10. Recover Heat from Refrigerant Gas	350	1638	-2.8	-123	347.2	1515	22000	15	0.76
11. Install Solar Film	--	--	42.6	1883	42.6	1883	51000	27	0.47
12. Install Storm Windows	130	609	6.1	270	136.1	879	39000	44	0.34
13. Change to VAV	--	--	341	15077	341	15077	680000	45	0.21
14. Economizer on Central AC	--	--	32	1413	32	1413	81000	57	0.17
15. Recover Waste Heat From Blowdown	14.5	68	--	--	14.5	68	7500	110	0.15
16. Replace Lighting	--	--	6.5	289	6.5	289	90000	311	0.03

TABLE E-3 SUMMARY OF RECOMMENDED NO COST ECO'S

	FUEL SAVINGS		ELECTRICAL SAVINGS		TOTAL SAVINGS	
	MBTU/YR	\$/YR	MBTU/YR	\$/YR	MBTU/YR	\$/YR
<b>BLDG 1</b>						
1. Reduce Outside Air	692	3245	11	492	703	3737
2. Adjust T-Stats	922	4322	47	2093	969	6415
SUBTOTAL	1614	7567	58	2585	1672	10152
<b>BLDG 8</b>						
1. Reduce Outside Air	885	4150	34	1105	919	5255
2. Adjust T-Stats	1042	4885	108	3515	1150	8400
3. Reduce Boiler Excess Air	562	2634			562	2634
4. Reduce Steam Pressure	68	317			68	317
SUBTOTAL	2557	11986	142	4620	2699	16606
<b>TOTAL SAVINGS FOR BUILDINGS 1 &amp; 8</b>						
	4171	19553	200	7205	4371	26758

TABLE E-4 SUMMARY OF RECOMMENDED ECO'S REQUIRING FUNDING

PROJECT TITLE	ANNUAL ENERGY SAVINGS		ANNUAL ENERGY COST SAVINGS	ANNUAL ENERGY OPERATIONAL/ MAINTENANCE SAVINGS	TOTAL ANNUAL SAVINGS COST	ESTIMATED CONSTRUCTION COST	PAYBACK YEARS	SIR	POSSIBLE SOURCES OF FUNDING	
	FUEL OIL MBTU/YR	ELECTRICITY MBTU/YR								TOTAL MBTU/YR
1. Shutdown restroom fans, Bldgs 1 & 8*	0	44	44	1581	0	1581	3500	2.2	3.9	PECIP
2. Install Economizer, Bldg 1, Telephone Exchange ACU	0	90	90	3992	0	3992	15000	3.8	2.6	PECIP
3. New 125 hp boiler w/ Oxygen trim	2445	0	2445	11458	5525	16983	76000	5	2.3	OMA
X 4. Install timeclock on boiler, Bldg 8	104	12	116	883	0	883	4100	5	2.2	OMA
5. Install switchgear to operate exist Generators	-3235	811 + 216 kw	-2424 + 216 kw	17798	0	17798	99000	5.6	1.6	OMA
6. Consolidate hvac plants/replace AHU's	2274	265	2639	19939	125348	145287	1000000	7	1.5	MCA
7. Install economizer Bldg 8 computer room/composing room ACU's	0	138	138	4499	0	4499	30000	7	1.4	OMA
8. New 250 ton centrifugal chiller	0	337 + 208 kw	337 + 208 kw	28229	0	28229	264000	9	1.03	OMA
TOTAL	1826	1559 + 424 kw	3385 + 424 kw	88379	130872	219252	1491600			

\*ECO's for shutdown of restroom fans for Bldgs 1 & 8 combined to qualify for PECIP funding.

both buildings after working hours.

- 2) Economizer cycles should be installed on the air conditioners serving the telephone exchange in Building 1 and the computer/composing areas in Building 8.
- 3) A time clock should be installed to shut down the hot water return pump and close the stem valve to the hot water heat exchanger in Building 8 after work hours.
- 4) Automatic switchgear should be installed to operate the existing emergency generators as peak demand sharing units during the summer months to reduce the peak demand charge for electricity.
- 5) The central plant at Building 1 should be eliminated and the heating and cooling loads consolidated into the central plant at Building 8. This would eliminate the need for maintenance, operation and repair of the boiler plant at Building 1 and the maintenance and repair of the separate air conditioning systems. Existing air handlers at both buildings should be replaced and the duct systems for AHU's "C" and "D" at Building 8 converted to 100% recirculation systems. All steam heating coils at Building 8 should also be converted to a hydronic heating system. These changes would allow the buildings to be heated and cooled by a central dual pipe hot water/chilled water system and eliminate the need for steam. This would further reduce the labor required for 24 hour operation of the boiler plant at Building 8. Reduction of the outside air used for air handlers "C" and "D" would also reduce the peak heating and cooling loads so that the capacity of the existing boiler and chilled water plant at Building 8 would be adequate to heat and cool both buildings.



- 6) One of the existing 80 hp boilers at Building 8 should be replaced with a new fully modulating oxygen trim central boiler. The existing boilers are relatively inefficient and are near the end of their useful lives. The other remaining boiler should serve as back-up to the new boiler. The new boiler would provide all of the heating for space and domestic water heating for the buildings.
- 7) The existing centrifugal chiller should be replaced with a new 250 ton centrifugal chiller because it is also near the end of its' useful life. The new chiller should be provided with demand limiting control to reduce its' capacity during the summer peak demand hours when the printing presses are also in operation.

IV. Projected Energy Consumption and Costs After Implementation of ECO's:

Impact of the implementation of the ECO's in present energy consumption and costs are summarized in Figures E-14 and E-15. No cost/low cost ECO's would generate a total savings of 4,171 MBtu per year or 30,072 gallons in fuel oil and 200 MBtu per year or 58,599 kwh in electricity, for a total annual energy savings of \$26,758. This would amount to a 21% reduction in energy consumption over present energy use and an 8% reduction in energy costs.

Implementation of all recommended ECO's requiring funding would reduce energy consumption by an additional 1,826 MBtu per year or 13,165 gallons in fuel oil, 1,559 MBtu per year or 456,703 kwh in electricity, and 424 kw in electrical demand, for a total annual energy cost savings of \$88,379. This would amount to an additional 17 percent reduction over present energy use and a 25% reduction in present energy costs.

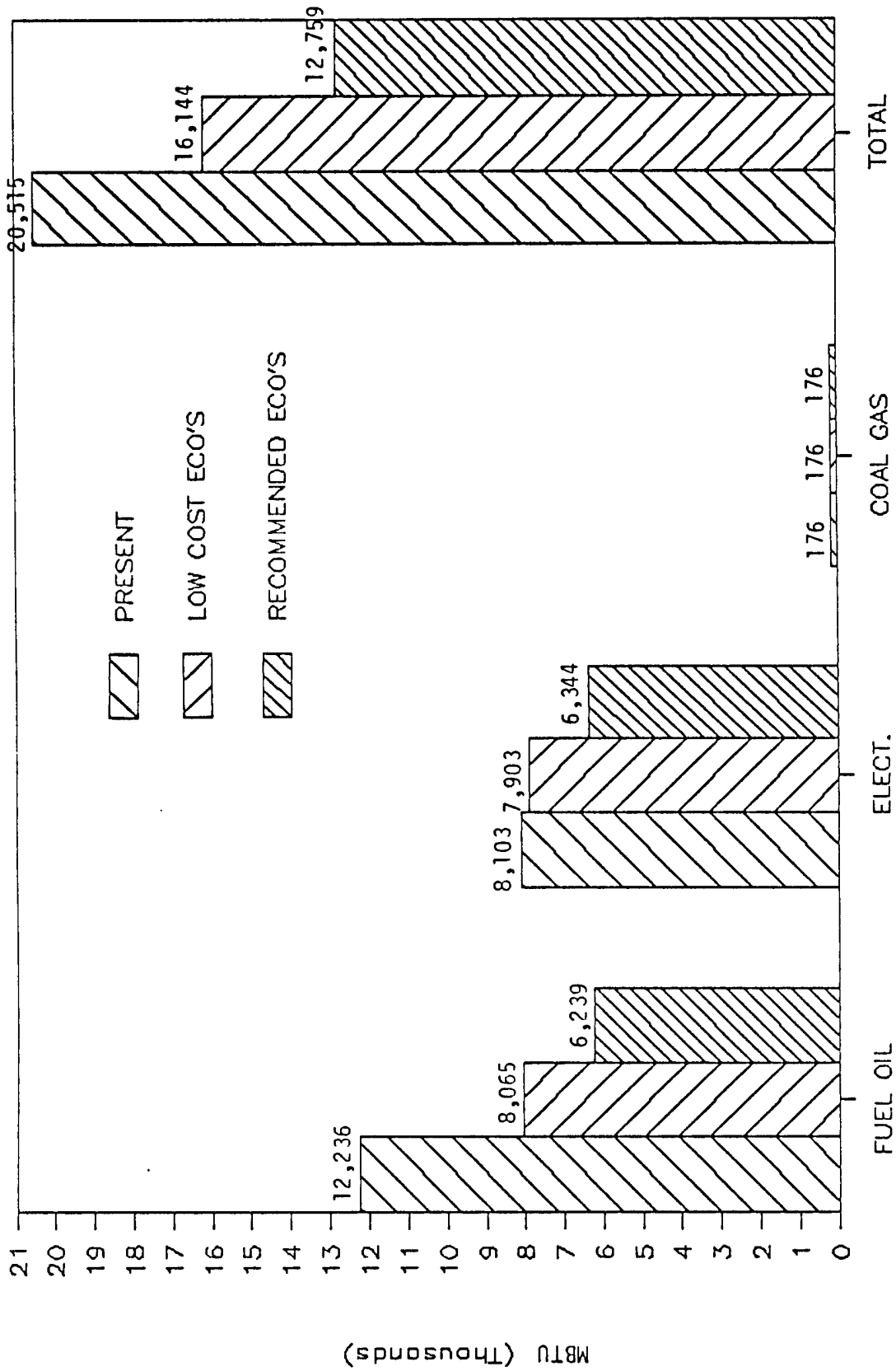

FIG. E-14: PROJECTED ANNUAL ENERGY USE FOR BUILDINGS 1 & 8

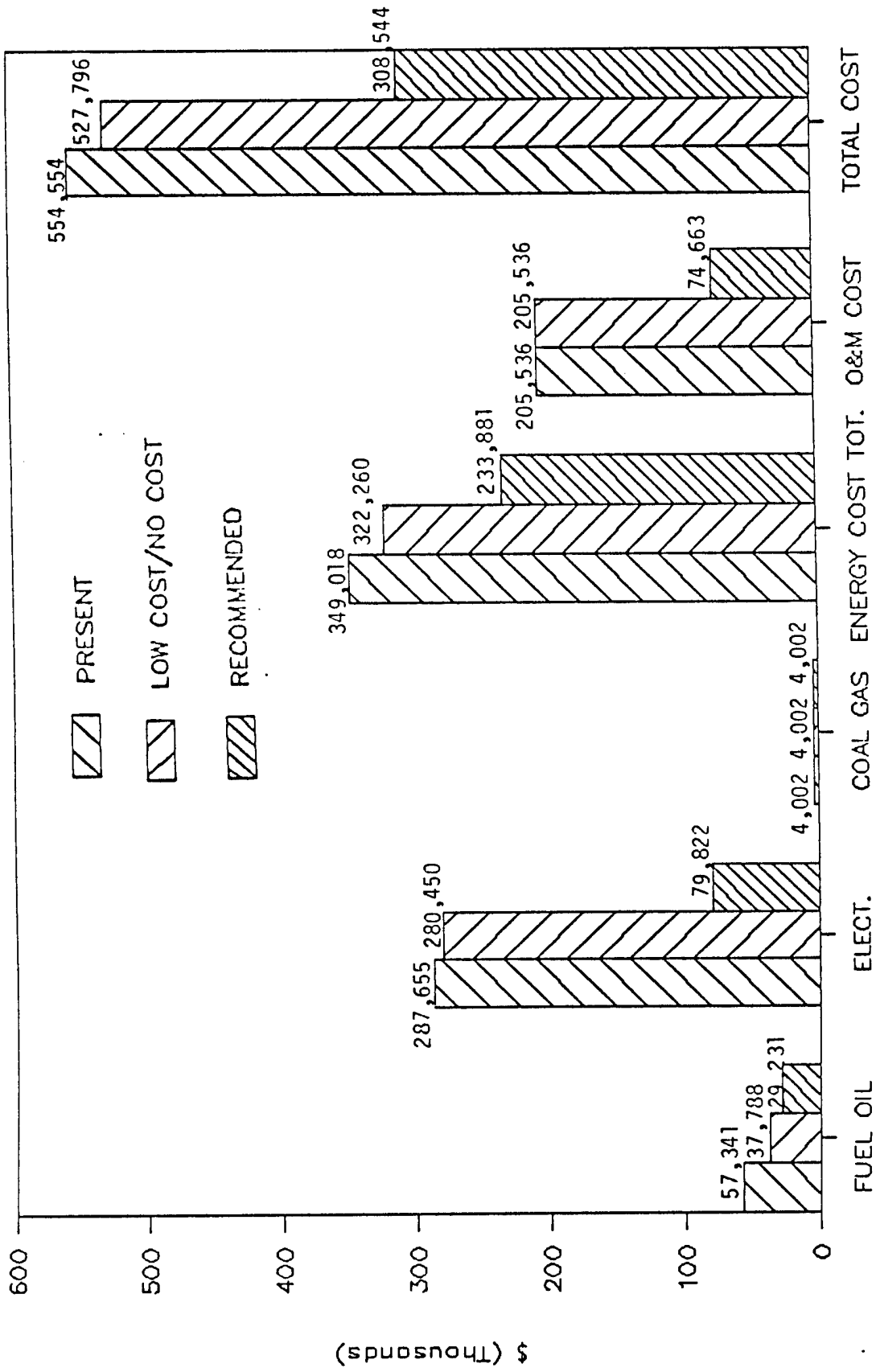

FIG. E-15: PROJECTED ANNUAL ENERGY, OPERATING & MAINTENANCE COSTS FOR BUILDINGS 1 & 8

An additional savings of \$130,873 or a 64% reduction in avoided operating and maintenance cost would also be realized.

Combined energy savings of all ECO's would result in an overall reduction in energy usage of 38% and an overall reduction in energy costs of 33%. Total cost savings for implementation of all recommended ECO's is estimated at \$115,137 per year in energy costs, and \$130,873 in maintenance, operation and repair costs, for a total of \$246,010 per year. This represents an overall cost reduction of 44% over the current utility, operating, and maintenance costs for the facilities.