

ENERGY ENGINEERING ANALYSIS PROGRAM

ANNISTON ARMY DEPOT

INCREMENT B, FINAL REPORT (EMCS)

EXECUTIVE SUMMARY

PREPARED FOR:

U.S. ARMY CORPS OF ENGINEERS

MOBILE DISTRICT

PREPARED BY:

SCIENCE APPLICATION INTERNATIONAL CORPORATION

6725 ODYSSEY DRIVE

HUNTSVILLE, ALABAMA 35806

JANUARY 1988

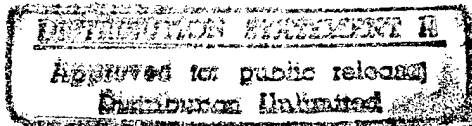

19971016 201



DEPARTMENT OF THE ARMY
CONSTRUCTION ENGINEERING RESEARCH LABORATORIES, CORPS OF ENGINEERS
P.O. BOX 9005
CHAMPAIGN, ILLINOIS 61826-9005

REPLY TO
ATTENTION OF: TR-I Library

17 Sep 1997

Based on SOW, these Energy Studies are unclassified/unlimited.
Distribution A. Approved for public release.

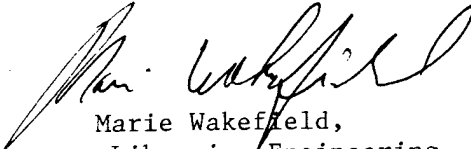
Marie Wakefield,
Librarian Engineering

ENERGY ENGINEERING ANALYSIS PROGRAM

ANNISTON ARMY DEPOT

INCREMENT B, FINAL REPORT

EXECUTIVE SUMMARY

PREPARED FOR:

U.S. ARMY CORPS OF ENGINEERS

MOBILE DISTRICT

PREPARED BY:

SCIENCE APPLICATION INTERNATIONAL CORPORATION

6725 ODYSSEY DRIVE

HUNTSVILLE, ALABAMA 35806

JANUARY 1988

1. INTRODUCTION

1.1 BACKGROUND

In July 1985, the Army Corps of Engineers, Mobile District, modified their existing contract to include the performance of an additional energy study. The contractual Scope of Work calls for an Energy Engineering Analysis Program (EEAP) study to be conducted at Anniston Army Depot (AAD). This report covers the Energy Monitoring and Control System (EMCS) portion of Increment B of the EEAP study.

1.2 SCOPE OF WORK

The Scope of Work, as specified in Army Contract number DACA01-83-C-0099 and included in this report as Appendix A, calls for the systematic evaluation of the cost effectiveness of an EMCS that will result in the reduction of the installation's energy use. The general Scope of Work for the EMCS portion of Increment B can be summarized as follows:

- o Review and make effective use of existing energy studies in preparing the EMCS project;
- o Field trips should be used to obtain information on facilities to develop the requirements necessary for the EMCS;
- o Determine the feasibility of an EMCS for building electrical, mechanical, and utility distribution systems;
- o Prepare Project Development Brochures (PDBs), DD Form 1391's, and supporting documentation for the proposed EMCS project if it meets ECIP criteria; and

- o Detailed recommendations are to be generated and a final report will be provided.

To assist in the identification of viable energy conservation projects, a list of potential buildings was given to SAIC for evaluation during the field survey. Most of the buildings listed are located in the process (east) area of the Depot. The Facility Engineer selected these buildings for evaluation because the process area uses the greatest percentage of the Depot's energy. The buildings surveyed and the possible EMCS energy conservation opportunities, as suggested by the Facility Engineer's office, are shown in Appendix A.

In August of 1987, Modification No. P0006 was made to the existing contract. This change required consideration of the impact of deleting additional points from the proposed EMCS. It was felt that this approach would maximize the energy savings per point. This final approach is reflected in the final report, and is entitled "Final Design".

1.3 ORGANIZATION OF THE REPORT

This report is organized into three sections as follows:

- o Section 1 describes the Scope of Work and gives an overview of SAIC's method and approach to the study;
- o Section 2 contains a description of the AAD facility and a profile of the Depot's energy use; and
- o Section 3 presents a general description of an EMCS and the various ECO's that have been investigated. Also presented in this section is a summary of savings achievable through implementation of the proposed EMCS.

Supporting material is located in the Appendices.

1.4 SURVEY APPROACH

In order to become familiar with AAD, past energy conservation reports were reviewed. Data contained in the reports were summarized for verification in the field. A list of proposed buildings to be surveyed was provided by AAS personnel and given a preliminary evaluation. From this evaluation, indications of the cost-effectiveness of various ECO's were obtained and additional data required for evaluating these projects were identified.

At this point, a field visit to AAD was necessary to obtain additional information. The selection of the engineers for the field visit was based upon the proposed energy conservation projects. A team of three engineers and one technician was assembled to collect data on:

- o Building wall and roof construction;
- o Electrical systems;
- o HVAC systems;
- o Central air compressors and boilers; and
- o Industrial processes.

Upon arrival at the site, a meeting was held with the Facility Engineer's staff to discuss SAIC requirements for field data and to coordinate those requirements with AAD operations and personnel. The data requirements were divided into two categories: 1) general information; and 2) specific building information. The general information requested consisted of:

- o Current energy/utility use and cost;
- o Current occupancy levels for each of the buildings;
- o Existing site maps and building information schedules; and
- o Specific process information (i.e., operations, constraints, etc.).

The specific building information was collected by visiting those buildings which were associated with potential energy conservation opportunities. The usual data collected included:

- o Boiler operating data;
- o Domestic hot water operation;
- o Hours of operation;
- o Roof and wall construction;
- o Heating/air conditioning system and its control system;
- o Operating temperatures of the HVAC and process equipment; and
- o Specific process related information.

The major data collected was presented in Appendix B of Phase I. Other data collected is identified in specific EMCS energy conservation option analyses.

In reviewing a previous EEAP study,¹ it is estimated that a 17 percent reduction in existing heating energy use can be realized for each facility controlled with the EMCS night setback/shutdown option.

An analysis has been performed to verify that these savings are reasonable for this application. All possible EMCS options were analyzed on an individual basis. All economically-favorable energy saving options were then grouped to form the base EMCS. Next, monitoring and recording functions were evaluated for application and costed for inclusion into the EMCS project to satisfy the scope of work requirements.

The initial design represents a Medium Size RF System - Two Way with the total capability desirable for the EMCS system at AAD.

This system, when developed and costed, did not prove to be an economically favorable approach. Therefore, the elements of the system were adjusted (primarily by the removal of monitoring functions) to achieve a lower cost level. This system is entitled Medium Size RF Two Way System, Minimal Approach. This system when developed and costed, was also not an economically feasible approach.

The final system represents a re-evaluation requested by Modification P0006. It represents final guidance on points to be deleted from the EMCS to maximize the energy savings per point. This system is entitled Medium Size RF Two Way System, Final Design.

¹EEAP Study Report, Anniston Army Depot, June 1982, by Day & Zimmerman, Inc.

2. DESCRIPTION OF FACILITIES

2.1 GENERAL

Anniston Army Depot (AAD) is located 10 miles west of Anniston, Alabama, and approximately 20 miles east of the Coosa River. This Depot is the largest combat vehicle repair/rebuild facility in the free world. There is a total of 2.2 million square feet of building area, of which 1.4 million are located in the process (east) area.¹ The following sections discuss the buildings and facilities surveyed in this study:

- (1) Building envelopes and structures;
- (2) HVAC systems;
- (3) Electrical systems;
- (4) Processes; and
- (5) Central plants

2.2 BUILDING STRUCTURES

A majority of the buildings evaluated at Anniston Army Depot are 30 to 40 years old, permanently constructed, and in good repair. Table 2-1 provides a summary of current building functions, size, and operating characteristics.

The building envelopes vary from metal siding to brick or concrete block, with a majority of the industrial activities located in open, high-bay areas.

¹In this report, the east process area will be referred to only as the process area.

TABLE 2-1. SUMMARY OF BUILDING OPERATING CHARACTERISTICS

Building Number	Function	Year Constructed	Size sq. ft.	Type Construction	Occupancy Schedule
7	Hq./Administration	1977	57,000	Permanent	7am-4pm, 5 days/week
53	Security Building	1942	32,396	Permanent	24 hours/day, 7 days/week
105	General Maintenance Facility	1942	29,732	Permanent	24 hours/day, 5 days/week
106	Electric Maintenance Shop	1942	31,705	Permanent	7am-3pm, 5 days/week
108	Machine Shop	1942	35,920	Permanent	7am-12:30am, 5 days/week and 5am-3:30pm Saturday
113	General Maintenance Facility	1942	38,619	Permanent	7am-4pm, 5 days/week
114	Metal Plating Shop	1981	48,200	Permanent	24 hours/day, 5 days/week
117	Welding Shop	1942	30,500	Permanent	5am-4pm, 5 days/week
118	Calibration Shop	1942	12,756	Permanent	6:30am-4:30pm, 5 days/week
128	Support Shop	1942	98,353	Permanent	7am-5:30pm, 5 days week
129	Warehouse/Machine Shop	1942	94,047	Permanent	7am-4pm, 5 days/week
130	Machine Shop/Drying Facility	1942	95,531	Permanent	7am-4pm, 5 days/week
143	Turret Rebuild Shop	1945	92,443	Permanent	7am-5:30pm, 5 days/week
147	Machine Shop	1957	14,070	Permanent	5:30am-3:30am, 2 shifts, 5 days/week
362	Administrative/Warehouse	1955	208,901	Permanent	7am-4pm, 5 days/week
363	Computer Storage Facility	1955	20,363	Permanent	24 hours/day, 7 days/week
400	Tank Body Repair	1953	229,321	Permanent	7am-4pm, 5 days/week
409	Sandblast Facility	1956	67,941	Permanent	7am-4pm, 5 days/week
410	Engine Test Facility	1956	30,441	Permanent	7am-12am, 2 shifts, 7 days/week
413	Burn and Shear Shop	1959	4,000	Permanent	7am-12am, 2 shifts, 5 days/week
421	Tool Room Checkout/Steam Cleaning	1967	14,898	Permanent	5am-4:30pm, 5 days/week
433	Painting and Sandblasting	1978	43,440	Permanent	7am-12am, 2 shifts, 5 days/week

TABLE 2-1. SUMMARY OF BUILDING OPERATING CHARACTERISTICS (Continued)

Building Number	Function	Year Constructed	Size sq. ft.	Type Construction	Occupancy Schedule
434	Parts Assembly and Burnoff	1954	16,665	Permanent	7am-5pm, 5 days/week, 5am-3:30pm, 2 days/week
652	Ammunition Renovation Shop	1974	10,000	Permanent	24 hours/day, 7 days/week
654	Ammunition Renovation Shop	1974	11,562	Permanent	24 hours/day, 7 days/week
680	Ammunition Renovation Shop	1969	24,238	Permanent	24 hours/day, 7 days/week

TABLE 2-2. SUMMARY OF BUILDING CONSTRUCTION CHARACTERISTICS

Building Number	Function	No Floors	Roof Type & U Value	Wall Type & U Value	Door Type & U Value	Floor Type & U Value	Window Type & U Value
7	Hq/Administration	3	Built-up .05	Precast Concrete .10	Metal (Vestibule) .05	Concrete S.O.G. .1	Double Pane .5
53	Security Building	1	Pitched w/ 0.06 insulation	Brick 0.07	--	Concrete S.O.G. .1	Single Pane 1.1
105	General Maintenance Facility	1	Built-up .05	Brick and CMU .3	--	Concrete S.O.G. .1	None
106	Electric Maintenance Shop	1	Built-up .05	Brick and CMU .3	--	Concrete S.O.G. .1	None
108	Machine Shop	1 High Bay	Pitched Metal w/ insulation .07	Metal w/ insulation .07	Metal O.H. .6	Concrete S.O.G. .1	Single Pane 1.1
113	General Maintenance Facility	1	Built-up .05	Brick and CMU .3	Metal O.H. .6	Concrete S.O.G. .1	None
114	Metal Plating Shop	1	Built-up wood deck .4	(A) Brick (B) Poured concrete .3	Metal O.H. .6	Concrete S.O.G. .1	None
117	Welding Shop	1	Built-up wood deck .4	Metal w/ insulation .07	Metal O.H. .6	Concrete S.O.G. .1	Single Pane 1.1
118	Calibration Shop	1	Built-up .05	Metal w/ insulation .07	--	Concrete S.O.G. .1	None
128	Support Shop	1	Built-up wood deck .4	Brick .3	Metal O.H. .6	Concrete S.O.G. .1	None
129	Warehouse/Machine Shop	1	Built-up wood deck .4	Brick .3	Metal O.H. .6	Concrete S.O.G. .1	Single Pane 1.1
130	Machine Shop/Drying Facility	1	Built-up wood deck .4	Brick .3	Metal O.H. .6	Concrete S.O.G. .1	None
143	Turret Rebuild Shop	1 High Bay	Pitched metal deck .18	Metal .18	Metal O.H. .6	Concrete S.O.G. .1	Single Pane (skylights) 1.1
147	Machine Shop	1	Pitched metal deck .18	Block (CMU) .2	Metal O.H. .6	Concrete S.O.G. .1	Single Pane 1.1
362	Administrative/Warehouse	1 High Bay	Built-up .06/.21	CMU .5	Metal O.H. .6	Concrete S.O.G. .1	Double Pane .5

TABLE 2-2. SUMMARY OF BUILDING CONSTRUCTION CHARACTERISTICS (Continued)

Building Number	Function	No Floors	Roof Type & U Value	Wall Type & U Value	Door Type & U Value	Floor Type & U Value	Window Type & U Value
363	Computer Storage Facility	1 High Bay	Built-up .15	CMU .3	Metal O.H. .6	Concrete S.O.G. .1	Single Pane w/ Storm 0.6
400	Tank Body Repair	1 High Bay	Pitched metal deck .18	20' CMU Rest Metal .9	Metal O.H. .6	Concrete S.O.G. .1	Single Pane 1.1
409	Sandblast Facility	1 High Bay	Pitched metal deck .18	CMU and metal w/ insulation .4	Metal O.H. .6	Concrete S.O.G. .1	None (skylights) -
410	Engine Test Facility	1 High Bay	Pitched metal w/ insulation .07	Metal insulation panels .07	Metal O.H. .6	Concrete S.O.G. .1	None
413	Burn and Shear Shop	1	Pitched metal deck .18	Metal .18	Metal O.H. .6	Concrete S.O.G. .1	None
421	Tool Room/Steam Cleaning	1	Built-up wood deck .4	Metal w/ insulation and plywood .05	Metal O.H. .6	Concrete S.O.G. .1	None (skylights)
433	Painting and Sandblasting	1 High Bay	Pitched metal deck .18	Metal w/ insulation .07	Metal O.H. .6	Concrete S.O.G. .1	None (skylights)
434	Parts Assembly and Burnoff	1	Pitched metal deck .18	Metal w/ insulation .07	Metal O.H. .6	Concrete S.O.G. .1	None
652	Ammunitions Renovation Shop	1	Pitched wood deck .06	Brick and CMU .3	Metal O.H. .6	Concrete S.O.G. .1	Single Pane 1.1
654	Ammunitions Renovation Shop	1	Pitched wood deck .06	Brick and CMU .3	Metal O.H. .6	Concrete S.O.G. .1	Single Pane 1.1
680	Ammunitions Renovation Shop	1	Pitched wood deck .06	Brick and CMU .3	Metal O.H. .6	Concrete S.O.G. .1	Single Pane 1.1

The high-bay areas have large areas of glass or fiberglass skylights in the upper levels to improve lighting and provide summer ventilation. Building structural characteristics are shown in Table 2-2. Boiler plants 19, 381-A, 401, and Air Compressor Plant 402 are not included in this table because they are central plants with no significant environmental loads.

2.3 HEATING, VENTILATING AND AIR CONDITIONING

2.3.1 Heating Systems

Many of the buildings visited during the field survey contain very simple environmental comfort equipment. All buildings are provided with heating capabilities. In the process area, the buildings are generally heated by unitary-type steam heaters with thermostat-regulated control valves. These unitary heaters are located throughout the building to provide localized heating of work areas. Buildings 114 and 105 are the only buildings observed in the process area that contain a central air heating/ventilating system. Steam is supplied to the process area buildings from the central heating plant (Building 401).

Two administrative buildings in the west area (Buildings 7 and 362) are heated by central HVAC systems which obtain steam from their own boilers. The system in Building 362 consists of several constant-volume air handling units with steam and chilled water coils. Building 7 has several multi-zone air handling units which are provided with economizer and zone optimization controls. These controls were in better condition than those observed in other buildings at AAD. Table 2-3 provides documentation of the HVAC systems in each of the buildings surveyed.

TABLE 2-3. SUMMARY OF BUILDING HVAC CHARACTERISTICS

BUILDING NUMBER	FUNCTION	HVAC DESCRIPTION
7	Hq. Administration	Air Handling Units, Heating and Cooling - Local Boiler
53	Security Building	Air Handling Units, Heating and Cooling - Local boiler
105	General Maintenance Facility	Air Handling Units, Heating and Cooling - Central Steam
106	Electrical Maintenance Shop	Air Handling Units, Heating and Cooling - Central Steam
108	Machine Shop	Heating and Ventilating Floor Units, heating Fan Coil Units - Central Steam
113	General Maintenance Facility	Heating Fan Coil Units - Central Steam
114	Metal Plating Shop	Fan Coil Units, Central warm Air System - Central Steam
117	Welding Shop	Heating and Ventilating Floor Units, Partial AHU system - Central Steam
118	Calibration Shop	Air Handling Unit - Heating and Cooling
128	Support Shop	Heating Fan Coil Units - Central Steam
129	Warehouse/Machine Shop	Heating Fan Coil Units - Central Steam
130	Machine Shop/Drying Facility	Heating and Ventilating Floor Units - Central Steam
143	Turret Rebuild Shop	Heating and Ventilating Units, Heating Fan Coil Units - Central Steam
147	Machine Shop	Heating and Ventilating Units, heating Fan Coil Units - Central Steam
362	Administrative/Warehouse	Air Handling Unit, Heating and Cooling Fan Coils, heating (Local Boiler)

TABLE 2-3. SUMMARY OF BUILDING HVAC CHARACTERISTICS (Continued)

BUILDING NUMBER	FUNCTION	HVAC DESCRIPTION
363	Computer Storage Facility	Air Handling Units - Heating and Cooling
400	Tank Body Repair	Heating and Ventilating Units - Central Steam
402	Central Air Compressor Plan	Fan Coils, Heating
409	Sandblast Facility	Heating and Ventilating Units, Heating Fan Coil Units - Central Steam
410	Engine Test Facility	Heating Fan Coil Units - Central Steam
413	Burn and Shear Shop	Air Handling unit, Heating & Colling in Control Rooms Unit Heaters (Oil-Fired)
421	Tool Room/Steam Cleaning	Heating Fan Coil Units - Central Steam
433	Painting and Sandblasting	Heating Fan Coil Units, heating and Ventilating Units - Central Steam
434	Parts Assembly and Burn-off	Unit Heaters (Oil-Fired)
652	Ammunitions Renovation Shop	Fan Coils, Heating
654	Ammunitions Renovation Shop	Fan Coils, Heating
680	Ammunitions Renovation Shop	Fan Coils, Heating

2.3.2 Ventilation

Most of the process buildings in the east area rely on portable fans, ceiling exhaust fans, and/or open fenestrations for necessary ventilation. Building 114 has a make-up and exhaust air system. Building 400 contains six large centrifugal fans connected to underground ducting for removal of welding fumes in the winter season; however, these fans are not used and considered inoperable.

2.3.3 Air Conditioning

The process area buildings, other than small administrative attachments, have very few air conditioning systems. The only significant air conditioning system in the process area is the unit serving the M-1 tank assembly lab in Building 128. Only three buildings visited in the west area have major air conditioning equipment. Building 362 contains a 200-ton water-cooled centrifugal chiller for cooling the administrative portion of the building. Building 363 has approximately 180 tons of air-cooled chiller capacity which air conditions three computer rooms. Building 7 has a 150-ton water-cooled centrifugal chiller for cooling the entire building.

2.4 ELECTRICAL SYSTEM

2.4.1 Distribution

Electric power is supplied to AAD by the Alabama Power Company from a single 44 kV feeder line. The main substation consists of 2 substations on the same site at the South end of the East Area. The East Area substation contains three 4666 kVa transformers and a spare transformer in parallel. The West and restricted area substation contains three 2500 kVa transformers. All substations reduce the voltage to 12.5 kV for distribution through the Depot.

One 12.5 kV line supplies the west administrative area, one 12.5 kV line supplies the west ammunition area, and two 12.5 kV feeders supply the process area. The government owns and maintains the 12.5 kV lines within the Depot boundaries. The distribution system is a looped design to provide two routes of electrical services from the substation to any point along the distribution lines.

2.4.2 Motors

Electric motors account for a significant amount of the electrical power consumption in the process area. The total load is fairly equally divided among synchronous and inductive motors. The largest consolidation of synchronous motors, 4300 hp, is located in the air compressor plant, while the inductive load is scattered throughout the shop areas.

2.4.3 Lighting

Building lighting at AAD is a mixture of various types that have evolved through the years since the buildings were built. Originally, incandescent luminaires were the main source of light. Through various changes, renovations, and upgrades fluorescent, mercury vapor, and high pressure sodium (HPS) luminaires are mostly used. A concern for energy conservation has reduced the amount of energy used for lighting. There is a program underway to convert many of the building areas to HPS.

In general, the shop buildings use incandescent, fluorescent, mercury vapor, and HPS luminaires. Storage and warehouse buildings use mostly incandescent and fluorescent luminaires, with HPS being installed as funds permit. For site lighting, a combination of mercury vapor and HPS is used.

2.5 PROCESS DESCRIPTION

All processes at AAD are directly or indirectly related to major overhauling and rebuilding at tanks, small arms repair, and missile maintenance. The processes are labor intensive and consist of machining, grinding, plating, welding, cleaning, painting, assembling, and testing. Table 2-4 illustrates where the processes are performed.

Machining, welding, and assembling are generally confined to large, open-bay shop areas such as Buildings 400, 143, 108, etc. Each building contains a number of work stations where an individual is assigned to weld, machine, or assemble a scheduled number of pieces each shift. All welding is electric arc or gas and most machining is accomplished by electrically-driven equipment (lathes, mills, drills, etc.)

Most cleaning, painting, and plating activities are confined to certain buildings, such as 409, 130, 114, and 433. Cleaning processes include chemical degreasing and dewaxing in large steam-heated or ambient-temperature vats. In these processes, pieces of equipment are mechanically-lowered by an attending operator into 3000 gallon vats of solvents, acids, or hot water and soaked for a certain time to remove foreign materials (such as wax or grease). Sand-blasting processes are also found throughout these buildings, such as Building 433, for cleaning of small accessories and entire tank bodies. Plating is generally confined to Building 114 where anodizing, phosphating, and chromating processes are performed.

Paint spraying and drying booths are primarily located in Buildings 117, 130, 433, 409, and 143. Paints are pneumatically applied to objects and allowed to dry naturally or in drying ovens, depending on the type of paint applied and the rate at which drying must be accomplished.

The quality assurance process is supported by the engine test facility and

ENERGY CONSUMING PROCESSES

BLDG. NO.	MACHINES	TOOLS	CHEMICAL VATS	TRICHLORO VATS	ABRASIVE BLAST CLEANING	SPRAY PAINTING	PAINT DRYING OVENS	DYNA-MOMETERS	STEAM CLEANERS	WELDING	METALIZING	FLAME CUTTING	OVERHEAD CRANES
108	X									X	X		
114			X		X								
117				X	X	X				X			
128	X												
129	X		X		X			X	X		X		
130			X		X	X	X		X	X			
143	X									X			X
147	X					X				X	X		
400	X				X					X			X
409			X		X	X	X		X	X			
410								X					
413	X											X	
421													
433					X	X	X		X				
434										X			

TABLE 2-4.

transmission test facility. Engines and transmissions are taken to their respective test facility where a load simulation is conducted over a given time period. Elsewhere, much of the other quality assurance involves visual inspection and bulk chemical testing.

2.6 CENTRAL PLANTS

2.6.1 Compressed Air

Building 402 is the primary compressed-air generation station for these processes: painting, sand blasting, and air motors. This plant contains seven synchronous motor-driven, positive displacement compressors. The plant is capable of supplying 18,950 scfm of 120 psig air with a total of 4300 motor hp. The normal compressed-air demand requires approximately one-third the total operating capacity between 7:30 a.m. and 12:00 a.m. each day.

2.6.2 Steam

Building 401 is the central steam heating plant for the east area. This plant contains five 30,000 pounds per hour coal-fired boilers which supply steam for heating and process needs. It is estimated that 30 percent of the yearly plant load is for process steam needs, 30 percent is used to run the steam plant including condensate pumps, induced draft (ID) fans, and for distribution system line losses. At least one boiler is required to operate 24 hours per day throughout the year to satisfy load requirements.

2.7 ENERGY USE OF COST

The primary sources of energy at AAD are coal and electricity. Figure 2-1 indicates the annual energy use by source for FY 80 through FY 85. A graph showing the history for total energy use if presented as Figure 2-2.

ANNISTON ARMY DEPOT

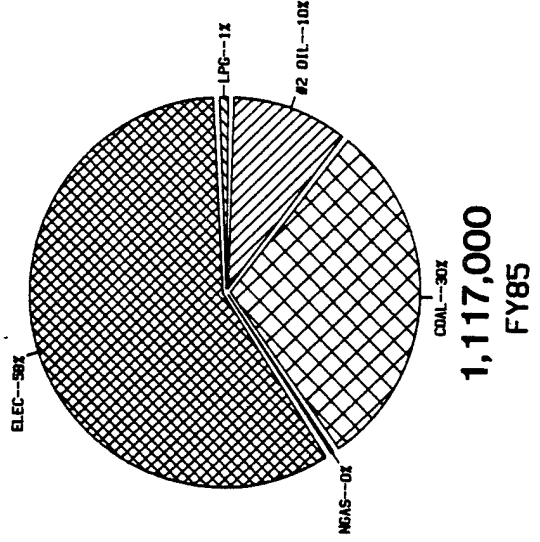
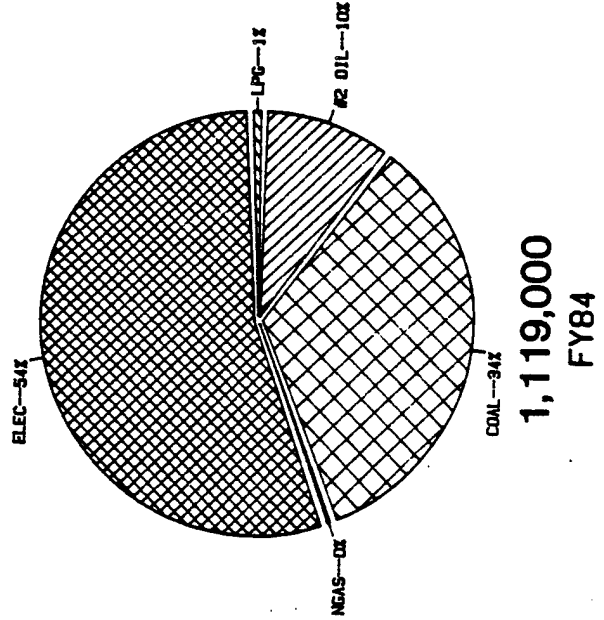
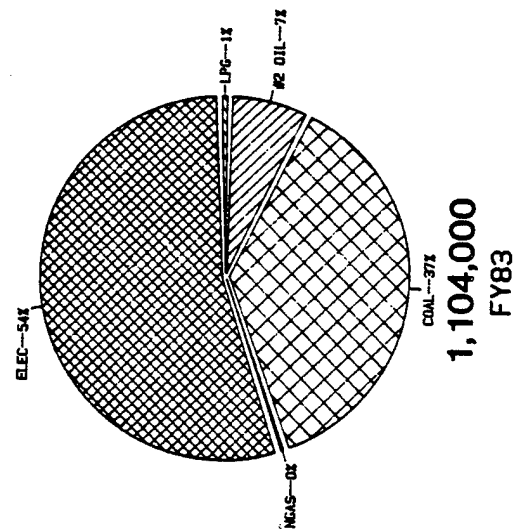
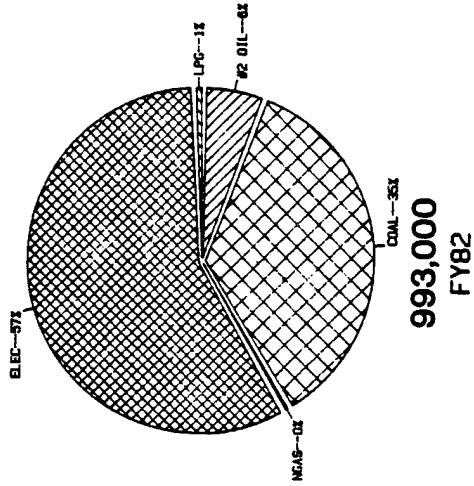
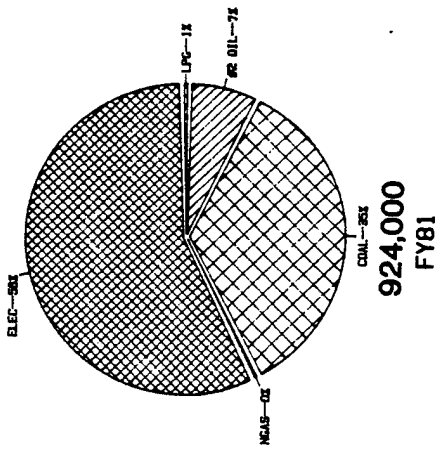
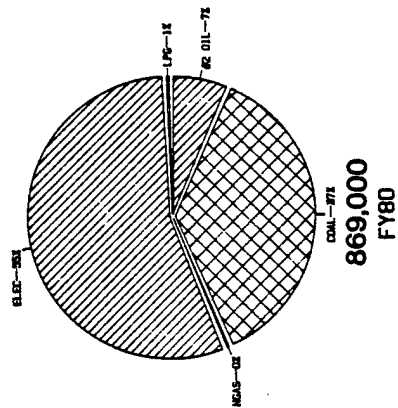

Figure 2-1 Annual Fuel Consumption: Facility (MBTU)

ANNISTON ARMY DEPOT
HISTORICAL FUEL CONSUMPTION: FACILITY (MBtu)

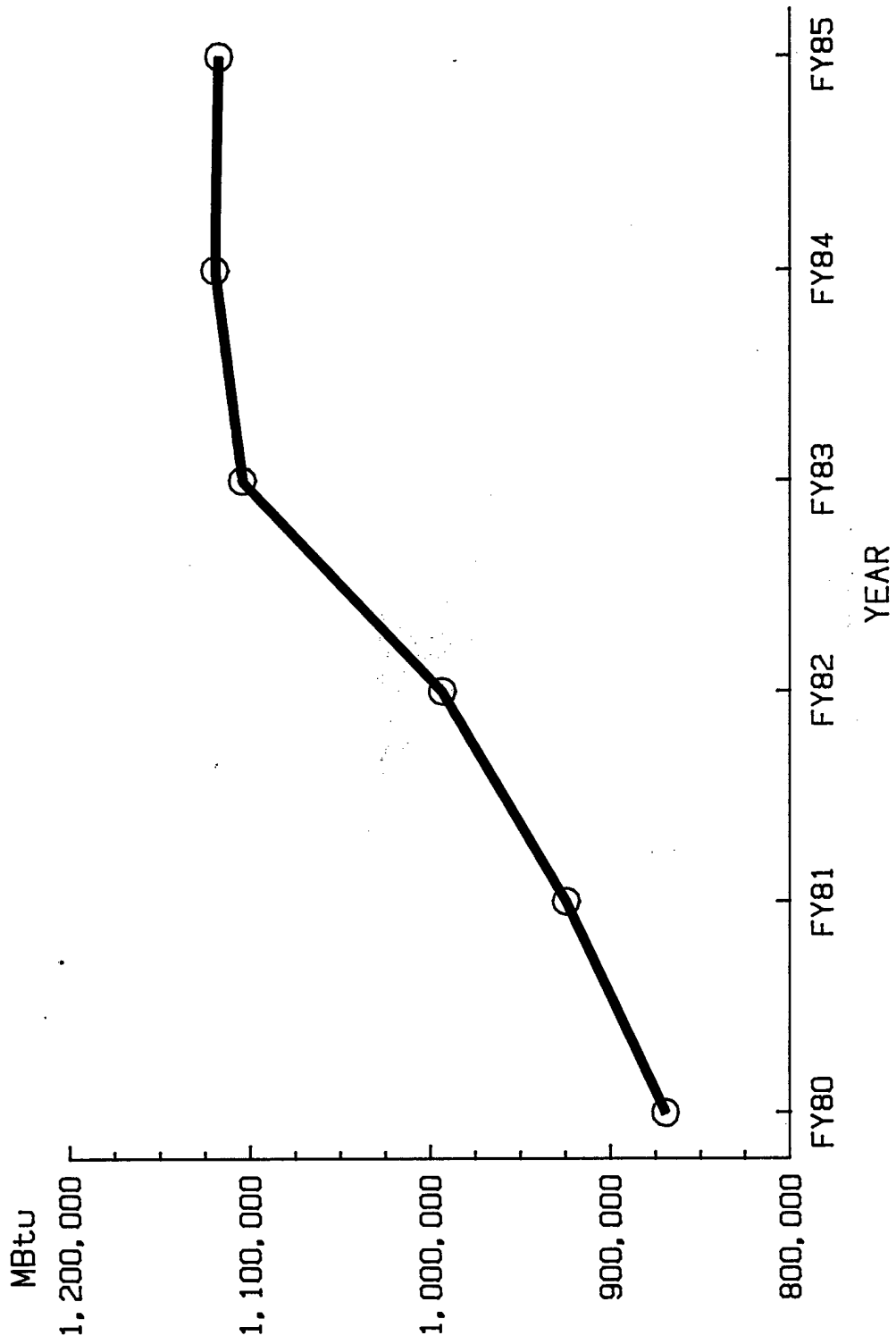

Figure 2-2 Historical Fuel Consumption

The cost of energy at AAD for FY 1985 is as follows:

Coal:	\$53.76/ton (delivered)
Fuel Oil No. 2:	\$0.95/gal
Natural Gas:	\$0.92/100cfm
LPG:	\$0.629/gal
Electric:3	\$0.055/kWh (includes \$5.25/kVa demand - cost derived from 1985 bills)

3FY 85 electric power bills are located in Appendix C

3. ENERGY MONITORING & CONTROL SYSTEM

The intent of the EMCS study is to provide a centralized automated system for management of the energy resources utilized at AAD. At this time each individual facility's mechanical and electrical system uses a de-centralized system for control.

EMCS study and design criteria is in accordance with TM5-815-2; system type and size are determined by the total number of input/output (I/O) points established by the study. The EMCS system is configured around the present operating schedule of five days per week, 0700 to 1630 hours daily. The system provides flexibility of operation in the event of unscheduled building occupancy. The system also provides for future expansion.

3.1 GENERAL DATA

The proposed system is a two-way, medium size, radio frequency system. The command center location will be finalized based on directives from base personnel. A system sketch is provided as Figure 3-1.

3.2 DATA TRANSMISSION MEDIA (DTM)

The chosen data transmission media is a two-way radio frequency (RF) system. The RF system was chosen due to guidance in documentation used for this project. Power line carrier systems would have been extremely costly for this project. No information was obtained from the base personnel as to the accessibility of the LAN system on base; hence, it could not be considered. The use of an RF system was directed by AAD and was coordinated with the base communication office.

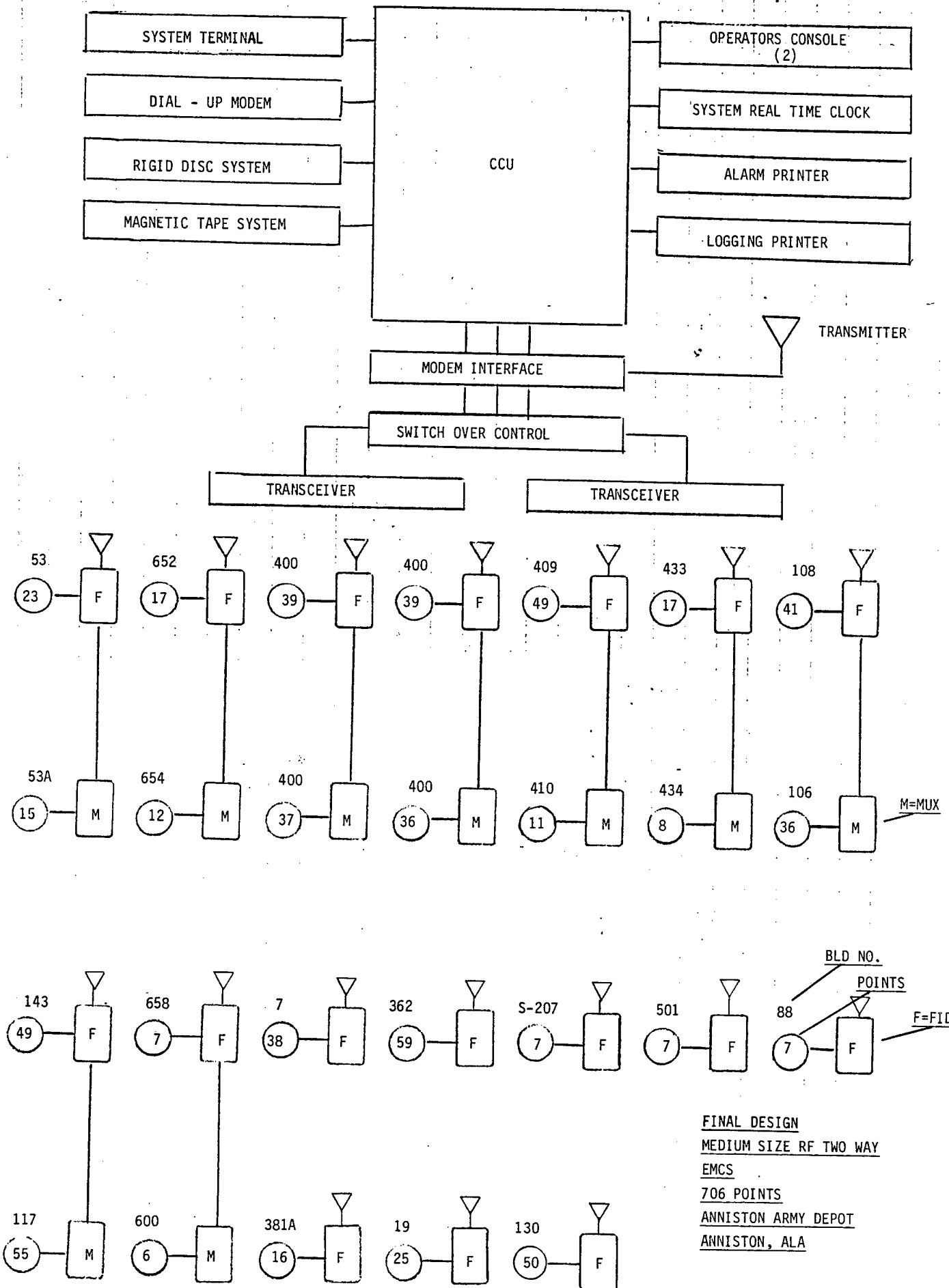

FINAL DESIGN
 MEDIUM SIZE RF TWO WAY
 EMCS
 706 POINTS
 ANNISTON ARMY DEPOT
 ANNISTON, ALA

10/87 P.W.

Comments on medium size RF Two Way EMCS Sketch.

(a) DATA TERMINAL CABINETS (9) used for FID/MUX combinations. Not shown for clarity associated building tie-in.

(b) Location of CCU in Building No 1.

(c) Following: FID/MUX associated building tie-in's.

FID - Located in Building 381A tied into control points in Buildings 168, 171, 172, 381, 381C.

FID - Located in Building 19 tied into control points in Buildings 4, 5, 8, 10, 6 55, 152, 77.

MUX - Located in Building 434 tied into control points in Buildings 421.

MUX - Located in Building 106 tied into control points in Buildings 104, 105, 107, 111, 112, 113.

MUX - Located in building 117 tied into control points in Buildings 127, 129, 140, 141, 142, 143, 144, 146, 147.

(d) ALL FIDS (17) To contain OUTSIDE AIR SENSOR.

3.3 ENERGY CONSERVATION PROGRAMS

The possible conservation programs are described in the following sections. More detailed descriptions are published in TM5-815-2. Energy conservation programs to be included in the AAD EMCS are shown in Appendix C. Also included in Appendix C are the energy conservation savings calculations for each building. A complete point schedule of proposed EMCS functions with respective equipment listings is shown in Appendix E.

3.3.1 Scheduled Start/Stop

Scheduled start/stop has good potential for energy savings at AAD. The program establishes a start/stop schedule for major pieces of electrical equipment, including fans, chillers, and oil-fired boilers. Heating will be controlled by the pressure reducing valve (PRV) stations where applicable. Generally this schedule is devised around occupancy hours; however, program scheduling is needed. For the purposes of this analysis, scheduling is based on observed occupancy hours for each building.

3.3.2 Start/Stop Optimization

The major emphasis of this program is to minimize run-time of the environmental equipment and still provide satisfactory conditions for human comfort. The primary savings generated from this program are based on reducing the operating time of HVAC equipment required to make the building comfortable for occupancy. The program inputs required are outside temperature, inside temperature, and building "U" value. These values are used to compute the time needed for warm-up prior to occupancy. In addition, the warm-up period is accomplished without ventilation air. Outside air is not drawn into the building until the programmed occupancy time. During night hours, no outside air

is brought into the building. Just before the building is to be occupied, outside air is sent in to flush out the space. Due to the nature of facility construction at AAD and the cost of this option, this option has very limited application. Hence, this option is deleted in favor of scheduled stop/start.

3.3.3 Duty Cycling

This program will automatically shut down heating and cooling equipment for predetermined periods. HVAC systems can be shut down for short periods allowing space temperature to drift. The savings from this operation is in reduced operation of auxiliary equipment such as fans and pumps. This program is specifically not recommended for centrifugal chillers because of possible excessive maintenance costs caused by starting/stopping chillers too frequently. Along these same lines, this option has been reviewed and found to be an unacceptable option due to the relationship with production processes including the ventilation of noxious gases, special temperature requirements of laboratories and special user equipment requirements.

3.3.4 Demand Limiting

The purpose of the demand limiting program is to reduce the total kVa draw for any given time during the day. This is accomplished by stopping equipment for short periods of time, on a prioritized basis, when the demand is predicted to exceed an acceptable level.

A difficulty in applying demand limiting at this facility is the adaptability to an industrial production process. Much of AAD electrical energy is consumed directly by production equipment in which priority load scheduling is difficult and can provide future complications with production goals. For this reason, only HVAC equipment that is non-essential to production is

considered for this program.

The additional equipment available for demand limiting will include new electrical metering to provide for compiling and recording of total electrical demand at AAD. The customer-supplied metering plan was reviewed and the proposed RF system provides the necessary capability for interfacing with the metering plan. The proposed metering plan is included in Appendix A.

3.3.5 Day/Night Setback

This program allows a variance in winter space temperature settings for occupied and unoccupied hours. Reasonable temperatures must be maintained during occupancy hours; however, when a building is not occupied, temperature need only be maintained for freeze protection. Time schedules for this program are based on the schedules for the start/stop program. In the summer, cooling systems are either used in spaces that require continuous temperature control or the systems are relatively small (<2 tons); therefore, no setback savings are calculated for cooling at AAD. The application of this program also includes the control of buildings where steam valves are proposed.

3.3.6 Hot Water Outside Air (OA) Reset

Environmental heating systems which use hot water media are designed for the lowest probable outside air temperatures. This program will reset the discharge heating water temperature in inverse proportion to the increase in outside temperature above the design value. Since design temperature values occur only a small percentage of the time, significant energy savings can be achieved with this program.

3.3.7 Economizer Control

Outside air can be used for "free cooling" in buildings during certain times of the year. Some geographic areas permit control of this changeover process by way of monitoring outside and return air temperatures. The high humidity at AAD requires humidity monitoring in addition to temperature monitoring. These two measurements determine the "enthalpy condition" of each air stream (Btu/lb) and will allow more OA for cooling as the OA enthalpy value drops below the return air enthalpy value. This program provides the comparison of enthalpy values and control changeover from outside/return air to return/outside air. Economizer controls exist in Building 7 and will be provided for in the EMCS. Other limited applications have been found to be economically unjustifiable.

3.3.8 Chilled Water Temperature Reset

Just as with heating systems, chillers are selected for design day conditions. Therefore, the chiller is operating at reduced supply/return temperature differentials during most of the cooling season. Most packaged chiller controls are set for a constant water supply temperature. It is possible to raise this temperature, within limits, in proportion to the decrease in return water temperature. This allows the compressor to operate at a lower pressure differential thereby reducing energy consumption for a given load. This program monitors the supply and return water temperatures and selects the temperature reset schedule that will meet the cooling load most efficiently.

3.3.9 Boiler Controls

The various "scattered" boilers at AAD can be monitored and controlled remotely. By starting and stopping oil-fired boilers, a reduction of fuel consumption will result due to a more prompt operating schedule. The safety aspects of remote control of boilers were coordinated with the AAD. A complete

evaluation of this program is found in Appendix C.

3.3.10 Steam Boiler Optimization

Steam boiler optimization can be implemented in heating plants with multiple boilers. Based on efficiency curves, fuel input vs. steam output, the boilers with the highest efficiency can be selected to satisfy the heating load. The EMCS would provide continuous monitoring of oxygen and carbon monoxide levels for each boiler to determine boiler efficiencies. These values will then be used in the selection of operating boilers.

3.3.11 Chiller Optimization

The chiller optimization program can be implemented in chilled water plants with multiple chillers. Based on chiller operating data and the energy input requirements obtained from the manufacturer for each chiller, the program will select the chiller or chillers required to meet the load with minimum energy consumption. When a chiller or chillers are started, chiller capacity must be limited (prevented from going to full load) for a predetermined period to allow the system to stabilize in order to determine the actual cooling load. Comparison of equipment characteristics vs. the actual operating chiller characteristics makes it possible to determine when heat transfer surfaces need cleaning to maintain the highest efficiency.

3.3.12 Ventilation/Recirculation Application

There is insufficient HVAC utilization at the AAD to make the ventilation/recirculation application program an applicable solution. The ventilation and recirculation program controls the operation of the outside air dampers when the introduction of outside air would impose an additional thermal load during warm-up or cool-down cycles prior to occupancy of the building.

This program is particularly useful in those facilities which must maintain environmental conditions such as electronic equipment installations during building unoccupied periods. During unoccupied periods, the OA dampers remain closed. During building occupied cycles, the OA, return and relief dampers are under local loop control.

4. CONCLUSIONS AND RECOMMENDATIONS

The intent of this study is to provide an EMCS for AAD which will be utilized to provide economic cost reduction and economic cost avoidance for fuel use at the site. Provision for a master control room is included in the study in accordance with TM5-815-2.

The majority of the energy savings is due to the scheduled start/stop of HVAC equipment, including remote boilers, and night setback of space temperatures. The individual EMCS energy saving options with their respective savings are presented below.

Option	Savings		
	Electric	Fuel Oil	Coal
Scheduled Start/Stop	476,700 kWh/yr	--	--
Demand Limiting	270 kVa/mo	--	--
Night Setback	--	1,708 MBtu/yr	6,749 MBtu/yr
Hot Water OA Reset	--	148 MBtu/yr	--
Chilled Water Reset	6,300 kWh/yr	--	--
Boiler Controls (Start/Stop)	--	5,540 MBtu/yr	--
Totals	483,000 kWh/yr	7,400 MBtu/yr	6,740 MBtu/yr
(Round-off)	3,260 kVa/yr		

During the course of the analysis, three different levels of EMCS capability were analyzed.

The initial system, entitled "Total Capability" in the report included a sizable number of monitoring functions that would enhance the technical and

functional needs of Anniston Army Depot. Unfortunately, these monitoring functions increased the cost and thus decreased the SIR to an unacceptable level.

The next system analyzed, entitled "Minimal Capability", in the report, represented a design approach initiated by SAIC which reduced the monitoring points in some areas, but still tried to observe the majority of the needs and desires of Anniston Army Depot. The cost of the system was reduced and the cost savings increased but the SIR did not increase by an appreciable amount.

The final system analyzed, entitled "Final Design"; in the report, represents new direction generated jointly by Corps of Engineer and Anniston Army Depot personnel. The new guidance included a point schedule which eliminated monitoring Functions and the use of a new cost estimating guide which reflected an overall reduction in the cost of EMCS components. This approach resulted in a sizable reduction in cost, but the SIR was still less than that required for an acceptable project.

EMCS Configuration Evaluated

	1.	2.	3.
	Total Capability	Minimal Approach	Final Design
Cost savings (First year)	35,133	43,409	69,393
Capitol Investment (Construction Cost)	2,187,555	1,776,878	890,669
SIR	.20	.28	.83

The initial capital investment for the "Final Design" system is \$890,669.

This cost includes all hardware and software necessary to achieve the estimated savings. The initial investment also includes money for checkout of existing controls to insure proper operation with the proposed EMCS. The cost estimate for checkout of existing controls is based on a cost per installed point as per the TM-5-815-2.

A summary of the entire system's energy savings potential and project economics are shown below for the Final design approach.

Electric savings	= 483,000 kWh/yr
Coal savings	= 6,750 MBtu/yr
Fuel oil savings	= 7,400 MBtu/yr
Cost savings	= \$69,393 first year
Capital investment	= \$890,669
SIR	= 0.83

These figures represent the cost and savings for a system developed in accordance with the following documentation:

- o Increment B (EMCS) Contract No. DAC01-83-C-0099 with supplementary Annex A-2, dated 6/6/85;
- o Mr. Phillip E. Holliday's letter of 3/24/84 with attachments;
- o Installation metering plan, dated 3/9/85;
- o HNDSP-84-076-ED-ME, dated January 1984;
- o HNDSP-83-049-ED-ME, EMCS Cost Estimating, dated February 1983; (Final Design used April 1987 revision)

- o TM 5-815-2;
- o EMCS policy letter, dated 8/31/84; and
- o Un-site conversations with Anniston Depot personnel
- o Mobile District COE Letter with Point Schedule.

Some of the prominent factors leading to the poor SIR value for this project are as follows:

- o Relatively low percentage of total base energy consumption is used for environmental space conditioning;
- o The lack of controllable, large air-conditioning loads; and
- o Relatively low energy prices (\$/unit).

Final Results

For this final submittal, the monitoring and all other marginally cost effective EMCS options were removed from the project. While this action reduced the cost from that of the "Minimal Approach" by \$886,209, it was not sufficient to increase the Savings Investment Ratio above 1. The SIR increased from .28 to .83, but this still indicates that the EMCS project at AAD is not presently cost effective.

The Final Design which dropped all monitoring can be summarized as shown below:

Electrical savings	= 483,000 kWh/yr.
Coal savings	= 6,750 MBtu/yr.
Fuel oil savings	= 7,400 MBtu/yr.
Cost savings	= \$69,393 first year
Capital Investment	= \$890,669
SIR	= 0.83

Since the discounted savings ratio (SIR) did not reach acceptable levels, project documentation has not been prepared.