

RL-TR-97-37
Final Technical Report
July 1997



JOINT ADAPTIVE COMMUNICATIONS SYSTEM (JACS) CONCEPT VALIDATION STUDY

David Sarnoff Research Center

N.P. Newman, T. Stiller, and W.E. Stephens

DTIC QUALITY INSPECTED 4

APPROVED FOR PUBLIC RELEASE; DISTRIBUTION UNLIMITED.

19971007 230

**Rome Laboratory
Air Force Materiel Command
Rome, New York**

This report has been reviewed by the Rome Laboratory Public Affairs Office (PA) and is releasable to the National Technical Information Service (NTIS). At NTIS it will be releasable to the general public, including foreign nations.

RL-TR-97-37 has been reviewed and is approved for publication.

APPROVED:

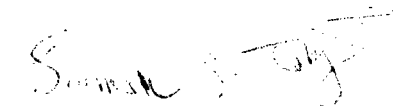

SIAMAK S. TABRIZI
Project Engineer

FOR THE COMMANDER:



JOHN A. GRANIERO, Chief Scientist
Command, Control & Communications Directorate

If your address has changed or if you wish to be removed from the Rome Laboratory mailing list, or if the addressee is no longer employed by your organization, please notify RL/C3BB, 525 Brooks Rd, Rome, NY 13441-4505. This will assist us in maintaining a current mailing list.

Do not return copies of this report unless contractual obligations or notices on a specific document require that it be returned.

REPORT DOCUMENTATION PAGE			Form Approved OMB No. 0704-0188	
Public reporting burden for this collection of information is estimated to average 1 hour per response, including the time for reviewing instructions, searching existing data sources, gathering and maintaining the data needed, and completing and reviewing the collection of information. Send comments regarding this burden estimate or any other aspect of this collection of information, including suggestions for reducing this burden, to Washington Headquarters Services, Directorate for Information Operations and Reports, 1215 Jefferson Davis Highway, Suite 1204, Arlington, VA 22202-4302, and to the Office of Management and Budget, Paperwork Reduction Project (0704-0188), Washington, DC 20503.				
1. AGENCY USE ONLY (Leave blank)	2. REPORT DATE July 1997	3. REPORT TYPE AND DATES COVERED Final Jun 96 - Sep 96		
4. TITLE AND SUBTITLE JOINT ADAPTIVE COMMUNICATIONS SYSTEM (JACS) CONCEPT VALIDATION STUDY		5. FUNDING NUMBERS C - F30602-96-C-0258 PE - 62702F PR - RDCN TA - 00 WU- 01		
6. AUTHOR(S) N.P. Newman, T. Stiller, and W.E. Stephens				
7. PERFORMING ORGANIZATION NAME(S) AND ADDRESS(ES) David Sarnoff Research Center CN5300 Princeton, NJ 08543-5300		8. PERFORMING ORGANIZATION REPORT NUMBER N/A		
9. SPONSORING/MONITORING AGENCY NAME(S) AND ADDRESS(ES) Rome Laboratory/C3BB 525 Brooks Rd Rome, NY 13441-4505		10. SPONSORING/MONITORING AGENCY REPORT NUMBER RL-TR-97-37		
11. SUPPLEMENTARY NOTES Rome Laboratory Project Engineer: Siamak S. Tabrizi/C3BB/315-330-4823				
12a. DISTRIBUTION AVAILABILITY STATEMENT Approved for public release; Distribution unlimited.		12b. DISTRIBUTION CODE		
13. ABSTRACT (Maximum 200 words) The Concept Validation Study of Joint Adaptive Communication System (JACS), conducted by David Sarnoff Research Center (Sarnoff) under contract to Air Force, focused on evaluation of network algorithms for a self-organizing, self-routing, self-maintaining and automatically reconfigurable communications network based on randomly scattered, inexpensive, disposable, rugged and air/ground-vehicle deployable nodes. JACS is capable of achieving the requirements of the network described above. JACS has a wide range of applications such as (a) downed pilot communications; (b) sensor array configurations; (c) special operations at the forward edge of battle; (d) tactical Internet and (e) Ad-Hoc network communications between multiple UAV's. During this study simulation network models for JACS were developed. The test network models are operational. The call set-up and routing algorithms work. The Call Set-up performance and End-to-end packet delay performance in JACS were evaluated using the network simulation models developed. Major performance characterizations have been obtained. The JACS concept is algorithmically feasible. Next steps include expanded validation of the JACS concept with reference to related radio propagation issues, phototyping and operational validation.				
14. SUBJECT TERMS instant infrastructure, low probability of intercept, self-organizing, network protocols, spread spectrum radio communications, access protocol, rapidly deployable		15. NUMBER OF PAGES 64		
		16. PRICE CODE		
17. SECURITY CLASSIFICATION OF REPORT UNCLASSIFIED	18. SECURITY CLASSIFICATION OF THIS PAGE UNCLASSIFIED	19. SECURITY CLASSIFICATION OF ABSTRACT UNCLASSIFIED	20. LIMITATION OF ABSTRACT UL	

Contents

Section		Page
	Executive Summary	1
1.	Introduction	5
	1.1 Objective.....	5
	1.1.1 Motivation.....	5
	1.1.2 Desirable Network Characteristics	6
	1.2 Scope of the Concept Validation Phase.....	7
	1.3 Concept Validation Approach.....	7
	1.4 Overall Recommendations.....	7
	1.5 Organization of the Report.....	8
2.	The JACS Architecture	9
	2.1 Radio Channel Structure.....	9
	2.2 Call Handling Mechanism	10
	2.2.1 Call Set-up Procedure	10
	2.2.2 Call Tear-down Procedure	11
	2.2.3 Channel (Busy/Idle) Status Update.....	11
	2.2.4 User Mobility.....	11
	2.3 Self-Organization and Self-Maintenance Issues.....	12
3.	Broadcast Strategy for Destination Paging	13
	3.1 Purpose/Function of a Broadcast Channel.....	13
	3.2 Collision Avoidance Techniques	14
	3.3 Call Set-up Packet Structure.....	15
	3.4 Example Call Set-up	16
4.	Routing Strategy for Connection Set-up	18
	4.1 Introduction	18
	4.2 The JITTER Protocol.....	18
	4.3 The MFR Protocol.....	19
	4.4 Example Route Establishment - JITTER and MFR	20
5.	Self-Organization and Self-Maintenance	23
	5.1 JITTER Protocol	23
	5.2 MFR Protocol	24
6.	Performance Evaluation	25
	6.1 Performance Characteristics.....	25
	6.2 JACS Test Network Model.....	26
	6.2.1 Physical layout.....	27

Contents (Cont'd.)

Section		Page
6.	Performance Evaluation	
	6.2.2 Node Distribution.....	27
	6.2.3 Node Density.....	27
	6.2.4 Number of Ongoing Calls.....	30
	6.2.5 User Distribution.....	30
6.3	JACS Test Radio Model.....	30
	6.3.1 Operating Frequency.....	31
	6.3.2 Channel Rate.....	31
	6.3.3 Modulation.....	32
	6.3.4 Antenna.....	32
6.4	Bit Error Rate Analysis.....	33
	6.4.1 Received Signal Power Calculations.....	33
	6.4.2 Node/User Transmit Power Variation.....	34
	6.4.3 Thermal Noise.....	34
	6.4.4 Multi-access Noise.....	34
	6.4.5 Uncoded Bit Error Probability.....	34
	6.4.6 Forward Error Correction.....	35
6.5	Network Node / User Architecture.....	36
	6.5.1 Node/User Transceiver Design.....	36
	6.5.2 Network Node/User Processor.....	37
6.6	Performance Results.....	38
	6.6.1 Probability of Failure of Call Request.....	39
	6.6.2 Call Set-up Delays.....	41
	6.6.3 End to End Packet Delay.....	
	6.6.4 Number of Hops per Route Established.....	43
	6.6.5 Multi-user Scenario.....	45
	6.6.6 Carrier Sense Effect.....	46
	6.6.7 Effect of Mean Wait Time Before Broadcast.....	47
	6.6.8 Effect of Node/User Time-out Duration.....	48
	6.6.9 MFR vs. JITTER Routing.....	48
7.	Conclusions and Recommendations	50
	7.1 Key Characteristics of JACS.....	50
	7.2 Application Scenarios.....	51
	7.3 Next Steps.....	52
8.	References	53

List of Figures

Figure		Page
1.	Example communication scenario for JACS application.....	6
2.	A generic call set-up packet structure.....	15
3.	Call request from A to B (with ongoing call between X and Y).....	17
4.	Route establishment - JITTER and MFR.....	21
5.	Details of example JITTER Call Set-up between A and B; User A calls B.....	21
6.	Details of example MFR Call Set-up between A and B; User A calls User B.....	22
7.	Random layout of 100 nodes in a 5 km x 5 km area.	28
8.	Random layout of 50 nodes in a 5 km x 5 km area.	29
9.	Network node transceiver architecture.....	36
10.	End-user JACS transceiver architecture.....	37
11.	State diagram representation of Node Process Model.....	37
12.	State diagram representation of End-User JACS Processor Process Model.....	38
13.	Probability of failure of Call Request higher for very low transmit powers and very high transmit powers.	40
14.	Probability of failure of Call Request lower for JITTER.	40
15.	Average delay for a successful call attempt decreases with increase in transmit power.	42
16.	Average delay for a successful call attempt does not significantly differ for MFR and JITTER.	42
17.	Average number of hops (end-to-end packet delay) decreases with increase in transmit power.	44
18.	Average number of hops for given transmit power does not significantly vary with node densities.	44
19.	Average number of hops in JITTER only a couple more than MFR.	45
20.	Multiple on-going calls; routes established by JITTER algorithm (100 nodes in a 5 x 5 km area).	46
21.	Carrier sense collision avoidance scheme decreases probability of failure.	47
22.	Carrier sense collision avoidance scheme does not effect the average delay per successful call attempt.	47

Executive Summary

The Concept Validation Study of Joint Adaptive Communication Systems (JACS), conducted by the David Sarnoff Research Center (Sarnoff) under contract to Air Force, focused on evaluation of network algorithms for a self-organizing, self-routing, self-maintaining and automatically reconfigurable communications network based on randomly scattered inexpensive, disposable, rugged and air/ground-vehicle deployable nodes.

What are Desirable Network Characteristics?

For a network meeting the above objective and capable of operating in military as well as commercial scenarios the following are desirable characteristics:

- Random placement of network nodes should be allowed
- Nodes capable of self-organizing themselves into networks
- Automatic reconfiguration to adapt to loss or addition of nodes
- LPI/LPD characteristics
- Tens of simultaneous local communication paths
- Robust operation in various terrains
- Node/Terminal capture does not compromise the network
- Small physical profile for low observability installation and easy deployment
- Supports secure communications
- Interoperability of network with existing transceivers such as Speakeasy, SINCGARS etc.

What are JACS characteristics?

Table 1 shows that JACS is capable of achieving the desired network characteristics.

Table 1. JACS is Capable of Achieving Desired Characteristics

Desirable Characteristics	JACS
Random configuration	Random network node configurations are acceptable
Self-organization	Network self-organizes itself from irregularly placed network nodes
Adaptive/Self-maintenance	Automatically adapts to addition or loss of network nodes
LPI/LPD	Spread spectrum radio communications for robust operation in hostile environments
Tens of communication paths	Capacity to support tens of simultaneous communications paths for digitized voice or medium speed data
Multi-terrain operation	Selected radio frequencies provide a proper balance among foliage penetration, spectrum availability and node density
Safety in the event of node/terminal capture	Minimal information stored in node memory; user location information not needed for network node operation [†]
Small, rugged, inexpensive network nodes	Network nodes are identical and require minimal hardware complexity; further study on node design/packaging needed
Secure communications	User security enhanced by requiring user broadcast only when using network for voice or data communications
Interoperability	User access protocols provide easy network access, however, interoperability with existing tactical communication systems needs further investigation

[†] True only for JITTER protocol (Section 4)

Hardware design is needed on various aspects of JACS such as : (a) antenna technology to provide robust communications at low physical elevation; (b) small physical profile for low observability installation; (c) ruggedized packaging; and (d) interoperability with existing tactical communications systems.

JACS Concept Validation Study

The scope of this Concept Validation study of JACS includes the following: For a random placement of network nodes, design and evaluate (a) call set-up procedure and (b) network self-organization and self-maintenance. The call set-up procedures involve broadcast strategy for destination user paging and routing strategies for connection set-up.

A broadcast strategy for destination user paging has been developed and simulated. JACS has a dedicated broadcast channel that obviates need of user registration with the network, thereby increasing end-user security and safety. Moreover, the dedicated broadcast channel provides easy network access to users and reduces node complexity. Suitable collision avoidance techniques have been implemented to increase throughput on the broadcast channel.

Two routing strategies were investigated - Maximum Forward Routing (MFR) and Just In Time Transceiver Endpoint Route (JITTER). The implementation of MFR introduces additional traffic on the broadcast channel and requires more complex hardware as compared to the JITTER algorithm. Although, JITTER algorithm may establish circuitous routes, our simulation shows that the average number of hops per route for JITTER are comparable to MFR.

The self-organization and self-maintenance for JACS with JITTER routing algorithm are implicit. In JACS with MFR routing algorithm additional broadcasts are needed for implementation of the MFR routing algorithm. The increased traffic on broadcast channel may degrade call set-up performance.

The JACS simulation models were developed using OPNET.¹ The test network models developed are operational. The broadcast and routing strategies work; there are no oscillations and instabilities in the network. The Call Set-up performance and End-to-end packet delay performance in JACS were evaluated using the network simulation models developed. Major performance characterizations have been obtained.

¹ OPNET is a commercially available network simulation tool from MIL3, Inc. Washington, D. C. The OPNET 2.5B (c) 1995, version was used for JACS simulation.

Conclusions

The JACS concept is algorithmically feasible. JITTER algorithm will support covert communication scenarios with low cost hardware and software requirements and limited desired functionality in terms of multiple protocol support. Example scenarios with these features are sensor arrays, downed pilot communications and special operations. MFR algorithm is more extensible to Tactical Internet applications.

JACS has a wide range of applications such as (a) downed pilot communications; (b) sensor array configurations; (c) special operations at the forward edge of battle; (d) tactical Internet; and (e) Ad-Hoc network communications between multiple UAV's. The specific application and desired functionalities will determine the routing algorithm that should be implemented.

Next Steps

Sarnoff recommends tasks focused on expanded validation of the JACS concept with reference to related radio propagation issues, prototyping and operational validation.

1. Introduction

This document is the Final Report of David Sarnoff Research Center (Sarnoff) for the Joint Adaptive Communications Systems (JACS) Concept Validation Study. The study was conducted by Sarnoff from June 1996 to September 1996, under contract to the AFMC Rome Laboratory, Rome, NY.

1.1 OBJECTIVE

The overall objective of the JACS program is to develop a self-organizing, self-routing and self-maintaining communications network based on randomly scattered nodes. These nodes should be inexpensive, disposable and rugged enough to allow rapid deployment by air drop or from ground vehicles. The resulting network should have the ability to adapt to loss and/or addition of nodes.

The scope of this Concept Validation Study of JACS is focused on the following: For a random placement of network nodes, design and evaluate (a) call set-up procedure and (b) network self-organization and self-maintenance. The call set-up procedures involve broadcast strategy for destination user paging and routing strategies for call set-up:

1.1.1 Motivation

An example scenario for JACS is illustrated in Fig. 1. Users A, B are located in the local area but the distance between User A and User B is much larger than their transceiver range. The objective of this program of JACS is to investigate the possibility of establishing a connection between the Users A and B by scattering some "Smart Rocks" in the area. These "Smart Rocks," besides being able to function as self-organizing and self-maintaining network nodes, are also rugged, inexpensive and disposable.

An adaptive communications system meeting the above objective has the potential to deliver extremely high value in many operational scenarios. This "Instant Infrastructure" can be utilized to establish initial communications as a forward deployed unit is establishing its more permanent command and control infrastructure. (The value of this network would then continue as a supplement to more permanent infrastructures.) Because of the ability to easily deploy the proposed network architecture over large geographic areas, it will have wide application in enhancing war-fighter communications in tactical environments. Such a network could also be used to establish communications access for downed pilots or air crew in Search And Rescue operations. This network will have valuable application in support of Special Operations, especially if enhanced Low

Probability of Intercept (LPI) and Low Probability of Detection (LPD) characteristics are incorporated into the network.

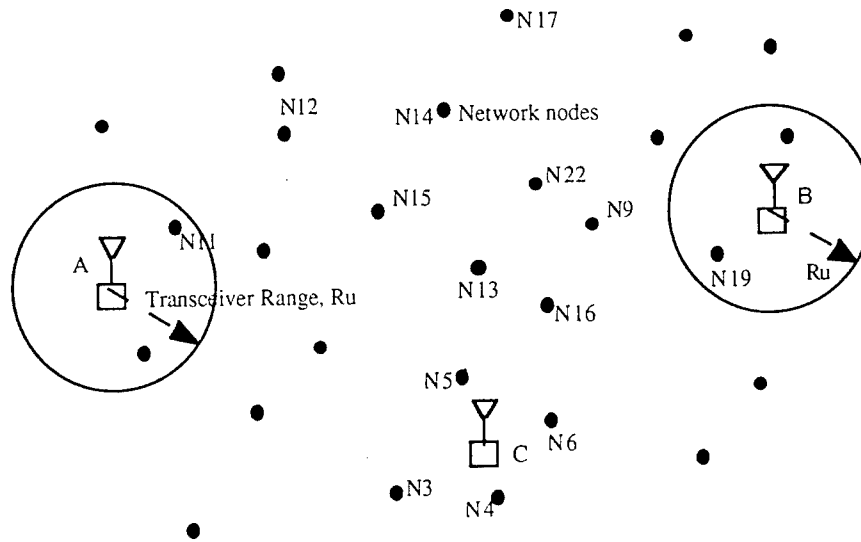

Figure 1. Example communication scenario for JACS application.

1.1.2 Desirable Network Characteristics

For a network meeting the above objective and capable of operating in military as well as commercial scenarios the following are desirable characteristics:

- Random placement of network nodes should be allowed
- Nodes capable of self-organizing themselves into networks
- Automatic reconfiguration to adapt to loss or addition of nodes
- LPI/LPD characteristics
- Tens of simultaneous local communication paths
- Robust operation in various terrains
- Node/Terminal capture does not compromise the network
- Small physical profile for low observability installation and easy deployment
- Supports secure communications
- Interoperability of network with existing transceivers such as Speakeasy, SINCGARS etc.

The proposed JACS network architecture is capable of achieving these desirable characteristics. Significant security features are inherent in the network design. However, specific security and interoperability features are not included at this time.

1.2 SCOPE OF THE CONCEPT VALIDATION PHASE

The Concept Validation Phase study of JACS focused on the following: For a random placement of network nodes, design and evaluate (a) call set-up procedure and (b) network self-organization and self-maintenance. The call set-up procedures involve broadcast strategy for destination user paging and routing strategies for call set-up.

1.3 CONCEPT VALIDATION APPROACH

The approach taken to validate the JACS concept can be outlined as follows:

- Development of a call set-up procedure - following aspects investigated:
 - Identify broadcast strategy for destination user paging
 - Routing strategies for connection set-up
 - Define packet structure for call set-up
- Build JACS simulation model using OPNET
- Performance Evaluation - Theoretical analysis and testing of network models
- Obtain numerical results based on the models developed

1.4 OVERALL RECOMMENDATIONS

This initial study has shown that JACS concept is algorithmically feasible.

Sarnoff recommends a 5-6 month task focused on the following elements:

- Further validation of algorithmic concept by evaluating models tailored for specific operational scenarios.
- Terrain modeling additions to OPNET simulation
- Code Division Multiple Access implementation considerations
- Investigate the associated radio propagation issues
- Antenna design
- Initial cut at size/weight/cost of JACS network node elements
- System design modification for mobile users
- Initial concept of operations

This task will enable rapid prototyping and operational validation. Sarnoff recommends building of about 10 network node prototypes and 4 end-user units to physically validate the JACS design. The interoperability with USAF units is also recommended.

1.5 Organization of the Report

Section 2 describes the basic architecture and protocols of JACS. The broadcast strategy for destination paging are described in Section 3. The two routing strategies investigated in the Concept Validation Phase are discussed in Section 4. The Section 5 describes the self-organization and self-maintenance protocols needed for JACS. The concept validation approach and performance results obtained from the JACS simulation model are presented in Section 6. The application scenarios for JACS are discussed in the final section.

2. The JACS Architecture

The JACS network utilizes physically small identical network node elements designed for rapid deployment. These network node elements may be deployed over a large area with minimal restrictions on node density or node spacing. The network nodes automatically organize themselves into a network that has self-routing and self-maintaining characteristics. In the event of loss of nodes, network architecture will have graceful degradation capabilities through its adaptive/self-maintenance capabilities.

The network node elements consist of cellular automatons that can function as a radio transceiver, as a network router, and as a network access point. The network protocols provides adaptive routing through the network, establishing communications paths between pairs of users. The available network resources are dynamically selected at the time the connection is established. The network can be deployed to extend over several miles, much beyond the communication range of typical end-unit transceivers, thereby extending the reach of user devices.

JACS uses dedicated multi-function channel and a set of dynamically assigned communication channels. Before describing how these channels are used to implement the network self-organization/self-maintenance and call set-up/call tear-down procedures, the channels JACS radio channel structure will be described.

2.1 RADIO CHANNEL STRUCTURE

Spread spectrum radio communications are envisioned for JACS. The channels may be separated by frequency division or code division or both, that is, several frequencies each with several codes.

There are two types of channels in JACS. A channel is a logical communication channel defined by a unique combination of frequency and spreading code.

- The *Broadcast channel* is a single, network wide dedicated channel for messages broadcasts. It is used both by a network node and by an end-unit transceiver. The idle end-users and idle nodes monitor this channel.

- The *Communication channels* are used for active voice or data communications. The number of these channels will be defined during the next phase of the program and will depend on the expected traffic load statistics and the Level Of Service (LOS) to be provided. The network node transceivers and end-user transceivers use these channels during active call communications. These channels are dynamically assigned during the call set-up procedure.

The choice of operating radio frequencies is critical for JACS. The selected frequencies should provide a proper balance among foliage penetration, antenna size, network node separation distance and spectrum availability. These factors are discussed in greater detail in Section 6.

2.2 CALL HANDLING MECHANISM

The call handling mechanism includes the call set-up and call tear-down procedures. The updated availability status of channels is needed for call set-up and this process is also described here. In the present analysis, large scale movement of users is not considered.

For the security and safety of end users, they communicate with the nodes only for call origination, call answer or during active communications on the network. No user registration is required. All idle nodes and idle users are tuned to the *Broadcast channel*.

2.2.1 Call Set-up Procedure

The call-originating user will broadcast a call-request packet on the *Broadcast channel*. The Call Set-up process is initiated by a node when it hears the call-request packet transmitted by the originating user. The completion of the Call Set-up process involves successful completion of all of the following three phases.

- *Destination user paging*: The destination user is located as the first step in the call set-up procedure. The destination paging is accomplished on the *Broadcast channel*. This process is discussed in detail in Section 3.
- *Route establishment*: The Call Set-up procedure continues with the establishment of a route through the network for communication between the call-originating user and the destination user. The route establishment process is based on the routing strategy. Two routing strategies were considered in the Concept Validation phase study. These are discussed in Section 4.

- *Channel assignment*: The link set-up is complete when there is a *Communication channel* assigned for each hop on the route.

A single call request made by the call-originating user may require multiple call attempts to establish an end-to-end communication link. Once the call is set-up, the participating nodes are listening to the *Communication channel* and not to the *Broadcast channel*.

2.2.2 Call Tear-down Procedure

Either the call-originating user or the destination can terminate the call. When the call is terminated, all the nodes in that communication path are notified and these nodes go back to monitoring the *Broadcast channel*. These nodes will broadcast a channel update information on the *Broadcast channel* notifying the neighboring nodes of the availability of that particular *Communication channel*.

If any of the participating nodes does not hear any packets on its communication path, it will time-out after a certain time. The node will then become idle and notify its neighbors that the *Communication channel* is now available.

2.2.3 Channel (Busy/Idle) Status Update

Each node maintains a channel status table containing the information on busy or idle status of a *Communication channels*. When a *Communication channel* is selected by a network node element for call set-up, it broadcasts an updated channel state indicating busy status of that *Communication channel*. On call completion, the availability of that *Communication channel* is broadcast to the neighboring nodes as part of call tear-down procedure. These broadcasts are on the *Broadcast channel*.

2.2.4 User Mobility

The absence of user registration allows users to move freely without impacting the network's ability to locate them when required. However, if the users move during the call, the route and channels will need to be dynamically adjusted. The hand-over issues associated with users moving during the call are not addressed. The users are assumed to be near-stationary during the call.

2.3 SELF-ORGANIZATION AND SELF-MAINTENANCE ISSUES

The self-organization of the network node elements is required initially after deployment. Self-maintenance is required as a continuing capability to maintain proper operation of the network in the presence of node failures, node additions and/or changes in the network node(s) placement.

In JACS, the network node elements may require some knowledge about its neighboring nodes in order to establish a route and assign channels during call set-up. The amount of information sharing necessary depends on the routing strategy implemented. As discussed in Section 4, the Maximum Forward Routing² (MFR) algorithm needs locations of its neighboring nodes for route establishment where as Just In Time Transceiver Endpoint Routing³ (JITTER) does not need any information exchange. In both routing algorithms, nodes broadcast updated channel status information during call set-up and call tear-down phase.

Since all idle nodes listen to the *Broadcast channel*, information exchanges between neighboring nodes, needed for MFR, are done on the *Broadcast channel*. This increases the traffic on the *Broadcast channel*, and hence may decrease the throughput, thereby, deteriorating the call set-up performance. The frequency of such information exchanges will depend on the network environment. For example, more frequent exchanges will be required in a hostile environment with a high probability of jamming and/or loss of nodes.

The specific details of self-organization and maintenance protocols for the two routing strategies, JITTER and MFR considered in this study are discussed in Section 5.

²MFR: An optimal route with lower number of hops is determined [3].

³ JITTER: The route is established by retracing the first broadcast path from the destination user to the call-originating user.

3. Broadcast Strategy for Destination Paging

JACS has a dedicated broadcast channel that provides easy network access to users, reduces node complexity and obviates need of user registration with the network, thereby increasing end-user security and safety. Suitable collision avoidance techniques have been implemented to increase throughput on the broadcast channel. A call set-up packet structure has been identified. The broadcast strategy is illustrated by an example.

3.1 PURPOSE/FUNCTION OF A BROADCAST CHANNEL

JACS has a dedicated broadcast channel, that is used for call set-up and network maintenance, as needed. This dedicated broadcast channel concept provides the following favorable characteristics to JACS:

- *Security and Safety of Users:* By avoiding the need for user registration with the network, the end-user security and safety is increased. Then user location information is not compromised as maximum radio silence can be maintained. In this context, a broadcast channel is used for destination user paging. An end-user transceiver is activated for communication with the network nodes during the user's own call-origination, call answer or during an active call to another end-user.
- *Easy Network Access:* To initiate a call, an end-user simply broadcasts its call-request packet over the broadcast channel. This provides easy access to available network resources as all idle nodes and idle users monitor the broadcast channel.
- *Reduced Hardware Complexity:* The information on network resource availability is shared via the same broadcast channel. This allows a simple network configuration at reduced node hardware complexity.

A broadcast strategy must be chosen to reduce/avoid contention on the broadcast channel. Suitable collision avoidance techniques have been implemented to increase throughput in JACS.

We distinguish between two types of broadcast packets, namely:

- (a) a *generic broadcast* packet not addressed to any specific user but is intended for simple re-broadcast over the network, and
- (b) a *directed broadcast* packet addressed to a specific end-user or node.

3.2 COLLISION AVOIDANCE TECHNIQUES

As discussed earlier in Section 2, the JACS architecture consists of only identical network nodes. The network operation does not rely on a centralized controller or a cellular base station type set-up to assist in collision detection or/and collision avoidance. The absence of the need of such a centralized controller provides an added useful feature to JACS - JACS can be configured by scattering *identical* network node elements, no other type of element is needed.

Distributed collision avoidance techniques are needed in JACS to improve the throughput on the *Broadcast channel*. The throughput on the *Broadcast channel* directly effects the call set-up performance. In the Concept Validation phase, three techniques to minimize collisions have been investigated.

- *No Repeat broadcasts of generic packet*: Since all nodes re-broadcast the *generic broadcast* packet, a node may receive multiple copies of the same packet. The nodes keep a record of the previous *generic broadcast* packet it broadcasted, and does not re-broadcast it. This avoids oscillations and back and forth bouncing of any *generic broadcast* packet.
- *Random delay before packet broadcast*: On packet reception, the node processes the packet. If after processing the node determines that it needs to broadcast a packet, it waits for a random amount of time before broadcasting the packet. If the mean random delay is long, the average traffic on broadcast channel will be low and throughput will be higher. However, the call set-up time will increase since at each node the call set-up packet waits for a longer time.
- *Carrier Sensing*: After the node waits for the random time, it checks its receiver. If the receiver is currently receiving a packet, it waits for another random period of time. The node will repeat this process until it finds its receiver is not locked to any signal.

There are other techniques that can be implemented to improve the throughput of *Broadcast channel* such as retransmission of packet if echo not heard. These techniques will be investigated in the next phase of JACS.

3.3 CALL SET-UP PACKET STRUCTURE

Figure 2 represents a generic call set-up packet that was used for simulation. The call set-up performance will remain same as long as the packet size is the same. The performance will improve with smaller packet size and deteriorate with increase in the packet size.

Sync Bits	Message Type	Channel Mask	Originator Call No.	Destination Call No.	From Node ID	To Node ID	FEC
32 bits	8 bits	8 bits	32 bits	32 bits	32 bits	32 bits	80 bits

Figure 2. A generic call set-up packet structure.

The packet consists of various fields needed to (a) locate the destination user, (b) establish connection between the call-originating user and destination user, and (c) channel status update information. Following is a description of individual fields in the call set-up packet:

Sync Bits: These enable the receiver to synchronize with the incoming packet. The minimum number of Sync bits needed to achieve reliable packet reception will be studied in the next phase. An estimation of length for reliable synchronization is between 14 and 20 bits.

Message Type: This identifies the different phases during the Call Set-up process. The first phase is to locate the destination user; once the destination user is located, the call set-up continues with route set-up, channel assignment and acknowledgments.

Channel Mask: This gives information on the busy/idle status of the channels in the node's neighborhood. This information is used by neighboring nodes to update the availability status of channels.

Originator Call Number: The (phone) number of the call-originating user.

Destination Call Number: The (phone) number of the destination user.

From Node ID: This field gives the ID of the node that broadcasted that packet. This number is used by neighboring nodes for route establishment and/or maintenance purposes.

To Node ID: For a directed broadcast packet, intended only for a specific node, this field gives the Node ID of that node. All the other nodes receiving this packet will ignore it. If it is a generic broadcast packet, the receiving nodes modify the *From Node ID* and *Channel Mask* as needed and then re-broadcast the packet.

FEC: A BCH (Bose-Chaudhuri-Hocquenghem) code with 10 bit error correction capability is assumed. This gives a code rate of 0.69, which is in the optimal range for asynchronous random access Spread Spectrum communications [1, 2].

3.4 EXAMPLE CALL SET-UP

Let us follow through an example to explain the call set-up process. Figure 3 represents a snapshot of a network in operation. There are many randomly placed nodes and five users A, B, C, X and Y on this network. The radio transmission range for a user and a network node are represented by radii, R_u and R_n respectively. A voice call is in progress between users X and Y. Therefore, the nodes involved in that connection are not available for a new call set-up.⁴ Now, user A wants to make a call to user B. We assume user B is idle.

Call Request and Destination User Paging

User A transmits a call request on the *Broadcast channel*, along with the identity of the destination (user B). This request may be received by the neighborhood nodes (N_3 , N_4 , N_5 and N_6) each within the user's transmission range, R_u . Since the destination position is unknown, a call-request packet (*generic broadcast packet*, Section 3.1) for the destination user will be broadcast throughout the network. Each of the nodes that received the user call request will broadcast a call-request packet with their own node ID and the destination user call number. These call request packet(s) are in turn re-broadcasted by other nodes. All these broadcasts occur on the *Broadcast channel*.

All idle users and node receivers listen to the *Broadcast channel* continuously. Since the destination user B is idle, its receiver is also tuned to the *Broadcast channel*. Let us assume that the first call request packet that destination user B hears traversed along the dotted path (Fig. 3) via N_5 , N_{31} , N_{35} , N_{32} , N_{33} and N_{17} . This process is equivalent to a "telephone ring". If the destination, user B, decides to answer the call, it responds by acknowledging the call request. User B may decide not to respond to the call request because of other immediate priorities.

⁴ We assumed that only one call could be supported per node. This assumption could be eliminated by adding more equipment to each node resulting in more network capability for more cost per node.

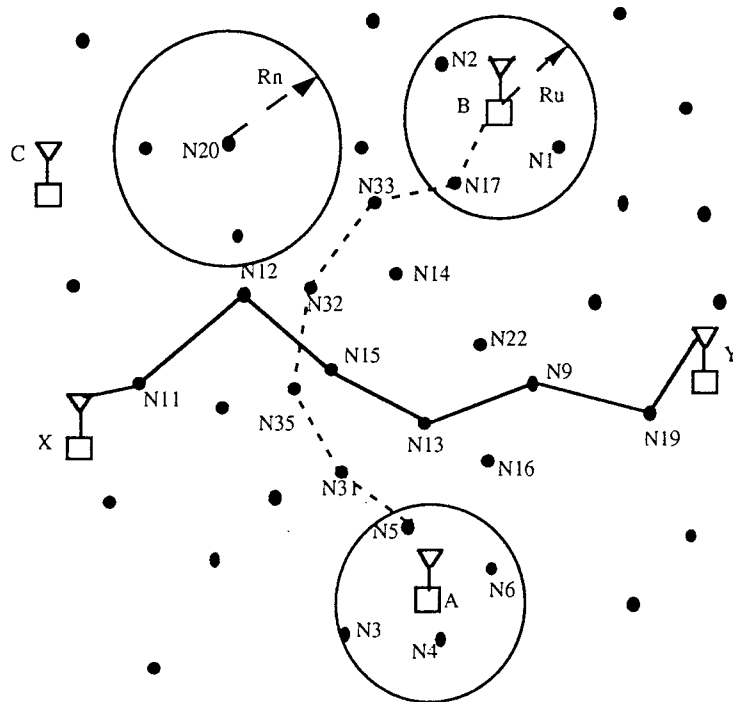

Figure 3. Call request from A to B (with ongoing call between X and Y).

If user B does respond to the call request, that action initiates the route set-up and channel assignment procedure for the call. Because of the broadcast nature of the call request, user B can expect to receive several call request messages for the same call. Once a request has been responded to, all further requests are ignored until the requested call has been terminated and the user returns to the idle state.

4. Routing Strategy for Connection Set-up

Two routing strategies were investigated - Maximum Forward Routing (MFR) and Just In Time Transceiver Endpoint Route (JITTER). The implementation of MFR introduces additional traffic on the broadcast channel and requires more complex hardware as compared to the JITTER algorithm. JITTER algorithm may establish circuitous routes, however, our simulation shows that the average number of hops per route for JITTER are comparable to MFR.

4.1 INTRODUCTION

In the Call Set-up process, once the destination user is located, the nodes establish a route from the destination user back to the call-originating user (Section 2.2.1). The route establishment process is based on the routing strategy implemented. In this Concept Validation phase of JACS, following two routing strategies were investigated.

- JITTER (Just In Time Transceiver Endpoint Route): The route is established by retracing the first broadcast path from the destination user to the call-originating user.
- MFR (Maximum Forward Routing): An optimal route with lower number of hops is determined [3].

Both these protocols do not require any regular ordering of nodes — random placement of nodes is acceptable. These protocols are described in the following sections. A detailed performance comparison of the two protocols is discussed in Section 6.6.9.

4.2 THE JITTER PROTOCOL

In the JITTER protocol, during the destination user paging phase, each node upon hearing the call-request packet, identifies (the *From Node ID* field of the call-request packet, Section 3.3) the node from which it heard. Then nodes wait for an answer from the destination user. In the mean time, these nodes do not process any other call-request. These nodes will wait for an answer to the call-request for a pre-specified time, after which they will time-out and become idle.

If the destination user decides to answer the call request, it will send a directed broadcast to the node from which it heard. Similarly, that node will send a directed broadcast (answering the call-request

packet) to the node from which it had heard. Each consecutive node will repeat this process until the call-originating user is reached. Hence, the first broadcast path is retraced. The JITTER protocol is illustrated by an example in Section 4.4, Fig. 5. If channels are available at each hop, then the connection between the two users is established.

The nodes do not need any information about the location of its neighbors or the end points. Therefore, even if the node on a route is tampered and the information in memory is extracted, it will only give the IDs of the two neighboring nodes on the route. Thus, node capture will not jeopardize the network. Of course, if a node on the route is lost, the call in progress will have to be set-up again.

The implementation of this protocol will need minimal computation complexity at nodes. However, the route established may be circuitous and may have large number of hops. Lower number of hops is desirable, since the end-to-end packet delay is directly proportional to number of hops (Section 6.6.3).

4.3 THE MFR PROTOCOL

The MFR protocol in general, except in some peculiar node layouts, will give a path with minimum possible number of hops. However, implementation of MFR introduces overhead on the *Broadcast channel* and also increases the hardware complexity of the network node elements.

In the MFR protocol, if the destination user responds to the call request, a route as per the MFR protocol will be established. That is, during the route establishment, the node will select a neighbor such that the hop maximizes the progress in the direction of the call-originating user. An example illustrating MFR protocol is described in Section 4.4, Fig. 6.

Implementation of MFR requires the following information at nodes:

- knowledge of positions of the neighboring nodes, i.e., nodes within the node's transceiver range; and
- the position of nodes at the end-point of the route to enable selection of the optimal node among its neighbors.

In order for the nodes to attain the above information needed to implement JACS with MFR, following requirements on system are imposed:

- A GPS type device will be needed in each network node that provides the position information,
- The nodes need to periodically broadcast identification packets giving their coordinates. These packets facilitate exchange of information among neighboring nodes to maintain neighborhood network configuration knowledge. These identification packets are not re-broadcasted.
- Based on the identification packets received the network nodes need to keep an updated table of the neighborhood nodes.

The consequences on the system performance due to above requirements are :

- Increased traffic on *Broadcast channel* , thereby degradation in call set-up performance.
- Increase in the complexity of the network node elements - more memory, more computational complexity.
- More battery power will be needed - effects the size and weight of nodes.
- Cost increases due to the GPS type receiver needed.
- The position of the end-point nodes of the route and neighboring nodes contained in memory of nodes. The capture of node element may jeopardize the safety of users.
- The ability to support a wide range of data protocols.

4.4 EXAMPLE ROUTE ESTABLISHMENT - JITTER AND MFR

Consider the call set-up example in Section 3.4, illustrated in Fig. 3. The user B responds to the call request packet heard by N_{17} . The route establishment procedure is initiated by the node N_{17} . Figure 4 shows the routes established according to the JITTER and MFR protocol.

The JITTER protocol just retraces the first broadcast route that was indicated in Fig. 3. A pictorial representation of the JITTER call set-up process is shown in Fig. 5.

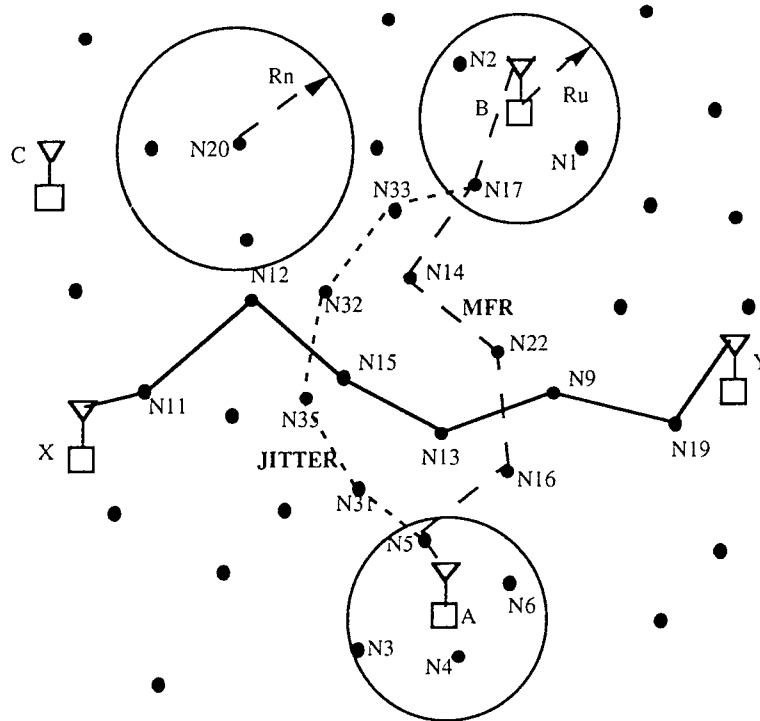

Figure 4. Route establishment - JITTER and MFR.

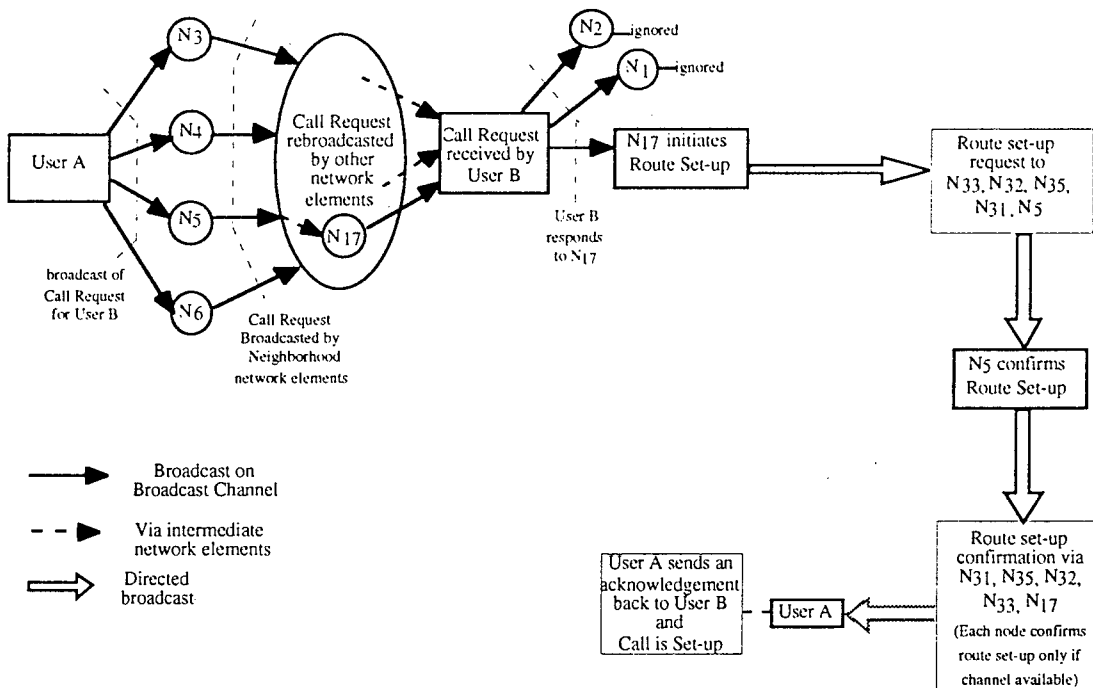

Figure 5. Details of example JITTER Call Set-up between A and B; User A calls B.

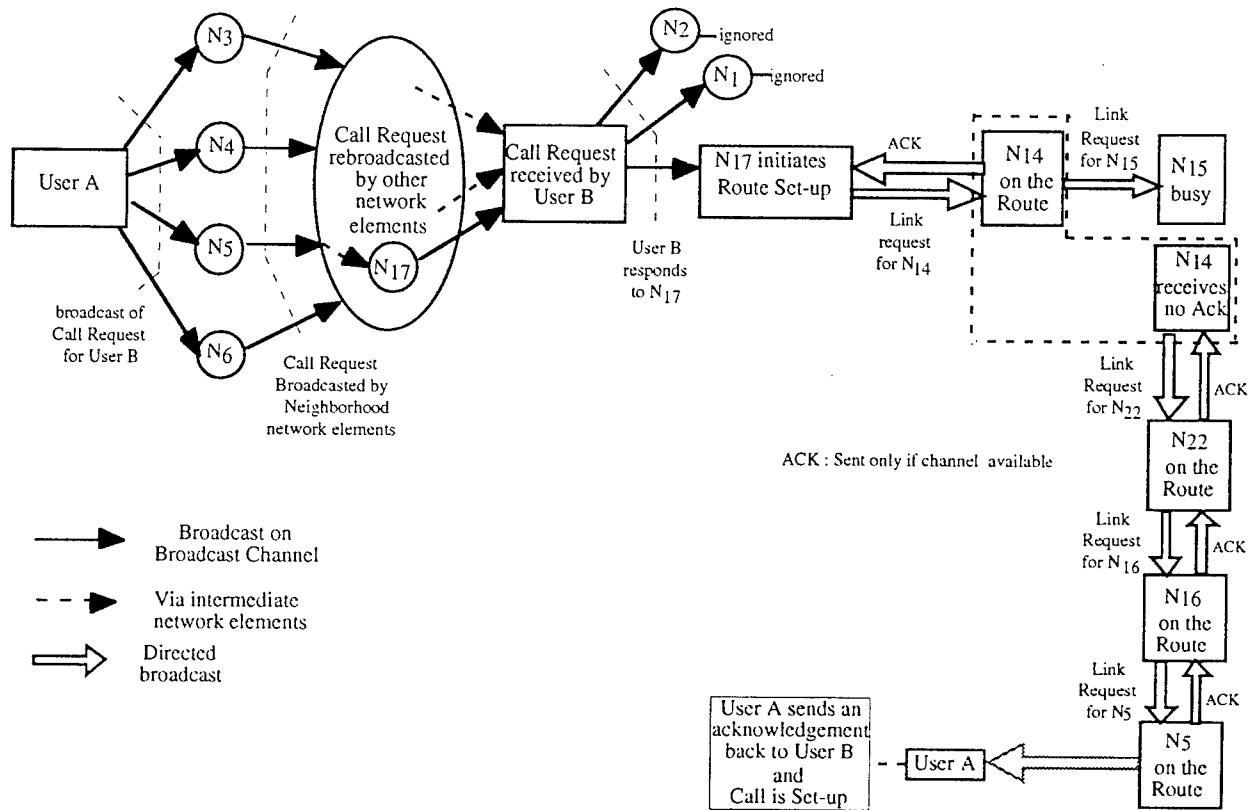

Figure 6. Details of example MFR Call Set-up between A and B; User A calls User B.

The complete call set-up process of MFR protocol is illustrated in Fig. 6. In the MFR protocol, the network node (N₁₇) sends a directed broadcast to a selected node in its neighborhood based on a Most Forward Routing (MFR) algorithm. In this example, N₁₇ will direct its link request to N₁₄. Since the node N₁₄ is idle, it will be monitoring the *Broadcast channel* and will hear the request for route set-up. Then, N₁₄ sends back an acknowledgment to N₁₇ and in turn proceeds to set-up the route to the next node as determined by the MFR algorithm.

The network node N₁₄ sends link request for node N₁₅, which has an ongoing call on C₃. Node N₁₅, because it is involved in an active call is not monitoring the *Broadcast channel*. Therefore, N₁₄ does not get an acknowledgment to its set-up request. Then, N₁₄ chooses another node, N₂₂, again chosen according the to MFR algorithm, and sends link set-up request. Finally, the call connection is completed, in this example, via N₂₂, N₁₆ and N₅ to the call-origination user A.

5. Self-Organization and Self-Maintenance

The self-organization and self-maintenance for JACS with JITTER routing algorithm are implicit. In JACS with MFR routing algorithm additional broadcasts are needed for implementation of the MFR routing algorithm. The increased traffic on broadcast channel may degrade call set-up performance.

The self-organization and self-maintenance imply following functional aspects of the network:

Self-Organization: JACS is deployed by randomly scattering the network node elements via air-drop or from ground vehicles. These network node elements need to self-organize themselves into an operational network, ready to establish connections between users in the local area. Depending on the routing algorithm implemented, the network node elements need to know specific information about their neighboring nodes that is used for route establishment during call set-up process.

There are other details that need to be taken into account at the time of initial organization such as excessive interference at couple of nodes that fell right next to each other. In this scenario, a possible solution is to include a logic that turns off a node with a certain probability for some time if it hears SNR greater than a specified value. These exact details of system operation will be studied in the future phases of JACS.

Self-Maintenance: Once the network is operational, self-maintenance capabilities are needed to maintain proper operation of the network in the presence of node failures, node additions and/or changes in the network node(s) placement.

5.1 JITTER PROTOCOL

In the JITTER protocol, the Self-organization and Self-maintenance are implicit. A node is activated only if it hears any packet. Each active node (participating in call set-up or active communications) needs to only keep track of the two neighborhood nodes it transmits to or hears from. No additional broadcasts are necessary to maintain the system and this has favorable outcomes such as: (a) reduces traffic on the *Broadcast channel*, thereby improving call set-up performance; (b) the power-on time on battery is lower, therefore increasing the battery life.

5.2 MFR PROTOCOL

As discussed in Section 4.3, the implementation of MFR requires the knowledge of locations of neighborhood nodes. Due to this constraint the following functions are necessary as part of self-organization and self-maintenance for JACS with MFR routing strategy.

Self-Organization:

- Node determines its coordinates after “power-on” using a GPS kind of device.
- After random delay it announces its presence by broadcasting identification packet giving its coordinates. The nodes do not re-broadcast this packet. These broadcasts need to be done on the *Broadcast channel* since all idle nodes listen to it.
- The nodes construct a table of neighboring nodes and their locations based on the identification packet they transmitted.

Self-Maintenance:

- Random periodic exchange of identification packets among neighboring nodes to maintain neighborhood network configuration knowledge.
- Network nodes will age their information about neighbors and eliminate the neighbor from their tables if new identification packets are not received somewhat periodically. The frequency of such identification transmissions will depend on the network environment (more frequent in a hostile environment with a high probability of jamming and/or loss of nodes).

The additional broadcasts necessary for maintenance in the JACS with MFR increase the traffic on the *Broadcast channel*. This deteriorates the call set-up performance. The degradation in performance is directly proportional to the frequency at which the identification packets need to be exchanged.

6. Performance Evaluation

The JACS simulation models were developed using OPNET 2.5B (c) 1995, MIL 3, Inc. The test network models developed are operational. The broadcast and routing strategies work; there are no oscillations and instabilities in the network. The Call Set-up performance and End-to-end packet delay performance in JACS were evaluated using the network simulation models developed. Major performance characterizations were obtained.

In this Concept Validation phase of JACS, the Call set-up and End-to-end packet delay performance were evaluated as a function of several parameters such as Node/User transmit power, number of actively communicating users, node density, user and node time-out parameters and distance between users.

Major performance trends are available that are discussed in Sections 6.6. Further investigation and evaluation of simulation models for different network parameter sets will present a comprehensive picture of the trade-offs in the overall system performance.

The current analysis assumes only a single transceiver per node, this minimizes the hardware complexity of the network node element. Consequently, each node can participate only in one call at any time. However, the network simulation model can be easily extended to represent JACS with multiple transceivers per node.

6.1 PERFORMANCE CHARACTERISTICS

In the Concept Validation phase, the following two major performance characteristics of JACS were investigated.

- Call Set-up performance:
 - Probability of success of each call request
 - Mean time delay to establish communication link
- End-to-end Data Packet delay

The JACS performance depends upon several system parameters such as

- Operating frequency

- Channel speed
- RF modulation
- Node/user transceiver antennas
- Node/user transmit power
- Number of actively communicating users
- Total traffic
- Number of communication channels
- Node density
- Network node layout
- User locations and distance between them
- Operating environment, terrain
- Spread spectrum codes
- User and node time-out parameters
- Fading, jamming and other radio propagation variables

6.2 JACS TEST NETWORK MODEL

The JACS simulation models were developed using OPNET 2.5B (c) 1995 MIL 3, Inc., Washington, DC. The test network models developed are operational. The broadcast and routing strategies work; there are no oscillations and instabilities in the network. The models can be further refined, enhanced and tailored to specific application scenarios to obtain a more accurate representation of a system, with given specifications.

The JACS simulation models were developed for a random layout of nodes in a flat terrain with attenuation due to foliage. The performance was evaluated for different node densities, node/user transmit powers, single or multiple on-going call attempts, node and user layouts. These parameters are discussed in the following sub-sections. The system performance was evaluated for a selected set of radio parameters that are discussed in Section 6.3.

6.2.1 Physical Layout

Two physical layouts were considered for simulation models: (a) 20 km by 1 km area that will closely resemble the layout obtained if the nodes were air-dropped by an airplane; (b) 5 km by 5 km area that is more manageable in terms of computation and simulation development. The results obtained for configuration (a) are not significantly different from configuration (b). The performance trends presented here are from simulation of configuration (b).

The JACS simulation model assumes a flat terrain with attenuation due to foliage.

6.2.2 Node Distribution

The nodes were randomly placed in the physical area modeled.

6.2.3 Node Density

The node density was varied by changing the total number of nodes in the given physical area defined by the simulation. In the simulation models the total number of nodes varied from 35 to 100 in a 25 square km area. The random layout of 100 nodes and 50 nodes used for simulations are shown in Figs. 7 and 8, respectively.

The circles in Fig. 7 represent the minimum and maximum transceiver range of the network nodes and users considered in the simulations.

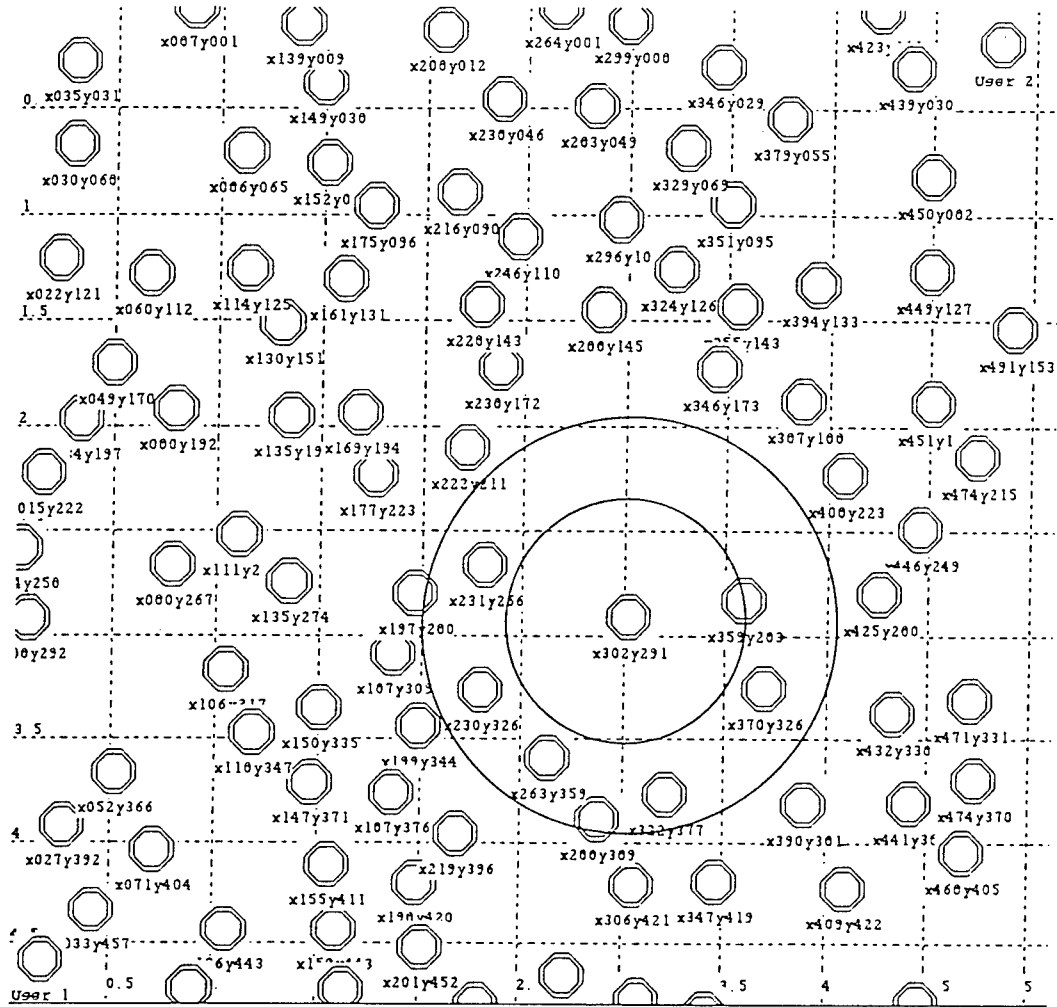

Figure 7. Random layout of 100 nodes in a 5 km x 5 km area.

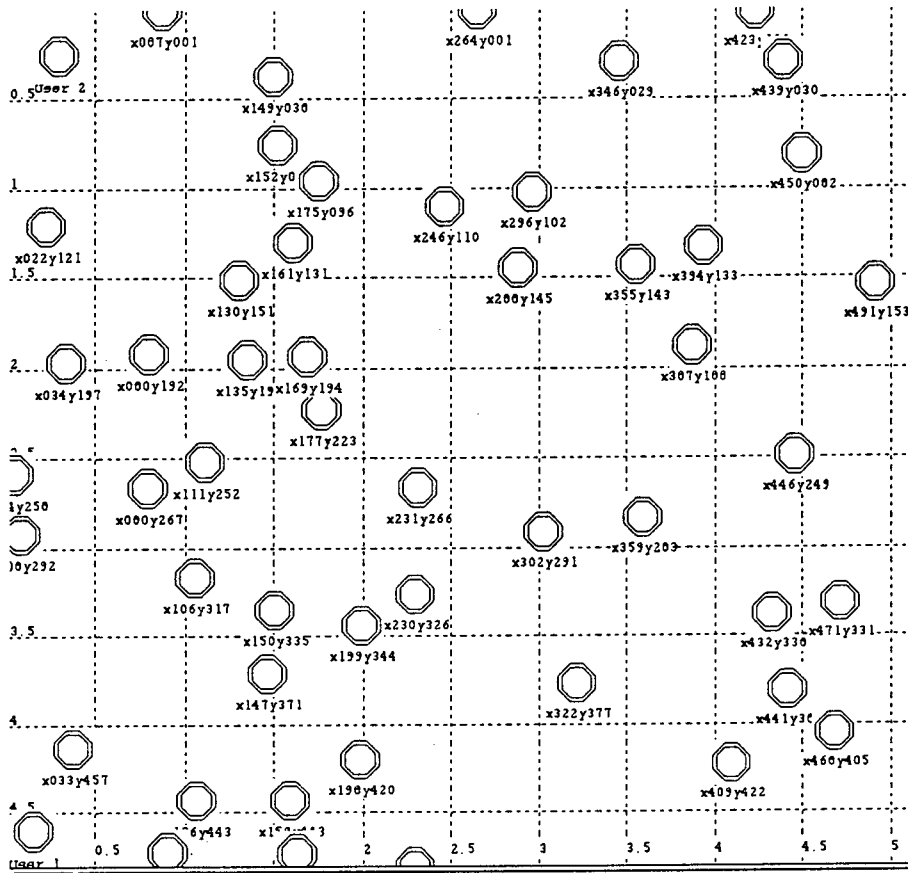

Figure 8. Random layout of 50 nodes in a 5 km x 5 km area.

The total number of nodes in the neighborhood of any node (that is, total number of nodes within the coverage area of any node) will determine the system performance. There have been several studies on the minimum average number of neighborhood nodes necessary for connectivity among any two points in a random network [4-6]. The optimal number of nodes in a neighborhood depends on factors such as the routing algorithm employed, radio modulation and the definition of connectivity itself. In literature, the optimal number has been shown to be any where in the range 6 - 15 depending on the parameter values.

If the nodes are randomly deployed over an infinitely large area, then

$$\text{Total number of nodes in area, } A = \frac{A}{\text{Coverage Area of Node}} * \text{Average number of neighborhood nodes}$$

Consider an example scenario with node transceiver range of 1 km. Then for an average of 10 nodes in the neighborhood of a node, a total of about 80 ($= 25 * 10 / \pi (1.0)^2$) nodes should be deployed in a 25 square km area.

6.2.4 Number of On-going Calls

The performance was evaluated with single or multiple users making call. The communicating user pairs are distinct. Each call-originating user calls a single destination user. Moreover, each destination user is called by only one call-originating user.

Nodes that are busy with on-going calls are not available for incoming call set-up. Since the current simulation assumes only a single transceiver per node, this minimizes the hardware complexity of the network node element. However, the network simulation model can be easily extended to represent JACS with multiple transceivers per node.

6.2.5 User Distribution

The performance results for communication between a pair of users was done under two user configurations:

- (a) Case 1: The two users across a diagonal, maximum possible distance in the given test physical layout, for example position of User 1 and User 2 in Fig. 7.
- (b) Case 2: Two users across an edge, for example User 1 and User 2 in Fig. 8. In this configuration fewer nodes are available between them, since the users are placed along the edge.

The performance trends in both cases were similar. The simulation results presented here are for Case 1 user configuration.

In the multiple user scenario, the user locations were randomly picked with intersecting communication paths over the given simulation area. An example scenario is illustrated in Section 6.6.5.

6.3 JACS TEST RADIO MODEL

The JACS test radio model parameters were selected so that the performance results are valid for a wide range of application scenarios. The radio link parameters selected for the JACS test model are described in following paragraphs.

6.3.1 Operating Frequency

The choice of radio frequencies is critical for JACS. The selected frequencies should provide a proper balance among foliage penetration, antenna size, battery requirements, network node separation distance, spectrum availability for commercial and military applications.

- Antenna size is small at high frequencies, this will help reduce the overall size of each network node. The smaller size of the network element enhances the low observability feature.
- Foliage loss and other propagation losses are larger at high frequencies. Therefore, at higher frequencies for a given transmit power the transceiver range will be smaller, thereby higher node density will be required to establish reliable communications in any given area.
- Another consequence of higher losses at high frequencies is more battery power requirement at network nodes. High battery power requirement directly impacts the size and weight of battery needed, hence, the volume and weight of the network node itself.
- It would be desirable to select operating frequencies for JACS such that it can be implemented for commercial as well as military applications without significant changes in the transceiver design.

An operating frequency of 900 MHz was selected for the JACS test model, since ISM band of 902 - 928 MHz is available for system operation without FCC license. As shown later in the bit error rate calculations (Section 6.4), with transmit power of about one-quarter watt a foliage penetration of up to quarter mile is possible.

The channels are separated by a combination of frequency division and code division. Each frequency band may support multiple channels each defined by a specific code. Since each logical channel has an IF bandwidth of 1.8 MHz (Section 6.3.3), enough bandwidth is available in the ISM bands to support tens of communication channels.

6.3.2 Channel Rate

A channel rate of 56 kbps is selected for voice and low data rate applications. The effective data rate will be lower than 56 kbps due to overhead such as FEC and synchronization preamble.

6.3.3 Modulation

Spread Spectrum radio communications is considered for JACS due to the following reasons:

- Provides low probability of intercept and low probability of detection feature.
- Enables operation of JACS in the ISM bands. As per FCC requirements (47CFR15.247) the devices in the ISM bands must use Spread Spectrum modulation with certain parameters.
- Multiple users can be supported using Code Division Multiple Access (CDMA).

In the JACS test model, PN spreading with BPSK modulation of binary data is considered. The chip rate for the test model is 1.8 Mbps. In a DS/BPSK system, a chip rate of 1.8 Mbps and data rate of 56 kbps implies a code length of 32. In this scenario, an IF bandwidth of about 1.8 MHz will maximize the SNR at receiver [7].

In jamming scenarios, PN Spreading with QPSK modulation may be used for more robust operation [8].

6.3.4 Antenna

The antenna has to be omni-directional for all node and user transceivers so that each transceiver can communicate to any other transceiver within the transceiver's range.

A small antenna size is desirable to keep the physical cross-section of nodes as small as possible. The antenna size is inversely proportional to the operating frequency.

A suitable antenna design for JACS will be investigated in the next phase of JACS.

6.4 BIT ERROR RATE ANALYSIS

For the bit error rate analysis, the received signal power, overall noise characteristics and noise power are needed. In JACS the total noise is due to the thermal noise and the multi-access noise. As per the discussion in Section 6.3, the following values have been considered for the radio parameters.

Operating Frequency = 900 MHz

Data rate = 56 kbps

Chip rate = 56 * 32 kbps = 1.792 Mbps

IF bandwidth = 1.8 MHz

Antenna gain = 6 dBi

Radio modulation: binary data, PN spreading and BPSK modulation

6.4.1 Received Signal Power Calculations

All the nodes are identical, therefore the transmit power at each of these network nodes is identical. It is assumed that the end-user transceiver also has the same transmit power as the network nodes. In practice however, the end-user transceiver design and specifications may be different from that of the network nodes.

At about 900 MHz frequency range the rain and other atmospheric losses are negligible for a propagation distance of a mile [9]. The received signal power at a node or user transceiver in presence of foliage and free space loss is given by the following relationship.

Received signal power = Transmit power + Antenna gains
- Free Space Path Loss - Foliage loss

The free space path loss at 900 MHz at a distance of 1 km is [10]

$$\begin{aligned}\text{Free space Path loss (in dB)} &= 32.45 + 20 \log D_{\text{km}} + 20 \log F_{\text{MHz}} \\ &= 32.45 + 20 \log 1.0 + 20 \log 900 = 91.5 \text{ dB}\end{aligned}$$

The foliage loss for a foliage penetration of 400 meters is [10]

$$\begin{aligned}\text{Foliage loss (in dB)} &= 1.33 * (F_{\text{GHz}})^{0.284} * (D_{\text{m}})^{0.588} \\ &= 1.33 * (0.9)^{0.284} * (400)^{0.588} \\ &= 43.7 \text{ dB} \sim 44 \text{ dB}\end{aligned}$$

Then,

$$\text{Received power, } P_R = P_T + 12 \text{ dB} - 92 - 44 = P_T - 124 \text{ dB}$$

If transmit power, $P_T = 0.25$ W then

Received power, $P_R = -130$ dBW

6.4.2 Node/User Transmit Power Variation

In the simulation results presented the transmit power is varied from one-tenth to one-quarter watt. A foliage attenuation of 44 dB is assumed, which gives about 400 meters penetration in dense foliage. Therefore, the change in transmit power effects the transceiver range only due to free space loss.

If the transmit power, P_T in above calculations is doubled, that is 0.5 W, then the same received power (-130 dB) will be obtained at a distance of 1.4 km.

6.4.3 Thermal Noise

The thermal noise at 290 K for the given parameters is given as

$$\begin{aligned}\text{Thermal Noise (at 290 K)} &= -204 \text{ dB/Hz} + 10 \log B_{IF} + NF (= 0 \text{ dB}) \\ &= -204 + 10 \log 1.8 * 10^6 \\ &= -141 \text{ dB}\end{aligned}$$

6.4.4 Multi-Access Noise

The multi-access noise due to several simultaneous users can be approximated as a Gaussian function under the central limit theorem. It is shown by Yao [11], that Gaussian assumption for multiple access noise is good for most situations except when the code length is low, the number of users is small and the SNR is quite large.

In the network simulation model developed, the multi-access noise is modeled as Gaussian noise. Hence, the overall noise in JACS is assumed to be Gaussian with total noise power as sum of the interference noise power due to overlapping packets and the thermal noise.

6.4.5 Uncoded Bit Error Probability

The error probability of asynchronous DS/SS multi-access communications depends on several factors such as the codeset selected, the pulse shape, modulation technique used. There are several papers that deal with performance evaluation of Spread Spectrum multi-access communication systems [11-15]. These analyses involves investigation of several approaches to calculate of average, lower and

upper bounds of error probabilities under different communication parameters. The bit error rate calculations have also been done for asynchronous direct sequence Spread Spectrum sequences over multipath fading channels [16]. These results should be incorporated in refined simulation models to obtain more accurate performance results.

Under the Gaussian assumption, for a binary data, PN spreading and BPSK modulation, the uncoded bit error probability for coherent BPSK is given as [17]

$$P_b \leq Q(\sqrt{2E_b/N_T}).$$

The received energy per bit, E_b is given as the received power/ data bit rate. The equivalent noise spectral density, N_T is the (Thermal noise + Interference noise) / Transmission bandwidth. The total interference power appears as a Gaussian noise of power spectral density bounded by $N_T/2$.

The received SNR is defined as Received power / Total noise. Then,

$$E_b/N_T = \text{SNR} * (\text{Transmission Bandwidth} / \text{data bit rate}).$$

If no multi-user interference is present, then the total noise is just the thermal noise. Therefore, for the example received signal and noise calculations earlier in Sections 6.4.1 and 6.4.3.

$$E_b/N_T = (-130 + 141) + 10 \log 1.8*10^6 - 10 \log (56*10^3) = 26 \text{ dB}$$

For a $E_b/N_T = 6 \text{ dB}$, the theoretical probability of error for a BPSK is approximately 2.5×10^{-3} . So for an uncoded BER of 2.5×10^{-3} , we have about 20 dB margin for implementation and multi-access interference.

6.4.6 Forward Error Correction

In case of asynchronous random access Spread Spectrum with a bandwidth expansion of 32, it has been shown that optimal code rate for block codes is in the range of 0.6 - 0.7 and is relatively insensitive to block length [1-2].

In the simulation model BCH codes are assumed. For a block size of 256 bits, there are 176 message bits giving a code rate of 0.6875. This gives an error correction capability of 10 bits in a packet size

of 256 bits. So in the simulation model, theoretically after FEC we can achieve a 10^{-10} bit error rate (uncoded bit error probability of 2.5×10^{-3}) for the Call set-up packets, with a margin of about 20 dB for multi-access interference and implementation margin.

The data packet size and FEC needed will be studied in the next phase of JACS.

6.5 NETWORK NODE / USER ARCHITECTURE

The network node and end-user unit architecture are similar in the simulation model developed. However, in practice the end-user unit may have a different design. These aspects will be considered as part of Interoperability Issues in the future phases of JACS.

6.5.1 Node/User Transceiver Design

The network node and end-user node will have a battery/power module besides the transceiver architecture described below.

Network Node Architecture: The network node architecture in the (OPNET) simulation model is shown in Fig. 9. The Direct Sequence Spread Spectrum BPSK transmitter and receiver are connected to a single omni-directional antenna. There is a single processor to process the received packets and if needed, modify the headers and broadcast them.

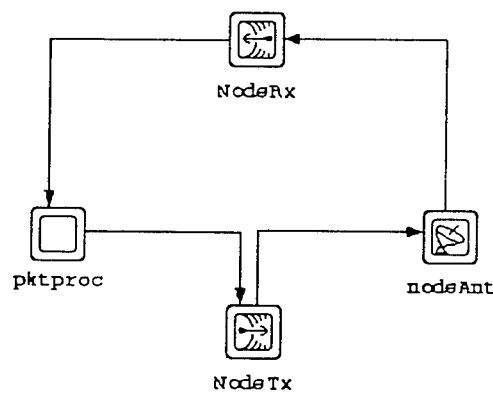

Figure 9. Network node transceiver architecture.

End-User JACS Transceiver Architecture: Figure 10 shows the End-User transceiver architecture. This is similar to the network node architecture except for the packet generator needed at the end-user transceiver.

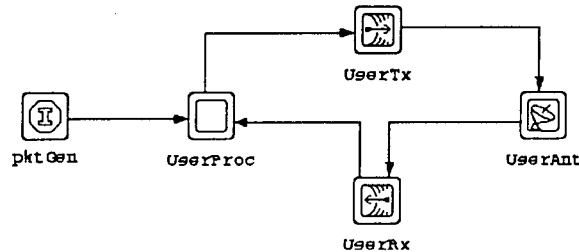

Figure 10. End-user JACS transceiver architecture.

6.5.2 Network Node/User Processor

Network Node Process: The network node process can be simply represented by the state diagram in Fig. 11. Once node process is activated the processor is usually in the idle state. If it receives a packet, it processes the packet in PROC_PKT state and returns to idle state. If it needs to re-broadcast the packet, it waits for a random time. At the end of the waiting period, the WAIT_END transition is activated, and depending on other parameters it may broadcast or wait for another random duration of time. The “broadcast or further wait” decision is based on the collision avoidance techniques implemented. Hence, the idle state is a very complex state with several in-built states.

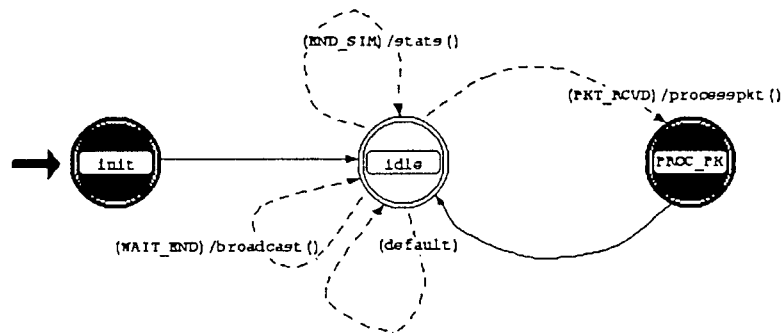

Figure 11. State diagram representation of Node Process Model.

End-User JACS Processor Process: This process is similar to the network node process, however, the state diagram representation is slightly different as shown in Fig. 12. Here the complete processing is represented under the PROCESS state. The packet processing itself is represented just as a transition, instead of a separate state as in the network node process state diagram.

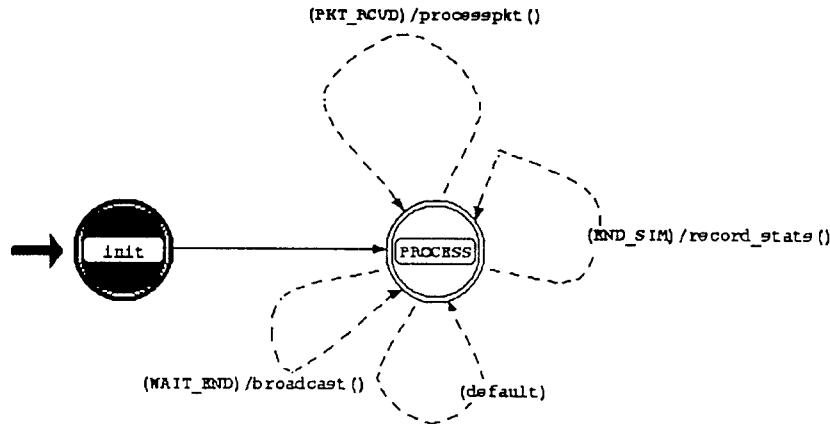

Figure 12. State diagram representation of End-User JACS Processor Process Model.

6.6 PERFORMANCE RESULTS

The system performance results obtained from the simulation model for several combination of parameters is presented in this section. It should be emphasized that only a sample of results obtained from the simulation are presented here. A more comprehensive simulation analysis for multiple sets of parameters with different random network layouts should be performed to determine the JACS overall performance. These results present major performance trends in JACS.

Most of the results presented here are for a scenario with two active users. In the simulation, one user makes and breaks connection over the duration of the simulation. Values such as call set-up delay, hop count and number of successful attempts were recorded. For all the results presented here, the mean wait time (Section 3.2) before a node broadcasts a packet is 25 ms (unless specified otherwise). In the simulation results here, after a node broadcasts a call-request packet it waits for the pre-specified node time-out period (Section 3.4) of 2.5 seconds before returning to idle state.

6.6.1 Probability of Failure of Call Request

The call-originating user initiates the Call Set-up procedure (Section 2.2.1). Each successful call request may take multiple call attempts. If each call request initiates at the most N call attempts, then call request will fail if all call attempts fail. Then the probability of failure of a call request is given as

$$\text{Probability of failure of a Call Request} = (1-p)^N,$$

where p is probability of success of each call attempt.

The probability of failure of call request as a function of node/user transmit power for various node densities is shown in Figs. 13 and 14. These results are for a random node layout over a 5 x 5 square km area. Each call request initiates a maximum of 10 call attempts.

In Fig. 13 the probability of failure is low for transmit powers in the range of 0.1 to 0.2 W and higher outside this range. The probability of failure is high for low transmit powers since on an average there will be fewer nodes within the transceiver range. As transmit power increases probability of failure decreases because the average number of nodes within the transceiver range also increases. However, if the transmit power is too high, the multi-access noise is high, thereby increasing the probability of failure.

Figure 13 shows probability of failure curves for three node densities - 2, 3, and 4 nodes per square mile. The probability of failure in the optimal range of transmit power are comparable. However, if there are multiple on-going calls, since each node can handle only one call, there may not be enough nodes to handle multiple calls, in low node density scenario.

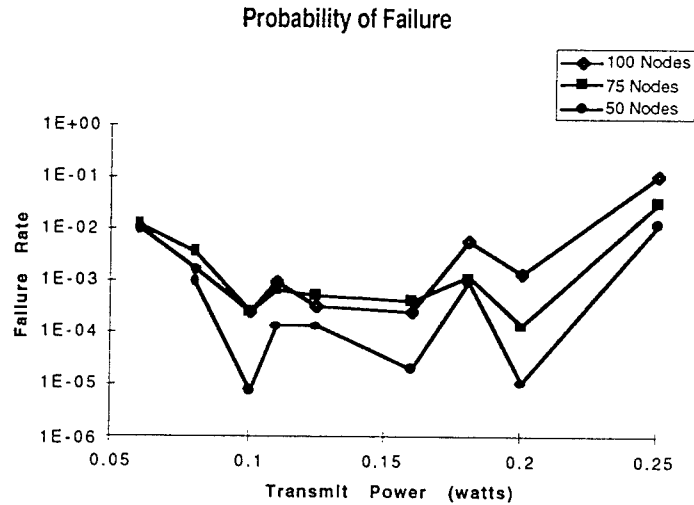

(100 nodes in 5 x 5 km square area; Two users across diagonal; Node Time-out duration = 2.5 sec.; Mean wait time before broadcast = 25 ms; Maximum number of attempts per call request = 10)

Figure 13. *Probability of failure of Call Request higher for very low transmit powers and very high transmit powers.*

The probability of failure with MFR and JITTER routing strategies are compared in Fig. 14. These are results for 100 nodes in 5 x 5 km square area. As expected, the probability of failure for JITTER are lower than MFR because of increased traffic on broadcast channel due to the random periodic exchange of identification packets needed for self-maintenance (Section 5.2). In this simulation, the nodes exchange packets every 5 seconds, however if the frequency of exchange is lower, the probability of failure for MFR will also be lower and comparable to JITTER.

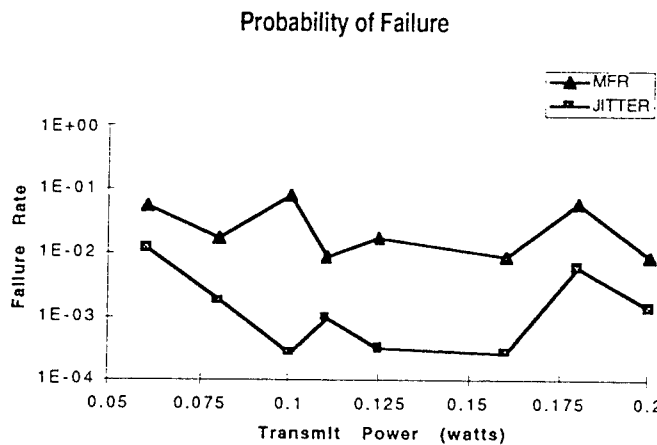

(100 nodes in 5 x 5 km square area; Two users across diagonal; Node Time-out duration = 2.5 sec.; Mean wait time before broadcast = 25 ms; Maximum number of attempts per call request = 10)

Figure 14. *Probability of failure of Call Request lower for JITTER.*

6.6.2 Call Set-up Delays

Each call request generates multiple call attempts (say, a maximum of N call attempts). First call attempt is made, if unsuccessful, next call attempt is made say D seconds later. Then, if it takes j attempts to establish the connection then the call set-up delay is $j \cdot D$. The average delay for a successful call set-up will be a weighted average of the call set up delays for $j = 1$ to N , that is,

$$\text{Average delay for successful call request} = \sum_{i=1}^N iD p(1-p)^{i-1}$$

where p is the probability of success of each call attempt.

The results in Figs. 15 and 16 show the variation of average delay for a successful call attempt (and not average delay for a successful call request). This is defined as the total time delay from the time that particular call attempt was initiated until the route was established.

The average delay of successful call attempt decreases with increase in transmit power as shown in Fig. 15, however, the average delay is only in the range of 1-2 seconds for the parameters considered here. For higher transmit power, the transceiver range is larger, hence fewer hops are involved in the route. Since, this is a store and forward type of network, each hop introduces delay, therefore lower number of hops per route implies smaller delay.

The results for average delay of successful call attempt show that the average delays are about 2 seconds at most. Therefore, an example value of D , the pre-specified time between successive attempts, can be 5 seconds. Then, the maximum delay for a call request will be less than a minute with a reliability of 0.999 for a call set-up.

Average Delay of a Successful Call Attempt

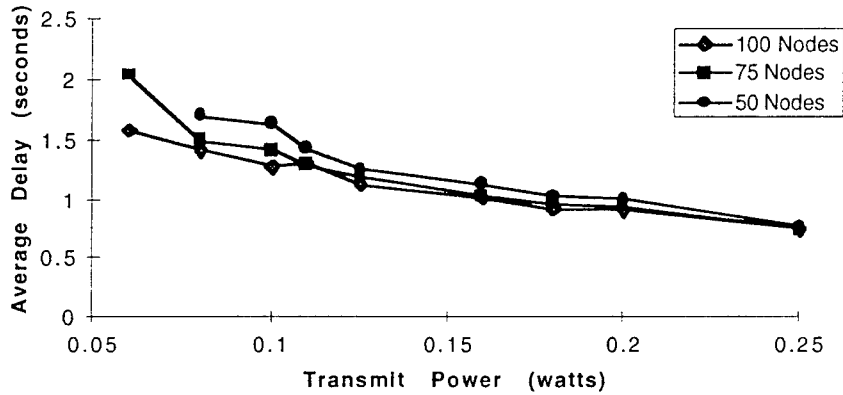

(Physical area of 5 x 5 km square area; Two users across diagonal; Node Time-out duration = 2.5 sec.; Mean wait time before broadcast = 25 ms)

Figure 15. Average delay for a successful call attempt decreases with increase in transmit power.

Figure 16 shows that there is no significant difference in the average delay of a successful call attempt for JACS with MFR or JITTER routing.

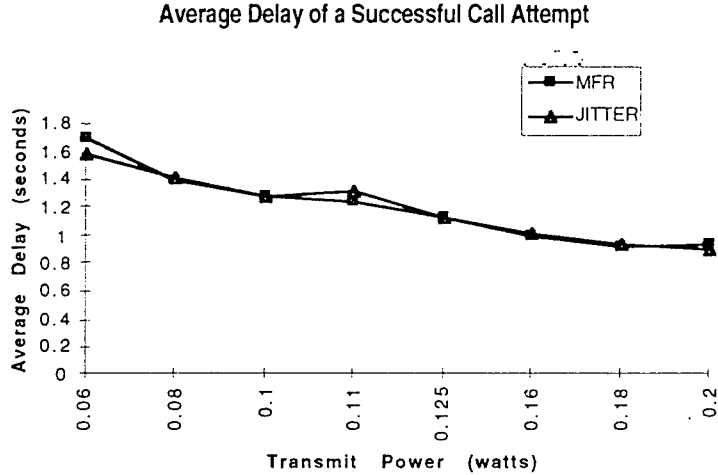

(100 nodes in 5 x 5 km square area; Two users across diagonal; Node Time-out duration = 2.5 sec.; Mean wait time before broadcast = 25 ms)

Figure 16. Average delay for a successful call attempt does not significantly differ for MFR and JITTER.

6.6.3 End-to-End Packet Delay

The end-to-end packet delay is defined as the total time taken by a packet to reach from one user to the other. Each node has a store and forward type of simple mechanism- the packet is received at the node, processed and then broadcasted, if needed. Hence, the total end-to-end packet delay is directly proportional to the number of hops in any route. It is also directly proportional to the packet transmission time, which is proportional to the packet length. Therefore,

$$\text{End-to-end packet delay} > \text{Number of Hops} * \text{Packet transmission duration.}$$

The variation of average number of hops per route thereby End-to-end packet delay is discussed in Section 6.6.4.

There are other additional factors contributing to the end to end packet delay such as repeat transmission of an unacknowledged packet, if that is implemented; processing time and propagation delay.

Length of Data Packet Trade-offs: There is a tradeoff involved in the selection of the length of data packet. The end-to-end delay is small for a small data packet. However, since each data packet needs overhead like synchronization preamble and FEC, smaller data packets will have lower channel utilization/efficiency.

6.6.4 Number of Hops per Route Established

As shown in the Section 6.6.3, the average number of hops per route determine the end-to-end packet delay. It also determines the reliability of the network to some extent — if there are several hops on a path, there are greater chances that a link may be jammed, effected by fading, destroyed in an hostile environment, or just fail. The average number of hops per route are essentially a function of the transmit power at the transceiver. As shown in Fig. 17, the average number of hops (end-to-end packet delay) decreases with increase in transmit power since each hop can cover a larger distance. The number of hops per route stays relatively constant for same transmit power in different node density scenarios, as shown Fig. 18.

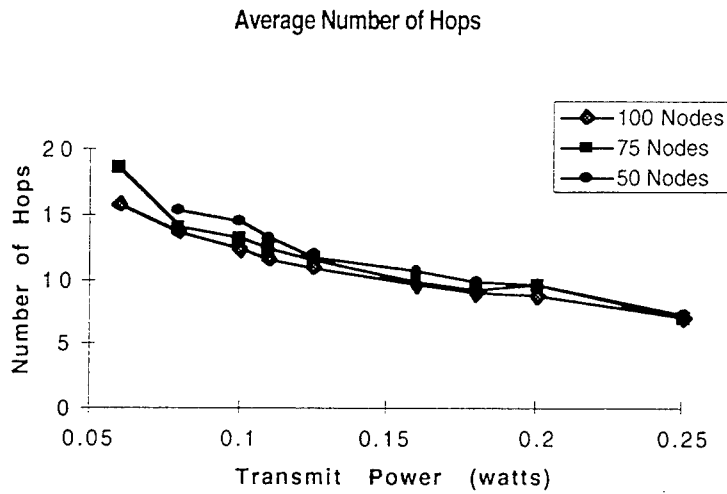

(Physical area of 5 x 5 km square area; Two users across diagonal; Node Time-out duration = 2.5 sec.; Mean wait time before broadcast = 25 ms)

Figure 17. Average number of hops (End-to-end packet delay) decreases with increase in transmit power

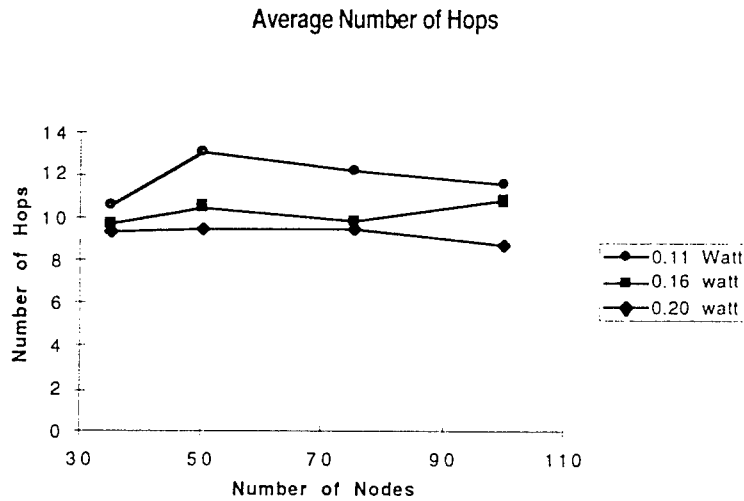

(Physical area of 5 x 5 km square area; Two users across diagonal; Node Time-out duration = 2.5 sec.; Mean wait time before broadcast = 25 ms)

Figure 18. Average number of hops for given transmit power does not significantly vary with node densities.

Figure 19 represents a comparison of average number of hops per route in JACS with MFR and JITTER. It shows the average and maximum number of hops in JITTER scenario. It also shows the number of hops in the MFR scenario. A significant finding is:

- The average number of hops per route obtained by JITTER is only couple of hops longer than the minimum. Therefore, hop count and thereby, end-to-end packet delay for JITTER and MFR are comparable.

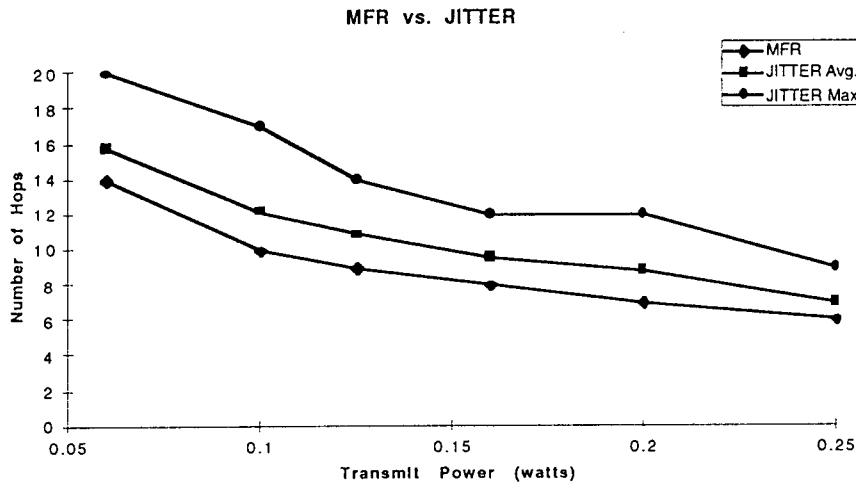

(100 nodes in a 5 x 5 km square area; Two users across diagonal; Node Time-out duration = 2.5 sec.; Mean wait time before broadcast = 25 ms)

Figure 19. Average number of hops in JITTER only couple more than MFR.

6.6.5 Multi-User Scenario

Figure 20 shows a multi-user scenario with 10 users, the connected lines represent the routes established using JITTER routing algorithm. In this configuration, the User1 calls User2, User3 calls User4, User5 calls User6, User7 calls User8, User9 calls User10. These users start initiating calls together at the beginning of the simulation. The call attempt at each user is randomly generated.

In the network here, the routes established via JITTER are mostly direct except a couple that are circuitous, for example, route from User7 to User8. The main reason for that is: the route between User3 and User4 was already established, and those nodes were busy, so route User7 to User8 took a longer path. In the MFR approach, for the connection from User7 to User8, the path after second hop would have crossed over the User3 to User4 route, thus, reducing number of hops in that path. All the other routes established via JITTER are comparable to MFR.

The maximum number of attempts made by any user, to establish a call in this setup was 5.

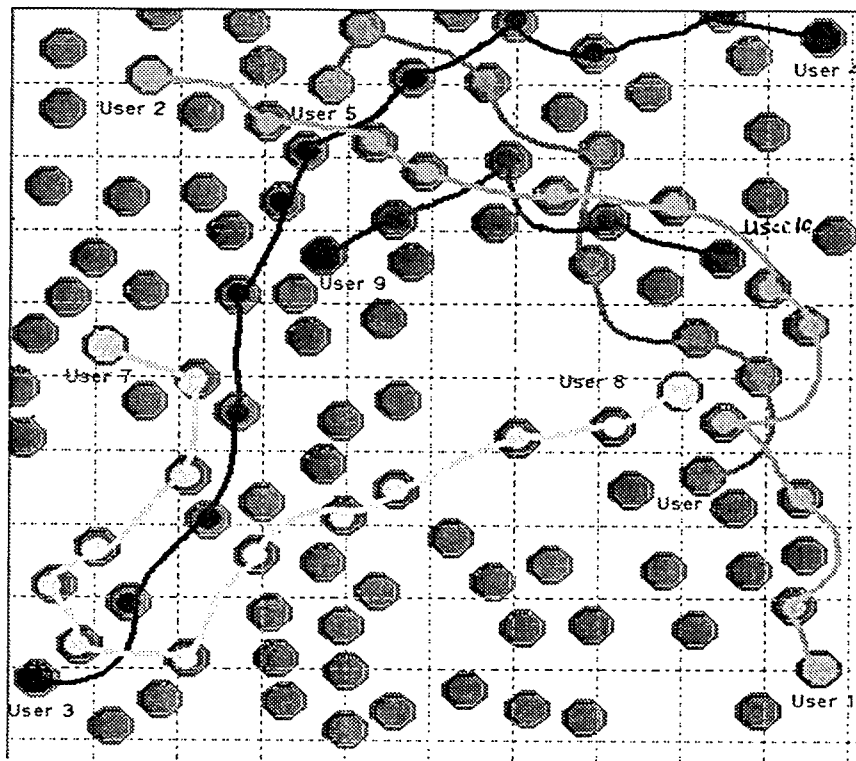
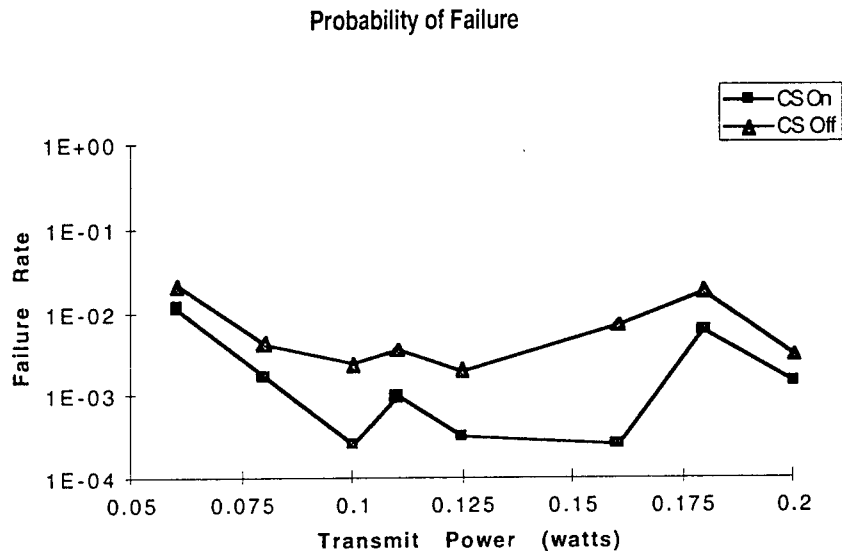

Figure 20. Multiple on-going calls; routes established by JITTER algorithm (100 nodes in a 5 x 5 km area)

6.6.6 Carrier Sense Effect

The effect of Carrier Sense collision avoidance scheme (Section 3.2) on probability of failure and average delay for each call attempt has been shown in Figs. 21 and 22. The conclusions are:

- Probability of failure improves by about an order of magnitude for some transmit powers, however, further analysis is needed to confirm this trend.
- Average delay per call attempt does not significantly differ due to carrier sense.



(100 nodes in a 5 x 5 km square area; Two users across diagonal; Node Time-out duration = 2.5 sec.; Mean wait time before broadcast = 25 ms)

Figure 21. Carrier sense collision avoidance scheme decreases probability of failure.

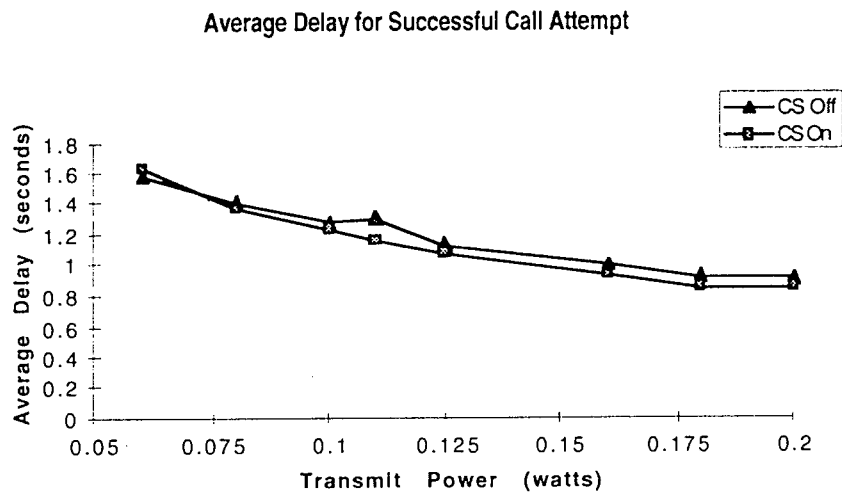

(100 nodes in a 5 x 5 km square area; Two users across diagonal; Node Time-out duration = 2.5 sec.; Mean wait time before broadcast = 25 ms)

Figure 22. Carrier sense collision avoidance scheme does not effect the average delay per successful call attempt.

6.6.7 Effect of Mean Wait Time Before Broadcast

As expected the average delay for a successful call attempt increases with increase in the mean wait time before each broadcast. The results are shown in Table 2. The probability of success of each call

attempt tends to go down with increase in mean wait time because if the packets wait longer at each node, some nodes on the route may time-out and that call attempt will fail.

Table 2. *Average Delay for a Successful Call Attempt Increases with Mean Wait Time Before Broadcast*

Mean wait time before broadcast (ms)	Probability of success in each call attempt	Average delay for a successful call attempt (sec.)
10	0.52	0.65
25	0.56	1.3
125	0.47	5.15

Transmit power = 0.1 W; 100 nodes in a 5 x 5 km square area; Two users across diagonal; Node Time-out duration = 2.5 sec.

6.6.8 Effect of Node/User Time-Out Duration

The results in Table 3 show that the Node Time-out duration does not effect the probability of success or average delay of successful attempt for the parameters considered.

Table 3. *Change in Node Time-Out Duration Does Not Effect the Performance*

Node Time-out duration (sec.)	Probability of success in each call attempt	Average delay for a successful call attempt (sec.)
1.0	0.55	1.26
2.5	0.56	1.31
5.0	0.57	1.31
10.0	0.55	1.39

Transmit power = 0.1 W; 100 nodes in a 5 x 5 km square area; Two users across diagonal; Mean wait time = 25 ms.

6.6.9 MFR vs. JITTER Routing

The comparison study of the two routing algorithm can be summarized as follows:

- *Call Set-up Performance* not significantly different. The probability of failure is not significantly different if identification exchange among neighboring nodes is infrequent. The call set-up delay is not very different either.

- *End-to-End Packet Delay:* The average packet delays do not differ significantly since the average number of hops are comparable. However, longer delays are possible with JITTER.
- *Node Hardware:* In JITTER nodes, the logic can be handled simply by a microcontroller, however for MFR node a microprocessor as well as memory will be needed.
- *Volume/Weight of Nodes:* The weight and volume of node is mainly determined by the battery size and weight. Since more memory and microprocessor is needed for MFR, the battery power requirements is higher for nodes.
- *GPS required:* GPS or Equivalent device is needed for the MFR node. This increases the cost of MFR node.
- *Network/User Safety:* In case of a network/user node capture network security may be compromised more for MFR than JITTER. The position of end-point nodes, next to the user, is needed for MFR, hence that information will be in the memory of all MFR nodes on the route at the time of call set-up. In JITTER, the actively communicating nodes only know the identity of the adjacent nodes in the route.
- *Application Requirements:* The application scenario may favor one approach over other based on functional requirements or availability of devices such as GPS, high power processor.

7. Conclusions and Recommendations

The Concept validation study presents major performance characterizations of JACS. It shows that the proposed innovative network and user access protocols for JACS are feasible and can be implemented using identical nodes with minimal hardware complexity. JACS architecture has several innovative characteristics that contribute to its unique ability to satisfy difficult military requirements. JACS has a wide range of application scenarios ranging from Covert communication scenarios to Tactical Internet Applications.

Another aspect of this study was comparison of two routing algorithms for JACS - JITTER and MFR. The preliminary results indicate that the choice of an appropriate routing algorithm depends on the particular application.

7.1 KEY CHARACTERISTICS OF JACS

The key characteristics of JACS can be summarized as follows:

- Self organizing network protocols automatically form networks from irregularly placed network nodes.
- All the network nodes are identical and require minimal hardware complexity.
- Self organizing network protocols can automatically adjust to changes in network configuration resulting from either the addition or loss of network node elements.
- Spread spectrum radio communications for robust operation in hostile environments as well as for low probability of intercept and low probability of detection operation.
- Random network node configurations are acceptable; this obviates the need for any specific configuration before deployment.
- Radio frequencies provide a proper balance among spectrum availability, node separation limits and foliage penetration.
- Network capacity to support tens of simultaneous communications paths with bandwidths suitable for support of digitized voice transmission or of medium speed data transmission.

- User access protocols provide easy network access; maintain maximum user security by requiring no user broadcast except when actually using the network for communications.

Hardware design is needed to achieve the following characteristics:

- Ruggedized packaging that allows rapid deployment by air drop or from ground vehicles
- Inter-operability with existing tactical communications systems
- Small physical profile for low observability installation
- Antenna technology to provide robust communications at low physical elevation above the ground.

7.2 APPLICATION SCENARIOS

JACS can be implemented in multiple special purpose communication systems. The specific application and desired functionalities will determine the routing algorithm that should be implemented.

JITTER algorithm will support covert communication scenarios with:

- Lowest cost hardware and software requirements
- Limited functionality desired in terms of multiple protocol support.

Example application scenarios with these features are:

- Sensor Arrays
- Downed Pilot Communications
- Special Operations - Forward edge of battle.

MFR algorithm is more extensible to Tactical Internet applications. These units may inherently have:

- GPS information; required by MFR
- High power processor; which can also calculate the routes for MFR
- Desire multiple protocol support.

Example scenarios include

- Warfighter's Internet
- Ad-Hoc Network Communications between Multiple UAV's.

7.3 NEXT STEPS

This initial study has shown that JACS concept is algorithmically feasible.

Sarnoff recommends a 5-6 month task focused on the following elements:

- Further validation of algorithmic concept by evaluating models tailored for specific operational scenarios
- Terrain modeling additions to OPNET simulation
- Code Division Multiple Access implementation considerations
- Investigate the associated radio propagation issues
- Antenna design
- Initial cut at size/weight/cost of JACS network node elements
- System design modification for mobile users
- Initial concept of operations.

This effort will enable:

- Rapid prototyping and operational validation program for Quick Insertion.
- Building of 10 network node prototypes and 4 end-user units to physically validate the JACS design. The operational validation with USAF units will be done.

The prototyping phase is expected to take about one year.

8. References

- [1] K. Joseph and D. Raychaudhuri, "Analysis of Asynchronous Random Access Spread Spectrum with Block Forward Error Correction," Proc. ICC 1989, pp. 1269 - 1277.
- [2] N. D. Wilson et al., "Packet CDMA vs. Dynamic TDMA for Multiple Access in an Integrated Voice/Data PCN," J. Sel. Areas of Commn., Vol. 11, No. 6, pp. 870-874.
- [3] T. Hou and V. O. K. Li, "Transmission Range Control in Multihop Radio Networks," IEEE Trans. on Commn., Vol. COM-34, No. 1, March 1986, pp. 38-44.
- [4] L. Kleinrock and J. A. Silvester, "Optimum Transmission Radii for Packet Radio Networks or Why Six is a Magic Number," in Conf. Rec., Nat. Telcomm. Conf., Dec. 1978, pp. 4.3.1-4.3.5.
- [5] H. Takagi and L. Kleinrock, "Optimal Transmission Ranges for Randomly Distributed Packet Radio Terminals," IEEE Trans. on Commn., Vol. COM-32, No. 3, March 1984, pp. 246-257.
- [6] J. Ni and S. A. G. Chandler, "Connectivity Properties of a Random Radio Network," IEE Proc.-Commn., Vol. 141, No. 4, August 1994, pp. 289-296.
- [7] R. C. Dixon, *Spread Spectrum Systems*, John Wiley & Sons, Inc. 1984.
- [8] M. K. Simon, J. K. Omura, R. A. Scholtz, and B. K. Levitt, *Spread Spectrum Communications Handbook*, McGraw Hill 1994.
- [9] R. L. Freeman, *Radio System Design for Telecommunications (1 - 100 GHz)*, John Wiley & Sons, 1987.
- [10] G. C. Hess, *Land Mobile System Engineering*, Artech House, Inc., 1993.
- [11] K. Yao, "Error Probability of Asynchronous Spread Spectrum Multiple Access Communications Systems," IEEE Trans. on Commn., Vol. COM-25, No. 8, Aug. 1977, pp. 803-809.
- [12] M. B. Pursley, "Performance Evaluation for Phase-Coded Spread-Spectrum Multiple-Access Communication - Part I: System Analysis," IEEE Trans. on Commn., Vol. COM-25, No. 8, Aug. 1977, pp. 795-799.
- [13] M. B. Pursley and D. V. Sarwate, "Performance Evaluation for Phase-Coded Spread-Spectrum Multiple-Access Communication - Part II: Code Sequence Analysis," IEEE Trans. on Commn., Vol. COM-25, No. 8, Aug. 1977, pp. 800-803.
- [14] M. B. Pursley, D. V. Sarwate, and W. E. Stark, "Error Probability of Direct-Sequence Spread-Spectrum Multiple-Access Communications - Part I: Upper and Lower Bounds," IEEE Trans. on Commn., Vol. COM-30, No. 5, May 1982, pp. 975-984.

- [15] E. A. Geraniotis and M. B. Pursley, "Error Probability of Direct-Sequence Spread-Spectrum Multiple-Access Communications - Part II: Approximations," IEEE Trans. on Commn., Vol. COM-30, No. 5, May 1982, pp. 985-995.
- [16] C. Trabelsi and A. Yongacoglu, "Bit-Error-Rate Performance for Asynchronous DS-CDMA Over Multi-path Fading Channels," IEE Proc. Commun, Vol. 142, No. 5, October 1995, pp. 307-314.
- [17] S. Haykin, *Digital Communications*, John Wiley and Sons, Inc. 1988.

***MISSION
OF
ROME LABORATORY***

Mission. The mission of Rome Laboratory is to advance the science and technologies of command, control, communications and intelligence and to transition them into systems to meet customer needs. To achieve this, Rome Lab:

- a. Conducts vigorous research, development and test programs in all applicable technologies;
- b. Transitions technology to current and future systems to improve operational capability, readiness, and supportability;
- c. Provides a full range of technical support to Air Force Material Command product centers and other Air Force organizations;
- d. Promotes transfer of technology to the private sector;
- e. Maintains leading edge technological expertise in the areas of surveillance, communications, command and control, intelligence, reliability science, electro-magnetic technology, photonics, signal processing, and computational science.

The thrust areas of technical competence include: Surveillance, Communications, Command and Control, Intelligence, Signal Processing, Computer Science and Technology, Electromagnetic Technology, Photonics and Reliability Sciences.