



**UNITED STATES AIR FORCE  
ARMSTRONG LABORATORY**

---

**Human Inhalation of Halon 1301,  
HFC-134a and HFC-227ea for  
Collection of Pharmacokinetic Data**

**Allen Vinegar  
Gary W. Jepson**

MANTECH ENVIRONMENTAL, INC.  
P.O. BOX 31009  
DAYTON, OH 45437-0009

**Robert S. Cook  
James D. McCafferty, III**

TOXICOLOGY DIVISION  
WRIGHT-PATTERSON AFB OH 45433-7400

**Melanie C. Caracci**

GEO-CENTERS, INC.  
7 WELLS AVENUE  
NEWTON CENTRE MA 02159

August 1997

19970918 108

**DMIC QUALITY INSPECTED 3**

*Approved for public release;  
distribution is unlimited.*

Occupational and Environmental Health  
Directorate  
Toxicology Division  
2856 G Street  
Wright-Patterson AFB OH 45433-7400

## NOTICES

When US Government drawings, specifications or other data are used for any purpose other than a definitely related Government procurement operation, the Government thereby incurs no responsibility nor any obligation whatsoever, and the fact that the Government may have formulated, furnished, or in any way supplied the said drawings, specifications, or other data is not to be regarded by implication or otherwise, as in any manner licensing the holder or any other person or corporation, or conveying any rights or permission to manufacture, use, or sell any patented invention that may in any way be related thereto.

Please do not request copies of this report from the Armstrong Laboratory. Additional copies may be purchased from:

NATIONAL TECHNICAL INFORMATION SERVICE  
5285 PORT ROYAL ROAD  
SPRINGFIELD, VIRGINIA 22161

Federal Government agencies and their contractors registered with the Defense Technical Information Center should direct requests for copies of this report to:

DEFENSE TECHNICAL INFORMATION CENTER  
8725 JOHN J. KINGMAN RD STE 0944  
FT BELVOIR VA 22060-6218

### DISCLAIMER

This Technical Report is published as received and has not been edited by the Technical Editing Staff of the Armstrong Laboratory.

### TECHNICAL REVIEW AND APPROVAL

AL/OE-TR-1997-0116

The voluntary, fully informed consent of the subjects used in this research was obtained as required by AFI 40-402.

This report has been reviewed by the Office of Public Affairs (PA) and is releasable to the National Technical Information Service (NTIS). At NTIS, it will be available to the general public, including foreign nations.

This technical report has been reviewed and is approved for publication.

**FOR THE COMMANDER**

  
**TERRY A. CHILDRRESS**, Lt Col, USAF, BSC  
Director, Toxicology Division  
Armstrong Laboratory

**REPORT DOCUMENTATION PAGE**

Form Approved  
OMB No. 0704-0188

Public reporting burden for this collection of information is estimated to average 1 hour per response, including the time for reviewing instructions, searching existing data sources, gathering and maintaining the data needed, and completing and reviewing the collection of information. Send comments regarding this burden estimate or any other aspect of this collection of information including suggestions for reducing this burden to Washington Headquarters Services, Directorate for Information Operations and Reports, 1215 Jefferson Davis Highway, Suite 1204, Arlington, VA 22202-4302, and to the Office of Management and Budget, Paperwork Reduction Project (0704-0188), Washington, DC 20503

<b>1. AGENCY USE ONLY (Leave Blank)</b>		<b>2. REPORT DATE</b> August 1997		<b>3. REPORT TYPE AND DATES COVERED</b> Interim January-August 1997	
<b>4. TITLE AND SUBTITLE</b> Human Inhalation of Halon 1301, HFC-134a and HFC-227ea for Collection of Pharmacokinetic Data				<b>5. FUNDING NUMBERS</b> Contract F41624-96-C-9010 PE 62202F PR 7757 TA 7757A1 WU 7757A102	
<b>6. AUTHOR(S)</b> Allen Vinegar, Robert S. Cook, James D. McCafferty III, Melanie C. Caracci and Gary W. Jepson					
<b>7. PERFORMING ORGANIZATION NAME(S) AND ADDRESS(ES)</b> ManTech / GEO-CENTERS Joint Venture Toxic Hazards Research P.O. Box 31009 Dayton OH 45437-0009				<b>8. PERFORMING ORGANIZATION REPORT NUMBER</b>	
<b>9. SPONSORING/MONITORING AGENCY NAME(S) AND ADDRESS(ES)</b> Armstrong Laboratory, Toxicology Division Wright-Patterson AFB OH 45433-7400 USEPA, Atmospheric Protection Branch, MD-63 Research Triangle Park NC 27711				<b>10. SPONSORING/MONITORING AGENCY REPORT NUMBER</b>  AL/OE-TR-1997-0116	
<b>11. SUPPLEMENTARY NOTES</b>					
<b>12a. DISTRIBUTION/AVAILABILITY STATEMENT</b> Approved for public release; distribution is unlimited.				<b>12b. DISTRIBUTION CODE</b>	
<b>13. ABSTRACT (Maximum 200 words)</b> International agreement and regulatory decisions have driven activities to replace ozone depleting chemicals (ODCs) in fire suppression and refrigeration applications. In order to validate a human physiologically based pharmacokinetic model designed for use in estimating chemical biodistribution and establishing egress times, human volunteers were exposed via inhalation to a series of chemicals relevant to ODC replacement activity. Seven male volunteers ranging from 21-49 years of age were selected to inhale bromotrifluoromethane (Halon 1301, 0.5%), 1,1,1,2-tetrafluoroethane (HFC-134a, 0.4%) and 1,1,1,2,3,3,3-heptafluoropropane (HFC-227ea, 0.6%). Each inhalation exposure was to a single chemical and was scheduled to last 30 minutes. Inhaled concentration and end alveolar expired concentration of chemical were continuously measured throughout the procedure using a non-rebreathing valve inhalation apparatus and a mass spectrometer. Blood samples were drawn through an indwelling cannula at times 0, 0.5, 1, 1.5, 2, 2.5, 3, 3.5, 4, 4.5, 5, 10, 15, 20, 25 and 30 minutes during the exposure and for five minutes at one minute intervals following the inhalation. The blood was analyzed for the chemical of interest to determine the chemical time course in blood. Throughout the exposure period, human subjects were monitored via ECG, blood pressure and pulse rate measurements. All seven volunteers completed the Halon 1301 exposures without effect on ECG, blood pressure or pulse rate. Halon 1301 concentrations in blood at exposure termination ranged from 0.19-1.24 mg/L. The HFC-134a and HFC-227ea exposures were terminated for safety reasons following unexpected and uncontrollable rapid rises in pulse rate during the inhalation exposure.					
<b>14. SUBJECT TERMS</b> Halon 1301 PBPK HFC-134a Human HFC-227ea Inhalation				<b>15. NUMBER OF PAGES</b> 22	
				<b>16. PRICE CODE</b>	
<b>17. SECURITY CLASSIFICATION OF REPORT</b> UNCLASSIFIED		<b>18. SECURITY CLASSIFICATION OF THIS PAGE</b> UNCLASSIFIED		<b>19. SECURITY CLASSIFICATION OF ABSTRACT</b> UNCLASSIFIED	
				<b>20. LIMITATION OF ABSTRACT</b> UL	

THIS PAGE INTENTIONALLY LEFT BLANK

## PREFACE

This non-peer-reviewed report summarizes the work performed to determine kinetic behavior of Halon 1301, HFC-227ea and HFC-134a in humans during a 30-minute inhalation. A report will follow describing medical evaluation and monitoring of volunteers participating in this study. This research began on 3 January 1997 and was completed in August 1997 under Department of the Air Force Contract No. F41624-96-C-9010. Lt Col Terry Childress served as the Contract Technical Monitor for the U.S. Air Force, Armstrong Laboratory, Toxicology Division and Dr. Darol Dodd served as Program Manager for the ManTech/GEO-CENTERS Joint Venture. Work was also performed by U.S. Air Force personnel under work unit 7757A102. Support for blood collection and medical monitoring were provided by Majors Paul Austin and Kim Davis of the Wright-Patterson AFB Medical Center. This work was cosponsored by the U.S. Environmental Protection Agency under Interagency Agreement DW57937570-01-0 with Dr. Theodore Brna serving as the EPA project monitor and Dr. Reva Rubenstein, USEPA, OAR/SPD, serving as the technical project point of contact.

**DTIC QUALITY INSPECTED 3**

## TABLE OF CONTENTS

<b><u>Item</u></b>	<b><u>Page</u></b>
Introduction	1
Methods and Materials	2
Test Materials	2
Test Subjects	2
Facility and Medical Personnel	3
Quality Control and Analytical Conditions	3
Pre-exposure Preparation	3
Exposure Procedure and Specimen Collection	4
Results	6
Halon 1301	6
HFC-134a	6
HFC-227ea	8
Discussion	10
References	12

## LIST OF FIGURES

Figure 1. Mixture Delivery System	4
Figure 2. Halon 1301 Blood Concentration vs. Time	6
Figure 3. HFC-134a Blood Concentration vs. Time	8
Figure 4. HFC-227ea Blood Concentration vs. Time	9

THIS PAGE INTENTIONALLY LEFT BLANK



## INTRODUCTION

International agreement and regulatory decisions have driven activities to replace ozone depleting chemicals (ODCs) in fire suppression, propellant and refrigeration applications. As part of the process for selection of ODC replacements, the human health consequences associated with the use of these chemicals must be evaluated. Furthermore, human health considerations should be assessed in the context of likely exposure scenarios.

Cardiac sensitization often associated with acute exposure to volatile, halogenated hydrocarbons, and consequently, the regulatory community has used cardiac sensitization for setting allowable exposure standards. Since it is likely that there is a critical chemical concentration in human tissue which is related to the onset of cardiac sensitization events, there is value in the ability to determine the chemical concentration in blood during and following inhalation of Halons and Halon replacement chemicals. A valuable tool for relating a chemical exposure scenario with the uptake and distribution of chemical in the human body is the physiologically based pharmacokinetic (PBPK) model. Using a PBPK model, a profile of chemical in the blood or other target tissue can be generated using information about the exposure concentration and duration. Combined with appropriate toxicity data, the target tissue concentration of chemical can be used to establish the length of exposure and protective posture required to protect human health while in the chemical environment. Specific details have been published describing the use of PBPK modeling to evaluate humans in an environment where halogenated hydrocarbon fire suppressants have been deployed (Vinegar and Jepson, 1996).

While PBPK models have tremendous utility in evaluating "what if" scenarios for human exposure to chemicals, they also demand a reasonable level of validation in order to have a high degree of credibility. The intent of this study was to collect PBPK model validation data for Halon 1301, HFC-134a and HFC-227ea in humans. The chemical exposure concentrations were designed to be well below any published Lowest Observable Adverse Effect Level (LOAEL). The goal was to produce chemical exposures sufficient for chemical quantitation in human expired breath and venous blood without adverse effects in the volunteers.

## METHODS AND MATERIALS

### Test Materials:

#### **Bromotrifluoromethane (Halon 1301):**

Manufacturer	Aldrich Chemical Co (Milwaukee, WI)
Trade Name	Halon 1301
CAS #	75-63-8
Mol. Weight	148.9 g
Empirical Formula	CF <sub>3</sub> -BR
Boiling Point	-57.8°C

#### **1,1,1,2-Tetrafluoroethane (HFC-134a/P):**

Manufacturer	DuPont Fluorochemicals (Wilmington, DE 19898)
Trade Name	HFC-134a, HFA-134a
CAS#	811-97-2
Mol. Weight	102.03 g
Empirical Formula	CH <sub>2</sub> F-CF <sub>3</sub>
Boiling Point	-26.1°C

#### **1,1,1,2,3,3,3-Heptafluoropropane (HFC-227ea/P):**

Manufacturer	Solvay Fluorides, Inc. (Greenwich, CT 06830)
Trade Name	Solkane ® 227 Pharma, HFA-227ea
CAS#	431-89-0
Mol. Weight	170.03 g
Empirical Formula	CF <sub>3</sub> -CHF-CF <sub>3</sub>
Boiling Point	-16.4 °C

### Test Subjects:

Seven human volunteers participated in this study. All were non-smoking healthy males in the age range of 21-49 years. Pre-exposure physical examinations were performed which included an assessment of hematological, hepatic, renal, and cardiac (EKG) status. Additionally, pulmonary function testing by plethysmography was accomplished to determine pulmonary parameters, and a seven site skin fold body fat determination was completed.

A written protocol detailing this study was reviewed and approved by the Armstrong Laboratory Human Use Review Committee on 20 March 97. Review by the Clinical and Biomedical Research and Development Division, Office of the Surgeon General, U.S. Air Force was also accomplished and approval granted on 5 June 97. Each volunteer was briefed on the generic health risks associated with halogenated hydrocarbons and told that this study was

designed to provide exposure concentrations well below any level that would likely produce adverse effects. Each subject then signed a consent form prior to participation in the study.

### **Facility and Medical Personnel:**

All exposures were accomplished in a minor surgery suite at the U.S.A.F. Medical Center, Wright-Patterson AFB, OH. Medical monitoring by personnel certified in Advance Cardiac Life Support was provided by the Department of Anesthesiology. These individuals were responsible for accomplishing catheterization, maintaining saline infusion, obtaining time interval blood specimens, and physiologic monitoring of subjects. The suite was fully equipped to facilitate treatment of cardiac emergency if required.

### **Quality Control and Analytical Conditions:**

Purity analysis of stock test materials was accomplished by mass spectrometry with each determined to be  $\geq 99.9\%$  pure. Test mixtures consisted of atmospheric air and test material. Quality control of test mixtures was accomplished by gas chromatography and random access mass spectrometry.

All Halon 1301 and HFC-134a exposures were conducted with subjects in a sitting position. For HFC-227ea exposures the subject was placed in a reclined position with back approximately 45 degrees above horizontal.

Four 100 liter Tedlar bags were prepared for each volunteer on the day of exposure. Each bag contained a 95L ml mixture of neat gaseous chemical and compressed breathing air. Target concentrations were: 5000 ppm Halon 1301, 4000 ppm HFC-134a, and 6000 ppm HFC-227ea. Each bag was analyzed and determined to be within 5% of the target concentration. For bag analysis, 0.1 mL of vapor from each bag was manually sampled on a gas chromatograph with a flame ionization detector (Model 5890; Hewlett-Packard, San Fernando, CA) and a Poraplot Q column (Supelco Inc., Bellefonte, PA). For Halon 1301 the oven temperature was 90°C, the injector temperature was 125°C, the helium carrier gas was 10 mL/min, and the detector temperature was 250°C. For HFC-134a the oven temperature was 105°C, the injector temperature was 80°C, the helium carrier gas was 10 ml/min, and the detector temperature was 250°C. For HFC-227ea the oven temperature was 100°C, the injector temperature was 76°C, the helium carrier gas was 10 ml/min, and the detector temperature was 250°C. Standard curves were prepared for each chemical to ensure linear responses for the appropriate range, and were periodically checked during the time a particular chemical was under study.

### **Pre-exposure Preparation:**

Subjects were advised to refrain from alcohol and caffeine for approximately 12 hours prior to exposure, and to consume normal meals and plenty of fluids.

Approximately 45 minutes prior to the exposure a local topical anesthetic (lidocaine ointment) was applied to the inside of both arms of the subject, covering approximately a 2 cm area around the antecubital vein. An additional local injection of lidocaine was administered

prior to catheter insertion. Catheterization was accomplished just prior to exposure with a 16G over-the-needle Vialon<sup>R</sup> catheter (INSYTE, Becton Dickinson, Sandy, UT). The catheter was attached by a small bore extension set (Burrton Medical, Bethlehem, PA) to a three-way large bore stopcock with rotating male luer lock adapter (Baxter, Deerfield, IL). Infusion solution was 0.9% sodium chloride. Time interval EKG was obtained using a three lead cardiac monitor. Pulse rate was monitored continuously and blood pressure was monitored approximately every five minutes.

Tedlar bags with modified sample ports containing desired concentrations of test materials were arranged in a parallel configuration. Bags were attached via silicone feeder tubes to a connector which simultaneously fed the mixture from each bag into the main inhalation tube and in turn to a two-way non-rebreathing valve (NRV) (Figure 1). The main inhalation tube and non-rebreathing valve were fabricated of stainless steel. Diaphragms of the valve consisted of silicon rubber (Hans Rudolph, Inc., Kansas City, MO). The valve was held in place in front of the subjects mouth with an adjustable support assembly, enabling subjects to place the mouthpiece of the valve in their mouth with minimal discomfort. The valve was cleaned with Sidex solution, thoroughly rinsed, dried, and a sterile mouthpiece (Baxter, Valencia, CA) placed on the mouthport of the valve prior to each exposure. Feeder tubes remained clamped until ready to commence exposures. Exhaust was accomplished by plastic tubing attached to a centralized salvage system.

**Figure 1**  
Mixture Delivery System

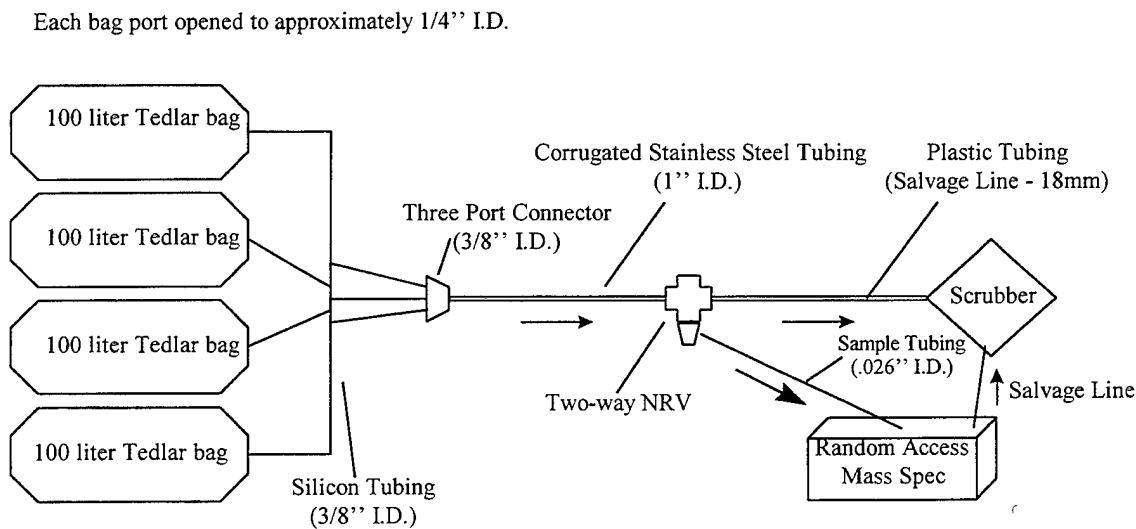

Bags are actually equidistant from three port connector.

## Exposure Procedure and Specimen Collection:

Immediately prior to commencement of the exposure, subjects placed their mouth over the breathing valve mouthpiece and continued to breath through their nose for approximately 5 minutes. Feeder tube clamps were removed and the main inhalation tube and valve were primed by gently applying pressure to the Tedlar bags. After priming the valve, a nose clip was placed on the subject's nose and inhalation through the valve commenced. Subjects were instructed to breath normally. Continuous end-tidal expired air sampling and real-time analysis of test material and atmospheric gases were accomplished by a random access mass spectrometer (RAMS M-100 General Purpose Gas Analyzer, Marquette Medical Systems, Milwaukee, WI). Inspired test material as well as atmospheric gases were also continuously monitored. Operation of the random access mass spectrometer was controlled by a computer which also displayed breath by breath values and stored data. Instrument calibration was accomplished prior to each exposure.

In order to obtain an undiluted blood specimen approximately 2.5 mL of blood was initially drawn into a sterile plastic syringe. This was discarded due to dilution by saline infusion fluid. Prior to beginning the exposure ( $T = 0$ ), 1 mL of blood was collected. All blood samples were drawn into a heparinized 3 mL glass syringe. After commencing the exposure a 1 mL blood specimen was obtained every 30 seconds until the 5 minute mark. After obtaining a specimen at the 5 minute mark, 1 mL of blood was obtained every 5 minutes for 25 minutes. After obtaining a specimen at the 30 minute mark (end of exposure) 1 mL specimens were then collected every minute for 5 minutes. At the 30 minute time point the Tedlar bag feeder tubes were clamped and disconnected from the main inhalation tube. The subject continued to breath through the valve for an additional 5 minutes while blood specimens were collected.

Prior to exposure, 10 mL headspace autosampler vials (Kimble Glass, Vinland, NJ) were tightly capped with 20 mm Teflon/silicon septa (National Scientific Company, Lawrenceville, GA) and the weights of each were recorded. Approximately 1 mL of blood was injected through the septa into the vial at the time of collection. The vials were then re-weighed and the exact amount of blood in each vial was determined. A temperature-controlled Vortex evaporator (Haake/Buchler Instrument Inc., Saddlebrook, NJ) was used to shake and incubate ( $55^{\circ}\text{C}$ ) the vials until all of the chemical was driven out of the blood, usually about 1.5 - 2.0 hours. Following incubation, the vials were transferred to an HP 19395A headspace sampler (Hewlett-Packard, San Fernando, CA) where they were held at  $55^{\circ}\text{C}$  until sampling. Blood headspace analysis was determined on a gas chromatograph with a flame ionization detector (Model 5890; Hewlett-Packard, San Fernando, CA) and a Poraplot Q column (Supelco Inc., Bellefonte, PA). Gas chromatograph conditions were the same as for those listed for bag analysis. Standard curves were prepared for each chemical to ensure linear responses for the appropriate range, and were periodically checked during the time a particular chemical was under study. After completion of the exposure procedure cardiac monitoring and fluid infusion continued for approximately 15 minutes.

## RESULTS

### Halon 1301 (bromotrifluoromethane):

Seven human volunteers were exposed to Halon 1301 at 5000 ppm (0.5% v/v) for 30 minutes and monitored for 5 minutes postexposure. No changes in ECG, blood pressure or heart rate were noted during the exposure. The Halon 1301 concentration in venous blood ranged approximately 7.1-fold across the volunteers. The Halon 1301 profiles in human blood are shown in Figure 2.

Figure 2. Halon 1301 Blood Concentration vs. Time.

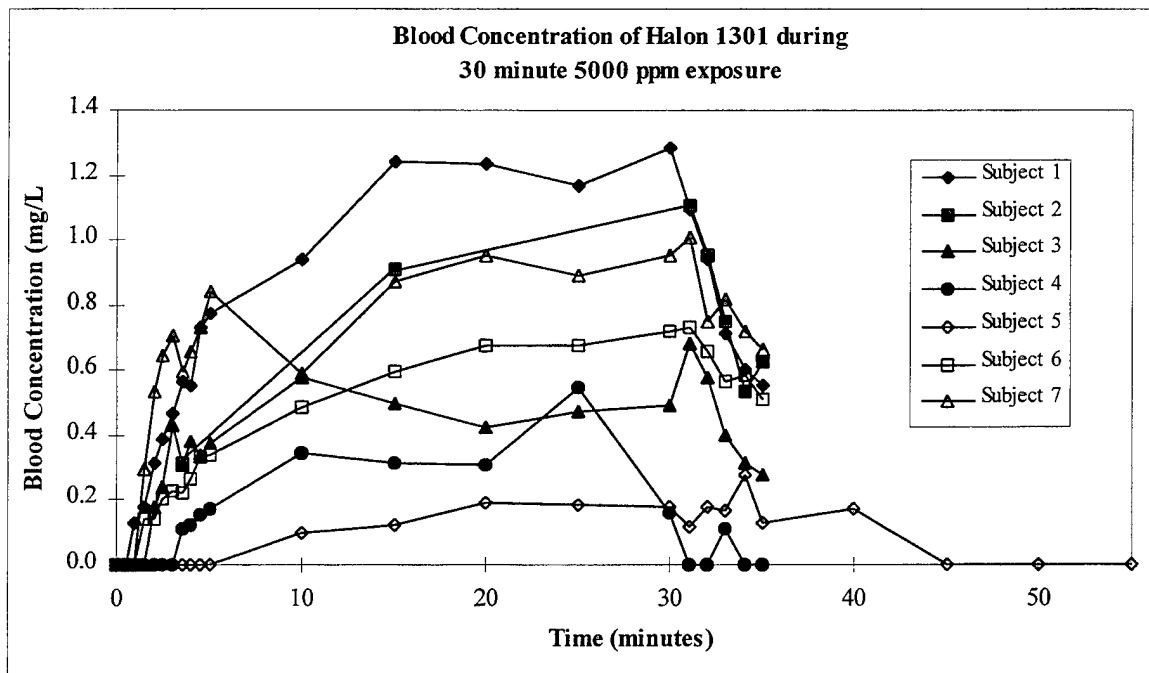

### HFC-134a (1,1,1,2-Tetrafluoroethane):

Subject #3 was the first volunteer exposed to HFC-134a. The exposure concentration was 4000 ppm (0.4% v/v) and was scheduled to last for 30 minutes with a 5-minute postexposure evaluation period as was accomplished in the Halon 1301 portion of the study. Approximately 4.5 minutes into the exposure, the subject lost consciousness and both pulse and blood pressure dropped to zero. The exposure was immediately aborted and the subject was removed from the

exposure apparatus. Medical personnel intervened and after pulse and blood pressure were restored the subject was administered 100% oxygen. Blood pressure and pulse remained low (approximately 1/2 of baseline) and the subject could not maintain consciousness in a seated position. The subject was reclined and moved to an operating room recovery area where he rested for approximately 1 hour after which the subject's vital signs had returned to pre-exposure values. Subject #3 displayed a rapid rise in blood concentration of HFC-134a which reached 1.29 mg/L at the 2.5 minute point in the exposure (Figure 3). The blood sample scheduled for 3 minutes was not collected. The medical representative had considerable difficulty getting blood from the cannula at the 3-minute point and significant manipulation of the indwelling cannula was noted. No further blood samples were taken.

Subject #5 was also exposed to 4000 ppm (0.4% v/v) HFC-134a. There was some difficulty with blood collection and manipulation of the cannula was noted, but exposure was uneventful through the first 10 minutes of exposure. Breathing effort and rate appeared normal. At approximately 10.5 minutes into the exposure the subject's blood pressure and pulse began to rise rapidly and the subject gave the hand signal for possible trouble. His pulse rose rapidly until it was double the pre-exposure value, at which time the subject gave the hand signal to terminate the exposure. The exposure was aborted and the subject began breathing room air, but the indwelling cannula was not removed from the subject. After 30 seconds, the subject's blood pressure and pulse were at pre-exposure levels. The HFC-134a concentration in blood reached 0.70 mg/L at the point where the exposure was terminated (Figure 3). Subject #5 breathed room air for 1 hour and was then re-exposed to 2000 ppm (0.2% v/v) HFC-134a. After 2.5 minutes of exposure, the subject's blood pressure and pulse again rose rapidly, the subject signaled trouble and the exposure was terminated. The subject's vital signs returned to pre-exposure levels within 30 seconds after the exposure was terminated. The in-dwelling cannula remained attached to the subject and blood was drawn for an additional 10 minutes at 1-minute intervals. The venous blood concentration of HFC-134a was 0.16 mg/L at the start of the 2000 ppm exposure and reached 0.38 mg/L at the time of exposure termination (Figure 3). The HFC-134a concentration was still at 0.2 mg/L 10 minutes after the exposure was terminated. No further human HFC-134a exposures were conducted.

In addition to the monitored effects, there were several subjective effects associated with the inhalation exposures to HFC-134a. Subject #3 reported problems with dizziness and balance following the exposure. At the time of this report (6 weeks post exposure), both the dizziness and balance problems still persisted. Subject #5 reported chest tightness and a headache with associated dizziness immediately following the exposure. The headache subsided by the time the subject woke up the day following the exposure. The day following the exposure, subject #5 reported unusual feelings in the chest resembling "flutters". The chest tightness was reported to subside within 3 days of the exposure and the "flutters" within 2 weeks of the exposure. As with subject #3, subject #5 was still experiencing dizziness and balance problems at the time of this report (6 weeks post exposure). Subject #5 also reported persistent ringing in the ears which was still present at the time of this report.

**Figure 3. HFC-134a Blood Concentration vs. Time**

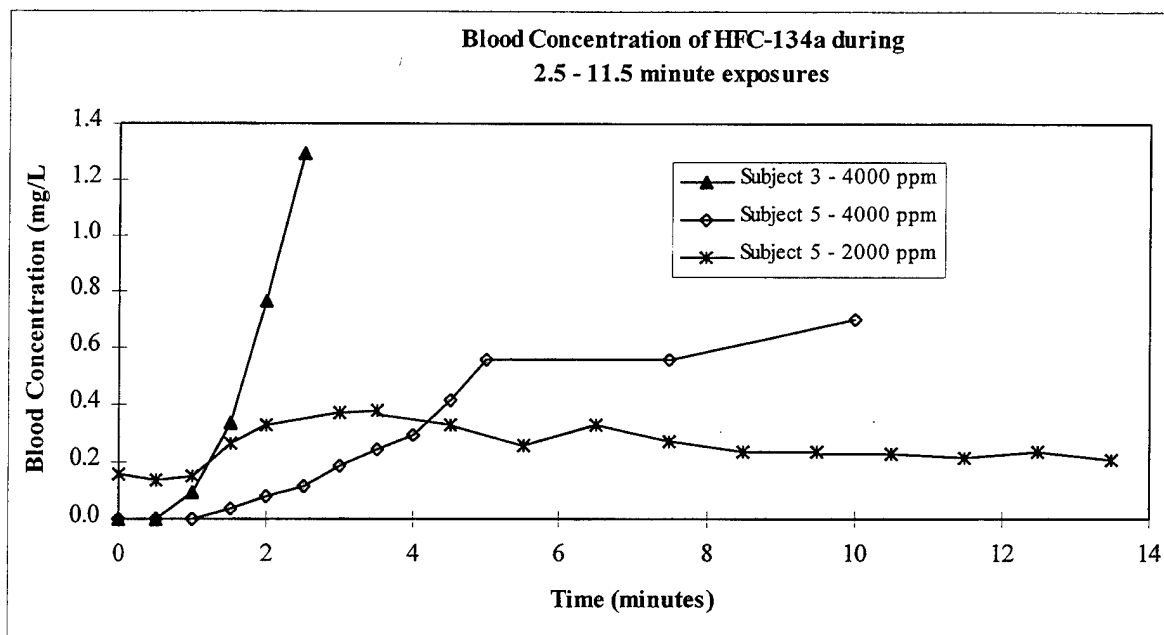

**HFC-227ea (1,1,1,2,3,3,3-Heptafluoropropane):**

The data collection and safety procedures were modified based on the experience using HFC-134a. The medical staff was increased to ensure that both the blood drawing and patient condition could be completely and simultaneously monitored. Additionally, instrumentation was reprogrammed to capture continuous ECG, blood pressure and pulse data throughout the exposures.

Subject #1 was exposed to 6400 ppm (0.64% v/v) HFC-227ea. Approximately 3.0 minutes into the exposure, the subject's pulse rose rapidly and uncontrollably to double the baseline (pre-exposure) value. The exposure was terminated after 3.5 minutes. The subject's pulse returned to its pre-exposure level within 30 seconds after the exposure was terminated. Blood continued to be drawn from the subject at 4.0, 4.5, 5.0, 6, 7, 8, 9 and 10 minutes after exposure start time (Figure 4). The HFC-227ea concentration in blood reached 0.19 mg/L. In the interest of safety, no further human exposures were conducted with HFC-227ea. However, the day following the HFC-227ea exposure, subject #1 was set up in the exposure apparatus to ensure that no system component was contributing to the observed effects. All aspects of the exposure were the same as in the HFC-227ea exposure, including blood collection, except instead of HFC-227ea, the sample bags contained breathing air. The subject completed the entire scheduled exposure without incident. No change in pre-exposure ECG, blood pressure or pulse rate were observed.

Subject #1 reported chest tightness, dizziness and balance problems following the HFC-227ea exposure. The chest tightness subsided within 3 days of the exposure but the dizziness and balance problems persisted for 6-7 days before subsiding. No further human exposures to HFC-227ea were attempted.



Figure 4. HFC-227ea Blood Concentration vs. Time

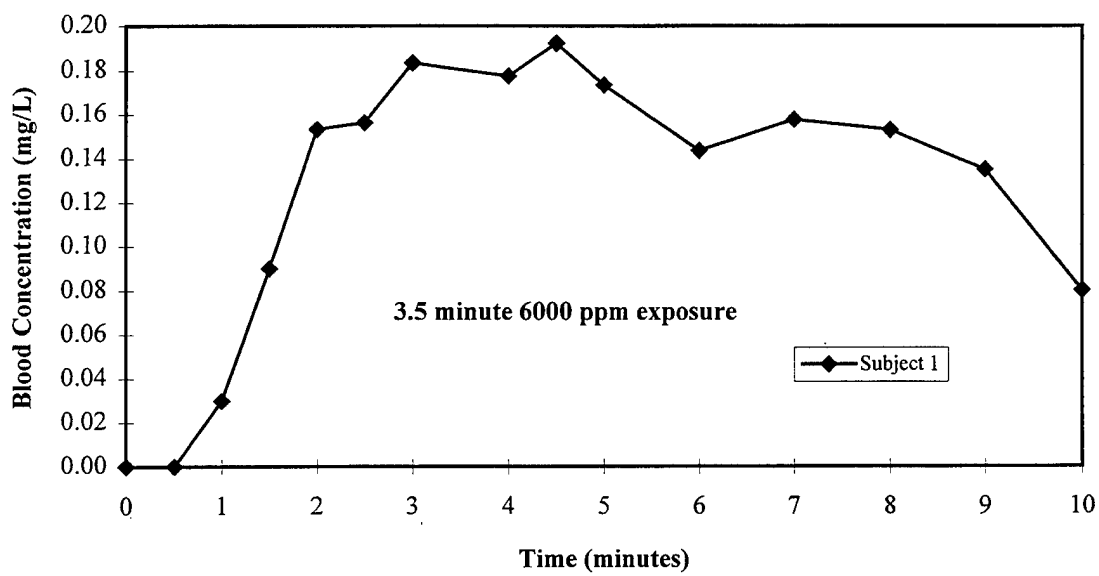

## DISCUSSION

The intent of this study was to generate kinetic data for Halon 1301, HFC-134a and HFC-227ea that could be used to evaluate and validate a human PBPK model. The chemical concentrations selected for the study were designed to be insignificant in terms of their potential for producing adverse effects in humans. The items considered during selection of the chemical concentrations were published exposure data in laboratory animals, intermittent inhalation exposure data in humans and regulatory standards set for human exposure to these chemicals.

The adverse events observed during the exposures to HFC-134a and HFC-227ea were unexpected and inconsistent with the published data. Based on the published data on HFC-134a and HFC-227ea, no adverse effects should have been observed at the 0.4% v/v and 0.6% levels, respectively, used in this study. Both HFC-134a and HFC-227ea have been considered to be inert compounds which exert toxic effects only after their concentrations are so high that oxygen deprivation effects prevail (Graepel and Alexander, 1991). Rats and mice have shown no acute toxicity during or after a 1-hour inhalation exposure to 810,000 ppm HFC-134a and dogs were essentially unaffected following an 80,000 ppm exposure (Alexander, 1995). Based on the laboratory animal data, Alexander, 1995, concluded that HFA-134a is devoid of acute and long term toxicity, is poorly absorbed and is rapidly excreted.

In addition to the claims of inertness, the chemicals of interest have been reported to rapidly leave the human system with an apparent half-life of only 5.1 minutes (Harrison, 1996). Similarly, another report states that only 10% of the administered dose of HFC-134a remained 10 minutes after termination of the exposure (Woodcock, 1995). The 5.1 minute half-life for HFC-134a and extremely rapid elimination is in contrast to the 31 minute apparent half-life reported as part of a clinical pharmacology study (Ventresca, 1995). While the sample size was extremely small in our study due to unplanned termination, the apparent half-lives of HFC-134a and HFC-227ea are estimated to be 12.6 and 7.5 minutes, respectively (Figures 2 and 3). This probably represents only the rapid elimination phase since data were not available to assess any slower elimination phases that may be present. As such, the half-life estimates could be quite low especially since measurable levels of HFC-134a were present 1 hour after the exposure was terminated (Figure 2). The presence of HFC-134a in the blood 1 hour after exposure was unexpected. Alexander, 1995, reported that there was no carry over in blood after 30 minutes. Halon 1301 cleared more rapidly with an estimated half-life of 3.6 minutes.

Based on published work, regulatory approval and commercial use of Halon 1301, HFC-134a and HFC-227ea, the exposure levels selected for the 30-minute inhalation exposures were expected to be without adverse effects in humans. Since the study was designed to collect only kinetic information for use in PBPK model validation and only at "no effect" concentration levels, clinical type experimental design was not adopted. Additionally, the subjects participating in the study were scientists or technicians and they were knowledgeable about the study results as they occurred.

Even though no plausible mechanism is apparent for all of the adverse effects observed in this study, it is reasonable to question the decision to expose a second subject to HFC-134a given the response of the first subject (subject #3) exposed to the chemical. Initial review of subject

#3's experience led investigators to interpret the events as a vasovagal reflex response. This seemed somewhat unlikely since subject #3 had successfully completed the Halon 1301 exposure, given multiple blood samples and donated blood without incident. However, at the time, no other explanation seemed reasonable as the exposure was presumably well within the "no adverse effects level" as based on available data. At the time of this report, the subjective effects reported by volunteers were not completely evaluated by medical personnel. Medical evaluation and monitoring are continuing and will be presented in subsequent reports.

In summary, all 7 human volunteers completed the Halon 1301 exposures without incident while both the HFC-134a and HFC-227ea exposures were terminated due to the adverse effects described in this report. Additionally, no adverse effects were reported during "blank" exposures where all conditions were the same as in chemical exposures except the test material was air. Based on the chemical similarity between HFC-134a and HFC-227ea and the similar human responses during the exposures, it became the opinion of the investigators that further exposures would constitute a study of human effects rather than simply of kinetics. Given this opinion, the study was terminated. In view of the sample size and experimental design, no conclusion or speculation about cause and effect is offered at this time. Rather, the purpose of this document is to report the unexpected events that occurred during human inhalation of HFC-134a and HFC-227ea under controlled conditions.

## REFERENCES

Alexander, D.J., Safety of Propellants. *Journal of Aerosol Medicine*, Vol 8, Supplement 1:s29-s33, (1995).

Graepel, P. and Alexander, D.J., CFC Replacements: Safety Testing, Approval for Use in Metered Dose Inhalers. *Journal of Aerosol Medicine*, Vol 4, No. 3:193-200, (1991).

Harrison, L.I., Pharmacokinetics of HFA-143a: A Preliminary Report. *American Journal of Therapeutics* 3:763-765, (1996).

Ventresca, G. Pietro, Clinical Pharmacology of HFA-134a. *Journal of Aerosol Medicine*, Vol 8, Supplement 1, (1995).

Vinegar, A. and G.W. Jepson: Cardiac Sensitization Thresholds of Halon Replacement Chemicals Predicted in Humans by Physiologically-Based Pharmacokinetic Modeling, Risk Analysis, Vol 16(4), 1996.

Woodcock, A., Continuing Patient Care with Metered-Dose Inhalers. *Journal of Aerosol Medicine*, Vol 8, Supplement 2:s5-s9, (1995).