



**US Army Corps
of Engineers**
Waterways Experiment
Station

Assessment of Soil Erosion Methods for Sludge Recovery, Savannah River Site

by *Lawson M. Smith*

DTIC QUALITY INSPECTED 2

DTIC QUALITY INSPECTED 2

Approved For Public Release; Distribution Is Unlimited

19970805 052

The contents of this report are not to be used for advertising, publication, or promotional purposes. Citation of trade names does not constitute an official endorsement or approval of the use of such commercial products.

The findings of this report are not to be construed as an official Department of the Army position, unless so designated by other authorized documents.



PRINTED ON RECYCLED PAPER

Technical Report GL-97-10
July 1997

Assessment of Soil Erosion Methods for Sludge Recovery, Savannah River Site

by Lawson M. Smith

U.S. Army Corps of Engineers
Waterways Experiment Station
3909 Halls Ferry Road
Vicksburg, MS 39180-6199

Final report

Approved for public release; distribution is unlimited

Prepared for Department of Energy
Savannah River Site
Aiken, SC 29808



**US Army Corps
of Engineers**
Waterways Experiment
Station

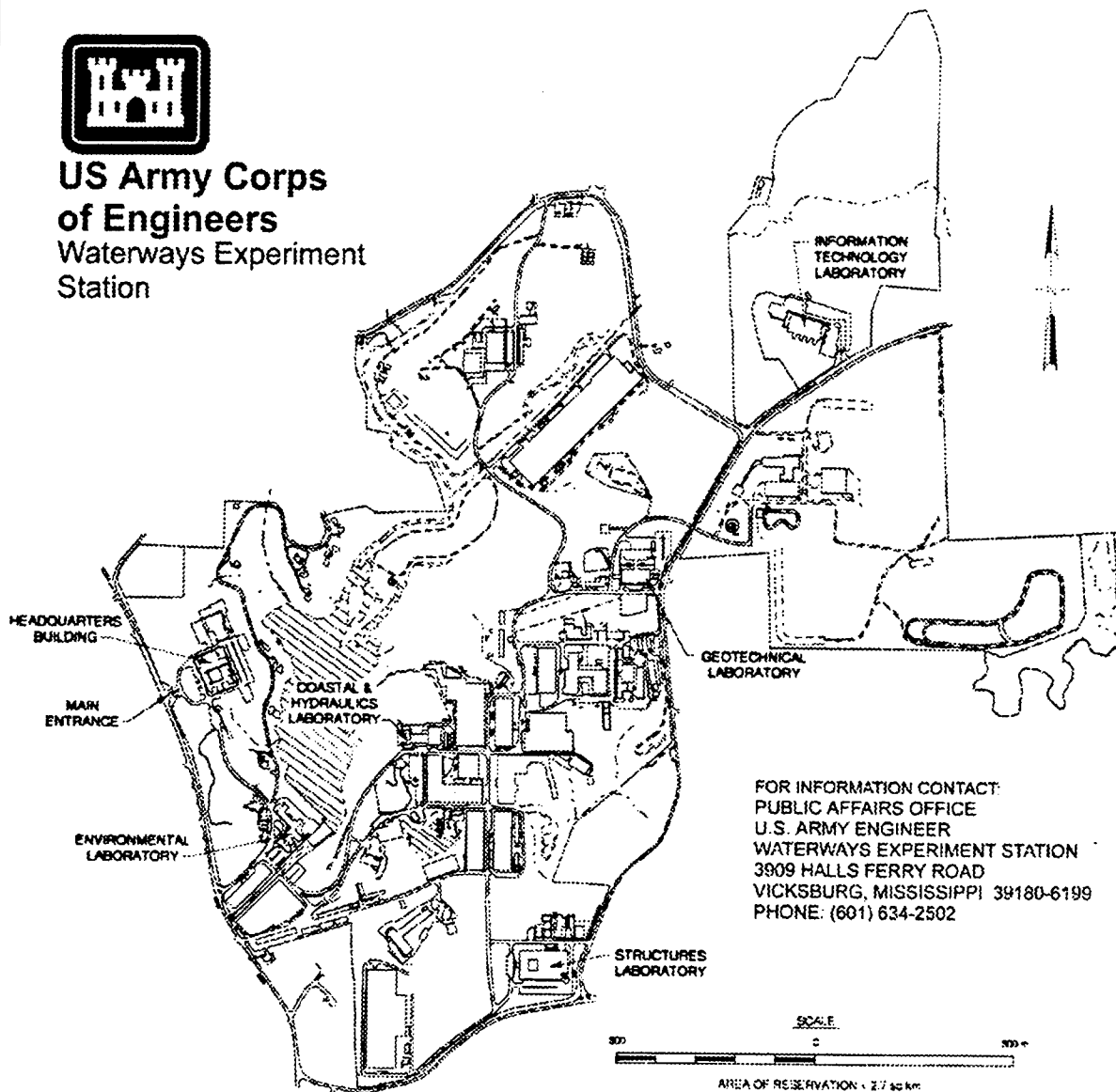

FOR INFORMATION CONTACT:
PUBLIC AFFAIRS OFFICE
U.S. ARMY ENGINEER
WATERWAYS EXPERIMENT STATION
3909 HALLS FERRY ROAD
VICKSBURG, MISSISSIPPI 39180-6199
PHONE: (601) 634-2502

Waterways Experiment Station Cataloging-in-Publication Data

Smith, Lawson M.

Assessment of soil erosion methods for sludge recovery, Savannah River Site / by Lawson M. Smith ; prepared for Department of Energy, Savannah River Site.

118 p. : ill. ; 28 cm. — (Technical report ; GL-97-10)

Includes bibliographic references.

1. Soil erosion — Mathematical models. 2. Solifluction. I. United States. Army. Corps of Engineers. II. U.S. Army Engineer Waterways Experiment Station. III. Geotechnical Laboratory (U.S. Army Engineer Waterways Experiment Station) IV. United States. Dept. Of Energy. Savannah River Site. V. Title. VI. Series: Technical report (U.S. Army Engineer Waterways Experiment Station) ; GL-97-10.

TA7 W34 no.GL-97-10

Contents

Preface	v
1—Introduction	1
Background	1
Purpose	1
Scope	2
2—Erosion Processes for Sludge Recovery	4
Erosion System	4
Soil Erosion Processes	6
Detachment	6
Transport	13
Deposition	14
Factors Influencing Soil Erosion Processes	16
Soil erosion energy	17
Soil material properties	18
Development of Erosion Networks	20
Development of Optimum Channel Network	24
3—Application of Soil Erosion Methods to Sludge Recovery	27
Objectives	27
Key Questions	28
Key questions: Fluid	28
Key questions: Waste sludge	29
Key questions: Pump	30
Key questions: Erosion system	30
4—Numerical Simulation of Sludge Erosion	32
Purpose and Approach	32
Simulation of Erosion System	33
Slope-area model	33
Results of erosion system simulation	33
Simulation of Sludge Erosion	35
WEPP model	35
Results of sludge erosion modeling	35
5—Summary and Recommendations	38
Summary	38

Recommendations	38
References	40
Appendix A: Scope of Work	A1
Appendix B: Monthly Progress Reports	B1
Appendix C: Study Plan	C1
Appendix D: Slope-Area Model	D1
Appendix E: WEPP Model Introduction	E1
Appendix F: WEPP Modeling Output	F1
Appendix G: Physical Modeling Study Plan	G1

SF 298

List of Figures

Figure 1. Physical elements of drainage basin erosion system	5
Figure 2. Rainsplash trajectories	7
Figure 3. Regimes of flow as a function of velocity and depth	9
Figure 4. Critical water velocities for erosion, transport, and deposition as a function of particle size	11
Figure 5. Interrelationships between sediment properties and strength parameters	12
Figure 6. Diagram of interrelationships of alluvial channel system	15
Figure 7. Typical drainage patterns	21
Figure 8. Graphical illustration of Horton's laws of drainage composition	23
Figure 9. Glock's drainage network evolution model	24
Figure 10. Parker's experimental development of a drainage network	25
Figure 11. Sediment load decline with drainage network development, Parker's experiment	25
Figure 12. Effect of increasing drainage density on discharge on a drainage network experiment	26
Figure 13. Slope-Area simulation of erosion network development	34

Preface

On 13 June 1996, the Department of Energy (DOE) authorized the Corps of Engineers through the U.S. Army Engineer District, Charleston (CESAC), to conduct an assessment of the potential use of soil erosion methods to recover high-level waste sludge from storage tanks at the Savannah River Site (SRS), Aiken, SC. A Military Interdepartmental Purchase Request (MIPR) from CESAC to the U.S. Army Engineer Waterways Experiment Station (WES) (MIPR No. CESAC-RM-96-52) authorizing the initiation of the project was issued on 26 June 1996. The project was initiated on 1 July 1996. Project officers were identified as Mr. Brent Gutierrez, DOE project manager; Dr. James Brooke, Westinghouse-SRS, technical monitor; Mr. Mickey Evans, CESAC project manager; and Dr. Lawson Smith, Earthquake Engineering and Geosciences Division (EEGD), Geotechnical Laboratory (GL), WES, was principal investigator. The numerical models were run by Ms. Denise Bullock, Mobility Systems Division, GL, and Ms. Nancy Renfroe, Mevatech, Inc.

The investigation was conducted by Dr. Smith under the direct supervision of Dr. Arley G. Franklin, Chief, EEGD, and the general supervision of Dr. W. F. Marcuson III, Director, GL.

At the time of the publication of this report, the Director of WES was Dr. Robert W. Whalin. The WES Commander was COL Bruce K. Howard, EN.

This report should be cited as follows:

Smith, L. M. (1997). "Assessment of soil erosion methods for sludge recovery, Savannah River Site," Technical Report GL-97-XX, U.S. Army Engineer Waterways Experiment Station, Vicksburg, MS.

The contents of this report are not to be used for advertising, publication, or promotional purposes. Citation of trade names does not constitute an official endorsement or approval of the use of such commercial products.

1 Introduction

Background

On 6 May 1996, Dr. W. F. Marcuson III, Director, Geotechnical Laboratory (GL), U.S. Army Engineer Waterways Experiment Station (WES), received a request from Dr. James Brooke, U.S. Army Engineer District, Charleston (CESAC), Savannah River Site (SRS), for technical assistance in the recovery of high-level wastes (HLW) from storage tanks at the SRS. Dr. Brooke believed that controlled soil erosion methods might be used to recover HLW from SRS tanks and requested a review and assessment of an attached draft scope of work (SOW) (Appendix A). Dr. Marcuson referred Dr. Brooke to Dr. Lawson M. Smith, GL, a specialist in soil erosion and geomorphology. Drs. Brooke and Smith subsequently discussed the SRS waste recovery problem and the potential application of controlled soil erosion methods. WES agreed to conduct a conceptual analysis of the application of controlled soil erosion methods to HLW recovery for SRS essentially as outlined by the original SOW. During the tenure of the project, Dr. Smith submitted monthly progress reports to these individuals (Appendix B).

During the week of 8-11 July 1996, Dr. Smith visited SRS to discuss the project in detail with appropriate SRS and CESAC personnel, view the HLRW storage tanks, and gather information pertinent to the project. A Study Plan for the project was presented to SRS and CESAC during the visit, which identified specific project tasks and subtasks to be accomplished (Appendix C). A presentation of the results of the conceptual assessment of soil erosion methods for sludge recovery was given to SRS personnel on 4 December 1996. This document comprises the final report of the conceptual assessment.

Purpose

The purpose of the project is to determine the potential applicability of soil erosion methods for recovery of HLW sludge from selected storage tanks at the SRS. Soil erosion methods are defined as the natural processes of soil erosion (including detachment, entrainment, transport, and deposition) controlled by the application of a fluid to the sludge surface for the purpose of maximizing the efficiency of the process for sludge recovery. Maximum efficiency may be

defined as optimum fluid volume (and sludge content in the fluid) over optimum time.

Soil erosion methods are particularly promising for sludge recovery at SRS because they offer several advantages over the present method of recovery. A first advantage is that *natural soil erosion processes are reasonably well understood and, consequently, are predictable*. The physical and chemical phenomena associated with the processes of particle detachment, entrainment, transport, and deposition by various fluids have been the subjects of extensive research. This research has resulted in the development of a number of computational methods for predicting particle erosion as well as explaining the factors which influence these processes.

A second advantage of using soil erosion methods for sludge recovery is that *soil erosion systems can be relatively simple and easily regulated*. Soil erosion systems typically consist of a mechanical device to apply the fluid (with the capability to vary the intensity, distribution, and direction of application) and a device to remove the sediment laden fluid (in this case, dilute sludge), such as a pump. Various processes of the system are regulated by controlling the fluid application and removal rates and locations. The erosion system may also be controlled by varying the gradient of the soil surface to be eroded and by modifying the soil to increase or decrease its erosivity. Two ways in which the erosivity of the sludge may be increased are (a) increasing the fluid content and (b) decreasing the cohesion of the solid particles (chemically or physically).

In terms of energy and matter (fluid) required by the recovery processes, *soil erosion can be an efficient means to move particulate matter* such as sludge. Natural soil erosion systems on the earth's surface are extraordinarily well organized. As natural systems, they quickly reach various equilibria states with respect to energy and matter input (precipitation), resulting system modification (development of hillslopes and channels on the soil surface), and output (runoff and sediment). When the characteristics of the soil system are simple and uniform (homogeneous sludge properties), equilibria states (and predictable response of the system) may be achieved rapidly.

Other methods of sludge recovery undoubtedly have their own "advantages" as well. However, with respect to soil erosion methods described in this report, these characteristics collectively have the potential to achieve a relatively low cost, mechanically simple, replicatable, dependable, and operationally predictable procedure for sludge recovery from SRS tanks.

Scope

This report describes the conceptual assessment of the use of soil erosion methods for sludge recovery from waste storage tanks at SRS. As defined in the Study Plan, the assessment involved four phases: (a) data collection, (b) evaluation of potentially applicable erosion models and methods,

(c) development of a numerical model of sludge erosion, and (d) documentation of methods and results in a report. Analyses described in this report were made on existing data developed at SRS using existing analytical methods and models. Specific tasks completed in the assessment are identified in the Study Plan (Appendix C). In the interest of providing a logical discussion of the assessment of soil erosion methods for sludge recovery, the following report is divided into four sections: (a) Erosion Processes for Sludge Recovery, (b) Application of Soil Erosion to Sludge Recovery at SRS, (c) Numerical Simulation of Sludge Erosion, and (d) Summary and Recommendations.

2 Erosion Processes for Sludge Recovery

Erosion System

The potential efficiency of erosional processes for sludge recovery from waste tanks at SRS may be seen in the development of erosion landforms on the Earth's surface. Erosion development of the Earth's landscapes is the result of the operation of one of the most orderly of earth surface systems. Most of the landforms that may be seen from the air are the product of the operation of erosional systems of various types and scales; systems which typically exhibit a high degree of natural order. This "natural order" is indicated by the significant interrelated nature of the elements of erosional systems such as the morphological characteristics of hillslopes and stream channels. The high degree of order of erosion systems is the product of adjustment of the system to variations in matter (precipitation) and energy (kinetic energy of precipitation and runoff and potential energy of maximum and minimum topographic elevations in the system).

Erosion systems produced by precipitation on a land surface are best understood as drainage basins, specific areas on the land surface defined by topography and drainage (stream channel) network (Figure 1). All the area within a drainage basin contributes runoff and sediment to a central outlet at the lowest elevation. Drainage basins are comprised of physical elements which are acted upon and modified by the input and processing of energy and matter through the system. In general terms, the physical elements of erosional systems consist of the hillslopes, stream channels, floodplains, and final depositional area or outflow (Figure 1).

For the purposes of assessing the transport of energy and matter (in this case, waste sludge) through the erosion system, these four drainage basin elements may be viewed as linked compartments. The hillslopes are the primary locus of energy input from precipitation and overland flow after runoff generation. Hillslopes are also the *source of sediment and runoff* to the next (downstream) compartment of the system, the stream channels. The stream channel compartment is principally characterized by *sediment and water transport* and conveyance but is also the origin of some sediment eroded from the bed and banks of the channels. As stream channels grow in size and develop a

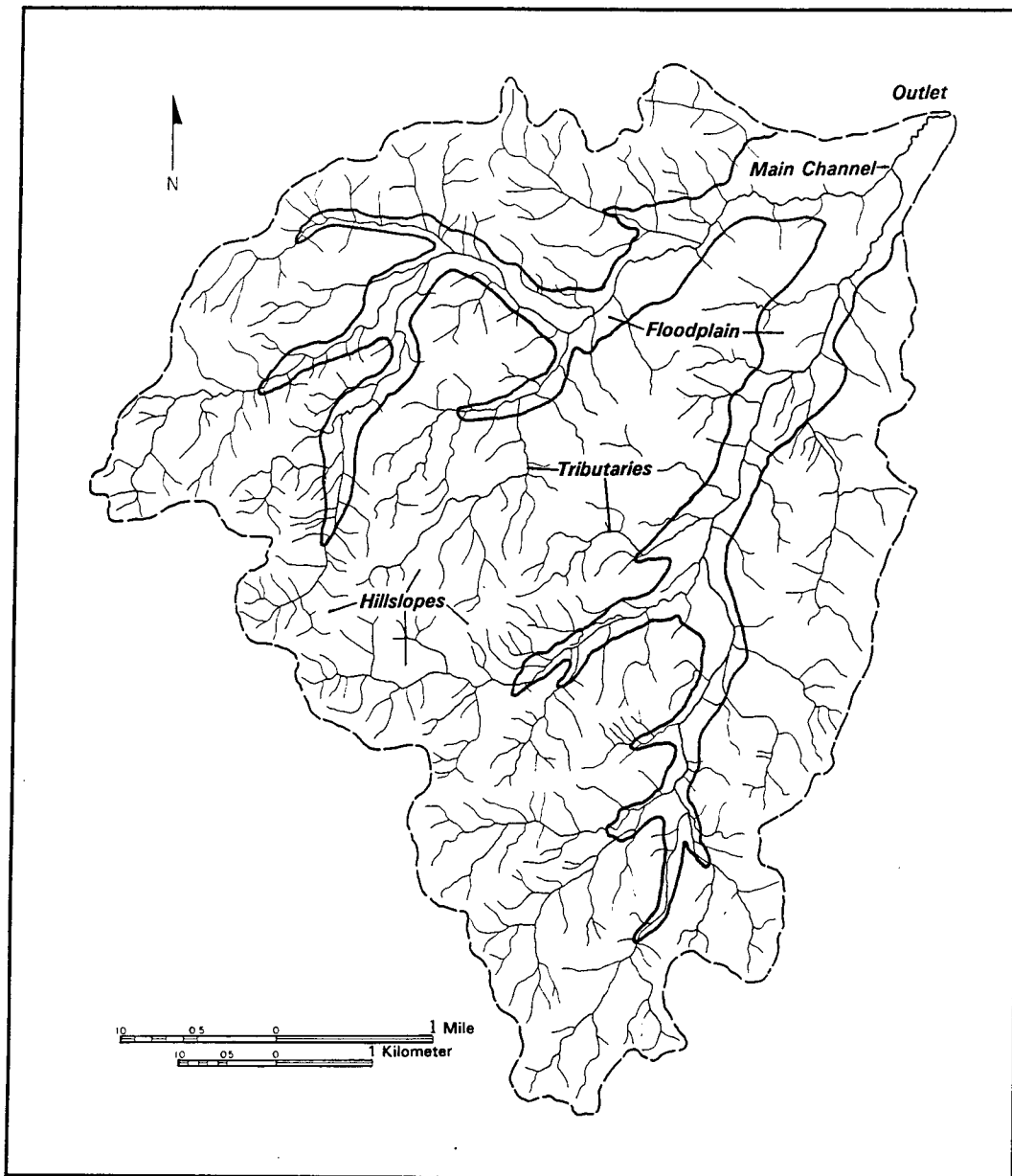

Figure 1. Physical elements of drainage basin erosion system

migrating planform, they typically develop a floodplain by lateral erosion and deposition. The floodplain is the locus of *temporary storage* of sediment deposited when the channels receive more flow than they can transport, overflow their banks, flow out onto the relatively flat floodplain, and deposit sediment. A final *depositional* area (for closed systems) or outflow point (for open systems) occurs at the lowest elevation of the system. In the case of the SRS waste tanks, the lowest point is the outflow pump.

The continuum of sediment, water, and energy movement through the drainage basin is evident in the linked compartments characterized by detachment, transport, temporary storage, and deposition (or outflow) in the

system. These four compartments are intricately interrelated (as internal elements of the system). They are modified by the magnitude, frequency, and duration of processes of the principal external element of the system, climate, or, in the case of the SRS tanks, fluid spray.

The strength of the interrelationships between the internal and external elements of the erosion system may be measured statistically by multivariate analyses such as factor analysis and multiple linear regression. Statistical analyses have been employed in the development of the first models of soil erosion like the Universal Soil Loss Equation (Wischmeier and Smith 1965) and the Wind Erosion Equation (Skidmore, Fisher, and Woodruff 1970). Statistical structure of the erosion system elements is a good indicator of the *efficiency* of the system to process system inputs (the energy and matter of precipitation). With the exception of some perturbations (threshold events) in their evolution, drainage basin erosion systems develop higher degrees of statistical interrelationship and efficiency with time, reaching various time-dependent states of equilibrium. During these states of equilibrium, the drainage basin erosion system does the least work per energy input. The efficiency of soil erosion methods for sludge recovery will be significantly influenced by the equilibrium state of the drainage system developed in the tank, a concept which will be discussed in greater detail in the report.

Soil Erosion Processes

As previously presented, soil erosion is a three-phase continuum: detachment, transport, and deposition. As sediment is moved through a drainage basin, this continuum may be repeated many times before a soil particle leaves the system. Successful application of soil erosion methods to sludge recovery requires understanding the fundamental mechanics of the three phases. In the following section, the mechanics of each of the three phases is presented followed by a review of the factors which influence these processes.

Detachment

Following the initiation of rainfall, soil erosion begins with the *detachment* of soil particles from the land surface by two separate but related phenomena, *raindrop splash* and *overland flow*. Raindrop splash represents the initial addition of kinetic energy and matter (rain water) into the erosion system and is assumed to occur isotopically in the erosion system. Overland flow is generated from rainfall that does not infiltrate the soil and is primarily generated on the hillslopes. Technically, a third form of soil detachment occurs in erosional systems that have developed stream channels. Stream banks typically fail by *mass failure* (falls, flows, and slides), detaching relatively large masses of soil for transport by the stream. All three of these detachment processes will be important in an erosion system developed in an SRS waste tank.

Raindrop splash. Raindrop splash during even a modest precipitation event imparts a substantial amount of kinetic energy to the soil. The amount of kinetic energy delivered to the ground surface by a raindrop is defined as

$$KE = 1/2mv^2 \quad (1)$$

where

m = mass (kg)

v = velocity (m/sec)²

KE = kinetic energy in joules

Rainsplash detaches soil particles in three ways: rebound, undermining, and pushing. When raindrops strike level ground, soil particles are detached and ejected radially with relatively little effect on soil movement off of the immediate area. However, when rainsplash occurs on a sloped surface, the amount of soil erosion can be significant due to the downslope impact force and the longer trajectories of particle ejection in the downslope direction (Figure 2). Moseley's rainsplash experiments showed that the total amount of downslope soil transport increased with slope about six times from 0 to 25 deg (Mosley 1972). The data show that at a surface angle of 25 deg, 95 percent of the detached soil moved downslope.

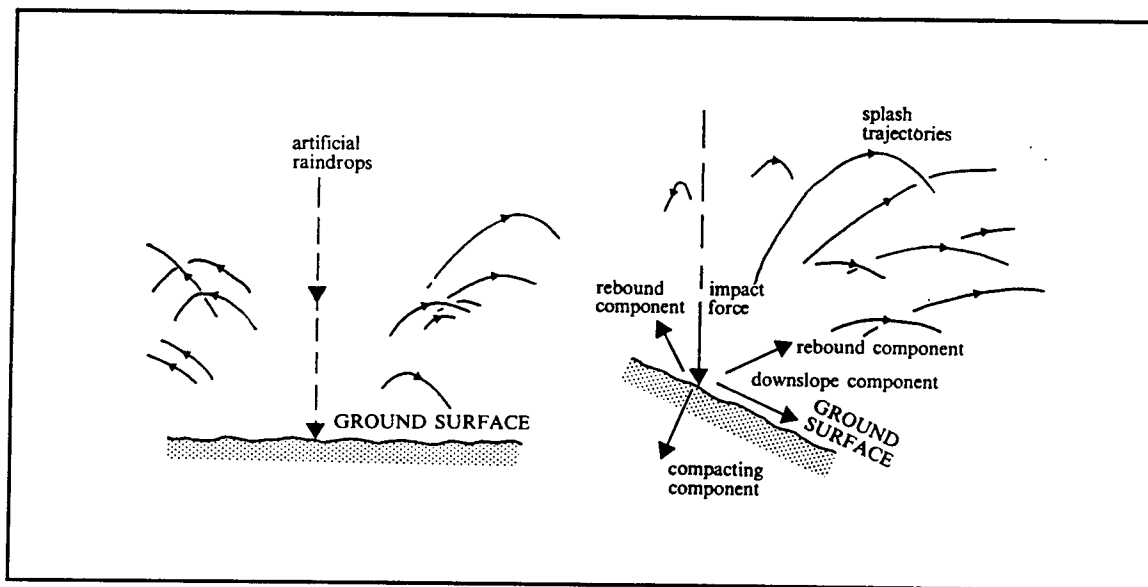

Figure 2. Rainsplash trajectories

The size of splashed soil particles, height of rebound, and distance transported downslope are a function of the drop size and velocity, soil characteristics, and surface slope. Kirkby and Kirkby (1974) observed the upper limit of rebound to be about 50 mm with 5-mm particles ejected to a height of 15 mm.

Rainsplash also has the effect of soil surface compaction, especially on flat soil surfaces. During high-intensity rain events, raindrops may actually seal the soil surface by compaction, accelerating the initiation of runoff. Soil compaction by rainsplash usually decreases the erosivity of the soil surface during the rainfall event as the bulk density and cohesion are increased by particle packing.

Overland flow. Overland flow is generated by two conditions during a rainfall event, as defined by Horton (1945). When the intensity of the rainfall exceeds the infiltration rate of the soil, the excess water becomes runoff. As mentioned above, a hard "packing" rain may significantly decrease the soil infiltration rate through rainsplash. A second condition of runoff generation occurs when the soil reaches field capacity (saturation) and surface depression storage is exceeded. This phenomena is also referred to as "sheet flow" because it appears to form a thin (typically less than 10 mm), broad, unconfined sheet of water of relatively uniform depth moving down the hillslope. In fact, the flow depth is usually not uniform, and upon close inspection, the flow often follows a braided or anastomosing course with no defined channels (Morgan 1986).

Overland flow is commonly referred to as "runoff," a term which actually describes the total production of water from a precipitation event in a drainage basin. Runoff includes channel precipitation, throughflow (downslope movement of water in the shallow subsoil), and groundwater flow, in addition to overland flow. All four of these types of flows will occur in the SRS tanks, once the drainage network becomes well established and entrenched into the sludge. However, only overland flow will be effective in actually recovering sludge.

Overland flow hydraulics are described by the dimensionless Reynolds (Re) and Froude (F) numbers, defined as

$$Re = \rho vr/u \quad (2)$$

$$F = v/\sqrt{gr} \quad (3)$$

where

ρ = density of water

r = hydraulic radius (which, for unconfined flow, is approximately equal to the mean flow depth)

g = acceleration due to gravity

u = kinematic viscosity of water

The Froude number distinguishes between different conditions of flow and is the ratio of inertial and gravitational forces. Tranquil (streaming) flow occurs

at $F < 1$, critical flow is defined by $F = 1$, and shooting (rapid) flow occurs when $F > 1$.

The Reynolds number differentiates laminar versus turbulent flow and is a ratio of the inertial and viscous forces in the fluid. Laminar flow occurs when $Re < 500$; turbulent flow occurs when $Re > 2,000$. In laminar flow, mixing in the fluid stream is achieved solely by molecular activity. In turbulent flow, mixing is accomplished by random eddy motion. Flows in the range of $Re = 500$ to $2,000$ are transitional. This broad transitional zone between turbulent and laminar flow is primarily a function of water temperature.

The typical hydraulic conditions of overland flow may be seen in Figure 3. As illustrated, several conditions of flow are possible, including laminar/tranquil, turbulent/tranquil, and turbulent/rapid. In nature, however, most unconfined and confined overland flows are turbulent/tranquil. In the SRS tanks, laminar/tranquil flows may exist on higher elevation sludge surfaces where overland flow is just beginning to occur. As the volume and depth of runoff increase downslope on the sludge surface, the flow will become turbulent/tranquil and its ability to erode the sludge will increase significantly. Note in Figure 3 that the transition from tranquil to rapid flow requires greater depth of flow with increasing flow velocity, whereas, the transition from laminar to turbulent flow requires less depth with greater flow velocity.

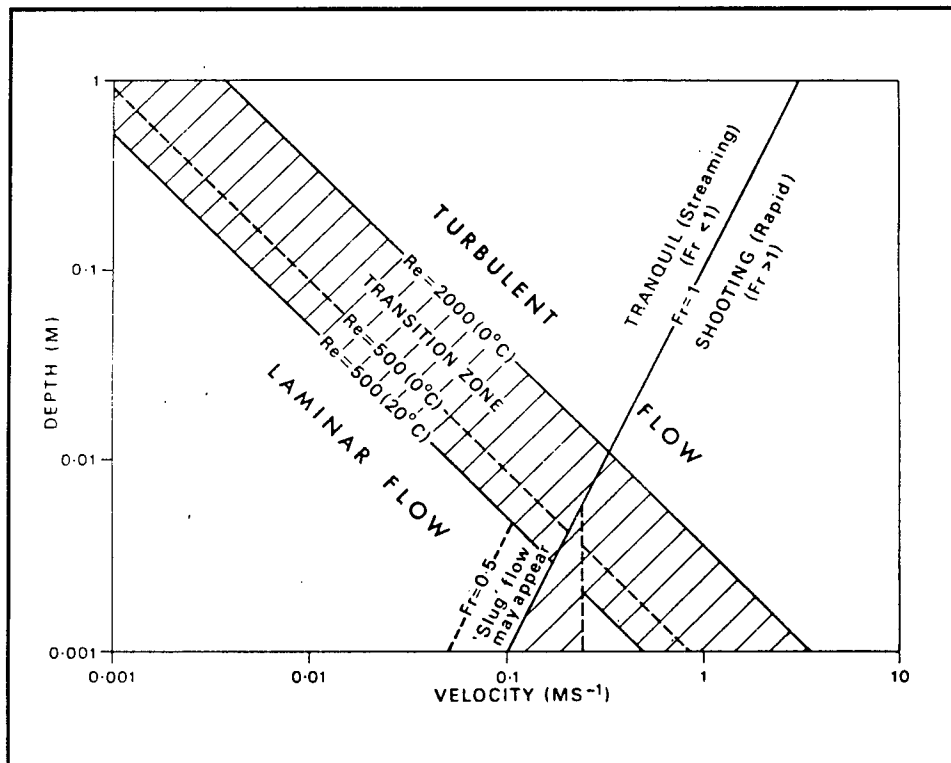

Figure 3. Regimes of flow as a function of velocity and depth

The velocity of overland flow may be estimated by the Manning equation

$$v = (r^{2/3} s^{1/2})/n \quad (4)$$

where

s = surface slope

n = dimensionless roughness coefficient

Obviously, when the velocity and/or turbulence of the flow is increased, the ability of the flow to detach soil particles is increased concomitantly.

Overland flow detaches soil by imparting shear stress on the soil particles and aggregates (Carson 1971). The amount of shear stress applied at the base of the flow may be defined by the DuBoys equation for boundary shear:

$$\tau_c = \gamma_w r s \quad (5)$$

where

τ_c = critical shear stress

γ_w = specific gravity of the fluid

Increasing the specific gravity (from clear water at 1.0 to as much as 1.34 for brine) of the fluid in the SRS tanks would substantially increase the shear stress applied by overland flow to the sludge surface. Additionally, increasing the slope angle (s) of the sludge surface and the slope length (which would increase the hydraulic radius (r) through the horizontal and vertical placement of the pump intake) would increase the shear stress on the sludge surface and possibly the efficiency of the recovery system.

Shear stress is directly related to velocity of overland flow defined by the Manning equation (Eq 4). Hjulstrom's (1935) pioneering experiments on flow velocities required to erode particles showed that clay-sized particles require greater flow velocity (and shear stress) for erosion to begin (Figure 4). Unlike larger grain sizes, clay particles have cohesive (resisting) forces which counteract erosive shear (driving) forces. Sludge, as a Bingham plastic, also has cohesive forces, similar to clay particles. In Figure 4, SRS sludge would probably plot in the 0.001- to 0.01-mm size range. Flow velocities required for erosion would most likely be less than those required for erosion of natural clay soils and would likely fall in the 10- to 100-cm/sec range. Once the sludge is eroded, relatively low-flow velocities would be required to transport the material to the pump intake.

The erosive processes of overland flow also occur in the bed and banks of the drainage channels. Because the depth of the fluid (and hydraulic radius) and the slope of the surface may be significantly higher, the shear stress imparted on the bed of the channels may be substantially higher than on the hillslopes. High shear stress on the bed will result in incision of the channel

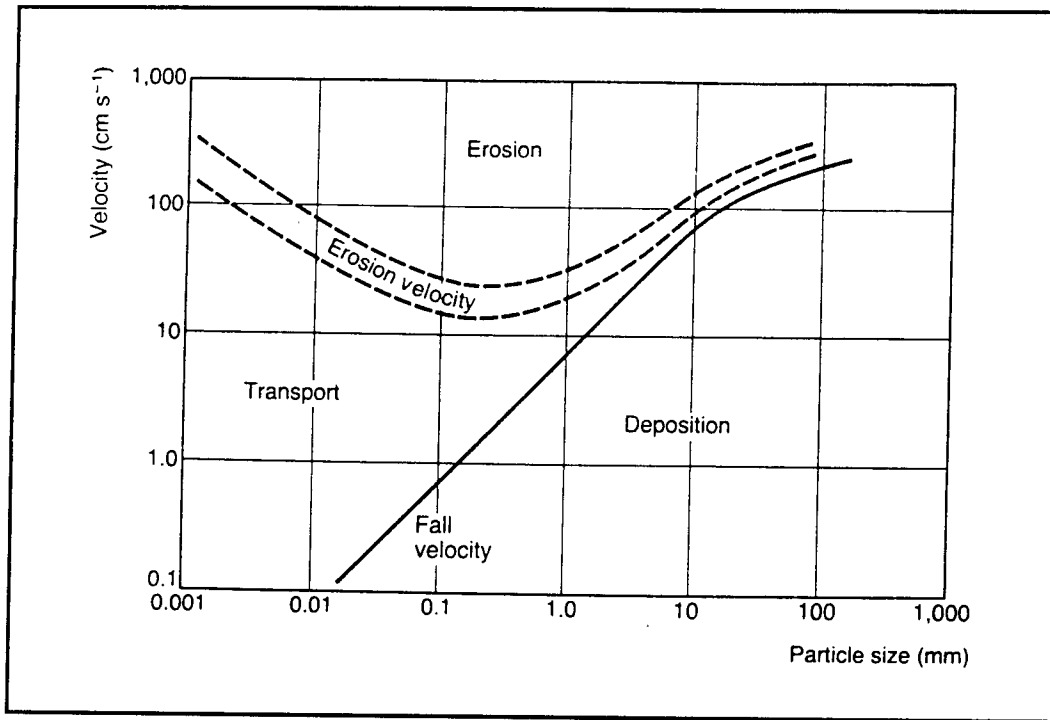

Figure 4. Critical water velocities for erosion, transport, and deposition as a function of particle size

and oversteepening of the channel bank, which in turn may result in mass failure of soil into the channel. The processes of mass failure of sludge into the erosional channels will most likely occur in the SRS tanks, particularly when the channels are deeply incised to a low pump intake elevation.

Mass failure. Sludge will be contributed to the principal drainage channels by mass failure as the channels develop and their banks reach a threshold height. Mass failures of sludge will be in the form of creeps, flows, slides, and falls of masses of material. The type of mass flow that will occur will be a function of the strength of the sludge to resist failure (resisting forces) versus driving forces. The strength of the sludge may be defined by Coulomb's equation

$$S = C + \sigma \tan \phi \quad (6)$$

where

S = shear strength

C = cohesion

σ = total normal stress

ϕ = angle of internal friction

Soil cohesion is a complex characteristic and the result of a combination of physical properties of the material. These physical properties and their interrelationships are shown in Figure 5.

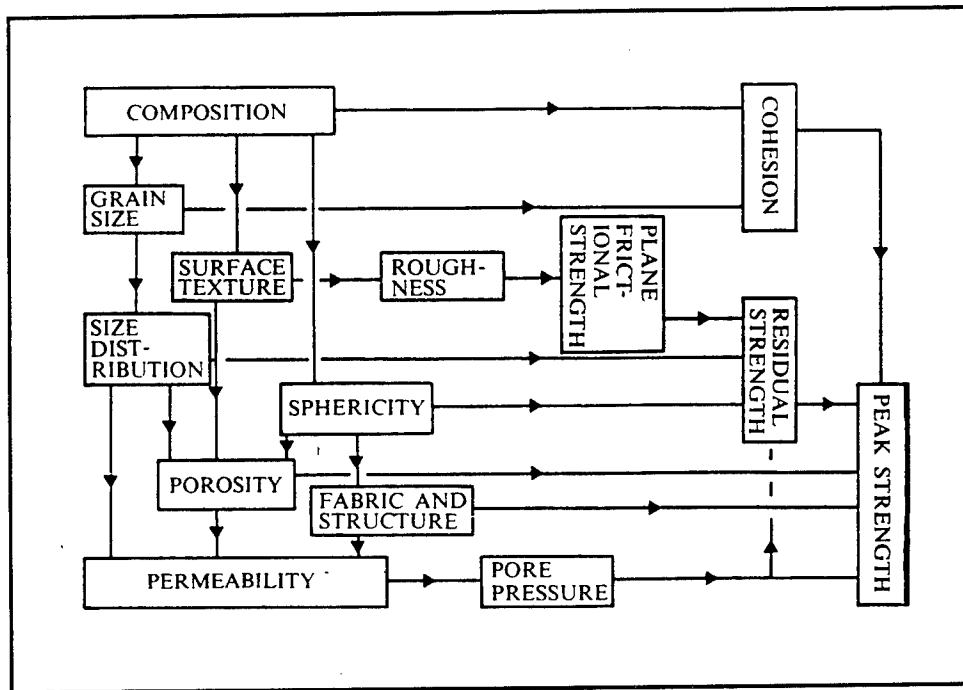

Figure 5. Interrelationships between sediment properties and strength parameters

Total normal stress is the characteristic of the material which holds it together and is the combination of effective normal stress and pore pressure. Effective normal stress is the product of gravitational force of the overburden weight of the soil. Pore pressure between discrete soil particles is produced by the hydrostatic pressure of water addition. As soils become wetter, interstitial soil pores become filled with water, pore pressures rise, and the total normal stress decreases, thereby decreasing the soil strength.

The angle of internal friction, ϕ , consists of two components, plane and interlocking friction. Plane friction is overcome by the sliding of particles along well defined planar surfaces. Interlocking friction requires soil particles to be moved up and over each other. High pore pressures produced by soil saturation also have the effect of radically decreasing the plane and interlocking frictional components of ϕ , therefore significantly decreasing soil strength. The interlocking friction of the SRS sludge is probably minimal, with the plane frictional component primarily controlling the angle of internal friction.

The primary driving force of mass failure is shear stress (τ). For the conditions in the SRS waste storage tanks, shear stress may be determined by the equation:

$$\tau = \gamma h \sin \theta \cos \theta \quad (7)$$

where

γ = unit weight of the sludge

h = vertical distance of the ground surface above the failure plane in the sludge

θ = sludge surface angle

In the SRS tanks, both h and θ are variable (typically increase) as the erosional channels develop and incise into the sludge. Lowering the pump intake elevation would increase the rate of incision of the channels and increase both h and θ , thus increasing the shear stress in the sludge and the propensity for mass failures of sludge to occur into the channels and/or the pump intake basin.

An analysis of the propensity of the sides of the drainage channels developed in the sludge to fail in mass may be accomplished through a stability analysis. The stability analysis is simply the balance of resisting versus driving forces or shear strength, S , divided by shear stress, τ . If the result (sometimes referred to as the "factor of safety") is greater than 1, mass failure should not occur.

Transport

Transport of soil particles (now sediment) occurs across the hillslope and in the drainage channels. On land surfaces, overland flow on hillslopes converges downslope at a threshold combination of flow volume and surface slope to form confined flow. Confined flow is first evident in the erosion development of rills, the smallest drainage channels. Rills may be only a few centimeters in width and small enough to be obliterated by rainsplash during the next precipitation event. The rills get larger downslope as the overland flow contributing area increases, eventually combining to form gullies. Gullies can become semipermanent channels when left unchecked for more than 1 year and develop the topological characteristics of stream channels (Smith 1993). On natural land surfaces where accelerated soil erosion is occurring, gullies may become several meters deep and tens of meters wide. Fortunately, in nature, most land surfaces do not have gullies formed on them. The larger erosional channels developed in the SRS tanks would be of the scale of a natural gully (up to 1 m deep and wide).

Typically, the smallest permanent channel on the landscape is a "first-order" stream, formed at a threshold value of contributing area. First-order streams rarely experience flow throughout the year unless they intercept a relatively high water table. When two first-order streams join, they form a second-order channel. A third-order channel is the product of the confluence of two second-order channels.

As an element of drainage basin erosion systems, the channel, like the hillslope, is actually a subsystem of the drainage basin. In well developed channels, the morphological characteristics and processes are strongly inter-related, as illustrated in Figure 6. The channels developed in the SRS tanks will begin to develop the strong interrelatedness illustrated in Figure 6 as they are allowed to evolve through continued precipitation (spray) in the tank.

Sediment transport in overland flow, rills, gullies, and channels is accomplished in three ways. When the flow velocity and turbulence is reasonably constant, the coarsest (largest) sediments are transported by *saltation* along the base of the fluid. Saltation of sediment occurs by sliding, rolling, and bouncing along the bottom of the channel. Smaller-sized sediment is buoyed by turbulent forces and is *suspended* in the fluid column. The smallest (clay-sized) sediments may actually be transported by *solution*. In the SRS waste storage tanks, it is likely that most of the sludge will be transported by suspension, however the sporadic sand- and granule-sized particles and aggregates of various sizes will be transported by saltation.

It is not surprising that the processes of detachment and transport are inter-related and mutually regulating. Research results of Meyer and Monke (1965) and Willis (1971) show that the rate of detachment of soil decreases as the rate of transport increases. The relationship of detachment and transport by flow has been expressed by Foster and Meyer (1975) as:

$$\frac{\text{detachment rate by flow}}{\text{detachment capacity of flow}} + \frac{\text{sediment load of flow}}{\text{transport capacity of flow}} = 1 \quad (8)$$

When the sediment load of the flow exceeds transport capacity, deposition occurs.

Deposition

As nominally defined above, deposition occurs when the capacity of the flow to transport sediment is exceeded by the amount or size of the sediment in transport. Usually, deposition is the product of decreasing sediment transport capacity of the flow due to a decrease in flow velocity or volume, as defined above. Deposition in the erosion channels in the sludge will occur in areas upslope of constricted width or decreased channel slope. When sludge is introduced to the erosion channels by mass wasting, a temporary surplus of sediment will exist, decreasing the local channel slope upstream of the failure and encouraging deposition and a temporary decrease in the efficiency of the erosion system for sludge recovery. This temporary decrease in recovery efficiency should be compensated by a subsequent increase in the transport of sludge through the channel as the higher slope channel below the failure incises headward through the failure mass.

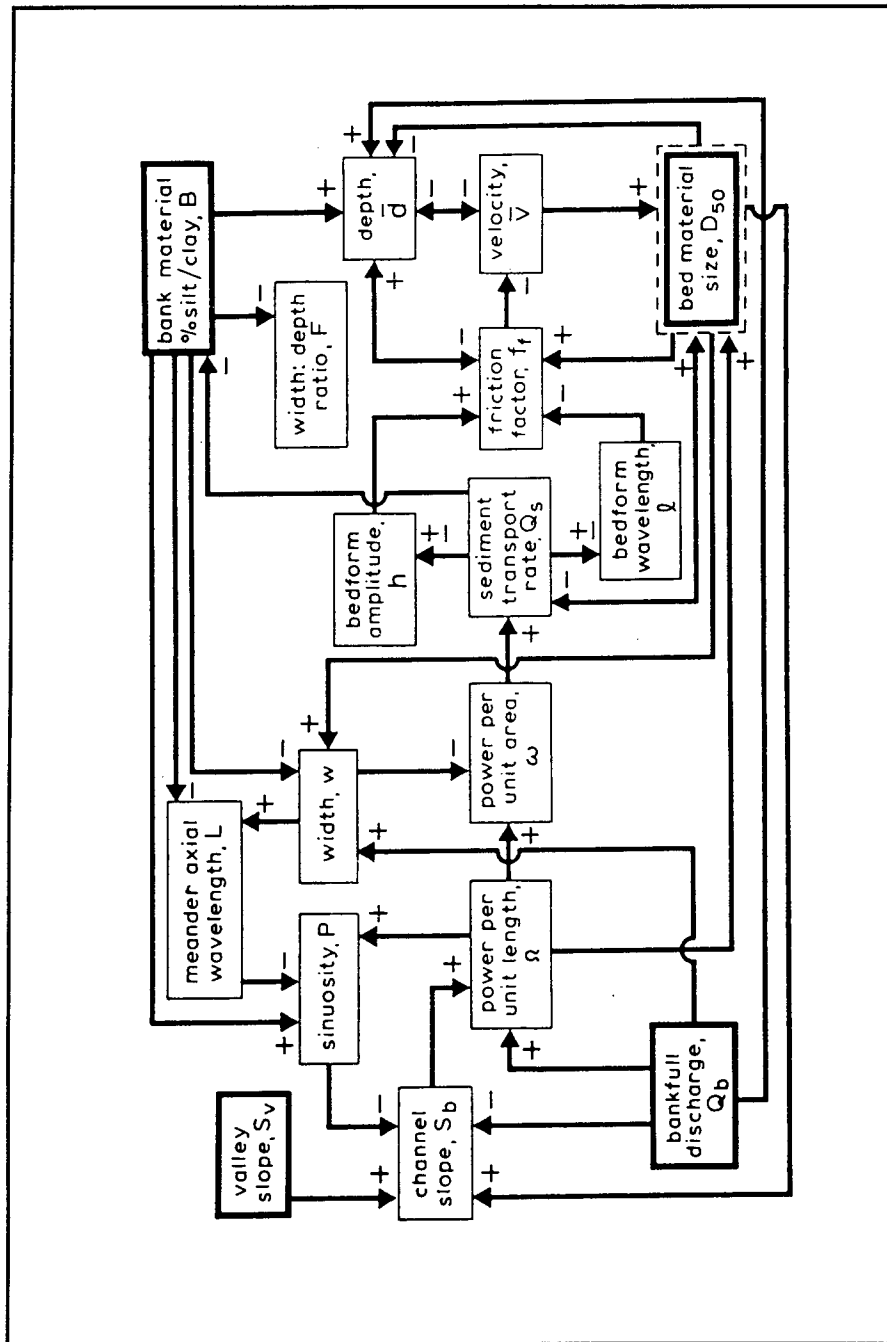

Figure 6. Diagram of interrelationships of alluvial channel system

The process of sediment deposition by a fluid may be described by Stoke's Law:

$$V_s = 2/9 (\rho_p - \rho_f) g r_p^2 / \nu \quad (9)$$

where

V_s = settling velocity

ρ_p and ρ_f = particle and fluid densities, respectively

g = acceleration due to gravity

r_p = particle radius

ν = fluid viscosity

The direct relationship between flow velocity (V) and particle size (r_p) is evident in Stoke's Law. This equation also states that the densest (heaviest) particles will be deposited first as flow competence drops.

In drainage basin erosion systems, deposition may occur on all four components of the landscape (hillslope, channel, floodplain, and the final depositional area or outlet). When sediment is deposited in the first three components, it is in *temporary storage* until the next, possibly larger event moves the sediment downslope. When sediment reaches the outlet, the result is referred to as *sediment delivery*. Sediment delivery is recovered sludge in the SRS tanks.

When an accounting of measured and/or predicted soil erosion and ultimate sediment yield at the downstream end of the erosion system is done for a drainage basin, a *sediment delivery ratio* for the basin is calculated. The sediment delivery ratio is defined as the volume of sediment yield measured at the outlet of the basin divided by volume of soil eroded throughout the basin. Typical sediment delivery ratios vary from 0.1 to 0.001. In general, as drainage basins increase in size, their sediment delivery ratio decreases due to temporary storage of sediment in the basin. Large basins have the capacity to store most of the soil eroded within it as sediment on the floodplains of the streams. The sediment delivery (sludge recovery) ratio for the SRS tanks will be large (> 0.1) due to the relatively small size and the minimum opportunity for temporary storage of sludge in the erosional systems of the tanks. Some temporary storage of eroded sludge will occur in the SRS waste tanks. The primary location of temporary storage should be the immediate vicinity of the outlet pump, the lower reaches of the largest channels, and the channel reaches above any mass failures.

Factors Influencing Soil Erosion Processes

More than 50 years of soil erosion research has demonstrated that soil erosion on land surfaces is influenced by a wide variety of factors. These

factors include physical properties of the soil, morphological aspects of the land surface, precipitation characteristics, climate, vegetation cover, and human modifications or treatment of the land. For the purposes of this assessment however, the factors which will affect the efficiency of soil erosion methods for sludge recovery from SRS waste tanks are: (a) *energy* imparted on the sludge, (b) *material properties* of the sludge, (c) *morphology* of the sludge surface, and (d) characteristics of the *fluid*.

Soil erosion energy

As mentioned above, the energy of the soil erosion system consists of the *kinetic energy* of rainfall on the system and the *potential energy* of the topographic elevation difference. The amount of energy imparted on the sludge surface will primarily depend upon the intensity and duration of rainfall, raindrop size, and the specific gravity of the fluid. Drizzle or light rain typically has a mean raindrop size of 200-500 microns and a maximum fall velocity of 1.5 - 3.0 m/sec with 0.006 - 0.019 gm of momentum (Pettersen 1958). Small rain drops are about 1,000 microns in diameter, fall at approximately 4 m/sec and have approximately 0.21 gm of momentum. Intense storm raindrops may be as much as 5,000 microns in diameter, fall at 9 m/sec, and have momentum of about 60 gm.

Low-intensity rainfall is usually characterized by small drop size, resulting in a precipitation event which has little erosive efficiency (Meyer 1986). Conversely, high-intensity rainfalls often have large drop sizes with substantial erosive power. Natural rainfall intensity and duration are often inversely related, with high-intensity events typically lasting a relatively short period of time (minutes) and low-intensity events longer (hours). Fournier's data for 183 rainfall events at Zanesville, OH, illustrate the relationship between rainfall intensity and soil erosion (Table 1) and the predicted erosion of soil by raindrops of a fluid with a specific gravity of 1.34 (potentially achievable in the SRS tanks).

The inverse relationship between natural raindrop size and storm duration can be changed in the SRS tanks with the creation of specific drop sizes and precipitation duration. The most efficient drop size and precipitation duration may be determined through laboratory testing. As previously stated, the erosion energy of the raindrops and subsequent overland flow could be increased by increasing the specific gravity of the fluid. Unlike natural storms, the amount and distribution of mass and energy contributed by the precipitation event would be controlled to achieve maximum sludge recovery.

Energy imparted upon the soil by overland flow and confined flows is more efficient than rainsplash impact in detaching soil particles for transport. Overland flow energy, as defined by Equation 5 (shear stress), is dependent upon *surface slope* and *depth of flow*. Obviously, greater slopes have greater shear stress of overland flow. Shear stress also increases with *slope length*. On a soil surface of constant slope, the depth of flow increases downslope. As the depth of flow increases, shear stress imparted on the soil surface increases,

Table 1			
Relationship Between Rainfall Intensity and Soil Loss			
Maximum 5-min. Intensity, mm/hr	Number of Rain Events	Avg. Erosion Per Rainfall Kg/m²	Erosion High S.G. Kg/m²
0-25.4	40	0.37	0.50
25.5-50.8	61	0.60	0.80
50.9-76.2	40	1.18	1.58
76.3-101.6	19	1.14	1.53
101.7-127.0	13	3.42	4.58
127.1-152.4	4	3.63	4.86
152.5-177.8	5	3.87	5.19
177.9-254.0	1	4.79	6.42
Data for Zanesville, OH, 1934-42.			

eventually to the point of generation of confined flow and the development of rills and/or gullies.

Soil material properties

The material properties of the soil also play a controlling role in soil erosion as indicated by Figure 5 and Equation 6. Figure 5 suggests that many soil properties influence the susceptibility of the soil to erosion. Of particular importance is the texture of the soil. Figure 4 illustrates that soils comprised primarily of silt are the least erosion resistant to moving fluids with cohesive clayey soils requiring higher flow velocities. It should be noted that Hjultstrom's research was conducted on natural materials (and obviously not SRS waste sludge). A significant part of the cohesion of natural clayey soils is contributed by organic colloids attached to the clay particles, a condition which does not exist in the waste sludge. As previously discussed, the sludge, being a Bingham plastic, certainly is cohesive, but probably not as cohesive as natural clay soils.

Previous investigations of the physical properties of SRS waste sludge and simulated sludge provide useful information in estimating the response of the sludge to erosive processes. The viscous nature of sludge samples from Tanks 7, 13, and 15 is illustrated by Stone, Kelley, and McMillan (1976). Motyka's (1984) comprehensive analysis of sludge properties for in-tank processing describes the physical properties of SRS sludge, including the density, rheology of the sludge at various percentages of insoluble solids/fluid, and the settling characteristics of the material. Motyka also describes the response of the sludge to in-tank slurring, information useful in the prediction of the erosive response of the sludge to "rain," and subsequent transport by fluid flow.

The rheological analyses of sludge samples from tanks 15H, 42H, and 8F as reported by Hamm (1984) describe the significant increase in yield stress of the sludge with increasing percent of insoluble solids to fluid.

Recent investigations by Packer Engineering, Inc., of the sluicing of waste sludge from storage tanks at the Hanford Site provide observations which are also useful in estimating the response of the SRS sludge to erosive processes. Ramsower (1996) reports on the response of waste simulants in wet and dry conditions to sluicing at various nozzle pressures, diameters, and standoff distances. The "wet sludge" (yield strength of 0.36 kg/cm^2 (0.51 psi)) and intermediate "dry sludge" 0.32 kg/cm^2 (4.6 psi) were immediately eroded by nozzle pressures of 5.27 kg/cm^2 (75 psi). A drier "sludge" stimulant 1.53 kg/cm^2 (21.8 psi) exhibited the development of a small crater in the material at a nozzle pressure of 5.27 kg/cm^2 (75 psi). The results of these tests indicate that both wet and dry sludge simulant would be readily erodible by in-tank "precipitation" and overland flow.

Soil permeability is inversely related to soil erosivity. Soils with relatively high permeability (soils of large grain sizes and extensive vertical structure) have high infiltration rates permitting surface flows to infiltrate, rather than run off and create overland flow. This phenomena partially explains why many hills in the natural landscape are above either erosion resistant rock or permeable sandy/gravelly deposits. Soil particles that are angular in shape have significantly higher angles of internal friction (Equation 6) and greater strength than soils comprised of rounded particles.

For soils which contain greater than approximately 30 percent clay, the mineralogy of the clay is a major factor influencing the erodibility of the material. Some soils contain clay minerals which disperse when they become wet (referred to as "dispersive" soils), radically reducing the cohesiveness and strength of the material. Some soils contain clays which expand upon hydration, in effect creating chemical mobility (pure montmorillonite will expand as much as 20 times when hydrated). These soils are referred to as "expansive" soils. When expansive soils subsequently desiccate, polygonal cracks are created at various scales which also tend to break down the cohesiveness of the soil. The waste sludge may be partially expansive (most mineral combinations are to some degree).

In the development of soil erosion equations like the Universal Soil Loss Equation (USLE) (Wischmeier and Smith 1965) and the Water Erosion Prediction Project equation (WEPP) (Flanagan and Livingston 1995) the "erosivity" of the soil is represented by a single value which incorporates a number of soil physical and chemical properties. A number of researchers have also attempted to measure the erosivity of the soil in the laboratory and in situ to develop an index or ratio of physical properties (Middleton 1930; Bouyoucos 1935; Henin, Monnier, and Combeau 1958; Chorley 1959; Andre and Anderson 1961; Lugo-Lopez 1969).

As mentioned above, various aspects of the surface slope, such as slope gradient and length, affect the amount of soil erosion which occurs across the landscape. Most erosion control practices are designed to decrease slope

length and/or gradient while establishing a protective vegetation or artificial cover for the soil. Another factor which is also important in the velocity (and shear stress) of overland flow is the surface roughness. Surface roughness is effective in two forms: (a) macro structure of depressions and clods, and (b) grain roughness of individual soil particles. The importance of roughness may be seen in Manning's equation in terms of the roughness parameter, "n" (Eq 4).

As the "agent" of soil erosion, properties of the fluid also influence the amount of erosion that may occur on a given soil surface. In Equation 1, the mass (specific gravity) of the fluid is a key condition in the amount of kinetic energy produced by raindrop impact and overland flow. In the SRS tanks, the specific gravity of the fluid may be as high as 1.34 (using brine), significantly increasing the kinetic energy of the fluid drops.

The amount of shear stress (as a function of laminar or turbulent flow) imparted upon the soil surface is directly influenced by the kinematic viscosity of the fluid (Eq 2). The kinematic viscosity of the fluid is influenced by its temperature and specific gravity, two variables which can be manipulated in the SRS tanks to achieve maximum recovery. The chemistry of the fluid is important in the erosion of clayey soils, particularly those soils that are expansive or dispersive. Fluid chemistry would also be a controlled variable in the SRS tanks.

Development of Erosion Networks

The efficiency of the erosion system for recovering waste sludge from tanks at SRS will be dependent upon and evident in the development of a network of surface flow channels. This network will consist of overland flow routes, rills, and gullies developed in the sludge and will serve as the conveyance system for detaching and transporting the sludge to the outlet pump. The specific characteristics of the erosion network will influence the efficiency of the soil erosion system for sludge recovery. As an important part of the recovery system, the drainage network should be designed to achieve optimum productivity. To achieve the optimum design, it is important to understand how drainage networks evolve naturally to various dynamic equilibria states with respect to the other properties of the drainage basin erosion system.

In nature, the erosion development of a drainage network produces a channel system which exhibits different patterns when viewed on maps or aerial photographs. These drainage patterns are a product of the climatic and geological histories of the area. Drainage patterns primarily reflect the surficial geological materials (particularly in terms of relative erodibility), geological structure, and recent geologic history. A number of different patterns have been identified, as illustrated in Figure 7. These different patterns are indicative of distinctive geologic conditions and histories. The most common drainage pattern is the "dendritic" pattern, a network which develops in areas of homogeneous geologic materials, little subsurface structural control, and a

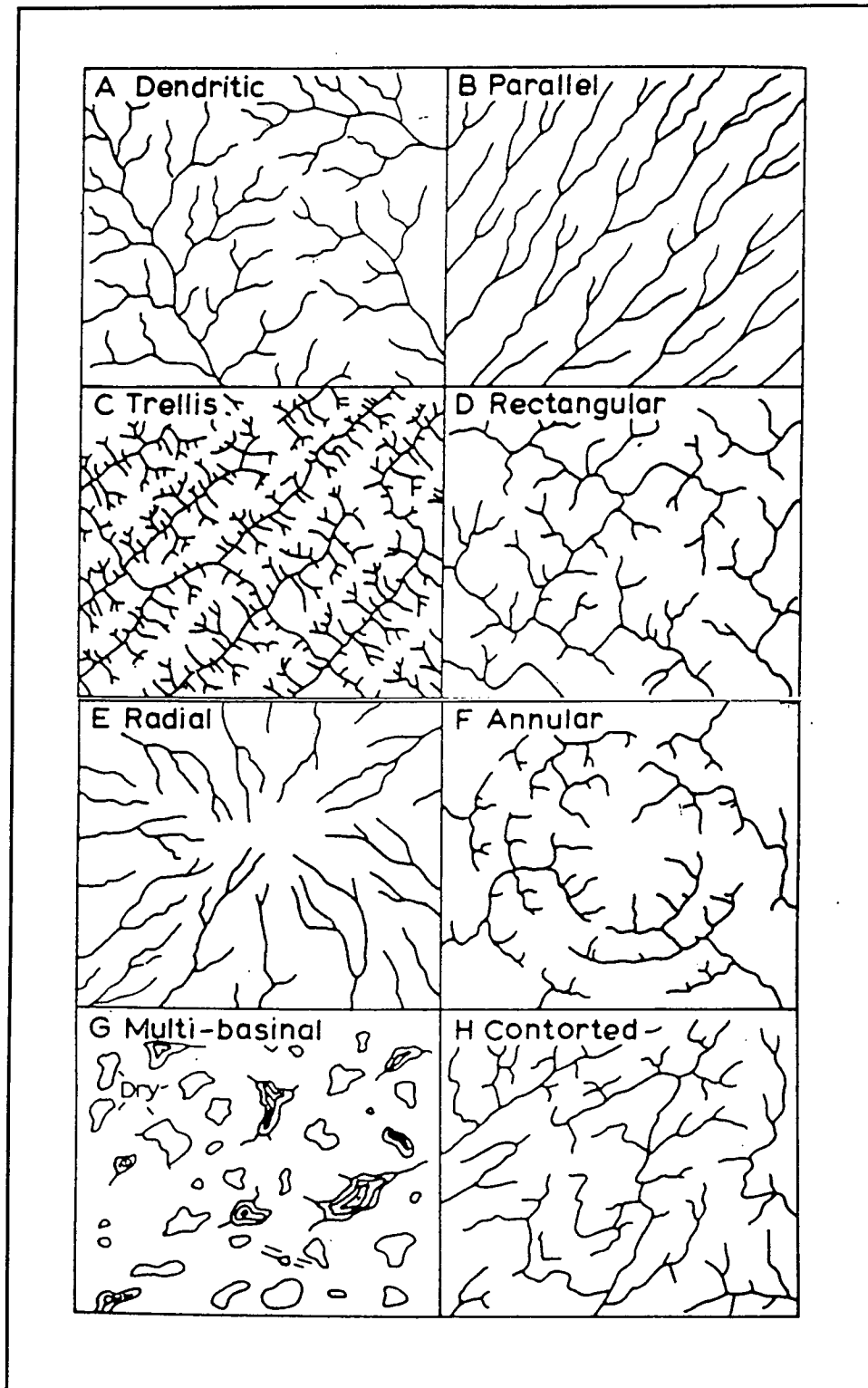

Figure 7. Typical drainage patterns

relatively long and uninterrupted period of erosion development. An erosion system of channels developed in the waste sludge of an SRS tank with a single outlet pump on the edge of the tank most likely would develop a dendritic system of channels.

Geomorphologists and hydrologists have developed a number of morphometric measurements of drainage network and basin characteristics which are useful in the analysis and assessment of the linear, areal, and relief properties of the drainage system. In his landmark statement on the analysis of drainage networks and basins, Horton described many of these morphometric parameters (Horton 1945). He noted the strong statistical relationships between the morphometric parameters and proposed a number of "laws of drainage composition." In general terms, these laws are: (a) the number of streams of a given order in a drainage basin is inversely related to the order, (b) the length of streams of a given order is directly related to the stream order, and (c) the length of the streams and their valleys is directly proportional to the area of their drainage basin.

Horton's laws of drainage composition have been used by many researchers to determine if the drainage system is sufficiently "mature" to have developed a high degree of internal order and reached a stage of dynamic equilibrium. These relationships will also be evident in the drainage systems developed in the SRS sludge and will be useful in analyzing the efficiency of the erosional systems. Graphical representation of Horton's laws are presented in Figure 8a-8c. In Figure 8d, a map of the drainage basin analyzed in Figures 8a-8b is presented showing the distribution of channel links per square kilometer illustrating Horton's law of stream numbers which states that the smallest streams are the most prolific. In the analysis and assessment of the drainage network developed in the SRS waste tanks, a morphometric analysis will be useful in evaluating the efficiency of the network with respect to the amount of fluid sprayed on the sludge surface to initiate recovery.

As the drainage basin erosion system develops, its network of channels evolves to achieve maximum efficiency. Observations of natural drainage network evolution by Glock led to his proposal of a six-phase evolutionary development of a dendritic drainage pattern (Figure 9) (Glock 1931). The developmental stages consist of (a) initial development of the trunk channel from a relatively flat plain, (b) elongation of the trunk and main tributary channels, (c) elaboration of the network, (d) maximum extension, (e) the beginning of stream abstraction, and (f) integration. In laboratory experiments, Parker (1977) verified Glock's basin development model and the hypothesis that networks lose channels once the system becomes integrated (Figure 10). Parker measured sediment yield from the experimental drainage basin system as it developed. He found that sediment yield diminished through time as the system equilibrated (Figure 11) (Parker 1976).

Zimpfer (1982) also modeled the erosion development of small drainage basins in the laboratory. He found that the impact of drainage channel evolution on the rate of runoff production was significant and direct (Figure 12). Zimpfer showed that as the drainage density increased, the hydrograph of runoff became more peaked with total synthetic storm runoff occurring over

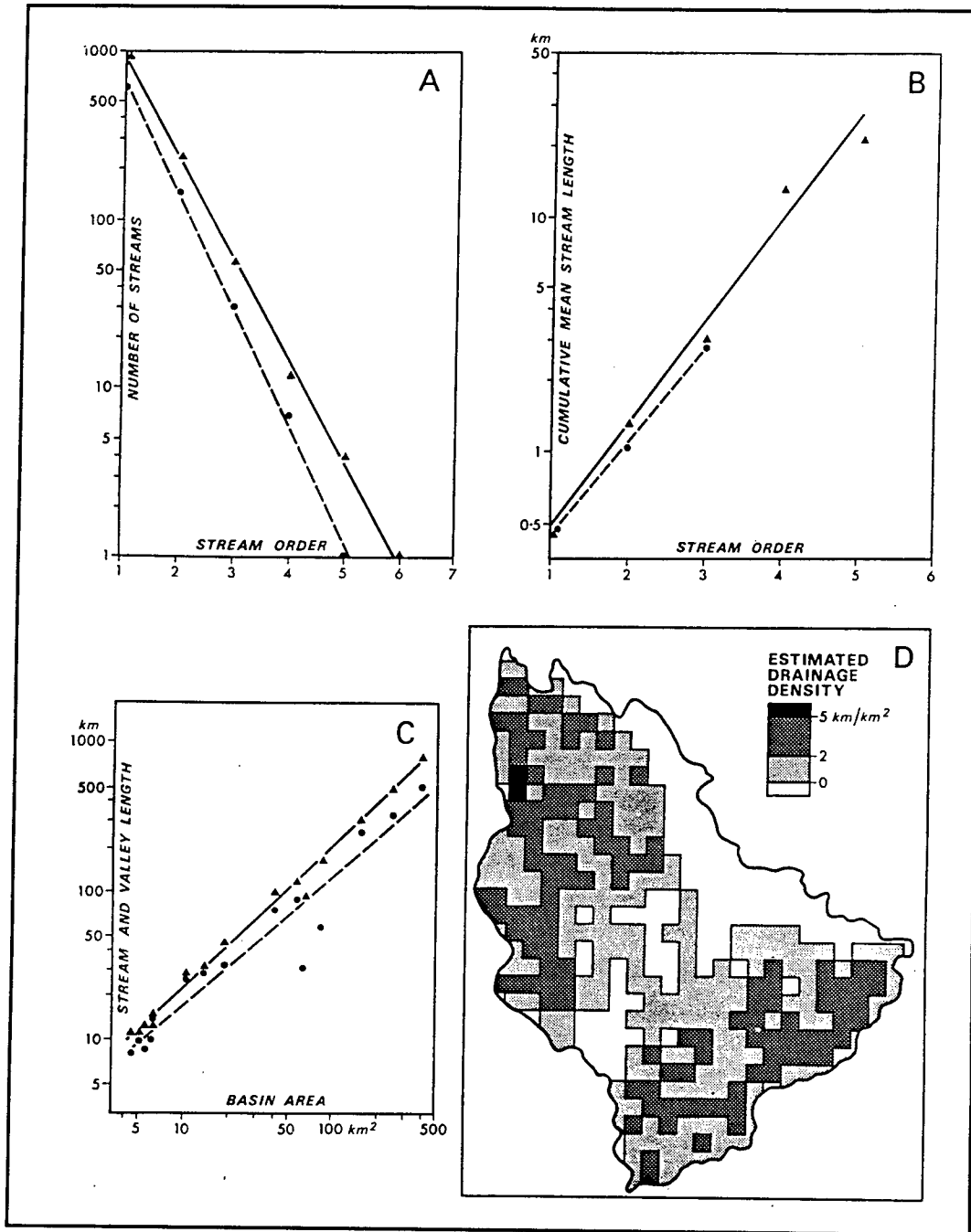

Figure 8. Graphical illustration of Horton's laws of drainage composition

shorter time periods. It is interesting that Zimpfer's laboratory experiments did not appear to reach the final stage proposed by Glock (1931) and documented by Parker (1977) when network integration is reached and the drainage density is reduced.

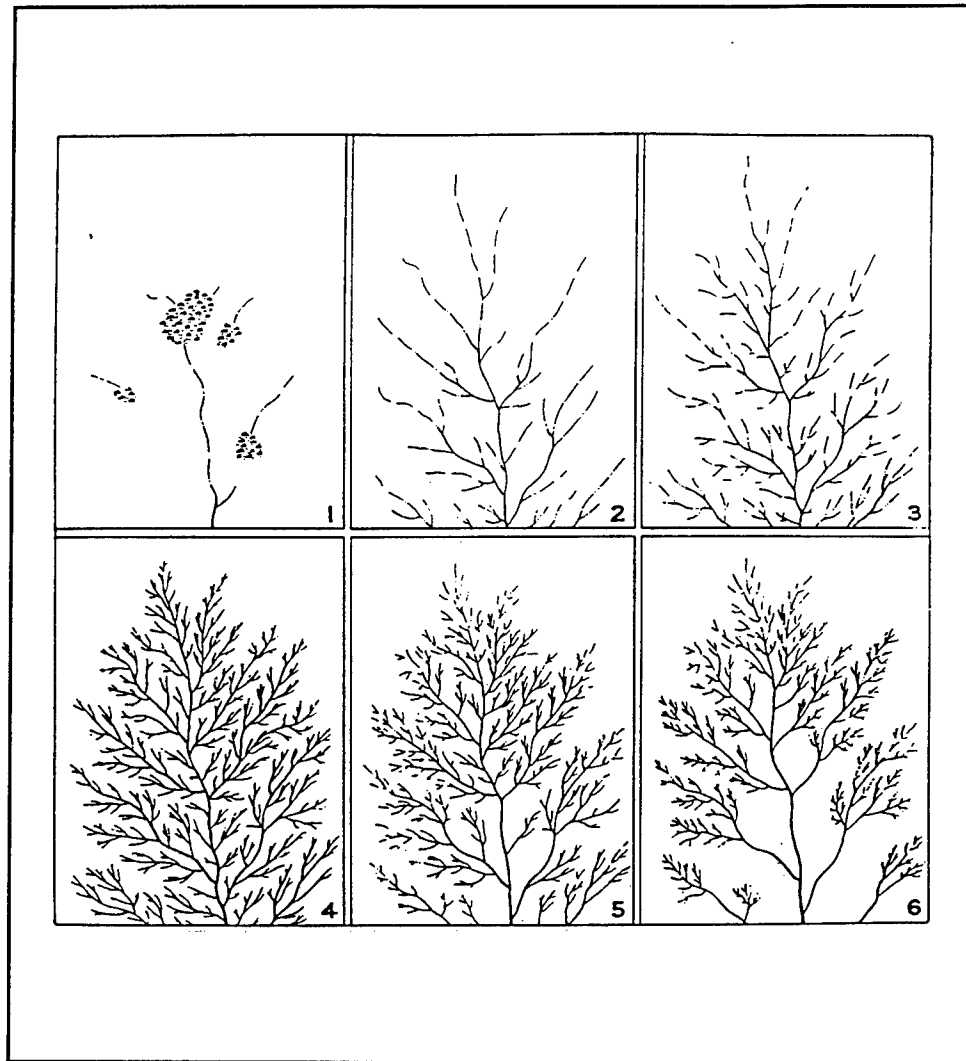

Figure 9. Glock's drainage network evolution model

Development of Optimum Channel Network

Recent research in the development of numerical models of drainage basin erosion systems has focused on the numerical statement of the underlying organization of drainage basins. Rigon et al. (1993) state that geomorphological thresholds, principles of minimum energy expenditure, and concepts of self-organized criticality are of "crucial importance for the understanding of basic general mechanisms which govern landscape evolution."

Ijjasz-Vasquez, et al. (1993) introduced the concept of "*optimum channel network*" (OCN) as a drainage network that drains a given area and has minimum total energy expenditure. They use a simulation model of drainage basin evolution based on the scaling relationships between slopes and areas to

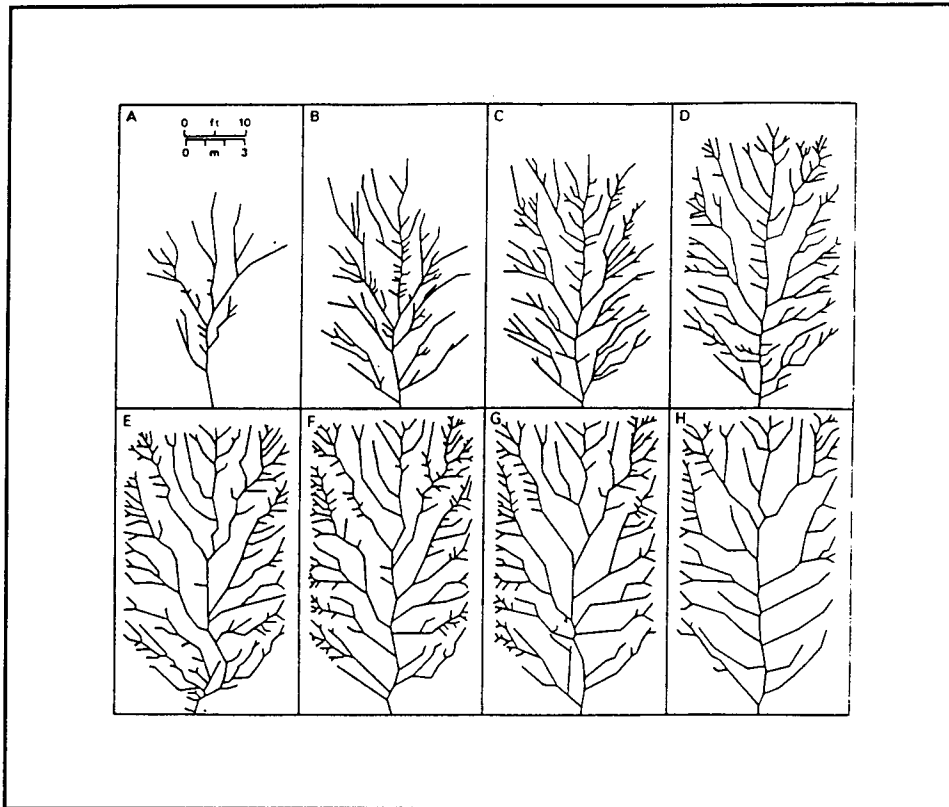

Figure 10. Parker's experimental development of a drainage network

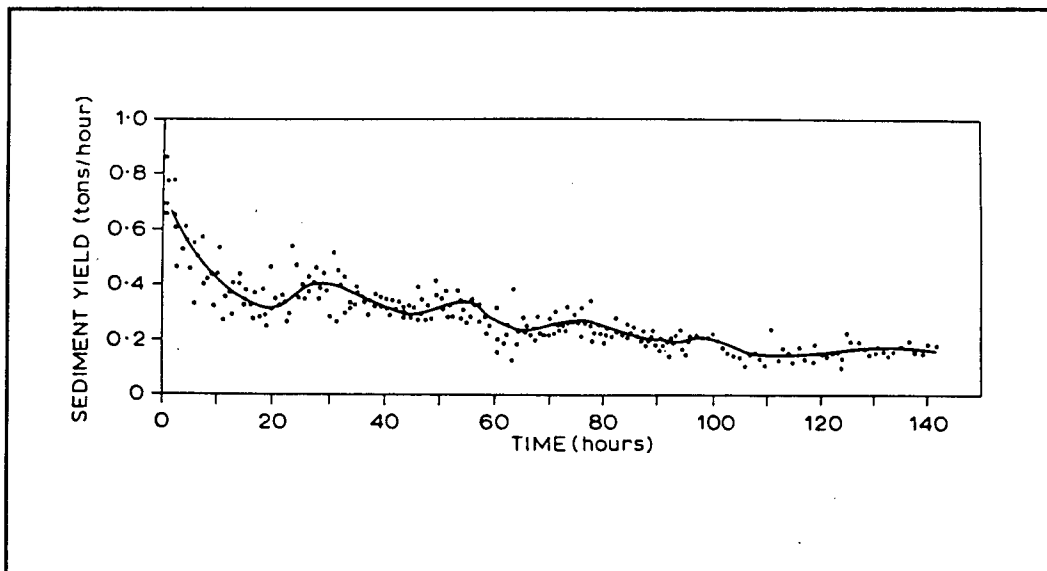

Figure 11. Sediment load decline with drainage network development, Parker's experiment

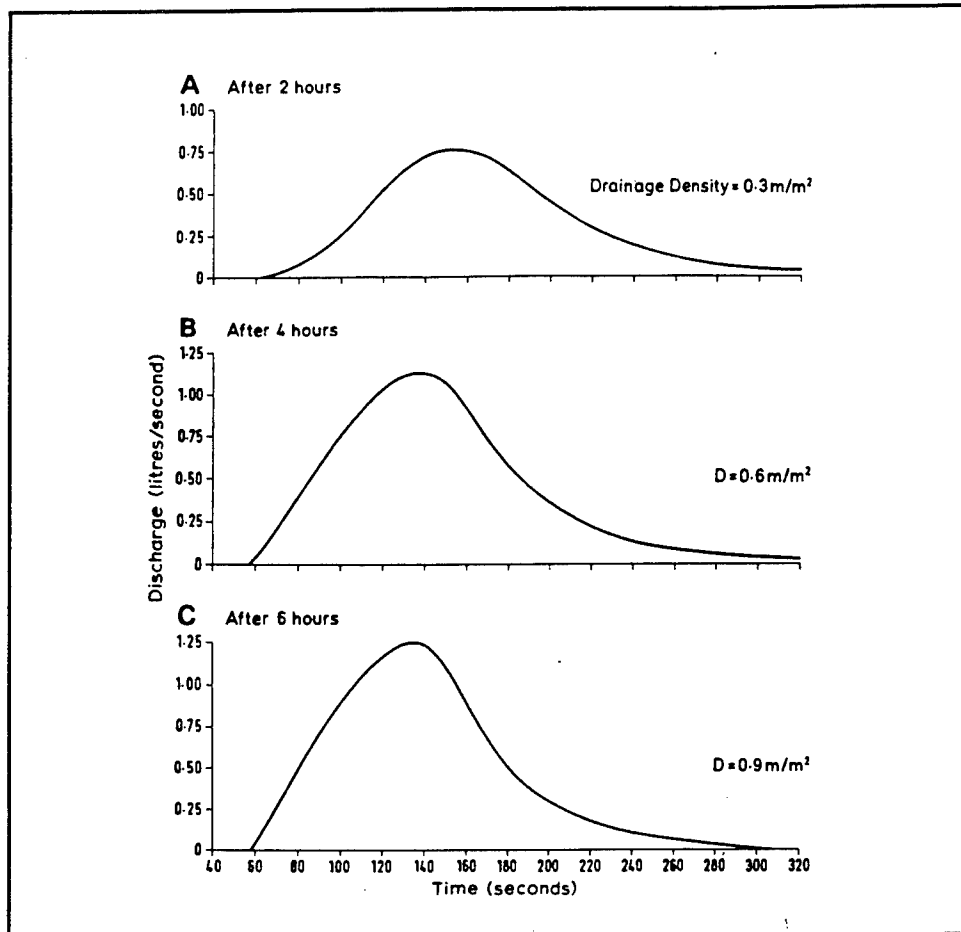

Figure 12. Effect of increasing drainage density on discharge on a drainage network experiment

compare real basins and a predicted OCN. The results of their comparison of real and simulated drainage networks showed that the values of total energy expenditure were very similar, supporting the idea that natural drainage networks organize themselves for minimum energy dissipation. They also found that when perturbed, the simulated networks rapidly evolved toward a new state of minimum energy dissipation.

The concept of the OCN may be of substantial value in the assessment of the drainage networks developed in the SRS tanks. The efficiency of the erosion network in an SRS waste storage tank to recover waste sludge may be evaluated on the basis of its proximity to a state of minimum energy dissipation. When the network reaches the state of minimum energy dissipation, its propensity to recover sludge through detachment and transport is also minimized, which is an undesirable condition for a recovery system. Therefore, the prediction of conditions met when the OCN is attained is useful in determining how to keep the network from achieving this condition and remaining effective in eroding (and recovering) waste sludge.

3 Application of Soil Erosion Methods to Sludge Recovery

Objectives

In discussions with personnel at SRS, it was determined that the successful application of soil erosion methods to waste sludge recovery from SRS storage tanks should achieve at least four fundamental objectives. These objectives are:

- a. *The soil erosion procedure for waste recovery should minimize the amount of fluid needed for recovery.* Fluid introduced into the tanks becomes HLW and must be treated downstream in the treatment system. Every effort should be made to minimize the production of new wastes that will require subsequent treatment as HLW.
- b. *The percent of recovered solid sludge in the outlet stream should be optimized as required by the treatment system downline.* Preliminary statements about the optimum percent of solid sludge in the outlet stream suggested 12 to 18 percent sludge in the fluid. These criteria are based on the optimum performance of the outlet pumps.
- c. *Downstream processing rate requirements for treating the sludge should be achieved.* The waste treatment system will have an optimum schedule for recovery of wastes from the tanks that is independent of the recovery process. This schedule may not correspond with the optimum procedure for waste recovery using soil erosion methods. The soil erosion methods will need to be designed and used in a manner that satisfies downstream requirements while achieving efficiency in recovering sludge.
- d. *The maximum amount of waste sludge should be recovered from the storage tanks.* It is probably realistic to assume that the last 5 to 10 percent of the sludge in the tanks will be the most challenging to recover. Development of a different method to recover this last 5 to 10 percent is not desirable. The soil erosion system should be able, with some modification, to erode all of the sludge from the tanks and transport it to the outlet pump.

These objectives are important to the conceptual assessment of the application of soil erosion methods to sludge recovery. In the laboratory (physical) modeling of sludge recovery, these objectives form the basis for the actual design of the system.

Key Questions

A number of key technical questions were identified in the investigation of the feasibility of soil erosion methods to recover waste sludge from storage tanks at SRS. These questions pertain to four technical areas: (a) the fluid used to develop and operate the erosion systems in the tanks, (b) the characteristics of the waste sludge, (c) the pumps used to remove the recovered sludge from the tanks, and (d) the erosion system itself. In the following paragraphs, specific questions in each of these four areas are presented.

Key questions: Fluid

As the active agent in the soil erosion process, the characteristics of the fluid to be used to recover sludge are critical. Some of the decisions about the fluid to be used may be determined by considerations beyond the development of the erosion systems in the tanks, such as the need for recycling of brine or other fluid contaminants already in the tank. There are at least four key questions about fluids used for the erosion system that should be addressed. These four questions are presented and discussed below.

How much fluid will be needed to recover all of the sludge from each tank? The question of how much fluid will be needed addresses the first objective and is one of the most important questions. The amount of fluid needed to recover all of the sludge in each tank will be dictated by the efficiency of the system and the control of the development of the erosion systems in the tanks.

What will be the optimum application of fluid to achieve maximum efficiency? System efficiency for sludge recovery will depend substantially on the physical characteristics of the sludge, primarily its erodibility and transportability by water or some other available fluid. Knowledge of the mechanics of the erosion/recovery process and manipulation of the processes to optimize the detachment, transport, and deposition of sludge will be critical to minimizing the amount of fluid needed to recover all of the sludge. For instance, it may be determined that in the initial development of the erosion system, the most effective procedure may be to jet the fluid at the sludge surface to develop a system of relatively deep channels leading to the pump intake and then saturate the sludge with a low intensity spray to initiate mass failures of sludge into the channels and down to the pump.

What will be the best placement for the fluid applicators (spray nozzles)? This question will be partially answered by nozzle and system control technology and partially by the answers to the previous two questions.

What is the best fluid for recovering the sludge? There are many considerations in choosing the best fluid for sludge recovery, a number of which go considerably beyond the recovery process. As previously stated, the specific gravity and kinematic viscosity of the fluid will affect how much energy is imparted on the sludge by the spray and the resulting overland unconfined and confined flows. These physical properties will also influence the capacity of the fluid to transport recovered sludge. The chemistry of the fluid will also be important, not only to its impact on the cohesiveness (and consequently erodibility) of the sludge, but on the operation of the spray applicators. The chemistry of the eroding fluid may vary from pure water to a saturated salt solution having a specific gravity of up to 1.34.

Key questions: Waste sludge

A number of reports have been published by SRS on the properties of the waste sludge. From these reports, it is apparent the chemical and radiological characteristics of the sludge are reasonably well known in a number of SRS tanks. The chemical characteristics are important in understanding the erodibility of the sludge to various fluids. However, the physical characteristics of the sludge with respect to the factors influencing the erodibility of the sludge is not well known. Especially problematic are those physical properties that effect cohesiveness and permeability.

What is the optimum fluid content for maximum efficiency of sludge erosion and recovery? The fluid content of the sludge will control not only the erodibility of the sludge, but also the mechanisms of detachment. The optimum fluid content (actually pore pressure) may be the range of pore pressures that provide some soil strength to support the development of an efficient network of channels (channel banks have the strength of a moist silt) while being readily erodible to rain drop impact and fluid shear. Conversely, it may be determined that the optimum pore pressure for maximum system efficiency may need to vary in time and location within the tank as the erosion system develops and is made to overcome the condition of minimum energy expenditure.

How can the optimum fluid content of the sludge be achieved? From existing SRS reports, it is evident that the waste tanks have had varied histories of sludge condition. Some tanks have been allowed to desiccate to some depth, resulting in at least a crust of dried sludge. Many tanks contain sludge that is covered by some thickness of supernatant, resulting in fluid content several times greater than the solids content. Once the optimum fluid content is determined, the questions become: (a) how do we achieve this sludge fluid content in the tank, or (b) would it be more efficient to attempt to recover the sludge at less than optimum fluid content.

Key questions: Pump

Similar to the questions about spray nozzles, some of the questions about the outlet pump will be answered by considerations other than the requirements of the erosion system. The number (one) and location (below specific access points in the top of the tank) of the pump are given. The pump questions that this investigation should address concern the location and operation of the pump.

What will be the optimum pumping rate? Determination of the optimum pumping rate will involve the simultaneous analysis of a variety of considerations that include: the fluid application rate, horizontal and vertical location of pump, fluid content of the sludge at the pump intake, and downstream processing requirements. It is probable that, like the application of the fluid, the rate of pumping may vary in time. Variations in pumping rate may also provide the perturbations needed to increase the erosion efficiency of the system once it reaches the "minimum energy expenditure" condition.

Key questions: Erosion system

The erosion system consists of the four elements or "compartments" of the system mentioned earlier. These compartments consist of the network of slopes, channels, and storage areas where sludge detachment, transport, and storage will take place.

What will be the optimum equilibrium state for maximizing efficiency in the erosion system? From previous discussions in this report, it is clear that the erosion system developed in the SRS tanks by spraying a fluid on the surface of the sludge will rapidly evolve to a state of minimum energy expenditure (MEE) and an "optimum channel network" (OCN). This MEE/OCN state will not be the most efficient state for sludge recovery because the "sediment load" of the system (amount of recovered sludge in transport) will be at a minimum with respect to the amount of fluid sprayed on the surface. The most efficient state of the system may be one that has been recently perturbed and is responding by entrenching the channels and increasing the gradient and length of the "hillslopes."

What combinations of system operation will achieve the optimum equilibrium state in the SRS waste tanks? Variations in the location, intensity and rate, and duration of precipitation (spraying) and pumping will be the primary means of developing and controlling the erosion system for sludge recovery. The best combination of these operations may not be immediately obvious without experimentation.

The "key questions" listed above are the result of this preliminary assessment of soil erosion methods for sludge recovery. These few questions certainly do not represent all of the many unknowns associated with the application of erosion methods to sludge recovery from SRS storage tanks. They do cover the most fundamental questions from the somewhat novel perspective of an erosion specialist. In the following section of the report, an attempt at

modeling the recovery of waste sludge using methods of predicting soil erosion and landscape evolution is presented in the interest of developing a first approximation of what might occur in the waste storage tanks.

4 Numerical Simulation of Sludge Erosion

Purpose and Approach

Numerical simulation is a powerful tool for the analysis of complex phenomena. The success of the application of numerical modeling rests on a variety of factors, such as the realism of the simulation method, the use of good data, and good judgment. In the numerical modeling presented in this section of the report, state-of-the-art simulation techniques were employed. Actual data and information from the SRS tanks are used where available. It was necessary to make a number of assumptions, particularly with respect to the physical properties of the sludge. These assumptions were based on the best information available.

The purpose of the numerical simulation of sludge erosion is to assess the key concepts and questions presented in the previous section. Initially, the development of an erosion system in a SRS waste tank is simulated for the purpose of assessing the fundamental feasibility of an erosion system for sludge recovery. Then the erosional recovery of sludge is modeled to examine the "key questions" given at the end of Section 3. In particular, the question of how much fluid (in this case water) will be necessary to achieve sludge recovery was examined. Additionally, the concentration of solids in the fluid recovered at the tank outlet was estimated.

Two approaches were used in the simulation of sludge recovery and the development of erosion systems in SRS tanks. The first approach involved using a "Slope-Area" model (Ijjasz-Vasquez et al. 1993; Appendix D) to test the development of an erosion system in a tank and then determine if the system reached the state of minimum energy expenditure and optimum channel network. The second approach consisted of the modeling of actual sludge erosion as a function of various soil, surface, and "precipitation" conditions in a tank using the WEPP (Water Erosion Prediction Program) model (Flanagan and Livingston 1995). Both of these simulation techniques are state-of-the-art methods for simulating natural systems and processes.

Simulation of Erosion System

Slope-area model

Simulation of the development of an erosion system for sludge recovery in an SRS waste storage tank was accomplished using the "Slope-Area" model developed by researchers in the Ralph M. Parsons (Hydraulics) Laboratory at the Massachusetts Institute of Technology (Ijjasz-Vasquez, et al. 1993; Appendix D). The Slope-Area model is a relatively simple procedure that simulates the three-dimensional (3-D) structure of a drainage basin and its channel network. The model exploits the scaling relationships between slopes and flows observed in many natural erosional systems. This scaling relationship states that slopes (S) are proportional to discharge (Q) times a common scaling exponent (M) which is typically 0.5. The scaling factor has been documented in a wide range of drainage basins by Leopold, Wolman, and Miller (1964) and Tarboton, Bras, and Rodriguez-Iturbe (1989). This relationship is the fundamental basis for every investigation of the 3-D study of drainage basins and their channel networks.

The computational method of the Slope-Area model uses the "traveling salesman" algorithm to simulate the elevation field over a gridded domain. At each iteration, the model calculates the drainage area of each grid cell and assigns overland flow directions based on the steepest slope direction. The elevation of the outlet is kept constant throughout the successive iterations of the computations of new slopes and drainages. The initial condition is a flat surface, single outlet at the lowest elevation and closed boundaries, except for the outlet. Input variables include the geometry of the erosion system, including elevation differences. Output consists of tables of elevations and areas which may be input to a graphics package to illustrate the 3-D development of the erosion system. The computer code for the model is given in Appendix D.

Results of erosion system simulation

Simulation of the development of an erosion system in an SRS tank using the Slope-Area model was completed and is presented graphically in Figure 13. The model produced an erosional system that rapidly developed an organized drainage network that achieved the condition of minimum energy expenditure. The development of a single trunk channel and an *optimum channel network* of tributaries in the sludge surface is evident in Figure 13.

The results of the simulation of the development of an erosion system in tank of sludge using fundamental scaling relationships of natural systems illustrates what the erosion system for sludge recovery is likely to look like when a single pump outlet is used on the edge of the tank. The results also indicate that the system will achieve *minimum energy expenditure* and will require perturbation for maximum efficiency in recovering all of the sludge.

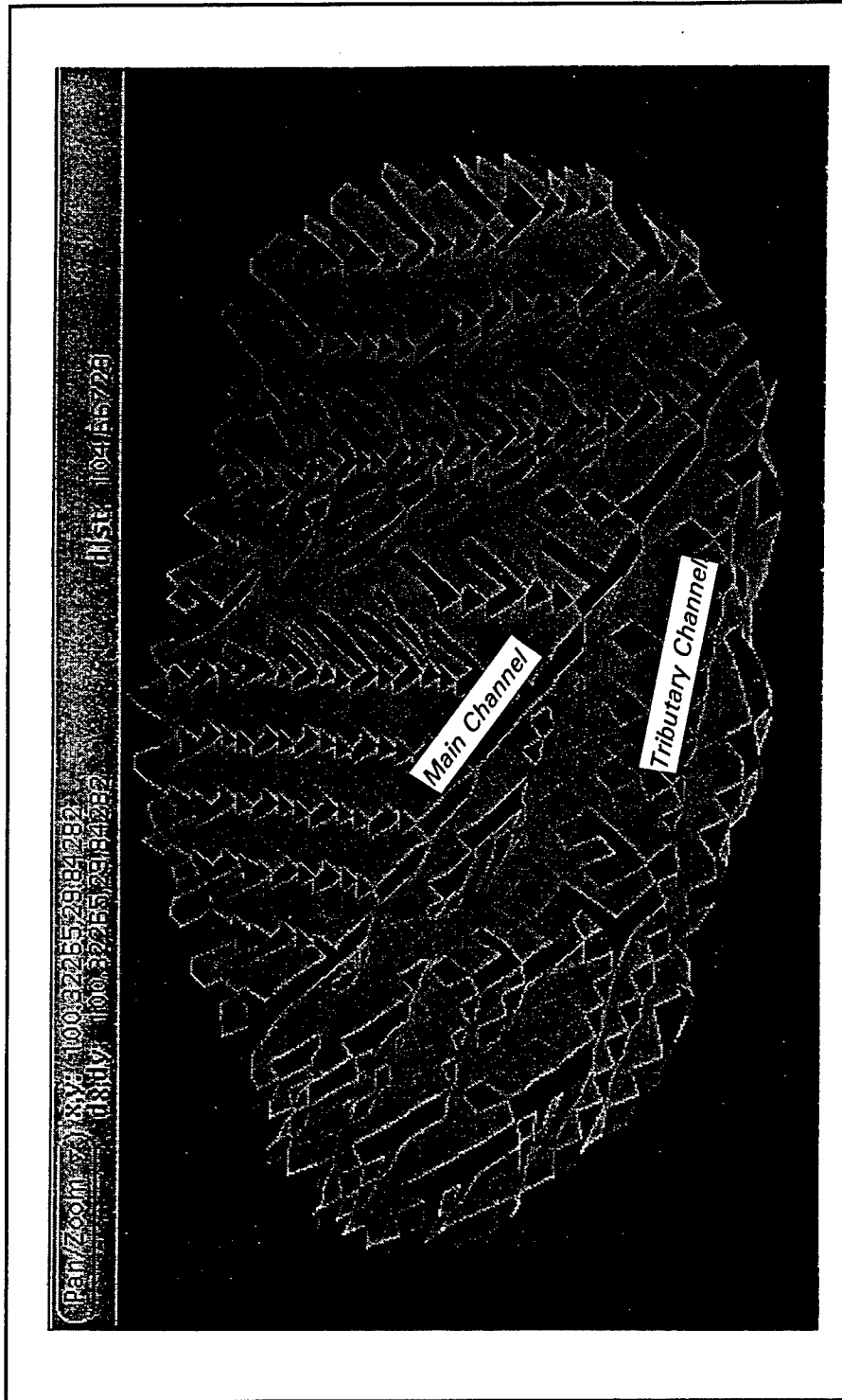

Figure 13. Slope-Area simulation of erosion network development

Simulation of Sludge Erosion

WEPP model

Simulation of the actual erosion of waste sludge as a function of variability in "precipitation," sludge conditions, and surface geometry requires the use of a robust model. The model should be mechanistic, simulating the actual detachment, transport, and storage processes that are involved in the development of the erosional system in the tanks. The state-of-the-art model that meets these requirements is the WEPP model (Appendix D).

The product of 10 years of research by a large team of erosion specialists around the globe, the WEPP family of models is a process-based system of many computational procedures for simulating the complex processes of soil erosion. The WEPP model was designed by researchers in the U.S. Department of Agriculture Research Service to replace the empirically based Revised Universal Soil Loss Equation (RUSLE), and its predecessor, the Universal Soil Loss Equation (USLE), used for 30 years to identify and manage soil erosion.

The WEPP model was chosen to simulate sludge erosion because it is capable of simulating actual processes as a product of actual events acting on actual conditions. Additionally, the WEPP model produces output in the form of the amount and location of soil loss (sludge recovered) over time produced by a specific precipitation event. WEPP computes surface runoff as a function of precipitation and soil conditions and the subsequent detachment, transport, and deposition of sediment across the hillslope and delivered to the channel. The watershed version of WEPP computes the erosion, transport, temporary storage, and delivery (at the system outlet) of sediment.

WEPP is a system of models for computing all of the aspects of the soil erosion processes. These models include hydrology, climate, soil moisture, and plant growth. To produce detailed results using WEPP, detailed data input is required. Much of the data for agricultural applications come from the results of field measurements of conditions and processes and the development of WEPP data bases of relevant data. For instance, critical soil input for many of the soils of the United States has been archived for use in WEPP. Data on climate, hydrology, and plant management have also been archived for use in WEPP. An introductory description of the WEPP model is given in Appendix E. Users of WEPP may obtain the user manual and software from the National Soil Erosion Laboratory in West Lafayette, IN. The software may also be downloaded from the WEPP web site at <http://soils.ecn.purdue.edu:20002/~wepp/nserl.html>.

Results of sludge erosion modeling

Data inputs required to run the WEPP model for the sludge in SRS tanks include data on surface slope, soil, rainfall, and climate. Surface slope variables include orientation, length, gradient, shape, and size. These data were taken from conditions in a type IV SRS waste tank with surface gradients

defined by a single pump located in the riser opening near the edge of the tank. Model runs were conducted using several different pump intake elevations to change the gradient of the erosion system.

Soil data input consisted of texture, porosity, initial saturation, baseline erodibility, critical shear parameter, cation exchange capacity, and effective hydraulic conductivity (the Green and Ampt parameter, K_e). Since most of these data are not known for the sludge, an inorganic clay soil (for which these data are provided in the WEPP data archive) was substituted. Precipitation inputs included the amount (94 and 161 mm), duration (60, 180, and 360 min), intensity distribution (various), and areal distribution (evenly distributed over whole surface) of the various precipitation events modeled. The model also required the input of the tank climate, including temperature (20 °C), wind (none), and solar radiation (none).

Output from the WEPP model includes tables of the temporal distribution of rainfall and runoff and the total rainfall and infiltration volumes. Hydrologic output include the runoff volume, peak runoff rate, effective runoff duration, and effective surface length of runoff. Soil erosion output consists of the area of soil erosion (on the hillslope overland flow profile), mean soil erosion, maximum soil erosion, maximum and minimum soil loss locations, and soil loss and deposition along surface profiles.

The results of two runs of the WEPP model on a type IV tank are provided in Appendix F for information and example. The input variables for these two runs were the most effective in moving sludge to the pump intake. In the first example, 93.77 mm of rain was applied over 72.6 min with a peak intensity of 122.97 mm/hr. Total runoff for the event was 92.03 mm (98.14 percent of rain) with a peak runoff rate of 122.22 mm/hr. The mean soil loss over the entire sludge surface was 7.970 kg/m², with a maximum erosion of 29.798 kg/m² occurring near the outlet. The mean soil/water concentration was 0.085 kg/liter.

In the second example, the same inputs were used with the exception of the amount, intensity, and duration of rain, which were 160.77 mm, 49.99 mm/hr, and 360 min, respectively. Total runoff for the second event was 157.04 mm (97.68 percent of rain) with a peak runoff rate of 49.69 mm/hr. The mean soil loss over the entire sludge surface was 9.439 kg/m², with a maximum erosion of 55.128 kg/m² occurring near the outlet. The mean soil/water concentration for the second example was 0.059 kg/liter.

Comparison of these two simulations reveals that the first example, a shorter-duration and higher-intensity rainfall event, was the most effective. In terms of soil delivery (sludge recovery), the shorter event was 44 percent more effective than the longer less intense event. There are several probable reasons for the shorter event being the most effective. Obviously, the mean kinetic energy application rate of raindrop impact was greater for the shorter event due to the higher rainfall intensity. The mean shear stress rate of overland flow was also probably greater for the shorter event due to higher overland flow velocities. During the longer second event, the erosion system may have

reached the condition of minimum energy expenditure and a lower efficiency for detaching and transporting soil.

5 Summary and Recommendations

Summary

The preliminary assessment of the potential applicability of soil erosion methods for recovery of waste sludge from storage tanks at SRS indicates that the processes of detachment, transport, and deposition in the development of an erosion system can be effective in the recovery of waste sludge. The natural internal order of erosion networks provide a system that is predictable, efficient, and quickly responsive to artificial control. Implementation of soil erosion methods for waste recovery can also be relatively inexpensive, consisting primarily of fluid application devices and an outlet pump.

Numerical simulation of erosion systems using a simple Slope-Area model developed from natural drainage networks indicates that an erosion system developed in the sludge deposits of an SRS type IV tank will reach the condition of minimum energy expenditure and will require perturbation to maximize efficiency. Modeling of sludge erosion/recovery using the WEPP system of models indicates that soil erosion methods could be an efficient way to recover sludge.

This assessment identified a number of key questions regarding the implementation of soil erosion methods for recovery of waste sludge. Some of these questions could be addressed by numerical simulation. Many of the questions are beyond the reasonable effort of numerical simulation and require investigation by physical (scale) testing.

Recommendations

Soil erosion methods offer substantial promise for recovery of waste sludge at SRS. However, prior to possible implementation of the technology, a number of key questions remain to be assessed. It is recommended that a program of physical testing of soil erosion methods for sludge recovery be conducted. Physical testing will not only provide answers to the key questions, the solutions will be visible. Physical testing will also discover and solve unforeseen

problems of implementation as well as demonstrating the feasibility of the technology. Additionally, the scale model will be invaluable in developing and testing the details of the erosion system design.

A "Study Plan" for the physical modeling of soil erosion methods in SRS tanks is presented in Appendix G. The plan consists of eight sequential tasks for the modeling of sludge recovery in all four types of tanks at SRS and is designed to address all of the key questions identified in this assessment.

References

- André, J. E., and Anderson, H. W. (1961). "Variation of soil erodibility with geology, geographic zone, elevation and vegetation type in northern California wildlands," *J. Geophys. Res* 66, 3351-8.
- Bouyoucos, G. J. (1935). "The clay ratio as a criterion of susceptibility of soils to erosion," *J. Am. Soc. Agron.* 27, 738-41.
- Carson, M. A. (1971). *The mechanics of erosion*. Pion, London.
- Chorley, R. J. (1959). "The geomorphic significance of some Oxford soils," *Am. J. Sci* 257, 503-15.
- Flanagan, D. C., and Livingston, S. J. (eds.). (1995). "USDA-water erosion prediction project," NSERL Report No. 11, National Soil Erosion Research Laboratory, West Lafayette, IN.
- Foster, G. R., and Meyer, L. D. (1975). "Mathematical simulation of upland erosion by fundamental erosion mechanics." *Present and prospective technology for predicting sediment yields and sources*. USDA Agr. Res. Serv. Pub. ARS-S-40, 190-207.
- Glock, W. S. (1931). "The development of drainage systems: a synoptic view," *Geographical Review* 21, 475-2.
- Gregory, K. J., and Walling, D. E. (1973). *Drainage basin form and process*. Halsted. New York, NY.
- Hamm, B. A. (1984). *High level rheological studies of Tanks 15H, 42H, and 8F sludge/slurries*, DPST-84-439. Savannah River Plant, Aiken, SC.
- Hénin, S. G., Monnier, G., and Combeau, A. (1958). "Méthode pour l'étude de la stabilité structural des sols," *Ann. Agron.* 9, 73-92.
- Hjulström, F. (1935). "Studies of the morphological activity of rivers as illustrated by the Rive Fyries," *Bull. Geol. Inst. Univ. Uppsala* 25, 221-527.

- Horton, R. E. (1945). "Erosional development of streams and their drainage basins: a hydrophysical approach to quantitative morphology," *Bull. Geol. Soc. Am.* 56, 275-370.
- Howard, A. D. (1967). "Drainage analysis in geologic interpretation: a summation," *Bulletin of the American Association of Petroleum Geologists*, 51, 2246-59.
- Ijjász-Vásquez, E. J., Bras, R. L., Rodriguez-Iturbe, I., Rigon, R., and Rinaldo, A. (1993). "Are river basins optimal channel networks?" *Advances in Water Resources* 16, 69-79.
- Kirkby, A. V. T., and Kirkby, M. J. (1974). "Surface wash at the semi-arid break in slope," *Z. f. Geomorph. Suppl.* 21, 151-76.
- Leopold, L. B., Wolman, M. G., and Miller, J. P. (1964). *Fluvial processes in geomorphology*, Freeman. San Francisco.
- Lugo-Lopez, M. A. (1969). "Prediction of the erosiveness of Puerto Rican soils on a basis of the percentage of particles of silt and clay when aggregated," *J. Agric. Univ. Puerto Rico* 53, 187-90.
- Meyer, L. D. (1986). "Erosion processes and sediment properties for agricultural cropland." *Hillslope Processes*. Abrahams, A. D. ed., Allen & Unwin, London & Sydney.
- Meyer, L. D., and Monke, E. J. (1965). "Mechanics of soil erosion by rainfall and overland flow," *Transactions of the American Society of Agricultural Engineers* 8, 572-577, 580.
- Middleton, H. E. (1930). "Properties of soils which influence soil erosion," USDA Tech. Bull. 178.
- Morgan, R. P. C. (1986). *Soil erosion and conservation*. Davidson, D. A. ed., Longman Scientific & Technical.
- Mosley, M. P. (1972). "Rainsplash and the convexity of badland divides," *Z. f. Geomorph. Suppl.* 18, 10-25.
- Motyka, T. (1984). *Technical data summary for in-tank sludge processing*. DSPT-84-100. Savannah River Plant, Aiken, SC.
- Parker, R. S. (1976). "Experimental study of drainage system evolution," unpublished report, Colorado State University.
- _____. (1977). "Experimental study of drainage basin evolution and its hydrologic implications," Hydrology Paper 90, Colorado State University.
- Pettersen, S. (1958). *Introduction to meteorology*, McGraw-Hill, New York.

- Ramsower, D. C. (1996). *Sluicing nozzle test report, volume 1*. WHC-SD-WM-TD-013, Rev.0. Westinghouse Hanford Company, Richland, WA.
- Rigon, R., Rinaldo, A., Rodríguez-Iturbe, I., Bras, R. L., and Ijjász-Vásquez, E. (1993). "Optimal channel networks: a framework for the study of river basin morphology," *Water Resources Research* 29(6), 1635-46.
- Skidmore, E. L., Fisher, P. S., and Woodruff, N. P. (1970). "Wind erosion equation: computer solution and application," *Soil Science Society of America Proceedings* 34, 931-935.
- Smith, L. M. (1993). "Investigation of ephemeral gullies in loessial soils in Mississippi," Technical Report GL-93-11, U.S. Army Engineer Waterways Experiment Station, Vicksburg, MS.
- Statham, I. (1977). *Earth surface sediment transport*. Clarendon Press. Oxford.
- Stone, J. A., Kelley, J. A., and McMillan, T. S. (1976). *Sampling and analysis of SRP high-level waste sludges*. DP-1399. E. I. DuPont de Nemours and Co., Savannah River Laboratory, Aiken, SC.
- Sundborg, A. (1956). "The River Klaralven. A study of fluvial processes." *Geografiska Annaler* 38, 127-316.
- Tarboton, D. G., Bras, R. L., Rodríguez-Iturbe, I. (1989). "Scaling and elevation in river networks," *Water Resources Research* 25(9), 2037-51.
- Willis, J. C. (1971). "Erosion by concentrated flow," *ARS* 41-179.
- Wischmeier, W. H., and Smith, D. D. (1965). "Predicting rainfall-erosion losses from cropland east of the Rocky Mountains," *USDA Agricultural Handbook* 282.
- Zimpfer, G. L. (1982). "*Hydrology and geomorphology of an experimental drainage basin*," unpublished Ph.D. diss., Colorado State University.

Appendix A

Scope of Work

From: <james.brooke@srs.gov>
To: GL.GLM(marcusw)
Date: 5/6/96 7:44am
Subject: can you or your guys help?

Date: Fri, 03 May 1996 15:35 -0400 (EDT)
From: James_Brooke@SRCCA01
Subject: can you or your guys help?
To: marcuw%exl.wes.army.mil@internet
MIME-version: 1.0
Content-type: MULTIPART/MIXED; BOUNDARY="Boundary (ID /tznUOjFYi7ZQOzYL/Y8ag) "

--Boundary (ID /tznUOjFYi7ZQOzYL/Y8ag)
Content-type: text/plain

Forward Header

Subject: can you or your guys help?
Author: James Brooke at SRCCA01
Date: 5/3/96 3:35 PM

I attach a Statement of Work that I am trying to turn into a procurement action. I hope that someone at your outfit would be good at this subject and would be able to work on it. Please give me some feedback. My e-mail is: james.brooke@srs.gov
My phone is: 803-725-2963

--Boundary (ID /tznUOjFYi7ZQOzYL/Y8ag)
Content-type: text/plain

STATEMENT OF WORK FOR ASSESSMENT OF SOIL EROSION METHODS FOR RECOVERY
OF SETTLED SLUDGE
REVISION # 0
MAY 1, 1996

1.0 SCOPE:

The effort of this contract shall be to perform an assessment of using soil erosion methods to recover settled sludge type nuclear waste from the waste tanks at DOE's Savannah River Site. A formal report and presentation shall be given to SRS management appraising the results of the assessment and fully describing the potential erosion methods.

1.1 Background:

The first step in processing High Level Waste is recovering the waste

from storage tanks. There are three waste forms, insoluble solids, crystallized salt, and matrix salt solution. In general the insoluble solid waste is stored in separate tanks from the crystallized salt. The insoluble solid waste is called sludge and the crystallized salt is called salt cake. The sludge is fully settled and is usually covered with a layer of salt solution called supernate.

The present process for recovery of settled sludge consists of the following steps:

1. install four slurry pumps for stirring and one transfer pump in the tank
2. transfer the supernate from the tank
3. add inhibited water to the designated level in the tank
4. stir the liquid with the slurry pumps to resuspend the sludge as a more dilute slurry
5. stop mixing and transfer the resuspended slurry from the tank
6. repeat steps 3-5 until all the settled sludge is recovered from the tank

1.2 Proposed Assessment:

The assessment is expected to combine SRS site visit(s) with work in the vendor's office. The site visit(s) is to collect and review data, and to gain an overall understanding of the existing sludge recovery process and the status of process improvement work. The assessment of using soil erosion methods to recover sludge will be done in the vendor's office, interacting with SRS personnel as necessary. The report shall fully describe the potential erosion methods recommended for use. The description shall include a comparison of the erosion method(s) proposed versus the present process. A presentation to SRS management will conclude the assessment.

2.0 REFERENCE DOCUMENTS:

None

3.0 WORK REQUIREMENTS:

3.1 Technical Requirements:

The subcontractor shall perform a preliminary assessment of soil erosion methods for recovery of settled sludge consisting of the following four components:

- 3.1.1 Site familiarization and data collection to support the assessment.
- 3.1.2 Perform the assessment by identifying possible erosion methods, model the possible methods (if practicable), prepare draft descriptions of the possible methods, and obtain preliminary review and comment from SRS personnel to verify practicability of the methods.
- 3.1.3 Prepare a final report including the modeling and comparison results.

3.1.4 Presentation to SRS management of the assessment with appraisal of probability of success of the possible methods.

3.2 WSRC Furnished Materials:

WSRC shall provide data on equipment, waste composition, and known options for using soil erosion methods.

3.3 Period of Performance/Schedule:

The period of performance shall begin upon contract award. Deliverables shall conform to the following maximum schedule:

Completed Study Plan	< 2 weeks after contract award
Complete Data Gathering	< 1 month after study plan approval
Complete Evaluation	< 2 months after study plan approval
Issue Final Report	< 1 month after evaluation completion
Presentation to WSRC	< 2 weeks after report issuance

SOW for Assessment of Hydrological Methods

5/3/96

Page 2 of 2

3.4 Personnel Qualifications/Certification:

The persons performing and interpreting the study shall have formal training and demonstrated experience in the technique and art of the work.

3.5 Deliverables:

In addition to the final report and presentation, the Subcontractor shall provide to WSRC a record of the calculations performed. The record shall be adequate such that the calculations can be checked by others experienced with the plant and processes. The checking will ensure that the conclusions reached have a valid basis. Finally, the subcontractor shall provide references and a summary description of the methodology used in the evaluation such that an experienced process engineer can understand and follow the report.

4.0 ACCEPTANCE OF SERVICES:

WSRC Subcontractor Technical Representative shall monitor all work performed by the subcontractor and ensure compliance with this statement of work.

5.0 ATTACHMENTS:

None

NB: no vendors identified at present
perhaps start with Corps of Engineers, Waterways Experiment
Station
or Bureau of Land Management
or US Geological Survey
or US Dept of Agriculture

--Boundary (ID /tznUOjFYi7ZQOzYL/Y8ag)--

Appendix B Monthly Progress Reports



REPLY TO
ATTENTION OF

DEPARTMENT OF THE ARMY
WATERWAYS EXPERIMENT STATION, CORPS OF ENGINEERS
3909 HALLS FERRY ROAD
VICKSBURG, MISSISSIPPI 39180-6199

CEWES-GG

6 August 1996

MEMORANDUM FOR Commander, U.S. Army Engineer District, Charleston,
ATTN: CESAC-SR (Mr. Mickey Evans), P.O. Box 100, Jackson,
SC 29831-0100

SUBJECT: Initial Progress Report, Soil Erosion Methods for Sludge Recovery, Savannah River Site (SRS)

1. **Background.** The subject investigation was initiated on 1 July 1996 following receipt on 27 June 1996 of Military Interdepartmental Purchase Request (MIPR) number CESAC-RM-96-52 in the amount of \$46,020.00. The purpose of the investigation is to conceptually evaluate various soil erosion processes for application to the removal of sludge in waste tanks at SRS. The product of the investigation will be a computerized numerical simulation of soil erosion processes applied to present conditions in several sludge holding tanks at SRS and an evaluation of the efficiency of these processes for sludge removal. In discussions among you, Dr. Lawson Smith (project investigator, U.S. Army Engineer Waterways Experiment Station (WES)), and Dr. James Brooke (Westinghouse, SRCCA) prior to the initiation of the project, the following tasks and schedule were established:

- a. Initiation of project - 1 July 1996.
- b. Completion of Study Plan - 15 July 1996.
- c. Completion of data collection - 12 August 1996.
- d. Completion of evaluation of methods - 13 September 1996.
- e. Completion of Final Report - 11 October 1996.
- f. Presentation of results at SRS - 22 October 1996.

This memorandum constitutes the first monthly status report for the project. The monthly reports will continue to be submitted to you for distribution to the appropriate individuals and offices at SRS, including Mr. Brent Gutierrez (Department of Energy (DOE), AMHS&TS-EAD), Mr. Tom Gutman (DOE, AMHLW), and Dr. Brooke. Additional status reports will be submitted on 1 September and 1 October 1996.

HYDRAULICS
LABORATORY

GEOTECHNICAL
LABORATORY

STRUCTURES
LABORATORY

ENVIRONMENTAL
LABORATORY

COASTAL ENGINEERING
RESEARCH CENTER

INFORMATION
TECHNOLOGY LABORATORY

CEWES-GG

SUBJECT: Initial Progress Report, Soil Erosion Methods for Sludge Recovery, Savannah River Site (SRS)

2. **Status.** The project began with the development of a study plan for a two-phased project (encl 1). The initial phase involves the conceptual evaluation of soil erosion methods for sludge recovery authorized and funded by the MIPR of 27 June 1996. The second phase, contingent upon the outcome of phase one, acceptance by the appropriate offices, and the availability of funding, describes the activities involved in the physical (scaled) modeling of soil erosion methods for sludge recovery. The study plan was presented to you and Dr. Brooke during Dr. Smith's visit to SRS, 9-11 July 1996, described in the following paragraph.

3. The objectives of Dr. Smith's visit were primarily to establish points of contact at SRS for various issues of the project, gather relevant data, become familiar with the many aspects of the problem of sludge recovery, and discuss various potentially useful ideas with Dr. Brooke. All of the objectives of the visit were successfully achieved. Through Dr. Brooke's arrangements, discussions with a number of knowledgeable engineers and scientists at SRS produced a substantial amount of valuable information about the overall problem of sludge recovery, characteristics of the sludge and the storage tanks, and the logistics of relevant storage tank operations. Your coordination of Dr. Smith's visit through assistance with various clearances and other details played a significant role in the success of his visit.

4. Upon returning from SRS, the focus of the project turned to the evaluation of the data and information obtained at SRS and the review of numerical models of soil erosion which may be applicable to the problem of sludge recovery. Although it is apparent that much is known about the chemical characteristics of the sludge, somewhat less is understood about its physical attributes with respect to its "soil-like" properties (Atterberg limits, shear strength, permeability). However, most of the physical properties which would be used in modeling erosion of the sludge are known or can be reasonably estimated.

5. The goals of the project require the use of an erosion simulation process that models both the development and growth of channels as well as the lowering of elevation as a function of precipitation. These two processes are typically simulated by two separate models. Efforts are now being focused on the evaluation of several models which simulate both processes separately but simultaneously and which can be modified to produce graphical and volumetric output.

6. Activities during the month of August will center around the testing of erosion models for applicability to SRS sludge tanks of various configurations. Simulation will begin with a tank configuration with no internal plumbing and evolve to more complex tank conditions.

CEWES-GG

SUBJECT: Initial Progress Report, Soil Erosion Methods for Sludge Recovery, Savannah River Site (SRS)

7. The next project deadline is 12 August - completion of data collection. We consider this task effectively complete at this time. No additional trips to SRS are anticipated before the presentation of results on 22 October and all available data sources have been examined.

8. Please contact Dr. Smith at (601) 634-2497 (voice), (601) 634-3153 (Fax), or E-mail at smithl@ex1.wes.army.mil with questions and/or comments.

FOR THE DIRECTOR:



W. F. MARCUSON III
Director, Geotechnical Laboratory

Encl

SOIL EROSION METHODS FOR SLUDGE REMOVAL, SRS STUDY PLAN

Phase One: Conceptual Evaluation and Development

1.1. Study Plan

1.2. Data Collection

1.2.1. SRS initial visit, project coordination

1.2.2. Specifics of all relevant tanks (drawings)

1.2.3. Tank interior environment

1.2.4. Physical and chemical properties of sludge

1.2.5. Logistics and requirements of sludge removal

1.2.6. Other relevant information

1.3. Evaluation of Potentially Applicable Erosion Models and Methods

1.3.1. Review and evaluation of empirical models of erosion

1.3.2. Review and evaluation of mechanistic models of erosion

1.3.3. Evaluation of erosion (water application) methods

1.4. Development of Numerical Model of Sludge Erosion

1.4.1. Selection of appropriate soil erosion model

1.4.2. Compilation of computer code for model

1.4.3. Computer simulation of sludge removal

1.4.4. Sensitivity analysis of simulations

1.5. Completion of Report

1.5.1. Documentation of purpose, methods, data, and results

1.5.2. Recommendations to SRS

1.5.3. Review and revision of report

- 1.6. Presentation of Results of Concept Study to SRS
 - 1.6.1. Preparation of briefing materials (graphics)
 - 1.6.2. Presentation at SRS
 - 1.6.3. Discussion of recommendations

Phase Two (If Required): Physical (Scale) Modeling of Sludge Removal

- 2.1. Development of Detailed Physical Modeling Plan
 - 2.1.1. Determination of water application methods
 - 2.1.2. Determination of variables and constants
 - 2.1.3. Development of modeling process and schedule
- 2.2. Selection of Model Scale and Design of Model
 - 2.2.1. Selection of scale (1/10th or suggested numerically?)
 - 2.2.2. Analysis of scaling factors
 - 2.2.3. Design of water application methods
 - 2.2.4. Design of tank and removal system
 - 2.2.5. Design of sludge
 - 2.2.6. Design of environmental control system
 - 2.2.7. Design of data acquisition system
 - 2.2.8. Acquisition of materials and equipment
- 2.3. Construction of Model
 - 2.3.1. Selection of model site
 - 2.3.2. Fabrication of tank and removal system
 - 2.3.3. Fabrication of water application methods
 - 2.3.4. Preparation of sludge
 - 2.3.5. Development of environmental control system

- 2.3.6. Development of data acquisition system
- 2.4. Model Calibration
 - 2.4.1. Calibration of sludge
 - 2.4.2. Calibration of water application system
 - 2.4.3. Calibration of sludge removal system
 - 2.4.4. Calibration of environmental control system
 - 2.4.5. Calibration of data acquisition system
- 2.5. Model Runs
- 2.6. Evaluation of Model Results
 - 2.6.1. Analysis of data from model runs
 - 2.6.2. Comparison of numerical and physical model results
- 2.7. Development of Recommendations for Implementation at SRS
 - 2.7.1. SRS engineers and scientists review model at WES
 - 2.7.2. Consultation with SRS on implementation design
- 2.8. Completion of Report to SRS
 - 2.8.1. Documentation of all phases of project
 - 2.8.2. Documentation of data, methods, and results
 - 2.8.3. Conclusions and recommendations
 - 2.8.4. Final presentation to SRS

MEMORANDUM FOR Commander, U.S. Army Engineer District, Charleston,
ATTN: CESAC-SR (Mr. Mickey Evans), P.O. Box 100, Jackson,
SC 29831-0100

SUBJECT: Progress Report, Soil Erosion Methods for Sludge Recovery, Savannah River Site (SRS)

1. The subject investigation is progressing on schedule as outlined in the initial progress report of 6 August 1996. During the month of August, efforts were focused on the evaluation of potentially applicable erosion models and simulation methods. In the study plan, empirical approaches to soil erosion were to be evaluated for application to sludge recovery followed by the evaluation of mechanistic models. After review of several empirical methods (such as the Universal Soil Loss Equation and the Revised Universal Soil Loss Equation), it was determined that no known empirical method would provide the type of data required to evaluate soil erosion processes. These data include the efficiency of developing a drainage network of erosional channels in the sludge for recovery by a pump at the outfall of the drainage network. Sludge recovery will be compared to variations in precipitation by sprinklers in the tanks. Consequently, most of the soil erosion model evaluation effort has focused on mechanistic models of drainage network development due to soil erosion.

2. Mechanistic models of soil erosion are based primarily on the numerical expression of physical and chemical processes and conditions. The principle conditions to be stated numerically include the physical and chemical properties of the sludge which influence its erodibility by rainsplash and fluid shear; the energy of rainsplash and subsequent fluid shear from water applied by the sprinklers; and geometric properties of the sludge in the tank, including surface area and slope. A number of sophisticated mechanistic models have been developed that simulate the development of erosional channels in a drainage network as a function of the variables listed above. Whereas these models represent state-of-the-art in erosion modeling, they are all still research models which require a significant amount of tuning for application to the problem of sludge recovery.

3. A type of mechanistic model which will be useful in evaluating soil erosion for sludge recovery at SRS is the "slope-area" model. Slope-area models are relatively uncomplicated numerical procedures which produce "optimum channel networks" based on the principle of "minimal energy expenditure" and the scaling relationships between slopes and areas. A slope-area model recently developed at the Massachusetts Institute of Technology was selected and is being programmed for use in simulating sludge recovery. This procedure will produce diagrams illustrating volumes of sludge eroded (and recovered) over time.

CMS SMITH/jcb/249

CEWES-GG

29 August 1996

SUBJECT: Progress Report, Soil Erosion Methods for Sludge Recovery, Savannah River Site (SRS)

4. Also during August, the feasibility of physically (scale) modeling the efficiency of sludge recovery by soil erosion has been examined. Dr. Smith met with a number of specialists at WES in scale model development to determine the specific methods, procedures, and requirements for modeling the recovery of sludge in three tanks (8F, 15H, and 18F) at SRS. The results of this examination will be submitted as a Scope of Work (with time and cost estimate) within the next several days.

5. Activities planned for September include completion of sludge erosion simulation and preparation and submittal of a draft report.

6. Please contact Dr. Smith at (601) 634-2497 (voice), (601) 634-3153 (Fax), or E-mail at smithl@ex1.wes.army.mil with questions and/or comments.

FOR THE DIRECTOR:

o/s/b

W. F. MARCUSON III
Director, Geotechnical Laboratory

AGL
FRANKLIN

0159
Bank



REPLY TO
ATTENTION OF

DEPARTMENT OF THE ARMY
WATERWAYS EXPERIMENT STATION, CORPS OF ENGINEERS
3909 HALLS FERRY ROAD
VICKSBURG, MISSISSIPPI 39180-6199

CEWES-GG

4 October 1996

MEMORANDUM FOR Commander, U.S. Army Engineer District, Charleston,
ATTN: CESAC-SR (Mr. Mickey Evans), P.O. Box 100, Jackson,
SC 29831-0100

SUBJECT: Progress Report, Soil Erosion Methods for Sludge Recovery, Savannah River Site
(SRS)

1. During the month of September, several important accomplishments were achieved in the subject investigation. The principle focus of research efforts was the evaluation of erosion methods for sludge recovery through the use of a numerical model. A second activity included refinement of a draft scope of work for the physical (scale) modeling of erosion methods for sludge recovery. In addition to these efforts, preparation of a draft report was initiated. These activities are discussed below.
2. As stated in the August progress report, several mechanistic numerical models are being used to evaluate soil erosion methods for use in SRS sludge tanks. Mechanistic models are numerical expressions of the mechanical processes of soil erosion (detachment and rainsplash), transport, and deposition. A relatively simple "slope-area" model was used initially to determine the fundamental requirements of the sludge erosion/recovery modeling effort. This model (set up for conditions in Tank 18) provided basic information on the pattern and efficiency of sludge erosion with changing pump intake elevation. Most of the evaluation process has been accomplished using a second soil erosion model, the Water Erosion Prediction Project (WEPP) model developed by the USDA Agricultural Research Service (ARS). WEPP is actually a system of interconnected models that simulates the complete erosion, transport, and deposition continuum for very specific soil (in this case sludge), land surface, and hydrologic conditions. The WEPP model is sufficiently complex to allow the evaluation of differences in water application, sludge conditions, and pump intake elevation with respect to the efficiency of the soil erosion process for sludge recovery. Sludge recovery modeling using the WEPP model is ongoing and should be complete by 7 October.
3. A draft study plan for physical modeling of sludge recovery was refined during the month of September (encl 1) at the request of Dr. James Brooke, SRS. A significant effort was given to identification of the specific methods and requirements of the proposed physical modeling investigation. We believe that physical modeling of the sludge recovery process by soil erosion would be a highly beneficial step in the design of an efficient and cost effective sludge recovery process. The study plan is formally submitted for consideration at this time.

HYDRAULICS
LABORATORY

GEOTECHNICAL
LABORATORY

STRUCTURES
LABORATORY

ENVIRONMENTAL
LABORATORY

COASTAL ENGINEERING
RESEARCH CENTER

INFORMATION
TECHNOLOGY LABORATORY

CEWES-GG

SUBJECT: Progress Report, Soil Erosion Methods for Sludge Recovery, Savannah River Site (SRS)

4. Preparation of the draft report was also initiated in September. The date for submission of the report stated in the study plan is 11 October. At this time, we plan to submit a draft final report by 11 October. An outline of the report is enclosed (encl 2).

5. Activities planned for October include the completion and submission of the project report and presentation of results to appropriate staff at SRS. The original date for the SRS presentation was scheduled as 22 October. If this date is not practical, please contact Dr. Lawson Smith at (601)634-2497 (voice), (601)634-3153 (FAX) or E-mail at smithl@ex1.wes.army.mil.

FOR THE DIRECTOR:



W. F. MARCUSON III
Director, Geotechnical Laboratory

2 Encls

Appendix C Study Plan

SOIL EROSION METHODS FOR SLUDGE REMOVAL, SRS STUDY PLAN

Phase One: Conceptual Evaluation and Development

- 1.1. Study Plan
- 1.2. Data Collection
 - 1.2.1. SRS initial visit, project coordination
 - 1.2.2. Specifics of all relevant tanks (drawings)
 - 1.2.3. Tank interior environment
 - 1.2.4. Physical and chemical properties of sludge
 - 1.2.5. Logistics and requirements of sludge removal
 - 1.2.6. Other relevant information
- 1.3. Evaluation of Potentially Applicable Erosion Models and Methods
 - 1.3.1. Review and evaluation of empirical models of erosion
 - 1.3.2. Review and evaluation of mechanistic models of erosion
 - 1.3.3. Evaluation of erosion (water application) methods
- 1.4. Development of Numerical Model of Sludge Erosion
 - 1.4.1. Selection of appropriate soil erosion model
 - 1.4.2. Compilation of computer code for model
 - 1.4.3. Computer simulation of sludge removal
 - 1.4.4. Sensitivity analysis of simulations
- 1.5. Completion of Report
 - 1.5.1. Documentation of purpose, methods, data, and results
 - 1.5.2. Recommendations to SRS
 - 1.5.3. Review and revision of report

1.6. Presentation of Results of Concept Study to SRS

1.6.1. Preparation of briefing materials (graphics)

1.6.2. Presentation at SRS

1.6.3. Discussion of recommendations

Phase Two (If Required): Physical (Scale) Modeling of Sludge Removal

2.1. Development of Detailed Physical Modeling Plan

2.1.1. Determination of water application methods

2.1.2. Determination of variables and constants

2.1.3. Development of modeling process and schedule

2.2. Selection of Model Scale and Design of Model

2.2.1. Selection of scale (1/10th or suggested numerically?)

2.2.2. Analysis of scaling factors

2.2.3. Design of water application methods

2.2.4. Design of tank and removal system

2.2.5. Design of sludge

2.2.6. Design of environmental control system

2.2.7. Design of data acquisition system

2.2.8. Acquisition of materials and equipment

2.3. Construction of Model

2.3.1. Selection of model site

2.3.2. Fabrication of tank and removal system

2.3.3. Fabrication of water application methods

2.3.4. Preparation of sludge

2.3.5. Development of environmental control system

- 2.3.6. Development of data acquisition system
- 2.4. Model Calibration
 - 2.4.1. Calibration of sludge
 - 2.4.2. Calibration of water application system
 - 2.4.3. Calibration of sludge removal system
 - 2.4.4. Calibration of environmental control system
 - 2.4.5. Calibration of data acquisition system
- 2.5. Model Runs
- 2.6. Evaluation of Model Results
 - 2.6.1. Analysis of data from model runs
 - 2.6.2. Comparison of numerical and physical model results
- 2.7. Development of Recommendations for Implementation at SRS
 - 2.7.1. SRS engineers and scientists review model at WES
 - 2.7.2. Consultation with SRS on implementation design
- 2.8. Completion of Report to SRS
 - 2.8.1. Documentation of all phases of project
 - 2.8.2. Documentation of data, methods, and results
 - 2.8.3. Conclusions and recommendations
 - 2.8.4. Final presentation to SRS

Appendix D

Slope-Area Model

From: Jeff Niemann <niemann@MIT.EDU>
To: GL.GLM(SMITHL)
Date: 9/4/96 2:29pm
Subject: Slope-Area Model

Dear Lawson,

I am one of Rafael Bras's graduate students. He mentioned to me that you are interested in the Slope-Area model. So following this email message, I am sending two messages to you. The first is the Slope-Area model code, and the second is the text file that it reads as input (must be named "sa.in").

The code is pretty straight forward. It is in FORTRAN and relatively well commented (I hope). I am the author of the code, so if you have any specific questions about it, let me know and I will do my best to answer them.

The maximum size of the simulation domain is 500x500. Reasonable parameters are shown in the input file. To change the values of these parameters in the model, just change the values in this file. Notice that the blank spaces up to the column of numbers are required. Here is another example input file just to show how to make some variations. This file reads in a file (elev.dat) which contains the initial elevations. It also establishes two outlets in opposite corners.

```
Number of rows (iwid):          50
Number of columns (jwid):      50
Pixel dimension (pix):         1.0
Initial elevation (zinit):     0.0
Elevations from file (1=yes, elevflag; elevfile): 1
                                                elev.dat
Use specified seed (1=yes, seedflag; iseed): 0
Number of outlets (numout; locout(row col)): 2
                                                1,1
                                                50,50
Coef of slope-area relation (ubeta): 1.00
Expon of slope-area relation (theta): 0.50
Iterations between output (itermark): 20
```

The input file which accompanies this message (my third message) generates a flat surface with random perturbations as an initial condition (it does not require any input data except sa.in).

Output from the model is in the form of two text files: elev.dat and area.dat. The elev.dat contains a matrix of elevation values for the pixels in the domain. The area.dat contains the contributing areas for all the pixels in the domain. A good way to look at the output is to plot (with the graphics package of your choice) elev.dat as a surface shaded according to log(area.dat). This will show you the surface with coloring which reveals the large channel locations.

I don't expect any particular tricks or flags should be necessary in compiling the code since no specialized functions are used in the code.

Probably "f77 -o sa sa.f" will do the job.

Hopefully that is enough to get you started. Let me know if there is more I can do.

Sincerely,

Jeff Niemann

From: <niemann@MIT.EDU>
To: GL.GLM(SMITHL)
Date: 9/4/96 2:31pm

```
program sa
C   The SLOPE-AREA Model
C   Written by: Jeffrey D. Niemann
C   Based upon the model by: Ede Ijjasz-Vasquez and Rafael Bras
C   Last updated: 9/4/96
C   Massachusetts Institute of Technology
C   (requires input file: sa.in)

C   VARIABLE DECLARATIONS
real pix, ubeta, theta, delta
real z(-1:502,-1:502), dl(500,500), area(500,500)
integer iwid, jwid, iseed, itercnt, itermark
integer act(250000,2), nact
integer idown(-1:502,-1:502), jdown(-1:502,-1:502)

C   DISPLAY THE TITLE AND ADJUSTMENT ALGORITHM IN USE
print *
print *, '                               Slope-Area Model'
print *

C   SET PARAMETERS AND INITIAL STATE
itercnt = 0
call initial (iwid, jwid, pix, iseed, ubeta, theta,
+   itermark, z, idown, jdown)
call flowdir (iwid, jwid, pix, z, idown, jdown, dl)
call contrib (iwid, jwid, pix, idown, jdown, area)
print 20, 'Iteration:', itercnt, '(Initial State)'
call output (iwid, jwid, z, area)

C   ERODE THE TERRAIN AND UPDATE CHARACTERIZATION
10 continue
   itercnt = itercnt + 1
   nact = 0
   delta = 0
   call erode (iwid, jwid, pix, ubeta, theta, z,
+   idown, jdown, dl, area, act, nact, delta)
   if (nact .ne. 0) then
     call flowdir (iwid, jwid, pix, z, idown, jdown, dl)
     call contrib (iwid, jwid, pix, idown, jdown, area)
     if (mod(itercnt,itermark) .eq. 0) then
       print 30, 'Iteration:', itercnt, 'Adjustments:', nact,
+       'Elev Change:', delta
       call output (iwid, jwid, z, area)
     endif
     goto 10
   endif
   print 20, 'Iteration:', itercnt, '(Final State)'
   call output (iwid, jwid, z, area)
20 format (2x, a, 2x, i7, 6x, a)
30 format (2x, a, 2x, i7, 6x, a, 2x, i6, 6x, a, 2x, f9.5)
```

```

end

subroutine initial (iwid, jwid, pix, iseed, ubeta, theta,
+ itermark, z, idown, jdown)
C   VARIABLE DECLARATIONS
    real pix, ubeta, theta, z(-1:502,-1:502), zinit
    integer iwid, jwid, iseed, itermark
    integer idown(-1:502,-1:502), jdown(-1:502,-1:502)
    integer elevflag, seedflag, numout, locout(10,2)
    character*30 elevfile

C   GET PARAMETERS FROM FILE
    open (unit = 11, file = 'sa.in', status = 'old')
    read (11,10) iwid, jwid, pix, zinit, elevflag
    if (elevflag .eq. 1) then
        read (11,20) elevfile
    endif
    read (11,30) seedflag
    if (seedflag .eq. 1) then
        read (11,30) iseed
    endif
    read (11,30) numout
    if (numout .gt. 0) then
        do i = 1, numout
            read (11,40) locout(i,1), locout(i,2)
        enddo
    endif
    read (11,50) ubeta, theta, itermark
    close (unit = 11)

C   SET OR READ IN INITIAL ELEVATIONS
    if (elevflag .eq. 0) then
        if (seedflag .eq. 0) then
            iseed = int(secnds(0.0))
            print *, ' Seed Value: ', iseed
            print *
        endif
        do i = 1, iwid
            do j = 1, jwid
                z(i,j) = zinit + rano(iseed + i*jwid + j)
            enddo
        enddo
    else
        if (seedflag .eq. 1) then
            print *, ' Ignoring Specified Seed'
            print *
        endif
        open (unit = 11, file = elevfile, status = 'old')
        do i = 1, iwid
            read (11,60) (z(i,j), j = 1, jwid)
            do j = 1, jwid
                z(i,j) = zinit + z(i,j)
            enddo
        enddo
    endif

```

```

        enddo
        close (unit = 11)
    endif

C      CREATE NO FLOW BOUNDARIES
do i = -1, iwid + 2
    z(i,-1) = 1000.*(zinit + 1000.)
    z(i,0) = 1000.*(zinit + 1000.)
    idown(i,-1) = i
    jdown(i,-1) = -1
    idown(i,0) = i
    jdown(i,0) = 0
    z(i,jwid+1) = 1000.*(zinit + 1000.)
    z(i,jwid+2) = 1000.*(zinit + 1000.)
    idown(i,jwid+1) = i
    jdown(i,jwid+1) = jwid+1
    idown(i,jwid+2) = i
    jdown(i,jwid+2) = jwid+2
enddo

do j = -1, jwid + 2
    z(-1,j) = 1000.*(zinit + 1000.)
    z(0,j) = 1000.*(zinit + 1000.)
    idown(-1,j) = -1
    jdown(-1,j) = j
    idown(0,j) = 0
    jdown(0,j) = j
    z(iwid+1,j) = 1000.*(zinit + 1000.)
    z(iwid+2,j) = 1000.*(zinit + 1000.)
    idown(iwid+1,j) = iwid+1
    jdown(iwid+1,j) = j
    idown(iwid+2,j) = iwid+2
    jdown(iwid+2,j) = j
enddo

C      CREATE OUTLETS
if (numout .lt. 0) then
    do i = 1, iwid
        z(i,1) = z(i,1) - zinit
        z(i,jwid) = z(i,jwid) - zinit
    enddo
    do j = 1, jwid
        z(1,j) = z(1,j) - zinit
        z(iwid,j) = z(iwid,j) - zinit
    enddo
else
    do i = 1, numout
        z(locout(i,1),locout(i,2)) = 0.
    enddo
endif

10  format(2(50x,i/)50x,f/50x,f/50x,i)
20  format(50x,a20)
30  format(50x,i)
40  format(50x,i,i)

```

```

50  format(2(50x,f/)50x,i5)
60  format(500(f9.5,1x))
    return
    end

subroutine flowdir (iwid, jwid, pix, z, idown, jdown, dl)
C   VARIABLE DECLARATIONS
    real pix, z(-1:502,-1:502), dl(500,500), pi, best, slope, dbor
    integer iwid, jwid, ibor, jbor
    integer idown(-1:502,-1:502), jdown(-1:502,-1:502)
    parameter (pi = 3.14159)

C   print *, ' Determining Flow Directions...'
C   FIND FLOW DIRECTIONS
    do i = 1, iwid
        do j = 1, jwid
            best = 0.
            idown(i,j) = i
            jdown(i,j) = j
            dl(i,j) = 0.
            do k = 0, 7
                kk = k*2
                ibor = i + nint((1+1.236*mod(kk,2))*sin(pi*kk/8))
                jbor = j + nint((1+1.236*mod(kk,2))*cos(pi*kk/8))
                if (mod(kk,4) .eq. 0) then
                    dbor = pix
                elseif (mod(kk,2) .eq. 0) then
                    dbor = 1.414*pix
                else
                    dbor = 2.236*pix
                endif
                slope = (z(i,j) - z(ibor,jbor))/dbor
                if (slope .ge. best) then
                    best = slope
                    idown(i,j) = ibor
                    jdown(i,j) = jbor
                    dl(i,j) = dbor
                endif
            enddo
        enddo
    enddo
    print *, ' Done.'
C   return
    end

subroutine contrib (iwid, jwid, pix, idown, jdown, area)
C   VARIABLE DECLARATIONS
    real pix, area(500,500), pi, area2
    integer iwid, jwid, idown(-1:502,-1:502)
    integer jdown(-1:502,-1:502), source(500,500)
    integer ibor, jbor, iloc, jloc, iold, jold, flag
    parameter (pi = 3.14159)

```

```

C      print *, ' Calculating Contributing Areas...'
C      LOCATE CHANNEL SOURCES:  1 -> A SOURCE
      do i = 1, iwid
        do j = 1, jwid
          source(i,j) = 1
          do k = 0, 7
            kk = k*2
            ibor = i + nint((1+1.236*mod(kk,2))*sin(pi*kk/8))
            jbor = j + nint((1+1.236*mod(kk,2))*cos(pi*kk/8))
            if (idown(ibor,jbor) .eq. i
+          .and. jdown(ibor,jbor) .eq. j) then
              source(i,j) = 0
            endif
          enddo
        enddo
      enddo

C      INITIALIZE AREA MATRIX
      do i = 1, iwid
        do j = 1, jwid
          area(i,j) = 0.
        enddo
      enddo

C      CALCULATE CONTRIBUTING AREAS
      do i = 1, iwid
        do j = 1, jwid
          if (source(i,j) .eq. 1) then
            area(i,j) = pix**2
            flag = 0
            iloc = i
            jloc = j
10         if (idown(iloc,jloc) .ne. iloc
+         .or. jdown(iloc,jloc) .ne. jloc) then
              iold = iloc
              jold = jloc
              iloc = idown(iold,jold)
              jloc = jdown(iold,jold)
              if (area(iloc, jloc) .lt. 0.999*pix**2) then
                area(iloc, jloc) = area(iold,jold) + pix**2
              else
                if (flag .eq. 0) then
                  flag = 1
                  area2 = area(iold,jold)
                endif
                area(iloc, jloc) = area(iloc,jloc) + area2
              endif
              goto 10
            endif
          endif
        enddo
      enddo

C      print *, ' Done.'

```

```

        return
    end

    subroutine erode (iwid, jwid, pix, ubeta, theta, z,
+ idown, jdown, dl, area, act, nact, delta)
C     ERODES BEGINNING AT PITS AND MOVING HEADWARD

C     VARIABLE DECLARATIONS
    real pix, ubeta, theta, delta, znew
    real z(-1:502,-1:502), dl(500,500), area(500,500)
    integer iwid, jwid, act(250000,2), nact, resolve(500,500)
    integer idown(-1:502,-1:502), jdown(-1:502,-1:502)
    integer changes, il, ih, jl, jh

C     print *, ' Adjusting Elevations...'
C     INITIALIZE RESOLVED LOCATIONS
    do i = 1, iwid
        do j = 1, jwid
            if (dl(i,j) .lt. 0.5*pix) then
                resolve(i,j) = 1
            else
                resolve(i,j) = 0
            endif
        enddo
    enddo

C     LOOP OVER ALL LOCATIONS IF CHANGES MUST BE MADE
10    continue
        do i = 1, iwid
            do j = 1, jwid
C             CONSIDER ONLY UNRESOLVED PTS BY RESOLVED PTS
                if (resolve(i,j) .eq. 0 .and.
+ resolve(idown(i,j),jdown(i,j)) .eq. 1) then
                    resolve(i,j) = 1
                    changes = 1
C             ADJUST BY UPLIFT-EROSION
                    znew = z(idown(i,j),jdown(i,j))
+                    + dl(i,j)*ubeta*area(i,j)**(-theta)
                    if (z(i,j) .gt. 1.0001*znew .or.
+ z(i,j) .lt. 0.9999*znew) then
                        delta = delta + znew - z(i,j)
                        z(i,j) = znew
                        nact = nact + 1
                        act(nact,1) = i
                        act(nact,2) = j
                    endif
                endif
            enddo
        enddo
        if (changes .eq. 1) then
            changes = 0
            goto 10
        endif
    endsubroutine

```

```

        delta = delta/(iwid*jwid)
C      print *, ' Done.'
      return
      end

      subroutine output (iwid, jwid, z, area)
C      VARIABLE DECLARATIONS
      real z(-1:502,-1:502), area(500,500)
      integer iwid, jwid

      print *, ' Writing Output...'
C      WRITE EITHER QUICK OR FULL OUTPUT FILES
C      OPEN FILES FOR OUTPUT
      open (unit = 11, file = 'area.dat', status = 'unknown')
      open (unit = 12, file = 'elev.dat', status = 'unknown')
      do i = 1, iwid
C      WRITE RESULTS TO FILES
      write (11,10) (area(i,j), j = 1, jwid)
      write (12,20) (z(i,j), j = 1, jwid)
      enddo
      close (unit = 11)
      close (unit = 12)
      print *, ' Done.'
10  format (500(f8.0,1x))
20  format (500(f9.5,1x))
      return
      end

      function rano (idum)
      real v(97)
      iff = 0
      if ((idum .lt. 0) .or. (iff .eq. 0)) then
        iff = 1
        iseed = abs(idum)
        idum = 1
        do j = 1, 97
          dum = ran(iseed)
        enddo
        do j = 1, 97
          v(j) = ran(iseed)
        enddo
        y = ran(iseed)
      endif
      j = 1 + int(97.*y)
      if ((j .gt. 97.) .or. (j .lt. 1)) pause
      y = v(j)
      rano = y
      v(j) = ran(iseed)
      return
      end

```

From: <niemann@MIT.EDU>
To: GL.GLM(SMITHL)
Date: 9/4/96 2:31pm

Number of rows (iwid): 50
Number of columns (jwid): 50
Pixel dimension (pix): 1.0
Initial elevation (zinit): 10.0
Elevations from file (1=yes, elevflag; elevfile): 0
Use specified seed (1=yes, seedflag; iseed): 1
40000
Number of outlets (numout; locout(row col)): 1
1,1
Coef of slope-area relation (ubeta): 1.00
Expon of slope-area relation (theta): 0.50
Iterations between output (itermark): 20

Appendix E

WEPP Model Introduction

THE WEPP MODEL AND ITS APPLICABILITY FOR PREDICTING EROSION ON DEPARTMENT OF DEFENSE AREAS

J. M. Laflen, Research Leader
USDA Agricultural Research Service
National Soil Erosion Research Laboratory
Purdue University
West Lafayette, IN

ABSTRACT

The Water Erosion Prediction Project (WEPP) model is intended to replace the Universal Soil Loss Equation for predicting soil erosion. WEPP is a fundamental process-based model that operates on a daily time step to estimate land, soil and vegetation conditions when a rainfall event occurs, and then uses this information to predict the hydrology and erosion of single events. WEPP is used in conjunction with an input climate data file; long term estimates are based on the accumulated erosion occurring over the period of record covered by the input climate file. This paper describes the application of WEPP for making estimates of the land, soil and vegetation conditions, and their effect on soil erosion estimates. Additionally, shortcomings and advantages of WEPP for erosion prediction is discussed.

WEPP brings to the natural resource manager a tool for not only the evaluation of the impacts of management on soil erosion but also for the evaluation of offsite impacts related to management decisions.

INTRODUCTION

The USLE (Universal Soil Loss Equation, Wischmeier and Smith, 1965, 1978) and its revision RUSLE (Revised USLE, Renard et al., 1991) is an erosion prediction technology that has served mankind well. However, because of its empirical nature, it has proven to be difficult to apply in some cases, particularly to offsite problems. Additionally, the empirical database to support its application to unique situations is very small.

In 1969, Meyer and Wischmeier presented a model of the water erosion process that was more basic in nature. The CREAMS model (Chemicals, Runoff and Erosion from Agricultural Management Systems, U. S. Dept. Agr., 1980) included the more fundamental processes of water erosion and sediment transport. A more recent effort was initiated to replace the USLE with fundamental erosion process technologies in a broad based project titled WEPP (Water Erosion Prediction Project, Foster and Lane, 1987; Nearing and Lane, 1989).

WEPP is ready for use at the field level. Work will continue on WEPP to further improve its ability to predict soil erosion and sediment delivery and to improve its user friendliness. Work will be required to apply WEPP and to develop parameters for its application to specific conditions. Considerable work is required by action agencies to prepare for implementation. These efforts include training, selection of equipment, development of input

data sets, and development of guidelines and procedures for use of WEPP. These are major tasks and require considerable time and effort.

WEPP is a well programmed maintainable model, with continuing efforts to improve performance and to apply sophisticated analysis to improving the code to insure maintainability. Additionally, it is expected that a partnership of the initial federal agencies, plus other partners, will develop a structure for managing model improvements and insuring that updates are effective and timely.

This paper is not intended to be an overall examination of all components of the model, but rather a look at model components that are most important in representing DoD conditions. These components are related to hydrology, plant growth, erosion, and soil.

DESCRIPTION OF WEPP

WEPP is a daily simulation model that computes the conditions of the soil and plant system that are important in runoff and soil erosion. If rainfall occurs, WEPP computes surface runoff. If surface runoff occurs, WEPP computes the soil that is detached and deposited down a hillslope and the amount delivered to a channel at the foot of a slope. These are all computed in the hillslope version of WEPP. Two additional versions (watershed or grid) are used to compute the erosion, deposition and delivery of sediment through the channel system on the area of interest.

WEPP represents the area where sheet and rill erosion occurs as a series of overland flow elements (OFE) beginning at the top of the slope and ending at a field boundary or a channel at the bottom of a slope. Each OFE is homogeneous with regard to the ecosystem, soil, and management.

Within an OFE, sediment detachment and transport occurs on rill and interrill areas. On interrill areas, the detachment is caused by raindrop impact, and transport is in very shallow flows that are impacted by raindrops. The detached and transported soil on an interrill area is delivered to a rill. Sediment detachment in a rill is caused by the hydraulic shear of the flow carried by the rill and is not affected by raindrops on the water surface. Sediment transport in a rill is also not affected by rainfall. Sediment deposition may occur in a rill if sediment load exceeds the transport capacity of the flow.

Plant Growth

The status of plants and plant residue when an erosion event occurs is vital to accurate estimation of soil detachment and transport. The status of below and above ground biomass must be accurately estimated to evaluate the effect of various management alternatives on soil erosion. WEPP calculates on a daily basis plant growth and the decomposition and accumulation of residue and litter.

Important plant growth characteristics include canopy cover and height, mass of live and dead below and above ground biomass, leaf area index and basal area, residue, and litter cover. Information about management is input to the model. Many annual and perennial crops,

management systems and operations that may occur on cropland, rangeland, forestland, pastures, vineyards and gardens have been parameterized. Major efforts are underway to develop an expert system for selection of parameters to use in WEPP (Deer-Ascough et al., 1993). While this work is presently for cropland parameters, it is expected that parameters for rangelands and forestlands may eventually be included.

Decomposition is important in estimating residue and litter cover and soil erosion on rangelands and croplands. Coefficients for use in estimating litter and residue decomposition have been determined for many crops, but there has been little work on estimation of decomposition rates of surface litter found on rangelands and forestlands. However, this work is underway.

Hydrology

The hydrologic cycle must be well represented if erosion and sediment delivery are to be accurately predicted. WEPP uses several climate variables, including storm rainfall amount and duration, ratio of peak rainfall intensity to average rainfall intensity, time to peak intensity, daily maximum and minimum temperature, daily miles of wind by station and its direction, and solar radiation. These variables are required in components related to plant growth and surface litter decomposition, water balance, and in estimating runoff volume, duration and peak rate.

The hydrologic component of the WEPP hillslope profile model is derived from the research Infiltration and Runoff Simulator (IRS) model (Stone et al., 1992). IRS is an event-based model that uses the Green-Ampt Mein-Larson (GAML) infiltration equation as modified by Chu (1978), and the kinematic wave equations as presented by Lane et al. (1988).

Several modifications have been incorporated into the IRS model to address the implementation constraints of simplicity and speed of execution. Rainfall disaggregation (Nicks and Lane, 1989) of daily precipitation was added to reduce the amount of data needed to describe rainfall intensity needed by both the GAML model and the interrill erosion model. An approximate method for computing the peak discharge at the bottom of a hillslope profile (Hernandez et al., 1989) was added to reduce model run time. Parameters for the hydrologic component can be identified through calibration, if observed data are available or estimated by the model from measurable physical properties of the soil and vegetation (Rawls et al., 1983; Weltz et al., 1992). In continuous simulation mode, baseline hydrologic parameters are adjusted in response to changes in canopy cover and litter caused either by vegetation growth and decomposition, herbicide application, burning or grazing by animals.

Preliminary testing of the WEPP model on rangelands has been started using data from the semiarid rangeland Walnut Gulch Experimental Watershed. Tiscareno et al. (1992) found that the hydrologic response of the hillslope model is most sensitive to rainfall amount, duration, and GAML baseline saturated hydraulic conductivity. For a given runoff producing rainfall event, the response is most sensitive to GAML baseline saturated hydraulic conductivity, soil moisture, and above ground biomass. The parameter estimation techniques within the model and the procedure used to disaggregate rainfall events have been identified (van der Zweep et al. 1991) as critical components of the model requiring additional research. Improvements in estimation of the GAML baseline saturated hydraulic conductivity parameter and in adjusting its

baseline value to account for the influence of changes in canopy cover and surface litter may greatly improve model accuracy.

Erosion

WEPP models erosion on a hillslope by dividing the soil surface into two regions: rill (concentrated flow paths) and interrill. Rills are flow paths which form as water flow concentrates. Detachment in these channels is largely a function of flow shear stress (force exerted by water flow on the bed and banks). In many landscapes, these flow paths form at fairly regular intervals.

The area between rill channels is called the interrill area. Water flow on interrill areas is shallow, and most of the soil detachment here is due to raindrops impacting the soil surface. The raindrops also act to enhance the transport of previously detached sediment from the interrill area to the rill channels. Rills are the major sediment transport pathway for all sediment detached, both that from the rills and that supplied to the rills from the interrill areas.

The basic equation used in the WEPP erosion component is a steady state sediment continuity equation:

$$dG/dx = D_i + D_r \quad [1]$$

where G is sediment load in the flow down a hillslope (kg/s/m), x is distance downslope (m), D_i is the interrill sediment delivery rate to the rills (kg/s/m^2) and D_r is the rill detachment or deposition rate (kg/s/m^2) (Nearing et al., 1989; Foster et al., 1989). For erosion computations for each individual storm, the time period used is the effective duration of runoff computed in the hydrology component of the model. Estimates of dG/dx are made at a minimum of 100 points down a profile, and a running total of the sum of all detachment and deposition at each point from each storm is used to obtain monthly, annual, and average annual values for the simulation.

The interrill component of WEPP is currently a fairly simple sediment delivery function:

$$D_i = K_i I_e^q G_e C_e S_f \quad [2]$$

where D_i is delivery of detached sediment to the rill (kg/m^2), K_i is the interrill erodibility (kg/s/m^4), I_e is the effective rainfall intensity (m/s) occurring during the period of rainfall excess, q is peak runoff rate (m/s), G_e is a ground cover effect adjustment factor, C_e is a canopy cover effect adjustment factor, and S_f is a slope adjustment factor. I_e is computed through a procedure that examines the time period over which rainfall excess is occurring. The effective duration of rainfall excess is passed to the erosion component from the hydrology component. Equation 2 lumps together the processes of detachment, transport and deposition on the interrill areas.

C_e is a function of the fraction of the soil surface area covered by canopy and the height of the canopy. G_e is a function of the fraction of the interrill area covered by surface litter, residue, and rocks. S_f is a function of the interrill slope:

$$Sf = 1.05 - 0.85 e^{(-4 \sin B)} \quad [3]$$

where B is the interrill slope angle. These functions are based on reasonable fits to data reported by Meyer (1981), Meyer and Harmon (1984, 1989), and Watson and Laflen (1986).

Concentrated flow paths are the major pathway for sediment movement down most hillslopes. Water flowing in such rills has the ability to both transport sediment and detach additional soil. When the rill flow becomes laden with sediment from either sediment supplied from the interrill areas or from sediment detached in the rill channel itself, the rill flow loses some of its ability to detach soil and transport sediment. If too much sediment is supplied and the flow system is overloaded, then no rill detachment can take place, and sediment deposition occurs. One of the strengths of WEPP is its ability to estimate both rill detachment and deposition, allowing comprehensive evaluation of both on-site and off-site effects of erosion.

WEPP uses separate equations to simulate rill detachment and deposition. Rill detachment is predicted to occur when the flow shear stress exerted on the soil exceeds a critical threshold value, and sediment transport capacity is greater than the sediment load:

$$Dr = Kr (TAU - TAUc) (1 - G/Tc) \quad [4]$$

where Dr is the rill detachment rate ($kg/s/m^2$), Kr is the adjusted rill erodibility parameter (s/m), TAU is the flow shear stress (Pa), $TAUc$ is the critical flow shear stress (Pa), G is sediment load ($kg/s/m$) and Tc is the flow sediment transport capacity ($kg/s/m$). One can see from this equation that as the flow fills with sediment (G approaches Tc) that the rill detachment rate will be predicted to decrease. Sediment transport capacity in the WEPP model is predicted using the equation:

$$Tc = kt TAU^{1.5} \quad [5]$$

where kt is a transport coefficient ($m^{0.5} s^2 / kg^{0.5}$) calibrated and obtained by applying the Yalin (1963) equation at the end of the slope profile (Finkner et al., 1989).

When the sediment load exceeds the sediment transport capacity, the equation used by WEPP to predict deposition is:

$$Dr = ((BETA * V_{eff})/q) (Tc - G) \quad [6]$$

where Dr is the rill deposition rate ($kg/s/m^2$), $BETA$ is a rainfall-induced turbulence factor (currently set to 0.5), V_{eff} is an effective particle fall velocity (m/s), and q is flow discharge per unit width (m^2/s). An area of concern with the current deposition equation is the estimation of the V_{eff} term based upon the particle size distribution. An evaluation of the procedure which uses the smallest size classes is underway to determine how well the method and the deposition equation perform. Other areas for future improvement in the prediction of deposition would be to: 1) compute the $BETA$ coefficient as a function of rainfall intensity and flow depth, instead of assigning it a constant value; and 2) alter the sediment transport equation used so that it includes a rainfall-enhancement term.

Rill characteristics such as spacing, width and shape are important in estimating soil erosion. For rangelands, rill spacing is estimated as the average spacing of vegetation but spacing is never less than .5 m or greater than 5 m. Estimation of rill width is based on flow and topographic characteristics, while rill shape is always assumed to be rectangular. These assumptions are being evaluated and are subject to change as additional information becomes available. Sensitivity analyses to date have indicated that rill characteristics are not as significant as several other characteristics in determining erosion and sediment delivery.

Soil

The soil component deals with temporal changes in soil properties important in the erosion process, and in estimation of surface runoff rates and volumes. These include random roughness, ridge height, saturated hydraulic conductivity, soil erodibilities and bulk density. The effects of tillage, weathering, consolidation and rainfall are considered in estimating the status of soil properties.

Baseline interrill and rill erodibility, and critical hydraulic shear for a freshly tilled condition, are adjusted to other conditions based on time since tillage for cropland soils. For rangeland soils, the baseline condition is that of a long-term undisturbed soil under rangeland conditions with surface residue removed. For both range and cropland soils, adjustments to interrill erodibility are based on live and dead roots in the upper 150 mm of the soil and to rill erodibility because of incorporated residue in the upper 150 mm of the soil.

Past efforts to model erosion processes have used USLE relationships for estimating soil erodibility. A major WEPP effort has been extensive field studies (Elliot et al., 1989; Simanton et al., 1987) to develop the technology to predict erodibility values for cropland and rangeland soils from soil properties. A major effort continues for both rangelands and croplands to expand the data bases that support WEPP.

WEPP INTERFACE

Successful use of any computer program requires a user friendly interface, and WEPP is no exception. Presently, there are no widely accepted standards for developing interfaces for natural resource models. Such standards are needed to fully develop the use of computer models for natural resource management decision making.

The user interface is used to build, modify, load and store all input data files. Programs that build the soils, climate (CLIGEN), topographic, management and watershed files are accessed from the interface. The building of a management file is accomplished using crop and tillage operations databases. These databases can be modified from the management file builder to adjust for different crops or tillage machinery.

The interface is also used to select output. There is a wide variety of outputs available. These include daily information on soil moisture, residue, biomass, canopy, runoff, and soil erosion. Also available are event, monthly and average annual values of runoff, soil detachment, soil deposition and sediment delivery. Size distribution of sediment delivered is

also computed for these periods. Information is also available for irrigation and for winter conditions.

The interface also produces two graphical outputs. One of these is the distribution of erosion and deposition down the slope. Another allows for plotting of various variables on up to 6 different graphs at once. As an example, one could plot sediment delivery versus runoff volume, canopy cover versus days in the simulation, or water storage for individual soil layers versus days in simulation. Almost any variable computed by WEPP is available for use in the graphical output.

The interface allows for batch operation. Multiple runs can be set up and run unattended. All input data files are checked before any runs are made, and error files are generated for use in troubleshooting. Individual runs are named, and output files generated are based upon these names and appropriate file extensions.

AVAILABILITY

The WEPP hillslope and watershed models and interfaces, along with databases, user guides and supporting information are available on the internet. These can be retrieved following the instructions appended to this paper. Additionally, the proceedings of a Soil and Water Conservation Society (Ankeny, Iowa) sponsored symposium (1995) will contain much of the WEPP information.

Databases are available. A climate file can be generated for almost any location in the U.S. using the climate information available on the internet. Similarly, a soils data base is available for the dominant phase of every soil type in the United States, also on the internet. The crop parameter expert system (CPIDS) is also part of the WEPP package available on the Internet. Default databases are available for various yield levels for much of the U.S. where these crops are commonly grown. Databases are available for many rangeland conditions.

TESTING

Extensive testing of WEPP has been conducted, and still continues. WEPP has been tested on long term natural runoff plots at numerous sites around the United States. It has been tested on forest and rangeland sites. It has been tested in Canada, Austria, Portugal and Italy. Testing is underway for the watershed version. Most reports seem to indicate that WEPP is performing satisfactorily. Additional testing is planned in other countries and for other conditions.

SUMMARY

The WEPP model for soil erosion prediction is being developed to work for all land situations in the United States. Its major limitations on DoD lands are accurate representation and parameterization of the DoD activities on these lands. It is expected that these limitations

will not be extremely difficult to overcome. Some programming of the interface will be required for best use by DoD.

WEPP brings to the manager's tool kit a new tool that provides new information of importance not only for protection of the soil and land resources, but for evaluation of offsite impacts of DoD management and conservation practices. As the demands of the twenty-first century increase our reliance on a dwindling natural resource base, WEPP and other natural resource models will assume greater roles in management of these resources.

REFERENCES

- Chu, S. T. 1978. Infiltration during an unsteady rain. *Water Resour. Res.* 14(3): 461-466.
- Deer-Ascough, L. A., G. A. Weesies, J. C. Ascough II, D. E. Stott, and J. M. Laflen. 1993. Plant database development and linkage with a knowledge-based system for use in erosion prediction models. In: *Proceedings, Application of Advanced Information Technologies for Management of Natural Resources*, Spokane, WA, June 18-19, 1993. Available from Am. Soc. Agric. Eng., St. Joseph, Michigan (In press).
- Elliot, W. J., A. M. Leibenow, J. M. Laflen and K. D. Kohl. 1989. A compendium of soil erodibility data from WEPP cropland soil field erodibility experiments 1987 and 1988. NSERL Report No. 3, National Soil Erosion Research Laboratory, USDA-ARS, West Lafayette, Indiana.
- Finkner, S. C., M. A. Nearing, G. R. Foster and J. E. Gilley. 1989. A simplified equation for modeling sediment transport capacity. *Trans. Am. Soc. Agric. Eng.* 32(5):1545-1550.
- Foster, G. R. and L. J. Lane. 1987. User Requirements: USDA-Water Erosion Prediction Project (WEPP). NSERL Report No. 1, National Soil Erosion Research Laboratory, USDA-ARS, West Lafayette, Indiana.
- Foster, G. R., L. J. Lane, M. A. Nearing, S. C. Finkner, and D. C. Flanagan. 1989. Erosion Component. p 10.1-10.12. In: L. J. Lane and M. A. Nearing (ed.). *USDA-Water Erosion Prediction Project: Hillslope Profile Model Documentation*. NSERL Report No. 2. USDA-ARS National Soil Erosion Research Laboratory, Purdue University. West Lafayette, Indiana.
- Hernandez, M., L. J. Lane, and J. J. Stone. 1989. Surface Runoff. p 5.1-5.18. In: L. J. Lane and M. A. Nearing (ed.). *USDA-Water Erosion Prediction Project: Hillslope Profile Model Documentation*. NSERL Report No. 2. USDA-ARS National Soil Erosion Research Laboratory, Purdue University. West Lafayette, Indiana.
- Johnson, C. W., G. A. Schumaker, and J. P. Smith. 1980. Effects of grazing and sagebrush control on potential erosion. *J. Range Manage.* 33: 451-454.
- Laflen, J. M., W. J. Elliot, J. R. Simanton, C. S. Holzhey, and K. D. Kohl. 1991. WEPP: soil erodibility experiments for rangeland and cropland soils. *J. Soil Water Cons.* 46(1): 39-44.

- Lane, L. J., E. D. Shirley, and V. P. Singh. 1988. Modeling erosion on hillslopes. p 287-308. In: M. G. Anderson (ed.). *Modeling Geomorphic Systems*. John Wiley and Sons, New York.
- Lindley, M. R., B. J. Barfield, B. N. Wilson, and J. M. Laflen. 1992. The surface impoundment element for WEPP-Farm pond hydraulics. Paper No. 92-2643. Am. Soc. Agric. Eng., St. Joseph, Michigan 1992 (Technical Report).
- Meyer, L. D. 1981. How rain intensity affects interrill erosion. *Trans. Am. Soc. Agric. Eng.* 24: 1472-1475.
- Meyer, L. D. and W. H. Wischmeier. 1969. Mathematical simulation of the process of soil erosion by water. *Trans. Am. Soc. Agric. Eng.* 12: 754-762.
- Meyer, L. D. and W. C. Harmon. 1984. Susceptibility of agricultural soils to interrill erosion. *Soil Sci. Soc. Am. J.* 48: 1152-1157.
- Meyer, L. D. and W. C. Harmon. 1989. How row-sideslope length and steepness affect sideslope erosion. *Trans. Am. Soc. Agric. Eng.* 32: 639-644.
- Nearing, M. A. and L. J. Lane. 1989. USDA-Water erosion prediction project: Hillslope profile model documentation. NSERL Report No. 2, National Soil Erosion Research Laboratory, USDA-ARS, West Lafayette, Indiana.
- Nearing, M. A., G. R. Foster, L. J. Lane and S. C. Finkner. 1989. A process-based soil erosion model for USDA-Water Erosion Prediction Project technology. *Trans. Am. Soc. Agric. Eng.* 32: 1587-1593.
- Nicks, A. D. and L. J. Lane. 1989. Ch. 2. Weather Generator. p 2.1-2.19. In: L. J. Lane and M. A. Nearing (ed.). *USDA-Water Erosion Prediction Project: Hillslope Profile Model Documentation*. NSERL Report No. 2. USDA-ARS National Soil Erosion Research Laboratory, Purdue University. West Lafayette, Indiana.
- Rawls, W. J., D. L. Brakensiek, and N. Miller, 1983. Green-Ampt infiltration parameters from soils data. *J. Hyd. Eng.* 109(1): 62-70.
- Renard, K. G., G. R. Foster, G. A. Weesies, and J. P. Porter. 1991. RUSLE: Revised Universal Soil Loss Equation. *J. Soil and Water Cons.* 46(1): 30-33.
- Simanton, J. R., M. A. Wertz, L. T. West, and G. D. Wingate. 1987. Rangeland experiments for water erosion prediction project. Paper No. 87-2545. Am. Soc. Agric. Eng., St. Joseph, Michigan.
- Stone, J. J., L. J. Lane, and E. D. Shirley, 1992. Infiltration and runoff simulation on a plane. *Trans. Am. Soc. Agric. Eng.* 35(1): 161-170.
- Tiscareno, M., V. L. Lopes, and J. J. Stone. 1992. Sensitivity of the WEPP Watershed model for rangeland conditions. Paper No. 92-2018, Am. Soc. Agric. Eng., St. Joseph, Michigan.

U.S. Department of Agriculture. 1980. CREAMS - A field scale model for chemicals, runoff, and erosion from agricultural management systems. Conservation Research Report No. 26. US Department of Agriculture, Science and Education Administration, US Government Printing Office, Washington, DC.

van der Zweep, R. V. L. Lopes, and J. J. Stone. 1991. Validation of the WEPP Watershed Model. Paper No. 91-2552, Am. Soc. Agric. Eng., St. Joseph, Michigan.

Watson, D. A. and J. M. Laflen. 1986. Soil strength, slope, and rainfall intensity effects on interrill erosion. *Trans. Am. Soc. Agric. Eng.* 29: 98-102.

Weltz, M. A., A. B. Arslan, and L. J. Lane. 1992. Hydraulic roughness coefficients for native rangelands. *ASCE Irrigation and Drainage*. 118(5): 776-790.

Wischmeier, W. H. and D. D. Smith, 1965. Predicting rainfall-erosion losses from cropland east of the Rocky Mountains-Guide for selection of practices for soil and water conservation. *Agricultural Handbook No. 282*. US Department of Agriculture, US Government Printing Office, Washington, DC.

Wischmeier, W. H. and D. D. Smith. 1978. Predicting rainfall erosion losses. *Agriculture Handbook No. 537*. US Department of Agriculture, Science and Education Administration, US Government Printing Office, Washington, DC.

Yalin, Y. S. 1963. An expression for bed-load transportation. *J. Hydraulic Div., Am. Soc. Civil. Eng.* 89 (HY3): 221-250.

APPENDIX

TO TRANSFER WEPP FILES TO YOUR PC VIA INTERNET:

1. Using the FTP program, connect to the file server storing the WEPP and CPIDS programs by typing: ftp soils.ecn.purdue.edu
2. Logon as anonymous. Enter your name as the password.
Name: anonymous
Password: yourname
3. Set the transfer type to binary by typing: binary
4. Set for noninteractive transfer by typing: prompt
5. Move to the directory of choice:
cd pub/wepp/wepp.??? (for the DOS executable WEPP programs)
[WEPP.??? extension depends on current version]
cd pub/wepp/document (for the WEPP??? user summary doc)
cd pub/wepp/cligen (for the CLIGEN program or state files)
cd pub/wepp/cligen/maps (for the climate file builder map files)
cd pub/cpids (for CPIDS programs and database)
6. Get the desired file(s) using the GET or MGET commands by typing:
mget *.* OR get cligen31.exe (for example)
7. Quit the FTP program by typing: quit

To Install WEPP Programs from a Hard Drive on a DOS computer:

1. Place the 3 installation executable files (WINSTALL.EXE, WDIST1.EXE, WDIST2.EXE) in the same directory on your drive
2. Move to this directory and type: WINSTALL
3. This will automatically install the WEPP/Shell programs on the hard drive/disk partition of your choice. You will be prompted for a change of diskettes [since the information for disk 2 (the WDIST2.EXE file) is already present, enter Yes].

To Use the WEPP programs after Installation:

Once installed, the WEPP programs are run by typing: SHELL when in the \WEPP\DIST directory. See the next page for the directory structure created during the WEPP installation.

The programs will prompt you for corrections if things are found not to be in order.

WEPP Installed Files

The following files and directories will be created during a WEPP installation:

\WEPP\DIST\README.1ST		- important notes on usage
\WEPP\DIST\SHELL.BAT		- entry-point for using the WEPP shell
\WEPP\DIST\WEPPKIDS.DEF		- common paths and defaults file
\WEPP\DIST\UTIL	<DIR>	- utilities for cloning the programs
\WEPP\DIST\SHELL	<DIR>	- the WEPP/Shell program
\WEPP\DIST\WEPP	<DIR>	- the WEPP model

\WEPP\DIST\INPUT	<DIR>	- input files and builders...
\INPUT\MAN	<DIR>	- WMAN management file builder & files
\INPUT\SLOPE	<DIR>	- WSLP slope builder and files
\INPUT\SOIL	<DIR>	- WSOL soil builder and files
\INPUT\CLIMATE	<DIR>	- CLIGEN climate builder and files
\INPUT\IRR	<DIR>	- WIRR irrigation builder and files
\WEPP\DIST\OUTPUT	<DIR>	- output files and viewers...
\OUTPUT\WGR	<DIR>	- WWGR graphical viewer
\OUTPUT\PLOT	<DIR>	- EGRAPH graphical viewer
\OUTPUT\EVENT	<DIR>	- event/ofe output files
\OUTPUT\WINTER	<DIR>	- winter routine output files
\OUTPUT\YIELD	<DIR>	- plant yield output files
\OUTPUT\ERROR	<DIR>	- error/warning output files
\OUTPUT\SINGLE	<DIR>	- single-storm output files
\OUTPUT\SUMMARY	<DIR>	- soil loss summary output files
\OUTPUT\SOILS	<DIR>	- water/plant/soil output files
\OUTPUT\RANGE	<DIR>	- rangeland/animal output files

Other WEPP Related Files Obtainable via Internet:

The anonymous FTP logon to "soils.ecn.purdue.edu" can also be used to obtain some other related WEPP programs, data files, and documents.

/pub/wepp/cligen-contains the CLIGEN executable program, stations file, and the state database files for the United States. The user needs to copy the state data files of choice (TX for example, for Texas) to their WEPP\DIST\INPUT\CLIMATE directory.

/pub/wepp/cligen/maps-contains the WEPP Climate File Builder interface state map files. The user needs to copy the state map files of choice (TX.* for example, for Texas) to their WEPP\DIST\INPUT\CLIMATE\MAPS directory.

/pub/wepp/document-contains the WEPP User Summary Document for the current version (94.3) in a REPLICa executable file, which must be executed under Microsoft Windows. To obtain the User Summary, put this file on the hard drive on your PC, start up Microsoft Windows, then from the Program Manager File Options, select "Run" and enter the REPLICa file name (DOCUMENT.EXE) The REPLICa viewing program will be installed on your PC under Windows, and you will automatically be put into viewing the User Summary Document. You can also print part or all of the document using REPLICa. REPLICa is a Microsoft Windows Application made by Farallon Computing Inc., Alameda, California.

/pub/cpids-contains the CPIDS (Crop Parameter Intelligent Database System) programs. These programs can be used to develop WEPP and RUSLE plant growth parameters for plants not in the default lists. See the CPIDS directory for more information.

Appendix F WEPP Modeling Output

Single storm

USDA WATER EROSION PREDICTION PROJECT

HILLSLOPE PROFILE AND WATERSHED MODEL
VERSION 95.700
July 10, 1995

TO REPORT PROBLEMS OR TO BE PUT ON THE MAILING
LIST FOR FUTURE WEPP MODEL AND DOCUMENTATION
RELEASES, PLEASE CONTACT

THE NATIONAL SOIL EROSION RESEARCH LABORATORY
PHONE: (317) 494-8673

AT THE FOLLOWING ADDRESS:

USDA-AGRICULTURAL RESEARCH SERVICE
NATIONAL SOIL EROSION RESEARCH LABORATORY
1196 SOIL BUILDING, PURDUE UNIVERSITY
WEST LAFAYETTE, IN 47907-1196
FAX: (317) 494-5948
email: wepp@ecn.purdue.edu

HILLSLOPE INPUT DATA FILES - VERSION 95.700
July 10, 1995

SOIL: C:\WEPP\INPUT\SOIL\DATA\LSSOIL.sol
PLANE 1 Sludge clay

I. SINGLE STORM HYDROLOGY

infiltration, rainfall excess, and runoff hydrograph for event of 1 7 93

hydrology summary

rainfall amount	93.77 (mm)
rainfall duration	72.60 (min)
normalized peak intensity	1.69
normalized time to peak	0.29

rainfall

time (min)	intensity (mm/hr)
---------------	----------------------

0.00	56.58
11.05	91.56
17.88	122.97
22.96	118.12
28.25	104.08
34.26	90.03
41.20	75.98
49.43	61.91
59.53	47.81
72.60	0.00

 hillslope 1

 overland flow element 1

infiltration input parameters

effective saturated conductivity	0.08 (mm/h)
effective matric potential	10.98 (mm)
effective porosity	0.44 (mm/mm)
saturation	95.00 (%)
canopy cover	0.00 (%)
surface cover	0.00 (%)

input runoff parameters

plane length	13.00 (m)
discharge exponent	1.50
average slope of profile	0.06
chezy coefficient	3.56 (m**0.5/s)

output runoff parameters

equivalent sat. hydr. cond.	0.08 (mm/hr)
equivalent matr. potential	10.98 (mm)
average pore fraction	0.44 (m/m)
average saturation fraction	0.42 (m/m)

runoff output

runoff volume	92.03 (mm)
peak runoff rate	122.22 (mm/hr)
effective runoff duration	45.18 (min)
effective length	13.00 (meters)

output runoff hydrograph for hillslope 1

index	time (min)	rate (mm/h)	cumul. depth (mm)
1	0.00	0.00	0.00
2	0.02	0.00	0.00
3	3.00	25.08	0.00
4	6.00	52.75	0.62
5	9.00	54.66	2.57
6	11.05	54.90	5.25
7	12.00	66.55	7.12
8	15.00	90.24	8.09
9	17.88	90.57	12.01
10	21.00	121.60	16.34
11	22.96	122.22	21.86
12	24.00	119.74	25.84
13	27.00	117.66	27.94
14	28.25	117.13	33.88
15	30.00	107.75	36.33
16	33.00	103.14	39.60
17	34.26	103.18	44.88
18	36.00	94.13	47.04
19	39.00	89.57	49.90
20	41.20	89.32	54.50
21	45.00	75.43	57.78
22	48.00	75.44	62.99
23	49.43	75.23	66.76
24	51.00	67.59	68.56
25	54.00	61.30	70.43
26	57.00	61.35	73.65
27	59.53	61.29	76.72
28	63.00	48.43	79.30
29	66.00	47.14	82.47
30	69.00	47.24	84.86
31	72.60	47.33	87.22
32	73.60	32.94	90.06

runoff hydrograph summary for hillslope 1

rainfall volume	93.77 (mm)
infiltration volume	1.74 (mm)
runoff volume	92.03 (mm)
peak rainfall intensity	122.97 (mm/h)
effective rainfall intensity	77.50 (mm/h)
effective rainfall duration	72.58 (min)
final infiltration rate	0.64 (mm/h)
peak runoff rate	122.22 (mm/h)
duration of rainfall	72.60 (min)
time to first ponding	0.02 (min)
effective runoff duration	45.18 (min)
effective length	13.00 (meters)

II. ON SITE EFFECTS ON SITE EFFECTS ON SITE EFFECTS

A. AREA OF NET SOIL LOSS

** Soil Loss (Avg. of Net Detachment Areas) = 7.970 kg/m2 **
 ** Maximum Soil Loss = 29.798 kg/m2 at 13.00 meters **

** Interrill Contribution = 3.962 kg/m2 for OFE # 1

Area of Net Loss (m)	Soil Loss MEAN (kg/m2)	Soil Loss STDEV (kg/m2)	MAX Loss (kg/m2)	MAX Loss Point (m)	MIN Loss (kg/m2)	MIN Loss Point (m)
0.00- 13.00	7.970	5.978	29.798	13.00	3.764	0.52

C. SOIL LOSS/DEPOSITION ALONG SLOPE PROFILE

Profile distances are from top to bottom of hillslope

distance (m)	soil loss (kg/m2)	flow elem	distance (m)	soil loss (kg/m2)	flow elem	distance (m)	soil loss (kg/m2)	flow elem
0.13	3.764	1	4.55	3.962	1	8.97	8.965	1
0.26	3.764	1	4.68	3.962	1	9.10	9.203	1
0.39	3.764	1	4.81	3.962	1	9.23	9.442	1
0.52	3.764	1	4.94	3.962	1	9.36	9.682	1
0.65	3.764	1	5.07	3.962	1	9.49	9.921	1
0.78	3.764	1	5.20	3.962	1	9.62	10.162	1
0.91	3.764	1	5.33	3.962	1	9.75	10.402	1
1.04	3.764	1	5.46	3.962	1	9.88	10.643	1
1.17	3.764	1	5.59	3.962	1	10.01	10.885	1
1.30	3.764	1	5.72	3.962	1	10.14	11.126	1
1.43	3.769	1	5.85	3.974	1	10.27	11.367	1
1.56	3.780	1	5.98	4.096	1	10.40	11.609	1
1.69	3.790	1	6.11	4.253	1	10.53	11.851	1
1.82	3.800	1	6.24	4.418	1	10.66	12.093	1
1.95	3.811	1	6.37	4.593	1	10.79	12.335	1
2.08	3.821	1	6.50	4.774	1	10.92	12.577	1
2.21	3.831	1	6.63	4.963	1	11.05	12.819	1
2.34	3.842	1	6.76	5.157	1	11.18	13.061	1
2.47	3.852	1	6.89	5.357	1	11.31	13.303	1
2.60	3.862	1	7.02	5.562	1	11.44	13.545	1
2.73	3.873	1	7.15	5.771	1	11.57	13.787	1
2.86	3.883	1	7.28	5.984	1	11.70	14.030	1
2.99	3.893	1	7.41	6.201	1	11.83	15.026	1
3.12	3.904	1	7.54	6.421	1	11.96	16.761	1
3.25	3.914	1	7.67	6.643	1	12.09	18.472	1
3.38	3.924	1	7.80	6.868	1	12.22	20.158	1
3.51	3.934	1	7.93	7.095	1	12.35	21.819	1
3.64	3.945	1	8.06	7.324	1	12.48	23.456	1
3.77	3.955	1	8.19	7.554	1	12.61	25.072	1

3.90	3.962	1	8.32	7.787	1	12.74	26.666	1
4.03	3.962	1	8.45	8.020	1	12.87	28.241	1
4.16	3.962	1	8.58	8.255	1	13.00	29.798	1
4.29	3.962	1	8.71	8.491	1			
4.42	3.962	1	8.84	8.727	1			

note: (+) soil loss - detachment (-) soil loss - deposition

III. OFF SITE EFFECTS OFF SITE EFFECTS OFF SITE EFFECTS

A. SEDIMENT LEAVING PROFILE for jul 1 93 103.613 kg/m

B. SEDIMENT CHARACTERISTICS AND ENRICHMENT

Sediment particle information leaving profile

Class	Diameter (mm)	Specific Gravity	Particle Composition				Detached Fraction Sediment Fraction	In Flow Fraction Exiting
			% Sand	% Silt	% Clay	% O.M.		
1	0.002	2.60	0.0	0.0	100.0	0.1	0.259	0.261
2	0.010	2.65	0.0	100.0	0.0	0.0	0.000	0.000
3	0.100	1.80	0.0	0.1	99.9	0.1	0.001	0.001
4	1.996	1.60	0.1	0.1	99.7	0.1	0.740	0.738
5	0.200	2.65	100.0	0.0	0.0	0.0	0.000	0.000

SSA enrichment ratio leaving profile for jul 1 93 = 1.01

Single storm

USDA WATER EROSION PREDICTION PROJECT

HILLSLOPE PROFILE AND WATERSHED MODEL
VERSION 95.700
July 10, 1995

TO REPORT PROBLEMS OR TO BE PUT ON THE MAILING
LIST FOR FUTURE WEPP MODEL AND DOCUMENTATION
RELEASES, PLEASE CONTACT

THE NATIONAL SOIL EROSION RESEARCH LABORATORY
PHONE: (317) 494-8673

AT THE FOLLOWING ADDRESS:

USDA-AGRICULTURAL RESEARCH SERVICE
NATIONAL SOIL EROSION RESEARCH LABORATORY
1196 SOIL BUILDING, PURDUE UNIVERSITY
WEST LAFAYETTE, IN 47907-1196
FAX: (317) 494-5948
email: wepp@ecn.purdue.edu

HILLSLOPE INPUT DATA FILES - VERSION 95.700
July 10, 1995

SOIL: C:\WEPP\INPUT\SOIL\DATA\LSSOIL.s01
PLANE 1 Sludge clay

I. SINGLE STORM HYDROLOGY

infiltration, rainfall excess, and runoff hydrograph for event of 1 1 93
hydrology summary

rainfall amount	160.77 (mm)
rainfall duration	360.00 (min)
normalized peak intensity	2.00
normalized time to peak	0.40

rainfall

time (min)	intensity (mm/hr)
0.00	15.61
61.79	26.55
98.12	37.35
123.95	48.10
144.00	49.99
163.29	42.85
185.81	35.70
212.82	28.54
246.62	21.37
291.76	14.14
360.00	0.00

 hillslope 1

 overland flow element 1

infiltration input parameters

effective saturated conductivity	0.08 (mm/h)
effective matric potential	10.98 (mm)
effective porosity	0.44 (mm/mm)
saturation	95.00 (%)
canopy cover	0.00 (%)
surface cover	0.00 (%)

input runoff parameters

plane length	13.00 (m)
discharge exponent	1.50
average slope of profile	0.06
chezy coefficient	3.56 (m**0.5/s)

output runoff parameters

equivalent sat. hydr. cond.	0.08 (mm/hr)
equivalent matr. potential	10.98 (mm)
average pore fraction	0.44 (m/m)
average saturation fraction	0.42 (m/m)

runoff output

runoff volume	157.04 (mm)
peak runoff rate	49.69 (mm/hr)
effective runoff duration	189.64 (min)
effective length	13.00 (meters)

output runoff hydrograph for hillslope 1

index	time (min)	rate (mm/h)	cumul. depth (mm)
1	0.00	0.00	0.00
2	0.21	0.00	0.00
3	5.00	3.97	0.00
4	10.00	12.88	0.16
5	15.00	14.09	0.86
6	20.00	14.37	1.98
7	25.00	14.53	3.17
8	30.00	14.63	4.37
9	35.00	14.71	5.59
10	40.00	14.78	6.81
11	45.00	14.83	8.04
12	50.00	14.87	9.27
13	55.00	14.91	10.51
14	60.00	14.94	11.75
15	61.79	14.91	13.00
16	65.00	22.53	13.44
17	70.00	25.89	14.44
18	75.00	25.91	16.46
19	80.00	25.93	18.62
20	85.00	25.95	20.78
21	90.00	25.97	22.94
22	95.00	25.98	25.11
23	98.12	26.02	27.27
24	100.00	31.31	28.62
25	105.00	36.97	29.52
26	110.00	36.82	32.37
27	115.00	36.83	35.44
28	120.00	36.84	38.51
29	123.95	36.98	41.58
30	125.00	40.25	44.00
31	130.00	47.61	44.68
32	135.00	47.61	48.34
33	140.00	47.62	52.31
34	144.00	47.86	56.28
35	145.00	48.24	59.46
36	150.00	49.53	60.26
37	155.00	49.54	64.34
38	160.00	49.55	68.46
39	163.29	49.69	72.59
40	165.00	45.85	75.32
41	170.00	42.41	76.68
42	175.00	42.42	80.35
43	180.00	42.43	83.89
44	185.81	42.43	87.42
45	190.00	35.72	91.53
46	195.00	35.29	94.26
47	200.00	35.30	97.22
48	205.00	35.30	100.16
49	210.00	35.30	103.10
50	212.82	35.35	106.04
51	215.00	31.19	107.71

52	220.00	28.15	108.91
53	225.00	28.16	111.39
54	230.00	28.16	113.73
55	235.00	28.16	116.08
56	240.00	28.17	118.43
57	245.00	28.17	120.77
58	246.62	28.18	123.12
59	250.00	22.74	123.88
60	255.00	21.00	125.31
61	260.00	21.09	127.14
62	265.00	21.09	128.89
63	270.00	21.10	130.65
64	275.00	21.10	132.41
65	280.00	21.10	134.16
66	285.00	21.10	135.92
67	290.00	21.11	137.68
68	291.76	21.02	139.44
69	295.00	16.14	140.06
70	300.00	13.84	141.06
71	305.00	13.83	142.31
72	310.00	13.84	143.46
73	315.00	13.84	144.62
74	320.00	13.84	145.77
75	325.00	13.84	146.92
76	330.00	13.85	148.08
77	331.00	13.81	149.23

runoff hydrograph summary for hillslope 1

rainfall volume	160.77 (mm)
infiltration volume	3.73 (mm)
runoff volume	157.04 (mm)
peak rainfall intensity	49.99 (mm/h)
effective rainfall intensity	26.80 (mm/h)
effective rainfall duration	359.79 (min)
final infiltration rate	0.32 (mm/h)
peak runoff rate	49.69 (mm/h)
duration of rainfall	360.00 (min)
time to first ponding	0.21 (min)
effective runoff duration	189.64 (min)
effective length	13.00 (meters)

II. ON SITE EFFECTS ON SITE EFFECTS ON SITE EFFECTS

A. AREA OF NET SOIL LOSS

** Soil Loss (Avg. of Net Detachment Areas) = 9.439 kg/m2 **

** Maximum Soil Loss = 55.128 kg/m2 at 13.00 meters **

** Interrill Contribution = 2.338 kg/m2 for OFE # 1

Area of	Soil Loss	Soil Loss	MAX	MAX Loss	MIN	MIN Loss
---------	-----------	-----------	-----	----------	-----	----------

Net Loss (m)	MEAN (kg/m ²)	STDEV (kg/m ²)	Loss (kg/m ²)	Point (m)	Loss (kg/m ²)	Point (m)
0.00- 13.00	9.439	12.250	55.128	13.00	2.070	0.65

C. SOIL LOSS/DEPOSITION ALONG SLOPE PROFILE

Profile distances are from top to bottom of hillslope

distance (m)	soil loss (kg/m ²)	flow elem	distance (m)	soil loss (kg/m ²)	flow elem	distance (m)	soil loss (kg/m ²)	flow elem
0.13	2.070	1	4.55	2.338	1	8.97	9.365	1
0.26	2.070	1	4.68	2.338	1	9.10	10.033	1
0.39	2.070	1	4.81	2.338	1	9.23	10.698	1
0.52	2.070	1	4.94	2.338	1	9.36	11.359	1
0.65	2.070	1	5.07	2.338	1	9.49	12.017	1
0.78	2.070	1	5.20	2.338	1	9.62	12.670	1
0.91	2.070	1	5.33	2.338	1	9.75	13.318	1
1.04	2.070	1	5.46	2.338	1	9.88	13.962	1
1.17	2.070	1	5.59	2.338	1	10.01	14.601	1
1.30	2.070	1	5.72	2.338	1	10.14	15.235	1
1.43	2.091	1	5.85	2.338	1	10.27	15.865	1
1.56	2.132	1	5.98	2.338	1	10.40	16.489	1
1.69	2.173	1	6.11	2.338	1	10.53	17.108	1
1.82	2.214	1	6.24	2.338	1	10.66	17.722	1
1.95	2.254	1	6.37	2.338	1	10.79	18.331	1
2.08	2.294	1	6.50	2.338	1	10.92	18.935	1
2.21	2.331	1	6.63	2.338	1	11.05	19.534	1
2.34	2.338	1	6.76	2.338	1	11.18	20.128	1
2.47	2.338	1	6.89	2.338	1	11.31	20.718	1
2.60	2.338	1	7.02	2.338	1	11.44	21.302	1
2.73	2.338	1	7.15	2.338	1	11.57	21.882	1
2.86	2.338	1	7.28	2.338	1	11.70	22.457	1
2.99	2.338	1	7.41	2.338	1	11.83	24.564	1
3.12	2.338	1	7.54	2.338	1	11.96	28.171	1
3.25	2.338	1	7.67	2.647	1	12.09	31.724	1
3.38	2.338	1	7.80	3.306	1	12.22	35.223	1
3.51	2.338	1	7.93	3.973	1	12.35	38.666	1
3.64	2.338	1	8.06	4.643	1	12.48	42.056	1
3.77	2.338	1	8.19	5.317	1	12.61	45.394	1
3.90	2.338	1	8.32	5.993	1	12.74	48.684	1
4.03	2.338	1	8.45	6.669	1	12.87	51.928	1
4.16	2.338	1	8.58	7.345	1	13.00	55.128	1
4.29	2.338	1	8.71	8.020	1			
4.42	2.338	1	8.84	8.694	1			

note: (+) soil loss - detachment (-) soil loss - deposition

III. OFF SITE EFFECTS OFF SITE EFFECTS OFF SITE EFFECTS

A. SEDIMENT LEAVING PROFILE for jan 1 93 122.711 kg/m²

B. SEDIMENT CHARACTERISTICS AND ENRICHMENT

Sediment particle information leaving profile

Class	Diameter (mm)	Specific Gravity	Particle Composition				Detached Sediment Fraction	Fraction In Flow Exiting
			% Sand	% Silt	% Clay	% O.M.		
1	0.002	2.60	0.0	0.0	100.0	0.1	0.259	0.260
2	0.010	2.65	0.0	100.0	0.0	0.0	0.000	0.000
3	0.100	1.80	0.0	0.1	99.9	0.1	0.001	0.001
4	1.996	1.60	0.1	0.1	99.7	0.1	0.740	0.739
5	0.200	2.65	100.0	0.0	0.0	0.0	0.000	0.000

SSA enrichment ratio leaving profile for jan 1 93 = 1.01

Appendix G

Physical Modeling Study Plan

PHYSICAL TESTING OF SLUDGE RECOVERY AT THE SAVANNAH RIVER SITE BY SOIL EROSION METHODS

STUDY PLAN

Introduction

Preliminary studies of the application of soil erosion methods to the recovery of high-level waste (HLW) sludge from storage tanks at the Department of Energy Savannah River Site (SRS) have been conducted by the U.S. Army Engineer Waterways Experiment Station (WES). Soil erosion processes are defined as the physical removal of sludge particles by running water applied by overhead sprinklers. Soil erosion processes include "raindrop splash" erosion from the kinetic energy of falling water droplets, dislodgement and entrainment of sludge particles by the fluid shear of overland flow, and the gravitational "mass failure" of sludge into channels created by fluid shear. These studies indicate that soil erosion processes should be effective in recovering waste sludge within the requirements of the waste processing system. Further verification and expanded analysis by physical (scale) testing is recommended to design the optimum system for use in each tank.

This document describes a plan for conducting scale tests of the soil erosion processes in scaled-down tanks containing simulated sludge for the *purpose of developing the most efficient procedure for using soil erosion methods in sludge recovery*. This study plan was developed by Lawson Smith, WES, in consultation with a number of engineers and scientists at SRS, most notably Dr. James Brooke. In the following paragraphs, the eight tasks of the project are described. The study plan is concluded with the definition of the product of the investigations.

This study plan describes a comprehensive program for testing the use of soil erosion methods for sludge recovery. It is recognized that funds may not be readily available to support a comprehensive program but are available in limited quantity to conduct fundamental physical tests of the concepts and mechanics of the proposed system. For example, it may be determined that limited tests of a single-tank type should be conducted before a more comprehensive (and costly) test program is initiated. In this case, the study plan can be modified to reflect a limited program of tests.

Task 1: Development of the Testing Research Plan.

The initial task of the project will be to develop a strategy for identifying and evaluating all of the variables and constants associated with the use of soil erosion methods for sludge recovery. Preliminary analyses suggest that the principal variables will be water drop size, chemistry, intensity, duration, density and coverage, and slope and initial geometry of the drainage network.

The research plan will involve detailed planning of Tasks 2 - 6 described below, including test design, fabrication and assembly of scale model tanks, calibration, operation, and evaluation of results. Tasks 7 and 8 of the study plan describe the documentation of the results of the testing investigations and the provision of recommendations to SRS.

Task 2: Design of the Tests.

Model design will first involve identification of the optimum scale of the test models. Optimum scale is defined as the ratio of scaled sizes to real sizes that provide the greatest confidence of achieving accurate similitude while being logistically efficient. Preliminary considerations indicate 1/10 scale may be optimum. Selection of optimum scale will be followed by the analysis of scaling factors for all variables and conditions of the models. It is most likely that all variables may not be scaled equally to achieve realistic and meaningful results. The appropriate water application methods (sprinklers?) will then be designed and specified. Three types of scaled-down tanks will be designed: types II, III, and IV. Tank designs will also include sludge removal systems (pumps). The mixture of simulated sludge and water will be designed to replicate HLW sludge in tanks at SRS. Finally, the data acquisition system will be designed. At least three types of data will be developed: water application parameters (drop size, pressure, volume, duration, coverage and direction); topography of the sludge surface/ drainage network (probably measured by scanning lasers and documented by high-definition photography and videography); and recovery pump data (flow rate, suspended solids).

Task 3: Fabrication and Assembly of the Testing Apparatus.

Upon completion of test design, fabrication and assembly of the testing apparatus (scale model tanks, fluid application assembly, outlet pump, effluent (recovered sludge) storage system, and data acquisition system) will proceed with the acquisition of materials and equipment. The testing system will be located in a large in-door structure at WES. Two model waste tank hulls will be fabricated to be used for the three types of tanks and recovery systems (primarily pumps) will be assembled. The fluid application system will be assembled, consisting of a water source, hoses, sprinklers, and a gantry to precisely position the sprinkler heads above the tanks. The effluent storage system will consist of an outlet pump and storage tanks. Simulated sludge (obtained from SRS) will be mixed with water to achieve the proper material characteristics of the scaled HLW sludge. The data acquisition systems will be acquired, fabricated, and assembled and integrated with a single computer system for data acquisition and display.

Task 4: Test System Calibration.

Before the actual running of the tests begin, the testing system will be calibrated to assure accurate and representative data are being produced. Calibration will include the fluid application and sludge recovery systems, simulated sludge, and data acquisition systems. Calibrations will insure replication and accuracy of data and similitude.

Task 5: Testing.

An appropriate amount of time will be spent operating the test systems and collecting data to determine the best strategy for creating and using soil erosion methods for HLW sludge recovery. The variables described in Task 1 (above) will be varied and measured, and the test results measured. Three types of tanks (types II, III, and IV) will be modeled, beginning with the simplest (type IV). Data will be gathered digitally and graphically and stored for evaluation in Task 6.

Task 6: Evaluation of Test Results.

The focus of the evaluation of the data from the operation of the tests will be the

determination of the most efficient (least amount of water used?) procedures for recovering simulated sludge at optimum percent solids at the pump. Data will be evaluated graphically, statistically, and numerically. The results of the physical models will be compared to numerical simulations for evaluating the utility of the numerical models.

Task 7: Development of Recommendations to SRS.

One of the primary products of this project is to provide recommendations to SRS on the use of soil erosion methods. Intuitively, these recommendations will most likely consist of the design, placement, and operation of fluid application systems, the best configurations of initial channels and pump head elevations, and development of sludge recovery (pumping) procedures. These recommendations will be developed for each of the three tanks modeled. Hopefully, appropriate SRS staff will visit WES during testing to see first hand the possible utility of soil erosion methods for HLW sludge recovery.

✓
Task 8: Completion of Report to SRS.

The final task of the project will be to document all phases of the project in a report to be submitted to SRS. The report will include discussions of what was done and why in all of the previously mentioned tasks. All of the data acquired will be stored on compact disk for independent analysis by SRS. A presentation of the results of the model studies will be given at SRS upon the completion of the project.

Contact

The point of contact for this proposed project at WES is Dr. Lawson Smith. He may be reached at the following address:

Dr. Lawson Smith
Geotechnical Laboratory
U.S.A.E. Waterways Experiment Station
3909 Halls Ferry Road
Vicksburg, MS 39180

Phone: (601) 634-2497
FAX: (601) 634-3153
E-Mail: *smithl@exl.wes.army.mil*

REPORT DOCUMENTATION PAGE

Form Approved
OMB No. 0704-0188

Public reporting burden for this collection of information is estimated to average 1 hour per response, including the time for reviewing instructions, searching existing data sources, gathering and maintaining the data needed, and completing and reviewing the collection of information. Send comments regarding this burden estimate or any other aspect of this collection of information, including suggestions for reducing this burden, to Washington Headquarters Services, Directorate for Information Operations and Reports, 1215 Jefferson Davis Highway, Suite 1204, Arlington, VA 22202-4302, and to the Office of Management and Budget, Paperwork Reduction Project (0704-0188), Washington, DC 20503.

1. AGENCY USE ONLY (Leave blank)	2. REPORT DATE July 1997	3. REPORT TYPE AND DATES COVERED Final report	
4. TITLE AND SUBTITLE Assessment of Soil Erosion Methods for Sludge Recovery, Savannah River Site		5. FUNDING NUMBERS	
6. AUTHOR(S) Lawson M. Smith			
7. PERFORMING ORGANIZATION NAME(S) AND ADDRESS(ES) U.S. Army Engineer Waterways Experiment Station, 3909 Halls Ferry Road, Vicksburg, MS 39180-6199; U.S. Army Engineer District, Charleston, Savannah River Site, Aiken, SC 29808		8. PERFORMING ORGANIZATION REPORT NUMBER Technical Report GL-97-10	
9. SPONSORING/MONITORING AGENCY NAME(S) AND ADDRESS(ES) Department of Energy Savannah River Site Aiken, SC 29808		10. SPONSORING/MONITORING AGENCY REPORT NUMBER	
11. SUPPLEMENTARY NOTES Available from National Technical Information Service, 5285 Port Royal Road, Springfield, VA 22161.			
12a. DISTRIBUTION/AVAILABILITY STATEMENT Approved for public release; distribution is unlimited.		12b. DISTRIBUTION CODE	
13. ABSTRACT (Maximum 200 words) The applicability of soil erosion methods for recovery of high-level radioactive waste (HLW) from selected storage tanks at the Savannah River Site (SRS) was assessed conceptually. Soil erosion methods are defined as the processes of soil detachment, entrainment, transport, and deposition. The assessment involved four phases: (a) data collection, (b) evaluation of potentially applicable erosion models and methods, (c) development of a numerical model of sludge erosion, and (d) documentation of methods and results. Analyses described in this report were made on existing data developed at SRS using existing analytical methods and models. Four topics are discussed: (a) erosion processes for sludge recovery, (b) application of soil erosion to sludge recovery at SRS, (c) numerical simulation of sludge erosion, and (d) summary and recommendations. Results of the investigation indicate that erosion methods can be effective in the recovery of waste sludge. The natural internal order of erosional networks provides a system that is predictable, efficient, and quickly responsive to artificial control. Numerical simulation of erosional systems indicated that an erosional system developed in SRS HLW would be an efficient way to recover HLW.			
14. SUBJECT TERMS Geomorphology Numerical modeling Savannah River Site		Soil erosion Waste recovery	15. NUMBER OF PAGES 118
			16. PRICE CODE
17. SECURITY CLASSIFICATION OF REPORT UNCLASSIFIED	18. SECURITY CLASSIFICATION OF THIS PAGE UNCLASSIFIED	19. SECURITY CLASSIFICATION OF ABSTRACT	20. LIMITATION OF ABSTRACT