

REPORT ON ALTERNATIVE DEVICES TO PYROTECHNICS ON SPACECRAFT

M.H.Lucy; R.C.Hardy; E.H.Kist, Jr.; J.J.Watson; Dr. S.A.Wise

Phone: (757) 864-7069 Fax: (757) 864-7009
e-mail address: m.h.lucy@larc.nasa.gov

1 N. Dryden St, M/S 434
NASA Langley Research Center
Hampton, VA 23681-0001

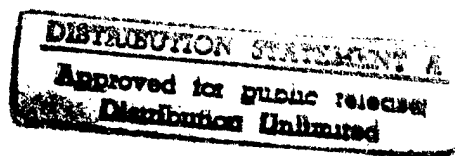

Note to recipients: Please provide the above with your current, correct address and e-mail address, and phone and fax numbers.

19970711 127

DTIC QUALITY INSPECTED 3

Presented at
10th Annual AIAA/USU Conference on Small Satellites
Utah State University; Logan, UT 84341-1942
September 17-19, 1996

REPORT ON ALTERNATIVE DEVICES TO PYROTECHNICS ON SPACECRAFT

M. Lucy, R. Hardy, E. Kist, J. Watson, S. Wise
National Aeronautics and Space Administration
Langley Research Center
Hampton, Virginia

Abstract

Pyrotechnics accomplish many functions on today's spacecraft, possessing minimum volume/weight, providing instantaneous operation on demand, and requiring little input energy. However, functional shock, safety, and overall system cost issues, combined with emergence and availability of new technologies question their continued use on space missions. Upon request from the National Aeronautics and Space Administration's (NASA) Program Management Council (PMC), Langley Research Center (LaRC) conducted a survey to identify and evaluate state-of-the-art non-explosively actuated (NEA) alternatives to pyrotechnics, identify NEA devices planned for NASA use, and investigate potential interagency cooperative efforts. In this study, over 135 organizations were contacted, including NASA field centers, Department of Defense (DOD) and other government laboratories, universities, and American and European industrial sources resulting in further detailed discussions with over half, and 18 face-to-face briefings. Unlike their single use pyrotechnic predecessors, NEA mechanisms are typically reusable or refurbishable, allowing flight of actual tested units. NEAs surveyed include spool-based devices, thermal knife, Fast Acting Shockless Separation Nut (FASSN), paraffin actuators, and shape memory alloy (SMA) devices (e.g., Frangibolt). The electro-mechanical spool, paraffin actuator and thermal knife are mature, flight proven technologies, while SMA devices have a limited flight history.

There is a relationship between shock, input energy requirements, and mechanism functioning rate. Some devices (e.g., Frangibolt and spool based mechanisms) produce significant levels of functional shock. Paraffin, thermal knife, and SMA devices can provide gentle, shock-free release but cannot perform critically timed, simultaneous functions. The FASSN flywheel-nut release device possesses significant potential for reducing functional shock while activating nearly instantaneously. Specific study recommendations include: (1) development of NEA standards, specifically in areas of material characterization, functioning rates, and test methods; (2) a systems level approach to assure successful NEA technology application; and (3) further investigations into user needs, along with industry/government system-level real spacecraft cost-benefit trade studies to determine NEA application foci and performance requirements. Additional survey observations reveal an industry and government desire to establish partnerships to investigate remaining

unknowns and formulate NEA standards, specifically those driven by SMAs. Finally, there is increased interest and need to investigate alternative devices for such functions as stage/shroud separation and high pressure valving. This paper summarizes results of the NASA-LaRC survey of pyrotechnic alternatives. State-of-the-art devices with their associated weight and cost savings are presented. Additionally, a comparison of functional shock characteristics of several devices are shown, and potentially related technology developments are highlighted.

Background

Several recent incidents in which pyrotechnics could be responsible for spacecraft failures have raised concerns within the aerospace community regarding their continued use on spacecraft. Other reasons to examine NEAs for spacecraft include: high functioning shock levels; overall operating and system costs; reusability; shrinking volume, weight, and power budgets; possible outgassing; emergence of new technologies; and the hazardous nature of pyrotechnic materials. In June 1994, at the request of the NASA's PMC, LaRC formed an investigative team to examine NEAs and report findings. The team consisted of Robin C. Hardy, Edward H. Kist, Jr., Melvin H. Lucy, Judith J. Watson, and Dr. Stephanie A. Wise, who provided expertise in mechanical systems and mechanisms, power and electronic systems, pyrotechnics, and smart and active materials technology. Anthony M. Agajanian - Jet Propulsion Laboratory (JPL), Charles S. Cornelius - Marshall Space Flight Center (MSFC), Frank M. Cumbo - Goddard Space Flight Center (GSFC), Dr. Rodney G. Galloway - United States Air Force-Phillips Laboratory (AFPL), and Darin N. McKinnis - Johnson Spacecraft Center (JSC) provided technical assistance.

A review of mechanism symposia proceedings, pyrotechnic workshops, and a literature search into smart actuators and structures were initiated. Contact was established with NASA/DOD Pyrotechnic Steering Committee participants, NASA field centers, several DOD groups, other government laboratories, pyrotechnic manufacturers, major aerospace contractors, universities, and European sources. A questionnaire was issued to the supplier and user communities, and telephone interviews with all identified points-of-contact were conducted. Over 135 organizations were contacted, in-depth telephone discussions were conducted with 75 selected contacts, and 18 of the latter made technical presentations to the team. These presentations were made on the West Coast on

2025 RELEASE UNDER E.O. 14176

September 20-22, 1994 and on the East Coast September 28-30, 1994; or by phone or visit to LaRC. On-site visits to several organizations took place in the Denver, CO and Washington, DC areas, and three ESA representatives were interviewed by phone. Discussions primarily involved spacecraft pyrotechnic alternatives; however, pyrotechnics used in launch systems, tactical missiles, aircraft, and even automotive applications were included. Investigation findings were presented to NASA's PMC at JPL on March 28, 1995. A matrix identifying NEAs as compared to pyrotechnics is presented in Figure 1.

Significant Findings

The investigation's significant findings are:

- (1) Alternative technologies exist and have been used or are planned for use on spacecraft. [(a) Five promising technologies were identified; electro-mechanical spool, paraffin actuator, rotary separation nut, shape memory alloy (SMA) devices, and thermal knife. (b) The majority of alternatives are used for separation and deployment. (c) No single technology is a panacea. (d) Not all technologies alleviate functional shock. (e) The elimination of pyrotechnics is being pursued.]
- (2) Alternative technologies require further development. [(a) Booster separation and staging is a critical area. (b) SMA based devices are the least mature. (c) Paraffin wax high transition temperature material needs development. (d) Standards are needed for NEAs.]
- (3) There are currently no alternative devices for some pyrotechnic applications. [(a) No alternatives exist for applications requiring high energy, rapid response, e.g., ignition, detonation, valving, cutting and some releases. (b) Mistakes of use and/or application cause many failures. (c) Pyrotechnic improvements are being investigated.]
- (4) Several industry and government small programs are potential partners for a larger focused effort to develop alternative technologies. [(a) SMA based devices have the most commercial interest. (b) A high degree of interest was shown in forming partnerships to develop NEA standards. (c) Most existing programs are of limited scope and could be combined to more adequately address the needs of this area.]

Several interesting points considered worthy of highlighting include the following (order does not imply importance): (1) The Naval Research Lab (NRL) has decided to replace pyrotechnics with NEAs on spacecraft. (2) Approximately 2/3 of the discussions involved SMA-based applications. (3) Several organizations are currently developing SMA-actuated separation nuts. (4) A very low shock, rotary release separation nut is being developed. (5) A thermal knife for performing release functions was described. (6) Numerous paraffin actuator applications were identified, including one for a passively controlled solar array tracking mechanism. (7) A combination miniaturized, remotely

programmable, optically initiated, electrically fired, multiple functioning safe and arm (S&A) firing system is being developed. (8) A passive thermal detection and initiation method to prevent munitions cook-off (chemical heat source with possible application to NEAs) was presented.

Pyrotechnics

Pyrotechnics consist of a broad family of sophisticated devices utilizing self-contained energy sources such as explosives, propellants and/or pyrotechnic compositions. Most pyrotechnics utilize a hot wire system consisting of a thin gage, high resistance bridgewire for terminating the electrical circuit at the initiating material. These are low voltage systems in which the bridgewire is heated to achieve auto-ignition of the material. When properly utilized and packaged, pyrotechnics perform functions such as release, cutting, pressurization, valving, ignition, switching, and other mechanical work. Pyrotechnic technology is mature and flight proven. Pyrotechnics typically possess a minimum volume to weight relationship as compared to other mechanisms, provide instantaneous operation on demand allowing simultaneity, have relatively long-term storage capability, are rugged, highly reliable, possess a good safety record, are relatively inexpensive, require a limited amount of input energy to function, and produce a high energy output. Commercial applications for pyrotechnic systems are expanding and are enjoying good safety records. Pyrotechnics, however, are single use devices containing hazardous materials, and flight hardware reliability depends on batch testing. End-to-end built-in-test (BIT) is difficult. Pyrotechnics may produce contaminants, and they typically exhibit high levels of functional shock (explosive and mechanical).

Functional Shock

Data from a 1985 paper by C.J. Moening¹ indicated that through 1984 eighty-three shock related failures had occurred in approximately 600 launches. Over 50 percent of these resulted in catastrophic loss of mission. Twenty-nine failures involved broken wires, leads and cracked glass; 28 involved dislodgment of contaminants; 22 had other shock-related effects, and four involved relay chatter and transfer problems. In a study performed for NRL by Hi-Shear Technology Corp. (HSTC), three sources of functional shock (referred to as "pyroshock") in a separation nut and each's percentage occurrence were identified: less than 10 percent results from the pyrotechnic event, approximately 50 percent from internal collisions within the device, and approximately 40 percent from preload release in the bolt or joint. Compact systems aboard future small or micro-spacecraft may be more strongly influenced by the majority of functional shock due to their small mass and distance limitations which effect attenuation. Some

examples of operational rates vs shock for pyrotechnics and NEAs are presented in Figure 2

State-of-the-Industry

In 1988 LaRC performed a survey² of NASA centers, JPL, and DOD to document pyrotechnic failures which had occurred in the previous 23 years, and identify their causes. Responders indicated that of the 84 failures which had occurred over that period (throughout the life cycle of the pyrotechnics being reported on), 12 failures occurred in flight. Of those 84 failures, approximately 42 percent were attributed to a lack of understanding pyrotechnics, 25 percent to inadequate design, 15 percent to inadequate manufacturing procedures, 11 percent to quality assurance deficiencies, and approximately 3 percent to misapplication of hardware. More recent incidents in which pyrotechnics are suspect seem to result from the misapplication of this technology. There are concerns that pyrotechnic valves may have contributed to several recent failures, and an industry wide investigative process is now underway. Over the years basic designs, materials, and manufacturing processes have been altered, and operational procedures modified. These successive changes have been made without integrated system testing to verify performance and reliability. It has been suggested that designs, once successfully tested, should be standardized. As a related issue, the pyrotechnic community is also highly dynamic and characterized by personnel mobility. Substitution of NEA technologies will introduce a whole new set of concerns. Obviously, good design, review, and test practices are mandatory requirements of a safe and reliable system regardless of the actuation method involved.

Comparing Pyrotechnics to NEA Devices

One must perform a systems level evaluation to adequately compare pyrotechnics to NEA devices. This is being done to a limited extent by members of the aerospace community. All factors (e.g., preload, handling, storage, shelf-life, transportation, environmental exposure, functioning time, simultaneity, performance margin, reusability, end-to-end monitoring, number of devices, shock level, power, heritage, reliability, weight, cost, volume, testing requirements, etc.) must be considered for a specific application. Several manufacturers, while trying to maintain device heritage, are pursuing NEAs or pyrotechnic device shock reduction strategies with varying degrees of success.

Cost Savings

Real cost savings are difficult to determine. At least two studies have suggested achievable system level savings when pyrotechnics are replaced with NEAs; TRW estimated approximately \$1M savings on the Tracking

and Data Relay Satellite System, and NRL estimated approximately \$0.5 M in recurring and approximately \$0.3 M non-recurring cost savings (total savings of approximately 24 percent) per spacecraft over a conventional hot-wire pyrotechnic system where 42 pyrotechnics are involved to perform ten release functions on their Spinning Upper Stage/Satellite Disperser. Estimated savings result from reduced overall weight, safety approvals, hazardous material handling and storage, testing and requirements, streamlined pre-launch operations, and reduced hardware needs. Some NEA devices are fully resettable and reusable without disassembly or refurbishment. During shock testing for LaRC³, Lockheed Martin Missile and Space Co. (LMMSC) and Starsys Research Corp. noted that approximately twelve tests per day could be performed using NEAs vs one test per day when pyrotechnics were involved. It should be noted that reducing device functional shock may not necessarily negate the need for shock testing. Other events (e.g., shroud separation) may now predominate in which case shock testing, albeit at lower levels, may still be required.

Replacement Commitment

No combination of present or known emerging technologies has been identified which would completely eliminate pyrotechnics. NRL is the only organization contacted to date with a firm commitment to replace most, if not all, spacecraft pyro-mechanisms with NEAs. Any remaining pyrotechnic operations would be performed with a laser initiated ordnance system (LIOS). In the telephone interview, some ESA participants also expressed an intention to replace some pyro-mechanisms with NEAs

Previous Improvements to Pyrotechnics

For approximately 20 years attempts to improve pyrotechnic device safety and reliability have been made including decreasing sensitivity to inadvertent initiation, insuring energy delivery and margin, and reducing contamination and functional shock. Exploding bridgewire initiators have been used in critical aerospace applications such as range safety flight termination. Linear explosive products using insensitive secondary explosives are well proven in aircraft, launch vehicle, and missile applications and have a significant safety record. Insensitive ordnance devices improve safety as they incorporate secondary explosives, thereby preventing a missile or bomb from being accidentally or inadvertently detonated (e.g., nuclear weapons). Exploding foil or semiconductor bridge (SCB) devices are used to initiate insensitive materials, thereby improving safety and possibly reducing costs. These latter devices are compatible with existing ignition circuitry; typically need very short-duration, high-firing current and voltage (low total energy); exhibit fast functioning times; are highly

repeatable; and permit tighter tolerance on all-fire/no-fire levels. These devices produce a high temperature plasma or shock wave output, pass the one amp/one watt (1A/1W)/five minute no-fire requirement, are electrostatic discharge tolerant, and are compatible with electronic microcircuits.

For 30 years LIOS has been investigated in over 28 projects. Some projects involved multiple event functioning. LIOS uses laser energy and fiber optic cables to replace electrical wiring or explosive transfer lines in moving energy from command systems to pyrotechnic initiators or detonators. Typically the pyrotechnic charge is initiated directly with laser energy. LIOS has potential for reducing cost, weight, sensitivity, and launch site operational restrictions of existing pyrotechnic systems. However, the only production line for the five-watt output laser diodes used is shut down due to low demand, low yields and high costs. Since August 1994, NASA, through a cooperative agreement with the Ensign Bickford Co., has sponsored LIOS work^{4 5} for solid motor ignition and launch vehicle flight termination, culminating in a 1995 Nike-Orion sounding rocket ignition/termination demonstration, and a Pegasus flight in which LIOS was used to ignite three of the nine first stage fin rockets. In November of 1995, to obtain safety data, LIOS flew as a "Solar Exposure to Laser Ordnance Devices Experiment" payload on the STS-72 Spartan Vehicle. NRL is developing a LIOS to demonstrate on their Advanced Release Technologies Spacecraft⁶ (ARTS). In a related NRL study, a weight savings of approximately 80 percent is anticipated through the use of a LIOS. Thiokol Corp.-Elkton Division is developing a LIOS which uses a low energy laser to charge a capacitor adjacent to a SCB initiator. The capacitor's energy is later discharged to effect device initiation. Thiokol estimates a systems weight savings of approximately 70 percent.

Alternative Technologies to Pyrotechnics

NEA Separation Nuts

G&H Technology Inc., Electro-Mechanical Spool and Separation Nut

The heart of various G&H NEAs is the electro-mechanical spool (Figure 3a). Linear motion of a spring loaded plunger is restrained by a sectioned spool, overwrapped by a retaining wire, the latter held in-place by a linkwire. Linkwire electrical characteristics were chosen to mimic a 1A/1W pyrotechnic initiator. Current passing through the linkwire causes it to fail, thereby releasing the retainer wire and allowing separation of the spool halves. Movement of the spring loaded plunger into the separated spool allows functioning of a toggle. The toggle allows use of two spools, thereby providing redundancy. Devices using the spool include separation nuts, pin-pullers, cable and ball release mechanisms,

tension release devices, electrical connector disconnects, and other special configurations. These devices represent mature, flight proven technology having flown on a variety of spaceflight missions. They are highly reliable, provide fast actuation, possess high energy output for limited power input, and are reusable following refurbishment. The primary disadvantage is mechanical shock. Figure 3b illustrate this function in a minimum shock separation nut. The toggle releases the stored mechanical energy in the spring loaded portion of the mechanism to effect primary device functioning. Total functioning time is approximately 20 msec, allowing for simultaneous operation of similar devices.

Shape Memory Alloy (SMA) Devices

The shape memory effect (SME), studied for six decades, became the focus of serious investigation and application with development by NRL of the nickel titanium (NiTi) family in the 1960s. The key to SME is the occurrence of a transformation which is reversible upon heating. Martensitic SMAs can undergo deformation which is retained until they are heated above a critical transition temperature at which point a reverse transformation occurs. The martensite returns to the austenitic parent phase thereby restoring the original undeformed shape. This reversible transformation is repeatable indefinitely provided the alloy does not experience excessive strain or temperature. Because of the unique reversible martensitic transformation, SMA properties show a very marked temperature dependence. The greatest force occurs when SMA is used in pure tension or compression. Finished SMA products include springs, strips, wires, and tubes for applications requiring linear motion, torsion or bending. In choosing the applicability and SMA type, one must consider the operating thermal environment. SMA has high electrical resistance, and excellent corrosion and fatigue capabilities. SMA can be electrically heated directly. When SMA wire is used in a hard vacuum, it requires approximately 1/4 the power to heat. As temperature is directly related to current density passing through the wire, care must be taken to heat, but not overheat the actuator wire. High current pulses can cause electro-magnetic interference (EMI). If using secondary heaters, some outgassing contaminants may be produced which must be captured by surrounding cold structure. SMAs generally exhibit notch sensitivity, and in some applications tend to elongate with time. SMA advantages include high work output, silent operation, design simplicity, and near step function operation. Disadvantages include environmental (thermal) capability, material notch sensitivity, improper SMA training leading to stress relaxation or pseudo-creep phenomenon, and, depending on size and configuration, the high power required to operate, and overall functioning time. There have been several SMA flight applications; as a back-up boom release on the ISEE-B spacecraft⁷, a solar array bearing pin off-load mechanism

and unlatching mechanism on the Hubble Space Telescope solar panels, and as solar panel releases on the Clementine spacecraft. As applications for SMAs expand, there is a concomitant need for alloys which can perform at higher temperatures, and much of the present research is devoted to high temperature performance. As NiTi alloys are quite expensive, another SMA research goal is to discover lower cost alloys. A nearly universal need was expressed for SMA standards, metrics, and training methods.

Hi-Shear Technology Corp. NEAs

HSTC is currently developing a NiTi actuated nut⁸, pin-puller, and cable release, all based on the same design concept. Their NEA No-Shock release nut concept (Figure 3c) is resettable, and requires from 10 sec to 1 minute to function. The bolt passes through a SMA slug containing an internal heater element. The threaded end of the bolt is engaged in a spring loaded segmented nut. When the SMA slug is heated to approximately 100 C, it shrinks, thus, relieving the preload and allowing the spring loaded segments to release the bolt. This nut can be functioned approximately 50 times.

Lockheed Martin Astronautics (LMA)-Denver NEAs

LMA has been exploring several approaches to SMA actuated NEA separation devices; two⁹ under AFPL contract, a Low Force Nut (LFN) (Figure 3d) and a Two Stage Nut (TSN) (Figure 3e), and FASSN under NRL contract. The LFN and TSN have preload capabilities of 1300 and 2500 kg, respectively, use redundant SMA initiation, and a ball detent arrangement. Both are resettable and operate in less than 50 msec. The short functioning time of the LFN and TSN is achieved by utilizing independent control electronics to preheat the SMA element to a temperature just below its transition temperature. The control electronics receive a pre-fire signal approximately 60 seconds prior to the signal for device actuation. The LFN utilizes mechanical advantage to reduce the required SMA initiation force, and incorporates SMA initiation, damper, and reset springs. The TSN utilizes SMA in an actuation cylinder (first stage) to remove bolt preload, and SMA springs (second stage) to separate the nut segments. Both concepts are baselined for flight as part of the AFPL MitiSat program and the Small Spacecraft Technology Initiative solar array release.

The FASSN (Figure 3f) is a joint LMA and Starsys Research Corp. development. It fundamentally consists of a housing containing a high lead, four start threaded bolt, rotary nut (which acts as a flywheel), and a redundant locking/unlocking mechanism. The locking/unlocking mechanism is a rotary SMA device furnished by TiNi Aerospace, Inc., but it can incorporate an electrical solenoid. The mechanism absorbs bolted

joint strain energy plus the energy in bolt retraction springs, and converts 95 percent of it into kinetic energy which upon actuation becomes stored in the flywheel. The device is fully reusable, requires minimal actuation energy, and functions in less than 20 msec. NRL, under their ARTS II Program, is currently evaluating FASSN with a 4500 to 5900 Kg preload capability, and the concept has been tested at preloads up to 17,000 Kg.

NEA Release Mechanisms

Boeing Defense and Space Group (BDSG) NEAs

BDSG is investigating several NEA separation devices, of which two use adaptations of the same NiTi mechanical fuse concept¹⁰. They use fusible elements (wires or foil) as a SuperZip^{*} replacement, and as a fusible link to perform a release function--the latter device (Figure 4a) currently being flown on the NRL ARTS I spacecraft. The first device, called the JSC-Structural Separation Feasibility Experiment, used 40, various length SMA wires (or foil elements) in an as-wrought, unannealed state as a mechanical "fuse" which acts as the main structural interface. The separation joint maintained and released a 900 Kg preload in less than a second. The elements were arranged in eight 5-element subsets. The shortest (hence least resistance) element in each subset draws the most current, heats the fastest, and releases first. Due to NiTi's inherently high electrical resistance, the material can be efficiently heated to its annealing temperature, thus drastically reducing its mechanical strength by an order of magnitude rendering it insufficient to maintain structural integrity. Power is switched to each successive subset to minimize the amount of instantaneous power required; however, this contributes to longer release times. This zipper effect would be especially useful to separate payload fairings. The concept is refurbishable--the tested hardware can be flown with only the NiTi elements being replaced. There are no shelf life limitations, safety hazards, EMI, or radio frequency interference (RFI) susceptibilities. Preload can be gradually released resulting in little or no functional shock. There is minimal contamination potential, and no sealing is required. This approach offers enhanced ground testing capability with minimal impact to surrounding subsystems. If wires and foils are used as mechanical fuses, and electrical power levels are sufficiently high so as to produce hot particles, this could produce an ignition source in an explosive environment.

The second device (Figure 4a), called the NRL-Fusible Link Release device, utilizes a single unannealed fusible element and successfully released a 900 Kg preload in less than 200 msec. The fusible element was used along with a 25:1 mechanical advantage to retain a tension

^{*} Trademark for Lockheed's patented separation joint.

link. Two spring loaded jaws capture the tension link, and the NiTi fusible link holds them in place. The fusible link requires low voltage and high current (3V/45A AC) hence a closely coupled step-down transformer and converter electronics are incorporated. Tests were also conducted at lower preloads which showed a corresponding increase in functioning time. At zero preload the release time increased approximately 50 percent. Separation times were consistently within 50 msec under identical test conditions (preload and power). Functional shock was judged to be insignificant.

Lockheed Martin Astronautics-Denver

LMA developed a resettable 900 to 4500 Kg preload high force thermal latch (HFTL)(Figure 4b). A low melting eutectic in a cylinder is hydrostatically loaded by a piston. Upon heating, the cylinder expands creating an annular orifice around the piston through which the liquid alloy flows. The piston translates to the unlatched position driven by the preload and drive springs. The spherical ended latch bolt is freed from the socket. Redundant heaters are used, and the device functions within 360 seconds. The slide gate allows latch bolt insertion or removal without heating the device.

Lockheed Martin Missile and Space Co.

The LMMSC NiTi Release Mechanism¹¹ (Figure 4c) is to be used to deploy solar panels on the Gravity Probe "B" spacecraft, and as an antenna release for the Cross Dipole Antenna Experiment. The device utilizes two-way actuation of bent NiTi rods with integral heaters for deployment to release a captive toggle--release occurs in less than 125 seconds. Preload on the toggle is approximately 66 Kg. A hole down the center of each fully annealed rod accommodates the heater. This device produces virtually no shock, is redundant, provides interface flexibility, is reusable, is resettable, and is easy to manufacture. The disadvantages are low preload capability, slow release, and lack of simultaneity. With LMMSC assistance and using the same SMA rod with external heater as a torsion bar, Stanford University demonstrated a solar array deployment mechanism concept¹². The torsion bar was mounted to a backbone structure and transmitted torque through a right-angle drive system. The drive system then rotated an arm which in-turn deployed solar panels.

NEA Pin-Pullers

G&H Technology Inc., Pin-Puller

Figure 5a depicts a commercially available, functioned G&H NEA pin-puller utilizing redundant spools. The toggle restrained a spring force of 245 Newtons acting on the retraction pin. The device functioned in approximately 20 msec. with a 12.7 mm stroke.

Starsys Research Corp., Paraffin Wax Actuator

The heart of Starsys Research Corp. devices is the High Output Paraffin (HOP) actuator (Figure 5c). Numerous devices using the HOP have flown. Other applications include actuators, restraint mechanisms, powered hinges, and cover release systems. HOP uses constrained volumetric expansion of a highly refined polymer at a well-defined transition temperature to produce large hydrostatic pressure and perform work. The polymer can be varied to change actuation temperature. The maximum non-actuation temperature currently available is 110 C. Hydrostatic pressure is translated to actuator extension through a hermetic "squeeze boot" seal. The device can be functioned repeatedly. A redundant heating element is internal to the HOP. The model IH-5055 actuator produces up to 1550 Newtons/31.75 mm stroke in approximately 180 seconds. Several items must be considered when evaluating this concept. The HOP must be thermally isolated to operate properly in cold temperatures, must be de-energized after extension has occurred, and it should incorporate a hard stop. The mechanisms should incorporate a return spring, and the actuator rod shouldn't be retracted past the zero position. The gentle stroke of the actuator needs to be taken into account when designing release mechanisms. HOPs are mature and flight proven, produce no shock, are highly reliable, and fully reversible. They produce a high force output, provide precise, repeatable positioning, and are insensitive to premature release from EMI, RFI, and electromagnetic potential (EMP). Disadvantages include long functioning time, non-simultaneous operation, high input power, and high temperature operating constraints.

TiNi Aerospace, Pin Puller and Rotary Actuator

The LeRC Small Business Innovation Research contract (NAS3-26834) for a TiNi Aerospace pin-puller was targeted towards a generic application that could be modified to meet specific requirements. The concept proven most practical resulted in a fast response device which uses a SMA wire to releases a ball-detent, which in-turn allows release of mechanical stored spring energy. The trigger mechanism (patent pending) is fundamental to TiNi's current product line of pin-pullers and rotary actuator. Figure 5b illustrates a pin-puller rated at 12.7 mm stroke and 110 Newtons. Also available are a 6.3 mm stroke and 22 Newton pin-puller, and a rotary actuator rated at 0.45 Joules with a 0.78 radian rotational capability. The rotational actuator is used to actuate the FASSN separation nut. All devices can be configured with a redundant SMA wire and a power cut-off switch. Each device can be manually reset. Planned uses of these devices are the JPL-Mars Global Observer and NRL ARTS spacecraft. Areas to consider when evaluating this design approach are SMA wire over

stressing, over straining, over heating, and functional shock resulting from the device's stored energy spring.

Other NEA Devices

Fokker Space and Systems, Thermal Knife Release Mechanism

The flight proven, patented thermal knife hold-down and release mechanism¹³ (Figure 6a) is a simple, effective device based on thermal degradation of a pretensioned Kevlar/Aramid cable. It is extensively used by the Europeans and can release all deployable spacecraft appendages. The electrically heated ceramic knife gradually melt through the cable causing degraded fibers to fail thus reducing cable cross-section. Residual tensile failure of the cable results in a low energy release, leading to extremely low functional shock. Functioning time is less than 60 seconds. The Kevlar/Aramid material thermally degrades at about 700 C, and limited outgassing from the melting process is realized. The spring loaded "blade" typically heats to 700 C with a 1200 C maximum rating. The device requires a voltage regulator to remain within its operating range. The device can be tested in-situ for approximately five seconds without causing cable damage. The device exhibits low weight and overall system costs, has a two year shelf life, and can be reused reliably up to eight times. Fokker has been negotiating with HSTC to become their U.S. representative.

TiNi Frangibolt

The commercially available, flight proven Frangibolt (Figure 6b) uses a SMA actuator to break a prenotched titanium bolt in tension. An external silicon heater causes the actuator to elongate when heated, transition temperature being approximately 100 C. The notched bolt stretches until it fails at the notch providing controlled breakage. This process reduces preload in the joint and produces a reduced functional shock. It is reported that some functional shock measurements have been made indicating a reduction of two orders of magnitude over pyrotechnic devices. Currently available Frangibolts can accommodate up to a 910 Kg preload and function in less than 25 seconds. The SMA actuator is reusable after cooling and recompression to its preactuation length. Some heater outgassing may be experienced. Several critical details must be understood to produce a working Frangibolt type device. Material characterization and proper bolt pre-notching are essential to the device's operation. The user must avoid bolt bending loads. Another concern, since resolved, was maintaining heater contact with the SMA slug during heating as the slug diameter shrinks. Special attention must be paid to heater design¹⁴, or its attachment, to insure sufficient contact. To control debris the user may want to incorporate lockwire on the bolt head.

Some Comparative Functional Shock Test Results and Device Physical Characteristics

Massachusetts Institute of Technology-Lincoln Laboratory in the mid 1970's, and later LaRC in March of 1985 tested a G&H pin-puller (Figure 5a) and found high levels of functional shock. At that time, LaRC's comparison was made between the G&H device and several pyrotechnic devices. LaRC's tests were conducted on a biaxial Hopkinson bar and on a LaRC Halogen Occultation Experiment instrument mass model. From the Hopkinson bar, recorded peak g levels for the G&H device and a NASA Standard Initiator (NSI) fired Space Ordnance Systems (SOS) Incorporated pin-puller were: in the transverse and axial directions, 680 and 1278 g's for the G&H, and 923 and 1250 g's for the SOS devices, respectively. The G&H pin-puller overall acceleration spectrum was below that of the various pyrotechnic pin-pullers tested over most of the frequency range. The SOS pin-puller was previously obtained for the NASA VIKING Mars mission.

In February, 1995, after presenting survey results to NASA's PMC, LaRC was invited to participate in a cooperative, cost sharing effort with LMMSC to evaluate functional shock produced by several pyrotechnic and NEA release devices. A task was initiated under an existing contract (Reference 3) to objectively investigate application of some NEAs to reduce small spacecraft and booster separation event shock. The primary goal was to demonstrate NEA mechanisms for release functions and compare resulting shock levels with those produced by standard pyrotechnic devices. Five different release mechanisms, immediately available from several sources, were tested on a single instrumented structural simulator, with and without mass simulators. This simulator represented a proposed Lockheed Martin Launch Vehicle Commercial Remote Sensing Satellite radial panel. The pyrotechnic separation nuts consisted of a 3/8-inch diameter Ordnance Engineering Associates (OEA) device, and HSTC 1/2-inch and 8 mm devices. The NEA devices were a G&H 3/8-inch diameter minimum shock separation nut, and FASSN release mechanism device (Figure 3f). The FASSN device, an engineering feasibility demonstration unit, was added to the task after it became apparent it might substantially alleviate functional shock.

Figure 7 compares resultant shock response spectra (SRS)(Q=10) for the ninety-fifth percentile level for these devices. Results are for multiple tests of the same release device design. The OEA 3/8-inch diameter separation nut, preloaded to 3175 Kg, produced the highest SRS, followed by HSTC's 1/2-inch and 8 mm diameter separation nuts. HSTC's devices were not optimized for "pyroshock" output. The HSTC 8 mm diameter separation nut could only be preloaded to 1225 Kg. The G&H separation nut generally showed lower overall levels when compared to the pyrotechnic

devices. The FASSN concept, which could only be preloaded up to 1905 Kg, produced the lowest SRS. In separate tests, in which FASSN preload was varied (1360 to 1905 Kg), increasing preload had no observable effect on SRS level. Figure 8 compares LMA SRS data at various preloads for several NEA release nuts (i.e., FASSN, LFN, TSN, and G&H low shock) against HSTC low-shock and OEA pyrotechnic devices. Device size and preload are indicated on the figure. These tests were performed on the LMA shock test plate. From these results it is obvious that several NEA release nut concepts are available to relieve functional shock concerns. Table I consolidates the SRS data herein into a more easily understood format, comparing the NEAs and pyrotechnics tested to the G&H low shock nut which was used as the baseline. The table compares the order of magnitude difference in SRS over the frequency range as compared to the baseline. Relative position in the table, with regard to the baseline, indicates a lessening or worsening of functional shock. Table II lists physical characteristics of some NEA release mechanisms described herein, some of these being used in the comparative functional shock tests.

In June 1995, HSTC conducted tests for the Lockheed Martin Aerospace-Princeton EOS-AM Program, using optimized internal cushioning in their 3/8-inch diameter low-shock pyrotechnic separation nut initiated by two NSIs. They demonstrated shock reduction factors of approximately 2.7 and 4.6 in peak g's when using a 4536 and 2268 Kg preload, respectively. Tests were conducted on HSTC's shock plate.

Possible Related Technologies

Starsys Research Corp., Smart, Passive Solar Panel Array Drive Mechanism

Although not an NEA, a unique application using the paraffin actuator was presented by Starsys; namely, a Smart, Passive Solar Panel Array Drive (SPSPAD) mechanism (Figure 9). SPSPAD is a passive, fully autonomous solar tracking and drive mechanism which can be incorporated into a spacecraft where passive/autonomous 1 to 10 degree accuracy is desired. It incorporates the paraffin actuator, a linear to rotational motion transmission, a sun sensor, an electrical circuit, and a hinge load bearing structure. It is approximately 2.54 cm diameter, 15 cm long, weighs 0.68 Kg, and produces about 14 Joules of work. The power required to drive the mechanism, which is derived from the solar panel, will range from an average of one to 10 watts depending on rate and torque outputs required.

Spacecraft power production capability is a general mission constraint. Small, simple, low-cost spacecraft have used body-mounted solar cells or simple fixed deployable solar panels to generate power. Increased or improved power production involves more solar array

area, deployments, articulations, increased cell efficiencies, or a combination of these. These methods to increase or improve power production effect cost, complexity, and reliability per watt of power produced, and all methods trend in the wrong direction. The SPSPAD device has potential to provide a cost-effective, easily integrated, and reliable solution to power production limitations; thereby optimizing solar power generation, saving payload weight, volume, power, command and control functions, and costs associated with same.

Starsys based their analysis on a 3-axis stabilized, nadir-pointing bus with body mounted solar panels on the velocity and anti-velocity faces. Panels could be deployed from the spacecraft's anti-nadir end to either a 1.57 radian fixed position or articulated from the zero stowed position to 3.14 radians. Comparing results to a system employing a standard stepper motor drive, Starsys drew the following conclusions regarding SPSPAD: drive mass decreased more than 60 percent, functional power decreased approximately 70 percent, drive costs were reduced more than 55 percent, considerably less volume was required, and lower parts count and complexity were coupled with higher reliability. The satellite would have increased power generation efficiency allowing improved mission capabilities.

SPSPAD development should provide extremely reliable actuation from a lightweight mechanism with a calculated transmission efficiency exceeding 90 percent. SPSPAD would operate independently of a flight computer and drive electronics, supply its own control (no software is required), eliminate encoders (it will support position feedback if required), and eliminate high-frequency drive vibrations. It would require simple power input from the solar array and would be controlled by a simple electrical circuit with no other electronic parts required. It would require a simple wet lubricant system, but it would not incorporate any operating parameters outside of typical lifetime issues which could trigger premature failure mechanisms. This concept could be used for antenna and wide band instrument pointing platforms, louvers and radiator covers, instrument covers and shades, instrument autonomous solar exposure protection, and solar collector array passive control for terrestrial power or thermal generation.

Thiokol Corp.-Elkton, Safe and Arm (S&A) and Initiation System

Thiokol Corp.-Elkton Div. has developed a new concept for pyrotechnic device S&A and initiation¹⁵ that incorporates several improvements made with pyrotechnics. Thiokol is developing for the mining industry (Figure 10) a combination miniaturized, multiple function, remotely programmable, low-

powered, optically initiated, electrically fired, inexpensive, S&A and initiation system. Their approach can mitigate significant LIOS associated disadvantages, namely; high power, optical damage, high-powered laser diode availability, higher weight, and larger volume. The heart of this system is incorporated in the initiator. Based on the mining requirement, the system consists of a laser (referred to as the blast machine) which sends out optically coded signals via a fiber optic cable to a terminal located up to 305 m away. The terminal sends the signals to the initiators on ten individual fiber optic channels. Each channel can accommodate up to 150 separately programmable initiators whose individual functioning time can be set in 1-msec increments up to 500 msec. Each initiator has a built-in light emitting diode which allows the blast machine to perform an end-to-end BIT to verify system integrity of each initiator.

Within the initiator (Figure 10), the received laser signal charges a capacitor via a photodiode. The capacitor has a built-in bleed for discharge in the event initiation is halted. The capacitor cannot discharge energy to the SCB initiator unless a properly coded 16-bit fire-signal is received. Solid-state microelectronics are used to decode signals, set timing, perform status monitoring, and control capacitor discharge. Thiokol is extending development of this system to launch vehicles and upper stages. The system has application to aircraft egress, weapons delivery, or spacecraft functions where multiple, sequenced events are required. In one study Thiokol estimated such a system might weigh only 15 percent of present hot wire systems, occupy only 20 percent of the volume, and require only 10 percent of the input energy if used on a typical two stage launch vehicle to perform two ignition and one separation functions. Optical cables can even be routed through composite structures by using SMA to form the initial cavity in the structure.

The Thiokol concept offers potential for a miniaturized S&A/initiating system that can perform multiple functions with no reduction in safety over currently used electro-mechanical designs. These combined technologies marry new technology (i.e., low-power laser diodes, microelectronics, and digital coding) with well-established, highly reliable state-of-the-art (i.e., SCB initiators); thereby providing a smooth transition between existing and emerging technologies which would assist acceptance of the latter. Figure 10 shows a sectioned view of a typical blasting cap with microelectronics substituted, and compares a NSI to the SCB and a miniature initiator from ICI America. Partially due to standardization, the current NSI costs more than \$400 each. The NSI weighs 9.9 grams. Both factors do not lend themselves readily to cost reduction or miniaturization. The ICI miniature initiator header assembly costs approximately \$1.20 each and weighs 0.15 grams. The SCB, which could be incorporated into

the ICI miniature initiator header assembly, costs approximately \$1.

The Thiokol concept provides a system possessing these advantages: every function has a separate S&A; the system is inexpensive; reduced weight and envelope requirements will be realized; the system provides a single upgradable initiation control module to service multiple functions; functioning time is fast; improved launch responsiveness will be realized through BIT capability; it meets MIL-STD-1901 for in-line ordnance; optical isolation provides protection against ESD, RFI, and EMP; it provides digital coding and multiple inhibits for increased safety; the fiber optic cable eliminates explosive transfer assemblies which provides safer handling, eliminates explosive aging (service life) issues, and improves routing flexibility between stages. This concept appears to be a fruitful area worthy of further exploration, especially in smaller spacecraft incorporating multiple functions.

Naval Air Warfare Center-China Lake, Intermetallic Thermal Sensor/Trigger

Naval Air Warfare Center, Weapons Division-China Lake, CA, is developing a device for active venting systems that mitigate the fast cook-off response of various munitions. This device has been successfully integrated into the Advanced Medium Range Air-to-Air Missile thermally initiated venting system (TIVS) enabling the TIVS to mitigate intermediate-to-slow cook-off thermal threats¹⁶. This miniature, passive intermetallic thermal sensor/actuator (Figure 11) may prove useful in conjunction with an external heat source and NEA technologies (e.g., SMA, paraffin actuator, thermal knife) to function non-time critical spacecraft separation/release/deployment mechanisms. This device operates independently of all other systems, requiring no power except an external heat source (e.g., solar or atmospheric entry heating) to raise its temperature sufficiently to the initiating temperature. This passive device consists of a thin walled steel shell containing alternating wafers of lithium and tin alloy with copper coating the tin alloy to serve as a diffusion barrier. As the device is heated and the lithium alloy begins to melt, a spontaneous and vigorous, gasless, exothermic intermetallic reaction occurs providing energy to initiate a thermite charge in the end of the device. This end charge produces the principal thermal output of the device (the tip can approach 1093 C). The process is fully contained and confined. Temperature at which the reaction initiates can be tailored from approximately 149 to 177 C, and the Army-Picatiny Arsenal, NJ is investigating initiation temperatures down to 93 C. There is no inadvertent actuation to within 1.6 C of the trigger temperature. The device has functioned successfully after cold soaking to -84.4 C. The current device concept is compact (approximately 3.8 cm, 0.76 cm diameter, 0.71 cubic cm), lightweight

(approximately 25 grams), low-cost (approximately \$400 each, produced in quantity), is insensitive to all other external stimuli, has a long shelf life, and is non-explosive. There is no other similar system which has the potential weight, volume and power reductions.

Existing Government Programs

NASA-

HQ - Laser initiation program for pyrotechnic improvement.

JPL - Developed SMA wire pin-puller as a fail-safe actuator for Hubble Aperture Window Mechanism in Wide Field Planetary Camera II. (Contact: Virginia Ford).

JSC - Four year program studying pyrotechnic alternatives, particularly SMAs. Patented a SMA actuated segmented release nut. Have on-line document archiving system for pyrotechnics and alternatives. (Contact: Darin McKinnis).

LaRC - Evaluated functional shock of various NEAs with pyrotechnic devices (Reference 3). Complete. (Contact: Melvin Lucy).

LeRC - SBIR Contract No. NAS3-26834 with TiNi Aerospace developing pin-puller for aerospace applications. Complete. (Contact: Doug Rohn).

MSFC - Program for electromechanical actuation applicable to release mechanisms as alternatives to spacecraft pyrotechnics (e.g., some Hubble Telescope appendages). (Contact: Charlie Cornelius or W. Neil Myers).

Other Government Laboratories-

AF/Phillips Laboratory; Kirtland AFB - SMA actuation and release devices program, also a general program for smart actuators and materials. AFPL conducts MiniSat flights demonstrating new technology. (Contact: Alok Das or Rodney Galloway).

ARL-Adelphi - Semi-conductor bridge (SCB) program for improvements to pyrotechnics. (Contact: Robert Reams).

NRL - Use of pyrotechnic alternatives and laser initiator technology in ARTS program. Previous work on Clementine spacecraft. Procurement of FASSN for evaluation. (Contact: Bill Purdy).

NAWC-China Lake - Heat source device, exothermic intermetallic thermal sensor/trigger. (Contact: James Gross).

Summary of Findings/Conclusions

Shock and safety issues have raised questions concerning continued use of pyrotechnics on space missions. Additionally, in today's environment of smaller spacecraft and the need to reduce overall system costs, the emergence of new technologies provides alternative methods to accomplish the functions of traditional pyrotechnic devices. Alternative devices exist which have been or are planned for use on

spacecraft. The majority of the alternative technologies perform separation and deployment functions. These mechanisms include G&H spool based devices, Fokker thermal knife, Starsys Research Corporation FASSN and paraffin wax actuators, and shape memory alloy (SMA) devices (e.g., TiNi Frangibolt). NEA mechanisms are typically either reusable or refurbishable, allowing for testing of the actual flight unit. No single technology, however, is a panacea. Some devices, such as the Frangibolt and the G&H spool based mechanisms, still produce high levels of functional shock. Paraffin and other SMA based devices can provide gentle, shock-free release but cannot perform critically timed simultaneous functions due to long actuation rates. A flywheel-nut release device possesses significant potential for reducing functional shock while activating instantaneously.

Although three alternative technologies (electro-mechanical spool, paraffin actuator, thermal knife) are considered mature, flight proven technologies, continued development is in progress. SMA devices are typically the least mature of the technologies, although one SMA device, the Frangibolt, has been flown. Standards for all NEAs are needed, specifically in the areas of material characterization, functioning rates, and test methods. A systems level approach will be needed to assure successful application of the new technologies. Recognizing that pyrotechnics will remain viable, industry and government are continuing to investigate technology improvements. Thiokol-Elkton is developing a miniaturized, optically initiated combination safe and arm firing system. The Navy at China Lake has developed a passive detection and initiation device that may be incorporated as an energy source for both pyrotechnics and NEAs.

Several government and industry laboratories are interested in potential partnerships to develop alternative technologies with SMAs having the most commercial interest. Several NASA centers and government installations have ongoing or completed programs in the area of pyrotechnic alternatives. Industry expressed a desire to cooperate with NASA to develop NEA standards to which their innovations could be shown to conform. An inter-agency ad-hoc team should be formed to define a need and strategy for pyrotechnic replacement technology efforts. This team would conduct a further investigation into needs of the user community. The team would perform industry/government system-level cost-benefit studies of real spacecraft to determine application foci and performance requirements for NEAs. The investigation would culminate in an industry/government workshop to prioritize identified technology needs and determine resource requirements and schedules.

To develop NEA standards and metrics, an NEA Steering Committee, similar to the Pyrotechnics

Steering Committee, should be established. The committee should initially include members of the ad-hoc team and representatives from industry, academia, DOD, and others. NASA should pursue opportunities for flight of NEAs on spacecraft where reasonable. NASA should allocate resources to develop NEAs. SBIR and IPD team contracts, and partnerships should be considered. Pyrotechnic replacements for functions such as stage/shroud separation and high pressure valving should be considered.

Recommendations

The LaRC team recommends several actions as a result of this investigation:

1. Form an inter-agency ad-hoc team to define need and strategy for a pyrotechnic replacement technology efforts.
 - a. Define user priorities, and payoffs. Conduct further explorations of needs with the user community as LaRCs time and initial scope constraints prevented an in-depth investigation of this aspect of the pre-Phase-A study.
 - b. Compare NEAs to pyrotechnics using a system-level cost-benefit analysis. Using in-place contracts, conduct up to two industry/government system level cost benefit trade studies of real spacecraft to define application foci and performance requirements.
 - c. Define specific funding requirements for any needed development activity.
 - d. Conduct industry/government workshop to prioritize technology needs and schedules.
2. Solicit Small Business Innovation Research (SBIR) contracts; form partnerships with government laboratories, DOD, industry. Conduct up to three competed IPD team contracts (expect cost sharing) to evaluate non-pyro stage/shroud separation devices, valves, latches, and releases, and demonstrate "soft" pyros and NEA devices capable of satisfying the identified needs.
3. Develop NEA standards, metrics, and training methods. Standard specifications needed include: basic material properties (comprehensive engineering database), basic material procurement, processing (e.g., heat treatment, tempering, hot/cold working), mechanical properties, training (e.g., stretching and heating cycles, percentage of stretch, methods to increase recoverable shrinkage), test methods, limitations of operability and amnesia, and terminology.
 - a. Establish an NEA Steering Committee (similar to the Pyrotechnic Steering Committee).
 - b. Include NASA participation in the SMA Association.
4. Pursue opportunities for flight of NEAs on spacecraft, and educate the spacecraft community. Remain competitive with others flying NEAs.

- 1 Moening, C.J., "Pyroshock Flight Failures," Proceedings of 31st Annual Technical Meeting of the Institute of Environmental Sciences, May 3, 1985.
- 2 Bement, L.J., "Pyrotechnic System Failures: Causes and Prevention." NASA TM 100633, June 1988.
- 3 Contract NAS1-19241, "Mission Systems and Operations Analyses of NASA Space Station Freedom Advanced Concepts," Task 31, "Low-Shock Booster Release System Engineering Feasibility Demonstration."
- 4 2nd NASA Aerospace Pyrotechnic Systems Workshop, Sandia National Laboratories, Albuquerque, NM, NASA Conference Publication 3258, February 8-9, 1994.
- 5 Applications of Laser Initiated Ordnance Technology Transfer Workshop, NASA-GSFC, NASA Conference Publication 10182, April 25-26, 1995.
- 6 Purdy, B., NRL; Fratta, M., Allied Signal Tech Serv.; Boucher, C., Ensign Bickford Aerospace, "Laser Ordnance System for NRL's ARTS Program," AIAA Paper No. 93-2361, AIAA/SAE/ASME/ASCE 29th Joint Propulsion Conference and Exhibit, Monterey, CA, June 28-30, 1993.
- 7 Brook, G.B., Fulmer Research Institute, Ltd., Powley, D.G., British Aircraft Corp., Ltd., "The Design and Testing of a Memory Metal Actuated Boom Release Mechanism," 12th Aerospace Mechanisms Conference, NASA Ames Research Center, 1978.
- 8 Webster, R.G., "No-Shock Separation Mechanism," Patent No. 5,248,233, September 28, 1993, Hi-Shear Technology Corp.
- 9 Carpenter, B., Clark, C., Weems, W., Lockheed Martin Astronautics, Denver, CO, "Shape Memory Actuated Release Devices," Proceedings of Society of Photo-Optical Instrumentation Engineers, 1996.
- 10 Robinson, S.P., Boeing Defense & Space Group, "A Very Low Shock Alternative to Conventional, Pyrotechnically Operated Release Devices," 2nd NASA Aerospace Pyrotechnic Systems Workshop, Albuquerque, NM, February 8-9, 1994.
- 11 McCloskey, T.E., Lockheed Martin Missile and Space Co., "Non-Pyrotechnic Release System," Patent No. 5,192,147, March 9, 1993.
- 12 Choi, S.J., Lu, C.A., Feland, J., Stanford University, Stanford, CA, "A Nitinol-Based Solar Array Deployment Mechanism," 30th Aerospace Mechanisms Symposium, NASA Conference Publication 3328, Hampton, VA, May 15-17, 1996.
- 13 VanHassel, R.H.A., Fokker Space BV, Leiden, The Netherlands, "The ARA Mark 3 Solar Array Design and Development," 30th Aerospace Mechanisms Symposium, NASA Conference Publication 3328, Hampton, VA, May 15-17, 1996.
- 14 Busch, J.D., Bokaie, M.D., TiNi Aerospace, Inc., Fremont, CA, "Implementation of Heaters on Thermally Actuated Spacecraft Mechanisms," 28th Aerospace Mechanisms Symposium, LeRC, Cleveland, OH, NASA Conference Publication 3260, May 18-20, 1994.

15 Gregg, W.B., Jr., Thiokol Corp.-Elkton Div.,
 "Semiconductor Bridge Electro-Optical Safe and Arm
 Device," Applications of Laser Initiated Ordnance
 Technology Transfer Workshop, NASA-GSFC, NASA
 Conference Publication 10182, April 25-26, 1995.

16 Diede, A., McCune, W., NAWCWPNS, China Lake,
 CA, "Intermetallic Thermal Sensor Development and
 Integration into AMRAAM TIVS," CN-162481,
 NAWCWPNS-TP-8093, December 1992.

Funct. Shock	Device	Supplier	Size inch	Funct. Time, ms	Test Method	Preload K kg	Max g Level x 1000	Order of Magnitude Chg Over Freq. Range
Lower ▲	TSN	LMA	3/8	50*	plate	4.5	0.002	0.8-3.2 less
	FASSN	LMA	1/2 3/8	< 20	plate panel	4.5 1.9	0.07 0.44	0.8-1.8 less 0.3-0.7 less
	LFN	LMA	1/4	50*	plate	1.4	0.4	0.9-1.9 less
	Low Shock	G&H	? 3/8	< 20	plate panel	? 3.2	3.8** 1.1	Baseline
Higher ▼	Pyro***	HSTC	8 mm	< 5	panel	1.2	1.7	0-0.4 incr.
	Pyro***	HSTC	? 1/2	< 5	plate panel	? 3.2	5.6** 2.8	0.4-1.1 incr. 0-0.8 incr.
	Pyro	OEA	1 3/8	< 5	plate panel	16.8 3.2	22 17	1.1-1.5 incr. 1 incr.

- * Requires Separate Electronic Heater Controller
- ** Designated as Low Shock
- *** Uncompensated

Table 1. Separation Nut Comparison

	G&H Spool	LMA FASSN	LMA LFN	LMA TSN	HSTC No Shock	LMA HFTL	BDSG Fuze Link	TiNi Frangibolt	LMSC Release Sys
Initiator	redundant spool	redundant NiTi actuator	redundant SMA spring	redundant heater, SMA cylinder	redundant heater, SMA slug	redundant heater, liquid metal	NiTi fuze element	redundant heater, SMA slug	redundant NiTi rod
Size, bolt, in. body, cm	0.375 5Dx5.5L	0.5 4.6 sq x13	0.25 3.8Dx8.9L	0.25 3.8Dx7.6L	0.375 4.1Dx6.4L	0.19 2.5Dx6.4 L	0.25 8.9x8.1x 3.8	0.25 2Dx3.2L	18x11x2.5
Weight, gms	225	800	250	300	250	-250	-225	71	453
Input Energy, J	~ 2 to 4	~1.5	90	90	10K	10K	35	375 - 1750	4750
Fly Tested Part	mech. yes	yes	yes	yes	yes	yes	mech. yes	bolt not refllyable	yes
Safety/ Handling	S/A req'd	excessive heat	excessive heat	excessive heat	excessive heat	excessive heat		excessive heat	excessive heat
Funct' Shock, g	~3000	<200	<500	<100	<800	0		~2000	
Response Time	15-30 ms	<20 ms	<50 ms (a)	<50 ms (a)	20 s	300 s	<250 ms (b)	15-25 s	<125 s
Pre-Load, kg	9K	10K	3K	8K	12K	1.3K	<2K	2K	0.15K
Simultaneity	yes	yes	yes	yes	no	no	no	no	no
# of Ops./ Uses	1 reuse mech.	50+	100	100	20-100	70+	1 mech. 50+	1 mech. 50+	200+
Reset w/o Disassem'	no	yes	yes	yes	yes	yes	no	no	yes
Survival Temp, C	-150 to 140	-40 to 71	-40 to 70	-40 to 62	-40 to 71	-40 to 80	-100 to 100	-51 to 93	
Contaminate	no	no	no	no	no	no	limited	no	no
Status	space flight.	qualification	proto-type	proto-type	proto-type	proto-type	qualification	1 flt., Clementine	proto-type
Availability	comm. product	comm. product	comm. product	comm. product		comm. product		comm. product	
Reliability	high	TBD	TBD	TBD	TBD	TBD	TBD	TBD	TBD
Application	sep. nut/bolt	sep. nut	sep. nut	sep. nut	sep. nut	release mech.	release mech.	sep. bolt	release mech.
Cost, Include Devel	moderate	high	moderate to high	moderate to high		moderate	low to moderate	low	

- (a) Requires separate electronic package to initially heat SMA near transition temperature.
(b) Requires separate closely coupled step-down transformer and voltage converter.

Table 2. Matrix of NEA Separation Devices Studied.

Device*	Pyrotechnics	G&H Spools	Paraffin Wax	Thermal Knife	SMA Devices
Pin pullers		H	M		M
Separation Nuts/Bolts		H			H-M
Release Mech.		H	M	M	M-L
Actuators		H	H-M		M-L
Switches		H			
Powered Hinges			H-M		M-L
Valves			L		

H ■ -High M ■ -Medium L ■ -Low □ - none

*Does not include Launch-vehicle or Booster-type applications

Figure 1. Developed spacecraft applications of NEAs.

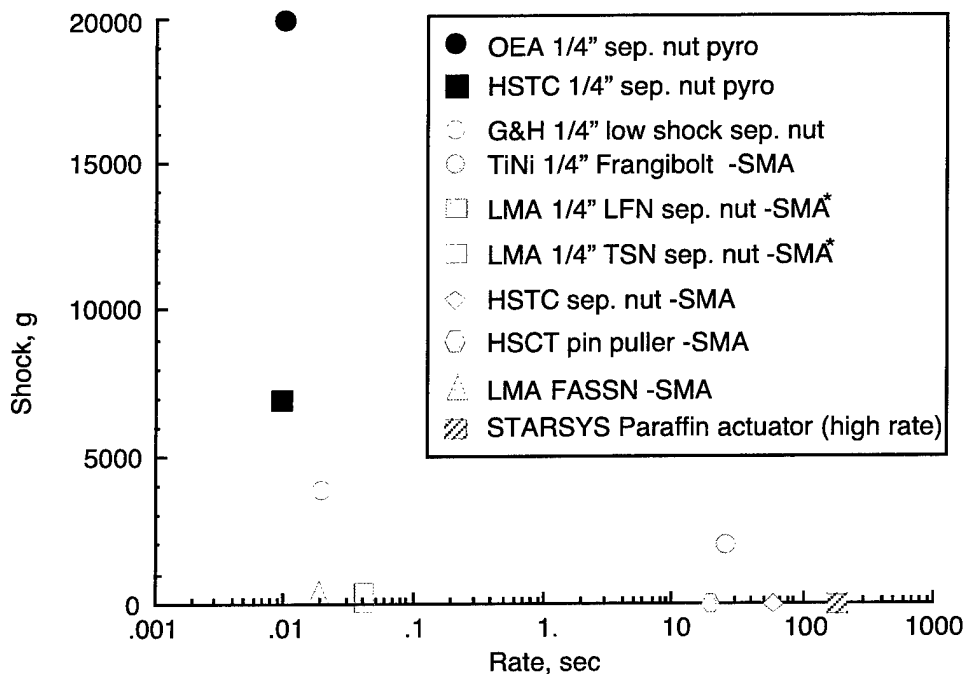

* From AFPL sep. nut device comparison study;
Rate is for preload release only, not total functioning time.

Figure 2. Functional shock versus operational rates for some pyrotechnics and NEAs.

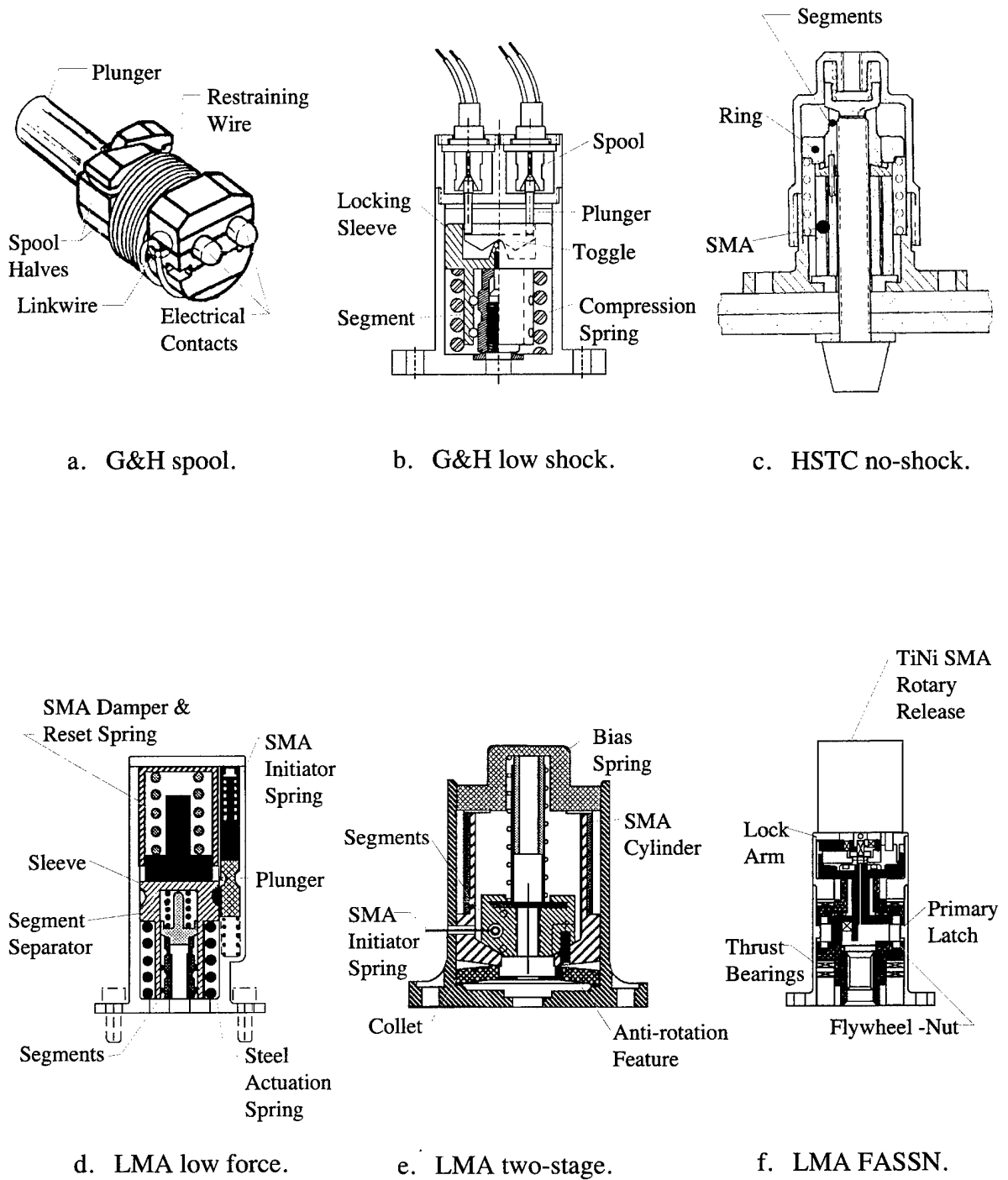

Figure 3. NEA Separation nuts - pre-release.

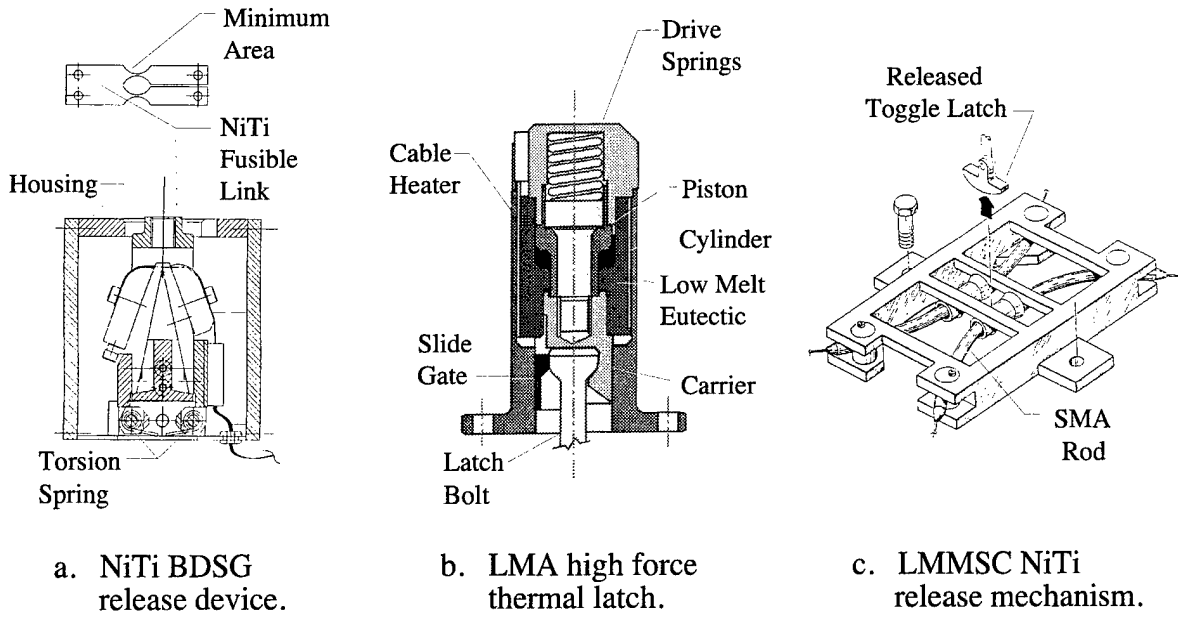

Figure 4. NEA release mechanisms.

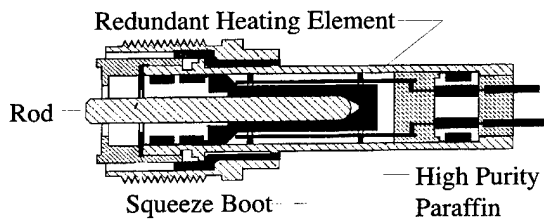
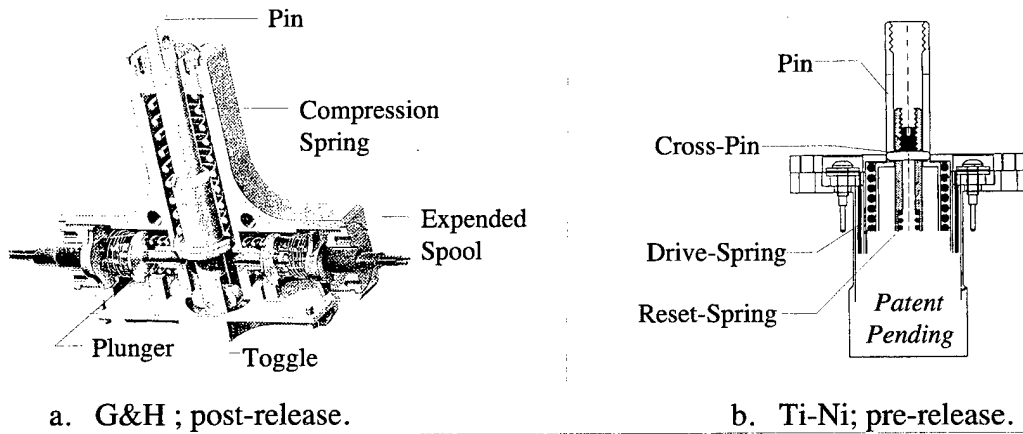
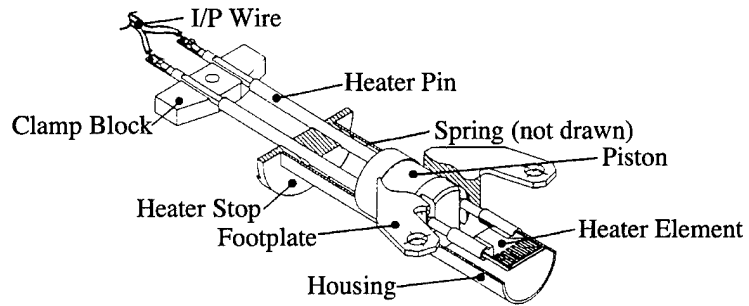
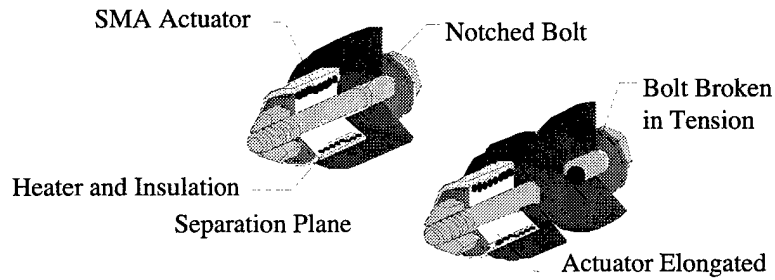

Figure 5. NEA pin-pullers.



a. Fokker thermal knife.



b. Ti-Ni Frangibolt.

Figure 6. Other NEA release devices.

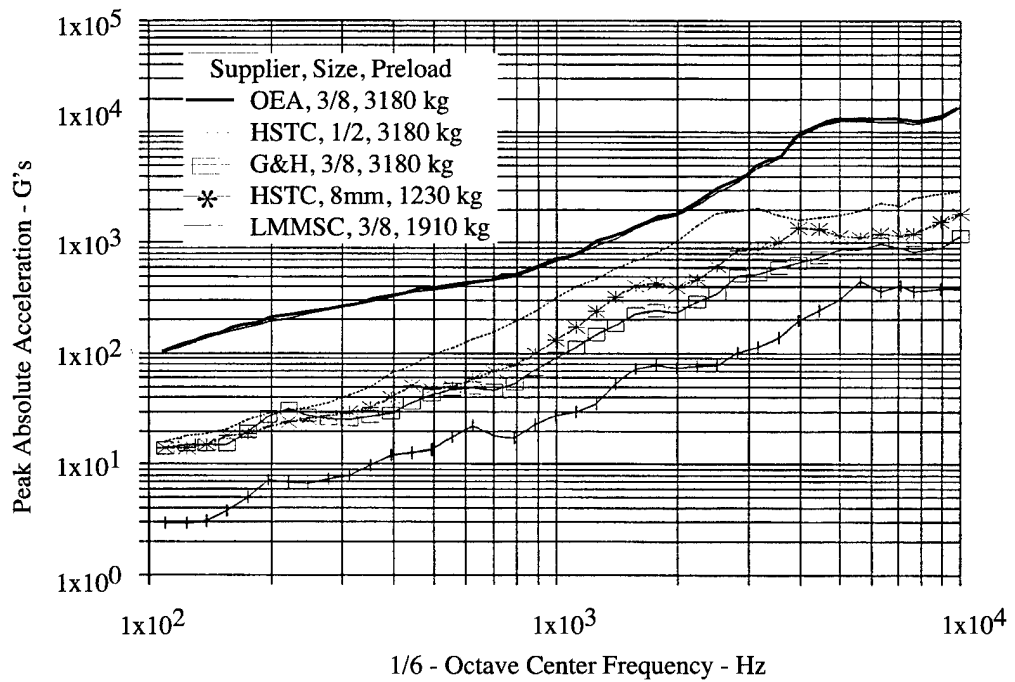

Figure 7. Device comparison, LMMSC panel simulator with masses, SRS ($\phi=10$), 95th percentile levels.

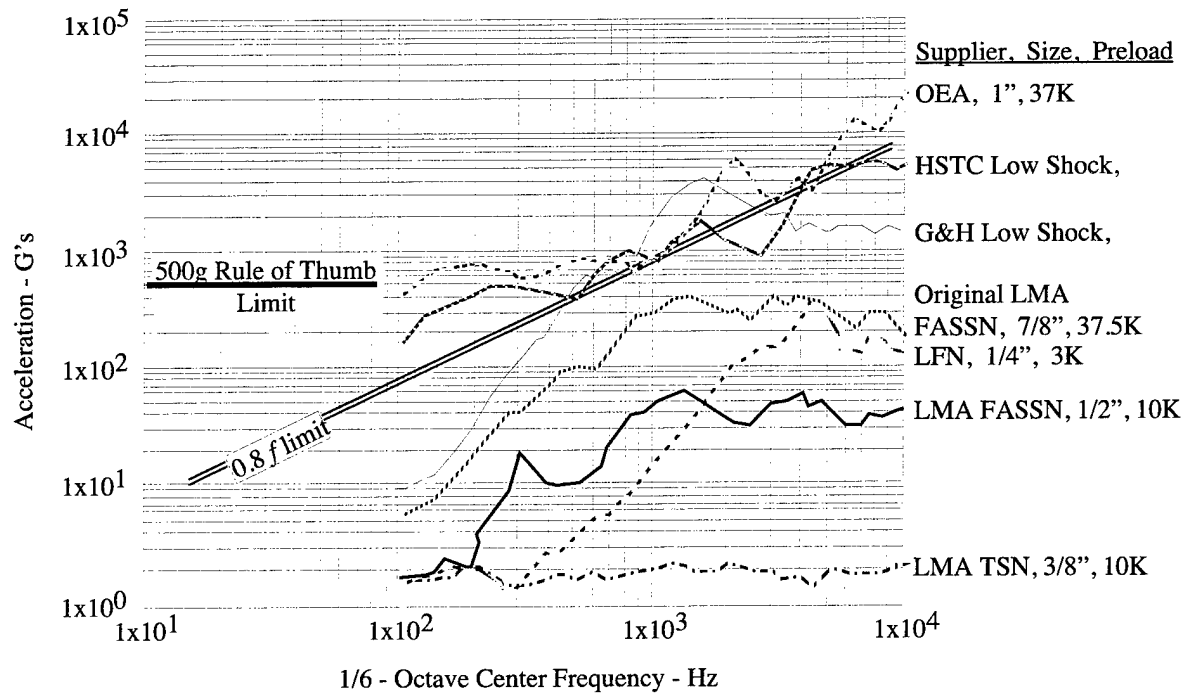

Figure 8. LMA plate tests - functional shock comparison.

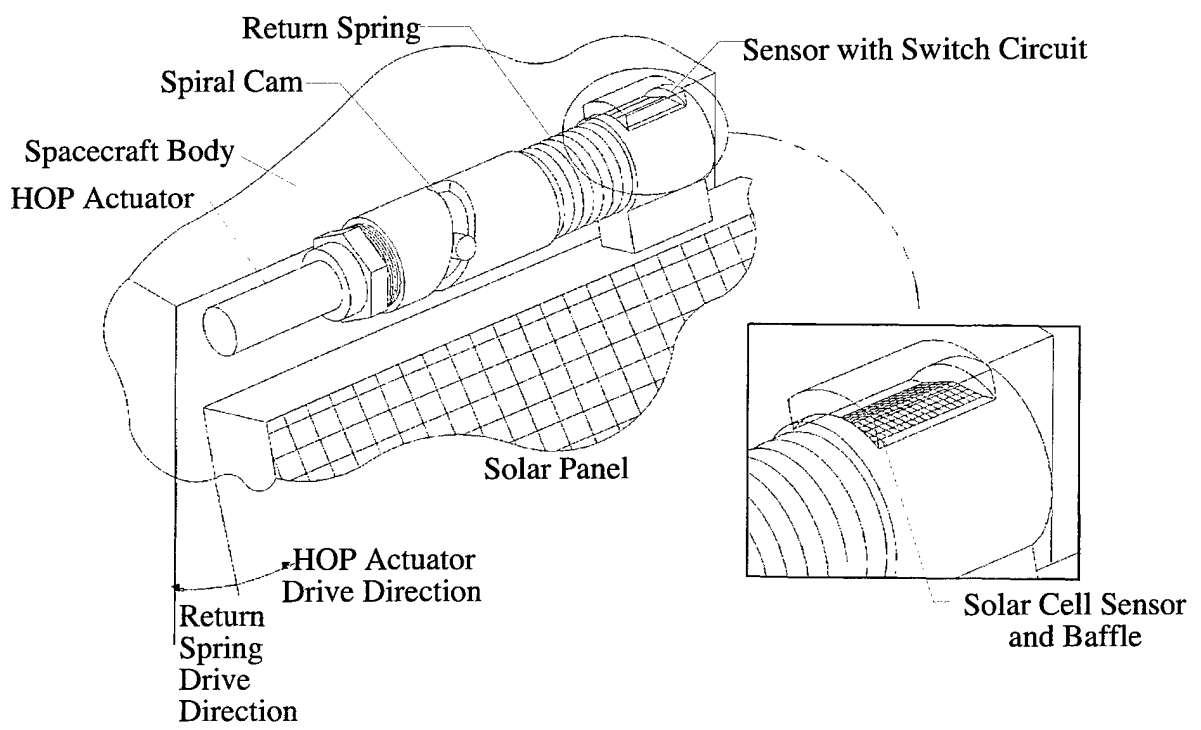

Figure 9. STARSYS Smart Passive Solar Panel Array Drive element layout.

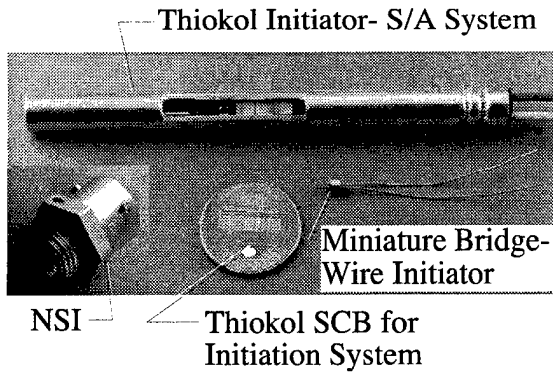

Figure 10. Thiokol miniaturized, programmable delay, SCB, electro-optical S/A and initiation system.

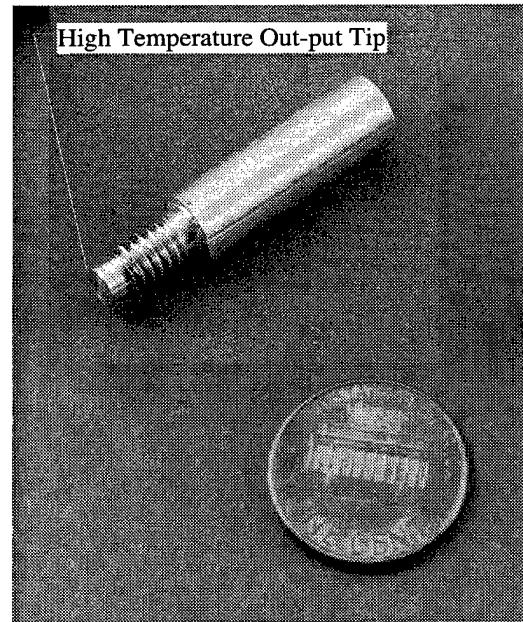

Figure 11. NAWC China Lake Intermetallic Thermal Sensor/Trigger.