



**US Army Corps
of Engineers**
Waterways Experiment
Station

Final Report
CPAR-GL-97-1
May 1997

CONSTRUCTION PRODUCTIVITY ADVANCEMENT RESEARCH (CPAR) PROGRAM

Controlled Field Tests of Retrievable Microtunneling
System with Reaming Capabilities

by

David Bennett, Kimberlie Staheli

Approved For Public Release; Distribution Is Unlimited

DTIC QUALITY INSPECTED 3

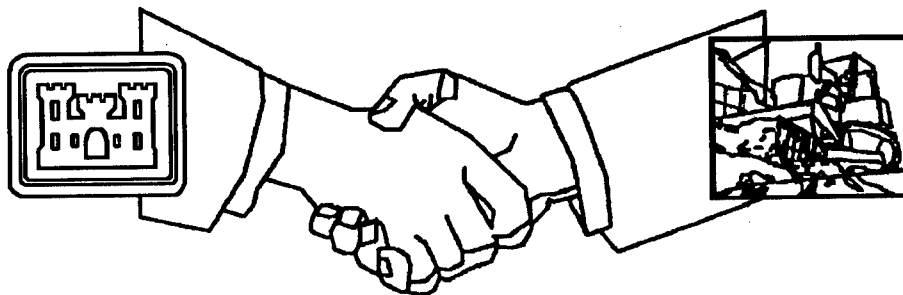

19970702 021

**A Corps/Industry Partnership to Advance
Construction Productivity and Reduce Costs**

The contents of this report are not to be used for advertising, publication, or promotional purposes. Citation of trade names does not constitute an official endorsement or approval of the use of such commercial products.

The findings of this report are not to be construed as an official Department of the Army position, unless so designated by other authorized documents.



PRINTED ON RECYCLED PAPER

**Construction Productivity Advancement
Research (CPAR) Program**

**Technical Report
CPAR-GL-97-1
May 1997**

Controlled Field Tests of Retrievable Microtunneling System with Reaming Capabilities

by **David Bennett, Kimberlie Staheli**

**U.S. Army Corps of Engineers
Waterways Experiment Station
3909 Halls Ferry Road
Vicksburg, MS 39180-6199**

Final report

Approved for public release; distribution is unlimited

Prepared for **U.S. Army Corps of Engineers
Washington, DC 20314-1000**



**US Army Corps
of Engineers**
Waterways Experiment
Station

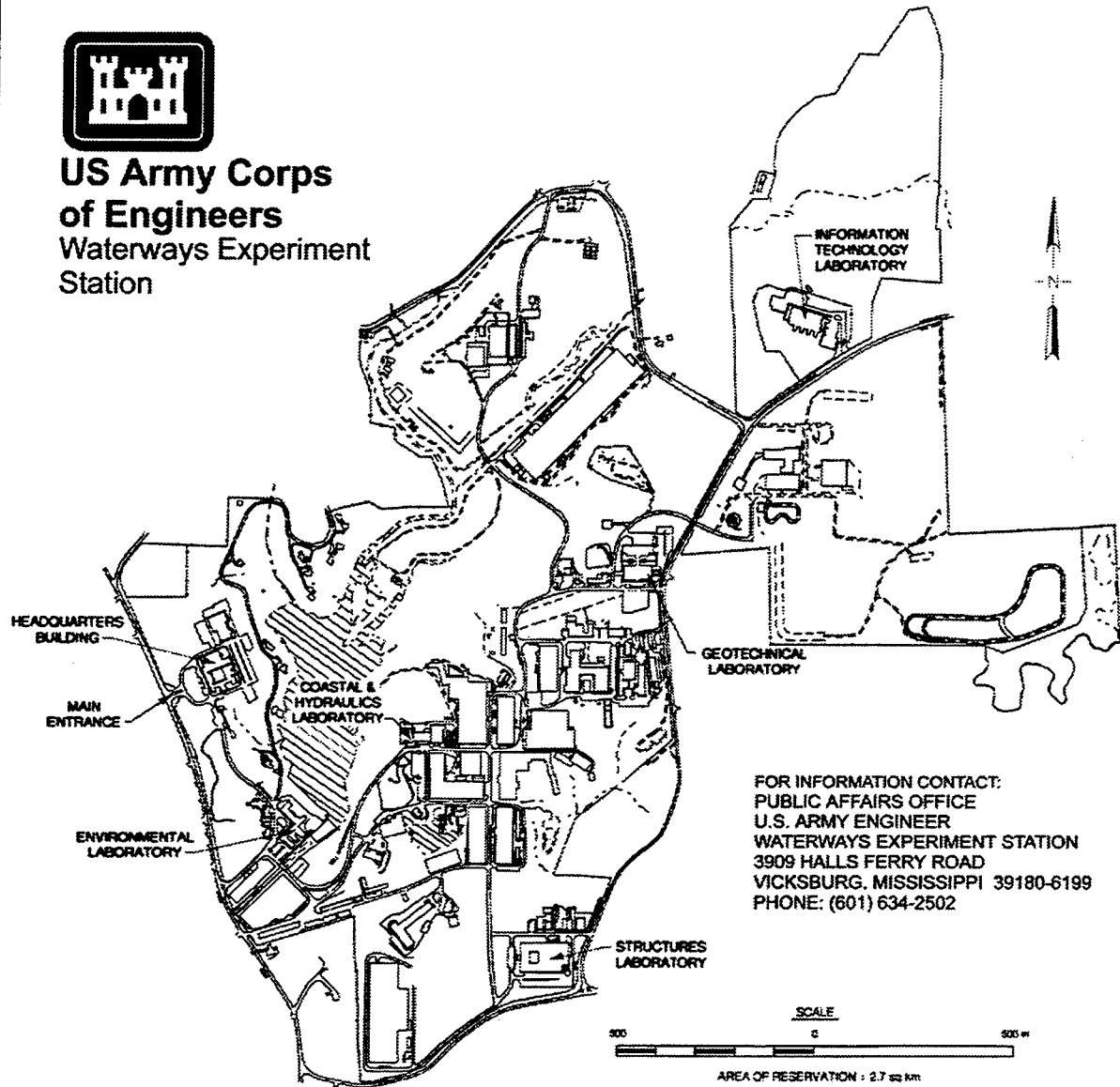

Waterways Experiment Station Cataloging-in-Publication Data

Bennett, Robert D.

Controlled field tests of retrievable microtunnelling system with reaming capabilities / by David Bennett, Kimberlie Staheli ; prepared for U.S. Army Corps of Engineers.

64 p. : ill. ; 28 cm. — (Technical report ; CPAR-GL-97-1)

Includes bibliographical references.

1. Tunnelling — Equipment and supplies — Testing.
 2. Trenchless construction.
 3. Reaming.
 4. Tunnels. I. Staheli, Kimberlie. II. United States. Army. Corps of Engineers. III. U.S. Army Engineer Waterways Experiment Station. IV. Geotechnical Laboratory (U.S. Army Engineer Waterways Experiment Station) V. Construction Productivity Advancement Research Program (U.S.) VI. Title. VII. Series: Technical report (U.S. Army Engineer Waterways Experiment Station) ; CPAR-GL-97-1.
- TA7 W34 no.CPAR-GL-97-1

Contents

Preface	vi
Executive Summary	ix
Conversion Factors, Non-SI to SI Units of Measurement	xi
1—Introduction	1
Background on CPAR Program	2
Objectives	4
Approach	5
Commercialization Plan	5
2—Design and Construction of the Test Bed	9
Construction Sequence	9
Description of Select Backfill Materials	12
3—Description of the McLaughlin/Markham Super-Mini Microtunneling System	15
4—Description of the Test	20
Initial 12-m (40-ft) Drive and Retraction	20
Ground movements during 12-m (40-ft) drive and retraction	20
Jacking forces during 12-m (40-ft) drive and retraction	23
100-m (330-ft) Drive with 660-mm- (26-in.-) Diameter Steel Temporary Pipes	23
Ground movements during drive with temporary steel pipes	23
Jacking forces during initial drive with temporary pipes	34
100-m (330-ft) Drive with Reamer and Concrete Pipe	40
Ground movements during reaming drive	40
Jacking force during reaming drive	45
5—Conclusions and Recommendations	47
References	50

SF 298

List of Figures

Figure 1.	Sequence of operations for the McLaughlin/Markham Super-Mini microtunneling and reaming system	3
Figure 2.	Profile and end views of WES microtunneling test bed for McLaughlin/Markham microtunneling test	6
Figure 3.	Photographs of test bed under construction	10
Figure 4.	Photograph of test bed instrumentation installation for retrievable microtunneling test	12
Figure 5.	Photograph of completed test bed for retrievable microtunneling test	13
Figure 6.	Photograph of McLaughlin/Markham Super-Mini microtunneling system	16
Figure 7.	Photograph and schematic of temporary bolt-together steel pipes used with McLaughlin/Markham retrievable microtunneling system	17
Figure 8.	Photograph of reaming system used with McLaughlin/Markham microtunneling system, including power jack, jacking frame, and reamer	18
Figure 9.	Photograph of double-entry ring seal with guillotine closure used for retraction and grouting tests	22
Figure 10.	Ground movements 0.6 m (2 ft) above crown after retraction (Negative movements are settlement.)	22
Figure 11.	Ground movements at settlement plates 0.6 and 1.2 m (2 and 4 ft) above pipe crown measured during initial drive of retrievable machine test	27
Figure 12.	Ground movements at settlement plates 0.6 and 1.2 m (2 and 4 ft) above pipe crown measured during initial drive of retrievable machine test (expanded scale)	28
Figure 13.	Surface settlements perpendicular to 100-m (330-ft) initial drive	29
Figure 14.	Volume loss around microtunnels - general relationships (modified from Cording 1993)	32
Figure 15.	Jacking forces during initial drive	34
Figure 16.	Machine penetration rate and cutterhead torque versus length for initial drive of retrievable machine test	38
Figure 17.	Jacking stresses during initial drive	39
Figure 18.	Ground movements at settlement plates 0.5 and 1.1 m (1.5 and 3.5 ft) above pipe crown measured during reaming drive of retrievable machine test	41

Figure 19. Photograph of surface void at sta 0+06 m (0+20 ft) during reaming drive of retrievable machine test	44
Figure 20. Jacking forces during reaming drive	45
Figure 21. Jacking stresses during reaming drive	46

List of Tables

Table 1. WES Test Bed Soil Characteristics for McLaughlin/Markham Microtunneling Test	7
Table 2. Controlled Low-Strength Material (CLSM) Components and Proportions	21
Table 3. Characterization of Ground Deformations Measured During Retrievable Microtunneling Machine Test	24
Table 4. Computed Settlements at 0.6, 1.2, 2.4, and 2.7 m (2, 4, 8, and 9 ft) above Pipe Crown for Initial Drive of Retrievable Machine Test	31
Table 5. Comparison of Measured and Computed Settlements During Initial Drive of Retrievable Machine Test	33
Table 6. Face Pressures Measured in Different Soils During McLaughlin Microtunneling Test	35
Table 7. Jacking Stresses for Various Soils in Test Bed During Initial Drive	40

Preface

This report, "Controlled Field Tests of Retrievable Microtunneling System with Reaming Capabilities," was prepared under the Construction Productivity Advancement Research (CPAR) Program. The project title was "Fail-Safe, Retrievable Microtunneling System Using Temporary Pipes and Reaming System for Critical Applications." The objectives of the project were to evaluate the microtunneling system and provide guidance for its use, based on its performance during extensive field tests at the U.S. Army Engineer Waterways Experiment Station (WES), Vicksburg, MS. The system tested has all the capabilities of conventional microtunneling systems, with the additional capability for retrieval and reaming. The versatility of the system offers intriguing possibilities with regard to critical applications. Technical monitors from Headquarters, U.S. Army Corps of Engineers, were Messrs. A. Hurlocker and G. Hughes.

This research was conducted by the industry and laboratory partners, McLaughlin Microtunneling Company and WES. Other industry participants included Markham and Company Ltd., Spun Concrete Limited, Baroid Corporation, and Laxfield Corporation. The participation and support of industry was the key to the success of this project and the CPAR program, in general, and is gratefully acknowledged.

The WES research team included:

Mr. David Bennett, Geotechnical Laboratory (GL), who was the laboratory partner principal investigator and lead author.

Mr. Perry A. "Pat" Taylor, GL, who led the construction of the WES microtunneling test facility and played a key role in the conduct of the tests.

Ms. Kimberlie Staheli, GL, who assisted in the conduct of the tests and played a key role in the collection, reduction, and analysis of the extensive body of test data. Ms. Staheli made substantial contributions as co-author of this report.

Mrs. Kris McNamara Walker, GL, who assisted in the construction of the test bed, conduct of the tests, and collection and reduction of test data, including tables, figures, and graphics for presentations and this report.

Messrs. Donald M. Walley and Brian H. Green, Structures Laboratory, Concrete Materials Division, who designed the special controlled low-strength material used on the retraction phase of the test and assisted on this portion of the field research.

Mmes. Judy Hudnall and Alfreda Thomas, and Mr. Larry Dunbar, GL, who provided assistance in the construction of the test facility, conduct of the tests, and data collection.

Messrs. William Dulaney and Dennis Bouseaulais, Engineering and Construction Services Division, who provided outstanding support during the conduct of the tests.

Mr. Bennie Washington, GL, who provided excellent drafting support during all phases of this research and development project.

Ms. Teresa Shirley, GL, who provided typing support in the preparation of this report, technical papers, and correspondence.

Ms. Gail Mason, GL, who proofread and prepared graphics, figures, and tables for the report and technical papers. Ms. Mason also assisted in preparation of quarterly progress reports and overall administrative management of the completion of the project.

Mr. William F. McCleese, WES, CPAR program manager, who has provided administrative and project management advice throughout the project.

Industry partner team members working with Mr. William Gilman, President, McLaughlin Microtunneling, industry partner principal investigator, were:

Mr. Dave Gasmovic, Vice President, McLaughlin Manufacturing Company
Mr. Eric Walker, McLaughlin Manufacturing Company
Mr. Rusty Bishop, McLaughlin Manufacturing Company
Ms. Patty Gilman, McLaughlin Manufacturing Company
Mr. Martin Soames, Markham and Company Ltd.
Mr. Nick Bristow, Markham and Company Ltd.
Mr. Richard Lewis, Markham and Company Ltd.
Mr. John H. Marshall, Spun Concrete Pipe, Ltd.
Mr. John Dutton, Laxfield Corporation
Mr. Mike Geary, Laxfield Corporation
Mr. Steve Herson, Laxfield Corporation
Mr. Frank Canon, Baroid Corporation, and

Messrs. Salam Khan, Wen-Xing Huang, and Alan Atalah, Louisiana Tech University, Ruston, LA, who provided assistance during the construction of the test facility and field tests.

The laboratory partner's research was conducted under the general guidance of Dr. Don Banks, Chief, Soil and Rock Mechanics Division, and

Dr. William F. Marcuson III, Director, GL. Mr. McCleese, was the WES CPAR point of contact.

At the time of the publication of this report, Dr. Robert W. Whalin was Director of WES. COL Bruce K. Howard, EN, was Commander.

The contents of this report are not to be used for advertising, publication, or promotional purposes. Citation of trade names does not constitute an official endorsement or approval of the use of such commercial products.

Executive Summary

The McLaughlin/Markham "Super-Mini" microtunneling system was evaluated under a variety of documented, challenging ground conditions at a specially built test bed at the U.S. Army Engineer Waterways Experiment Station (WES). The McLaughlin/Markham system uses temporary, bolt-together, steel pipes for the initial drive. When the machine reaches the reception shaft, product pipes of approximately the same diameter, 660 mm (26 in.) can be jacked behind the temporary pipes to complete the installation. Alternatively, a reamer assembly can be installed in place of the microtunneling machine at the reception shaft and the hole enlarged to accept a larger-diameter (up to 1,070-mm (42-in.)) product pipe.

These tests clearly demonstrated the ability of the system to maintain stability of the excavation during retraction of the microtunneling machine. The tests also demonstrated the capability of the system to successfully install upsized pipes using the reamer assembly. The versatility of this system offers intriguing possibilities with regard to critical applications.

In addition to the evaluation of the performance of the McLaughlin/Markham microtunneling system, this research and development offered opportunities to gain a better understanding of issues that are important to microtunneling in general. These tests and analyses added to the knowledge gained from the first series of microtunneling tests performed at WES in 1992. Questions that were raised during and subsequent to the first series of tests were addressed during these tests. The combined results were used in the development of the "Guidelines for Trenchless Technology," Final Report CPAR GL-95-2, (Bennet, Guice, Khan, and Staheli 1995). The guidelines were greatly improved by this synergistic effort. The lessons learned from the current tests were, in turn, rapidly transferred to the potential users through inclusion in the guidelines. Some of the specific observations from these tests are summarized below and described in more detail in the body of the report.

Measurements of ground movements during the test provided an opportunity to evaluate methods for predicting normal (small) systematic settlements and potential causes and preventative measures for heaves and for large settlements. These measurements indicated that reasonable, conservative estimates of normal systematic settlements could be obtained using relationships developed for large diameter, soft-ground, shield-driven tunnels. Actual settlements were typically lower than calculated settlements. The calculations did not

account for filling of the annular space between the pipe and microtunnel with bentonite lubricant, or for arching and volume increase in the soil mass. Both of these factors lead to observed settlements that are lower than the calculated values.

Large settlement events observed during this test were mainly attributable to loss of stability at the face caused by continued circulation of the slurry while the machine was stopped. This test also showed that slurry viscosities must be sufficiently high to allow stabilizing pressures to be developed at the face and to allow relatively low operating slurry velocities and flow rates. This was demonstrated by using a low-viscosity, polymer-based slurry in a cohesionless soil which resulted in a large settlement. This planned large settlement demonstrated the importance of proper slurry selection and illustrated that overemphasis on slurry separation/sedimentation, at the expense of face stability, must be avoided. Small heaves were caused by over-pushing, i.e., applying machine thrust loads that exceeded the passive resistance of the earth.

The experiments carried out to isolate face pressure and skin friction components of jacking force showed that face pressures can be significantly higher in clays than in sands, as expected. These tests also confirmed the relatively low magnitudes of the face pressure component of jacking force, compared to the skin friction component, in soft-ground conditions.

A significant reduction in total jacking forces was observed as the machine exited sand sections and progressed through the clay and clay gravel sections of the test bed. The reduction in frictional resistance on the unlubricated portion of the shield can be quite significant when exiting sands and entering clays and could partially account for the observed drop in total jacking forces.

Commercialization of this new technology began at the onset of the planning stages for Construction Productivity Advancement Research (CPAR) participation. The industry partner, McLaughlin Manufacturing Company, used the Microtunneling Data Base, developed under a previous WES CPAR project by the Trenchless Technology Center, Louisiana Tech University, to notify contractors, owners, and engineers of the critical dates (Launch, Retract, Drive, and Ream) of the testing. They were encouraged to visit the project. New product literature and video tapes were prepared stressing the attributes of the system: Nonconventional (use of Temporary Pipes and Reamer Option), and Conventional. Reprints of articles on the system and the tests from the report published in *Pipeline Utilities Construction* (Laxfield Corporation 1995) were used as part of the initial literature package, together with a section on Microtunneling Considerations and Draft Specifications for Microtunneling. The system was also exhibited at numerous tunneling and trenchless equipment trade shows and conferences, including the International No.-DIG'96 Conference.

Conversion Factors, Non-SI to SI Units of Measurement

Non-SI units of measurement used in this report can be converted to SI units as follows:

Multiply	By	To Obtain
cubic feet	0.02831685	cubic meters
cubic yards	0.764549	cubic meters
Fahrenheit degrees	5/9	Celsius degrees or Kelvins ¹
feet	0.3048	meters
inches	2.54	centimeters
pounds (mass)	0.4535924	kilograms
pounds (mass) per cubic foot	16.01846	kilograms per cubic meter
pounds per gallon	119.8264	kilograms per cubic meter
pounds per square inch	6894.757	pascals

¹ To obtain Celsius (C) temperature readings, use the following formula: $C = (5/9) (F-32)$.
To obtain Kelvin (K) readings, use: $K = (5/9) (F-32) + 273.15$.

1 Introduction

A major concern to municipal officials and engineers contemplating the use of microtunneling in congested urban areas is the impact of underground obstructions that can halt the advance of the machine, often leading to claims that cause delays in projects and increased costs. In microtunneling, the common obstructions include rock or boulders, building debris, and mislocated or unmarked utilities (active or abandoned). Mixed-face soils, abrupt changes in soil types or unforeseen groundwater conditions can also cause problems. In addition, machines are occasionally unable to proceed because of mechanical failures or incompatibility of the machine and ground.

The value of accurate and sufficient geotechnical information cannot be overemphasized, but even the most thorough geotechnical investigation cannot be expected to always give a complete picture when tunneling in complex subsurface conditions. Experience and good judgment can minimize the number and adverse impacts of problems.

Once an obstruction is encountered, the list of remedial measures available to the contractor is brief and usually requires retrieval of the machine or access to the face. In some instances, the obstruction can be cleared without requiring access to the face. This should always be attempted before proceeding to more costly time-consuming measures. If access or retrieval is required, essentially four choices are available:

- a.* Sink an access shaft at the face.
- b.* Sink an off-line access shaft at a location that is more convenient than at the face and hand-mine to the machine. (This option can include using the reception shaft, depending on the distance to the machine.)
- c.* Retrieve the machine through the launch shaft.
- d.* Pull the machine back to a more convenient location for an access shaft.

The third option is viable if a steel casing has been used or if the tunnel is large enough for personnel entry. If an obstruction is encountered by a machine large enough for personnel to enter the pipeline, steel rods can be installed from the jacking frame to the shield and the machine can be pulled back using these rods. Personnel entry is not required for retrieval with a steel

casing, because the continuous welded pipe string can be pulled back without special provisions.

McLaughlin Manufacturing Company, Greenville, South Carolina, and Markham and Company Ltd., Chesterfield, England, have teamed up to address this potential problem by marketing an innovative retrievable microtunneling system first developed in Japan by Okamura (Thompson 1993). This system uses temporary, bolt-together, steel pipes for the microtunneling operation. When the machine reaches the reception shaft, product pipes of approximately the same diameter can be jacked behind the temporary pipes to complete the installation. Alternatively, a reamer assembly developed by Markham, can be installed in place of the microtunneling machine at the reception shaft and the hole enlarged to accept larger-diameter-product pipe by jacking from a secondary jacking frame set up in the reception shaft (Bristow 1993). The sequence of operations for the Supermini and reamer systems is shown in Figure 1. This reaming feature broadens the range of installable diameters using a single microtunneling machine, which is typically limited to the installation of a narrow range of diameters. This versatility offers some intriguing possibilities with regard to critical applications: for locations where rescue shafts cannot be sunk, for environmental remediation, and for more cost-effective use of a single machine to install a range of diameters.

Background on CPAR Program

The U.S. construction industry is facing growing international competition in a changing market for construction services, with an increasing share of the domestic market going to foreign firms. At the same time, the United States is at a critical stage in infrastructure and environmental rehabilitation and development which depend heavily on the capability of our construction industry.

The Federal Government is the largest single domestic buyer of construction services. Technology advancements that improve construction productivity will reduce construction costs. Cost savings would accrue directly to the Federal Government's construction program, as well as benefit the U.S. economy in general.

Since both the Federal Government and the U.S. construction industry will benefit from improved construction productivity, it is logical and important that they work together toward this goal. The U.S. construction industry is fragmented and, generally, has limited research and development capabilities. In 1988, the Secretary of the Army recognized that access to Corps expertise and laboratory facilities would benefit the U.S. construction industry in pursuing innovative ideas for improving productivity. This concept was formulated and presented to the construction industry as a new cost-shared, Corps/industry research and development (R&D) program during July 1988. The program was called the "Construction Productivity Advancement Research (CPAR) Program" and received strong support from the U.S. construction industry.

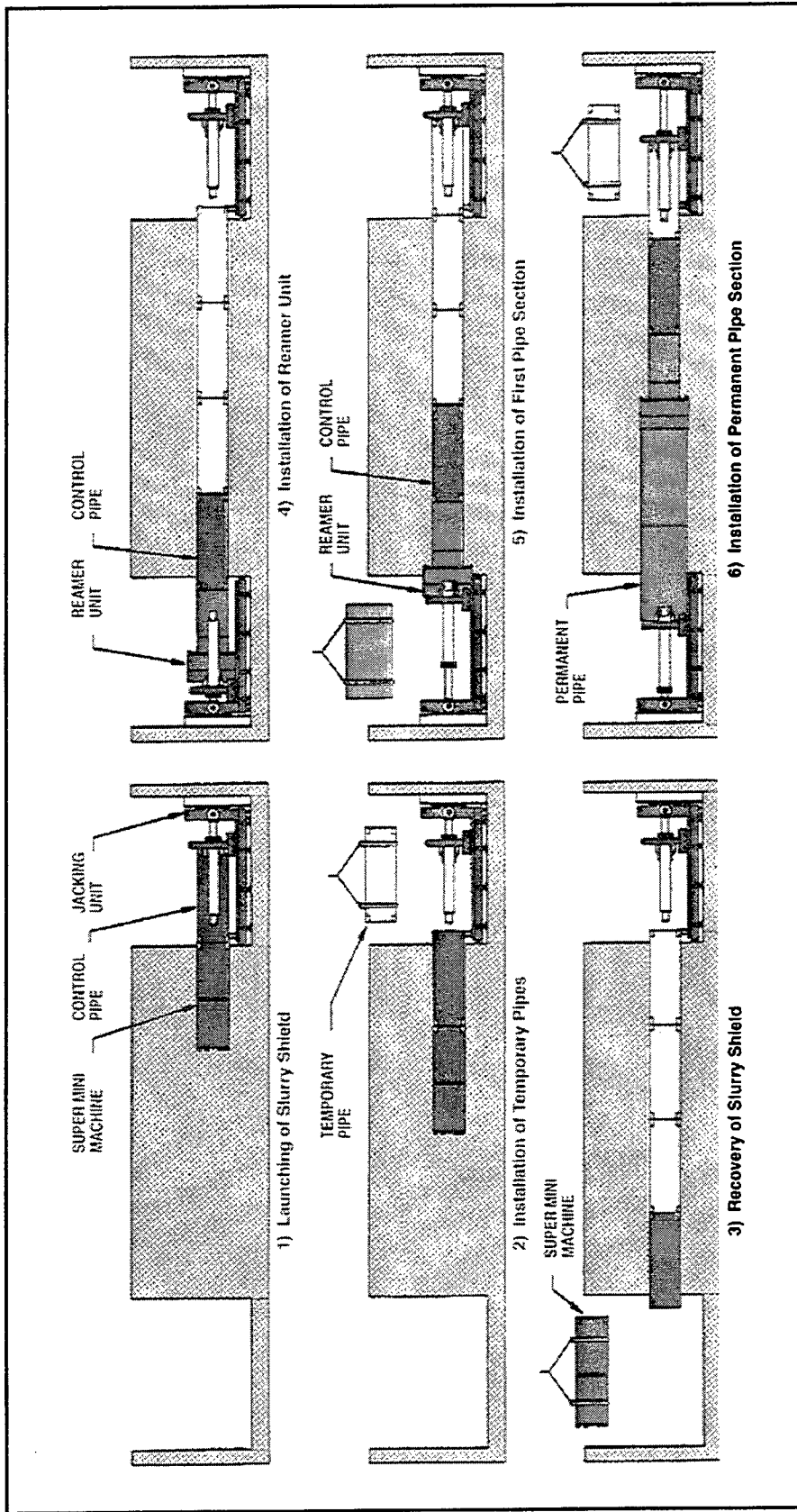

Figure 1. Sequence of operations for the McLaughlin/Markham Super-Mini microtunneling and reaming system

Over 60 CPAR projects have been jointly funded since the program began in 1989. Section 7 of the Water Resources Development Act of 1988, P. L. 100-676, 33 U.S.C. 2313, and the Stevenson-Wydler Technology Innovation Act of 1980, as amended, 15 U.S.C. 3710a *et seq.*, provide the legislative authority for the CPAR program.

CPAR is a cost-shared R&D partnership between the Corps and the U.S. construction industry. CPAR was created to help the domestic construction industry improve productivity and regain its competitive edge nationally and internationally by building on the foundation of the existing Corps construction R&D program and laboratory resources through the expansion and leveraging effect that cost-shared partnerships provide. The objective of CPAR was to facilitate productivity-improving research, development, and application of advanced technologies through cooperative R&D, field demonstration, licensing agreements, and other means of technology transfer.

CPAR is designed to promote and assist in the advancement and commercialization of ideas and technologies that have a direct positive impact on construction productivity and project costs and support the Corps mission. R&D and commercialization/technology transfer under CPAR was based on proposals received from the U.S. construction industry which could be addressed effectively by a partnership and which benefitted both the construction industry and the Corps.

This project, "Fail-Safe, Retrievable Microtunneling System Using Temporary Pipes and Reaming System for Critical Applications," was funded under a CPAR-Cooperative Research and Development Agreement (CRDA) signed by the Corps and Industry Partner, McLaughlin Manufacturing Company, 15 June 1994. Other industry participants included Markham Microtunneling, Spun Concrete Limited, Baroid Corporation, and Laxfield Corporation. The participation and support provided by industry was critical to the success of this project and the CPAR program.

Objectives

The overall objective of this project was to demonstrate, evaluate, and promote commercial acceptance of microtunneling and the retrievable microtunneling system through impartial documentation of performance. The specific primary objectives were to test the manufacturer's claims of retrievability and reaming capabilities and evaluate performance of the system under a variety of documented, challenging ground conditions. These tests allowed a practical evaluation of the skin friction and face pressure components of the jacking force. The effectiveness of various slurry mixtures and lubricants for providing stability to the excavation face and for reducing jacking loads was also evaluated. Ground deformations were also measured and analyzed to gain a better understanding of settlements and heaves associated with microtunneling. The product of the research is the documentation of performance and guidance for use of the system, as described in this report.

Approach

A heavily instrumented test bed was constructed for this test. This test bed was constructed at the same location, in the same manner, and with the same layout as the test bed constructed for the first series of U.S. Army Engineer Waterways Experiment Station (WES) microtunneling tests in 1992 (Bennett and Taylor 1993; Bennett, Cording, and Iseley 1994). The test bed consisted of five different soil sections (flooded, poorly graded clean sand; buckshot clay; dry sand, sandy clay gravel, and silt), each approximately 20 m (65 ft) long, for a total length of 100 m (330 ft) between drive and reception shafts. The depth of soil cover was 2.4 to 2.7 m (8 to 9 ft) above the pipe crown. The transitions from one soil type to the next were designed to simulate mixed face conditions and provide challenges to alignment control, grade control, and ground stabilization. Profile and end views of the test bed are shown in Figure 2. Soil properties for the five soil sections are summarized in Table 1.

The test was divided into three phases:

- a. Initial drive of 12 m (40 ft) into flooded, running sands, followed by retraction of the machine while simultaneously grouting the face to maintain stability and avoid settlement or heave.
- b. Completion of the 660-mm (26-in.), 100-m (330-ft) long drive through the five soil types using the McLaughlin/Markham Super-Mini and steel temporary pipes.
- c. Use of the 915-mm (36-in.) diameter reamer assembly to redrive from the reception shaft to the launch shaft, while installing 850-mm (33.5-in.) outside diameter (OD) concrete pipe.

The measurements and observations made during the various phases of the tests provided the basis for the performance assessment and guidance presented in this report.

Commercialization Plan

Commercialization of this new technology began at the onset of the planning stages for CPAR participation. The industry partner, McLaughlin Manufacturing Company, used the Microtunneling Data Base to notify contractors, owners, and engineers of the critical dates (Launch, Retract, Drive, and Ream) of the testing. They were encouraged to visit the project.

Throughout the entire time of the driving and reaming process, progress of testing through in-house news releases and product information bulletins were provided.

New product literature and video tapes were prepared stressing the attributes of the system: Nonconventional (use of Temporary Pipes and Reamer

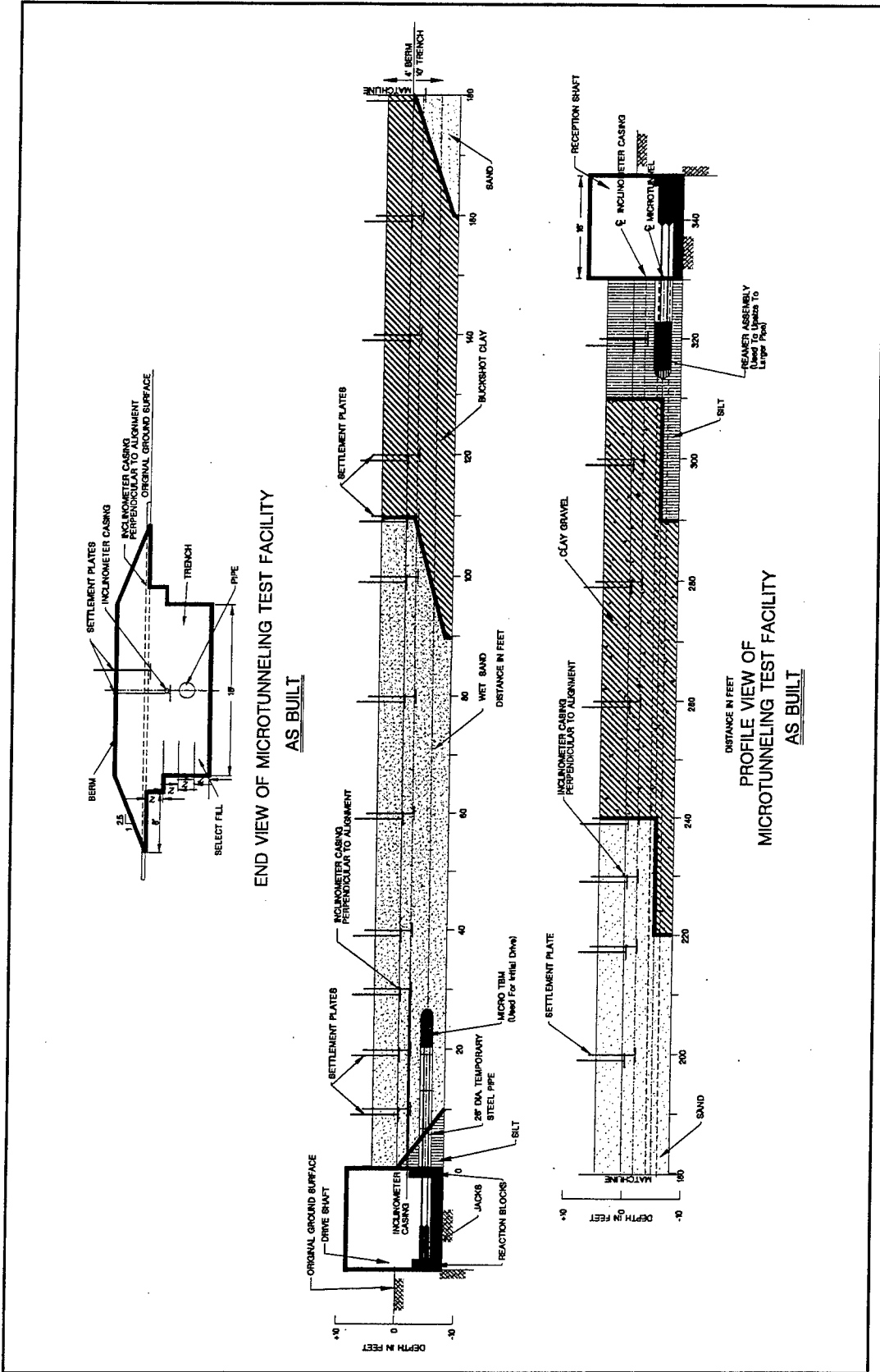

Figure 2. Profile and end views of WES microtunneling test bed for McLaughlin/Markham microtunneling test (To convert feet to meters, multiply feet by 0.0348)

Table 1

WES Test Bed Soil Characteristics for McLaughlin/Markham Microtunneling Test

Test Bed Section	USCS Soil Classification	Max. Density Kg/m ³ (lb/ft ³)	Optimum Moisture Content (w%)	Average As-Built Conditions		Other Test Data and Comments
				Dry Density Kg/m ³ (lb/ft ³)	Moisture Content (w%)	
1	Sand, medium to fine, poorly graded (SP), flooded, running	1,871 (116.6) maximum 1,599 (99.6) minimum	--	1,661 (103.5)	7.7	
2	Plastic clay (CH)	1,509 (94.0)	23.2	1,401 (87.3)	36.8	LL = 66, PL = 22, PI = 44 UC = 14.4 to 15.7 tonnes/m ² (1.47 to 1.60 tons/ft ²) Su _{unsat} = 6,113 kg/m ² to 7,482 kg/m ² (1,250 to 1,530 psf) Swell Press. = 4.9 to 9.9 tonnes/m ² (0.5 to 1.0 tons/ft ²) Swell Volume = 7.9 percent
3	Sand, medium to fine, poorly graded (SP)	1,871 (116.6) maximum 1,599 (99.6) minimum	--	1,661 (103.5)	7.7	
4	Gravelly clayey sand (SC)	2,119 (132.0)	7.3	1,843 (114.8)	7.8	LL = 20, PL = 12, PI = 8 Presence of gravel makes interpretation of SPT values problematic
5	Clayey silt (ML)	1,698 (105.8)	19.1	1,672 (104.2)	18.9	LL = 39, PL = 25, PI = 14

Option) and Conventional. Reprints of articles on the system and the tests from *Pipeline and Utilities Construction* (Laxfield Corporation 1995) were used as part of the initial literature package, together with a section on Micro-tunneling Considerations and Draft Specifications for Microtunneling.

Finally, participation at various trade shows and seminars was undertaken to introduce the technology to owners, engineers, and contractors. These included the National Utility Contractors Association (NUCA) Annual Conventions, the Underground Construction Technology (UCT) shows in Houston in 1995 and in New Orleans in 1996, the NO-DIG Conferences in Toronto in 1995 and New Orleans in 1996, the Microtunneling Short Course sponsored by the Colorado School of Mines and others in 1995, and the Seminar on Trenchless Technology sponsored by Missouri Western State College in 1995.

2 Design and Construction of the Test Bed

The design objectives for the test bed were to:

- a. Provide realistic but challenging ground conditions that would test the limits of the microtunneling system capabilities.
- b. Provide ground conditions that varied, in a controlled fashion, and minimized boundary effects so performance could be correlated with known ground conditions.
- c. Allow measurements for evaluation of machine-ground interaction, including cutterhead torque, jacking thrust, effects of lubricants on jacking pipe loads, and effect of slurry mixtures on ground settlement.

The primary features and construction sequence are summarized below.

Construction Sequence

First a 100-m- (330-ft-) long, 5-5.5-m- (16- to 18-ft-) wide trench was excavated approximately 3 m (10 ft) deep. The zones of select backfill were then placed and compacted in approximately 30-cm (1-ft) lifts, to bring the fill up uniformly along the length of the test bed. Figure 3 is a photograph of the test bed under construction. Elevations and interfaces between soil sections were surveyed, and the trench was staked to allow the sloping interfaces to be constructed as planned. Stringlines and stakes were supplemented by painting the elevations and interfaces on the trench sidewalls. Each lift was compacted with a vibratory pad foot roller, weighing approximately 62,000 N (14,000 lb). Moisture and density tests were performed on each material at a nominal depth of 15 cm (6 in.) in each compacted lift to ensure desired uniformity. If there were a significant discrepancy between test values, another test was run to try to identify the problem. If the densities were confirmed to be below desired levels, additional compaction effort was applied to bring the lift into compliance and confirmed by additional tests. All density and moisture determinations were made with a Troxler-Nuclear Density Device following American

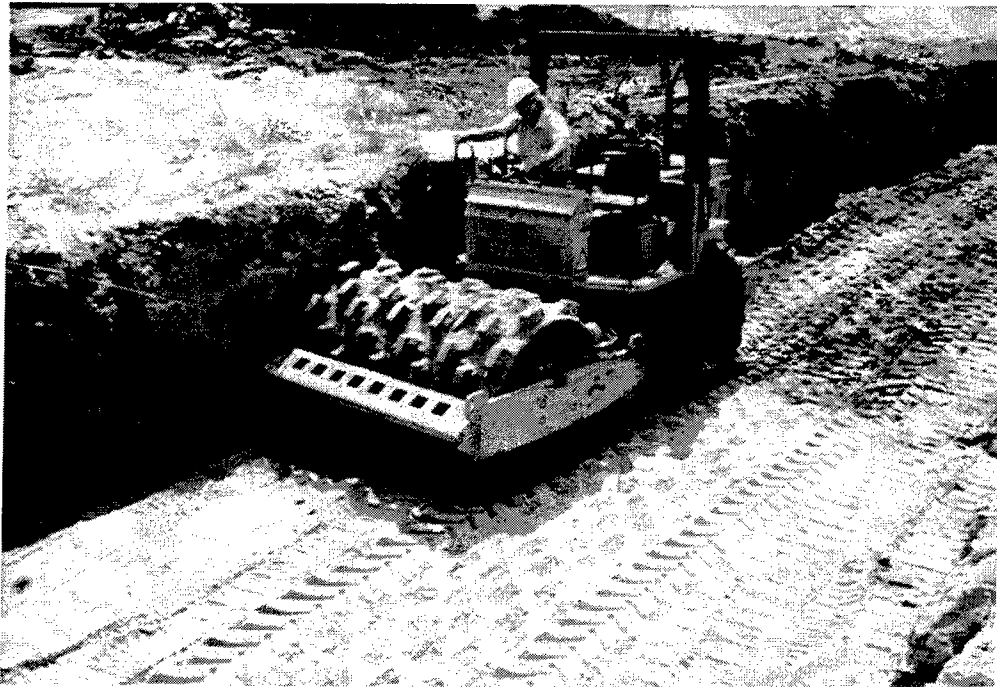
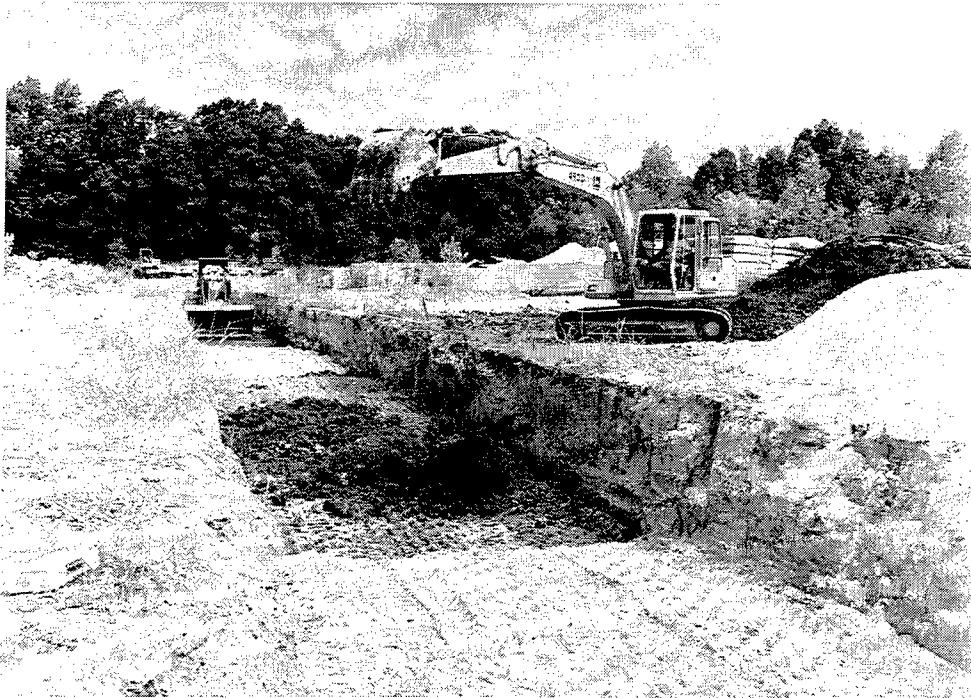

Figure 3. Photographs of test bed under construction for retrievable microtunneling tests

Society for Testing and Materials (ASTM) D 2922 (ASTM 1996b). Soil specimens collected adjacent to the density tests were occasionally oven-dried to check moisture contents determined with the nuclear device. (The criterion used to judge acceptance of the compacted fill was based on uniformity instead of a minimum allowable density, but 95 percent of maximum dry density as determined by ASTM D 698 Standard Proctor density test (ASTM 1996a) was the target value.) Backfill classification, Proctor tests, average placement dry density, moisture contents, and other soil data are shown in Table 1 and summarized later.

The interface angles between soil sections were sloped at approximately 1 on 2-1/2 to 1 on 3 at all interfaces except those between the flooded sand and clay gravel and between the clay gravel and silt. As shown in Figure 2, these interfaces were comprised of stepped vertical and horizontal segments with the horizontal segment located at the elevation of the center line of the pipe. This interface design created a mixed face with sand above dense clay gravel at the first interface and silt below the dense clay gravel at the second interface. The first interface was designed as a challenge to ground control, and the second was designed as a challenge to grade control.

When the backfill reached the original ground surface, placement and compaction were temporarily interrupted. Instrumentation was then installed in the partially completed test bed, as depicted in Figure 4. Horizontal inclinometer casings were installed 0.6 m (2 ft) above the crown of the planned tunnel drive for the full 100-m (330-ft) length of the test bed. The casings were installed using a small trencher to dig 30-cm- (1-ft-) wide by 0.6-m- (2-ft-) deep trenches in the compacted backfill above the center line of the planned tunnel. The trench bottom elevation was surveyed and adjusted by hand excavation, as necessary, to ensure that the casings were 0.6 m (2 ft) above the tunnels. Settlement plates and inclinometer casings were then installed and covered by hand placement of sand to a level approximately 15 cm (6 in.) above the casings. A small vibratory shoe compactor was used to compact the sand bedding material around the casings. The settlement plates were fabricated from 15-cm (6-in.) by 15-cm (6-in.) by 0.5-cm (3/16-in.) thick plates, with a No. 6 rebar welded perpendicular to the center of the plate. PVC pipe, 3-cm (1-1/4-in.) diameter, was installed over the rebar to isolate it from the surrounding backfill. These settlement plates were installed as shown in the test bed profile drawing, at 3- to 6-m (10- to 20-ft) intervals, as shown in Figure 2. The inclinometer casings rested on the settlement plate shoes at this level, so the settlement plates provided a mechanical check on the electronic inclinometer sensor readings. A second level of settlement plates was installed along the center line of each tunnel 1.2 m (4 ft) above the crown, or approximately at the original ground surface, at the same 3- to 6-m (10- to 20-ft) intervals as the lower level of plates.

Backfilling operations then continued until a 1.2-m- (4-ft-) high trapezoidal berm was completed over the test bed as shown in Figure 2. The berm was constructed of the same select backfill materials as the underlying test bed sections, using the same placement and compaction procedures.



Figure 4. Photograph of test bed instrumentation installation for retrievable microtunneling tests

Surface survey rods were then installed by driving No. 6 rebar, approximately 30 cm (1 ft) long, into the berm to provide measurements of surface deformations directly above the planned tunnels, and laterally across the test bed, to measure the settlement troughs perpendicular to the tunnel. These surface points were established at stations 0+10, 0+30, 0+60, 0+80, 1+00, 1+20, 1+60, 2+00, 2+20, and 3+00. The surface points were located directly above the center lines of each planned tunnel and at offsets of 0.3 m (1 ft), 0.6 m (2 ft), and 1.5 m (5 ft) on either side of the center lines.

All of the settlement plates and rods were surveyed to provide initial readings before the tests began. Initial readings were also obtained at 0.6 m (2 ft) intervals within the inclinometer casings. The test bed was completed with construction of the drive and reception shafts. Figure 5 is a photograph of the completed test bed.

Description of Select Backfill Materials

The soil sections were comprised of a flooded, poorly graded sand, buck-shot clay, poorly graded sand, clay gravel, and silt. Soil properties are summarized in Table 1 for each select backfill type. The types of soils and soil properties were essentially the same as those used in the construction of the

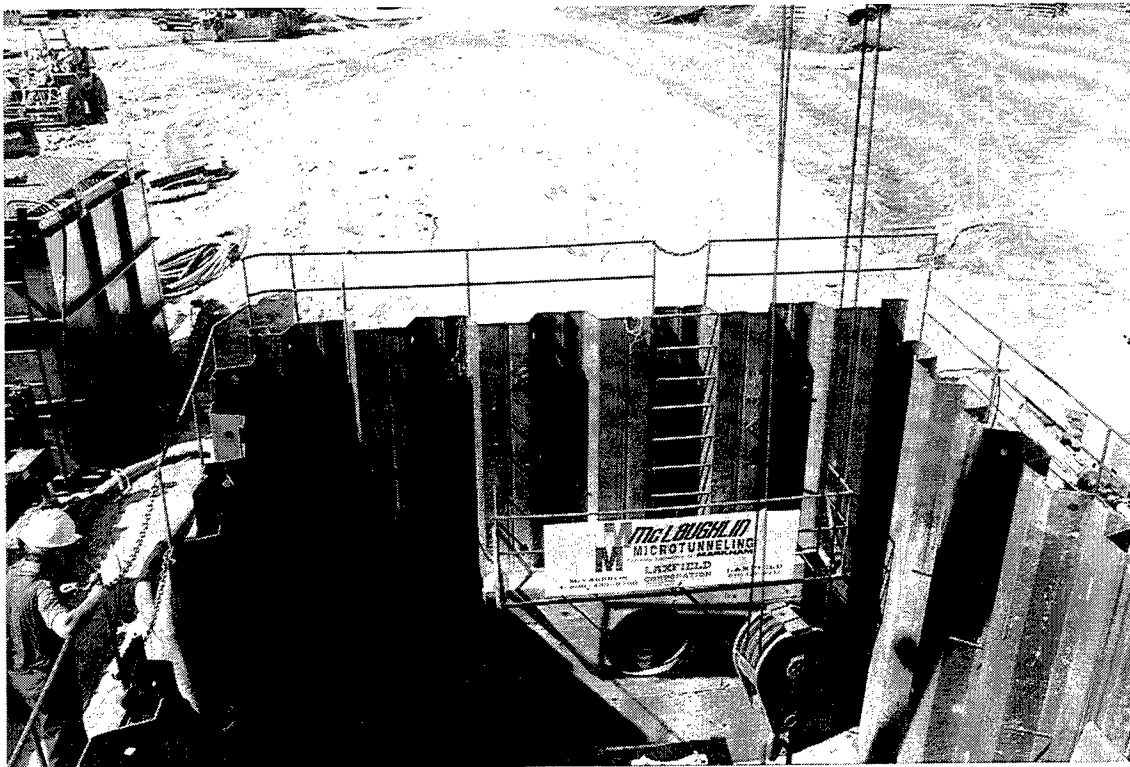

Figure 5. Photograph of completed test bed for retrievable microtunneling tests

original test bed in 1992 (Bennett and Taylor 1993). In fact, much of the borrow material was recycled, to minimize cost of construction and changes in test bed conditions that might make interpretation and correlation of results difficult.

The first section consisted of poorly graded sand (SP). Maximum and minimum density tests produced values of $1,868 \text{ Kg/m}^3$ (116.6 lb/ft^3) and $1,595 \text{ Kg/m}^3$ (99.6 lb/ft^3), respectively. This sand had no particles larger than 1.3 cm (1/2 in.) and about 70 percent by weight was between the No. 30 sieve (0.6 mm) and the No. 70 sieve (0.2 mm), so its classification was a medium to fine poorly graded sand.

Density and moisture test results ranged from $1,533 \text{ Kg/m}^3$ (97.3 lb/ft^3) at 9.2 percent to $1,722 \text{ Kg/m}^3$ (109.3 lb/ft^3) at 6.2 percent moisture. The average density was $1,630 \text{ Kg/m}^3$ (103.5 lb/ft^3) at 7.7 percent or 89 percent of maximum density. The densities were lower than desired, due in part to the heavy rains, resulting in poor moisture content control during construction. However, the flooding and frequent storms that occurred after placement of the sands probably caused densities to increase after placement.

The second section was a dark gray buckshot clay (CH) with a liquid limit (LL) of 66, plastic limit (PL) of 22, and plasticity index (PI) of 44. Maximum dry density was $1,481 \text{ Kg/m}^3$ (94.0 lb/ft^3) at 23.2 percent optimum moisture content. In place densities and moisture contents ranged from $1,263 \text{ Kg/m}^3$ (80.2 lb/ft^3) at 39.5 percent moisture to $1,471 \text{ Kg/m}^3$ (93.4 lb/ft^3) and

36.7 percent. The average density was $1,401 \text{ kg/m}^3$ (87.3 lb/ft^3) or 93 percent of maximum Standard Proctor density at average moisture content of 36.8 percent or 13.8 percent above optimum.

The third section was the same poorly graded SP sand as used in the first section. In-place densities and moisture contents were comparable to section 1 values. Values ranged from $1,533 \text{ Kg/m}^3$ (97.3 lb/ft^3) at 9.2 percent moisture content to $1,722 \text{ Kg/m}^3$ (109.3 lb/ft^3) at 6.2 percent.

The fourth section consisted of a soil locally called red clay gravel, classified as an SC gravelly clayey sand. The Atterberg Limits of the clay gravel were $LL=20$ and $PL=12$ for a PI of 8. Standard Proctor test maximum dry density was determined to be $2,079 \text{ Kg/m}^3$ (132.0 lb/ft^3) at 7.3 percent optimum moisture content. Actual in-place densities and moisture contents ranged from $1,682 \text{ Kg/m}^3$ (106.8 lb/ft^3) at 7.7 percent to $1,914 \text{ Kg/m}^3$ (121.5 lb/ft^3) at 9.1 percent. Average values were $1,868 \text{ Kg/m}^3$ (114.8 lb/ft^3) and 7.8 percent for dry density and moisture content, respectively.

The last soil section was a windblown silty clay (CL) to clayey silt (ML), Vicksburg loess, that is the predominant local surficial soil type. The LL was 39, the PL was 25, and the PI was 14. The maximum dry density achieved in the Standard Proctor test ((ASTM 698) (1996a)) was $1,695 \text{ Kg/m}^3$ (105.8 lb/ft^3) at an optimum moisture content of 19.1 percent. Moisture and density tests values ranged from $1,463 \text{ Kg/m}^3$ (92.9 lb/ft^3) at 25.8 percent moisture content to $1,802 \text{ Kg/m}^3$ (114.4 lb/ft^3) at 14.0 percent moisture content. The average dry density was $1,642 \text{ Kg/m}^3$ (104.2 lb/ft^3) or 98 percent of maximum dry density ((ASTM 698) (1996a)) at 18.9 percent moisture content.

3 Description of the McLaughlin/Markham Super-Mini Microtunneling System

The McLaughlin/Markham Super-Mini microtunneling system, depicted in Figure 6, was originally developed by Okumura in Japan. The slurry-pressure balance head is capable of tunneling through a range of soil conditions, with groundwater heads up to 25 m (80 ft) (Thompson 1993). It is classified as a "two-pass" system, as explained below, which differs from conventional, one-pass, microtunneling systems. The system uses temporary, bolt-together steel pipes for the initial microtunneling pass. Each temporary pipe contains all slurry and service pipes with connections being made and sealed automatically as each new pipe is fitted. The electric cable carrying all power, control, and signal lines is continuous from surface to machine and is laid in a slot in the top of the temporary pipe which is then protected with a bolted steel cover. This essentially eliminates the risk resulting from water entering into cable connectors. The temporary pipes are shown in Figure 7. High rates of progress are achievable, according to the manufacturer, because pipe changeover time is minimal and tunneling rates of 42 m (138 ft) per shift have been claimed. The two-pass nature of the system is one of the features that allows it to be adapted to variable pipe sizes.

Claims of accurate line and level control and long drive distance capabilities result from the inherent stiffness of the temporary pipe column. Usually, thrust forces are low on the permanent pipes, because the tunneling has already been finished with the temporary pipes, and a clean, straight, lubricated hole is already prepared in the ground for the permanent pipes to push into as they push the temporary pipes out through the reception shaft.

The bolted column of temporary pipes allows the system to be put into reverse, at will, from the control station to enable slight pulling back to relieve thrust or torque buildup. The system can be fully retracted should a drive have to be aborted for any reason. During this latter process, grout can be injected through the slurry lines to refill the void created by the retraction of the machine. The weak grout can be injected through the machine's slurry system such that it gives full support to the ground but also allows reexcavation later.

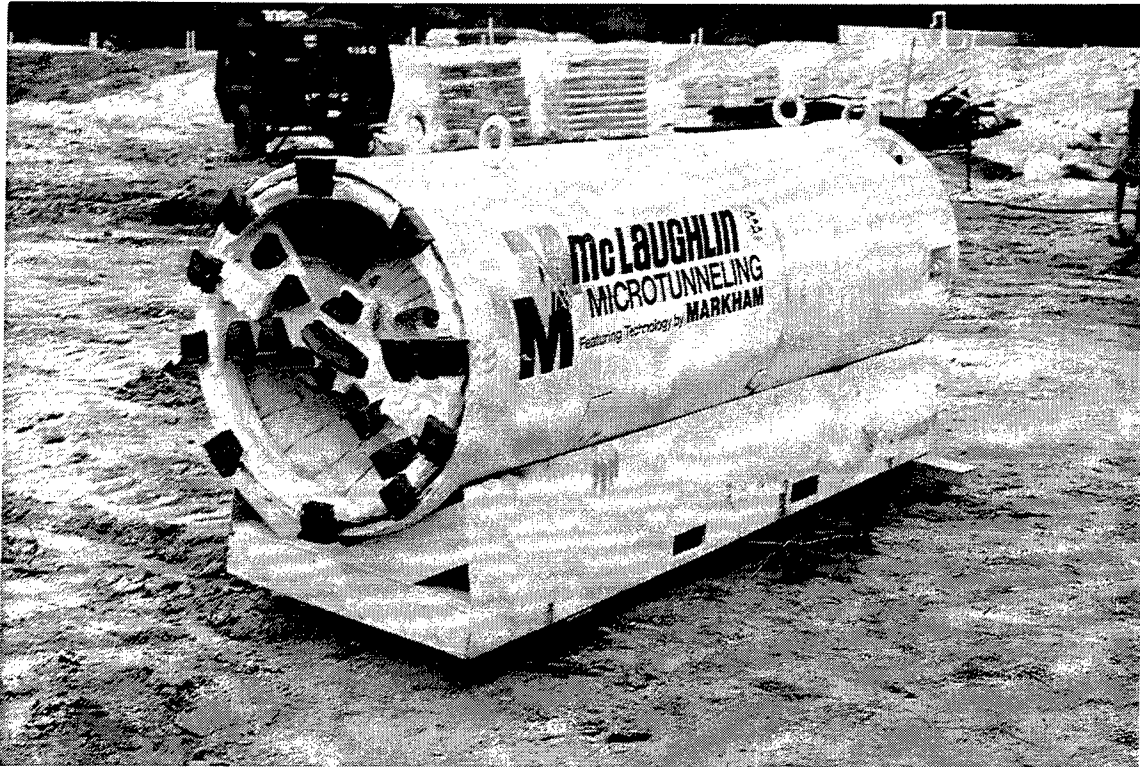
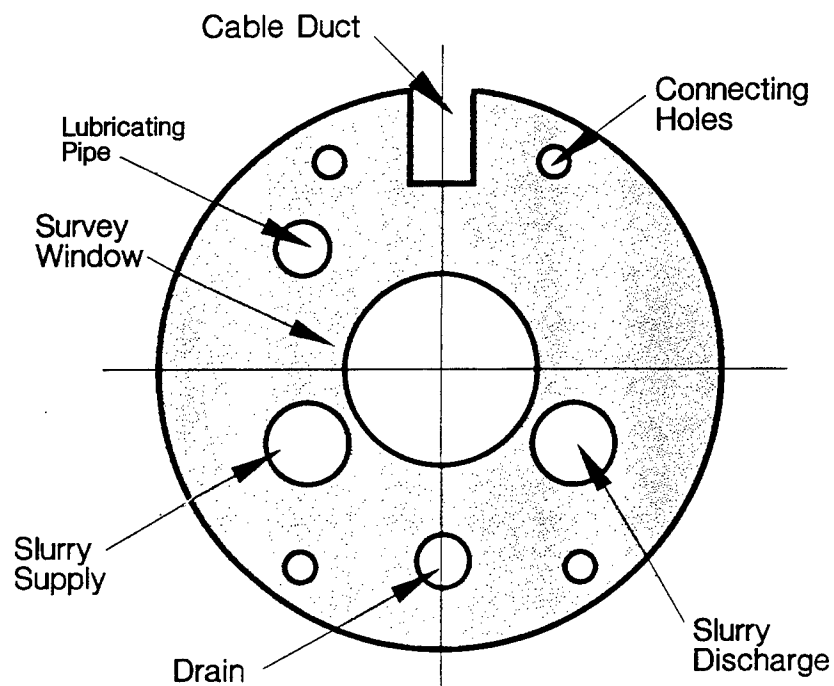
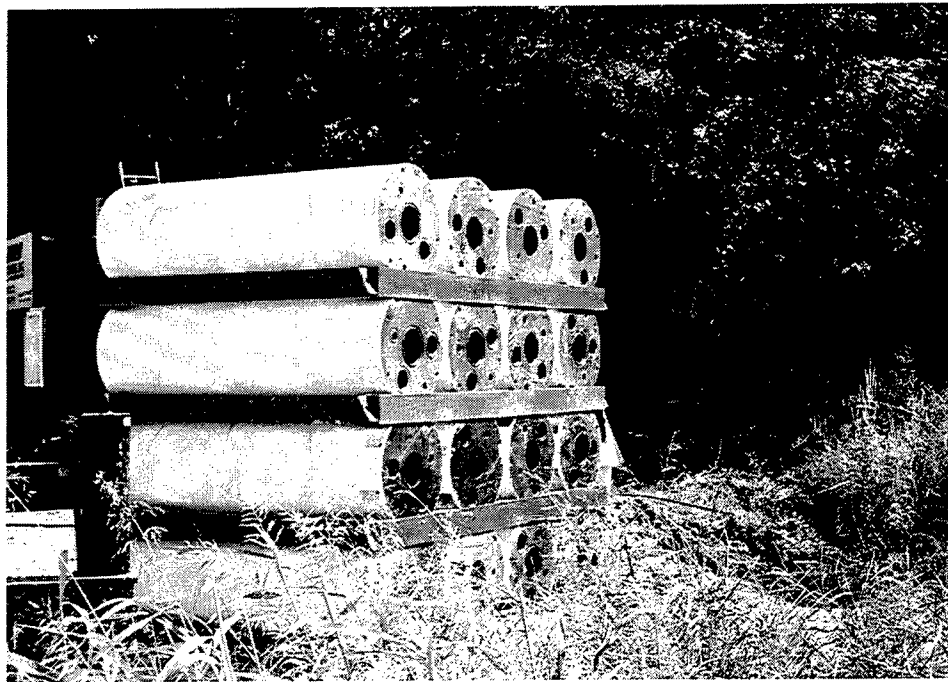

Figure 6. Photograph of McLaughlin/Markham Super-Mini microtunneling system

With this option available, the manufacturer claims high risk jobs can be confidently undertaken.

However, the use of temporary pipes described above has three potential disadvantages when compared to conventional microtunneling systems. First, there is an additional capital cost directly resulting from the need to have temporary pipes available for the drive lengths to be undertaken. Although, once acquired, the temporary pipes need little or no maintenance and last almost indefinitely. Second, the two-pass system requires the use of two cranes and two crews on the second pass for lowering permanent product pipes and removing temporary pipes from the drive and reception shafts, respectively. Third, the temporary pipes, along with the tunneling machine itself are fixed in diameter and are therefore only capable of producing a pipeline of one outside diameter.

However, a major advantage of the system over conventional microtunneling is that with the addition of the relatively low-cost reamer, secondary jacking frame, and power pack, a range of diameters can be bored on the second pass. This allows the system to back ream the pipeline to any size from the original nominal size up to a limit of about two times its original diameter. The reamer unit is shown in Figure 8, and consists of the powered cutting module, fitted with whatever size of cutter is required, plus an additional jacking station to assist in pushing the reamer back to the start shaft as the



Temporary Pipes are equipped with all necessary lines and cables in a premade condition for fast section make-up.

Figure 7. Photograph and schematic of temporary bolt-together steel pipes used with McLaughlin/Markham retrievable microtunneling system

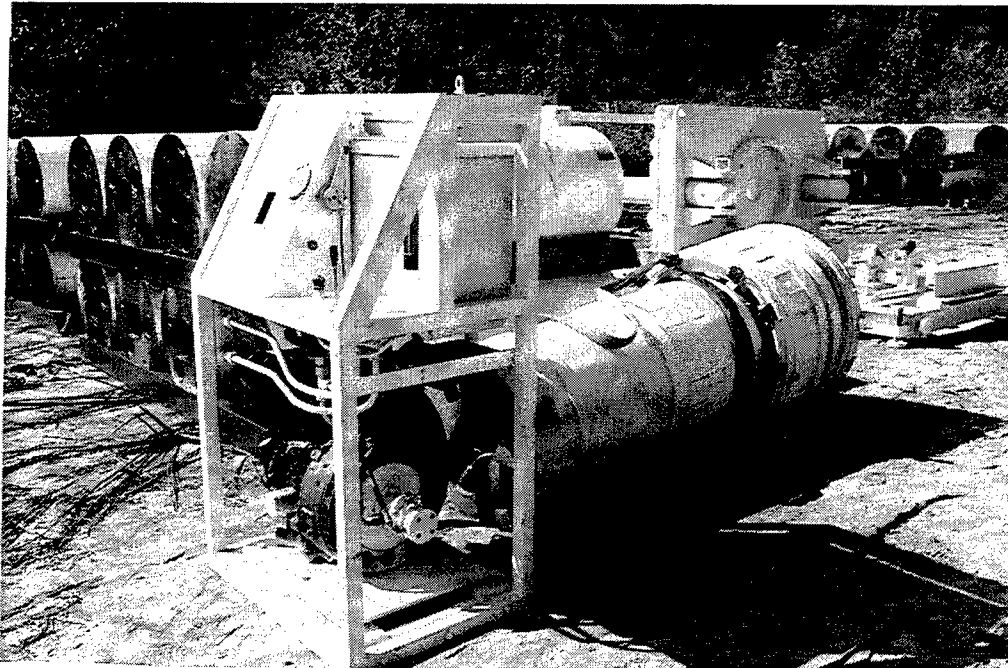

Figure 8. Photograph of reaming system used with McLaughlin/Markham microtunneling system, including power pack, jacking frame, and reamer

permanent pipes are installed. All the other capital equipment including the control can for the machine, the surface control station, and the slurry pumping and treatment plant remain in use in their original locations.

The sequence of operations (Figure 1) simply entails removing the Super-Mini machine (but not its control can) at the original reception shaft, replacing it with the Reamer Unit, and back reaming to the original reception shaft.

Slurry flow within the reamer and the general design of the cutting unit were based on the Super-Mini design (Bristow 1993). All control and slurry pipes and cables are used exactly as for the Super-Mini but ahead of the reamer and shortened as the reamer progresses. No steering control is needed as the reamer follows the previously excavated tunnel line. Ideally, permanent pipes of the same individual length as the temporary pipes should be installed to minimize problems of coordination between starting and reception shafts, but this is not essential. In fact, on this project, the reamer was used to install 2.5-m (8.2-ft) concrete pipes behind 2.0-m (6.6-ft) temporary pipes. A 0.5-m (1.6-ft-) long adaptor ring was used in the jacking shaft to adjust for this length difference. The permanent pipes are installed free of any tunneling equipment. The reamer module is designed around a central power unit with a bolted-on cutting disc so that the diameter is easily changed. The manufacturers claim that, for example, a nominal 660-mm (26-in.) OD Super-Mini system could be equipped with a reamer to increase the outer diameter up to 1,067 mm (42 in.). This versatility offers some intriguing possibilities with regard to critical applications: locations where rescue shafts cannot be sunk, environmental

remediation, and more cost-effective use of a single machine to install a range of diameters.

4 Description of the Test

Initial 12-m (40-ft) Drive and Retraction

During the first portion of the test, the McLaughlin/Markham machine, with its temporary pipe system, was driven 12 m (40 ft) through running sands with groundwater levels approximately 1 m (3 ft) above the pipe crown. The machine was then retracted by reversing the jacking force and removing the temporary pipes through the launch shaft. A specially designed Controlled Low-Strength Material (CLSM) containing ASTM Class C flyash, bentonite, ASTM Type I Portland cement, and water was pumped through the slurry inlet line to the face of the machine. The unconfined compressive strength of the CLSM was 4.93 kg/m² (70 psi) at 28 days. The mixture proportion of the CLSM is given in Table 2. The grout pressure was carefully monitored at the operator's control console to balance grout injection pressures with earth and groundwater pressures. A specially designed double-entry ring seal, with a guillotine closure between the seals and a grout injection nipple (Figure 9), was fabricated to ensure that grout pressures could be maintained as the machine was fully retracted.

Ground movements during 12-m (40-ft) drive and retraction

Ground movements measured during this phase of the test are shown in Figure 10. The maximum settlement of 9 mm (0.35 in.) occurred near the drive shaft and was partly caused by loss of soil into the shaft through the sheet-pile walls. Settlements were less than 6 mm (0.25 in.) elsewhere, or well within typical specification tolerances.

This phase of the test was an unqualified success (Bennett and Staheli 1995). The ability of the McLaughlin/Markham machine to maintain stability of the excavation and avoid settlements was conclusively demonstrated under very challenging ground conditions. The double-entry ring seal with the guillotine closure was critical to this success of the retraction and could be used with different machines if retraction through unstable soils were a potential necessity. The CLSM was also critical to the success of the operation and has many applications in microtunneling, including shaft stabilization. This retraction and grouting capability could have significant potential applications in

Table 2 Controlled Low-Strength Material (CLSM) Components and Proportions									
Mixture Serial No. MTBM-9		GROUT MIXTURE PROPORTIONS			Date 4-Oct-94				
Project GL CPAR Project					Structures Laboratory Donald Walley and Brian Green				
Cement Type No. 1 ASTM Type 1 MS. Materials CTD# 940257		Mineral Admix. No. 1 Sodium Bentonite "Aqualgel," NL Baroid Industries			Chemical Admix. No. 1 Anhydrous Citric Acid				
Pozzolan ASTM Class C Fly Ash MS. Materials CTD# 940258		Aggregate No. 2			Other Admix.				
MATERIALS AND PROPERTIES									
Materials	Bulk Specific Gravity	Unit Wgt. (Solid) lb/cu ft	Actual Batch Data (1 cu yd)			Actual Batch Data (1 cu ft)			
			Solid Volume cu ft/batch	S.S.D. Batch Wgt. (lb)	Factor	S.S.D. Batch Wgt. (lb)	Act. Batch Wgt. (lb or g)		
Cement	3.15	196.25	0.692	135.81	0.037001	5			
Fly Ash	2.68	166.96	6.067	1013	0.037001	37.5			
Bentonite	2.39	148.9	0.691	102.87	0.037001	3.8			
Citric Acid (Retards set)						0.07			
Water	1	62.3	19.576	1219.59	0.037001	45.1			
Air									
		Air Free	27.026						
		Yield	27.026	2471.31		91.47	0		
Moisture Corrections				Mixture Data					
Material	Absorption Percent	Total Moisture Content Percent	Net Moisture Content Percent	Theo. Unit Wgt.	91.5 lb/cu ft				
			0.00%	Act. Unit Wgt.	_____ lb/cu ft				
			0.00%	Act. Unit Wgt.	_____ lb/gal				
				Air Content	_____ %				
				Bleeding	_____ %				
				Mixing Water	_____ F				
				Ambient	_____ F				
				Grout	_____ F				
				Setting Times: Initial 20 Hours	Final 24 Hours				
				Theo. Cem. Fac.	1.4 Cem. Only				
				Act. Cem. Fac.	12.2 Cem. and Fly Ash				
				W/C	8.98 Cem. Only 1.062 Cement and Fly Ash				
LABORATORY DATA									
Criteria	Flow Data			Slump Data			Expansion Data		
Set in 24 hours	Age, minutes	Flow, sec	Temp F	Age, minutes	Slump, in.	Temp F	Age, days	Unrestrained	Restrained
< 100 psi	10	9.4							
Pump through a 3 in. grout line.	60	9.4							
	120	9.6							
	240	10.2							
Water flows through the flow cone at 8.2 sec									
Hardened Physical Data					Special Laboratory Tests and Remarks				
Age, days	Specimen Size	Pulse Velocity FPS	Density lb/cu ft	Unconf. Compres. Strength psi	Modulus E x10e-6 psi				
28	3x6			70					

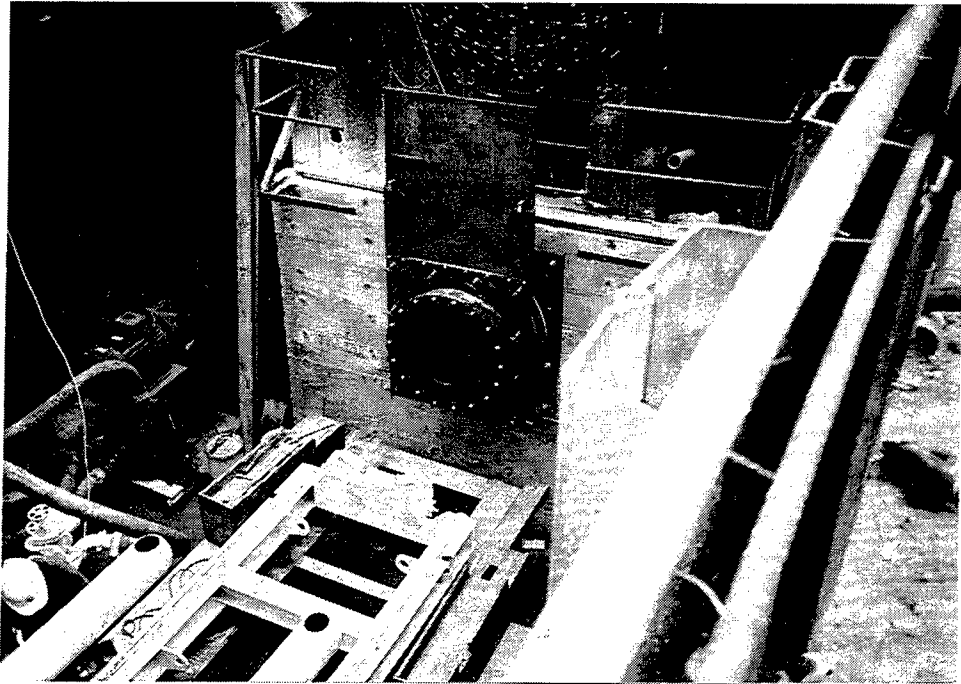

Figure 9. Photograph of double-entry ring seal with guillotine closure used for retraction and grouting tests

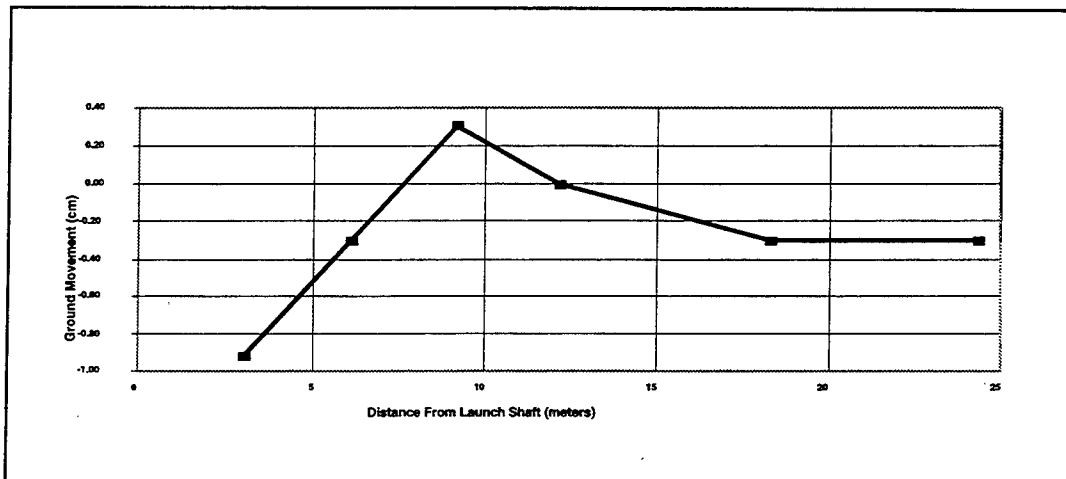

Figure 10. Ground movements 0.6 m (2 ft) above crown after retraction (Negative movements are settlement.)

environmental remediation, e.g., in constructing horizontal barriers to contaminant migration beneath waste sites.

Jacking forces during 12-m (40-ft) drive and retraction

Jacking forces for the initial 12-m (40-ft) drive reached a maximum of 23.6 tonnes (26 tons). The average force due to face pressure in the sand was 1.4 tonnes (1.5 tons), so the average frictional resistance on the shield and pipe over the 12-m (40-ft) drive was

$$f_r = \frac{24.5 \text{ tons}}{\pi (26 \text{ in.}/12 \text{ in./ft}) 40 \text{ ft}} = 0.090 \text{ tsf}$$

The frictional resistance on the 9.5-m- (31.2-ft-) long unlubricated portion of the shield and first three temporary pipes was 18.4 tonnes (20.5 tons) or 0.9 tonnes/m² (0.097 tsf). The frictional force increased by only 3.6 tonnes (4 tons) over the last two pipes pushed in this phase of the test, after lubrication began with the fourth pipe, clearly demonstrating the important benefits of lubrication.

100-m (330-ft) Drive with 660-mm- (26-in.-) Diameter Steel Temporary Pipes

After the retraction and grouting phase of the project was successfully executed, the machine was relaunched and tunneled 100 m (330 ft) to the reception shaft. The machine was driven through all the different soils and zones of mixed-face conditions in 8 days for an average advance rate of 12.5 m/day (41 ft/day).

Ground movements during drive with temporary steel pipes

All ground movements observed during this experiment are summarized in Table 3 and are plotted in Figures 11 and 12, based on surveys of settlement plates 0.6 and 1.2 m (2 and 4 ft) above the pipe crown. Settlements of the ground surface 2.4 to 2.7 m (8 to 9 ft) above the crown (Figure 13) were generally much lower than those closer to the pipe elevation, as expected.

As shown by Figure 11, one large but very localized settlement event occurred near station 0+60 m (2+00 ft) in the sand. The measured settlement at 0.6 m (2 ft) above the pipe was 35.3 cm (13.9 in.) and was accompanied by a chimney effect and a void that developed at the ground surface. This event was caused by allowing the slurry to circulate to the face while the machine was stopped at this location. This resulted in over excavation without the installation of additional pipe, i.e., a void. As shown in Figure 11, the settlement plate 1.2 m (4 ft) above the pipe crown at station 0+60 m (1+99 ft) did not settle. The inclinometer casing apparently bridged over the void, as no

Table 3
Characterization of Ground Deformations Measured During Retrievable Microtunneling Machine Test

Event	Description	Location and Soil Type	Circumstances and Comments
Large Settlement			
Initial Drive	<p>13.9 in. at s.p. level 2 ft above crown 2-ft-deep by 2-ft-diameter cone-shaped void at surface at 2 +00 s.p. No settlement measured by s.p. 4 ft above crown 0.14-in. settlement measured by inclinometer</p>	Sta 2 +00 in sand	<p>Operator error on initial 330-ft drive with 26-in. OD steel temporary pipes. Slurry circulation continued while machine stopped. Sand eroded from face. Void developed above and in front of cutterhead that extended to surface. Event manifested at settlement plate 2 ft above crown and surface. Inclinometer casing partially bridged over void, measured settlement only 0.14 in. (Surface void and settlement larger than measured settlement at inclinometer, s.p.) No settlement measured by s.p. 4 ft above crown at sta 1 +99. No settlement of surface points.</p>
Reaming Drive	<p>3.8 in. at s.p. 1.5 ft above crown 22.4 in. at s.p. 3.5 ft above crown 0.25 to 0.60 in. at inclinometer 1.5 ft above crown No surface points at this location Cylindrical-shaped void app 3 ft deep by 2 ft wide at surface, filled with slurry. Caved in after short time, becoming shallower, wider, and cone-shaped.</p>	<p>Sta 1 +80 in sand Sta 1 +79 in sand Sta 1 +63 to 1 +90 Sta 1 +79 in sand</p>	<p>Void developed above face and propagated back from the face to s.p. at 1 +79. Inclinometer casing partially bridged over void. Measured settlement only 0.6 in. at inclinometer. S.P. at 1 +80 partially bridged over void; measured 3.8-in. settlement.</p>
	<p>App 3-ft-deep by 2-ft-wide cylindrical-shaped void at surface, filled with slurry. Caved in after short time, becoming shallower, wider, and cone-shaped. No s.p.s or surface points at this location. Inclinometer bridged over.</p>	Sta 0 +95 in sand Near interface with buckshot clay	<p>Planned event to evaluate effectiveness of different slurry mixtures for stabilizing face. Thin, low-viscosity polymer and water mixture used as slurry make-up. Worked well in buckshot clay. As soon as machine exited clay and entered sand, void developed. Inclinometer bridged over void. No s.p.s in vicinity; event does not appear in plots.</p>
	<p>21.7 in. at s.p. 3.5 ft above crown 21.4 in. at s.p. 1.5 ft above crown App 3-ft-deep by 2-ft-wide cylindrical-shaped void at surface. Caved after short time, becoming cone-shaped, wider, and shallower. 1.42 in. at inclinometer 1.5 ft above crown</p>	Sta 0 +19 in sand Sta 0 +20 in sand	<p>Operator error on reaming drive with 33.5-in. OD concrete pipes. Slurry circulation continued while machine stopped. Sand eroded from face. Inclinometer casing partially bridged over void. S.P. at 0 +20 tilted slightly. Maximum actual settlement of this s.p. should have been 18 in., the distance from crown to plate.</p>

Table 3 (Continued)			
Event	Description	Location and Soil Type	Circumstances and Comments
Heaves			
330 ft Initial Drive	0.10 to 0.33 in. at inclinometer 2 ft above crown	Sta 0 to 0 + 35 sand	No heaves indicated by s.p.s. or surface points in vicinity. Inclinometer readings alone not sufficient evidence to confirm heaves.
	0.25 to 1.80 in. at s.p. 2 ft above crown 0.12 to 0.36 in. at s.p. 4 ft above crown 0 to 0.48 in. at inclinometer 2 ft above crown	Sta 1 + 00 to 1 + 60 buckshot clay Sta 0 + 99 to 1 + 19 buckshot clay Sta 0 + 95 to 1 + 20 buckshot clay	
	0.06 to 0.17 in. at inclinometer 2 ft above crown 0.12 to 0.24 in. at surface points 9 ft above crown 0.24 in. at s.p. 2 ft above crown very localized < 0.10 in. at inclinometer 2 ft above crown	Sta 1 + 90 to 2 + 18 sand Sta 2 + 00 sand Sta 2 + 18 sand	
Reaming Drive	1.60 in. at surface 8 ft above crown 1.20 in. at s.p. 2 ft above crown 0.84 in. at s.p. 4 ft above crown 0.35 to 0.52 in. at inclinometer 2 ft above crown	Sta 3 + 20 silt Sta 3 + 19 silt Sta 3 + 18 to 3 + 25 silt	Operator error. Machine pushed too fast. Thrust exceeded passive earth pressures.
	0.30 to 0.33 in. at inclinometer 1.5 ft above crown 0.12 in. at surface points 9 ft above crown 0.18 to 0.30 in. at surface points 0.12 in. at s.p.s. 1.5 ft above crown 0.12 to 0.18 in. s.p. 3.5 ft above crown	Sta 0 + 00 to 0 + 15 sand Sta 0 + 30 sand Sta 0 + 60 sand Sta 0 + 30 to 0 + 80 sand Sta 0 + 39 to 0 + 79 sand	
	0.12 to 0.24 in. at surface points 8 ft above crown 0.06 to 0.48 in. at s.p. 1.5 ft above crown 0.10 to 0.27 in. at inclinometer	Sta 1 + 00 sand/buckshot clay interface Sta 1 + 20 to 1 + 60 buckshot clay Sta 1 + 30 to 1 + 57 buckshot clay	
(Sheet 2 of 3)			
NOTE: Large apparent heaves indicated by inclinometer readings during reaming drive at stations 0 + 23, 1 + 85, and 2 + 80 to 3 + 00 resulted from buckling and distortion of casing, associated with large settlement events in those zones.			

Table 3 (Concluded)

Event	Description	Location and Soil Type	Circumstances and Comments
Systematic Settlements			
Initial Drive	0.12 to 0.48 in. at s.p.s 2 ft above crown	Sta 0 + 10 to 0 + 60 sand	Settlements of 0 + 10 surface points related to loss of material into shaft through sheet-pile joints. Not typical of systematic settlements.
	0.12 to 0.48 in. at s.p.s 4 ft above crown	Sta 0 + 10 to 0 + 60 sand	
	0.48 to 0.72 in., at surface points 9 ft above crown	Sta 0 + 10 sand	
	0.24 to 0.48 in. at surface points 9 ft above crown	Sta 0 + 30 sand	
	0 to 0.24 in. at surface points 8 ft above crown	Sta 1 + 60 buckshot clay	
	0 to 0.12 in. at surface points 8 ft above crown	Sta 2 + 20 sand/clay gravel interface	
	0.06 to 0.24 in. at surface points 8 ft above crown	Sta 2 + 60 clay gravel	
	0.12 in. at s.p.s 4 ft above crown	Sta 2 + 59 to 2 + 79 clay gravel	
	0.12 in. at s.p.s 2 ft above crown	Sta 2 + 60 to 2 + 80 clay gravel	
	0 to 0.12 in. at surface points 8 ft above crown	Sta 3 + 00 silt/clay gravel mixed face	
0.24 in. at s.p.s 4 ft above crown	Sta 2 + 99 silt/clay gravel mixed face		
0.12 in. at s.p.s 2 ft above crown	Sta 3 + 00 silt/clay gravel mixed face		
Reaming Drive	0.12 to 0.48 in. at surface points 7.5 ft above crown	Sta 1 + 20 buckshot clay	
	0.12 to 0.18 in. at surface points 7.5 ft above crown	Sta 1 + 60 buckshot clay	
	0 to 0.12 in. at surface points 8.5 ft above crown	Sta 2 + 00 sand	
	0.12 to 0.18 in. at surface points 7.5 ft above crown	Sta 2 + 20 sand/clay gravel interface	
	0.24 to 0.36 in. at s.p.s 1.5 ft above crown	Sta 2 + 18 to 2 + 40 clay gravel/sand mixed face	
	0 to 0.24 in. at s.p.s 3.5 ft above crown	Sta 2 + 17 to 2 + 39 clay gravel/sand mixed face	
0 to 0.030 in. at surface points 7.5 ft above crown	Sta 2 + 60 clay gravel		
0.30 to 0.48 in. at surface points 7.5 ft above crown	Sta 3 + 00 silt/clay gravel mixed face		
0.24 in. at s.p. 1.5 ft above crown	Sta 3 + 00 clay gravel/silt mixed face		
0.72 in. at s.p. 3.5 ft above crown	Sta 2 + 99 clay gravel/silt mixed face		

(Sheet 3 of 3)

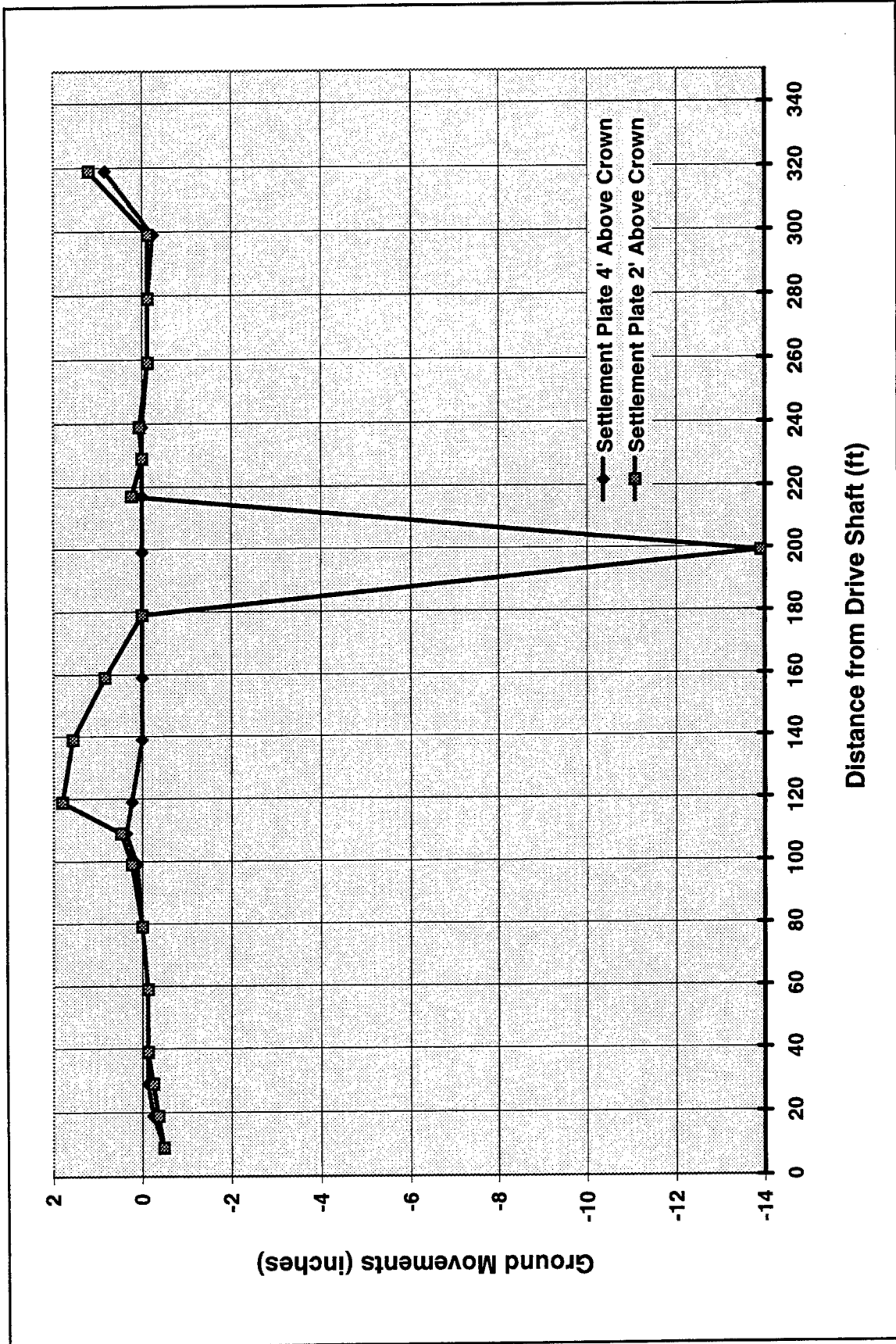

Figure 11. Ground movements at settlement plates 0.6 and 1.2 m (2 and 4 ft) above pipe crown measured during initial drive of retrievable machine test

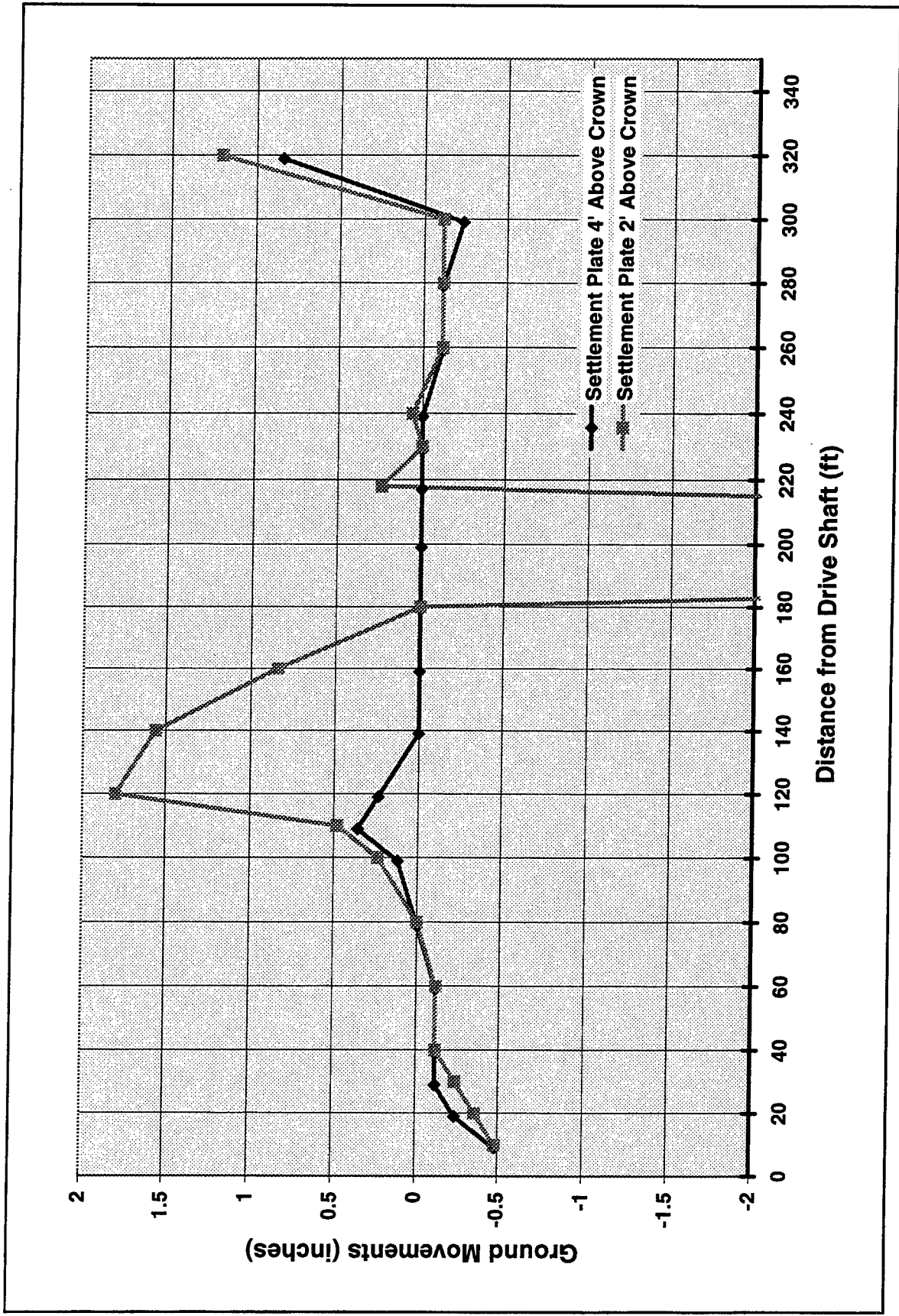

Figure 12. Ground movements at settlement plates 0.6 and 1.2 m (2 and 4 ft) above pipe crown measured during initial drive of retrievable machine test (expanded scale).

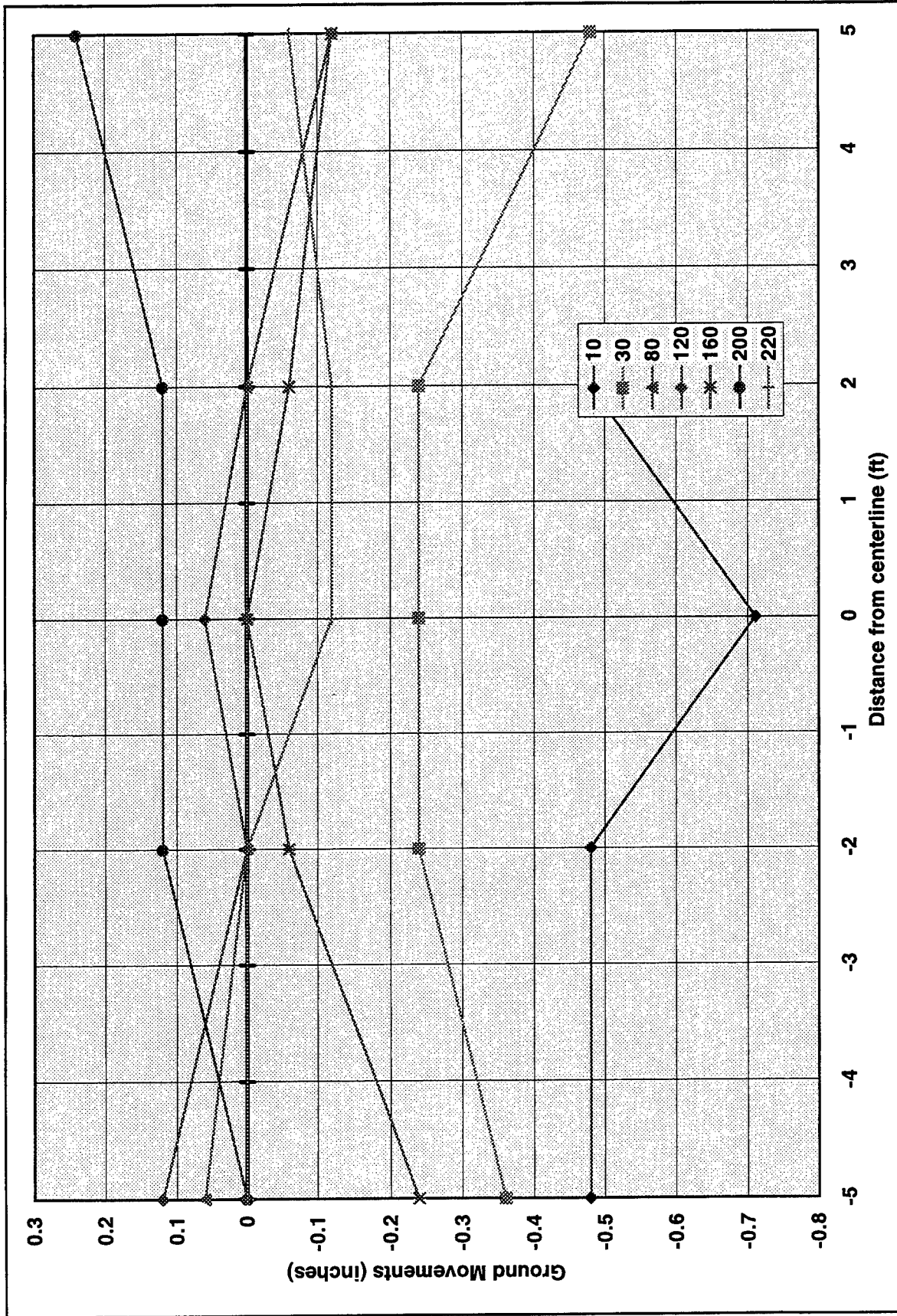

Figure 13. Surface settlements perpendicular to 100-m (330-ft) initial drive

settlements were measured by the inclinometer. In addition, no settlements were detected by the surface points.

As shown in Table 3, other than this large settlement event, ground movements throughout the initial drive were generally within typical specification limits (± 1.3 to 2.5 cm (0.5 to 1 in.)). Maximum observed settlements were less than 1.8 cm (0.75 in.), and heaves were less than 12 mm (0.5 in.), except between stations $0+36$ m and $0+43$ m ($1+20$ ft and $1+40$ ft) in the buckshot clay, where swelling may have contributed to a maximum measured heave of 4.6 cm (1.8 in.). Near the end of the drive, at station $0+98$ m ($3+20$ ft), the machine thrust exceeded the passive resistance of the soil and this overpushing resulted in a heave of approximately 4.1 cm (1.6 in.).

Surface settlement troughs were measured 2.4 m to 2.7 m (8 to 9 ft) above the pipe crown at seven locations perpendicular to the drive using surface survey pins. The cumulative settlements perpendicular to the drive are shown in Figure 13. During the initial drive, only three zones where measurement points existed experienced small systematic settlements. These were located in the following soil sections: in the first, flooded sand section from sta 0 to $0+18$ m ($0+60$ ft), in the buckshot clay near the interface with the sand at sta $0+49$ m ($1+60$ ft), and in the clay gravel section at sta $0+67$ to $0+91$ m ($2+20$ to $3+00$ ft).

In the flooded sand, systematic settlements ranged from 0.3 to 1.2 cm (0.12 to 0.48 in.) at settlement plates 0.6 and 1.2 m (2 and 4 ft) above the crown at sta $0+03$ to $0+18$ m ($0+10$ ft to $0+60$ ft) as shown in Figure 12. The largest settlements were near the drive shaft at sta $0+03$ m ($0+10$ ft) and may have been partly attributable to minor losses of sand through the sheet-pile joints into the shaft. This suggested cause is supported by the relatively large surface settlements of 1.2 to 1.8 cm (0.48 to 0.72 in.) at $0+03$ m ($0+10$ ft), as shown in Figure 13. These were the largest surface settlements measured at any location during the initial drive (except for the voids and large events described previously). In the buckshot clay at sta $0+49$ m ($1+60$ ft), the surface points indicated settlements of 0 to 0.6 cm (0.24 in.) as shown in Figure 13. Interestingly, the 0.6 -cm (0.24 -in.) settlement was measured 1.5 m (5 ft) from the center line, while measured surface settlement was zero at the center line.

The settlement at sta $0+50$ m ($1+63$ ft) measured by the inclinometer located 0.6 m (2 ft) above the crown was 0.9 cm (0.36 in.). The settlement plates at sta $0+49$ m ($1+59$ and $1+60$ ft) detected no settlements, as shown in Figure 12. Consequently, the 0.6 -cm (0.24 -in.) measured surface settlement at a distance of 1.5 m (5 ft) from the center line is not considered reliable.

In the clay gravel section and near the contacts of this section with the sand and silt sections between sta $0+67$ m ($2+20$ ft) and $0+98$ m ($3+20$ ft), systematic settlements of less than 0.6 cm (0.24 in.) were detected by all the measurement devices. The surface points at sta $0+49$ m ($1+60$ ft) and $0+67$ m ($2+20$ ft) indicated settlements of 0 to 0.6 cm (0.24 in.), as shown in Figure 13. Surface settlements were also 0 to 0.6 cm (0.24 in.) at stations $0+79$ and $0+91$ m ($2+60$ and $3+00$ ft). Figure 12 shows that settlements 0.6 m (2 ft) above the crown ranged from 0 at sta $0+70$ m ($2+30$ ft) to 0.3 cm

(0.12 in.) at sta 0+79, 0+85, and 0+91 m (2+60, 2+80, and 3+00 ft). Settlements 1.2 m (4 ft) above the crown were 0.3 cm (0.12 in.) to 0.6 cm (0.24 in.) in the clay gravel.

The measured settlement profiles do not conform closely to the shape of normal probability distribution curves, the shape proposed for modeling systematic movements; however, the shape of the curves is sufficiently close to this shape to allow useful predictions using this approach.

For comparison, the maximum estimated settlement and trough widths were calculated and summarized in Table 4, using relationships developed for large-diameter, shield-driven tunnels (Peck 1969; Peck, Hendron, and Mohraz 1972; Hansmire and Cording 1972; Cording and Hansmire 1975; and Cording 1993). General relationships are shown in Figure 14 for this approach to estimating settlements. Actual and calculated settlements are compared in Table 5. In the calculations, it has been assumed that no change in volume of the soil mass occurs above the pipe. If the soil mass consolidates, surface settlements will be larger than predicted; if the soil mass dilates (expands), the surface settlements will be smaller than predicted. In addition, the entire annular volume was used in the calculations. The reduction in settlements that results from

Table 4
Computed Settlements at 0.6, 1.2, 2.4, and 2.7 m (2, 4, 8, and 9 ft) above Pipe Crown for Initial Drive of Retrievable Machine Test

Soil Section	w ₂	Δh ₂	w ₄	Δh ₄	w ₈	Δh ₈	w ₉	Δh ₉
Sand φ = 37°	32.0 in.	0.97 in.	44.0 in.	0.71 in.	68.0 in.	0.46 in.	74.0 in.	0.42 in.
Buckshot clay φ = 24°	37.7 in.	0.82 in.	53.2 in.	0.58 in.	84.4 in.	0.37 in.	92.2 in.	0.34 in.
Sand φ = 37°	32.0 in.	0.97 in.	44.0 in.	0.71 in.	68.0 in.	0.46 in.	74.0 in.	0.42 in.
Clay gravel φ = 40°	30.8 in.	1.00 in.	42.0 in.	0.74 in.	64.4 in.	0.48 in.	70.0 in.	0.44 in.
Silt φ = 26°	36.8 in.	0.85 in.	51.8 in.	0.60 in.	81.8 in.	0.38 in.	89.3 in.	0.35 in.

d_b = 26.75 in.
d_p = 26.00 in.
o.c. = 0.375-in. radius
 $V_L = \frac{\pi}{4} (26.75^2 - 26.00^2)$
V_L = 31.1 in.³/in.
V_L = 0.22 ft³/ft

$$w = \frac{d_b}{2} + \left(h_c + \frac{d_b}{2} \right) \tan \left(45 - \frac{\phi}{2} \right)$$

$$\Delta h_{\max} = \frac{V_L}{w}$$

Note: Δh₂ = maximum center-line settlement 0.6 m (2 ft) above pipe crown. Δh₄, Δh₈, and Δh₉ refer to maximum center-line settlements 1.2, 2.4, and 2.7 m (4, 8, and 9 ft) above crown, respectively.

Example: Sand Section 1:

$$w_9 = \frac{26.75 \text{ in.}}{2} + \left(108 \text{ in.} + \frac{26.75 \text{ in.}}{2} \right) \tan \left(45 - \frac{37^\circ}{2} \right) = 74.0 \text{ in.} = 1/2 \text{ width of trough}$$

$$\Delta h_{\max} = \frac{31.1 \text{ in.}^3/\text{in.}}{74.0 \text{ in.}} = 0.42 \text{ in.}$$

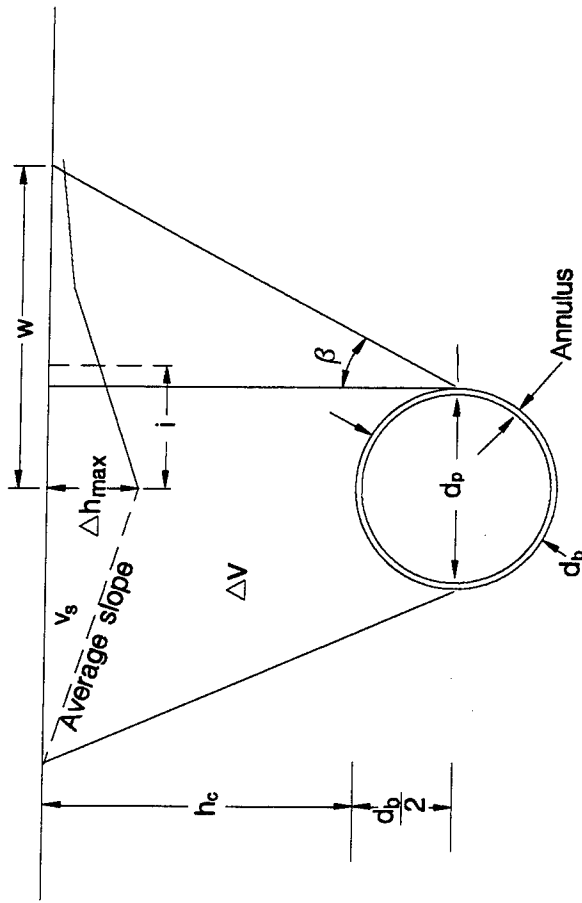

Settlement trough above microtunnel approximated by inverted normal probability distribution curve:

$$\Delta h_x = \Delta h_{\max} e^{(-x^2/2i^2)}$$

$$\text{Average slope} = \frac{\Delta h_{\max}}{w}$$

$$\Delta h_{\max} = \frac{V_s}{w}$$

$$w = \frac{d_b}{2} + \left(h_c + \frac{d_b}{2}\right) \tan \beta \approx 2.5i$$

i = distance from ζ to inflection pt

h_c = depth of cover above crown

V_L = volume loss around or into tunnel

$$V_L = \frac{\pi}{4} (d_b^2 - d_p^2)$$

d_b = bore diameter

d_p = pipe diameter

ΔV = change in volume of soil mass above tunnel

V_s = volume of settlement trough

$$V_s = V_L - \Delta V$$

Figure 14. Volume loss around microtunnels - general relationships (modified from Cording 1993)

Table 5
Comparison of Measured and Computed Settlements During Initial Drive of Retrievable Machine Test

Soil Type	Location	Measured Settlements, Δh_m	Computed Settlements, Δh_c	$\Delta h_m/\Delta h_c$	Comments
Sand (Section 1)	2 ft above crown	0.12 to 0.48 in.	0.97 in.	12 to 50%	Maximum indicated surface settlement of 0.48 in. may be due to disturbance of surface point
	4 ft above crown	0.12 to 0.48 in.	0.71 in.	17 to 68%	
	9 ft above crown	0.24 to 0.48 in.	0.42 in.	57 to 114%	
Buckshot clay	2 ft above crown	--	0.82 in.	--	
	4 ft above crown	--	0.58 in.	--	
	8 ft above crown	0 to 0.24 in.	0.37 in.	0 to 65%	
Sand (Section 3)	2 ft above crown	--	0.97 in.		No systematic settlements observed in this section. Small heaves and one large settlement event measured.
	4 ft above crown	--	0.71 in.		
	9 ft above crown	--	0.42 in.		
Clay gravel	2 ft above crown	0.12 in.	1.00 in.	12%	
	4 ft above crown	0.12 in.	0.74 in.	16%	
	8 ft above crown	0.06 to 0.24 in.	0.48 in.	12 to 50%	
Silt/clay gravel mixed face	2 ft above crown	0.12 in.	0.85 in.	14%	
	4 ft above crown	0.24 in.	0.60 in.	40%	
	8 ft above crown	0 to 0.12 in.	0.38 in.	0 to 32%	

Note: To convert feet to meters, multiply by 0.3048.
 To convert inches to centimeters, multiply by 2.54.

filling this space with bentonite lubricant was not accounted for in the calculations.

Table 5 shows that measured settlements, with one exception, were always less than settlements calculated using the approach suggested by Peck and others (Peck 1969) for the initial drive. The one exception where measured settlements exceeded computed settlement was at 1.5 m (5 ft) from the center line at a surface point 2.7 m (9 ft) above the crown at station 0+09 m (0+30 ft) (Figure 13). High-volume foot traffic in this area near the slurry tanks may have caused disturbance at this point. Other surface points at this station indicated settlements of 0.6 to 0.9 cm (0.24 to 0.36 in.). The measured value cannot be ruled out as inaccurate, but it is not considered reliable.

For all soil types and all depths of measurement, the ratio of measured to computed settlement ranged from 0 to 114 percent, including the suspect measurement. If this measurement is excluded and only nonzero settlements are considered, the ratio of measured to computed settlements ranged from 12 to 68 percent. In general, it appears that settlements are more seriously overpredicted as the distance from the crown of the tunnel decreases, although the number of settlements measured does not allow a strong correlation.

The results of this exercise do tend to support the validity of this approach as a convenient, reliable method for conservatively estimating maximum systematic center-line settlements.

The important conclusion from this exercise is that systematic settlements associated with reasonable overcuts rarely exceed allowable limits set out in specifications. The predicted systematic settlements can be easily checked against specified maximum values, using this approach.

Jacking forces during initial drive with temporary pipes

Figure 15 summarizes the jacking forces as the machine and temporary pipes progressed through the 100-m (330-ft) drive with the 660-mm (26-in.) OD steel temporary pipes.

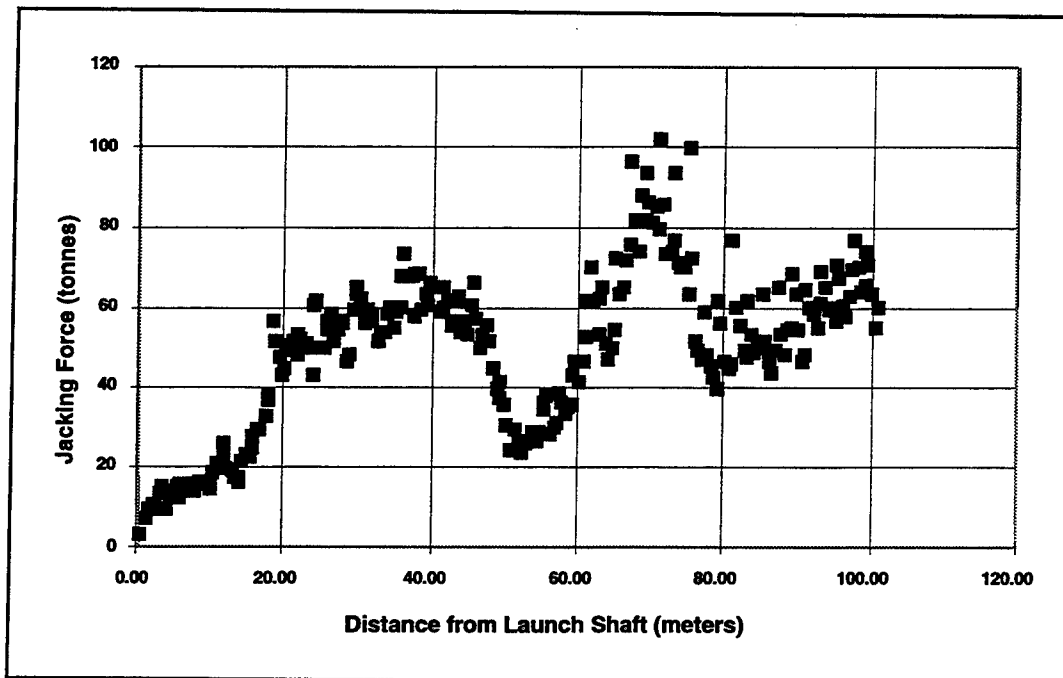

Figure 15. Jacking forces during initial drive

Predictably, significant changes in jacking forces occurred at the interface of each soil zone. In addition, at two locations (43 to 52 m (140 to 170 ft) and 73 to 78 m (240 to 255 ft)) jacking forces decreased sharply. In both cases, this phenomenon occurred when the machine exited a sandy zone and entered cohesive soils. It would be expected that the frictional component of the jacking force would increase at a slower rate in cohesive soils. This effect is largely due to two major factors. First the normal stresses acting on the pipe are generally lower in clays than in sands at the same depth of cover. The lower normal stresses are due in part to the clay's cohesion, providing a stable overcut around the pipe, whereas sand tends to close in around the pipe quickly. Secondly, the coefficient of friction is lower for clay than for sand.

However, even if the frictional resistance in the newly encountered soil approached zero, the total jacking load would not decrease, unless one or both of the following conditions occurred:

- a. The face pressure comprised a significant portion of the total jacking resistance in the previous soil profile and decreased dramatically as the subsequent profile was entered.
- b. The frictional component of the total jacking force decreased faster than the expected increase in face pressure, due to unloading of the unlubricated portion of the shield or enhanced effectiveness of the lubricant in the current and previous soil section.

In the case under consideration, a decrease in the face pressure did not occur and, therefore, did not cause a decrease in jacking force. The machine was exiting a sand section, with low face pressures (1.4 tonnes (1.5 tons)), and entering a clay with higher face pressures (5.3 tonnes (5.8 tons)). Face pressures in the various soil sections are summarized in Table 6.

Zone	Soil	Range of Face Pressure Component of Jacking Force tonnes (tons)	Average Face Pressure Component of Jacking Force tonnes (tons)	Remarks
0 - 40	Grouted sand	0.55 - 3.64 (0.6 - 4.0)	2.1 (2.3)	
40 - 90	Flooded sand	0.91 - 2.55 (1.0 - 2.8)	1.4 (1.5)	
90 - 165	Buckshot clay	4.3 - 6.4 (4.7 - 7.0)	5.2 (5.8)	
165 - 205	Sand	0.8 - 1.9 (0.9 - 2.1)	1.4 (1.6)	Large settlements at 61 m (200 ft); Slurry circulation continued while machine stopped
205 - 240	Sand/clay gravel mixed face	1.0 - 3.2 (1.1 - 3.5)	1.7 (1.9)	
240 - 290	Clay gravel	0.9 - 3.3 (1.0 - 3.7)	2.1 (2.3)	
290 - 310	Clay gravel/silt mixed face	1.5 - 3.1 (1.7 - 3.4)	2.3 (2.6)	
310 - 320	Silt	3.0 - 3.9 (3.3 - 4.3)	3.3 (3.7)	Overpushing caused high face pressure and ground heave

However, it is possible that the frictional component of the overall jacking force decreased faster than the face pressure increased as the machine entered the clay. The lubrication ports were located near the back end of the machine, so the leading 3.5 m (11.5 ft) received virtually no benefit from the lubrication. Therefore, the first 3.5 m (11.5 ft) carried a disproportionate amount of the overall frictional component of the jacking force while in the sand. As the

shield exited the sand and entered the clay, the frictional component on the shield dropped dramatically, which overshadowed the increase in face pressure.

The reasonableness of a reduction in frictional resistance as a cause for the overall decrease in jacking forces is explored below. The average face pressure measured in the sand was 1.4 tonnes (1.5 tons) and in the clay was 5.3 tonnes (5.8 tons). The total jacking force measured as the machine entered the clay was 59.1 tonnes (65 tons). The total jacking force when the machine exited the clay and reentered the sand was 22.7 tonnes (25 tons), for an overall reduction of 36.4 tonnes (40 tons). If the difference in measured face pressures is taken into account, the net decrease in the frictional jacking force component is 32.5 tonnes (36 tons). If this net decrease of 32.5 tonnes (36 tons) is assumed to be attributable entirely to the reduced friction on the unlubricated portion of the shield, then the reduction in jacking stresses on the shield may be calculated as shown below:

$$\Delta JF = 32.5 \text{ tonnes} = F_{r_{shield}}$$

$$F_{r_{shield}} = f_r A_{shield}$$

$$f_{r_{shield}} = \frac{32.5 \text{ tonnes}}{7.26 \text{ m}^2} = 4.45 \text{ tonnes/m}^2$$

This reduction in frictional stress on the shield does not appear reasonable as an explanation of the net reduction in jacking forces. First, the shape of the jacking force graph does not support this explanation. If the entire reduction of 33 tonnes (36 tons) was due to unloading of the shield, the graph would exhibit a steep, negative slope over the first 3.3 m (11 ft) in the clay. It does not. The jacking forces would then remain constant or increase marginally until the end of the clay interval. It does not.

The shape of the jacking force curve in the buckshot clay interval suggests a second approach for determining the cause of the reduction in jacking forces. In the preceding discussion, the graph was characterized as three segments with decreasing slopes from the first to last segment. In reality, the slope of the graph appears to gradually decrease from a small positive value to a sharply negative value over the full interval. This shape suggests that the reduction in jacking forces may have been attributable to increased effectiveness of lubrication over the full length of shield and pipe pushed through the clay interval and for some portion of the preceding interval in sand. This explanation relies on two conditions as examined below:

- a. Frictional resistance in the clay was very small, but not negative.
- b. Reduction in jacking forces occurred because of increased effectiveness of the lubrication process in both the clay and the preceding sand section.

It seems clear that the lubrication process had to be far more effective in the clay interval itself, especially for decreasing the load on the shield. Yet this phenomenon, by itself, cannot completely explain the decrease in jacking forces. It is proposed that the increased effectiveness of lubrication had to extend back into the preceding sand section. To determine how much load was shed in the sand, it is necessary to determine the effective frictional resistance on the unlubricated portion of the shield. This can be estimated by inspection of the first 3.5 m (11.5 ft) of the graph in Figure 15. The total jacking force at 3.5 m (11.5 ft) was 13.6 tonnes (15 tons), with a face pressure component of 3.6 tonnes (4 tons), yielding a net frictional resistance of 10 tonnes (11 tons) in the clay. Therefore, the reduction in frictional resistance in the preceding sand section had to account for at least 22.7 tonnes (25 tons), if no frictional resistance was exerted by the clay on the shield and pipe string. If it is assumed that the average frictional resistance in the clay was not zero, but some small value, e.g., 0.1 tonnes/m² (0.01 tons/ft²), the increase in jacking load in the 22.5 m (74-ft) clay interval would be:

$$\Delta JF_{clay} = 0.1 \times 22.6 \times 2.1 = 4.6 \text{ tonnes}$$

For this scenario, the load that was shed in the sand would have to be 23 + 4 = 27 tonnes (25 + 5 = 30 tons). If the frictional resistance in the sand was reduced from the initial values to 0.2 tonnes/m² (0.02 tons/ft²) as a result of increased effectiveness of the lubrication process, the distance over which this increased effectiveness of lubrication process was exerted can be back-calculated. In the interval from 20 to 39 m (66 to 127 ft), the jacking stress was 0.3 tonnes/m² (0.031 tons/ft²), respectively. The computed average jacking stress in the sand interval between 12 and 20 m (40 and 66 ft) was 1.7 tonnes/m² (0.181 tons/ft²), and 23.0 tonnes (25.4 tons) was shed in this zone, by a reduction in the frictional resistance of 1.4 tonnes/m² (0.143 ton/ft²), from 1.7 to 0.3 tonnes/m² (0.181 to 0.038 tons/ft²) as shown below:

$$\frac{23.0 \text{ tonnes}}{8 \text{ m}(2.1 \text{ m}^2/\text{m})} = 1.4 \text{ tonnes/m}^2 = \begin{array}{l} \text{required reduction in jacking} \\ \text{stress due to increased effec-} \\ \text{tiveness of lubrication process} \end{array}$$

The net frictional resistance remaining on the pipe in the interval from 12 to 20 m (40 to 66 ft) was then 1.7 - 1.4 = 0.3 tonnes/m² (0.181 - 0.143 = 0.038 ton/ft²). These values appear far more reasonable and this explanation is more consistent with the shape of the jacking force graph. Another factor that lends credibility to this explanation is that the advance rates in the clay were about one-fourth to one-fifth the advance rates in the sand as shown in Figure 16. The slower advance rates greatly enhanced the effectiveness of the lubrication process, by allowing a thicker, more uniform coating of the pipes. Some lubrication probably traveled up and down the pipe string and shield, reducing jacking loads. It should be pointed out that the foregoing scenario is consistent with the data but is not a unique solution. The apportionment of jacking load reduction in the sand is speculative. The same rationale could be

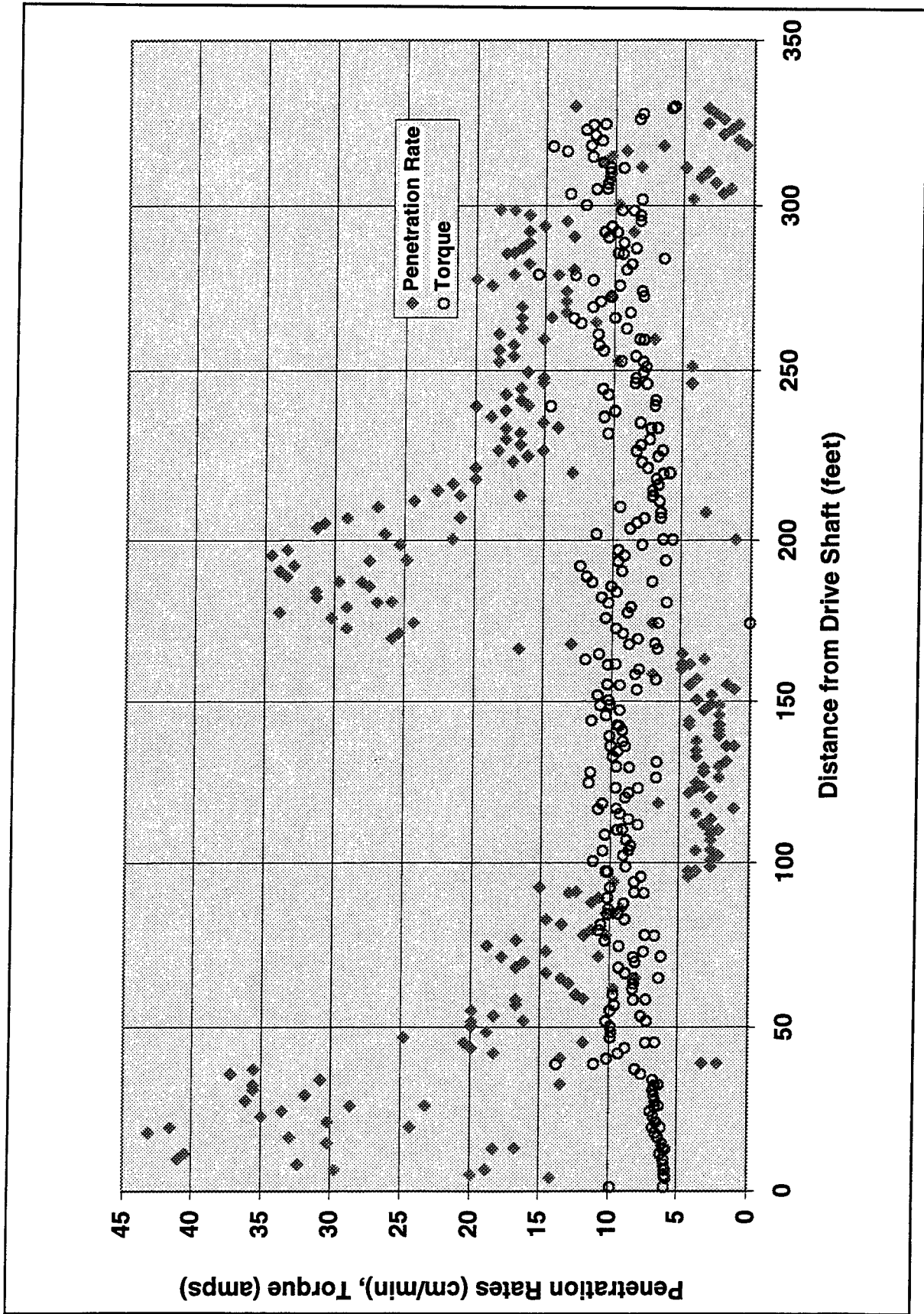

Figure 16. Machine penetration rate and cutterhead torque versus length for initial drive of retrievable machine test

applied to explain the decrease in jacking forces observed in the sand/clay gravel mixed face interval shown in Figure 15.

As shown in Figure 17, average jacking stresses (Jacking Force/Surface Area) for the initial drive declined sharply from approximately 3.3 to 1.0 tonnes/m² (0.33 to 0.10 tsf) at approximately 6 m (20 ft) into the initial drive with steel temporary pipes. This is typical since the face pressure is a significant component of the total jacking force at the beginning of the drive where there is little surface area over which frictional forces can act. The frictional component over the unlubricated shield section is also disproportionately high, for reasons explained above. The average jacking stress remained constant at approximately 1.0 tonnes/m² (0.10 tsf) through the sand zone, then decreased gradually through the buckshot clay zone to a minimum value of 0.3 tonnes/m² (0.03 tsf) near the end of this section at 50 m (165 ft) into the drive. As the machine exited the clay and reentered the next zone of sand, the average jacking stresses again increased gradually to 0.6 tonnes/m² (0.06 tsf). As the machine exited the sand at 73 m (240 ft) and entered the clay gravel section, the average jacking stress again gradually decreased to 0.3 tonnes/m² (0.03 tsf) and remained approximately constant for the final 90 ft (27 m) of the

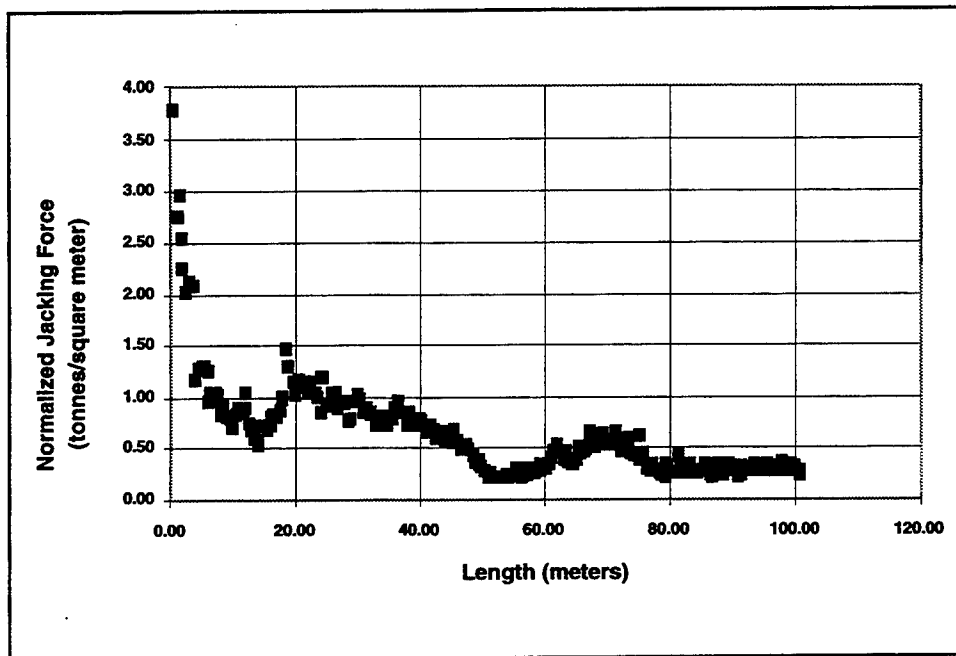

Figure 17. Jacking stresses during initial drive

drive. It should be noted that the above jacking stress values are not those that were measured in the individual soil sections but are the running average values. These values were calculated as total jacking force divided by total pipe and shield surface area. The jacking stresses were also computed for various zones of the test using the slope segments of the jacking force curves and are summarized in Table 7.

Table 7
Jacking Stresses for Various Soils in Test Bed During Initial Drive

Zone	Distance, L m (ft)	Material	Jacking Force, tonnes (tons)		Change in Jacking Force ΔJF tonnes (tons)	Jacking Stress f_j , tonnes/m ² (tons/ft ²)
			At Beginning	At End		
0 - 12 m (0 - 40 ft)	12.2 (40)	Grouted sand	3.6 (4)	19.8 (22)	16.2 (18)	0.64 (0.066)
12 - 20 m (40 - 66 ft)	7.9 (26)	Sand	19.8 (22)	48.6 (54)	28.8 (32)	1.8 (0.181)
20 - 39 m (66 - 127 ft)	18.6 (61)	Sand→Clay	48.6 (54)	60.3 (67)	11.7 (13)	0.3 (0.031)
39 - 47 m (127 - 155 ft)	8.5 (28)	Buckshot clay	60.3 (67)	51.3 (57)	-9 (-10)	-0.5 (-0.052)
47 - 52 m (155 - 172 ft)	5.2 (17)	Buckshot clay	51.3 (57)	23.4 (26)	-27.9 (-31)	-2.6 (-0.268)
52 - 71 m (172 - 232 ft)	18.3 (60)	Sand	23.4 (6)	86.4 (96)	63 (70)	1.7 (0.171)
71 - 78 m (232 - 256 ft)	7.3 (24)	Sand→Clay gravel	86.4 (96)	49.5 (55)	-36.9 (-41)	-2.4 (-0.251)
78 - 101 m (256 - 330 ft)	22.6 (74)	Clay gravel→Silt	49.5 (55)	67.5 (75)	18 (20)	0.39 (0.040)

Note: A_p = pipe surface area = $\pi d_p L = 2.08 \text{ m}^2/\text{m}$ (6.81 ft²/ft)
 f_j = jacking stress = $\frac{\text{Change in Jacking Force}}{A_p}$
L = distance over which change in jacking force occurs

100-m (330-ft) Drive with Reamer and Concrete Pipe

When the initial drive was completed, the microtunneling machine was removed at the reception shaft and the reamer was installed. The reamer assembly consists of the reamer, a secondary jacking station, and a power pack. During this final phase of the test, the excavation was enlarged to 900-m (36-in.) diameter, and 850-mm (33.5-in.) OD Spun-Cast™ concrete pipes were installed from the reception shaft by jacking the pipe in the opposite direction of the original 660-mm (26-in.) tunnel. The concrete pipe was successfully installed over the full 100-m (330-ft) length; however, there were some sealing problems associated with the reamer. The reaming operation required careful coordination of the primary and secondary jacking operations through remote voice communications to balance the sequence of operations. This was critical for precise slurry control, especially in unstable ground conditions. At some locations in the sandy zones of the test beds, slurry migrated to the surface. This was accompanied by ground settlements (Figure 18) and is described below.

Ground movements during reaming drive

During the reaming drive, three large settlement events occurred, as summarized in Table 3. However, only two of these events were detected by settlement plates and inclinometer readings (Figure 18). The reaming drive

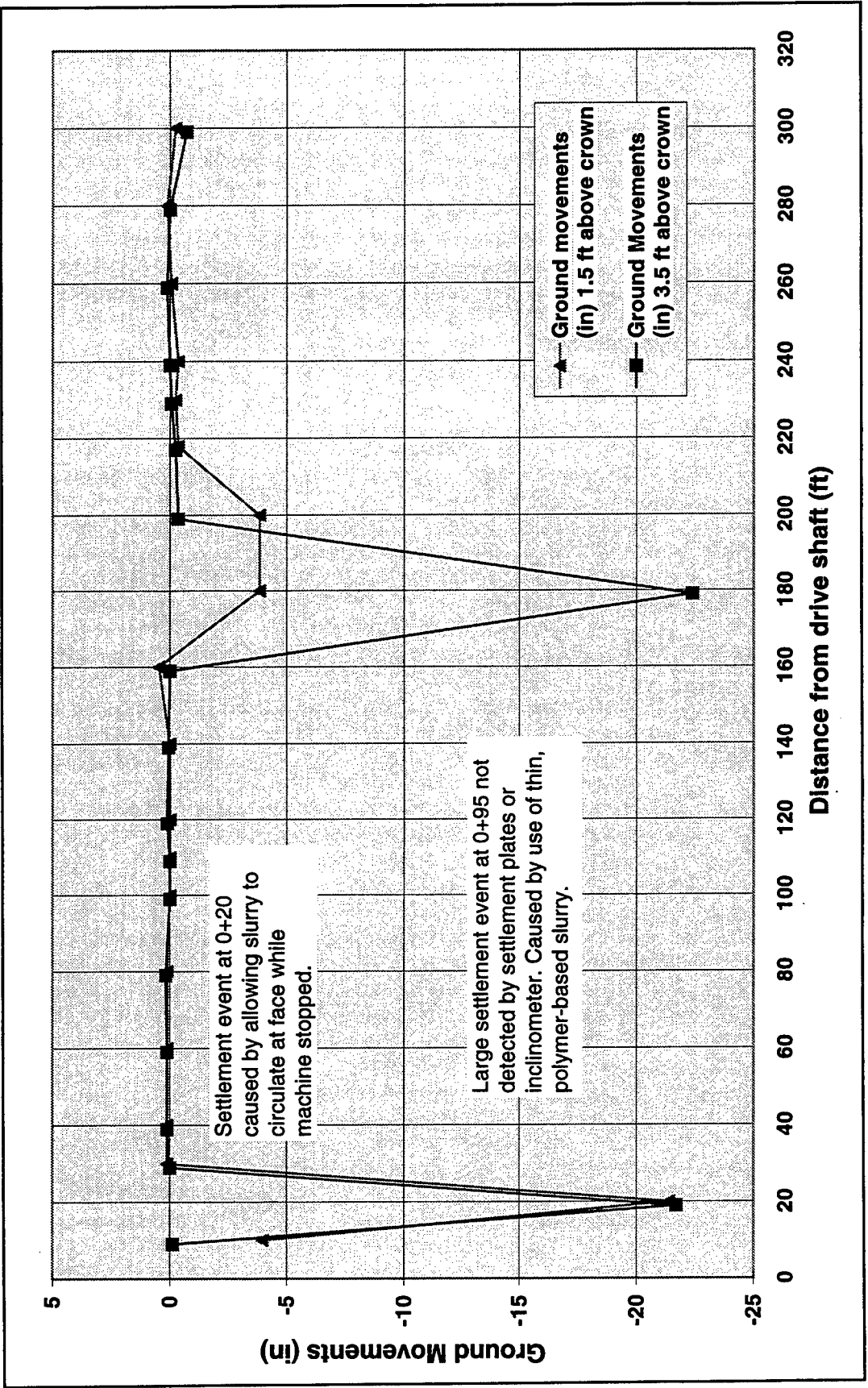

Figure 18. Ground movements at settlement plates 0.5 and 1.1 m (1.5 and 3.5 ft) above pipe crown measured during reaming drive of retrievable machine test (Note: To convert from feet to meters, multiply by 0.3048)

proceeded from the original reception shaft at sta 0+98 m (3+20 ft) back to the original drive shaft at sta 0+00. The settlement events are described in the chronological order of occurrence, from higher to lower station numbers.

The first large settlement event during the reaming drive occurred at sta 0+55 m (1+79 ft) in the sand. The event was marked by settlement of 57 cm (22.4 in.) of the plate 1.1 m (3.5 ft) above the crown at this location (Figure 18). The settlement at sta 0+55 m (1+80 ft), measured by the settlement plate 0.5 m (1.5 ft) above the crown, was only 10 cm (3.84 in.), indicating that the void was very localized and may have propagated from the face back toward the settlement plate at sta 0+55 m (1+79 ft) after the machine had passed this point.

Inspection of the profile view of the test bed in Figure 2 shows that the inclined contact surface between the sand and buckshot clay was very near the location of this settlement. Part of the settlement may be related to machine advance rates. Advance rates are typically much lower in clays than in sands because the torque required to turn the cutterhead is much higher in clays than in sands for the same advance rate. This trend is confirmed for this test by Figure 16, which shows penetration rates and cutterhead torque (indicated by amperage draw of the electric motor) plotted against distance along the test bed. Penetration rates were approximately four to five times higher in sand than in the buckshot clay, because the operator correctly maintained cutterhead torque at a nearly constant rate. It is believed that as the machine exited the sand and encountered the overhanging cantilever of buckshot clay, the slower advance of the machine allowed the sand near the contact to be eroded. The erosion progressed along the contact back toward the settlement plate at sta 0+55 m (1+79 ft). Once the base of this plate was undermined, the void progressively developed around the riser of this plate to the surface. This explanation of the event is supported by field notes made at the time of occurrence and by the inclinometer measurements. When the reamer head was located at sta 0+50 m (1+63 ft), large slurry losses occurred through the riser of this settlement plate. Once this preferential flowpath was established, slurry flowrates quickly increased and were estimated at 10 gpm from crude measurements. (Slurry flow rates were sufficient to cause erosion of the sides of the test bed berm.) The inclinometer measurements showed settlements were 0.6 to 1.5 cm (0.25 to 0.60 in.) between sta 0+50 m and 0+58 m (1+63 and 1+90 ft) at 0.5 m (1.5 ft) above the crown. Although an apparent heave of 1 cm (0.4 in.) was measured in the inclinometer casing at sta 0+56 m (1+85 ft), this heave was likely due to an upward buckling of the casing in response to large settlements on either side of this location. The factors that contributed to this large settlement event are believed to be the following: slower penetration rates in the mixed face of the highly plastic clay, cantilevered over the wet sand; poor control of the slurry through the reamer; and the availability of a preferential slurry flow path along the clay/sand contact and through the settlement plate riser to the surface. As mentioned in the description of the reamer system and the reaming test, the capability to control the slurry flow was less than ideal. The seal behind the reamer was also inadequate and allowed substantial losses back along the annulus, which was 2.8 cm (1.1 in.) on the radius.

The second large settlement event on the reaming drive occurred at sta 0+29 m (0+95 ft), just as the machine exited the buckshot clay and entered the sand. This event was a planned evaluation of slurry mixtures required to maintain face stability in sands and clays. When low-viscosity, thin water-based polymer or bentonite slurry mixtures are used in coarse-grained soils, it is difficult to maintain stability. The slurry velocities and flowrates must be maintained at high levels with thin slurries to prevent the excavated material from settling out in the slurry lines. Since no filter cake can be developed, a pressure bulb propagates away from the face. Sand is eroded by the high, turbulent flow rates and velocities, a void develops at the face, and this is typically manifested by large surface settlements.

When the machine was approximately halfway through the buckshot clay section, the bentonite and water slurry mixture was replaced with a thin water and polymer-based slurry mixture. This thin slurry was an adequate mixture for excavation in the buckshot clay. However, as the machine exited the clay and entered the sand, a void developed progressively until the surface collapsed into the void at sta 0+29 m (0+95 ft). This void measured 1 m deep by 0.6 m wide (3 ft deep by 2 ft wide), and was filled with slurry when it first formed. It later caved in and took on the shape of a truncated cone. This void was similar in size to the other surface voids but, unlike the others, did not occur at a settlement plate. This event showed that slurry mixtures must be properly selected to provide sufficient viscosity and gel strengths to ensure stability of the face.

Highly skilled operators can sometimes overcome potential problems with use of thin slurries by operating the machine in the mode of a mechanical earth pressure balance machine. That is, the torque is closely monitored and maintained at a relatively high level. The cutterhead is kept packed with sand to prevent uncontrolled inflows. This is achieved by alternately opening and closing the slurry bypass valves. However, this type of operation results in frequent plugging of the slurry outlet lines. The claimed disadvantage of using thicker bentonite-based slurry mixtures is that it creates problems with slow sedimentation of the spoil in the tanks at the shaft. This problem leads to high pump pressures due to the thickening of the slurry with the suspended cuttings being recirculated to the face. Eventually, the slurry tanks must be emptied and the contents hauled to an acceptable disposal site, at some cost of time and money. However, concerns about slurry disposal should not override legitimate concerns about face stability and large settlements. Means are available to aid in the separation of excavated spoil from the slurry, such as the use of shaker screens, hydrocyclones, or flocculants. Almost every instance of large settlement that the authors are aware of resulted from slurry mixture and circulation mistakes. The event discussed in the preceding paragraphs was planned and executed to highlight this concern.

The third and last large settlement event on the reamer drive occurred at sta 0+06 m (0+19 ft) in the sand near the original drive shaft. This event was caused by allowing the slurry to continue to circulate, for less than 1 minute, while the machine was stopped. The result was settlement of 55 cm (21.7 in.) at the settlement plate, 1.1 m (3.5 ft) above the crown, and 54 cm (21.4 in.) at the settlement plate, 0.5 m (1.5 ft) above the crown. (The measured settlement

exceeded the nominal distance between the settlement plate and the pipe crown because the plate tipped somewhat as it settled.) A surface void approximately 1 m deep by 0.6 m wide (3 ft deep and 2 ft wide) developed, as shown in the photograph in Figure 19. The surface appearance of this void was quite similar to all the large settlement events observed during this test. The inclinometer casing partially bridged over the void, registering only 3.6 cm (1.42 in.) settlement 0.5 m (1.5 ft) above the crown. This event, like the others, highlights the importance of careful attention to small details by the operator and crew. At the high slurry flowrates and velocities typically used in microtunneling, only a very short time is required to erode soil at the face and cause large settlements. The operator must vigilantly control slurry circulation and machine torque to avoid such unacceptable events.



Figure 19. Photograph of surface void at sta 0+06 m (0+20 ft) during reaming drive of retrievable machine test

Ground movements elsewhere were generally small, with maximum measured heaves and settlements of 1.8 cm (0.75 in.) or less, as shown in Table 3 and Figure 18. The maximum predicted settlement due to overcut, calculated using the approach illustrated previously for the 100-m (330-ft) initial drive, was 46 mm (1.8 in.). This calculated value was for the relatively large overcut of 28 mm (1.1 in.) on the radius, 850-mm (33.5-in.) pipe OD, and relatively shallow cover of 2.3 to 2.6 m (7.5 to 8.5 ft) above the crown, or 2.7 to 3.0 m (9 to 10 ft) above the center line. Since observed settlements were generally less than one-third of this value, some benefits (at least in the short term) were apparently realized by the filling of the annular space with lubricant.

Jacking force during reaming drive

During the reaming operation, jacking loads were continuously monitored. As shown in Figure 20, maximum jacking forces for the reamer drive were 100 tonnes (110 tons). This was approximately the same as for the initial drive, even though the surface area per running meter (running foot) of the concrete pipe was 30 percent greater at 2.7 m^2 (8.8 ft^2), compared to 2.1 m^2 ($6.8 \text{ ft}^2/\text{ft}$) for the steel temporary pipe. The overcut on the steel temporary pipes was 10 mm ($3/8$ in.), while the overcut was 28 mm (1.1 in.) on the concrete pipe, both measured on the radius.

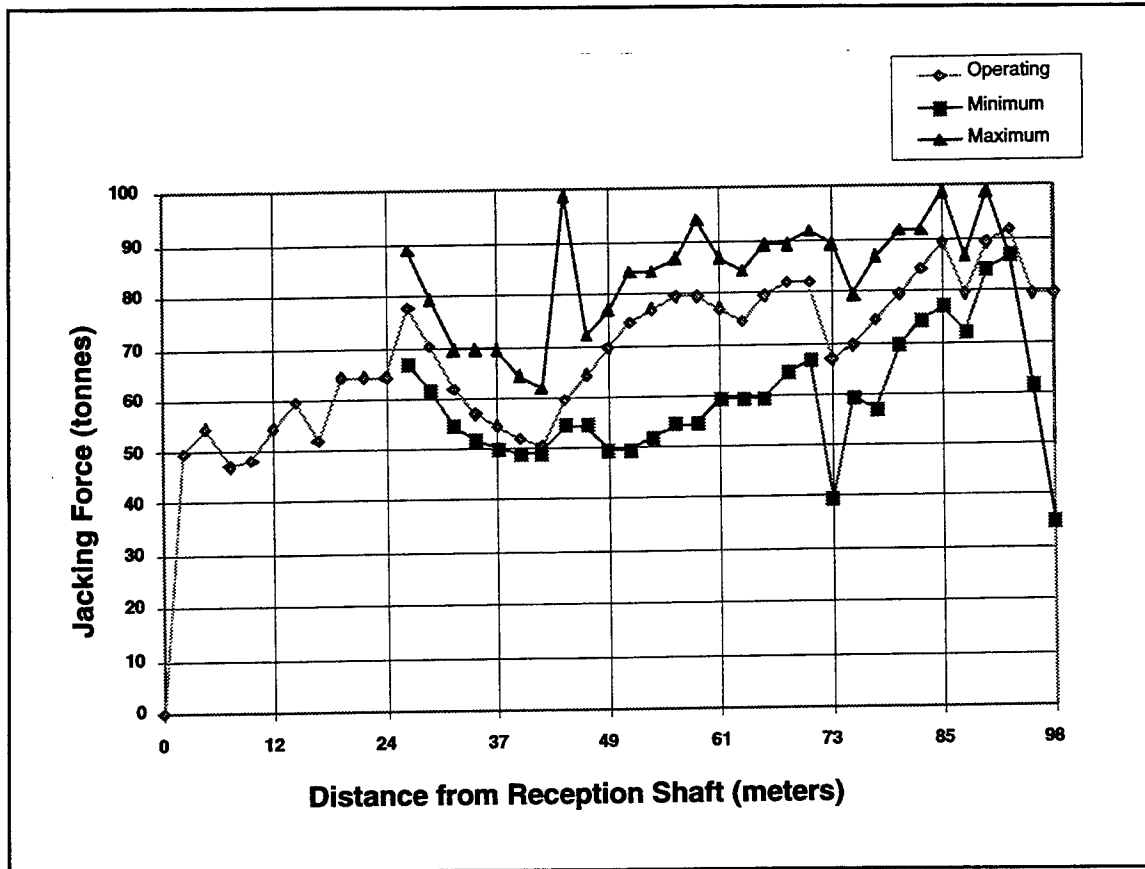

Figure 20. Jacking forces during reaming drive

Changes in jacking forces as the machine progressed through different soil types were much less dramatic during the reaming operation. In addition, the large decreases in jacking force which occurred on the initial drive did not occur during reaming. Much of this can be attributed to the configuration of the reamer face and relatively short body. It is noteworthy that the jacking force quickly reached 55 tonnes (60 tons), unlike the gradual increase in jacking force that was seen on the initial drive. This is again indicative of high face pressures at the heading; in this case, the reamer inlet. The remaining jacking force can then be attributed to frictional loading; however, it is important to consider that surface settlement and slurry losses can greatly affect the

overall jacking force. Since settlement and slurry losses occurred in the sand zones, where frictional increases are usually the highest, the total jacking load may not be representative of loads that would have been measured if an effective seal had been achieved and circulation had been satisfactorily controlled.

The average running jacking stresses during reaming and concrete pipe installation decreased sharply from 7.8 tonnes/m² (0.78 tons/ft²) to 2.0 tonnes/m² (0.20 tons/ft²) over the first 9 m (30 ft) of the drive. These decreases were due to the disproportional effects that the face pressure and skin friction on the reamer body exerted on the overall jacking force in the first few meters of the drive. The jacking stress then gradually decreased to a minimum value of approximately 0.3 tonnes/m² (0.03 tons/ft²) toward the end of the drive. This trend indicates that face pressures and skin friction on the body of the reamer and control assembly were significant factors in the overall jacking force during reaming. Frictional forces on the pipe were relatively low, again due to the large overcut and generous lubrication. Jacking stresses on the 850-mm (33.5-in.) OD concrete pipe measured during the reaming operations are summarized in Figure 21. As with the jacking stresses for the initial drive, these values are the running averages, not jacking stresses for the individual soil sections.

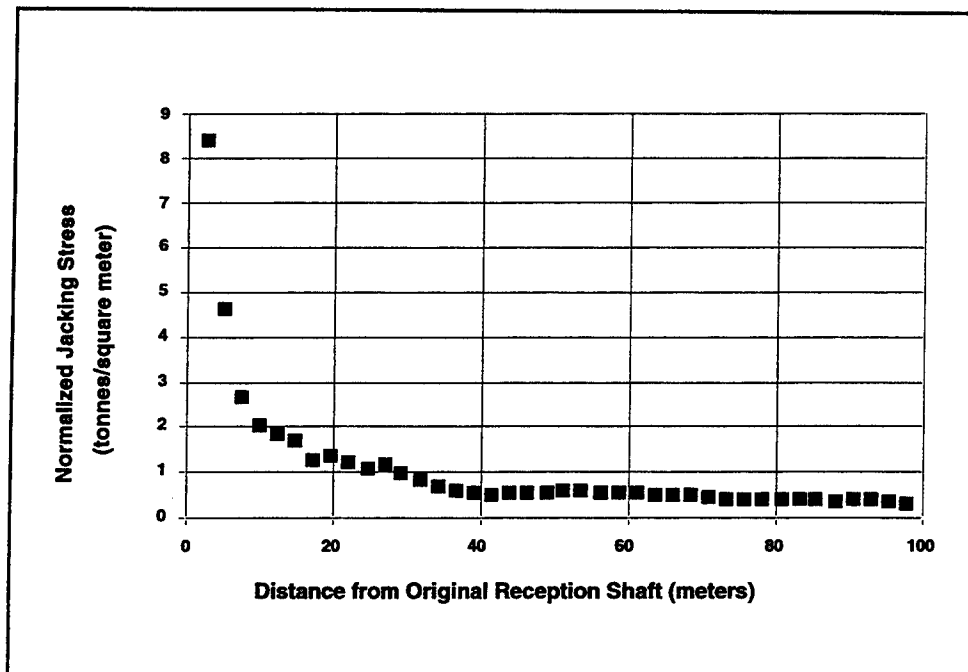

Figure 21. Jacking stresses during reaming drive

5 Conclusions and Recommendations

These tests and the subsequent analyses of results provided insight into the performance of microtunneling machines in different soil conditions and proper selection and use of slurry mixtures. This information was used along with the results of the first series of microtunneling tests at WES in 1992 in developing the recently published microtunneling guidelines (Bennett et al. 1995).

These tests clearly demonstrated the ability to maintain stability of the excavation during retraction of the microtunneling machine. The fly ash-based CLSM, specially designed double-entry ring seal and guillotine closure, and developed retractive procedures worked flawlessly and could, with minor changes, have broad applications in trenchless work.

The initial drive with the steel, bolt-together temporary pipes was a complete success, and allowed development of improved understanding of machine-soil interaction and appreciation for the importance of proper slurry and lubricant mixture selection and application.

The reaming system was used to install 100 m (330 ft) of concrete pipe in 7 days. These tests clearly demonstrated the reaming system's ability to install upsized pipes. The versatility of this system offers intriguing possibilities with regard to critical applications. These enhanced capabilities come with some penalty for cost and operational complexity. For example, the two-pass system requires the use of two cranes and two crews, one at each shaft, during the second pass. This system also requires a capital investment in the temporary pipes.

Measurements of ground movements during the test provided an opportunity to evaluate methods for predicting normal settlements and potential causes and preventative measures for heaves and for large settlements. These measurements indicated that reasonable estimates of normal systematic settlements could be obtained using relationships developed for large-diameter, soft-ground, shield-driven tunnels. Large settlement events observed during this test were largely attributable to continued circulation of the slurry while the machine was stopped.

A large settlement event was planned and purposely caused by using a low-viscosity polymer-based slurry in cohesionless soils. The point demonstrated was that, when microtunneling in cohesionless soils, the slurry viscosity must be sufficiently high to allow stabilizing pressures to be developed at the excavation face and to allow relatively low velocities and flow rates to be used. Removal of cuttings can be achieved through proper selection and operation of the slurry separation system. Overemphasis on slurry sedimentation at the expense of face stability must be avoided. Small heaves were caused by over pushing, i.e., applying machine thrust loads that exceeded the passive resistance of the earth.

The experiments carried out to isolate face pressure and skin friction components of jacking force showed that face pressures can be significantly higher in clays than in sands. These tests also confirmed the relatively low magnitudes of the face pressure component of jacking force for small machines, compared to the skin friction component.

A significant reduction in total jacking forces was observed as the machine exited sand sections and progressed through the clay and clay gravel sections of the test bed. The reduction in frictional resistance on the unlubricated portion of the shield and in the preceding sand section was quite significant when exiting sands and entering clays and accounted for a portion of the observed drop in total jacking forces. Decrease in advance rates as the machine entered the cohesive soils may also have played a significant role in the jacking force decrease, as this increased the effectiveness of the lubrication process.

The capability to retrieve the machine, using the steel, bolt-together, temporary pipes, makes this system ideally suited to complex environmental site characterization and remediation projects. For example, the system could be used to install a series of interlocked or continuous microtunnels beneath waste sites. The microtunnels could be grouted with a bentonite and Portland cement grout, or other suitable grout mixture, as the machine is retracted, to form a virtually impermeable horizontal cutoff as first proposed by Myers (1993). At some existing sites, this approach may be the only practical method for constructing a barrier to vertical migration of contaminants. This approach could also be used to construct vertical cutoff walls to prevent horizontal contaminant migration. The tested system could also be used to install drainage and collection systems beneath existing waste sites, through or beneath earth embankments, and beneath concrete gravity dams.

The system could be used for construction of water supply intake pipelines from dry-land shafts to an intake structure within the reservoir. This type of application has been conducted successfully, but underwater retrieval is required. The underwater retrieval must be accomplished at a preselected exit shaft with conventional systems. If for any reason the microtunneling machine could not reach the exit shaft, a new exit shaft would be required. With the retrievable system tested, the machine could be retracted to the dry-land drive shaft if the bore could not be successfully completed.

The reaming capability should be considered for extending the range of applicability of the basic Super-Mini system. The reamer allows a variety of

pipe diameters to be installed. However, needed improvements were identified by the Corps research team and industry partners with the prototype that would make this feature more practical and versatile. The operation and control of the reamer system should be integrated with the primary system, such that all operations are controlled from the operator's main console at the original drive shaft. This would eliminate problems with communication and coordination of activities between the main operator control console and the reamer control console. The seal between the reamer head and the excavation should be improved to minimize the potential for slurry losses past the seal. This was a recurring problem during the test and caused erosion of soil and ground disturbance at some locations. The slurry nozzles should be reconfigured to minimize the potential for scour and erosion of soil at the face. The needed refinements are being effected by the manufacturer. When completed, the reamer system should greatly improve the versatility and range of the basic system.

In general, the tested system has all the attributes of conventional microtunneling systems, and is, therefore, well suited to the same types of conventional applications as other systems. The retrievability and reaming capabilities of this system make it ideally suited to unusual, critical applications.

References

- American Society for Testing and Materials. (1996a). "Test methods for laboratory compaction characteristics of soil using standard effort (12,400 ft-lb/ft³ (600 kN-m/m³)," Designation D 6980, Philadelphia, PA.
- _____. (1996b). "Test method for density of soil and soil-aggregate in place by nuclear methods (shallow depth)," Designation D 2922, Philadelphia, PA.
- Bennett, Robert D., Guice, Leslie K., Khan, Salam, and Staheli, Kimberlie. (1995). "Guidelines for trenchless technology: Cured-in-place pipe (CIPP), fold and formed pipe (FFP), Mini horizontal directional drilling (Mini-HDD), and microtunneling," Technical Report, CPAR-GL-95-2, U.S. Army Engineer Waterways Experiment Station, Vicksburg, MS.
- Bennett, David, and Staheli, Kimberlie. (1995). "Retrievability and reaming capabilities tested in 3rd WES Microtunneling Test," *NO-DIG Engineering*.
- Bennett, David, Cording, E. J., and Iseley, T. (1994). "Auger and slurry microtunneling tests under controlled ground conditions," Transportation Research Record, No. 1431, National Academy Press, Washington, DC, 75-82.
- Bennett, David, and Taylor, P. A. (1993). "Construction of microtunneling test facility at WES and preliminary test results," *Proceedings of Trenchless Technology: An Advanced Technical Seminar*. Vicksburg, MS, 289-328. Available from Trenchless Technology Center Louisiana Tech University, Ruston, LA.
- Bristow, Nick. (1993). "A variable diameter microtunneling system," *Proceedings of Trenchless Technology: An Advanced Technical Seminar*, Vicksburg, MS, 329-334. Available from Trenchless Technology Center, Louisiana Tech University, Ruston, LA.
- Cording, E. J., and Hansmire, W. H. (1975). "Displacements around soft ground tunnels." *Proceedings, 5th Pan American Congress on Soil Mechanics and Foundation Engineering*. Buenos Aires, Argentina.

- Cording, Edward J. (1993). "Ground Movements Around Tunnels in Soil." *Proceedings, Trenchless Technology: An Advanced Technical Seminar*. Vicksburg, MS, 237-247. Available from Trenchless Technology Center, Louisiana Tech University, Ruston, LA.
- Hansmire, W. H., and Cording, E. J. (1972). "Performance of a soft ground tunnel on the Washington metro." *Proceedings, 1st North American Rapid Excavation and Tunneling Conference (RETC)*. American Institute for Mining Engineers, Vol 2, 371-389.
- Laxfield Corporation. (1995). "CPAR field testing: McLaughlin microtunneling," *Pipeline and Utilities Construction*, Boston, MA
- Myers, Dennis R. (1993). "A subsurface confinement barrier system for tank farms and other subsurface waste storage and disposal facilities," Report No. WHC-MR-0414, prepared for the U.S. Department of Energy, Office of Environmental Restoration and Waste Management by Westinghouse, Hanford Company, Richmond, WA.
- Peck, R. B. (1969). "Deep excavations and tunneling in soft ground, State of the art report." *Proceedings, 7th International Conference on Soil Mechanics*. State-of-the-art volume, Mexico City, 225-290.
- Peck, R. B., Hendron, Jr., A. J., and Mohraz, B. (1972). "State of the art of soft ground tunneling." *Proceedings, 1st North American Rapid Excavation and Tunneling Conference (RETC)*. American Institute for Mining Engineers, Vol 1, 259-286.
- Thompson, J. C. (1993). *Pipejacking and microtunneling*, Blackie Academic and Professional Press, Glasgow, U.K.

REPORT DOCUMENTATION PAGE

Form Approved
OMB No. 0704-0188

Public reporting burden for this collection of information is estimated to average 1 hour per response, including the time for reviewing instructions, searching existing data sources, gathering and maintaining the data needed, and completing and reviewing the collection of information. Send comments regarding this burden estimate or any other aspect of this collection of information, including suggestions for reducing this burden, to Washington Headquarters Services, Directorate for Information Operations and Reports, 1215 Jefferson Davis Highway, Suite 1204, Arlington, VA 22202-4302, and to the Office of Management and Budget, Paperwork Reduction Project (0704-0188), Washington, DC 20503.

1. AGENCY USE ONLY (Leave blank)	2. REPORT DATE May 1997	3. REPORT TYPE AND DATES COVERED Final report	
4. TITLE AND SUBTITLE Controlled Field Tests of Retrievable Microtunneling System with Reaming Capabilities		5. FUNDING NUMBERS	
6. AUTHOR(S) David Bennett, Kimberlie Staheli		8. PERFORMING ORGANIZATION REPORT NUMBER Technical Report CPAR-GL-97-1	
7. PERFORMING ORGANIZATION NAME(S) AND ADDRESS(ES) U.S. Army Engineer Waterways Experiment Station 3909 Halls Ferry Road, Vicksburg, MS 39180-6199		10. SPONSORING/MONITORING AGENCY REPORT NUMBER	
9. SPONSORING/MONITORING AGENCY NAME(S) AND ADDRESS(ES) U.S. Army Corps of Engineers Washington, DC 20314-1000		11. SUPPLEMENTARY NOTES Available from National Technical Information Service, 5285 Port Royal Road, Springfield, VA 22161.	
12a. DISTRIBUTION/AVAILABILITY STATEMENT Approved for public release; distribution is unlimited.		12b. DISTRIBUTION CODE	
13. ABSTRACT (Maximum 200 words) <p>The McLaughlin/Markham microtunneling system tested at the U.S. Army Engineer Waterways Experiment Station test facility has all the capabilities of conventional microtunneling systems, with the additional capability for retrieval and reaming. Both of these unique capabilities were evaluated under documented, controlled ground conditions. These tests clearly demonstrated the ability of the system to maintain stability of the excavation face during retraction of the machine through flooded, running sand. The test also demonstrated the capability of the system to successfully install upsized pipes using the reamer assembly. The versatility of this system offers intriguing possibilities with regard to critical applications.</p> <p>In addition, these tests provided an opportunity to gain a better understanding of ground deformations and jacking forces associated with microtunneling. Methods for predicting and controlling ground deformations were evaluated. The influence of lubrication on jacking forces was assessed, along with the influence of different ground conditions on jacking forces.</p>			
14. SUBJECT TERMS CPAR Test Controlled ground conditions Controlled low strength material (CLSM) Ground deformations			15. NUMBER OF PAGES 64
Jacking forces McLaughlin/Markham System Microtunneling Reaming capabilities			16. PRICE CODE
17. SECURITY CLASSIFICATION OF REPORT UNCLASSIFIED	18. SECURITY CLASSIFICATION OF THIS PAGE UNCLASSIFIED	19. SECURITY CLASSIFICATION OF ABSTRACT UNCLASSIFIED	20. LIMITATION OF ABSTRACT