

REPORT DOCUMENTATION PAGE

Form approved
OMB No. 0704-0188

The reporting burden for this collection of information is estimated to average 1 hour per response, including the time for reviewing instructions, searching existing data sources, gathering and maintaining the data needed, and completing and reviewing the collection of information. Send comments regarding this burden estimate or any other aspect of this collection of information, including suggestions for reducing this burden, to Washington Headquarters Services, Directorate for Information Operations and Reports, 1215 Jefferson Davis Highway, Suite 1204, Arlington, VA 22202-4302, and to the office of Management and Budget, Paperwork Reduction Project (0704-0188) Washington, D.C. 20503.

1. AGENCY USE ONLY (Leave blank) 2. REPORT DATE 6/13/97 3. REPORT TYPE AND DATES COVERED SBIR Phase I Final Report-12/13/96-6/13/97

4. TITLE AND SUBTITLE SBIR Phase I Technical Report CERL SBIR Contract DACA88-97-C-0003 5. FUNDING NUMBERS W52EU2-6264-2025 A96-113

6. AUTHOR(S) Guy Davis, Chester Dacres, Mark Shook, John Sewell

7. PERFORMING ORGANIZATION NAME(S) AND ADDRESS(ES) DACCO SCI, INC. 10260 Old Columbia Rd., Columbia, MD 21046 8. PERFORMING ORGANIZATION REPORT NUMBER

9. SPONSORING/MONITORING AGENCY NAME(S) AND ADDRESS(ES) US Army Construction Engineering Research Laboratories P.O. Box 9005 Champaign, IL 61826-9005 10. SPONSORING/MONITORING AGENCY REPORT NUMBER

11. SUPPLEMENTARY NOTES

12. DISTRIBUTION/AVAILABILITY STATEMENT Approved for public release, ~~SBIR Report~~, distribution unlimited 12b. DISTRIBUTION CODE unlimited

13. ABSTRACT (Maximum 200 words)
Under SBIR contract DACA88-97-C-0003, an electrochemical impedance spectroscopy (EIS)-based *in-situ* corrosion sensor has been adapted and evaluated for use with steel heat exchanger tubes in boilers, coated buried steel pipes, and painted steel structures. An excellent correlation was obtained between the logarithm of the ratio of the breakpoint frequencies, as measured by the sensor, and corrosion rate for the boiler tubes. Use of this sensor and appropriate electronics would allow the corrosion of the boiler tubes to be monitored in real time and the inhibitor concentration automatically controlled to prevent excessive corrosion. A separate acoustic sensor was shown suitable for detecting extensive corrosion of boiler tubes. It has the potential to nondestructively and efficiently detect and locate boiler tube damage. The EIS sensor is also sensitive to the quality of coating of a buried steel pipe with and without the application of cathodic protection. Similar results were obtained from a sensor attached to the pipe and from a separate electrode driven into the soil. A hand-held version of the EIS *in-situ* sensor is suitable for inspecting painted metal structures, such as storage tanks and locks and dams, under ambient, service conditions. An excellent correlation was obtained between the sensor measurements and the amount of corrosion on test panels immersed for up to 28 years.

14. SUBJECT TERMS Corrosion, Sensors, Electrochemistry, Boilers, Pipes Acoustics, NDE, In-Process Monitoring, SBIR Report 15. NUMBER OF PAGES 26 16. PRICE CODE

17. SECURITY CLASSIFICATION OF REPORT unclassified 18. SECURITY CLASSIFICATION OF THIS PAGE unclassified 19. SECURITY CLASSIFICATION OF ABSTRACT unclassified 20. LIMITATION OF ABSTRACT unlimited

SBIR Phase I Technical Report

CERL SBIR Contract DACA88-97-C-0003

Submitted to

Vincent F. Hock
US Army Corps of Engineers
Construction Engineering Research Laboratories
Facilities Technology Lab
Materials Science and Technology Division (FL-M)
P.O. Box 9005
Champaign, IL 61826-9005

Submitted by

Guy Davis, Chester Dacres, Mark Shook, and John Sewell*

DACCO SCI, INC.
10260 Old Columbia Road
Columbia, MD 21046

June 13, 1997

Executive Summary

Under SBIR contract DACA88-97-C-0003, an electrochemical impedance spectroscopy (EIS)-based *in-situ* corrosion sensor has been adapted and evaluated for use with steel heat exchanger tubes in boilers, coated buried steel pipes, and painted steel structures. An excellent correlation was obtained between the logarithm of the ratio of the breakpoint frequencies, as measured by the sensor, and corrosion rate for the boiler tubes. Use of this sensor and appropriate electronics would allow the corrosion of the boiler tubes to be monitored in real time and the inhibitor concentration automatically controlled to prevent excessive corrosion. A separate acoustic sensor was shown suitable for detecting extensive corrosion of boiler tubes. It has the potential to nondestructively and efficiently detect and locate boiler tube damage. The EIS sensor is also sensitive to the quality of coating of a buried steel pipe with and without the application of cathodic protection. Similar results were obtained from a sensor attached to the pipe and from a separate electrode driven into the soil. A hand-held version of the EIS *in-situ* sensor is suitable for inspecting painted metal structures, such as storage tanks and locks and dams, under ambient, service conditions. An excellent correlation was obtained between the sensor measurements and the amount of corrosion on test panels immersed for up to 28 years.

19970613 025

* Active Signal Technologies, 13025 Beaver Dam Road, Cockeysville, MD 2103.

• DACCO SCI, INC. • 10260 Old Columbia Road, Columbia, MD 21046 • (410) 381-9475 •
<http://members.aol.com/gddaccosci/DACCOSCI.htm>

DTIC QUALITY INSPECTED 3

Background

The cost of degradation of the nation's infrastructure is difficult to determine, but is known to be very large. Studies by the National Bureau of Standards (NBS) estimate that overall corrosion costs in the United States are 4.2% of the Gross National Product (GNP) or \$290 billion in 1996 – more than \$1000 per capita. The nation's infrastructure is aging and maintenance budgets are inadequate to prevent deterioration. New construction and major repairs/refurbishment are being reduced or delayed so that current hardware and structures must last longer than their design lifetimes.

Army installations are experiencing the same corrosion issues. Pipelines, storage tanks, and boilers are all subject to corrosion. Corroding infrastructure can cause ground water contamination, explosion potential, and/or loss of service or material. Although various corrosion control procedures (cathodic protection, paints, inhibitors) are utilized, human error, design limitations, environmental changes, material degradation and other factors can cause these procedures to partially fail over time.

One means to increase the lifetime of hardware and structures and to get the most out of stretched maintenance budgets is to track structure health from the *early stages* of deterioration so that its progression can be monitored and predicted. Consequently, maintenance can be performed on a needs basis when it is relatively inexpensive before damage and loss of capability becomes critical and expensive remedial action is needed. The maintenance schedule would be a proactive one rather than one that reacts to failures.

DACCO SCI, INC., (DSI) has been developing an *in-situ* corrosion sensor for detecting corrosion under paint coatings for aging aircraft. This sensor uses the established electrochemical impedance spectroscopy (EIS, also known as ac impedance) to monitor corrosion in real time beginning at the initial stages of moisture ingress through the paint film and incipient attack of the underlying metal well before any visible signs of corrosion are present. Active Signals Technology (AST) has been developing an acoustic sensor for a variety of applications, including detection of material loss due to corrosion. It is anticipated that the sensors and data acquisition/interpretation can be readily adapted for aging infrastructure. Quantification of the corrosion by use of the sensors would facilitate maintenance records and decisions.

The focus of study in this program has been the corrosion that occurs in boilers, specifically, heat exchanger tubes. Corrosion control of boilers is currently limited to adjusting the chemistry of the water to inhibit corrosion. This involves manual sampling and water chemistry modification, which is an inadequate means to control the corrosivity of the water. Such procedures are manpower extensive and subject to human error and omissions. Furthermore, although the water parameters measured are related to corrosion of the tubes, the extent or rate of corrosion, itself, is not measured. Nondestructive inspection of boilers during maintenance is also difficult due to lack of convenient access of many boiler tubes.

Underground, trenched, and overhead pipe systems are also of concern. The Army currently owns 4000 miles of underground gas distribution pipes alone. Hot water or steam pipes supply heat to most military bases from a central heating boiler. For example, Fort Drum has a 20-mile-long piping system, installed in 1989 at a cost of \$55 million, to deliver hot water at 350 psi and

• DACCO SCI, INC. • 10260 Old Columbia Road, Columbia, MD 21046 • (410) 381-9475 •
<http://members.aol.com/gddaccosci/DACCOSCI.htm>

350°F. Underground pipeline systems are subject to soil-side corrosion and generally are protected with coatings and cathodic protection systems. Inspection is needed to assure that the corrosion protection system is working. Pipeline corrosion-induced leaks can be difficult to detect and locate when they occur and are even more difficult to predict. Leaks and other damage can result in loss of performance and readiness, environmental and structural damage, and high costs (e.g., repairs to the Fort Drum system costs \$300/foot). External corrosion of overhead and trenched pipelines is less of a problem because of the lack of electrolyte in direct contact with the system unless the insulation around overhead lines absorbs moisture. A secondary aspect of the program involved inspection of cathodically protected, buried coated steel pipe. Such inspections would provide assurances that the corrosion protection is effective and working well.

The Army owns and maintains approximately 20,000 underground fuel storage tanks. Buried and above ground storage tanks and locks and dams pose similar problems and solutions to pipelines. Thus inspection/monitoring techniques developed for pipelines will be applicable to the soil-side of underground tanks. Above ground structures, the interior of underground structures, and locks and dams are typically painted for corrosion protection as cathodic protection is not feasible. Inspection of painted metal is also important and was evaluated in this program.

Repairs to and refurbishment of certain structures involve reinforcement by polymeric composites. A minor area of interest to this program was evaluating the feasibility of using the *in-situ* sensor to monitor the health of a composite-metal structure.

Objectives

The primary objective of this program was to adapt the DACCO SCI, INC., EIS *in-situ* corrosion sensor and an Active Signals Technology (AST) acoustic sensor to monitor corrosion of boiler heat exchanger tubes. These experiments utilized the use of electrochemical techniques such as Electrochemical Impedance Spectroscopy (EIS) and polarization resistance and acoustic techniques. Laboratory experiments were designed to simulate environments with chemical treatment at ambient and elevated temperatures.

Another application of the sensor was to use the EIS sensor to monitor a cathodically protected (CP) buried coated steel pipe and to monitor polymeric composite/steel structures. The CP buried coated steel pipe was monitored using the electrochemical techniques of EIS and polarization decay. The purpose of this study was to detect changes in the pipe and coating during various cathodic protection levels.

A third application of the sensor was to inspect vinyl-coated steel specimens that have been immersed in natural fresh water for various lengths of time, up to 28 years. Some of these coatings appeared visually to be in very good condition; others exhibited significant amounts of corrosion.

A fourth and final application was to inspect a graphite-epoxy/aluminum structure. These samples were used to determine if the EIS sensor could inspect the bondline between the composite and the metal or the moisture content of the composite.

Technique Descriptions

Theory

Electrochemical Impedance Spectroscopy

EIS uses very small excitation voltages, generally in the range of 5 to 10 mV peak-to-peak, between a specimen and a reference electrode. The current induced by this voltage is measured and an impedance determined as a function of frequency. Excitation amplitudes of this magnitude cause only minimal perturbation of the electrochemical test system, thus reducing errors caused by the measurement technique itself. Since EIS experiments can provide data on both electrode capacitance and charge-transfer kinetics, the technique offers valuable mechanistic information. In addition, because the method does not involve a potential scan, measurements can be made in low conductivity solutions where DC techniques are subject to serious potential control errors.

EIS is based on the fact that the behavior of an electrochemical cell and that of an electronic circuit are analogous. This allows equivalent circuit modeling of a given electrochemical cell. Fundamental AC circuit theory can then be applied to the circuit model and the results accurately correlated to reveal physical and chemical properties of the electrochemical cell.

In an electrochemical cell, the presence of a coating, an electrolyte, and diffusion, act to slow the flow of electrons and each can be modeled as resistors, capacitors, inductors or a combination of elements. These factors give rise to a particular circuit for a given electrochemical cell, such as the one shown in Figure 1.

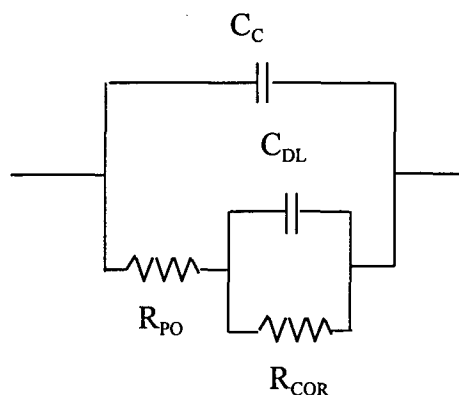

Figure 1. Equivalent Circuit Model for a Coated Specimen

The pore resistance (R_{po}) is the reflection of the amount of penetration by the electrolyte into the coating. The coating capacitance (C_c) is a measure of the effectiveness of the coating. The double layer capacitance C_{dl} and the resistance R_{COR} characterize the coating/metal interface.

Performing conventional EIS on a sample involves applying ac voltage of varying frequencies between a reference electrode and the sample which is immersed in a conductive electrolyte. The current or impedance (magnitude and phase) is measured between the sample and a separate counter electrode. With the DACCO SCI *in-situ* sensor, a single electrode is applied to a coated

metal and this electrode acts as both the reference and counter electrodes. Equivalent results are obtained for the two approaches.

Figure 2 shows examples of EIS data, expressed in the Bode magnitude and phase formats, which demonstrates how a typical coated metal degrades in moisture. Initially the coating exhibits purely capacitive behavior (slope of -1 in the magnitude plot and phase angle near 90° in the phase angle plot) with the resistances shown in the equivalent circuit of Figure 1 being very high. As moisture permeates the coating, these resistances decrease and the impedance at low frequencies drops and becomes independent of frequency, corresponding to resistive behavior (phase angle near 0°). As degradation proceeds, the frequency range over which the coating exhibits resistive behavior increases.

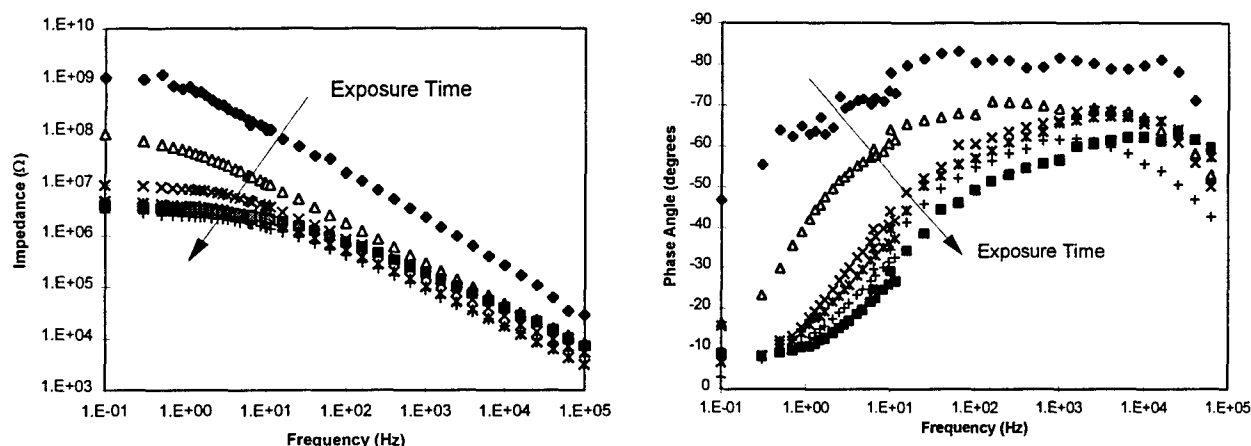

Figure 2. Bode magnitude(left) and phase (right) plots showing degradation of a coated metal over time.

Electrochemical Testing - Polarization Resistance

The polarization resistance technique is used to determine the corrosion resistance a sample has in a given medium or electrolyte. This essentially nondestructive test involves first finding the corrosion potential, E_{corr} , of the sample. A controlled-potential scan is then applied over a small range, typically ± 20 mV with respect to E_{corr} . The resulting current is linearly plotted versus the potential. The slope of this potential-current function at $E_{i=0}$ is referred to as the polarization resistance (R_p) and is used to determine the instantaneous corrosion rate and the corrosion current, I_{corr} . Since the applied voltage is never far from the corrosion potential, no polarization-induced changes in the surface occur.

Polarization Decay Testing

Polarization decay testing is useful in determining the condition of an immersed or buried structure. This test is obtained using NACE Standard RP-0290-90. In addition, polarization decay testing is useful in determining the effectiveness of a cathodic protection system and is used as a criteria for cathodic protection as outlined in NACE Standard RP-0285-90.

Polarization decay testing consists of impressing a current on a structure for a period of time and then removing the current source to allow the structure to decay to its natural potential. The initial potential shift after removing the current source is recorded and is used as the initial voltage reading. The voltage is recorded over a period of time. The polarization decay curve is used to determine if the amount of cathodic protection is adequate (a -100 mV shift). Furthermore this test can be used to determine the condition of the structure since the potential of a well coated structure will generally decay at a faster rate than a corroded structure.

Acoustic Testing

The application of acoustic techniques to corrosion level determination rests largely on the tracking of the integrity of the structure being monitored using active interrogation methods. The general mechanism used for this testing is to attach an actuator(s) to the structure and, while exciting the structure, measure the structure's response either as reflected in the variation of the input impedance to the actuator or by monitoring a sensor which is detecting the response of the structure to the exciting actuator. In an ideal structure, the actuator's energy will couple very well to the entire structure and set up resonances at the normal mode frequencies of the structure, whether pipes, plates, bars, etc. Under conditions where the structure has imperfections, the coupling will be compromised, and the energy transferred to the structure, and thus measured either at the monitoring sensor or as reflected back to the exciting source, will be diminished or attenuated. Once the pattern has been detected of a diminished frequency response, measured by either method, the results can be correlated against corrosion levels to generate a score card of the structure's loss of integrity, whether through corrosion, cracking, pitting, or even property changes, such as phase changes in the material.

While the theory in general is straightforward, reducing the theory to practice requires attention to a host of issues which if overlooked will result in compromised results. The most critical of these which received particular note in the boiler tube effort are listed below.

- **Actuator/Sensor/Structure Impedance Matching.** Often impedance refers to the electrical units which measure the relationship of volts to amps, but here we are speaking of the mechanical analogue which measures the relationship of force to velocity, or the mechanical analogue to the electrical impedance which enables the generation of equivalent circuits. Evaluating a structure's mechanical impedance involves an estimation of how much force will be required to generate some desired displacement at a specified frequency. "Softer" materials or more compliant structures will use a lower mechanical impedance driver/sensor combination and the converse with stiffer structures. Typically the structures which resonate at lower frequencies will utilize lower impedance drivers, thus the woofers for low frequencies in audio systems and tweeters for higher frequencies. Using its AntiSubmarine Warfare (ASW) background, Active Signal has developed a range of actuators and sensors with varying mechanical impedances to match structures in such a way as to increase the sensitivity of the measurements taken.
- **Bandwidth.** In some applications, the structure has several significant modes which can beneficially be excited. In this case, a broad band system should be used. Some types of actuators are better suited to this type of operation than others, specifically because of tuning

• *DACCO SCI, INC. • 10260 Old Columbia Road, Columbia, MD 21046 • (410) 381-9475 • <http://members.aol.com/gddaccosci/DACCOSCI.htm>*

requirements in the case of PZT (lead-zirconate-titanate) and PMN (lead-magnesium-niobate), or at higher frequencies, controlling eddy current losses in the case of Terfenol.

- **Temperature and Vibration Conditions.** Demands on actuators and sensors increase with the level of temperature shifts or extremes which they experience during operation as well as the vibration and or shock environment in which they operate. In this application for instance, PZT and PMN materials are suitable for only low temperatures while Terfenol has an excellent temperature range (well over 200°C). In the same fashion, high shock environments are not suitable for PZT actuators except in cases where they are very heavily pre-stressed since PZT is a ceramic. Again, Terfenol fares better, and can even continue to operate when it has been cracked – a feature which PZT and PMN do not share.

Other elements are also significant, but the above listed are the most critical. A summary table is given below (Table 1) to indicate how a matrix might be made up prior to material selection and actuator construction, in the case for instance where mechanical transformers or amplifiers must become part of the design to enhance impedance matching. The table has no weighting and thus the strong showing of Terfenol does not reflect that it is neither the highest energy dense material (PMN) nor the most mature engineering material (PZT). Thus for each application, the matrix will continue to be refined according to the extended requirements of the intended use.

Table 1. Properties of Different Actuator/Sensor Types

Property	Actuator/Sensor Type			
	PZT or PMN	Terfenol	Electrodynamic	Mechanically amplified
Low Stiffness		X	X	X
High stiffness	X			
Several Modes	X	X		
High Temperature		X	X	X
Water applications	X	X	X	X
Size constrained		X		X
Simple Electronics		X	X	X
High vibration environment		X		
High duty cycle		X		X

Instrumentation

Electrochemical Impedance

Most of the measurements on this program were taken with a Gamry Instruments, Inc. Potentiostat/EIS System. This system is completely portable and the EIS experiments and analysis are

performed using the CMS300 Electrochemical Impedance Spectroscopy System Software. It would be suitable for field use.

In other cases, data were acquired with an EG&G PAR Model 398 Electrochemical Impedance System. This is a bench-top unit that is not suitable for field use, but has greater capability than the Gamry, particularly in the maximum frequency obtainable.

Electrochemical Testing - Polarization Resistance

The EG&G PAR Model 273 Potentiostat was used to perform polarization resistance scans. The scans were performed over the range of 20mV above and below the open circuit potential of the sample. The data were acquired and analyzed using the EG&G PAR Model 352 SoftCorr II Corrosion Measurement and Analysis Software to determine the values of E_{corr} , the instantaneous corrosion rate and R_p .

Acoustic Testing

The general instrumentation set-up for a structural test is similar from one case to the other. There will be variations in the type of processing which is done to the signal, as will be discussed in the results of the current testing approach, but the equipment will retain the same basic elements. A block diagram of a typical set-up (Figure 3) will help to visualize how the testing for Phase I was undertaken as well as communicate the principles which will be involved in testing for future phases.

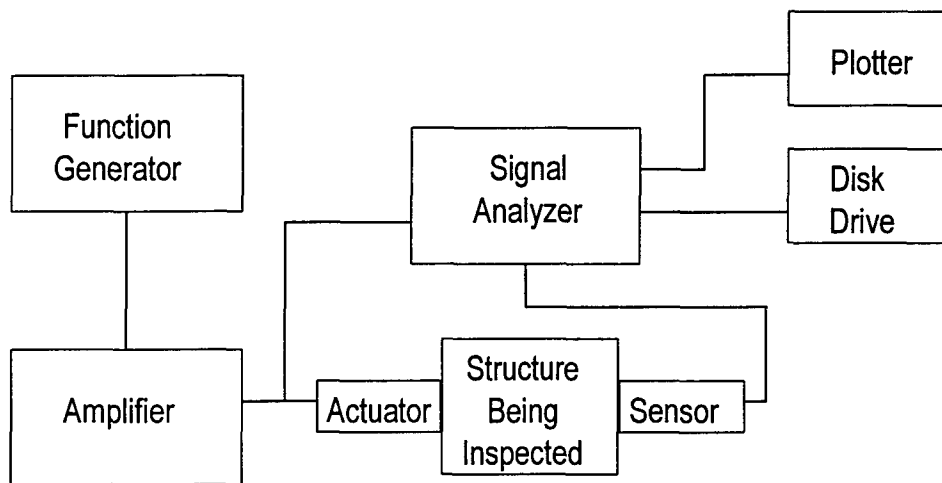

Figure 3. Block Diagram of Structural Analysis Instrumentation

The elements of the system and their respective functions as shown are:

- The function generator which can be either stand alone or a signal generated by the analyzer. In most of our measurements, we use the latter.

- The amplifier also assumes incorporation of any matching electronics which may be required, although these are not always necessary. Clearly the amplifier power is a function of the actuator.
- The actuator type and location depends upon many of the variables discussed above and summarized in Table 1.
- The device under test is a generic term, but in this phase, was a section of a boiler tube
- The sensor is shown, but also we have indicated that the response signal to the analyzer may come from the input to the actuator itself
- The analyzer used is a multichannel, variable function analyzer which has outputs to a plotter and disk drive for later data analysis.

Approach

Four different applications of the corrosion sensors were evaluated:

- Boiler tubes
- Cathodically protected buried steel pipe
- Vinyl-coated steel following long-term immersion in natural fresh water
- Graphite-epoxy composite/aluminum structure.

Boiler tubes.

The *in-situ* EIS corrosion sensor was modified to monitor corrosion inside a boiler tube (1.25 in. diameter ASTM/ASME A/SA 178-A/214-90A ERW Grade W1010). Figure 4 gives a schematic representation of the experimental set-up. Different solutions were used to obtain a variety of corrosion rates:

- Aggressive (5% NaCl, as received and abraded)
- Neutral (5% Na₂SO₄)
- Inhibitive (5% Na₃PO₄ + NaOH, pH 10).

The response of the sensor was correlated with corrosion rates determined by polarization resistance. Most measurements were taken at room temperature although some data were acquired in boiling water.

A separate boiler tube was aggressively corroded to demonstrate the ability of the acoustic sensor to detect extensive corrosion. The acoustic impedance spectra obtained from the corroded tube (Figure 5) was compared to the spectra taken from an identical tube that has not been corroded.

The structural test of the boiler tube proceeded in two stages, the first was an impulse response characterization of the tube in air to determine the sizing of the actuator as a function of the resonance of the tube, and the second was the actual test of the baseline uncorroded tube compared with the corroded tube.

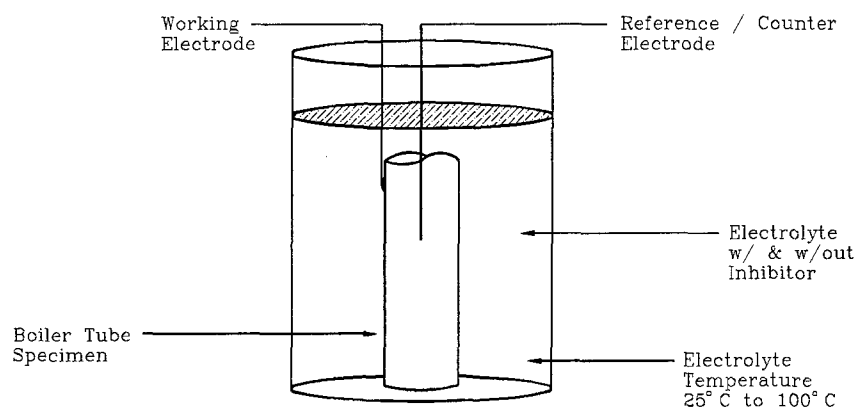

Figure 4. Schematic diagram of boiler tube test conditions. For some experiments, the electrolyte was in the tube only.

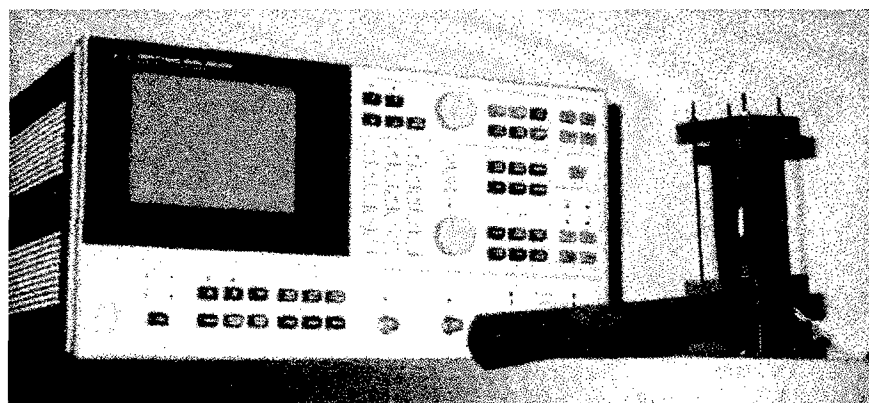

Figure 5. Severely corroded boiler tube with actuator driver. The function generator/signal analyzer is shown in the background.

Buried steel pipe.

Three sections of 24-in long, 12-in. diameter ASTM A53 Grade B steel pipe were obtained. One received a good covering of Royston R28 Roskote Mastic protective coating. One received a poor covering of Mastic and the last one was left bare. The average coating thickness was 40 mils. Two *in-situ* corrosion sensors were applied to each pipe section (Figure 6, left). In the case of the bare pipe, the sensor was isolated from the pipe with spray enamel. The pipes were subsequently separately buried in containers in the laboratory (Figure 6, right). An impressed current anode was inserted into the soil of each container (Figure 7). The clay soil characteristics are given in Table 2. The pipe potentials were allowed to reach equilibrium in their containers for several days. Baseline EIS measurements were made throughout this period. An impressed current was then applied to each pipe to polarize it to a protection potential of -850 mV vs Cu/CuSO₄ (NACE STD RP-0169). EIS measurements using the *in-situ* sensor were taken as a function of time, with and without the impressed current. A limited number of measurements were also taken using the impressed current anode itself as the electrode instead of the attached sensor.

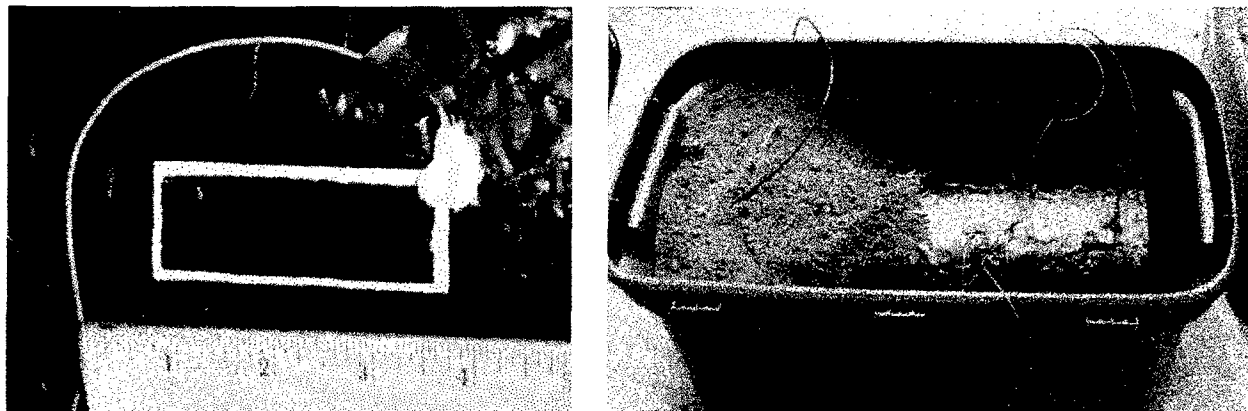

Figure 6. Left: In-situ sensor applied to coated pipe prior to burying. Right: Coated pipe being buried in the laboratory.

Table 2. Soil Characteristics

	pH	Moisture Content %	Soil Box Resistivity (Ω .cm)		Chloride ppm/100 g Soil	Sulfate
			As Received	Wet		
Bare Pipe	6.36	10.43	89,000	48,000	0.68	0
Partially Coated Pipe	6.64	9.61	80,000	45,000	0.37	0
Completely Coated Pipe	6.27	11.27	88,000	63,000	0.32	0

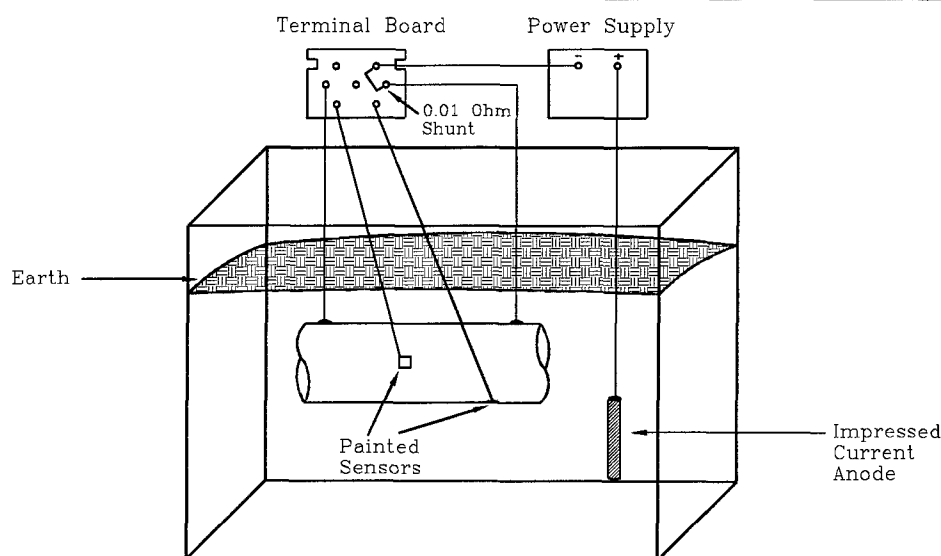

Figure 7. Schematic diagram of the buried pipe corrosion tests.

Vinyl-coated steel.

Five vinyl-coated steel panels that had been immersed in natural fresh water for up to 28 years were provided by CERL (Figure 8). Some specimens were in excellent condition while others were in poor condition. EIS spectra were obtained with the Gamry portable potentiostat using

• **DACCO SCI, INC.** • 10260 Old Columbia Road, Columbia, MD 21046 • (410) 381-9475 •
<http://members.aol.com/gddaccosci/DACCOSCI.htm>

both the hand-held *in-situ* corrosion sensor and a flat cell with conventional remote-electrodes. The specimens are described as follows:

- 4K194 2-yr old gray vinyl in excellent condition
- R115 young vinyl in very poor condition
- 2429 22-yr old red vinyl in good condition
- 2176 28-yr old vinyl zinc-rich with white vinyl topcoat in fair condition
- 2578 17-yr old vinyl zinc-rich with white vinyl topcoat in excellent condition.

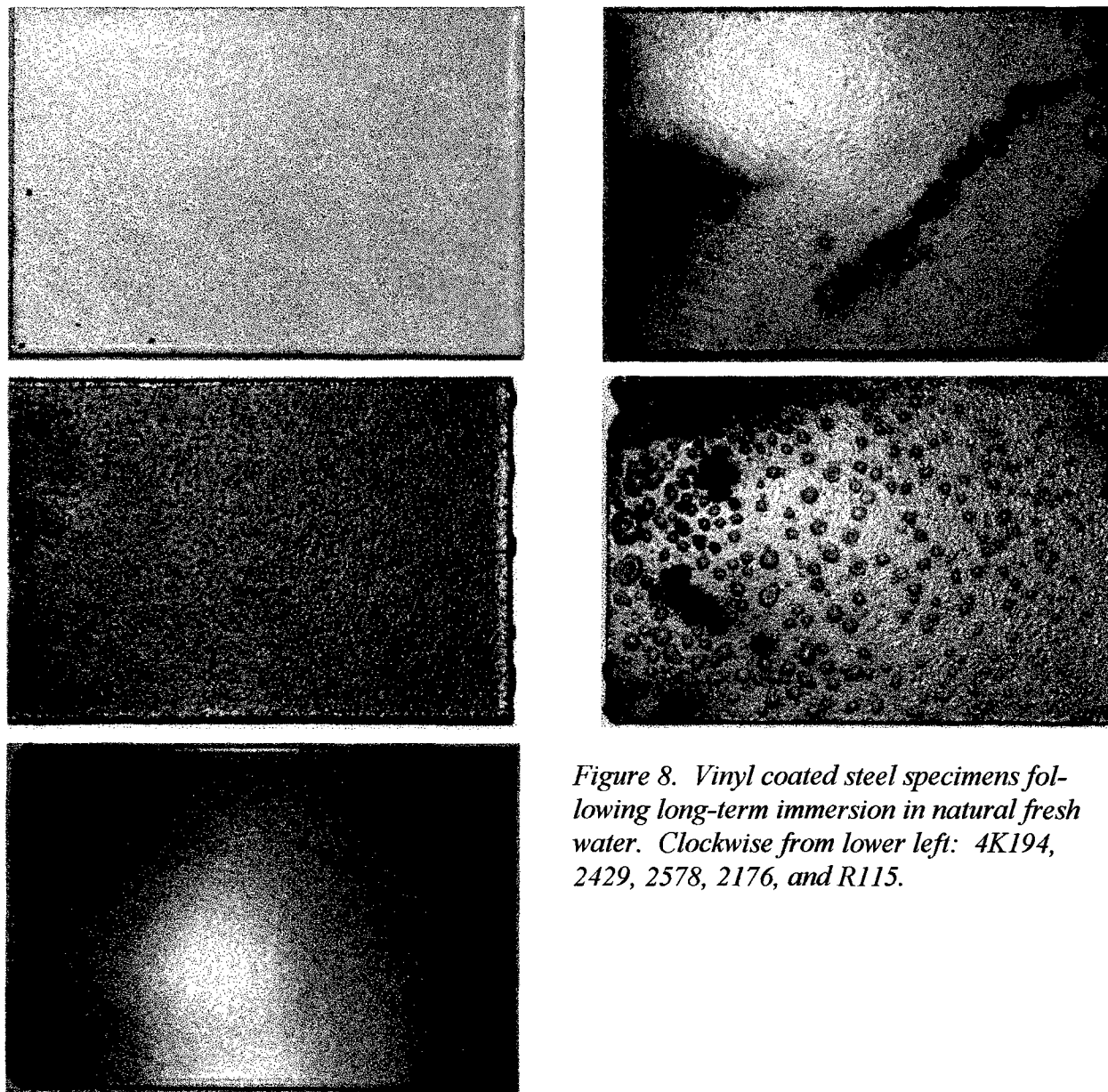

Figure 8. Vinyl coated steel specimens following long-term immersion in natural fresh water. Clockwise from lower left: 4K194, 2429, 2578, 2176, and R115.

Composite aluminum structure.

A graphite-epoxy composite/aluminum specimen previously used for tensile testing was provided by CERL. The specimen was 7075-T6 aluminum that was anodized in phosphoric acid, treated with Z-6040 Dow Chemical silane. Cytec FM-300 epoxy adhesive was applied to the aluminum and Hercules AS4/3501-6 graphite epoxy composite was filament wound around the adhesive.

EIS measurements were taken from the aluminum substrate to the composite and from one area of the composite to another. Measurements were taken as-received, after baking in an oven at 100°C for 24 hours, and after immersion in water at 40°C for 24 hours.

Results

Boiler tubes.

EIS Sensor.

An excellent correlation (Figure 9) was obtained between the logarithm of the ratio of the high and low breakpoint frequencies (frequencies at which the phase angle of the EIS spectrum is 45°, see, e.g., Figure 10) and the corrosion rates for rates less than ~8mpy. The linear trend in the figure holds for both the aggressive (NaCl, with and without abrasion), benign (Na₂SO₄), and inhibitive solutions at room temperature. At higher corrosion rates, the difference in log breakpoint frequencies saturates near 6 which coincidentally is near the upper limit of frequency measurements with the EG&G instrument. Because anticipated corrosion rates of boiler tubes are less than 1 mpy, the linear region of the correlation provides adequate range for inspection. Representative phase angle spectra are given in Figure 10 to illustrate the changes in width of the capacitive region (log of ratio of the breakpoint frequencies) that occur with time as the iron passivated and the corrosion rate decreased.

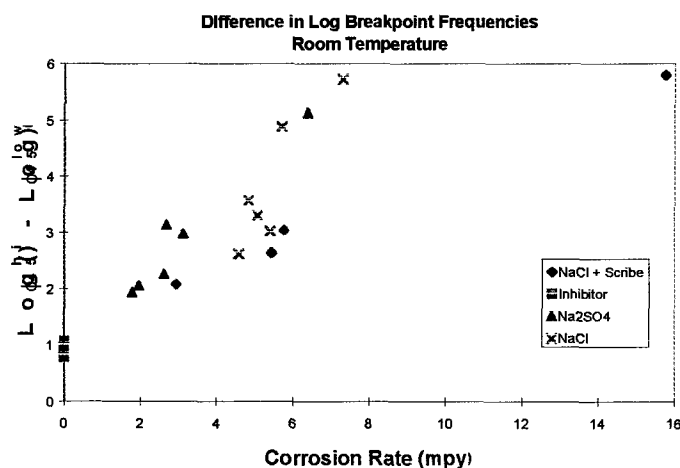

Figure 9. Difference of the logarithms of the high and low breakpoint frequencies, i.e., the ratio of the two frequencies, as a function of corrosion rate for boiler tubes in different solutions at room temperature.

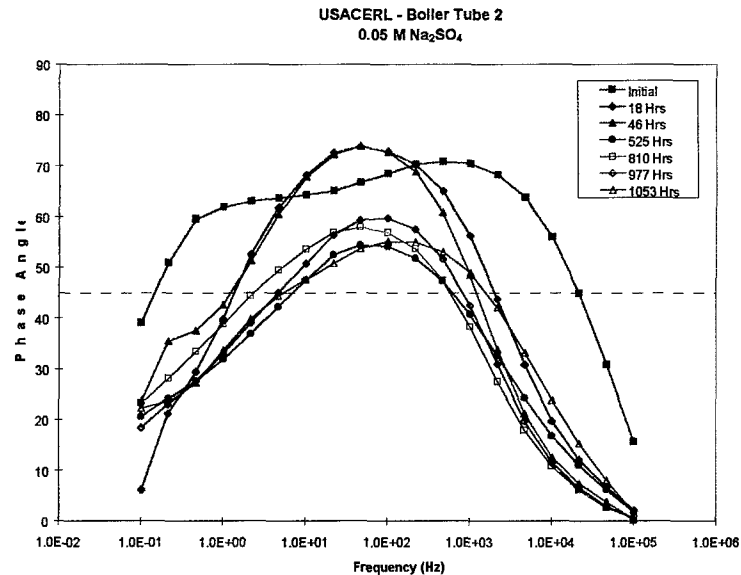

Figure 10. Bode phase angle spectra for boiler tubes immersed in Na₂SO₄ solution for different lengths of time. The breakpoint frequency is defined as the frequency at which the graph crosses the 45° line (shown as dotted).

The low-frequency impedance exhibits a poorer correlation with corrosion rates than the breakpoint frequencies as indicated in Figure 11. Both parameters (low-frequency impedance and breakpoint frequency) have been used previously to monitor corrosion and degradation. Because the low frequency impedance (Figure 12) is easier to obtain, more investigations have concentrated on this parameter. Our results indicate that the breakpoint frequencies work best with bare metals and the low-frequency impedance works best with coated metals.

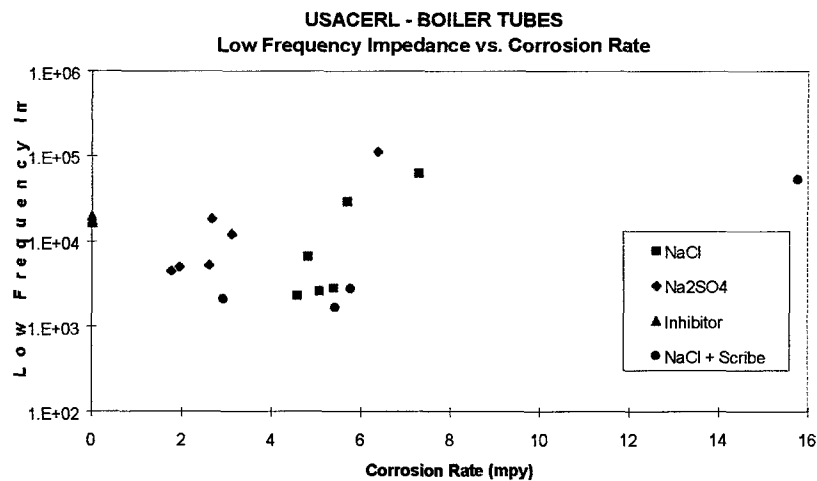

Figure 11. Low-frequency impedance as a function of corrosion rate for the boiler tubes in different room-temperature solutions.

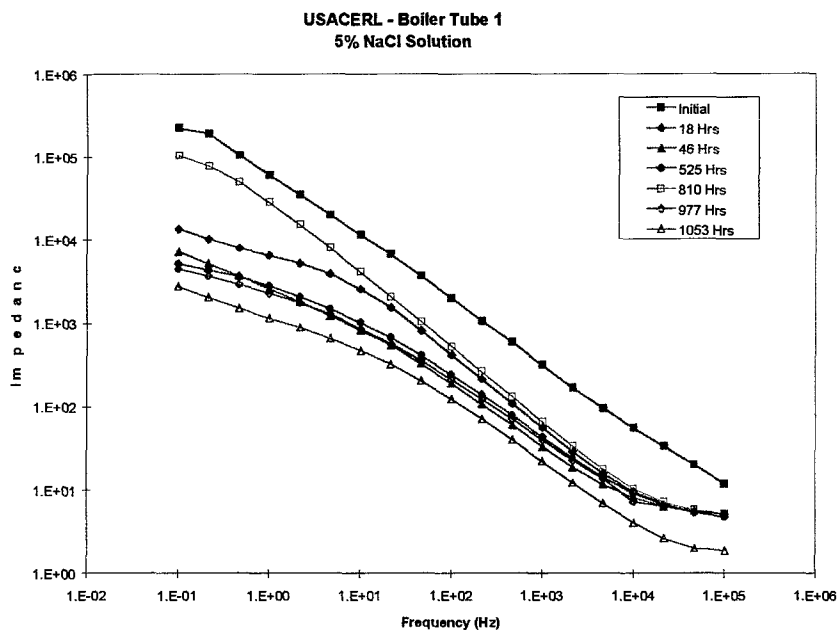

Figure 12. Impedance spectra of a boiler tube immersed in NaCl for different times. The last measurement was at 100°C; the remainder were at room temperature.

Limited data were acquired at 100°C. The results suggest that a correlation between the logarithm of the ratio of the two breakpoint frequencies and the corrosion rate is present (Figure 13), but that it is different from the one at room temperature. In the region of low corrosion rates (<1 mpy), the two sets of data appear to converge. This convergence, the effect of temperature, and the correlation at low corrosion rates need to be investigated further.

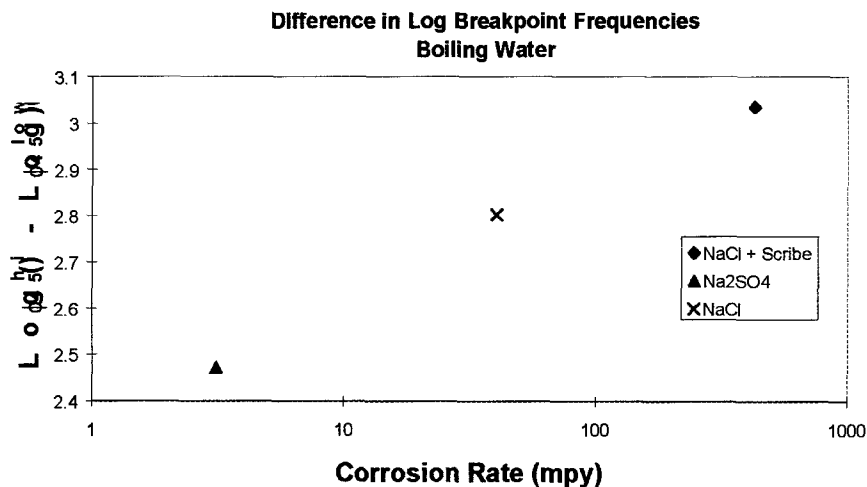

Figure 13. Log of the ratio of two breakpoint frequencies (difference of the logarithms of the two frequencies) as a function of corrosion rate for boiler tubes at 100°C.

Acoustic Sensor.

In-air tube characterization. The results of the first series of impulse testing are shown in Table 3. The strongest resonance appeared to be the flexural mode, and is represented by the column entitled "Second Resonance". These values are slightly below those of a half wave resonator, but appeared to be reasonable for a flexural mode the integrity of which was also a function of corrosion. The notable result of the initial test was that it demonstrated that indeed a Terfenol actuator could be used, which as indicated from Table 1 was the choice here for a low impedance, temperature tolerant material.

Table 3. Dominant Resonance Frequencies of Boiler Tubes

Tube Length (ft)	First Resonance (Hz)	Second Resonance (Hz)
0.5	7125	8138
1	1950	4900
2	1375	2583
3	1187	1912

In-air baseline vs. corroded tube frequency response test and results. Since the impulse measurements indicated that the original choice of a Terfenol actuator would be satisfactory, the only items remaining were how to configure it and how to mount the device. With respect to the configuration, we decided upon a stiffer rod than earlier thought to achieve the higher frequencies. Also, since stiffer rods are generally larger in diameter and we wanted to avoid eddy current losses, even for the prototype actuator, we had the rod laminated to reduce these losses. Thus, magnetically, the final actuator had a closed circuit configuration using alnico magnets for the biasing circuit (due to their higher permeability than the typical high strength magnets such as Samarium cobalt or neodymium iron boron which are used). The rod was 0.600-in. diameter x 3-in. long with one lamination through the center of the rod. The configuration is shown in Figure 14.

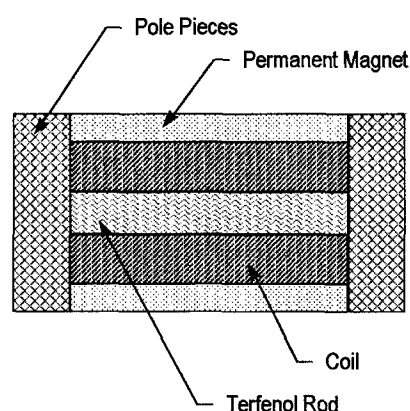

Figure 14. Elements of High Energy Self Biased Terfenol Actuator

The mounting fixture for the actuator was a simple aluminum housing which contained an accommodation for the prestress of the system when attached to the pipe. This would guarantee

• **DACCO SCI, INC.** • 10260 Old Columbia Road, Columbia, MD 21046 • (410) 381-9475 •
<http://members.aol.com/gddaccosci/DACCOSCI.htm>

maximum coupling in place, rather than attach a prestressed actuator to the pipe. The complete set-up is shown in Figure 5, which is a photo of the fixture attached to the corroded pipe.

The actuator was attached to the pipe with 4 4-40 threaded rods which provided a high compliance prestress. Since the actuator was already magnetically biased after assembly, it was prestressed in place to match the magnetic bias as Terfenol has a unique mechanical bias point which matches a given prestress. Thus, they must be tuned in place for maximum coupling. This process is typically achieved with a small signal generated to the Terfenol and the input impedance measured with an analyzer, in this case a HP 3562A Signal Analyzer. When the maximum impedance is achieved, the unit is considered tuned.

Test Procedures. The tests on the pipe were somewhat of a repeat of the actuator tuning. With the actuator tuned, an accelerometer was placed at the end, first of the uncorroded pipe and then of the corroded pipe. In both cases, the actuator was coupled and optimally tuned, and the tests run. What we were looking for, as indicated in the "Theory" section above, was a reduction of signal amplitude at the fundamental resonance tested with a broadening of the Q of the response curve. All measurements were power spectrum measurements.

As indicated in Figure 15, the corroded pipe, indeed, had both a lower amplitude at resonance and a broader Q, indicating a reduction in the integrity of the pipe. While the figure shown is an example of one data run, we repeated the experiment several times. There was some slight difference in the response, largely due to the positioning of the actuator mounting on the pipe, but the relative difference in amplitude and Q remained constant.

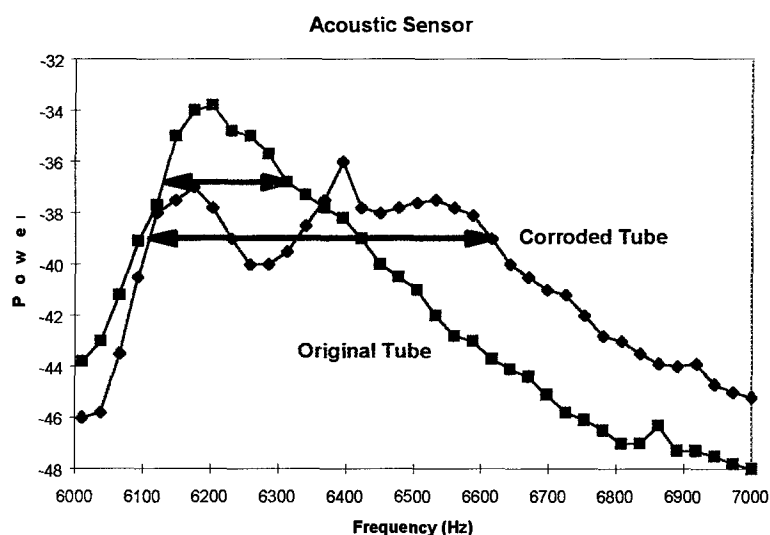

Figure 15. Transmitted acoustic power using as-received and severely corroded boiler tube segments.

Buried steel pipe.

EIS measurements from the *in-situ* sensor track well with the degree of coating of the buried pipe. As shown in Figure 16, the fully coated pipe has the highest impedance while the pipe with no coating has the lowest impedance. After initiation of the impressed current cathodic protection

at 7 days, the differences between the low frequency impedances increase even though the measurements shown in this figure were taken with the impressed current temporarily turned off.

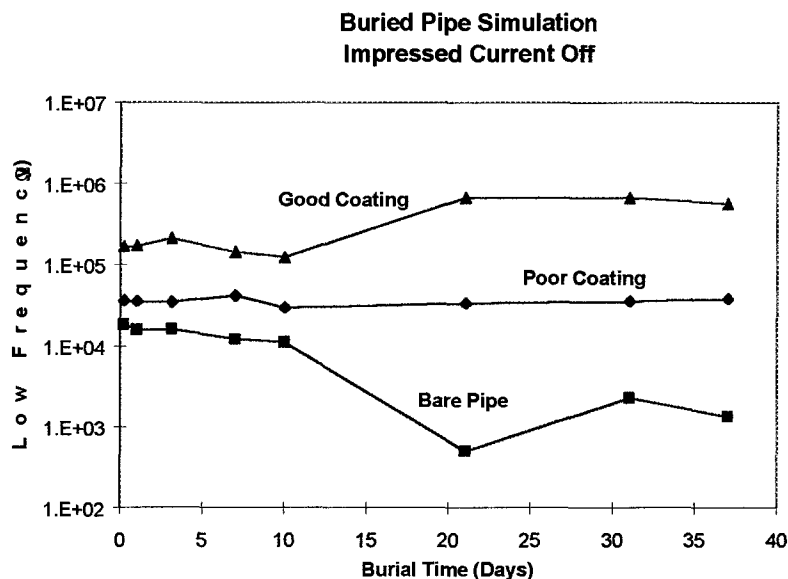

Figure 16. Low frequency impedance measured using the attached sensor as a function of time for three buried pipes: bare, partially coated, and fully coated.

Introduction of impressed current cathodic protection has two effects (Figure 17):

- Increased noise at high frequencies
- Increased impedance at low frequencies.

Such behavior was observed for all three pipes. The low-frequency impedance continues to be a function of the quality of the coating (Figure 18). The magnitude of the difference is similar to that observed with the impressed current turned off (but following initiation of the impressed current, Figure 16) – the pipe with the good coating exhibits a low-frequency impedance approximately 3 orders of magnitude higher than the bare pipe.

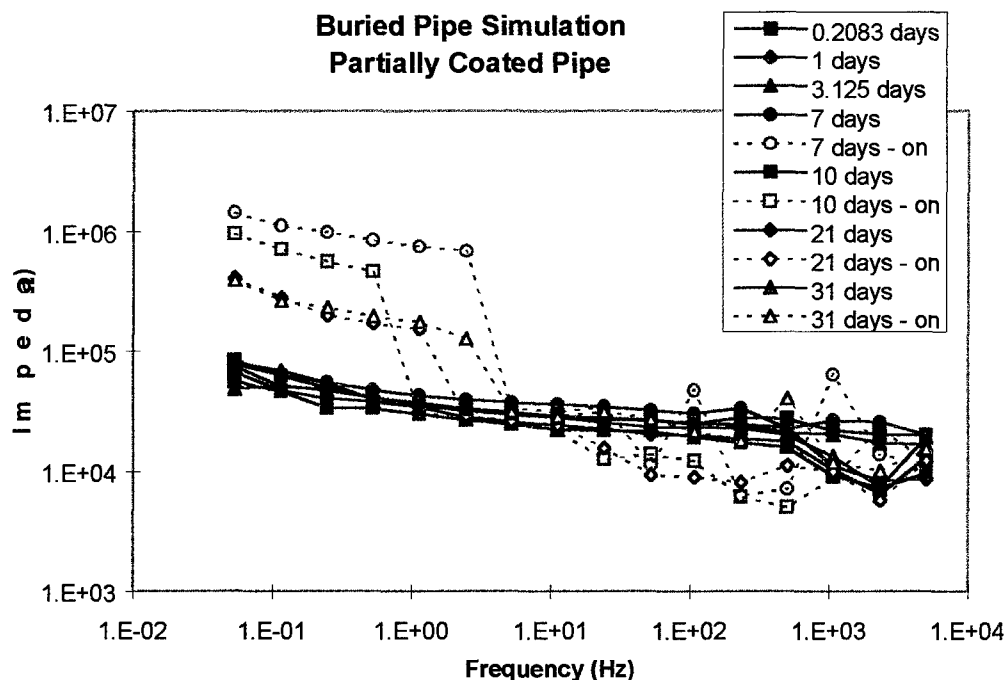

Figure 17. EIS spectra of the partially coated pipe with and without impressed current cathodic protection. The attached sensor was used to acquire the measurements.

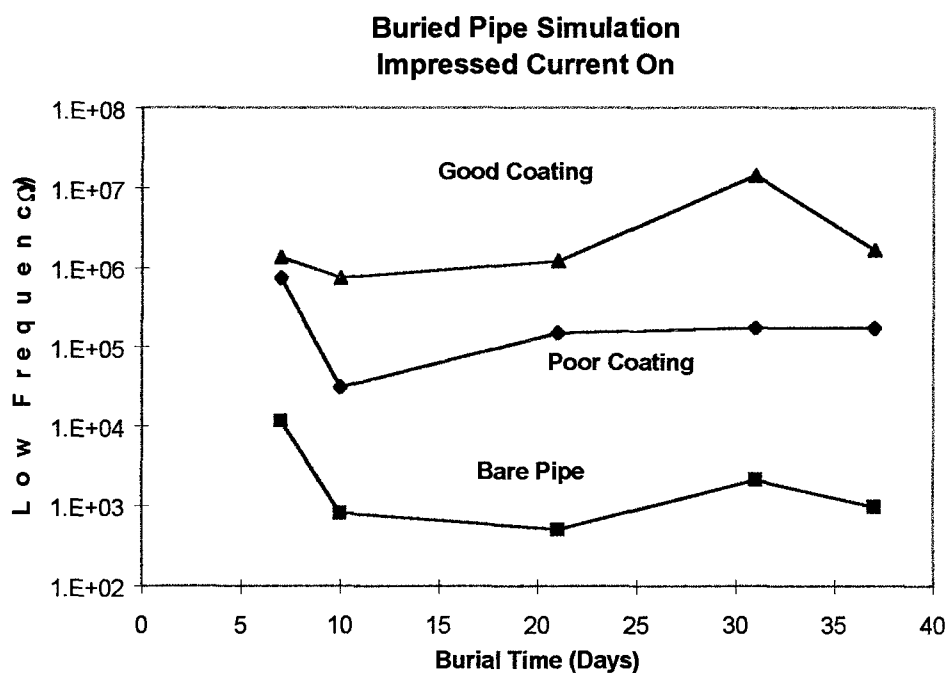

Figure 18. Low-frequency impedance measurements taken with the attached sensor with the impressed current on as a function of burial time.

The utility of this approach to inspect pipes would be enhanced if similar measurements could be acquired without the use of an attached sensor. Such inspection, then, would be suitable for the millions of miles of pipes currently in service. Figure 19 shows that similar results are obtained from a remote electrode (the impressed current anode) and from the attached sensor provided that the impressed current is temporarily turned off during the EIS measurement. (EIS measurements acquired with the impressed current on were dominated by the impressed current and did not reflect the condition of the pipe.) The same ranking of the three pipes and their coatings were obtained. Differences between the two sets of spectra likely result from soil properties. Further evaluation is needed to establish acceptable soil conditions and analysis procedures for use of remote electrodes.

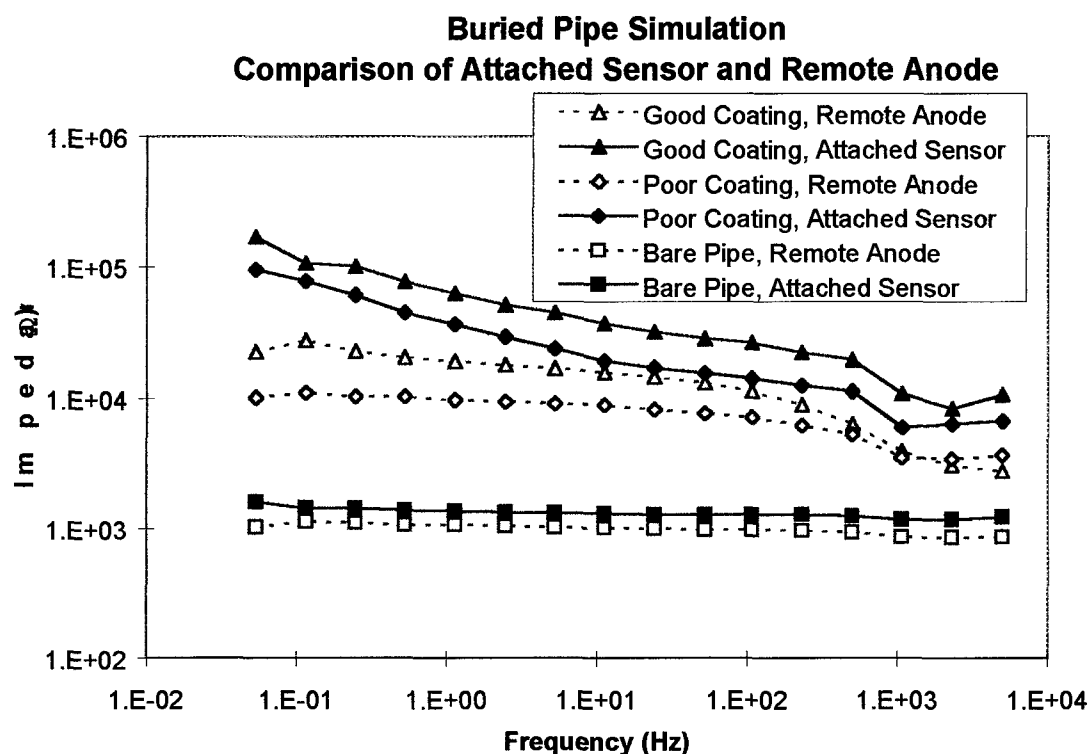

Figure 19. EIS spectra of the three buried pipes comparing data acquired with the attached sensor and with the impressed current anode as the sensor. The impressed current was turned off during the measurement.

Vinyl-coated steel.

Electrochemical impedance spectra of the five vinyl-coated panels using the hand-held corrosion sensor are given in Figure 20. Excellent correlation was obtained between the visual condition of the panels and the electrochemical measurements: Panels in excellent condition exhibited very high impedance (up to $10^9 \Omega$ at low frequencies) with capacitive behavior (log impedance vs log frequency slope of -1). In contrast, panels in poor condition showed relatively low impedance ($\sim 10^4 \Omega$) with mostly resistive behavior (impedance independent of frequency). These spectra are typical of good and bad coatings, respectively.

• DACCO SCI, INC. • 10260 Old Columbia Road, Columbia, MD 21046 • (410) 381-9475 •
<http://members.aol.com/gddaccosci/DACCOSCI.htm>

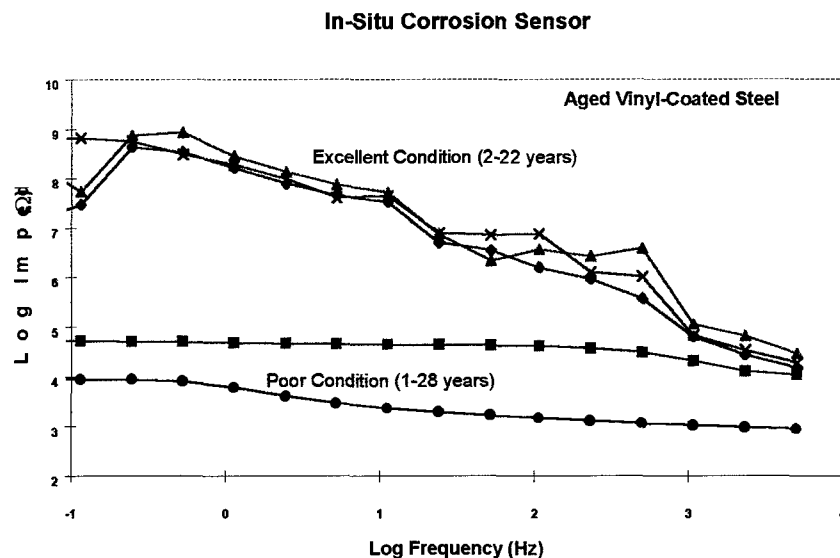

Figure 20. Impedance spectra of vinyl-coated steel specimens following immersion in fresh water. The data were acquired by the hand-held sensor and the portable Gamry potentiostat.

For comparison, equivalent spectra were taken using a flat electrochemical cell and conventional remote electrodes. These results are presented in Figure 21. Comparison with Figure 20 shows that the two methods of data acquisition – hand-held *in-situ* sensor and conventional electrodes – give equivalent results. This agreement, along with many other comparisons, serve to validate the *in-situ* sensor and connect the sensor results with the historical database of EIS measurements.

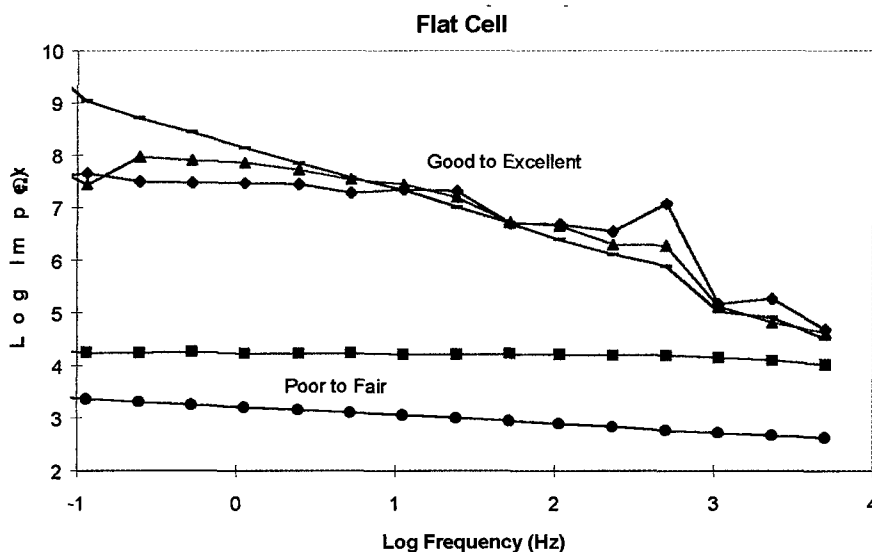

Figure 21. Impedance spectra of vinyl-coated steel specimens following immersion in fresh water. The data were acquired by a flat cell with conventional remote electrodes and the portable Gamry potentiostat.

It is interesting to note that one of the bad specimens (2176) had some areas in which the coating looked relatively good. When the hand-held sensor was used to separately inspect the good and

bad areas, significant differences were seen in the spectra (Figure 22) with the measurements from the good area approaching that of the good specimens. In contrast, the flat cell was unable to distinguish between the good and bad areas. We attribute this difference to the conventional EIS measurements being dominated by defects or other small bad areas within the analysis area. In this usage of the hand-held sensor, the measurements are more localized and controllable so that results are indicative of small good areas. Other measurements have shown that the detection range of the hand-held sensor (and the permanent *in-situ* sensor) is highly dependent on the surface conductivity of the coating – a dry coating will give a very localized corrosion reading while a wet coating will give a wider ranging corrosion reading. Under carefully controlled laboratory conditions, detection of a scratch 15 feet away from the sensor has been achieved.

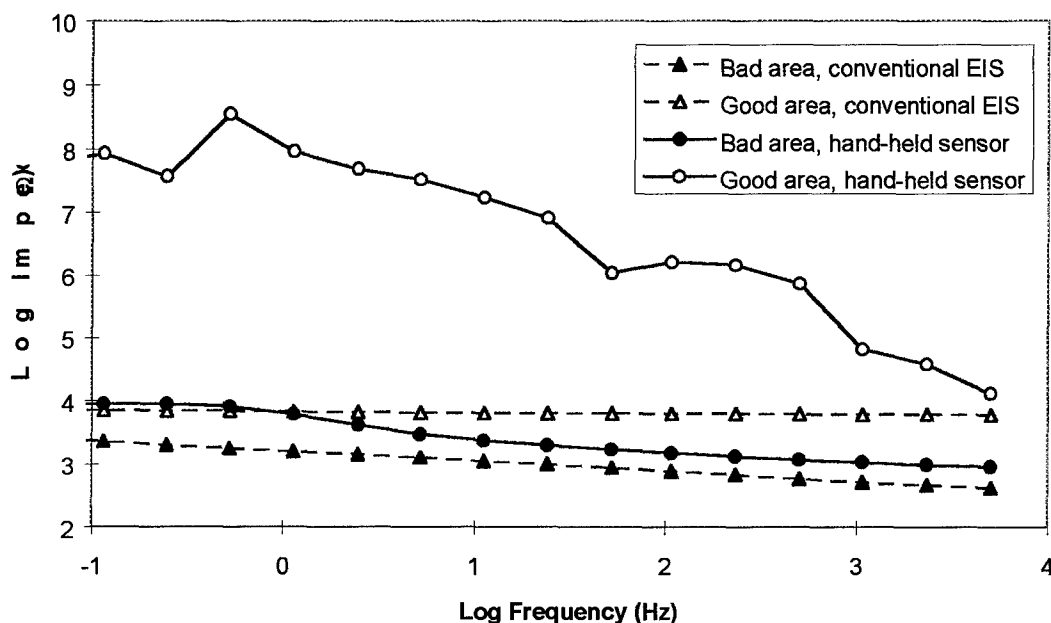

Figure 22. Impedance spectra for poor vinyl specimen 2176 in both "good" and "bad" areas. Measurements were taken with both the hand-held sensor and conventional EIS.

Composite aluminum structure.

Initial measurements of the graphite-epoxy/aluminum structure showed that the composite was electrically shorted to the metal. This short prevented us from obtaining typical EIS measurements using the aluminum and composite as the two electrodes. That is, the spectra showed completely resistive behavior over all frequencies. We examined this specimen under three conditions to determine if the measurements could detect the uptake of moisture – as received, after baking, and after immersion in water. The results, shown in Figure 23, indicate that differences in impedance are readily seen and appear reproducible. Based on our work with paints and other insulative coatings, we would have expected the impedance measured after baking to be highest and that measured after immersion to be the lowest. The increase observed after immersion implies mechanisms more complicated than simple moisture uptake of the matrix are occurring. These mechanisms may involve the resistance of the graphite fibers upon moisture absorption or

These mechanisms may involve the resistance of the graphite fibers upon moisture absorption or interfacial effects between the fiber and the resin. Because this effort was the lowest priority of tasks, we did not pursue identification of the mechanisms involved.

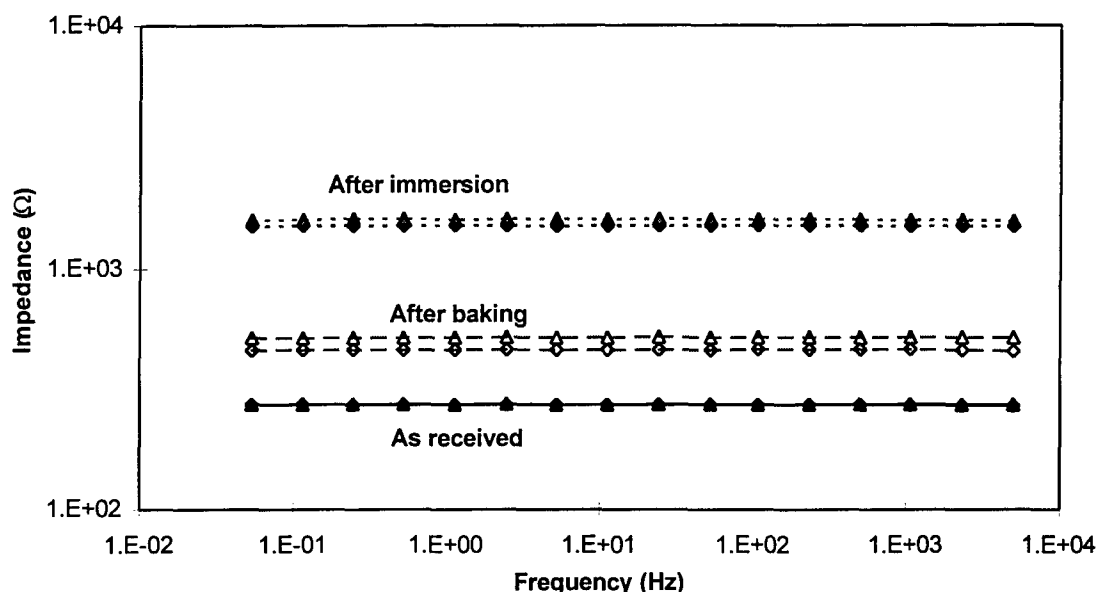

Figure 23. EIS spectra of a graphite-epoxy/aluminum structure: as-received, after baking, and after immersion in water. The working electrode was the aluminum substrate. The sensor was attached to two different areas of the composite to test reproducibility.

Potential Sensor Data Fusion And Electronics

The purpose of the Corrosion Monitoring System is to correlate electrochemical impedance spectroscopy (EIS) and electro-acoustic measurements with corrosion of boilers and other structures. We will describe briefly the ultimate configuration of the system as it will be built in Phase II of the program. The system for Phase I consisted of off-the-shelf discrete components which enabled the necessary measurements to take place for the ultimate requirements definition of the system shown below.

The Corrosion Monitoring System consists of a portable computer equipped with a Gamry PC3 potentiostat and CMS300 software, Lab View software, a data acquisition card, a 100 watt power amplifier, an actuator and LED indicators (Figure 24). The system will operate both the EIS and acoustic corrosion sensors. It supplies swept sine wave outputs to interrogate the EIS sensor and stimulate the amplifier and acoustic actuator. It measures current and/or voltage of the sensors. It then provides three digital outputs to illuminate green, red, and yellow LEDs, which will provide a simplified indication of the pipe's condition. The thresholds of the LEDs are TBD at this time. The results from the EIS tests will yield an impedance spectrum - namely the response of the impedance of the sample to the frequency. The swept sine wave, and the current and voltage of the actuator will be used to generate another impedance spectrum of the pipe. A change in impedance, due to a build up of corrosion on the pipe, will be indicated. And finally, at some predetermined level, the system will generate a signal to an inhibitor controller which will add more

• DACCOSCI, INC. • 10260 Old Columbia Road, Columbia, MD 21046 • (410) 381-9475 •
<http://members.aol.com/gddaccosci/DACCOSCI.htm>

inhibitor to the system to deter corrosion, thus preventing further damage to the system, making the system a smart monitoring system.

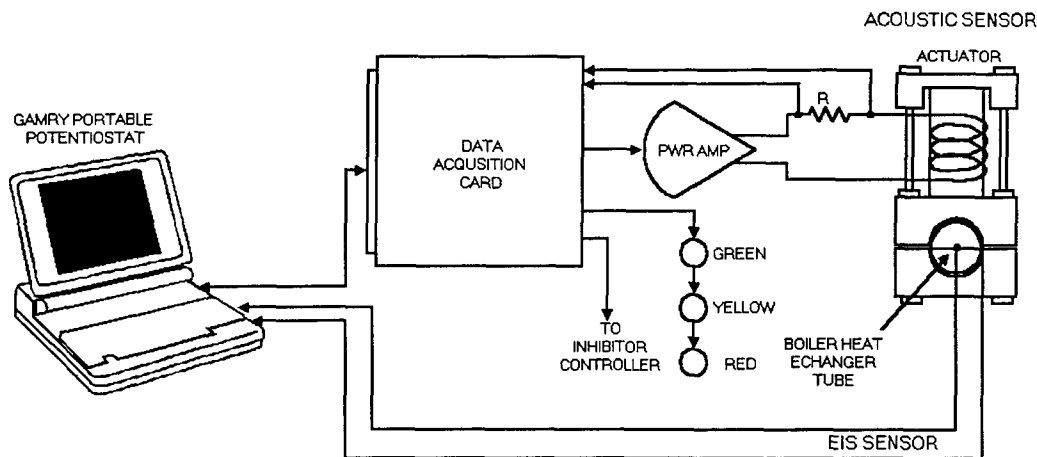

Figure 24. Schematic block diagram of corrosion monitoring system.

Referring to the enclosed block diagram the system operates as a collection or fusion of data from two monitoring inputs, EIS sensor and the actuator. A sequential operation of the system is as follows:

An EIS sensor is inserted into a boiler tube with a location and configuration TBD. Its principle of operation involves applying AC voltage of varying frequencies through the sample which is immersed in a conductive electrolyte. At the same time, the impedance is measured based upon the current and the voltage required to transmit the AC current through the sample. The system can be modeled as an electrical circuit and the characteristics of the circuit can be monitored and evaluated, with respect to corrosion rate. At the point where the corrosion has progressed to an impedance level indicating a problem, it will trigger an alert in the system and cause additional inhibitor to be released into the boiler. The combination of the two sensing system makes the system both a fail safe system and a system with the capability to provide early alerts as to an incipient problem as well as to enable a prolongation of life of the system by constant monitoring.

In parallel with the EIS system, and feeding into the same diagnostic system will be an acoustic sensor which is also attached to the tube. The actuator shown is envisioned to be a Terfenol actuator coupled to the boiler tube in such a way as to resonate the tube. The active material in the actuator is an alloy of Terbium, Dysprosium and Iron, and can operate in very high temperature environments. In addition, its impedance is low, making it ideal for operation in humid or liquid environments such as boilers. The actuator is attached to the tube and driven in a narrow range as described in the system above. The impedance from the actuator is then monitored so that the real part of the impedance will indicate a resonance(s). The monitoring sequence will consist of a repeat measurement over time, perhaps at weekly intervals. When the real part of the imped-

ance diminishes by an amount known to suggest the onset of corrosion from laboratory testing at the DACCO SCI, INC., an alert will signal and inhibitor will be added.

Summary and Conclusions

This Phase I SBIR has established the feasibility of the EIS *in situ* sensor and/or the acoustic sensor to monitor or inspect corrosion of boiler tubes, buried pipes, coated steel structures, and, potentially, composite/metal structures. Specific findings and conclusions include:

- The EIS *in-situ* sensor can be adapted for use in a boiler system to monitor the corrosion rate of the interior of the tube.
- An excellent correlation was obtained between the logarithm of the ratio of the two break-point frequencies and the corrosion rates in the range of 0-8 mpy. The specific correlation may be temperature dependent.
- This sensor and appropriate electronics can feasibly monitor the corrosion rates in real time during boiler operation and control servo valves to increase the inhibitor concentration if the corrosion rate increases.
- The acoustic sensor is capable of inspecting boiler tubes to detect and, possibly, locate severely corroded areas. The actual weight loss was on the order of 3%, well below the danger zone for boiler tubes, assuming relatively uniform corrosion, at least in designated areas.
- The EIS sensor is capable of determining the quality of a coating on a buried pipe and the presence of impressed current cathodic protection.
- Similar measurements can be obtained using remote electrodes, such as the impressed current anode itself. This capability would allow inspection of existing pipes without attached sensors.
- The hand-held version of the EIS *in-situ* sensor is suitable for inspection of painted steel structures, such as storage tanks, locks and dams, etc. The measurements clearly reflected the extent of corrosion on specimens immersed for up to 28 years.
- EIS measurements, acquired with the hand-held EIS *in-situ* sensor, on an epoxy-graphite/aluminum structure depended on the amount of moisture present in the composite, suggesting the sensor could be suitable to monitor such composites.

Recommendations for Future Work

Further work in Phase II of this program should remain focused on boiler tubes. Two distinct areas need to be addressed: in-process monitoring of corrosion rates and NDE inspection of boiler tubes during maintenance. The first issue would involve the EIS *in-situ* sensor. Development of the sensor probe and analysis protocols, determination of the effects of temperature and the detection range of the sensor, and development of appropriate electronics, including inhibitor control, are all needed before this approach can be put into practice. The second issue involves the acoustic sensor. Similar topics must be addressed: development of the sensor probe and inspection/analysis protocols, determination of the effect of different defects/damage, bends, and

• DACCO SCI, INC. • 10260 Old Columbia Road, Columbia, MD 21046 • (410) 381-9475 •
<http://members.aol.com/gddaccosci/DACCOSCI.htm>

clamps, establishment of typical detection lengths of tubing, and development of suitable electronics.

A second focus should be pipes and other buried structures. Both the location of buried structures and determination of the extent of corrosion or corrosion susceptibility are important. A fusion of the electrochemical and acoustic sensors should improve the detection/location of buried metallic structures while reducing false positives. Development of a combined approach and the detection procedures is needed. Use of the electrochemical sensor to inspect buried pipes for corrosion will require development of a remote electrode and inspection procedures and determination of the effects of different soils and different coatings and coating defects.

Other applications, including painted structures and composite/concrete structures, also deserve some attention. Adaptation of the sensors for these structures and development of inspection procedures are required before utilization of this technology.