

Indochina Monographs

Pacification

by

Brig. Gen. Tran Dinh Tho

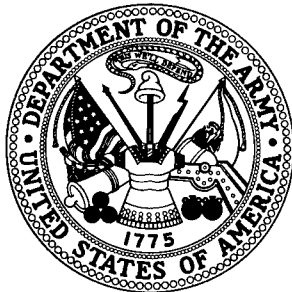
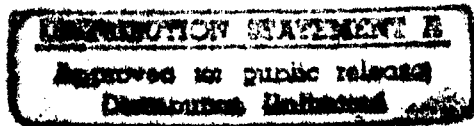

19970423 186

U.S. ARMY CENTER OF MILITARY HISTORY

WASHINGTON, D.C.

DTIC QUALITY INSPECTED 1

Library of Congress Cataloging in Publication Data

Tho, Tran Dinh.
Pacification.

(Indochina monographs)

Supt. of Docs. no.: D 114.2:P11

1. Vietnam--Politics and government--1945-1975.
 2. Vietnamese Conflict, 1961-1975--Underground movements.
 3. Guerrillas--Vietnam. I. Title.
- II. Series.

DS556.9.T48

959.704'31

79-607913

This book is not copyrighted and may be reproduced in whole or in part without consulting the publisher

First printing 1980

Indochina Monographs

This is one of a series published by the U.S. Army Center of Military History. They were written by officers who held responsible positions in the Cambodian, Laotian, and South Vietnamese armed forces during the war in Indochina. The General Research Corporation provided writing facilities and other necessary support under an Army contract with the Center of Military History. The monographs were not edited or altered and reflect the views of their authors--not necessarily those of the U.S. Army or the Department of Defense. The authors were not attempting to write definitive accounts but to set down how they saw the war in Southeast Asia.

Colonel William E. Le Gro, U.S. Army, retired, has written a forthcoming work allied with this series, Vietnam: From Cease-Fire to Capitulation. Another book, The Final Collapse by General Cao Van Vien, the last chairman of the South Vietnamese Joint General Staff, will be formally published and sold by the Superintendent of Documents.

Taken together these works should provide useful source materials for serious historians pending publication of the more definitive series, the U.S. Army in Vietnam.

JAMES L. COLLINS, JR.
Brigadier General, USA
Chief of Military History

Preface

Pacification is the military, political, economic, and social process of establishing or reestablishing local government responsive to and involving the participation of the people. It includes the provision of sustained, credible territorial security, the destruction of the enemy's underground government, the assertion or re-assertion of political control and involvement of the people in government, and the initiation of economic and social activity capable of self-sustenance and expansion.

Defined as such, pacification is a broad and complex strategic concept which encompasses many fields of national endeavor. As a program implemented jointly with the U.S. military effort in South Vietnam, pacification appears to have involved every American serviceman and civilian who served there, many of whom indeed participated in conceiving the idea and helping put it to work.

As they and other responsible Vietnamese officials may have realized, the magnitude and intricacies of pacification problems defy even the most diligent attempt to analyze and present them as cohesive subjects within the limited scope of a monograph. To the general reader, unless he has a comprehensive background of the Vietnam situation, the implementation of pacification through time and space can also frustrate any effort to arrive at comprehensive generalizations. The fact is — and I am certain that many will share my opinion — there exist but a few authorities on pacification as a total subject. However, there are many Vietnamese and Americans who were highly professional and effective in their areas of responsibility within the overall program.

In the attempt to present every relevant aspect of the GVN pacification effort, I have mostly relied on my personal experience as one of the many architects who helped draw part of the blueprint and oversaw its progress, and complemented it by conducting interviews with responsible officials and studying available documentation.

Several people have contributed to the completion of this monograph to whom I feel particularly indebted. I certainly owe a debt of gratitude to General Cao Van Vien, Chairman of the Joint General Staff and Lieutenant General Dong Van Khuyen, Chief of Staff and Commanding General of the Central Logistics Command, RVNAF — under whom I served many years as Assistant Chief of Staff for Operations — for their valuable guidance and suggestions concerning the pacification planning and coordination process at the GVN level. To Lieutenant General Ngo Quang Truong, Commanding General of I Corps, and Major General Nguyen Duy Hinh, Commander of the 3d ARVN Infantry Division, I owe insight and an unbiased viewpoint with regard to the actual implementation of the pacification program at the field level and the many problems involved. Colonel Hoang Ngoc Lung, my colleague of many years as J-2, JGS, has helped me with his always thoughtful critical remarks and his authoritative knowledge of enemy schemes and actions.

Finally, I am particularly indebted to Lieutenant Colonel Chu Xuan Vien and Ms. Pham Thi Bong. Lt. Colonel Vien, the last Army Attache serving at the Vietnamese Embassy in Washington, D.C., has done a highly professional job of translating and editing that helps impart unity and cohesiveness to the manuscript. Ms. Bong, a former Captain in the Republic of Vietnam Armed Forces and also a former member of the Vietnamese Embassy staff, spent long hours typing, editing and in the administrative preparation of my manuscript in final form.

McLean, Virginia
10 October, 1977

Tran Dinh Tho
Brigadier General, ARVN

Contents

<i>Chapter</i>	<i>Page</i>
I. INTRODUCTION	1
II. PACIFICATION STRATEGY AND OBJECTIVES	9
<i>The Enemy Threat</i>	9
<i>System Evolution</i>	11
<i>Strategy and Operational Concept</i>	19
<i>Interim Objectives and Priorities</i>	22
<i>The Ultimate National Goals</i>	26
III. OPERATION AND SUPPORT	32
<i>The GVN Organization For Pacification</i>	32
<i>Employment of Forces in Support of Pacification</i>	40
<i>U.S. Organization for Pacification Support</i>	56
<i>The Phoenix Program</i>	66
IV. RVN-US COOPERATION AND COORDINATION IN PACIFICATION	75
<i>The Central Level</i>	75
<i>The Corps Tactical Zone/Military Region Level</i>	81
<i>The Division Tactical Area Level</i>	83
<i>The Province/Sector Level</i>	83
<i>An Evaluation</i>	85
V. PACIFICATION TECHNIQUES AND OPERATIONS	89
<i>Pacification Techniques</i>	91
<i>Coordination in Security Activities</i>	99
<i>Training</i>	104
<i>The Hamlet Evaluation System</i>	106
VI. SOCIAL REFORM AND ECONOMIC DEVELOPMENT	109
<i>Objectives</i>	109
<i>The Self-Help Hamlet Development Program</i>	110
<i>Rural Health</i>	111
<i>The Rural Education Development Program</i>	114
<i>The Relief and Resettlement of Refugees</i>	116
<i>Agricultural Development</i>	122
<i>The Fisheries Program</i>	125
<i>An Evaluation</i>	126

<i>Chapter</i>	<i>Page</i>
VII. THE GVN POLITICAL, INFORMATION AND CHIEU HOI EFFORTS . . .	132
<i>Information and Propaganda</i>	132
<i>The Chieu Hoi (Open Arms) Program</i>	134
<i>Relations with Ethnic Minorities</i>	137
<i>Land Reform and the "Land-To-The-Tiller" Program</i> . . .	140
<i>Village and Hamlet Elections</i>	144
<i>People's Self-Defense Forces</i>	150
<i>An Evaluation</i>	155
VIII. AN ASSESSMENT OF PACIFICATION: SOME ACHIEVEMENTS, DIFFICULTIES AND SHORTCOMINGS	160
<i>The Ideological Aspect of Pacification</i>	160
<i>Statistics Versus Achievements</i>	162
<i>The Communist Challenge to Pacification</i>	169
<i>The Problems of Cadres and Territorial Forces</i>	175
<i>The Impact of U.S. Policies</i>	180
IX. OBSERVATIONS AND CONCLUSIONS	183
 <i>Appendix</i>	
A. DECREE - MILITARY ORGANIZATION OF THE NATIONAL TERRITORY . . .	196
<i>Territorial Organization</i>	196
<i>Chain of Command</i>	197
<i>Functions</i>	198
<i>Coordination</i>	202
<i>Special Provisions</i>	202
B. DECREE - REORGANIZATION OF VILLAGE AND HAMLET ADMINISTRATION	203
<i>Village People's Council</i>	203
<i>The Village Administrative Committee</i>	209
<i>Hamlet Management Committee</i>	213
<i>General Provisions</i>	214
GLOSSARY	217

Tables

<i>No.</i>	
1. Casualties Caused by Enemy Anti-Pacification Terrorist Activities (From 1968 to 1970)	170

Charts

1. Central Revolutionary Development Council, 1968	33
2. GVN Revolutionary Development Councils, 1967-68	34
3. Pacification Councils and U.S. Support Organization (as of 1970)	36
4. RVNAF Organization for Pacification Support	41

<i>No.</i>		<i>Page</i>
5.	Command and Control, Regional and Popular Forces	45
6.	Organization, Province Regional and Popular Forces	46
7.	Organization, National Police	49
8.	Expansion of National Police Forces	50
9.	Organization, 59-man Revolutionary Development Cadre Group	52
10.	Organization, Province RD Cadre Group Headquarters	54
11.	Organization, Office of the Assistant Chief of Staff for CORDS, USMACV	58
12.	Organization, CTZ/MR CORDS in 1968	62
13.	U.S. Advisory Relationship with ARVN	64
14.	Phoenix Operation and Control System	67
15.	Organization, Province Phoenix Committee	68
16.	Organization, District Phoenix Committee	69
17.	US-RVN Relationship in Pacification, before 1971	76
18.	Refugee Relief and Resettlement	121
19.	Rice Production and Supplementary Crops	130
20.	Organization, Village and Hamlet Government	147
21.	Village and Hamlet Elections, 1970	149
22.	Organization, PSDF	152
23.	Organization, PSDF Combat Group	153
24.	Achievements in Population and Hamlet Control, 1971	165
25.	Expansion of PSDF, 1968-1970	168
26.	Enemy Anti-Pacification Activities	172

Maps

1.	RVN Military Territorial Organization	43
2.	Quang Nam Pacification Campaign	94

CHAPTER I

Introduction

The war in Vietnam was a continuation of the basic conflict, begun in 1946, which pitted the Communists against the free, nationalistic Vietnamese. Punctuated by a short pause following the Geneva Accords, the Communist-led struggle in the South followed fundamentally consistent policies and strategies aimed at achieving complete political dominance over all of Vietnam.

The Viet Cong insurgents operating behind a screen of a national liberation movement were fronts for the Vietnamese Communist Party whose Politbureau in Hanoi directed the total war effort. Although the Viet Cong profited from the Viet Minh experience and knew how to conceal their true identity, they were unable to make the appeal of their cause as strong as the feverish desire for independence was for the Viet Minh in 1949. The Viet Minh had been able to take over the control of the nationalist and anti-colonial movements and eliminate most of the nationalist contenders in the process. They had enjoyed an undisputed cause and derived from it great strength and popularity. The Viet Cong also attempted to revive the anti-colonial, anti-imperialist issue but the old magic failed to work because South Vietnam, despite its heavy reliance on U.S. aid, had become a truly independent nation.

The regime of the Republic of Vietnam, under Ngo Dinh Diem and successive military and civilian governments, was thus faced with a double challenge, that of nation building and the threat of insurgency and outright invasion from the north. In many respects, the war against the Viet Cong bore the characteristics of a civil war, although both sides received aid and were supported with troops from outside sources.

The cells of the Viet Cong infrastructure, aided by and in concert with local and NVA main forces, acted on the body of South Vietnam like cancerous tumors and sapped the strength of the GVN. The GVN task of nation building stood little chance of success unless these tumors were removed, and the GVN military effort was inextricably entwined with political, social and economic endeavors. Together, they made up the total effort known as pacification.

Nowhere was this total effort more arduous than in the Vietnamese countryside, the main battleground of the war and pacification.

The Vietnamese countryside suffered most from destruction and privations and was the feeding ground for social injustice, crimes, oppressions, and all the vices generated by a colonialist and feudalistic heritage. Land was inequitably distributed; most private land being in the possession of wealthy landlords. The majority of farmers did not own the land they cultivated but had to lease it from landlords who charged exorbitant rents. It was also plagued by debilitating diseases, lack of medication and sanitation, shortages of food and clothing, and widespread illiteracy. Because of the lack of schools and teachers, most rural children were denied an education and forced at an early age to work as farmhands under harsh and difficult conditions. The prospects for the future looked grim and disheartening.

South Vietnam, before the French-Viet Minh war began in 1946, ranked as one of the top rice producers among Southeast Asian countries. About 90% of its population lived on rice farming and depended on agriculture as a principal means of subsistence. Yet during the war South Vietnam had to import rice in increasing quantities each year. The escalating war forced the peasants to relinquish their land and farming, quit breeding cattle and poultry and move to urban areas as refugees. Unemployment was widespread and became more serious every year. The national economy deteriorated and functioned only as a result of aid transfusions. As a result of population growth and increasing imports through U.S. aid programs, consumption rose, surpassing production by a five-to-one ratio.

The village and hamlet governmental structure was truly the relic of a feudalistic age. Local leaders, who in most cases inherited their positions, domineered and exploited the peasants by levying high rents and taxes. The farm worker led a miserable life, barely subsisting on what was left of the fruit of his toil after land rents, and going further into debt with each decade. The undercurrent of discontent among the rural people was widespread.

In addition to suffering social vices and economic misfortunes, South Vietnam was also the victim of blatant invasion from Communist North Vietnam, assisted by the Communist bloc. In the face of this situation, the government and people of South Vietnam endeavored on the one hand to defeat the Communist aggressors, and on the other hand to reform their own society. It was a difficult enterprise because both tasks demanded equal priority. National resources and manpower were utilized to the full, augmented by considerable contributions in combat forces, material resources, and money from the United States and the Free World.

To our side as well as to the enemy, the rural area of South Vietnam was to be the decisive battlefield. Without it, the enemy would lose his foothold and the opportunities to protract his war, for the rural area was his major source of subsistence and manpower. The countryside was the arena for the ideological struggle between the Free World and Communism. It was where the battle for the hearts and minds of the people was fought and whoever won their trust, cooperation, and support would be the final victor. Without the rural area, which in Communist doctrine included not only the agricultural lands but also the forests, swamps and mountains, the nation could hardly survive.

To win the battle for the rural area, the enemy conceived the strategy on "encircling the cities with the rural area," while on the RVN side, "all efforts of the nation were to focus on the rural area." In fact, one element of the enemy's strategy in attacking the cities and towns in his general offensive of 1968 was to draw the GVN and allied forces out of the countryside where they were enjoying considerable success in

pacification. The Communists believed control of the rural area was the key to success in a people's war.

The importance of the rural area was obvious. Vietnam, like China, was an agricultural country. Peasants were the largest social group and compared to other social elements were the most underprivileged. Like the Chinese peasants, the Vietnamese peasants were used by the Communists as a front for their "revolutionary war." After the Communists took over control of North Vietnam, one of the first policies they implemented was land reform which redistributed land among the peasants. This policy turned peasants into private landowners, which served well the purpose of winning them over.

In the economic battle, the rural area also played a key role. It was the source of food supplies, and Communist control would certainly help them to achieve self-sufficiency and sustain the war effort. Because of this economic importance, the enemy tried to cut us off from the rural area with his policy of "encircling the adversary's economy" and causing economic difficulties in order to make South Vietnam increasingly dependent on foreign aid.

In the ideological struggle, the rural area was also a fecund ground for political indoctrination and for fomenting class hatred and class struggle. The marked inequality between rural life and urban life existed not only in terms of material comfort and basic necessities but also in the disparity with which law and order were enforced. In many instances, rural life appeared to be governed by a different set of laws and regulations. Too frequently, central government directives were interpreted and manipulated by village authorities to suit their own purposes or merely disregarded in favor of their own rules.

The Communists strove to acquire the inexhaustible manpower of the rural areas. This dependence of the Communists on the rural area was in a certain sense similar to the bond that tied the Nationalists to the cities and urban areas, which were a major source of Nationalist manpower.

The RVN government was fully aware of the Communist dependence on the rural area, and the national strategy of "Pacification and

Development" was designed to separate the Communists from it. The strategy also sought to establish the GVN presence in less secure, contested areas with a view of controlling the nation's manpower and resources and denying them to the enemy. Despite its awareness, the RVN initially appeared not to be truly cognizant of the full implications of the problem at hand. Its efforts to implement pacification were not pushed hard enough and sometimes appeared to be devoid of genuine enthusiasm. These efforts also met with vigorous opposition from the Communists who persistently sought to thwart or offset whatever achievements the RVN happened to gain.

One of the Communists' first reactions was, characteristically enough, to oppose the establishment of local government at the village and hamlet level since this was an extension of the prestige, laws, and political influence of the RVN central government. Unable to wreck the RVN governmental infrastructure, the Communists resorted to effective methods of intimidation, repression, and terror. Through machinations and manipulations, they managed to help into office those who were considered "middle-of-the-roaders," men who were too weak and too indifferent to serve in any effective way and obstructed the nomination of local leaders who enjoyed prestige, affection, and respect among the population. The Communists resorted to kidnapping or outright assassination if intimidation failed to remove those local officials whom they considered too devoted or too zealous. Countless officials at the grass-roots level were reduced to silence or became casualties. The enemy's goal was to instill fear, disenchantment, and anxiety among the active GVN cadre and force them into inaction.

In addition to their effort to neutralize or paralyze our local government structure, the Communists also systematically set about to undermine and disrupt every program the RVN initiated at the local level. Such key programs as "Land to the Tiller" and "Farm Credit" met with vicious slander or outright sabotage. For example, Communist cadres instigated the peasants to apply in mass for credits in order to overtax the bureaucracy and exhaust the funds; then they urged the peasants not to make repayments. The fish-breeding program also failed to

interest farmers at first because Communist cadres spread the rumor that the type of fish that the GVN had imported from the Philippines would cause leprosy.

The most significant Communist opposition to pacification dated back to the early days of the First Republic's Strategic Hamlet system which the Communists vilified as a program designed to "repress the population" and to "imprison the population behind the hamlet's barrier." In addition to the vilification campaign, the Communists stepped up attacks and shellings against Strategic Hamlets.

After their defeat during the 1968 general offensive, Communist main force units had to withdraw to border base areas leaving much of the countryside to GVN control. The pacification program subsequently made remarkable progress across the country. This took the Communist command in the south by surprise, and it resolved to wreck the GVN's pacification and development program at all costs. As a matter of fact, almost all directives issued by COSVN during that period focused on a determined effort to defeat the GVN pacification program.¹ A document captured in 1971 admitted that the loss of the rural area would eventually make it impossible for the Communists to gain victory.²

To confront the enemy and compete with him in the rural area, the GVN first sought to place all villages and hamlets across the country under military control. In addition to protecting the population, the GVN also strived to regiment it into organizations and arm its able-bodied members. The goal was to turn villages and hamlets into centers of resistance against the enemy and to make him feel unsafe wherever he went. Once this was done, development could take place with more chance of success. Regional and Popular Forces (RF and PF) and People's Self-Defense Forces (PSDF) were employed to defend and protect their own villages. The tactic was based on a guerrilla warfare precept: if the enemy force was small, destroy it; if it was sizeable, harass and pin

¹COSVN: Central Office South Vietnam; the Communist Headquarters located near the Cambodian border north of Saigon.

²Enemy document captured in 1971 and confirmed by J-2, JGS.

it down, or withdraw to conserve force and call for regular reinforcements to destroy it. ARVN regular units, meanwhile, would concentrate on attacking and destroying the enemy's logistical bases and his main force units, thus denying him the chance to rest, recuperate, or reorganize.

To help advance the democratic process and to expand national authority, the governmental structure was to be consolidated and made to function effectively. All basic institutions of the regime were to be founded on popular vote, and the government was to assist the people and to respond to their aspirations. National laws were to be enforced so as to eliminate village tyrants who repressed and exploited the people.

For the success of the pacification effort, the GVN deemed it important to improve the welfare of the entire population. In its view, pacification would not be complete if it did not lay the foundation for economic development and social betterment. As a result, several programs related to pacification such as land reform, farm credit, and farmers' associations were implemented on a large scale in conjunction with the military and political efforts. Through these programs, the GVN eventually turned farm tenants and farm workers into land owners and eradicated the abominable land rent system. At the same time, it created conditions for agricultural development by teaching farmers modern techniques, making available seeds, fertilizers, insecticides and encouraging the breeding of farm animals and the planting of supplementary crops. The economic element of pacification also included opening roads and waterways and maintaining lines of communication which were vital to economic and military progress.

In health and education, the effort concentrated on eliminating illiteracy, making primary and secondary education available to the rural population, providing free medical care and improving sanitation. Such programs as the construction of classrooms, dispensaries, maternity wards, and the recruiting and training of teachers, nurses, technicians, were undertaken as pacification progressed.

In conclusion, in place of the social disruption caused by deliberate sabotage by the Communists, the government and people of South Vietnam were determined, with the assistance provided by the United States and the Free World, to transform South Vietnam into an anti-Communist outpost of the Free World, to heal the social ills inherited from colonialism and feudalism, and to make their country prosperous.

The efforts of the GVN in pacification could be summed up by the three national goals that pacification sought to achieve, namely:

- (1) to end the war, which implied eliminating Viet Cong infrastructure (VCI), defeating invasion forces and maintaining security;
- (2) to develop democracy, which implied the establishment of elective government and democratic institutions and enlisting the participation of the people in national life;
- and (3) to reform society by eliminating injustice and social vices, and providing every citizen equal opportunities for advancement and equal protection under the law.

CHAPTER II

Pacification Strategy and Objectives

The Enemy Threat

The war was first waged under the cover of a popular uprising against the South Vietnamese government and not as an outright invasion. The Communists created the National Liberation Front (NLF) on 20 December 1960 to give the war a political cover. The NLF was in fact just what its name conveyed, a front. The actual authority for conducting the war in South Vietnam remained in the hands of the Politbureau in Hanoi which directed the war in the South through five major commands: the B5 Front was responsible for the DMZ area, Military Region Tri Thien Hue (MRTTH) for the provinces of Quang Tri and Thua Thien, Military Region 5 for the coastal provinces from Quang Nam in the north through Khanh Hoa in the south, B3 Front generally for the highland area in western GVN MR-2, and COSVN, the Central Office for South Vietnam. COSVN was responsible for South Vietnam's southern half, a geographical area corresponding to GVN MR-3, MR-4 and the southern part of MR-2 of the Republic of Vietnam.

The conflict, according to the Communists, was a "people's war," a war waged by all the people in all aspects: military, political, economic, social, cultural, etc. The enemy used the same strategy it used with success during the First Indochina war, 1949-1954, a three-phased strategy adapted from Mao Tse Tung's theory of protracted war, which was supposed to progress from strategic defensive to strategic offensive. Guerrilla warfare was the form during the first phase. Its purpose was to harass and wear down the opponent. The second phase involved the beginning of mobile warfare and consisted of attacks against enemy fortifications with the purpose of attriting the enemy's

military potential and driving him into a strategic defense. The final phase was an all-out offensive employing mobile warfare combined with fortification warfare, aimed at complete destruction of enemy forces.

Communist forces in South Vietnam consisted of three principal components: (1) the infrastructure (political and support) and guerrillas; (2) regional forces; and (3) regular or main forces. There were two types of guerrillas: the para-military and the full military or unattached. Guerrilla activities were generally localized and consisted of sabotage, assassination, harassment, which were aimed at sowing confusion, terror and loss of confidence among the population and forcing the RVN forces to spread thin and lose mobility. Guerrillas also constituted a source of manpower for regional forces whose scope of activities was more extensive and whose combat effectiveness and armament were better. Regional forces were generally employed in a supporting role when regular forces were committed and they both used the tactics of mobile warfare.

Guerrillas were organized into squads and platoons while regional forces consisted of battalions and regiments. Regular forces were initially of battalion or regimental size but were gradually upgraded into divisions and finally army corps.

By 1959, when the enemy began to rekindle war activities in South Vietnam, Communist forces consisted primarily of Viet Cong elements or South Vietnamese Communists. Their cadre were mainly former Viet Minh elements regrouped to North Vietnam in 1954 but re-introduced into the South after 1959. In 1962, however, North Vietnam began to infiltrate men into the South to help the Viet Cong build up its multi-level military force and also as replacements for increasing losses. By 1964, entire NVA regiments were introduced into the South and after US combat forces entered the war a year later, division-size NVA units were recorded fighting on southern battlefields. The infiltration of NVA men and units, together with combat and logistic support assets continued unabated despite heavy US bombardments. During this period, intelligence reports indicated a constant movement of NVA divisions in and out of South Vietnam. At the time of the 1972 invasion, there were

14 NVA infantry divisions committed to three main fronts in South Vietnam, supported by one sapper division, one artillery division and one AAA division. These forces remained in the South until the cease-fire in January 1973 and constituted a permanent military threat for the RVN. By this time, 90% of Communist combat units in South Vietnam were NVA and only one-third of total Communist strength were Viet Cong.

The enemy infrastructure which existed in South Vietnam from the beginning of the war did not cause grave concern to the GVN until 1967 when its role became prominent in combat support. Despite heavy losses incurred by enemy main force units, this infrastructure continued its activities such as tax collection, supply, recruitment, etc., even in the areas adjacent to cities and US and RVNAF bases. The war in Vietnam was being fought on two levels: the conspicuous, violent, high level of combat against Communist armed forces, and the silent, ubiquitous low-key but no less deadly struggle against the enemy infrastructure.

The elimination of the VCI proved to be a task much more difficult than the destruction of enemy combat units because of its cellular, well-dispersed and well-concealed organization. The VCI was in fact so well woven into the South Vietnamese social fabric that it was almost invulnerable to detection. Even if one VCI cell was discovered, it would be difficult to trace it to others because of airtight compartmentalization.

System Evolution

Under the First Republic (1955-1963), the concept of strategic hamlets took shape in a piecemeal manner in some localities during 1961. It was subsequently expanded and developed into a cohesive, nation-wide system.

In the beginning, some local authorities merely duplicated the village defense system as it had been employed with success against the Viet Minh in Bui Chu and Phat Diem, the two oldest Roman Catholic diocesan areas in North Vietnam. In Ninh Thuan province, for example, Lieutenant Colonel Khanh, the province chief, initiated a village defense

program by encouraging villagers to plant a special kind of cactus around their village. Growing rapidly to over a meter in height, the spiny and thorn-bristled cactus hedge formed a difficult barrier which discouraged enemy infiltrators from penetrating the village. Male and female youths were tasked for security and guard duties, using rudimentary weapons such as pointed sticks, lances and spears.

In Darlac Province, Trung Hoa village was fashioned into a North Vietnam-type village by Father Hoa, a Catholic priest of Chinese origin who fled North Vietnam in 1954. Father Hoa had brought with him a large number of Nung people, a North Vietnamese ethnic group, whom he helped resettle in the village.¹ The Nung resettlement area soon became a tightly stockaded village whose defense enclosure of wooden stakes was reinforced by a system of camouflaged trap holes lined with poison-soaked spikes. The poison would cause hard-to-heal and sometimes fatal infections. For the defense against Viet Cong attacks, villagers were armed with crossbows and arrows, lances and spears in addition to a few obsolete rifles.

Despite crude weapons, the defense of the two villages was effective. This success inspired the Vinh Long province chief, Lieutenant Colonel Le Van Phuoc, to establish self-defense systems in a number of villages located along National Route QL-4, patterned after Ninh Thuan and Trung Hoa. Although experimental, these village defense systems proved successful counters to guerrilla activities.

In order to develop a village defense system for the entire country, Counselor Ngo Dinh Nhu developed the concept of Strategic Hamlets.² This concept was an amalgamation of ideas derived from Vietnamese self-defense villages, British anti-Communist tactics successfully used in Malaya, and the Israeli Kibbutz defense system. By 1961, Mr. Nhu's concept developed into a cohesive national policy and its ensuing Strategic Hamlet program, which he himself directed, was initiated on a nation-wide basis. Designed

¹Another important Nung resettlement area was established at Nam Can, a district of An Xuyen Province in the Mekong Delta.

²Mr. Ngo Dinh Nhu was the younger brother of President Ngo Dinh Diem. In addition to his official position as Political Adviser to the President, he was also the founder of the Can Lao Party.

to transform villages and hamlets into anti-guerrilla bastions, the basic idea was to oppose the Communists with a ubiquitous resistance and defense system whose "main and long frontline" was the villages and hamlets themselves. With each village and hamlet fortified and armed, the enemy would find it very difficult to select a weak point to attack. He would find strong resistance everywhere.

According to Mr. Nhu, the enemy enjoyed the advantage of fighting a frontless war. To offset that advantage, he said, we had to turn the rural areas into a "crisscrossed line of defense." The regular army would not be able to spread its troops over this line anyway, so there was no need to greatly expand it. Instead, the army would be kept at a reasonable size and improved in combat effectiveness; it would concentrate primarily on enemy base areas and main force units. The people would become the primary force in the fight against enemy guerrillas. Toward that end, they would organize the defense of villages and hamlets by themselves and fight the enemy by employing "people's guerrilla tactics."

The Strategic Hamlet program progressed slowly but proved effective enough in the face of an insurgency still in its embryonic stage. The slow progress could be attributed to the fact that the program did not enjoy such large-scale US support as its successor later did. It was partly funded by the national budget and partly by the Military Assistance Program. Despite this, by the end of 1962 statistics showed that out of a total of 11,864 hamlets, 3,235 had been completed and about 34% of the total population was considered as living under the GVN protection.³

³A Strategic Hamlet was considered completed when it met the following criteria:

- a. The enemy infrastructure had been neutralized.
- b. The population had been organized for hamlet defense.
- c. The defense system (barrier, moat, trenches, traps, etc.) had been physically established.
- d. Secret underground shelters for weapons and personnel had been constructed for the hamlet defense force.
- e. The hamlet council and administrative body had been elected and functioning.

The population of South Vietnam in 1961 was estimated at 14 million.

The percentage of population under GVN control was computed on the basis of reports submitted through the administrative hierarchy, from village to district to province, and from province to the central government. This reporting procedure was not as accurate as the Hamlet Evaluation System (HES) which the US later initiated in 1967. There was the possibility that Viet Cong infrastructure members were among the population recorded as living in GVN-controlled hamlets.

To ensure tight population control, some local governments adopted stringent measures such as a census file for every household, containing not only names and other particulars of its members but also a group photograph showing every member of the household. Those households having members or relatives who had regrouped to North Vietnam or were active Viet Cong were identified by red dots, one dot for each such member, painted on a pillar in front of the house. Blue dots were used for other members of the household. Thus, at a glance, local government officials could tell which households had members cooperating with the other side. Naturally, these households were subject to discreet surveillance by the local government.

In 1963, several political upheavals slowed the accomplishment of the objectives of the Strategic Hamlet program and eventually terminated it altogether, but until that year the program was achieving considerable success in neutralizing the local VCI and in organizing effective local defenses. The Buddhist opposition movement in 1963 led to a military coup which overthrew the Ngo Dinh Diem regime and ushered in a period of turmoil and instability. At the same time, the military situation deteriorated markedly through the escalation of attacks by the Viet Cong. The Strategic Hamlet program, as a consequence, came to a complete stop. Those cadre who had managed and directed the program were either arrested or removed for having been part of the old regime. The few cadre who remained free dissassociated themselves from the program. Soon after the military junta took over, its president officially announced the abolition of the Strategic

Hamlet program in a proclamation that was widely acclaimed by the public and secretly enjoyed by the enemy. In some localities, the gains achieved through two years of hard toil disintegrated almost overnight. The Military Revolutionary Council had acted out of political necessity but had not foreseen the detrimental consequences.

The countryside was once again left without governmental control, and the enemy at once filled this void with his own apparatus. During the months immediately following the overthrow of President Diem, the overall situation became utterly chaotic with coups and countercoups, power struggles, and an increased level of enemy attacks.

In the face of the deteriorating situation, the GVN was in a dilemma. On the one hand, there was no way to reinstate the Strategic Hamlet program since it had been linked with the old regime and officially abolished. On the other hand, the GVN could not give the enemy free reign over the countryside. As a solution, the government instituted a new pacification program, the "New Life Hamlet" program. As a matter of fact, there was nothing that could distinguish this program from its predecessor, only a change in name.

The New Life program began to move unsteadily forward. At first it was a loosely controlled, hesitant, unenthusiastic effort. There were not enough resources to commit to the program, and the new cadre were reluctant to implement it forcefully for fear of being identified with the old regime cadre. Furthermore, the leadership gave it no clear-cut direction and the organizations that were to operate the program were plagued by ineffectiveness and incompetence. Very few local authorities knew exactly what to do or how to do it.

The year 1965 came as a miracle that saved South Vietnam from probable collapse. US combat troops followed by Free World Military Assistance forces were committed to South Vietnam to ward off an imminent Communist victory and the US poured in material resources to help

the RVN regain its military footing. After initial successes that restored stability and maintained a fair military balance, both the US and the RVN governments could turn their attention to pacification.

Based on lessons learned through the Strategic Hamlet and the New Life Hamlet, the GVN initiated the Rural Development program in 1966. This was followed, in 1967, by the so-called New Model Pacification program. To give a good start to this effort, centralized planning was initiated but there was a clear lack of coordination between the military plan and its civilian counterpart. As a result, the organizational structure for operational control was not effective and there was little mutual support between the military and the civilian efforts. Moreover, there was a shortage of cadre at all levels and the training effort failed to turn them out in sufficient numbers. The ARVN, meanwhile, considered pacification a responsibility of the civilians; it claimed to have no part in it since its mission was to conduct mobile operations to destroy the enemy. During this period, the Regional and Popular Forces were still in their nascent stage; they were not yet capable of taking up the pacification responsibilities. In order to provide effective support for the pacification program, the RF and PF (formerly Civil Guard and People's Militia or Self-Defense Corps, respectively) required expansion, reorganization and more intensive training.

Despite all these constraints, the pacification program seemed to be well on its way to progress. Its chances of success, however, were undermined by the enemy's general offensive in 1968. All the forces that had been committed to the pacification program, regular and territorial alike, had to be redeployed for the defense of provincial capitals and district towns. The countryside was once again left open to enemy control.

After successively defeating the enemy's attack in 1968, the GVN and RVNAF followed up their victories by initiating a three-month pacification plan called the "Accelerated Pacification Campaign," from November 1968 to January 1969. The campaign was designed to enlarge the extent of GVN control, and this was a most appropriate time for

the special pacification effort to succeed since enemy forces had by then withdrawn to their border base areas for refitting and reorganizing. The RVNAF, with the support of the US and all other allied troops, enjoyed the initiative on all battlefields. As a result, the pacification effort was crowned with success.

In 1969 and 1970, pacification progressed by leaps and bounds. The total number of people and the extent of territory under GVN control surpassed all expectations. The enemy was effectively driven back to his bases over the border, and his units were unable to undertake any major action, preoccupied as they were with refitting and regrouping. Pursuing their military gains, the RVNAF took the initiative and struck across the border, first into enemy bases in Cambodia in 1970 and then into lower Laos. As a result, during 1971 the GVN had time to consolidate the gains achieved during the two previous years without major confrontations with enemy main-force units. In view of the markedly improved situation, the GVN found it appropriate to choose another name for its pacification effort. From 1971 on it was called "Community Defense and Development," the ultimate goal for which the GVN was striving.

During this period, the enemy studied the lessons learned from his military defeat in 1968. Meanwhile, in view of the remarkable gains achieved by the GVN in its pacification program, the enemy was in danger of being denied the countryside altogether.

In 1972, the Communists launched a new general offensive, an offensive which was radically different from the 1968 Tet offensive. Supported by tanks and artillery, nearly five NVA infantry divisions crossed the DMZ and invaded Quang Tri. Simultaneously, three divisions attacked north of Kontum and three others north of Binh Long. This offensive was aimed at forcing a coalition government on South Vietnam, defeating the Vietnamization program so that the RVNAF would be unable to take over the combat role from US forces, and finally, forcing the RVN to accept terms advantageous to the Communist side at the Paris talks. The GVN and the RVNAF were determined to defend the countryside at all costs, and the RVNAF had, by this time, improved and

matured into a formidable fighting force. Furthermore, despite the gradual withdrawal of US combat forces from Vietnam, there still remained in country sizable US strategic and tactical air, naval firepower, and logistical support to assist the RVNAF.

With effective US support, the RVNAF were able to hold out against the greatly reinforced regular NVA forces and prevent further inroads into the countryside. Following these military achievements, the GVN concentrated on consolidating the pacification gains instead of pushing for further expansion. Rather than renewing another annual effort, the government looked farther ahead and developed a four-year pacification plan. This was known as "1972-1975 Community Defense and Local Development" plan which was designed, as the name implied, to consolidate territorial security on the one hand and to develop the nation in all aspects on the other.

No sooner had the plan been implemented than it was obstructed by the disadvantages brought about by the Paris Agreement of 28 January 1973. Taking advantage of the Agreement, the enemy increased his strength in the countryside through infiltrations of weapons, equipment, and manpower from North Vietnam.

Thus over the long war years, the pacification effort had been revitalized time and again under several different names: Strategic Hamlet, New Life Hamlet, Rural or Revolutionary Development, National Pacification and Development, and finally Community Defense and Local Development. Despite the various names which changed with each regime in power, the basic national objectives laid out in each plan remained essentially the same. The only differences between early and later plans were some operational procedures, the ever-expanding scale and extent of the effort, and the increasing contributions in financial and material resources made by the United States and other friendly nations.

Strategy and Operational Concept

Pacification was designed to achieve three basic objectives: (1) to end the war and restore peace; (2) to develop democracy; and (3) to reform society. These were the proclaimed objectives that President Nguyen Van Thieu reiterated time and again in his public statements.

To achieve the first objective—end the war and restore peace—it was paramount in the first place to defeat Communist aggression and to provide security for the entire national territory, and finally to extend the influences and services of the government over the population. In more concrete terms, the objective was to provide protection for the people against kidnappings, assassinations, and other forms of terrorism caused by Communist guerrilla activities; to destroy the enemy main force; and to eliminate the enemy infrastructure. Once the enemy's presence was removed, the people would be able to enjoy a peaceful life.

The second objective—develop democracy—implied the establishment of a solid and effective governmental structure in the rural areas and the active participation of the rural population in national affairs. Democracy was to be developed at the grass-roots level through village and hamlet elections in which the people would choose their own representatives to help run their own affairs.

Finally, in order to reform society, the third objective, it would be necessary to develop the national economy, to stabilize and improve rural living conditions and to bring about prosperity and welfare for the people, with the ultimate goal of achieving self-sufficiency and terminating reliance on foreign aid.

To provide security for pacification, the RVNAF and US forces adopted the strategic concept of "clear-and-hold." In practice, clear-and-hold operations were designed to destroy the enemy, neutralize his forces, and drive them away from the area to be pacified. Then by maintaining a permanent ARVN force in the area to ensure security, a local government could be established, and in time elections could be held to institute democracy. When the area reached that stage of development,

the enemy would be unable to return to harass and to take revenge on the people.

"Clear-and-hold" differed greatly from "search-and-destroy" which was widely employed during the initial stage of active US participation in the war. For even when Communist units had been effectively defeated or driven away from a certain area, they were still able to return and renew their activities if there was no friendly force to secure the area. An area was considered "cleared" when the enemy's main or local forces, guerrilla and infrastructure had been destroyed or neutralized. The principal role in this stage was given to major ARVN units, augmented sometimes by Regional Forces, and often supported and assisted by US or Free World Military Assistance (FWMA) forces. ARVN forces were also assisted by National Police (NP) forces who provided information concerning the enemy's infrastructure and helped screen and interrogate persons detained.

As the term implied, activities during the "securing" stage were aimed at eliminating remnants of enemy forces or infrastructure, protecting the population and preventing the enemy from reviving his activities. At the same time, the government tried to establish its presence in villages and hamlets in order to create the conditions for developmental projects to flourish. An area was designated totally secure when the villages and hamlets in it were assigned enough military and police forces to deter all terrorist activities directed against the population. Police field forces were employed in the elimination of the VCI or, in coordination with territorial forces, the maintenance of security in villages and hamlets. ARVN and US forces meanwhile operated in adjacent areas as a shield to divert the enemy's regular forces from the area being pacified, and to relieve any pressure the enemy might exert on it. As soon as the area became secure, Regional Forces began to take over from ARVN forces, thus releasing them for new operations.

Another type of local defense force was created to assist territorial forces in local security: the People's Self-Defense Force.

Organized and trained locally, the PSDF performed guard duties in hamlets and sounded the alert when the enemy attacked but were usually unable to counter an enemy attack without the support of other territorial or regular forces.

As a continuation of the pacification process, the "development" stage consolidated the village and hamlet governmental structure and expanded GVN authority and prestige. An area was considered as developed when its villages and hamlets had been completely and effectively brought under GVN control and after local government had been established through elections and was functioning effectively. Thereafter, security and order were entrusted to police and people's self-defense forces. Regional and popular forces were thus released for longer range security operations to prevent the enemy from re-infiltrating. During this stage, national cadre teams arrived to initiate developmental programs such as self-help economic projects, school and classroom building, and public health.

In summary, pacification was a phased process involving the cooperation and coordination of both military and civilian efforts. The military effort was provided by the RVNAF and US/FWMA forces who conducted search-and-destroy operations in order to foster the security which the civilian effort required. As pacification was a responsibility shared by military forces, government cadre and the people, joint planning and supervision were required at every level. To achieve effectiveness in coordination, control, and supervision, a Pacification Council, which consisted of military and civilian representatives, was established at each level, from the central government down to districts.

The Central Pacification Council, which was chaired in 1970 by the Prime Minister and consisted of cabinet ministers and the Chairman of the Joint General Staff as members, directed and controlled overall policies and plans. Civilian programs were managed and directed by the Ministry of Rural Development which also supervised implementation at province and district level.⁴ Other specialized activities were directed

⁴In 1971, the Ministry of Rural Development was disbanded and its role was assumed by the newly created Central Pacification and Development Center, directly under control of the Prime Minister.

by respective ministries through their own control channels, which reached down to province level. Military activities were directed and supervised through the military hierarchy which included the Ministry of Defense, the Joint General Staff, Military Region Commands, Sectors (provinces), and Subsectors (districts).

Pacification Councils at the province level were responsible for detailed planning and execution. Each year, the province chief and his staff established the province's pacification plan which was reviewed by the Military Region Pacification Council and finally approved by the Central Pacification Council. Upon approval, the plan was sent back to the province chief for execution. Military forces that were required to support the provincial plan were placed under the operational control of the province chief/sector commander. Funds, materiel and equipment were allocated by respective ministries directly to the province.

Interim Objectives and Priorities

While the ultimate national goals to be achieved through pacification remained unchanged, the GVN established yearly programs with specific objectives to be met during the year. For example, the pacification effort prior to 1968 focused on populated, prosperous urban areas, those areas bordering on important lines of communication and waterways, and those villages and hamlets surrounding provincial capitals and district towns. The strategic concept then, which was labeled "the spreading oil stain," consisted of consolidating pacified nuclei from which the pacification effort would spread out in all directions. Since urban areas were the hubs of the RVN strategy, the enemy chose to strike directly into them during his general offensive of 1968 although his ultimate goal remained liberating the rural areas.

As soon as the last enemy attacks were driven back, the GVN immediately set about to restore control of the rural areas through a special, large-scale, and intensive pacification campaign which lasted three months, from 1 November 1968 to 31 January 1969. The goal of this campaign was to retake the hamlets lost to the enemy and to expand the

territory under GVN control. This was a departure from the 1968 pacification effort which concentrated on populated areas and urban centers.

The Special Campaign was designed to achieve these major objectives:

(1) to expand the territory under GVN control; (2) to destroy the enemy infrastructure; (3) to organize and arm the Peoples' Self-Defense Forces; (4) to establish the local governmental structure wherever it had never been established.

As a result of the achievements of the Special Campaign, the pacification effort was pushed more vigorously during 1969. Under GVN directives, those provinces that met all the objectives of the campaign were to continue adding to the areas under GVN control and consolidating their gains. On the other hand, if a province had not met the objectives, it was required to achieve them before proceeding with the 1969 plan. In addition, to ensure the maintainance and consolidation of these gains, new directives were issued by the GVN for the new campaign:

1. The pacification effort had to be closely coordinated with the development effort.

2. The pacification and development effort was to focus on the village rather than on the hamlet since the village was the basic administratively organized unit which controlled resources and had a budget of its own.

3. Pacification and development were continuing, protracted processes involving many agencies, hence effective coordination was necessary. In addition, it was most important to enlist the people's participation. To foster this participation, there had to be close cooperation and coordination between government authorities and the population, among governmental agencies, and among the people.

4. The policies and programs were to be realistic and befitting the local situation. They were to be kept simple to facilitate understanding and execution and to be tailored to the people's needs and capabilities so that the people could responsibly contribute to the common national effort.

Since the 1969 pacification concept focused on expanding governmental control into contested areas and on the village as the basic

unit instead of the hamlet, the displacement of the local populace from one hamlet to another for purpose of pacification was deemed unnecessary and disadvantageous. Displacement of landbound peasants would be an unpopular act that would have adverse consequences on their daily life.

To implement this overall concept, the GVN laid out objectives to be achieved by year's end:

1. An increase in percentage of population under GVN control, up to 90% across the country.
2. To destroy, by all means, at least 23,400 enemy infrastructure cadre.
3. To build the PSDF to a strength of two million members, and equip this force with 400,000 individual weapons.
4. To establish local governments for all villages and hamlets over the entire national territory.
5. To secure the defection of at least 36,000 enemy cadre and troops.
6. To reduce the total number of war victims and refugees below the one-million mark; and to resettle or return to their home villages 300,000 people.
7. To step up information and propaganda activities.
8. To encourage the development of the rural economy.

All the objectives that had been set forth for the previous year were retained in 1970. Like the previous year, the 1970 pacification objectives focused primarily on the protection of the population against Communist terrorism and the maximum destruction of the enemy infrastructure. To achieve this, the GVN pushed the buildup of PSDF to four million, double the 1969 strength and including 1,500,000 combat members and 2,500,000 support members. At the same time, it made an effort to train and equip this force in order to turn it into a combat effective force ready to take over from popular forces when required. To expand GVN control, it was required that village and hamlet government and district and provincial councils be established throughout the country. The Chieu Hoi program, meanwhile, was aimed at the high and middle echelon enemy cadre: it appealed for their cooperation in the common

task of nation building. To alleviate a perennial burden that had adversely affected the GVN effort, programs were initiated to help war victims and refugees find opportunities for a better life. Other short-term projects designed to pave the way for long-range efforts during the following years were also initiated in agriculture, public health and sanitation, and education. In addition, emphasis was placed on such programs as increasing the rural police force, village and hamlet self-help, land reform, ethnic minority development, and urban development.

The government set forth priorities for the achievement of the various objectives and their related programs:

Priority 1: C-class hamlets were to be upgraded to B- or A- class in order to provide total security and protection to 90% of the national population.⁵

To meet this goal, the government attempted to bring the popular forces up to full authorized strength. At the same time, people's self-defense forces, armed or unarmed, were more formally organized and received more adequate training. Since the incipient local governments were still plagued by a shortage of cadre, efforts were made to assign them additional personnel. An emphasis was placed on their qualifications, efficiency, and willingness to stay permanently in their place of work, day or night. Finally, an adequate and permanent police force was required to maintain security and order in villages and hamlets.

Priority 2: To consolidate C-class hamlets and prevent them from downgrading to D-class.⁶

⁵ Before the advent of the Hamlet Evaluation System (HES), which American officials instituted in 1967, the GVN only considered three categories of hamlets and rated them accordingly: A: 100% secure hamlets or hamlets affording free access day and night; B: semi-secure hamlets, affording free access during daytime and limited access during night time; C: insecure hamlets or those under VC control.

⁶ Hamlets were classified into seven classes:

- A- and B-classes: totally secure, day and night
- C-class: relatively secure
- D- and E-classes: undergoing pacification
- N-class: unevaluated for lack of data
- V-class: not under GVN control

In summary, all hamlets were to be upgraded to A, B, or C category and at least 90% of the people would be living in A or B hamlets.

The Ultimate National Goals

The year 1971 ushered in a period of improved security throughout the nation. The RVNAF held the initiative on all battlefields, crossed the heretofore inviolable national border and struck destructive blows on the enemy's logistical bases and sanctuaries. Cross-border operations conducted by US-RVNAF units into Cambodia in 1970 and the Laos incursion in 1971, in addition to the closing of Sihanoukville port by the new Cambodian government in 1970, effectively upset Communist plans for an early summer offensive against Saigon, a repetition of their 1968 offensive. As a result, the Communists were compelled to reorganize their bases and replace their battle losses. Almost the entire population of South Vietnam lived under effective protection of the government and the armed forces. The situation was so good that the GVN deemed it a most appropriate time to pass on to the nation-building phase, particularly economic development and social reform. Pacification was considered an anachronistic term since its most important objective had been achieved.

The new pacification plan for 1971 was thus redesignated "Community Defense and Development." It was designed to destroy whatever was left of the enemy infrastructure, achieve maximum efficiency in the governmental structure, expand and develop the national economy, and push ahead more vigorously the land reform program. The ARVN regular forces, which had been partially pinned down by their pacification duties, were to turn over territorial responsibilities to the RF and PF. The goal was to release ARVN forces for mobile operations while affording the RF and PF the opportunity to prove themselves in combating enemy local forces and guerrillas.

The objectives set forth for the 1971 Community Defense and Development plan were grouped under three basic national goals which remained the ultimate goals for which the RVN was striving. These were called the "Three Selves," namely: Self-Defense, Self-Management, and Self-Sufficiency.

Under the goal of Self-Defense, five programs were initiated: (1) territorial security; (2) people's self-defense forces; (3) national police; (4) destruction of the enemy infrastructure; and (5) Chieu Hoi (Open Arms).

The objectives to be met in territorial security during 1971 were to upgrade all hamlets into A- or B-class, provide security and protection for 95% of the total population, and remove all V-class hamlets. These efforts required the RF and PF to step up mobile operations against enemy local forces while the ARVN infantry divisions were to be entirely free to concentrate on large-scale search-and-destroy operations against enemy mainforce units.

The PSDF which had been built up to required strength were to be formally organized into teams and groups and armed with 500,000 individual weapons.

The national police force, whose primary role was to destroy the enemy infrastructure, was to be increased to 122,000 men by year's end in order to provide every village with a police force strong enough to maintain law and order.

To free the local population from Communist terrorism and safeguard the GVN program against sabotage, an effort was to be made to eliminate all types of enemy cadre, to include econo-financial cadre (tax collectors or procurement agents) and commo-liaison cadre (guides or messengers) in particular, and to destroy every enemy infrastructure organization. In addition, the local population was encouraged to cooperate with governmental authorities by providing information concerning enemy activities.

The task of appealing for returnees from enemy ranks was not only undertaken by specialized government cadre but was also performed by PSDF by appealing to their own relatives or friends who had sided with the enemy. In addition, armed propaganda teams, which consisted primarily of former returnees, were employed in proselyting activities aimed at enemy main force units.

The Self-Management goal meant that the government would increase its efficiency. In the first place, national cadre at all levels including province, district, village and hamlet chiefs, were to be trained.

Periodic seminars were to be conducted by mobile training teams to afford the national cadre an opportunity to exchange views and communicate experiences. Furthermore, the government hoped that by the end of 1971 the entire local government structure would have been instituted through elections.

With regard to the local population, an effort was made to instill in them the spirit and political awareness of struggling against the Communists. This was conceived as an obligation, a duty that every citizen had to carry as his share toward the "Three Selves" program. To foster the spirit of democracy and encourage participation, local self-help development projects were initiated to which the GVN provided part of the funds needed but whose implementation relied primarily on the people's financial contributions and labor. The local population actively participated in such projects as market place, school and maternity ward construction, road building and bridge repair. The final goal was to make every cadre and every serviceman thoroughly conversant with GVN policies and programs and responsive to the aspirations of the people by acting as eyes and ears for the central government. The local population was to be rallied into organizations with the purpose of fostering mutual assistance and mutual affection. If someone became ill or was in distress, he could always expect help and comfort from members of his organization. With regard to youths, a program of physical education and sports was initiated in both urban and rural areas in order to encourage physical fitness and competitiveness. This program was also intended to promote political education among young people with the view of preparing them for active participation in future social activities.

Improved security and increased effectiveness of the local government structure and national cadre would allow the GVN to switch more energy to self-sufficiency, the task of improving, socially and economically, the living conditions of the population. Toward that end, the "Land to the Tiller" program, a bold land reform measure which was initiated late in 1970, had the planned purpose of distributing 400,000

hectares of farmland to landless farm workers.⁷ This was intended both as an incentive to help boost farm production and as a means to achieve social justice and win the peasants over to the RVN cause. Other agricultural improvement programs such as forestry, fisheries, and farm breeding were also pushed vigorously forward. At the same time, the GVN also undertook an extensive project of irrigation, encouraged the planting of two or three crops of "miracle rice," and established rural development banks throughout the country to provide needed credit for farmers to plant rice or other supplementary crops and to breed cattle or poultry.

With regard to strengthening the national economy and in keeping with long-range plans, the GVN designed short-term programs to encourage production increase, stem inflation, stabilize consumer prices, and increase personal income. To meet national requirements and conserve manpower, the government placed emphasis on the training, assignment, and employment of technicians and specialists. ARVN engineers and contractors repaired, rebuilt or rehabilitated roads and bridges to provide convenient communication between urban and rural areas, particularly between villages or hamlets and district towns, and to facilitate the flow of goods and services. Also in support of economic development, sections of the railroad system were kept in operation and electric power production was substantially increased in urban and suburban areas. This was a step toward the final goal of providing electricity and running water to remote areas of the countryside.

Up to 1971, all local self-help or self-sufficiency programs were entirely funded and managed by the central government. To set democracy in motion and to help the local infrastructure develop its own initiatives, these programs were turned over to the local governments and people who would, from then on, decide what specific projects suited their own needs and decide how to finance them on their own. The GVN would thus be able to save sizable funds needed for other programs of national importance.

⁷Hectare is a unit of area measurement in the metric system, equivalent to 10,000 square meters or approximately 2.47 acres.

In 1972, the GVN took a longer view of the future and, to achieve the ultimate national goals, initiated a four-year Community Defense and Local Development plan whose implementation was graduated into yearly programs to be completed by 1975. The plan provided comprehensive guidance for the national efforts in each of the major areas.

Militarily, the GVN contemplated the reduction of its armed forces. The maintenance of a large, standing military force depended essentially on the security status, US aid, and existing national resources and capabilities. If it was possible to reduce strength without endangering or undermining the capabilities to defend the nation against the enemy within or without, then this would be done. But most importantly, for future defense purposes, attempts should be made to create a "peoples' army," if only to alleviate the financial burden presently imposed on the national budget. Territorial security could be further improved by military activities directed toward destroying enemy main force units, enemy base areas and sanctuaries, and eradicating enemy local guerrillas and infrastructure.

Politically, the goal was to achieve a solid foundation for democracy. Toward that end, the administrative structure at every level would be made efficient, and the people would be educated to become fully aware of their civic duties. When this was done, they would enthusiastically participate in every national activity. To improve the administration, work procedures would be simplified to the maximum extent and the national cadre at all levels would be endowed with a responsible "public service" spirit in addition to professional qualifications.

Economically, it was possible to increase domestic and foreign investments as the security situation improved. Production and exports would be boosted in order to earn additional foreign currency and to reduce inflation. On the other hand, to compete with foreign products and also to meet domestic demands, agriculture and industry would be expanded and made increasingly productive. Personal income taxes would be gradually increased, not only to boost national income but also to make citizens fully cognizant of their obligation with regard to the

national development effort. Although consumer prices would continue to rise at an annual rate of 10%, efforts were made to cut down on government expenditures, including national defense. In any case, for its own survival, South Vietnam would have to rely on continued US economic and financial aid, even if true peace was restored.

In summary, the 1972-1975 Community Defense and Local Development plan was designed to consolidate security and increase development efforts in local communities with the view of achieving the three basic goals of Self-Defense, Self-Management and Self-Sufficiency.

The war the Communists waged was purported to be a people's war. This was a myth perpetuated by Communist dogmatism and propaganda. The part played by the South Vietnamese people in prosecuting the war on the Communist side was minimal and insignificant. In fact, the South Vietnamese people always chose to flee in the face of Communist incursions.

Winning support, the strategic goal of pacification was paramount to the RVN cause. Yet the people seemed indifferent to the GVN courtship. If successful, the pacification effort would replace this indifference with a solid commitment on the part of the people; a commitment that would support the defense of the nation and achieve a just peace.

CHAPTER III

Operation and Support

The GVN Organization For Pacification

Beginning in 1966, when pacification became a cohesively organized effort and was subjected to centralized annual planning, the GVN established a nation-wide control and monitoring system designed to coordinate activities of the various organizations and agencies involved in the program. As far as the civilian government was concerned, there was always a shortage of qualified personnel required for key executive positions. Consequently, several high-ranking military officers were appointed cabinet ministers or to highly responsible positions in the pacification program.

In 1966 the GVN organization for pacification consisted essentially of a system of standing committees spanning the entire governmental hierarchy and reaching down to the district level. At the central government level, there was established a Central Rural (or Revolutionary) Development Council chaired by the Prime Minister. (*Chart 1*) Members of the Council included, on the civilian side: the Ministers of Interior, Land Reform, Public Works, Health, Social Welfare, Open Arms, Ethnic Minorities, the Minister in charge of the Prime Minister's Office, and the under-secretaries of Education and Youth. On the military side, there were: the Minister of Defense, the Chairman of the Joint General Staff and the four Corps Commanders who participated in the Council as Government Delegates (or Regional Governors). The Minister of Rural Development was appointed Secretary General of the Council. (*Chart 2*)

Chart 1 – Central Revolutionary Development Council, 1968

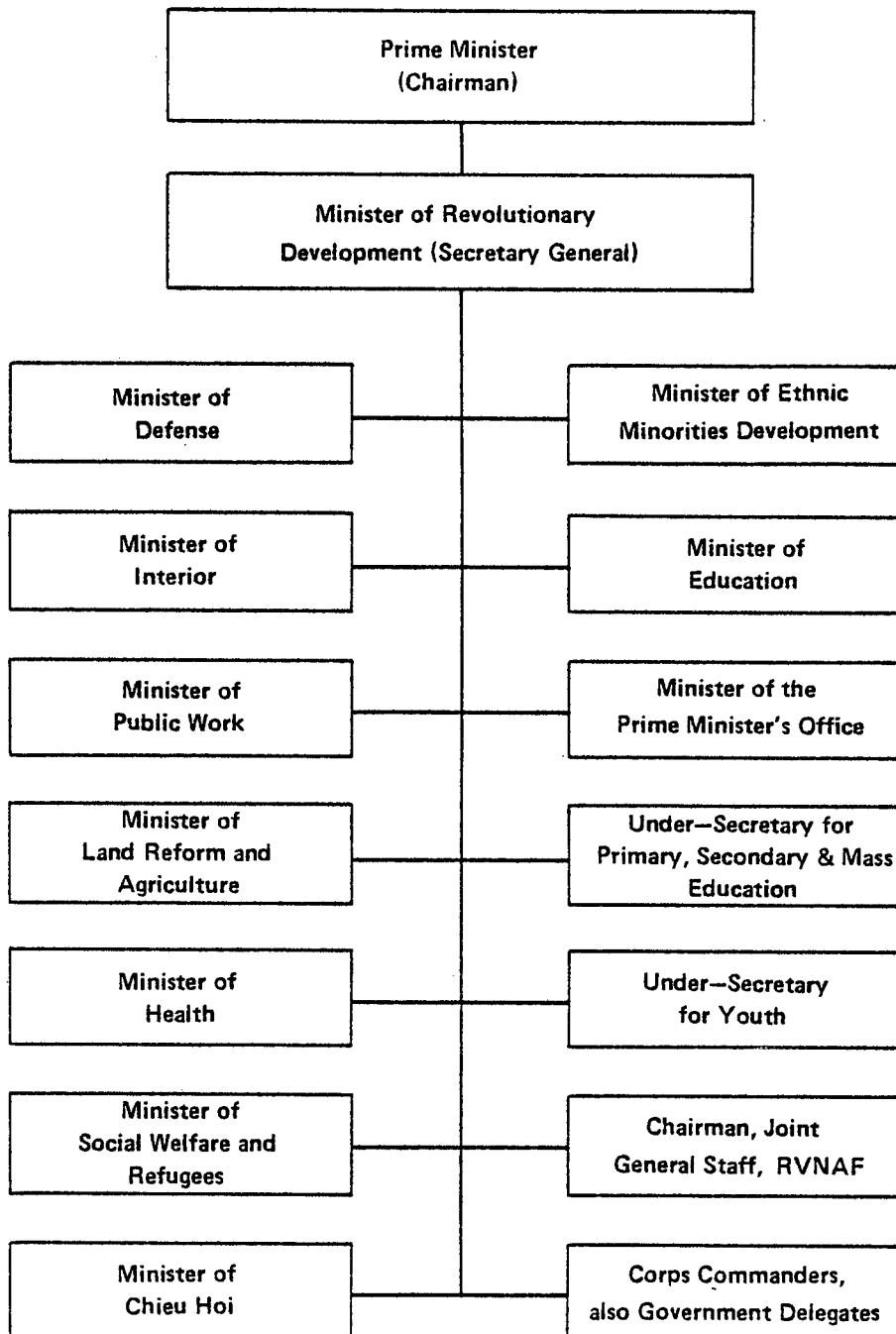

*The Chairman, Joint General Staff, RVNAF has the rank of a Cabinet Minister.

Chart 2 — GVN Revolutionary Development Councils, 1967 - 68

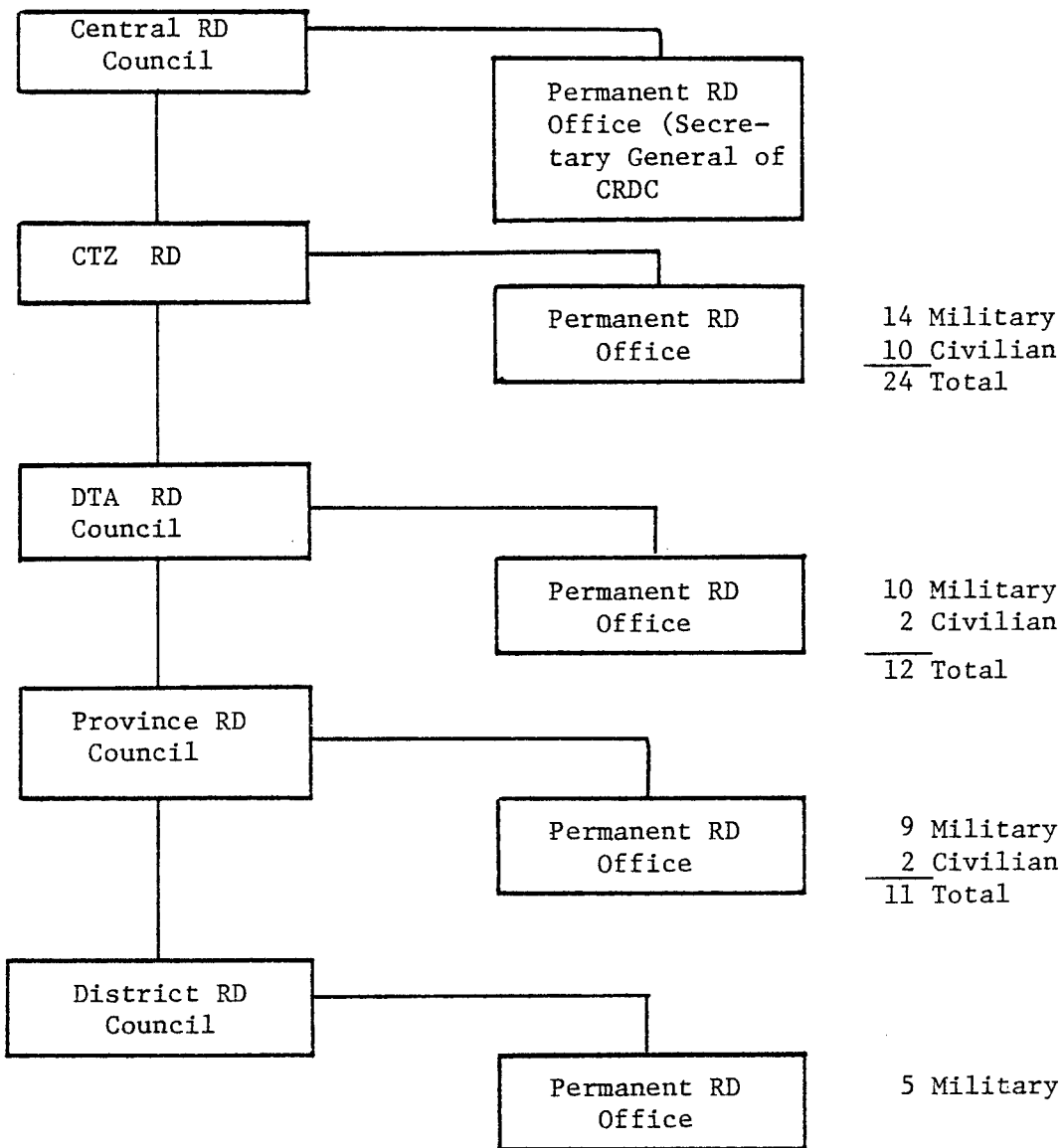

The Rural Development (RD) councils at all levels were redesignated "Pacification and Development" (PD) councils in 1969. Cabinet ministers continued to serve as members of the Central Pacification and Development Council (CPDC) under the chairmanship of the Prime Minister. In 1970, the chairmanship of CPDC was assumed by the President of the Republic. At the same time, Corps Commanders were excluded as Council members since they no longer served as Government Delegates. The Prime Minister in his new capacity as Secretary General was assisted by a permanent staff organization called Center for Coordination of Pacification and Development whose functions were to monitor, coordinate and supervise pacification programs.

In practice, however, the Prime Minister played the role of the Chairman as he always had, and the Director of the Center for Coordination, a Lieutenant General, served as Secretary General. (*Chart 3*)

This gave rise to a redundancy in functions since the Minister of Rural Development still served as the nominal Secretary General of the CPDC. The problem was solved in 1971 when the Ministry of Rural Development was dissolved.

As members of the CPDC, the cabinet ministers were responsible for recommending pacification policies and operational procedures, and reviewing and providing support for provincial pacification programs.

At the Corps Tactical Zone (Military Region after 1970) level, the same organization existed. The Corps Commander was Chairman of the Regional Pacification and Development Council (RPDC). He was assisted in his functions by a Permanent Office, redesignated Regional Pacification and Development Center in 1970. Members of the RPDC included: the Corps Deputy Commander for territory, division commanders province chiefs and representatives of the ministers who made up the CPDC. These ministerial representatives had the rank of inspector or director. The director of the RPDC, usually an Army Colonel, served as Secretary General. Corps commanders were responsible to the central government for both military and civilian activities since prior to 1970 they also served as government delegates in their respective Corps Tactical Zones.

Chart 3 – Pacification Councils and US Support Organization (as of 1970)

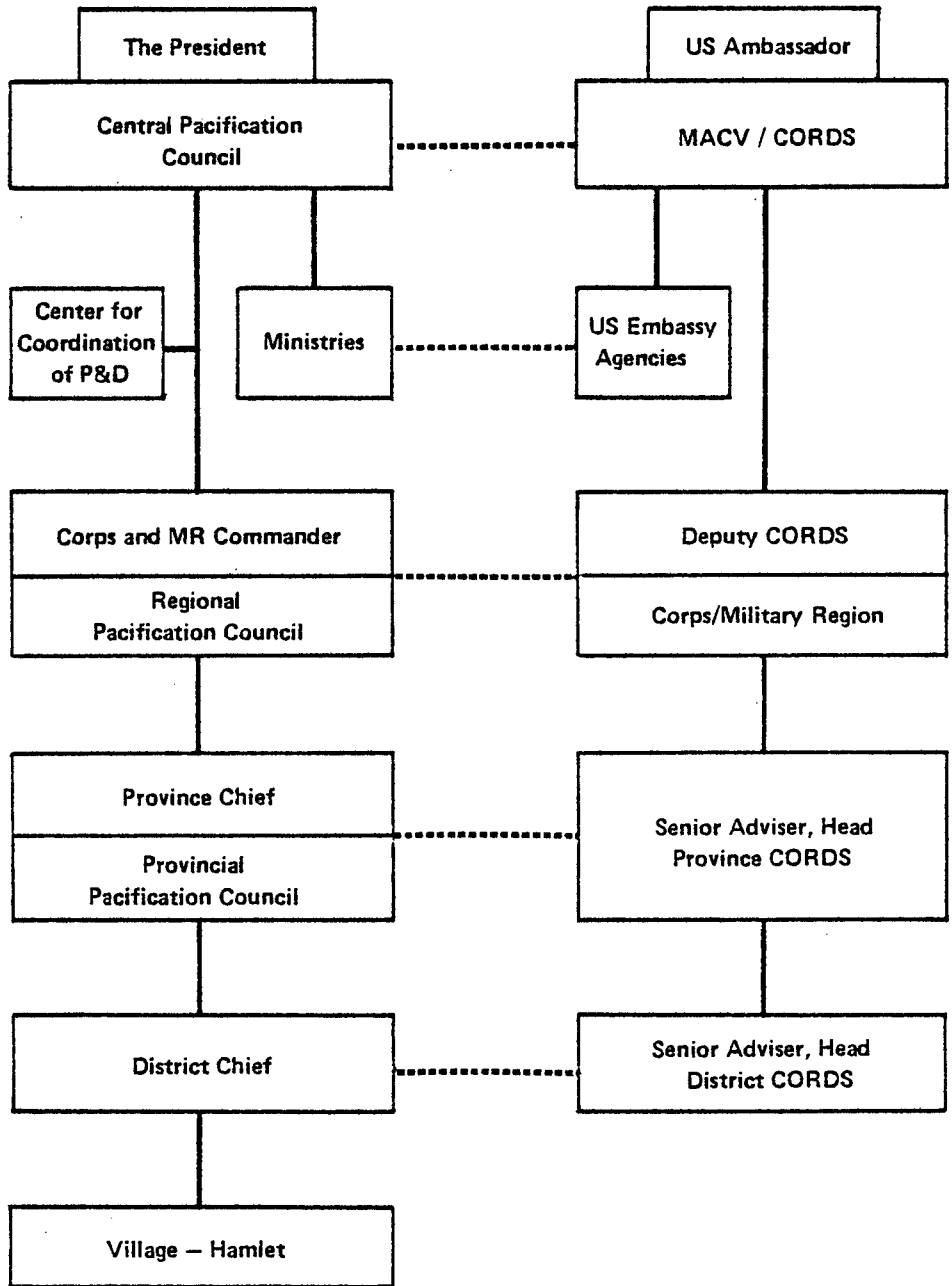

— Command
 - - - - - Coordination – Advisory

In 1970 when Corps Tactical Zones (CTZ) became Military Regions (MR), the GVN abolished the position of government delegate with a view to making corps commanders more responsive to tactical problems. In his capacity as Chairman of the RPDC, a corps commander was responsible to the central government for all problems concerning territorial security in the Military Region. His pacification duties included conducting military operations in support of pacification; determining priorities for the employment of military forces (regular and territorial) in support for pacification; reviewing provincial pacification plans; and providing guidance and supervision for the implementation of the military forces (regular and territorial) in support of pacification.

At the Division Tactical Area (DTA) level, the division commander was responsible for all matters pertaining to territorial security and pacification within his area of responsibility which generally included several provinces. Prior to 1970, at the DTA level, there was also a DTA Rural Development Committee chaired by the division commander but with very limited civilian membership. As a result of the abolition of the DTA in 1970, the DTA Rural Development Committee was also dissolved, but the division commander was still responsible for territorial security and, to a lesser extent, pacification support in his area of responsibility. He performed his pacification duties only when directed by corps commanders. These duties were coordinated with province chiefs and consisted of providing support, and conducting clear-and-hold operations in areas targeted for pacification.

Whether responsible or not for pacification, division commanders were usually overburdened by problems concerning territorial security. Almost 80% of their time was spent solving these problems, and as a consequence, a division commander had little time left for mobile operations. After 1970 a significant effort was made to alleviate division commanders' territorial responsibilities and to permit them to concentrate more on mobile tactical operations since divisions were to gradually take over combat responsibilities from the departing US forces. This effort was made by releasing divisional units from their static pacification support mission and replacing them gradually

with Regional Forces. Thus, Sectors or Provinces were made directly subordinate to the Military Region as far as territorial security and pacification support were concerned. As of that time, at corps headquarters, the position of Deputy Corps Commander for Territory was created and he was placed in charge of territorial security and pacification support within his Military Region.

The province was the primary level responsible for actually carrying out the pacification program. As a result, a province chief usually enjoyed great powers. As Chairman of the Provincial Pacification and Development Council (PPDC), he was directly responsible to the corps commander for military affairs and to the central government for administrative affairs and the management of national resources committed to the pacification program. Province chiefs were appointed by presidential decree upon recommendation of the corps commander and with prior concurrence of the Prime Minister. They were mostly Army officers, usually with the rank of colonel or lieutenant colonel. Within his province, the province chief was responsible for everything, tactical operations, administration, and politics.

A province chief was assisted by two deputies: a deputy for administration, always a civilian, and a deputy for military affairs who was also called Deputy Sector Commander since the province chief was the Sector Commander. The deputy sector commander assisted the province chief in all matters concerning territorial security, tactical operations, the employment, organization, and control of Regional/Popular Forces, and the control of para-military forces in the province (national police, RD cadre, PSDF). The deputy province chief for administration assisted the province chief in the administration and management of provincial affairs and directing and controlling the activities of departmental services. These included: Reconstruction, Public Works, Agriculture, Taxation, Social Affairs, Finances, Open Arms, Information, Health, Education and other services which operated under direct control of the province chiefs but were subordinated to their respective ministries administratively.

As Chairman of the PPDC, the province chief's pacification duties consisted of developing the annual provincial pacification plan

based on guidelines and policies of the CDPC and specific directives of the corps commander and directing the coordinated employment of military and para-military forces in support of his pacification program. The province chief was at the same time the planner and executor of his own pacification program and he was held entirely responsible for its success or failure.

The lowest echelon in the GVN organization for pacification was the district or subsector. Prior to 1970, there existed at the district level a District Rural Development Committee but it was dissolved at the same time as the DTA Rural Development Committees. District chiefs were for the most part Army officers, usually lieutenant colonels or majors, appointed by a ministerial decree of the Minister of Interior, acting on orders of the Prime Minister and upon recommendation of the corps commander, often without the province chief's consultation. The district chief was responsible for all problems concerning territorial security and pacification in his area of responsibility. His pacification-related duties were to assist the province chief in the preparation and implementation of the provincial pacification and development plan; direct and supervise subordinate RF and PF units in the support of pacification; and provide guidance for village chiefs concerning security and defense plans.

Like the province chief, the district chief was assisted by two deputies: one for administration, always a civilian, who helped run the district office and manage district administrative affairs and the other, the deputy subsector commander. A district chief commanded and controlled all subordinate or attached RF and PF units, and other para-military forces of the district. In his major role of pacification support, a district chief's responsibilities were burdensome. His staffs, civilian and military alike were small and usually plagued by ineffectiveness due to the lack of qualified personnel.

Security problems always constituted major headaches for the district chief and occupied most of his time. The subsector staff was capable of only routine operation; it had neither the capability

nor the assets to direct and control tactical operations, or coordinate military and civilian activities at village and hamlet level.

In an effort to facilitate district command and control, the GVN created sub-subsector commands at the village level in 1973. The sub-subsector was the lowest military command of the RVN territorial organization, designed to control and coordinate military and paramilitary forces at the village level. This greatly reduced the control burden placed on the district chief and made the coordination of forces more effective for the support of pacification, for which he was held totally responsible.

Each district was composed of several villages and hamlets which constituted the very foundation of Vietnamese society. Consequently, villages and hamlets were the focus of the pacification and development effort. The village was the lowest level of the GVN administrative structure and village affairs were run by a village council whose members were popularly elected as was the village chief. Hamlets were geographical subdivisions of a village and run by administrative committees whose members were also popularly elected.

Employment of Forces in Support of Pacification

The Republic of Vietnam Armed Forces were responsible for providing military support for the GVN pacification program. The Chairman of the Joint General Staff (JGS) as a member of the Central PD Council was assisted by a deputy in charge of pacification who was also commander of the RF and PF. This position was established expressly for the purpose of directing and supervising the organization, training, equipping, and employment of the RF and PF in support of pacification. (Chart 4)

The RVNAF consisted of three services: the Army, the Air Force, and the Navy (including Marines). The Army was deployed in the four Military Regions and most units were placed under the tactical command of the Corps Headquarters. Infantry was the largest combat arm of the Army of the Republic of Vietnam (ARVN). It consisted of infantry divisions, separate infantry units and Regional Force and

Chart 4 – RVNAF Organization for Pacification Support

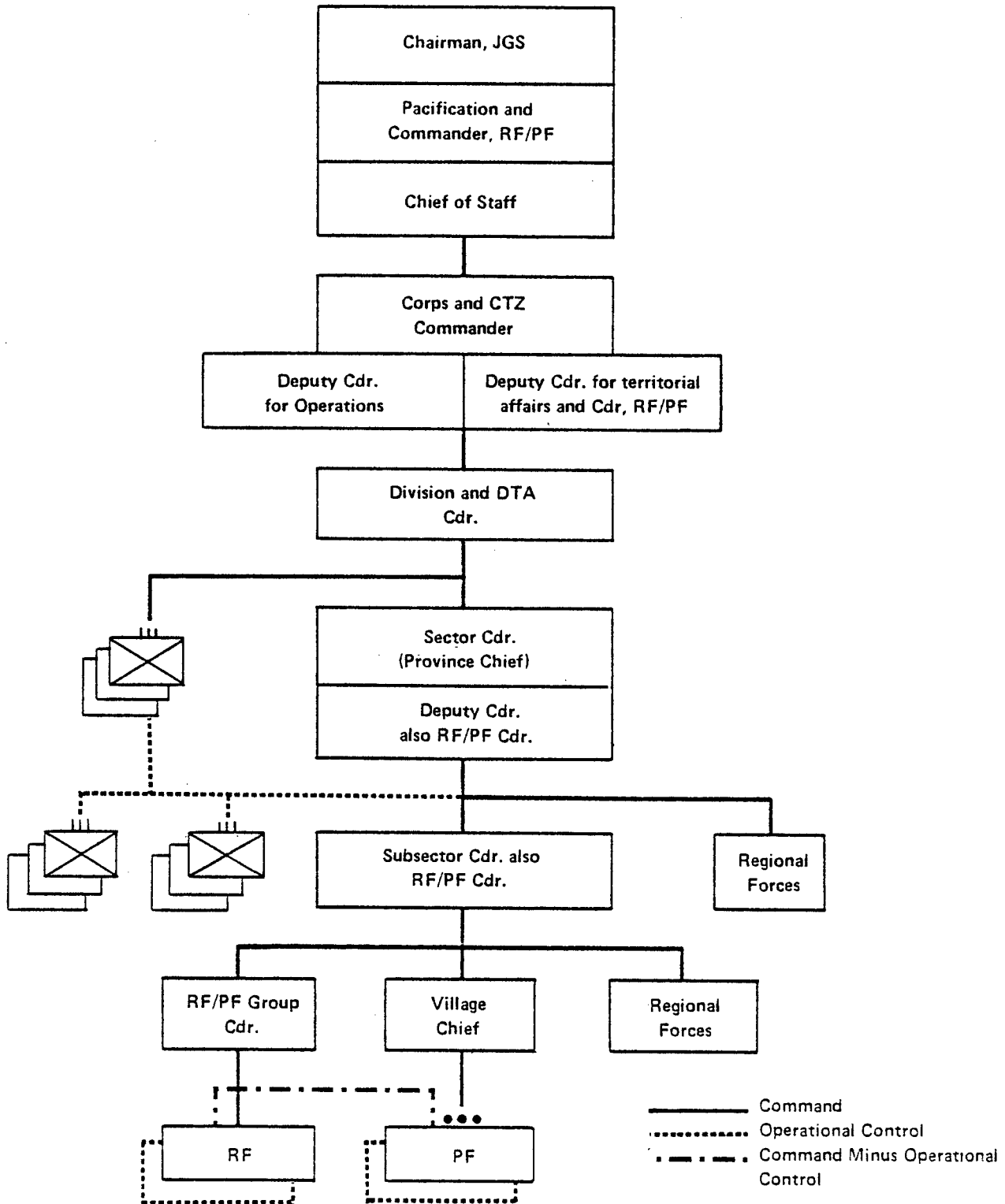

Popular Force units.¹ Other combat arms of importance included the Airborne and the Rangers. The Airborne Division and the Marine Division made up the General Reserve while Ranger units (battalions and groups) operated as corps reserves or reaction forces, in addition to border defense duties.

Under direct control of the JGS, the four Army Corps Commands also functioned as Military Region (MR) Commands. Corps/MR commanders were responsible for all military activities in their respective areas of responsibility. Regular forces organic to corps included from two to three infantry divisions depending on the size of the corps area of responsibility (MR). (*Map 1*) A number of Ranger groups were also attached to each corps.

Divisional units such as infantry regiments or battalions were sometimes attached to province/sector commands as reinforcements. In these instances, the relationship between the province chief/sector commander and the attached unit commander tended to be one of mutual support, not of subordination, and this created command difficulties. As a result, whenever they were attached to sectors, regular force battalions were placed under operational control of the sector commander while still administratively subordinated to their regiments.

Ranger forces played a role in the defense of border areas and in interdicting enemy infiltrations from Cambodia and Laos. As a result of the merging of Civilian Irregular Defense Groups (CIDG) with regular ARVN forces, Ranger forces were greatly expanded in strength. The majority of Ranger units manned border outposts while the remaining constituted corps reserve or reaction forces. During the post ceasefire period, some Ranger groups were placed in general reserve since the Airborne and Marine divisions were committed to MR-1.

Territorial forces usually made up more than 50% of overall RVNAF strength. As authorized for FY-73, for example, RF and PF strength

¹Reference: RVN Presidential Decree No. 614a-TT/SL of 1 July 1970, which establishes the organization, missions, functions and responsibilities of the RVN Defense and Armed Forces components.

stood at 530,589 against the regular tri-service strength of 448,953.

During their incipient stage of development, the Regional and Popular Forces were poorly equipped and under strength. After being made part of the RVNAF and thus qualifying for US support under the Military Assistance Program (MAP), RF and PF units expanded considerably in numbers and were equipped with the same types of infantry weapons as regular forces. In addition, regional and popular troops enjoyed the same status in pay and special allowances as regular troops. The only difference was in tactical employment and the size of units. (*Chart 5*)

Regional Forces, in their role as provincial and district main force, were organized into companies. Due to tactical requirements, RF companies were sometimes assembled into groups. In keeping with the RVNAF improvement and modernization trends and as required by the security situation, RF units were subsequently upgraded into maneuver battalions and, at a later stage, into Regional Mobile Groups (RMG) with organic artillery support provided by a battery of four 105-mm howitzers. RMG headquarters were activated with the capability to command and control from 3 to 5 battalions. They were designed to replace the former Sector Tactical Commands which, due to shortages of personnel, were ineffective in the exercise of operational control. The allocation of RF units to each province depended on the local security situation and provincial manpower resources and recruiting prospects.

Popular Forces while assuming the role of village and hamlet main force were organic to districts and placed under the command and control of village chiefs. Although equipped with the same infantry weapons as RF units, PF units were confined to platoon size with an authorized strength of 35 men per platoon. Each village was authorized a PF platoon, but as a result of significant gains in the pacification programs, the number of villages under GVN control increased considerably every year and there were not enough platoons to go around. To offset the shortage, the strength of a PF platoon was reduced to 29, providing extra spaces to be used in activating additional platoons. (*Chart 6*)

Chart 6 – Organization, Province Regional and Popular Forces

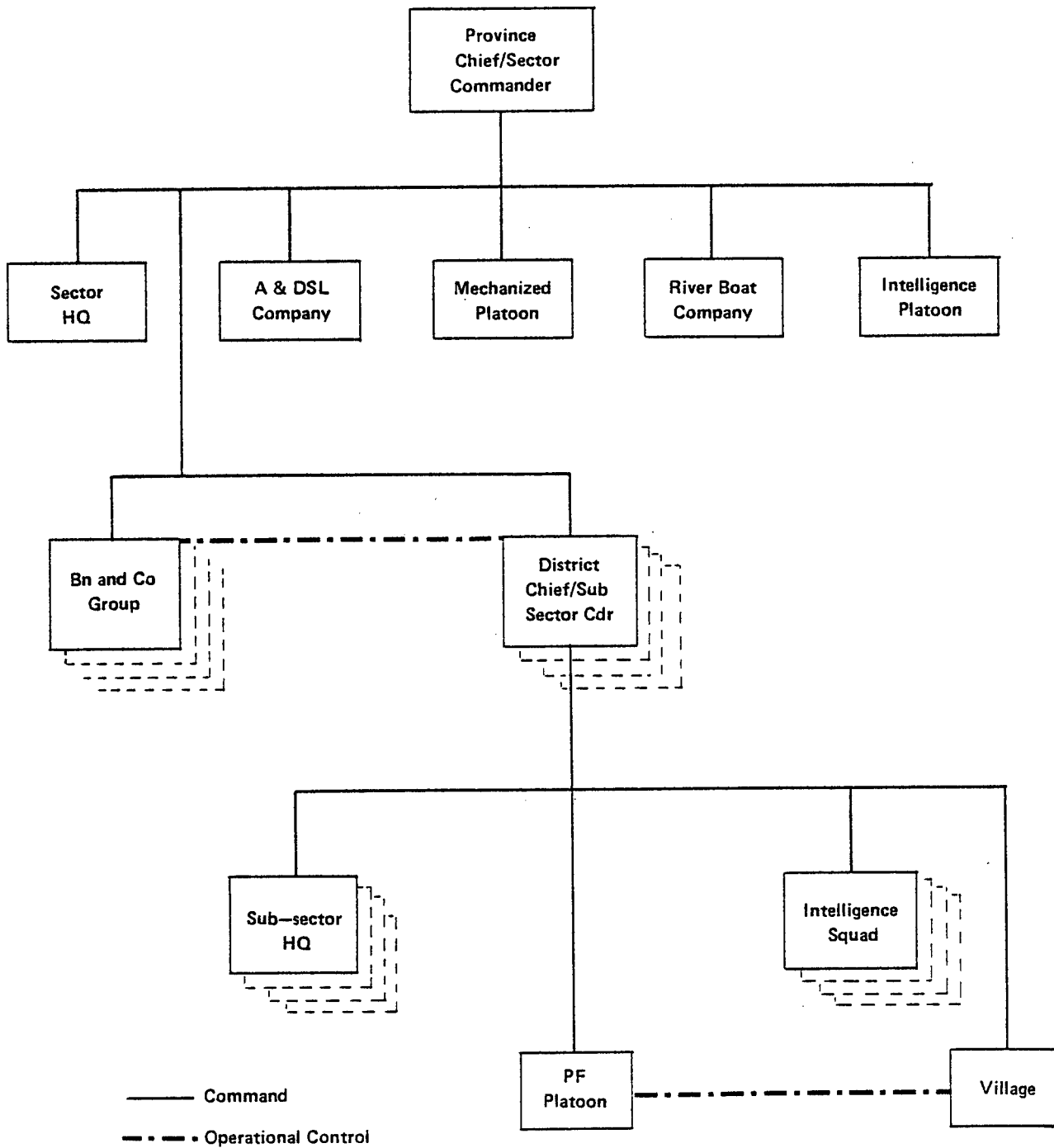

The usual area of operation of RF units, when their organization was still limited to company and company-group size, was within their province and occasionally in the provincial boundary areas. After they were upgraded into maneuver battalions and mobile groups, RF units were employed in areas extending into adjacent provinces as well, or even far away from their home province, but only for limited periods of time that never exceeded two months. In MR-4 for example, RF units organic to the provinces of Go Cong and Vinh Long were deployed to operate in My Tho and Chuong Thien provinces, respectively. Also, a number of RF units organic to An Giang province were committed to operations in far away Kien Giang province. When operating as mobile tactical units in those instances, RF units often proved as effective as regular ARVN units.

To provide administrative and logistical support to RF and PF units, each province was assigned an Administrative and Logistical Support Company (ALSC) whose size varied depending on the number of RF and PF units to be supported. These ALSCs were subsequently upgraded into Administrative and Logistical Support Centers which were organized into five different standard sizes or classes: A, B, C, D, and E, in decreasing order. Each center provided support for a province with the exception of Binh Dinh, Quang Nam and Dinh Tuong which, because of their unusual concentration of RF and PF units, were assigned two Administration and Logistic Centers each.

Artillery support for RF and PF units was also greatly enhanced by the activation of a total of 174 artillery sections across the country, each section equipped with two 105-mm howitzers. These artillery sections were assigned to sectors as organic units to provide direct support to RF and PF. The availability of territorial artillery units allowed the release of divisional artillery units for mobile operations. In addition to artillery, each province was also assigned an armored platoon equipped with V-100 armored reconnaissance vehicles for the protection of lines of communication, and, in case of areas such as the Mekong Delta, a river boat section to facilitate movements on waterways.

Prior to 1966, the role of the National Police was generally

confined to maintaining law and order in urban areas, cities, provincial capitals and district towns; there was no police force in villages and hamlets. National police forces were subordinated to the Ministry of Interior and placed under the control of a NP General Directorate. Over the years, the NP expanded considerably in keeping with its growing role and finally developed into an authorized 122,000-man strong para-military force. NP forces included uniformed police, special police, combat or field police, and harbor police. (*Charts 7 & 8*) In addition to the NP central command, there were four regional commands, one for each military region, and the Saigon command. At the province level, there was a NP service, at district level, a NP section and at village level, a NP subsection.

During the period of intensified pacification effort, the NP made significant contributions in the destruction of the enemy infrastructure and maintenance of law and order in villages and hamlets.

Police field forces (PFF) were well equipped and organized into companies. PFF companies were deployed in provinces where they operated in cooperation and coordination with rural development cadre groups.

During the pacification process, NP subsections were established in villages as soon as they became secure. The strength of each village NP subsection varied according to the size of the village population. Villages having upwards of 10,000 inhabitants were assigned one 18-man NP subsection each. Villages having between 5,000 and 10,000 inhabitants were assigned a 12-man NP subsection. A 6-man NP subsection was assigned to each village with less than 5,000 inhabitants. A village NP subsection had the mission to maintain law and order in order to protect the lives and properties of villagers; coordinate activities with military and para-military forces to destroy or arrest members of the enemy infrastructure; control and screen the village population; develop and maintain an agent net; investigate and interrogate Viet Cong suspects; and control village resources.

Police field forces were directly subordinated to the NP central command. The commander of NP field forces served as an assistant to the NP commander. While equipped and trained in the same way as

Chart 7 – Organization, National Police

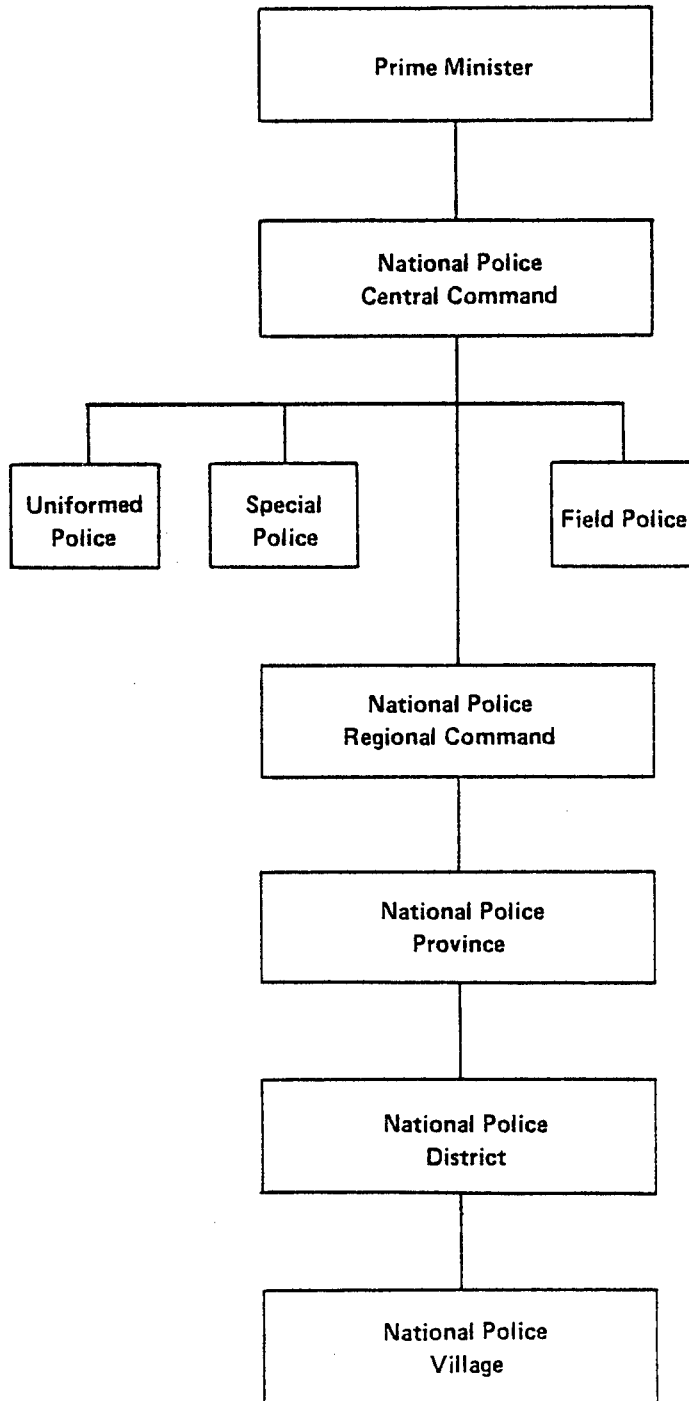

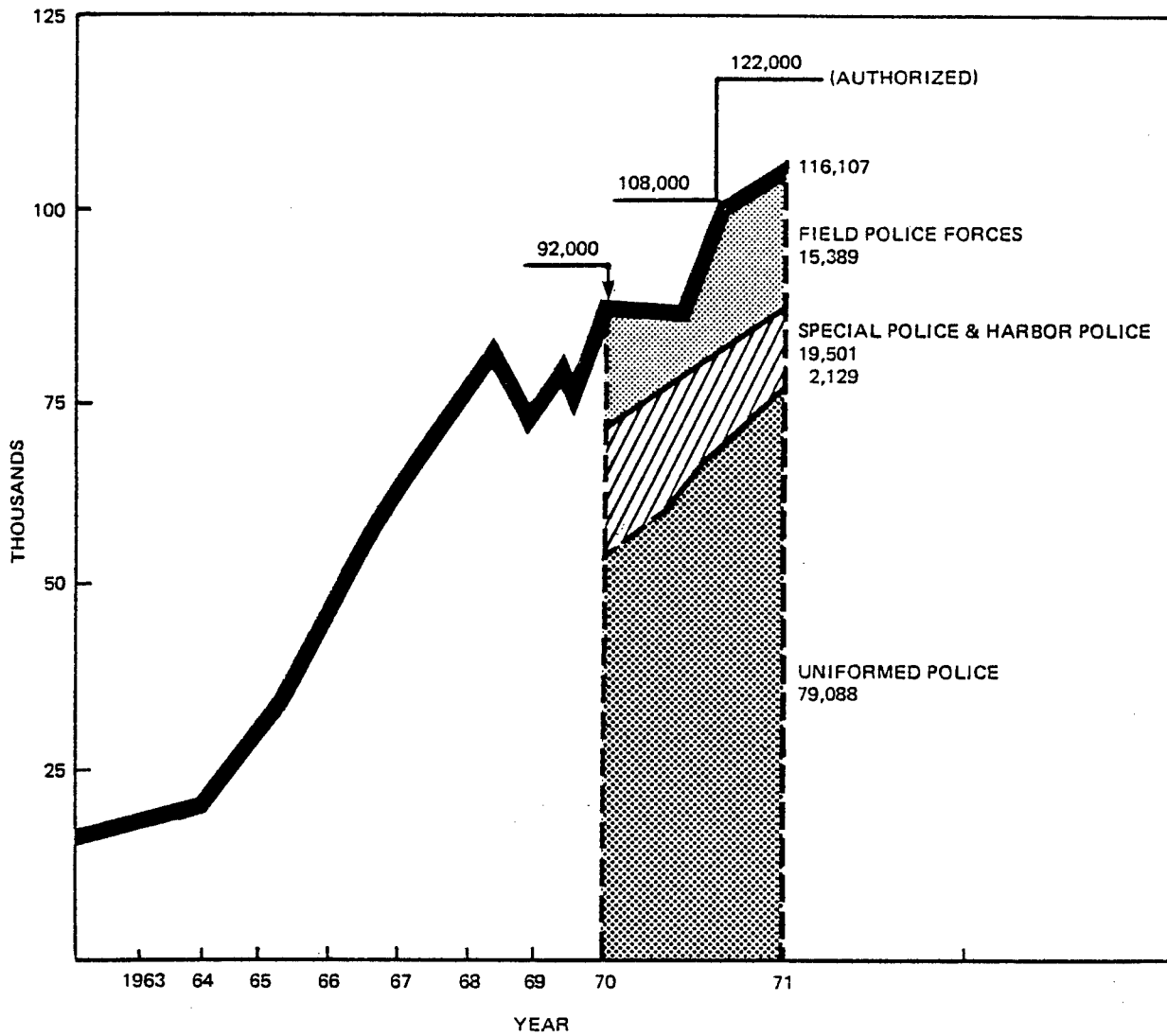

Chart 8 – Expansion of National Police Forces

other police forces, the PFF specialized in the role of anti-violence and anti-rebellion and had combat capabilities similar to military forces. PFF companies were attached to provinces to support pacification but retained their police command channel and were administratively supported by the NP central command. At each NP regional command there was a PFF representative whose mission was to coordinate PFF efforts within a military region. The province chief, however, had full authority in the employment of PFF companies assigned to his province. He was assisted by a PFF provincial representative.

At the district level, the NP section chief and the PFF company commander assisted the district chief in determining the employment of PFF platoons for the support of pacification. When required, PFF platoons were also deployed to operate in villages. A PFF platoon leader would cooperate with the village chief on the basis of mutual support and neither was under the control of the other.

Rural Development (RD) cadre were organized into groups of 39 men each. In the central highlands, RD cadre were called Rural Mountaineers and organized into groups of 70 men each. RD cadre were recruited in each province and sent to the Vung Tau RD Training Center for training. Upon completion of training they were sent back to their provinces of origin. Each RD group was composed of a group headquarters, a military section and a reconstruction section.² (*Chart 9*) While the organization of the military section was fairly consistent, the composition of the reconstruction section varied greatly according to local requirement. Thus specialized members of a RD reconstruction section were selected on the basis of local activities where they would serve. If the local population lived on fishing, the RD group would include specialists in fisheries and the manufacturing of fish

²As of 1970, the military section was removed from the organization of RD cadre teams, thus reducing the authorized strength of each team to 25. This resulted from a marked improvement of the security situation and the sizable expansion of regional and popular forces. In 1971, following the deactivation of the Ministry of Rural Development, RD cadre personnel were reintegrated into various ministries such as Information/Open Arms, Agriculture, and Public Works.

Chart 9 — Organization, 59—Man Revolutionary Development Cadre Group

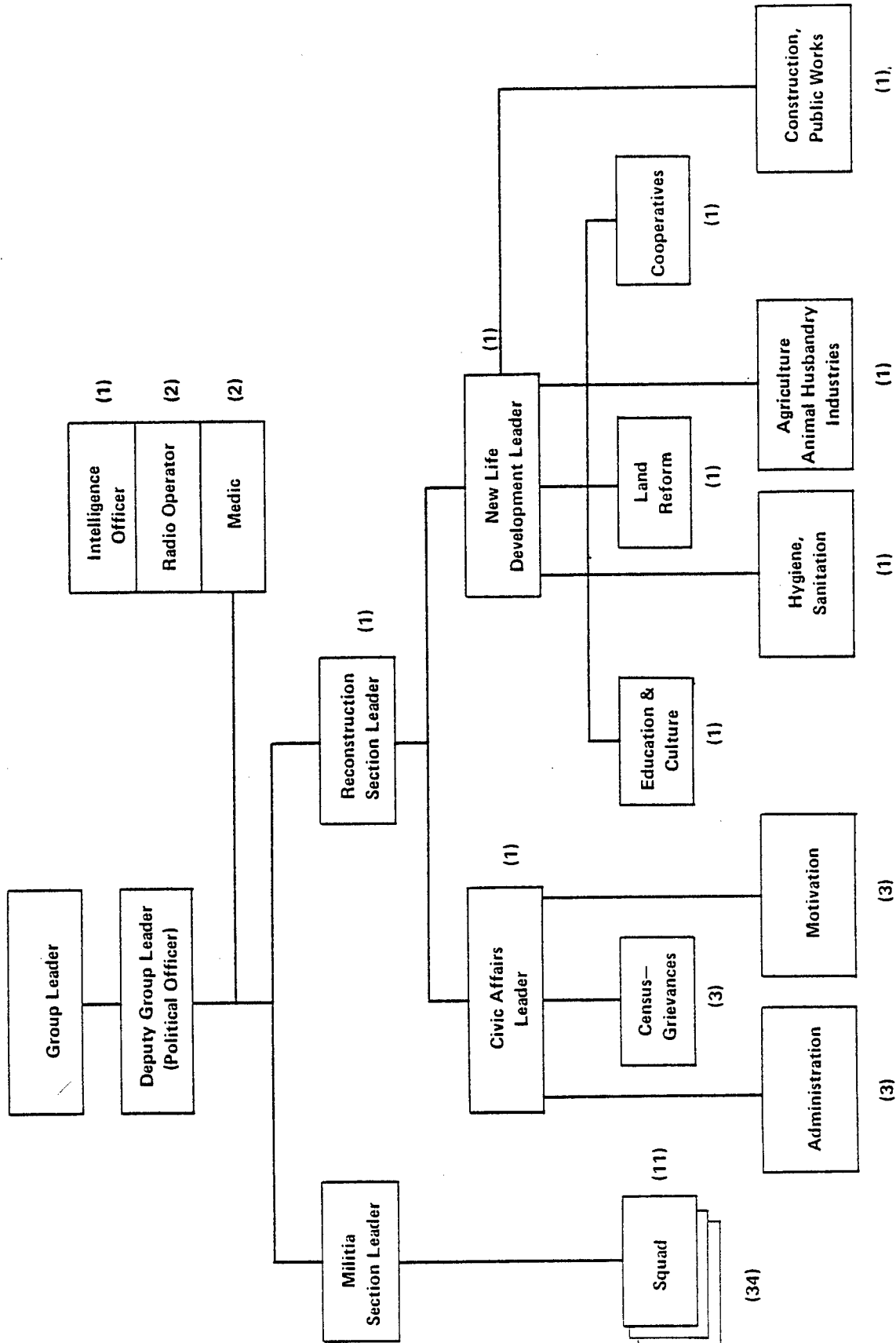

sauce. Likewise, in those areas where the local inhabitants were farmers, the composition of the RD groups would invariably include specialists in agriculture and farm animal breeding. The need for those RD specialists was formulated by the provinces and the RD training center was responsible for their training.

A RD group mission was to study and improve local political, cultural, social, and economic programs; find out the true aspirations of the local population; study and recommend local self-help projects; and encourage the local population in the maintenance of the local road system. With an authorized strength of 34, the military section of a RD group planned security measures for the protection of the group headquarters and the reconstruction section, coordinated activities with friendly forces, and organized and trained the village PSDF.

A provincial RD headquarters coordinated RD activities and helped the province chief control assigned RD groups. (*Chart 10*) In addition to its specified mission, a provincial RD headquarters also cooperated with departmental services to develop programs to meet the needs of the local population. Other tasks performed by the provincial RD headquarters included census and classification of the population; encouraging the population to participate in community activities; improving education programs and combating illiteracy; assisting the population in the maintenance of public hygiene such as house sanitation and the digging of wells; organizing and conducting political indoctrination sessions; and assisting the population in the organization of farmers' associations.

During the period from 1965 to 1970, RD cadre groups played key roles in the pacification and development effort. As of 1971, however, since the pacification program focused on community defense and community development, it was directly operated by the specialized cadre of various ministries. As a result, RD cadre groups were deactivated and the personnel were absorbed into the ministries, such as Information and Open Arms, Agriculture, etc., depending on their qualifications. The pacification effort was also centralized under the Central Pacification and Development Council and the Ministry of Rural

Chart 10 — Organization, Province RD Cadre Group Headquarters

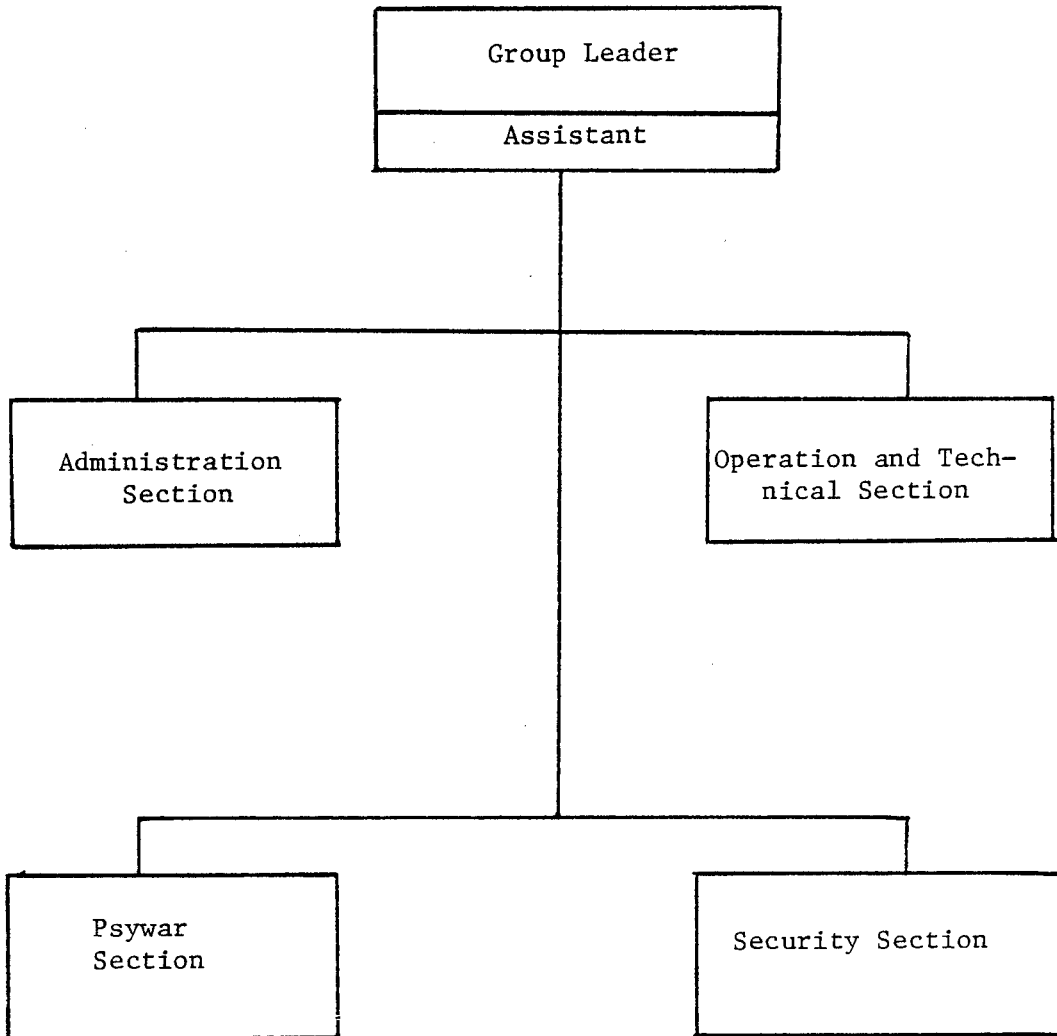

Development was dissolved. In its place, a Center for Pacification and Development was created and subordinated to the Office of the Prime Minister. The director of the center served as secretary general for the CPDC.

Although RF units were provincial and district forces, and PF units, village and hamlet forces, their employment was flexible. To provide better security, province and district chiefs were free to employ their forces where, when, and how they deemed best. RF battalions, because of their independent operational capabilities, were usually employed in combined operations with regular ARVN forces or as province reaction forces. Seldom were they broken down into smaller elements to man static defense positions. The deployment of RF battalions into other provinces, however, was the prerogative of the Military Region commander. In the event the MR commander ordered an RF battalion into another province, he would specify the command relationships under which the battalion would operate; the duration of the attachment and arrangements for operational control and combat support; and logistical and administrative support. In general, a RF battalion deployed out of its home province continued to be administratively supported by its home ALSC but received logistical support from the ALSC in its new area of operation.

The case of RF company groups was somewhat different. Because of their limited command and control capabilities, RF company groups were generally employed in well-defined areas of operation and always confined to the home province. They were mostly employed for local security missions. RF company groups were best suited for providing security for limited areas within a district; supervising national police forces and the people's self-defense forces; and providing guidance for village and hamlet chiefs in organizing and consolidating their local defense systems. Separate RF companies which were not organic to any group or battalion were mostly employed for the protection of public utility installations, roads and bridges.

Popular force platoons were assigned to villages and operated according to the village chief's defense plan under the control of his deputy for security. Depending on the situation, PF platoons might

be deployed to operate in village boundary areas or in adjacent villages. The long-duration deployment of a PF platoon from its home village was discouraged and subject to approval by the Military Region Command. When operating away from its home village, a PF platoon received free rations of rice.

People's Self-Defense Forces were not usually employed in a military capacity. Being an auxiliary force, PSDF members assisted popular forces in the enforcement of security in the villages and participated in activities involving the villagers and their families. In secure areas, PSDFs were also employed to guard roads and bridges and in mixed patrols with PFs. However, PSDFs were almost never entrusted the task of manning the defense of important GVN installations or vital lines of communication.

The great number of military forces employed in support of pacification never seemed to keep up with the requirements occasioned by the necessity to deploy a permanent occupation force to every hamlet. The situation was such that when protection forces were deployed from a certain area considered "secure", that area might relapse into insecurity and the local population would lose confidence in the GVN. To ensure a judicious employment of forces, the Central Pacification and Development Council devised certain principles which were embodied in the concept of area security. According to this concept, whenever an area had been pacified and deemed secure, its military forces would be reduced and partly redeployed to other less secure areas. This redistribution of forces generally occurred within a Military Region and was a function of the changing situation and the MR commander made the decisions affecting the redeployment of regular ARVN forces and RF battalions.

U.S. Organization for Pacification Support

The Office of Civil Operations and Revolutionary Development Support (CORDS) was organized in May 1967 as an effort designed to unify US pacification support activities heretofore conducted separately by such US agencies as United States Agency for International

Development (USAID), the CIA, Joint United States Public Affairs Office (JUSPAO) and the military advisory system. CORDS provided support to the GVN in all aspects concerning the pacification program. Placed under the control of the Commander, USMACV (COMUSMACV), it directed and supervised both military and civilian support activities. COMUSMACV was assisted by a Deputy for CORDS, a US official with ambassador's rank, whose functions were to coordinate and supervise all pacification support activities, military and civilian. In particular, the Deputy COMUSMACV for CORDS was responsible for formulating policies and programs designed to interface with the GVN pacification effort. (*Chart 11*)

The Assistant Chief of Staff for Civil Operations and Rural Development Support (CORDS) was the principal staff assistant to COMUSMACV and DEPCORDS/MACV on US Civil-Military Support for the GVN pacification and development program. He had primary general staff responsibilities for: providing advice on all aspects of US Civil/Military Support for the Community Defense and Local Development Program; in conjunction with GVN authorities, developing joint and combined plans, policies, concepts, and programs concerning US Civil/Military support for community defense and local development; supervising the execution of plans and programs for US Civil/Military support for Community Defense and Local Development; providing advice and assistance to GVN, including the Central Pacification and Development Council, the various ministries, the RVNAF JGS, and other GVN agencies on US Civil/Military support for Community Defense and Local Development; managing and directing US civil assistance to the autonomous cities in the fields of integral security, political mobilization, and technical support; serving as the focal point for local development programs, population and resources control, and for civic action by US forces; serving as point of contact with sponsoring US agencies for the Community Defense and Local Development Programs; evaluating Civil/Military Community Defense and Local Development activities and reports on the progress, status, and problems of community defense and local development support; carrying out US representation to the GVN Chieu Hoi ministry, recommending basic

Chart 11 – Organization, Office of the Assistant Chief of Staff for CORDS, USMACV

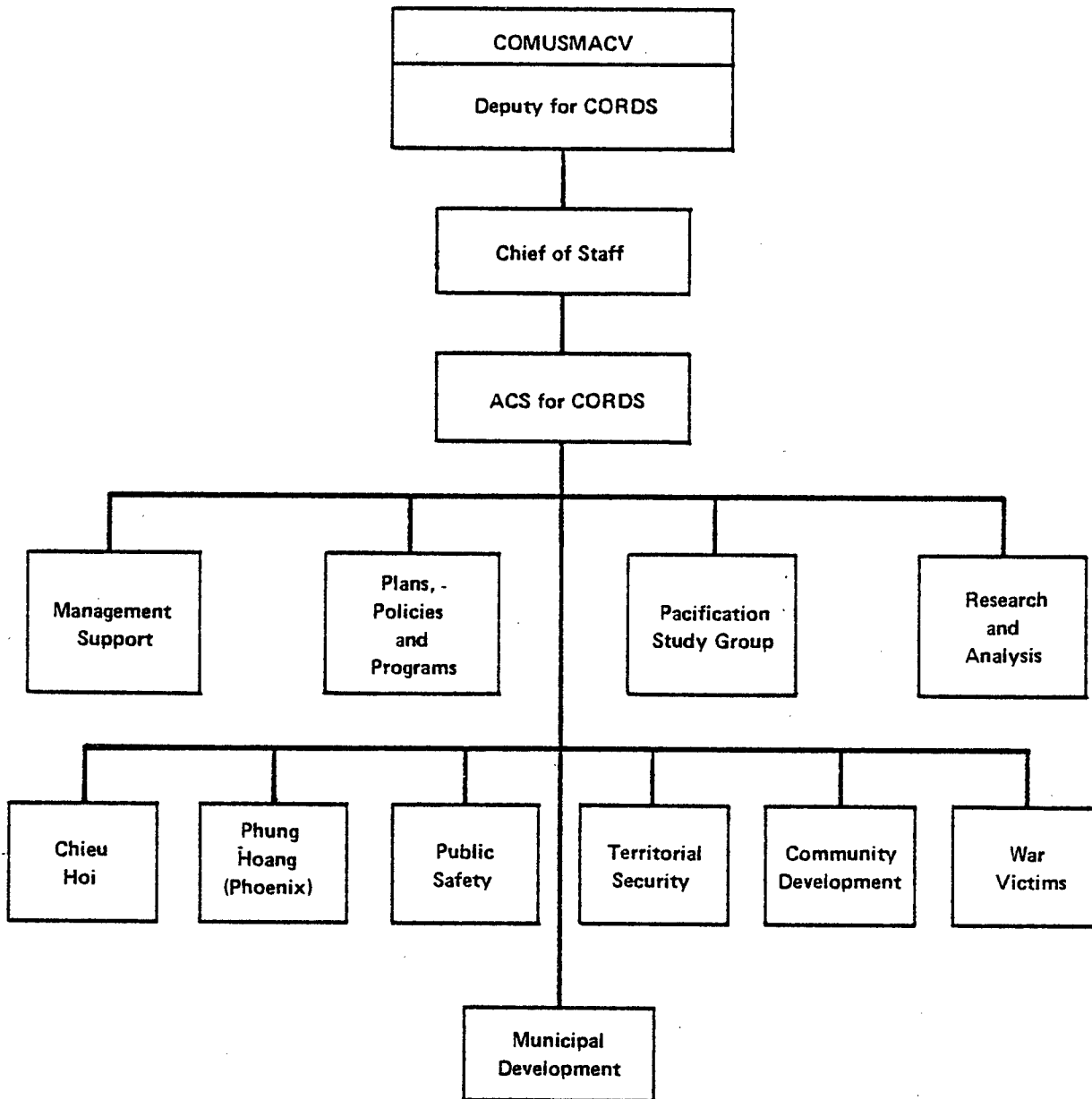

policies, goals and guidelines for planning purpose, and acting on all Community Defense and Local Development program support policy matters pertaining to subordinate echelons.

The principal functions of CORDS Directorates were as follows:

Pacification Study Group

Conducted field studies of community defense and local defense programs, and other programs to the extent they affected community defense and local development.

Management Support Directorate

Supervised and coordinated activities in the management and administrative area, including manpower planning and control, management analysis, and manpower development, administrative services, general services and communications; and air operations in support for CORDS activities.

Plans, Policies, and Programs Directorate

Advised and assisted the GVN Central Pacification and Development Council and other GVN agencies in the development of community defense and local development plans, policies and concepts; developed military political and economic plans, as well as policies and concepts concerning community defense and local development activities; contributed to plans and policies developed by other MACV staff sections, determined MACCORDS piaster requirements; negotiated with USAID and the GVN on all resource levels; advised the Director for CORDS on the impact on defense and development of military strategies and tactics; through senior advisers and regional DEPCORDS, coordinated with US and GVN field commanders, province senior advisers and province chiefs regarding implementation of programs; and coordinated CORDS responses to all audits.

Research and Analysis Directorate

Operated the MACCORDS management information systems; developed and operated automated data processing systems in support of CORDS and GVN community defense and development objectives; controlled CORDS field reporting, analyzed reports to provide quantitatives and qualitative measurement of community defense and local development progress; analyzed the dynamics of the community defense and local development

process to define problems and recommended solutions; advised and assisted the GVN central pacification and development council on matters pertaining to measurement of pacification progress; advised and assisted the office of the Prime Minister in the establishment of a GVN computer center; provided staff support services to CORDS directorates relating to ADP, reports, graphics and briefings.

Phung Hoang Directorate

Advised and assisted the GVN Phung Hoang Division of Headquarters, National Police Command and recommended and developed Phung Hoang plans and policies.

Municipal Development Directorate

Advised and assisted the urban committee of the CPDC, the Director General of Reconstruction and Urban Planning and other GVN agencies in the formulation of policy, programs and projects for development of the urban areas of the RVN; coordinated the function of CORDS and other US mission agencies, as appropriate, in matters relating to the administration, physical planning, and technical and social development in urban areas; promoted the involvement of the private sector urban programs and projects. Assisted and advised the Mayor of Saigon and was responsible for all US assistance to the city of Saigon, to include personnel, commodities and funding.

War Victims Directorate

Developed policy goals, objectives and guidelines for US assistance to GVN programs assisting refugees, war veterans, and other people in need of social and economic help and to the GVN programs of land development and hamlet building benefiting victims of war; advised the GVN Ministry of Social Welfare, Ministry of War Veterans, and the Directorate General of Land Development and Hamlet Building.

Territorial Security Directorate

Advised and assisted the RVNAF JGS on regional forces and popular forces, the Ministry of Interior on people's self-defense forces, and the Director General of Youth and Sports on youth affairs; developed and recommended policies and programs on the employment and improvement of regional forces/popular forces units.

Community Development Directorate

Advised and assisted in implementation of programs under the auspices of the central pacification and development council, the Ministry of Rural Development (MORD), the Ministry for the Development of Ethnic Minorities (MDEM), and Ministry of the Interior (MOI) overall responsibility within CORDS for advisory efforts aimed at improving the operation of province and lower levels of government; tasked with support and technical supervision of regional and provincial advisory operations in development; served as direct counterpart to MORD and MDEM; advised appropriate subdivisions of CPDC, MOI and other ministries, as required, to assist in implementation of specific programs assigned to the directorate in the GVN pacification programs, the national fund for local development, the province development council, the village self-development fund, the rural credit program, the rural development cadre program, and the Son Thon Rural Development Cadre (Mountaineer RD) program.

Public Safety Directorate

Served as the principal advisor to the Director CORDS and the Director, USAID, and developed and recommended basic policy, goals, objectives, and guideline for US civil military support to the GVN national police command; developed and recommended basic policy, priorities, goals, objectives and guidelines for the US public safety programs supporting these agencies. Assessed the progress and priorities of law enforcement and related security actions.

At the Corps and Military Region level, the Commander, US Field Force, in his capacity as senior adviser to the ARVN Corps commander, was responsible to MACV for all efforts concerning pacification and security in his area of responsibility. He was assisted by a Deputy for CORDS, usually a civilian, whose functions were to coordinate and supervise US activities in support of the pacification program in the MR. In addition, the Commander, US Field Force was also assisted by a military deputy, responsible for military activities. (*Chart 12*)

At the province/sector level, the civilian and military advisory efforts were integrated under the control of the Province Senior Advisor who, as Director, Province CORDS, was a civilian or a military

Chart 12 – Organization, CTZ/MR CORDS in 1968

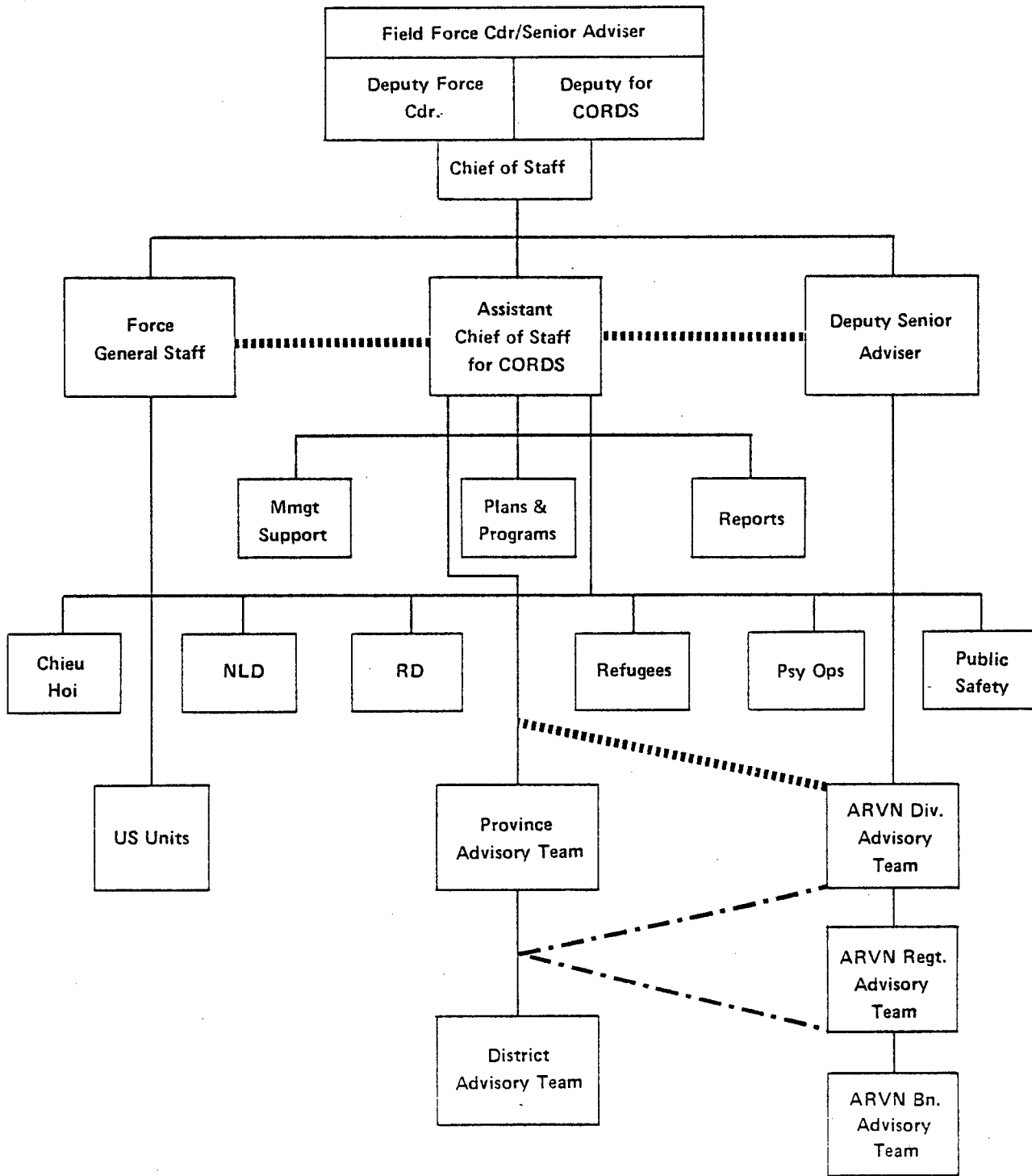

- Coordination of Military & CORDS matters
- - - - Operational Control when unit assigned on RD direct support mission

officer. As director, province CORDS, the province senior adviser reported to and received directives from the deputy CORDS, US Field Force. When a regular ARVN battalion was attached to the province as reinforcement for pacification support, the battalion's adviser was placed under the control of the director, province CORDS. In general, the province senior adviser/CORDS director advised and assisted the province chief in all areas related to the pacification program of the province.

At the district level, CORDS also integrated civilian and military support and advisory activities concerning pacification. The director, district CORDS, district senior adviser, was responsible for implementing and following up on pacification support activities. The CORDS district adviser was usually a military officer since his duties as senior district adviser included mostly military activities.

In addition to the CORDS system, the US placed advisers with Vietnamese forces, adding to the RVN military effort to support pacification. Greatly expanded in organization and personnel, the US advisory system encompassed the entire RVNAF hierarchy and reached down to the battalion level. Advisory groups and teams advised and assisted RVNAF units in all areas of operation. They were supported by a communication system of their own which provided a continuous link from the central echelon to corps, divisions, regiments and battalions. At corps level, US Field Force commanders also played the role of corps senior advisers. (*Chart 13*)

In conjunction with their combat efforts, US forces also performed civic action activities which were highly praiseworthy in view of their effective contributions to the GVN pacification effort. US civic action programs underwent some changes in emphasis; in 1964, for example, US civic action efforts were focused on providing health protection and sanitation for the peasantry in rural areas. They included such programs as well digging, and anti-malaria operations. In 1965, however, in view of the massive US participation, US civic programs emphasized the necessity to reduce casualties and damage to the civilian population, foster good rapport between US forces and the population, and assist the peasants in their farm work, particularly

Chart 13 — US Advisory Relationship with ARVN

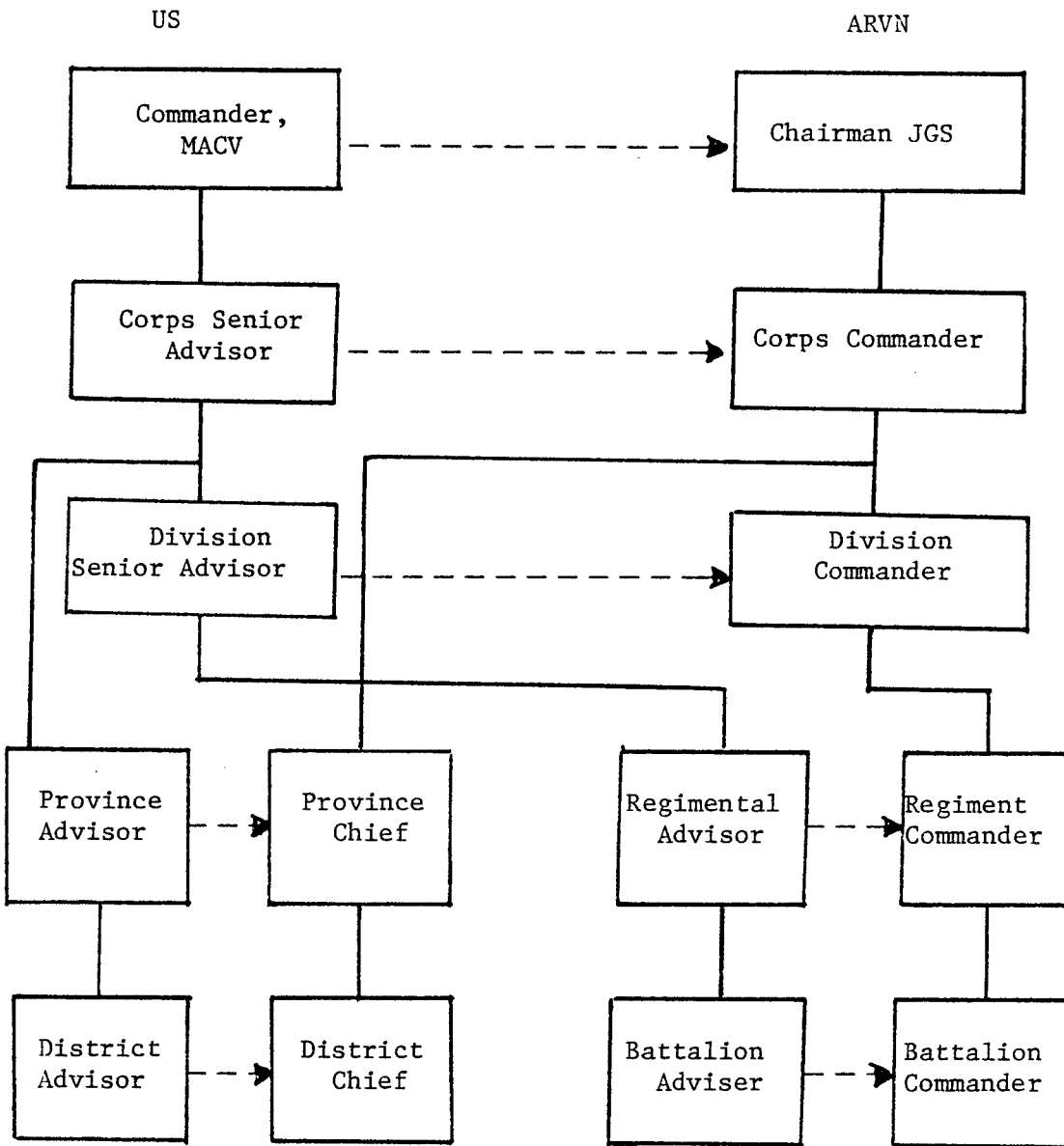

————— Command
 - - - - - Advisory Relationship

in those areas adjacent to US bases. US civic action programs also helped the local population to repair roads and build bridges, schools, maternity wards and dispensaries.

Civic action programs implemented by US forces gained popular sympathy and developed excellent rapport between them and the civilian population. In addition to the building task, US forces took good care of the civilian population whenever casualties and damage occurred. Injured civilians were always immediately evacuated for treatment, and all damages were compensated for with fairness. In this respect, US forces seldom incurred criticism since they carried out with zeal MACV directives to "limit to the maximum extent casualties and damages to the civilian population."

Within the first six months of 1966 alone, US forces built 78 schools, 29 dispensaries, 43 bridges, and repaired 246 miles of rural road. In addition, a total of 12,860 tons of clothing, food, and medicine donated by the International Catholic Relief Service were distributed to the local population during military operations.² Nevertheless, the most realistically useful civic operation undertaken by US forces was the Medical Civil Action Program (MEDCAP). It was widely appreciated by the rural population since it provided for much-needed medical treatment and medicine.

US civic action operations were also helpful in bringing relief to the increasing number of war refugees. In this regard, the US effort was particularly effective during 1968 when thousands of people became victims of heavy fighting. Relief programs of long duration were undertaken by US forces who assisted the RVN in building resettlement centers and distributing food, medicine, and clothing to the refugees.

²General William C. Westmoreland, Report on the War in Vietnam: 1964-1968, Ground Operations, Appendix E, p. 239.

The Phoenix Program

The Phoenix program was proposed by US authorities in 1967 as a means to consolidate and unify intelligence activities aimed at the destruction of the VCI. Despite GVN concurrence, it was nearly a year before the government approved Phoenix by executive decree. The delay stemmed from difficulties in defining terms of reference for the program and in selecting the agency responsible for its execution.

To implement the program, Phoenix committees were established from the central government to the districts with the missions of collecting information on the VCI, and planning for the organizing operations to neutralize it. (*Charts 14, 15, & 16*)

Corps commanders, province and district chiefs served as chairmen of the Phoenix committees at their respective levels. In this organization, the Regional National Police director, the provincial NP chief and the district NP chief played the role of committee secretary general. Members of a Phoenix committee included representatives of the police field force, the special police, the military security service, the provincial reconnaissance unit (PRU) and Chieu Hoi, RD cadre, Sector S-2 and other military organizations.

The coordination of intelligence and operations among various military and civilian agencies included the following tasks: (1) to collect, corroborate and disseminate information pertaining to key cadre, organization, and plans of the VCI; (2) to exploit information gathered in a timely manner so as to conduct quick reaction military operations; and (3) to classify, interrogate, and recommend the adjudication of suspects temporarily detained.

The task of eliminating the VCI was carried out in close coordination with search-and-destroy and pacification operations, making full use of propaganda and psywar techniques and resources. The Phoenix effort was supported by military units in combined operations, closely coordinated with police forces. The goal was maximum coordination; police field forces and the PRU joined in the task of eliminating the VCI. RF and

Chart 14 – Phoenix Operation and Control System

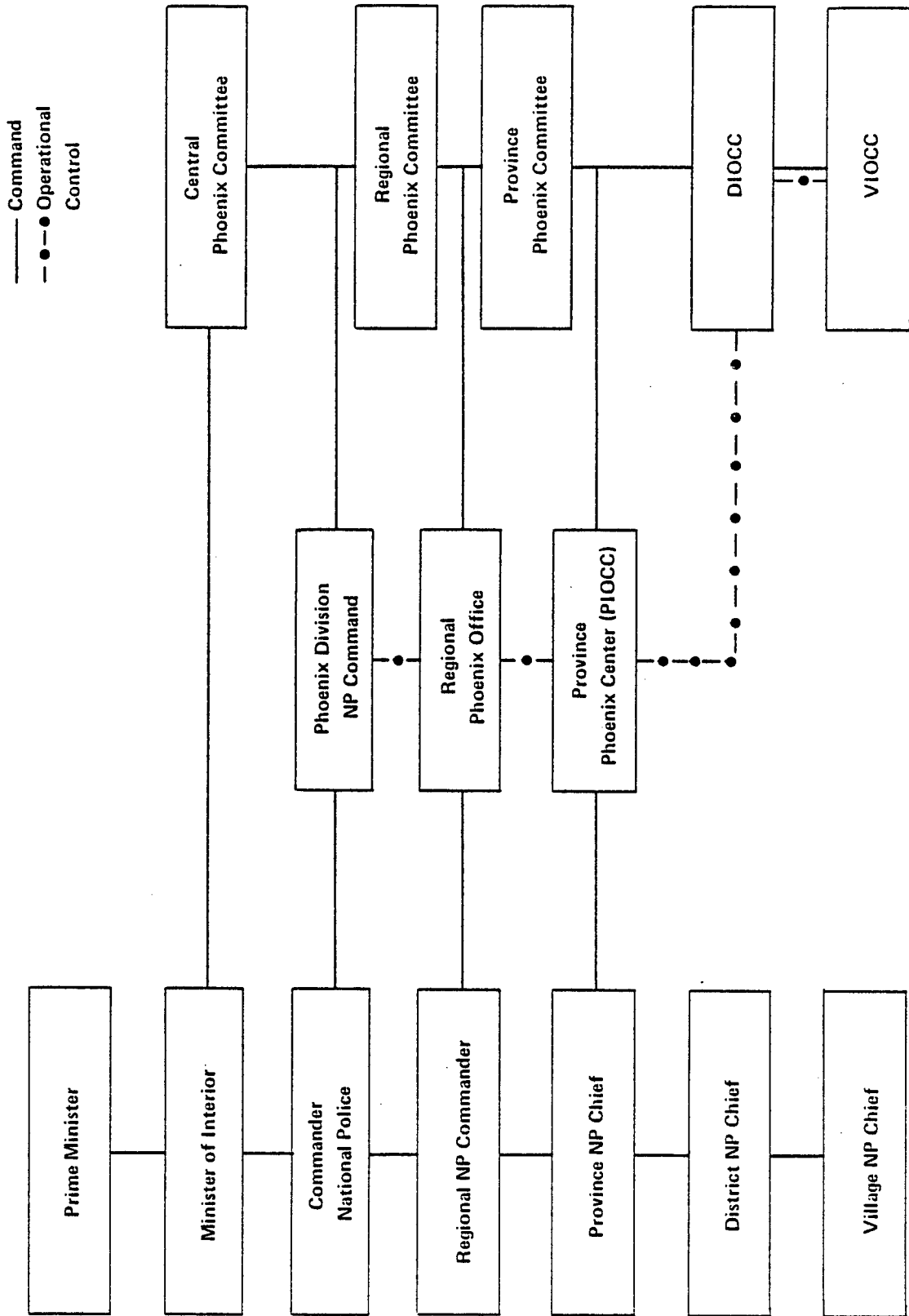
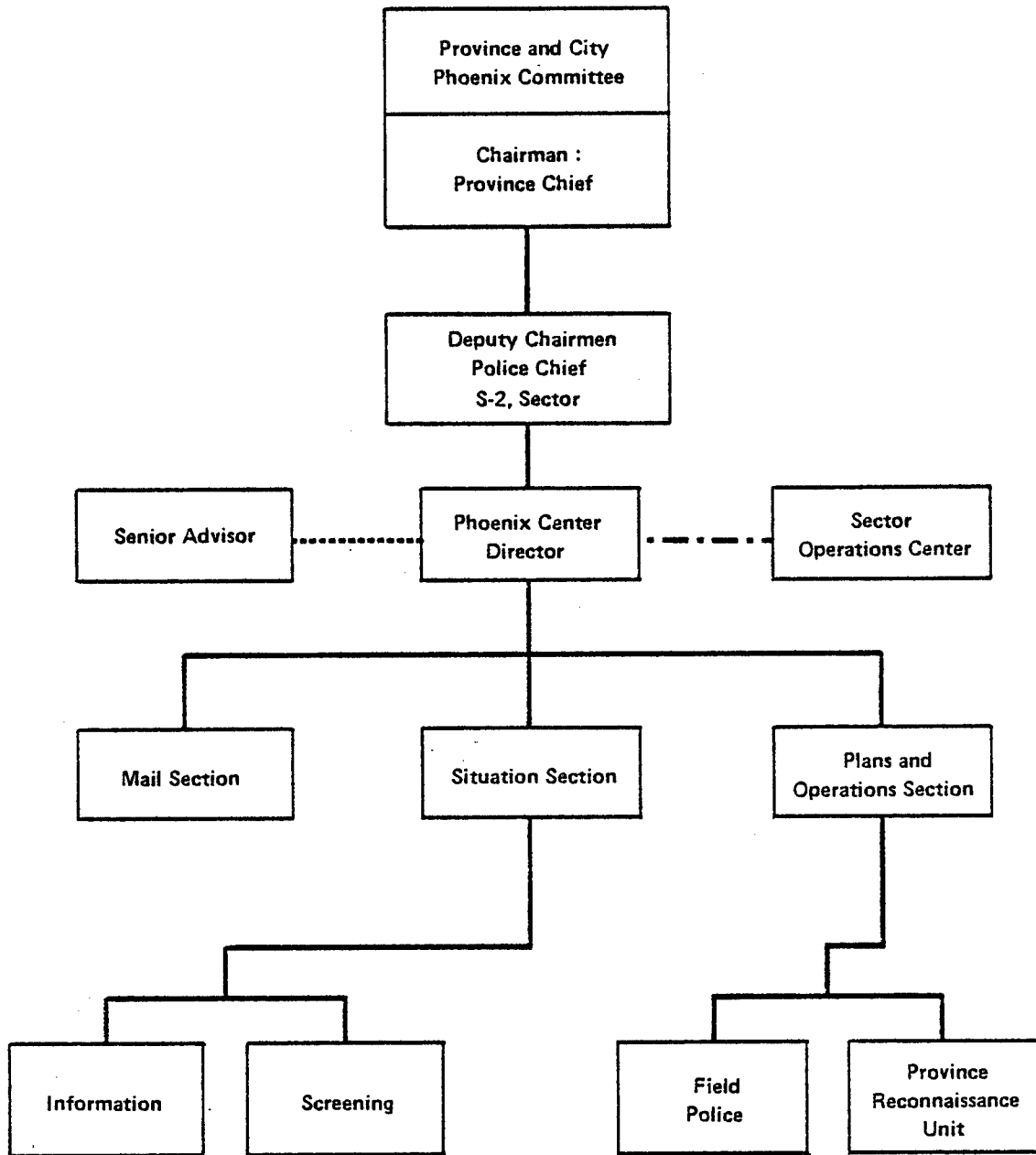
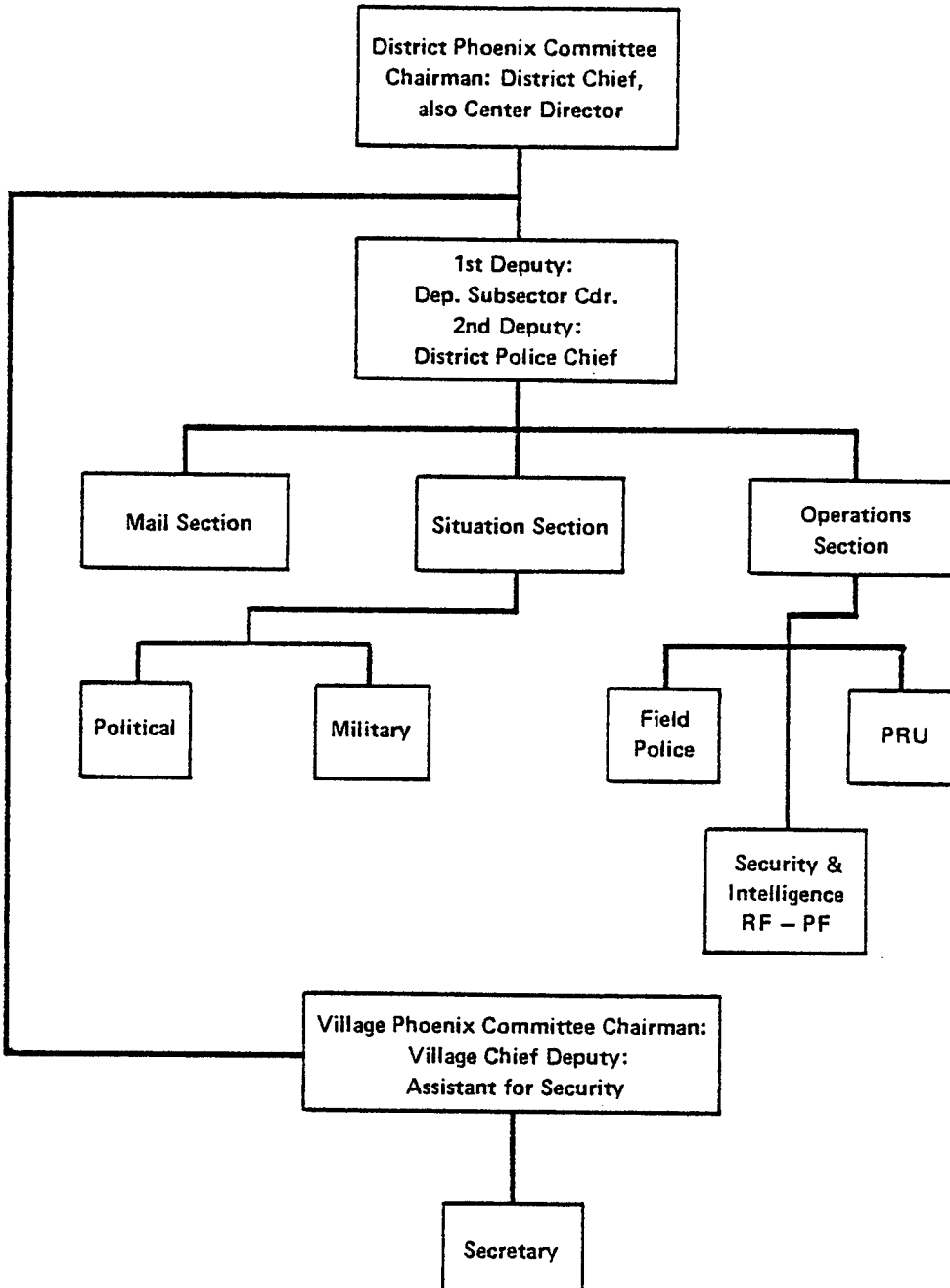

Chart 15 – Organization, Province PHOENIX Committee



————— Command
 Advisory
 - - - - - Coordination

Chart 16 – Organization, District PHOENIX Committee



PF units participated in operations designed to attack and destroy the VCI. For example, these units provided the information, held or cordoned the target, and protected searching and screening parties made up of the special police, police field force, and military security personnel.

Information on the VCI, collected by intelligence agencies during military operations, or by the provincial interrogation center, was immediately disseminated to related units or agencies, to the DIOCC, and to the provincial permanent center for exploitation.

Provincial reconnaissance units (PRU) conducted special operations to collect or exploit information and participated in combined operations with other forces. Organized and armed by the US Embassy, PRUs were placed under the control of and employed by the provincial police chiefs when the National Police was assigned the responsibility of implementing the Phoenix program. Together with police field force units, PRUs made up the main police striking force in the task of eliminating the VCI.

The National Police was the principal active component of the Phoenix organization. The Special Police were responsible for collecting, corroborating and evaluating information concerning the VCI. The police field force units were the NP reaction forces who actually conducted police operations designed to destroy the VCI.

RD cadre teams were also given the mission of supporting the elimination of the VCI by providing information leading to the discovery of the VCI and participating in reaction operations conducted by friendly forces.

Chieu Hoi (Open Arms) cadre, because of their specialized knowledge of the enemy, were particularly useful in the elimination of the VCI. They were most effective in appealing for enemy personnel's return and providing support to intelligence collection activities or reaction operations. Selected returnees were employed in the interrogation of VC suspects or to identify VCI personnel among refugees.

The enemy infrastructure usually conveyed the general impression that its personnel were a special breed of fanatic Communist cadres. In fact, a distinction had to be made between those VCI cadre who were

truly indoctrinated party members and the sympathizers or common people who were induced into serving in the VCI. In most cases, the second category of VCI personnel was made up of ordinary, poor people who cooperated with the enemy either because of his pressure or for profit. They included smugglers of medicine and other essential commodities plying their trade between GVN-controlled and VC areas.

People detained by police and security forces during military operations were first classified into three categories, VC or NVA soldier, suspected member of the VCI, or undetermined identity. If subsequent interrogation, documentation, police records check, and possibly possession of weapons proved conclusively that the individual was clearly an enemy soldier or a VCI operative, he (or she) was sent to the PW camp (in the first instance) or remanded to trial (if a member of the VCI). If, on the other hand, no evidence was found to implicate the person as a VCI member, he was released. Those detainees who were suspected of being members of the VCI but could not be convicted as such for lack of evidence were placed under the jurisdiction of the provincial security committee which had the authority to either release or detain them temporarily pending investigation. This committee was chaired by the province chief and included the provincial judge or prosecutor, the police chief, the MSS representative, the sector S-2 and representatives of operational forces as members. The role of the MSS representative was particularly significant since the MSS, a counter-intelligence agency, collected and provided information on the VCI to the PIOCC and DIOCC. The committee was empowered to release or detain a suspect at the provincial reeducation center (jail) for a period of time ranging from three months to a maximum of two years. The "trial" of suspects took place once a month and its procedure began with a presentation of records by the police chief. If there were no complications, the committee immediately decided on each case.

This procedure was criticized as unconstitutional and undemocratic because it amounted to a trial without due legal process. However, the GVN contended that it was simply an administrative, not a judicial act, hence not determined by national laws. And since it was not a trial

process in the legal sense the suspect could not have legal counsel nor was his presence required when the committee made its decision.

The reason the GVN resorted to this procedure against the VCI was that it was nearly impossible in most cases to produce enough hard evidence for indictment, yet the suspect's culpability was certain beyond reasonable doubt. Thus to stay on the safe side, the official reasoning went, it was better to detain the suspect than to free the criminal, even at the expense of incurring some wrath. On the other hand, the GVN authorities were faced with the problem of identifying hard-core VCI members from among the suspects who, for the most part, were just sympathizers or innocent people induced into the VCI service under persuasion, coercion or threats of blackmail, or simply to earn a living. To provide enough time for thorough research and investigation, temporary detention of the suspects was necessary.

For all the criticism directed against it, the detention power authorized provincial security committees failed to deter the VCI members still at large since the maximum two years behind bars was not really too high a price for the hard-core VC. Compared to what had been done under the First Republic which outlawed the Communists altogether, detention appeared mild and even democratic. Under President Diem's secret directives, province chiefs were allowed to "dispose of" VCI members in whichever way they deemed appropriate including murder, without legal justification. The VCI members were especially fearful of the "Central Vietnam Special Task Force" organized and directed by Diem's brother, Mr. Ngo Dinh Can in the early 60's. The task force members indiscriminately slaughtered every VCI member they hunted down and this deterred VCI overt activities for some time.

Under the Second Republic, the spirit of democracy was strong and pervasive, precluding the use of harsh measures. Against members of the VCI captured, the strongest measure taken was detention which, to hard-core elements, could be looked upon as a period of rest pending release and renewed activities. To the innocent people detained because of suspicion, however, detention was apt to alienate them from the GVN cause and, under Communist proselyting influence, could well turn them into sympathizers and eventually members of the VCI.

The GVN had no choice than proceed with the program of eliminating the VCI, which could be equated with a military force in terms of destructive effectiveness. GVN officials responsible for the program were fond of saying that eliminating a district or province political commissar of the VCI was tantamount to putting a whole VC company out of action. Given the effect of the program on VCI activities, this was not an inflated statement.

The period from the inception of the Phoenix program up to 1971, which was considered the best year of the RVN in terms of security and pacification achievements, saw a marked decline in VCI activities. Out of an estimated total of 40,000 members recorded by 1971, the VCI suffered 15,603 eliminated or neutralized, broken down into 5,615 killed, 4,391 detained, and 5,597 returnees, or more than one third of its strength. In 1968 the VCI suffered the biggest loss ever in its ranks, because it was pushed into overt military activities in support of the "general offensive-general uprising" campaign.

In retrospect, the Phoenix program can be termed a reasonable success. This success could have been maintained and furthered as long as South Vietnam was free from NVA incursions. Like pacification in general, its achievements could be offset by military reverses. The momentum of the program came to a standstill in 1972, for example, when NVA units launched the Easter offensive. The same was true of the post-cease-fire period during which pacification and other programs suffered severe setbacks in the face of stepped-up enemy attacks which the RVNAF alone, thinly spread as they were and with reduced war supplies, were unable to contain effectively.

The program was also beset by internal problems among which the most serious was the shortage of capable intelligence personnel at the province and district levels for effective coordination of activities against the VCI. Next came the lack of appropriate support and weight given to the program by province and district chiefs who, either because of their overburdened responsibilities or failure to realize the importance of the program and take proper interest in it, placed its execution squarely into the hands of the national police. Left to its own

initiative, the politically-oriented national police was generally reluctant to take forceful actions and became ineffective against the VCI.

Then there was the problem of identifying and prosecuting VCI members operating under cover and living mixed with the population. Identification was particularly difficult against planted agents in crowded urban and suburban areas where the mass of working people lived. Very seldom, if ever, was their presence detected by the national police.

The problem was even harder in the rural areas where village and hamlet councilmen operated in constant fear of retaliation which accounted for their lack of enthusiasm or even dereliction in eliminating the VCI. More often than not, they failed to take action even when they knew there were enemy agents living in the community, for sometimes these agents turned out to be the relatives of certain councilmen themselves. The fear of retaliation led to a propensity toward accommodation and finally developed into a philosophy of "live and let live" which was at the root of passivity and inaction. In a few extreme cases, some councilmen might turn out to be the very VCI that the Phoenix effort set out to eliminate.

CHAPTER IV

RVN-US Cooperation and Coordination in Pacification

The Central Level

Prior to 1968, during which period the Minister of Revolutionary Development (RD) served as secretary general of the Central Revolutionary (Rural) Development Council, all pacification plans and programs were developed by the RD Ministry in cooperation and coordination with US Embassy agencies and other GVN ministries. When approved and signed by the Prime Minister, these plans and programs were disseminated to GVN ministries and the Joint General Staff for implementation.

To develop a pacification plan or program, every year the Central Pacification and Development Council (CPDC) formulated a set of concepts and objectives as guidance for the pacification effort during the year. Before these concepts and objectives were disseminated to the ministries and the Joint General Staff (JGS) for planning, they were subject to discussion and agreement between the President of the Republic and the US Ambassador.

As far as the JGS was concerned, the CPDC concepts and objectives served as bases for planning the military support requirement which was formalized by the annual Combined Campaign Plan, a planning effort jointly made by the JGS and the US Military Assistance Command (USMACV). To the ministries of the GVN, these pacification concepts and objectives also constituted guidelines for their own specific plans and programs which they worked out in coordination with counterpart US agencies.

(Chart 17)

On the military side, the yearly planning process involved the establishment of a combined staff made up of elements from the JGS and MACV. It was this combined staff that worked out the military plan in support of the GVN pacification effort. The combined JGS-MACV staff

Chart 17 — US-RVN Relationship in Pacification, before 1971

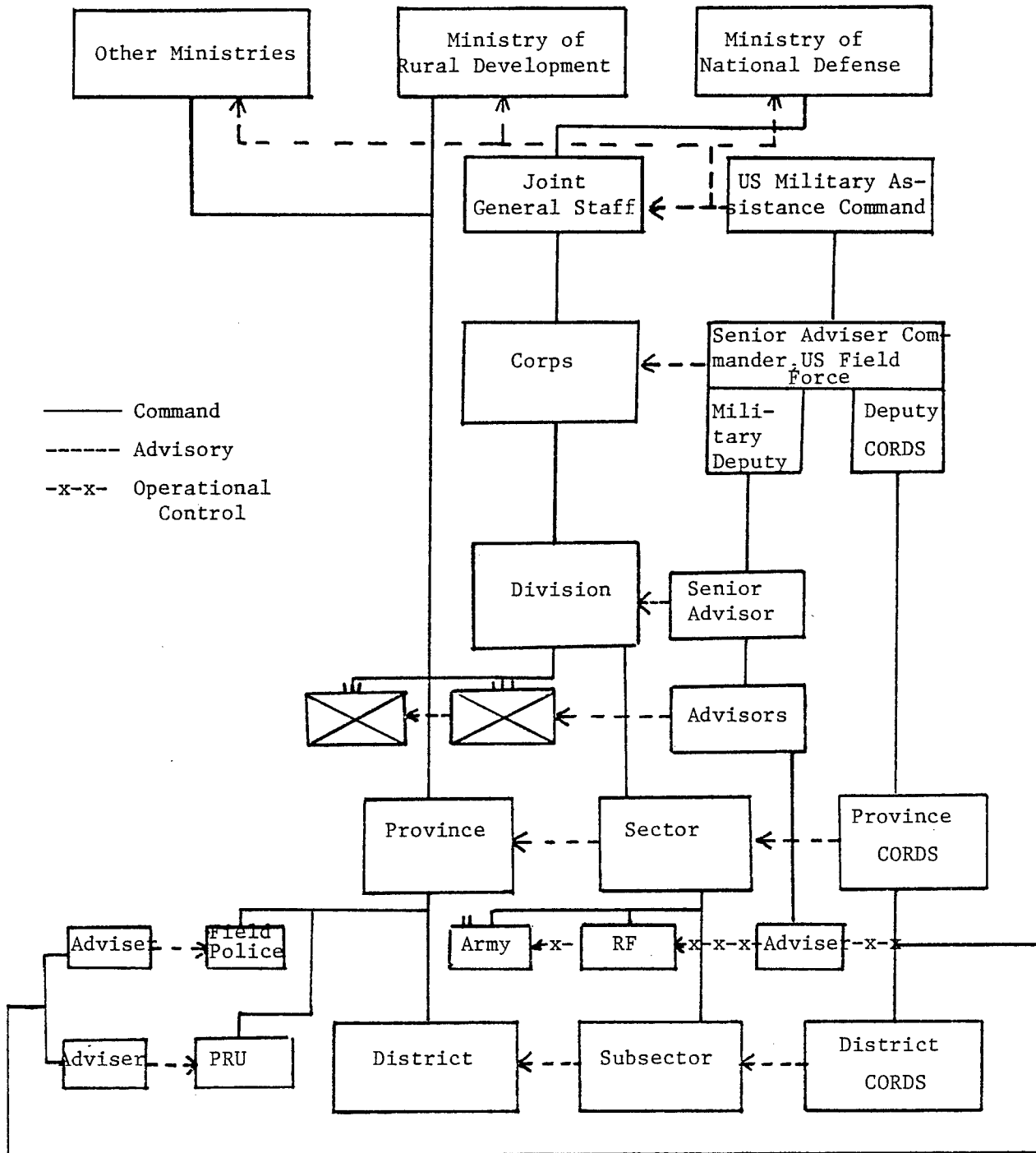

was presided over by two co-chairmen, one from the JGS, the other from MACV, usually general officers. Members of the combined staff on the JGS side included: the Assistant Chiefs of Staff for J-1, J-2 and J-3, the commanding generals of the Central Logistic Command and the Training Command, the director of the General Political Warfare Department, and the commanders of the Air Force and Navy. The Assistant Chief of Staff, J-3 served as deputy chairman and secretary general. On the MACV side, there was the same array of corresponding staff division chiefs. In addition, the combined staff also included representatives of Free World Military Assistance Forces (FWMAF) fighting in Vietnam, such as the Republic of Korea, Thailand, the Philippines, Australia and New Zealand.

As soon as the combined staff was established, the co-chairmen convened a preliminary meeting during which staff components of each side were introduced and working procedures determined. After agreement on working procedures and locations, the co-chairmen proceeded to form combined RVN-US staff subcommittees and assigned specific tasks to each of them. The mission of each combined staff subcommittee was to draft the military plan as related to its staff functions and based on the guidelines provided by the CPDC as well as specific complementary directives as may be issued by the chairman of the JGS and the commander, USMACV. Staff officers of each combined subcommittee cooperated and coordinated with each other during the entire planning process.

During the last meeting session, subcommittees finalized their reports and presented them to the combined staff co-chairmen who sometimes suggested modifications or elaboration before the final draft was submitted to the chairman of the JGS and the commander, USMACV. The final draft was always translated into English and made into two copies: Vietnamese and English. The co-chairmen reviewed the final text of the copies, then submitted them to the chairman, JGS and the commander, USMACV, and after their review and comments, might order another session to make necessary modifications as directed.

The printing of the final text of the plan was usually done by MACV since the JGS did not have the assets required for the rapid production of copies. The final step in the process was a formal ceremony in which

the chairman, JGS and the commander, USMACV signed the documents. Since the plan involved FWMA forces, the commanders of these forces were also invited to attend the ceremony and co-sign the document.

The plan was then disseminated by quickest means to ARVN Corps, US Field Forces, FWMA forces and the services and arms. Upon receipt of the plan, ARVN corps and US Field Forces proceeded to study and work out their own plans, based on the concepts and directives contained in the Combined Campaign Plan. As far as ARVN Corps were concerned, they were responsible for establishing projects, plans and programs in accordance with the basic JGS-MACV plan and in cooperation with US Field Forces concerning military activities. Corps plans were then submitted to the JGS for approval before being implemented. These plans also served as basic guidelines for province chiefs to establish provincial plans.

Central, corps, and provincial plans were completed before the end of the year so that they could be implemented as of the beginning of the new year. To provide effective support for the GVN pacification effort, and also to follow up on the implementation of the pacification plan, the JGS and MACV jointly conducted program review trips every quarter. During these field trips, the chairman, JGS and the commander, USMACV personally visited each corps headquarters where they reviewed the progress being made and gave appropriate directives to help solve problems beyond corps capabilities. These quarterly review meetings were attended by major unit commanders of all forces operating in the corps tactical zone, including US, ARVN, and FWMAF and their staffs. In addition to efforts on the military side, every six months the President of the Republic, as chairman of CPDC, also made field trips to corps headquarters to review pacification progress being made in each corps tactical zone. He was usually accompanied by the entire cabinet and high-ranking military authorities. At each presidential review meeting held at corps headquarters, all province chiefs were present. On the US side, there was also the participation of high-ranking officials from the US Embassy, CORDS, and other agencies involved in pacification support.

The MACV-JGS quarterly reviews centered on the problem of security in each corps area and the military effort made by each corps in support of the GVN pacification program. Of particular interest to the US and RVN military leaders was the employment of military forces. They were mostly concerned to see whether this employment was judicious and responsive enough to each corps area pacification requirements, and whether forces available were appropriately distributed among the four corps areas for the effort. The presidential reviews, on the other hand, focused primarily on national development and the progress made by each province in meeting the pacification criteria set forth by the CPDC.

Apart from periodically scheduled review sessions conducted by the president and high-ranking military authorities, there were also frequent field trips by ministerial representatives, JGS staff officers and their US counterparts. These trips were made to provinces, districts, and sometimes villages, with the purpose of assessing local problems and difficulties and helping local authorities to solve them or giving them additional resources and support, if required.

As was the case with the JGS, every year the various GVN ministries also received guidance directives from the CPDC to establish their own plans and programs. Each ministerial plan was drafted by the ministry staff and signed by the minister himself. These plans became appendices of the annual overall national pacification plan, called the Pacification and Development Plan or the Community Defense and Local Development Plan.

The establishment of these individual plans required elaborate coordination among the various ministries, between the ministries and their US counterpart agencies and between the ministries and the JGS. The coordination was vital and indispensable since the pacification effort required substantial US assistance and support in funding and technicians on the one hand and the guarantee of security provided by military forces on the other.

The task of coordination among civilian ministries was complex and difficult to trace with accuracy since a ministerial plan involved many different elements and required the assistance and support of several different organizations. The Ministry of Agriculture (MOA), for example,

was responsible for making plans and programs related to the development of agriculture. In this program, MOA was required to obtain funds for the purchase of seeds, and for the publication of pamphlets or instructional materials on the use of fertilizers and insecticides for distribution to provinces before the crop season started. It was also necessary to plan for farm credits through the rural development bank, organize and conduct seminars in provinces to help farmers acquire better farming methods, and encourage them to increase the planting of "miracle rice." Also, it was necessary to keep track of special agricultural projects and to train all types of specialists for the provinces in order to guarantee the success of these projects.

To implement this program, MOA had to coordinate and cooperate with several other ministries or agencies. For example, MOA needed the help of the Ministry of Economic Affairs to plan for foreign currency funds for the import of fertilizers, insecticides, and farm equipment. Likewise, the Ministry of Economic Affairs had to coordinate with MOA on rice import and export policies, agricultural products, and farm breeding. MOA then needed the assistance of the Ministry of Finance to reduce tariffs imposed on imported agricultural equipment and machinery. From the Ministry of Defense, MOA had to request special transfers of drafted agricultural specialists serving in the RVNAF so that they could help with programs, help with the clearance of interdicted fishing zones along the coastline, and to guarantee the security for MOA specialists in rural areas. The Ministry of Information was also asked to cooperate in disseminating information about MOA projects and programs by radio and television. To help facilitate the movement of local products to consumer markets across the country, MOA had to coordinate with the Minister of Public Works for the repair, improvement, and development of the communication system. Finally, MOA coordinated with the Ministry of Education to help conduct classes for the training of specialists and to promote the 4T programs in schools, and coordinated with the Ministry of Rural Development and the Ministry of Ethnic Minorities for the attachment to MOA of qualified cadre.¹

¹The 4T program was similar to American 4-H clubs. The four Ts stand for: Than (Health), Tri (Head), Tam (Heart), and Thu (Hands).

The Corps Tactical Zone/Military Region Level

The corps commander, as chairman of the Regional Pacification and Development Council, was responsible for developing a regional pacification plan. The CTZ pacification plan reflected the regional variances and was designed to reach the regional objectives set forth by the CPDC. It was developed in cooperation and coordination with the US Field Force as far as military or operational support was concerned and with ministerial representatives and the regional CORDS in matters dealing with civilian programs. As soon as the CTZ pacification plan was approved, it was disseminated to divisions/DTAs and to provinces for planning. The DTAs were primarily responsible for planning tactical operations to support the provinces while the provinces had to plan for every activity to implement the program. To develop his own pacification plan, the province chief had to rely on directives contained in the corps plan and reinforcement support provided by the DTA or CTZ. The provincial pacification plan was reviewed by the corps commander before being submitted to the CPDC for approval.

As chairman of the regional pacification and development council, it was the corps commander's prerogative to reject or modify province plans. In a few cases, he just returned the plan to the province chief for modification. In general, however, the corps commander seldom exercised his prerogative and usually transmitted province plans as they were submitted.

The most difficult problem encountered by corps in providing support for the provinces was the shortage of military forces. There were several ways corps could solve this problem without asking for additional forces from the JGS. The corps commander could redistribute territorial force allocations; request additional authorized strength in territorial forces and allocate the authorized spaces to needy provinces; redeploy regular forces or deploy RF units from one province to another for short durations; and coordinate with US/FWMA forces for operational support if corps organic forces had been fully committed and in case the areas to be pacified lay within the US/FWMA areas of responsibility.

The redistribution of territorial force allocations was most widely used since it was within one commander's authority. Several provinces were plagued by a constant shortage of territorial forces due to exhausted manpower resources and difficulties in recruiting and replacements. The 1968 general mobilization law, for one thing, authorized only the conscription of male citizens aged 18 and above, while the Viet Cong effectively pre-empted this manpower by abducting teenagers of 17 and 16, sometimes younger, into their ranks. As a result, territorial units were constantly under strength and their authorized quotas were never fulfilled. To solve this problem, a corps commander could transfer the unfulfilled authorized strength quotas to other provinces that enjoyed abundant manpower resources and recruiting facilities. This redistribution of allocations would then be administratively adjusted by the JGS. It was an effective means that permitted the increase of territorial forces on the one hand and the release of regular ARVN forces for operational purposes on the other.

The primary role of US and FWMA forces was to conduct search-and-destroy operations against enemy main force units and bases. However, in case an area targeted for pacification lay within the TAOR of a US or FWMA major unit, coordination with the US Field Force could be made so that the operational activities of this unit helped in the pacification task. Sometimes search-and-destroy operations conducted by US and FWMA forces near pacification areas could be tremendously beneficial, although indirectly, to the pacification program by keeping enemy forces away from these areas.

Similarly, the deployment and disposition of ARVN forces to expand GVN control could be beneficial to US and FWMA areas of tactical responsibility since ARVN forces might interdict the penetration of enemy forces in the areas. In general, there was an effort to combine or coordinate combat activities between ARVN and US forces to provide the kind of mutual support that benefited both.

The Division Tactical Area Level

The DTA was responsible for providing military support for the pacification program through the tactical employment of its regular forces. Provincial pacification plans were usually worked out with the assistance of the DTA since they involved sizable military support by regular forces. During the planning phase, the division commander usually advised the province chief as to what regular forces would be available for his support, and the division senior adviser provided advice and assistance to the ARVN division commander on the coordinated employment of forces and combat support. When the plan was implemented, the division senior adviser assisted the DTA commander in requesting US support. In this regard, the division senior adviser constantly coordinated and exchanged viewpoints with province senior advisers to ensure adequate support for the provincial effort in pacification.

The employment of forces within a DTA to support provincial pacification programs was subjected to careful consideration and planning. The primary concern of the DTA commander when planning the employment of his forces was directed at such questions as: What would happen to the overall DTA situation once forces had been committed to the province? Was there any reaction force left for the division to be used when required? Was the relocation of forces to the provinces judiciously made? Would the provinces be able to employ correctly and judiciously the attached regular forces? Such worries compelled the DTA commander to constantly monitor the employment of his forces and to plan for contingencies in close coordination with his adviser. It became the rule for most DTAs that an infantry division never fully committed all its forces for pacification support. It always retained a reasonable reaction force for use in emergencies.

The Province/Sector Level

In his role as chairman of the province pacification and development council, the province chief was responsible for establishing the

provincial pacification plan, in close cooperation and coordination with the province senior adviser, the ministerial service chiefs of the province, and other civilian and military agencies. The provincial pacification plan was reviewed by Corps/MR, then submitted to the CPDC for approval. When the plan had been approved, funds and material required to support it were directly allotted to the province chief. As far as military support was concerned, it was provided by the DTA upon approval of the corps commander. Corps could also provide support to the province by allotting authorized RF/PF spaces for recruiting purposes.

The province chief was not only the planner of the provincial pacification program, he was also its executor. In general, most provincial shortcomings which usually delayed pacification progress could be traced to three major shortages: support forces, materiel, and cadre.

With the assistance of his senior adviser, the province chief had to plan for the effective employment of forces allotted by the DTA or corps. He had to decide where to employ regular forces, where to employ territorial forces, and where to replace regular forces by territorial forces. He had to base such decisions on the particular areas to be pacified and the province's ability to recruit and train new troops so that when the pacification program started, he would have adequate and readily available support forces.

Once funds and materiel were made available to a province, the corps commander had to maintain the amount of regular forces committed to its support as required by the province plan. If a transfer of these forces was contemplated for any reason, the corps commander would have to ensure that they be replaced by other forces.

There was some rigidity in the way province plans were implemented. Unless warranted by extremely adverse circumstances, a plan usually underwent few changes during the course of the year. For one thing, it was geared to the funds and materiel the province had requested. In practice, however, the province did not always obtain what it needed in time, and there were many reasons for this. First, there were not enough transportation facilities; most of the materiels were import items and their availability depended on delivery schedules; and finally,

materiel was damaged or lost during transportation. Although seemingly unimportant, the shortage of materiel such as barbed wire, iron posts, and cement, adversely affected the provincial pacification effort. In order to provide timely and adequate support to the provinces, US agencies closely monitored the delivery and movement of materiels and took care not to cause undue obstacles to the provincial pacification programs. Sometimes, to gain time and speed up the delivery of materiel, ARVN corps obtained temporary loans from US Field Forces for such items as barbed wire, fence posts, boards, and cement, and distributed them to provinces as advance issues to be reimbursed when imported materiels were delivered.

An Evaluation

US assistance played a vital role in the total pacification effort, beginning with the top level where the GVN ministries, as planners and supervisors of their own programs, seemed to need it the most. They were usually plagued by a shortage of personnel required for the various programs. In addition, there was not always qualified cadre for all specialized fields. Training and qualifying such specialists in sufficient numbers took a long time and close support from various US agencies. Planning for specialist requirements was also a time-consuming task since it involved the compilation and review of individual requests received from all the provinces. Despite these shortcomings, the assistance provided by CORDS and other US agencies usually satisfied every need in personnel training required by the ministries. This was due to the very close cooperation and coordination between the GVN agencies and CORDS and other US agencies. Every plan and program was subject to careful studies by both sides.

At the CTZ/MR level, however, it seemed that the US side usually held the initiative in planning. For one thing, at this level there was always a substantial US staff with a wide variety of specialists and qualified personnel. Sometimes a plan was subjected to careful studies by the US staff for five or six months before actually being

forwarded for the first time. In general, US Army staffs were made up of talented and experienced officers who had become experts in their own right. They were extremely efficient and helpful in assessing and evaluating pacification results. In particular, they proved to be unequalled experts in evaluating hamlets, monitoring and assessing the employment and capabilities of territorial forces, and in monitoring the implementation of such programs as Phoenix, Chieu Hoi, and war refugees. Their contributions of opinions, ideas, and suggestions were always pertinent and valuable for remedying deficiencies; their role in pacification support was particularly valuable and in many cases indispensable.

On the RVN side, it was admitted that at the field levels, corps and division, staff officers did not always possess a thorough understanding of the pacification concept and its programs. As a result, most of the planning was initiated and undertaken by the US side. At the beginning of the pacification effort, for example, a plan disseminated by the central level to corps was merely duplicated and sent verbatim to provinces without comments or specific guidance. The corps staff responsible for pacification usually consisted of inexperienced officers who were not familiar with planning or studies and often they were assigned to pacification because they did not fit into any other staff capability. As a result, corps were unable to make studies or plans that could help improve the pacification effort.

By contrast, at the execution level, i.e., province, there were many talented and experienced province chiefs. Some held their positions for several years and consequently had a full grasp of provincial problems, the local terrain and the local population. Others had innovative ideas and achieved spectacular gains in pacification. Province senior advisers usually stayed in their jobs only one year, or sometimes a little longer, and as a result they were not entirely knowledgeable about the province and its pacification problems. Nevertheless, they played key roles in providing assistance and support for their counterparts. If a province was well supplied with materiel or received adequate military support, it was invariably due to the province senior

adviser's active role. His connections and resourcefulness were invaluable assets that made him extremely useful to the province chief. Through his connections with higher echelon commands, for example, a province senior adviser could always communicate his counterpart's problems and obtain immediate response and help. Sometimes a province senior adviser even used MACV or the US Embassy leverage to get things done quickly through the ARVN or GVN channel in support of his counterpart; advisers were effective in cutting through red tape.

The role of the district adviser was particularly a difficult and demanding one, even more so than that of the province adviser. To be effective, the district adviser had to assume a dual role: military and political. He advised and assisted the district chief not only in military and operational matters but also in the use of national resources, the supervision of village and hamlet councils, civic actions, and public relations. In other words, the district adviser had to double as an administrative and political counselor to help his counterpart manage district affairs. Given the relatively young and inexperienced district staff and the extent of work involved in the management of a district, the adviser's role was an uphill task indeed. To give an example, each district managed an average of 30-40 PF platoons, three to six RF companies, thousands of PSDF, police field force, and the RD cadre.

But by and large, US district advisers performed extremely well despite the alien environment. Mostly young army officers at the beginning of their assignment, they usually became inveterate oldtimers of the Vietnam war, wiser though not older, and extremely adept at handling counterinsurgency problems by the time their tour of duty was over. Their contributions to the pacification effort were most significant in the areas of security and rural development. As a special breed of politico-military advisers, they were very popular with the local officials and population.

In summary, US senior advisers at the province and district level played very important roles in pacification support and made substantial

contributions to the provinces and districts where they were assigned. There were indeed several advisers who were more active and devoted to pacification than their counterparts. Many were seen making visits to villages and hamlets if there was a requirement to know more about the real situation. Finally, there were many who sacrificed their lives in the pursuit of their advisory duties.

CHAPTER V

Pacification Techniques and Operations

The pacification process usually began with a tactical operation which went through three major phases, each involving the employment of different forces.

In the initial phase, regular ARVN or territorial forces or both conducted a securing operation in the area targeted for pacification. Their objective was to destroy or drive away enemy main or local force units and guerrillas. Since the area to be pacified was usually populated, the use of firepower was subject to limitations to minimize casualties and damage. As soon as the enemy units were destroyed or driven away, friendly forces usually broke down into small elements for a careful search to destroy the remnants of the enemy or those enemy who tried to escape by mixing with the populace. At the same time, psywar and propaganda activities were conducted, first to publicize the victory and secondly to intimidate or proselytize enemy cadre into surrendering or rallying to the GVN side. At night, small units conducted and laid ambushes around the village to prevent the enemy from escaping under the cover of darkness. After a period of two or three days, they deployed to adjacent areas to pursue the enemy still in the area or to strike into enemy bases or communication routes nearby to prevent the enemy from staging a comeback.

During the second phase, while friendly forces shifted their activities further away to ensure complete protection for the village, cadre teams and regional forces began to enter the village to take over control, replacing the operational forces. This was time for the true pacification effort to begin. By this time, local guerrillas

and the VCI in the village had either been destroyed or neutralized, but there might still be some elements hidden in underground shelters. The mission of the RF was to provide security and protection for the national cadre teams and to conduct searches to root out any remaining enemy. National cadre teams then began the process of separating the enemy from the people. This process consisted of investigation, screening, classification, and checking identification papers. This job was performed by the national police. Other cadre organized an information and propaganda service, initiated civic action programs, and conducted meetings during which they explained the purpose and merits of the pacification program. They also began to organize village defense systems and the election of village officials who would make up the village administrative council. Regional forces, meanwhile, started building watch towers and other fortifications to consolidate the defense system. The goal was to demonstrate to the villager the credible presence of security forces who would stay in the village as long as required to protect them.

The last phase was devoted to developmental works. It began as soon as the village had become secure and free from enemy interference or harassment, either by the VCI or guerrillas. National cadre teams began long-term works such as building a school, a maternity ward, an information office, a market place and repairing roads, and erecting bridges. All these efforts had the goal of bringing about security and prosperity for the villagers and letting them appreciate the contrast between what the GVN was doing and what the enemy had said they would do.

The division of a pacification operation into three separate phases was purely theoretical and phases were not identified in terms of time elapsed but rather by actions taken. All three phases could begin simultaneously if conditions permitted; also, an operation might never get beyond the initial or securing phase. The succession of phases was contingent upon the security situation and counteractions of enemy forces in the area.

Pacification Techniques

First priority in pacification was usually given to populated and economically prosperous areas, urban centers, and villages and hamlets bordering on vital lines of communication and waterways. As soon as these areas were pacified, the effort would shift to adjacent areas. The idea was to spread out as an "oil stain" from secure areas into less secure or semi-secure areas, and from there into insecure areas. Areas targeted for pacification which were termed semi-secure or insecure were usually selected so that they interconnected with secure areas by convenient communications.

Cordon-and-search was a technique designed to search for and destroy the enemy in which a large military force was used to encircle and seal off an area, usually a village or hamlet. It was usually conducted by night to obtain the element of surprise. A force conducting a cordon-and-search operation usually consisted of two elements: a cordon element to encircle and seal off, and a search element which looked for and destroyed the enemy inside the cordon. The cordon force stood ready to counteract any enemy effort to deploy his reinforcements from other areas in order to relieve the elements that had been surrounded, or to face reactions from the enemy being encircled.

After the target area had been sealed off, the search element would wait until daybreak and only then did its members enter the area and began searching. This was when, caught by surprise inside the trap, enemy guerrillas or VCI cadre, or even fugitives such as draft dodgers, deserters and criminals, attempted to slip out through the cordon. The cordon force on the outside perimeter then would arrest them or destroy any enemy element who resisted. The searching task was planned in minute detail and the target village divided into several sections; each search party was assigned a specific section. The search was a painstaking and time-consuming process

which required patience and a thorough familiarity with enemy methods of camouflage and concealment. Enemy underground shelters or weapon caches were usually well laid out and skillfully camouflaged and search parties were carefully trained in enemy concealment and camouflage techniques.

In general, regular ARVN units were employed as the cordon force. They were sometimes augmented by US or FWMA forces if the objective area lay within a US or FWMA TAOR. Search elements were usually made up of RF and PF units, the national police, and sometimes PSDF. The success of cordon-and-search operations depended on detailed organization of forces, close coordination, effective control, thorough understanding of the roles to be performed by participating forces and adequate training in search techniques.

Security patrol activities constituted a technique to search for and destroy enemy forces. There were several forms of searching and destroying, each of which utilized a different technique.

Patrols were used against guerrillas and small units. Patrols were small and lightly equipped, but capable of operating independently. Their mission was to attack and annihilate the enemy, if he was of small size, and to locate or follow large enemy units. They then called on large friendly forces, tactical air or artillery to destroy them. Troops selected for patrols were good combat soldiers - courageous, audacious - with high morale. Patrols were deployed far from their base for periods of from three to five days without support or resupply. Their activities helped the main force rest and recuperate, and stand ready to strike when required. This employed the principle of economy of force.

Another technique used in pacification, especially during the securing phase, was hunter-killer teamwork. This technique was designed to hunt down and destroy isolated enemy elements such as VCI cadre and guerrillas. The hunter-killer team consisted of two elements: the hunters and the killers. The hunter element was lightly equipped and highly mobile. Its mission was to track down enemy forces while maintaining constant touch with the killer element, which stood ready for action. When contact was made the hunter

element notified the killer element which swiftly moved in with tactical air and artillery support. The killers usually moved into the target area by the swiftest means, by helicopters in most cases, to prevent the enemy from breaking contact and escaping.

Terrain transformation was a pacification technique designed to transform an insecure, enemy-controlled area into GVN-controlled villages and hamlets. It was employed in all military regions and with significant success by the ARVN 3d Infantry Division in western Duy Xuyen district, Quang Nam province.

The security situation in Quang Nam province was poor; the enemy frequently attacked friendly forces and shelled Da Nang airfield. Three months before the cease-fire, the 3d Infantry Division was assigned the mission of restoring security and protecting the Da Nang airfield in particular. For this mission, the division created a security zone for Da Nang city out to the range of enemy rockets and artillery - an anti-rocket and anti-shelling belt. At the same time it made plans to restore security to the area west of Hoi An (15 miles southeast of Da Nang) through an intensive pacification campaign which encompassed all the villages and hamlets in this area. (*Map 2*) Nevertheless, a larger part of the province, the flat plain area in particular, was still under enemy control. This terrain was covered by lush vegetation and crisscrossed by rivers and streams; it included many natural obstacles and the enemy had established many bases which were connected by a trench network and surrounded by mine fields, booby traps, and extensive defense positions. Up until that time, operations into this area had met with serious difficulties and heavy losses.

About three days before the cease-fire became effective, the 3d Infantry Division clashed violently with the NVA 711th Division and inflicted serious losses. With the 711th Division nearly paralyzed, the 3d Division redeployed its forces to hold ground and maintain control of the population in the area around Da Nang. With the ARVN 3d Division spread out, the enemy renewed his attacks and threatened to destroy the 3d Division piecemeal.

Map 2 — Quang Nam Pacification Campaign

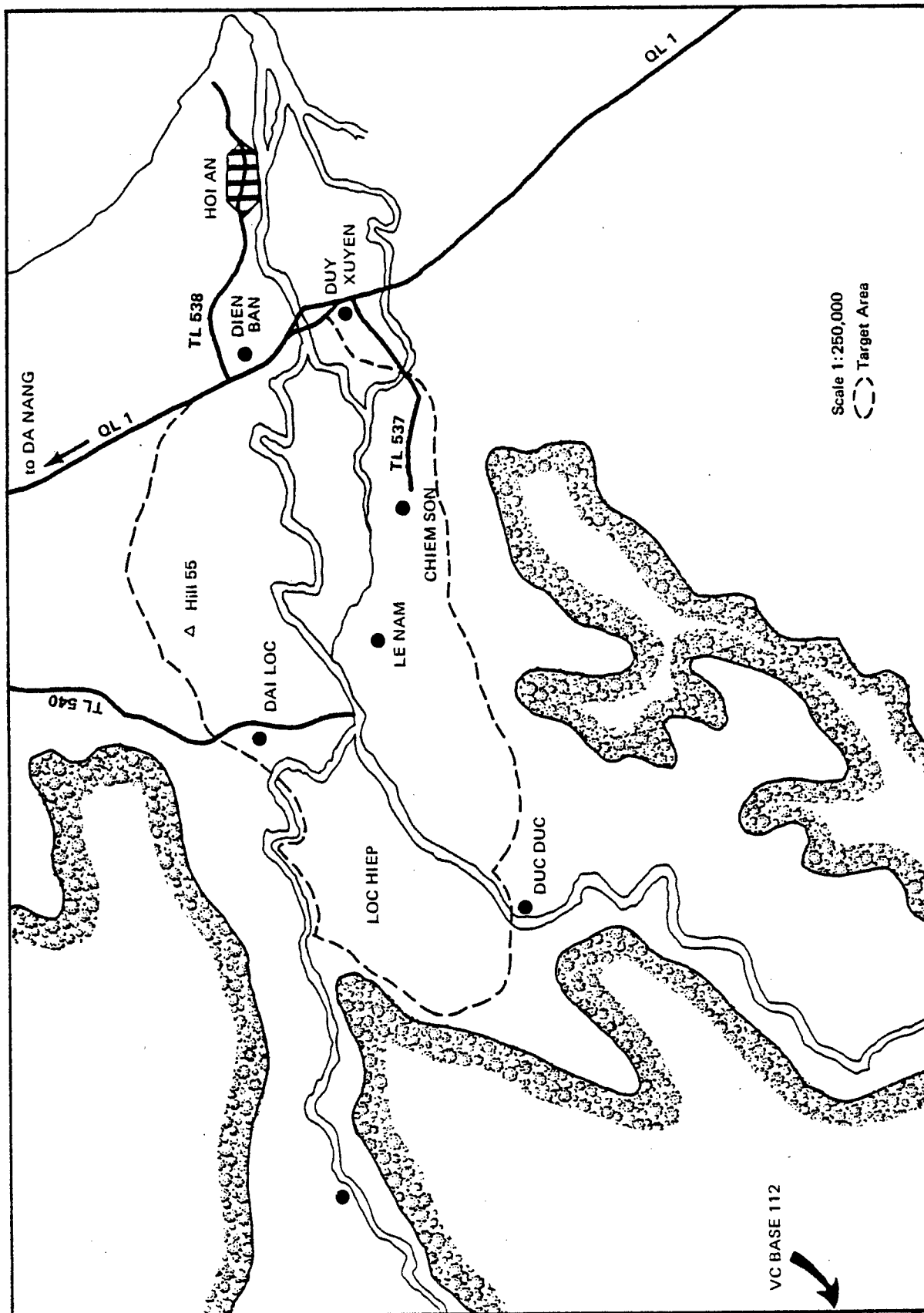

With additional support from engineer and armor elements, however, the division was able to stabilize the situation and regain the initiative. As the first step in the pacification effort, the division used bulldozers to clear the densely vegetated areas where the enemy sought cover. Then it deployed the 57th Infantry Regiment to occupy Hill 55, the Go Noi area, and the area northwest of Duy Xuyen district town. The 2d Regiment, with armored reinforcements, meanwhile crossed the Thu Bon river and reoccupied the Loc Hiep area.

After destroying enemy bases in this area, the 3d Division maintained its disposition of forces throughout the area, not only to confront the enemy, but also to demonstrate to the International Commission of Control and Supervision (ICCS) that the area was under effective control.

Terrain transformation operations were also conducted in several villages and hamlets in the Go Noi area, and others in the districts of Dien Ban, Dai Loc, Duc Duc and Duy Xuyen. The villages and hamlets in this area had not been under GVN control for ten years, and the enemy had turned this fertile but densely covered area into a fortified and defended base system. In addition to having the advantage of the protection provided by natural obstacles and an elaborate system of fortifications, minefields, and booby traps, the enemy was thoroughly familiar with the terrain. Most of the local population had migrated toward other localities, and those remaining consisted of about 300 households, the majority of which had connections with or relatives among enemy ranks.

In order to reoccupy this heavily defended guerrilla base area, which sheltered the enemy 44th Front forces and other local force units, it was obvious that friendly forces had to be sizable and adequately supported. The 3d Division made sure that all of its units were built up to strength before launching the operation. Its basic maneuver concept was to overrun the enemy positions with an overpowering force, inflicting on him maximum losses and forcing him out of the area. Despite heavy casualties to friendly forces, caused mostly by enemy mines and booby traps, the 3d Division succeeded in overrunning the area and driving enemy forces away. Then its forces

held the area and proceeded systematically to eliminate remnants of enemy forces, not only there but in adjacent areas. Its goal was to secure the target area and prevent the enemy from coming back.

In order to achieve this, the 3d Division obviously needed more troops but since reinforcements were hard to obtain, it made use of the terrain transformation technique. The first requirement was to destroy all enemy fortifications, trench and shelter system, minefields, and booby traps. In addition to manpower, artillery firepower and bulldozers proved highly effective in this task. Within a short time, the area was effectively cleared of all obstacles and its outlook was entirely transformed. Then engineer units began to repair roads and build new ones, and finally devoted themselves to the task of rebuilding the villages and hamlets without altering their configuration and boundaries.

The next phase consisted of consolidating the defense system by the building of outposts and watch towers and by maintaining security. For this purpose, the division permanently installed one of its infantry battalions in the area. The battalion established its operational base at Le Nam and employed its companies in constant mobile operations in and out of the area. The presence of regular friendly troops inspired confidence among the local population, who realized that they could stay in the area indefinitely. This was entirely different from previous sweeping operations.

To maintain security, 3d Division troops conducted searches, patrols, and ambushes. These activities gradually eliminated the enemy infrastructure, rehabilitated roads and buildings, and paved the way for the next phase of reopening the area. At the same time, popular force platoons were introduced into the area and they were deployed to occupy the Chiem Son area and to secure a series of hillocks connecting it with the Le Nam area. Regular forces, meanwhile, held the areas of Tra Son and Duong Dong, to the south. Part of the Go Noi area was taken over by regional forces.

By this time, security had been restored over the entire area and soldiers were encouraged to grow manioc and vegetables during their idle hours. To begin resettling the population in the villages

and hamlets north of Duc Duc and west of Xuyen Truong, the ARVN regimental commander and the district chiefs worked out plans to return those village officials who had fled the area to their original villages and hamlets in the district of Duy Xuyen and north of Duc Duc where they would reestablish local government, with the assistance of the national police and popular forces; return the people, the refugees in particular, to their home villages; build watch towers and village offices; and conduct training and combined ARVN-PF activities.

These efforts brought about remarkable results. With the help of ARVN units, the local people gradually moved back. ARVN units conducted medical civic actions, while competing with one another to build market places and schools. Encouraged by these ARVN efforts, people from outlying, insecure areas soon moved into the area, and even people who had fled and had lived in the province capital for a long time returned to their villages.

As the security situation improved, the number of people returning to their villages increased. The village councils began organizing people's self-defense forces and taking a census of the population. By the time the provincial and district governments initiated development programs, all the villages and hamlets in the area had been resettled and were living in stable, peaceful conditions.

The technique of terrain transformation was first used by US forces against the enemy's "iron triangle" base area in MR-3. It involved the use of heavy bulldozers to level bunkers, trees and destroy underground shelters during a period of several months. Against another enemy base area, Ho Bo - Bo Loi, US forces also used napalm bombs to burn down whole stretches of dense jungle. The purpose of these operations was to deny enemy forces a safe haven to conduct and support spoiling activities against the GVN pacification effort in Binh Duong and Hau Nghia provinces which were adjacent to these base areas. Without these operations, no progress in pacification was possible in these provinces.

In MR-4, the liquidation of Communist mini-bases, using the same technique, was conducted on a large-scale from early 1970 to

early 1972. These were usually swampy and densely covered areas located along canals and near inhabited hamlets. Heavily mined and booby-trapped, these mini-bases had been considered impenetrable despite their close proximity to GVN-controlled hamlets.

Another special pacification technique was the county fair or village festival - a combination of cordon-and-search, civic action and intelligence collection. It required the formation of a special task force which consisted of cordon units, search elements, and a village festival organization.

While the missions assigned to the cordon units and search elements were the same as those given to similar elements in a cordon-and-search operation, the village festival organization added another dimension: winning over the hearts and minds of the population by psychological and civic actions, and at the same time gathering information on the enemy infrastructure.

The village festival organization consisted of a provincial element and an ARVN element. The provincial element included an RD cadre group, the national police, and popular forces. The RD cadre group was the principal actor in the village festival show. It usually consisted of several teams: an information team, an armed propaganda team, a cultural team, an agricultural team, and a small artist troupe. The information team organized film shows, distributed propaganda materials and held education sessions for the villagers to promote the GVN cause and policies while countering enemy propaganda. The armed propaganda team, which was usually made up of former enemy ralliers, served as guides and informants to the NP and popular forces. They pinpointed the families that had members working with the enemy, families that sympathized with the enemy and whose members had regrouped to North Vietnam, and finally, enemy weapon caches, underground shelters, and messenger routes. The agricultural team provided guidance to the farmers on improved techniques of crop planting and livestock breeding. The cultural team organized games and sports, while the artist troupe performed short propagandistic plays, songs and variety shows.

The National Police element usually included an interrogation

team, an identification team, and the Special Police. Its mission was to check identification papers and family records, take photographs and fingerprints, search suspect areas for enemy documents, organize an agent net, interrogate suspects, and supply information to friendly forces. The popular forces conducted a census among village youths to establish a list of draft-age people and to try to recruit them into their ranks.

The ARVN element usually consisted of a MEDCAP team and a psywar team. The MEDCAP team organized sick calls and a dispensary service, and also distributed candy for the children and clothing for the poor. The psywar team held political indoctrination sessions to brief the population on the purpose of pacification and on the reason why GVN troops came to the village. It also maintained morale among friendly troops and made appeals to enemy cadre, persuading them to surrender or rally to the GVN cause.

The technique of village festival was chiefly employed in those villages and hamlets where the GVN wanted to maintain permanent control and presence and the emphasis of the entire effort was on winning the sympathy of the villagers and gathering information on the enemy.

Coordination in Security Activities

Because the pacification effort involved the conduct of security activities by a variety of military forces, coordination was vital for its success. Aside from tactical coordination among operational forces of different nationalities in case of combined activities, coordination between operating forces and the local government was the most important, since military activities in support of pacification were generally conducted in populated areas. When US forces operated separately, coordination with the local government was usually made through the local adviser. One of the major concerns was to minimize casualties and damage caused to the civilian population. The use of firepower, whether by tactical air or artillery, on an area targeted for pacification was, therefore, subjected to elaborate regulations and directives that both the JGS and MACV agreed to publish in a

joint Standing Operating Procedure (SOP) for ARVN as well as US forces.

Two examples of coordination in security activities are provided to show how it was actually done.

1. Combined Activities of US Marines and GVN Popular Forces.

This was a valuable experience which was started by US Marines in the 1st CTZ (MR-1) as soon as they completed their initial deployment in this area in late 1965. One of their immediate tasks was to initiate a pilot program of pacification in populated areas near Da Nang, and after this proved a success, the program was expanded to other areas around Hue. The key element of this program was the concept of "combined action" which joined small US Marine elements with popular forces platoons. This concept was based on the premise that the PF were the GVN forces that enjoyed the closest relationship with the population. They were no strangers to the villages; in fact all of them were relatives of villagers. They knew the local people, the local enemy, and the local terrain. But at the same time, PF were loosely trained, poorly equipped, and poorly led. Thus the combined action concept was also designed to train these forces and make them combat effective.

The combined action program called for the deployment of US Marine squads in villages where each of them was integrated with a PF platoon; they lived and operated together as a single unit. A US Marine squad was further broken down into teams or cells which teamed up with PF squads to improve their combativeness, make maximum use of firepower, and familiarize PF troops with Marine combat techniques. The presence of US Marines among PF platoons inspired confidence and boosted morale and combat effectiveness.

A combined action platoon (CAP) was an integrated unit consisting of one 14-man US Marine squad and a PF platoon whose authorized strength was 38 men. Their mission was to help maintain law and order in the villages where they were stationed; to conduct patrol and ambush activities; and to gather intelligence and perform civic actions.

The US Marine squad leader could call for tactical air and artillery support and medical evacuation by helicopter. This capability was the main source of PF morale, although the support was

seldom needed. To control and supervise the activities of the CAPs, a combined Marine-PF headquarters was established at the district command post with the US Marine company commander and the district chief in command.

CAPs did not always operate separately and individually. When major operations were conducted by US Marine units in the areas where the CAPs were assigned, CAPs served as guides and provided intelligence. Conversely, US Marine units were always prepared to relieve or support the CAPs whenever required. Although their mission involved civic action, CAPs had very limited capabilities in this regard. Their civic action efforts were primarily designed to stimulate the local governments and encourage them to provide more help and assistance to the villages.

The combined action program brought about many realistic benefits. The local population, living under permanent protection of these combined units, developed trust and confidence in the GVN. The presence of the CAPs also denied the enemy infrastructure freedom of action. In addition, they also trained the PSDF and were instrumental in more rigorous activities on the part of village officials.

2. Operation Rang Dong/Fairfax.

During 1966 and in early 1967, US forces in the III Corps Tactical Zone conducted major actions against enemy main force units and bases such as in Operations Cedar Falls and Junction City. The security situation in areas surrounding Saigon, and in Gia Dinh province in particular, had deteriorated but not because of the presence of enemy main force units - in fact there was no more than one enemy local force battalion in the area - but because the enemy infrastructure increased its activities. The VCI in Gia Dinh province was particularly elaborate and almost had a free hand.

To eliminate the enemy's forces and his infrastructure in the area around Saigon, a US infantry brigade was assigned the task of helping in the pacification effort. On the GVN side, forces committed in the pacification operation included one Ranger group and the provincial territorial units.

The principle of combined activities in Operation Rang Dong/Fairfax

was the integration of US and ARVN units. During the initial phase of the operation, battalions of the ARVN 5th Ranger Group and those of the US 199th Light Infantry Brigade operated in parallel with each other and were responsible for one or more districts of Gia Dinh province, depending on the situation. As the operation progressed, and with experience gained, both US and ARVN battalions operated in the boundary area between districts and even beyond the provincial boundary. This concept of operation differed radically from the US Marines' combined action program in that it involved the pairing-off of regular battalions and not lower echelon units such as RF companies or PF platoons. But the basic principle of combined activities was practically the same. The ARVN units were more familiar with the local terrain and environment and could establish good rapport with the local government and people. US forces, on the contrary, enjoyed superior resources, had more firepower, especially that provided by organic artillery - a battery per infantry battalion - and modern communications. In addition, US forces were supported by tactical air, helilift, and rapid medical evacuation, and these assets could benefit ARVN units as well.

During the initial phase, ARVN ranger battalions operated without artillery support, moved on foot, and were limited to daylight activities. Lacking helilift support, they were unable to penetrate outlying enemy base areas. Because of combined operations with US forces and the sharing of US support assets, these constraints were no longer problems for ARVN units.

Operation Rang Dong/Fairfax was designed to achieve two basic objectives: to improve the security situation around Saigon, and particularly in Gia Dinh province, and to completely pacify this area. To carry out the latter, US forces conducted training not only for ARVN regular units but also for all territorial units.

To ensure close cooperation and coordination, US and ARVN units established an Area Security Coordination Committee and a Combined Intelligence Center. The Area Security Coordination Committee included US and ARVN battalion commanders and the district chiefs. These three commanders met periodically to discuss plans or decide on the efforts

to be made. The committee was without a chairman or executive authority. All the decisions were based on mutual agreement or understanding, and the purpose of each meeting was only to affirm the agreements arrived at among the leaders before each of them issued orders to his own subordinate units. The Combined Intelligence Center was designed to collect and disseminate in a timely manner all intelligence pertaining to the enemy so that quick response actions could be taken.

The ARVN ranger battalion, consisting of four companies, was similar in organization to the US infantry battalion. This organizational similarity permitted the integration of one ARVN company with one US company. At lower echelons, platoons and squads were also integrated so that every activity conducted was effectively an integrated US-ARVN activity, whether it was a battalion-level operation or a squad ambush. Sometimes all eight companies participated in operations at one time; at other times only individual platoon-level activities were conducted, depending on the situation and the distance from friendly bases. Movements of penetration into enemy bases were either by helicopters, by boats, or on foot. In general, daylight combined activities were no smaller than platoon-size but at night they were mostly of squad size. Through this method of operation, an infantry battalion was able to lay up to forty ambushes within the limits of a district in any one night. On a few special occasions, ARVN and US battalions also conducted separate company-size activities in combination with RF or PF units.

In order to improve security in villages, ARVN units once a week conducted district-wide cordon and search operations at night in cooperation with the national police. These operations contributed to improving overall security.

After a period of large-scale activities which inflicted heavy losses to the enemy main force in the Capital Military District, ARVN and US forces switched to small-unit tactics, focusing on the destruction of enemy guerrillas. Friendly units were broken down into small elements which deployed against the enemy supply and infiltration routes. Another friendly tactic which proved particularly effective in Operation Rang Dong/Fairfax was the concentration of efforts on a particular objective area. This type of operation was based on

reliable intelligence reports and involved repeated bombardments by tactical air and artillery against adjacent base areas that the enemy used as staging areas or safe havens. These continuous attacks by fire flushed the enemy out into the objective area where he would be destroyed.

Operation Rang Dong/Fairfax succeeded in radically changing the security situation in the Capital Military District within a short time. Not designed to be as permanent and as continuous as the Combined Action Program in the I CTZ, the operation ended in November 1967.

In 1964, well before the success of Operation Rang Dong/Fairfax, the government began the Hop Tac pacification campaign in the Capital Military District with the purpose of clearing and securing this area. The Hop Tac campaign was conducted by III Corps forces and was operationally controlled by a command post at the CMD headquarters. The staff in charge of the campaign was a joint, military-civilian organization which combined III Corps military officers with GVN ministerial and US embassy representatives.

The Hop Tac campaign failed to achieve its objectives because of several difficulties. First, there were not enough police to maintain law and order in all hamlets. Second, there was a shortage of territorial forces to provide protection and maintain security in those areas cleared by regular forces. Third, civilian development projects such as the construction of schools, market places, and maternity wards, were unable to make any progress due to political instability in the national capital; this was a period of turmoil during which several governments succeeded each other within a short time. Finally, there was a total lack of guidance and direction from the central government. Without a central pacification control body and specialized cadre, the campaign was doomed to failure and was suspended in September 1965.

Training

An inherent weakness of ARVN forces lay in the fact that, being trained to fight the enemy with conventional tactics, they did not thoroughly understand the role of pacification support. Hence training

for this role was required.

In view of the security situation which required the permanent presence of military forces and because of the inability of schools and training centers to handle at any one time a large training load, special emphasis was placed by MACV on the use of combined US-ARVN mobile training teams (MTT), which were activated in 1967.

In the beginning, MACV initiated the training of fourteen MTTs, each team consisting of twelve officers, one team for each of the four corps and ten infantry divisions. Each province would later be assigned from two to three MTTs depending on its size and the number of its territorial units. Each of the MTTs earmarked for the ARVN regular forces was assigned a US adviser and provincial MTTs also had US members. Training programs conducted by MTTs lasted about two weeks for regular forces and three weeks for regional forces. This was followed by the training and formation of forty-four MTTs for popular forces, each team composed of five members (two officers and three NCOs). These teams were to provide training for all popular forces located in 243 districts throughout the country.

US Field Forces at the same time also came up with other mobile training variants but all were designed to achieve the same goal, that of improving territorial forces for their pacification support task. Each team was composed of five US members and two Vietnamese. These MTTs were placed under the control of province senior advisers who deployed them to districts to help RF and PF units organize outpost defense systems and train them in small unit tactics, with particular emphasis on night ambushes and the use of combat support such as artillery and tactical air.

There were also Combined Mobile Improvement Teams (CMIT) and Combined Mobile Training Teams (CMTT) that the US I Field Force activated in II Corps area. The composition of these teams and the concept of their employment included some variations but their mission and purpose remained the same, i.e., improving the combat effectiveness of territorial forces. However, this regional training effort was not sustained for long and in the end all CMITs and CMTTs were reorganized into standardized Mobile Advisory Teams that MACV had initiated throughout the country.

The Hamlet Evaluation System

In January 1967, MACV/CORDS first used the Hamlet Evaluation System (HES), a computer based measurement to discern the status of rural security, the progress of the pacification program, and identify problem areas. The district senior adviser filled in a questionnaire on each hamlet. The hamlet data was forwarded through the chain of command to MACV/CORDS where it was collated and analyzed. The questionnaire covered two major areas: hamlet security and progress in civil operations.

To ascertain the extent of security, the questionnaire covered all enemy disruptive activities in a hamlet or in adjacent areas such as harassment fire or shelling, terrorist actions, sabotages, propaganda, proselytizing actions, kidnappings, and assassinations. Other data concerning friendly activities to provide security and protection for the local population were also recorded in the form of answers to such questions as (1) How effective were those activities? (2) Who actually held the initiative: friendly or enemy forces? (3) Were friendly forces capable of providing security? (4) What results did friendly activities achieve? (5) What casualties and damage were caused to the local population in terms of human lives and property, both by friendly and by enemy forces?

In addition to security, the HES also measured the progress of efforts in civil operations. Data for this part included answers to questions about the maintenance of law and order in the hamlet, the behavior and attitude of local government officials, the degree of popular sympathy toward GVN cadre, the elections of village and hamlet councils, the influence of the GVN and that of the enemy on the local population, the extent of development in public health and education, the availability of schools, dispensaries, maternity wards, and the influence of local political parties.

All the questions concerning security and civil operations were printed on a card. The district senior adviser filled out the appropriate answers on the card and submitted it through channels. The data provided in the cards were elaborate and scientifically devised. They were tremendously helpful to higher authorities or field commanders, who were able at a glance to visualize what happened in a certain area and to assess correctly the situation. There were, however, certain shortcomings inherent in the HES, the most readily discernible of which was the relative time-lag of the reporting system.

Reports submitted by district senior advisers, for example, took weeks to reach the central echelon, and before MACV/CORDS compiled and sent them to agencies and major units for exploitation at least one month had elapsed. There were other data contained in the HES monthly report, concerning actions to be taken by various agencies for example, which were no longer effective since by the time the HES report was published these actions had already been taken. A HES report recorded, for example, that the PF unit in a certain village was short of M-79s or M-60s due to combat losses; but in reality these losses had been replaced during the month it took the district senior adviser's report to reach MACV/CORDS and get published. A major cause for the slow reporting system was the delay in the RVNAF postal service or the lack of mail routing facilities, which became especially serious after the redeployment of US forces.

The data recorded by district senior advisers were obtained partly from village and hamlet officials' reports, partly from information provided by friendly forces or through the advisory channel, and partly from actual visits to villages and hamlets by the senior adviser and the district chief. A question arose, however, as to the validity and reliability of the reports thus obtained; doubts about accuracy and timeliness. The most reliable way to have accurate data was to make visits to the villages and hamlets and see for oneself. But the truth was that even if all the time available were devoted to visits, and even if road communication and transportation facilities and helicopters were available at all times, no one could possibly cover all the villages

and hamlets of a district in a single month.

The HES was subsequently transferred from MACV/CORDS to Vietnamese authorities. The JGS took over the task of evaluating territorial forces while the Central Pacification and Development Center took charge of civil operations reporting. The operation of the system became less efficient, partly because at the district level the GVN did not have officials as knowledgeable as the advisers to estimate and record with accuracy HES elements, and partly because of the large costs involved in supporting the system, which the GVN could scarcely afford.

CHAPTER VI

Social Reform and Economic Development

Objectives

South Vietnam subsisted on foreign aid, primarily US aid. Its consumption far surpassed its production because of the lack of an extensive industrial base. Due to security improvements after 1970, the GVN set about to achieve long range goals that can be summarized in a "three selves" policy. All plans and programs were geared to and guided by this policy.

Self-Defense meant the people were to defend themselves, their families and their communities. The PSDF were a means to provide this kind of self-defense, being organized and manned by the people themselves, and armed and assisted by the government. The goal to be achieved gradually was to use PSDF for the defense of villages and hamlets in place of territorial forces who would take over territorial security responsibilities from regular ARVN forces. Then the ARVN could be freed to take over combat responsibilities from US forces.

Self-Management was designed to promote democracy and a democratic way of life. The people elected representatives to run their own affairs, administer their own villages, and manage their own budget. The people also participated in groups, associations designed to develop a mutual assistance spirit. Village properties and resources were managed by the people through their representatives with the technical assistance of the government.

Self-Sufficiency was to be achieved through self-help programs and projects in which the people contributed their own capital and labor.

The government provided assistance only when required. Self-help projects were initiated and managed by the people, from start to finish. The ultimate goal was not only to bring about a more prosperous life for the people but also to sustain the war effort for as long as it was required, without relying too heavily on foreign aid.

The Self-Help Hamlet Development Program

The purpose of the Self-Help Hamlet Development Program was to promote moderate and short-range projects which were of practical value to the population of the hamlets. It did not require advanced techniques and was not a duplication of the projects in the permanent programs supported by various ministries.

Examples of self-help projects were:

1. Irrigation equipment for the production of two crops in a year.
2. Repair of village and communal roads, and construction of small bridges and of sewage systems.
3. Construction of dams, and digging of drainage ditches to prevent floods.
4. Digging of ponds for hamlet fish breeding.
5. Construction of pens for pigs, cattle and poultry.
6. Construction of brick-making factories.
7. Digging of wells.
8. Construction or repair of market places.
9. Cultivation of plants for the production of seedling plants.
10. Repair of hospital and maternity dispensaries that involved no new construction.
11. Repair of schools.
12. Construction of latrines, wells, water tanks, and a flag pole for the hamlet school.
13. Repair or erection of religious structures.

The programs would lead to success when they reflected the true aspirations of the population, and would fail if the provincial and district authorities compelled the people to work only according to officials' desires. All projects were to be deliberated and decided

by the population under the guidance of the hamlet managing committees, and with the assistance of the provincial technical cadres who would provide advice during discussions.

The efforts of the hamlet population were considered as the main factor while the support coming from the outside, such as funds and materials, was only of secondary importance and used primarily to get the projects off to a good start. Invitations to bid on the projects under the self-help hamlet development program were absolutely prohibited.

All projects would be established by a committee composed of the representatives of the Hamlet Managing Committee, the RF cadre team operating in the hamlet, the Parents and Teachers' Association, and the popular associations in the hamlet. A decision was then made by the province chief to provide funds and materials for the projects. Each project received the same funding of VN \$50,000 without distinction as to locality.¹ To assist the project, materials such as cement, iron, and roofing sheets were provided by CORDS.

The provinces were authorized to carry out projects for more or less than VN \$50,000, depending on circumstances but the allotted funds should be less than the total expenditures and the provinces were not allowed to spend more than VN \$150,000 for three projects. In very special cases, if the project required more than VN \$150,000, it was subject to prior approval by GVN authorities.

Rural Health

Health service was poor in rural areas. The traditional method used by peasants to heal wounds and cure diseases was through the

¹In October 1969, the exchange rate was set at \$1 US: VN \$285. As inflation worsened, the VN piaster continued to be devalued every year. In 1972, the exchange rate was adjusted at \$1 US: VN \$240, the \$1 US: VN \$475 in 1973 and \$1 US: VN \$560 in 1974. By 1975, it was set at \$1 US: VN \$700.

administration of medicinal herbs, or Oriental medicine while city inhabitants relied on modern medicine and there was a critical shortage of doctors in the rural areas.

There was usually a hospital in each province but its medical facilities were deficient and medicine was frequently in short supply. Provincial hospitals had small capacities and could not accommodate an entire province population, particularly during the periods of heavy fighting. Each district was equipped with only a dispensary, but it did not have a resident doctor or registered nurses. It dispensed first aid in emergency cases but patients were evacuated to the provincial hospital because the district dispensary did not have hospitalization facilities. Each village had a rural medicine chest but its limited supplies were inadequate for the needs of the village population.

With the active participation of US forces the public health effort improved in keeping with the pacification program. The GVN public health program received substantial support and assistance from the US as well as from international humanitarian organizations. Such projects as constructing additional provincial hospitals; equipping, modernizing, and expanding existing hospitals; providing doctors, nurses, and technicians to work with Vietnamese medical personnel; and constructing and increasing the equipment of district dispensaries so as to have limited medical treatment were all undertaken with American and allied support.

A major goal of the GVN public health program was to improve rural health service. In each hamlet, for example, a maternity dispensary and drug station operated by a rural midwife and a laborer were to be established. The model design included a room for prenatal care or for delivery of babies; a confinement room; a drug dispensary; a bedroom; a kitchen; two latrines; and a water well or tank. The hamlet maternity dispensary and drug station was constructed with good, strong, durable materials. A funding of VN \$250,000 was allotted by the Central Rural Development Council to cover construction. Support provided by CORDS included, for each construction project: 175 bags

of cement, 153 roofing sheets, and 100 kilos of iron. The cost of training midwives was covered by a special allocation granted to the Ministry of Health by the CRDC. With this allocation, the province was able to purchase training equipment, instructional materials, and office supplies for the organization of re-training classes for rural midwives for a period of three months. Rural midwives and laborers were recruited by the provincial health service, which was also responsible for conducting training classes for rural midwives.

To make full use of the support provided by the US and other Free World nations, the RVNAF, in coordination and cooperation with the Ministry of Health, initiated a program called "Civil-Military Medical Cooperation," designed to establish jointly operated medical facilities for the benefit of both the civilian population and servicemen. A coordination committee which included representatives of the RVNAF Medical Service and the Ministry of Health was set up to manage the program.

During 1968, the Civil-Military Cooperation program operated in 10 out of 26 provincial hospitals and in 86 out of 193 district dispensaries. The Ministry of Health was responsible for additional construction and for providing medical equipment and medicine supplies while the RVNAF Medical Service provided medical personnel. These jointly run medical facilities accommodated wounded servicemen, as well as civilians, free of charge.

In other hospitals and dispensaries not covered and operated by the program, the treatment of servicemen was subject to reimbursement by RVNAF Medical Service for the cost of food during the hospitalization period.

In addition, other humanitarian organizations such as the West German and the New Zealand Medical Groups, the Philippine Civil Action Group (PHILCAG), and, particularly, US charity and relief organizations, all operated with philanthropic devotion in rural areas. In these rural areas doctors and nurses treated thousands of peasants and distributed free medicine to others.

US forces also contributed significantly to the GVN rural health effort through their Medical Civic Action Program (MEDCAP). While conducting military operations, US forces placed special emphasis on organizing sick calls and dispensary service for the local civilian population. US medical evacuation helicopters, while primarily serving US servicemen, were frequently used to evacuate civilians in emergency cases, especially casualties caused by the fighting. It was estimated that about 70% of civilian casualties were evacuated by US MEDEVAC helicopters and many lives were saved.

Finally, US contributions to the GVN health program also included the invaluable service rendered by the hospital ship HOPE which twice called at South Vietnamese ports, each time staying for a period of several months. This floating medical facility succeeded in saving the lives of many Vietnamese whose illnesses or diseases could not be cured by local doctors or with local medical facilities and technology.

The Rural Education Development Program

The rural education development program was designed to provide educational facilities and opportunities for children. It was an interim step toward compulsory education at the primary level and for the construction of hamlet classrooms. For pacified and consolidated hamlets, the maximum number of classrooms allotted to each hamlet was three which corresponded to the three lower grades — 5, 4 and 3 — of an elementary school.²

²Prior to 1973, Vietnamese elementary schools had 5 grades: 5, 4, 3, 2, 1, which corresponded to US grades 1, 2, 3, 4, 5 respectively. After 1973, the RVN education systems was patterned after the US model: elementary, 6 grades (from 1 to 6), and secondary, 6 grades (from 7 to 12).

Hamlet classrooms were usually built as semi-permanent structures with brick or cinder block walls and a tin roof. The GVN policy was to implement the rural education program through community development or under state supervision just as for the rural health program. Similarly, the construction of classrooms by private contractors was also unauthorized.

In order to achieve lasting results in the establishment and protection of schools, the following guidance was provided by the GVN:

1. An imprest fund was established by the province and cash was distributed to districts for construction under government supervision.

2. The hamlet population, especially parents and teachers, were urged to volunteer their efforts in the construction of classrooms. All forms of commandeered labor were forbidden. More than any other program, the rural education program was widely acclaimed by the people. There was absolutely no coercion of any kind for their participation.

3. A committee in charge of project management was to be created that included representatives of the local government and population in order to supervise the construction and provide protection for the school.

Funds and materials for the construction of rural classrooms were allocated by the CRDC. For each classroom, VN \$60,000 were allotted for construction and VN \$25,000 for furniture (desks, tables, benches, blackboards and bookcases). Construction materials were provided by the regional CORDS. These included, for each classroom, 75 bags of cement, 80 roofing sheets, and 600 kilos of iron rods.

The province chief was authorized to use funds earmarked for self-help projects or other special funds at his discretion, to build school facilities as might be required. In the case of schools built before 1966, the provincial and municipal RD councils were authorized

to use self-help project funds to build such school facilities as latrines, water tanks or wells, and flag poles. Each site having from one to three classrooms was allotted VN \$25,000 by the GVN and construction materials by the regional CORDS. The materials included 60 roofing sheets, 45 bags of cement, and 500 kilos of iron for the construction of two latrines, one water tank and three water jars.

Teachers recruited underwent a three-month training course and upon graduation and assignment, received a monthly salary of VN \$3,500. The need for hamlet teachers was decided by the provincial and municipal RD councils, upon recommendation by the regional education service, and based on procedures and criteria established by the Ministry of Education.

Finally, to assist peasant families in supporting their children in school, a special allowance of VN \$300 was granted each family to cover school supplies.

The Relief and Resettlement of Refugees

Prior to 1965, there was no GVN agency created for the care, relief, and resettlement of refugees and war victims. As of 1965, however, with the increasing number of refugees and war victims, the GVN began to care for them. The responsibility was shared by differing agencies. The Ministry of Social Welfare, for example, assumed responsibility for dispensing emergency assistance while the Ministry of Rural Development made resettlement payments to people who, because of continued insecurity, acquired a semi-permanent refugee status.

In March 1966, a Special Commissariat for Refugees was established to take over full responsibility for refugee assistance and resettlement. The Commissioner General for refugees was empowered

to co-opt both personnel and financial resources from the two ministries which had previously shared this responsibility. A considerable institutional structure was thus built in a very short time. At the GVN level, for example, the Special Commissariat for refugees had over 200 staff members and at the regional level it was represented by over 800 field personnel who constituted the staff of 46 provincial and municipal refugee relief services.

The next stage in the evolution of organizational arrangements to deal with refugee problems came less than two years later when, in November 1967, the Special Commissariat for Refugees was integrated with the Ministry of Social Welfare to become the Ministry of Social Welfare and Refugees. At the same time, provincial and municipal refugee relief services were merged with local social welfare services.

The final change was the integration of the refugee relief and resettlement effort into the pacification and development program. As of January 1969, all provincial and municipal pacification and development councils were required to include plans for refugee relief and resettlement in their annual pacification plans, and the Ministry of Social Welfare and Refugees became the Ministry of Health, Social Welfare and Relief. This Ministry was responsible for keeping a census of resettled and returned refugees, for disbursing funds and materials, and for providing personnel and equipment to operate hamlet or village dispensaries and maternities.

The GVN policy of relief for refugees was a realistic one in that it sought first to provide emergency help and then to resettle the refugees in secure areas where they would find opportunities to make a living by themselves. Depending on the circumstances, the GVN might in a few instances allow refugees to return to their home villages. This home-returning effort was particularly strong during 1969.

The relief and resettlement program included three distinct programs in one, each concerned with one specific phase of the refugees' reception and care by the responsible authorities.

Initially, the program provided for emergency or temporary care for a period of thirty days, or in certain cases, up to a maximum of sixty days. At the end of this time the refugees should, either with or without government assistance, have been able to return to their homes or, if security conditions did not permit, have been resettled in a secure area where some means of livelihood was obtainable. The alternative to the second phase or resettlement in a new location, if this was not possible, was the conversion of the temporary center in which a refugee had been provided shelter into a permanent resettlement site, the refugee being eligible for resettlement assistance both in cash and in kind, and the site receiving priority in government development programs. The third phase of resettlement was the "Return to the Village" program.

Due to the difficulties in screening and classifying people fleeing from the war and from the Communists, it was required that a refugee meet certain conditions to be entitled to assistance. By GVN definition, a refugee was a person who had been displaced from his home village for reasons of insecurity and unwillingness to submit to Communist control, or a person whose family had been compelled to evacuate his home village by local authorities or by friendly operational forces.

Refugees were also classified into two categories: those who lived in camps and those who lived outside. Refugees who lived in a temporary refugee center received assistance, protection, and control from the GVN. Those who lived out of camps were people who were not under the control of GVN refugee authorities but made up separate colonies or lived with their relatives.

Refugees living in GVN-controlled camps were issued a "green" card which entitled them to emergency relief during a period not exceeding 30 days, each day being worth VN \$15 in cash or 500 grams of rice and VN \$5 for meat and vegetables, for each person; and temporary relief during a period which could be classified as "resettled", with each being allotted a lump sum of VN \$7,500 and 10 roofing sheets, and rice rations for six months on the basis of 15 kilos per person per month. Montagnard refugees received, additionally, 600 grams of salt per month for six months.

Even though classified as resettled and having received these benefits, a refugee might still, at any time, apply for assistance to return to his home hamlet if it had become secure. If he did, he also became eligible for aid under the "Return to Village" program, amounting to cash payment of VN \$5,000 per family for housing, cement, and roofing, or cash in lieu, and a six-month rice allowance.

An out-of-camp refugee, because he was in principle outside government control, had to be accepted for registration and issued a "white" card before he could claim any of these benefits, and in his case, the benefits were somewhat reduced. To be accepted for registration, such a refugee had to meet at least two of the following conditions: (1) he must have become a refugee since 1964; (2) he must have originated in an insecure village or hamlet and have fled to avoid VC influence or control; and (3) he must be living in controllable groups of twenty or more families. If he met all three registration criteria, he was entitled to temporary aid and return-to-village benefits only, not resettlement allowance. If he satisfied the first two conditions, then he might claim only return-to-village benefits, forfeiting temporary and resettlement allowances.

Non-registered refugees forfeited all assistance under the relief and resettlement program but retained the right to claim return-to-village benefits provided that their home villages had been pacified and that they had returned to them during the 1968 and 1969 pacification campaigns.

The last category of refugees were those who had become refugees

after 1 January 1969, either by moving voluntarily or by being evacuated by military authorities from insecure villages. If their villages were not scheduled for pacification, they were given temporary aid for seven days only, and then the resettlement allowance at the established rate during the period they stayed in the reception camp. If, on the other hand, their villages were scheduled for pacification, they were entitled to seven days emergency aid which, depending on the pacification progress, might be extended to 30 days, but in no case were they entitled to resettlement benefits. They had to apply to return to their villages as soon as security conditions permitted, and when they did, they received a full back-to-village allowance, whether or not their homes were destroyed by military operations.

The cost of the the refugee relief and resettlement program was enormous. Food allowances for refugees living in-camp amounted to VN \$526 million in 1967, VN \$835 million in 1968, then was reduced to VN \$709 million in 1970 and only VN \$236 million in 1971. Resettlement costs amounted to VN \$760 million in 1967, VN \$1.2 billion in 1968, and up to VN \$2.2 billion and VN \$2.4 billion for 1969 and 1970, respectively. These expenditures provided relief and assistance for 3.5 million refugees during the war years. (*Chart 18*)

Refugee resettlement centers or camps were each provided with an elementary school. The cost of operating these schools, including teachers' salaries, was supported by the school programs which were transferred to the Ministry of Education. In addition, each resettlement center was also provided with a maternity ward and a dispensary if the refugee population amounted to 10,000. Other self-help projects such as sewage, drainage ditches, road repairs, etc., were undertaken under the community development program and allotted VN \$50,000 each. On an average, each resettlement center received about VN \$1.5 million for self-help projects.

The refugee relief and resettlement program was a gigantic effort that succeeded only because of the great financial assistance provided by the US government and other Free World countries. It was a truly humanitarian program that helped to heal the wounds caused by the war.

Chart 18 — Refugee Relief and Resettlement

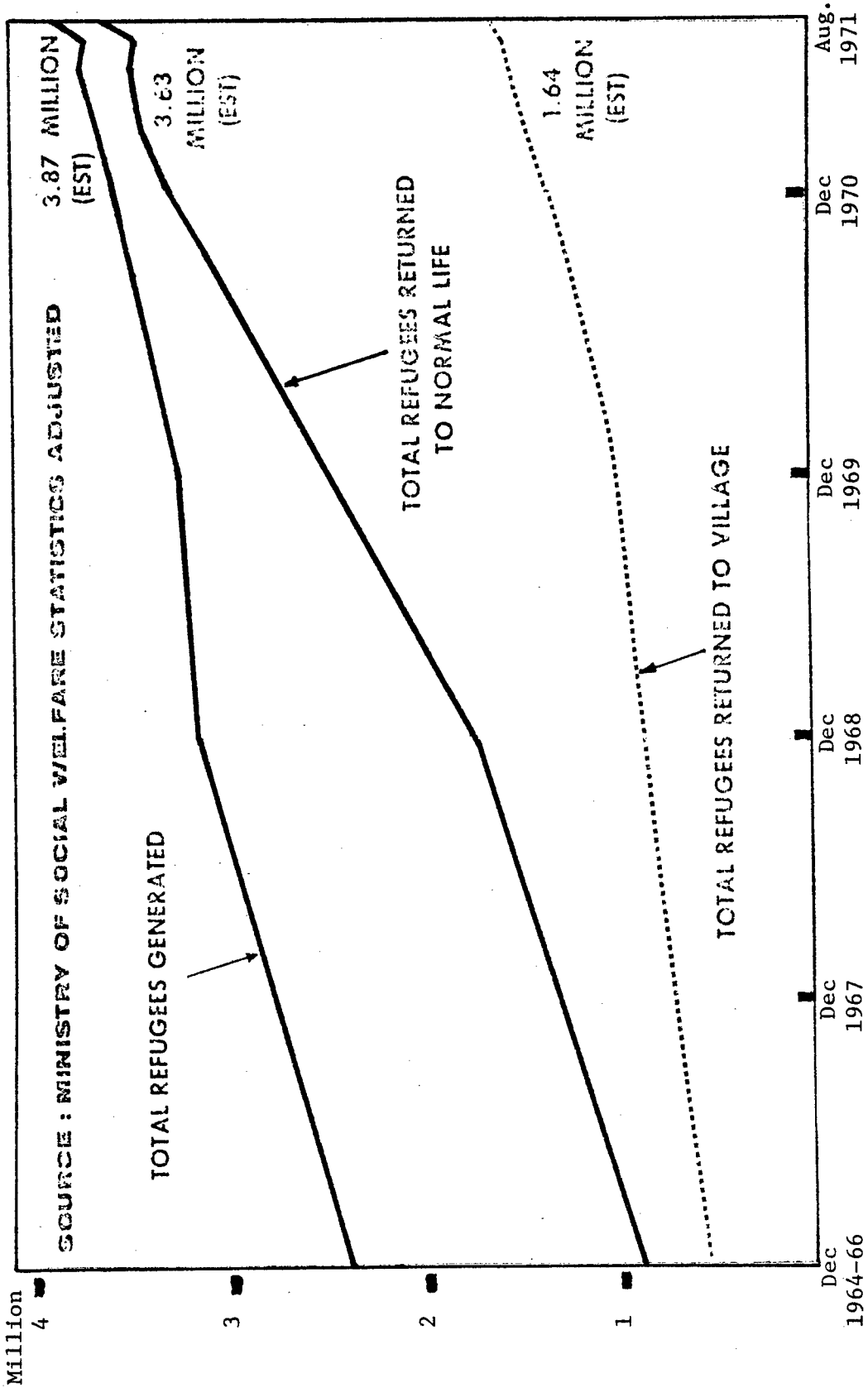

US agencies and some other international organizations played key roles in contributing to the success of the program. They provided refugees with medicine, food, and relief necessities. They helped in vocational training, in developing education, and in caring for orphans and the sick and the wounded. Altogether, 12 US and international organizations were involved in the refugee relief and resettlement program. Some were responsible for distributing relief items donated by US government or charity organizations. Others, such as the American Red Cross and the International Red Cross provided personnel and staff to assist in the operation of refugee camps or resettlement centers. In addition, these organizations also helped train refugees in farming techniques, handicraft, construction work, and in cattle and poultry breeding, and assisted them in the settlement or resettlement process. The Community Development Foundation, in particular, conducted training courses in refugee camp operation for personnel of the Ministry of Health, Social Welfare and Relief. Other vocational training courses were also organized by charity and non-profit organizations to train refugees in new occupations.

Agricultural Development

Vietnam is basically an agricultural country. Its production output was still low because of its conservative techniques. Agricultural reform therefore became a concern and the GVN initiated many programs to pursue it within the pacification framework. Such programs as animal husbandry, agricultural affairs, Montagnard agriculture and animal husbandry, and fisheries were designed to contribute to the rural development effort and to improve the national agriculture. In each province, these programs were established and implemented by the provincial rural development council, with the cooperation of technical services.

The Animal Husbandry Program

The purposes of this program were to teach farmers modern animal husbandry methods, to protect livestock with preventive immunization

and medical treatment, and to distribute livestock to poor farmers. In hamlets other than those earmarked for pacification, the scope of program activities was limited and aimed only at continuing and consolidating the achievements obtained during the previous years. They included the recovery of the livestock distributed for profit-sharing in the previous years and its redistribution to farmers living in the same hamlet, and continuation of preventive immunization and medical treatment. The GVN also provided additional funds for each province to purchase more livestock for distribution.

In the New Life Hamlets, the program was more extensive. It included training farmers and distributing pigs, chickens, and ducks, and other kinds of livestock. Farmer training taught new animal husbandry methods, how to build pens and farms, how to choose livestock breeds, the advantages provided by mixed feed to livestock and how to cure livestock diseases. The purpose of pig distribution was to popularize the improved breeds of pigs and at the same time to support to some extent the poor farmers who could not afford animal husbandry. Each needy family willing to raise livestock was allotted two breeding pigs, and on an average, each hamlet was allotted 40 pigs.

The distribution of pigs to hamlet households was implemented on the basis of certain criteria. First, piglets raised for meat should be crossbred from Yorkshire, Berkshire or Danish breeds, weighing more than eight kilos. Sows should be almost of pure Yorkshire, Berkshire or Danish breeds, weighing more than nine kilos. Boars should be of pure Yorkshire, Berkshire or Danish breeds, weighing more than two kilos. Then medicine for the elimination of parasites and preventive shots should be given to the pigs kept for distribution. The procedure used for distribution determined that sows were allotted on the basis of the sharing of litters, but boars were allotted free. The animal husbandry office would take one two-month piglet from the first litter.

Chickens and ducks were only distributed to the hamlets that had not received an allocation of pigs. However, chickens and pigs could be distributed simultaneously to those hamlets having a large population and animal husbandry abilities. Each family was allotted 10

breeding chickens or from 40 to 50 ducks, all free of charge. For the province that had requested a distribution of chickens but had not received it in due time, ducks could be provided in lieu of chickens.

As to other kinds of livestock, depending on the local situation, the province could provide a distribution of oxen, goats and rabbits for farmers. This was on the basis of profit-sharing in the case of cows and goats.

The Agriculture Affairs Program

The agricultural affairs program was designed to provide guidance to farmers concerning advanced agricultural methods, distribute seeds and seedlings to poor farmers, protect crops against insects and diseases, and train Montagnards in agriculture.

For the hamlets that were not targeted for pacification, the scope of program activities was limited to continuing operations initiated in previous years, especially the protection of crops and limited distribution of seeds and seedlings to very needy farmers.

In New Life Hamlets, the program was focused on training farmers in advanced farming methods, particularly in the methods adopted for new and improved breeds, on distributing seeds and seedlings of new or improved types, and on helping poor farmers with farming facilities. The seeds varied according to the region: rice, corn, beans, etc. Each needy family having farming abilities received an allocation of from 20 to 40 kilos of seed for the planting of about one hectare of land.

To protect crops, sprayers and pumps were distributed to each hamlet as common property of the community, but were placed under the control of agricultural cadres. Pumps were only provided where such a need could be justified and for minor farming activities. The distribution of powerful water pumps to carry water to rice fields lay within the scope of the irrigation program. Insecticides were provided free.

Montagnard Agriculture and Animal Husbandry

In provinces where many Montagnards were settled, a Montagnard agriculture and animal husbandry center was established with the purpose of training Montagnards in farming, animal husbandry, and fish culture

methods. Guidance was also provided to Montagnards concerning certain trades, such as blacksmith, carpentry, sewing, etc.

An average Montagnard agriculture and animal husbandry center was operated by a manager, an assistant manager, two instructors, five laborers and one clerk. Montagnard RD cadres were also assigned to each center; their role was to encourage agricultural activities in Montagnard villages. Each Montagnard undergoing training at the center received a daily food allowance of VN \$50.

The Fisheries Program

The fisheries program was designed to provide guidance to farmers concerning fresh water fisheries and to fishermen concerning salt water fisheries, provide support to poor fishermen such as breeding fish and fishing gear for the development of fisheries, and to improve fisheries by motorizing fishing boats. In addition, the Ministry of Agriculture also ran a permanent program which provided for activities concerning salt water fisheries, the survey of lakes and ponds to determine fishing suitability, the compilation of fishing statistics, the digging of fish ponds, and the construction of refrigerating rooms.

At the hamlet level, the program provided training for farmers and fishermen in fish culture methods, the use of fishing equipment, the digging of ponds for fish breeding and rearing, the preparation of fish food, etc. To encourage fish breeding and rearing, breeding fish were distributed free to the hamlet people who had the abilities for such activities. Different kinds of fish were provided depending on the availability of fresh or salt water in the areas. Fish were distributed on the basis of one fish per square meter of lake or pond.

Outboard motors, boats and fishing gear were provided for by loans and were to be reimbursed in cash. The terms of payment were one year for fishing gear, and two years for outboard motors and boats. Fishing gear worth less than VN \$200 were distributed free.

For the construction of fish market places, a fund of VN \$250,000 was allotted for each site for the construction work and the digging of

drainage ditches. Market places were constructed according to a standardized plan provided by the Bridges and Highways Program and with the support of CORDS, which supplied for each construction work 80 roofing sheets, 1,000 kilos of iron and 200 bags of cement. For fish drying yards, a fund of VN \$20,000 was allotted for each yard. This program was implemented by the province through self-help projects.

The implementation of the fisheries program as well as other programs such as agricultural affairs and animal husbandry was handled by technical offices staffed by technical personnel and cadres. Depending on requirements, each office was assigned one or two technicians who were selected from engineers, controllers or instructors. Contract salaries were paid to technical personnel on the basis of diplomas and according to a pay scale determined by the Ministry of Agriculture. Salaries included cost of living allowance and family allowance but no per diem allowance.

Cadres worked in hamlets and received a monthly contract salary of VN \$3,500. They were technically trained in various schools of agriculture, forestry, and animal husbandry prior to assignment. Technical personnel and cadres had to pledge to serve the programs for at least one year and they were released when the programs were terminated.

An Evaluation

The GVN faced a tremendously difficult task in trying to reform a rural society as complex and as backward as South Vietnam's. Despite the trend toward urbanization and the depletion of male population during the most intensive war years, the countryside remained the major ground of contest where the GVN emphasis was placed on restoring the rural economic infrastructure and improving health and education. These efforts were the mainstay of pacification and development.

The Hamlet Self-Help program was a move in the right direction since the hamlet was the basic communal unit. The range of projects embraced by the program reflected its realistic goal of rebuilding the war-shattered rural infrastructure and bringing about immediate,

practical benefits for the peasantry. The GVN also hoped that a rebuilt rural area could contribute significantly toward developing the national economy. A key feature which accounted for its initial acceptance by the local population was the self-help character of the program. Experience showed that when their own interests were at stake, and when they had a voice in the management of their own affairs, the people volunteered and willingly cooperated. In the district of Cu Chi, Hau Nghia Province, for example, the local population repaired rural roads and culverts, built market places, and classrooms, all within the space of one year. In the Mekong Delta, peasants in the Plains of Reeds took up by themselves the task of dredging and clearing canals of obstacles because farming and business depended on these waterways. Civic actions conducted by US and FWMA forces during the period of their commitment, 1965-1972, gave the program great support, particularly in those areas near operational bases. In addition to providing construction materials, the allied troops frequently contributed labor and turned the finished work over to the local population as gifts. Some overzealous local governments, however, turned the program into a coercive enterprise, requiring the people to meet arbitrarily established deadlines, often at the cost of relinquishing their own business. Despite this, the overall program received wide acceptance by the peasantry.

In health and education, the period from 1969 to 1972 was a period of vigorous development in terms of efforts committed and results achieved. The rural education program virtually eradicated illiteracy among peasant children and youth, and effectively increased the elementary student population multifold. More students went up to high schools because the majority of villages were provided with a first-level middle-school (four-year program, equivalent to US 7th, 8th, 9th and 10th grades). This was an unprecedented opportunity for rural students who during the previous years had to go to the only middle-school at the district town, sometimes at prohibitive distances from their villages. The remarkable progress made in rural education was possible due primarily to aid funds which helped subsidize higher salaries for rural teachers, build new schools or additional classrooms and provide free textbooks,

and not infrequently free school supplies as well, for the under-privileged students. But extensive as it was, the development in rural education was but part of an outdated educational system, based primarily on old French methodology and devoid of a new national spirit. The system belatedly underwent some improvement and modernization in 1974.

Despite the GVN efforts, the benefits the rural population enjoyed in terms of medical care seemed to derive chiefly from programs sponsored by allied countries, international organizations and, in particular, US forces in Vietnam. The US MEDCAP program was especially beneficial to the local population living in US areas of operation. Allied medical teams and international charity organizations were active in several provinces in the 2d and 3d Military Regions. In the central highlands, the US Special Forces did a splendid job helping the Montangards fight diseases and improve sanitation. The GVN rural health program was a laudable effort but it was inefficiently managed and plagued by problems such as the lack of medical personnel and medicine. Pilferages and illicit traffic in drugs further aggravated the problem by enabling the Viet Cong to purchase large quantities of critical medicine.

By far the heaviest burden the GVN had to shoulder during the war years was the problem of refugees. The highest figure recorded after the 1968 Tet offensive was about three million or 1/6 of the total population. The GVN effort was twofold: providing temporary relief and helping in resettlement. Despite the availability of aid funds which provided up to 80% for the refugee resettlement costs and the humanitarian help of US charity organizations, the task was monumental and the effort an uphill struggle. From 1969 to 1971, the problem was alleviated thanks to improved security which allowed most refugees to return to their villages. There remained, however, about 300,000 refugees living in camps for whom care and resettlement were constantly needed. Most relief items donated by US charity organizations such as powdered milk and western clothes usually found their way to local markets since they were alien to the Vietnamese rural way of life. Part of them also never reached the refugees but were resold to pad the greedy camp officials' pocketbooks.

The GVN effort to resettle refugees was not very successful since most resettlement areas were located in insecure areas and became targets of VC harassments. There was also not enough cultivable land and water for irrigation. The result was, after a certain time living under relief, refugees drifted away again and not infrequently ended up in a refugee camp. Several refugees did this five or six times, all at the expense of the GVN. But the resettlement effort greatly improved with Dr. Phan Quang Dan's program of Land Reclamation and Hamlet Resettlement which began in early 1974. This was a large-scale effort, well-planned and well-supported, which was welcomed not only by refugees but also by veterans who voluntarily joined the program. The program had a good chance of resolving the refugee problem when it was thrown in utter disarray by events in early 1975.

In keeping with the pacification progress, agricultural development projects also brought about rosy achievements during 1969-1971. This was possible due to the availability of seeds, insecticides, fertilizers and farm machines purchased through the economic aid program. For a time at least, the rural area took on a prosperous outlook. Cultivated acreage was expanded and rice production per hectare greatly increased. The fishing industry also improved and expanded, thanks to motor boats and refrigeration technology. Increased production in rice, however, failed to meet consumption demands with the results that in 1972, the year of greatest expectations, South Vietnam continued to rely on imports. (*Chart 19*) This did not make sense, however, because estimates of actual production indicated at least a level of self-sufficiency. Most province chiefs did testify in effect that there were no rice shortages, except in the MR-1 provinces. The problem, therefore, seemed to involve speculation by greedy Chinese businessmen in the Mekong Delta and purchases made by the Viet Cong who always offered to buy at high prices. A belated effort made by GVN authorities in 1974 to control the traffic in rice failed to produce any significant results. The rice problem seemed beyond the GVN capability to solve, this hurt its efforts at rebuilding the national economy and achieving real progress in pacification.

Chart 19 – Rice Production and Supplementary Crops

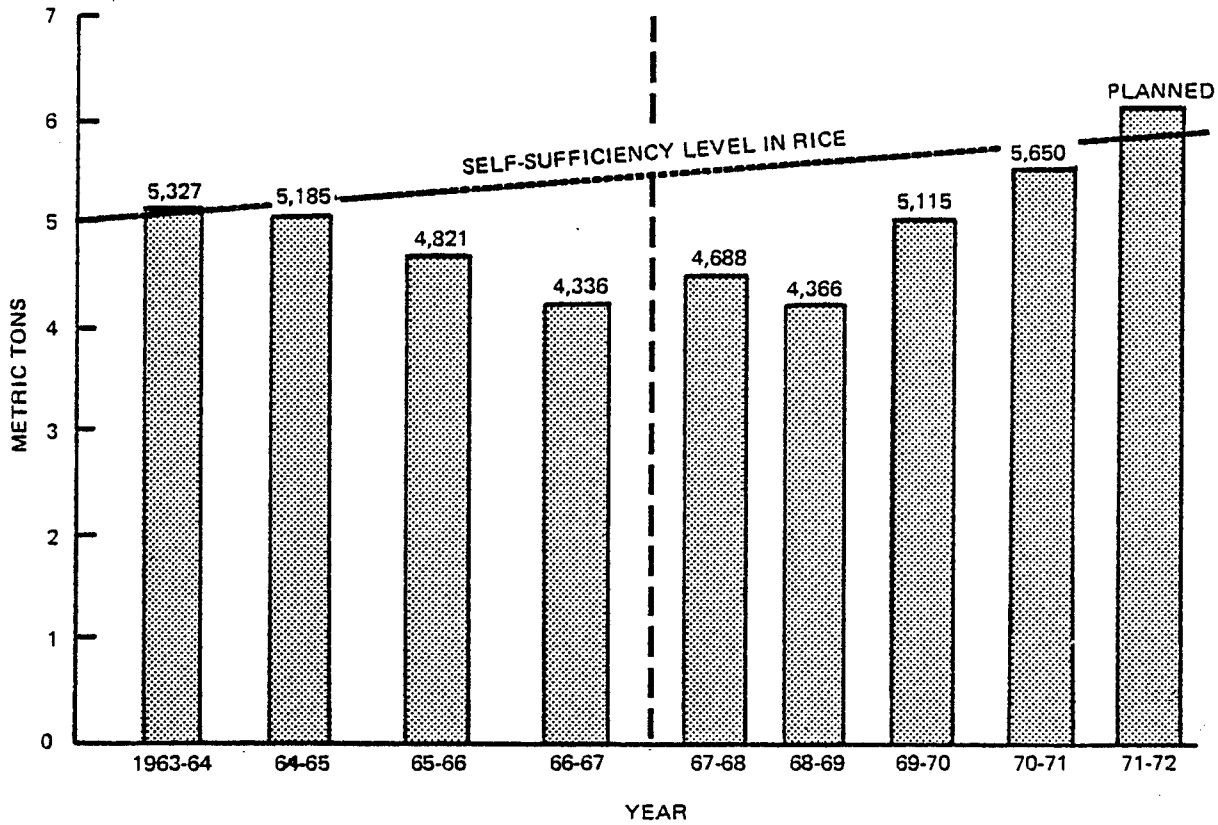

BANANAS:	15,500 HECTARES	} SUPPLEMENTARY CROPS
SUGAR CANE:	32,000 HECTARES	
CORN:	28,000 HECTARES	
MIRACLE RICE:	UP TO 850,000 HECTARES	

For all its efforts, the GVN was still a long way from solving the social and economic problems that plagued South Vietnam, especially in the context of a war in which the enemy always held the initiative and had the capability to wreck any achievements any time he chose. This happened in 1968 and again in 1972 when a few months of attacks undid years of hard toil. Unless South Vietnam was free from North Vietnam's military threat, pacification or any nation-building task remained a hopeless proposition.

CHAPTER VII

The GVN Political, Information and Chieu Hoi Efforts

Information and Propaganda

Information and propaganda were designed to exert a favorable influence on the population by publicizing the government policies and programs and eliciting popular trust and support for them. When employed properly, they were sharp-edged tools for the advancement of political and military goals, shattered the enemy's morale, made him feel disenchanted, and incited him to rally.

As they were practiced in South Vietnam, all information and propaganda activities were conducted and coordinated by the GVN Ministry of Information through a system that reached down to the village level. At the province level, there was an information service; at the district level, an information section; and in villages, an information hall. Prior to 1965, the GVN information and propaganda facilities were scant. In each district town there was only a tiny information hall adorned with outdated pictures and magazines. Information personnel were few because the entire GVN information service was organized as a general directorate, and not as a ministry as it was later under the Second Republic.

After the active participation of US forces in the Vietnam War, however, the GVN information service expanded substantially due to the considerable assistance and support provided by such US agencies as the United States Operations Mission (USOM), United States Information Service (USIS), and Joint US Public Affairs Office (JUSPAO). Each province information service was provided with movie projectors, a film library, and a mobile projection unit using Lambretta van-scooters as vehicles for shows in villages and hamlets. The rural population was given the opportunity to watch film shows at least once a month, a kind of entertainment

unavailable to most of them before then. USOM and USIS also provided funds and information equipment for all provinces and even district information halls were supplied with domestic and foreign newspapers and pictures. The GVN Information Ministry, with the support of JUSPAO, purchased nineteen out of twenty-four daily newspapers published in Saigon and distributed them to village information halls.

Additional radio stations were built in major cities and, to expand radio broadcasts into rural areas, a total of 100,000 JUSPAO-supplied transistorized radios were distributed free to peasant families living in villages and hamlets. In addition, the GVN also imported great quantities of inexpensive radio receivers so that the population could afford to buy them. The voice of the GVN could thus reach the majority of the population across the country. Even in the central highlands, a radio transmitting station was built to broadcast programs in several Montagnard languages. Twelve radio stations eventually operated across the nation. In outlying areas not covered by the GVN information service, aircraft were used, again with US support, to drop leaflets or to broadcast messages. These psychological operations were designed both to inform the population and to call upon enemy cadre to surrender or rally.

South Vietnam did not have a TV broadcasting station until 1966. At first, JUSPAO made TV broadcasts through an airborne transmitting station. A TV studio and broadcast station were subsequently built in Saigon and GVN information personnel were trained by JUSPAO in the operation of the station and the production of TV programs. The TV network was later expanded through additional transmitting and relay stations at Hue, Can Tho and Nha Trang.

Aided by the US, the GVN was in command of a vast array of information and propaganda instruments which were more numerous and sophisticated than those that the enemy possessed. The problem was that the information cadre did not properly exploit these instruments to produce the desired effect. Despite his meager resources, the enemy appeared to get more results out of his propaganda efforts. It seemed that the enemy knew how to make better use of his propaganda means and, by properly exploiting mass psychology, he was also able to arouse popular sympathy more successfully.

For a short period following the Paris Agreement, some progress was achieved by the GVN in information and propaganda. It purposefully built up and exploited the people's hatred toward the Communists. For the first time a genuine effort was made to put the arts and literature at the service of propaganda. Songs and plays, for example, no longer displayed languid lyricism as in the old days. But the most extensively read news mediums in the country, the daily newspapers, were left unexploited for propaganda purposes. The majority of them were owned and operated by private entrepreneurs who were more concerned about commercial success than the anti-Communist cause. The GVN was unable to exert any influence on the daily newspapers, except for the ARVN-owned "Tien Tuyen" (Front Line). Despite several stringent measures that the GVN imposed on the free press such as censure, temporary suspension, fines, revocation of license and legal prosecution, they were all ineffective in rallying the press to the national cause.

The Chieu Hoi (Open Arms) Program

The Chieu Hoi (Open Arms), or Great National Solidarity program was initiated by the GVN to subvert the morale of enemy cadre and troops and call upon them to leave their ranks and rally to the national cause. The basic theme was that both sides were brothers in the same family and, since both wanted to end the war, the best and least costly way was to renounce internecine bloodletting, forsake hatred, and cooperate with each other to rebuild the shattered nation.

During a decade of implementation, from 1963 to 1973, the Chieu Hoi program produced impressive results; 159,741 enemy troops and cadre rallied to the GVN cause.¹ Most notorious among the ralliers were some high-ranking military cadre such as Tam Ha, Huynh Cu, and Le Xuan Chuyen, who returned to the GVN side well before the cease fire period, and the

¹This total breaks down into: 97,696 military cadre and troops; 45,173 political cadre and 16,872 others. These ralliers also surrendered 10,699 individual weapons and 545 crew-served weapons to GVN authorities.

political commissar of Lam Dong province and the personal secretary to the Saigon-Cholon political commissar, both of whom rallied during the post-cease fire period. The number of ralliers reached an all-time high during 1969 when 47,087 enemy cadre and troops chose to side with the GVN, apparently as a result of Communist setbacks during the previous year.

The Chieu Hoi Ministry controlled a country-wide organization which consisted of Chieu Hoi services and centers in the provinces, Chieu Hoi sections at the district level, and Chieu Hoi offices at the village level. Enemy ralliers were grouped at provincial Chieu Hoi centers or at centers in Saigon where they underwent reeducation and readjustment to a free and decent life.

During the period of reeducation and readjustment, ralliers were well fed and well treated. They were allowed to correspond with their families and receive visits. They were never roughly treated or compelled to do hard labor as in enemy-run so-called "reeducation centers". While living in a Chieu Hoi center, ralliers were free to converse, watch TV, listen to radio broadcasts, read books, or just relax. Depending on personal desires, ralliers were given vocational training in such courses as tailoring, embroidering, handicraft, etc. The GVN policy was to help each of them acquire a skill to earn a living when he was returned to normal life. The reeducation period usually lasted from 45 to 60 days, and upon release from Chieu Hoi centers, ralliers were permitted, depending on their readjustment and repentance, to apply for public service jobs, enlist in the armed forces, or seek jobs in private industries. Those who wanted to return to their home villages and live a quiet, honest life, were given transportation allowances.

Another GVN effort to win over ralliers completely —politically and psychologically — and also to make the Chieu Hoi effort more meaningful, was to provide the ralliers with housing facilities once they were released from reeducation centers. The GVN constructed a total of 42 Chieu Hoi villages, one for each province, consisting of housing units which were allocated free of charge to ralliers. This was a most welcomed program which really helped the ralliers begin a new life without hardship.

In general, ralliers were more extensively employed by U.S. forces and U.S. Embassy agencies than the GVN. In MR-1, for example, U.S. Marine units used ralliers as informants, interrogators or scouts during operations, especially when U.S. units staged raids against Communist bases. Because of their intimate knowledge of local terrain, ralliers were very effective as scouts.

In addition, ralliers were also used in intelligence work against the VCI by U.S. Embassy agencies. Ralliers made up the bulk of Provincial Reconnaissance Units (PRU), a para-military force organized, armed and financed by the U.S. Embassy. Later, the PRUs were placed under the control of provincial police chiefs as a striking force for the elimination of the VCI. This was done after the National Police was made responsible for the implementation of the Phoenix program in 1968.

Out of the total ralliers who volunteered for GVN service as of October 1970, it was calculated that 27.1 percent were employed in civil servant positions in the GVN or served in regular, territorial, and para-military forces and in national cadre teams such as RD, armed propaganda and PRUs. Another 20.5 percent was employed by private industries or businesses and the remaining returned to their home villages and lived as farmers after being given tilling land by the GVN, like other citizens.

All told, the Chieu Hoi program was a meaningful and humanitarian effort which provided real opportunities for wrongdoers to mend their ways and begin a new life. The large number of enemy personnel who chose freedom gave some measure of the effect of the program. The figures differed from year to year; the higher figures were recorded when the fighting was more intense. Ralliers generally helped our side know more about the true situation on the other side, and they sometimes provided invaluable intelligence. It was learned from their stories that by and large, Communist morale was low and the troops were confused. Because of protracted fighting, most of them became disenchanted with the war and longed for reunion with their families. Other ralliers told of the lack of medical treatment and medicine, spartan living conditions, unbearable hardships and human losses that sometimes edged entire enemy units toward despair and to defection attempts. Had it not been for

fears of retaliation against their relatives, several complete enemy units would have chosen to defect after their 1968 defeat.

Because of the potential of the Chieu Hoi program, the enemy made efforts to counter it. Communist political commissars, for example, told their troops that ralliers were all killed by the GVN.

For all its merits, the Chieu Hoi program had some shortcomings. For one thing, the GVN placed no control over those ralliers who had been released to return to their home villages. The local governments also failed to keep track of the former ralliers. As a result, there occurred several cases of false rallying. Upon release, they conducted subversive activities for awhile and then returned to their base areas. The allocation of free housing for ralliers also caused great animosity and jealousy among ARVN troops and veterans, many of whom were disabled. The disabled veterans' grievances soon gave rise to unlawful acts of house squatting in open defiance of the GVN. They felt that as soldiers who had risked their lives to fight the Communists, and had become casualties as a result, they were not treated as well as the ralliers who only recently had shot at them.

The GVN had pushed the program too far without due consideration for the sensitivities and welfare of war veterans. In a program such as Chieu Hoi, the pros and cons of certain benefits should have been carefully weighed in the context of a war-ravaged society and sounder priorities should have been established. Despite this, however, the Chieu Hoi program was one of the most effective and least costly ways of ending the war. After all, the cost of killing an enemy soldier was much greater than the amount spent to induce him to rally.

Relations with Ethnic Minorities

The Central Highlands of South Vietnam occupied an important strategic position in view of its continuity with Laos, Cambodia, and especially with the enemy North-South infiltration and supply corridor, which ran along the entire length of South Vietnam's western border. The area was sparsely populated, mostly inhabited by Montagnards who numbered

nearly 1 million and consisted of 29 different tribal groups, each having its own language and customs.² These tribal groups usually lived in isolation from the Vietnamese and were generally oblivious to the fact that there existed a GVN and national laws.

Under the Bao Dai government, the central highlands were decreed a "territory of the Imperial Court", a kind of government reservation where homesteaders had to secure a special permit. During the first Indochina War, from 1949 to 1954, the French paid special attention to the central highlands, where they set up a separate administrative apparatus. The Viet Minh were equally interested in the area and made a special effort to win over the Montagnards to their cause. Some Viet Minh underground cadre even went as far as filing their front teeth and stretching their ears to make them look like Montagnards. Some Viet Minh lived with the Montagnard tribes and some married Montagnard girls and were accepted as tribe members. After the French withdrew from Indochina in 1956, the central highlands were virtually forsaken by the GVN.

Beginning in 1961, the GVN took renewed interest in the highlands and sought to rally the ethnic minorities by making certain overtures such as forbidding the use of the derogatory appellation *Moi* (savage) by Vietnamese and encouraging the use of the newly-coined substitute "new Vietnamese compatriot" when referring to Montagnards. In addition, a special education program was initiated which encouraged them to learn Vietnamese and granted special credits and waivers in all kinds of examinations. Finally, special tribunals were established to provide Montagnards with a fair trial process, based not on Vietnamese laws but on each tribe's customs and manners.

At the same time, with the concurrence of the GVN, the U.S. Special Forces began to make inroads into the highlands. They initiated civic action programs such as dispensary service and the distribution of medicine with the purpose of rallying their support. The Special Forces'

² Among these tribal groups, the Rhade were relatively more numerous and more civilized. Some Rhade tribesmen had enlisted in French Union forces.

objective was to shake off the lingering influence of the French and Viet Minh among the Montagnards and turn them into guerrilla fighters, gradually organizing and arming tribal villages for self defense. The first of such self-defense villages was Enao in Ban Me Thuot province. Despite these efforts, the Montagnards were still heavily influenced by the French and especially by the Viet Minh-instilled idea of an autonomous state which would replace GVN authority and prohibit Vietnamese home-steaders among them. These feelings were fomented by Montagnards who made up the FULRO (Unified Front of Struggle for the Oppressed Races) movement and erupted into open rebellion in 1964 in Ban Me Thuot. The FULRO, masquerading as representative of all tribal groups, demanded an autonomous state in the central highlands and equal rights with the Vietnamese. Some Civilian Irregular Defense Groups (CIDG), trained by U.S. Special Forces and led by ARVN officers, joined the rebellion on 20 September 1964, killed their commanders, and took hostages to press for their demands.

The rebellion was finally quelled but this was a sobering experience for the GVN. To deal with the Montagnards' grievances the GVN initiated a systematic effort designed to improve their political and social standing, beginning in 1965 under the Nguyen Cao Ky administration. The government created a Ministry of Ethnic Minorities, headed by a Montagnard, whose responsibility was to look after all problems concerning the development of tribal groups. Provinces of the central highlands, such as Ban Me Thuot, Pleiku and Kontum were placed under the control of Montagnard province chiefs; the departmental services in these provinces were also headed by Montagnards. In the ARVN and territorial forces, Montagnards were also promoted to field-grade officers and given commands or responsible positions. Elected officials in village, city councils, and in the Senate and the Lower House also included Montagnards.

Montagnards were given certain privileges such as a specially designed education program, compensatory grades in examinations, and an increase in draft age so that they could compete in fairness with Vietnamese and pursue their education without interference. A special training program for Montagnard teachers was conducted by the Ministry of Education to supply adequate teachers for tribal villages.

In public health, emphasis was placed by the GVN on teaching Montagnards body hygiene, public hygiene, house sanitation, and child care and upbringing. To further Montagnard education and to broaden Montagnard knowledge of domestic affairs, the GVN constructed local radio stations in the central highlands that broadcasted in Montagnard languages. Information cadre employed by the GVN in the area were all Montagnards. Efforts were also made to publish propaganda pamphlets and other education and information materials in Montagnards languages.

To operate the pacification program in the central highlands, the GVN created Montagnard RD cadre groups whose members were trained in a special RD training center in Pleiku, the Truong Son Training Center, which was established in early 1967 as a Montagnard counterpart to the RD Training Center for Vietnamese at Vung Tau. Developmental programs were also undertaken by the GVN for the benefit of Montagnards without any hint of racial discrimination. Montagnards were taught new methods of farming to replace their old slash-and-burn technique, and were given modern agriculture equipment. At the same time, crop lands reserved for Montagnards were greatly expanded and the conservation of forest and forest resources were emphasized. In addition, Montagnards were encouraged to grow fruit plants such as bananas, oranges, and prunes, to plant tea, coffee and corn, to build reservoirs for irrigation, and to construct fish ponds.

In general, the GVN strove to improve the Montagnards' lot through the pacification program. But the rate of progress in the highlands was somehow slower than elsewhere, perhaps because they were still suspicious of the GVN goodwill, and probably because the Montagnards were chary of a newly transplanted culture which was not at all like their way of life.

Land Reform and The "Land-To-The-Tiller" Program

To the Communists and the GVN alike, the rural area was of strategic importance and both admitted this fact. The majority of the rural population were peasants who as a class could be rallied to any worthy cause

if properly motivated. One of the best incentives for their motivation was land ownership since for generations the Vietnamese peasants who eked out a meager living from the land were mostly landless farm workers or sharecroppers. At the root of the conflict, there were also problems of social injustice, oppressive landlords, and the class struggle which could all be attributable to the inequality between the haves and the have nots.

Land reform became a conscious effort undertaken with variable degrees of success by successive governments of South Vietnam which felt they had to beat the Communists at their own game. For, to both sides, land reform was the indispensable tool to bring about social justice and a better life.

Under the Bao Dai regime, land reform was initiated through the distribution of public land to peasants, and by a reduction of land rents whereby no more than 15% of crop returns were allowed to be levied by land owners. In addition, no farmer was authorized to own more than 100 hectares of farmland. The maximum amount of farmland then authorized each owner varied according to the region and his capabilities for production. In North Vietnam, the range was from 12 to 36 hectares per head of household; in Central Vietnam, from 15 to 45 hectares; and in South Vietnam (old Cochinchina), from 30 to 100 hectares.

The First Republic of Vietnam also decreed, by an ordinance in 1957, that no landowner was allowed to keep more than 100 hectares for his own farming effort. All farmlands in excess of this maximum allowance were confiscated and reimbursed by the government. Reimbursements were made by a 10% cash advance, the rest to be paid back in 12 years at an annual interest rate of 3%. The GVN was able to purchase, both from departing Frenchmen and from Vietnamese landowners, 450,000 hectares, but only 122,000 hectares had been redistributed by the time President Diem was overthrown. Special measures were taken by the government to help farmers struck by natural disasters.

The Viet Minh also undertook a land reform program in North Vietnam after 1954, but their goal was entirely different from what South Vietnam tried to achieve. The Viet Minh began the program with a campaign of

inciting the hatred and enmity of landless peasants toward landowners. The Viet Minh coaxed the peasants to denounce crimes committed by landowners such as their enriching themselves by the peasant's blood and sweat and levying excessive land rents. It was true that in some areas, landowners in North Vietnam took away from the sharecroppers from 34 to 50% of the crop returns and charged interest rates ranging from 57 to 73% on credits extended for farming. As a result, this land reform program turned into a class struggle movement in which, after being denounced and indicted by their former sharecroppers and summarily tried by a people's court, landowners were stripped of all their possessions. The land thus confiscated was distributed to the landless peasants who had worked for the revolutionary government and to disabled veterans. The true goal of the Communists was obvious enough. Their land reform was nothing but a way of eliminating the landowner and petite bourgeoisie class and reinforcing what they called the proletariat and peasant class, and equalizing all differences between these two classes.

Under the Second Republic of Vietnam, there were also attempts at land reform during the initial years, but not until 1970 were there any significant and purposeful efforts. Land reform was undertaken on a scale extensive enough to take on a revolutionary outlook through the issuance of Presidential Decree No. 3/70 which authorized all peasants to become small landowners. Each peasant was allocated a fair amount of land for farming purposes entirely free of charge. The decree also officially terminated the practice of land rent and determined that the farmer was entitled to all the fruits of his labor and in fact owned the piece of land he actually tilled.

Due to the political significance of the "Land-to-the-Tiller" program, the date of the Presidential Decree that initiated it — 26 March 1970 — was proclaimed as a national holiday. For the rural population, this was truly the greatest and most total revolution ever attempted. For the first time in generations the peasants' aspirations had been realized and this was indeed the boldest move that any government had ever made in South Vietnam.

During 1970 a total of 210,371 hectares of land was distributed, a figure that surpassed the planned objective by 5%. By April 1973, the amount of land which had been planned for free distribution to landless farmers during the period from 1970 to 1973, had all been allocated, a total of one million hectares or 2.47 million acres.³ The rapid progress of the program was made possible by the substantial assistance provided by the U.S. in terms of experts, automatic data processing facilities, land surveying aircraft and the enormous fund of 500 million dollars which had been earmarked for the entire program.

In addition to free distribution of land, the GVN also established the Rural Development Bank (RDB) to extend credit to farmers. By the end of 1970, a total of 22 branch offices of the RDB had been established across the country; the goal was to establish 42 of them, one for each province. Total credit extended to farmers by the end of 1970 reached VN \$3.6 billion out of \$5.7 billion earmarked.

Other agricultural development projects were also undertaken such as modernization of farm equipment and machinery, the digging of new canals and the cleaning of ditches, irrigation, use of herbicides, insecticides, and fertilizers, import of better hybrid seeds of miracle rice (which could yield up to three crops per year). All of these projects had the devoted support of the U.S. In addition to agricultural development, the GVN also sought to improve nutrition for the population by importing cattle and poultry, increasing meat production and family income by importing better farm animal feed.

The "Land-to-the-Tiller" program in time became one of the GVN's major successes. Its achievements by far surpassed whatever previous governments had obtained. Its success depended primarily on the large assistance provided by the U.S. in terms of technology and the funds required to reimburse former land proprietors and to purchase land and farm machinery.

³The basic allocation was three hectares per farmer.

Politically, the program was also a resounding success. It brought about prosperity and a decent life for the great mass of the peasants, eradicated injustice and created a new class of landowner-peasants. Although the peasants appreciated land reform, the program met with some adverse reactions on the part of urban people who thought that they had been forsaken. It was true that urban areas also needed help since inflation was rampant and unemployment was widespread. To solve these problems, the GVN initiated programs to develop urban areas, clear slums, and create jobs for slum-dwelling people.

The impact of the "Land-to-the-Tiller" program was profound and far-reaching. Social justice was restored, the GVN prestige grew everyday, and it appeared that it was on the way to win the war. The enemy, in the meantime, strove hard to wreck these achievements. By devious means, he incited the people to oppose and undermine the program; for example, he forbade them to pay back loans owed the GVN, sabotaged the machinery imported for the farmers, stole farm machines, or took them away from farmers for ransom.

Village and Hamlet Elections

Traditionally the village is the basic political, social and economical unit of Vietnam. It has its own territorial boundary, a population and its own resources, and usually enjoys administrative autonomy. In the old days, the village was a self-contained microcosm with its own government and laws, and the village chief was not unlike a lord who reigned over his tiny kingdom. In most instances, the village customs prevailed over the laws decreed by the imperial court and the village was governed by a council of notables which made all the important decisions for the village chief. This system was perpetuated over the generations and, with some modification in organization and name, became what it was in modern times, the village council, with the exception that its members in modern times were chosen through the popular vote.

Village elections were an effort by the GVN to develop democracy at the grass-roots level and at the same time to expand GVN control and authority throughout the nation. In contrast to traditional times, members of the village council were now elected instead of being appointed. This ensured that only people with prestige and popularity could hold office, in the place of the rich people who traditionally bought their way into office and exclusively shared among themselves the prerogatives of power.

As an administrative unit, the village incorporated several hamlets. Hamlets were geographic subdivisions of a village and placed under its administration. Throughout South Vietnam, there were 2,151 villages with a total of 10,522 hamlets.

The village government consisted of two bodies, the Village People's Council (VPC), and the Village Administrative Committee (VAC), which represented the legislative and executive branches, respectively. In 1966, a GVN decree determined that the Village People's Council was composed of from six to 12 members elected by the village through universal suffrage, direct and secret ballot.⁴ This represented a big step toward democracy at the grass-roots level as compared to village elections enacted under the First Republic, since the 1966 decree instituted a legislative body which had been missing up until then.

During the balloting, the member who won the largest number of votes became the chairman of the VPC and the member who ranked second in popular votes, the deputy chairman. After election, the Village People's Council convened its first session to elect the chairman of the Village Administrative Committee from among its members.

⁴The specific number of village council members to be elected was determined by the province chief on the basis of village population:

Up to 2,000 inhabitants: 6 members

From 2,000 to 5,000 inhabitants: 8 members

From 5,000 to 10,000 inhabitants: 10 members

Above 10,000 inhabitants: 12 members

(Reference: Decree No. 199-SL/DUHC, dated 24 December 1966)

The Village Administrative Committee was composed of one village chief, one deputy village chief, and from one to four commissioners to perform the functions of security, propaganda and civic action, social welfare and agriculture. The other two important functions, civil status and economy-finance were assumed by the village chief and his deputy, respectively. (*Chart 20*)

The village chief or chairman of the VAC was elected by the village council from among its members, but he was not authorized to assume concurrently the functions of chairman, deputy chairman or secretary general of the village council. If the chairman of the village council happened to be elected village chief, the deputy chairman, VPC would take over his functions. The term of office of the VAC was three years. It terminated at the same time as the village council. The deputy village chief and commissioners were appointed by the village chief with the concurrence of the village council and the ratification of the province chief or district chief.

The village chief was responsible for enforcing laws and regulations, implementing GVN policies, and maintaining order and security in the village. His commissioner for security was usually the leader of the popular forces platoon assigned to protect the village.

The hamlet was placed under the administration of a Hamlet Management Committee which was composed of one hamlet chief and two assistants, one for security, one for propaganda and civic action. In hamlets with a population exceeding 3,000, the hamlet chief was assisted by a deputy. Both the hamlet chief and his deputy were elected by hamlet people through secret ballot in the same way as the village council.

People running for public office at the village and hamlet level were usually selected from among the anti-Communists who had good records, and frequently included veterans or retired civil servants. Any village resident could apply to run for office. His application was submitted to the district, and if his police record was clean, the application was forwarded to the province. There, the province election committee which included members of the security committee would screen

Chart 20 – Organization, Village and Hamlet Government

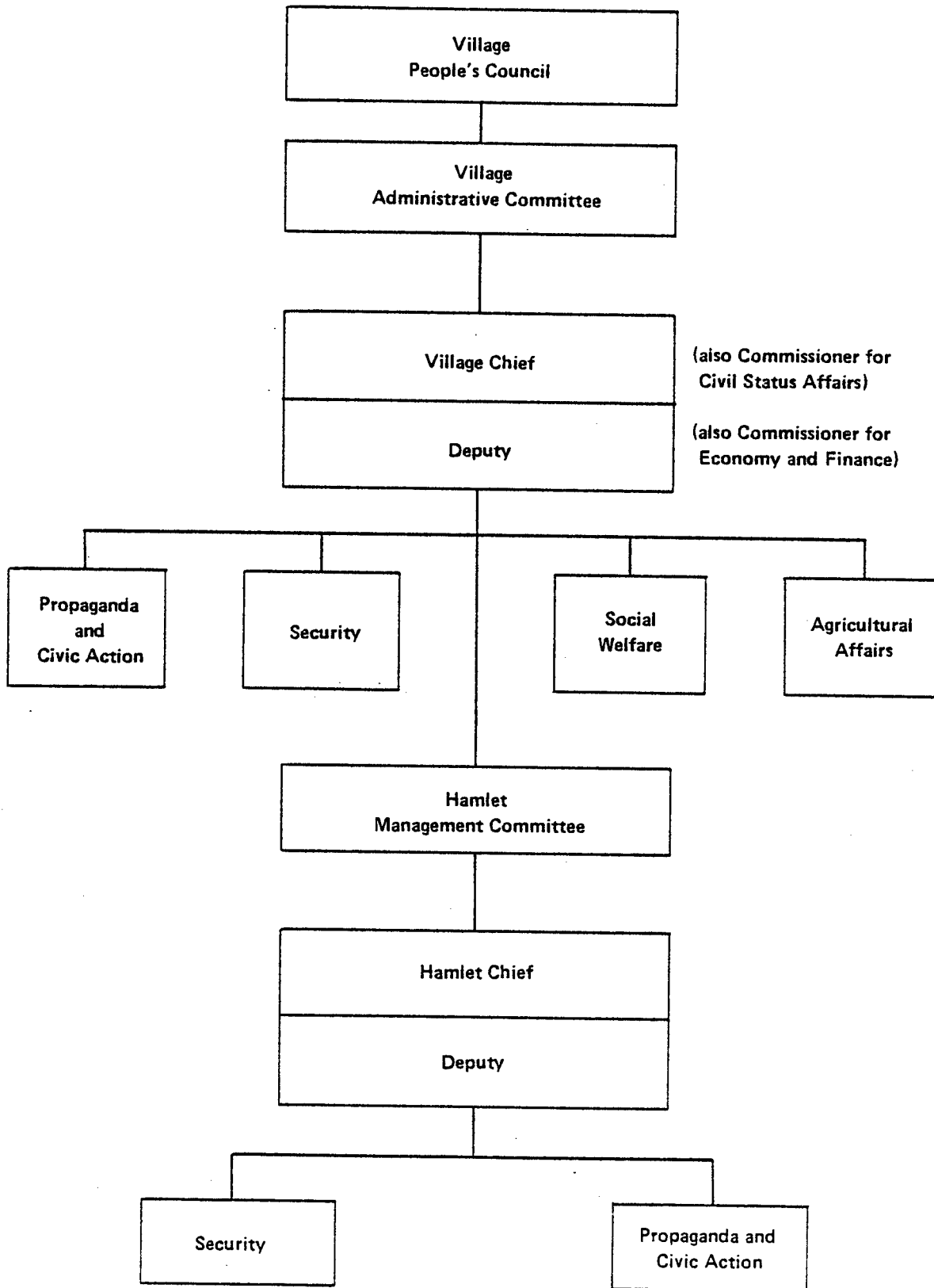

all applications and make its recommendation to the province chief. Again, if the applicant's record was clean, he could be placed on the ballot. In practice, the province election committee exercised control over who would run for office at the local level. After the first term, village and hamlet officials might be reelected several times. With a view to improving the effectiveness of the local government apparatus, the GVN conducted training courses for village and hamlet officials at the National Cadre Training Center at Vung Tau. The purpose was to consolidate the village and hamlet officials' anti-Communist spirit and train them in administrative procedures so that they could serve the people more efficiently. This was also in keeping with the pacification long-range goals that the GVN had set to achieve: self-defense, self-management, and self-sufficiency. Since only a solid infrastructure could bring about the conditions for achieving these national goals, efforts focused on the village and hamlet officials who operated and maintained that infrastructural foundation.

Elections at the village and hamlet level were a political innovation which attempted to institute democracy in a rural society still heavily influenced by traditions. Held within the context of a raging war, these elections met with some serious difficulties. In many villages there were very few youths left and the majority of their population consisted of elderly people, women and children. As a result, the GVN had to bring in people from other localities and even allowed servicemen on active duty to run for office. When elected, these officials could not function effectively, partly because they were strangers, and partly because the village population would not work with those they did not feel were their own people. Thus, despite their devotedness and hard work, such officials could achieve very little because they did not enjoy trust and support of the villagers.

Despite difficulties, village and hamlet elections proceeded with remarkably good results, due to improved security. By 1971, out of a total of 2,151 villages, 2,053 or 95.5% had elected village councils.

(Chart 21)

Chart 21 – Village and Hamlet Elections, 1970

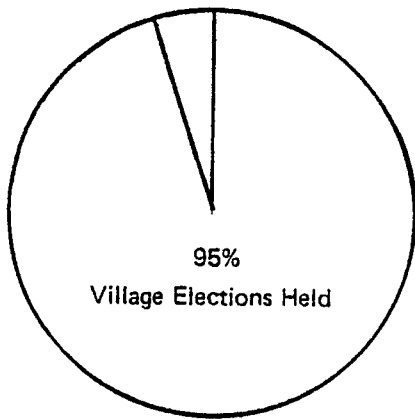

$\frac{2,053 \text{ VILLAGES}}{2,151 \text{ VILLAGES}}$

VILLAGE OFFICIALS ELECTED

$\frac{17,305}{18,109} = 95\%$

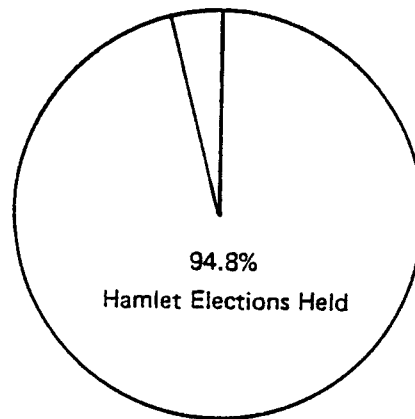

$\frac{9,985 \text{ HAMLETS}}{10,522 \text{ HAMLETS}}$

HAMLET OFFICIALS ELECTED

$\frac{47,296}{52,610} = 89\%$

In 1972, however, the village and hamlet elections program had to be suspended in the wake of the Communist Easter offensive because of deteriorating security.

In addition to elections and training of village officials, the GVN still wanted to move toward total democratization by reforming the old administrative apparatus. The first step toward complete reform was the decentralization of authority. Province and district chiefs were empowered, for example, to solve all problems concerning the local population's aspirations; the central government would not meddle into local affairs. The GVN encouraged village and hamlet inhabitants to participate in various groups and organizations that served their interests such as farmer's associations, 4T clubs, etc. All these groups and associations were designed to foster a mutual assistance spirit among the population and to provide them with needed help in case of illness or disease.

People's Self-Defense Forces

The People's Self-Defense Forces (PSDF) was not a political or military organization or an affiliate of some religion, but a people's organization. With government assistance in armament and training, its members were supposed to defend themselves, their families, and their property against the Communists.

The need for a PSDF organization arose in the wake of the enemy 1968 Tet offensive as a result of the spontaneous demand from the people. The attacks waged by the Communists during 1968 completely alienated the people who had incurred heavy losses, not so much because of the fighting but because of Communist atrocities. Several thousands of Vietnamese, among them Catholic refugees from North Vietnam, asked the GVN to give them arms so that they could defend themselves and their communities. In response to this popular demand, the GVN initiated the People's Self-Defense program, which was established by the Mobilization Law of June 1968. The basic objectives of the PSDF program were to provide the people with the means to defend their families, homes, and

hamlets or villages in both rural and urban areas; to assist the National Police and RVNAF in maintaining security and order; to promote community development activities for self-help and improvement in both rural and urban areas, and to assist the police in identifying the enemy.

A National People's Self-Defense Committee, chaired by the Prime Minister, served as a policy-making body under the operational control of the Central Pacification and Development Council. The implementation and operation of the PSD program was the responsibility of the PSDF Directorate under the Ministry of Interior. The PSDF director's duties included the detailed direction of the PSDF program, and guidance to the subordinate echelons on PSDF matters.

At each lower echelon of the administration, save for the corps tactical zone level, a PSDF committee administered and supervised the program. Thus there were PSDF committees at provinces, in Saigon and other autonomous cities, at districts (or precincts), and at village (wards or quarters) and hamlets. (*Chart 22*)

Under the Mobilization Law, all able-bodied men in the age groups of 16-17 and 39-50, except those joining the RVNAF on a voluntary basis, and males between 18 and 38 (draft age) deferred from military service were required to be members of the PSDF: Veterans who had served full terms of military service, elderly people, and women who were not physically capable to serve as combat PSDF could join support groups.

Combat PSDF were organized into groups with an authorized strength of 134 and consisted of three inter-teams of 44 members each. Each inter-teams was further broken down into three 14-member teams. A team was composed of a team leader, an assistant leader, three cells of three male members each and one cell of three female members. In case there were no woman volunteers as combat members, the strength of a group was reduced to 107. (*Chart 23*)

The positions of PSDF commanders at the capital, provinces, cities, and districts were assumed by the deputy mayor, deputy province chiefs, deputy mayors and deputy district chiefs, respectively. These officials served as the formal heads of PSDF in their areas but were not expected to exercise tactical control since PSDF were not designed to fight

Chart 22 – Organization, PSDF

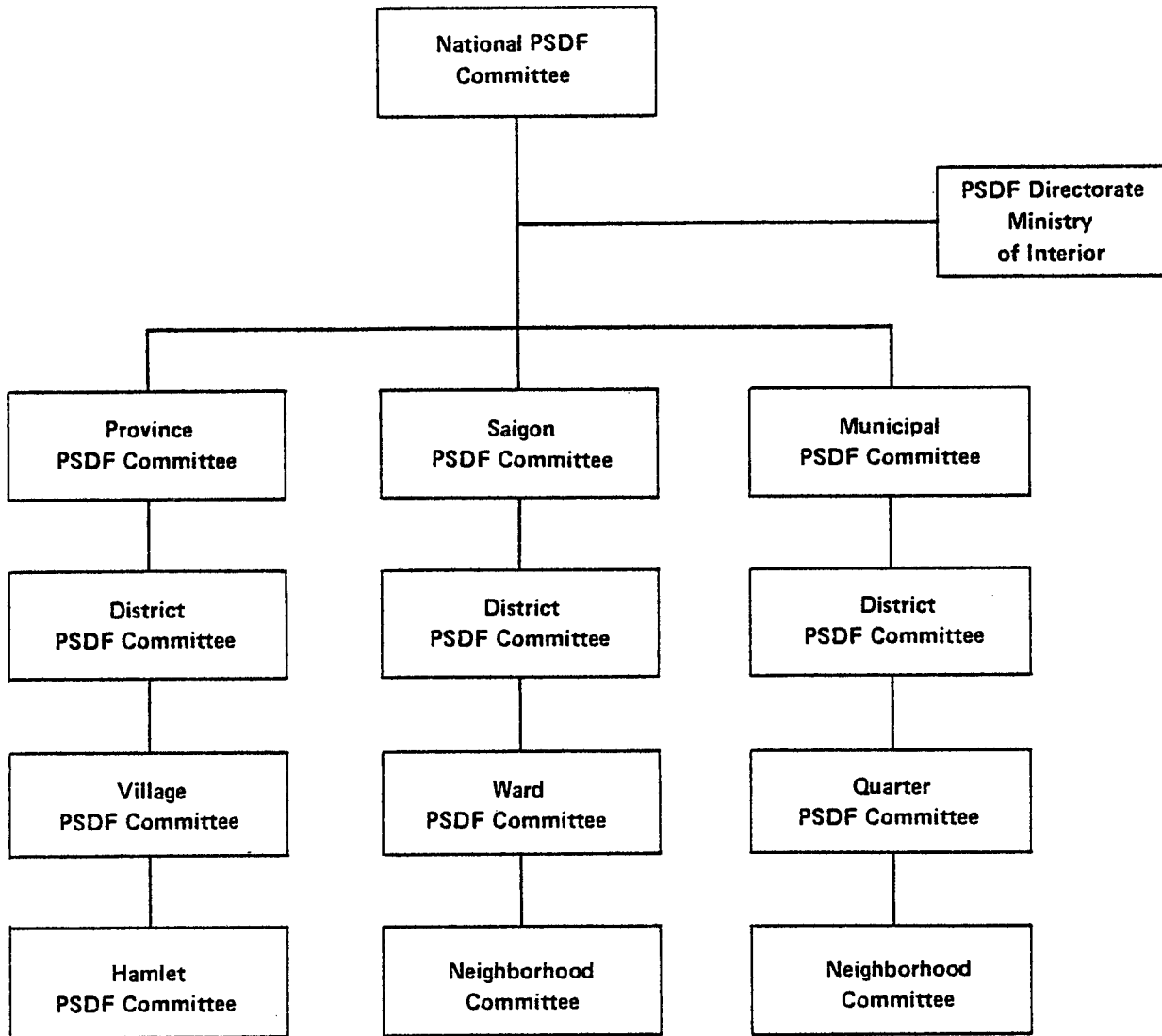

large-scale operations. Combat group, inter-team and team leaders were all elected by PSDF members themselves.

By the end of 1970, the PSDF had grown into a sizable force which included a total of 1,397,000 combat members out of 1,500,000 planned and 2,400,156 support members out of a planned 2.5 million. Combat PSDF members were armed with 463,752 individual weapons of assorted types. Across the country, 95% of villages and hamlets had their own PSDF organizations by this time.

People's Self-Defense Forces were employed primarily in villages, hamlets and urban and suburban neighborhoods against local enemy guerrillas. They generally operated in 3-man cells out of a fixed command post but frequently changed their guard stations, particularly at night. The village chief was responsible for the employment of PSDF. His commissioner for security, usually a PF platoon leader, assisted him in planning and controlling the deployment of PSDF for the village defense. The PF platoon was usually used as a reaction or back up force, supporting the PSDF by patrol and ambush activities outside the village. In city wards and neighborhoods, PSDF cooperated with the National Police in maintaining law and order, fighting crimes and social vices, and guarding against enemy sabotage or propaganda activities. Combat PSDF were supported by support elements who provided such assistance as first aid, medical evacuation, supply, morale, and comfort.

At this early stage of organization the PSDF were plagued by several problems, particularly an acute shortage of able leaders. In several instances, PSDF group leaders turned out to be draft dodgers and it became difficult to apprehend them for military service without undermining the PSDF program. The problem was obviously sensitive and was not solved despite joint efforts by the Directorate of Manpower and the PSDF Directorate.

In addition, although self-defense duties were a civil obligation, in big cities many residents sought to avoid PSDF guard duties by hiring other people as replacements. This practice was widespread among the rich and the influential people, particularly among wealthy Chinese-businessmen. The result was that many PSDF members turned into

"professional" men for hire, whose sole occupation was to take up permanent guard duties for a fee.

The PSDF were regarded as a handy source of weapons by the enemy and he focused on proselyting or intimidating PSDF members. Many weapons were thus lost to the enemy but the number of weapons captured from him and lost to him by PSDF members about cancelled out each other. The loss of weapons to the enemy through PSDF turncoats was particularly serious in the Mekong Delta. Therefore plans were made by the JGS at one time to employ NCOs on active duty or those approaching retirement age as PSDF group leaders in their home towns or villages. The PSDF could have turned into a most effective defense force if properly commanded and led.

An Evaluation

The GVN efforts at instituting grass-roots democracy, informing and educating the people, winning over their support, rallying the enemy's infrastructure members, and bringing about social and racial justice achieved only mild, superficial successes, except in the case of the "Land-To-The-Tiller" program. The truth seemed to indicate that the political achievements of a regime could never be better than the regime itself which was built on personal loyalties rather than popular consent. The "soloist performance" during the presidential elections in 1971 reflected the true light of a democracy which existed only for form's sake. Many knowledgeable Vietnamese believed that as a nation, South Vietnam failed because of bad political leadership.

Through the balloting process, the GVN attempted to institute democracy at the village and hamlet level. The quantitative results obtained by 1971 were impressive but failed to convey a true picture of real political life. The first truth was that the Vietnamese villages could do without elections if people were allowed to manage their own affairs without interference from the central government. For generations, the traditional Vietnamese village had been the most democratic institution even under the most despotic monarchies.

Villagers used to manage their own affairs through a council of respected elders and notables. Village customs defied and always won over the monarch' laws and the mandarins' authority. And French colonial rule never affected nor dared touch the autonomous microcosm of the village. But things began to deteriorate when the village chief was appointed, not by the council of notables who were installed by popular invitation, but by executive orders back in 1955; hence, the need for elections to re-institute a lost popular way of managing village affairs.

But the new generation of elected village councilmen seemed not to enjoy popularity nor command respect among villagers. Many of them were young people, introduced and backed by the district government, and some were not even villagers. The electoral process thus degenerated into some sort of wholesale appointment under the cover of ballots. As a result, most village councilmen behaved in a subservient way as if they were the province chief's appointees, not the people's representatives. They operated under pressure and direction of the provincial government, always mindful that the province chief was empowered by law to remove any of them from office any time he found a convenient pretext for it. The remarkable thing about it all was that elections were held only where GVN control was tight to give the provincial government effective leverage over village councils. And when this control was in jeopardy such as in the aftermath of the 1972 Easter offensive, the opportunity to stop the elective process altogether was too good to pass over.

Information as a national activity was for some time paired off with the Chieu Hoi effort. It was hoped in effect that through effective, straightforward information, the people would become more aware of the GVN achievements, of the free and prosperous way of life under the RVN regimen as contrasted to coercive and spartan life with the Communists and that enlightened elements of the other side would be attracted by it and come over. This policy worked but the results were modest. Somehow, the GVN information effort, to include clumsy attempts at propagandizing, never seemed effective enough despite advanced techniques and large budgetary outlays. The reason seemed to

derive partly from the blase mood of the educated public, partly from the fact that the GVN had very little to show for its political cause. To the rural population, occasional movie shows, propaganda leaflets, and outdated newspapers were just curious things that seemed far removed from reality. The case of the neglected hamlet information hall spoke eloquently, for the GVN always measured success in information in terms of misleading statistics, never in terms of popular responsiveness.

This perhaps accounted for the modest results achieved through the Chieu Hoi program. While the statistics appeared impressive — the number of ralliers was always on the rise — a closer look usually revealed that almost all returnees were low level military and cadre or even stray people who chose to rally to stay away from war hazards, for family reasons or for a chance to earn a living and seldom because they were ideologically convinced by the GVN overtures. The most important catches merely totaled a few relatively high-ranking cadre and most of them defected in the wake of the 1968 Communist military fiasco. The reason? They simply believed they could not win militarily.

For all its potential and merits, the Chieu Hoi effort may not have been fully worth its cost and returns. For one thing, the GVN was only half-hearted in employing ralliers for any useful purpose, out of suspicion and fear of its inability to control. This was not the case with US forces who employed the same people with remarkable success. For another, the program was costly and caused frustration among the troops who felt their lot was much worse than a rallier's.

As to the problem of ethnic minorities and the Montagnards in particular, it was more of a political than a socio-racial issue. The GVN became more alert to this issue after the FULRO-instilled rebellion erupted in 1964. The rebel leader, Y Bham, demanded autonomous status for the Montagnards, which practically amounted to political secession. This was entirely unpalatable to the GVN and to the Vietnamese in general. Racially, the Vietnamese always felt superior to the Montagnards whom they condescended to treat as equals only for political purposes. But the integration process, like other socio-racial problems, was slow and frustrating, for both sides. It might take generations

or it might perhaps remain a problem forever. But the GVN policy and actions seemed to be consistent with the long-range goal of achieving national unity.

One of the key pacification objectives for the GVN was to institute self-protection for the people, hence the creation of People's Self-Defense Forces. This effort fell in line with the overall pacification strategy of employing different forces against different levels of enemy organization. It was also the least expensive among the military efforts. But the PSDF idea, like the RD cadre, was not entirely a GVN invention. It was rather an imitation of Communist people's war doctrine adapted to the RVN cause. Unfortunately, the PSDF were neither as well disciplined nor as ideologically indoctrinated as the Communist militia. The initial gung-ho fervor gained in 1968 soon faded and gave way to a tedious routine in which stand-in guard duties were sometimes performed for a fee. This happened mostly in urban centers where wealthy people could afford hiring substitutes. But in insecure hamlets and in certain areas under religious influence, the PSDF performed much better and were rather well disciplined. In both cases, they appeared to be genuinely motivated by the need to protect their communities. The pattern seemed to indicate that voluntary work succeeded only where motivation and self-interest came into play. In general, the PSDF were plagued by several problems, the most serious being the lack of direction and supervision. If well motivated and under good control, the PSDF could have been a formidable force to contend with.

Among the pacification achievements, only the "Land-To-The-Tiller" program stood out as a resounding success which might portend considerable political gains in the long range. It might eventually become the model for social justice in backward agrarian countries if sustained and capped by a more popular political regime. In the case of Vietnam, agrarian reform had always been a political instrument. The Viet Minh did it in 1954 in North Vietnam to hasten the process of conversion to socialism. Ngo Dinh Diem tried it to bolster his regime but his half-hearted, small-scale program failed. The success achieved by the

Second Republic in 1970 was possible only because of the availability of American financial and technical aid. It succeeded because it was the right thing to do at the right moment. But while the peasantry acclaimed it, it also turned a cool back on the regime that sponsored it. Nevertheless, the program was a bold step in the right direction. Its long-range impact, unfortunately, did not have the chance to materialize.

The political experience gained through pacification thus seemed to demonstrate that whatever instrument or ploy the GVN used to gain popular consent and support only worked to the extent of credibility and popularity of the regime. The results expected could in no way be better than the regime itself. In fact, they mirrored accurately the standing of the regime and its acceptance by the citizenship.

CHAPTER VIII

An Assessment of Pacification: Some Achievements, Difficulties and Shortcomings

The Ideological Aspect of Pacification

The war in South Vietnam polarized Vietnamese into Communists and anti-Communists and brought them onto a head-on collision course. Some called this war an ideological conflict. This was true but only to some extent because although opposed to Marx-Leninism, the nationalist cause hardly showed a doctrinary cohesion worthy of being an ideological rival. Several Vietnamese intellectuals, therefore, felt the need and actually searched for a codified, political doctrine capable of providing ideological guidance and motivation to the nationalist cause. Ngo Dinh Nhu for some time succeeded in selling this syncretistic version of "personalism" from which he also derived certain cohesive concepts as the doctrinal basis for his strategic hamlet program. Genuine as his concern was, the complexity of his philosophy enlightened no one, much less the peasantry, and served no useful purposes. Other efforts in general never went beyond "tea room" chats or magazine articles. The futility with which the search for an ideology met indicated that this was perhaps a pseudo-problem, which interested only the educated elite and that the peasantry, faced with the pressing and immediate questions of livelihood and security, would benefit more from a pragmatic approach to pacification and nation-building.

The conflict was also termed a civil war, which is probably more appropriate, since the issues at stake had deep roots in the political, social and economic fabric of Vietnam. The Communists, Viet Minh or Viet Cong, were dedicated revolutionaries in the sense that they wanted to destroy all traditional institutions and values and move toward disciplinarian and collectivized life under socialism. Those who opposed

them, by contrast, adhered to a liberal, humanistic way of life sustained by cultural traditions and economic prosperity. Pacification, therefore, provided the RVN with the opportunities to preserve and develop this way of life which most Vietnamese, I believe, if given a free choice, would certainly prefer over dehumanized, coercive collectivization.

It was in this direction that every GVN effort had moved, regardless of the regime or the name assigned to it. The strategy of pacification underwent very little change over the years. The Ngo Dinh Diem government was more ambitious in trying to make its strategic hamlet philosophy a national doctrine but its Communist-inspired methods were harsh and self-serving. The five-family group system, for example, despite its purported goal of "mutual assistance" and protection against Communist penetration, was a Machiavellian scheme, an instrument for control and repression. The dominant role of the village youth leader, who was the sole appointee among elected councilmen and directly responsive to Mr. Nhu's Republican Youth, was another example of the control techniques so common in authoritarian states. It was, in the end, the methods that negated and defeated the doctrine which itself professed to be humanistic.

The next few military governments that succeeded Mr. Diem attempted to improve on and revitalize the Strategic Hamlet program by adopting a new attitude toward pacification, symbolized by a new name: New Life. In essence, the effort amounted to pouring the same old wine into a new bottle since the center of interest was still the hamlet. It was remarkable not in what it professed to do but in its efforts to avoid treading the path of abuses and excesses that had led to Mr. Diem's demise. Hesitant and half-hearted, the New Life effort made no new inroads of any significance.

Pacification was greatly aided by the CORDS arrangement which for the first time provided cohesive support for the GVN effort under Nguyen Cao Ky. Also, Ky attempted to cover pacification with an ideological veneer. He professed that his government was a "poor man's government" and made use of revolutionary terminology to suit his good intent. He called himself "Chairman of the Central Executive Committee" instead of prime minister and addressed his cabinet ministers as "commissioners."

He even coined the term "Revolutionary Development" for the pacification effort although in Vietnamese, it was never called that. The new pacification czar, Major General Nguyen Duc Thang, was his trusted friend, an energetic, hard-driving, gung-ho type of a leader. To boost the image of a revolutionary working for the poor man's cause, Thang usually donned the peasant's black calico pajama chosen as the uniform for his RD cadre. He even appointed a former Viet Minh battalion commander, Colonel Nguyen Be, as commandant of the RD Training Center at Vung Tau. In all respects, Thang was the perfect match for his new US counterpart, Ambassador Robert Komer, an equally positive leader and hard-driver. The remarkable thing about it all was the charismatic effect of the new momentum given to the pacification effort by the Thang-Komer duo. But all these outward manifestations betrayed an obsessive preoccupation with appearances which led to the tendency of substituting statistical results for true achievements.

The only reliable parameter of pacification success was found in the "hearts and minds" of the people, not in self-serving figures. A million propaganda leaflets dropped did not even guarantee that a single soul was won over. This showed to what extent statistical results, even those backed up by the most advanced techniques, could be misleading.

Statistics Versus Achievements

If we believe official statistics, in 1963 more than ten million South Vietnamese inhabitants were living in about 9,000 strategic hamlets and in urban centers. Given the total number of hamlets (11,864) and the population at that time (14.4 million), GVN control was fairly well established over approximately 70 percent of the nation. As far as statistics went, that was an encouraging prospect and the Strategic Hamlet program was anything but a failure. But a quick verification undertaken in 1964 revealed that only 10 percent of these hamlets were really defensible and the remaining were either indefensible or penetrated by the VCI. The lesson here was well learned. It showed how unreliable the reports were from province chiefs, on which these statistics were based.

The scientific measurements used in the Hamlet Evaluation System, however, increased the accuracy of reports and the validity of statistical results. The system, however, had its shortcomings. Apart from the time lag between information gathering and final reports, we were again confronted with the unreliability of the basic data fed by village and hamlet officials. As has been said, the district chief or his adviser had no way of verifying the accuracy of these data unless he personally made spot checks, which was something nearly impossible to do often enough to meet requirements. Thus the final monthly report's reliability was largely a matter of faith, a matter of whether or not we could trust the hamlet officials, and to what extent.

The GVN pacification efforts were twofold: hamlet security and hamlet development. These were measured by statistical results showing the progress being made in each area. Security was measured in terms of hamlets and population under GVN control, the amount of protection forces available for their defense and the maintenance of law and order. Directly linked with security was the viability of the VCI including guerrillas, which could be evaluated by the number of its personnel being destroyed or rallied to the GVN.

On the developmental side, statistics were used to measure progress in such political, social and economic programs as village and hamlet elections, land reform, health and education, refugee resettlement and agricultural development. There were also incidental programs that contributed indirectly toward the development task such as information, cadre training, and public works, but they were rather the tools with which the task was performed.

The lack of adequate data for the entire lifetime of the pacification program, particularly the period after the cease-fire, makes any attempt at assessment difficult. With the amount of data available, it is possible, however, to discern certain trends or patterns indicative of both progress and problems. The most discernible pattern in pacification was that progress depended entirely on security and that it was generally better than during the Strategic Hamlet period. A less obvious but still discernible trend showed that pacification progress was a

curve with peaks and troughs. 1967 and 1971 were the years when the best statistical results were gained but 1971 reached a peak never before attained. Characteristically enough, these peaks were invariably followed by troughs which were when security was at a lower ebb: 1968 and 1972, the years of the enemy's big offensives. This pointed toward another significant pattern: a major enemy spoiling action could always be expected when pacification seemed to attain a reasonable degree of success. The last major enemy offensive in early 1975 did not run counter to this pattern. It was attempted at a time when the GVN, despite its difficulties and some territorial losses, seemed to be consolidating its foothold in the rural area,

But statistical results told only part of the story. In 1971, for example, the GVN was apparently in firm control in terms of hamlet security, claiming that 85.3 percent of all hamlets were entirely or relatively secure, while the enemy controlled a mere 3.6 percent and about 11 percent were contested. Population control achieved the same spectacular results; 92.4 percent of South Vietnamese inhabitants were reported living in secure or reasonably secure hamlets, to include urban centers. The Viet Cong, meanwhile, controlled only 1.1 percent. Again, about 11 percent were contested. (*Chart 24*) These results were obtained at a time when VCI activities were at their lowest level and when Communists main and local forces were avoiding engagements in preparation for their next big push. The situation then appeared as if the GVN was left alone to go about its nation-building task. But it was only the calm that precedes a big storm.

The security attained was not a guarantee that it would be immune to enemy spoiling actions and that the trend was irreversible. The results only reflected the situation at a certain time; they did not represent the kind of solid, permanent achievements that defied retrogression. Also, to attain these results, the GVN overextended its capabilities and relied heavily on American support. The lesson of 1972 indicated that without the military protective shield, pacification setbacks could occur anytime the enemy chose to strike in force. By 1974, the GVN had run out of strategic reserves to maintain a reasonable

Chart 24 – Achievements in Population and Hamlet Control, 1971

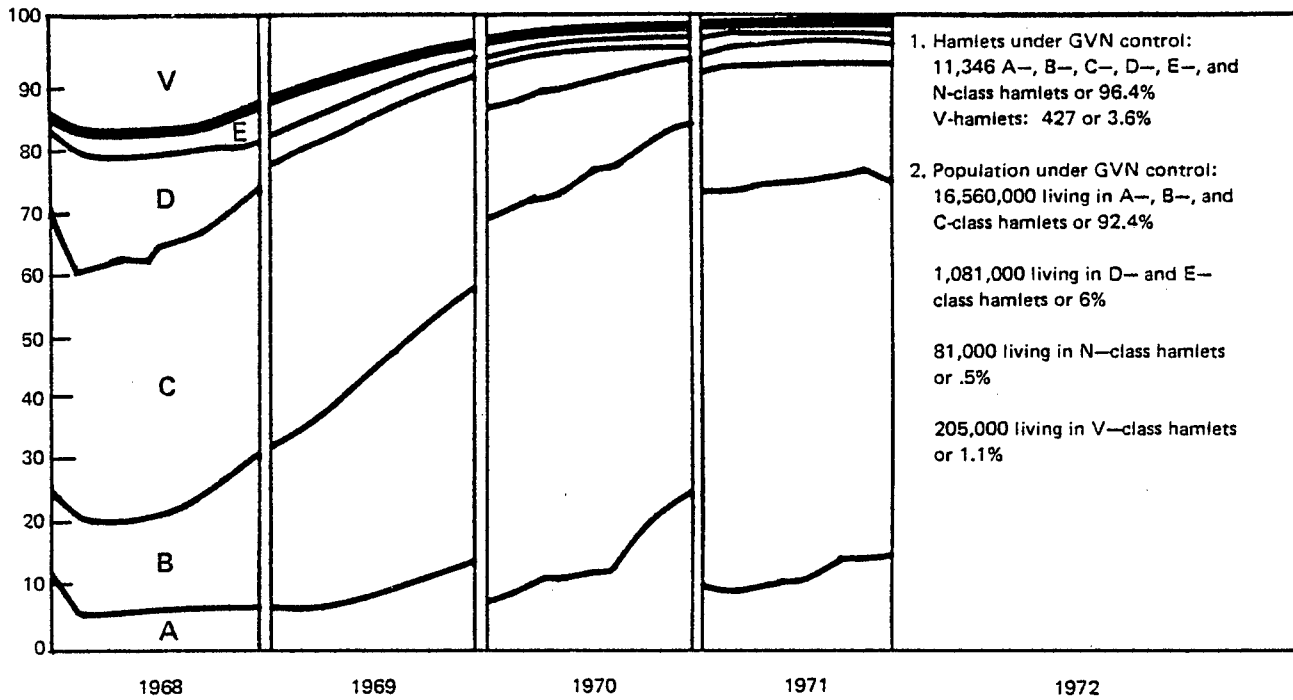

Total South Vietnamese Population: 17,928,000

Total Hamlets: 11,173

degree of security and control in the face of stepped up enemy attacks. Its strategic options were limited. It was finally reduced to a simple matter of how much control it could afford.

GVN efforts at eliminating the VCI and winning over its members at the same time seemed to be reasonably effective if statistics could be trusted. In fact, reports gave the Phung Hoang (Phoenix) program credit for making a sizable dent in the VCI ranks: 15,603 casualties by 1971 or about one fourth of total VCI size, estimated at 63,757. But this casualty figure included the VCI greatest losses incurred during 1968 when its members surfaced and actively participated in the Tet offensive. It also included a number of VC killed in local firefights by ARVN forces. Chieu Hoi results were equally encouraging: by 1971, a total of 159,741 "enemy" personnel had crossed the line to freedom. This included 97,696 military troops and cadres, 45,173 political cadres and 16,872 undefinable "others."

But apart from the low caliber of enemy personnel killed or rallied, the statistical results included a substantial number of undefinable "enemy" personnel who were classified as such primarily because they were either innocents caught under suspicion or inhabitants of the other side coming over for safety and a decent livelihood. The fact that several among ralliers switched sides many times over the years was a clear indication that except for a few enemy agents they were something besides enemy personnel. One may question that if so many enemy personnel had rallied or had been eliminated, how could the VCI continue to pose a permanent threat to the pacification effort? Indeed, if statistics were useful, they strongly indicated the enemy's capability to recruit and replace surpassed everything we usually attributed to him.

To ensure security and provide protection for the people living under GVN control, a military shield was indispensable. While US forces did not always participate in pacification operations, their powerful combat support assets and intervention capabilities directly contributed to the clearing of several pacification areas. Their most significant effectiveness was the destruction of enemy bases and lines of communication, which indirectly accounted for the improvement of security in rural

areas. But the main responsibility for providing the protective shield remained with the regular and territorial units of the RVNAF. That shield was indispensable because hamlet security forces — the PF, the PSDF and the police — could not survive enemy attacks without it. The interdependence of forces thus became a key feature of the pacification strategy.

During the period 1967-1972, the RVNAF grew rapidly in strength, reaching a peak of nearly 1.1 million men. More than half that strength was composed of territorial forces, an indication of their maturity and increasing role in pacification. Sheer numerical strength, however, failed to convey the true picture of combat effectiveness. A conclusion that one may draw is that the RF and PF failed in areas where enemy forces were superior and that this failure accounted for the continued bogdown of ARVN regular divisions in territorial security missions. One of my constant headaches as J-3, JGS came from requests for reinforcements from field commanders who always asked for more and never seemed happy to settle for less. This was perhaps another indication of the RF and PF ineffectiveness. Somehow I got the impression that pacification support was like a leaking tank. No matter how much more manpower you put in it, it never seemed to be enough for the task.

Hamlet security forces also increased substantially during this period. The PSDF, for example, reached a total of nearly 4 million by 1970, of which 1,326,571 were combat members, equipped with a total of 463,752 individual weapons. (*Chart 25*) Statistics also showed that 95 percent of secure and relatively secure hamlets were defended by PSDF and each of these hamlets had from one to several teams (11 men each) depending on its size. What the statistics did not reveal was the high density of PSDF in cities and urban areas where their role was light and a much lower distribution in rural areas where the PSDF role was more critical. This imbalance in distribution reflected the lower male population in rural areas and was one defect that could never be corrected unless the trend of urbanization was reversed. But even in urban areas, the nominal strength of PSDF was not indicative of their effectiveness. Their notorious trigger-happy unruliness was particularly

Chart 25 – Expansion of PSDF, 1968-1970

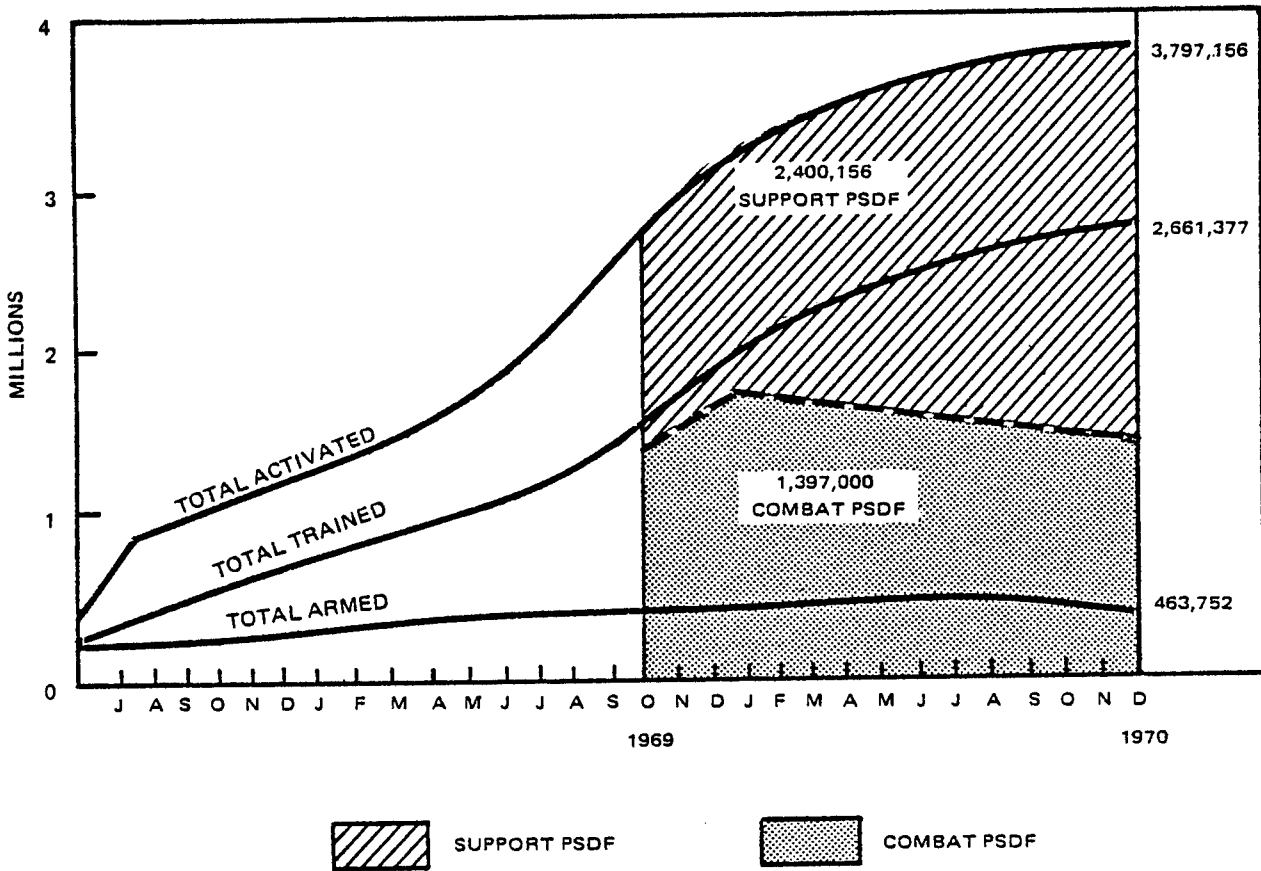

irritating to the urban people. Some thought that they stood a better chance of being fired on when stopped by a PSDF than by a Viet Cong.

The expansion of police forces to rural areas was also a significant effort to combat the VCI, in addition to maintaining law and order. The modest strength of the police, however, limited its capabilities. There were no police available at the hamlet level which was the most important natural subdivision of South Vietnamese rural society.

All in all, the statistical results of pacification showed steady progress, particularly after the momentum was gained through the 3-month accelerated program in late 1968. They reached an all-high record in 1971 but suffered some setbacks during the 1972 Easter offensive. Pacification gains were stabilized again after the short, disruptive campaign of "Land and Population Grab" that the enemy launched without success immediately after the cease-fire. Despite stepped-up activities during 1974, the Communists seemed to have lost their foothold in the rural areas. And the pacification gains were being consolidated when North Vietnam decided to go all-out once again in early 1975. South Vietnam was lost, not because pacification had failed but because its weakened military forces, hampered by the flow of panicky refugees, were unable to hold the entire North Vietnamese Army in check.

The Communist Challenge to Pacification

The ups and downs of pacification illustrate the familiar pattern of Communist activities designed to spoil the GVN nation-building efforts and ultimately take over South Vietnam. During the first few years of the war, 1959-1963, the strategy that dominated Communist thinking was basically political and social. Their aim was to disrupt and discredit the newly established republic, create social dissatisfaction and unrest and move toward either a general uprising or a coalition government.

Communist activities during this period began with and concentrated on the rural area. They consisted largely of subversive and terrorist actions against village and other GVN officials at the grass-roots level. These were conducted by the underground Viet Minh agents, estimated at

about 10,000, who remained in the South after the Geneva Accords and were gradually augmented by new recruits and Viet Minh regroupes re-infiltrated from the North. An estimated 61,000 village officials and GVN civil servants were reported to be assassinated or executed from 1958 to 1966. During the next three-year period, from 1968 to 1970, casualties caused by the VC to the civilian population more than doubled, even tripled the yearly rate of the previous period. (Table 1)

Table 1 — Casualties Caused by Enemy Anti-Pacification Terrorist Activities (From 1968 to 1970)

<u>Categories of Casualties</u>	<u>1968</u>	<u>1969</u>	<u>1970</u>
Kidnapped	10,108	6,096	6,245
Wounded	15,918	15,603	11,177
Killed	6,338	6,090	5,298
Totals	32,364	27,790	22,720

The extent of terrorism and sabotage was such that to save the countryside from Communist control, the GVN initiated the Strategic Hamlet program in 1962. The program produced good effects despite inflated reports by province chiefs. Its progress prompted the Viet Cong in late 1963 to demand the dismantling of these fortified hamlets which they denounced as "disguised concentration camps." Profiting from the political unrest and instability in Saigon before and after Mr. Diem's downfall, the Viet Cong systematically wrecked the program by penetrations and attacks. They came perilously close to success with widespread disorder and violence but the general uprising never came about.

Recognizing the futility of guerrilla warfare as a means of conquest, the Communists decided in early 1964 to shift their strategy toward military violence and began to infiltrate regular NVA units of regimental size into the South. This was the beginning of a force buildup accompanied by the revival or construction of logistical bases in the border areas. From 1965 to 1967, the war had a predominantly

military outlook with pitched battles between US and Communist forces and large scale US search and destroy operations against Viet Cong base areas. These military actions completely overshadowed the other war being fought on a lesser scale against the VCI and guerrillas at the grass-roots level: the war for the control of the rural area for which the GVN and its forces were primarily responsible.

The Viet Cong sought to wreck the pacification effort by a three-pronged strategy based on offensive tactics, political maneuvers and proselytizing actions aimed at the RVNAF. This came to be known as the three offensive spearheads: military, political and proselytizing, which the Viet Cong used selectively or in combination throughout the war.

The offensive tactics most extensively used by the VC were: ambush, hit-and-run attack, road interdiction, shelling, and more or less conventional attacks. The GVN recorded these activities as enemy-initiated incidents. During the period from 1968 to 1970, as an example, a yearly average of slightly more than 10,000 incidents were reported. (*Chart 26*) The ambush was the most important since it served well the Viet Cong political and psychological purposes. A successful ambush always had repercussions which affected the GVN credibility and the morale of ARVN troops. Enemy ambushes were directed against a variety of targets: GVN officials, ARVN troops, supply convoys etc. but most notoriously, they were laid against reinforcements. This was one favorite Communist tactic called *công đồn dã viện* (attack the outpost to smash the reinforcement) which the Viet Cong used with great success despite ARVN precautions. With the increasing use of air cover and helicopters, however, large-scale ambushes became less efficient, and gradually diminished, especially since the participation of US combat troops.

Ambushes were frequently used by the VC in conjunction with mines and roadblocks. During the early part of the war, mines caused extensive civilian casualties while roadblocks, sometimes mere physical obstacles rigged with booby traps, only caused delays in traffic. Most sabotage acts against the railway were conducted by mines; canals and rivers in the Mekong Delta were also frequently blocked or mined and

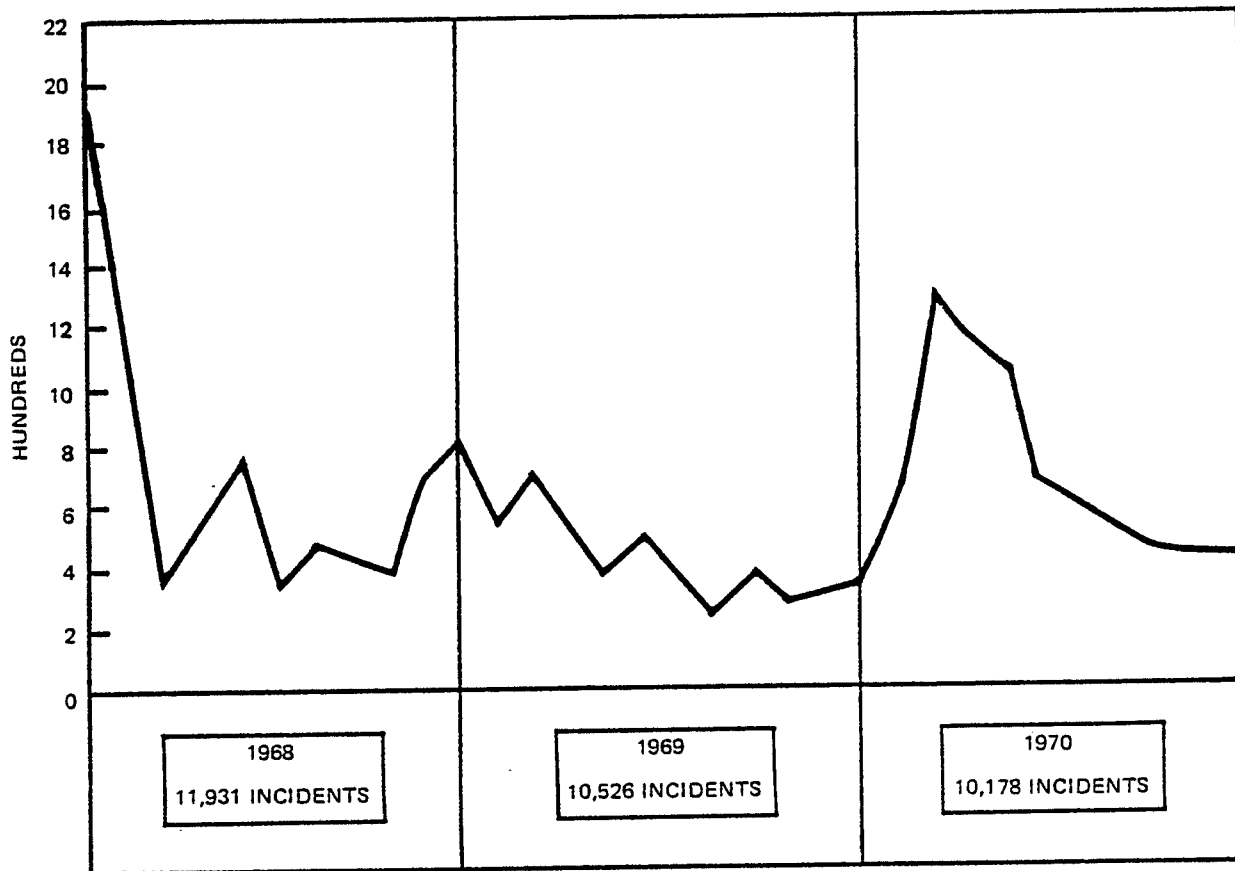

Chart 26 – Enemy Anti-Pacification Activities

ambushed. With the construction of modern, surfaced highways, mines became less and less a hazard. Still, a few key supply routes were frequent targets for mines or blocking actions. The enemy purpose in road interdiction was primarily economic, seeking to disrupt the flow of supplies into cities. When conducted in conjunction with attacks or other actions, it was used to isolate outposts or even larger targets. Enemy road interdiction actions accounted for the increased use of air-lift and helilift in troop movements and in resupply activities.

Another important VC tactic used against pacification was the hit and run, or harassment attack. While this was a guerrilla warfare tactic, it was also used in some large-scale attacks. The enemy's basic tenet was always to ensure victory in hit-and-run attacks which, therefore, were carefully planned and swiftly executed. This tactic was primarily used against isolated outposts, the RF and PF, small ARVN installations and pacified hamlets. Like most other VC tactics, hit-and-run attacks caused adverse psychological effects to the GVN besides inflicting casualties and losses to its forces. After the introduction of NVA units in the south, the enemy became bolder and switched to more conventional attacks in 1965.

In 1968, the Communists unexpectedly launched their Tet offensive. Its most serious impact was the temporary disruption of pacification efforts in the rural areas since ARVN forces were redeployed for the defense of major cities, provincial capitals and district towns. Despite this, the enemy infrastructure was unable to exploit the situation because it was committed to the general offensive effort. A large part of the VCI was thus destroyed during 1968, which accounted for the success of the accelerated pacification campaign late that year. It was also during and after this offensive that the enemy began to make extensive use of a new deadly weapon: the 122-mm rocket. Most enemy shellings were conducted against military and air bases but also against cities and urban areas. The indiscriminate firing of rockets against urban centers caused extensive civilian casualties and a feeling of terror among the population. Saigon was most heavily struck by rockets during May 1968 and this shelling seemed to work against the Viet Cong

psychologically. To the population it was an indication of their desperation in the face of military defeat.

Pacification also suffered setbacks as a result of the 1972 Easter offensive. Although the enemy offensive was localized in three major areas, the deployment of ARVN forces to meet the challenge created some voids in pacification support. The influx of refugees fleeing the embattled areas also caused additional burdens to the GVN. The most serious effect caused by the offensive was the complete absorption of the RVNAF general reserves in territorial defense and the ARVN seemed to be immobilized in territorial security missions, gradually losing tactical mobility.

When the cease-fire was announced, the enemy launched a vicious campaign designed to wrest more control. This was known as the "Land and Population Grab" campaign during which enemy forces succeeded in penetrating more than 400 villages across the country. But the campaign was short-lived; the enemy's effort met with determined RVNAF counter-action and failed. But while the enemy was unable to grab more control, the GVN pacification effort also came to a standstill as a result of US aid cutbacks and a preoccupation for force conservation. The cease-fire thus ushered in a period during which the GVN strived to hold on to as much geographical area as possible. The deployment of ARVN combat forces for territorial security enabled the enemy to prepare extensively for his ultimate offensive. Border outposts and ranger camps successively fell into enemy hands. By the end of 1974, while the enemy was assured of a military advantage through his force buildup, the GVN seemed barely able to maintain its widely dispersed defensive posture which by now had become more and more costly. The loss of Phuoc Long followed by Ban Me Thuot brought to light the strategic weaknesses of the RVN. The question now was how long the country could survive in the face of all-out invasion.

The enemy's capabilities for propaganda and proselyting actions were always as redoubtable as his military activities throughout the war and pacification was the primary target. His propaganda apparatus seemed to be able to exploit the RVN weaknesses. It succeeded, for example, to

convey the image of strategic hamlets as "disguised concentration camps." It also thrived on the mistakes committed by GVN officials in pushing too hard the pacification effort. Self-help projects which required the participation of the local population were denounced as forced labor. The enemy was also adept at inducing the people to voice petty grievances against the GVN, grievances designed to harass and embarrass local officials and deter their zealotry.

Proselyting actions were mainly directed against the ARVN and the RF and PF in particular. Their effectiveness on the ARVN was limited but the RF and PF troopers were less resistant victims. In the Mekong Delta, the VCI was successful in transforming several RF and PF soldiers into turncoats. This accounted for the loss of many outposts that reached a worrisome level in certain provinces such as Chuong Thien and Kien Hoa. Proselyting actions were usually accompanied by threats, blackmail or terror whose purpose was to induce fear, loss of confidence and the lowering of morale. These actions were usually carried out by planted agents who successfully penetrated into RF and PF ranks.

The enemy's challenge to pacification was multi-faceted and persistent. It was a combined political and military effort which fell in line with his overall strategy of conquest. But as long as this effort was made on a local level, the enemy stood no chance of success. He must have realized this and decided to conquer the south by military invasion instead. This was no proof, however, that pacification had failed as a strategy.

The Problems of Cadres and Territorial Forces

Conceived as a revolutionary effort, pacification depended primarily on the cadres for its implementation. The concept of cadre or *can bo* espoused by the GVN, like some other organizational concepts and operational methods, was Communist by origin but adapted by the GVN. Mr. Ngo Dinh Nhu was in fact the man who pioneered the creation of various categories of cadres for his Strategic Hamlet program. The "armed propaganda teams" were but one among these categories. Although the Ngos

were overthrown, their idea was later picked up by pacification authorities and translated into the concept of Rural Development cadre. At a later stage, in keeping with the GVN effort to reform its administration, cadre was understood to encompass executives of all management levels, including the military.

The RD cadre teams, which were activated when the pacification program was set in motion, initially consisted of volunteers but their leaders came mostly from wealthy and influential families, including those seeking refuge from mandatory military service. Although RD cadres were recruited among the local population and assigned to local governments, they were directly controlled by the RD ministry. RD group leaders were authorized, for example, to report directly to the minister in Saigon, by-passing the local government channel. This practice infuriated local officials and other national cadres. The RD cadres even had the upper hand over PF troops, who were the natives of their localities. The animosity and competition between RD cadres and PF troops were such that there was little cooperation or mutual assistance. During 1966 and 1967, when RD cadres operated in conjunction with RF troops in villages and hamlets, RF troops were assigned to outposts and watchtowers while RD cadres conducted activities and lived among the people. But there were instances in which RF troops ignored requests for relief by RD cadre teams who were under enemy attack. This rivalry existed primarily in the provinces of Binh Duong and Bien Hoa where RD cadre teams suffered significant losses at the hands of the enemy. It stemmed from the fact that RD cadres considered themselves emissaries of the central government, hence superior to the RF, the para-military forces, or other cadres, whom they held in low esteem.

Other categories of civilian cadre, usually called national cadres, were usually found to be slow-moving, excessively bureaucratic, imperious, but dependent on the military for almost everything. It was as if they were unable to shake off the influence of French colonialism of which indigenous civil servants were made a loyal instrument. They rarely made inspection trips to villages and hamlets to examine and assess personally the situation. Instead, they depended primarily on reports

from subordinates, reports which usually did not reflect the true or complete situation. Sometimes higher level cadres were aware of the inaccuracy of formal reports but still forwarded these self-serving reports without adequate investigation or comments.

The success of the pacification program depended in a large measure on the capability and attitude of the national cadres. Some were genuinely devoted and determined in serving the national cause. However some, most unfortunately, only thought of themselves and avoiding hardship. As a result, the abuse of power for personal benefit and the pursuit of worldly pleasures were widespread. Cadres were not always ideologically motivated; many of them were materially oriented. The "cadre" concept thus became devoid of significance because by vocation, a cadre must be the personification of the national ideology and a representative of the political regime. As originally conceived, cadres should have been the antidote of the basically lethargic bureaucracy. As such, cadres would endure hardship, overcome difficulties, and prove themselves as examples of personal sacrifice for the national cause. It is generally admitted that one can evaluate the merits of a certain regime by looking at how its cadre behave and perform. In the context of the Vietnam conflict, the lack of enthusiasm and determination on the part of some national cadres was one reason why the GVN was unable to motivate and rally all the population. The disheartening fact was that some cadres who enjoyed power and authority only thought of consolidating their positions. Those who were wealthy kept seeking more enrichment, and those who were enterprising sought ways to transfer their wealth into foreign bank accounts, preparing for an eventual exit, if and when the opportunity or requirement arose. The sons of wealthy and influential cadres could avoid the draft. Through bribery, they could stay free of military service or go overseas to continue their studies. As for the lower level cadres, they were economically the most underprivileged of all, like the private soldiers. Hard-pressed by soaring prices and meager salaries, they were usually compelled to make ends meet through petty corruption or moonlighting. The few who were well-off could always buy their way to desk jobs in secure areas. In the

end, no matter how good or significant a plan or program might be, it could be retarded by the very cadres responsible for its implementation.

This is not to say that all GVN cadres fell into the undesirable categories depicted above. There were many highly capable individuals who were truly devoted to the national cause. But the circumstances were such that they were not always given the chance or the freedom to prove their talent and devotion. Being frequently a minority among the cadre ranks, there was little they could do to redress the situation.

In the employment of forces, although ARVN regular forces were committed to support the GVN pacification effort, the Regional and Popular Forces were the mainstay of pacification. In time, territorial forces made up 55 percent of total RVNAF strength but due to their rapid expansion, most RF and PF unit commanders were relatively inexperienced.

RF units served as the provincial main force while PF units were the village main forces. Both forces were employed as small units, usually companies and platoons for the maintenance of territorial security. Being thinly spread out and lacking adequate support, they were extremely vulnerable to enemy attacks. This vulnerability was exploited to the maximum by enemy forces who usually attacked with a superior force, inflicting heavy losses on the RF and PF. Nevertheless, this was a sound concept of force employment in the pacification effort since territorial forces consisted of men who were born and grew up in the very villages where they were assigned. As a result, the territorial trooper was well familiar with the local terrain. But despite their authorized strength, territorial forces suffered constantly from a shortage of personnel. Some RF battalions participated in operations with only 120 men. The gravest problem that plagued the RF and PF was a high percentage of absentees who were included on the unit roll calls, and often on payrolls. These absentees included deserters, AWOLs, hospital patients, trainees, and those permanently detached to guard and escort duties of province, and district chiefs and elected officials. There was also the deplorable phenomenon of "ghost" and "ornamental" soldiers — those who had died and those who only occasionally reported for duties respectively — but whose names were still recorded in roll calls and

payrolls. In addition, there were losses but no replacements because of recruiting difficulties, and there were deserters who sought protection from religious or political organizations. These conditions resulted in most RF and PF units never being at full strength and it was almost impossible to remedy this situation.

Despite being plagued with understrength and a shortage of experienced cadres, the RF and PF were employed in a wide variety of capacities. There were some units which seemed condemned to operational duties year in and year out without rest, refitting or training. There were others which permanently manned outposts and watchtowers and guarded bridges, lines of communication, and government installations. Despite mandatory training programs designed to improve RF and PF combat effectiveness, which prescribed the rotation of units to undergo training, very few province and district chiefs complied with these programs. Village chiefs managed to justify their non-compliance by various pretexts. When a RF unit underwent training at some center, its strength usually included office and general service personnel in order to comply with the JGS requirements for unit strength. But as soon as the unit completed training, it returned the "borrowed" personnel and found itself understrength again. Thus the "trained unit" never had the chance to operate as a unit.

The RF and PF usually suffered from a serious shortage of non-commissioned officers and specialists. Several platoons were commanded by corporals or corporals first class. Companies were usually commanded by young second lieutenants fresh out of school. Because of these shortcomings and weaknesses, the territorial forces never effectively fulfilled their mission and, as a result, regular ARVN forces were frequently required to perform the territorial role. When taking over combat responsibility from departing US forces, ARVN was spread thin in its attempt to fill in the void where territorial forces were incapable of maintaining security. The enemy was thus given the chance to infiltrate and resume local activities because many areas were left undefended for lack of forces.

The RF and PF improvement program as initiated by the JGS was based on the innovative policy of assigning new recruits and draftees to RF units, and authorizing recruitment without regard to age limitations, provided RF and PF units were brought up to authorized strength. In order to improve command and control, the JGS also adopted certain special measures and incentives such as accelerated NCO training courses, battlefield promotions, and promotions for combat worthy cadres without regard to rank seniority, all with the objective of increasing cadre strength and effectiveness for the territorial forces. Disciplinary and replacement measures were also taken against those territorial commanders who neglected to improve and develop their forces. However, the task of improving the RF and PF demanded more time, more perseverance, and more patience; a military force of such proportions could not reach desired standards without a long-range program.

The Impact of U.S. Policies

The RVN depended almost entirely on the US for its nation-building effort and defense against Communist subversion and invasion. American policies, therefore, could help make or break that effort.

When the Communists rekindled their war of aggression in South Vietnam, the US came to the relief of its embattled ally by providing money, equipment, weapons, advisers and even its own air force and combat troops to fight the war for several years. The varying emphasis of US policies in South Vietnam always bore a direct consequence on the outcome of the conflict and American military doctrine and strategy affected the Vietnamese conduct of the war.

During the five years that preceded the outbreak of war, American military policy sought to train and equip the Vietnamese military as a conventional force to face an eventual conventional invasion. However, this invasion first materialized under the unconventional form of subversion sustained by guerrilla warfare. The RVNAF, tailored to the US Army image, were hard-pressed to fight this kind of war for which they were ill-prepared. Increased US military aid and the availability of US

combat support assets failed to solve the basic problems of the long-term conflict.

On its own initiative, the GVN came up with its Strategic Hamlet program to counter the subversive war. Instead of providing this program with adequate material and technical support, the US continued with regular military aid. Instead of encouraging this new program, American officials were inclined to find fault with it and criticize its shortcomings. When South Vietnam nearly came apart in late 1964 as a result of political instability and military setbacks, the US decided to save it the American way. Perhaps this was the only way at the time, but having regained the military advantage, the US decided to proceed with the military war and only showed lukewarm interest in the "other war" which was left to the GVN to fight.

Four precious years were thus lost before the US renewed any interest in the other war. It seemed as if the US had failed to realize the dual aspect of the war whose nature was even ignored by some US commanders. That was a regrettable error of strategic proportions that cost human lives, political support and time. Only after military emphasis failed did the US become more conscious of the nature of the total conflict and make a truly cohesive effort to help the GVN with its other war. But the years had been lost that could have perhaps radically changed the outcome of the war for rural control had the Strategic Hamlet program received the full weight of US support from the start.

The Communists benefited the most from fishing in those troubled waters during this time. In addition to force buildup, they succeeded in reestablishing nearly invulnerable bases along the border areas and even "mini" guerrilla bases in the midst of GVN territory. The VCI was also provided the opportunity to gain a firm foothold in the rural areas where it seemed to flourish.

The US insistence on political stability and elective, democratic government as preconditions to continued aid and support effectively molded the RVN regime into a Western style democracy that functioned primarily in form, not in substance. The true nature of the regime remained intrigue-ridden, dictatorial, and repressive. Perhaps the

Vietnamese peasantry was not yet ready to cope with ballots and senators. In any case they were more preoccupied with down-to-earth things such as a decent living, social justice, and security that hopefully pacification would bring about. These also happened to be the implied goals of US aid and support.

But only two years after its first cohesive effort to support pacification, the US already thought of disengagement. While these intensive two years were enough to inculcate progress and momentum to the pacification effort, the gradual removal of the US military protective shield began to overtax the RVNAF capabilities to fight two wars at the same time despite force structure increase and modernization. Still, benefiting from the initial momentum, pacification harvested its most abundant results during the following three years, 1969-1971, with continued US support.

The Paris Agreement soon ushered in a most difficult period for the GVN which had to face with complete US withdrawal, continued enemy harassment, an eventual resumption of the war and most unfortunately, a sizable cutback in US aid. All these events reduced the GVN strategic options to a simple matter of survival; pacification could hardly progress when the nation's survival was at stake. It was finally the US people who repudiated even the last flimsy hope of survival and sealed the fate of South Vietnam as a free nation.

CHAPTER IX

Observations and Conclusions

After completing my previous chapters and conducting in-depth discussions with Vietnamese associates, I wish to emphasize several general observations and conclusions.

Of the strategic alternatives available to the GVN and the US in South Vietnam, pacification was probably the most sensible option that not only potentially met the Communist politico-military challenge but was also basically consistent with American policies and Vietnamese national goals. Given the historical context of the war, perhaps it was the only sensible strategy.

In fact South Vietnam had very little choice, if any. The war it fought was first and foremost a legitimate defense occasioned by insurgency and aggression. Otherwise, South Vietnam was perfectly happy to be left alone with its task of nation-building south of the 17th parallel. It never bore any aggressive design against North Vietnam and had little capability for it. Its strategy was and had always been a strategy of defense and survival.

This strategy did not seek a military victory as an end in itself because the war was not simply a military war. Even if the conflict had been reduced to a military showdown, there were chances of its going on almost indefinitely as long as the insurgents were kept revitalized by an interminable flow of men and supplies from the north. At the height of military gains, some Vietnamese and American leaders talked exuberantly of the war fading away or reverting to brushfire guerrilla warfare. This only showed how mistaken they were as to the enemy's intentions and capabilities. The enemy, in fact, enjoyed a wide range of options. The use of military force, albeit a prominent feature of his strategy, was

but one among other options. He could switch from one to another without ever lessening the threat to the GVN. More importantly, he always seemed to be able to maintain his military pressure on two levels of warfare, simultaneously or alternately. The absence of one did not preclude the presence of the other and either one posed a continuous security problem for the GVN.

The highest level of pacification success from 1969 to 1971 was possible primarily due to improved security and the military advantage that the US, RVN and free world forces enjoyed over the Communists. Indeed, with 1,100,000 men of the RVNAF and over half a million of US and FWMA troops, and with overwhelming firepower and other combat support assets, we truly held the initiative on the entire South Vietnamese battlefield and caused the enemy severe losses in human lives and equipment. For sometime, all Communist main forces were effectively driven away from populated areas and over the national border.

Meanwhile, the United States air and naval bombardments also brought havoc to North Vietnam, the Communist "rear area" that sustained the war in South Vietnam, and effectively reduced the flow of NVA troops and supplies into the South. This was a period during which North Vietnam, its troops in the South and the Viet Cong suffered severe setbacks and were in real difficulty.

To regain their initiative and restore control over the rural area, the Communists launched their Tet "General Offensive — General Uprising" in 1968, but met with determined reactions by the RVNAF and US/FWMA forces and suffered a resounding military defeat. Over 120,000 Communist troops were either killed or wounded and in excess of 37,000 weapons were captured by our side. More of the rural area, as a result, progressively came under control of the GVN and friendly forces.

In subsequent actions, the RVN and US forces drove enemy forces farther away from border areas and repeatedly struck at logistical bases that the enemy had built during previous years along the Cambodian and Laotian borders. The Cambodian incursion of 1970, and the cross-border

operation into lower Laos in early 1971 were victorious examples of combined RVN-US military effort. The rural areas during this period were almost free of enemy main force units. Whatever remnant forces the enemy had inside South Vietnam were merely local forces or guerilla elements and his considerably weakened infrastructure.

In 1972, the pacification effort began to decrease in effectiveness because there were not enough combat forces to hold the initiative on the battlefield and provide security for the population at the same time. The US and Allied countries had by that time withdrawn 90% of their ground troops. US combat support in terms of B-52 strikes, tactical air, naval firepower while still available was greatly reduced. The reduction in combat power was considerable. Whereas the US, other Allies, and the RVN committed up to 22 divisions at the height of the US buildup, by 1972 there were only 13 divisions. This represented a reduction of 40% in combat strength. Other reductions in firepower and support assets were so great that no comparison was possible between what the US had deployed and what the RVNAF could now muster.

It was estimated that at the time of the cease-fire, Communist forces in South Vietnam numbered about 293,000 men to include 14 infantry divisions and four combat support divisions, but excluding the five general reserve NVA divisions which served as a backup and accounted for another 50,000 to 60,000 men. The trend was such that while the enemy nearly doubled in combat strength, our side was reduced by nearly one half its former strength. Also beginning in 1972, the North Vietnamese Army became more modernized. Its movements were mechanized and its infantry units fought with a complete array of artillery and armor support. Its modern capabilities and assets were on obvious display during the 1972 Easter invasion. Over the years of US buildup, the Communist bloc also responded by escalating its aid to North Vietnam, with the end result that, after US withdrawal, the RVNAF were to face the increased Communist might alone.

As a direct result of the US troop withdrawal, and bound by a rigid strategy of territorial control, the RVN regular forces became overextended. They no longer had adequate mobile combat strength. Search

and destroy operations against enemy infiltration along the western border gradually became impossible to conduct. The RVNAF were finally incapable of conducting mobile operations and supporting pacification at the same time, as had been done during the period of US participation. From 1972 on, the RVNAF gradually lost the initiative and were increasingly on the defensive.

The biggest shortcoming in pacification, aside from the shortage of forces, was the artificiality of its reporting. Despite impressive statistics, the figures were often misleading. They frequently served a political purpose and did not reflect realistic gains. Moreover, real gains could be easily upset by Communist spoiling actions.

The Paris Agreement in 1973 prescribed a "leopard skin" or standstill cease-fire which was a disadvantage for the RVN and a blessing for the enemy. No longer impeded by mines and destroyed by bombs, North Vietnam devoted its energy to rebuilding its shattered economy on the one hand, and making preparations to invade the South on the other. Once again, the rural areas of South Vietnam were in turmoil. The enemy was striving to regain his control by military actions ranging from limited attacks to all-out offensive. Not only had war been resumed, it also escalated in terms of forces committed and target size and culminated in open invasion. But the US protective shield had been removed; the RVN was left to fend for itself with less and less assistance. Unenforced warnings by the US in the face of blatant violations only encouraged the enemy to proceed with his conquest.

Another RVN shortcoming was its total dependence on US aid. Without this aid it could neither maintain its military force nor continue its pacification effort. US policies, therefore, always had a decisive effect on the RVN ability to defend itself and consolidate its national posture. We have already seen how the US varying emphasis on pacification affected its progress. In military assistance, this effect was even more conspicuous. During the period US forces fought in Vietnam, US military aid was substantial and adequately met RVNAF combat needs. However, from nearly

\$1.5 billion in FY-73, U.S. military aid suddenly dropped to \$1 billion in FY-74 and finally to \$700 million in FY-75. This drastic cutback gravely affected not only the RVNAF combat capabilities but also the morale of their cadres and troops. It was obvious that the RVN ability to defend itself and its chances of survival depended to a large extent on the amount of US military aid appropriated. As a result of this huge and unexpected cutback, the RVN was unable to keep its territorial integrity intact and as the RVNAF capability to provide security diminished the GVN pacification effort also decreased proportionately.

Ever since US support became a unified, cohesive effort in 1967, the GVN pacification program was given a momentum that sustained its steady progress, despite occasional setbacks. But from the beginning, this program was plagued by problems of control and coordination, inadequate supporting forces and cadres and an over-anxious propensity for immediate results.

From an organizational point of view, the basic weakness of the system during its first two years, 1966-1967, was the concentration of too much power into the Ministry of Revolutionary Development which regarded itself as an all-important super-ministry with overriding authority. RD cadre, consequently, often acted as if they were a breed of super-cadre with special powers. When other cadres and agencies were assigned lesser responsibilities, they were hurt because of their unfavored standing. As a result, they were inclined to shun responsibilities and let the RD cadre do all the work.

The province chief, coordinator of pacification, was usually assigned too much responsibility. It was simply beyond his capacity or capability to carry out so many tasks at the same time. He was, for example, the chairman of at least ten committees, in addition to being a military commander and an administrative chief. One can hardly imagine how he managed to carry out these duties and at the same time play host to a constant flow of visitors, senators, representatives, GVN officials, foreign dignitaries, and military commanders. Receiving guests and visitors alone was apt to keep him busy around the clock. Yet, in the pacification program, it was the province chief who played the primary role of both planner and executor, and success or failure rested on him, and on him alone.

US agencies were indispensable in their pacification support role. Adequately staffed with qualified, experienced personnel and experts, these US agencies were strong in planning and in problem-solving studies. They not only recommended plans and programs for the GVN agencies to implement, but also provided realistic advice and suggestions for effective problem-solving. Therefore, when the US presence was drastically reduced, the void it created was huge and impossible to fill. Despite a certain familiarity with US methods and procedures which they learned during the years of cooperation, GVN officials apparently were never able to function as effectively as with US assistance. The fact was the GVN did not have adequate experts or specialists for every field of activity, and was basically weak in research work, planning, and management. GVN agencies could only do routine work. This does not mean that the GVN was without initiative or creativity; this simply recognizes the fact that GVN shortcomings existed and were significant.

The experience of Revolutionary Development indicated that pacification, as a total effort involving equal contributions from several agencies, could not simply be entrusted to any single ministry, but should have been made the responsibility of an inter-ministerial council deriving its authority from the President or the Prime Minister. Also there should not have been so many different categories of cadres for, by human nature, they tended to compete with each other, to the detriment of the common effort. However, under existing conditions, cadres should have been assigned clearly defined responsibilities and employed to the maximum extent of their capabilities. It also appeared that US advisers sometimes overshadowed their Vietnamese counterparts by simply being too devoted and too eager to get things done. Perhaps a better approach for advisers would have been to suggest ideas and fully exploit the good relationship with counterparts, to stimulate them to initiating their own plans and programs in order to obtain the desired objectives. The simple fact, which was paramount in pacification work, was that no one understood the Vietnamese people's aspiration better than the Vietnamese themselves. What should have been avoided was the imposition of ideas and forcing Vietnamese to do things in ways that they did not consider their own. In the long run, this could make them overly dependent on advisers.

Pacification was a vast enterprise which required an efficient administrative machinery and massive resources, not only in terms of materiel and equipment but also in cadres and supporting forces. Anti-subversive experience showed that the ratio of forces between the government and the insurgents was the key to success. The successful anti-insurgent campaign in Malaya required a 12 to 1 personnel ratio while in the GVN pacification effort, a ratio of 8 to 1 was the most ever achieved. And when the US withdrew, that force ratio was further reduced to a mere 2 or 3 to 1. The simple fact was in order to achieve security and maintain it continuously for the benefit of pacification, an adequate military force was required as long as the enemy military threat was there. A second requirement was the destruction of enemy logistical bases and sanctuaries to cut off his supplies and prevent his force buildup. As long as these two requirements were not fully met, pacification gains stood little chance of being sustained.

As has been said, statistical results reported could provide a false impression. A village was considered as pacified, for example, when certain criteria had been met such as the establishment of the village council, the installation of a village office, an information hall, a first aid station, etc. But in some cases, the village office was installed in a PF outpost whose facilities it shared and council members usually commuted from a nearby town or city to work during office hours and almost never stayed in the village after dark. More often than not, the village information hall was just a squalid shack or hut covered by a few roofing sheets and adorned with old newspapers and faded pictures. But on a report, there was no doubt that the information hall existed and that one objective had been achieved for the village pacification effort even though its effectiveness was below desired standards. The same was true of first aid stations, another important objective to be achieved. Undoubtedly, there existed such a station for every pacified village, but medicine was always in short supply, often locked up and the resident nurse not in the area when patients called. No one knew exactly how much and what types of medicine the station had. Thus, for all practical purposes, it was impossible to obtain from a report the true situation.

Pacification objectives, as conceived and set forth by the CPDC, were all sound and reasonable although somewhat arbitrary and mechanical. The problem seemed to lay with some local governments which tended to implement them in a perfunctory manner, substituting form for substance, and reporting token as true and complete achievements. Then there was the problem of cadres, on whom the success of pacification depended in a large measure.

The cadres were supposed to serve as a transmission belt between the central government and the population. Their role was to organize, teach, persuade and push the people to greater exertions in accepting the GVN programs and participating in them. In the social context of the Vietnam war, the cadres were also supposed to fill in the gap and hopefully resolve the dichotomy between the urban leadership and the rural peasantry. This was perhaps one of the most crucial and problematic issues that the GVN had to face in its efforts to rally popular support for its cause. Conceived as such, the cadre's role was indeed burdensome.

Most of the cadres, RD and others, were recruited among villagers and given special training at Vung Tau before field assignments. Group and team chiefs, however, were invariably selected from among the educated urban minority. Cadre training emphasized the need for winning popular credibility and support and to achieve this, cadres were taught to live by the Communist formula of the *Tom Cung* or "three withs" (eating, living, and working with the people), and by setting personal examples of self-sacrifice, hard work and political awareness. With regard to relations with the people, cadres were also taught to abide by certain codified rules which required them to speak politely, pay for the things they damaged, and above all to protect the lives of and behave correctly toward the peasants. These were also the rules that ARVN, RF and PF troops were taught during special indoctrination courses. The RVNAF political education effort in fact stressed that each soldier had to behave toward the people as if he were a political warfare cadre.

The things learned, however, seemed to be far removed from what actually happened when contact was made with the people. But the mischievous

acts were mostly committed by unruly troops during the course of operations. Such practices as petty larceny, failure to return borrowed items, and buying goods at a "favored" price sometimes occurred in hard-pressed circumstances but they were mostly committed without the commander's knowledge. There was usually confusion as to who the culprits were. Since a pacification operation involved a variety of units and cadre teams, it was almost impossible to ascertain which troops, regular or territorial, were actually responsible for the misconduct. But the finger was usually pointed at the soldiers since they were the most numerous. The cadres in general behaved better than the soldiers not because they were better disciplined but because of their intensive indoctrination. Still their conduct was not always exemplary.

For all their training, indoctrination, and efforts, the cadres seemed not to be very effective in their assigned role as the intermediary link between the central government and the people. They also failed to lessen the urban-rural bipolarity and win the peasantry over to the GVN cause. Some attributed this to war weariness and apathy, but while there was some truth in it, the problem seemed to be more profound. Also, some GVN high-ranking officials in their frustration tended to blame the system's failure to develop an attractive political dynamism on the "lack of dedicated cadres". This was equally true but such lack was more effect than cause of the failure. For one thing, the Communist-inspired concepts such as cadres and mass organizations could not simply be transplanted or adapted in a piecemeal manner with comparable results. The fact was in addition to ideological motivation, the Communists also used coercion and terror in a manner unique to totalitarianism. Unfortunately, these methods were intrinsically alien to such a regime as the GVN's and if mechanically adapted for any purpose, they invariably worked against the regime that used them. There was also the social malaise that a long war had produced and such vices as corruption, graft, and abuse of power were usually the product not the cause. This was also true of war weariness, apathy, or divisiveness.

So the cadres and other pacification supporting forces could be the strength or weakness of the GVN or for that matter of any political regime.

The crucial factor was whether or not such a regime could inspire political awareness or motivation. There was also the danger that the cadres could become "degenerated", to use Communist terminology, or in the case of the GVN, simply bureaucratized. This was what actually happened to the so-called "cadres", RD or others, who by exposure to the system, acted and behaved as functionaries which they truly were.

As to the general population, hardened and disenchanted as they were by the long, destructive war, disillusioned and frustrated by an elusive peace, and ever worried about an uncertain future, many naturally remained uncommitted to the GVN cause and its efforts. Perhaps this was the common syndrome of war weariness and social malaise. But to most of them the crucial and immediate concern was how to subsist materially and survive war hazards. Everything else, including political awareness, or even democracy was less significant; and as long as they lived with privations and hardships, and insecurity, and uncertainty as to the future, no one could blame them for lack of commitment or apathy.

But the Vietnamese people were inherently alien to Communism and always longed for freedom. The million or so North Vietnamese people who first chose to flee south in 1954 eloquently spoke for their love of freedom above everything else, including careers and personal properties. The people's insurrection at Quynh Luu in Nghe An Province, North Vietnam in November 1956 and the subsequent movements of refugees fleeing the advance of Communists in South Vietnam during the period from 1968 to 1972 and in 1975 indicated that, given a choice, the Vietnamese always opted for freedom. Even now that South Vietnam has come under Communist control, refugees still escaping from Vietnam report continuing resistance.

Pacification was a long process that just could not be completed effectively during a short campaign. To succeed in building outposts, filling them with qualified defense troops, and completing the election of village councils within a certain area could not be evaluated as a successful pacification program. These accomplishments were only interim objectives. The nature of true pacification success lay in the hearts and minds of the people and this was a long range proposition which demanded much more time.

The war in Vietnam encompassed many fields of challenge. In the military effort, RVNAF and Free World Forces succeeded temporarily in stabilizing the situation but were never able to gain absolute and permanent superiority over the enemy. Due partly to the indecisive military situation, efforts to achieve political cohesion and enlist popular support were unsuccessful. The conflict, being essentially political rather than military in nature, could only be resolved if there was political cohesion and success in rallying the people to support the GVN cause.

Finally, there was the fundamental question of leadership that truly lay at the core of all successes and failures. Even if adequate time could be bought for the processes of pacification to proceed, there was still doubt that political cohesion would occur and provide effective leadership at the national and all local levels. The profuse availability of material assets or even manpower simply furnished the tools, not the motivation to carry the task to ultimate success. To instill motivation effective leadership was required. Thus the problem seemed to be a circular one: both pacification and political cohesion were essentially interdependent.

The basic weakness of South Vietnamese leadership lay in the fact that GVN officials were all recruited from among the educated urban petty bourgeoisie and this only served to perpetuate the wide gap between them and the rural peasantry. In fact, the national leaders, the province and district chiefs were either military officers or intellectuals who made up the elite minority of the nation. Mostly Western-oriented and sustained by interrelated class or clan interests, they were by nature alien to and unassimilable with the peasantry's cause. Their inability to identify with the peasantry who made up 80% of the population was perhaps a major cause for ineffective leadership.

The same could be said of military leadership which affected the pacification effort in a most significant way. While the national leaders were imbued with revolutionary ideas, they failed to inculcate the same idealistic spirit to some military commanders who behaved as if they existed outside the social mainstream. Political indoctrination also failed to instill

that spirit because not only did it sidestep social reform as a major theme, it also sought to teach exotic, high-strung ideas such as the theory of the "Six Great Warfares", a Nationalist China adaptation of Mao's theory of total war. As a result, troops under this unenlightened, uninvolved military leadership, tended to develop a haughty but false sense of pride not always in full service of the people. This explained the repulsive syndrome of the vain soldier some of whom considered themselves the guardian angels of the regime. But some unit commanders seemed to encourage this false sense of pride which accounted for so many mischievous acts detrimental not only to the prestigious standing of their units but also to the common cause.

Pacification, in the final analysis, was a revolutionary process which affected the peasant majority. The fundamental question was, as had been oftentimes discussed among Vietnamese intellectuals and scholars, who, as a class, could effectively lead that revolution to success? To the anti-Communists who repudiated proletarian dictatorship or even peasantry leadership, this was a question that seemed to have no answer.

Although considerable progress was made, pacification remained a problematic issue for the GVN which seemed unable to bring it to total success. Besides political cohesion, the GVN seemed to be lacking the credibility, the ability and the time required to unify its main efforts. In particular, the GVN credibility suffered a marked decline since the day the National Liberation Front was allowed an equal standing at the Paris talks. It declined further when, despite President's Thieu's vows, northern Quang Tri remained in enemy hands. The population, therefore, grew more and more suspicious of the GVN capability to protect them against the Communists. Pacification also required from the Free World allies which came to its assistance, patience, perseverance, and more determination above all since the time element and will power appeared to be the key to success.

In conclusion, the amount of assistance contributed by the United States to help the RVN was tremendous in terms of money, equipment and manpower. This assistance was greatly appreciated by the people of South Vietnam. However, as long as North Vietnam could quietly enjoy the option

to pursue its aggressive scheme, and as long as the GVN itself could not overcome its internal difficulties, provide effective leadership, and achieve a unified, total effort, there was no way pacification could continue to progress toward its intended goal.

Appendix A

D E C R E E 614-TT/SL

Republic of Vietnam
President's Office
1 July 1970

SUBJECT: Military Organization of the National Territory

The President of The Republic of Vietnam decrees:

Article 1. This Decree defines the military organization of the national territory based on the following provisions:

SECTION 1

Territorial Organization

Article 2. The National territory is divided into four Military Regions. The composition of each Military Region is determined as follows:

1. Military Region I consists of (5) five provinces and two cities:
Quang Tri, Thua Thien and Hue City, Quang Nam and Da Nang City, Quang Tin, and Quang Ngai.
2. Military Region II consists of twelve provinces and two cities:
Binh Dinh, Phu Yen, Phu Bon, Kontum, Pleiku, Darlac, Khanh Hoa and Cam Ranh City, Quang Duc, Ninh Thuan, Binh Thuan, Lam Dong, Tuyen Duc and Dalat City.
3. Military Region III consists of Saigon Capital, Con Son Island, eleven provinces and one city:
Phuoc Long, Binh Long, Binh Duong, Long Khanh, Binh Tuy, Phuoc Tuy and Vung Tau City, Bien Hoa, Tay Ninh, Hau Nghia, Long An, and Gia Dinh.
4. Military Region IV consists of sixteen provinces:
Kien Tuong, Dinh Tuong, Go Cong, Kien Hoa, Kien Phong, Sa Dec, Vinh Long, Vinh Binh, Chau Doc, An Giang, Kien Giang, Phong Dinh, Chuong Thien, Bac Lieu, An Xuyen, and Ba Xuyen.

Article 3. In the new organization, each province will become a Sector. Each administrative District or each Area under an Administrative Delegate will become a Sub-Sector. Those cities which are far from province capitals, and vital areas will become Special Sectors. A Special Sector may have several Sub-Sectors. Saigon Capital will have a special territorial organization which will be specified by a separate document.

Article 4. Rung Sat Special Sector will comprise two Districts of Gia Dinh Province, Quang Xuyen and Can Gio, which are within the territory of Military Region III. Con Son Island will retain its present status as Special Sector.

Article 5. Saigon Capital will become the Special Capital Military District which includes Saigon Capital, Gia Dinh Sector and Con Son Special Sector.

Article 6. All Corps Tactical Zones are abolished. Each Infantry Division will be in charge of a tactical area. The boundaries of these areas will be determined by JGS/RVNAF depending on local security situation and based on the recommendation of Commanders of Army Corps and Military Regions.

SECTION 2

Chain of Command

Article 7. The responsibility for each Military Region rests with an Army Corps.

- Army Corps I is responsible for Military Region 1.
- Army Corps II is responsible for Military Region 2.
- Army Corps III is responsible for Military Region 3.
- Army Corps IV is responsible for Military Region 4.

Article 8. Army Corps Headquarters are also Military Region Headquarters. Army Corps Commanders are also Military Region Commanders. All Army Corps and Military Regions are directly under the command of JGS/RVNAF.

Article 9. The Special Capital District is subordinate to Military Region 3.

Article 10. Military Sectors are included in Military Regions. Mayors and Province Chiefs will be concurrently Sector or Special Sector Commanders if they are military. If they are civilian, the position of Sector or Special Sector Commander will be held by a field grade officer.

Article 11. Sub-Sectors are included in Sectors. The District Chief will be concurrently Sub-Sector Commander if he is military. If he is civilian, this position will be held by a military officer.

SECTION 3

Functions

Article 12. Army Corps and Military Regions have the following responsibilities:

A. Mobile Operations:

- Plan and conduct search-and-destroy operations against units of enemy Main Force, Regional Force, Guerrillas and infrastructure.
- Conduct reaction, and relief operations designed to ease enemy pressure.
- Supervise and support operations conducted by an infantry division or a sector.

B. Territorial Security:

- Conduct border defense operations against enemy incursions.
- Defend lines of communication, vital points, villages, hamlets, and all administrative and economic establishments.
- Protect the people and national resources.
- Strengthen the system of outposts, operational bases, and fire-support bases.

C. Pacification and Development:

- Conduct military efforts in support of the Pacification and Development Program.
- Review Pacification and Development Plans submitted by sector commanders and province chiefs.
- Determine priorities for the use of armed forces and their deployment in support of the Pacification and Development Program.
- Monitor, supervise and control the implementation of the military plan in support of the Pacification and Development Program.

D. Other functions:

- Civilian defense:
 - Advise and assist local authorities in organizing people's associations and PSDF.
 - Advise local authorities in counter-riot action and maintenance of order.
- Command, train and administer Territorial Forces, and all attached units.
- Plan and operate a Territorial Intelligence network and an area communication network.
- Administer national defense resources in personnel and materiel.
- Direct and supervise the administration of manpower and material resources.

- Organize and train home reservists.
- Coordinate logistic activities in support of all agencies and military units located or operating in Military Regions.
- Political Warfare.
- Accomplish polwar activities in order to win the people's hearts and minds.
- Provide care and assistance to military dependents of all mobile units stationed in military regions.
- Promote and sustain popular support for front-line units.

Article 13. The Special Capital District has the following responsibility:

A. Mobile operations:

- Organize and conduct mobile operations as required or as directed by the Commander of III Corps and Military Region 3.
- Supervise and support operations organized by subordinate sectors.

B. Territorial Security:

- Defend Saigon Capital, vital points, villages and hamlets and all administrative and economic establishments.
- Protect the people and national resources in the Special Capital District.
- Establish and consolidate the system of outposts, operational bases and fire support bases.

C. Pacification and Development:

- Deploy armed forces and conduct military efforts to support Pacification and Development Programs in all sectors.
- Follow up, direct and control the implementation of the military plan in support of Pacification and Development.

D. Other functions:

- Civilian Defense:
Assist local authorities in organizing people's associations and PSDF.
Assist local authorities in counter-riot action and maintenance of order.
- Command all attached units.
- Plan and operate a territorial intelligence network.
- Direct and supervise the administration of personnel and materiel.
- Organize and plan military training for home reservists.
- Carry out polwar operations in the Special Capital District.

Article 14. Infantry divisions have the following responsibilities:

A. Mobile Operations:

- Conduct mobile operations as required or as directed by commanders of Army Corps and Military Regions. Efforts will be focused on enemy main force units and bases.

B. Territorial Security:

- Conduct reaction operations at the request of sector headquarters. Priority for these operations will be decided by commanders of Army Corps and Military Regions.

- Provide combat units, fire support and other supports to sectors as ordered by commanders of Army Corps and Military Regions.

- Protect important establishments and open roads and waterways as directed by commanders of Army Corps and Military Regions.

- Protect important establishments and open roads and waterways as directed by Commanders of Army Corps and Military Regions.

C. Pacification and Development:

When instructed by commanders of Army Corps and Military Regions, coordinate activities with sector headquarters to provide effective support for the Pacification and Development Program.

When instructed by commanders of Army Corps and Military Regions, in conjunction with sector headquarters, launch securing operations in order to pave the way for the Pacification and Development Programs of provinces and sectors.

D. Other functions:

- Assist sector Headquarters in providing military training for RF and PF when requested.

- Assist local authorities in the control of national resources and population, restore and maintain order when required.

Article 15. Sectors have the following responsibilities:

A. Territorial Security:

- Plan and conduct search-and-destroy operations against units of enemy provincial main force, guerrillas and infrastructure.

- Establish sector security plans and carry them out after approval by Army Corps and Military Region Headquarters.

- Recommend to Army Corps and Military Region Headquarters reinforcements required for the maintenance of sector security in case of shortage of armed forces.

- Direct all activities of RF, PF and other forces in sectors (National Police, Pacification and Development Cadres, People's Self-Defense Forces).

B. Pacification and Development:

- Formulate a military plan in support of the Pacification and Development Program based on the policy and guidelines of Army Corps and Military Region Headquarters.

- Monitor, supervise and control the implementation of military plan in support of Pacification and Development Program, and be responsible for this to Army Corps and Military Region Headquarters.

C. Other functions:

- Inspect, direct, train and support RF and PF in sectors and maintain their morale.

- Control the supply and maintenance of weapons distributed to PSDF members.

- Carry out territorial intelligence tasks.

- Coordinate and install communications systems.

- Control manpower and material resources and administer home reservists.

Article 16. Sub-Sectors have the following responsibilities:

- Assist sectors in the preparation and implementation of Sector Security Plans and Pacification and Development Plans.

- Direct RF and other forces (NP, Pacification and Development cadres, PSDF) belonging to sub-sectors in the support of Village and Hamlet Defense Plans.

- Direct and supervise subordinate units in the support of Pacification and Development Programs.

- Maintain sub-sector reaction forces to relief Villages and hamlets under attack.

- Recommend to sector headquarters the conduct of operations in support of Pacification and Development Plans.

- Provide guidance to village chiefs in the establishment of village defense plans and fire support requests.

- Command, and control sub-sector RF and PF units.

- Carry out intelligence and counter-intelligence tasks.

- When instructed by sector headquarters, transmit mobilization order to home reservists, commandeer and control them.

- Issue and check PSDF weapons and ammunitions.

Article 17. Special Sectors are in charge of the following:

- Direct search-and-destroy operations against provincial units of enemy main force, guerrillas and infrastructure.

- Support the Pacification and Development Program in accordance with the policy and guidelines of Army Corps and Military Region headquarters.

- Protect villages, hamlets, vital points, and all administrative and economic establishments.

- Command and control RF and PF units as well as other assigned units.

- Carry out intelligence and counter-intelligence tasks.
- Assist local authorities in the restoration and maintenance of peace and order.
- Assist local authorities in the organization of people's associations and PSDF.

SECTION 4

Coordination

Article 18. In their responsibilities, Sector Commanders, Special Sector Commanders and Sub-Sector Commanders will act as soldiers; the Saigon Mayor, Province Chiefs, Mayors and District Chiefs continue to retain their political and administrative powers and as far as these powers are concerned, they remain subordinate to the Ministry of Interior.

Article 19. If in the exercise of duties, there is a disagreement between military officers and administrative officials, priority will be given to military actions in emergencies; however, this must be reported immediately to higher headquarters.

Article 20. In order to effectively defend the Special Capital District III Corps and Military Region 3 Headquarters must pay special attention to security conditions in Bien Hoa, Binh Duong, Hau Nghia and Long An Provinces.

SECTION 5

Special Provisions

Article 21. All previous documents and provisions which are contrary to this Decree, will be abrogated, in particular:

Decree 227/QP, 9 December 1965, and Directive 089/QP, 9 December 1965.

Article 22. The Prime Minister, the Minister of Defense, the Minister of Interior and the Chief Joint General Staff/RVNAF are responsible for implementing this Decree in keeping with their respective duties and functions.

This Decree will be published in the Republic of Vietnam Gazette.

Nguyen Van Thieu

(Translation by Translations and Publications Branch, MSD/CORDS, APO 96243, 10 July 1970)

Appendix B

D E C R E E 198-SL/DUHC

Republic of Vietnam
Office of the Chairman
Central Executive Committee
24 December 1966

SUBJECT: Reorganization of Village and Hamlet Administration

The Chairman of the Central Executive Committee

DECREES:

Article 1. This hereby places the village under the responsibility of two bodies:

- Village People's Council, and
- Village Administrative Committee

The organization, authority, duties, and functioning of these two bodies are defined as follows:

CHAPTER I

Village People's Council

Section 1: Organization

Article 2. The Village People's Council is composed of from six (6) to twelve (12) members elected by the village people through universal suffrage, direct and secret ballot. The election procedure shall be determined by a separate decree.

The member who wins the largest number of votes shall be the Chairman of the Village People's Council. The member who wins the next largest number of votes shall be the Deputy Chairman of the Village People's Council.

In case the Chairman of the Village People's Council is elected Chairman of the Village Administrative Committee as defined in Article 24, the members who obtained the next highest number of votes in the election of the Village Council shall hold respectively the positions of Chairman and Deputy Chairman of the Village People's Council.

In case the deputy chairman of the Village People's Council is elected Chairman of the Village Administrative Committee, the elected member who obtained the next largest number of votes shall hold the position of deputy Chairman of Village People's Council.

In case of a tie, the eldest member is declared elected.

Article 3. The term of office of the Village People's Council is three years. Members may be re-elected.

Article 4. Members of the Village People's Council are not authorized to hold any salaried public positions but they may hold another elected position. Any member of the Village People's Council may be appointed Chairman of the Village Administrative Committee, but during such tenure, has no vote in the Council.

Members are not authorized to bid for contracts with the village.

Parents and children, blood brothers and sisters, wives and husbands may not hold various responsibilities in the same Village Council.

Article 5. Village Council members may send individual requests for resignation to the Province Chief through the Village Council Chairman. The resignation shall be effective on the date of receipt of the decision of the Province Chief, or, if no decision is received from the Province Chief, the resignation shall be effective one month after the request for resignation is submitted.

Article 6. Any member of the Village Council shall be declared automatically resigned by decision of the Province Chief for the following reasons:

a. Violation of the regulation excluding a person from holding more than one salaried public office or failure to fulfill all the conditions for eligibility laid down by the Decree fixing the Council electoral procedures, whether discovered during or after his elections

b. Three consecutive absences during the regular or special sessions, without any just reason recognized as well-founded by the council.

Subject to a two-thirds majority of the Council, the Province Chief may remove from office any Village Council member who without justification, fails to fulfill the duties assigned to him by the council.

Article 7. In case the Village People's Council proves to be inoperative or there is evidence that activities of more than half of the Village Council members are pro-Communist or neutralist in favor of Communism, the Special Commissioner for Administration may sign a decision to dissolve the Village Council upon the recommendation of a committee composed of:

- | | |
|--|----------|
| -The Province Chief or his representative | Chairman |
| -A local Presiding Judge, Court of First Instance, or Court with Extended Powers or Justice of Peace | Member |
| -One member of the Provincial Council | Member |

The Chairman or any member representing the Village People's Council concerned has the right to plead before the Committee.

Article 8. In case of dissolution of the Village Council, the election of a new Council will be held within a maximum period of three months. In addition, a by-election will be held, also within the maximum period of three months, to replace any members who have resigned, died, or terminated their responsibilities for whatever reason, provided that:

- The number of missing members is at least one third of the total membership;
- The members so elected have at least one year to serve prior to the expiration of the term.

Section 2: Authority

Article 9. Within the limits of current laws, the Village Council is empowered to discuss and decide on the following matters:

1. Plans of construction and programs of public interest in the village;
2. Village budget;
3. Miscellaneous taxes, fees, additional percentages, rentals and all receipts for Village budget;
4. Regulations governing the collection of the income of the village;
5. Purchase, transfer, exchange, leasing or renting of village properties and general administration and maintenance work on these properties;
6. Bids for procurement, supply or transportation for the Village;
7. Receipt of donations and legacies for the village;
8. Concessions for public services;
9. Creation and modification of Village construction plans;
10. Projects for construction of roads, bridges, dams, etc.;
11. Creation, abolition, naming, renaming, modification of boundaries, and removal of Village, hamlet offices;
12. Loans, subsidies;
13. Organization, management of markets and fairs;
14. Legal proceeding in order to defend village interests, and out-of-court settlements subject to approval by the Province Chief;
15. All issues that must be submitted to the Village Council for discussion and decision in accordance with regulations in force.

Article 10. The Village Council is empowered to control the following matters:

1. Implementation of policies and programs of the Government and all decisions of the Village Council;
2. Annual report of expenditures in relation to the village budget;
3. Accounting ledgers of villages;
4. Behavior of personnel and cadres at all levels in village, particularly their attitudes toward serving the people.

The Council is empowered to warn the Chairman, Deputy Chairman and members of the Village Administrative Committee as well as the Chief Secretary and assistants if it finds irregularities in the exercise of their duties.

The Council is empowered, subject to a three-fourths majority of its total membership, to propose the removal from office of the Village Administrative Committee Chairman, Deputy Chairman or other members, if it finds grave faults in the exercise of their duties.

Article 11. The Village Council must be consulted by the Village Administrative Committee in regard to the following matters:

- Land affairs in the Village;
- Problems relative to professional practice by Villagers;
- Recruitment of personnel, and
- All questions that must be submitted to the Council for decision in accordance with regulations.

Article 12. On any problem of general interest to the village, the Village Council may express opinions, proposals or aspirations to the local District Chief, Province Chief, Provincial Council, or Special Commissioner for Administration.

All such ideas, recommendations and suggestions received from the Council must be considered and resolved within the shortest period of time. Results of the consideration must be made known to the Council.

Article 13. Except for the matters prescribed in Articles 14 and 15, all decisions made by the Village Council must be carried out by the Village Chief within 15 days after transmittal to the Village Administrative Committee.

In case the decisions of the Council cannot be carried out, the Village Chief shall give explanations to the Council for reconsideration if necessary.

After reconsideration by the Council, if disagreement still exists, the Village Council as well as the Village Administrative Committee may submit the matter directly to the local District Chief or the Province Chief for solution.

Article 14. The following decisions must be ratified by the Ministry involved before implementation:

1. Construction projects, equipment, and programs affecting the public interest, expenses for which exceed \$1,000,000;
2. Village budget, the total of which exceeds \$1,000,000;
3. Miscellaneous taxes, fees, receipts for Village budget;
4. Leasing or rental of real estate or properties for a period of over three years with rental cost exceeding \$500,000 per year;
5. Receipt of donations and legacies with additional charges and conditions;
6. Transfer, purchase and exchange of village properties, the expenses of which exceed \$500,000;
7. Creation, and maintenance of village public properties, the expenses of which exceed \$500,000;
8. Creation and modification of village construction plans;
9. Establishment, naming, abolition, modification of official boundaries or moving of village offices;
10. Loans, special subsidies;
11. Concessions for public services extending as long as three years, the estimate for which exceeds \$500,000;
12. Establishment of contracts costing over \$500,000 which involve financial responsibility for villages.

Article 15. The following decisions must be ratified by the Province Chief before implementation:

1. Establishment of Village budget, the total of which amounts to \$1,000,000 or less;
2. Establishment of the percentage rate on any kind of taxes that the village has been authorized to levy;
3. Leasing or rental of real estate or other properties for a period of three years or less with the rental cost ranging from \$50,000 to \$500,000 per year;
4. Receipt of donations and legacies with no additional charges and conditions;
5. Purchase, transfer and exchange of Village properties, the expenses for which range from \$50,000 to \$500,000;
6. Creation or maintenance of Village properties, the expenses for which range from \$50,000 to \$500,000;
7. Projects for construction of roads and plazas, alignment of roads and construction of village roads;
8. Projects for modifying hamlet boundaries;
9. Concession for public services for a period of three years or less, the cost of which does not exceed \$500,000;
10. Establishment of contracts costing \$500,000 or less that require financial responsibility of the village.

Section 3: Functioning

Article 16. Five days at the latest after the result of the election is ratified, the Village Council will convene its first session under the chairmanship of the Chairman of the Village Council to elect the Chairman of the Village Administrative Committee and to establish the Standing Committee of the Council and the internal regulations.

Article 17. The Standing Committee of the Village People's Council is composed of the Chairman, the Deputy Chairman and a Secretary General. The Secretary General is elected through a single secret ballot and with simple majority. In case of a tie, the eldest is declared elected.

The result of election and internal regulations of the Council must be submitted within seven days to the Province Chief through the local District Chief for approval.

Article 18. The Village Council convened by its Chairman shall meet in regular sessions at least once a month; its monthly meeting shall not last more than four days.

In addition, the Council may convene in special session at the request of the Chairman of the Village Council, the Chairman of the Village Administrative Committee or one-third of the Council members. Special sessions shall not last more than two days in a month.

The agenda of regular and special sessions shall be fixed by the Village Council Chairman after the latter discusses it with the Village Administrative Committee Chairman and the Standing Committee of the Council.

Every Council member has the right to suggest one or several questions to be listed on the agenda. In case such suggestion is not approved, it must be recorded in the minutes of the meeting and accompanied by an explanatory statement by the Secretary General of the Council.

Article 19. The Council session and vote shall be valid if more than one half of the total Council members are present. In case a meeting is duly convened but the above mentioned quorum cannot be formed, the Council can reconvene twenty-four hours later and its vote will be valid irrespective of the number of Council members present.

All decisions made by the Council are considered valid if they are approved by more than half of the members present unless otherwise prescribed by this decree.

In case of a tie, the vote of the Chairman shall be decisive.

Any decisions, ideas, recommendations expressed outside the regular sessions, against current laws, or outside the authority of the Council as prescribed in this Decree are automatically void.

Article 20. Meetings of the Village People's Council shall be public unless otherwise requested by the Chairman of the Village Council, the Chairman of the Village Administrative Committee, or more than one half of the total Council members.

The chairman, deputy chairman and members of the Village Administrative Committee have the duty to attend sessions of the Village Council and, whenever deemed necessary, have the right to present their opinions.

On urgent matters arising when the Council is not in session the Village Council Chairman may consult individual members of the Council.

Article 21. Proceedings of meeting of the Village Council must be recorded by the Council Secretary General in a separate register which is kept in the Office of the Village Administrative Committee and a copy must be submitted to the Chairman of the Village Administrative Committee for action within five days after each meeting.

CHAPTER II

The Village Administrative Committee

Section 1: Composition

Article 22. The Village Administrative Committee is composed of:

- One Village Chief concurrently Commissioner for Civil Status;
- One Deputy Village Chief concurrently Commissioner for Economy-Finance and;

From one to four Commissioners to assume the following functions:

- Security
- Propaganda and Civic Action
- Social Welfare
- Agricultural Affairs

Article 23. The term of office of the Village Administrative Committee terminates at the same time as that of the Village Council. In case the Village Council is dissolved before completing its term of office, the Province Chief, upon recommendation of the District Chief, can designate a temporary Administrative Committee according to the procedure provided for by Article 44. He may designate the Chairman, the Deputy Chairman and any other members of the temporary Administrative Committee from members of the former Village Administrative Committee.

Article 24. The Chairman of the Village Administrative Committee is elected by the Village Council from among its members at the first

meeting of the Council as specified in article 16 above. The election must be held in a public meeting session and through secret ballot, using an absolute majority. If no member receives the number of votes required on the first ballot, simple majority is required on the second ballot.

The Chairman of the Village Administrative Committee is not authorized to assume concurrently the functions of Chairman, Deputy Chairman, or Secretary General of the Village Council.

The Chairman of the Village Administrative Committee can be declared automatically resigned in accordance with procedures specified in Article 6. The Chairman of the Village Administrative Committee can be declared resigned by decision of the Province Chief upon recommendation of the Village Council in accordance with procedures specified in Article 10, or he may be removed upon recommendation of the District Chief, with the agreement of the Village Council, for failure in duty or serious fault.

In case he is prosecuted before the court and put in jail, his functioning will be suspended by decision of the Province Chief.

In case the Chairman of the Village Administrative Committee terminates his duty as a result of death, resignation, dismissal, being declared to have resigned or for any other reason, the Village Council will elect another Chairman.

Article 25. The Deputy Chairman and Commissioners of the Village Administrative Committee are appointed and removed from office by decision of the Chairman of the Village Administrative Committee with the concurrence of the Village Council.

Such appointment must be made in accordance with procedures set forth by the Province Chief. A copy of the decision concerning such appointment must be submitted by the Chairman to the District Chief of Province Chief concerned for ratification.

The Province Chief, or District Chief upon authorization of the Province Chief, has the right to disapprove the appointment of a member if this member does not meet the prescribed conditions. In this case, the appointment decision will be returned to the Chairman of the Village Administrative Committee with explanatory statement attached.

If no action is taken by the Province Chief or District Chief within twenty (20) days after receipt of the copy of the appointment decision, the appointment is considered valid.

Section 2: Duty and Authority

Article 26. The Chairman of the Village Administrative Committee represents the Village administration and is vested with the following responsibilities:

- Publishes and enforces laws and regulations and implements policies of the Government at the village level;
- Sees to maintenance of security and public order in the village; in this respect he has the right to mobilize the organic forces in the village and, if required, to request the Popular Forces of the locality to provide support for security measures;
- Reports to the Province Chief and District Chief any occurrences in his village, submitting to them reports on special questions as may be required;
- Certifies documents pertaining to movable and fixed property and issues administrative certificates (certificate of good character, certificate of residence, etc.);
- Prepares a list of questions to be brought before the Village Council for discussion and executes decisions made by the Village Council;
- Supervises the Village Administrative Committee and assumes responsibility for the whole Committee to the Village Council;
- Serves as representative of the village before the law: signs contracts, takes legal proceedings, etc.
- Oversees the functioning of other governmental agencies at the village level;
- Provides direction for and operates village administrative affairs;
- Signs receipts and authorizations within the limit of appropriations covered by the Village budget;
- Serves as conciliator for minor disputes in the village.

The Chairman of the Village Administrative Committee has the authority to reward or punish subordinate personnel and make recommendations on rewards, punishment of employees and cadres of various echelons working in the village.

In his capacity as member for Civil Status Affairs, the Chairman is responsible for maintaining civil status registers and for recording and issuing birth, marriage and death certificates to the people in his village. He also presides over wedding ceremonies held in his office.

Article 27. The Deputy Chairman of the Village Administrative Committee coordinates the activities of members of Village Administrative Committee in accordance with instructions of the Chairman and replaces the latter when he is absent or occupied with other duties.

In addition, the Deputy Chairman may be permanently delegated by the Chairman to sign certain categories of papers dealing with matters provided for in Article 26 above, except for civil status matters and expenditure authorizations.

In his capacity of Commissioner for Economy and Finance, the Deputy Chairman administers finance and village properties and handles problems concerning village budget, taxation, economy and supply.

Article 28. The Commissioner for Security handles problems concerning administrative and judicial police, public order, military draft and military affairs.

He also serves as a judicial police agent.

Article 29. The Commissioner for Propaganda and Civic Action is in charge of problems pertaining to popular associations, information, open-arms, civil proselyting, youth, and village postal service.

Article 30. The Commissioner for Social Welfare handles problems concerning culture, education, social welfare, construction, labor, public sanitation, and public health.

Article 31. The Commissioner for Agricultural Affairs handles problems concerning land administration and agriculture. He cooperates with the Deputy Chairman, concurrently Commissioner for Economy and Finance, in the administration of village public land and rice fields.

Section 3: Functioning

Article 32. The Deputy Chairman and Commissioners of the Village Administrative Committee, are subordinate to the Chairman of the Village Administrative Committee.

Article 33. The Village Administrative Committee shall meet at least twice a month under the chairmanship of the Chairman of the Village Administrative Committee to review the work completed and, at the same time, to work out plans of action for the months to come and to coordinate with other agencies in the Village.

In addition, the Village Administrative Committee shall meet at least once a month with the Village Council, upon convocation of the Village Council Chairman, under the joint chairmanship of the Village Council Chairman and the Chairman of the Village Administrative Committee.

Article 34. There is a secretariat placed at the service of the Village Administrative Committee. This secretariat is headed by a Chief Secretary who is assisted by one or two assistants.

The Chief Secretary and Assistants are selected and removed from office by decision of the Province Chief upon recommendation of the local District Chief.

Article 35. The Chief Secretary of the Village Administrative Committee has the following responsibilities:

- To supervise the village secretariat;
- To handle general administrative problems;
- To keep seals, registers and village records;
- To act as the Village Cashier.

The Assistant to the Chief Secretary is in charge of the Civil Status Section, assists the latter in the performance of the above-cited duties and replaces him during his absence or when he is busy with other duties.

CHAPTER III

Hamlet Management Committee

Article 36. The Hamlet is placed under the management of a Hamlet Management Committee which is composed of:

- One Hamlet Chief
- One Assistant for Security
- One Assistant for Propaganda and Civic Action

In hamlets where the population exceeds three thousand (3,000) the Hamlet Chief may be assisted by a Deputy Hamlet Chief.

Article 37. The Hamlet Chief and his Deputy are elected by the people in the hamlet through universal and direct suffrage with secret ballot. The election procedure will be provided for in a separate decree.

The term of office of the Hamlet Chief and his Deputy is three years. They may be re-elected.

The Hamlet Chief and his Deputy are not entitled to enter into contracts with their village.

Parents and children, brothers and sisters, husbands and wives may not hold various memberships in the same Hamlet Management Committee.

Article 38. The Hamlet Chief and his Deputy may tender their resignation, be declared resigned or removed from office in accordance with the same procedure governing the bodies at village level, but the term of the Hamlet Chief and Deputy Hamlet Chief has no connection with the term of these bodies.

In case the Hamlet Chief terminates his duties before completing his term for any reason, the Deputy Hamlet Chief will perform the duties of Hamlet Chief and an election will be held within a maximum period of three months to elect another Deputy Hamlet Chief.

In case there is no Deputy Hamlet Chief or the Hamlet Chief and Deputy Hamlet Chief both terminate their duties, an election will be held within a maximum period of three months to fill these positions.

Article 39. The Hamlet Chief represents the Village Chief in his hamlet and is vested with the following duties:

- To carry out the laws, policies and regulations of the government and the directives of local administrative authorities;
- To maintain order and security in his hamlet;
- To supervise the Hamlet Management Committee;
- To report to the Village Administrative Committee on the general situation and activities of his hamlet;
- To represent the hamlet before the Village Administrative Committee;
- To certify routine administrative papers before submitting them to the Village Administrative Committee;
- To maintain hamlet registers;
- To assist the Village Administrative Committee in the collection of taxes;

The Deputy Hamlet Chief replaces the Hamlet Chief during his absence or when he is busy with other duties.

Article 40. The Assistant for Security and the Assistant for Propaganda and Civic Action are appointed by the Chairman of the Village Administrative Committee in accordance with the conditions prescribed by the Province Chief, upon the recommendation of the Hamlet Chief and with the concurrence of the Village Council. The District Chief may disapprove such appointments in accordance with the procedure set forth in Article 25 above.

The Assistant for Security assists the Hamlet Chief in the maintenance of order, security and defense of the hamlet.

The Assistant for Propaganda and Civic Action assists the Hamlet Chief in problems concerning popular associations, information, open-arms, social welfare, youth and public sanitation.

CHAPTER IV

General Provisions

Article 41. In the exercise of their duties, the members of the Village Council are not entitled to any salary but are granted an allowance computed on the basis of the number of days of attendance at Council meetings. Members of the Standing Committee of the Village Council receive a special allowance to be determined later. The special allowance of the Chairman of the Village Council must be equal to the monthly compensation received by the Chairman of the Village Administrative Committee.

The Chairman and his Deputy and other members of the Village Administrative Committee, the Chief Secretary and his Assistant, the Hamlet Chief, the Deputy Hamlet Chief and Assistants are granted monthly compensations.

The allowances and compensations mentioned above are supported by the village budget in accordance with a rate to be fixed by a decree of the Special Commissioner for Administration with the concurrence of the Central Budget Agency.

Article 42. During their period of service, all village and hamlet officials mentioned in this Decree, together with their spouses and legitimate children, are entitled to receive second class treatment in government hospitals. Hospitalization fees will be paid in accordance with regulations applicable to government officials.

In case a village or hamlet official is fatally wounded or missing in the course of exercising his duty, his legal beneficiary is entitled to a compensation equal to twelve times his last month's salary. This compensation is supported by the village budget. In the case of a member of the Village Council, the death benefit will be the equivalent of twelve times his monthly allowance on the basis of 30 days a month.

Article 43. Temporarily during the pacification period, and in areas where elections cannot be held, local authorities will establish by decree and upon consultation with representatives of all strata of people in the village:

- A provisional Village Administrative Committee (at village level)
- A provisional Hamlet Management Committee (at hamlet level)

Article 44. The Provisional Village Administrative Committee is established by a decree of the Province Chief. Its composition is limited to the following members:

- One Chairman concurrently Commissioner for Civil Status;
- One Deputy Chairman concurrently Commissioner for Economy, Finance and Agricultural Affairs;
- One Commissioner for Security;
- One Commissioner for Propaganda and Civic Action, concurrently Commissioner for Social Welfare;

The Provisional Village Administrative Committee assumes the combined responsibilities and holds the authority of both the Village Council and Village Administrative Committee.

The provisional Village Administrative Committee has a small secretariat appointed by the Province Chief.

Article 45. The Provisional Hamlet Management Committee is created by Service Order of the District Chief concerned. Its composition can be limited to one Hamlet Chief and one Assistant.

Article 46. Village and hamlet operating expenditures are ordinarily covered by the village budget.

In the pacification period, all organizing and operating expenditures incurred by the Provisional Village Administrative Committee and the Provisional Hamlet Management Committee are supported by the national budget.

Article 47. This Decree cancels and supersedes Decree No. 203-d/NV dated 31 May 1964.

Article 48. The Deputy Chairman of the Central Executive Committee, the Commissioners General, Commissioners, Deputy Commissioners, Special Commissioners and Province Chiefs are charged, each as to that which concerns him, with the execution of this Decree.

This Decree will be published in the RVN Gazette.

Nguyen Cao Ky

Glossary

ALSC	Administrative and Logistical Support Center (for RF and PF)
ARVN	Army of Vietnam. The common term used to refer to regular army forces to include airborne and ranger units
CAP	Combined Action Platoon
CAT	Combined Action Team
Chieu Hoi	The "Open Arms" program for encouraging the VC defect to the GVN side
CIDG	Civilian Irregular Defense Group
CMD	Capital Military District
COMUSMACV	Commander, US Military Assistance Command Vietnam
CORDS	Civil Operations and Revolutionary Development Support. The MACV agency that provided single manager direction of all US Civil/Military pacification activities in the RVN
COSVN	Central Office for South Vietnam (Politbureau)
CPDC	Central Pacification and Development Council
CRDC	Central Revolutionary Development Council
CSCC	Combat Support Coordination Center
CTZ	Corps Tactical Zone. The geographical area of responsibility of a Corps, but frequently and erroneously used to refer to the Corps headquarters itself: e.g. "CTZ will review...", "DTA will submit to CTZ ..." The term "Region" is sometimes used interchangeably with CTZ since both areas encompass the same geographical area
DIOCC	District Intelligence and Operations Coordination Center
DSA	District Senior Advisor
DTA	Division tactical area. The geographical area of responsibility of a division (prior to 1970)

FULRO	Front Unifié pour la Lutte des Races Opprimées (Unified Front of Struggle for Oppressed Races)
FWMAF	Free World Military Assistance Forces
GVN	Government of South Vietnam. Used to refer to the national government, to the entire governmental structure, or as an apposition to indicate one of its agents or agencies.
HES	Hamlet Evaluation System
Hoi Chanh	A returnee coming in under the Chieu Hoi "Open Arms" program
Hop Tac	"Working Together". The program for priority attention to expanding GVN control in critical areas. Hop Tac I is a program designed to expand GVN control in the Saigon - Cholon area
JGS	Joint General Staff (RVNAF)
JUSPAO	Joint United States Public Affairs Office. Served US interest as well as adviser
MACV	Military Assistance Command Vietnam
MAT	Mobile Assistance Team
MEDCAP	Medical Civic Action Program
MR	Military Region
MTT	Mobile Training Team
NPFF or PFF	National Police Field Force
PF	Popular Forces. Military forces recruited and employed within a district, and basically organized into platoons
PIOCC	Provincial Intelligence and Operations Coordination Center
PRU	Provincial Reconnaissance Unit
PSDF	People's Self-Defense Forces
RD	Revolutionary (or Rural) Development
RF	Regional Forces. Military forces recruited and employed within a province and later within a military region. Primarily organized into companies
RPDC	Regional Pacification and Development Council
RVN	Republic of Vietnam
RVNAF	Republic of Vietnam Armed Forces. Refers to all three services

SP	Special Police
TAOR	Tactical Area of Responsibility
USAID	United States Agency for International Development. The Section of the US Mission generally responsible for the civil side of US advice and assistance with the exception of the information service.
USARV	United States Army, Vietnam
VC	Viet Cong. Communist insurgents against the South Vietnamese Government
VCI	Viet Cong Infrastructure
VN	Vietnam, Vietnamese
VNAF	Vietnamese Air Force
VNN	Vietnamese Navy
VNMC	Vietnamese Marine Corps