

REPORT DOCUMENTATION PAGE			Form Approved OMB No. 0704-018	
Public reporting burden for this collection of information is estimated to average 1 hour per response, including the time for reviewing instructions, searching existing data sources, gathering and maintaining the data needed, and completing and reviewing the collection of information. Send comments regarding this burden estimate or any other aspect of this collection information, including suggestions for reducing this burden, to Washington Headquarters Services, Directorate for Information and Reports, 1215 Jefferson Davis Highway, Suite 1204, Arlington, VA 22202-4302, and to the Office of Management and Budget, Paperwork Reduction Project (0704-0188), Washington, DC 20503.				
1. AGENCY USE ONLY (Leave blank)		2. REPORT DATE March 1997		3. REPORT TYPE AND DATES COVERED
4. TITLE AND SUBTITLE Want to Know About Steam Traps			5. FUNDING NUMBERS	
6. AUTHOR(S) Mike Rocha				
7. PERFORMING ORGANIZATION NAME(S) AND ADDRESS(S) Naval Facilities Engineering Service Center Port Hueneme, CA 93043-4370			8. PERFORMING ORGANIZATION REPORT NUMBER TDS-2037-E&U	
9. SPONSORING/MONITORING AGENCY NAME(S) AND ADDRESSES			10. SPONSORING/MONITORING AGENCY REPORT NUMBER 19970512 141	
11. SUPPLEMENTARY NOTES				
12a. DISTRIBUTION/AVAILABILITY STATEMENT Approved for public release; distribution is unlimited.			12b. DISTRIBUTION CODE	
13. ABSTRACT (Maximum 200 words) Steam traps are a small but very important component in any steam distribution system. They represent a significant source of wasted energy when not properly used and maintained. Surveys have shown that on Navy shore facilities 30 to 35 percent of traps are either inoperative or misused. This has led to energy loss in steam lines for many years. There have been TechData Sheets, articles, and specs written for steam traps but there is not universal program that applies to every application. Steam pressure, age of pipe, amount of impurities in steam, annual steam load variation, and maintenance structure all play a part in determining what the best program is for steam traps. This TechData Sheet will familiarize the reader with the characteristics of each trap type, provide information on the art of sizing and maintaining traps, and give estimates for losses from failed traps.				
14. SUBJECT TERMS Steam traps, thermostatic traps, mechanical traps, thermodynamic traps.			15. NUMBER OF PAGES 8	
			16. PRICE CODE	
17. SECURITY CLASSIFICATION OF REPORT Unclassified	18. SECURITY CLASSIFICATION OF THIS PAGE Unclassified	19. SECURITY CLASSIFICATION OF ABSTRACT Unclassified	20. LIMITATION OF ABSTRACT UL	



TechData Sheet

Naval Facilities Engineering Service Center
Port Hueneme, California 93043-4370

TDS-2037-E&U

March 1997

Want to Know About Steam Traps??

Steam traps are a small but very important component in any steam distribution system. They represent a significant source of wasted energy when not properly used and maintained. Surveys have shown that on Navy shore facilities 30 to 35 percent of traps are either inoperative or misused. This has led to energy loss in steam lines for many years. There have been TechData Sheets, articles, and specs written for steam traps but there is no universal program that applies to every application. Steam pressure, age of pipe, amount of impurities in steam, annual steam load variation, and maintenance structure all play a part in determining what the best program is for steam traps.

This TechData Sheet will familiarize the reader with the characteristics of each trap type, provide information on the art of sizing and maintaining traps, and give estimates for losses from failed traps.

Steam Trap Types

Steam trap design, with a few exceptions, has not changed significantly since the 1930's. Most of the current traps are slight modifications of very old designs. There are three main categories of steam traps:

- Thermostatic
- Mechanical
- Thermodynamic

All three traps release condensate from the steam line to the condensate return based on a difference in properties between the live steam and the liquid condensate. Thermostatic traps use temperature difference, mechanical traps use density, and thermodynamic traps use kinetic energy or velocity.

Thermostatic Traps

The balanced pressure or bellows trap is a common thermostatic trap design. When the bellows is surrounded by steam the fluid in its center is in the vapor state, this will keep the valve closed. When surrounded by cooler condensate the

fluid will condense to liquid, contract and open the valve allowing the condensate to pass from the steam line to the condensate return. Figure 1 shows a bellows trap cross section.

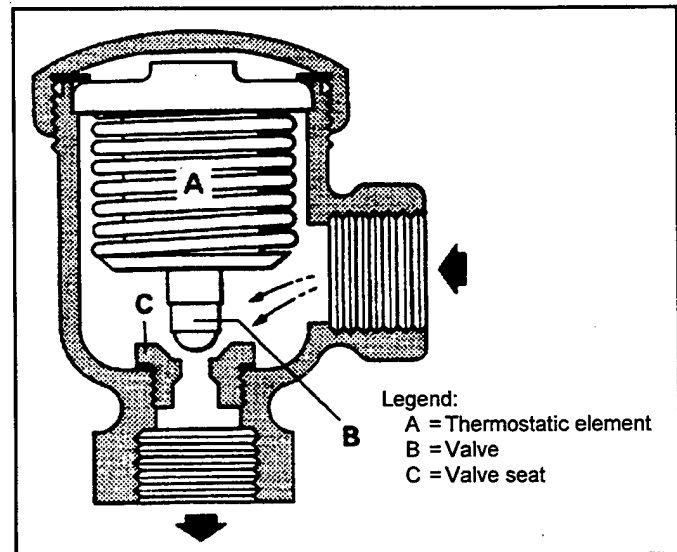

Figure 1. Bellows trap.

(Reprinted from "The Steam Trap Handbook" by special permission of The Fairmont Press, Inc., Lilburn, GA.)

Thermal expansion traps are another common type of thermostatic trap. These traps operate under the same principle as bellows traps but have a slightly different mechanism. The thermal element that expands and opens and closes the valve can be wax, plastic, or liquid. Figure 2 shows a thermal expansion trap.

Bimetallic traps open and close when a composite strip or disk of two dissimilar metals bends. The two metals have different thermal expansion rates. When the temperature rises, the strip curves or bends, which closes a valve and does not allow the higher temperature steam to pass. Figure 3 shows a bimetallic trap cross section.

It should be noted that bimetallic traps require a slightly longer condensate cool down period before the valve opens than other traps. This means that a cooling leg is usually

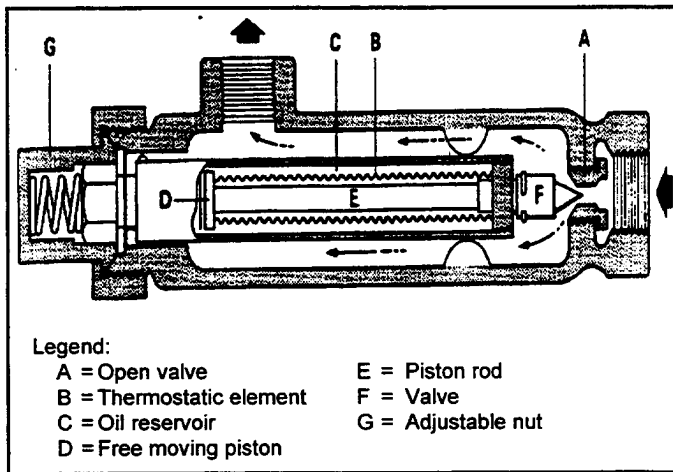

Figure 2. Thermal expansion trap.

(Reprinted from "The Steam Trap Handbook" by special permission of The Fairmont Press, Inc., Lilburn, GA.)

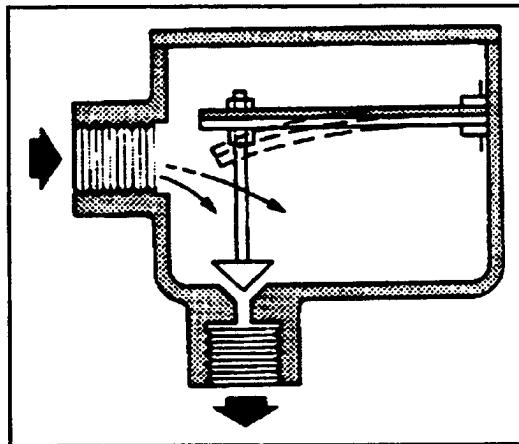

Figure 3. Bimetallic trap.

(Reprinted from "The Steam Trap Handbook" by special permission of The Fairmont Press, Inc., Lilburn, GA.)

required in front of the trap to allow condensate to gather while it is cooling down, otherwise waterlogging may occur. Bimetallic traps are not recommended for use with equipment that requires immediate condensate removal for efficient operation.

Mechanical Traps

The simplest type of mechanical trap is the loose float trap. The loose float trap usually has a ball float that rises when its chamber is filled with condensate. As the ball float rises, it uncovers the valve opening and allows condensate to pass. These traps have continuous discharge. Figure 4 shows a ball float trap.

The float and lever trap is a more elaborate version of the loose float trap. The float and lever trap uses the same float in a chamber mechanism but has a lever attached to the float. The lever is attached to the outlet valve. When the lever is high enough the valve opens and condensate passes. One

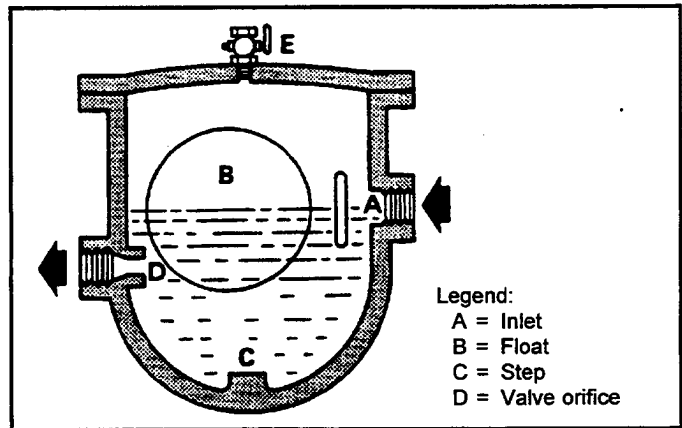

Figure 4. Ball float trap.

(Reprinted from "The Steam Trap Handbook" by special permission of The Fairmont Press, Inc., Lilburn, GA.)

problem with the float and lever trap is that it will not automatically pass air on startup. There is usually a manual valve on top, see Figure 5, to allow for air venting. This requires manual opening of the valve whenever there is a shut down.

Most float traps now have a thermostatic valve that

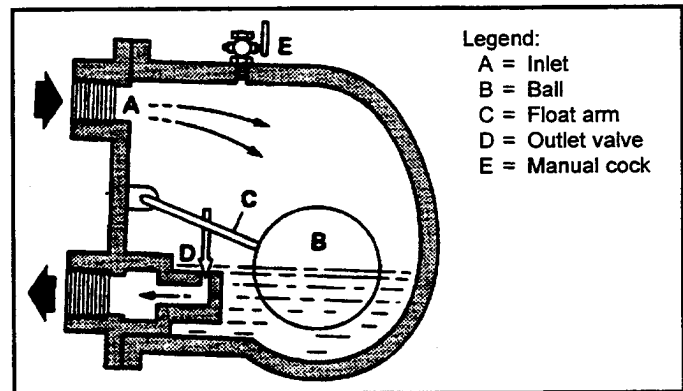

Figure 5. Float and lever trap.

(Reprinted from "The Steam Trap Handbook" by special permission of The Fairmont Press, Inc., Lilburn, GA.)

automatically releases air when the trap is cold. This type of trap is commonly known as a float and thermostatic trap. Figure 6 shows a float and thermostatic trap. This thermostatic valve will also allow air to pass during normal operation by allowing air trapped at the top of the chamber to cool the thermostatic element and open the valve.

Bucket traps are another common type of mechanical trap. The most common has an inverted bucket inside the body of the trap as shown in Figure 7. When condensate fills the body, the bucket sits on the bottom and the valve opens, allowing condensate to pass through. As the trap fills with steam the bucket rises and closes the valve. Unlike float traps, these buckets have an intermittent discharge. There are some "open" designs in which the bucket is right side up but most manufacturers have gone to the inverted bucket.

Thermodynamic Traps

The disk trap is a standard thermodynamic design. When condensate or air flows through the trap body, the disk is held up and the valve opens. The condensate will eventually begin to flash to steam and this saturated steam will gather above the disk. The steam below the disk will be traveling at a higher velocity and thus will be at a lower pressure, by Bernoulli's Theorem. This pressure differential across the disk

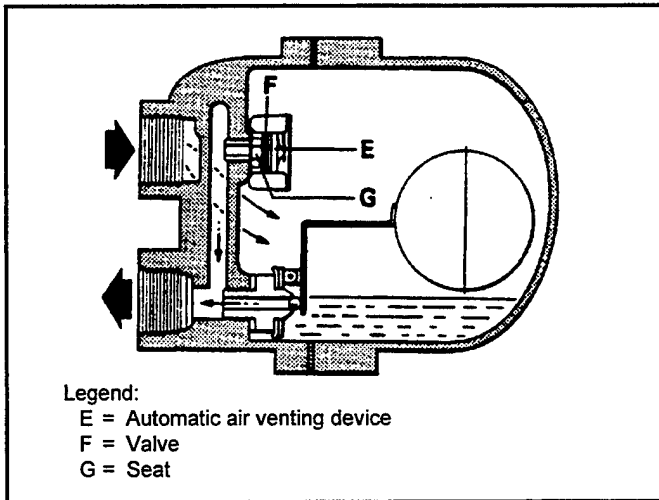

Figure 6. Float and thermostatic trap.

(Reprinted from "The Steam Trap Handbook" by special permission of The Fairmont Press, Inc., Lilburn, GA.)

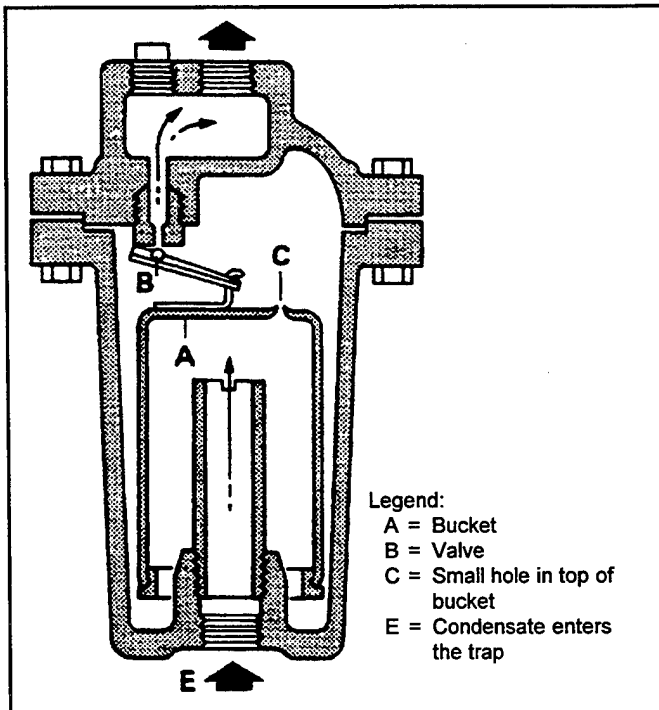

Figure 7. Inverted bucket trap.

(Reprinted from "The Steam Trap Handbook" by special permission of The Fairmont Press, Inc., Lilburn, GA.)

will force it down. Disk traps normally fail open and have an intermittent discharge. Figure 8 is a disk trap.

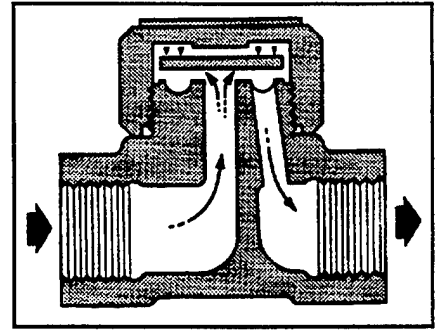

Figure 8. Disk trap.

(Reprinted from "The Steam Trap Handbook" by special permission of The Fairmont Press, Inc., Lilburn, GA.)

Impulse traps are a less common type of thermodynamic trap. The mechanism by which an impulse trap passes condensate is rather complicated. The simplest explanation is that condensate that has passed through the valve begins to flash to steam and decreases in pressure. Because this flash steam travels slower than the condensate in the outlet chamber, pressure builds up and eventually forces the valve closed. Impulse traps have an intermittent discharge and can fail either open or closed. Figure 9 shows a simple impulse trap cross section.

There are other types of thermodynamic traps that are less common such as the Labyrinth trap, which has a series of adjustable baffles in a tapered inlet. These traps make up a small percentage of the market and are not covered here.

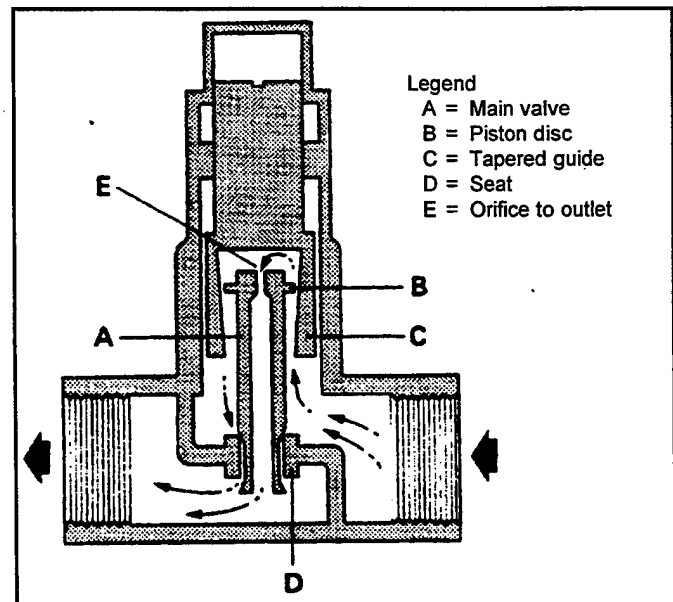

Figure 9. Impulse trap.

(Reprinted from "The Steam Trap Handbook" by special permission of The Fairmont Press, Inc., Lilburn, GA.)

Orifice Traps

Orifice traps are usually categorized as thermodynamic traps but are, by nature of their mode of operation, their own category. The orifice trap continuously removes condensate from the steam line through a small hole, or orifice, drilled

into a plate. As long as there is condensate in the line the trap will pass it. However, when there is no condensate the trap will pass live steam. The orifice is much smaller than the valve opening in a conventional trap so the loss through an orifice trap when no steam is present is much smaller than the loss through a conventional trap that has failed open. If a conventional trap has failed closed it will not remove any condensate.

The argument for orifice traps has been that the small loss when no condensate is present is cheaper than the loss from a failed conventional trap. If traps were easy and inexpensive to maintain, there would be less of an argument for orifice traps. Few studies have agreed on what a common percent of failure is for Navy bases but none have shown that all traps were functioning. There is also the point that in many locations there will always be some condensate to be drained and thus no losses from an orifice trap.

There are other problems associated with orifice traps, however. For instance, since the orifice is so small they are subject to blockage from impurities in the steam. The orifice can be subject to erosion over time which, would allow both steam and condensate to pass if the orifice is opened to wide. They must also be sized carefully because an undersized orifice will cause a backlog of water to build up and defeat the purpose of the trap. Many orifice traps are now designed so the orifice can be changed without removing the trap. The sizing problem should also be considered when steam flow varies greatly. In locations where the load is likely to vary by a factor of two to three times it is questionable whether an orifice trap will prove cost effective over a conventional trap.

Given all of this there is no conclusion on orifice traps. Based on the Navy's past experience with trap maintenance it seems likely that in places where the steam is relatively clean and the load does not vary too much they make good sense. In 1964 the Navy conducted a study using orifice traps on board fossil fuel powered ships using orifice traps. The tests were so successful the Navy decided to convert the entire fossil fuel powered fleet to orifice traps. Conditions are not the same for shore facilities, of course, but the experiment is encouraging.

Summary of Characteristics

Table 1 summarizes the characteristics of the most common traps. Failure mode, durability, and venting capability all play a part in choosing the best trap.

Selecting a Trap

Selecting a trap for a given application can be a difficult process. The decision is usually based on practical experience. The two most often selected traps are: inverted buckets and float and thermostatic (F&T).

Experience has shown that these two traps can handle most common applications. This does not mean you should limit your selection to these two traps, however. There are

circumstances under which neither an inverted bucket nor an F&T trap will work correctly.

There are many things to consider when selecting a trap. The following list should get you started and can be used with Table 1 to make a preliminary selection.

- Pressure of system
- Continuous or intermittent removal of condensate
- Range of load on trap
- Rate of change of load on trap
- Air venting
- Start up load handling
- Reliability
- Amount of steam loss during normal operation
- Most likely failure mode
- Water hammer potential
- Danger from freezing
- Life of trap
- Initial cost
- Ease of installation
- Ease of inspection and replacement

Table 2 lists common trap applications and the recommended trap. The safety factors provided here are for trap sizing, explained in the next section.

To help in selecting and procuring traps, a specification written and used by Naval Facilities Engineering Command, Atlantic Division is shown below.

Steam Traps: All traps must meet all the criteria set forth in Federal Specification WW-T-696, in addition to these specifications:

- a. Traps shall have replaceable internals.
- b. Pressure and temperature range shall be suitable for the intended service.
- c. Maintain tight shutoff under no load condition.
- d. Fail in the desired mode.
- e. Each trap installed will be capable of eliminating air and noncondensable gas both during startup and normal operations.
- f. No Type IV traps, as stated in Federal Specification WW-T-696E, will be allowed to be purchased.
- g. Warranted not to fail for one year from date of installation.
- h. The replacement steam traps shall have the same or nearly the same discharge capacity as the existing trap unless the contractor can show that deviation of the capacity is beneficial to the Government. Discharge capacities can be

Table 1. Characteristics of Most Common Traps

Item	Trap --					
	Bellows	Bimetallic	Float and Thermostatic	Inverted Bucket	Disk	Orifice
Type of Discharge	Continuous	Intermittent	Continuous	Intermittent	Intermittent	Continuous
Failure Mode	Either	Open	Closed	Open	Open	Closed
Freeze Resistance	Excellent	Excellent	Poor	Excellent	Good	Excellent
Venting Air at Low Pressure	Good	Good	Excellent	Poor	N/A ¹	Poor
Venting Air at Steam Temperature	No	No	No	Yes	No	No
Operation Against Back Pressure	Excellent	Poor	Excellent	Excellent	Poor	Poor
Start Up Load Handling	Excellent	Good	Excellent	Fair	Poor	Poor
Size	Small	Small	Large	Large	Small	Small
Water Hammer Resistance	Poor	Excellent	Poor	Excellent	Excellent	Good
Resistance to Wear	Fair	Good	Good	Excellent	Poor	Good
Handles Dirt	Fair to Good	Good	Poor to Good	Excellent	Poor	Poor

¹N/A = Not applicable.

determined by using the trap inlet pressure, trap type (i. e., manufacturer's model number) and trap inlet supplied in the database.

i. Listed are the major steam trap application categories along with additional criteria unique to each application.

Drip Leg

1. Fail open design
2. Bucket design

Radiator

1. Fail close design
2. In-line repairable (The mechanism valve and seat must all be replaceable in line.)
3. Thermostatic design

Unit Heater

1. Fail closed design
2. Float and thermostatic design

Air Handler Traps

1. Fail closed design
2. Float and thermostatic design

Process Equipment Type

1. Fail open design
2. Bucket design

Sizing Traps

To achieve maximum performance and energy savings, sizing traps is critical. Fortunately there is a methodology for sizing that has proven effective over the years. The basic steps are:

1. Meter, calculate, or estimate the condensate load in lb/hr.
2. Choose an appropriate safety factor.
3. Determine the pressure differential.
4. Determine the maximum allowable pressure.
5. Choose the appropriate sized trap from a manufacturer's catalog.

The **pressure differential** is the difference in absolute pressure from the steam main to the trap outlet or condensate return system. The **maximum allowable pressure** is the maximum steam main pressure. Both of these pressures are important when choosing a particular trap.

Steam trap manufacturers are good sources of information on trap sizing. Some manufacturers have developed software and other useful sizing guides to make the process easier. Many of them have estimates of condensate loads for various equipment, which is often the most difficult part of sizing a trap. Another good source for trap sizing information is NAVFAC MO-209, "Maintenance of Steam, Hot Water, and Compressed Air Distribution Systems."

Table 2. Common Trap Application and Recommended Trap

Application	1st Choice	2nd Choice	Safety Factor
Boiler Header (Superheat)	IBLV IBCV burnished	F&T Water	1.5:1 Start up load
Steam Mains & Branch Lines (Non-Freezing) (Freezing)	IB (CV if pressure varies) IBF	F&T Thermostatic or disk	2:1, 3:1 if at end of main, ahead of valve, or on branch Same as above
Steam Separator Steam quality 90% or less	IBLV DC	DC ---	3:1 3:1
Tracer Lines	IB	Thermostatic or disk	2:1
Unit Heaters & Air Handlers (Constant Pressure) (0-15 Variable Pressure) (16-30 Variable Pressure) (> 30 Variable Pressure)	IBLV F&T F&T F&T	F&T IBLV IBLV IBLV	3:1 2:1 at 1/2 psi differential 2:1 at 2 psi differential 3:1 at 1/2 max pressure differential
Finned Radiation & Pipe Coils (Constant Pressure) (Variable Pressure)	IB F&T	Thermostatic IBLV	3:1 for quick heating; 2:1 normally 3:1 for quick heating; 2:1 normally
Process Air Heaters (Constant Pressure) (Variable Pressure)	IB F&T	F&T IBLV	2:1 3:1 at 1/2 max pressure differential
Steam Absorption Machine Chiller	F&T	IB external air vent	2:1 at 1/2 psi differential
Shell and Tube Heat Exchangers, Pipe and Embossed Coils (Constant Pressure) (Variable Pressure)	IB F&T	DC or F&T DC or IBT (if > psi IBLV)	2:1 < 15 psi 2:1 at 1/2 psi 16-30 psi 2:1 at 2 psi > 30 psi 3:1 at 1/2 max pressure differential
Evaporator Single Effect and Multiple Effect	DC	IBLV or F&T	2:1, if load 50,000 lbs/hr use 3:1
Jacketed Kettles (Gravity Drain) (Syphon Drain)	IBLV DC	F&T or thermostatic IBLV	3:1 3:1
Rotating Dryers	DC	IBLV	3:1 for DC. 8:1 for IB constant pressure. 10:1 for IB variable pressure
Flash Tanks	IBLV	DC or F&T	3:1

Legend:

- IBLV = Inverted Bucket Large Vent
- IBCV = Inverted Bucket Internal Check Valve
- IB = Inverted Bucket
- IBT = Inverted Bucket Thermic Vent
- F&T = Float and Thermostatic
- DC = Differential Condensate Controller
- Thermo = Thermostatic

Note: Use an IB with external air vent above the F&T pressure limitations or if the steam is dirty. All safety factors are at the operating pressure differential unless otherwise noted.

Inspecting Traps

Only trained and qualified personnel should inspect and diagnose traps since each trap type has its own best method for inspection. Even when the best method is used, there is still some skill required to accurately assess a trap's condition. Inspectors develop a knack for diagnosis over time. Manufacturers often offer courses in trap inspection and maintenance and any serious trap program should include local personnel who are trained inspectors.

The three basic methods of inspection are:

- Sight
- Sound
- Temperature

Each of these methods work well with certain trap types and piping configurations. Of these three, *sight* is probably the most reliable method. Actually watching the discharge of a trap is the best way to determine if it is operating properly. This method is only possible on traps that are equipped with a discharge valve, all new installations should be piped this way. The only problem with this method is that the condensate when discharged will flash to steam. This can make it difficult to determine if live steam is escaping a failed trap or if condensate is flashing to steam from an operating trap. Only an experienced eye can tell the difference.

Listening to a trap through an ultra sonic listening device provides good information about its performance. This test used to be done by placing a screwdriver on the trap and the other end on the ear, or with an industrial stethoscope. The new listening devices have become quite affordable and filter out background noise. The only ambiguity involved is interpreting the sounds a trap makes. Each trap makes a different sound when it cycles or when it is passing steam through a worn valve seat. Chances for an incorrect diagnosis are high.

Temperature is the last method to use. Disk, bucket, and float traps all discharge condensate close to steam temperature so the trap temperature should be 5 to 10 percent below the steam temperature. If the trap is cold, there could be an obstruction in the pipe that is keeping condensate from reaching it. If the trap is somewhere in between in temperature, then it could be failed closed and backing condensate up. These rules are opposite for traps designed to discharge condensate at temperatures much lower than steam temperature, thermostatic traps for example.

The uncertainty is when the trap is hot. What does that mean? It could mean that the trap is failed open. Most often, inspectors will check the temperature upstream and downstream of the trap and assess operation by the difference in temperature. This is risky also since traps have different discharge cycle durations and the temperature difference can vary considerably depending on trap type.

Again NAVFAC MO-209 has a good section on trap inspection. There are pictures of flash steam and live steam that can help determine trap failure.

Economics

Cost of Traps

Trap cost varies according to line size, pressure rating, and features. For instance, an F&T trap could be as low \$40 for a low pressure, low load model with a cast iron body. The same manufacturer may have a high pressure, high load model with a stainless steel body for \$3,000. A reasonable estimate for most applications would \$50 to \$90.

Cost of Leaks

Table 4 shows steam loss through various orifice sizes. These numbers are based on steam at 100 psig venting to atmosphere. Note that if the condensate return system is at a pressure higher than atmospheric the loss will be slightly lower.

Table 4. Steam Loss Through Different Orifice Sizes

Orifice Diameter (inches)	Steam Loss (lb/hr)
1/2	845
1/4	210
1/8	55
1/16	13

Table 5 lists multipliers for other steam pressures.

Table 5. Multipliers for Steam Pressures

Pressure (psig)	Multiplier
15	0.26
50	0.56
150	1.43
200	1.87
300	2.74
600	5.35

To illustrate the cost of leaking traps, assume that a trap has a worn valve seat with a hole 1/8 inch wide. If the steam is at 15 psig and the condensate drains to the atmosphere, the loss would be:

$$55 \text{ lb/hr} \times 0.26 = 14.3 \text{ lb/hr}$$

Assume that the cost of steam is \$9/1,000 pounds. The cost of this leak per month would be:

$$14.3 \text{ lb/hr} \times 720 \text{ hr/month} \times \$9/1,000 \text{ lb} = \$93/\text{month}$$

Almost \$100 per month lost in one very small, low pressure trap. The same hole in a trap at 100 psig would cost about \$356/month. It is easy to see how high the cost of failed traps could be when considering there may be several hundred traps on a base. Some will have worn valve seats and others will have failed completely open, in either case the costs are high. Since the cost of traps is low and their expense is high when they fail, they pay back quickly when replaced.

FEMP energy project money cannot be used for projects covered by routine maintenance. ECIP MILCON money can be used for maintenance related items provided that there is some energy savings associated with the project. Steam traps are considered a maintenance issue and are not eligible for energy project funding when they have failed through normal wear. However, if a group of traps were misapplied or oversized they could be replaced as an energy project. Given the low cost of traps it would take quite a few to meet the

minimum funding levels of energy project money. Most often, trap replacement is funded through station operation and maintenance money (O&M).

Conclusion

Steam traps have always been a headache to facility managers. They are difficult to apply, size, and maintain. This TechData Sheet is only an introduction to a very complicated issue. In fact, many industrial facilities have gone to a group replacement strategy. All traps are replaced at a given year and are never tested. The best time to replace traps depends on the steam pressure and type of trap, but most facilities change their traps between 3 and 7 years.

The important thing to remember about steam traps is that they are big wasters of energy when not operating correctly and to ignore them would be missing out on large potential savings. A well planned and dynamic program for maintaining them can be worth the effort.

For more information on steam traps, contact *Mr. Mike Rocha*, ESC22, at (805) 982-3597, DSN: 551-3597, or Internet: mrocha@nfesc.navy.mil.