

New Text Document.txt

9 May 1997

This paper was downloaded from the Internet.

Distribution Statement A: Approved for public release;
distribution is unlimited.

POC: MITRE Corporation
ATTN: J. C. Moody



Time Division Multiple Access (TDMA) System

Description: A One-Step Approach to the Future VHF A/G System

J. C. Moody
MTR94W0000035
March 1994

Approved for public release, distribution unlimited
MITRE Corporation, McLean, Virginia

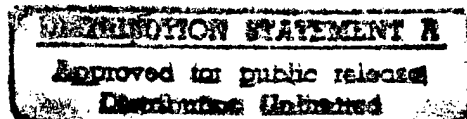

ABSTRACT

The current very high frequency (VHF) air/ground (A/G) communication system is based on Double Sideband Amplitude Modulation at a channel spacing of 25 kilohertz (kHz). Communications within this band for air traffic control communications is now almost entirely by voice. The system is approaching capacity in the high traffic density areas of Europe resulting in the need for a new more spectrum efficient radio architecture. European States favor transition to an analog "channel split" system. This paper describes an alternative approach wherein transition would proceed directly to a digital system. This digital system is based on a time division multiple access (TDMA) approach that maintains the current 25 kHz channelization. This alternative approach emphasizes near-term implementation of the voice function with data link functionality to follow later.

KEYWORDS: A/G communications, data link, TDMA, VHF radio, voice coding

TABLE OF CONTENTS

- 1 Introduction
 - 1.1 Basic Radio Characteristics of the TDMA System
 - 1.1.1 Radio Frequency (RF) and Modulation
 - 1.1.2 Timing Structure
 - 1.1.3 Transmit-Receive and Receive-Transmit Switching Time Requirements
 - 1.2 Achieving Flexibility in the TDMA System
 - 1.2.1 Radio Range
 - 1.2.2 Functional Capabilities Supported
 - 1.2.3 TDMA System Configurations
- 2 Voice Operation (Near-Term Implementation)
 - 2.1 Background
 - 2.1.1 Vocoder Operation
 - 2.1.2 Subchannel Bursts Supporting Voice-Only Operation
 - 2.2 Four Voice-Only Slots (System Configuration 4V)
 - 2.2.1 Application
 - 2.2.2 Circuit Initialization
 - 2.2.3 Voice Signalling
 - 2.3 Two Station Area Coverage (System Configuration 2V2S)
 - 2.3.1 Application
 - 2.3.2 Frame Structure and Time Reference Requirements for Ground Radio Sites
 - 2.3.3 Assignment of Slots
 - 2.3.4 DOC Geometry Requirements
 - 2.3.5 Circuit Initialization
 - 2.3.6 Ground System Transmitter Operation

DTIC QUALITY INSPECTED

19970513 019

- 2.3.7 Site Selection by Airborne Receiver
- 2.3.8 Airborne Transmitter Operation
- 2.3.9 Ground System Site Selection (Receiver Voting)
- 2.4 Coded Squelch Effect
 - 2.4.1 Cochannel Discrimination Offered by TDMA Signal Architecture
 - 2.4.2 Role of Coded Squelch in Increasing Tolerance to Cochannel Interference
 - 2.4.3 Coded Squelch Benefits
- 2.5 TDMA Voice Operation Summary

- 3 Discrete Addressed V/D Link
 - 3.1 Background
 - 3.1.1 Discrete Addressing and User Groups
 - 3.1.2 Subchannel Bursts Supporting Discrete Addressed V/D Operation
 - 3.2 Dedicated V/D Circuits (System Configuration 2V2D)
 - 3.2.1 Application
 - 3.2.2 Media Access Protocol
 - 3.2.3 Circuit Initialization
 - 3.2.4 Voice Operation
 - 3.2.5 Data Operation
 - 3.2.6 Connection Management
 - 3.3 Dedicated Voice/Shared Data (System Configuration 3V1D)
 - 3.3.1 Application
 - 3.3.2 Media Access Protocol
 - 3.4 Demand Assigned V/D (System Configuration 3T)
 - 3.4.1 Application
 - 3.4.2 Media Access Protocol
 - 3.5 Discrete Addressed V/D Summary

Appendix A Transmit-Receive and Receive-Transmit Switching Time Requirements
Glossary





Time Division Multiple Access (TDMA) System Description: A One-Step Approach to the Future VHF A/G System

J. C. Moody
MTR94W0000035
March 1994

Approved for public release, distribution unlimited
MITRE Corporation, McLean, Virginia
Table of Contents

SECTION 1 INTRODUCTION

European States in high traffic density areas of Western Europe have expressed a need for a new air/ground (A/G) radio system --operational by 1998--that increases voice circuit capacity. A channel split to 8.33 kilohertz (kHz) Double Sideband Amplitude Modulation (DSBAM) from the current 25 kHz DSBAM is currently favored by the affected European States. This is considered an "interim" solution resulting in what is referred to as a "two-step" approach to the target all-digital *voice or data* (V/D) very high frequency (VHF) radio system. Alternatives proceeding directly to the target all-digital system without an interim analog system have been referred to as the "one-step" approach as radio re-equipage (ground and airborne) occurs only once.

This paper describes an alternative one-step approach based on a Time Division Multiple Access (TDMA) signal-in-space architecture. The objective of this architecture is to support a spectrum efficient voice system to meet near-term needs for increased voice capacity, while providing a natural time-phased evolution toward a mixed V/D environment that maintains spectrum efficiency with increasing levels of data traffic. The remainder of this section is devoted to describing the TDMA system architectural framework: the physical layer characteristics of the system and the approach used to achieve operational flexibility. Section 2 address implementation of a voice-only TDMA system capability focused on meeting near-term needs for increased voice capacity. Finally, Section 3 addresses the evolution to discrete addressed V/D operation.

1.1 BASIC RADIO CHARACTERISTICS OF THE TDMA SYSTEM

1.1.1 Radio Frequency (RF) and Modulation

At the physical layer, the TDMA system architecture is completely consistent with that of the VHF Digital Link (VDL) standards activity now underway in the International Civil Aviation Organization (ICAO). This offers the dual benefit of: 1) simplifying the TDMA system standardization process since part of an existing standard will apply; and 2) of providing a path by which initial implementation of the voice capability can be upgraded to provide integrated data link communications. The physical layer characteristics relevant to the TDMA system description presented in this paper are as follows:

- Frequency Band: 118-137 megahertz
- RF Channelization: 25 kHz centers
- Channel Structure: Single frequency (for uplink and downlink)
- Modulation: Digital, non-coherent detection (3 bits per symbol)
- Aggregate channel rate: 31.5 kilobits per second (kbps) (10.5 k symbols/sec)
- Operating Modes: a dual mode backward compatible, with 25 kHz DSBAM

1.1.2 Timing Structure

All TDMA system operation is based on 120 millisecond (ms) *TDMA frames*. Each TDMA frame contains four 30 ms *slots*.(1) Each of these slots form the basis for an independent two-way A/G circuit capable of supporting two-way realtime V/D link applications. Each slot contains bursts for two independently accessed subchannels (Figure 1-1 (TDMA System Timing Hierarchy)). The first of these is a *management (M) subchannel* that carries system data for signalling and circuit initialization functions. The second is the V/D that carries user information. The following paragraphs describe the components and timing budget required for each of the two subchannel bursts. See Figure 1-2 for a depiction of the timing budget for the 30 ms slot.

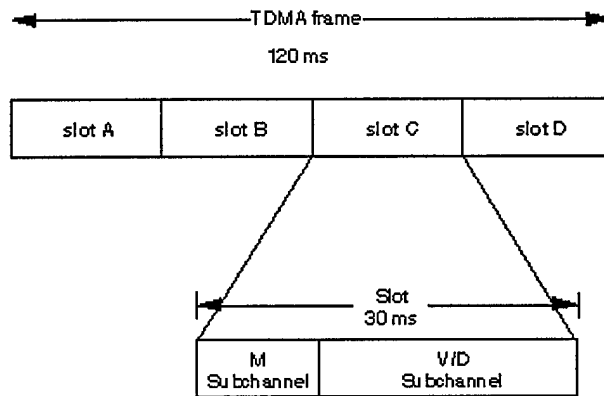

30 ms slot at 31.5 kbps (10.5 K symbol/sec)

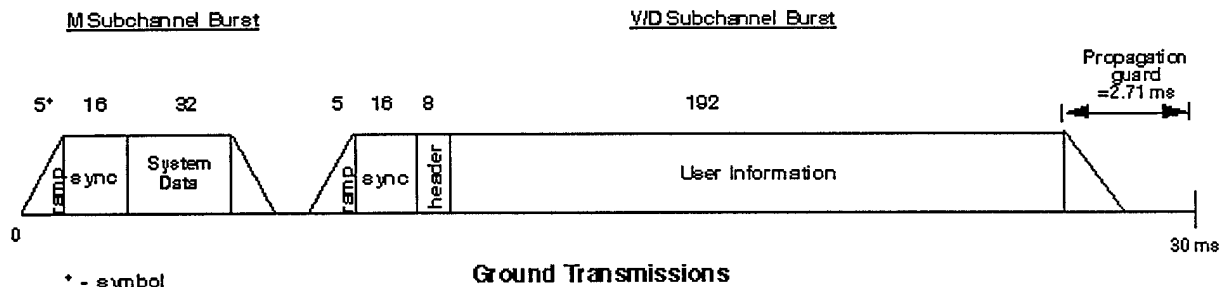
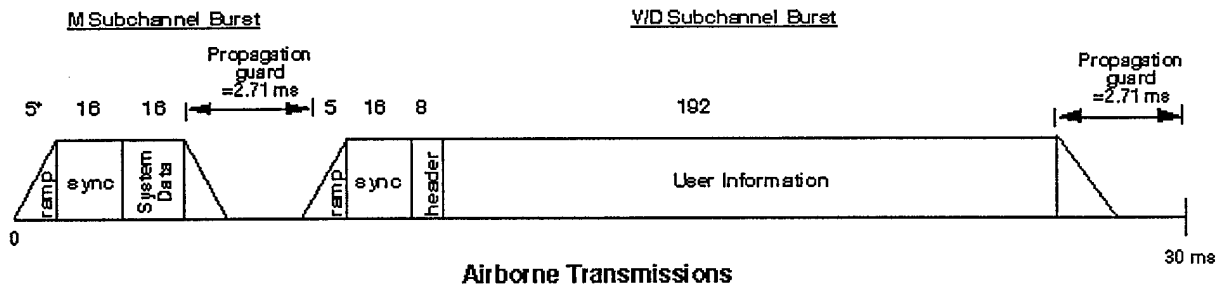

Figure 1-2. TDMA Timing Budget

1.1.2.1 Management Subchannel

The M subchannel format varies depending on whether the burst is an uplink transmission from the ground or a downlink transmission from an aircraft. In either case, there are four components that must be time-budgeted as follows:

1. Ramp up time: This allowance is 5 symbol periods.
2. Synchronization sequence: This allowance is 16 symbols.
3. System data: A one-half rate forward error correction code in blocks of 24 bits is employed. The uplink burst contains four 24 bit codewords for an allowance of 32 symbols; the downlink contains two 24 bit codewords for an allowance of 16 symbols.
4. Propagation guard time: The time available for this component determines the maximum operating range from the radio site and is dictated by the downlink transmission at maximum range. Beyond this range, round trip propagation delay could result in overlap between the subchannel bursts potentially resulting in interference. For the standard range configurations, the time allowed is 2.7 ms which supports ranges of up to 215 nautical miles (nmi) from the radio site. This maximum range of 215 nmi provides some margin in meeting the established range requirement of 200 nmi.

1.1.2.2 V/D Subchannel

The V/D subchannel format is consistent between uplink and downlink transmissions. In this case, there are five components that must be time-budgeted as follows:

1. Ramp up time: This allowance is 5 symbol periods.
2. Synchronization sequence: This allowance is 16 symbols.
3. Header field: A one-half rate forward error correction code block of 24 bits makes up this field. The allowance is 8 symbols.
4. User information: This represents the user payload for V/D traffic. The allowance is 192 symbols.
5. Propagation guard time: As was the case with the M subchannel, the time available for this component determines the maximum operating range from the radio site and will be dictated by downlink transmissions. Beyond this range, round trip propagation delay could result in overlap between slots potentially resulting in interference. For the standard range configurations, the time allowed is 2.7 ms which supports ranges of up to 215 nmi from the radio site.

Ramp up and down times of 5 symbol periods are allowed for spectral containment. However, ramp down times do not have to appear in the timing budget, since this time can overlap with the ramp up time of the subsequent burst.

1.1.3 Transmit-Receive and Receive-Transmit Switching Time Requirements

The TDMA timing structure places requirements on the radio hardware relative to the time allowed for the airborne transceiver to switch from transmit to receive and vice versa. Appendix A shows all the possible switching scenarios that will be encountered by the airborne transceiver in the four slot, standard range system configurations and the most stringent switching time. (Appendix A assumes the reader is familiar with the use of the management subchannels as described in Sections 2 and 3.) This time corresponds to the round trip propagation guard time. Therefore the switching must occur within 2.7 ms.

1.2 Achieving Flexibility in the TDMA System

1.2 Achieving Flexibility in the TDMA System

A key attribute of the TDMA system architecture is the flexibility to accommodate a range of operational requirements through a set of predefined *system configurations*. These system configurations provide the flexibility to tailor the ground station to specific requirements for operating range and functional capability desired by the Civil Aeronautics Administration (CAA) or a service provider. A given system configuration is established on a static basis within the ground radio and communicated to the airborne radios as initialization information in the M subchannel uplink. This enables airborne radios to adapt to differing ground system configurations in a manner completely transparent to the users. The concept of system configurations is discussed further in Section 1.2.3.

1.2.1 Radio Range

In the timing budget, guard times are required to compensate for propagation delay. In order to reach the best trade-off of spectrum efficiency and flexibility, system configurations supporting different operational ranges have been established. *Standard range* system configurations support four slots per TDMA frame. These configurations support operational ranges of up to 215 nmi from the ground radio site and should satisfy the majority of A/G communication requirements. *Extended range* system configurations of three slots would be used in cases where longer range is required.

1.2.2 Functional Capabilities Supported

Two basic levels of functional capability have been defined for the system as follows:

1. Voice-only operation: This level allows CAAs to immediately obtain the benefit of maximum voice circuit capacity increase with minimal ground infrastructure investment (limited to upgrades at the ground radio site). With additional logic functions in the ground radio, signalling capability that enforces a channel access protocol to help mitigate the problems of "stuck microphone" and "walk-on" can be implemented at this level if desired. Additionally, at this level, a system configuration has been defined that supports two station area coverage site diversity operation.
2. Discrete addressed V/D applications: This is the level that would be implemented when discrete addressing and data link functionality is desired and can be supported by the air traffic control (ATC) infrastructure. In this configuration, one or more of the four 30 ms time slots are reserved for data link traffic. Within this level, several system configurations exist that support various combinations of V/D link capacity.

1.2.3 TDMA System Configurations

Within the fixed 120 ms TDMA frame structure, a predefined set of system configurations are established to achieve flexibility. Each system configuration corresponds to a specific preconfigured static allocation of the capacity of each 25 kHz frequency (i.e., individual time slots) to certain users and functions. In the ATC environment, distinct *user groups* exist based on ATC control positions or sectors. Each user group includes the ground user (usually an air traffic controller) and the "client" aircraft of that ground user. A fundamental objective of the TDMA system is to provide voice circuit resources to each user group on a dedicated basis while simultaneously providing access to data link with a single airborne radio transceiver.

Additionally, one configuration is defined where there is no predetermined static allocation of resources within the 25 kHz channel; resource allocations for both V/D are made strictly on a demand basis. This configuration is established for non-ATC applications and possibly for ATC applications in the long-term future where voice traffic volume is reduced significantly through the use of data link.

The system configuration established for a ground radio is communicated to the airborne radios through an initialization message contained in the M subchannel uplink. Airborne radios, therefore, "sense" and adapt to the system configuration of the ground radio with which communications will be established. This adaptation to the proper system configuration is completely transparent to the users.

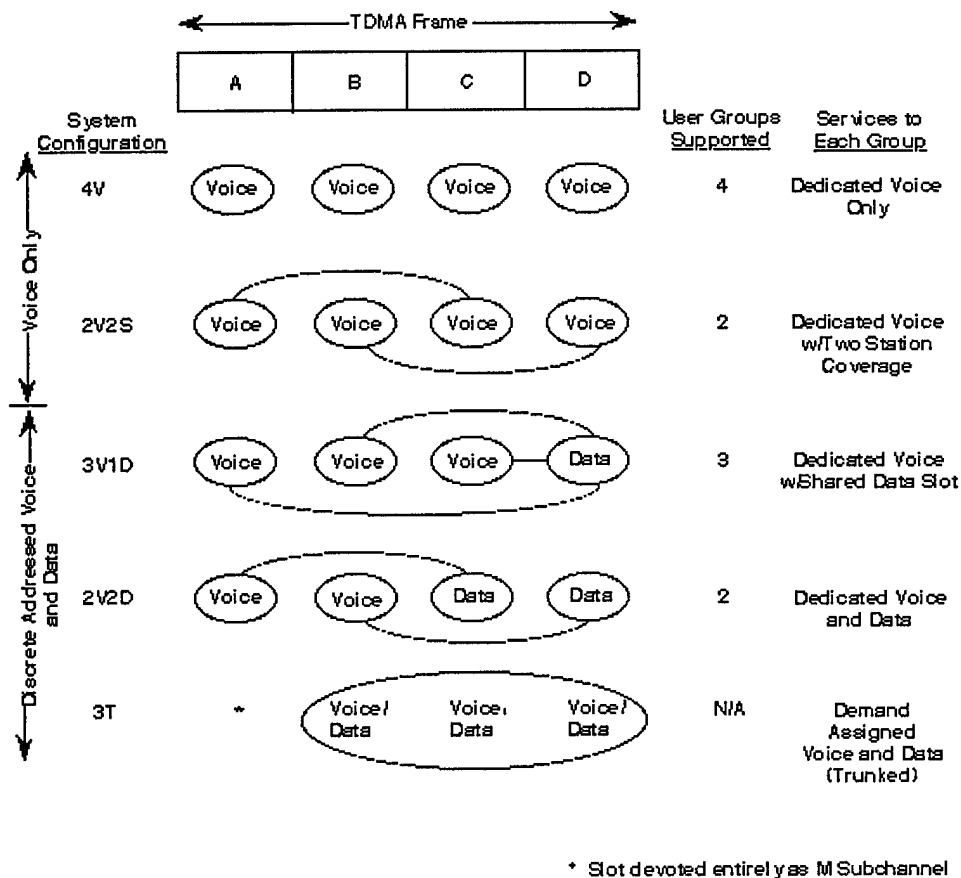

Figure 1-3. TDMA System Configurations (Standard Range)

Figure 1-3 shows the system configurations for the standard range--four slot frame. A similar but more limited range of configurations exist for the extended range--three slot frame. Other system configurations could be readily defined and supported to meet specialized requirements if needed. The five configurations described here are believed to be representative of CAA or service provider requirements. An overview of the application of each system configuration is discussed in the paragraphs to follow.

1.2.3.1 System Configuration "4V"

This configuration is used where increased voice circuit capacity is required, and discrete addressing and data link is not required. Four user groups are each provided dedicated voice slots from a single radio site.

1.2.3.2 System Configuration "2V2S"

This configuration has been established primarily for use where increased voice circuit capacity is required with two station coverage. Discrete addressing and data link is not supported. Two user groups are allocated dedicated voice slots with two station coverage for each group.

1.2.3.3 System Configuration "3V1D"

This configuration is used where increased voice circuit capacity and limited discrete addressed data link capacity is required. This configuration supports three user groups, each with dedicated voice slots but sharing a common data slot.

1.2.3.4 System Configuration "2V2D"

This configuration is used where increased voice circuit capacity and high discrete addressed data link capacity is required. This configuration supports two user groups, each allocated a dedicated V/D slot.

1.2.3.5 System Configuration "3T"

This configuration is used when user group boundaries are not required. This configuration provides access to V/D with a centralized demand access across the entire channel resource. This configuration, therefore, provides full trunking efficiency of the 25 kHz channel. This configuration is therefore referred to as "3T" since *three slots* are used in a *trunked* mode where any slot is dynamically allocated to V/D on demand to any user on the channel. This configuration is intended primarily for use where voice access time requirements can be relaxed.





Operational Impacts of Air Carrier Access to the Aircraft Situation Display (ASD)

Thor R. Abrahamsen

Andrew R. Lacher

Stephanie B. Fraser

MTR 94W000090

November 1994

Approved for public release, distribution unlimited

MITRE Corporation, McLean, Virginia

Abstract

The MITRE Corporation's Center for Advanced Aviation System Development (CAASD) was tasked by the Research and Development Service (ARD) of the Federal Aviation Administration (FAA) to assess the operational impact of air carrier access to the FAA's Aircraft Situation Display (ASD). The results of this study are documented in this report and can be categorized in two areas: the impact on the FAA/air carrier relationship and the impact on air carrier internal decision making. These results are based on information collected from both FAA and air carrier operations personnel. This report also contains recommendations for follow-on actions intended to benefit the air traffic flow management process and the aviation industry.

Suggested Keywords: Aircraft Situation Display (ASD), Enhanced Traffic Management System (ETMS), Air Carrier Operations, Collaborative Decision Making, Traffic Flow Management (TFM).

Acknowledgements

This study would not have been possible without the cooperation of operations personnel at the Federal Aviation Administration (FAA) and the air carriers. We would like to thank the supervisors and staff who took the time to complete our surveys, welcomed us as visitors, and patiently answered our questions. We also appreciated the help of the FAA Regional Offices that distributed our surveys to the Air Route Traffic Control Centers (ARTCCs).

In addition, we would like to thank the following individuals: Bill Sears (Air Transport Association) for reviewing the air carrier surveys and for providing us with the right air carrier contacts; Don Eddy (FAA) for contributing his thoughts and for facilitating our Air Traffic Control System Command Center (ATCSCC) visit; Tim Flemming (FAA) for reviewing our surveys and facilitating our ARTCC visits; and Steve Alvania (FAA), who defined and supported this study.

We would also like to convey our appreciation to the following MITRE staff: Don Bull for his air carrier expertise and his help in reviewing our surveys and this report; Joe Sinnott for his insights and comments; Dr. Gary Klein for his thorough review; Sherrie Cherdak for her Enhanced Traffic Management System expertise; Doyle Peed and Rodney Simmons for their technical inputs; Diane Boone, Dr. Gail Walker, and Scott Bayles for their assistance in conducting field visits; and Elizabeth May for assistance in the production of the report.

Table of Contents

- 1 INTRODUCTION
 - 1.1 BACKGROUND
 - 1.2 PURPOSE
 - 1.3 SCOPE
 - 1.4 AUDIENCE
 - 1.5 REPORT ORGANIZATION
- 2 ASD AND THE AIR CARRIERS
 - 2.1 ENHANCED TRAFFIC MANAGEMENT SYSTEM (ETMS) BACKGROUND
 - 2.2 ASD AVAILABILITY AT THE AIR CARRIERS
- 3 ANALYSIS APPROACH
 - 3.1 OVERVIEW
 - 3.2 AIR CARRIERS
 - 3.2.1 Survey
 - 3.2.2 Operations Center Visits
 - 3.3 FAA
 - 3.3.1 Survey
 - 3.3.2 Facility Visits
- 4 ASD INTEGRATION INTO AIR CARRIER OPERATIONAL SYSTEMS
 - 4.1 AIR CARRIER POSITIONS USING ASD
 - 4.2 AIR CARRIER CUSTOMIZED IMPLEMENTATIONS
- 5 IMPACT ON FAA/AIR CARRIER RELATIONSHIP
 - 5.1 FAA PERSPECTIVE
 - 5.1.1 ASD's Impact
 - 5.1.2 FAA/Air Carrier Collaboration on Traffic Flow Management Decisions
 - 5.2 AIR CARRIER PERSPECTIVE
- 6 IMPACT ON AIR CARRIER INTERNAL OPERATIONS
 - 6.1 DIVERSIONS
 - 6.1.1 Avoidance of Diversions
 - 6.1.2 Better Diversion Management
 - 6.2 SEVERE WEATHER REROUTES
 - 6.3 FUEL-EFFICIENT ROUTES
 - 6.4 AIRPORT (HUB) OPERATIONS
 - 6.5 FLIGHT FOLLOWING
 - 6.6 FLAG STOPS
 - 6.7 COMMUTER CARRIER COMMUNICATIONS
 - 6.8 ANTICIPATED APPLICATIONS
- 7 DESIRED ASD INTERFACE ENHANCEMENTS
 - 7.1 ADDITIONAL DATA
 - 7.1.1 Position Updates for Terminal Areas
 - 7.1.2 Position Reports for GA Aircraft
 - 7.1.3 Oceanic Position Updates
 - 7.1.4 Real-Time Indication of Airport Configurations and Airport Acceptance Rate
 - 7.1.5 Real-Time Indication of Saturated Sectors
 - 7.1.6 Integrated Weather
 - 7.1.7 Real-Time Indication of En Route Restrictions and Severe Weather Avoidance
 - 7.2 FUNCTIONAL ENHANCEMENTS
 - 7.2.1 FAA ASD Software Enhancements
 - 7.2.2 Reliability Improvements
 - 7.2.3 Increased Update Rate
- 8 SUMMARY AND CONCLUSIONS
 - 8.1 FAA/AIR CARRIER RELATIONSHIP
 - 8.2 AIR CARRIER INTERNAL OPERATIONS
- 9 RECOMMENDATIONS

LIST OF REFERENCESAppendix A AIR CARRIER SURVEYAppendix B FAA SURVEYGLOSSARY

EXECUTIVE SUMMARY

INTRODUCTION

In February 1992, the Federal Aviation Administration (FAA) and the Air Transport Association of America (ATA) entered into a Cooperative Research and Development Agreement (CRDA) to release Aircraft Situation Display (ASD) and associated real-time operational data to the air carrier industry. The purpose of the CRDA is as follows:

- Establish a "mechanism by which the ASD flow management data can be provided to commercial operators" (CRDA, 1992, p. 2).
- Establish a "forum through which FAA and those [i.e., commercial] operators can work cooperatively to identify effective applications and extensions of the ASD flow management data that will benefit the ATC [air traffic control] flow management process" (CRDA, 1992, p. 2).
- Evaluate "the degree to which ASD data is of value to the aviation industry" (CRDA, 1992, p. 1).

As part of this effort, the FAA's Research and Development Service (ARD) requested that The MITRE Corporation's Center for Advanced Aviation System Development (CAASD) conduct a study to determine the operational impact of air carrier access to ASD. This study is part of a larger effort, coordinated by ARD, to examine the potential for increased information exchange and interaction among the FAA and the air carriers.

Initially, 6 air carriers entered into the agreement in September 1992 and began receiving real-time ASD data shortly thereafter. As of this writing, 13 air carriers have signed the agreement, and 11 have an operating ASD interface.

As part of the CRDA, the FAA agreed to provide a reduced-capability version of ASD to the air carriers (e.g., Monitor Alert [M/A] and list count features were not provided). The real-time data provided is limited to commercial air carrier and air taxi flight operations, including position updates, and departure and arrival messages. Because of national security and privacy issues, the FAA does not provide information (e.g., position updates) for general aviation or military flights. In addition, the FAA is unable to provide Official Airline Guide or real-time weather data.

ANALYSIS APPROACH

For this study, data collection and analysis concentrated on the operational impacts of air carrier access to ASD in two areas:

- FAA/air carrier relationship
- Air carrier internal operations

Data collection and analysis was mainly qualitative, focusing on anecdotes and perceptions, rather than on quantitative information. This was due primarily to the lack of quantitative

data from the air carriers: in general, the air carriers did not perform formal quantitative analyses to support their internal justification of ASD acquisition or development.

To collect information, the study team distributed two written surveys to FAA and air carrier operations personnel. In addition, the team made a number of visits to FAA and air carrier facilities to observe operations and interview the operations personnel.

ASD INTEGRATION INTO AIR CARRIER OPERATIONAL SYSTEMS

The CRDA not only provided an opportunity for the air carriers to receive real-time ASD data, but also contained provisions for distribution of the FAA-developed ASD software. Several air carriers initially used the FAA software. However, since this software runs under the DOMAIN operating system on specialized hardware (Hewlett-Packard Apollos), most of the air carriers were unable to distribute ASD widely within their operations centers. They did not want to bear the cost of purchasing large numbers of additional computer workstations and the burden of placing new equipment in already crowded workspaces. Thus, most of the carriers either have developed or plan to develop customized ASD applications that are integrated with their existing automation, eliminating the need to operate the FAA version. Also, integrating ASD data with existing automation systems offers an opportunity for consistency among applications and user interfaces, and for better integration with other information sources and internal databases. Since each air carrier has a preferred computing environment, the air carriers have created ASD applications for a variety of platforms, including Macintosh, PC-DOS, and UNIX.

At most of the air carriers, ASD was first made available to system operations control center personnel, who act as liaisons to the FAA. As the air carriers' customized applications develop, ASD is being made available to additional positions, mainly flight dispatchers. The number of work positions currently using ASD at the various air carriers ranges from 1 to over 60.

IMPACT ON FAA/AIR CARRIER RELATIONSHIP

In response to the surveys and during interviews, both the air carriers and some FAA operations personnel noted a benefit from everyone's being able to view the same information. In general, the study team found that FAA "fears about [air carriers] 'second guessing' [the FAA by using ASD] did not materialize." Most FAA operations personnel reported no "observable detriment" due to air carrier access to ASD.

The air carriers indicated that they now have more knowledge about system operations, and now feel on a more equal footing with the FAA in conducting negotiations.

IMPACT ON AIR CARRIER INTERNAL OPERATIONS

The most significant impact of air carrier access to ASD has been on the carriers' internal decision making. Overall, ASD is seen as a valuable resource not only in helping to reduce costs, but also in increasing confidence in the decisions being made. Almost all air carriers receiving ASD have incorporated it into their decision-making process in a short period of time. ASD is being used in the following manner:

- Avoid and better manage diversions.
- Avoid severe weather.
- Plan more fuel-efficient routes.
- Manage ground operations at airports.
- Follow flight progress.

- Determine possibility of flag stops.
- Coordinate with commuter carrier and express partners.

Based on data provided by the air carriers, it can be concluded that these uses of ASD help the air carriers reduce operating costs by millions of dollars a year.

DESIRED ASD ENHANCEMENTS

During this study, potential enhancements to the FAA's ASD interface were examined, in terms of both additional data and additional functionality. Both the FAA and the air carriers were asked to suggest enhancements to the ASD interface. In addition, FAA operations personnel were asked to comment on enhancements suggested by the air carriers.

When asked about additional data that could be included on the ASD data stream, the air carriers made several suggestions for information related to both traffic flow management and air traffic control. There was fairly high consistency across the air carriers in the requests for various data items. Each of the following data items was requested by several air carriers:

- Position updates for terminal areas
- Position reports for general aviation aircraft
- Oceanic position updates
- Real-time indication of airport configurations and airport acceptance rates
- Real-time indication of saturated sectors
- Integrated weather
- Real-time indication of en route restrictions
- Real-time indication of severe weather avoidance routes in use

In general, FAA operations personnel were supportive of the air carriers receiving terminal area and oceanic updates as this information becomes part of the Enhanced Traffic Management System (ETMS). There was a difference of opinion on whether the air carriers should receive general aviation aircraft position reports, the majority believing that they should not. Most operations personnel suggested that the other information requested by the air carriers is already being shared sufficiently through FAA advisory messages.

The air carriers also expressed a desire for additional functional enhancements to the FAA's ASD interface, such as improved reliability and an increase in the update rate for aircraft position reports.

SUMMARY AND CONCLUSIONS

ASD's specific impact is difficult to quantify, and therefore most of the findings documented in this report were drawn from qualitative information. In general, air carrier access to ASD should be viewed as an overall success. As documented in this report, ASD has had a positive effect in both of the areas examined--the FAA/air carrier relationship and air carrier internal operations. Access to ASD is providing the air carriers with a valuable service they did not previously have. The carriers are using ASD to make better decisions, thereby reducing their operating costs, as well as helping to foster a better working relationship with the FAA. In general, the FAA reports that the air carriers are not using ASD in a negative fashion or for evaluating FAA decisions.

RECOMMENDATIONS

Given the positive effect of ASD access on both the FAA/air carrier relationship and air carrier internal operations, the FAA should provide ASD to the air carriers as a permanent

service. To that end, it is recommended that the FAA do the following:

- Explore the feasibility and impact of providing the desired enhancements summarized above and detailed in Section 7 of this report.
- Investigate techniques for ensuring the reliability of the ASD data feed.
- Explore a mechanism by which air carriers using FAA software can receive updated versions of the software.
- Investigate the configuration management issues associated with continuing an ETMS version 4.2.5 interface with the air carriers while the FAA moves towards version 5.0.
- Since the air carriers' use of ASD continues to evolve, and the number of air carriers receiving ASD is expected to increase, continue to monitor the impact of air carrier access.
- Continue to investigate the two-way exchange of operational information between the air carriers and the FAA. ASD would be one component of this exchange.
- Define and implement a permanent institution responsible for providing ASD data.





Operational Impacts of Air Carrier Access to the Aircraft Situation Display (ASD)

Thor R. Abrahamsen

Andrew R. Lacher

Stephanie B. Fraser

MTR 94W0000090

November 1994

Approved for public release, distribution unlimited

MITRE Corporation, McLean, Virginia

Table of Contents

SECTION 1 INTRODUCTION

1.1 BACKGROUND

In the mid-1980s, the Aircraft Situation Display (ASD) was developed by the Federal Aviation Administration (FAA) and the Department of Transportation's Volpe National Transportation System Center (VNTSC) as a prototype strategic planning tool to assist in the management of traffic flows within the National Airspace System (NAS). ASD depicts the geographical positions of all aircraft operating on instrument flight plans in the en route environment. In addition, it provides aircraft identity data blocks, map data (boundaries, airways, jet routes, navigational aids [NAVAIDS], airports, fixes, and special use airspace [SUA]), zoom, and filter selection features. Developed originally as a prototype, the system was declared operational in the late 1980s and is part of the Enhanced Traffic Management System (ETMS).

In February 1992, the FAA and the Air Transport Association of America (ATA) entered into a Cooperative Research and Development Agreement (CRDA) to release ASD and associated real-time operational data to the air carrier industry. The purpose of the CRDA is as follows:

- Establish a "mechanism by which the ASD flow management data can be provided to commercial operators" (CRDA, 1992, p. 2).
- Establish a "forum through which FAA and those [i.e., commercial] operators can work cooperatively to identify effective applications and extensions of the ASD flow management data that will benefit the ATC [air traffic control] flow management process" (CRDA, 1992, p. 2).
- Evaluate "the degree to which ASD data is of value to the aviation industry" (CRDA, 1992, p. 1).

Initially, 6 air carriers entered into the agreement in September 1992 and began receiving real-time ASD data shortly thereafter. As of this writing, 13 air carriers have signed the agreement, and 11 have an operating ASD interface.

1.2 PURPOSE

As part of the effort to evaluate the degree to which ASD data is of value to the aviation industry, the FAA's Research and Development Service (ARD) requested that The MITRE Corporation's Center for Advanced Aviation System Development (CAASD) conduct a study to determine the operational impact of air carrier[1] access to ASD. Specifically, CAASD was tasked to do the following:

- Evaluate the usefulness of providing ASD data directly to air carriers.
- Identify effective applications and extensions of ASD data exchange.
- Recommend follow-on courses of action that will benefit the air traffic flow management process and the aviation industry.

This study is part of a larger effort, coordinated by ARD, to examine the potential for increased information exchange and interaction between the FAA and the air carriers.

1.3 SCOPE

This report documents the impacts of providing ASD access to the air carriers in two categories: (1) how access has affected the FAA/air carrier relationship, and (2) how it has affected air carrier internal operations. In addition, this report summarizes enhancements to the current air carrier ASD interface suggested by both FAA and air carrier personnel.

In 1992, a similar study was conducted by VNTSC to determine the current and projected impact of the FAA's use of ETMS and ASD on the overall operations of the NAS. That study, performed prior to ASD's availability to the air carriers, examined the "benefits accrued by the airlines, airline passengers, and the FAA, based on current and projected operations of the ASD and [Monitor/Alert]" (Goeddell, et al., 1992).

1.4 AUDIENCE

This document is intended for personnel involved with FAA system development and traffic flow management (TFM) operations, as well as for air carrier operations personnel. The reader is assumed to have some knowledge of ASD, TFM, and air carrier operations. Additional information concerning air carrier operations is provided in Lacher and Klein (1993). More information about ASD and ETMS can be obtained from the ETMS System Description (VNTSC, 1994).

1.5 REPORT ORGANIZATION

Section 2 provides an overview of ETMS and ASD; in addition, it describes the version of ASD made available to the air carriers. Section 3 describes the approach used in conducting this assessment. Section 4 describes how the air carriers have integrated ASD into their operational systems. Section 5 documents how air carrier access to ASD has impacted the relationship between the FAA and the air carriers, and Section 6 describes how it has impacted the air carriers' internal operations. Section 7 details the desired enhancements to ASD recommended by FAA and air carrier personnel. Section 8 presents a summary and conclusions, while Section 9 lists recommended follow-on actions that would benefit both the air traffic flow management process and the aviation industry. Following the list of references, Appendix A provides the survey distributed to the air carriers, and Appendix B the survey distributed to FAA personnel. The report ends with a glossary of acronyms.



Operational Impacts of Air Carrier Access to the Aircraft Situation Display (ASD)

Thor R. Abrahamsen

Andrew R. Lacher

Stephanie B. Fraser

MTR 94W000090

November 1994

Approved for public release, distribution unlimited

MITRE Corporation, McLean, Virginia

Table of Contents

SECTION 2 ASD AND THE AIR CARRIERS

2.1 ENHANCED TRAFFIC MANAGEMENT SYSTEM (ETMS) BACKGROUND

ASD is one of five functional components of the ETMS. Its purpose is to display graphically aircraft positions within the contiguous United States (CONUS) relative to National Airspace System (NAS) resources, such as airports, NAVAIDs, and routes. Using ASD, flights can be selectively displayed and color coded by characteristics such as aircraft type, arrival airport, and flight level. Filed flight plans can also be displayed. An example ASD display is shown in Figure 2-1. This example depicts only those flights arriving into six specified airports. These flights are color coded by arrival airport as follows: arrivals into Chicago O'Hare International (ORD) airport are shown in white, arrivals into Miami International (MIA) airport in yellow, arrivals into Dallas/Fort Worth International (DFW) airport in light blue, arrivals into Los Angeles International (LAX) airport in red, arrivals into Seattle-Tacoma International (SEA) airport in green, and arrivals into Stapelton International (DEN) airport in purple.

In addition to aircraft position data, ASD can display dynamic weather data, including lightning strikes, precipitation radar returns, and winds aloft. Static map data such as jet routes, sector boundaries, NAVAIDs, and airports can also be displayed. ASD is enhanced by the ability to create a textual list of aircraft that satisfy selection criteria such as destination, origin, or aircraft type.

Other ETMS functionality is available or planned via ASD. Monitor/Alert (M/A) identifies times when demand on sectors (and fixes) exceeds capacity. The remaining ASD components--Automated Demand Resolution, Strategy Evaluation and Recommendation, and Directive Distribution Function--are not yet implemented, but will rely on M/A to detect imbalances.

ETMS was initially deployed at the Air Traffic Control System Command Center (ATCSCC) in 1987. Traffic Management Units (TMUs) in all 20 CONUS Air Route Traffic Control Centers (ARTCCs) and in some larger Terminal Radar Approach Control (TRACON) facilities now have ASD/ETMS. Typically, ETMS and ASD functions are used to monitor traffic flows and to aid traffic managers[2] in strategic planning. ETMS receives

position report updates every 5 minutes from the host computers located at each of the 20 CONUS ARTCCs, as well as data for the Anchorage and Honolulu ARTCCs. Currently, version 4.3 is in use by the FAA, with version 5.0 planned for implementation in early 1995.

2.2 ASD AVAILABILITY AT THE AIR CARRIERS

The air carriers requested access to ASD during the late 1980s. This request was finally granted with the creation of the CRDA between the FAA and the ATA in 1992.

Prior to enactment of the CRDA, FAA traffic managers and their administrative management expressed concern that the air carriers would use ASD data to evaluate FAA decisions related to TFM, and would use ASD to usurp FAA TFM authority. Thus, any air carrier wishing to receive a real-time ASD data feed is required to agree to certain "ground rules for non-FAA use of ASD," as stated in the CRDA:

- "ASD data shall not be used for repositioning aircraft to gain a competitive advantage over other aircraft displayed on the ASD" (CRDA, 1992, Appendix A, p. vii).
- "The FAA bears sole responsibility for the management of all air traffic in the NAS" (CRDA, 1992, Appendix A, p. vii).
- "ASD data is shared with non-FAA users as a planning tool to augment other available operational information, but is not intended to abridge the FAA's system management mandate or share its associated responsibilities" (CRDA, 1992, Appendix A, p. vii).
- "All traffic data is not provided [i.e., no military and GA] . . . therefore, judgements based on the ASD as an operational evaluation tool may be incomplete when attempting to validate miles-in-trail restrictions, arrival spacing, capacity-related rerouting, or displayed demand versus traffic management program acceptance rates." (CRDA, 1992, Appendix A, p. vii).
- "[N]o conclusions should be drawn about overall strategies being used by field facilities or the ATCSCC to manage flows of traffic." (CRDA, 1992, Appendix A, p. vii).
- ". . . critiques and discussion must be addressed at the administrative level to prevent impact to the operational air traffic system. Feedback must be channeled through the FAA's chain of command . . ."[3] (CRDA, 1992, Appendix A, p. iv).
- ". . . ASD position data is provided to augment other available flight information and is not intended to replace or change existing requirements of FAR Part 121 or 135 for flight operations and monitoring flight progress" (CRDA, 1992, Appendix A, p. viii).

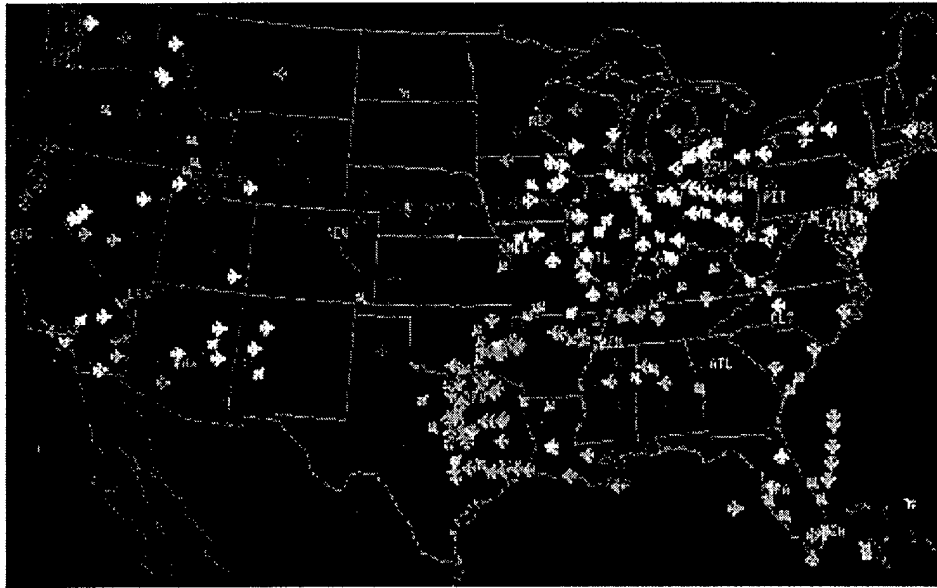

- White = Arrivals into Chicago O'Hare (ORD)
- Yellow = Arrivals into Miami International (MIA)
- Blue = Arrivals into Dallas/Ft. Worth International (DFW)
- Red = Arrivals into Los Angeles International (LAX)
- Green = Arrivals into Seattle-Tacoma International (SEA)
- Purple = Arrivals into Stapleton International (DEN)

Figure 2-1. An Example ASD Display

If an air carrier fails to comply with the above ground rules, it can lose its access to ASD data.

As part of the CRDA, the FAA agreed to provide the air carriers with a reduced-capability version of ASD. Specifically, the FAA agreed to provide the following:

- **Real-Time Data Stream:** The real-time data provided is limited to commercial air carrier and air taxi flight operations, including position updates, and departure and arrival messages. Because of national security and privacy issues, the FAA does not provide information (e.g., position updates) regarding general aviation (GA) or military flights. Moreover, because of licensing limitations, the FAA is unable to provide Official Airline Guide (OAG) or real-time weather data. Specifically, the FAA provides the flight information listed below for all commercial air carrier and air taxi flight operations:
 - Aircraft identification
 - Aircraft type
 - Altitude
 - Ground speed
 - En route time
 - Latitude and longitude (current)
 - Origin and destination
 - Route of flight (along with the ability to display route of flight graphically)
- **Display Software:** In addition to the real-time data stream, the FAA has made available a specialized version of the ETMS software (corresponding to version 4.2) that contains a subset of the features available to the FAA. M/A and list count features are not provided. ASD features provided to the air carriers include the following: (1) a graphical user interface; (2) the ability to draw range rings; and (3) the ability to

display airports, NAVAIDs, fixes, center boundaries, SUAs, and airways.

- **ASD Documentation:** The FAA also agreed to provide documentation including an operator's handbook, training materials, data rates, protocols, message formats, source code for ASD version 4.2, and update information regarding any subsequent changes to the ASD data stream.

The FAA has created a single ASD data interface to the ATA. The FAA is responsible for continued maintenance of the hardware, software, and other related equipment necessary to support its side of this interface. ATA, in turn, has contracted with a telecommunications service provider for multiplexing and data communications services to distribute the ASD data to participating air carriers. Air carriers who choose to receive ASD need to do the following:

- Agree to the FAA ground rules by signing the CRDA.
- Contract with the telecommunications service provider to pay for the communications link from the multiplexer to the air carrier's demark point.
- Provide computer hardware to receive the ASD data stream and run the FAA-provided ASD software.

In addition to obtaining the FAA version, many air carriers have developed their own versions of ASD software, using the real-time data stream provided by the FAA. Air carrier implementations are discussed in more detail in Section 4.2.





Operational Impacts of Air Carrier Access to the Aircraft Situation Display (ASD)

Thor R. Abrahamsen

Andrew R. Lacher

Stephanie B. Fraser

MTR 94W000090

November 1994

Approved for public release, distribution unlimited

MITRE Corporation, McLean, Virginia

Table of Contents

SECTION 3 ANALYSIS APPROACH

For this study, data collection and analysis concentrated on the impacts of air carrier access to ASD in two operational areas:

- FAA/air carrier relationship
- Air carrier internal operations

Data collection and analysis was mainly qualitative, focusing on anecdotes and perceptions rather than on quantitative information. This was due primarily to the fact that not much quantitative data was available. The air carriers participating in this study did not perform formal quantitative analysis to support their justification for ASD acquisition or development because the anticipated benefits seemed obviously to outweigh the costs. Thus the carriers relied more on their own intuition to justify ASD. Some air carriers, however, have indicated that they intend to conduct formal quantitative analyses in the future.

Another reason for focusing on qualitative benefits was that in general, the air carriers continue to make the same kinds of decisions they made before acquiring ASD, though they now have more information available on which to base those decisions. It is thus difficult to quantify how having more information impacts air carrier decision making because the additional information is not used independently of other information sources.

The air carriers are still discovering new uses for ASD and expanding their customized implementations, thus increasing the potential benefits. It is anticipated that the subject of this study will be revisited again in the future.

This section briefly summarizes the approach used by the study team for data collection and analysis.

3.1 OVERVIEW

Data for this study was initially collected through two different written surveys: one for the air carriers currently receiving ASD and another for the FAA. The multipage surveys were distributed by U.S. mail and returned by either facsimile or mail. Site visits to some air carrier operations centers and FAA facilities were conducted to ask follow-up questions.

These visits gave the study team an opportunity to view both air carrier and FAA operations and the role ASD plays in supporting those operations. Some interviews were conducted over the telephone with air carrier personnel in cases where a visit was not possible. In addition, the study team visited the ATCSCC to conduct in-depth interviews with operational personnel. The following subsections describe the air carrier and FAA surveys and site visits.

3.2 AIR CARRIERS

A survey was sent to the 11 air carriers that currently receive ASD, listed in Table 3-1. The table also indicates the status of the survey responses and the completion of site visits.

Table 3-1. Survey Response and Site Visits

Air Carrier	Survey Status	Field Visit Status
Airborne Express	Received	
American Airlines	Received*	Completed
Continental Airlines	Received	Completed
Delta Airlines	Received	Completed
Federal Express	Received	
Kittyhawk Aircargo	Received	Completed
Northwest Airlines	Received	Completed
Southwest Airlines	Received	Completed
United Airlines	Received	Completed
United Parcel Service	Not Received	
US Air	Received	

* During a field visit, the study team reviewed the survey in detail with multiple operations personnel who had individually completed the survey. A formal written response combining all of the individual inputs was not returned to CAASD by the carrier.

During the time this study was being conducted, two other organizations, Trans World Airlines (TWA) and Yip Group Inc. (a collection of charter, air taxi, and cargo operators), signed the CRDA; they are expected to receive ASD in the near future. Since these air carriers have not had sufficient time to incorporate ASD into their operational systems, an assessment of ASD impact on their operations was not undertaken for the present study, and should be performed at a later date.

3.2.1 Survey

A copy of the survey sent to the 11 air carriers is contained in Appendix A. This survey, which was created by CAASD with the help of an ATA representative, was mailed to air carrier points of contact identified by the ATA. The survey requested that each air carrier provide the following information:

- General background information about their operations
 - Number of flights
 - Number of aircraft
 - Percentage of aircraft equipped with the Aircraft Communications Addressing and Reporting System (ACARS)
- How they have incorporated ASD into their operations
 - Overview of their ASD implementation

- Who has access to ASD, who uses it
- The benefit ASD has had for decision making, both quantitatively and qualitatively; how they use ASD and what decisions are impacted
- Possible operational extensions to ASD

The cover letter that accompanied the surveys (also in Appendix A) indicated that the responses received by CAASD would be treated as privileged information and would not be shared with other air carriers. The carriers were assured that their responses to survey questions would be aggregated prior to any distribution of survey results.

In general, the air carriers that returned surveys seemed to take the exercise seriously, and the completed surveys proved to be very useful. It is evident that some carriers spent a great deal of time completing the survey.

3.2.2 Operations Center Visits

Seven air carrier system operations centers were visited. These visits consisted of observing operations, interviewing operations personnel and management, and viewing the automation software that takes advantage of ASD data. In all cases, the survey team was warmly welcomed and their questions freely answered. At each carrier, the survey team interviewed a variety of individuals to obtain multiple perspectives on the impact of ASD on their operations. In general, there seemed to be consistency regarding ASD among the individuals at each carrier. To aid the study team in fully appreciating ASD usage, the air carriers provided an overview of their operations and how ASD is used to augment other available information.

Despite the differences in size and structure among the various air carriers, there was some commonality in the decisions being made and the role of ASD in their overall operations.

3.3 FAA

The study team focused its efforts on eliciting FAA inputs at the ARTCCs and the ATCSCC. The team felt that the towers and TRACONS have little interaction with the air carriers that would be impacted by access to ASD.

3.3.1 Survey

A copy of the survey sent to the FAA flow managers is contained in Appendix B. The ARTCC surveys, which were created by CAASD, were sent to the FAA regional offices by the Air Traffic Management (ATM) Service. The regional offices in turn distributed the surveys to the appropriate FAA personnel at the ARTCCs. In most cases, this was the Assistant Manager for Traffic Management at each ARTCC.

The questions in these surveys focused on the impact of air carrier access to ASD on the FAA's relationship with the air carriers, and more specifically on operational communications with the air carriers. Given the concern noted earlier among air traffic managers regarding air carriers evaluating FAA decisions by using ASD, a number of questions were included in the survey which attempted to elicit any evidence in this area. There were some questions about the opinions of operations personnel on the further sharing of ASD/ETMS data with the air carriers and on their ideas for future FAA/air carrier collaboration.

Of the 20 CONUS ARTCCs, 14 returned completed surveys to CAASD. These ARTCCs are shaded in Figure 3-1. It is unfortunate that survey responses from the remaining 6 ARTCCs were not received prior to the writing of this report since those ARTCCs represent

areas of significant traffic congestion.

Some of the regional offices not only passed the survey on to the ARTCCs, but also sent it to some TRACON/towers. Two of the latter responded: Boston and Dallas/Fort Worth. Their input has been aggregated with the other FAA responses. A response was also received from the Anchorage ARTCC.

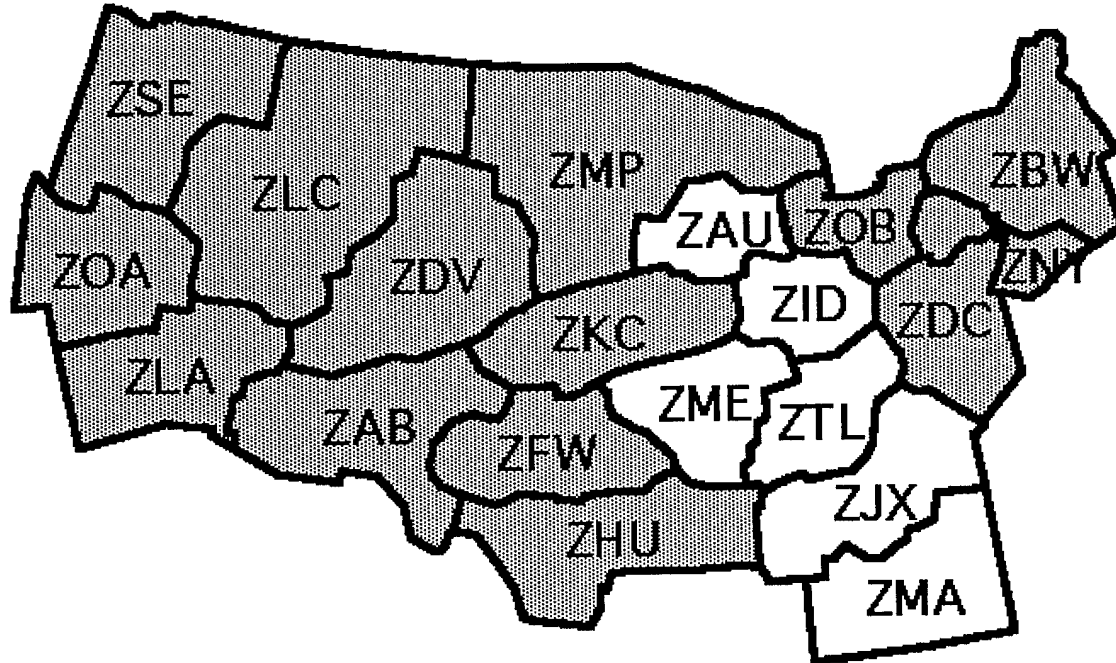

Figure 3-1. ARTCCs That Returned Surveys (indicated by shaded areas)

3.3.2 Facility Visits

One TRACON/tower and three ARTCC visits were coordinated with visits to air carrier system operations centers:

- Fort Worth ARTCC
- Houston ARTCC
- Minneapolis ARTCC and Minneapolis TRACON/tower

During these visits, the study team interviewed traffic management coordinators (TMCs) and staff who work in the TMU. In some cases, the study team was able to interview the Assistant Manager for Traffic Management.

Operations personnel in the ATCSCC were not asked to complete a survey. However, the study team visited the ATCSCC to conduct interviews with traffic managers who interact with the air carriers.



Operational Impacts of Air Carrier Access to the Aircraft Situation Display (ASD)

Thor R. Abrahamsen

Andrew R. Lacher

Stephanie B. Fraser

MTR 94W000090

November 1994

Approved for public release, distribution unlimited

MITRE Corporation, McLean, Virginia

Table of Contents

SECTION 4

ASD INTEGRATION INTO AIR CARRIER OPERATIONAL SYSTEMS

Most air carriers initially used the ASD software provided by the FAA. This allowed them to implement ASD quickly and take advantage of its capabilities. However, since the FAA ASD software runs under the DOMAIN operating system on specialized hardware (Hewlett-Packard Apollos[®]), most of the air carriers were unable to distribute ASD widely within their operations centers. They did not want to bear the cost of purchasing large numbers of additional computer workstations and the burden of placing new equipment in already crowded workspaces. Thus, most carriers either have developed or plan to develop customized ASD applications that are integrated with their existing automation, eliminating the need to operate the FAA version. However, even after developing their own ASD applications, some air carriers still use the FAA software at some positions. For example, one air carrier's customized version of ASD is limited to that carrier's flights because of processing limitations; at the air traffic control (ATC) liaison position, which needs to view all flights, the FAA version is still used. Only three of the nine carriers having customized ASD applications indicated that they are no longer using the FAA version of the ASD software at any position.

This section briefly summarizes the various air carrier implementations of ASD.

4.1 AIR CARRIER POSITIONS USING ASD

At most of the air carriers, ASD was first made available to system operations control center personnel, who act as liaisons to the FAA. As customized applications are developed, ASD is being made available to additional positions, mainly flight dispatchers. (For an overview of air carrier operations and the responsibilities of various positions, see Lacher and Klein, 1993.) The number of work positions currently using ASD at the various air carriers ranges from 1 to over 60.

At some of the cargo carriers, ASD is not only used by those responsible for flight operations, but also has been given to customer service agents and account managers, who use ASD to help track the location of shipments and cargo space.

One air carrier, which is still using the FAA software, has two ASD workstations--one

located at its operations control center and the other at a major hub airport. Other air carriers plan on locating ASD workstations at major hub stations. Some also plan to locate ASD at major crew bases and with senior corporate management. One carrier has plans to make ASD available to reservation agents.

4.2 AIR CARRIER CUSTOMIZED IMPLEMENTATIONS

Only two air carriers are still using FAA software exclusively for their implementation of ASD. Most of the carriers quickly[4] developed customized applications and continue to improve them with further upgrades. The air carriers' customized applications are generally incorporated and integrated with larger operational systems, eliminating the need for additional workstations. By integrating ASD data with existing automation systems, the carriers can ensure consistency among applications and user interfaces, and better integration with other information sources and internal databases. Since each air carrier has a preferred computing environment, the carriers have created ASD applications for a variety of platforms, including Macintosh, PC-DOS, and UNIX.

Typically, an air carrier's version of ASD has many of the same features found in the FAA version given to the carriers, such as the following:

- Multicolor display
- Graphical user interface
- Graphical display of aircraft position reports with data blocks
- Color coding of select aircraft
- Display of static information such as routes, NAVAIDS, airports, and boundaries

In addition to integrating their customized applications with existing automation, the air carriers have included additional features to help support functions and decisions unique to their operations. Some additional features currently or planned to be incorporated into the air carriers' versions of ASD are as follows:

- **Weather Overlay:** This is one of the most commonly added features and one of the main drivers for customized applications. The relationship of weather to a flight's planned route is extremely important. Most of the air carriers have integrated existing graphical weather products and displays with ASD data. Typically, radar precipitation, satellite images, turbulence plots, and winds aloft plots are integrated with ASD aircraft position reports into a single display. Weather is so significant to using ASD that at one air carrier, the ASD display is known as the "weather display"; graphical aircraft positions are almost secondary to the weather information.
- **Compass Rose:** A compass rose display provides dispatchers with range and bearing information between two points (e.g., aircraft and weather). This allows the dispatcher to notify pilots of severe weather with more precise distance and bearing information. This feature was implemented by most carriers with customized implementations.
- **Additional Color-Coding and Selection Features:** The nature of air carrier operations requires that the air carriers sort and select flights by different attributes than those used by the FAA (e.g., all flights being managed by dispatch desk 21; all flights more than 20 minutes late). This feature has been implemented by most of the carriers.
- **Graphical Flight Planning:** This feature makes it possible for a dispatcher having to reroute an airborne flight simply to observe the location of the aircraft and draw on the screen a new route that avoids severe weather and/or anticipated congestion, rather than having to assemble the reroute by hand. The automation will then

assemble either a route using the nearest jet routes and fixes, or a route using latitude and longitude coordinates. This feature has been implemented by one carrier and is planned by others.

- **Automatic Dependent Surveillance (ADS):** One air carrier has integrated ADS position reports from satellite, high-frequency radar, and ACARS with its ASD display. This allows the ASD application to display those flights (e.g., European and oceanic flights) which are not controlled by one of the 20 CONUS ARTCCs and thus are not available from the ETMS.

A resale market for ASD applications is developing. Some of the air carriers are actively marketing their customized ASD software. Some independent software development companies are beginning to try to market their services to the air carriers as well.





Operational Impacts of Air Carrier Access to the Aircraft Situation Display (ASD)

Thor R. Abrahamsen

Andrew R. Lacher

Stephanie B. Fraser

MTR 94W0000090

November 1994

Approved for public release, distribution unlimited

MITRE Corporation, McLean, Virginia

Table of Contents

SECTION 5 IMPACT ON FAA/AIR CARRIER RELATIONSHIP

This section examines the impact of air carrier access to ASD on the relationship between the FAA and the air carriers. In general, both the air carriers and some FAA operations personnel noted a benefit from everyone's being able to view the same information. Both the FAA and the air carriers suggested that sharing additional data should help improve the air carriers' situation awareness and communications.

5.1 FAA PERSPECTIVE

In general, the study team found that FAA "fears about [the air carriers] 'second guessing' [the FAA by using ASD] did not materialize." Most FAA operations personnel reported no "observable detriment" due to air carrier access to ASD.

5.1.1 ASD's Impact

Responses to both the surveys and the interviews indicate that the impact on the FAA/air carrier relationship due to ASD as perceived by FAA personnel ranges from none to positive. Responses from FAA personnel indicate no additional workload due to air carrier access to ASD. Some ARTCCs suggested that the air carriers are now more informed when they contact the FAA and are more patient with FAA actions and explanations. Many indicated that the air carriers no longer call to locate the positions of flights en route.

Although no FAA respondent suggested that the air carriers are using ASD in a negative fashion, several respondents noted a slight increase in the number of requests for explanation of FAA strategies. In general, prior to having ASD, the air carriers would contact the FAA to ask questions and raise concerns. ASD has shifted these questions/concerns: some of the old questions/concerns can now be answered by observing ASD; however, new ones are now being raised.

Some interactions are not wholly benign. One ARTCC reported that some interactions "while not adversarial . . . seem confrontational almost accusing the FAA personnel of treating some system users unfairly." This same ARTCC indicated that while it has "never experienced an airline actually second guessing any FAA traffic management action, [it has] experienced questions that seem to go beyond information gathering." The ARTCC

indicated that these questions were really suggested TFM alternatives. However, these suggestions often proved infeasible. The respondent attributed this to the air carriers' lack of information. To help improve the air carriers' situation awareness, the respondent supported the notion of providing GA information, as well as M/A threshold data, which "may answer in advance some of the possible questions the air carriers might have concerning restrictions or reroutes that may affect their flights."

5.1.2 FAA/Air Carrier Collaboration on Traffic Flow Management Decisions

Most FAA operations personnel contacted by the study team indicated that the relationship between the FAA and the air carriers is improving, and that access to ASD is only part of the reason. Most FAA personnel credit the improved relationship to an increased willingness on the part of the FAA to address air carrier concerns.

When asked how TFM decision making should change in the future, FAA operations personnel often cited the importance of collaborative decision making, incorporating air carrier input into the decision-making process. This collaboration was cited as being of particular importance during the operations planning phases, in order to allow air carriers time to react to FAA decisions. A more collaborative TFM decision-making process would result in "joint accountability" for decisions made. At the same time, an FAA response noted that "there comes a point where too many people get involved in making a tactical decision [and where] the air traffic system [Traffic Management] supervisors need to make timely decisions and adjustments."

Several responses identified the need for dispatchers and TMCs to have a better understanding of each other's roles.

5.2 AIR CARRIER PERSPECTIVE

Air carrier respondents suggested that ASD has improved their situation awareness. Instead of contacting the FAA to figure out what is happening in the system, they now use ASD to observe traffic patterns and congested areas. Instead of spending time trying to reach a consensus on what is happening in the system, they can now focus better on solving flow management problems. The air carriers reported that they are much more knowledgeable about system operations and feel on a more equal footing with the FAA in conducting negotiations. As one air carrier stated, the "answers/responses we get [from the FAA] show respect for our knowledge."

Several air carriers responded that differences between their and the FAA's versions of ASD limit the effectiveness of communications. One air carrier stated that "at times when we refer to ASD [the FAA has] more accurate data that results in miscommunications." Most of the cited differences between the two versions concern data the air carriers do not receive (e.g., GA position updates). Section 7.1 details additional FAA data the air carriers would like to receive.

The air carriers also indicated that they now have a better appreciation for the problems faced by the FAA and a better understanding of the FAA's flow management role. In discussing ASD's impact on communications with the FAA, one air carrier stated that ASD has led to an "improved understanding of delay and traffic situations."

Most of the air carriers indicated that they no longer must place calls to find out the location of an en route flight or to ask whether a flight has departed. Most indicated that since they spend less time having the FAA explain information they now can derive from ASD, phone conversations have been reduced in length.

The air carriers indicated that they are trying not to use ASD to evaluate FAA decisions, as required by the ground rules in the CRDA (see Section 2.2). FAA fears in this regard did not materialize because the ground rules contained in the CRDA were so strong, and the threat of removal of ASD access was so extreme. As one individual put it, "they [the FAA] scared the heck out of us."

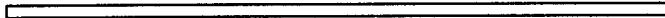



Operational Impacts of Air Carrier Access to the Aircraft Situation Display (ASD)

Thor R. Abrahamsen

Andrew R. Lacher

Stephanie B. Fraser

MTR 94W000090

November 1994

Approved for public release, distribution unlimited

MITRE Corporation, McLean, Virginia

Table of Contents

SECTION 6

IMPACT ON AIR CARRIER INTERNAL OPERATIONS

The most significant impact of air carrier access to ASD has been on the carriers' internal decision making related to operations. Overall, ASD is seen as a valuable resource not only in helping to reduce costs, but also in increasing confidence in the decisions being made. Almost all air carriers receiving ASD have incorporated it into their decision-making process in a short period of time. The air carriers indicated that soon after receiving ASD, they could not imagine how they were able to run their operations without it. One carrier made an analogy with running a business without a fax machine: it just cannot be done in today's environment.

The following sections address ASD's impact on several key decisions made daily by the air carriers. (For a detailed discussion of air carrier operations, see Lacher and Klein, 1993; Lacher, et al., 1993; or Grandeau, 1993.)

6.1 DIVERSIONS

A common theme in the air carrier responses was that ASD supports internal air carrier decisions regarding diversions in two ways: (1) avoidance of unnecessary diversions, and (2) better diversion management.

6.1.1 Avoidance of Diversions

There are many reasons why a commercial aircraft may need to divert from its original destination and land at an alternate airport. However, this section addresses mainly diversions resulting from congestion around a destination airport and from the inability of an aircraft to maintain an airborne holding pattern for the time period required. Each diversion costs the air carrier thousands of dollars. In interviews with the carriers, estimates of the cost of an individual diversion varied widely from \$10,000 to \$100,000 and even \$500,000. It is difficult to pin down an average cost for a diversion because the actual cost depends on many factors, including the nature of the flight (domestic or international), the type of equipment, the duration of the diversion, [5] connections, and whether passenger accommodations are necessary.

When more aircraft arrive for service at an arrival fix than can be accommodated, they are

put into a holding pattern. Pilots are given a hold time by a controller as an Expected Further Clearance (EFC) time message.[6] The controller estimates an EFC that is greater than the expected holding time. Often the EFC is much greater than the actual holding time. This is especially true for longer-duration holds (i.e., more than 30 minutes). The EFC is the pilot's only indication of the actual hold time. If an air carrier does not have access to ASD, dispatchers on the ground must rely on the EFC as an estimate of the holding time. A pilot with an EFC too long for the available fuel is required to divert. This can be further complicated if the controller does not know when the aircraft will be able to continue, indicating delays are indefinite. However, if the carrier has access to ASD, the pilot can contact the dispatcher, who can estimate actual hold times by observing ASD. Moreover, dispatchers can monitor the rate of aircraft arriving at the destination airport and estimate the degree of congestion, thus better gauging actual holding times. The dispatchers can be more proactive and contact flight crews with this information, prior to their receipt of an EFC.

The following is an illustration of how ASD is used by the air carriers to reduce diversions:

- Flight ABC123 is inbound to DFW. It is currently 2251 GMT.
- Controller: "Hold at Paris as published. Expect further clearance at two three four zero [2340]."
- The pilot has just been given an estimate that indicates he will be holding for 49 minutes. He has only 30 minutes of hold fuel. He contacts his dispatcher, who has been monitoring ASD. The dispatcher indicates that holds are running approximately 20 minutes and that he does not expect the flight's hold fuel of 30 minutes to be exhausted. The pilot and dispatcher choose to hold without compromising safety. The pilot and dispatcher will continue to monitor fuel and hold conditions. Without ASD, this flight would likely have diverted.

Nine of the ten carriers responding to the survey reported using ASD to avoid diversions. The number of diversions avoided is difficult to quantify precisely. For the five carriers providing an estimate, the number ranges from 36 to 100 a year. A conservative estimate of total savings for the five carriers as a result of avoiding diversions is over \$1.6 million a year.[7] This figure should be viewed as a lower bound on the cost savings due to reduced diversions resulting from ASD access.

Most of the ten responding air carriers indicated that their cost for ASD development can be justified by the savings resulting from reduced diversions alone. One carrier estimated that saving an average of 2.5 diversions a month would justify ASD development costs.

6.1.2 Better Diversion Management

If diversions are necessary, air carriers have found that they can use ASD for more proactive planning. Before having access to ASD, an air carrier's first indication of airborne holding and the possible need for a diversion often came when a pilot was issued an EFC. This usually afforded an air carrier very little time to manage diversions effectively. This problem was exacerbated when a bank[8] of flights was involved. Using ASD, the air carriers can determine that flights are experiencing airborne holding by observing other carriers' flights. One air carrier's ASD application includes software that alerts dispatchers when it detects flights experiencing airborne holding.

Dispatchers can now suggest more appropriate alternates by looking at the current location of a flight in relation to the current weather conditions at available airports. They can also choose an alternate whereby they can better accommodate passengers and make better use of equipment and crews.

For large numbers of diversions, dispatchers can more uniformly distribute the chosen

alternates, facilitating management of ground operations. Typically, dispatchers will put the same alternate in the flight releases for all flights bound to a destination. If large numbers of diversions are necessary, the air carriers do not necessarily want all their flights at the same alternate, creating potential gridlock. This is especially true when the original destination is an air carrier's hub. Using ASD, dispatchers can dynamically change the alternates suggested to flight crews, spreading the workload among various ground stations.

One air carrier noted that ASD has helped them prioritize their flights inbound into a hub airport experiencing airborne holding. This prioritizing has allowed them to divert the narrow-bodied aircraft in order to land the wide-bodied aircraft.^[9]

Occasionally, EFC times are underestimates of actual hold times, or there may be additional points of holding occurring in the system. By using ASD, the dispatcher can notify the crew that they will not be able to hold for the duration of all the holds ahead. Rather than exhaust fuel holding and then be forced to divert, dispatchers and flight crews can make the decision to divert sooner, thereby saving fuel.

Only one air carrier reported no impact from ASD on diversion-related decisions. This carrier does not have ASD distributed to all dispatchers and has, in general, not made significant use of the ASD information. In the interviews, they indicated that they plan a significant integration of ASD into their decision-making processes in the near future.

6.2 SEVERE WEATHER REROUTES

One other significant benefit of ASD has been the ability of dispatchers to see an aircraft's location in relation to the location of severe weather conditions. This allows an air carrier to be proactive when faced with severe weather conditions, which in turn results in reduced costs and increased safety. This is especially evident for air carriers that have integrated ASD and weather data into a single application.

In general, dispatchers have found that access to ASD allows them to give better inflight weather briefings to flight crews. While aircraft have their own weather radar, typically this radar can see only the first line of precipitation, giving the pilots little information about the conditions behind. However, the information available to dispatchers with ASD gives them a more complete representation of the weather conditions. Using ASD, dispatchers can determine the position of an airborne flight in relation to severe weather conditions and provide better information to the pilot, improving the efficiency of operations and increasing safety. Dispatchers can also use ASD to help flight crews efficiently avoid areas of significant turbulence, improving passenger comfort and safety.

One air carrier described how a dispatcher was able to give routing information en route to a pilot whose weather radar had failed. The pilot was able to request from the air traffic controllers desirable routing that avoided severe weather. The pilot was so impressed with the dispatcher's capability that he requested and received a demonstration of ASD upon arrival.

Air carriers reported that with ASD, they are better able to monitor the severe weather avoidance routes being used by the FAA. This allows them to be more proactive, and improves the communications and decision making among dispatchers and flight crews.

Finally, ASD is beneficial in determining a route's status during severe weather. Before having access to ASD, a dispatcher would assume a route was unusable by looking at weather reports for that area. With ASD, dispatchers can determine the status of a questionable route by observing whether other flights are using it. ASD helps raise a dispatcher's confidence that a route is usable and make better judgments about the real effects of weather on a route.

Some of the air carriers did not cite ASD as being beneficial for severe weather avoidance. In general, these air carriers use the FAA version of the ASD software and therefore do not have weather data integrated on the same display as aircraft position reports.

6.3 FUEL-EFFICIENT ROUTES

Some of the air carriers reported that ASD has been beneficial in identifying fuel-efficient routes. One air carrier reported that they spend close to \$2 billion a year on fuel. Reducing fuel costs is a high priority for the air carriers. Huge savings can be realized by reducing the fuel cost for each flight even by a small amount (e.g., hundreds of dollars per flight).

The air carriers reported that ASD has helped reduced fuel costs by enabling them to do the following:

- **Monitor route availability:** The dispatcher is able to determine that a fuel-efficient route is without congestion or severe weather.
- **Monitor National Route Program (NRP) compliance:** Through the NRP, air carriers realize significant savings annually (Bull and Dundzila, 1994). Occasionally, even after a nonpreferred route^[10] has been coordinated with the ATCSCC, the air traffic controllers and/or the air carrier pilots involved digress from this route. Using ASD, the dispatcher can monitor and correct the route if necessary.
- **Make use of SUA:** With ASD, the air carriers are better able to make use of SUAs. Dispatchers sometimes plan for a flight to fly through an active SUA. They then monitor the progress of the flight using ASD. When the flight is beginning to approach the area, the dispatcher contacts the appropriate center to determine whether the area is actively being used. If not, the flight proceeds as filed. If the area is truly active, the dispatcher/pilot reroutes. One air carrier reported that they save an average of \$100 per flight by using SUAs. Currently, this carrier has 100 flights/day using this technique, for a daily savings of \$10,000. Air carriers are expanding this use of ASD. In addition, air carriers are sometimes able to infer whether an SUA is active by determining whether other commercial aircraft are flying in the area.

In general, ASD has enhanced the efficiency of fuel planning by allowing the air carriers to be more proactive in selecting fuel-efficient routes, reducing hold fuel requirements, and using fuel-efficient routes to avoid severe weather.

6.4 AIRPORT (HUB) OPERATIONS

ASD facilitates the ability to estimate aircraft arrival times. Accuracy in estimated times of arrival (ETAs) is extremely important for gate and connection planning. This is especially true for those air carriers which operate using a hub-and-spoke route topology. ASD is also useful for identifying out-of-bank flights and prioritizing critical flights within a bank. It is used as well in making decisions on whether to hold a departing flight waiting for connecting passengers on an incoming flight.

Because of these uses, one air carrier has installed ASD in its operations control center at a major hub airport. This is in addition to an ASD at the carrier's system operations control center. Other air carriers are planning ASD deployment at major hub airport operations control centers.

Cargo carriers use ASD to track shipments en route and to facilitate the coordination of ground transportation with a flight's arrival. Ground transport costs are computed based on when the truck is ready to receive cargo. Rather than having trucks sitting idle waiting for an arriving flight, agents can coordinate with ground transport to arrive just prior to a flight's arrival.

6.5 FLIGHT FOLLOWING

Air carrier dispatchers reported that ASD greatly facilitates flight following, [11] a very important aspect of their work. While ASD does not replace the need for periodic position reports from aircraft, it greatly enhances the dispatchers' ability to track the location of all flights in a single graphical display. The dispatchers reported that ASD helps them better visualize the actual location of aircraft, especially their relationship to weather (see Sections 6.1.2 and 6.2). Some air carriers also report that ASD is beneficial in determining whether a flight has departed. Before having access to ASD, if dispatchers were unable to locate a flight or determine whether it had departed, they would have to contact the FAA. Now they can simply use ASD to find the flight's exact location of a flight.

ACARS also facilitates flight following, but many air carriers have aircraft that are not ACARS-equipped. The number of ACARS-equipped aircraft among the responding air carriers varies between 0 and 100 percent. Among the ten responding carriers, fewer than 75 percent of the total aircraft are ACARS-equipped. In addition, some of the air carriers reported that ASD has proven useful as a backup for ACARS should an ACARS message fail to be delivered. Some of the carriers reported that ASD has been useful for lowering air-ground communications costs by eliminating position report requests by dispatchers.

In some situations, pilots take action without informing the responsible dispatcher in a timely manner. For example, one air carrier noted that pilots occasionally make the decision to divert to an alternate airport because of the holding time (i.e., EFC) they have received, without prior consultation with the responsible dispatcher. The dispatcher can now keep track of pilot actions without increasing pilot workload.

For those cargo carriers which specialize in delivering cargo within several hours, the ability to track the exact position of an aircraft is critical. This is part of the service contracted for and advertised by these carriers. Thus, they make ASD available not just to their flight dispatchers, but also to their customer service and account agents.

6.6 FLAG STOPS

ASD has allowed cargo carriers to take advantage of business opportunities dynamically. When an opportunity to pick up cargo arises, a cargo carrier's customer service agent can determine whether an airborne aircraft with available cargo space is located near the additional cargo. If so, the aircraft can be diverted to make an additional stop (known as a "flag stop" [12]) before continuing on to its original destination. According to some cargo carriers, this is a daily occurrence in their operations.

Some of the passenger air carriers reported that ASD made it possible for them to make flag stops for passengers, but noted that this is rarely done because of passenger complaints.

6.7 COMMUTER CARRIER COMMUNICATIONS

Some air carriers have used ASD to facilitate coordination with their commuter carriers. ASD has allowed them to provide accurate information on traffic conditions. One air carrier stated that ASD has "reduced the need for much verbal coordination effort" with their commuter carrier. Although none of the air carriers' commuter carriers have access to ASD, some plan to provide their partners with an ASD capability at a later date.

6.8 ANTICIPATED APPLICATIONS

The air carriers' use of ASD is expanding. Most of the responding air carriers indicated that

they continue learning new ways of using ASD to improve the efficiency and safety of their operations. Uses of ASD will also change with the receipt of additional data (see Section 7.1). The air carriers that are not using ASD for the purposes discussed in Sections 6.1 through 6.7 anticipate doing so in the near future.

Some of the air carriers plan to use ASD in a non-real-time post-analysis role. The carriers would like to be able to compare filed routes of flight with the routes of flight actually flown. They plan to use this information to better gauge the efficiency of their operations. For example, while a dispatcher is filing a flight plan that adheres to FAA preferred routes and the NAS route structure, pilots requesting and receiving direct routes may greatly increase the efficiency of operations. However, the reverse may also be true: a nonpreferred route that has been coordinated with the ATCSCC may be more fuel-efficient than a direct route requested by the flight crew. The air carriers would also like to be able to measure the effects of miles-in-trail and other en route restrictions on the efficiency of their operations.





Operational Impacts of Air Carrier Access to the Aircraft Situation Display (ASD)

Thor R. Abrahamsen

Andrew R. Lacher

Stephanie B. Fraser

MTR 94W000090

November 1994

Approved for public release, distribution unlimited

MITRE Corporation, McLean, Virginia

Table of Contents

SECTION 7 DESIRED ASD INTERFACE ENHANCEMENTS

In the course of this study, the study team asked both the FAA and the air carriers to suggest potential enhancements to the FAA ASD interface to the air carriers in two areas: additional data and enhanced functionality. In addition, FAA operations personnel were asked to comment on the enhancements suggested by the air carriers.

7.1 ADDITIONAL DATA

When asked about additional data that could be included on the ASD data stream, the air carriers made several suggestions for information related to both TFM and ATC. There was fairly high consistency across the air carriers in the requests for various data items. Each of the following data items was requested by several air carriers:

- Position updates for terminal areas
- Position reports for GA aircraft
- Oceanic position updates
- Real-time indication of airport configurations and airport acceptance rates (AARs)
- Real-time indication of saturated sectors
- Integrated weather
- Real-time indication of en route restrictions
- Real-time indication of severe weather avoidance routes in use

The rationale for these data items expressed by the air carriers and some of the associated FAA comments and concerns are contained in the subsections below.

7.1.1 Position Updates for Terminal Areas

Position updates for traffic in the terminal areas would be useful to the air carriers in managing their gate and ramp operations, particularly at hub airports. The air carriers would like to use this data to better estimate gate arrival times for inbound flights. They are also interested in knowing the extent of "s-turns" being taken in the terminal area.

As evidence of the importance of terminal area data, it was noted that two air carriers have acquired systems to provide similar information. United Airlines developed a graphical

system, known as the Passive Surveillance System (PasSurS), to intercept transponder and Airport Surveillance Radar (ASR) signals in the terminal area. This information is then displayed graphically at both United's airport operations center and the system operations control center. PasSurS provides the ability to view arriving or departing traffic and calculate very accurate ETAs. United Airlines also uses PasSurS in discussing terminal area congestion and approach procedures with the FAA. United claims they can frequently negotiate with the ATCSCC to cancel national ground delay and ground stop programs based on the information they obtain using PasSurS. PasSurS is currently operating at two hub airports, San Francisco International (SFO) airport and ORD. A third system is planned for the new Denver airport.

Delta Airlines and the Atlanta tower have jointly developed an experimental system, the Airport Resource Management Tool (ARMT). Among other things, ARMT provides Delta with status messages regarding approaching flights. Previously, Delta had to have two employees in the operations control center listening to tower air-ground frequencies to estimate ETAs (Atlanta ATCT Automation, 1994).

Currently, terminal area updates are not part of the ETMS system. The FAA is working on integrating Automated Radar Terminal System (ARTS) data into ETMS. Every air carrier that responded to the survey expressed an interest in receiving terminal area or ARTS data. No FAA operations personnel expressed reservations about sharing terminal area data with the air carriers once it is part of ETMS.

7.1.2 Position Reports for GA Aircraft

GA position reports would enhance the air carriers' situation awareness. Using ASD, the carriers will sometimes detect what appears to be unused airspace or space in a traffic stream. In fact, this space may be occupied by either GA or military traffic[13] that the air carriers cannot see. Every air carrier that responded to the survey expressed an interest in receiving updates for GA aircraft to have a more complete picture of the overall traffic flow and congestion patterns.

Many air carriers suggested that privacy concerns[14] regarding the disclosure of registration numbers associated with GA aircraft can be accommodated by stripping the *N* number of the data block and replacing it with the letters *GA*. Most of the carriers indicated that they do not need to know what aircraft is part of a stream of traffic; they just need to be aware that an aircraft is there. However, some of the air carriers, especially those which deal with on-demand charter operations, the brokering of other carriers' flights, and contract dispatch services, would like to have registration numbers in order to track the location of specific flights. In a more strategic sense, some brokers indicated a desire to track the location and status of all aircraft.

FAA opinions on whether the air carriers should receive GA position updates varied. Slightly more than half indicated that the air carriers should receive GA updates. One FAA survey response stated that GA updates should be shared "in order for everyone to be able to communicate with the same knowledge." Those that responded negatively saw no apparent need for the air carriers to have access to the data. Concerns were expressed that the air carriers would use this information to judge whether the FAA is adequately meeting capacity. The CRDA notes that since the air carriers do not have GA and military position updates, the ". . . presentation they are receiving is not the total picture, and no conclusions should be drawn about overall strategies being used by field facilities [ARTCCs and TRACONS] or the ATCSCC to manage flows of traffic" (CRDA, 1992, Appendix A, p. 7).

7.1.3 Oceanic Position Updates

Oceanic data would support flight following for international flights. This data would

eliminate the need for some calls to aircraft requesting position reports, thereby saving communications costs. In addition, this data could impact decisions concerning the coordination of flights in cases where connecting passengers are on board flights flying over oceanic airspace. The FAA is currently investigating incorporating oceanic data into ETMS. FAA operations personnel indicated no concerns about sharing this data with the air carriers.

7.1.4 Real-Time Indication of Airport Configurations and Airport Acceptance Rates

The air carriers indicated that access to a constantly updated database of real-time airport configuration and AAR information would be helpful in their planning. This information would facilitate decision making with regard to both diversions, as described in Section 6.1, and cancellations.

Currently, the FAA maintains no such database. Many FAA traffic managers indicated that such a database would be of use in facilitating their decision making as well. Some of the FAA traffic managers feel that pertinent airport configuration and AAR information is currently shared with the air carriers through advisory messages.

7.1.5 Real-Time Indication of Saturated Sectors

The air carriers indicated that one of the major impacts ASD has had on their relationship with the FAA has been their ability to see congestion problems being faced by the FAA. The carriers noted that having a real-time indication of saturated sectors, either through the inclusion of M/A features or through the FAA's sharing capacity threshold data, would further enhance their ability to anticipate congested areas. Many of the carriers believe this would move the system from one in which the FAA tells the carriers where to fly to avoid congestion, toward a system where the FAA tells the carriers which areas to avoid, allowing them to choose how and where to fly in doing so. Information about saturated sectors would allow the air carriers to be proactive in avoiding congested airspace.

FAA operations personnel expressed reservations about sharing M/A and/or capacity threshold data with the air carriers. More than half of the FAA personnel interviewed or surveyed indicated that M/A and threshold data should not be shared. According to one respondent, "air carriers should not be given access to threshold data [because] this data does not take into consideration traffic flows or complexity."

Many FAA operations personnel seemed to feel that the air carriers would use this information to evaluate FAA decisions, a concern very similar to the original concerns expressed about sharing ASD with the air carriers. Other FAA operations personnel indicated that M/A is not currently accurate enough to be useful and should not be shared with the air carriers until it is sufficiently improved.

7.1.6 Integrated Weather

The air carriers cited the importance of being able to see the positions of aircraft in relation to weather. Thus, as discussed in Section 4.2, many of the carriers have created customized versions of ASD that integrate real-time position reports received from the FAA ASD interface and real-time weather updates received from various weather product vendors. However, not all of the carriers have been or will be able to develop customized versions of ASD, and these carriers thus continue to use the FAA version. For these carriers, there is a strong desire to receive weather updates as part of the FAA's ASD interface. In addition, some of the carriers believe there is a benefit in seeing the same weather data the FAA is using in order to make better negotiated decisions. Although weather data is not shared with

air carriers via ASD because of licensing limitations (CRDA), no one from the FAA has cited any other problems with providing such information.

7.1.7 Real-Time Indication of En Route Restrictions and Severe Weather Avoidance Routes in Use

The air carriers indicated a desire for the FAA to create a shared database of all dynamic en route restrictions (e.g., miles-in-trail) and severe weather avoidance routes that are currently implemented. This information would allow the carriers to be proactive and perform better flight planning. The FAA currently does not have such a database. Some at the FAA suggested that the current method of notifying the air carriers of such restrictions through advisory messages is sufficient.

7.2 FUNCTIONAL ENHANCEMENTS

In addition to the data discussed in Section 7.1, the air carriers expressed a desire for functional enhancements to the ASD interface.

7.2.1 FAA ASD Software Enhancements

Some air carriers expressed interest in additional features to be included with the FAA version of the ASD software provided to the carriers. The following two features were suggested:

- **Capability to display specified airline flights:** Some of the air carriers use their own versions of ASD to display flights that belong only to them. This is not possible using the FAA version of ASD currently provided to the carriers.
- **Display exact time of departure:** This information is included in the current ASD data stream, but the FAA software provided to the air carriers does not allow for its retrieval.

7.2.2 Reliability Improvements

As noted in Section 6, the air carriers rely heavily on ASD data for internal decision making, and this data is becoming crucial for operations. One air carrier has designed its operations automation and system command center around the ASD data stream. Outages and service disruptions can be very expensive. One air carrier recommended that the FAA "move [the] airline ASD from R[esearch] and D[evelopment] into a full operational system [and] provide better communications system with backup lines, etc."

7.2.3 Increased Update Rate

The air carriers expressed a desire for more frequent position updates than those currently available from ASD. One carrier claimed that the time between two position reports for the same flight can be as long as 8 minutes. This may be explained by aircraft crossing ARTCC boundaries since each ARTCC transmits track information to ETMS at different times. The air carriers believe that a 1-minute update rate would improve the quality of position reports currently received. This data would be particularly useful for flights near or in the terminal area and would facilitate determining a flight's status (e.g., whether it is experiencing airborne holding or has departed). Accurately determining airborne holding allows an air carrier to be more proactive in managing diversions (see Section 6.1.2). The FAA is working on improving the update rate to 1 minute versus the current rate of 5 minutes. No FAA personnel expressed reservations about increasing the air carrier update rate, along

with improvements to the rate of FAA updates.

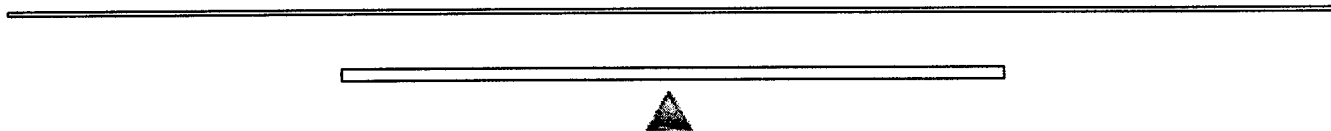



Operational Impacts of Air Carrier Access to the Aircraft Situation Display (ASD)

Thor R. Abrahamsen

Andrew R. Lacher

Stephanie B. Fraser

MTR 94W000090

November 1994

Approved for public release, distribution unlimited

MITRE Corporation, McLean, Virginia

Table of Contents

SECTION 8 SUMMARY AND CONCLUSIONS

Air carrier access to ASD should be viewed as an overall success. As documented in this report, ASD has had a positive effect in two areas: (1) the relationship between the FAA and the air carriers, and (2) the air carriers' internal operations. Access to ASD is providing the air carriers a valuable service they did not previously have. The carriers are using ASD to make better decisions, thereby reducing their operating costs, as well as helping to foster a better working relationship with the FAA. In general, the FAA reports that the air carriers are not using ASD in a negative fashion to evaluate FAA decisions.

ASD's specific impact is difficult to quantify, and therefore most of the findings documented in this report were drawn from qualitative information. However, based on limited quantitative information, [15] we can conclude that the air carriers can save millions of dollars per year by using ASD in their internal decision making.

8.1 FAA/AIR CARRIER RELATIONSHIP

As noted earlier, prior to the CRDA, there was a major concern that the air carriers would use ASD negatively to evaluate FAA decisions. Neither the FAA nor the air carriers feel that this has occurred. It is unclear, however, whether this is due to the language contained in the agreement an air carrier must sign in order to receive ASD.

Both the FAA and the air carriers perceive that their relationship has been improving in the past few years. While air carrier access to ASD has contributed to this improvement, other initiatives and an FAA cultural shift can also be credited.

ASD has changed the nature of FAA/air carrier interaction. It has eliminated the need for some phone calls to the FAA (e.g., questions concerning the position of aircraft), but has made possible additional special requests (e.g., requesting reroutes around severe weather or prioritizing critical flights). In general, it is felt that these additional requests are more focused and indicate that the air carriers are better informed and more knowledgeable. FAA/air carrier interactions are no longer tied up in exchanging information that can be viewed from ASD, allowing both to focus better on solving particular traffic flow problems.

8.2 AIR CARRIER INTERNAL OPERATIONS

Air carrier access to ASD has had an even more noticeable impact on the air carriers' internal decision-making process. Although the air carriers still make the same types of decisions, they now have an additional data source because of ASD. This has allowed the carriers to make better decisions that have resulted in reduced operating costs. Access to ASD has impacted decisions regarding diversions, severe weather avoidance, fuel planning, flight following, cargo tracking, gate management, and hub operations. At the same time, although access to ASD has allowed some air carriers to be proactive in avoiding congested areas, it is realized that this is by no means a silver bullet for solving TFM problems.

Air carriers have become highly reliant on ASD data and have quickly incorporated it into their operations. Their use of ASD continues to evolve. Some air carrier customized implementations of ASD are quite complex. The carriers are still expanding ASD's capabilities, for example, adding weather information to their displays. Additional features, such as support for post-analysis, are future capabilities of interest.

The air carriers are still in the process of expanding internal access to ASD. For example, some of the carriers have not yet made ASD available to dispatchers. Therefore, it is reasonable to expect that once the carriers have completed their ASD development and have made ASD available to all key personnel, the benefits due to air carrier access will be greater than those documented in this report.





Operational Impacts of Air Carrier Access to the Aircraft Situation Display (ASD)

Thor R. Abrahamsen

Andrew R. Lacher

Stephanie B. Fraser

MTR 94W000090

November 1994

Approved for public release, distribution unlimited

MITRE Corporation, McLean, Virginia

Table of Contents

SECTION 9 RECOMMENDATIONS

As discussed in Section 8, air carrier access to ASD has had a positive effect on both the relationship between the FAA and air carriers and the air carriers' internal operations. Therefore the FAA should provide ASD to the air carriers as a permanent service. To that end, it is recommended that the FAA do the following:

- Explore the feasibility and impact of providing the desired enhancements listed in Section 7.
- Investigate techniques for ensuring the reliability of the ASD data feed.
- Explore a mechanism by which air carriers using FAA software can receive updated versions of the software.
- Investigate the configuration management issues associated with continuing an ETMS version 4.2 interface with the air carriers while the FAA moves towards version 5.0.
- Since the air carriers' use of ASD continues to evolve, and the number of air carriers receiving ASD is expected to increase, continue to monitor the impact of air carrier access.
- Continue to investigate the two-way exchange of operational information between the air carriers and the FAA. ASD would be one component of this exchange.
- Define and implement a permanent institution responsible for providing ASD data.

Additional analysis is needed to determine the anticipated benefits to the aviation industry, and indirectly to the flying public, of providing ASD to other, non-air carrier entities, including GA pilots.



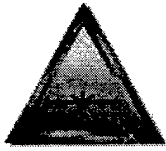

Operational Impacts of Air Carrier Access to the Aircraft Situation Display (ASD)

Thor R. Abrahamsen

Andrew R. Lacher

Stephanie B. Fraser

MTR 94W0000090

November 1994

Approved for public release, distribution unlimited

MITRE Corporation, McLean, Virginia

Table of Contents

LIST OF REFERENCES

Cooperative Research and Development Agreement (CRDA), Agreement #92-CRDA-23, 14 February 1992, Washington, DC.

Atlanta ATCT Automation, February 1994, *Overview FAA/Industry Development Program Atlanta Airport Resource Management Tool*, Atlanta, GA.

Bull, D. A., and A. V. Dundzila, 1994, *Coordination Draft: Airline Survey on the National Route Program for the FAA R,E&D Plan User-Preferred Trajectory Goal*, WN 94W0000167, The MITRE Corporation, McLean, VA.

Goeddell, D. L., et al., December 1992, *A Benefits Assessment of the FAA's Enhanced Traffic Management System (ETMS): The Impact of Initial Products of the ATMS Program*, Volpe National Transportation System Center Research and Special Programs Administration, U.S. Department of Transportation, Cambridge, MA.

Grandeau, S., October 1993, *A Description of System Operations Control Centers*, Paper for Seminar on Air Traffic Flow Management, October 12-13, 1993, MIT Flight Transportation Laboratory, MIT Cambridge, MA.

Lacher, A. R., and G. L. Klein, 1993, *Air Carrier Operations and Collaborative Decision-Making Study*, MTR 93W0000244, The MITRE Corporation, McLean, VA.

Lacher, A. R., et al., 22 March 1993, *Trip Report United Airlines (UAL) Operations Control Center and O'Hare International Airport (ORD) Station Control Center*, Memorandum No. F045-M-390, The MITRE Corporation, McLean, Virginia.

Volpe National Transportation System Center (VNTSC), January 1994, *Enhanced Traffic Management System (ETMS) Functional Description, Version 4.2.5, Report*

No. TSC-DTS56-TMS-004, U.S. Department of Transportation, Kendall Square, Cambridge, MA.

APPENDIX A: AIR CARRIER SURVEY

This survey was designed to elicit air carrier assistance in meeting the objectives of this

study, and to ensure that air carrier perspectives would be reflected in the study report.

[Text unavailable]

APPENDIX B: FAA SURVEY

This survey was designed to elicit FAA assistance in meeting the objectives of this study, and to ensure that FAA perspectives would be reflected in the study report.

[Text unavailable]

GLOSSARY

AAR	airport acceptance rate
ACARS	Aircraft Communications Addressing and Reporting System
ARD	FAA's Research and Development Service
ARMT	Airport Resource Management Tool
ARTCC	Air Route Traffic Control Center
ARTS	Automated Radar Terminal System
ASD	Aircraft Situation Display
ASR	Airport Surveillance Radar
ATA	Air Transport Association
ATC	air traffic control
ATCSCC	Air Traffic Control System Command Center
ATM	Air Traffic Management
CAASD	Center for Advanced Aviation System Development
CONUS	contiguous United States
CRDA	Cooperative Research and Development Agreement
DEN	Stapelton International airport
DFW	Dallas/Fort Worth International airport
EFC	Expected Further Clearance
ETA	estimated time of arrival
ETMS	Enhanced Traffic Management System
FAA	Federal Aviation Administration
GA	general aviation
LAX	Los Angeles International airport
M/A	Monitor/Alert
MIA	Miami International airport
NAS	National Airspace System
NAVAIDS	navigational aids
NRP	National Route Program
OAG	Official Airline Guide
ORD	Chicago O'Hare International airport
PasSurS	Passive Surveillance System
SEA	Seattle-Tacoma International airport
SFO	San Francisco International airport
SUA	special use airspace
SWAP	Severe Weather Avoidance Program
TFM	traffic flow management
TMC	traffic management coordinator
TMU	Traffic Management Unit
TRACON	Terminal Approach Radar Control
TWA	Trans World Airlines
VNTSC	Volpe National Transportation System Center





Time Division Multiple Access (TDMA) System Description: A One-Step Approach to the Future VHF A/G System

J. C. Moody
MTR94W0000035
March 1994

Approved for public release, distribution unlimited
MITRE Corporation, McLean, Virginia

Table of Contents

SECTION 2 VOICE OPERATION (NEAR-TERM IMPLEMENTATION)

2.1 BACKGROUND

One objective of the TDMA system architecture is to provide increased voice circuit capacity to meet near-term needs in a manner that is nearly transparent to the preexisting ATC infrastructure and procedures. This section addresses this level of functionality.

2.1.1 Vocoder Operation

Low bit rate digital voice coding (vocoding) is the key enabling technology that gives digital mobile radios high spectrum efficiency for voice operation. Digital voice operation in the TDMA system is based on a low bit rate voice coder (vocoder) operating at 4.8 kbps. The most commonly used vocoders at this rate operate on either 20 or 30 ms *voice frames*. A voice frame is the basic unit of time used by the vocoder for the processes of *analysis* and *synthesis* of the user's speech. Analysis is the process of converting a voice sample into its compressed digital representation. Synthesis is the inverse process of recovering the voice waveform from the compressed digital representation. While the exact vocoder algorithm to be used in the TDMA system is to be determined (TBD), the description presented in this paper is based on a vocoder voice framing of 20 ms. However, the TDMA frame structure could accommodate a vocoder voice frame of 30 ms if that were ultimately selected.

In the TDMA system, the time alignment of vocoder voice frames is derived from the TDMA frame timing as established by the ground radio via the M subchannel uplink burst. Vocoder voice framing is such that TDMA frame boundaries always align with voice frames. Since the vocoder operates in realtime at a rate of 4.8 kbps, analysis of each 20 ms voice frame results in a digitally compressed output of 96 bits. The digitally compressed output of six voice frames are mapped into each TDMA frame, thus exactly filling the user information portion (576 bits) of each V/D subchannel burst. Figure 2-1 shows vocoder timing in relationship to the TDMA frame timing for a downlink transmission.

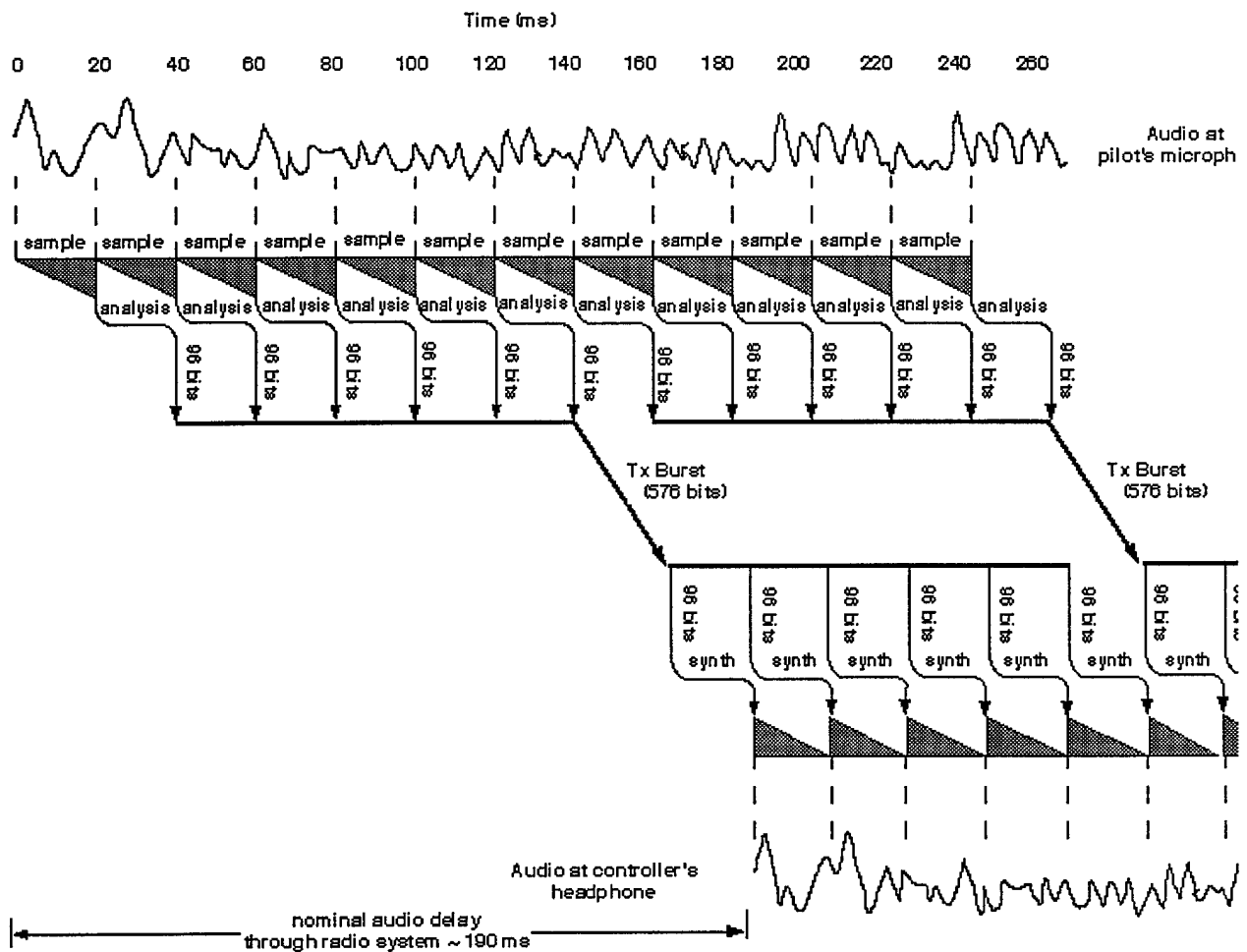

Figure 2-1. Vocoder Operation in TDMA Radio Environment

The objective of this section is to describe the operation of the voice-only implementation of the TDMA system. However, the system structure has also been designed to support discrete addressed V/D link. As a result, certain elements of the overall system structure are unused at this level of implementation. When this occurs, a given element will be labeled as "not used." Elements so labeled in this section are explained in Section 3.

The following two subsections describe the formats of each burst type in detail.

2.1.2 Subchannel Bursts Supporting Voice-Only Operation

Time slots supporting realtime two-way voice circuits employ two types of data bursts, each of which supports one of two embedded subchannels of the A/G voice circuit. The first of these is known as the V/D burst or subchannel for carrying user information, and the other is known as the M burst or subchannel used for carrying system data (i.e., signalling and circuit initialization overhead). Each burst type has a distinct format depending on whether it is used for uplink or downlink.

2.1.2.1 V/D Subchannel Burst Format

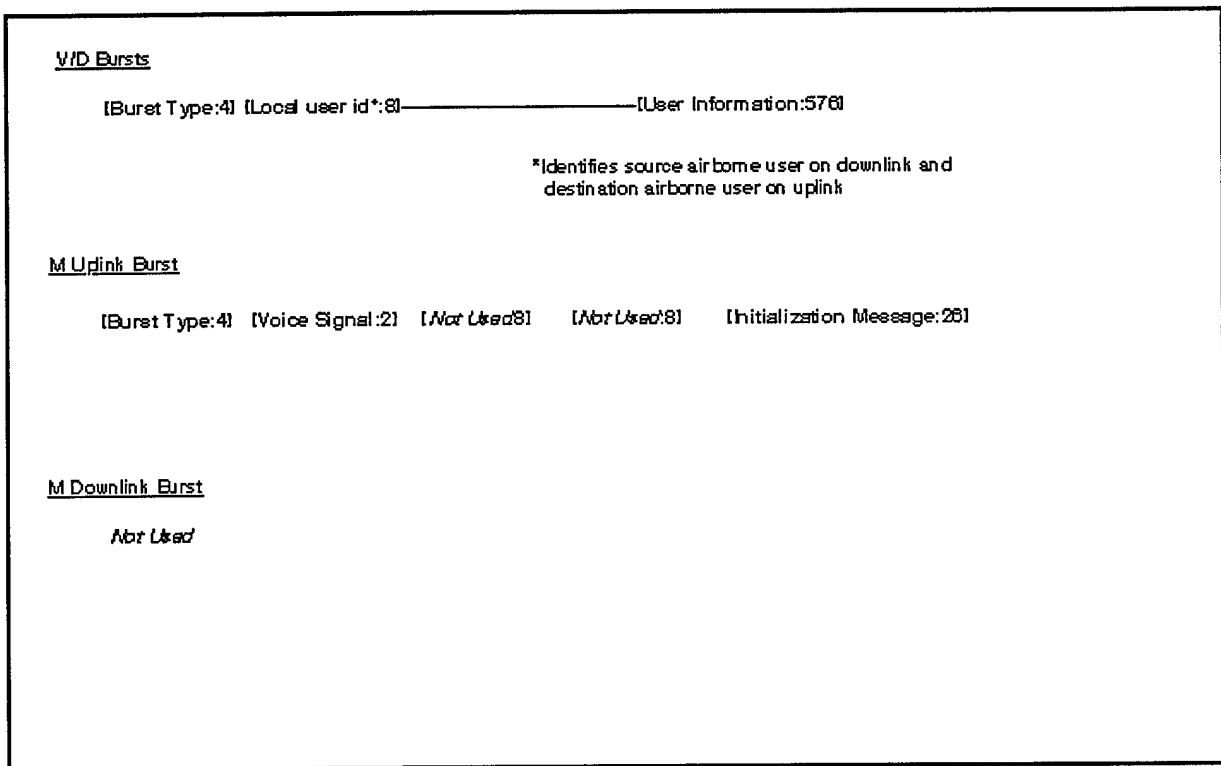

Figure 2-2. Subchannel Burst Fields (Voice-Only System Configurations)

The V/D subchannel burst contains a header portion containing two fields and a third field that carries the user information (see [Figure 2-2](#)). The header contains the Burst Type field and the Local User Identification (Id) field. The third field is the User Information field. The use of each field in the context of the V/D subchannel burst is explained below:

- **Burst Type**--This field is used to allow the receiver to properly identify a received burst. As shown in [Figure 2-3](#), this field contains three 1 bit subfields plus one spare. The *Up/Down* subfield is coded as "down" by airborne transmitters and as "up" by ground transmitters. The *Subchannel* subfield is used to identify the burst as type M or V/D always coded as "V/D" by both airborne and ground transmitters. The *V/D* subfield is always coded as "voice" by both airborne and ground radios.

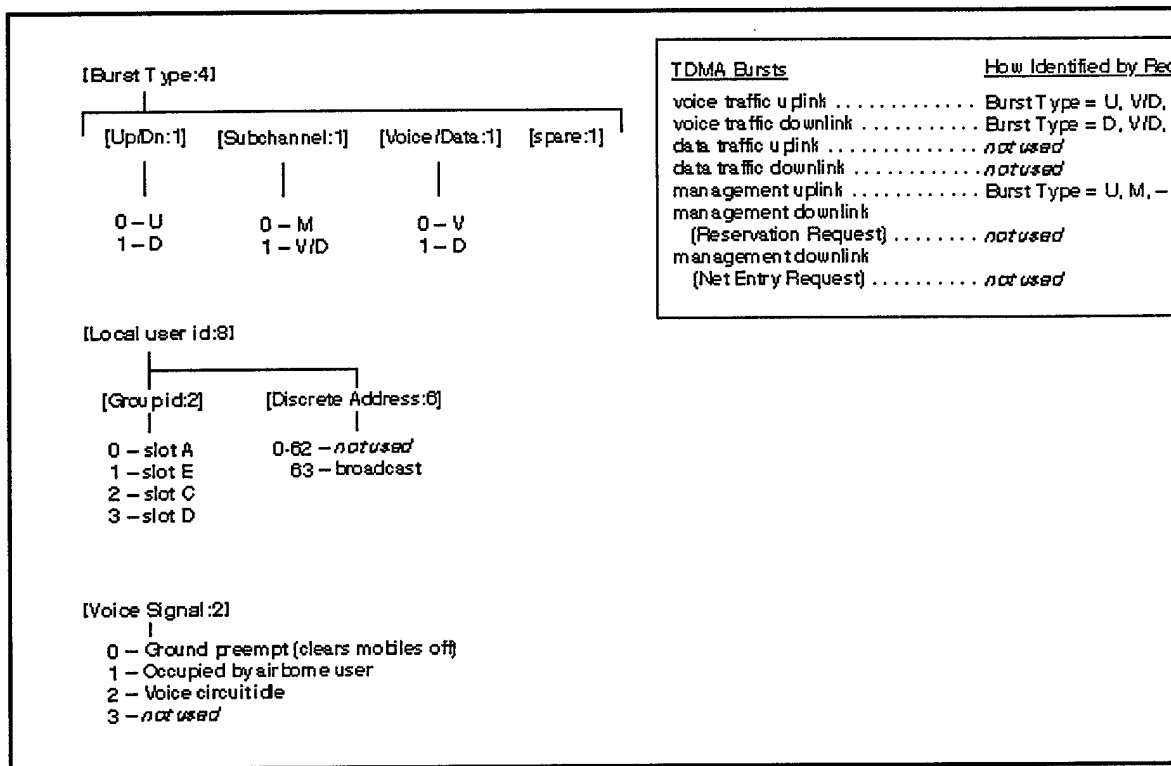

Figure 2-3. Burst Type, Local User Id and Voice Signal Fields (Voice-Only System Configurations)

- Local User Id**--This field is used to uniquely identify all users on the channel. As shown in [Figure 2-3](#), it is composed of two subfields. The first is the *Group Id*, used to identify the slot the user is associated with. The second subfield is the *Discrete Address* used to identify each user of the user group (slot). This subfield is used for identification of source airborne users on downlink transmissions and for identification of destination airborne users on uplink. For voice-only early implementation, the Group Id is statically set to the predetermined slot allocation, and the Discrete Address subfield is always set to the "broadcast" code.
- User Information**--This field contains the compressed digital representation of up to 120 ms of the user's speech.

The header portion (Burst Type and Local User Id fields) of the V/D subchannel burst is protected with a rate one-half forward error correcting code in a single Golay codeword block of 24 bits. No forward error coding beyond that internal to the vocoder (i.e., already included in the 4.8 kbps vocoder rate) is used in the User Information field.

2.1.2.2 Management Subchannel Burst Format

For the system configurations supporting voice-only operation, only the uplink M subchannel is used. The most basic function of the M uplink burst is that of providing the time reference for the airborne radio. The M subchannel uplink also provides signalling and circuit initialization functions. The M subchannel uplink burst contains the following fields (see [Figure 2-2](#)):

- Burst Type:** This field is used to allow the receiver to properly identify a received burst. As shown in [Figure 2-3](#), this field contains three 1 bit subfields plus one spare. The *Up/Down* subfield is coded as "up" by the ground transmitter. The *Subchannel*

subfield is always coded as "M" by the ground transmitter. The coding of the *V/D* subfield is not relevant to the M subchannel burst.

- **Voice Signal:** This field is used to signal airborne radios of the current status of the voice circuit. The following set of signals to the airborne radios are supported:
 - Ground preempt: This signals any airborne radios in Push to Talk (PTT) mode to immediately discontinue transmission. This gives the ground user control of the voice circuit. The ground radio can be configured to set this bit upon receipt of the PTT signal from the ground user.
 - Occupied by airborne user: This signals airborne radios that the circuit is busy when PTT is asserted by one airborne user subsequent to another airborne user still occupying the circuit. This gives airborne users already occupying the circuit preferential access relative to those airborne users that are not.
 - Voice circuit idle: This signals airborne radios that the voice circuit is available for access by any user on a "listen before talk" basis.

Implementation of voice signalling is optional and at the discretion of the CAA or service provider. If voice signalling is not desired, the code for "voice circuit idle" is transmitted continuously. In this case, system operation defaults to no preferential treatment for any user of the voice circuit as is the case in the current 25 kHz DSBAM system.

- **Initialization Message:** A set of initialization messages enable airborne radios arriving on a new voice circuit adapt themselves properly for operation within that circuit. As shown in [Figure 2-4](#), four Initialization Messages are supported; however, only two apply to the voice-only system. These are discussed below:

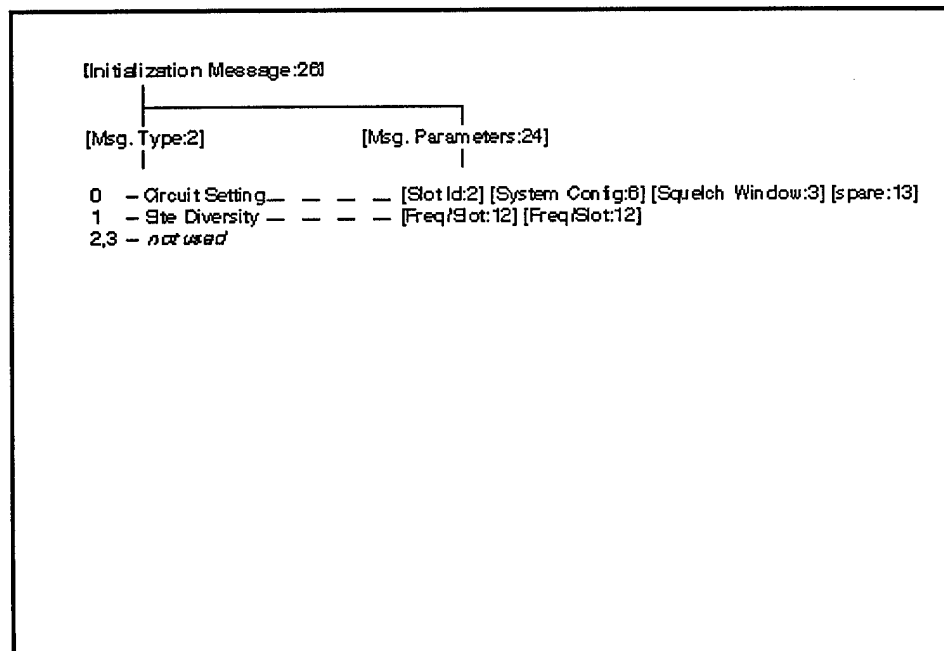

Figure 2-4. Initialization Message (Voice-Only System Configurations)

- Circuit Settings: This message contains several parameters described below:

- *Slot Id*--Informs the airborne radio of the slot associated with the M subchannel uplink burst.
- *System Configuration*--Informs the airborne radio of the specific system configuration used by the ground radio with which it is to communicate. Up to 64 codes are supported. Note that the set of system configurations identified in [Figure 1-3](#) requires five codes.
- *Squelch Window*--Used by the airborne radio to limit or "squelch out" cochannel interference received in the absence of a desired signal. This parameter informs the airborne radio of the allowable time of arrival window within which all desired voice transmissions will arrive. This parameter will be dependent on the Defined Operational Coverage (DOC) (i.e., the protected service volume) dimension and location relative to the ground radio site. This parameter can be defaulted to the full propagation time provided thus giving the largest "squelch opening" for acceptance of cochannel transmissions. This is related to the concept of "coded squelch" discussed further in Section 2.4.
- *Site Diversity*: This message can be used to inform the airborne radio of up to two alternative circuit resources to scan (presumably at diverse sites) in the event of loss of connectivity on the current circuit. Implementing site diversity requiring scanning in the airborne radio is optional and at the discretion of the CAA or service provider. If no site diversity is required, or if diverse sites employ the same frequency and slot as the primary (thus requiring no scanning in the airborne radio), this field is defaulted to the frequency/slot identifier of the current circuit.

The System Data portion of the M uplink subchannel burst is protected with a rate one-half forward error correcting code in Golay codeword blocks of 24 bits. The total System Data portion of the burst requires four codeword blocks resulting in 48 total bits available for System Data.

Note that M subchannel uplinks occur only once per *two* TDMA frames (i.e., once per 240 ms) in order to make room for M subchannel downlinks employed later for discrete addressed V/D; there is no M subchannel downlink burst for the system configurations supporting voice-only capability.

Also note that any given M subchannel uplink burst can contain only one Initialization Message. [Figure 2-5](#) shows, for a given slot, the ground radio's scheduled usage of the M subchannel uplink burst. The established schedule allows for an *Initialization Message period* of 960 ms (corresponding to eight TDMA frames).

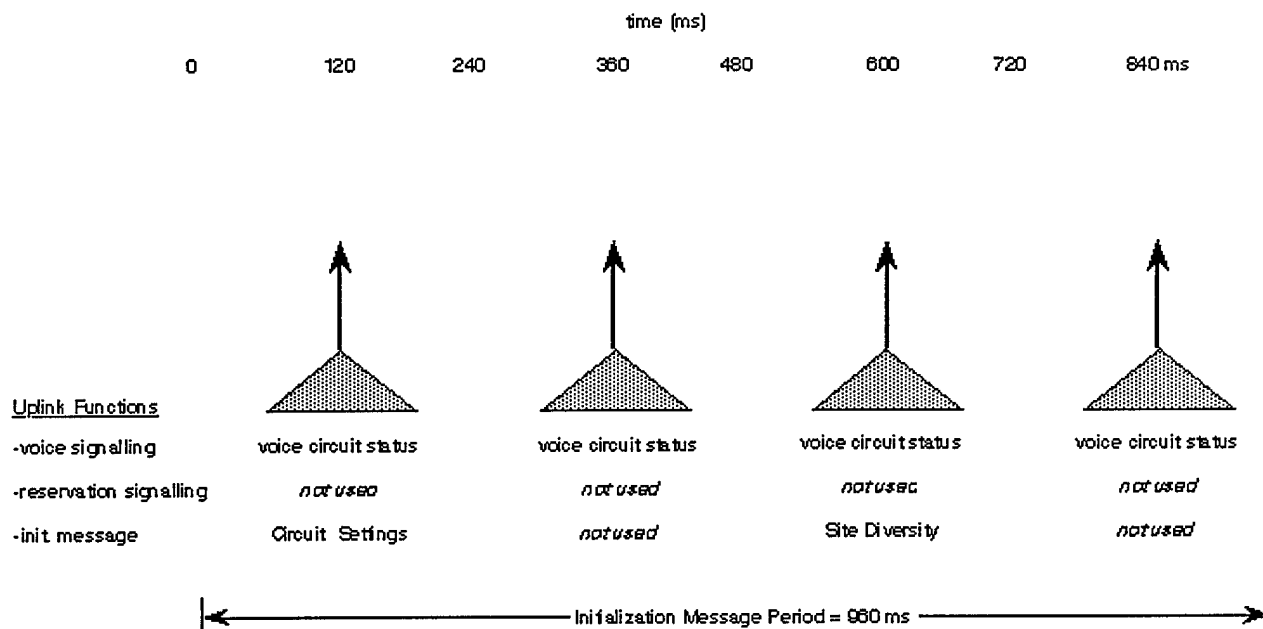

Figure 2-5. M Subchannel Uplink Usage for Single User Group
(Voice-Only System Configurations)

2.2 FOUR VOICE-ONLY SLOTS (SYSTEM CONFIGURATION 4V)

2.2.1 Application

This configuration offers four independent two-way voice circuits (slots "A," "B," "C," and "D") with a single 25 kHz frequency assignment from a single ground radio site at a range of 215 nmi.

2.2.2 Circuit Initialization

Upon entry of the frequency and slot identifier into the airborne radio, the airborne radio immediately begins monitoring the M subchannel uplink associated with the selected slot. The initialization messages associated with the selected slot are used to configure the airborne radio for operation on the circuit. Initialization takes less than 1 second.

Upon circuit initialization, the pilot is able to monitor the transmissions of any user on the circuit. For transmit, the pilot observes the same "listen before talk" discipline used in the current 25 kHz DSBAM system. When the pilot asserts PTT, the airborne radio automatically adjusts the offset timing for the downlink V/D subchannel bursts in accordance with the system configuration supplied as part of the Initialization Message. Figure 2-6 shows the timing of the subchannel bursts by the airborne and ground radios associated with a single slot (or circuit).

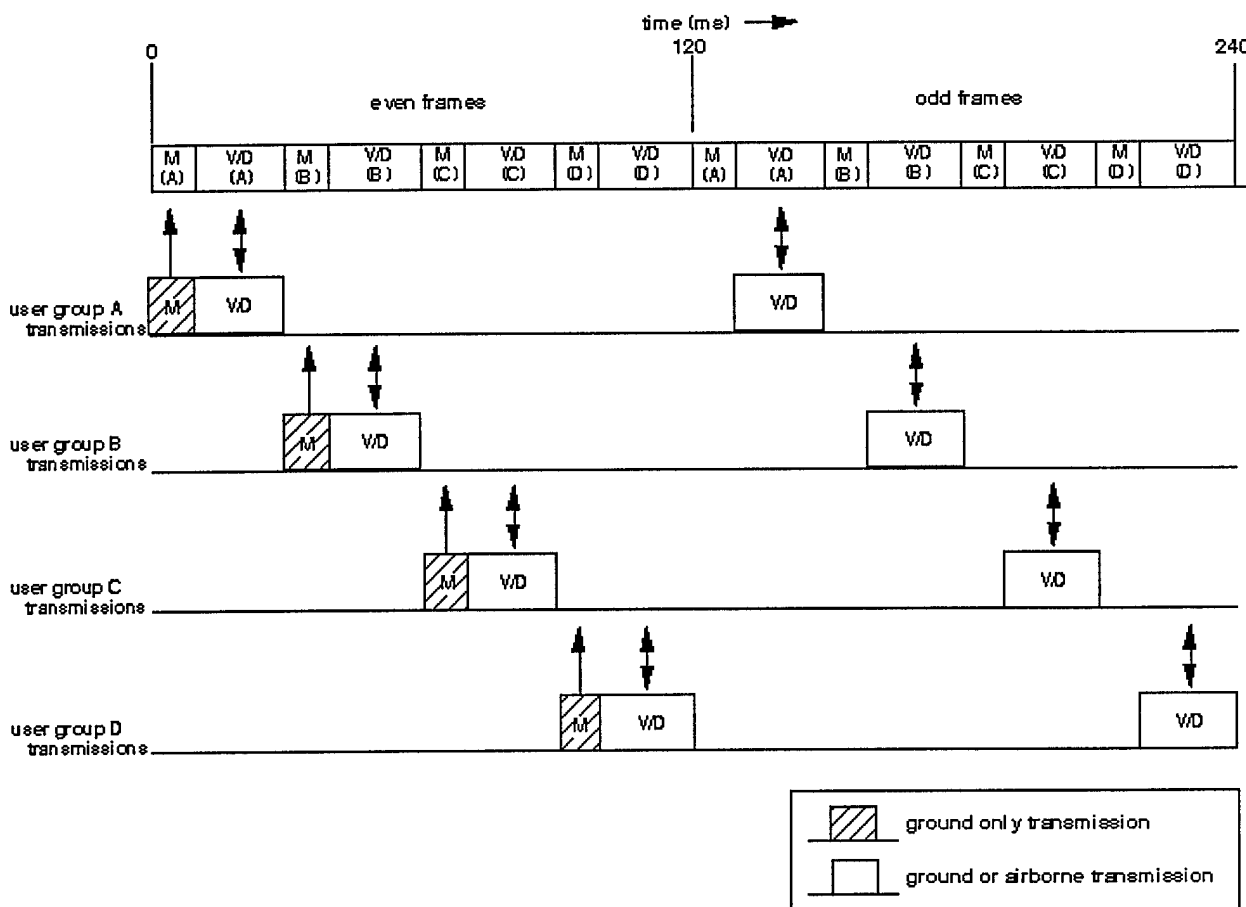

Figure 2-6. Burst Timing for Configuration 4V

2.2.3 Voice Signalling

Since all airborne radios (even those in PTT transmit mode) continue to monitor the M subchannel uplink, voice signalling features can be supported. The ground user can be given special status on the voice circuit with the ability to assert PTT at any time and cause any airborne radio in PTT mode to cease transmitting. This is accomplished by issuing the "ground preempt" code in the M subchannel uplink burst when PTT is asserted by the ground user. This, in turn, results in the termination of any transmissions in progress by any airborne radio on the circuit. The airborne user could be informed of the preemption by the loss of local sidetone (and presence of ground user audio). Lockout of this airborne user would be reset by release of PTT by the ground user *and* release of PTT by the airborne user.

An additional similar capability supported is the ability to resolve contention among airborne users attempting to access the channel. If one airborne user asserts PTT more than one signalling interval (240 ms) ahead of another competing airborne user, the logic and signalling would support access on a "first come-first serve" basis. Additionally, overlapping transmissions by multiple airborne users could be cleared by the ground user if desired by a momentary PTT, thus terminating the transmissions of the airborne users.

2.3 TWO STATION AREA COVERAGE (SYSTEM CONFIGURATION 2V2S)

2.3.1 Application

This system configuration is structured to operate each of the four voice slots out of diverse ground sites. The primary application envisioned for this system configuration is in support of a two station area coverage capability for a given sector (or DOC). One 25 kHz channel could serve two adjacent sectors where each requires two station operation. However, any combination of user groups and ground sites could be supported where the flexibility to "distribute the capacity" of the 25 kHz channel among different ground sites is required.

2.3.2 Frame Structure and Time Reference Requirements for Ground Radio Sites

This system configuration requires the distribution of a common timing reference among the sites sharing a common frequency. (2) In order that a substantial relative timing error among the sites can be tolerated, the frame structure of this system configuration deviates slightly from the standard range frame shown in Figure 1-1. This is accomplished by altering the placement of the M uplink subchannels in the frame as shown in Figure 2-7. This allows a new guard time for timing tolerance among ground sites of 2 ms as shown. Therefore--while still allowing for propagation guard time corresponding to a maximum range of 215 nmi--a relative timing drift between sites of up to 2 ms could be tolerated before intersite/interslot overlap would result. See Figure 2-8 for time scheduling of the subchannel bursts used for this system configuration. Note that although the arrangement of the M subchannel bursts is different than the "standard" frame structure used for system configuration 4V, the periodicity of 240 ms is preserved, thus Figure 2-5 remains applicable to this system configuration.

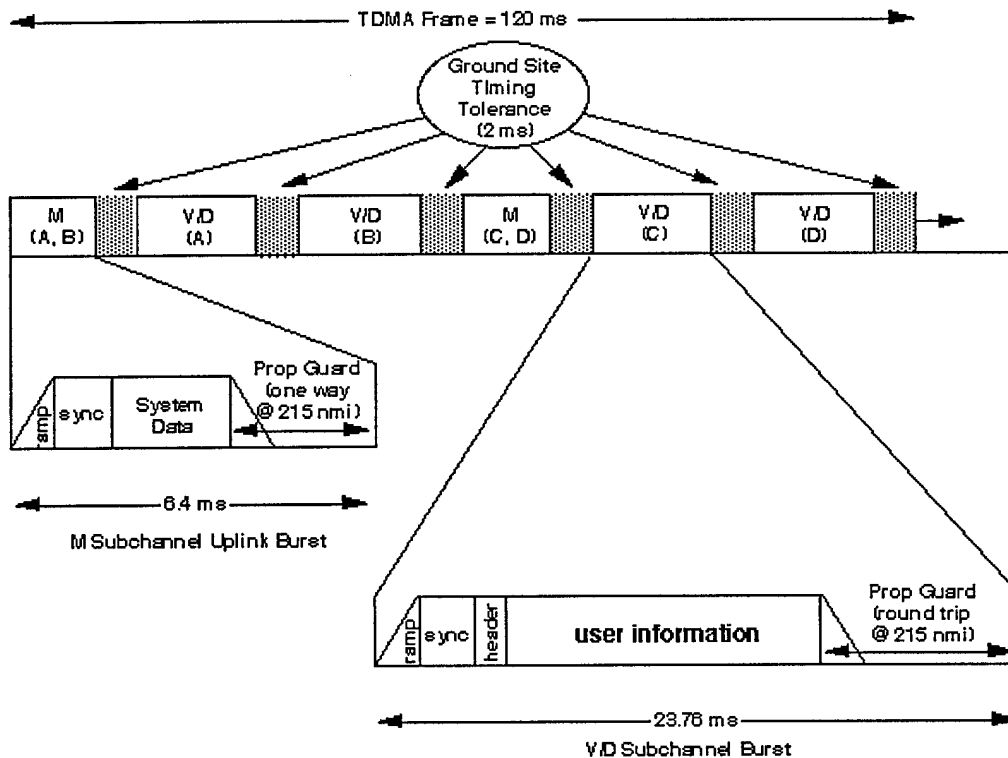

Figure 2-7. Modified Frame Structure for System Configuration 2V2S

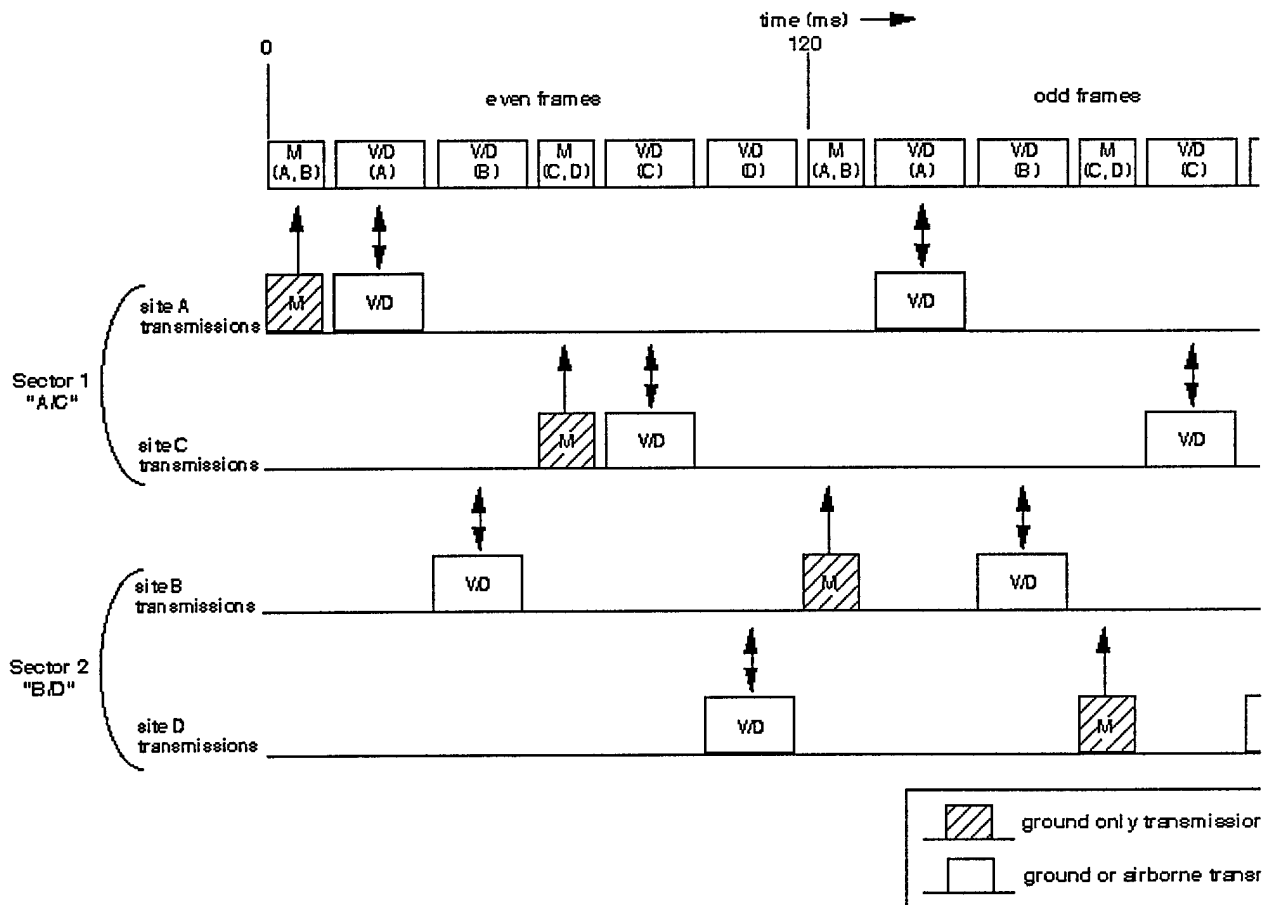

Figure 2-8. Burst Timing of Users A associated with Each Site for Configuration 2V2S

With this allowable budget for timing drift, at least two approaches exist for distribution of timing to each of the ground sites sharing the common 25 kHz frequency assignment:

1. Use of high frequency (HF) broadcast receivers--Information from one vendor indicates accuracies of ± 1.0 ms are achievable with propagation delay compensation. According to this information, England and Germany support HF time broadcast that cover most of Western Europe.
2. Use of Global Navigation Satellite System (GNSS) receivers--GNSS receivers are capable of supporting time distribution with an accuracy far greater than that required for distributed TDMA radio sites. It should also be noted such a system could be made highly survivable/available. First, only one satellite is required to be in view of the receiver in order to receive the timing reference. Second, stable oscillators--continually disciplined by the GNSS receiver--can "coast" autonomously should the GNSS receiving function fail. GNSS receiver timing products are commercially available that include internal disciplined oscillators with the stability to "coast" and maintain site timing tolerance for over a day if failure of the GNSS receive function should occur.

2.3.3 Assignment of Slots

Each of the two user groups (or sectors) supported in this configuration can operate from two separate ground sites. Slot A and C are assigned to one user group and slot B and D are assigned to the other user group. Therefore, in addition to the slot selectors "A," "B," "C,"

and "D," system configuration 2V2S requires two additional selectors: "A/C" and "B/D."

2.3.4 DOC Geometry Requirements

To provide immediate increased spectrum efficiency relative to the offset carrier system used in the current 25 kHz DSBAM system, a single 25 kHz frequency assignment using system configuration 2V2S would have to be applied to two adjacent user groups/sectors. The propagation guard time budgeted for each of the subchannel bursts dictates that the frequency serve two adjacent sectors where some limitation will apply to the size of the combined DOCs of these adjacent sectors. The permissible size of the combined DOC volume will be highly dependent on the geometry of the DOCs relative to the ground radio sites employed by those DOCs. Therefore, candidate DOC pairs for operation under configuration 2V2S must be considered on a case by case basis. However, Figure 2-9 shows a simplistic example of two adjacent sectors with ground sites that would be candidates for 2V2S. Also, Figure 2-10 shows the critical geometry of the ground sites relative to the combined DOC volume boundary for determining suitability of the DOC pair as candidates for system configuration 2V2S. It should be noted that the limiting DOC geometry shown in Figure 2-10 assumes all 2 ms of ground site timing tolerance is required. Increasing the performance of the time reference would ease DOC geometry restrictions by allowing an increase in propagation guard time.

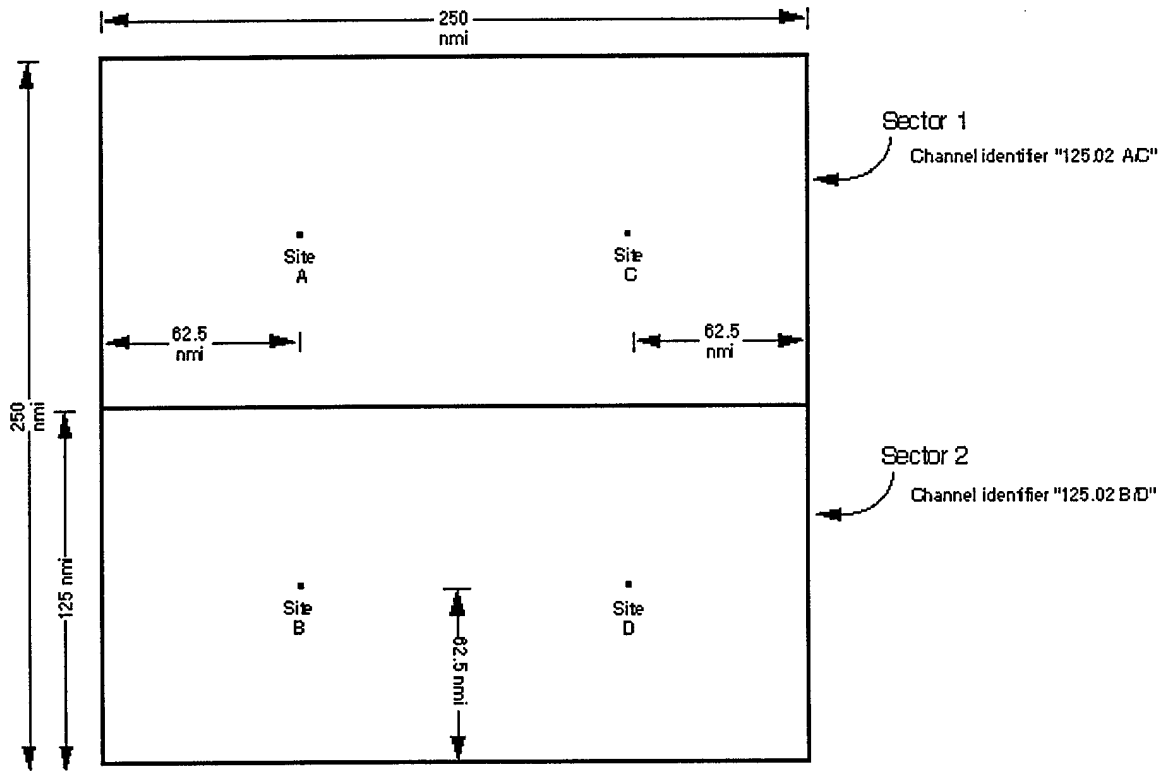
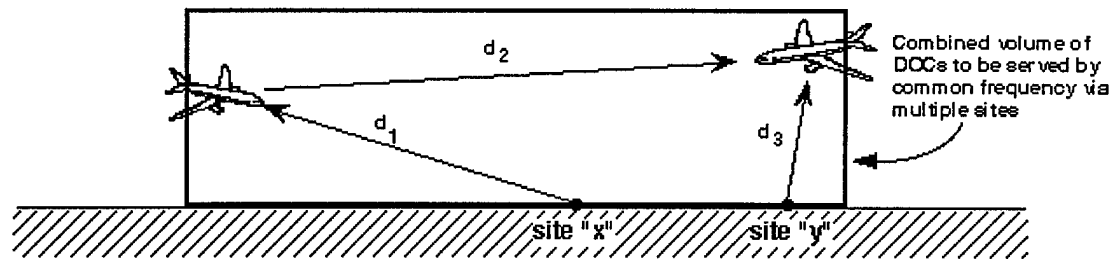

Figure 2-9. Example Sector and Site Geometry for Two Adjacent Sectors for System Configuration 2V2S



Budgeted propagation guard time requires:

$$d_1 + d_2 - d_3 \leq 400 \text{ nmi}$$

for any two aircraft in combined DOC volume

Figure 2-10. Critical Geometry in Determining DOC Sizes for System Configuration 2V2S

2.3.5 Circuit Initialization

Referring to Figure 2-9, assume a pilot is approaching a sector using two station coverage on slots "A/C." Upon handoff, the pilot is given the new channel identifier (e.g., "125.02A/C") which is dialed into the airborne radio. The "A/C" selection entered into the radio informs it to continuously monitor the M subchannel uplinks of both "A" and "C" slots. The M subchannel uplink serves the same initialization functions as previously described for system configuration 4V, but here, even more use is made by the airborne radio of the M subchannel in order to effect site switching as discussed in Section 2.3.7.

2.3.6 Ground System Transmitter Operation

PTT by the ground user results in simulcast transmissions from site "A" and site "C" ("sites" and "slots" are synonymous for purposes of this discussion). Note that since these radio sites are time synchronized to each other--and assuming that the differential audio delay from the control facility to each of the sites is small--the coded voice representation in the last half of V/D burst "A" is identical (or very nearly so) to that in the first half of V/D burst "C." This is true likewise from V/D burst "C" to the following V/D burst "A" (see Figure 2-11). This overlap is important for smooth switching of sites by the airborne radio as described in the next section.

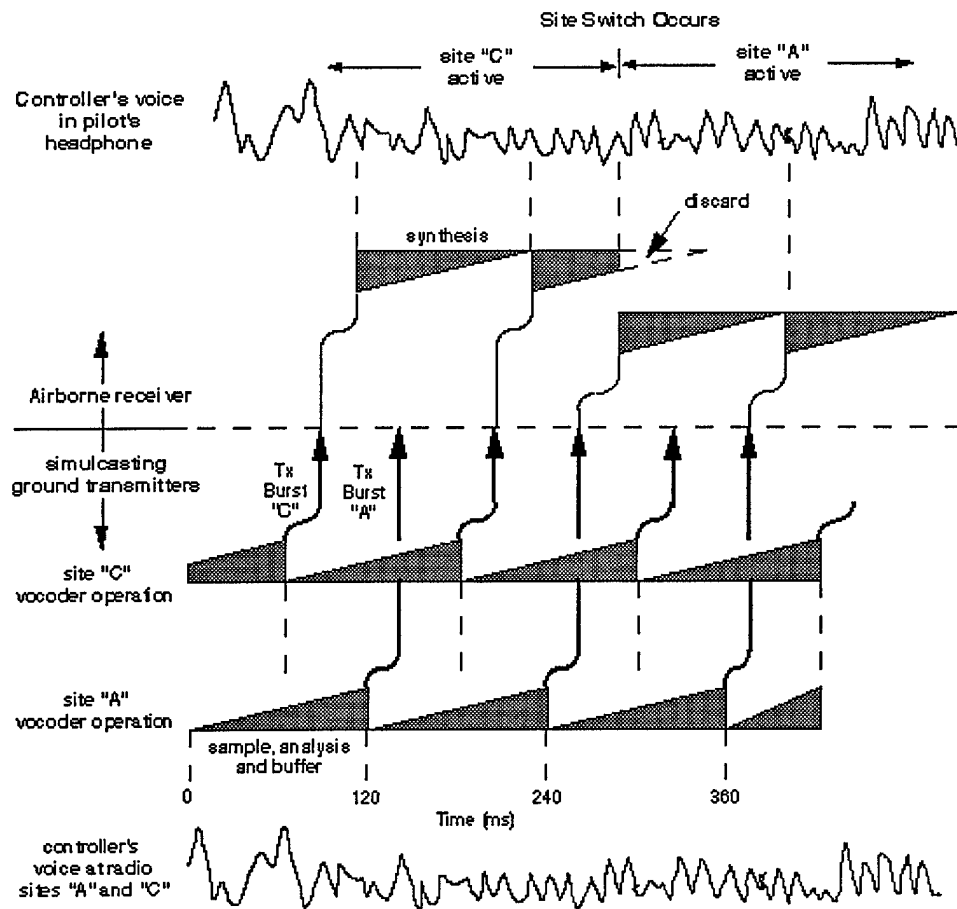

Figure 2-11. Ground Site Transmissions and Airborne Receiver Site Switching for Configuration 2V2S

2.3.7 Site Selection by Airborne Receiver

Through continual monitoring of the M subchannel associated with the slots at both sites, the airborne radio makes a determination as to which of the ground sites is to be selected as *active*. The active site determines the slot selected for receiving voice transmissions from all sources, airborne and ground. Logic for selection of the active site in the airborne radio is based on the total error output from decoding of the four Golay codewords that make up the System Data portion of the M subchannel uplink. While an exact algorithm for switching active sites is TBD, detection of one or two total bit errors over the four codewords for two consecutive M subchannel bursts (480 ms) would be indicative of reduced voice quality ($>10^{-2}$ Bit Error Rate) requiring a site switch *if* the other site has exhibited a more favorable error rate. Although the switching function can be nearly seamless as discussed below, the switching logic should ideally provide some degree of hysteresis to prevent periods of continual switching.

Figure 2-11 shows the continuity of the voice operation through the transition from one active site to the other. From the figure it can be seen that what makes this nearly seamless transition possible is that not only is the TDMA frame itself an integral number of vocoder voice frames, but one-half of the TDMA frame (60 ms) is also an integral number of voice frames (3).

2.3.8 Airborne Transmitter Operation

In order to provide the desired "party line" effect whereby all users in a sector have air-air voice connectivity with all others, PTT by an airborne user will result in simulcast transmissions on both slots (e.g., "A" and "C"). Therefore, any user will receive voice from any other airborne user (within line of sight) on the slot declared active by the individual airborne receiver. As a result, "cross coupling" of sites by the ground system would *not* be required.

2.3.9 Ground System Site Selection (Receiver Voting)

Some method is required for "voting" the best of the two receiver sites in order to give the ground user the best received voice signal from an airborne transmitter. Voting systems that are currently part of the ATC infrastructure are likely to operate in one of two ways:

- Voting systems based on audio signal to noise: Both audio signals are input to the voting unit where--based on a signal to noise analysis of each signal--the best is determined and fed to the output for delivery to the ground user's headset.
- Voting systems based on discrete receiver signalling: Each receiver provides a discrete signal (typically Automatic Gain Control voltage) that is indicative of signal quality. These inputs are used to determine which audio signal is to be fed to the output for delivery to the ground user's headset.

The approach to be taken with the TDMA system under system configuration 2V2S may depend on which of the two above methods is currently in use. In either case, the receivers at each of the two sites are capable of determining signal quality through the sync correlation value attained in detection of the synchronization sequence of every V/D downlink burst received. This provides a signal quality metric that can be used for injecting noise onto the received audio signal if S/N voting is used, or that can be used directly as a substitute for the discrete signalling if that voting method is used.

2.3.10 Voice Signalling

As was the case for system configuration 4V, signalling can be supported that gives the ground user special status on the voice circuit. Ground user PTT at any time can clear any airborne radios currently in PTT mode off the air. This is accomplished by signalling the airborne radios that the ground user is accessing the circuit. This in turn results in the termination of any transmissions in progress by any airborne radio on the circuit (operating from either site). The airborne user could be informed of the preemption by the loss of local sidetone (and presence of ground user audio). Lockout of this airborne user would be reset by release of PTT by the ground user *and* release of PTT by the airborne user.

Signalling to support the ability to resolve contention among airborne users attempting to access the channel as discussed for configuration 4V cannot be guaranteed under configuration 2V2S without coordination among ground sites that likely will not exist.

2.4 CODED SQUELCH EFFECT

The ability to prevent "nuisance" squelch openings in the absence of a desired signal is an attractive attribute for the future VHF A/G radio system. Many analog mobile radio system use what is known as tone coded squelch to prevent nuisance squelch openings. Any digital system naturally offers discrimination against adjacent channel interference and other inband noise-type signals in the absence of a desired signal since these are uncorrelated with desired signals and are thus readily discriminated by a receiver.

The ability to discriminate against cochannel interference in the absence of a desired signal is more of a challenge in the VHF A/G environment. This is due to the fact that the

interference is highly correlated with the desired signal and so must be discriminated by some other logic. This section discusses the attractive attribute of the TDMA system architecture relative to offering discrimination against cochannel interference in the absence of a desired signal. A way to exploit this benefit to effectively increase the system's tolerance to cochannel interference is discussed.

2.4.1 Cochannel Discrimination Offered by TDMA Signal Architecture

In the TDMA system approach, airborne radios continually receive management channel uplink bursts at a period of 240 ms. These uplink bursts establish the timing reference used by all airborne radios operating on the circuit. This time reference establishes the exact transmission times for the V/D bursts from the individual airborne radios. Likewise, this time reference also defines an allowable "time window" within which desired air-air "party line" transmissions must be received by each airborne radio. The time alignment of any received V/D bursts by an airborne receiver relative to the time window established by the ground station thus provides a natural mechanism for discriminating desired transmissions ("party line," originating within the DOC) from undesired cochannel transmissions ("interference," originating in another DOC).

In a free running network of ground stations where no common time reference is employed by ground stations, the probability of a transmission from a cochannel DOC falling within the time window of a receiver in an opposing cochannel DOC is small. To allow for round trip propagation delay in a ground station with maximum range of 215 nmi, the resulting time window is 2.7 ms. Since a TDMA frame is 120 ms, and since burst transmissions are always identified as to which of the four slots they belong (i.e., "A," "B," "C," and "D"), the probability of receiving a burst from a given cochannel aircraft from outside the DOC of the proper slot identifier with the proper alignment within the time window is $2.7 \text{ ms}/120 \text{ ms} = .023$. This probability must, of course, be multiplied by the usual probabilities of experiencing the proper aircraft geometry and of experiencing transmissions from the proper aircraft. This joint probability is thus the probability of the pilot hearing cochannel interference in the absence of a desired signal.

In many DOC and ground radio site geometries, the full propagation delay may not be needed; therefore, a more restrictive time window could be applied by the airborne receivers thus further improving discrimination of cochannel signals. The ability to apply reduced time windows must be determined on a circuit by circuit basis. The "Squelch Window" parameter of the Circuit Settings initialization message is used to apply the reduced time window when appropriate.

2.4.2 Role of Coded Squelch in Increasing Tolerance to Cochannel Interference

How can this discrimination against cochannel interference in the absence of a desired signal be used to advantage in the VHF A/G environment? Currently in the U.S., rules for establishing cochannel DOCs are based on a ratio of desired signal power to undesired signal power. This in turn results in a simple distance ratio value, assuming all transmitters are of equal power. The current U.S. standard is 14 decibel (dB) of desired to undesired signal strength, which in turn results in a distance ratio of 5:1.

In principle, due to the nature and geometry of cochannel DOCs, higher ground transmitter power could be used to advantage to place cochannel assignments closer. Assume, for example, a given transmitter power (say 12 watts for all transmitters, air and ground) and that uplink and downlink budgets are reasonably balanced with adequate margin, then a ground transmitter power increased to 25 watts will provide an additional 3 dB cochannel margin for the desired uplink signal. This would have the effect of allowing the undesired distance to be reduced as though the distance ratio were based on an 11 dB cochannel criteria (14 dB-3 dB). This results in a distance ratio of under 4:1. Note that the power

increase offers no benefit for the downlink and is not needed, because ground stations are seldom victims of cochannel interference. By the same token, increasing the transmitter power of the ground station has no cochannel interference consequences. This is because cochannel interference is almost always dictated by air-air geometries between DOCs; A/G interference geometries between DOCs will virtually always involve substantial horizon blockage.

Use of this increased power technique to further reduce cochannel distances below the 5:1 ratio are not practical with the current system due to the lack of any ability to discriminate against cochannel signals from outside the DOC in the absence of a desired signal. As the cochannel distance is reduced beyond the 5:1 ratio, pilots could begin to suffer significant "nuisance" squelch openings from airborne transmissions in the cochannel DOCs. The coded squelch effect offered by the TDMA architecture offers the ability to discriminate between cochannel signals originating from within the DOC against those originating from outside the DOC.

Although increased ground transmit power provides guaranteed cochannel protection for uplink from the ground, reduced cochannel distances could result in some degradation in protection for airborne reception of desired airborne signals (e.g., party line) in certain DOC geometries. While the probability and impact of occurrence of this interference would have to be determined, it should be noted that the TDMA architecture supports a signalling feature to notify airborne radios of the occupancy of the channel thus largely precluding the "step on" condition that would otherwise be a symptom of loss of air-air connectivity.

2.4.3 Coded Squelch Benefits

The TDMA system architecture provides a coded squelch effect resulting in added cochannel interference rejection in the absence of a desired signal. To provide cochannel discrimination, traditional coded squelch systems would require some form of active code management and selection similar to the way frequencies are managed and selected in the current 25 kHz DSBAM system. This is undesirable in the A/G environment as it adds to pilot workload and communication error modes. The TDMA system architecture offers this effect in a natural, passive way more suited to the A/G operational environment. This is as a result of the ability of airborne receivers to discriminate desired from undesired signals by their arrival time at the receiver. While this paper is not proposing a reduction of cochannel DOC separations below the 5:1 ratio now used in the U.S., the benefits of the coded squelch effect may make this possible in the long-term future and must be considered as an added benefit of the TDMA VHF system architecture.

2.5 TDMA VOICE OPERATION SUMMARY

This section has described the capability of the TDMA system architecture to support increased voice circuit capacity to address near-term needs. From the CAA or service provider perspective, system implementation is nearly transparent to the existing ATC infrastructure. From the aircraft operator perspective, the VDL system currently being standardized provides the basis at the physical layer for the TDMA system operation.

Inherent in the TDMA system approach is the ability to support voice signalling features if desired by the CAA; however, operation can always be defaulted to emulate that of the current 25 kHz DSBAM system. The system also supports two station area coverage that emulates the capabilities of offset carrier operation in the current 25 kHz DSBAM system. Additionally, the TDMA system provides a mechanism that provides a coded squelch effect to reduce the effects of all types of interference in the absence of a desired signal. Finally, the TDMA system signal structure readily supports the transition to discrete addressed V/D applications when the ATC infrastructure can support this. The operation of this next level of service is the subject of the next section.





Time Division Multiple Access (TDMA) System Description: A One-Step Approach to the Future VHF A/G System

J. C. Moody

MTR94W0000035

March 1994

Approved for public release, distribution unlimited

MITRE Corporation, McLean, Virginia

Table of Contents

SECTION 3 DISCRETE ADDRESSED V/D LINK

3.1 BACKGROUND

In addition to the system configurations established to support the voice-only level of service described in Section 2, the TDMA system has several other system configurations designed to support discrete addressing and data link capability at such time as it can be supported by the ATC ground infrastructure. At that point, CAA ground stations previously supporting the TDMA voice-only level of service can be reconfigured to *additionally* support discrete addressing and data link.

3.1.1 Discrete Addressing and User Groups

Within the fixed 120 ms TDMA frame structure, a predefined set of system configurations are established to achieve flexibility. Each system configuration corresponds to a specific preconfigured static allocation of the capacity of each 25 kHz frequency (i.e., individual time slots) to certain users and functions. In the ATC environment, distinct *user groups* exist based on ATC control positions or sectors. Each user group includes the ground user (usually an air traffic controller) and the "client" aircraft of that ground user. A fundamental objective of the TDMA system is to provide voice circuit resources to each user group on a dedicated basis while simultaneously providing access to data link with a single airborne radio transceiver.

Discrete addressing in the TDMA system is coupled to the user group. A Local User Id is established for each new airborne user that enters the group (or net). A process known as *net entry* serves to automatically "log in" a new arrival to the group and resolve the full 24 bit ICAO aircraft address to the compressed 8 bit Local User Id. The Local User Id address space accommodates up to 60 aircraft per user group and four user groups per 25 kHz frequency assignment.

Additionally, one configuration is defined where there is no predetermined static allocation of resources to user groups within the 25 kHz channel; resource allocations for both V/D are made strictly on a demand basis. This configuration is established for non-ATC applications and possibly for ATC applications in the long-term future where voice traffic volume is reduced significantly through the use of data link.

3.1.2 Subchannel Bursts Supporting Discrete Addressed V/D Operation

The description of the M and V/D bursts given in Section 2 for the voice-only level of service also apply to the system configurations that support discrete addressed V/D service. However, this section will mainly highlight details of the subchannel bursts that apply only to discrete addressed V/D operation, and therefore were omitted (i.e., elements labelled "not used") from the description in Section 2. In the figures that follow, the details applicable only to system configurations supporting discrete addressed V/D are highlighted by underscoring.

3.1.2.1 V/D Subchannel Burst Format

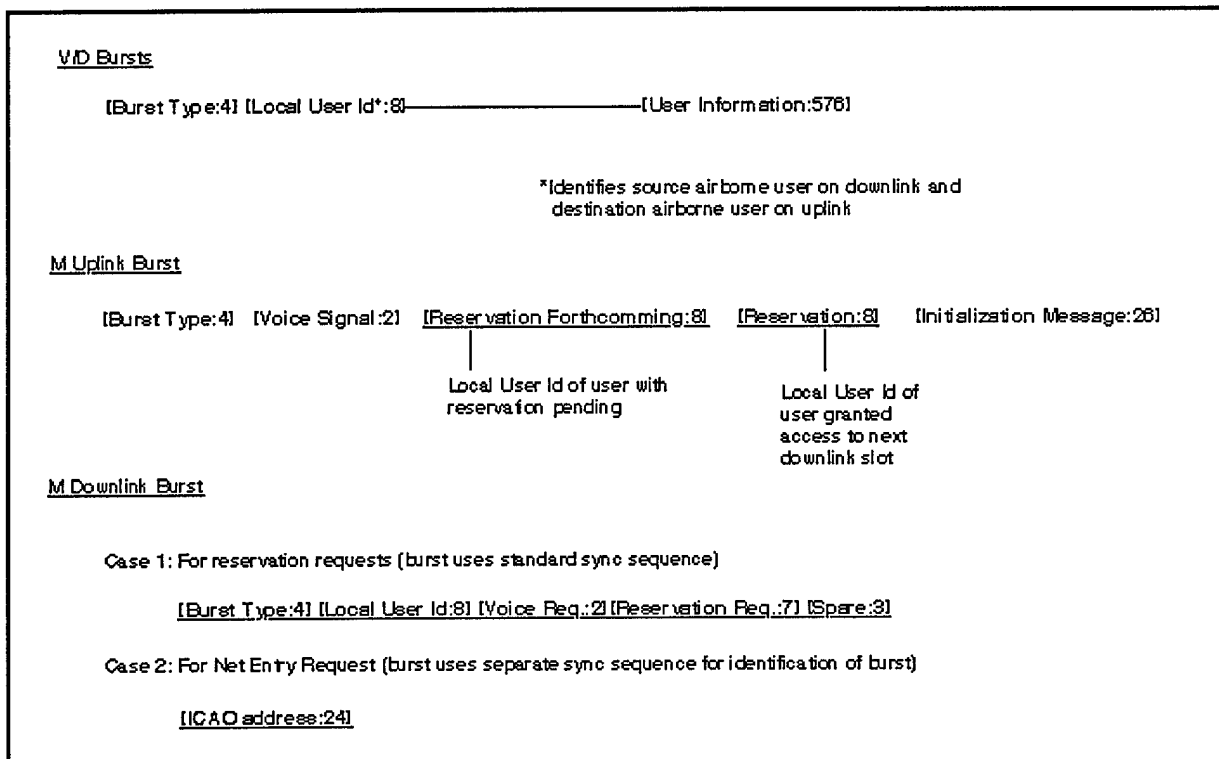

Figure 3-1. Subchannel Burst Fields (Discrete Addressed V/D System Configurations)

The V/D subchannel burst components are shown in Figure 3-1. The header portion contains two fields and a third field carries the user information. The header contains the Burst Type field and the Local User Id field. The third field is the User Information field. The use of each field in the context of the V/D subchannel burst is explained below:

- **Burst Type:** This field is used to allow the receiver to properly identify a received burst. As shown in Figure 3-2, this field contains three 1 bit subfields plus one spare. The *Up/Down* subfield is coded as "down" by airborne transmitters and as "up" by ground transmitters. The *Subchannel* subfield is always coded as "V/D" by both airborne and ground transmitters. The *V/D* subfield is coded as "voice" or "data" by both airborne and ground radios as appropriate.
- **Local User Id:** This field is used to uniquely identify all users on the channel. As shown in Figure 3-2, it is composed of two subfields. The first is the *Group Id*, used to identify the slot the user is associated with. The second subfield is the *Discrete Address* used to identify each user of the user group. This subfield is used for identification of source airborne users on downlink transmissions and for

identification of destination airborne users on uplink. Discrete address codes of 1-60 are assigned to aircraft in the group during the net entry procedure.

- **User Information:** This field contains the compressed digital representation of up to 120 ms of the user's speech if the time slot is dedicated to voice and contains user data if the time slot is dedicated to data link.

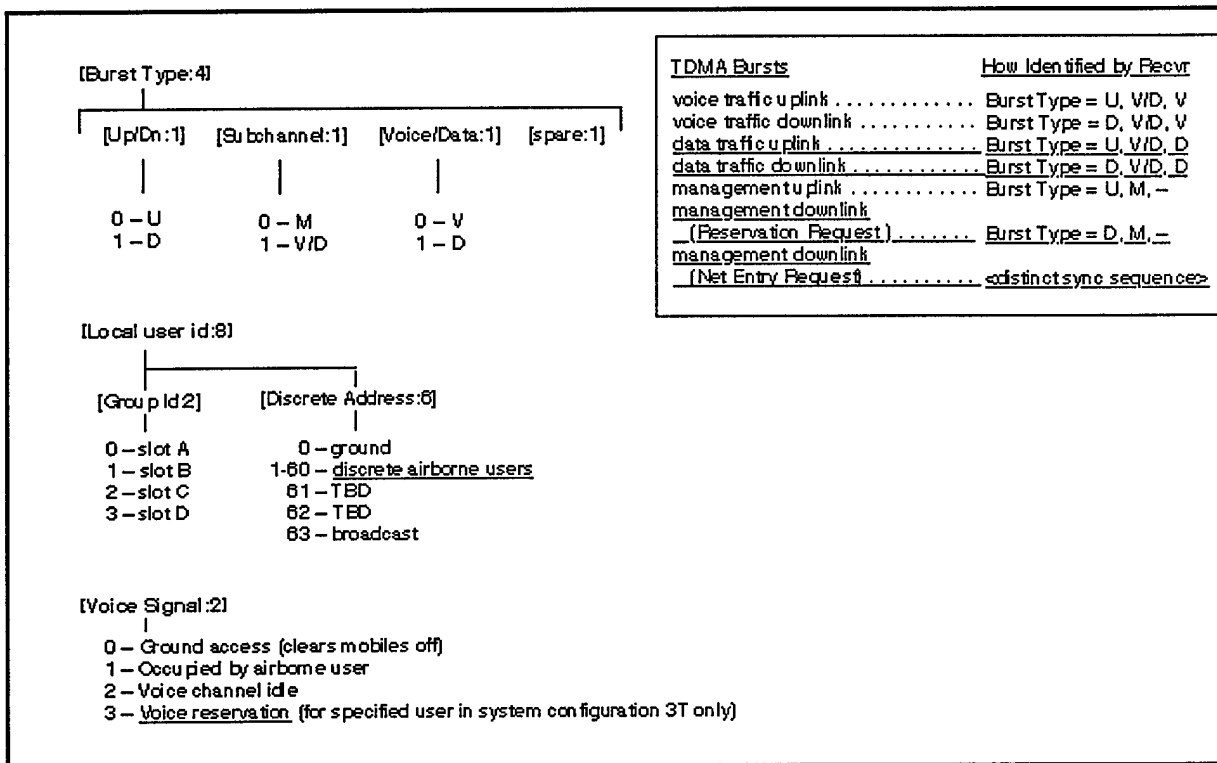

Figure 3-2. Burst Type, Local User Id, and Voice Signal Fields (Discrete Addressed V/D System Configurations)

The header portion (Burst Type and Local User Id fields) of the V/D subchannel burst is protected with a rate one-half forward error correcting code in a single Golay codeword block of 24 bits. When used for voice, no forward error coding beyond that internal to the vocoder (and included in the 4.8 kbps vocoder rate) is used in the User Information field. When used for data, the User Information field employs a forward error correcting (FEC) scheme TBD. Use of an FEC scheme similar to that used in the VDL system would require a total of 6 octets of FEC overhead.

3.1.2.2 Management Subchannel Burst Format (Uplink)

The M subchannel burst components are shown in Figure 3-1. The M subchannel uplink burst contains the following fields shown in Figure 3-2:

- **Burst Type:** <as per Section 2 description>.
- **Voice Signal:** This field is used to signal airborne radios of the current status of the voice circuit. The following set of signals to the airborne radios are supported:
 - Ground preempt--<as per Section 2 description>.
 - Occupied by airborne user--<as per Section 2 description>.
 - Voice circuit idle--<as per Section 2 description>.
 - Voice reservation--used to grant voice access to user specified in Reservation

field. This is used only in system configuration "3T" and is explained in Section 3.4.2.

- **Reservation Forthcoming:** Local User Id of user that has made a Reservation Request. It is used to indicate that the request has been received and is pending.
- **Reservation:** Local User Id of user that is granted access to the next available downlink V/D burst allocated for user data traffic.

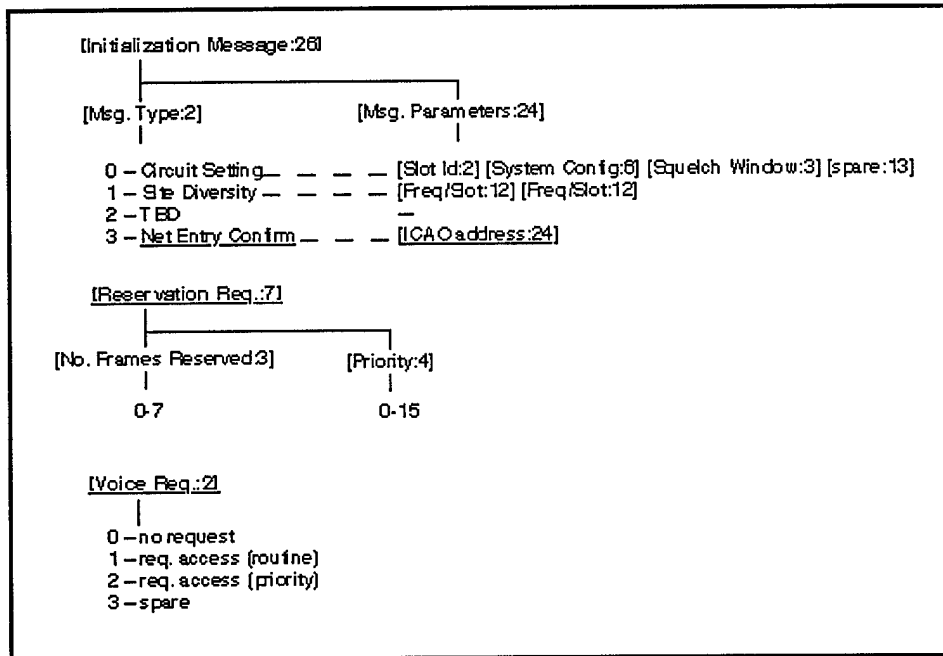

Figure 3-3. Initialization Message and Reservation Request Fields
(Discrete Addressed V/D System Configurations)

- **Initialization Message:** A set of initialization messages are used in order that airborne radios arriving on a new voice circuit properly adapt themselves for operation within that circuit. As shown in [Figure 3-3](#), four Initialization Messages are supported. These are discussed below:
 - Circuit Settings--<as per Section 2 description>.
 - Site Diversity--<as per Section 2 description>.
 - Net Entry Confirm--used to confirm a random access Net Entry Request. The Message Parameters subfield is used to reply to the newly arrived user with the full 24 bit ICAO address of the aircraft. The address contained in the Reservation field of the same burst becomes the Local User Id of the newly entered user.

The forward error coding of the System Data portion of the M uplink subchannel burst is as per the description given in Section 2. The total System Data portion of the burst requires four codeword blocks resulting in 24 total bits available for System Data.

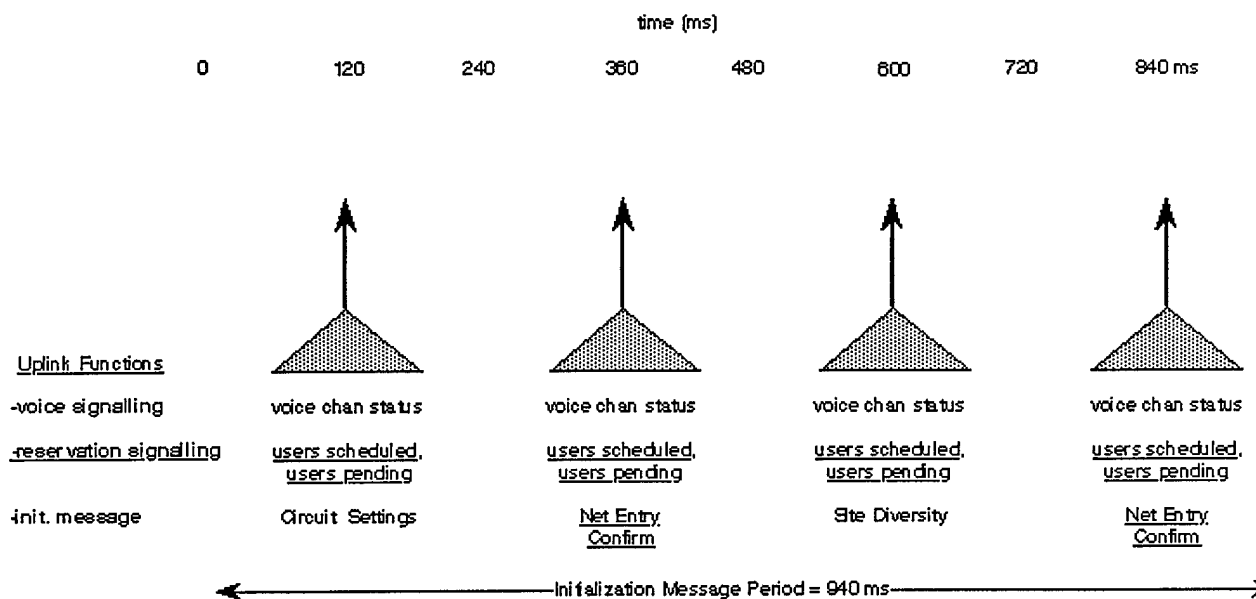

Figure 3-4. M Subchannel Uplink Usage for Single User Group
(Discrete Addressed V/D System Configurations)

Note that any given M subchannel uplink burst can contain only one Initialization Message. Figure 3-4 shows, for a given user group, the ground radio's scheduled usage of the M subchannel uplink burst. The established schedule allows for an *Initialization Message period* of 960 ms (corresponding to eight TDMA frames). Note that all opportunities to provide the Net Entry Confirm message may not be needed. Since new arrivals on the net--or circuit--will be relatively infrequent, there will often be no need for the Net Entry Confirm message during its scheduled time. When this is the case, a null address code is used, thus making the Reservation field available for granting access to users with downlink traffic when there is no Net Entry Request to be serviced.

3.1.2.3 Management Subchannel Burst Format (Downlink)

The M subchannel downlink burst is used by airborne radios only for random access in a slotted ALOHA scheme. The M subchannel downlink burst is used for two separate cases. Case 1 is for use by the airborne radio in making Reservation Requests for downlink data traffic. Case 2 is for use by the airborne radio in making the Net Entry Request. The fields used for both of these cases is shown in Figure 3-1 and explained below:

For Case 1

- **Burst Type:** This field is used to allow the receiver to properly identify a received burst. As shown in Figure 3-2, this field contains three 1 bit subfields plus one spare. The *Up/Down* subfield is coded as "down" by airborne transmitters. The *Subchannel* subfield is always coded as "M" by the airborne transmitters. The *V/D* subfield coding is not relevant to the M subchannel.
- **Local User Id:** This field is used to indicate the user making the Reservation Request.
- **Voice Request:** This field is used to indicate that the airborne user identified in the Local User Id field is requesting voice access. In system configurations that support dedicated circuit resources for each user group, the codes are used in order to provide an indication to the ground user who in turn arbitrates access to the circuit. In system

configuration 3T where there is no dedicated voice circuit resource, the codes are used to initiate an access request for a voice transmission.

- **Reservation Request:** This field is used to indicate that the airborne user identified in the Local User Id field is requesting access for downlink data. The elements of this field are the number of slots being reserved for the downlink message, and the priority of the downlink message.

For Case 2

- **ICAO Address:** This field contains the full 24 bit ICAO address. This constitutes the Net Entry Request. A second special dedicated 16 symbol synchronization sequence is used for M subchannel downlink bursts used for net entry in order that they can be identified by the ground receivers. (Note: airborne radios are *not* required to detect/decode this second sequence.)

3.2 DEDICATED V/D CIRCUITS (SYSTEM CONFIGURATION 2V2D)

In system configuration 2V2D, each of two user groups are provided dedicated slots for V/D traffic. All aspects of basic voice operation as described in Section 2 apply. In addition to this basic voice capability, the ability to discretely address airborne users offers additional features associated with voice operation, such as "selective calling" on uplink and "caller Id" on downlink.

3.2.1 Application

This configuration provides dedicated V/D resources to each of two user groups with a single 25 kHz frequency assignment from a single ground radio site at ranges of up to 215 nmi. The TDMA frame and slot structure as depicted in [Figure 1-1](#) apply to system configuration 2V2D. One user group uses slot "A" for voice traffic and slot "C" for data traffic. The second user group uses "B" for voice and "D" for data. Each of the two user groups in this system configuration gain their identity from the voice slot. Therefore, channel selector codes "A" and "B" would be the only valid codes applicable to 25 kHz frequency assignments employing this system configuration, since only two user groups are supported.

3.2.2 Media Access Protocol

For voice operation, the media access protocol is exactly as described in Section 2: based strictly on a "listen before talk" protocol (competition limited only to users within the group) with the added ability for voice signalling as described in Section 2.2.3.

For data operation, media access employs a centrally managed reservation protocol for all data traffic. This approach gives the ground station maximum flexibility for making efficient use of channel capacity and for implementing prioritization in the media access layer. No carrier detection is required, either by the airborne or ground radios.

The management channels of the data slot and the associated voice slot play a key role in media access for downlink data traffic. The M subchannel uplink burst associated with the voice slot occupies alternate TDMA frames as shown in [Figure 3-4](#). The interleaved TDMA frames are used for M subchannel downlink bursts. The M subchannel bursts associated with the voice slot are referred to as "MV" bursts.

All M subchannel bursts associated with the data slot are used for downlink M subchannel

bursts. The M subchannel bursts associated with the data slot are referred to as "MD" bursts. Figure 3-5 shows the scheduled usage of the M subchannel for the combined V/D slot pair of a single user group. Note that a complete media access protocol cycle requires two TDMA frames for a total of 240 ms.

Access for downlink data traffic is granted by the ground station based on reservation requests made by airborne radios on a slotted ALOHA basis in designated M subchannel downlink bursts. Access for uplink data traffic is managed directly by the ground station. A complete *media access protocol cycle* requires two TDMA frames for a total of 240 ms.

3.2.3 Circuit Initialization

Upon entry of the frequency and slot identifier into the airborne radio, the airborne radio immediately begins monitoring the M subchannel uplink associated with the selected slot. The initialization messages associated with the selected slot are used to configure the airborne radio for operation on the circuit. Initialization takes less than 1 second.

Upon circuit initialization, the pilot is able to monitor the transmissions of any user on the circuit. For transmit, the pilot observes the same "listen before talk" discipline used in the current 25 kHz Amplitude Modulation system. When the pilot asserts PTT, the airborne radio automatically adjusts the offset timing for the downlink V/D subchannel bursts in accordance with the system configuration supplied as part of the Initialization Message.

The net entry procedure is initiated by the airborne radio immediately upon initialization. To accomplish net entry, the airborne radio transmits a Net Entry Request at random among one of the three opportunities for M subchannel downlink slots in the media access protocol cycle. Transmission of the Net Entry Request is made on a slotted ALOHA basis. A successfully received Net Entry Request will result in a Net Entry Confirm message from the ground station at the next opportunity, thus "logging in" the airborne user to the circuit and providing the Local User Id.

3.2.4 Voice Operation

The same level of voice operational capability described in Section 2 is available to the newly arrived user as soon as the initialization process is complete. *Voice operation to this level is not dependent on the net entry process or aircraft participation in discrete addressing and data link.* For airborne users that are participating in discrete addressing/data link, some enhancements to voice operation can be supported if found operationally desirable from the ground user's perspective. Essentially this would entail a "caller Id" feature that could reinforce/replace the verbal identities used by the pilot on downlink and a "selective call" feature that enables the ground user to selectively signal the airborne user that is the recipient of a voice call. The Local User Id in the header of the V/D bursts used for voice traffic is used to implement these capabilities.

3.2.5 Data Operation

Addressing for data link is based on the Local User Id assigned by the ground radio at the time of net entry: uplink V/D bursts used for data traffic employ the Local User Id in the header portion of the burst to identify the airborne recipient; the downlink bursts from airborne radios employ the Local User Id to identify the source airborne user. On downlink, destination addressing is not required. Since the system is assumed to operate in a frequency-protected service volume environment, there is never any ground station ambiguity.

On uplink, the ground station schedules its traffic for the V/D uplink bursts. The ground station can use both the uplink and downlink data burst (in a given media access cycle) if no

downlink traffic is to be scheduled.

On downlink, airborne radios with traffic make Reservation Requests in one of the three M subchannel burst downlink opportunities in a media access cycle. The request includes the message length in terms of the number of V/D bursts required and the priority of the downlink message. Upon successful receipt of a Reservation Request, the ground station issues either a Reservation Request or a Reservation Forthcoming in the next M subchannel uplink. Which of these is issued will depend on the indicated priority and the backlogged reservations from other aircraft that are pending. Since collisions can occur on the Reservation Request downlink, a retransmission algorithm is required.

3.2.6 Connection Management

Connection management can be automated to the degree desired by the CAA or service provider. A completely manual approach to connection management (as is required in the voice-only system) is always available as an option. Alternatively, a semiautomated approach could be used whereby the new channel assignment is uplinked to the proper airborne radio under initiation by the ground user which is then "activated" by the pilot to effect the actual channel change. Finally, a fully automated approach could be used where no ground user or pilot intervention is required. All approaches, however, must be driven by an external ground-based application (e.g., ATC procedures or automation).

3.3 DEDICATED VOICE/SHARED DATA (SYSTEM CONFIGURATION 3V1D)

3.3.1 Application

This configuration provides dedicated voice circuits to each of three user groups with shared access to a single data slot with a single 25 kHz frequency assignment from a single ground radio site. The TDMA frame and slot structure as depicted in Figure 1-1 apply to system configuration 3V1D. Slots "A," "B," and "C" are used for voice traffic for each of the user groups. Slot "D" is the shared slot used for data traffic. Each of the three user groups in this system configuration gain their identity from the voice slot. Therefore, channel selector codes "A," "B," and "C" would be the only valid codes applicable to 25 kHz frequency assignments employing this system configuration since only three user groups are supported.

3.3.2 Media Access Protocol

For voice operation, the media access protocol is exactly as described in Section 2: based strictly on a "listen before talk" protocol (competition limited only to users within the group) with the added ability for voice signalling as described in Section 2.2.3.

For data operation, media access is consistent with the approach described in Section 3.2.2. However, in this case the aircraft of three different user groups are all sharing access to the same slot used for data link traffic. Reservation scheduling of downlinks are coordinated across the user groups by the ground station to prevent conflicts. This system configuration would be appropriate where data link traffic was relatively light (e.g., when few applications are supported or when few aircraft are properly equipped for data link).

Voice operation, data operation, and connection management are consistent with that described for system configuration 2V2D.

3.4 DEMAND ASSIGNED V/D (SYSTEM CONFIGURATION

3T)

3.4.1 Application

This system configuration differs fundamentally from all others described relative to the concept of user groups. In configuration 3T, the concept of user groups is used only to provide addressing: they are not used to establish any preallocation of channel resources as is done in all other system configurations. This configuration could be useful for maintaining high overall channel efficiency when total voice traffic is expected to be light and insensitive to some access delay. Slots "B," "C," and "D" are used for either V/D traffic on demand for any user on the 25 kHz channel. These represent the valid channel selector codes for frequency assignments under this system configuration. In this case, the code selected would serve only to establish the identity of the ground user that voice traffic is to be routed to; the airborne radio is not actually limited to that slot for V/D traffic. The address space accommodates a total of 180 aircraft maximum per channel for system configuration 3T.

3.4.2 Media Access Protocol

In this system configuration, the portion of the TDMA frame associated with slot "A" is used for three M subchannel bursts rather than an M subchannel burst and a V/D subchannel burst. More than adequate guard time is available between the individual M subchannel bursts. To keep the media access protocol consistent with that of 2V2D and 3V1D, the M subchannel of what would be slot "A," becomes the MV subchannel of the media access cycle as per Figure 3-5.

For voice operation, media access is granted on a reservation basis rather than the "listen before talk" approach used in the other system configurations. Depressing the microphone switch serves to issue a Reservation Request downlink indicating that voice access is desired. The downlink uses all of the available M subchannel downlink opportunities on the channel without regard to slot boundaries. The ground, when able, accommodates the request in any M subchannel uplink burst by setting the requesting user's Local User Id in the Reservation field and setting the proper code in the Voice Signal field. These settings remain in these fields for subsequent M uplink bursts until the user releases PTT or higher priority traffic preempts the voice call.

For data operation, media access is consistent with the approach described in Section 3.2.2. However, in this case, any aircraft on the 25 kHz channel is able to utilize the appropriate resources associated with any of the three traffic slots on the channel.

3.5 DISCRETE ADDRESSED V/D SUMMARY

This section has described the capability of the TDMA system architecture to support data link operation in several operational contexts. System configuration 2V2D supports discrete addressing and data link in a manner that is functionally simultaneous with voice operation where voice resources are provided to each user group on a dedicated basis. System configuration 3V1D similarly supports simultaneous V/D where data traffic demands are lower. Finally, system configuration 3T supports simultaneous access to V/D without channel partitioning to establish user group boundaries or dedicated voice resources. Collectively, these three system configurations coupled with the voice-only level of operation presented in Section 2 provide a natural time phased evolution toward increased use of data communications with a single avionics radio system. Through the application of the various system configurations, the pace and degree of this evolution is placed under control of the CAA or service provider of each individual State.





Time Division Multiple Access (TDMA) System Description: A One-Step Approach to the Future VHF A/G System

J. C. Moody
MTR94W0000035
March 1994

Approved for public release, distribution unlimited
MITRE Corporation, McLean, Virginia
Table Of Contents

APPENDIX A TRANSMIT-RECEIVE AND RECEIVE-TRANSMIT SWITCHING TIME REQUIREMENTS

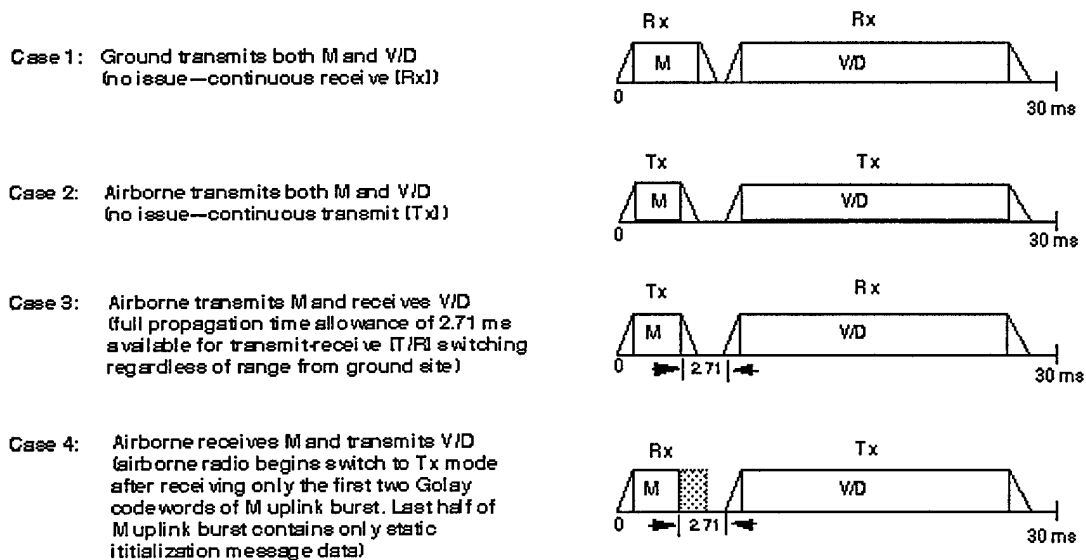

Note: Cellular IS54 standard requires ~2 ms T/R switching time

Figure A-1. Airborne Radio T/R and Receive-Transmit Switching Time Requirements: 2.7 ms

Figure A-1 shows each of four possible permutations of the transmit receive combinations encountered in a given TDMA slot of 30 ms.

GLOSSARY

A/G Air/Ground
ATC Air Traffic Control
CAA Civil Aeronautics Administration

dB Decibel
DOC Defined Operational Coverage
DSBAM Double Sideband Amplitude Modulation
FEC Forward Error Correcting
GNSS Global Navigation Satellite System
HF High Frequency
ICAO International Civil Aviation Organization
Id Identification
Kbps Kilobits Per Second
kHz Kilohertz
M Management
ms Millisecond
nmi Nautical Miles
PTT Push to Talk
RF Radio Frequency
Rx Receive
TBD To Be Determined
TDMA Time Division Multiple Access
T/R Transmit-Receive
Tx Transmit
V/D Voice or Data
VDL VHF Digital Link
VHF Very High Frequency



Time Division Multiple Access (TDMA) System

Description: A One-Step Approach to the Future VHF A/G System

J. C. Moody
MTR94W0000035
March 1994

Approved for public release, distribution unlimited
MITRE Corporation, McLean, Virginia
Table Of Contents

APPENDIX A

TRANSMIT-RECEIVE AND RECEIVE-TRANSMIT SWITCHING TIME REQUIREMENTS

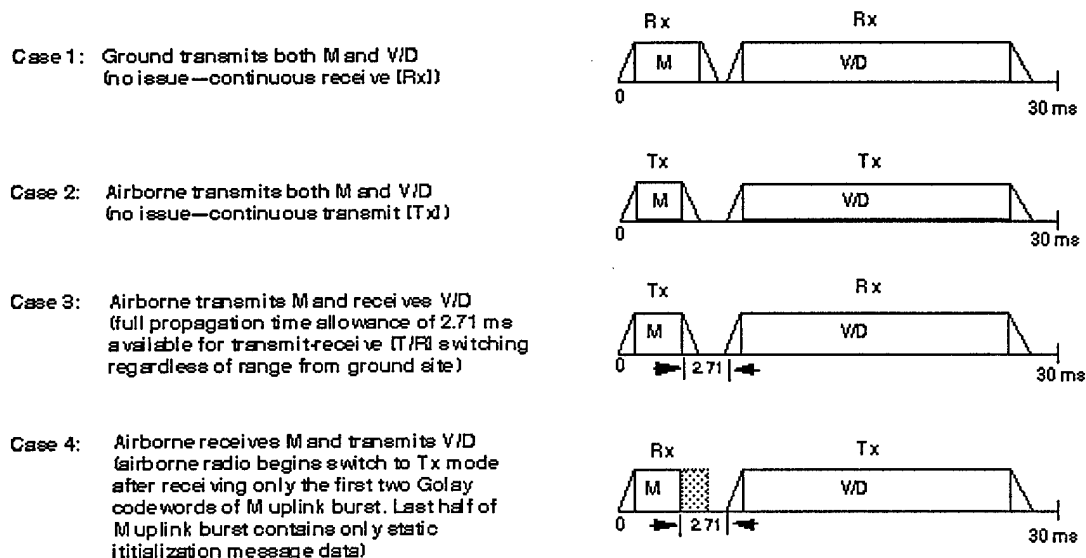

Note: Cellular IS4 standard requires ~2 ms T/R switching time

Figure A-1. Airborne Radio T/R and Receive-Transmit Switching Time Requirements: 2.7 ms

Figure A-1 shows each of four possible permutations of the transmit receive combinations encountered in a given TDMA slot of 30 ms.

GLOSSARY

A/G Air/Ground
ATC Air Traffic Control
CAA Civil Aeronautics Administration

dB Decibel
DOC Defined Operational Coverage
DSBAM Double Sideband Amplitude Modulation
FEC Forward Error Correcting
GNSS Global Navigation Satellite System
HF High Frequency
ICAO International Civil Aviation Organization
Id Identification
Kbps Kilobits Per Second
kHz Kilohertz
M Management
ms Millisecond
nmi Nautical Miles
PTT Push to Talk
RF Radio Frequency
Rx Receive
TBD To Be Determined
TDMA Time Division Multiple Access
T/R Transmit-Receive
Tx Transmit
V/D Voice or Data
VDL VHF Digital Link
VHF Very High Frequency

