

Naval Surface Warfare Center Carderock Division

West Bethesda, MD 20817-5700

NSWCCD-TR-65-96/05 April 1997

Survivability, Structures, and Materials Directorate

Technical Report

Uncertainty in Marine Structural Strength Due to Variability in Geometry and Material Properties

by

Bilal M. Ayyub, Rafi Muhanna and Daniel D. Bruchman

FORM QUALITY INSPECTED 3

19970507 122



Approved for Public Release; distribution is unlimited.



DEPARTMENT OF THE NAVY

NAVAL SURFACE WARFARE CENTER, CARDEROCK DIVISION
9500 MACARTHUR BOULEVARD
WEST BETHESDA MD 20817-5700

9100
Ser 65-34
18 Apr 97

From: Commander, Naval Surface Warfare Center, Carderock Division

To: Chief of Naval Research (ONR 334)

Subj: ADVANCED METALLIC STRUCTURES PROJECT (PE 602121N)

Ref: (a) Reliable Metallics Task

Encl: (1) NSWCCD-TR-65-96/05, *Uncertainty in Marine Structural Strength Due to Variability in Geometry and Material Properties*

1. Reference (a) directed the Naval Surface Warfare Center, Carderock Division (NSWCCD) to develop prototype computational methodology for reliability assessment of continuum structures. Enclosure (1) describes the parametric finite element analysis, reliability assessment and ancillary computer programs developed in the course of this task. Geometric and material uncertainties were considered in the finite element model, and examples are included to demonstrate and test the methodology. A portion of this work was performed under contract with the University of Maryland.

2. Comments or questions may be referred to the principal investigator, Mr. Daniel D. Bruchman, Code 651; telephone (301) 227-4113; e-mail, bruchman@oasys.dt.navy.mil.

A handwritten signature in black ink, appearing to read "J. E. Beach", is positioned above the typed name.

J. E. BEACH
By direction

Subj: ADVANCED METALLIC STRUCTURES PROJECT (PE 602121N)

Copy to:

ATTN ONR 334 (GAGORIK)
CHIEF OF NAVAL RESEARCH
BALLSTON CENTRE TOWER ONE
800 NORTH QUINCY ST
ARLINGTON VA 22217-5660

ATTN 03P
03P1
03P1 (WALZ)
03P4
COMMANDER
NAVAL SEA SYSTEMS COMMAND
2531 JEFFERSON DAVIS HWY
ARLINGTON VA 22242-5160

NSWCCD
3442 (TIC)
60 (w/o encl)
65
65R (2)
651 (15)
652
653
654
654 (Melton)
655
CF (2)

DEFENSE TECHNICAL INFORMATION
CENTER
8725 JOHN KINGMAN ROAD
SUITE 0944
FORT BELVOIR VA 22060-6218

**Naval Surface Warfare Center
Carderock Division**

West Bethesda, MD 20817-5700

NSWCCD-TR-65-96/05 April 1997

Survivability, Structures, and Materials Directorate

Technical Report

**Uncertainty in Marine Structural Strength Due to
Variability in Geometry and Material Properties**

by

Bilal M. Ayyub, Rafi Muhanna and Daniel D. Bruchman



Approved for Public Release; distribution is unlimited.

Enclosure (1)

REPORT DOCUMENTATION PAGE

Form Approved
OMB No. 0704-0188

Public reporting burden for this collection of information is estimated to average 1 hour per response, including the time for reviewing instructions, searching existing data sources, gathering and maintaining the data needed, and completing and reviewing the collection of information. Send comments regarding this burden estimate or any other aspect of this collection of information, including suggestions for reducing this burden, to Washington Headquarters services, Directorate for Information Operations and Reports, 1215 Jefferson Davis Highway, Suite 1204, Arlington, VA 22202-4302, and to the Office of Management and Budget, Paperwork Reduction Project (0704-0188), Washington, DC 20503.

1. AGENCY USE ONLY (Leave blank)	2. REPORT DATE April 1997	3. REPORT TYPE AND DATES COVERED Final	
4. TITLE AND SUBTITLE Uncertainty in Marine Structural Strength Due to Variability in Geometry and Material Properties		5. FUNDING NUMBERS PE 602121N	
6. AUTHOR(S) Bilal M. Ayyub, Rafi Muhanna and Daniel D. Bruchman			
7. PERFORMING ORGANIZATION NAME(S) AND ADDRESS(ES) Naval Surface Warfare Center Carderock Division 9500 MacArthur Boulevard West Bethesda, MD 20817-5700		8. PERFORMING ORGANIZATION REPORT NUMBER NSWCCD-TR-65-97/05	
9. SPONSORING/MONITORING AGENCY NAME(S) AND ADDRESS(ES) Chief of Naval Research (ONR 334) Ballston Centre Tower One 800 North Quincy St Arlington, VA 22217-5660		10. SPONSORING/MONITORING AGENCY REPORT NUMBER	
11. SUPPLEMENTARY NOTES			
12a. DISTRIBUTION/AVAILABILITY STATEMENT Approved for public release; distribution is unlimited.		12b. DISTRIBUTION CODE	
13. ABSTRACT (Maximum 200 words) This report describes the development of a prototype computational methodology for the reliability assessment of continuum structures using finite element analysis with instability failure modes. Geometric and material uncertainties were considered in the finite element model. The reliability assessment was performed using Monte Carlo simulations with variance reduction techniques that consisted of the conditional expectation method. According to Monte Carlo methods, the applied load was randomly generated, and finite element analysis was used to predict the response of the structure under the generated loads in the form of a deformation field. A simulation procedure was applied to compare the response with a specified failure definition and failures were then counted. By repeating the simulation procedure several times, the failure probability defined by the specified failure definition was estimated as the failure fraction of simulation repetitions. A parametric study was performed for a stiffened panel strength to illustrate the procedure.			
14. SUBJECT TERMS geometric variability material variability structural reliability parametric finite element analysis		15. NUMBER OF PAGES 86	16. PRICE CODE
17. SECURITY CLASSIFICATION OF REPORT UNCLASSIFIED	18. SECURITY CLASSIFICATION OF THIS PAGE UNCLASSIFIED	19. SECURITY CLASSIFICATION OF ABSTRACT UNCLASSIFIED	20. LIMITATION OF ABSTRACT SAR

TABLE OF CONTENTS

TABLE OF CONTENTS	iii
LIST OF TABLES	iv
LIST OF FIGURES	iv
SUMMARY	1
ADMINISTRATIVE INFORMATION	1
ACKNOWLEDGMENT	2
1. INTRODUCTION AND OBJECTIVES	2
2. METHODOLOGY	3
2.1. General Description	3
2.2. Finite Element Method	4
2.2.1. Selecting a FE-package	4
2.3. Random Number Generation	5
2.4. Random Variables in FEM	5
2.5. Reproduction of FE Input Files	6
2.6. Post Processing of Output	7
2.6.2. Reliability Assessment	7
3. EXAMPLE	9
3.1. Geometry and Material	9
3.2. Loading and Boundary Conditions	9
3.3. FE model	9
3.4. Random Variables	10
3.5. Strength and Reliability Assessment	10
3.5.1. Concentric Axial Compression Loading	10
3.5.2. Concentric Axial Compression Loading With Lateral Pressure	11
3.6. Parametric Analysis	11
4. SUMMARY, CONCLUSIONS, AND RECOMMENDATIONS FOR FUTURE WORK	13
4.1. Summary and Conclusions	13
4.2. Recommendations for Future Work	13
GLOSSARY	14
REFERENCES	15
APPENDIX A. COMPUTER PROGRAMS	A-1
A.1. FE-INPUT	A-1
A.2. READIN	A-26
A.3. STRENGTH	A-27
A.4. STATISTICS	A-29

LIST OF TABLES

Table 1. Geometric And Material Random Variables for the Stiffened Panel	17
Table 2. Thickness and Plate Geometric Variables	18
Table 3. Web Height Variables.....	19
Table 4. Web Tilting Variables.....	20
Table 5. Web Bowing Variables.....	20
Table 6. Flange Width Variables	21
Table 7. Flange Tilting Variables	22
Table 8. Material Variability.....	23
Table 9. Variation of Coefficient of Variation or Standard Deviation	24
Table 10. Parametric Analysis Results	25

LIST OF FIGURES

Figure 1. Failure Classification.....	26
Figure 2. Failure Recognition and Classification	27
Figure 3. Typical Stiffened Panel	28
Figure 4. Finite Element Mesh of the Stiffened Panel.....	29
Figure 5. Plate Width Variability and Plate Distortion.....	30
Figure 6. Web Height Variability and Web Tilting	31
Figure 7. Web Bowing.....	32
Figure 8. Flange Width Variability and Flange Tilting	33
Figure 9. Methodology for <i>ith</i> Simulation Cycle.....	34
Figure 10. C-Shell Script Flow Chart for <i>ith</i> Simulation Cycle-Machine Level	35
Figure 11. Conditional Expectation for Probability of Failure.....	36
Figure 12. Stiffened Panel (dimensions and assumptions).....	37
Figure 13. Buckling Shape of the Stiffened Panel.....	38
Figure 14. Axial Strength Statistics of the Stiffened Panel-500 Cycles	39
Figure 15. Probability of Failure Statistics of the Stiffened Panel-500 Cycles	40
Figure 16. Stiffened Panel Subjected to Concentric Axial Compression and Lateral Pressure	41
Figure 17. Strength and Probability of Failure Due to Plate Width Variability	42
Figure 18. Strength and Probability of Failure Due to Plate Distortion Variability	43
Figure 19. Strength and Probability of Failure Due to Web Height Variability	44
Figure 20. Strength and Probability of Failure Due to Web Tilting Variability	45
Figure 21. Strength and Probability of Failure Due to Web Bowing Variability	46
Figure 22. Strength and Probability of Failure Due to Flange Width Variability	47
Figure 23. Strength and Probability of Failure Due to Flange Tilting Variability.....	48
Figure 24. Strength and Probability of Failure Due to Modulus of Elasticity and Thickness Variability	49

SUMMARY

This report describes a prototype computational methodology for reliability assessment of continuum structures using finite element analysis with instability failure modes. Examples are included to illustrate and test the methodology. Geometric and material uncertainties were considered in the finite element model. A computer program was developed that integrates uncertainty formulations to create a finite element input file, and conducts the reliability assessment using FORTRAN. A commercial finite element package was used as a basis for strength assessment. Another computer program was used to control and manage the data flow between the reliability assessment routine and the finite element software. A parametric study for a stiffened panel strength was also carried out.

The finite element model was based on the 8-node doubly curved shell element, which can provide the non-linear behavior prediction of the stiffened panel. The mesh was designed to ensure the convergence of eigenvalue estimates. Failure modes were predicted on the basis of elastic non-linear analysis using the finite element model.

Reliability assessment was performed using Monte Carlo simulation with variance reduction techniques that consisted of the conditional expectation method. According to Monte Carlo methods, the applied load was randomly generated, and finite element analysis was used to predict the response of the structure under the generated loads in the form of a deformation field. A crude simulation procedure was applied to compare the response with a specified failure definition, and failures were then counted. By repeating the simulation procedure several times, the failure probability according to the specified failure definition was estimated as the failure fraction of simulation repetitions. Alternatively, conditional expectation was used to estimate the failure probability in each simulation cycle in this study, then the average failure probability and its statistical error were computed.

The developed method is expected to have significant impact on the reliability assessment of structural components and systems; more specifically, the safety and reliability evaluation of continuum structures, the formulation of associated design criteria, evaluation of important variables that influence failures, the possibility of revising some codes of practice, reduction of the number of required costly experiments in structural testing, and the safety evaluation of existing structures for the purpose of life extension. The impact of this study can extend beyond structural reliability into the generalized field of engineering mechanics.

ADMINISTRATIVE INFORMATION

This work was performed by the Structures and Composites Department, Code 65, of the Survivability, Structures and Materials Directorate under the sponsorship of the Office of Naval Research (ONR 334). This report is submitted in the support of Reliable Metallics Task of the Advanced Metallic Structures Project (PE 602121N). A portion of this work was performed at the University of Maryland (College Park, Maryland) by Dr. Bilal M. Ayyub and Dr. Rafi Muhanna under contract N0016794M1227.

ACKNOWLEDGMENT

The authors would like to acknowledge the input and cooperation from researchers and engineers of the Survivability, Structures and Materials Directorate of the Carderock Division of the Naval Surface Warfare Center, especially from J.C. Adamchak, J.E. Beach, P.E. Hess, W. Melton, W.M. Richardson, and J.P. Sikora.

1. INTRODUCTION AND OBJECTIVES

The main objective of engineering design is to ensure the safety and performance of an engineering system for a given period of time and for specified loading conditions. The absolute safety of a system cannot be guaranteed due to the uncertainties involved in structures, their loading and behavior. However, through reliability methods, the system probability of failure of the system can be limited to an acceptable level. In order to control the reliability of structural systems, the failure probability needs first to be estimated and assessed. In the area of structural reliability assessment, structural systems with discrete components, such as trusses and frames, have received more attention and research than continuum structures. However, dealing with a structure as a continuum can provide a generalized basis of analysis. Such a modeling approach can lead to a better understanding of its behavior and analysis of its performance under different conditions. Also, it can deal with uncertainties in geometric and material properties for conventional and innovative materials, as well as uncertainties in failure definition and failure modes. Therefore, a need exists to adapt and use state-of-the art reliability assessment methods to deal with continuum structures.

Reliability assessment requires the knowledge of structural strength which is associated with different types of geometric and material uncertainties. In general, uncertainties in structural behavior and performance may be associated with physical phenomena that are inherently random or with predictions of reality performed under conditions of incomplete or inadequate information. Therefore, uncertainty may be associated with inherent variability of a physical process or with imperfection in the modeling of a physical process. Moreover, prediction or modeling error may contain two components, the systematic component and the random component. In measurement theory, these are known as the *systematic error* and *random error*, respectively. From a practical standpoint, inherent variability is essentially a state of nature and the resulting uncertainty may not be controlled or reduced. The uncertainty associated with prediction or modeling error may be reduced through the use of more accurate models or acquisition of additional data. Uncertainties associated with inherent variability, as well as random error, can be expressed in terms of coefficients of variation. These uncertainty measures are needed to accurately assess probabilities of interest. Methods for evaluating uncertainty measures including biasedness depend on the form of the available data and information (Ang and Tang, 1984). Failure or survival of real structures according to the different serviceability or strength criteria are continuous and gradual rather than crisp and abrupt. Consequently, failure or survival definitions are accompanied with uncertainty as discussed in Section 2.1. The

uncertainty in a failure definition can be considered to be of the vagueness type. Fuzzy set theory can be used to deal with this type as demonstrated by Ayyub and Lai (1992).

Simulation methods can be used for structural reliability assessment. In their fundamental form, applied loads to a structure can be randomly generated, then finite element analysis can be used to predict the response of the structure under a combined state of the generated loads. The response can be in the form of a stress field, strain field, or deformation field, or their combinations. Using a crude simulation procedure, the response needs to be compared with a specified failure definition, and failures counted. By repeating the simulation procedure several times, the failure probability according to the specified failure definition can be estimated as the failure fraction of simulation repetitions.

The objectives of this study are to develop a prototype computational procedure for reliability assessment of a continuum structure using finite element analysis with instability failure modes, and to test the procedure. A state-of-the art Finite Element (FE) commercial package is used in this study to assess the strength of a continuum structure. In addition, parametric analyses for the strength and reliability of a stiffened panel due to changes in the uncertainties in geometric and material properties are performed.

2. METHODOLOGY

2.1. General Description

The development of a methodology for the reliability assessment of continuum ship structural components or systems requires the consideration of the following three components: (1) loads, (2) structural strength, and (3) methods of reliability analysis. Also, the reliability analysis requires the probabilistic characteristics of the operational-sea profile of a ship, failure modes, and failure definitions. A reliability assessment methodology can be developed in the form of the following modules: operational-sea profile and loads; nonlinear structural analysis; extreme analysis and stochastic load combination; failure modes, their load effects, load combinations, and structural strength; library of probability distributions; reliability assessment methods; uncertainty modeling and analysis; failure definitions; and system analysis. Each module can be independently investigated and developed, although some knowledge about the details of other modules is needed for the development of a module. These modules are described by Ayyub, Beach and Packard (1995).

Prediction of structural failure modes of continuum ship structural components or systems requires the use of nonlinear structural analysis. Also, the identification, i.e., recognition, and proper classification of failures based on a structural response within the simulation process needs to be performed based on deformations. Therefore, failure definitions need to be expressed using deformations rather than forces or stresses. The process of failure classification and recognition needs to be automated in order to facilitate its use in a simulation algorithm for structural reliability assessment. Figure 1 shows a procedure for an automated failure classification that can be implemented in a simulation algorithm for reliability assessment. The failure classification is based on matching a deformation or stress field with a record within a knowledge base of response and failure classes. In cases of no match, a list of approximate matches is provided, with assessed applicability factors. The user can then be prompted for any

changes to the approximate matches and their applicability factors. In the case of a poor match, the user can have the option of activating the failure recognition algorithm shown in Fig. 2 to establish a new record in the knowledge base. The adaptive or neural nature of this algorithm allows the updating of the knowledge base of responses and failure classes. The failure recognition and classification algorithm shown in Fig. 2 evaluates the impact of the computed deformation or stress field on several systems of a ship. The impact assessment includes evaluating the remaining strength, stability, repair criticality, propulsion and power systems, combat systems, and hydrodynamic performance. The input of experts in ship performance is needed to make these evaluations using either numeric or linguistic measures. Then, the assessed impacts need to be aggregated and combined to obtain an overall failure recognition and classification within the established failure classes. The result of this process is then used to update the knowledge base.

2.2. Finite Element Method

The development of a general Finite Element (FE) computational approach for continuum mechanics has dominated the efforts of researchers over the past three decades. The efforts have followed three main courses: (1) the so-called degenerated solid approach, which finds its point of departure in the work of Ahmad, Irons and Zienkiewicz (1970); (2) the natural approach of Argyris et al. (1968 and 1969), which illustrated their development of the SHEBA family of shell elements; and (3) recently the shell theory which was initially presented in the paper of Simo and Fox (1989).

Stochastic finite element methods were also developed to calculate the stochastic response and reliability of linear and non-linear engineering systems by first-order or second-order reliability methods (FORM and SORM). In these methods geometric and materials property randomness are incorporated into a finite element formulation using approximate moment-based formulations. For example, the works of Contreras (1980), Hisada and Nakagiri (1985), Liu, et al (1986), Liu, et al (1988), Mochio, et al (1985), Sarras, et al (1993), Spanos, et al (1989), Vanmarcke and Grigoriu (1984), and Vanmarcke, et al (1986) provide such formulations and examples. Faravelli (1988) describes the use of finite element methods for reliability assessment based on response surface techniques.

Finite element methods have been used extensively in many areas such as vibration and dynamic response, buckling and postbuckling analysis with or without geometrical and material nonlinearities, thermal effect, fluid-structural interaction, aeroelasticity, structure-acoustics interaction, fracture, laminated composites, wave propagation, structural dynamics and control interaction of aircraft and space structures, random dynamic response, and others. Therefore, any development in the field of reliability assessment of continuum structures can have some impact on these areas.

2.2.1. Selecting a FE-package

The purpose of a finite element analysis is to predict the response of a model to some form of external loading, or to some nonequilibrium conditions. Reliability assessment of a structure requires the prediction of the structural response due to extreme loading. Generally, this response reflects both linear and/or non-linear behavior in geometry and material of the structure. The structural behavior could be expressed by local or global deformations, stress fields, strain

fields, static or dynamic criteria. Therefore, any selected FE-package for estimating the structural response needs to be capable of calculating all relevant values with acceptable accuracy levels. In addition, the output files of the selected FE-package should be in a suitable format to facilitate finding and reading strength prediction values for failure recognition and ultimately reliability assessment.

2.3. Random Number Generation

Numerical simulation is associated with random number generation of random variables in accordance with their respective or prescribed probability distributions. The random generation of each random variable can be accomplished systematically by first generating uniformly distributed random numbers between 0 and 1, and through appropriate transformations obtaining the corresponding random values with the specified probability distribution. The random generation efforts in a simulation process include generating random numbers (e.g., by a pseudo random number generator) and generating random variates through transformation (e.g., by substituting the generated random numbers into the inverse cumulative distribution functions of the respective random variables). A random number generator (Press et al. 1992) is then used to produce random numbers for all random variables.

Ayyub and Chao (1994) developed a library of subroutines for generating random variables with any of the following distribution types: uniform, triangular, normal, lognormal, Poisson, binomial, geometric, exponential, Rayleigh, extreme value type I - largest, extreme value type II - largest, extreme value type III - smallest (Weibull), and Gamma, experimental distributions. For each distribution, the following computations are needed: probability density values, or probability mass value; cumulative distribution value; inverse of cumulative distribution; random generation; and relationship between its parameters and moments. This library of subroutines was used in this study.

2.4. Random Variables in FEM

Finite element methods have a flexibility to represent different types of geometric and material uncertainties. In this study and as an illustrative example, a stiffened panel as shown in Fig. 3 was analyzed for different types of variability. The panel consisted of a thin rectangular plate with parallel stiffeners spaced at equal distances. The finite element model was based on the 8-node doubly curved shell element which can give the non-linear behavior prediction of the stiffened panel. The mesh, as shown in Fig. 4, was designed to ensure the convergence of eigenvalue estimates of its buckling loads. A systematic variability analysis of the panel required the hypothetical division of the panel into three levels: the plate level (level-0), the web level (level-1) and the flange level (level-2). The dimensions of the plate, the web, and the flange sides were denoted as L_{0i} , L_{1i} and L_{2i} ($i = 1, \dots, 4$), respectively. Geometric and material uncertainties in the form of random variables were accounted for in the three levels, i.e., plate, web, and flange levels. The underlying geometric and strength random variables were defined based on reported values, practical aspects, and judgment (Ayyub, et al 1994, Ellingwood, et al 1980).

The plate level as shown in Fig. 5, included three types of variability: its sides' dimensions, out-of plane distortion, and thickness. The variability in the sides' dimensions for the plate (Fig. 5) was modeled using random variables for the first and third sides of the plate, i.e., sides L_{01}

and L03. Such a variability subjects the stiffeners to possible out of plane moments. The second variability, as shown in Fig. 5, is the plate out-of-plane distortion modeled using three random variables for the z coordinates of its three corners, namely, zP02, zP03 and zP04. The third variability is the plate thickness and it is represented by a single, random variable t0.

The variability at the web level is shown in Fig. 6 to consist of four types: web tilting, web height, web bowing, and web thickness. The web tilting of Fig. 6 was represented by two random variables X21i and X23i per web, where (i = 1,....., number of stiffeners). These random variables model the horizontal deviation of the web top from the vertical position. The variability in the web height, as shown in Fig 6, was represented by two random variables (L11i and L13i) per web, where (i = 1,....., number of stiffeners). The web bowing is shown in Fig. 7 and was represented by the random variable XBOi, where (i = 1,....., number of stiffeners). This variable represents the possible out-of-plane deviation of the mid-web from the original plane position. The fourth variability uses the web thickness that is represented by the random variable t1.

The variability at the flange level is shown in Fig. 8 with its three types: flange tilting, flange height, and flange thickness. The flange tilting, as shown in Fig. 8, was represented by two random variables (Z2i0 and Z2iL) per flange, where (i = 1,....., number of stiffeners). These random variables represent the vertical deviation of the flange front and back sides from the horizontal position assuming that the web meets the flange at mid-width. The variability in the flange width as shown in Fig 8 was represented by two random variables (L21i and L23i) per flange, where (i = 1,....., number of stiffeners). The third variability uses the flange thickness that is represented by the random variable t2.

2.5. Reproduction of FE Input Files

Reliability assessment based on finite element analysis requires automated access to the input and output of a finite element package. Most general-purpose, finite element packages restrict automated changes in their input files in a sequence of runs as needed especially in simulation-based reliability assessment methods. Usually input files are prepared for specific models with deterministic values for the model variables. FE package uses in a simulation process requires the reproduction of the FE input file corresponding to the generated random variable in a simulation cycle. Figure 9 shows a developed procedure for FE input file reproduction in the *i*th simulation cycle. The block corresponding to FE input file reproduction consists of a main program which calls a random number generator (Press, et al 1992), a distributions library, and a subroutine for creating FE input file and calculating the related FE model parameters. At the start, a seed input value is fed manually to the random number generator where a random number is generated then the distribution library is called to calculate a value for a random variable based on a prescribed distribution type. Inverse transformation of the cumulative distribution function (CDF) of the random variable is used to obtain the random value for the variable based on the generated random number. The resulting random value for the variable is then saved. The seed input value is updated automatically based on the internally produced new seed in the random number generator. The previous operation is repeated to generate all random variables under consideration. The second step calls the FE input file subroutine designed specifically for a selected FE package. The subroutine takes the generated random variables from the previous step for the structural geometry, loads, and strength parameters to reproduce the FE input file according to the format required by the FE package.

2.6. Post Processing of Output

The post processing of the FE output files is the step that follows running the FE package in each simulation cycle as shown in Fig. 10. Subroutines were developed to conduct the post processing on a machine level. The first step is to read the FE output files and extract the values of interest. The extracted values are manipulated and used in failure recognition, then structural strength is evaluated. The probability of failure is then estimated, for example based on the conditional expectation variance reduction technique as described in Section 2.5.2. This technique requires load definition in the form of a probability distribution in order to use the strength-load reliability model shown in Fig. 11. The use of this model is also described in Section 2.5.2. Finally, relevant statistical measures for the failure probability are calculated. The statistical measures include the average failure probability, the coefficient of variation of failure probability, and the coefficient of variation of the sample average failure probability.

2.6.2. Reliability Assessment

Commonly used structural reliability assessment methods can be classified into two types, moment and simulation methods.

The moment methods were studied and described by many researchers (e.g., Ang and Tang 1984; Ayyub and Haldar 1984; Grigoriu 1982; Hasofer and Lind 1974; Melchers 1987; Shinozuka 1983; Thoft-Christensen and Baker 1982; and White and Ayyub 1985). In these methods, approximations are made about the distribution types, linearity of the failure surface, design or failure points, statistical characteristics of the basic random variables, and other parameters. Some of these methods are based on step-by-step approximations of the previous parameters in an optimization scheme and, consequently, lead to an improved estimate of the structure's reliability or probability of failure. However, such methods can have problems in convergence due to limitations in the level of nonlinearity of the failure surface that can be considered by the methods, the number of random variables that can be considered in the performance functions defining the potential failure modes of the structure, and the level of skewness of the probability distributions of the basic random variables.

In structural reliability, simulation-based methods determine the probability of failure of a structural component or system according to a specified performance function. They require complete information about the probabilistic characteristics of the basic random variables. In the classical use of the simulation-based methods, all the basic random variables are randomly generated and a performance equation for a failure mode is evaluated. Failures are then counted depending on the outcome of the evaluation. The probability of failure is estimated as the ratio of the number of failures to the total number of simulation cycles. Therefore, the smaller the probability of failure, the larger the needed number of simulation cycles to estimate the probability of failure with an acceptable level of statistical error. The efficiency of simulation can largely be improved by using variance reduction techniques. The result is a reduced level of computational effort and an increased analytical level. For example, Ayyub and Haldar (1984) and White and Ayyub (1985) suggested using conditional expectation and antithetic variates variance reduction techniques for structural reliability assessment. This method was determined to be efficient, and converges to the correct probability of failure in a relatively small number of simulation cycles. Other methods are based on common random numbers, importance sampling, and antithetic variates variance reduction techniques. Simulation methods are commonly used by researchers to validate other (non-simulation) methods and are generally considered accurate.

The main shortcoming of simulation methods is a large computational effort requirement for their use. This shortcoming is valid for the direct (hit or miss) method but not necessarily true for simulation with variance reduction techniques or selective sampling algorithms.

In this study, simulation with conditional expectation as a variance reduction technique is used for reliability assessment (Ayyub and Haldar 1984). The non-closed nature of the predicted strength based on finite element (B) does not allow for choosing any basic variable X_i in B as the conditioned random variable even if X_i is the one with the highest variability level. Because B has to be computed using a non-closed form based on FE methods. The only remaining choices are the load variables, for example, stillwater load (Q_s) or wave load (Q_w). If Q_w has a higher variability level than Q_s , then the survival probability P_s is given by

$$\begin{aligned} P_s &= P(Y > 0) \\ &= P(B - Q_s - Q_w > 0) \\ &= P(Q_w < B - Q_s) \\ &= E[F_{Q_w}(B - Q_s)] \end{aligned} \quad (2-1)$$

where Y = performance function; $B = B(X_1, X_2, \dots, X_{n-2})$ as the strength variable that is a function of $n-2$ basic random variables, Q_w = the cumulative distribution function of Q_w , and $E(\cdot)$ is the expected value. Therefore, the failure probability P_f can be determined as

$$P_f = 1 - P_s = 1 - E[F_{Q_w}(B - Q_s)] \quad (2-2)$$

Therefore, each simulation cycle (i th cycle) is expected to produce a failure probability P_{fi} based on evaluating the cumulative distribution function of Q_w at generated values of B and Q_s (i.e., B_i and Q_{si}). The sample mean of the probability of failure (\bar{P}_f) is then computed as

$$\bar{P}_f = \frac{1}{N} \left(\sum_{i=1}^N P_{fi} \right) \quad (2-3)$$

in which N = the number of simulation cycles. This estimate of P_f can be considered an unbiased estimator of the population value. The variance associated with this estimated value is (Ang and Tang 1975)

$$Var(\bar{P}_f) = \frac{Var(P_f)}{N} = \frac{1}{N} \left(\frac{1}{N-1} \sum_{i=1}^N (P_{fi} - \bar{P}_f)^2 \right) \quad (2-4a)$$

where $Var(\bar{P}_f)$ indicates the accuracy in estimating \bar{P}_f . A smaller value of $Var(\bar{P}_f)$ is always preferred. The coefficient of variation (COV) for the estimated failure probability is given by

$$COV(\bar{P}_f) = \frac{\sqrt{\frac{1}{N} \left(\frac{1}{N-1} \sum_{i=1}^N (P_{fi} - \bar{P}_f)^2 \right)}}{\bar{P}_f} \quad (2-4b)$$

3. EXAMPLE

The example presented in this section illustrates the application of the methodology to a stiffened shell-type structure. A small-scale stiffened panel of a ship structure tested by Faulkner (1977) is used in this example. The panel was also investigated by Hess, et al (1994). The panel was modeled as a simply-supported structure with two states of loading: (1) concentric axial compression only, and (2) concentric axial compression with lateral pressure. The primary failure mode for this panel is an elastic non-linear instability. A commercially-available FE package was selected based on its ability to deal with this failure mode. The selected package, ABAQUS, was used to predict the buckling eigenvalues.

3.1. Geometry and Material

The panel consists of a rectangular thin plate stiffened with equally spaced parallel T-shaped stiffeners as shown in Fig. 12. The overall plate dimensions are 854×790 mm with a 3.0 mm plate thickness. The web height is 26.66 mm with a web thickness of 4.9 mm. The flange width is 25.4 mm with a flange thickness of 5.84 mm. The five equally-spaced stiffeners are 183-mm apart, they are parallel to the short side of the plate and the plate extends equally beyond the external stiffeners a distance equal to 61 mm each way. The material is assumed to be isotropic elastic with a modulus of elasticity $E = 208000$ MPa and Poisson's ratio $\nu = 0.3$.

3.2. Loading and Boundary Conditions

Two loading conditions were considered: (1) the panel was loaded in the short direction by a concentric uniformly distributed edge load, and (2) the panel was simultaneously loaded in the short direction by concentric uniformly distributed edge loads and a lateral pressure on the plate surface. The lateral pressure values of -0.07, -0.035, 0.0, 0.035, and 0.07 MPa were taken (where a positive pressure is normal to the plate creating compressive bending stress in the plate). The concentric, uniformly-distributed edge loads were thickness dependent to account for the possible variability in the thickness. The panel was simply supported in the plate level on two opposite edge, namely, L01 and L03.

3.3. FE model

For the purpose of FE modeling, the middle planes of the plate, webs, and flanges were considered reference planes for dimensioning. Consequently, the considered dimensions of the FE model were $854 \times 970 \times 3$ mm for the plate, 31.08×4.9 mm for the web and 25.4×5.84 mm for the flange. The model was based on the 8-node doubly-curved shell element S8R5, which could provide the eigenvalue buckling estimates. In general, shell buckling stability requires two types of analysis. First, eigenvalue analysis was used to obtain estimates of the buckling loads and modes. This type of analysis provides guidance in mesh design to ensure the convergence of eigenvalue estimates of buckling loads. The mesh needs to be adequate to model the buckling modes which are usually more complex than the prebuckling deformation mode. The second phase of the study is to perform load-displacement analyses.

The key aspect of the eigenvalue analysis is the mesh design. For the example under study, the buckling could be an overall buckling of the whole panel or a local buckling in either the

plate, the web, or the flange. In this demonstration, the whole panel was modeled without accounting to any possible symmetry. The following meshes were used: 6×10 for the plate, 1×6 for each web, and 2×6 for each flange as shown in Fig. 4.

3.4. Random Variables

The basic geometric and material random variables were defined based on reported values, practical aspects, and judgment (Ayyub, et al 1994, Ellingwood, et al 1980). The adopted values are summarized in Table 1 and detailed in Tables 2 through 8. The overall number of random variables that were considered in this example is 55. They included random variables at the three levels, i.e., the plate, web, and flange that are described in section 2.4. Six geometric variables were defined at the plate level, 25 variables at the web level, and 20 variables at the flange level. In addition, three variables were defined for thickness one for each level and the modulus of elasticity was assumed to be the same for the three levels and expressed by one random variable. The random variables were divided into two categories. A random variable in the first category was defined by its mean values and standard deviations whereas a random variable in the second category was defined by its mean values and coefficients of variation (COV). The standard deviation for the overall plate size was assumed to be 4.0 mm and for its out-of-plane distortion was assumed to be 1.0 mm. The web tilting, bowing, and flange tilting have standard deviations of 0.5 mm, 0.1 mm, and 0.2 mm respectively. The variability of the thickness at all levels was expressed by 4% COV, and the web height and the flange width by 2.5% COV. The COV of the modulus of elasticity was taken as 4%. A normal probability distribution function (PDF) was used for all basic random variables.

3.5. Strength and Reliability Assessment

The panel strength prediction and reliability assessments were based on generated values of the basic random variables and those of the applied load. The axial strength (buckling load) for the panel was evaluated by manipulating the estimated eigenvalues obtained by the FE analysis. The load was assumed to have a lognormal distribution with an assumed mean value two thirds of the nominal buckling strength and COV of 10%. Reliability assessment was conducted using simulation with conditional expectation variance reduction technique as described in Section 2.5.2. For the purpose of demonstration, conditional expectation as defined in Equations. 2-1 through 2-4 was used with one loading type. The cumulative distribution function of the load (lognormal distribution) was used to determine the failure probability in each simulation cycle.

3.5.1. Concentric Axial Compression Loading

Two cases are discussed in this section, the nominal case which does not account for any type of variability and the reference case which is defined according to the data in Tables 2 through 8.

3.5.1.1. Nominal Case

Panel strength Prediction for this case was based on the nominal values of all variables without accounting for any type of variability. The panel was loaded in the short direction (parallel to the stiffeners) by a uniformly distributed concentric compressive load acting on both edges, and simply supported at the plate level in the short direction. The estimated axial strength (buckling load) was determined to be 273.3 MPa, the failure probability based on random

loading was assessed to be 1.51×10^{-5} , and the predicted failure mode was a local buckling in the plate as shown in Fig. 13. The same panel was investigated by Hess, et al (1994) using several combinations of concentric axial and transverse in-plane loads, and lateral pressure. The model was simply supported at the elastic centroid. Strength statistics were estimated using Monte Carlo simulation. The panel axial strength was predicted using an algorithm as defined by Hughes (1988). The examples presented by Hess et al (1994) were analyzed with an assumed eccentricity. The predicted mean axial strengths for the case of zero lateral pressure and zero transverse loads, which corresponds to the nominal case, but with an eccentricities of -0.5273 mm and $+0.5273$ mm were 247.5 MPa and 156.5 MPa, respectively. The differences in the axial strength values between the presented work herein and that of Hess et al (1994) can be attributed to the presence of the eccentricity and the difference in boundary conditions.

3.5.1.2. Reference Case

The reference case accounts for geometric and material variability as defined in Tables 2 through 8. The axial strength and failure probability results are shown in Figs. 14 and 15 respectively. Figure 14 shows the histograms and statistical measures for both axial strength and a normalized axial strength with respect to the nominal case based on 500 simulation cycles. The average axial strength value was predicted to be 273.9 MPa. Figure 15 shows the convergence of the average failure probability as the number of simulation cycles is increased and the statistical measures of the failure probability with its histogram using 500 simulation cycles.

3.5.2. Concentric Axial Compression Loading With Lateral Pressure

The axial strength of the panel under concentric axial compression loading and lateral pressure was predicted for both the nominal and reference cases. The lateral pressure was varied from 0.07 MPa to -0.07 Mpa (a positive pressure is in the positive direction of a normal vector to the plate, i.e., its direction from the plate to the stiffeners). The mean strength, nominal strength, and the mean strength plus and minus one and two standard deviations are shown in Fig. 16 for the whole range of the lateral pressure from -0.07 to $+0.07$ Mpa. The strength decreases with the increase in pressure which is in agreement with the predicted failure mode. For a local buckling failure mode for the plate, applying a positive pressure means an increase in the compressive stresses in the plate, consequently a decrease in the axial strength of the panel.

3.6. Parametric Analysis

A parametric analysis was conducted for the axial strength and failure probability of the panel. The analysis was carried out by individually varying the coefficients of variation or standard deviations of the basic random variables. The notations, mean values, and ranges of COV and standard deviations of the random variables are given in Table 9. The following observations were developed based on the results of the parametric analysis using 100 simulation cycles:

- For the plate width, Fig. 17 shows that increasing the COV from 0.47% to 0.94%, the normalized strength decreases from 1.007 to 0.988, the COV of the axial strength decreases from 8.87% to 7.79%, and the average of probability of failure decreases from 8.20×10^{-4} to 6.45×10^{-4} .

- For the plate out-of-plane distortion, Fig. 18 shows that increasing the standard deviation from 1.0 to 3.0, the normalized strength increases from 1.007 to 1.009, the COV of the axial strength decreases from 8.87% to 7.42%, and the average of probability of failure decreases from 8.20×10^{-4} to 6.45×10^{-4} .
- For the web height, Fig. 19 shows that increasing the COV from 2.5% to 5.0%, the normalized strength increases from 1.007 to 1.011, the COV of the axial strength decreases from 8.87% to 7.37%, and the average of probability of failure decreases from 8.20×10^{-4} to 3.94×10^{-4} .
- For the web tilting, Fig. 20 shows that increasing the standard deviation from 0.2 mm to 0.5 mm, the normalized strength increases from 1.005 to 1.007, the COV of the axial strength increases from 7.17% to 9%, and the average of probability of failure increases from 5.0×10^{-4} to 8.45×10^{-4} .
- For the web bowing, Fig. 21 shows that increasing the standard deviation from 0.1 mm to 0.2 mm, the normalized strength decreases from 1.007 to 0.99, the COV of the axial strength decreases from 9.0% to 7.8%, and the average of probability of failure decreases from 8.2×10^{-4} to 4.84×10^{-4} .
- For the flange width, Fig. 22 shows that increasing the COV from 2.5% to 5.0%, the normalized strength decreases from 1.007 to 1.004, the COV of the axial strength decreases from 9.0% to 7.26%, and the average of probability of failure decreases from 8.2×10^{-4} to 2.23×10^{-4} .
- For the flange tilting, Fig. 23 shows that increasing the standard deviation from 0.2 mm to 0.5 mm, the normalized strength decreases from 1.007 to 0.995, the COV of the axial strength decreases from 9.0% to 8.0%, and the average of failure probability increases from 8.2×10^{-4} to 1.77×10^{-3} .
- For the thicknesses, Fig. 24 shows that increasing the COV from 4.0% to 8.0%, the normalized strength decreases from 1.007 to 0.994, the COV of the axial strength increases from 8.87% to 13.0%, and the average of probability of failure decreases from 8.28×10^{-4} to 1.53×10^{-2} .
- For the modulus of elasticity, Fig. 24 shows that increasing the COV from 4.0% to 8.0%, the normalized strength decreases from 1.007 to 1.002, the COV of the axial strength remains constant at the value of 8.90%, and the average of probability of failure decreases from 8.2×10^{-4} to 1.49×10^{-3} .

The above failure probability observations were based on results from 100 simulation cycles. The number of simulation cycles might not be adequate for obtaining accurate failure probability results, but it is sufficient for determining the axial strength. The number of cycles was limited to 100 in order to make the study feasible within the planned time frame of the project.

Table 10 shows a summary of the results of the parametric study. According to the table, variations in the variability of plate size and web bowing produced the largest effect on the mean axial strength ratio; whereas variations in the variability of thickness of the plate, webs, and flanges produced the largest effect on the coefficient of variation of the axial strength.

4. SUMMARY, CONCLUSIONS, AND RECOMMENDATIONS FOR FUTURE WORK

4.1. Summary and Conclusions

A prototype computational methodology for reliability assessment of continuum structures using finite element analysis with instability failure modes was described in this report. Examples were used to illustrate and test the methodology. Geometric and material uncertainties were considered in the finite element model. A computer program was developed to implement this methodology by integrating uncertainty formulations to create a finite element input file and to conduct the reliability assessment on a machine level. A commercial finite element package was used as a basis for the strength assessment in the presented procedure. A parametric study for a stiffened panel strength was also carried out. The following observations were made based on the parametric study:

- Increasing the COV of the plate width resulted in a slight decrease of the normalized strength, and its COV.
- Increasing the standard deviation of the plate out-of-plane distortion resulted in a slight increase of the normalized strength and a moderate decrease in its COV.
- Increasing the COV of the web height resulted in a moderate increase of the normalized strength and a moderate decrease of its COV.
- Increasing the standard deviation of the web tilting resulted in a slight increase of the normalized strength and a significant increase of its COV.
- Increasing the standard deviation of the web bowing resulted in a moderate decrease of the normalized strength and a moderate decrease of its COV.
- Increasing the COV of the flange width resulted in a slight decrease of the normalized strength and a moderate decrease of its COV.
- Increasing the standard deviation of the flange tilting resulted in a moderate decrease of the normalized strength and a slight decrease in its COV.
- Increasing the COV of the thickness resulted in a moderate decrease of the normalized strength and a significant increase of its COV.
- Increasing the COV of the modulus of elasticity resulted in a slight decrease of the normalized strength and no change for its COV.
- It can be concluded that variations in the variability of plate size and web bowing produced the largest effect on the mean axial strength ratio whereas variations in the variability of thickness of the plate, webs, and flanges produced the largest effect on the coefficient of variation of the axial strength.

4.2. Recommendations for Future Work

Based on this study, for future work we recommend:

- The feasibility of using the developed method for complex structures with multiple failure modes needs to be investigated. The structures need to be selected such that methods for failure recognition and classification as demonstrated in Figs. 1 and 2 can be developed.
- The effects of failure recognition and classification for continuum structures on reliability estimates need to be studied.

GLOSSARY

The following symbols are used in this paper:

B	=	predicted strength
CDF	=	cumulative distribution function
COV	=	coefficient of variation
F	=	cumulative distribution function
L0i	=	plate side dimensions
L1i	=	web side dimensions
L2i	=	flange side dimensions
L11i	=	web height, side 1
L13i	=	web height, side 3
L21i	=	flange width, side 1
L23i	=	flange width, side 3
N	=	number of simulation cycles
PDF	=	probability density function
Q_s	=	still water load
Q_w	=	wave load
P_f	=	failure probability
\bar{P}_f	=	sample mean of failure probability
P_s	=	survival probability
t0	=	plate thickness
t1	=	web thickness
t2	=	flange thickness
Var	=	Variance
X21i	=	web tilting, side 1
X23i	=	web tilting, side 3
Y	=	performance function
zP0i	=	plate corners coordinates
Z2i0	=	flange tilting, side $y = 0$
Z2iL	=	flange tilting, side $y = L$
XBOi	=	web bowing

REFERENCES

- Ahmad, S, Irons, B.M., and Zienkiewicz, O.C. (1970), "Analysis of thick and thin shell structures by curved elements," *Int. J. Num. Meth. Engng.*, 2, 419-451.
- Ang, A. H-S., and Tang, W. H. (1975), *Probability concepts in engineering planning and design volume I- basic principles*, John Wiley & Sons, Inc. New York.
- Ang, A. H-S., and Tang, W. H., (1984), *Probability concepts in engineering planning and design Volume II- decision, risk, and reliability*, John Wiley & Sons, Inc. New York.
- Argyris, J.H., and Scharpf, D.W. (1968), "The SHEBA family of shell elements for the matrix displacement method. Part I. Natural definition of geometry and strains," *Aeron. J. Roy. Aeron. Soc.*, 72 873-878.
- Argyris, J.H., and Scharpf, D.W. (1968), "The SHEBA family of shell elements for the matrix displacement method. Part II. Interpolation scheme and stiffness matrix," *Aeron. J. Roy. Aeron. Soc.*, 71, 878-883.
- Argyris, J.H., and Scharpf, D.W. (1969), The SHEBA family of shell elements for the matrix displacement method. Part III. Large displacements," *Aeron. J. Roy. Aeron. Soc.*, 73, 423-426.
- Ayyub, B.M., and Lai, K-L. (1992), "Structural reliability assessment with ambiguity and vagueness in failure," *Naval Engineers Journal*, ASNE, 104(3), 21-35.
- Ayyub, B. M., and Chao, R.-J. (1994), *Probability distributions for reliability-based design of naval vessels*. CARDEROCKDIV-U-SSM-65-94/12, Naval Surface Warfare Center, Bethesda, Maryland.
- Ayyub, B. M., and Haldar, A. (1984), Practical structural reliability techniques. *Journal of Structural Engineering*," ASCE, 110(8), 1707-1724.
- Ayyub, B. M., Beach, J. E., and Thomas Packard, W. (1995), Methodology for the development of reliability-based design criteria for surface ship structures," *Naval Engineers Journal*.
- Contreras, H. (1980). "The stochastic finite-element method," *Computers and Structures*, 12, 341-348.
- Ellingwood, B., Galambos, T.V., MacGregor, J.C., and Cornell, C.A. (1980), Development of a probability based load criterion for American National Standard A58," *National Bureau of Standards Publication 577*, Washington D.C.
- Faravelli, L. (1988), "Stochastic finite elements by response surface techniques," ASME, *AMD-Vol. 93*, 197-203.
- Faulkner, D. (1977), "Compression tests on welded eccentrically stiffened plate panels. *steel plated structures*," Ed. by P.J. Dowling et al, Crosby Lockwood Publishers, 581-617
- Grigoriu, M.(1982), "Methods for approximate reliability analysis," *Structural Safety*, 1, 1982, pp. 155-165.
- Hasofer, A.M., and Lind N.C. (1974), "Exact and invariant second-moment code format," *Journal of Engineering Mechanics Division*, ASCE, 100(EM1), 111-121.
- Hess, P.E., Nikolaidis, E., Ayyub, B.M., and Hughes, O.F. (1994), Uncertainty in marine structural strength with application to compressive failure of longitudinally stiffened panels," CARDEROCKDIV-U-SSM-65-94/07, the Naval Surface Warfare Center, Bethesda, Maryland.
- Hisada, T., and Nakagiri, S. (1985), "Role of the stochastic finite element method in structural safety and reliability," *Proceedings ICOSSAR I*, 385-394.

- Hughes, O.F. (1988). *Ship Structural Design*, SNAME, Jersey City, N.J., second edition (first edition published by Wiley, 1983).
- Liu, W.K., Belytschko, T., and Mani, A. (1986), "Probabilistic finite elements for nonlinear structural dynamics, *Computer Methods in Applied Mechanics and Engineering*," 56, 61-81.
- Liu, W.K., Besterfield, G., and Belytschko, T. (1988), "Transient Probabilistic Systems," *Computer Methods in Applied Mechanics and Engineering*, 67, 27-54.
- Melchers, R.E. (1987), *Structural reliability analysis and prediction*, Ellis Horwood Limited, UK.
- Mochio, T., Samaras, E., and Shinozuka, M. (1985), Stochastic equivalent linearization for finite element-based reliability analysis," *Proceedings ICOSSAR I*, 375-384.
- Press, W.H., Teukolsky, S.A., Vetterling, W.T., and Flannery, B.P. (1992), *Numerical Recipe in FORTRAN: The Art of Scientific Computing*, Second Edition, Cambridge University Press.
- Sarras, T.A., Diekmann, R.M., Matthies, H., Moore, C.S. (1993), "Stochastic finite elements: An interface approach," *OMAE, Vol. II Safety and Reliability*, ASME, 57-63.
- Shinozuka, M. (1983), Basic analysis of structural safety," *Journal of Structural Engineering*, ASCE, 109(3), 721-740.
- Simo, J.C., and Fox, D.D. (1989), On a stress resultant geometrically exact shell model, Part I: Formulations and optional parametrization," *Comp. Meth. Appl. Mech. Eng.* 72, 267-304.
- Spanos, P.D., and Ghanem, Roger (1989), "Stochastic finite element expansion for random Media," *Journal of Engineering Mechanics*, ASCE, 115(5).
- Throft-Christensen, P., and Baker, M. J. (1982), *Structural reliability theory and its applications*, Springer-Verlag, New York, 96-101.
- Vanmarcke, E., and Grigoriu, M. (1984), Stochastic finite element analysis of simple beams," *J. of Engineering Mechanics*, ASCE, 109(5), 1203-1214.
- Vanmarcke, E., Shinozuka, M., Nakagiri, S., Schüeller, G.I., and Grigoriu, M. (1986), Random fields and stochastic finite elements," *Structural Safety*, 3, 143-166.
- White, G. J., and Ayyub, B. M. (1985), Reliability methods for ship structures," *Naval Engineers Journal*, 86-96.

Table 1. Geometric And Material Random Variables for the Stiffened Panel

Variable no	Geometrical variables	Notation	Mean value	Coefficient of variation (COV)	Standard deviation
1	Plate size (mm)	L0i	854		4.0
2	Plate thickness (mm)	t ₀	3.0	4%	0.12
3	Web thickness (mm)	t ₁	4.9	4%	0.196
4	Flange thickness (mm)	t ₂	5.84	4%	0.234
5	Plate-out of plane distortion (mm)	zP0i	0.0		1.0
6	Web height (mm)	L1ji	31.08	2.5%	0.77
7	Web tilting (mm)	X2ji	0.0		0.5
8	Web bowing (mm)	XB0i	0.0		0.1
9	Flange width (mm)	L2ji	25.4	2.5%	0.635
10	Flange tilting (mm)	Z2i0, Z2iL	0.0		0.2
11	Modulus of elasticity (MPa)	E	208000	4%	8320
12	Poisson's ratio	v			
13	Yield stress (KPa) ¹	F _y	250000	7%	17500

¹ Nominal yield stress = 240000 kPa

Table 2. Thickness and Plate Geometric Variables

Variable no.		Geometrical variables	Notation	Mean value (mm)	Coefficient of variation (COV)	Standard deviation (mm)
global	local					
1	1	Panel width (side 1)	L_{01}	854.0		4.0
2	2	Panel width (side 3)	L_{03}	854.0		4.0
3	3	Plate thickness	t_p	3.0	4%	0.12
4	4	Web thickness	t_w	4.9	4%	0.196
5	5	Flange thickness	t_f	5.84	4%	0.234
6	6	Plate-out of plane distortion (corner2)	Z_{P02}	0.0		1.0
7	7	Plate-out of plane distortion (corner3)	Z_{P03}	0.0		1.0
8	8	Plate-out of plane distortion (corner4)	Z_{P04}	0.0		1.0

Table 3. Web Height Variables

Variable no.		Geometrical variables	Notation	Mean value (mm)	Coefficient of variation (COV)	Standard deviation (mm)
global	local					
9	1	Height of web no. 1 (side 1)	L ₁₁₁	31.08	2.5%	0.77
10	2	Height of web no. 2 (side 1)	L ₁₁₂	31.08	2.5%	0.77
11	3	Height of web no. 3 (side 1)	L ₁₁₃	31.08	2.5%	0.77
13	4	Height of web no. 4 (side 1)	L ₁₁₄	31.08	2.5%	0.77
14	5	Height of web no. 5 (side 1)	L ₁₁₅	31.08	2.5%	0.77
15	6	Height of web no.1 (side 3)	L ₁₃₁	31.08	2.5%	0.77
16	7	Height of web no.2 (side 3)	L ₁₃₂	31.08	2.5%	0.77
17	8	Height of web no.3 (side 3)	L ₁₃₃	31.08	2.5%	0.77
18	9	Height of web no.4 (side 3)	L ₁₃₄	31.08	2.5%	0.77
19	10	Height of web no.5 (side 3)	L ₁₃₅	31.08	2.5%	0.77

Table 4. Web Tilting Variables

Variable no.		Geometrical variables	Notation	Mean value (mm)	Coefficient of variation (COV)	Standard deviation (mm)
global	local					
20	1	Tilting of web no.1 (side 1)	X_{211}	0.0		0.5
21	2	Tilting of web no.2 (side 1)	X_{212}	0.0		0.5
22	3	Tilting of web no.3 (side 1)	X_{213}	0.0		0.5
23	4	Tilting of web no.4 (side 1)	X_{214}	0.0		0.5
24	5	Tilting of web no.5 (side 1)	X_{215}	0.0		0.5
25	6	Tilting of web no.1 (side 3)	X_{231}	0.0		0.5
26	7	Tilting of web no.2 (side 3)	X_{232}	0.0		0.5
27	8	Tilting of web no.3 (side 3)	X_{233}	0.0		0.5
28	9	Tilting of web no.4 (side 3)	X_{234}	0.0		0.5
29	10	Tilting of web no.5 (side 3)	X_{235}	0.0		0.5

Table 5. Web Bowing Variables

Variable no.		Geometrical variables	Notation	Mean value (mm)	Coefficient of variation (COV)	Standard deviation (mm)
global	local					
45	1	Bowing of web no. 1 (side 3)	X_{B01}	0.0		0.1
46	2	Bowing of web no. 2 (side 3)	X_{B02}	0.0		0.1
47	3	Bowing of web no. 3 (side 3)	X_{B03}	0.0		0.1
48	4	Bowing of web no. 4 (side 3)	X_{B04}	0.0		0.1
49	5	Bowing of web no. 5 (side 3)	X_{B05}	0.0		0.1

Table 6. Flange Width Variables

Variable no.		Geometrical variables	Notation	Mean value (mm)	Coefficient of variation (COV)	Standard deviation (mm)
global	local					
30	1	Width of flange no. 1 (side 1)	L ₂₁₁	25.4	2.5%	0.635
31	2	Width of flange no. 2 (side 1)	L ₂₁₂	25.4	2.5%	0.635
32	3	Width of flange no.3 (side 1)	L ₂₁₃	25.4	2.5%	0.635
33	4	Width of flange no. 4 (side 1)	L ₂₁₄	25.4	2.5%	0.635
34	5	Width of flange no. 5 (side 1)	L ₂₁₅	25.4	2.5%	0.635
35	6	Width of flange no.1 (side 3)	L ₂₃₁	25.4	2.5%	0.635
36	7	Width of flange no.2 (side 3)	L ₂₃₂	25.4	2.5%	0.635
37	8	Width of flange no.3 (side 3)	L ₂₃₃	25.4	2.5%	0.635
38	9	Width of flange no.4 (side 3)	L ₂₃₄	25.4	2.5%	0.635
39	10	Width of flange no.5 (side 3)	L ₂₃₅	25.4	2.5%	0.635

Table 7. Flange Tilting Variables

Variable no.		Geometrical variables	Notation	Mean value (mm)	Coefficient of variation (COV)	Standard deviation (mm)
global	local					
40	1	Tilting of flange no.1 (side 1)	Z_{210}	0.0		0.2
41	2	Tilting of flange no.2 (side 1)	Z_{220}	0.0		0.2
42	3	Tilting of flange no.3 (side 1)	Z_{230}	0.0		0.2
43	4	Tilting of flange no.4 (side 1)	Z_{240}	0.0		0.2
44	5	Tilting of flange no.5 (side 1)	Z_{250}	0.0		0.2
45	6	Tilting of flange no.1 (side 3)	Z_{21L}	0.0		0.2
46	7	Tilting of flange no.2 (side 3)	Z_{22L}	0.0		0.2
47	8	Tilting of flange no.3 (side 3)	Z_{23L}	0.0		0.2
48	9	Tilting of flange no.4 (side 3)	Z_{24L}	0.0		0.2
49	10	Tilting of flange no.5 (side 3)	Z_{25L}	0.0		0.2

Table 8. Material Variability

Variable no.		Material variables	Notation	Mean value	Coefficient of variation (COV)	Standard deviation
global	local					
50	1	Modulus of elasticity of plate material (MPa)	E_0	208000	4%	8320
51	2	Modulus of elasticity of web material (MPa)	E_1	208000	4%	8320
52	3	Modulus of elasticity of flange material (MPa)	E_2	208000	4%	8320
53	4	Poisson's ratio of plate	ν_0			
54	5	Poisson's ratio of web	ν_1			
55	6	Poisson's ratio of flange	ν_2			
56	7	Yield stress of plate (kPa) ¹	F_{y0}	250000	7%	17500
57	8	Yield stress of web (kPa) ¹	F_{y1}	250000	7%	17500
57	9	Yield stress of flange (kPa) ¹	F_{y2}	250000	7%	17500

¹ Nominal yield stress = 240000 kPa

Table 9. Variation of Coefficient of Variation or Standard Deviation

Variab le no.	Geometrical variables	Notation	Mean value	Coefficient of variation (COV)	Standard deviation
1	Plate size (mm)	L0i	854		4.0 to 8
2	Plate thickness (mm)	t ₀	3.0	4 to 8%	
3	Web thickness (mm)	t ₁	4.9	4 to 8%	
4	Flange thickness (mm)	t ₂	5.84	4 to 8%	
5	Plate-out of plane distortion (mm)	zP0i	0.0		1.0 to 3.0
6	Web height (mm)	L1ji	31.08	2.5 to 5%	
7	Web tilting (mm)	X2ji	0.0		0.2 to 0.5
8	Web bowing (mm)	XB0i	0.0		0.1 to 0.2
9	Flange width (mm)	L2ji	25.4	2.5 to 5%	
10	Flange tilting (mm)	Z2i0, Z2iL	0.0		0.2 to 0.5
11	Modulus of elasticity (MPa)	E	208000	4 to 8%	

Table 10. Parametric Analysis Results

Variable no.	Geometrical Variables	Mean value	Variation of coefficient of variation	Variation of standard deviation	Effect on axial strength ratio	Effect on coefficient of variation of strength
1	Plate size (mm)	854		4.0 to 8.0	High	Medium/Low
2	Plate thickness (mm)	3.0	4 to 8%	0.12 to 0.24	Medium	High
3	Web thickness (mm)	4.9	4 to 8%	0.196 to 0.392	Medium	High
4	Flange thickness (mm)	5.84	4 to 8%	0.234 to 0.468	Medium	High
5	Plate-out of plane distortion (mm)	0.0		1.0 to 3.0	Low	Medium/Low
6	Web height (mm)	31.08	2.5 to 5%	0.77 to 1.54	Low	Medium/Low
7	Web tilting (mm)	0.0		0.2 to 0.5	Low	Medium/Low
8	Web bowing (mm)	0.0		0.1 to 0.2	High	Medium/Low
9	Flange width (mm)	25.4	2.5 to 5%	0.635 to 1.27	Low	Medium/Low
10	Flange tilting (mm)	0.0		0.2 to 0.5	Medium	Medium/Low
11	Modulus of elasticity (MPa)	208000	4 to 8%	8320 to 16640	Low	None

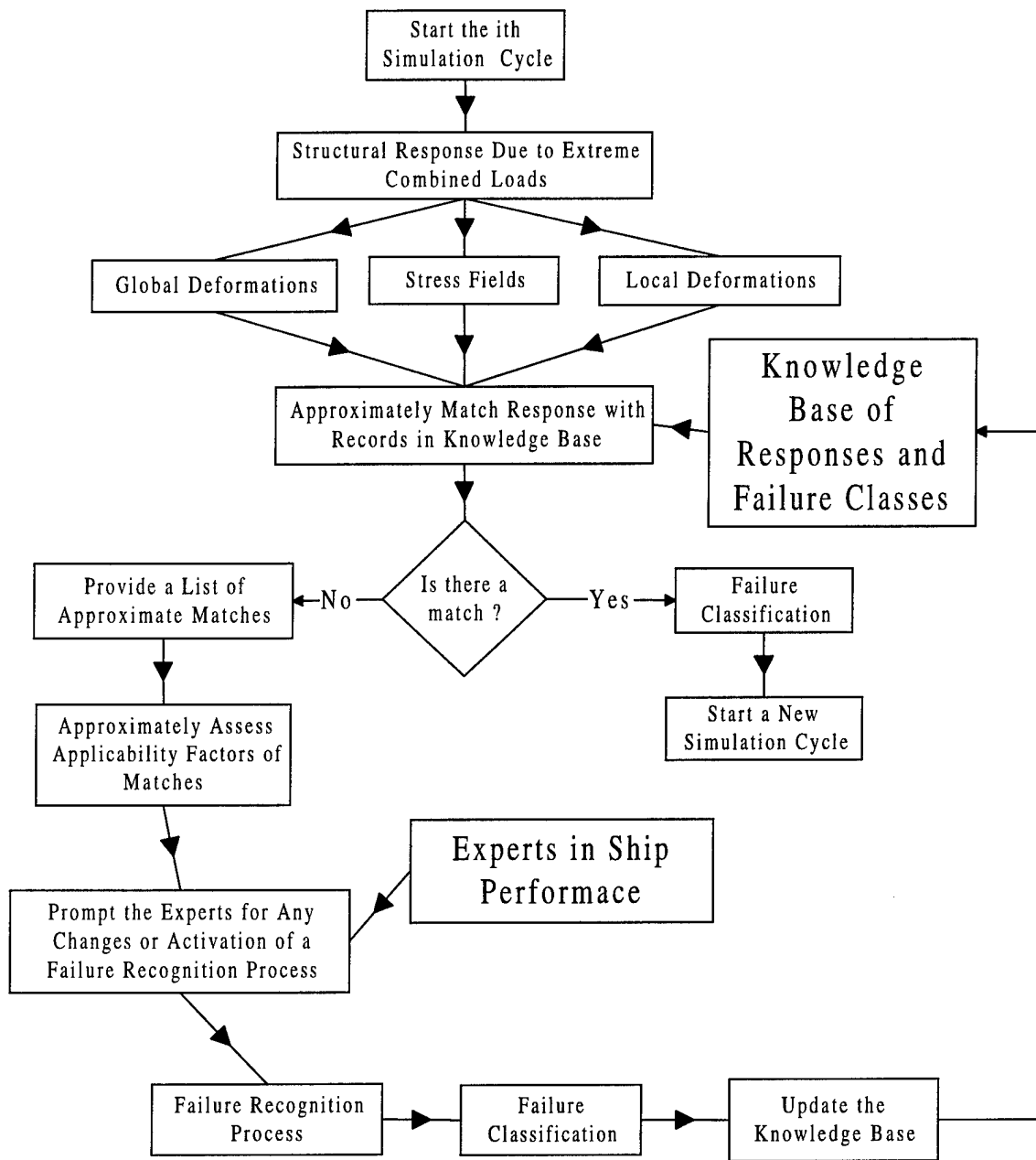

Figure 1. Failure Classification

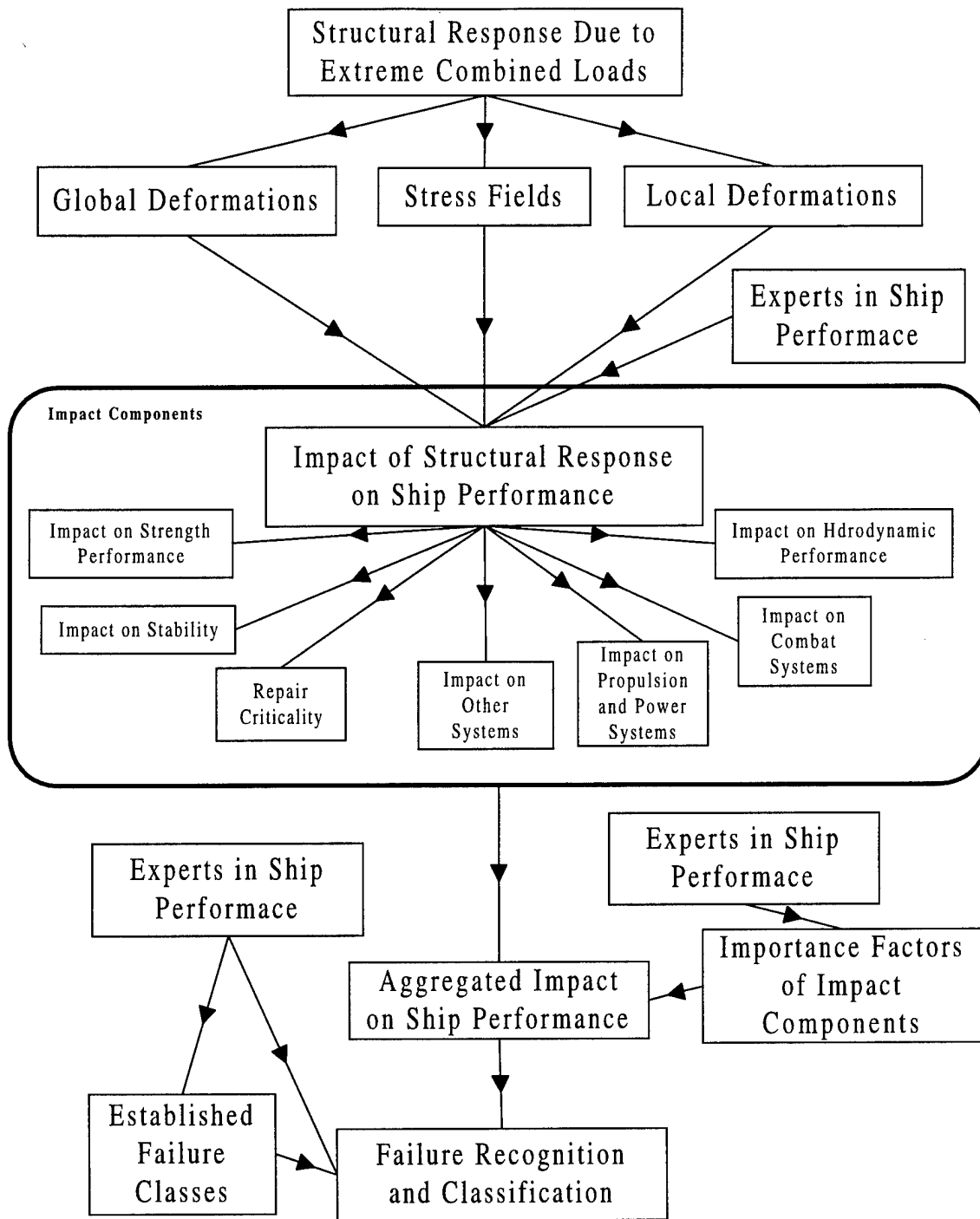
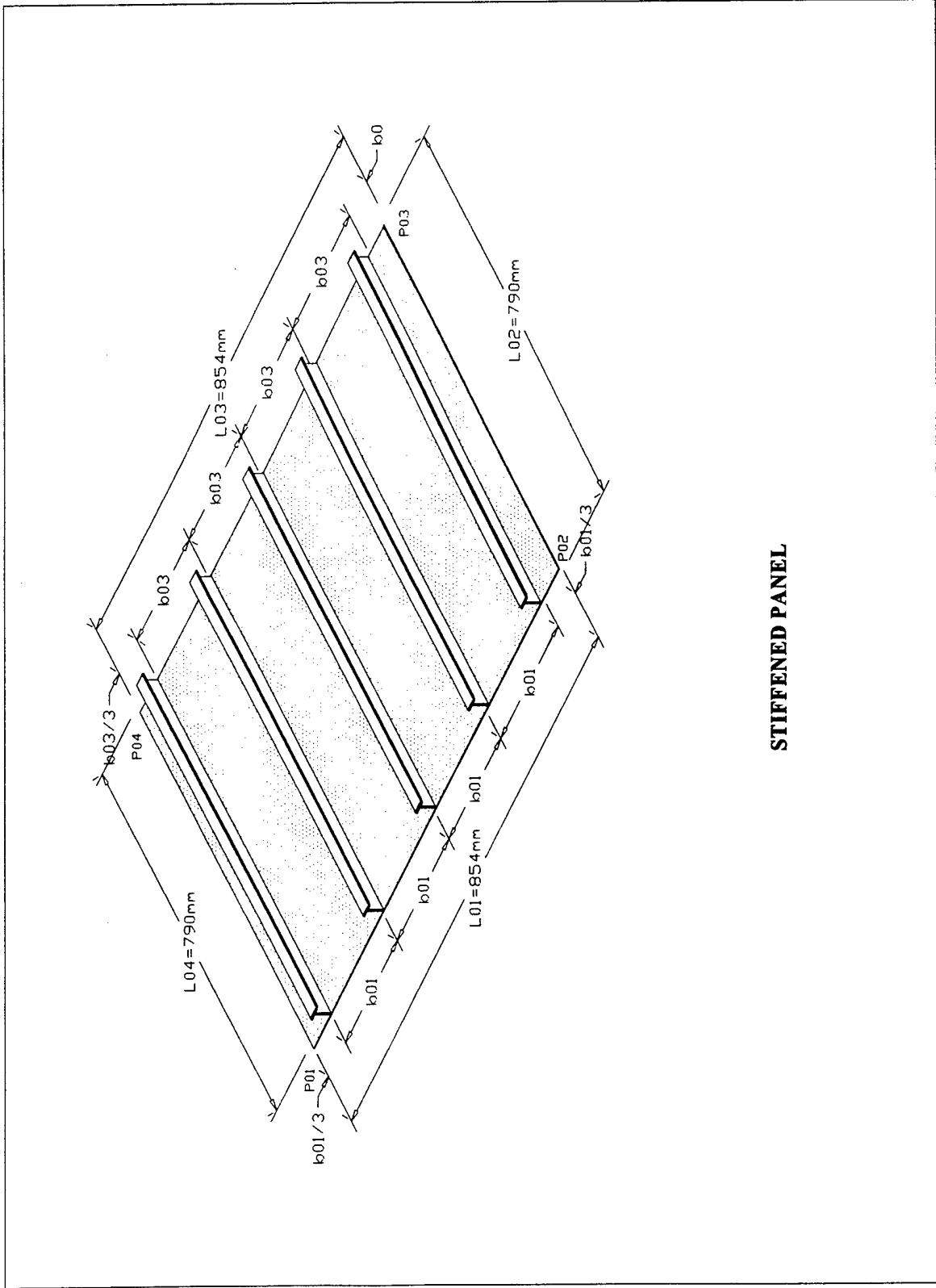

Figure 2. Failure Recognition and Classification



STIFFENED PANEL

Figure 3. Typical Stiffened Panel

ABAQUS

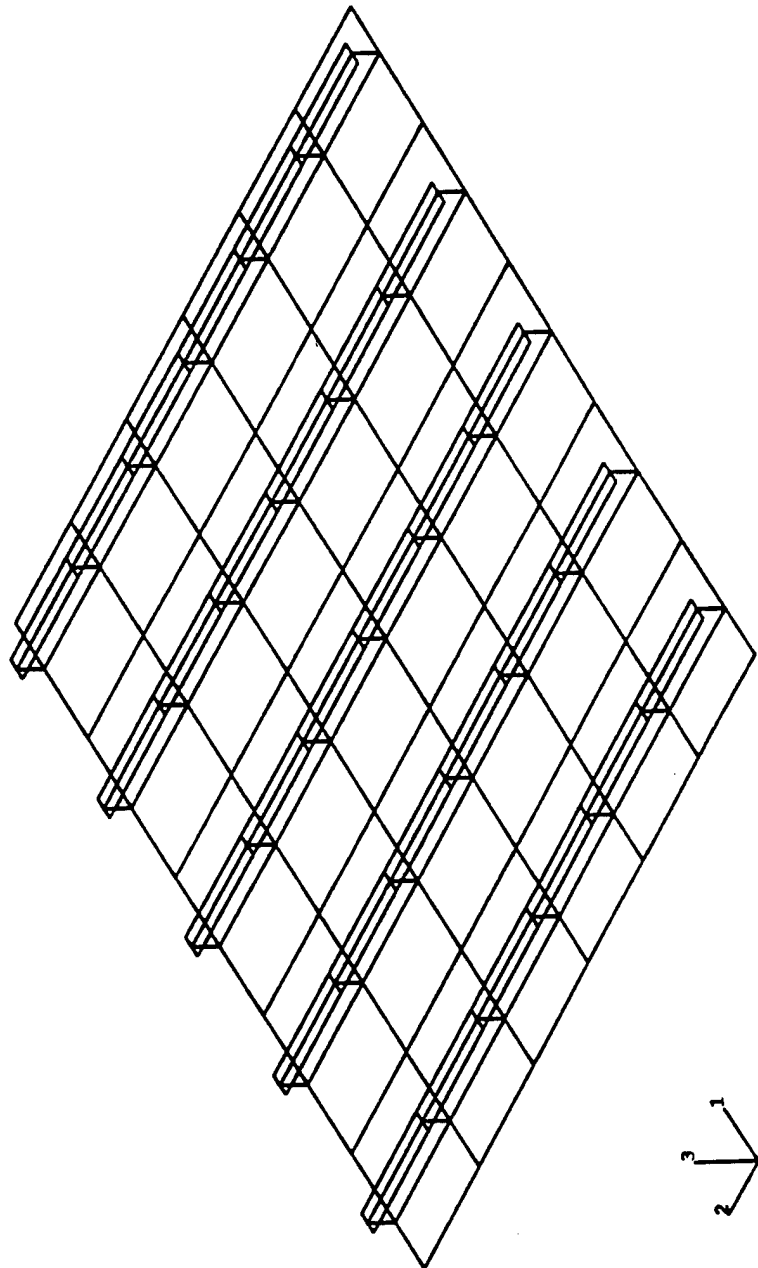

Figure 4. Finite Element Mesh of the Stiffened Panel

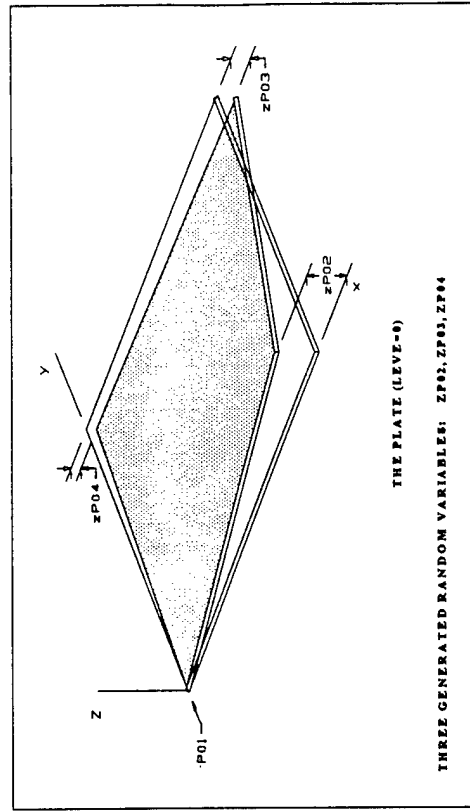
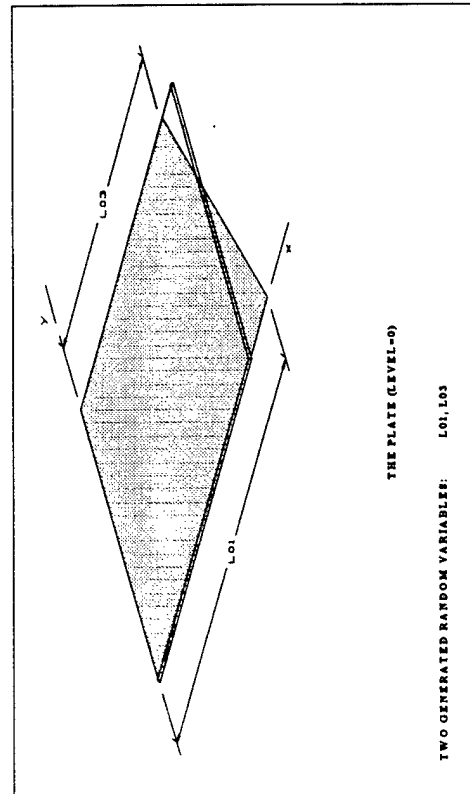
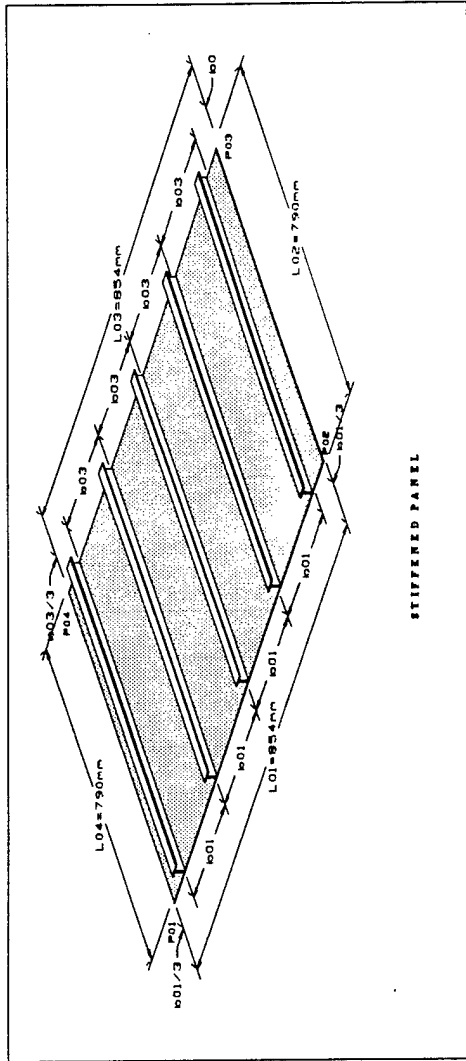

Figure 5. Plate Width Variability and Plate Distortion

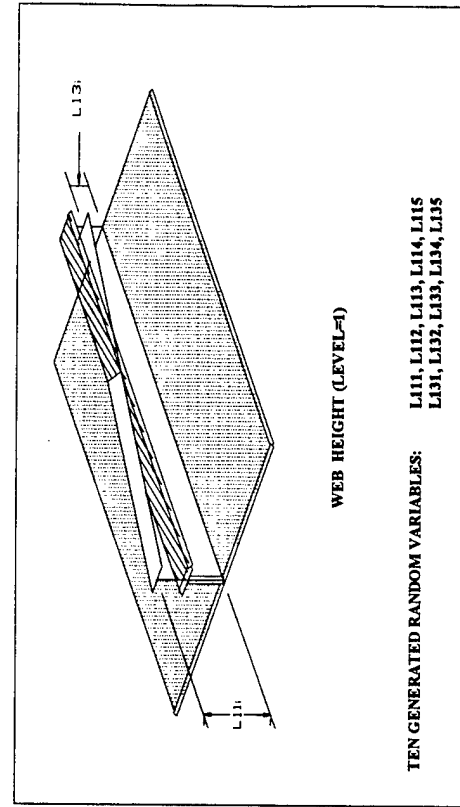
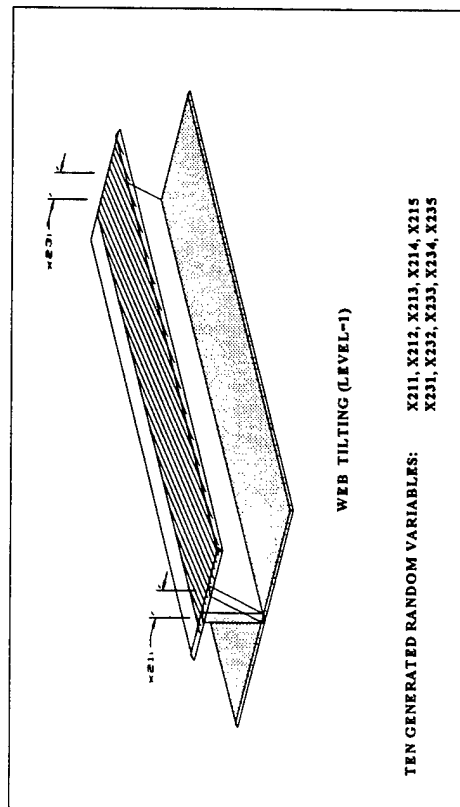
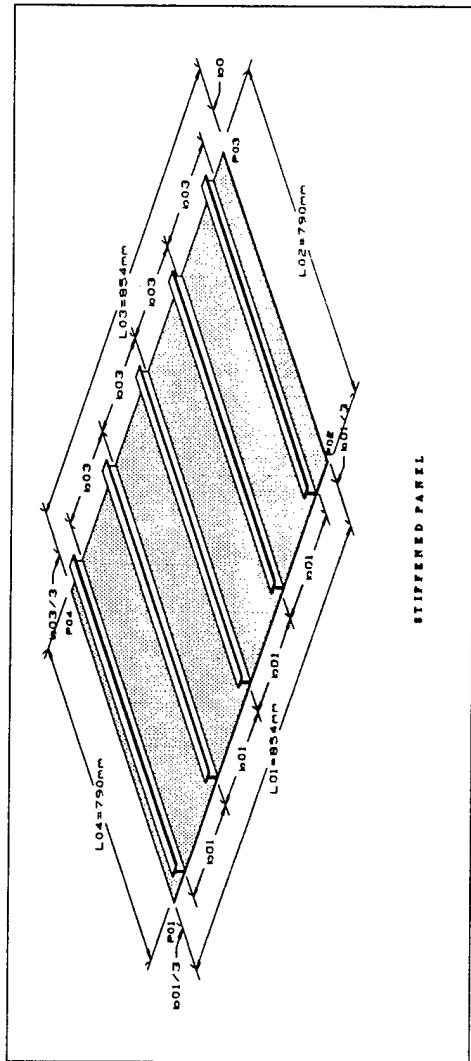

Figure 6. Web Height Variability and Web Tilting

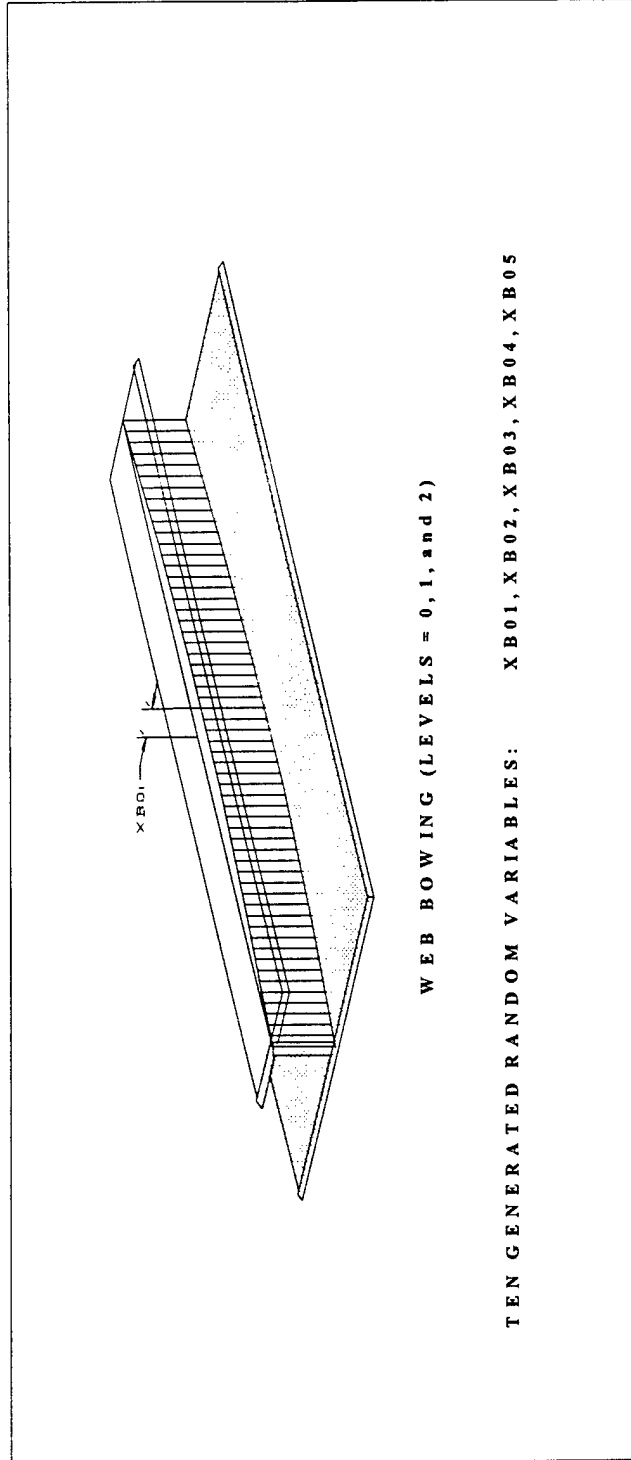
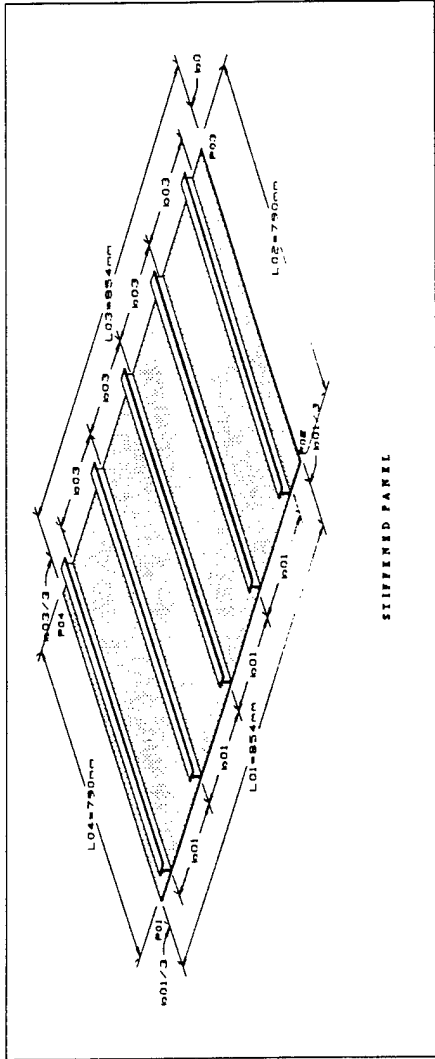
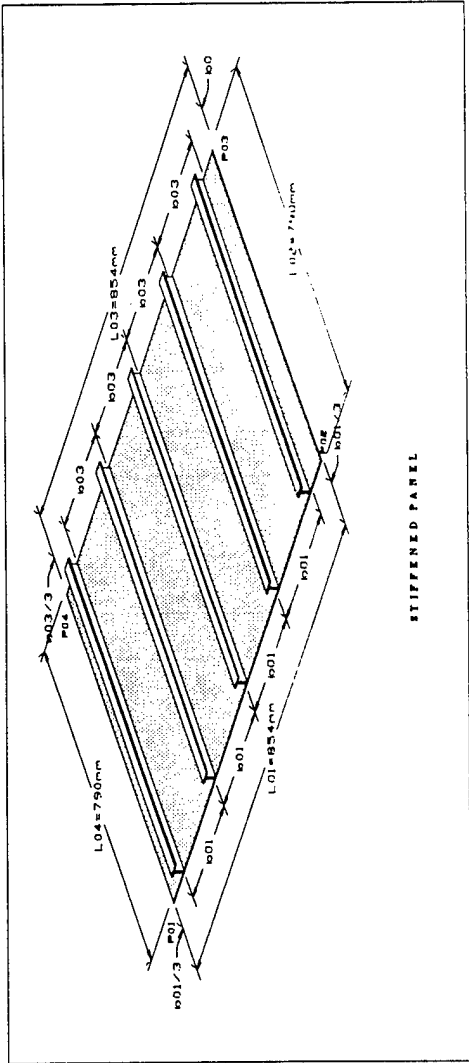

Figure 7. Web Bowing



STIFFENED PANEL

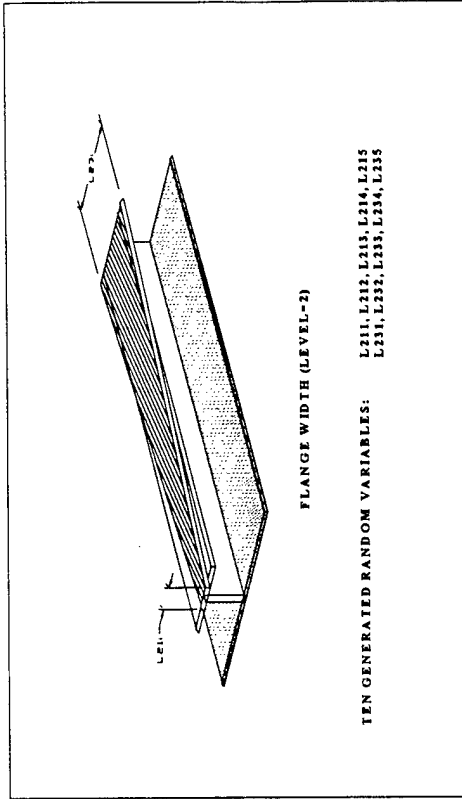
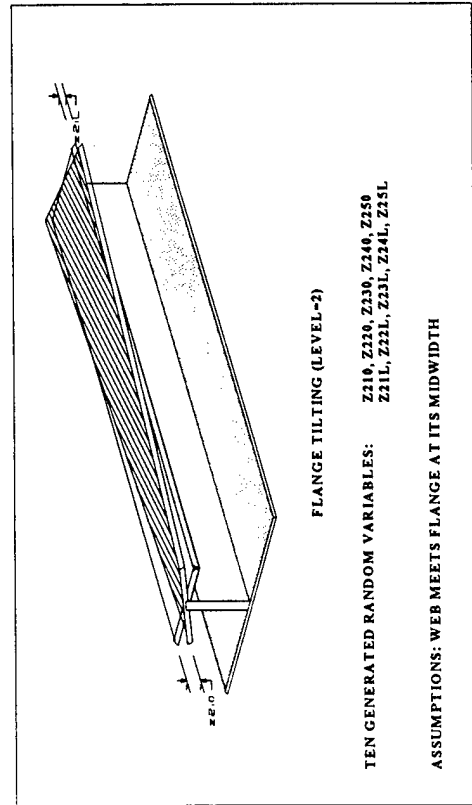

Figure 8. Flange Width Variability and Flange Tilting

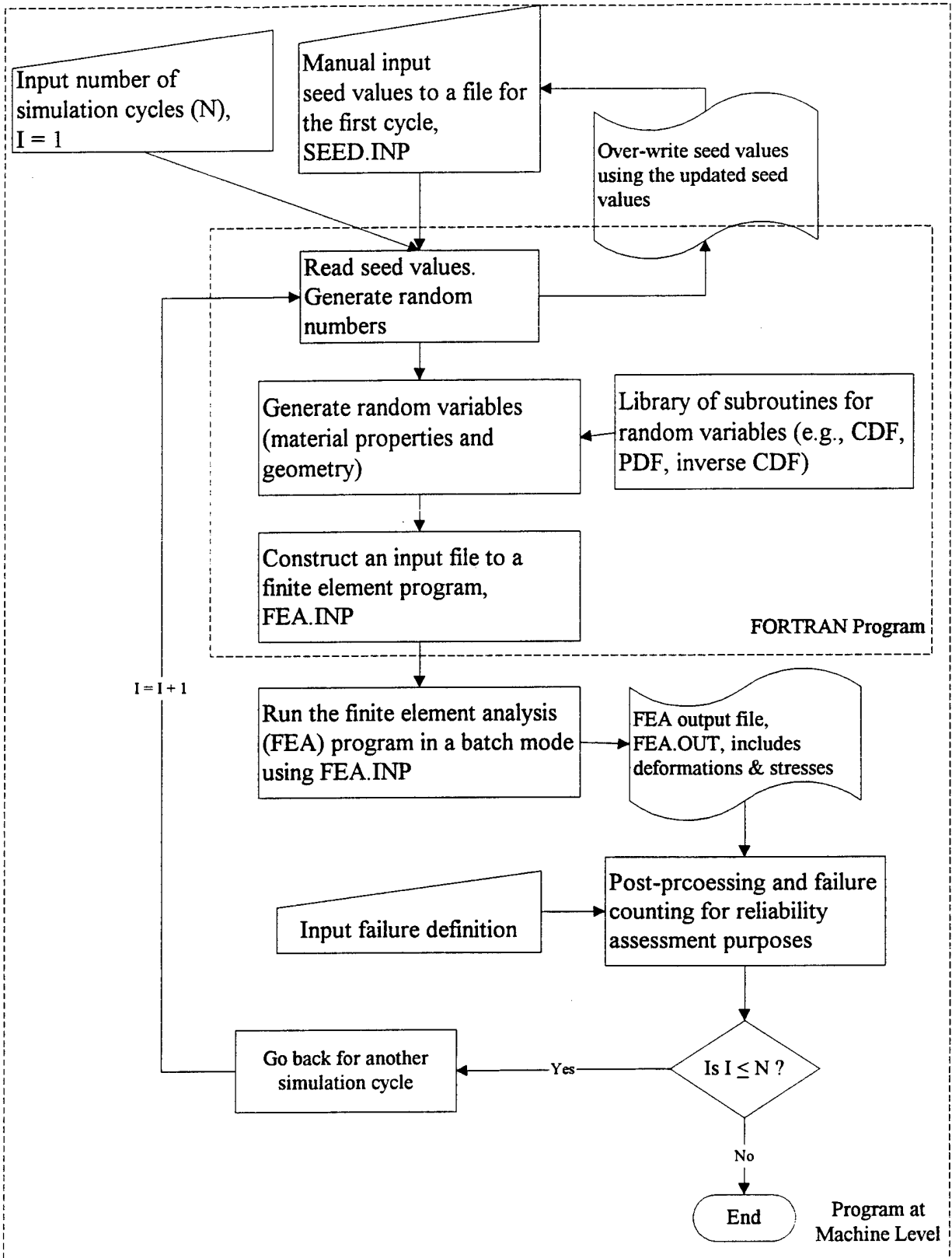

Figure 9. Methodology for *i*th Simulation Cycle

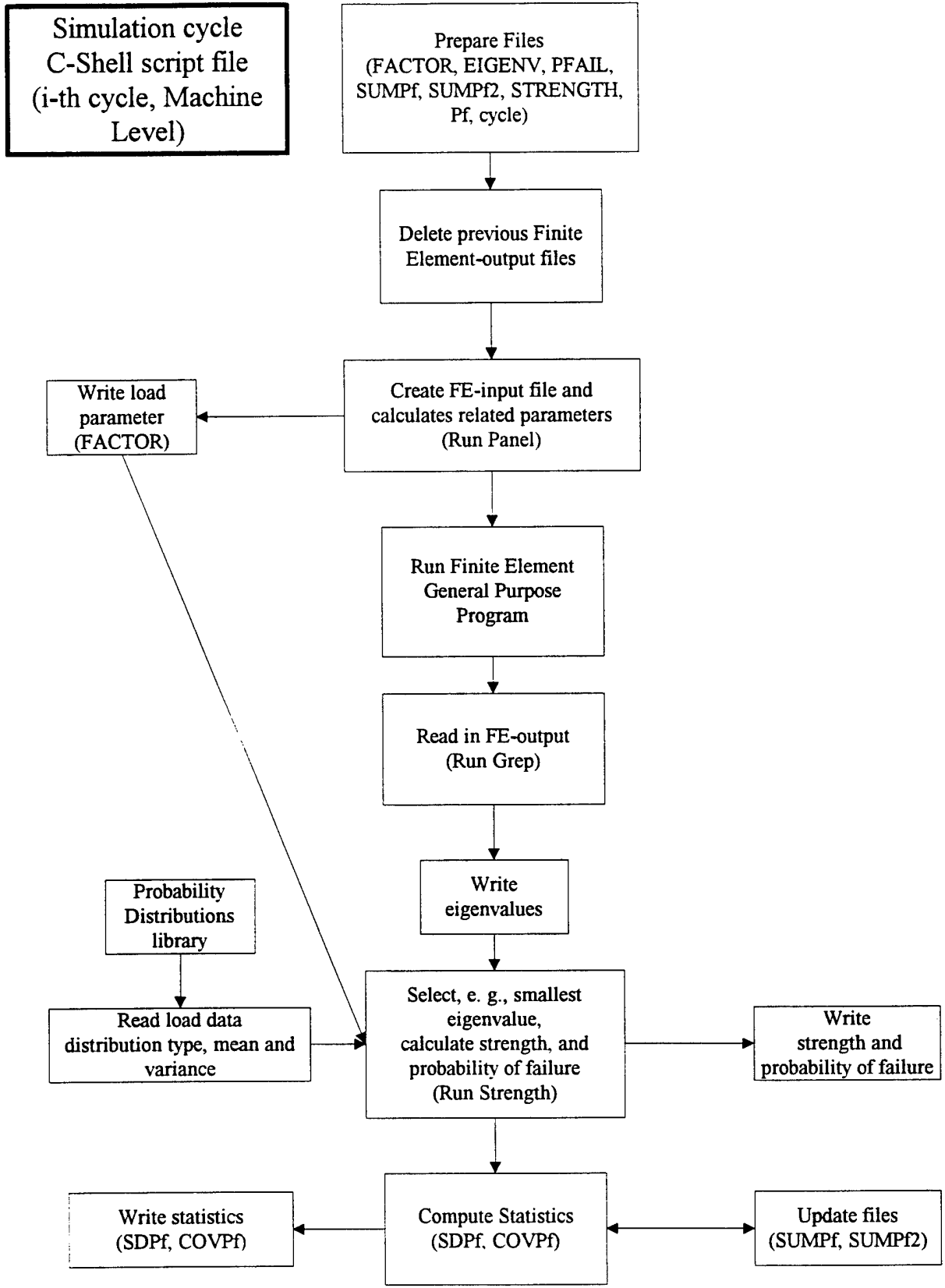

Figure 10. C-Shell Script Flow Chart for *i*th Simulation Cycle-Machine Level

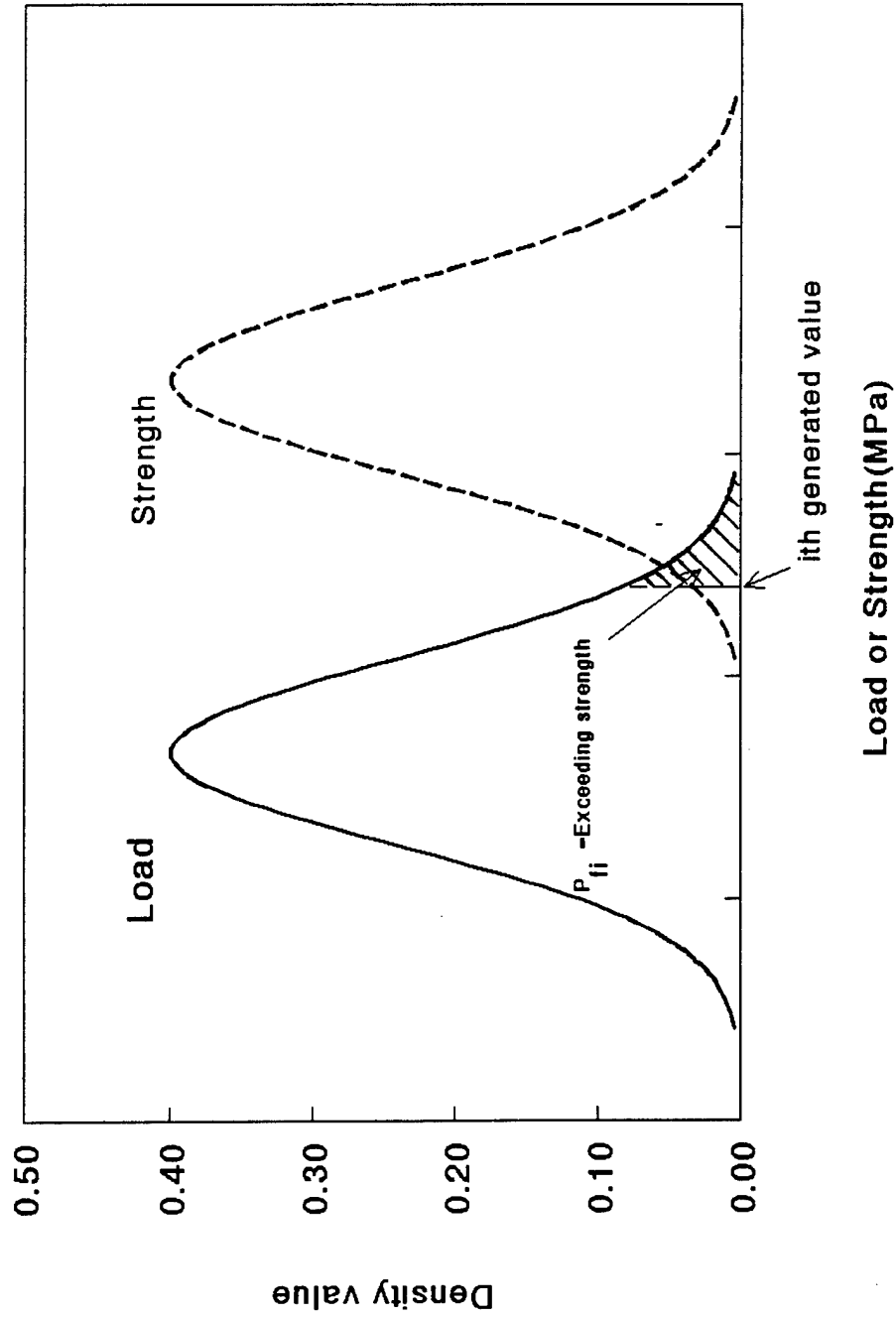

Figure 11. Conditional Expectation for Probability of Failure

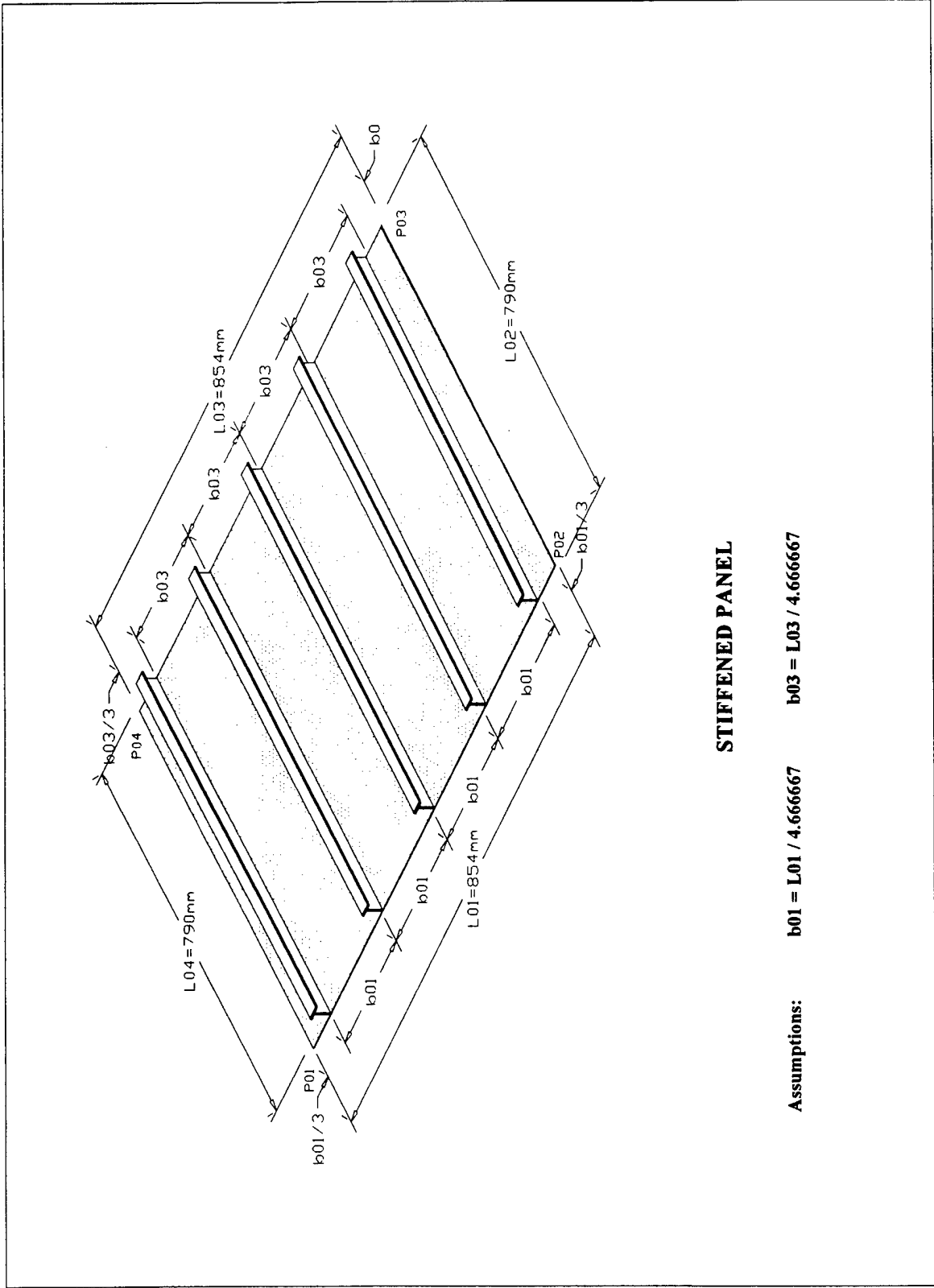

Figure 12. Stiffened Panel (dimensions and assumptions)

ABAQUS

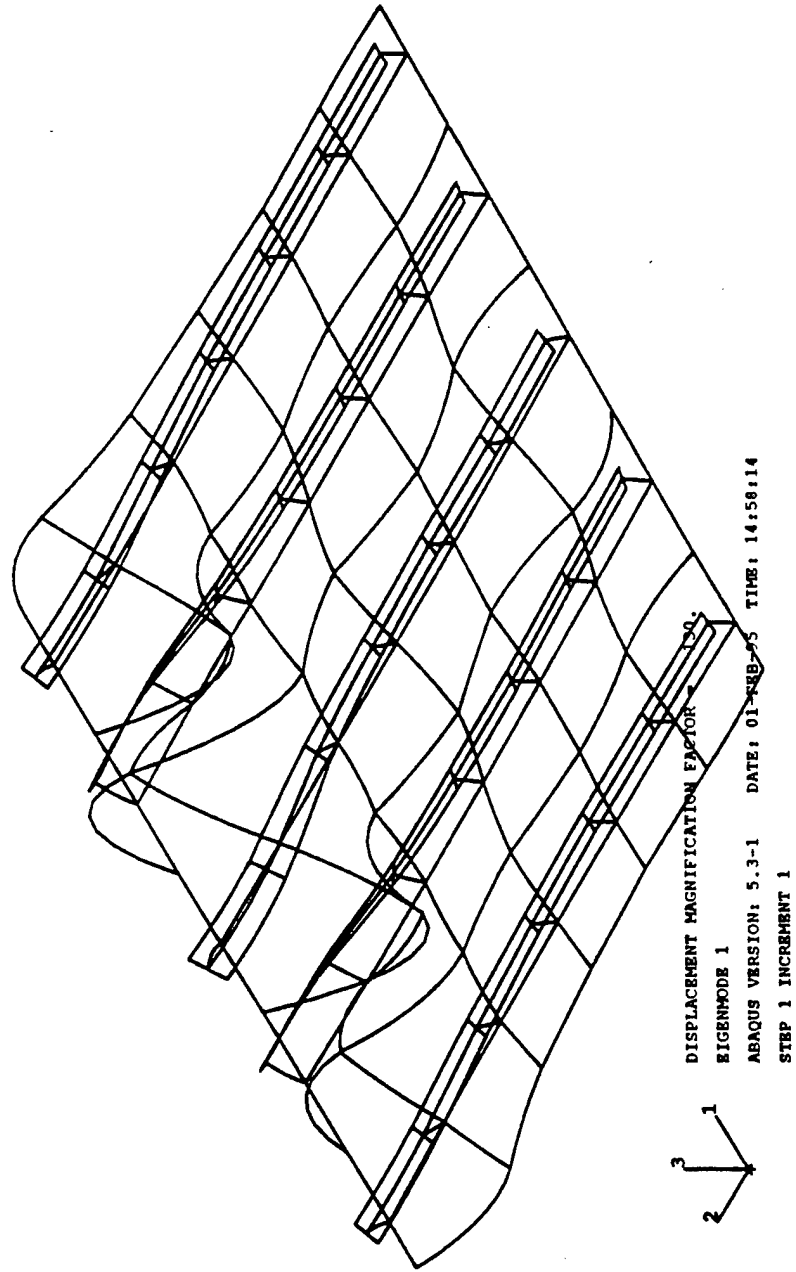
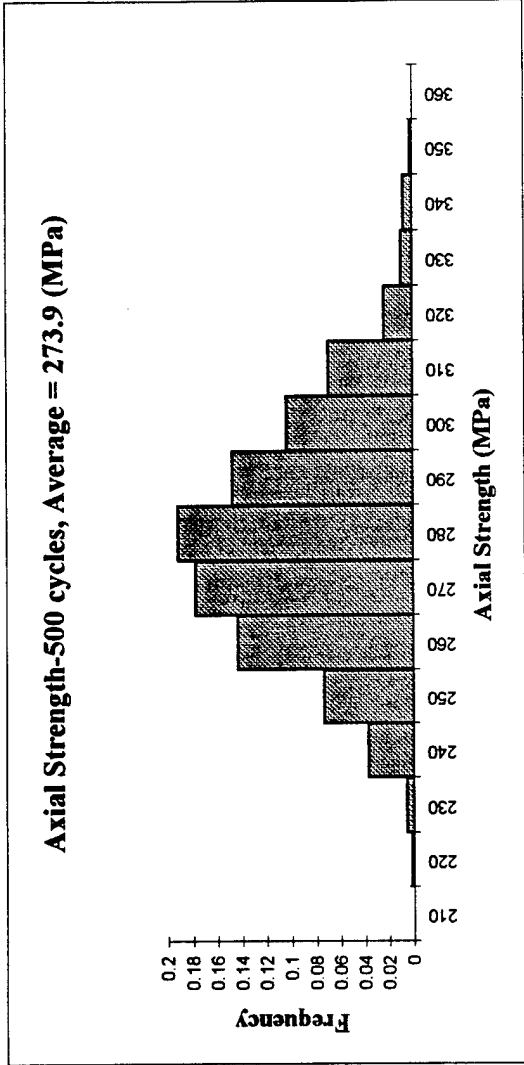

Figure 13. Buckling Shape of the Stiffened Panel

Statistical Measures	Axial Strength
Mean	273.9064
Standard Error	0.933275
Median	272.1663
Standard Deviation	20.86865
Sample Variance	435.5007
Kurtosis	0.031126
Skewness	0.278253
Range	121.3818
Minimum	219.5003
Maximum	340.8821
Sum	136953.2
Count	500
Confidence Level(95%)	1.829182



Statistical Measures	Normalized Axial Strength
Mean	1.00221868
Standard Error	0.00341484
Median	0.99585163
Standard Deviation	0.07635806
Sample Variance	0.00583055
Kurtosis	0.03112581
Skewness	0.27825334
Range	0.44413392
Minimum	0.80314782
Maximum	1.24728174
Sum	501.109341
Count	500
Confidence Level(95%)	0.006692946

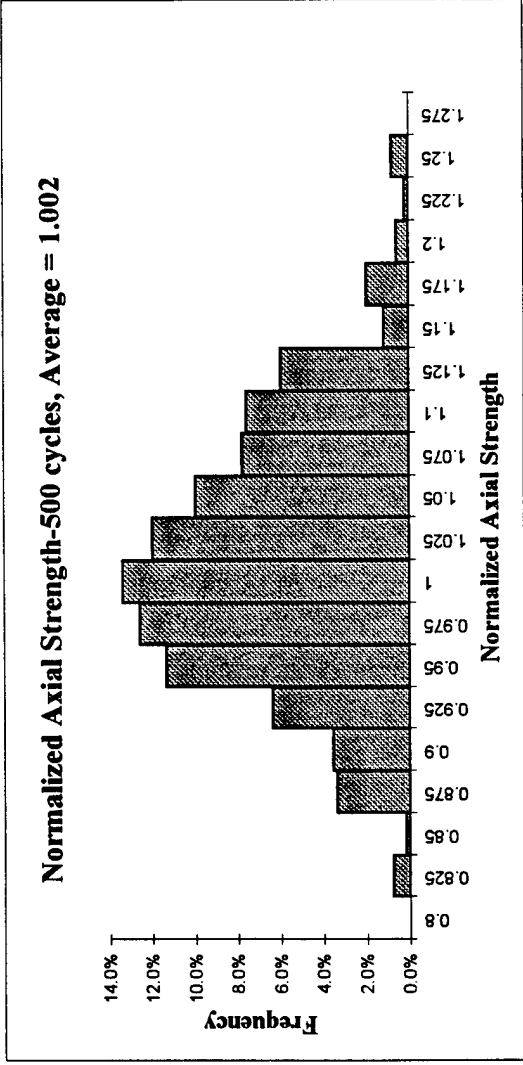
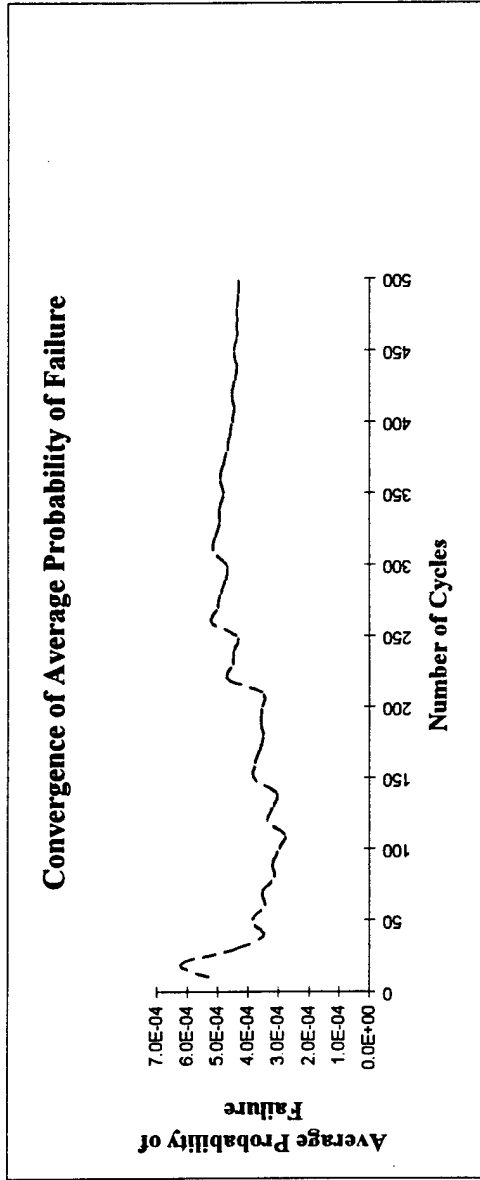

Figure 14. Axial Strength Statistics of the Stiffened Panel-500 Cycles



Statistical Measures	Probability of Failure
Mean	0.000431
Standard Error	8.83E-05
Median	1.83E-05
Standard Deviation	0.001973
Sample Variance	3.89E-06
Kurtosis	104.3945
Range	9.528373
Minimum	0.025693
Maximum	7.28E-11
Sum	0.025693
Count	0.215415
Confidence Level (95.0%)	500
	0.000173

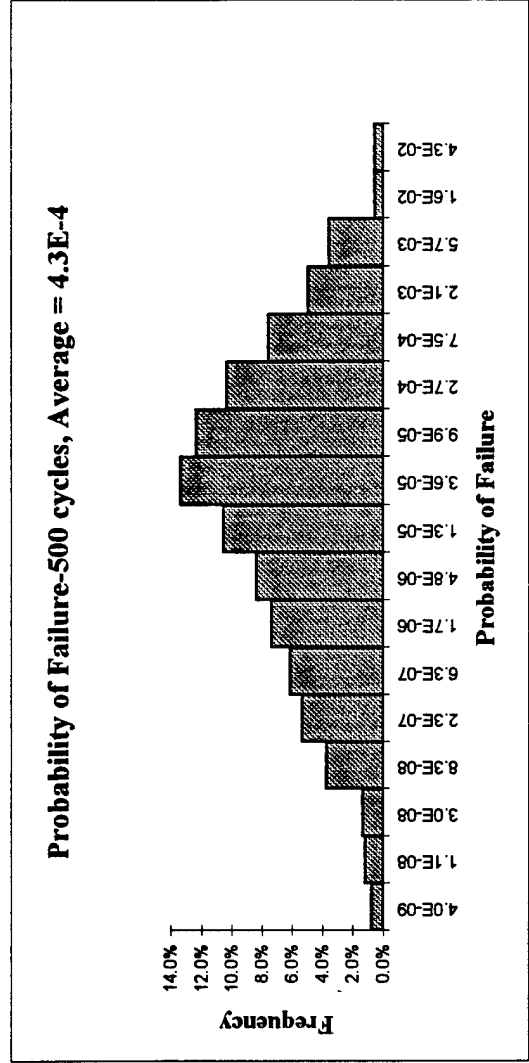

Figure 15. Probability of Failure Statistics of the Stiffened Panel-500 Cycles

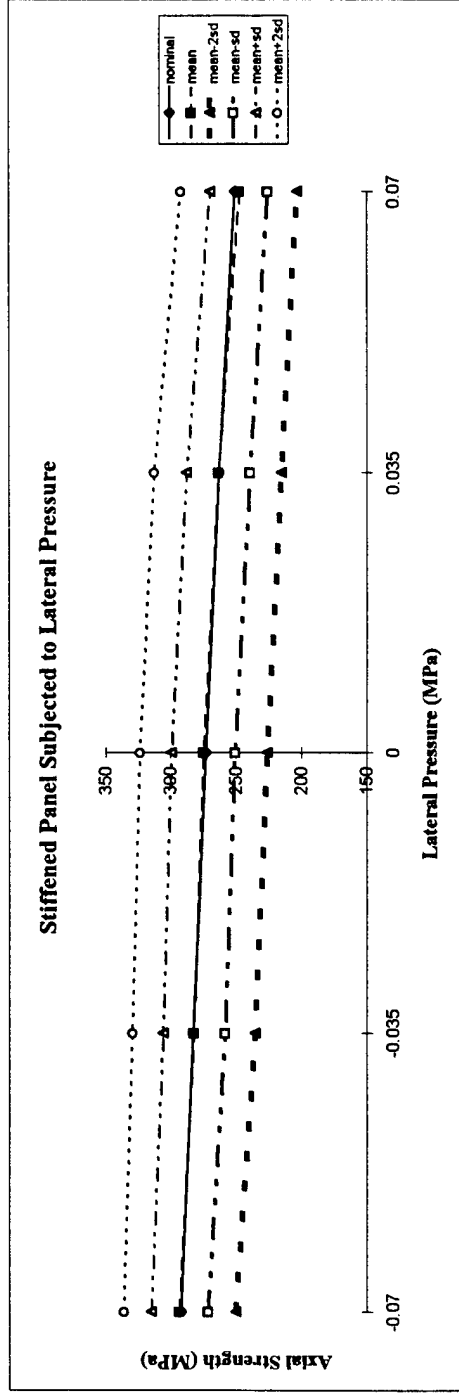
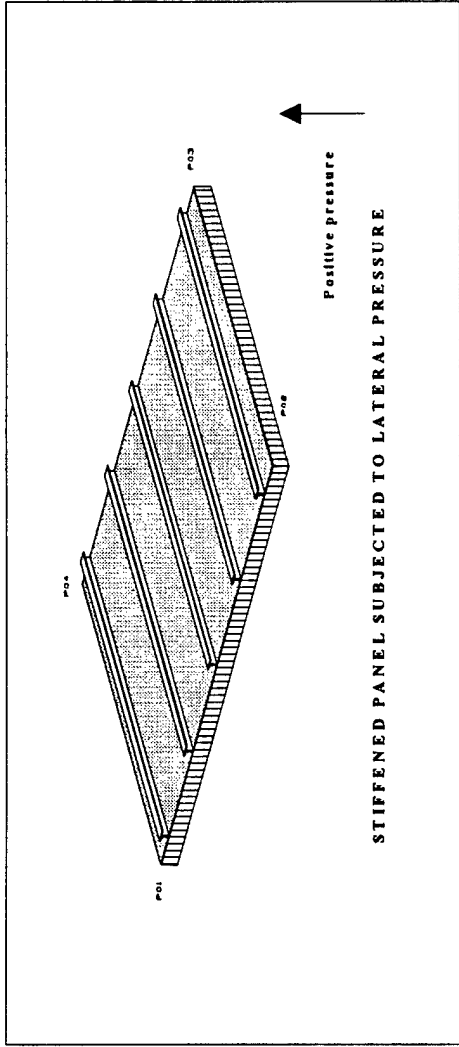

Figure 16. Stiffened Panel Subjected to Concentric Axial Compression and Lateral Pressure

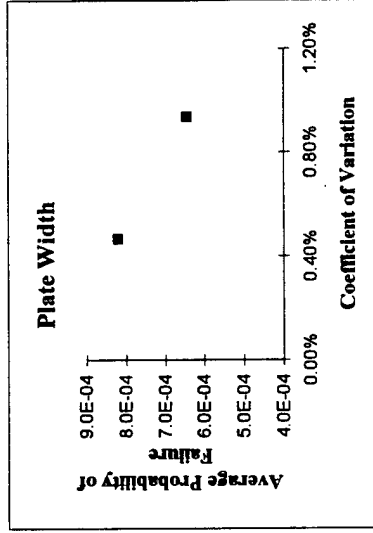
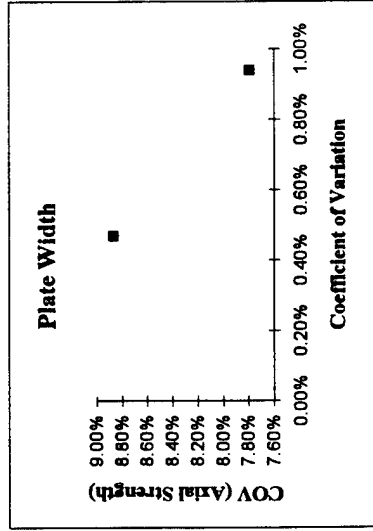
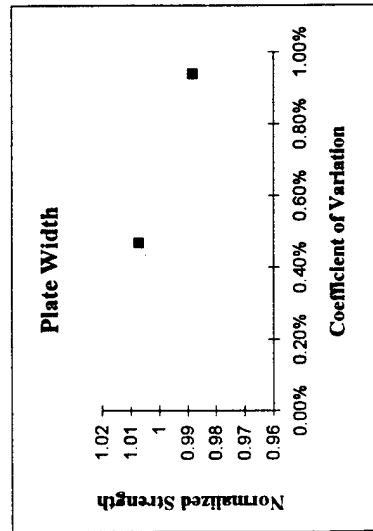
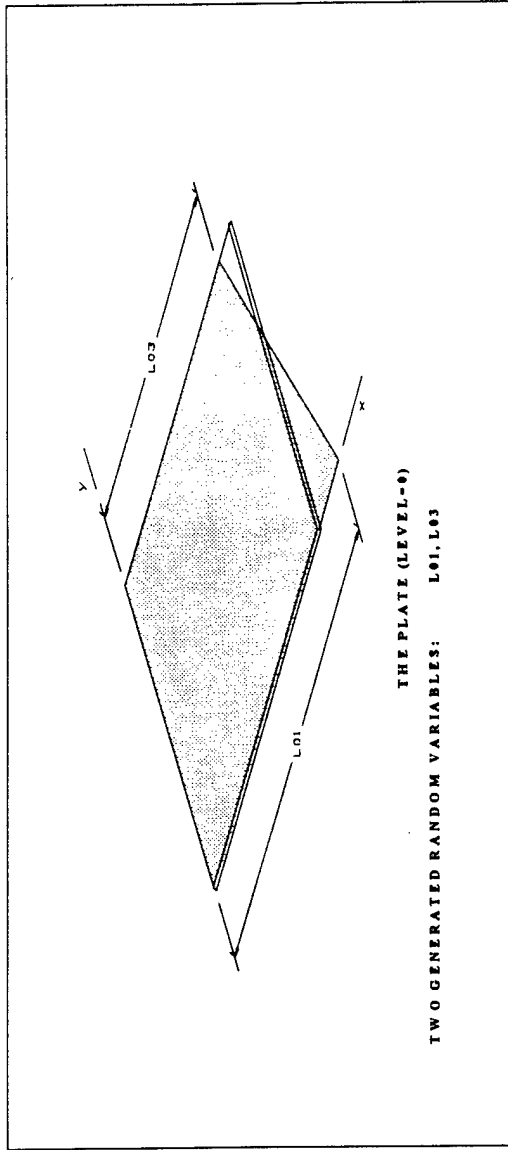

Figure 17. Strength and Probability of Failure Due to Plate Width Variability

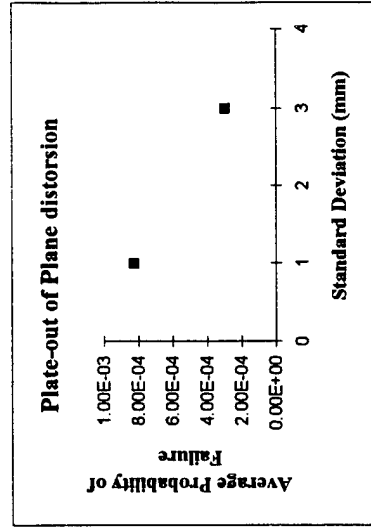
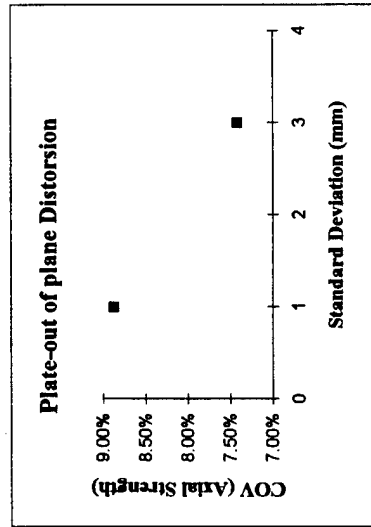
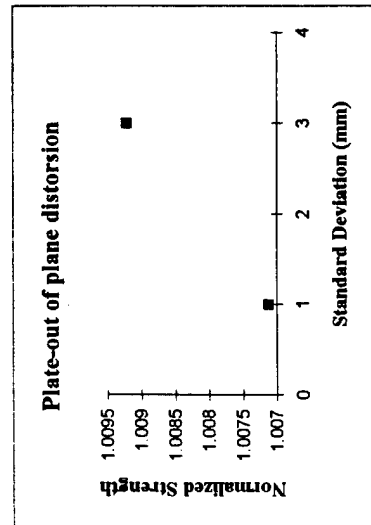
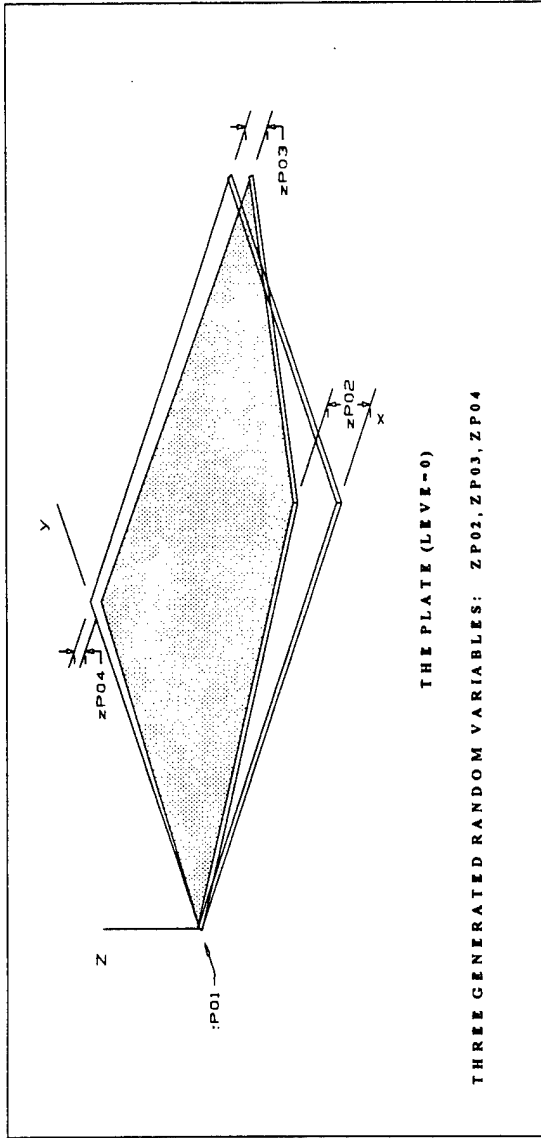

Figure 18. Strength and Probability of Failure Due to Plate Distortion Variability

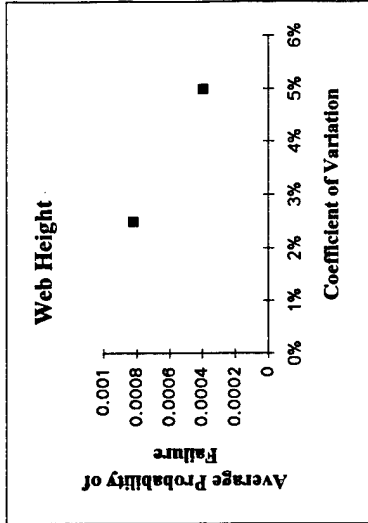
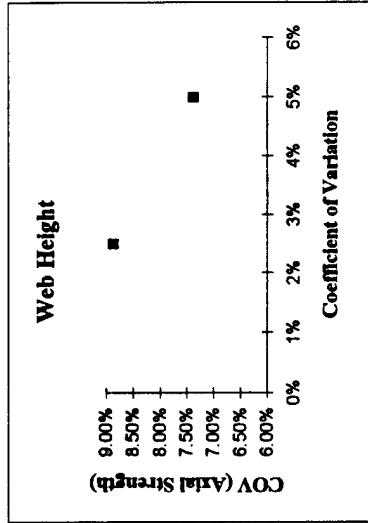
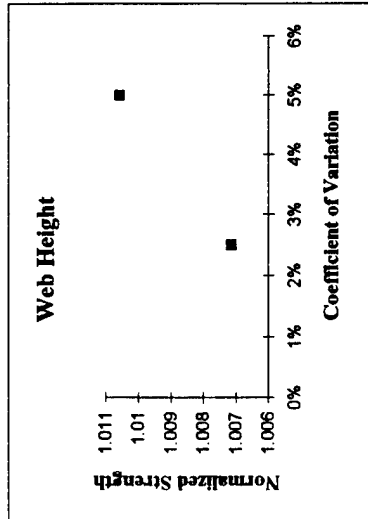
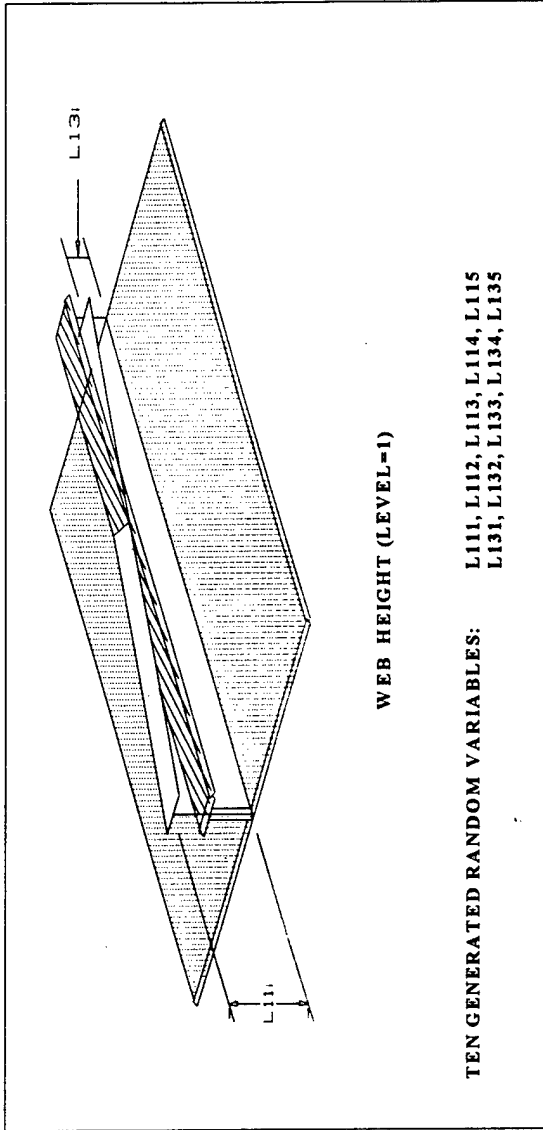

Figure 19. Strength and Probability of Failure Due to Web Height Variability

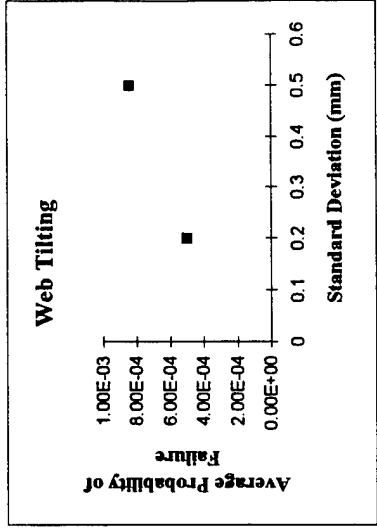
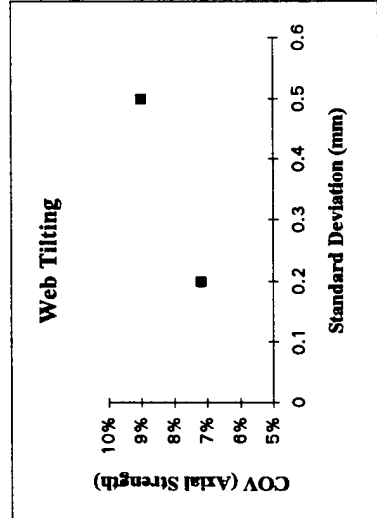
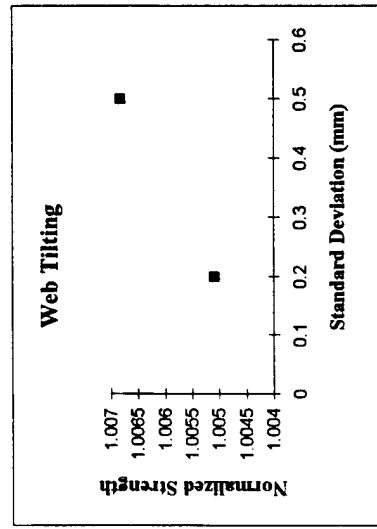
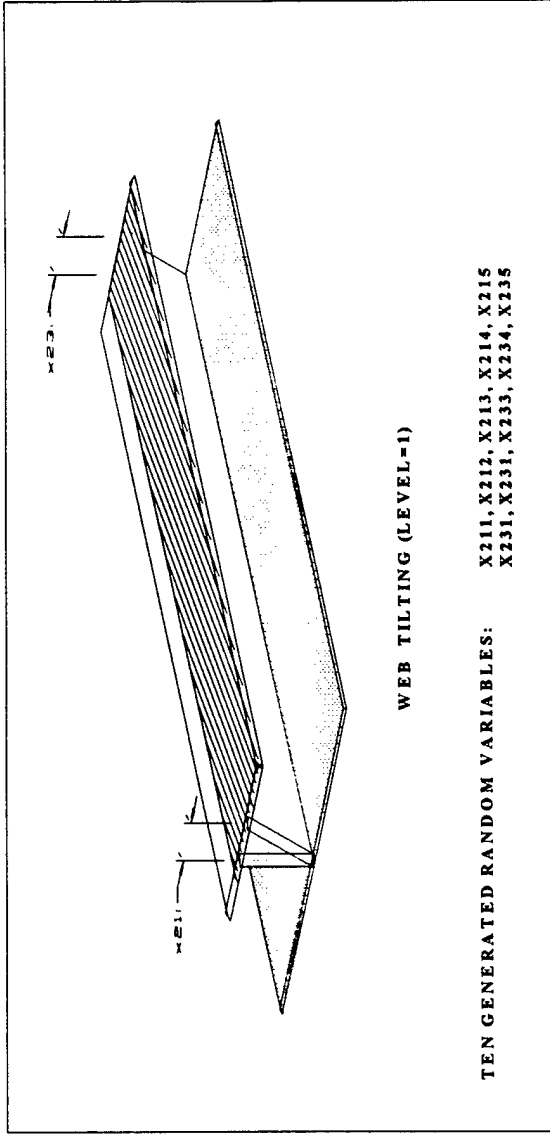

Figure 20. Strength and Probability of Failure Due to Web Tilting Variability

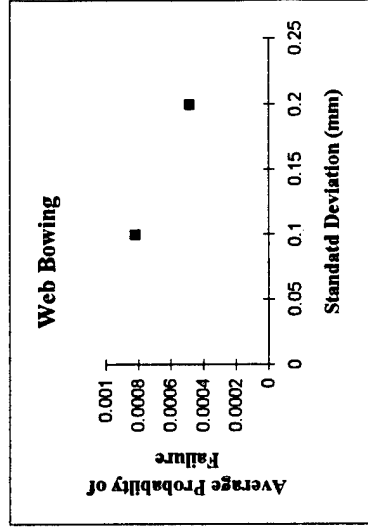
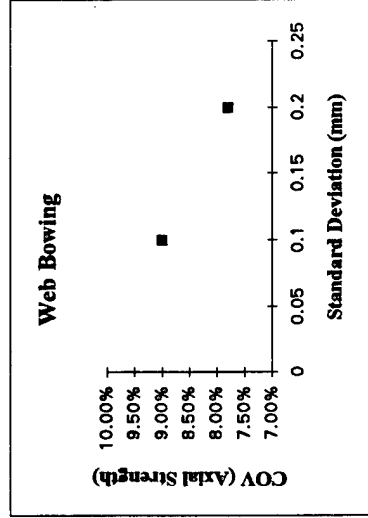
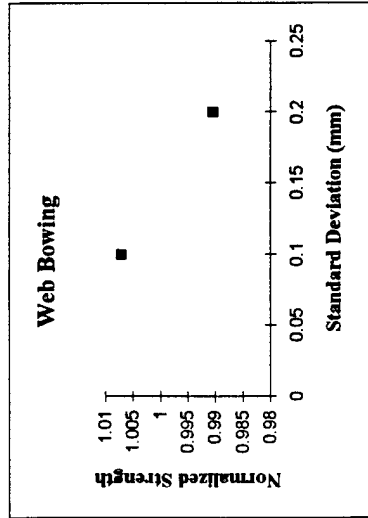
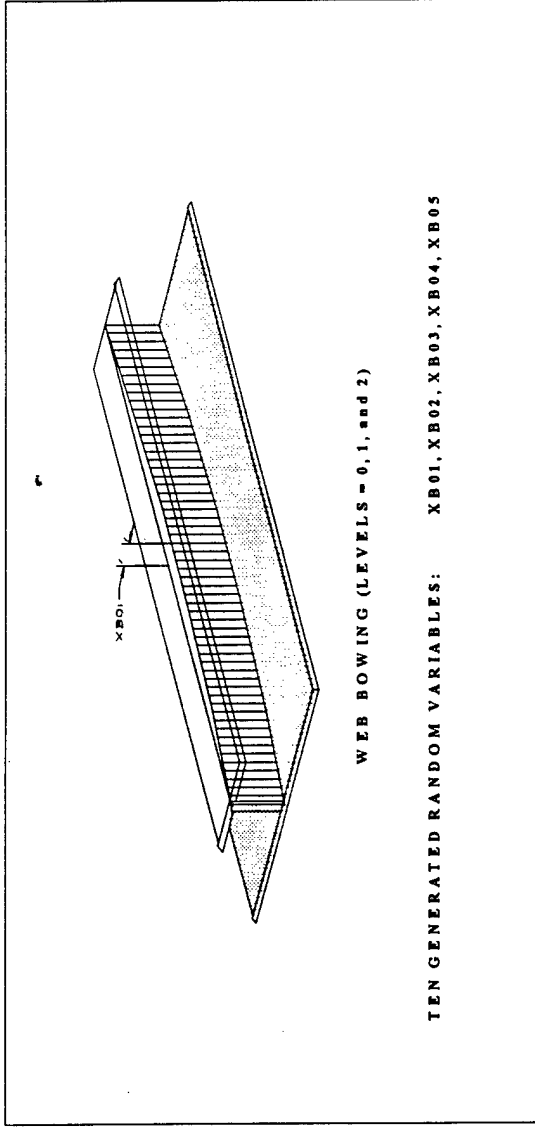

Figure 21. Strength and Probability of Failure Due to Web Bowing Variability

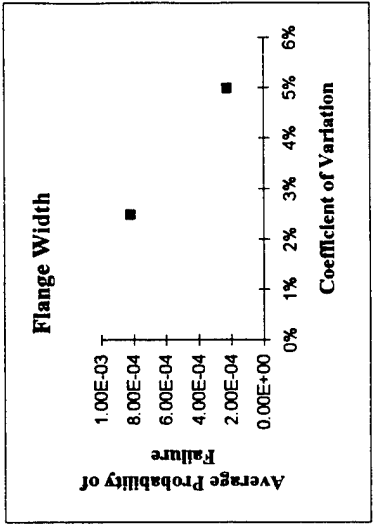
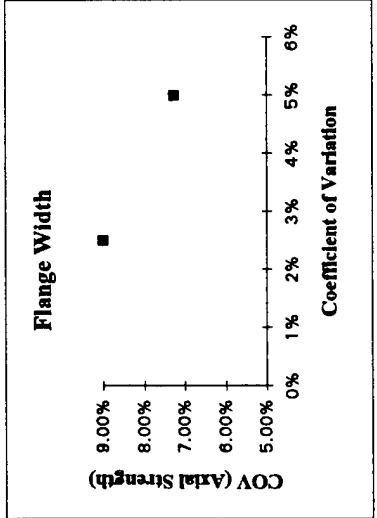
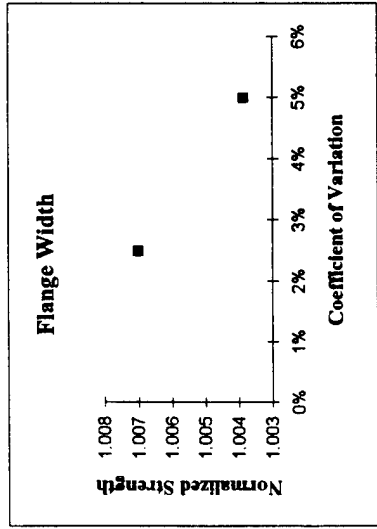
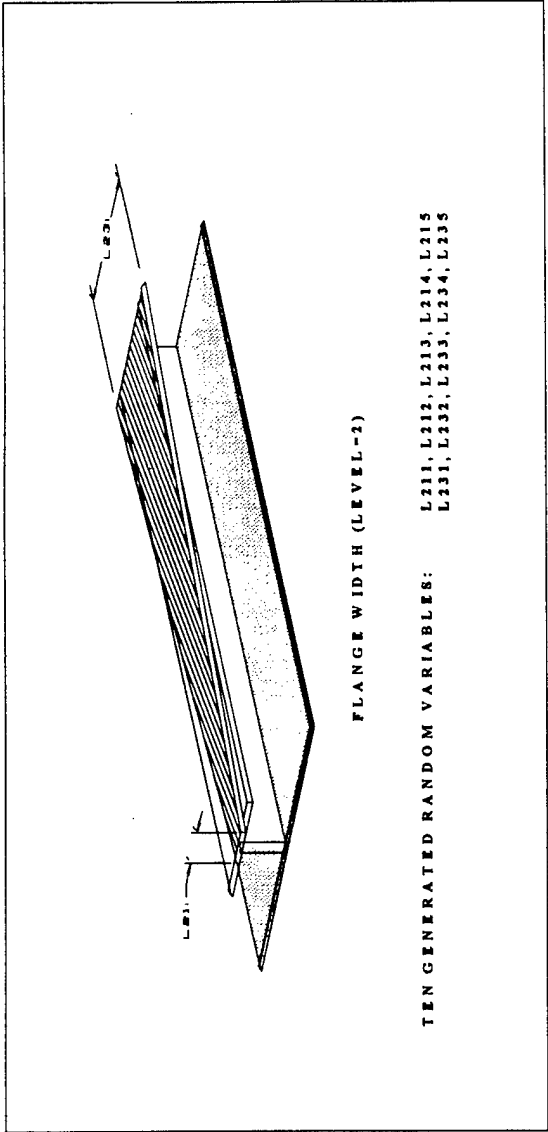

Figure 22. Strength and Probability of Failure Due to Flange Width Variability

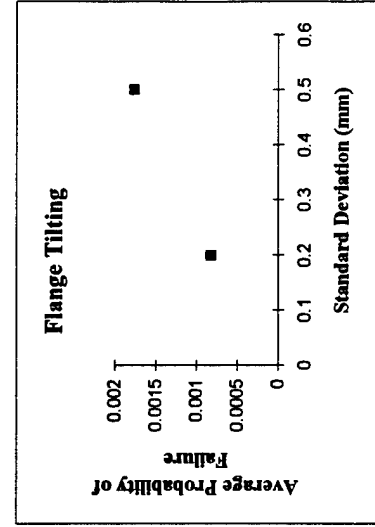
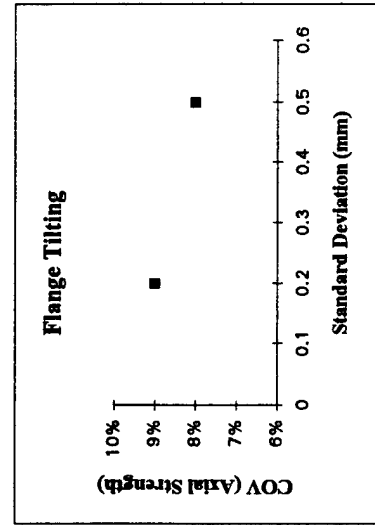
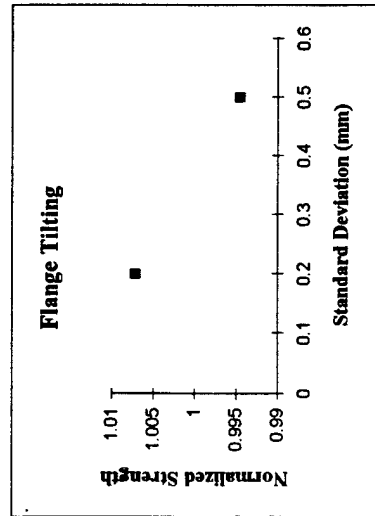
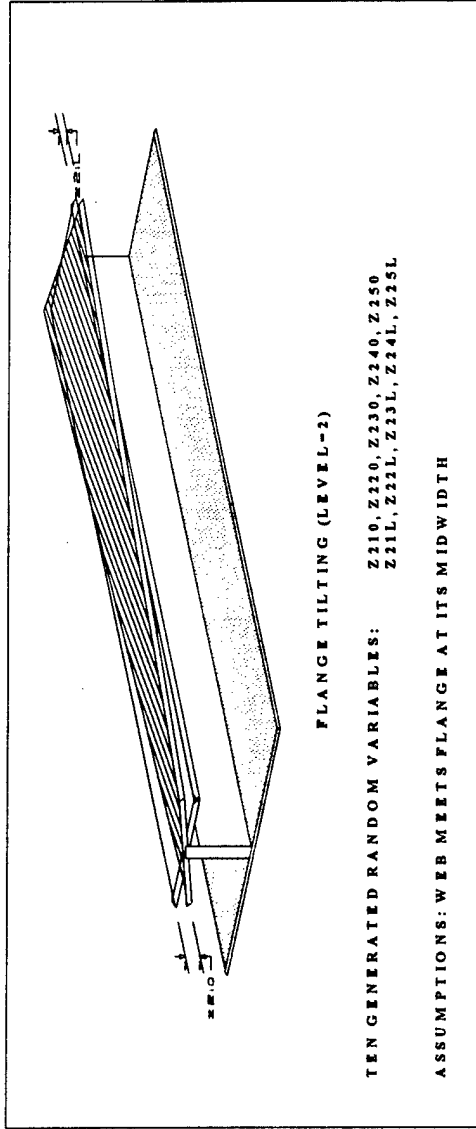

Figure 23. Strength and Probability of Failure Due to Flange Tilting Variability

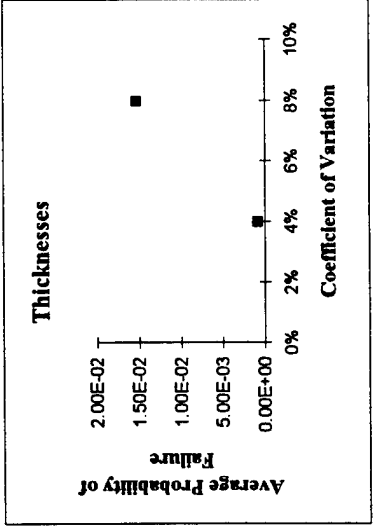
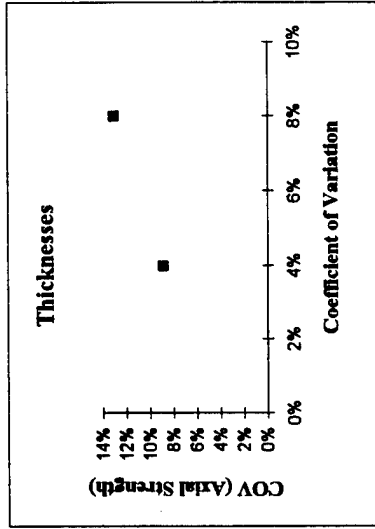
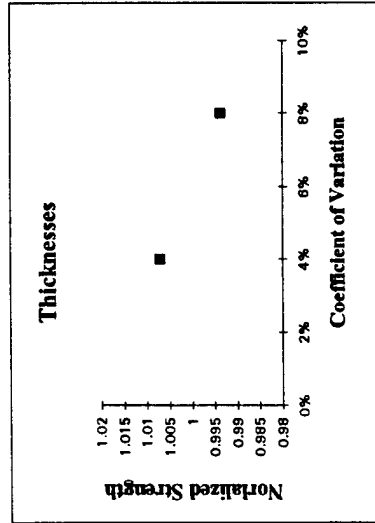
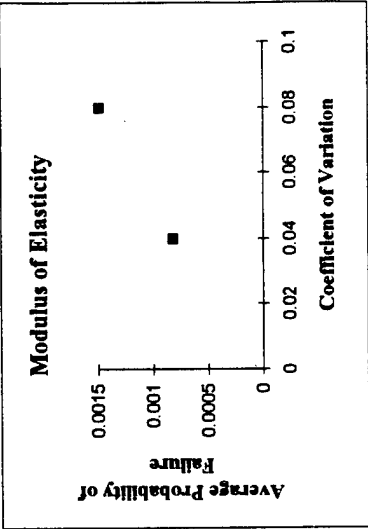
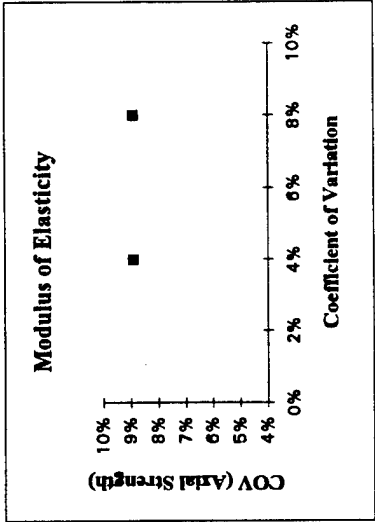
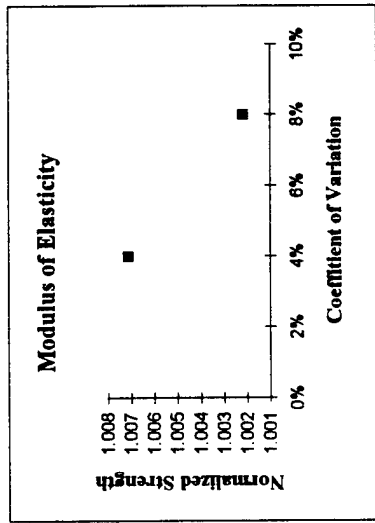
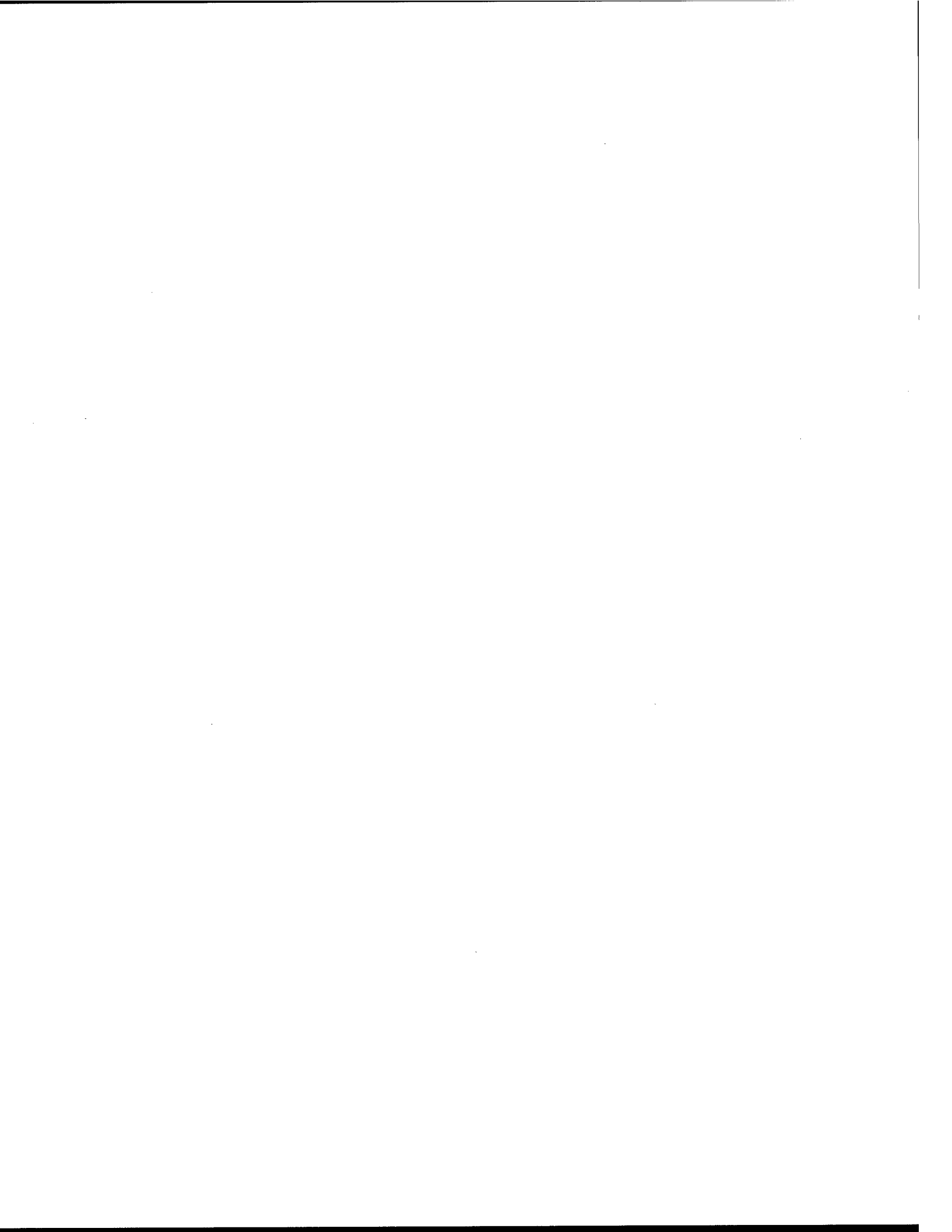

Figure 24. Strength and Probability of Failure Due to Modulus of Elasticity and Thicknesses Variability



APPENDIX A. COMPUTER PROGRAMS

A.1. FE-INPUT

PROGRAM INPUTFILE

```
REAL*8 x,xx,mean,sigma,cdf
REAL*8 H(51)
REAL*8 L01,L03,TH0,TH1,TH2
REAL*8 L111,L112,L113,L114,L115,L131,L132,L133,L134,L135
REAL*8 L211,L212,L213,L214,L215,L231,L232,L233,L234,L235
REAL*8 Z210,Z220,Z230,Z240,Z250,Z21L,Z22L,Z23L,Z24L,Z25L
REAL*8 X211,X212,X213,X214,X215,X231,X232,X233,X234,X235
REAL*8 ZP02,ZP03,ZP04
REAL*8 E0,E1,E2,NU0,NU1,NU2,FY0,FY1,FY2
REAL*8 XB01,XB02,XB03,XB04,XB05,PRESS
C.....
COMMON/LEVEL0/ L01,L03,TH0,TH1,TH2,ZP02,ZP03,ZP04,XB01,XB02,
* XB03,XB04,XB05,PRESS
COMMON/PHYS/ E0,E1,E2,NU0,NU1,NU2,FY0,FY1,FY2
COMMON/LEVEL1/ L111,L112,L113,L114,L115,L131,L132,L133,L134,L135
COMMON/LEVEL20/ L211,L212,L213,L214,L215,Z210,Z220,Z230,Z240,Z250,
* X211,X212,X213,X214,X215
COMMON/LEVEL2L/ L231,L232,L233,L234,L235,Z21L,Z22L,Z23L,Z24L,Z25L,
* X231,X232,X233,X234,X235
C.....
INTEGER SEED,NDIST
C.....
OPEN(UNIT=1,FILE='seed.inp',STATUS='UNKNOWN')
REWIND(UNIT=1)
READ(1,*) SEED
PRINT*,'SEED = ',SEED
CLOSE(UNIT=1)
OPEN(UNIT=2,FILE='dist.inp',STATUS='UNKNOWN')
REWIND(UNIT=2)
DO 10 I=1,51
C.....
CALL RANDOM(SEED,XX)
CDF=XX
OPEN(UNIT=1,FILE='seed.inp',STATUS='UNKNOWN')
REWIND(UNIT=1)
WRITE(1,*) SEED
C
C.....DISTRIBUTIONS INPUT FILE.....
C
READ(2,*) NDIST,MEAN,SIGMA,C
C
C..... DISTRIBUTIONS.....
C
C...1- NORMAL DISTRIBUTION.
C
IF (NDIST.EQ.1) THEN
CALL norinv(x, mean, sigma, cdf)
ENDIF
C
C.....END DISTRIBUTIONS.....
C
H(I)=X
L01=H(1)
L03=H(2)
TH0=H(3)
TH1=H(4)
TH2=H(5)
ZP02=H(6)
```

```

ZP03=H(7)
ZP04=H(8)
E0=H(9)
NU0A=H(10)
L111=H(11)
L112=H(12)
L113=H(13)
L114=H(14)
L115=H(15)
L211=H(16)
L212=H(17)
L213=H(18)
L214=H(19)
L215=H(20)
Z210=H(21)
Z220=H(22)
Z230=H(23)
Z240=H(24)
Z250=H(25)
X211=H(26)
X212=H(27)
X213=H(28)
X214=H(29)
X215=H(30)
L231=H(31)
L232=H(32)
L233=H(33)
L234=H(34)
L235=H(35)
L131=H(36)
L132=H(37)
L133=H(38)
L134=H(39)
L135=H(40)
Z21L=H(41)
Z22L=H(42)
Z23L=H(43)
Z24L=H(44)
Z25L=H(45)
XB01=H(46)
XB02=H(47)
XB03=H(48)
XB04=H(49)
XB05=H(50)
PRESS=H(51)
CLOSE(UNIT=1)
10 CONTINUE
   CALL INPUT
   STOP
   END
C
C.....RANDOM NUMBER GENERATOR.....
C
SUBROUTINE RANDOM(SEED,RANDX)
INTEGER SEED
REAL*8 RANDX
SEED=2045*SEED+1
SEED=SEED-(SEED/1048576)*1048576
RANDX=REAL(SEED+1)/1048577.0
RETURN
END
C
C.....THIS SUBROUTINE WRITES INPUT FILE FOR ABAQUS.....
C
SUBROUTINE INPUT
REAL*8 A,B00,B0L,AVB0,C,L1,X121,X,L,DL,FACTOR
REAL*8 L01,L03,TH0,TH1,TH2

```

```

REAL*8 ZP02,ZP03,ZP04,Z01,Z03
REAL*8 E0,E1,E2,NU0,NU1,NU2,FY0,FY1,FY2
REAL*8 L111,L112,L113,L114,L115,L131,L132,L133,L134,L135
REAL*8 L211,L212,L213,L214,L215,L231,L232,L233,L234,L235
REAL*8 Z210,Z220,Z230,Z240,Z250,Z21L,Z22L,Z23L,Z24L,Z25L
REAL*8 X211,X212,X213,X214,X215,X231,X232,X233,X234,X235
C
REAL*8 LL00,LL1,LL2,LL10,LL20,LTOT
REAL*8 LL111,LL112,LL113,LL114,LL115,LL131,LL132,LL133,
* LL134,LL135
C
REAL*8 LL211,LL212,LL213,LL214,LL215,LL231,LL232,LL233,
* LL234,LL235
C
REAL*8 A00,A01,A03,A10,A20,A1L,A2L,ATOT
REAL*8 A111,A112,A113,A114,A115,A131,A132,A133,A134,A135
REAL*8 A211,A212,A213,A214,A215,A231,A232,A233,A234,A235
C
REAL*8 Q1,Q2,Q3
REAL*8 L10,L20,L310,L320,L330,L340,L350
REAL*8 L410,L420,L430,L440,L450
C
REAL*8 L1L,L2L,L31L,L32L,L33L,L34L,L35L
REAL*8 L41L,L42L,L43L,L44L,L45L
C
REAL*8 XB01,XB02,XB03,XB04,XB05,PRESS
C.....
COMMON/LEVEL0/ L01,L03,TH0,TH1,TH2,ZP02,ZP03,ZP04,XB01,XB02,
* XB03,XB04,XB05,PRESS
COMMON/PHYS/ E0,E1,E2,NU0,NU1,NU2,FY0,FY1,FY2
COMMON/LEVEL1/ L111,L112,L113,L114,L115,L131,L132,L133,L134,L135
COMMON/LEVEL20/ L211,L212,L213,L214,L215,Z210,Z220,Z230,Z240,Z250,
* X211,X212,X213,X214,X215
COMMON/LEVEL2L/ L231,L232,L233,L234,L235,Z21L,Z22L,Z23L,Z24L,Z25L,
* X231,X232,X233,X234,X235
C.....
OPEN(UNIT=3,FILE='pl.inp',STATUS='UNKNOWN')
WRITE(3,100)
100 FORMAT('*HEADING'/
*, '*RESTART, WRITE'/
*, '*NODE'/
*, '**'/
*, '** LEVEL=0, X=0'/
*, '**'/
*, '101')
C=2.*1./3.
A=4.+(2./3.)
C
C.....CALCULATING THE SLOPE OF Y=0 AND Y=L.....
C
Z01=ZP02/L01
Z03=(ZP03-ZP04)/L03
B00=L01/A
B0L=L03/A
X102=(1./6.)*B00
Y102=0.0
Z102=Z01*(1./6.)*B00
WRITE(3,110) X102,Y102,Z102
110 FORMAT('102',',',',F10.6,',',',F10.6,',',',F10.6)
X103=(1./3.)*B00
Y103=0.0
Z103=Z01*(1./3.)*B00
WRITE(3,120) X103,Y103,Z103
120 FORMAT('103',',',',F10.6,',',',F10.6,',',',F10.6)
X107=(4./3.)*B00
Y107=0.0
Z107=Z01*(4./3.)*B00

```

```

121 WRITE(3,121) X107,Y107,Z107
    FORMAT('107',' ',',',F10.6,',',',F10.6,',',',F10.6)
    X111=(7./3.)*B00
    Y111=0.0
    Z111=Z01*(6./3.)*B00
122 WRITE(3,122) X111,Y111,Z111
    FORMAT('111',' ',',',F10.6,',',',F10.6,',',',F10.6)
    X115=(10./3.)*B00
    Y115=0.0
    Z115=Z01*(10./3.)*B00
123 WRITE(3,123) X115,Y115,Z115
    FORMAT('115',' ',',',F10.6,',',',F10.6,',',',F10.6)
    X119=(13./3.)*B00
    Y119=0.0
    Z119=Z01*(13./3.)*B00
130 WRITE(3,130)X119,Y119,Z119
    FORMAT('119',' ',',',F10.6,',',',F10.6,',',',F10.6)
    X120=4.5*B00
    Y120=0.0
    Z120=Z01*4.5*B00
140 WRITE(3,140)X120,Y120,Z120
    FORMAT('120',' ',',',F10.6,',',',F10.6,',',',F10.6)
    X121=L01
    Y121=0.0
    Z121=ZP02
150 WRITE(3,150) X121,Y121,Z121
    FORMAT('121',' ',',',F10.6,',',',F10.6,',',',F10.6)
C
C.....COORDINATES DUE TO WEB BOWING FOR LEVEL=0 X=L/2.....
C
    WRITE(3,151)
151  FORMAT('**'/
*, '** LEVEL=0, X=L/2' /
*, '**')
    AVB0=0.5*(B00+B0L)
    Z1303=ZP04+Z03*B0L/3.
    X703=(1./3.)*AVB0+XB01
    Y703=395.0
    Z703=0.5*(Z1303-Z103)+Z103
152 WRITE(3,152) X703,Y703,Z703
    FORMAT('703',' ',',',F10.6,',',',F10.6,',',',F10.6)
    Z1307=ZP04+Z03*(4./3.)*B0L
    X707=(4./3.)*AVB0+XB02
    Y707=395.0
    Z707=0.5*(Z1307-Z107)+Z107
153 WRITE(3,153) X707,Y707,Z707
    FORMAT('707',' ',',',F10.6,',',',F10.6,',',',F10.6)
    Z1311=ZP04+Z03*(7./3.)*B0L
    X711=(7./3.)*AVB0+XB03
    Y711=395.0
    Z711=0.5*(Z1311-Z111)+Z111
154 WRITE(3,154) X711,Y711,Z711
    FORMAT('711',' ',',',F10.6,',',',F10.6,',',',F10.6)
    Z1315=ZP04+Z03*(10./3.)*B0L
    X715=(10./3.)*AVB0+XB04
    Y715=395.0
    Z715=0.5*(Z1315-Z115)+Z115
155 WRITE(3,155) X715,Y715,Z715
    FORMAT('715',' ',',',F10.6,',',',F10.6,',',',F10.6)
    Z1319=ZP04+Z03*(13./3.)*B0L
    X719=(13./3.)*AVB0+XB05
    Y719=395.0
    Z719=0.5*(Z1319-Z119)+Z119
156 WRITE(3,156) X719,Y719,Z719
    FORMAT('719',' ',',',F10.6,',',',F10.6,',',',F10.6)
C
C.....

```

```

C
  WRITE(3,160)
  L1=DSQRT(X121**2+Z121**2)
C
C.....COORDINATES OF LEVEL=0, X=L.....
C
160  FORMAT('**'/
*, '** LEVEL=0, X=L'/
*, '**')
  X1301=0.0
  Y1301=790.0
  Z1301=ZP04
  WRITE(3,200) X1301,Y1301,Z1301
200  FORMAT('1301',',',',F10.6,',',',F10.6,',',',F10.6)
  X1302=(1./6.)*B0L
  Y1302=790.0
  Z1302=ZP04+Z03*B0L/6.
  WRITE(3,210) X1302,Y1302,Z1302
210  FORMAT('1302',',',',F10.6,',',',F10.6,',',',F10.6)
  X1303=(1./3.)*B0L
  Y1303=790.0
  WRITE(3,220) X1303,Y1303,Z1303
220  FORMAT('1303',',',',F10.6,',',',F10.6,',',',F10.6)
  X1307=(4./3.)*B0L
  Y1307=790.0
  WRITE(3,221) X1307,Y1307,Z1307
221  FORMAT('1307',',',',F10.6,',',',F10.6,',',',F10.6)
  X1311=(7./3.)*B0L
  Y1311=790.0
  WRITE(3,222) X1311,Y1311,Z1311
222  FORMAT('1311',',',',F10.6,',',',F10.6,',',',F10.6)
  X1315=(10./3.)*B0L
  Y1315=790.0
  WRITE(3,223) X1315,Y1315,Z1315
223  FORMAT('1315',',',',F10.6,',',',F10.6,',',',F10.6)
  X1319=(13./3.)*B0L
  Y1319=790.0
  WRITE(3,230) X1319,Y1319,Z1319
230  FORMAT('1319',',',',F10.6,',',',F10.6,',',',F10.6)
  X1320=4.5*B0L
  Y1320=790.0
  Z1320=ZP04+Z03*(4.5*B0L)
  WRITE(3,240) X1320,Y1320,Z1320
240  FORMAT('1320',',',',F10.6,',',',F10.6,',',',F10.6)
  X1321=L03
  Y1321=790.0
  Z1321=ZP03
  WRITE(3,250) X1321,Y1321,Z1321
250  FORMAT('1321',',',',F10.6,',',',F10.6,',',',F10.6)
C
C.....COORDINATE OF LEVEL=1, X=0.....
C
  WRITE(3,260)
260  FORMAT('**'/
*, '** LEVEL=1, X=0'/
*, '**')
  X231=X211
  X232=X212
  X233=X213
  X234=X214
  X235=X215
  X2101=(1./3.)*B00+X211/2.
  Y2101=0.0
  Z2101=L111/2.+Z01*(1./3.)*B00
  WRITE(3,270) X2101,Y2101,Z2101
270  FORMAT('2101',',',',F10.6,',',',F10.6,',',',F10.6)
  X2102=(4./3.)*B00+X212/2.

```

```

Y2102=0.0
Z2102=L112/2.+Z01*(4./3.)*B00
WRITE(3,271) X2102,Y2102,Z2102
271 FORMAT('2102',' ',',',F10.6,',',',F10.6,',',',F10.6)
X2103=(7./3.)*B00+X213/2.
Y2103=0.0
Z2103=L113/2.+Z01*(7./3.)*B00
WRITE(3,272) X2103,Y2103,Z2103
272 FORMAT('2103',' ',',',F10.6,',',',F10.6,',',',F10.6)
X2104=(10./3.)*B00+X214/2.
Y2104=0.0
Z2104=L114/2.+Z01*(10./3.)*B00
WRITE(3,273) X2104,Y2104,Z2104
273 FORMAT('2104',' ',',',F10.6,',',',F10.6,',',',F10.6)
X2105=(13./3.)*B00+X215/2.
Y2105=0.0
Z2105=L115/2.+Z01*(13./3.)*B00
WRITE(3,300) X2105,Y2105,Z2105
300 FORMAT('2105',' ',',',F10.6,',',',F10.6,',',',F10.6/
C
C.....COORDINATES OF LEVEL=1, Y=L/2 DUE TO BOWING....
C
*, '***'/
*, '** LEVEL=1, Y=L/2'/'
*, '***')
AVLW1=0.5*(L111+L131)
AVLW2=0.5*(L112+L132)
AVLW3=0.5*(L113+L133)
AVLW4=0.5*(L114+L134)
AVLW5=0.5*(L115+L135)
C
AVLF1=0.5*(L211+L231)
AVLF2=0.5*(L212+L232)
AVLF3=0.5*(L213+L233)
AVLF4=0.5*(L214+L234)
AVLF5=0.5*(L215+L235)
C
X2701=(1./3.)*AVB0+X211/2.+XB01
Y2701=395.0
Z2701=AVLW1/2.+Z703
WRITE(3,301) X2701,Y2701,Z2701
301 FORMAT('2701',' ',',',F10.6,',',',F10.6,',',',F10.6)
C
X2702=(4./3.)*AVB0+X212/2.+XB02
Y2702=395.0
Z2702=AVLW2/2.+Z707
WRITE(3,302) X2702,Y2702,Z2702
302 FORMAT('2702',' ',',',F10.6,',',',F10.6,',',',F10.6)
C
X2703=(7./3.)*AVB0+X213/2.+XB03
Y2703=395.0
Z2703=AVLW3/2.+Z711
WRITE(3,303) X2703,Y2703,Z2703
303 FORMAT('2703',' ',',',F10.6,',',',F10.6,',',',F10.6)
C
X2704=(10./3.)*AVB0+X214/2.+XB04
Y2704=395.0
Z2704=AVLW4/2.+Z715
WRITE(3,304) X2704,Y2704,Z2704
304 FORMAT('2704',' ',',',F10.6,',',',F10.6,',',',F10.6)
C
X2705=(13./3.)*AVB0+X215/2.+XB05
Y2705=395.0
Z2705=AVLW5/2.+Z719
WRITE(3,305) X2705,Y2705,Z2705
305 FORMAT('2705',' ',',',F10.6,',',',F10.6,',',',F10.6)
C

```

C.....COORDINATES OF LEVE=1, X=L.....

```
C
  WRITE(3,311)
311  FORMAT('**'/
*, '** LEVEL=1, X=L'/
*, '**')
  X3301=(1./3.)*B0L+X231/2.
  Y3301=790.0
  Z3301=L131/2.+Z03*(1./3.)*B0L
  WRITE(3,312) X3301,Y3301,Z3301
312  FORMAT('3301',',',',F10.6,',',',F10.6,',',',F10.6)
  X3302=(4./3.)*B0L+X232/2.
  Y3302=790.0
  Z3302=L132/2.+Z03*(4./3.)*B0L
  WRITE(3,313) X3302,Y3302,Z3302
313  FORMAT('3302',',',',F10.6,',',',F10.6,',',',F10.6)
  X3303=(7./3.)*B0L+X233/2.
  Y3303=790.0
  Z3303=L133/2.+Z03*(7./3.)*B0L
  WRITE(3,314) X3303,Y3303,Z3303
314  FORMAT('3303',',',',F10.6,',',',F10.6,',',',F10.6)
  X3304=(10./3.)*B0L+X234/2.
  Y3304=790.0
  Z3304=L134/2.+Z03*(10./3.)*B0L
  WRITE(3,315) X3304,Y3304,Z3304
315  FORMAT('3304',',',',F10.6,',',',F10.6,',',',F10.6)
  X3305=(13./3.)*B0L+X235/2.
  Y3305=790.0
  Z3305=L135/2.+Z03*(13./3.)*B0L
  WRITE(3,316) X3305,Y3305,Z3305
316  FORMAT('3305',',',',F10.6,',',',F10.6,',',',F10.6)
```

C.....COORDINATES OF LEVEL=2, Y=0, FLANGE=1.....

```
C
  WRITE(3,330)
330  FORMAT('**'/
*, '** LEVEL=2, Y=0, FLANGE=1'/
*, '**')
  Z211=2.*Z210/L211
  X4101=B00/3.-L211/2.+X211
  Y4101=0.0
  Z4101=Z103+L111-Z211*L211/2.
  WRITE(3,340) X4101,Y4101,Z4101
340  FORMAT('4101',',',',F10.6,',',',F10.6,',',',F10.6)
  X4102=B00/3.-L211/4.+X211
  Y4102=0.0
  Z4102=Z103+L111-Z211*L211/4.
  WRITE(3,350) X4102,Y4102,Z4102
350  FORMAT('4102',',',',F10.6,',',',F10.6,',',',F10.6)
  X4103=B00/3.+X211
  Y4103=0.0
  Z4103=Z103+L111
  WRITE(3,360) X4103,Y4103,Z4103
360  FORMAT('4103',',',',F10.6,',',',F10.6,',',',F10.6)
  X4104=B00/3.+L211/4.+X211
  Y4104=0.0
  Z4104=Z103+L111+Z211*L211/4.
  WRITE(3,370) X4104,Y4104,Z4104
370  FORMAT('4104',',',',F10.6,',',',F10.6,',',',F10.6)
  X4105=B00/3.+L211/2.+X211
  Y4105=0.0
  Z4105=Z103+L111+Z211*L211/2.
  WRITE(3,380) X4105,Y4105,Z4105
380  FORMAT('4105',',',',F10.6,',',',F10.6,',',',F10.6)
  X=X4105-X4101
  L=DSQRT(X**2+Z210**2)
  DL=L-X
```

C
C.....COORDINATES OF LEVEL=2, Y=0, FLANGE=2.....
C

```
WRITE(3,390)
390 FORMAT('**'/
*, '** LEVEL=2, Y=0, FLANGE=2' /
*, '**')
Z212=2.*Z220/L212
X4106=(4./3.)*B00-L212/2.+X212
Y4106=0.0
Z4106=Z107+L112-Z212*L212/2.
WRITE(3,400) X4106,Y4106,Z4106
400 FORMAT('4106',',',',F10.6,',',',F10.6,',',',F10.6)
X4107=(4./3.)*B00-L212/4.+X212
Y4107=0.0
Z4107=Z107+L112-Z212*L212/4.
WRITE(3,410) X4107,Y4107,Z4107
410 FORMAT('4107',',',',F10.6,',',',F10.6,',',',F10.6)
X4108=(4./3.)*B00+X212
Y4108=0.0
Z4108=Z107+L112
WRITE(3,420) X4108,Y4108,Z4108
420 FORMAT('4108',',',',F10.6,',',',F10.6,',',',F10.6)
X4109=(4./3.)*B00+L212/4.+X212
Y4109=0.0
Z4109=Z107+L112+Z212*L212/4.
WRITE(3,430) X4109,Y4109,Z4109
430 FORMAT('4109',',',',F10.6,',',',F10.6,',',',F10.6)
X4110=(4./3.)*B00+L212/2.+X212
Y4110=0.0
Z4110=Z107+L112+Z212*L212/2.
WRITE(3,440) X4110,Y4110,Z4110
440 FORMAT('4110',',',',F10.6,',',',F10.6,',',',F10.6)
```

C
C.....COORDINATES OF LEVEL=2, Y=0, FLANGE=3.....
C

```
WRITE(3,450)
450 FORMAT('**'/
*, '** LEVEL=2, Y=0, FLANGE=3' /
*, '**')
Z213=2*Z230/L213
X4111=(7./3.)*B00-L213/2.
Y4111=0.0
Z4111=Z111+L113-Z213*L213/2.
WRITE(3,460) X4111,Y4111,Z4111
460 FORMAT('4111',',',',F10.6,',',',F10.6,',',',F10.6)
X4112=(7./3.)*B00-L213/4.+X213
Y4112=0.0
Z4112=Z111+L113-Z213*L213/4.
WRITE(3,470) X4112,Y4112,Z4112
470 FORMAT('4112',',',',F10.6,',',',F10.6,',',',F10.6)
X4113=(7./3.)*B00+X213
Y4113=0.0
Z4113=Z111+L113
WRITE(3,480) X4113,Y4113,Z4113
480 FORMAT('4113',',',',F10.6,',',',F10.6,',',',F10.6)
X4114=(7./3.)*B00+L213/4.+X213
Y4114=0.0
Z4114=Z111+L113+Z213*L213/4.
WRITE(3,490) X4114,Y4114,Z4114
490 FORMAT('4114',',',',F10.6,',',',F10.6,',',',F10.6)
X4115=(7./3.)*B00+L213/2.+X213
Y4115=0.0
Z4115=Z111+L113+Z213*L213/2.
WRITE(3,500) X4115,Y4115,Z4115
500 FORMAT('4115',',',',F10.6,',',',F10.6,',',',F10.6)
```

C

C.....COORDINATES OF LEVEL=2, Y=0, FLANGE=4.....

```
C
WRITE(3,510)
510  FORMAT('**'/
*, '** LEVEL=2, Y=0, FLANGE=4'/
*, '**')
Z214=2.*Z240/L214
X4116=(10./3.)*B00-L214/2.+X214
Y4116=0.0
Z4116=Z115+L114-Z214*L214/2.
WRITE(3,520) X4116,Y4116,Z4116
520  FORMAT('4116',',',',F10.6,',',',F10.6,',',',F10.6)
X4117=(10./3.)*B00-L214/4.+X214
Y4117=0.0
Z4117=Z115+L114-Z214*L214/4.
WRITE(3,530) X4117,Y4117,Z4117
530  FORMAT('4117',',',',F10.6,',',',F10.6,',',',F10.6)
X4118=(10./3.)*B00+X214
Y4118=0.0
Z4118=Z115+L114
WRITE(3,540) X4118,Y4118,Z4118
540  FORMAT('4118',',',',F10.6,',',',F10.6,',',',F10.6)
X4119=(10./3.)*B00+L214/4.+X214
Y4119=0.0
Z4119=Z115+L114+Z214*L214/4.
WRITE(3,550) X4119,Y4119,Z4119
550  FORMAT('4119',',',',F10.6,',',',F10.6,',',',F10.6)
X4120=(10./3.)*B00+L214/2.+X214
Y4120=0.0
Z4120=Z115+L114+Z214*L214/2.
WRITE(3,560) X4120,Y4120,Z4120
560  FORMAT('4120',',',',F10.6,',',',F10.6,',',',F10.6)
```

C.....COORDINATES OF LEVEL=2, Y=0, FLANGE=5.....

```
C
WRITE(3,551)
551  FORMAT('**'/
*, '** LEVEL=2, Y=0, FLANGE=5'/
*, '**')
Z215=2.*Z250/L215
X4121=(13./3.)*B00-L215/2.+X215
Y4121=0.0
Z4121=Z119+L115-Z215*L215/2.
WRITE(3,570) X4121,Y4121,Z4121
570  FORMAT('4121',',',',F10.6,',',',F10.6,',',',F10.6)
X4122=(13./3.)*B00-L215/4.+X215
Y4122=0.0
Z4122=Z119+L115-Z215*L215/4.
WRITE(3,580) X4122,Y4122,Z4122
580  FORMAT('4122',',',',F10.6,',',',F10.6,',',',F10.6)
X4123=(13./3.)*B00+X215
Y4123=0.0
Z4123=Z119+L115
WRITE(3,590) X4123,Y4123,Z4123
590  FORMAT('4123',',',',F10.6,',',',F10.6,',',',F10.6)
X4124=(13./3.)*B00+L215/4.+X215
Y4124=0.0
Z4124=Z119+L115+Z215*L215/4.
WRITE(3,600) X4124,Y4124,Z4124
600  FORMAT('4124',',',',F10.6,',',',F10.6,',',',F10.6)
X4125=(13./3.)*B00+L215/2.+X215
Y4125=0.0
Z4125=Z119+L115+Z215*L215/2.
WRITE(3,610) X4125,Y4125,Z4125
610  FORMAT('4125',',',',F10.6,',',',F10.6,',',',F10.6/
```

C.....COORDINATES OF LEVEL=2, Y=L/2 FLANGE=1....

```

C
*, '***' /
*, '*** LEVEL=2, Y=L/2' /
*, '***' )
X4703=(1./3.)*AVB0+X211+XB01
Y4703=395.0
Z4703=Z703+AVLW1
611 WRITE(3,611) X4703,Y4703,Z4703
FORMAT('4703',' ', ' ', F10.6, ' ', ' ', F10.6, ' ', ' ', F10.6)
X4708=(4./3.)*AVB0+X212+XB02
Y4708=395.0
Z4708=Z707+AVLW2
612 WRITE(3,612) X4708,Y4708,Z4708
FORMAT('4708',' ', ' ', F10.6, ' ', ' ', F10.6, ' ', ' ', F10.6)
X4713=(7./3.)*AVB0+X213+XB03
Y4713=395.0
Z4713=Z711+AVLW3
613 WRITE(3,613) X4713,Y4713,Z4713
FORMAT('4713',' ', ' ', F10.6, ' ', ' ', F10.6, ' ', ' ', F10.6)
X4718=(10./3.)*AVB0+X214+XB04
Y4718=395.0
Z4718=Z715+AVLW4
614 WRITE(3,614) X4718,Y4718,Z4718
FORMAT('4718',' ', ' ', F10.6, ' ', ' ', F10.6, ' ', ' ', F10.6)
X4723=(13./3.)*AVB0+X215+XB05
Y4723=395.0
Z4723=Z719+AVLW5
615 WRITE(3,615) X4723,Y4723,Z4723
FORMAT('4723',' ', ' ', F10.6, ' ', ' ', F10.6, ' ', ' ', F10.6)
C
C.....COORDINATES OF LEVEL=2, Y=L, FLANGE=1.....
C
WRITE(3,620)
620 FORMAT('***' /
*, '*** LEVEL=2, Y=L, FLANGE=1' /
*, '***' )
Z231=2.*Z21L/L231
X5301=B0L/3.-L231/2.+X231
Y5301=790.0
Z5301=Z1303+L131-Z231*L231/2.
630 WRITE(3,630) X5301,Y5301,Z5301
FORMAT('5301',' ', ' ', F10.6, ' ', ' ', F10.6, ' ', ' ', F10.6)
X5302=B0L/3.-L231/4.+X231
Y5302=790.0
Z5302=Z1303+L131-Z231*L231/4.
640 WRITE(3,640) X5302,Y5302,Z5302
FORMAT('5302',' ', ' ', F10.6, ' ', ' ', F10.6, ' ', ' ', F10.6)
X5303=B0L/3.+X231
Y5303=790.0
Z5303=Z1303+L131
650 WRITE(3,650) X5303,Y5303,Z5303
FORMAT('5303',' ', ' ', F10.6, ' ', ' ', F10.6, ' ', ' ', F10.6)
X5304=B0L/3.+L231/4.+X231
Y5304=790.0
Z5304=Z1303+L131+Z231*L231/4.
660 WRITE(3,660) X5304,Y5304,Z5304
FORMAT('5304',' ', ' ', F10.6, ' ', ' ', F10.6, ' ', ' ', F10.6)
X5305=B0L/3.+L231/2.+X231
Y5305=790.0
Z5305=Z1303+L131+Z231*L231/2.
670 WRITE(3,670) X5305,Y5305,Z5305
FORMAT('5305',' ', ' ', F10.6, ' ', ' ', F10.6, ' ', ' ', F10.6)
C
C.....COORDINATES OF LEVEL=2, Y=L, FLANGE=2.....
C
WRITE(3,680)

```

```

680  FORMAT('**'/
*, '** LEVEL=2, Y=L, FLANGE=2' /
*, '**')
Z232=2.*Z22L/L232
X5306=(4./3.)*B0L-L232/2.+X232
Y5306=790.0
Z5306=Z1307+L132-Z232*L232/2.
WRITE(3,690) X5306,Y5306,Z5306
690  FORMAT('5306',',',',F10.6,',',',F10.6,',',',F10.6)
X5307=(4./3.)*B0L-L232/4.+X232
Y5307=790.0
Z5307=Z1307+L132-Z232*L232/4.
WRITE(3,700) X5307,Y5307,Z5307
700  FORMAT('5307',',',',F10.6,',',',F10.6,',',',F10.6)
X5308=(4./3.)*B0L+X232
Y5308=790.0
Z5308=Z1307+L132
WRITE(3,710) X5308,Y5308,Z5308
710  FORMAT('5308',',',',F10.6,',',',F10.6,',',',F10.6)
X5309=(4./3.)*B0L+L232/4.+X232
Y5309=790.0
Z5309=Z1307+L132+Z232*L232/4.
WRITE(3,720) X5309,Y5309,Z5309
720  FORMAT('5309',',',',F10.6,',',',F10.6,',',',F10.6)
X5310=(4./3.)*B0L+L232/2.+X232
Y5310=790.0
Z5310=Z1307+L132+Z232*L232/2.
WRITE(3,730) X5310,Y5310,Z5310
730  FORMAT('5310',',',',F10.6,',',',F10.6,',',',F10.6)
C
C.....COORDINATES OF LEVEL=2, Y=L, FLANGE=3.....
C

```

```

WRITE(3,740)
740  FORMAT('**'/
*, '** LEVEL=2, Y=L, FLANGE=3' /
*, '**')
Z233=2*Z23L/L233
X5311=(7./3.)*B0L-L233/2.+X233
Y5311=790.0
Z5311=Z1311+L133-Z233*L233/2.
WRITE(3,750) X5311,Y5311,Z5311
750  FORMAT('5311',',',',F10.6,',',',F10.6,',',',F10.6)
X5312=(7./3.)*B0L-L233/4.+X233
Y5312=790.0
Z5312=Z1311+L133-Z233*L233/4.
WRITE(3,760) X5312,Y5312,Z5312
760  FORMAT('5312',',',',F10.6,',',',F10.6,',',',F10.6)
X5313=(7./3.)*B0L+X233
Y5313=790.0
Z5313=Z1311+L133
WRITE(3,770) X5313,Y5313,Z5313
770  FORMAT('5313',',',',F10.6,',',',F10.6,',',',F10.6)
X5314=(7./3.)*2*B0L+L233/4.+X233
Y5314=790.0
Z5314=Z1311+L133+Z233*L233/4.
WRITE(3,780) X5314,Y5314,Z5314
780  FORMAT('5314',',',',F10.6,',',',F10.6,',',',F10.6)
X5315=(7./3.)*B0L+L233/2.+X233
Y5315=790.0
Z5315=Z1311+L133+Z233*L233/2.
WRITE(3,790) X5315,Y5315,Z5315
790  FORMAT('5315',',',',F10.6,',',',F10.6,',',',F10.6)
C
C.....COORDINATES OF LEVEL=2, Y=L, FLANGE=4.....
C
WRITE(3,800)

```

```

800  FORMAT('**'/
*, '** LEVEL=2, Y=L, FLANGE=4'/
*, '**')
Z234=2.*Z24L/L234
X5316=(10./3.)*B0L-L234/2.+X234
Y5316=790.0
Z5316=Z1315+L134-Z234*L234/2.
WRITE(3,810) X5316,Y5316,Z5316
810  FORMAT('5316',',',',F10.6',',',',F10.6',',',',F10.6)
X5317=(10./3.)*B0L-L234/4.+X234
Y5317=790.0
Z5317=Z1315+L134-Z234*L234/4.
WRITE(3,820) X5317,Y5317,Z5317
820  FORMAT('5317',',',',F10.6',',',',F10.6',',',',F10.6)
X5318=(10./3.)*B0L+X234
Y5318=790.0
Z5318=Z1315+L134
WRITE(3,830) X5318,Y5318,Z5318
830  FORMAT('5318',',',',F10.6',',',',F10.6',',',',F10.6)
X5319=(10./3.)*B0L+L234/4.+X234
Y5319=790.0
Z5319=Z1315+L134+Z234*L234/4.
WRITE(3,840) X5319,Y5319,Z5319
840  FORMAT('5319',',',',F10.6',',',',F10.6',',',',F10.6)
X5320=(10./3.)*B0L+L234/2.+X234
Y5320=790.0
Z5320=Z1315+L134+Z234*L234/2.
WRITE(3,860) X5320,Y5320,Z5320
860  FORMAT('5320',',',',F10.6',',',',F10.6',',',',F10.6)
C
C.....COORDINATES OF LEVEL=2, Y=L, FLANGE=5.....
C
WRITE(3,850)
850  FORMAT('**'/
*, '** LEVEL=2, Y=L, FLANGE=5'/
*, '**')
Z235=2.*Z25L/L235
X5321=(13./3.)*B0L-L235/2.+X235
Y5321=790.0
Z5321=Z1319+L135-Z235*L235/2.
WRITE(3,870) X5321,Y5321,Z5321
870  FORMAT('5321',',',',F10.6',',',',F10.6',',',',F10.6)
X5322=(13./3.)*B0L-L235/4.+X235
Y5322=790.0
Z5322=Z1319+L135-Z235*L235/4.
WRITE(3,890) X5322,Y5322,Z5322
890  FORMAT('5322',',',',F10.6',',',',F10.6',',',',F10.6)
X5323=(13./3.)*B0L+X235
Y5323=790.0
Z5323=Z1319+L135
WRITE(3,900) X5323,Y5323,Z5323
900  FORMAT('5323',',',',F10.6',',',',F10.6',',',',F10.6)
X5324=(13./3.)*B0L+L235/4.+X235
Y5324=790.0
Z5324=Z1319+L135+Z235*L235/4.
WRITE(3,910) X5324,Y5324,Z5324
910  FORMAT('5324',',',',F10.6',',',',F10.6',',',',F10.6)
X5325=(13./3.)*B0L+L235/2.+X235
Y5325=790.0
Z5325=Z1319+L135+Z235*L235/2.
WRITE(3,920) X5325,Y5325,Z5325
920  FORMAT('5325',',',',F10.6',',',',F10.6',',',',F10.6)
C
C.....ASSIGNING LEVEL=0, Y=0, INTO SETS.....
C
WRITE(3,1000)
1000 FORMAT('**'/

```

```

*, '** ASSIGNING LEVEL=0, NODES INTO SETS' /
*, '**' /
*, '*NGEN' /
*, '101,103' /
*, '*NGEN' /
*, '103,119' /
*, '*NGEN' /
*, '119,121' /
*, '*NSET, NSET=Y00EG1' /
*, '101,102' )
WRITE(3,1010)
1010 FORMAT('*NSET, NSET=Y00EG2' /
*, '104,105,106' /
*, '*NSET, NSET=Y00EG3' /
*, '108,109,110' /
*, '*NSET, NSET=Y00EG4' /
*, '112,113,114' /
*, '*NSET, NSET=Y00EG5' /
*, '116,117,118' /
*, '*NSET, NSET=Y00EG6' /
*, '120,121' )
C
C.....ASSINGNING LEVEL=0, Y=L, INTO SETS....
C
WRITE(3,1011)
1011 FORMAT('*NGEN' /
*, '1301,1303' /
*, '*NGEN' /
*, '1303,1319' /
*, '*NGEN' )
WRITE(3,1012)
1012 FORMAT('1319,1321' /
*, '*NSET, NSET=YLOEG1' /
*, '1301,1302' /
*, '*NSET, NSET=YLOEG2' /
*, '1304,1305,1306' /
*, '*NSET, NSET=YLOEG3' /
*, '1308,1309,1310' /
*, '*NSET, NSET=YLOEG4' /
*, '1312,1313,1314' /
*, '*NSET, NSET=YLOEG5' /
*, '1316,1317,1318' )
WRITE(3,1015)
1015 FORMAT('*NSET, NSET=YLOEG6' /
*, '1320,1321' /
*, '*NSET, NSET=YY00EG' /
*, 'Y00EG1,Y00EG2,Y00EG3,Y00EG4,Y00EG5,Y00EG6' /
*, '*NSET, NSET=YYLOEG' /
*, 'YLOEG1,YLOEG2,YLOEG3,YLOEG4,YLOEG5,YLOEG6' /
*, '*NFILL' /
*, 'YY00EG,YYLOEG,12,100' /
*, '*NSET, NSET=Y00EG' /
*, 'YY00EG,103,107,111,115,119' )
WRITE(3,1020)
1020 FORMAT('*NSET, NSET=YLOEG' /
*, 'YYLOEG,1303,1307,1311,1315,1319' /
*, '**' /
*, '** GENERATING LEVEL=0, WEB LINES' /
*, '**' )
WRITE(3,1021)
1021 FORMAT('*NGEN,NSET=WB01,LINE=P' /
*, '103,1303,100,703' /
*, '*NGEN,NSET=WB02,LINE=P' /
*, '107,1307,100,707' /
*, '*NGEN,NSET=WB03,LINE=P' /
*, '111,1311,100,711' /
*, '*NGEN,NSET=WB04,LINE=P' /

```

```

*, '115,1315,100,715' /
*, '*NGEN,NSET=WB05,LINE=P' /
*, '119,1319,100,719' /
*, '***' /
*, '** LEVEL=0, X-EDGES IN SETS' /
*, '***' /
*, '*NGEN,NSET=X00EG' )
WRITE(3,1100)
1100 FORMAT('101,1301,100' /
*, '*NGEN,NSET=XLOEG' /
*, '121,1321,100' /
*, '***' /
C
C.....GENERATE LEVEL=1, X=0, NODES.....
C
*, '** GENERATE LEVEL=1, X=0, NODES' /
*, '***' /
*, '*NSET,NSET=Y01EG' /
*, '2101,2102,2103,2104,2105' /
*, '*NSET,NSET=YL1EG' /
*, '3301,3302,3303,3304,3305' )
WRITE(3,1200)
1200 FORMAT('*NGEN,NSET=WB11,LINE=P' /
*, '2101,3301,100,2701' /
*, '*NGEN,NSET=WB12,LINE=P' /
*, '2102,3302,100,2702' /
*, '*NGEN,NSET=WB13,LINE=P' /
*, '2103,3303,100,2703' /
*, '*NGEN,NSET=WB14,LINE=P' /
*, '2104,3304,100,2704' /
*, '*NGEN,NSET=WB15,LINE=P' /
*, '2105,3305,100,2705' )
WRITE(3,1210)
1210 FORMAT('***' /
*, '** GENERATE LEVEL=2, Y=0, NODES' /
*, '***' /
*, '*NSET, NSET=A' /
*, '4101,4102,4104,4105' /
*, '*NSET, NSET=B' /
*, '4106,4107,4109,4110' /
*, '*NSET, NSET=C' /
*, '4111,4112,4114,4115' /
*, '*NSET, NSET=D' )
WRITE(3,1300)
1300 FORMAT('4116,4117,4119,4120' /
*, '*NSET, NSET=F' /
*, '4121,4122,4124,4125' /
*, '*NSET, NSET=YY02EG' /
*, 'A,B,C,D,F' /
*, '***' /
C
C.....GENERATE LEVEL=2, X=L, NODES.....
C
*, '** GENERATE LEVEL=2, X=L, NODES' /
*, '***' /
*, '*NSET, NSET=G' /
*, '5301,5302,5304,5305' /
*, '*NSET, NSET=H' )
WRITE(3,1400)
1400 FORMAT('5306,5307,5309,5310' /
*, '*NSET, NSET=I' /
*, '5311,5312,5314,5315' /
*, '*NSET, NSET=K' /
*, '5316,5317,5319,5320' /
*, '*NSET, NSET=L' /
*, '5321,5322,5324,5325' /
*, '*NSET, NSET=YYL2EG' /

```

```

*, 'G,H,I,K,L' /
*, '*NFILL' /
*, 'YY02EG, YL2EG, 12, 100' /
WRITE(3, 1410)
1410 FORMAT('*NSET, NSET=Y02EG' /
*, 'YY02EG, 4103, 4108, 4113, 4118, 4123' /
*, '*NSET, NSET=YL2EG' /
*, 'YLL2EG, 5303, 5308, 5313, 5318, 5323' /
WRITE(3, 1500)
1500 FORMAT('**' /
*, '** GENERATING LEVEL=2, WEB LINES' /
*, '**' /
*, '*NGEN, NSET=WB21, LINE=P' /
*, '4103, 5303, 100, 4703' /
*, '*NGEN, NSET=WB22, LINE=P' /
*, '4108, 5308, 100, 4708' /
*, '*NGEN, NSET=WB23, LINE=P' /
*, '4113, 5313, 100, 4713' /
*, '*NGEN, NSET=WB24, LINE=P' /
*, '4118, 5318, 100, 4718' /
WRITE(3, 1510)
1510 FORMAT('*NGEN, NSET=WB25, LINE=P' /
*, '4123, 5323, 100, 4723' /
*, '**' /
*, '** ASSIGNING Y-BOUNDARY SETS' /
*, '**' /
*, '** 1- Y=0, Y0EDG' /
*, '**' /
*, '*NSET, NSET=Y0EDG' /
*, 'Y00EG, Y01EG, Y02EG' /
*, '**' /
*, '** 2- Y=L, YLEDG' /
*, '**' /
WRITE(3, 1600)
1600 FORMAT('*NSET, NSET=YLEDG' /
*, 'YL0EG, YL1EG, YL2EG' /
*, '**' /
*, '** ASSIGNING X-BOUNDARY SETS' /
*, '**' /
*, '** 1- X=0, X0EDG' /
*, '**' /
*, '*NSET, NSET=X0EDG' /
*, '101, 1301, 100' /
*, '**' /
WRITE(3, 1700)
1700 FORMAT('** 2- X=L, XLEDG' /
*, '**' /
*, '*NSET, NSET=XLEDG' /
*, '121, 1321, 100' /
*, '**' /
*, '** DEFINING REFERENCE ELEMENT' /
*, '**' /
*, '** 1- LEVEL=0' /
*, '**' /
*, '*ELEMENT, TYPE=S8R5, ELSET=ONE' /
*, '1, 101, 103, 303, 301, 102, 203, 302, 201' /
*, '*ELGEN, ELSET=ONE' /
WRITE(3, 1800)
1800 FORMAT('1, 10, 2, 1, 6, 200, 10' /
*, '*SHELL SECTION, MATERIAL=PLATE, ELSET=ONE' /
WRITE(3, 1810) TH0
1810 FORMAT(F5.3, ' ', '3')
WRITE(3, 1820)
1820 FORMAT('**' /
*, '** 2- LEVEL=1' /
*, '**' /
*, '*ELEMENT, TYPE=S8R5, ELSET=TWO' /

```



```

*, '61,103,303,4303,4103,203,2301,4203,2101' /
*, '*ELGEN, ELSET=TWO' /
*, '61,1,0,0,6,200,5' /
WRITE(3,1900)
1900 FORMAT('*ELEMENT, TYPE=S8R5, ELSET=TWO' /
*, '62,107,307,4308,4108,207,2302,4208,2102' /
*, '*ELGEN, ELSET=TWO' /
*, '62,1,0,0,6,200,5' /
*, '*ELEMENT, TYPE=S8R5, ELSET=TWO' /
*, '63,111,311,4313,4113,211,2303,4213,2103' /
*, '*ELGEN, ELSET=TWO' /
*, '63,1,0,0,6,200,5' /
*, '*ELEMENT, TYPE=S8R5, ELSET=TWO' /
WRITE(3,2000)
2000 FORMAT('64,115,315,4318,4118,215,2304,4218,2104' /
*, '*ELGEN, ELSET=TWO' /
*, '64,1,0,0,6,200,5' /
*, '*ELEMENT, TYPE=S8R5, ELSET=TWO' /
*, '65,119,319,4323,4123,219,2305,4223,2105' /
*, '*ELGEN, ELSET=TWO' /
*, '65,1,0,0,6,200,5' /
*, '*SHELL SECTION, MATERIAL=PLATE, ELSET=TWO' /
WRITE(3,2110) TH1
2110 FORMAT(F5.3, ', ', '3')
WRITE(3,2120)
2120 FORMAT('**')
WRITE(3,2200)
2200 FORMAT('**' /
*, '** 3- LEVEL=2' /
*, '**' /
*, '*ELEMENT, TYPE=S8R5, ELSET=THREE' /
*, '91,4101,4103,4303,4301,4102,4203,4302,4201' /
*, '*ELGEN, ELSET=THREE' /
*, '91,5,5,2,6,200,10' /
*, '*ELEMENT, TYPE=S8R5, ELSET=THREE' /
*, '92,4103,4105,4305,4303,4104,4205,4304,4203' /
*, '*ELGEN, ELSET=THREE' /
*, '92,5,5,2,6,200,10' /
WRITE(3,2300)
2300 FORMAT('*SHELL SECTION, MATERIAL=PLATE, ELSET=THREE' /
WRITE(3,2310) TH2
2310 FORMAT(F5.3, ', ', '3')
WRITE(3,2320)
2320 FORMAT('**' /
*, '*MATERIAL, NAME=PLATE' /
*, '*ELASTIC' /
WRITE(3,2330) E0,NU0
2330 FORMAT(F8.1, ', ', 'F4.2')
WRITE(3,2340)
2340 FORMAT('*BOUNDARY' /
*, 'Y00EG,1' /
*, 'Y00EG,3' /
*, 'Y00EG,5' /
WRITE(3,2400)
2400 FORMAT('Y00EG,6' /
*, 'YLOEG,1' /
*, 'YLOEG,2' /
*, 'YLOEG,3' /
*, 'YLOEG,5' /
*, 'YLOEG,6' /
*, '*DRAW, ELNUM' /
*, '*DRAW, NODENUM' /
WRITE(3,3100)
3100 FORMAT('**' /
*, '*STEP' /
*, '*STATIC' /
*, '*DLOAD' /

```

```

WRITE(3,3101) PRESS
3101 FORMAT('ONE,P,',F7.5/
*, '*END STEP'/
*, '*STEP'/
*, '*BUCKLE')

```

```

C
C.....CACULATIONS OF NODAL FORCES.....
C

```

```

C..... 1- LEVEL=0, X=0 .....
C

```

```

Q1=1
Q2=Q1*TH1/TH0
Q3=Q1*TH2/TH0
L10=B00/3.
P101=Q1*L10/6.
P102=Q1*4*(L10/6.)
P103L=Q1*L10/6.
L20=B00/2.
P103R=Q1*L20/6.
P103B=P103L+P103R
P104=Q1*4*(L20/6.)
P105=2*Q1*(L20/6.)
P106=P104
P107B=2*Q1*(L20/6.)
P108=P104
P109=P105
P110=P104
P111B=P107B
P112=P104
P113=P105
P114=P104
P115B=P107B
P116=P104
P117=P105
P118=P104
P119B=P103B
P120=P102
P121=P101

```

```

C
C..... LEVEL=1, X=0 .....
C

```

```

L310=L111
P103T=Q2*L310/6.
P2101=4*Q2*L310/6.
P4103B=P103T
L320=L112
P107T=Q2*L320/6.
P2102=4*Q2*L320/6.
P4108B=P107T
L330=L113
P111T=Q2*L330/6.
P2103=4*Q2*L330/6.
P4113B=P111T
L340=L114
P115T=Q2*L340/6.
P2104=4*Q2*L340/6.
P4118B=P115T
L350=L115
P119T=Q2*L350/6.
P2105=4*Q2*L350/6.
P4123B=P119T

```

```

C
C..... LEVEL=2, X=0 .....
C

```

```

L410=L211/2.
P4101=Q3*L410/6.
P4102=4*Q3*L410/6.

```

P4103T=2*Q3*L410/6.
 P4104=P4102
 P4105=P4101
 L420=L212/2.
 P4106=Q3*L420/6.
 P4107=4*Q3*L420/6.
 P4108T=2*Q3*L420/6.
 P4109=P4107
 P4110=P4106
 L430=L213/2.
 P4111=Q3*L430/6.
 P4112=4*Q3*L430/6.
 P4113T=2*Q3*L430/6.
 P4114=P4112
 P4115=P4111
 L440=L214/2.
 P4116=Q3*L440/6.
 P4117=4*Q3*L440/6.
 P4118T=2*Q3*L440/6.
 P4119=P4117
 P4120=P4116
 L450=L215/2.
 P4121=Q3*L450/6.
 P4122=4*Q3*L450/6.
 P4123T=2*Q3*L450/6.
 P4124=P4122
 P4125=P4121

C
 C..... FINAL LOAD VALUES, X=0
 C

P103=P103B+P103T
 P107=P107B+P107T
 P111=P111B+P111T
 P115=P115B+P115T
 P119=P119B+P119T
 P4103=P4103B+P4103T
 P4108=P4108B+P4108T
 P4113=P4113B+P4113T
 P4118=P4118B+P4118T
 P4123=P4123B+P4123T

C
 C..... 1- LEVEL=0, X=L
 C

L1L=B00/3.
 P1301=-Q1*L1L/6.
 P1302=-Q1*4*(L1L/6.)
 P1303L=-Q1*L1L/6.
 L2L=B00/2.
 P1303R=-Q1*L2L/6.
 P1303B=-(P103L+P103R)
 P1304=-Q1*4*(L2L/6.)
 P1305=-2*Q1*(L2L/6.)
 P1306=-P104
 P1307B=-2*Q1*(L2L/6.)
 P1308=-P104
 P1309=-P105
 P1310=-P104
 P1311B=-P107B
 P1312=-P104
 P1313=-P105
 P1314=-P104
 P1315B=-P107B
 P1316=-P104
 P1317=-P105
 P1318=-P104
 P1319B=-P103B
 P1320=-P102

P1321=-P101

C
C..... LEVEL=1, X=L
C

L31L=L111
P1303T=-Q3*L31L/6.
P3301=-4*Q2*L31L/6.
P5303B=P1303T
L32L=L112
P1307T=-Q2*L32L/6.
P3302=-4*Q2*L32L/6.
P5308B=P1307T
L33L=L113
P1311T=-Q2*L33L/6.
P3303=-4*Q2*L33L/6.
P5313B=P1311T
L34L=L114
P1315T=-Q2*L34L/6.
P3304=-4*Q2*L34L/6.
P5318B=P1315T
L35L=L115
P1319T=-Q2*L35L/6.
P3305=-4*Q2*L35L/6.
P5323B=P1319T

C
C..... LEVEL=2, X=L
C

L41L=L211/2.
P5301=-Q3*L41L/6.
P5302=-4*Q3*L41L/6.
P5303T=-2*Q3*L41L/6.
P5304=P5302
P5305=P5301
L42L=L212/2.
P5306=-Q3*L42L/6.
P5307=-4*Q3*L42L/6.
P5308T=-2*Q3*L42L/6.
P5309=P5307
P5310=P5306
L43L=L213/2.
P5311=-Q3*L43L/6.
P5312=-4*Q3*L43L/6.
P5313T=-2*Q3*L43L/6.
P5314=P5312
P5315=P5311
L44L=L214/2.
P5316=-Q3*L44L/6.
P5317=-4*Q3*L44L/6.
P5318T=-2*Q2*L44L/6.
P5319=P5317
P5320=P5316
L45L=L215/2.
P5321=-Q3*L45L/6.
P5322=-4*Q3*L45L/6.
P5323T=-2*Q3*L45L/6.
P5324=P5322
P5325=P5321

C
C..... FINAL LOAD VALUES, X=L
C

P1303=P1303B+P1303T
P1307=P1307B+P1307T
P1311=P1311B+P1311T
P1315=P1315B+P1315T
P1319=P1319B+P1319T
P5303=P5303B+P5303T
P5308=P5308B+P5308T

P5313=P5313B+P5313T
P5318=P5318B+P5318T
P5323=P5323B+P5323T

C

C..... CALCULATING TOTAL APPLIED AXIAL LOAD

C

LL00=L01+L03
A01=L01*TH0
A03=L03*TH0
A00=A01+A03
LL1=TH1/TH0
LL2=TH2/TH0

C

C.....THE WEB, X=0.....

C

LL111=L111*LL1
LL112=L112*LL1
LL113=L113*LL1
LL114=L114*LL1
LL115=L115*LL1

C.....

A111=L111*TH1
A112=L112*TH1
A113=L113*TH1
A114=L114*TH1
A115=L115*TH1
A10=A111+A112+A113+A114+3*A115

C.....

LL211=L211*LL2
LL212=L212*LL2
LL213=L213*LL2
LL214=L214*LL2
LL215=L215*LL2

C.....

A211=L211*TH2
A212=L212*TH2
A213=L213*TH2
A214=L214*TH2
A215=L215*TH2
A20=A211+A212+A213+A214+A215

C.....

LL131=L131*LL1
LL132=L132*LL1
LL133=L133*LL1
LL134=L134*LL1
LL135=L135*LL1

C.....

A131=L131*TH1
A132=L132*TH1
A133=L133*TH1
A134=L134*TH1
A135=L135*TH1
A1L=A131+A132+A133+A134+A135

C.....

LL231=L231*LL2
LL232=L232*LL2
LL233=L233*LL2
LL234=L234*LL2
LL235=L235*LL2

C.....

A231=L231*TH2
A232=L232*TH2
A233=L233*TH2
A234=L234*TH2
A235=L235*TH2
A2L=A231+A232+A233+A234+A235

C.....

```

LL10=LL111+LL112+LL113+LL114+LL115+LL131+LL132+LL133+
*LL134+LL135
C.....
LL20=LL211+LL212+LL213+LL214+LL215+LL231+LL232+LL233+
*LL234+LL235
C.....
LTOT=LL00+LL10+LL20
ATOT=A00+2*A10+A20+A1L+A2L
C
FACTOR=LTOT/ATOT
C
PRINT*, 'FACTOR=', FACTOR
WRITE(3,2500)
2500 FORMAT('1, '/
*, '***'/
*, '*MODAL FILE' /
*, '***'/
*, '** LEVEL=0, X=0, LOAD SETS' /
*, '***'/
*, '*NSET, NSET=LOAD001' /
*, '101,121' /
*, '*NSET, NSET=LOAD002' /
*, '102,120' )
WRITE(3,2600)
2600 FORMAT('*NSET, NSET=LOAD003' /
*, '103,119' )
WRITE(3,2610)
2610 FORMAT('*NSET, NSET=LOAD004' /
*, '104,106,108,110,112,114,116,118' /
*, '*NSET, NSET=LOAD005' /
*, '105,109,113,117' /
*, '*NSET, NSET=LOAD006' /
*, '107,111,115' )
WRITE(3,2700)
2700 FORMAT('***' /
*, '** LEVEL=2, X=0, LOAD SETS' /
*, '***' /
*, '*NSET, NSET=LOAD021' /
*, '4101,4105' /
*, '*NSET, NSET=LOAD022' /
*, '4102,4104' /
*, '*NSET, NSET=LOAD023' /
*, '4106,4110' )
WRITE(3,2710)
2710 FORMAT('*NSET, NSET=LOAD024' /
*, '4107,4109' /
*, '*NSET, NSET=LOAD025' /
*, '4111,4115' /
*, '*NSET, NSET=LOAD026' /
*, '4112,4114' /
*, '*NSET, NSET=LOAD027' /
*, '4116,4120' /
*, '*NSET, NSET=LOAD028' /
*, '4117,4119' )
WRITE(3,2720)
2720 FORMAT('*NSET, NSET=LOAD029' /
*, '4121,4125' /
*, '*NSET, NSET=LOAD0210' /
*, '4122,4124' )
WRITE(3,2800)
2800 FORMAT('***' /
*, '** LEVEL=0, X=L, LOAD SETS' /
*, '***' /
*, '*NSET, NSET=LOADL01' /
*, '1301,1321' /
*, '*NSET, NSET=LOADL02' /
*, '1302,1320' /

```

```

    *, '*NSET, NSET=LOADL03')
    WRITE(3,2900)
2900 FORMAT('1303,1319'/
    *, '*NSET, NSET=LOADL04'/
    *, '1304,1306,1308,1310,1312,1314,1316,1318'/
    *, '*NSET, NSET=LOADL05'/
    *, '1305,1309,1313,1317'/
    *, '*NSET, NSET=LOADL06'/
    *, '1307,1311,1315'/
    *, '***'/
    *, '** LEVEL=1, X=L, LOAD SETS'/
    *, '***')
    WRITE(3,3000)
3000 FORMAT('*NSET, NSET=LOADL1'/
    *, '3301,3302,3303,3304,3305'/
    *, '***'/
    *, '** LEVEL=2, X=L, LOAD SETS'/
    *, '***'/
    *, '*NSET, NSET=LOADL21'/
    *, '5301,5305'/
    *, '*NSET, NSET=LOADL22'/
    *, '5302,5304'/
    *, '*NSET, NSET=LOADL23')
    WRITE(3,3010)
3010 FORMAT('5306,5310'/
    *, '*NSET, NSET=LOADL24'/
    *, '5307,5309'/
    *, '*NSET, NSET=LOADL25'/
    *, '5311,5315'/
    *, '*NSET, NSET=LOADL26'/
    *, '5312,5314'/
    *, '*NSET, NSET=LOADL27'/
    *, '5316,5320'/
    *, '*NSET, NSET=LOADL28')
    WRITE(3,3020)
3020 FORMAT('5317,5319'/
    *, '*NSET, NSET=LOADL29'/
    *, '5321,5325'/
    *, '*NSET, NSET=LOADL210'/
    *, '5322,5324')
    WRITE(3,3030)
3030 FORMAT('*CLOAD'/
    *, '***'/
    *, '**LEVEL=0, X=0'/
    *, '***')
    WRITE(3,3102)P101
3102 FORMAT('LOAD001,2,',F10.6)
    WRITE(3,3103)P102
3103 FORMAT('LOAD002,2,',F10.6)
    WRITE(3,3104)P103
3104 FORMAT('LOAD003,2,',F10.6)
    WRITE(3,3105)P104
3105 FORMAT('LOAD004,2,',F10.6)
    WRITE(3,3200)P105
3200 FORMAT('LOAD005,2,',F10.6)
    WRITE(3,3201)P107
3201 FORMAT('LOAD006,2,',F10.6)
3204 FORMAT('119,2,',F10.6)
    WRITE(3,3205)
3205 FORMAT('***'/
    *, '**LEVEL=1, X=0'/
    *, '***')
    WRITE(3,3206)P2101
3206 FORMAT('2101,2,',F10.6)
    WRITE(3,3207)P2102
3207 FORMAT('2102,2,',F10.6)
    WRITE(3,3208)P2103

```

```

3208 FORMAT('2103,2,',F10.6)
      WRITE(3,3209)P2104
3209 FORMAT('2104,2,',F10.6)
      WRITE(3,3210)P2105
3210 FORMAT('2105,2,',F10.6)
      WRITE(3,3220)
3220 FORMAT('**'/
      *, '**LEVEL=2, X=0' /
      *, '**')
      WRITE(3,3130)P4101
3130 FORMAT('LOAD021,2,',F10.6)
      WRITE(3,3131)P4102
3131 FORMAT('LOAD022,2,',F10.6)
      WRITE(3,3132)P4106
3132 FORMAT('LOAD023,2,',F10.6)
      WRITE(3,3133)P4107
3133 FORMAT('LOAD024,2,',F10.6)
      WRITE(3,3134)P4111
3134 FORMAT('LOAD025,2,',F10.6)
      WRITE(3,3135)P4112
3135 FORMAT('LOAD026,2,',F10.6)
      WRITE(3,3136)P4116
3136 FORMAT('LOAD027,2,',F10.6)
      WRITE(3,3137)P4117
3137 FORMAT('LOAD028,2,',F10.6)
      WRITE(3,3138)P4121
3138 FORMAT('LOAD029,2,',F10.6)
      WRITE(3,3139)P4122
3139 FORMAT('LOAD0210,2,',F10.6)
      WRITE(3,3250)P4103
3250 FORMAT('4103,2,',F10.6)
      WRITE(3,3251)P4108
3251 FORMAT('4108,2,',F10.6)
      WRITE(3,3252)P4113
3252 FORMAT('4113,2,',F10.6)
      WRITE(3,3253)P4118
3253 FORMAT('4118,2,',F10.6)
      WRITE(3,3254)P4123
3254 FORMAT('4123,2,',F10.6)
      WRITE(3,3255)
3255 FORMAT('**'/
      *, '**LEVEL=0, X=L' /
      *, '**')
      WRITE(3,4101)P1301
4101 FORMAT('LOADL01,2,',F10.6)
      WRITE(3,4102)P1302
4102 FORMAT('LOADL02,2,',F10.6)
      WRITE(3,4103)P1303
4103 FORMAT('LOADL03,2,',F10.6)
      WRITE(3,4104)P1304
4104 FORMAT('LOADL04,2,',F10.6)
      WRITE(3,4200)P1305
4200 FORMAT('LOADL05,2,',F10.6)
      WRITE(3,4201)P1307
4201 FORMAT('LOADL06,2,',F10.6)
      WRITE(3,4205)
4205 FORMAT('**'/
      *, '**LEVEL=1 X=L' /
      *, '**')
      WRITE(3,4206)P3301
4206 FORMAT('3301,2,',F10.6)
      WRITE(3,4207)P3302
4207 FORMAT('3302,2,',F10.6)
      WRITE(3,4208)P3303
4208 FORMAT('3303,2,',F10.6)
      WRITE(3,4209)P3304
4209 FORMAT('3304,2,',F10.6)

```



```

WRITE(3,4210)P3305
4210 FORMAT('3305,2,',F10.6)
WRITE(3,4220)
4220 FORMAT('**'/
*, '**LEVEL=2, X=L'/
*, '**')
WRITE(3,4130)P5301
4130 FORMAT('LOADL21,2,',F10.6)
WRITE(3,4131)P5302
4131 FORMAT('LOADL22,2,',F10.6)
WRITE(3,4132)P5306
4132 FORMAT('LOADL23,2,',F10.6)
WRITE(3,4133)P5307
4133 FORMAT('LOADL24,2,',F10.6)
WRITE(3,4134)P5311
4134 FORMAT('LOADL25,2,',F10.6)
WRITE(3,4135)P5312
4135 FORMAT('LOADL26,2,',F10.6)
WRITE(3,4136)P5316
4136 FORMAT('LOADL27,2,',F10.6)
WRITE(3,4137)P5317
4137 FORMAT('LOADL28,2,',F10.6)
WRITE(3,4138)P5321
4138 FORMAT('LOADL29,2,',F10.6)
WRITE(3,4139)P5322
4139 FORMAT('LOADL210,2,',F10.6)
WRITE(3,4250)P5303
4250 FORMAT('5303,2,',F10.6)
WRITE(3,4251)P5308
4251 FORMAT('5308,2,',F10.6)
WRITE(3,4252)P5313
4252 FORMAT('5313,2,',F10.6)
WRITE(3,4253)P5318
4253 FORMAT('5318,2,',F10.6)
WRITE(3,4254)P5323
4254 FORMAT('5323,2,',F10.6)
WRITE(3,4255)
4255 FORMAT('**'/
*, '*NODE PRINT'/
*, 'U'/
*, '*FILE FORMAT, ASCII'/
*, '*END STEP')
RETURN
END

```

C

C.... This subroutine returns the pdf of normal distribution....

C Input

C x : random variable
C mean : mean value
C sigma : standard deviation

C Output

C pdf : Probability density function

C

```

SUBROUTINE norpdf(x,mean,sigma,pdf)
REAL*8 x,mean,sigma,pdf
REAL*8 pi,z
DATA pi/3.1415926535898/
z=(x-mean)/sigma
pdf=DEXP(-(z*z/2.))/(sigma*DSQRT(2.*pi))
RETURN
END

```

C

C.... This subroutine returns the cdf of normal distribution....

C The range of xx should be restricted between -13.0 - +13.0

C Input

C x - random variable

```

C mean - mean value
C sigma - standard deviation
C Output
C cdf - cummulative distribution function
C iw - warning message,
C iw = 0 - ok ;
C iw = 1 - warning, x is out of range
C

```

```

SUBROUTINE norcdf(X,MEAN,SIGMA,CDF,IW)
REAL*8 X,MEAN,SIGMA,CDF
REAL*8 PA(8),QA(9),XX,Y,Z,YABS,PNUM,QDEN

```

```

XX=(X-MEAN)/SIGMA
IF (ABS(XX).GT.13.) THEN
  IW=1
ELSE
  IW=0
ENDIF
PA(1)=883.47894260849
PA(2)=1549.6793124037
PA(3)=1347.1941340976
PA(4)=723.04000277753
PA(5)=255.50049469496
PA(6)=59.240010112914
PA(7)=8.376531081419699
PA(8)=.56418955944261
QA(1)=883.4789426085
QA(2)=2546.5785458098
QA(3)=3337.2213699893
QA(4)=2606.7120152651
QA(5)=1333.569975678
QA(6)=460.2851236916
QA(7)=105.50025439769
QA(8)=14.847012237523
QA(9)=1.
Y=XX/DSQRT(2D+00)
IF (DABS(Y).LT.1D-75) THEN
  CDF=.5
  RETURN
ENDIF
Z=DEXP(-Y**2)
YABS=DABS(Y)
PNUM=PA(8)
DO 10 I=1, 7
  INDX=8-I
  PNUM=PA(INDX)+YABS*PNUM
10 CONTINUE
QDEN=QA(9)
DO 20 I=1, 8
  INDX=9-I
  QDEN=QA(INDX)+YABS*QDEN
20 CONTINUE
CDF=(PNUM/QDEN)*.5*Z
IF (XX.LT.0) RETURN
CDF=1.-CDF
RETURN
END

```

```

C
C..... This subroutine returns the inverse value (x, r.v.) of cdf....

```

```

C   Input :
C       cdf : cumulative distribution function
C       mean : mean value
C   Output :
C       x : random value
C

```

```

SUBROUTINE norinv(x, mean, sigma, cdf)
REAL*8 x,mean,sigma,cdf

```

```

REAL*8 p, xp, p1, t1, t2, t3, t4, d1, d2

p = 1. - cdf
IF (p .EQ. .5) THEN
    XP = 0.
    X = mean
    RETURN
ENDIF
IF (p .GT. .5) THEN
    p1 = cdf
ELSE
    p1 = p
ENDIF
t1 = p1**2
t2 = 1/t1
t3 = DLOG(t2)
t4 = DSQRT(t3)
d1 = 2.515517 + .802853 * t4 + .010328 * t4**2
d2 = 1.432788 * t4 + .189269 * t4**2 + .001308 * t4**3
xp = t4 - d1 / (1. + d2)
IF (p .LT. .5) THEN
    x = xp * sigma + mean
ELSE
    x = -xp * sigma + mean
ENDIF
RETURN
END

```

A.2. READIN

PROGRAM POST

```

C
C   GETING THE EIGENVALUE NUMBER AND THE EIGENVALUE
C
    IMPLICIT REAL*8 (A-H,O-Z)
    CHARACTER*80 FNAME
    DOUBLE PRECISION ARRAY
    DIMENSION ARRAY(513), JRRAY(2,513), LRUNIT(1,1)
    EQUIVALENCE (ARRAY(1), JRRAY(1,1))
    NRU=1
    LRUNIT(1, NRU)=8
    LRUNIT(2, NRU)=1
    LOUTF=0
C.....
C   OPEN OUTPUT FILE
C.....
C   OPEN(UNIT=15, FILE='eignv.out', STATUS='UNKNOWN')
C.....
C   PROMPT USER FOR EIGENVALUE NUMBER
C
    JEIGNO=1
    IF(JEIGNO.EQ.0) GOTO 200
C.....
C   ACCESS ABAQUS LIBRARY TO SET INPUT FILE.
C.....
    CALL INITPF(FNAME, NRU, LRUNIT, LOUTF)
    JUNIT=LRUNIT(1, NRU)
    CALL DBRNU(JUNIT)
    DO 100 K1=1, 99999
    CALL DBFILE (0, ARRAY, JRCD)
    IF(JRCD.NE.0) go to 200
    IF (JRRAY(1,2) . EQ. 1980) THEN
        IEIGNO = ARRAY(3)
        EIGENV=ARRAY(4)
        WRITE(*,*) 'EIGENV = ', EIGENV

```

```

        END IF
100 CONTINUE
200 CONTINUE
    STOP
    END

```

A.3. STRENGTH

```

PROGRAM STRENGTH
    REAL*8 meanY, sigmaY
    REAL*8 x, mean, sigma, cdf
    REAL*8 FACTOR, EIGENV(1), HOLD, STRENGTH, Pf
    INTEGER NDIST
    OPEN(UNIT=1, FILE='FACTOR', STATUS='UNKNOWN')
    OPEN(UNIT=2, FILE='EIGENV', STATUS='UNKNOWN')
    READ(1, *) FACTOR
    PRINT*, 'FACTOR = ', FACTOR

C
C.....SELECTION OF SMALLEST EIGEN VALUE.....
C
    OPEN(UNIT=3, FILE='load.inp', STATUS='UNKNOWN')
    REWIND(UNIT=3)

C
C.....N is number of calculated eigenvalues.....
C
    READ(3, *) NDIST, MEAN, SIGMA, N
    READ(2, *) (EIGENV(I), I=1, N)
    PRINT*, 'EIGENV = ', (EIGENV(I), I=1, N)
    REWIND(UNIT=2)
    READ(2, *) HOLD
    DO 10 I=1, N
        PRINT*, 'EIGENV = ', EIGENV(I)
        IF (HOLD.LT.EIGENV(I)) GO TO 10
        HOLD = EIGENV(I)
        PRINT*, 'HOLD = ', HOLD
10 CONTINUE
        PRINT*, 'HOLD = ', HOLD
    STRENGTH=FACTOR*HOLD
    X = STRENGTH
    PRINT*, 'STRENGTH = ', STRENGTH

C
C.....DISTRIBUTIONS INPUT FILE.....
C
C.....DISTRIBUTIONS.....
C
C...2- LOGNORMAL DISTRIBUTION.
C
    PRINT*, 'SIGMA = ', SIGMA
    CALL logpar(mean, sigma, meanY, sigmaY)
    IF (NDIST.EQ.2) THEN
        CALL logcdf(x, meanY, sigmaY, cdf)
    ENDIF
    Pf=1-CDF
    PRINT*, 'Pf      = ', Pf
    END

C
C.... This subroutine returns the value of lognormal cdf.....
C Input
C   x : random value
C   mean : mean value (parameter)
C   sigma: standard deviation (parameter)
C Output
C   cdf : cumulative distribution function
C
SUBROUTINE logcdf(x, meanY, sigmaY, cdf)
    REAL*8 x, meanY, sigmaY, cdf

```

```

REAL*8 xx
REAL*8 pa(9),qa(9),y,z,yabs,pnum,qden,temp

xx =(DLOG(X)-meanY)/sigmaY

pa(1) = 883.47894260849
pa(2) = 1549.6793124037
pa(3) = 1347.1941340976
pa(4) = 723.04000277753
pa(5) = 255.50049469496
pa(6) = 59.240010112914
pa(7) = 8.376531081419699
pa(8) = .56418955944261
C
qa(1) = 883.4789426085
qa(2) = 2546.5785458098
qa(3) = 3337.2213699893
qa(4) = 2606.7120152651
qa(5) = 1333.569975678
qa(6) = 460.2851236916
qa(7) = 105.50025439769
qa(8) = 14.847012237523
qa(9) = 1.
C
temp=2.0
y = xx / DSQRT(temp)
IF (DABS(y) .LT. 1D-75) THEN
  cdf = .5
  RETURN
ENDIF
C
z = DEXP(-y**2)
yabs = DABS(y)
pnum = pa(8)
C
DO 100 I = 1, 7
  indx = 8 - I
  pnum = pa(indx) + yabs * pnum
100 CONTINUE
C
qden = qa(9)
DO 200 I = 1, 8
  indx = 9 - I
  qden = qa(indx) + yabs * qden
200 CONTINUE
C
cdf = (pnum / qden) * .5 * z
IF (xx .LT. 0.) RETURN
cdf = 1 - cdf
RETURN
END

C
C.... This subroutine returns the lognormal parameters meanY & sigmaY..
C
C   Input
C   meanX : mean value of X
C   sigmaX : standard deviation of X
C
C   Output
C   meanY : mean value of Y
C   sigmaY: standard deviation of Y
C
SUBROUTINE logpar(meanX,sigmaX,meanY,sigmaY)
REAL*8 meanX,sigmaX,meanY,sigmaY
REAL*8 cvX,varY

cvX=sigmaX/meanX
varY=DLOG(1.+cvX*cvX)
sigmaY=DSQRT(varY)

```

```

meanY=DLOG(meanX)-varY/2.
RETURN
END

```

A.4. STATISTICS

PROGRAM STATISTICS

```

REAL*8 Pf, SUMPf, AVEPf, SUMPf2, SDPf, COVPf, A, B, C, D
INTEGER N
OPEN(UNIT=1, FILE='cycle', STATUS='unknown')
READ(1, *) N
PRINT*, '-----'
PRINT*, 'CYCLE No.=' ,N
PRINT*, '-----'
OPEN(UNIT=2, FILE='PFAIL', STATUS='unknown')
READ(2, *) Pf
PRINT*, 'Pf      =', Pf
OPEN(UNIT=3, FILE='SUMPf', STATUS='unknown')
READ(3, *) SUMPf
SUMPf=SUMPf+Pf
PRINT*, 'SUMPf   =', SUMPf
AVEPf=SUMPf/N
PRINT*, 'AVEPf   =', AVEPf
REWIND(UNIT=3)
WRITE(3, *) SUMPf
C
OPEN(UNIT=4, FILE='SUMPf2', STATUS='unknown')
READ(4, *) SUMPf2
SUMPf2=SUMPf2+Pf**2
PRINT*, 'SUMPf2 =', SUMPf2
REWIND(UNIT=4)
WRITE(4, *) SUMPf2
C= 1. / (N*REAL(N-1))
A = DSQRT(C)
D=SUMPf2-N*AVEPf**2
B = DSQRT(D)
SDPf=A*B
PRINT*, 'SDPf    =', SDPf
COVPf=SDPf/AVEPf
PRINT*, 'COVPf   =', COVPf
END

```