



NET-CENTRIC  
DESIGN AND ANALYSIS  
OF  
INFORMATION SYSTEMS

THESIS  
Timothy R. Schmoyer  
Captain, USA

AFIT/GE/ENG/97M-03

DEPARTMENT OF THE AIR FORCE  
AIR UNIVERSITY  
**AIR FORCE INSTITUTE OF TECHNOLOGY**

19970430 003

Wright-Patterson Air Force Base, Ohio

DTIC QUALITY INSPECTED 1

DISTRIBUTION STATEMENT A  
Approved for public release;  
Distribution unlimited

AFIT/GE/ENG/97M-03

NET-CENTRIC  
DESIGN AND ANALYSIS  
OF  
INFORMATION SYSTEMS

THESIS  
Timothy R. Schmoyer  
Captain, USA

AFIT/GE/ENG/97M-03

Approved for public release; distribution unlimited

The views expressed in this thesis are those of the author and do not reflect the official policy or position of the Department of Defense or the U. S. Government.

AFIT/GE/ENG/97M-03

NET-CENTRIC  
DESIGN AND ANALYSIS  
OF  
INFORMATION SYSTEMS

THESIS

Presented to the Faculty of the School of Engineering  
of the Air Force Institute of Technology

Air University

In Partial Fulfillment of the  
Requirements for the Degree of  
Master of Science

Timothy R. Schmoyer, B.S.E.E.

Captain, USA

March 1997

Approved for public release; distribution unlimited

### *Acknowledgements*

There are many people who have contributed their time, support, and expertise to this research. I thank everyone I talked to at the Pentagon for helping me to understand the issues and terms that are involved in such ambitious projects as Force XXI, the Army Enterprise Strategy, battlefield digitization, situational awareness and situational age.

For their patience, ability to always find time to help, and willingness to explain more than once, I would like to thank Colonel Deale and Major Renner of the Office of the Director of Information Systems for Command, Control, Communications and Computers. Without their expertise and sponsorship, this would never have been possible.

For his interest and time spent discussing with me Joint communications and perishability of information, I thank Lieutenant Colonel Spalviero of the Joint Chiefs of Staff J6.

For his friendship, guidance, and willingness to provide resources, I am once again indebted to Mr. Joe Landa of Trident Systems, Inc. He not only allowed me to overcome the learning curve at the expense of his leisure time, he opened his home to me while I was at the Pentagon. Thanks again, Joe!

Special thanks to the instructors in the Electrical Engineering and Computer Science Department at the Air Force Institute of Technology. To my thesis advisor, Captain Rick Raines, thanks for your guidance, direction and uncanny ability to lift up and push at the same time. To Captain Mike Talbert, I never would have believed it possible to find excitement in developing database technology, but you made it happen, thanks for all your input and patience.

Finally, and most importantly, thank you Rachel for always being there. Your encouragement, support, and willingness to endure the hazards of my chosen profession make everything possible.

Timothy R. Schmoyer

## *Table of Contents*

	Page
Acknowledgements . . . . .	ii
List of Figures . . . . .	vii
List of Tables . . . . .	ix
List of Symbols . . . . .	x
List of Abbreviations . . . . .	xii
Abstract . . . . .	xv
I. Introduction . . . . .	1-1
1.1 Background . . . . .	1-1
1.2 Motivating Factors . . . . .	1-1
1.2.1 Simulation Disparities . . . . .	1-1
1.2.2 Communications in C4I Systems . . . . .	1-2
1.3 Problem Statement and Scope . . . . .	1-5
1.3.1 Review of the Problem . . . . .	1-5
1.3.2 Scope of the Problem . . . . .	1-6
1.4 General Approach . . . . .	1-7
1.4.1 Develop the Model . . . . .	1-7
1.4.2 Develop Simulation Object . . . . .	1-9
1.4.3 Develop Simulation Network Architecture . . . . .	1-9
1.5 Thesis Organization . . . . .	1-10
II. Background . . . . .	2-1
2.1 Introduction . . . . .	2-1
2.2 The Technical, Operational, and Systems Architecture . . . . .	2-2

	Page
2.2.1 Operational Architecture . . . . .	2-3
2.2.2 System Architecture . . . . .	2-6
2.2.3 Technical Architecture . . . . .	2-7
2.3 Integrating the Three Architectures into Executable Simulation Objects	2-10
2.4 Distributed Databases and the Internet . . . . .	2-13
2.5 The Three-tiered Network Architecture . . . . .	2-16
2.6 Summary . . . . .	2-17
III. Methodology . . . . .	3-1
3.1 Introduction . . . . .	3-1
3.2 Developing the Operational Architecture . . . . .	3-1
3.2.1 Developing the Entity Relationship Model . . . . .	3-2
3.2.2 Developing the Activity Model . . . . .	3-4
3.3 Integrating the Technical Architecture . . . . .	3-6
3.4 Developing the System Architecture . . . . .	3-7
3.5 Coding the OE254_Path Object/Applet . . . . .	3-8
3.6 Storing the OE254_Path Object in the Object Database . . . . .	3-10
3.7 Using a CORBA ORB to Request and Implement Objects . . . . .	3-11
3.7.1 Requesting the Ant_Path Object from the Simulation . . . . .	3-13
3.7.2 Processing the Request . . . . .	3-15
3.7.3 Accessing the object/data . . . . .	3-17
3.7.4 Implementing the Object . . . . .	3-17
3.7.5 Returning Results to the Simulation . . . . .	3-18
3.8 Summary . . . . .	3-18
IV. Analysis . . . . .	4-1
4.1 Introduction . . . . .	4-1
4.2 Background . . . . .	4-1

	Page
4.3 Summary . . . . .	4-2
4.4 Review of the Results . . . . .	4-3
4.5 Comparison with Other Distributed Simulation Architectures . . . . .	4-5
4.5.1 Common Operational Modeling, Planning, and Simulation Strategy (COMPASS) . . . . .	4-5
4.5.2 Joint Modeling and Simulation System (J-MASS) . . . . .	4-6
4.6 Goals Achieved . . . . .	4-7
4.7 Goals Not Achieved . . . . .	4-8
V. Recommended Continuing Research . . . . .	5-1
5.1 Introduction . . . . .	5-1
5.2 Review . . . . .	5-1
5.3 Recommended Research . . . . .	5-1
Appendix A. IDEF1X Antenna Model . . . . .	A-1
Appendix B. IDEF0 Antenna Model . . . . .	B-1
Appendix C. C4I Modeling and Simulation . . . . .	C-1
C.1 Network Layering . . . . .	C-1
C.2 Abstract vs. Detail Modeling . . . . .	C-2
C.3 Real-Time vs. Analytical . . . . .	C-2
C.4 Constructive, Virtual and Live Simulations . . . . .	C-3
C.5 Modeling Radiowave Propagation . . . . .	C-3
C.6 Ionospheric effects . . . . .	C-4
C.7 Clouds and Fog . . . . .	C-6
C.8 Rain . . . . .	C-7
C.9 Sand and Dust Storms (Haboobs) . . . . .	C-11
C.10 Determining Received Power and Link Margin . . . . .	C-13
C.11 Need for Automation . . . . .	C-16



	Page
C.12 Perishability of Information and Situational Age . . . . .	C-18
C.13 Modeling Temporal Events . . . . .	C-19
Appendix D. IDEF4 Overview . . . . .	D-1
Bibliography . . . . .	BIB-1
Vita . . . . .	VITA-1

*List of Figures*

Figure	Page
1.1. Disparate Simulations . . . . .	1-2
1.2. Interactive, Consistent Simulations . . . . .	1-3
1.3. Expanding and Dynamic Battlefield (12) . . . . .	1-4
1.4. Precision Strike Scenario . . . . .	1-5
1.5. From the Real-World Scenario to the Distributed Simulation Architecture . . . . .	1-7
1.6. Example of an IDEF1x Entity Relationship Model . . . . .	1-8
1.7. Example of an IDEF0 Activity Model . . . . .	1-8
1.8. Linking and Embedding Objects . . . . .	1-10
2.1. Architecture Interfaces (29) . . . . .	2-2
2.2. Systems Architecture Development (29) . . . . .	2-3
2.3. Example Activity Model (IDEF0) . . . . .	2-4
2.4. Information Model . . . . .	2-5
2.5. Operational Architecture Development (29) . . . . .	2-6
2.6. Architecture Relationships (29) . . . . .	2-7
2.7. Architecture Products (29) . . . . .	2-10
2.8. Architecture Product Interrelationships (29) . . . . .	2-11
2.9. Today's RDBMS Client/Server (2) . . . . .	2-13
2.10. Today's Object DBMS Client/Server (2) . . . . .	2-14
2.11. Multidimensional Database Example . . . . .	2-14
2.12. Distributed Database Example . . . . .	2-15
2.13. Three-tiered Architecture Example . . . . .	2-16
3.1. Information Flow Diagram . . . . .	3-1
3.2. IDEF1X Antenna ER Diagram . . . . .	3-3
3.3. ANTENNA_TYPE Table for the OE-254()/GRC . . . . .	3-4

Figure	Page
3.4. IDEF0 OE-254/GRC Top-level (A-0) Diagram . . . . .	3-5
3.5. IDEF0 OE-254/GRC (A-0) Child Diagram . . . . .	3-5
3.6. IDEF0 OE-254/GRC (A-0) Diagram with Constraint . . . . .	3-6
3.7. IDEF0 OE-254/GRC (A-0) Child Diagram with Constraint . . . . .	3-7
3.8. System Architecture of OE-254/GRC Antenna System . . . . .	3-8
3.9. Semantic Model for a Communication Net. . . . .	3-12
3.10. The Common Object Request Broker Architecture for a Distributed Simulation	3-12
3.11. The CORBA Client Architecture . . . . .	3-13
3.12. Example of a Client GUI to Select Objects for Simulation . . . . .	3-14
3.13. Filling in the Parameters for the Operations to be Performed . . . . .	3-14
3.14. The CORBA ORB Architecture . . . . .	3-15
3.15. The CORBA Object Implementation Architecture . . . . .	3-18
4.1. Developing the Model, Simulation Object, and Distributed Simulation Network .	4-2
C.1. Open Systems Interconnection Reference Model Architecture(34) . . . . .	C-1
C.2. Satellite Transmitter-to-Receiver Link with Typical Loss and Noise Sources(32)	C-4
C.3. Schematic Presentation of Propagation Impairment Mechanisms(14) . . . . .	C-5
C.4. Global Rain Rate Regions(13) . . . . .	C-9
C.5. Rain Rates as a Function of Percent of Year Exceeded(13) . . . . .	C-9
C.6. Degradation in Signal-to-Noise Ratio (C/X) versus Atmospheric Absorption, for Various Values of T(14) . . . . .	C-11
C.7. Cross-Section through a Thunderstorm that is Producing a Haboob(14) . . . . .	C-12
C.8. Schematic of the Dust Cell Model(14) . . . . .	C-13
C.9. Attenuation as a Function of Frequency for Falling Dust Particles(14) . . . . .	C-14
C.10. Major Noise Contributors of a Receiving System(32) . . . . .	C-16
C.11. Situational Age, an Example of the Perishability of Information. . . . .	C-18

*List of Tables*

Table	Page
C.1. Sample Cloud Models and S-, X-, K-Band Zenith Effects(14) . . . . .	C-7
C.2. Regression Coefficients for Estimating the Attenuation Coefficients(14) . . . . .	C-8
C.3. Rain Rates Exceeded as a Function of Percentage of Year, for Regions A to H(13)	C-8

### List of Symbols

Symbol	Page
N the electron density of the ionosphere in electrons/m <sup>3</sup> . . . . .	C-5
$n_r$ the real part of the index of refraction . . . . .	C-5
$\nu$ the collision frequency in Hz . . . . .	C-5
$\alpha_p$ attenuation coefficient (dB/km) . . . . .	C-6
$\lambda_{cm}$ wavelength (cm) . . . . .	C-6
$K_c$ the complex relative dielectric constant of water . . . . .	C-6
$\rho_l$ the liquid water content of the cloud (g/m <sup>3</sup> ) . . . . .	C-6
$T_b$ the brightness temperature . . . . .	C-6
$T_s$ source temperature . . . . .	C-6
$T_i$ effective temperature of absorbing region . . . . .	C-6
$\tau$ the integral of the power attenuation constant across the path . . . . .	C-6
$T_{sys}$ system temperature . . . . .	C-6
R rain rate in mm/hr . . . . .	C-7
$\Theta$ latitude in degrees . . . . .	C-10
$\theta$ elevation angle . . . . .	C-10
$Kr_o$ effective earth radius . . . . .	C-10
$r_p$ empirical path reduction factor . . . . .	C-10
V visibility in km . . . . .	C-12
$a$ average particle radius in m . . . . .	C-12
$\lambda_m$ wavelength in m . . . . .	C-12
$P_r$ received signal power in Watts . . . . .	C-13
EIRP Effective Isotropic Radiated Power in Watts . . . . .	C-14
$P_t$ transmitted power in Watts . . . . .	C-14
$G_t$ gain of the transmit antenna . . . . .	C-14
$G_r$ gain of the receive antenna . . . . .	C-14
$L_s$ path loss . . . . .	C-14

Symbol	Page
$c$ speed of light ( $\simeq 3 \times 10^8$ m/s) . . . . .	C-14
$f$ frequency in Hz . . . . .	C-14
$K_s$ the constant of attenuation over the radiowave path . . . . .	C-14
$R_s$ the communication path distance in meters . . . . .	C-15
$l_s$ the attenuation exponent of the communication path . . . . .	C-15
$L_o$ losses from the antenna, cable, connector and receiver . . . . .	C-15
$E_b$ energy per bit . . . . .	C-15
$R_b$ information rate in bits/second . . . . .	C-15
$N_o$ the noise power spectral density . . . . .	C-15
$G$ gain of the receiver . . . . .	C-15
$\kappa$ Boltzmann's constant ( $1.38 \times 10^{-23}$ W-K/Hz) . . . . .	C-15
$T_s^\circ$ the system effective temperature . . . . .	C-16
$W$ the bandwidth of the received signal in Hertz . . . . .	C-16
$T_A^\circ$ antenna temperature, Kelvin . . . . .	C-16
$F_L$ noise figure of lossy line . . . . .	C-16
$F_R$ noise figure of the receiver . . . . .	C-16

*List of Abbreviations*

Abbreviation	Page
C4I Command, Control, Communications, Computers, and Intelligence . . . . .	xv
IDEF Integrated Definition . . . . .	xv
CORBA Common Object Request Broker Architecture . . . . .	xv
M&S Modeling and Simulation . . . . .	1-6
DMSO Defense Modeling & Simulation Office . . . . .	1-7
HLA High Level Architecture . . . . .	1-7
ER Entity-Relationship . . . . .	1-7
DISA Defense Information Systems Agency . . . . .	2-1
ODISC4 Office of the Director of Information Systems for Command, Control, Com- munications and Computers . . . . .	2-1
TRADOC US Army Training and Doctrine Command . . . . .	2-2
C2CDM C2 Core Data Model . . . . .	2-3
FIPS Federal Information Processing Standards . . . . .	2-4
ICOMs Inputs, Controls, Outputs, and Mechanisms . . . . .	2-4
LANs Local Area Networks . . . . .	2-6
COE Common Operating Environment . . . . .	2-8
VMF Variable Message Format . . . . .	2-8
TAFIM Technical Architecture Framework for Information Management . . . . .	2-8
PDU Protocol Data Unit . . . . .	2-9
USMTF United Service Message Text Format . . . . .	2-9
LOS Line of Sight . . . . .	2-9
TACSAT Tactical Satellite . . . . .	2-9
SATCOM Satellite Communications . . . . .	2-9
TCP Transport Control Protocol . . . . .	2-11
OMG Object Management Group . . . . .	2-11
MDBMS multi-database management system . . . . .	2-12

Abbreviation	Page
RDBMS Relational Database Management System . . . . .	2-13
ODBC Open Database Connectivity . . . . .	2-13
SQL Structured Query Language . . . . .	2-13
O/S Operating System . . . . .	2-13
ODBMS Object-Oriented Database Management System . . . . .	2-13
DBMS database management system . . . . .	2-16
GUI Graphical User Interface . . . . .	3-8
OQL Object Query Language . . . . .	3-8
OID object identity . . . . .	3-10
ORB Object Request Broker . . . . .	3-15
DII Dynamic Invocation Interface . . . . .	3-15
IDL Interface Definition Language . . . . .	3-16
GIOP General Inter-ORB Protocol . . . . .	3-16
ESIOP Environment-Specific Inter-ORB Protocols . . . . .	3-16
IIOP Internet Inter-ORB Protocol . . . . .	3-16
DCE Distributed Computing Environment . . . . .	3-17
BOA Basic Object Adapter . . . . .	3-17
DSI Dynamic Skeleton Interface . . . . .	3-17
REDIS Reverse Engineering for Data Integration and Sharing . . . . .	4-3
MSRR Modeling and Simulation Resource Repository . . . . .	4-3
OMDG Object Management Database Group . . . . .	4-5
COMPASS Common Operational Modeling, Planning, and Simulation Strategy . . . . .	4-5
DIS Distributed Interactive Simulation . . . . .	4-5
PDU Protocol Data Unit . . . . .	4-5
J-MASS Joint Modeling and Simulation System . . . . .	4-6
ISO International Standards Organization . . . . .	C-1
OSI Open Systems Interconnect . . . . .	C-1



Abbreviation	Page
ISYSCON Integrated System Control . . . . .	C-17
EPLRS Enhanced Position Locating and Ranging System . . . . .	C-17
CNR Combat Net Radio . . . . .	C-17

*Abstract*

This thesis presents an unique methodology merging state of the art Internet and distributed database technology to support distributed simulations with programming language and platform independence. Standardized models of Command, Control, Communications, Computers and Intelligence (C4I) systems using Integrated Definition (IDEF) models and executable simulation objects are placed in database repositories which can be accessed and implemented over a distributed simulation network using the Common Object Request Broker Architecture (CORBA). The CORBA distributed simulation network accesses heterogeneous distributed databases and performs distributed processes, and supports portability and reuse of simulation objects and interoperability across operating systems and programming languages.

NET-CENTRIC  
DESIGN AND ANALYSIS  
OF  
INFORMATION SYSTEMS

*I. Introduction*

*1.1 Background*

My experiences as a communications officer in the U.S. Army have led me to realize the usefulness of modeling and simulation in the planning and analysis of communications networks, the design of communications systems, and the importance of including communications in larger wargaming simulations. As the military becomes more "info-centric", or reliant on the timely exchange of information, communication capability and reliability become increasingly important in our mission planning and assessments. Especially as the U.S. military engages in world-wide, multi-national operations, communication interoperability and reliability are integral factors to the decisions of our military and civilian leaders. Distributed modeling and simulation provide the means to bring together heterogeneous communications systems, and conduct trade-off analysis and optimization within the battlefield scenario, to ensure the highest possible communications interoperability and reliability.

*1.2 Motivating Factors*

*1.2.1 Simulation Disparities.* There are two types of simulation disparities which must be overcome in future battlefield simulations:

1. Simulations which can not interact with each other(31).

2. Simulation objects which represent the same real world system, but do not behave similarly in different simulations.

These disparities result because of “stovepipe” simulation applications and the creation of simulation objects without consideration for their reuse or portability (Figure 1.1). Both disparities can be overcome by using an *open* architecture distributed simulation network. Simulations can interact with each other through interfaces which translate requests from one programming language to another. The architecture also directs these requests to repositories where approved simulation objects are stored (Figure 1.2). These simulation objects are based on standardized models to ensure consistent behavior, and enforcing the use of approved objects ensures simulation consistency.

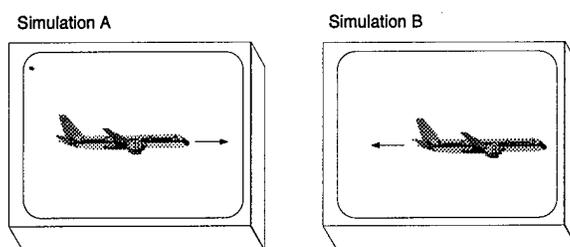

Simulation A cannot  
interact with Simulation B?

Why does the plane  
fly backward in  
Simulation B?

Figure 1.1 Disparate Simulations

*1.2.2 Communications in C4I Systems.* Situational awareness on the modern battlefield relies on information. The acquisition, analysis, exchange, presentation and use of that information is supported by C4I systems. Communications, within the context of C4I, is the key factor or element that links all the other elements to form a cohesive system. Advances in communica-

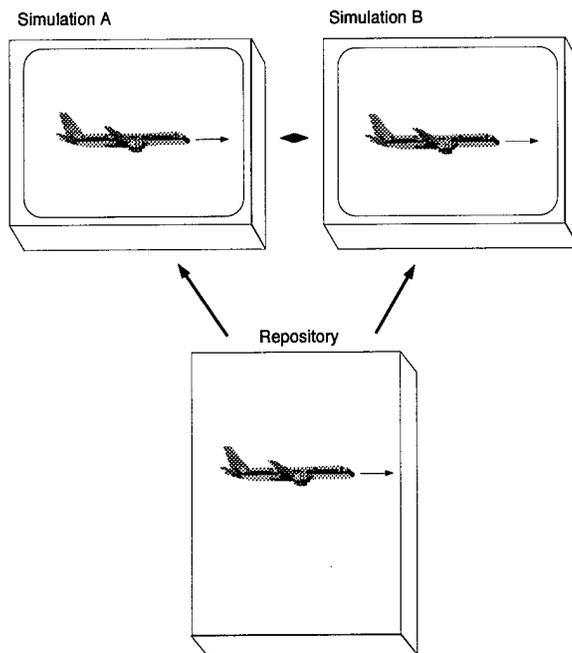

Figure 1.2 Interactive, Consistent Simulations

tions technologies and methods together with inherent changing architectures make consideration of system reliability and availability of services key elements in the decision making process. Unless communications is included as an integral element of wargaming, modeling, and simulations, decisions by our most senior civilian and military leaders will be flawed(24).

The importance of information in the 21st century, demands a fully integrated (horizontally and vertically), robust, stable battle command infrastructure. To support the battle command infrastructure, complex management and communications systems must provide the flexibility and robustness to meet the needs of the highest and lowest echelons of command.

In order to meet the growing demand for information, the information infrastructure must move away from "stove pipe" systems(17) to seamless, interoperable, and worldwide systems. This requirement is reflected in the U.S. Army's Force XXI program. The goal of this program is to create a digital battlefield which can be used to develop tactics, doctrine, training, and evaluate future systems to enhance lethality, survivability, tempo, sustainability, deployability, joint/combined

linkages, and versatility(5). To achieve the goal of Force XXI, communications, the backbone of the 21st century force, must be realistically modeled in the digital battlefield.

The digital battlefield provides a virtual world in which highly complex, distributed simulation can be used to test and analyze current and future systems. However, for the digital battlefield to be useful, the virtual world must realistically represent actual battlefield characteristics and conditions faced by the military today and in the future. The digital battlefield must represent how the military organizes and communicates as a function of the mission, environment, terrain and time.

In the dynamic environment of the battlefield, where mobile communications are being extended deep into the enemy's area, the need for timely information over line-of-sight radio, satellite and cable from the farthest forward warfighter to the highest decision maker is increasing. In the 21st century force, communications dependence and its reliability become more important as the rear support area may be within the continental United States, while the mission forces are conducting operations around the world (Figure 1.3).

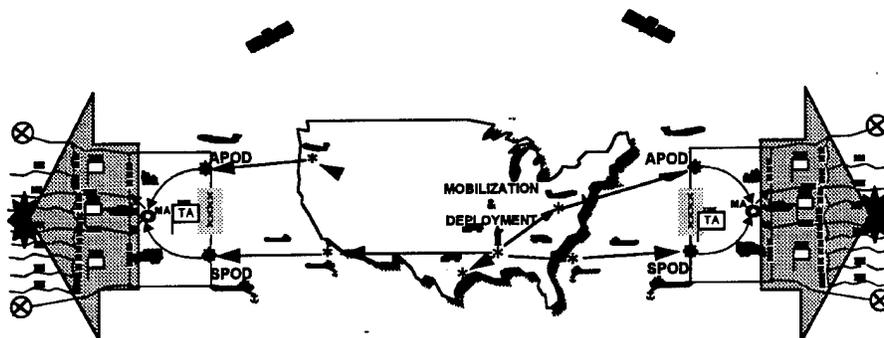

Figure 1.3 Expanding and Dynamic Battlefield (12)

In addition, a communications network is never static; the network is mobile, changing topology constantly. The environment is also changing. Weather and ionospheric changes affect radio paths, and external forces affect cable (more than once a wire was cut by the treads of an armored

vehicle during Desert Shield/Desert Storm). These temporally varying conditions must also be realistic in the digital battlefield - reflecting that communications are especially susceptible to these dynamic changes in operations and the environment.

An example scenario is shown in Figure 1.4 to illustrate the dynamics involved in modern scenarios. An enemy tank (A) is observed by an airborne sensor system (B). Both the tank and aircraft are mobile. The sensor's ability to observe the tank is affected by environmental conditions (C) in the path. The information from the sensor is sent to a U.S. Army command organization (D) which identifies the tank, via satellite (E) to a helicopter (F) as a target. A simulation would have to update the scenario based on the mobility of the tank, aircraft, and changes in the environmental conditions which may interfere with the sensor's "visibility" and the communications systems. These obstacles, to name only a few, must be overcome to achieve true models of the actual world in the digital battlefield.

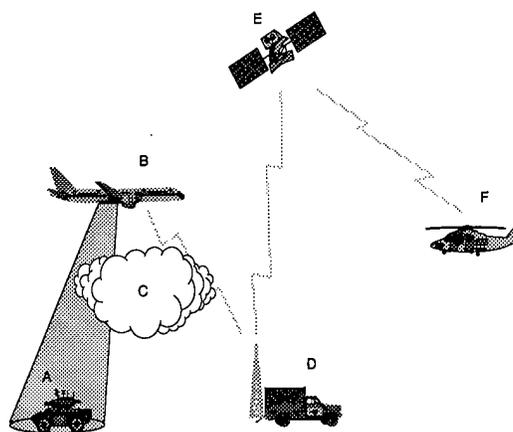

Figure 1.4 Precision Strike Scenario

### 1.3 Problem Statement and Scope

1.3.1 *Review of the Problem.* C4I simulations must realistically represent the battlefield conditions the military faces today and will face tomorrow. These simulations must use common ob-

jects to ensure consistent behavior and results. These simulations must also be able to interact with each other, regardless of application programming language or operating system inhomogeneities. Finally, communications, which is often overlooked in C4I simulations(24), must be included as the backbone of any information system.

*1.3.2 Scope of the Problem.* In order to develop an open distributed simulation network using standardized models and simulation objects stored in repositories, three steps must be completed:

1. Model a system described by a given scenario.
2. Develop simulation object(s) from the model.
3. Develop a network architecture to store and access objects using heterogeneous databases, over distinct geographical locations, and return results regardless of programming language and operating platform diversities.

For the purposes of this study, a narrowly defined scenario is chosen to be modeled. The scenario consists of receiving a signal at an OE-254()/GRC Antenna Group and measuring the link margin at the receiver to determine if the message was received. Recall from Figure 1.4 that environmental conditions may affect the strength of the signal actually received by the antenna. This is a representative scenario of all radiowave communication systems. It also uses a metric to determine if the information was successfully received, and can be included as part of a larger scenario.

The contribution of this thesis then, is a methodology to support standardization of the modeling and simulation (M&S) object development process, which combines emerging database and Internet technologies to present a realistic, executable, distributed simulation architecture. The methodology (as shown in Figure 1.5) proposes a process to describe any given scenario by its specific architectures, from which persistent data and executable simulation objects can be



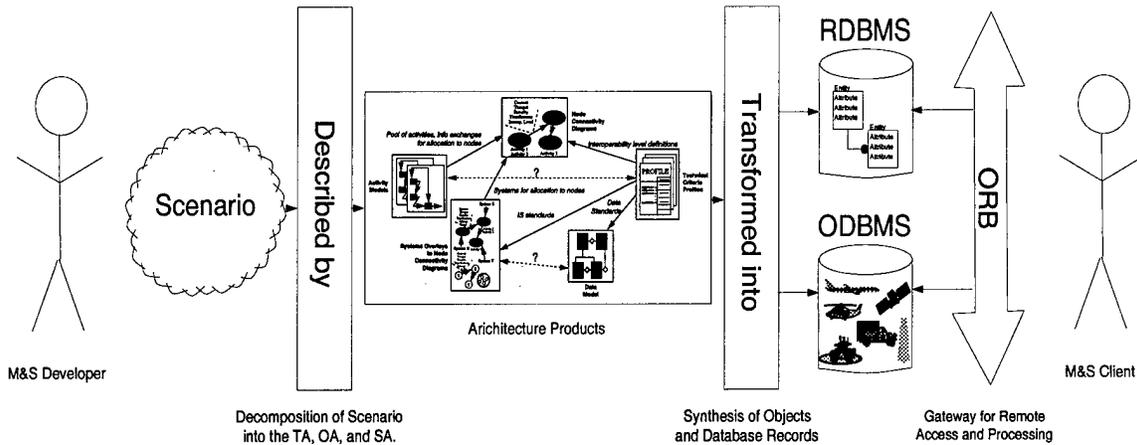

Figure 1.5 From the Real-World Scenario to the Distributed Simulation Architecture

derived for storage in databases. The information and objects in these databases can then be accessed over the Internet using an Object Request Broker. By implementing this development process and distributed architecture, simulations will meet the portability, interoperability and reuse requirements described in the DoD Modeling and Simulation Master Plan (DoD 5000.59-P) and the Defense Modeling and Simulation Office (DMSO) High Level Architecture (HLA).

#### 1.4 General Approach

*1.4.1 Develop the Model.* The antenna example is modeled by describing its technical characteristics, activities, and the internal and external relationships of the system. The information required to describe the antenna's technical characteristics is modeled in an Entity-Relationship (ER) diagram according to the IDEF1X design method. An example of an ER model is shown in Figure 1.6.

The ER model captures non-transitory data requirements and relationships describing the system. The functions of the system must then be described in an activity model according to the IDEF0 design method. An example of an activity model for a mobile radiowave propagation path is shown in Figure 1.7. The examples are simplistic to give the reader without a background in

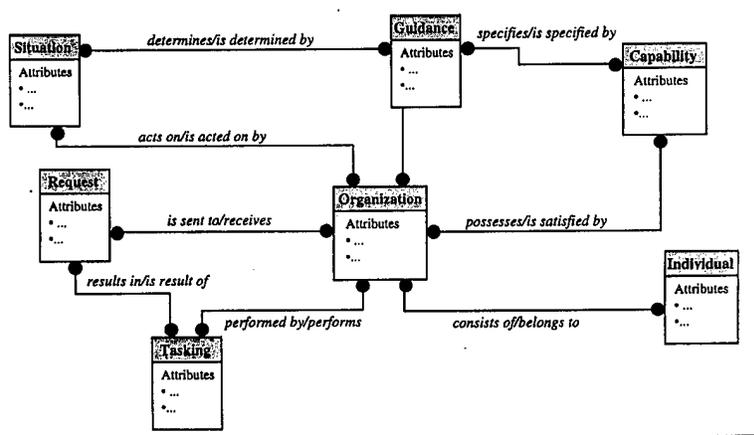

Figure 1.6 Example of an IDEF1x Entity Relationship Model

IDEF modeling an idea of what type of information is captured in each model. IDEF models are further described in Chapter 2.

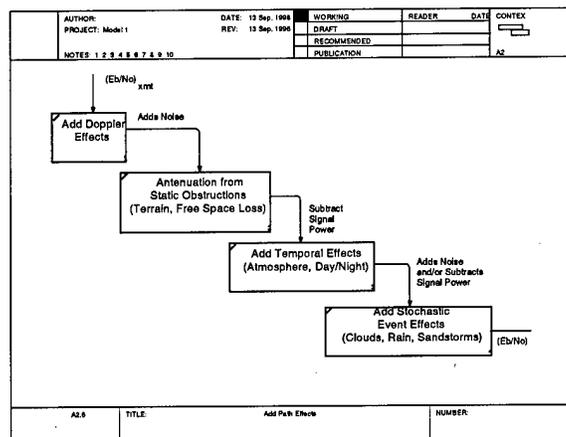

Figure 1.7 Example of an IDEF0 Activity Model

Once the antenna's technical characteristics have been described in the IDEF1X model, they are mapped to the schema of a relational database. Each entity (table) in the database is populated by instances of particular antenna configurations. For example, the OE-254()/GRC Antenna Group is one instance of an antenna, and the antenna entities' attributes are populated using data from MIL-A-49204A, ANTENNA GROUP OE-254()/GRC and Training Circular 24-24, Signal Data

References: Communications-Electronics Equipment. Many antenna configurations can be represented in a relational DBMS in this way, each identified by a unique set of attribute values.

*1.4.2 Develop Simulation Object.* An executable antenna object is created based upon the IDEF0 activity model. The object is written in an object-oriented language such as ADA, C++, or JAVA. A data sublanguage such as SQL is used to access the data stored in the relational database. The compiled object and any associated objects such as images or sounds are then stored in an object database. This method is chosen to take advantage of the well established relational model for data handling, and to maintain independence between the data and the object. Therefore, the object does not need to be recompiled for minor changes in data values.

An additional advantage to using an object-oriented programming language is the ability to embed objects within objects. For example, a super object could be created which would perform the functions of the airborne sensor and have embedded links to other objects. The links would call other objects which would, for example:

- list the technical references (TA),
- open a graphic of the operational architecture (OA),
- open a graphic of the system architecture (SA) and,
- retrieve model validation documentation.

Each of these embedded objects could also contain other embedded objects or links. This concept of a super object is illustrated in Figure 1.8.

*1.4.3 Develop Simulation Network Architecture.* These objects would be available to the M&S community over the Internet by an implementation of the Object Management Group's CORBA. A database connectivity bridge to the database(s) where the objects and data are stored would also be required. The complexity and modularity of C4I systems makes object-oriented

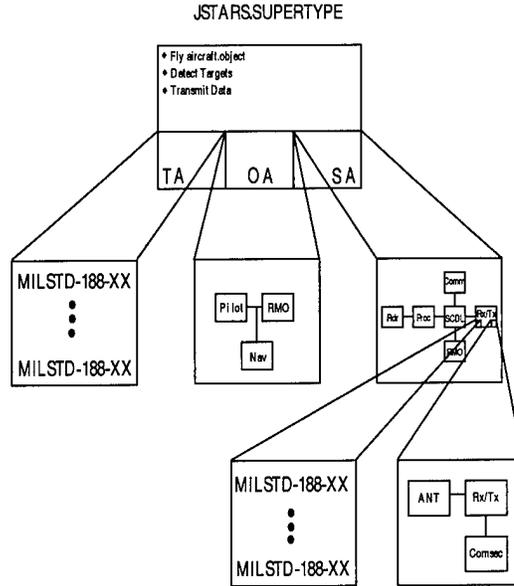

Figure 1.8 Linking and Embedding Objects

modeling and database technology an obvious approach. This approach takes advantage of the distributed nature of the Internet; the interactive, multimedia, and security capabilities of object-oriented databases; and the data handling and security capabilities of relational databases.

### 1.5 Thesis Organization

This chapter identifies the problem and its scope. Chapter 2 highlights published results which are synthesized to accomplish the goals of this thesis. Chapter 3 elaborates facets of the methodology and describes the process of employing the methodology to solve the problem. Chapter 4 reports the results and importance of the outcomes achieved by this research. Chapter 5 summarizes the problem and the results of this effort and makes recommendations for further research.

## *II. Background*

### *2.1 Introduction*

The first chapter presents a brief explanation and context for the problems faced by developers of C4I systems simulations. These problems are described as disparate simulations which cannot interact with each other, simulation objects which are not standardized among simulations, and simulations which do not account for the fragilities of the communications backbone. The recommended methodology to solve these problems is illustrated by developing an OE-254()/GRC Antenna model and executable simulation object which can be accessed over the Internet using distributed databases and a CORBA implementation. The purpose of this methodology is to ensure standardized, consistent, simulations which can interact with each other; regardless of differences in underlying programming languages or operating systems. This chapter presents background material essential to understanding the methodology described in Chapter Three and the analysis of the results in Chapter Four.

A clear approach to developing standardized models is to describe systems in a standardized way. A system can be described by its technical characteristics and constraints, by its role and function in a larger activity, and by its construction and components. Each of these views provides a unique description of the system. The Defense Information Systems Agency (DISA) and the Office of the Director of Information Systems for Command, Control, Communications and Computers (ODISC4) have defined three architectures which describe C4I systems: the technical, operational, and system architecture. These three architectures together completely define the system and form the basis for the system model. ODISC4 has adopted the IDEF model method to capture and communicate the operational architecture of the system. The IDEF models serve as tools to develop executable simulation objects and map relational and object-oriented databases. The Internet provides the infrastructure to access and process the simulation object and system definition over a distributed network. The following topics are covered in this chapter: 1) The

technical, operational, and system architectures, 2) IDEF modeling, 3) Integrating the three architectures into an executable simulation, 4) Distributed databases and the Internet, and 5) The three-tiered network architecture.

## 2.2 The Technical, Operational, and Systems Architecture

Figure 2.1 illustrates the relationship between the three architectures. Primary inputs to the systems architecture are the operational architecture (defining the process and task flows, logical connectivities and performance bounds to be supported) and the technical architecture (defining the protocols and standards mandated for use to ensure interoperability and seamless connectivity between these component systems). The technical architecture provides the “building code” to the systems architecture(29).

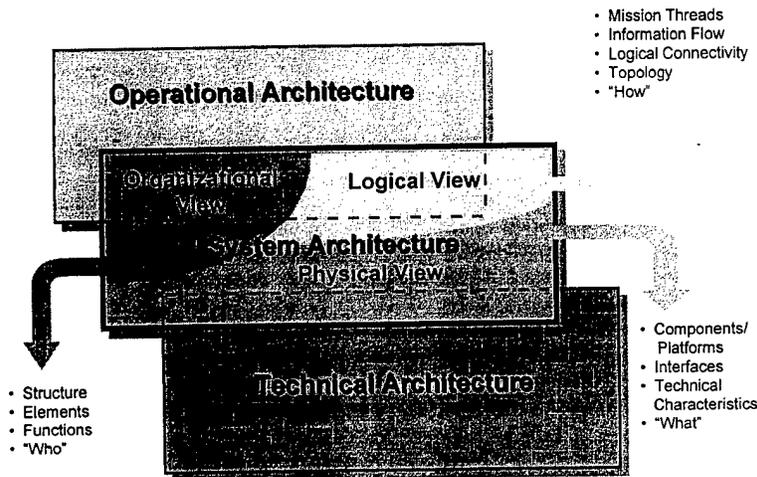

Figure 2.1 Architecture Interfaces (29)

Figure 2.2 illustrates the development of the systems architecture from the operational architecture within the constraints (i.e., “under the umbrella”) of the technical architecture. The operational architecture is developed in concert with the US Army Training and Doctrine Command (TRADOC) schools and centers and consequently incorporates current doctrine. The operational architecture describes the information exchange requirements, force structure, movement

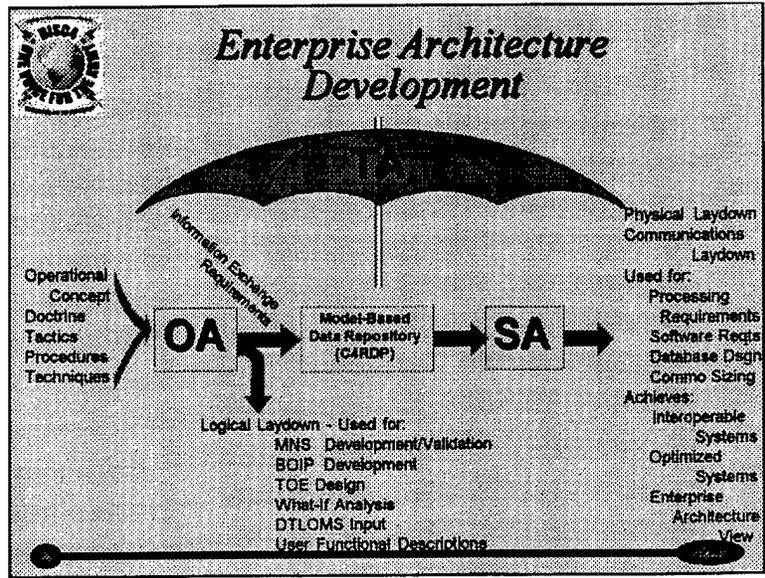

Figure 2.2 Systems Architecture Development (29)

plans, and logical connectivity among organizations and personnel. These are necessary inputs to the system architecture. This information captures connectivity requirements, informational content of exchanges, frequency, speed, perishability, impact of failure and security requirements. The model-based data repository (C4RDP, now known as the C2 Core Data Model (C2CDM) ) serves two purposes: 1) it provides standardization of model entities and 2) it takes the product of the operational architecture as an input, and transforms it to the format of the representation needed as input to the system architecture. The system architecture then overlays system solutions to the information requirements to produce the physical and communications structure. In short, the operational architecture represents the information exchange perspective, and the resultant system architecture captures how the hardware and software support those needs.

*2.2.1 Operational Architecture.* The operational architecture describes who needs to exchange information, what information needs to be exchanged, and how that information will be used. This architecture describes the functions, processes and data required to meet the needs

of the warfighter. The operational architecture is captured and communicated using the IDEF modeling methods described in Federal Information Processing Standards (FIPS) 183 and 184.

The IDEF0 method is used to specify function models, which are “what do I do” models. The IDEF0 models let the modeler portray a view of the process using inputs (I), controls (C), outputs (O), and mechanisms (M) (referred to as ICOMs). *Inputs* to an activity consist of resources consumed or transformed by a process and state outputs from other activities. *Controls* are the standards, policies, and guidelines that constrain and guide the process. *Outputs* are the products created by the transformations of the inputs by the process. *Mechanisms* are the agents (people, manual tools, automated tools, etc.) that accomplish the actions delineated within the process. Once these blocks are defined, their relationship to the process and the “flow” of the input through the controls and mechanisms to its final output must be defined(15, 26). An example of an activity model for a radio path is illustrated in Figure 2.3.

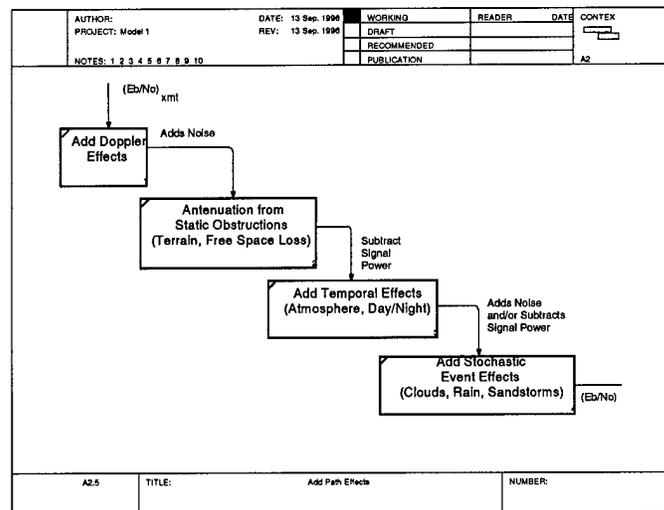

Figure 2.3 Example Activity Model (IDEF0)

The IDEF1X method is based on an ER model(25) and used for data modeling. It captures the logical view of the activity’s data. It is a method for logical database (library) design once the information requirements are known. The focus is on the actual data entities, their attributes, and



their relationships to other entities in the information system to be developed. This description of the system supports the development of the operational component and system modules once the primitive ICOMs have been defined(15, 25, 21, 8). An example of an information entity relationship model is illustrated in Figure 2.4.

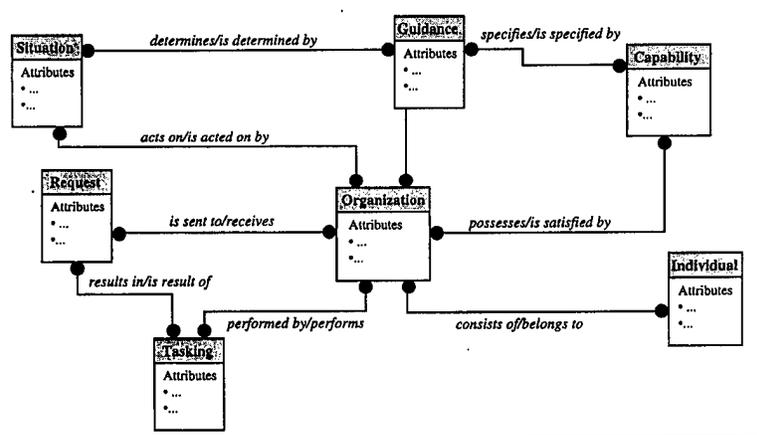

Figure 2.4 Information Model

Therefore, we can take a scenario, or an operational concept, and break it into its functional (IDEF0) and physical architectures (IDEF1X). An operational architecture is obtained by mapping a functional architecture onto a physical one, *for a given operational concept* (Figure 2.5). The operational architecture shows the allocation of resources to functions, the flow of data, and the order in which functions are performed(3).

The operational architecture is then used to(12, 5):

- Conceptualize operational requirements
- Identify unsatisfied requirements
- Prioritize requirements
- Plan evolution of systems
- Develop data standards

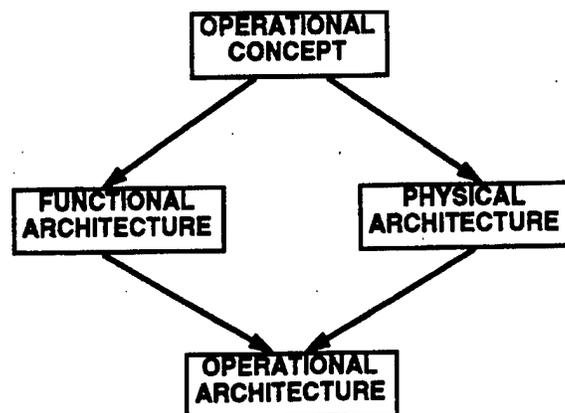

Figure 2.5 Operational Architecture Development (29)

- Measure resource utilization
- Identify interoperability requirements
- Drive the technical architecture

*2.2.2 System Architecture.* The system architecture shows the specific hardware needed and network topology to provide the connectivity required in the operational architecture. Both architectures are very closely linked. The system architecture is a description of the physical connectivity of an information system, which includes: identification of all equipment (radios, switches, terminals, computers, inter-networking devices, and local area nets (LANs)), their physical deployment, the specification of such parameters as the bandwidth required on each circuit, and the description of the technical characteristics and interconnection of all parts of an information system(5). The system architecture is made up of the top-level diagram in the network model or simulation and each successive component-level diagram in a top-down system of systems model.

The system architecture permits trade-off analysis to optimize overall network and system performance within the performance bounds defined in the operational architecture(5). This top-level view of the information system indicates to the mission and network planner when the system is meeting performance requirements or when new requirements or unsatisfied requirements must

be addressed. The requirements in the operational architecture drive this feedback to the planner. However, the system diagram must also identify the impact on the operational architecture as the system degrades as well as the component(s) in the technical architecture which are restricting the system performance. This architectural relationship is illustrated in Figure 2.6 (5, 29).

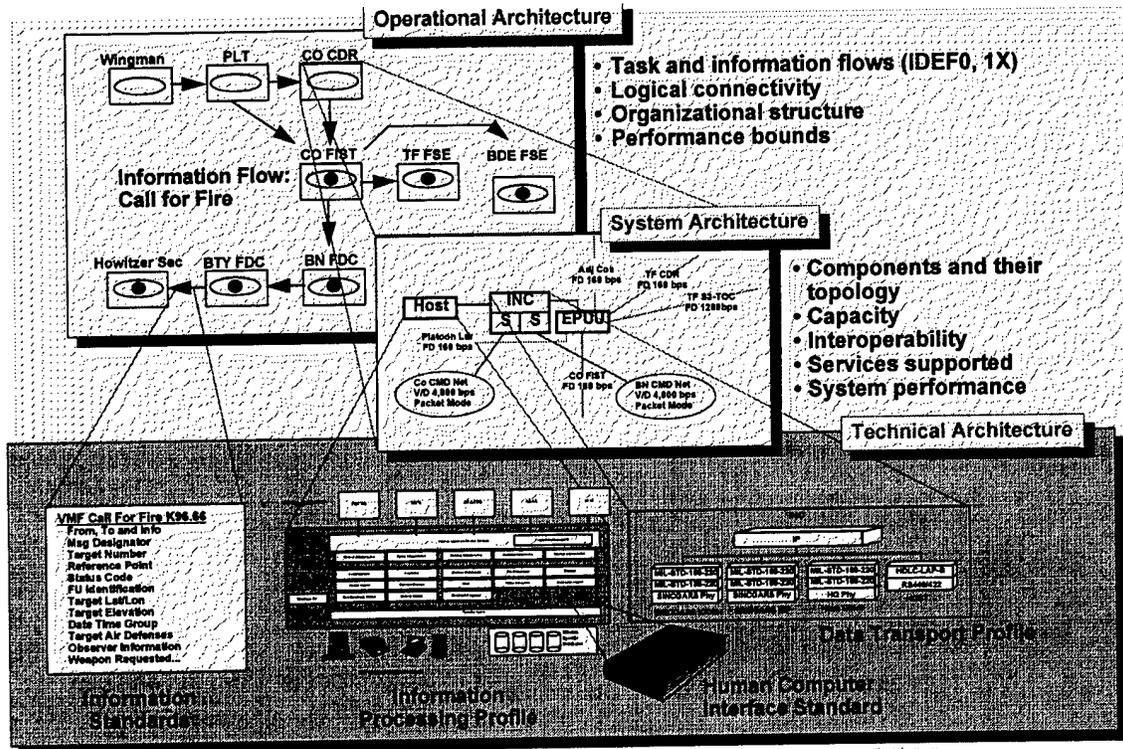

Figure 2.6 Architecture Relationships (29)

**2.2.3 Technical Architecture.** The technical architecture is defined as a minimal set of rules governing the arrangement, interaction, and interdependence of the parts of an information system. The technical architecture does not say what to build (that is defined by the planner in the operational architecture), nor does it say how to build (that is defined by the planner in the system architecture), but it does say that when you build you must adhere to the set of rules/protocols/standards that it specifies. The standards in the technical architecture establish the

framework for achieving interoperability and commonality among component hardware/software and seamless communications connectivity between battlefield elements(5).

The technical architecture provides the "building code" for the systems architecture to meet the requirements in the operational architecture. It addresses the technical aspects of how to integrate the command, control, communications, computers and intelligence (C4I) systems to achieve the operational requirements set forth by the operational architecture. The technical architecture establishes the spectrum of available and approved system implementation options. The technical architecture therefore consists of standards which can be referenced (i.e., COE, C2CDM, use of ADA, HCI standards, MILSTD-188-220 and VMF)(5) and standardized components which meet these technical standards. Upon completion, the technical architecture identifies a frame of standards and includes top-level system specifications, architecture wiring diagrams for technical interface specifications, identification of transactions between equipment and the protocols used in this interface, and supporting performance and modeling results(12).

The Army technical architecture consists of four elements: 1) the information processing profile, 2) the information transport profile, 3) information standards, and 4) human-computer interface (HCI)(35). The information processing profile details standards consistent with commercial and Department of Defense (DoD) Technical Architecture Framework for Information Management (TAFIM)(10). It provides guidance for developing technical information system architectures at all organizational levels of DoD environments that share functions and data. The information transport profile defines the communications support required to provide seamless, reliable, and timely data exchange between users, regardless of the specific communications system(s) used to access the network infrastructure. A communication system conforming to the Open System Interconnection (OSI) Reference Model is an example of this type of information system. Information standards, such as standardized data elements and message format standards, provide the basis for sharing information across gateways using common interfaces. These standards are recorded in

DOD 8320.1 series guidance (Standard Data Elements for Automated Information Systems (AIS) Design and Development), Military Standards (MIL-STD), and commercial Internet standards. Most notable examples for military systems standardization are the Protocol Data Unit (PDU) and the LINK16/Variable Message Format (VMF) (replacement to the United Service Message Text Format (USMTF)). Finally, standardizing the HCI to attain a user interface that presents a common appearance and behavior across joint service systems requires a common set of HCI standards and a common approach to implement them. Volume 8 of the DOD TAFIM contains the DOD HCI Style Guide. This style guide sets the basic standards for graphical HCIs.

The technical architecture describes the major aspects of(12):

- Functions which must be performed to meet required operational capabilities
- Information (e.g., databases, data elements and data definitions, images, sound, text, etc.)
- Applications (e.g., E-Mail, maps, targeting systems, data collection systems, control systems, mission planning systems, office tools)
- Technology (e.g., hardware, systems software, standards, protocols, and communications)

The antenna described in the previous section has predetermined technical architecture constraints and requirements. Once these standards are captured and represented in the IDEF models of the operational architecture, the information can be stored in a model library or repository. If the technical architecture does not allow the system to meet the operational requirements, the operational requirements must be changed. For example, a network planner may be using the antenna in a communications network. However, the antenna may not have the gain required (as set by the technical architecture) to meet link margin requirements across a specific path in the network. A common change to the system architecture by the network planner to maintain satisfactory performance in the network is in the network topology. For example, a platform may move from communicating by one means (e.g., LOS) to another (TACSAT, SATCOM) or the size of the network may be altered by adding or dropping nodes to increase reliability. If the network

cannot be modified to maintain communications while meeting the requirements of the operational architecture, the operational architecture must be examined to measure the effect of a loss of communications. The result may be a different tactic or a new requirement. Finally, an operational requirement may be met through an improvement in the technical architecture which removes a constraint that prevented the performance of the system from meeting the operational requirement. The interrelationships of the architecture products discussed in this section are illustrated in Figures 2.7 and 2.8.

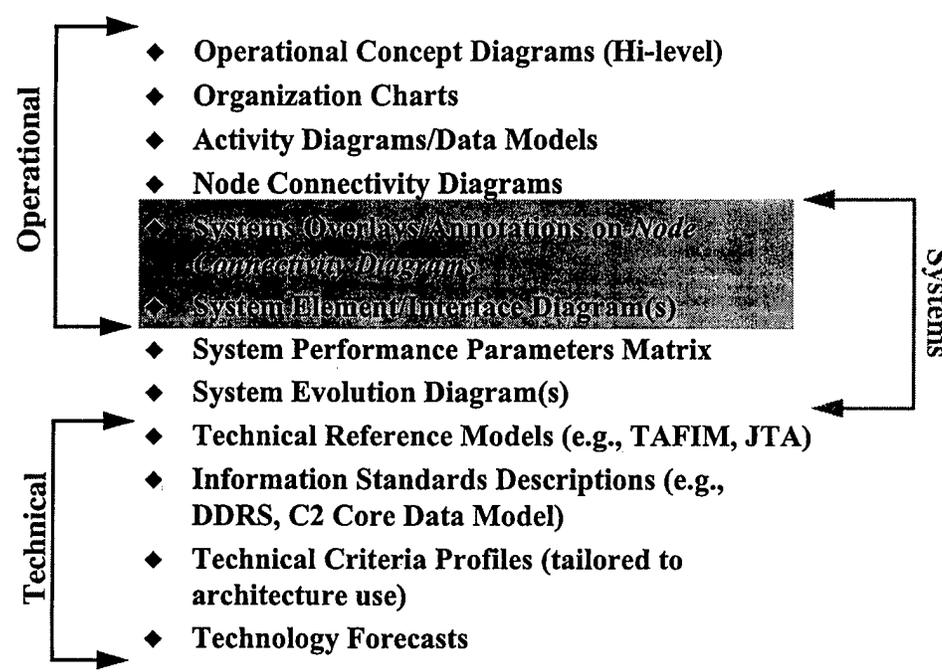

Figure 2.7 Architecture Products (29)

### 2.3 Integrating the Three Architectures into Executable Simulation Objects

The requirements for the distributed simulation architecture are similar to the requirements described in the Information Mesh project by Sollins of MIT and Dyke of Trilogy Development Group for a General Information Architecture. The General Information Architecture lays out a common, extremely general substrate that sits between network-based systems such as distributed

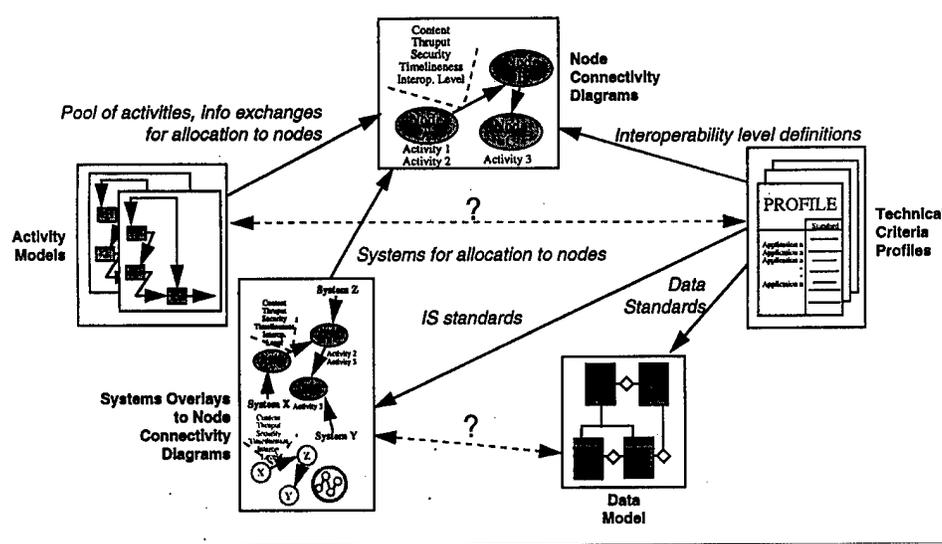

Figure 2.8 Architecture Product Interrelationships (29)

programming or database environments and network transport protocols such as TCP or other bit stream protocols. The intention of the information mesh is to provide sharing and exchange of potentially persistent information independent of the underlying platform operating systems, programming languages, transport protocols and related infrastructure. Although the methodology uses the Object Management Group's (OMG) CORBA, the requirements of the General Information Architecture are identical to the requirements for the distributed simulation network and are listed here(33):

- *Multiplicity.* One must be able to express relationships between two or more objects.
- *Link Typing.* It is important to be able to express the nature of a link or relationship extensively and with unlimited scope, in order to support evolution in the representation of knowledge.
- *Linking into the structure of objects.* In order to provide generality and flexibility in linking objects, it is necessary to be able to link components, aspects, views, or parts of objects to each other.

- *Linking to links.* There are situations in which the ideas being linked may be themselves links. We must be able to relate to links.
- *Composition of objects.* Relationships can be divided into those that are intrinsic or integral to an object and those that are not. If a relationship is intrinsic to an object, that composite object is unable to behave in the intended manner without its components. In contrast, other extrinsic relationships do not have a direct bearing on whether or not the related objects behave as expected. It is important to be able to express this distinction and support composite objects.
- *Support existing models of linking.* Existing systems define the minimum set of characteristics we must be able to support.

The links and composition of objects are the relationships and ICOMs in the IDEF models discussed in previous sections. These links and relationships can then be encoded into objects through the methods and data sublanguage of an object-oriented programming language. The objects can then be stored in an object-oriented database and the data values in a relational database. The advantage to this independence is being able to alter data values without having to recompile objects. The disadvantage is they must be managed jointly, so if the antenna object was deleted from the object database, the antenna records or tables would also need to be deleted from the relational database. This weakness is resolved by using a multi-database management system (MDBMS). An MDBMS would manage relational **and** object-oriented databases, or a hybrid database which combines the two. A great degree of research is currently being conducted to perform this service, and some proprietary systems have been produced to varying degrees of success(36). However, for the purposes of this research, the databases must be carefully managed by the Database Administrator to ensure they are kept current.



## 2.4 Distributed Databases and the Internet

Having the data and objects needed for a simulation stored in databases is only useful if they can be called and executed by any user, even when non-located with the system hosting the objects. Relational database management systems (RDBMS) are commonly accessed remotely through a client/server architecture today (see Figure 2.9)(2). These applications are often proprietary and operating system specific. However, the recent introduction of open database connectivity (ODBC) applications such as SQL\*Net have allowed clients to connect to different vendors' SQL databases over networks, independent of the client's operating system (O/S) platform.

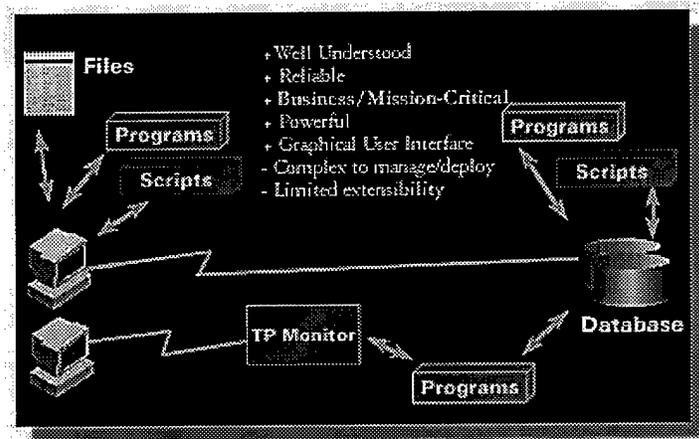

Figure 2.9 Today's RDBMS Client/Server (2)

Object-oriented database management systems (ODBMS) are also accessible in the same manner as relational databases(20, 19) (see Figure 2.10). The object-oriented database provides the capability to store compiled object-oriented programming files and multimedia data types that relational databases cannot. By combining the use of object-oriented databases and relational databases, a multidimensional database is created that is transparent to the client. An example of this multidimensional database system is shown in Figure 2.11.

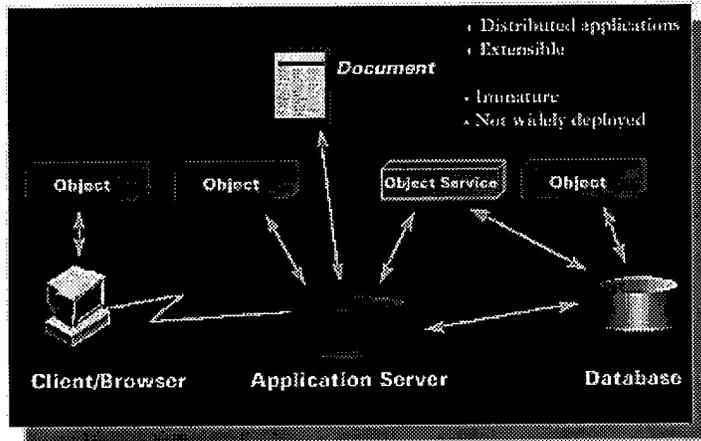

Figure 2.10 Today's Object DBMS Client/Server (2)

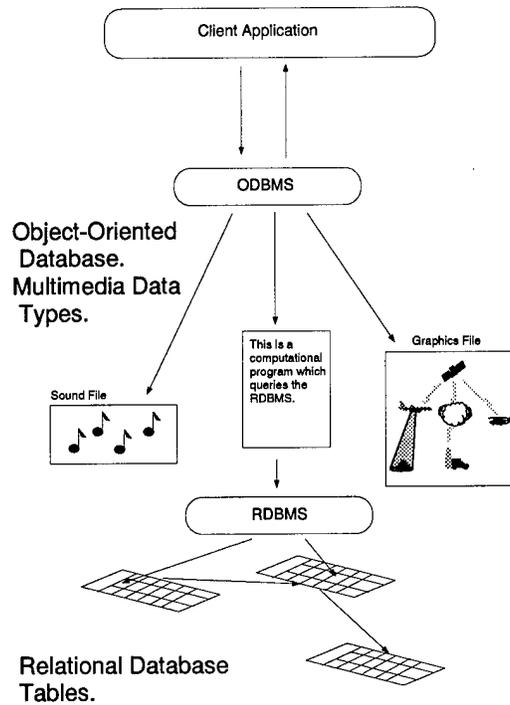

Figure 2.11 Multidimensional Database Example

The desire for the ability of a single client application to access more than one database motivates the creation of distributed databases. A properly implemented distributed database system has the following characteristic(11):

... full support for distributed database implies that a single application should be able to operate transparently on data that is spread across a variety of different databases, managed by a variety of different DBMSs, running on a variety of different machines, supported by a variety of different operating systems, and connected by a variety of different communication networks—where the term *transparently* means that the application operates from a logical point of view as if the data were all managed by a single DBMS running on a single machine.

In a distributed database system, the client may access a remote object database and retrieve a program which calls data from another remotely located relational database. The program may be processed at the client's machine, the local host, or on a remote host, meaning not only is the information distributed, but the processing is also distributed. This sharing of information and processing has the advantage of using resources efficiently, if managed properly. An example of a distributed database system is shown in Figure 2.12

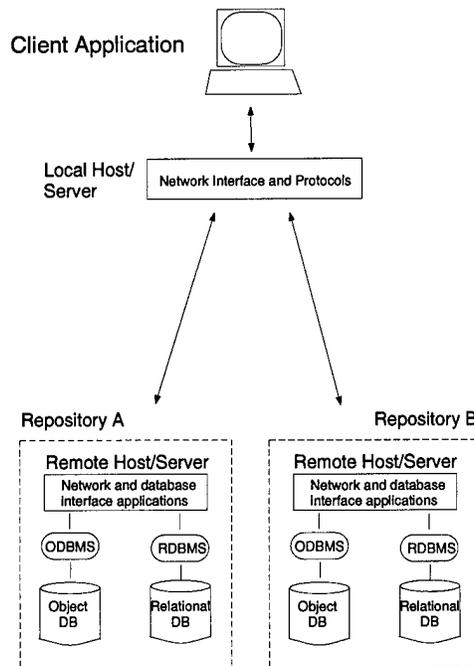

Figure 2.12 Distributed Database Example

## 2.5 The Three-tiered Network Architecture

The client/server terminology of the past becomes vague when discussing distributed systems over the Internet. The client in one transaction could be the server for a client in the next transaction. Therefore, the requester for any transaction is considered the client and the applications making the request and providing the user interface are considered the front-end or client side. The applications which retrieve the information requested by the client are considered to be the back-end. An example of a back-end application is the database management system (DBMS). The software that acts as an intermediary between the client's application program and the DBMS is called *middleware*(7). An example of such middleware is the ODBC. This grouping of the software with some examples shown is illustrated in Figure 2.13

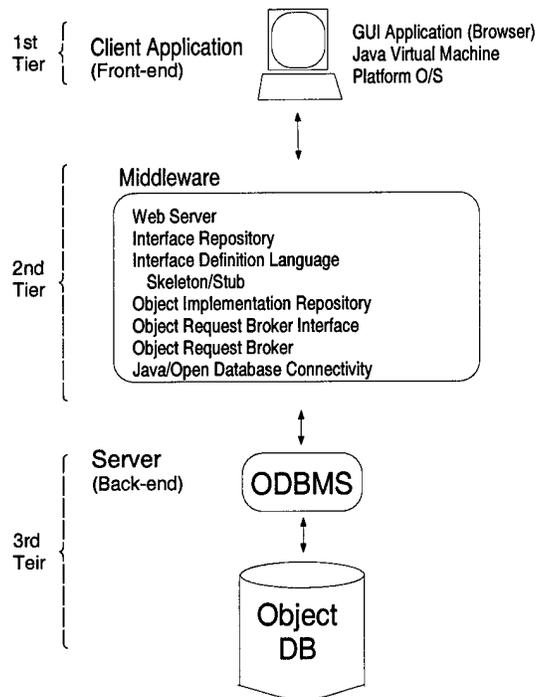

Figure 2.13 Three-tiered Architecture Example

## *2.6 Summary*

This chapter has provided an overview of the operational, technical and system architectures used to model C4I systems. Additionally this chapter describes and motivates the terminology and structure of the Internet architecture which allows interoperability and portability of objects and data, via IDEF modeling, relational and ODBMS, as well as the OMG CORBA standard. The next chapter describes the antenna model and object, creating relational database tables to store the persistent data identified in the antenna IDEF1X model and storing the object-oriented antenna program in an object database. The structure of each tier is then developed to allow the antenna object to be accessed and implemented as part of a client's simulation application.

### III. Methodology

#### 3.1 Introduction

The first chapter presents a brief historical background of the problems faced by simulators of C4I systems, and states the problem to be solved. The second chapter presents background material essential to understanding the solution presented in this chapter and the analysis of the architecture in Chapter Four. This chapter presents the methodology used to develop the models, executable objects and distributed architecture for distributed simulations.

#### 3.2 Developing the Operational Architecture

The ER model and activity model are developed jointly to describe the operational architecture. Although each can be developed independently, the process of developing them jointly serves to check that each is complete. Later, when the antenna model is used to develop relational database tables, and object-oriented code, the advantage to developing these IDEF models jointly will become obvious.

In this thesis, the illustrative scenario is defined as the reception of a message using an OE-254()/GRC Antenna Group and compatible receiver. The modeler should identify the agents in this scenario as an antenna, receiver and radiowave propagation path. The receiver object which will require information from the antenna and a path object will pass information to the antenna (see Figure 3.1).

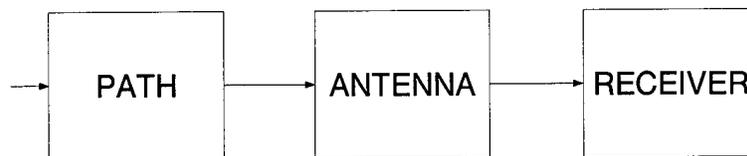

Figure 3.1 Information Flow Diagram

Recall from Figure 1.4, the path is not assumed to be degradation free. To determine if the message was received in a simulated transmission, the link margin is calculated given a required bit energy per noise power spectral density. The link margin is calculated using the Equation 3.1 (see appendix C):

$$M = \left( \frac{E_b}{N_o} \right)_{recvd} - \left( \frac{E_b}{N_o} \right)_{reqd} \quad (3.1)$$

where  $M$  is the link margin,  $E_b$  is the bit energy,  $N_o$  is the noise power spectral density, and all quantities are in dB.

*3.2.1 Developing the Entity Relationship Model.* IDEF1X is used to produce a graphical information model which represents the structure and semantics of data relevant to an enterprise or system. This model can then be used to develop relational databases which contain the information used by simulation objects, and the embedded SQL code for the host simulation language. Each block in the IDEF1X model represents an entity. An entity represents an item of interest to the modeler from a "relational" perspective. An entity is described by a set of attributes. An attribute is a property or characteristic that is common to some or all of the instances of an entity. An attribute draws legal values from a natural or prescribed domain of values, consistent with the system and scenario being modeled. A domain is a named set of data values all of the same data type, upon which the actual value for an attribute instance is drawn. Every attribute must be defined on exactly one underlying domain. Multiple attributes may be based on the same underlying domain.

Often, entities in the real world are related to other entities. For example, one entity may be the component of another entity. A relationship is an association between two entities or between instances of the same entity. It is important to identify the relationships between entities. The relationships are part of the definition of the system and help to properly manage and access

information about the system which may be stored in many entities. IDEF1X models can become quite large as entities and relationships are identified, as shown in the JDBE ER antenna model in Appendix A, but a simple model for this scenario is shown in Figure 3.2 (25).

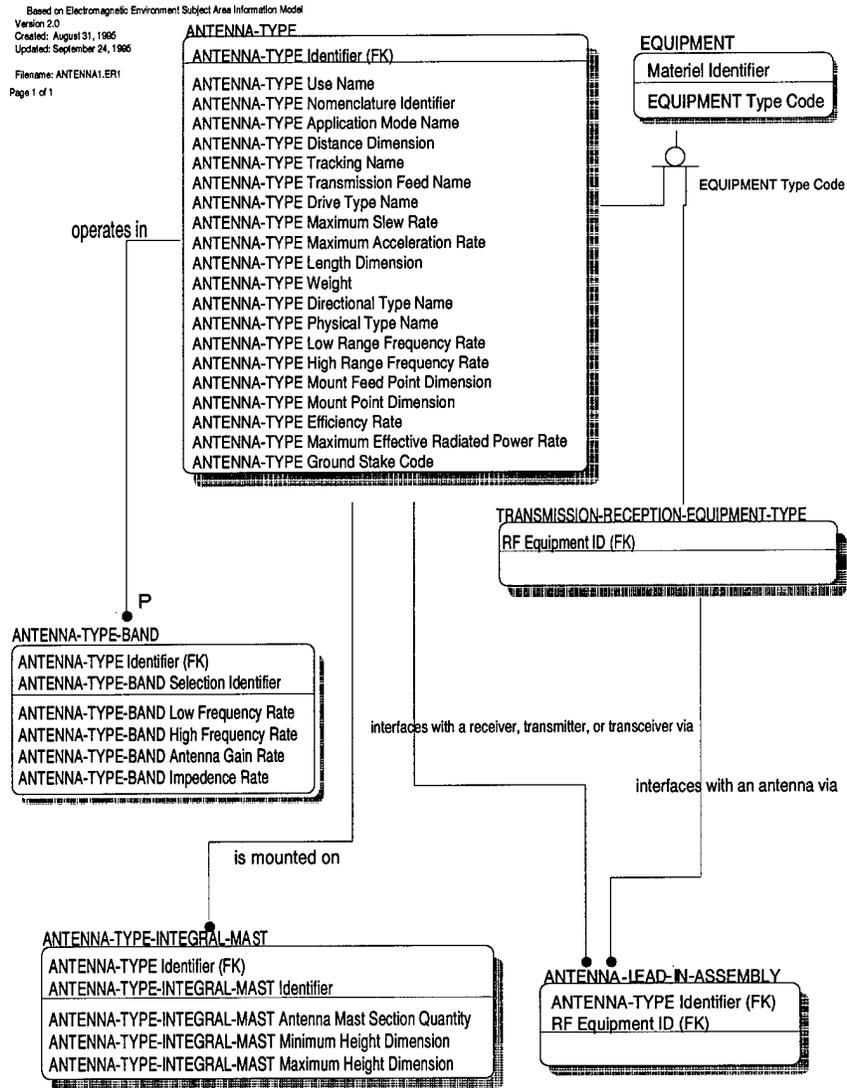

Figure 3.2 IDEF1X Antenna ER Diagram

The IDEF1X diagram supports defining relational database elements which are populated with instances and values representing the real world system being modeled. For example, the



ANTENNA\_TYPE table for the OE-254()/GRC is shown in Figure 3.3. All the attribute values represent the persistent data of the antenna system of interest for the level of abstraction required by the scenario (all lengths and distances are in meters, and all weights are in pounds).

ANTENNA-TYPE	
Material_ID	5985-01-063-1574
ant_use_name	transmit and receive
Ant_Nomenclature	OE-254()/GRC
Ant_Application	linear
Ant_Distance	13.70
Ant_Tracking	manual
Ant_Transmission	coax
Ant_Drive_Type	
ant_max_slew_rate	
ant_max_accelerati	
ant_length	0.16
Ant_Weight	45
ant_direction_type	OMNIDIRECTIONAL
Ant_Physical_Type	CONICAL-SPIRAL
Ant_Low_Freq	30
Ant_High_Freq	88
Ant_Mount_Feed	10.30
Ant_Mount_Point	5.15
Ant_Efficiency	.75
Ant_Max_ERP	350
Ant_Ground_Stake	Y

Figure 3.3 ANTENNA\_TYPE Table for the OE-254()/GRC

Each table captures the persistent data from the technical specifications and operational architecture products (refer to Figure 2.7) relating to the OE-254()/GRC antenna and relevant to the scenario provided. However, the relational database is not an executable system and does not capture the process, function, or activity of the antenna. For this purpose, the IDEF0 activity model is developed.

*3.2.2 Developing the Activity Model.* The IDEF0 model begins with only one block identifying the complete activity; this is the top-level diagram (Figure 3.4) (26).

The single function represented on the top-level context diagram is decomposed into its major sub-functions as shown in Figure 3.5.

These diagrams describe the basic functions of the antenna required to calculate the link margin based on the scenario provided.

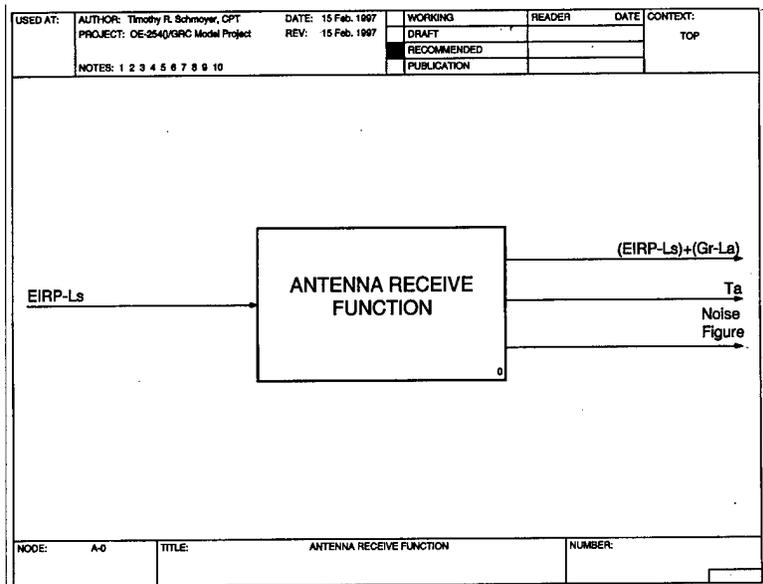

Figure 3.4 IDEF0 OE-254/GRC Top-level (A-0) Diagram

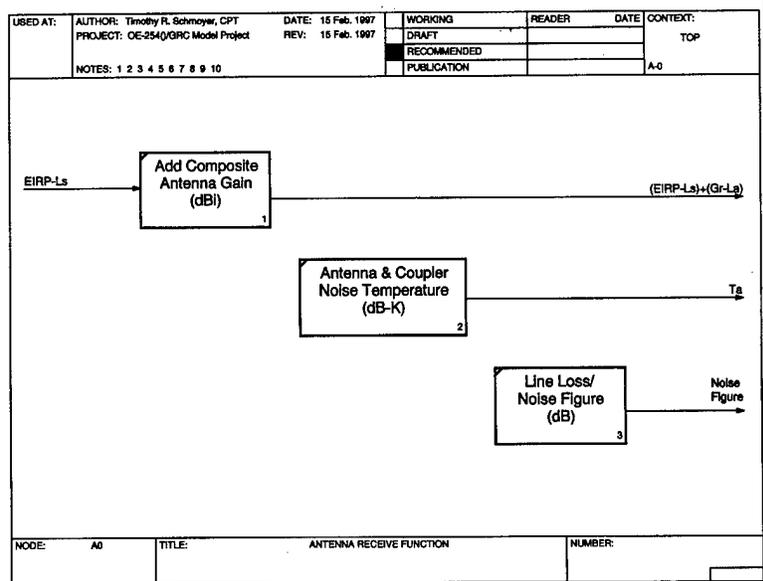

Figure 3.5 IDEF0 OE-254/GRC (A-0) Child Diagram

### 3.3 Integrating the Technical Architecture

The activity model presented in the last section describes the basic functions of the antenna; however, the *constraints* of the technical architecture have not been included. For example, the frequency range of the antenna is specified to be between 30 and 88 MHz by the technical architecture. To achieve operational realism, it would be useful to verify that the signal received across the path has a center frequency in the specified range. A similar constraint could be added to verify that the receiver uses the same frequency range as the antenna and that it is a type of receiver which can use the OE-254()/GRC antenna system. These constraints are included in the activity model as *f* and Receiver-Type, as shown in Figures 3.6 and 3.7 (see Appendix B for IDEF0 model documentation).

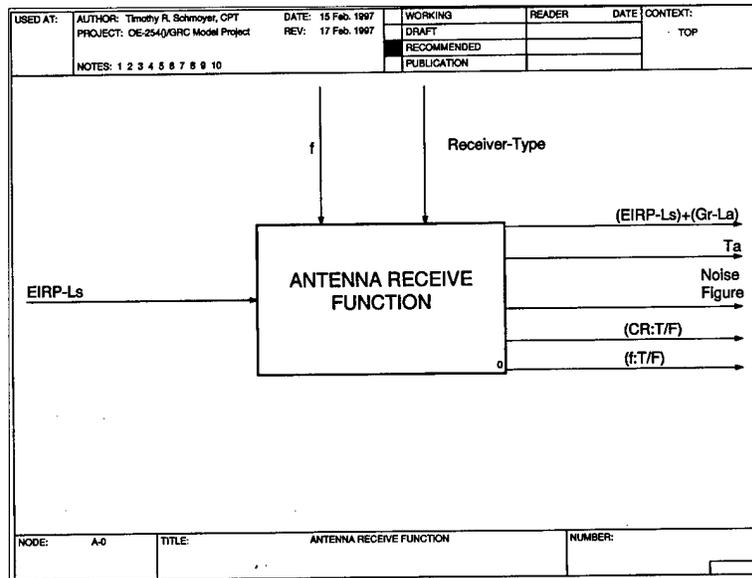

Figure 3.6 IDEF0 OE-254/GRC (A-0) Diagram with Constraint

These constraints ensure that incompatible radio systems with different frequency ranges are not connected across the path in a model, or if they are, the simulation does not allow the radios to communicate.



**OE-254()/GRC  
Antenna Group**

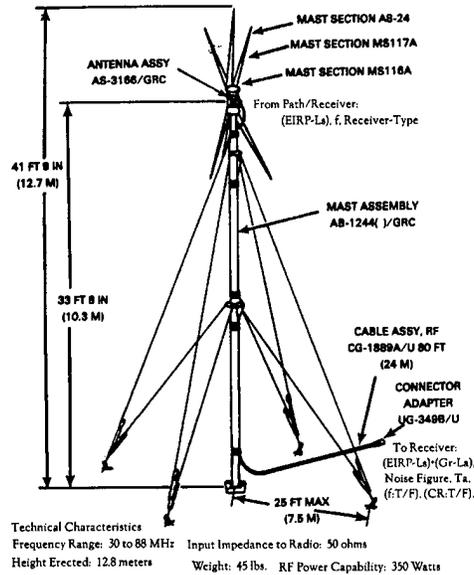

Figure 3.8 System Architecture of OE-254()/GRC Antenna System

3.5 Coding the OE254\_Path Object/Applet

The OE-254()/GRC antenna model is then coded as an executable object using an object-oriented programming language. The executable applet can be referenced from a client's GUI application and implemented at run-time as a complete simulation, or as part of a larger simulation. The object-oriented language chosen is not important, since the Common Object Request Broker Architecture discussed later will allow objects written in different languages to communicate fluidly in a distributed simulation environment. The salient point from this discussion is the use of embedded SQL and OQL to allow the object-oriented program to access persistent objects or data and perform the computational logic over a distributed network. For example, the technical architecture constraints are enforced by using the data in relational and object-oriented databases. Therefore, the OE254\_Path antenna object would use the data in these databases to verify that the parameters it receives from the path and receiver objects are in fact valid values.

Assume an antenna class already exists and has been defined. The first step is to create and initialize the OE254\_Path object(18, 37, 11):

```
Antenna OE254_Path = new Antenna();
```

Now, to get the frequency range of the antenna from the ANTENNA-TYPE table in the Relational database:

```
/* connect to the database system using the database connectivity method, location,  
/* id, password and name of the database.  
database.connect("ODBC", "FTGORDON", "myname", "mypwd", "ANTENNA")  
if (!database.connected()) {  
write ("Unable to connect to the database.")}  
  
:  
  
/* SQL to get frequency range  
select ANTENNA.Ant_Low_Freq  
into :LowFreq  
from ANTENNA_TYPE  
where ANTENNA.Ant_Nomenclature = "OE-254()/GRC"  
  
:  
  
select ANTENNA.Ant_High_Freq  
into :HighFreq  
from ANTENNA  
where ANTENNA.Ant_Nomenclature = "OE-254()/GRC"  
/* end SQL  
  
:  
  
if (PathFreq < LowFreq OR > HighFreq) {  
write ("Received frequency is not within operating range of the antenna.")}
```

Also we want to check an array named *receivers* in an object-oriented database to verify that the receiver is compatible with the antenna(9):

```
/* SQL to get NSN of the receiver  
select ANTENNA.Material_ID  
into :OE254ID  
from ANTENNA_TYPE
```

```

where ANTENNA.Ant_Nomenclature = "OE-254()/GRC"
select RF_EQUIPMENT.Material_ID
into :Receiver
from ANTENNA_LEAD_IN_ASSY
where ANTENNA.Material_ID = OE254ID /*NSN of OE-254
/*end SQL
:
database.connect("ODBC", "FTGORDON", "myname", "mypwd", "COMPATIBIL-
ITY")
if (!database.connected()) {
write ("Unable to connect to the database.")}
:
/* OQL to check array
if (!exists Receiver in COMPATIBILITY.receivers : COMPATIBILITY.antenna = OE254ID)
{ write("Receiver not compatible with OE-254()/GRC antenna group." ) }
/* end OQL

```

The embedded query languages serve two purposes. Once the program has been written, changes to the persistent data do not require changes to the program and subsequent recompiling and linking. The reliance on the database improves data management and use of the current standardized values.

### *3.6 Storing the OE254\_Path Object in the Object Database*

The antenna object is stored in the object database with a unique object identity (OID). Object identity is the property of an object that distinguishes it from all other objects(19), even similar or duplicate objects. Each object in the database must have a unique identity for the ODBMS to recognize which object is being requested. This is especially important when many duplicate objects are being used in a scenario. For example, in a communication network, several OE-254()/GRC antenna systems may be employed. The ODBMS must be able to distinguish each duplicate object as a unique instance of an OE-254()/GRC antenna system.

Objects may be shared by other objects. For example, a graphic file with a universal antenna symbol may be shared by all antenna objects for display in a client's GUI simulation application. In some directory systems (e.g., DOS), to share a file among directories, the file must be copied to each directory. To avoid the redundancy that results and the requirement for the user to maintain consistency by making changes to each copy every time an update is made, the identity method must allow linking between objects.

Several methods are appropriate to ensure a unique OID. One method is to use the name of the object's creator, birth place of the file, and a file name. A global repository identifies each object this way, and the birthplace repository tracks the location of the file in case it is ported to another location. Type-State-Identity Trichotomy (19) is also used to uniquely identify objects. Using this method, the antenna object is identified by its class, instance and state. For example, the OE-254()/GRC antenna object is stored as OE254\_PATH and the OID "path" notation is 24thIDCmdNet/NodeE1/OpsSINCGARS/ANTENNA/RECEIVE/OE254\_PATH (see Figure 3.9). If the antenna object is copied, or ported to another location, it is still uniquely identified by changing the name of the net, node, or communication system.

### *3.7 Using a CORBA ORB to Request and Implement Objects*

The OE254\_PATH object is made available to distributed simulation clients using the CORBA shown in Figure 3.10 (27). The following sections explain the function of each component, from requesting the object in the client's simulation application through returning results to the simulation.



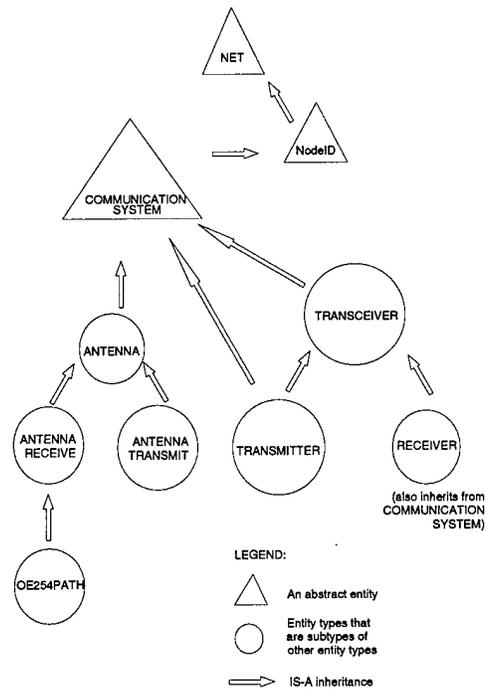

Figure 3.9 Semantic Model for a Communication Net.

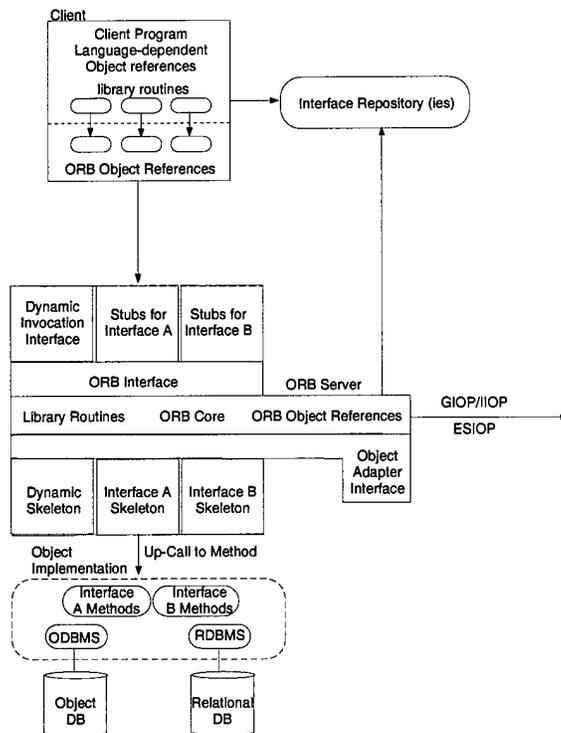

Figure 3.10 The Common Object Request Broker Architecture for a Distributed Simulation

3.7.1 *Requesting the Ant\_Path Object from the Simulation.* The simulation executing on a client requests an object using an object reference. An object reference is a token that may be invoked or passed as a parameter to an invocation on a different object. Invocation of an object involves specifying the object to be invoked, the operation to be performed, and the parameters to be given to the operation or returned from it. The client knows only the logical structure of the object according to its interface, and experiences the behavior of the object only through the object's invocation. Clients access object-type-specific stubs as library routines in their program (see Figure 3.11). The client program thus sees routines callable in the normal way in its programming language. This language-specific data type to refer to objects is often an opaque (hidden) pointer. The client then passes that object reference to the stub routines to initiate an invocation(27).

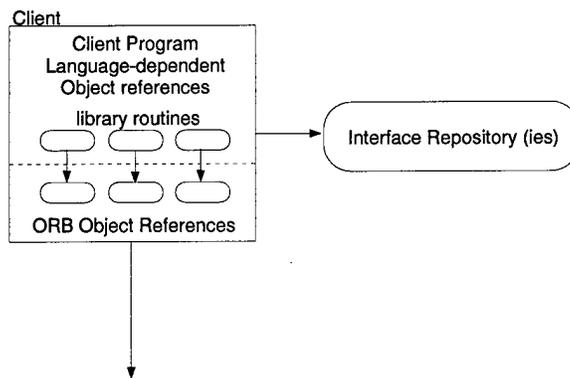

Figure 3.11 The CORBA Client Architecture

Clients generally see objects and ORB interfaces through the perspective of a GUI and language mapping. Clients have no knowledge of the implementation of the object, which object adapter is used by the implementation, or which ORB is used to access it. The client may only see drop down menus which allow a selection of resident object references (and stubs) to be chosen. In simulation and modeling software this is very common. Only after the modeler has developed the system model is the simulation code generated, compiled, and run (see Figures 3.12 and 3.13).

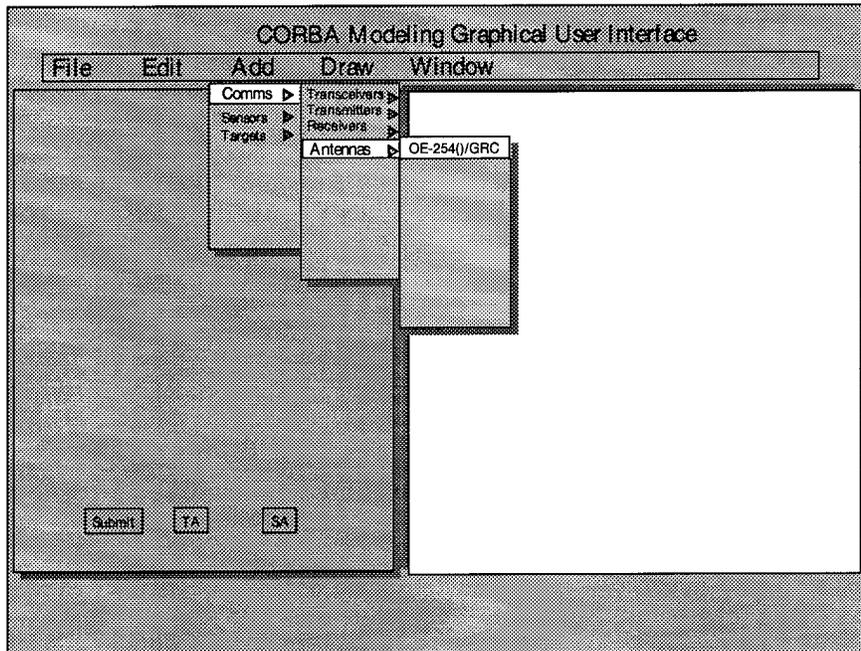

Figure 3.12 Example of a Client GUI to Select Objects for Simulation

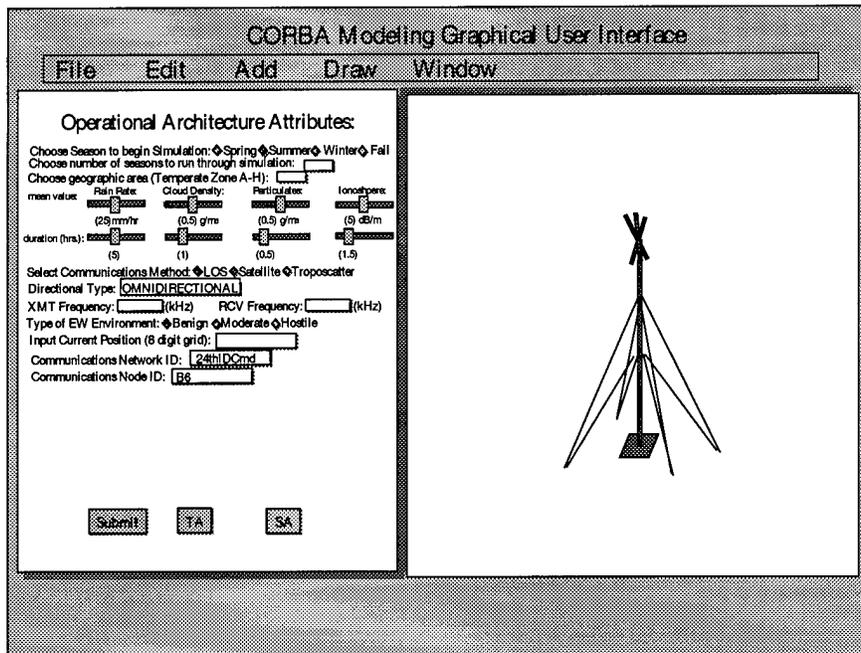

Figure 3.13 Filling in the Parameters for the Operations to be Performed

3.7.2 *Processing the Request.* The Object Request Broker (ORB) receives the request from the client through the stubs or the Dynamic Invocation Interface (DII) (Figure 3.14). The stubs have access to the object reference representation and interact with the ORB to perform the invocations. The stubs make calls on the rest of the ORB using interfaces that are private to, and presumably optimized for, the particular ORB Core. The ORB core provides the basic services of control, representation of objects and communication of requests. The operations of the ORB, which serve as an interface between the client's request and implementation of the requested object are:

- Operations that are the same for all ORB implementations
- Operations that are specific to particular types of objects
- Operations that are specific to particular styles of object implementation

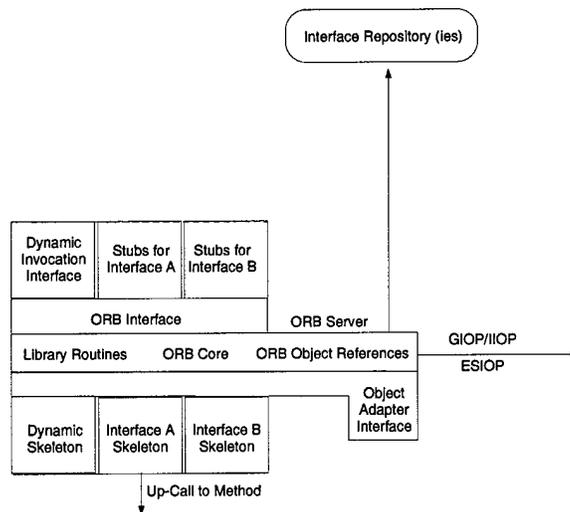

Figure 3.14 The CORBA ORB Architecture

An interface is also available that allows the dynamic construction of object invocations, that is, rather than calling a stub routine that is specific to a particular operation on a particular object, a client may obtain the information required for an object reference from an Interface Repository. The Interface Repository is a service that provides persistent objects that represent the Interface

Definition Language (IDL) information in a form available at runtime. In addition to its role in the functioning of the ORB, the Interface Repository is a common place to store additional information associated with interfaces to ORB objects. For example, libraries of stubs or skeletons and routines that can format or browse particular kinds of objects might be associated with the Interface Repository. This provides the client with the ability to search for a simulation object and include its object reference in the simulation model(27).

The operations that are the same for all ORB implementations are sent through the ORB Interface. These operations include converting the object reference to a string for storage, duplicating and releasing copies of object references to clients and implementations, equivalence checking and object reference identity(27).

There are a wide variety of ORB implementations possible within the CORBA. The implementations which best support distributed simulations are the Server-based ORB and the Library-based ORB. The Server-based ORB centralizes the management of the ORB and all clients and implementations can communicate with one or more servers whose job it is to route requests from clients to implementations. In some cases, where the objects are "light-weight" with regards to processing and storage, and their implementations can be shared, the implementation might actually be in a library. In this case, the stubs could be the actual methods. For example, the client could request the OE254 simulation, which would request information from the relational database and return results to the client. This is a Server-based ORB. Or the client could run the simulation as a resident program, which invokes objects to access the relational database(s). This assumes that the client's privileges allow access to the data for the objects and that the implementation trusts the client not to damage the data in the relational database(27).

The ORB also provides interoperability to other ORBs through the General Inter-ORB Protocol (GIOP) and Environment-Specific Inter-ORB Protocols (ESIOP). The Internet Inter-ORB Protocol (IIOP) specifies how GIOP messages are exchanged using TCP/IP connections. The DCE

ESIOP specifies how CORBA ORBs communicate with The Open Group's Distributed Computing Environment (DCE).

*3.7.3 Accessing the object/data.* The ORB determines if the object reference is implemented through another ORB or not. If the object is implemented locally, the object adapter performs the management functions for the object implementation. The Basic Object Adapter (BOA) supports convenient interfaces for generating object references, registering implementations that consist of one or more programs, activating implementations, and authenticating requests. It also provides a limited amount of persistent storage for objects that can be used for connecting to a larger or more general storage facility, for storing access control information, or other purposes.

The Object-Oriented Database Adapter performs the task of accessing the ODBMS where the OE254.Path object is stored and passing any control or authentication information required by the DBMS. During the execution of the antenna object, the object adapter is responsible for generating object references and passing them to the ORB if other objects are requested by the antenna object. The object adapter also informs the ORB when execution is complete, so the ORB can pass control back to the client with the results(27).

For a particular language mapping, and depending on the object adapter, there will be an interface to the methods that implement each type of object. There is also a Dynamic Skeleton Interface (DSI) which is the server side analogue to the client side DII. The DSI is a way to deliver requests from an ORB to an object implementation that does not have compile-time knowledge of the type of the object it is requesting.

*3.7.4 Implementing the Object.* The OE254.PATH object is implemented as an *executable module* or by a file server integrated with the DMBS(19) (Figure 3.15). The implementation is transparent to the client and distributed processing is supported easily in large simulations through the distributed database storage of simulation objects. Control is maintained by the ORB(s) and

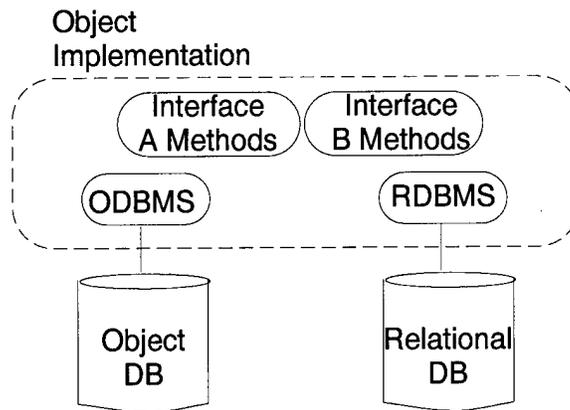

Figure 3.15 The CORBA Object Implementation Architecture

DBMS until all requested objects have been executed. When execution is complete, the results are returned to the object adapter and any locks are removed.

*3.7.5 Returning Results to the Simulation.* Results are returned to the client by reversing the process by which the request was made. The results are provided to the ORB by the object adapter. The stubs provide the language mapping to provide the results to the client. Regardless of what language the object was implemented in or what operating system the client is using, appropriate implementations of the CORBA architecture allow distributed processing and heterogeneous distributed database access over possibly several operating systems in the process.

### 3.8 Summary

Objective 1-1 of the DoD Modeling & Simulation Master Plan states(28):

- Establish a common high-level simulation architecture to facilitate the interoperability of all types of models and simulations among themselves and with C4I systems, as well as to facilitate the reuse of M&S components.
  - Simulations developed for particular DoD Components or Functional Areas must conform to the High Level Architecture.
  - Further definition and detailed implementation of specific simulation system architectures remain the responsibility of the developing Component.

The CORBA distributed simulation architecture described in this chapter, fully supports the objective stated above. The mapping of programming languages to OMG IDL facilitates interoperability of all types of models and simulations. Additionally, the standardized development of models using the IDEF method provides a "paper trail" process to approve the further development of simulation objects for use in the distributed network. All objects of the same type would be required to provide similar in/out parameters, or the interface between specific simulations would be clearly defined and provided as a stub, skeleton and/or object adapter. Simulation objects are reusable by referencing the object during simulation development and their code can be copied or ported for local use by using a unique OID naming system.

Each Service Component can maintain a federated interface and implementation repository for the simulation objects they maintain. These repositories can be further federated to organizations responsible for specific C4I systems. For example, within the U.S. Army, Fort Gordon would maintain communications repositories and Fort Huachuca would maintain the repository for intelligence systems.



## *IV. Analysis*

### *4.1 Introduction*

The first chapter presents a brief historical background of the problems faced by simulators of C4I systems, and the exact problem to be solved is stated. The second chapter presents background material essential to understanding the approach Chapter Three presents. This chapter presents an analysis of the methodology and determines which goals were achieved and which were not.

### *4.2 Background*

In 1991, the Joint Analysis Directorate of the Joint Chiefs of Staff cataloged over 700 simulations, war games, exercises, and models in general use throughout the U.S Department of Defense, as well as in Australia, Canada, England, and Germany. There was almost no ability for these simulations to interact and no evidence was found that communications availability and fragility was included in any of the simulations(24).

Only in recent years, have computer scientists begun to write interfaces for disparate simulations. Pratt and Johnson's work(31) in 1993 to interface the Janus Combat Model and DIS is an example of a simulation specific interface. However, there is no flexibility for handling objects written in varying programming languages or to take advantage of distributed processing across the network. The World Modeler application they developed only provided translation and control for Janus and DIS. The CORBA distributed simulation would use client stubs and server skeletons to perform language translation to and from OMG IDL, as well as providing network management and transaction control.

In 1995, the U.S. Army Communications-Electronics Command introduced the Integrated Terrain-Environment-Multipath Model to add communications realism to simulations using radiowave communications systems in their models. A distributed simulation architecture would make this program available for inclusion within other client simulation applications.

### 4.3 Summary

As stated in the first chapter, the problem to be solved by this thesis is to develop a methodology using a standardized modeling process which integrates the technical, operational, and situational architectures, and results in a distributed simulation architecture by which current systems can be evaluated and future systems analyzed. The proposed methodology is illustrated in Figure 4.1, and is described below.

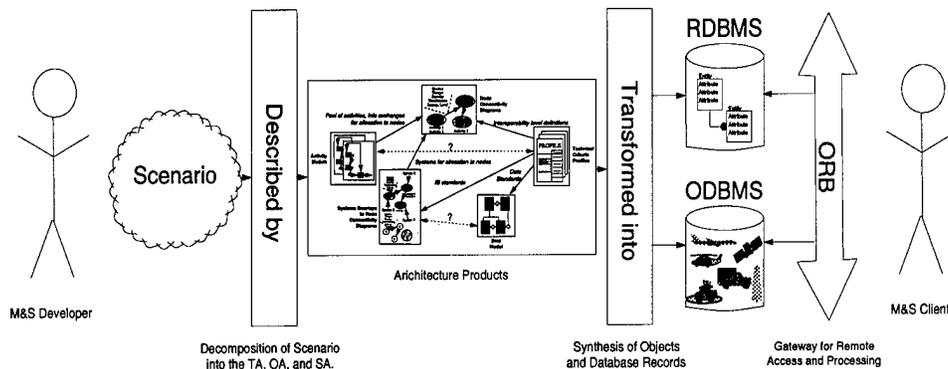

Figure 4.1 Developing the Model, Simulation Object, and Distributed Simulation Network

An antenna, the OE-254()/GRC, was modeled using IDEF modeling methods to describe the operational architecture of the antenna given a common scenario. By including the technical architecture constraints in the IDEF models, these architectures were integrated to describe the system architecture. This standardized process provides the foundation for developing the object-oriented code for an executable simulation object. The development of the object-oriented code could be further mapped using the IDEF4 object-oriented design method not discussed in this thesis. A brief overview of IDEF4 by Knowledge Based Systems, Inc. is provided in Appendix D.

The persistent data describing the OE-254()/GRC antenna from the IDEF1X model is then stored in a relational database. Embedded SQL in the executable simulation object is used to apply the technical constraints. Other objects could be embedded with the antenna object, or the antenna object could be embedded in a larger communication system. Embedding objects only requires the

CORBA object reference as a pointer within the host program to invoke and implement the object. The storage of the simulation object using an unique OID in an ODBMS was then discussed.

Finally, an approach to achieve a fully distributed simulation architecture using the CORBA was conceptually provided by stepping through each of the component blocks. The ability to access heterogeneous distributed databases and perform distributed processes was discussed as part of the capabilities, as well as support for portability and reuse of simulations and interoperability across operating systems and programming languages.

#### *4.4 Review of the Results*

The value of this research is the feasibility of implementing the methodology described in Chapter 3, and the integration of current modeling techniques with emerging distributed object technology. The results of this research are described below:

- The modeling standardization process proposed in the research uses the Reverse Engineering for Data Integration and Sharing (REDIS) Methodology currently incorporated in the DMSO Modeling and Simulation Resource Repository (MSRR) standards. REDIS provides a solution to the lack of common or standard data definitions in the M&S community.
- The IDEF0 modeling method is used to describe the behavior of the simulation object, its functions, methods and constraints. The IDEF0 model clearly defines the input parameters and output parameters required by the operational architecture to simulate the given real-world scenario. The IDEF0 and IDEF1X (ER) models provide the historical documentation necessary to validate the model of the system to be simulated. The advantage is once the model has been validated, it can be reused by others in the M&S community without the time and expense of re-validating the model.
- The REDIS ER product can then be used to define a relational database to store and manage data for the real world objects to be simulated. The relational model provides a strong

foundation for the definition and management of the persistent data, which is not available in current object models. This moves the information from the bookshelf into a standardized format which can be easily accessed and reused. By incorporating the data in the simulation object programming language through embedded SQL, the data comes alive in the simulation. The data is no longer just reference material, but is put to use validating input parameters, providing output parameters to other objects, and enforcing technical constraints. The integration of relational and object-oriented modeling allows us to take advantage of the strengths in each model while avoiding some of the weaknesses.

- The development of modular object-oriented simulation objects serves two purposes. Objects can more realistically represent real-world systems. Inheritance, embedding or linking objects through their methods, OQL, and ORB object references (pointers), allow a hierarchical and multidimensional representation of the real-world scenario. Additionally, modular objects can be created at the fidelity required by a simulation and reused as components by other simulations.
- By placing the simulation objects in an object-oriented database and using a CORBA compliant ORB, the distributed simulation network allows simulation clients to find and reference simulation objects through the Interface Repository. The ORB provides the means to manage network connections and processing resources for the distributed processing of multiple objects in a simulation, or to allow the client to port simulation objects to a local processor. Simulation objects can then be reused in many simulation applications. In the distributed processing implementation, the client references the objects used by the simulation without regard to the programming language the object or application uses or the operating platform capabilities of the client. The client simply references the simulation object(s) using the information provided by the interface repository and receives the results from the ORB.

- Additionally, the combination of emerging database and Internet technologies into a unique infrastructure for distributed simulation is realistic. The CORBA is an industry standard developed by the OMG consortium. It is supported by the Object Management Database Group (OMDG) consortium and many applications using CORBA compliant ORBs are currently being demonstrated, or are in use today(36). Also, many database software companies are moving to make their DBMSs CORBA and Internet accessible(39). The framework recommended in the methodology is achievable using commercially developed products such as; LogicWorks ERWin and BPWin; KBSI AI0WIN, SmartER, and ProSim&trade; Oracle 7 Relational Database; Object Design's ObjectStore; and DEC's ObjectBroker, HP's ORB Plus, or IONA's Orbix. This is not a complete listing of all the products available which could be used to implement the methodology, nor is it an endorsement of any product. However, it is included to support the feasibility of implementing the proposed distributed simulation framework.

#### *4.5 Comparison with Other Distributed Simulation Architectures*

##### *4.5.1 Common Operational Modeling, Planning, and Simulation Strategy (COMPASS).*

COMPASS Technology is a middleware application which interfaces existing M&S programs by formatting data into Distributed Interactive Simulation (DIS) Protocol Data Units (PDU)(1). DIS protocols can be exchanged with any other program that implements the DIS protocol interface standard over a network.

At the moment, DIS is working well. However, DIS captures entity interactions in a flat (non-hierarchical manner). Since DIS PDU's cannot inherit from each other, interactions among entities must be individually developed. This means that every entity must have a set of PDU's developed for every other entity with which it must interact. DIS also suffers from a lack of abstraction. Every

entity in DIS exists independently and equally. This means that DIS fails to exploit hierarchical structures and commonalities which exist among varying real-world entities(30).

The proposed methodology exploits the object-oriented model and uses distributed object processing, database management and the CORBA to build the distributed simulation network. Object-oriented design allows the structured characterization of entities based on the hierarchical relationships of real-world systems, and inheritance from higher (base) classes to lower (sub) classes derived from the base classes. The object-oriented model also allows the encapsulation of data, and linking (or embedding) of objects, to represent complex behaviors, instead of crafting an entirely new DIS PDU. In fact, DIS itself could be encapsulated in an object using this paradigm.

COMPASS is successful in providing interactivity between current C4I systems using the DIS PDU and the Internet. However, the proposed methodology provides:

- the scalability of object-oriented design not found in DIS PDU based simulation systems,
- scalar data definition and management using the relational model,
- data independence by integrating the two,
- and interoperability with platform and programming language independence.

*4.5.2 Joint Modeling and Simulation System (J-MASS).* Although the methodology presented was developed independent of any knowledge of J-MASS, the simulation architectures are strikingly similar. The major efforts of J-MASS have been(23):

- Development of a common digital simulation architecture
- Definition of standard interfaces
- Application of commercial standards (e.g., POSIX, MOTIF, X-Windows, CORBA)
- Visual Computer Assisted Support Environment (CASE) tool environment
- Application of modeling and simulation to the acquisition lifecycle

The J-MASS is currently a software application that runs on SUN and SGI machines. It uses an ODBMS for object storage and does not use relational databases. The architecture proposed in the methodology integrates relational and object-oriented databases to strengthen the underlying model and simulation repositories. Also, J-MASS does not use a commercially standard CORBA, but has developed a unique CORBA-like architecture called the Simulation Support Environment (SSE) Interconnect Backplane (IBP). Since J-MASS states individual organizations would solicit solutions from the commercial marketplace for unique requirements and capabilities, these products would have to be created or existing products made "J-MASS compliant". The added J-MASS compliance means added cost to the client. Finally, J-MASS does not specify a process for developing DoD standardized models of real-world systems, as the proposed methodology does with the technical, operational, and system architectures, and IDEF modeling methods. J-MASS does require objects representing those real-world systems to be structured compliant with the J-MASS Software Structural Model (SSM). The SSM enforces software structure and interface standards for all levels of object decomposition to ensure any object in the J-MASS system can be syntactically "connected" with any other objects in the system with guaranteed success.

Since J-MASS is current technology developed by the U.S. Air Force, the ODISC4 should use this system as a basis for developing a CORBA compliant distributed simulation architecture, enforcing the standardize model development process, and employing the multi-database architecture proposed in the methodology.

#### *4.6 Goals Achieved*

The goals achieved by the proposed methodology are:

- a process for standardization of C4I data models,
- integration of the technical and operational architectures into the simulation,
- historical records of data collection and process description, and

- distributed database access and processing using CORBA.

CORBA supports heterogeneous distributed systems incorporating object-oriented databases, relational databases, operating systems independence, and programming language independence. As a result, requirements for portability, re-usability and interoperability described in the DMSO HLA can be achieved using this architecture.

#### *4.7 Goals Not Achieved*

The original intent of this research was to implement a distributed simulation network using a CORBA compliant ORB and the modeling standardization, object development, and database techniques described by the methodology. Additionally, the simulation to be run over the distributed network was to include time-dependent weather characteristics found in a desert environment. The research conducted to include weather in a C4I simulation utilizing radiowave communications is included in Appendix C. This goal proved too ambitious given the time and resources required to complete such a goal. However, the need for a clear methodology to construct such a network motivated the research and publication of this work.



## *V. Recommended Continuing Research*

### *5.1 Introduction*

The first chapter presents a brief overview of the problems faced by simulators of C4I systems, and the problem addressed by this research was stated. The second chapter presents background material essential to understanding the process and infrastructure described in Chapter 3. Chapter 4 presents a brief summary of the methodology and discussion of its availability and applicability. This chapter reviews the problem and the answers provided by this thesis and makes recommendations for further research.

### *5.2 Review*

The development of a multi-database federated repository system, using CORBA to manage the distributed simulation network combines the power of state-of-the-art technologies with time tested simulation applications and data management techniques. The explosive growth of the Internet and the enabling technologies that have grown with it, provide the simulation community with an opportunity to achieve greater interoperability, re-usability and portability. The framework provided by this research sets the foundation for taking greater advantage of this technology.

### *5.3 Recommended Research*

The recommended research is directed at the steps necessary to implement the distributed simulation network described in this research. These are listed as areas of recommended research.

1. Expand the model standardization process by combining IDEF2 (Simulation Model Design) and IDEF4 (Object-oriented Design) methods with the IDEF0 and IDEF1X methods described in Chapter 2.
2. Develop a client GUI Modeling and Simulation application using CORBA object references.

3. Create and populate an Object-Oriented database and Relational database and use the CORBA gateway architecture as a multi-database management system(20).
4. Integrate a file server with the multi-database system to perform distributed processing.
5. Create a simulation of simulations invoking objects over multiple ORBs.
6. Develop a geographic mapping of the distributed simulation network to optimize accessibility and object processing. The distributed capabilities of the recommended architecture require management of resources to optimize the network. Component models and simulations can be developed and stored at facilities which have responsibility for technical and doctrinal development of the systems. Not discussed in this thesis is the structure of a federated model and simulation repository for the Department of the Army. For example, Fort Gordon would administer the CORBA ORB server, relational databases, object-oriented databases and federated interface repository for U.S. Army communications systems. The Global Interface Repository and approval authority for including models and simulations in the federated simulation repository would be controlled by a Defense Department agency.

### *Appendix A. IDEF1X Antenna Model*

The following diagrams show the entity relationship model of an antenna, as reverse engineered by the Joint Database Element, Fort Huachuca, and schema for the entities required in this thesis.

Electromagnetic Environment Subject Area Information Model

Version 2.0

Created: August 31, 1995

Updated: September 24, 1995

Filename: ANTENNA.ER1

Page 1 of 13

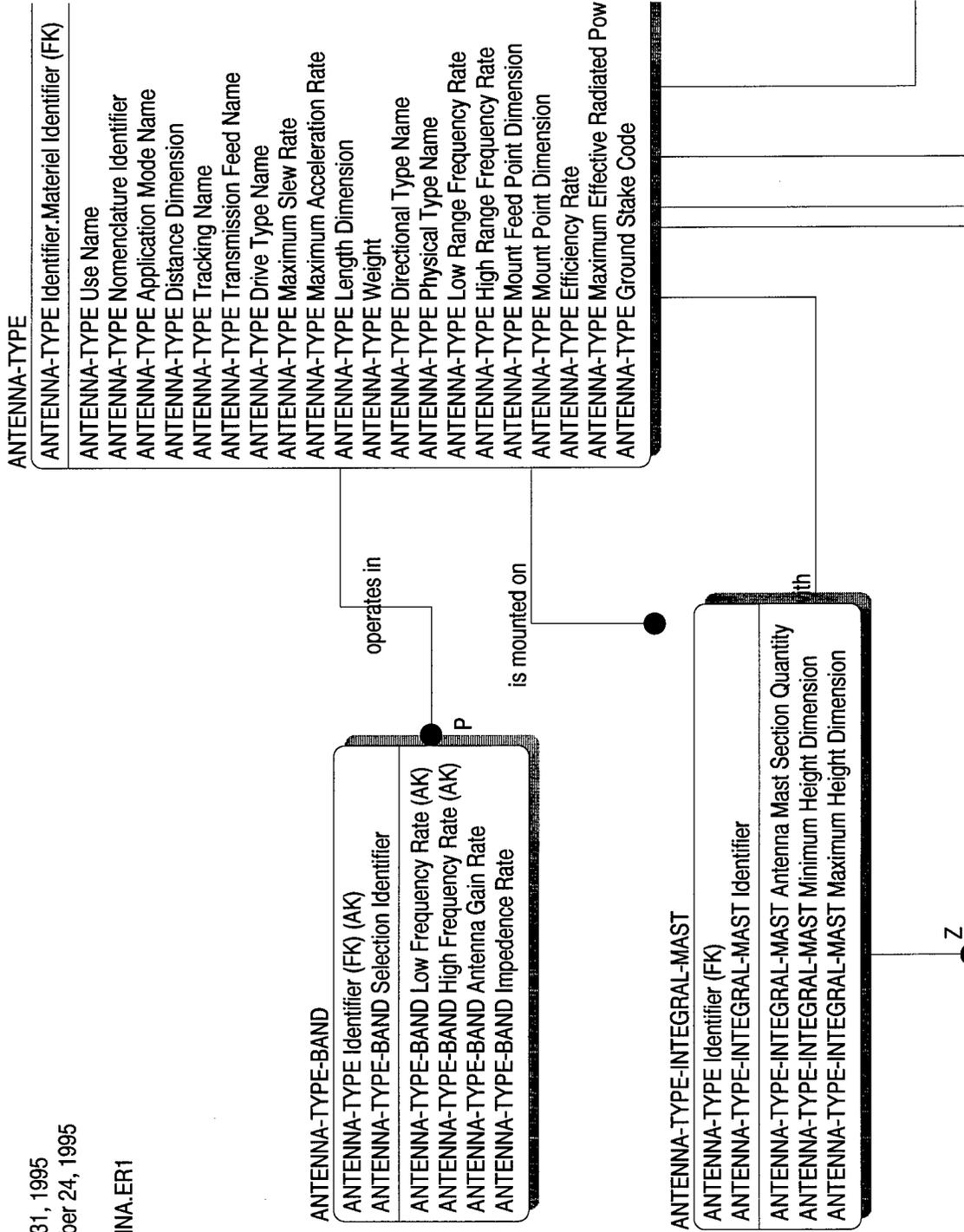

LE L L L L L

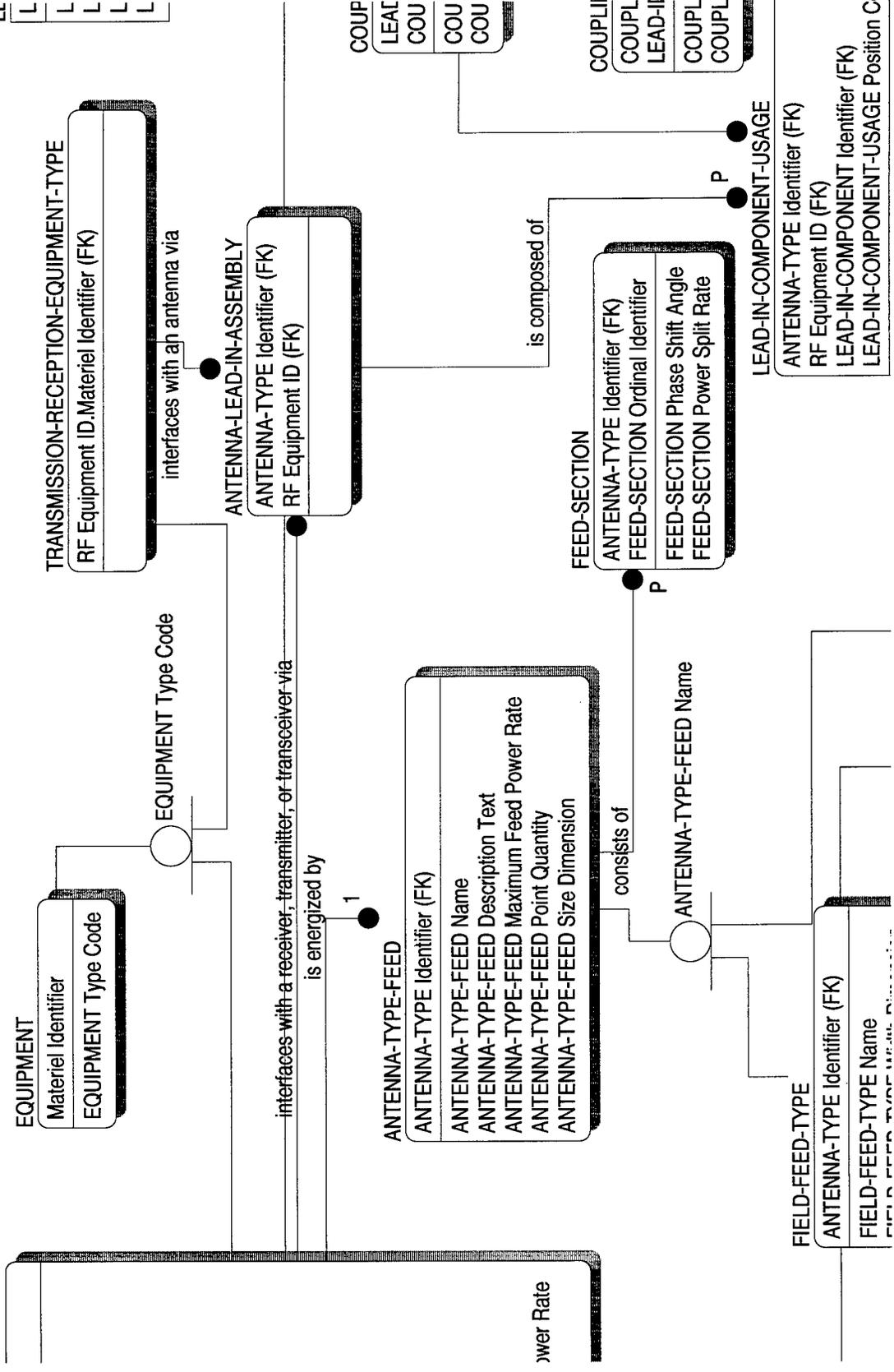



**COUPLER**

LEAD-IN-COMPONENT Identifier (FK)
COUPLER Forward Loss Rate
COUPLER Reverse Loss Rate
COUPLER Passband Separation Rate
COUPLER Port Isolation Rate
COUPLER Input Port Quantity
COUPLER Output Port Quantity
COUPLER Passband Quantity

Name
Length Dimension
Maximum Pressurization Rate
Minimum Pressurization Rate
Insertion Loss Rate

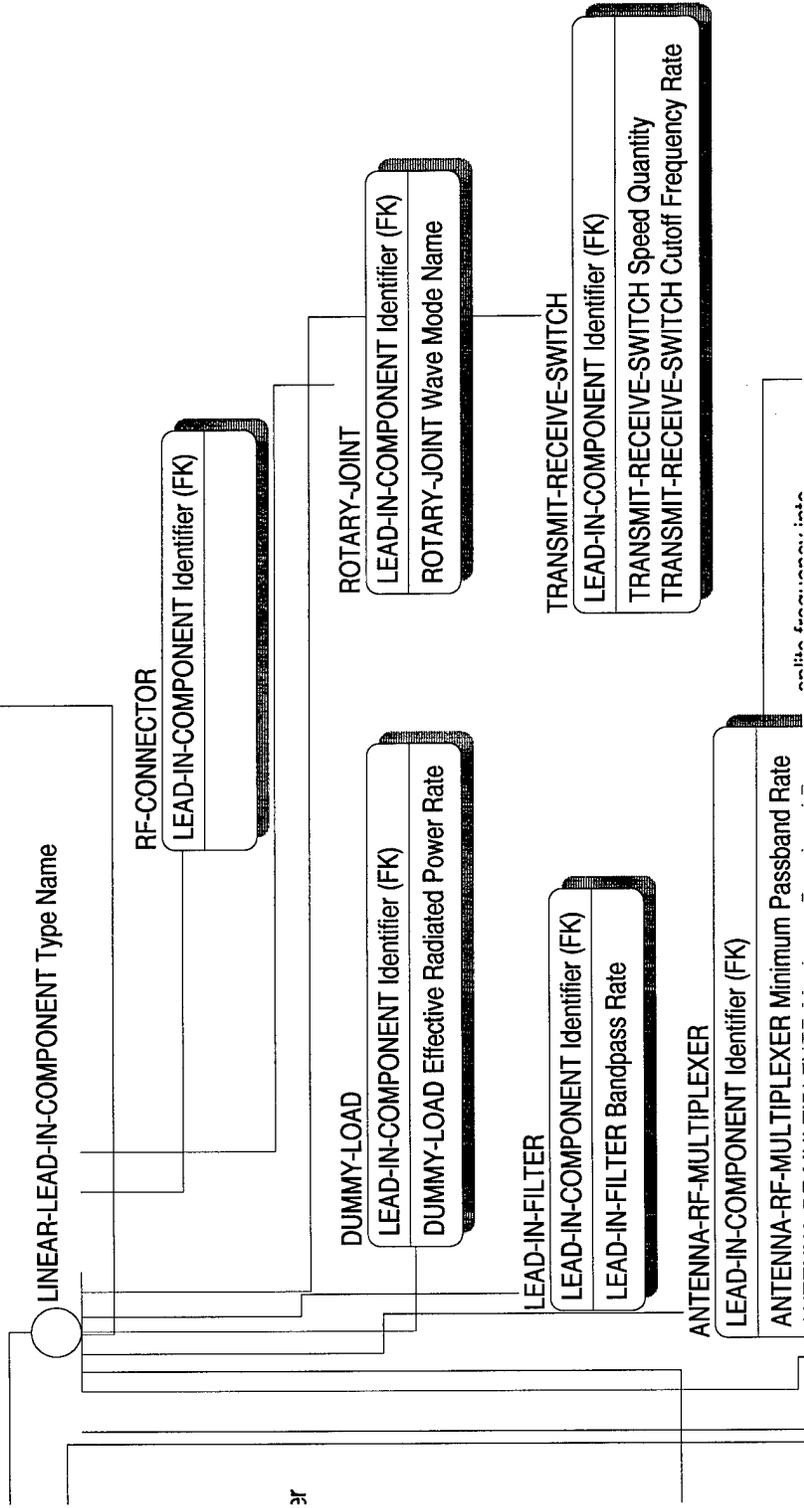

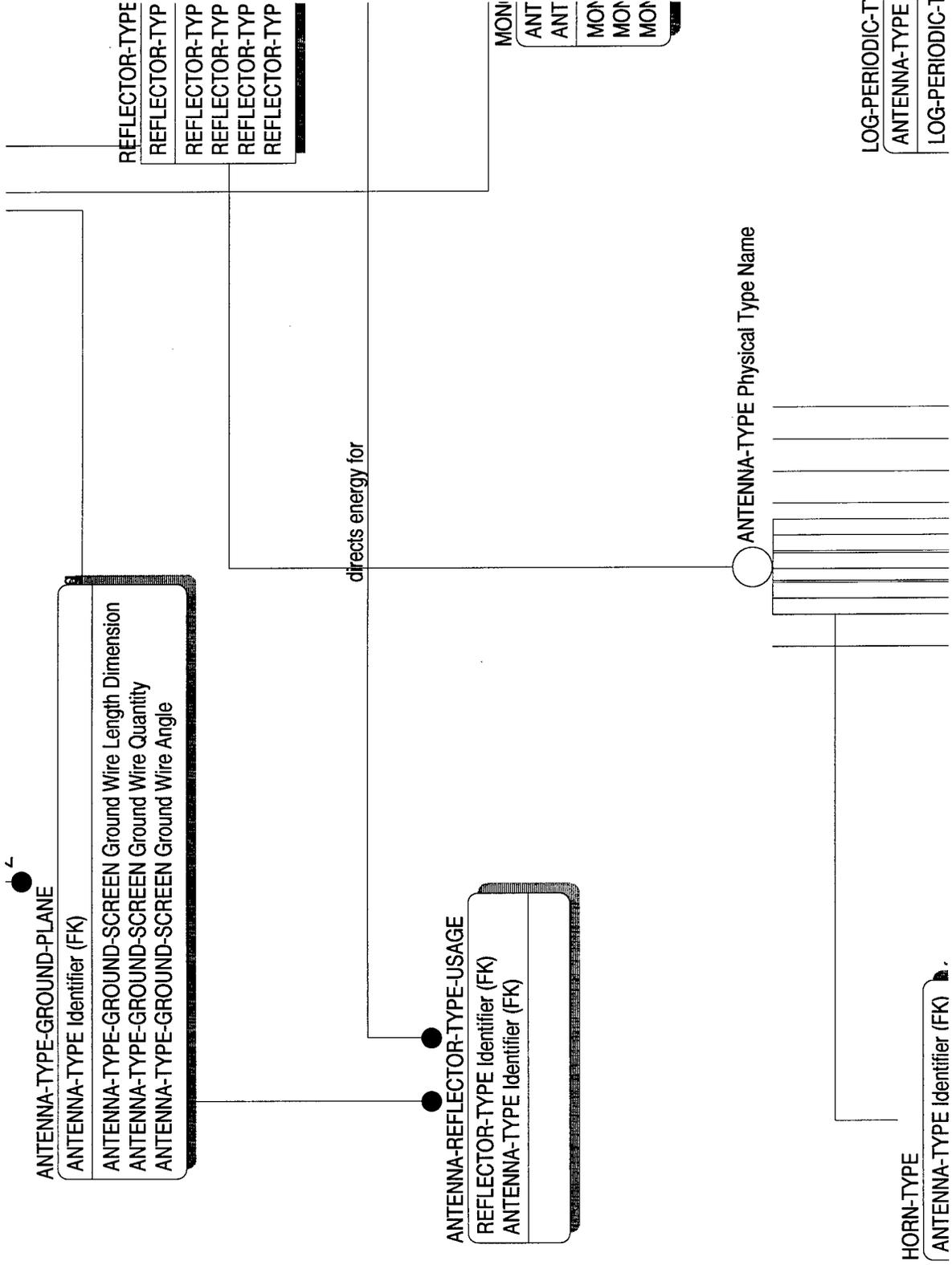



FIELD-FEED-TYPE Width Dimension  
 FIELD-FEED-TYPE Height Dimension

CONNECTED-FEED-TYPE  
 ANTENNA-TYPE Identifier (FK)  
 CONNECTED-FEED-TYPE Type Name  
 CONNECTED-FEED-TYPE Impedance Rate

PE  
 /PE Identifier  
 /PE Length Dimension  
 /PE Width Dimension  
 /PE Diameter Dimension  
 /PE Shape Name

ANTENNA-TYPE-ECCM  
 ANTENNA-TYPE Identifier (FK)  
 ANTENNA-TYPE-ECCM Identifier  
 ANTENNA-TYPE-ECCM Polarization ECCM Code  
 ANTENNA-TYPE-ECCM Sidelobe Blanking Code  
 ANTENNA-TYPE-ECCM Sidelobe Canceller Code  
 ANTENNA-TYPE-ECCM Variation Technique Type Name  
 ANTENNA-TYPE-ECCM Type Code  
 ANTENNA-TYPE-ECCM Signal Combination Name

INOPULSE-ECCM-TYPE  
 ANTENNA-TYPE Identifier (FK)  
 ANTENNA-TYPE-ECCM Identifier (FK)  
 INOPULSE-ECCM-TYPE Antenna Feed Quantity  
 INOPULSE-ECCM-TYPE Monopulse Null Depth Rate  
 INOPULSE-ECCM-TYPE Aperture Distribution Text

utilizes

HORIZONTAL-SECTOR-BLANKING  
 ANTENNA-TYPE Identifier (FK)  
 ANTENNA-TYPE-ECCM Identifier (FK)  
 HORIZONTAL-SECTOR-BLANKING Sector Quantity  
 HORIZONTAL-SECTOR-BLANKING Adjustability Code  
 HORIZONTAL-SECTOR-BLANKING Fixed Sector Quantity  
 HORIZONTAL-SECTOR-BLANKING Minimum Adjustable Sector Quantity  
 HORIZONTAL-SECTOR-BLANKING Maximum Adjustable Sector Quantity

VERTICAL-SECTOR-BLANKING  
 ANTENNA-TYPE Identifier (FK)  
 ANTENNA-TYPE-ECCM Identifier (FK)  
 VERTICAL-SECTOR-BLANKING Sect  
 VERTICAL-SECTOR-BLANKING Adjus  
 VERTICAL-SECTOR-BLANKING Fixec  
 VERTICAL-SECTOR-BLANKING Minin  
 VERTICAL-SECTOR-BLANKING Maxi

-TYPE  
 'E Identifier (FK)  
 >-TYPE Tip Array Axis Angle



ACTIVE-NONLINEAR-COUPLING-TYPE Crossmodulation Conversion Loss Quantity  
 ACTIVE-NONLINEAR-COUPLING-TYPE Crossmodulation Conversion Loss Standard Deviation Quantity  
 ACTIVE-NONLINEAR-COUPLING-TYPE Desensitization Coefficient Rate  
 ACTIVE-NONLINEAR-COUPLING-TYPE Desensitization Power Breakpoint Quantity  
 ACTIVE-NONLINEAR-COUPLING-TYPE First Power Breakpoint Crossmodulation Power Region Quantity  
 ACTIVE-NONLINEAR-COUPLING-TYPE Second Power Breakpoint Crossmodulation Power Region Quantity  
 ACTIVE-NONLINEAR-COUPLING-TYPE First Crossmodulation Power Region Slope Quantity  
 ACTIVE-NONLINEAR-COUPLING-TYPE Second Crossmodulation Power Region Slope Absolute Value Quantity  
 ACTIVE-NONLINEAR-COUPLING-TYPE Crossmodulation Power Region Second Slope Sign Code

rac  
 rec  
 sig

ANTENNA-TUNER

ANTENNA-TUNER  
 LEAD-IN-COMPONENT Identifier (FK)  
 ANTENNA-TUNER Input Impedance Rate  
 ANTENNA-TUNER Output Impedance Rate  
 ANTENNA-TUNER Bandwidth Rate

ANGLE-SCAN-DIVERSITY  
 ANTENNA-TYPE Identifier (FK)  
 ANTENNA-TYPE-ECCM Identifier (FK)  
 ANGLE-SCAN-DIVERSITY Type Code

K)  
 ctor Quantity  
 justability Code  
 ed Vertical Quantity  
 imum Adjustable Sector Quantity  
 ximum Adjustable Sector Quantity

WAVEGUIDE  
 LEAD-IN-COMPONENT Identifier (FK)  
 WAVEGUIDE Wave Mode Name

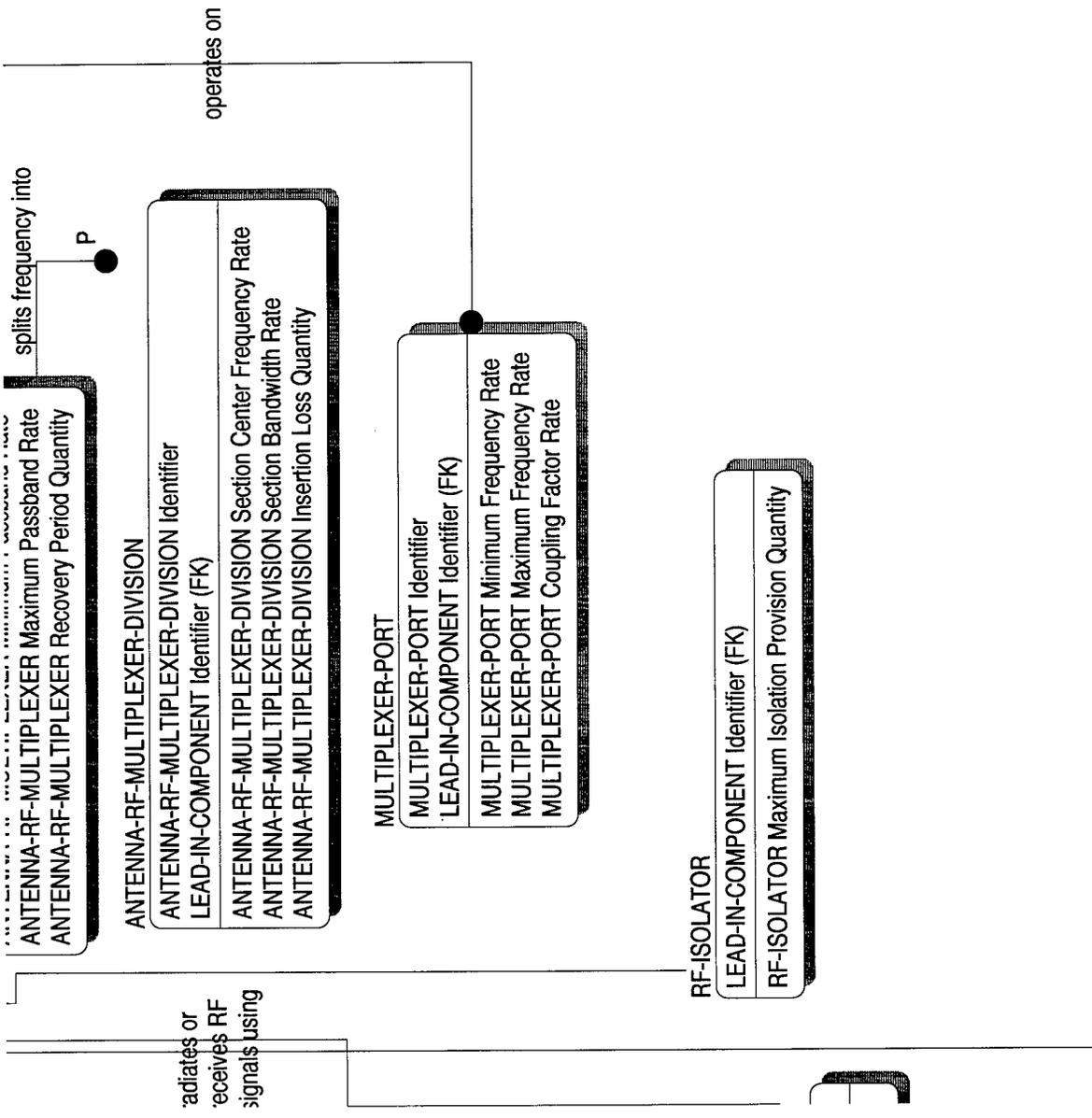

ANTENNA-TYPE Identifier (FK)  
 HORN-TYPE Height Dimension  
 HORN-TYPE Length Dimension  
 HORN-TYPE Type Name  
 HORN-TYPE Width Dimension

**MONOPOLE-TYPE**

ANTENNA-TYPE Identifier (FK)  
 MONOPOLE-TYPE Conductor Quantity

**PARABOLIC-TYPE**

ANTENNA-TYPE Identifier (FK)  
 PARABOLIC-TYPE Section Angle

**SLOPING-V-TYPE**

ANTENNA-TYPE Identifier (FK)  
 SLOPING-V-TYPE Half Apex Angle  
 SLOPING-V-TYPE Leg Length Dimension  
 SLOPING-V-TYPE Leg Slope Angle  
 SLOPING-V-TYPE Termination Height Dimension  
 SLOPING-V-TYPE Impedance Rate

**SLOTTED-WAVEGUIDE-TYPE**

ANTENNA-TYPE Identifier (FK)

LOG-PERIODIC-T  
 LOG-PERIODIC-T  
 LOG-PERIODIC-T  
 LOG-PERIODIC-T  
 LOG-PERIODIC-T  
 LOG-PERIODIC-T

**SLOPING-LONG-WIRE-TYPE**

ANTENNA-TYPE Identifier (FK)  
 SLOPING-LONG-WIRE-TYPE Wire Length  
 SLOPING-LONG-WIRE-TYPE Wire Spacing  
 SLOPING-LONG-WIRE-TYPE Wire In

**COLLINEAR-ARRAY-TYPE**

- >TYPE Tip Array Axis Angle
- >TYPE Array Tilt Angle
- >TYPE Geometric Ratio Rate
- >TYPE Element Quantity
- >TYPE Half Length Radius Ratio Rate
- >TYPE Rear Element Half Length Rate

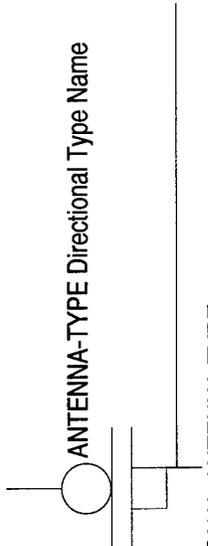

**INVERTED-L-TYPE**

- ANTENNA-TYPE Identifier (FK)
- INVERTED-L-TYPE Horizontal Length Dimension
- INVERTED-L-TYPE Vertical Length Dimension

**ARBITRARILY-TILTED-DIPOLE-TYPE**

- ANTENNA-TYPE Identifier (FK)
- ARBITRARILY-TILTED-DIPOLE-TYPE Tilt Angle
- ARBITRARILY-TILTED-DIPOLE-TYPE Dipole Half Length Rate

**YAGI-TYPE**

- ANTENNA-TYPE Identifier (FK)
- YAGI-TYPE Driver Length Dimension
- YAGI-TYPE Reflector Length Dimension
- YAGI-TYPE Reflector Distance Dimension

- Length Dimension
- Slope Angle
- Impedance Rate

**YAGI-DIRECTOR**

- YAGI-DIRECTOR Ordinal Code
- ANTENNA-TYPE Identifier (FK)
- YAGI-DIRECTOR Length Dimension
- YAGI-DIRECTOR Spacing Dimension

**HFIICAI-TYPE**

**DIRECTIONAL-ANTENNA-TYPE**

**ANTENNA-TYPE Identifier (FK)**

- DIRECTIONAL-ANTENNA-TYPE Simultaneous Beam Quantit
- DIRECTIONAL-ANTENNA-TYPE Independent Simultaneous E
- DIRECTIONAL-ANTENNA-TYPE Beam Position Use Text
- DIRECTIONAL-ANTENNA-TYPE Beam Position Capability Te
- DIRECTIONAL-ANTENNA-TYPE Coverage Azimuth Angle
- DIRECTIONAL-ANTENNA-TYPE Boresight Azimuth Angle
- DIRECTIONAL-ANTENNA-TYPE Relative Beam Position Bore
- DIRECTIONAL-ANTENNA-TYPE Coverage Elevation Angle
- DIRECTIONAL-ANTENNA-TYPE Boresight Elevation Angle
- DIRECTIONAL-ANTENNA-TYPE Maximum Boresight Elevatic
- DIRECTIONAL-ANTENNA-TYPE Minimum Boresight Elevation
- DIRECTIONAL-ANTENNA-TYPE Relative Beam Position Bore
- DIRECTIONAL-ANTENNA-TYPE RMS Sidelobe Rate
- DIRECTIONAL-ANTENNA-TYPE Scanning Type Name
- DIRECTIONAL-ANTENNA-TYPE Maximum Mainbeam Gain R
- DIRECTIONAL-ANTENNA-TYPE Minimum Mainbeam Gain R;

uses p

is covered by

is ins

VERTIC.  
ANTEN

ANTENNA-POLARIZATION  
 ANTENNA-POLARIZATION Identifier  
 ANTENNA-TYPE Identifier (FK)  
 ANTENNA-POLARIZATION Type Code

DDDS page6

OMNIDIRECTIONAL-ANTENNA-TYPE  
 ANTENNA-TYPE Identifier (FK)  
 OMNIDIRECTIONAL-ANTENNA-TYPE Elevation Coverage Angle  
 OMNIDIRECTIONAL-ANTENNA-TYPE Name  
 OMNIDIRECTIONAL-ANTENNA-TYPE Conductor Radius Dimension  
 OMNIDIRECTIONAL-ANTENNA-TYPE Element Height Dimension

HORIZONTAL-POSITION-LIMIT  
 ANTENNA-TYPE Identifier (FK)  
 HORIZONTAL-POSITION-LIMIT Stop Sector Quantity  
 HORIZONTAL-POSITION-LIMIT Installation Adjustment Rate

ity  
 s Beam Quantity  
 Text  
 orsight Azimuth Angle  
 tion Angle  
 ion Angle  
 orsight Elevation Angle  
 i Rate  
 Rate

has gains and losses according to

\*ANTENNA-PATTERN  
 ANTENNA-PATTERN Identifier  
 ANTENNA-TYPE Identifier (FK) (AK)  
 ANTENNA-POLARIZATION Identifier (FK) (AK)  
 ANTENNA-PATTERN Frequency Rate (AK)  
 ANTENNA-PATTERN Polarization Name (AK)  
 ANTENNA-PATTERN Main Beam Gain Standard Deviation Quantity

installed within

Z

ICAL-POSITION-LIMIT  
 ANTENNA-TYPE Identifier (FK)

determines

P

VARIABLE-POLARIZATION-TYPE

ANTENNA-POLARIZATION Identifier (FK)
ANTENNA-TYPE Identifier (FK)
VARIABLE-POLARIZATION-TYPE Code
VARIABLE-POLARIZATION-TYPE Change Quantity
VARIABLE-POLARIZATION-TYPE Change Pattern Text

VARIABLE-POLARIZATION-TYPE Code

ANTENNA-POLARIZATION Type Code

POLARIZATION-MODULATION

ANTENNA-POLARIZATION Identifier (FK)
ANTENNA-TYPE Identifier (FK)
POLARIZATION-MODULATION Polarization Name
POLARIZATION-MODULATION Waveform Name
POLARIZATION-MODULATION Modulation Rate
POLARIZATION-MODULATION Discrete Polarization Quantity
POLARIZATION-MODULATION Bit Length Quantity
POLARIZATION-MODULATION Bit Quantity

SLOTTED-WAVEGUIDE-TYPE WaveGuide Quantity  
 SLOTTED-WAVEGUIDE-TYPE WaveGuide Slot Quantity  
 SLOTTED-WAVEGUIDE-TYPE Slot Width Dimension  
 SLOTTED-WAVEGUIDE-TYPE Slot Height Dimension  
 SLOTTED-WAVEGUIDE-TYPE Slot Spacing Dimension  
 SLOTTED-WAVEGUIDE-TYPE Slot Orientation Angle  
 SLOTTED-WAVEGUIDE-TYPE Slot Dielectric Name

ANTENNA-TYPE Identifier (FK)  
 COLLINEAR-ARRAY-TYPE Segment Quantity  
 COLLINEAR-ARRAY-TYPE Segment Length Quantity  
 COLLINEAR-ARRAY-TYPE Segment Spacing Quantity

REFLECTOR-ARRAY-TYPE

ANTENNA-TYPE Identifier (FK)  
 REFLECTOR-ARRAY-TYPE Element Half Length Rate  
 REFLECTOR-ARRAY-TYPE Lowest Element Height Dimension  
 REFLECTOR-ARRAY-TYPE Horizontal Element Spacing Dimension  
 REFLECTOR-ARRAY-TYPE Horizontal Bay Quantity  
 REFLECTOR-ARRAY-TYPE Bay Element Quantity  
 REFLECTOR-ARRAY-TYPE Maximum Beam Azimuth Angle  
 REFLECTOR-ARRAY-TYPE Maximum Beam Elevation Angle  
 REFLECTOR-ARRAY-TYPE Reflector Spacing Dimension  
 REFLECTOR-ARRAY-TYPE Vertical Element Spacing Dimension

SPIRAL-TYPE

ANTENNA-TYPE Identifier (FK)  
 SPIRAL-TYPE Diameter Dimension  
 SPIRAL-TYPE Spiral Turn Quantity  
 SPIRAL-TYPE Arm Quantity  
 SPIRAL-TYPE Antenna Code



CONIC  
 ANTE  
 CONI  
 CONI

ARCHEMEDIAN-SPIRAL-TYPE

ANTENNA-TYPE Identifier (FK)  
 ARCHEMEDIAN-SPIRAL-TYPE Pitch Angle

RHOMBIC-TYPE

ANTENNA-TYPE Identifier (FK)  
 RHOMBIC-TYPE Termination Height Dimension  
 RHOMBIC-TYPE Feed Height Dimension  
 RHOMBIC-TYPE Identifier  
 RHOMBIC-TYPE Sloping Rhombic Slope Angle  
 RHOMBIC-TYPE Impedance Rate



HELICAL-TYPE

ANTENNA-TYPE Identifier (FK)
HELICAL-TYPE Helix Length Dimension
HELICAL-TYPE Helix Diameter Dimension
HELICAL-TYPE Total Helix Coil Quantity

ANTENNA-RADOME-TYPE-USAGE

RADOME-TYPE Identifier (FK)
ANTENNA-TYPE Identifier (FK)

covers

RADOME-TYPE

RADOME-TYPE Identifier
RADOME-TYPE Function Text
RADOME-TYPE Shape Name
RADOME-TYPE Material Spectral Response Text
RADOME-TYPE RF Passband Rate
RADOME-TYPE Insertion Loss Quantity
RADOME-TYPE Reflection Loss Quantity
RADOME-TYPE Beam Distortion Quantity
RADOME-TYPE Cover Loss Quantity
RADOME-TYPE Cover Type Text

1a Code

NICAL-SPIRAL-TYPE

TENNA-TYPE Identifier (FK)
NICAL-SPIRAL-TYPE Cone Angle
NICAL-SPIRAL-TYPE Conical Pitch Angle

VERTIC
VERTIC
VERTIC
VERTIC

ANTENNA-SI
ANTENNA-P
ANTENNA-S
ANTENNA-S
ANTENNA-S
ANTENNA-S
ANTENNA-S

SP
AI
SI
SI
SI
SI

APERTUF
APERTU
ANTENN
APERTU

can be describe

emits or receives along

ANTENNA-TYPE-BEAM

ANTENNA-TYPE-BEAM Identifier
ANTENNA-TYPE Identifier (FK)
ANTENNA-TYPE-BEAM Name
ANTENNA-TYPE-BEAM Null Offset Angle
ANTENNA-TYPE-BEAM Null Suppression Level Rate
ANTENNA-TYPE-BEAM Description Name
ANTENNA-TYPE-BEAM Front Back Ratio Rate

P

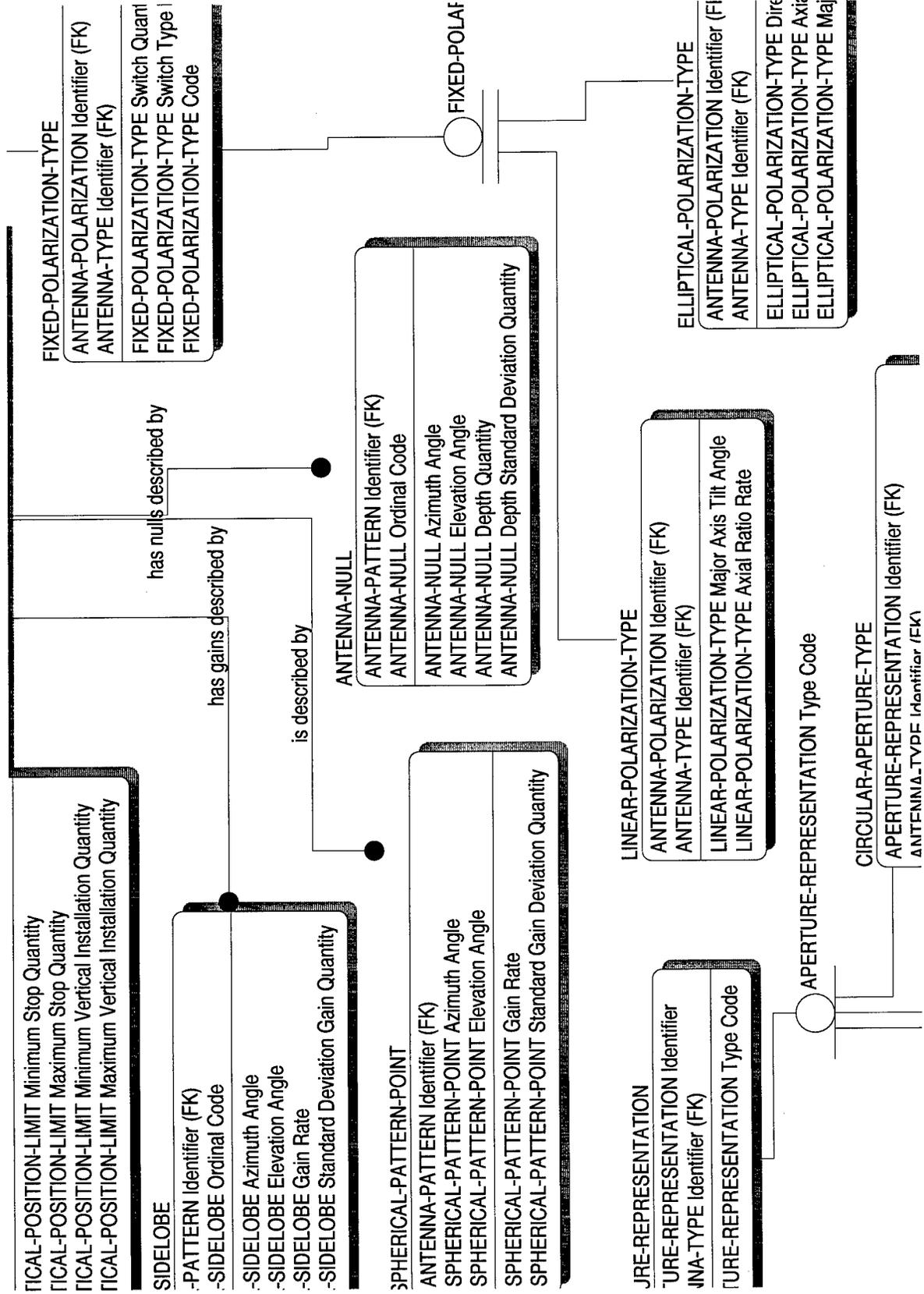

Entity Name
----------------

ADAPTIVE-POLARIZATION

ANTENNA-POLARIZATION Identifier (FK)
ANTENNA-TYPE Identifier (FK)
ADAPTIVE-POLARIZATION-TYPE Change Reason Name
ADAPTIVE-POLARIZATION-TYPE Code

ARIZATION-TYPE Code

(FK)
Direction Sensor Code
Axial Ratio Rate
Major Axis Tilt Angle

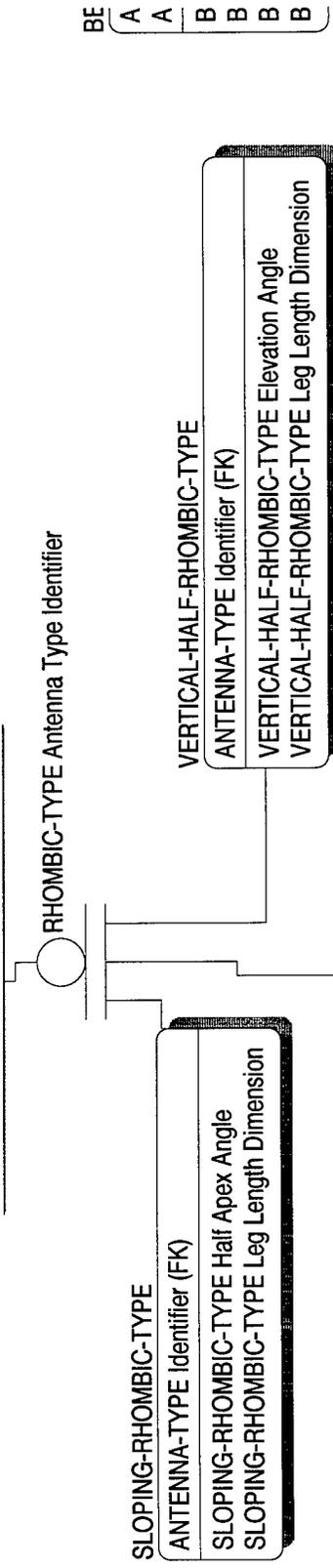

SLOPING-DOUBLE-RHOMBIC-TYPE  
 ANTENNA-TYPE Identifier (FK)  
 SLOPING-DOUBLE-RHOMBIC-TYPE Long Leg Half Apex Angle  
 SLOPING-DOUBLE-RHOMBIC-TYPE Short Leg Half Apex Angle  
 SLOPING-DOUBLE-RHOMBIC-TYPE Principal Antenna Axis Angle  
 SLOPING-DOUBLE-RHOMBIC-TYPE Long Leg Length Dimension  
 SLOPING-DOUBLE-RHOMBIC-TYPE Short Leg Length Dimension

PHASE-DIRECTION-TYPE  
 ANTENNA-TYPE-BEAM Identifier (FK)  
 ANTENNA-TYPE Identifier (FK)  
 PHASE-DIRECTION-TYPE Beam Direction Shift C  
 PHASE-DIRECTION-TYPE Discrete Direction Pha

FREQUENCY-DIRECTION-TYPE  
 ANTENNA-TYPE-BEAM Identifier (FK)  
 ANTENNA-TYPE Identifier (FK)  
 FREQUENCY-DIRECTION-TYPE Beam Direction Shift Frequency Change Rate  
 FREQUENCY-DIRECTION-TYPE Total Direction Frequency Quantity

BEAM-FORMATION-METHOD  
 SCAN-MODE Identifier (FK)

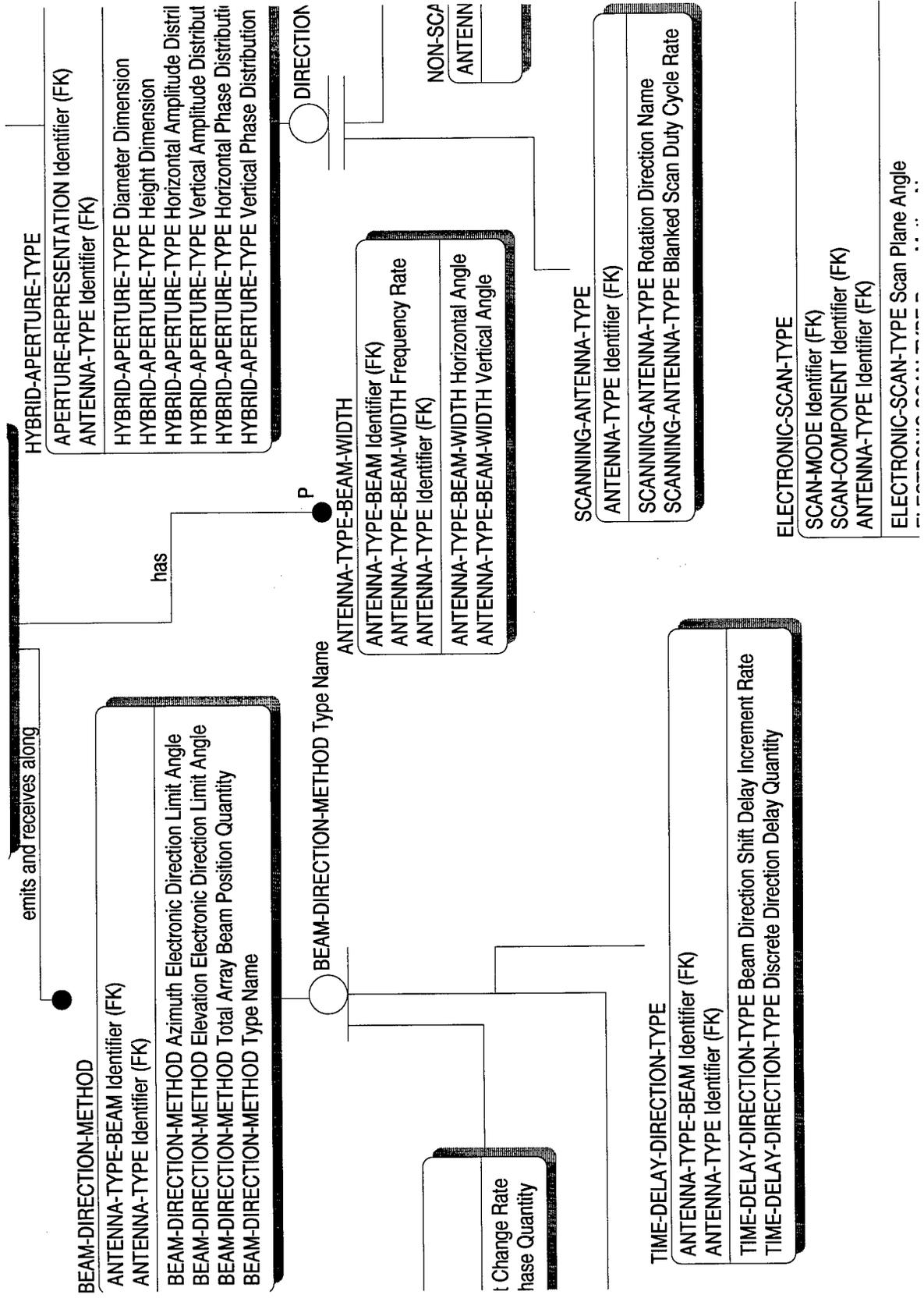

ANTENNA-TYPE Identifier (FK)
CIRCULAR-APERTURE-TYPE Diameter Dimension
CIRCULAR-APERTURE-TYPE Amplitude Distribution Name
CIRCULAR-APERTURE-TYPE Phase Distribution Name

RECTANGULAR-APERTURE-TYPE
APERTURE-REPRESENTATION Identifier (FK)
ANTENNA-TYPE Identifier (FK)
RECTANGULAR-APERTURE-TYPE Height Dimension
RECTANGULAR-APERTURE-TYPE Horizontal Amplitude Distribution Name
RECTANGULAR-APERTURE-TYPE Vertical Amplitude Distribution Name
RECTANGULAR-APERTURE-TYPE Horizontal Phase Distribution Name
RECTANGULAR-APERTURE-TYPE Vertical Phase Distribution Name
RECTANGULAR-APERTURE-TYPE Width Dimension

Distribution Name
Location Name
Position Name
Scan Name

CYCLICAL-ANTENNA-TYPE Scanning Type Name

CANNING-ANTENNA-TYPE
ANTENNA-TYPE Identifier (FK)

SCAN-MODE
SCAN-MODE Identifier
ANTENNA-TYPE Identifier (FK)
SCAN-MODE Scan Name

SCAN-COMPONENT
SCAN-MODE Identifier (FK)
SCAN-COMPONENT Identifier
ANTENNA-TYPE Identifier (FK)
SCAN-COMPONENT Scan Method Name
SCAN-COMPONENT Scan Plane Angle

operates in

consists of

P

P

SCANNING UNIT

SCAN-COMPONENT Identifier (FK)

ANTENNA-TYPE Identifier (FK)

BEAM-FORMATION-METHOD Period Quantity  
BEAM-FORMATION-METHOD Scan Limit Azimuth Angle  
BEAM-FORMATION-METHOD Azimuth Shift Rate  
BEAM-FORMATION-METHOD Scan Limit Elevation Angle  
BEAM-FORMATION-METHOD Beam Shift Elevation Rate  
BEAM-FORMATION-METHOD Beam Dwell Period Quantity  
BEAM-FORMATION-METHOD Pulse Beam Dwell Quantity  
BEAM-FORMATION-METHOD Amplitude Change Beam Shift Rate  
BEAM-FORMATION-METHOD Total Beam Position Quantity  
BEAM-FORMATION-METHOD Type Code  
BEAM-FORMATION-METHOD Maximum Horizontal Steering Angle  
BEAM-FORMATION-METHOD Maximum Horizontal Steering Rate  
BEAM-FORMATION-METHOD Maximum Vertical Steering Angle  
BEAM-FORMATION-METHOD Maximum Vertical Steering Rate

BEAM-FORMATION-METHOD Type Code

SC  
S S A S S

1

PHASE-SCAN-TYPE

SCAN-MODE Identifier (FK)

SCAN-COMPONENT Identifier (FK)

ANTENNA-TYPE Identifier (FK)

PHASE-SCAN-TYPE Beam Shift Phase Change Rate

PHASE-SCAN-TYPE Discrete Phase Quantity

PHASE-SCAN-TYPE Shift Phase Period Quantity

TIME-DELAY-STEERING

SCAN-MODE Identifier (FK)

SCAN-COMPONENT Identifier (FK)

ANTENNA-TYPE Identifier (FK)

TIME-DELAY-STEERING Beam Shift Delay Increment Rate

TIME-DELAY-STEERING Discrete Delay Quantity

TIME-DELAY-STEERING Shift Delay Period Quantity

FREQUENCY-SCAN-TYPE

SCAN-MODE Identifier (FK)

SCAN-COMPONENT Identifier (FK)

ANTENNA-TYPE Identifier (FK)

FREQUENCY-SCAN-TYPE Beam Shift Frequency Change Rate

FREQUENCY-SCAN-TYPE Total Frequency Step Quantity

ELECTRONIC-SCAN-TYPE Beam Motion Name  
 ELECTRONIC-SCAN-TYPE Array Design Name  
 ELECTRONIC-SCAN-TYPE Tilt Angle  
 ELECTRONIC-SCAN-TYPE Array Face Quantity  
 ELECTRONIC-SCAN-TYPE Face Coverage Angle  
 ELECTRONIC-SCAN-TYPE Element Type Name  
 ELECTRONIC-SCAN-TYPE Total Antenna Element Quantity  
 ELECTRONIC-SCAN-TYPE Element Spacing Azimuth Dimension  
 ELECTRONIC-SCAN-TYPE Element Spacing Elevation Dimension  
 ELECTRONIC-SCAN-TYPE Element Distribution Text  
 ELECTRONIC-SCAN-TYPE Beamwidth Variation Quantity  
 ELECTRONIC-SCAN-TYPE Maximum Managed Program Quantity  
 ELECTRONIC-SCAN-TYPE Identifier

is implemented via

is used to perform

SCAN-FUNCTION

SCAN-MODE Identifier (FK)  
 SCAN-COMPONENT Identifier (FK)  
 ANTENNA-TYPE Identifier (FK)  
 SCAN-FUNCTION Program Description Text  
 SCAN-FUNCTION Program Type Code

P

PERIODIC-ELECTRONIC-SCAN-TYPE

SCAN-MODE Identifier (FK)  
 SCAN-COMPONENT Identifier (FK)  
 ANTENNA-TYPE Identifier (FK)  
 PERIODIC-ELECTRONIC-SCAN-TYPE Most Probable Azimuth Beam Switch Rate  
 PERIODIC-ELECTRONIC-SCAN-TYPE Most Probable Beam Switching Elevation Rate  
 PERIODIC-ELECTRONIC-SCAN-TYPE Azimuth Beam Position Quantity  
 PERIODIC-ELECTRONIC-SCAN-TYPE Azimuth Pulse Scan Quantity  
 PERIODIC-ELECTRONIC-SCAN-TYPE Elevation Beam Position Scan Quantity  
 PERIODIC-ELECTRONIC-SCAN-TYPE Elevation Pulse Scan Quantity  
 PERIODIC-ELECTRONIC-SCAN-TYPE Scan Mode Quantity  
 PERIODIC-ELECTRONIC-SCAN-TYPE Change Scan Mode Period Quantity  
 PERIODIC-ELECTRONIC-SCAN-TYPE Switching Name  
 PERIODIC-ELECTRONIC-SCAN-TYPE Program Period Limit Quantity

Electronic-Scan-Type

MANUAL-SCAN  
 SCAN-MODE Identifier  
 SCAN-COMPONENT  
 ANTENNA-TYPE  
 MANUAL-SCAN /  
 MANUAL-SCAN E

ate

SCAN-FUNCTION

SCAN-FUNCTION Program Description Text  
 SCAN-FUNCTION Program Type Code



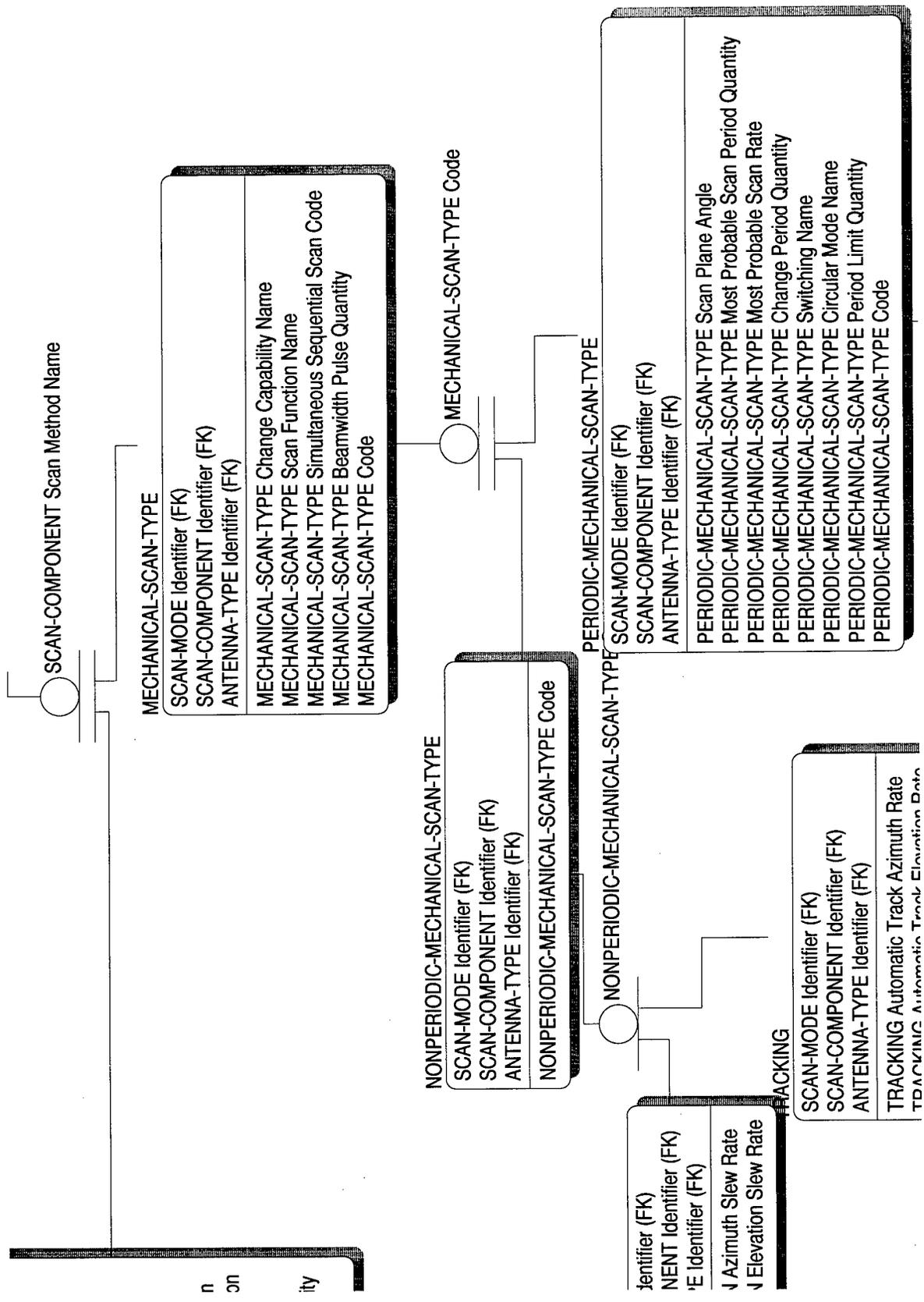

n  
on  
ity

entifier (FK)  
ENT Identifier (FK)  
E Identifier (FK)  
Azimuth Slew Rate  
Elevation Slew Rate

TRACKING  
SCAN-MODE Identifier (FK)  
SCAN-COMPONENT Identifier (FK)  
ANTENNA-TYPE Identifier (FK)  
TRACKING Automatic Track Azimuth Rate  
TRACKING Automatic Track Elevation Rate

NONPERIODIC-MECHANICAL-SCAN-TYPE  
SCAN-MODE Identifier (FK)  
SCAN-COMPONENT Identifier (FK)  
ANTENNA-TYPE Identifier (FK)  
NONPERIODIC-MECHANICAL-SCAN-TYPE Code

PERIODIC-MECHANICAL-SCAN-TYPE  
SCAN-MODE Identifier (FK)  
SCAN-COMPONENT Identifier (FK)  
ANTENNA-TYPE Identifier (FK)  
PERIODIC-MECHANICAL-SCAN-TYPE Scan Plane Angle  
PERIODIC-MECHANICAL-SCAN-TYPE Most Probable Scan Rate  
PERIODIC-MECHANICAL-SCAN-TYPE Change Period Quantity  
PERIODIC-MECHANICAL-SCAN-TYPE Switching Name  
PERIODIC-MECHANICAL-SCAN-TYPE Circular Mode Name  
PERIODIC-MECHANICAL-SCAN-TYPE Period Limit Quantity  
PERIODIC-MECHANICAL-SCAN-TYPE Code

PERIODIC-MECHANICAL-RASTER-SCAN-TYPE

SCAN-MODE Identifier (FK)

SCAN-COMPONENT Identifier (FK)

ANTENNA-TYPE Identifier (FK)

PERIODIC-MECHANICAL-RASTER-SCAN-TYPE Code

PERIODIC-MECHANICAL-RASTER-SCAN-TYPE Raster Type Text

PERIODIC-MECHANICAL-RASTER-SCAN-TYPE Raster Width Azimuth Angle

PERIODIC-MECHANICAL-RASTER-SCAN-TYPE Raster Width Elevation Angle

PERIODIC-MECHANICAL-RASTER-SCAN-TYPE Raster Bar Quantity

PERIODIC-MECHANICAL-RASTER-SCAN-TYPE Bar Orientation Name

PERIODIC-MECHANICAL-RASTER-SCAN-TYPE Bar Start Point Name

PERIODIC-MECHANICAL-RASTER-SCAN-TYPE Bar Period Quantity

PERIODIC-MECHANICAL-RASTER-SCAN-TYPE Bar Beam Position Quantity

PERIODIC-MECHANICAL-RASTER-SCAN-TYPE Blank Bar Period Quantity

PERIODIC-MECHANICAL-RASTER-SCAN-TYPE Flyback Period Quantity

PERIODIC-MECHANICAL-RASTER-SCAN-TYPE Raster Scan Period Quantity

FREQUENCY-SCAN-TYPE Total Frequency Step Quantity  
 FREQUENCY-SCAN-TYPE Frequency Shift Period Quantity

TARGET-ILLUMINATION-PROGRAM  
 SCAN-MODE Identifier (FK)  
 SCAN-COMPONENT Identifier (FK)  
 ANTENNA-TYPE Identifier (FK)  
 TARGET-ILLUMINATION-PROGRAM Simultaneous Target Program Quantity  
 TARGET-ILLUMINATION-PROGRAM Program Update Rate

TRACK-PROGRAM  
 SCAN-MODE Identifier (FK)  
 SCAN-COMPONENT Identifier (FK)  
 ANTENNA-TYPE Identifier (FK)  
 TRACK-PROGRAM Type Code  
 TRACK-PROGRAM Simultaneous Track Quantity  
 TRACK-PROGRAM Track Revisitation Interval Quantity  
 TRACK-PROGRAM Pulse Revisitation Rate

VERIFICATION-PROGRAM  
 SCAN-MODE Identifier (FK)  
 SCAN-COMPONENT Identifier (FK)  
 ANTENNA-TYPE Identifier (FK)  
 VERIFICATION-PROGRAM Pulse Beam Position Quantity  
 VERIFICATION-PROGRAM Revisitation Interval Quantity

TRACK-PROGRAM Type Code

TARGET-TRACK-PROGRAM  
 SCAN-MODE Identifier (FK)  
 SCAN-COMPONENT Identifier (FK)  
 ANTENNA-TYPE Identifier (FK)  
 TARGET-TRACK-PROGRAM Switch Target Track Quantity

WEAPON-TRACK-PROGRAM  
 SCAN-MODE Identifier (FK)  
 SCAN-COMPONENT Identifier (FK)  
 ANTENNA-TYPE Identifier (FK)

PERIODIC-ELECTRONIC-SCAN-TYPE Program Period Limit Quantity  
 PERIODIC-ELECTRONIC-SCAN-TYPE Beam Position Rule Text  
 PERIODIC-ELECTRONIC-SCAN-TYPE Code

HELICAL-SCAI  
 SCAN-MODE  
 SCAN-COMP  
 ANTENNA-TY  
 HELICAL-SCA  
 HELICAL-SCA  
 HELICAL-SCA  
 HELICAL-SCA  
 HELICAL-SCA

PERIODIC-ELECTRONIC-SCAN-TYPE Code

SEARCH-PROGRAM

SCAN-MODE Identifier (FK)  
 SCAN-COMPONENT Identifier (FK)  
 ANTENNA-TYPE Identifier (FK)  
 SEARCH-PROGRAM Pulse Position Quantity

NONPERIODIC-ELECTRONIC-SCAN-TYPE

SCAN-MODE Identifier (FK)  
 SCAN-COMPONENT Identifier (FK)  
 ANTENNA-TYPE Identifier (FK)

ELECTRONIC-CIRCULAR-SCAN

SCAN-MODE Identifier (FK)  
 SCAN-COMPONENT Identifier (FK)  
 ANTENNA-TYPE Identifier (FK)  
 ELECTRONIC-CIRCULAR-SCAN Minimum Period Quantity  
 ELECTRONIC-CIRCULAR-SCAN Maximum Period Quantity  
 ELECTRONIC-CIRCULAR-SCAN Nominal Period Quantity

ELECTRONIC-RASTER-SCAN

SCAN-MODE Identifier (FK)  
 SCAN-COMPONENT Identifier (FK)  
 ANTENNA-TYPE Identifier (FK)

ELECTRONIC-RASTER-SCAN Mode Type Text  
 ELECTRONIC-RASTER-SCAN Width Azimuth Ang  
 ELECTRONIC-RASTER-SCAN Width Elevation An  
 ELECTRONIC-RASTER-SCAN Bar Quantity  
 ELECTRONIC-RASTER-SCAN Bar Orientation Nai

ELECTRONIC-SECTOR-SCAN

SCAN-MODE Identifier (FK)  
 SCAN-COMPONENT Identifier (FK)  
 ANTENNA-TYPE Identifier (FK)

TRACKING Automatic Track Elevation Rate  
 TRACKING Switch Target Track Quantity

PERIODIC-MECHANICAL-SCAN-TYPE C00

- CONICAL-SCAN-TYPE
- SCAN-MODE Identifier
- SCAN-COMPONENT
- ANTENNA-TYPE Identifier
- CONICAL-SCAN-TYP
- CONICAL-SCAN-TYP
- CONICAL-SCAN-TYP
- CONICAL-SCAN-TYP
- CONICAL-SCAN-TYP
- CONICAL-SCAN-TYP

- SCAN-TYPE
- E Identifier (FK)
- COMPONENT Identifier (FK)
- TYPE Identifier (FK)
- SCAN-TYPE Helix Revolution Quantity
- SCAN-TYPE Helix Cycle Limit Quantity
- SCAN-TYPE Scan Turn Quantity
- SCAN-TYPE Width Elevation Angle
- SCAN-TYPE Discrete Elevation Step Quantity

MECHANICAL-LOBING-SCAN-TYPE

- SCAN-MODE Identifier (FK)
- SCAN-COMPONENT Identifier (FK)
- ANTENNA-TYPE Identifier (FK)
- MECHANICAL-LOBING-SCAN-TYPE Type Name
- MECHANICAL-LOBING-SCAN-TYPE Scan Function Type Name
- MECHANICAL-LOBING-SCAN-TYPE Lobing Limit Rate
- MECHANICAL-LOBING-SCAN-TYPE Change Period Quantity
- MECHANICAL-LOBING-SCAN-TYPE Change Waveform Name
- MECHANICAL-LOBING-SCAN-TYPE Pattern Name
- MECHANICAL-LOBING-SCAN-TYPE Scan Lobe Quantity
- MECHANICAL-LOBING-SCAN-TYPE Scanner Characteristic Name
- MECHANICAL-LOBING-SCAN-TYPE Scan Control Method Name
- MECHANICAL-LOBING-SCAN-TYPE Squint Angle
- MECHANICAL-LOBING-SCAN-TYPE Pseudo Random Lobing Name
- MECHANICAL-LOBING-SCAN-TYPE Switch Rate

RASTER-SCAN-TYPE

- SCAN-MODE Identifier (FK)
- SCAN-COMPONENT Identifier (FK)
- ANTENNA-TYPE Identifier (FK)

Angle  
 Angle  
 Name

MECHANICAL-CIRCULAR-SCAN

- SCAN-MODE Identifier (FK)
- SCAN-COMPONENT Identifier (FK)

PERIODIC-MECHANICAL-RASTER-SCAN-TYPE Raster Scan Period Quantity

code

PERIODIC-MECHANICAL-RASTER-SCAN-TYPE Code

PE

ier (FK)  
IT Identifier (FK)  
entifier (FK)

/PE Rotation Direction Name  
/PE Scan Limit Rate  
/PE Squint Angle  
/PE Superimposed Scan Name  
/PE Nutation Rate  
/PE Rotation Rate

SPIRAL-CARDIOID-SCAN-TYPE

SCAN-MODE Identifier (FK)  
SCAN-COMPONENT Identifier (FK)  
ANTENNA-TYPE Identifier (FK)

SPIRAL-CARDIOID-SCAN-TYPE Scan Limit Quantity  
SPIRAL-CARDIOID-SCAN-TYPE Sequence Text  
SPIRAL-CARDIOID-SCAN-TYPE Scan Coverage Angle

PALMER-RASTER-SCAN-TYPE

SCAN-MODE Identifier (FK)  
SCAN-COMPONENT Identifier (FK)  
ANTENNA-TYPE Identifier (FK)  
PALMER-RASTER-SCAN-TYPE Conical Scan Rate

:K)

ELECTRONIC-SECTOR-SCAN Type Name

ELECTRONIC-SECTOR-SCAN Scan Direction Text  
ELECTRONIC-SECTOR-SCAN Scan Flyback Quantity  
ELECTRONIC-SECTOR-SCAN Width Azimuth Angle  
ELECTRONIC-SECTOR-SCAN Width Elevation Angle

ELECTRONIC-RASTER-SCAN Bar Start Point Nan  
ELECTRONIC-RASTER-SCAN Bar Period Quantity  
ELECTRONIC-RASTER-SCAN Beam Position Qua  
ELECTRONIC-RASTER-SCAN Flyback Quantity

ELECTRONIC-LOBING-SCAN

SCAN-MODE Identifier (FK)

SCAN-COMPONENT Identifier (FK)

ANTENNA-TYPE Identifier (FK)

ELECTRONIC-LOBING-SCAN Monopulse Type Name

ELECTRONIC-LOBING-SCAN Waveform Change Name

ame  
tity  
uantity

ANTENNA-TYPE Identifier (FK)

MECHANICAL-SECTOR-SCAN-TYPE

- SCAN-MODE Identifier (FK)
- SCAN-COMPONENT Identifier (FK)
- ANTENNA-TYPE Identifier (FK)
- MECHANICAL-SECTOR-SCAN-TYPE Scan Pattern Description Text
- MECHANICAL-SECTOR-SCAN-TYPE Scan Relation Description Text
- MECHANICAL-SECTOR-SCAN-TYPE Scan Component Azimuth Period Quantity
- MECHANICAL-SECTOR-SCAN-TYPE Scan Component Elevation Period Quantity
- MECHANICAL-SECTOR-SCAN-TYPE Sector Scan Rate
- MECHANICAL-SECTOR-SCAN-TYPE Sector Beamwidth Ratio Rate
- MECHANICAL-SECTOR-SCAN-TYPE Sector Type Name
- MECHANICAL-SECTOR-SCAN-TYPE Scan Direction Name
- MECHANICAL-SECTOR-SCAN-TYPE Flyback Period Quantity
- MECHANICAL-SECTOR-SCAN-TYPE Sector Width Azimuth Angle
- MECHANICAL-SECTOR-SCAN-TYPE Sector Width Elevation Angle



Entity Name: ANTENNA-LEAD-IN-ASSEMBLY  
 Entity Definition: The equipment that connects an antenna with its possible receivers, transmitters, and transceivers.  
 Table Name: ANTENNA\_COUPLING\_U  
 Attribute Names: ANTENNA-TYPE Identifier (PK) (FK)  
 Column Names: Materiel\_ID CHAR(35) NOT NULL  
 Primary Key: Materiel\_ID  
 Foreign Keys: ANTENNA-TYPE Identifier References: ANTENNA-TYPE  
 FK Referential Integ: U - Restrict I - Restrict D - Restrict CU - Restrict PI - Restrict CD -

Attribute Names: RF Equipment ID (PK) (FK)  
 Column Names: Materiel\_ID CHAR(18) NOT NULL  
 Primary Key: Materiel\_ID  
 Foreign Keys: RF Equipment ID References: TRANSMISSION-RECEPTION-EQUIPMENT-TYPE  
 FK Referential Integ: U - Restrict I - Restrict D - Restrict CU - Restrict PI - Restrict CD -

Entity Name: ANTENNA-TYPE  
 Entity Definition: The classification of a device for the collection or radiation of electromagnetic signals.  
 Table Name: ANTENNA  
 Attribute Names: ANTENNA-TYPE Identifier (PK) (FK)  
 Column Names: Materiel\_ID CHAR(35) NOT NULL  
 Primary Key: Materiel\_ID  
 Foreign Keys: ANTENNA-TYPE Identifier References: EQUIPMENT  
 FK Referential Integ: U - Restrict I - Restrict D - Cascade CU - PI - CD -

Attribute Names: ANTENNA-TYPE Use Name  
 Column Names: ant\_use\_name CHAR(35)

Attribute Names: ANTENNA-TYPE Nomenclature Identifier  
 Column Names: Ant\_Nomenclature CHAR(35)

Attribute Names: ANTENNA-TYPE Application Mode Name  
 Column Names: Ant\_Application CHAR(20)

Attribute Names: ANTENNA-TYPE Distance Dimension  
 Column Names: Ant\_Distance FLOAT(6,2)

Attribute Names: ANTENNA-TYPE Tracking Name  
 Column Names: Ant\_Tracking CHAR(15)

Attribute Names: ANTENNA-TYPE Transmission Feed Name  
 Column Names: Ant\_Transmission CHAR(15)

Attribute Names: ANTENNA-TYPE Drive Type Name  
 Column Names: Ant\_Drive\_Type CHAR(250)

Attribute Names: ANTENNA-TYPE Maximum Slew Rate  
 Column Names: ant\_max\_slew\_rate FLOAT(10)

Attribute Names: ANTENNA-TYPE Maximum Acceleration Rate  
Column Names: ant\_max\_accelerati FLOAT(7)

Attribute Names: ANTENNA-TYPE Length Dimension  
Column Names: ant\_length FLOAT(6,2)

Attribute Names: ANTENNA-TYPE Weight  
Column Names: Ant\_Weight FLOAT(10)

Attribute Names: ANTENNA-TYPE Directional Type Name  
Column Names: ant\_direction\_type CHAR(250)

Attribute Names: ANTENNA-TYPE Physical Type Name  
Column Names: Ant\_Physical\_Type CHAR(250)

Attribute Names: ANTENNA-TYPE Low Range Frequency Rate  
Column Names: Ant\_Low\_Freq FLOAT(7)

Attribute Names: ANTENNA-TYPE High Range Frequency Rate  
Column Names: Ant\_High\_Freq FLOAT(7)

Attribute Names: ANTENNA-TYPE Mount Feed Point Dimension  
Column Names: Ant\_Mount\_Feed FLOAT(6,2)

Attribute Names: ANTENNA-TYPE Mount Point Dimension  
Column Names: Ant\_Mount\_Point FLOAT(6,2)

Attribute Names: ANTENNA-TYPE Efficiency Rate  
Column Names: Ant\_Efficiency FLOAT(10)

Attribute Names: ANTENNA-TYPE Maximum Effective Radiated Power Rate  
Column Names: Ant\_Max\_ERP FLOAT(7)

Attribute Names: ANTENNA-TYPE Ground Stake Code  
Column Names: Ant\_Ground\_Stake CHAR(1)

Entity Name: ANTENNA-TYPE-BAND

Entity Definition: The operation of an antenna in a frequency range.

Table Name: ANTENNA\_BAND\_SELECT

Attribute Names: ANTENNA-TYPE Identifier (PK) (FK) (AK)

Column Names: Materiel\_ID CHAR(35) NOT NULL

Primary Key: Materiel\_ID

Foreign Keys: ANTENNA-TYPE Identifier References: ANTENNA-TYPE

FK Referential Integ: U - Restrict I - Restrict D - Restrict CU - Restrict PI - Restrict CD -

Attribute Names: ANTENNA-TYPE-BAND Selection Identifier (PK)

Column Names: Band\_Selection\_ID CHAR(35) NOT NULL

Primary Key: Band\_Selection\_ID

Attribute Names: ANTENNA-TYPE-BAND Low Frequency Rate (AK)

Column Names: Ant\_Band\_Low\_Freq FLOAT(7) NOT NULL

Attribute Names: ANTENNA-TYPE-BAND High Frequency Rate (AK)

Column Names: Ant\_Band\_High\_Freq FLOAT(7) NOT NULL

Attribute Names: ANTENNA-TYPE-BAND Antenna Gain Rate

Column Names: Ant\_Band\_Gain FLOAT(7)

Attribute Names: ANTENNA-TYPE-BAND Impedence Rate

Column Names: Ant\_Band\_Impedence FLOAT(7)

Entity Name: ANTENNA-TYPE-INTEGRAL-MAST

Entity Definition: The supporting structure for raising an antenna above the ground or the platform provided as an integral part of the antenna assembly.

Table Name: Integral\_Mast

Attribute Names: ANTENNA-TYPE Identifier (PK) (FK)

Column Names: Materiel\_ID CHAR(35) NOT NULL

Primary Key: Materiel\_ID

Foreign Keys: ANTENNA-TYPE Identifier References: ANTENNA-TYPE

FK Referential Integ: U - Restrict I - Restrict D - Restrict CU - Restrict PI - Restrict CD -

Attribute Names: ANTENNA-TYPE-INTEGRAL-MAST Identifier (PK)

Column Names: Mast\_ID CHAR(35) NOT NULL

Primary Key: Mast\_ID

Attribute Names: ANTENNA-TYPE-INTEGRAL-MAST Antenna Mast Section Quantity

Column Names: Mast\_Num\_Sections INTEGER

Attribute Names: ANTENNA-TYPE-INTEGRAL-MAST Minimum Height Dimension

Column Names: Mast\_Height\_Min FLOAT(6,2)

Attribute Names: ANTENNA-TYPE-INTEGRAL-MAST Maximum Height Dimension

Column Names: Mast\_Height\_Max FLOAT(6,2)

Entity Name: EQUIPMENT

Entity Definition: Materiel that is not consumed in use, retains its original identity during the period of use, and requires accountability. All non-expendable items needed to

Table Name: EQUIPMENT

Attribute Names: Materiel Identifier (PK)

Column Names: Materiel\_ID CHAR(18) NOT NULL

Primary Key: Materiel\_ID

Attribute Names: EQUIPMENT Type Code

Column Names: Equipment\_Type CHAR(18)

Entity Name: TRANSMISSION-RECEPTION-EQUIPMENT-TYPE

Entity Definition: The classification of the equipment that is a transmitter, receiver or transceiver.

Table Name: RF\_EQUIPMENT

Attribute Names: RF Equipment ID (PK) (FK)

Column Names: Materiel\_ID CHAR(18) NOT NULL

Primary Key: Materiel\_ID

Foreign Keys: RF Equipment ID References: EQUIPMENT

FK Referential Integ: U - Cascade I - Restrict D - Cascade CU - Restrict PI - CD -

*Appendix B. IDEF0 Antenna Model*

The following diagrams show the activity model of the OE-254()/GRC antenna and schema for each activity, input, control and output.

USED AT:	AUTHOR: Timothy R. Schmoyer, CPT	DATE: 15 Feb. 1997	WORKING	READER	DATE	CONTEXT:
	PROJECT: OE-254()/GRC Model Project	REV: 17 Feb. 1997	DRAFT			TOP
	NOTES: 1 2 3 4 5 6 7 8 9 10		RECOMMENDED			
			PUBLICATION			

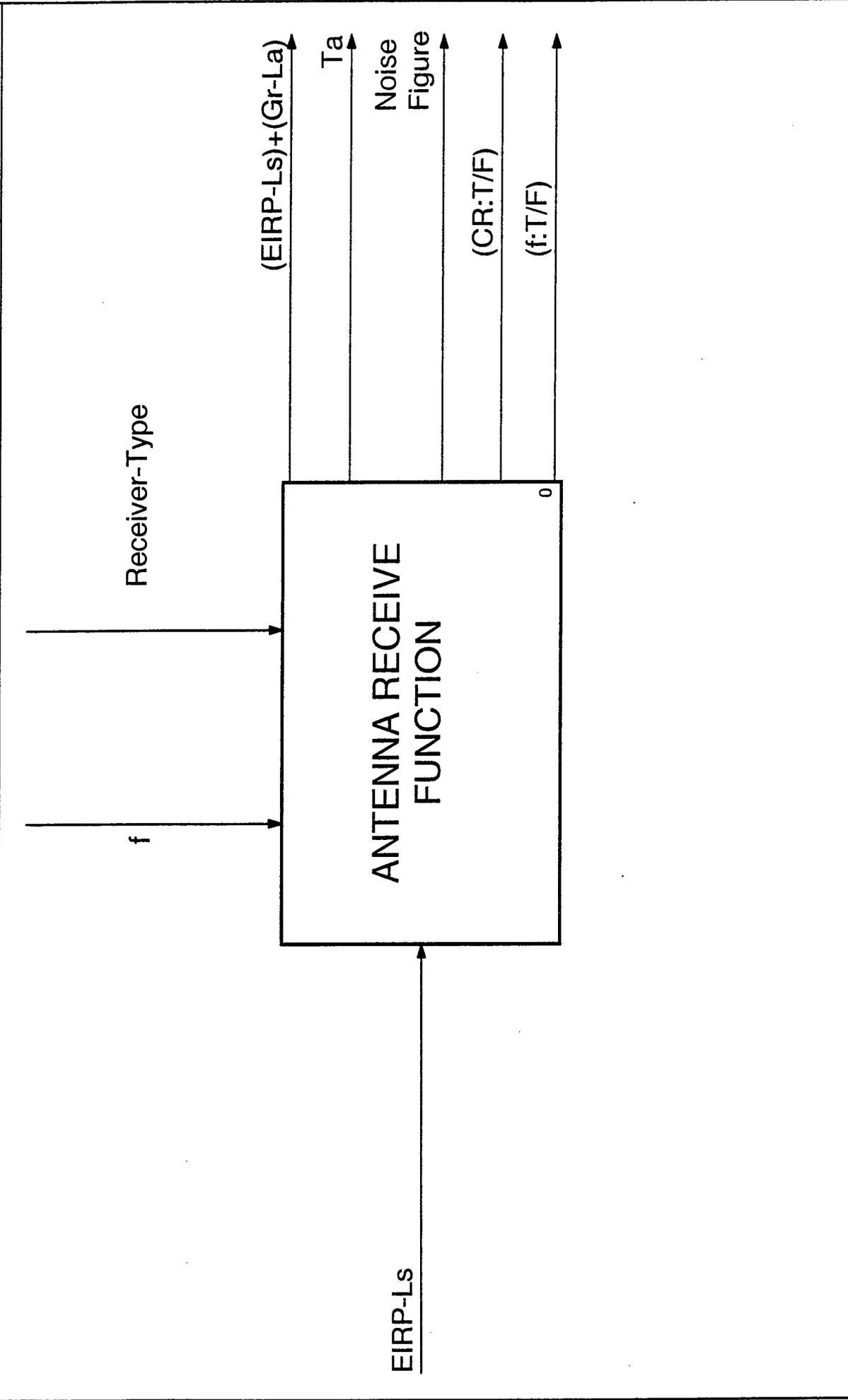

NODE: A-0	TITLE: ANTENNA RECEIVE FUNCTION	NUMBER:
-----------	---------------------------------	---------

USED AT:	AUTHOR: Timothy R. Schmoyer, CPT	DATE: 15 Feb. 1997	WORKING	READER	DATE	CONTEXT:
	PROJECT: OE-254()/GRC Model Project	REV: 17 Feb. 1997	DRAFT			TOP
	NOTES: 1 2 3 4 5 6 7 8 9 10		RECOMMENDED			A-0
			PUBLICATION			

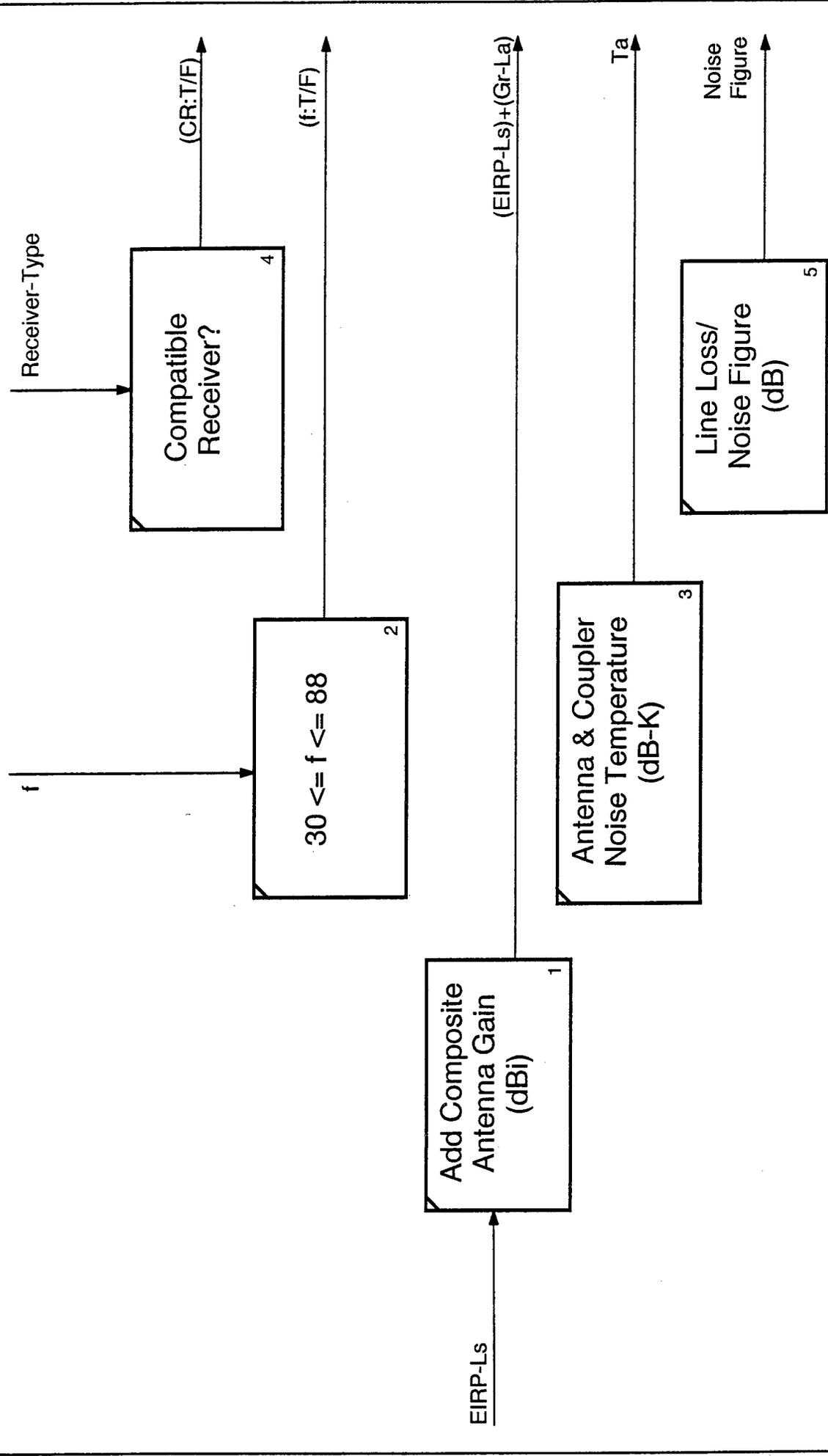

NODE: A0	TITLE: ANTENNA RECEIVE FUNCTION	NUMBER:
----------	---------------------------------	---------

Model Name: OE-254()/GRC  
Definition: This model represents the activities of the antenna when receiving a signal across a path and providing that signal to the receiver to determine bit energy per noise power spectral density and link margin.  
Scope: OE-254()/GRC operations; path to receiver.  
Viewpoint: At the antenna.  
Purpose: To standardize antenna models for for net centric simulation.  
Source: MIL-A-49204A  
TC 24-24  
Sklar, Bernard; DIGITAL COMMUNICATIONS Fundamentals and Applications; PTR Prentice Hall, Englewood Cliffs, NJ 07632; 1988  
Author Name: Timothy R. Schmoyer, CPT



Activity Name	Activity Definition	Input Name	Input Definition
ANTENNA RECEIVE FUNCTION	The process required in RF reception to add antenna effects to path loss and noise for determining bit energy per noise power spectral density and link margin	EIRP-Ls	Effective Isotropic Power (dBW) from minus the path loss
Add Composite Antenna Gain (dBi)	Antenna gain is a function of frequency and effective area. $G = 4(\pi)A_e / (3E8/f)^2$ $A_e = (\text{efficiency})A_p$	EIRP-Ls	Effective Isotropic Power (dBW) from minus the path loss
30 <= f <= 88	Is the center frequency greater than 30 (MHz) and less than 88 (MHz)? Returns true if it is, and false if f falls outside		

sn	Control Name	Control Definition	Output Name
ropic Radiated om the transmitter loss (dB).	f	Center frequency of transmitted signal over the radiowave propagation path which is compared with the frequency range of the antenna.	(EIRP-Ls)+(Gr-La)
Receiver-Type		Identity of Receiver which is compared with an array of Receivers to verify compatibility.	Ta
		Noise Figure	
			(CR:T/F)
			(f:T/F)
ropic Radiated om the transmitter loss (dB).			(EIRP-Ls)+(Gr-La)
	f	Center frequency of transmitted signal over the radiowave propagation path which is compared with the frequency	(f:T/F)

Output Definition

---

Antenna gain (dBi) minus the line and coupler loss (dB) (which must be 3 dB or greater for this antenna) plus the Effective Isotropic Radiated Power (dBW) from the transmitter minus the path loss (dB).

Noise Temperature of the Antenna (dB-K).

Noise Figure of the cable and coupler (dB).

Returns a boolean value depending if Receiver-Type matched a value (NSN) in the Compatible Receiver Array.

Returns a boolean value depending if f is within antenna's frequency range.

Antenna gain (dBi) minus the line and coupler loss (dB) (which must be 3 dB or greater for this antenna) plus the Effective Isotropic Radiated Power (dBW) from the transmitter minus the path loss (dB).

Returns a boolean value depending if f is within antenna's frequency range.

this range.

The Noise Temperature into the Receiver Pre-amplifier.

Antenna & Coupler Noise Temperature (dB-K)

Compatible Receiver?

Compares Receive-Type with list of compatible Receivers:  
5820-00-857-0759 (AN/PRC-25)  
5820-00-223-7412 (AN/VRC-12)  
5820-01-151-9915 (AN/PRC-119)  
5820-01-151-9916 (AN/VRC-87)  
5820-01-151-9917 (AN/VRC-88)  
5820-01-151-9918 (AN/VRC-89)  
5820-01-151-9919 (AN/VRC-90)  
5820-01-151-9920 (AN/VRC-91)  
5820-01-151-9921 (AN/VRC-92)

Added to Losses/Noise in Receiver for Lo in Link Margin equation.

Line Loss/ Noise Figure (dB)

range of the antenna.

Ta

(CR:T/F)

Identity of Receiver which is compared with an array of Receivers to verify compatibility.

Receiver-Type

Noise Figure

Noise Temperature of the Antenna  
(dB-K).

Returns a boolean value  
depending if Receiver-Type  
matched a value (NSN) in the  
Compatible Receiver Array.

Noise Figure of the cable and  
coupler (dB).

## *Appendix C. C4I Modeling and Simulation*

In this appendix, the hierarchy of communications systems is described and a brief discussion of types of simulations is provided. A detailed discussion is also provided concerning the modeling of radiowave propagation to arrive at accurate received power and link margin calculations. The importance of developing simulations based on accurate models is discussed in the need for automation and determining the perishability of information.

### *C.1 Network Layering*

Communications networks are modeled according to the network architecture. The most common network architecture for computer networks is the International Standards Organization (ISO) Open Systems Interconnect (OSI) model (Figure C.1). There are other network architectures based on the OSI model, such as the Internet Protocol (IP) architecture, Systems Network Architecture, and Digital Network architecture, but the OSI model provides the framework(34). The network control functions are performed in the session, transport, network, and data link layer. The radios, antenna and associated hardware are the physical layer.

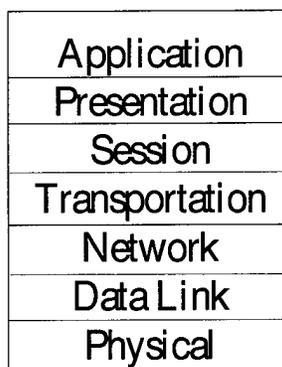

Figure C.1 Open Systems Interconnection Reference Model Architecture(34)

### *C.2 Abstract vs. Detail Modeling*

The tension between detailed and abstract modeling (often referred to as the fidelity of the model) is a fundamental issue for the network simulator. Detailed models provide accurate results, but can take a long time to develop and consume large amounts of computer resources to generate results. Abstract models typically generate results much more quickly, but their results may not be useful if too many simplifying assumptions have been made in the abstraction(16, 22). The key input from the network engineer is recognition of the key components of the system that must be modeled in detail and what abstractions can be used to reduce simulation run times(4). An important consideration when modeling communications systems is communication realism in the network due to changes on the battlefield. The temporal effects of the environment on a radio path is often left out of many battlefield simulations encompassing communications. Environmental effects are modeled in the links, and are measured in data errors and received signal levels.

### *C.3 Real-Time vs. Analytical*

There are two types of simulations in use today, real-time and analytical. Real-Time simulations provide output in near real-time (approximately every 5 seconds) for use by other simulations (distributed interactive simulations) or humans (training and war-gaming). Real-time simulations often required more abstraction to meet the 5 second requirement, however, communications realism in Real-Time simulations is necessary in a dynamic environment to provide feedback when communications are operating reliably, stressed or no longer possible. If a communications link experiences a loss for a fraction of a second, the digital message which had been transmitted over several seconds or minutes may have to be resent. However, in a voice message, the same error may cause an insignificant or even unnoticeable chirp. Analytical simulations can "elongate" time and be more detailed, but are less useful in interactive or distributed simulations. Communications



realism is also important in these simulations to determine reliability and the causes of failures in the network.

Expanding the previous discussion, the use of "visual physics", the practice of making something look realistic, whether or not physically correct, is common in real-time simulations. By contrast, analytic simulations rely heavily on deterministic, discrete, closed, event-driven models which are reproducible and accurate. Many of the analytic models have undergone a rigorous validation and verification process to ensure the accuracy and truthfulness of their algorithm. In order to verify that the real-time simulation is accurately reflecting real world expectations, analytical simulations based on measured data must be completed(31). The verification, validation and accreditation process of a *realistic communications* algorithm is the basis for this thesis.

#### *C.4 Constructive, Virtual and Live Simulations*

Simulations are also described as constructive, virtual and live. Constructive simulations require little or no interaction from humans. These are usually purely analytical. Virtual simulations require some interaction between the computer and human. Manned simulators and war-gaming exercises are examples of virtual simulations. Live simulations are real-time experiments, training exercises, demonstrations and tests that take place in a field like environment(5).

#### *C.5 Modeling Radiowave Propagation*

Figure C.2 is a block diagram of a satellite communications link, emphasizing the sources of signal loss and noise. In the figure, a signal loss is distinguished from a noise source by a dot pattern or line pattern, respectively. The contributors of *both* signal loss and noise are identified by a crosshatched line pattern. There are 21 sources of degradation cataloged by the figure. This is only a partial list(32). This section will discuss the sources of signal loss and noise as a result of the environment.

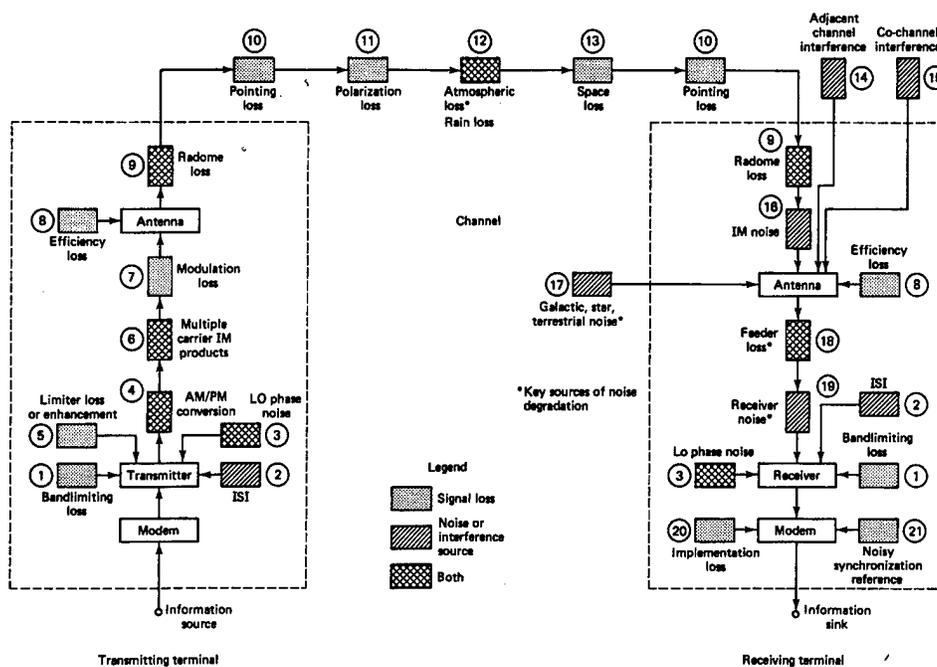

Figure C.2 Satellite Transmitter-to-Receiver Link with Typical Loss and Noise Sources(32)

There are many environmental factors which degrade communications over the path. Many of these factors are temporal and cause severe fading or increased noise when they occur. Figure C.3 shows some of the environmental factors which can affect communications(14).

### C.6 Ionospheric effects

Radio frequency waves propagating in the ionosphere experience dissipative attenuation which becomes increasingly important with decreasing frequency. A principal mechanism of attenuation is collisions of free electrons with neutral atoms and molecules. An electromagnetic wave propagating in a plasma imparts an ordered component of velocity to the electrons but the electrons lose some of the associated energy in the collision process. Hence the electromagnetic wave is attenuated. For frequencies above about 30 MHz or for transverse propagation of the ordinary wave, the attenuation constant varies inversely with frequency squared and can be found using Equation C.1 (13):

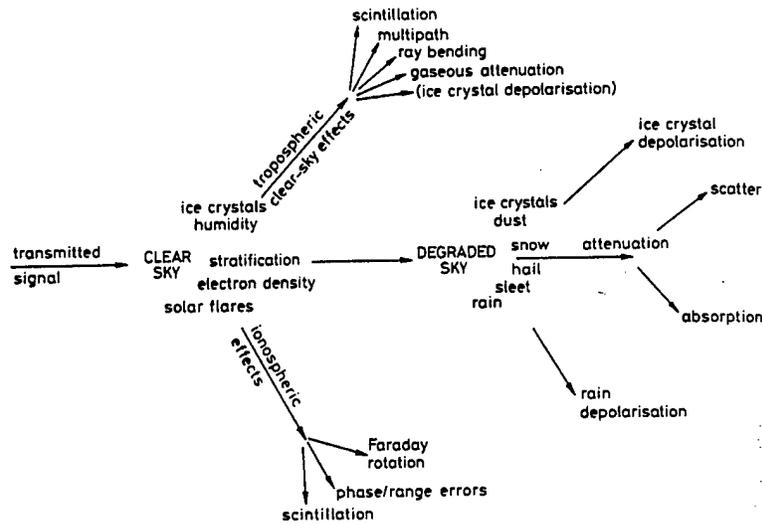

Figure C.3 Schematic Presentation of Propagation Impairment Mechanisms(14)

$$\alpha = 8.686 \left( \frac{Nq^2\nu}{2m\epsilon_0 n_r c \omega^2} \right) \quad \text{dB/m} \quad (\text{C.1})$$

where:

$N$  is the electron density of the ionosphere in electrons/ $\text{m}^3$

$n_r$  is the real part of the index of refraction

$$q = 1.6022 \times 10^{-19} \text{ C}$$

$$m = 9.1096 \times 10^{-31} \text{ kg}$$

$$\epsilon_0 = 8.854 \times 10^{-12} \text{ F/m}$$

$$c = 2.9979 \times 10^8 \text{ m/s}$$

$$\omega = 2\pi f \text{ with } f \text{ in Hz}$$

and  $\nu$  is the collision frequency in Hz.

### C.7 Clouds and Fog

Clouds and fog are both composed of minute water droplets or ice crystals suspended in air. Fog forms near the Earth's surface, and clouds occur at higher levels. The water droplets in fog and clouds cause attenuation of electromagnetic waves and add noise by acting as an elementary antenna that radiates energy. The attenuation caused by clouds for frequencies between 1GHz and 50GHz can be found by using Equation C.2,(13)

$$\alpha_p = \left( 0.4343 \frac{6\pi}{\lambda} \text{Im} \left[ -\frac{K_c - 1}{K_c + 2} \right] \right) \rho_l \quad \text{dB/km} \quad (\text{C.2})$$

where

$\alpha_p$  is the attenuation coefficient (dB/km)

$\lambda_{cm}$  is the wavelength (cm)

$K_c$  is the complex relative dielectric constant of water

$\rho_l$  is the liquid water content of the cloud ( $\text{g/m}^3$ )

and the noise caused by the cloud can be found using Equation C.3,

$$T_b = T_s e^{-\tau} + T_i (1 - e^{-\tau}) \quad (\text{C.3})$$

where  $T_b$  is the brightness temperature when a source at a temperature of  $T_s$  is viewed through an absorbing region having an effective temperature of  $T_i$ . The parameter  $\tau$  represents the integral of the power attenuation constant across the path. This noise,  $T_b$  is then added to the system temperature,  $T_{sys}$ , through the antenna(13). The attenuation and noise temperature as a result of clouds as a function of frequency is shown in Table C.1.

Case	Lower Cloud				Upper Cloud				Remarks	S-Band (2.3 GHz) Zenith		X-Band (8.5 GHz) Zenith		Y-Band (10 GHz) Zenith	
	Density g/m <sup>3</sup>	Base km	Top km	Thick- ness km	Density g/m <sup>3</sup>	Base km	Top km	Thick- ness km		T(K)	A(dB)	T(K)	A(dB)	T(K)	A(dB)
1	-	-	-	-	-	-	-	-	Clear Air	2.15	.035	2.78	0.45	3.05	.049
2	0.2	1.0	1.2	0.2	-	-	-	-	Thin Clouds	2.16	.036	2.90	.047	3.22	.052
3	-	-	-	-	0.2	3.0	3.2	0.2		2.16	.036	2.94	.048	3.28	.053
4	0.5	1.0	1.5	0.5	-	-	-	-		2.20	.036	3.55	.057	4.12	.066
5	-	-	-	-	0.5	3.0	3.5	0.5		2.22	.037	3.83	.062	4.50	.073
6	0.5	1.0	2.0	1.0	-	-	-	-	Medium Clouds	2.27	.037	4.38	.070	5.27	.084
7	-	-	-	-	0.5	3.0	4.0	1.0		2.31	.038	4.96	.081	6.06	.098
8	0.5	1.0	2.0	1.0	0.5	3.0	4.0	1.0	Heavy Clouds	2.43	.040	6.55	.105	8.25	.133
9	0.7	1.0	2.0	1.0	0.7	3.0	4.0	1.0		2.54	.042	8.04	.130	10.31	.166
10	1.0	1.0	2.0	1.0	1.0	3.0	4.0	1.0		2.70	.044	10.27	.166	13.35	.216
11	1.0	1.0	2.5	1.5	1.0	3.5	5.0	1.5	Very Heavy Clouds	3.06	.050	14.89	.245	19.66	.326
12	1.0	1.0	3.0	2.0	1.0	4.0	6.0	2.0		3.47	.057	20.20	.340	26.84	.457

Table C.1 Sample Cloud Models and S-, X-, K-Band Zenith Effects(14)

### C.8 Rain

Raindrops, like clouds but more severe, cause attenuation of radio waves by both absorption and scatter. Absorption involves dissipation of some of the energy of an electromagnetic wave as heat. Scatter involves diversion of some of the energy of the wave into directions other than the forward direction. The attenuation coefficient from rain can be found using Equation C.4 (13)

$$\gamma = kR^\alpha \text{ dB/km} \quad (C.4)$$

where R is the rain rate in mm/hr, and k and  $\alpha$  have been recorded in Table C.2 for the index of refraction of water at 20° C and spheroidal drops in the range of 1-150 mm/h.

The rain rate for different geographic areas around the world have been measured and regions have been identified by their rain rate climate. These eight regions are shown in Figures C.4 and C.5 as well as the rain rates exceeded as a percentage of the year. Table C.3 provides a more detailed chart for the rain rates exceeded in regions A to H as a percentage of the year.

Frequency (GHz)	$k_H$	$k_V$	$\alpha_H$	$\alpha_V$
1	0-000387	0-000352	0-912	0-880
2	0-000154	0-000138	0-963	0-923
4	0-000650	0-000591	1-121	1-075
6	0-00175	0-00155	1-308	1-265
7	0-00301	0-00265	1-332	1-312
8	0-00454	0-00395	1-327	1-310
10	0-0101	0-00887	1-276	1-264
12	0-0188	0-0168	1-217	1-200
15	0-0367	0-0335	1-154	1-128
20	0-0751	0-0691	1-099	1-065
25	0-124	0-113	1-061	1-030
30	0-187	0-167	1-021	1-000
35	0-263	0-233	0-979	0-963
40	0-350	0-310	0-939	0-929
45	0-442	0-393	0-903	0-897
50	0-536	0-479	0-873	0-868
60	0-707	0-642	0-826	0-824
70	0-851	0-784	0-793	0-793
80	0-975	0-906	0-769	0-769
90	1-06	0-999	0-753	0-754
100	1-12	1-06	0-743	0-744
120	1-18	1-13	0-731	0-732
150	1-31	1-27	0-710	0-711
200	1-45	1-42	0-689	0-690
300	1-36	1-35	0-688	0-689
400	1-32	1-31	0-683	0-684

Laws and Parsons droppsize distribution [7]  
 Gunn and Ginzer terminal velocities [8]  
 Index of refraction of water at 20°C after Ray [9]  
 Values of  $k_H$ ,  $k_V$ ,  $\alpha_H$ , and  $\alpha_V$  for spheroidal drops [10, 11] in the range 1-150 mm/h

Table C.2 Regression Coefficients for Estimating the Attenuation Coefficients(14)

Percent of Year	RAIN CLIMATE REGION												Minutes per Year	Hours per Year
	A	B <sub>1</sub>	B	B <sub>2</sub>	C	D <sub>1</sub>	D=D <sub>2</sub>	D <sub>3</sub>	E	F	G	H		
0.001	28.5	45	57.5	70	78	90	108	126	165	66	185	253	5.26	0.09
0.002	21	34	44	54	62	72	89	106	144	51	157	220.5	10.5	0.18
0.005	13.5	22	28.5	35	41	50	64.5	80.5	118	34	120.5	178	26.3	0.44
0.01	10.0	15.5	19.5	23.5	28	35.5	49	63	98	23	94	147	52.6	0.88
0.02	7.0	11.0	13.5	16	18	24	35	48	78	15	72	119	105	1.75
0.05	4.0	6.4	8.0	9.5	11	14.5	22	32	52	8.3	47	86.5	263	4.38
0.1	2.5	4.2	5.2	6.1	7.2	9.8	14.5	22	35	5.2	32	64	526	8.77
0.2	1.5	2.8	3.4	4.0	4.8	6.4	9.5	14.5	21	3.1	21.8	43.5	1052	17.5
0.5	0.7	1.5	1.9	2.3	2.7	3.6	5.2	7.8	10.6	1.4	12.2	22.5	2630	43.8
1.0	0.4	1.0	1.3	1.5	1.8	2.2	3.0	4.7	6.0	0.7	8.0	12.0	5260	87.7
2.0	0.1	0.5	0.7	0.8	1.1	1.2	1.5	1.9	2.9	0.2	5.0	5.2	10520	175
5.0	0.0	0.2	0.3	0.3	0.5	0.0	0.0	0.0	0.5	0.0	1.8	1.2	26298	438

Table C.3 Rain Rates Exceeded as a Function of Percentage of Year, for Regions A to H(13)

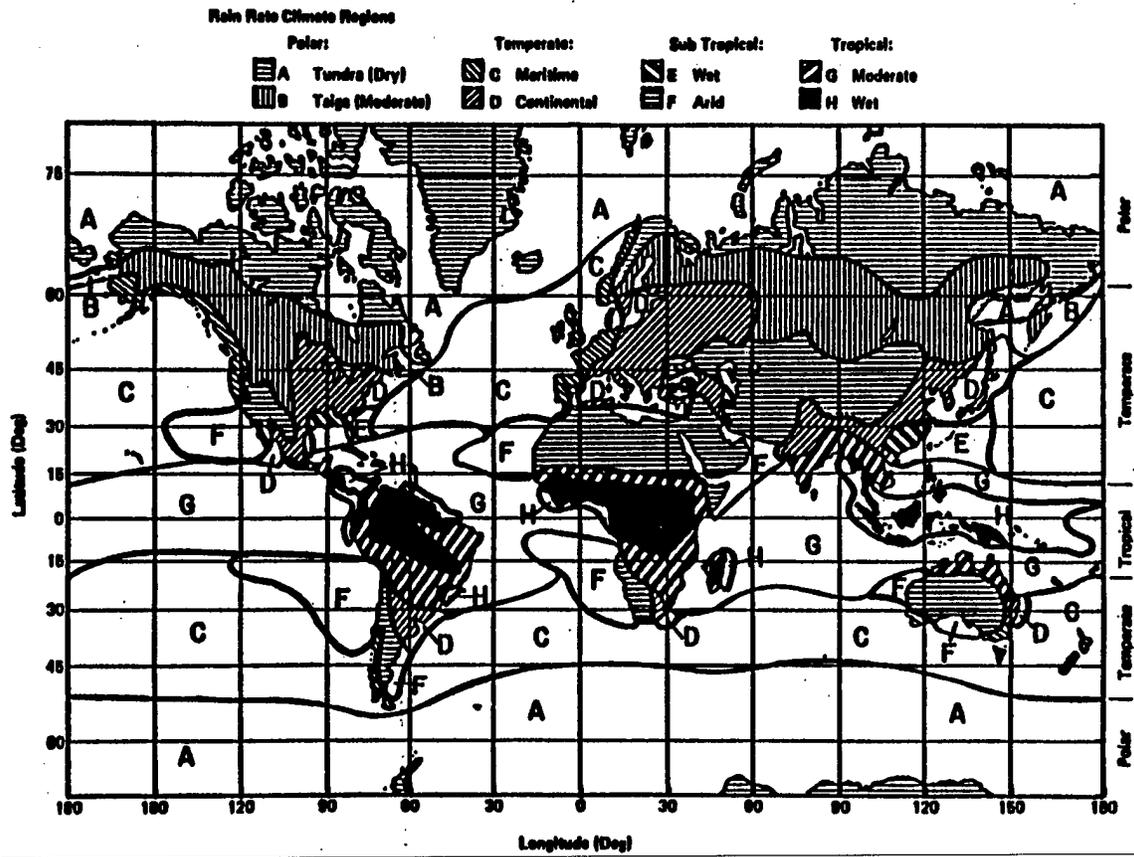

Figure C.4 Global Rain Rate Regions(13)

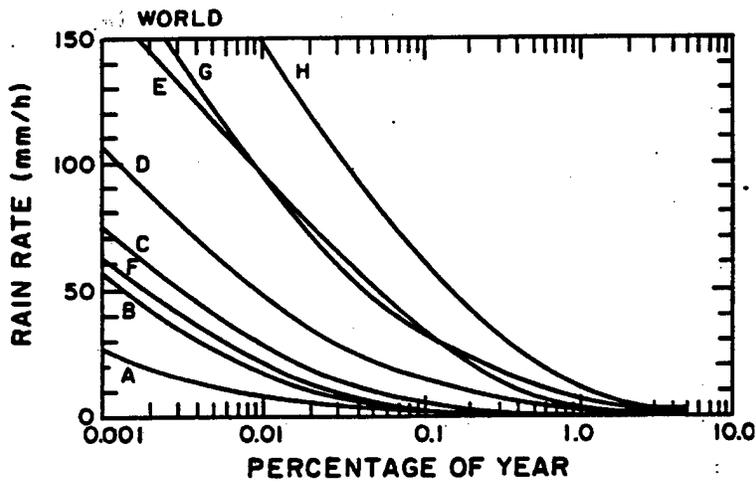

Figure C.5 Rain Rates as a Function of Percent of Year Exceeded(13)

The attenuation over the path is a function of the path length traveling through the rain. For satellite paths, it is necessary to measure the path length as a function of the height of the rain storm. For latitudes below  $36^\circ$ , use a rain height of 4 km. For latitudes of  $36^\circ$  and above, use the Equation(13)

$$H = 4.0 - 0.75(\Theta - 36^\circ) \quad (\text{C.5})$$

where  $\Theta$  is the latitude in degrees.

Then by using trigonometry, the path length can be found as a function of the height and elevation angle,  $\theta$  (13)

$$L = \begin{cases} \frac{H}{\sin \theta}, & \theta \geq 10^\circ \\ \frac{2H}{(\sin^2 \theta + \frac{2H}{Kr_o})^{1/2} + \sin \theta}, & \theta < 10^\circ \end{cases} \quad (\text{C.6})$$

where  $\theta$  is the elevation angle and  $Kr_o$  is the effective earth radius.

Therefore we can solve for the attenuation across the length of the path affected by the rain using (13)

$$A = \gamma L r_p \quad (\text{C.7})$$

where  $r_p$  is a factor to account for the variability of the rain rate along the path (known as an empirical path reduction factor). We can first solve the attenuation problem for a probability of 0.01, for which  $r_p$  is given by

$$r_p = \frac{1}{1 + 0.045(L \cos \theta)} \quad (\text{C.8})$$



Then we can determine the attenuation,  $A_p$ , equaled or exceeded with a probability other than 0.01 using (13)

$$A_p = A_{0.01} 0.12p^{-(0.546+0.043 \log p)} \quad (C.9)$$

The degradation of the signal to noise ratio can be found using the same Equation as was used for clouds in the previous section. The effect of atmospheric absorption from rain can be large, as Figure C.6 demonstrates (SNR is shown as  $C/X$  in this figure).

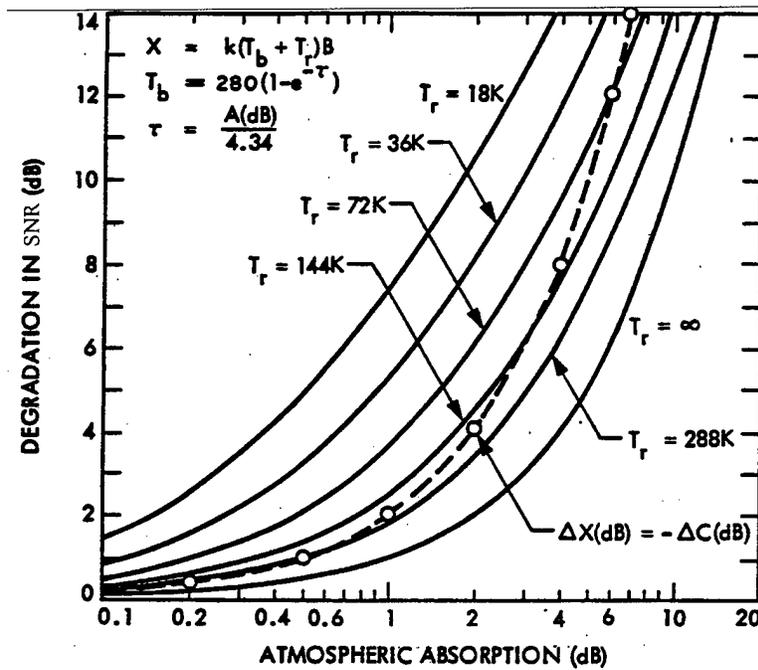

Figure C.6 Degradation in Signal-to-Noise Ratio ( $C/X$ ) versus Atmospheric Absorption, for Various Values of  $T_r$

### C.9 Sand and Dust Storms (Haboobs)

Haboobs are storms of particulates which act on radio waves with the same mechanisms as rain and clouds. A haboob is a unique storm primarily affecting equatorial regions in the rain rate climate regions F, G, and H (refer back to Figure C.4). Strong gusts from the cold down draft

within the thunderstorm produce the dust storm. The air is usually fairly humid, leading to a significant uptake of water by the dust which will increase the propagation effects (Figure C.7).

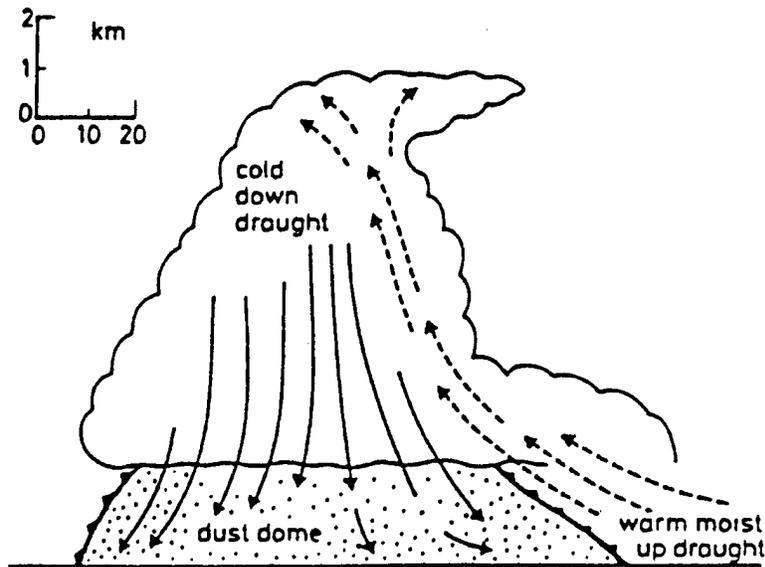

Figure C.7 Cross-Section through a Thunderstorm that is Producing a Haboob(14)

To find the attenuation as a result of a haboob, a model of the dust cylinder must be created to calculate the amount of dust in the path (Figure C.8). The dust is assumed to be of uniform density horizontally with all of the significant dust contained within a symmetrical right cylinder of diameter 10 km. The dust density falls off with height, following a power law decay, the index of which is determined by the initial visibility at a height of 2m.

The attenuation can be found using the same Equations as rain for the path length and replacing  $\gamma$  by (13)

$$\gamma = \frac{189 a}{V \lambda} \left[ \frac{3K_i}{(K_r + 2)^2 + K_i^2} \right] \quad (C.10)$$

where  $V$  is the visibility in km,  $a$  is the average particle radius in m,  $\lambda_m$  is the wavelength in m, and  $\epsilon_r = K_r - jK_i$  is the relative dielectric constant of the dust.

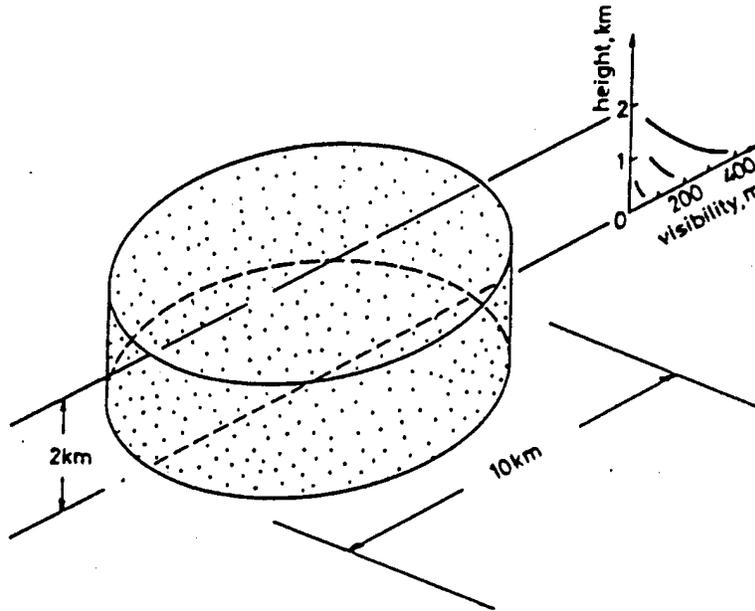

Figure C.8 Schematic of the Dust Cell Model(14)

Assuming a visibility of 10m and all dust particles are spherical and uniformly distributed along the path, the attenuation in dB/km is shown in Figure C.9. The lower line (with dots) is for a 0.3% mixture of water and dust (g H<sub>2</sub>O/g soil). The upper line (with x's) is for a higher concentration of water (10% (g H<sub>2</sub>O/g soil)).

#### C.10 Determining Received Power and Link Margin

The power received at the communication receiver is a function of the transmitted power, gain of the transmit antenna, path loss and attenuation, and losses from the antenna, cable, connector and receiver. The received power is expressed as C.11 (32, 38):

$$P_r = \frac{(EIRP)G_r}{L_s L_o} \quad (C.11)$$

where:

$P_r$  is the received signal power in Watts;

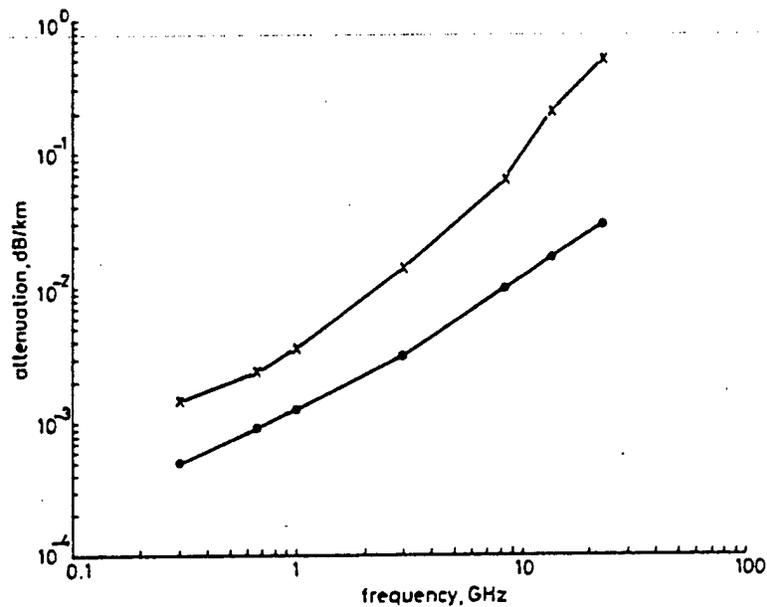

Figure C.9 Attenuation as a Function of Frequency for Falling Dust Particles(14)

EIRP is the Effective Isotropic Radiated Power in Watts and can be expressed as C.12:

$$EIRP = P_t G_t \tag{C.12}$$

where  $P_t$  is the transmitted power in Watts and  $G_t$  is the gain of the transmit antenna;

$G_r$  is the gain of the receive antenna;

$L_s$  is the path loss expressed as C.13:

$$L_s = \left( \frac{4\pi}{(c/f)} \right)^2 \frac{K_s}{R_s^2} \tag{C.13}$$

where:

$c$  is the speed of light ( $\approx 3 \times 10^8$  m/s),

$f$  is the frequency in Hz,

$K_s$  is the constant of attenuation over the radiowave path,

$R_s$  is the communication path distance in meters, and

$l_s$  is the attenuation exponent on the communication path ( $l_s = 2$  for free space communications such as air to air and air to ground, and  $l_s = 4$  for ground to ground communications (38)); and  $L_o$  are losses from the antenna, cable, connector and receiver.

The link margin (or safety margin) is an expression which relates the received power and the receiver thermal noise power spectral density with a required bit energy per noise power spectral density to yield a specified error probability. The received signal power (no noise) is the product of the received energy per bit and the information rate C.14:

$$P_r = E_b R_b \quad (\text{C.14})$$

where  $E_b$  is the received energy per bit and  $R_b$  is the received information rate or roughly the baseband bandwidth.

Therefore, the link margin, ( $M$ ), can be expressed as C.15:

$$M = \left( \frac{E_b}{N_o} \right)_{recvd} \text{ (dB)} - \left( \frac{E_b}{N_o} \right)_{reqd} \text{ (dB)} \quad (\text{C.15})$$

where  $N_o$  is the noise power spectral density to the Predetection output of the receiver and is expressed as C.16 (32):

$$N_o = G \kappa T_s^{\circ} W \quad (\text{C.16})$$

where:

$G$  is the gain of the receiver,

$\kappa$  is Boltzmann's constant ( $1.38 \times 10^{-23}$  W-K/Hz),

$T_s^\circ$  is the system effective temperature, and

$W$  is the bandwidth of the received signal in Hertz.

The system effective temperature is expressed as:

$$T_s^\circ = T_A^\circ + (10^{F_L F_R / 10} - 1) 290K \quad (C.17)$$

where  $T_A^\circ$  is the antenna temperature and  $F_L$  and  $F_R$  are the noise figure of the antenna cable and coupler and the noise figure of the receiver, respectively. Figure C.10 represents a simplified schematic of a receiving system (32).

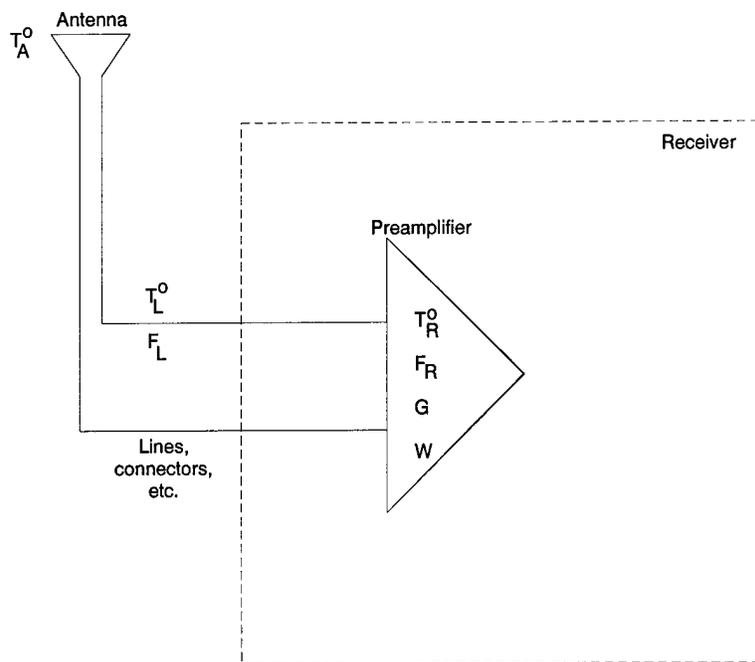

Figure C.10 Major Noise Contributors of a Receiving System(32)

### C.11 Need for Automation

Current methods of manual network design and analysis use acetate overlays on paper maps, self-adhesive dots for unit location, push pins for nodes, and tape, grease pencil or colored string

for transmission routes. Link performance is driven solely on basic specifications for line of site distance, terrain obstacles, and average power available at the transmitter. Network topology is often changed several times during the planning stage, and then reactive during mission operation. For example, a site which has been selected to maximize subscriber access may be shifted to satisfy terrain constraints, and then this site may be adjusted again because of logistics considerations. By this time, the subscriber access has been degraded and must be revisited. This problem will be many times more difficult with the implementation of the Army's Integrated System Control (ISYSCON) which will require the coordination of all communications assets including Enhanced Position Locating and Ranging System (EPLRS), Joint Tactical Information Distribution System (JTIDS), Satellite Communications System (SATCOM), Combat Net Radio (CNR) and other communications assets at all levels of command. Additionally, as the operation develops, the network becomes mobile on the ground(6).

Computer assistance in the network design process will increase the planner's effectiveness and reduce the major part of the work load. It will allow planners to develop plans in the reduced time necessary to support the mobility, flexibility, and robustness required of today's communications equipment in the rapidly changing tactical environment(6). Additionally, the plan that is developed will be available for direct transfer to others and the communications network can be simulated in advance (simulated war game) based on operational plans as they develop. Applying realism in the simulation avoids mistakes commonly made during network planning when using basic specifications in the manual method and gives decision makers more realistic expectations of the communications backbone.

Despite the extensive research during the past decade on network performance assessment and optimization, the need to develop automated tools to assess system performance in more than one network layer, responsive to the dynamic battlefield environment still exists.

### C.12 Perishability of Information and Situational Age

Certain types of information is perishable and loses usefulness if not updated frequently. An example of this is situational age. Consider a sensor that takes a snapshot in time of an enemy tank. The tank is moving, so the sensor reports the tank's direction and speed. However, immediately after this information is sent, the degree of uncertainty of the tanks position increases with time (Figure C.11). The tank may have changed direction or speed.

#### Situational Age: Position vs. Time

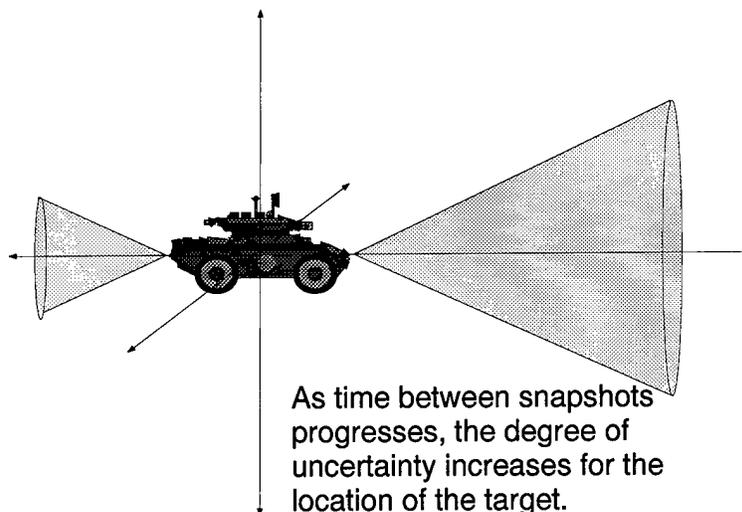

Figure C.11 Situational Age, an Example of the Perishability of Information.

Unless the sensor updates this information, it becomes useless as the degree of uncertainty grows. In order for the information to be useful, it must be received and acted upon before the tank could leave the kill radius of the weapon system chosen to destroy it, or the sensor must update the decision maker and/or weapon system to ensure the tank is within the kill radius of the weapon when it arrives. Information perishability is an important metric of C4I systems and relies on an accurate model of the radiowave propagation path. A haboob which hides the target from the sensor is important to include in the model and may result in a different result during a wargame simulation. This case is also true if the target is initiated by an observer or sensor;



however, information needed to update the weapon system and achieve a "kill" upon arrival is lost as a result of environmental conditions between the observer/sensor and weapon system.

### *C.13 Modeling Temporal Events*

Environmental conditions discussed in this appendix are time dependent. IDEF2 provides a model by which these events can be captured and described(15). This model can be included in the architectural design process recommended by this thesis, to capture and include in C4I simulations, the radiowave propagation effects discussed in this appendix.

#### *Appendix D. IDEF4 Overview*

The following overview of the IDEF4 Object-Oriented Design Method by Knowledge Base Systems, Inc. is provided, with permission, to encourage further standardization of the simulation object development process. Simulation developers, as computer programmers, need the documentation produced by IDEF4 to identify existing classes, instances, and object parameters and behavior. The IDEF4 products would also be used to validate and approve objects for storage in an ODBMS in the distributed simulation network.

---

## IDEF4 Object-Oriented Design Method

The intuitive nature of object-oriented programming makes it easier to produce code. Unfortunately, the ease with which software is produced also makes it easier to create software of poor design, resulting in systems lacking re-usability, modularity, and maintainability. The IDEF4 method is designed to assist in the correct application of this technology.

With over thirty object-oriented design methods in existence today, why should we chose IDEF4? Most importantly, IDEF4 views object-oriented design as part of a larger system development framework, rather than an object-oriented analysis and design method that is ambiguous. IDEF4 stresses the object-oriented design process over the graphical syntax, using the graphical syntax and diagrams as aids to focus and communicate important design issues. IDEF4 is significantly different from other object design methods, primarily in its support of "least commitment" strategies and its support for assessing the design impact of the interaction between class inheritance, object composition, functional decomposition, and polymorphism.

### IDEF4 Concepts

IDEF4 divides the object-oriented design activity into discrete, manageable chunks. Each subactivity is supported by a graphical syntax that highlights the design decisions that must be made and their impact on other perspectives of the design. No single diagram shows all the information contained in the IDEF4 design model, thus limiting confusion and allowing rapid inspection of the desired information. Carefully designed overlap among diagram types serves to ensure compatibility between the different submodels. The IDEF4 method allows the designer to easily make trade-offs between class composition, class inheritance, functional decomposition, and polymorphism in a design. IDEF4 is more than a graphical syntax--the graphical syntax provides a convenient framework for navigating an evolving object-oriented design that is ultimately specified on class invariant data sheets and method set contracts.

Figure 1 shows the basic organization of an IDEF4 model. Conceptually, an IDEF4 model consists of two submodels, the class submodel and the method submodel. The two submodels are linked through a dispatch mapping. These two structures capture all the information represented in a design model. Due to the size of the class and method submodels, the IDEF4 object designer never sees these structures in their entirety. Instead, the designer makes use of the collection of smaller diagrams and data sheets that effectively capture the information represented in the class and method submodels.

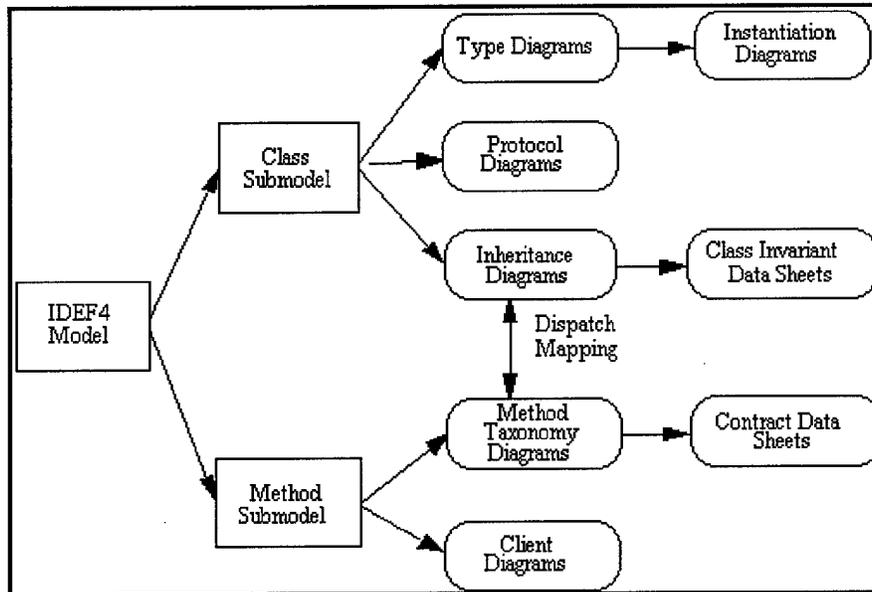

**Figure 1. Organization of the IDEF4 Model**

The class submodel is composed of the following diagram types: 1) Inheritance diagrams that specify class inheritance relations; 2) Type diagrams that specify class composition; 3) Protocol diagrams that specify method invocation protocols; and 4) Instantiation diagrams that describe object instantiation scenarios that assist the designer in validating the design.

The method submodel is composed of the following two diagram types: 1) Method taxonomy diagrams which classify method types by behavior similarity and 2) Client diagrams which illustrate clients and suppliers of methods, to specify functional decomposition.

## IDEF4 Class Submodel

The class submodel consists of inheritance diagrams, type diagrams, instantiation diagrams, protocol diagrams, and class-invariant data sheets. The class submodel shows class inheritance and class composition structure.

## IDEF4 Inheritance Diagrams

Inheritance diagrams specify the inheritance relations among classes. For example, Figure 2 shows the class Filled-rectangle inheriting structure and behavior directly from the classes Rectangle and Filled-object and indirectly from the class Object.

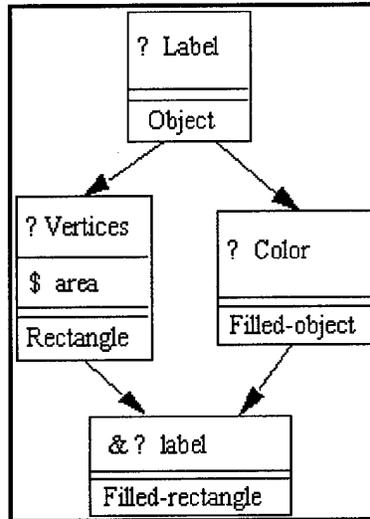

Figure 2. Inheritance Diagram

## IDEF4 Instantiation Diagrams

Instantiation diagrams are associated with type diagrams in the class submodel. The instantiation diagrams describe the anticipated situations of composite links between instantiated objects that are used for validating the design.

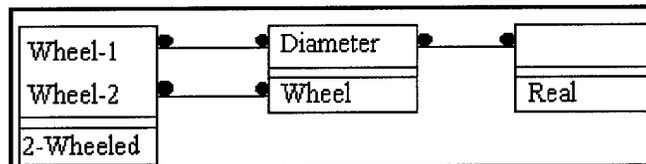

Figure 3. Type Diagram

## IDEF4 Protocol Diagrams

Protocol diagrams specify the class argument types for method invocation. Figure 4 illustrates a protocol diagram for the Fill-closed-object: Polygon routine-class pair. From the diagram, the reader can tell that Fill-closed-object will accept an instance of the class Polygon as its primary (self) argument and an instance of the class Color as a secondary argument, and will return an instance of a Polygon.

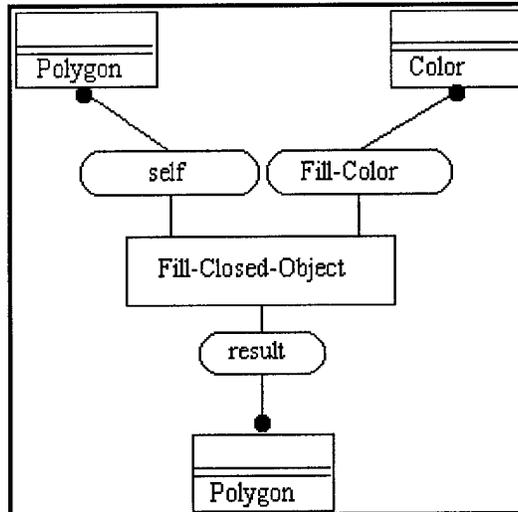

Figure 4. Protocol Diagram

## The IDEF4 Method Submodel

The method submodel consists of method taxonomy diagrams, client diagrams, and data sheets.

### Method Taxonomy Diagrams

Method taxonomy diagrams classify method types by behavioral similarity. A method taxonomy diagram classifies a specific system behavior type according to the constraints placed on the method sets represented in the taxonomy. The arrows indicate additional constraints placed on the method sets. Figure 5 shows a Print method taxonomy diagram. The method sets in the taxonomy are grouped according to the additional contracts placed on the methods in each set. In the example, the first method set, Print, has a contract that states that the object must be printable. The Print-text method set contract would have constraints such as "the object to be printed must be text."

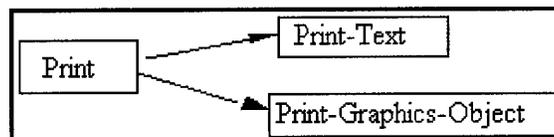
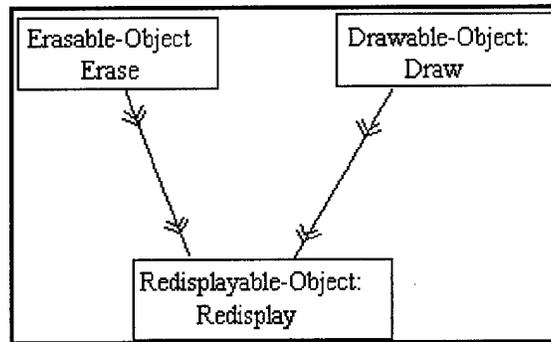

Figure 5. Method Taxonomy Diagram

### Client Diagrams

Client diagrams illustrate clients and suppliers of routine-class pairs. Double-headed arrows point from the routine that is called to the calling routine. Figure 6 shows a client diagram where the Redisplay routine attached to the class Redisplayable-object calls the Erase routine of the Erasable-object class and the Draw routine on the Drawable-object class.



**Figure 6. Client Diagram**

## Data Sheets

Because IDEF4 is not just a graphical language, additional information about the inheritance diagrams, method taxonomy diagrams and type diagrams is maintained in detailed data sheets.

### Class Invariant Data Sheets

Class-invariant data sheets are associated with inheritance diagrams and specify constraints that apply to every instance of a particular class of objects. There is one class-invariant data sheet for each class. The constraint, "Every triangle has three sides," is a class-invariant constraint on the class Triangle.

### Contract Data Sheets

Contract data sheets are associated with the method sets in method taxonomy diagrams and specify contracts that the implemented methods in a method set must satisfy. There is one contract data sheet for each method set. A method set called Pop, for popping values off a stack, would have a contract that specified that it would not attempt to "pop" a the stack if the stack was empty.

## Summary

The IDEF4 method, developed under sponsorship of the U.S. Air Force Armstrong Laboratory, is designed to assist in the correct application of object-oriented technology. IDEF4 was developed by professional object-oriented designers and programmers. The most important reason for choosing the IDEF4 method is that it views object-oriented design as part of a larger system development framework, rather than an object-oriented analysis and design method that is everything to everyone. It stresses the object-oriented design procedure over the graphical syntax, using the graphical syntax and diagrams as aids to focus on and communicate important design issues.

KBSI has developed an automated Object-Oriented Design tool, SmartClass, to support the IDEF4 method.

## Bibliography

1. "The COMPASS Story." Science Applications International Corporation (SAIC), August 1995. <http://compass.saic.com/files/compass-story.html>.
2. "Network Computing Architecture; An Oracle White Paper," September 1996. [http://www.oracle.com/nca/html/nca\\_wp.html](http://www.oracle.com/nca/html/nca_wp.html).
3. Alexander H. Levis, Didier M. Perdu, Robert F. Phelps. *Architecting Information Systems* (gmu/c31-165-r Edition). Center of Excellence in Command, Control, Communications and Intelligence, George Mason University, Fairfax, VA 22030-4444, December 1995.
4. Alta Group of Cadence Design Systems, Inc., 919 East Hillsdale Blvd, Foster City, CA 94404. *BONeS DESIGNER Modeling Guide* (Des8005 Edition), December 1994.
5. Army Digitization Office, Washington, DC. *Army Digitization Master Plan*, January 1995.
6. Atwater, Frederick M. "Application of Neural Network Computing to Tactical Communications Planning," *1991 IEEE Military Communications Conference, MILCOM 91*, 4.7.1-4.7.5 (1991).
7. Barkakati, Naba. *UNIX Webmaster Bible*. IDG Books Worldwide, 1996.
8. Bruce, Thomas A. *Designing Quality Databases with IDEF1X Information Models*. 353 West 12th St., New York, NY 10014: Dorset House Publishing, 1992.
9. Cattell, R.G.G., editor. *Object Database Standard: ODMG-93*. 2929 Campus Drive, Suite 260, San Mateo, CA 94403: Morgan Kaufmann Publishers, 1994.
10. Center for Architecture, Defense Information Systems Agency. *Department of Defense Technical Architecture Framework for Information Management (TAFIM), Version 2.0: Technical Reference Model and Standards Profile Summary*.
11. Date, C. J. *An Introduction to Database Systems*. Addison-Wesley Publishing Company, August 1995.
12. Department of the Army, Washington, DC 20310-5200. *Army Enterprise Implementation Plan*, 1994.
13. Flock, Warren L. *Propagation Effects on Satellite Systems at Frequencies Below 10 GHz: A Handbook for Satellite Systems Design* (nasa rp-1108(02) Edition). Scientific and Technical Information Division, National Aeronautics and Space Administration, Washington, DC 20546, December 1987.
14. Gerald C. Gerace, MAJ, "Radiowave Propagation Theory and Models." Lecture handouts, September 1995.
15. Hanrahan, Robert P. "The IDEF Process Modeling Methodology," *Cross Talk*, 19-23 (June 1995). Robert P. Hanrahan is a Software Technology Support Center technology domain lead for Process, Software Engineering Environment and Requirements Analysis and Design technologies.
16. Jerry Banks, John S. Carson II and Barry L. Nelson. *Discrete-Event System Simulation*. Upper Saddle River, NJ 07458: Prentice Hall, 1996.
17. Joint Interoperability and Engineering Organization, Defense Information Systems Agency. *JIEO Report 8125, Joint Task Force Tactical Communications Architecture*, March 1995.
18. Ken Arnold, James Gosling. *The Java Programming Language*. One Jacob Way, Reading, MA 01867: Addison-Wesley Publishing Company, Inc., May 1996.
19. Khoshafian, Setrag. *Object-Oriented Databases*. John Wiley and Sons, Inc., 1993.



20. Kim, Won, editor. *Modern Database Systems*. ACM Press, New York, New York: Addison-Wesley Publishing Company, January 1995.
21. Korth, Henry F. and Abraham Silberschatz. *Database System Concepts*. McGraw-Hill, Inc, 1986.
22. Lewis, P. A. W. and E. J. Orav. *Simulation Methodology for Statisticians, Operations Analysts, and Engineers*. Pacific Grove, CA: Wadsworth & Brooks/Cole Advance Books & Software, 1989.
23. McFarland, Dave, "A Technical Overview of the J-MASS Architecture." J-MASS Program Office, June 1995. <http://www.jmass.wpafb.af.mil/overview.html>.
24. Muirragui, Lieutenant Colonel Richard A. *Communications, The Forgotten Element of C3I: A Study of WarGaming, Modeling, and Simulations*. Individual Study Project DTIC AD-A239 302, Carlisle Barracks, PA 17013: U.S. Army War College, June 1991.
25. National Institute of Standards and Technology, National Information Service, Dept. of Commerce, Springfield VA 22161. *Integrated Definition for Information Modeling (IDEF1X)*, December 1993.
26. National Institute of Standards and Technology, National Technical Information Service. Dept. of Commerce, Springfield VA 22161. *Integration Definition for Function Modeling (IDEF0)*, December 1993.
27. Object Management Group (OMG), OMG Headquarters, 492 Old Connecticut Path, Framingham, MA 01701. *The Common Object Request Broker: Architecture and Specification* (2.0 Edition), July 1996.
28. Office, Defense Modeling & Simulation, "Annotated Briefing on the DoD High Level Architecture for Simulation," September 1996. <http://www.dmsomil>.
29. Office of the Director for Information Systems for Command, Control, Communications Computers and Intelligence. "Systems Architecture for Battlefield Digitization and Assorted Slides." Provided by MAJ Renner, ODISC4, July 1995.
30. Paul F. Reynolds, Jr., "DISorientation." Department of Computer Science, University of Virginia, 1994. <http://www.mystech.com/~smithr/elecsim94/disori/disori.txt>.
31. Pratt, David R. and Matthew A. Johnson. "Constructive and Virtual Model Linkage," *Proceedings of the 1995 Winter Simulation Conference*, 1222-1229 (December 1995).
32. Sklar, Bernard. *Digital Communications*. Englewood Cliffs, NJ 07632: Prentice Hall, 1988.
33. Sollins, Karen R. and Jeffrey R. Van Dyke. *Linking in a Global Information Architecture*. MIT, 1996. [http://www.lcs.mit.edu/web\\_project/anaweb/links.html](http://www.lcs.mit.edu/web_project/anaweb/links.html) and <http://www.w3.org/pub/Conferences/WWW4/Papers/193/>.
34. Tarek N. Saadawi, Mostafa H. Ammar and Ahmed El Hakeem. *Fundamentals of Telecommunication Networks*. NY, NY: John Wiley & Sons, Inc., 1994.
35. Teter, LTC William A. *Technical Architecture, Version 4.0*. Department of the Army.
36. Tomlinson, Bob, "CORBA and OMG Information Resources." Advance Computing Laboratory, Los Alamos National Laboratory, January 1997. <http://www.acl.lanl.gov/CORBA/>.
37. Wagner, Richard. *JavaScript Unleashed* (First Edition). 201 W. 103rd St., Indianapolis, IN 46290: Sams.net Publishing, 1996.
38. William J. O'Brien, Jeffrey Seibert, Brian Vogel. *On Achieving Network LPI for Spread Spectrum Communications*. Final DTIC AD-A163 985, 11225 Waples Mill Rd., Fairfax, VA 22030: E-Systems, Inc., Melpar Division, Special Processing Group, October 1985.

39. Ye, Zhou and Ankur Sharma, "Java - CORBA Binding." Oracle Corporation, June 1996.  
[http://www.w3.org/pub/WWW/OOP/9606\\_Workshop/submissions/64.html](http://www.w3.org/pub/WWW/OOP/9606_Workshop/submissions/64.html).

## *Vita*

Captain Timothy R. Schmoyer is a 1987 graduate of Worcester Polytechnic Institute and the Reserve Officer Training Corps. He received a Bachelor of Science degree in Electrical Engineering and Regular Army commission. He started his career as an ROTC Recruiter at Fitchburg State College, MA.

His engineering assignments include Test Engineer at Electronic Proving Ground, Ft. Huachuca, AZ; Quality Assurance Engineer for Wideband Defense Communications Systems (Information Systems Engineering Command-Europe), Germany; and New Equipment Training and Development, USA John F. Kennedy Special Warfare Center and School, Ft. Bragg, NC.

His tactical assignments include Platoon Leader and Company Executive Officer with the 1st Signal Battalion, Germany; Company Commander, 112th Signal Battalion (Special Operations) (Airborne); and Communications-Electronics Officer, 3rd Battalion, 7th Special Forces Group (Airborne), Ft. Bragg, NC. Captain Schmoyer's military schooling includes: the Airborne Course, Signal Officer Basic Course, the Ranger Course, Signal Officer Advance Course, the Tactical Signal Staff Officer Course and the 3rd Special Forces Group (Airborne) Jumpmaster Course.

His awards and decorations include: the Parachutist Badge, Ranger Tab, Meritorious Service Medal (1 oak leaf cluster), Army Commendation Medal (2 oak leaf clusters), Army Achievement Medal (3 oak leaf clusters), National Defense Service Medal, Armed Forces Expeditionary Medal, Southwest Asia Service Medal (3 bronze stars), Humanitarian Service Medal, Army Service Ribbon, Overseas Service Ribbon, Kuwaiti Liberation Medal-Saudi Arabia, Kuwaiti Liberation Medal-Kuwait, Joint Meritorious Unit Award, Army Superior Unit Award and the German Army Proficiency Badge (Leistungsabzeichen) in Bronze.

He is married to the former Rachel L. Kardon and is currently assigned to the Air Force Institute of Technology for his Masters of Science in Electrical Engineering. They reside in Dayton, Ohio.

Permanent address: 430 East Paoli Street  
Allentown, PA 18103

REPORT DOCUMENTATION PAGE			Form Approved OMB No. 0704-0188	
Public reporting burden for this collection of information is estimated to average 1 hour per response, including the time for reviewing instructions, searching existing data sources, gathering and maintaining the data needed, and completing and reviewing the collection of information. Send comments regarding this burden estimate or any other aspect of this collection of information, including suggestions for reducing this burden, to Washington Headquarters Services, Directorate for Information Operations and Reports, 1215 Jefferson Davis Highway, Suite 1204, Arlington, VA 22202-4302, and to the Office of Management and Budget, Paperwork Reduction Project (0704-0188), Washington, DC 20503.				
1. AGENCY USE ONLY (Leave blank)	2. REPORT DATE 20 March 1997	3. REPORT TYPE AND DATES COVERED Master of Science Thesis		
4. TITLE AND SUBTITLE Net-Centric Design and Analysis of Information Systems			5. FUNDING NUMBERS	
6. AUTHOR(S) Timothy R. Schmoyer, Captain, U.S. Army				
7. PERFORMING ORGANIZATION NAME(S) AND ADDRESS(ES) Air Force Institute of Technology Department of Electrical Engineering 2950 P. Street Wright-Patterson AFB, OH 45433			8. PERFORMING ORGANIZATION REPORT NUMBER  AFIT/GE/ENG/97M-03	
9. SPONSORING / MONITORING AGENCY NAME(S) AND ADDRESS(ES) Office of the Director of Information Systems for Command, Control, Communications and Computers 107 Pentagon (Army) Washington DC 20310-0107			10. SPONSORING / MONITORING AGENCY REPORT NUMBER	
11. SUPPLEMENTARY NOTES				
12a. DISTRIBUTION / AVAILABILITY STATEMENT Approved for public release; distribution unlimited			12b. DISTRIBUTION CODE  A	
13. ABSTRACT (Maximum 200 words) This thesis presents an unique methodology merging state of the art Internet and distributed database technology to support distributed simulations with programming language and platform independence. Standardized models of Command, Control, Communications, Computers, and Intelligence (C4I) systems using Integrated Definition (IDEF) models and executable simulation objects are placed in database repositories which can be accessed and implemented over a distributed simulation network using the Common Object Request Broker Architecture (CORBA). The CORBA distributed simulation network accesses heterogeneous distributed databases, performs distributed processes, and supports portability and reuse of simulation objects and interoperability across operating systems and programming languages.				
14. SUBJECT TERMS Simulation, Distributed, Object-Oriented, CORBA, C4I, IDEF, Communication, Database, Modeling, and Networks			15. NUMBER OF PAGES 150	
			16. PRICE CODE	
17. SECURITY CLASSIFICATION OF REPORT UNCLAS	18. SECURITY CLASSIFICATION OF THIS PAGE UNCLAS	19. SECURITY CLASSIFICATION OF ABSTRACT UNCLAS	20. LIMITATION OF ABSTRACT UNLIMITED	