



**TEST PLAN AND TECHNICAL
PROTOCOL FOR A FIELD TREATABILITY
TEST FOR BIOVENTING**

MAY 1992

Distribution is unlimited; approved for public release

**ENVIRONMENTAL SERVICES OFFICE
AIR FORCE CENTER FOR ENVIRONMENTAL EXCELLENCE (AFCEE)**

DTIC QUALITY INSPECTED 3

19970425 033



DEPARTMENT OF THE AIR FORCE
WASHINGTON DC 20330

OFFICE OF THE ASSISTANT SECRETARY

MEMORANDUM FOR: REMEDIAL PROJECT MANAGERS (RPMs) AND PROJECT TEAMS
SUBJECT: Test Plan and Technical Protocol for Bioventing

Bioventing is an extremely cost-effective method for treating soils contaminated with fuels (JP-4, diesel, gasoline, and heating oil) and non-chlorinated solvents. In April of this year, the Air Force Center for Environmental Excellence (AFCEE) launched a nation-wide "bioventing initiative" to test the effectiveness of this innovative process at 55 contaminated sites in nineteen states. Twenty systems have already been installed and tested.

To ensure that systems were installed and tested consistently, AFCEE developed this comprehensive protocol document. With minimal site specific modifications, the protocol is also used as a regulatory test plan. This concept significantly reduces test plan preparation costs. This AFCEE document introduces the bioventing technology and describes the technical procedures used to set up a bioventing system for field evaluation. It also provides testing, equipment, measurements, and other relevant quantitative data.

The Environmental Protection Agency is very supportive of the Air Force bioventing initiative and has provided a strong endorsement of the program. This endorsement (found in the front of this document) has been sent to all EPA Regions by Mr. Richard Guimond, Deputy Assistant Administrator, Office of Solid Waste and Emergency Response.

We believe the "Test Plan and Technical Protocol for a Field Treatability Test for Bioventing" will be a valuable tool for bases and commands that want to use this innovative technology in their cleanup efforts. Please use this with your service centers and/or contractors.

This publication is the result of a cooperative effort with AFCEE, Battelle Memorial Institute, Columbus, OH and Engineering-Sciences, Inc., Denver, CO. We invite your comments and suggestions. Please contact Major Ross Miller, AFCEE/EST, Brooks AFB, TX, 78235, DSN 240-4331, commercial (512)536-4331.

J. B. Cole
Director, Air Force
Center for
Environmental
Excellence

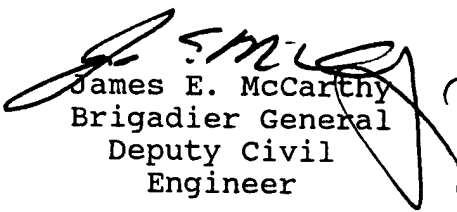
James E. McCarthy
Brigadier General
Deputy Civil
Engineer

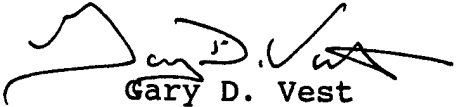
Gary D. Vest
Deputy Asst. Secretary
of the Air Force
(Environment, Safety and
Occupational Health)



UNITED STATES ENVIRONMENTAL PROTECTION AGENCY
WASHINGTON, D.C. 20460

JUL 10 1992

OFFICE OF
SOLID WASTE AND EMERGENCY RESPONSE

MEMORANDUM

SUBJECT: Remediation for JP-4 Contaminated Soils

FROM: Richard Guimond
Deputy Assistant Administrator
Office of Solid Waste and Emergency Response

Thomas L. McCall, Jr.
Acting Deputy Assistant Administrator
for Federal Facilities Enforcement

TO: Waste Management Division Directors,
Regions I, IV, V, and VII
Air and Waste Management Division Director, Region II
Hazardous Waste Management Division Director,
Regions III, VI, VIII, and IX
Hazardous Waste Division Director, Region X
Water Division Directors, Regions IV and X
Regional Counsels, Regions I - X

The purpose of this memorandum is to alert you to a recent EPA assessment of the validity of bioventing as a clean-up option for soil contaminated with JP-4. In addition, we want to raise your awareness of this innovative technology as a clean-up option and request that you consider cooperating with the Air Force on a nation-wide pilot. Such field pilots will allow EPA to quickly generate additional cost and performance data to validate the efficacy and cost-effectiveness of bioventing for jet fuel-contaminated soils. Bioventing has great potential for similar soil contamination problems at other Federal and private sites with Superfund, RCRA and UST problems. We encourage you to review the protocol and assist the Air Force in their pilot efforts by considering the ORD evaluation and encouraging innovation in site remediation.

Background

Recently, the Air force Center for Environmental Excellence asked EPA to review their "Test Plan and Technical Protocol for a Field Treatability Test for Bioventing" that was developed for remediating JP-4 contaminated soils (Attachment A). The plan was reviewed by EPA's Risk Reduction Engineering Laboratory (RREL) in Cincinnati. Also attached for your consideration is RREL's review of the Air Force's bioventing protocol (Attachment B).

The EPA review highlighted the Air Force's leadership role in developing bioventing. RREL stated that the protocol is a logical extension of outstanding collaborative research between the Air Force, RREL, Battelle Laboratory and other groups. The review distinguishes between soil venting (high air flow rates/high volatilization) and bioventing (low air flow rates/low volatilization). RREL noted also that collaborative research between RREL and the Air Force supports a finding that continuous air monitoring is not needed in most circumstances. If air flow rates are optimized to minimize volatilization, up to 85% JP-4 removal by biodegradation can be achieved.

Recent Developments

It is our understanding that the Air Force would like to undertake a bioventing initiative at 55 JP-4 contaminated sites across the nation (Attachment C). We support the Air Force's initiative and commend them for their leadership and commitment to facility restoration through innovation. In the spirit of the OSWER Directive (9380.0-17) on furthering the use of innovative technologies, we encourage your careful examination of the Air Force bioventing protocol and consideration of their bioventing initiative for sites in your Regions. In addition, we solicit your leadership in working to educate and partner with the States on these sites. As you may know, there is a considerable body of technical information on the efficiency of bioventing. It was even the subject of a nationwide satellite seminar series which your staff attended.

We remain committed to inter-agency collaboration that takes meaningful steps toward environmental restoration. We believe that the Air Force initiative, in cooperation with EPA and States, will go a long way toward restoring their contaminated sites and will provide a lot of cost and performance data on bioventing in a very short time.

Thank you for your consideration of this matter. If you have any questions regarding bioventing or the Air Force initiative, please contact Walt Kovalick, FTS (703) 308-8800 or Gordon Davidson, FTS (202) 260-9801.

Attachments

cc: Henry Longest, Director, OERR
Bruce Diamond, Director, OWPE
Sylvia Lowrance, Director, OSW
David Ziegele, Director, OUST
Timothy Fields, Director, Superfund Revitalization Team
Federal Facility Leadership Council Representatives
Federal Facilities Coordinators, Regions I-X



UNITED STATES ENVIRONMENTAL PROTECTION AGENCY
OFFICE OF RESEARCH AND DEVELOPMENT
RISK REDUCTION ENGINEERING LABORATORY
CINCINNATI, OHIO 45242

May 15 1992

DATE: May 12, 1992

SUBJECT: Review of the "Test Plan and Technical Protocol for a Field Treatability Test for Bioventing" by the U.S. Air Force Center for Environmental Excellence

FROM: Gregory D. Sayles *Gregory D Sayles*
Chemical Engineer, Biosystems Engineering Section
Biosystems Branch, Water and Hazardous Waste
Treatment Research Division

TO: Walter W. Kovalick, Jr.
Director, Technology Innovation Office,
Office of Solid Waste and Emergency Response (OS-110W)

Gordon M. Davidson
Director, Office of Federal Facilities Enforcement,
Office of Enforcement (OS-530)

THRU: Richard C. Brenner *Richard C Brenner*
Chief, Biosystems Engineering Section
Biosystems Branch, Water and Hazardous Waste
Treatment Research Division

Dolloff F. Bishop *Dolloff F Bishop*
Chief, Biosystems Branch
Water and Hazardous Waste Treatment
Research Division

Per your request, below is my review of the "Test Plan and Technical Protocol for a Field Treatability Test for Bioventing" by the U.S. Air Force Center for Environmental Excellence, and a discussion of expected releases of organic compounds to the atmosphere when bioventing.

Bioventing is the process of delivering oxygen by forced air movement to contaminated unsaturated soils in order to stimulate biodegradation of the contaminants. Unlike the physical/chemical processes of soil vacuum extraction and soil venting where large flow rates of air are forced through contaminated soils to remove volatile organic compounds, bioventing employs low air flow rates that provide only the necessary amount of oxygen for biodegradation while minimizing volatilization. Typically, air flow rates for soil venting are 10 times higher than those employed for bioventing. Also, bioventing can destroy all biodegradable contamination, volatile or not, while soil venting simply transports the volatile components out of the soil either to the atmosphere or to an above-ground gas treatment system. In its most simple form, bioventing can be implemented by either injecting air through a screened well in the plume or by withdrawing air through a screened well,

thereby drawing air into the contaminated soil from the surrounding clean soil.

Bioventing is a technology in the incipient stage of large-scale operation. Because of its rapid development over the last 5 years, no standardized protocol exists for determining the treatability of soils by bioventing. The Air Force protocol would fill this important need.

The content of the Air Force protocol is a logical outcome of extensive experience with bioventing by the U.S. Air Force, the U.S. EPA Risk Reduction Engineering Laboratory, Battelle Laboratories, and other research groups. The U.S. Air Force Center for Environmental Excellence has been a major contributor in bringing this technology to its current state of development.

The individual sequential steps employed in the protocol, i.e., site characterization, test experimental design for soil gas permeability and bioventing, test monitoring, and data interpretation, are now well-evaluated methods in the implementation of bioventing and soil venting. The protocol places these activities into a logical framework to meet the objectives of the protocol. Thus, I recommend that the protocol be accepted in its current form.

Because of its apparent similarity to soil venting and vacuum extraction technologies, questions may persist as to whether bioventing actually destroys the contaminants of interest or merely transports the volatile components of the contaminants away from the contaminated area into the surrounding soil and into the atmosphere. Results from a U.S. Air Force sponsored bioventing field study of JP-4 jet fuel contamination at Tyndall AFB, Florida, conducted in 1989 and 1990, suggested that biodegradation would be the probable fate of most of the organic contamination under optimized operating conditions. At Tyndall, measurements revealed that, on average, 55% of the removal of the total hydrocarbons was by biodegradation. However, air flow rates utilized were not optimized to minimize volatilization. Calculations based on the results of the study indicated that adequate soil aeration could have been provided at much lower air flow rates such that as much as 85% removal by biodegradation could have been achieved.

The study at Tyndall AFB provides an upper bound of the fraction of removal due to volatilization when bioventing because aeration of the soil was accomplished by air withdrawal from the center of the plume rather than air injection. Air-withdrawal bioventing provides a relatively short pathway (and, thus, a short time) for volatilized organics to biodegrade because the withdrawal well is in contact with and extracting air directly from contaminated soil. In contrast, air injection generates relatively long airflow pathways away from the well into the surrounding soil. As a result, volatile organics tend to remain in the soil for a greater amount of time, increasing the fraction of the contamination that is biodegraded relative to that when air-withdrawal configurations are utilized.

The study at Tyndall AFB and other studies indicate that because low air flow rates are employed for bioventing, volatilization rates of organics to the atmosphere are very low and should not be of concern. For example, at

Tyndall, the maximum volatilization rate measured from the test plots was about 0.04 lb/day of total hydrocarbon. The volatile compound of most concern in hydrocarbon spills is typically benzene, which might constitute at most 10% of the total volatile hydrocarbons released, thus yielding an almost insignificant 0.004 lb/day.

Little atmospheric air monitoring has been conducted in association with air-injection bioventing because, most likely, only very low release rates of organics are expected. Data from several studies including an ongoing collaborative bioventing study between the U.S. EPA Risk Reduction Engineering Laboratory and the U.S. Air Force at Eielson Air Force Base, Alaska, confirm this expectation. At the commencement of air injection at this site, when releases of volatile organics to the atmosphere would be maximum relative to later times, the concentrations of total petroleum hydrocarbons and of benzene at 2 ft above the aerated soil were only 61 ppm and 3.3 ppm, respectively. In most instances, therefore, continuous air monitoring is unnecessary.

In summary, I support the contents of the protocol as proposed. If you have any questions, do not hesitate to call me at 513-569-7607.

TEST PLAN AND TECHNICAL PROTOCOL
FOR
A FIELD TREATABILITY TEST FOR BIOVENTING

by

R. E. Hinchee and S. K. Ong
Battelle
Columbus, Ohio

R. N. Miller
U.S. Air Force
Center for Environmental Excellence
Brooks Air Force Base, Texas

D. C. Downey and R. Frandt
Engineering-Sciences, Inc.
Denver, Colorado

for

U.S. Air Force
Center for Environmental Excellence
Brooks Air Force Base, Texas

This report is a work prepared for the United States Government by Battelle. In no event shall either the United States Government or Battelle have any responsibility or liability for any consequences of any use, misuse, inability to use, or reliance upon the information contained herein, nor does either warrant or otherwise represent in any way the accuracy, adequacy, efficacy, or applicability of the contents hereof.

TABLE OF CONTENTS

	<u>Page</u>
1.0 <u>TEST OBJECTIVES</u>	1
1.1 Conduct Air Permeability and In Situ Respiration Tests	1
1.2 Conduct Bioventing Test	1
1.3 Use of Existing Wells and Monitoring Points	1
2.0 <u>INTRODUCTION TO BIOVENTING AND FIELD TREATABILITY TESTS</u>	2
2.1 Bioventing Background	2
2.1.1 Conventional Enhanced Biodegradation	2
2.1.2 Bioventing	3
2.1.3 Applications	5
2.1.4 Hill AFB Site	11
2.1.5 Tyndall AFB Site	14
2.2 Soil Gas Permeability and Radius of Influence	16
2.3 In Situ Respiration Testing	18
3.0 <u>IN SITU RESPIRATION/AIR PERMEABILITY TEST PREPARATION</u>	24
3.1 Site Characterization Review	24
3.2 Development of Site-Specific Test Plan	24
3.3 Application for Required Permits	26
4.0 <u>TEST WELLS AND EQUIPMENT</u>	27
4.1 Vent Wells	27
4.2 Soil Gas Monitoring Points	28
4.2.1 Location of Monitoring Points	30
4.2.2 Depth of Monitoring Points	30
4.2.3 Construction of Monitoring Points	31
4.2.4 Thermocouples	34
4.3 Background Well	34
4.4 Blower System	35
4.5 Field Instrumentation and Measurements	38
4.5.1 Oxygen and Carbon Dioxide	38
4.5.2 Hydrocarbon Concentration	38
4.5.3 Helium Monitoring	40
4.5.4 Temperature Monitoring	40
4.5.5 Pressure/Vacuum Monitoring	40
4.5.6 Airflow	40
4.5.6.1 Airflow Measurement — Air Permeability Test	41
4.5.6.2 Airflow Measurement — Respiration Test	41
4.5.6.3 Airflow Measurement — Bioventing Test	41

5.0	<u>TEST PROCEDURES</u>	42
5.1	Location of Optimum Test Volume	42
5.1.1	Soil Gas Survey (for contamination < 20 ft)	42
5.1.2	Exploratory Boring in Deep Soils	43
5.2	Drilling and Installation of the Vent Well	45
5.3	Drilling and Installation of Monitoring Points	45
5.4	Background Well Installation	45
5.5	Collection of Soil Samples	45
5.6	Soil Gas Permeability Test Procedures	47
5.6.1	System Check	47
5.6.2	Soil Gas Permeability Test	47
5.6.3	Post-Permeability Test Soil Gas Monitoring	49
5.7	In Situ Respiration-Test	49
5.7.1	Test Implementation	49
5.7.2	Data Interpretation	50
5.7.2.1	Oxygen Utilization	50
5.7.2.2	Helium Monitoring	54
5.8	Bioventing Test	54
5.8.1	Criteria for Conducting the Bioventing Test	57
5.8.1.1	Air Permeability/Radius of Influence	57
5.8.1.2	Biodegradation Rate	57
5.8.1.3	Regulatory Approval	58
5.8.1.4	U.S. Air Force Approval	58
5.8.2	Air Injection vs. Extraction Considerations	58
5.8.3	Blower System Installation	58
5.8.4	Blower Operation and Maintenance	59
5.8.5	Long-Term Monitoring	59
6.0	<u>SCHEDULE</u>	60
7.0	<u>REPORTING</u>	62
7.1	Test Plan	63
7.2	Monthly Reports	63
7.3	Verbal Communication	63
7.4	Site Reports	63
8.0	<u>RECORD OF DATA AND QUALITY ASSURANCE</u>	64
9.0	<u>REFERENCES</u>	68
APPENDIX	<u>RECOMMENDED ESTIMATION METHODS FOR AIR PERMEABILITY</u>	71

TABLE OF CONTENTS
(Continued)

Page

LIST OF TABLES

Table 2-1. Soil Gas Permeability Values	18
Table 2-2. Summary of Reported In Situ Respiration and Bioventing Rate Data	22
Table 4-1. Recommended Spacing for Monitoring Points	31
Table 4-2. Monitoring Points for Example Site #2 at Millersworth AFB	34
Table 5-1. Parameters to Be Measured for the In Situ Respiration Tests	51
Table 5-2. Sample Data Set for Two In Situ Respiration Tests	52
Table A-1. Air Permeability Data Set	75
Table A-2. Field Test Data for Soil Determination of Soil Permeability at a Gasoline-Contaminated Site	78

LIST OF FIGURES

Figure 2-1. Conceptual Layout of Bioventing Process with Air Injection Only.	7
Figure 2-2. Conceptual Layout of Bioventing Process with Air Withdrawn from Clean Soil	8
Figure 2-3. Conceptual Layout of Bioventing Process with Soil Gas Reinjection	9
Figure 2-4. Conceptual Layout of Bioventing Process with Air Injection into Contaminated Soil, Coupled with Dewatering and Nutrient Application	10
Figure 2-5. Cumulative Hydrocarbon Removal from the Hill AFB Building 914 Soil Venting Site.	12
Figure 2-6. Results of Soil Analysis at Hill AFB Before and After Venting	13
Figure 2-7. Results of Soil Analysis from Plot V2 at Tyndall AFB Before and After Venting.	15
Figure 2-8. Cumulative Percent Hydrocarbon Removal at Tyndall AFB for Sites V1 and V2.	17
Figure 2-9. Gas Injection/Soil Gas Sampling Monitoring Point Used by Hinchee et al. (1991) in Their In Situ Respiration Studies.	20
Figure 2-10. Average Oxygen Utilization Rates Measured at Four Test Sites	21
Figure 3-1. Flow Chart for Conducting Bioventing Treatability Test.	25
Figure 4-1. Typical Injection/Vacuum Venting Well Construction.	29
Figure 4-2. Typical Monitoring Point Construction Detail	33
Figure 4-3. Soil Gas Permeability Instrumentation Diagram for Soil Gas Extraction.	36
Figure 4-4. Soil Gas Permeability Blower System Instrumentation Diagram for Air Injection.	37
Figure 4-5. Schematic Setup for Calibration of Soil Gas Instruments: (a) CO ₂ , O ₂ , and Total Hydrocarbon Analyzers (b) Helium Detector.	39

TABLE OF CONTENTS
(Continued)

	<u>Page</u>
Figure 5-1. Schematic Diagram of Soil Gas Sampling Using the Stainless Steel Soil Gas Probe.	44
Figure 5-2. In Situ Respiration Test Results for Two Bioventing Test Sites: Fallon NAS, Nevada (Monitoring Point A2) and Kenai, Alaska (Monitoring Point K1)	53
Figure 5-3. In Situ Respiration Test Results for Monitoring Point S1, Tinker AFB, Oklahoma.	55
Figure 5-4. In Situ Respiration Test Results for Monitoring Point K3, Kenai, Alaska	56
Figure 8-1. Typical Record Sheet for In Situ Respiration Test	65
Figure 8-2. Typical Record Sheet for Air Permeability Test	66
Figure 8-3. Typical Record Sheet for Long-Term Bioventing Test	67
Figure A-1. Vacuum vs. In Time, Test 2, Bioventing Pilot Test, Site 22-A20, Beale AFB, California	76
Figure A-2. Results of a Field Test to Determine Soil Permeability to Airflow, k, September 16, 1991	79

TEST PLAN AND TECHNICAL PROTOCOL
FOR
A FIELD TREATABILITY TEST FOR BIOVENTING

1.0 TEST OBJECTIVES

This test plan and technical protocol describes the methods for conducting a field treatability test for the bioventing technology. The purpose of these field test methods is to measure the soil gas permeability and microbial activity at a contaminated site and to evaluate the potential application of the bioventing technology to remediate the contaminated site. The specific test objectives are stated below.

1.1 Conduct Air Permeability and In Situ Respiration Tests

At every site, the air permeability of the soil and the air vent (well) radius of influence will be determined. This will require air to be withdrawn or injected for approximately 8 hours at vent wells located in contaminated soils. Pressure changes will be monitored in an array of monitoring points. Immediately following this test, an in situ respiration test will be conducted. Air will be injected into selected monitoring points to aerate the soils. The in situ oxygen utilization and carbon dioxide production rates will be measured.

1.2 Conduct Bioventing Test

Using the data from the soil air permeability and in situ respiration tests, an air injection/withdrawal rate will be determined for use in the bioventing test. A blower will be selected, installed, and operated for 6 to 12 months, and periodic measurements of the soil gas composition will be made, to evaluate the long-term effectiveness of bioventing.

1.3 Use of Existing Wells and Monitoring Points

The U.S. Air Force has already installed monitoring points or other wells at many sites that will be suitable for use in this study. In keeping with the objective of developing a cost-effective program for site remediation, every effort will be made to use existing wells and minimize drilling costs.

2.0 INTRODUCTION TO BIOVENTING AND FIELD TREATABILITY TESTS

Bioventing is the process of aerating subsurface soils to stimulate in situ biological activity and promote bioremediation. Although it is related to the process of soil venting (aka soil vacuum extraction, soil gas extraction, and in situ soil stripping), their primary objectives are different. Soil venting is designed and operated to maximize the volatilization of low-molecular-weight compounds, with some biodegradation occurring. In contrast, bioventing is designed to maximize biodegradation of aerobically biodegradable compounds, regardless of their molecular weight, with some volatilization occurring. The major difference between these technologies is that the objective of soil venting is volatilization, and the objective of bioventing is biodegradation. Although both technologies involve venting of air through the subsurface, the differences in objectives result in different design and operation of the remedial systems.

2.1 Bioventing Background

Petroleum distillate hydrocarbons such as JP-4 jet fuel are generally biodegradable if the naturally occurring microorganisms that acclimate to the fuels as a carbon source are provided an adequate supply of oxygen and basic nutrients (Atlas, 1986). Natural biodegradation does occur, and at many sites microorganisms may eventually mineralize most of the fuel contamination. However, the process is dependent on natural oxygen diffusion rates (Ostendorf and Kambell, 1989). As a result, natural biodegradation is frequently too slow to prevent the spread of contamination and sites may require remediation to protect sensitive aquifers. Acceleration or enhancement of the natural biodegradation process may prove to be the most cost-effective remediation for hydrocarbon-contaminated sites.

Understanding the distribution of contaminants is important to any in situ remediation process. Much of the hydrocarbon residue at a fuel-contaminated site is found in the unsaturated zone soils, in the capillary fringe, and immediately below the water table. Seasonal water table fluctuations typically spread residues in the area immediately above and below the water table. Any successful bioremediation effort must treat these areas. Bioventing provides oxygen to unsaturated zone soils and can be extended below the water table when integrated with a dewatering system.

2.1.1 Conventional Enhanced Biodegradation

The practice of enhanced biodegradation for treating soluble fuel components in groundwater has increased over the past two decades (Lee et al., 1988), with less emphasis given to enhancing biodegradation in the unsaturated zone. Currently, conventional enhanced bioreclamation processes use water to carry oxygen or an alternative electron acceptor to the contaminated zone. This is common whether the contamination is present in the groundwater or in the unsaturated zone.

A recent field experiment at a jet fuel-contaminated site used infiltration galleries and spray irrigation to introduce oxygen (as hydrogen peroxide), nitrogen, and phosphorus to unsaturated, sandy soils. The experiment was unsuccessful because the rapid decomposition of hydrogen peroxide resulted in poor oxygen distribution (Hinchee et al., 1989).

Other attempts have been made using pure oxygen or hydrogen peroxide as oxygen sources, and recently nitrate has been added as an alternative to oxygen. Although results indicate better hydrogen peroxide stability than achieved by Hinchee et al. (1989), it was concluded that most of the hydrogen peroxide decomposed rapidly (Huling et al., 1990). Some degradation of aromatic hydrocarbons appears to have occurred; however, no change in total hydrocarbon contamination levels was detected in the soils (Ward, 1988).

In most cases where water is used as the oxygen carrier, the solubility of oxygen is the limiting factor for biodegradation. If pure oxygen is used and 40 mg/l of dissolved oxygen is achieved, approximately 80,000 lb of water must be delivered to the formation to degrade 1 lb of hydrocarbon. If 500 mg/l of hydrogen peroxide is successfully delivered, then approximately 13,000 lb of water must be used to degrade the same amount of hydrocarbon. As a result, even if hydrogen peroxide can be successfully used, substantial volumes of water must be pumped through the contaminated formation to deliver sufficient oxygen.

2.1.2 Bioventing

A system engineered to increase the microbial biodegradation of fuel hydrocarbons in the unsaturated zone using forced air as the oxygen source may be a cost-effective alternative to conventional systems. This process provides oxygen to indigenous soil microorganisms promoting aerobic metabolism of fuel hydrocarbons in unsaturated soils. Depending on airflow rates, some volatile compounds may be simultaneously stripped from contaminated soils.

When air is used as an oxygen source, 13 lb of air must be delivered to provide the minimum oxygen required to degrade 1 lb of hydrocarbon, compared to the more than 13,000 lb of water with 500 mg/l of hydrogen peroxide that must be delivered by conventional water phase-enhanced bioreclamation processes. An additional advantage of using a gas phase process is that gases have greater diffusivity than liquids. At many sites, geological heterogeneities cause fluid that is pumped through the formation to be channeled into the more permeable pathways (e.g., in an alluvial soil with interbedded sand and clay, all of the fluid flow initially takes place in the sand). As a result, oxygen must be delivered to the less permeable clay lenses through diffusion. In a gaseous system (as found in unsaturated soils), this diffusion can be expected to take place at rates several orders of magnitude greater than rates in a liquid system (as is found in saturated soils). Although it is not realistic to expect diffusion to aid significantly in water-based bioreclamation, diffusion of oxygen in a gas phase system may be a significant mechanism for oxygen delivery to less permeable zones.

To the authors' knowledge, the first documented evidence of unsaturated zone biodegradation resulting from forced aeration was reported by the Texas Research Institute, Inc., in a study for the American Petroleum Institute. A large-scale model experiment was conducted to test the effectiveness of a surfactant treatment to enhance the recovery of spilled gasoline. The experiment accounted for only 8 gal of the 65 gal originally spilled and raised questions about the fate of the gasoline. Subsequently, a column study was conducted to determine a diffusion coefficient for soil venting. This column study evolved into a biodegradation study in which it was concluded that as much as 38% of the fuel hydrocarbon was biologically mineralized. Researchers concluded that venting would not only remove gasoline by physical means, but also could enhance microbial activity and promote biodegradation of the gasoline (Texas Research Institute, 1980; 1984).

To the authors' knowledge, the first actual field-scale bioventing experiments were conducted by van Eyk for Shell Oil. In 1982 at van Eyk's direction, Delft Geotechnics in The Netherlands initiated a series of experiments to investigate the effectiveness of bioventing for treating hydrocarbon-contaminated soils. These studies are reported in a series of papers (Anonymous, 1986; Staatsuitgeverij, 1986; van Eyk and Vreeken, 1988, 1989a and 1989b).

Wilson and Ward (1986) suggested that using air as a carrier for oxygen could be 1,000 times more efficient than using water, especially in deep, hard-to-flood unsaturated zones. They made the connection between soil venting and biodegradation by observing that "soil venting uses the same principle to remove volatile components of the hydrocarbon." In a general overview of the soil venting process, Bennedsen et al. (1987) concluded that soil venting provides large quantities of oxygen to the unsaturated zone, possibly stimulating aerobic degradation. They suggested that water and nutrients would also be required for significant degradation and encouraged additional investigation into this area.

Biodegradation enhanced by soil venting has been observed at several field sites. Investigators claim that at a soil venting site for remediation of gasoline-contaminated soil significant biodegradation occurred (measured by a temperature rise) when air was supplied. Investigators pumped pulses of air through a pile of excavated soil and observed a consistent rise in temperature, which they attributed to biodegradation. They claimed that the pile was cleaned up during the summer primarily by biodegradation (Conner, 1988). However, they did not control for natural volatilization from the aboveground pile, and not enough data were published to critically review their biodegradation claim.

Researchers at Traverse City, Michigan, observed a decrease in the toluene concentration in unsaturated zone soil gas, which they measured as an indicator of fuel contamination in the unsaturated zone. They assumed that advection had not occurred and attributed the toluene loss to biodegradation. The investigators concluded that because toluene concentrations decayed near the oxygenated ground surface, soil venting is an attractive remediation alternative for biodegrading light volatile hydrocarbon spills (Ostendorf and Kambell, 1989).

The U.S. Air Force initiated its research and development (R&D) program in bioventing in 1988 with a study at Hill Air Force Base (AFB) in Utah. During this study it became apparent that bioventing had great potential for remediating JP-4 fuel-contaminated soils. It was also apparent that additional research would be needed before the technology could be routinely applied in the field. The work was initially supported by the U.S. Air Force Civil Engineering Support Agency (AFCESA), previously known as the Air Force Engineering and Services Center. Subsequently, they were joined in R&D support of the technology by the U.S. Air Force Center for Environmental Excellence (AFCEE) and later by Hill and Eielson AFBs. Following the Hill AFB study, a more controlled bioventing study was completed at Tyndall AFB in Florida.

The Air Force currently supports a number of field programs to further test and demonstrate the technology. After completion of the initial site testing at Hill AFB, a low-intensity bioreclamation research program at another site was initiated in late 1989. At Eielson AFB near Fairbanks, Alaska, a field demonstration of bioventing in a subarctic environment was initiated in the summer of 1991. This study includes a soil heating experiment to attempt to increase biodegradation rates.

The U.S. EPA Risk Reduction Engineering Laboratory (RREL) has become interested in the Air Force's program, and has jointly funded and technically supported the work at both Hill and Eielson AFBs. Additionally, the AFCESA is supporting a well-documented bioventing demonstration at a cold weather site with field work scheduled to begin in the summer of 1992.

2.1.3 Applications

The use of an air-based oxygen supply for enhancing biodegradation relies on airflow through hydrocarbon-contaminated soils at rates and configurations that will (1) ensure adequate oxygenation for aerobic biodegradation, and (2) minimize or eliminate the production of a hydrocarbon-contaminated off-gas. The addition of nutrients and moisture may be desirable to increase biodegradation rates; however, field research to date does not indicate the need for these additions (Dupont et al., 1991; Miller et al., 1991). If found necessary, nutrient and moisture addition could take any of a variety of configurations. Dewatering may at times be necessary, depending on the distribution of contaminants relative to the water table. A key feature of bioventing is the use of narrowly screened soil gas monitoring points to sample gas in short vertical sections of the soil. These points are required to monitor local oxygen concentrations, because oxygen levels in the vent well are not representative of local conditions.

A conventional soil venting system could be installed to draw air from a vent well in the area of greatest contamination. This configuration would allow straightforward monitoring of the off-gases. However, its disadvantage is that hydrocarbon off-gas concentration would probably be maximized, and could require permitting and treatment. Furthermore, all of the capillary fringe contamination may not be treated.

Figure 2-1 is a schematic representation of a bioventing system that involves air injection only. Although this is the lowest cost configuration, careful consideration must be given to the fate of injected air. The objective is for most, if not all, of the hydrocarbons to be degraded, and for CO₂ to be emitted at some distance from the injection point. If a building or subsurface structure were to exist within the radius of influence of the well, hydrocarbon vapors might be forced into that structure. Thus, protection of subsurface structures may be required.

Figure 2-2 is an illustration of a configuration in which air is injected (the injection may also be by passive well) into the contaminated zone and withdrawn from clean soils. This configuration allows the more volatile hydrocarbons to degrade prior to being withdrawn, thereby eliminating contaminated off-gases. This configuration typically does not require air emission permitting (site-specific exceptions may apply).

Figure 2-3 illustrates a configuration that may alleviate the threat to subsurface structures while achieving the same basic effect as air injection alone. In this configuration, soil gas is extracted near the structure of concern and reinjected at a safe distance. If necessary, makeup air can be added before injection.

Figure 2-4 illustrates a conventional soil venting configuration at sites where hydrocarbon emissions to the atmosphere are not a problem. This may be the preferred configuration. Dewatering, nutrient, and moisture additions are also illustrated. Dewatering will allow more effective treatment of deeper soils. The optimal configuration for any given site will, of course, depend on site-specific conditions and remedial objectives.

The significant features of this technology include the following:

- Optimizing airflow to reduce volatilization while maintaining aerobic conditions for biodegradation
- Monitoring local soil gas conditions to assure aerobic conditions, not just monitoring vent gas composition
- Adding moisture and nutrients as required to increase biodegradation rates although, as stated earlier, it appears from field studies that this may not be necessary at many if not most sites
- Manipulating the water table (dewatering) as required for air/contaminant contact.

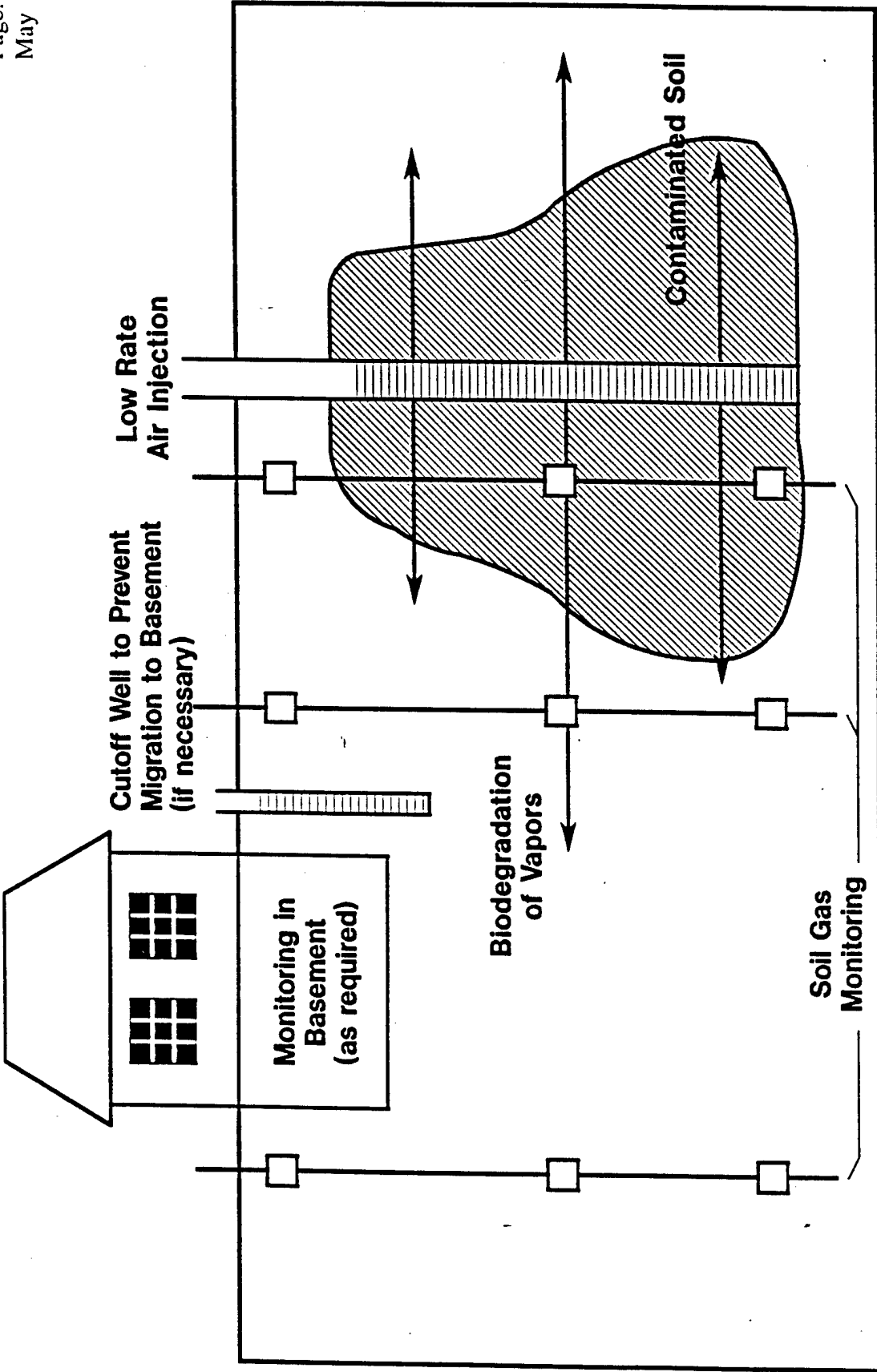

Figure 2-1. Conceptual Layout of Bioventing Process with Air Injection Only.

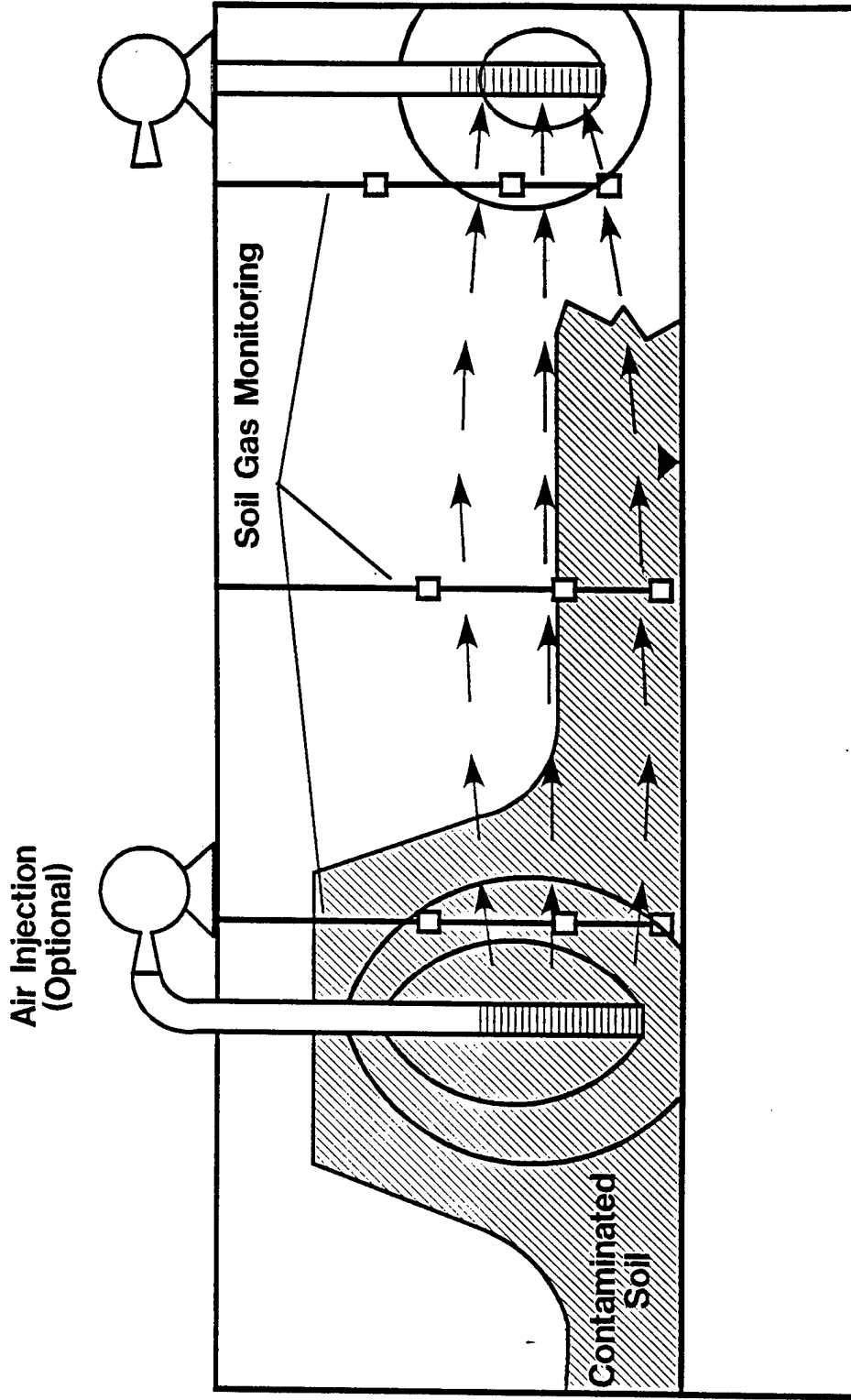

Figure 2-2. Conceptual Layout of Bioventing Process
with Air Withdrawn from Clean Soil.

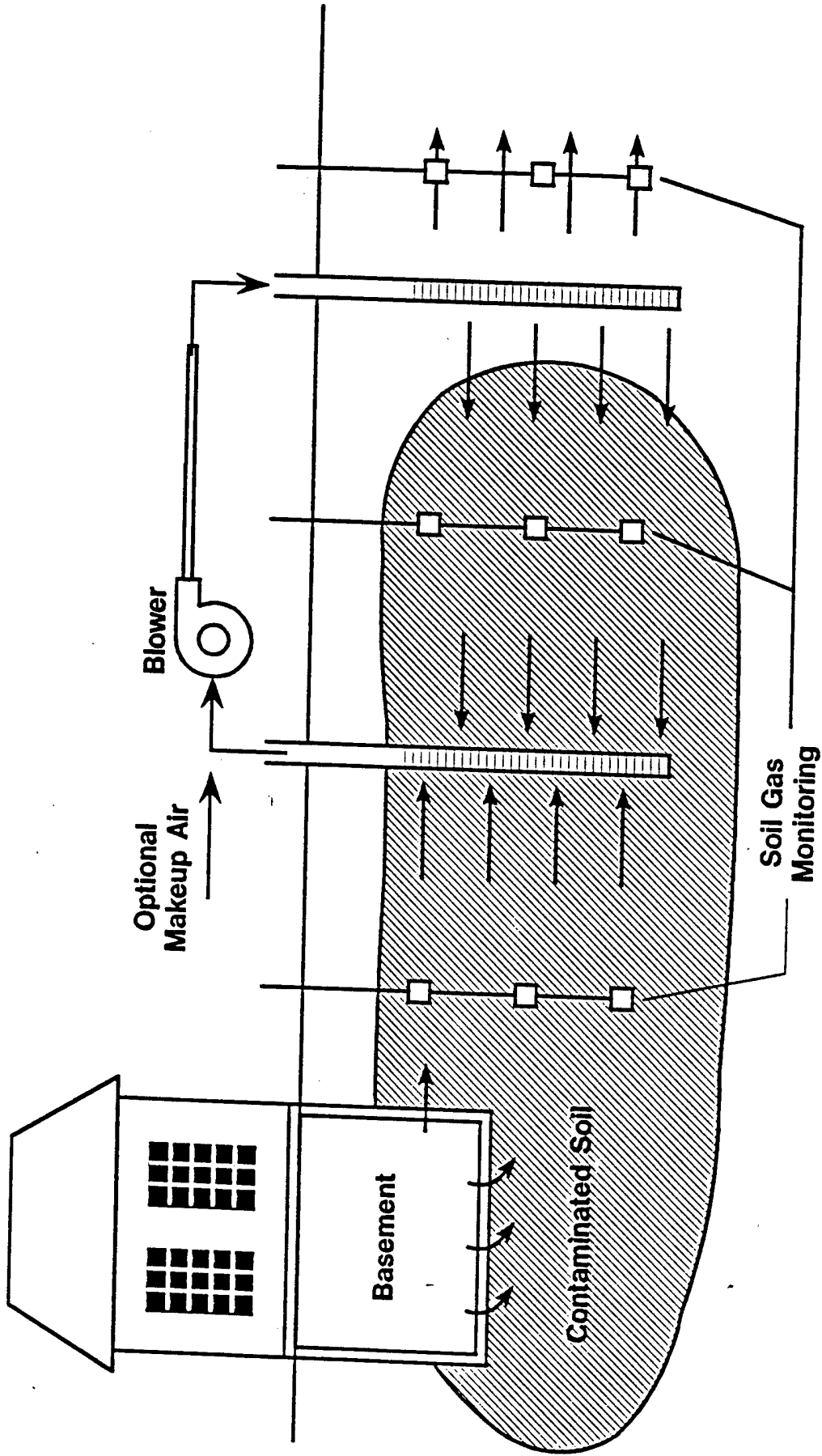

Figure 2-3. Conceptual Layout of Bioventing Process with Soil Gas Reinjection.

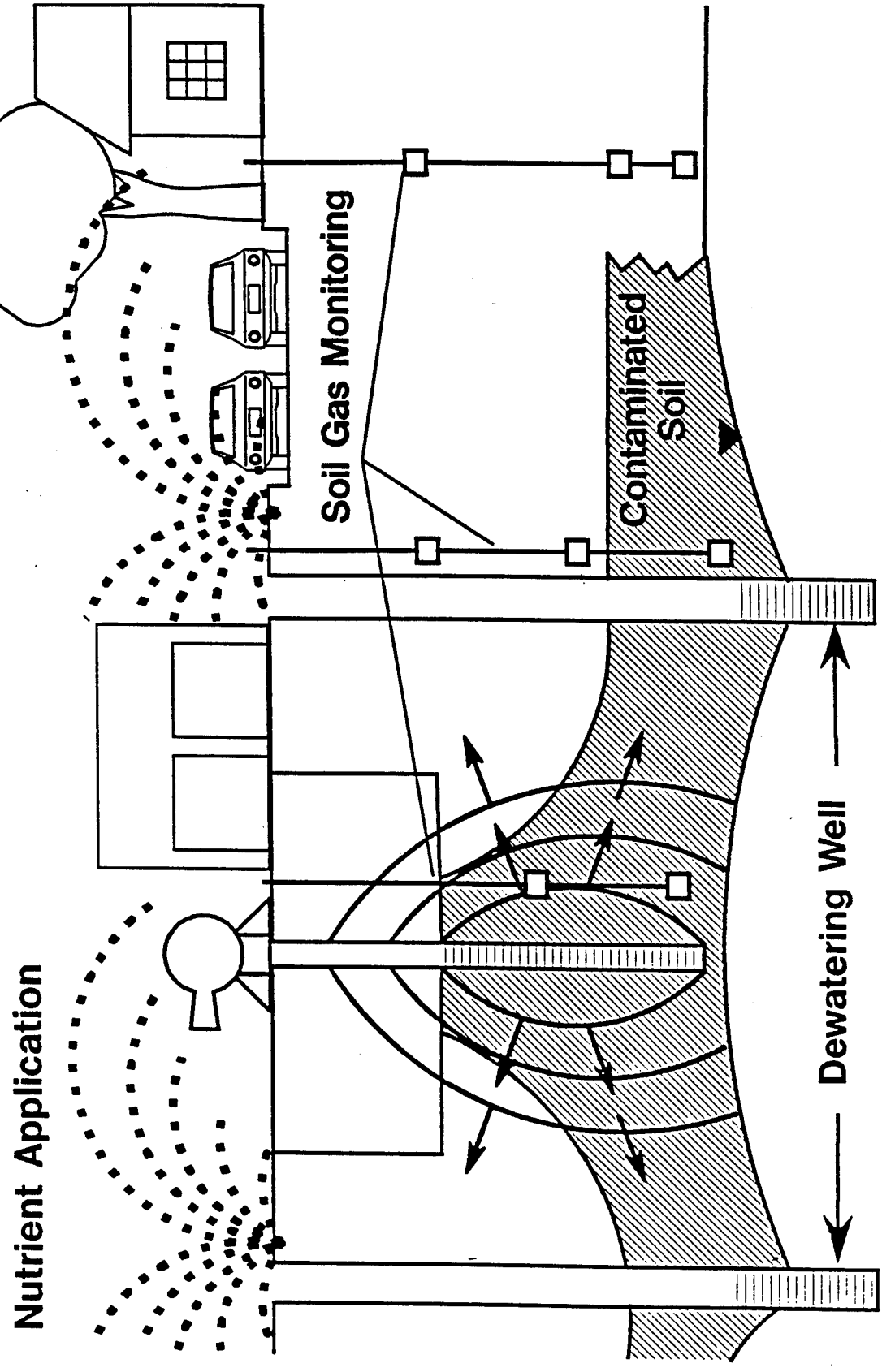

Figure 2-4. Conceptual Layout of Bioventing Process with Air Injection into Contaminated Soil, Coupled with Dewatering and Nutrient Application.

2.1.4 Hill AFB Site

A spill of approximately 25,000 gal of JP-4 jet fuel occurred when an automatic overflow device failed at Hill AFB in Ogden, Utah. Contamination was limited to the upper 65 ft of a delta outwash of the Weber River. This surficial formation extends from the surface to a depth of approximately 65 ft and is composed of mixed sand and gravel with occasional clay stringers. Depth to regional groundwater is approximately 600 ft; however, water may occasionally be found in discontinuous perched zones. Soil moisture averaged less than 6% in the contaminated soils.

The collected soil samples had JP-4 fuel concentrations up to 20,000 mg/kg, with an average concentration of approximately 400 mg/kg (Oak Ridge National Laboratory, 1989). Contaminants were unevenly distributed to depths of 65 ft. Vent wells were drilled to approximately 65 ft below the ground surface and were screened from 10 to 60 ft below the surface. A background vent was installed in an uncontaminated location in the same geological formation approximately 700 ft north of the site.

Venting was initiated in December 1988 by air extraction at a rate of ~25 cfm. The off-gas was treated by catalytic incineration, and it was initially necessary to dilute the highly concentrated gas to remain below explosive limits and within the incinerator's hydrocarbon operating limits. The venting rate was gradually increased to ~1,500 cfm as hydrocarbon concentration levels dropped. During the period between December 1988 and November 1990, more than 3.5×10^8 ft³ of soil gas were extracted from the site. In November 1989, ventilation rates were reduced to between ~300 and 600 cfm to provide aeration for bioremediation while reducing off-gas generation. This change allowed removal of the catalytic incinerator, saving ~\$6,000 per month.

During extraction, oxygen and hydrocarbon concentrations in the off-gas were measured. To quantify the extent of biodegradation at the site, the oxygen was converted to an equivalent basis. This was based on the stoichiometric oxygen requirement for hexane mineralization. JP-4 hydrocarbon concentrations were determined based on direct readings of a total hydrocarbon analyzer calibrated to hexane. Based on these calculations, the mass of the JP-4 fuel as carbon removed was ~115,000 lb volatilized and 93,000 lb biodegraded. Figures 2-5 and 2-6 illustrate these results.

Hinchee and Arthur (1991) conducted bench-scale studies using soils from this site and found that, in the laboratory, both moisture and nutrients became limiting after aerobic conditions were achieved. This led to the addition of first moisture and then nutrients in the field. The results of these field additions are shown in Figure 2-5. Moisture addition clearly stimulated biodegradation; nutrient addition did not.

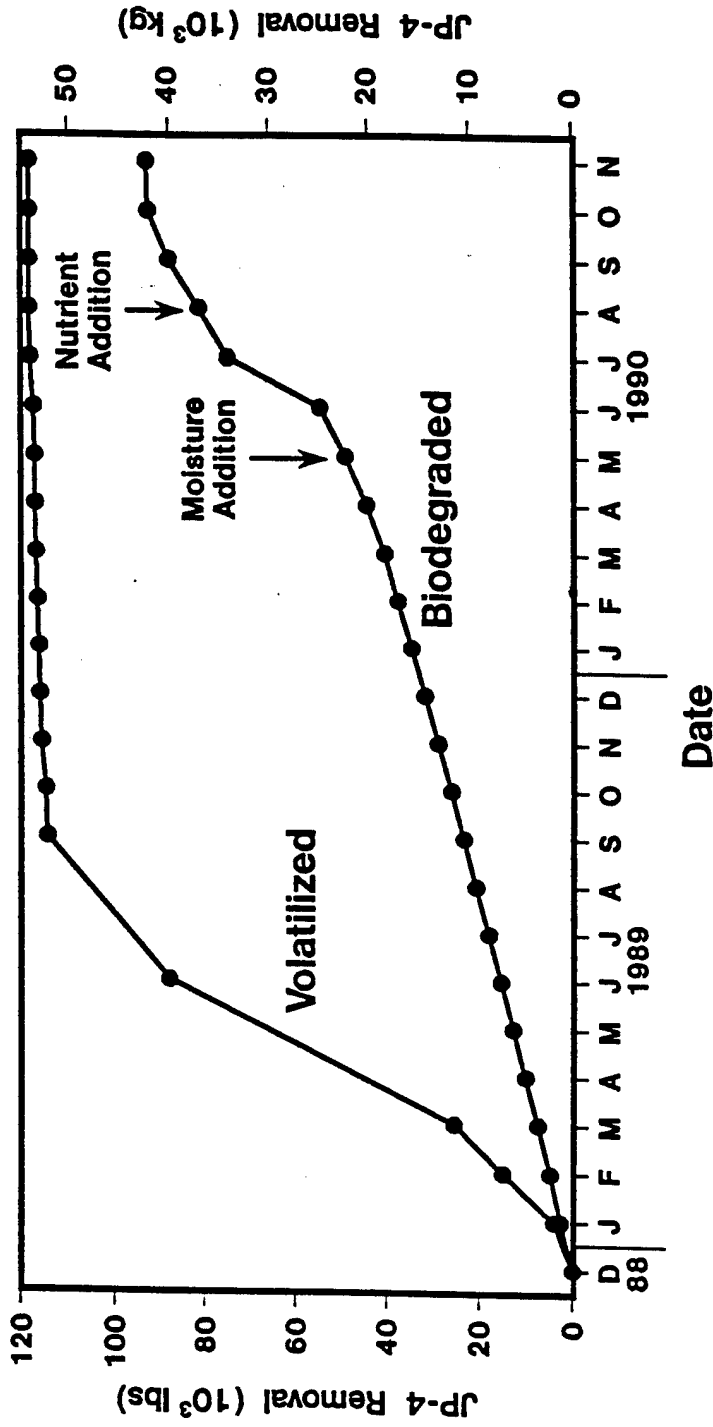

Figure 2-5. Cumulative Hydrocarbon Removal from the Hill AFB Building 914 Soil Venting Site.

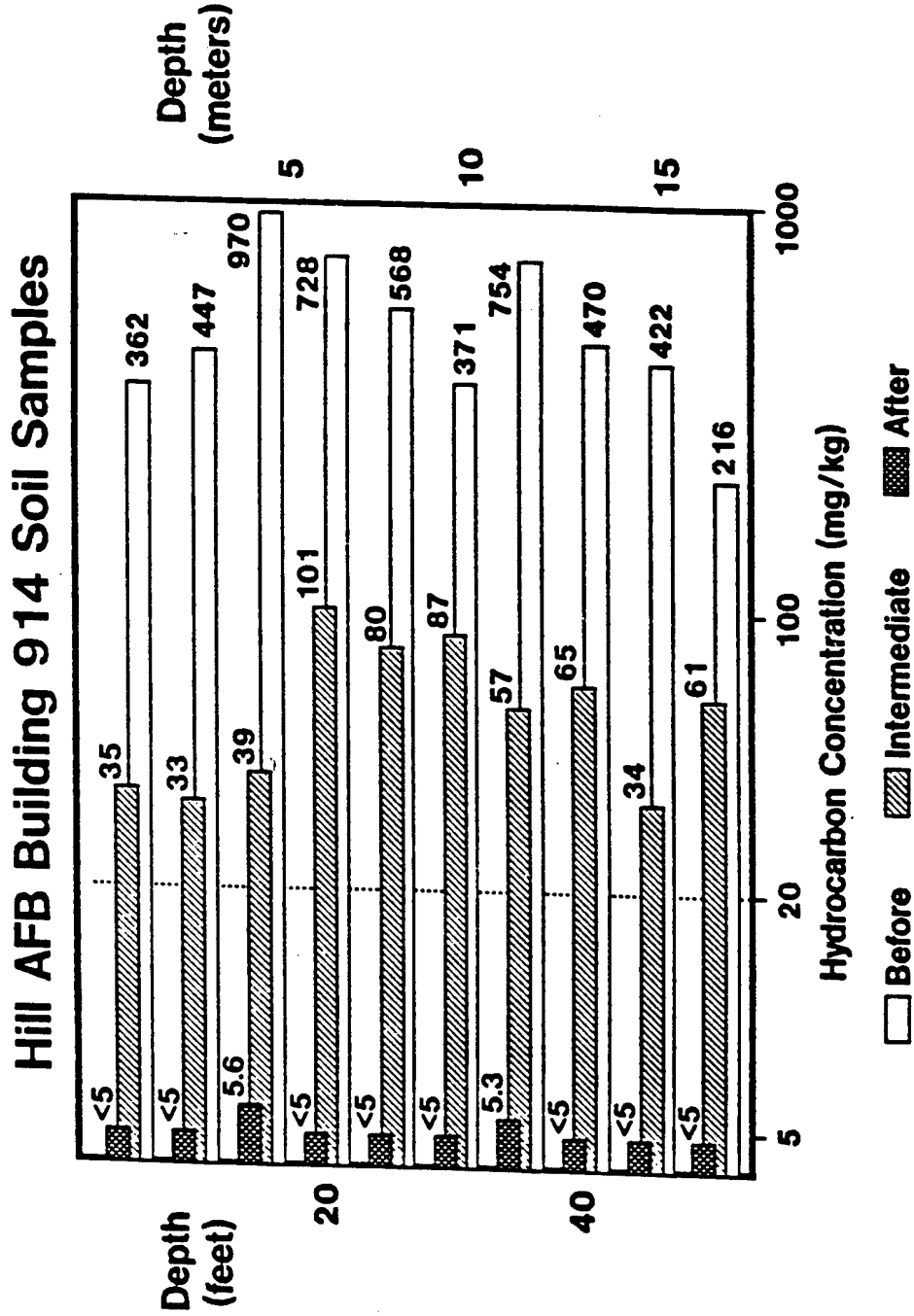

Figure 2-6. Results of Soil Analysis at Hill AFB Before and After Venting.
 (Each bar represents the average of 14 or more samples.)

The failure to observe an effect of nutrient addition could be explained by a number of factors, including:

- The nutrients failed to move in the soils; this is a problem particularly for ammonia and phosphorus (see Aggarwal et al., 1991).
- Remediation of the site was entering its final phase, and the nutrient addition may have been too late to result in an observed change.
- Nutrients simply may have not been limiting.

2.1.5 Tyndall AFB Site

As a follow-up to the Hill AFB research, a more controlled study was designed at Tyndall AFB. The experimental area in this study was located at a site where past JP-4 fuel storage had resulted in contaminated soils. The nature and volume of fuel spilled or leaked were unknown. The site soils are a fine- to medium-grained quartz sand. The depth to groundwater is 2 to 4 ft.

Four test cells were constructed to allow control of gas flow, water flow, and nutrient addition. Test cells V1 and V2 were installed in the hydrocarbon-contaminated zone; the other two were installed in uncontaminated soils. Initial site characterization indicated the mean soil hydrocarbon levels were 5,100 and 7,700 mg of hexane-equivalent/kg in treatment plots V1 and V2, respectively. The contaminated area was dewatered, and hydraulic control was maintained to keep the depth to water at ~5.25 ft. This exposed more of the contaminated soil to aeration. During normal operation, airflow rates were maintained at approximately one air-filled void volume per day.

Biodegradation and volatilization rates were much higher at the Tyndall AFB site than those observed at Hill AFB; these higher rates were likely due to higher average levels of contamination, warmer temperatures, and the presence of moisture. After 200 days of aeration, an average hydrocarbon reduction of ~2,900 mg/kg was observed. This represents a reduction in total hydrocarbons of approximately 40%.

The study was terminated because the process monitoring objectives had been met; biodegradation was still vigorous. Although the total petroleum hydrocarbons had been reduced by only 40%, the low-molecular-weight aromatics — benzene, toluene, ethylbenzene, and xylenes (BTEX) — were reduced by more than 90% (see Figure 2-7). It appears that the bioventing process more rapidly removes the BTEX compounds than the other JP-4 fuel constituents.

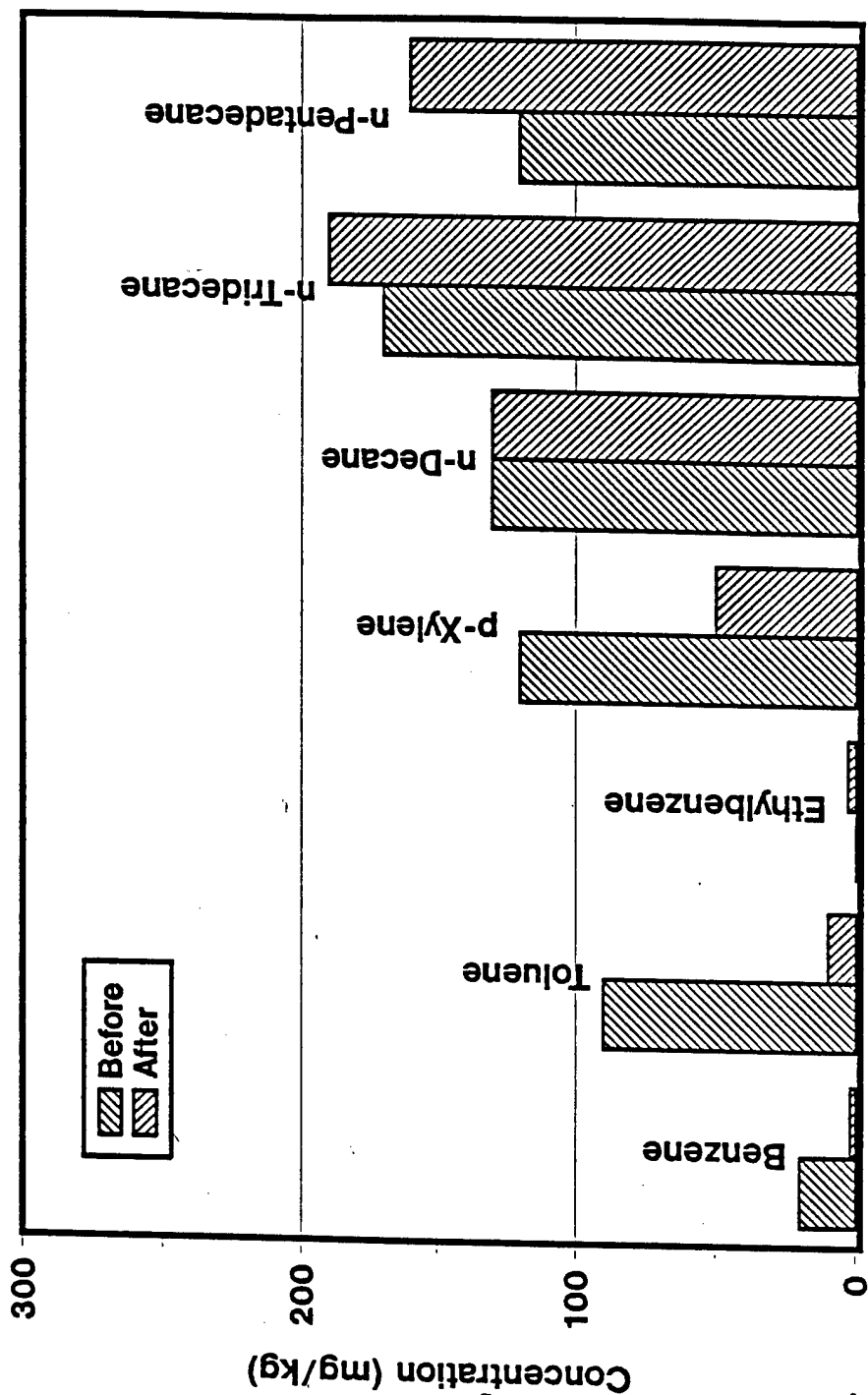

Figure 2-7. Results of Soil Analysis from Plot V2 at Tyndall AFB Before and After Venting. Each bar represents the average of 21 or more soil samples.

Another important observation of this study is the effect of temperature on the biodegradation rate. Miller (1990) found that the van Hoff-Arrhenius equation provided an excellent model of temperature effects. In the Tyndall AFB study, soil temperature varied by only -7°C , yet biodegradation rates were approximately twice as high at 25°C than at 18°C .

In the Tyndall AFB study, the effects of moisture and nutrients were observed in a field test. Two side-by-side plots received identical treatment, except that one (V2) received both moisture and nutrients from the outset of the study while the other plot (V1) received neither for 8 weeks; then moisture only for 14 weeks, followed by both moisture and nutrients for 7 weeks. As illustrated in Figure 2-8, no significant effect of moisture or nutrients was observed. The lack of moisture effect contrasts with the Hill AFB findings, but is most likely the result of contrasting climatic and hydrogeologic conditions. Hill AFB is located on a high-elevation desert with a very deep water table. Tyndall AFB is located in a moist subtropical environment, and at the site studied, the water table was maintained at a depth of approximately 5.25 ft.

The nutrient findings support field observations at Hill AFB that the addition of nutrients does not stimulate biodegradation. Based on acetylene reduction studies, Miller (1990) speculates that adequate nitrogen was present due to nitrogen fixation. Both the Hill and Tyndall AFB sites were contaminated for several years before the bioventing studies, and both sites were anaerobic. It is possible that nitrogen fixation, which is maximized under these conditions, provided the required nutrients. In any case, these findings show that nutrient addition is not always required.

In the Tyndall study, a careful evaluation of the relationship between air flow rates and biodegradation and volatilization was made. It was found that extracting air at the optimal rate for biodegradation resulted in 90% removal by biodegradation and 10% removal by volatilization. It was also found that passing the 10% volatilized through clean soil resulted in complete biodegradation.

2.2 Soil Gas Permeability and Radius of Influence

An estimate of the soil's permeability to fluid flow (k) and the radius of influence (R_f) of venting wells are both important elements of a full-scale bioventing design. On-site testing provides the most accurate estimate of the soil gas permeability, k . On-site testing can also be used to determine the radius of influence that can be achieved for a given well configuration and its flow rate and air pressure. These data are used to design full-scale systems, specifically to space venting wells, to size blower equipment, and to ensure that the entire site receives a supply of oxygen-rich air to sustain in situ biodegradation.

Soil gas permeability, or intrinsic permeability, can be defined as a soil's capacity for fluid flow, and varies according to grain size, soil uniformity, porosity, and moisture content. The value of k is a physical property of the soil; k does not change with different extraction/injection rates or different pressure levels.

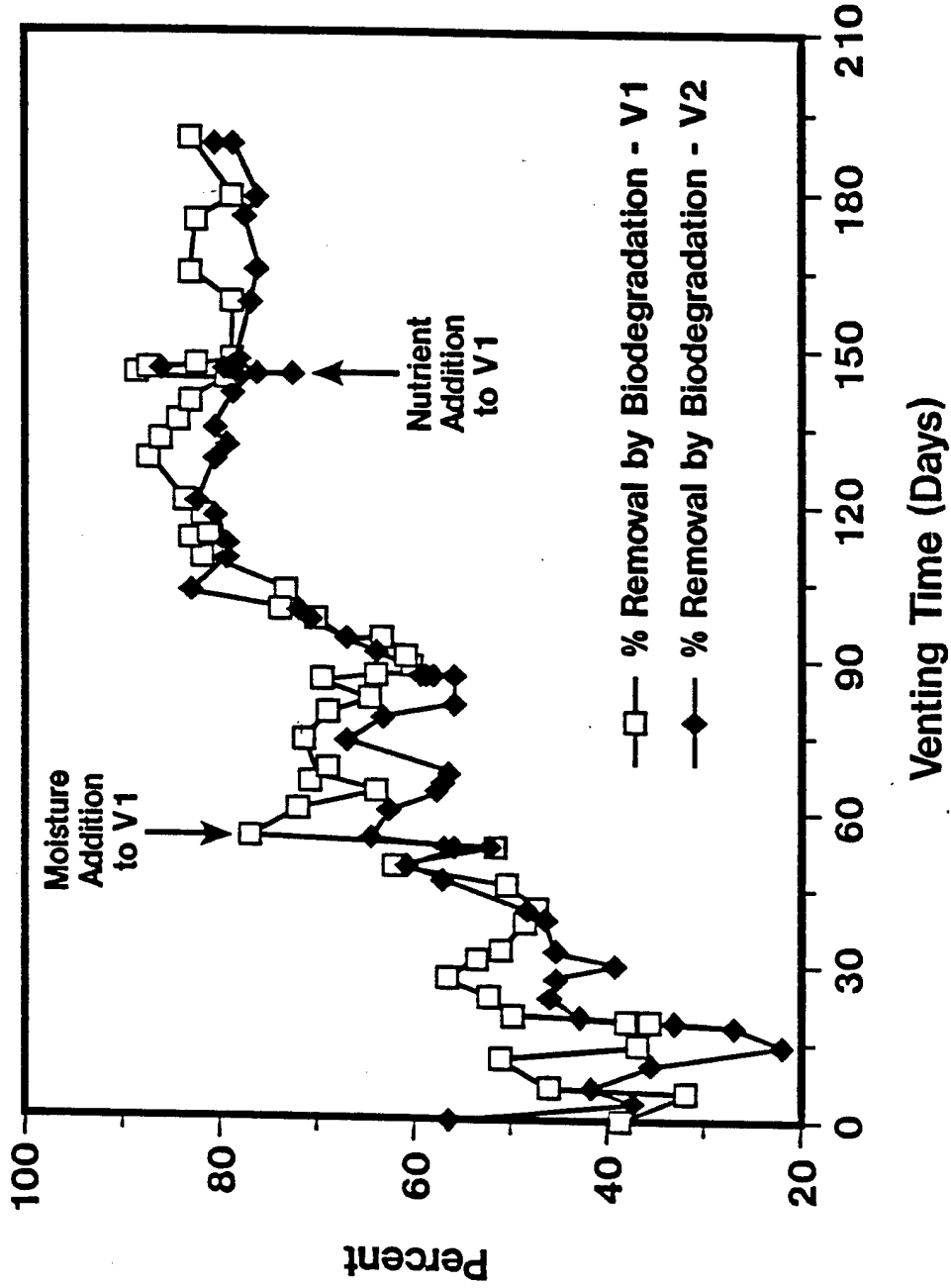

Figure 2-8. Cumulative Percent Hydrocarbon Removal at Tyndall AFB for Sites V1 and V2.

Soil gas permeability is generally expressed in the units cm^2 or darcy (1 darcy = $1 \times 10^{-8} \text{ cm}^2$). Like hydraulic conductivity, soil gas permeability may vary by more than an order of magnitude on the same site due to soil variability. Table 2-1 illustrates the range of typical k values to be expected with different soil types.

TABLE 2-1. Soil Gas Permeability Values

Soil Type	k in Darcy
Coarse Sand	100-1000
Medium Sand	1-100
Fine Sand	0.1-1.0
Silts/Clays	<0.1

Source: Johnson et al. (1990)

The radius of influence is defined as the maximum distance from the air extraction or injection well where measurable vacuum or pressure (soil gas movement) occurs. R_I is a function of soil properties, but is also dependent on the configuration of the venting well and extraction or injection flow rates, and is altered by soil stratification. On sites with shallow contamination, the radius of influence can also be increased by impermeable surface barriers such as asphalt or concrete. These paved surfaces may or may not act as vapor barriers. Without a tight seal to the native soil surface, the pavement will not significantly impact soil gas flow.

Several field methods have been developed for determining soil gas permeability (see review by Sellers and Fan, 1991). The most favored field test method is probably the modified field drawdown method developed by Paul Johnson and associates at the Shell Development Company. This method involves the injection or extraction of air at a constant rate from a single venting well while measuring the pressure/vacuum changes over time at several monitoring points in the soil away from the venting well. A detailed description of the method, including equations to compute k, is presented in the Appendix.

2.3 In Situ Respiration Testing

As part of the Air Force's bioventing R&D program, a test was identified to provide rapid field measurement of in situ biodegradation rates so that a full-scale bioventing system can be designed. This section describes such a test as developed by Hinchee et al. (1991b). This respiration test has been used at numerous sites throughout the United States.

The in situ respiration test described in this protocol (Sections 4.0 and 5.0) is essentially the same with minor modifications.

The in situ respiration test consists of placing narrowly screened soil gas monitoring points into the unsaturated zone fuel-contaminated and uncontaminated soils and venting these soils with air containing an inert tracer gas for a given period of time. The apparatus for the respiration test is illustrated in Figure 2-9. In a typical experiment, two monitoring point locations — the test location and a background control location — were used. A cluster of three to four probes were usually placed in the contaminated soil of the test location. A 1 to 3% concentration of inert gas was added to the air, which was injected for about 24 hours. The air provided oxygen to the soil, while inert gas measurements provided data on the diffusion of O₂ from the ground surface and the surrounding soil and assured that the soil gas sampling system did not leak. The background control location was placed in an uncontaminated site with air injection to monitor natural background respiration.

Measurements of CO₂ and O₂ concentrations in the soil gas were taken before any air and inert gas injection. After air and inert gas injection were turned off, CO₂ and O₂ and inert gas concentrations were monitored over time. Before a reading was taken, the probe was purged for a few minutes until the CO₂ and O₂ readings were constant. Initial readings were taken every 2 hours and then progressively over 4- to 8-hour intervals. The experiment was usually terminated when the O₂ concentration of the soil gas was ~5%.

The monitoring points in contaminated soil at each site showed a significant decline in O₂ over a 40- to 80-hour monitoring period. Figure 2-10 illustrates the average results from four sites, along with the corresponding O₂ utilization rates in terms of percent of O₂ consumed per hour. In general, little or no O₂ utilization was measured in the uncontaminated background well. Inorganic uptake of O₂ was assumed to be negligible, as seen by the low available iron present in the soil. Aerating the soil for 24 hours was assumed to be sufficient to oxidize any ferrous ions. Table 2-2 provides a summary of in situ respiration rates and reported bioventing data.

The biodegradation rates measured by the in situ respiration test appear to be representative of those for a full-scale bioventing system. Miller (1990) conducted a 9-month bioventing pilot project at Tyndall AFB at the same time Hinchee et al. (1991b) were conducting their in situ respiration test. The O₂ utilization rates (Miller, 1990) measured from nearby active treatment areas were virtually identical to those measured in the in situ respiration test.

CO₂ production proved to be a less useful measure of biodegradation than O₂ disappearance. The biodegradation rate in milligrams of hexane-equivalent/kilograms of soil per day based on CO₂ appearance is usually less than can be accounted for by the O₂ disappearance. The Tyndall AFB site was an exception. That site had low-alkalinity soils and low-pH quartz sands, and CO₂ production actually resulted in a slightly higher estimate of biodegradation (Miller, 1990).

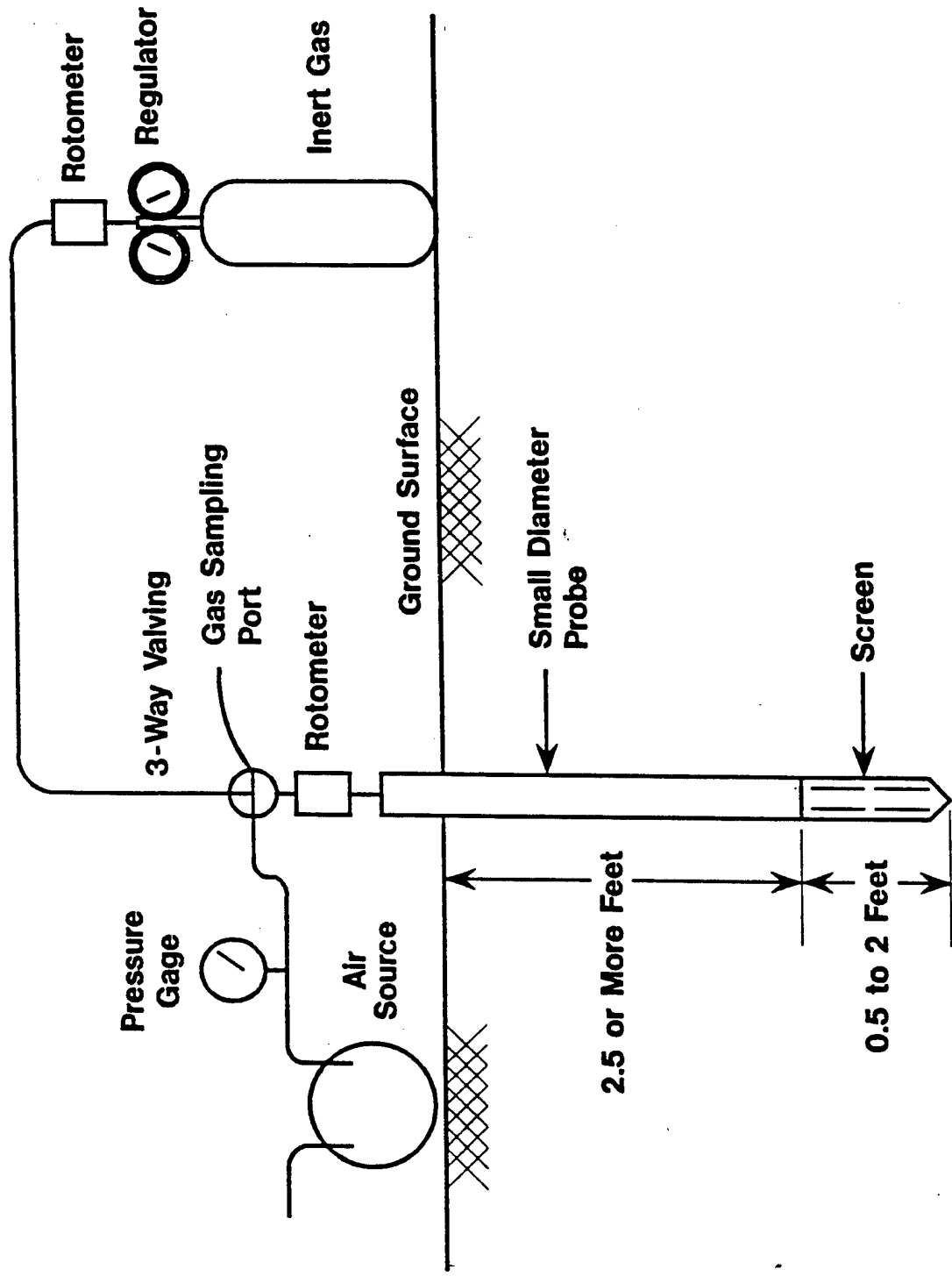

Figure 2-9. Gas Injection/Soil Gas Sampling Monitoring Point Used by Hinchee et al. (1991) in Their In Situ Respiration Studies.

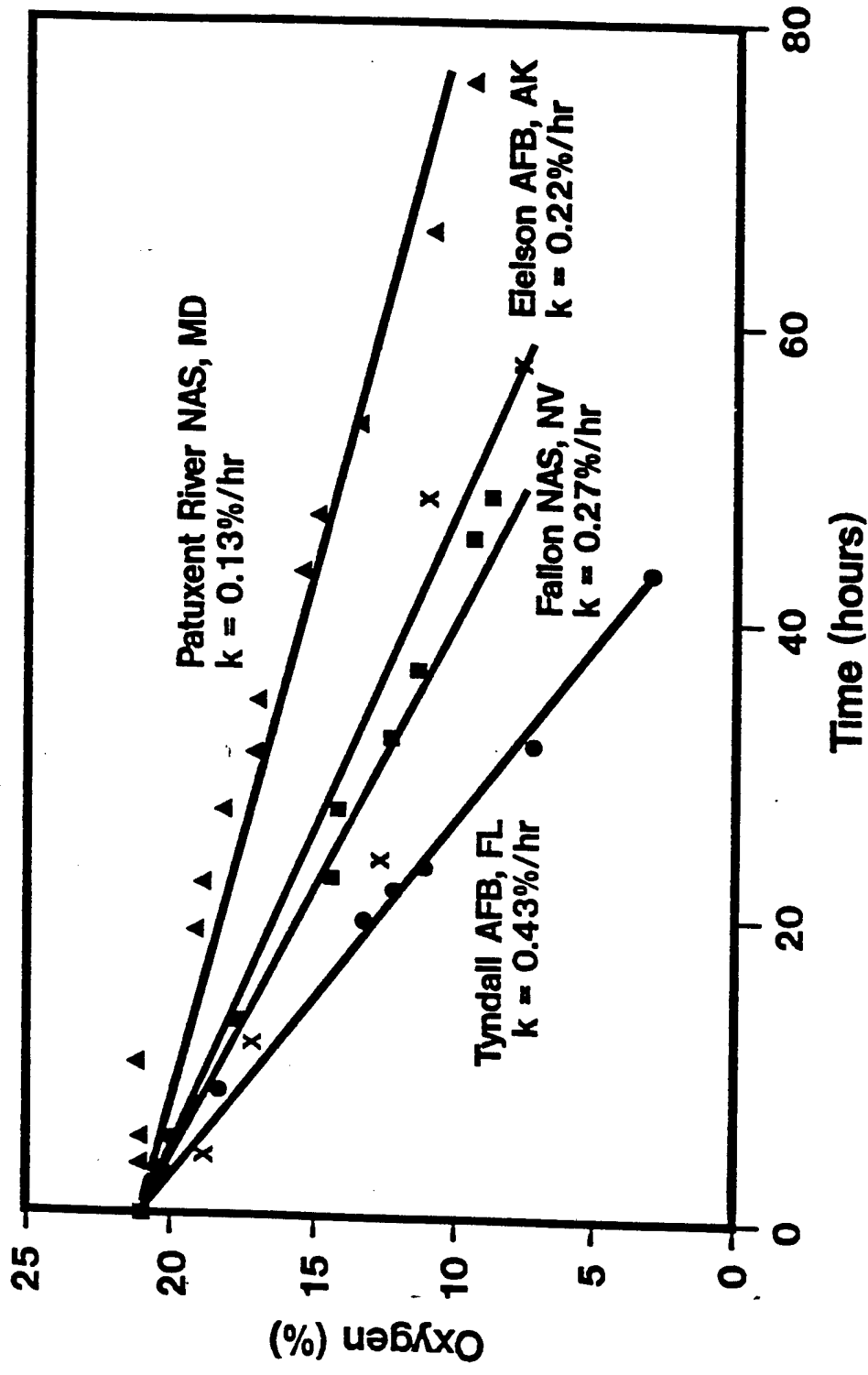

Figure 2-10. Average Oxygen Utilization Rates Measured at Four Test Sites.

TABLE 2-2. Summary of Reported In Situ Respiration and Bioventing Rate Data.

Site	Scale of Application	Contaminant	In Situ Respiration Rates (% O ₂ /hr)	Estimated Biodegradation Rates	Reference
Hill AFB, Utah	Full-scale, 2 years	JP-4 jet fuel	up to 0.52	Up to 10 mg/(kg day) ^(a,b)	Hinchee et al., 1991a
Tyndall AFB, Florida	Field pilot, 1 year and in situ respiration test	JP-4 jet fuel	0.1 - 1.0	2-20 mg/(kg day)	Miller, 1990 and Hinchee et al., 1991b
The Netherlands	Undefined	Undefined	0.1 - 0.26	2-5 mg/(kg day) ^b	Urlings et al., 1990
The Netherlands	Field pilot, 1 year	Diesel	0.42	8 mg/(kg day)	van Eyk and Vreeken, 1989b
Undefined	Full scale	Gasoline and diesel	—	50 kg/(well day) ^c	Ely and Heffner, 1988
Undefined	Full scale	Diesel	—	100 kg/(well day) ^c	Ely and Heffner, 1988
Undefined	Full scale	Fuel oil	—	60 kg/(well day) ^c	Ely and Heffner, 1988
Patuxent River NAS, Maryland	In situ respiration test	JP-5 jet fuel	0.16	3 mg/(kg day)	Hinchee et al., 1991b
Fallon NAS, Nevada	In situ respiration test	JP-5 jet fuel	0.26	5 mg/(kg day)	Hinchee et al., 1991b
Eielson AFB, Alaska	In situ respiration test	JP-4 jet fuel	0.05 - 0.5	1-10 mg/(kg day)	Hinchee et al., 1991b
Kenai, Alaska	In situ respiration test	Crude Petroleum	1.1	21 mg/(kg day)	Hinchee and Ong, 1991
Tinker AFB, Oklahoma	In situ respiration test	JP-4 and mixed fuels	0.14 - 0.94	2.7 - 18 mg/(kg day)	Hinchee and Smith, 1991

^a Rates reported by Hinchee et al., (1991) were first order with respect to oxygen; for comparative purposes, these have been converted to zero order with respect to hydrocarbons at an assumed oxygen concentration of 10%.

^b Rates were reported as oxygen consumption rates; these have been converted to hydrocarbon degradation rates assuming a 3:1 oxygen-to-hydrocarbon ratio.

^c Units are in kilograms of hydrocarbon degraded per 30 standard cubic feet per minute (scfm) extraction vent well per day.

In the case of the higher pH and higher alkalinity soils at Fallon NAS and Eielson AFB, little or no gaseous CO₂ production was measured (Hinchee et al., 1991b). This could be due to the formation of carbonates from the gaseous evolution of CO₂ produced by biodegradation at these sites. A similar problem was encountered by van Eyk and Vreeken (1988) in their attempt to use CO₂ evolution to quantify biodegradation associated with soil venting.

3.0 IN SITU RESPIRATION/AIR PERMEABILITY TEST PREPARATION

The necessary preparation, procedures, and specific tasks to conduct the in situ respiration/air permeability test are presented in the following subsections. Figure 3-1 shows a generalized flow chart of the process.

3.1 Site Characterization Review

To initiate site characterization, the project officer will inform the contractor of the Air Force facilities and specific sites where these tests will be conducted. The project officer will also provide a contact person at each Air Force facility (hereafter called base point-of-contact, or base POC). The project officer and/or the base POC will supply any relevant documents (site characterization reports, underground utility drawings, remedial investigation/feasibility studies, etc.) pertaining to the contaminated area.

A tentative test site will be selected after reviewing all preliminary documents and consulting with the project officer and the base POC. Final approval of the test area will be obtained from the project officer.

3.2 Development of Site-Specific Test Plan

All involved parties for a given site will be provided with a site-specific test plan. The site-specific test plan will consist of this generic test plan with a site-specific cover letter. The following information will typically be provided in the cover letter:

- A map showing the chosen test location, and if possible, tentative vent well and monitoring point locations
- Construction details for tentative vent well and monitoring points
- Details of any required permits and actions taken to obtain the permits
- Estimated field start date
- Any anticipated deviations from the generic test plan
- Site-specific support required from the base
- Site-specific health and safety requirements, if required.

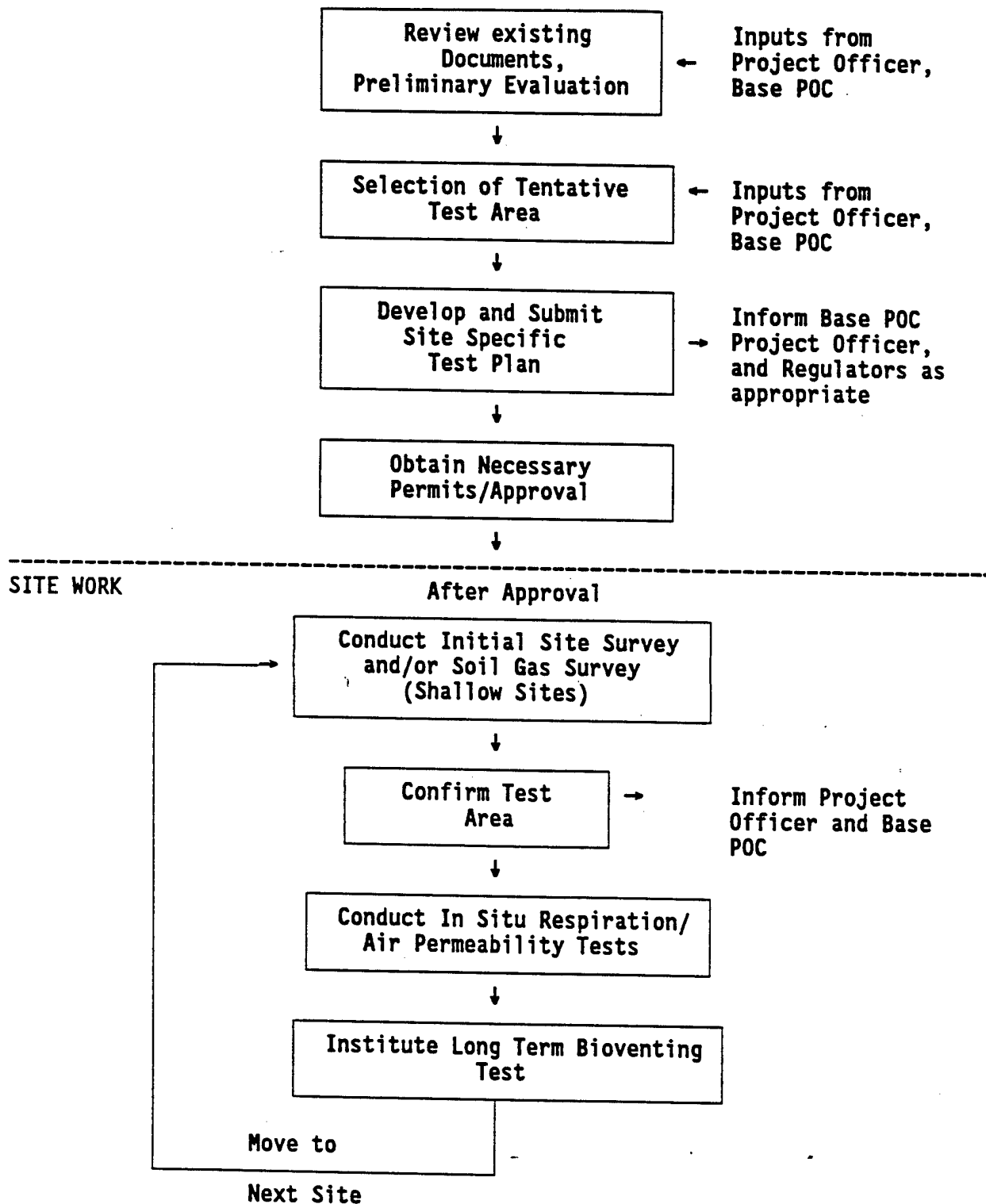

Figure 3-1. Flow Chart for Conducting Bioventing Treatability Test.

The site-specific test plan will be submitted to the project officer, base POC, and any necessary regulatory agencies for approval. The test plan will normally be submitted to outside regulatory agencies by either the project officer or the base POC. Unless specifically directed otherwise by the project officer, the contractor will not directly contact regulatory agencies or submit plans to them. No site work will be initiated without the necessary approval.

3.3 Application for Required Permits

As soon as a candidate site is identified by the Air Force project officer, applications must be submitted for the required permits. Obtaining permits frequently is the greatest holdup in accomplishing this type of field work. It is likely that no state or local permits will be required, but this must be determined early. Types of permits that may be required include:

- Drilling and/or well installation permits for the vent well and/or monitoring points
- Air Emission Permit for the vent well if air is extracted.
- Site Investigation Permit or Approval. This usually will not be necessary; however, some regulatory jurisdictions may require permitting. This test should not normally be considered a CERCLA treatability test.

No direct contact will be made by the contractor with regulatory agencies without project officer and base POC approval. In many cases the project officer or base POC will handle regulatory contacts, if they are necessary.

The contractor will coordinate with the base POC to obtain access and necessary clearance to conduct the tests at the candidate test area. The contractor will arrange with the base for the utilities — electricity and water — needed to execute the tests. If electricity is not available, the contractor will provide power from portable generators. The contractor will coordinate with the base POC to obtain any necessary security clearances or badges.

As early as possible, the contractor will supply the base POC with a list of all personnel to be used on base, including name, social security number, place and date of birth, and expected arrival date. The contractor will also request that the base POC initiate the process of obtaining a digging permit.

4.0 TEST WELLS AND EQUIPMENT

This section describes the test wells and equipment that are required to conduct the field treatability tests. It must be recognized that site-specific flexibility will be required, and thus, details will vary. Local and/or state regulatory agencies and at times individual Air Force bases will have specific requirements that differ from specifications in this test plan. All testing must comply with regulations, and must be acceptable to the host base.

Field notes will be maintained describing all vent well and monitoring point construction. Deviations from standard design will be noted in the final report.

4.1 Vent Wells

A vent well and blower system will be established to provide airflow through the subsurface, creating a pressure/vacuum gradient for air permeability testing and increasing subsurface oxygen levels for in situ respiration testing. This 2- to 4-in. vent well will be placed with the screened section in contaminated soil and will be located near the center of the fuel spill. The siting and construction of the venting well will follow these general criteria:

1. The vent well will be sited as near to the center of the spill area as possible. This location will ensure that data gathered from the test will be as representative as possible of contaminated soil conditions. On many small sites, the vent well used during the treatability test can be converted into the primary vent well for extended testing.
2. The diameter of the vent well may vary between 2 and 4 in. and will depend on the ease of drilling and the area and depth of the contaminated volume. On most sites a 2-in.-diameter vent will provide adequate airflow for air permeability/radius of influence testing. For sites with contamination extending below 30 ft, a 3- or 4-in. vent well is recommended. The cost of a larger well is a minor component of the total drilling cost because a drill rig will be required to drill to this depth, regardless of well diameter. Groundwater monitoring points screened several ft above the existing water table can also be converted to vent wells. This option is appropriate for air injection systems but will be less successful for air extraction systems because the applied vacuum will cause a rise in the water table which could rapidly submerge the screened interval.

3. The vent well will normally be constructed of schedule 40 polyvinyl chloride (PVC), and will be screened with a slot size that maximizes airflow through the soil. The screened interval will extend through as much of the contaminated profile as possible, with the bottom of the screen corresponding to the top of the capillary fringe. For shallow sites with groundwater less than 20 ft deep, the vent well will be screened over the bottom half of the unsaturated zone. For deeper wells, care must be taken in determining the depth of the top of the screen. A deeper screen is normally better. If the top of the screen is close to the ground surface, much of the airflow may follow the shortest path from near the top of the screen to the ground surface.
4. Hollow-stem augering is the recommended drilling method; however, a solid-stem auger is also acceptable in more cohesive soils. Whenever possible, the diameter of the annular space will be at least two times greater than the vent well outside diameter. The annular space corresponding to the screened interval will be filled with silica sand or equivalent. In shallow softer soils, hand-augering may be feasible. The annular space above the screened interval will be sealed with wet bentonite and grout to prevent short-circuiting of air to or from the surface. Figure 4-1 shows a typical vent well.

4.2 Soil Gas Monitoring Points

Soil gas monitoring points will be used for pressure and soil gas measurements and will be installed at a minimum of three locations, and at each location to at least three depths. The total number will vary, with up to six monitoring point locations, and six or more depths, depending on site conditions.

To the extent possible, the monitoring points will be located in contaminated soils with >1,000 mg/kg of total petroleum hydrocarbon. These soils will have a strong odor and will feel oily to the touch. It may not be possible to locate all monitoring points in contaminated soil, especially the points furthest from the vent well. If this is the case, it is important to ensure that the point closest to the vent well be located in contaminated soil, and if possible, the intermediate point be placed in contaminated soils. If no monitoring points are located in contaminated soil, no meaningful in situ respiration test can be conducted. If the initial oxygen levels in the soil gas are not low, i.e., below 2 to 5%, and the soil gas hydrocarbon levels are not high, say above 10,000 ppm for relatively fresh JP-4 fuel, the monitoring point may not be suitable for an in situ respiration test.

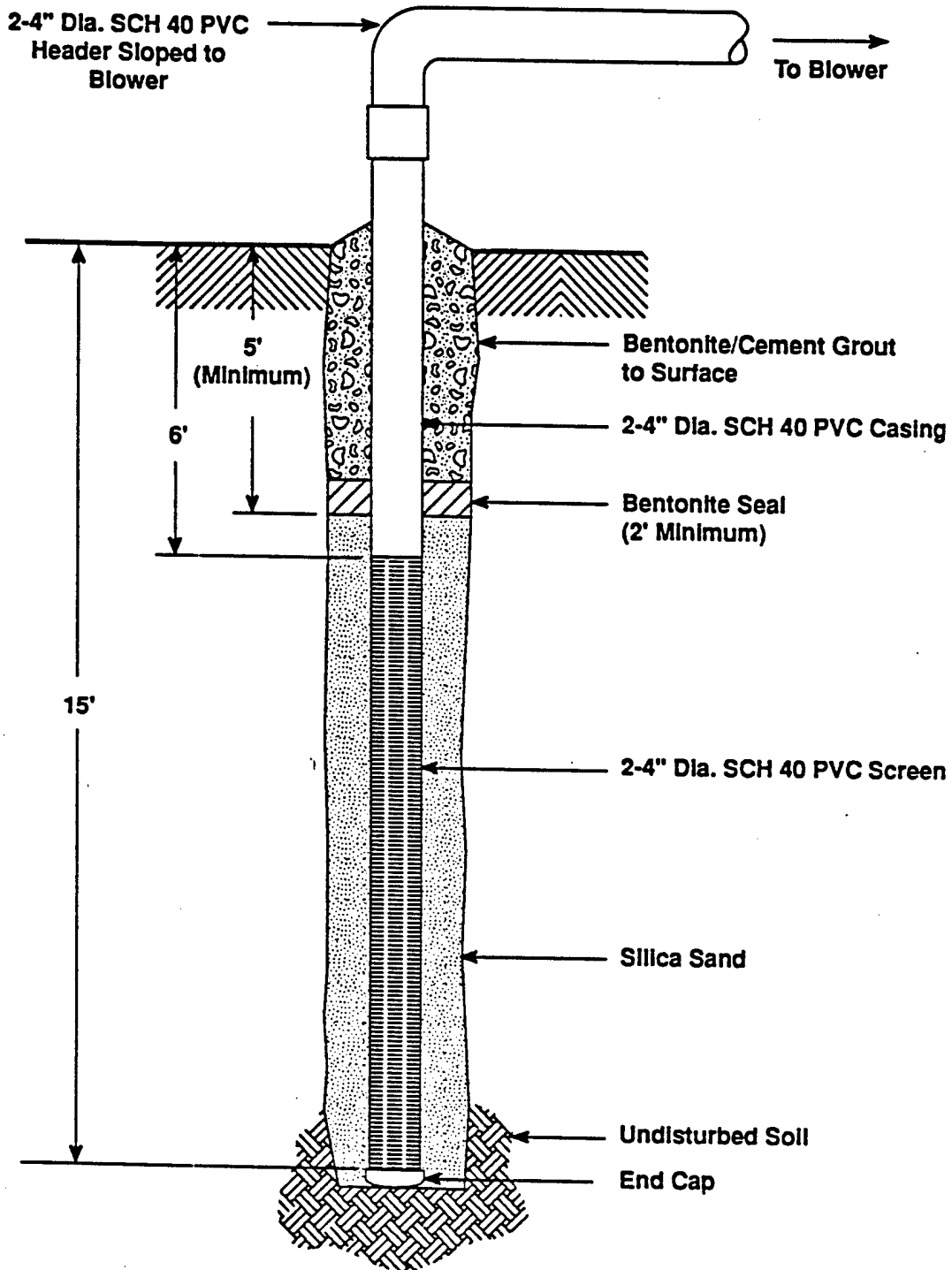

Not to Scale

Figure 4-1. Typical Injection/Vacuum Venting Well Construction.

Higher oxygen concentrations would indicate that the microbial activity is not oxygen-limited or that there is sufficient exchange of air with the atmosphere to keep the soil gas well-aerated. In either case, bioventing will not increase biodegradation rates. At some sites, where less contaminated soils and low O₂ concentrations are encountered, bioventing may still be feasible. If these conditions are found, care must be taken to place the monitoring points in the most contaminated soil possible.

4.2.1 Location of Monitoring Points

A minimum of 3 monitoring points is recommended; ideally these will be in a straight line and at the intervals recommended in Table 4-1. In an unobstructed heterogeneous site, 3 monitoring points at these spacings are appropriate. Additional monitoring point locations may be necessary for a variety of site-specific reasons including, but not limited to, spatial heterogeneities, obstructions, or the desire to monitor a specific location. Additional discussion related to monitoring point placement is found in Section 5.0, Test Procedures.

4.2.2 Depth of Monitoring Points

In general, each monitoring point will be screened to at least 3 depths. The deepest screen will be placed either at or near the bottom of contamination if a water table is not encountered, or a minimum of 2 to 3 ft above the water table if it is encountered. Consideration will be given to potential seasonal water table fluctuations and soil type in finalizing the depth. In a more permeable soil the monitoring point can be screened closer to the water table. In a less permeable soil it must be screened further above the water table. The shallowest screen will normally be 3 to 5 ft below land surface. The intermediate screen will be placed at a reasonable interval at a depth corresponding to the center to upper ¼ of the depth of the vent well screen.

As an example, in a sandy soil with groundwater at 30 ft and a vent well screened from 17.5 to 27.5 ft below land surface, reasonable screened depths for the monitoring points would be 28 ft, 22.5 ft, and 3 ft. For sites with vent wells deeper than 30 ft, more depths may be screened, depending on stratigraphy.

It will be necessary in some cases to add additional screened depths to ensure a well-oiled soil is encountered, to monitor differing stratigraphic intervals, or to adequately monitor deeper sites with broadly screened vent wells. If air injection is being considered in the bioventing test, a monitoring point must be located between the vent well and any buildings that may be at risk to assure that they are well beyond the radius of influence.

TABLE 4-1. Recommended Spacing for Monitoring Points

Soil Type	Depth to Top of Vent Well Screen (ft) ⁽¹⁾	Spacing Interval (ft) ⁽²⁾
Coarse Sand	5	5-10-20
	10	10-20-40
	>15	20-30-60
Medium Sand	5	10-20-30
	10	15-25-40
	>15	20-40-60
Fine Sand	5	10-20-40
	10	15-30-60
	>15	20-40-80
Silts	5	10-20-40
	10	15-30-60
	>15	20-40-80
Clays	5	10-20-30
	10	10-20-40
	>15	15-30-60

- (1) Assuming 10 ft of vent well screen, if more screen is used, the >15-ft spacing will be used.
- (2) Note that monitoring point intervals are based on a venting flow rate range of 1 cfm/ft screened interval for clays to 3 cfm/ft screened interval for coarse sands.

4.2.3 Construction of Monitoring Points

Most state and local regulatory agencies do not regulate unsaturated zone soil gas monitoring point construction. Nevertheless, prior to construction it is necessary to check with regulators to assure compliance with any regulations that may exist.

Monitoring point construction will vary depending on the depth of drilling and the drilling technique. Basically, the monitoring points will consist of a small-diameter ¼-in. tube to the specified depth with a screen approximately 6 in. long and ½ to 1 in. in diameter. In shallow hand-augered installations, rigid tubing (i.e., Schedule 80 ¼" PVC) terminating in the center of a gravel or sand pack may be adequate. The gravel or sand pack will normally extend for an interval of 1 to 2 ft with the screen centered. In low-permeability soils, a larger gravel pack may be desirable. In wet soils a longer gravel pack with the screen near the top may be desirable. A bentonite seal at least 2 ft thick is normally required above and below the gravel pack. Figure 4-2 shows a typical installation.

For relatively shallow installations in more permeable soils, a hand-driven system, such as that of KVA Associates, may be used. In such a system, a sacrificial drive point with Tygon™, Teflon™, or other appropriate tubing is driven to the desired depth. Then, the steel outer tubing is retrieved, leaving the drive point and the inner flexible tubing in place. Because this type of installation allows little or no sand pack or seal placement, it should be used only in relatively permeable soils where sample collection will not be a problem or in soils that will "self heal" to prevent short-circuiting. Surface completion of the hand-driven points should be the same as for those installed in borings.

Tubes will be used to collect soil gas for CO₂ and O₂ analysis in the 0.25% range, and for JP-4 hydrocarbons in the 100 ppm range or higher. The tubing material must have sufficient strength and be nonreactive. Sorption and gas interaction with the tubing materials have not been significant problems for this application. If a monitoring point will be used to monitor specific organics in the low ppm or ppb range, teflon or stainless steel may be necessary. However, this will not normally be the case.

All tubing from each monitoring point will be finished with quick-connect couplings and will be labeled twice. Each screened depth will be labeled as follows:

[Code for Site] – [Code for Monitoring Point] – [Depth to Center of Screened Interval].

Table 4-2 lists the labels used for example site #2 at Millersworth AFB. In M2, the M is for Millersworth AFB, and the 2 is for site #2 at Millersworth. The tubing will be labeled with a firmly attached metal tag or directly by engraving or in waterproof ink. Instead of a metal tag, a metal plate may be placed at the bottom of the monitoring point compartment with holes drilled for each tube. The metal plate will then be engraved, identifying each tube where it passes through the plate. If this method is used, the tube itself must still be labeled with ink or by engraving. The label will be placed close to the ground so that, if the tube is damaged, the label is likely to survive.

The top of each monitoring point will be labeled to be visible from above. This will be done either by writing in the concrete or with spray paint.

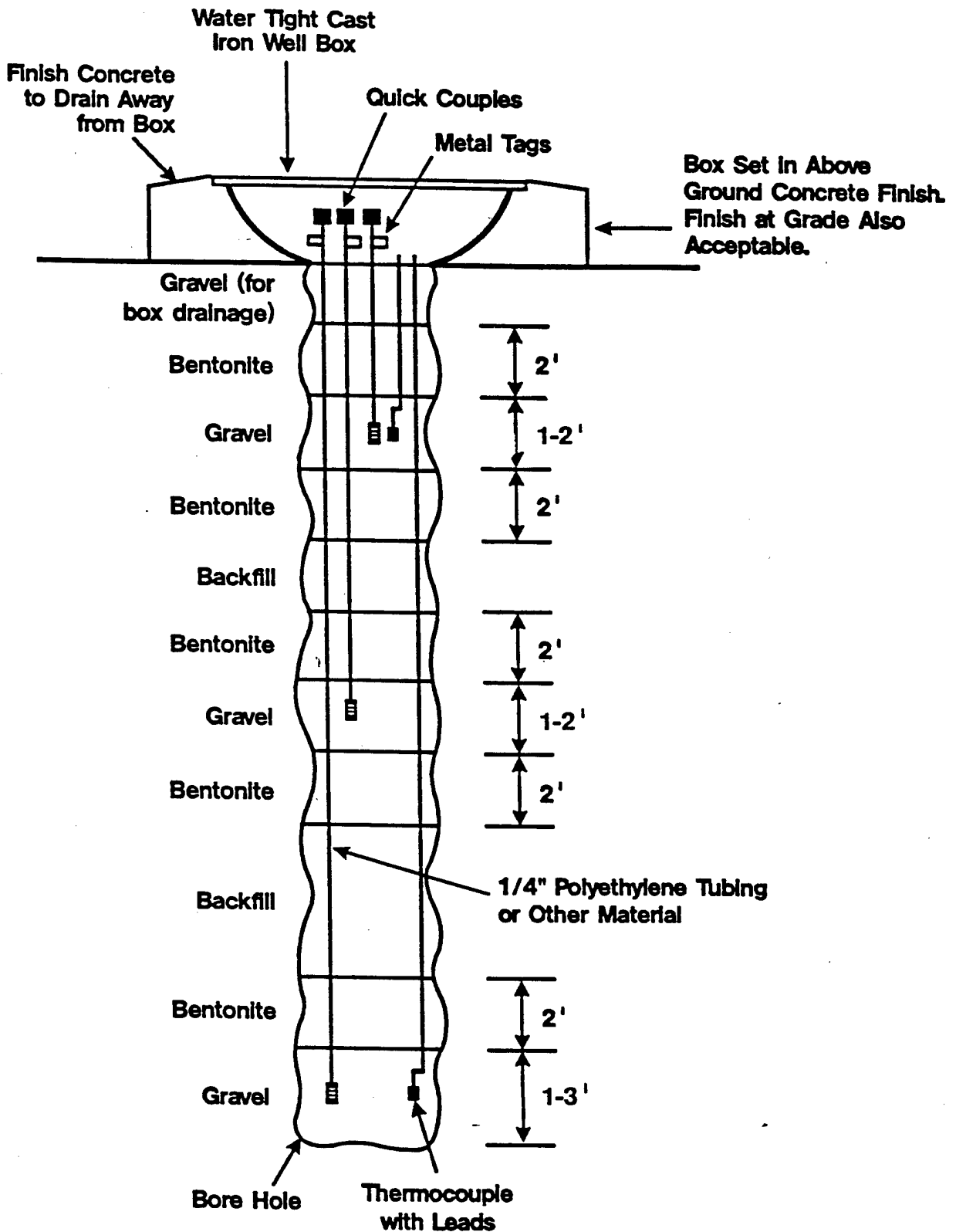

Figure 4-2. Typical Monitoring Point Construction Detail.
(Dimensions will vary for specific installations.)

**TABLE 4-2. Monitoring Points for Example Site #2
at Millersworth AFB**

M2-A-3	(3 ft deep)	Monitoring Point A, Closest to the vent well
M2-A-15	(15 ft deep)	
M2-A-25	(25 ft deep)	
M2-B-3	(3 ft deep)	Monitoring Point B, Intermediate from vent well
M2-B-15	(15 ft deep)	
M2-B-27	(27 ft deep)	
M2-C-3	(3 ft deep)	Monitoring Point C, Farthest from vent well
M2-C-14	(14 ft deep)	
M2-C-23	(23 ft deep)	

The monitoring points will be finished by placement in a watertight cast iron well box. The well box will be placed either aboveground in a concrete pad or at grade, also in concrete. The box will be drained to prevent water accumulation.

4.2.4 Thermocouples

Two thermocouples will be installed at each site. They will be installed at the monitoring point closest to the vent well and, as shown in Figure 4-2, at the depth of the shallowest and deepest screen. Thermocouples used are either J or K type. The thermocouple wires will be labeled using the same system as for the tubings, except that a two-letter word, TC, will be added to the identification label (e.g., M2-TCA-3, for the thermocouple installed at the second Millersworth AFB site monitoring point A at the 3-ft depth).

4.3 Background Well

In addition to the vent well and the monitoring points installed in contaminated soils, a background well will be installed in uncontaminated soil to monitor the background respiration of natural organic matter. Soil gas in uncontaminated soil generally has O₂ levels between 15 and 20% and CO₂ levels between 1 and 5%. The background well will be similar in construction to the vent well (Figure 4-1), except that the length of the screen will be approximately 5 ft.

To the extent possible, the screen of the background well will be located at a depth similar to that of the monitoring points and in the same stratigraphic formation. For

sites deeper than 20 ft, the screen portion of the background well will be placed at 20 to 25 feet. For depths less than 20 ft, the screen portion of the background well will be placed between 5 and 15 ft.

4.4 Blower System

The type and size of blower used on a test site will be determined based upon the soil type, depth and area of contamination, and available power. In an attempt to reduce the number of blower units in the pilot test inventory and to standardize piping and instrumentation, two typical blowers are specified:

Blower One

Application:

Contaminated interval in sandy soils and mixed sandy/silt and sandy/clay soils.

Typical Specifications:

- Explosion-proof regenerative blower
- 20 to 90 scfm at 20" to 100" H₂O, respectively
- 3-HP explosion-proof motor
- Single-phase 230-V power source

Blower Two

Application:

Predominantly silt and clay soils.

Typical Specifications:

- Explosion-proof pneumatic blower
- 50 scfm at 130" H₂O.
- 5-HP explosion-proof motor
- Single-phase 230-V power source.

Each blower will be fitted with mounting brackets and pipe fittings to make it compatible with the basic blower systems shown in Figures 4-3 and 4-4. Explosion-proof blowers and motors are required when soil gas extraction is used. Explosion-proof equipment may be required for air injection systems as well.

The blower system will be instrumented to monitor blower performance and to provide test data such as the vent well pressure (P_w) and the gas stream flow rate (Q) adjusted for air density. Using these data and pressure data from each soil gas monitoring point, k and R_1 can be estimated.

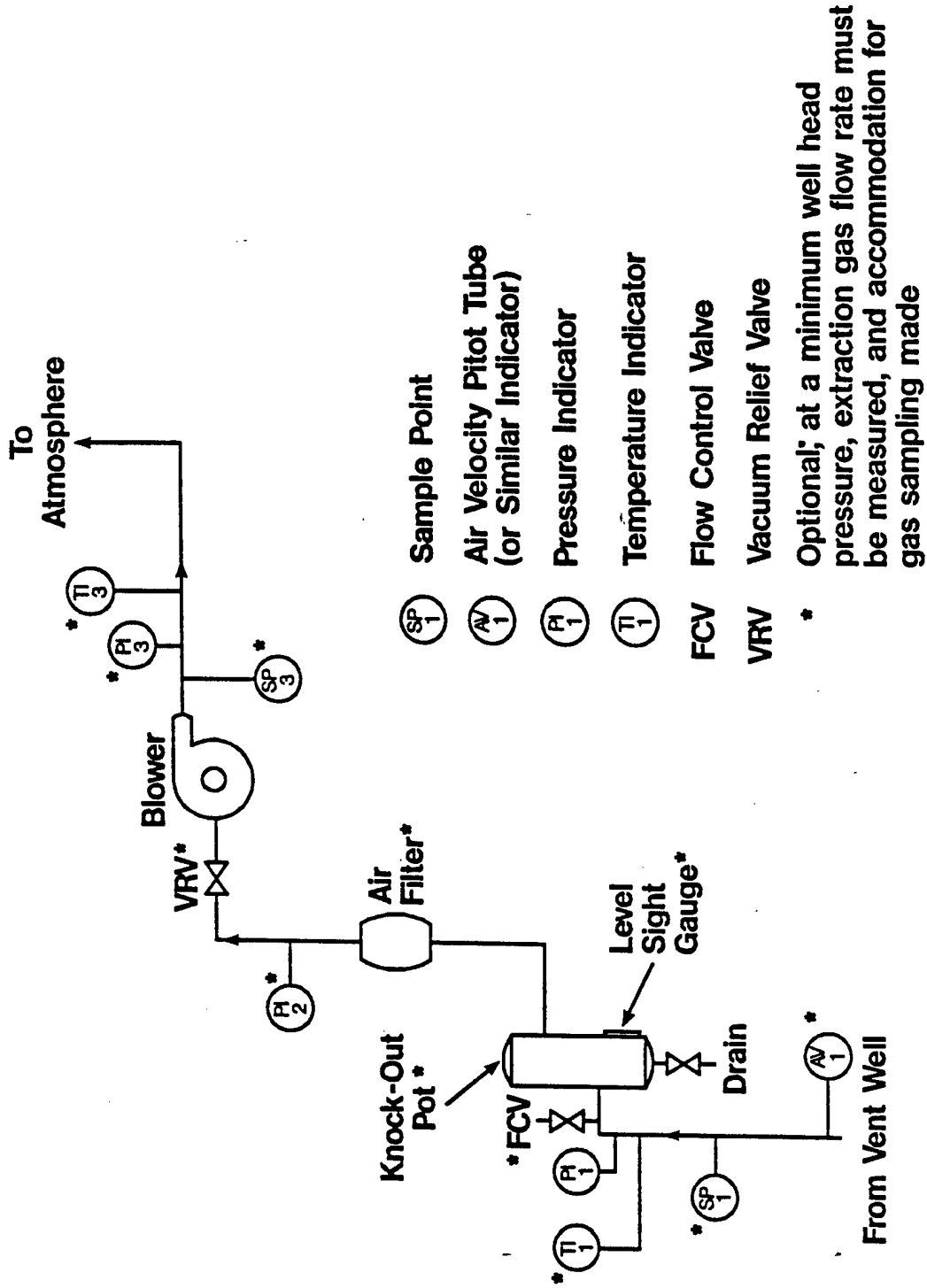
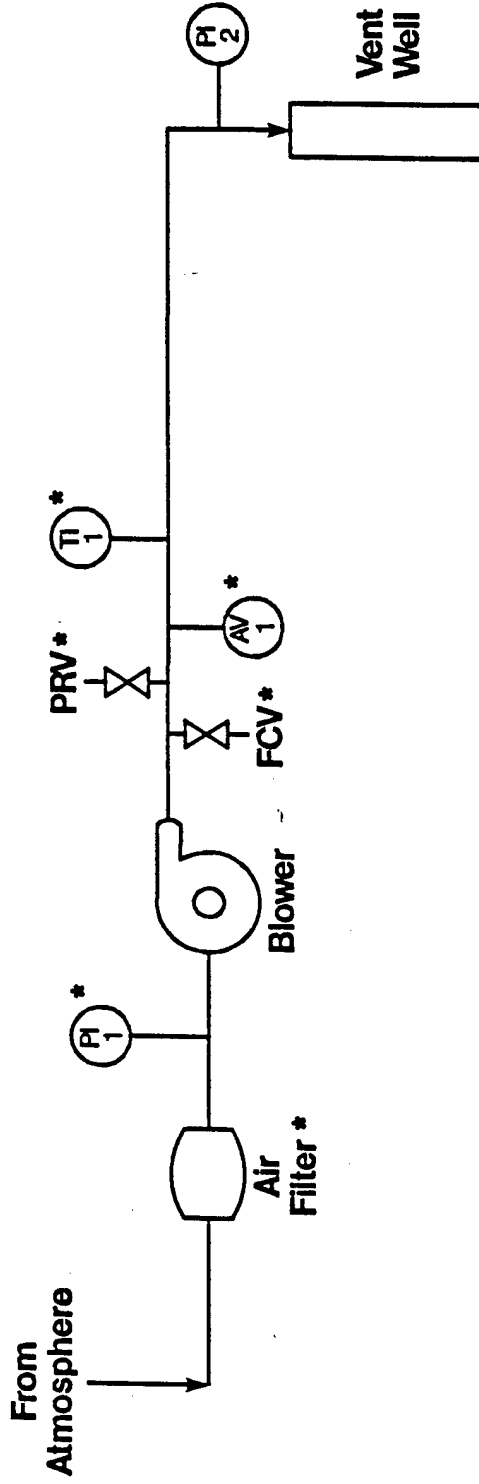

Figure 4-3. Soil Gas Permeability Blower System Instrumentation Diagram for Soil Gas Extraction.



AV 1
 Air Velocity Pitot Tube
 (or Similar Indicator)

PI 1
 Pressure Indicator

TI 1
 Temperature Indicator

FCV Flow Control Valve

PRV Pressure Relief Valve

* Optional

Figure 4-4. Soil Gas Permeability Blower System Instrumentation Diagram
 for Air Injection.

4.5 Field Instrumentation and Measurements

Sections 4.5.1 through 4.5.6 discuss the equipment used for measurements. Figures supplement the text.

4.5.1 Oxygen and Carbon Dioxide

Gaseous concentrations of CO₂ and O₂ will be analyzed using a GasTech model 3252OX CO₂/O₂ analyzer or equivalent. The battery charge level will be checked to ensure proper operation. The air filters will be checked and, if necessary, cleaned or replaced before the experiment is started. The instrument will be turned on and equilibrated for at least 30 minutes before conducting calibration or obtaining measurements. The sampling pump of the instrument will be checked to ensure that it is functioning. Low flow of the sampling pump can indicate that the battery level is low or that some fines are trapped in the pump or tubing.

Meters will be calibrated each day prior to use against purchased CO₂ and O₂ calibration standards. These standards will be selected to be in the concentration range of the soil gas to be sampled. The CO₂ calibration will be performed against atmospheric CO₂ (0.05%) and a 5% standard. The O₂ will be calibrated using atmospheric O₂ (20.9%) and against a 5% and 0% standard. Standard gases will be purchased from a specialty gas supplier. To calibrate the instrument with standard gases, a Tedlar™ bag (capacity ~1 l) is filled with the standard gas, and the valve on the bag is closed. The inlet nozzle of the instrument is connected to the Tedlar™ bag, and the valve on the bag is opened (see Figure 4-5). The instrument is then calibrated against the standard gas according to the manufacturer's instructions. Next, the inlet nozzle of the instrument is disconnected from the Tedlar™ bag and the valve on the bag is shut off. The instrument will be rechecked against atmospheric concentration. If recalibration is required, the above steps will be repeated.

4.5.2 Hydrocarbon Concentration

Petroleum hydrocarbon concentrations will be analyzed using a GasTech Trace-Techtor™ hydrocarbon analyzer (or equivalent) with range settings of 100 ppm, 1,000 ppm, and 10,000 ppm. The analyzer will be calibrated against two hexane calibration gases (500 ppm and 4,400 ppm). The Trace-Techtor™ has a dilution fitting that can be used to calibrate the instrument in the low-concentration range.

Calibration of the GasTech Trace-Techtor™ is similar to the GasTech Model 32402X, except that a mylar bag is used instead of a Tedlar™ bag. The O₂ concentration must be above 10% for the Trace-Techtor™ analyzer to be accurate. When the O₂ drops below 10%, a dilution fitting must be added to provide adequate oxygen for analysis.

Hydrocarbon concentrations can also be determined with a flame ionization detector (FID), which can detect low (below 100 ppm) concentrations. A photoionization detector (PID) is *not* acceptable.

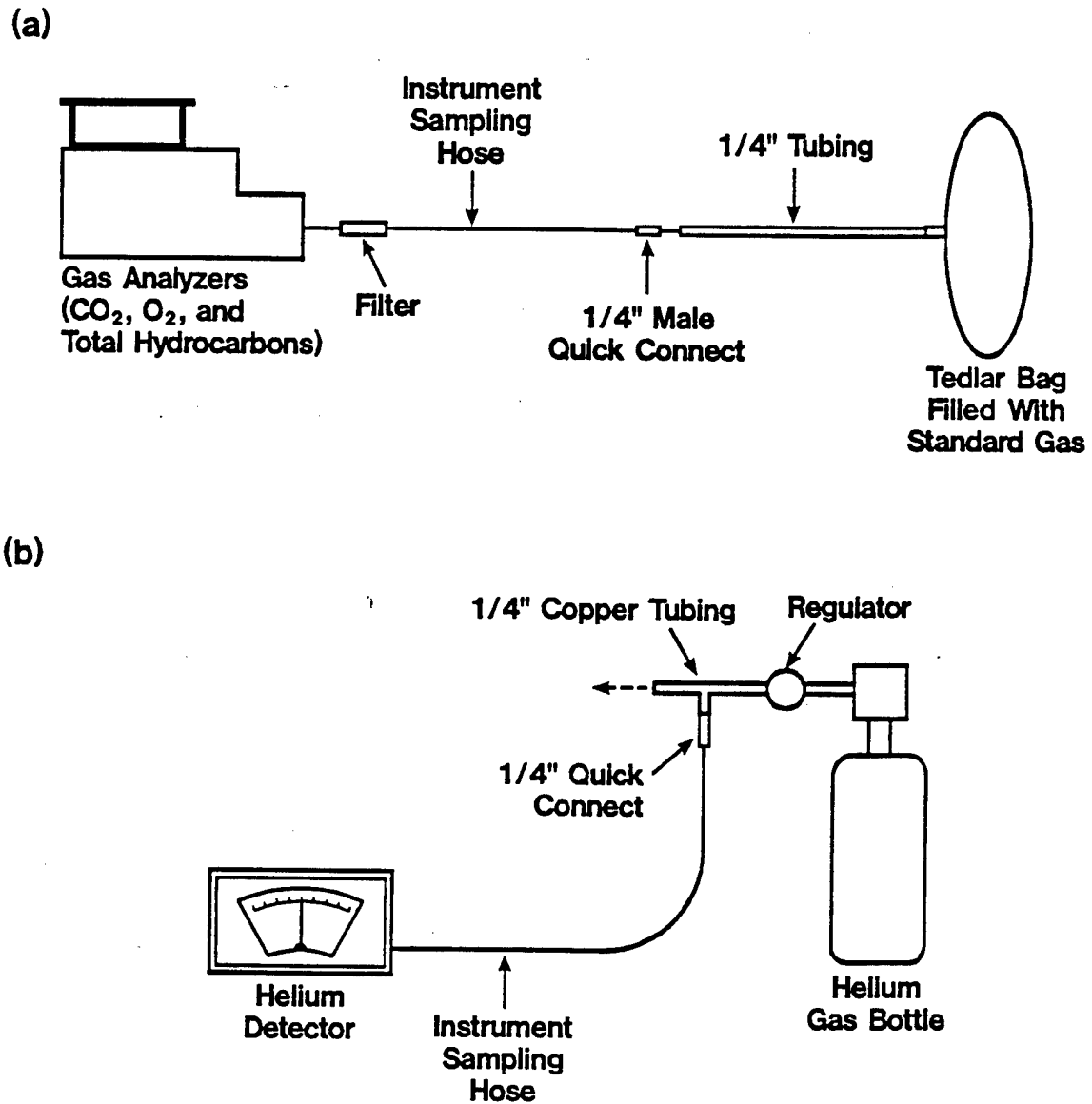

Figure 4-5. Schematic Setup for Calibration of Soil Gas Instruments.
(a) CO₂, O₂, and Total Hydrocarbon Analyzers.
(b) Helium Detector.

4.5.3 Helium Monitoring

Helium in the soil gas will be measured with a Marks Helium Detector Model 9821 or equivalent with a minimum sensitivity of 100 ppm (0.01%). Calibration of the helium detector follows the same basic procedure described for oxygen calibration, except that the setup for calibration is different (see Figure 4-5). Helium standards used are 100 ppm (0.01%), 5,000 ppm (0.5%), and 10,000 ppm (1%).

4.5.4 Temperature Monitoring

In situ soil temperature will be monitored using Omega Type J or K thermocouples (or equivalent). The thermocouples will be connected to an Omega OM-400 Thermocouple Thermometer (or equivalent). Each thermocouple will be calibrated against ice water and boiling water by the contractor before field installation.

4.5.5 Pressure/Vacuum Monitoring

Changes in soil gas pressure during the air permeability test will be measured at monitoring points using Magnehelic™ or equivalent gauges. Tygon™ or equivalent tubing will be used to connect the pressure/vacuum gauge to the quick-disconnect on the top of each monitoring point. Similar gauges will be positioned before and after the blower unit to measure pressure at the blower and at the head of the venting well. Pressure gauges are available in a variety of pressure ranges, and the same gauge can be used to measure either positive or negative (vacuum) pressure by simply switching inlet ports. Gauges are sealed and calibrated at the factory and will be rezeroed before each test. The following pressure ranges (in inches H₂O) will typically be available for this field test:

0-1", 0-5", 0-10", 0-20", 0-50", 0-100", and 0-200"

Air pressure during injection for the in situ respiration test will be measured with a pressure gauge with a minimum range of 0 to 30 psig.

4.5.6 Airflow

Airflow measurements will be taken for both the air permeability test and the respiration test. These measurements are described in Sections 4.5.6.1 and 4.5.6.2.

4.5.6.1 Airflow Measurement — Air Permeability Test

During the air permeability test an accurate estimate of flow (Q) entering or exiting the vent well is required to determine k and R_p. Several airflow measuring devices are acceptable for this test procedure.

Pitot tubes or orifice plates combined with an inclined manometer or differential pressure gauge are acceptable for measuring flow velocities of 1,000 ft/min or greater (~20 scfm in a 2-in. pipe). For lower flow rates, a large rotometer will provide a more accurate measurement. If an inclined manometer is used, the manometer must be rezeroed before and after the test to account for thermal expansion/contraction of the water. Devices to measure static and dynamic pressure must also be installed in straight pipe sections according to manufacturer's specifications. All flow rates will be corrected to standard temperature and ambient pressure (altitude) conditions.

4.5.6.2 Airflow Measurement — Respiration Test

Prior to initiating respiration tests at individual monitoring points, air will be pumped into each monitoring point using a small air compressor as described in Section 5.7. Airflow rates of 1 to 1.5 cfm will be used, and flow will be measured using a Cole-Palmer Variable Area Flowmeter No. N03291-4 (or equivalent). Helium will be introduced into the injected air at a 1% concentration. A helium flow rate of approximately 0.01 to 0.015 cfm (0.6 to 1.0 cfh) will be required to achieve this concentration. A Cole-Palmer Model L-03291-00 flowmeter or equivalent will be used to measure the flow rate of the helium feed stream.

4.5.6.3 Airflow Measurement — Bioventing Test

Airflow measurements during the bioventing tests may be made as described for the air permeability test (Section 4.5.6.1). If a single vent well and blower are used and 100% of the flow to the blower comes from the extraction well, the air flow measurement may not be necessary. If a blower with a known pump curve is used and intake and exhaust pressures are monitored, flow rate can be estimated from the pump curve.

5.0 TEST PROCEDURES

5.1 Location of Optimum Test Area

A soil gas survey will be conducted to locate an optimum site for the vent well and the soil gas monitoring points. Ideally, the vent well and monitoring points will be located in well-oiled soils where the O₂ is depleted and the CO₂ levels are elevated (see discussion in 4.2). If at least three monitoring point screens are not located in the most contaminated soils, then the in situ respiration test may not provide adequate information on the biodegradation rates for the site.

5.1.1 Soil Gas Survey (for contamination < 20 ft)

A soil gas survey will be conducted prior to locating the vent well and monitoring points at sites with relatively shallow groundwater where soils are penetrable to a depth of within 5 ft of the water table using hand-driven gas probes. The survey will not be a complete site soil gas survey to fully delineate contamination.

Accessibility to the site will be confirmed, along with possible restrictions that may hamper the tests. Existing groundwater and soil gas monitoring wells near the test area will be identified. Groundwater will be checked for free floating product, and soil gas from any existing monitoring points or wells will be analyzed for O₂, CO₂, and total hydrocarbons before proceeding with the soil gas survey. To assist in the soil gas survey, a simple sampling grid will be established using existing monitoring wells or prominent landmarks for identification.

Soil gas sampling will be conducted using small-diameter ($\frac{5}{8}$ -inch OD) stainless steel probes (KVA Associates or equivalent) with a slotted well point assembly. The maximum depth for hand-driven probes will typically be 10 to 15 ft, depending on soil texture. In some dense silts or clays, penetration of the soil gas probe will be less, while in some unconsolidated sands, deeper penetration may be possible. At a given location on the grid, a probe will be driven (manually or with a power hammer) to a depth determined by preliminary review of the site contamination documents. Soil gas at this depth will be analyzed for O₂, CO₂, and total hydrocarbons. The probe will then be driven deeper, and the soil gas will be measured. For a typical site with a depth to groundwater of 9 ft, soil gas will be measured at depths of 2.5 ft, 5 ft, and 7.5 ft.

The main criterion for selecting a suitable test site is that the microbial activity should be oxygen-limited. Under such conditions, the O₂ level will be low (usually 0 to 2%), CO₂ will be high (typically 5 to 20%, depending on soil type), and hydrocarbon content will be high (> 10,000 ppm for most fresh JP-4 sites).

An uncontaminated site also will be located to be used as an experimental control to monitor background respiration of natural organic matter and inorganic sources of CO₂.

Typical O₂ and CO₂ levels at an uncontaminated site are 15 to 20% and 1 to 5%, respectively. The hydrocarbon content in the soil gas of a contaminated site is generally below 100 ppm.

Prior to sampling, soil gas probes will be purged with a sample pump. To determine adequate purging time, soil gas concentrations will be monitored until the concentrations stabilize. This will not always be possible, particularly when shallow soil gas samples are being collected, as atmospheric air may be drawn into the probe and produce false readings. When shallow soil gas samples are collected, air withdrawal will be kept to a minimum. Figure 5-1 shows a typical setup for monitoring soil gas.

5.1.2 Exploratory Boring in Deep Soils

On sites where contamination extends to depths greater than 20 ft, exploratory borings will be used to ensure that the vent well and monitoring points are located in fuel-contaminated soils. Exploratory borings that encounter significant fuel contamination will then be completed and used as vent wells or monitoring points.

A hollow-stem auger will be used to advance the boring, and drill cuttings will be visually checked and analyzed with a GasTech Trace-Tehtor™ (or equivalent) hydrocarbon analyzer, an equivalent explosimeter, or a FID, to determine the relative fuel contamination of each 2- to 3-ft interval. Drill cuttings will be inspected at each contaminated interval selected for monitoring point installations.

As the boring advances beyond 20 ft, a split-spoon sampling device will be recommended for sampling at 5-ft intervals. Split-spoon samples will be visually checked for fuel contamination and screened for volatile emissions by passing a hydrocarbon analyzer slowly over the open split spoon.

The purpose of this simple monitoring technique will be to provide air monitoring for worker health and safety, to rapidly locate the interval of highest contamination, and to attempt to locate the maximum depth of contamination at each site. A geologic driller's log will be kept to identify changes in lithology, depths of apparent fuel contamination, and sample locations. Exploratory borings will also be required to locate a clean area for installing the background monitoring point. Careful inspection of drill cuttings and volatile hydrocarbon monitoring will be required to ensure that soils in the control area are free of fuel hydrocarbons.

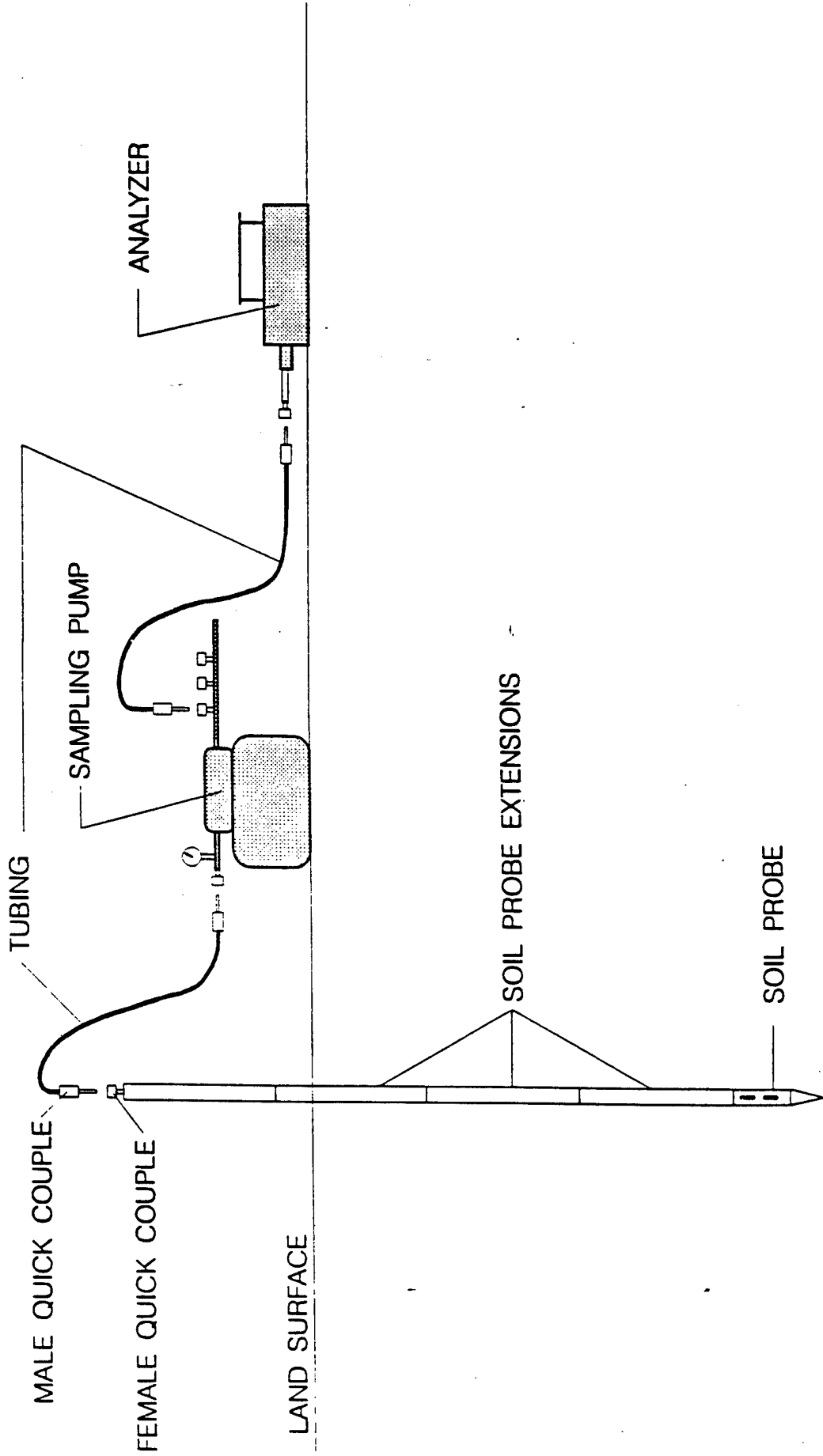

Figure 5-1. Schematic Diagram of Soil Gas Sampling
Using the Stainless Steel Soil Gas Probe.

5.2 Drilling and Installation of the Vent Well

Based on a review of available site characterization data, a preliminary location will be proposed for the vent well. Following the soil gas survey and/or exploratory boring, a final vent well location will be determined. If soils were proved to be sufficiently contaminated, the exploratory boring will be completed as the vent well. Soil samples will be collected at a minimum interval of 5 ft in the vent well boring following the procedures outlined in Section 5.5. Siting and construction of the vent well will follow the criteria provided in Section 4.1.

5.3 Drilling and Installation of Monitoring Points

Based on the location of the vent well and available site characterization data, the monitoring points will be located at points where sufficient data for the air permeability tests can be obtained and, at the same time, they can be used for the in situ respiration test. Table 4-1 will be used as a guide to locate the monitoring points in relation to the location of the vent well. The location of the monitoring points will also take into consideration the long-term bioventing test that will be conducted after the in situ respiration test. The monitoring points will generally be located in a contaminated area. Screens for the monitoring points will have the same slot sizes as those for the vent well (see discussion in Section 4.2).

When possible, the monitoring points will be placed in hand-augered borings or in borings augered with a small portable drill. At deeper sites, it will be necessary to hire a driller for both the monitoring points and the vent well. When a drill rig is used, a hollow-stem auger will most likely be used. A smaller ID auger will be used, as required, for the vent well installation. Also as required, a solid auger will be used in shallow or cohesive soils.

5.4 Background Well Installation

A background well will be installed in an uncontaminated location to obtain soil gas measurements of O_2 and CO_2 concentrations to monitor background respiration. The well will be constructed in a manner similar to the vent well, except that it will normally be 1 in. in diameter with a screen length of 5 ft. At sites deeper than 20 ft, the screened portion of the background well will be placed at 20 to 25 ft, so long as it is screened in the same geological formation as the vent well. Normally, deeper screening will be required only if necessary to intercept the vented formation.

5.5 Collection of Soil Samples

A minimum of three to four soil samples will be collected from each site and analyzed for physical/chemical characteristics, including nutrient concentration. At least one representative sample of each contaminated soil type will be collected. It is important that samples for nutrient analyses be collected from a contaminated zone; otherwise, if fixation

has already occurred, the nitrogen concentration may not be representative. Soil samples will be collected from the exploratory boring or from the borings for the vent well or monitoring points. Soil samples will be collected from cuttings if the borings are shallow, by hand from a hand-augered hole, or with a split-spoon sampler. Enough soil will be collected to fill a 500-ml polyethylene or glass container. The container will be sealed with a teflon-lined cap and then placed in a cooler for shipment. Special procedures for preserving the sample will not be required, as only inorganics and the physical properties of the soil will be analyzed. Each soil sample will be labeled to identify the site, boring location and depth, and time of collection. Soil samples may also be collected for total petroleum hydrocarbon (TPH) analysis and for benzene, toluene, ethylbenzene, and xylene (BTEX) analysis. Samples to be used for TPH, BTEX, or any other volatility analysis must be collected, bundled, stored, and shipped in a manner that will prevent volatilization losses. The methods for this sampling are described in other sources.

Chain-of-custody forms will accompany each shipment to the laboratory. The soil samples will be analyzed for at least the following parameters:

- pH
- total kjeldahl nitrogen (TKN)
- total phosphorus
- alkalinity
- particle size analysis
- total iron
- moisture content.

In addition to the chain-of-custody forms, each sample will be logged into the project record book along with a complete description of where and how it was collected. Each sample will be labeled with an identification code corresponding to its sampling location. The code will follow the system described for labeling the monitoring points in Section 4.2.3 as follows:

[Code for Site] — [Code for Location] — [Depth]

Location codes will include the abbreviations VW for vent well, MP for monitoring point, BG for background well, or EB for an exploratory boring or other boring not completed as a vent well, monitoring point, or background well. For the example site #2 at Millersworth AFB the following codes might be used:

- M2—VW—12 for a sample from site #2 at Millersworth AFB from a depth of 12 ft from the vent well boring
- M2—MPC—28 for a sample from a depth of 28 ft from the monitoring point C boring

- M2-BG-4 for a sample from a depth of 4 ft from the background boring
- M2-EB2-20 for a sample from a depth of 20 ft from the second exploratory boring, which was subsequently grouted and not completed as a well or monitoring point.

5.6 Soil Gas Permeability Test Procedures

This section describes the field procedures that will be used to gather data to determine k and to estimate R_f . The Appendix provides an example data set and calculations for the radius of influence using the dynamic and steady-state solution methods.

Prior to initiating the soil gas permeability test, the site will be examined for any wells (or other structures) that will not be used in the test but may serve as vertical conduits for gas flow. These will be sealed to prevent short-circuiting and to ensure the validity of the soil gas permeability test.

5.6.1 System Check

Before proceeding with this test, soil gas samples will be collected from the vent well, the background well, and all monitoring points, and analyzed for O_2 , CO_2 , and volatile hydrocarbons. After the blower system has been connected to the vent well and the power has been hooked up, a brief system check will be performed to ensure proper operation of the blower and the pressure and airflow gauges, and to measure an initial pressure response at each monitoring point. This test is essential to ensure that the proper range of Magnehelic™ gauges are available for each monitoring point at the onset of the soil gas permeability test. Generally, a 10- to 15-minute period of air extraction or injection will be sufficient to predict the magnitude of the pressure response, and the ability of the blower to influence the test volume.

5.6.2 Soil Gas Permeability Test

After the system check, and when all monitoring point pressures have returned to zero, the soil gas permeability test will begin. Two people will be required during the initial hour of this test. One person will be responsible for reading the Magnehelic™ gauges, and the other person will be responsible for recording pressure (P') vs. time on the example data sheet (see Appendix Table A-2). This will improve the consistency in reading the gauges and will reduce confusion. Typically, the following test sequence will be followed:

1. Connect the Magnehelic™ gauges to the top of each monitoring point with the stopcock opened. Return the gauges to zero.

2. Turn the blower unit on, and record the starting time to the nearest second.
3. At 1-minute intervals, record the pressure at each monitoring point beginning at $t = 60$ s.
4. After 10 minutes, extend the interval to 2 minutes. Return to the blower unit and record the pressure reading at the well head, the temperature readings, and the flow rate from the vent well.
5. After 20 minutes, measure P' at each monitoring point in 3-minute intervals. Continue to record all blower data at 3-minute intervals during the first hour of the test.
6. Continue to record monitoring point pressure data at 3-minute intervals until the 3-minute change in P' is less than 0.1 in. of H_2O . At this time, a 5- to 20-minute interval can be used. Review data to ensure accurate data were collected during the first 20 minutes. If the quality of these data is in question, turn off the blower, allow all monitoring points to return to zero pressure, and restart the test.
7. Begin to measure pressure at any groundwater monitoring points that have been converted to monitoring points. Record all readings, including zero readings and the time of the measurement. Record all blower data at 30-minute intervals.
8. Once the interval of pressure data collection has increased, collect soil gas samples from monitoring points and the blower exhaust (if extraction system), and analyze for O_2 , CO_2 , and hydrocarbons. Continue to gather pressure data for 4 to 8 hours. The test will normally be continued until the outermost monitoring point with a pressure reading does not increase by more than 10% over a 1-hour interval.
9. Calculate the values of k and R_1 with the data from the completed test: use of the HyperVentilate™ computer program is recommended. The Appendix shows sample calculation methods for determining k and R_1 .

5.6.3 Post-Permeability Test Soil Gas Monitoring

Immediately after completion of the permeability test, soil gas samples will be collected from the vent well, the background well, and all monitoring points, and analyzed for O₂, CO₂, and hydrocarbons. If the O₂ concentration in the vent well has increased by 5% or more, O₂ and CO₂ will be monitored in the vent well in a manner similar to that described for the monitoring points in the in situ respiration test. (Initial monitoring may be less frequent.) The monitoring will provide additional in situ respiration data for the site.

5.7 In Situ Respiration Test

The in situ respiration test will be conducted using four screened intervals of the monitoring points and a background well. The results from this test will determine if in situ microbial activity is occurring and if it is O₂-limited.

5.7.1 Test Implementation

Air with 1 to 2% helium will be injected into the monitoring points and background well. Following injection, the change of O₂, CO₂, total hydrocarbon, and helium in the soil gas will be measured over time. Helium will be used as an inert tracer gas to assess the extent of diffusion of soil gases within the aerated zone. If the background well is screened over an interval of greater than 10 ft, the required air injection rate may be too high to allow helium injection. The background monitoring point will be used to monitor natural degradation of organic matter in the soil. A schematic of the apparatus to be used in the in situ respiration test is presented in Figure 2-9.

The O₂, CO₂, and total hydrocarbon levels will be measured at the monitoring points before air injection. Normally, air will be injected into the ground for at least 20 hours at rates ranging from 1.0 to 1.7 cfm (60 to 100 cfh). Blowers to be used will be diaphragm compressors Model 4Z024 from Grainger (or equivalent) with a nominal capacity of 1.7 cfm (100 cfh) at 10 psi. The helium used as a tracer will be 99% or greater purity, which is available from most welding supply stores. The flow rate of helium will be adjusted to 0.6 to 1.0 cfh to obtain about 1% in the final air mixture which will be injected into the contaminated area. Helium in the soil gas will be measured with a Marks Helium Detector Model 9821 (or equivalent) with a minimum sensitivity of 0.01%.

After air and helium injection is completed, the soil gas will be measured for O₂, CO₂, helium, and total hydrocarbon. Soil gas will be extracted from the contaminated area with a soil gas sampling pump system similar to that shown in Figure 5-1. Typically, measurement of the soil gas will be conducted at 2, 4, 6, and 8 hours and then every 4 to 12 hours, depending on the rate at which the oxygen is utilized. If oxygen uptake is rapid, more frequent monitoring will be required. If it is slower, less frequent readings will be acceptable.

At shallow monitoring points, there is a risk of pulling in atmospheric air in the process of purging and sampling. Excessive purging and sampling may result in erroneous readings. There is no benefit in over sampling, and when sampling shallow points, care will be taken to minimize the volume of air extraction. In these cases, a low-flow extraction pump of about 0.03 to 0.07 cfm (2.0 to 4.0 cfh) will be used. Field judgment will be required at each site in determining the sampling frequency. Table 5-1 provides a summary of the various parameters which will be measured and their frequency.

The in situ respiration test will be terminated when the oxygen level is about 5%, or after 5 days of sampling. The temperature of the soil before air injection and after the in situ respiration test will be recorded.

5.7.2 Data Interpretation

Data from the in situ respiration and air permeability tests will be summarized, and their O₂ utilization rates, air permeability, and R₁ will be computed. Further details on data interpretation are presented in Sections 5.7.2.1 and 5.7.2.2.

5.7.2.1 Oxygen Utilization

Oxygen utilization rates will be determined from the data obtained during the bioventing tests. The rates will be calculated as the percent change in O₂ over time. Table 5-2 contains the two sets of sample data which are illustrated in Figure 5-2. The O₂ utilization rate is determined as the slope of the O₂% vs. time line. A zero-order respiration rate as seen in the Fallon NAS data is typical of most sites; however, a fairly rapid change in oxygen levels may be seen as in the data from Kenai, Alaska. In the later, the oxygen utilization rate was obtained from the initial linear portion of the respiration curve.

To estimate biodegradation rates of hydrocarbon from the oxygen utilization rates, a stoichiometric relationship for the oxidation of the hydrocarbon will be used. Hexane will be used as the representative hydrocarbon, and the stoichiometric relationship used to determine degradation rates will be:

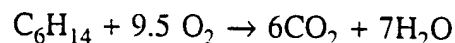

Based on the utilization rates (change of oxygen [%] per day), the biodegradation rate in terms of mg of hexane-equivalent per kg of soil per day will be estimated using the following equation.

$$K_B = -K_o A D_o C/100 \quad (1)$$

where:

K_B = biodegradation rate (mg/kg day)

K_o = oxygen utilization rate (percent per day)

TABLE 5-1. Parameters to be Measured for the In Situ Respiration Tests

Parameter/Media	Suggested Method	Suggested Frequency	Instrument Sensitivity (Accuracy)
Carbon dioxide/soil gas	Infrared adsorption method, GasTech Model 32520X (0 to 5% and 0 to 25% carbon dioxide)	Initial soil gas sample before pumping air, immediately after pump shut off, every 2 hours for the first 8 hours, and then every 8 to 10 hours	±0.2%
Oxygen/soil gas	Electrochemical cell method, GasTech Model 32520X (0 to 21% oxygen)	Same as above	±0.5%
Total hydrocarbons (THC)/soil gas	GasTech hydrocarbon detector or similar field instrumentation	Initial soil gas sample before pumping air, then same as above if practical	±1 ppm
Helium	Marks Helium Detector Model 9821 or equivalent	Same as for carbon dioxide	±0.01%
Pressure	Pressure gauge (0 to 30 psia)	During air injection	0.5 psia
Flow rate/air	Flowmeter	Reading taken during air injection	±5 cfh

- A = volume of air/kg of soil (l/kg)
- D_o = density of oxygen gas (mg/l)
- C = mass ratio of hydrocarbon to oxygen required for mineralization.

Using several assumptions, values for A, D_o, and C can be calculated and substituted into equation 1. Assumptions used for these calculations are:

- Porosity of 0.3 (the air-filled porosity, which can range from 0.0 to 0.6 depending on the site soils and varies with moisture content in any given soil)
- Soil bulk density of 1,440 kg/m³

TABLE 5-2. Sample Data Set for Two In Situ Respiration Tests

Fallon NAS, Nevada (Test Well A2)			Kenai, Alaska (Test Well K1)			
Time (Hours)	O ₂ (%)	CO ₂ (%)	Time (Hours)	O ₂ (%)	CO ₂ (%)	Helium
-23.5	0.05	20.4	-22.0	3.0	17.5	—
0	20.9	0.05	0	20.9	0.05	1.8
2.5	20.3	0.08	7.0	11.0	2.7	1.4
5.25	19.8	0.10	12.25	4.8	4.6	1.4
8.75	18.7	0.13	19.50	3.5	6.0	1.3
13.25	18.1	0.16	26.25	1.8	6.5	1.0
22.75	15.3	0.14	46.00	2.0	7.0	0.9
27.0	15.2	0.22				
32.5	13.8	0.14				
37.0	12.9	0.23				
46.0	11.2	0.22				
49.5	10.6	0.16				

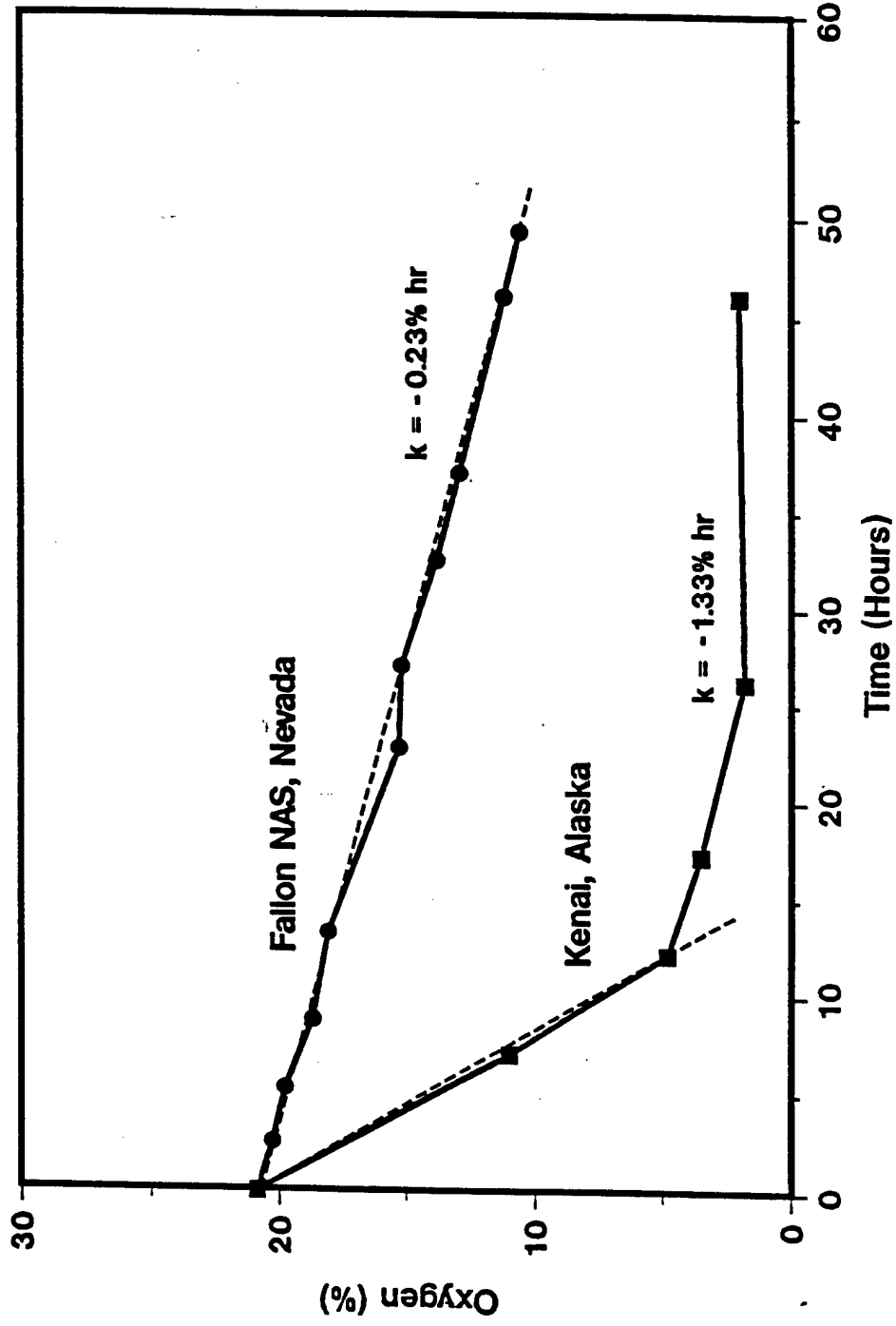

Figure 5-2. In Situ Respiration Test Results for Two Bioventing Test Sites:
Fallon NAS, Nevada (Monitoring Point A2) and
Kenai, Alaska (Monitoring Point K1).

- D_o oxygen density of 1,330 mg/l (varies with temperature, altitude, and atmospheric pressure)
- C, hydrocarbon-to-oxygen ratio of 1/3.5 from the above equation for hexane.

Based on the above assumed porosity and bulk density, the term A, volume of air/mg of soil, becomes $300/1,440 = 0.21$. The resulting equation is:

$$K_B = - (K_o)(0.21)(1330)(1/3.5)/100 = 0.8 K_o \quad (2)$$

This conversion factor, 0.8, was used by Hinchee et al. (1991b) in their calculations of biodegradation rates of hydrocarbons. Another way to estimate biodegradation rates is based on CO_2 generation rates, but as discussed in Section 2.3, this is less reliable than using O_2 utilization rates.

5.7.2.2 Helium Monitoring

Figures 5-3 and 5-4 show typical helium data for two test wells. The helium concentration at monitoring point S1 (Figure 5-3) at Tinker AFB started at 1.5% and after 108 hours had dropped to 1.1%, i.e., a fractional loss of ~0.25. In contrast, for Kenai K3 (Figure 5-4), the change in helium was rapid (a fractional drop of about 0.8 in 7 hours), indicating that there was possible short-circuiting at this monitoring point. This suggested that the data from this monitoring point were unreliable, and so the data were not used in calculating degradation rates.

As a rough estimate, diffusion of gas molecules is inversely proportional to the square root of the molecular weight of the gas. Based on the molecular weights of 4 and 32 g mol for helium and oxygen, respectively, helium diffuses about 2.8 times faster than oxygen. This translates into a fractional oxygen loss of ~0.095 for S1 of Tinker AFB, a minimal loss. The data from this monitoring point were used in the calculation rates. As a guide, data from tests where fractional helium loss is 0.4 or less over 100 hours, or an equivalent fractional oxygen loss of 0.15, are acceptable.

5.8 Bioventing Test

The bioventing test is the third and final part of the field treatability study and will consist of a longer term (6 months or more) air injection or withdrawal procedure. A blower will be installed immediately following completion of the air permeability and in situ respiration tests, and will be started before the field crew leaves the site. At some sites where regulatory approval is pending, the bioventing blower will be installed and started at a later date.

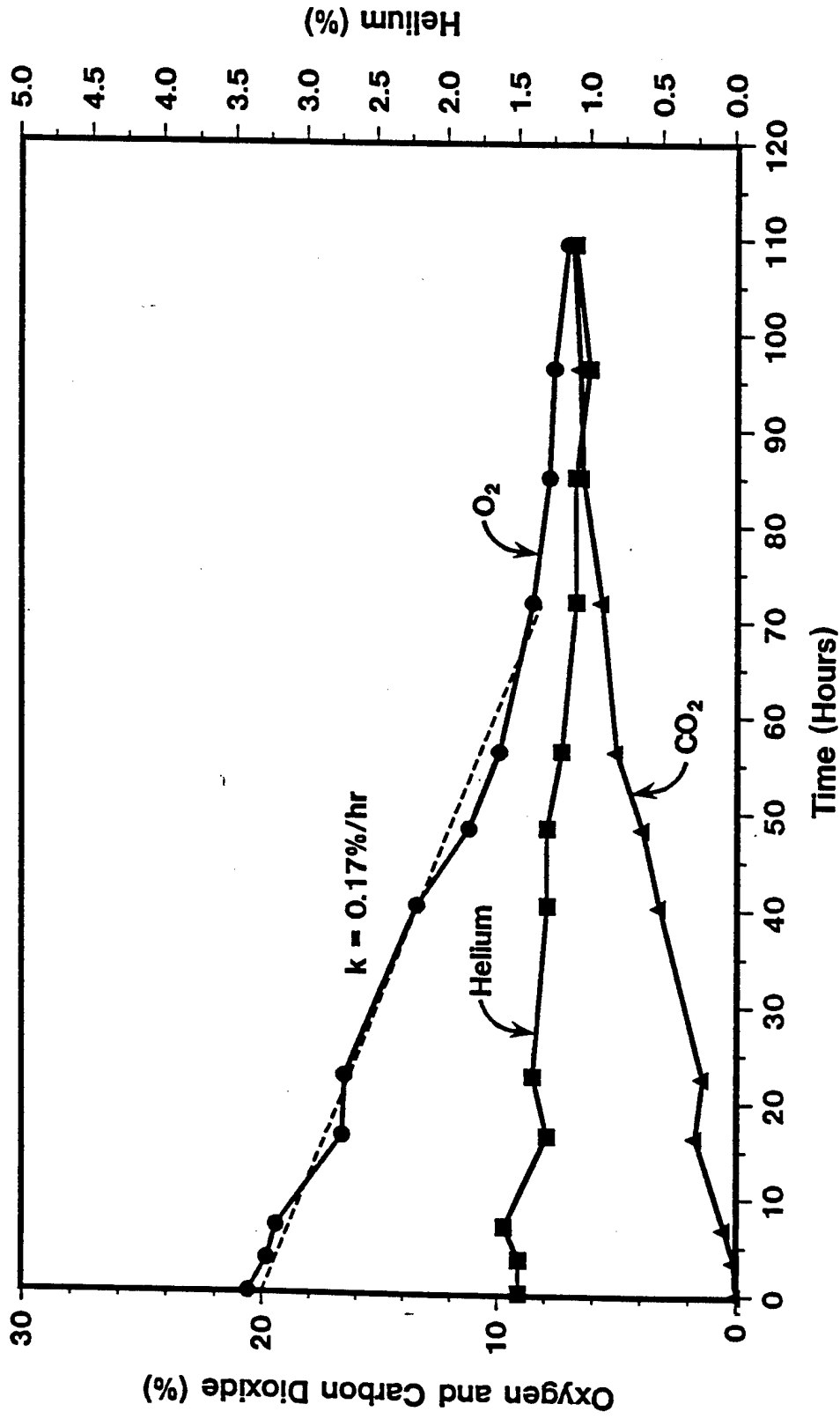

Figure 5-3. In Situ Respiration Test Results for Monitoring Point S1, Tinker AFB, Oklahoma.

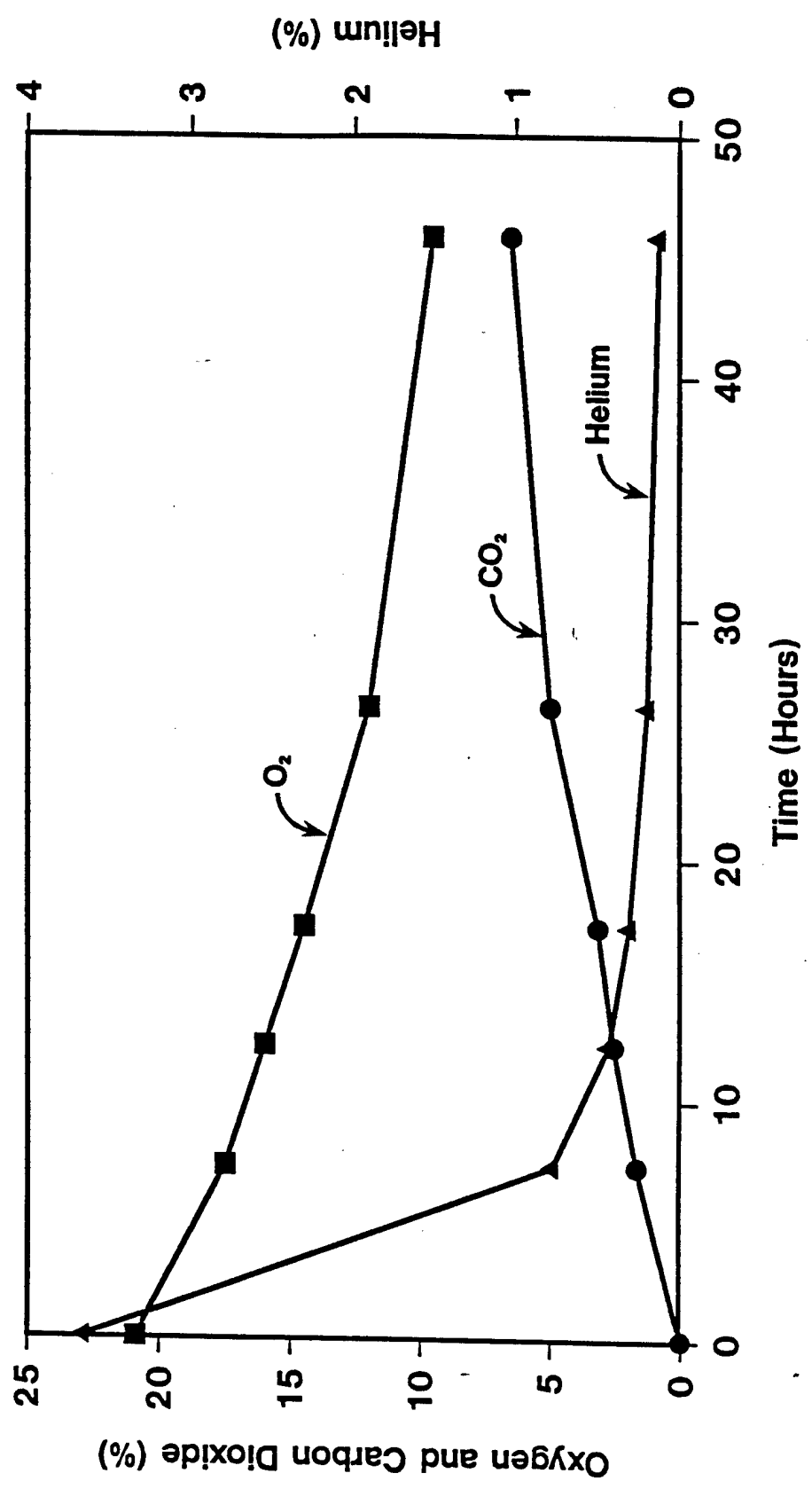

Figure 5-4. In Situ Respiration Test Results for Monitoring Point K3, Kenai, Alaska.

5.8.1 Criteria for Conducting the Bioventing Test

The contractor will plan on conducting the bioventing test at each site; however, at some sites the bioventing test may not be appropriate (e.g., where no bioremediation is stimulated). Upon completion of the soil gas permeability and the in situ respiration tests, the data will be analyzed and a decision will be made as to whether the bioventing test is to be implemented. This decision will be confirmed before the field crew leaves the site.

5.8.1.1 Air Permeability and Radius of Influence

The technology of soil venting has not advanced far enough to provide firm quantitative criteria for determining the applicability of venting based solely on values of k or R_I . In general, k must be sufficiently high to allow movement of oxygen in a reasonable time frame (1 or 2 days) from either the vent well, in the case of injection, or the atmosphere or uncontaminated soils, in the case of extraction. If such a flow rate cannot be achieved, O_2 cannot be supplied at a rate to match its demand.

The estimated radius of influence (R_I) is actually an estimate of the radius in which measurable soil gas pressures are affected and does not always equate to gas flow. In highly permeable gravel, for example, significant gas flow can occur well beyond the measurable radius of influence. On the other hand, in a low-permeability clay a small pressure gradient may not result in significant gas flow. In this study, the assumption will be made that the R_I does equate to the area of significant gas flow; however, care must be taken in applying this assumption. During air permeability testing, an increase in O_2 concentration within the monitoring points is often an additional indicator of R_I .

In general, if the R_I is greater than the depth of the vent well, the site is probably suitable for bioventing. If the R_I is less than the vent well depth, the question of practicality arises. To scale up a bioventing project at such a site may require more closely spaced vent wells than is either economically feasible or physically possible. The decision to proceed with bioventing will be site-specific and somewhat subjective.

5.8.1.2 Biodegradation Rate

The decision to proceed with the bioventing will be based on the results of the degradation rate calculations. From previous studies, the oxygen utilization rates that can be expected from sites contaminated with jet fuel are between 0.05 to 1.0% O_2 /hour. If rates within this range are obtained and are significantly greater than background, there is sufficient evidence to assume that some microbial activity is occurring and that the addition of O_2 in these contaminated areas will enhance biodegradation. If soil gas O_2 levels are above 2 to 5% prior to any air injection, or if oxygen utilization rates are not greater than background, venting will most probably not stimulate biodegradation and consideration will be given to terminate the bioventing effort.

5.8.1.3 Regulatory Approval

Regulatory approval requirements will be defined, and if necessary, approvals will be obtained prior to initiating the bioventing test procedures. If approval is pending, a blower will be installed for startup at a later date. This will reduce costs by eliminating the need for a second visit.

5.8.1.4 U.S. Air Force Approval

Both the project officer and the base POC will be notified either verbally or in writing of the plans for initiating the bioventing test, and their approval will be required before the test is initiated. Verbal approval will be documented by the contractor.

5.8.2 Air Injection vs. Extraction Considerations

Air injection will be used as the method of choice to provide oxygen for the initial and extended pilot tests. Air injection does not result in a direct discharge of volatile organics to the atmosphere and is less expensive to operate and maintain than extraction systems. Air injection systems produce no condensate, no liquid wastes, and no contaminated air stream, and they usually do not require air permitting. Under some circumstances the use of soil gas extraction systems will need to be incorporated into the air injection system design. For example, whenever the radius of pressure influence ($> 0.1'' \text{ H}_2\text{O}$) of a vent well is close to basements or occupied surface structures, an air extraction system will be used to reduce the risk of moving gases into these areas. This precaution will prevent the accumulation of explosive or toxic vapors in these structures.

When necessary, soil gas will be extracted away from these structures and then reinjected in a unsaturated zone well on the opposite side of the extraction well. If necessary, makeup air will be added prior to reinjection to maintain oxygen levels sufficient for biodegradation (see Figure 2-3). This configuration will also have the advantage of producing no direct discharge of volatile organics to the atmosphere, as the volatiles will be returned to the contaminated zone for treatment by the soil's active biomass.

5.8.3 Blower System Installation

On sites where initial pilot testing is successful, and the criteria in Section 5.8.1 are met, a blower system will be installed for the extended bioventing test. The blower will be configured and instrumented as shown in Figure 4-3 or 4-4. This instrumentation will ensure that important flow rate, temperature, and pressure data can be collected by base personnel during extended testing. The blower will be sized to provide a soil gas flow that is sufficient to influence all monitoring points within the contaminated zone and to provide oxygen at a rate that exceeds the highest oxygen utilization rate measured during initial testing.

Whenever possible, the blower will be sized to use the existing power source at or near the site. All electrical connections and disconnect devices will conform to local and base electrical codes. An explosion-proof blower and motor will be required for all extraction systems and in all fuel storage areas where explosion-proof equipment is mandatory. After coordination with base officials, the blower will be sited and placed in a secure and unobtrusive place. The blower will be placed in a small, portable protective shelter that is painted to conform to base color schemes. This enclosure will seldom exceed a 3-ft x 4-ft footprint and a height of 4 ft. The enclosure will protect the motor and blower from the weather and must be adequately ventilated to prevent the motor from overheating during summer months.

If necessary in high-traffic areas, piping from the vent well to the blower will be buried several inches below the surface to prevent damage. The blower system, monitoring points, and piping will be installed so as to minimize interference with existing site activities.

5.8.4 Blower Operation and Maintenance

If the site is selected for extended testing, base personnel will be required to perform a simple weekly system check to ensure that the blower is operating within its intended flow rate, pressure, and temperature range. This check must be coordinated with the base POC. Prior to departing the site, the contractor will provide a 1-hour on-site briefing for base personnel who will be responsible for blower system checks. The principle of operation will be explained, and a simple checklist and logbook will be provided for blower data. Bioventing systems are very simple, with minimal mechanical and electrical parts. Minor maintenance such as replacing filters or gauges, or draining condensate from knockout chambers, will be performed by base personnel, but they will not be expected to perform complicated repairs or analyze gas samples. Replacement filters and gauges will be provided and shipped to the base by the contractor. Serious problems such as motor or blower failures will be corrected by the contractor.

5.8.5 Long-Term Monitoring

Most bioventing systems will require 2 or 3 years of operation to significantly reduce soil hydrocarbon levels. The progress of this system will be monitored by conducting semiannual respiration tests in the vent well and in each monitoring point, and by regularly measuring the O₂, CO₂, and hydrocarbon concentrations in the extracted soil gas and comparing them to background levels. If air injection is used, the blower can be temporarily reversed and the extracted soil gas monitored for O₂, CO₂, and hydrocarbons. Soil gas monitoring will be performed by specialized Air Force or contractor personnel on a quarterly basis. Semiannual respiration tests will be performed by the Air Force or by contractor personnel. At least twice each year, the progress of the bioventing test will be reported to the base POC.

6.0 SCHEDULE

The expected schedule for the on-site air permeability, in situ respiration, and bioventing tests is dependent on the depth to groundwater, as follows:

<u>Case I – (Shallow Groundwater, ~20 ft or less)</u>	<u>Day After Initiation</u>
– Review available data and develop plan	0-5 ^(a)
– Air Force review	8-12
– Soil gas survey	13-15
– Install vent well/monitoring points	16-18
– Soil permeability test	19
– In situ respiration test	20-24
– Install blower and start up bioventing system	24-26
<u>Case II – (Deep Groundwater, ~20 ft or more)</u>	
– Review available data and develop plan	0-5 ^(a)
– Air Force review	8-12
– Exploratory borings	13-15
– Install vent well/monitoring points	16-19
– Soil permeability test	20
– In situ respiration test	21-25
– Install blower and start up bioventing system ^{b,c}	26-27
<u>Case I and II – Bioventing Test</u>	<u>Month After Initiation</u>
– Determine regulatory requirements ^(b) (if any)	0
– Install and start ^(c) blower	1
– Conduct on-site testing	Every 6 months

(a) It will be necessary to begin the process of permitting and contracting with drillers as soon as possible after contract award, and this must be nearly complete by day 0.

(b) Regulatory requirements will need to be investigated and any required permitting or approvals initiated as soon as possible after a site is identified as a potential candidate. It is assumed in this schedule that any required permits or approvals will have been obtained prior to starting.

(c) The blower will be started only after any required regulatory approvals are received, and with the concurrence of the base POC and project officer.

These schedules are based on the assumptions that (1) no special problems will be encountered; (2) the sites will be easily accessible; and (3) useable vent well and monitoring point locations will be quickly identified. Any problems or deviations will result in a longer time frame. Deeper drilling requirements will extend the testing schedule.

7.0 REPORTING

The section describes the reports to be generated. For consistency, the following units will be used:

- English measurements for length, volume, flow, pressure, and mass, specifically:
 - feet and inches for length
 - gallons and ft^3 for volume
 - cfh and cfm for flow
 - psig for pressure
 - lb for mass
- Metric units for concentrations, rates, and temperature, specifically:
 - mg/l for aqueous concentrations
 - mg/kg for soil concentrations
 - mg/(kg day) for hydrocarbon degradation
 - °C for temperature
- Gaseous concentrations and O_2 utilization rates as follows:
 - ppm for hydrocarbons (parts per million, i.e., $\mu\text{l/l}$, by volume)
 - percent (%) for O_2 , CO_2 , and He (percent by volume, i.e., $1 \times 100\%/l$)
 - %/hr for O_2 utilization

To avoid confusion when discussing gases, the term percent (%) will refer only to concentration. Relative changes will be expressed as fractions. For example, if the O_2 concentration changes from 20% to 15%, the change will be referred to as a 5% reduction or a fractional reduction of 0.25, *not* a 25% reduction.

7.1 Test Plan

A Test Plan for each site will be prepared and submitted to the project officer and the base POC for approval. The Test Plan will consist of this generic Test Plan which provides the scope and planned activities, and a cover letter describing site-specific applications. The Test Plan will be submitted to the project officer and base POC as early as possible before the start of the on-site test.

7.2 Monthly Reports

The contractor will provide a written monthly progress report to the project officer outlining the work accomplished for the month, the problems encountered, approaches to overcome the problems, and anticipated progress for the following month. Included in this report will be the monthly expenditure and the accumulated expenditure to date.

7.3 Verbal Communication

The contractor will be in communication with the project officer and the base POC and will report on field activities and associated problems. Oral reports will be made either to the project officer or base POC, upon demand and at least weekly to the project officer.

7.4 Site Reports

The contractor will provide a letter report (normally less than 15 pages) for each site describing the results of the soil gas permeability and in situ respiration tests as well as a description of the bioventing test initiated. This report will normally be submitted to the project officer, base POC, and others as directed by the project officer 60 days after completion of the treatability test.

8.0 RECORD OF DATA AND QUALITY ASSURANCE

A project record book will be maintained during the field tests to record events pertaining to site activities, including sampling, changes in process conditions (flow, temperature, and pressure), equipment failure, location of the test wells, calibration, and data for the respiration/air permeability tests and long-term bioventing test. The record book will be reviewed by the contractor's project manager. The project officer may review the record book upon request. Typical record sheets for the respiration and air permeability tests are shown in Figure 8-1 and 8-2, respectively. Figure 8-3 shows a typical record sheet for the long-term bioventing test.

Quality assurance will be implemented throughout the project through quality planning, quality control and quality assessment. This will include daily calibration of field analytical instrument with purchased calibration standards prior to use. Field blanks will consist of ambient air drawn through the entire sampling train set-up in an uncontaminated area of the field site. Quality assurance activities include a review of all field activities and procedures by the project manager to ensure compliance with this protocol and quality guidelines. Monthly reports to the project officer will include any significant quality assurance problems and recommended solutions.

9.0 REFERENCES

Aggarwal, P.K., J.L. Means, and R.E. Hinchee. 1991. "Formulation of Nutrient Solutions for In Situ Bioremediation." In: R.E. Hinchee and R.F. Olfenbittel, Eds., *In Situ Bioreclamation*, Butterworth-Heinemann, Stoneham, Massachusetts, pp. 51-66.

Anonymous. 1986. "In Situ Reclamation of Petroleum Contaminated Sub-soil by Subsurface Venting and Enhanced Biodegradation." *Research Disclosure*, No. 26233, 92-93.

Atlas, R.M. 1986. "Microbial Degradation of Petroleum Hydrocarbons: An Environmental Perspective," *Microbiol. Rev.* 45: 180-209.

Bennedsen, M.B., J.P. Scott, and J.D. Hartley. 1987. "Use of Vapor Extraction Systems for In Situ Removal of Volatile Organic Compounds from Soil." In: *Proceedings of National Conference on Hazardous Wastes and Hazardous Materials*, Washington, DC, 92-95.

Conner, J.S. 1988. "Case Study of Soil Venting," *Poll. Eng.* 7: 74-78.

Dupont, R.R., W. Doucette, and R.E. Hinchee. 1991. "Assessment of In Situ Bioremediation Potential and the Application of Bioventing at a Fuel-Contaminated Site." In: *In Situ and On-Site Bioreclamation*, R.E. Hinchee and R.F. Olfenbittel, Eds., Butterworth-Heinemann, Stoneham, MA, pp. 262-282.

Ely, D.L., and D.A. Heffner. 1988. Process for In-Situ Biodegradation of Hydrocarbon Contaminated Soil, U.S. Patent Number 4,765,902.

van Eyk et al. See the alphabetical listing for "V."

Hinchee, R.E., and S.K. Ong. 1991. Unpublished Data, Battelle, Columbus, Ohio.

Hinchee, R.E., and G. Smith. 1991. Unpublished Data, Battelle, Columbus, Ohio.

Hinchee, R.E., D.C. Downey, R.R. Dupont, P. Aggarwal, and R.N. Miller. 1991a. "Enhancing Biodegradation of Petroleum Hydrocarbon through Soil Venting." *J. Hazardous Materials* 27: 315-325.

Hinchee, R.E., S.K. Ong, and R. Hoeppe. 1991b. "A Field Treatability Test for Bioventing." *Proceedings of the Air and Waste Management Association*, Paper 91-19.4, Vancouver, British Columbia.

Hinchee, R.E., and M. Arthur. 1991. "Bench-Scale Studies of the Soil Aeration Process for Bioremediation of Petroleum Hydrocarbons." *J. Appl. Biochem. Biotech.* 28/29: 901-906.

Hinchee, R.E., D.C. Downey, J.K. Slaughter, and M. Westray. 1989. *Enhanced Bioremediation of Jet Fuels: A Full Scale Test at Eglin Air Force Base, Florida*. Air Force Engineering and Services Center Report ESL/TR/88-78.

Huling, S.G., B.E. Bledose, and M.V. White. 1990. *Enhanced Biodegradation Utilizing Hydrogen Peroxide as a Supplemental Source of Oxygen: A Laboratory and Field Study*. EPA/600-290-006, 48 pp.

Johnson, P.C., M.W. Kemblowski, and J.D. Colthart. 1990. "Quantitative Analysis for the Cleanup of Hydrocarbon-Contaminated Soils by In-Situ Soil Venting." *Ground Water* 28(3), May-June.

Lee, M.D., et al. 1988. "Bioremediation of Aquifers Contaminated With Organic Compounds," *CRC Critical Reviews in Env. Control* 18: 29-89.

Miller, R.N., R.E. Hinchee, and C. Vogel. 1991. "A Field-Scale Investigation of Petroleum Hydrocarbon Biodegradation in the Vadose Zone Enhanced by Soil Venting at Tyndall AFB, Florida." in: *In Situ and On-Site Bioremediation*, R.E. Hinchee and R. F. Olfenbittel, Eds., Vol. 1., Stoneham, MA: Butterworth Publishers.

Miller, R.N. 1990. A Field Scale Investigation of Enhanced Petroleum Hydrocarbon Biodegradation in the Vadose Zone Combining Soil Venting as an Oxygen Source with Moisture and Nutrient Additions. Ph.D. Dissertation. Utah State University, Logan, Utah.

Oak Ridge National Laboratory. 1989. Soil Characteristics: Data Summary, Hill Air Force Base Building 914 Fuel Spill Soil Venting Project, an unpublished report to the U.S. Air Force.

Ostendorf, D.W., and D.H. Kambell. 1989. "Vertical Profiles and Near Surface Traps for Field Measurement of Volatile Pollution in the Subsurface Environment." In: *Proceedings of NWWA Conference on New Techniques for Quantifying the Physical and Chemical Properties of Heterogeneous Aquifers*, Dallas, TX.

Sellers, K., and C.Y. Fan. 1991. "Soil Vapor Extraction: Air Permeability Testing and Estimation Methods." In: *Proceedings of the 17th RREL Hazardous Waste Research Symposium*, EPA/600/9-91/002, April.

Staatsuitgeverij. 1986. Proceedings of a Workshop, 20-21 March, 1986. *Bodembeschermingsreeks* No. 9; *Biotechnologische Bodemsanering*, pp. 31-33. Rapportnr. 851105002, ISBN 90-12-054133, Ordernr. 250-154-59; Staatsuitgeverij Den Haag: The Netherlands.

Texas Research Institute. 1980. *Laboratory Scale Gasoline Spill and Venting Experiment*. American Petroleum Institute, Interim Report No. 7743-5:JST.

Texas Research Institute. 1984. *Forced Venting to Remove Gasoline Vapor from a Large-Scale Model Aquifer*, American Petroleum Institute, Final Report No. 82101-F:TAV.

Urlings, L.G.C.M., H.B.R.J. van Vree, and W. van der Galien. 1990. "Application of Biotechnology in Soil Remediation." *Envirotech Vienna*, pp. 238-251.

van Eyk, J., and C. Vreeken. 1988. "Venting-Mediated Removal of Petrol from Subsurface Soil Strata as a Result of Stimulated Evaporation and Enhanced Biodegradation." *Med. Fac. Landbouww. Rijksuniv. Gent* 53(4b): 1873-1884.

van Eyk, J., and C. Vreeken. 1989a. "Model of Petroleum Mineralization Response to Soil Aeration to Aid in Site-Specific, In Situ Biological Remediation." In: *Groundwater Contamination: Use of Models in Decision-Making, Proceedings of an International Conference on Groundwater Contamination*. Jousma et al., Eds., Kluwer Boston/London, pp. 365-371.

van Eyk, J., and C. Vreeken. 1989b. "Venting-Mediated Removal of Diesel Oil from Subsurface Soil Strata as a Result of Stimulated Evaporation and Enhanced Biodegradation." In: *Hazardous Waste and Contaminated Sites, Envirotech Vienna*, Vol. 2, Session 3, ISBN 389432-009-5, Westarp Wiss., Essen, pp. 475-485.

Ward, C.H. 1988. "A Quantitative Demonstration of the Raymond Process for In-Situ Bioremediation of Contaminated Aquifers." *Proceedings of NWWA/API Conference on Petroleum Hydrocarbons and Organic Chemicals in Groundwater*, pp. 723-746.

Wilson, J.T., and C.H. Ward. 1986. "Opportunities for Bioremediation of Aquifers Contaminated with Petroleum Hydrocarbons." *J. Ind. Microbiol.* 27: 109-116.

APPENDIX

RECOMMENDED ESTIMATION METHODS FOR AIR PERMEABILITY

The U.S. Environmental Protection Agency's Risk Reduction Engineering Laboratory recently reviewed several field, laboratory, and empirical methods for determining soil gas permeability (k) and for their appropriateness in determining the feasibility of soil vapor extraction (Sellers and Fan, 1991). The conclusion of this literature review was a strong endorsement for a modified field drawdown method (Johnson et al., 1990).

The field drawdown method is based on Darcy's Law and equations for steady-state radial flow to or from a vent well. A full mathematical development of this method and supporting calculations are provided by Johnson et al. (1990). A computer program known as HyperVentilate™ has been produced by Johnson for storing field data and computing k and R₁. This program will be used to speed the calculation and data presentation process. The two solution methods for k are presented below. The first solution is based on carefully measuring the dynamic response of the soil to a constant injection or extraction rate. The second solution for k is based on steady-state conditions and the measurement or estimation of R₁ at steady state. The limitations and recommended application of each method are presented below. Whenever possible, field data will be collected to support both solution methods, because one or both of the solution methods may be appropriate, depending on site-specific conditions.

Dynamic Method

This test method requires that air be extracted or injected at a constant rate from a single venting well, while measuring the pressure changes at several soil gas monitoring points throughout the contaminated soil volume. The equation:

$$P' = \frac{Q}{4\pi m(k/\mu)} \left[\frac{-0.5772 - \ln(r^2 e\mu) + \ln(t)}{4k Patm} \right] \tag{1}$$

is used to describe the dynamic changes in soil gas pressure/vacuum where:

- P' = "gauge" pressure measured at distance r from the vent well at time t(g/cm-s²)
- m = stratum thickness, generally the vent well screened interval (cm)
- r = radial distance from monitoring point to vent well (cm)
- k = soil gas permeability (cm²)
- μ = viscosity of air (1.8 × 10⁻⁴ g/cm-s at 18°C)
- e = soil's air-filled void volume (dimensionless)
- t = time from the start of the test (s)
- Q = volumetric flow rate from the vent well (cm³/s)
- Patm = ambient pressure (at sea level 1.013 × 10⁶ g/cm-s²)

Equation (1) predicts that the dynamic range of P' -vs.- $\ln(t)$ is a straight line with a slope of A where:

$$A = \frac{Q}{4\pi m (k/\mu)}$$

solving

$$k = \frac{Q\mu}{4A\pi m}$$

The HyperVentilate™ model is based on the dynamic method and a determination of the slope, A . This method of determining k requires accurate field measurements of Q at the vent well and P' 's-vs.-time at each monitoring point. It is most appropriately applied at sites with less permeable soils where changes in P' occur over a longer time period (10 minutes or more to monitoring point steady state). This method can be accurate for fine sandy soils where the screened interval extends to depths of over 10 ft and when monitoring points are screened at depths of 10 ft or greater. It is less accurate for sites where a high water table or shallow contamination limits the total depth of the vent well screen and monitoring points to less than 10 ft. In shallow and coarse-grained soils, vacuum or pressure levels reach steady state too rapidly to accurately plot P' -vs.- $\ln(t)$. Venting systems on shallow sandy sites are subject to higher vertical airflow which is not as accurately described by this one-dimensional radial flow equation.

Steady State-Method

This method for determining k can be used in situations where the dynamic method is inappropriate. This method is based on the steady-state solution to equation (1).

$$k = \frac{Q\mu \ln(R_w/R_r)}{H\pi P_w [1 - (P_{atm}/P_w)^2]} \quad (2)$$

Note: Equation (2) applies only to vent wells operating under a vacuum. If air is being injected into the vent well the equation is modified as shown below:

$$k = \frac{Q\mu \ln(R_w/R_r)}{H\pi P_{atm} [1 - (P_w/P_{atm})^2]} \quad (3)$$

where Q , m , μ , and P_{atm} have been previously defined, and

R_w = the radius of the venting well (cm)

H = depth of screen (cm)

R_1 = the maximum radius of venting influence at steady state (cm)

P_w = the absolute pressure at the venting well ($g/cm-s^2$)

The value of R_1 can be determined by actually measuring the outer limit of vacuum/pressure influence under steady-state conditions, or by plotting the vacuum/pressure at each monitoring point vs. the log of its radial distance from the vent well and extrapolating the straight line to zero vacuum or pressure. An example of this solution method is included in Calculation Data Set Two below.

Sample Calculations

Data Set One

Table A-1 and Figure A-1 present the results of an air permeability test conducted at Beale AFB, CA. The soils on this site were silty with a contaminated interval (and vent well screen interval) extending from 10 to 40 feet below ground surface. Note that the plot of P' -vs.- $\ln(\text{time})$ is a relatively straight line during the initial 10 minutes, $\ln(10) = 2.3$, making these data good candidates for the dynamic solution method. Data from the initial 10 minutes of this test were entered into the Hyper-Ventilate™ computer model to calculate a range of k values. An example of the input and output data for this model is provided in windows AP7 and AP8.

HyperVentilate© 1991

Air Permeability Test - Data Analysis (cont.)

The permeability, k , can then be calculated by one of two methods:

- ① The first is applicable when both Q (flowrate) and m (well screen interval) are known accurately. The calculated slope A is used:
$$k = \frac{Q \mu}{4 A \pi m}$$
- ② The second approach is used whenever Q or m are not known with confidence. In this case, both the slope, A , and intercept, B , are used:
$$k = \frac{r^2 \epsilon \mu}{4 P_{Atm}} \exp\left[0.5772 + \frac{B}{A}\right]$$

Return AP7

Air Permeability Test - Data Analysis (cont.)

① Enter radial distances of monitoring points → r= (ft)

r= (ft)

r= (ft)

	(min)	(in H2O)		(min)	(in H2O)		(min)	(in H2O)
② Enter measured times and gauge vacuums →	.5	0.1	↑	.5	.4	↑	.5	1.5
	1	0.21	↓	1	1.4	↓	1	4.5
	1.5	0.62	↓	1.5	2.8	↓	1.5	7.5
	2	1.00	↓	2	3.6	↓	2	9
③ Enter (optional):	2.5	1.25	↓	2.5	4	↓	2.5	10
a) flowrate	3	1.41	↓	3	4.4	↓	3	10.7
<input type="text" value="51"/> (SCFM)	3.5	1.60	↓	3.5	5	↓	3.5	11.2
b) screened interval thickness	4	1.8	↓	4	5.3	↓	4	11.8
<input type="text" value="30"/> (ft)	4.5	1.98	↓	4.5	5.6	↓	4.5	12
	5	2.12	↓	5	5.8	↓	5	12.4

clear

k= darcy (A)
k= darcy (B)

clear

k= darcy (A)
k= darcy (B)

clear

k= darcy (A)
k= darcy (B)

→ Calculate ←
Return
Explanation & Statistics
AP8

Air Permeability Test - Data Analysis (cont.)

① Enter radial distances of monitoring points → r= (ft)

r= (ft)

r= (ft)

	(min)	(in H2O)		(min)	(in H2O)		(min)	(in H2O)
② Enter measured times and gauge vacuums →	5.5	2.25	↑	5.5	6	↑	5.5	12.5
	6	2.37	↓	6	6.1	↓	6	12.6
	6.5	2.48	↓	6.5	6.2	↓	6.5	12.6
	7	2.55	↓	7	6.3	↓	7	12.7
③ Enter (optional):	7.5	2.63	↓	7.5	6.4	↓	7.5	12.7
a) flowrate	8.5	2.82	↓	8.5	6.5	↓	8.5	12.4
<input type="text" value="51"/> (SCFM)	9.5	2.92	↓	9.5	6.5	↓	9.5	12.5
b) screened interval thickness			↓			↓		
<input type="text" value="30"/> (ft)			↓			↓		

clear

k= darcy (A)
k= darcy (B)

clear

k= darcy (A)
k= darcy (B)

clear

k= darcy (A)
k= darcy (B)

→ Calculate ←
Return
Explanation & Statistics
AP8

TABLE A-1. Air Permeability Data Set

Steady-State Flow Rate 51 SCFM

Test Time Elapsed (min)	In Time (min)	Vacuum (inches of water) at Monitoring Points (MPs)										Distance from VE - 2			
		MP 1	MP 2	MP 3	MP 4	MP 5	MP 6	MP 7	MP 8	MP 9	Screen interval depth				
0.0	-	0.00	0.00	0.00	0.00	0.00	0.00	0.00	0.00	0.00	0.00	0.00	0.00	10	<---
0.5	-	-	-	-	-	-	-	-	-	-	-	-	-	38-40	<---
1.0	0.00	-	-	-	-	-	-	-	-	-	-	-	-	20	<---
1.5	0.41	-	-	-	-	-	-	-	-	-	-	-	-	38-40	<---
2.0	0.69	-	-	-	-	-	-	-	-	-	-	-	-	38-40	<---
2.5	0.92	-	-	-	-	-	-	-	-	-	-	-	-	38-40	<---
3.0	1.10	-	-	-	-	-	-	-	-	-	-	-	-	38-40	<---
3.5	1.25	-	-	-	-	-	-	-	-	-	-	-	-	38-40	<---
4.0	1.39	-	-	-	-	-	-	-	-	-	-	-	-	38-40	<---
4.5	1.50	-	-	-	-	-	-	-	-	-	-	-	-	38-40	<---
5.0	1.61	-	-	-	-	-	-	-	-	-	-	-	-	38-40	<---
5.5	1.70	-	-	-	-	-	-	-	-	-	-	-	-	38-40	<---
6.0	1.79	-	-	-	-	-	-	-	-	-	-	-	-	38-40	<---
6.5	1.87	-	-	-	-	-	-	-	-	-	-	-	-	38-40	<---
7.0	1.95	-	-	-	-	-	-	-	-	-	-	-	-	38-40	<---
7.5	2.01	-	-	-	-	-	-	-	-	-	-	-	-	38-40	<---
8.5	2.14	-	-	-	-	-	-	-	-	-	-	-	-	38-40	<---
9.5	2.25	-	-	-	-	-	-	-	-	-	-	-	-	38-40	<---
10.5	2.35	-	-	-	-	-	-	-	-	-	-	-	-	38-40	<---
14.0	2.64	-	-	-	-	-	-	-	-	-	-	-	-	38-40	<---
19.0	2.94	-	-	-	-	-	-	-	-	-	-	-	-	38-40	<---
24.0	3.18	-	-	-	-	-	-	-	-	-	-	-	-	38-40	<---
29.0	3.37	-	-	-	-	-	-	-	-	-	-	-	-	38-40	<---
34.0	3.53	-	-	-	-	-	-	-	-	-	-	-	-	38-40	<---
39.0	3.66	-	0.8	0.4	0.7	2.2	1.7	3.40	-	-	-	-	-	38-40	<---
44.0	3.78	0.3	-	-	-	-	-	-	-	-	-	-	-	38-40	<---

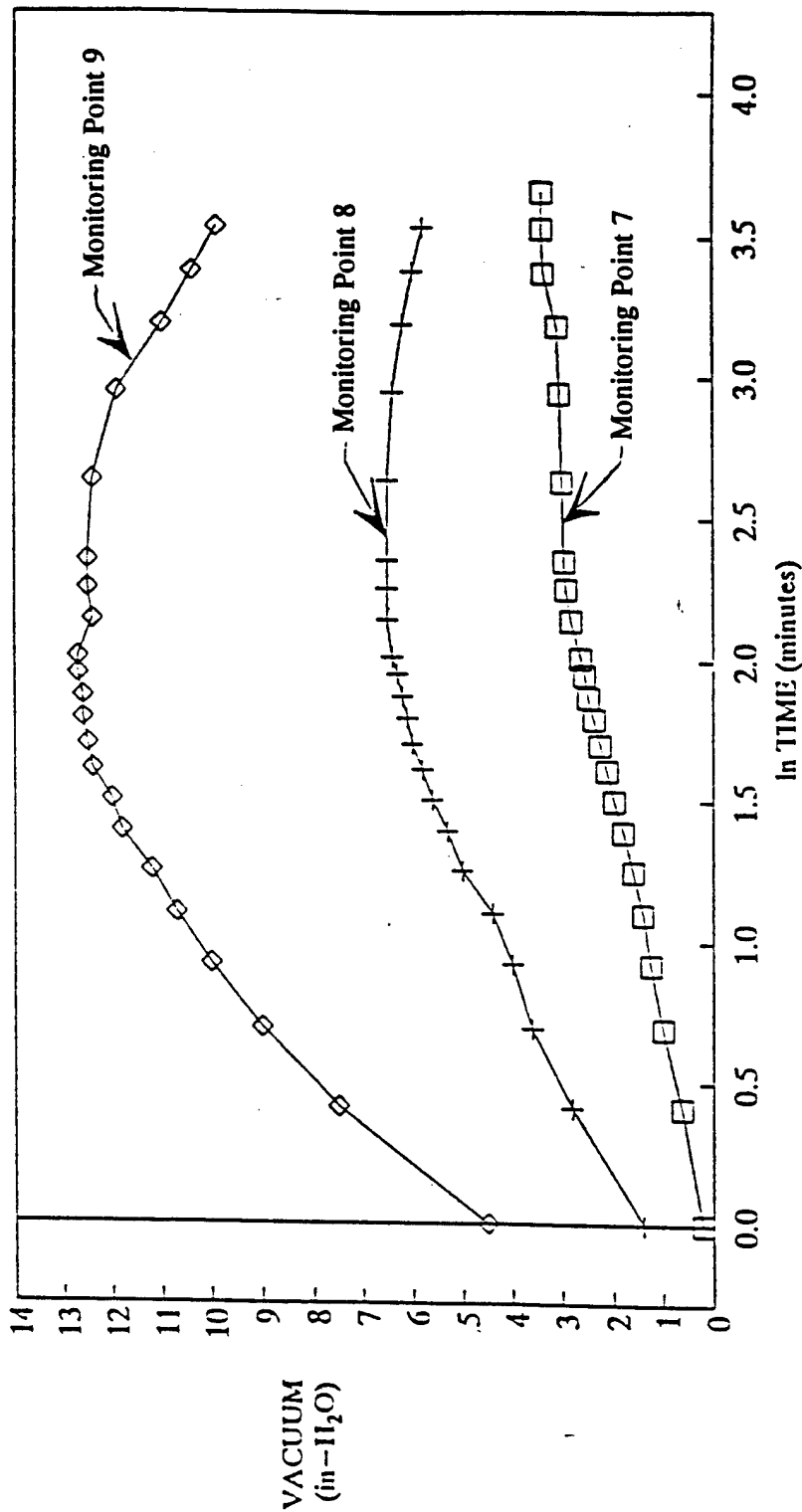

Figure A-1. Vacuum vs. In Time,
Test 2, Bioventing Pilot Test,
Site 22-A20, Beale AFB, California

Computer window AP7 provides a summary of two mathematical solutions for air permeability (k) using the dynamic method. Window AP8 is the example data entry and solution sheet. The calculated range of k values for this test is shown at the bottom of window AP8. Permeability values of 4 to 14 darcy are based on Equation 1 in window AP7 and provide the most accurate estimate, because both the extraction rate (Q) and the screened interval (m) were known for this test. The more conservative range of 4 to 14 darcy will be used for full-scale design. These air permeability values are approximately one order of magnitude higher than would be expected for silty soils. The presence of 10 to 15% sand (by weight) in this soil has increased the average permeability at this site.

Data Set Two

Table A-2 and Figure A-2 are the results from a test conducted in a silty loam with a contaminated interval of only 5.2 ft and a screened interval from 2.7 to 5.2 ft below ground surface. Note that the almost immediate steady state reached at this site does not produce the P'-vs.-ln(time) plot required for the dynamic solution method. In this case the steady-state solution offers the only approximation of k and R₁.

$$k = \frac{Q\mu \ln(R_w/R_1)}{H\pi P_w [1 - (P_{atm}/P_w)^2]}$$

For this test:

$$Q = 1.4 \times 10^4 \text{ cm}^3/\text{s}$$

$$H = 2 \text{ ft (61 cm)}$$

$$\mu = 1.8 \times 10^{-4} \text{ g/cm-s}$$

$$P_w = 80 \text{ "H}_2\text{O vacuum} \times 3.61 \times 10^{-2} \frac{\text{psia}}{\text{"H}_2\text{O}} = 2.88 \text{ psia}$$

$$P_w \text{ absolute} = 14.7 \text{ psia} - 2.88 \text{ psia} = 11.82 \text{ psia}$$

$$11.82 \text{ psia} \times 6.9 \times \frac{10^4 \text{ g/cm-s}^2}{\text{psia}} = 8.16 \times 10^5 \text{ g/cm-s}^2$$

$$P_{atm} = 1.01 \times 10^6 \text{ g/cm-s}^2$$

$$R_w = 1 \text{ in.} = 2.54 \text{ cm}$$

$$R_1 = -15 \text{ ft (457 cm)} \text{ based on all monitoring points reported in Table A-2}$$

TABLE A-2. Field Test Data for Soil Determination of Soil Permeability
 at a Gasoline-Contaminated Site

Time (min)	Air Flow (cfm)	Vacuum (inches of water) measured at various monitoring points												
		Unit	Well	F	E	G	D	H	C	I	B	A		
0.0	0	0	2	0.10	0.00	0.00	0.00	0.00	0.00	0.00	0.00	0.00	0.00	0.00
0.5	30	109	80	1.90	0.90	0.25	0.15	0.00	0.00	0.00	0.00	0.00	0.00	0.00
1.5	30	109	80	1.90	0.90	0.30	0.20	0.05	0.00	0.00	0.00	0.00	0.00	0.00
5.0	30	109	80	1.90	0.90	0.30	0.20	0.05	0.00	0.00	0.00	0.00	0.00	0.00
10.0	30	109	80	1.90	0.95	0.30	0.20	0.05	0.00	0.00	0.00	0.00	0.00	0.00
15.0	30	109	80	1.90	0.95	0.30	0.20	0.05	0.00	0.00	0.00	0.00	0.00	0.00
20.0	30	109	80	1.90	0.95	0.30	0.20	0.05	0.00	0.00	0.00	0.00	0.00	0.00
		Distance from well (ft)		3	6	9	12	15	18	21	24	27		

$R_w = 2.54 \text{ cm}$

$\mu = 1.8 \times 10^{-4} \text{ g/cm-s}$

$H = 60.96 \text{ cm}$

$P_{atm} = 8.14 \times 10^5 \text{ Dynes/cm}^2$

$Q = 14,158 \text{ cm}^3/\text{sec}$

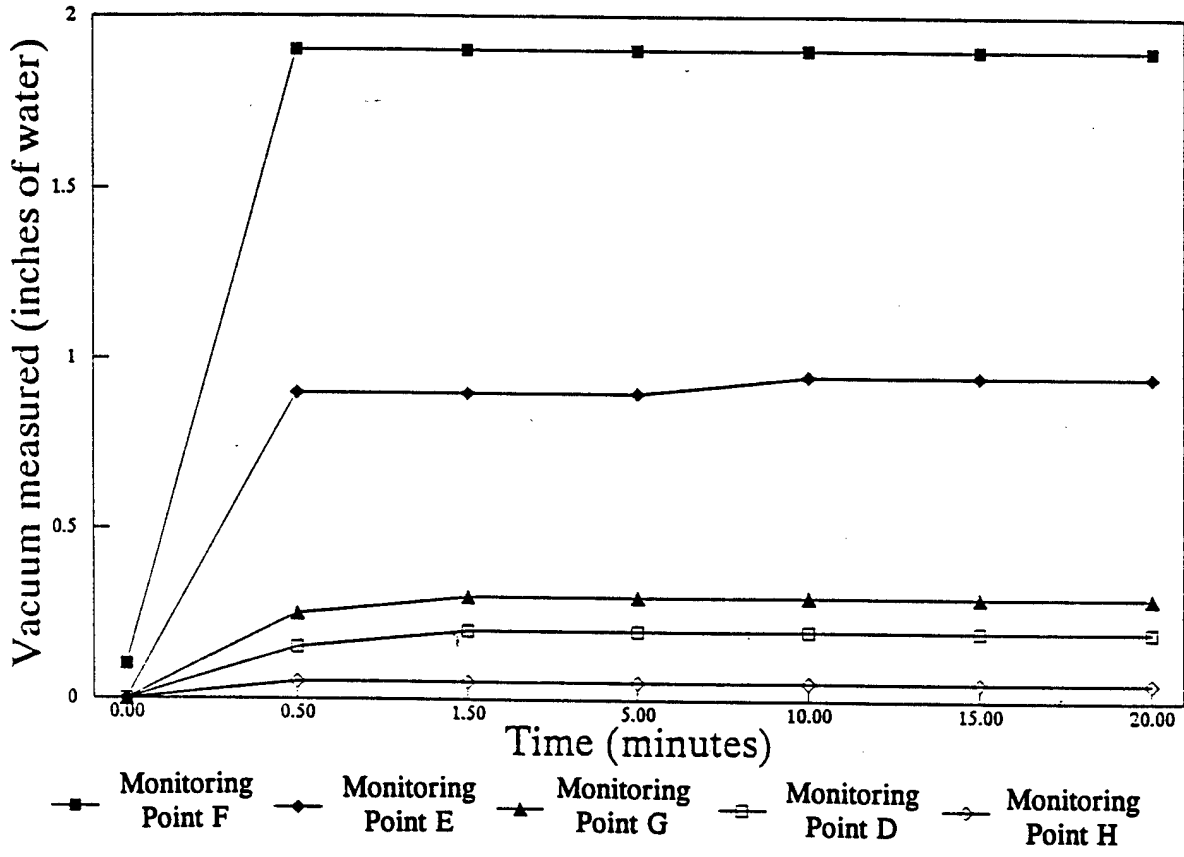

Figure A-2. Results of a Field Test to Determine Soil Permeability to Airflow, k, September 16, 1991

$$k = \frac{(1.4 \times 10^4 \text{ cm}^3/\text{s})(1.8 \times 10^{-4} \text{ g/cm-s})\ln(2.54/457)}{(61 \text{ cm})(3.14)(8.16 \times 10^{-5} \text{ g/cm-s})(1 - [1.01/0.816]^2)}$$

$k = 1.6 \times 10^{-7} \text{ cm}^2$ or 0.16 darcy, which is typical for silty soils.

References

Johnson, P.C., M.W. Kemblowski, and J.D. Colthart. 1990. "Quantitative Analysis for the Cleanup of Hydrocarbon-Contaminated Soils by In-Situ Soil Venting." *Ground Water* 28(3), May-June.

Sellers, K., and C.Y. Fan. 1991. "Soil Vapor Extraction: Air Permeability Testing and Estimation Methods." In: *Proceedings of the 17th RREL Hazardous Waste Research Symposium*, EPA/600/991/002, April.