



HABITAT SUITABILITY MAPPING
THROUGH INTEGRATION OF MULTICRITERIA
EVALUATION TECHNIQUES WITH A
GEOGRAPHIC INFORMATION SYSTEM (GIS)

THESIS

Anthony A. Ference, Captain, USMC

AFIT/GEE/ENV/96D-03

DISTRIBUTION STATEMENT A

Approved for public release
Distribution Unlimited

DEPARTMENT OF THE AIR FORCE
AIR UNIVERSITY

AIR FORCE INSTITUTE OF TECHNOLOGY

Wright-Patterson Air Force Base, Ohio

DTIC QUALITY INSPECTED 1

19970429 220

DISCLAIMER NOTICE

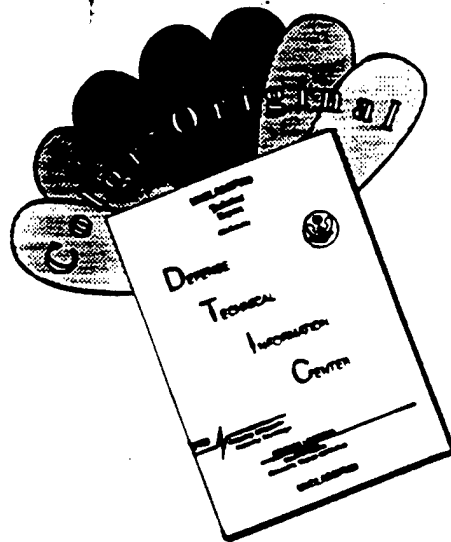

THIS DOCUMENT IS BEST QUALITY AVAILABLE. THE COPY FURNISHED TO DTIC CONTAINED A SIGNIFICANT NUMBER OF COLOR PAGES WHICH DO NOT REPRODUCE LEGIBLY ON BLACK AND WHITE MICROFICHE.

AFIT/GEE/ENV/96D-03

HABITAT SUITABILITY MAPPING
THROUGH INTEGRATION OF MULTICRITERIA
EVALUATION TECHNIQUES WITH A
GEOGRAPHIC INFORMATION SYSTEM (GIS)

THESIS

Anthony A. Ference, Captain, USMC

AFIT/GEE/ENV/96D-03

Disclaimer

The views expressed in this thesis are those of the author and do not reflect the official policy or position of the Department of Defense or the U. S. Government.

HABITAT SUITABILITY MAPPING THROUGH
INTEGRATION OF MULTICRITERIA EVALUATION TECHNIQUES
WITH A GEOGRAPHIC INFORMATION SYSTEM (GIS)

THESIS

Presented to the Faculty of the Graduate School of
Engineering of the Air Force Institute of Technology
Air University in Partial Fulfillment of the
Requirements for the Degree of Masters of Science
in Engineering and Environmental Management

Anthony A. Ference, B.S.

Captain, USMC

December, 1996

HABITAT SUITABILITY MAPPING THROUGH
INTEGRATION OF MULTICRITERIA EVALUATION TECHNIQUES
WITH A GEOGRAPHIC INFORMATION SYSTEM (GIS)

THESIS

Anthony A. Ference, B.S.

Captain, USMC

Presented to the Faculty of the Graduate School of
Engineering of the Air Force Institute of Technology
Air University in Partial Fulfillment of the
Requirements for the Degree of Master of Science
in Engineering and Environmental Management

Mr. Harold Dusko

Maj. Edward Pohl

LtCol. Michael Shelley

Acknowledgments

I am extremely grateful to my thesis advisor, Lieutenant Colonel Michael Shelley, for keeping this research effort focused and preventing straying along tangential directions. Additionally, I would like to thank Major Edward Pohl for help in sorting through the multitude of multicriteria evaluation techniques. I would also like to thank Mr. Harold Dusko without whose help the production of GIS based maps would not have been possible.

This entire project would not have been possible without the help of several additional key players. First, I am grateful to the questionnaire respondents for taking time from their busy schedules to complete the questionnaire. I wish to thank Major Caspers, Mr. Dave Boyer, and Mr. Jay Cary from Camp Pendleton's environmental security office. I am also grateful to Mr. Tony Alexander and the Center for Urban and Public Affairs at Wright State University. Additionally, I wish to thank First Lieutenant Jeffrey Blackmon for editing drafts and providing quality input. Finally, I would like to thank my wife, Laura, who provided support and understanding during the time consuming process.

Anthony A. Ference

Table of Contents

	Page
Acknowledgments.....	ii
List of Figures.....	vi
List of Tables.....	vii
Abstract.....	viii
I. Introduction.....	1-1
Background	1-1
Purpose of Research	1-7
Problem Statement	1-7
General.....	1-7
Specific.....	1-7
Research Objectives	1-8
II. Literature Review.....	2-1
Introduction.....	2-1
Pacific Pocket Mouse	2-2
Multicriteria Evaluation	2-5
Criterion Selection.....	2-6
Criterion Evaluation.....	2-8
Pairwise Comparison	2-9
Seven Points Scale	2-13
Rating	2-14
Ranking	2-14
Comparison of Techniques	2-15
Aggregation Techniques.....	2-16
Compensatory	2-18
Noncompensatory	2-19
Interdependence.....	2-19

Geographic Information Systems	2-21
Soil Type	2-23
Slope	2-24
Texture	2-24
Stoniness	2-26
Drainage	2-27
Depth	2-28
Vegetation Classes	2-28
Coastal Distance	2-28
Prior Agricultural Land Use	2-28
 III. Methodology	 3-1
Introduction	3-1
Questionnaire Respondent Selection	3-1
Questionnaire Development	3-2
Criterion Evaluation	3-3
Soil Type	3-4
Soil Habitat Suitability Score Calculation ...	3-7
Vegetation Class	3-9
Coastal Distance	3-10
Questionnaire Evaluation	3-10
Intraclass Correlations	3-11
Kendall Coefficient of Concordance	3-12
Statistical Significance	3-14
Map Development	3-15
Criterion Suitability Maps	3-16
Compensatory Habitat Suitability	3-18
Ideal Point Habitat Suitability	3-18
Noncompensatory Habitat Suitability	3-21
 IV. Results	 4-1
Introduction	4-1
Pacific Pocket Mouse Habitat Requirements	4-1
Soil Requirements	4-1
Vegetation Requirements	4-3
Coastal Distance Requirements	4-3
Agricultural Land Use	4-4
General Suitability Issues	4-5
Questionnaire Evaluation	4-5

Habitat Suitability Map Evaluation	4-9
Criterion Habitat Suitability Maps.....	4-9
Coastal Distance	4-10
Vegetation	4-13
Soil	4-15
Overall Habitat Suitability Maps.....	4-17
Compensatory Habitat Suitability	4-17
Ideal Point Habitat Suitability	4-21
Noncompensatory Habitat Suitability	4-24
V. Conclusions.....	5-1
Introduction	5-1
Conclusions	5-1
Habitat Requirements.....	5-1
Questionnaire Evaluation.....	5-2
Map Evaluations.....	5-2
Future Research Recommendations	5-4
Appendix A: Questionnaire.....	A-1
Appendix B: Questionnaire Data, Weights, and Scores	B-1
Appendix C: Intraclass Correlation Coefficient Calculations	C-1
Appendix D: Converted Ranks and Kendall Coefficients of Concordance	D-1
Appendix E: P Value Calculations.....	E-1
Appendix F: Soil Type Scores.....	F-1
Appendix G: Respondent Cut-off Summary.....	G-1
Appendix H: Stone Material Significance Calculations	H-1
Bibliography.....	BIB-1
Vita.....	V-1

List of Figures

Figure	Page
2-1. Pairwise Comparison Matrix.....	2-9
2-2. Nine Point Scale.....	2-11
2-3. Seven Point Scale.....	2-13
2-4. Decision Hierarchy Example.....	2-17
2-5. GIS Map Layers.....	2-21
2-6. Sample Data Layer: Population Density.....	2-22
2-7. Slope Percentage Illustration.....	2-24
3-1. Problem Structure Overview.....	3-4
3-2. Soil Evaluation Structure.....	3-5
4-1. Coastal Distance Habitat Suitability Map With Known PPM Locations	4-11
4-2. Vegetation Habitat Suitability Map With Known PPM Locations	4-14
4-3. Soil Habitat Suitability Map With Known PPM Locations	4-16
4-4. Compensatory Habitat Suitability Map.....	4-18
4-5. Compensatory Habitat Suitability Map With Known PPM Locations	4-19
4-6. Ideal Point Compensatory Habitat Suitability Map	4-22
4-7. Ideal Point Noncompensatory Habitat Suitability Map	4-23
4-8. Noncompensatory Habitat Suitability Map.....	4-25
4-9. Noncompensatory Habitat Suitability Map With Known PPM Locations	4-26

List of Tables

Table	Page
3-1. Organization of Ranking Data for Kendall Coefficient of Concordance	3-13
3-2. Polygon Suitabilities.....	3-17
3-3. Distance From Ideal Polygon Suitabilities.....	3-20
3-4. Unsuitable Criterion Characteristics.....	3-22
4-1. Intraclass Correlation Coefficients and Kendall Coefficients of Concordance for Questionnaire Data	4-6
4-2. Q and P Values for Questionnaire Data.....	4-7
4-3. PPM Distributions Within Criterion Suitability Maps	4-12
4-4. PPM Distributions Within Combined Suitability Maps	4-20
4-5. Polygon and Acreage Distributions for Combined Suitability Maps	4-27

Abstract

The presence of an endangered species, the Pacific Pocket Mouse (PPM), in critical Marine Corps training areas aboard Camp Pendleton may adversely affect training activities that are crucial to meeting the Marine Corps' mission. Camp Pendleton must focus limited budgetary assets for live trapping surveys of the PPM in the areas of best habitat suitability and the purpose of this study was to develop a PPM habitat suitability map of Camp Pendleton.

Suitability maps were developed by integrating expert opinion with the Camp Pendleton Geographic Information System (GIS) database. The seven points scale multicriteria evaluation methodology was implemented to solicit the importance of ground characteristics (criteria) for PPM habitat from field experts. The criteria of interest were coastal proximity, soil type, and vegetation class. The evaluations of the respondents were in agreement. Suitability scores and preference weights were determined from questionnaire responses and input into the ARC/INFO[®] GIS program. Habitat suitabilities were calculated as weighted averages of suitability scores of individual ground characteristics. The criterion and combined suitability maps produced agreed well with known locations of the PPM.

This indicated that the evaluations and methodology were valid. Coastal proximity was determined to be unimportant and should be eliminated from future research in this area.

HABITAT SUITABILITY MAPPING THROUGH
INTEGRATION OF MULTICRITERIA EVALUATION TECHNIQUES
WITH A GEOGRAPHIC INFORMATION SYSTEM (GIS)

I. Introduction

Background

Although species extinction is considered to be a natural process, mankind's actions have accelerated the rate of extinction to the point of being far from natural (Vaughan, 1994:6-8). It has been estimated that half of all species that have become extinct during recorded human history have gone extinct in the twentieth century (Watkins, 1991:17). In an attempt to counter this trend, the United States took the first legislative steps toward protecting species on the brink of extinction in the mid 1960s.

The first legislative act occurred in 1966 with the passing of the Endangered Species Preservation Act. This act provided for the listing of endangered species and allowed for land acquisitions for the protection of those species. However, the act had many limitations, only addressed wildlife of the United States, and quickly proved to be ineffective (Vaughan, 1994:9-10). In 1969, the

Endangered Species Conservation Act was passed. This expanded the coverage of the listing process to allow inclusion of endangered and threatened species (and subspecies) of the world. However, the act did not provide for penalties for destruction of species and also proved to be ineffective (Vaughan, 1994:10).

In 1973, the Endangered Species Act was passed by Congress. The Act's major goals are: (1) to identify endangered and threatened species and the means to protect and recover these species, (2) prevent harm to protected species prior to federal action, and (3) prevent and punish takings of protected species and damage to habitat (Vaughan, 1994:18). The responsibility of enforcing the Act belongs to the Department of the Interior (for terrestrial species) and the Department of Commerce (for marine species). To enable accomplishment of the missions, the Act is structured into three basic sections. The first, section 4, outlines the process for listing endangered and threatened species and their habitats. Additionally, it mandates that a recovery plan be drafted for each listed species so protection and recovery procedures can be implemented (Vaughan, 1994:14-15). The next basic section, section 7, requires all federal agencies to protect listed species and consult with the Secretary (Interior or Commerce) prior to

any action that may affect any listed species to prevent adverse effects (Vaughan, 1994:15). Finally, section 9 outlines the prohibitions against "takings" of listed species where takings are broadly defined to include everything from killing of individuals of the species to damaging of species habitat (Vaughan, 1994:15-16).

Marine Corps Base (MCB) Camp Pendleton encompasses 506,000 square kilometers of coastal southern California extending from the Pacific Ocean to the coastal mountains (Frank, 1995:1). Because this area contains many unique and relatively undisturbed ecosystems, it is prime habitat for many species and several endangered species inhabit the base. One such species is the Little Pacific Pocket Mouse (PPM).

A relatively unknown species, the Pacific Pocket Mouse was initially discovered on the base during project surveys in 1994 as the result of an inadvertent capture during a herpetological survey. Previous to this, the PPM was thought to have been largely extirpated from its historical range along the coast of southern California and to exist only at one site, known as the Dana Point Headlands. The PPM was listed as an endangered species and entitled federal protection under the Endangered Species Act (ESA) in September 1994 (Department of the Interior, 1994:49752).

After the initial point discovery of the mouse aboard the base, three subpopulations of the mouse have been located on base as a result of focused live trapping efforts. Prior to initiating live trapping, owl casting (regurgitated animal remains) surveys were conducted in an attempt to locate areas where the PPM would most likely exist. The casting surveys were inconclusive (U.S. Fish and Wildlife Service, 1995:14).

Historically, the PPM has been found along the coastal areas of southern California (from Los Angeles to the Mexican border) extending inland only about three kilometers (Department of the Interior, 1994:49752). Presently, Camp Pendleton represents one of the last extended tracts of open coastal terrain within this historical habitat region. Because the coastal front of Camp Pendleton represents 17 miles, a large area of the base exists where survey efforts could be directed.

Because the PPM is an ESA protected species, federal agencies (to include MCB Camp Pendleton) must consult with the Fish and Wildlife Service (FWS) if an action may affect the species (Vaughan, 1994:15). Although this typically pertains to construction projects, Marine Corps training activities could be construed as causing takings of the species. The base training activities include everything

from aircraft bombing and live-fire artillery training, to mechanized vehicle and infantry training. Because of the potential harm these activities may cause the PPM and its habitat, they are subject to Cease and Desist letters from the Fish and Wildlife Service.

The training conducted on base is crucial to Marine Corps readiness. In order to comply with the ESA requirements and continue Marine Corps training, Camp Pendleton is conducting live trapping surveys to determine the spatial distribution of the species within its critical maneuver training areas. Interim conservation measures, while the sampling is being completed, include continuing foot traffic, continuing vehicle access on existing roads and trails, and restricting activities that cause sub-surface soil disturbance (Boyer, 1996:3). The two major goals are: (1) to improve survey effectiveness through better understanding of species biology, and (2) to complete basewide surveys to identify species distribution and abundance (Boyer, 1996:4). By actively working with the FWS to protect the species, Camp Pendleton hopes to preclude any Cease and Desist letters for training in coastal areas.

Because costs for live trapping surveys are quite expensive, the trapping efforts must be focused in the most likely areas of mouse occurrence to cost effectively use the

available environmental program budget. This research will work toward development of a tool to help focus these sampling efforts. Specifically, a PPM habitat suitability map for the base will be developed through evaluation of ground characteristics. This map can then be used for directing the live trapping survey efforts toward areas of highest habitat suitability. Creation of this map contributes to achieving the goal of improving survey effectiveness through identification of suitable habitats for the PPM.

Because there is not much specific information available on PPM habitat features, a map cannot be directly constructed from historical records. However, since the initial discovery of the PPM population at Dana Point, numerous trapping efforts (with both positive and negative results) have been conducted within the historic range of the PPM and much knowledge has been gained. To harness this knowledge, multicriteria evaluation techniques will be employed to gather expert opinion (from the various people who have conducted the trapping efforts over the past three years) and gain insight into the important characteristics of suitable PPM habitat.

Knowledge about the importance of ground characteristics can only be useful in map development if the

spatial distributions of ground characteristics for the base are known. A Geographic Information System (GIS) database fulfills this need for Camp Pendleton. This database contains information about the vegetation classes, soil types, and other spatially distributed features aboard the base. After multicriteria evaluation, the importance of ground characteristics (with respect to PPM habitat) can be integrated with the GIS database to develop the PPM habitat suitability map.

Purpose of Research

The purpose of this study is to develop a PPM habitat suitability map of Camp Pendleton to aid environmental resource managers in effectively allocating funds for survey efforts to characterize the base PPM population.

Problem Statement

General. The presence of the Pacific Pocket Mouse in critical Marine Corps training areas aboard Camp Pendleton may adversely affect training activities that are crucial to meeting the Marine Corps' mission.

Specific. Camp Pendleton must focus limited budgetary assets for live trapping surveys of the Pacific Pocket Mouse in the areas of best habitat suitability which are unknown.

Research Objectives

1. Use multicriteria evaluation techniques to survey expert opinion and gain insight into the important habitat characteristics of the PPM.

2. Develop methodology for integrating expert opinion with a GIS database to develop a PPM habitat suitability map of Camp Pendleton.

3. Compare the habitat suitability maps with known Pacific Pocket Mouse locations to evaluate the effectiveness of the maps.

II. Literature Review

Introduction

To create a Pacific Pocket Mouse (PPM) habitat suitability map using a GIS database that includes various ground characteristics (such as vegetation and soil types), it is necessary to understand the importance of the characteristics as they pertain to habitat suitability. Although there are volumes of information available about the Heteromyid family (of which the PPM is a member) and the little pocket mouse (of which the PPM is a subspecies), there is not much specific information available about the PPM. Additionally, while the PPM has only been found along the immediate Pacific coast (within 3 km) of southern California (Department of the Interior, 1994:49752), the little pocket mouse has been found throughout the entire southwestern United States and northwestern Mexico (Hall, 1981:538). Because these areas represent many different climates and habitat conditions, it follows that the habitat requirements for the Pacific Pocket Mouse cannot be equated to those of the little pocket mouse in general. Since the discovery of the PPM population at the Dana Point Headlands, there have been numerous live trapping efforts conducted over the PPM historic range. Marine Corps Base Camp

Pendleton, the Fish and Wildlife Service, and several contractors have participated in these efforts and much has been learned about the environment that the PPM seems to inhabit. Therefore, the expert opinions of these ladies and gentlemen are a source of information about the PPM that can be harnessed for determining the importance of ground characteristics pertaining to the PPM habitat. These opinions will be gathered and quantified using multicriteria evaluation techniques.

This literature review is organized into three sections. The first section outlines the historical information available about the Pacific Pocket Mouse and its habitat. The next section briefly reviews a few of the multicriteria evaluation techniques available for surveying expert opinion. Finally, the last section addresses the Geographic Information System (GIS) database and GIS technology.

Pacific Pocket Mouse

The Pacific Pocket Mouse (*Perognathus longimembris pacificus*) is the smallest of 19 subspecies of the Little Pocket Mouse (*Perognathus longimembris*) which is part of the Heteromyid family of rodents that includes the kangaroo rat, kangaroo mouse, and little pocket mouse. The PPM was originally identified as a distinct species in the 1890s and

was later determined to be a subspecies of the little pocket mouse in the 1930s. As a recognized subspecies, the PPM is considered to be a "species" in the context of the Endangered Species Act and, after its listing as an endangered species in September 1994, was entitled protection under the act (Department of the Interior, 1994:49752).

The Pacific Pocket Mouse has been historically found along the southern California coast from the El Segundo/Marina del Rey area in Los Angeles county, south to the Mexican border area in San Diego county (Department of the Interior, 1994:49752; Genoways and Brown, 1993:182). It has not been reliably recorded more than three kilometers inland or higher than 180 meters of elevation. Additionally, it has not been recorded outside the state of California (Department of the Interior, 1994:49752).

The PPM is a granivorous, nocturnal rodent. It feeds primarily on the seeds of grasses and forbs but also may feed on grassy vegetation, and soil-dwelling insects (Department of the Interior, 1994:49753; U.S. Fish and Wildlife Service, 1995:7). Its habitat seems to be characterized by fine grained, sandy soil substrates which are in the vicinity of the Pacific coast and the PPM has been found to inhabit coastal strand, coastal dunes, river

alluvium, and coastal sage scrub on marine terraces (Department of the Interior, 1994:49752). The majority of PPM have been captured in "open, sparsely vegetated" areas of "relatively loose, uncompacted, sandy soils" (U.S. Fish and Wildlife Service, 1995:6). The PPM dwells in underground burrows and can become torpid (dormant/suspended animation) or hibernate in response to changing weather conditions (Department of the Interior, 1994:49753).

Historically, the PPM was found in Los Angeles, Orange, and San Diego counties. In Los Angeles county, many PPM specimens were captured between 1918 and 1938 but none have been recorded in the county since that time. In Orange county, the PPM was recorded in the San Joaquin hills from 1968 to 1971 and a population was recorded on the Dana Point Headlands in 1932. In 1994, Dr. Phil Brylski rediscovered this population at the Headlands. Prior to this rediscovery, no PPM were recorded in California since 1971. In San Diego county, the PPM were found in the San Onofre Area, Santa Margarita River Estuary, and Tijuana River Valley (Department of the Interior, 1994:49753-4). The San Onofre Area and the Santa Margarita River Estuary are both located aboard Marine Corps Base Camp Pendleton. In 1995, biological consultants found the PPM in three locations on base (U.S. Fish and Wildlife Service, 1995:3). Two

locations were in the San Onofre Area and the third was near the Santa Margarita River Estuary (U.S. Fish and Wildlife Service, 1995:39; Michael Brandman Associates, 1995:8; Boyer, 1995). Prior to this, no PPM had been confirmed in San Diego county since 1932 (Department of the Interior, 1994:49753).

Multicriteria Evaluation

Each location on the base can be characterized by different ground characteristics (i.e. soil type, vegetation class, etc.). The decision of which areas should be sampled with live trapping is based on the relative habitat suitabilities of different areas aboard the base and these suitabilities can be judged from the on-site ground characteristics. The objective of multicriteria evaluation is to evaluate different choice possibilities (i.e. areas for sampling) based on "standards of judging" or criteria (Voogd, 1983:28). For the PPM problem, the different ground characteristics are considered to be the criteria for habitat suitability and each criterion category (i.e. each soil type, vegetation class, etc.) must be evaluated for its individual habitat suitability. A location's overall habitat suitability can then be calculated as a combination of its different ground characteristic scores. In order to combine expert opinion about the individual criteria to

determine a location's habitat suitability, suitability values for the criteria must be quantified. A multitude of multicriteria evaluation techniques have been developed for quantification of criterion values and many have specific applications that depend on problem complexity and structure.

The remainder of this multicriteria evaluation section outlines the criterion selection process for this problem, reviews and compares multicriteria evaluation techniques, reviews aggregation techniques for combining criterion scores, and discusses the problem of interdependence among criterion.

Criterion Selection. Initially, a GIS model was constructed by Camp Pendleton's Environmental and Natural Resources Management Office. From historical records and live trapping experience, wildlife biologist Dave Boyer determined the following four factors to be the major criteria for PPM habitat suitability: soil type, vegetation class, coastal distance, and elevation. On a zero to three point scale, Dave subjectively evaluated each of the criterion categories for probability of mouse occurrence (where 0 = no probability, 1 = low, 2 = medium, and 3 = high) and integrated these scores into the GIS database by averaging the individual scores (a compensatory approach).

The map provided a good starting point for focusing sampling funds but didn't correlate well with actual on site findings of the PPM. Because of this, the map was opened to scrutiny during the PPM workshop in San Diego on March 5, 1996. Many of the key individuals involved with live trapping over the past two years were present (including Camp Pendleton and FWS personnel, as well as independent contractors).

During the PPM workshop, the criterion category scores and criterion selection were reviewed. Although several of the participants disagreed with some of the criterion category evaluations (i.e. individual soil scores), they generally agreed with the model assumption that soil, vegetation, and coastal distance were important factors for habitat suitability. These factors were considered to be important for the following reasons. Soil type is important for habitat suitability because the PPM will only inhabit soil types that are loose enough to enable burrowing but hold together to support a rodent burrow's structure. Vegetation class was determined to be important based largely on previous trapping experience of the participants and correlational data. In other words, specific vegetation requirements for PPM habitat could not be identified at the time but, in general, the mouse seemed to occur in certain sparse vegetative communities. Finally, coastal distance

was also determined to be important due to previous trapping experience and correlational data. Because the PPM had never been found further inland than three kilometers, distance from the coast seemed to be important. Although the participants felt that soil, vegetation, and coastal distance were important, they did not agree with the model assumption that elevation was a crucial factor and felt that it probably could be eliminated. This was largely because elevation generally is correlated with coastal distance and since distance is addressed in the model, it was concluded that elevation was unnecessary. Finally, there was a consensus of the participants regarding replacement of elevation with prior agricultural land use. This was due to the fact that it did not appear (at that time) that the PPM reinhabited areas that had previously been agriculturally cultivated. From this workshop input, the criteria for evaluation of PPM habitat suitability were determined to be soil type, vegetation class, coastal distance, and prior agricultural land use.

Criterion Evaluation. According to Voogd, there are five ways to determine criterion priorities or weights: preference analysis, behavioral analysis, direct system description, indirect system description, and hypothetical priorities (Voogd, 1983:100-102). These priority scores

represent criterion importance scores relative to the other criteria. Of the five methods listed above, the preference analysis approach involves the questioning of experts or decisionmakers through direct interview or questionnaire and is the most relevant to this research. Four preference analysis techniques considered for evaluation of the PPM habitat criterion scores are pairwise comparison, seven points scale, rating, and ranking.

Pairwise Comparison. The pairwise comparison technique quantifies criterion scores through evaluation of the relative importance of each criterion relative to all other criteria. A pairwise comparison approach for an individual criterion (i.e. soil type) involves construction of a pairwise comparison matrix as illustrated in Figure 2-1 (Voogd, 1983:83).

		SOIL TYPES				
		1	2	3	4	5
SOIL TYPES	1					
	2					
	3					
	4					
	5					

Figure 2-1. Pairwise Comparison Matrix

Each category of the criterion (i.e. each soil type) is evaluated for its relative importance compared to each of the other categories to determine whether the categories are equally significant or one is more significant than any others. The relative importance values can be directly evaluated by the person completing the questionnaire, can be evaluated using a nine point scale, or can be indirectly calculated (Jankowsky, 1995:265; Saaty, 1980:18,55-57; Voogd, 1983:83). A complete pairwise comparison entails comparing each pair of criteria twice, once in the order A-B, then in the order B-A, to complete the matrix (Eckenrode, 1965:182). Partial pairwise comparison asks each pair of criteria to be evaluated only once which effectively fills in half of the matrix. The remaining matrix elements are then calculated as the reciprocal of the evaluated values (Saaty, 1980:18-19).

For a multiple participant questionnaire, direct evaluation could prove to be unwieldy because of the varying degrees of importance that may be reported. For example, if questionnaire respondents were asked to evaluate the relative importance of soil type 1 versus soil type 2 on a scale from 0 to 100, importance values may span a very large range even if the experts are in general agreement about the relative importance. In addition, direct evaluation without

limits (effectively a scale from 0 to ∞) may not be useful because it assumes that human judgment can evaluate relative dominance of two objects which is not the case (Saaty, 1980:57).

A nine point scale system minimizes the range of answers possible by limiting the answers to single digit integer values between one and nine (illustrated in Figure 2-2).

- | | |
|---|---------------------------------------|
| 1 | Equal importance |
| 2 | |
| 3 | Weak importance of one over the other |
| 4 | |
| 5 | Essential or strong importance |
| 6 | |
| 7 | Demonstrated importance |
| 8 | |
| 9 | Absolute importance |

Figure 2-2. Nine Point Scale
(Anselin and others, 1989:220)

The nine point scale has been developed by Saaty because psychologists have concluded that nine objects are the most that can be simultaneously compared, and ranked by individuals (Anselin and others, 1989:220; Voogd, 1983:93). Additionally, in a comparison of scales, the 1-9 scale distinguished itself and seemed to indicate a human affinity for "correspondence between shades of feeling and the numbers 1-9" (Saaty, 1980:57). Once the matrix is

completed, importance weights can be developed by using the largest eigenvalue to calculate the associated eigenvectors (Anselin and others, 1989:220-221).

An indirect evaluation method for calculating the importance values can also be employed. According to Voogd, it is easier to ask questionnaire respondents only to select the more important criterion category without additional evaluation of the relative importance values (Voogd, 1983:103). The pairwise comparison matrix is then filled in with zeros and ones where a value of one represents more important. Addition of these values over the columns yields values for the importance of each criterion category over all other categories (Voogd, 1983:103).

The pairwise comparison technique is best for a limited number of criteria. Even with partial paired comparison, the number of questions necessary to complete the matrix can be overwhelming. For n criteria, there are $n(n-1)/2$ questions necessary. For a moderately complex problem with only seven criteria, this results in 21 questions. If the problem has several levels of complexity (i.e. each criterion includes subcriteria that must be evaluated), this could lead to an enormous questionnaire.

Seven Points Scale. Evaluation of importance

values for criteria on a seven points scale has been advocated since 1957 when it was found that seven categories were enough to allow people to evaluate their preferences (Voogd, 1983:104). Respondents are presented with a question for each criteria (or categories within a given criterion) and asked to circle the number that corresponds to their evaluation of the criterion's importance. The seven points are accompanied by verbal descriptions of the extremes to aid in the evaluation (see Figure 2-3).

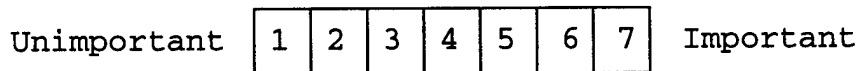

Figure 2-3. Seven Point Scale
(Voogd, 1983:104)

Each criterion is given a value of importance between one and seven. These criterion scores can then be normalized between zero and one to develop weights (Voogd, 1983:104). There are two clear advantages to the seven points scale evaluation technique. First, it is effective for evaluation of a large number of criteria because each criterion is individually evaluated. Second, evaluating each criterion on a seven points scale allows for ties among the categories.

Rating. Rating refers to evaluation of the importance of criterion based on a distribution of points. A common method involves the constant sum approach in which the respondents are given a total number of points (i.e. 100) to distribute over the entire set of different criteria. The points assigned to each criterion represent the criterion importance value (Voogd, 1983:105). A disadvantage of this method is that questionnaire respondents can often become confused as to how to distribute the points (Voogd, 1983:105). Additionally, as the number of criteria increases, the distribution of points can become increasingly difficult.

Ranking. This approach involves simply ranking of the criteria in order of importance. The ranks are considered units on a cardinal scale and the scores can be normalized. Although it is a simple technique, the accuracy of the ranking method decreases as the number of criteria increases. It has been found that the optimal number of criteria that can be discriminated by respondents is about seven (Voogd, 1983:103). Partial ranking is one method for handling problems with more than the optimal number of criteria. In partial ranking, the set of criteria is first divided into subsets (i.e. more important and less important) and the subsets are then ranked. The lowest

ranked criterion of the more important subset is considered to be higher in importance than the highest ranked in the less important subset. From this evaluation, ranks for the entire set can be derived (Voogd, 1983:104). Other potential drawbacks of the ranking system are that none of the criterion can be rated as equal in importance to any other criterion, and the differences in importance are considered to be the same. In other words, the importance value difference between the most important criterion and the second most important criterion is the same as the difference between the second and third most important criteria. This may not actually be the case if one (or several of the) criterion are much more important than all others. The ranking technique will not capture the strengths of the differences.

Comparison of Techniques. Many researchers have compared the different evaluation techniques and have determined that the methods do not significantly differ in terms of priority weight results but do differ in terms of ease of use, and time of implementation. For example, Voogd applied five different methods to two problems with three groups of respondents. In this study, he found the resulting priority scores from the different techniques to be very comparable (Voogd, 1983:324). However, in the same

study, he found that the techniques did differ in terms of ease of use and time requirements and concluded that that the seven points scale and ranking techniques were consistently better in both categories (Voogd, 1983:318,327). Frank integrated multicriteria evaluation techniques with GIS technology in his masters research at San Diego State University and found that there was no appreciable difference in results from the seven points scale, ranking, and paired comparison. However, he did find that the seven points scale and ranking offered advantages over paired comparison in terms of "ease of implementation and time requirements" (Frank, 1995:106). Finally, Eckenrode compared ranking, rating, and three different paired comparisons and found that there were no significant differences in the weights derived from each of the techniques and they were equally reliable (Eckenrode, 1965:180,183).

Aggregation Techniques. Often, a complex problem can be viewed as a hierarchy of different sets of criteria. For example, PPM habitat suitability may be evaluated by focusing on soil, vegetation, and coastal proximity. The relative value of each site is calculated as a combination of the values of the different criteria that characterize that site. In addition to evaluating the relative

importance of each of the major criterion to establish weights, the different categories within each criterion (i.e. each soil type) must be scored. The decision hierarchy may be viewed as in Figure 2-4. In this hierarchy, five different soil types, vegetation classes, and coastal distances are considered.

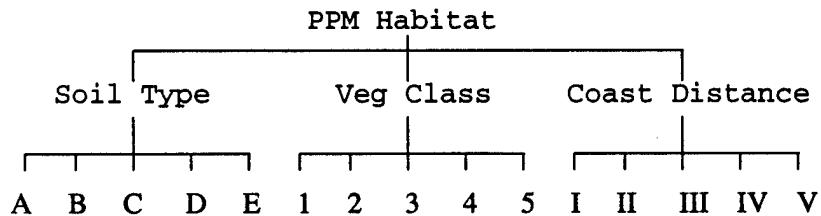

Figure 2-4. Decision Hierarchy Example

Each potential habitat area will be characterized by one category of each criterion. For example, location X may be characterized by soil type B, vegetation class 3, and coastal distance category V. A habitat suitability score is associated with each one of these characteristics and the combining of these scores will give an overall estimate of the habitat suitability of location X. An aggregation function will be used to facilitate this score combination.

Aggregation functions can be viewed as either compensatory or noncompensatory. A compensatory aggregation function is based on the assumption that high performance for one criteria can compensate for low performance in other

criteria (Jankowsky, 1995:256). In other words, a high score on a high priority criterion may compensate for low scores on other lower priority criteria. Additionally, high scores for two low priority criteria may be able to compensate for a low score on a high priority criterion. With the noncompensatory approach, a low criterion score cannot be compensated by a high score for another criterion (Jankowsky, 1995:257).

Compensatory. Compensatory techniques can be divided into additive and ideal point approaches. With the additive approaches, the total score for an alternative (i.e. habitat score for a location) is calculated by multiplying the criterion weights (i.e. normalized importance value for soil) by the criterion category scores (i.e. normalized soil type score) and adding the values (Jankowsky, 1995:257). The additive approaches basically differ in the techniques employed to evaluate criterion weights and scores. All weights and scores must be normalized so alternatives can be compared on a common scale and the alternative with the highest overall score is considered to be the best choice. With the ideal point techniques, the evaluator chooses the best category for each criterion (i.e. which soil type is best for PPM habitat). A theoretical location, characterized by the best of each

criterion, is viewed as the ideal point. The distance between each alternative and the ideal point is calculated to arrive at a ranking of the alternatives (Jankowsky, 1995:258).

Noncompensatory. The noncompensatory multicriteria techniques involve stepwise reduction of alternatives by comparing alternatives and eliminating rejects (Jankowsky, 1995:259). The techniques differ by the rules of elimination. With the dominance technique, alternatives are compared based on criterion scores and alternatives that are dominated are eliminated. The conjunctive and disjunctive methods employ minimum cut-off values for each criterion. Finally, the lexicographic method involves ranking alternatives from most to least important. The alternatives are first ranked with respect to the most important criterion. Every alternative except the winner of the criterion is eliminated. If there is a tie, evaluation continues with the next most important criterion (Jankowsky, 1995:259).

Interdependence. The majority of multicriteria evaluation techniques assume independence between criteria. Often, with natural systems, this is not the case and techniques capable of handling interdependence have been developed. Unlike the aggregation techniques addressed

previously, a nonlinear combination equation is capable of handling the interdependence of criteria. For example, soil type and vegetation class may be interrelated. If the relationship is known and can be expressed as a mathematical function, the nonlinear combination method is ideal (Hopkins, 1977:392).

Another method of dealing with dependence is that of explicit identification of regions (Hopkins, 1977:393). This class of techniques involves identifying all unique combinations of the interdependent criteria. For example, if soil and vegetation were considered to be interrelated, the unique soil/vegetation combinations would be identified and evaluated for habitat suitability. These techniques, however, are suitable for studies involving only a few factors because of the large number of combinations that may be possible. For example, if two factors are considered, with seven classes each, there are potentially 49 unique combinations that must be evaluated.

In land suitability problems, methods that assume independence among criteria (such as linear combination) are often used for several reasons. First, linear combination (although imperfect) is the "best method available in the sense that the benefits from any alternative method would not exceed the cost of applying that alternative" (Hopkins,

1977:392). Additionally, criteria typically used (to include soils, slope, and vegetation) "can be deductively determined to be independent" (Hopkins, 1977:392). Finally, ignoring interactions often introduces very little error (Eckenrode, 1965:189).

Geographic Information Systems

Geographic Information Systems (GIS) are computer systems that are able to store, manipulate, and display geographically referenced data (Environmental Systems Research Institute, 1993:1-2). Geographically referenced indicates that the stored data pertains to specific locations on the earth's surface. Different types of data are considered as layers of information (see Figure 2-5) which can be stored in the GIS and accessed to gain specific information about locations included in the database.

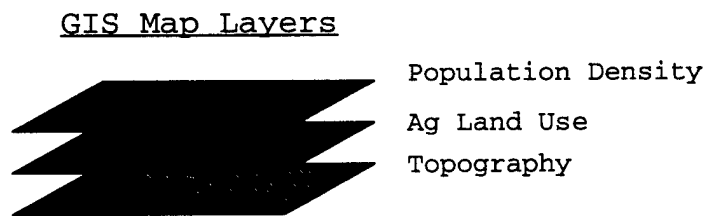

Figure 2-5. GIS Map Layers

The different layers can represent many unique geographies of the real world. For example, a county may be described by its population density, agricultural land use, or

topography, and each location within the county can be characterized by a given category of each. Each of these data sets constitutes a data layer for that county. The layers can be described by areas (polygons) of uniform characteristics (i.e. density) separated by boundary lines (arcs) (see Figure 2-6). The GIS facilitates storing, handling, and displaying this type of information.

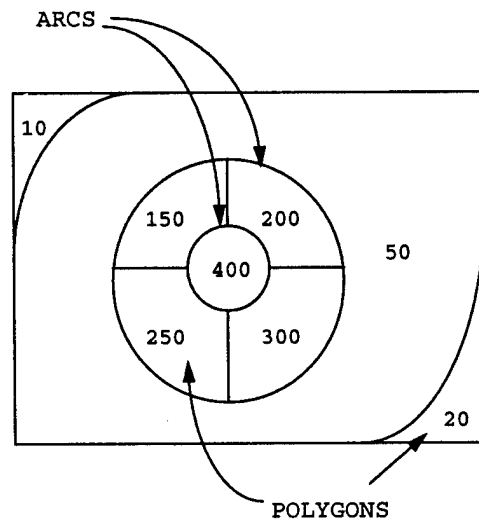

Figure 2-6. Sample Data Layer: Population Density.

For the pacific pocket mouse, it has been identified that soil type, coastal distance, and vegetation class are the most important land features for predicting habitat suitability (Pacific Pocket Mouse Workshop, 1996). To be able to integrate the evaluations of each of these criterion into a habitat suitability map, GIS data layers for each criterion must be available. Soil type and vegetation class

layers are contained in the Camp Pendleton database and coastal distance can be developed with the ARC/INFO® GIS software package.

Soil Type. Soil can be described as the plant supporting medium created from weathering of bedrock material. In particular, the Soil Survey Manual defines soil as:

Soil is the collection of natural bodies occupying portions of the earth's surface that supports plants and that have properties due to the integrated effect of climate and living matter, acting upon parent material, as conditioned by relief, over periods of time (Department of Agriculture, 1951:8).

The soil data layer for Camp Pendleton is taken from the soil survey conducted for San Diego County in 1973. During this survey, soil profiles were compared and soils were classified into series and phases and named according to accepted procedures (Department of Agriculture, 1973:6). A soil profile refers to the collection of different soil horizons (or layers) that includes organic layers at the surface and parent material below (Department of Agriculture, 1951:173). Soils with generally the same profiles (and individual horizon characteristics) make up a soil series and each series is named for a town or geographic feature near where the series was first observed. Soils within each series may vary in other soil

characteristics (i.e. slope, stoniness, texture) and these differences lead to dividing the series into phases (Department of Agriculture, 1973:6).

The following soil characteristics were identified as potentially important to PPM habitat suitability through various conversations with PPM workshop participants: slope, texture, stoniness, drainage class, and depth.

Slope. "Soil slope refers to the incline of the surface of the soil area" (Department of Agriculture, 1951:158). Slope is often defined in percentages by the measured elevation change (in feet) over a 100 foot horizontal distance change (see Figure 2-7). A 45° hill, therefore, has a percentage slope of 100% because the elevation change is equal to the horizontal distance change.

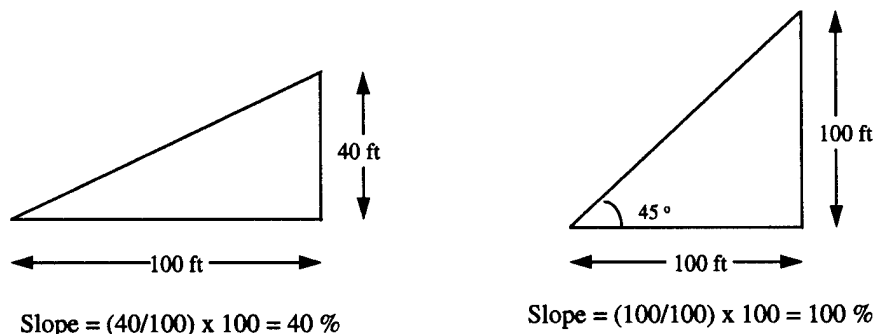

Figure 2-7. Slope Percentage Illustration.

Texture. "Soil texture refers to the relative percentages of sand, silt, and clay in a soil" (Donahue, 1965:25) and the textural classes are based on the different

combinations of these particles (Department of Agriculture, 1951:207). Particles less than 2 mm in diameter are considered soil separates and separates are classified as either sand, silt, or clay. The following is the size breakdown of these separates as defined by the USDA (Department of Agriculture, 1951:209-210).

Sand.	0.05-2.0 mm diameter
Silt.	0.002-0.05 mm diameter
Clay.	below 0.002 mm diameter

Twelve major textural classes have been defined by the USDA and the following general groupings of the soil textural classes have been identified (Department of Agriculture, 1951:210-213).

Sandy Soils.		
Coarse-textured soils		Sands Loamy Sands
Loamy Soils.		
Moderately coarse-textured soils		Sandy Loam
Medium-textured soils		Loam Silt Loam Silt
Moderately fine-textured soils		Clay Loam Sandy Clay Loam Silty Clay Loam
Clayey Soils.		
Fine-textured soils		Sandy Clay Silty Clay Clay

Specific definitions of the textural classes are included in the glossary of the questionnaire (Appendix A). The

textural class definitions include some soil consistency terms (i.e. plasticity, friability, etc.) which may be important to PPM habitat and these terms are also defined in the questionnaire glossary.

Stoniness. Besides the actual soil material, there are often significant proportions of other coarse fragmentary materials present mixed in with the soil. The size and percentage of this fragmentary material present may affect the habitat suitability of a given land area. Therefore, this potential on-site characteristic is additionally addressed as part of the makeup of the soil texture. The following size classes are adopted from the "Draft, Results of Focused Surveys for the Pacific Pocket Mouse Foothill Transportation Corridor-South" (Michael Brandman Associates and LSA Associates, Inc., 1995:Appendix 2).

Fine Pebbles (2-5 mm)

Medium Pebbles (5-20 mm)

Coarse Pebbles (20-75 mm)

Cobbles (75-250 mm)

Stones (250-600 mm)

Boulders (>600 mm)

Besides the size of the fragmentary material present, the percentage (by volume including the soil material) of the

rock fragmentary material may also potentially affect the suitability of a given location. The following percentage classes and descriptive modifiers are adopted from the "Draft, Results of Focused Surveys for the Pacific Pocket Mouse Foothill Transportation Corridor-South" (Michael Brandman Associates and LSA Associates, Inc., 1995:Appendix 2).

<u>% Rock Fragments</u>	<u>Modifier</u>
0-15	None
15-35	Adjective for the dominant rock size (i.e. gravelly or cobbly)
35-60	Adjective plus modifier "very" (i.e. very cobbly)
> 60	Adjective plus modifier "extremely". If less than 10% earth, material referred to as gravel, cobbles, etc.

Drainage. Soil-drainage classes incorporate runoff, permeability, and internal drainage to classify how easily water is removed from the soil. This gives an indication of how wet a soil type may be during the year which may be important to PPM habitat. Drainage classes and

definitions taken from the Soil Survey Manual are included in the questionnaire glossary (Department of Agriculture, 1951:170-172).

Depth. Soil depth simply refers to the depth of the soil material from the surface to the bedrock material.

Vegetation Classes. The vegetation data layer has been developed using a classification system originated by Cheatham and Haller, and modified by the Natural Diversity Data Base (NDDB) (Holland, 1986:I). This classification system divides the California landscape into roughly 375 natural communities of which twenty eight occur aboard Camp Pendleton. In 1986, Holland consolidated literature and personal interview information about the communities to try and rectify the Cheatham and Haller system with the NDDB list and published a descriptions of the communities that will be used for the questionnaire portion of this research.

Coastal Distance. Coastal distance for given locations within a GIS database can be directly calculated within the system. If gradations of habitat suitability (with respect to coastal distance) are determined to be appropriate, lines of demarcation can be generated within the GIS.

Prior Agricultural Land Use. Because land recovery from cultivation is a function of time (i.e. after cultivation ceases, land begins succession to a more natural

state), it is necessary to have spatial and temporal information on the prior agricultural land use. Although Camp Pendleton does have spatial data on agricultural land use, the layer only contains information as to whether areas have been previously cultivated but does not include the time frame of cultivation or when cultivation ceased. Because of this, agricultural land use will be addressed as a potential limiting factor of areas to be considered as PPM habitat. Therefore, for the multicriteria evaluation portion of the questionnaire, only soil type, vegetation class, and coastal distance will be addressed.

III. Methodology

Introduction

This chapter outlines the methods used for evaluating expert opinion and integrating that information with the Geographic Information System database to develop the Pacific Pocket Mouse (PPM) habitat suitability map. It is organized into four sections. The first section discusses questionnaire respondent selection. Next, multicriteria evaluation techniques employed and questionnaire development are addressed. The next section discusses questionnaire evaluation to determine agreement between respondents. Finally, the methods used for integrating evaluation scores into the GIS to develop PPM habitat suitability maps are discussed.

Questionnaire Respondent Selection

Because there are different views on endangered species issues, it is important to have questionnaire respondents who represent all sides of the Pacific Pocket Mouse issue to ensure development of impartial maps. Of the nine questionnaire respondents employed for this study, one works directly for Camp Pendleton, one worked with the Fish and Wildlife Service in drafting the PPM endangered species listing, one is employed in the educational community and

studied the PPM in the early 1970s, and the remaining six respondents are independent contractors/consultants.

Because questionnaire evaluations are used for development of the predictive habitat suitability map, it is also important that questionnaire respondents are knowledgeable about the PPM to ensure that evaluations are meaningful. The respondents for this study have various levels of experience and educational backgrounds in the areas of biology, ecology, zoology, and wildlife management. Of the nine respondents, five have doctorate degrees, three have masters degrees, and one has a bachelors degree. Eight of the nine respondents have extensive experience with live trapping sampling of the Pacific Pocket Mouse subsequent to its rediscovery in 1994 and the ninth has previously studied the rodent from 1970 to 1971.

Questionnaire Development

Because there is limited knowledge about the Pacific Pocket Mouse, the questionnaire was designed to accomplish two tasks. The first goal was to consolidate information that has been gained from the respondents' trapping and research experience about the important PPM habitat characteristics. Each section of the questionnaire began with open-ended, general questions that allowed the respondents to discuss the important habitat characteristics

for each criterion. The second (and primary) goal of the questionnaire was to evaluate each of the criterion for habitat suitability in order to calculate habitat suitability of given areas characterized by different values of each criterion. This goal was accomplished through employment of multicriteria evaluation techniques.

Criterion Evaluation. To limit complexity and reduce confusion of the respondents, the questionnaire was designed to employ the same multicriteria evaluation technique for all sections. Therefore, each of the criterion evaluation techniques discussed in chapter two were considered for each of the major criteria (soil type, vegetation class, and coastal distance). A graphic overview of the problem structure is included in Figure 3-1. This structure views the habitat suitability as a hierarchy of three levels and the overall suitability of any location can be calculated as a combination of its soil, vegetation, and coastal distance suitabilities. The hierarchical treatment of the problem is

further addressed in the next section which explains how the soil suitability scores were calculated from combinations of slope, texture, drainage, and depth suitabilities.

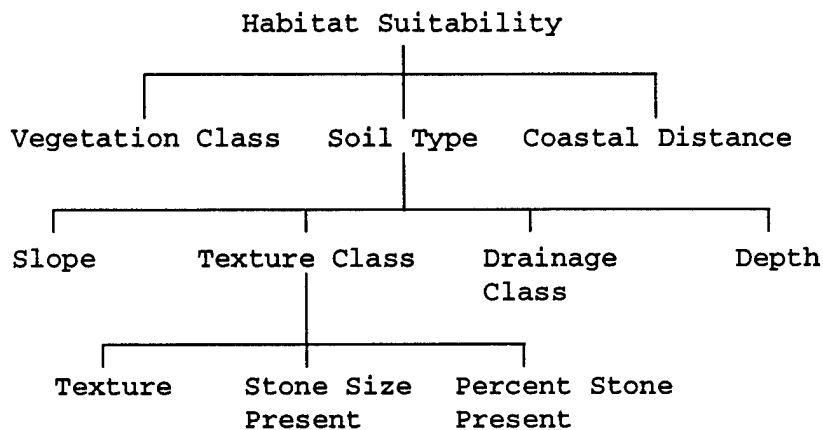

Figure 3-1. Problem Structure Overview

Soil Type. Because there are one hundred twenty one different soil types in the Camp Pendleton GIS database, it would be infeasible to address each soil type in a comparative questionnaire. Additionally, subjective evaluation of each soil type does not address the importance of soil characteristics as they pertain to the PPM. To facilitate addressing important soil characteristics and allow for a more systems oriented model, the important characteristics of each soil type were evaluated. Through discussions with several questionnaire respondents and through literature review of the PPM, it was determined that the important habitat characteristics of soil are slope,

texture, drainage, and depth. In addition, because soil textures are often distinguished by stoniness (which may have an effect on suitability), sizes and percentages of stony material present were evaluated within the texture category. This allows for soil types of similar texture to be distinguished in terms of suitability (i.e. sandy loam and stony sandy loam may have different suitabilities). Once the characteristic features were evaluated, each soil type was scored for habitat suitability based on a combination of the suitabilities of its characteristics. A graphic representation of this concept is shown in Figure 3-2 below.

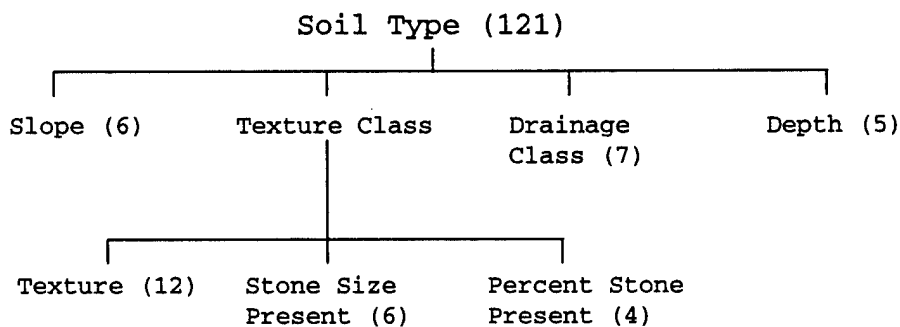

Figure 3-2. Soil Evaluation Structure
Note: Numbers in parentheses indicate the number of categories that must be evaluated.

This structure essentially views soil type suitability as a hierarchy of two levels. In order to combine the suitability scores of individual soil features, all soil features (such as the 6 slope categories) must be scored for

suitability. Additionally, the importance weights between criteria on the same level (i.e. slope, texture, drainage, and depth) must be established.

The seven points scale technique was employed for evaluation of these scores and weights for several reasons. First, because soil texture has twelve classes that must be compared and evaluated, the paired comparison and rating methods can be considered unsuitable. For a partial paired comparison, it would be necessary to ask sixty six ($n=12$, $n*(n-1)/2=66$) questions to determine the relative importance of the twelve textural classes. Considering that texture is only one of many criteria that must be evaluated, the paired comparison method would lead to a large and unwieldy questionnaire. The rating method can also be considered unsuitable because there can be difficulty and confusion involved with distributing points over twelve classes. Although the ranking method could conceivably be used for evaluating both the suitability scores and importance weights, it is not considered to be the best because it only gives an ordering of criterion without strength of preference. Furthermore, it does not allow for ties in importance (as discussed in chapter 2). Because these

points are also relevant to the vegetation class criterion (28 classes to be evaluated), the seven points scale was used for the entire questionnaire.

Soil Habitat Suitability Score Calculation.

Because the seven points scale was employed for the questionnaire, all raw score values reported were between one and seven. In order to consolidate the opinions of knowledgeable experts, scores reported by all respondents were averaged to determine final scores for all categories. Across the levels of the hierarchy, it was necessary to determine intercriterion weights of preference (i.e. slope vs. texture vs. drainage, etc.). This was accomplished by dividing the averaged scores for each criterion (i.e. texture) by the total of the averaged scores for all criteria across the hierarchy. For the different categories contained within each criterion (i.e. the twelve textural classes) the averaged scores were used directly for the categories. For example, the textural class, sand, was assigned a habitat suitability score which was calculated from the average of the scores evaluated by all questionnaire respondents for sand.

Using the category scores and preference weights, habitat suitability scores for the different soil types were then calculated as weighted averages of the important soil

characteristic scores. Two methods were employed and compared for the soil types. Method A viewed soil suitability as a combination of only four soil criteria: slope, texture, drainage, and depth. Method B included the hierarchy in method A but also included the further clarification of textural class to address stoniness. To accomplish this, the textural class scores were calculated as a combination of three textural class criteria: texture, stone size present, and percent of stone present. Both methods are outlined below.

Method A:
$$SHS = \sum_{i=1}^4 \omega_i CSS_i$$

Where: SHS = soil habitat suitability
 ω_i = importance weight for soil criterion i
 CSS_i = criterion i suitability score

Method B: Same as method A except CSS for textural class is calculated as:

$$CSS_{\text{texclass}} = \sum_n^3 w_n TCSS_n$$

Where: w_n = importance weight for texture criterion n
 $TCSS_n$ = texture criterion n suitability score

Note: All weights are numerically between zero and one with the sum of weights across a hierarchical level being equal to one. This yields habitat suitability scores between one and seven.

After evaluation of criterion classes, each section of the questionnaire allowed the respondents to identify classes that the PPM would not inhabit. If criterion classes were evaluated as completely unsuitable by all respondents, those classes were considered rejects. Once reject characteristics were identified, areas aboard Camp Pendleton could be screened to eliminate locations that could be considered absolute rejects. For example, if clay was determined to be a completely unsuitable soil texture for the PPM, all locations with clay soils could be considered unsuitable regardless of other characteristics. This screening of absolute rejects is discussed by Jankowsky with reference to integration of GIS and multicriteria evaluation (Jankowsky, 1995:259-260).

Vegetation Class. Because the vegetation classes cannot be easily separated into suitability components like soil types (i.e. slope, texture, etc.), the classes were directly evaluated by questionnaire respondents. The twenty eight communities found aboard Camp Pendleton were defined in the questionnaire glossary and were evaluated on the seven points scale. Habitat suitability scores were determined by averaging the values assigned by the respondents.

Coastal Distance. During the Pacific Pocket Mouse workshop, coastal distance was determined to be a potentially important factor due to the fact that the species has, historically, not been found more than three kilometers inland. Based on discussions with questionnaire respondents, four coastal distance categories were established for evaluation. These categories were defined to focus on the coastal ranges (three categories cover up to six km inland), fully bracket the three kilometer benchmark, and still encompass the entire base to ensure a conservative approach by preventing exclusion of any areas due to distance. After evaluation, distance category suitability scores were determined by averaging the values assigned by the respondents.

Questionnaire Evaluation

Because respondent evaluations are averaged to determine criterion weights and scores, it is necessary to determine the level of agreement between the respondents. This gives an indication of the usefulness of averaging the scores. If the responses reflect absolute disagreement, the average of the importance values reported is not a meaningful measure of habitat suitability. For example, if respondent one considers soil texture to be extremely important and assigns an importance value of seven, and

respondent two disagrees and assigns a value of one, the average of these two values is not in agreement with either of the expert's opinions. However, if there is close agreement, the averaging narrows the value to a group consensus of the importance. For example, if respondent one assigns a value of seven and respondent two assigns a value of six, the average of the two values is generally in agreement with both of the respondents initial evaluations and is a consensus of the two.

Intraclass Correlations. To determine the level of agreement between respondents, intraclass correlations were calculated for each section of the questionnaire. In 1979, Shrout and Fleiss published an article which outlined and compared six forms of the intraclass correlation coefficient (ICC). The ICC is the correlation between one evaluation of a target (criterion or criterion category) and another evaluation of the same target (Shrout and Fleiss, 1979:422). The ICC is based on analysis of variance (ANOVA) and the different forms of the ICC are appropriate for evaluating different types of studies and give different measures.

When data is combined for analysis, such as averaging of scores, and the ICC is used for determining respondent agreement, the functional form for estimating the ICC outlined below (referred to as $ICC(2,1)$ by Shrout and

Fleiss) is the appropriate choice (Shrout and Fleiss, 1979:425).

$$ICC = \frac{BMS - EMS}{BMS + (k - 1)EMS + k(JMS - EMS) / n}$$

Where: *BMS* = between-targets mean square

EMS = error mean square

JMS = between-judges mean square

k = number of judges

n = number of targets evaluated

Kendall Coefficient of Concordance. An additional measure of agreement between questionnaire respondents was calculated by employing the Kendall Coefficient of Concordance. This coefficient can be used as a measure of agreement between sets of rankings evaluated by *k* judges (Gibbons, 1976:301). The value of the coefficient is always between zero and one. A coefficient value of zero represents no agreement of rankings, and a value of one represents perfect agreement (Gibbons, 1976:304).

Because the Kendall Coefficient of Concordance is based on sets of rankings, the seven point scale ratings returned by the respondents had to be converted. This was simply accomplished by ranking the criterion categories based on rating values for each of the *k* judges. To accomplish this, it was assumed that the category with the highest rating was

the most important and should be assigned a rank of one. This yielded k sets of rankings for each criterion set (i.e. soil textures).

Once rankings were established, the rankings were organized as illustrated in Table 3-1 and column sums of rankings were calculated. The column sums were used to

TABLE 3-1
ORGANIZATION OF RANKING DATA FOR
KENDALL COEFFICIENT OF CONCORDANCE

	Texture A	Texture B	Texture C	Texture D
Judge 1	1	2	3	4
Judge 2	2	1	4	3
Judge 3	1	2	4	3
Column Sums R_j :	4	5	11	10

calculate the sum of squares (denoted by S) of the deviations between expected and observed column sums. The sum of squares is then used to determine the Kendall

coefficient of concordance. The functional forms for calculating the sum of squares and coefficient are outlined below (Gibbons, 1976:304).

$$S = \sum_{j=1}^n \left[R_j - \frac{k(n+1)}{2} \right]^2$$

$$W = \frac{12S}{k^2 n(n^2 - 1)}$$

Where: S = Sum of Squares
 W = Kendall Coefficient of Concordance
 R_j = sum of ranks for column j
 k = number of judges
 n = number of targets evaluated

Statistical Significance. To test the statistical significance of the Kendall Coefficients of Concordance, the test statistic, Q , was calculated using the following equation outlined by Gibbons (Gibbons, 1976:306).

$$Q = k(n-1)W$$

Because Q can be approximated by the chi-square distribution it can be used to test the null hypothesis of no association between respondents' evaluations. No association would indicate that there is no agreement between the respondents. To test for significance, a right tailed test of the Q statistic was performed. The P -value returned from that

test reflects the probability of mistakenly concluding that an association exists given that no association exists.

Map Development

For map development, the ARC/INFO[®] Geographic Information System was used for storing, editing, and combining the Camp Pendleton spatial data layers.

To develop the habitat suitability map using Camp Pendleton spatial data and questionnaire evaluation scores, it was necessary to add the soil, vegetation, and coastal distance scores to the spatial data. To accomplish this task for the soil and vegetation data layers, dBase IV files were created that included soil type and vegetation class scores. By joining the database files with the data layer files in ARC/INFO[®], the polygons within the soil and vegetation data layers were assigned respective habitat suitability scores.

To add coastal distance suitability scores to the database, a coastal distance layer first had to be created. To accomplish this, the Camp Pendleton boundary layer was modified to create the new layer. First, all arcs for the boundary were deleted except for the Pacific ocean coastal boundary. Next, 2000, 4000, and 6000 meter buffer lines were created around the coast. By combining the buffers and

the original base boundary layer, intersecting all arcs, and deleting unnecessary arcs drawn outside the boundary, the new coastal distance layer was created. Once created, the distance scores were added to the polygon attribute table.

To develop habitat suitability maps from criterion suitability scores, it is necessary to have a data layer which contains the polygons and polygon information from each criterion data layer. To create this layer, the three criterion data layers were overlaid and combined using the ARC/INFO® program. This overlaying of roughly 1000 vegetation polygons, 1000 soil polygons, and four coastal distance polygons resulted in a combined data layer with over 8000 different polygons. After the layers are combined, soil, vegetation, and coastal distance categories and scores are maintained for each polygon in the data layer. Once this combined layer was created, the scores were combined within each polygon to calculate habitat suitabilities.

Criterion Suitability Maps. Before creating overall habitat suitability maps, criterion suitability maps based on evaluation scores were produced for the three criterion: soils, vegetation, and distance. By displaying the separate criterion suitability maps and overlaying known locations of the Pacific Pocket Mouse, the effectiveness of

the criterion scores could be qualitatively evaluated. For each criterion, maps were produced using the ARCVIEW® program and suitability codings of polygons were based on criterion suitability score ranges outlined in Table 3-2.

TABLE 3-2
POLYGON SUITABILITIES

Criterion Suitability Score Range	Descriptive Suitability
0 - 0.999	Unsuitable
1 - 1.999	Very Poor
2 - 2.999	Poor
3 - 3.999	Fair
4 - 4.999	Good
5 - 5.999	Very Good
6 - 7.000	Extremely Good

Because the original evaluations were based on the seven points scale, values from one to seven covered the span of suitability and any values less than one were considered to be completely unsuitable. Although no criterion category would receive a suitability value of less than one from a seven points scale evaluation, a few criterion categories were not evaluated in the questionnaire and were assigned suitability values of zero. These values were assigned because the categories were previously determined to be unsuitable (i.e. developed lands are considered unsuitable). Additionally, because some polygons were assigned suitability values of zero in the noncompensatory approach

(for unsuitable characteristics), the above scale can be uniformly applied to the criterion maps as well as the overall habitat suitability maps. To obtain the frequency of known PPM locations within each polygon suitability category, the points from the known locations were intersected with the suitability polygon layers.

Compensatory Habitat Suitability. Initially, a compensatory habitat suitability map was created by calculating habitat suitability as a weighted average of soil type, vegetation class, and coastal distance suitability scores. In the calculations, method A soil scores (no stoniness considered) were used because there was a lack of agreement between questionnaire respondents pertaining to rock size (further discussed in chapter 4).

Ideal Point Habitat Suitability. To determine whether a noncompensatory map would be worth pursuing, the ideal point methodology addressed by Pereira and Duckstein was employed (Pereira and Duckstein, 1993:407-424). In this methodology, each location is characterized by criteria corresponding to map layers and each criterion has at least one ideal value (Pereira and Duckstein, 1993:409). The ideal point (often a theoretical location) is characterized

by the best value from each criterion and all other points are rated based on a distance from this ideal point. The distances are calculated using the following equation.

$$d_p = \left[\sum \beta_i^p (x_i^* - x_i^k)^p \right]^{1/p}$$

- Where:
- d_p = distance for exponent value p
 - β_i^p = importance weight for criterion i
 - x_i^* = ideal value for criterion i
 - x_i^k = location k score for criterion i
 - p = exponent which reflects degree of compensatoriness

Rescaling all suitability scores relative to the ideal values for each criterion yields x_i^* values of unity and all other scores between zero and one. For this study, the ideal values for each criterion were considered to be the criterion categories with the highest suitability scores and all suitability scores were normalized relative to these scores. This normalization was conducted by dividing suitability scores, within each criterion (i.e. soils), by the top score within the criterion.

After normalization of scores, the ideal point distance methodology was employed with exponent values of one and ten to calculate two different sets of distances from ideal. An

exponent value of one allows total compensation between criteria and is essentially equivalent to a weighted linear additive model and the exponent value of ten simulates a totally noncompensatory model (Pereira and Duckstein, 1993:410). The distances returned from the calculations are all between zero and one with a value of zero reflecting the ideal point (distance from ideal = 0). Two ideal point habitat suitability maps were produced using the ARCVIEW® program and suitability codings of polygons were based on distance from ideal value ranges outlined in Table 3-3.

TABLE 3-3
DISTANCE FROM IDEAL POLYGON SUITABILITIES

Distance From Ideal Range	Descriptive Suitability
0.0 - 0.2	Very Good
0.2 - 0.4	Good
0.4 - 0.6	Fair
0.6 - 0.8	Poor
0.8 - 1.0	Very Poor

Comparison of the ideal point compensatory and noncompensatory maps showed distinct differences in suitability ranges for polygons. To find the best model of suitability, the exponent p is often varied to allow for compromise between fully compensatory and fully noncompensatory methods for combining scores. Because it is

difficult to determine a value of p that reflects the appropriate level of compromise, a more traditional noncompensatory method was employed.

Noncompensatory Habitat Suitability. All noncompensatory techniques employ the stepwise reduction of alternatives and differences between techniques stem from different rules of elimination. For this study, the conjunctive method of elimination was employed. With the conjunctive method, each criterion has minimum cut-off values specified by the decisionmaker that must be exceeded for an alternative to be considered. Any alternative that fails to meet a cut-off for any of the evaluation criteria is eliminated (Jankowsky, 1995:259).

The decisionmakers for this study are the questionnaire respondents. Unsuitable criterion categories were solicited from the respondents and the results are outlined in Appendix G. To develop conservative cut-off values from these responses, only categories that were considered to be unsuitable by all respondents were classified as unsuitable.

Table 3-4 contains the list of unsuitable characteristics employed for the noncompensatory habitat suitability map. For development of the noncompensatory habitat suitability

TABLE 3-4
UNSUITABLE CRITERION CHARACTERISTICS

Criterion	Unsuitable Characteristics
Slope	None
Texture	Clay
Stone Size	None
Stone Percent	> 60 %
Drainage Class	Very Poorly Drained Poorly Drained
Depth	None
Vegetation Class	Coastal and Valley Freshwater Marsh Freshwater Seep
Coastal Distance	None

map, binary variables were added to the polygon attribute table to identify any polygons that contained unsuitable characteristics (a value of one indicated unsuitable characteristics). Polygons with binary variable values of one were then selected and habitat suitability scores were set to zero for all polygons with any unsuitable characteristics. This process eliminated over 1000 of the 8000 polygons considered as potential PPM habitat.

IV. Results

Introduction

This chapter discusses the results of the methodology outlined in chapter III. It is organized into three sections. The first section addresses insights gained about Pacific Pocket Mouse (PPM) habitat requirements from the questionnaire responses. The next section evaluates the level of agreement attained from questionnaire respondents. Finally, the last section evaluates the maps produced.

Pacific Pocket Mouse Habitat Requirements

Solicitation of important habitat characteristics from questionnaire respondents yielded the following insights about soil, vegetation, coastal distance, and prior agricultural land use as they pertain to the PPM.

Soil Requirements. There seem to be several characteristics that make certain soil types more suitable for the Pacific Pocket Mouse than others. These characteristics are described by the friability, structural feasibility, drainage, depth, slope, and stoniness. Suitable soils for the PPM must be friable to allow for small rodent burrowing activities yet they must be of a consistency that will ensure the integrity of the burrow's structure. For example, sand, although very friable, cannot

hold the burrow structure. Clay, however, has a strong structural holding capability but is not friable enough to allow for burrowing. A well-drained soil condition is also necessary because wet soil conditions may lead to hypothermia for the rodent and molding of seed caches. It seems that soils must also be at least ten to twelve inches deep to be suitable for the PPM. This may be due to temperature regulation needs of the rodent during hibernation periods. In addition, more shallow soils are often less well drained which would not support the species. Although there was not a consensus on the importance of slope, a few feasible theories were presented by respondents to explain why the PPM seem to prefer gentle slopes. First, steeper slopes tend to have more shallow soils than are necessary for the PPM and are more prone to erosion which would be detrimental to rodent burrows. Furthermore, on the steeper sloped areas, other important habitat characteristics (such as vegetative cover requirements) do not generally occur. There was no consensus attained on stoniness of the soil but, in general, it was agreed that low percentages of stony material present would not affect suitability. In general, the Pacific Pocket Mouse (PPM) has

consistently been located in areas of well-drained, sandy/sandy-loam soils that occur on gentle slopes for a variety of reasons.

Vegetation Requirements. Characteristics that determine vegetation community suitability seem to be related to openness and plant type distribution. The Pacific Pocket Mouse apparently prefers open vegetative communities with at least twenty to fifty percent bare soil. A dense grass cover at the surface may inhibit movement of the rodent and a thick shrub canopy may prevent the growth of food producing plants. The PPM have been most consistently located in open areas with a mixture of Coastal Sage Scrub (CSS), grasses, and forbs. The CSS shrubs provide cover for the rodent while the grasses and forbs provide a food source. Open tree communities do not seem to be suitable which may be due to predation. Trees provide perches and nesting areas for owls which are primary predators for the PPM.

Coastal Distance Requirements. Questionnaire respondents generally agreed that coastal distance, alone, is probably not an important factor for determining suitability. However, because the initial problem structure included distance as a major factor (see Figure 3-1), and distance was evaluated with the soil type and vegetation

class criteria for relative importance, coastal distance remained in the problem structure for map development. Although, as previously mentioned, respondents agreed that coastal distance, itself, may not be an important factor, they also agreed that there are probably other habitat factors that correlate with coastal distance and this may explain why the PPM tend to inhabit areas within a few kilometers of the coast. For example, because inland vegetation communities and soil types are different from coastal areas, the requirements necessary for PPM habitation may only be met near the coastal region. Additionally, the coastal region has more moderate temperature extremes and widely varying temperatures that occur further inland create higher energy requirements for maintaining body temperature. Finally, the coastal mountain range may form a barrier with other rodent species and other species that occur further inland may outcompete the PPM.

Agricultural Land Use. Because agricultural cultivation changes soil characteristics and vegetation, the suitabilities of cultivated lands can be altered. Soils become more compacted and less well drained, and the soil organic content may increase which can cause unsuitable conditions. Furthermore, because the coastal sage communities typically recolonize slowly, revegetation is

subject to invasion of dense, exotic, annual grasses. These may cover one hundred percent of the ground and preclude the return of the Pacific Pocket Mouse. However, it is feasible that soil conditions may recover to a suitable state after a period of time. If this occurs, and native plant species are able to reestablish themselves in the area, cultivated lands may become suitable for the PPM.

General Suitability Issues. Habitat connectivity is important for the Pacific Pocket Mouse. Fragmentation of suitable habitat due to roads can isolate populations which may reduce genetic diversity. Isolated populations are more prone to local extinctions and the isolated habitat becomes less likely to be recolonized.

Questionnaire Evaluation

The raw data questionnaire responses and respective Intraclass Correlation Coefficient (*ICC*) values for each questionnaire section are included in Appendices B and C. Appendix D contains the converted importance rankings of the criteria and respective Kendall Coefficients of Concordance (*KCC*). Both of these measures of agreement are summarized in Table 4-1. In general, the values are similar for each questionnaire section. Although the statistical significance of the *KCC* values is addressed in the next

section, qualitative judgments can be directly made from the coefficients. The strongest levels of agreement between respondents have been achieved for soil type, slope, texture, stone percent, drainage, depth, and vegetation. Conversely, weaker relationships between respondents seem to exist for the problem overview, stone size, and coastal distance.

TABLE 4-1
INTRACLASS CORRELATION COEFFICIENTS AND
KENDALL COEFFICIENTS OF CONCORDANCE FOR QUESTIONNAIRE DATA

Questionnaire Section	Intraclass Correlation Coefficient (ICC)	Kendall Coefficient of Concordance (KCC)
Overview	0.375	0.466
Soil Type	0.637	0.704
Slope	0.900	0.881
Texture	0.729	0.693
Stone Size	0.137	0.344
Stone Percent	0.764	0.958
Drainage Class	0.875	0.850
Depth	0.843	0.807
Vegetation Class	0.698	0.656
Coastal Distance	0.539	0.546

Note: Coefficient values may range from zero to one with one reflecting perfect agreement between respondents.

To evaluate the statistical significance of the measures of agreement, Q (the chi-squared statistic) was calculated for all KCC values (Appendix D). Implementing right-tailed tests for the Q values yielded P values which represent the probability of obtaining a test statistic value greater than or equal to Q given that there is no

association between responses. A small P value indicates that a rare event has occurred and it can be concluded that agreement exists. The P value cut-off is the statistical significance, α . Calculations are included in Appendix E, and Q and P values are summarized in Table 4-2.

TABLE 4-2
 Q AND P VALUES FOR QUESTIONNAIRE DATA

Questionnaire Section	Q Value	P Value
Overview	8.39	1.50×10^{-2}
Soil Type	19.00	2.73×10^{-4}
Slope	39.63	1.77×10^{-7}
Texture	68.63	2.22×10^{-10}
Stone Size	15.48	8.00×10^{-3}
Stone Percent	25.87	1.02×10^{-5}
Drainage Class	45.90	3.10×10^{-8}
Depth	29.07	7.60×10^{-6}
Vegetation Class	159.30	0.00
Coastal Distance	14.73	2.00×10^{-3}

For a statistical level of significance of $\alpha=0.001$, P values for all categories, except problem overview, stone size, and coastal distance, suggest agreement. At $\alpha=0.01$, stone size and coastal distance P values indicate agreement and for $\alpha=0.02$, the problem overview P value reflects agreement. Therefore, at a level of $\alpha=0.02$, agreement can be concluded for all questionnaire sections. In other words, the probability of wrongly concluding agreement

between questionnaire respondents, given that no agreement exists, is less than or equal to one in fifty.

Although the P values do not suggest a lack of agreement for any of the questionnaire sections (at $\alpha=0.02$), the weakest levels of agreement are indicated by the high P values for the problem overview, stone size, and coastal distance sections. Additionally, low ICC and KCC values for these sections also indicate weak levels of agreement with the stone size category displaying the weakest performance. Because the weights derived from the problem overview section, and scores derived from the coastal distance section are used in the primary hierarchical level of the problem (see Figure 3-1), these values are necessary for map construction and cannot be eliminated. However, because the stone size values are only used for distinguishing between similar soil textures at a lower level of the hierarchy, these values can be eliminated. This was done to avoid the altering of soil values based on scores and weights derived from low agreement and, therefore, method A was implemented for calculating soil suitability scores (as discussed in chapter III).

To determine the significance of eliminating this lower level in calculating soil scores, the effects of stoniness on habitat suitability scores was investigated.

Calculations contained in Appendix H show that, for identical areas with different stoniness characteristics, the greatest possible effect (due to stoniness) on overall habitat suitability would be 0.18 on a seven point scale. Because the purpose of including stoniness was to distinguish between identical areas with different stoniness characteristics, it is concluded that stoniness is not necessary for habitat suitability calculations.

Habitat Suitability Map Evaluation

The following section will discuss the habitat suitability maps created from the questionnaire evaluations of habitat criteria. Figures 4-1 to 4-3 are the individual criterion (i.e. coastal distance) habitat suitability maps with known Pacific Pocket Mouse locations. Figures 4-4 to 4-9 are combined habitat suitability maps created through different combination methods of criterion suitability scores.

Criterion Habitat Suitability Maps. Figures 4-1 to 4-3 illustrate the individual criterion maps for coastal distance, vegetation, and soil type respectfully. Table 4-3 lists the distributions of known Pacific Pocket Mouse (PPM) locations pertaining to the individual criterion maps.

Coastal Distance. The coastal distance habitat suitability map is illustrated in Figure 4-1. From this figure, it appears that all known locations of the PPM occur within the areas predicted as extremely good or very good distance. Table 4-3 confirms this and shows that 223 of the 239 known PPM do occur in the regions predicted as extremely good distance. Although this seems to indicate that the coastal distance map is in agreement with the known locations, negative locations for PPM occurrence are not available (within a GIS format) for comparison at this time. Therefore, a numerical correlation between the map and known locations cannot be calculated. Although the negative locations are not contained within a GIS data layer, it is known that some of the negative locations do occur within the high suitability regions which would indicate that distance alone is not a strong predictor of habitat suitability. Much of the reason for known locations coinciding with the good distance suitability regions on the map is the fact that live trapping operations have been concentrated in these areas.

From the map, it can be seen that habitat suitability does not change greatly with coastal proximity. All locations can be considered to be at least fair in terms of suitability and from zero to six kilometers inland, the

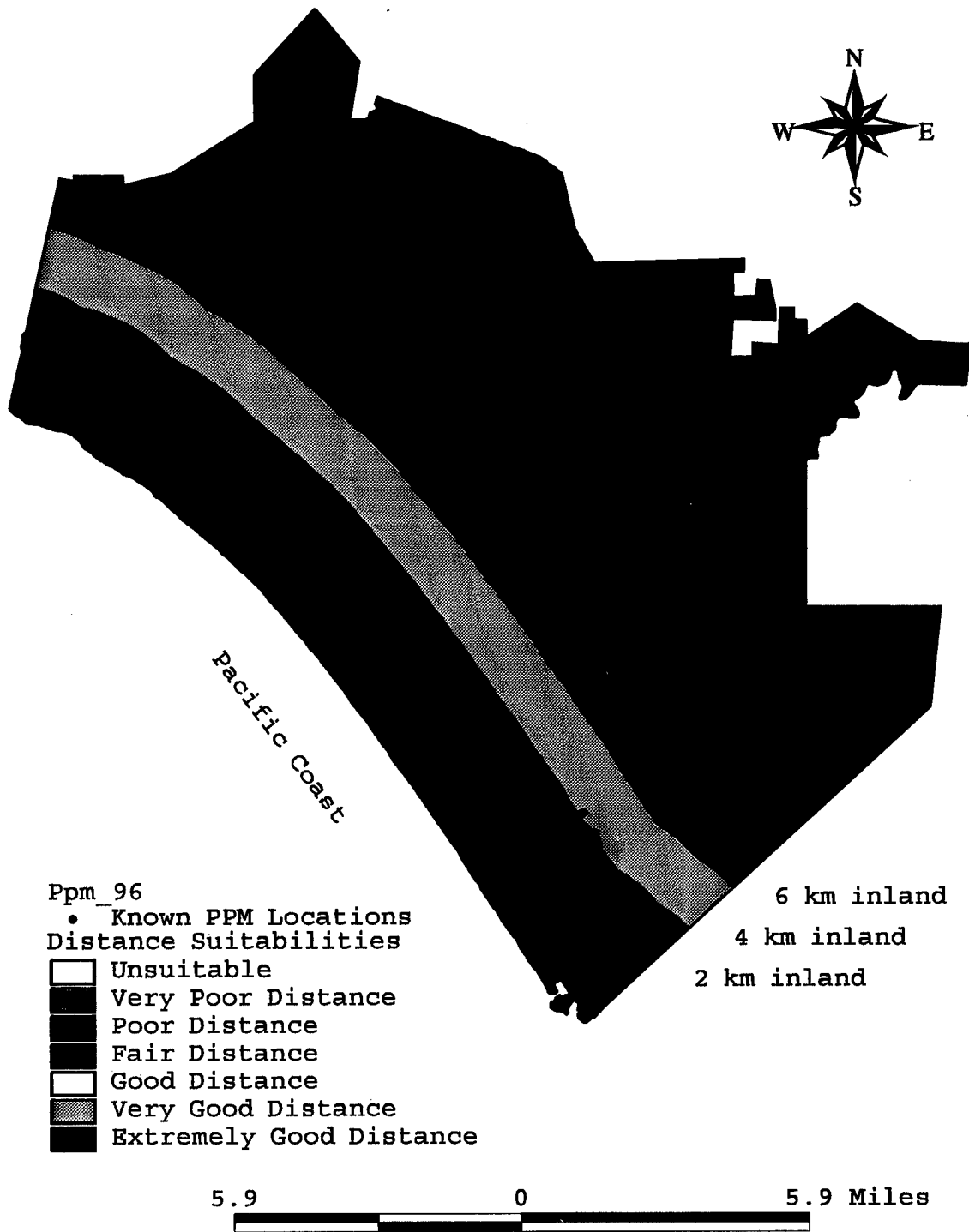

Figure 4-1. Coastal Distance Habitat Suitability Map With Known PPM Locations

suitabilities are very comparable. Numerically, the worst suitability score is 3.78 and the best is 6.89 (see Appendix B). Because of this small range of values, and the low importance weight (0.298) for the coastal distance category, differences in coastal distance can only affect the numeric habitat suitability scores by a maximum of 0.96 on a seven point scale. For example, if two sites had identical soil and vegetation characteristics but one had the best coastal distance score and the other had the worst, the overall habitat suitability scores would differ by less than one. Categorically, this can only reflect a change in habitat suitability of one category (i.e. Very Good to Extremely Good). From these analyses, it can be concluded that coastal distance is not an important factor and is not necessary for inclusion in an overall habitat suitability map.

TABLE 4-3
PPM DISTRIBUTIONS WITHIN CRITERION SUITABILITY MAPS

Suitability Class	Coastal Distance (Fig. 4-1)	Vegetation (Fig. 4-2)	Soil (Fig. 4-3)
Ext. Good	223	0	2
Very Good	16	43	214
Good	0	142	17
Fair	0	0	0
Poor	0	3	0
Very Poor	0	0	0
Unsuitable	0	51	6

Vegetation. Figure 4-2 illustrates the vegetation habitat suitability map. Referencing this map and Table 4-3 shows that the known PPM locations coincide largely with the very good to good suitability regions. However, 51 known locations occur within the unsuitable vegetation regions predicted by the map. Although this would seem to indicate that vegetation evaluations are not very reliable, further investigation using the GIS system showed that the vegetation data layer does not include all areas of the base. In the figure, the base boundary has been overlaid with the vegetation layer and it can be seen that the northwest edge and the northern beach section of the base are not covered by the vegetation layer. When vegetation scores were input into the system, it was not known that undefined areas existed and if attribute values are not specified, the ARC/INFO[®] system automatically assigns values of zero. As a result, all undefined areas were assigned vegetation suitability values of zero which correspond to unsuitable vegetation. Forty seven of the 51 known locations that occur in unsuitable vegetation areas actually occur in areas that are not covered by the vegetation data layer. Because these are incomplete data areas, they are

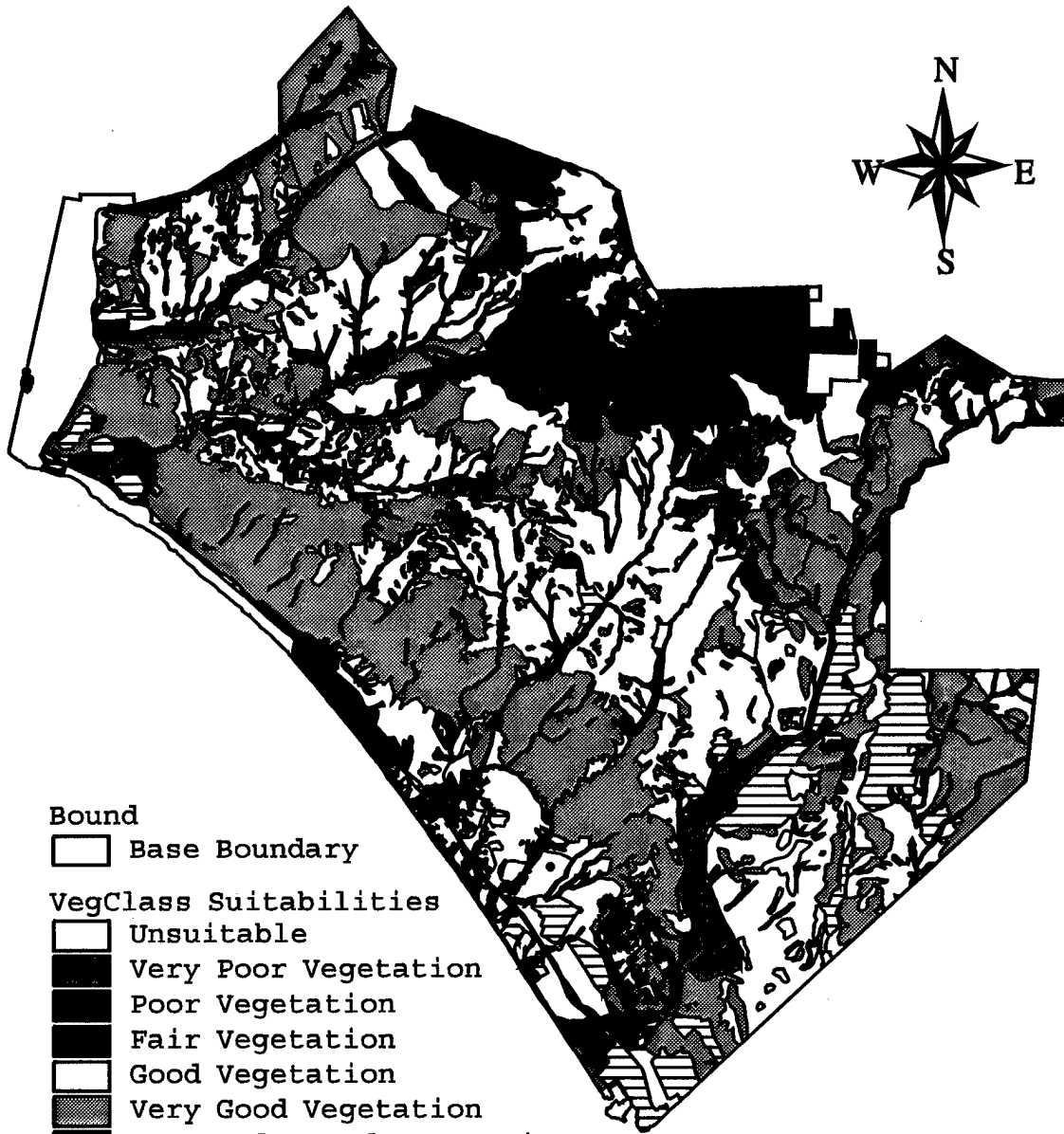

Bound

□ Base Boundary

VegClass Suitabilities

- Unsuitable
- Very Poor Vegetation
- Poor Vegetation
- Fair Vegetation
- Good Vegetation
- Very Good Vegetation
- Extremely Good Vegetation

Ppm_96

• Known PPM Locations

Vegclas

- ▨ DEVELOPED
- UNDEFINED



Figure 4-2. Vegetation Habitat Suitability Map With Known PPM Locations

not relevant to the vegetation or overall habitat suitability maps and can be excluded from evaluation until further data is available.

The remaining four PPM locations that occur in unsuitable vegetation areas coincide with areas that are classified as developed. These areas were deliberately assigned values of zero because developed areas will not be the focus of live trapping efforts due to Camp Pendleton budgetary issues. Considering that no developed locations have yet been sampled for the PPM, the fact that four known PPM locations are classified as developed areas indicates that the vegetation layer may not be in complete agreement with actual ground characteristics. Although, the developed areas have been marked for easy identification in the figure, these areas are classified as unsuitable.

Focusing on the PPM locations that do not occur on undefined or developed areas suggests that the vegetation map is in general agreement with known locations. Again, negative locations are not available for comparison and calculation of correlation.

Soil. Figure 4-3 illustrates the soil habitat suitability map. From this map and Table 4-3, it can be seen that 233 of the 239 known locations occur in the extremely good to good suitability areas predicted by the

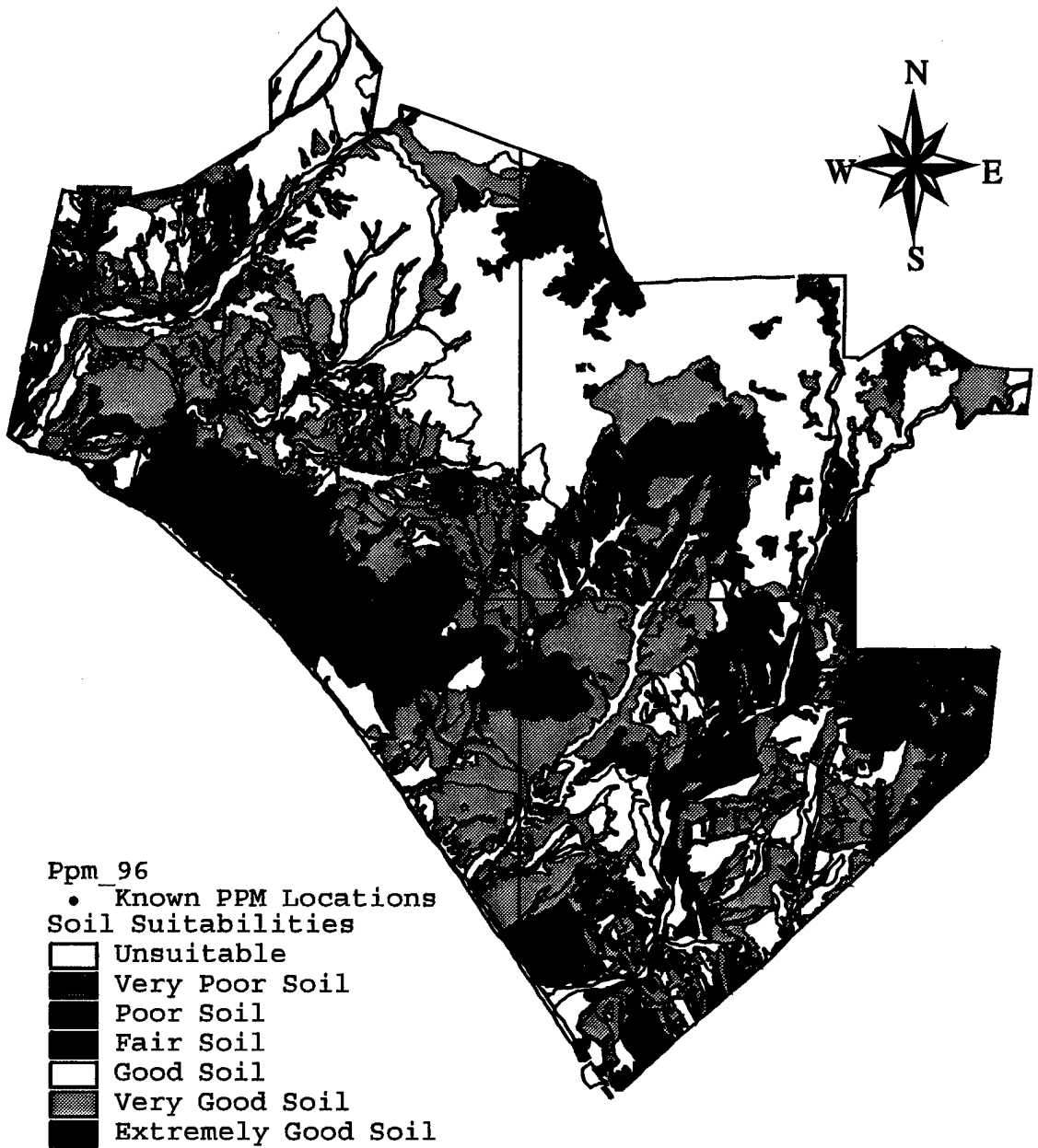

6.2 0 6.2 Miles

Figure 4-3. Soil Habitat Suitability Map
With Known PPM Locations





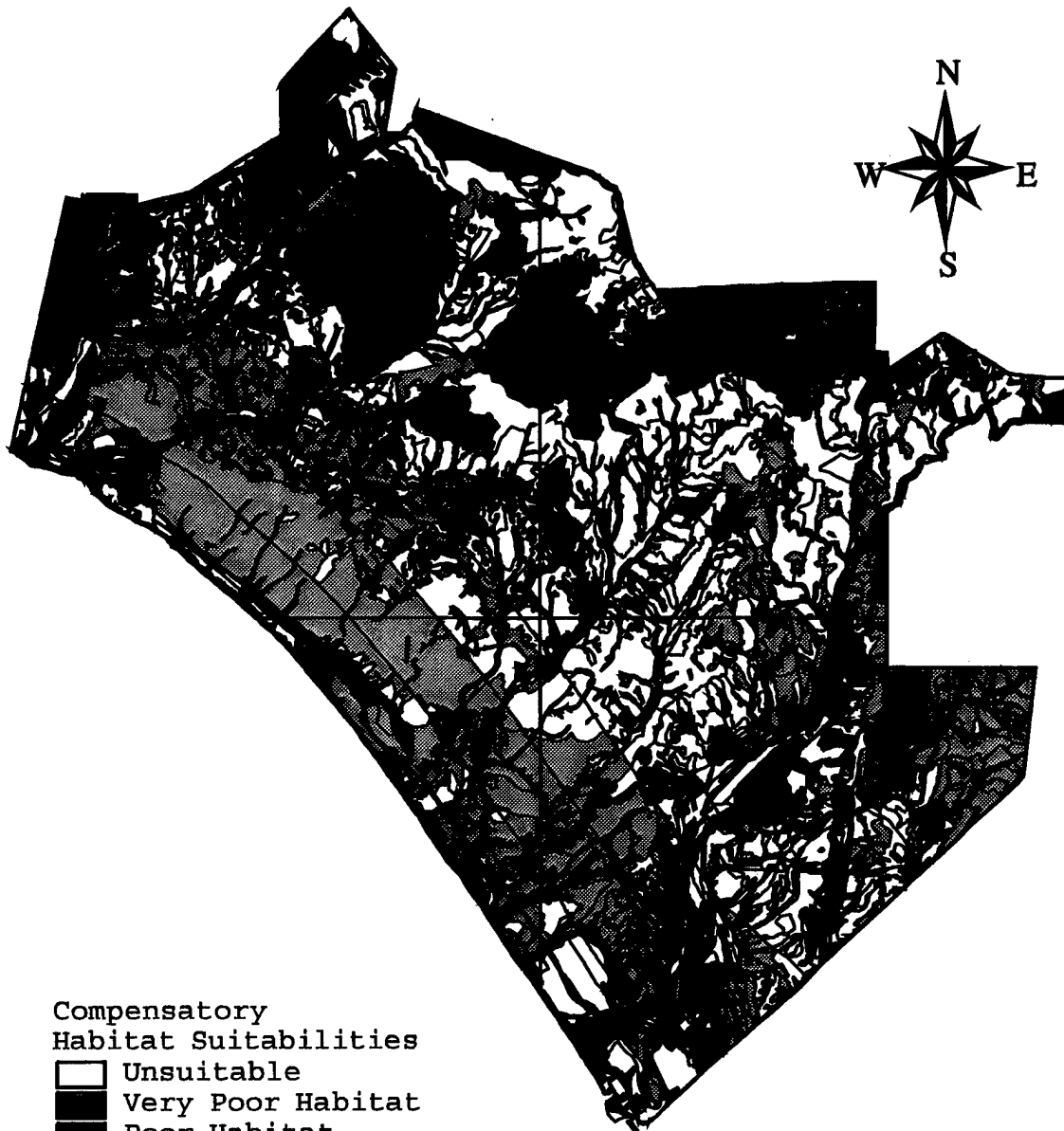

map. The vast majority of these points are within the very good suitability range. Although this suggests very good agreement between known locations and the suitability map, six known locations coincide with predicted unsuitable habitat regions. All six locations are characterized by a terrace escarpment soil type. Because this soil type is extremely shallow (4-10 inches), steep to very steep in slope, and could not be easily separated into soil components to calculate soil suitability, it was assigned a suitability value of zero based on its soil characteristics. However, since this type of area is sometimes characterized by a sparse brush cover with annual forbs and grasses (Department of Agriculture, 1973:79) the suitability value of zero is not always appropriate.

Overall Habitat Suitability Maps. Figures 4-4 to 4-9 contain the compensatory, ideal point, and noncompensatory habitat suitability maps.

Compensatory Habitat Suitability. Figures 4-4 and 4-5 contain the compensatory habitat suitability map created by the weighted average methodology. From the figures, and Table 4-4 (which contains the known PPM distribution), it can be seen that all known locations occur within areas of fair to extremely good predicted habitat suitability. Forty seven of the 52 PPM locations that occur within the good



Compensatory
Habitat Suitabilities

	Unsuitable
	Very Poor Habitat
	Poor Habitat
	Fair Habitat
	Good Habitat
	Very Good Habitat
	Extremely Good Habitat





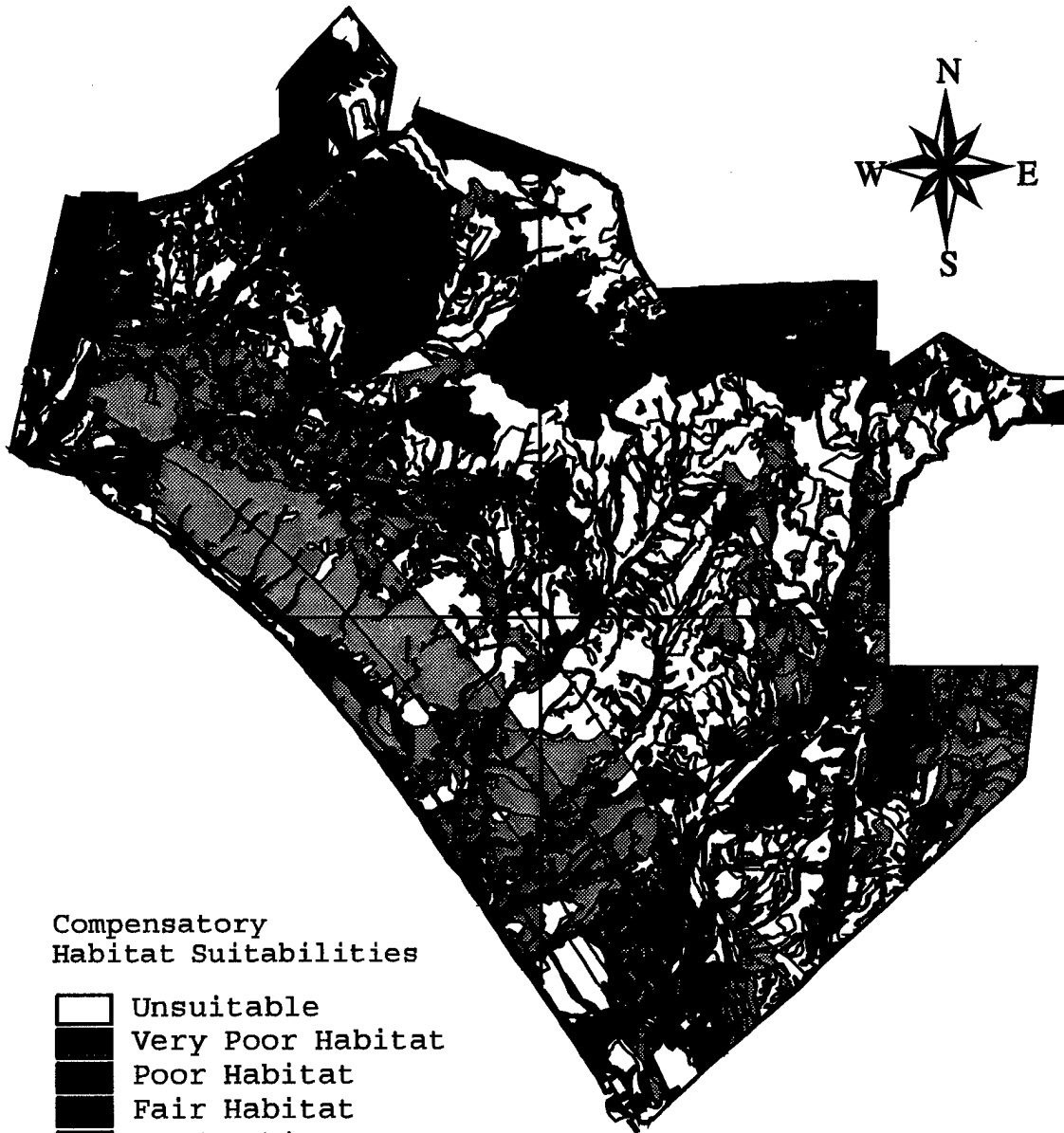

6.5 0 6.5 Miles



Figure 4-4. Compensatory Habitat Suitability Map



Compensatory
Habitat Suitabilities

-  Unsuitable
-  Very Poor Habitat
-  Poor Habitat
-  Fair Habitat
-  Good Habitat
-  Very Good Habitat
-  Extremely Good Habitat

Ppm_96

- Known PPM Locations

6.5 0 6.5 Miles



Figure 4-5. Compensatory Habitat Suitability Map
With Known PPM Locations

suitability regions are actually the locations that are characterized by incomplete vegetation data (as discussed earlier). The suitability scores for these areas are falsely deflated by the vegetation scores of zero and the points are irrelevant to the analysis. Ignoring these points yields that 181 of the remaining 192 locations coincide with areas of very good and extremely good suitabilities. Because no known locations coincide with poor to unsuitable areas and the majority of known locations occur within the very good suitability range, the predictive map seems to be in agreement with ground truth. However, because negative locations are not available, a true evaluation cannot be made at this time.



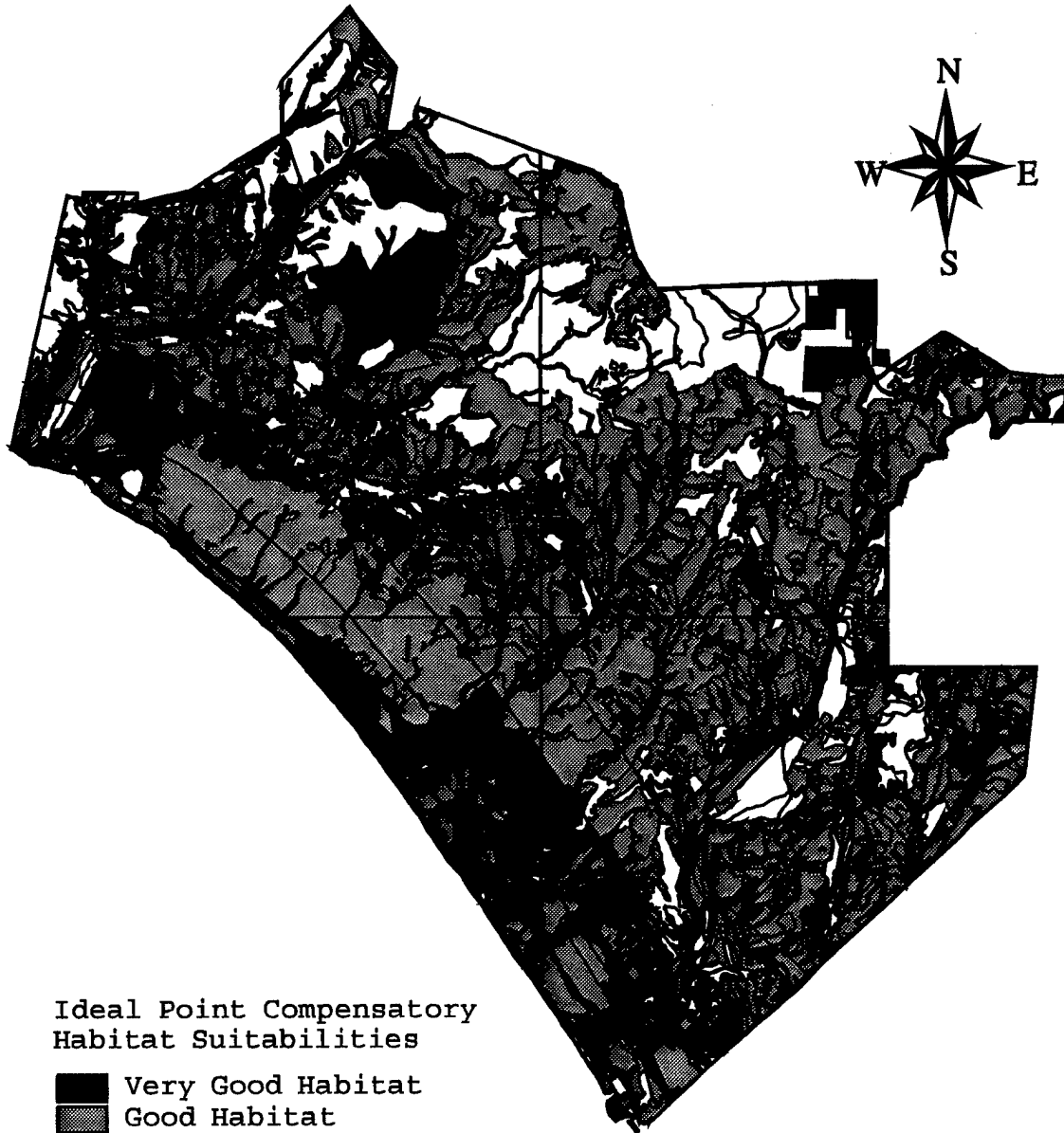

TABLE 4-4
PPM DISTRIBUTIONS WITHIN COMBINED SUITABILITY MAPS

Suitability Class	Compensatory (Figs 4-4, 4-5)	Noncompensatory (Figs 4-8, 4-9)
Ext. Good	8	8
Very Good	173	173
Good	52	48
Fair	6	6
Poor	0	0
Very Poor	0	0
Unsuitable	0	4

Ideal Point Habitat Suitability. Figures 4-6 and 4-7 are the ideal point compensatory and noncompensatory maps respectively. These maps were produced to determine whether a noncompensatory approach would yield significant differences in predicted habitat suitabilities. From comparison of the figures, it can be seen that, with the ideal point approach, habitat suitabilities can vary significantly. One of the most drastic differences can be seen in the northwest area of the base where some areas considered to be good habitat with the compensatory approach are considered to be very poor with the noncompensatory approach. This can be explained by the fact that the noncompensatory approach focuses on the lowest scores for a region and some of the northwest areas are incomplete data areas (as discussed earlier) and were assigned vegetation suitability values of zero.



**Ideal Point Compensatory
Habitat Suitabilities**

-  Very Good Habitat
-  Good Habitat
-  Fair Habitat
-  Poor Habitat
-  Very Poor Habitat



**Figure 4-6. Ideal Point Compensatory
Habitat Suitability Map**

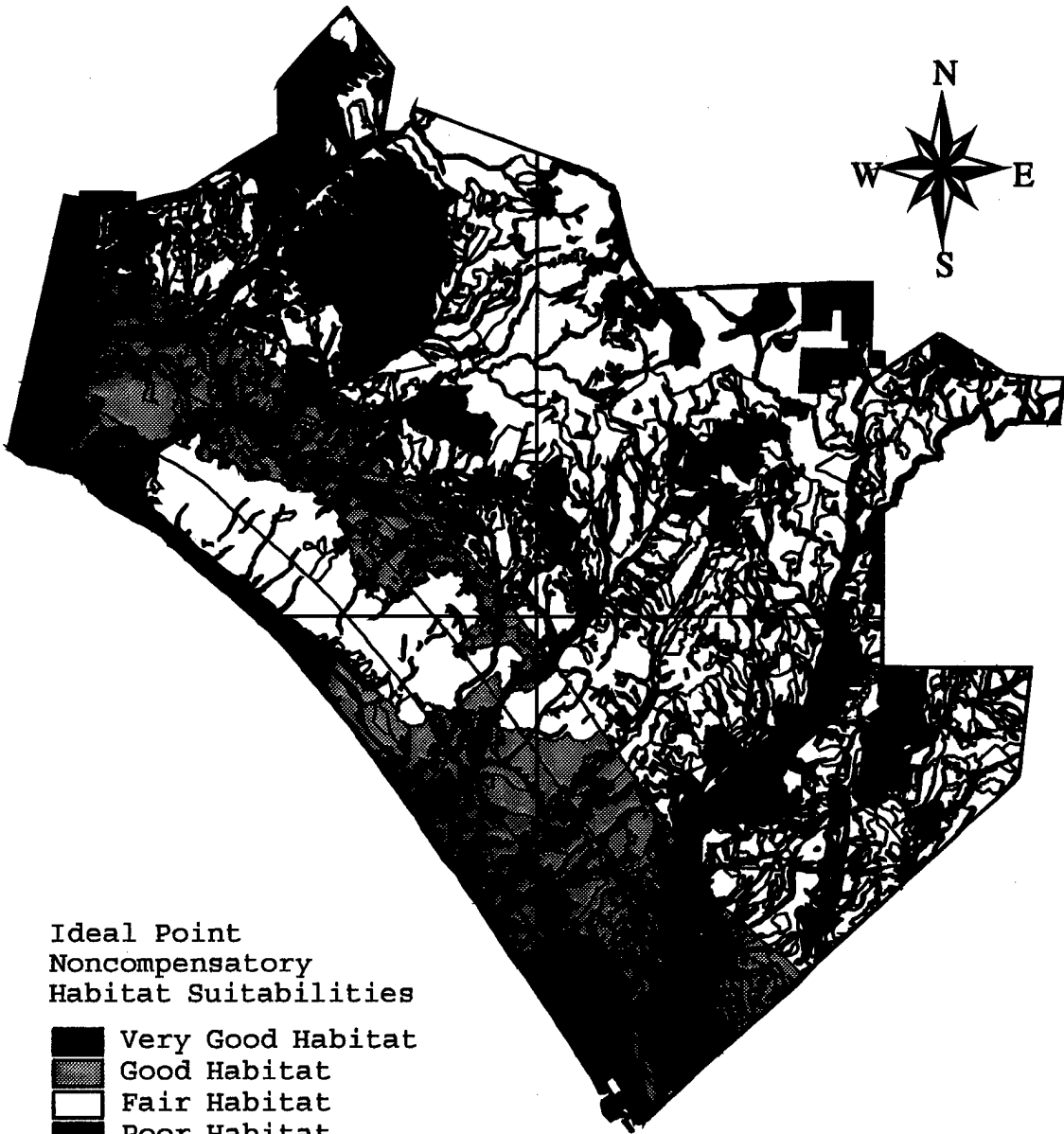

Ideal Point
Noncompensatory
Habitat Suitabilities

- Very Good Habitat
- Good Habitat
- Fair Habitat
- Poor Habitat
- Very Poor Habitat

6.2 0 6.2 Miles





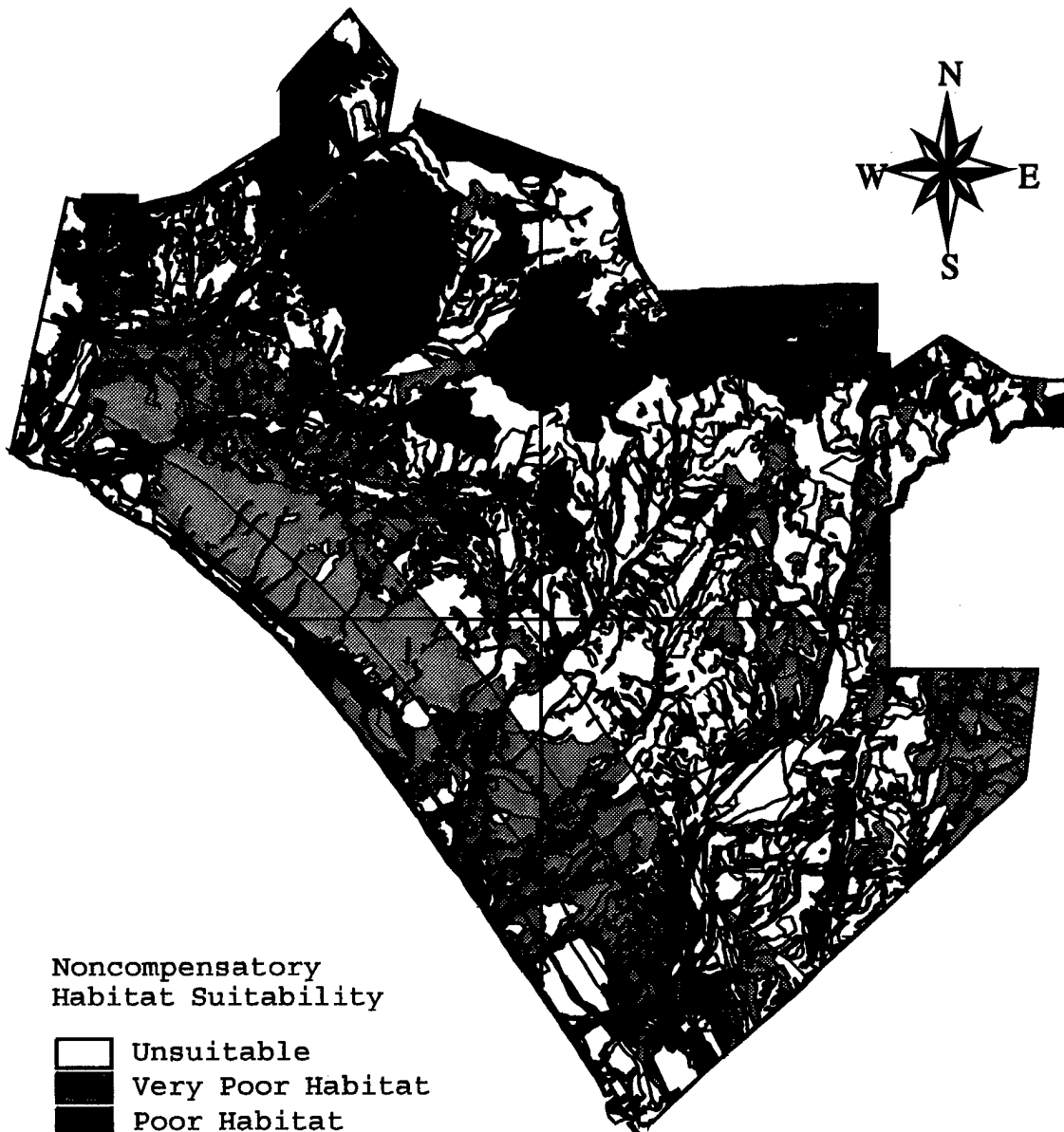

Figure 4-7. Ideal Point Noncompensatory
Habitat Suitability Map

Noncompensatory Habitat Suitability. Differences

between Figures 4-6 and 4-7 lead to development of the noncompensatory maps in Figures 4-8 and 4-9. From Table 4-4, it can be seen that the agreement with known PPM locations does not significantly differ from that of the compensatory map. Again, 47 of the 52 points in the good suitability regions are located in the incomplete data areas. Additionally, the four PPM locations that coincide with unsuitable locations are the same four points that occur in developed areas. Ignoring these 51 locations yields very good agreement between the map and ground truth. Although the compensatory and noncompensatory do not significantly differ in ground truth agreement, comparison of the maps does show differences in the amounts of acreage that can be considered unsuitable. For the compensatory map, no areas are considered unsuitable because an unsuitable area would have to have unsuitable characteristics for all three major components and, as



**Noncompensatory
Habitat Suitability**

-  Unsuitable
-  Very Poor Habitat
-  Poor Habitat
-  Fair Habitat
-  Good Habitat
-  Very Good Habitat
-  Extremely Good Habitat

6.5 0 6.5 Miles



Figure 4-8. Noncompensatory Habitat Suitability Map



Ppm_96

• Known PPM Locations

Noncompensatory
Habitat Suitabilities

- Unsuitable
- Very Poor Habitat
- Poor Habitat
- Fair Habitat
- Good Habitat
- Very Good Habitat
- Extremely Good Habitat

6.5 0 6.5 Miles

Figure 4-9. Noncompensatory Habitat Suitability Map
With Known PPM Locations

discussed earlier, no coastal distances are considered to be unsuitable. The true value of these differences can be seen in Table 4-5.

TABLE 4-5
 POLYGON AND ACREAGE DISTRIBUTIONS
 FOR COMBINED SUITABILITY MAPS

Suitability Class	Compensatory (Figs. 4-4, 4-5)		Noncompensatory (Figs 4-8, 4-9)		Δ Area
	# Poly-gons	Area (acres)	# Poly-gons	Area (acres)	
Ext. Good	302	2731	302	2731	0
Very Good	1892	31729	1775	30889	-840
Good	2852	50822	2389	44112	-6710
Fair	1469	22722	1061	16560	-6162
Poor	1044	13956	942	12943	-1013
Very Poor	418	4629	345	4035	-594
Unsuitable	120	454	1283	15773	15319

Using a noncompensatory map approach is very valuable when implementing the map results as decision tools. Because unsuitable sites will probably not be considered for sampling, the noncompensatory approach has eliminated 1163 additional polygons from consideration. More importantly, these polygons represent 15,319 acres of land that may have initially been considered for focusing sampling funds. Even if only the areas with good to extremely good suitabilities are considered for sampling, 7550 acres have been dropped from consideration. Each area that can be eliminated from consideration represents potential savings to the organization paying for the live trapping surveys.

V. Conclusions

Introduction

The purpose of this research was to develop a Pacific Pocket Mouse Habitat Suitability map of Camp Pendleton to aid environmental resource managers in effectively allocating funds for survey efforts to characterize the base PPM population. In pursuing this goal, multicriteria evaluation techniques were employed and several suitability maps were produced. Each map was evaluated for effectiveness through comparison with known PPM locations. From these analyses and questionnaire responses/evaluations, several conclusions can be made. This chapter discusses the important conclusions drawn from the research results and addresses recommendations for future research.

Conclusions

Habitat Requirements. Locations must be characterized by several important features in order to be considered suitable habitat for the Pacific Pocket Mouse. Soils must be friable to allow burrowing and yet must have a consistency that supports a burrow structure. Furthermore, the soil must be well drained and of a depth sufficient to support hibernation. Vegetation communities must be relatively open, provide cover for the rodents, and have a

mixture of grasses and forbs to provide a food source. Coastal distance and slope of the terrain are not crucial factors for determining habitat suitability. Additionally, size of fragmented material (stones) present in the soil is not important but percent present may be important. Finally, previous agricultural cultivation of land does not preclude an area from becoming suitable for the PPM.

Questionnaire Evaluation. Generally, statistically significant agreement between the respondents existed for all categories of the questionnaire. However, the problem overview, coastal distance, and stone size sections all yielded weaker correlations between respondents than other sections. Inclusion of coastal distance within the overview structure of the problem led to the low correlation coefficient values for this section and an overview structured with only vegetation and soil would yield greater agreement and give better preference weight values. The stone size evaluation section had the weakest correlations and elimination of the stoniness hierarchical level had an insignificant impact on calculated habitat suitabilities.

Map Evaluations. The vegetation and soil criterion maps agreed well with known PPM locations. This indicates that questionnaire respondents have a good understanding of vegetation and soil requirements of the PPM. It also

indicates that the method of soliciting expert opinion through the seven points scale and averaging to determine scores is a valid methodology. However, because negative PPM locations are not currently available, numerical evaluation of the maps cannot be calculated at this time. Although the coastal distance criterion map also agreed well with known locations, the majority of live trappings have been conducted in the coastal region and, therefore, data is not available for areas further inland.

The compensatory and noncompensatory habitat suitability maps both provide an excellent means for prioritizing sampling areas based on ground characteristics. However, the maps can only be considered valid for areas which have complete data available (i.e. vegetation, soil, and distance) and should not be applied for the few areas that are not complete. Both maps were equally reliable and agreed well with known PPM locations. The strong level of agreement between the maps and known PPM locations indicates that the hierarchical method of combining scores to calculate suitabilities is a valid methodology. Because the noncompensatory approach provides a valid methodology for

eliminating unsuitable areas and the number of areas considered for sampling can be reduced, it is the preferred method for cost effective prioritization of sites.

Future Research Recommendations

1. Update the PPM locations data layer to include all known sampling results. Once negative and positive locations are available, conduct a correlational analysis to determine the level of agreement attained between the habitat suitability maps (compensatory and noncompensatory) and ground truth.

2. Restructure the problem so habitat suitability is calculated from vegetation and soil characteristics only. Resolicit preference weights for the overview and develop new compensatory and noncompensatory maps. Conduct correlational analysis with known positive and negative locations.

3. If stoniness is to be addressed, structure using percentage present only. Do not include stone size.

4. Complete the data for the vegetation layer so the maps are valid for the entire base area. If any areas are characterized by incomplete data (i.e. vegetation or soil), mark the areas in the map output to identify them as

incomplete data areas. Do not assign suitability values of zero to undefined areas and include these areas in the overall habitat suitability map.

Appendix A: Questionnaire

Questionnaire Overview

This questionnaire is part of a Master's Thesis effort I am completing at the Air Force Institute of Technology (AFIT) at Wright Patterson Air Force Base, Dayton, Ohio. I am working with Marine Corps Base, Camp Pendleton, California, to develop a predictive model of suitable habitat for the Pacific Pocket Mouse (PPM). This model will be used to focus limited resources and funding toward surveying areas of the base that are most likely to hold populations of the PPM. The model will integrate expert opinion about PPM habitat with a Geographic Information System (GIS) database. The GIS database contains spatial information about Camp Pendleton (i.e. vegetation, soils, etc.) that may be useful in predicting areas that are most suitable for PPM habitat.

The purpose of this questionnaire is to evaluate the importance of on-site characteristics in determining habitat suitability of land areas. The following four factors were determined to be important to habitat suitability during the 5 March PPM workshop conducted in San Diego: soil type, vegetation class, coastal distance, and prior agricultural land use. Each factor will be addressed in a different section of the questionnaire. The first three factors will be investigated in depth and the fourth will be addressed as to its usefulness as a limiting factor.

The questionnaire is structured in the following manner. Section I, PPM Habitat, will focus on the characteristics of suitable PPM habitat and investigate the relative importance of soil type, vegetation class, and coastal distance. Sections IIA, IIB, and IIC will then delve into the important characteristics of the three factors, respectively. Each of these sections will begin with a question that asks you to qualitatively discuss the important features of that factor that pertain to habitat suitability. The subsequent questions then implement multicriteria evaluation techniques to quantify the importance of the GIS database factors. Finally, section

IID will focus on the importance of prior agricultural land use. The overall structure is graphically represented by the figure below. Please answer the questions based on your own personal experience with the PPM.

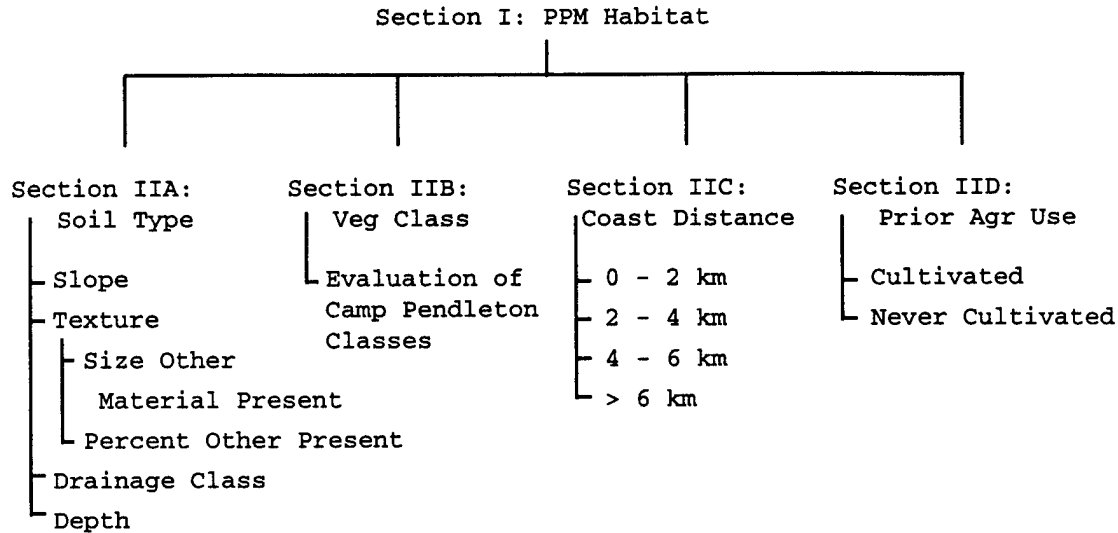

Figure A-1. Questionnaire Overview

A glossary of pertinent terms is attached for use in completing the questionnaire. If there are any questions, please feel free to contact me (Captain Tony Ference, USMC) at 513-429-9805 (Home #) or 513-255-3636 ext. 6289 (Business voice mail). **Please return the questionnaire by 31 July.** A postage-paid, self-addressed return envelope is included for your convenience. The return postage is based on the questionnaire weight only so please only return the questionnaire and do not return the glossary. Thank you for your time and effort.

Section I: PPM Habitat

From your experience and historical knowledge of the PPM, list and describe the habitat characteristics that you feel are important to maintaining suitable habitat for the PPM.

Section I: PPM Habitat (cont'd)

Each location aboard Camp Pendleton can be characterized by different on-site features. This portion of the questionnaire will focus on determining the relative importance of soil type, vegetation class, and distance from the coast. These factors will then be further investigated in later sections of the questionnaire.

Evaluation of the three factors listed above will be conducted via a seven point scale system and a ranking system. The 7-point scale portion of the questionnaire asks you to rate, on a scale from 1 to 7, the importance of the different factors as they pertain to PPM habitat suitability. For each factor listed, circle the number that corresponds to your judgment of the importance of that factor. Each factor does not have to be assigned a unique number and more than one factor can be assigned the same importance value.

The following example illustrates how to complete this portion of the questionnaire.

Example:	Relatively						Very
	Unimportant						Important
1. Vegetation Class	1	2	3	4	5	6	7

A circled value of 7 indicates that vegetation class is very important to mouse habitat and a value of 1 indicates that the vegetation is relatively unimportant.

Following this evaluation, the ranking portion then asks you to rank order the factors from most important to least important.

The following example illustrates how to complete this portion of the questionnaire.

Example: Purchasing Shoes		Most Important
A. Comfort/Fit		1. <u>B</u>
B. Price		2. <u>A</u>
C. Style		3. <u>C</u>
		Least Important

The answers above indicate that for the person responding, Price is the most important factor when buying shoes, Style is least important, and Comfort/Fit is between the two in importance.

Section I: PPM Habitat (cont'd)

Keeping in mind the important habitat characteristics that you identified at the beginning of this section, evaluate the following habitat factors for habitat importance.

I. Seven Point Scale Rating

	Relatively Unimportant				Very Important		
1. Soil Type	1	2	3	4	5	6	7
2. Coastal Distance	1	2	3	4	5	6	7
3. Vegetation Class	1	2	3	4	5	6	7

II. Ranking

A. Soil Type	Most Important
	1. ____
B. Coastal Distance	2. ____
C. Vegetation Class	3. ____
	Least Important

Section IIA: Soil Type

From your experience and historical knowledge of the PPM, discuss the characteristics of soil that you feel are important to maintaining suitable habitat for the PPM.

Each soil type within the Camp Pendleton GIS database can be characterized by slope, texture, drainage class, and depth. For the purposes of this questionnaire, definitions for these categories are included in the glossary. The relative importance of each of these characteristics and the subcategories of each (i.e. the different soil textures) will be investigated. An overview of the soil type breakdown for questionnaire purposes is as follows.

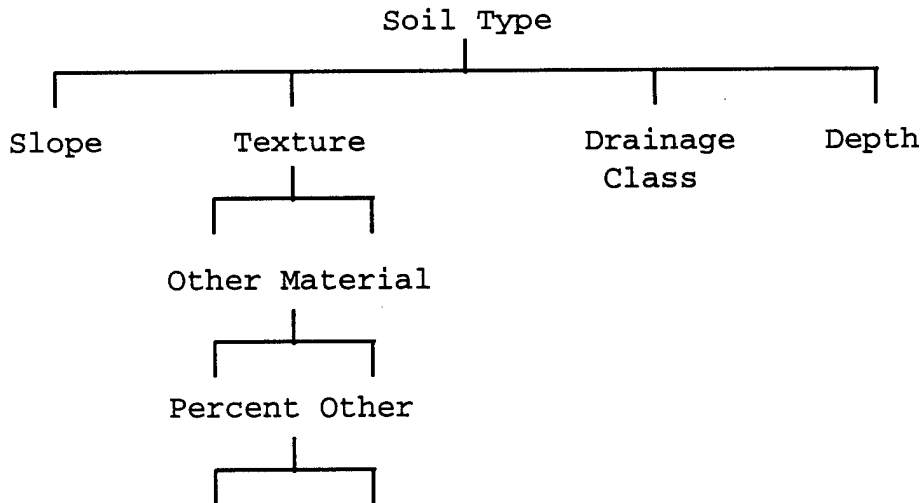

Figure A-2. Soil Type Questionnaire Overview

Evaluation of the four major soil factors listed above will be conducted via a seven point scale system. This portion of the questionnaire asks you to rate, on a scale from 1 to 7, the importance of the different factors as they pertain to PPM habitat suitability. For each factor listed, circle the number that corresponds to your judgment of the importance of that factor. Each factor does not have to be assigned a unique number and more than one factor can be assigned the same importance value.

Section IIA: Soil Type (cont'd)

The following example illustrates how to complete this portion of the questionnaire.

	Relatively Unimportant					Very Important	
	1	2	3	4	5	6	7
EX. Soil Texture (i.e. Loam, Sandy Loam, etc.)							

A circled value of 7 indicates that soil texture is very important to mouse habitat and a value of 1 indicates that texture is relatively unimportant.

Keeping in mind the important soil characteristics that you identified at the beginning of this section, evaluate the following major soil factors for habitat suitability. In evaluating the soil factors, please refer to the definitions provided in the glossary.

	Relatively Unimportant					Very Important	
	1	2	3	4	5	6	7
1. Slope							
2. Soil Texture							
3. Drainage Class							
4. Soil Depth							

Do you consider any of the above categories to be unimportant? If so, which ones and why?

Section IIA (cont'd): Slope

Keeping in mind the important soil characteristics that you identified at the beginning of this section, evaluate the following slopes for habitat suitability. In evaluating the slopes, please refer to the definitions provided in the glossary.

	Unsuitable					Highly Suitable	
1. 0 - 5 % slope	1	2	3	4	5	6	7
2. 5 - 9 % slope	1	2	3	4	5	6	7
3. 9 - 15 % slope	1	2	3	4	5	6	7
4. 15 - 30 % slope	1	2	3	4	5	6	7
5. 30 - 65 % slope	1	2	3	4	5	6	7
6. > 65 % slope	1	2	3	4	5	6	7

Which of the above slope categories do you feel is the best for PPM habitat?

Are any of the above slope categories completely unsuitable for the PPM? If so, please list them and briefly describe why you feel they are unsuitable.

Section IIA (cont'd): Texture

Keeping in mind the important soil characteristics that you identified at the beginning of this section, evaluate the following soil textures for habitat suitability. In evaluating the soil textural classes, please refer to the definitions provided in the glossary. These definitions include clay, sand, and silt percentages as well as some descriptive terms to include consistency measures. When referring to the textural class definitions, keep in mind that most soil types aboard Camp Pendleton are classified as moist.

	Unsuitable						Highly Suitable	
1. Sand	1	2	3	4	5	6	7	
2. Loamy Sand	1	2	3	4	5	6	7	
3. Sandy Loam	1	2	3	4	5	6	7	
4. Loam	1	2	3	4	5	6	7	
5. Silt Loam	1	2	3	4	5	6	7	
6. Silt	1	2	3	4	5	6	7	
7. Sandy Clay Loam	1	2	3	4	5	6	7	
8. Clay Loam	1	2	3	4	5	6	7	
9. Silty Clay Loam	1	2	3	4	5	6	7	
10. Sandy Clay	1	2	3	4	5	6	7	
11. Silty Clay	1	2	3	4	5	6	7	
12. Clay	1	2	3	4	5	6	7	

Which of the above soil textures do you feel is the best for PPM habitat?

Are any of the above soil textures completely unsuitable for the PPM? If so, please list them and briefly describe why you feel they are unsuitable.

Section IIA (cont'd): Other Material

Besides the actual soil material, there are often significant proportions of other coarse fragmentary materials present mixed in with the soil. The percentage and size of this fragmentary material present may affect the habitat suitability of a given land area. Therefore, this potential on-site characteristic is additionally addressed as part of the makeup of the soil texture.

Keeping in mind the important soil characteristics that you identified at the beginning of this section, evaluate the following fragment sizes for the potential to adversely affect PPM habitat suitability given that you have the ideal soil type. Size classes are adopted from the "Draft, Results of Focused Surveys for the Pacific Pocket Mouse Foothill Transportation Corridor-South" (Michael Brandman Associates and LSA Associates, Inc., 1995:Appendix 2).

	Significant Adverse Affect on Suitability of Soil					No Adverse Affect on Suitability of Soil		
1. Fine Pebbles (2-5 mm)	1	2	3	4	5	6	7	
2. Medium Pebbles (5-20 mm)	1	2	3	4	5	6	7	
3. Coarse Pebbles (20-75 mm)	1	2	3	4	5	6	7	
4. Cobbles (75-250 mm)	1	2	3	4	5	6	7	
5. Stones (250-600 mm)	1	2	3	4	5	6	7	
6. Boulders (>600 mm)	1	2	3	4	5	6	7	

Do you feel that any of the above size categories would not affect the suitability of the soil type? If so, which one(s) and why?

Would any of the above size categories prevent the PPM from living in a given soil type? If so, which one(s) and why?

Section IIA (cont'd): Percent Other

Besides the size of the fragmentary material present, the percentage (by volume including the soil material) of the rock fragmentary material may potentially affect the suitability of a given location. Keeping in mind the important soil characteristics that you identified at the beginning of this section, evaluate the following fragment percentages for the potential to adversely affect PPM habitat suitability given that you have the ideal soil type. Percentage classes are adopted from the "Draft, Results of Focused Surveys for the Pacific Pocket Mouse Foothill Transportation Corridor-South" (Michael Brandman Associates and LSA Associates, Inc., 1995:Appendix 2).

	Significant Adverse Affect on Suitability of Soil				No Adverse Affect on Suitability of Soil			
1. 0-15% Rock Fragments	1	2	3	4	5	6	7	
2. 15-35% Rock Fragments	1	2	3	4	5	6	7	
3. 35-60% Rock Fragments	1	2	3	4	5	6	7	
4. > 60% Rock Fragments	1	2	3	4	5	6	7	

Do you feel that any of the above percentage categories would not affect the suitability of the soil type? If so, which one(s) and why?

Would any of the above percentage categories prevent the PPM from living in a given soil type? If so, which one(s) and why?

Section IIA (cont'd): Drainage Class

Keeping in mind the important soil characteristics that you identified at the beginning of this section, evaluate the following soil drainage classes for habitat suitability. In evaluating the soil drainage classes, please refer to the definitions provided in the glossary.

	Unsuitable						Highly Suitable
1. Very Poorly Drained	1	2	3	4	5	6	7
2. Poorly Drained	1	2	3	4	5	6	7
3. Somewhat Poorly Drained	1	2	3	4	5	6	7
4. Moderately Well Drained	1	2	3	4	5	6	7
5. Well Drained	1	2	3	4	5	6	7
6. Somewhat Excessively Drained	1	2	3	4	5	6	7
7. Excessively Drained	1	2	3	4	5	6	7

Which of the above soil drainage classes do you feel is the best for PPM habitat?

Are any of the above soil drainage classes completely unsuitable for the PPM? If so, please list them and briefly describe why you feel they are unsuitable.

Section IIA (cont'd): Depth

Keeping in mind the important soil characteristics that you identified at the beginning of this section, evaluate the following soil depths for habitat suitability. Depth classes are adopted from the "Draft, Results of Focused Surveys for the Pacific Pocket Mouse Foothill Transportation Corridor-South" (Michael Brandman Associates and LSA Associates, Inc., 1995:Appendix 2).

	Unsuitable					Highly Suitable		
1. < 10 inches	1	2	3	4	5	6	7	
2. 10 - 20 inches	1	2	3	4	5	6	7	
3. 20 - 40 inches	1	2	3	4	5	6	7	
4. 40 - 60 inches	1	2	3	4	5	6	7	
5. > 60 inches	1	2	3	4	5	6	7	

Which of the above depth classes do you feel is the best for PPM habitat?

Are any of the above depth classes completely unsuitable for the PPM? If so, please list them and briefly describe why you feel they are unsuitable.

Section IIB: Vegetation Class

From your experience and historical knowledge of the PPM, discuss the characteristics of vegetation that you feel are important to maintaining suitable habitat for the PPM.

Evaluation of the vegetation classes found aboard Camp Pendleton will be conducted via a seven point scale system. This portion of the questionnaire asks you to rate, on a scale from 1 to 7, the habitat suitability of each of the vegetation classes. For each class listed, circle the number that corresponds to your judgment of the suitability of that class. Each class does not have to be assigned a unique number and more than one class can be assigned the same habitat suitability value.

Keeping in mind the important vegetation characteristics that you identified at the beginning of this section, evaluate the following vegetation classes for habitat suitability. In evaluating the vegetation classes, please refer to the definitions provided in the glossary.

	Unsuitable						Highly Suitable
1. <u>Ceanothus Crassifolius</u> Chaparral	1	2	3	4	5	6	7
2. Chamise Chaparral	1	2	3	4	5	6	7
3. Coast Live Oak Woodland	1	2	3	4	5	6	7
4. Coastal and Valley Freshwater Marsh	1	2	3	4	5	6	7
5. Coastal Brackish Marsh	1	2	3	4	5	6	7
6. Coastal Sage/Chaparral Scrub	1	2	3	4	5	6	7
7. Coastal Sage/Chaparral Scrub-Sparse	1	2	3	4	5	6	7

Section IIB (cont'd): Vegetation Class

	Unsuitable							Highly Suitable
8. Dense Englemann Oak Woodland	1	2	3	4	5	6	7	
9. Open Englemann Oak Woodland	1	2	3	4	5	6	7	
10. Diegan Coastal Sage Scrub	1	2	3	4	5	6	7	
11. Diegan Coastal Sage Scrub-Sparse	1	2	3	4	5	6	7	
12. Freshwater Seep	1	2	3	4	5	6	7	
13. Non-Native Grassland	1	2	3	4	5	6	7	
14. S. Coast Live Oak Riparian Forest	1	2	3	4	5	6	7	
15. S. Cottonwood/Willow Riparian Forest	1	2	3	4	5	6	7	
16. S. Sycamore/Alder Riparian Woodland	1	2	3	4	5	6	7	
17. San Diego Mesa Hardpan Vernal Pool	1	2	3	4	5	6	7	
18. Scrub Oak Chaparral	1	2	3	4	5	6	7	
19. Southern Coastal Bluff Scrub	1	2	3	4	5	6	7	
20. Southern Coastal Salt Marsh	1	2	3	4	5	6	7	
21. Southern Coastal Salt Marsh-Sparse	1	2	3	4	5	6	7	
22. Southern Foredune	1	2	3	4	5	6	7	

Section IIB (cont'd): Vegetation Class

	Unsuitable						Highly Suitable
23. Southern Foredune-Sparse	1	2	3	4	5	6	7
24. Southern Mixed Chaparral-Granitic	1	2	3	4	5	6	7
25. Southern Willow Scrub	1	2	3	4	5	6	7
26. Southern Willow Scrub-Sparse	1	2	3	4	5	6	7
27. Valley Needlegrass	1	2	3	4	5	6	7
28. Valley Needlegrass-Sparse	1	2	3	4	5	6	7

Which of the above vegetation classes do you feel is the best for PPM habitat?

Are any of the above vegetation classes completely unsuitable for the PPM? If so, please list them and briefly describe why you feel they are unsuitable.

Section IIC: Coastal Distance

From your experience and historical knowledge of the PPM, explain why coastal distance is important to maintaining suitable habitat for the PPM and discuss the importance characteristics of coastal distance as it pertains to suitable PPM habitat.

Keeping in mind the important coastal distance characteristics that you identified at the beginning of this section, evaluate the following coastal distances for habitat suitability.

	Unsuitable					Highly Suitable	
1. 0 - 2 km	1	2	3	4	5	6	7
2. 2 - 4 km	1	2	3	4	5	6	7
3. 4 - 6 km	1	2	3	4	5	6	7
4. > 6 km	1	2	3	4	5	6	7

Which of the above coastal distance classes do you feel is the best for PPM habitat?

Are any of the above coastal distance classes completely unsuitable for the PPM? If so, please list them and briefly describe why you feel they are unsuitable.

What is the furthest inland coastal distance that you would expect to find the PPM?

Section IID: Prior Agricultural Land Use

During the PPM workshop in San Diego, prior agricultural land use was identified as being important to PPM habitat. From your experience and historical knowledge of the PPM, explain why prior agricultural land use is important to habitat suitability of a given site for the PPM and discuss the importance characteristics of prior agricultural land use as it pertains to suitable PPM habitat.

If an area of land has been previously cultivated for agricultural purposes, does that indicate that the land is not suitable for PPM habitat? Why or why not?

Glossary

Soil Terms:

1. Slope: "Soil slope refers to the incline of the surface of the soil area" (USDA, 1951:158). For the purposes of this questionnaire, the slope will be defined, percentage-wise, by the measured elevation change (in feet) over a 100 foot horizontal distance change (see fig. G1 below). A 45° hill would therefore have a slope of 100% because the elevation change is equal to the horizontal distance change.

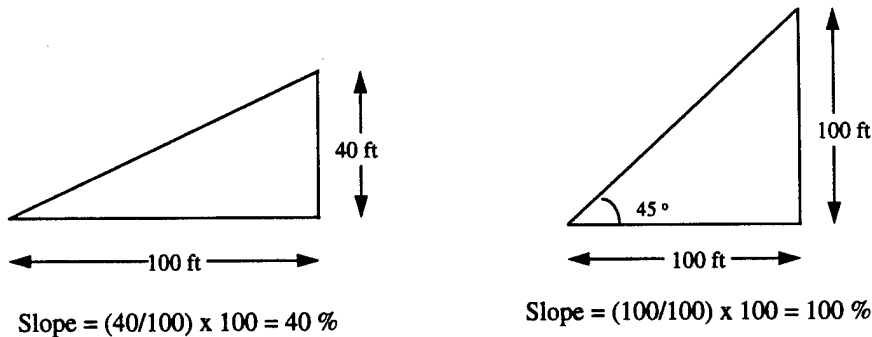

Figure G-1

Some pertinent slopes for the questionnaire are as follows:

- 5 % slope = 2.86 degrees incline
- 9 % slope = 5.14 degrees incline
- 15 % slope = 8.53 degrees incline
- 30 % slope = 16.70 degrees incline
- 65 % slope = 33.02 degrees incline

2. Soil Texture: "Soil texture refers to the relative percentages of sand, silt, and clay in a soil" (Donahue, 1965:25) and the textural classes are based on the different combinations of these particles (USDA, 1951:207). Particles less than 2 mm in diameter are considered soil separates and separates are classified as either sand, silt, or clay. The following is the size breakdown of these separates as defined by the USDA (USDA, 1951:209-210).

- | | |
|-------|-------------------------|
| Sand. | 0.05-2.0 mm diameter |
| Silt. | 0.002-0.05 mm diameter |
| Clay. | below 0.002 mm diameter |

The USDA has defined the following general groupings of the soil textural classes (USDA, 1951:213). The definitions of the classes follow these groupings.

Sandy Soils.

Coarse-textured soils

Sands

Loamy Sands

Loamy Soils.

Moderately coarse-textured soils

Sandy Loam

Medium-textured soils

Loam

Silt Loam

Silt

Moderately fine-textured soils

Clay Loam

Sandy Clay Loam

Silty Clay Loam

Clayey Soils.

Fine-textured soils

Sandy Clay

Silty Clay

Clay

The following are the 12 major textural classes in order of increasing fineness as defined by the USDA (USDA, 1951:210-211). Additional clarification is added from the "Draft, Results of Focused Surveys for the Pacific Pocket Mouse Foothill Transportation Corridor-South" (Michael Brandman Associates and LSA Associates, Inc., 1995:Appendix 2).

(*) The textural class definitions include some soil consistency terms (i.e. plasticity, friability, etc.) that are further defined after the textural class definitions. Please refer to these consistency definitions for clarification.

Sands. "Soil material that contains 85 percent or more of sand; percentage of silt, plus 1.5 times the percentage of clay, shall not exceed 15 (USDA, 1951:210)." "Sand is loose and single grained. The individual grains can readily be seen and felt. Squeezed in the hand when moist, it will fall apart when the pressure is released. Squeezed when moist, it will form a cast, but will crumble when touched (Michael Brandman Associates and LSA Associates, Inc., 1995:Appendix 2)."

Loamy Sands. "Soil materials that contains at the upper limit 85 to 90 percent sand, and the percentage of silt plus 1.5 times the percentage of clay is not less than 15; at the lower limit it contains not less than 70 to 85 percent sand, and the percentage of silt plus twice the percentage of clay does not exceed 30 (USDA, 1951:210)." "Dry is loose, single grained; gritty, forms very weak aggregates, does not ribbon, wet lacks stickiness (*), but may show faint clay staining. Individual grains can be readily seen and felt (Michael Brandman Associates and LSA Associates, Inc., 1995:Appendix 2)."

Sandy Loams. "Soil materials that contains either 20 percent clay or less, and the percentage of silt plus twice the percentage of clay exceeds 30, and 52 percent or more sand; or less than 7 percent clay, less than 50 percent silt, and between 43 percent and 52 percent sand (USDA, 1951:210)." "Forms weak aggregates... somewhat coherent. Individual sand grains can be seen and felt. Squeezed when dry, it will form a cast that will readily fall apart; but when moist, it will form a cast that will bear careful handling without breaking; it will definitely stain fingers and clouds water. (Michael Brandman Associates and LSA Associates, Inc., 1995:Appendix 2).

Loam. "Soil material that contains 7 to 27 percent clay, 28 to 50 percent silt, and less than 52 percent sand (USDA, 1951:210)." "Loam is a soil having a relatively even mixture of different grades of sand, silt, and clay. It is mellow with a somewhat gritty feel, yet fairly smooth and slightly sticky (*) and slightly plastic (*). Dry aggregates are slightly hard (*) or hard to break; moist, it will form a cast that can be handled without breaking, stains fingers and clouds water (Michael Brandman Associates and LSA Associates, Inc., 1995:Appendix 2)."

Silt Loam. "Soil material that contains 50 percent or more silt and 12 to 27 percent clay (or) 50 to 80 percent silt and less than 12 percent clay (USDA, 1951:210)." "A soil having moderate amounts of fine grains of sand and less than 27% clay, over half of the particles are of the size of silt. When dry, aggregates break with some difficulty. Moist forms a ball and ribbons fairly well. Either dry or moist, it will form casts that can be freely handled without breaking (Michael Brandman Associates and LSA Associates, Inc., 1995:Appendix 2)."

Silt. "Soil material that contains 80 percent or more silt and less than 12 percent clay (USDA, 1951:210)." "Rare textural class that is not easy to find in nature...Silt feels quite floury, soft when dry and is not sticky (*) or plastic (*) (Michael Brandman Associates and LSA Associates, Inc., 1995:Appendix 2).

Sandy Clay Loam. "Soil material that contains 20 to 35 percent clay, less than 28 percent silt, and 45 percent or more sand (USDA, 1951:210)." "Dry, it is hard (*) or very hard (*), aggregates can be broken with difficulty. Moist, is friable (*), and forms a firm ball. Wet, is sticky (*) and plastic (*), will form a cast that can bear moderate handling, ribbons well, may show a fingerprint, stains fingers and clouds water. Sand grains can be readily felt (Michael Brandman Associates and LSA Associates, Inc., 1995:Appendix 2)."

Clay Loam. "Soil material that contains 27 to 40 percent clay and 20 to 45 percent sand (USDA, 1951:210)." "A moderately fine textured soil which usually breaks into aggregates that are hard (*) when dry and friable (*) or firm (*) moist. Moist, the soil ribbons well, shows a good fingerprint, is sticky (*) and plastic (*) and will form a cast that can bear much handling; stains fingers (Michael Brandman Associates and LSA Associates, Inc., 1995:Appendix 2)."

Silty Clay Loam. "Soil material that contains 27 to 40 percent clay and less than 20 percent sand (USDA, 1951:211)."

Sandy Clay. "Soil material that contains 35 percent or more clay and 45 percent or more sand (USDA, 1951:211)." "A fine textured soil...Dry, it is very hard (*) or extremely hard (*), aggregates can be broken with extreme pressure. Moist, it is sticky (*) or very sticky (*) and plastic (*); shows a good fingerprint, ribbons well and stains fingers (Michael Brandman Associates and LSA Associates, Inc., 1995:Appendix 2)."

Silty Clay. "Soil material that contains 40 percent or more clay and 40 percent or more silt (USDA, 1951:211)." "A fine textured soil...Dry is extremely hard (*), moist is firm (*) or very firm (*) and wet is very sticky (*) and very plastic (*), feels quite floury; shows a good fingerprint, forms a cast that bears much handling; ribbons very well and clouds water and stains fingers (Michael Brandman Associates and LSA Associates, Inc., 1995:Appendix 2)."

Clay. "Soil material that contains 40 percent or more clay, less than 45 percent sand, and less than 40 percent silt (USDA, 1951:211)." "Also a fine textured soil that when dry, usually forms very hard (*) or extremely hard (*) blocks, columns or prisms, it is very sticky (*) and very plastic (*) wet and very firm (*) or extremely firm (*) moist; ribbons very well and forms a very good fingerprint (Michael Brandman Associates and LSA Associates, Inc., 1995:Appendix 2)."

2. a. Soil Consistency: "Consistence refers to the attribute of cohesion and adhesion or resistance of soil to rupture or deform...consistence has reference to the force required to rupture soil material or to the properties of a deformed soil mass (Donahue, 1965:32)." There are consistency measures for wet, moist, and dry soil conditions. The following terms are commonly used to describe the consistency of soils. The definitions are taken from the Soil Survey, Sand Diego Area, California (USDA, 1973:102).

Loose - Noncoherent when dry or moist; does not hold together in a mass.

Friable - When moist, crushes easily under gentle pressure between thumb and forefinger and can be pressed together into a lump.

Firm - When moist, crushes under moderate pressure between thumb and forefinger but resistance is distinctly noticeable.

Plastic - When wet, readily deformed by moderate pressure but can be pressed into a lump; will form a "wire" when rolled between thumb and forefinger.

Sticky - When wet, adheres to other material, and tends to stretch somewhat and pull apart, rather than to pull free from other material.

Hard - When dry, moderately resistant to pressure; can be broken with difficulty between thumb and forefinger.

Soft - When dry, breaks into powder or individual grains under very slight pressure.

3. Drainage Class: Soil-drainage classes incorporate runoff, permeability, and internal drainage to classify how easily water is removed from the soil. This gives an indication of how wet a soil type may be during the year. The following drainage class definitions are taken from the Soil Survey Manual (USDA, 1951:170-172).

Very Poorly Drained - "Water is removed from the soil so slowly that the water table remains at or on the surface the greater part of the time. Soils of this drainage class usually occupy level or depressed sites and are frequently ponded."

Poorly Drained - "Water is removed so slowly that the soil remains wet for a large part of the time."

Somewhat Poorly Drained - "Water is removed from the soil slowly enough to keep it wet for significant periods but not all of the time."

Moderately Well Drained - "Water is removed from the soil somewhat slowly, so that the profile is wet for a small but significant part of the time."

Well Drained - "Water is removed from the soil readily but not rapidly."

Somewhat Excessively Drained - "Water is removed from the soil rapidly."

Excessively Drained - "Water is removed from the soil very rapidly."

Vegetation Terms:

The following vegetation class definitions are from Preliminary Descriptions of the Terrestrial Natural Communities of California (Holland, 1986).

1. Ceanothus Crassifolius Chaparral - "A stiff, gray-green chaparral to 2-3 m tall...considerably more leaf litter than in chamise chaparral" (see next definition).
2. Chamise Chaparral - "A 1-3 m tall chaparral overwhelmingly dominated by chamise. Associated species contribute little to cover. Adapted to repeated fires by stump sprouting. Mature stands are densely interwoven with very little herbaceous understory or litter."
3. Coast Live Oak Woodland - "varies from pure, closed-canopy stands...to open savannas." With "only one dominant tree, Quercus agrifolia, which is evergreen and reaches 10-25 m in height. The shrub layer is poorly developed" and the "herb component is continuous and dominated by [Bronus diandrus] and several other introduced taxa."
4. Coastal and Valley Freshwater Marsh - "Dominated by perennial, emergent monocots to 4-5 m tall. Often forming completely closed canopies. Scripus and Typha dominated types and their environmental and floristic distinctions require clarification." "Permanently flooded by freshwater."
5. Coastal Brackish Marsh - "Dominated by perennial, emergent, herbaceous monocots to 2 m tall. Cover is often complete and dense." "Subject to regular tidal inundation", "brackish from freshwater input", and "salinity may vary considerably."
6. Coastal Sage/Chaparral Scrub - "A mix of sclerophyllous, woody chaparral species and drought-deciduous, malacophyllous sage scrub species." "Apparently a post-fire successional community." "Intermediate between coastal scrubs and chaparrals."

7. Dense Englemann Oak Woodland - "Very similar to Open Englemann Oak Woodland" (see definition below), "but has Quercus agrifolia as an additional significant constituent. Canopy cover is very similar to that observed in Open Englemann Oak Woodland, but stem densities are much greater due to Q. agrifolia being superimposed on the Q. engelmannii.

8. Diegan Coastal Sage Scrub - "Low, soft-woody subshrubs (to ca. 1 m high) that are most active in winter and early spring. Many taxa are facultatively drought-deciduous."

9. Freshwater Seep - "Mostly perennial herbs, especially sedges and grasses, usually forming complete cover, often low-growing but sometimes taller, growing throughout the year in areas with mild winters."

10. Non-Native Grassland - "A dense to sparse cover of annual grasses with flowering culms 0.2-0.5 (1.0) m high. Often associated with numerous species of showy-flowered, native annual forbs ("wildflowers"), especially in years of favorable rainfall. Germination occurs with the onset of late fall rains; growth, flowering, and seed-set occur from winter through spring. With a few exceptions, the plants are dead through the summer-fall dry season, persisting as seeds."

11. Open Englemann Oak Woodland - "An evergreen woodland quite reminiscent of Blue Oak Woodland but dominated by Quercus engelmannii with an understory of typical "grassland" species." Blue Oak Woodland is "a highly variable climax woodland." Blue Oak Woodland "stands vary from open savannas with grassy understories (usually at lower elevations) to fairly dense woodland with shrubby understories."

12. Southern Coast Live Oak Riparian Forest - "Open to locally dense evergreen sclerophyllous riparian woodlands dominated by Quercus agrifolia. This type appears to be richer in herbs and poorer in understory shrubs than other riparian communities. Similar to and questionably distinct from Central Coast Live Oak Riparian Forest" which has "an open appearance" and "grasses usually form a fairly extensive ground layer."

13. Southern Cottonwood-Willow Riparian Forest - "Tall, open, broadleaved, winter-deciduous riparian forests dominated by Populus fremontii, P. trichocarpa, and several tree willows...Understories usually are shrubby willows."
14. Southern Sycamore-Alder Riparian Woodland - "A tall, open, broadleaved, winter-deciduous streamside woodland dominated by Platanus racemosa (and often also Alnus rhombifolia). These stands seldom form closed canopy forests, and even may appear as trees scattered in a shrubby thicket of sclerophyllous and deciduous species."
15. San Diego Mesa Hardpan Vernal Pool - "Very similar to Northern Hardpan Vernal Pools, but with different species composition. Surrounding high ground, however, usually mantled with chamisal rather than grassland. Pool sizes range from very small to moderate (up to ca. 700 square meters)." A Northern Hardpan Vernal Pool is "a low, amphibious, herbaceous community dominated by annual herbs and grasses...rising spring temperatures evaporate the pools."
16. Scrub Oak Chaparral - "A dense, evergreen chaparral to 20 feet tall." "These more favorable sites recover from fire more quickly than other chaparrals. Substantial leaf litter accumulates."
17. Southern Coastal Bluff Scrub - "A low, often prostrate, scrub...(up to 2 m tall). Most plants woody and/or succulent. Most growth and flowering occur from late winter through spring." Exposed to "moisture-laden winds."
18. Southern Coastal Salt Marsh - "Highly productive, herbaceous and suffrutescent, salt-tolerant hydrophytes forming moderate to dense cover and up to 1 m tall."
19. Southern Foredune - Dominated by "low, often succulent, perennial herbs and subshrubs (about 10 cm tall)...and suffrutescent plants (to 30 cm tall). Coverage varies from nearly complete to scattered."
20. Southern Mixed Chaparral-Granitic - "Broadleaved sclerophyll shrubs" (1.5-3 m tall) and somewhat dense. "Occasionally with patches of bare soil or forming a mosaic with Venturan Coastal Sage Scrub or Riversidean Sage Scrub." Granitic refers to substrate type.

21. Southern Willow Scrub - "Dense, broadleafed, winter-deciduous riparian thickets dominated by several Salix species, with scattered emergent Populus fremontii and Platanus racemosa. Most stands are too dense to allow much understory development.

22. Valley Needlegrass - "A midheight (to 2 ft) grassland dominated by perennial, tussock-forming Stipa pulchra. Native and introduced annuals occur between the perennials, often actually exceeding the bunchgrasses in cover."

Appendix B: Questionnaire Data, Weights, and Scores

TABLE B-1
PROBLEM OVERVIEW EVALUATIONS AND WEIGHTS

Respondents	Soil Type	Coastal Distance	Vegetation Class
1	7	5	4
2	7	6.5	4
3	7	7	5
4	6	6	6
5	6	3	6
6	7	4	6
7	7	6	5
8	7	1	4
9	7	6	4
Averages	6.7778	4.9444	4.8889
Sum of Avgs.	16.6111		
Weights	0.4080	0.2977	0.2943

TABLE B-2
SOIL TYPE EVALUATIONS AND WEIGHTS

Respondents	Slope	Soil Texture	Drainage Class	Soil Depth
1	3	7	6	4
2	3.5	7	5.5	5.5
3	3	7	5	1
4	5	6	6	4
5	4	7	7	5
6	5	7	7	
7	3	7	5	7
8	4	7	6	2
9	4	7	6	5
Averages	3.8333	6.8889	5.9444	4.1875
Sum of Avgs.	20.8542			
Weights	0.1838	0.3303	0.2850	0.2008

TABLE B-3
SLOPE EVALUATIONS AND AVERAGE SCORES

Respondents	0-5%	5-9%	9-15%	15-30%	30-65%	> 65%
1	6	7	7	6	4	2
2	7	7	7	6	3.5	3.5
3	7	7	6	5	4	3
4	7	7	7	5	3	1
5	7	7	6	4	1	1
6	7	7	6	4	1	1
7	7	7	6	6	3	2
8	7	7	6	5	2	1
9	7	7	6	4	2	1
Averages	6.8889	7.0000	6.3333	5.0000	2.6111	1.7222

TABLE B-4
DRAINAGE CLASS EVALUATIONS AND AVERAGE SCORES

Resps.	Very Poorly Drained	Poorly Drained	Some-what Poorly Drained	Mod. Well Drained	Well Drained	Some-what Excessively Drained	Excessively Drained
1	1	1	1	4	7	7	7
2	1	1	1	6	6.5	6.5	5.5
3	1	1	3	5	7	7	7
4	1	1	1	4	6	6	4
5	1	1	3	6	7	7	7
6	1	1	2	4	6	4	3
7	1	1	2	3	5	7	7
8	1	1	2	4	6	7	7
9	1	2	2	3	5	6	7
Avg.	1.0000	1.1111	1.8889	4.3333	6.1667	6.3889	6.0556

TABLE B-5
SOIL DEPTH EVALUATIONS AND AVERAGE SCORES

Resps.	< 10 inches	10-20 inches	20-40 inches	40-60 inches	> 60 inches
1	2	6	7	7	7
2	5	6.5	7	7	7
3	3	4	7	7	7
4	3	6	7	7	7
5	3	5	7	7	7
6	No evaluations provided.				
7	1	3	7	7	7
8	2	3	6	7	7
9	4	5	7	7	7
Avg.	2.8750	4.8125	6.8750	7.0000	7.0000

TABLE B-6
STONE SIZE EVALUATIONS AND AVERAGE SCORES

Resps.	Fine Pebbles	Medium Pebbles	Coarse Pebbles	Cobbles	Stones	Boulders
1	6	6	6	6	6	6
2	7	6	6	5.5	5.5	5.5
3	7	7	7	7	7	7
4	2	2	1	1	1	1
5	7	6	1	1	1	1
6	4	4	3	3	2	1
7	7	6	4	3	2	2
8	7	7	7	7	7	7
9	6	5	3	2	1	1
Avg.	5.8889	5.4444	4.2222	3.9444	3.6111	3.5000

TABLE B-7
STONE PERCENT EVALUATIONS AND AVERAGE SCORES

Respondents	0-15 %	15-35 %	35-60 %	> 60 %
1	6	3	2	1
2	6.5	6.5	5	4
3	7	6	4	2
4	6	4	2	1
5	6	2	1	1
6	5	4	2	1
7	7	5	3	1
8	7	4	2	1
9	5	4	3	1
Averages	6.1667	4.2778	2.6667	1.4444

TABLE B-8
COASTAL DISTANCE EVALUATIONS AND AVERAGE SCORES

Respondents	0-2 km	2-4 km	4-6 km	> 6 km
1	7	7	6	5
2	7	7	5.5	4
3	7	6	3	1
4	7	7	6	3
5	7	7	7	7
6	6	6	4	2
7	7	7	5	2
8	7	7	7	7
9	7	7	4	3
Averages	6.8889	6.7778	5.2778	3.7778

TABLE B-9
SOIL TEXTURE EVALUATIONS AND AVERAGE SCORES

Resps.	Sand	Loamy Sand	Sandy Loam	Loam	Silt Loam	Silt	Sandy Clay Loam	Clay Loam	Silty Clay Loam	Sandy Clay	Silty Clay	Clay
1	6	7	6	4	2	1	2	1	1	2	1	1
2	7	7	5.5	3.5	1.5	1.5	1.5	1	1	1	1	1
3	7	7	6	1	1	1	1	1	1	1	1	1
4	5	6	6	4	2	2	4	2	2	2	2	1
5	7	5	7	4	4	3	2	1	1	1	1	1
6	2	6	6	6	7	1	1	1	1	1	1	1
7	4	7	7	5	4	3	4	1	2	3	1	1
8	7	6	4	2	2	2	2	2	2	2	2	1
9	7	7	7	5	4	3	5	3	3	5	3	1
Avg.	5.78	6.44	6.06	3.83	3.06	1.94	2.50	1.44	1.56	2.00	1.44	1.00

TABLE B-10
 VEGETATION CLASS EVALUATIONS AND AVERAGE SCORES
 (PART 1 OF 4)

Resps.	Ceanothus Crassi- folius Chaparral	Chamise Chaparral	Coast Live Oak Woodland	Coastal and Valley Freshwater Marsh	Coastal Brackish Marsh	Coastal Sage/ Chaparral Scrub	Coastal Sage/Chap. Scrub- Sparse
1	1	2	1	1	1	5	7
2	1.5	1	1	1	1	6.5	6
3	1	2	1	1	4	3	5
4	1	1	3	1	1	4	5
5	3	3	1	1	1	3	3
6	3	2	*	1	1	5	6
7	3	3	4	1	1	4	7
8	4	4	3	1	1	4	7
9	1	1	1	1	1	4	7
AVGS.	2.0556	2.1111	1.8750	1.0000	1.3333	4.2778	5.8889

* => Denotes missing data point because no evaluation provided.

TABLE B-11
 VEGETATION CLASS EVALUATIONS AND AVERAGE SCORES
 (PART 2 OF 4)

Resps.	Dense Englemann Oak Woodland	Open Englemann Oak Woodland	Diegan Coastal Sage Scrub	Diegan Coastal Sage Scrub-Sparse	Freshwater Seep	Non-Native Grassland	S. Coast Live Oak Riparian Forest
1	1	1	6	7	1	6	1
2	1	1	7	7	1	7	1
3	1	1	7	7	1	2	1
4	2	2	5	6	1	5	2
5	1	1	6	6	1	1	1
6	*	*	6	7	1	5	*
7	1	3	5	7	1	6	3
8	2	3	4	7	1	7	2
9	1	1	5	7	1	4	1
Avg.	1.2500	1.6250	5.6667	6.7778	1.0000	4.7778	1.5000

* => Denotes missing data point because no evaluation provided.

TABLE B-12
 VEGETATION CLASS EVALUATIONS AND AVERAGE SCORES
 (PART 3 OF 4)

Resps.	S. Cottonwood/ Willow Riparian Forest	S. Sycamore/ Alder Riparian Woodland	San Diego Mesa Hardpan Vernal Pool	Scrub Oak Chaparral	Southern Coastal Bluff Scrub	Southern Coastal Salt Marsh	Southern Coastal Salt Marsh- Sparse
1	1	1	1	3	7	1	1
2	1	1	2	2	7	1	1
3	2	2	2	1	7	4	5
4	2	2	2	2	5	1	1
5	1	1	1	3	5	1	1
6	*	*	2	2	4	1	2
7	3	4	2	2	6	1	1
8	2	2	2	2	6	2	2
9	1	1	4	1	6	1	1
Avg.	1.6250	1.7500	2.0000	2.0000	5.8889	1.4444	1.6667

* => Denotes missing data point because no evaluation provided.

TABLE B-13
 VEGETATION CLASS EVALUATIONS AND AVERAGE SCORES
 (PART 4 OF 4)

Resps.	Southern Foredune	Southern Foredune- Sparse	Southern Mixed Chaparral- Granitic	Southern Willow Scrub	Southern Willow Scrub- Sparse	Valley Needlegrass	Valley Needlegrass -Sparse
1	7	7	4	1	1	5	6
2	6.5	6	1	1	1	5.5	5.5
3	7	7	3	2	4	2	3
4	4	4	2	2	3	4	5
5	3	3	1	1	1	1	1
6	3	3	3	2	2	3	4
7	5	5	3	4	5	6	7
8	7	7	4	2	2	7	7
9	5	6	1	1	1	4	5
Avg.	5.2778	5.3333	2.4444	1.7778	2.2222	4.1667	4.8333

Appendix C: Intraclass Correlation Coefficient Calculations

TABLE C-1
EVALUATION SUMMARY FOR PROBLEM OVERVIEW

SUMMARY	Count	Sum	Average	Variance
Resp. 1	3	16	5.333	2.333
Resp. 2	3	17.5	5.833	2.583
Resp. 3	3	19	6.333	1.333
Resp. 4	3	18	6.000	0.000
Resp. 5	3	15	5.000	3.000
Resp. 6	3	17	5.667	2.333
Resp. 7	3	18	6.000	1.000
Resp. 8	3	12	4.000	9.000
Resp. 9	3	17	5.667	2.333
Soil Type	9	61	6.778	0.194
Coastal Distance	9	44.5	4.944	3.778
Vegetation Class	9	44	4.889	0.861

TABLE C-2
ANALYSIS OF VARIANCE FOR PROBLEM OVERVIEW

Source of Variation	SS	df	MS	F	P-value	F crit
Rows	11.630	8	1.454	0.860	0.567	2.591
Columns	20.796	2	10.398	6.153	0.010	3.634
Error	27.037	16	1.690			
Total	59.463	26				

With $k = 9$ respondents and $n = 3$ targets, this analysis yields $ICC = 0.375$.

TABLE C-3
EVALUATION SUMMARY FOR SOIL TYPE

SUMMARY	Count	Sum	Average	Variance
Resp. 1	4	20	5.000	3.333
Resp. 2	4	21.5	5.375	2.063
Resp. 3	4	16	4.000	6.667
Resp. 4	4	21	5.250	0.917
Resp. 5	4	23	5.750	2.250
Resp. 6	4	23.19	5.797	2.040
Resp. 7	4	22	5.500	3.667
Resp. 8	4	19	4.750	4.917
Resp. 9	4	22	5.500	1.667
Slope	9	34.5	3.833	0.625
Texture	9	62	6.889	0.111
Drainage	9	53.5	5.944	0.528
Depth	9	37.69	4.188	3.246

TABLE C-4
ANALYSIS OF VARIANCE FOR SOIL TYPE

Source of Variation	SS	df	MS	F	P-value	F crit
Rows	10.211	8	1.276	1.184	0.349	2.355
Columns	56.689	3	18.896	17.531	0.000	3.009
Error	25.869	24	1.078			
Total	92.769	35				

With $k = 9$ respondents and $n = 4$ targets, this analysis yields $ICC = 0.637$.

TABLE C-5
EVALUATION SUMMARY FOR SOIL SLOPE

SUMMARY	Count	Sum	Average	Variance
Resp. 1	6	32	5.333	3.867
Resp. 2	6	34	5.667	2.967
Resp. 3	6	32	5.333	2.667
Resp. 4	6	30	5.000	6.400
Resp. 5	6	26	4.333	7.867
Resp. 6	6	26	4.333	7.867
Resp. 7	6	31	5.167	4.567
Resp. 8	6	28	4.667	6.667
Resp. 9	6	27	4.500	6.700
0-5 %	9	62	6.889	0.111
5-9 %	9	63	7.000	0.000
9-15 %	9	57	6.333	0.250
15-30 %	9	45	5.000	0.750
30-65 %	9	23.5	2.611	1.361
> 65 %	9	15.5	1.722	0.944

TABLE C-6
ANALYSIS OF VARIANCE FOR SOIL SLOPE

Source of Variation	SS	df	MS	F	P-value	F crit
Rows	11.370	8	1.421	3.561	0.003	2.180
Columns	231.870	5	46.374	116.204	0.000	2.449
Error	15.963	40	0.399			
Total	259.204	53				

With $k = 9$ respondents and $n = 6$ targets, this analysis yields $ICC = 0.900$.

TABLE C-7
EVALUATION SUMMARY FOR SOIL DRAINAGE

SUMMARY	Count	Sum	Average	Variance
Resp. 1	7	28	4.000	9.000
Resp. 2	7	27.5	3.929	7.619
Resp. 3	7	31	4.429	7.619
Resp. 4	7	23	3.286	5.238
Resp. 5	7	32	4.571	7.952
Resp. 6	7	21	3.000	3.333
Resp. 7	7	26	3.714	6.905
Resp. 8	7	28	4.000	7.333
Resp. 9	7	26	3.714	5.238
Very Poorly Drained	9	9	1.000	0.000
Poorly Drained	9	10	1.111	0.111
Somewhat Poorly Drained	9	17	1.889	0.611
Moderately Well Drained	9	39	4.333	1.250
Well Drained	9	55.5	6.167	0.625
Somewhat Excessively Drained	9	57.5	6.389	0.986
Excessively Drained	9	54.5	6.056	2.403

TABLE C-8
ANALYSIS OF VARIANCE FOR SOIL DRAINAGE

Source of Variation	SS	df	MS	F	P-value	F crit
Rows	13.889	8	1.736	2.451	0.026	2.138
Columns	327.429	6	54.571	77.042	0.000	2.295
Error	34.000	48	0.708			
Total	375.317	62				

With $k = 9$ respondents and $n = 7$ targets, this analysis yields $ICC = 0.875$.

TABLE C-9
EVALUATION SUMMARY FOR SOIL DEPTH

SUMMARY	Count	Sum	Average	Variance
Resp. 1	5	29	5.800	4.700
Resp. 2	5	32.5	6.500	0.750
Resp. 3	5	28	5.600	3.800
Resp. 4	5	30	6.000	3.000
Resp. 5	5	29	5.800	3.200
Resp. 6	5	28.56	5.713	3.382
Resp. 7	5	25	5.000	8.000
Resp. 8	5	25	5.000	5.500
Resp. 9	5	30	6.000	2.000
< 10 inches	9	25.88	2.875	1.359
10-20 inches	9	43.31	4.813	1.621
20-40 inches	9	61.88	6.875	0.109
40-60 inches	9	63	7.000	0.000
> 60 inches	9	63	7.000	0.000

TABLE C-10
ANALYSIS OF VARIANCE FOR SOIL DRAINAGE

Source of Variation	SS	df	MS	F	P-value	F crit
Rows	9.144	8	1.143	2.348	0.041	2.244
Columns	121.753	4	30.438	62.538	0.000	2.668
Error	15.575	32	0.487			
Total	146.472	44				

With $k = 9$ respondents and $n = 5$ targets, this analysis yields $ICC = 0.843$.

TABLE C-11
EVALUATION SUMMARY FOR STONE SIZE

SUMMARY	Count	Sum	Average	Variance
Resp. 1	6	36	6.000	0.000
Resp. 2	6	35.5	5.917	0.342
Resp. 3	6	42	7.000	0.000
Resp. 4	6	8	1.333	0.267
Resp. 5	6	17	2.833	8.167
Resp. 6	6	17	2.833	1.367
Resp. 7	6	24	4.000	4.400
Resp. 8	6	42	7.000	0.000
Resp. 9	6	18	3.000	4.400
Fine Pebbles	9	53	5.889	3.111
Medium Pebbles	9	49	5.444	2.528
Coarse Pebbles	9	38	4.222	5.694
Cobbles	9	35.5	3.944	6.028
Stones	9	32.5	3.611	7.236
Boulders	9	31.5	3.500	7.750

TABLE C-12
ANALYSIS OF VARIANCE FOR STONE SIZE

Source of Variation	SS	df	MS	F	P-value	F crit
Rows	208.815	8	26.102	20.897	0.000	2.180
Columns	44.745	5	8.949	7.165	0.000	2.449
Error	49.963	40	1.249			
Total	303.523	53				

With $k = 9$ respondents and $n = 6$ targets, this analysis yields $ICC = 0.137$.

TABLE C-13
EVALUATION SUMMARY FOR STONE PERCENT

SUMMARY	Count	Sum	Average	Variance
Resp. 1	4	12	3.000	4.667
Resp. 2	4	22	5.500	1.500
Resp. 3	4	19	4.750	4.917
Resp. 4	4	13	3.250	4.917
Resp. 5	4	10	2.500	5.667
Resp. 6	4	12	3.000	3.333
Resp. 7	4	16	4.000	6.667
Resp. 8	4	14	3.500	7.000
Resp. 9	4	13	3.250	2.917
0-15 %	9	55.5	6.167	0.625
15-35 %	9	38.5	4.278	1.944
35-60 %	9	24	2.667	1.500
> 60 %	9	13	1.444	1.028

TABLE C-14
ANALYSIS OF VARIANCE FOR STONE PERCENT

Source of Variation	SS	df	MS	F	P-value	F crit
Rows	29.056	8	3.632	7.436	0.000	2.355
Columns	113.028	3	37.676	77.137	0.000	3.009
Error	11.722	24	0.488			
Total	153.806	35				

With $k = 9$ respondents and $n = 4$ targets, this analysis yields $ICC = 0.764$.

TABLE C-15
EVALUATION SUMMARY FOR COASTAL DISTANCE

SUMMARY	Count	Sum	Average	Variance
Resp. 1	4	25	6.250	0.917
Resp. 2	4	23.5	5.875	2.063
Resp. 3	4	17	4.250	7.583
Resp. 4	4	23	5.750	3.583
Resp. 5	4	28	7.000	0.000
Resp. 6	4	18	4.500	3.667
Resp. 7	4	21	5.250	5.583
Resp. 8	4	28	7.000	0.000
Resp. 9	4	21	5.250	4.250
0-2 km	9	62	6.889	0.111
2-4 km	9	61	6.778	0.194
4-6 km	9	47.5	5.278	1.944
> 6 km	9	34	3.778	4.694

TABLE C-16
ANALYSIS OF VARIANCE FOR COASTAL DISTANCE

Source of Variation	SS	df	MS	F	P-value	F crit
Rows	30.639	8	3.830	3.689	0.006	2.355
Columns	58.021	3	19.340	18.629	0.000	3.009
Error	24.917	24	1.038			
Total	113.576	35				

With $k = 9$ respondents and $n = 4$ targets, this analysis yields $ICC = 0.539$.

TABLE C-17
EVALUATION SUMMARY FOR SOIL TEXTURE

SUMMARY	Count	Sum	Average	Variance
Resp. 1	12	34	2.833	5.242
Resp. 2	12	32.5	2.708	5.839
Resp. 3	12	29	2.417	6.629
Resp. 4	12	38	3.167	3.061
Resp. 5	12	37	3.083	5.356
Resp. 6	12	34	2.833	6.515
Resp. 7	12	42	3.500	4.455
Resp. 8	12	34	2.833	3.424
Resp. 9	12	53	4.417	3.720
Sand	9	52	5.778	3.194
Loamy Sand	9	58	6.444	0.528
Sandy Loam	9	54.5	6.056	0.903
Loam	9	34.5	3.833	2.375
Silt Loam	9	27.5	3.056	3.528
Silt	9	17.5	1.944	0.778
Sandy Clay Loam	9	22.5	2.500	2.125
Clay Loam	9	13	1.444	0.528
Silty Clay Loam	9	14	1.556	0.528
Sandy Clay	9	18	2.000	1.750
Silty Clay	9	13	1.444	0.528
Clay	9	9	1.000	0.000

TABLE C-18
ANALYSIS OF VARIANCE FOR SOIL TEXTURE

Source of Variation	SS	df	MS	F	P-value	F crit
Rows	32.769	8	4.096	3.557	0.001	2.045
Columns	385.303	11	35.028	30.416	0.000	1.899
Error	101.343	88	1.152			
Total	519.414	107				

With $k = 9$ respondents and $n = 12$ targets, this analysis yields $ICC = 0.729$.

TABLE C-19
EVALUATION SUMMARY FOR VEGETATION CLASS
(PART 1 OF 2)

SUMMARY	Count	Sum	Average	Variance
Resp. 1	28	87	3.107	6.544
Resp. 2	28	84.5	3.018	6.787
Resp. 3	28	88	3.143	4.794
Resp. 4	28	78	2.786	2.545
Resp. 5	28	56	2.000	2.444
Resp. 6	28	77.63	2.772	2.832
Resp. 7	28	103	3.679	4.004
Resp. 8	28	104	3.714	4.952
Resp. 9	28	74	2.643	4.831
Ceanothus Crassifolius Chaparral	9	18.5	2.056	1.403
Chamise Chaparral	9	19	2.111	1.111
Coast Live Oak Woodland	9	16.88	1.875	1.359
Coastal and Valley Freshwater Marsh	9	9	1.000	0.000
Coastal Brackish Marsh	9	12	1.333	1.000
Coastal Sage/Chaparral Scrub	9	38.5	4.278	1.194
Coastal Sage/Chap. Scrub- Sparse	9	53	5.889	1.861
Dense Englemann Oak Woodland	9	11.25	1.250	0.188
Open Englemann Oak Woodland	9	14.63	1.625	0.734
Diegan Coastal Sage Scrub	9	51	5.667	1.000
Diegan Coastal Sage Scrub- Sparse	9	61	6.778	0.194
Freshwater Seep	9	9	1.000	0.000
Non-Native Grassland	9	43	4.778	4.444
S. Coast Live Oak Riparian Forest	9	13.5	1.500	0.500
S. Cottonwood/Willow Riparian Forest	9	14.63	1.625	0.484
S. Sycamore/Alder Riparian Woodland	9	15.75	1.750	0.938
San Diego Mesa Hardpan Vernal Pool	9	18	2.000	0.750
Scrub Oak Chaparral	9	18	2.000	0.500

TABLE C-20
EVALUATION SUMMARY FOR VEGETATION CLASS
(PART 2 OF 2)

SUMMARY	Count	Sum	Average	Variance
Southern Coastal Bluff Scrub	9	53	5.889	1.111
Southern Coastal Salt Marsh	9	13	1.444	1.028
Southern Coastal Salt Marsh-Sparse	9	15	1.667	1.750
Sothern Foredune	9	47.5	5.278	2.819
Southern Foredune-Sparse	9	48	5.333	2.750
Southern Mixed Chaparral-Granitic	9	22	2.444	1.528
Southern Willow Scrub	9	16	1.778	0.944
Southern Willow Scrub-Sparse	9	20	2.222	2.194
Valley Needlegrass	9	37.5	4.167	3.750
Valley Needlegrass-Sparse	9	43.5	4.833	3.750

TABLE C-21
ANALYSIS OF VARIANCE FOR VEGETATION CLASS

Source of Variation	SS	df	MS	F	P-value	F crit
Rows	62.329	8	7.791	6.679	0.000	1.981
Columns	820.821	27	30.401	26.062	0.000	1.538
Error	251.962	216	1.166			
Total	1135.112	251				

With $k = 9$ respondents and $n = 28$ targets, this analysis yields $ICC = 0.698$.

Appendix D: Converted Rankings
and Kendall Coefficients of Concordance

The following spreadsheets include the rating conversions for all questionnaire sections, and respective Kendall Coefficients of Concordance.

OVERVIEW						
Respondents	Soil Type	Coastal Distance	Vegetation Class	Row Sums		
1	1	2	3	6		
2	1	2	3	6		
3	1.5	1.5	3	6		
4	2	2	2	6		
5	1.5	3	1.5	6		
6	1	3	2	6		
7	1	2	3	6		
8	1	3	2	6		
9	1	2	3	6		
ColSums	11	20.5	22.5			
	k=	9	n=	3		
	S=	75.5				
	W=	0.466	Kendall Coefficient of Concordance			
	Q=	8.3889	Chi Squared Test Statistic			
	df=	2	degrees of freedom			
SOIL TYPE						
Respondents	Slope	Soil Texture	Drainage Class	Soil Depth	Row Sums	
1	4	1	2	3	10	
2	4	1	2.5	2.5	10	
3	3	1	2	4	10	
4	3	1.5	1.5	4	10	
5	4	1.5	1.5	3	10	
6	3	1.5	1.5	4	10	
7	4	1.5	3	1.5	10	
8	3	1	2	4	10	
9	4	1	2	3	10	
ColSums	32	11	18	29		
	n2=	4				
	S=	285				
	W=	0.7037	Kendall Coefficient of Concordance			
	Q=	19	Chi Squared Test Statistic			
	df=	3	degrees of freedom			

		SLOPE						
Respondents	0-5 %	5-9 %	9-15 %	15-30 %	30-65 %	> 65 %	Row Sums	
1	3.5	1.5	1.5	3.5	5	6	21	
2	2	2	2	4	5.5	5.5	21	
3	1.5	1.5	3	4	5	6	21	
4	2	2	2	4	5	6	21	
5	1.5	1.5	3	4	5.5	5.5	21	
6	1.5	1.5	3	4	5.5	5.5	21	
7	1.5	1.5	3.5	3.5	5	6	21	
8	1.5	1.5	3	4	5	6	21	
9	1.5	1.5	3	4	5	6	21	
ColSums	16.5	14.5	24	35	46.5	52.5		
n3=	6							
S=	1248.5							
W=	0.8808	Kendall Coefficient of Concordance						
Q=	39.635	Chi Squared Test Statistic						
df=	5 degrees of freedom							
SOIL DRAINAGE CLASS								
Respondents	Very Poorly Drained	Poorly Drained	Somewhat Poorly Drained	Moderately Well Drained	Well Drained	Somewhat Excessively Drained	Excessively Drained	Row Sums
1	6	6	6	4	2	2	2	28
2	6	6	6	4	2	2	2	28
3	6.5	6.5	5	4	2	2	2	28
4	6	6	6	3.5	1.5	1.5	3.5	28
5	6.5	6.5	5	4	2	2	2	28
6	6.5	6.5	5	2.5	1	2.5	4	28
7	6.5	6.5	5	4	3	1.5	1.5	28
8	6.5	6.5	5	4	3	1.5	1.5	28
9	7	5.5	5.5	4	3	2	1	28
ColSums	57.5	56	48.5	34	19.5	17	19.5	
nd=	7							
S=	1928							
W=	0.8501	Kendall Coefficient of Concordance						
Q=	45.905	Chi Squared Test Statistic						
df=	6 degrees of freedom							

		SOIL DEPTH						
Respondents	< 10 inches	10-20 inches	20-40 inches	40-60 inches	> 60 inches	Row Sums		
1	5	4	2	2	2	15		
2	5	4	2	2	2	15		
3	5	4	2	2	2	15		
4	5	4	2	2	2	15		
5	5	4	2	2	2	15		
6	5	4	3	1.5	1.5	15		
7	5	4	2	2	2	15		
8	5	4	3	1.5	1.5	15		
9	5	4	2	2	2	15		
ColSums	45	36	20	17	17			
	ndp=	5						
	S=	654						
	W=	0.8074	Kendall Coefficient of Concordance					
	Q=	29.067	Chi Squared Test Statistic					
	df=	4	degrees of freedom					
		STONE SIZE						
Respondents	Fine Pebbles	Medium Pebbles	Coarse Pebbles	Cobbles	Stones	Boulders	Row Sums	
1	3.5	3.5	3.5	3.5	3.5	3.5	21	
2	1	2.5	2.5	5	5	5	21	
3	3.5	3.5	3.5	3.5	3.5	3.5	21	
4	1.5	1.5	4.5	4.5	4.5	4.5	21	
5	1	2	4.5	4.5	4.5	4.5	21	
6	1.5	1.5	3.5	3.5	5	6	21	
7	1	2	3	4	5.5	5.5	21	
8	3.5	3.5	3.5	3.5	3.5	3.5	21	
9	1	2	3	4	5.5	5.5	21	
ColSums	17.5	22	31.5	36	40.5	41.5		
	nto=	6						
	S=	487.5						
	W=	0.3439	Kendall Coefficient of Concordance					
	Q=	15.476	Chi Squared Test Statistic					
	df=	5	degrees of freedom					

		PERCENT STONE							
Respondents					Row Sums				
	0-15 %	15-35 %	35-60 %	60 %					
1	1	2	3	4	10				
2	1.5	1.5	3	4	10				
3	1	2	3	4	10				
4	1	2	3	4	10				
5	1	2	3.5	3.5	10				
6	1	2	3	4	10				
7	1	2	3	4	10				
8	1	2	3	4	10				
9	1	2	3	4	10				
ColSums	9.5	17.5	27.5	35.5					
		ntp=	4						
		S=	388						
		W=	0.958	Kendall Coefficient of Concordance					
		Q=	25.867	Chi Squared Test Statistic					
		df=	3	degrees of freedom					
		COASTAL DISTANCE							
Respondents					Row Sums				
	0-2 km	2-4 km	4-6 km	6 km					
1	1.5	1.5	3	4	10				
2	1.5	1.5	3	4	10				
3	1	2	3	4	10				
4	1.5	1.5	3	4	10				
5	2.5	2.5	2.5	2.5	10				
6	1.5	1.5	3	4	10				
7	1.5	1.5	3	4	10				
8	2.5	2.5	2.5	2.5	10				
9	1.5	1.5	3	4	10				
ColSums	15	16	26	33					
		nc=	4						
		S=	221						
		W=	0.5457	Kendall Coefficient of Concordance					
		Q=	14.733	Chi Squared Test Statistic					
		df=	3	degrees of freedom					

		TEXTURE												
	Respondents	Sand	Loamy Sand	Sandy Loam	Loam	Silt Loam	Silt	Sandy Clay Loam	Clay Loam	Silty Clay Loam	Sandy Clay	Silty Clay	Clay	Row Sums
1	2.5	1	2.5	4	6	10	6	10	10	10	6	10	10	78
2	1.5	1.5	3	4	6	6	6	10	10	10	10	10	10	78
3	1.5	1.5	3	8	8	8	8	8	8	8	8	8	8	78
4	3	1.5	1.5	4.5	8.5	8.5	4.5	8.5	8.5	8.5	8.5	8.5	12	78
5	1.5	3	1.5	4.5	4.5	6	7	10	10	10	10	10	10	78
6	5	3	3	3	1	9	9	9	9	9	9	9	9	78
7	5	1.5	1.5	3	5	7.5	5	11	9	7.5	11	11	11	78
8	1	2	3	7.5	7.5	7.5	7.5	7.5	7.5	7.5	7.5	7.5	12	78
9	2	2	2	5	7	9.5	5	9.5	9.5	9.5	9.5	9.5	12	78
ColSums	23	17	21	43.5	53.5	72	58	83.5	81.5	71.5	83.5	94		
nt=		12												
S=		8029.5												
W=		0.6932	Kendall Coefficient of Concordance											
Q=		68.628	Chi Squared Test Statistic											
df=		11	degrees of freedom											

		VEGETATION CLASS (PART 2 OF 2)	
21	S. Cottonwood/Willow Riparian Forest	21	406
21	S. Sycamore/Alder Riparian Woodland	21	406
17	San Diego Mesa Hardpan Vernal Pool	17	406
17	Scrub Oak Chaparral	17	406
17	Southern Coastal Bluff Scrub	17	406
19.5	Southern Coastal Salt Marsh	19.5	406
21.5	Southern Coastal Salt Marsh-Sparse	21.5	406
17.5	Sothern Foredune	17.5	406
20.5	Southern Foredune-Sparse	20.5	406
20	Southern Mixed Chaparral-Granitic	20	406
175	Southern Willow Scrub	175	406
168.5	Southern Willow Scrub-Sparse	168.5	406
153	Valley Needlegrass	153	406
149.5	Valley Needlegrass-Sparse	149.5	406
38.5	Row Sums	38.5	406
188		188	
174.5		174.5	
55.5		55.5	
55		55	
139		139	
164		164	
146.5		146.5	
92.5		92.5	
70.5		70.5	

Appendix E: P Value Calculations

Probability of concluding association (agreement) between questionnaire respondent evaluations given that no association exists. The $\text{pchisq}(X^2, df)$ returns the cumulative probability for the X^2 statistic with degrees of freedom = df . The value of $(1-\text{pchisq})$ gives the right tailed probability of interest.

		<u>P Value</u>
Problem Overview:	Over := $1 - \text{pchisq}(8.39, 2)$	Over = 0.015
Soil Type:	Soil := $1 - \text{pchisq}(19, 3)$	Soil = $2.734 \cdot 10^{-4}$
Slope:	Slope := $1 - \text{pchisq}(39.63, 5)$	Slope = $1.773 \cdot 10^{-7}$
Soil Texture:	Text := $1 - \text{pchisq}(68.63, 11)$	Text = $2.223 \cdot 10^{-10}$
Stone Size:	Rock := $1 - \text{pchisq}(15.48, 5)$	Rock = $8.497 \cdot 10^{-3}$
Stone Percent:	Percent := $1 - \text{pchisq}(25.87, 3)$	Percent = $1.015 \cdot 10^{-5}$
Drainage Class:	Drain := $1 - \text{pchisq}(45.9, 6)$	Drain = $3.099 \cdot 10^{-8}$
Soil Depth:	Depth := $1 - \text{pchisq}(29.06, 4)$	Depth = $7.601 \cdot 10^{-6}$
Vegetation Class:	Veg := $1 - \text{pchisq}(159.3, 27)$	Veg = 0
Coastal Distance:	Dist := $1 - \text{pchisq}(14.73, 3)$	Dist = $2.063 \cdot 10^{-3}$

Appendix F: Soil Type Scores

The following spreadsheets contain the calculated scores from methods A and B for each soil type.

Soil Type	Descriptive Title	Method A Score: No Rock Material	Method B Score: Rock Size And Percent
ACG	Acid Igneous Rock Land	0.000	0.000
ATC	Altamont Clay 5-9% slope	4.768	5.774
ATD	Altamont Clay 9-15% slope	4.633	5.639
ATE	Altamont Clay 15-30% slope	4.388	5.394
ATF	Altamont Clay 30-50% slope	3.949	4.955
B1C	Bonsall Sandy Loam 2-9% slope	5.918	5.990
B1C2	BSL 2-9% slope, eroded	5.918	5.990
B1D2	BSL 9-15% slope, eroded	5.805	5.877
BEE	Blasingame Loam 9-30 % slope	5.446	5.929
BGF	Blasingame Stony Loam 30-50%	4.677	4.719
BSC	Bosanko Clay 2-9% slope	4.745	5.751
C1D2	Cieneba Crse Sandy Loam 5-15%, eroded	5.918	5.990
C1E2	Cieneba Crse Sandy Loam 15-30%, eroded	5.612	5.684
C1G2	Cieneba Crse Sandy Loam 30-65%, eroded	5.173	5.245
CBB	Carlsbad Gravelly Loamy Sand 2-5%	6.011	5.666
CBC	Carlsbad Gravelly Loamy Sand 5-9%	6.031	5.687
CBD	Carlsbad Gravelly Loamy Sand 9-15%	5.909	5.564
CBE	Carlsbad Gravelly Loamy Sand 15-30%	5.664	5.319
CCC	Carlsbad Urban Land Complex 2-9%	0.000	0.000
CFB	Chesterton Fine Sandy Loam 2-5%	5.882	5.954

Soil Type	Descriptive Title	Method A Score: No Rock Material	Method B Score: Rock Size And Percent
CFC	Chesterton Fine Sandy Loam 5-9%	5.903	5.975
CME2	Cieneba Rocky Crse S. Loam 9-30%, eroded	5.540	5.612
CMRG	Cieneba Very Rocky CSL. 30-75%, eroded	4.897	4.968
CNE2	Cieneba-Fallbrook Rocky SL 9-30%, eroded	5.957	6.029
CNG2	Cieneba-Fallbrook Rocky SL 30-65%, eroded	5.396	5.468
CR	Coastal Beaches	0.000	0.000
DAC	Diablo Clay, 2-9%	4.745	5.751
DAD	Diablo Clay, 9-15%	4.633	5.639
DAE	Diablo Clay, 15-30%	4.388	5.394
DAE2	Diablo Clay, 15-30%, eroded	4.388	5.394
DAF	Diablo Clay, 30-50%	3.949	4.955
DOE	Diablo-Olivenhain Complex, 9-30%	4.978	5.722
EDC	Elder Shaly Fine Sandy Loam 2-9%	6.432	6.159
ESC	Escondido Very Fine Sandy Loam 5-9%	6.425	6.497
ESD2	Escondido V F Sandy Loam 9-15%, eroded	6.096	6.168
ESE2	Escondido V F Sandy Loam 15-30%, eroded	6.058	6.130
EXG	Exchequer Rocky Silt Loam 30-70%	3.937	4.563
FAB	Fallbrook Sandy Loam 2-5%	6.417	6.489
FAC	Fallbrook Sandy Loam 5-9%	6.442	6.514
FAC2	Fallbrook Sandy Loam 5-9%, eroded	6.438	6.510

Soil Type	Descriptive Title	Method A Score: No Rock Material	Method B Score: Rock Size And Percent
FAD2	Fallbrook Sandy Loam 9-15%, eroded	6.315	6.387
FAE2	Fallbrook Sandy Loam 15-30%, eroded	6.070	6.142
FAE3	Fallbrook S Loam 9-30%, severely eroded	6.180	6.252
FEC	Fallbrook Rocky Sandy Loam 5-9%	6.425	6.497
FEE	Fallbrook Rocky Sandy Loam 9-30%	6.180	6.252
FEE2	Fallbrook Rocky Sandy Loam 9-30%, eroded	6.180	6.252
FVD	Fallbrook-Vista Sandy Loams 9-15%	6.315	6.387
FXE	Friant Rocky Fine Sandy Loam 9-30%	5.572	5.643
FXG	Friant Rocky Fine Sandy Loam 30-70%	4.928	5.000
GAE	Gaviota Fine Sandy Loam 9-30%	5.572	5.643
GAF	Gaviota Fine Sandy Loam 30-50%	5.010	5.082
GOA	Grangeville Fine Sandy Loam 0-2%	5.211	5.283
GRA	Greenfield Sandy Loam 0-2%	6.430	6.502
GRB	Greenfield Sandy Loam 2-5%	6.430	6.502
GRC	Greenfield Sandy Loam 5-9%	6.450	6.522
HAG	Hambright Gravelly Clay Loam 30-75%	3.600	4.179
HRC	Huerhuero Loam 2-9%	5.171	5.653
HRD	Huerhuero Loam 9-15%	5.046	5.529
HRD2	Huerhuero Loam 9-15%, eroded	5.046	5.529

Soil Type	Descriptive Title	Method A Score: No Rock Material	Method B Score: Rock Size And Percent
HRE2	Huerhuero Loam 15-30%, eroded	4.801	5.284
HUC	Huerhuero-Urban Land Complex 2-9%	0.000	0.000
HUE	Huerhuero-Urban Land Complex 9-30%	0.000	0.000
LEC	Las Flores Loamy Fine Sand 2-9%	6.046	6.046
LEC2	Las Flores Loamy Fine Sand 5-9%, eroded	6.056	6.056
LED	Las Flores Loamy Fine Sand 9-15%	5.934	5.934
LED2	Las Flores Loamy Fine Sand 9-15%, eroded	5.934	5.934
LEE	Las Flores Loamy Fine Sand 15-30%	5.689	5.689
LEE2	Las Flores Loamy Fine Sand 15-30%, eroded	5.689	5.689
LEE3	Las Flores LFS 9-30%, severely eroded	5.811	5.811
LFC	Las Flores-Urban Land Complex 2-9%	0.000	0.000
LPC	Las Posas Fine Sandy Loam 5-9%	6.425	6.497
LPD2	Las Posas Fine Sandy Loam 9-15%, eroded	6.303	6.375
LPE2	Las Posas Fine Sandy Loam 15-30%, eroded	6.058	6.130
LRE	Las Posas Stony Fine Sandy Loam 9-30%	6.180	5.811
LRG	Las Posas Stony Fine Sandy Loam 30-65%	5.838	5.469
LSE	Linne Clay Loam 9-30%	4.657	5.581
LSF	Linne Clay Loam 30-50%	4.315	5.239

Soil Type	Descriptive Title	Method A Score: No Rock Material	Method B Score: Rock Size And Percent
LVF3	Loamy Alluvial Land-Huerhuero Complex 9-50%, severely eroded	4.303	4.480
M1C	Marina Loamy Coarse Sand 2-9%	6.632	6.632
M1E	Marina Loamy Coarse Sand 9-30%	6.397	6.397
MD	Made Land	0.000	0.000
OHC	Olivenhain Cobbly Loam 2-9%	5.694	5.755
OHE	Olivenhain Cobbly Loam 9-30%	5.459	5.520
OHF	Olivenhain Cobbly Loam 30-50%	4.897	4.959
OKC	Olivenhain-Urban Land Complex 2-9%	0.000	0.000
PEC	Placentia Sandy Loam 2-9%	5.909	5.981
PEC2	Placentia Sandy Loam 5-9%, eroded	5.920	5.991
PFC	Placentia Sandy Loam, thick surface 2-9%	5.909	5.981
RAB	Ramona Sandy Loam 2-5%	6.430	6.502
RAC2	Ramona Sandy Loam 5-9%, eroded	6.450	6.522
RAD2	Ramona Sandy Loam 9-15%, eroded	6.328	6.400
RCD	Ramona Gravelly Sandy Loam 9-15%	6.328	6.055
RCE	Ramona Gravelly Sandy Loam 15-30%	6.083	5.810
RKB	Reiff Fine Sandy Loam 2-5%	6.430	6.502
RKC	Reiff Fine Sandy Loam 5-9%	6.450	6.522
RM	River Wash	0.000	0.000

Soil Type	Descriptive Title	Method A Score: No Rock Material	Method B Score: Rock Size And Percent
RUG	Rough Broken Land	0.000	0.000
SBA	Salinas Clay Loam 0-2%	4.646	5.569
SBC	Salinas Clay Loam 2-9%	4.656	5.580
SCA	Salinas Clay 0-2%	4.499	5.505
SCB	Salinas Clay 2-5%	4.499	5.505
STG	Steep Gullied Land	0.000	0.000
SVE	Stony Land	0.000	0.000
TEF	Terrace Escarpments	0.000	0.000
TF	Tidal Flats	0.000	0.000
TUB	Tujunga Sand 0-5%	6.307	6.430
VAA	Visalia Sandy Loam 0-2%	5.907	5.979
VAB	Visalia Sandy Loam 2-5%	5.907	5.979
VAC	Visalia Sandy Loam 5-9%	5.928	6.000
VAD	Visalia Sandy Loam 9-15%	5.805	5.877
VBB	Visalia Gravelly Sandy Loam 2-5%	5.907	5.635
VBC	Visalia Gravelly Sandy Loam 5-9%	5.928	5.655
VSC	Vista Coarse Sandy Loam 5-9%	6.438	6.510
VSD	Vista Coarse Sandy Loam 9-15%	6.315	6.387
VSD2	Vista Coarse Sandy Loam 9-15%, eroded	6.315	6.387
VSE	Vista Coarse Sandy Loam 15-30%	6.070	6.142
VSE2	Vista Coarse Sandy Loam 15-30%, eroded	6.058	6.130
VVD	Vista Rocky Coarse Sandy Loam 5-15%	6.364	6.436
VVE	Vista Rocky Coarse Sandy Loam 15-30%	6.058	6.130

Appendix G: Respondent Cut-off Summary

The following spreadsheets include cut-off categories specified for each criterion by questionnaire respondents. One hundred percent agreement was necessary for employment of cut-offs in the noncompensatory map.

~~G-3~~

		STONE SIZE				PERCENT STONE				TEXTURE				
1	Respondents													
2		-												
3														
4				X				X	X					
5				X				X	X					
6								-	X					
7									X					
8									X					
9									X					

G-3

9	8	7	6	5	4	3	2	1	Respondents	
X			-		X	X	-		<u>Ceanothus Crassifolius</u> Chaparral	
X			-		X		-		Chamise Chaparral	
X			-	X		X	-	X	Coast Live Oak Woodland	
X	X	X	-	X	X	X	-	X	Coastal and Valley Freshwater Marsh	
X	X	X	-	X	X		-	X	Coastal Brackish Marsh	
			-				-		Coastal Sage/Chaparral Scrub	
			-				-		Coastal Sage/Chap. Scrub-Sparse	
X			-	X		X	-	X	Dense Englemann Oak Woodland	
X			-	X		X	-	X	Open Englemann Oak Woodland	
			-				-		Diegan Coastal Sage Scrub	
			-				-		Diegan Coastal Sage Scrub-Sparse	
X	X	X	-	X	X	X	-	X	Freshwater Seep	VEGETATION CLASS
			-	X			-		Non-Native Grassland	
X			-	X	X	X	-	X	S. Coast Live Oak Riparian Forest	
X			-	X	X		-	X	S. Cottonwood/Willow Riparian Forest	
X			-	X	X		-	X	S. Sycamore/Alder Riparian Woodland	
			-	X	X		-	X	San Diego Mesa Hardpan Vernal Pool	
X			-		X	X	-		Scrub Oak Chaparral	
			-				-		Southern Coastal Bluff Scrub	
X	X	X	-	X	X		-	X	Southern Coastal Salt Marsh	
X	X	X	-	X			-	X	Southern Coastal Salt Marsh-Sparse	
			-				-		Sothern Foredune	
			-				-		Southern Foredune-Sparse	
X			-	X			-		Southern Mixed Chaparral-Granitic	
X			-	X			-	X	Southern Willow Scrub	
X			-	X			-	X	Southern Willow Scrub-Sparse	
			-	X			-		Valley Needlegrass	
			-	X			-		Valley Needlegrass-Sparse	

Appendix H: Stone Material Significance Calculations

To investigate the significance of eliminating stone material from calculations of soil scores (i.e. using method A vs method B), the maximum difference between habitat suitabilities for identical sites with different stoniness characteristics is calculated below. The weights of preference for the hierarchical levels are as follows.

Top Hierarchy Level Weights:

Soil := .408 Dist := .298 Veg := .294

Soil Hierarchy Level 1 Weights:

Slop := .184 TexClas := .330 Drain := .285 Depth := .201

Soil Hierarchy Level 2 Weights:

Text := .441 Size := .186 Perc := .373

The maximum possible effect due to inclusion of stone material would be illustrated by calculating the maximum and minimum possible contributions to habitat suitability due to stone material. The difference is the range of effects due to stone material. The lowest and highest scores for percent and size of stone material present are listed below.

PERCLOW := 1.44 PERCHIGH := 6.17

SIZELOW := 3.5 SIZEHIGH := 7

Highest addition to habitat suitability due to stone material.

HIGHab := (PERCHIGH·Perc + SIZEHIGH·Size)·TexClas·Soil HIGHab = 0.485

Lowest addition to habitat suitability due to stone material.

LOWhab := (PERCLOW·Perc + SIZELOW·Size)·TexClas·Soil LOWhab = 0.16

Maximum difference. MaxDif := HIGHab - LOWhab MaxDif = 0.325

Although the above value is the maximum possible difference, no locations have greater than 15 - 35% stone material present which changes the low percentage score to 4.28 instead of 1.44. Additionally, the largest stone material present (in the soil classifications) which is within the soil matrices on base is stone which changes the size low score to 3.61 instead of 3.5. This yields an actual maximum difference which is much lower.

PERCLOW :=4.28 SIZELOW :=3.61

Highest addition to habitat suitability due to stone material.

HIGHab :=(PERCHIGH·Perc+ SIZEHIGH·Size)·TexClas·Soil HIGHab =0.485

Lowest addition to habitat suitability due to stone material.

LOWhab :=(PERCLOW·Perc+ SIZELOW·Size)·TexClas·Soil LOWhab =0.305

Maximum difference. MaxDif :=HIGHab - LOWhab MaxDif =0.18

This analysis yields that the maximum difference in habitat suitability scores that would be realized for identical sites on base with different stoniness characteristics would only be equal to 0.18.

An example of two possible sites with identical characteristics except for stoniness is demonstrated below.

Site 1: Visalia Sandy Loam =>	TEX1 :=6.06
No Stone Present =>	STON1 :=7
0 % Stone =>	PERC1 :=6.17
2-5% slope =>	SLOP1 :=6.89
60 Inches Deep =>	DEP1 :=7
Moderately Well Drained =>	DR1 :=4.33
Coastal Sage/Chaparral	
Scrub - Sparse =>	VEG1 :=5.89
0 - 2 km Distance =>	DIST1 :=6.89

Soil Score:

$SSC1 := Slop \cdot SLOP1 + Drain \cdot DR1 + Depth \cdot DEP1 + TexClas \cdot (Text \cdot TEX1 + Size \cdot STON1 + Perc \cdot PERC1)$

SSC1 = 5.98

Habitat Suitability: $HS1 := Soil \cdot SSC1 + Dist \cdot DIST1 + Veg \cdot VEG1$

HS1 = 6.225

Site 2: Visalia Gravelly Sandy Loam =>	TEX2 :=6.06
Gravel (Pebbles of all 3 sizes) =>	STON2 :=5.19
15 - 35 % Stone =>	PERC2 :=4.28
2-5% slope =>	SLOP2 :=6.89
60 Inches Deep =>	DEP2 :=7
Moderately Well Drained =>	DR2 :=4.33
Coastal Sage/Chaparral	
Scrub - Sparse =>	VEG2 :=5.89
0 - 2 km Distance =>	DIST2 :=6.89

Soil Score:

$SSC2 := Slop \cdot SLOP2 + Drain \cdot DR2 + Depth \cdot DEP2 + TexClas \cdot (Text \cdot TEX2 + Size \cdot STON2 + Perc \cdot PERC2)$

SSC2 = 5.636

Habitat Suitability: $HS2 := Soil \cdot SSC2 + Dist \cdot DIST2 + Veg \cdot VEG2$

HS2 = 6.084

For these sites, the habitat suitability difference is only 0.14 on a seven point scale.

$HS1 - HS2 = 0.14$

Bibliography

- Anselin, A., P. Meire, and L. Anselin. "Multicriteria Techniques in Ecological Evaluation: an Example Using the Analytical Hierarchy Process," Biological Conservation, 49: 215-229 (1989).
- Boyer, David. Wildlife Biologist, Environmental and Natural Resource Management Office, Camp Pendleton CA. Personal Correspondence. Spring 1996.
- Boyer, David. PPM brief handout. Environmental and Natural Resource Management Office, Camp Pendleton CA, 1996.
- Department of Agriculture. Soil Survey Manual. United States Department of Agriculture, Handbook No. 18, 1951.
- Department of Agriculture. Soil Survey, San Diego Area, California. United States Department of Agriculture, 1973.
- Department of the Interior. "Endangered and Threatened Wildlife and Plants; Determination of Endangered Status for the Pacific Pocket Mouse," Federal Register, 59: 49752-49764 (September 1994).
- Donahue, Roy L. Soils: An Introduction to Soils and Plant Growth. New Jersey: Prentice-Hall, 1965.
- Eckenrode, Robert T. "Weighting Multiple Criteria," Management Science, 12: 180-192 (1965).
- Environmental Systems Research Institute, Inc. Understanding GIS, The ARC/INFO Method. New York: John Wiley and Sons, 1993.
- Frank, Bruce David. Fire Fuel Modeling at Camp Pendleton: Evaluating the Effectiveness of the Use of Preference Analysis Techniques in a Geographic Information System. San Diego State University, San Diego, CA, 1995.
- Genoways, Hugh H. and James H. Brown. Biology of the Heteromyidae (Special Publication No. 10). Stillwater, Oklahoma: The American Society of Mammalogists, 1993.

- Gibbons, Jean Dickinson. Nonparametric Methods for Quantitative Analysis. New York: Holt, Rinehart, and Winston, 1976.
- Hall, E. Raymond. The Mammals of North America (Volume I, Second Edition). New York: John Wiley & Sons, 1981.
- Holland, Robert F. Preliminary Descriptions of the Terrestrial Natural Communities of California. Sacramento: State of California, The Resources Agency, Department of Fish and Game, October 1986.
- Hopkins, Lewis D. "Methods for Generating Land Suitability Maps: A Comprehensive Evaluation," Journal of the American Institute of Planning: 386-400 (1977).
- Jankowsky, Piotr. "Integrating Geographic Information Systems and Multiple Criteria Decision-Making Methods," International Journal of Geographical Information Systems, 9: 251-273 (1995).
- Michael Brandman Associates and LSA Associates, Inc. "Draft, Results of Focused Surveys for the Pacific Pocket Mouse Foothill Transportation Corridor-South". Report to the Foothill Transportation Corridor-South, Michael Brandman Associates and LSA Associates, Inc., 13 December 1995.
- Pacific Pocket Mouse Workshop. San Diego CA, 5 March 1996.
- Saaty, Thomas L. The Analytic Hierarchy Process. New York: McGraw-Hill, 1980.
- Shrout, Patrick E. and Joseph L. Fleiss. "Intraclass Correlations: Uses in Assessing Rater Reliability," Psychological Bulletin, 86: 420-428 (1979).
- United States Fish and Wildlife Service. "Surveys and Studies of the Pacific Pocket Mouse on Marine Corps Base Camp Pendleton, California 1994-1995." Draft Report. Carlsbad Field Office, Carlsbad CA, 1995.
- Vaughan, Ray. Endangered Species Act Handbook. Rockville MD: Government Institutes Inc., 1994.

Voogd, Henk. Multicriteria Evaluation for Urban and Regional Planning. London: Pion Limited, 1983.

Watkins, T. H. "Life List, U.S.A." Wilderness, 54: 17-21 (1991).

Vita

Captain Anthony A. Ference was born on 30 August 1967 in Washington, DC. He graduated from Penn Trafford High School in 1985 and entered undergraduate studies at the Penn State University in State College, Pennsylvania. He graduated with a Bachelor of Science degree in Aerospace Engineering on 6 January 1990. He received his Marine Corps commission on the same day.

He attended The Basic School (TBS) at Quantico and the Combat Engineer School at Camp Lejeune. He served with the Combat Replacement Regiment in Al Jubayl, Saudi Arabia during Operation Desert Storm in 1991. He was next assigned to First Combat Engineer Battalion, Camp Pendleton where he held the positions of platoon commander, assistant operations officer, and company executive officer. As platoon commander, he deployed with the Thirteenth Marine Expeditionary Unit (MEU) in support of Battalion Landing Team 1/9. After deployment, he was assigned to the First Marine Expeditionary Force G-3 as administrative officer and in May 1995, he entered the Graduate School of Engineering, Air Force Institute of Technology.

Permanent Address: 323 Edgewood Ave.
Trafford, Pa. 15085

REPORT DOCUMENTATION PAGE

Form Approved
OMB No. 0704-0188

Public reporting burden for this collection of information is estimated to average 1 hour per response, including the time for reviewing instructions, searching existing data sources, gathering and maintaining the data needed, and completing and reviewing the collection of information. Send comments regarding this burden estimate or any other aspect of this collection of information, including suggestions for reducing this burden, to Washington Headquarters Services, Directorate for Information Operations and Reports, 1215 Jefferson Davis Highway, Suite 1204, Arlington, VA 22202-4302, and to the Office of Management and Budget, Paperwork Reduction Project (0704-0188), Washington, DC 20503.

1. AGENCY USE ONLY (Leave blank)	2. REPORT DATE December 1996	3. REPORT TYPE AND DATES COVERED Master's Thesis	
4. TITLE AND SUBTITLE Habitat Suitability Mapping Through Integration of Multicriteria Evaluation Techniques With a Geographic Information System (GIS)			5. FUNDING NUMBERS
6. AUTHOR(S) ANTHONY A. FERENCE, Capt, USMC			
7. PERFORMING ORGANIZATION NAME(S) AND ADDRESS(ES) Air Force Institute of Technology (AFIT) Wright Patterson AFB, OH 45433-6583			8. PERFORMING ORGANIZATION REPORT NUMBER AFIT/GEE/ENV/96D-03
9. SPONSORING / MONITORING AGENCY NAME(S) AND ADDRESS(ES)			10. SPONSORING / MONITORING AGENCY REPORT NUMBER
11. SUPPLEMENTARY NOTES			
12a. DISTRIBUTION / AVAILABILITY STATEMENT Approved for public release; distribution unlimited			12b. DISTRIBUTION CODE
13. ABSTRACT (Maximum 200 words) <p>The presence of an endangered species, the Pacific Pocket Mouse (PPM), in critical Marine Corps training areas aboard Camp Pendleton may adversely affect training activities that are crucial to meeting the Marine Corps' mission. Camp Pendleton must focus limited budgetary assets for live trapping surveys of the PPM in the areas of best habitat suitability and the purpose of this study was to develop a PPM habitat suitability map of Camp Pendleton.</p> <p>Suitability maps were developed by integrating expert opinion with the Camp Pendleton Geographic Information System (GIS) database. The seven points scale multicriteria evaluation methodology was implemented to solicit the importance of ground characteristics (criteria) for PPM habitat from field experts. The criteria of interest were coastal proximity, soil type, and vegetation class. The evaluations of the respondents were in agreement. Suitability scores and preference weights were determined from questionnaire responses and input into the ARC/INFO® GIS program. Habitat suitabilities were calculated as weighted averages of suitability scores of individual ground characteristics. The criterion and combined suitability maps produced agreed well with known locations of the PPM. This indicated that the evaluations and methodology were valid. Coastal proximity was determined to be unimportant and should be eliminated from future research in this area.</p>			
14. SUBJECT TERMS environment, environmental, endangered species, habitat suitability, mapping, multicriteria evaluation, geographic information systems (GIS), multicriteria decision making (MCDM)			15. NUMBER OF PAGES 180
			16. PRICE CODE
17. SECURITY CLASSIFICATION OF REPORT Unclassified	18. SECURITY CLASSIFICATION OF THIS PAGE Unclassified	19. SECURITY CLASSIFICATION OF ABSTRACT Unclassified	20. LIMITATION OF ABSTRACT UL