



**A PERFORMANCE AND COST
EVALUATION OF INTERNAL
COMBUSTION ENGINES FOR
THE DESTRUCTION OF HYDROCARBON
VAPORS FROM FUEL-CONTAMINATED SOILS**

DTIC QUALITY INSPECTED 2

DECEMBER 1994

Distribution is unlimited; approved for public release

**AIR FORCE CENTER FOR ENVIRONMENTAL EXCELLENCE (AFCEE)
TECHNOLOGY TRANSFER DIVISION**

19970425 058

**A PERFORMANCE AND COST
EVALUATION OF INTERNAL
COMBUSTION ENGINES FOR
THE DESTRUCTION OF HYDROCARBON
VAPORS FROM FUEL-CONTAMINATED SOILS**

by

S.R. Archabal and D.C. Downey

Engineering-Science, Inc.

Denver, Colorado

for

U.S. Air Force

Center for Environmental Excellence

Brooks Air Force Base, Texas

This document was prepared for the United States Government by Engineering-Science, Inc. In no event shall either the United States Government or Engineering-Science, Inc. have any responsibility or liability for any consequences of any use, misuse, inability to use, or reliance upon the information contained herein, nor does either warrant or otherwise represent in any way the accuracy, adequacy, or applicability of the contents hereof.

CONTENTS

	<u>Page</u>
1.0 Introduction	1-1
2.0 Description of Technology	2-1
2.1 Vapor Extraction and Combustion	2-1
2.2 Vendor's Statement of System Capabilities/Costs	2-2
2.2.1 Capabilities	2-2
2.2.2 Special Considerations/Limitations	2-2
2.2.3 Vendor Costs	2-6
2.3 Regulatory Acceptance.....	2-8
3.0 Field Demonstration Results	3-1
3.1 Site Description	3-1
3.2 Regulatory Approval/Requirements.....	3-1
3.3 Test Conditions	3-2
3.4 Observed Performance.....	3-2
3.4.1 Initial 2-Days at 150 scfm	3-2
3.4.2 Long-Term (Weeks 2-13) Performance.....	3-5
3.4.3 Destruction Efficiency	3-5
3.4.4 Cost of Extended Operations.....	3-8
3.5 Reliability.....	3-8
3.6 Maintainability	3-8
4.0 Summary.....	4-1
4.1 Technology Performance	4-1
4.1.1 Destruction Efficiency	4-1
4.1.2 Reliability	4-1
4.1.3 Maintainability	4-2
4.2 Cost.....	4-2
4.2.1 Purchase or Rental.....	4-2
4.2.2 Operating Costs	4-2
4.2.3 Cost Per kilogram of TVH/BTEX.....	4-3
4.3 Integration with <i>In Situ</i> Bioventing	4-3
4.4 Future Work.....	4-3
5.0 References	5-1
APPENDIX A.....	A-1

CONTENTS (Continued)

TABLES

<u>No.</u>	<u>Title</u>	<u>Page</u>
2.1	Dimensions for VR Systems Models V2C, V3, and V4	2-4
2.2	Manufacturer Performance Specifications for VR Systems Models V2C, V3, and V4	2-5
2.3	Capital and Operating Costs	2-7
3.1	Change in Influent Concentrations for TVH and BTEX Over Time at 150 scfm	3-3

FIGURES

<u>No.</u>	<u>Title</u>	<u>Page</u>
2.1	Schematic Diagram of V3 Vapor Recovery Unit	2-3
3.1	Cost Per Kilogram of BTEX and TVH Destroyed at 150 scfm Initial Flow Rate	3-4
3.2	Influent BTEX and TVH Concentration Reduction vs. Total scfm Treated	3-6
3.3	VR Systems Destruction Efficiency for BTEX and TVH.....	3-7
3.4	Cost Per Kilogram of BTEX and TVH Destroyed at 80 scfm Flow Rate	3-9

SECTION 1

INTRODUCTION

This document describes the performance and costs associated with a modified internal combustion engine (ICE) used for the destruction of hydrocarbon vapors extracted from fuel contaminated soils. During the period of 18 October 1993 to 14 January 1994, an ICE treatment system manufactured by VR Systems Inc. in Anaheim, California was tested at the Patrick Air Force Base (AFB), Florida, active Base Exchange (BX) service station. The ICE test was conducted in conjunction with an ongoing soil vapor extraction/bioventing pilot test directed and funded by the Air Force Center for Environmental Excellence (AFCEE), Technology Transfer Division (ERT). The purpose of this test was to independently measure both the performance and the cost of ICE operation, and to determine how this technology can be most effectively used to complement the bioventing technology.

Bioventing is an *in situ* remediation technology which is best suited for less volatile hydrocarbons commonly found in jet fuels, diesel fuels, and heating oils. Bioventing can be accomplished through air injection or extraction; however, injection of air into sites contaminated with more volatile hydrocarbon products (e.g., gasoline) can result in uncontrolled migration of high concentrations of volatile organic compounds (VOCs). One solution to this problem is the use of soil vapor extraction techniques during the initial months of remediation to remove and treat high levels of soil gas VOCs. Additionally, while the VOCs are being extracted from the soil, they are replaced by atmospheric air which contains the oxygen (i.e., electron acceptor) required to subsequently promote *in situ* biodegradation. This short period of vapor extraction (higher cost) is then followed by long-term air injection (lower cost) to provide oxygen for the biodegradation of less volatile or adsorbed hydrocarbons in the soil.

In many states, VOCs must be treated before discharge into the atmosphere. In the State of Florida, soil vapor extraction must include a vapor treatment technology capable of removing 99 percent of the VOCs prior to discharge. Activated carbon canisters and thermal destruction units, such as ICEs, are used for treatment of hydrocarbon vapors. Significant information on the performance and cost of activated carbon is already available. Less information is available on ICE performance, particularly data that have been independently measured and verified.

This document is organized into five sections including this introduction. Section 2 provides a more complete description of the technology and the vendor's information on performance and cost. Section 3 reports the results of the 3-month field test with an

emphasis on VOC destruction efficiency, operating costs, and reliability and maintainability issues. Section 4 provides a summary of this technology evaluation and discusses how this technology can best be integrated into an *in situ* bioventing project. Section 5 includes the references cited in this report.

SECTION 2

DESCRIPTION OF TECHNOLOGY

2.1 VAPOR EXTRACTION AND COMBUSTION

Vapor extraction and combustion is an innovative technology which uses a gasoline-burning ICE with advanced emission controls to extract and burn hydrocarbon vapors from the vadose zone of contaminated soil. Vapors are extracted from the ground by the intake manifold vacuum of the engine. The vapors are then burned as fuel to run the engine. The exhaust gases pass through catalytic converters for final purification before exiting to the atmosphere.

VR Systems, Inc. of Anaheim, California¹ has developed a vapor extraction technology which incorporates the use of a modified ICE. The VR Systems Model V3 unit uses a Ford Motor Company® 460-cubic-inch-displacement (CID) engine block, heads, and accessories along with an onboard computer system which monitors engine performance. The intake manifold of the engine provides the vacuum source, up to 18 inches of mercury (Hg) or approximately 245 inches of water. Flow rates range from 0 to 250 standard cubic feet per minute (scfm), depending on soil conditions and the hydrocarbon concentrations of the extracted soil gas.

The VR System units are not designed to remove or treat chlorinated vapors from soil. These vapors once thermally treated can produce an off-gas air stream containing hydrochloric acid (HCl) vapor and potentially other highly toxic gases, depending on which type of chlorinated vapor is being destroyed. Additionally, the highly corrosive vapors produced as a treatment by-product destroys the engine and related equipment. There are other thermal oxidation systems equipped with condensing units (scrubbers) on the exhaust to effectively treat chlorinated vapors.

The VR System units are designed to remove nonchlorinated hydrocarbon vapors from contaminated soil utilizing a vapor extraction vent well like the one installed at the Patrick AFB, BX Service Station as part of the bioventing pilot test (ES, 1993). The extracted vapors flow through a computer-monitored fuel control system, and into the intake manifold of the engine. Destruction of the majority of hydrocarbon vapors occurs through combustion within the engine. Exhaust gases from the engine pass through a small catalytic converter which completes the treatment process.

An on-board computer system provides the necessary monitoring for engine control. The data acquisition system includes a 16-channel data reporting system which

¹ Point of Contact: Mr. Tom Davis, Telephone: 714-826-0483, FAX: 714-826-8746

monitors the engine's vital signs (oil pressure/temperature, coolant temperature, exhaust temperature, exhaust percent oxygen, and engine speed), and operation (flow rates, inches of vacuum pressure, supplemental fuel consumption, air/fuel ratio, and engine hours). The V3 unit also is equipped with an automatic engine shutdown system. Monitored by the on-board computer, automatic shutdown occurs if one or more of the following conditions is present: engine overspeed, high coolant temperature, high oil temperature, low oil pressure, fire, or high water level in the well gas filter assembly. The computer is programmed to store and report (in a printout) the reason for the automatic engine shut down.

Supplemental fuel (propane or natural gas) is used to provide smooth operation of the engine as extracted soil gas vapor concentrations fluctuate. Elimination of supplemental fuel usage can be achieved if the extracted soil gas vapor concentrations provide sufficient fuel to sustain combustion and smooth operation of the engine. The computer regulates the fuel requirements of the engine by the means of a master control unit (MCU). The MCU makes adjustments in the supplemental fuel flow to compensate for the changing influent hydrocarbon concentrations and to maintain the stoichiometric air-to-fuel ratio. By maintaining the proper air/fuel ratio, the total hydrocarbon vapor destruction efficiency typically exceeds 99 percent.

The V3 unit also is equipped with a flame arrestor to protect the vapor extraction system from "flash back" from the engine. A fire control system equipped with a dry chemical extinguisher is provided to automatically discharge in case of a fire.

External electrical power is not required. The electronic ignition system is battery-powered and adjusts automatically in response to commands from the computer. The V3 unit is also equipped with a modem for remote monitoring and to make necessary adjustments to vacuum or engine speed to optimize engine performance and minimize supplemental fuel consumption. During high water table conditions, it may be necessary to set limits on flow rate and vacuum pressure to prevent a high water shut down of the unit. The remote monitoring capability also allows for adjustments to be made while the unit is operating.

2.2 VENDOR'S STATEMENT OF SYSTEM CAPABILITIES/COSTS

2.2.1 Capabilities

VR Systems, Inc. manufactures vapor recovery systems in three sizes. A system schematic of the V3 unit is provided in Figure 2.1. Other VR System models and system schematics are provided in Appendix A. Table 2.1 provides the physical dimensions of each model. The specifications of each model are provided in Table 2.2. Additional costs for accessories [e.g., a modem for remote monitoring, cellular phone adaptation, liquid crystal display (LCD) monitor, 3.5-inch disk drive (Model V3), and other equipment] can be found in Appendix A.

2.2.2 Special Considerations/Limitations

Site-specific conditions can limit the application and performance of ICEs. Limitations pertaining to the VR Systems technology and appropriate corrective actions (CAs) are listed below:

- Optimum ambient temperature operating range is 0° to 56°C (32° to 125°F).

Figure 2.1

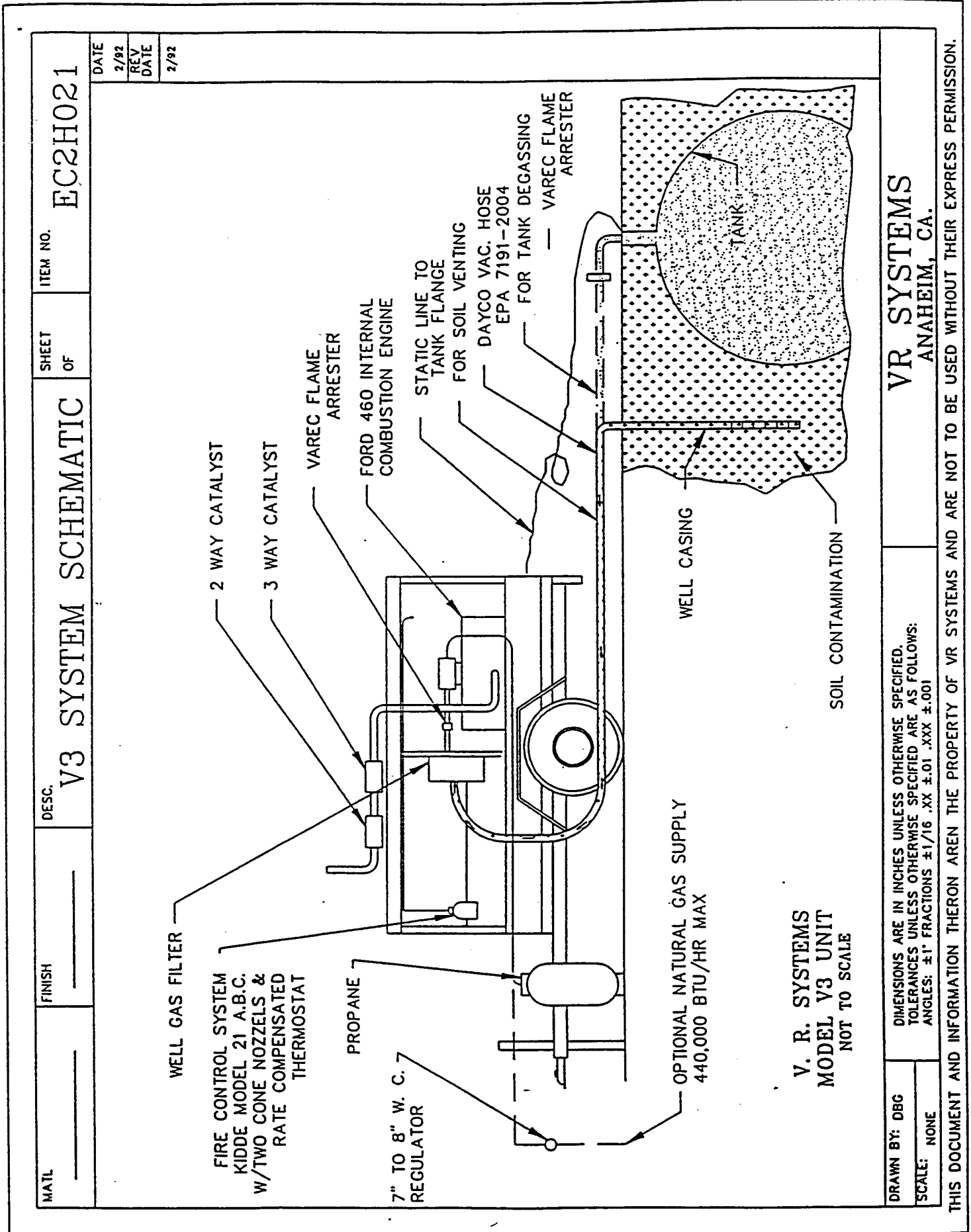

TABLE 2.1

**DIMENSIONS FOR VR SYSTEMS MODELS V2C, V3, V4^{a/}
VAPOR EXTRACTION/INTERNAL COMBUSTION ENGINE EVALUATION
PATRICK AFB, FLORIDA**

Model	Length	Width	Height ^{b/}
V2C	10'9"	5'4"	5'4"
V3	13'5"	6'4"	5'5"
V4	15'7"	6'4"	5'5"

a/ Dimensions are approximate and subject to change.

b/ Does not include exhaust stack.

TABLE 2.2

**MANUFACTURER PERFORMANCE SPECIFICATIONS
FOR VR SYSTEMS MODELS V2C, V3, AND V4
VAPOR EXTRACTION/INTERNAL COMBUSTION ENGINE EVALUATION
PATRICK AFB, FLORIDA**

Feature	V2C	V3	V4
Max. Hydrocarbon Destruction Rate	15 lbs/hr	55 lbs/hr	110 lbs/hr
Destruction Efficiency for TVH/BTEX ^{a/}	> 99%	> 99%	> 99%
Engine Size in Cubic Inch Displacement	140	460	920 (2 x 460)
Max. Flow Rate in Cubic Feet/Min	65	250	500
Max. Vacuum in Inches of Mercury/Approx. Inches of Water	18/245	18/245	18/245
Required Soil Gas Hydrocarbon concentration (ppmv as gasoline) ^{b/}	40,000	40,000	40,000

^{a/} TVH = total volatile hydrocarbons; BTEX = benzene, toluene, ethylbenzene, and xylenes.

^{b/} The influent vapor concentration in ppmv = parts per million, volume per volume required to sustain > 99% destruction efficiency without the addition of supplemental fuel (propane or natural gas).

- Relative humidity of the extracted air stream must be less than 95% or noncondensing.

CA: If a high water table exists or condensation occurs in the extraction hose, then a water knock-out chamber can be installed in-line between the vapor extraction well and the ICE unit to prevent high-water shut down of the system.

- ICE will require supplemental fuel at some point during cleanup activities (propane or natural gas).

CA: Optimize engine speed and vapor flow rate to reduce excessive supplemental fuel consumption.

- Limited basic engine warranty, covers the first 4,000 hours or 12 months of operation, whichever comes first. The warranty does not include accessories such as the starter, alternator, plugs, wires, etc.

CA: If factory-recommended maintenance is conducted, VR Systems, Inc. has demonstrated a life expectancy of the engine ranging from 16,000 to 20,000 hours. This equates to around 2 to 2.5 years of continuous operation, 24 hours per day, at 1,800 to 2,200 revolutions per minute (rpm). To rebuild the engine costs around \$3,500, which equates to around \$0.18 per hour of operation.

- Noise associated with the operation of the engine could be considered a potential concern for areas near residential areas or other occupied buildings. The noise level varies accordingly with engine speed. A noise test was conducted by VR Systems on April 9, 1991, with the Model V3 unit at various rpms and radial distances from the unit of 3 and 10 meters. Results of the test are provided in Appendix A.

CA: Noise abatement in areas where noise is a concern, can be controlled by instituting one or more of the following: programming the computer to adjust engine speeds at certain times of day to minimize noise impacts to local receptors; constructing a 6- or 8-foot privacy fence around the unit and possibly installing noise suppression insulation to the inside of the fence; or purchasing one of the new Quiet Run models now available in the V2 and V3 series. More information on the Quiet Run models is available through VR Systems.

- Soil type is a consideration for areas where low-permeability soil conditions are present and where minimal vapor flow rates from the soil are expected.

CA: An evaluation of the radius of influence and extraction rates of vapor extraction wells determined during pilot testing should be taken into consideration during equipment selection.

2.2.3 Vendor Costs

Table 2.3 provides a summary of the VR Systems capital, rental, estimated supplemental fuel operating costs, and an approximate monthly service schedule operating cost.

Should a customer decide to rent the equipment, the rental equipment would be maintained by the customer for normal wear items like those provided on Table 2.3. If a major repair becomes necessary during a rental period, such as excessive wear of

TABLE 2.3

**CAPITAL AND OPERATING COSTS
(2/15/94)
VAPOR EXTRACTION/INTERNAL COMBUSTION ENGINE EVALUATION
PATRICK AFB, FLORIDA**

Cost Item	V2C	V3	V4
Purchase	\$40,450.00	\$73,450.00	98,880.00
Rental (Monthly)	\$3,480.00	\$6,235.00	\$8,923.00
Mobilization/Demobilization 500 miles from vendor via commercial carrier	\$1,000.00	\$1,000.00	\$1,400.00
Daily Maximum Supplemental Fuel Costs (Approx.)@ 2,000-rpm Engine Speed (Assumes all BTUs are supplied by supplemental fuel - propane at \$0.80/gal.)	\$20.00	\$70.00	\$140.00
Monthly Service Maintenance ^{a/} (Approximate as of 2/16/94)	\$220.00	\$220.00	\$374.00
Miscellaneous Services/Equipment ^{b/} (As required as of 2/16/94)			

^{a/} Monthly service estimates include: engine oil, oil filters, air filter(s), spark plugs, well gas filter(s), and labor (performed by a VR Systems trained technician).

^{b/} Additional labor and equipment pricing as required may include:

- Maintenance Labor @ \$45/hr.
- Travel time @ \$30.00/hr.
- Mileage (first 20 miles free) @ \$0.28/mi.
- Long Distance (requiring air travel), air fare plus per diem
- Additional equipment not included in the monthly service, will be installed only as required are:

- Computer air cleaner @\$7.22/each
- Distributor cap @ \$23.75/each
- Spark plug wires @\$63.00/set
- Rotor @ \$3.82/each

Note: All materials shown are at retail cost, and can be purchased in bulk for generally 40 to 50% less.

engine rings and valves, or other critical engine or computer parts, VR Systems would be responsible for repairing the unit to meet factory specifications.

2.3 REGULATORY ACCEPTANCE

The acceptance of this technology has been widespread. VR Systems has provided a list of jurisdictions where their systems have been tested and/or are currently operating. The states and countries are as follows:

<u>Permitted</u>	<u>1- to 5-Day Pilot Testing</u>
Arizona	Alabama
California:	Colorado
Great Basin Valleys	Georgia
Lake Tahoe	Kansas
Mountain Counties	Louisiana
North Central Coast	Oklahoma
North Coast	Michigan
Northwest Plateau	Missouri
Sacramento Valley	Montana
San Diego	Nevada
San Francisco Bay	North Carolina
San Joaquin Valley	Tennessee
South Central Coast	Texas
South Coast	Utah
Southeast Desert	Alberta, Canada
Florida	
Hawaii	
Idaho	
Illinois	
Massachusetts	
New Jersey	
New Mexico	
New York	
Ohio	
Oregon	
Pennsylvania	
Washington	
Ontario, Canada	
Mexico	
Argentina	

During the Patrick AFB field demonstration, a work plan describing the bioventing pilot test and the vapor extraction treatment technology was submitted to the State of Florida for approval prior to commencing the field activities. For long-term testing (more than a 1- to 5-day pilot test), regulatory approval is generally required. Approval for long-term vapor extraction treatment is site-specific (geographically) and may or may not require a permit application, and possibly only a work plan or letter notification will be necessary. For shorter term pilot tests (1-5 days), permits may not be required. Local regulatory officials should be contacted to verify local policy.

SECTION 3

FIELD DEMONSTRATION RESULTS

3.1 SITE DESCRIPTION

An extended pilot study evaluation of the Model V3 vapor extraction ICE unit was conducted between October 18, 1993 and January 14, 1994. The field demonstration was performed at Patrick AFB, Florida at the BX Service Station.

The BX Service Station site is part of an ongoing bioventing pilot test study. Soil and groundwater contamination exists from previous unleaded gasoline leaks from underground storage tanks (USTs). A soil gas survey was initially conducted to verify site conditions, and to ensure that sufficient soil contamination existed to conduct the bioventing pilot test. The initial soil gas sample laboratory results ranged from 38,000 parts per million, volume per volume (ppmv) to 100,000 ppmv for total volatile hydrocarbons (TVH) within the study area (ES, 1993).

The average water table depth is approximately 5 feet below ground surface (bgs). A horizontal vent well (HVW) was installed at 4 feet bgs as part of the bioventing pilot test. The HVW was placed in the center of the highest TVH readings obtained during the initial soil gas survey at this site. The HVW was constructed of 4-inch, Schedule 40 polyvinyl chloride (PVC) pipe with 30 feet of 0.03-inch slotted well screen. The entire length of screened interval was placed within the contaminated soil area. The entire study area at this site is paved, which significantly reduces or eliminates the potential for short-circuiting and increases the area of influence for air injection or soil vapor extraction through the HVW.

Because initial soil vapor concentrations at this site were very high, bioventing through the use of air injection was ruled out due to the potential for vapor migration. Soil vapor extraction was required to significantly reduce soil vapor concentrations before the system could be converted to a more standard air injection bioventing system. Several emission control technologies were evaluated based on efficiency, maximum TVH influent concentration capacities, maintenance requirements, and cost over the period necessary for vapor extraction. Based on the technology review, a decision was made to use the ICE vapor extraction system manufactured by VR Systems, Inc. and to evaluate its performance and cost of operation.

3.2. REGULATORY APPROVAL/REQUIREMENTS

Florida Department of Environmental Protection (FDEP) policy states that all vacuum extraction units must use a catalytic or thermal oxidation device, or its

equivalent (carbon absorption), to reduce VOC emissions by at least 99 percent during the first two months of operation. After 2 months of operation, the reduced untreated effluent concentrations are evaluated with the SCREEN air modeling program. If the results show that the emissions are below acceptable ambient air standards at the area of greatest impact, the air emissions controls may be discontinued after concurrence from the FDEP.

3.3 TEST CONDITIONS

Table 2.2 provides the performance specifications for the V3 model. The range of extraction flow rates for this model is 0 to 250 scfm, with a vacuum capacity of up to 245 inches of water. During the initial 2-day demonstration, a maximum flow rate of 150 scfm was established. This flow rate was used because it was the maximum achievable through the HVW and required the least amount of supplemental fuel. During the extended test, an average flow rate of 80 scfm was used. The reduction in flow from 150 scfm to 80 scfm was due primarily to a higher water table condition which restricted air flow through the HVW. When a higher vapor extraction flow rate was attempted, the greater vacuum produced a mounding of the water table into the HVW.

A 55-gallon condensate knockout drum was installed between the HVW and the VR Systems unit. The drum was installed to reduce the potential for high-humidity soil gas (>95% relative humidity) condensing and accumulating within the intake hose and filter assembly that would result in a high-water shut down of the system. Following the installation of the drum, no significant accumulation of condensate occurred in the lines.

Propane was used as the supplemental fuel during the test. For the extended test period, a 500-gallon propane tank was setup approximately 30 feet from the VR System unit. During the test period, a local propane distributor would top off the propane tank approximately twice per week. This servicing was performed with the system operating and no supervision was needed during this activity.

3.4 OBSERVED PERFORMANCE

3.4.1 Initial 2-Days at 150 SCFM

Table 3.1 reflects the changes in influent concentrations over time for TVH and BTEX during the initial 2 days of the test. The average flow rate during this period was 150 scfm at an average engine speed of 1,790 rpm. Due to the age and natural weathering of the gasoline spill, initial BTEX concentrations at this site comprised a relatively small fraction of the TVH.

TABLE 3.1

CHANGE IN INFLUENT CONCENTRATIONS FOR TVH
AND BTEX OVER TIME @ 150 SCFM
VAPOR EXTRACTION/INTERNAL COMBUSTION ENGINE EVALUATION
PATRICK AFB, FLORIDA

Influent Constituent	Concentrations	
	Initial (ppmv)	After 2-Days (ppmv)
TVH	26,800	4,400
Benzene	-- ^{a/}	-- ^{a/}
Toluene	15	4.7
Ethylbenzene	14	12
Xylenes	200	110

^{a/} Below Detection Limit.

During the 2-day initial test period, a variety of rpm ranges were used to find the optimum engine speed which yielded the highest vapor flow from the well, while using the least amount of supplemental propane. Also, during the initial 13 hours of operation, the VR System engine was treating a severely oxygen-depleted soil gas. Bioactivity in the area had completely depleted soil gas oxygen supplies. Adjustments by the onboard computer of the influent flow rates were made to maintain the proper oxygen/fuel ratio and a VOC destruction efficiency of >99 percent. As the influent soil gas was oxygen depleted (<2%), the computer had to compensate by adding dilution air through the carburetor and supplemental propane until the soil gas oxygen supply increased to greater than 17 to 18 percent. The majority of the supplemental fuel used over the course of the 2-day test was consumed during this initial 13-hour adjustment period.

Propane consumption during the initial 2 days (44 hours) was 1,925 cubic feet (cf) at an average rate of 43.75 cf/hour. Propane costs during this test were \$0.80 per gallon. Using a conversion factor of 36 cf/gallon of propane, an average cost for the supplemental fuel propane was approximately \$1.00/hr. Based on laboratory influent and effluent sampling results, the cost per kilogram (kg) of TVH and BTEX destroyed was calculated. Based on the laboratory results and an initial flow rate of 150 scfm, a graphical representation of the cost per kg of TVH and BTEX destroyed was generated for the initial 800,000 standard cubic feet (SCF) of soil gas treated during the first 5 days of operation (Figure 3.1). During this period, the average operating cost was \$325.00 per day. A breakdown of the daily operating cost is as follows:

Figure 3.1
Cost Per Kilogram of BTEX and TVH Destroyed
at 150 SCFM Initial Flow Rate

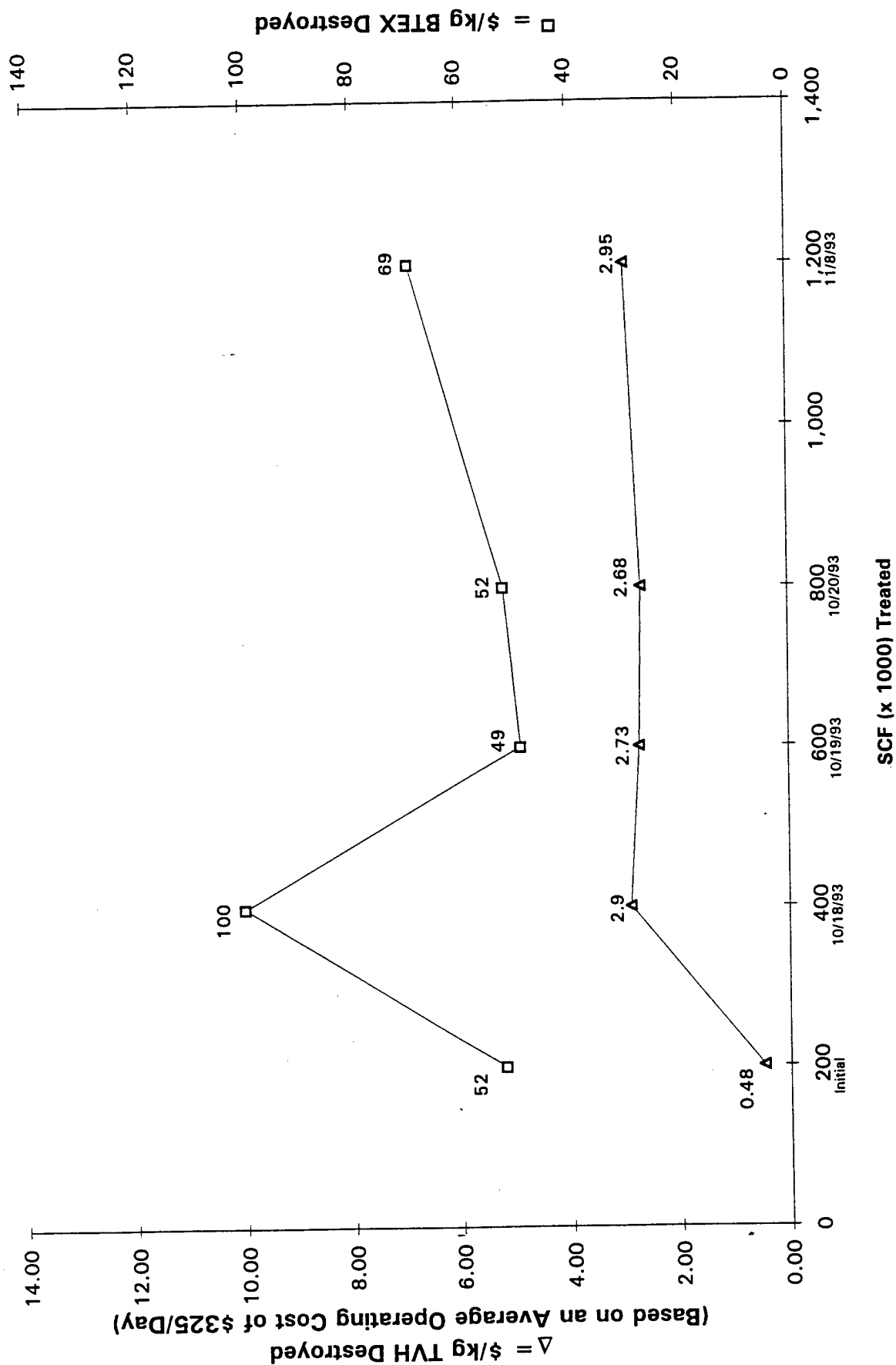

- Equipment rental \$230.00/day,
- Supplemental fuel (propane) \$24.00 to \$57.00/day, and
- Labor (1 hour per day) \$50.00/hour to check on and sample system.

As the actual daily costs ranged from \$305.00 to \$337.00, an average daily cost of \$325.00 was used.

During the initial startup of vapor extraction, the soil gas being removed will typically be oxygen depleted and contain elevated concentrations of carbon dioxide (CO₂) and methane, which are produced by the *in situ* biological activity. During the initial 800,000 scf of soil gas removal at Patrick AFB, a wide range of operating costs were observed. After the initial soil gas had been replaced by oxygenated soil gas, the need for dilution air subsided and contaminant destruction rates became more uniform.

The ratio of BTEX to TVH at this site is not representative of a recent spill or leak, where BTEX comprises up to 20 percent of the TVH. It appears that the majority of the BTEX constituents normally expected in unweathered gasoline were no longer present. During the initial startup period at this site, BTEX comprised 5 percent of the TVH, indicating an older (weathered) gasoline. The cost for each kilogram of BTEX destroyed will vary based on the site-specific BTEX concentrations. At this site, costs for BTEX destruction were high due to the low percentage of BTEX in the residual fuel.

3.4.2 Long-Term (Weeks 2-13) Performance

During the extended test period, the average flow rate was reduced from 150 scfm (initially) to 80 scfm due to a seasonally high water table which reduced the HWV efficiency. To minimize upconing, the onboard computer was programmed to operate the engine at 7 to 11 inches of water vacuum to prevent high-water shut down of the equipment. Limitations placed on the vacuum reduced the overall efficiency of the V3 unit. Despite these inefficiencies, the primary goals of determining the destruction efficiency, operating cost range, reliability, and maintainability were successfully achieved during the evaluation.

3.4.3 Destruction Efficiency

The VR System provided greater than 99-percent destruction efficiency for BTEX and greater than 96-percent destruction efficiency for TVH throughout the test period. Figure 3.2 illustrates the range of soil gas influent BTEX and TVH concentrations encountered during the test and the significant reduction that occurred as a result of 80 days of soil vapor extraction. Figure 3.3 illustrates the destruction efficiencies that were achieved. A 4-percent reduction in TVH destruction efficiency occurred when the engine rings and valves began to wear, allowing a fraction of the supplemental propane to pass unburned through the engine exhaust. When a new replacement unit was installed at the site, destruction efficiencies returned to greater than 99 percent for all hydrocarbons. It is important to note that laboratory analysis confirmed that the unburned fuel was propane and not BTEX compounds from the soil vapor extraction

Figure 3.2
Influent BTEX and TVH Concentration Reduction
over Total SCF Treated

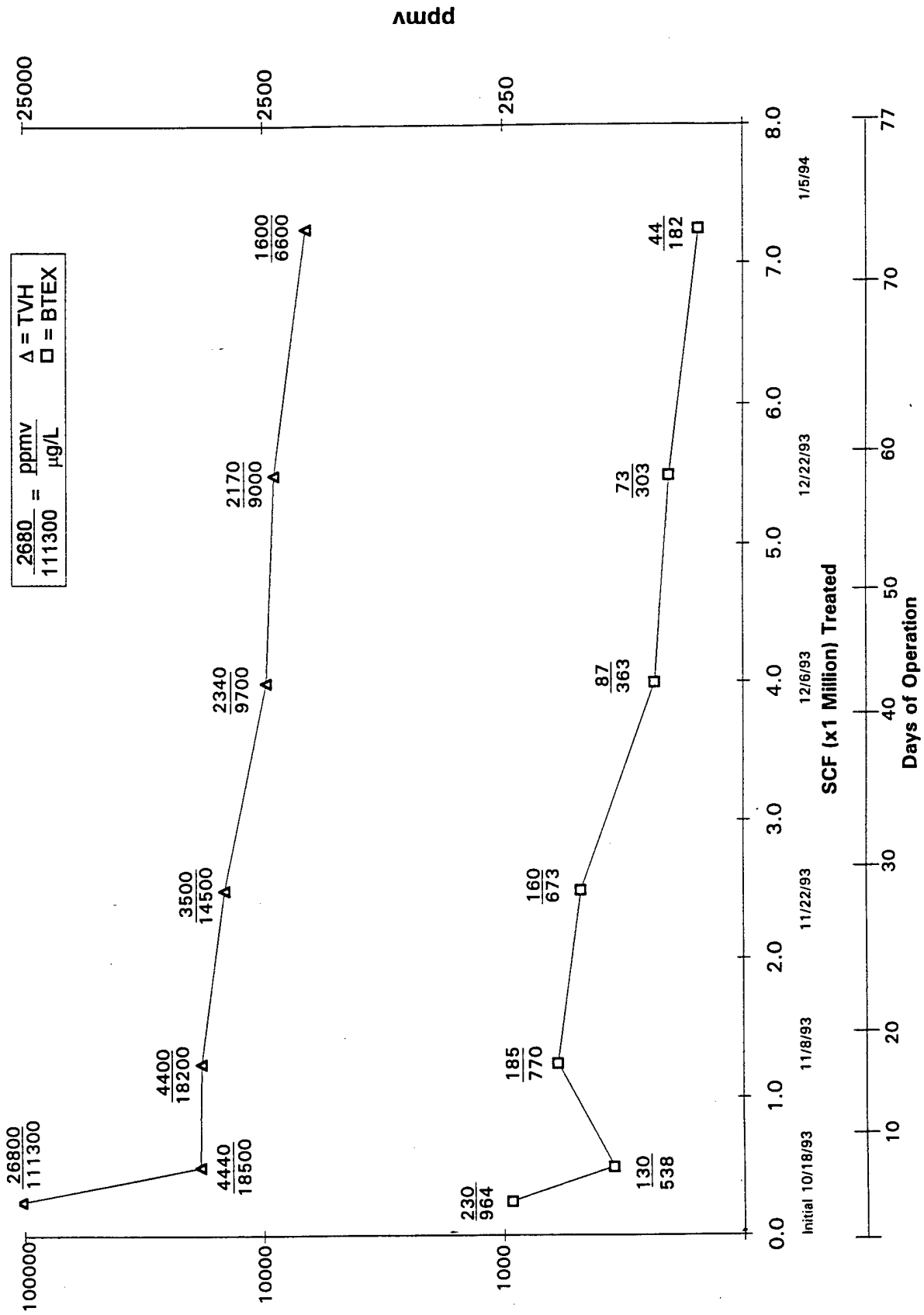

1/6th

Figure 3.3
VR Systems Destruction Efficiency for BTEX and TVH
of Influent Vs. Effluent

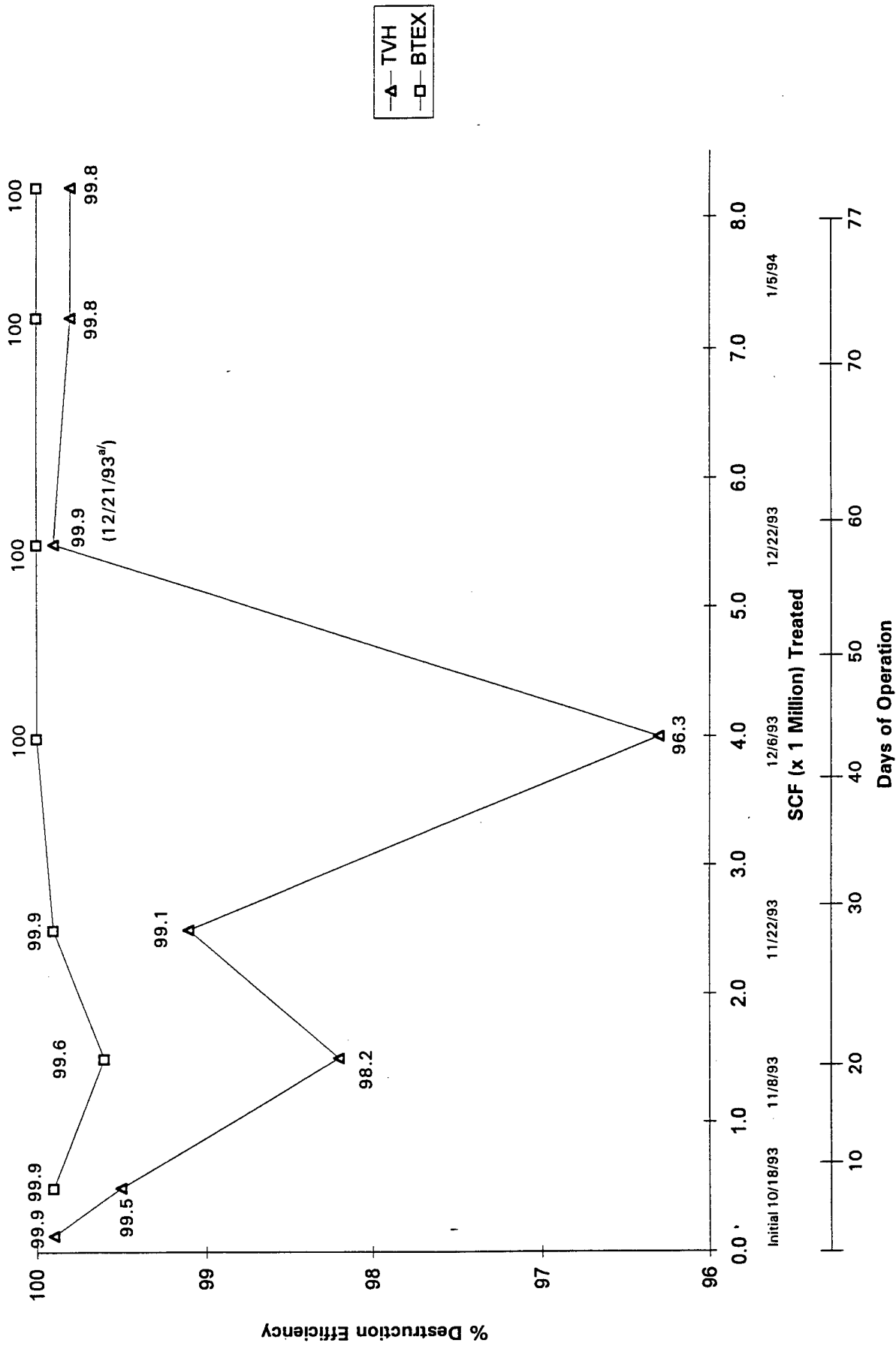

^{a/} NOTE: 12/21/93 Replaced VR Systems Unit With Upgraded V3 Model.

system. Weekly monitoring of influent and effluent TVH is recommended to ensure that normal engine wear does not result in unacceptable emissions to the atmosphere.

3.4.4 Cost of Extended Operation

During the extended test, an average influent flow rate of 80 scfm was achieved. As shown in Figure 3.4, the cost per kilogram of TVH and BTEX destroyed ranged from \$0.83 to \$15.40 and \$97.00 to \$550.00, respectively. The cost increase is due to the decreasing soil vapor concentrations and increased supplemental fuel requirements.

3.5 RELIABILITY

The VR Systems, Inc. Model V3 ICE proved very reliable during the overall evaluation. However, during the normal operation of an ICE, certain mechanical parts may become worn over time, resulting in a decrease in destruction efficiency. The engine parts that directly impact destruction efficiency include rings, exhaust valves, and the catalytic converter.

A reduction in destruction efficiency occurred at this site as a result of ring wear and improper clearance of the exhaust valve seats. This resulted in unburned propane passing through the exhaust system, an elevated TVH reading during effluent sampling, and a reduced TVH destruction efficiency during the December 6, 1993 sampling event (Figure 3.3). To correct this problem, a VR System technician replaced the engine valves at no cost. When the problem reoccurred, a new version of the V3 system was brought in to replace the older system. The upgraded V3 model included a different ring package as well as a new type of valve seating. Approximately 10.5 days of downtime (12 percent) were incurred during the 3-month evaluation. Replacement of the original unit ensured that the 99-percent destruction rate required by the State of Florida could be achieved throughout the duration of the test.

3.6 MAINTAINABILITY

All ICE units require routine maintenance. As with an automobile, the extent of maintenance is dependent upon the total engine running time.

During the Patrick AFB test, the engine spark plugs, oil, and oil filter were changed monthly. It is recommended that a person familiar with the ICEs be used for primary system oversight. Familiarity with the proper tools, and engine parts is very useful during routine ICE maintenance and/or troubleshooting. Routine maintenance (i.e., for every 720 hours of engine operation) can be performed by either a qualified engine mechanic from the base motor pool, specifically assigned to and familiar with the required unit maintenance, or for a fee of \$220 for the Model V3, plus transportation and per diem (if applicable), VR Systems will perform the routine monthly engine maintenance.

VR Systems recommends the following maintenance schedule:

Figure 3.4
Cost Per Kilogram of BTEX and TVH Destroyed
at 80 SCFM Flow Rate

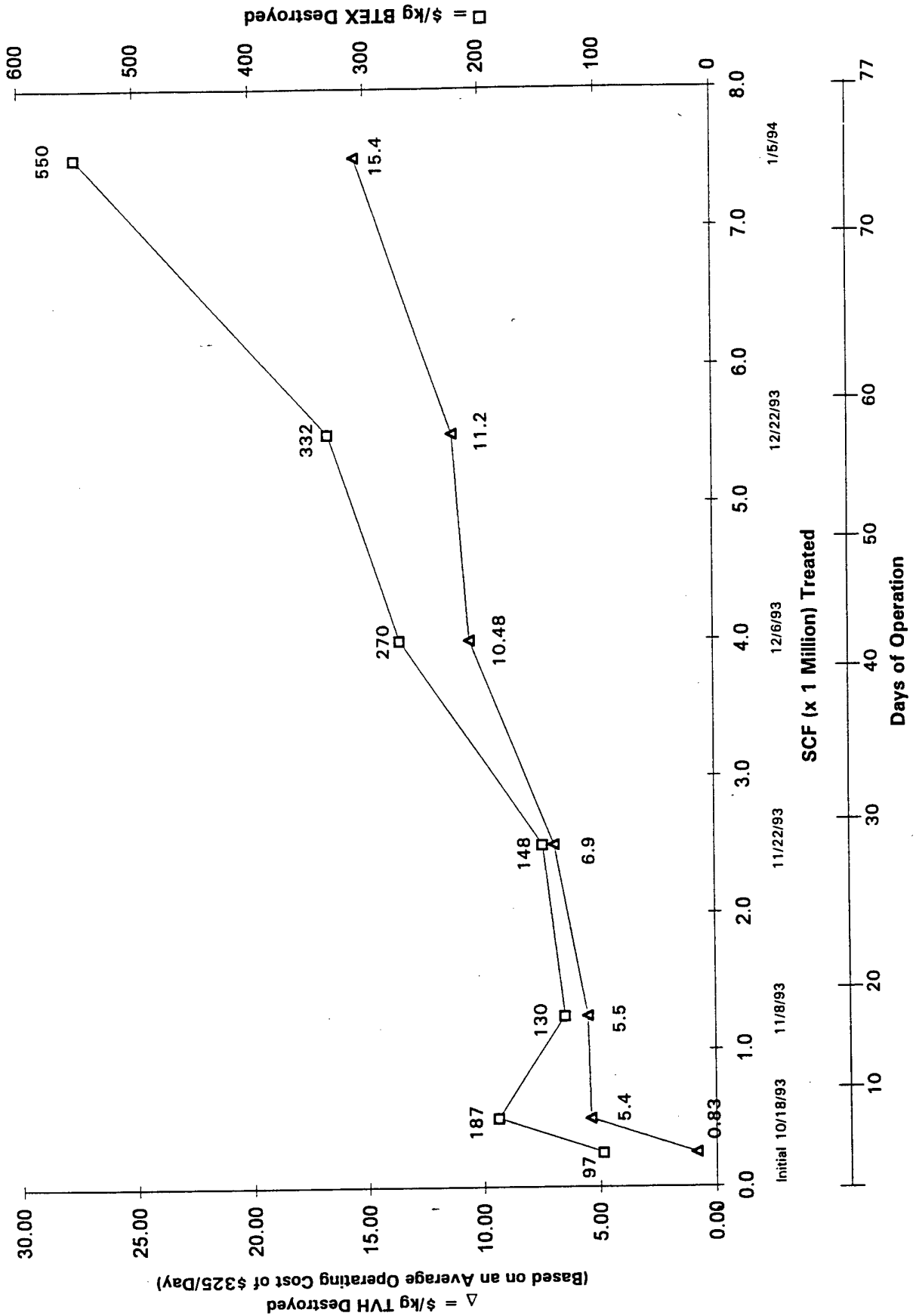

MAINTENANCE SCHEDULE

Initial Startup Sequence ^{a/}	Operation	Every 720 HRS ^{b/}	Every 1440 HRS
1	Set Up Supplemental Fuel Schedule With Vendor ^{c/}		
2	Oil, Check Level	X	
3	Coolant, Check Level	X	
4	Oil & Coolant Leaks, Check	X	
	Oil, Change	X	
	Oil Filter, Replace	X	
5	Air Cleaner, Replace ^{d/}	X	
6	Well Gas Element, Replace		X
7	Battery, Check Charge		X
	Battery Cables, Clean		X
8	Water Pump & Alternator Belts Check & Adjust		X
9	Spark Plugs, Replace		X
10	Filters, Check/Replace		X
11	Transporter Tires, Check Pressure & Condition		X
12	All Bolts & Nuts, Check for Tightness & Hose Clamps		X

^{a/} Also use for startup after storage.

^{b/} Intervals are established on approximate monthly runs. Do not exceed these limits. Service sooner if necessary or under severe conditions.

^{c/} Scheduling of supplemental fuel is necessary prior to initial startup of the system.

^{d/} More often if in dusty atmosphere.

SECTION 4

SUMMARY

4.1 TECHNOLOGY PERFORMANCE

4.1.1 Destruction Efficiency

During the 3-month Patrick AFB test, soil gas TVH concentrations were reduced from 26,800 to 1,600 ppmv and BTEX concentrations were reduced from 230 ppmv to 44 ppmv (Figure 3.2). Throughout the test period, greater than 99-percent destruction of BTEX was achieved by the ICE. TVH destruction ranged from 96 to 99+ percent. The 4-percent loss in TVH destruction efficiency occurred when worn engine rings and valves allowed unburned propane (supplemental fuel) to pass through the unit. When a newer ICE replaced the worn unit, TVH destruction efficiencies returned to greater than 99 percent.

4.1.2 Reliability

Following an initial week of system startup and optimization, the VR System unit operated with minimum interruptions. During the 3-month test, the unit experienced four unscheduled shutdowns accounting for 12 percent of the 2,160 available operating hours. Two of the unscheduled shutdowns were associated with repairs to the engine rings and valve assembly and ICE replacement, which were required to maintain a 99-percent destruction efficiency, and two shutdowns were due to a high water table condition at the site resulting in the need for installing a water knock-out drum before the unit. A factory representative completed the engine repairs at no additional cost to the Air Force.

Based on this test, weekly influent and effluent TVH sampling is recommended to verify system performance and to identify potential VOC pass through resulting from worn engine parts. This sampling can be accomplished with handheld instruments which are capable of detecting unburned propane as well as other fuel hydrocarbons.

The reliability of ICE systems also depends on the engineered elimination of condensate from the extracted soil vapor. The VR System unit is equipped with a water sensor which will automatically shut down the system when water approaches the carburetor intake. A water knockout drum is recommended for all applications, but is particularly important on sites with shallow aquifers where groundwater can be pulled into the vapor extraction system. At the Patrick AFB site, flow rates were reduced and a knockout drum was placed in front of the ICE to prevent ICE shutdown during seasonally high water table conditions.

4.1.3 Maintainability

Proper maintenance of ICE units is important to ensure that destruction efficiencies remain high and supplemental fuel use is minimized. Because these vapor treatment units are simply modified automobile engines, maintenance is virtually identical. Based on experience at the Patrick AFB test site, it may be advantageous to pay the additional maintenance fee and have a factory representative conduct monthly maintenance on the unit to ensure it is operating at peak efficiency. Although the onboard computer provides a straight forward diagnostic printout of the engine vital signs, corrections of problems are best left to experts who have full responsibility for the performance of the unit. One exception would be when a qualified engine mechanic from the base motor pool could be specifically assigned for unit maintenance. This could result in significant savings, particularly if the ICE operation exceeds 3 months.

In addition to routine maintenance, supplemental fuel must be supplied to the unit. If a natural gas line near the site can be inexpensively tapped, operation costs will be approximately 60 percent of the cost of using propane as a supplemental fuel. Propane also requires additional time to ensure that deliveries are completed.

4.2 COST

4.2.1 Purchase or Rental

The decision to purchase or rent an ICE depends on the number of months of operation expected at the site or sites. Purchase prices range from \$40,450 for Model V2C to \$98,880 for Model V4 (1994 prices). Although each ICE vendor has a different pricing schedule, it will almost always be more economical to rent a unit if the total period of operation will not exceed 10 months. Rental also places greater responsibility on the vendor to ensure proper unit operation. Also, if rented, major maintenance remains the responsibility of the vendor. If units are purchased, many manufacturers offer a monthly maintenance and service agreement. The VR System maintenance agreement costs \$220/month for Models V2C and V3, and \$374/month for the Model V4, plus travel and per diem. Maintenance agreements may be needed if the base is unable to provide necessary maintenance. Factors such as the level of contamination, size of the site, and degree of vapor treatment will determine the number of months of ICE operation. Air Force bases (or MAJCOMs) with three or more gasoline-contaminated sites may find it economically advantageous to purchase one of these units and move it from site to site.

4.2.2 Operating Costs

The cost of operating an ICE will increase over time as soil vapor VOCs are reduced and additional supplemental fuel is required. Based on the Patrick AFB test, daily operating costs of \$74 to \$107 per day were estimated. Propane accounted for \$24 to \$57 of the daily operating costs, and 1 hour of contract labor to check and monitor the unit was estimated at \$50 per day. To reduce labor costs, every attempt should be made to use base personnel for system monitoring and basic maintenance.

4.2.3 Cost Per Kilogram of TVH/BTEX

The unit cost for each kg of TVH (including BTEX) or specifically for BTEX destroyed is a convenient way of comparing different vapor treatment technologies. The ICE system used at the Patrick AFB site was oversized, and unit costs derived from this test are considered conservative. During the initial days of operation when VOC concentrations were high, TVH treatment costs as low as \$0.48 per kilogram were achieved. During the final days of operation, TVH treatment costs had increased to \$15.40 per kilogram. BTEX treatment costs ranged from \$49 to \$550 per kilogram (Figure 3.4). These costs are site specific and were inflated at the Patrick AFB BX Site due to the low BTEX content of the soil gas.

4.3 Integration With *In Situ* Bioventing

At sites with high levels (> 10,000 ppmv) of soil gas TVH, it may be necessary to extract these vapors before long-term air injection/bioventing can begin. Of particular concern are sites with gasoline- or light-distillate-contaminated soils and sites near buildings and utility corridors which could be adversely impacted by vapor migration caused by air injection.

Based on both vendor information and Patrick AFB tests, the ICE technology is an effective method of controlling vapor emissions and destroying contaminants. These units are most effective when initial soil gas TVH is greater than 40,000 ppmv. At these high concentrations, the ICE will operate without supplemental fuel. ICE units come in a variety of sizes and can be optimized based on the desired soil vapor extraction rate and site-specific soil gas permeability.

The length of ICE operation at each site will depend on several factors. The decision to begin air injection bioventing must be based on the potential risk of vapor migration into buildings and utility corridors and the ability of soil bacteria to biodegrade mobilized VOCs. Biodegradation rates established during bioventing pilot tests can be used to determine the approximate mass of soil "biofilter" required to biodegrade a known mass of migrating hydrocarbons. By minimizing air flow rates to just satisfy *in situ* oxygen demand, the flux of volatile hydrocarbons to the atmosphere from the contaminated soil will also be minimized.

4.4 Future Work

Other *ex situ* vapor treatment technologies have been evaluated including the Biocube® and PURUS PADRE®. Reports similar to this will be provided on each technology. A summary report will compare cost and performance of each and assist in remedial design decisions.

REFERENCES

Engineering Science, Inc. 1993. *Interim Test Results Report for Bioventing at the Patrick AFB BX Service Station*. Report provided to the Air Force Center for Environmental Excellence (AFCEE/ERT).

APPENDIX A

MATL _____

FINISH _____

DESC.
V2C SYSTEM SCHEMATIC

SHEET _____ OF _____

ITEM NO.
EC3D029

DATE	2/92
REV DATE	12/93
A	12/93
B	2/94

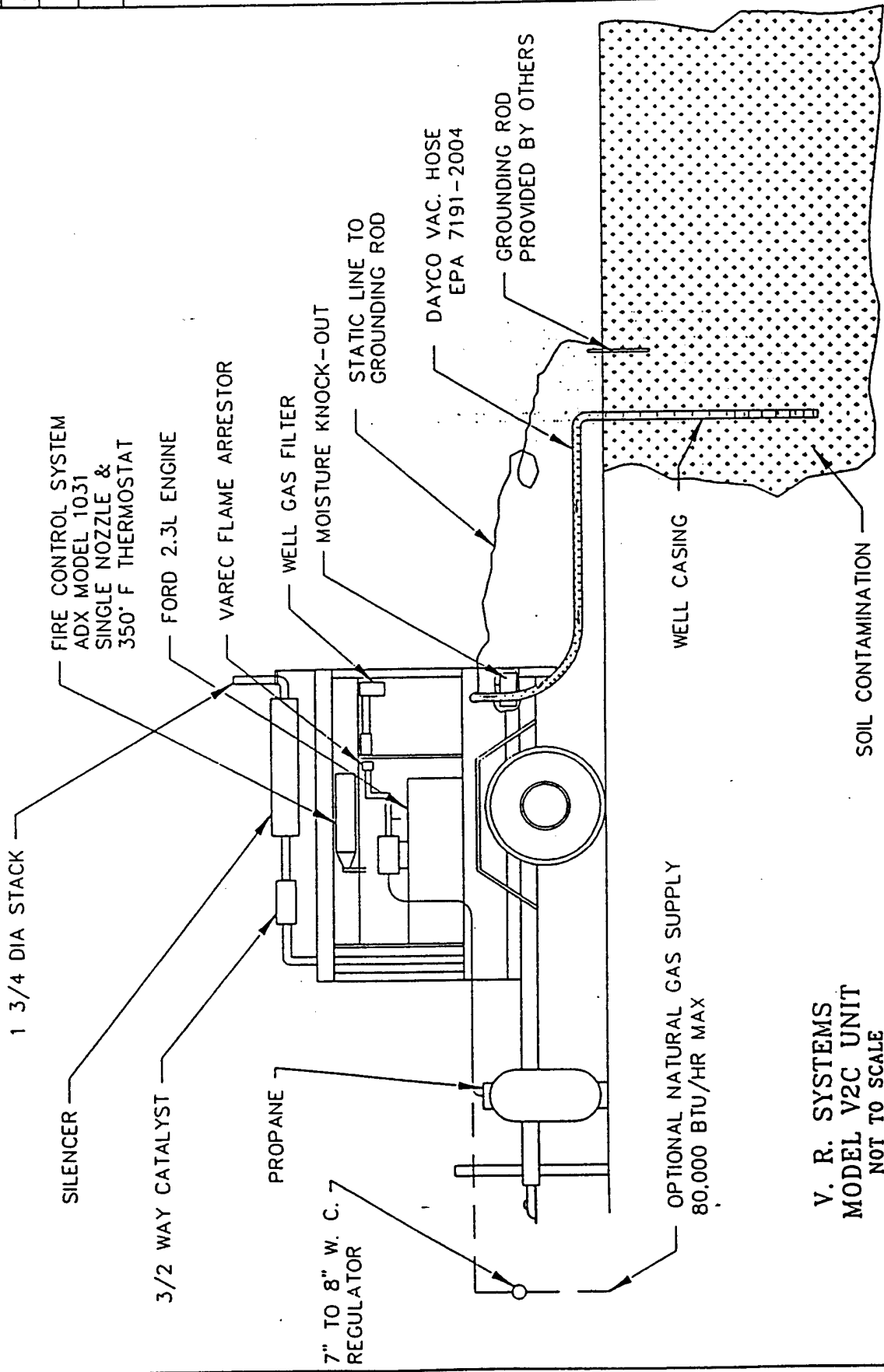

V. R. SYSTEMS
MODEL V2C UNIT
NOT TO SCALE

DRAWN BY: DBG
SCALE: NONE

DIMENSIONS ARE IN INCHES UNLESS OTHERWISE SPECIFIED.
TOLERANCES UNLESS OTHERWISE SPECIFIED ARE AS FOLLOWS:
ANGLES: ±1° FRACTIONS ±1/16 .XX ±.01 .XXX ±.001

VR SYSTEMS
ANAHEIM, CA.

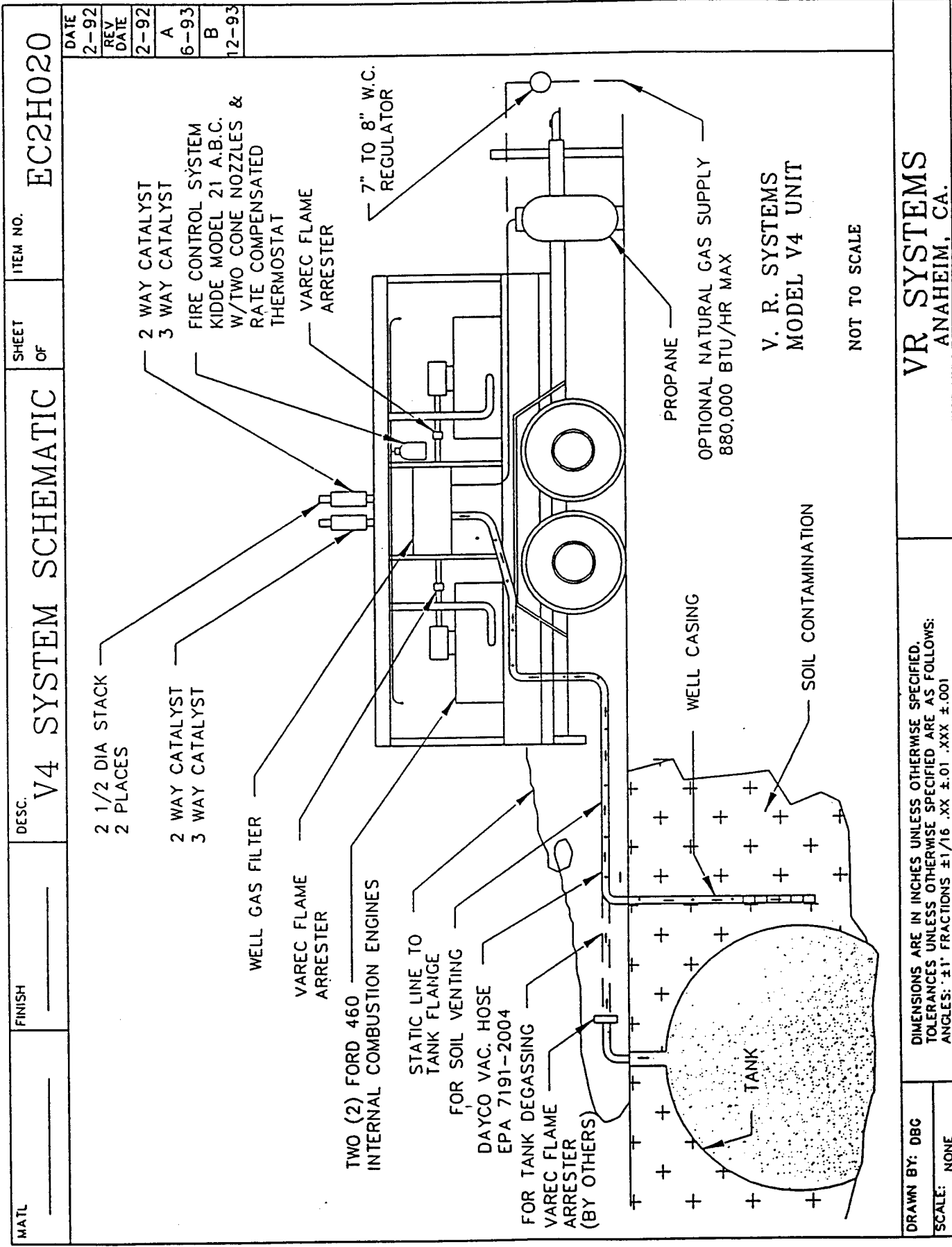

MATL _____ FINISH _____ DESC. **V4 SYSTEM SCHEMATIC** SHEET _____ OF _____ ITEM NO. **EC2H020**

DATE	REV	DATE
2-92		
2-92	A	6-93
	B	12-93

2 1/2 DIA STACK
2 PLACES

2 WAY CATALYST
3 WAY CATALYST

FIRE CONTROL SYSTEM
KIDDE MODEL 21 A.B.C.
W/TWO CONE NOZZLES &
RATE COMPENSATED
THERMOSTAT

WELL GAS FILTER

VAREC FLAME ARRESTER

TWO (2) FORD 460
INTERNAL COMBUSTION ENGINES

STATIC LINE TO
TANK FLANGE
FOR SOIL VENTING

DAYCO VAC. HOSE
EPA 7191-2004
FOR TANK DEGASSING

VAREC FLAME
ARRESTER
(BY OTHERS)

7" TO 8" W.C.
REGULATOR

PROPRANE

OPTIONAL NATURAL GAS SUPPLY
880,000 BTU/HR MAX

WELL CASING

TANK

SOIL CONTAMINATION

V. R. SYSTEMS
MODEL V4 UNIT

NOT TO SCALE

DRAWN BY: DBG
SCALE: NONE

DIMENSIONS ARE IN INCHES UNLESS OTHERWISE SPECIFIED.
TOLERANCES UNLESS OTHERWISE SPECIFIED ARE AS FOLLOWS:
ANGLES: $\pm 1'$ FRACTIONS $\pm 1/16$.XX ± 0.1 .XXX ± 0.001

VR SYSTEMS
ANAHEIM, CA.



Technology In Support of the Environment.

NOISE TEST

4/9/91

MODEL V3 STD S/N 11

ON HARD PACKED DIRT dBA SLOW RESPONSE

H

C

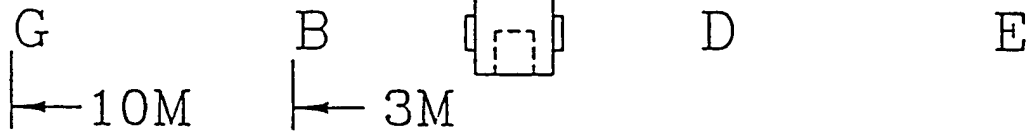

A

F

	3MTRS				10MTRS			
RPM	A	B	C	D	E	F	G	H
AMBIENT	50-52	52	50-52	50-52	50-52	52	50-52	50
1800	81.5	77.5	77	77	69.5	72.75	71	69.5
2200	88	81.5	79.5	81	76	78.75	77	76
2750	91	88	86.5	87	79	83.5	82	79



Technology In Support of the Environment.

V2C STANDARD FEATURES

- * "QUIET RUN" PACKAGE
- * FIRE CONTROL SYSTEM
- * INPUT FLAME ARRESTER
- * AUTO SHUT DOWN
 - High Water Temperature
 - High Oil Temperature
 - Low Oil Level
- * AUTOMATIC OIL LEVEL REGULATOR
- * WELL GAS FLOW METER
- * EASILY TRANSPORTED - ONE MAN SETUP
- * SHUTDOWN/CALL-UP CAPABILITY
- * PERMITTABILITY IN SCAQMD
 - Soil Remediation (Various Locations)
- * 20 MINUTE INSTALLATION CAPABILITY
- * SLIDE IN/SLIDE OUT ENGINE PACKAGE
- * PERMANENT STAND OR TRANSPORTABILITY
- * 15' X 1 1/2" INTERNALLY GROUNDED VAPOR HOSE
- * 50' STATIC REEL
- * LCD MONITOR W/16 ITEM READOUT & DISC DRIVE
 - For Report Accumulation
- * INVERTER PACKAGE
 - For "Stand Alone" Capability

AVAILABLE OPTIONS

- * MONITORING BY MODEM
- * KIT FOR NATURAL GAS OPERATION

10/19/93



Technology In Support of the Environment.

SPECIFICATIONS - MODEL V2C

1.00 GENERAL

It is the intent of these specifications to describe a "State of the Art" Soil Remediation System including an internal combustion engine capable of extracting hydrocarbon vapors from contaminated soil or storage tanks without the use of a compressor or pump, and destruct such vapors as fuel in a controlled manner by the use of an on-board computer system.

2.00 DETAILED DESCRIPTION

System shall conform to the following minimum requirements:

2.01 ENGINE

The engine shall be a Ford, liquid cooled, 140 C.I.D., Model LSG-423. The engine shall be totally controlled by the computer system described below and shall be capable of operating three weeks without need of servicing. The engine shall be equipped with an automatic oil level device together with one (1) automotive type cartridge filter. The engine serves as both a vacuum pump and as a means of destroying hydrocarbon vapors removed from the soil. Engine cooling shall be by means of an oversized radiator.

2.02 FUEL CONTROL SYSTEM

Supplemental fuel, as may be required for proper combustion, shall be either Propane (LPG) or Natural Gas. The control of the fuel to the engine shall be by the means of an electro/mechanical system including a Master Control Unit (MCU). The MCU shall adjust the supplemental fuel flow to compensate for changing influent hydrocarbon concentrations and maintain an air/fuel ratio at stoichiometric.

2.03 IGNITION SYSTEM

The Ignition System shall be an electronic type, automatically adjusted by commands from the computer.

2.04 ELECTRICAL POWER

Electrical power required shall be supplied by an on-board 12 volt DC battery for "stand-alone" operation. This battery also provides power for starting the engine and is charged by the engine's alternator. An internal DC to DC converter provides the necessary +5, +12 and -12 volts required to power the control system.

2.05 ON-BOARD COMPUTER CONTROL

The system shall include a "State of the Art" Data Acquisition System for monitoring the engine control.

2.06 MONITORING

Monitoring shall include a 16 channel data reporting system on engine vital signs and operation. Reporting can be on regular intervals (every hour or half hour) or manually at the discretion of the operator, or stored (30 days max.) for future retrieval. Remote monitoring by hardwire or cellular shall also be available.

2.07 WELL GAS FILTER

The system shall include a Well Gas Filter and moisture knock out. A Transducer shall be included to indicate well gas vacuum levels.

2.08 EXHAUST SYSTEM

The Exhaust System shall include a dual NOx reduction monolith and a dual HC/CO monolith. The oxygen supply to the NOx reduction unit shall be controlled at all times at 0.5% to 0.7% as read by an O₂ sensor in the exhaust manifold.

2.09 QUIET RUN

The system shall be capable of operating at a noise level of 55db measured at 10 meters without additional noise screening.

3.00 OPERATION

The operation of the system shall be automatic (except for start up, shut down and RPM set point) and shall not require manual adjustment of influent gas, supplemental fuel or combustion air.

4.00 CAPACITIES

4.01 VACUUM AND FLOW

The system shall be capable of developing up to 18" Hg at the well gas inlet. Flow rates shall be from 0 to 65 CFM. These conditions will depend on soil conditions, hydrocarbon concentrations and level of inerts encountered.

4.02 HYDROCARBON REMOVAL

The system shall be capable of removing up to 15 lbs/hr of hydrocarbons at a total destruction efficiency of 99.97%.

5.00 SAFETY FEATURES

5.01 FIRE CONTROL SYSTEM

A Fire Control System shall be included as an integral part of the unit. This system consists of a ADX 1021 dry chemical automatic package utilizing a fusible link type actuator and 8 lbs. of dry chemical with 20 sq. feet of coverage.

5.02 FLAME ARRESTER

A 3" Flame Arrester shall be included to protect the well gas source from any "Flash Back" from the engine.

5.03 GROUNDING

A 50' Static Line and Reel shall be included.

5.04 AUTOMATIC ENGINE SHUT DOWN

The system shall be protected by automatic shut down under the following conditions:

- Overspeed
- High Coolant Temperature
- High Oil Temperature
- Low Oil Pressure
- Fire
- High Water Level (Well Gas Filter)

The computer shall be programmed to store and report the reason for the automatic engine shut down.

5.05 FUEL SHUT OFF

Means shall be included to shut off the fuel supply should the engine shut down for any reason.

5.06 LABEL AND INSTRUCTIONS

An Operation and Maintenance Manual shall be included, establishing safe operation and required maintenance, together with pertinent Material Safety Data Sheets from various suppliers. Safety and Warning Labels shall be appropriately affixed to the unit according to accepted standards. Safety and Operation instructions shall be conspicuously posted at the operation console within easy view of the operator.

6.00 TRANSPORTATION AND INSTALLATION

A transporter, to safely move the unit from one site to another, shall be included as part of the package. Also, a stand shall be available and means supplied to slide the unit off of the transporter onto the stand (and vice versa) as a one-man operation.

7.00 GENERAL APPROVAL

The system shall have an approval by a registered third party testing laboratory for safety and operations.

8.00 WARRANTY

The system shall carry a one-year warranty on all items manufactured by the seller and the seller will pass on the guarantee of the manufacturer of purchased parts installed on the unit.

9.00 MANUFACTURE

The unit shall be manufactured in the United States of America and the supplier shall hold the owner and/or its various departments free and harmless from any patent infringement suit arising out of the purchase of this Soil Venting System.

U.S. PATENTS: 4,846,134, 5,070,850, 5,101,799
CANADIAN PATENT: 1,287,805

10/6/93



Technology In Support of the Environment.

V4 STANDARD FEATURES

- * FIRE CONTROL SYSTEM
- * INPUT FLAME ARRESTER
- * AUTO SHUT DOWN
 - High Water Temperature
 - High Oil Temperature
 - Low Oil Level
- * AUTOMATIC OIL LEVEL REGULATOR
- * "0" PRESSURE COOLANT SYSTEM
 - (Safety & Long Life)
- * WELL GAS FLOW METER
- * EASILY TRANSPORTED - ONE MAN SETUP
- * SHUTDOWN/CALL-UP CAPABILITY
- * PERMITTABILITY IN SCAQMD
 - Soil Remediation (Various Locations)
 - Underground Tank Degassing (Various Locations)
 - Above Ground Tank Degassing (In Progress)
- * L.A. CITY FIRE DEPARTMENT
 - General Approval
- * SANTA ANA FIRE DEPARTMENT
 - General Approval
- * 20 MINUTE INSTALLATION CAPABILITY
- * SLIDE IN/SLIDE OUT ENGINE PACKAGE
- * LARGE SERVICE DOORS
- * PERMANENT STAND OR TRANSPORTABILITY
- * 15' x 3" INTERNALLY GROUNDED VAPOR HOSE
- * 50' STATIC REELS
- * LCD MONITOR W/16 ITEM READOUT & DISC DRIVE
 - For Report Accumulation
- * INVERTER PACKAGE
 - For "Stand Alone" Capability

AVAILABLE OPTIONS

- * MONITORING BY MODEM
- * FOXBORO OVA
- * KIT FOR NATURAL GAS OPERATION
- * LONG RUN OIL TANK

4/27/93



Technology In Support of the Environment.

SPECIFICATIONS - MODEL V4

1.00 GENERAL

It is the intent of these specifications to describe a "State of the Art" Soil Remediation and Tank Degassing System including internal combustion engines capable of extracting hydrocarbon vapors from contaminated soil or storage tanks without the use of a compressor or pump, and destruct such vapors as fuel in a controlled manner by the use of an on-board computer system.

2.00 DETAILED DESCRIPTION

System shall conform to the following minimum requirements:

2.01 ENGINE

These VR Systems engines have been re-configured to design specification exclusive to VR Systems Vapor Extraction Equipment using a Ford Motor Company 460 C.I.D. engine block, heads and accessories. The engine shall be totally controlled by the computer system described below and shall be capable of operating one month without need of servicing. The engine shall be equipped with an automatic oil level device together with three (3) automotive type cartridge filters. The engine serves as both a vacuum pump and as a means of destroying hydrocarbon vapors removed from the soil. Engine cooling shall be by means of an oversized radiator and zero-pressure coolant system to insure safety and long life.

2.02 FUEL CONTROL SYSTEM

Supplemental fuel, as may be required for proper combustion, shall be either Propane (LPG) or Natural Gas. The control of the fuel to the engine shall be by the means of an electro/mechanical system including a Master Control Unit (MCU). The MCU shall adjust the supplemental fuel flow to compensate for changing influent hydrocarbon concentrations and maintain an air/fuel ratio at stoichiometric.

2.03 IGNITION SYSTEM

The Ignition System shall be an electronic type, automatically adjusted by commands from the computer.

2.04 ELECTRICAL POWER

Not required.

2.05 ON-BOARD COMPUTER CONTROL

The system shall include a "State of the Art" Data Acquisition System for monitoring and engine control.

2.06 MONITORING

Monitoring shall include a 36 channel data reporting system on engine vital signs and operation. An LCD monitor shall be supplied to continuously view the operational data. Also supplied shall be a 720K, 3.5 inch floppy drive, for data storage. Remote monitoring by modem shall also be available.

2.07 WELL GAS HOSE

A hose assembly w/sampling port is supplied for ease of hook up out either side of the housing. An internally grounded 15' main well gas vacuum hose is also supplied.

2.08 WELL GAS FILTER

The system shall include a Well Gas Filter and moisture knock out. A transducer shall be included to indicate well gas vacuum levels.

2.09 EXHAUST SYSTEM

The Exhaust System shall include a dual NOx reduction monolith and a dual HC/CO monolith. The oxygen supply to the NOx reduction unit shall be controlled at all times at 0.5% to 0.7% as read by an O₂ sensor in the exhaust manifold.

3.00 OPERATION

The operation of the system shall be automatic (except for start up, shut down and RPM set point) and shall not require manual adjustment of influent gas, supplemental fuel or combustion air.

4.00 CAPACITIES

4.01 VACUUM AND FLOW

The system shall be capable of developing up to 18" Hg at the well gas inlet. Flow rates shall be from 0 to 500 CFM. These conditions will depend on soil conditions, hydrocarbon concentrations and level of inerts encountered.

4.02 HYDROCARBON REMOVAL

The system shall be capable of removing up to 110 lbs/hr of hydrocarbons at a total destruction efficiency of 99.97%.

5.00 SAFETY FEATURES

5.01 FIRE CONTROL SYSTEM

A Fire Control System shall be included as an integral part of the unit and consists of a Kidde 21# dry chemical automatic package with dual "Rate of Rise" temperature probes and a manual emergency override.

5.02 FLAME ARRESTER

A 3" Flame Arrester shall be included to protect the well gas source from any "Flash Back" from the engine.

5.03 GROUNDING

A 50' Static Line and Reel shall be included.

5.04 AUTOMATIC ENGINE SHUT DOWN

The system shall be protected by automatic shut down under the following conditions:

- Overspeed
- High Coolant Temperature
- High Oil Temperature
- Low Oil Pressure
- Fire
- High Water Level (Well Gas Filter)

The computer shall be programmed to store and report the reason for the automatic engine shut down.

5.05 FUEL SHUT OFF

Means shall be included to shut off the fuel supply should the engine shut down for any reason.

5.06 LABEL AND INSTRUCTIONS

An Operation and Maintenance Manual shall be included establishing safe operation and required maintenance together with pertinent Material Safety Data Sheets from various suppliers. Safety and warning labels shall be appropriately affixed to the unit according to accepted standards. Safety and Operation instructions shall be conspicuously posted at the operation console within easy view of the operator.

6.00 TRANSPORTATION AND INSTALLATION

Included as part of the package shall be a transporter to safely move the unit from one site to another. Also, a stand shall be available and means supplied to slide the unit off of the transporter and onto the stand (and vice versa).

7.00 GENERAL APPROVAL

The system shall have an approval by a registered third party testing laboratory for safety and operations.

8.00 WARRANTY

The system shall carry a one-year warranty on all items manufactured by the sellers and the seller will pass on the guarantee of the manufacturer of purchased parts installed on the unit.

9.00 MANUFACTURE

The unit shall be manufactured in the United States of American and the supplier shall hold the owner and/or its various departments free and harmless from any patent infringement suit arising out of the purchase of this Soil Venting System.

U.S. PATENTS: 4,846,134, 5,070,850, 5,101,799
CANADIAN PATENT 1,287,805

REV: 4/7/94