



NRL/MR/6101--97-7926

# Methane Hydrate, A Special Clathrate: Its Attributes and Potential

M.D. MAX  
R.E. PELLANBARG  
B.G. HURDLE

*Chemistry Division*

February 28, 1997

DTIC QUALITY INSPECTED 4

Approved for public release; distribution unlimited.

19970307 040

# REPORT DOCUMENTATION PAGE

*Form Approved*  
OMB No. 0704-0188

Public reporting burden for this collection of information is estimated to average 1 hour per response, including the time for reviewing instructions, searching existing data sources, gathering and maintaining the data needed, and completing and reviewing the collection of information. Send comments regarding this burden estimate or any other aspect of this collection of information, including suggestions for reducing this burden, to Washington Headquarters Services, Directorate for Information Operations and Reports, 1215 Jefferson Davis Highway, Suite 1204, Arlington, VA 22202-4302, and to the Office of Management and Budget, Paperwork Reduction Project (0704-0188), Washington, DC 20503.

1. AGENCY USE ONLY ( <i>Leave Blank</i> )	2. REPORT DATE  February 28, 1997	3. REPORT TYPE AND DATES COVERED  Final: Oct 1995 - Oct 1996	
4. TITLE AND SUBTITLE  Methane Hydrate, A Special Clathrate: Its Attributes and Potential		5. FUNDING NUMBERS  66173/6010	
6. AUTHOR(S)  M.D. Max, R.E. Pellanbarg, and B.G. Hurdle			
7. PERFORMING ORGANIZATION NAME(S) AND ADDRESS(ES)  Naval Research Laboratory Washington, DC 20375-5320		8. PERFORMING ORGANIZATION REPORT NUMBER  NRL/MR/6101-97-7926	
9. SPONSORING/MONITORING AGENCY NAME(S) AND ADDRESS(ES)		10. SPONSORING/MONITORING AGENCY REPORT NUMBER	
11. SUPPLEMENTARY NOTES			
12a. DISTRIBUTION/AVAILABILITY STATEMENT  Approved for public release; distribution unlimited.		12b. DISTRIBUTION CODE	
13. ABSTRACT ( <i>Maximum 200 words</i> )  Gas hydrates are pressure-stabilized, ice-like compounds found in the cold deep-ocean environment, especially Polar oceans. Natural gas, primarily methane, is held within a water-molecule crystal lattice and thermodynamically stabilizes the structure via hydrogen bonding. Hydrate readily forms in the Hydrate Stability Zone in which hydrate is thermodynamically stable. This region extends downward from the sediment surface at the sea bottom to a depth determined by the local heat flow and water depth, e.g. pressure. Although many publications have recorded the presence of gas hydrate, which commonly stores 160 - 180 volumes of gas (methane, STP) per volume of hydrate, in virtually all of the world's oceans, widespread perception of their extent is unclear because hydrates have been mainly treated as a scientific curiosity or engineering hazard. It is increasingly clear that the unique chemistry of hydrates may allow for new fuel storage and transport applications. This report is intended as a general reference text for non-gas hydrate specialist scientists and for non-scientists with a technical background.			
14. SUBJECT TERMS  Gas hydrate                      Distribution Clathrate                        Fuel storage and transport Methane		15. NUMBER OF PAGES  77	
		16. PRICE CODE	
17. SECURITY CLASSIFICATION OF REPORT  UNCLASSIFIED	18. SECURITY CLASSIFICATION OF THIS PAGE  UNCLASSIFIED	19. SECURITY CLASSIFICATION OF ABSTRACT  UNCLASSIFIED	20. LIMITATION OF ABSTRACT  UL

## CONTENTS

<b>PART 1. METHANE HYDRATE: ITS CHARACTERISTICS AND SIGNIFICANCE</b> .....	<b>2</b>
<b>INTRODUCTION</b> .....	<b>2</b>
<b>CLATHRATES AND CRYSTALLINE METHANE HYDRATES</b> .....	<b>3</b>
<b>PHYSICAL PROPERTIES OF GAS HYDRATES</b> .....	<b>6</b>
<b>CONDITIONS GOVERNING THE PRESENCE OF GAS HYDRATES</b> .....	<b>9</b>
<b>FORMATION AND STABILITY OF GAS HYDRATE</b> .....	<b>16</b>
<b>IDENTIFICATION OF GAS HYDRATE</b> .....	<b>18</b>
<b>DISTRIBUTION OF GAS HYDRATE</b> .....	<b>20</b>
<b>NATURAL GAS AS A FUEL</b> .....	<b>26</b>
<b>LAW OF THE SEA</b> .....	<b>33</b>
<b>ATMOSPHERIC IMPACT OF METHANE</b> .....	<b>33</b>
<b>GAS HYDRATE: GEODYNAMICS AND GEOLOGY IMPACT</b> .....	<b>37</b>
<b>PART 2. NEW RESEARCH TOPICS: SPECIAL ISSUES IN CLATHRATE TECHNOLOGY</b> ..	<b>46</b>
<b>GAS HYDRATE RESEARCH AND ITS FUTURE</b> .....	<b>59</b>
<b>REFERENCES</b> .....	<b>60</b>

# **METHANE HYDRATE, A SPECIAL CLATHRATE: ITS ATTRIBUTES AND POTENTIAL**

M.D. Max, R. E. Pellenbarg, & B.G. Hurdle  
Naval Research Laboratory, Washington, D.C. 20375

## **ABSTRACT**

Gas hydrates are methane-water ice-like crystalline materials that are stable and naturally occur in the pressure-temperature conditions of the deep-oceans and polar permafrost areas. In the open oceans they are stable below about 45 atmospheres total pressure; in cold Polar areas they occur as part of a compound permafrost horizon at lower pressures. Natural gas, primarily methane, is held within a water molecule crystal lattice and thermodynamically stabilizes the structure through hydrogen bonding. Hydrate forms in the Hydrate Stability Zone (HSZ) in which hydrate is thermodynamically stable. This region extends downward from the sediment surface at the sea bottom to a depth determined by the local heat flow and water depth, which determines the ambient pressure. The HSZ is thicker in deeper water where hydrostatic pressure is higher. Gas generated in the sediment below the HSZ rises buoyantly in the sediment fluids and can be trapped as hydrate in the HSZ. Because the base of the HSZ is continually exposed to gas rising from the sediment and from gas inverting from hydrate at the base of the HSZ where the stability field moves upward to accommodate sedimentation, more gas is usually found in the lower part of the HSZ. The lower part of the HSZ can become solid and can act as a gas trap and the base of the HSZ is the pressure - temperature phase boundary of the gas+water/hydrate stability field. From 160 to 180 volumes of gas (STP) are commonly concentrated in one volume of hydrate. Hydrate formation and trapping of gas is part of a complex marine basin genesis.

Many publications have recorded the presence of gas hydrates in sediments of virtually all of the world's oceans, but their extent, concentration, and characteristics are not generally well known. This is because hydrates have been mainly treated as a scientific curiosity or an engineering hazard and have only been known in the deep ocean since the early 1970's. Hydrates have been positively identified over broad thickly sedimented areas below 0.5 km water depth in the recent past. Growing awareness of their potential as a major energy source will probably be the main factor driving significant hydrate survey and research, even though there are acoustic, atmospheric, and other scientific issues that may prove of equal or greater importance as the world transitions from an oil-based to a gas-based economy.

Although the issues of energy and atmospheric change will be the primary focus of gas hydrate research, the unique chemistry of hydrates may allow new fuel storage compounds and transport applications to be developed.

---

Manuscript approved January 24, 1997.

## **PART 1. METHANE HYDRATE: ITS CHARACTERISTICS AND SIGNIFICANCE**

### **INTRODUCTION**

Gas hydrates are a particular type of clathrates, which are ice-like materials that are stable and naturally occur in the pressure-temperature conditions of the deep-oceans and polar permafrost areas. Natural gas, primarily methane, is held within a water molecule crystal lattice and thermodynamically stabilizes the structure through hydrogen bonding. Hydrates and related gas deposits are a newly recognized vast store of combustible energy and industrial feedstock found in two relatively accessible situations; in Polar permafrost and continental shelf areas and in shallowly buried deep ocean sediments. Methane hydrates are now acknowledged as being very widespread in marine sediments and in permafrost regions, and may constitute the single largest store of fixed carbon on earth (Kvenvolden, 1993).

Geologically, gas hydrates originally were thought to be a peculiar feature of subareal permafrost terrains in the Arctic (Collett, 1983; Makogon, 1988). The compound hydrate/water-ice permafrost horizon was confirmed as a natural resource in Arctic regions in the late 1960's and early 1970's (Hitchon, 1974). Gas hydrate in the ocean basins was originally identified on continental shelves in the presence of subsea permafrost that extended from land out beneath the seafloor to virtually the continental shelf edge. In 1972, ARCO/EXXON first recovered a pressurized specimen of naturally occurring gas hydrate from a depth of 666 meters from a Prudhoe Bay, Alaska exploration well (Collett, 1983). Hydrates have since been identified in other Arctic regions. In the Barents Sea, hydrates are thought to have formed independently of the presence of permafrost (Solheim and Larsson, 1987; Løvø et al., 1990; Andreassen et al., 1990; Laberg and Andreassen, 1996). Hydrates are also found in other continental shelves and slopes at moderate depths which preclude the formation of subsea permafrost. In the deep oceans, hydrates are not associated with pure water-ice, as they are in permafrost regions. Significant quantities of gas hydrates have since been detected in many continental and shallow water permafrost regions and on the continental shelves of the USSR and North America (Kvenvolden & McMenamin, 1980). Many areas in which hydrate was not previously identified (Kaplan, 1974) are now recognized as gas hydrate provinces.

The recognition of gas hydrate in deep ocean sediments was a major discovery of the Deep Sea Drilling Project. Drill samples and gas analyses confirmed earlier, tentative identification from seismic reflection records (Bryan and Markle, 1966; Paull and Dillon, 1981; Kvenvolden and Barnard, 1983; Kvenvolden and McDonald, 1982). This submarine ground verification that related the seismic response to occurrence of hydrates has increasingly allowed identification of some hydrates deposits to be carried out using straightforward seismic-stratigraphic techniques. In addition to the presence of hydrate in the uppermost marine and polar sediments, hydrate appears to form seals to gas migration and cause it to concentrate.

This report is intended as a general reference and general review text for non-gas hydrate specialist scientists and for non-scientists with technical background. The authors have attempted to reduce scientific jargon to a minimum while describing a deceptively simple material with a wide range of complex chemical interactions and thermal implications. Gas hydrates or natural gas hydrates have only recently been observed in stupendous abundance in marine sediments in the world's ocean basins. Our aim is to describe the material and its characteristics along with present and future issues that may strongly influence our technological future.

## CLATHRATES AND CRYSTALLINE METHANE HYDRATES

Generally, a clathrate is a compound formed by the inclusion of molecules of one kind in cavities of the crystal lattice of another (Webster, 1979). There are many types of clathrates, which are also known as container compounds (Cram, 1992). Specifically, gas hydrates are solid crystalline materials formed from host (e.g., water) and guest (methane) molecules. The generic name, clathrate, is taken from the Latin word *clathratus*, which means enclosed by bars or grating (Barer and Stuart, 1957; Brown, 1962). "Hydrate" refers to the presence of water in the system.

Conventional chemical wisdom holds that a chemical compound consists of atoms linked, or bonded, to one another in a definite ratio, giving a fixed atomic structure to the molecule. Thus, salt is NaCl or sodium chloride, hexane is C<sub>6</sub>H<sub>14</sub>, or a chain of 6 carbon atoms with 14 hydrogen atoms attached. Either ionic (salt) or covalent (hexane) bonds serve to hold these, and countless other, molecular entities together, either as gases, liquids, or solids.

Further, most pure solid compounds exhibit a regular molecular structure. This ordering on the molecular level is manifested by a crystal form, a material characteristic in all compounds save certain supercooled fluids such as glass. The crystal (solid) structure of a compound is clearly and directly linked to the atomic structure of the compound, and can be effected by the geometry of the molecule. Some crystals of simple compounds, such as salt, are dense solids, and consist essentially of a series of spheres laid adjacent to one another in a three dimensional array. However, a great variety of more complex molecules will crystallize (solidify) under the proper conditions of temperature and pressure to give a rather open structure. The molecules of the clathrate substances in question will form an open lattice, a rigid three dimensional structure with open space within the lattice.

Generally, the open space in the crystal lattice remains just that: open space. For example, many silicate minerals (especially zeolites) crystallize into solids with linear channels, or planar sheets of open volume in the crystal. However, under certain conditions, these crystalline voids can be occupied by foreign molecules of such a size and configuration that the guest molecule fits into the crystalline voids of the host lattice. This situation is the essence of the definition of hydrate mentioned earlier. A key characteristic of a clathrate is that the molecular association exhibited by the clathrate is largely physical, rather than chemical, i.e. bonding, in nature. Since a host lattice has a well

defined structure with a clearly defined void volume in the lattice, a clathrate can exhibit a definite formula, quite analogous to that of a true chemical (bonded) compound. This state of affairs, that is, a combination of chemicals with a fixed ratio of components (atoms), implies a strong chemical bonding which, in the case of clathrates, does not in fact exist. Chemical wisdom does not apply completely in the case of clathrates, and to the physical forces which serve to hold them together.

Clathrates can form naturally under special conditions. A host material, which can form into an open lattice structure, is first needed, then a guest molecule of suitable size and molecular attribute to fit into lattice voids (Fig. 1) is required to complete the clathrate crystalline structure. Often, the system must be subjected to a bit of pressure, to force the guest molecule into the host lattice, as the host substance solidifies. Once formed, though, the clathrate can be more or less stable under atmospheric pressure, and rather normal temperatures. This situation makes clathrates both useful and troublesome in a variety of circumstances.

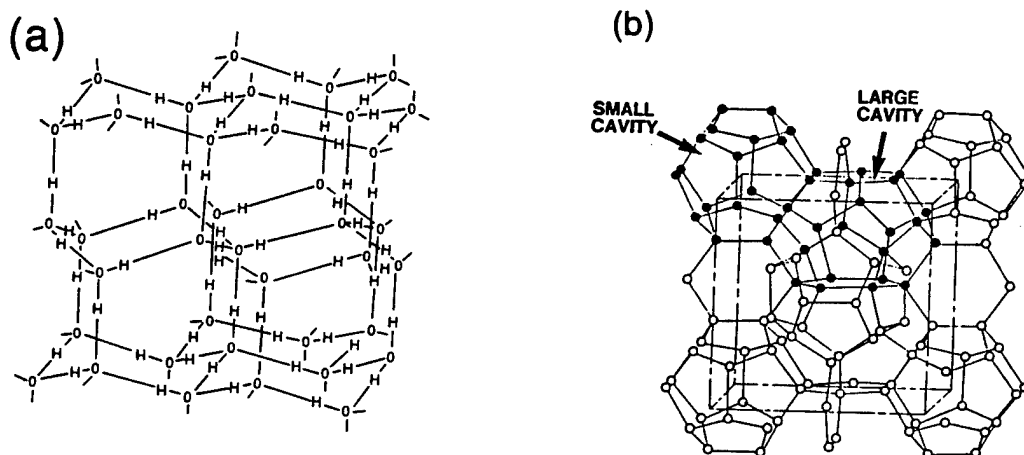

Figure 1. Molecular diagram of the open structure of gas hydrates. a. After Horne (1969) based on water molecules in lattice positions. b. Beta-quinol in lattice positions after Cotton and Wilkinson (1980).

A variety of molecular compounds can form clathrates (Table 1). The entry gas hydrates deserves special consideration, because these clathrates all use water 'ice' as the host lattice. Water, of course, is ubiquitous on planet Earth, a fact of major geological significance with regards to clathrates. The uniqueness of clathrates as a material has interested scientists since the early 1800's. For over a century, however, gas hydrates were little more than a laboratory curiosity. The first reported (1810) gas hydrate was chlorine hydrate ( $\text{Cl}_2 \cdot 6\text{H}_2\text{O}$ ), which was also thought to be a solid form of chlorine (Davy, 1811). It was then confirmed as a compound substance with chlorine gas occupying a slightly expanded ice lattice (Faraday, 1823). Because chlorine hydrate is easily formed from a cold mixture of chlorine gas and water (the water ice lattice easily accommodates the size of the ~3 Å diameter chlorine molecule), chlorine hydrates persisted until recently as a research curiosity (Pauling and Marsh, 1952). Basic clathrate research

has also expanded to include other guest molecules which can form hydrates with water and more complicated host and guest materials that substantially raise the complexity of the molecular structures (Flippen et al., 1970; Flippen and Karle, 1971; Hollander and Jeffrey, 1977).

Host	Guest
Urea	Straight chain hydrocarbons
Thiourea	Branched chain and cyclic hydrocarbons
Dinitrodiphenyl	Derivatives of diphenyl
Phenol	Hydrogen chloride, sulfur dioxide, acetylene
Water (ice)	Halogens, noble gases, sulfur hexafluoride, low molecular weight hydrocarbons, CO <sub>2</sub> , SO <sub>3</sub>
Nickel dicyanobenzene,	Benzene, chloroform
Clay minerals (molecular sieves)	Hydrophilic substances
Zeolites	Wide range of adsorbed substances
Graphite	Oxygen, alkali metals hydrocarbons (in sheet-like cavities and buckyballs)
Cellulose	Water, hydrocarbons, dyes, iodine

Table 1. Common clathrate, mineral, and solid other hosts and guests.

In the 1930's and 1940's the natural gas industry recognized that formation of gas hydrate, a crystalline, wax-like material, was clogging natural gas pipelines. This pipeline material often remained stable and continued to clog the pipes (Hammerschmidt, 1934) up to ambient temperatures and pressures; complex hydrates have a stability field much greater than methane hydrate alone. The solution to the hydrate problem was simply to dry the gas carried in the pipe lines; dry methane would not form the troublesome clathrate (hydrate), or use a combination of thermal energy and inhibitor solution to melt or solve already formed hydrates or hydrates that formed from gas-oil mixtures that were not possible to dry completely. In 1964 naturally occurring gas hydrates were discovered associated with permafrost terrane in Siberia, and successful experiments to develop methane extraction techniques began shortly afterward. Discovery of oceanic gas hydrates took place soon afterward (Tucholke et al., 1977). Identification of the distribution of methane hydrate is only in its preliminary stages.

The Earth possesses immense quantities of methane, and naturally occurring methane is far from dry; it is usually mixed with considerable amounts of water vapor and other



natural gases such as carbon dioxide and higher molecular weight hydrocarbon gases. The atmosphere has trace quantities of methane, which also occurs as a trace gas in the oceans, and as a constituent in hydrocarbon and coal deposits of geological importance. Biological processes on, and under, the Earth's surface produce much of this methane, and such methane is in intimate contact with water. The water-methane clathrate system has a stability field (Fig. 2) which is matched by natural conditions on the Earth. Methane hydrate forms readily when methane and water is cooled and pressurized slightly over Earth's ambient surface conditions. Thus, in the deep sea (cold and high pressure), in the Arctic (very cold, moderate pressure), or even in areas with a high methane partial pressure, it is possible for methane hydrate to form. Indeed, gas hydrates in deep ocean regimes have only recently been recognized (Schleak, 1951; Barron, 1957).

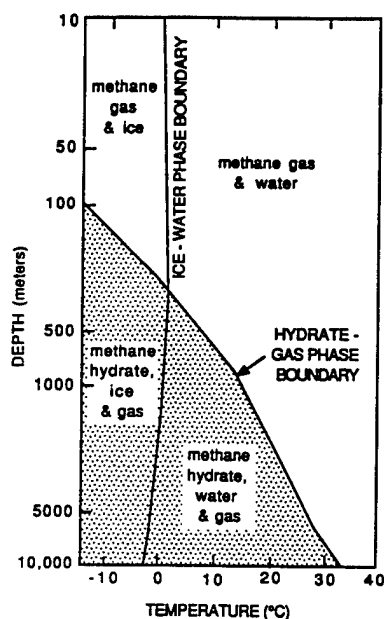

Figure 2. Phase boundary diagram of water-ice-gas-hydrate stability field for fresh water. From Kvenvolden & McMennamin (1980) and Collett (1983), attributed to redrawing from Katz et al. (1959). Addition of NaCl to water mixture shifts the curve to the left; addition of CO<sub>2</sub>, H<sub>2</sub>S, ethane, and propane to the mixture shifts the boundary to the right and increases the hydrate stability field. (10 m = 1 Atm or 1 bar at sea level. 100 Atm. or 1,470 lb/in<sup>2</sup> = 1 Megapascal, [MP])

### PHYSICAL PROPERTIES OF GAS HYDRATES

Gas hydrates crystallize with cubic crystal symmetry, in contrast to water ice alone that crystallizes with hexagonal symmetry. Hydrates exist in two distinct but different crystal structures depending on the size of the guest molecule. Structure I hydrates (Fig. 3) contain 46 water molecules per unit cell and can contain a maximum of eight guest molecules having a molecular diameter of less than 5.8 Angstroms (Macleod,

1982). Some of these guests are: Ar, Kr, CH<sub>4</sub>, C<sub>2</sub>H<sub>6</sub>, H<sub>2</sub>S and CH<sub>3</sub>Cl. The unit cells have 46 host water molecules and 8 cavities where the guest molecules may be located. Structure II hydrates contain 136 water molecules per unit cell and can also contain up to eight guest molecules up to a molecular diameter of 6.7 Angstroms, such as C<sub>3</sub>H<sub>8</sub>, CHCl<sub>3</sub>, and C<sub>2</sub>H<sub>5</sub>Cl.

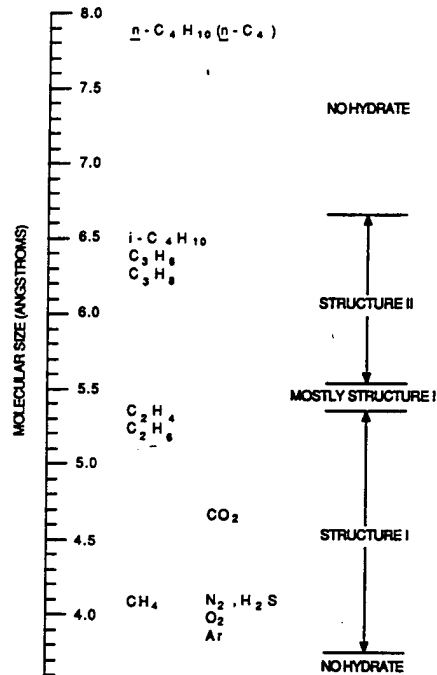

Figure 3. Diagram of hydrates of paraffin series natural gas and other gases in relation to atomic size of guest molecules. Allowable size of gas molecules that can be incorporated in natural gas clathrate series is no larger than 6.7 angstroms. Structure 1 hydrates are body centered cubic lattices; Structure 2 hydrates are face centered lattices (diamond packing). After Davidson et al. (1973) and Hand et al. (1974).

Gas hydrates are nonstoichiometric crystalline materials in that a variable amount of gas (up to a maximum allowed by the crystal lattice structure) can be contained within the guest structure volumes. The amount of gas varies dependent on composition, pressure, and temperature (Sharma et al., 1987). The lattice becomes increasingly occupied by gas at lower temperatures and higher pressures. One volume of water can accommodate from 70 to over 160 volumes of gas. Natural hydrates are often undersaturated in that some of the guest sites may not be occupied. A fully saturated methane hydrate, however, has a higher energy density (btu/litre) than liquified methane (Max and Pellenbarg, in press) because the methane sites in the crystal lattice are closer together than the methane molecules in the liquid.

The density of methane hydrates is about 0.9 g/cm<sup>3</sup>; density varies according to the degree of methane saturation of the hydrate lattice and the local incorporation of other molecules (e.g., H<sub>2</sub>S) taking the place of methane in the lattice. Molecular pressure of gas in the hydrate lattice can reach several kilobar with increasing saturation. Heat of fusion / dissociation: The heat of hydrate formation and the heat of hydrate dissociation are equal in absolute magnitude but are of opposite sign. When hydrate forms heat is released from the system and when they dissociate, heat is taken into the system. A nominal value for methane hydrate formation enthalpy at 273° K is 54 kJ/mol (Sloan, 1990). Heat capacity: Hydrates have a constant pressure heat capacity of 257 kJ/mol (Handa, 1986; Sloan, 1990). Heat of solution of methane: The heat of solution (absorption) of methane gas is 13.26 kJ/mol. (Franks and Reid, 1973; Sloan, 1990). Conductivity: Thermal conductivity of a hydrate-sediment mixture is 2.2-2.8 W/m-K. For comparison the conductivity of a water-ice sediment mixture is 4.7-5.8 W/m-K (Table 2). Conductivity for a gas-sediment mixture, such as exists in natural gas pools is very low, in the 0.05-0.4 W/m-K (Watt per metre-degree Kelvin) range (Sloan, 1990). Because the hydrate is rarely developed uniformly within the Hydrate Stability Zone (HSZ), this high conductivity will rarely be attained. Taking into account physical heat transport by geothermal circulation cells, some free gas and a rapidly varying porosity and permeability, 1.5 W/m-K, about 50% higher than for tight sediment with no hydrate, is a reasonable working estimate for modeling thermal conductivity within the HSZ.

Heat of fusion / dissociation:	at 273° K: 54 kJ/mol
Heat capacity:	257 kJ/mol
Heat of solution of methane:	13.26 kJ/mol.
Conductivity:	2.2-2.8 W/m-K.
water ice	4.7-5.8 W/m-K
gas-sediment mixture	1.5 W/m-K
Coefficient of expansion	2/7 (greater volume as hydrate)
water ice	1/7 (greater volume as hydrate)

Table 2. Physical properties of methane hydrate

Heat conduction in gas hydrate is considerably lower than that of ice, probably because heat retention is enhanced by the high specific heat of methane. The critical temperature of methane is  $-82.6^{\circ}\text{C}$  at 45.44 Atmospheres pressure (Dean, 1974). At  $200^{\circ}\text{K}$ , methane-hydrate heat conduction is 8 times lower than that of ice. It is possible that gas hydrates, once formed, might form thermal high anomalies in the ocean floor without the hydrate becoming unstable and breaking down to a water-gas solution. Although Davis et al. (1990) use a conductivity of  $0.394 \text{ W /m-K}$ , which is less than that of  $0.57\text{-}6 \text{ W /m-K}$  for water, this figure was derived for propane hydrate alone. Sloan (1990) noted conductivities for pure methane hydrate of  $0.45 \text{ W /m-K}$  to  $0.5 \text{ W /m-K}$  and shows that the conductivity for hydrate and sediment is in the  $2.3\text{-}2.9 \text{ W /m-K}$  range, overlapping the lower part of the  $2.5\text{-}3.3 \text{ W /m-K}$  range of conductivities for water plus sediment. Up to 20% hydrate in water-saturated sediment appears to only have the effect of slightly lowering the range of conductivity. Build-up of massive zones of hydrate in bands or widely in the lower part of the HSZ could have the effect of significantly lowering conductivity. Vogt et al. (1994) have estimated that an overall conductivity of about  $1500 \text{ mW}\cdot\text{m}^{-1}\cdot^{\circ}\text{C}^{-1}$  for the high heat flow HSZ in the Vestnesa sediment ridge along the base of the continental slope to the west of northern Svalbard in the northern Nordic Sea.

Hydrate hardness is not well characterized; however available data (Makogon, 1988) show that may be up to twice water-ice hardness. Fully bonded gas hydrate sediments are apparently not common, however, and thus the hardness of the hydrate-bearing sediment layer would probably not be much increased. A significant proportion of gas hydrate in sediment would cause an increase in ductility or rigidity that would have an effect on the penetration of any foreign object (e.g. gravity core barrel) that was emplaced largely through simple displacement of sediment. Details of the thermodynamics of gas hydrate, reaction rates, and methane solubility and diffusability are discussed by Godbole and Kamath (1987).

Hydrates are mainly inferred from geophysical measurements both in drill holes and from acoustic methods. Hydrates characteristically induce high electric resistivities and are thus quite distinctive from unhydrated sediments (Pearson et al., 1983) on geophysical records of exploration boreholes in the Arctic continental shelves. Sound velocity in hydrates is substantially above that which would be expected in the sedimentary sequences without gas hydrates. Collett (1983) reported Vp-wave measurements of naturally occurring gas hydrates from drill holes at between  $3.1 \text{ km/s}$  and  $4.4 \text{ km/s}$ . Hydrate-sediment velocities are commonly in the  $2.3\text{-}3.2 \text{ km/s}$  range. Velocity of seismoacoustic waves through porous rock saturated with gas hydrates can be 60 to 100% higher than through the same rock saturated with free gas. However, virtually no experimental data concerning sound attenuation exists.

### **CONDITIONS GOVERNING THE PRESENCE OF GAS HYDRATES**

For sedimentary gas hydrates to form, a number of conditions must be met: 1. Adequate gas must be produced in the subjacent sediment; sediment thickness, organic source material, and heat flow act to control this gas production reaction. 2. Gas must

either percolate upward into the hydrate stability zone near the sediment surface or pass into the zone along pathways; no significant cap rocks can occur in the gas-pathway section. 3. Water must be present; some brines may be tolerated although fresh to brackish water facilitates hydrate formation. 4. Suitable thermodynamic conditions (lower temperature / higher pressure) must prevail for the crystallization of gas hydrate.

### **1. Hydrocarbon sources and mechanisms of concentration**

Petroleum source beds are sediments that contain significant disseminated sedimentary organic matter (kerogen) that becomes involved in mainly first-order chemical reactions during burial and heating (Dow, 1978) and produces enough petroleum products to allow migration and subsequent formation of economically significant petroleum accumulations. Sedimentary organic matter is derived from: 1. Amorphous aquatic or lipidmatic organic material from lower marine or lacustrine plants, which typically yields oil, 2. Terrestrial or humic organic material from higher animals or plants, which yields gas and some condensate, and, 3. Recycled organic material from erosion of older sedimentary rocks, which normally yields some gas but little oil. Because this discussion concerns an area that has only been drilled on a small proportion of the continental shelves, with no deep water drilling except for a few sites in the Nordic Sea, discussion of the local potential for petroleum production is speculative. Nonetheless, evidence for the existence of gas concentrations, combined with deduced heat flow and sediment composition, sedimentological history, and thickness, may be used to make inferences about widespread petroleum production.

Terrestrial organic material is usually found on inner continental shelves, especially near deltas of large rivers draining well-vegetated areas. Organic material, in the form of dissolved carbon, lipids, and particulates, comprise an unusually high volume and proportion of both clay and silt-rich near-surface sediments in the Arctic Basin and the Barents Sea (Danyushevskaya et al, 1980; Darby et al., 1989; Belyaeva et al., 1989), where fine-grained clay sediments commonly contain over 2% organic carbon (Romankevich, 1984). Because of the low temperatures and consequently reduced bacteriological activity in Arctic seas, there tends to be significant preservation of organic material dissolved in Arctic waters (Darby et al., 1989) that is available for incorporation into sediments. Arctic climatic conditions probably extended back into the upper- to mid- Tertiary, an important factor in sedimentation. There are periods during which Arctic glacial lakes have had catastrophic flooding at rates up to  $5 \times 10^5$  m<sup>3</sup>/sec (Teller and Thorleifson, 1983; Kehew and Lord, 1986) and  $10^6$  m<sup>3</sup>/sec that can significantly increase the amount of transported organic material in rivers (Lowrie, 1986). Similar processes must have characterized Arctic rivers well back into the Tertiary. Organic material brought to depositional sites in the Arctic by the many north-flowing rivers preferentially forms gas and because a great deal of organic material is liable to be brought over relatively short time periods, it is very likely to become bound in anoxic sediments without being oxidized. Ecosystem productivity or import of organic carbon appears to be more important to the development of organic carbon rich source

beds than anoxia (Pedersen and Calvert, 1990), a condition that is rare in open oceans. Because of nutrient availability (Fairbridge, 1966) and marine productivity (Degens and Mapper, 1976), especially during complex interglacial cycles that introduce vertical circulation and mixing (Aagaard, et al., 1985; Marquard and Clark, 1987), organic material produced in the Arctic and in water masses derived from the Arctic that flow into more southerly oceans is liable to become bound in the sediment. Comparable areas, such as the North Atlantic and the northern Pacific will have similar petroleum generating capability; southern Polar seas may also be comparable.

For source beds to yield significant petroleum, there must be at least 0.5 wt% organic matter in sediment surviving sediment transport processes and seabed organic consumption processes. Most recognized source beds contain between 0.8 and 2.0 wt % organic carbon and some contain as much as 10 wt % (Dow, 1978). 7,300 analyses from DSDP legs 1-23 show 17.3% exceeded 0.5 wt %, and 4.3 exceeded 1.0 wt % (McIver, 1975). Dow (1978) shows that organic carbon in normal ocean depths, correspond to that in continental slopes and rises along the organic rich province of the Louisiana Gulf Coast. Favorable sites for deposition of organic-rich sediment include the oxygen-minima zones on continental slopes and rises. Because sedimentation is most pronounced in these areas, through turbidite activity associated with variable sea levels (Dow, 1978, 1984; Emery and Uchupi, 1984), rise and slope deposition is likely to fix sufficient organics in sediment to allow generation of significant petroleum.

Maturation of sediments proceeds with increasing depth and duration of burial (Dow, 1978; Tissot and Welte, 1978; Tissot and Welte, 1984), although the nature of the sediment can contribute to thermal evolution. Mudstones of continental provenance, for instance, characteristically have higher heat productivity than sandstones (Oxburgh and Wilson, 1989). Significant hydrocarbon generation begins when temperatures in the sediment reach about 50°-65° C, the 'gas floor'. From this temperature to about 135 ° C, oil and gas are produced, and gas only is produced above about 135° C (Martini, 1980). Peak hydrocarbon generation occurs at about 100° C (Tissot and Welte, 1984), but in pressurized sediments may occur at slightly higher temperatures because of the inhibiting effect of pressure on generation of water-related volatiles. At temperatures above the 'gas floor', about 190°-250° depending on water and thermal rate, CO<sub>2</sub> rather than methane is produced.

From the sediment surface down to a depth of a little over a km (depending on water depth and total pressure), biogenic gas is the principal petroleum product (Fig. 4), especially in near-surface sediment where macroscopic biological activity is high. Biogenic gas produced in sediment is mainly methane, which is stable and persistent in anoxic conditions. Production of oil in the 'oil generation window' takes place if suitable hydrocarbons occur, otherwise gas remains the main product as generation changes to thermogenic because of the temperature rise. Thermogenic gas often consists of dominantly heavier density gases. Maturation continues with increasing depth with cracking of oils and higher density gases to methane, which because of its high diffusability migrates upward leaving carbonaceous residue. Temperature is probably the most important single factor in determining paths of organic matter loss during

maturation (Raiswell and Berner, 1987). Deeply buried (>8 km) sediments in the Polar oceans are probably less than 200°C/100m, given geothermal gradients on the order of 3°/100 m, a 'warm' figure for conservative estimation of potential (Kvenvolden and Barnard, 1983), certainly no higher than the low pressure and temperature mid Zeolite facies of a low temperature metamorphic series (Yardley, 1989). Dow (1978) shows that at constant geothermal gradients for different prograding continental margin sequences (2.6° C for the U.S. Gulf Coast), the depth of oil generation and destruction decreases with increased regional heat flow.

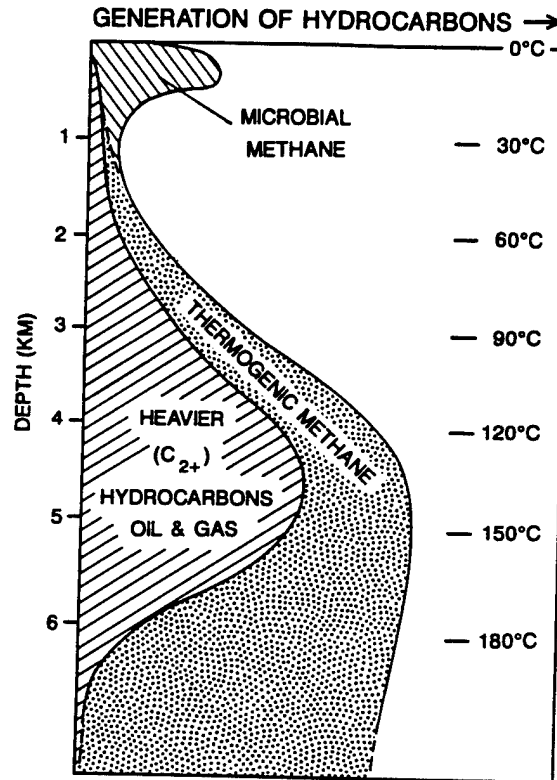

Figure 4. Main petroleum products likely to be produced as a function of depth and with an assumed constant geothermal gradient of 3.0° C/ 100 m (30 ° C/ 100 m), seafloor = 0° C. Actual thermal profile depends on burial history and geothermal gradient changes, which often change with depth. Generation potential for microbial methane immediately below surface is probably exaggerated. Higher geothermal gradients increase temperatures at depths and telescope the generation curves. The oil generation window does not occur without suitable organic hydrocarbons. Thermal cracking of oil yields gas. After Tissot and Welte (1984), Hedberg (1974).

Mid- and Upper Mesozoic age sedimentary successions are known to be important sources of hydrocarbons. Results from the Deep Sea Drilling Project (Jansa and MacQueen, 1978; McCave, 1979, and Arthur, 1979; Summerhayes, 1981; Dean, et al., 1984) reveal the existence of thick Mesozoic aged sediments in the Atlantic. Similar deposits are found in the Gulf of Mexico (Buffler et al., 1984). These sediments are

generally fine-grained with significant organic matter and are commonly referred to as black shales. These black shales are thought to be the major sources for the Gulf of Mexico petroleum deposits (Sassen et al., 1988) and are the expected sources of potential U.S. east coast margin hydrate deposits (Dillon and Paull, 1983). Black shales were originally more organic-rich and more organic material has survived organic carbon loss during burial diagenesis than in less organic-rich sediment because, depositional carbon loss in sediment appears to take place at a constant rate in sediment of varying carbon content, at least since the Devonian (Raiswell and Berner, 1987). Because at least the North American margin of the Canada Basin was established early enough to also contain sediments of this age and type (Grantz and May, 1982), potential deep hydrocarbon source rocks probably exist in the Canada Basin, as well as in the Makarov Basin. Source rocks in the Nansen-Amundsen Basin are probably no older than Tertiary in age, except in the marginal continental crust. Here, Mesozoic rocks forming part of the Barents shelf may have provided gas to younger sediments along the continental margin and possibly in the Lomonosov Ridge area of the European Arctic Ocean.

High quality dense data sets from the Louisiana Gulf Coast provides an insight into potential petroleum generating character of the Arctic and other sediment prisms in cold water regimes. Most of the present continental slopes and rises are covered by sediments in excess of 4 km thick. This sediment thickness is critical because the total pressure (hydrostatic plus lithostatic) and temperature must be high enough to generate petroleum from Tertiary source beds, although petroleum generation in as little as 2 km of more compacted source bed (Gulf Coast Cretaceous; Dow, 1978) is possible. In addition, sedimentological/climate/sea level processes that acted to deposit organic-rich sediments in the Gulf Coast were likely also applicable in the Arctic for at least the Cenozoic. Global cooling may have begun in the Arctic as early as the Eocene (Dalland, 1976) even though long-lasting sea-ice cover may not have existed in the Arctic until Plio-Pleistocene times (Clark et al., 1980). North Atlantic break-through into the Arctic in the mid-Cenozoic allowed the cold, organic-rich bottom waters to enter into the Atlantic circulation pattern.

Extensive hydrates can be built up from thick sediment areas having a long history of sedimentation owing to the concentrating effect of the 'gas hydrate conservation cycle' (Max and Lowrie, 1996), which acts to hold methane within the HSZ while capturing newly produced subjacent methane. Hydrate formed in the HSZ gasifies when it becomes too deeply buried beneath a seafloor undergoing active sedimentation, and passes down out of the HSZ, whose thickness is tied to the seafloor. Once gasification occurs, the methane buoyantly rises to reenter the hydrate stability zone HSZ. However, little has been known about methane producing bacterial action below the hydrate layer, a biogenic component of which would provide a significant steady source of gas that would rise into the HSZ. If there were no mechanism for widespread bacteriological methane production, then there would be a strong constraint on the production of methane and the consequent formation of oceanic hydrates. It is now known that the active bacteriological biosphere does extend to significant depths (Parkes et al., 1994; Cragg et al., 1995; Cragg et al., 1996). Preliminary results from ODP Leg 164 drilling of the S.E. U.S. Coast shows orders of magnitude increases in both bioavailable acetate (food supply) and bacteriological methanogenesis below the HSZ (Parks, pers. comm.). These results indicate that there is



an important, but as yet little understood, mechanism for the widespread *in-situ* generation of methane, even where the gas hydrate conservation cycle may not be an important concentrator of methane in hydrate. The volumetric presence of methane at depth appears to be tied to new production and not to an increase due to increased partial pressures at greater total pressures with increased depth.

## 2. Origins of Methane: Gas Productivity

Methane gas in sediments is produced mainly through biogenic and higher temperature, thermogenic means, but also through igneous, metamorphic and volcanic processes. Factors which favor the generation of gas in sediments include: 1. Thick sediments that were deposited with high and episodic high rates of sedimentation. 2. Sediments with a high degree of biogenic material; particularly muddy sediments derived from land areas or continental shelves. 3. Sediments overlying lithosphere which has moderate to high geothermal gradients (High geothermal gradients may also serve to thin the hydrate zone and thus allow a higher gas to hydrate ratio). 4. Suitable porosity and permeability that allows percolation of gas.

The likelihood of gas hydrates in a particular sedimentary regime is predicated on the probability of gas generation, which itself is dependant on the availability of organic carbon material in sediments. Although paleogeographic reconstructions of organic carbon in sediments of this region are not available, Romankevich (1984) shows the distribution of organic carbon in the upper sediment (0-5 cm) layer, with the exception of the high Arctic. Extrapolation of this depositional zonation back into the Tertiary is possible because the world's oceans have had about the same configuration since at least the time that the Atlantic plate margin spread into the Arctic ocean and established the present inter-ocean water circulation patterns at about 30 million years ago (Vogt et al., 1979). The Arctic Ocean and the North Atlantic basin north of Iceland and the Greenland-Iceland-UK trans-ocean ridge, forms the largest contiguous area in which significant amounts of organic carbon is being deposited (Premuzic, 1980).

Pockmarks are now being widely recognized on the ocean floor; pockmarks record bursting of gas (often with liquids) from the sea floor (Hovland and Judd, 1988). Individual gas accumulations off the U.S. SE coast (Dillon and Paull, 1983) are on the order of 16 km x 12 km in area with closure of from 125 to 200 m in over 3 km water depth (> 300 Atm) and could contain from 5,000 to 10,000 km<sup>3</sup> of gas. Large amounts of gas might enter the ocean and atmosphere following catastrophic rupturing of a hydrate-cap gas reservoir as an induced as well as a natural occurrence. The presence of pockmarks is commonly used to indicate that concentrations of gas below the surface-parallel hydrate stability zone is held in metastable reservoirs; although the hydrate forms a cap that causes the hydrate to concentrate in bathymetric culminations the seal is often breached locally. Research in the physical state of hydrate-cap reservoirs in the deep oceans will have to resolve these complex interrelated problems. Location of pockmark fields may prove to be a primary exploration technique to identify areas of economic potential but pockmarking will also alter the bottom roughness.

### 3. Heat Flow and hydrates

Heat flow is important to the development of methane hydrate because it drives the generation of gas from a sediment pile, and is associated with fluid circulation that delivers gas to the upper sediment, and particularly the HSZ. Heat flow and available free energy is thus the main factor, at any given depth, that determines the thickness of the HSZ from place to place.

Ocean ridges are the major heat leak from deep within the earth. Sea floor in the age range 100-200 Ma (Million years before present) heat flows at 45-55 mw/m<sup>2</sup>; younger oceanic crust sea floor has higher heat flows. Active ridge sites to 3-4 Ma (million years) at depth off-ridge heat flows average about 300 mw/m<sup>2</sup> with some heat flow measurements nearly 400 mw/m<sup>2</sup> (Davis, 1989). Oceanic crust cools as it is forced away from the spreading ridge by formation of new crust at the ridge crest. Average oceanic crust 80 mw/m<sup>2</sup> heat flow is likely for ocean areas such as the Canada Basin, which contains substantial areas of older oceanic crust. Extensive sediment may reduce heat flow from subjacent oceanic crust by introducing an insulating low conductivity blanket that often can develop local 'hot spots' through fluid or gas circulation tapping the deep-seated heat. Hydrothermal heat redistribution by fluids is now recognized as an important heat distribution mechanism. Hydrate in sediment can effect heat flow measurements because it has a higher conductivity than the sediment in which it forms. Heat flow data are restricted in the Alaskan margin and the central Arctic basin, but is more widespread in the northern North Atlantic (Louden and Wright, 1989).

The relationship between geothermal gradient and measured heat flow depends on the conductivity of the materials below the ocean floor. Local geothermal gradients are commonly measured as a function of depth in drill holes while heat flow measurements are done at or immediately below the sediment surface (Louden and Wright, 1989). The theoretical one-dimensional model of thermal conductivity being equal to the product of heat flow and thermal gradient ( $q=k\beta$ ; Oxburgh and Wilson, 1989) is rarely achieved in nature, largely because of non-linear transfer introduced by fluid and gas transfer. 2.6° C/100 m appears to be a characteristic heat flow for a prograding continental shelf slopes (Dow, 1978) that have heat flow values of from 25 to 45 mw/m<sup>2</sup>. This type of continental margin bounds most of the Arctic and Nordic seas, but because of the local proximity of ridge sites to some margins, heat flow in some Arctic and Nordic Sea areas are higher than older passive margins further south in the Atlantic.

The northern Greenland-Norwegian Sea is the highest heat flow region yet measured in the Arctic, and abnormally high heat flows along the Norwegian-Barents Sea-Svalbard margin are attributed at least in part to the presence of methane hydrate (Vogt and Sundvor, 1996). Even in the thick sediment blanket along the west Svalbard margin, heat flows of between 100 and 200 mw/m<sup>2</sup> are common. Although these margin heat flows may be associated with their shear zone origin, with heat being transmitted through steep fault zones in the basement, the abnormally high heat flows from the Boreas Basin must have a different explanation (Crane et al., 1988) that we do not speculate upon. Emery and Uchupi (1984) prefer 3.4° C/100 m for continental rises, at least of the U.S. east coast type. Heat flow in sedimentary basins and sedimentary slope prisms on the upper

slab of major subduction complexes around the North Pacific are about 3 °C/100 m. Basins in extensional crust not directly related to subduction such as occur in the Arctic and Nordic Seas, may be higher, especially where sedimentation does not keep pace with subsidence (Oxburgh and Wilson, 1989). Thermal gradients for subduction related troughs at slab junctions can be on the order of 5.3 °C/100 m (Kvenvolden and von Huene, 1985). Although no subduction margins now occur in this region, restricted subduction may have occurred along the Canada Basins-Lomonosov Ridge during generation of the Amundsen-Nansen basin and would have effected coeval sediments.

### FORMATION AND STABILITY OF GAS HYDRATE

The general thermodynamic conditions for methane hydrate formation are strongly influenced by pressure (Katz et al., 1959), which gives hydrate a wide pressure-temperature field of stability (Fig. 2). Where higher molecular weight gases, such as ethane and propane are part of the guest molecule mixture, a common feature of ocean sediment gases, the hydrate stability field expands considerably (Fig. 5). 1% propane in the gas mixture can reduce the pressure at which the hydrate forms by nearly 40% (Brown, 1962). Although hydrates are ice-like and hydrogen bond water molecules, their formation in the deep oceans is to be generally expected at temperatures well above the freezing point of water (up to 23° C in 3.5 km water depth), although colder temperatures facilitate formation.

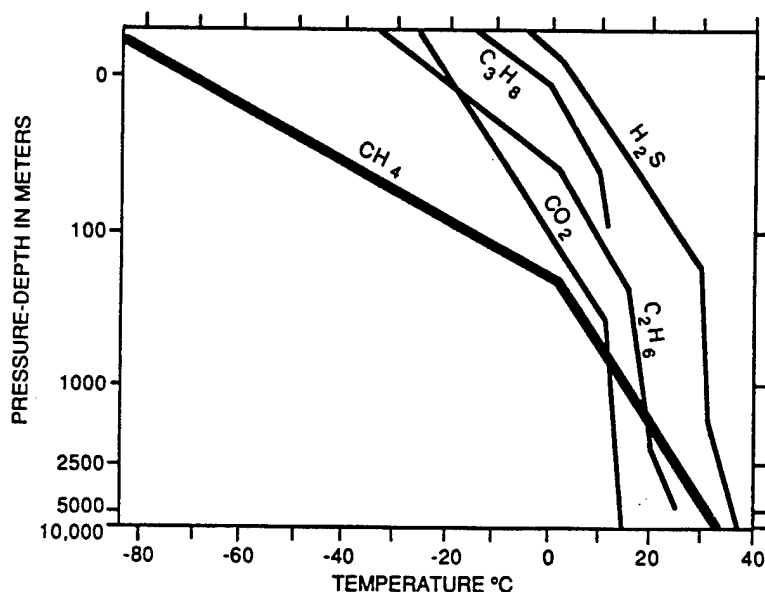

Figure 5. Natural hydrate phase boundaries for different common gases. From Makogon (1988). Replotted with temperature in normal scale and pressure-depth in meters seawater. 0 is atmospheric pressure at sea level. CH<sub>4</sub>, methane; C<sub>2</sub>H<sub>6</sub>, ethane; C<sub>3</sub>H<sub>8</sub>, propane; C<sub>4</sub>H<sub>10</sub>, butane, the most dense of the hydrate-forming paraffin gases. CO<sub>2</sub>, Carbon Dioxide; H<sub>2</sub>S, Hydrogen sulphide.

Natural gas hydrates occur in disseminated, nodular, layered and massive forms (DOE, 1987). Within a HSZ variable acoustic structure, both vertically and laterally, has been identified as fine-structured representation of the relative amounts of hydrate development (Rowe and Gettrust, 1989). The lower part of a hydrate can be expected to be more massive and thoroughly gas saturated (Max, 1990). In its upper portion, where more immature hydrates occur and where the gas supply is inherently more limited, highly variable hydrate development can be expected.

The sedimentary hydrate layer is a steady state, aggrading phenomenon in which gas produced in or below sediment becomes fixed in the zone of hydrate stability in the uppermost sediments. The hydrate stability zone is a zone of thermodynamic balance in which the heat rising from within the earth is dissipated into the ocean is a relatively steep thermal gradient (Fig. 6). The upper surface of the hydrate is commonly near or at the sea bottom below about 400 m water depth. Polar hydrates are up to 1700 meters thick on land. On continental shelves and in the deep ocean, hydrates up to nearly 800 meters thick have been identified (Dillon and Paull, 1983). At relatively constant geothermal gradients, the thickness of the hydrate stability zone increases with increasing water depth and increased pressures. A single long seismic line in the vicinity of the Blake Outer Ridge off the North Carolina coast (Fig. 7) clearly images the gas hydrate horizon which thins from almost 1 sec of twt (two way travel time) at a water depth of slightly greater than six sec of twt to less than 0.2 sec twt at a water depth of about 0.5 sec twt (Bryan and Markle, 1966, Fig. 14; Markle and Bryan, 1983).

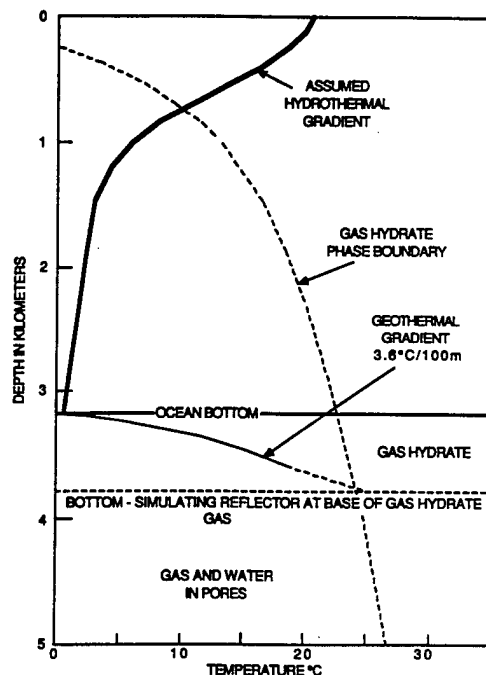

Figure 6. Position of the hydrate stability zone in the upper sediment. Heat rising from below is transferred into the cold sea water. Base of Hydrate Stability Zone (HSZ) is the phase boundary. Representative hydrothermal and geothermal temperatures shown.

The hydrate blanket can form because there is a thermal balance between the pressure-temperature conditions of the hydrate stability zone, rising heat, and transfer of the heat energy into the water column at the ocean bottom. The base of the hydrate moves upward as sedimentation proceeds, to keep the thermodynamic system in balance. Where hydrate at the base of the layer becomes unstable owing to the rise in temperature from upward migrating heat, it inverts to gas and because of buoyancy, tends to rise upward into the hydrate stability zone. The gas tends to be retarded in its movement through the HSZ because hydrate forms seals that can trap the gas (de Boer et al., 1985) and allow more time for hydration. This long term process of gas concentration means that whatever gas is produced in oceanic sediment and migrates into the uppermost part of the sediment column tends to be concentrated in the hydrate stability zone or in gas pools below it. Only gas that bursts the hydrate layer can normally escape through a hydrate cap (cf., Solheim and Elverhoi, 1985).

### IDENTIFICATION OF GAS HYDRATE

Gas hydrate has been primarily identified using reflection seismics that image: 1. the acoustically more transparent zone of high velocities caused by the presence of hydrate and, 2. the Bottom Simulating Reflector (BSR), which is the impedance contrast at the bottom of the hydrate (Pecher et al., 1996). The presence of gas hydrate in marine sediments dramatically alters the normal physical properties of the sediment (Dillon and Paull, 1983). The presence of hydrate appears to lower attenuation, especially if pore-space gas is converted to solid hydrate. The general diminution of reflection coefficient between originally high and low porosity sediment layers through filling of pore space with higher acoustic velocity hydrate gives the sediment as a whole a more uniform seismo-acoustic character (Max, 1990a; 1990b). Because the hydrate may not develop as a solid mat, but rather as a series of hydrate-rich bands controlled by porosity contrasts in the bedded sediments, the characteristic blanking (Fig. 7) of the whole zone may not be seen, even though substantial hydrate is present. Also, if the BSR is parallel to primary sedimentary acoustic structure, it may be difficult to identify. Identification of the seismo-acoustic attributes of the hydrate has been ground-verified by drilling and acquisition of hydrate in pressurized cores, and more recently in normal cores that have been recovered more rapidly than in the past. Shipley et al. (1979) noted that there was widespread evidence of bottom simulating reflectors (BSR) that identified the anomalously high acoustic velocity layer formed by gas hydrate. Continued examination of seismic data suggests an almost pervasive gas hydrate development in deep ocean sediments, especially in the light of recent work that indicates that hydrates can be present even where their presence is difficult to interpret from reflection seismic records that were not optimized to identify reflectors and acoustic structure of the upper 1 - 1.5 km of ocean sediment.

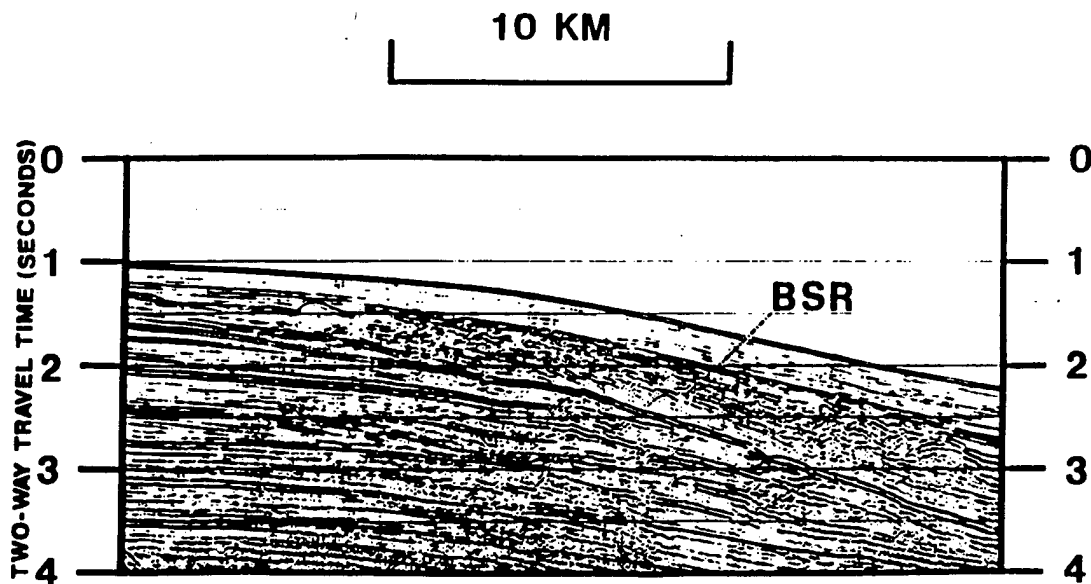

Figure 7. Seismic section showing acoustic blanking in the hydrate stability zone above Bottom Simulating Reflector (BSR). Note reduction in thickness of zone in shallower water. Vertical scale in seconds of two-way travel time (sound speed in water about 1,500 m/sec). Supplied by W. Dillon.

Seismic data (Dillon et al., 1995) suggest that the BSR can be quite discontinuous, reflecting where gas is developed beneath the hydrate and where little gas is present. Hydrate has been recovered by coring outside of a zone of recognized BSR (Holbrook et al., 1996), confirming the modeling of Max (1990) in reevaluating seismic reflection data off the S.E. U.S. coast, that BSR only provides a minimum geographic identification of the extent of hydrate development. Other criteria, such as suppression of the normal impedance structure as indicated by signal amplitude, or lack of recorded porosity decrease with increasing depth in DSDP cores, as well as by other small scale reflection seismic effects such as the generation of hyperbolae on the record associated with blocky structure at the base of the hydrate zone, may also become to be regarded as diagnostic for hydrate (Lee et al., 1994). Reevaluation of seismic data off northern Alaska has shown that gas hydrate occurs in an upper seafloor blanket over a large area of the continental slope (Fig. 8). Initially recognition of hydrate BSR here was made on a few seismic lines and the hydrate was regarded as having limited extent; it has now been recognized on more than 70% of the line mileage of all seismics reexamined (Grantz, pers. comm.), and it is likely that reprocessing of the seismic data (von Huene, pers. comm.) and examining drilling and coring records (Dillon, pers. comm.) will reveal a substantially greater occurrence of gas hydrate in world ocean basins.

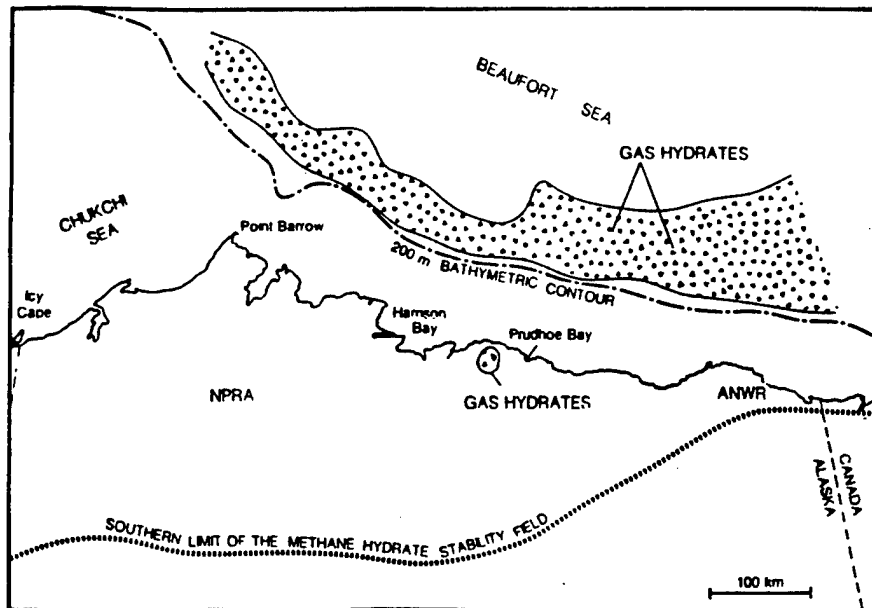

Figure 8. Gas hydrate disposition in the North Slope of Alaska. Continuous hydrate in the continental slope is inferred from close-spaced seismics. Supplied by T. Collett, U.S. Geological Survey.

### DISTRIBUTION OF GAS HYDRATE

Hydrates are widely distributed geographically, and preliminary volumetric estimates suggest that marine gas hydrates constitutes a very large body of natural gases. This report does not exhaustively examine each identification and list the area and volume, because each reference to the presence of the hydrate is inherently fragmentary and conservative, and almost certainly does not represent a true geographic distribution. The most commonly referenced map of hydrate occurrences is that of Kvenvolden (1988), which has been updated for this report (Fig. 9). This map represents each reference as a point location and does not reflect the geographical extent of hydrates. A general location figure of those deposits continuous to the U.S., which serves as the basis for a U.S. Department of Energy analysis of unconventional gas reserves held in gas hydrate shows a better estimate of the geographical areas of gas hydrate development (Fig. 10). These map almost certainly also under-represents the geographic distribution of gas hydrate as it shows administrative research areas rather than geological distribution. As more becomes known about the distribution of gas hydrate; its extent continually enlarges.

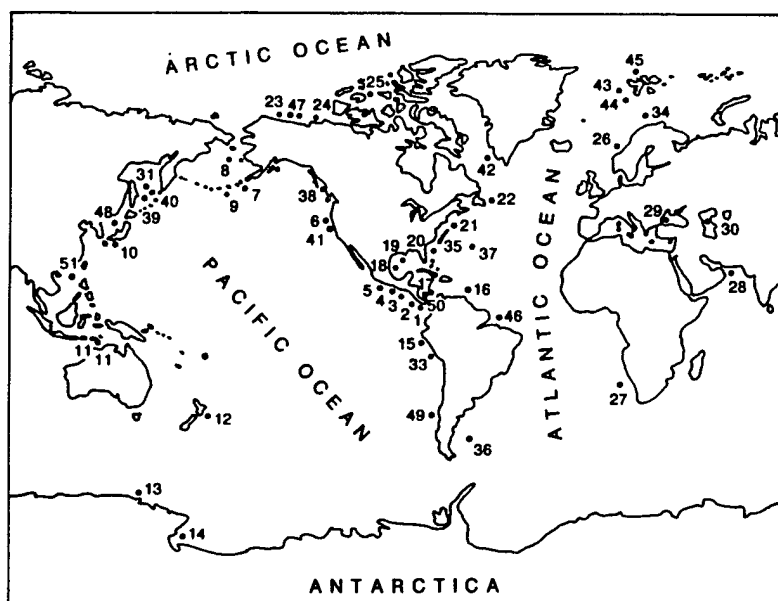

Figure 9. General location map showing centers of hydrate localities. Sites 1-32 from Kvenvolden (1988) and Sloan (1990) with subsequent sites added. [re] designates identified as a possible site on reexamination of data during the course of this research. 1. Shipley et al. (1979), Krason and Ciesnik (1986); 2. Shipley et al. (1979), Finley and Krason (1986), 3. Kvenvolden and McDonald (1985), Finley and Krason (1986); 4. Shipley et al (1979), Harrison and Curiale (1982), Kvenvolden and McDonald (1985), Finley and Krason (1986); 5. Shipley et al. (1979), Finley and Krason (1986); 6. Field and Kvenvolden (1985), Krason and Ciesnik (1986), Kennicut et al. (1989); 7. Kvenvolden and von Heune (1985); 8. Marlow et al. (1981), Krason and Ciesnik (1987), Sharma et al. (1987); 9. McCarthy et al. (1984), Krason and Ciesnik (1987); 10. Aoki et al. (1983); 11. McKirdy and Cook (1980); 12. Katz et al. (1981); 13. Kvenvolden et al. (1987); 14. McIver (1975); 15. Shepard (1979), Kvenvolden and Kastner (1988); 16. Ladd et al. (1982); 17. Shipley et al. (1979), Finley and Krason (1986); 18. Shipley et al. (1979), Hedberg (1980), Krason et al. (1985); 19. Brooks et al. (1984), Brooks and Bryant (1985), Bennett, R. (1988); 20. Markl et al. (1970), Tuholke et al. (1977), Shipley et al. (1979), Dillon et al. (1980), Paull and Dillon (1981), Kvenvolden and Barnard (1983), Dillon and Paull (1983), Krason and Ridley (1985); 21. Taylor et al. (1979), Dillon et al. (1980), Dillon and Paull (1983), Krason and Ridley (1985); 22. Taylor et al. (1977), Krason and Rudloff (1985); 23. Grantz et al. (1976); 24. Weaver and Stuart (1982); 25. Judge (1982); 26. Bugge et al. (1987); 27. Summerhayes et al. (1979); 28. White (1979); 29. Yefremova and Zhizhchenko (1972), Ciesnik and Krason (1987); 30. Yefremova and Gritshina (1981); 31. Makogon (1988); 32. Makegon (1988); 33. Yamano and Uyeda (1990); 34. Andreassen et al. (1990); 35. Dillon et al. (1980), Dillon and Paull (1983), Dillon and Popenoe (1988); 36. Manley and Flood (1989); 37. Gettrust et al. (1988) [re]; 38. Cheeseman et al. (1990); 39. Pashkina and Yesikov (1989); 40. Zonenshayn et al. (1987); 41. Brooks et al. (in press); 42. Max (1990c); 43. Eiken and Austegard (1989), Eiken and Hintz (1989); 44. Vogt et al. (1990); 45. Max et al. (in press); 46. Manley and Flood (1988); 47. Grantz et al. (1989); 48. Geotimes (1989). 49. Personal inspection of seismics. 50. Liu, et al. (1990). 51. Howell (1989), 52. Leggett et al. (1985)



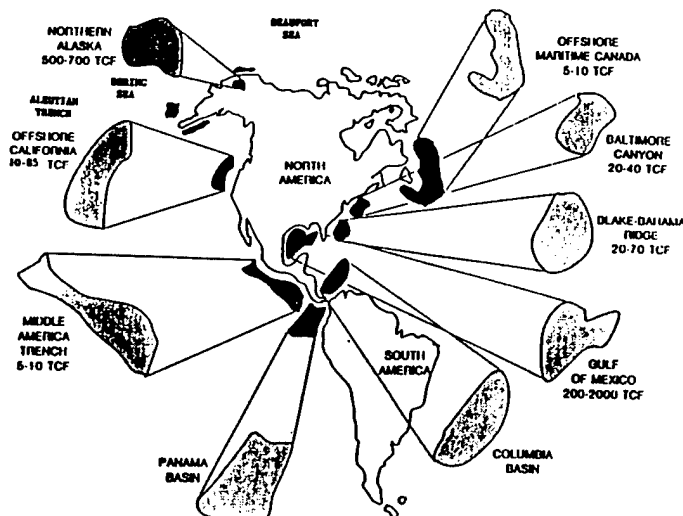

Figure 10. Department of Energy (1986) administrative research areas. Volumes of methane in trillions of cubic feet (TCF) may be understated by an order of magnitude.

**Polar region continental shelves and slopes:** Natural gas hydrates have been identified in the land and nearshore areas of the Alaskan and Canadian North Slope (Grantz and May, 1982) associated with subsea permafrost (Lachenbruch et al., 1988). On continental shelves, hydrates are found most commonly in sedimentary basin provinces, although they may be found in thinly sedimented areas where gas can be introduced. Over half of the 200+ petroleum wells drilled in the Beaufort Sea-McKenzie Delta area have encountered gas hydrate, but its distribution and volumes are at present not known (Moritz et al., 1990).

Both shallow gas and hydrate have been identified in sediments of the west Barents slope (Eiken and Austegard, 1989; Eiken and Hinz, 1989) as have seismic velocity profiles that might identify gas trapped below hydrate on the upper continental slope (Austegard, 1982). Dowdeswell (1988) notes that vitrinite reflectance data from Paleogene sediments in Spitsbergen indicate that they were once deeply enough buried to have undergone a thermal history suitable for generation of oil. More deeply buried, widely distributed Paleogene sediments would likely have undergone a more extensive thermal history that would source large volumes of gas, and these sediments occur broadly in the west Barents sedimentary prism. Makogon (1988) has extended the area in which hydrate deposits are known in Siberia to essentially the continental margin of virtually the whole Asian Arctic, but the extent of hydrate deposits there is unknown at this time because the detailed Quaternary history of the shelves, particularly the distribution of ice cover, is not well known in this little studied area. Gas hydrates associated with permafrost in the Polar continental shelves is now known to pass further offshore into gas

hydrates in deeper water whose development did not depend on the presence of subsea permafrost. Along the continental margins of shelves that do not have a subsea permafrost/gas hydrate affiliation, gas hydrates have been recognized widely. The quantity of gas in the global inventory is comparable to or exceeds the amount of combustible carbon available in the sum total of all other fossil fuels, including conventional gas deposits (Moritz et al., 1990).

**Polar ocean basins:** These deeper water gas hydrates have been recognized in Arctic and North Atlantic continental slopes and in continental rise sediments, but their presence in abyssal depths is less well substantiated. The full extent of gas hydrate development has not yet been established. Even very recent compilations of hydrate recognitions are fragmentary (Sloan, 1990), however, and areal extent is usually undervalued on location maps leading to the misconception that hydrates are only of restricted lateral development. Identification of hydrate has tended to be conservative and based on recognition of the bottom simulating reflector (BSR), which is a strong acoustic impedance contrast at the base of a saturated, high seismic velocity hydrate and the low seismic velocity gas trapped beneath. Hydrates are known to be developed where BSR is not developed. Exploration techniques utilizing velocity, impedance amplitude, and attenuation information gained from seismic survey offer more sophisticated means of extending hydrate recognition beyond first-order BSR recognition (Max, 1990). Localities (Fig. 11) where hydrates are recognized or suspected is increasing rapidly. Gas hydrates may occur over  $1.5 \times 10^6$  km<sup>2</sup> of the Arctic Ocean and northern Nordic Sea (Max and Lowrie, 1993).

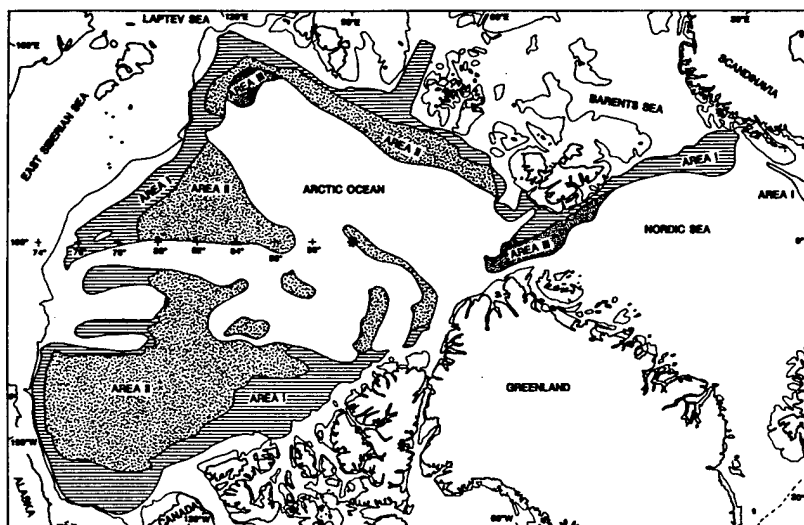

Figure 11. Clathrate likelihood areas in Arctic Ocean Basin. Slope and abyssal areas separated in Arctic at about the 3,000 m contour. 2,500 m contour used in separating Wrangel Abyssal Plain from East Siberian Sea continental margin. No abyssal areas in Nordic Sea Sediment thickness data not included for areas to the south of dashed line passing across south Iceland. Area I. Continental slope areas between 500 m and 3,000 m following recognized clathrate development in

continental slope north of Alaska (Grantz et al, 1989) where sediment thickness exceeds 3 km. Area II, Abyssal areas and sedimentary basins not tied to continental shelf structure where sediment thickness exceeds 3 km. Area III. areas of abnormally high heat flow associated with plate margin where gas could be sourced from thin sediments or where juvenile gas from volcanic exhalation could be trapped within the HSZ in overlying sediment. Area III minimum sediment thickness of between 0.75 km -1 km in ridge vicinities (Knipovich and Laptev).

Gas hydrates have been recognized in the Arctic (Bily and Dick, 1974; Grantz et al., 1976; Grantz and May, 1982) and the North Atlantic (Bugge, 1983), the Aleutian basin and trench and in shallower basins of the Bering Sea (Grantz and May, 1982; Cooper et al., 1986; Krason and Ciesnik, 1987) and possibly the Antarctic (Hitchon, 1974). Soviet interest in gas hydrates is currently in those areas where identifications have been made and along the Antarctic continental margins (Malone, pers. comm). Slumping, which is thought to have been triggered by sediment instability initiated by gas inversions beneath the gas hydrate blanket has been recognized in the North Atlantic (Bugge, 1983). Pockmarks in the Vestnesa Ridge in the west Svalbard continental slope are commonly up to 100 m across; over 100 have been imaged on a recent SeaMARC II survey (Vogt et al., 1990). Given that the 10 m depth commonly seen in pockmarks of this size represents the volume of expelled gas, each could have vented on the order of 10 km<sup>3</sup> of gas.

**Vøring Plateau, Central Norwegian continental slope:** Low levels of methane and minor propane from three ODP drill sites on the Vøring Plateau (Kvenvolden et al., 1989) are dominated by biogenic gas (Whiticar and Faber, 1989). This occurrence suggests that hydrocarbons derived from more deeply buried sediments have not reached the present HSZ. Interbedded basalt sills and flows forming strong seaward dipping reflectors in the sedimentary succession (Mutter et al., 1982) may be sufficiently impermeable to impede vertical petroleum migration and duct gas and fluids up slope toward the continent. On the middle and upper Vøring Plateau, less than 400 m of sediments overlie the uppermost thick basalt horizon (Eldholm et al., 1986). Because these sediments are entirely within the HSZ, locally produced methane would not be expected to migrate sufficiently to concentrate. Methane that may have been derived from hydrate has been identified in sediments of the upper continental slope (Kvenvolden et al., 1989) to the east of the interfingering basalts in the Vøring Plateau. In the eastern Vøring Plateau sedimentary succession, which is several km thick, there appear to be few basalts and 'mud' diapirs over structural contour 'culminations' of possible Eocene and older source beds (Mutter, 1984). These 'mud' diapirs may be in part driven by gas fluidization. Similar mud diapirism elsewhere is almost certainly associated with large volumes of fluid and methane that become the driving buoyancy mechanism (Brown, 1990). Seaward dipping basalts in the structurally analogous Greenland margin (Hinz et al., 1987) have a thicker sediment cover, probably largely because of thick Quaternary sedimentation across a narrower continental shelf (Lowrie and Hinz, 1986).

**Pacific Ocean:** The Pacific margin appears to have hydrates developed in almost all accretionary margins from the tip of South America (Yamano and Uyeda, 1990; Kvenvolden and Kastner, 1990; Brown et al., 1996) through the North American margin

and Alaska (Scholl and Creager, 1973 ; Field and Kvenvolden, 1985; Krason and Ciesnik, 1986), the Aleutian basin and trench and in shallower basins of the Bering Sea (Cooper et al., 1986; Krason and Ciesnik, 1987), to off Japan (Aoki et al., 1982); and the complex of subduction zones along the Americas (Pecher et al., 1996; Brown et al., 1996) and sediment wedges in the Pacific in general (Kvenvolden and Cooper, 1987). It is quite likely that the entire accretionary margin of the Pacific ocean basin will be found to have widespread gas hydrates developed within it. Subducted sediment will almost certainly develop gas that will migrate upward with other expelled gas and fluids. Sediment thicknesses away from continental margin areas are too thin to support much gas generation, and therefore development of significant gas hydrate in the central Pacific is unlikely. Thermally produced hydrocarbons were recovered from unconsolidated sediment ponded within a bathymetric depression on the surface of a shale diapir in the offshore Eel River Basin of northern California (Kvenvolden and Field, 1981). Evidence that the hydrocarbons are thermogenic consists of the following: (1) very high concentrations hydrocarbon gases, particularly ethane through butane; (2) methane having a carbon isotopic composition (relative to the PDB standard) of 43 and -44 per mil; (3) presence of gasoline-range (C<sub>5</sub>) hydrocarbons; and (4) presence of a complex mixture of heavy hydrocarbons (C<sub>15</sub>) with n-alkanes having a petroleum-like distribution. This mixture of gaseous and liquid hydrocarbons likely originated deep within the basin and migrated to the surface through fractures and faults (Zwart et al., 1996). The presence of thermogenic hydrocarbons in unconsolidated surface sediment indicates that conditions for petroleum generation have existed within this offshore basin.

**Atlantic Ocean:** Gas hydrates were first recognized in the west central Atlantic off the U.S. SE coast. Because of the high quality data sets available in this area and deep drill holes that penetrated into gas hydrate, it is probably one of the best known hydrate localities in the world (Ewing et al., 1966; Tucholke et al., 1977; Paull and Dillon, 1981; Pinet et al., 1981; Dillon, W.P. & Popenoe, 1988; and Paull et al., 1989; Katzman and Holbrook, 1994), the South Atlantic (Manley and Flood, 1988; Flood, 1989);. It has been recently mapped in detail with respect to estimated hydrate volumes (Dillon et al., 1993; 1994; 1995). Recognition of gas hydrates now includes other regions in the Atlantic (Flood, 1989; Manley and Flood, 1988). Methane along the passive continental margins of the Atlantic ocean appears to be dominantly of biogenic origin (Kvenvolden et al., 1989)

**Other ocean areas:** Bottom trawling near diapir-generated gas seeps in the Gulf of Mexico recovered amalgamated concentrations of nodules consisting of gas hydrates and sedimentary clasts with interspersed layers and solid masses (>150mm thick) of both thermogenic and biogenic origin (Brooks et al, in press). Gas filled mounds sealed by hydrate bonded sediments have been identified from drill cores in the Gulf of Mexico (Prior et al., 1989). Gas release from gas trapped beneath a gas hydrate blanket has been used to infer the widespread presence of gas hydrate in the Sea of Okhotsk (Zonenshayn, et al., 1987).

Gas hydrate has also been identified in the abyssal depths of warmer oceans such as the Gulf of Mexico and the Caribbean (Edgar, 1973; Von Huene, 1980; Brooks and Bryant,

1985; Hovland and Judd, 1988; Prior et al., 1989), off western Central America (Finlay and Krason, 1986) and other locations such as the northern Australian shelf, off New Zealand, in the Brazilian continental slope (Manley and Flood, 1988) in the Arabian Sea and west of South Africa (Kvenvolden and Barnard, 1983) and the northwest Indian Ocean (Fowler et al., 1985; White, 1985). Malone (1983) and Kvenvolden (1988) give additional references in this region. Bernstein et al. (1988) show about 450 m HSZ thickness in laminated sediments of both the back and forearc basins in the warm bottom water area of the Solomon Sea, where polar water can be expected to have a minimal influence. Gas hydrate may be widespread in the deeper water sediments of the Black Sea (Ciesnik and Krason, 1987) and Lake Biakal. Hydrates might also be expected in other deep, restricted bodies of fresh water, especially where lake floors are anoxic.

### **NATURAL GAS AS A FUEL**

Natural gas, primarily methane, is an excellent fuel for combustion, either in open-flame burning to produce heat or in controlled circumstances within fuel cells, for a number of reasons. In comparison with other natural gases, methane contains the highest H:C ratio. That is, there is more hydrogen with respect to carbon in methane than in all the other hydrocarbon gases. When methane is burned it produces less carbon dioxide per mole than any other fossil fuel. Methane also produces less carbon dioxide per mole than alcohols, where OH substitutes for one molecule of H, and much less than in liquid petroleum gasoline and oil based fuels. Solid fuel, such as coal, which in rare cases can be virtually pure carbon and yield only CO<sub>2</sub> on combustion. In addition, natural gas contains very little sulfur, phosphorus, or nitrogen, and other pollutants that can become aerosols when fuels rich (e.g., coal) in these pollutants are burned. Natural gas (methane) produces almost pure carbon dioxide and water when burned because of its initial purity. Being a gas, further purification is possible using relatively inexpensive continuous industrial processes. Carbon dioxide and the exhaust gas produced from methane combustion do not produce smog because the pollutants that are cooked and mixed into a photochemical smog by sunlight radiation are not present in the exhaust to begin with, as is the situation with both liquid hydrocarbon and solid fuels without emission control purification.

#### **The oil or gas-based economy**

Use of methane or a liquid derivative of methane, such as methyl alcohol as fuels in the place of oil-based fuels would provide for a dramatic reduction in unwelcome byproducts of the combustion. Use of methane or methanol as one of a mix of fuels would undoubtedly be environmentally positive (Saricks, 1989). Although the primary focus of economists dealing with fuels has tended to focus on the bottom-line cost of production, transport and end-user cost of fuels, the awareness that environmental concerns and external costs may have to be factored into the fuel cost equation, may cause revision of the present conclusion that oil-based fuels are preferable to methane or one of its derivatives. A strong case can be made that a large number of hidden subsidies support the current low

price of oil-based fuels (Hubbard, 1991). Several states in the United States, principally California, New York, and Wisconsin, have already enacted legislation requiring some external costs to be taken into account when proposing new energy generating activities. Fuller external accounting that include costs to society, economies, transportation infrastructure, environment, health, etc., rather than the bottom-line oil company accounting, all tend to favor gas over oil-based fuels. Bringing market prices in line with energy's hidden burdens will be one of the great challenges of the coming decades.

Even with no disruptions of petroleum supply to the World economy, the economic energy base will have to shift from oil to gas in the course of the next quarter century or so; such a shift will be dictated by nothing more than the limited amounts of petroleum liquids, tar sands, oil shales, etc. that are available. However, geopolitical considerations, such as significant perturbation of the oil flow from major producing regions like the Mideast, and environmental considerations that concern emissions from combustion, may force an earlier transition to the gas economy than could be predicted from an analysis of energy cost economics alone. Thus, the shift from oil to gas as the primary non-nuclear source of power is a matter of concern today, and not an obscure concern of the future. Deep gas, gas from shales, and gas hydrates are the primary unconventional gas resources. Of these, only gas hydrate is currently part of a potential resource base. In the first instance, gas hydrate on land in polar regions will be exploited to add to the national reserves. This action will be followed by gas hydrate exploration and exploitation from suitable polar continental shelves, but it is in the deep oceans where the major stores of gas hydrate occur.

### **Energy resources**

Distribution and volume estimations of gas hydrates have only been made in a restricted number of subareal permafrost-related examples to date. Soviets have been producing methane 'commercially' from the Messoyhaka field in the West Siberia hydrocarbon region since 1974 (Fig. 12). According to Sloan (1990), 0.2% of current Soviet production (1990) was from gas hydrates and it is intended that up to 5% of total Soviet gas production will be from hydrate sources by the year 2,000. Exact production figures, however, are not available, as the Soviet and subsequent Russian hydrocarbon recovery costs are either not known or otherwise available. Even the actual production figures are not known. Commercial tests of an Alaskan gas hydrate resource were carried out in the Prudhoe Bay field of Alaska in 1991 (Malone, pers. comm). Gas production from the Norman Wells gas deposit in northern Canada may have been in part from hydrates because the record of extraction closely resembles theoretical and supposed Soviet practical experience. After some draw-down from the gas deposit immediately below the permafrost zone, gas pressure in the reservoir has remained the about the same for over 25 years (Edgar, USGS, pers. comm.). This attribute of the Norman Wells deposit corresponds with no other known deposit outside of a permafrost zone but can be explained by inversion of gas hydrate to gas and water within at the phase boundary at the base of the hydrate.

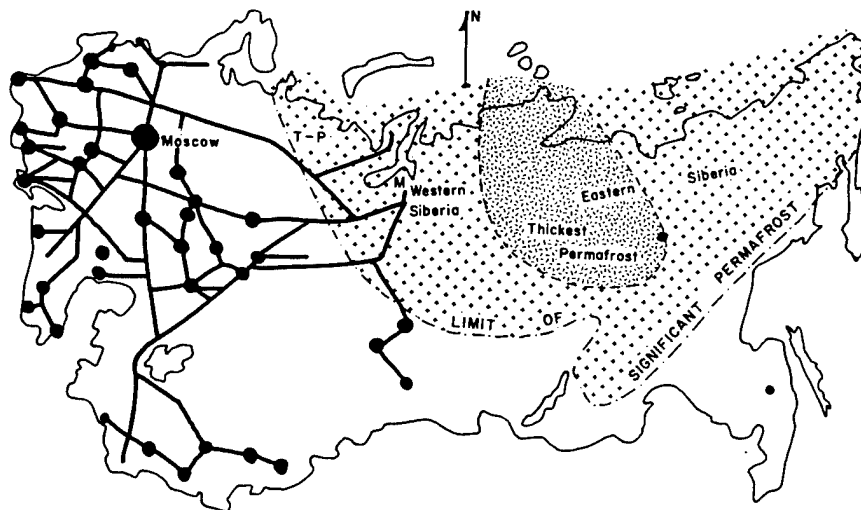

Figure 12. Diagram of Soviet gas distribution grid. Courtesy of R. Malone, U.S. DoE, from a viewgraph shown by Yu. Makogon. Polar projection of the Soviet Union. Approximate limits of significant permanent permafrost with which gas hydrate deposits on land are associated; simplified from Yershov et al. (1988). M, Messoyakha gas hydrate gas field in Western Siberia region.

Recovery of gas from gas hydrate can be accomplished in three main ways. Essentially all techniques for converting gas hydrate to gas in the ground are secondary recovery techniques; the primary recovery technique of mining is not feasible with gas hydrate. The most costly recovery technique is steam or hot water injection; a commonly used secondary recovery technique for heavy petroleum deposits (Fig. 13). With gas hydrate deposits this procedure works by melting the hydrate and recovering the gas up the drill hole. This method is expensive and continually floods the reservoir making movement of the hot gas or fluid downward and the gas upward more difficult. Another technique is inhibitor injection, which involves pumping an antifreeze such as methanol (alcohol) into the deposit where it again effectively melts the hydrate. This is not as costly as steam or hot water injection because the fluid is reusable without the same energy input that is necessary to reheat water, but the tendency to flood the reservoir is the same.

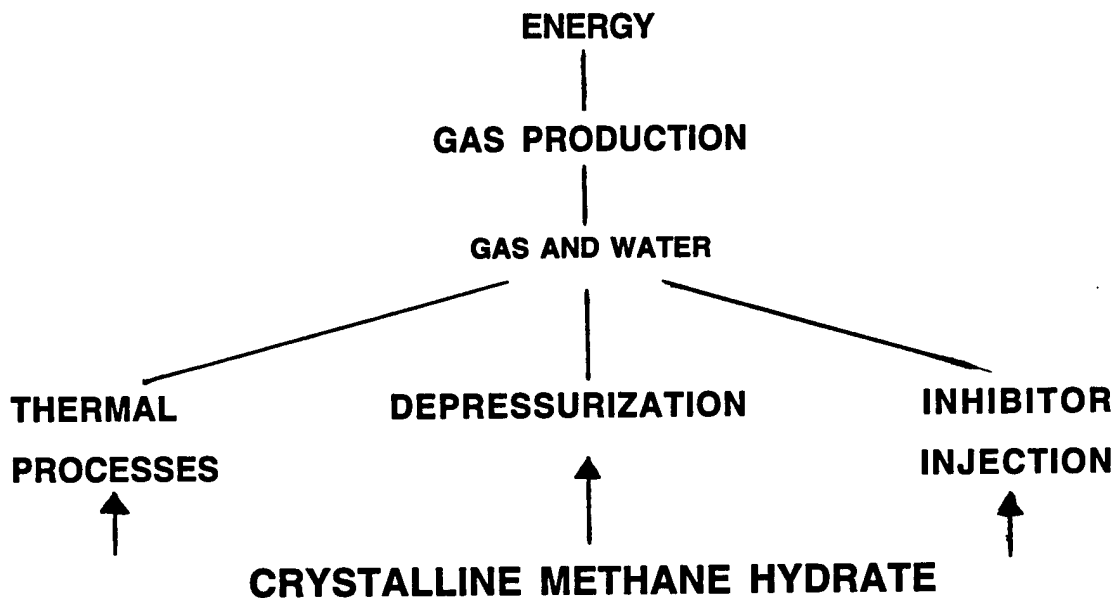

Figure 13. Diagram showing main techniques for gas hydrate recovery. Thermal recovery involves pumping down steam or hot water that melts the hydrate. Inhibitor injection involves pumping down an antifreeze such as methanol that melts the hydrate. Depressurization recovers hydrate by utilizing the lowered pressure in the reservoir to cause inversion of hydrate at the phase boundary junction.

The primary recovery technique that will probably be used to recover gas hydrate is the depressurization technique. This technique is currently being used by the Soviets in the Messoyhaka gas field in the western Siberia hydrocarbon province. It is based on utilizing the stability field of the gas hydrate, and operates by simply lowering the pressure in a subjacent gas reservoir that is in contact with an overlying gas hydrate. When pressure in the reservoir decreases, gas hydrate at the interface, which is a phase boundary stability surface, inverts to gas and water. This mode of recovery uses no more energy than is required for normal drilling and gas recovery and causes recharging of the reservoir. It is, in effect, a secondary recovery technique with a positive recharge rate. The decompression technique should prove most useful in deposits where the phase boundary surface between hydrate and subjacent gas is greatest; for instance in the huge deep sea deposits. Where subjacent gas does not exist, thermal or inhibitor stimulation that creates a gas pocket that can be depressurized, is entirely feasible.

The recovery of natural gas from geological reservoirs is more efficient than recovery of raw liquid petroleum, and gas normally does not need the same level of expensive processing that liquid petroleum products do. Whereas only about 40% of liquid petroleum is recoverable from a geological reservoir, over 85% of gas in a reservoir can commonly be recovered. If a more safe, practical, and economic way existed to transfer natural gas to usage sites could be developed, natural gas probably would have broader application. In addition, methane gas can be produced biotechnically (e.g. from sewage and



other organic waste); if the gas could be condensed into a high btu/volume material, it could have an immense impact as a new fuel that would be gasified immediately prior to combustion.

An example of a single gas deposit trapped below gas hydrate in a broad bathymetric culmination off the U.S. SE coast can be volumetrically assessed because two seismic lines cross it (Dillon and Paull, 1983). The closure can be resolved from the two seismic lines that cross at about a 30° angle into an ellipse shape that is about 18 X 9 km across with closure of from 100 to 200 m. Total volume in the area of closure is thus about 20 km<sup>3</sup> (Fig. 14). Because the ambient pressure in the accumulation zone is over 300 atmospheres, total gas volume will be the product of porous space occupied by gas and the volume of closure (Lowrie and Max, 1991). Taking a 10% porosity for this example, which is probably a conservative estimate, natural gas potential would be about 450 km<sup>3</sup> to 600 km<sup>3</sup>, or about 20 Trillion Cubic Feet (TCF). The current annual North American usage is about 20 TCF. In addition, however, removal of gas from a deep hydrate-capped reservoir will prompt the inversion of hydrate to gas at the base of the HSZ. This will have the effect of increasing gas recovery from this type of reservoir, but there is currently little guidance for estimating recovery parameters where so many attributes of the deposit are not known in detail.

Recoverability of gas from these deep marine structures, however, is very problematical at this stage. Important constraints such as permeability are not taken into consideration here, but new drilling technology, such as horizontal drilling through the reservoir to enlarge the drill hole face area, may compensate for the low permeabilities normally found in marine sediments. Other constraints might be compensated for by other technological applications. It could be expected that given similar geological situations along the thickly sedimented Arctic and Nordic Sea margins, similar accumulations (gas plus sediment) on the order of 20 km<sup>3</sup> could also be expected. Gas trapped below hydrates, however, may be more easily recovered. Aspects of hydrate and their presence in the deep oceans other than energy, such as their impact on acoustics and atmospheric sciences are of immediate to medium term importance.

Sedimentary provinces in deeper ocean areas than are normally found on continental shelves have not been seriously considered as hydrocarbon exploration areas (St. John et al., 1984), even though current drilling and wellhead technology may already be adequate to deal with deep water exploration and extraction. As the world's combustible energy resource base shifts from oil to gas, however, gas held in and trapped by hydrates in the deep oceans must be exploited.

The amount of gas trapped in hydrate and subjacent free gas is very large but has not been fully determined; exploration of hydrate-related gas reserves is only beginning. Makogon (1981) estimated that there may be up to 100,000 Gt C[CH<sub>4</sub>] (Gigatons of carbon in the form of methane) in seafloor hydrates while Kvenvolden's (1988) tabulated estimates for deep ocean hydrates vary up to 4,100,000 Gt; continental hydrates vary up to 18,000 Gt. Estimates for seven sites adjacent to North and Central America ranged up to 2840 TCF (1Gt = about 65 TCF) (DOE, 1987) with small areas of offshore Japan and Timor to 200 TCF, with up to 20 TCF of free trapped gas (Finlay and Krason, 1989). U.S.

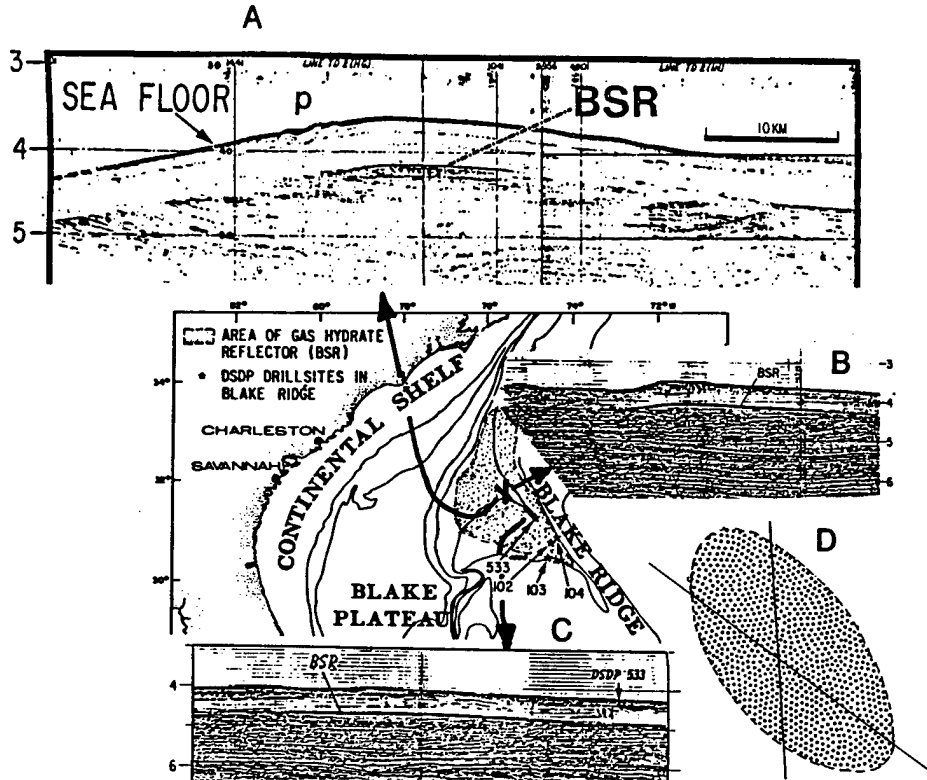

Figure 14. Composite figure after Dillon and Paull (1983) showing location and orientation of seismic sections and the position of trapped gas beneath the BSR in relation to seafloor and BSR culminations off the U.S. SE coast. Sedimentary structure appears to pass up into zone toward sea floor possibly indicating that the present bottom here is an erosional surface. 10 scale for all sections. Note that the lower part of the HSZ is more transparent, indicating more massive and saturated clathrate. Apparent differences in HSZ thickness is due to different vertical scale on A, horizontal scale same for B, C, D.

A. Note discontinuous nature of BSR indicating that gas is not present in appreciable quantities in those locations where the impedance contrast is great. p, possible pockmarks on the seabed are situated at the apparent transition from strong BSR in the culmination to weak BSR, where little or no gas is ponded.

B. N-S section showing single gas concentration

C. NW-SE section ground-verified by DSDP drilling at hole 533. Base of clathrate not penetrated.

D. Approximate shape and size of gas concentration assuming closure on the two seismic lines approximates an oval section. Same horizontal scale as A, B, with crossing lines indicating relative positions shown on location map

Department of Energy estimates have increased the methane volumes up to 5,500 TCF for 13 sites (Malone, 1990). These figures may be low, however, because new acoustic techniques for estimating gas hydrate volumes indicate that at least for the Blake-Bahama area, previous estimates may be low by an order of magnitude (Dillon, et al., 1993; Paull et al., 1995). Estimates of probable hydrate volumes for the Arctic basin and the northern Nordic Sea alone may be as large as 1,000,000 Gt C[CH<sub>4</sub>] (Max and Lowrie, 1993), which is in general agreement with estimates of Kvenvolden and Grantz (1990). Dillon, et al. (1991) estimate that in the Blake Outer Ridge hydrate deposits there could be up to 66 x 10<sup>6</sup> m<sup>3</sup> or 370 TCF per each square km beneath the sea floor. Based on drilling results from ODP leg 164, however, Holbrook et al. (1996), regard the hydrate volumes in this area at about 1/3 of this figure. Volumetric estimates of hydrate-related methane are continually being revised upwards and may prove to be the major combustible carbon store on the planet (Moritz, et al., 1990). Although we do not know precisely how much hydrate exists in polar regions and in the oceans, we do know that the volumes are very large in relation to other forms of carbon storage in the atmosphere, oceans, and lithosphere. Kvenvolden estimates that there may be as much as twice the fixed carbon held in methane hydrates as in the total of all other hydrocarbon fuels (gas, oil, coal) on earth.

Current techniques and methods for estimating the quantity of gas within a given formation or reservoir do not easily apply to hydrate deposits. Therefore, technology to evaluate hydrate deposits needs to be developed. While many studies have estimated the quantity of gas in hydrate reservoirs, these volumes are primarily based on areal extent of hydrate-related seismic reflectors (BSR), which only provides a minimum value. There are no current methods for accurate estimation of the total volume of hydrates. In order to evaluate hydrate deposits it will be necessary to develop special seismic methods or techniques. There are three main questions: 1. Is it possible to detect hydrate layers at various levels within the hydrate stability zone? 2. Can we detect hydrate deposits laterally away from well bores in the absence of well defined BSR? 3. Is it possible to detect hydrate layers and BSR in onshore environments; will offshore techniques have onshore application?

Hydrate estimation must be based on a wide-area survey technique subject to ground-truth confirmation through drilling. Seismic reflection data has proven sufficient for locating and defining conventional liquid and gas hydrocarbon deposits, but a more detailed seismo-acoustic modeling will be necessary to evaluate the amount of methane in oceanic hydrates. Both deep-towed, wide-angle multichannel seismic survey (Roe and Gettrust, 1989; 1993) and seismic refraction analysis using ocean bottom seismometers (OBS) will probably need to be employed to allow both pressure and shear wave and attenuation analysis. A total HSZ numerical assessment technique based on modeling the blanking effect of the normal marine sediment impedance structure (Lee et al., 1992; 1993a; 1993b) has resulted in better volumetric analyses than estimates based on likely porosity and likely pore fill based on a few drilling results (Max and Lowrie, 1993), but there is still much uncertainty. There is a need to establish a broad research program that will develop techniques for resolving methane volumes within the HSZ and result in predictive methods of commercial quality.

Extraction strategies (Max and Lowrie, 1996) such as depressurization and

thermal injection techniques need to be investigated both in the laboratory and in the field. The costs, as well as engineering design associated with these concepts, need to be developed. Production concepts need to be verified in the field. Investigations concerning the issues, problems, potentials, and techniques of dredging and/or mining hydrates from very shallow deposits in the offshore environment also require evaluation. Investigation of the potential problems associated with producing gas or oil in the presence of hydrates need to be addressed. Areas where pressure-temperature conditions are suitable for hydrate formation within the well bore may present a geotechnical problem, such as subsidence or excessive gas release, in or near the drilling platform or subsea ocean engineering establishments.

### **LAW OF THE SEA**

In 1982 the United Nations Convention on the Law of the Sea (UNCLOS) (The Law of the Sea, Official Text 1983, published by Croom Helm, and St. Martin's Press, for the United Nations) was signed in Jamaica. The Convention document has to be ratified by national legislatures before it becomes international law, but in the meantime it may be regarded as a norm to which many countries adhere in principle at sea in UNCLOS, but there are many references to the conduct of marine scientific research. If and when gas hydrate in the deep oceans becomes a major source of energy, international law will have to take a substantive interest because much of the hydrate lies outside of the 200 mile EEZ. The Arctic basin provides a good example of this situation. Figure 22 shows that almost an equal area of gas hydrate likelihood lies outside of U.S., Soviet, Norwegian, Greenland and Canadian EEZs.

From a legal perspective, two main sea area types will have to be considered. Enclosed seas that are bounded by a limited number of states may be the subject of treaties between a limited number of states whereas open continental margins, such as along the east coast of the U.S. involve a relationship between individual states and the international community. Legal approaches to gas hydrates may involve an extension of hydrocarbon or mining law into the deep ocean or a new approach might be made. One thing is certain; the current abeyance of interest by coastal states in the promulgation of law to the deep oceans will be come renewed once there is official awareness that there is something of great potential value in the deep sea sediments.

### **ATMOSPHERIC IMPACT OF METHANE**

Analysis of gas hydrates is important to the study of global climate change because methane (the primary hydrate gas) is a significant greenhouse gas, and therefore, any change in its atmospheric concentration would have major climatic importance. Many oceanic chemical and global climate models (Schlitzer, 1988) that consider the thermal character of the atmosphere (Shaffer, 1989) do not include methane produced or stored in the sea because more than 80% of atmospheric methane has been thought to be produced at or near the earth's surface and vented rapidly to the atmosphere (Ehnhalt and Schmidt, 1983; Lasaga, 1985). Oceans have been regarded as an inconsequential source for methane but CH<sub>4</sub> is increasingly being recognized as an important greenhouse gas in its own right and as a contributor to global CO<sub>2</sub> (Khalil and Rasmussen, 1983; Ramathan et al., 1985; Kasting, et al., 1986; Khalil and Dickinson, 1987). Bell (1982) and

Kvenvolden (1988) drew attention to previously unrecognized shallow hydrate and gas deposits associated with subsea and subareal permafrost in Polar regions and suggest that methane evolution to the atmosphere could cause positive feedback and development of a greenhouse atmosphere. Lorius, et al. (1990) have demonstrated a direct relationship between atmospheric methane concentrations and atmospheric temperature changes over the last 150,000 years (Fig. 15). CO<sub>2</sub> atmospheric concentration variation follows methane and can be regarded at least in part as a daughter product of the methane.

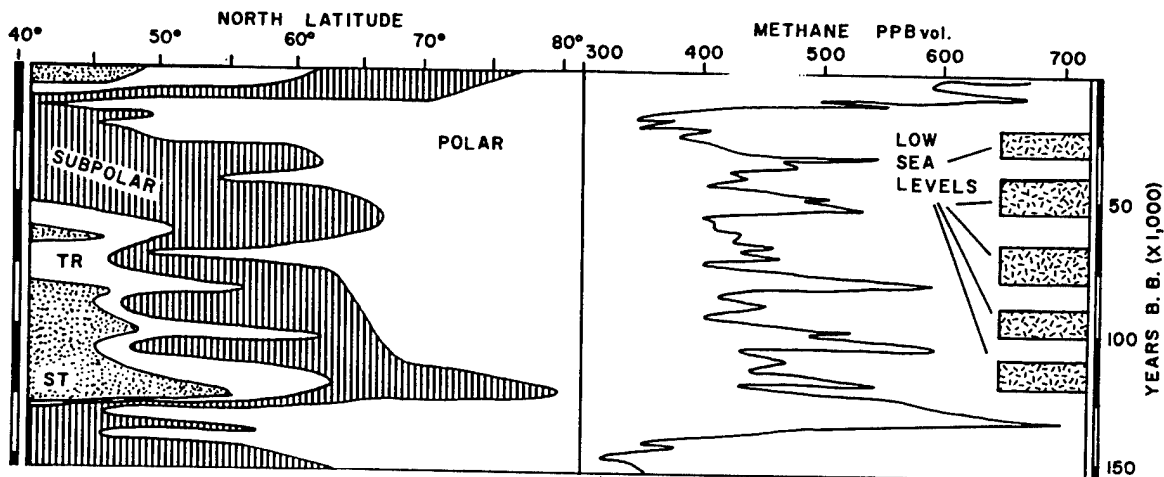

Figure 15. Atmospheric methane and temperature in the last 150,000 years plotted against paleotemperatures interpreted from sediment cores in the North Atlantic from near the Azores to the northern Nordic (Norwegian-Greenland Sea). Methane data after Lorius et al. (1990); sediment data redrawn after Vogt (1986). Oxygen Delta-18 values indicating temperature (not shown here) follow methane amounts. Similar curves from both the northern and southern hemispheres indicate coupled global temperature variation of atmosphere and seawater.

Gas hydrates represent the major, but largely unquantitized reservoir of methane on earth. Methane's role as a greenhouse gas is significant because energy absorption occurs at wavelengths in which carbon dioxide and water vapor (the primary greenhouse gases) do not absorb strongly. A comparison of the contributions of various gases to a potential greenhouse effect indicates that methane may be as much as 10 times more important than CO<sub>2</sub> (Rodhe, 1990; Lashof and Ahuja, 1990). At present concentrations, methane accounts for about 1% of the greenhouse heating (nitrous oxide and ozone each account for about 1% as well, whereas CO<sub>2</sub> accounts for almost 1/3 and water vapor almost 2/3 of the total greenhouse heating). Because of its relatively small concentration in the atmosphere, however, an increase in methane will cause a much more significant increase in the overall greenhouse effect than a comparable increase in carbon dioxide. For comparison a 1 ppm increase in methane would have about the same effect as a 50 ppm increase in CO<sub>2</sub>.

absorbs infrared radiation and converts the radiation to heat (Ramathan et al., 1985). There is between 3.6 and 5 Gt C[CH<sub>4</sub>] in the earth's atmosphere (Chamberlain et al., 1982). In addition to the methane greenhouse effect, however, is methane's oxidized product, CO<sub>2</sub> (Logan, et al., 1981). The process by which methane becomes CO<sub>2</sub> begins with OH capture (Fig. 16). In the stratosphere, oxidation associated with ozone is a minor CH<sub>4</sub> sink. Atmospheric methane survives for up to 10-14 years (Wang, et al., 1976; Chamberlain et al., 1982; Bell, 1982); and oxidizes to CO<sub>2</sub> rapidly (10 yr half-life).

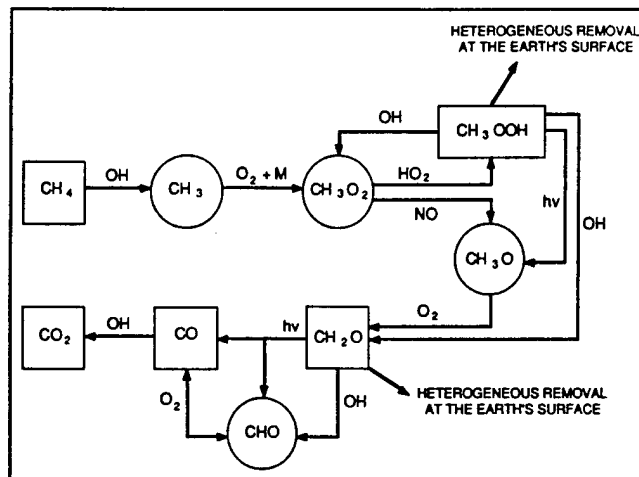

Figure 16. Diagram of the atmospheric methane - carbon dioxide cycle showing intermediate chemical steps in the consumption of methane. After Logan et al. (1981). The entire system tends to acidification:

1. CH<sub>4</sub> initially interacts with OH radical, which is produced by the photosynthesis of H<sub>2</sub>O mostly in the upper atmosphere. CH<sub>4</sub>+OH = CH<sub>3</sub>+H<sub>2</sub>O.

2. On a reactive surface (M) such as charged dust particle or soot, CH<sub>3</sub> reacts with O<sub>2</sub> to give a methylperoxal species, CH<sub>3</sub>O<sub>2</sub>.

3. CH<sub>3</sub>O<sub>2</sub> reacts with H<sub>2</sub>O to give methyl hydroperoxide which can be removed to earth surface or interact with OH radical (H extraction) to return to CH<sub>3</sub>O<sub>2</sub> or interact with (photosynthetic) NO to give CH<sub>3</sub>O (CH<sub>3</sub>O<sub>2</sub>+NO = CH<sub>3</sub>O+NO<sub>2</sub>, NO<sub>2</sub>+H<sub>2</sub>O = H<sub>2</sub>NO<sub>3</sub>). This step in the reaction series has the largest potential to increase acidity in the reaction series

4. Interaction with *hν* (statistical expression of plank's constant x frequency of interaction) results in OH loss and the production of CH<sub>3</sub>O, interaction with O<sub>2</sub> produces CH<sub>2</sub>O (formaldehyde). Combining with OH radical to produce CH<sub>2</sub>O (plus H<sub>2</sub>O) also results in production of CH<sub>2</sub>O (formaldehyde).

5. CH<sub>2</sub>O photolyzes to carbon monoxide (with production of OH) or loses an H via interaction with OH radical to give formyl radical CHO, which interacts with oxygen to also produce CO.

6. CO reacts with OH radical (and perhaps other intermediate chemical products) to give CO<sub>2</sub>, the highest carbon oxidation state and the most stable.

1.7 ppm atmospheric methane accounts for about 1.7 W m<sup>-2</sup> of the current

greenhouse effect of about  $155 \text{ W m}^{-2}$  (Mitchell, 1989). The addition of 1 Gt of methane carbon to the atmosphere would increase greenhouse heating by approximately  $0.42 \text{ W m}^{-2}$ . In comparison, methane tied up in gas hydrates represents at least 10,000 gigatons and possibly up to 50,000 gigatons of carbon (1 gigaton =  $10^{15}\text{g}$ ) of carbon, so even a fairly small proportion of this could have significant impact on climate if it escaped. Escape of methane from the marine gas hydrate reservoir seems possible, considering that, at the base of the hydrate cemented zone the material is at its stability limit, the phase boundary. At that point, any small increase in temperature or decrease in pressure will cause hydrate breakdown, with release of methane to the oceans and atmosphere.

The potential for dissociating hydrate formations in the offshore environment and its subsequent potential for release of large quantities of methane gas to the atmosphere is a major concern. Methane release from oil and gas wells, coal mine and gas hydrates may be among the major hidden sources of atmospheric methane. This question should be initially approached through a feasibility study of hydrates that focuses on their extent and the quantity of methane that is available to be evolved to the atmosphere in specific time periods, with different scenarios of atmospheric and ocean warming and water depth variation.

Slight warming of the atmosphere and ocean water, and slight modifications of ocean water depth have an immediate impact on the methane-holding character of the methane hydrate zone. The base of the hydrate stability zone is by definition a thermodynamically metastable zone of reversing reactions and thus it is particularly liable to either release or hold more gas when conditions alter. Conductivity within the zone is high enough to allow for virtually instantaneous adjustment. Because the hydrate stability zone is very accessible to thermal or pressure changes, it should be regarded as a first-order response mechanism that interacts directly with the oceans and atmosphere, rather than being dealt with mainly as a solid earth process in global climate change (USGCRP, 1991) because solid earth processes are longer-term mechanisms. Particularly in the Arctic, changes in sea-ice cover could be very influential in diminishing the production of cold brines and warming bottom waters.

In contrast to  $\text{CO}_2$ , which is a rather inert gas that normally participates in the formation of weak acids, methane is highly reactive, once the initial C-H bond is broken. It can be regarded as a simple greenhouse gas along with  $\text{CO}_2$ , but it also acts in a number of other ways to effect atmospheric dynamics. Because the first step of the oxidation process of methane involves OH capture (Fig. 16), it may be regarded as an OH scavenger in the atmosphere, selectively removing OH while participating in the formation of a number of other complex carbon molecules. In addition, it appears to be influential in the formation of high altitude clouds, particularly in polar regions (Thomas, et al, 1990). Formation of high altitude clouds can significantly effect the earth's albedo (Cess, et al., 1989; Ramanathan, 1989; Slingo, 1990). Change in sea-ice cover can also significantly alter albedo (Taylor and Dickinson, 1991). Environmentalists should not necessarily come to the conclusion that because methane is a greenhouse gas and its volume in the atmosphere is increasing, it will force atmospheric heating (Kiehl, 1991). Modification of the albedo toward greater reflectance of sunlight will have the opposite effect of cooling.

The actual thermal and energy balance of the atmosphere has not been modeled even as a first order function of even those few ways in which we know methane participates in effecting atmosphere and weather, and this should be a fruitful research topic.

Gas hydrate may be the major factor that controls the thermal and hydrous character of the atmosphere within the narrow range that supports Earth's current biology, but its role is as yet unclear. The hydrate zone can release methane to the atmosphere when sea level falls during a major glaciation as well as when water temperature increases. This would have the effect of increasing the short-term greenhouse character of the atmosphere and modifying precipitation patterns. On the other hand, modeling the effects of variable warming with respect to variable sea levels and the impact on gas hydrate retention or release has not been carried out. Lorius et al. (1990) noted from the Vostok (Antarctica) ice cores (Fig. 15) that methane peaks generally anticipated periods of sea level fall during the last 200,000 years. Abnormally high atmospheric temperature trends cause by overproduction of CO<sub>2</sub> and/or methane may be limited by albedo modification in the upper atmosphere, shielding the Earth. Although abundant CO<sub>2</sub> and methane in the atmosphere increase the ability of the lower atmosphere to hold thermal energy, if sunlight to the lower atmosphere is reduced, that capacity is not occupied. Other compensation mechanisms, such as increased formation of carbonate in the ocean, then can act to restore the thermal character of the atmosphere. Oscillation within this range is obviously a complex matter, but methane both as a solid and as a gas must be one of the main participants in the carbon cycle because of the volumes of gas available and its accessible geological position.

### **GAS HYDRATE: GEODYNAMICS AND GEOLOGY IMPACT**

Geodynamics refers to the dynamic framework of the formation of the earth's surface that is revealed through the study of geology and related sciences. The earth's crust is a highly dynamic environment with large structural plates, some of which contain continents, moving on the surface of the globe. Where plates are forming such as along the Atlantic mid-ocean ridge, the ocean margin is widening. Where plates are driven toward each other they collide and one plate usually is driven beneath the other in a subduction zone. Most mountain belts formed or are currently related to subduction zones, which must be regarded as the major site of geodynamic processes. Gas hydrate may have an influence on these important geodynamic sites.

Sediments that form significant volumes of natural gases will form hydrates in subduction zones even at temperatures far higher than normal for ocean floor hydrates. The presence of natural gas (mostly methane) and the formation and disassociation of hydrate, and removal of the gas form part of the hydrate geothermal cycle that can have a strong influence on the early pressure-temperature metamorphic path of the subducting sediments. The hydrates geothermal cycle in a confined environment of a subduction complex introduces the concept of heat absorption and removal, a natural refrigeration effect, that has not been previously been modeled. Alteration of the thermal response of subducting sediment because of the presence of gas hydrates may be used to explain the



attainment of high pressures prior to significant warming, and the preservation through a cooling effect. Rapid subduction and elevation may prove to be less of a critical factor than the effect of gas generation and the formation and dissolution of gas hydrates in the generation of high pressure - low temperature metamorphic terranes. Gas hydrate in subduction zones may also be responsible for lubrication of the upper part of the zone.

Unexplained mass movements of sediments on continental slopes and rises may result from formation and especially breakdown of gas hydrates. Development of gas hydrate probably tends to stabilize a deposit, but breakdown of the hydrate will not only remove a solid cement, but replace it with a gassy, possibly overpressured layer that has essentially no strength at the base of the hydrate stability zone where the hydrate is normally metastable with subjacent gas and water (Fig. 17). Such a breakdown is anticipated if sea level falls, as happened during the last glaciation, when a breakdown of about 20 meters of hydrate at the base of hydrated sediments would have been expected. On the U.S. eastern continental margin heads of landslide scars appear to cluster near the shallow depth limit of hydrate development, providing circumstantial evidence for a causal relationship. Such a process of the breakdown of hydrate and the triggering of landslides may be significant not only for mass movement of sediments on the continental margin, but also may be instrumental in release of methane to the atmosphere, with potential climatic impact.

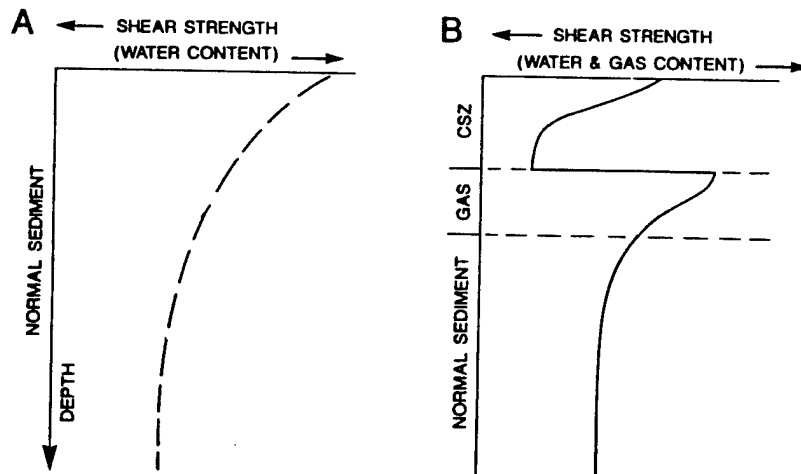

Figure 17. Shear strength profile of a generalized sediment column with clathrate trapping gas charged fluids. The position of any line showing incipient failure in relation to the generalized shear strength lines are inherently very complex, depending on sediment particle size and composition, cohesion, porosity and permeability, etc. No particular case is modeled because of the lack of detailed sediment data from the area from the surface and the underlying sedimentary succession.

A. Shear strength profile of normal sediment. Cohesiveness of sediment in absence of thixotropic triggering mechanism may prevent slumping.

B. Shear strength profile of sediment with clathrate and trapped gas/fluid.

## Seismo-acoustic character and geoacoustic effects

Modeling of ocean sediment geoenvironmental properties for transmission-loss prediction for Navy interests has concentrated on determining and estimating primary geological attributes such as sediment density, nature of solid components, and porosity, etc. Important SECONDARY geoenvironmental factors, such as gas hydrates induce significant variation from expected geoacoustic response in deep sea sediments. Bottom-acoustic interaction characteristics of ocean sediments may be more strongly effected by secondary geoacoustic parameters than by primary parameters. Hydrates are directly observable using reflection seismics (Fig. 18), and this means that their presence has a marked effect on the seismo-acoustic response which differentiates it from the response anticipated from marine sediments alone.

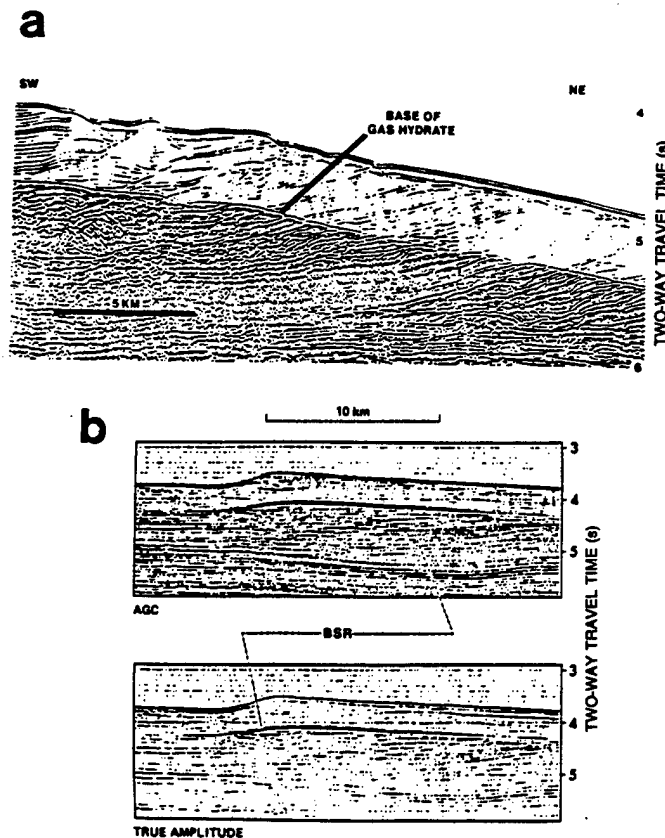

Figure 18. a. BSR seen in 12-fold multichannel seismic reflection profile developed in continental slope sediment from crest and eastern flank of Blake Outer Ridge, off shore SE U.S., in which bedding is not parallel with the seafloor. The apparent lower amplitude above the gas hydrate reflector probably results from reduced acoustic impedance differences in the primary acoustically laminated sediment caused by the presence of the gas hydrate. This reduced impedance, or wipe-out blanked serves to identify gas hydrate in the absence of a strong reflector at the base of the HSZ where there is subjacent gas. After Shipley et al. (1979).

b. Discontinuous BSR seen in a sediment rise. AGC, Automatic Gain Control. After Stoll and Bryan (1979). Although the blanking effect of the hydrate layer can be followed across the section away from the knoll, it can be inferred to lie more widely at the surface than would be indicated from the presence of the BSR alone. Presence of gas in the area of the knoll, may be an effect of a limited amount of free gas beneath the hydrate having migrated to the hydrate induced culmination trap in the vicinity of the knoll. Note the presence of hyperbolic signals from the left termination of the BSR. This may be an edge effect or may simply be associated with the presence of free gas. The same seismic section enhanced shows more hyperbolic signals generally beneath the gas (personal inspection of draft DSDP Figure supplied by T. Edgar).

Secondary geological attributes can be of great importance to bottom-acoustic interaction. These attributes mainly concern the modification or the development of characteristic geoacoustic properties such as attenuation and velocity, and the establishment of velocity profiles. The most widely recognized secondary geological attribute in deep ocean sediments is compaction caused mainly by burial, which by altering the porosity and telescoping impedance contrasts, exerts the primary control over development of velocity gradients and acoustic structure. Cementation and the filling of porous spaces through diagenetic processes can also be important in deep ocean sediments.

Initially, hydrate crystallization will have the effect of expelling fluid from sediment as the individual crystals form. As hydration continues, interstitial spaces will fill by the formation of new crystals and by their joining together, which will have the result of forming a solid mesh of hydrate crystals. As saturation of hydrate progresses, the solid becomes more dense, and of greater interest to bottom-acoustic interaction, introduces both much higher velocities and a proposed new velocity structure that should be applied to ocean bottom sediments where clathrate has developed (Fig. 19). Where density, velocity, attenuation and porosity have been previously considered as being regularly altering parameters that are dominantly controlled by compaction as a function of the sedimentary material and depth of burial, the presence of clathrate has the potential of strongly changing those parameters.

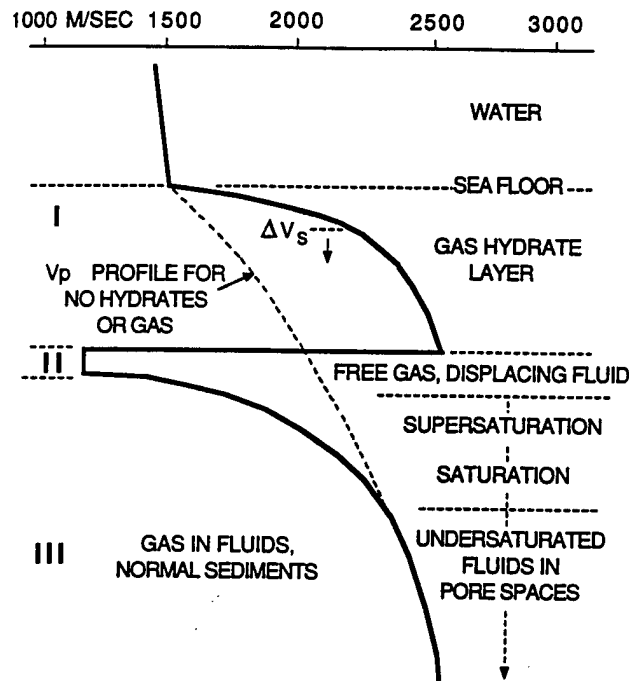

Figure 19. Geoacoustic profile for hydrated sediments. From Max (1990a). Other physical properties such as  $V_s$  and attenuation, density, porosity, etc. can be inferred or calculated with respect to data derived from permafrost terrane where many physical measurements exist.

It is well established that strong reflections can be generated from beds much thinner than the wavelength (Widess, 1973) and also by constructive interference from a zone of alternating high and low acoustic impedance (Kind, 1976; Jones and Nur 1982; Fountain, et al., 1984; Kennett, 1985). Synthetic modeling of various laminated structures was carried out by Jones and Nur (1982), but their units of acoustic impedance were of 110m thickness and the results may not be directly proportional to more thinly laminated materials. Constructive interference based on the individual acoustic impedances may be important where the individual lamina are not too thin in comparison with the normal reflection seismic wavelengths. Best constructive reinforcement takes place at  $1/4$  wavelength spacing, but multiples such as  $1/32$  and  $1/64$  of wavelength will also introduce frequency/grazing angles dependent relationships. Thus units of rhythmically bedded strata have the potential to cause selective constructive reinforcement of incident acoustic energy. If the lateral extent of the anisotropic 'units' is less than the Fresnel zone, however, this would diminish the amplitude of the reflected wave.

It is probable that significant acoustic energy can be returned to water by reflection even from sediments that might appear, from a primary geological point of view, to be rather homogeneous. The secondary geological attribute of hydrate in sediment can at first alter, induce or accentuate porosity lamination and has the potential to

strongly alter the primary geological character of that part of the sediment column most relevant to bottom-acoustic interaction. For instance, when a unit of sediment is hydrating at a constant rate, the bands of minimum porosity appear to solidify first, while the fluid in the more porous beds becomes more viscous with hydrate crystallization, but still exhibits the acoustic character of a fluid. This selective tightening of alternating sedimentary bands will accentuate the acoustic character, beginning within meters of the biological zone of the sediment surface. Theoretical and experimental work is necessary to constrain acoustic modeling and the implications of acoustically laminated sediments, while assessing the potential differences between *in-situ* and laboratory determinations of velocity structure.

The ability of a rock or sediment to cause reflection in preference to refraction is largely controlled by frequency and the angle of incident energy with respect to the impedance of contrast planes. Sediment particle size and the predicted degree of compaction, which is directly inferred as a depth function, are related to tables of laboratory measured values determined from sediments. Sediment particle size, porosity, and provenance are given the highest status in inferring bottom-acoustic interaction (Urlick, 1975; Hamilton, 1980). Unfortunately, no significant allowance has yet been made in taking the presence of gas and gas hydrates into account in identifying realistic acoustic velocity structures in bottom sediments.

P-wave acoustic velocity of gas hydrate is in the 2.5-4.1 km/sec range, although sediment-gas hydrate is more commonly in the 2.3-3.6 km/sec range. The presence of hydrate and the velocity structure they impart to bottom sediments can radically alter overall geoacoustic response. Recognition of the significance of secondary geoenvironmental attributes should cause a widespread reassessment of the overall seismo-acoustic character of ocean floor sediments, as well as radically changing the ways in which these properties are currently estimated. Although the acoustic effects of hydrate is relatively well known, application of this knowledge has not previously been made available in a manner that is relevant to Navy needs.

Gas hydrate deposits act in two manners to alter bottom-acoustic interaction. The upper part of the hydrate stability zone can acquire an accentuated acoustical lamination, which will strongly increase the reflective character;. Instead of a sediment-fluid transition, hydrate formation selectively in more porous zones can introduce alternating fluid sediment solid transitions. The base of the hydrate can be a strong reflector, especially where there is subjacent trapped gas (Katzman, et al., 1994). Where there is pervasive hydrate development, commonly in the lower part of the hydrate, strongly upward refracting velocity profiles are developed along with lowered attenuation; this allows for significant refraction. Both effects act to lower bottom loss but their relative influence is strongly frequency dependant. Future assessment of bottom properties important for bottom acoustic interaction will almost certainly be made *in-situ* because of the transitory nature of gas and gas hydrates in seabed sediments, and the difficulty of reproducing the actual conditions in the laboratory.

A new set of depth-dependent geoacoustic parameters relating to a new Vp curve, reflecting the presence of gas hydrate, has been developed (Fig. 19) and the reflection loss

coefficient of a variety of frequencies have been modeled using the range-independent SAFARI-FIPR algorithm (Max, 1990a, 1990b).  $V_p$ ,  $V_s$ , their attendant attenuations and density have been modeled as gradients that have been approximated by selection of arbitrary layers. Three environmental cases, unhydrated sediment, hydrated sediment, and hydrated sediment with subjacent free gas, have been modeled for a number of frequencies. The gas hydrate layer effects both low and high grazing angle energy (Fig. 20). The presence of the layer appears to lower reflection coefficient loss by about 8 dB at low grazing angles, while at higher grazing angles the gain is up to a factor of 5 over ponded gas deposits. It is clear that if actual system performance follows the reflection coefficient modeling, certain sites will naturally optimize acoustic propagation. At frequencies below 350 Hz there is a direct relationship between reflection loss coefficient and frequency; lower frequencies show lower loss (Fig. 21). Above 400 Hz the effect of gas hydrates is less and reflection loss is not frequency dependent and it would appear that bottom interaction above this frequency is primarily a matter of reflection and backscatter from the sediment or rock surface.

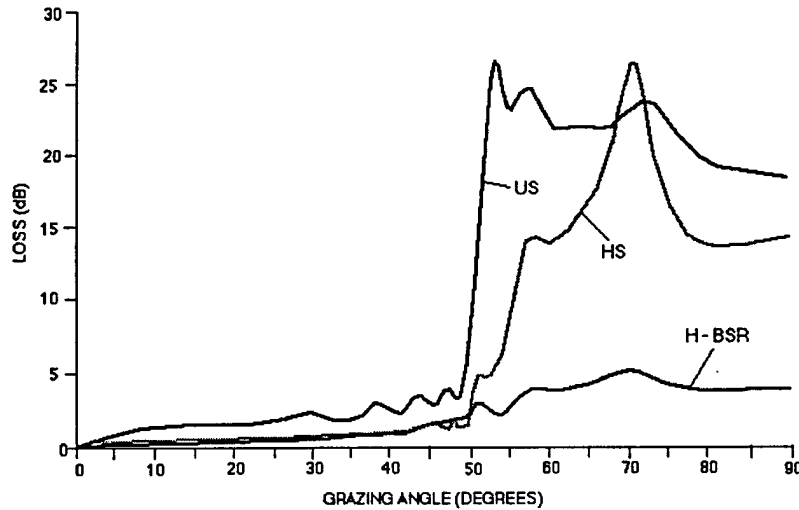

Figure 20. Acoustic loss as a function of reflection coefficient for 10 Hz. Other frequencies modeled not shown here can be found in Max (1990a, 1990b). US, Unhydrated Sediment; HS, Hydrated Sediment; H-BSR, Hydrated Sediment with BSR

The presence of hydrates in sea bottom sediments appears to enhance the propagation of acoustic energy. In particular, high grazing angle energy loss is greatly reduced; for a near-field bottom-mounted acoustic detection system that would have primarily high grazing angle characteristics, detection would be enhanced by an apparent broadening of the suprajacent detection envelope, and a diminishment of acoustic loss (Fig. 21). Where gas deposits occur beneath the hydrate layer, the effect of diminishment of bottom loss is apparently enhanced. Because the presence of hydrates hardens the sediments, it may be possible to consider using boundary or shear wave detection to supplement or replace P-wave detection. The physical properties of the combined sediment-hydrate that are important to shear wave propagation will be investigated, particularly with respect to single and multiple seismic receivers.

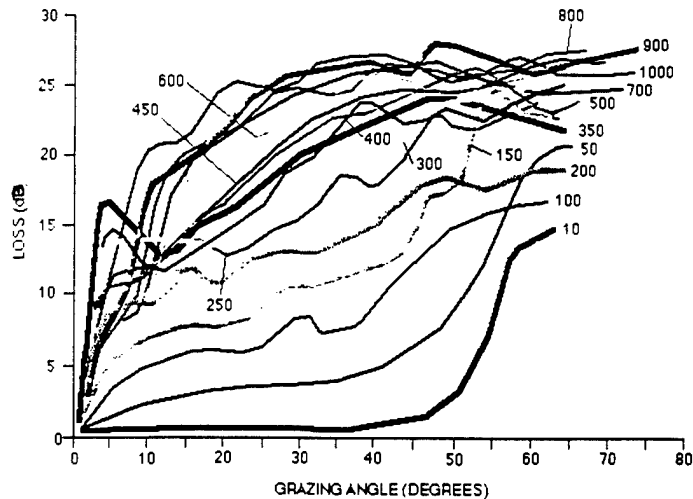

Figure 21. Reflection coefficients in Hydrated sediments as a frequency dependent relationship. Loss in dB. Linear averaging of 15° segments with 5° overlap. Note that the frequency independent regime above 350 Hz defines an area showing different calculated responses that are interacting with the different arbitrary layers chosen for the modeling in different, but related, manners.

Extensive data sets need to be examined and reassessed, in addition the published literature and data normally available to the Navy. Norwegian and other European geological, magnetic, seismic and gravity data, in addition to more detailed bathymetric data, must be acquired; a substantial part of the effort put toward data acquisition from non-standard sources. This is accomplished through international contacts and joint research interests maintained by the Naval Research Laboratory, and produces access to data that would otherwise be unavailable to the Navy. Experience in acquiring data from non-standard sources in the Barents Sea and other areas of the Norwegian, British, Irish and French marginal seas, indicates that information necessary to carry out this work can be accessed.

Even though oceanic hydrate layers are widespread, very little is known about the actual acoustic structure of hydrate layers or variability both locally and from area to area. Because of the ephemeral nature of hydrates once they are removed from the seafloor, and the potential cost of collection, it is unlikely that the true acoustic characteristics of naturally occurring sediment plus hydrate can be entirely defined through physical sampling and laboratory measurements. *In-situ* verification of the acoustic structure and its variation both within sedimentary provinces and between provinces is necessary before acoustic transmission loss and reflection loss character can be modeled in a predictive manner for operational Navy purposes.

A combination of seismic reflection and seismic refraction data will be necessary to characterize the acoustic structure of the ocean hydrate layers. Reflection seismics establish the overall character of the hydrate zone as well as clearly defining the depth of the base of the hydrate where there is a well defined BSR. Seismic reflection records can at least confirm the presence of a hydrate layer. Much reflection seismic data

incorporated in a normal hard-copy record exists in digital form by hydrocarbon exploration companies, universities, and marine institutes and can be retrieved and reprocessed to give the detailed examination necessary to establish the acoustic structure of a hydrate zone. This reexamination of seismic data would require a significant effort because of the size of the seismic data base; much of the information necessary to confirm the more widespread existence of hydrate probably exists but has been overlooked. As recently as 1989, for instance, the unique DTAGS deep-towed seismic survey apparatus that is now being used almost exclusively for gas hydrate research, was producing detailed data that almost certainly shows hydrate (Rowe and Gettrust, 1989), although this was unrecognized at the time. Seismic refraction experiments can be modeled to the velocity/depth inversion so that acoustic structure of the hydrate itself can be more accurately calculated as a many-layered zone.



## **PART 2. NEW RESEARCH TOPICS: SPECIAL ISSUES IN CLATHRATE TECHNOLOGY**

### **1. Synthetic methane hydrate as a fuel and gas transport media**

Clathrates, particularly methane and other hydrocarbon gas hydrates, have been known as laboratory curiosities since the early 1800s. In the 1930's and 1940's the natural gas industry had problems with the formation of a crystalline, wax-like material in natural gas transport pipes. This material clogged the pipes and research was focused on understanding the origin and physical chemistry of the material so that the pipelines could be cleared of it. Indeed, older literature contains many references to gas hydrates forming spontaneously in natural gas transmission pipelines, and often blocking them; which requires the drying of gas prior to pipeline transportation (DoE, 1987). Our present knowledge about methane hydrate physical chemistry, and the potential large volumes of recoverable methane argues strongly that methane is likely to be the fuel of the future, especially if the aspect of compressing methane within a clathrate crystal lattice can be developed on an industrial scale.

There is currently an increasing interest in methane as a fuel because the technology for handling it as a fuel, the direct (e.g., direct combustion for heating) and indirect (electricity generation) energy conversion technologies are well understood and cost effective. In addition, because methane contains more hydrogen atoms for each carbon atom in its molecule, less carbon dioxide is produced upon combustion and because methane is usually relatively pure, and as a gas easy to purify, its use as a fuel is environmentally more benign than all other more complex hydrocarbon fuels.

Methane ("natural gas") produced from conventional gas deposits is plentiful, easily delivered (as a gas) to the user by an in-place domestic distribution system, and as a fuel, methane is clean burning and has a respectable heat content. The prospect of methane recovery from oceanic gas hydrate deposits, however, may result in an almost indefinite supply of methane, the recovery of which will probably speed the development of the gas-energy economy and replace the current oil-based economy. In addition to this development being ecologically sound, oil may be viewed better as an industrial feedstock than as a direct fuel, so long as a convenient source of energy such as methane may be made available.

Methane is particularly amenable to transport and handling as a gas in pipelines and transport to point use in pipes within contiguous land areas. Current technology frequently requires that methane fuel be moved as either compressed gas or as liquefied gas, as when natural gas is imported to the U.S. distribution grid from foreign gas fields. Of course, many fixed-site utilizations for natural gas (e.g. space heating, electrical power generation, or cooking) rely exclusively on gaseous methane as a fuel stock. Where technical or geographic difficulties prohibit the use of piped distribution, however, other means of distributing gas must be used. Storage of methane at the point of use may also be a problem so long as a continuous piped supply is not available.

Liquified natural gas transport, or major gas pipeline networks are currently the only alternatives for transporting methane from production to usage site, and these transport media introduce hazards and these alternatives introduce physical/economical problems. Gas hydrate fuel offers a physically simple, non-polluting, economically attractive and potentially more safe alternative to traditional gas transport use technology. Storage of energy at remote sites might be more advantageous using clathrates rather than other fuels. Liquified natural gas requires expensive installations, and current oil-based fuels have long range instability problems. Both compressed gas and liquified gas, as transport media, possess serious safety concerns associated with the flammability of the material (compressed natural gas) or the cold temperatures and ultimate flammability/potentially explosive nature of the liquified medium. This contribution suggests a new application of clathrate chemistry, which could have a significant impact on methane fuel use and distribution if implemented. There is a third alternative for bulk gas transport and point-of-use storage, which is energy dense, fairly stable, non-flammable (until gas is released from the hydrate), easy to transport, and potentially useable as-is for motor fuels.

#### **Synthetic methane clathrate fuel media (SMCF)**

Ships and aircraft are currently propelled using high flash point liquid hydrocarbon fuels derived from oil. But for the long term, methane resources greatly exceed those of petroleum. Therefore, looking ahead, the fuels industry should be exploring the use of methane for vehicle propulsion. In addition to modifying existing engines for methane use, it is possible to conceive of using specially fabricated hydrate for storing methane in a safe, compressed form.

Naturally occurring methane hydrates are not stable at sea level ambient temperatures and pressures. However, it is not intended to use pure methane hydrate as the basis for the new fuel transport and storage media. Current experimental results show that gas hydrates can be fabricated with specific physical property ranges in solid and pseudo-fluid (slush) forms that are stable at and above ambient pressures and temperatures. The relationship between methane hydrate and pure water ice is also not well understood with respect to their stability fields (Stern et al., 1996). In fact, most of the early work into the chemistry of methane hydrates was undertaken by the gas transport industry because hydrates were forming and clogging gas pipelines even at relatively high temperatures. This broader stability of naturally occurring complex clathrates leads us to suggest that research fabricating special property methane clathrates is a feasibility and that research should be undertaken in an attempt to fabricate a new methane fuel storage and transport media. It should be emphasized that this discussion is an outline of a new research area, rather than a description of existing materials.

The gas to be transported would be carried as a stabilized water-gas hydrate, or as a clathrate utilizing selected (probably gaseous) additives which could expand the stability field for pure methane-pure water clathrates (Fig. 2). It is clear that development and

adoption of a clathrate-based fuel transportation/distribution system, to augment the in-place domestic gaseous-state fuel distribution complex, would offer many advantages above and beyond those associated with safety.

Although the energy density of methane clathrate is low compared with common liquid fuels (Table 3), its potential energy density is actually greater than a similar volume of liquid methane, and up to 164 times (Kvenvolden, 1993) the same volume of methane gas (at STP). The compression factor is obtained because methane molecules are forced closer together in the crystalline solid methane hydrate than is obtain by any other form of methane compression. For our energy conversion factor we use 160 times compression factor, although it is unlikely that the industrial synthetic fuel will actually have a compression factor that high, because it is conservatively less than the maximum amount of methane allowable in the crystal lattice.

Fuel or form of methane	Formula	Density g/cc	Energy Content Btu/lb	Energy Content Btu/ft <sup>3</sup>
1. Methane Gas	CH <sub>4</sub>	7x10 <sup>-4</sup>	160 * <sup>3</sup>	1,150 * <sup>3</sup>
2. Methane Liquid at 20° C and 4,200 psi	CH <sub>4</sub>	0.42* <sup>2</sup>	1,500 * <sup>4</sup>	152,000 * <sup>4</sup>
3. Methane hydrate energy conversion equivalent	CH <sub>4</sub> (H <sub>2</sub> O) <sub>6</sub>	~ 1.0	277 * <sup>4</sup>	15,800 * <sup>4</sup> * <sup>5</sup>
4. Methane hydrate energy potential	CH <sub>4</sub> (H <sub>2</sub> O) <sub>6</sub>	~ 1.0	277 * <sup>4</sup>	184,000* <sup>4</sup> * <sup>6</sup>
5. Octane (gasoline)	C <sub>8</sub> H <sub>18</sub>	0.70	19,000 * <sup>3</sup>	840,000 * <sup>3</sup>
6. JP-5* <sup>1</sup>	C <sub>14</sub> H <sub>30</sub>	0.77	18,500 * <sup>3</sup>	930,000 * <sup>3</sup>

Table 3. Energy content of various Hydrocarbon Fuels. #4, Independent of pressure and temperature within the pressure-temperature field of hydrate (subject to minor variations). \*1. Less volatile jet fuel used by Navy, mandated for use on carriers to reduce danger of explosion. \*2, boiling point - 161 C. \*3, STP Conditions, gas phase. \*4, Energy may be consumed producing gaseous methane from these forms or in containing them. \*5. Combustion products are H<sub>2</sub>O and CO<sub>2</sub>. Energy content takes into account energy required to decompose hydrate to H<sub>2</sub> and CH<sub>4</sub>; this figure represents energy content after conversion at 150 volumes of methane in hydrate per volume of methane STP .

\*6. Total potential energy content with no account taken of dissociation energy requirements based on 160 volumes of methane in hydrate per 1 volume of methane at STP (engineering may reduce the energy requirements for dissociation from specially fabricated clathrate or natural heat sinks may be used as an energy source).

It must be pointed out that the precise nature of SMCF is not known because it has yet to be fabricated. Thus, the energy density, energy losses upon fabrication and gasification, and the equivalent energy of methane after conversion, in addition to the cost of the conversion and other engineering necessary for an SMCF system need to be known before a commercial value can be placed on the SMCF media. The potential energy content of naturally occurring methane hydrate is high enough to allow for some energy loss and still remain an attractive new fuel storage and transport media. Thus, if an energy efficient means for gasifying synthetic methane hydrate fuel (SMCF), can be found, it may prove to be a more efficient means of compressing methane fuel than liquification. In addition, synthetic methane clathrates may be hydrogenated to increase their energy density.

Because it is unlikely that the energy density of a clathrate-based fuel media will ever significantly approach that of liquid petroleum fuels, the clathrate fuel is clearly not appropriate for all vehicles. For instance, vehicles with small volumes capacity for fuel storage, such as private motor vehicles and aircraft, where weight/volume is a major factor, are not likely end-point users. Larger platforms, however, such as ships and possibly high-speed trains which could be made environmentally friendly (with respect to noise of energy generation and exhaust), might be possible end-users, especially when the other attributes of clathrate based fuel media, such as inhibiting uncontrolled fires and explosions in commercial applications and explosion damping and deflecting in military applications, are taken into consideration.

Specially fabricated, especially non-water based clathrates could have widespread industrial application by allowing methane or hydrogen to be safely compressed and transported in the clathrate where it is bound strongly within the crystal structure. The material will have application both as a transport media (e.g., for transporting methane from source to market where pipelines are inappropriate) and as a fuel (e.g., clathrates directly providing fuel on the platform or vehicle on which it is being carried). Alternative clathrate compounds could be formed to suit particular situations, containment pressure-temperature environments, formation or gas evolution conditions. For instance, lightly or unconfined hydrate fuels may be especially feasible for very cold localities such as Antarctica, where pollution is a considerable concern, even if their unit cost is somewhat higher than liquid petroleum fuels.

Methane, alone among industrial fuels, is a renewable resource in that it is a common by-product of microbiological decay or organic matter. It can be recovered from natural reservoirs or manufactured, and small-scale methane production plants based on agricultural waste have been developed in a number of countries where high disposal costs make methane generation economically feasible. Methane hydrate fuel might be produced any place that methane is produced (e.g., sewage, slurry treatment plants, etc., as well as conventional gas distribution points). Industrial plants that manufacture methane almost invariably reduces local pollution and the input of methane into the atmosphere, which in itself is a worthwhile

objective. The ability to manufacture methane in remote locations may substantially reduce the need to transport liquid fuels to those localities.

Because methane can only be evolved from hydrate with thermal energy over time. Because the fuel store would be a stable crystalline solid, hydrate fuel would be effectively non-explosive, with combustion only proceeding at the rate that methane could be evolved. Small leaks that could form explosive mixtures normally would not be associated with the hydrate fuel store as they are with pressurized or cold store- liquid fuel.

### **Fuel system requirements**

The proposed SMCF storage and transport system would consist of three separate components: (1) Formation Module, (2) Transport Vessels, and (3) Gas Separation Unit.

(1). Hydrate Formation Module (HFM). The HFM will consist of a pressure vessel into which are pumped water spray, methane, and stabilizer. Recent research shows that hydrate can form in seawater immediately upon mixing water with the gas, when the system is within the stability field of the clathrates (P. Brewer, Monterey Bay Aquarium Research Institute, pers. comm., November, 1996). Once the hydrate is formed, the material would be removed from the HFM, and transferred to the transport vessel for movement to point of use or distribution.

(2) Hydrate Transport Vessel (HTV). The HTV would consist of a insulated container which could contain moderate pressures (less than 10 atm, for example). The insulation would more than likely consist of plastic foam such as is used by the refrigeration industry; vacuum jackets would be avoided because of cost and safety concerns. The HTV could assume essentially any desired shape, and may evolve to be conformal to the platform supporting an engine using the stored gas as a fuel, for example.

(3) Gas Separation Unit (GSU). The GSU could be integral to the HTV, or separate, as mandated by the ultimate use of the released fuel gas. The clathrates are unstable to heat; the hydrate could be decomposed by direct heating (e.g. a clathrate slush would be transferred to a heated vessel: gas evolves from the slush and escapes for use, and the water from the hydrate is discarded or retained for use in making more hydrate later). Alternatively, the hydrate slush could be sprayed with water, the heat in which would be sufficient to decompose the hydrate. In either case, the evolved gas would be routed to a device (e.g. engine) which could use the combustible gas as a fuel.

It must be noted that there is no inherent reason why the units listed above would necessarily be separate components. For example, the storage vessel could contain integral sub-sections which would allow both formation of and decomposition of the gas hydrate right in the HTV. Further, it is technically possible to design and build an internal combustion engine which would use hydrate as the only, or majority, fuel; such a system would be similar to water-injection technology as applied to internal combustion engines, as in some experimental fighter plane engines and race cars.

It is appropriate to examine the effects of adding a clathrate-based fuel on the current

energy economy of a developed society. Where would the SMCF system be applied and how would it develop? These questions cannot be fully answered because: 1. the engineering possibilities have yet to be explored, 2. the effect on market forces cannot be assessed beyond observing that the technology and potential fuel handling systems largely exist or can be developed at low cost, and, 3. government regulations that would apply (but do not yet exist) could either inhibit or promote development of both the SMCF itself and a world gas economy.

In the broadest sense, a SMCF-based fuel economy would be akin to the system based on liquid hydrocarbons. Specially formulated clathrates would be transported in the form of slush in much the same way as present liquid hydrocarbons. Transportation in solid form could utilize much of the present container-handling equipment and facilities including much of the sea, rail, and road equipment already in existence. Moreover, where safety concerns are paramount, the SMCF might be used because of could greatly enhance safety; even in the presence of open flames, methane is evolved from hydrates through breakdown of the crystal structure. This means that all of the gas or liquid methane available as an explosive component in present conventional methane storage media can only be evolved at a rate at which it could feed a fire, but not an explosion without first collecting evolved gas. In addition, upon gas evolution, is also produced, whose presence could be engineered to inhibit accidental fire-lighting attributes of the system.

## **2. The all-electric Navy and some implications**

Navies are studying the concept of the all-electric ship. Electric drive propulsion is regarded as the key to 21st century surface combatants (Walsh, 1989). These new ships will not have a central engine room and long drive shafts. There will be electrical generation from a number of units that will supply electrical power as necessary. The ships will depend on redundancy of generator capacity for combat survival, rather than protection of a centralized engine room. It is likely that the next design of a surface ship will reflect current decisions to transition to an all-electric surface fleet. The ability to change power allocation to meet demands should have an impact upon ship design because the robust mechanical drive train (especially propeller shaft and transmissions will not be necessary. Power and propulsion systems may be relocated and additional space created for fuel, weapons, and other new, high-technology applications.

Electric drive ships are not new to the Navy. Following WWI, Maryland and Tennessee Class battleships and the aircraft carriers Lexington and Saratoga had steam turbine- electric generators driving individual electric motor-shaft propellers. For example, the battleship Colorado, commissioned in 1923, had two main turbines of 11,000 kw @ 2,065 rpm utilizing steam at 250 lbs pressure. Each individual electric generator was rated at 13,400 kva to 4,325v (series), 1,550 a @ 82 % power. Either or both generators drove the four individual electric motors rated at 7,000 hp @ 170 rpm. The electric drive technology was also transitioned to merchant marine ships in the 1920's. An interesting non-Navy application of the electric ships took place from 17 December, 1929 to 16 January, 1930, when the USS Lexington supplied power to Tacoma, Washington from her main propulsion generators because local hydroelectric generators were off-line (Jolliff and Schumacher, 1989).

The early application of electric drive featured several large generators confined in near-traditional engine rooms amidships. The turbine generators were steam turbines that were placed in close proximity to the oil-fired, steam generating boilers. The 21st century embodiment of the electric ship, however, is not confined by boiler technology. High speed complex electric gas turbines run directly from liquid or gas fuels; these turbines are small, often being less than 0.5 m diameter and 1-2 m long, and are light weight per volume, especially in contrast to diesel electric units. Joint Japanese-American industrial development of specialized gas turbine combined-cycle motors are aiming at 210 megawatts of generating capacity (Melvin, 1989).

If the concept of clathrate fuel can be realized and mated to standardized, relatively small gas-turbine electric generators or Sterling engines, the engineering character of a surface platform could be dramatically altered. It may prove possible to design an integrated gas turbine-electrical generator that is specially designed to optimize power operating on specially compounded methane hydrate fuel composed of methane and water. The object of such a power-generator would be to efficiently produce electrical power. Design and production of a turbine electrical generating unit (TGU) could have the advantage of producing a single engine type for virtually all Navy vessels. It will be possible to produce large numbers of the units that can be incorporated within ship design as a requirement of electric demand of the platform. In other words, small ships will have relatively few of the TGUs while larger ships will have more of the TGUs. The unit cost of each TGU can thus be reduced through economy of scale. The turbine-electric motor would be a lightweight, high power unit. In various output configurations it should be suitable for ships, in high speed and other trains, as a power source for electric motor tanks and heavy vehicles, and possibly in aircraft and individual transport. It would also have application as a fixed source of electricity generation.

Methane fuel would be non-polluting in the marine environment. Every ship during ballasting pumps a certain amount of tank oil into the sea (ONR, 1989). Methane clathrate fuel would not spread over the surface as does oil when a ship sinks, but would be stable at depth. Spills on the surface would evolve to gas and pass directly into the atmosphere where the gas would rise, whether it ignited or not, leaving little or no surface pollution or fire hazard.

Methane clathrate fuel could be fabricated in fuel tanks as a non-explosive solid that will absorb shock. Vertical fuel tanks along the side of an armored vehicle, with a lightly armored outer section and a heavily armored inner section, may have the same response to anti-tank shaped charge projectiles as reactive armor. Tank fuel tanks can be blow-out vented to allow an ignited fuel cell to burn off without further damage to the tank or crew (gas burns up and away from its source, leaving no residue behind). In addition, uncontrolled evolution of methane from a ruptured fuel tank will evolve about 5 or 6 times as much water per volume methane, and this should have a significant quenching action. Thus, in addition to the design applications that a turbine-electric driven armored vehicle might have, such as allowing rear access and extra internal space, the fuel can be designed to act as reactive armor.

Although the focus of this report is primarily on methane as a fuel, other gases may be stored in a clathrate form. For example, the Navy uses large quantities of acetylene for cutting and other metal work in its industrial complexes. Acetylene is thermodynamically unstable and must be stored at pressure and be stabilized in the tank (usually with acetone). Although we are

not aware of acetylene hydrate studies, if could be manufactured, they might impart stability to acetylene, and reduce the need for high pressure systems. As such, a study of acetylene clathrates might have significant pay-offs, both in handling problems and in safety. Also, a study would importantly contribute to our technology base.

### 3. *In-situ* energy and the positive energy balance of recovery

Gas hydrates often form a surface layer in marine sediments that may trap gas immediately below. There is a pressure and temperature differential between the gas in the shallow reservoir and the water at the seafloor. This pressure differential can drive a simple turbine generator or provide force for other applications. Technological innovation at the well head will produce a long-term continuous or controlled intermittent, *in-situ* energy. This energy will power undersea systems or directly drive an acoustic source. The pressure differential between the gas reservoir and the seafloor is great enough to drive a turbine electric or some other electric generator (i.e., fuel cells). A hole connecting a wellhead completion at a site to the reservoir would have a strong pressure differential. In deep water the hydrate stability zone is thicker than in shallow water; off the SE US coast (water depth 3,200 m) the zone is about 600 m thick and in the SW Barents Sea (water depth 345 m) it is about 180 m. Pressure differentials are thus about 60 and 18 atmospheres; both of which are sufficient to drive high and low power turbine-electric generators. Gas turbines operating on well-head hole pressure have been used to provide power at remote drilling sites (Gas Research Institute), and their engineering needs to be researched for applicability to this project. Air-gun and CW acoustic source technology is known for compressed air and electrical source. Although polar shallow gas deposits have been proven, no practical effort has been made to utilize gas hydrate-gas for *in-situ* energy away from high temperature variation hydrothermal systems has been attempted.

There are a number of technical issues:

1. What are the gas deposit pressure differentials at different water depths; how does lithostatic pressure modify hydrostatic pressure?
2. What *in-situ* energy can be produced from the shallow gas and what would be the nature of equipment development necessary to utilize this energy?
3. Can the deep ocean drilling technology be developed at low enough cost to justify development?
4. Can low-grade power be provided by thermocouple systems based on the temperature differential in the hole to provide some capability between high energy demands?
5. Drilling hardware and exploitation hardware development are significant concerns.
6. Integration with existing and impending Navy fixed-site systems will be necessary.
7. Can the *in-situ* gas deposits be used for acoustic sources for ocean tomography and anti-submarine warfare applications?
8. Once a hole is completed between the sea bottom wellhead and the higher pressure,



higher temperature gas reservoir, how much low grade energy could be produced using thermocouple technology?

Small, shallow deposits of gas will provide only moderate pressures and will thus have applications that are limited to functions that pertain to the site itself. Where very large gas deposits exist, however, such as within 200 km of the U.S. southeast coast, it may be possible to pipe the gas to shore where it can be distributed in a North American gas grid pipeline. Because the pressure differences are huge, up to 42 MPa (Megapascals, 1MPa=100 Atm. or 1,470 lb/in<sup>2</sup>), the placing of turbines in the gas line from the deposit to shore should allow considerable power generation during gas recovery. It is entirely possible that there could be a positive energy balance. Although the main object would be to recover gas for distribution to use points by gas grid, the power generated through this secondary recovery technique may prove to be of equal or greater energy value.

The presence of hydrates in the immediate sub-bottom also raises the issue of local energy sources for open fuel cell-thermocouple technology. Local fuel sourcing for related bottom-mounted devices with a low to medium energy requirement becomes a research possibility. [Even though the energy required to disassociate water to O<sub>2</sub> ( $2\text{H}_2\text{O} + \text{O}_2 = 2\text{H}_2$ , [273,660 cal]) may be greater than that derived from burning methane ( $\text{CH}_4 + 2\text{O}_2 = \text{CO}_2 + 2\text{H}_2\text{O}$ , (211,933 cal)), research should be initiated to find some way around the problem.] The hydrate might provide all of the fuel for a hydrate-water disassociation oxidation reaction that might be driven by a catalytic plate or wire of a thermocouple array. Dissolved O<sub>2</sub> in the water might also be used instead of disassociating water, with an artificial gill as the oxygen source.

It is also conceivable that specialized autonomous remotely operated vehicles could draw methane either from methane seeps or indirectly from seafloor hydrate deposits that are increasingly being recognized as local features of the seafloor that are apparently widespread in the world's oceans. This usage would be very specialized and probably only relevant to military application.

#### **4. Gas hydrate as a marine construction material**

Because gas combines with water in the deep oceans to form solid crystalline gas hydrates, it should be possible to use to solidly fix objects within or to sediment. Marine construction using hydraulic cement that will crystallize under water is difficult enough in shallow water, but when it becomes necessary to develop deep marine engineering sites, the transport of cement to the sea bottom and the forming will be extremely expensive and possibly logistically unobtainable. Many marine constructions, however, require only mass to fix or support objects such as pipelines or steel constructions such as well-heads and do not need to be of great strength. It may prove possible to replace cement with gas hydrate for some engineering applications. Whereas the cement is a complex calcium silicate crystal mesh, the gas hydrate is a complex mesh of complex ice crystals. Although the hydrate ice is not of the same engineering character in terms of strength, it does share a number of other attributes of cement that would allow it to substitute for cement in certain applications.

The basic function of the cement is to provide for a rigid shape. It is commonly used with

aggregate and is reinforced with steel rods where greater strength is required. On the sea bottom gas hydrate could substitute for this shape function where relatively low strength was allowed. Aggregate could be supplied from the sea floor itself, and the main material in the ice would be the ocean water itself. Only the gas would need to be transported to the sea bottom, and this could be done in high pressure tanks or by pipe-line with multi-stage compressors in the line. Objectively, it is easier to envisage transport of gas to the seafloor than cement and aggregate. Forms for the gas hydrate could be constructed of plastic or fabric materials that would assume the required shape as the gas was pumped into the 'gas bag'. It would also be possible to include reinforcing by constructing the reinforcing on the surface and lowering it and the outer form bag to the site. Pumping of gas into the form and the crystallization of hydrate would take place on-site. Some of the applications for which gas hydrate (hydcrete) could be envisaged are:

1. Cementing in pipelines or cables to make them less liable to disruption.
2. Mine warfare applications, especially in Polar regions
3. Securing well-head completions to aid blow-out protection.
4. Constructing undersea habitats.

One attribute of using gas hydrate as a construction material that does not pertain to concrete is that engineering constructions are easily reversible. Whereas concrete is difficult to modify once it has formed, and removal or destruction is often impossible, a gas hydrate construction can be 'melted' using a local low temperature thermal source that would be much easier to manage than existing high temperature devices such as thermite lances. If a wellhead or pipeline connector needed reentry, a thermal source such as a hot water jet or a heating pad would be all that would be required. Reforming the gas hydrate construction would also be a relatively easy matter.

## **5. Industrial feedstock**

Methane can serve as a chemical feedstock for conversion to a variety of materials of interest to the Navy. Specifically, methane can be catalytically converted to higher molecular weight hydrocarbons (motor fuels), to surfactant substances, or even to high weight rigid polymers for structural uses in the undersea environment. The key point in this issue is that methane provides the source for a great variety of organic materials that are unavailable without a source of fixed carbon. Methane is easily converted to methanol catalytically, and methanol can be built into other organic molecules. It would be relatively easy to process methane *in-situ* in the deep ocean because the high ambient pressures, coupled with an appropriate power source, would allow chemical processing and conversion of methane.

Hydrates and gas trapped below them appear to constitute vast volumes of methane, which is a primary fuel. Future energy sourcing may involve hydrates to a great degree. This is a DoE area of responsibility. Research concerning hydrate volumes, availability, recovery, and utilization should be part of an on-going long term assessment of national energy availability. Because much of the hydrate is outside of EEZ's, its availability and future exploitation may have

an impact upon even near-term government foreign policy. This brings the energy and Navy issues into the area of concern of the State Department, because there will be an inevitable impact upon foreign affairs.

## **6. Desalination**

Desalination is normally carried out through evaporation, either by boiling or through the use of sunlight or by reverse osmosis processes. Desalination by freezing is too expensive and slow a process, owing to the manner in which brines may be expelled from the individual ice crystals, but held in intergrain spaces and larger pockets. Desalination of sea water by a process of filtering and evaporation is efficient if water is relatively unpolluted, but if the water is polluted, especially by hydrocarbons or dissolved metals, the process of producing large volumes of pure water economically becomes more difficult. Existing water purification plants in the Persian Gulf region, for instance may have to operate at reduced capacity or they might require extensive and costly modification to operate a process designed primarily for relatively clean sea water.

It should be possible to use the process of hydrate formation to purify polluted seawater using a hydrate fractionation column in the sea (Fig. 22). Formation of hydrate crystals is a process of atomic bonding specific molecules at specific crystallographic locations in a crystal lattice. Only those molecules participating in the bonding are accepted into the lattice. Thus the hydrate crystals are almost pure natural gas and water. This crystallization process is similar to those seen in silicate crystals where in highly mixed solutions, crystals form under certain pressure-temperature conditions, and extract from the solution only those molecules that comprise the specific crystal lattices. This process is called fractionation because only a certain fraction of the solution is extracted at any time over the changing pressure-temperature conditions, and the unused residue is left behind. Fractionation is a semi-continuous process that could operate without primary fine filtering, which is necessary in conventional desalination processes. Desalination using fractionation may be developed as a continuous industrial process with the polluted seawater, minus some fraction of water removed by gas hydration, flowing through the desalination plant. If large volumes of water were to be processed, the residues would not necessarily be much more polluted than the intake. Complete dewatering of the input seawater to a muddy fluid or a solid should also be feasible.

## GAS HYDRATE DESALINATION DIAGRAM

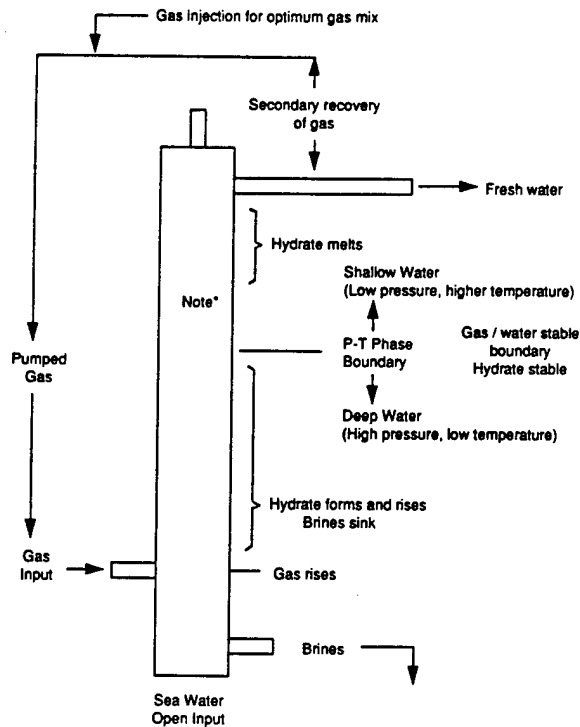

Figure 22. Diagram of desalination column to be operated in the ocean. Natural gas is pumped into the lower part of a desalination column at P-T conditions that are favorable to its forming natural clathrate in the saline water. The natural gas essentially instantly forms a clathrate and heavier brines. The clathrate rises owing to its inherent buoyancy into the upper part of the column, where it melts to release gas and fresh water. Heat produced by the process of hydrate formation is dissipated at depth by both the rising hydrate crystals and the heavier brines, which sink after cooling. A natural fractionation takes place in the column, which will have fresh water in the upper part, where it can be pumped off. Brines will sink toward the bottom of the column and dissipate into the seawater.

The gas is recycled. The only significant moving part is a gas pump. Engineering for brine exclusion is necessary, as may special engineering for brine separation. Advantages are that any site adjacent to deep open ocean having the normal hydrothermal gradient may be a site where a virtually unlimited supply of fresh water can be produced with a low energy input.

Both bubble expansion and segmentation will facilitate the hydration process by continually developing new gas-water interfaces on which hydrate will take place.

Note that the shape of the tube may have to be engineered differently from the straight column diagram shown here to provide settling chambers and/or internal vented ducts to separate and duct hydrate and brines.

Two gases have the proven capability to take the part of the active gas in an oceanic clathrate desalination column. Others may prove feasible.

**Case 1: Methane (CH<sub>4</sub>).** Little methane would remain in the captured fresh water fluid because of its inherent poor solubility. Even though methane is tasteless and without smell, it may be necessary to pass the fresh water through an oxygenation process to displace significant methane to guarantee that no methane gas will accumulate in the finished product.

**Case 2: Carbon Dioxide (CO<sub>2</sub>).** There is only a narrow pressure window where CO<sub>2</sub> is still a gas and its clathrates will form. At greater pressures it forms a fluid that will hydrate with difficulty, is more difficult to handle, and is corrosive. However, if the clathrate oceanic desalination method can use CO<sub>2</sub> instead of methane, it would produce fresh soda water, which would need no subsequent processing before use.

A number of issues of a thermodynamic and engineering nature will need to be resolved in the development of a working ocean hydrate desalination column.

1. Entrainment of saline water by rising clathrate and gas/water mixture.
2. Thermodynamic imbalance. More heat is produced during crystallization than during dissolution. There is a possibility of heat exchange between the rising hydrate-gas and entrained warm brine mixture, and the surrounding or descending cold ocean water.
3. Bubble expansion and segmentation. As bubbles rise and depressurize, they cool and expand. The adiabatic cooling may actually accelerate the hydration process, but must be controlled so as not to cool the seawater enough to form pure water ice. In addition, as the bubbles expand they tend to segment, and even large bubbles at depth become froths of smaller bubbles with ascent. There is a possibility that the water-gas mixture in the desalination column may become fluidized and move upward as a buoyant mass more rapidly than bubbles and hydrate moving through seawater in the column. Mass movement would also entrain the expelled saline brines, retarding or inhibiting the fresh water - saline water fractionation process.

The likely engineering response to these problems is to slow the ascent rate of fluid to allow the best heat transfer situation. Baffled pipes or a climbing circular 'corkscrew' shaped desalination column may prove better than a straight, vertical pipe.

Purification of polluted water is also possible using clathrates, but probably not in an oceanic environment. Forcing formation of natural gas clathrate in polluted sea water should have the effect of removing only water and natural gas molecules from the polluted water (industrial feedstock). Methane would probably not be useful in developing a hydrate desalination system, because the pressure-temperature field of pure methane hydrate is too different from the normal atmospheric ambient conditions. Mixed gas or higher molecular density gas such as ethane, propane, or butane (other gases such as argon or sulfur hexafluoride) could well provide the reactant in a closed cycle process of hydrate formation, hydrate separation (probably through the buoyancy effect of hydrate), and gas separation from fluid that would form the basis of a commercial process that would be particularly appropriate to polluted conditions. Because both heating and cooling would almost certainly be part of the process, heat pumping would be an attractive alternative to wasteful energy input.

Although desalination and purification of complex liquids by clathrates has been suggested in the literature (Barduhn, 1967; Englezos & Bishnoi, 1988), we propose carrying out the desalination using a special desalination column (Fig. 22), fabricated and operated in, or adjacent to the sea, to take advantage of heat transfer upon crystallization and dissolution, natural buoyancy of light gas clathrates and fresh water and cooled supersaline seawater. The cool water and high pressures at depth and the warmer water at lower pressure shallow depths are all envisaged as being used to naturally provide for crystallization, density separation, cooling, and separation of fresh water from normal seawater. Surface water even in Polar regions is warm and low pressure enough to allow the fractionation, albeit at a slower rate than where warm surface waters exist.

### **GAS HYDRATE RESEARCH AND ITS FUTURE**

Gas hydrates were originally regarded as a nuisance by the petroleum, natural gas, and petrochemical industries, and as a safety hazard by drilling and marine engineering interests. And then they were discovered, almost by accident, in the deep oceans in the late 1960's. It is now recognized that gas hydrate has the potential to interact broadly within the biosphere and upper lithosphere, and also has enormous potential as an energy resource (Monastersky, 1996). Hydrates now demand focused and coordinated research.

The main hydrate research topics are: seafloor stability, climate change, energy, and special-focus topics, such as sonar response affects and local biological impact; of these, only energy has immediate national security impact because energy is the basis of the U.S. economy and methane hydrates developed contiguous to North America have the potential to again make the U.S. geographically and geopolitically energy independent. A combination of marine seismic research, chemical and laboratory studies, and industrial assessments are necessary to identify gas hydrate economic targets and opportunities.

A first national workshop sponsored by the Department of Energy, U.S. Geological Survey, and the Naval Research Laboratory in 1991 (Max et al., 1991) brought together industrial, government, and research bodies concerned with oceanic gas hydrates for the first time. Although the aim of the meeting was in part to develop an outline of a national gas hydrate research program, because the scope of hydrate research is broader than any individual Federal Government Department or research agency, such as NSF or ODP, no agency stepped forward to oversee the development of a national research program. Since then, a number of agencies, such as NRL and U.S.G.S. (with DoE support), have developed their own gas hydrate research programs. In addition, NSF has supported ODP gas hydrate research and the basis for a national gas hydrate research program is now more well established. More is known about hydrates and estimating their occurrence and *in-situ* volumes, and a number of other nations (India, Japan, Norway, European Union) have developed national and cooperative gas hydrate research programs. At least one major industrial nation (Japan) has initiated an undertaking to develop the capability of economic recovery of methane from oceanic hydrates in its contiguous seabed as national policy.

It may now be the appropriate time for the United States to develop a broad, national gas hydrate research program. The research and technical skills are available, the interest of a

number of government and research funding agencies has translated to limited funding support, and the need to develop U.S. energy independence has never been greater. Failure to develop and implement a national gas hydrate research program in the immediate future may mean that the U.S. would fall behind in the scientific and technical race to develop oceanic gas hydrate resources. This would have a major impact for intellectual property rights and ocean technology and ocean engineering developments and have many other economic implications. Successful implementation of a national gas hydrate research program is thus a true national interest. Hydrates have the potential to develop into a major research program that may become one of the national and global economic engines of the next century and beyond.

## References

- Aagaard, K., Swift, J.H. & Carmack, E.C. 1985. Thermohaline circulation in the Arctic Mediterranean Sea. *Journal Geophysical Research* 90, (C3), 4833-4846.
- Andreassen, K., Hogstad, K. & Berteussen, K.A. 1990. Gas hydrate in the southern Barents Sea, indicated by a shallow seismic anomaly. *First Break* 8, 235-245.
- Aoki, Y., Tamano, T. & Kato, S. 1983. Detailed structure of the Nankai Trough from migrated seismic sections. In: Watkins, J.S. & Drake, C.L. (eds). *Studies In Continental Margin Geology*. American Association of Petroleum Geologists Memoir 34, 309-322.
- Arthur, M.A. 1979. North Atlantic Cretaceous Black shales: the record at Site 398 and a brief comparison with other occurrences. In: Sibuet, J.C., Ryan, W.B.F. et al. *Initial reports of the Deep Sea Drilling Project 47, 2*. U.S. Government Printing Office, Washington, D.C., 719-751.
- Austegard, A. 1982. Velocity analysis of sonobuoy data from the northern Svalbard margin. Norwegian Petroleum Directorate, Scientific Report 9, University of Bergen. 13pp., 12 Figs.
- Barduhn, A.J. 1967. Desalination by crystalline process. *Chemical Engineering Progress* 63, 1, 98.
- Baron, M. 1951. Inclusion compounds. *Organic Chemical Bulletin* 29, 1-4.
- Barrer, R.M. & Stuart, W.I. 1957. Non-stoichiometric clathrate compounds of water. *Proceedings of the Royal Society, London, Series A* 243, 172-189.
- Bell, P.R. 1982. Methane hydrate and the carbon dioxide question. In: Clark, W.C. (ed). *Carbon Dioxide Review 1982*. Clarendon Press, Oxford, 401-410.
- Belyaeva, A.N., Danushevskaya, A.I. & Romankevich, E.A. 1989. 28: Organic geochemistry of Barents Sea Sediments. In: Herman, Y. *The Arctic Seas. Climatology, Oceanography, Geology, and Biology*. Van Nostrand Reinhold Co. New York, 761-795.
- Bennett, R. 1988. Gas hydrate research in the Gulf of Mexico. Morgantown Energy Technology Center, Morgantown, WV. DOE/MC/23145-2616 (DE88010279), 41pp.
- Bernstein, B.L., Silver, E.A., Reed, D.L. & Kirchoff-Stein, K.S. 1988. Poster: Basement duplexes within an accretionary wedge, western Solomon Sea (Abstract). *EOS* 69, 1443.
- Bily, C. & Dick, J.W.L. 1974. Naturally occurring gas hydrates in the Mackenzie Delta, N.W.T. *Bulletin of Canadian Petroleum Geology* 22, 320-352.
- Brooks, J.M. & Bryant, W.R. 1985. Geological and geochemical implications of gas hydrates in the Gulf of Mexico. U.S. Department of Energy DOE/MC/21088-1964 (DE86001011), 129.

- Brooks, J.M., Field, M.E. & Kennicutt, M.C.II. Observations of gas hydrates offshore northern California. *Marine Geology* (in press).
- Brown, J.F. Jr. 1962. Inclusion compounds. *Scientific American* 207, 82-92.
- Brown, K.M. 1990. The nature and hydrogeologic significance of mud diapirs and diatremes for accretionary systems. *Journal of Geophysical Research* 95, 8969-8982.
- Brown, K.M., Bangs, N.L., Froelich, P.N. & Kvenvolden, K.A. 1996. The nature, distribution, and origin of gas hydrate in the Chile Triple Junction region. *Earth and Planetary Science Letters* 139, 471-483.
- Bryan, G.M. & Markl, R.G. 1966. Microtopography of the Blake-Bahama Region. Columbia University, Lamont Geological Observatory Technical Report No. 8 (CU-8-66-NOpBSR 85077), 26pp, 16 figures.
- Buffler, R.T., Locker, S.D., Bryant, W.R., Hall, S.A. & Pilger, R.H. 1984. Gulf of Mexico: Ocean margin drilling program, regional Atlas series: Atlas 6, *Marine Science International*, 36pp.
- Bugge, T. 1983. Submarine slides on the Norwegian continental margin with special emphasis on the Storegga area, Continental Shelf Norway. IKU, Trondheim, Norway Publication 10, Section 5.7.3.
- Bugge, T., Befring, S., Belderson, R.H., Eidvin, T., Jansen, E., Kenyon, N.H., Holtedahl, H. & Sejrup, H.P. 1987. A giant three-stage submarine slide off Norway. *Geo-Marine Letters* 7, 191-198.
- Cess, R.D., Potter, G.L., Blanchet, J.P., Boer, G.J., Ghan, S.J., Kiehl, J.T., Le Treut, H., Li, Z-X., Lian, Z., Mitchell, J.F.B., Morcrette, J-J., Randall, D.A., Riches, M.R., Roeckner, E., Schlese, U., Slingo, A., Taylor, K.E., Washington, W.M., Wetheral, R.T. & Yagai, I. 1989. Interpretation of cloud-climate feedback as procuded by 14 atmospheric general circulation models. *Science*, 245, 513.
- Chamberlain, J.W., Foley, H.M, MacDonald, G.J. & Ruderman, M.A. 1982. Climate effects of minor atmospheric constituents. In: Clark, W.C. (ed). *Carbon Dioxide Review 1982*. Clarendon Press, Oxford, 255-277.
- Cheeseman, S.J., Law, L.K. & Edwards, R.N. 1990. Detection of gas hydrates using a towed, short baseline transient EM system. *EOS* 71, 1969.
- Cherkis, N.Z., Max, M.D., Midthassel, A., Crane, K., Sundvor, E. & Vogt, P.R. 1992. Deep ice scour and mass-wasting features on the northern Svalbard insular shelf and slope. (abs). *International Conference on Arctic Margins (ICAM)*, Anchorage, Alaska, 2-4 September, 1992.
- Ciesnik, M.S. & Krason, J. 1987. Geological evolution and analysis of confirmed or suspected gas hydrate localities. V. 11. Basin analysis, formation and stability of gas hydrates in the Black Sea. U.S. Department of Energy, Morgantown. DOE/MC/21181-1959 (DE88001052), 88pp.
- Collett, T.S. 1983. Detection and evaluation of natural gas hydrates from well logs, Prudhoe Bay, Alaska. In: *Proceedings of the Fourth International Permafrost Conference*, Fairbanks, Alaska, July 17-22 169-174.
- Cooper, A.K., Scholl, D.W. & Marlow, M.S. 1986. Structural framework, sedimentary sequences, and the hydrocarbon potential of the Aleutian and Bowers Basins, Bering Sea. In: Scholl, D.W., Grantz, A. & Vedder, J.G. (eds). *Geology and Resource Potential of the Continental Margin of Western North America and Adjacent Ocean Basins - Beaufort Sea to Baja California*. Circum-Pacific council for Energy and Mineral Resources Earth Science Series, Volume 6, 473-502.
- Cotton, F.A. & Wilkinson, G. 1980. *Advanced Inorganic Chemistry*. Fourth and earlier editions, John



Wiley and Sons, New York, 1396pp.

- Cram, D.J. 1992. Molecular container compounds. *Nature* 356, 29-36.
- Crane, K., Sundvor, E., Foucher, J.-P., Hobart, M. Myhre, A.M. & LeDouaran, S. 1988. Thermal evolution of the western Svalbard margin. *Marine Geophysical Researches* 9, 165-194.
- Cragg, B.A., Parkes, R.J., Fry, J.C., Weightman, A.J., Rochelle, P.A. & Maxwell, J.R. 1996. Bacteriological populations and processes in sediments containing gas hydrates (ODP Leg 146: Cascadia Margin). *Earth and Planetary Science Letters* 139, 497-507.
- Cragg, B.A., Parkes, R.J., Fry, J.C., Weightman, A.J., Rochelle, P.A., Maxwell, J.R., Kastner, M., Hovland, M., Whiticar, M.J. & Sample, J.C. 1995. Chapter 27. The impact of fluid and gas venting on bacterial populations and processes in sediments from the Cascadia margin accretionary system (Sites 888-892) and the geochemical consequences In: Carson, B., Westbrook, G.K., Musgrave, R.J. & Suess, E. (eds). *Proceedings of the Ocean Drilling Program Scientific Results* 146, 399-411.
- Dalland, A. 1976. Erratic clasts in the lower Tertiary deposits of Svalbard - evidence of transport by winter ice. *Norsk Polarinstitutt Arbok* 1976, 151-165.
- Danyushevskaya, A.I., Yashin, D.S. & Kirillov, O.V. 1980. Geochemical patterns of distribution of organic carbon in the bottom sediments of Arctic seas. *Oceanology* 20, 183-188.
- Darby, D.A., Naidu, A.S., Mowatt, T.C. & Jones, G. 1989. Chapter 24: Sediment composition and sedimentary processes in the Arctic Ocean. In: Herman, Y. *The Arctic Seas. Climatology, Oceanography, Geology, and Biology*. Van Nostrand Reinhold Co. New York, 657-720.
- Davidson, D.W. et al. 1978. Natural gas hydrates in northern Canada: Proceedings, 3rd International Conference on Permafrost, v. 1, 937-943.
- Davis, E.E. 1989. Thermal aging of oceanic lithosphere. In: Wright, J.A. & Loudon, K.E. (eds). *Handbook of Seafloor Heatflow*. CRC Press, Inc. Boca Raton, Florida, 145-167.
- Davis, E.E., Hyndman, R.D. & Villinger, H. 1990. Rates of fluid expulsion across the northern Cascadian accretionary prism: Constraints from new heat flow and multichannel seismic reflection data. *Journal of Geophysical Research* 95, 8869-8889.
- Davy, H. 1811. On a combination of ocymuriatic gas and oxygen gas. *Philosophical Transactions of the Royal Society* 101, 155.
- Dean, J.A. 1974. *Lang's Handbook of Chemistry*. McGraw-Hill Book Company, New York.
- Dean, W.E., Arthur, M.A. & Stow, D.A.V. 1984. Origin and geochemistry of Cretaceous deep-sea black shales and multicolored claystones, with emphasis on Deep Sea Drilling Project Site 530, Southern Angola Basin. In Hay, W.W., Sibuet, J.C., et al., *Initial Reports of the Deep Sea Drilling Project* 41, U.S. Government Printing Office, Washington, D.C., 819-844.
- De Boer, R.B., Houbolt, J.J.H.C. & Lagrand, J. 1985. Formation of gas hydrates in a permeable medium. *Geologie en Mijnbouw* 64, 245-249.
- Degens, E.T. & Mapper, K., 1976. Factors controlling the distribution and early diagenesis of organic material in marine sediments.. *Chemical Oceanography* 6, 53-113.
- Dillon, W.P., Felhaber, K., Lee, M.W., Booth, J.S. & Paull, C.K. 1991. Methane hydrate in sea floor sediments of the southeratarn U.S.: Amount and implication for climate change. NE/SE Geological Society of America meeting Abstracts, Baltimore.

- Dillon, W.P., Fehlhaber, K., Coleman, D.F., Lee, M.W. & Hutchinson, D.R. 1995. Maps showing gas-hydrate distribution off the east coast of the United States. U.S. Geological Survey Miscellaneous Field Studies Map (Scale 1:1,000,000), MF-2268.
- Dillon, W.P., Grow, J.A. & Paull, C.K. 1980. Unconventional gas hydrate seals may trap gas off Southeast U.S. Oil and Gas Journal, Jan 7, 1980, 124-130.
- Dillon, W.P., Lee, M.W. & Coleman D.F. 1994. Identification of marine hydrates in situ and their distribution off the Atlantic coast of the United States. International Conference on Natural Gas Hydrates: Annals of the New York Academy of Sciences 715, 364-380.
- Dillon, W.P., Lee, M.W., Fehlhaber, K & Coleman, D.F. 1993. Gas hydrates on the Atlantic continental margin of the United States: controls on concentration In: Howell, D.G. (ed). *The Future of Energy Gases*: U.S. Geological Survey Professional Paper 1570, 313-330.
- Dillon, W.P. & Paull, C.K. 1983. Marine gas hydrates -Chapter II: Geophysical evidence. In: Cox, J.L. (ed). *Natural Gas Hydrates: Properties, Occurrences, and Recovery*. Butterworth Publishers, Boston, MA, 128pp.
- Dillon, W.P. & Popenoe, P. 1988. The Blake Plateau Basin and Carolina Trough. In: Sheridan, R.E. & Grow, J.A. (eds). *The Atlantic Continental Margin*, U.S. Geological Society of America, The Geology of North America v. 1-2.
- Dillon, W.P. & Paull, C.K. 1983. Marine gas hydrates-II: Geophysical evidence, in: Cox, J.L. (ed). *Natural Gas Hydrates--Properties, Occurrences and Recovery*: Butterworth Publishers, Boston, Mass, U.S.A., 73-90.
- Dillon, W.P., Popenoe, P., Grow, J.A., Klitgord, K.D., Swift, B.A., Paull, C.K. & Cashman, K.V. 1982. Growth faulting and salt diapirism: their relationship and control in the Carolina Trough, eastern North America. In: Watkins, J.S. & Drake, C.L. (eds). *Studies in Continental Margin Geology*. American Association of Petroleum Geologists Memoir 34, 21-46.
- DoE. 1987. Gas Hydrates Technology Status Report. U.S. Department of Energy, Office of Fossil Energy, Morgantown, West Virginia. DOE/METC-87/0246 (DOE)87001027), 25pp.
- DoE, 1987. Gas hydrates Technology Status Report. Department of Energy DOE/METC-870246 (DE8700127) 54pp.
- Dow, W.C. 1978. Petroleum source beds on continental slopes and rises. American Association of Petroleum Geologists Bulletin 62, 1548-1606.
- Dow, W.C. 1978. Petroleum source beds on continental slopes and rises. American Association of Petroleum Geologists Bulletin 62, 1548-1606.
- Dowdeswell, E.K. 1988b. The Cenozoic Stratigraphy and Tectonic Development of the Barents Shelf. In: Harland, W.B. & Dowdeswell, E.K. (eds). *Geological Evolution of the Barents Shelf Region*. Grahm & Trotman, London/Boston, MA, 131-155.
- Edgar, N.T. 1973. Discoveries from Deep Ocean Drilling. Transactions Gulf Coast Association Geological Society 23.
- Eiken, O. & Austegard, A. 1989. The Tertiary orogenic belt of West-Spitsbergen: Seismic expressions of the offshore sedimentary basins. In: Eiken, O. Aspekter ved refleksjonsseismikk. Ni bidrag om innsamling, prosessering og tolkning med geografisk tyngde i Svalbard. Universitetet i Bergen, Norway, 81-92.

- Eiken, O. & Hinz, 1989. Contourites in the Fram Strait. In: Eiken, O. (ed). In: Eiken, O. Aspekter ved refleksjonsseismikk. Ni bidrag om innsamling, prosessering og tolkning med geografisk tyngde i Svalbard. Universitetet i Bergen, Norway, 93-121.
- Eldholm, O., Thiede, J. et al. 1986. Dipping reflectors in the Norwegian Sea - ODP Leg 104 drilling results. *Journal of the Geological Society*, London 143, 911-912.
- Emery, K.O. & Uchupi, E. 1984. *The Geology of the Atlantic Ocean*. Springer-Verlag, 1050pp.
- Englezos, P. & Bishnoi, P.R. 1988. Prediction of gas hydrate formation conditions in aqueous electrolyte solutions. *AIChE JI* 34, 10, 1718-1721.
- Erhalt, D.H. & Schmidt, U. 1983. Sources and sinks of atmospheric methane. *Pure Applied Geophysics* 116, 452.
- Ewing, J., Ewing, M. & Leyden, R. 1966. Seismic profiler survey of Blake Plateau: American Association of Petroleum Geologists Bulletin 50, 1948-1971.
- Fairbridge, R. W. (ed). 1966. *The Encyclopedia of Oceanography*, V. 1. Encyclopedia of Earth Science Series, Reinhold Publishing Corporation, New York.
- Faraday, M. 1823. On fluid chlorine. *Philosophical Transactions Royal Society of London* 22A, 160-189.
- Field, M.E. & Kvenvolden, K.A. 1985. Gas hydrates on the northern California continental margin. *Geology* 13, 517-520.
- Finley, P. & Krasen, J. 1986. Geological evolution and analysis of confirmed or suspected gas hydrate localities. V. 9. Formation and stability of gas hydrates of the Middle America Trench. U.S. Department of Energy DOE/MC/21181-1950 (DE88001007), 243pp.
- Flippen, J.L. & Karle, J. 1971. Heptanol as a guest molecule in Dianin's Compound. *Journal of Physical Chemistry* 75, 23, 3566-3567.
- Flippen, J.L. & Karle, J. & Karle, I.L. 1970. The crystal structure of a versatile organic clathrate. 4-p-Hydroxyphenyl-2,2,4-trimethylchroman (Dianin's Compound). *Journal of the American Chemical Society* 92, 3749-3755.
- Flood, R.D. 1989. Morphological and Dynamic Studies of Sediment Waves in the Argentine Basin (Project Mudwaves). Geology and Geophysics Program Summary for FY 88. Office of Naval Research, ONR 112589-11, 226-227.
- Fountain, D.M., Hurich, C.A. & Smithson, S.B. 1984. Seismic reflectivity of mylonite zones in the crust. *Geology* 12, 195-198.
- Fowler, S.R., White, R.S. & Loudon, K.E. 1985. Sediment dewatering in the Makran accretionary prism. *Earth and Planetary Sciences Letters* 75, 427-438.
- Franks, F. & Reid, D.S. 1973. Chapter 5. Water: A Comprehensive Treatise., V. 2
- Geotimes, 1989. Exploring the Japan Sea. *Geotimes* 34, 19-21.
- Gettrust, J.F., Grimm, M., Madosik & Rowe, M. 1988. Results of a deep-tow multichannel survey on the Bermuda rise. *Geophysical Research Letters* 15, 1413-1416.
- Grantz, A. & May, S.D. 1982. Rifting history and structural development of the continental margin north of Alaska. In: Watkins, J.S. & Drake, C.L. (eds). *Studies in Continental Margin Geology*. American Association of Petroleum Geologists Memoir 34, 77-100.

- Grantz, A., Boucher, G.W. & Whitney, O.T. 1976. Possible solid gas hydrate and natural gas deposits beneath the continental slope of the Beaufort Sea. U.S. Geological Survey Circular 733, 17.
- Grantz, A., Hart, P.E. & Kvenvolden, K.A. 1989. Seismic reflection character, distribution, estimated volume and stability of gas hydrate deposits beneath the Arctic Ocean north of Alaska. American Geophysical Union. EOS, 70, 43, 1152.
- Grow, J.A., Dillon, W.P., Popenoe, P. & Sheridan, R.E. 1979. Diapirs along the continental slope southeast of Cape Hatteras (abs). S.E. section of the Geological Society of America 28th annual meeting.
- Hamilton, E.L. 1980. Geoacoustic modeling of the sea floor. Journal of the Acoustical Society of America 68, 1313-1340.
- Hammerschmidt, E.G. 1934. Formation of gas hydrates in natural gas transmission lines. Industrial and Engineering Chemistry 26, 851.
- Hand, J.H., Katz, D.L. & Verma, V.K. 1974. Review of gas hydrates with implications for ocean sediments. In: Kaplan, L.R. (ed). *Natural Gases in Marine Sediments*. Plenum, New York, 197-194.
- Handa, Y.P. 1986. Journal of Chemical Thermodynamics 18, 891.
- Harrison, W.E. & Curiale, J.A. 1982. Gas hydrates in sediments of Holes 497 and 498A, Deep Sea Drilling Project Leg 67. In: Auboin, J. et al. *Initial reports of the deep sea drilling project 67*. Washington D.C. U.S. Government Printing Office, 591-594.
- Hedberg, H. 1974. American Association of Petroleum Geologists Bulletin 58, 661-673.
- Hedberg, H.D. 1980. Problems of Petroleum Migration. In: Roberts, W. H. & Cordell, R.J. (eds). American Association of Petroleum Geologists Studies in Geology No. 10.
- Holbrook, W.S., Hoskins, H., Wood, W.T., Stephen, R.A. & Lizarralde, D. 1996. Methane hydrate and free gas on the Blake Ridge from vertical seismic profiling. 1996. Methane hydrate and free gas on the Blake Ridge from vertical seismic profiling, Science, 273, 27, 1840-1843.
- Hollander, F. & Jeffrey, G.A. 1977. Neutron diffraction study of the crystal structure of ethylene oxide deuterohydrate at 80° K. Journal of Chemical Physics 66, 4699-4674.
- Hinz, K., Mutter, J.C., Zehnder, C.M. & NGT Study Group. 1987. Symmetric conjugation of continent-ocean boundary structures along the Norwegian and East Greenland Margins. Marine and Petroleum Geology, 4, 166-187.
- Hitchon, B. 1974. Occurrence of natural gas hydrates in sedimentary basins. In: Kaplan, I.R (ed). 1974. *Natural Gases in Marine Sediments*. Plenum Press, New York and London 195-225.
- Horne, R.A. 1969. *Marine Chemistry*. John Wiley and Sons, New York, 568pp.
- Hovland, M. & Judd, A.G. 1988. Seabed Pockmarks and Seepages. Impact on Geology, Biology and the Marine Environment. Graham and Trotman, London, 293pp.
- Howell, D.G. 1989. *Tectonics of Suspect Terranes Mountain Building and Continental Growth*. Topics in the Earth Sciences. Chapman and Hall, London, New York, 232pp. (Fig. 6.8, p. 166).
- Hubbard, H.M. 1991. The real cost of energy. Scientific American 264 (4), 36-42.
- Jansa, L.F. & MacQueen, J.M. 1978. Stratigraphy and hydrocarbon potential of the central North Atlantic Basin. Geoscience Canada 5, 176-183.

- Jolliff, J.V. & Schumacher, K.B. 1989. *The Declining Years*. In: King, R.W., Palmer, P. & Meader, B.I. (eds). *Naval Engineering and American Seapower*. The Nautical & Aviation Publishing Company of America Inc. Baltimore, MD, 119-158.
- Jones, T. & Nur, A. 1982. Seismic velocity and anisotropy in mylonites and the reflectivity of deep crustal faults. *Geology* 10, 260-263.
- Judge, A. 1982. Natural gas hydrates in Canada. Proceedings, 4th Canadian Permafrost Conference, 320-328.
- Kaplan, I.R (ed). 1974. *Natural Gases in Marine Sediments*. Plenum Press, New York and London, 324pp.
- Kasting, J.F., Richardson, S.M., Pollack, J.B. & Toon, O.B. 1986. A hybrid model of the CO<sub>2</sub> geochemical cycle and its application to large impact events. *American Journal of Science* 286, 361-389.
- Katz, D.L., Cornell, D., Kobayashi, R., Poettmann, F.H., Vary, J.A., Elenbass, J.R. & Weinaug, C.F. 1959. *Handbook of Natural Gas Engineering*. McGraw-Hill, New York, 802pp.
- Katzman, R. & Holbrook, W.S. 1994. Combined vertical-incidence and wide-angle seismic study of a gas hydrate zone, Blake Ridge. *Journal of Geophysical Research* 99, 17,975-17,995.
- Kehew, A.E. & Lord, M.L. 1986. Origin and large-scale erosional features of glacial-lake spillways in the northern Great Plains. *Geological Society of America Bulletin* 97, 162-177.
- Kennett, B.L.N. 1985. *Seismic Wave Propagation in Stratified Media*. Cambridge University Press. Cambridge, England, 342pp.
- Kennicut, M.C., Brooks, J.M., Bidigare, R.R., McDonald, S.J. Adkinson, D.L. & Macko, S.A. 1989. *Limnology and Oceanography*, (in press).
- Khalil, J.T. & Dickinson, R.E. 1987. A study of the radiative effects of enhanced atmospheric CO<sub>2</sub> and CH<sub>4</sub> on early earth surface temperatures. *Journal of Geophysical Research* 92, 2991-2998.
- Khalil, M.A.K. & Rasmussen, R.A. 1983. Sources, sinks, and seasonal cycles of atmospheric methane. *Journal of Geophysical Research* 88, 5131-5144.
- Kiehl, J.T. 1991. Clouds and climate change. *American Geophysical Union. EOS*. 72 (10), 112.
- Kind, R. 1976. Computation of reflection coefficients for layer media. *Journal of Geophysical Research* 42, 191-200.
- Krason, J. & Ciesnik, M.S. 1986. Geological evolution and analysis of confirmed or suspected gas hydrate localities. V. 8. Basin analysis, formation and stability of gas hydrates in the northern California offshore. U.S. Department of Energy DOE/MC/21181-1950 (DE87001078), 54pp.
- Krason, J. & Ciesnik, M.S. 1987. Geological evolution and analysis of confirmed or suspected gas hydrate localities. V. 10. Basin analysis, formation and stability of gas hydrates of the Aleutian Trench and the Bering Sea. U.S. Department of Energy DOE/MC/21181-1950 (DE88001008), 152pp.
- Krason, J. & Ridley, W.I. 1985a. Geological evolution and analysis of confirmed or suspected gas hydrate localities: Blake-Bahama Outer Ridge - U.S. East Coast. U.S. Department of Energy, DOE/MC/21181-1950, Vol. 1.
- Krason, J. & Ridley, W.I. 1985b. Geological evolution and analysis of confirmed or suspected gas

hydrate localities: Baltimore Canyon Trough and environs - U.S. Department of Energy, DOE/MC/21181-1950, Vol. 2.

Krason, J. & Rudloff, B. 1985. Geological evolution and analysis of confirmed or suspected gas hydrate localities: Offshore of Newfoundland and Labrador. U.S. Department of Energy, COE/MC/21181-1950. Vol. 4.

Krason, J. Finley, P.D. & Gudloff, B. 1985. Geological evolution and analysis of confirmed or suspected gas hydrate localities: Basin Analysis, Formation and Stability of Gas Hydrates in the western Gulf of Mexico. U.S. East Coast. U.S. Department of Energy, DOE/MC/21181-1950, Vol. 3.

Kvenvolden, K.A. & Barnard, L.A. 1982. Gas hydrates of the Blake Outer Ridge, Site 533, DSDP Leg 76. In: Initial reports of the Deep Sea Drilling Project 76, 353-368.

Kvenvolden, K.A. & Cooper, A.K. 1987. Natural gas hydrates of the offshore circum-Pacific margin - a future energy resource? In: Horn, M.K. (ed). Transactions of the Circum-Pacific energy and Mineral Resources Conference. Circum-Pacific Council for Energy and Mineral Resources, 285.

Kvenvolden, K. A., & Field, M. E. 1981. Thermogenic hydrocarbons in unconsolidated sediment of Eel River Basin offshore northern California. American Association of Petroleum Geologists Bull., 65, 1642-1646.

Kvenvolden, K.A. & Kastner, M. 1988. Initial Reports ODP, Part B, Suess, B., von Huene, R., Emels, K-C. et al. (eds). U.S. Government Printing Office, Washington, D.C., 112.

Kvenvolden, K.A. & Kastner, M. 1990. Gas hydrates of the Peruvian outer continental margin. In: Suess, E & von Huene, R. et al. (eds). Proceedings of the Ocean Drilling Program, scientific results 112 College Station, Texas. Ocean Drilling Program, Texas A&M university, 517-526.

Kvenvolden, K.A. & McDonald, T.J. 1982. Gas hydrates in the Middle America Trench, DSDP Leg 84. EOS, Transactions of the American Geophysical Union 63, 101.

Kvenvolden, K.A. & McMenamin, M.A. 1980. Hydrates of natural gas: A review of their geologic occurrence. U.S. Geological Survey Circular 825, 11pp.

Kvenvolden, K.A. & von Huene, R. 1985. Natural gas generation in sediments of the convergent margin of the eastern Aleutian trench area In: Howel, D.G. (ed). *Tectonostratigraphic Terranes of the Circum-Pacific Region*. Circum-Pacific Council for Energy and Mineral Resources Earth Science Series, Number 1, 31-49.

Kvenvolden, K.A. 1988. Methane hydrates and global climate. *Global Biogeochemical Cycles* 2, 221-229.

Kvenvolden, K.A. 1993. A primer on gas hydrate. In: Howell, D.G. et al (eds). *The Future of Energy Gases*. USGS Professional Paper 1570, 279-291.

Kvenvolden, K.A., Golan-Bac, M., McDonald, T.J., Pflaum, R.C. & Brooks, J.M. 1987. Chapter 15. Hydrocarbon gases in sediment of the Vøring Plateau, Norwegian Sea. In: Eldholm, O., Thiede, J., Taylor, E., et al. Proceeding of the Ocean Drilling Program, Scientific Results, 104, 319-326.

Lachenbruch, A.H., Galanis, P.S. & Moses, T.H. 1988. A thermal cross section for the permafrost and hydrate stability zone in the Kuparuk and Prudhoe Bay oil fields. In: Galloway, J.P. & Hamilton, T.D. (eds). *Geologic Studies in Alaska by the U.S. Geological Survey During 1987*. U.S. Geological Survey Circular 1016, 47-51.

Laberg, J.S. & Andreassen, K. 1996. Gas hydrate and free gas indications within the Cenozoic succession of the Bjørnøya Basin, western Barents Sea. *Marine and Petroleum Geology* 13, 921-940.

- Ladd, J., Westbrook, G. & Lewis, S. 1982. Lamont-Doherty Geological Observatory Yearbook, 1981-1982, 8, 17.
- Lahof, D.A. & Ahuja, D.R. 1990. Relative contributions of greenhouse gas emissions to global warming. *Nature* 344, 529-531.
- Lasaga, A.C. 1985. An improved geochemical model of atmospheric CO<sub>2</sub> fluctuations over the past 100 million years. In: *The Carbon Cycle and Atmospheric CO<sub>2</sub>: Natural Variations Archean to Present*. American Geophysical Union Geophysical Monograph 0065-8448, 32, 397-411.
- Lee, M.W., Dillon, W.P. & Hutchinson, D.R. 1992. Estimating the amount of gas hydrate in marine sediments in the Blake Ridge area, southeastern U.S. continental margin. U.S. Geological Survey Open File Report 92-275, 24pp.
- Lee, M.W., Hutchinson, D.R., Agena, W.F., Dillon, W.P., Miller, J.J. & Swift, B.A. 1994. Seismic character of gas hydrates on the southeastern U.S. continental margin. *Marine Geophysical Research* 16, 163-184.
- Lee, M.W., Hutchinson, D.R., Dillon, W.P., Miller, J.J., Agena, W.F. & Swift, B.A. 1993a. Method of estimating the amount of *in-situ* gas hydrates in deep marine sediments. *Marine and Petroleum Geology* 10, 5, 493-506.
- Lee, M.W., Hutchinson, D.R., Dillon, W.P., Miller, J.J., Agena, W.F. & Swift, B.A. 1993b. Use of seismic data in estimating the amount of *in-situ* gas hydrates in deep marine sediment. In: Howell, D.G. (ed). *The Future of Energy Gases*. U.S. Geological Survey Professional Paper 1570, 563-582.
- Leggett, J.K., Aoki, Y. & Toba, T. 1985. Transition from frontal accretion to underplating in a part of the Nankai Trough accretionary complex off Shikoku (SW Japan) and extensional features on the lower trench slope. *Marine Petroleum Geology* 2, 131-141.
- Liu, G.S., Su, J.C., Shyu, C.T., Lundberg, N. & Reed, D. 1990. Sedimentary structure of the arc-continent collision zone off southeastern Taiwan. *EOS*, 71, 43, 1591 and Poster.
- Logan, J.A., Prather, M.J., Wofsy, S.C. & McElroy, M. 1981. Tropospheric chemistry: a global perspective. *Journal of Geophysical Research* 86, 7210-7254.
- Lorius, C., Jouzel, J., Raynaud, D., Hansen, J. & Le Treut, H. 1990. The ice-core record: climate sensitivity and future greenhouse warming. *Nature* 347, 139-145.
- Louden, K.E. & Wright, J.A. 1989. Marine heat flow data: a new compilation of observations and brief review of its analysis. In: Wright, J.A. & Louden, K.E. (eds). *Handbook of Seafloor Heatflow*. CRC Press, Inc. Boca Raton, Florida, 3-67.
- Lowrie, A. & Hinz, K. 1988. Seismic Stratigraphy of East Greenland. Poster Session IV, AAPG Seismic Stratigraphy, AAPG-SEPM-EMD Annual convention, Atlanta (15-18 June, 1986) Abstracts, American Association Petroleum Geologists Bulletin 70, 613.
- Lowrie, A., 1986. Model of fine-scale growth fault movements, derived from climate/sealevel oscillations, along the Louisiana offshore. *Gulf Coast Association Geological Society Transactions* 36, 497-509.
- Løvø, V., Elverhøi, A., Antonsen, P., Solheim, A., Butenko, G., Gregersen, O. & Liestøl, O. 1990. Submarine permafrost and gas hydrates in the northern Barents Sea. *Norsk Polarinstitutt Rapportserie Nr 56*, 171pp.

- Macleod, M.K. 1982. Gas hydrates in ocean bottom sediments. *American Association of Petroleum Geologists Bulletin* 66, 2649-2662.
- Makogon, Yu.F. 1988. Gas-hydrate accumulations and permafrost development. In: Senneset, K. (ed). *Permafrost. Fifth International Conference Proceedings*, 95-101.
- Makogon, Yu.F. 1988. Gas-hydrate accumulations and permafrost development. In: Senneset, K. (ed). *Permafrost. Fifth International Conference Proceedings*, 95-101.
- Malone, R.D. 1983. Interdisciplinary gas hydrate literature bibliography. U.S. Department of Energy DOE/METC-83-65 (DE83013785), 55pp.
- Manley, P.L. & Flood, R.D. 1988. Cyclic sediment deposition within Amazon deep-sea fan. *American Association of Petroleum Geologists* 72, 912-925.
- Manley, P.L. & Flood, R.D. 1989. Anomalous sound velocities in near-surface, organic-rich, gassy sediments in the central Argentine Basin. *Deep-Sea Research* 36, 611-623.
- Markle, R.G. & Bryan, G.M. 1983. Stratigraphic evolution of Blake Outer Ridge. *American Association of Petroleum Geologists Bulletin* 67, 666-683.
- Markle, R.G., Bryan, G.M. & Ewing, J.I. 1970. *Journal of Geophysical Research* 75, 4539.
- Marlow, M.S., Carlson, P., Cooper, A.K., Karl, H., McLean, H., McMullin, R. & Lynch, M.B. 1981. U.S. Geological Survey Open File Report 81-252, 83pp.
- Marquard, R.S. & Clark, D.L. 1987. Pleistocene paleoceanographic correlations: northern Greenland Sea to central Arctic Ocean. *Marine Micropaleontology*. 12, 325-341.
- Martini, A.V. 1980. Exploration frontiers - A quartet of challenges. In: *Proceedings of Symposium on petroleum potential in island arcs, small ocean basins, submerged margins and related areas*. New Zealand Department of Scientific and Industrial Research, 7-13.
- Max, M.D. 1990a. Gas hydrate and acoustically laminated sediments: probable environmental cause of anomalously low acoustic-interaction bottom loss in deep ocean sediments. *Naval Research Laboratory Report* 9235, 68pp.
- Max, M.D. 1990b. Natural gas clathrates: Geoacoustic inducement of low bottom loss. *Science and technology for a new oceans decade, Vol. III. Proceedings of MTS '90; Marine Technological Society*. 26-28 September 1990, Washington, D.C., 578-583.
- Max, M.D. 1990c. Examination of Greenland Geological Survey seismics at Tromsø, Norway. Meeting of Norwegian Petroleum Society, 17 August, 1990 (Unpublished).
- Max, M.D. 1990. Oceanic natural gas clathrates: (abs) *Proceedings Arctic Geology and Petroleum Potential Conference, Tromsø, Norway, 15-17 August, Norwegian Petroleum Society*, 17.
- Max, M.D. 1991. Natural Gas Clathrates, Arctic and Nordic Sea Potential. *European Science Notes Information Bulletin*. Office of Naval Research, European office. 91-103, 1-5.
- Max, M.D., Dillon, W.P. & Malone, R.D. 1991. *Proceedings: Report on National Workshop on Gas Hydrates*. 23, 24 April, 1991. U.S. Geological Survey, Reston, VA, U.S. Department of Energy DOE/METC - 91/6/24, DE 91016654, 38pp.
- Max, M.D. & Lowrie, A. 1993. Natural gas hydrates: Arctic and Nordic Sea potential. In: Vorren, T.O., Bergsager, E., Dahl-Stamnes, Ø. A., Holter, E., Johansen, B., Lie, E. & Lund, T.B. *Arctic Geology*



- and Petroleum Potential, Proceedings of the Norwegian Petroleum Society Conference, 15-17 August 1990, Tromsø, Norway. Norwegian Petroleum Society (NPF), Special Publication 2 Elsevier, Amsterdam, 27-53.
- Max, M.D. & Lowrie, A. 1996. Methane hydrate: A frontier for exploration of new gas resources. *Journal of Petroleum Geology* 19, 41-56.
- Max, M.D. & Pellenbarg, R.E. 1997. Clathrate-based fuel storage and transport media: Potential impact. *Journal/Proceedings Fuel Chemistry Division of the American Chemical Society, San Francisco, April 13-1, 1997, (in press).*
- McCarthy, J., Stevenson, A.J., Scholl, D.W. & Vallier, T.L. 1981. *Marine and Petroleum Geology* 2, 713-
- McCave, I.N. 1979. Depositional features of organic carbon rich black and green mudstones at DSDP Sites 386 and 387. Western North Atlantic. In: Tucholke, B.E., Vogt, P.R., et al. *Initial Reports of the Deep Sea Drilling Project 43*. U.S. Government Printing Office, Washington, D.C. 411-420.
- McIver, R.D. 1975. In: Hayes, D.E. & Frakes, L.A. (eds). *Initial Reports of the Deep Sea Drilling Project 28*, 815.
- McKirdy, D.M. & Cook, P.J. 1980. *American Association of Petroleum Geologists Bulletin* 64, 2118.
- Melvin, A. 1989. Gas taps its natural flare. *New Scientist* 7 October, 1989, 59-61.
- Mitchell, J.B. 1989. The 'greenhouse' effect and climate change. *Reviews Geophysics* 27, 115-139.
- Moritz, R.E., Aagaard, K., Baker, D.J., Codispoti, L.A., Smith, S.L., Smith, W.O., Tipper, R.C. & Walsh, J.E. 1990. Global change and the cycling of biogenic materials in the Arctic Ocean and its adjacent seas. In: *Conference Report Arctic System Science Ocean-Atmosphere-Ice interactions*. Joint Oceanographic Institutions Incorporated, Washington, D.C., 51-74.
- Morris, T.H., Clark, D.L. & Blasco, S.M. 1985. Sediments of Lomonosov Ridge and Makarov Basin: A Pleistocene stratigraphy for the North Pole. *Geological Society of America Bulletin* 96, 901-910.
- Monastersky, R. 1996. The mother lode of natural gas. *Science News* 150, 298-299.
- Mutter, J.C. 1984. Cenozoic and late Mesozoic stratigraphy and subsidence history of the Norwegian margin. *Geological Society of America Bulletin* 95, 1135-1149.
- Mutter, J.C., Talwani, M. & Stoffa, P.L. 1982. Origin of seaward-dipping reflectors in oceanic crust off the Norwegian margin by sub-aerial seafloor spreading. *Geology* 10, 353-357.
- ONR. 1989. *Oceanography from the space shuttle*. University Corporation for Atmospheric Research and Office of Naval Research. July, 1989, 250pp.
- Oxburgh, E.R. & Wilson, N. 1989. Temperature, fluid flow, and hydrocarbon maturation. In: Wright, J.A. & Loudon, K.E. (eds). *Handbook of Seafloor Heatflow*. CRC Press, Inc. Boca Raton, FL, 191-229.
- Parkes, R.J., Cragg, B.A., Bale, S.J., Getliff, J.M., Goodman, K., Rochelle, P.A., Fry, J.C., Weightman, A.J. & Harvey, S.M. 1994. Deep bacterial biosphere in Pacific Ocean sediments. *Nature* 371, 410-413.

- Pashkina, V.I. & Yesikov, A.D. 1989. Isotope investigations of bottom and interstitial waters of the Sea of Okhotsk in an area of gas hydrate occurrence. *Oceanology* 29, 173-177.
- Pauling, L. & Marsh, R.E. 1952. The crystal structure of chlorine hydrate. *Proceedings National Association of Science* 38, 112-118.
- Paull, C.K. & Dillon, W.P. 1981. The appearance and distribution of the gas hydrate reflector off the southeastern United States. U.S. Geological Survey Open File Report 80-88, 24pp.
- Paull, C.K. Spiess, F.N., Ussler, W. and Borowski, W.A., 1995. Gas hydrate horizon detected in seismic reflection-profiler data from the western North Atlantic. *American Association of Petroleum Geologists Bulletin* 61, 698-707.
- Pecher, I.A., Minshull, T.A., Singh, S.C. & von Huene, R. 1996. Velocity structure of a bottom simulating reflector offshore Peru: Results from full waveform inversion. *Earth and Planetary Science Letters* 139, 459-469.
- Pedersen, T.F. & Calvert, S.E. 1990. Anoxia vs. productivity: What controls the formation of organic-carbon-rich sediments and sedimentary rocks? *American Association of Petroleum Geologists Bulletin* 74, 454-466.
- Pinet, P.R., Popenoe, P. & Nelligan, D.F. 1981. Reconstruction of Cenozoic flow patterns over the Blake Plateau. *Geology* 9, 266-270.
- Powell, A. 1982. To foster innovation in Naval ships. *Naval Engineers Journal*, ASNE.
- Premuzic, E.T. 1980. Organic carbon and nitrogen in the surface sediments of world oceans and seas: distribution and relationship to bottom topography. Brookhaven National Laboratory. Report BNL 51084 for the U.S. Department of Energy, 117pp.
- Prior, D.B., Doyle, E.H. & Kaluza, M.J. 1989. Evidence for sediment eruption on deep sea floor, Gulf of Mexico. *Science* 243, 517-519.
- Raiswell, R. & Berner, R.A. Organic carbon losses during burial and thermal maturation of normal marine shales. *Geology* 15, 853-856.
- Ramanathan, V. 1989. Cloud-radiative forcing and climate: Results from the Earth Radiation Budget Experiment. *Science* 243, 57.
- Ramanathan, V., Cicerone, R.J., Singh, H.B. & Khalil, J.T. 1985. Trace gas trends and their potential role in climate change. *Journal of Geophysical Research* 90, 5547.
- Reed, D.L., Silver, E.A., Tagudin, J.E., Shipley, T.H. & Vrolijk, P. 1990. Relations between mud volcanoes, thrust deformation, slope sedimentation, and gas hydrate, offshore north Panama. *Marine and Petroleum Geology* 7, 44-54.
- Rodhe, H. 1990. A comparison of the contributions of various gases to the greenhouse effect. *Science*, 248, 1217-1219.
- Romankevich, E.A. 1984. *Geochemistry of Organic Matter in the Ocean*. Springer-Verlag, Berlin, New York, 334.
- Rowe, M.M. & Gettrust, J.F. 1989. DTAGS deep-towed seismic survey of the Blake-Bahama Basin NORDA Cruise 707A October-November, 1988. NORDA Technical Note 449 Naval Ocean Research

and Development Activity, 36pp.

- Rowe, M.M. & Gettrust, J.F. 1993. Fine structure of methane bearing sediments on the Blake Outer Ridge as determined from deep-tow multichannel seismic data. *Journal of Geophysical Research* 98, 463-473.
- Saricks, C.L. 1989. Environmental considerations of a fuel-flexible transportation system. Presented at the 1988 Air Pollution Control Association Specialty Conference on Environmental Challenges in Energy Utilization Cleveland, Ohio, 12-13 October, 1988. Department of Energy Technical Information Center Document DE89 003659.
- Sassen, R., Tye, R.S., Chinn, E.W. & Lemoine, R.C. 1988. Origin of crude oil in the Wilcox trend of Louisiana and Mississippi; evidence of long-range migration. *Gulf Coast Association Geological Society Transactions* 38, 27-36.
- Schlenk, W. Jr. 1951. Organic occlusion compounds. *Fortschritt Chemica Forsch.* 2, 92-145.
- Schlitzer, R. 1988. Modeling the nutrient and carbon cycles of the North Atlantic 1. Circulation, mixing coefficients, and heat fluxes. *Journal of Geophysical Research* 93, 10699-10723.
- Scholl, D.W. & Creager, J.S. 1973. Geologic synthesis of Leg 19 (DSDP) results: Far North Pacific, and Aleutian Ridge, and Bering Sea. In: Creager, J.S. et al. (eds). *Initial Reports of the Deep Sea Drilling Project*, V 19, 897-913.
- Scott, M.I., Randolph, P.L. & Pangborn, J.B. 1980. Assessment of Methane Hydrates. Final report for period December 1978 through June 1980. Department of Energy Report GRI-79/0070, Contract #5011-310-0097.
- Shaffer, G. 1989. A model of biogeochemical cycling of phosphorus, nitrogen, oxygen, and sulphur in the ocean: one step toward a global climate model. *Journal of Geophysical Research* 94, 1979-2004.
- Sharma, G.D, Kamath, V.A., Godbole, S.P., Patil, S.L., Paranjpe, S.G., Mutalik, P.N. & Nadem, N. 1987. Development of Alaskan gas hydrate resources. Annual Report, U.S. Department of Energy DOE/MC/61114-2608 (DE88010270), 233pp.
- Shibley, T.H., Houston, M.H., Buffler, R.T., Shaub, F.J., McMillen, K.J., Ladd, J.W. & Worzel, J.L. 1979. Seismic reflection evidence for the widespread occurrence of possible gas-hydrate horizons on continental slopes and rises. *American Association of Petroleum Geologists Bulletin* 63, 2204-2213.
- Sloan, E.D., Jr. 1990. *Clathrate Hydrates of Natural Gases*. Marcel Dekker, Inc., New York and Basel. 641pp.
- Slingo, A. 1990. Sensitivity of the Earth's radiation budget to changes in low clouds. *Nature* 343, 49.
- Solheim, A. & Elverhoi, A. 1985. A pockmark field in the Central Barents Sea; gas from a petrogenic source? *Polar Research* 3, 11-19.
- Solheim, A. & Larsson, F.R. 1987. Seismic indications of shallow gas in the northern Barents Sea. *Norsk Polarinstitutt Rapportserie Nr. 36*, 30pp., Map.
- Sonensheim, N. 1959. The costs and risks of engineering progress. *Naval Engineers Journal*, ASNE.
- St. John, B., Bally, A.W. & Klemme, H.D. 1984. Sedimentary provinces of the world - hydrocarbon

- productive and nonproductive. Accompanying memoir to: Sedimentary Provinces of the World. American Association of Petroleum Geologists, 35pp.
- Stern, L.A., Kirby, S.H. & Durham, W.B. 1996. Peculiarities of methane clathrate hydrate formation and solid-state deformation, including possible superheating of water ice. *Science* 273, 1843-1847.
- Stoll, R.D. & Bryan, G.M. 1979. Physical properties of sediments containing gas hydrates. *Journal of Geophysical Research* 84, 1629-1634.
- Summerhayes, C.P. 1981. Organic facies of middle Cretaceous black shales in deep North Atlantic. *American Association Petroleum Geologists Bulletin* 65, 2364-2380.
- Summerhayes, C.P., Bornhold, B.D. & Embley, R.W. 1979. *Marine Geology* 31, 256.
- Taylor, A.E., Wehmiller, R.J. & Judge, A.S. 1979. In: Denver, W. (ed). Symposium on research in the Labrador coastal and offshore region. Memorial University of Newfoundland, 91-
- Taylor, K.E. & Kickinson, R.E. 1991. Upper limit for sea ice albedo feedback contributions to global warming. Abstract. In: American Geophysical Union Geophysical Abstracts EOS February, 1991, 10.
- Teller, J.T. & Thorleifson, L.H. 1983. The Lake Agassiz - Lake Superior connection. In: Teller, J.T. & Clayton, L. (eds). *Glacial Lake Agassiz*. Geological Association Canada. Special Paper 26, 261-290.
- Tissot, B.P. & Welte, J.P. 1978. *Petroleum Formation and Occurrence: A New Approach to Oil and Gas Exploration*. Springer Verlag, New York, 538pp.
- Tissot, B.P. & Welte, J.P. 1984. *Petroleum Formation and Occurrence*. Springer-Verlag, New York, 699pp.
- Tucholke, B.F., Bryan, G.M. & Ewing, J.I. 1977. Gas hydrate horizons detected in seismic-profile data from the western North Atlantic. *American Association of Petroleum Geologists Bulletin* 61, 698-707.
- Urick, R.J. 1975. *Principles of Underwater Sound*. McGraw-Hill Book Company. 384pp.
- USGCRP. 1991. Our Changing Planet: The FY1991 U.S. Global Change Research Program. Report by the Committee on Earth and Environmental Sciences. A Supplement to the U.S. President's Fiscal Year 1992 Budget. U.S. Geological Survey Special Publication, 90pp.
- Vogt, P.R. 1986. Seafloor topography, sediments, and paleoenvironments. In: Hurdle, B.G. (ed). *The Nordic Seas*. Springer-Verlag, New York, Berlin, 237-410.
- Vogt, P.R., Kovacs, L.C., Johnson, G.L. & Feden, R.H. 1979. The Eurasia Basin In: Proceedings of the Norwegian Sea Symposium, September, 1979. *Norsk Petroleumsforening (NPF)*, 3:1-3:29.
- Vogt, P.R., Crane, K., Sundvor, E., Max, M.D. & Pfirman, S.L. 1994. Methane-generated(?) pockmarks on young, thickly sedimented oceanic crust in the Arctic: Vestnesa ridge, Fram strait. *Geology* 22, 255-258.
- Vogt, P.R. & Sundvor, E. 1996. Heat flow highs on the Norwegian-Barents-Svalbard continental slope: Deep crustal fractures, dewatering or "memory in the mud". *Geophysical Research Letters* 23, 3571-3574.

- Vogt, P.R., Sundvor, E., Crane, K, Pfirman, S., Nishimura, C. & Max, M.D. 1990. SeaMARC II and Associated Geophysical Investigation of the Knipovich Ridge, Molloy Ridge/Fracture Zone, and Barents/Spitsbergen Continental Margin: Part III, Sedimentary Processes. American Geophysical Union Spring Meeting, Baltimore. EOS 71, 17, 622.
- Von Huene, R. 1980. Leg 67: The Deep Sea Drilling Project Mid America Trench Transect off Guatemala. Geological Society America Bulletin 91, 421-432.
- Walsh, E.J. 1989. US surface Navy plans ahead to 2020. Armed Forces Journal International, July, 1989, 64-69.
- Wang, W.C., Yung, Y.L., Laxis, A.A., Mo, T. & Hansen, J.E. 1976. Greenhouse effects due to man-made perturbations of trace gases. Science 194, 685-690.
- Weaver, J.S. & Stewart, J.M. 1982. In situ hydrates under the Beaufort Sea shelf. Proceedings, 4th Canadian Permafrost Conference.
- White, R.S. 1979. Gas hydrate layers trapping free gas in the Gulf of Oman. Earth and Planetary Science Letters 42, 1214-120.
- White, R.S. 1985. Frozen energy in the depths of the oceans. New Scientist 107, 29.
- Whiticar, M.J. & Faber, E. 1989. Chapter 16. Molecular and stable isotope composition of headspace and total hydrocarbon gases at ODP Leg 104, Sites 642, 643, and 644, Vøring Plateau, Norwegian Sea. In: Eldholm, O., Thiede, J., Taylor, E., et al. Proceeding of the Ocean Drilling Program, Scientific Results, v 104, 327-334.
- Widness, M.B. 1973. How thick is a thin bed? Geophysics 38, 1176-1180.
- Yamano, M. & Uyeda, S. 1990. Heat-flow studies in the Peru trench subduction zone. In Suess, E., von Huene, R. et al. (eds). Proceedings of the Ocean Drilling Program, Scientific Results 112, 653-661.
- Yardley, B.W.D. 1989. An Introduction to Metamorphic Petrology. Longman Scientific & Technical, John Wiley & Sons, Inc, New York, 248pp.
- Yefremova, A.G. & Gritchina, N.D. 1981, Gazogidraty v morskikh osadkakh i problema ikh prakticheskogo ispol' zovaniya (Gas hydrates in marine sediments and the problem of their practical use), In: Geologiya Nefti i Gaza 2, 32-35
- Yerfemova, A.G. & Zhizhchenko, B.P. 1975, Occurrence of crystal hydrates of gases in the sediments of modern marine basins, In: Doklady-Earth Science Section 214, 219-220.
- Yershov, E.D., Kondratyeva, K.A., Zamolotchikova, S.A., Trush, N.J. & Dunaeva Ye.N. 1988. The geocryological map of the USSR of 1:2,500,00 scale. In: Senneset, K. (ed). Proceedings V1 of the Permafrost Fifth International Conference, Tapir Publishers, Trondheim, Norway, 274-277.
- Zonenshayn, L.P., Murdmaa, I.O., Baranov, B.V., Kuznetsov, A.P., Kuzin, V.S., Kuz'min, M.I., Avdeyko, G.P., Stunzhas, P.A., Lukashin, V.N., Barash, M.S., Valyashko, G.M. & Demina, L.L. 1987. An underwater gas source in the Sea of Okhotsk west of Paramushir Island. Oceanology 27, 598-602.
- Zwart, G., Moore, J.C. & Cochrane, G.R. 1996. Variations in temperature gradients identify active faults in the Oregon accretionary prism. Earth and Planetary Science Letters 139, 485-495.