**REPORT TO THE CONGRESS
ON THE
STRATEGIC DEFENSE INITIATIVE**



DTIC QUALITY INSPECTED 8

DISTRIBUTION STATEMENT A
Approved for public release
Distribution Unlimited

Prepared by
The Strategic Defense Initiative Organization

19970206 151

TABLE OF CONTENTS

	<u>Page</u>
LIST OF FIGURES	v
LIST OF TABLES	vii
1.0 PROGRAM IN PERSPECTIVE.....	1-1
2.0 PROGRAM STRUCTURE AND STRATEGY.....	2-1
3.0 PROGRAMS AND SYSTEMS.....	3-1
3.1 SDS Phase I.....	3-2
3.2 SDS Engineering and Support.....	3-6
3.3 National Test Bed.....	3-8
3.4 BM/C ³ Program.....	3-10
3.5 Theater Missile Defense.....	3-19
3.6 Operations Interface.....	3-21
3.7 Funding Impact.....	3-23
4.0 TECHNOLOGY	4-1
4.1 Surveillance, Acquisition, Tracking, and Kill Assessment Program.....	4.1-1
4.2 Kinetic Energy Weapons Technology Program.....	4.2-1
4.3 Directed Energy Weapons Technology Program.....	4.3-1
4.4 Survivability, Lethality, and Key Technologies Program.....	4.4-1
4.5 Innovative Science and Technology Program.....	4.5-1
5.0 TEST AND EVALUATION.....	5-1
APPENDIX A: SDI and the Allies.....	A-1
APPENDIX B: Soviet Strategic Defense Programs and Soviet Response to SDI.....	B-1
APPENDIX C: SDI Compliance with the ABM Treaty.....	C-1
APPENDIX D: SDI Organization and Comptrollership.....	D-1
APPENDIX E: SDI Technology Applications Program.....	E-1
APPENDIX F: SDI Technology and Other Defensive Missions.....	F-1
APPENDIX G: Implications of No ABM Treaty Restrictions on the SDI Program.....	G-1
LIST OF ACRONYMS	ix
GLOSSARY.....	xxiii
INDEX.....	xxix

THIS PAGE INTENTIONALLY LEFT BLANK

LIST OF FIGURES

		<u>Page</u>
1-1	Strategic Missions Derived from National Security Interests	1-7
1-2	Fundamental Missions of Strategic Defense.....	1-8
2-1	Phase I System Concepts.....	2-4
2-2	Follow-on System Concepts.....	2-5
2-3	SDI Budget Requests vs. Appropriations.....	2-6
3-1	Programs and Systems Deputate Organization	3-1
3-2	Overall BM/C ³ Development Schedule.....	3-12
4.1-1	Two Competing BSTS Concepts.....	4.1-3
4.1-2	BSTS System Confidence.....	4.1-9
4.1-3	SSTS Artist's Concept	4.1-10
4.1-4	Airborne Optical Adjunct.....	4.1-12
4.1-5	SSTS/GSTS System Confidence	4.1-18
4.1-6	GBR-X Model	4.1-20
4.1-7	GBR-X Confidence	4.1-23
4.1-8	SIE Control Center	4.1-25
4.2-1	SBI Functions and Requirements.....	4.2-3
4.2-2	SBI System Confidence	4.2-6
4.2-3	ERIS Flight Test and Operational Configurations.....	4.2-8
4.2-4	ERIS Confidence.....	4.2-9
4.2-5	HEDI Technology Issues.....	4.2-11
4.2-6	HEDI System Confidence	4.2-12
4.2-7	LEAP Projectile Overview.....	4.2-14
4.2-8	Space-Based Hypervelocity Gun.....	4.2-15
4.2-9	LEAP and D-2 Baseline Projectiles	4.2-16
4.2-10	LEAP Technology Program	4.2-17
4.2-11	Ground-Based EML Program	4.2.18
4.3-1	Diamond Turned Beam Compactor	4.3-5
4.3-2	Gain Generator Assembly.....	4.3-6
4.3-3	Test Facility with Space Chamber and Pressure Recovery System	4.3-7
4.3-4	LODE Beam Expander.....	4.3-8
4.3-5	Space-Based Laser Confidence	4.3-10
4.3-6	Recent Progress for Induction Linac FEL.....	4.3-13
4.3-7	Ground-Based Laser Confidence.....	4.3-16
4.3-8	NPB Functional Schematic.....	4.3-17
4.3-9	Neutral Particle Beam Confidence.....	4.3-20
4.4-1	Survivability Approach Confidence.....	4.4-7
4.4-2	Technology Development Confidence.....	4.4-9
4.4-3	Technology Transfer/Infusion Confidence.....	4.4-10
4.4-4	Test/Evaluation/Validation Confidence.....	4.4-13
4.4-5	High-Irradiance Test Showing Debris Blowoff	4.4-16

4.4-6	Concept Illustration of a 100K SP-100 Nuclear Reactor System Coupled to a Space-Based Radar Array	4.4-20
4.4-7	Baseload Power Confidence.....	4.4-23
4.4-8	Burst Power Confidence	4.4-24
4.4-9	Artist's Concept of an ALS	4.4-26
4.4-10	ALS Technology Confidence..	4.4-27
4.4-11	PACOSS Dynamic Test Article.....	4.4-29
4.4-12	Structures Confidence	4.4-31
4.4-13	Structural Materials Confidence.....	4.4-32
4.4-14	Large Area, Small Device, and High Current HTS Components.....	4.4-33
5-1	Expanding the Integration "Flight Envelope".....	5-2
5-2	Test and Evaluation Working Group Subcommittees.....	5-4
5-3	Allocation of System Issues to Element Tests	5-5
D-1	Current Organizational Structure of the SDIO	D-2
E-1	Potential SDI Technology Spinoffs.....	E-5
F-1	Potential SDI Military Spinbacks.....	F-3

LIST OF TABLES

		<u>Page</u>
D-1	Fiscal Obligation and Expenditure Comparisons Within DOD (Fiscal Year 1987).....	D-3
D-2	SDI FY 1989 Amended Budget Submission Project List.....	D-4

THIS PAGE INTENTIONALLY LEFT BLANK

1.0 PROGRAM IN PERSPECTIVE

1.0 PROGRAM IN PERSPECTIVE

This section describes the strategic context of the Strategic Defense Initiative (SDI), the challenge to United States security and the response to that challenge, U.S. national security strategy, and operational requirements for potential initial ballistic missile defenses.

1.1 THE STRATEGIC CONTEXT OF THE SDI

The basic objectives of the SDI are best explained and understood in terms of the strategic environment the United States faces for the balance of this century and into the next. The United States and its allies face a number of challenges that threaten our security. Each of these challenges imposes demands and presents opportunities. Preserving peace and freedom is, and always will be, this country's fundamental goal. The essential purpose of U.S. military forces is to deter aggression, threats of aggression, and coercion against the United States and its allies. The deterrence provided by U.S. and allied military forces in the past has permitted the American people and their allies to enjoy peace and freedom.

For the past 20 years, assumptions of how nuclear deterrence can best be assured have been based on the concept that if the United States and the U.S.S.R. both maintain the ability to retaliate against nuclear attack, and if the United States could impose on the Soviet Union costs that are clearly out of balance with any potential gains, this threat would suffice to prevent nuclear war. The emphasis placed on particular Soviet assets which must be held at risk by U.S. forces to deter aggression has changed over time. Nevertheless, the strategy of relying on retaliation, provided by offensive nuclear forces as the primary means of deterring aggression, has not changed. This assumption served as the foundation for the U.S. approach to the Strategic Arms Limitation Talks (SALT). At the time the process began in 1969, the United States concluded that deterrence based on mutual vulnerability was not only sensible but necessary. The United States believed that both sides were far from being able to develop the technology for defensive systems which could play an effective deterrence role. However, since 1972 the Soviet Union has failed to show the necessary restraint, in both strategic offensive and defensive forces, that was an essential assumption of the U.S. strategic concept when the SALT process began. In addition, technologies that are applicable to ballistic missile defense have made such dramatic advances since 1972 that it may no longer be necessary to base deterrence on mutual vulnerability.

The U.S. response to the strategic threat has, out of necessity, undergone a period of evolution during the past four decades that adapted to the changing nature of the threat itself. The current strategic environment is characterized by (1) quantitative and qualitative improvements in Soviet strategic offensive and defensive forces, (2) a long-standing and intensive Soviet research program in many of the same basic technological areas that the SDI Program addresses, and (3) a growing pattern of Soviet deception and noncompliance with existing arms control agreements.

1.2 THE CHALLENGE TO U.S. SECURITY

The Soviet Union remains the principal threat to U.S. security and that of our allies. As part of its wide-ranging effort to further increase its military capabilities, the Soviet Union has improved its ballistic missile force, increasingly threatening the survivability of U.S. and allied deterrent forces and the leadership structure that commands them. Soviet forces equally threaten many critical fixed installations in the United States and in allied nations that support the nuclear retaliatory and conventional forces which provide the collective ability to deter conflict and aggression.

Since 1969, when the SALT I negotiations began, the Soviet Union has built five new types of intercontinental ballistic missiles (ICBMs) and upgraded them seven times. The Soviet Union has also built seven new classes of ballistic missile submarines, five new types of submarine-launched ballistic missiles (SLBMs), and upgraded them three times. As a result, their missiles are much more powerful and accurate than they were several years ago. The alarming growth, in the capability of Soviet ballistic missiles and in the number of ballistic missile warheads over the last decade, is yielding a prompt hard-target force capable of rapidly and significantly degrading our land-based retaliatory capability. In contrast, the United States has fielded only one ICBM since 1969--the Peacekeeper--and only in limited numbers. The United States has also recently completed the dismantlement of its Titan II missiles. Since 1969, the U.S. has deployed only one new class of ballistic missile submarine and two new types of SLBMs. The resulting asymmetry between Soviet and U.S. forces has led to a destabilizing situation, one that must be redressed.

At the same time that it has worked to improve its offenses, the Soviet Union has continued to pursue strategic advantage through the development, improvement, and expansion of Soviet active and passive defense capabilities. These defenses provide the Soviet Union with a steadily increasing capability to counter the effectiveness of the retaliatory forces of the United States and its allies,

especially if those forces were to be degraded by a Soviet offensive first strike, as provided by Soviet military doctrine. This enables the Soviet Union to provide increasing protection for assets which it values highly. Furthermore, current patterns of Soviet research and development on advanced defenses indicate that these trends will continue for the foreseeable future. If unanswered, continued Soviet defensive improvements will further erode the effectiveness of the existing U.S. strategic deterrent which is based almost exclusively on the threat of retaliation by offensive nuclear forces. Therefore, the long-standing Soviet program of defensive improvements, in itself, poses a challenge to deterrence which must be addressed.

Today, Soviet active defenses are extensive. The Soviets have the world's largest air defense network, which they vigorously continue to improve, and the world's only operational antisatellite (ASAT) capability. The Soviet Union is improving all elements of the world's only operational antiballistic missile (ABM) system which is deployed around Moscow. In addition, the Soviets are also developing new ABM components that could allow construction of individual ABM sites in a matter of months rather than the years required for older ABM components. In addition, the Soviet Union has an extensive and expanding network of ballistic missile detection and tracking radars.

The U.S.S.R. spends significant resources on passive defensive measures aimed at improving the survivability of its forces, military command structure, and national leadership. These efforts range from providing mobility for its latest generation of ICBMs to extensive hardening of various critical military and civil defense installations. All of these active and passive elements taken together provide the Soviet Union an area of relative advantage in deployed defensive capability and near-term defensive deployment options.

Finally, the U.S. is very seriously concerned about Soviet noncompliance with arms control agreements in both offensive and defensive areas, including the ABM Treaty. The new Soviet large phased-array radar (LPAR) under construction near Krasnoyarsk in central Siberia has significant consequences. When considered as a part of a Soviet network of new radars, the Krasnoyarsk radar has the inherent potential to contribute to ABM radar coverage of a significant portion of the central U.S.S.R. The ABM Treaty, recognizing the contribution these radars could make, restricts deployment of early warning LPARs to the periphery of the national territory and oriented outward as one of the primary mechanisms for ensuring the effectiveness of the Treaty. Due to its location, orientation, and capability, the Krasnoyarsk radar is a violation of the ABM Treaty.

Against the backdrop of the Soviet pattern of noncompliance with existing arms control agreements, the Soviet Union is taking other actions which affect this country's ability to verify Soviet compliance. Some Soviet actions, like the increased use of encryption during missile testing, are aimed directly at degrading the U.S. ability to monitor treaty compliance. Other Soviet actions contribute to the problems associated with monitoring Soviet compliance. For example, increasing quantities of Soviet mobile land-based strategic and short-range ballistic missiles (SRBMs) will make monitoring and verification far more difficult.

1.3 THE RESPONSE TO THE CHALLENGE

In response to the long-term pattern of Soviet offensive and defensive expansion, the United States is compelled to take complementary actions designed both to maintain security and stability in the near term and to ensure these conditions in the future. It must act in three main areas.

First, in the near term, offensive nuclear retaliatory forces must be modernized. This is necessary to reestablish and maintain the offensive balance in the near term and to create the strategic conditions that will permit the United States to pursue parallel actions in the areas of arms reduction negotiations and defensive research. In 1981, the United States embarked on a strategic modernization program aimed at reversing a long period of relative neglect. This modernization program was specifically designed to preserve stable deterrence and, at the same time, to provide the incentives necessary to cause the Soviet Union to join the U.S. in negotiating significant reductions in the nuclear arsenals of both sides.

In addition to the U.S. strategic modernization program, our British and French allies have important programs under way to improve their strategic nuclear retaliatory forces. The SDI research program does not negate the need for these U.S. and allied programs. Rather, the SDI Program depends on collective and national modernization efforts to maintain deterrence today as options are explored for possible future decisions on how the United States might enhance security and stability over the longer term.

Second, steps must be taken to provide options for ensuring deterrence and stability over the long term, allowing the United States to counter the destabilizing growth of Soviet offensive forces and to channel long-standing Soviet propensities for defenses toward more stabilizing and mutually beneficial ends. In the near term, the SDI Program also responds directly to the ongoing and

extensive Soviet ABM effort, including the existing Soviet deployments permitted under the ABM Treaty. The SDI research program provides a necessary and powerful deterrent to any near-term Soviet decision to rapidly expand its ABM capability beyond that permitted by the ABM Treaty. This, in itself, is a critical task. However, the overriding, longer-term importance of the SDI is that it offers the possibility of reversing the dangerous Soviet military buildup by moving to a better, more stable basis for deterrence and by providing new and compelling incentives to the Soviet Union for seriously negotiating reductions in existing offensive nuclear arsenals.

In our investigation of the potential of advanced defensive systems, the U.S. seeks neither superiority nor unilateral advantage. Rather, if the promise of SDI technologies is proven, the destabilizing characteristics of the current strategic environment could be rectified. And, in the process, deterrence would be strengthened significantly and placed on a foundation made more stable by reducing the role of ballistic missile weapons and placing greater reliance on defenses.

Third, the U.S. must continue its strong commitment to arms control. The near-term objective is to radically reduce offensive nuclear arms, as well as to make safer the balance between nuclear offensive and defensive arms. We are now looking forward to a period of transition to a more stable world, with greatly reduced levels of nuclear arms and an enhanced ability to deter war based on the increasing contribution of non-nuclear defenses against offensive nuclear arms. A world free of the threat of aggression and free of nuclear arms is an objective which the United States, the Soviet Union, and all other nations can agree to pursue.

To support these goals, this country will continue to pursue vigorously the negotiation of equitable and verifiable agreements leading to significant reductions of existing nuclear arsenals and the eventual elimination of all ballistic missiles, as proposed by the President. Thus, arms control can complement our other ongoing efforts to maintain security and stability, but it is not an end in itself.

If the SDI Program demonstrates that future defenses are feasible, we will consult with Congress and U.S. allies about the next steps. Unless the United States and the Soviet Union have already agreed to a specific, comprehensive arms control plan to reduce or eliminate ballistic missiles and deploy defensive forces, the United States would also consult and, as appropriate, negotiate with the Soviet Union pursuant to the terms of the ABM Treaty which provide for such consultations. These consultations and negotiations would focus on how deterrence might be strengthened through the phased introduction of strategic ballistic missile defense systems into the force structures of both

sides. This commitment does not mean that the United States will give the Soviets any veto power over a future U.S. decision on strategic defense. In anticipation of a possible future decision to deploy defenses, the United States has already begun the process of bilateral discussions with the Soviet Union. The United States and the U.S.S.R. have met in Geneva, Reykjavik, Vienna, Washington, and Moscow to address questions which included those related to the U.S. objective of a jointly managed transition integrating advanced defenses into the forces of both sides.

1.4 NATIONAL SECURITY STRATEGY AND MISSIONS

The national security strategy of the United States is our national plan for achieving the very fundamental goals that, in sum, constitute our national interest. U.S. national security objectives are statements of the broad goals which, in turn, support our national interests and provide the framework within which we can determine the specific missions to be assigned to our military forces and hence the size, characteristics, and composition of forces our nation needs. A strategic defense must contribute--in combination with other U.S. forces and in concert with our allies--to the ability of the United States to carry out its national security strategy and thereby sustain our national interests.

Figure 1-1 shows the key basic national interests of the United States which U.S. military forces must support and protect. For example:

- o The survival of the United States as a free and independent nation, with its fundamental values and institutions intact
- o The growth of freedom and democratic institutions throughout the world
- o A stable and secure world, free of major threats to U.S. interests
- o Healthy and vigorous U.S. alliance relationships.

Our national security objectives--the broad goals that support and advance U.S. national interests--in turn provide the framework from which military missions can be derived. Military forces are able to contribute most directly to the following national security objectives:

FIGURE 1-1
Strategic Missions Derived from National Security Interests

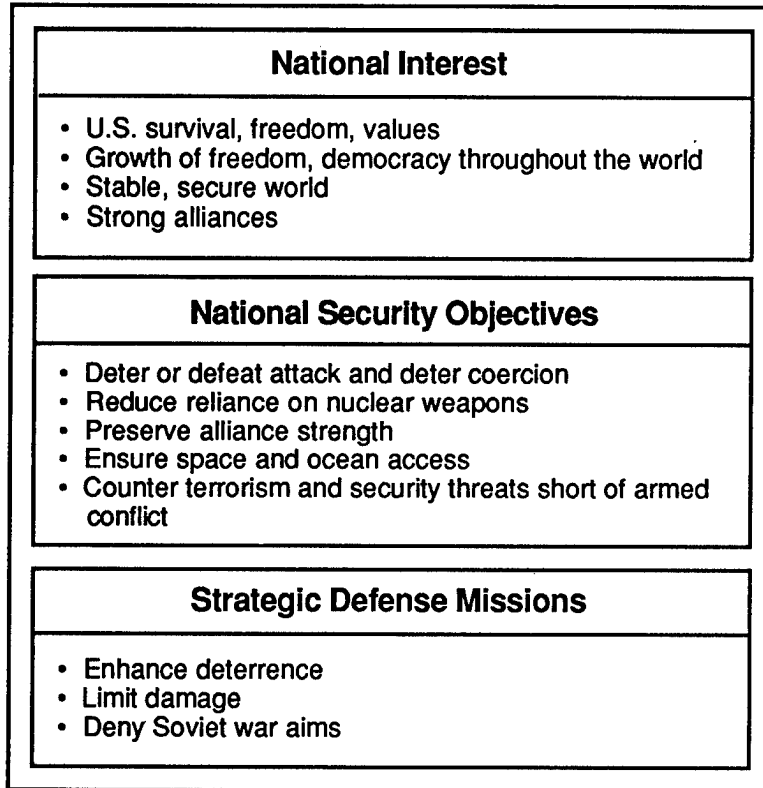

- o In cooperation with our allies, deter hostile attack and deter coercion.
- o Maintain the strength and vitality of U.S. alliance relationships.
- o Reduce, over the long term, reliance on nuclear weapons and work for strong conventional forces, verifiable arms reductions, and new technologies for strategic defense.
- o Counter security threats short of armed conflict, including terrorism.
- o Ensure unimpeded access to the oceans and space.

From these national security objectives, specific missions are derived for our military forces to employ in support of our overall national strategy, i.e., to enhance deterrence, limit damage to the United States and its allies, and deny Soviet war aims. Figure 1-2 shows the specific missions of an initial defense against ballistic missiles that support our national strategy.

FIGURE 1-2
Fundamental Missions of Strategic Defense

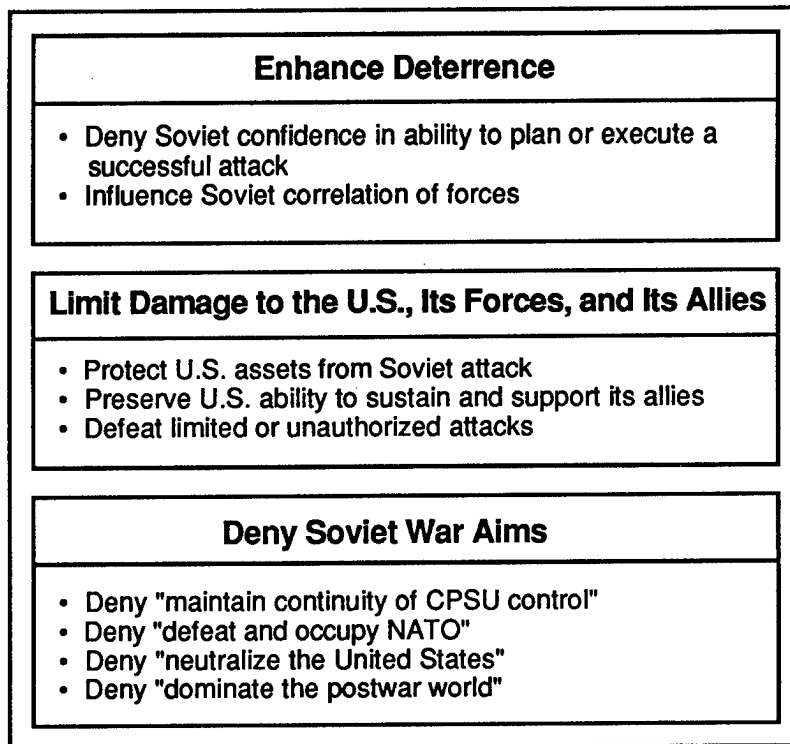

Deterrence requires that Soviet leaders believe they could not achieve any meaningful gain through resort to war and that the risks clearly outweigh any possible benefits. The Soviets must not only be denied confidence that an initial attack might succeed in its objectives, but they must know that even after such an attack, the United States would still possess a credible capability to continue to deny Soviet war aims. U.S. capabilities to limit damage to the nation, our forces, and our allies and to effectively deny Soviet war aims are thus essential contributors to deterrence.

1.5 JOINT CHIEFS OF STAFF (JCS) OPERATIONAL REQUIREMENTS

The translation of national interests and national security objectives into military missions is the responsibility of the JCS. The JCS have formally provided operational requirements for a Phase I Strategic Defense System (SDS). The initial requirements acknowledge and confirm the President's long-term objective "to develop a thoroughly effective defense that will protect the United States and its allies from the threat of attack from ballistic missiles of all ranges" and also prescribe a minimum performance level which must be achieved in the early phases of deployment.

THIS PAGE INTENTIONALLY LEFT BLANK

2.0 PROGRAM STRUCTURE AND STRATEGY

2.0 PROGRAM STRUCTURE AND STRATEGY

This section describes the SDI Program goal, the criteria to meet the goal, the basic program structure to meet these criteria, the overall investment strategy, and an acquisition strategy that could develop, produce, and deploy a Strategic Defense System (SDS).

2.1 PROGRAM GOAL

From the very beginning, the SDIO has maintained the same overall goal--to conduct a vigorous research and technology program that could provide the basis for an informed decision regarding the feasibility of eliminating the threat posed by nuclear ballistic missiles of all ranges and increasing the contribution of defensive systems to U.S. and allied security. Within this goal, the SDI Program is oriented to protect options for near-term deployment of limited ballistic missile defenses as a hedge against Soviet breakout of the ABM Treaty. Moreover, the Program is carried out in full consultation with and, where appropriate, participation of, our allies. The Program is being conducted in compliance with all existing treaty obligations. Program emphasis is on non-nuclear technologies.

2.2 CRITERIA

An effective SDS that will counter offensive ballistic missiles to a meaningful degree will have to meet three specific criteria.

The first criterion is military effectiveness. A defense against ballistic missiles must be able to destroy a sufficient portion of an aggressor's attacking force to deny him confidence that he can achieve his objectives. In so doing, the defense should have the potential to deny that aggressor the ability to destroy a militarily significant portion of the target base he wishes to attack.

The second criterion is adequate survivability. Defenses must maintain a sufficient degree of effectiveness to fulfill their mission, even in the face of determined attacks on the defenses and, perhaps, loss of some individual components. Such a capability will maintain stability by discouraging such attacks. Survivability means that the elements of the defensive system must not be an appealing target for defense suppression attacks. The offense must be forced to pay a penalty if it attempts to negate the defense. This penalty should be sufficiently high on cost and/or uncertainty in achieving

the required outcome that such an attack would not be contemplated seriously. Additionally, the defense system must not have an "Achilles' heel." In the context of the SDI, survivability would be provided not only by specific technical "fixes" such as employing maneuver, sensor blinding, and protective shielding materials, but also by using such strategy and tactical measures as proliferation, deception, and self-defense. System survivability does not mean that each and every element of the system need survive under all sets of circumstances; rather, the defensive force as a whole must be able to achieve its mission, despite any degradation in the capability of some of its components.

The third criterion is that the defensive options generated discourage an adversary from overwhelming them with additional offensive capability. The SDIO seeks defensive options--as with other military systems--that are able to maintain their defense capabilities more easily than countermeasures could be taken to try to defeat them. This criterion is couched in terms of cost-effectiveness at the margin; however, it is much more than an economic concept.

2.3 BASIC PROGRAM STRUCTURE

The Program is structured to provide a balance between technology for the first phase of the SDS and technology aimed at building onto the first phase to achieve a fully effective SDS.

Technology demonstration and validation (Dem/Val) projects are intended to develop confidence for a decision to proceed with full-scale development of the first phase of the SDS. All test, evaluation, simulation, and analysis activities planned for the Dem/Val phase comply with all U.S. treaty obligations, including the 1972 ABM Treaty. In addition, technology base development is required to counter changing threats by permitting evolution to follow-on phases of an SDS in an affordable fashion. If a deployed defensive system is to have lasting value, technology and tactics must be available for the system to evolve over an extended period to counter any plausible responsive threats. Such a robust defense should have both the effect of deterring a strong offensive response and the potential capability to increase defense effectiveness.

2.4 SDIO'S PROGRAM STRATEGY

The SDI Program is investing in a technology base that can support a decision to enter into full-scale development (FSD) for an initial SDS and provide a basis for entering into Dem/Val of follow-on system concepts prior to the FSD decision. This phasing of technology is intended to provide the

basis for improvements to an initial defense capability and introduce advanced technology concepts such as directed energy into the evolving defense system. This approach allows maturation of technology consistent with threat evolution.

The SDI Program is continuing with Dem/Val activities of those system elements approved for Phase I by the Defense Acquisition Board (DAB) and concurrently conducting research in support of concepts for follow-on phases of an SDS.

Activities in Dem/Val are intended to validate the system concept by establishing (1) the system and element requirements and trade-offs that lead to development designs, (2) a technology base which supports the designs, and (3) designs that are appropriate and will work.

The elements being considered for Phase I are listed in Figure 2-1. Assessments of scientific research from 1985 to 1987 showed that there are no technological barriers to the success of the Phase I Dem/Val program. Nevertheless, vigorous research, development, and Dem/Val are required to ensure continued progress in these areas and support a Milestone II (MSII) decision to enter FSD.

Following a decision in the future to proceed with FSD of a Phase I SDS, testing and demonstration of engineering prototypes will begin. Long-lead items and low-rate initial production will be funded for SDS elements commensurate with the status of development and role of those elements in relation to the total SDS architecture.

Follow-on SDS concepts are shown in Figure 2-2. These less mature programs are being explored as part of a vigorous technology base and are expected to be candidate improvements to and/or upgrades of the Phase I SDS. Milestone I approval of follow-on elements is required before the FSD for the Phase I SDS will be approved by the DAB.

The following summarizes the concept of the phased development and deployment approach:

- o A balanced research program of Dem/Val activities for Phase I SDS elements with technology development for follow-on SDS elements until a decision could be made on whether to proceed with system development and deployment.
- o Upon completion of all DOD Milestone I criteria, Phase I SDS FSD could begin.

**FIGURE 2-1
Phase I System Concepts**

SYSTEM ELEMENT	FUNCTIONS
Boost Surveillance and Tracking System (BSTS)	<ul style="list-style-type: none"> • Detection of missile launches • Acquisition and tracking of boosters and PBVs • Kill assessment
Space-Based Surveillance and Tracking System (SSTS)	<ul style="list-style-type: none"> • Acquire and track PBVs, RVs, and ASATs • Discrimination
Ground-Based Surveillance and Tracking System (GSTS)	<ul style="list-style-type: none"> • Acquisition • Tracking • Discrimination
Space-Based Interceptor (SBI)	<ul style="list-style-type: none"> • Disabling of boosters, PBVs, RVs, and ASATs • Sensors on carrier vehicle (CV) could provide enhanced midcourse sensor capability
Exoatmospheric Reentry Vehicle Interceptor System (ERIS)	<ul style="list-style-type: none"> • Disabling of RVs in late midcourse
Battle Management/Command and Control, and Communications (BM/C3)	<ul style="list-style-type: none"> • Man-in-the-loop control • Engagement management • Maintaining track data • Target assignment • Communications

- o During FSD of a Phase I SDS, Dem/Val of concepts using advanced defensive technologies would continue.

- o A transition period of phased deployment of defensive systems would be designed so that each increment would further enhance deterrence and reduce the risk of nuclear war. Preferably, this transition would be jointly managed by the United States and the Soviet Union, although Soviet cooperation would not be a prerequisite for initiation of U.S. deployments.

- o Finally, a period of time during which deployment of highly effective, multitiered defensive systems would be completed.

**FIGURE 2-2
Follow-on System Concepts**

SYSTEM ELEMENTS	FUNCTIONS
Space-Based Neutral Particle Beam (NPB) Weapon	<ul style="list-style-type: none"> • Interactive discrimination • Disabling of boosters, PBVs, RVs, and ASATs
High-Endoatmospheric Defense Interceptor (HEDI)	<ul style="list-style-type: none"> • Disabling of RVs after reentry
Airborne Optical System (AOS)	<ul style="list-style-type: none"> • Midcourse and terminal acquisition and tracking
Ground-Based Radar (GBR) *	<ul style="list-style-type: none"> • Terminal acquisition and tracking • Discrimination
Space-Based Laser (SBL)	<ul style="list-style-type: none"> • Disabling of boosters and ASATs • Interactive discrimination
Ground-Based Hypervelocity Gun (HVG)	<ul style="list-style-type: none"> • Disabling RVs in terminal phase
Ground-Based Laser (GBL)	<ul style="list-style-type: none"> • Disabling of boosters

* GBR is being considered as an option for Phase I.

2.5 IMPACT OF BUDGET REDUCTIONS

Large budget reductions from the FY 1985, FY 1986, and FY 1987 requested levels caused a reduction in the number of promising technologies being pursued in parallel and increased the difficulty of realizing adequate solutions to specific technical issues. Further significant reductions made in FY 1988 have placed SDIO in a position where simply scaling back alternatives is no longer viable. While the Congress has increased SDI funding every year, the difference between what the Administration has requested and what the Congress has appropriated is so large (see Figure 2-3) that it has had a substantial and increasingly detrimental impact on the Program. We are faced with either delaying the time when a decision on whether to deploy defenses could be made, or eliminating some technology efforts, thereby reducing the number of defense options that can support a decision. Specifically:

- o The progress of some portions of the SDI Program has been slowed approximately 1 to 2 years. The SDIO has, in essence, slowed its rate of progress on some technologies needed to hedge against potential Soviet countermeasures. In light of the potential Soviet threat cited above, the SDIO is extremely concerned about this slowdown. Despite reductions in

the Administration's requests, the SDIO is still pursuing a program in which both technology base and technology validation efforts receive a balanced emphasis. However, the SDIO will not be able to maintain this essential balance if the trend of relatively large cuts from SDI budget requests continues.

- o The SDIO has focused on the technologies that could be used to sustain performance growth to increasing levels of defense. However, effort on some technology candidates has been either reduced or eliminated. The SDIO has retained its pursuit of innovation, but at a smaller rate of investment. There are changes, some of which may be irreversible, that have lengthened the time schedule when a decision whether to deploy effective defenses might be made and limited the technical options that will be available. In addition, by eliminating alternatives, including higher-risk but higher-payoff alternatives, the possibility of not achieving SDIO's goals has increased.

FIGURE 2-3
SDI Budget Requests vs. Appropriations

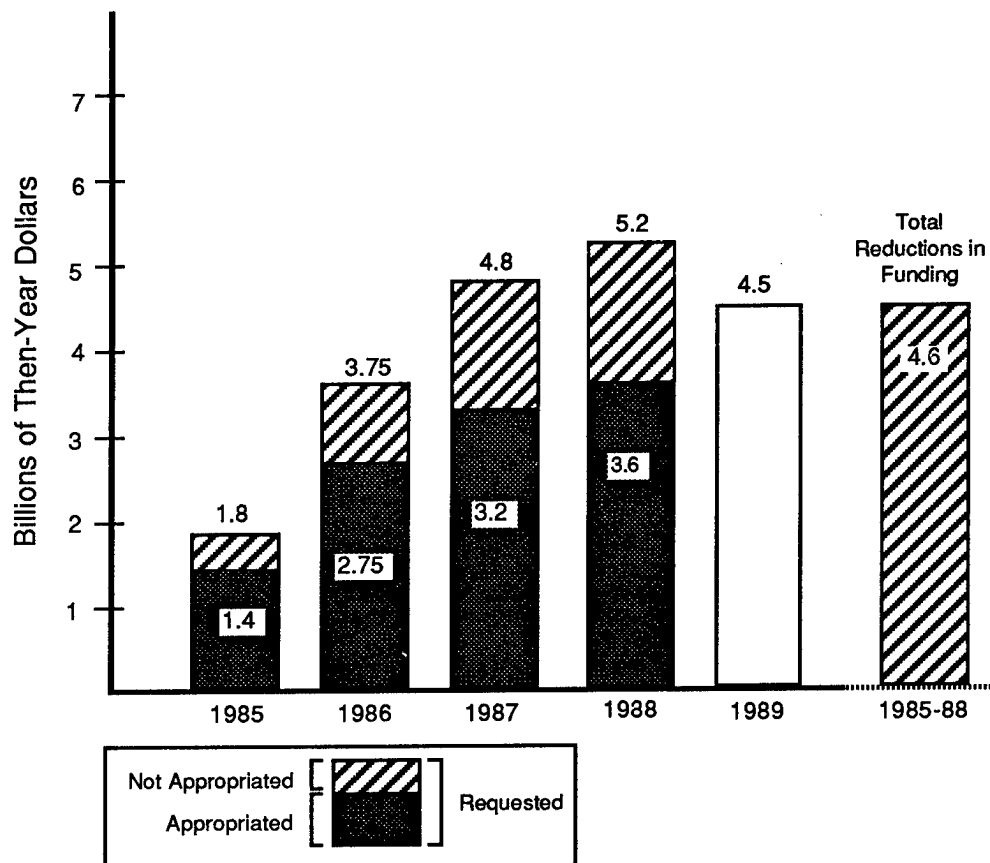

- o The SDIO is reducing some of its programs. For example, cuts to the SSTS program have forced the systems program office to renegotiate awarded contracts, adding cost, increasing risks, and delaying critical technology program demonstrations. The same type of decision was made in the Kinetic Energy Weapons Technology Program, where validation work on electromagnetic launchers was cut back to support the technology validation of the more mature chemically propelled kinetic-kill vehicles.

The SDIO remains resolute in its pursuit of a focused and decision-oriented program with well-defined objectives, despite Congressional refusal to fund the SDI budget at the requested levels. However, this goal is threatened by proposals to limit real growth to an annual 3 percent budget increase. Such limited funding will destroy the vital balance between development of a technology base and technology validation efforts essential to support a development and deployment decision. It will not allow the United States to keep pace with expected Soviet offensive and defensive developments. If SDI funding continues to be limited, the United States will not only waste its greatest leverage--the innovation possible in a free society--but it cannot expect to do more than react to Soviet initiatives in strategic defense. If U.S. efforts to develop options for a thoroughly reliable defense are to be fulfilled, funding must be restored to levels that will allow the SDIO to effectively pursue options for strategic defense of the United States and its allies.

THIS PAGE INTENTIONALLY LEFT BLANK

3.0 PROGRAMS AND SYSTEMS

3.0 PROGRAMS AND SYSTEMS

On September 17, 1987, the Secretary of Defense approved the Defense Acquisition Board (DAB) recommendation that selected SDI concepts and technologies enter the demonstration and validation (Dem/Val) phase of the systems engineering process. In pursuing this effort, SDIO maintains a balanced program of demonstration and validation of mature technologies while continuing a vigorous program of research and technology that can be used to enhance the capability of the potential Phase I system elements and follow-on phase concepts. The Office for Programs and Systems was reorganized as part of the DAB process. (See Figure 3-1.)

FIGURE 3-1
Programs and Systems Deputate Organization

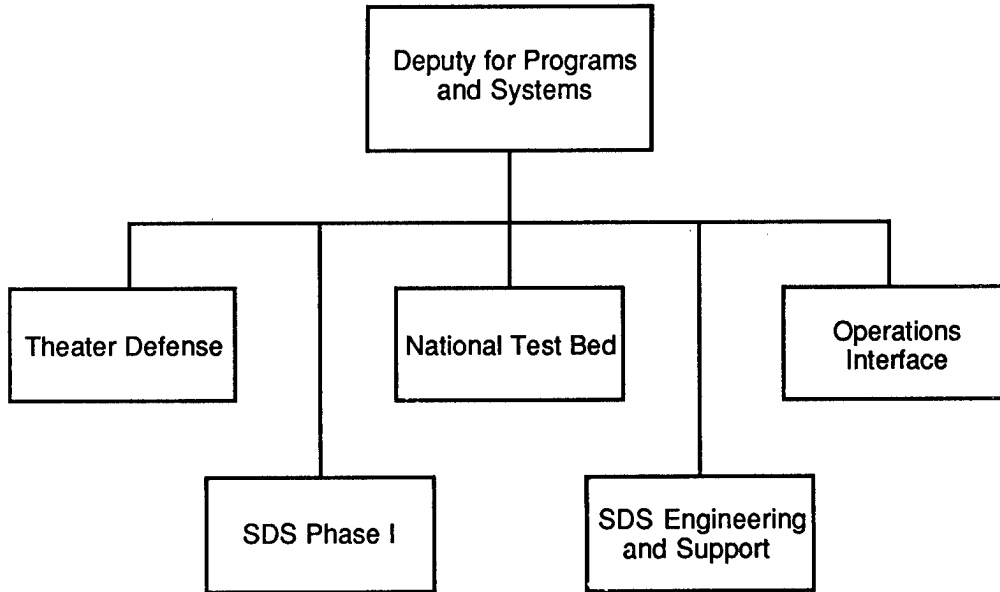

The Deputate for Programs and Systems organization reflects SDIO's management approach to the Dem/Val of the Phase I Strategic Defense System (SDS) concepts. It provides the interface between the SDS systems engineering and the technology program office.

This section provides an overview of five directorates that report to the Deputy for Programs and Systems and discusses their technical objectives, accomplishments, and future plans. The Battle Management, Command and Control, and Communications (BM/C³) program is also discussed.

3.1 SDS PHASE I

3.1.1 Project Description

The SDS Phase I Engineering Project Directorate is responsible for managing the activities necessary to design, develop, test, and integrate the Phase I SDS. This includes the synthesis of individual SDS elements into an optimum system which adequately balances performance, cost, and reliability. This directorate manages the element interfaces, provides analysis of engineering trade-offs, resolves technology integration issues, and participates in the definition and management of the required multi-element tests. The Phase I project is linked closely to the National Test Bed (NTB) project which will provide a base for integrating BM/C³, sensors, and weapons. The SDS Phase I Directorate is responsible for the Dem/Val of the Phase I system elements and the integration of those elements into an SDS. The purpose of the Dem/Val phase is to demonstrate and validate concepts for SDS through research, development, test, and evaluation (RDT&E). These Phase I system elements and the technology concepts follow. Details on each of the approved elements are provided in Section 4.0 of this report.

Boost Surveillance and Tracking System (BSTS) Concept

The BSTS concept is an orbiting surveillance system based on infrared (IR) technology which provides the capability to detect and track attacking intercontinental ballistic missiles (ICBMs) and submarine-launched ballistic missiles (SLBMs) during the boost phase or powered-flight portion of their launches. The BSTS detects a launch and begins to track the objects. The information is broadcast to BM/C³ and all other elements of the SDS. Based on attack confirmation, the system is enabled, and the BM/C³ communicates target assignments to weapon elements such as the space-based interceptor to destroy the incoming missiles.

The plans for BSTS technology Dem/Val phase include ground test and simulation at the subsystem level, culminating in the construction of a fully capable satellite. Prior to satellite launch, all essential functions will have been ground tested in an end-to-end sensor test. Data from this system

test, which is driven by a scenario generator, will be fed to the NTB for systems integration simulations and hardware-in-the-loop tests.

Midcourse Sensor Concept

The midcourse surveillance, acquisition, tracking, and kill assessment (SATKA) concept under development for the Phase I SDS utilizes passive IR and microwave radar sensors to accomplish the surveillance, tracking, and discrimination functions. A principal IR sensor system under consideration for the Phase I SDS is the Space-Based Surveillance and Tracking System (SSTS). The initial SSTS will consist of relatively small, passive LWIR sensors placed in medium earth orbit. This system will provide continuous peacetime surveillance and, in the event of war, it will detect and track post-boost vehicles (PBVs) and reentry vehicles (RVs) during the deployment and midcourse phases of the ICBM trajectory. SSTS will also track antisatellites (ASATs) and perform the sensor functions necessary to defend the SDS.

LWIR sensors on probe-based platforms, called the Ground-Based Surveillance and Tracking System (GSTS), are being considered as an augmentation for the SSTS. In the recently completed Midcourse Sensor Study (MCSS), the ground-based radar (GBR) was included as another principal element for midcourse sensing. The GBR will be reviewed by the DAB at its next meeting.

Space-Based Interceptor (SBI) Concept

The SBI is a space vehicle in low earth orbit which houses multiple rocket-propelled interceptors. These non-nuclear interceptors will destroy attacking missiles in the boost phase, RV buses in the post-boost phase, and RVs in the midcourse phase of their flight. The interceptors will destroy the respective targets upon impact with them at extremely high speed.

Dem/Val of SBI will require tests of the SBI homing subsystem and space platform. A system simulator will be used to test the space platform and evaluate the interface between all the subcomponents and to predict overall performance. Output from the system simulator will be used by the NTB to develop a top-level BM/C³ data flow.

Exoatmospheric Reentry Vehicle Interceptor System (ERIS) Concept

ERIS is a ground-launched exoatmospheric interceptor that will conduct non-nuclear intercepts of ICBMs and SLBMs in the midcourse phases of their flights. ERIS is being designed to operate with other components of a midcourse defense system and will be integrated with the midcourse sensor system through the BM/C³ system.

ERIS technology will be validated by ground tests and simulations and flight experiments. The ground tests will include rocket tests, homing kill vehicle tests, integration of subsystems, and hardware-in-the-loop simulations. The flight testing will involve ERIS flights against increasingly complex targets and will also simulate handover to ERIS end-to-end, that is, from surveillance sensors via BM/C³.

Battle Management/Command and Control, and Communications (BM/C³)

The BM/C³ system will be responsible for monitoring and controlling the activities of all the elements of an SDS. Information from surveillance satellites, sensors, and radars would be relayed to the battle managers. Upon confirmation of an attack, the information then would be processed with man-in-the-loop, and target assignments communicated to space- and ground-based weapons. This complex communications system must be able to rapidly assess data concerning a ballistic missile attack and provide timely, reliable information to the command structure. Once a defense response has been determined, the BM/C³ system must carry out the response, assess its effectiveness, and revise the response if necessary. The BM/C³ will have to be able to withstand enemy jamming and effects of nuclear radiation.

BM/C³ Dem/Val phase activities will include analyses, simulation, and subcomponent/assembly testing of the computer hardware and for software communications, battle management, and command and control.

3.1.2 Accomplishments

The SDS Phase I Directorate is a new office within Programs and Systems; therefore, many of its accomplishments are shared across directorates. The SDS Phase I accomplishments are exemplified in the DAB decision. Working closely with the Engineering Support Directorate, each of the SDI

technology offices, and the services, the initial analysis and documentation to support the MS-I decision were accomplished. The Phase I Directorate is now completing the definition of the SDS Phase I architecture and initiation of the top-level system design to establish Phase I SDS functional requirements. The objective of this systems engineering effort is to achieve a design that is balanced and cost effective. The Phase I Directorate is drawing upon government agencies, Federally Funded Research and Development Centers (FFRDCs) working under sponsorship of government agencies and under contracts with not-for-profit organizations, for technical support to this Phase I SDS engineering effort.

3.1.3 Future Plans

In addition to managing the Dem/Val of individual Phase I system elements, the Phase I Directorate is responsible for allocating element specifications to ensure interoperability across the entire SDS. Successful accomplishment of the systems engineering and integration (SE&I) task is critical to meeting the Dem/Val program goals. The effectiveness of the SDS depends on each of the elements being able to operate as part of a defense layer involving other elements and to concurrently interface with elements in other layers when the defensive system is engaged. The ability to perform this role successfully is a function of how well integration designs are developed and applied to the elements. Additionally, there are other aspects such as systems support, facilities design, reliability, survivability, and producibility which must be orchestrated through the SE&I activities. To help achieve the integration of the system elements, SDIO will contract for a single, major industry team this fiscal year. The Request for Proposals (RFP) was released, and a May contract award is anticipated.

SDS Phase I activities focus on achieving an overall system design for the SDS. To achieve this goal and to provide timely system design, the Directorate will implement an integrated engineering force for each element. The Directorate will ensure that system requirements are inserted into element designs at the earliest possible time to conserve cost and time. A System Requirements Review for the initial system design is scheduled for FY 1989. The SDS Phase I activities will be supported by the SDS Engineering and Support Directorate.

3.2 SDS ENGINEERING AND SUPPORT

3.2.1 Project Description

The SDS Engineering and Support Directorate provides matrix support to the SDS Phase I program office and overall support for SDS follow-on phases. This Directorate is responsible for assuring that engineering, analytical, and technical disciplines are applied to the conceptual development and evolution of the full range of SDS architectures. The efforts of systems analysis and engineering provides the top-down support for both the initial system elements which constitute Phase I of the SDS and the follow-on phases. The Directorate performs architectural trade-offs, industrial base analyses, logistical and supportability studies, cost research, and environmental assessments. The Engineering and Support Directorate also identifies and analyzes system concepts which address threat and mission requirements. Task areas include:

- o Systems Engineering -- To provide systems engineering support to the Phase I Program Manager; provide the mechanism for performing Interim Requirements Reviews (IRRs) and System Requirements Analysis (SRA); ensure the evolution of the SDS Phase I system to a more effective, low-leakage system is performed in a consistent, coordinated manner; conduct the Near-Term Systems Integration Test/Evaluation (NSITE) program.
- o Integrated Logistics and Support (ILS) -- To provide a strong front-end emphasis on SDS supportability as concepts are formulated and designs selected; assure that any SDS concept/architecture or systems element will be supportable throughout its life cycle and will achieve system effectiveness and readiness goals at affordable costs.
- o Cost Analysis -- To assure a credible and firmly based cost program is fully engaged across the SDI Program and to perform research and analysis in support of this program; perform cost estimates and affordability analyses for supporting SDS program decisions and DAB milestone decisions/updates; perform Cost and Operational Effectiveness Analyses (COEAs).
- o Producibility and Manufacturing -- To plan for and perform research to support a robust, fully responsive manufacturing capability and industrial base to support an SDS; develop and

Implement the Manufacturing Operations Development and Integration Laboratory (MODIL) concept.

- o Civil Engineering/Environmental Analysis -- To assure full compliance of the SDI with all applicable environmental regulations and a broadly based planning capability in support of potential siting, basing, and facility requirements; develop, manage, and execute the SDS Environmental Impact Analysis Program (EIAP).

- o BM/C³ and Strategic Architectures -- To develop strategic defense architecture concepts and alternatives which will evolve to meet the threat and to provide full connectivity and compatibility with SDS Phase I and other U.S. defense capabilities; assure that the SDI Program understands and pursues a balanced technology program to meet the longer term needs of an evolutionary SDS.

3.2.2 Accomplishments

The successful completion of the DAB Milestone I (MS-I) decision can be directly linked to the work of the Engineering and Support Directorate. The supporting analysis and documentation needed to achieve this important decision were produced by the directorate. These included the definition of a baseline concept for architectures, the System Concept Paper (SCP), and an SDI Test and Evaluation Master Plan (TEMP). A requirement for MS-I, the SCP identified an architecture for Phase I of the SDS. A Blue Team, described in Appendix B, supports the development and analysis of alternative architecture concepts. The TEMP provides the integrated plan for accomplishing the Dem/Val of an SDS and its elements.

3.2.3 Future Plans

In support of the Phase I Program Manager and the Phase One Engineering Team (POET), the Engineering and Support Directorate will initiate the Interim Requirements Review and participate in completing the System Requirements Review.

Environmental documentation in the form of programmatic environmental assessments (EAs) will be prepared to support SDS program decisions. An Environmental Impact Statement (EIS) is

currently being prepared and will be completed for Kwajalein Atoll. An environmental integrator contract is scheduled for award on 31 March 1988.

Cost research and estimating for all phases of the SDI Program to support Dem/Val activity will be continued. Challenging but attainable life-cycle cost management goals are being defined for all elements of SDS Phase I.

Architecture efforts will concentrate on the evolution of follow-on architectures. Follow-on architecture analysis is needed to ensure integration of evolutionary and alternative architectures into the SDS. SDIO will conduct the analysis needed to test and evaluate excursions from the baseline architecture.

An initial system level Logistics Support Analysis (LSA) is being conducted. Integrated logistics support plans are being developed for each element of the Phase I SDS. The results of the Space Assembly and Maintenance Study (SAMS) will be used in all architectural design trade-off studies.

MODIL is the cornerstone of the SDI producibility strategy. MODILs focus industry, university, and government resources on an SDI critical technology issue to reduce producibility cost and risk. The first MODIL at Oak Ridge National Laboratory will be established this year and focus on survivable optics. Other MODILs in sensors, launch, and software are in the planning stages. MODILs are expected to provide manufacturing enabling technologies which are expected to result in significantly lower cost of producing advanced technology components.

3.3 NATIONAL TEST BED

3.3.1 Project Description

The NTB Directorate manages the activities necessary to develop and maintain the NTB to evaluate and test the elements and performance of the Phase I SDS and follow-on elements. The mission objective of the NTB is to support a future decision whether to deploy strategic defenses. The NTB will provide the capability to simulate all SDS functions and direct multi-element Phase I tests. An Allied Test Bed (ATB) will be an adjunct to evaluate, test, and compare theater defense elements and concepts.

One of the ways to validate the functions of the entire SDS is simulation. The NTB provides a comprehensive capability for comparison, evaluation, and test of the alternative architecture configurations for the SDS. It also provides the capability to evaluate specific technology applications in the system framework required by these architecture alternatives.

From the beginning, the NTB will have extensive SDS simulation capabilities for identifying and resolving integration issues. When NTB operations begin, the simulations will be medium-fidelity, non-real-time codes whose results will be verified by checking for consistency with predicted outcomes, by engineering judgment, and by limited off-line manual computations. As development continues, however, the simulations will be improved and validated against the results of ground and flight tests of the surrogate elements. Finally, these simulations will evolve into full function, high-fidelity, real-time versions which accommodate hardware- and software-in-the-loop testing. By such means, substantial confidence can be gained that the simulation is a valid representation of the SDS.

The NTB will eventually consist of a number of geographically separated experiment and simulation facilities that can be electronically linked to model the SDS. At the center of these facilities will be the National Test Facility (NTF) which will serve as the central control, coordinating, and computing center for the NTB and will be the primary test facility of the SE&I contractor. As an integrated set of resources, the NTB will be the single national resource dedicated to the SDI for addressing the many critical issues associated with validating BM/C³, architectures, and technologies and determining the feasibility of an SDS.

3.3.2 Accomplishments

Major milestones have been achieved in the NTB program. The Joint Program Office (JPO), which is responsible for the management of the NTB program, has been relocated to Falcon AFS, the site of the NTF. Early analysis capabilities for the NTB were defined to include the use of existing government and contractor facilities nationwide. In February 1988, a single contract for NTB integration (Phase III) was awarded.

3.3.3 Future Plans

The NTB integration effort will be performed at the Consolidated Space Operations Center (CSOC) at Falcon AFS until a facility devoted entirely to the NTB can be built. The NTF is scheduled

for completion in mid 1989. An initial Video Conferencing Network will be available in the April 1988 timeframe. Additionally, integrated capabilities will continue to evolve. The result will be the development of communications networks and interoperability standards capable of supporting the NTB simulations and experiments.

3.4 BM/C³ PROGRAM

The BM/C³ system for controlling an execution of an SDS must provide both high-performance levels and be robust, survivable, testable, and capable of evolving to meet the needs of later deployment phases. A baseline BM/C³ system which is likely to achieve these requirements was identified and presented as the MS-I baseline. This section describes the activities being pursued to achieve the requirement to validate the BM/C³ system design and to develop the needed technology.

The SDI BM/C³ program is addressing the computing requirements of an SDS through a combination of a battle management software-driven system design and appropriate technology research and development. This approach is aimed at resolving the principal critical issues associated with BM/C³, as well as system design, development testing, command and control (C²), concept of operations, and technology availability issues.

The BM/C³ program is structured into two projects--BM/C³ Experimental Systems and BM/C³ Technology. The Experimental Systems project evaluates BM/C³ concepts developed within system architectures and experimentally validates these concepts by developing experimental versions to test the tactical configuration of the BM/C³ system. The Technology project develops the various technologies needed in the BM/C³ system.

3.4.1 BM/C³ Experimental Systems Project

Project Description

The BM/C³ Experimental Systems project develops and evaluates BM/C³ concepts and experimentally validates these concepts by developing and testing experimental versions (EVs) of the BM/C³ system. The project contains two main tasks: BM/C³ architecture definition and BM/C³ experimental systems development.

The first task, architecture definition, includes the analyses, research and development (R&D), and design for the BM/C³ element of a potential SDS. It will establish the quantitative functional requirements and specifications. Activities will include technology trade-offs and development of experimental BM/C³ operational concepts. This work is being closely coordinated with the system architecture efforts in the SDI systems analysis project. The architecture definition task will also establish requirements for BM/C³ EVs and for the BM/C³ Technology project.

BM/C³ experimental systems development is the second main task and concerns the analyses, R&D, and design leading to the validation of EVs of the tactical configuration of the BM/C³ system for strategic defense. This task validates the EV as a representation of the essential battle management technology and develops the experimental version as a prototype of the battle management element. EVs are validated by a series of technology validation experiments (TVEs) that demonstrate EV performance in resolving various BM/C³ technology issues. An experimental systems integration group will ensure consistency among BM/C³ EVs, system architecture, MS-I test and evaluation plans, and system component concepts evaluation plans.

Confidence in feasibility of the BM/C³ concept (see Figure 3-2) for the Phase I SDS improved significantly during FY 1987. Evolving from a series of system and BM/C³ architecture studies, a point design called the Baseline Concept Description (BCD) was presented to the DAB as meeting the mission performance requirements. The BCD exhibited many of the attributes considered necessary by the Eastport Study and was a logical follow-on to the concepts first codified during the Zero-One Architecture Study. Focusing on the design for the Phase I system, the BM/C³ program has directed both the Experimental Systems project and the Technology project to conduct activities that support the concept. A series of EVs will provide in-depth performance analysis that will increase confidence in and the level of understanding of the point design, as well as various excursions from the point design. Coupled to the EV task is the BM/C³ Technology project which provides the technology research and development environment for BM/C³ prototype hardware and software that will be inserted into the EVs. Technology Insertion is key to ensuring the enabling technology will provide capabilities as required by the system design. Confidence in the BM/C³ concept and supporting technology for the Phase I SDS is enhanced by the interaction of the EVs and technology which acts as a check and balance. Provided that projected funding continues, SDIO will be able to validate a BM/C³ design for the Phase I SDS in the early 1990s.

FIGURE 3-2
Overall BM/C3 Development Schedule

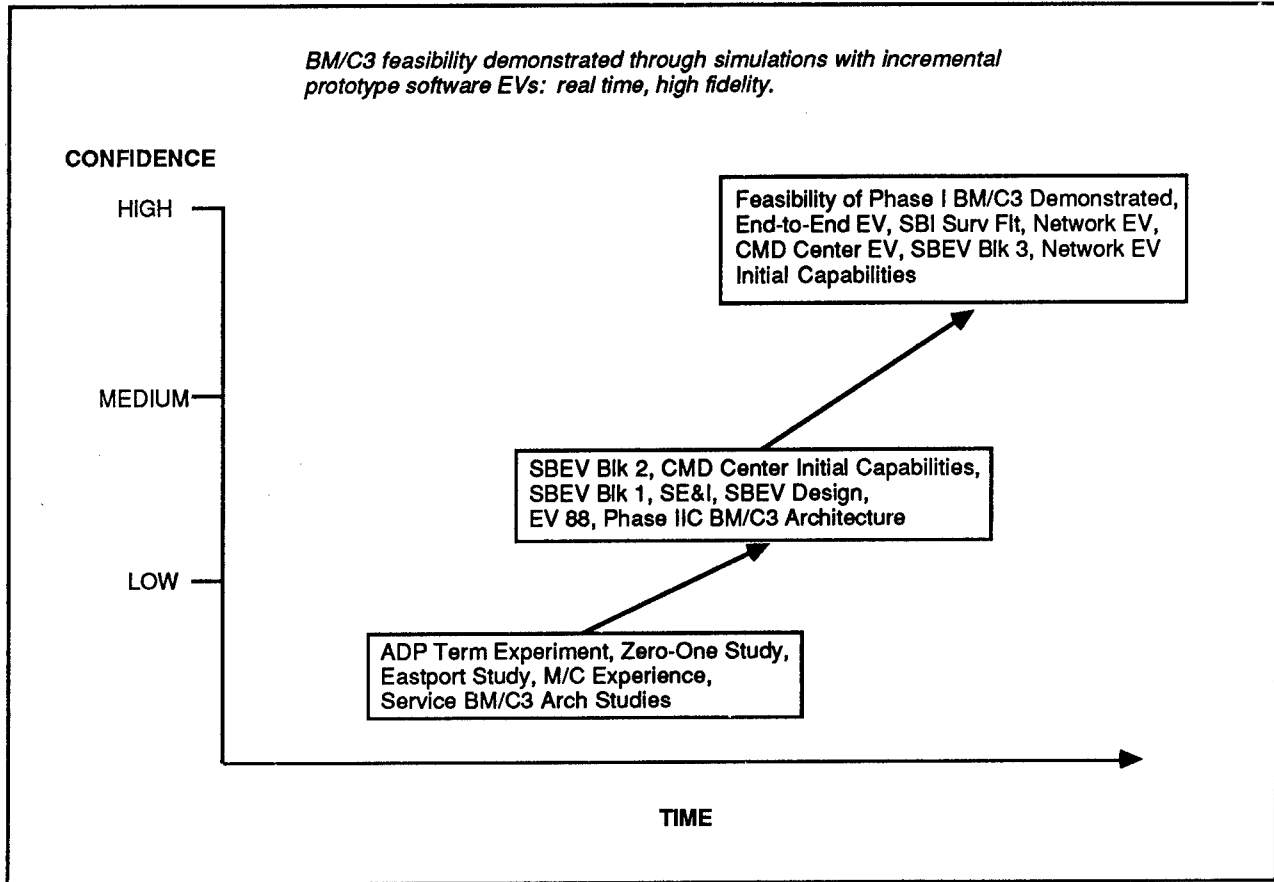

Accomplishments

A major achievement of the BM/C³ Architecture Definition Task in FY 1987 was the identification of a baseline concept for the BM/C³ element of a first phase SDS. This concept was presented as the MS-I baseline and is being further refined within the system architecture effort. In support of the architecture definition work, system requirements analysis and definition tools have been built. Two representative tools are: SDI system design language (SDL), a high-level representation language for systems, and SDI Ada Dataflow Modeling Technique (SADMT), a tool to represent processes. The automated tools are being developed for direct conversion of architecture representations in SDL to simulations that can be used in architecture and trade-off analysis. Design analysis requires a detailed simulation of the system. SADMT will provide the SDL for detailed simulation. An interface between SDI-SDL and SADMT is being developed and a preliminary version of SADMT has been defined. This

process description language (PDL) will become the standard for process descriptions within SDI BM/C³ and will be used to ensure architecture descriptions, algorithms, and software are compatible.

In FY 1987, Experimental Version plans were consolidated and refined. Initial requirements have been established for additional EVs, including a network, a command center, and an end-to-end EV to be designed and implemented during the SDS Dem/Val phase. The already-defined EVs (the Army ground-based and the Air Force space-based EV) will be integrated with these additional EVs within the framework of the NTB.

During FY 1987, the experimental systems program made significant progress toward designing and implementing the ground-based BM/C³ EV. An architecture evaluation methodology was developed and the concept definition was adapted to represent the Phase I SDS BM/C³ concept. The core of this activity was the establishment of the BM/C³ functions to be implemented in the EV.

Initial experiments have been conducted which compared communications concepts and identified real-time display loading effects. Early prototyping efforts to provide design guidance for the EV programs and rapid insight/resolution of critical BM/C³ issues have been performed. These activities provided a framework to model a range of BM/C³ architectures, evaluate alternative software engineering tools for distributed simulation, and to prototype man-machine interface displays. EV-88, the first major BM/C³ EV, has been initiated and is making progress.

Future Plans

The space-based EV will be in the design phase in FY 1988. Ground-based experiments will continue leading to an early BM/C³ prototype in mid 1988 and a full-scale real-time BM/C³ prototype in late 1989. The ground-based experiments will provide early validation of terrestrially based elements of the BM/C³ system architecture and will also be the vehicle for integrating distributed test bed resources through the NTB. In FY 1988, definition and design of the additional EVs (network EV, command center EV, and end-to-end EV) will proceed.

3.4.2 BM/C³ Technology Project

Project Description

This project develops technologies required to support responsive, reliable, survivable BM/C³ for strategic defense. The following technology tasks have been identified:

- o Battle management algorithms
- o C³ network concepts
- o Processors
- o Communications
- o Software engineering.

The **Battle Management Algorithms task** will analyze and develop battle management algorithms for the BM/C³ Experimental Systems project. Battle management algorithms are the mathematical/logical processes and procedures needed to perform resource allocation, manage and form the track file, execute command and control actions, and generally operate an SDS. Research of software designs appropriate for use in a loosely coupled, widely dispersed, heterogeneous multiprocessor environment is an aspect of this task. Because of the unique inputs and operational environment of the SDS, tested, proven algorithms do not exist. Specific attention will be given to system-level algorithms peculiar to an SDI-layered defense and not addressed in other program elements. System-level algorithms to be developed include track initiation and maintenance, target discrimination, weapon/target assignment, kill assessment, and system reconfiguration.

The **Network Concepts task** analyzes and researches the development of BM/C³ networks responsive to the architecture requirements. C³ network concepts are the node and link constructs and control procedures of the C³ network. This project will design and validate alternative BM/C³ network concepts. An SDS will require efficient communications network operation in a dynamic traffic loading environment. Adaptive, secure, multimedia communications networks are needed to achieve the required levels of survivability and reliability.

The **Processors task** develops the information processing technology, devices, and subsystems for the SDS battle management system. An SDS requires dependable, fault-tolerant, high-performance

computer systems. This task will develop the critical component and system technologies and computer architectures required for high-performance, fault-tolerant processing. Results from hardened microelectronics, high-performance parallel processors, and fault-tolerant technologies will be combined to meet critical SDI processor requirements.

The **Communications task** develops the communications technology, devices, and subsystems that are secure and robust and support mission-required data rates. This task also includes developing embedded software and firmware for the communications environment. Included are communications system planning and design, communications protocols, candidate communications network architectures, critical communications technologies, and demonstration of survivable dynamic communication networks.

The **Software Engineering task** develops the methodologies, techniques, and strategies to provide reliable BM/C³ software to meet requirements of the SDS. Efforts include analysis, evaluation, and research leading to the creation of secure software development environments which provide the capability to produce quality software at a high manufacturing rate. The approach being taken is to upgrade, tailor, and expand existing software development products being produced by DOD and industry so that these products meet strategic defense needs. Primary emphasis is on upgrading an existing software engineering environment, the Distributed Computer Design System (DCDS); however, additional efforts are being directed at techniques to meet SDI-unique software requirements such as trusted software.

Accomplishments

Battle Management Algorithms task for trajectory estimation, multiple track correlation, network control, discrimination, and weapon-target assignment have been modeled and analyzed. Selected algorithms have been run on parallel computing test beds to evaluate performances.

A hybrid tracker/correlator system that combines statistical estimation techniques with reasoning- and knowledge-based system techniques was developed and tested during the past year. The system uses an extended Kalman filter for track extrapolation and a knowledge-based system for report-to-track correlation. The techniques demonstrated are especially effective for partitioning of midcourse threats. This effort has established the feasibility of this approach by experiment and has determined the functional performance and computational resource requirements.

The **Network Concepts task** developed and built tailored link simulation models and candidate network and control concepts in FY 1987. The development of operating systems for distributed computer networks and distributed system evaluation environments has been continued. Experiments were conducted demonstrating landline and satellite connectivity between multi-cluster networks. This work will form the basis of later network technology validation experiments. Test bed tools were also developed for assessment of distributed system fault tolerance. Distributed data base management systems consistent with SDS requirements have been developed, and software requirements and required performance parameters have been established.

Processor efforts in FY 1987 concentrated on the evaluation of competing parallel processing environments and fault tolerance and computer security issues. Assessment of computer security issues was initiated through definition of the threat and potential security techniques. A risk analysis model has been developed to assist in the evaluation of security for various computer architectures. Initial assessments of high-performance computer architectures for fault tolerance were also initiated.

Development of advanced computer architectures has been accelerated taking advantage of programs in the Defense Advanced Research Project Agency's (DARPA's) Strategic Computing Program. Building on work performed under this program and at the National Aeronautics and Space Administration's (NASA's) Jet Propulsion Lab, near-term experiments were performed to assess different high-performance, fault-tolerant multiprocessor implementation concepts.

A number of high-performance advanced computer architectures are being pursued. The Connection Machine is a data parallel computing system which permits association of one processor with each data element and exploits natural computational parallelism in data-intensive problems. In some cases, execution time can be reduced in proportion to the number of data elements in the computation. The programming effort can be reduced because naturally parallel problems no longer must be expressed in a serial manner. Current models of the Connection Machine contain up to 64,000 processors. By using the operating system of a more traditional front-end processor connected to the Connection Machine, the user can program the Connection Machine using familiar languages and programming constructs.

Parallel processing methods promise to provide the high processing rates needed for real-time execution of battle management algorithms. Practical experience with all aspects of parallel

computing will be required to capitalize on their promise. During FY 1987, the acquisition of parallel computer systems and tools for their evaluation in various SDI laboratories was initiated.

The MOSAIC Advanced Signal Processor parallel computer architecture has been used to develop and scale applications of large parallel architectures to demonstrate the feasibility of using these techniques for SDI. For this architecture, the switch system and interfaces have been designed, and a macro dataflow language has been prototyped. The addition of VHSIC component processor modules to MOSAIC will produce an experimental computing facility. This performance is sufficient to meet projected requirements for a first phase SDS.

In the **Communication task**, contracts have been placed for development of component technology needed to support 60 GHz radio frequency (RF) and laser communications links. These efforts covered advanced communications signal processors, including optical processors, traveling wave tubes, and low-noise amplifiers. Laser communications studies were performed to identify the advantages and technology drivers associated with using this technology for SDI space links.

The **software engineering** environment for Ada was developed in a DCDS and implemented in Sun workstations during FY 1987. DCDS, an operational software development environment, provides a systematic approach to organizing and employing software programmers, languages, tools, and methods to develop large, distributed real-time software systems.

SDI is also supporting STARS, DARPA, and other service programs to build a next-generation software engineering environment for large-scale multiprocessor-based systems. The development of a distributed Ada programming support environment is being supported. A set of supporting tools for rapid prototyping system and software requirements is being developed in conjunction with the Air Force.

Future Plans

The **Battle Management Algorithms task** in FY 1988 is aimed at the formulation and specification of algorithms and the transition of these algorithms into processor environments. Emphasis will be placed on the design and analysis of algorithms for emerging processor architecture designs, including parallel processors. Parallel computing laboratories will be established, and prototype parallel software will be developed. Algorithms will be implemented and tested on parallel

processor test beds. A situation assessment and strategic planning algorithm will be implemented and tested. EVs of selected battle management algorithms will be used in candidate processor architectures. These will be evaluated in the Experimental Systems project against real and simulated threats.

The **Network Concepts task** in FY 1988 will develop security systems, internetting techniques, routing protocols, and packet switching techniques applicable to high-speed ground and space networks including fiber optic networks and cooperating space systems. Effort will begin on development of prototype hardware and software for SDI network interface processing elements. Alternative network approaches are being developed and implemented in simulations of operating systems. A trusted distributed operating system will be developed.

The **Processors task** in FY 1988 will concentrate on advanced computing evaluation environments which will be fully implemented. Evaluation will continue with increased intensity and models of fault-tolerant aspects of multiprocessors will be generated. The product of this effort will be a range of candidate, high-performance computer architectures and associated tools for applying them to SDS development. To further the technology for secure computing in a multiprocessing environment, security architecture models and specifications and designs for security prototypes will be generated.

Critical circuit technology development will continue drawing upon developments in the SATKA Program. Results of the efforts in hardened microelectronics and fault-tolerant computing are being combined with research on high-performance architectures. This will lead to space-qualified systems that integrate requisite characteristics for SDS processing.

For communication technology in FY 1988, 60 GHz solid amplifier technology will be pursued and work will begin on monolithic array and multi-beam antennas. For laser communications, a technology risk-reduction program will be initiated, and acquisition, tracking, and pointing requirements will be defined. Designs of RF and laser communications links for both space-to-space and space-to-ground links will also be completed. Proof-of-concept hardware and software will be developed for RF and laser links to provide highly reliable, secure, robust, and survivable communications for space-to-space links.

The **Software Engineering task** in FY 1988 will focus on the further upgrading of DCDS to improve user interfaces. A software management program will be defined, taking the approach of reusing appropriate predecessor products from other DOD programs and employing commercial products extensively. Software engineering tools emerging from DARPA's Strategic Computing Program will be evaluated for its application to strategic defense missions.

Standards and guidelines for software development will be established. Computer-aided graphic design tools and commercial software tools will be selected, refined, and integrated, leading to a "model" software producing environment which can be employed by numerous contractors and service agents executing SDS system elements.

3.5 THEATER MISSILE DEFENSE

The Theater Defense Directorate is responsible for developing, in coordination with NATO and other allied participants, the strategy for theater missile defenses. This includes proposed theater defense architectures, critical technology requirements, identification of theater, and the application of new technology efforts that can address problems peculiar to the theater defense perspective. The Directorate for Theater Defense oversees the multinational efforts to execute experiments, research, test bed development, architecture studies, and other programs.

The Intermediate-Range Nuclear Forces (INF) Treaty, signed by President Reagan and Soviet General Secretary Gorbachev, now subject to ratification by the Senate, would provide for the removal and destruction of intermediate-range ground-launched cruise and ballistic missiles from the inventories of both the United States and the Soviet Union. To some it may seem that this eliminates the requirement for ballistic missile defense for the allies. However, short-range ballistic missiles (SRBMs) will remain in the Soviet inventory, and ICBMs and SLBMs can be used against the allies. Active defense could contribute significantly to deterring the use of those systems and would provide an insurance policy against cheating by the Soviets. Furthermore, because the INF Treaty is limited to the U.S. and the U.S.S.R., intermediate range-ballistic missiles will not be proscribed for other nations, although a policy, namely, the Missile Technology Control Regime (MTCR) has been agreed upon by seven Western nations to restrict the transfer of relevant technologies. Although the INF agreement serves the U.S. objective of eliminating a class of missiles from the arsenals of the Soviet Union and the United States, the requirement for theater missile defense (TMD) remains intact. It is important that

the United States continue its efforts to develop a partnership with the allies in the pursuit of TMD for the common defense.

3.5.1 Project Description

The theater defense effort (previously referred to as theater architecture) combines architecture studies, technology development tests, and test bed development to form the cornerstone of an essential set of layers in the global defense against ballistic missiles. This effort defines the mission objectives and derives candidate architectures for the NATO region and other theaters against the threat of theater ballistic missiles. Concept definition and architecture studies are conducted through both government-to-government agreements with our allies, and through U.S.-managed procurements with multinational contractor consortia. These studies address candidate architectures, technology requirements, interfaces with existing defensive capabilities, and technology risks within current allied and American technology programs. Additionally, this effort directs the Allied Test Bed program which will develop the capability to simulate and evaluate the contribution of various theater architecture systems/elements to a layered defense. The principal goal of the theater defense effort is to focus TMD activities in a coherent and comprehensive manner necessary to the development and exploitation of necessary technologies.

3.5.2 Accomplishments

The initial phase of the Theater Missile Defense Architecture Studies (TMDAS) was completed with the identification and selection of five contractor teams that are developing architectures. The first phase provided the following conclusions: (1) missile and aircraft attacks are synergistic and pose a significant threat; (2) passive countermeasures and counterforce are important, but active missile defenses are required to defeat the synergism, and (3) effective active missile defenses are possible.

National architecture studies were also a part of the 1987 program. The U.S.-U.K. program resulted in the identification/validation of the threat and development of appropriate top-level system simulation models leading to architecture proposals. The U.S.-Israeli study led to the development of a candidate architecture and the identification of a variety of experiments to validate portions of the architecture.

The variety of data presented by these different studies was compiled and evaluated in terms of technical risk, similarity, and acceptability.

3.5.3 Future Plans

The primary thrusts for future theater defense efforts are to continue the progress made within the regional context of NATO and Israel and to expand theater considerations to address specific regional requirements in the Pacific basin. The focus of future efforts with our European allies and Israel will be to define technology experiments and efforts based on the regional requirements generated by the architecture studies, including accounting for the potential impact of the INF Treaty. This technology focus will include experiments under the Invite, Show, and Test (IS&T) program described in Appendix F; the definition of capabilities required for regional test beds to compare, evaluate, and test alternative architectural, BM/C³, functional, and performance alternatives; and more detailed investigations of specific technology areas such as lethality. Concurrent with these primary thrusts, theater defense will continue to study and identify the future requirements and technologies necessary to preempt Soviet offensive options in a changing environment.

3.6 OPERATIONS INTERFACE

3.6.1 Project Description

The responsibility of the Operations Interface Directorate is to ensure the user operational perspectives are properly addressed as the SDI Program continues in the acquisition process. It is a centralized liaison office which is responsive to commands which have operational interests concerning ongoing and planned research into the potential for effective strategic defenses. Additionally, the Directorate maintains contact with the service staffs and the JCS concerning operational issues and to ensure that the operational perspectives of these outside agencies are provided to the Phase I Program Manager. In that responsibility, it presents the views of the operational community to the SDIO Phase I Configuration Control Board (CCB).

The Directorate discharges its functions in three basic areas:

- o Operational analyses (essentially computer simulations, based on research results and predictions) of the effectiveness of Phase I.

- o Operational integration, where the functional capability of a potential strategic defense is analyzed for system interface points with existing and planned offensive and defensive force structures. (This integration is from an employment perspective--how such capability might be meshed in terms of C³ connections with other forces.)

- o Gaming (where the capability of potential defenses are analyzed in seminar settings to demonstrate the possible impacts of ballistic missile defenses, from Red and Blue perspectives, during peace, crisis, and conflict situations).

3.6.2 Accomplishments

In 1987-1988, initial operational analysis showed that the architecture presented to the DAB could, in fact, meet JCS requirements.

During 1987, liaison personnel were assigned from the Strategic Air Command (SAC)/Joint Strategic Target Planning Staff (JSTPS) and the Military Airlift Command Air Weather Service. The Operations Interface Directorate has established the SDS interface with the CINC SPACE, Commanders-in-Chief (CINCs) of offensive forces (CINCSAC; CINC, Atlantic [CINCLANT], etc.), the JSTPS, and the Organization of the Joint Chiefs of Staff (OJCS), required for the analysis of offense and defense interaction and integration.

Another example of an operations interface is the liaison between SDIO and the military services required for scheduling and orchestrating Phase I element testing at various U.S. test ranges.

3.6.3 Future Plans

Future activities for the Operations Interface Directorate include the more refined analysis of a potential Phase I deployment's operational effectiveness. The Directorate is also coordinating activities with the Unified Space Command concerning the tasking it has received from the JCS Chairman to develop a concept of operations for Phase I. This concept of operations is due in late 1988 at which time it is scheduled for presentation to the DAB. This work will take a significant step in refining operational integration requirements and will be of great assistance to the POET efforts. The Directorate's emphasis will be on simulating the initial and final concepts of operations developed by

USSPACECOM. Parallel gaming work, at a lower level of effort, will also address more specifically how defenses complicate Soviet conflict planning efforts. In the near future, SDIO anticipates a representative to be assigned from the Unified Space Command.

3.7 FUNDING IMPACT

Significant program adjustments were made to accommodate the reductions to the FY 1988 budget request. For the SDS Phase I project the SE&I effort was reduced. This will delay the system requirement definition and a Milestone II decision on the Phase I SDS. Reductions to the SDS Engineering and Support project will delay manufacturing initiatives, reduce integrated logistics support studies, and severely curtail the producibility program. The result of these adjustments is increased risk in new production technologies, delays to designed-in supportability and high payoff areas such as on-orbit support, and critical impact on our ability to address affordability through new producibility efforts.

In the theater defense effort, there will be a delay to the TMDAS. This has the potential to adversely impact the interest and cooperative efforts shown by the allies. Reductions to the BM/C³ program have caused delays to both the Command Center and Network experiments. These delays also result in a delay to the integrated experiment. The net result to the BM/C³ program will be a delay in validating the operational concept. Finally, reductions to the NTB project will cause a delay in achieving an initial operating capability. The result will be increased risk to the validation of BM/C³ concepts.

THIS PAGE INTENTIONALLY LEFT BLANK

4.0 TECHNOLOGY

4.0 TECHNOLOGY

Building upon the foundation provided by the Fletcher Study, a broad-based, vigorous, technical program was defined and put into action within the SDI Program. Technical efforts were aggregated into Program Elements, each examining a specified portion of a crucial SDI technology. This chapter describes the progress that has been made in each of the Program Elements, their objectives, and plans for the future. The technology programs fall under the direction of the Deputy for Technology.

The technical program is organized to support future decisions on defensive options. Various accomplishments in the research performed under each Program Element in past years have answered a number of questions. More importantly, these achievements have provided the basis for our current confidence in resolving key technical issues. They have also allowed us to refine the technical goals that are on the road to a confident decision on whether to proceed with a Strategic Defense System.

Recognizing the importance of innovation, the SDIO continues to support an activity in the office reporting to Deputy for Technology to promote innovative ideas (Innovative Science and Technology Office). A fixed fraction of each Program Element is set aside to fund promising innovative concepts. This work is characterized by high-risk, high-payoff, low-cost research that can be performed anywhere (laboratories, small business, industry, universities). The work involves mostly unclassified fundamental research, and its results, once evaluated, will help create new opportunities for other Program Elements.

THIS PAGE INTENTIONALLY LEFT BLANK.

4.1 SURVEILLANCE, ACQUISITION, TRACKING, AND KILL ASSESSMENT PROGRAM

4.1 SURVEILLANCE, ACQUISITION, TRACKING, AND KILL ASSESSMENT (SATKA) PROGRAM

This section provides an overview of the SATKA Program and discusses its technical objectives.

4.1.1 Program Overview

Sensors in a strategic defense system are used:

- o To detect the launch of enemy ballistic missiles
- o To acquire targets
- o To track each target and enable aimpoint prediction
- o To discriminate the reentry vehicles (RVs) from nonthreatening objects
- o To designate the targets
- o To provide specific intercept point predictions to the weapons systems
- o To provide guidance updates to kinetic energy interceptors
- o To provide kill assessment information to the battle manager.

To perform the functions described above, specific sensor requirements are established for the boost, post-boost and midcourse, and terminal phases. The nature and observable features of the targets change dramatically during each of these phases of ballistic missile flight. The sensor concepts being considered for each phase are discussed in the remainder of this section.

4.1.2 Technical Objectives

The objective of the SATKA Program is to develop sensors which are capable of performing birth-to-death tracking and discrimination. The sensors must be able to accomplish their mission in the most adverse wartime environment by providing the requisite data to the other elements of the Strategic Defense System (SDS). The sensors program is comprised of a large number of separate projects which, when combined, provide the technology, measurements, and experimental base for the development of deployable systems.

Sensors for the Boost Phase

Project Description

The launch of an intercontinental ballistic missile (ICBM) or a submarine-launched ballistic missile (SLBM) can be detected from deep in space by downward-looking sensors designed to detect the infrared (IR) radiation from the booster's exhaust. These sensors operate at wavelengths where the lower atmosphere is relatively opaque. This reduces the possibility of false alarms from other bright IR sources such as fires, explosions, or lightning strikes.

SDS requirements, however, include accurate counting and typing of the enemy's boosters during a mass attack and providing handover data accurate enough for initial use by space-based interceptors (SBIs) and/or directed energy weapons (DEWs). (The requirements for boost-phase sensors would satisfy current and future tactical warning, and attack assessment [TW/AA] requirements.) All these functions must be performed in a wartime environment, where the sensors themselves may be subject to both direct attack and the effects of radiation from nuclear detonations. The sensor system concept being examined to perform these functions is called the Boost Surveillance and Tracking System (BSTS).

Deployed in an earth orbit for optimum viewing, the BSTS will use IR sensors to track the hot exhaust plumes of ballistic missiles from launch through the end of powered flight. The BSTS constellation ensures global coverage of all potential launch points. Target detection and tracking will be accomplished by either scanning or staring sensors.

Accomplishments

The requirements definition and concept evaluation phases of the development and acquisition process have been completed. The BSTS program has begun the Demonstration and Validation (Dem/Val) phase. During the requirements definition phase, four contractors conducted a detailed evaluation of boost-phase surveillance requirements. In the concept definition phase, three of these contractors were selected to develop preliminary BSTS design concepts. Analytical test methods were used to determine the capability of each design to meet identified requirements. Starting in FY 1987 with a downselection to two contractors, the SATKA Program began the ground Dem/Val of critical technology and primary subsystems of the BSTS. Artist's concepts for two competing concepts,

scanning and staring, are shown in Figure 4.1-1. Ultimately, these efforts will lead to the selection of a single contractor in FY 1990 to build a fully capable satellite for flight test.

**FIGURE 4.1-1
Two Competing BSTS Concepts**

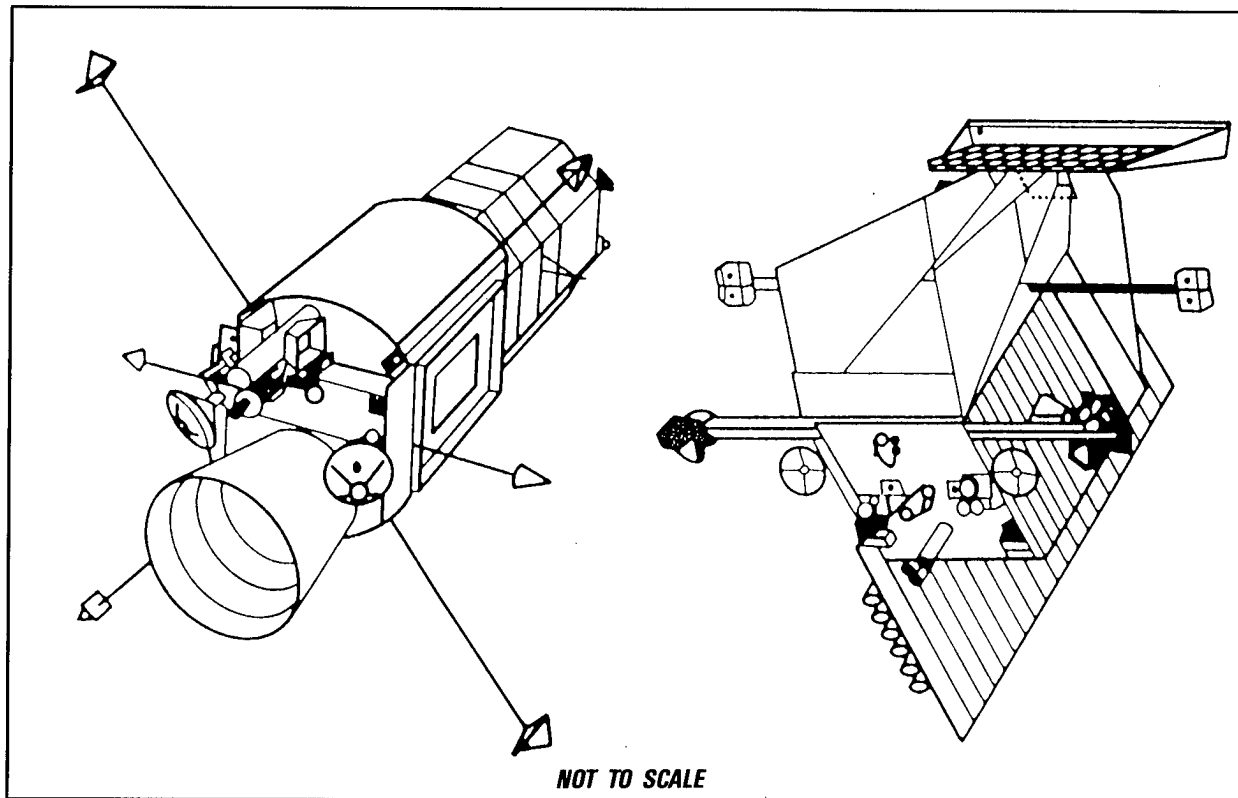

Measurements Supporting Boost Phase

A vital part of the BSTS program effort is the collection and analysis of measurement data. To design and build boost phase sensors like the BSTS, it is necessary to understand the boost-phase environment in which these sensors must operate. This environment is composed of three principal categories: the signature of the burning boosters, the natural IR background, which is always present, and the enhanced IR background created by nuclear detonations.

Data bases on missile detection are extensive and well documented for selected wavelengths under multiple conditions for BSTS system analysis and end-to-end sensor demonstrations. Two

experiments designed to make up this data shortfall, the Visible Light/Ultraviolet Experiment (VUE) and the Three Color Experiment (TCE), are scheduled to fly. These experiments will provide data necessary to measure plume signatures over extended wavelength regimes and evaluate satellite tracking, thereby clarifying the potential capabilities of the BSTS design.

Additional information on backgrounds and signatures will be obtained from a variety of measurement programs including, the Infrared Background Signature Survey (IBSS). The IBSS, which flies on a Shuttle Pallet Satellite (SPAS), will carry a number of sensors including radiometers and spectrometers. Carried aloft by the Space Shuttle and then released to operate in a free-flyer mode, IBSS will gather data on the Space Shuttle plumes, the shuttle environment and contaminants, chemical and gas releases, and the earth limb. These measurements will be made by a cryogenically cooled IR spectrometer and radiometer, the Arizona imager/spectrometer, a low-light level television, and other instrumentation mounted on the SPAS. Unlike many other space-based measurement experiments, the IBSS package will be recovered by the shuttle and returned to earth for later use. The system completed its Critical Design Review (CDR) in June 1987, reflecting the successful transition from the design phase into the integration and test phases. During FY 1988, the program will complete the Integrated System Review and significant system-level testing. The first mission is currently manifested for a Space Shuttle flight in FY 1990.

Technology Supporting Boost Phase

Critical technologies for boost phase sensors include high-density, radiation-hardened circuits for signal and data processing, mass-produced low-cost IR detectors for focal plane arrays (FPAs), large lightweight, high-quality mirrors for sensor optics, and advanced cooling techniques.

Signal and Data Processing. High-density, radiation-hardened integrated circuits are necessary on all sensor platforms to perform data and signal processing. Major technology concerns center on design and availability of low-power, radiation-hardened, very large-scale integrated circuits and high-speed analog to digital (A/D) converters. To perform the required tasks, these electronics must be capable of performing at a data throughput rate, be fault tolerant, use less than 4 kw of power, and be hardened against high levels of radiation.

The centerpiece of the component hardware technology program is the Generic VHSIC Spaceborne Computer (GVSC) project. The GVSC project is demonstrating a space-qualified

computer fabricated in special VHSIC technology to have sufficient radiation hardening to accomplish the BSTS mission. Computer simulations based on hardware test data and existing components have already indicated that GVSC will meet performance. The GVSC program has fabricated over 20,000 test chips. A prototype GVSC processor will be available in FY 1989.

Radiation-hardened random access memories (RAMs) will constitute the majority of chips for a spacecraft on-board processor. Development of 64k static RAMs uses the equivalent transistor technology of VHSIC circuits. Samples of 64k RAMs have been fabricated that have met hardness goals and have 80 nanosecond access time at room temperatures. Design changes will improve the access time to 50 nanoseconds across the military temperature range while increasing the hardness. Samples in 8k x 8 and 64k x 1 configurations suitable for BSTS signal and data processing will be available in 1989.

For the signal processor to perform its function, the analog signals from the focal plane must be converted to digital data. For BSTS, this will require analog-to-digital converters with greater dynamic range than have previously been built. Like all other electronics on the sensor, these devices must operate at very high throughput rates and in the presence of potentially high levels of radiation. The BSTS program office foresees very high promise for a combined bipolar-CMOS technology to provide the high speed with the low-power device it needs.

Besides radiation hardening, spacecraft computer systems must have a high availability, be designed for a long mean time between failures, and possess a self-repair capability. The Advanced On-board Signal Processor (AOSP) project has designed a local area network that supports fault-tolerant, loosely coupled, distributed multiprocessors. A network that will meet ground segment processing functions will be demonstrated. This network will coordinate the operations of very large-scale integrated (VLSI) processors exceeding the performance of three mainframes plus having the capability for self repairs by fault-tolerant system design.

Focal Plane Array (FPA). The BSTS senses the optical radiation emitted by the missile using IR detectors organized into FPAs. The number of detectors required for a typical BSTS focal plane is several orders of magnitude greater than that required for current IR systems. Production lines must be developed to reliably produce these large quantities of detectors and to assemble them into functional arrays. For effective use, these detectors must be cooled to increase their sensitivity and

reduce noise which requires advances in passive cooling technology. Finally, these detectors must be capable of operating in the same nuclear environment as the signal processors described above.

Because of its sensitivity and inherent radiation hardness, one of the detector technologies being considered for the BSTS FPA is mercury cadmium telluride (HgCdTe). Currently, the production rate for HgCdTe detectors which meet all specifications are on the order of tens of chips per month, having a low yield rate. Pilot lines and laboratory fabrication experiments have already been identified and are addressing key issues in both fabrication and production. Automation of selected manufacturing steps and elimination of production line bottlenecks have already reduced costs by almost three orders of magnitude. Through application of lessons learned and, in some cases, modification of manufacturing hardware from the commercial computer chip, industry will be able to provide the dedicated production facilities central to resolving FPA production issues. Production rates 10/30 times greater than current capabilities are expected in the immediate future and a space-qualified HgCdTe single chip array will be demonstrated by FY 1989.

Optics. The principal risks associated with optics technology for space-based sensors are concerned with fabrication and assembly of radiation-hardened, large, lightweight mirrors with the required optical properties. Current programs under development include both fused silica and beryllium (Be) mirror technologies.

The radiation hardness of the reflecting surface depends principally on the atomic number of material from which it is constructed. The most radiation-resistant, highly reflective material is Be. Multiple techniques for machining and polishing Be mirrors have recently been successfully demonstrated, including the fabrication of a 1-meter class Be mirror. Moreover, the use of alternate materials (e.g., fused silica) for mirrors protected from direct radiation exposure by the spacecraft structure has been demonstrated at sizes above 1 meter. The use of polished Be coatings on a fused silica primary mirror also provides an option that can reduce program risks.

Programs to improve the producibility of high-quality, radiation-hardened mirrors are being addressed. In FY 1987, the replica mirror process, which uses molds to produce mirror shapes that require minimal polishing, demonstrated the capability to reproduce high-quality 6-inch mirrors. Another process, developed in the Be-on-Be program, demonstrated automated turning and polishing techniques to dramatically reduce the "hands on" time for producing large mirrors. In FY 1988, both of these programs will demonstrate scaled-up versions of their production processes.

Cryogenics. Adequate heat dissipation on the FPA will be essential to achieving system performance. Design and fabrication of an effective, hardened FPA cooling system are key factors in overall FPA performance.

Future Plans

The BSTS program and SATKA technology base provide a firm foundation for meeting BSTS program milestones and have already yielded at least medium confidence that the system could be successfully developed and deployed. Nevertheless, continued effort is needed to assure concept and design verification. The extensive hardware ground testing, phenomenology experiments, and the potential focal plane flight experiments will provide the very high level of confidence needed to support a BSTS development decision for both TW/AA and future strategic defense requirements.

Major BSTS Technology and Measurement efforts are being conducted in the areas of optics, FPAs, signal and data processing, radiation hardening of critical components, and background and target measurements.

Optics. Technology and fabrication of large lightweight silica mirrors are well understood. The use of Be shows promise due to its light weight and strength. It is also inherently radiation hard. A full 1-meter-diameter Be mirror blank has already been completed. Demonstration of polishing and testing of this mirror should be completed in 1988. Additionally, advanced mirror surfacing technology should reduce production complexity and increase delivery of required optical elements.

FPA. The number and quality of detector elements must be increased to meet demands of future production. Key to this producibility question will be demonstrations of detector pilot production, integration, and test lines by CDR. Already the value of automation from the commercial semiconductor industry has allowed significant yield increases and reduced production choke points.

Signal and Data Processing. With the increase in numbers of detectors and commensurate increases in both the amount and speed of signals, new data processing capability is required. New signal processing designs must be developed and tested. These circuits must resist radiation upset and provide clean signals to the data processors. BSTS data processors must be hundreds of times faster than current space processors and memory capacity must be increased by a factor of 8 to 16

times over current radiation hard chips. Already demonstrated in the AOSP sensor data processor program is an advanced concept for a highly fault-tolerant distributed network space computer with the equivalent processing power of 3 IBM 3030 mainframes.

Radiation Hardening. Verification of the radiation hardness of critical components will also be accomplished through individual parts tests.

Phenomenology and Backgrounds. Although an extensive library exists from previous programs, further data is required to insure proper operation of the planned system. The planned target, signature, and background experiments are critical for sensor calibrations and signal/data software development.

Successful development of these technologies and measurement efforts and production techniques supporting the BSTS will permit the program to proceed within cost and on schedule. Figure 4.1-2 shows an approximate schedule for the BSTS program and the level of confidence gained with each experiment supporting the boost-phase sensor.

Sensors for the Midcourse Phase

Project Description/Accomplishments

Sensor concepts for the midcourse phase include the Space Surveillance and Tracking System (SSTS), the Ground-Based Surveillance and Tracking System (GSTS), and sensors on board the space-based interceptor (SBI) platform. The ground-based radar (GBR) is also under consideration to support the midcourse. Since the GBR also provides support for the terminal phase, it is addressed as part of the late midcourse/terminal sensors. The requirements for sensors operating in the midcourse are varied and demanding, and these requirements will become even more stressing as the Soviet threat evolves. The most demanding requirements fall into two areas: (1) discrimination and (2) accurate tracking of identified threat objects. Moreover, while passive sensors can provide accurate tracking and some degree of discrimination against early threats, it may be necessary to use active sensors (e.g., laser or microwave radars) to counter more advanced offensive threats. These active sensors could enhance discrimination.

**FIGURE 4.1-2
BSTS System Confidence**

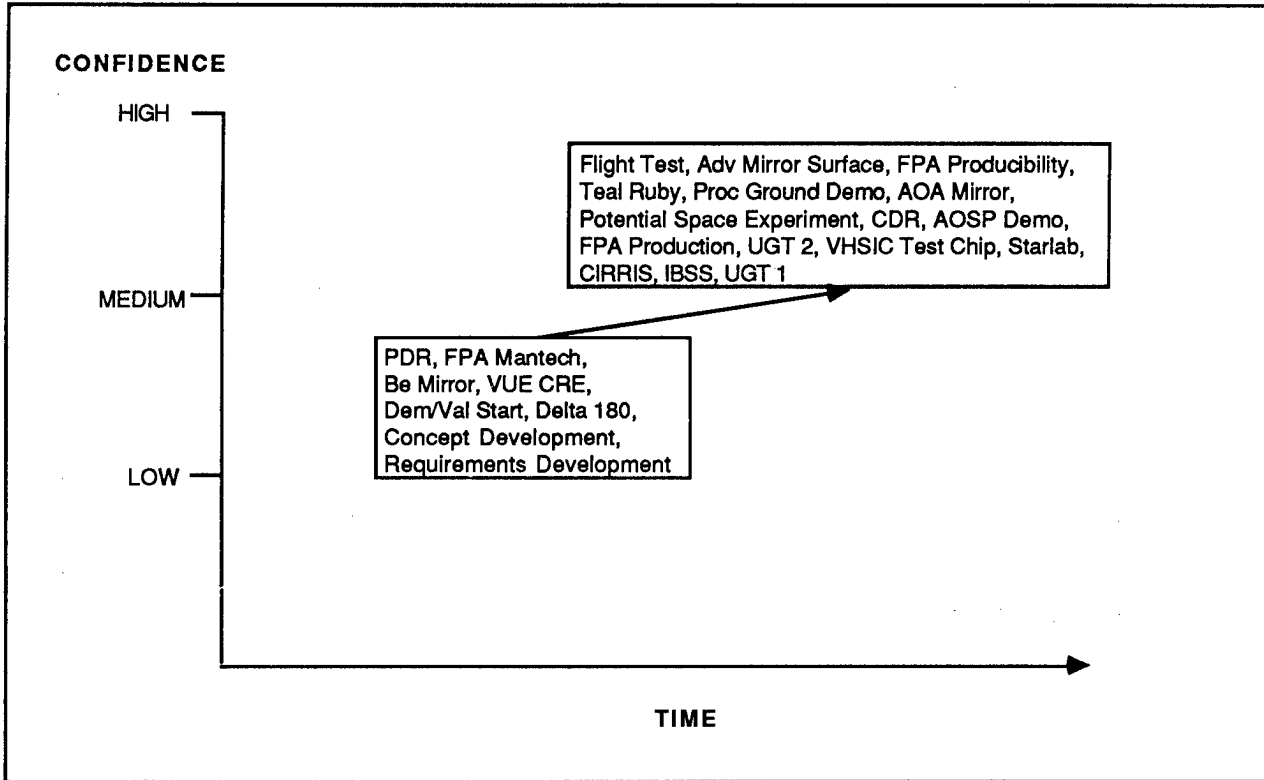

The Midcourse Sensor Study (MCSS) provided sensors concepts for the midcourse that employed the SSTS and GBR, complemented by the GSTS. It has not been decided which midcourse sensors should be pursued for an early system. These might be satellite-based, launched on rocket probes, carried on SBI platforms, supported by GBR, or a combination of all four. Although the sensors appropriate to the three optical sensor platforms are similar, there are, nonetheless, significant differences in capabilities, technology, and relevant phenomenology. The three optical sensor concepts under consideration are the SSTS (a satellite platform), the GSTS (a rocket-launched probe), and the SBI sensors. Until the differences between these approaches are more thoroughly understood and the relative merits of each platform established, all three options will be retained.

SSTS. The SSTS will perform the tracking necessary to commit weapon systems, such as the SBI and Exoatmospheric Reentry Vehicle Interceptor Subsystem (ERIS), during the post-boost and

midcourse phases. In an initial SDS, it will perform bulk filtering, and track post-boost vehicles (PBVs) and RVs accurately. As the offensive threat becomes more stressing, with the addition of high-fidelity decoys and fast-burn boosters, the SSTS will continue to mature. Enhanced capabilities which are projected include detailed assessment of RV deployment, birth-to-death tracking, and discrimination by active sensors to develop these advanced capabilities. Supporting technology programs are now under way.

In addition to its role in midcourse surveillance and tracking, the SSTS will also have a major role in space system defense by providing warning. The SSTS will provide warning. In peacetime, the SSTS will be able to perform valuable target-signature collecting functions. Additionally, the early satellites will gather phenomenological data required for design optimization of later systems, such as reacquisition sensors on the SBI.

The general concept for the SSTS is illustrated in Figure 4.1-3. Two contractors are refining concepts based on the requirements derived during the requirements definition phase. These contractors are also conducting ground demonstrations of certain critical elements of SSTS technology and are developing detailed plans for a space-based Dem/Val phase.

**FIGURE 4.1-3
SSTS Artist's Concept**

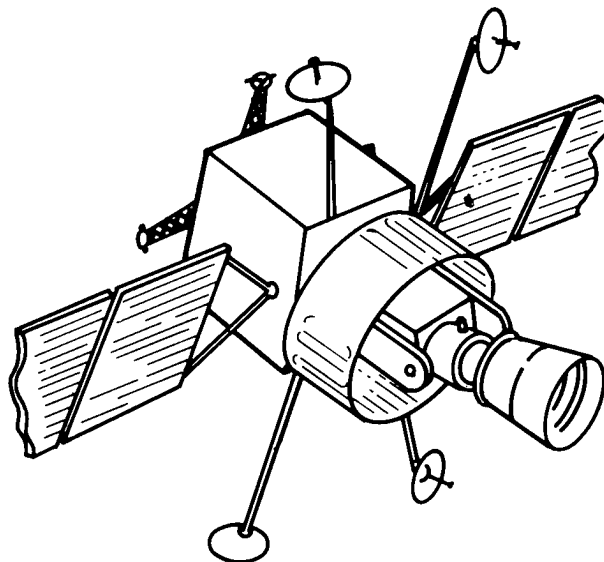

GSTS. A second option for the midcourse sensor is the GSTS. The GSTS (formerly called the Probe) will support the midcourse phase using sensors carried into space by a rocket booster. Under the current concept, pairs of boosters, launched at appropriate times after receipt of attack warning from the boost-phase sensors, will provide correlated data for midcourse tracking and discrimination. A contract award for the GSTS is pending and the prime GSTS contractor will then select two subcontractors under competitive procurement for final sensor definition.

Studies which examine the interactions of GSTS with the other SDS elements, particularly ERIS, High Endoatmospheric Defense Interceptor (HEDI), SSTS, and Battle Management/Command and Control, and Communications (BM/C³) have shown that GSTS has a role as a near-term surveillance system. The system can also be used to augment the performance of the SSTS constellation by covering gaps in coverage due to antisatellite (ASAT) attacks or nuclear detonations.

SBI Sensors. The third option for the midcourse sensor system would be to enhance the fire control sensors on the SBI carrier vehicles. Analyses show that sensors deployed on the SBI platforms will operate at shorter ranges than the GSTS or SSTS thereby allowing a simpler, but technically challenging, design.

Active Sensors for the Midcourse. As the Soviet threat becomes more sophisticated, the SDS may require ground- or space-based microwave or laser radars for midcourse discrimination. These active sensors would supplement the passive IR sensors by providing three-dimensional target data, aiding in the discrimination of warheads from decoys and debris, and providing more accurate update commands for the interceptors. The technology required to build such active sensors for space applications is new and its development will be a challenge.

Experiments Supporting Midcourse Sensors

A number of experiments are under way which have direct application to the midcourse sensors. The AOA is a major experimental test bed to resolve many of the passive sensor issues related to all midcourse sensor systems. It will carry an LWIR sensor on a modified Boeing-767 airplane and will be used at USAKA to measure radiometric characteristics. The AOA is shown in Figure 4.1-4.

Recent accomplishments on the AOA program include completion of the modifications to the aircraft and airworthiness testing, verification of the aero-optical control design, fabrication of the

sensor optics, and their integration into the telescope. In addition, the detector chips have been manufactured and assembled into the FPA, and the gimbal assembly has been completed.

As described above, SDS IR sensors will require FPAs comprised of large numbers of detector elements and the associated signal and data processors to handle billions of signals per second. The

FIGURE 4.1-4
Airborne Optical Adjunct



FPA for the AOA has been fabricated, tested, and found to meet or exceed all specifications. Installation in the AOA aircraft will be completed in FY 1988. This "largest" LWIR FPA, which has over 30,000 detectors operating in three bands, demonstrates the feasibility of meeting SDS IR sensor requirements in the future.

Similarly, the AOA signal and data processors have been completed and tested. This is significant as they demonstrate that such processors can be built to meet the real-time specifications for acceptable performance in SDS applications. Before this demonstration of processors, the requirement would have taxed the capabilities of several large mainframe computer manufacturers. It remains to miniaturize the components, reduce power consumption, increase the data rate, and harden them for operation on a satellite or other SDS platform.

Potential Space Sensor Experiment. Recent experience has shown that many of the models being used to predict optical signatures are inadequate. To overcome this difficulty, a space experiment is planned using a midcourse-type sensor satellite. Such an experiment would provide the space-based, high-resolution data necessary to make decisions on SDS designs. The experiment has the added advantage of collecting data for an extended period of time, ensuring that multiple targets are observed against varied backgrounds.

Airborne Laser Experiment (ALE). A number of experiments are planned and under way to improve our understanding of laser radars. These include modifications to the Firepond Radar and installation of the Kwajalein Imaging System. An ALE is also in the planning stages. This experiment will mount a laser radar capable of making high-precision doppler measurements on the AOA aircraft. The passive IR sensor and the laser will then be used to measure the RV deployment from the PBV.

Spirit I. Spirit I is an IR spectrometer which has already been tested. The measured data are still being analyzed, but one unanticipated result has already been demonstrated. Substantial radiation was measured in a spectral band previously assumed to be a "window" that would allow viewing close to the earth. The measured radiation may be natural or it may have been caused by gases seeping out of the probe. In either case, this discovery is significant and may influence sensor design.

Spirit II. The follow-on Spirit II experiment will provide data with improved spectral and spatial resolution and will demonstrate state-of-the-art midcourse sensor technology by incorporating some of the advances in focal planes and optics. It is scheduled to be launched during the sunspot maximum in 1990. Future plans are being considered to duplicate this sensor on a satellite to allow collection (for the first time) of space LWIR data over a wide range of diurnal, seasonal, and geographic parameters.

Large Microwave Radars. For possible use in space, large microwave radars will require a means of deploying very large radar antennas in orbit. The Lens Antenna Deployment Demonstration (LADD), designed to test the deployment of a large membrane antenna, is well under way. All major components are available and the CDR has been completed.

Measurements Supporting the Midcourse Sensors. The measurements programs supporting the midcourse sensors activities focus on collecting phenomenology data.

OAMP. The Optical Aircraft Measurement Program (OAMP), also known as Cobra Eye, is an important field experiment.

The Sounding Rocket Measurements Program (HAVE JEEP VII) is being conducted to obtain LWIR and dynamics data on postulated threat targets in the exoatmosphere. Each launch will deploy a payload design to eject up to seven objects and then observe them from on-board instrumentation. The HAVE JEEP flight test program consists of three separate sounding rocket missions which will be launched from the island of Roi-Namut in the Kwajalein Atoll.

Technology Programs Supporting Midcourse

There are four especially critical technologies for passive midcourse sensors: signal and data processing, IR focal plane arrays, cryocoolers, and optics.

Signal and Data Processing. While midcourse sensors will obviously draw as much as possible upon processing technology developed in support of the BSTS program, midcourse sensors have certain requirements significantly more stressing than those of the BSTS. Thus, advances over BSTS processing technology will be required in all areas, including hardware, software, and processing architectures. Specific issues that must be addressed include processor throughput, fault tolerance, software complexity, and radiation hardening.

During FY 1987, significant progress was made on an improved method of electronic circuit fabrication known as silicon-on-insulator (SOI) technology which provides circuits with improved radiation hardness and yield over the silicon-on-sapphire (SOS). Important to the design of midcourse sensors, this technique has been successfully demonstrated on complex circuits. Instead of fabricating single complex microelectronic circuits, wafer-scale integration produces an array of

circuits, properly interconnected, on a larger silicon wafer. These wafers may demonstrate an easier fabrication method for highly complex electronics, which have higher reliability, higher speed, lower power consumption, and lower cost.

IR FPA. All midcourse sensors and weapons require IR sensors. Critical issues for components are noise, speed, power, radiation hardness, and producibility. SSTS FPA technology development has drawn heavily upon the Sensor Experiment Evaluation and Review (SEER) and Precursor Above-the-Horizon Sensor (PATHS) projects to provide the required performance in detector arrays for the SSTS mission. This effort will continue under the Hybrids With Advanced Yield for Surveillance (HYWAYS) project, for pilot line production of FPAs and continued improvement of radiation hardness candidates.

The SEER and the PATHS projects have achieved higher sensitivities, lower power requirements, higher speeds, denser packing, and increased radiation hardness of individual detector elements. These achievements allow midcourse surveillance systems to achieve longer acquisition and discrimination ranges, faster scan rates, and higher resolution in severe radiation environments.

The IR detector technology project has also enhanced the ability of sensor elements to operate in a nuclear environment. Under the Nuclear Hardened Mosaic Technology project, the Intrinsic Event Discrimination (IED) concept has been validated as a technique to significantly reduce the noise induced in infrared detectors by gamma rays generated by a nuclear explosion. The SEER and PATHS projects have also developed detector and readout arrays demonstrated to survive total radiation doses a factor of 50 greater than pre-SDI detectors. These accomplishments greatly improve the ability of midcourse sensors to see through the noise generated by the nuclear environment and to continue to operate.

Another significant achievement is the large improvement in the sensitivity of LWIR HgCdTe detector arrays. This was achieved under the LWIR producibility programs and is being extended in the Scanning LWIR Module (SLIM) effort. LWIR HgCdTe is capable of achieving high sensitivities at operating temperatures three times higher than the extrinsic silicon technologies being produced on the PATHS program, and will reduce the cooling power required for long-life space-based surveillance systems. Currently, the production rate for HgCdTe detectors which meet all specifications are on the order of tens of chips per month, having a yield rate of about 1 percent. A significant technology effort will be conducted to ensure technology maturity for LWIR HgCdTe FPAs.

Another breakthrough of the SATKA technology project has been the development and demonstration of the solid-state photomultiplier (SSPM). Capable of counting individual photons, this device has the potential of achieving two orders-of-magnitude improvement in sensitivity. The SSPM is ideally suited for missions requiring high spectral resolution and will significantly improve the ability of follow-on SDS elements to discriminate targets in more sophisticated threats.

Cryogenics. To achieve the required sensitivity, LWIR sensors must be maintained at very cold temperatures. Because these temperatures must be maintained throughout the lifetime of the satellite, cryotechnology represents one of the significant technological risk areas in the SSTS program.

Risk reduction has been the central goal of the cryogenics technology program over the past few years. This program has demonstrated a cryocooler which meets the requirements of the SSTS. During FY 1987, critical mechanical components of a 3-stage prototype flight cryocooler (PFC) were demonstrated. Life-limiting mechanisms, such as bearings and rubbing seals, have been eliminated in the PFC designs. New innovations in magnetic drives, gas bearings, and miniature turbomachinery have been successfully performed on a cryocooler capable of producing 2.5 watts of output cooling. It now remains to demonstrate that both temperature and heat load requirements can be met with a single cryocooler which can also meet SSTS lifetime requirements. These issues are being addressed in the program, in which two contractors will demonstrate the performance of separate cryocooler concepts, the Rotary Reciprocating Refrigerator (R³) and the Turbo-Brayton, through life-cycle test.

A 2-stage turbo-Brayton cryocooler has been built to support higher temperature cooling requirements, such as MWIR and HgCdTe detectors. It will begin life testing in FY 1988. Another 2-stage R³ cooler will also begin life tests. Mechanical cryocooler performance has been successfully demonstrated at most temperatures; however, associated electronic control systems remain to be developed and proven to successful flight qualification.

Optics. This technology is similar to the optics technology previously addressed under the Boost Phase program.

Laser and Microwave Radars. Laser and microwave radars can provide useful information. Theoretical predictions indicate, as an example, that this technique could achieve resolution of basketball-sized objects over Chicago using a microwave or laser radar located in Washington, DC.

There are four principal technologies that must be developed to support laser radar development: laser transmitters, laser receivers, large optics, and beam agility.

The laser radar project is nearing the demonstration of high-power range-doppler imaging of space targets from the MIT/Lincoln Laboratory Firepond facility. Parallel design and construction of wideband and narrowband amplifiers, a modulation system for mixing microwave and optical signals to produce chirped waveforms, optical isolators, and beam steering components are also on schedule. High-resolution range-doppler imaging using CO₂ laser radar technology at low power levels was demonstrated this year. Significant progress was made in the design and fabrication of components that will extend this capability.

For laser receivers, an increase of 35 percent in the heterodyne sensitivity of CO₂ laser coherent detectors has been achieved and the bandwidth of HgCdTe detectors has significantly increased.

The goal of the beam agility program is to develop laser radar systems capable of randomly addressing targets spaced across a wide field of view. Several unique concepts involving phased arrays of optical subapertures have been analyzed and are being tested in laboratory experiments. An alternative concept using a frequency-tunable solid-state laser in conjunction with an optical grating has matured to a low-power laboratory demonstration capable of retargeting times of less than 1 millisecond.

Future Plans

The midcourse sensors will be combined in one coordinated program as a result of the MCSS. The program includes technical validation experiments (TVE) for the passive midcourse sensors that support both the SSTS and the GSTS (see Figure 4.1-5). These experiments include end-to-end ground demonstrations and space sensor experiments which will culminate in a fully capable flight test. Planning and acquisition of hardware for pre-prototype tests will continue in FY 1989 and will support this fully capable flight test. The AOA is being used as an early test bed for many of these functions. These experiments require space viewing of targets to verify phenomenology, provide critical data on targets, and demonstrate key system functions. System developments required for an informed FSD decision fall basically into five areas: large hardened optics, FPAs, signal and data processing, cryocooling and phenomenology. All five of these areas have been described in detail in

the preceding Midcourse Sensors and Boost-Phase Sensors sections with respect to similar technologies (e.g., optics and signal/data processing). A few specific midcourse sensor comments follow.

**FIGURE 4.1-5
SSTS/GSTS Confidence**

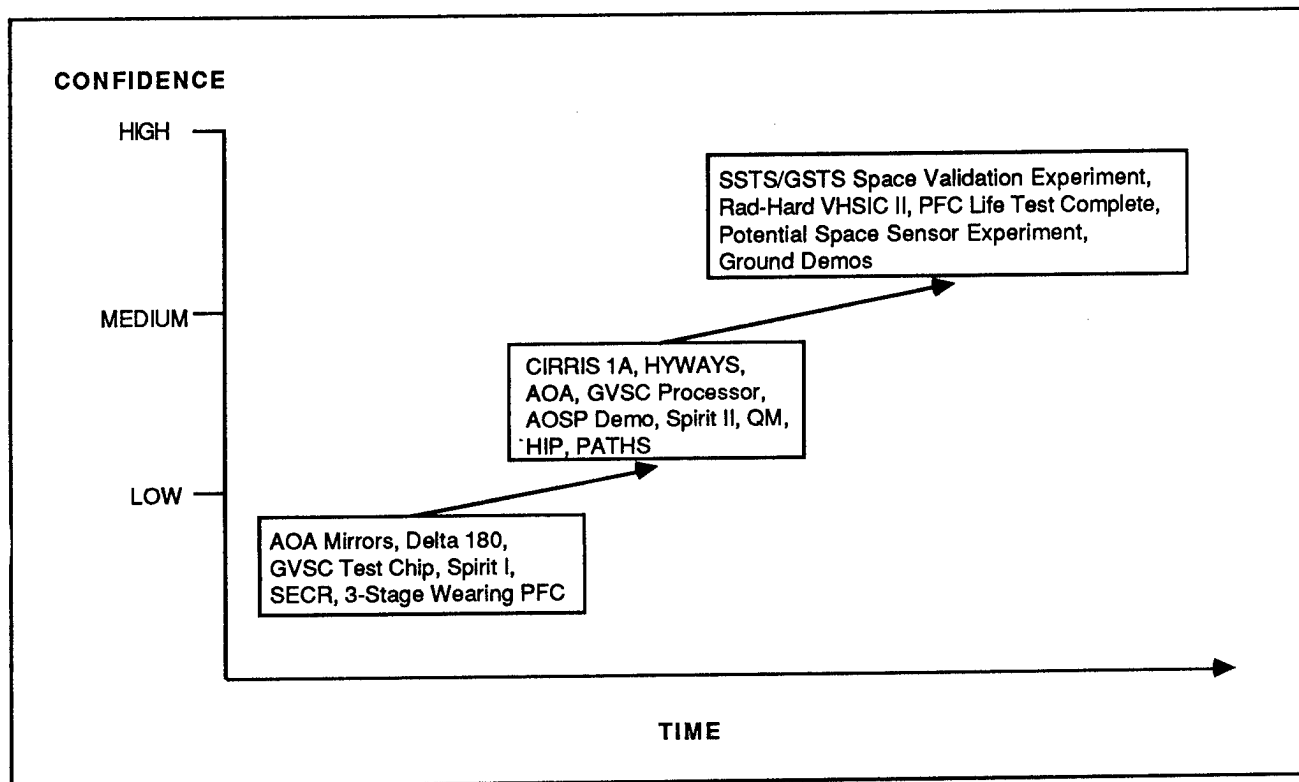

Optics. The critical areas to be demonstrated in large hardened optics are producibility, hardness, and optical quality. Experience is based on the AOA mirrors and the HIP 1-meter Be mirror development project.

Focal Planes. Producibility of FPAs at the required sensitivity is again a concern. This is addressed by the SEER, PATHS, and HYWAYS projects.

Signal/Data Processing. The necessity for a single SSTS satellite to be capable of processing approximately 100,000 simultaneous targets requires advances in both data and signal processing

hardware (e.g., 256 K SRAM, VHSIC I and II, WSI, 32 bit microprocessor, GVSC, and AOSP) to achieve the necessary throughput rates.

Cryocooling. The need for long-life focal plane cooling (SSTS only) to near absolute zero requires design and qualification of cryocoolers considerably more capable than those previously required for operational systems. The prototype flight cooler project will demonstrate the performance and lifetime capabilities required.

Phenomenology. Although ultra-narrow FOV LWIR systems have been in use in the field of astronomy for years, no long-term satellite system experience exists. Thus, both background and target phenomenology along with a "space qualified" system requirements definition are needed prior to an informed FSD decision. In terms of phenomenology, a two-phased approach has been initiated. Basic background (and some cooperative target) phenomenologies are being pursued in such experiments and the Delta 180/181, IBSS, CIRRIS IA, and the Spirit experiments. Additionally, the space experiment described above will gather phenomenological data in the defined SSTS/GSTS operational configuration. These data sets will allow both the design and test of the FSD SSTS/GSTS system.

Late Midcourse/Terminal Sensors

Project Description

Although the Phase I SDS does not contain a terminal phase defense layer, follow-on phases may require terminal phase sensors for discrimination against an advanced threat. A major candidate for the terminal phase sensors is the GBR. The objective of the GBR is to provide a late midcourse and terminal phase sensor system to track and discriminate reentry objects that have survived the boost, post-boost, and early midcourse phases. The GBR must perform the following critical functions: accept target handover from other sensors; acquire, track, and discriminate during late midcourse and reentry; and provide track and homing data for interceptor systems.

The Ground-Based Radar Experiment (GBR-X) is a major TVE for single-faced, phased-array radars. An artist's concept for the GBR-X is shown in Figure 4.1-6. The GBR-X will form the basis for an operational GBR. A 48-month development contract was awarded in March 1987, and under the current schedule, the GBR-X will be operational in mid 1993.

**FIGURE 4.1-6
GBR-X Model**

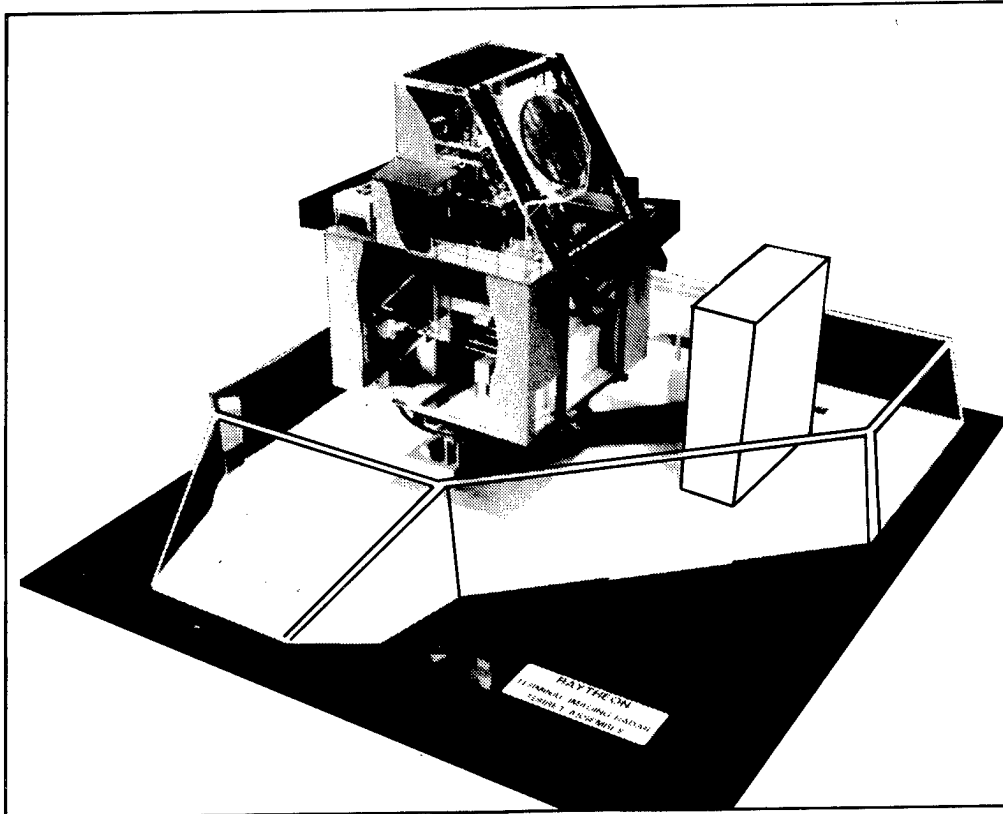

Accomplishments

During FY 1987, a number of significant studies relating to GBR-X utilization and capabilities were performed. These analyses served to validate the design concepts incorporated into GBR-X and to form a basis for developing detailed algorithms and operational procedures.

Measurements for Late Midcourse/Terminal Sensors

Cobra Judy and Cobra Dane. Cobra Judy, a ship-based radar, and Cobra Dane, a land-based radar, are two radar sensor complexes used by SDIO for data collection.

Lexington Discrimination System (LDS) and Kwajalein Discrimination System (KDS). In conjunction with data collection programs, coordinated radar, laser, and algorithm development efforts are under way. The most significant of these efforts is a near-term imaging demonstration

program which includes the development of the LDS and the KDS. These systems were put on line over the past year and, together, are being used as a discrimination development test bed.

The LDS is being used to develop advanced discrimination algorithms which combine data from active sensors with information collected by passive sensors. By comparing these two classes of data, sophisticated new discrimination algorithms are possible. Once developed, the algorithms will be tested using the KDS and AOA before being provided to GSTS and SSTS system engineers.

Technologies for Late Midcourse/Terminal Sensors

RTIM. A new computer program, Radar Technology Identification Methodology (RTIM), which uses expert systems technology to assist in the identification of requirements, is being developed to assess critical technology issues and cost/performance relationships. To date, radar technology progress includes the functional partitioning and definition of the software, a review of the expert systems package, and a review of the pertinent radar design codes. Cost relationships are being analyzed and the code will be capable of relating cost and performance issues.

Technology Development for Solid-State Phased Arrays (TDSSPA). The TDSSPA project is developing high-power, high-efficiency transceiver modules of the kind required for construction of a GBR. Using newly developed field effect transistor (FET) cells, a power amplifier has been built which demonstrates significant improvement in efficiency. A number of these devices are being combined to form a high-power, high-efficiency power amplifier which will help reduce the weight and costs of phased-array radars while greatly improving their reliability. This improved output and efficiency should reduce the radar's power requirements by half.

Transmit/Receive (T/R) Module Development. A module validation program is demonstrating the performance and producibility of solid-state X-band, (T/R). Eighty modules have been produced and demonstrated to meet the required performance levels. Radiation and reliability tests are being planned for over 100 of these modules. A subarray of 100 solid-state T/R elements will be fabricated to use as the basis for long-term reliability testing.

Combining these modules into a usable radar requires innovative antenna design. A wideband, wide-scan subarray architecture has been developed for this purpose. The phase shifter design has

been validated, a test feed system for the subarray fabricated, and measurements obtained which demonstrate the advantages of the technology.

Future Plans

Reorientation of the GBR-X project to encompass midcourse operation and use with ERIS resulted from conclusions of the MCSS group. Providing the enhanced capability entails doubling of transmitter power and redesigning the antenna to provide a larger aperture, because increased range capability is needed for operation. In addition, development of midcourse discriminants is required. The design changes to implement these enhancements are now under way. The GBR-X radar design and experiment will provide a traceable growth path toward an operational GBR.

The GBR represents a capable system that greatly enhances the overall sensors performance. There are several issues that impact the design for deployment. These include resistance to electronic countermeasures, operation in a nuclear environment, discrimination, and technology performance enhancements to existing technology. Figure 4.1-7 depicts some of the major activities leading to the present level of confidence and the projected events leading to resolution of the major issues remaining.

Discrimination and Electronic Countermeasures. New technology development for the GBR-X is limited to the dual field of view (FOV) antennas needed to support the long-range limited FOV requirements of the midcourse exoatmospheric sensor with the wide FOV, shorter range (high-endoatmospheric) of the terminal phase sensor. The transmitter makes use of a proven TWT design which is being modified to provide longer pulse widths for an increased sensitivity and ECM resistance. Jammers on RVs and escort jammers provide the major threat to GBR acquisition, tracking, and discrimination functions, and complicate antenna and transmitter designs.

Midcourse discrimination algorithms will be developed in a parallel path to GBR-X and will be integrated into the GBR-X design shortly after CDR. The Continental U.S. (CONUS) readiness review will verify that the hardware and software design of the GBR-X supports multiple-target, real-time, high-throughput discrimination requirements. Shortly after the U.S. Army Kwajalein Atoll (USAKA) readiness review, the Dem/Val of the GBR-X using the midcourse and terminal discrimination algorithms will take place.

**FIGURE 4.1-7
GBR-X Confidence**

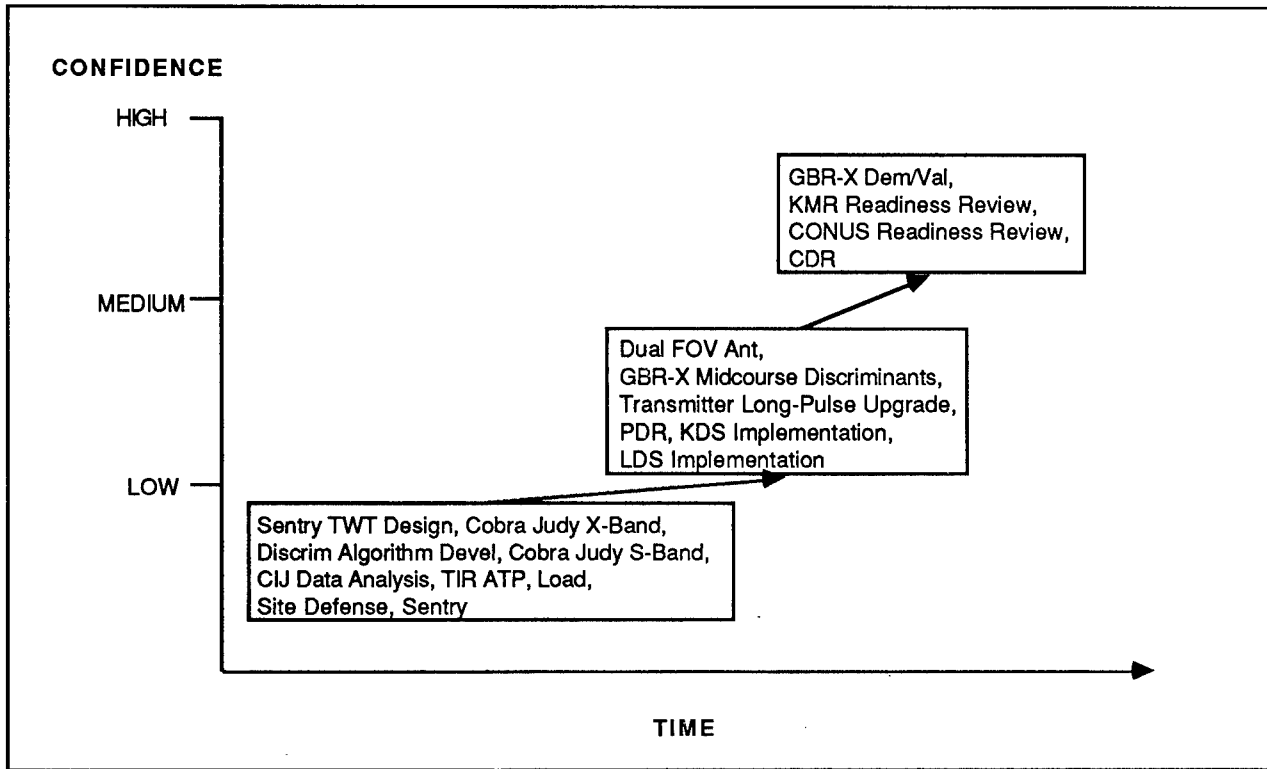

In addition, the technology considered through the GBR-X Dem/Val phase will be integrated with other midcourse sensors. GBR-X will validate acquisition, tracking and handover function via the airborne optical adjunct at USAKA. The acquisition of hardware for the GBR-X will continue in FY 1989.

Radar Technology. Technology enhancements will continue to be developed that offer improved performance for the GBR. These enhancements include a wide bandwidth analog-to-digital convertors. Other technologies will be pursued for solid-state phased arrays and robust waveform generators and processors to add improved performance for GBR.

Other Efforts

Nuclear Effects. SDS sensors must be designed both to survive and to function in a wartime environment. This environment will require electronic, optical, and structural components to be hardened against nuclear effects. In addition to component hardening, system architectures and sensor signal processing techniques must be developed which will allow the SDS to function despite

obscurations caused by nuclear bursts. The formulation of functional and survivability requirements for the nuclear environment depends largely on computer simulations. Part of the sensors program is devoted to designing and executing non-nuclear experiments that can improve our ability to simulate the nuclear environment.

Because nuclear testing in the atmosphere to measure such effects is banned by the Limited Test Ban Treaty, SDI research and development relies heavily on computer models and simulations of nuclear effects to assess system performance. Until recently, such codes could only represent a few bursts. A new code, SCENARIO, was developed for SDI by the Defense Nuclear Agency. A number of phenomena, such as molecular emissions, must yet be added to the code in the future. However, the initial capability to predict key features, such as radiation from very hot ionized air, temperature, and atmospheric heave, have been demonstrated.

SATKA Integrated Experiment (SIE). The purpose of the SIE is to use various sensors to provide birth-to-death tracking of ballistic objects launched from Vandenberg AFB into USAKA. SIE initiated the first experiment after only a 10-month development period. The SIE Control Center (SCC), shown in Figure 4.1-8, became fully operational in time for the first mission.

The first three missions of the SIE were flown in 1987. One significant achievement was the operational development of the SCC in time for the first flight. SCC algorithms are fully operational. The experiment was successful and all sensors acquired and recorded significant data. The continued development of the Experimental Network Surveillance System (ENSS), Enhanced Longwave Spectrometer/Imager (ELSI), the Laser Interferometer Detection and Ranging (LIDAR), LIDAR Acquisition and Sizing Experiment (LASE) have provided insight on real-time optical and radar discrimination phenomenology. The ENSS was completed and made fully operational. Sensor upgrades on the ELSI, the LASE, and the Narrow Band Coherent Data Collection System on the FPQ-14 radar at Hawaii are nearing completion. A duplicate SCC was installed at the National Test Facility (NTF) at Falcon AFS, Colorado, and is operational. The Knowledge Based Sensor Fusion system development work has progressed as planned with the prototype near completion. The SIE series of tests will be ongoing to support continued verification of integrated sensor performance.

**FIGURE 4.1-8
SIE Control Center**



4.1.3 Funding Impacts

Notwithstanding the successes described above, a serious funding shortfall exists, and continued advances and achievements will depend on adequate funding. The budget reductions which have been made in the program over the last few years have resulted in considerable loss of time and effort. Many programs have been initiated only to subsequently be slowed or canceled altogether due to budget cuts. Perhaps even more significantly, funds have not always been available to follow up vigorously on demonstrated technological successes. These constraints have slowed our progress and prevented demonstration of even more technical accomplishments. The FY 1988 program has been carefully balanced to support both the Phase I SDS and the technologies needed for more responsive follow-on strategic defense systems.

Congressionally mandated cuts to the SDI Program have had a serious impact on the SSTS program. Appropriated funds are considerably less than requirements for the two concept definition contracts which were awarded in the last quarter of FY 1986. This shortfall has forced the System Program Office to renegotiate both contracts thereby adding costs, increasing risks, and delaying critical technology demonstration programs. The GSTS TVE will be seriously impacted as well.

4.1.4 Summary

The SDI SATKA program has made exceptional progress over the last few years. FY 1987 has been significant in that a number of key programs such as AOA, Queen Match, and OAMP started early in the SDI effort are now coming to fruition. Perhaps even more significant, however, is the progress being made on the technology front. Although much remains to be done, the advances in signal processing, focal planes, optics, and cryogenic cooling have removed many of the more serious obstacles which faced the program. The following issues will receive special emphasis during the remainder of FY 1988 and in FY 1989.

Passive Discrimination

Currently planned SDS sensors must be able to perform passive discrimination. Obtaining the data to validate passive discrimination techniques is a high-priority effort.

Threat Characterization

Current techniques for discriminating real targets from decoys and debris depend on a knowledge of threat characteristics. Efforts to obtain the necessary data through measurements and experiments are a major part of next year's program.

Refine Nuclear Threat

Sensor systems must be able to operate in an environment disturbed by a large number of nuclear detonations. The planned SATKA program emphasizes functional survivability through hardening of individual components and the design of sensor architectures.

Modularity

The design of components and subsystems in a manner that allows their use on a number of different systems will reduce the overall cost and technical challenge. Significant efforts are planned to promote such modularity.

Technology Base

The success of the SDI SATKA program depends on the availability of adequate technology. As in past years, a major portion of the SATKA budget will be dedicated to developing these technologies. As highlighted in this report, signal and data processing, focal planes, optics, and cryogenics are among our highest priorities.

THIS PAGE INTENTIONALLY LEFT BLANK

4.2 KINETIC ENERGY WEAPONS TECHNOLOGY PROGRAM

4.2 KINETIC ENERGY WEAPONS (KEW) TECHNOLOGY PROGRAM

This section provides an overview of the Kinetic Energy Weapons (KEW) Technology Program and discusses its technical objectives.

The objective of the KEW Program is to identify, pursue the development of, and demonstrate advanced kinetic energy technologies and concepts. These demonstrations require proof-of-principle experiments designed to supply empirical data to support FSD decisions.

4.2.1 Program Overview

Kinetic Energy (KE) technology development is focused on the physical intercept and destruction of ballistic missiles by ground-based and/or space-based non-nuclear weapons. These interceptors are the most mature technologies in the SDI, prompting their selection for the Phase I Strategic Defense System concept. KEWs may be guided or unguided, launched by chemical rocket boosters, or projected by hypervelocity electromagnetic or electrothermal guns. The technology under research and development is suited for all phases of a defense (boost, post-boost, midcourse, and terminal).

4.2.2 Technical Objectives

The KEW Program is grouped into seven areas. The first two, Space-Based Interceptor (SBI) development and Exoatmospheric Reentry Vehicle Interceptor System (ERIS) development, are part of the SDS Phase I architecture. The third, High Endoatmospheric Defense Interceptor (HEDI) development, is an SDS Phase I architecture option.

The remaining four areas are miniature projectile technology, test and evaluation (T&E), technology support, including theater missile defense and foreign technologies, and support programs, including innovative science and support technologies. These last four areas provide potential technologies for follow-on phases of strategic defense to include the transition from Dem/Val concepts to prototypical interceptor systems.

Miniature projectiles include the Lightweight Exoatmospheric Advanced Projectile (LEAP) and hypervelocity guns (HVGs). The technology projects within each interceptor development and the mini-

projectile project are structured to address the component development issues and interrelationships of the KEW interceptor requirements.

The T&E effort provides generic KE test range support and technical management of unique near-term experiments that provide data not available elsewhere for the baseline of the overall KEW Program.

The objective of technology support is to extend technology from the strategic arena to the shorter-range threat and to support allied efforts.

Space-Based Interceptor

Project Description

The SBI project will develop rocket interceptors launched from space platforms to home in on, impact, and destroy strategic missiles during the first phases of ballistic flight. Specific targets are boosters, post-boost vehicles (PBVs), reentry vehicles (RVs), and direct ascent antisatellite (ASAT) missiles. Space-based sensors will identify the beginning of a strategic missile attack.

External battle management will select the strategic missiles to be engaged by each platform. Upon receipt of a release command, the selected interceptors will be sent to a predicted impact point. The interceptors will continue to get target data from the SBI weapon platform fire control sensors during their flight. Upon arrival at the predicted midcourse point, the passive IR seeker on the interceptor will be turned on to acquire the target. This seeker has sufficient resolution, when combined with the interceptor's maneuver capability, to give very high probabilities of direct impact kill against all types of targets (boosters, PBVs, and RVs) against all types of backgrounds (earth, space, nuclear). Kill assessment will be performed by the fire control sensors on the weapon platforms and by external space-based sensors. Figure 4.2-1 provides a summary of SBI functions and requirements.

The SBI program is planned and managed to provide a cost-effective Phase I element of the SDS. Plans for orbital servicing of SBI platforms may dramatically cut satellite expenses by eliminating the requirement for long, unattended system lifetime. Three SBI contracts were awarded in June 1987. Two contractors have parallel contracts to refine concepts that satisfy militarily significant missions as specified by the Joint Chiefs of Staff (JCS). The contractors are designing, fabricating, and executing hardware demonstrations to resolve critical technology issues required for SBI deployment. Demonstrations will place

SBI element simulators on a real-world footing for reliable end-to-end flight intercept validation of system effectiveness.

**FIGURE 4.2-1
SBI Functions and Requirements**

FUNCTIONS
<p>Intercept Booster, PBVs, RVs, Direct-Ascent ASATs</p> <p>Carrier Vehicle</p> <ul style="list-style-type: none"> • Store and Launch Interceptors • Generate Target State Vector Using Initial Sensor Handoff • Acquire and Track Targets • Guide Interceptors in Midcourse <p>Interceptor</p> <ul style="list-style-type: none"> • Acquire and Home on Target • Destroy Target on Impact
REQUIREMENTS
<p>Carrier Vehicle</p> <ul style="list-style-type: none"> • Acquire • Determine ASAT Track <p>Interceptor</p> <ul style="list-style-type: none"> • Acquire and Home on Boosters and PBVs • Acquire and Home on Cold Body RVs and ASATs <p>Both Interceptor and CV Must Have Ability to Perform After Extended Dormancy Period in Orbit</p> <p>Low-Cost Interceptor; Overall Element Cost Reduction</p>

A third contract has been awarded to gather critical seeker performance data and to demonstrate maneuver capability through ballistic tests. All three contracts support the technical objectives of the SBI program to have a selection of the most cost-effective SBI concept.

These contracts are working on two areas of critical issues to develop a lightweight, low-cost, survivable, and effective SBI element. The first area concerns the development of the interceptor. The interceptor's seeker must accomplish booster plume to hardbody handover during intercept of boosting targets and acquire small cold bodies against the earth's background. Additionally, the interceptor must have closed loop guidance for stability and control during flyout. All of these interceptor issues must be resolved at a low cost.

The second area of critical issues is the weapon platform. It must achieve functional requirements and have an extended space life. The platform must have accurate fire control capability to guide the interceptor to the designated target. It also must be survivable against direct ascent and co-orbital threats. Additionally, the capability must exist for worldwide command and control of, and communications to, the SBI subsystems. Finally, the weapon platform should have a minimum weight at minimum cost. This requires maximum producibility and maintainability.

Real-world phenomenological data are required from experiments and demonstrations to validate SBI simulators required for reliable end-to-end flight-ground interceptor testing, and validation of system effectiveness. Confidence in the simulation capabilities will assist in the analysis and the design of prototype interceptors and weapon platforms.

Accomplishments

Because of progress in developing and demonstrating SBI technology, the SBI was approved by the DAB to enter the Dem/Val phase. Goals were identified for a lightweight, low-cost, survivable, effective SBI element, including, a kinetic kill vehicle (KKV), an interceptor, and a platform. This important milestone is indicative of the relative maturity exhibited by SBI technology.

Technology work on interceptor propulsion, sensors, seekers, data processors, inertial reference units, power, communications, cooling and weapon platform fire control sensors, structures, and survivability indicates that these component difficulties are being resolved. Space tests such as Delta 180 and Delta 181 have greatly increased our data base on target signatures against which the SBI sensors must find their targets. Both tests demonstrated the feasibility of worldwide command and control, and communication (C³) techniques that will be needed for an SBI element.

Specific accomplishments in the SBI task address the critical issues of integrating new technology into hardware. As an example, two different algorithms have been developed and tested to demonstrate the rocket plume to booster hardbody handover function. These algorithms can accommodate large uncertainties in the spatial and temporal plume features of boosters, with which we would doubtless have to contend. We can therefore project with moderate confidence that the plume to hardbody issue will be resolved.

Future Plans

The SBI contractors have made significant progress in addressing the technology issues and bringing them to a level of moderate confidence, as depicted in Figure 4.2-2. Similar progress has been made in reducing the weight, size, and cost estimates for the interceptor. Weapon platform survivability has been supported by a number of passive hardening contracts that provided nuclear effects, laser, and system generated electromagnetic pulse (EMP) hardening.

Another example of recent accomplishments is the identification by the Survivability, Lethality, and Key Technologies Program of combinations of hardening, maneuvering tactics, and shoot-back compatibility which give the SBI configuration the ability to satisfy JCS mission requirements in the presence of possible Soviet defense suppression tactics.

The challenge to reduce the present costs of producing and maintaining satellites is very significant to the SBI program with large potential payoffs for all future satellites. Work on this critical issue is only in the design stage, but the producibility technology development for subcomponents and concepts such as redundancy and on-orbit maintenance and replenishment are strong candidates to bring down future satellite costs.

We expect to have sufficient hardware and test data in hand so that in combination with the computer analysis, we will have resolved all of the critical issues with high confidence. For instance, new studies to combine passive hardening of the weapon platform with maneuvering tactics and SBI shoot-back will increase confidence the enemy will have to pay a large penalty to successfully negate even a portion of the SBI element. Further work will continue in space platform tests of survivability concepts and will culminate in SBI integrated test.

**FIGURE 4.2-2
SBI System Confidence**

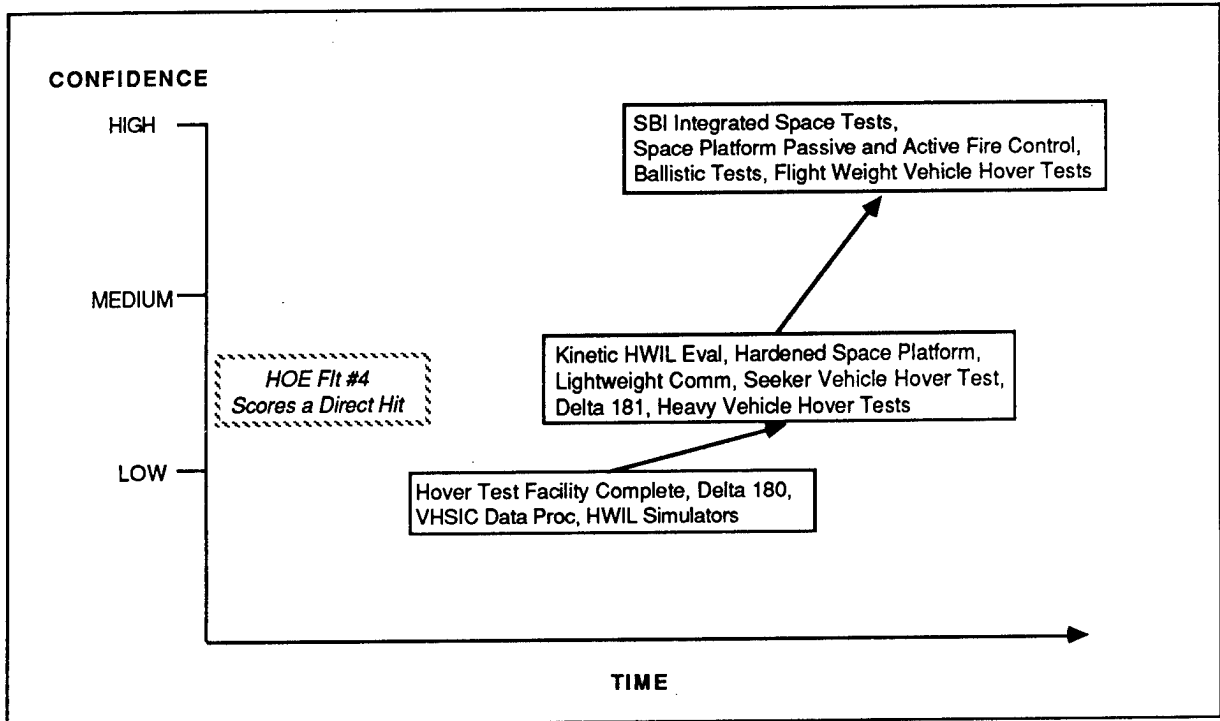

Expansion of the hover test capability at Edwards AFB is under way. This ground facility will allow checkout of stability and control software and hardware. In addition, scaled seeker tests can be done to demonstrate plume-to-hardbody handover algorithms for different types of solid and liquid boosters. While the anticipated data from these ground hover tests cannot make up for the needed high-altitude data against an earth background, the scaled results can be used in computer simulations to maintain program progress. Flight vehicle weight hover tests of the KKV payload of the interceptor are planned at the Edwards facility.

Integration of selected subcomponent technology will begin in early FY 1989. Ground testing of components is also planned to begin in FY 1989 with hardware-in-the-loop simulations at government and contractor facilities. Additional decisions will be made to incorporate advanced technologies, as developed in the Light Exoatmospheric Projectile (LEAP) projects, and supporting technologies in the FY 1994 timeframe leading to the baseline design of prototypical operational interceptors and weapon platforms for a possible space deployment. Hardware procurement is under way in FY 1988/1989 for several ballistic tests of partially capable interceptors.

Exoatmospheric Reentry Vehicle Interceptor System (ERIS)

Project Description

ERIS is a ground-launched exoatmospheric interceptor which can conduct hit-to-kill intercepts of intercontinental ballistic missile (ICBM) and submarine-launched ballistic missile (SLBM) RVs in the late midcourse phase of their trajectory. ERIS is designed to be inexpensive enough to permit substantial numbers of engagements of RVs as well as sophisticated decoys, thus providing a hedge against less than perfect exoatmospheric discrimination. Similar to the SBI scenario, midcourse sensors will acquire, track, and pass target information to the Battle Management/Command and Control, and Communications (BM/C³) element. Battle management will determine which objects should be intercepted, provide trajectory and launch data to the interceptor, and communicate updates to the interceptor to designate the handover targets from the SBI regime. The midcourse sensors, like the Space Surveillance and Tracking System (SSTS), will provide kill assessment.

The SDS Phase I ERIS is optimized for low life-cycle cost. Phase I ERIS technology has been selected to provide the lowest cost hit-to-kill performance at lowest projected interceptor weight and life-cycle cost. Technology development programs supporting this system include a low-cost miniature kill vehicle technology; advanced propellants and structures; and guidance, control, and missile electronics. For follow-on phases of the SDS, a preplanned product improvement (P³I) program is anticipated to include such modifications as an updated, cooled optical seeker and other improvements.

The ERIS functional test vehicle (FTV) program will demonstrate and validate the projected ERIS configuration. The FTV, compared with the operational ERIS designed for Phase I is shown in Figure 4.2-3. Both the FTV and the operational ERIS consist of a two-stage booster and a kinetic energy kill vehicle.

Accomplishments

Test results to date have increased the confidence in the ERIS development. These tests included a burst test of the second-stage booster assembly, validation of low-cost focal plane fabrication techniques, completion of advanced mirror manufacturing techniques which showed 20 percent improvement in seeker sensitivity, a successful testing of the reaction control system in the AEDC wind tunnel, and a cryogenic blow-down test to demonstrate the dormant seeker concept. In addition, 11 hot firings of a KV divert

propulsion system have been completed, and the first fully functional data processor allowing software/hardware integration to commence has been delivered.

**FIGURE 4.2-3
ERIS Flight Test and Operational Configurations***

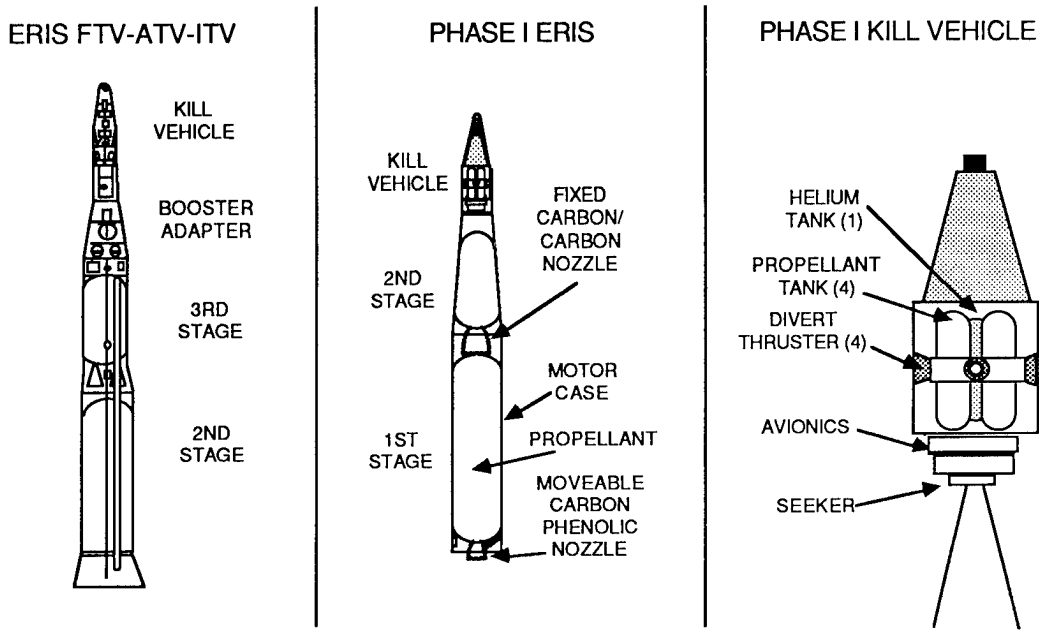

* Not shown to scale.

A major technology research program is under way to reduce life-cycle costs for ERIS and increase its capabilities. The ERIS program has demonstrated significant technical progress in the last 12 months. Technical developments to date include improved seeker sensitivity and performance which reduces the requirements placed on the midcourse sensor. Increased seeker performance extends the acquisition range and supports an increased sensor field of view. ERIS has also demonstrated improved inertial measurement (IMU) capability and smaller avionics and signal processing.

Future Plans

The functional technology validation (FTV) test series (shown in figure 4.2-4) will demonstrate low-cost, producible technology against a representative target. The Advanced Technology Validation (ATV) test

series will demonstrate and validate on-board discrimination and advanced seekers and avionics. The Integrated Technology Validation (ITV) (also shown in figure 4.2-4) test series will take the BM/C³, midcourse sensor(s) and interceptors, and demonstrate and validate them in an integrated series of tests.

**FIGURE 4.2-4
ERIS Confidence**

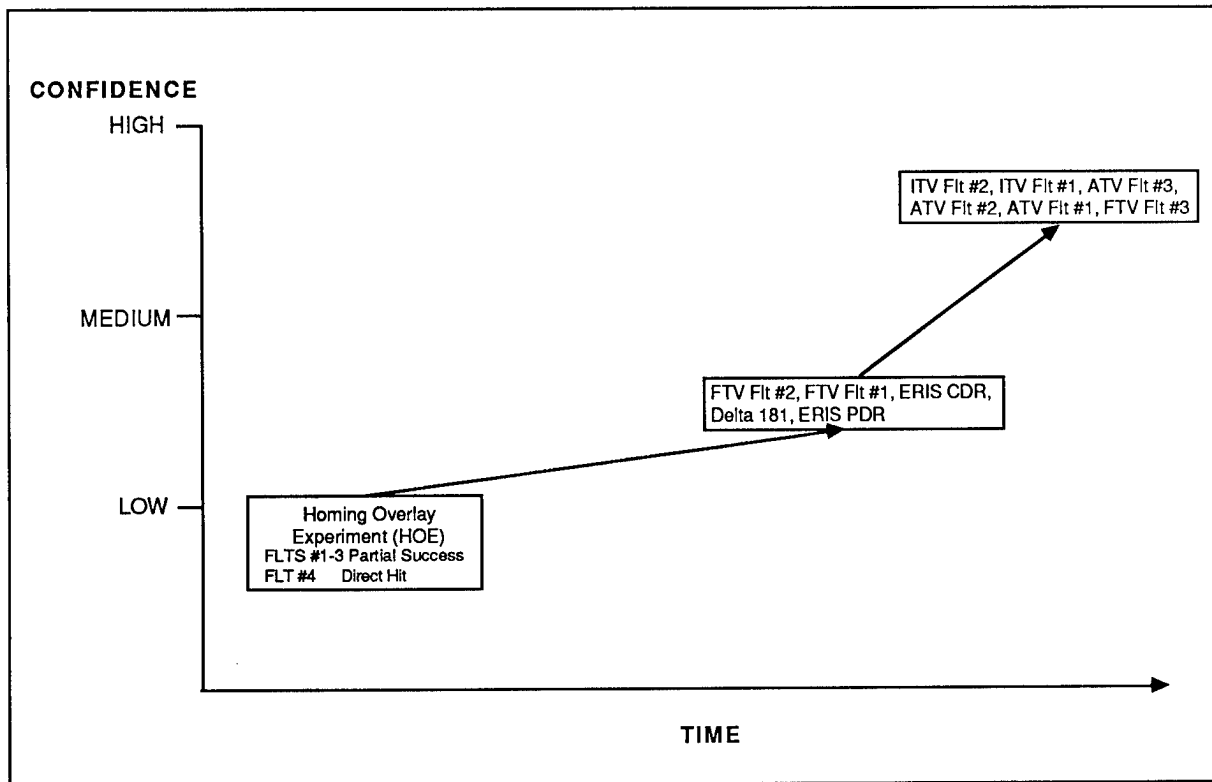

The critical issues in the development of ERIS are, first, to increase the probability of a hit-to-kill (Pk) while reducing the divert propulsion requirements. ERIS must use sophisticated software and avionics to reduce the cost to ERIS while seeking the optimal contribution to reducing the overall SDS cost. The seeker should be capable of being dormant and without maintenance for long periods and still capable of maintaining high sensitivity at relatively high temperatures.

A study is currently under way to examine those other technologies under development within the SDI program (SBI, LEAP, etc.) that could be tested in the ERIS Dem/Val test bed (ARIES II booster, observer

package, and kill vehicle). The ATVs include advanced 2-D staring seekers; lighter, more compact IMUs; advanced thrusters for divert propulsion; and an extended radius lethality enhancer for sweeping away decoys or closely spaced objects. The goal of this ATV program is to demonstrate and validate those advanced ERIS technologies which could be placed into the ERIS FSD to reduce requirements upon, and therefore the cost of, the midcourse sensor(s).

ERIS test vehicles may be employed to test pre-prototype BM/C³ and midcourse sensor elements in an interceptor end-to-end flight technical feasibility demonstration. These integrated technology validation (ITV) flights will model a realistic engagement against ballistic missiles. Planning and acquisition for FTV and ATV tests will continue in FY 1989.

High Endoatmospheric Defense Interceptor (HEDI)

Project Description

HEDI is the primary weapon of the final ballistic flight layer, or terminal phase, of the multitiered SDS concept. HEDI is a ground-launched, high-endoatmospheric interceptor capable of intercepting and destroying ICBM and SLBM RVs which enter the atmosphere from the midcourse phase. HEDI, when mixed in some ratio with ERIS, makes a penetration-aided, or "penaided," threat very costly. HEDI is an option for the SDS Phase I architecture.

HEDI is designed to accept its launch information from the battle manager. (Whether the information comes from an endoatmospheric sensor or an exoatmospheric sensor is immaterial to HEDI.) The launch information is loaded into the HEDI which then flies out inertially to a point in the atmosphere. Upon reaching this point, HEDI removes its shroud and begins to home in on the target using a passive IR seeker. For extremely long flyouts or target redirection, HEDI can accept updates.

Accomplishments

Test results to date have verified the window cooling concept and the warhead shape, fragmentation pattern, and velocity. Demonstrations have shown the propellant tank expulsion feasibility and the feasibility of delayed aerothermal kill. The first flight hybrid detector array has been produced and over 100 cool-down cycles demonstrated. In addition, the nose-tip platelet cooling injection concept has been validated and the shroud design completed. The first test of the Spartan rocket motor stored under controlled conditions was

conducted. Under ARCJET tests, the efficiency of a thermal protection system using forebody and window cooling was proved. The capability to grow and cut sapphire windows for HEDI using 13-inch boules was demonstrated and the first sapphire window was delivered on 2 February 1988.

Future Plans

There are five groups of key technical issues that are being resolved in the HEDI program. The first, window and forebody, deals with the types of materials to be used in the design of the window and forebody and the method to be used for cooling these critical components. The second, the seeker, requires the development of a sophisticated focal plane/hybrid detector array. The third is the design of a shroud. The fourth, the non-nuclear warhead, requires a design that will provide a high kill probability. The final issue concerns the KV's controls. This includes optimizing and characterizing the performance of each of the lateral thrusters. Figure 4.2-5 displays these technology issues. Milestones scheduled through FY 1990 will address the remaining critical issues. Once these issues are resolved, a high level of confidence in the HEDI to meet its operating requirements will ensue.

**FIGURE 4.2-5
HEDI Technology Issues**

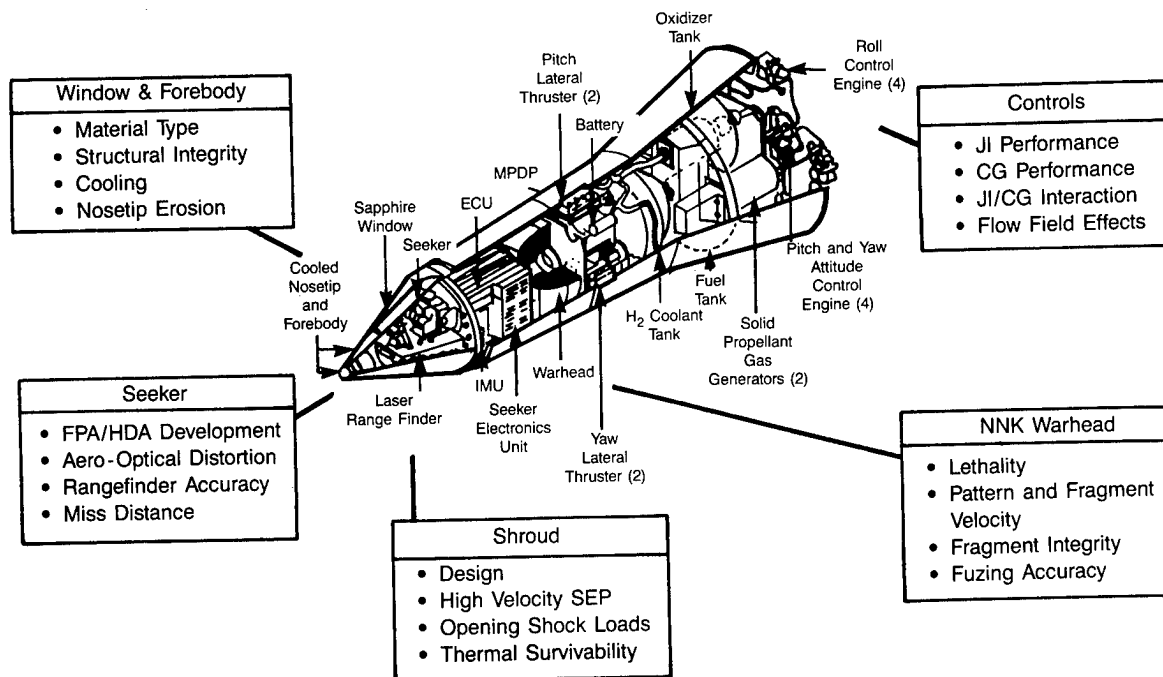

The HEDI Kinetic Kill Integrated Technology Experiment (KITE) program is an ongoing study program (initiated in January 1986) structured to resolve critical issues using existing and developing technologies. Completion of the KITE milestones will lead to flight test demonstrations of HEDI technology at White Sands Missile Range (WSMR). Each flight will demonstrate a greater complexity of technology than the last, culminating with the intercept of an actual target. The flight tests will be followed by intercepts of strategic-type targets at the U.S. Army Kwajalein Atoll (USAKA). These flights will have as their objective the realization of the operational system parameters.

Several key tests and milestones are scheduled in the near-term for HEDI as shown in Figure 4.2-6. The shroud and forebody will be delivered for integration in the third quarter, FY 1988, followed soon after by a sled test at Holloman AFB, New Mexico. The next two most significant ground tests are the aero-optics test at the Naval Surface Weapons Center, Tunnel #9, at high Mach, low-temperature conditions. These tests will be followed by tests in the AEDC under low Mach, but high-temperature, conditions.

**FIGURE 4.2-6
HEDI System Confidence**

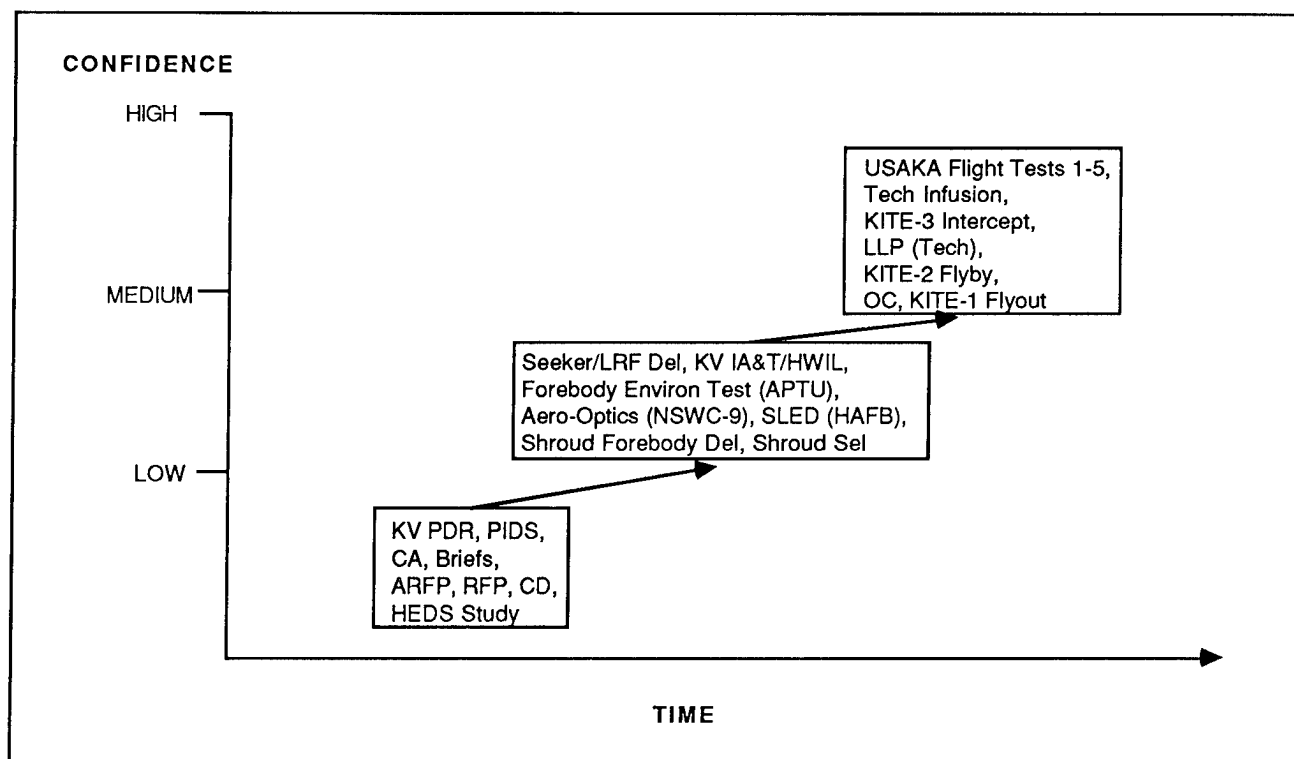

In FY 1989, the KV will be integrated and tested to be launched as KITE-1. With the completion of the seeker and laser rangefinder work, the second KITE test will occur. A third KITE test will follow.

The Dem/Val flights scheduled for the USAKA range will validate the infusion of baseline technology into the HEDI baseline technology interceptor. Starting with the first flight, a new IMU will replace the KITE inertial navigation units. By the third flight, an advanced fuzing device will be incorporated into the warhead.

Finally, later flights will use aerothermal seeker error compensation, improving the hit-to-kill ability at greater fly-out speeds. Each of these tests and the advanced propellant work will lead to confidence in the design of the prototype HEDI baseline technology interceptor. Integrated tests may be incorporated in the last two USAKA flight tests. Acquisition for the KITE tests will continue in FY 1989.

Miniature Projectiles

Project Description

The fourth major area of the KEW Technology Program, miniature projectile technology, provides advanced integration and launch technology concepts to support the interceptor development from FTVs and concepts through the FSD designs. The program stresses kinetic hit-to-kill coverage of the same ICBM flight regimes of boost, post-boost, midcourse, and terminal, as the previous programs. The program is broken down into three major areas: miniature projectiles, hypervelocity launchers, and fire control integration.

The first area is divided into space- and ground-based projectiles. The Lightweight Exoatmospheric Advanced Projectile (LEAP) is designed to intercept boosters, PBVs, and RVs. The low-weight, ground-based, endoatmospheric projectile (D-2) is designed to intercept terminal RVs. It is primarily configured to be launched from a hypervelocity gun with rapid energy switching. LEAP is an integrated component technology projectile and fire control program with technology goals designed to address the current and projected threat. Projectile development is occurring at an accelerated pace. State-of-the-art miniaturization technologies (propulsion, signal processing, seekers, avionics) are being integrated into a complete projectile with an ultimate light weight goal. The individual technologies developed in this program are being cross-linked into other KEW programs to eliminate redundancy and to best use the available funding. Figure 4.2-7 reviews the projectile portion of the LEAP program.

**FIGURE 4.2-7
LEAP Projectile Overview**

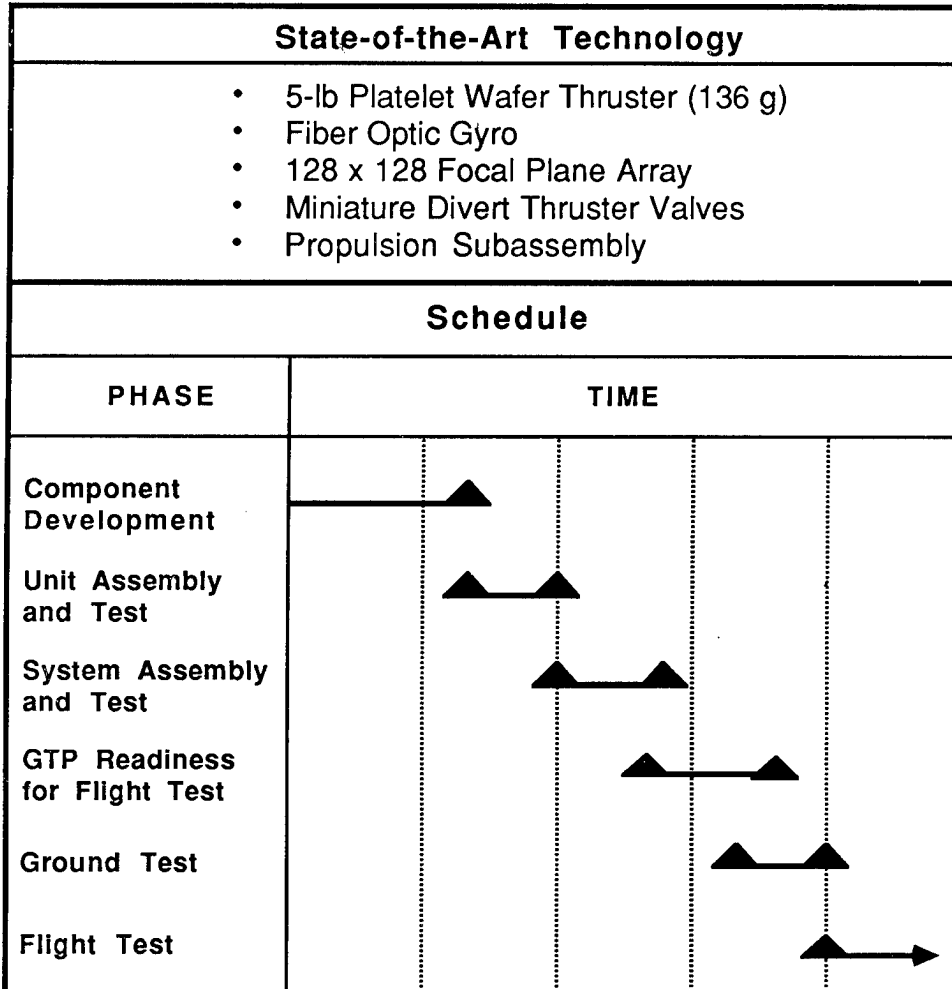

The LEAP Fire Control program will demonstrate the hardware to track targets (range, velocity, acceleration, etc.). This algorithm and hardware development effort will allow the fire control system to control many projectiles and intercept many targets simultaneously. Handover of targets to the fire control system is from the appropriate sensor for the application, i.e., a midcourse sensor for space-based systems or a terminal sensor for ground-based HVG and miniature projectile combination systems.

The hypervelocity gun (HVG) is the second area of research in the mini-projectile technology program. The program is a low-cost way to accelerate projectiles over a wide velocity range. This provides enhanced capabilities for space-based intercept of boost, post-boost, and midcourse targets (see Figure

4.2-8). In this role the HVG could negate threats to Phase I and follow-on strategic defenses. The HVG technology may also provide alternative launchers for the terminal defense and space-based interactive discrimination. These alternate launch devices are tied closely to the miniature projectile technology programs where weight is the critical issue which is yielding and producing payoffs across all KE interceptor development programs.

**FIGURE 4.2-8
Space-Based Hypervelocity Gun**

Expand the rapid fire EMG technology base to support a full-scale engineering and development decision for strategic defense.

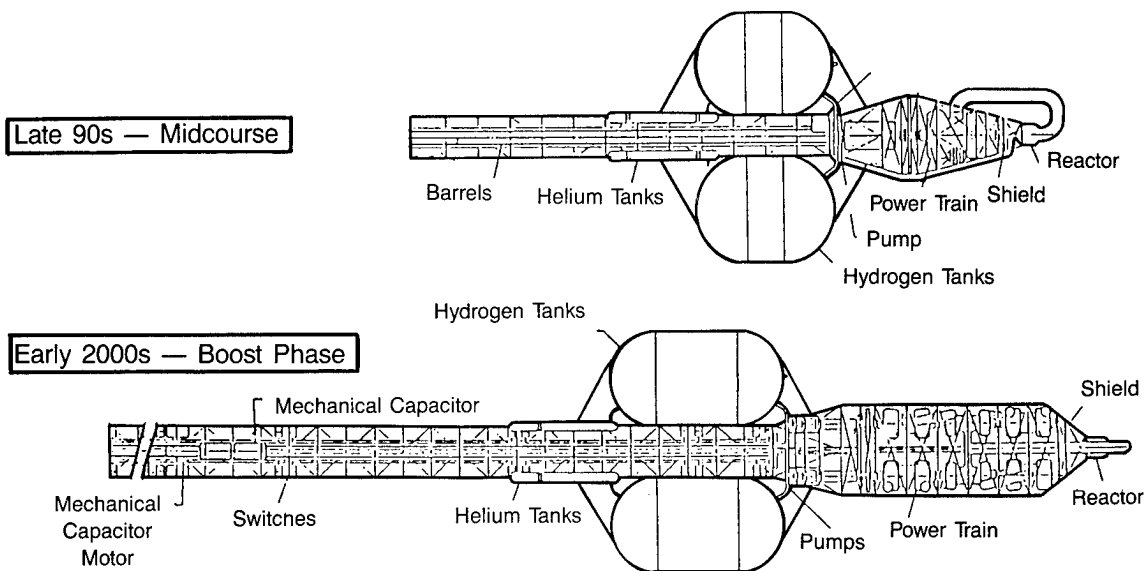

Accomplishments

The major technical accomplishment in FY 1987 for the LEAP program was the selection of baseline projectiles shown in Figure 4.2-9. Significant technical developments have been made in the design and testing of very lightweight components and subsystems including the FPA, seeker, IMU, propulsion, and electronics to address the critical issues associated with miniaturization of projectiles.

The HVG program is now at the component stage and is building toward a full-size integration demonstration. State-of-the-art programs have demonstrated separately the hardware performance

requirements of these components. For instance, high-speed switch programs validated the required firing rate for boost-phase intercept. This program has advanced the state of the art in switching by a factor of 150 in just 3 years. This fiscal year's testing showed that a gun could be directly fired with a special form of generator, called a compulsator, which eliminates more complicated power trains. Barrel efficiency has also increased in just 2 years, and barrel erosion issues are resolving such that many shots may be fired from a single barrel.

**FIGURE 4.2-9
LEAP and D-2 Baseline Projectiles**

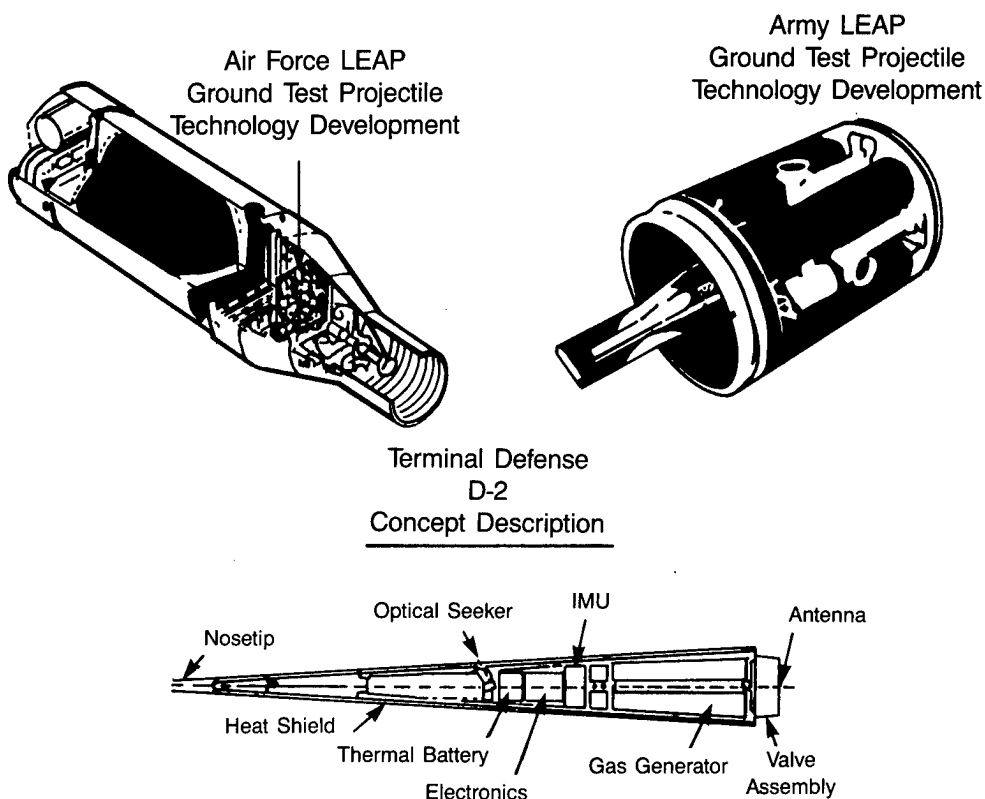

Future Plans

Critical issues in the LEAP projects are the miniaturization technologies (propulsion, signal processing, seekers, avionics) and the integration technologies to develop a complete projectile with an ultimate light weight goal. The projectiles must be able to withstand acceleration to greater than normal gravity. The critical issues of the HVG are to solve the efficiency issues in converting energy, improving the

barrel life and weight reduction, providing adequate switching for rapid and multiple engagements, and having sufficient thermal management of the large resistive loads that might cause thermal stresses.

The fully integrated program to develop the space- and ground-based variants of the miniature projectile, hypervelocity launcher, and fire control system are shown in Figures 4.2-10 and 4.2-11.

**FIGURE 4.2-10
LEAP Technology Program**

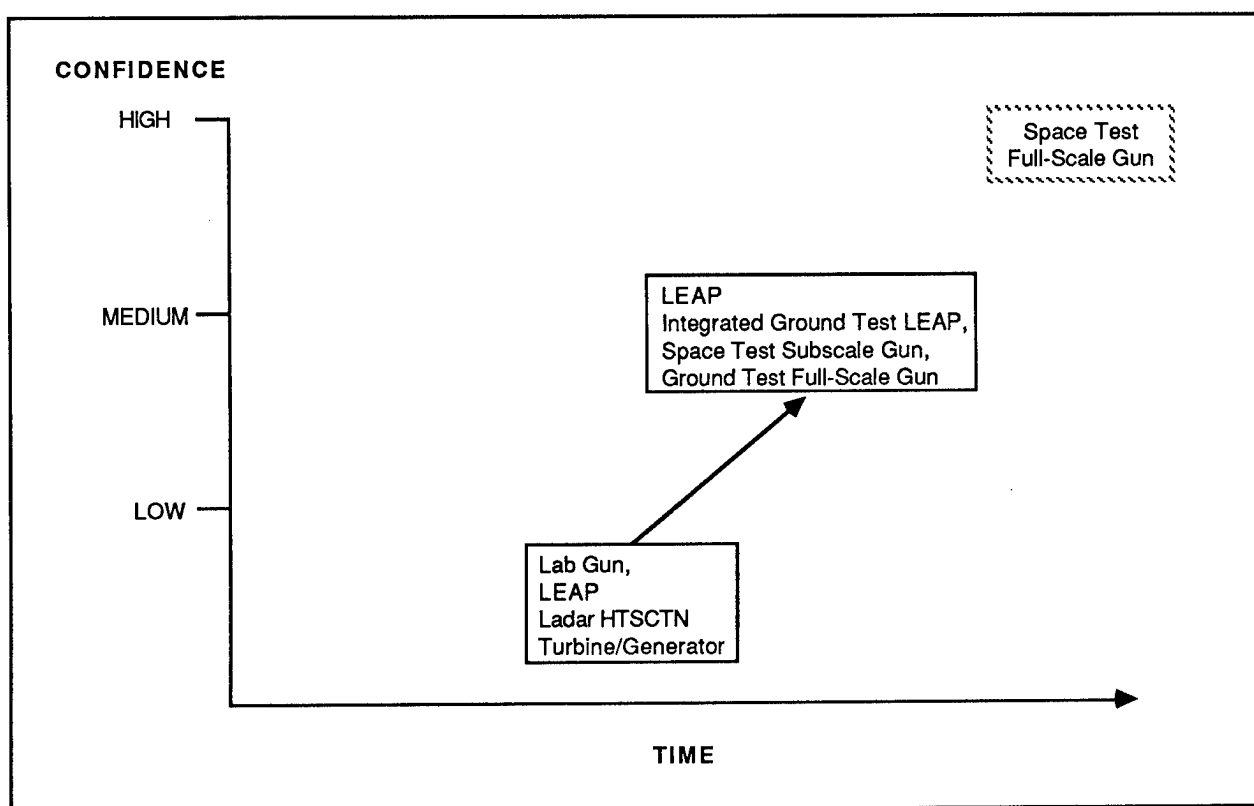

For the miniature projectiles in FY 1988, many subcomponents will be going into hardware-in-the-loop testing, including the seeker with its FPA, the divert propulsion, the avionic electronics, and auto pilot. Future testing will include a fully integrated projectile hover test and ground tests. The opportunity exists for exoatmospheric flight testing the LEAP or several of its components on one of the ERIS integrated technology flights (ITVs). The Air Force version of LEAP will be reviewed after the ground tests to determine its possible inclusion in the SBI as the KKV or by utilizing its advanced components. Advances in the

hypervelocity gun work indicate that testing of the LEAP or the D-2 in the HVG will begin. Advanced D-2 components could be integrated into the USAKA functional technology validation flights for the HEDI.

**FIGURE 4.2-11
Ground-Based EML Program**

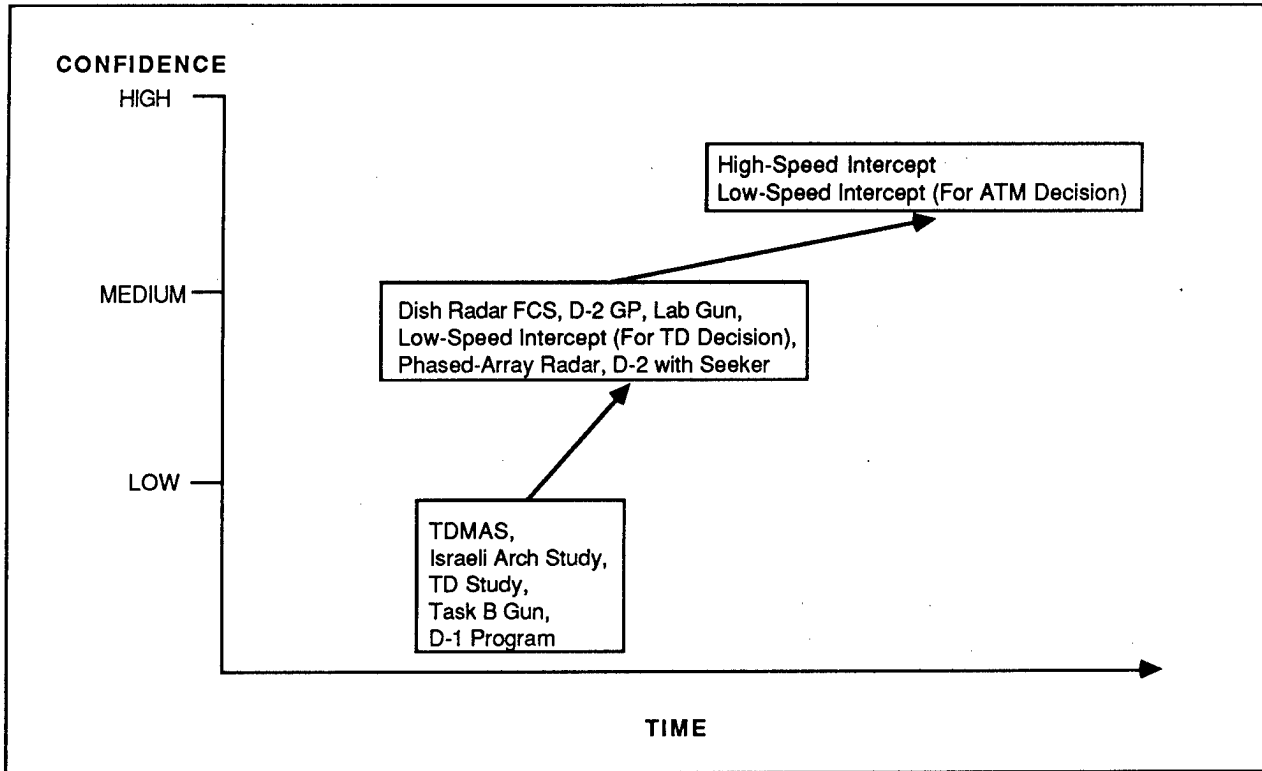

The construction of a 30-giga-joule battery power will enable testing of hypervelocity guns in the near future. Continued work in the switching research coupled with the increased power will provide multiple shot engagements in a realistic threat environment. An initial test of the space-based system is possible.

Test and Evaluation

Project Description

The T&E effort provides generic KE test range support and technical management of unique near-term experiments. Data from these experiments are essential to the formulation of KE demonstration and

evaluation tests. Included in these efforts are two significant technical milestones (STMs), as well as the Chief of Naval Operations Initiative, known as JANUS, and all KE-related range support, target development, and the hardware-in-the-loop (HWIL) simulation efforts that couple KE elements to the National Test Bed (NTB).

The objectives of the STM II, or Delta 181, experiment were to obtain various types of data on objects in a realistic space environment, missile exhaust plumes, the space interceptor environment, and backgrounds of interest to space surveillance systems, such as the Boost Surveillance and Tracking System (BSTS) and the SSTS. These data will aid in the development of programs such as the SBI and the ERIS.

Accomplishments

In the STM arena, STM-1, known as Delta 180, flew September 5, 1986. This experiment was a great success, well beyond expectations. The flight, which was conceived, designed, built, and executed over a 14-month period, accomplished all scientific objectives. These accomplishments included plume phenomenology measurements and high-speed space intercept with both intercept vehicles under thrust.

STM-II, known as Delta 181, was launched February 8, 1988, from the Eastern Test Range. The objectives of this experiment were to obtain various types of data on objects in a realistic space environment, missile exhaust plumes, the space environment, and backgrounds of interest to space surveillance systems such as the BSTS and the SSTS. These data will aid in the development of programs such as the SBI and the ERIS. All objectives for the midcourse and background tests were met, and a substantial amount for the plume tests objectives were accomplished. Hardware for the Delta 181 experiment was completed, integrated, and tested in preparation for execution of this extremely complex experiment in less than 2 years. A data base of over 8 gigabits of information is being developed and is expected to be operational by the end of 1988.

JANUS is a cooperative experimental test program between SDIO and the Navy. It uses Navy Trident C-4 missiles carrying space experimental payloads. Missions are planned which Concurrent SDIO experiments will provide vital phenomenology data needed for SDIO development programs.

JANUS Mission I was conducted in FY 1987 during which reentry bodies (RBs) for four JANUS phenomenology experiments were successfully designed, fabricated, and ground tested. RBs for three of the experiments were flown on a Trident (C-4) missile during its demonstration and shakedown operations

(DASO) at the Eastern Test Range. Due to an in flight failure very limited experimental data were collected. The JANUS Mission 1 objectives remain valid, and the program has been restructured to meet the schedule for later missions. The follow-on JANUS missions are just as vital. During FY 1987, studies and designs were completed for Mission 1 recovery flights.

Future Plans

The critical issue in the T&E project is the integration of advanced components into experimental payloads to obtain the phenomenology required for accurate validation of the KE interceptor's development. This is being accomplished using available booster hardware and launch facilities where appropriate. Future STMs are being planned that will build upon our Delta flight experience. As T&E support is required for the FTV test flights and beyond, appropriate emphasis will be shifted to the construction of the necessary launching and tracking facilities at the existing ranges.

Technology Support Project (Includes Theater Missile Defense and Technology)

Project Description

The technology support area, the sixth of the KEW Technology Program, includes theater missile defense (TMD) and foreign technology projects. The objective of the KE TMD and foreign technology program is to extend technology from the strategic arena to the intermediate- and short-range threat regime.

The TMD program will perform research on simulators, components, subsystems, and interceptor technologies and arrange for integration and test of hardware that can be used in theater defense applications. The objectives of the TMD program are being accomplished under three projects: Invite, Show, and Test (IS&T); Combined Allied Defense Experiment (CADE); and Extended Range Interceptor (ERINT). IS&T allows both U.S. and allied contractors to identify existing hardware or modifications to existing hardware for use in an interim TMD system. Selected components, subcomponents, or systems will be tested in appropriate test beds or ground-test facilities or by actual flights. CADE provides system, test, and hardware support for all KE theater defense programs. ERINT will modify the Flexible Lightweight Agile Guided Experiment (FLAGE) technologies with increased radar seeker performance, a reduced-weight warhead with fuzing function, larger attitude control motors, and the addition of a large booster rocket. The engagement scenario and target vehicle will be configured to validate non-nuclear kill of a tactical missile at realistic velocities, altitudes, and crossing angles.

A second objective of the KE technology support effort is to evaluate and develop unique allied technology which has applicability to SDIO's theater defense architecture. Tasks executed will be short in duration (3 years or less) and can be accomplished at a relatively nominal cost. As technology materializes, it will be folded into continuing work being performed by one of the SDIO executing agencies. These foreign technology objectives will be accomplished under the following joint programs: the electromagnetic gun technology of the United Kingdom; the Arrow missile, combined propulsion programs, and HVG demonstration with Israel; the cooperative U.S.-Netherlands HVG research program; and the exoatmospheric pop-up antenna with Italy.

Accomplishments

The FLAGE program concluded in FY 1987 with two successful target intercepts. The ERINT program will build on the existing FLAGE technologies to extend the range and velocity of TMD missiles. This technology uses millimeter-wave radar as the homing mechanism (as opposed to IR wave homing like the other interceptors). This homing methodology was demonstrated using modified off-the-shelf tracking radars to provide the intercept point updates during the interceptor's flyout.

A combined propulsion effort with the objective of exploring the feasibility of using a combination of electrical and chemical energy sources to produce hypervelocities in a travelling charged gun scheme continues with satisfactory results. A cooperative contract with an Italian firm continues to investigate the possibility of a pop-up millimeter wave radar seeker to acquire, track, and intercept RVs in the exoatmosphere as an alternative to IR seekers. A fluidic diverter valve contract was signed with a U.K. firm and work will begin in the U.S. at its main subcontractor's facility.

Future Plans

The critical issues for technology support are the ability to intercept tactical ballistic missiles in much shorter ranges and less time than the strategic interceptor developments. Additionally, the weight, size, and cost trade-offs must be favorable to continue these efforts.

All efforts with allied countries are structured to last 3 years on each task. There will be continuation of work under the memorandum of understanding the United States has with each country. However, the scope of the issues may change.

The Arrow theater missile defense program with Israel will be negotiated in FY 1988. The objectives of the program are to demonstrate Israeli Arrow missile technology and to conduct intercept tests against a surrogate tactical ballistic missile target. A joint U.S. and Israel HVG-theater defense experiment is being planned. The overall objective includes the design and fabrication of an experimental electromagnetic gun and demonstration of the electromagnetic gun's capabilities to intercept SRBM type targets.

Testing of subcomponent, component, and system hardware from the U.S. and foreign countries will be continued in the IS&T with support from the CADE and target support from the T&E program.

Support Project

Project Description

Support Project consists of advanced technology programs supporting, and funded within, each major interceptor and the miniature projectiles development projects. There are also projects supporting the Innovative Science and Technology (IST) Directorate. The advanced technology programs provide component transition from the functional technology Dem/Val programs to programs of a deployed SDS. These components include advanced seekers and sensors, inertial navigation units, signal and control processors, fire control elements, and divert and axial propulsion units.

Accomplishments

Roadmaps were laid out for each potential system element which link the near-term demonstration flight test subsystem technologies to those required for a systematically deployed SDS series of interceptors.

Component development and component integration efforts are producing designs and hardware for space- and ground-based projectiles of less than 4 kg in mass. During the past year, a significant technical breakthrough was achieved for inertial navigation units which will lead to two orders of magnitude cost and weight reductions over conventional devices. Sensors and seeker technology has demonstrated imaging focal plane arrays in the LWIR which are routinely being used to study tracking algorithms necessary for intercepting boost, post-boost, midcourse, and reentry simulated targets. Miniaturization of the computer chips and processors necessary for these tasks are well under way. Combustion chambers, nozzles, and valves which operate from off, to on, in less than 2 milliseconds have been demonstrated in the program. Axial propulsion units have been fired in research which supports both the space- and ground-based

interceptor requirements of the Phase I SDS. Of particular significance was the demonstration of a 6,300 pounds per square inch, absolute, burst test of a motor case which will allow the high pressure burning of safe conventional propellants in order to achieve high accelerations of ground-based endoatmospheric interceptor.

With the system requirements on the interceptor development being defined, this year will see advanced technology procurement in the areas of high burn rate boosters, liquid and solid miniature boosters, UV seekers and sensors, cooled optics, multi-color seekers and sensors, parallel processing test beds, radiation-hardened processor foundries, and mechanically steered agile beam tracking lasers. Work will continue on low-cost booster, resonant fiber-optic navigation units, electrically steered agile beam tracking lasers, divert propulsion units, and endoatmospheric computational fluid dynamics. In addition, recent advances in phased array millimeter wave radars and radomes will be added to the program. The innovative science technologies, which are emerging into the follow-on phases of the SDS, will be reviewed as to their readiness for entry into interceptor concepts and programs.

4.2.3 Funding Impacts

Funding reductions in FY 1988 forced a significant reduction in the ongoing technology programs that are critical to reducing cost and weight while increasing performance and survivability. The most visible impact on ERIS of the FY 1988 funding reductions was a slip in the first ballistic flight at the Kwajalein Missile Range. The reduction in the ERIS program of \$60 million, down to \$117 million, caused the prime and related subcontracts to be restructured and forced significant reductions in contractor and government agency efforts. Funding reductions also forced a significant restructuring of the HEDI program. The number of WSMR flight tests was reduced. The thruster and controls work was deferred until FY 1989. The number of ground and sled tests was reduced. The work on the testing of the Sprint and Spartan motors was delayed. Greater emphasis has been placed on the risk reduction program. Reduced funding levels now appear to be the only impediment to the building of an HVG. The near-term hypervelocity system would support the area of ground-based terminal defense. The budget constraints will limit the effort of follow-on JANUS missions to preliminary trajectory development, payload prefabrication design, and concept development validation by the Navy's SSPO.

4.2.4 Summary

The SBI is proceeding with a hover near-term test to validate many interceptor dynamics and vibrational technologies. The ERIS will soon move from component validation to the first full flight experiments designed to validate the system. The HEDI proceeds to resolve the very demanding issues of intercepts at high Mach speeds within the atmosphere with the planned stepped approach to flight demonstrations. The miniature projectile program will begin ground test projectile demonstrations while starting work on launch hardening components for HVG launches. Once the power facility is completed, HVG launches will begin. The KE program also supports TMD and allied tactical missile defense efforts with continuing demonstration of innovative and alternative technologies. We are addressing each of these elements in detail, conducting live-fire tests while concurrently developing the required parallel technologies, albeit at reduced funding levels. The KE program has already enjoyed several spectacular successes, Delta 180 and Delta 181, which fully justify the DAB decision to move KE elements into Dem/Val.

4.3 DIRECTED ENERGY WEAPONS TECHNOLOGY PROGRAM

4.3 DIRECTED ENERGY WEAPONS (DEW) TECHNOLOGY PROGRAM

This section provides an overview of the Directed Energy Weapons (DEW) Technology Program and discusses its technical objectives.

4.3.1 Program Overview

The objective of the DEW Technology Program is to identify and validate DEW candidates for ballistic missile defense missions. Bringing DEWs to bear on potential enemy responses to initial defense deployments could negate such responses by making maximum use of speed-of-light delivery of energy and the capability to store energy for multiple engagements.

The task of the Directed Energy Office (DEO) is to organize and manage research on directed energy technologies that could lead to candidate missile defense systems by: (1) determining whether there are DEW concepts that meet the criteria for development established by the DAB and the SDIO Director and (2) supporting a decision whether to proceed with the initial defense deployment by demonstrating that DEW concepts could be ready for FSD in a timeframe that would satisfy the needs of the evolving, sequentially deployed, SDS.

The DEW Technology Program brings together directed energy research efforts addressing the following four basic concepts identified as promising approaches to the needs of a multitiered defense:

- o Space-based lasers (SBLs)
- o Ground-based lasers (GBLs)
- o Space-based particle beams (SBPBs)
- o Nuclear directed energy weapons (NDEW).

The SBL concept consists of self-contained, modular, laser battle stations deployed in orbits to engage ballistic missile launches. Once deployed, such stations could engage ballistic missiles launched from anywhere on the earth in the critical boost phase, including broad ocean areas for submarine-launched ballistic missiles (SLBMs) and any potential launch sites for tactical ballistic missiles. SBL platforms not participating in the boost-phase battle (the "absentees") could provide extensive support to the midcourse mission and to overall SDS surveillance. The SBL could provide interactive discrimination (ID) in midcourse by destroying simple decoys, thermally tagging heavier

objects, and imparting a velocity change to heavy decoys. The SBL element has potential to provide target designation for the space-based interceptor (SBI) and the exoatmospheric reentry vehicle interceptor system (ERIS).

In the GBL concept, a high-energy laser beam is generated on the ground, propagated up through the atmosphere to one or more orbiting space relay mirrors, and then focused on the target. A GBL weapon system would ultimately consist of a number of ground sites with laser devices and the appropriate acquisition, tracking, pointing, and advanced beam control subsystems providing the compensation necessary to transmit the laser beam through the atmosphere to a space relay mirror, at geostationary orbit, then to a mission mirror at lower orbit and then to the target. By this means, ground stations located in the United States could engage targets worldwide.

The SBPB concept consists of a series of battle stations in space capable of engaging ballistic missile boosters and post-boost vehicles (PBVs) as they rise above the earth's atmosphere, as well as reentry vehicles (RVs) in the midcourse of their trajectory. Such a weapon has several potential kill mechanisms, ranging from structural melt at the high end, to high explosive detonation and electronics kill in the mid-range, to electronics disruption at very low levels. In addition, SBPB battle stations could play a significant role in fulfilling the discrimination function during the post-boost and midcourse phases and also pose a threat to hostile space-based assets.

The SDI research program is focused primarily on non-nuclear technologies. However, it is critical to the program to explore the feasibility of nuclear-driven directed energy concepts, in order to understand the potential impact of any such systems that the Soviet Union might develop, as well as to determine the feasibility of these concepts for future SDI options.

The Soviet Union has been conducting research on NDEWs for the past several years and some of its research predates our own. Because of this, a particularly important aspect of our NDEW research is to understand the extent to which such weapons, if used by the Soviets, could counter U.S. retaliatory forces, and destroy space-based elements of the U.S. surveillance systems and of a future U.S. strategic defense system.

As a direct result of its acquisition, tracking, and pointing capability, an SBL, GBL, or SBPB element has inherent potential to significantly enhance the SDS surveillance segment. Space units not

dedicated to the boost-phase intercept mission could provide extensive support to midcourse surveillance as well as to the satellite attack warning function.

Laser concepts also have the capability to provide the other elements of the defenses with target designation while advanced SBPB concepts could engage and destroy RVs in the midcourse phase, and ground-based pop-up particle beams could engage and destroy RVs in the late midcourse/early terminal phases.

4.3.2 Technical Objectives

The directed energy research efforts that support the four basic DEW concepts are grouped into six project areas: chemical lasers; free electron lasers (FELs); neutral particle beams (NPBs); acquisition, tracking, pointing, and fire control (ATP-FC); Mid Infrared Advanced Chemical Lasers (MIRACL); and concept definition for technology identification (CDTI)/emerging technologies. A summary description of each of these areas, the progress made in the past year, and future plans follow.

Chemical Laser Technology

Project Description

The primary effort in the area of chemical laser technology involves demonstrating the feasibility and scalability of the hydrogen fluoride (HF) chemical laser and associated beam control operating at mid-infrared wavelengths. The Alpha chemical laser represents the primary laser device thrust in this program. Alpha is a high-power, 2.7-micrometer wavelength, HF, cylindrical chemical laser currently in the final phases of integration and testing.

Also included in this technology area are optics efforts that seek to develop and evaluate high-performance materials, structures, and coatings for primary mirrors and advanced resonators required for very high-brightness, space- and ground-based laser systems. This includes a fabrication technology for manufacturing large, segmented mirrors; development and testing of high-power infrared (IR) and short-wavelength mirror coatings; and development of advanced cooling concepts for mirrors under very high radiation loads. Development of transmissive elements and unique components for beam control applications is part of these efforts.

Design and development efforts in the Large Advanced Mirror Program (LAMP) are also included in this area. LAMP, a large, lightweight, segmented space mirror, consists of face sheets, fine figure actuators, reaction structures, segment actuators, base plates, and the sensors and electronics necessary for active mirror surface control. Such active control is used to maintain the mirror figure in the face of thermally induced distortions.

A last group of efforts included as part of the chemical laser technologies area are wavefront control activities investigating beam sensing, beam control, and optical rapid retargeting concepts. These concepts are being investigated for high-power infrared (IR) and ultraviolet (UV)/visible beams from single and multiple aperture systems. Efforts include the development and testing of various advanced beam control concepts: nonlinear optics, wide field-of-view telescopes, and phased-array technology.

These wavefront control activities also include the Large Optics Demonstration Experiment (LODE) program. LODE addresses the generic technical issues associated with the ability to sense and control the high-energy laser wavefront in the presence of a dynamic structural environment. The LODE program consists of two elements: (1) a laboratory model experiment with a segmented primary mirror, and (2) beam control technology experiments. The latter will demonstrate single aperture beam control technology which is scalable to very high-brightness laser performance levels. To validate wavefront technology at high power, an adaptive mirror was installed and operated with MIRACL to accomplish laser beam cleanup.

The Zenith Star studies currently being conducted are maintaining the option for integrating key device and beam control elements and conducting experiments in space. These conceptual design efforts will ensure that the SBL remains a viable candidate for future deployments by generating a technology roadmap for the potential space flight of the Alpha laser and LAMP Mirror.

Accomplishments

Rapid progress has been made in developing the technologies required for single module weapon platforms. The Alpha HF laser device components are being integrated. The associated testing began in 1987. Recent accomplishments of the Alpha program include: completion of the diamond-turned annular resonator optics (Figure 4.3-1) to the required root mean square figure

accuracy; completion of the gain generator assembly (Figure 4.3-2); and completion of the space chamber/pressure recovery system in which the device will be tested (Figure 4.3-3). The rugged, highly reflective coatings required for the high-power beam train components have been developed, tested, and validated. Radiation-hard coatings with similar capabilities have been designed and fabricated. High-power testing of these coatings will occur this summer.

**FIGURE 4.3-1
Diamond Turned Beam Compactor**

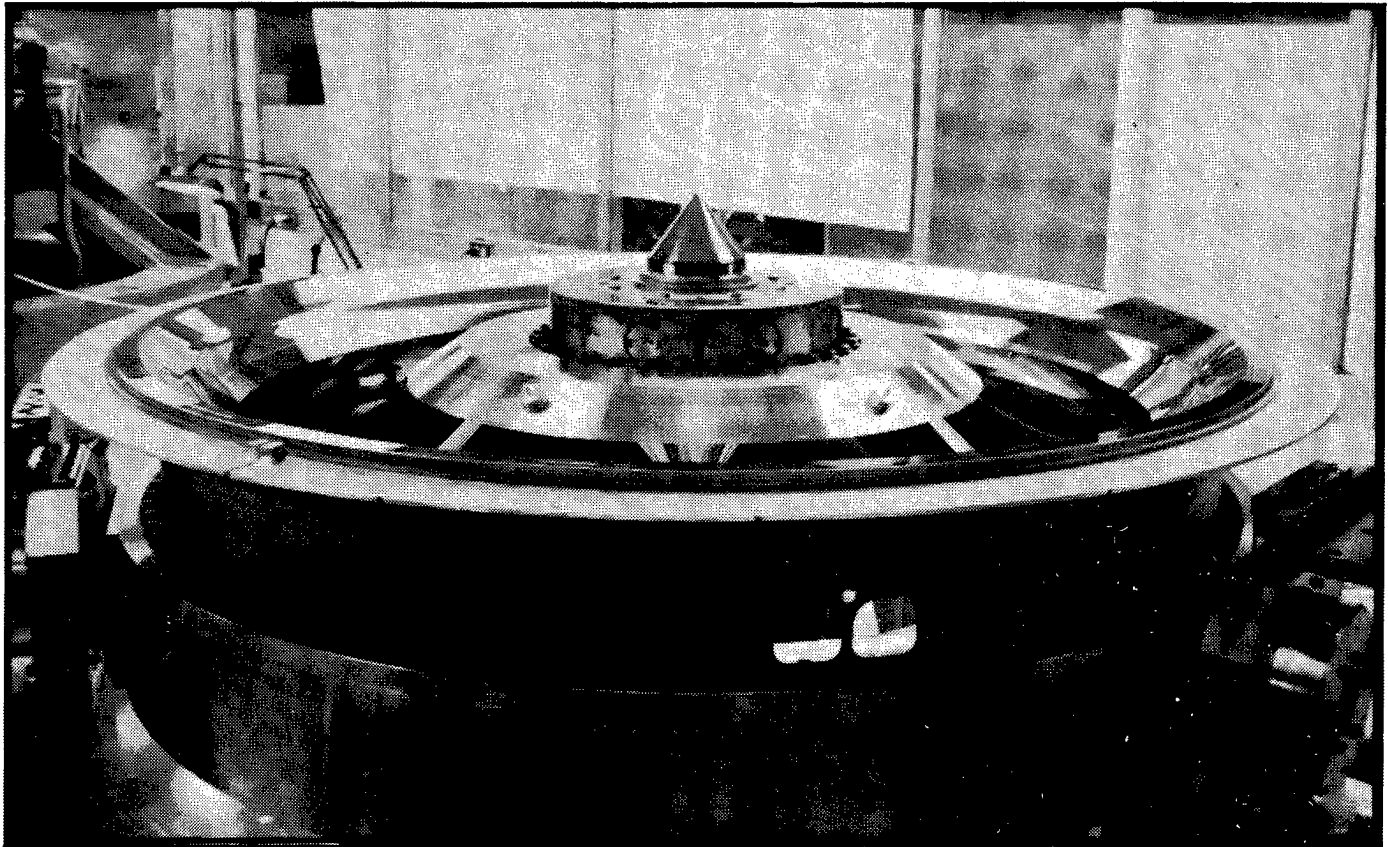

Fabrication of a large lightweight, segmented adaptive mirror (LAMP) has been completed. Testing will be completed in FY 1988. The mirror design and fabrication techniques were selected with scaling to very large apertures as a primary goal. The mirror segments were produced with a largely automated polishing procedure specifically developed for this purpose. This greatly relieves concerns for producing large quantities of precision optics.

FIGURE 4.3-2
Gain Generator Assembly

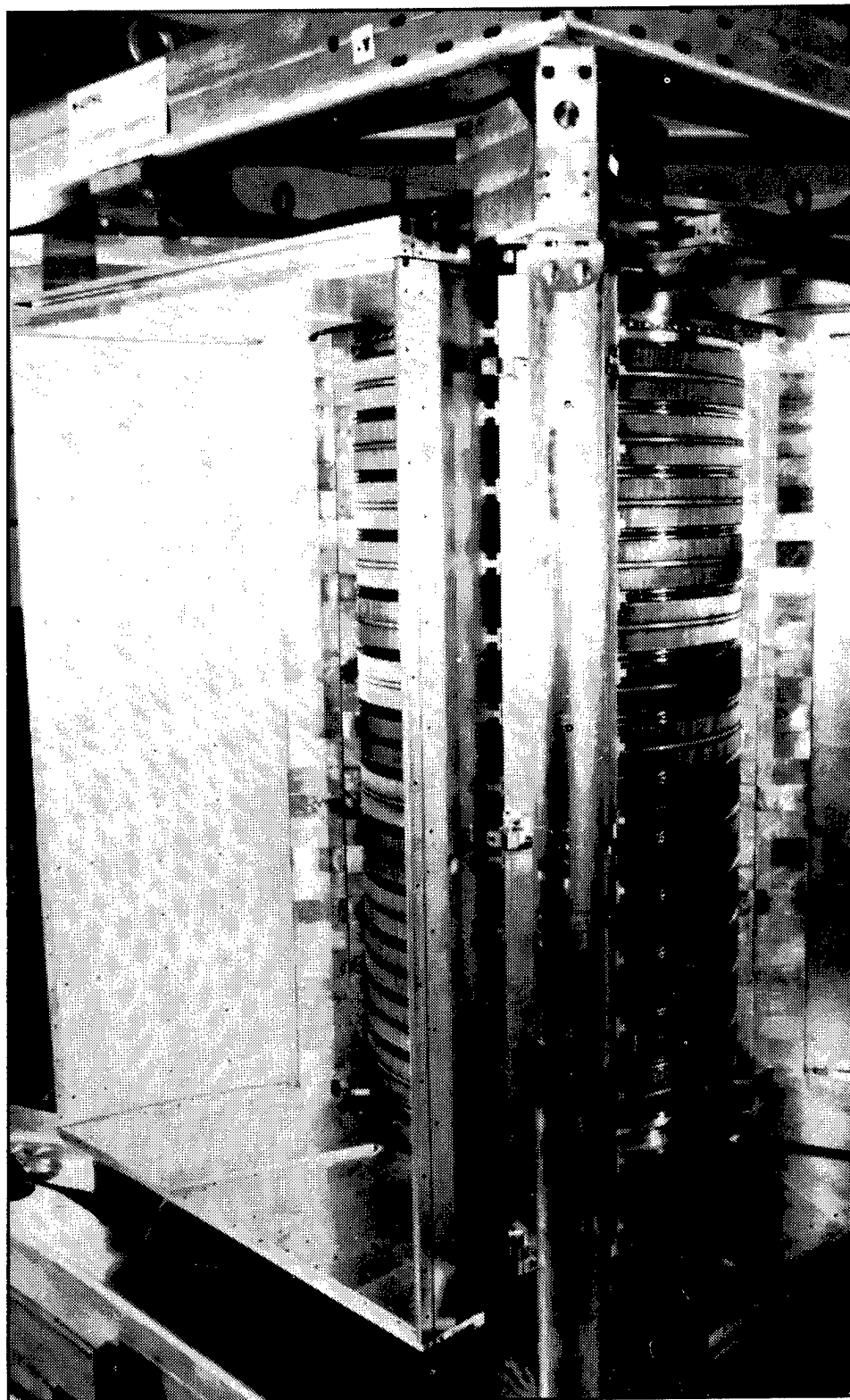

FIGURE 4.3-3
Test Facility with Space Chamber and
Pressure Recovery System



LODE laboratory model tests were successfully completed in 1987 (Figure 4.3-4), confirming the utility of outgoing wavefront sensing for beam control. This laboratory model is a high-fidelity emulation of the hardware and controls needed for correcting the jitter and higher order aberrations of a laser beam to the performance levels required for strategic defense. In separate technology programs during 1987, technology was scaled to fabricate holographic elements in highly reflective multilayer dielectric coatings, and a laboratory model of an outgoing wavefront sensor was tested which scales to the size and performance required to meet system requirements.

Experiments designed to confirm growth potential to very high laser powers were completed in 1987. They proved that beams from combustion-driven, hydrogen fluoride chemical lasers could be

coherently combined either by coupling the resonators themselves or by employing master oscillator-power amplifier configurations. On-axis phasing of multiple apertures at low power has been demonstrated in several laboratories. The critical issues of off-axis steering and control are being resolved by SBL technology base activities.

FIGURE 4.3-4
LODE Beam Expander

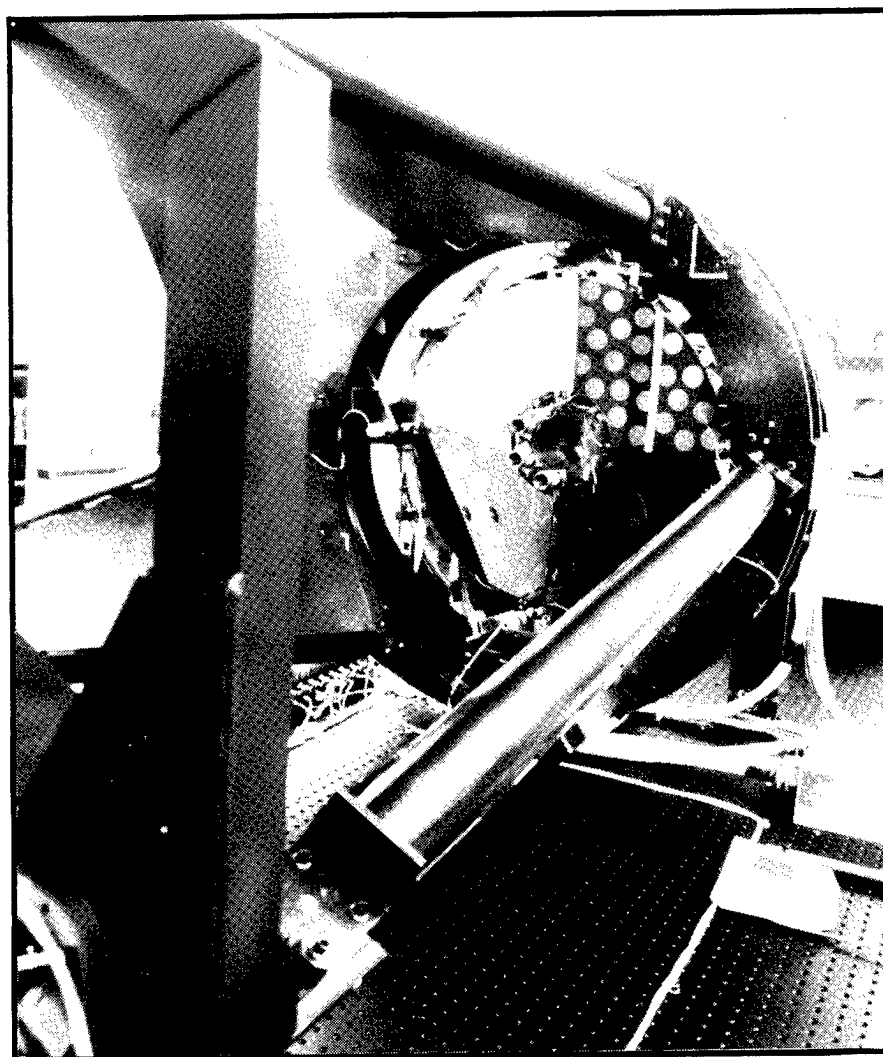

During the past several years, considerable progress has been achieved in "high-leverage" technologies that may considerably enhance the performance, affordability, and producibility of both initial and advanced SBL platforms. In 1987, experiments were performed which indicate that use of stimulated Brillouin scattering, a nonlinear optical process, is very promising and may also greatly relieve mirror fabrication specifications, further enhancing producibility and affordability.

Future Plans

For the future, the chemical laser technology program will continue with the development of chemical lasers and related technologies and then concentrate on integration into the SBL program as shown in Figure 4.3-5. Knowledge gained from Alpha will be applied as subscale testing progresses and complete system integration and testing begins. The LAMP mirror will also undergo final acceptance tests. The Starlab experiment will help resolve ATP issues. Information from these programs and experiments will then be applied to the Zenith Star ground and flight tests. Successful completion of Zenith Star will essentially serve as concept validation and enable the start of complete systems tests.

Zenith Star studies maintain the option for integrating key device and beam control elements and conducting experiments in space. These conceptual design efforts ensure that the SBL remains a viable candidate for future deployments by generating a technology roadmap for the potential space flight of the Alpha laser and LAMP mirror.

Zenith Star ground and space experiments will complete the data base for a decision in the early 1990s on developing the space-based chemical laser for strategic defense. The ground experiments will integrate and functionally test the two principal segments of the Zenith Star research spacecraft: the forebody, consisting of a large beam expander incorporating the LAMP mirror and sensors for ATP, and the aft-body, consisting of the Alpha laser and high-power beam control system. Subsequent to ground testing, these two segments will be integrated for a series of high-and-low-power space tests to resolve the majority of critical technical issues determining effectiveness of the HF space-based chemical laser and its readiness for development. These tests will also resolve critical ATP and space beam control issues for GBL concepts.

**FIGURE 4.3-5
Space-Based Laser Confidence**

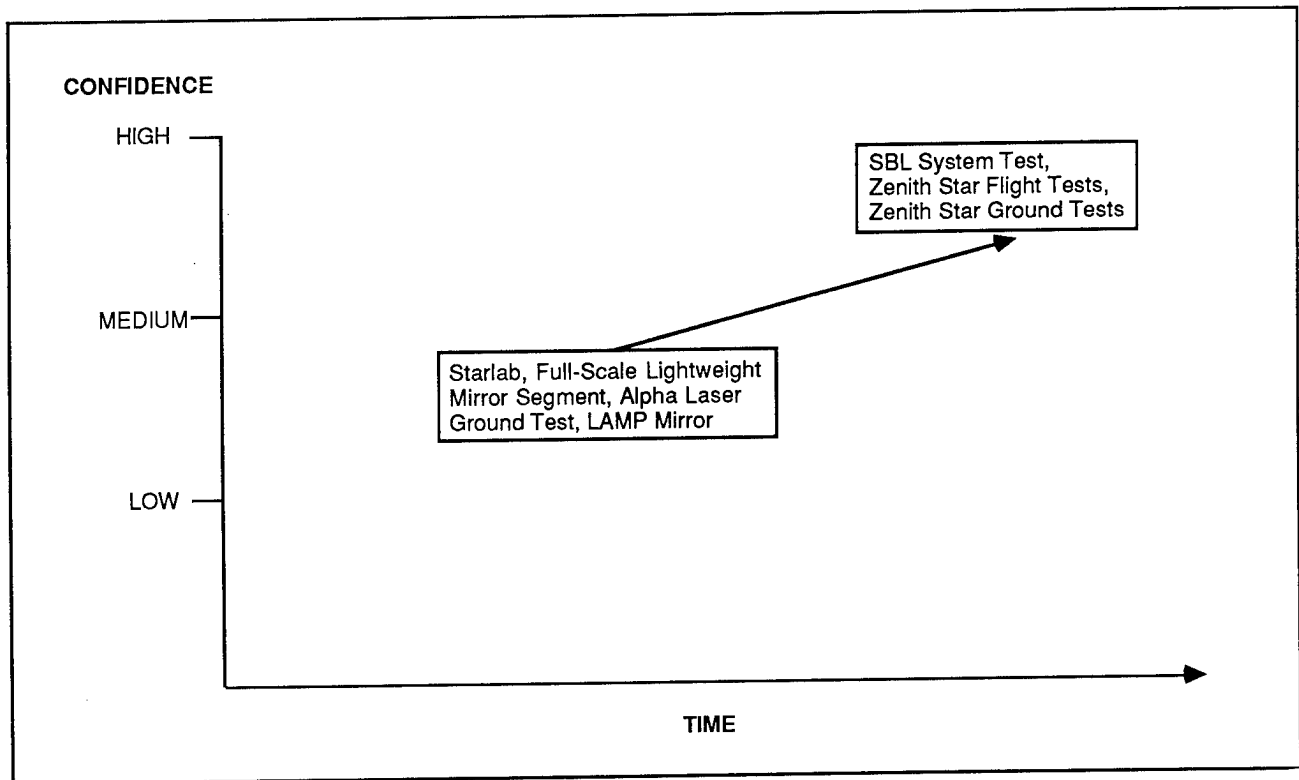

The critical technical issues for the SBL element revolve around the high-energy laser device, high-power beam control and optics, ATP, and platform integration. Most of the critical issues for the high-energy laser device will be resolved during ground testing, but the issue of laser exhaust management can only be resolved by space tests. HF and other gases are ejected radially outward during HF chemical laser operation. To avoid the possibility of degrading optics or other components, immediate and longer term distributions of gases about the spacecraft must be well known.

Space tests with a high-power beam are required to resolve the principal high-power beam control and optics issues. Excellent beam quality and line-of-sight stability on accelerating targets must be maintained. These requirements are so stressing that very long, optically quiet paths are required to obtain sufficiently accurate measurements. The spacecraft is a large, lightweight, complex two-body structure in a zero-g environment. A very large, lightweight, flexible pointer acting as a beam expander is required. Both spacecraft segments contain many load paths and disturbance sources,

including coolant flowing at tens of gallons per minute, and reactants, propellants, and exhaust flowing at tens of pounds per second. This extremely complex spacecraft cannot be modeled with the accuracy required to confidently predict the efficacy of the high-power beam control system. Because the high-power device and beam control components are closely coupled through the space-based laser platform and very high performance levels are required, only a high-power space test can provide the confidence needed for a development decision.

ATP issues include detection of the plume, acquisition, and fine track of the missile, and aimpoint selection and maintenance during high-power irradiation. Zenith Star space experiments contribute to resolution of these issues with a series of low-power experiments using thrusting, unaugmented and cooperative targets against realistic backgrounds, and high-power tests using critically augmented, cooperative targets. The high-power tests confirm that low power results are not compromised by effects such as flow-induced disturbances, thermal loading of the high-power beam on the optics, and scattered high-power radiation.

Platform integration issues will be studied initially with ground tests simulating critical aspects of the operational environment, such as vacuum, thermal, and dynamic loading. However, space tests are required prior to a development decision to establish, with confidence, the functioning of the numerous and complex interfaces on this large spacecraft. Zenith Star flight tests will support a comprehensive test of the space-based laser system.

Free Electron Laser Technology

Project Description

This project focuses on the technology needed for the GBL weapon system. The state of the art of the laser beam generator (the FEL) and associated beam control are being advanced to demonstrate the capability of high-power, ground-based lasers to perform the strategic defense mission of boost-phase intercept of ICBMs and SLBMs. A second major objective is to demonstrate the boost-phase GBL system's potential to perform midcourse ID. Also included in this project are efforts to develop FEL beam generators applicable to space basing.

The ground-based FEL program is an intensive laboratory and field research project that will demonstrate the GBL technology needed to enter FSD. It is focused on four major objectives. First,

the program will show that FELs can be built, integrated, and operated at multimewatt power levels. Second, the program will demonstrate that a very high-power laser beam can be steered through a beam director, acquire and track a space target board, and deposit its energy on that space target. Third, the program will show that distortions on the laser beam caused by uneven heating of the atmosphere and other phenomena can be corrected and compensated for on the ground using an adaptive optics subsystem. Fourth, the program will demonstrate the systems integration and operation of a FEL, a beam control system, and an atmospheric compensation subsystem. Additionally the program will demonstrate the feasibility of a space-based relay mirror integrated with ground elements of GBL systems to validate the GBL concept for strategic defenses.

The other part of the FEL technology area deals with the development of a space-based FEL that will be able to address the strategic defense mission of boost-phase intercept of ICBMs and SLBMs. It should also provide an alternate path to the high brightness sought in the phased chemical laser program. To accomplish this goal in the most cost-effective manner, the NPB and Ground-Based FEL (GBFEL) programs are being used to complement this effort. Specifically, the NPB will address the issues of operating an accelerator in space, while the physics of laser operation will be addressed by the GBFEL program. The space-based FEL will concentrate on those technologies necessary to bridge the gap between the other two programs.

Accomplishments

The FEL technology category has experienced rapid gains in the last several years. The induction linear accelerator (linac) version (Figure 4.3-6) uses a high-current electron beam in a series of short pulses at moderate repetition rates. Because of the high-current electron beam, this type of FEL makes an efficient amplifier.

In experiments at Lawrence Livermore National Laboratory (LLNL), the induction linac FEL has been demonstrated to operate with high efficiency at long wavelengths. Experiments with a 4-megaelectronvolt electron beam and tapered wiggler produced peak powers greater than 1 gigawatt at a 9-mm wavelength. Current experiments with the 50-megaelectronvolt Advanced Test Accelerator (ATA) and 5-meter-long wiggler have already demonstrated amplification at the 10.6-micron carbon dioxide laser wavelength.

High-brightness electron beams have been produced using thermionic dispenser cathodes. These brightness levels have increased several orders of magnitude since the first experiments on the experimental test accelerator. Current brightness levels are already adequate for the 1-micron wavelength which is the goal of this program. Furthermore, these high brightnesses have been achieved at high repetition rates using magnetic switching technology. A technique of guiding the electron beam through the accelerator, resulting in extremely small transverse motion, has been developed. This makes use of a low-density ion channel formed by ionization.

FIGURE 4.3-6
Recent Progress for Induction Linac FEL

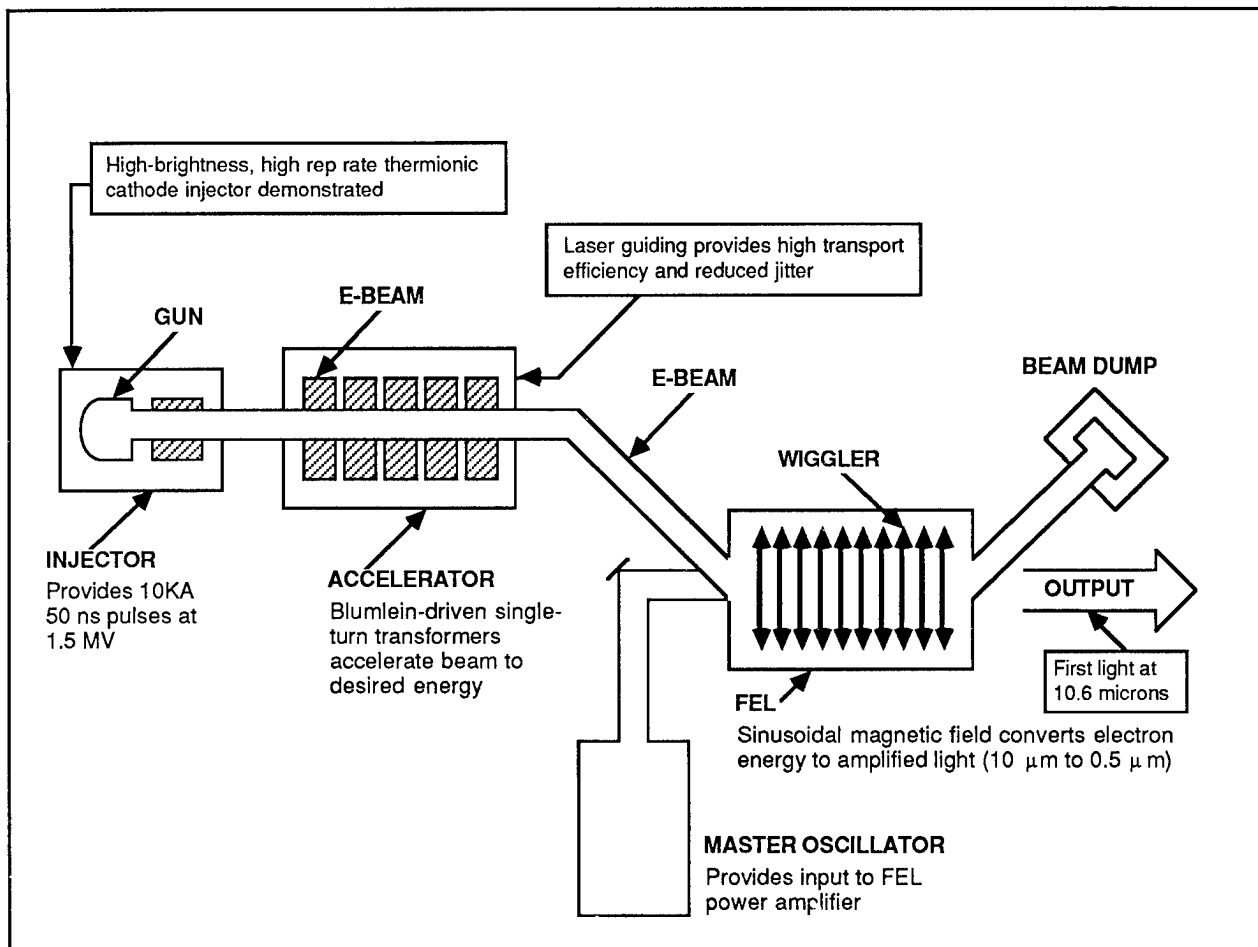

The second type of FEL candidate uses an RF linac to produce a lower peak power beam in a series of short, high-repetition rate micropulses. The beam is accelerated directly by RF fields applied

to a series of hollow cavities. This type of device, with its lower peak current, has been developed mainly as an oscillator, but amplifier configurations have also been designed.

RF linac devices have lased at extremely short wavelengths, demonstrated high efficiency, and served as test beds for the development of new, very high-brightness injectors. These injectors use a series of short visible laser pulses to eject electrons from the cathode by photoemission, resulting in high peak currents with high brightness. Grazing incidence optics have been developed and tested for ring resonators for radio-frequency FELs. In experiments at Los Alamos National Laboratory, parabolically shaped optical surfaces have expanded the optical beam and reduced the power loading on optical surfaces by a factor of about 50.

Experiments using low-power laser beams have demonstrated the ability to compensate for distortions in the atmosphere caused by turbulence. Using adaptive optics ("rubber mirrors"), a blue laser beam was propagated to aircraft, rockets, and the Space Shuttle. Corner cube reflectors were used to obtain a return beam which provided a reference signal of wave front distortion. Using adaptive optics to predistort the outgoing wave front, the brightness of the outgoing beam at instrumented target rockets up to 600 kilometers away was improved by a factor of more than 1,000, as compared to an uncompensated beam.

Substantial progress has also been made in developing both adaptive optical elements and other optics for GBL. A 2,000-channel, uncooled deformable mirror and wavefront sensor have been completed and are being tested. A 31-channel, cooled deformable mirror as well as a heat exchanger for a 241-channel, cooled mirror have been fabricated and are now being evaluated. A facility to evaluate coating damage has been completed and is now being used to evaluate FEL coatings.

At intensities greater than 1-megawatt per square centimeter, GBLs lose intensity in passing through the atmosphere by stimulated Raman scattering from atmospheric nitrogen. Laboratory experiments at Lincoln Laboratory have suggested that the effects of Raman scattering can be mitigated by broadening the frequency spectrum of the outgoing laser beam.

Future Plans

To provide the earliest answers about the technology potential for these high-leverage boost-phase concepts, the GBL program is focused on three major areas of parallel research. The first is the

Ground-Based Free Electron Laser Technology Integration Experiment (GBFEL TIE). This experiment addresses the ground segment components of lasers, beam control, adaptive optics, and facilities necessary to conduct a GBL proof-of-principle systems experiment at the White Sands Missile Range (WSMR), New Mexico.

This ground segment experiment will resolve the most important issues of laser power generation and control, systems scaling, atmospheric compensation and beam propagation, and systems integration during the Dem/Val phase of GBL systems development. Following a successful experiment, this ground segment technology will provide the basis for full-scale development (FSD) of a beam control system.

The second major activity of the GBL program is concerned with the space segments of the system. Here, relay and mission mirror spacecraft will be designed and subscale hardware fabricated during the Dem/Val phase. Once the GBL concept has been validated, a full-scale spacecraft will be fabricated.

An important aspect of the space segment research concerns ATP technology necessary to ensure that the laser beam can be relayed from mirror to target with the necessary accuracy and stability. The GBL program has joined with the other space research efforts within the SDI Program to resolve these critical early ATP issues. Experiments, such as the Relay Mirror Experiment (RME) and Starlab and Zenith Star, will provide the essential design information necessary for the GBL full- and subscale satellites to reach their 1990s launch schedules with the ATP data needed. This will be done without duplicating other already funded and scheduled research.

The third major focus of the GBL program deals with risk reduction and supporting technology. Issues of producibility, manufacturability, and quality assurance will be addressed. Of particular importance are the issues of nonlinear and cooled optics, large optical components fabrication, and coatings application which are pursued in coordinated efforts with optics development in the chemical laser area. Because many of the ground and space segments of the GBL require high-quality optics, it is imperative that this area of technical research proceed in parallel with fundamental equipment research.

Likewise, the questions of atmospheric propagation, thermal blooming, turbulence correction, and stimulated Raman scattering require supplemental computer modeling, laboratory research, and

field experiments to ensure that the predictions for the larger scale WSMR experiments will be successful. Understanding the interaction of high-power laser energy with the atmosphere is also vital to the success of the GBL program. Therefore, several supporting national laboratory and university research projects have been established as risk-reduction efforts. LACE, a space experiment, will correlate laboratory results on low-power atmospheric compensation.

In the future, basic physics problems will continue to be resolved and then integrated into the GBL program, as shown in Figure 4.3-7. Laboratory tests should resolve the remaining basic physics problems and allow progression to subscale tests. Subscale tests should resolve any remaining propagation and scaling issues and allow fabrication of hardware for systems integration and testing. The relay mirror experiments if successful, will validate the systems concepts and enable full-scale testing to begin. The relay and mission mirror tests will serve to complete concept validation and will progress simultaneously with full systems tests. Detailed design and acquisition for lasers and the Beam Control System (BCS) experiment will begin in FY 1989.

**FIGURE 4.3-7
Ground-Based Laser Confidence**

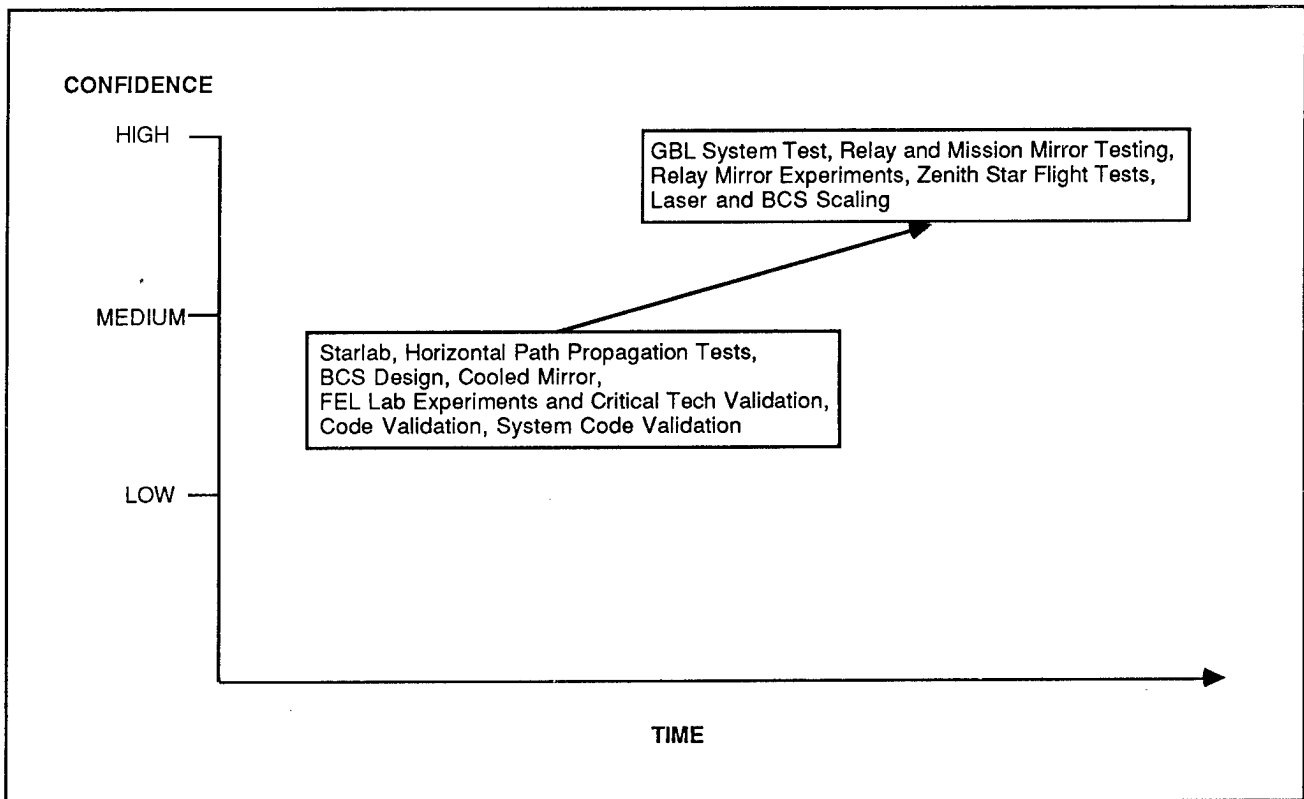

Neutral Particle Beam Technology

Project Description

NPBs are produced by accelerating moderate current pulses of hydrogen ions to high energies, directing the pulse toward a target, and stripping off the electrons, leaving the neutral hydrogen ion to proceed in a straight line to its target impervious to magnetic fields. Once at the target, the pulse of ions will interactively discriminate RVs from decoys by mass discrimination. A heavy RV hit by the ion pulse will yield a shower of neutrons and gamma rays that can then be detected by sensor systems. A light decoy yields a much weaker, easily discriminable signal. The entry level ID system is also capable of effecting electronics kill on launch systems in the boost and post-boost phases. The more robust NPB systems will increase target handling rates and will have the ability to attack and kill RVs in the midcourse phase of the attack. A functional schematic of the NPB is shown in Figure 4.3-8.

**FIGURE 4.3-8
NPB Functional Schematic**

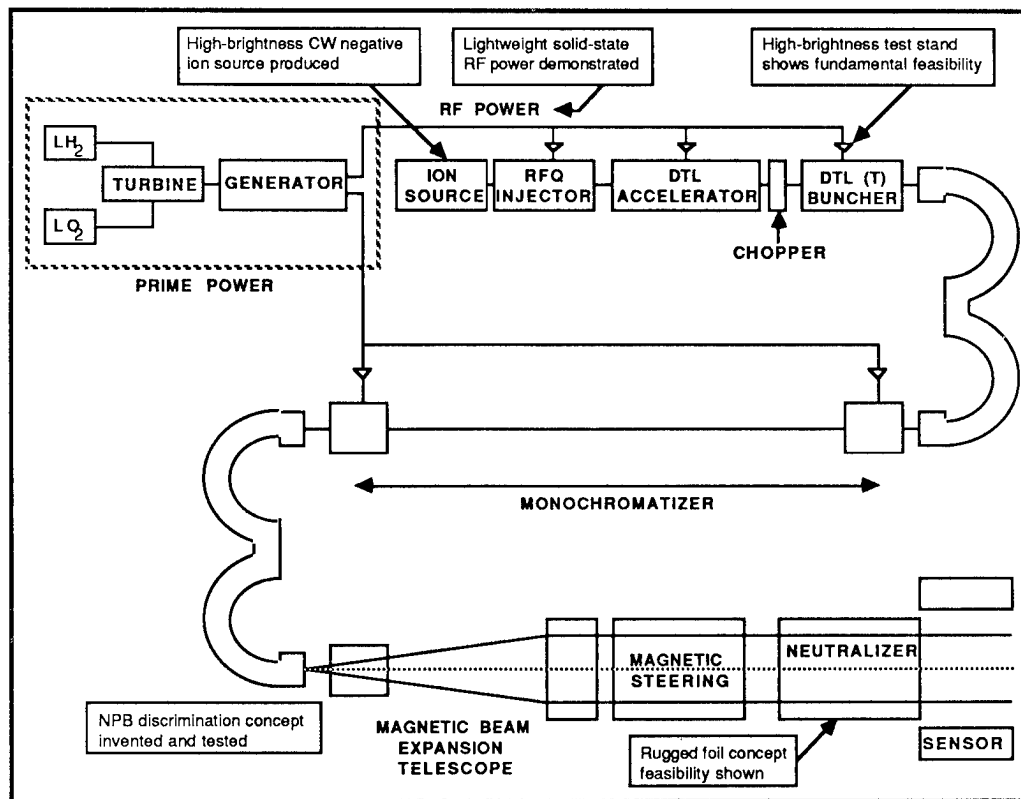

The NPB program has two integrated ground-based experimental efforts, two space experiments and a technology development program which, together, specifically address the technical issues pertinent to the feasibility of deploying an NPB system capable of interactive discrimination and boost-phase intercept. The two integrated ground based experiments are the Ground Test Accelerator (GTA), which addresses all the issues pertinent to optics and beam quality, and the Continuous Wave Deuterium Demonstrator (CWDD), which addresses high duty factor (CW) operation and operation with the deuterium ion. The two space experiments are the Beam Experiment Aboard Rocket (BEAR), which addresses the basic space operability issues of the NPB accelerator front end on a non-orbital rocket flight, and the Pegasus orbital experiment which addresses all the integrated NPB system operability issues that cannot be addressed on the ground having to do with zero-g operation and operation in the space plasma environment.

The GTA is the primary test bed for the NPB ID/weapon system. It is designed to demonstrate scalability to the performance parameters established in the Concept Definition and Technology Integration (CDTI) Studies. The design philosophy for GTA is to incorporate space traceable technologies where appropriate. The technologies which will be required for space-based NPBs include the 180-degree bend for compactness, cryogenic operation for higher electrical efficiency/lower platform weight, and automated operation for rapid remote start-up and operation.

The CWDD addresses the technical issues unique to 100 percent duty factor operation, which are: (1) generation of continuous-wave ion beams with the requisite quality, current, and particle type; (2) stable operation of such a beam for expected mission-level time intervals; and (3) management of the waste heat generated during continuous-wave operation. The requirement for continuous-wave operation is imposed by expected target handling rates for the ID mission as determined by the CDTI studies in conjunction with electrical power generator issues (pulsed vs. CW). The CWDD will consist of an ion source/injector, a radio-frequency quadrupole (RFQ), and one or more drift tube linac sections. This configuration includes the components critical to ion accelerator operation while minimizing the cost of continuous-wave RF power hardware and greatly reducing the radiation hazards that would be associated with a higher energy deuterium accelerator research and development effort.

The NPB technology effort addresses all of the technical issues that are not addressed by the NPB integrated experiments or other technology/systems directorate programs, plus some of those technical issues which are addressed in the integrated experiments that show promise of significantly

enhancing NPB system performance with additional development of higher risk approaches. NPB-specific technology development efforts have resulted in feasibility demonstrations of NPB accelerator components (e.g., injectors, RFQs, drift tube linacs on the Accelerator Test Stand at Los Alamos National Laboratory, and neutralizer foils at Los Alamos and a contractor's facility).

However, full-scale demonstrations of beam control components such as magnetic optics, steering magnets, neutralizers, beaming sensing, and ATP require further development. The NPB sensor program is separately managed by the SDIO SATKA Office but is closely coordinated with the DEO NPB program. NPB-specific technology efforts will also emphasize high-payoff areas such as laser photoneutralizers, superconductivity applications, very high gradient accelerators, etc.

The NPB space experiments are designed to address specific experimental issues requiring resolution in the space environment. The BEAR rocket flight results will provide preliminary data relevant to the Pegasus design and to the overall feasibility of NPB space operation. The Pegasus orbital experiment will be designed to answer specific space operability issues at the proposed system deployment attitude. Pegasus performance parameters will be set at the minimum required to adequately resolve all the experimental space issues, while minimizing the cost issues.

Accomplishments

The NPB program has made significant progress in a broad spectrum of technologies key to the feasibility of developing the NPB. Great strides have been made in solving some of the problems originally considered potential "show stoppers," and steady progress is being made in formalizing the design codes and manufacturing processes necessary to the consideration of deploying an NPB element (See Figure 4.3-9).

Ion source technology is proceeding on two major fronts, with both surface and volume technologies demonstrating significant performance advances. Ion source technology is also being transferred to industry.

The Accelerator Test Stand operating at Los Alamos National Laboratory has demonstrated the ability to produce and accelerate a negative hydrogen beam. The Accelerator Test Stand is currently the highest brightness accelerator in the free world. Equally important is the fact that Test Stand accelerating components are built by industry to design code specifications and are operating at

design specification performance levels. This ensures that the technology is transferable to industry and is not a one-of-a-kind scientific oddity.

**FIGURE 4.3-9
Neutral Particle Beam Confidence**

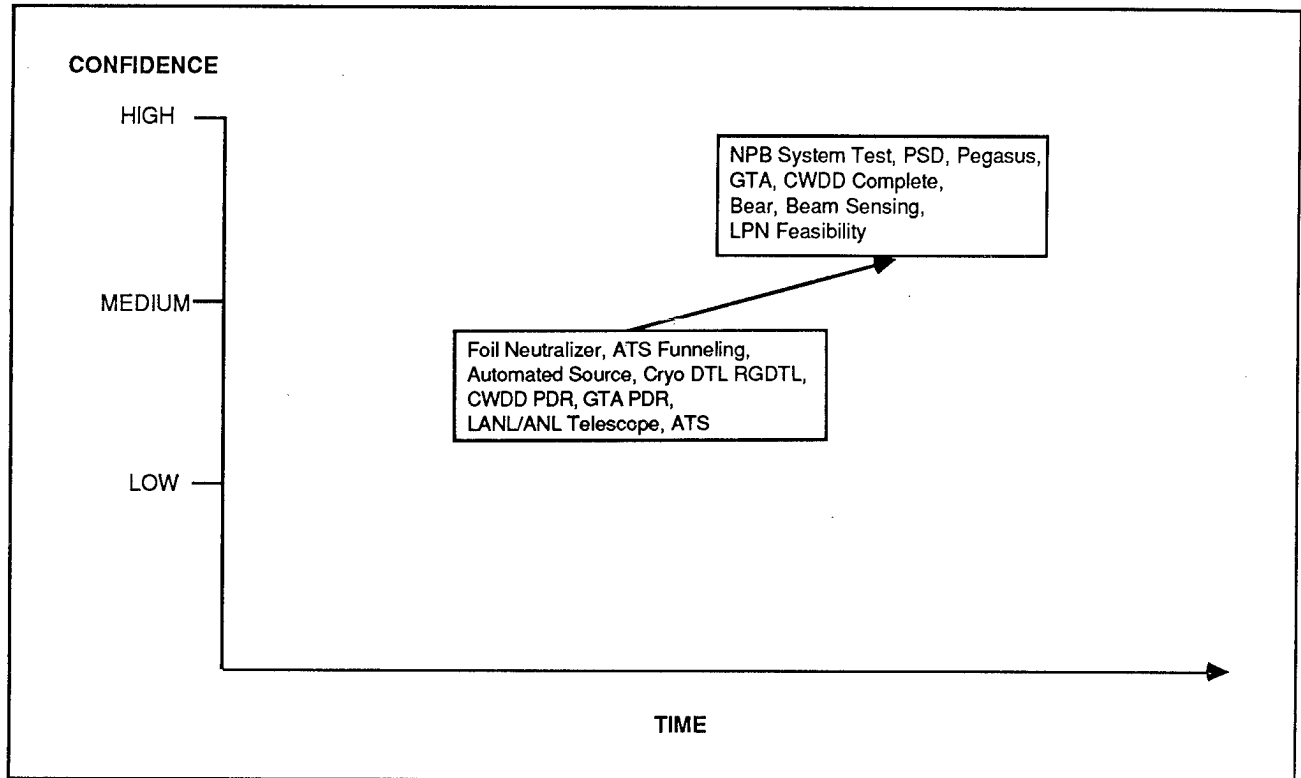

The design and fabrication of the GTA magnetic objective lens were completed at Lawrence Livermore National Laboratory in March 1987. Because the GTA beam line is not complete, preliminary plans are to test this lens at Argonne National Laboratory during FY 1988. A 30-centimeter objective lens has also been fabricated and shipped to Argonne National Laboratory and was successfully tested. The GTA expansion telescope is being designed and, once built, may be tested at Argonne National Laboratory and/or Brookhaven National Laboratory prior to installation on the GTA beamline.

The neutralizer required to strip the electron from the hydrogen/deuterium ion after it has been accelerated and pointed was originally conceived as a large gas cell. The realization of a gas

neutralizer for a deployable NPB element was considered very high risk. The primary neutralizer concept currently being developed uses a thin foil to strip the electron. While this is not a new technology, it was originally rejected on the basis of being too fragile and not adequately scalable to deployable system requirements. The NPB program has demonstrated that foil technology can be made structurally durable enough using graphite materials.

The RF power required to operate an NPB platform comprises a significant portion of the total projected platform weight. A concerted design effort within the NPB program has brought the figure of merit, grams per watt, down. Design efforts are aimed at further reductions for deployable system applications. This weight-reducing, space-saving technology advancement will have immediate application to the tactical systems from which it was derived. A joint program with SDIO/SLKT has been initiated to demonstrate integrated power generation compatible with NPB platform requirements.

Other NPB program technology advancements are finding immediate spin-offs into civilian applications. The permanent magnetic material developed for magnetic optic systems will appear in the automotive starter motors of some 1988-1989 automobiles. The space-qualified manufacturing techniques for RF quadripoles are key to the radiation therapy equipment being developed for the National Cancer Institute. This equipment makes ion radiation therapy feasible for hospital use in cancer treatment. The RF quadripole accelerators are also under serious consideration by the FAA for scanning luggage, etc., at airports.

The NPB program has seen a drastic reduction in key developmental programs that were originally rated as high-risk efforts. Research efforts to date have shown the technology to be easier to develop and manufacture than was originally thought.

Future Plans

Several major technical development efforts have been initiated and will be pursued to resolve the technical issues pertinent to NPB system feasibility. The GTA will address all but two of the technical issues (CW operation and the deuterium particle) pertinent to the generation of a weapon/discriminator grade particle beam. While the accelerator will be constructed to be CW capable, it will be operated in the pulsed mode to reduce costs. The GTA is being constructed at LANL in a joint effort with an aerospace contractor.

The CWDD will address the remaining two issues of beam generation not addressed by the GTA. The difficult issues concerning CW particle beam generation occur at the low-energy end of the accelerator, and therefore, it proved to be more economical to address these issues using a separate accelerator. The CWDD will be built and tested by industry (final contractual negotiations are currently in progress).

The two NPB space experiments will build on and contribute to the ground based experiments. The BEAR flight from will provide valuable data concerning space operability that will directly feed, in conjunction with the GTA 24 MeV experimental hardware, the design of the Pegasus hardware. The flight of Pegasus will complete the space experimental requirements for the NPB system.

For the future, the NPB program will progress from subscale testing through integration and testing to a validated concept. Space Power Experiments Aboard Rockets (SPEAR), an IST project being developed in conjunction with the NPB program, will look at power conditioning components exposed to a space environment. The Army Background Experiment (ABE), which is "piggybacked" on the Laser Atmospheric Compensation Experiment (LACE)/Relay Mirror Experiment (RME) experiments in the ATP-FC project, will measure the atmosphere-reflected neutron background. The information gathered from SPEAR, ABE, and the ATP experiments will provide the technical base needed for GTA experiments. These low-power GTA tests, followed by high-power GTA tests will essentially serve as concept validation of the NPB. Successful completion will enable the start of complete systems tests. Detailed design and acquisition for BEAR and PEGASUS will begin in FY 1989.

Acquisition, Tracking, Pointing, and Fire Control Technology

Project Description

ATP-FC technology base efforts will advance requisite technologies to perform critical functions for candidate DEW concepts, both space and ground based. These functions include acquiring and prioritizing the targets to be engaged, establishing the line of sight to hit the aimpoint, holding the beam on the aimpoint, assessing the resulting damage, and reinitiating the sequence to engage a new target. The ATP-FC technology base includes technology development for boost/post-boost phase

intercept, midcourse discrimination applications of SBLs, the space segment of the GBL, SBPBs, and several concepts incorporating nuclear-driven DE devices.

Efforts in the ATP-FC technology base are divided into five tasks: (1) ATP-FC integration, (2) rapid retargeting, (3) pointing and control, (4) advanced tracking, and (5) space ATP experiments.

The ATP-FC integration task provides integration of ATP-FC technology development and demonstrates the feasibility of attack management decisions in an operational timeline. The rapid retargeting task provides a feasibility demonstration of rapid retargeting at operational performance levels. The pointing and control task provides the technology elements for precision beam pointing from large agile DE platforms. The advanced tracking task provides the technology to generate DEW beam fine-pointing direction and commands to the target aimpoint. The space ATP experiments task is essentially a long-range planning effort. Among candidate experiments being considered is a project to demonstrate the agile control of a large structure in a space environment in the post FY 1990 timeframe.

In addition to the ATP-FC tasks, efforts are under way in coordination with GBL efforts to provide the requisite space relay technology. Space relay technology development efforts apply to relay mirrors which reflect the laser beam transmitted from the ground station and to mission mirrors which receive the relayed beam and focus it on the target. Surfaces of mirrors must be figured and controlled within a small fraction of a wavelength. The two candidate concepts for the relay/fighting mirrors being pursued are: (1) the flat, or nearly flat, monocoil and afocal mirrors, and (2) the bifocal mirrors with two coupled beam receiver and director telescopes.

Accomplishments

Concepts have been developed for both relay and fighting mirrors for the space segment of the GBL. Both planar afocal mirrors and bifocal mirrors with rapid retargeting capability have been designed. The fabrication of lightweight, half-scale mirror segments has been completed, and an integrated ground experiment is under way.

The Talon Gold ground experiment has demonstrated the capability for performance of an integrated pointing and tracking system. The technologies developed and validated include high-bandwidth beam stabilization, low-bandwidth target tracking, and vibration isolation using magnetic

suspension. This experiment has contributed to resolution of key SBL system issues including boresight accuracy, closed-loop stabilization in the presence of mechanical and optical disturbances, and boresighted tracking accuracy.

Development, fabrication, assembly, and checkout of the Rapid Retargeting and Precision Pointing simulator were completed. This simulator is a hybrid which includes both software and hardware and is a unique resource in the world. Through the testing of modal avoidance retargeting control algorithms, the feasibility of mechanical rapid retargeting was demonstrated.

ATP-FC integration activities include collecting booster plume data using available sensors such as Probe and HICAMP and observing both static firings and actual launches. There have also been laboratory demonstrations of booster handover algorithms using computer-generated plume and background scenes.

In pointing and control efforts, analytical predictions of mechanical disturbances on board SBLs, the space segment of the GBL system, and SBPBs were completed. The Space Active Vibration Isolation laboratory model demonstrated large-scale broadband isolation in one degree of freedom. In the Passive and Active Control of Space Structures program, critical structural damping was demonstrated on substructures similar to those which might be used on a DEW platform. The Talon Gold laboratory model demonstrated isolation and precision stabilization for first-generation systems. There were also a demonstration of beacon tracking in the laboratory which is applicable to the space segment of GBLs. Several gyroscopes were tested to determine performance. In space relay technology efforts, a single segment of a monochrome mirror was completed, including actuators. Work has begun on a laboratory model for critical elements of the bifocal system, the precision alignment system, and a shared aperture component. Two promising concepts for afocal space segments with rapid retargeting capabilities were developed.

Future Plans

The Fire Control Test Bed will be completed and will incorporate validated booster engagement, damage assessment, and multiple-target algorithms. Fire control operations will demonstrate the feasibility of autonomous execution of ATP-FC functions within ballistic missile defense timeline constraints. Pointing and control activities to demonstrate the attenuation of severe mechanical disturbances will include completion of an integrated structural control simulation model.

Demonstration of optimal retargeting control strategies and an investigation of the utility of wide FOV optical designs will be accomplished on the rapid retargeting simulator.

As a result of the Challenger disaster and the Titan and Delta failures, the entire space ATP experiments program has slipped. During the past year, the decision to delay further the resumption of Shuttle flights has resulted in delays and uncertainties in the space experiments program. However, a technical program review, in the last quarter of FY 1986, did result in approval of various activities. The old tracking and pointing experiments flight, now designated Starlab, was redirected to use the 7-day mission timeline of the NASA Spacelab. A more technically robust experiment was designed with a planned launch date in FY 1990. The core objective of this flight is to demonstrate, using active and passive sensor arrays, precision tracking of and precision pointing to an unaugmented and cooperative booster during launch. This is done by performing handover of the booster hardbody location from coarse plume tracking to a fine tracking sensor, actively tracking the booster hardbody, and pointing a controlled, low-power laser beam at a selected aimpoint on the booster.

The planned RME is scheduled for launch on an expendable launch vehicle. The purpose of the RME experiment is to receive a laser beam generated on the ground and transmitted through the atmosphere and to precisely reflect the beam to a ground diagnostic target array.

During the initial phase of the GBFEL TIE program, a lower power laser beam will be directed toward a diagnostic satellite. The LACE spacecraft is currently being built and tested. LACE and RME will both be launched on a single expendable launch vehicle. LACE is expected to carry a sensor to collect high-payoff data on rocket plumes and earth backgrounds. LACE will also carry an experiment to measure neutron background flux to support the NPB program.

Mid Infrared Advanced Chemical Laser

Project Description

The MIRACL/SKYLITE program is a technology development and risk-reduction program which supports the ground-based and space-based laser programs. The objectives of the MIRACL/SKYLITE program include the integration of the MIRACL and Sealite beam director (SLBD) into the highest power high-energy laser (HEL) system in the free world; development and demonstration of a high-power local loop adaptive optics system for improvement of the beam quality of a multi-line infrared

HEL; development and demonstration of a high-power target loop adaptive optics system for ground to space atmospheric compensation in the presence of turbulence and strong thermal blooming; performance of atmospheric propagation experiments to explore the conditions under which stable correction can be achieved and the degree of correction possible.

Accomplishments

Several significant accomplishments have been achieved in the MIRACL/SKYLITE program. Low-power dynamic checkout tests were completed. A high-power dynamic checkout test was also conducted. Local loop adaptive optics correction of the MIRACL beam at high power was successfully demonstrated. Finally, the fabrication of target loop adaptive optics components is 75 percent complete. System design is now 90 percent complete.

Future Plans

The MIRACL/SKYLITE program has been slowed until future use of an integrated system is determined. A decision is expected in April of this year. In the meantime, key personnel with the ability to resume the program at full pace will be maintained and used to make limited progress toward program goals with minimum expenditures.

CDTI/Emerging Technologies

Project Description

This project includes work on emerging and alternative technologies, including excimer lasers, charged particle beams (CPBs), nuclear directed energy weapons (NDEW), and CDTI. In addition, a variety of supporting technologies are being funded by the SDIO/IST Office in the area of advanced directed energy concepts. This research is in novel areas at the forefront of science and technology and is spread throughout the scientific community, including universities, government laboratories, and small and large businesses.

In the excimer laser technology area, efforts will establish and demonstrate the feasibility of repetitively pulsed excimer lasers. Excimer laser devices operate at wavelengths in the near-UV region of the spectrum. They are likely to be limited to ground-based systems because of size, weight, and

efficiency considerations. The repetitively pulsed laser can produce target damage in a manner similar to a continuous wave laser, producing a thermal kill. The extent of this impulse damage from repetitive pulses is being explored. High pulse repetition frequency device candidates are being pursued under the excimer, moderate power, Raman-shifted laser.

The CPB technology development program is investigating a concept called DELPHI in which a high-energy pulse of electrons is propagated down a channel generated in the upper atmosphere by a laser. The laser points at the target, and the pulse of electrons interactively discriminates the object or destroys it. DELPHI operates in the ionosphere and is currently envisioned as a ground-based rocket-launched system. In its initial configuration it would interactively discriminate decoys from RVs for a ground-based rocket-launched kinetic kill system. The discrimination signal from the DELPHI system gives a very high-confidence sorting of decoys from RVs and probably destroys all electronics on board any such vehicle identified. This electronics kill would negate most fuzing mechanisms and maneuvering RV capabilities, further enhancing the kinetic kill/DELPHI system effectiveness. A moderate scaling up of DELPHI performance parameters would produce a pop-up DEW capable of catastrophic kill of RVs.

The DELPHI technology development program is focusing on three primary efforts required to demonstrate concept feasibility. These efforts are: (1) beam propagation to ensure that once launched down the laser-generated channel, the electron pulse will remain in that channel and propagate to the target; (2) laser research to develop a laser capable of ionizing the upper atmosphere to generate the required channel; and (3) lightweight electron accelerator development to determine if a system can be made light enough to be launched within the timelines of a ground-based scenario.

In accordance with prescribed roles and procedures, the DOE has responsibility for the development and testing of nuclear devices in underground nuclear tests at the Nevada Test Site. DOD has primary responsibility to perform concept definition studies, develop support technology, and perform integrated experiments that allow assessment of the military utility of NDEW system concepts. DOD is, therefore, responsible for developing the ATP technology required for X-ray lasers and other NDEW concepts. The major thrust of the DOD effort is to investigate, theoretically and experimentally, phenomena that bear upon the military utility of NDEW.

Efforts in the area of CDTI involve the four basic DEW concepts, currently at different levels of maturity. The ongoing initial concept formulation effort is designed to identify the technology content

of the weapon system to guide technology development and provide conceptual designs for evaluation by the overall architect.

Accomplishments

Substantial progress has occurred in the area of single-and repetitively-pulsed excimer lasers. The excimer laser has been developed as a backup candidate to the FEL. The ability to clean up and combine beams has been demonstrated using Raman scattering in an amplifier geometry. This provides the capability for "Raman look-through" (i.e., the ability to perform atmospheric compensation on a low-power beam from an oscillator using adaptive optics). This Raman look-through technique was successfully tested using a xenon fluoride excimer laser and a 69-channel deformable mirror. The beam is then amplified to produce high power while retaining wave front correction. The pulsed power used to operate an excimer laser at 100 hertz repetition rate has been demonstrated, and a 40-kilowatt xenon fluoride-based system consisting of an oscillator, an amplifier, and a Raman amplifier is now being assembled at WSMR.

Recent accomplishments in the CPB program include completion of the Troll long-pulse accelerator. This accelerator represents a considerable improvement to the previous state of the art. The Troll accelerator was installed in the EPOCH (Electron Propagation On Channels) facility which required the construction of an underground tunnel. During FY 1987, limited meters of propagation tank were purchased because of funding shortfalls. Initial erosion rate measurements were made on propagating electron beam.

Future Plans

An FSD laser will be completed and integrated with its beam control system, and in the area of charged particle beams, rocket-borne space flights will be conducted to verify space operability of the accelerator hardware and to verify channel generation in the atmosphere.

The DOE will continue NDEW efforts. A non-nuclear pop-up launcher demonstration, as well as determination of overall weapon concept feasibility, will continue to be studied by DOD.

In the area of CDTI, concepts selected as candidates for development and deployment will undergo a concept formulation in the FY 1991-1992 timeframe to identify the overall construct of an

operational system and to provide initial designs of system-level demonstrations that will validate technology.

4.3.3 Funding Impacts

Significant program adjustments were made to accommodate congressional reductions to the FY 1988 President's budget request. In the area of chemical laser technology, all major technology base programs have been slipped one year. Free electron laser efforts supporting the GBFEL TIE have been downscoped, due to a 20 percent reduction in both the FY 1988 and FY 1989 programs. Device selection has been deferred, and power has been limited. WSMR site preparation has been slowed one year. The beam control contract has been descope in run time capability and delayed six months. SBFEL activities have been severely curtailed. Milestone I has been rescheduled for FY 1993-1994 for this technology.

In the NPB technology project, there has been a 50-percent reduction in the FY 1988 and FY 1989 programs to meet congressional cuts. Specifically, technology base activities have been limited, especially in the area of sensors. The Integrated Space Experiment (ISE) has been cancelled. The Ground Test Accelerator (GTA) has been delayed one year. Milestone I for this technology will be delayed until FY 1992. The ATP-FC area has experienced a 12 percent reduction in its FY 1988 and FY 1989 programs. The relay program technology base has been terminated, with the possibility of start up again in FY 1989. The Starlab launch date has slipped to at least FY 1990. Finally, Milestone I for this technology will be delayed until FY 1990. The MIRACL project has been cut by 45 percent in FY 1988 and FY 1989 to meet congressionally mandated cuts. Unless outside funding from agencies other than SDI is forthcoming, current plans call for closeout of at least the beam director by the end of FY 1988. The program is now on hold, awaiting a decision in April or May of this year. In the meantime, costs are being minimized consistent with current program guidance. In the area of CDTI, SBL, GBL, and NPB studies have been reduced in scope and the NDEW study reduced to maintenance level. Midcourse ID analysis, NDEW concept analysis, and the SBFEL study have all been delayed by one year.

4.3.4 Summary

The focus of the major projects included in the Directed Energy Program can be summarized as follows. The chemical laser program has brought the major subsystems of a SBL into the final stages

of scaling experiments. This project is now defining in the Zenith Star studies, the next step for chemical lasers system-level experiments. The FEL project has focused in the near term on the ground segment of the GBL. The selection of the FEL to be used and design of the beam control will be followed by fabrication and installation into a test bed at WSMR. The activities on the space segments of the GBL will be limited in scope in the near term and built to support the Dem/Val phase. In the area of particle beams, the emphasis is on two integrated ground experiments and a technology development program that will act as test beds for the technology needed and its integration into a system-level environment. Future experiments that must be conducted in space include initial suborbital flights in the near term. System level experiments in orbit are under investigation. ATP-FC technology efforts are focused on a series of necessary tests in the space environment supported by a technology base with appropriate ground experiments. The maturing directed energy technology base efforts are pointing toward early- to mid-1990s decisions that the weapon concepts are feasible and that system-level tests and demonstrations are warranted.

4.4 SURVIVABILITY, LETHALITY, AND KEY TECHNOLOGIES PROGRAM

4.4 SURVIVABILITY, LETHALITY, AND KEY TECHNOLOGIES (SLKT) PROGRAM

This section provides a program overview of the Survivability, Lethality, and Key Technologies (SLKT) Program and discusses its technical objectives.

4.4.1 Program Overview

The SLKT Program performs research in technologies critical to the development of a survivable and effective Strategic Defense System. The objectives of the SLKT Program are to:

- o Develop the critical survivability/lethality and other technologies necessary to support the development and deployment of initial SDS elements
- o Develop lethality criteria (i.e., determine what is required to kill the target for candidate weapon concepts)
- o Coordinate the development of a power generation, conversion, and conditioning subsystem
- o Develop the space transportation architectures, supporting technologies, and vehicle concepts and systems to meet maintenance, and cost requirements
- o Ensure materials and structures needed for engineering development of the SDS are available.

4.4.2 Technical Objectives

The major thrust of the System Survivability project is to provide survivability technology for the SDS elements such that JCS mission requirements can be met in the face of the defense suppression threat (DST). To accomplish this objective, five issues must be addressed: threat definition; survivability technology development; survivability enhancement options; technology infusion; and test, evaluation, and validation. Survivability is driven by threat. The DST must be understood in sufficient detail to assess the susceptibility and potential impact on system elements. Understanding these susceptibilities will aid in defining the survivability technologies necessary for the element designers. Developing survivability technologies and ensuring that they are infused into the system

design process are major objectives of the program. The combination of different survivability approaches into packages of survivability enhancement options allows element designers to meet survivability requirements while minimizing cost and performance impacts. Once the element is designed, the Survivability project is responsible for independent assessment and evaluation to validate survivability achieved.

The Lethality and Target Hardening (LTH) project is continuing its effort to narrow the uncertainty in our understanding of weapon-target interaction. We need to minimize this uncertainty so that weapons are neither overdesigned with large "safety factors" to compensate for our lack of knowledge, nor underdesigned as a result of our not recognizing the limitations of our theoretical models that are used to determine required weapon performance parameters. With weapons that must be lofted into space, every ounce of additional weight resulting from overdesign is especially costly.

The Power and Power Conditioning project has initiated a three-pronged effort in cooperation with and jointly funded by the Air Force to develop survivable solar power supplies for space applications. The three efforts are to augment existing Survivable Solar Concentrator Photovoltaic Array (SCOPA) work; increase work in related technology development areas; and initiate an effort to create a Survivable Solar Power Module (SUPER), which will integrate the most advanced state-of-the-art components into a modular power supply capable of meeting a wide range of platform power requirements.

The major FY 1988 thrust of the Space Transportation and Support project will be to continue defining the ALS concepts and preparation of the preliminary designs of the ALS elements. Efforts will also be directed toward the development of technologies in high-payoff areas such as testing of LOX/hydrocarbon booster engine components, propulsion test facilities, structural components demonstrations (propellant tankage), subsystem hardware demonstrations (fuel cell power), recovery system demonstrations for propulsion avionics module applications, operations, and demonstrations.

The objective of the Materials and Structures (M&S) project is to perform the R&D necessary to ensure the availability of the needed materials and structures for SDS elements. The major thrusts for the M&S project include: rapid development of devices or components using high-temperature superconducting (HTS) materials to enhance capabilities of the SDS elements; insertion of experimentally verified passive and active space structures control concepts into Phases I and II

element developments; acceleration of critical path tribomaterials development for non-redundant moving mechanical assemblies located on space platforms, extended-life sensor cryocoolers and ALS turbopumps; Dem/Val of lightweight structural materials with emphasis on polymeric, ceramic, and metal matrix composites and very lightweight metal alloys; development and Dem/Val of optical components using materials that meet SDS performance requirements, including sensor optical baffles and IR transparent windows; and defining advanced materials properties and processing technology that interface with SDI element manufacturing development and evaluation efforts.

System Survivability Project

Project Description

The SDS may be subject to direct attack by the Soviets during deployment, peacetime operations, in the early stages of conflict, or while serving as a precursor to a ballistic missile attack. The objective of the Survivability project is to ensure that the SDS can withstand a determined defense suppression threat (DST) and retain the functionality to meet or exceed the JCS requirements for effectiveness against the ballistic missile threat. The system can be made to survive through the application of "brute force" approaches, but not without significant cost and performance impacts. By selectively using and balancing both active and passive survivability techniques, a survivable system could be achieved. Survivability must be enduring and insensitive to the changing and growing Soviet DST.

Prior to SDI, there was a tendency to investigate survivability on a case-by-case basis: one system, one threat, and one survivability enhancement technique. With the advent of SDI, it became necessary to address the problem of the simultaneous defense of multiple systems. Also, as the Soviets are not bound and are not likely to use a single threat to stress the SDS, the system may need to survive against multiple simultaneous threats. Since 1984, the survivability community has been addressing system enhancements against SDS-specific threats as outlined above. Since 1986, the community has extensively investigated the effectiveness of synergistic combinations of survivability techniques and technologies. This approach is the development of what is termed "balanced survivability." Various combinations of the following passive and active survivability enhancement options (SEOs) provide excellent levels of survivability, in simulation, against postulated DST scenarios:

- o Hardening
- o Shielding
- o Decoys
- o Shoot-back
- o Maneuver
- o Electronic Countermeasures.

As SDI is a complex, long-term program, it has been divided into several phases, allowing for interim deployments of SDS. The current focus of the survivability project is Phase I SDS. Phase I will employ current and near-term technologies in addressing the near-term DST. Phase II and subsequent phases will address far-term threats utilizing future technical achievements. The Survivability project's objective is to produce the necessary survivability technology to provide high-confidence, low-risk solutions for a survivable defense, which is insensitive to DST excursions. To accomplish this objective, five key issues must be addressed and incorporated into an integrated project which will lead to overall SDS functional survivability. The issues are: (1) threat definition, (2) survivability approaches, (3) technology development, (4) technology infusion, and (5) test, evaluation, and validation.

For Phase I, this meant that the SDI Planning Study and the Zero-One Study identified creative near-term survivability solutions that are dependent less on technical breakthroughs and rely more on extrapolations of the present survivability state of the art. The initial results of this work have been validated by the system architects and the NTB contractors. Two significant results of the use of SEO "packages" are: (1) the projected reduction in overall survivability cost at the architecture level and (2) a technology development program with a lower associated risk. The system developers will have a greater flexibility to take advantage of cost and performance trade-offs within identified options.

Accomplishments

Approximately 70 projects, ranging from basic research to subsystem level survivability tests, are under way. A carbon-carbon base composite laser shield material has been developed that can survive. This composite appears significantly more effective than carbon-carbon shields and may possibly be combined with the kinetic shield to reduce the thermal loading to the protected package by three orders of magnitude. This shield offers the opportunity to provide lightweight effective protection over a wide range of postulated threats.

In preparation for and in anticipation of the Phase One Threat Specification (POTS), extensive work has already been done in threat definition by the Survivability project. The goal is to define a comprehensive common engineering threat to be used as a design basis for all SDS elements. SDIO and the Survivability project have made significant progress in this process.

Threat definitions have been generated using available threat sources and are described in sufficient detail to allow system designers to understand their potential threat. The application of the DST capabilities have also been investigated to examine effective ways in which the Soviets can attack the SDS.

Significant results have been achieved in development of kinetic shield designs. A low-density multi-material layered shield has been developed for effectively stopping projectiles. Multi-material shields comprised of a thin aluminum front layer separated from a thin stainless steel layer by low density porous carbon were sufficient to stop the projectile without damage to the back surface. This new material has an areal density which results in a significant weight reduction. The implication is clear: Design of a lightweight shield for space-based assets against the high velocity projectiles is achievable.

The SLKT Directorate, while not having direct responsibility for the development of specific survivability requirements, has developed suggested guidelines and distributed these to the System Program Offices (SPOs) and the POET. These guideline documents, one for each SDS system, will serve as the basis for the Technical Requirements Documents (TRDs). The TRDs, in turn, will serve as the guides to the system developers. It is this strong requirements phase that will set the stage for an orderly and timely technology infusion.

Other achievements include optical coating hardening techniques that demonstrate a three- to sixfold increase in resistance to nuclear X-ray fluence; the development of an analytical model that provides the measurements of optical mirror deformations caused by X-ray effects; the development of a prototype inert gas shielding system to protect optical systems; communications components capable of withstanding the postulated laser threat; and the demonstration of thermionic integrated circuits for applications requiring extremely high-radiation hardness is required.

Future Plans

As a result of the DAB decision, the focus of the System Survivability project centered on accomplishing the Phase I goals while laying the groundwork on the follow-on architectures. Since we are now well under way towards the Phase I goals, FY 1989 will be a year of transition for the project. Many of the technologies that have been under development will be mature enough to transfer to the system designers in the course of the year. Significantly expanded projects, particularly in the active survivability technology area, will be focused on FSD of Phase I elements. Additionally, the definition of Phase II system requirements will also be a key focus. The System Survivability project objectives for the future are as follows:

- o Continue efforts from the FY 1988 project to support Phase I technology requirements.
- o Address funding shortfalls and technology deficiencies from the FY 1988 project.
- o Significantly expand efforts in the area of active technology started in FY 1988 while focusing passive technology efforts.
- o Initiate technology efforts for Phase II systems and threats.
- o Technology for infusion in other programs at appropriate milestones.

Figure 4.4-1 shows our expected path toward demonstrating high confidence in credible survivability approaches. The goal is to demonstrate, well before FSD, survivability approaches that will allow the mission to be accomplished in the face of a determined defense suppression threat (DST) at an acceptable risk and cost level.

Continuation of Current Efforts. The FY 1988 Survivability project will provide extensive technology advancement in the areas of passive survivability enhancements. Principal among these are spacecraft shields for protection against laser, kinetic energy, and nuclear threats. Electronic and optical component hardening techniques, communication and computer hardening technologies, and investigations into inherently hard materials constitute the remaining portion of the passive program.

Component level testing, and in some cases subsystem level validation testing, and evaluations will continue in FY 1989.

Priority will be placed on providing mature technologies for transfer into the element design process prior to FSD. Projects will be initiated in FY 1989 to support the Phase II elements and threats as well. A key focus of the FY 1989 Survivability Technology project will be to ensure that demonstrations of key technologies will be accomplished.

The Technology Development effort will provide a solid technical base on which to build survivability. Presently available and near-term technology will be joined with survivability tactics to produce a balanced survivability capability for Phase I, with an increased emphasis on active survivability.

**FIGURE 4.4-1
Survivability Approach Confidence**

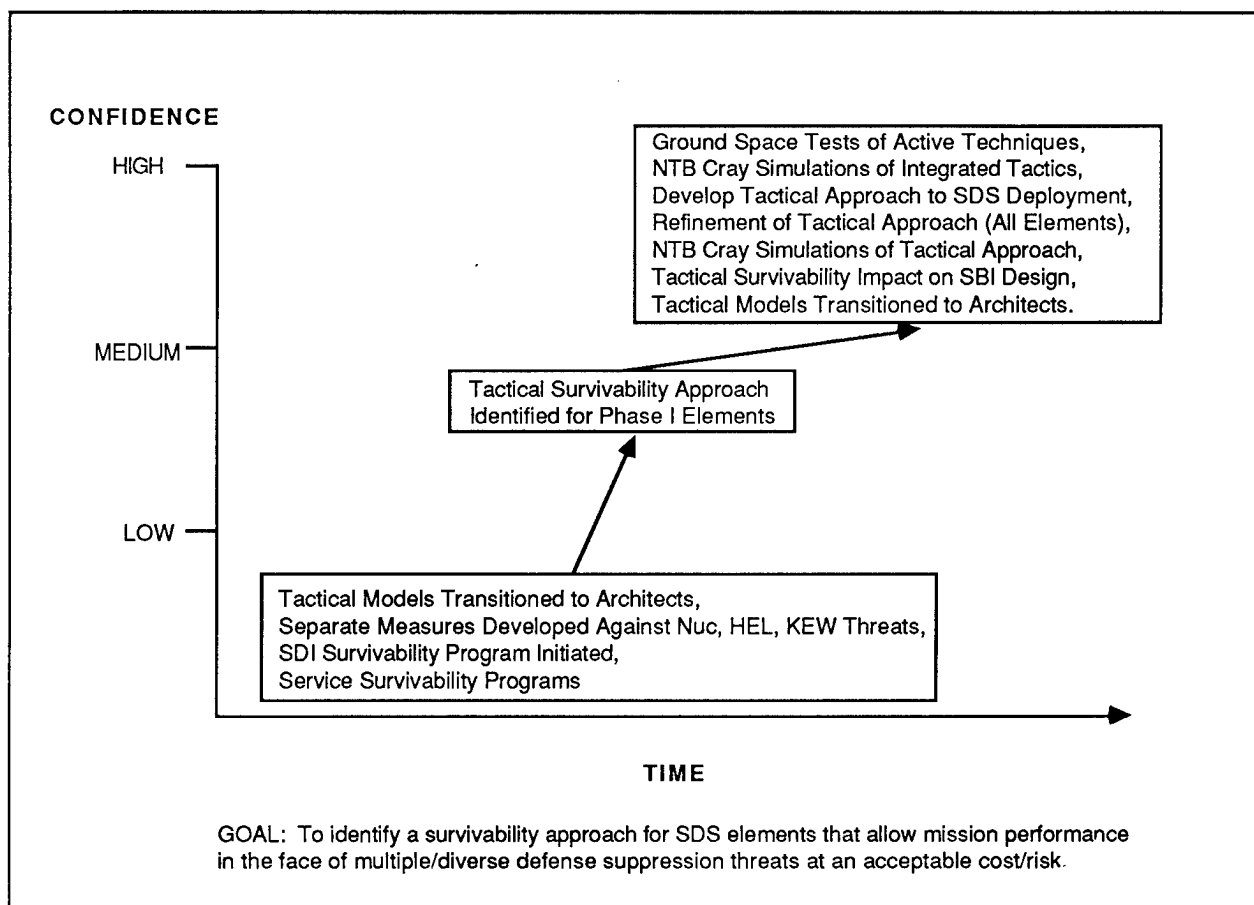

These technologies will also be enhanced over time to assist in meeting the far-term threat. Promising development areas for the Phase I program will be investigated based on five criteria:

- o Relevance of the project to the near-term threat and SDS elements
- o Validity of the technology to the postulated threat
- o Appropriateness of the technology to the Phase I elements
- o Criticality of the technology to the success of the mission
- o Relative maturity of the technology to meet the needs of the Phase I elements.

As a sampling of technology under investigation, current and near-term capabilities include:

- o Nuclear hardening
- o Laser hardening
- o Kinetic energy shield
- o Laser shield.

Anticipated milestones include:

- o HPM hardening
- o Nuclear hardening
- o Kinetic energy shield.

Figure 4.4-2 shows current progress and anticipated achievements in developing these survivability technologies for the SDS.

For system element design implementation to be feasible, the validated technologies and methods must be incorporated prior to FSD. Some survivability methods may be added/updated on a continual basis, but the majority will be implemented early to avoid costly retrofitting. Therefore, it is vital that the technology transfer efforts be comprehensive and orderly from the start, so as to avoid any unnecessary delays. The Survivability project is structured to foster technology transfer/infusion throughout research and development by relying heavily on aerospace contractor involvement in its programs. Regular interchange meetings are held among the Army, Air Force, and the associated contractors to identify program overlaps and introduce survivability technologies to the contractors early on.

Our goal is to incorporate validated survivability technology into element designs before FSD. Figure 4.4-3 shows the confidence building milestones we expect to achieve to meet this goal.

The strongest jump in confidence for technology transfer will be when the hardware contractors are fully integrated into the Survivability project. They will be most affected by the new survivability enhancements and will also be most familiar with them. As the hardware is manufactured, the initial cost/risk assumptions will be reassessed to evaluate their continuing validity.

FY 1989 Active and Passive Projects. The active survivability technology project will be dramatically expanded. This expansion is the result of the realization through analysis that survivability

**FIGURE 4.4-2
Technology Development Confidence**

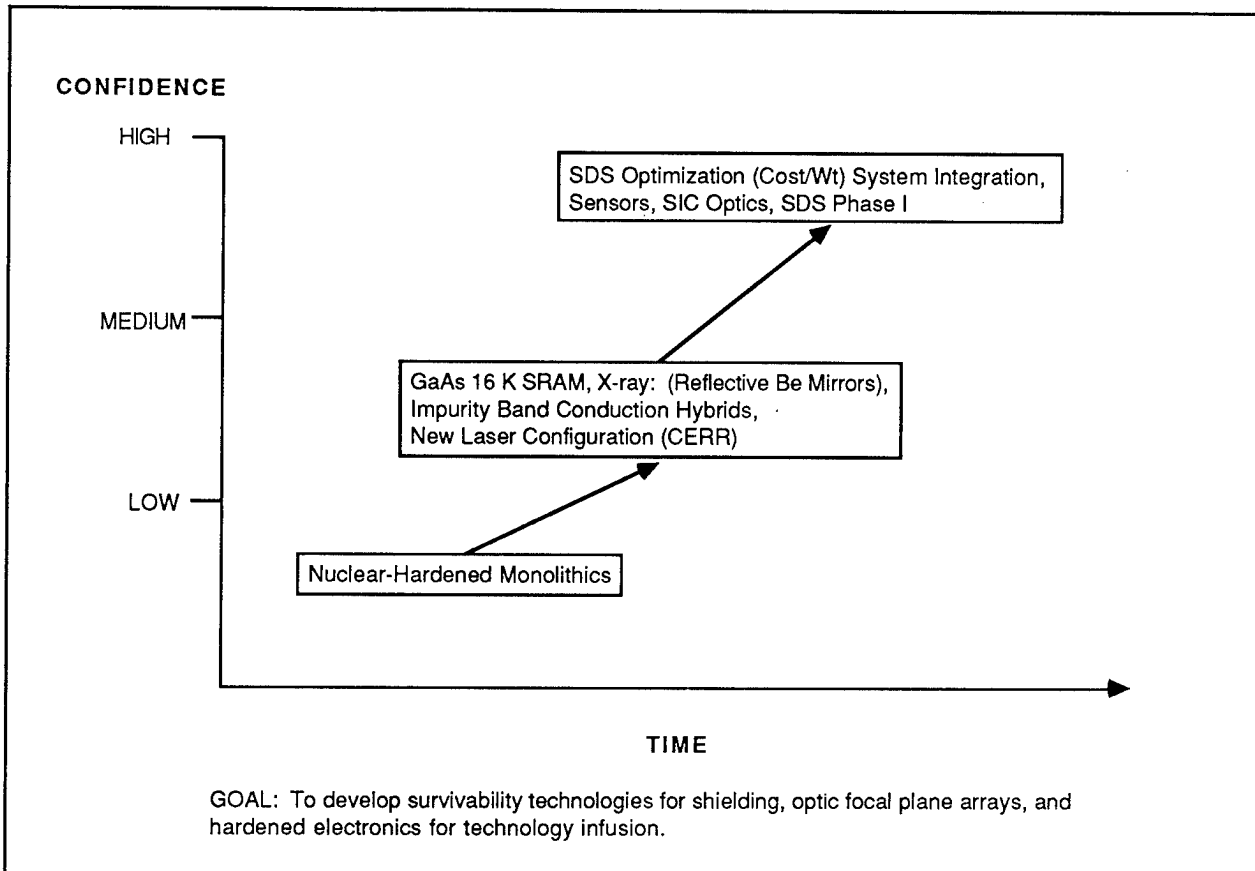

**FIGURE 4.4-3
Technology Transfer/Infusion Confidence**

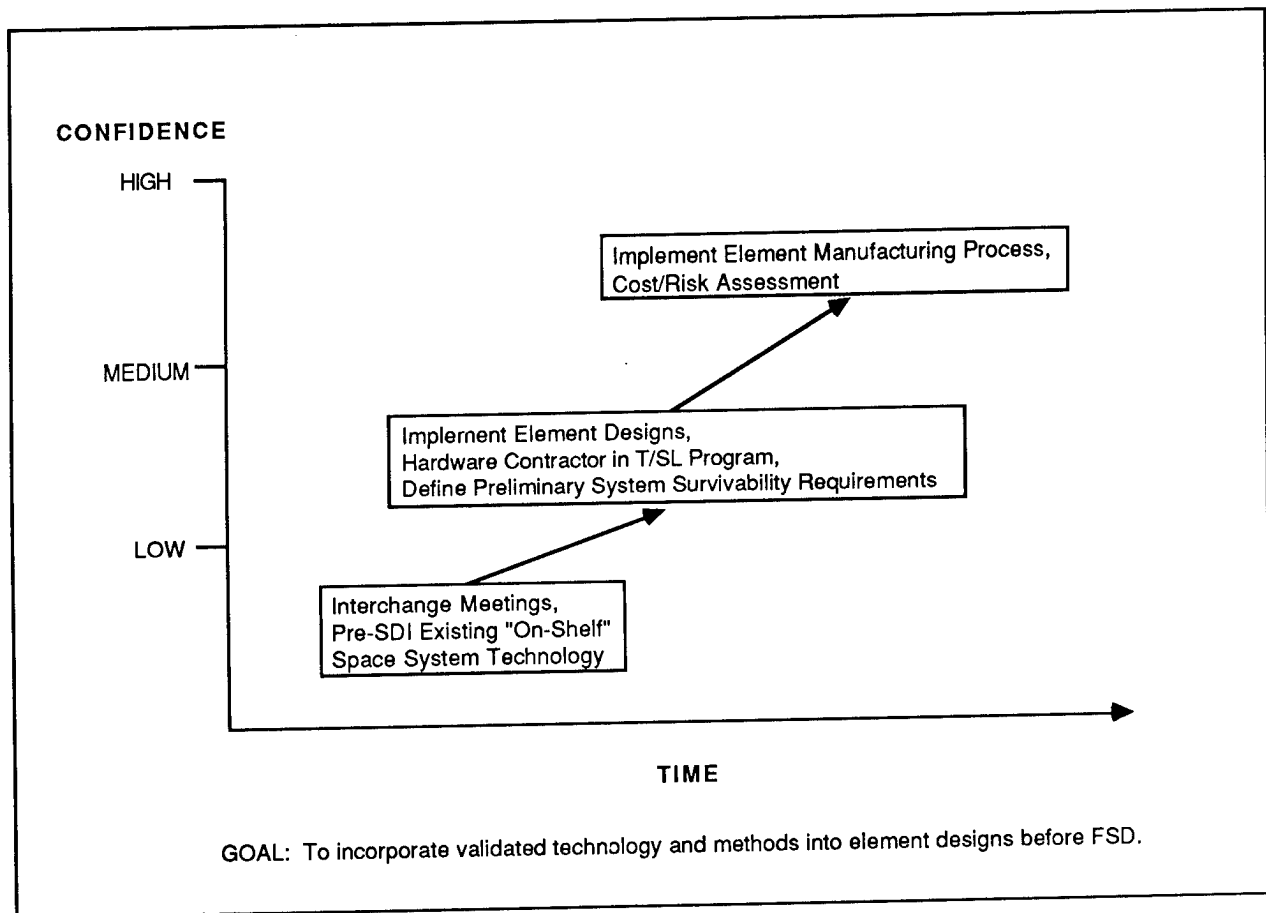

can be significantly enhanced through active means and that there is a synergistic effect of combining both active and passive techniques. The active project will include the following as a minimum:

- o Short-Term Tactical Decoys for Low Earth Orbit (LEO) Satellites
- o Antisimulation Technology
- o Optical and RF Jamming
- o Long- and Short-Term Decoys for Medium Earth Orbit (MEO) and High Earth Orbit (HEO) Satellites
- o Modified SBI for Shoot-back
- o Unique Defense Suppression Threat SATKA
- o System-Level Self-Reconfiguration

Planned Incremental Hardenability. This project establishes bounds of survivability requirements for sets of likely missions, time-phased scenarios, and defense architectures to help ensure that responses should be available to rapidly apply in response to changes that might occur in system objectives or schedules.

This approach is achieved by implementing a preplanned hardening improvement program that is initially applied to the functional technology flight vehicle. Hardenability enhancements can then be incrementally added so that limited initial capability can be systematically increased in a cost-effective manner to meet full long-term SDI requirements.

Nuclear Mitigation Software Development. This project addresses development of nuclear mitigation software which is integrated into hardware designed to operate in operational threat environments. Initial survivability/operability will be evaluated through sub-element testing but this does not by itself insure high confidence. Attainment of the necessary confidence level to support an FSD decision requires that software/hardware be tested at the National Test Bed level. Synergism with other elements must be demonstrated by integrated testing.

Active Survivability Measures. Active survivability measures have demonstrated the ability to provide large increases in survivability while reducing system requirements for passive hardening in certain situations for low to moderate investment. This program will identify those measures that can enhance ground-based element survivability and compare the cost effectiveness to alternative measures. Initial results are required to support System Requirements Review (SRR).

Theater Missile Defense (TMD) Survivability Analysis. This effort is the major initiative through which survivability issues are addressed in depth for theater missile defense architectures. These results are required to support development requisite survivability technologies and near-term system A-specifications.

Technology Efforts for Phase II Systems and Threats. The FY 1989 program will begin to identify and develop survivability technologies for the Phase II elements to support a Phase II Milestone I decision. The threats associated with the Phase II elements will be defined. Threat changes associated with the Phase II system may include increasing capability in direct ascent nuclear antisatellite (DANASAT) force numbers, increasing Soviet capability to locate and track (both radar and optical) SDS assets, increased homing ASAT capability both in co-orbital and direct ascent ASATs, growing electronic warfare (EW), HPM and NPB capability, and others. These threats will drive the composition of the technology programs in FY 1989 for both Phases I and II systems.

Test, Evaluation, and Validation. The magnitude of SDS will require carefully conceived and novel test and evaluation methods. It will not be possible to test every SDS subsystem at every conceivable operating condition, so simulation will continue to play a major role in SDS development. Those tests that are infeasible to conduct will be simulated/modeled using previously collected live-test data as a basis for extrapolation.

For those tests that will be conducted, much of the effort so far has been directed toward facility update and new construction, specifically for aboveground test (AGT), UGT, and laser test facilities. Much of the other testing will be conducted at, or coordinated by, the National Test Bed (NTB), for which a contractor has recently been chosen. Figure 4.4-4 shows the expected progress toward reducing risk in ineffective incorporation of survivability through test, evaluation, and validation activities. Once element design prototypes and preproduction hardware are available, survivability will be validated through system and subsystem level testing. Additional simulations and modeling activities will substantiate survivability enhancements and techniques.

Lethality and Target Hardening

Project Description

Due to the new physical principles and performance regimes which strategic defense weapons are projected to employ and the limited knowledge of the characteristics of strategic targets, there are many uncertainties associated with candidate weapons effects. The LTH project has the mission of addressing the important issues of weapons effectiveness and weapon target interaction signatures. The LTH project is a comprehensive research effort that studies the damage effects created by

**FIGURE 4.4-4
Test/Evaluation/Validation Confidence**

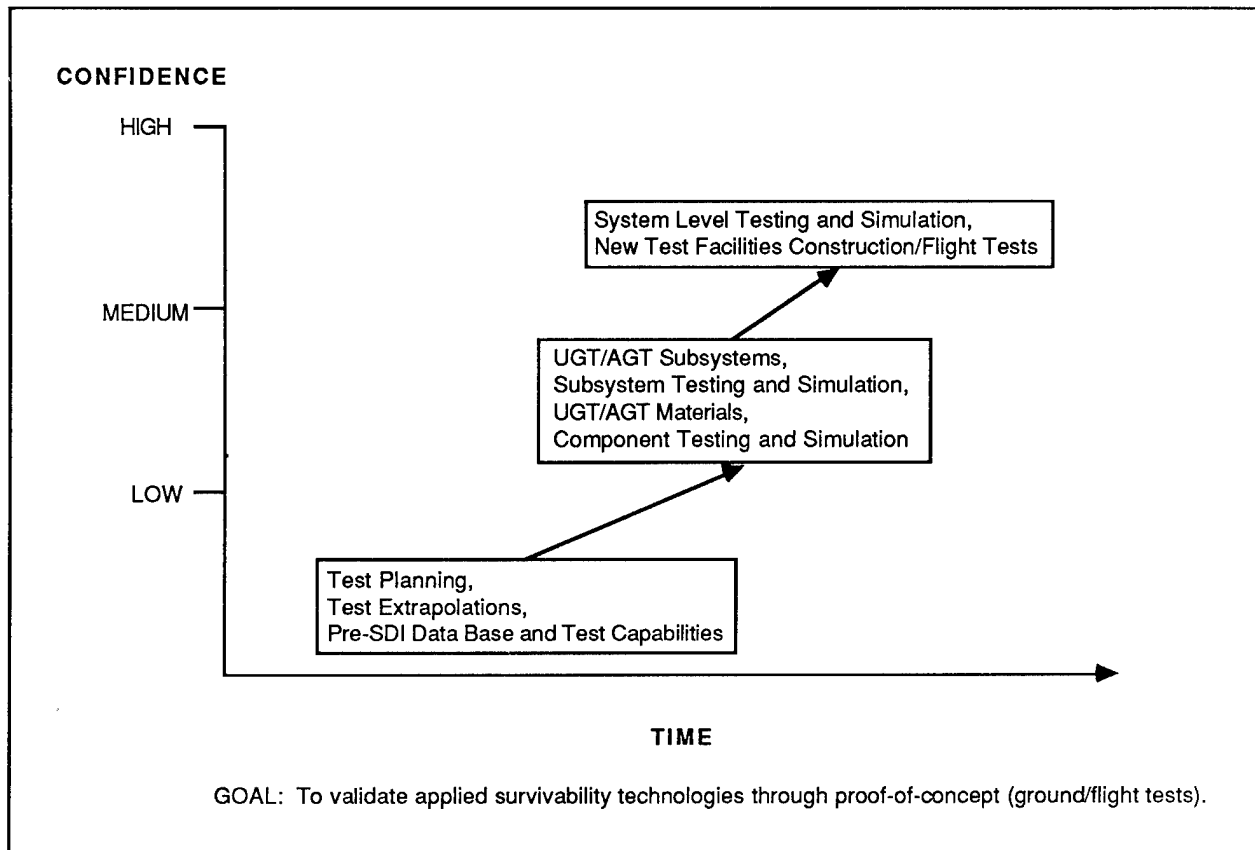

weapons technologies and predicts the corresponding vulnerability of Soviet current, retrofit, and responsively hardened targets. Current lethality work includes KEWs and DEWs. Studies are being conducted on target interaction observables that may permit kill assessment and weapon (probe)-target interaction effects and observables that may be useful for interactive discrimination. In addition to weapons effects, the LTH project also studies material hardening to determine potential achievable levels and differences from the Soviet perspective of hardening offensive systems. Materials are developed and tested against weapons technologies to generate a new set of performance requirements for defensive weapons. An iterative approach to lethality and target hardening is designed to reduce the uncertainties and broaden our understanding of weapons effects.

This project determines for each weapons concept the required performance characteristics to achieve a "sure kill" against the full spectrum of Soviet targets (current, retrofit, and responsive). These performance characteristics, or kill criteria, generally are described in terms of the energy required to be delivered to the target but involve other parameters as well. Weapon-target interaction observables are studied for the purposes of kill assessment, discrimination and other potential missions. This process of using a mechanism such as a moderate power laser or particle beam to disturb an object enough to create an observable signature is called interactive discrimination (ID). Efforts in the LTH project include developing and basic theory and validating and testing the resulting predictive models. The validation experiments are conducted at sub- and full-scale to provide handbook data necessary for use by weapon designers and system architects conducting trade-off analyses.

Accomplishments

The experiments and tests of the LTH project are performed at a number of facilities around the country. For example, thermal laser testing is accomplished at the DOD High Energy Laser Systems Test Facility (HELSTF) at White Sands Missile Range (WSMR). This is currently the highest power laser facility in the free world. A large vacuum chamber is under construction at WSMR to allow for testing in an environment that simulates the vacuum of outer space. The SDIO recently achieved full operational capability for particle beam testing at Brookhaven National Laboratory with near-weapon level fluences of protons. A neodymium laser at the Battelle National Laboratory has been modified to provide waveforms suitable for testing under conditions that simulate a FEL. The REP III laser has become operational at the Naval Research Laboratory (NRL).

In support of this experiment, the LTH project developed and generated all the aerothermal models used to predict RV breakup. This support included wind tunnel tests, subscale firings of the Delco light gas gun, and computer-generated predictive models. The damaged area causes it to pitch and roll over time. This area subsequently melts as calculated by the thermal response codes and leads to strong aerodynamic forces placed on the RV which finally leads to structural breakup. This breakup happens in a matter of seconds.

Several recent significant computer modeling and experimental tests have been accomplished. HPM lethality testing against a PBV has been completed.

Plato II experiments at the Brookhaven National Laboratory addressed warhead failure modes by irradiating an RV with a beam of hydrogen atoms (protons).

The methodology for design and vulnerability assessment has been well developed in studies of current generation liquid and solid booster rockets, and the damage required to cause catastrophic failure (bursting or collapse of the motor case). Some confidence in those designs has been estimated. Of importance is the tentative conclusion that solid boosters with composite motor cases will burst evenly within a very small damage area. However, designs that resist bursting, ways to defeat those designs, and the efficacy of venting as a kill mechanism are yet to be studied. As a result of the recent high-irradiance (Hi-I) tests at WSMR, the uncertainty in the heat of ablation for target materials when irradiated with a very high intensity beam has been narrowed considerably. Figure 4.4-5 shows debris blow-off of the test. Reasonable working values (within about a factor of two) appear to be in the range. Many materials which seemed to be very hard when irradiated with very small diameter beams have proven to be less hard than projected when irradiated with a larger diameter beam. However, our understanding of the physics and chemistry of the laser ablation process is limited to date, especially with respect to mechanisms of reflection and plume shielding. The likelihood of being able to develop materials with significantly higher heat of ablation is not low enough, and further study and experimentation are required.

In support of the LTH project we are annually updating and publishing an integrated lethality assessment document that will provide an ever improving design handbook for the weapon engineer. Through a combination of theoretical modeling and necessary subscale and full-scale lethality experiments, we are providing the mathematical relationships necessary for weapon system design and strategic architecture trade-off studies. Additionally, we are studying the signatures produced in weapon (probe beam)-target interactions for their utility in performing interactive discrimination in the midcourse phase.

Future Plans

In FY 1988, a full-scale test of a continuous laser against a highly reflective, rolling missile will be conducted using the Mid Infrared Advanced Chemical Laser (MIRACL) at WSMR and a modified Titan booster. In the impulse laser program, the principal effort will be on improving our understanding of ID and on planning for UGT. Instrumentation for the measurement of critical physical and chemical phenomena at the target in an underground test is being developed and validated.

FIGURE 4.4-5
High-Irradiance Test Showing Debris Blowoff

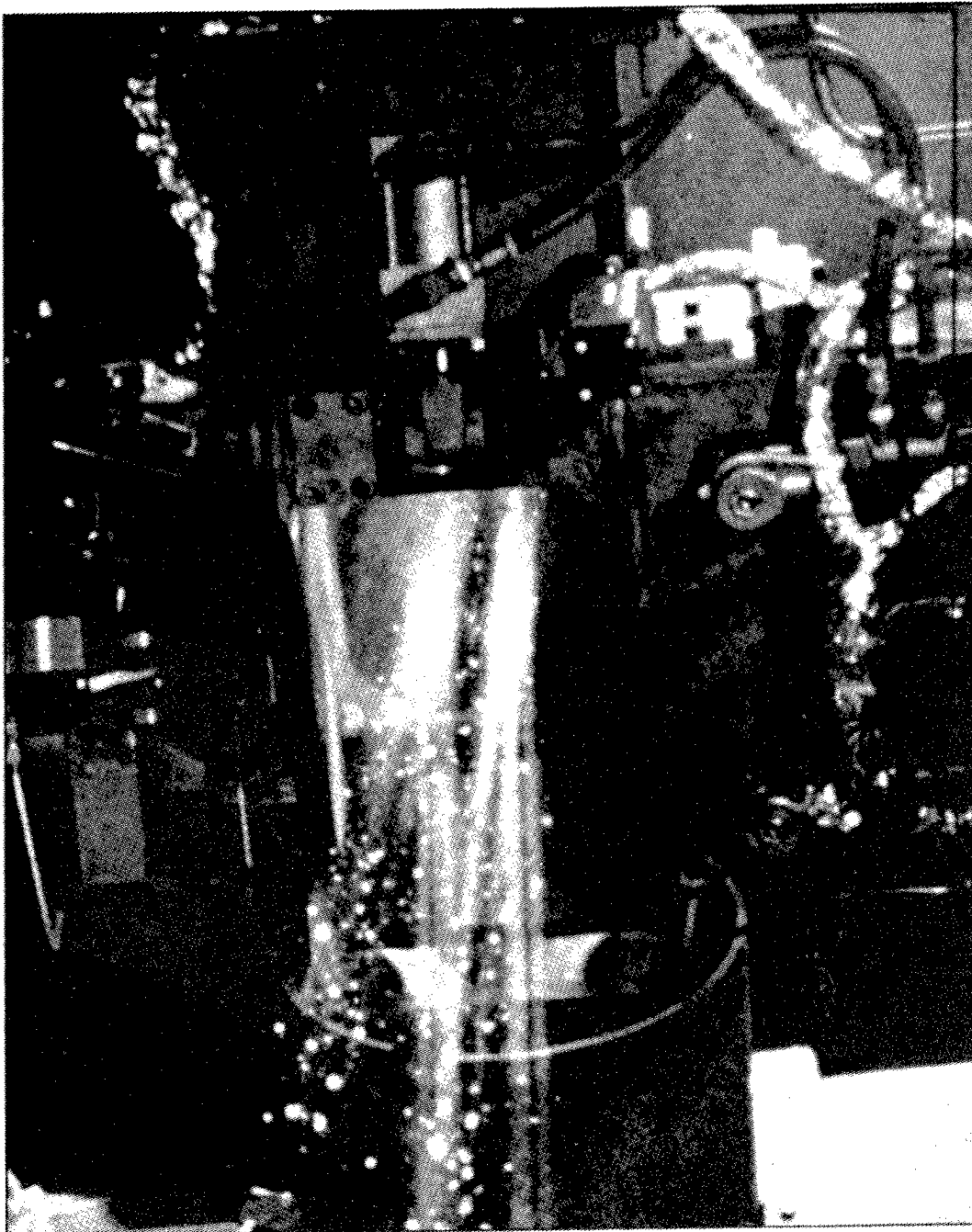

A number of additions and improvements are planned for the REP III laser, and alternatives for testing with deuterons are being examined. Rather than construct a facility that would be useful only as a test range, we plan to use experimental hypervelocity projectile launchers (SUVAC and Thunderbolt) under development in the KEW and Invite, Show and Test (IS&T) programs as KE lethality test ranges when they are up and running. The LTH project is therefore partially funding these programs. An integrator to smooth the laser beam and an apparatus to switch a greater number of individual samples of hardened materials during a single laser run are being provided for the HELSTF at WSMR. In particle beam lethality, a computer model will be developed for simulating the interaction of a particle beam with a solid booster ICBM. This follows an earlier effort with a liquid booster. Measurement of proton-induced target returns will be made from targets of varying thickness. In the KEW lethality program, analysis will continue of the data obtained in experiments already conducted on large liquid and medium solid ICBMs. Analyses will investigate new targets, including the large RV, the DST, and the targets associated with theater missile defense. Due to facility limitations, testing conducted to date has been limited in projectile velocity and mass. An experimental hypervelocity launcher whose design goal is to fire projectiles at a velocity that will cause material vaporization on impact is being funded.

By the end of 1989, the SDIO will have achieved a hypervelocity test capability to address KE projectile/target vaporization. The continuous wave (CW) laser lethality effort will have been completed and will have conducted a full-scale test of a hardened solid booster. The effort will achieve a decision milestone that will specify fluence, minimum spot size, dwell time, and aimpoint sensitivity. In addition, the SDIO will be near completion of a large-scale surface discharge simulator that will serve as an interim lethality test facility until the ground-based free electron laser is available at the WSMR.

In FY 1990 and beyond, the focus of the program will shift to the fully responsive, fully hardened threat and to ID. In the KEW Program, additional flight tests of aerothermal/structural kill will be conducted. Specific lethality enhancer concepts will be designed and tested in the flight tests of the ERIS and HEDI programs. A series of experiments using the Thunderbolt apparatus will be conducted to validate the theory of weapon-target interaction in the vaporization regime.

The thermal laser lethality program will complete the validation of lethality estimates for fully hardened post-boost vehicles and will shift focus to advanced decoy designs and ID. The X-ray laser program will validate weapon-target interaction by conducting experiments on DOE or DOD X-ray laser UGTs.

The NPB will proceed with a number of experiments to validate concepts for hardening electronics and other elements of PBVs and RVs. Computer codes will be developed to predict emissions generated by a target irradiated with a particle beam for the purpose of discriminating decoys from RVs. Validation experiments will be conducted.

Space Power and Power Conditioning

Project Description

The success of nearly all elements of an SDS depends on advances in the areas of prime power generation and power conditioning. Sources capable of generating the necessary baseload power and multimegawatt burst power will be required to operate reliably while concurrently meeting constraints relative to size, weight, life-cycle costs, and survivability. The Space Power and Power Conditioning task seeks to develop the technology base required to support the spectrum of requirements for space- and ground-based weapons, discriminators, and surveillance systems, as well as communication and battle management systems. The purpose of this task is to establish the feasibility of meeting the multimegawatt burst power requirements, develop and validate baseload power technologies, and advance requisite power conditioning technologies. The project includes four major subtask areas: requirements and analysis, baseload power technology, multimegawatt power technology, and pulse power and power functioning.

Requirements and Analysis. The goal of this subtask is to perform the necessary trades and analyses required to guide the technology investment strategy. These studies identify the most promising power options for use in the SDS, the principal technology issues related to those technologies, and any technology gaps that currently exist in those technologies.

Baseload Power Technology. The cornerstone of the SDI baseload power development is the SP-100 nuclear reactor system. Established in 1983, the effort has focused on developing the technology base needed to provide safe, reliable nuclear-generated electric power in the range of a

few tens of kilowatts up to approximately 1 megawatt. Survivable, hardened solar array technology is also under development to enable near-term, low-power system elements which face relatively modest DSTs. This subtask area focuses on the refinement and validation of these technologies to the point where mission-driven requirements can be achieved.

Multimegawatt Power Technology. Multimegawatt burst mode power is required to power weapons and active sensor systems during engagement. Power levels of 10's to 100's of megawatts for 100's to 1,000's of seconds could be required for some weapons systems. The development of both nuclear and non-nuclear multimegawatt burst power technologies are under way to support the power needs of a wide spectrum of ground- and space-based strategic defense weapons systems.

Pulse Power and Power Conditioning. Pulse Power and Power Conditioning technology development addresses the special energy forms and delivery requirements of the weapons and sensor systems. This is a broad-based effort that seeks to expand the existing technology base through fundamental research and development with emphasis on critical element development. Significant advances in pulsed power and power conditioning technologies are essential to the realization of many of the high-energy weapons systems. A number of components and systems are under development which are required to match electrical requirements of the load to that of the prime power source. These components and systems include energy storage devices, high-power switches, and power conditioning devices.

Accomplishments

Two major Power Architecture Studies (PAS) were completed in FY 1987. Separate efforts were performed for space-based and ground-based applications to evaluate candidate technologies relative to SDIO needs. The studies evaluated current and projected technologies and identified the most attractive power options consistent with SDIO applications, identified critical technology issues which must be resolved to enable feasibility of the technology, and identified gaps in the present technology that must also be addressed to render the power options valid.

The SP-100 Ground Engineering System (GES) contract was signed early in FY 1987. A prototype SP-100 nuclear reactor rated at 100 kilowatts (We) of electrical output is currently being fabricated. Figure 4.4-6 illustrates a potential SP-100 configuration. The fuel fabrication and test facility preparations are proceeding. The SP-100 GES reactor will be installed in a government nuclear

test facility in Hanford, WA. After initial testing, the reactor will undergo a 6-month full-power demonstration run to validate its operation.

Multimegawatt technology development activities have begun with the goal of establishing the feasibility of providing high levels of burst power for weapons and high-power surveillance systems. During FY 1987, a request for proposal was issued for multimegawatt nuclear power source concepts suitable for development. Presently, DOE is evaluating the submitted proposals with the intent of funding five to eight 1-year concept development efforts. The two or three most promising of these concepts are intended to proceed into an intensive system design and development phase with the intent of establishing feasibility of at least one concept by the early 1990s. The Air Force is currently

FIGURE 4.4-6
Concept Illustration of a 100K SP-100 Nuclear Reactor System
Coupled to a Space-Based Radar Array

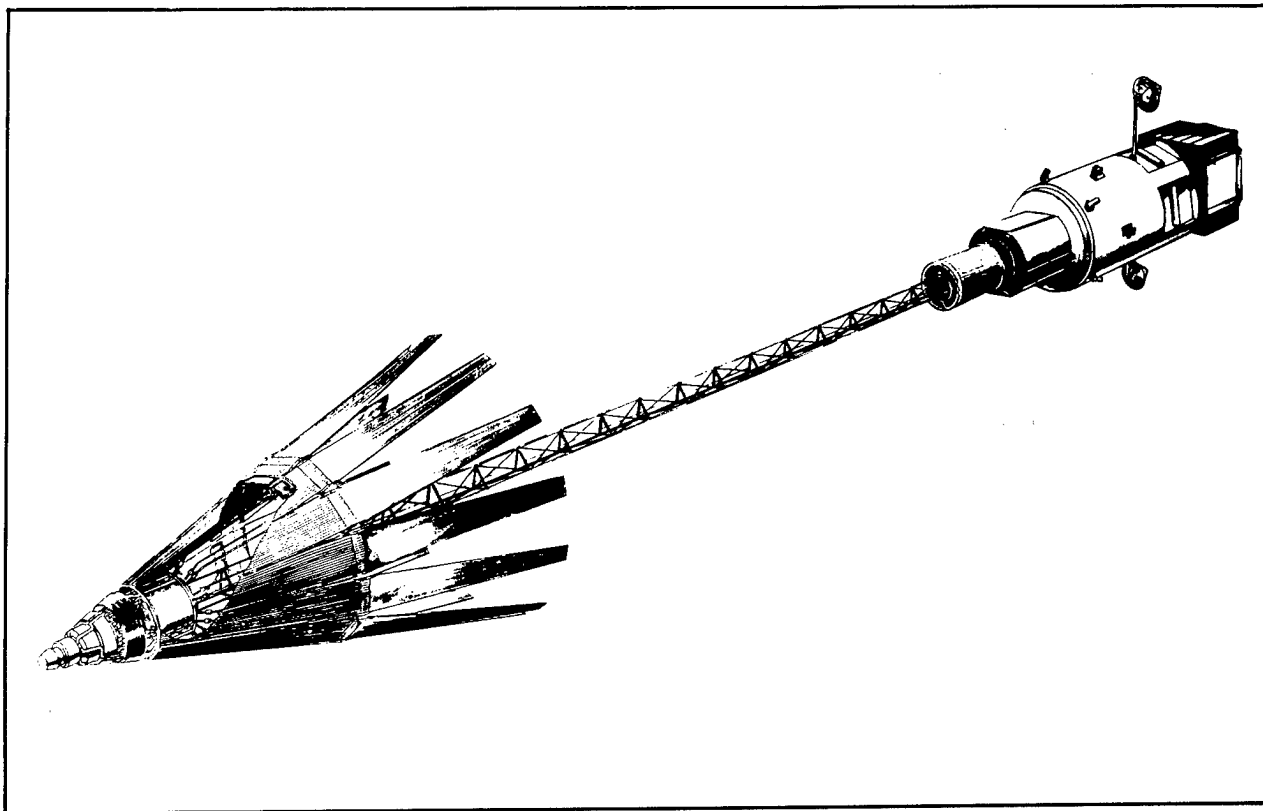

managing a rigorous non-nuclear multimegawatt development program which has realized significant advances in fuel cell technology as well as rotating machine/superconducting generator technology. Non-nuclear efforts are also progressing. Current non-nuclear efforts are rotating machinery (turbines and superconducting generators), electrochemical components (batteries and fuel cells), and magnetohydrodynamics (MHD).

A major element in the pulse power and power conditioning area is the development of radio frequency sources needed to drive weapon accelerators. Major advances have been made in the two competing approaches of solid-state and tube technology. In the solid-state area, improved understanding of thermal considerations has led to high-power per device operation at continuous wave operation. In the tube area, cathode research has led to devices with "instant-on" capability as contrasted to current tube devices which take several minutes to warm up from a dormant state.

Future Plans

Continuous baseload power is required to maintain surveillance, communication, and stationkeeping functions throughout the on-orbit system life (7 to 10 years). An SP-100 GES demonstration project has been implemented to allow the testing, demonstration, and validation of the SP-100 nuclear reactor. This project began in early 1987 and has since initiated modifications to a government nuclear test facility, the fabrication of an SP-100 prototype unit, and the fabrication of fuel. Future efforts will be focused on the continued fabrication of the fuel and the SP-100 prototype unit. Test facility modifications will proceed and the prototype unit will be installed in the test facility, resulting in early 1990's demonstration. Following successful Dem/Val testing of the SP-100 prototype, a flight test is anticipated for the mid 1990s.

A major new project will be initiated in FY 1988 to develop survivable solar power systems to provide an alternative baseload power technology option for low-power, near-term deployment options until such time that the SP-100 nuclear reactor systems are available for deployment. Specific efforts under way are to accelerate the schedule for existing SCOPA work, to increase effort in related technology areas such as battery storage and power conversion systems, and to initiate an effort to create SUPER which has survivability as the primary engineering design driver. The SUPER project will result in detailed design, fabrication, and qualification testing of a survivable power subsystem integration with a host vehicle and flight test.

While the principal driver in the power area results from the potential for space applications of the technology, ground-based defensive systems also present stressing requirements. In light of this consideration, effort to develop Superconducting Magnetic Energy Storage (SMES) has been initiated with the goal of establishing the feasibility of the technology to power ground-based laser systems for SDI. Structured as a 5-year program, the first 2 years will be spent resolving critical technology issues, establishing detailed cost and scaling models, developing a detailed design for the follow-on 3-year construction, and preparing for the evaluation phase. The demonstration system will be sized to power the Ground-Based Free Electron Laser technology integration experiment. Because SMES holds great promise for utility load-leveling applications it has been under examination by the electric utility industry under DOE and Electric Power Research Institute (EPRI) sponsorship. Due to the synergism between the SDI and utility applications, DOE and EPRI are cosponsoring the SMES development effort.

In the burst power area, the demonstration of SMES will take place. The device will operate at a power level within a factor of 2 to 3 from the weapon power requirement with a run time within an order of magnitude of the mission engagement time for the GBL. NPB applicable power technology for near-term discrimination will be demonstrated in a ground test of space traceable hardware. Confidence in the multimewatt technologies used in the NPB demonstration will reach the medium level. High confidence will be reached by addressing space-specific issues such as effluent management and integrated platform dynamics.

Future pulse power and power conditioning efforts will concentrate on high-power RF sources, high-power closing switches, inverter development, and other related technologies. Efforts will continue in the development of power conditioning components, with emphasis on weight reduction and volume reduction. Significant benefits will result from the size and weight reduction since more than half the mass of a weapons platform is expected to be attributed to pulse power and power conditioning components. The development and validation of prime power generation and energy storage subsystems to provide continuous power for maintenance of on-orbit stationkeeping functions are currently in progress.

An NPB system demonstrator is currently being planned for integrated system testing and demonstration in the early 1990s. This program will integrate a number of power components already developed to allow technical demonstration of power technology for the NPB concept while providing

traceability to space. This system demonstrator will provide a mechanism for the resolution of identified system issues.

Figures 4.4-7 and 4.4-8 depict the evolution of our confidence levels in the baseload and burst power areas. In the baseload areas, the SP-100 GES testing will include a nuclear assembly test (NAT) and an integrated assembly test (IAT). The NAT testing consists of a full-scale reactor core and primary heat transport loop under space vacuum conditions. The test will include the determination of the reactor characteristics by cold start-up and determination of control characteristics. The IAT consists of a test of the modules thermoelectric conversion and radiator system modules comprising one-twelfth of the total capacity under simulated space conditions. High confidence should result from the on-orbit flight test of an SP-100 reactor in the mid 1990s. The test will include the demonstration of electric propulsion technology for spacecraft orbit changing and maneuverability to enhance survivability. Similarly, high confidence should also result from the flight test of SUPER. Extensive

**FIGURE 4.4-7
Baseload Power Confidence**

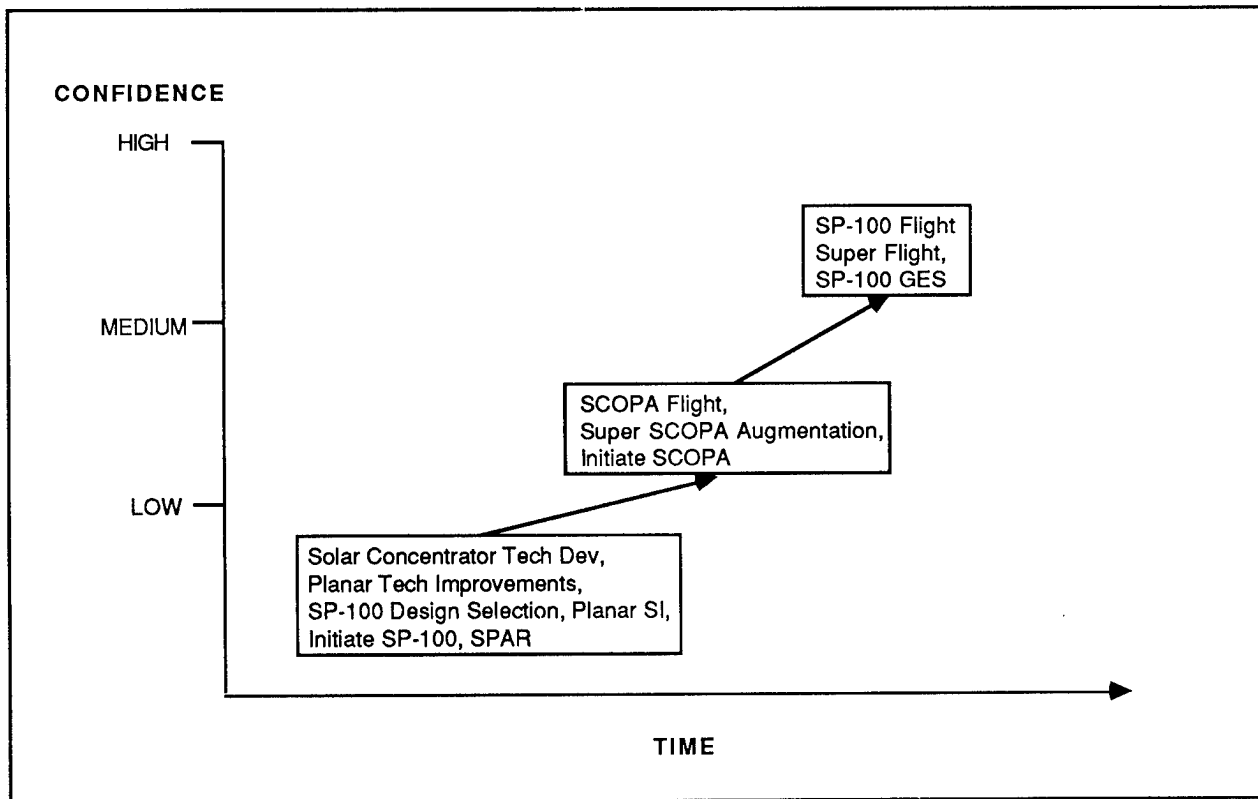

ground testing for survivability against a spectrum of threats will precede the actual flight, including thermal laser, nuclear, and pellet.

Space Transportation

Project Description

Because current launch systems cannot easily satisfy the launch requirements of an SDS, deployment of space-based defenses depends on high-capacity, low-cost space transportation. The Space Transportation and Support project aids the development of technologies necessary for space transportation that will enable an SDS to be economically deployed and maintained. Advances in technologies, such as propulsion, ground and flight operations, avionics, and materials/structures, are necessary to reduce launch costs significantly.

**FIGURE 4.4-8
Burst Power Confidence**

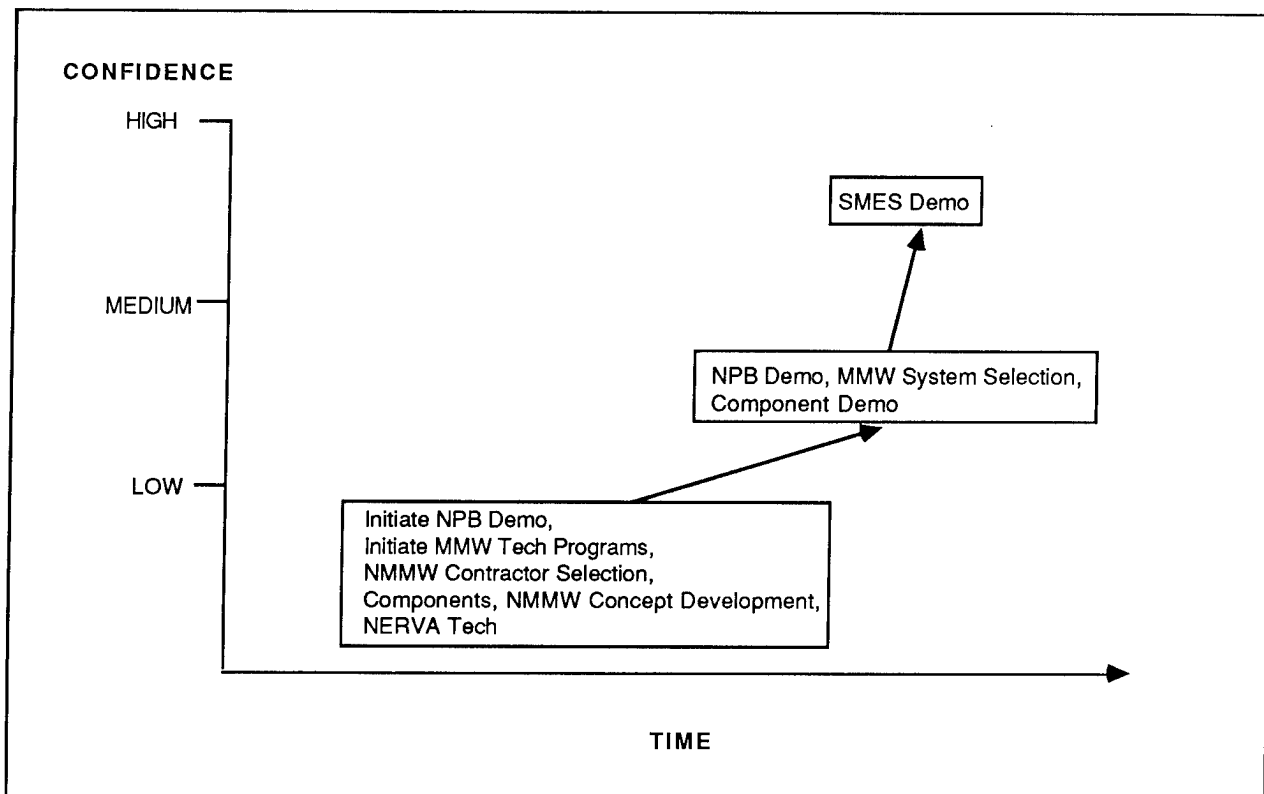

Studies have revealed that a new-generation, unmanned, heavy-lift launch vehicle is required to satisfy the broad range of military and civilian national payload requirements, including those associated with deployment of a defense system. Consequently, the DOD, with NASA's participation, has initiated the Advanced Launch System (ALS) with the objectives of providing a tenfold reduction in launch costs, an increase in launch capacity and flexibility, and ensured access to space for the DOD and NASA payloads. This balanced approach to space transportation, focused on technology and the development of a new cost-driven launch vehicle, will satisfy the future U.S. launch requirements, substantially reduce the cost of space operations, and provide a flexible robust space transportation system.

Accomplishments

The DOD/NASA Space Transportation Architecture Study (STAS) provided a comprehensive analysis of future U.S. space launch and operations needs. Completed in November 1986, the STAS-identified key technologies, a technology roadmap, and a preferred architecture for future U.S. launch systems were identified. An important goal of the study was to identify those potential systems and operating concepts that will afford the U.S. the greatest reduction in launch costs. The STAS concluded the most pressing shortfall in the nation's space transportation capabilities was that of unmanned space lift.

The ALS will be a system to support civil and national security users in providing low-cost, reliable high-launch rate capabilities. Additionally, the ALS will increase space lift capability in terms of poundage and volume over current launch capacity. In April 1987, the DOD issued a Program Research and Development Announcement to solicit bids for an ALS concept definition effort (see Figure 4.4-9). In July 1987, contractors were selected to perform a 1-year concept definition study. In August 1987, an ALS Technology Fair was held to provide the ALS contractors with a description of the relevant technologies being pursued in government laboratories or by industry. The first major Systems Requirements Review of the concept definition studies was held in October 1987. Based on the results of this concept definition phase, two contracts will be selected to accomplish the ALS preliminary design review (PDR) of the respective elements of the ALS. Following a (PDR), the FSD phase with supporting focused technology efforts will begin.

Future Plans

A DAB Milestone Zero Review will be held to approve the mission need and acquisition approach for the ALS to be followed shortly by a Milestone I Review. The purpose of the Phase II concept validation phase is to further develop and refine concepts to identify the most promising approaches to meeting the ALS objectives and to conduct PDRs. Following the completion of Phase II, Phase III FSD will be initiated. Its purpose is to complete development of the ALS through a Concept Design Review (CDR) leading to the first launch, or initial launch capability (ILC), of the ALS by 1996, and operational capability no later than 1998. DOD and NASA are conducting focused supporting technology efforts in parallel with the contracted studies. These efforts are necessary to provide the technology needed for ALS on a timely basis. Most of the technology efforts will be centered on the ALS core engine. As a

**FIGURE 4.4-9
Artist's Concept of an ALS**

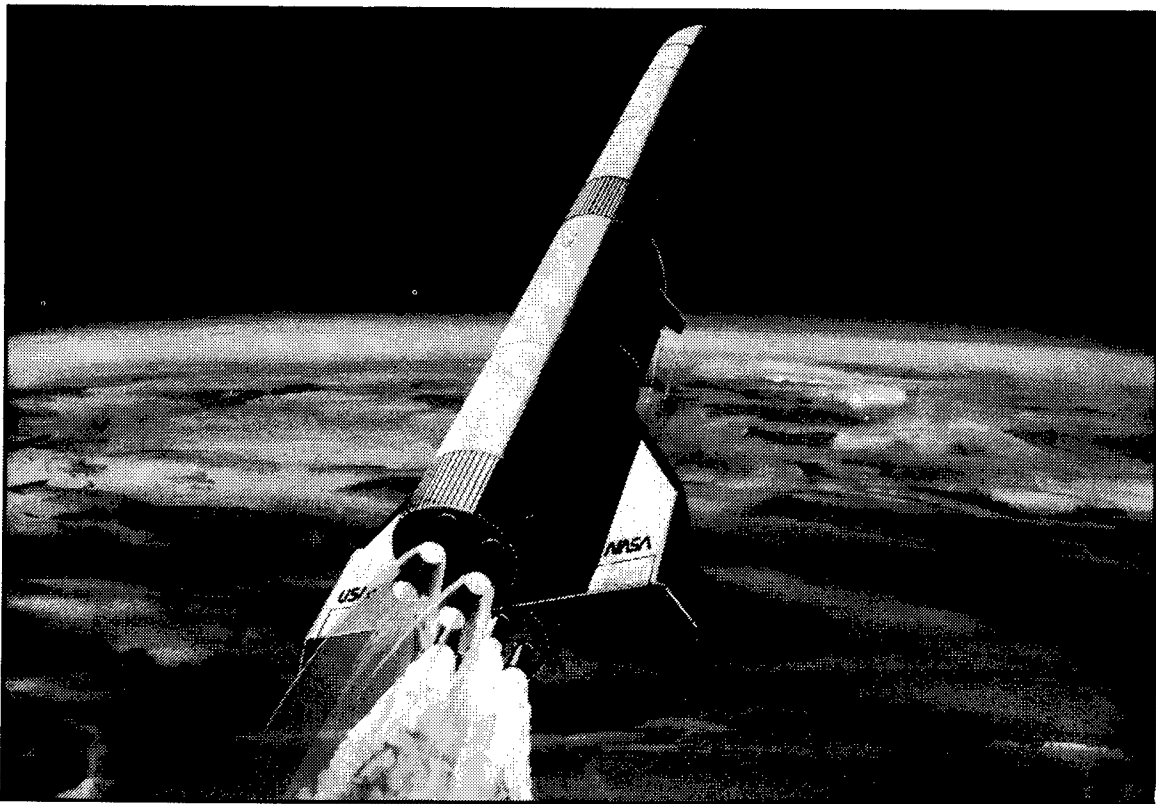

result of the engine test and the accomplishments of other technology programs, the design of the core engine should be complete by FY 1991. A full-scale demonstration of the engine is scheduled and demonstration of the entire core should occur by FY 1993. Figure 4.4-10 is a top-level schedule of ALS technology efforts and associated confidence levels.

Materials and Structures

Project Description

The M&S project addresses the need for a centralized clearinghouse for its new technology developments. The technological challenge and breadth of the enabling M&S advances and breakthroughs have dictated the organization of a project that builds on the technology base of the

**FIGURE 4.4-10
ALS Technology Confidence**

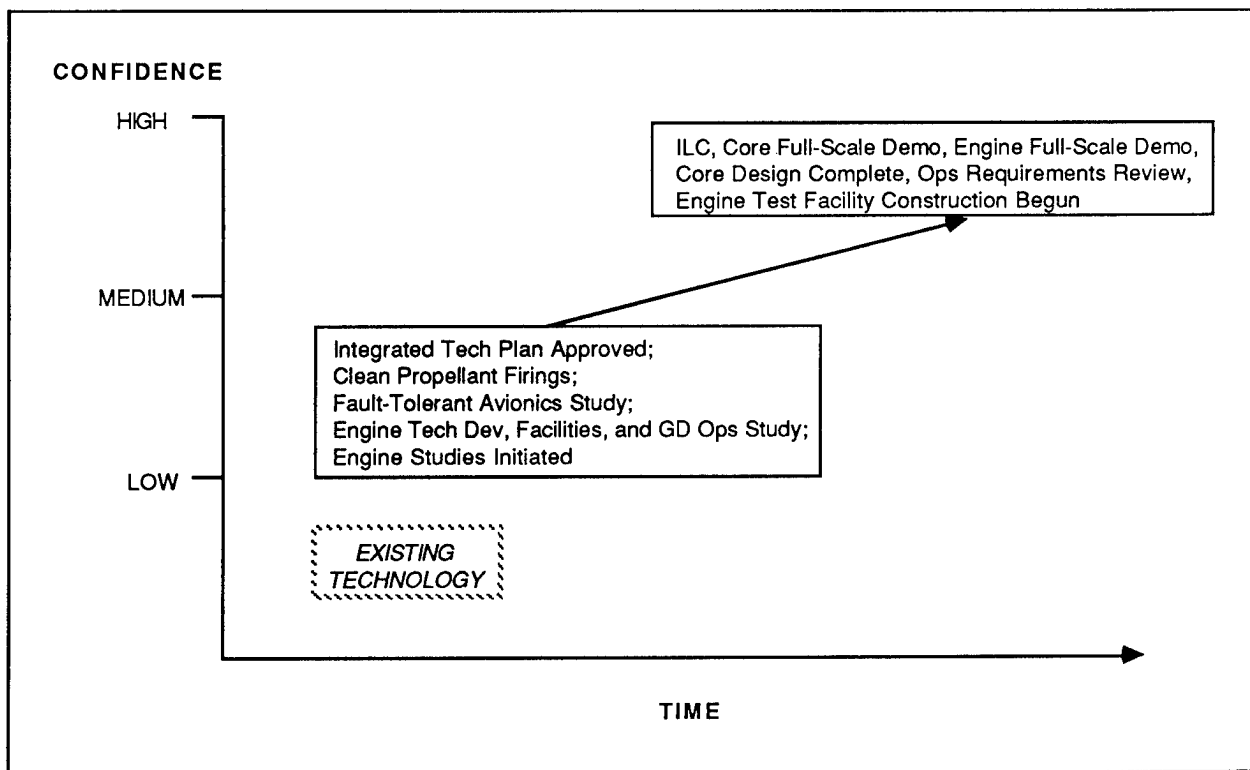

entire nation. Research is being conducted in six major technology areas: lightweight structural materials, optical system materials, tribological system materials, power system materials, thermal management system materials, and lightweight structures. These areas focus on the critical path technology development tied to major development milestones.

The M&S project addresses technologies that have multiple SDI element applications and serve both near-term and longer-term element needs. The project will accelerate the transfer of laboratory advances into practical devices and ensure the technology is inserted into system development elements at critical decision points. The project provides a critical link between developing technologies and projected SDS elements to ensure affordable, reliable, capable, and survivable hardware is available.

Additionally, the project formulates new M&S thrusts that address serious gaps or deficiencies in current or planned technology base efforts for ground- and space-based elements. In doing so, the M&S project leverages other services -- DNA, DARPA, NASA, and DOE M&S technology base efforts.

Accomplishments

The M&S project has developed formal interfaces with other SDI Program Elements, supporting DOD service organizations, and SDI system contractors to ensure the transition of advanced M&S technologies from the laboratory is accomplished. Requirements for M&S research have been defined, and focused tasks are under way to achieve these requirements by 1992.

In FY 1987, the Passive and Active Controls of Space Structures (PACOSS) project made significant progress in the development of vibration suppression materials for all SDI systems. Previously it was believed that designed-in passive damping beyond the 1-percent level was difficult to predict and achieve. However, 5 types of passive damping materials were investigated, and predictable model damping was shown to be achievable. As a consequence, it is estimated that up to 80 percent of the propellant mass for active-controlled space platforms can be saved. Additionally, over 200 viscoelastic damping materials were characterized and added to the PACOSS reference data base. Tests are continuing in FY 1988. The dynamic test is illustrated in Figure 4.4-11. The data are being used to develop and validate analytical techniques for predicting space platform structure dynamic responses.

FIGURE 4.4-11
PACOSS Dynamic Test Article



Major accomplishments in FY 1987 were achieved in the tribomaterials area which improve the performance and reliability of moving surfaces in mechanical assemblies and rotating equipment. An associate contractor agreement was established between two SDI contracts for developing tribomaterials for extended life bearings and seals for the ALS turbopumps. This component has the most frequent change-out requirement in current high-thrust, liquid-fueled rocket engines, such as the system shuttle.

Additionally, a technology transfer program was initiated with the National Tribology Centre and European Space Tribology Laboratory in Risley, England, to transfer ultra-low friction films and lightweight gear and bearing technology to the United States. The United States has no counterpart laboratory.

The HTS project has the highest potential payoff for a multitude of SDI systems, from IR sensors to RF cavities and shields. The acceleration of this particular project could provide immediate and essential improvements in the cost effectiveness and efficiency of any SDS.

During FY 1987, the M&S project also defined and prepared an implementation plan to accelerate the translation of HTS materials technology into practical devices to reduce the weight, power, and costs of future systems. The initial effort has been to assist the SDS Program Manager (PM) and the SPO in identifying and quantifying high-impact components, and then to solicit program participation in the rapid technical development and transfer process. This process will continue throughout the HTS project evolution.

Lastly, thermoplastic composites promise to meet some of the unique requirements of a low-cost, lightweight, low-outgassing, and survivable materials for rigid space platforms. In FY 1987, a thermoplastics evaluation project, was planned by a workshop of technical specialists. Material test specimens were acquired. Tests of sheets and tubes have provided important material properties data, and a representative platform truss section was built to evaluate fabrication and joining technologies. Resistance of the material to a laser threat is being evaluated in survivability tests. The next step in thermoplastic materials development is to build and test components representative of the SBI.

Future Plans

Future M&S project efforts in three key technology areas are depicted in Figures 4.4-12 and 4.4-13. These charts summarize prior related efforts, ongoing technology advancement tasks and planned ground and space technology demonstrations required to assure timely technology infusion into SDI Phase I and follow-on phase system activities.

**FIGURE 4.4-12
Structures Confidence**

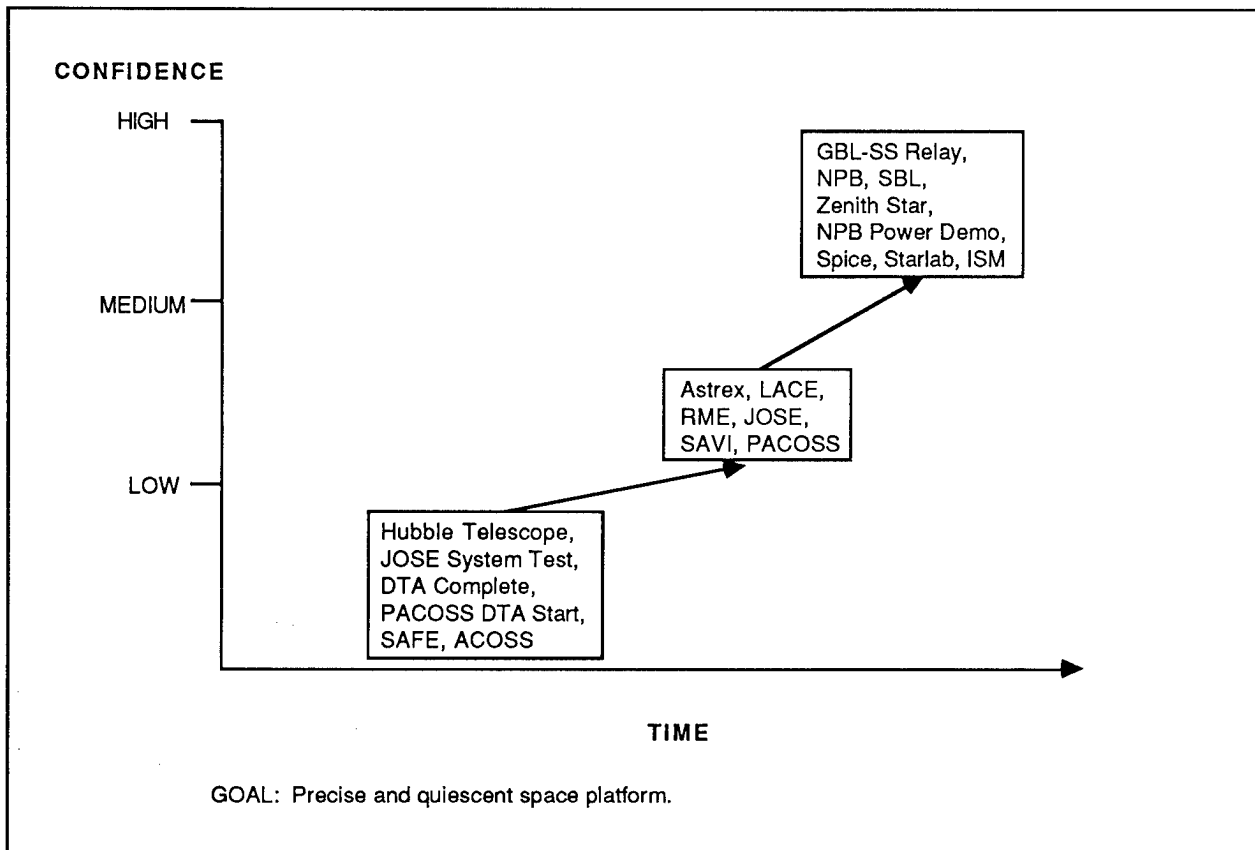

**FIGURE 4.4-13
Structural Materials Confidence**

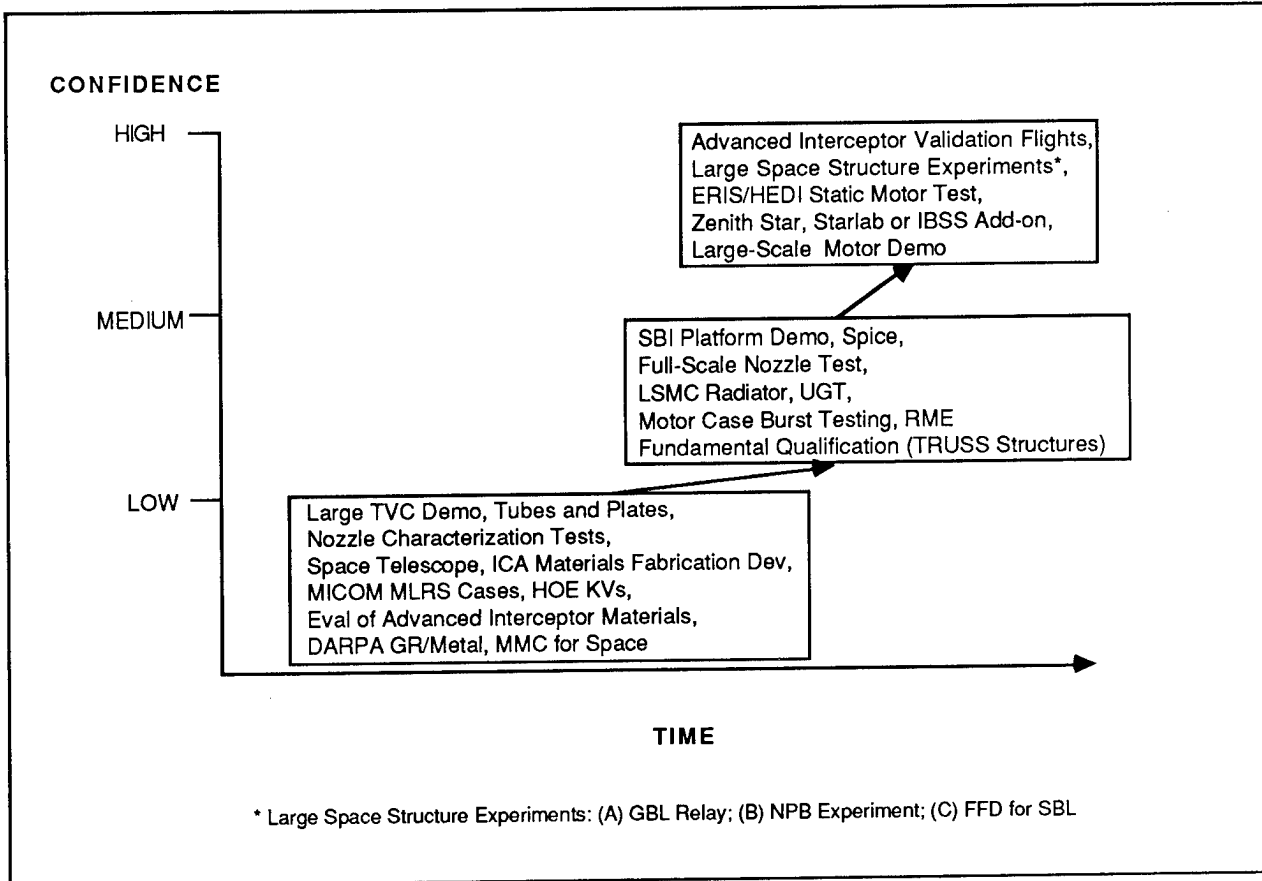

Large space structures for NPB, GBL, and SBL weapons pose a unique challenge in structures design and vibration control because of the expected severe dynamic environment. Development of hardware concepts for controlling vibrations and unwanted platform motions and validating analytical techniques for predicting precise structural responses is continuing. These developments will lead to a

ground test of a representative large space structure to demonstrate the integration of vibration isolation (SAVI), passive damping (PACOSS), and active damping technologies (JOSE), acting in unison in a single-space structure experiment called SPICE.

The M&S project will continue to develop an integral composite adapter propulsion case and one-piece rocket nozzle using advanced composites. These composites (see Figure 4.4-14) are

FIGURE 4.4-14
Large Area, Small Device, and High Current HTS Components

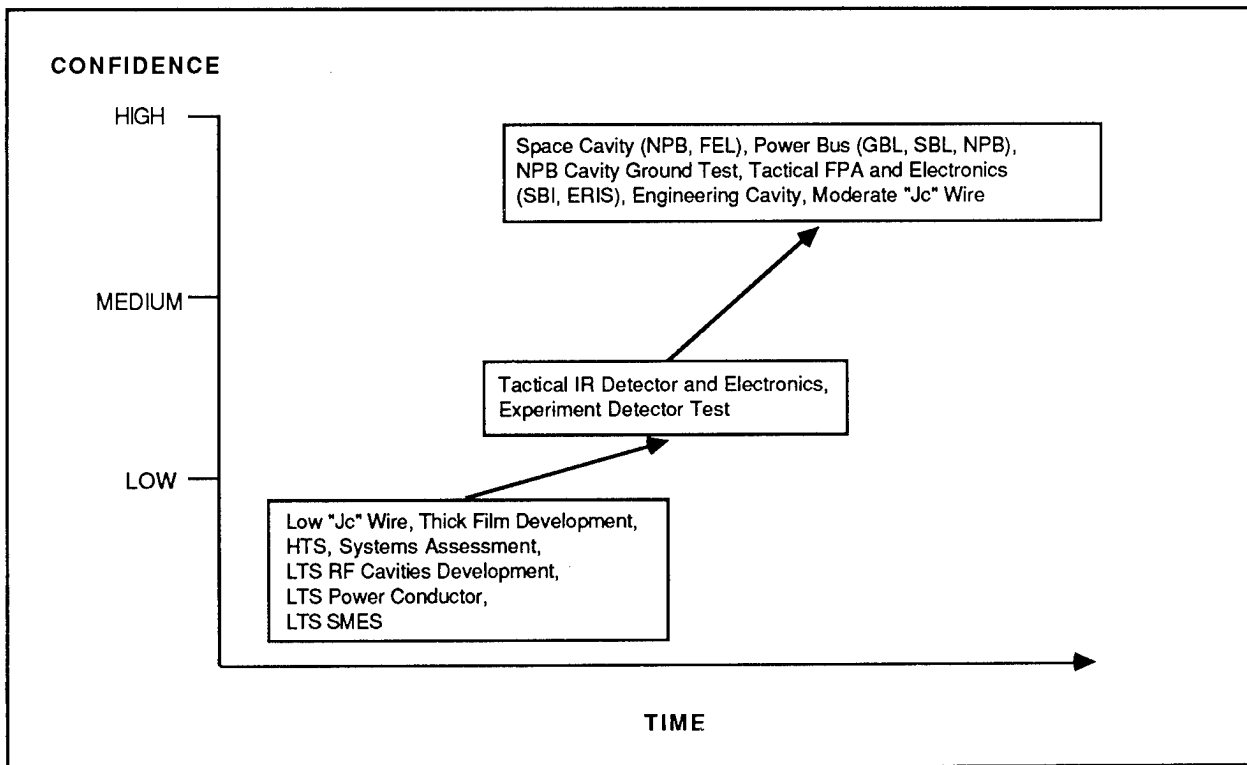

capable of withstanding the combination of pressures and temperatures associated with a realistic demonstration of an advanced propellant being developed by the KE Directorate. This integrated multiyear effort is expected to lead to a jointly funded M&S and KE rocket motor test and to ensure infusion of the technology into interceptor systems.

The M&S project expects to participate substantially in forthcoming major ground demonstrations and space experiments that will be focused on systems validation of space structures technology. These include the ground-NPB-power system demonstration project, a joint Directed Energy Directorate/SLKT undertaking, and the Zenith Star experiment.

A multiyear technology insertion activity has been started to demonstrate the usefulness of emerging M&S technologies to meet the needs of the SBI space platform. It is planned to integrate advanced composite materials, structural damping, and tribological materials systems into a ground technology demonstration unit for testing. Building on the materials experiment gain from this

demonstration, the M&S project will be working toward acceptance of precision composite materials in the Zenith Star experiment.

Also, development of advanced composites for lighter weight interceptor structures is continuing. The objective is to achieve a lightweight material that can withstand high thermal heating and enable interceptor weight reduction by removing components required for structural cooling. Currently, the effort is focused on the ERIS interceptor structure and plans are being developed with the KE Directorate to demonstrate the improved composites, possible as early as 1990.

A vigorous project began in FY 1988 to translate recent research breakthroughs in HTS materials into advanced performance components for SDI systems. The HTS M&S project is focused on early high-payoff components for space surveillance systems and providing the technology base for ground- and space-based DEWs. Early demonstrations of HTS technology are expected in IR detectors and associated electronics in Phase I tracking and surveillance systems and RF cavities for NPB and FEL DEWs.

A significant materials effort will continue to improve the capability of interceptor optical components such as mirrors, baffles, and windows. Materials research will continue toward the goal of improving the capability of baffles to reduce unwanted background signals from reaching on-board sensors. Related Be mirror developments to improve surface quality will continue, and a new effort will be started to enhance the optical and mechanical strength of SWIR window materials. A related effort will be started to develop the materials technology for LWIR windows required for airborne acquisition systems.

Space platforms require precision mechanical assemblies that must move reliably and predictably after long periods of dormancy. Investigations of low-friction lubricants and films and improved tribological materials for moving parts such as gimbals and gears are being continued.

Tests of gimbals and other moving assemblies with advanced lubricants will be included as part of space structures ground experiments. Tribological material development for the ALS turbopump to improve in-service life and reduce launch vehicle operational costs is continuing and is expected to lead to a demonstration of the improved materials in the full-scale ALS turbopump.

The space environment, particularly atomic oxygen found at low- to medium-altitude orbits, can interact adversely with on-orbit space materials. The M&S project is identifying material experiments that can be conducted in ground simulation facilities and low-cost opportunities to gain substantiating materials measurements in space, by joining already planned launches. This type of activity is expected to grow in future years.

The M&S project will continue to initiate activities in response to newly identified critical M&S needs. Planning has started for a new task in FY 1989, to develop and demonstrate the potential of advanced composite materials, to reduce the weight and increase the hardness of spacecraft radiators, and to address other spacecraft thermal management. A materials task is planned to increase the reliability of cryogenic pumps, an indispensable component of space-based DEW platforms.

4.4.3 Funding Impacts

Survivability. The deficiencies that resulted in the FY 1988 project because of funding shortfalls will be addressed as a priority issue in FY 1989. These include evaluations of the NPB and HPMW/EW threats against Phase I elements. These threats represent an increasingly stressful environment for SDS elements and will require new programs to be started in FY 1989. Due to funding shortfalls, all subsystem and system level validation testing of survivability technologies were deferred in FY 1989. Additionally, increased component level testing will be accomplished to increase the confidence in technologies developed.

Lethality. Because of budget constraints, the new areas of deuteron beam lethality and nuclear-driven KE concepts will not receive adequate lethality support. The theater missile defense portion of the lethality project will be funded at lower levels than requested, most likely resulting in heavier warheads and higher system costs. Uncertainty bounds for lethality estimates of the damage to RVs and PBVs by thermal lasers will not be available until after 1992, and uncertainty of the lethality assets due to variations in nuclear weapon designs will not be validated in underground tests.

Power and Power Conditioning. The budget shortfalls experienced have had a significant impact on the progress and on the risk reduction involved in the power project. Overall project confidence has been slightly reduced as a result of the elimination of follow-on work to the Ground Power Study (GPS) and the SPAS. Homopolar generator efforts have been reduced and are facing termination following a sizeable investment, resulting in reduced non-nuclear multimegawatt capabilities for near-term burst power applications. Other non-nuclear multimegawatt projects have been slipped, thus deferring the availability date of the near-term multimegawatt power sources. The SP-100 GES project has been slipped and some of the ground tests have been reduced in scope. The nuclear multimegawatt concept development project has been reduced from eight concepts to six thus increasing the risks associated with the development of a nuclear multimegawatt power source. All of the impacts identified above increase the risks associated with the program.

Materials and Structures. Shortfalls will exist in the SBI platform project demonstration which will provide for the full integration of the supporting technologies for this critical program in the development of glass-ceramic composites, space structures technologies, and HTS projects.

4.5 INNOVATIVE SCIENCE AND TECHNOLOGY PROGRAM

4.5 INNOVATIVE SCIENCE AND TECHNOLOGY (IST) PROGRAM

This section describes the Innovative Science and Technology Office, its objectives, significant accomplishments, current activities, and future plans.

4.5.1 Program Overview

The IST Office is a technical division within the SDIO tasked with seeking out new and innovative approaches to ballistic missile defense. It sponsors research in these approaches and assures that the other technical divisions within the SDIO learn of useful results emerging from IST programs. FY 1988 funding for SDIO/IST is \$108.63 million (3 percent of the total SDIO RDT&E appropriation). Additionally, approximately \$33.95 million was appropriated for the SBIR Program.

The IST Office has several roles. First, it establishes a technology base for strategic defense via fundamental research. This research effort is conducted throughout the scientific community in universities, government and national laboratories, small businesses, and large industries. Second, the IST program brings infant technologies to a stage where they can be validated for potential SDI use. At that point either the technology transitions into applications or it goes on the shelf for possible use in the future. In FY 1987, the IST Office funded about 200 university research groups from more than 110 different American universities and an equal amount to other research institutions. Third, the IST Office administers the SDIO SBIR program. This federally mandated program requires that 1.25 percent of the total SDIO extramural R&D funding be allocated to small businesses via the SBIR mechanism.

4.5.2 Technical Objectives

Project Description

The IST Office sponsors fundamental research programs in six major thrust areas: (1) advanced high-speed computing, (2) materials and structures for space applications, (3) sensing and discrimination, (4) advanced space power, (5) advanced propellants and propulsion, and (6) directed/kinetic energy concepts. The research program is centrally managed by IST personnel and implemented through Science & Technology Agents (STAs) located at other government agencies (such as the Office of Naval Research, Air Force Office of Scientific Research, Army Research Office,

Defense Nuclear Agency, NASA, DOE, and other DOD laboratories). Proposal review, contracting, and day-to-day technical management of the IST research programs is the responsibility of the STA.

The SBIR program has selected 400 winners of their Phase I effort. Of those 400, over 100 have so far submitted Phase II proposals, and 50 have been selected for Phase II. The first Phase II contract started in April 1987. Of the 37 Phase I contracts funded from the FY 1985 solicitation, 31 submitted Phase II proposals and two became large businesses, presumably because they exploited the successes that won them Phase I awards.

Accomplishments

SDIO's Innovative Science & Technology research program has existed for only 3 years. But notable technical accomplishments have already been made, in part because many projects have been accelerated by IST funding or started anew. Some of the best examples of these are:

- o IST intends to develop electronics materials for the next generation of ultrahigh-speed signal processing and computing. Researchers made monocrystalline films of electronic-grade diamond in the laboratory for the first time in this country. Diamond epitaxy brings critical benefits to next-generation semi-conductors: thermal conductivity, high electric-field breakdown strength, radiation-hardness, n-type carrier mobility.
- o Electronics materials research has dramatically improved the sharpness of the edges of thin films and thus created a visible laser with dramatically better performance than the best in the world last year; a high-speed switch (only 4 picoseconds) was developed using a resonant tunneling diode device; the first room temperature continuous wave gallium arsenide lasers on a silicon substrate were made. Atomic layer epitaxy promises a new technique for dramatically increasing the usable production of VHSIC-wafer silicon. Exploitation of scanning tunneling microscopy has led to miniature accelerometers.
- o An IST program in materials has advanced the art of producing optically clear, durable, large-diameter glass by using the low-temperature process known as Sol-Gel (Solution-Gelatin). The low-temperature Sol-Gel technology offers the potential for rapid, large-scale production of large, near-net-shape optical components with a wide range of optical and physical properties not possible with standard glass-melting methods. These materials

have lower thermal expansion than standard silica glass and would need less grinding time to produce SDI-quality optics.

- o IST researchers in space power have recently fabricated a prototype super-capacitor capable of storing 200 kJ of electrical energy in a can less than 3 cubic feet in size and 110 kg in weight. The enabling technology was provided by the computer-aided molecular engineering of a dielectric of polyvinylidene fluoride copolymer with a dielectric constant around 14. This advance represents a fourfold increase in energy storage per unit weight over the state of the art in FY 1986.
- o Research teams have found increasingly convincing evidence of the feasibility of ultra-short wavelength lasers. One team demonstrated short wavelength lasing at about 1,000 Angstroms using a bench-top pumping laser with output of less than 1 Joule of energy. Such a breakthrough will well advance the art of electronic materials fabrication via laser lithography, where a compact, inexpensive source of coherent radiation below 1,000 Angstroms would be a powerful tool for the electronics industry. This team also developed a traveling-wave ultraviolet laser that is pumped via an X-ray emitting plasma at high power density from a tungsten target, demonstrating a critical technology advance in the geometry of such devices. Another team found the first evidence of X-ray lasing driven by a Z-pinch, a route to X-ray lasing from an electric current.
- o The sensitivity of infrared, staring array, high-altitude sensors looking for ballistic missile launch paths has been enhanced by superconducting focal plane elements that can provide a sharp image in dim light. Niobium nitride has proven an excellent superconductor and is being advanced into technology proof-of-principle experiments.
- o Phase I SBIR contracts found many innovative ideas which merited a Phase II for full development of the concept. Each Phase II success will create a new technical opportunity for SDI. The ideas are active magnetic bearings for vibration-sensitive devices like accurately pointed mirrors, a zero-gravity heat pump for space power heat dissipation, a new source of ultrafine boron carbide powder now available only from foreign producers, a megapixel bistable optical device for optical computing, a logic array for image processing, a software scheme for data base transfers in heavy traffic, a decentralized tracking algorithm for radars, microelectrode batteries for more concentrated battery power, a focal

plane multiplexer for immediate image assembly for processing, electron trapping compounds for optical computing, a miniature accelerometer impervious to radiation damage, a solid-state neutron detector for lightweight interactive discriminators, a two-phase cooling scheme for sodium-potassium-lithium mixtures for more heat dissipation from space power generators, an agile laser imager for active sensing, a new range measuring laser, an expert system for Kalman filtering to make computing more reliable, microfilamentary higher strength electrical conductors for electromagnetic guns, cubane derivatives for higher energy propellants, a new number scheme for faster computing.

The IST program in composite material for space applications produced several innovative concepts for advanced materials in new applications. Nickel-aluminide tripled its high temperature strength when reinforced with titanium diboride fibers precipitated from the melt. A new silicon carbide reinforced-aluminum bar measured 20 times the toughness when made as a mini-discontinuous composite. Boron nitride fibers were made that can replace carbon fibers that are susceptible to atomic oxygen in space. The innovative process pyrolyzes borazines and replaces the expensive process of converting boria in an ammonia atmosphere. Another project found a carbon fiber reinforced glass to make it lighter than aluminum, unidirectionally stiff as steel, and crossply stiff as titanium.

The CHECMATE electromagnetic launcher (EML) facility was completed early in FY 1986. This facility is capable of accelerating 150 to 250 gram projectiles to velocities of 2 to 3.5 kilometers per second. After CHECMATE yielded early data on EML performance for SDI needs, it now serves as a test bed for anti-armor technology through the Balanced Technology Initiative (BTI) program.

Future Plans

In addition to the accomplishments in many of the programs described above, the IST Office anticipates significant progress in many of the ongoing IST-sponsored projects. A few examples are described in the remainder of this section.

The THUNDERBOLT EML program is scheduled to provide the first demonstration of acceleration of a macro-projectile (over 100 grams) to hypervelocities (greater than 10 kilometers per second). The hypervelocity behavior of projectiles, the power conditioning of EMLs, material erosion in the barrel, and the effect on homer electronics by the plasma generated in the gun are many of the

key issues to be investigated on this new facility. THUNDERBOLT will be a test bed for EML programs where new concepts can be tested that could one day be turned into electromagnetic guns. IST will hand over the operation to a development group within SDIO, having crossed the threshold of solving the technological challenges of achieving such high velocities.

Detection of ballistic missiles in the boost phase usually depends on the sensing of the infrared signal from the rocket exhaust. The IST Office sponsors a program to theoretically model (and eventually measure) the non-equilibrium ultraviolet radiation signature emanating from the continuous shock wave produced by the missile hardbody. The problem is an extremely difficult one, combining three-dimensional fluid dynamics with detailed non-equilibrium air chemistry, radiation transport, and UV spectroscopy. Preliminary results from the first year of exploration showed that it might be more useful to look for the shock wave emanating from the hardbody of the missile than the hot products of the plume. If successful, the program will define how to detect the missile body.

The generation and handling of high power in space will be affected by the space environment which cannot be adequately simulated on the ground. Thus a rocket-borne experiment SPEAR (Space Power Experiments Aboard Rockets) will measure those aspects of the ionosphere that affect electrical operations. An experiment conducted in late 1987 characterized the ionosphere for a positively charged probe to tens of kilovolts. The second experiment in 1988 will use the data from the first experiment to test the design of high voltage (100 kilovolt) and high current (100 kiloamps) components with little or no electrical insulation. These will be the highest quantities of electricity ever operated in space and the results will guide future designs of SDI electrical equipment toward lower weight and volume. The results of the experiments will guide design engineers in how high voltage/high power actually behaves in space.

Capacitors for space applications promise a high payoff in terms of energy storage and power conditioning for burst-mode weapon concepts. As a result of the diamond film research sponsored by IST and discussed above, engineers are now exploring the possibility of using diamond films as insulating layers in novel capacitors. Because of the high breakdown field strength, high thermal conductivity, and controlled layer growth of diamond, the application for capacitors is extremely promising for extending the energy storage presently attainable with existing technology.

THIS PAGE INTENTIONALLY LEFT BLANK

5.0 TEST AND EVALUATION

5.0 TEST AND EVALUATION

This section provides background on the SDI Test and Evaluation (T&E) Program, its strategy, scope, the management framework within which it will be conducted, and accomplishments and future plans.

5.1 BACKGROUND

The T&E Directorate was established in mid 1987 to begin integrating test activities that will be necessary to conduct the demonstration and validation (Dem/Val) phase of the Phase I SDS and future development phases. The Directorate establishes the overall policy necessary to formalize the SDS test process and to ensure a comprehensive test program. The Directorate oversees all SDI T&E to ensure that both system and element key technology and operational critical issues are addressed and that the essential data to properly evaluate these critical issues are collected in the tests, experiments, and demonstrations that comprise the T&E program. The Directorate also provides an independent and thorough review within SDIO of the planning and results of these tests, experiments, and demonstrations. The Directorate's initial focus has been on the development of an initial Test and Evaluation Master Plan (TEMP) to define the T&E program and its objectives as well as to develop an overall facility investment strategy to ensure that needed test facility/capability requirements are validated, programmed, and acquired to support test activities.

5.2 T&E STRATEGY

The T&E strategy is designed to achieve the test objectives for the overall program. During the Dem/Val phase these objectives are to assess the degree of system functionality and performance in meeting the operational requirements, to validate the system concept reducing risk prior to entry into a full-scale development (FSD) phase, and to structure the necessary system test capabilities needed for FSD and deployment phases. Test objectives for future system acquisition phases will be time phased and defined according to milestone requirements. Simulations and ground tests will be the principal design, verification, and evaluation tools. Flight and field tests will demonstrate the capabilities to support the design, verification, and evaluation process.

The SDI TEMP is the top-level planning document describing the program for accomplishing T&E strategy and objectives. The methodology to accomplish Dem/Val T&E objectives is based on three key elements of the T&E approach: ensure a top-down integration of system and test requirements; perform a

bottom-up validation of performance through hardware and software testing; and accomplish early integration testing. Figure 5-1 shows the relationship between simulation and testing in this T&E approach. Simulations will be used to examine the full scope of the SDS. They will be used as an analysis tool for defining how system design and test requirements are allocated to the SDS elements. Hardware and software testing of portions of the SDS will be used to assess performance and technology maturity, and to validate simulation tools. Early integration testing, such as Delta 181, SATKA Integrated Experiments (SIEs), and System Exploration Experiments (SEEs), will be performed, whenever practical, to examine systems integration and performance capabilities as well as to assess test capabilities and develop test procedures. Later in Dem/Val, integration testing will be accomplished through cooperative modification of SDS element test programs and, if practical, selected dedicated integration tests. All test results will be used to support system and element evaluation and early operational assessment of the Phase I SDS configuration.

FIGURE 5-1
Expanding the Integration "Flight Envelope"

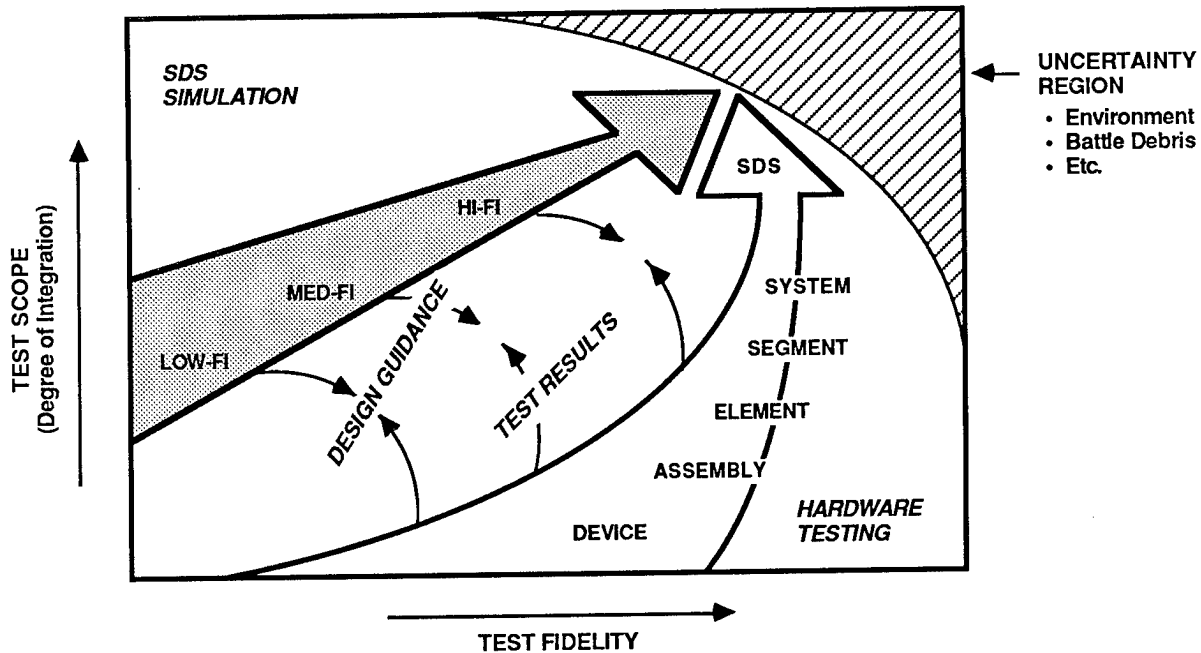

5.3 T&E MANAGEMENT AND RESPONSIBILITIES

The SDIO Director, Test and Evaluation (SDIO/TE), will establish overall T&E policy and top-level direction of the test program. This direction will be at various degrees of involvement ranging from review and evaluation of element T&E programs to the actual conduct of selected integration experiments. Agents conducting the research and development of SDS elements manage their respective T&E programs in accordance with established SDIO T&E policies. As a minimum, the SDIO/TE will independently review and evaluate T&E activities conducted by the Phase I SDS program manager for the assessment of integrated system performance. It is anticipated that during the Dem/Val phase, early operational assessments of the Phase I SDS and its elements will be accomplished under the direction of a special SDS Operational Test Organization (OTO) reporting to the Director, Operational Test and Evaluation (DOT&E), Office of the Secretary of Defense. These assessments will be conducted by evaluating data collected during the T&E activities of the Phase I program manager and service agents and will not require special tests or demonstrations. SDIO/TE will be the primary SDIO contact with the OTO for validation of test data requirements.

To facilitate the coordination and planning of T&E activities, a number of T&E Working Groups (TEWGs) are being established. An SDI Test and Evaluation Working Group (TEWG) chaired by SDIO/TE, has membership from SDIO, Office of the Joint Chiefs of Staff (OJCS), U.S. Space Command, appropriate test agencies (DT and OT), key test ranges, service program agents, and other organizations as appropriate. (See Figure 5-2.) Each SDS element program will also establish a TEWG function to conduct the element program.

5.4 THE T&E PROGRAM

The program will focus on key critical system-level issues which form the basis for establishing the essential feasibility of the SDS concept. These issues may generally be categorized as technical feasibility, survivability, and system effectiveness. Each category embodies important technology, operability, and cost/benefit questions which must be answered before proceeding to the acquisition process. The SDI T&E program has been structured with that focus in mind. This top-down approach establishes the framework within which the current test program will be conducted.

**FIGURE 5-2
Test and Evaluation Working Group Subcommittees**

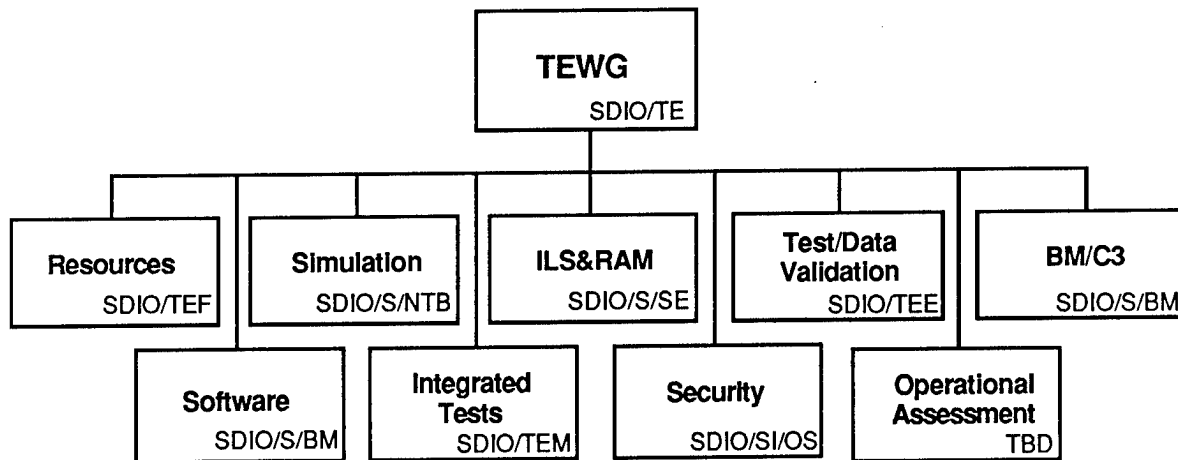

The key to optimizing the T&E program lies in the efficient allocation of system issues (and related testing requirements) to the element test programs. Element level testing activities must be planned to properly support the resolution of the top-level questions of technical feasibility, survivability, and system effectiveness. Figure 5-3 shows this allocation process. Detailed test designs, for each allocated test, support requisite element design criteria and appropriate system-level integration requirements to meet the overall goals of the test program.

These integrated tests facilitate the development of confidence in performance capability and the reduction of risk for entry into FSD. This confidence is accomplished incrementally over time. The process is accelerated and enhanced by early integration testing. As assessments are made, there is a steady and accelerating buildup in confidence that performance requirements are met and that risks are lessened. This incremental buildup is based on the increasing level of maturity of the test article and test capability. During Dem/Val, analysis, simulation, and ground testing of element component brassboards will be the primary test configurations available for test and evaluation. These configurations will meet minimum requirements for establishing system feasibility.

FIGURE 5-3
Allocation of System Issues to Element Tests

		ELEMENTS									
		BSTS	MCS	GBR	AOS	ERIS	SBI	HEDI	GBR	SBL	BM/C3
ISSUES	Boost/PBV Track Initiation, Maintenance, and Handover	S									S
	Midcourse Tracking, Discrimination, and Handover		F	S	S						S
	Critical Path Timelines										S
	Timing and Synchronization										S
	Software Assurance	G	G	S	S	G	G	S	S	S	G
	Fault/Flaw Tolerance										S
	Survivability	G	G			G	G				
	System Security										G
	Growth Capability	S	S	S	S	S	S	S	S	S	S
	Interoperability										S
	System Effectiveness	S	S	S	S	S	S	S	S	S	S

<p>LEGEND: S = Analysis/Simulation G = Ground Test F = Flight Test</p>
--

The National Test Bed (NTB) will be the primary tool for systems integration and Battle Management/Command and Control, and Communications (BM/C³) test and evaluation. It will be a comprehensive capability to compare, evaluate, and test alternative system architectures, including their BM/C³, and to evaluate technologies in a total system framework defined by these architectures. The NTB will consist of a National Test Facility (NTF) and a network of geographically distributed simulation and test facilities to conduct test and simulation activities in a highly distributed but integrated manner. Central to the NTB concept is a highly distributed simulation framework that will integrate simulation modules of the SDS elements into a simulation of the end-to-end SDS. This simulation will evolve over time to serve as a baseline to validate the overall concept, predict system effectiveness, and determine performance requirements and thresholds for allocation to the element design and evaluation process. The NTB capability is critical for the

test and evaluation of proposed BM/C³ concepts and algorithms because it provides the master simulation to drive the candidate BM/C³ solutions. The simulation framework, environment and threat drivers, data collection, and assessment capabilities will be located at the NTF. Portions of the BM/C³ evaluations will provide further evidence that the BM/C³ for a highly distributed system such as the SDS is feasible.

During FSD, both development and initial operational testing will be conducted on the Phase I SDS and its system elements. Development tests and initial operational tests will be combined whenever possible during this phase to save costs in these test programs. Follow-on T&E (FOT&E) in Phase I will be integrated into the program per the requirements of the SDS Operational Test Organization (OTO) and/or the Using Command after Milestone II. Also during FSD of Phase I, initial development tests and early operational assessments of follow-on system elements and their integration into the SDS will begin. As SDS elements enter the production and deployment phase, FOT&E will be conducted. Follow-on phases and their elements will be managed using the same T&E strategy to maintain the flow of elements moving through the process and to enhance SDS capabilities.

5.5 T&E FACILITY REQUIREMENTS

The T&E Directorate is consolidating efforts to identify, validate, and budget for outyear test facility/capability requirements. As a major contribution in this arena, the T&E Director cochairs the OSD-sponsored Space Systems Test Capabilities Study. This study focuses on national needs for space testing facilities/capabilities. SDIO participation ensures that SDI requirements are considered and incorporated as well as preventing duplication of a facility investment plan. This plan will identify selected areas for further study. As a result of initial efforts, SDIO/TE will sponsor a study to determine the national need, feasibility, and implementation options for a space test range. This study will be conducted jointly among the services, with the U.S. Air Force Space and Missile Test Organization (SAMTO) taking the lead for SDIO.

5.6 SIGNIFICANT ACCOMPLISHMENTS

Significant progress has been made by the T&E Directorate in the following areas:

- o An initial TEMP (dated 30 June 1987) has been produced, coordinated through the services, and submitted to OSD for approval. This TEMP identifies an initial T&E methodology as well as initial integration test objectives, issues, and measures of performance.

- o A TEWG has been formed to integrate the SDI T&E program and to provide a forum for SDIO, DOD, service program agents, and test agencies to address T&E issues, resolve problems, and monitor test programs.
- o A program has been initiated to collect data on existing and planned test programs throughout the SDI Program to establish a consolidated T&E data base and integrated test schedule.
- o A program has been initiated to assess the capabilities of current DOD test resources and develop a facility investment strategy.

5.7 FUTURE PLANS

T&E methodology defined in the SDI TEMP will be executed incrementally over time, increasing the overall confidence in system feasibility and performance. In the near term, the T&E Directorate will expand on the program in several areas.

The SDI TEMP will be revised to validate the methodology described and detail the T&E program. Initial emphasis will be on:

- o Improving traceability of operational requirements to the Joint Operational Requirements and Operational Concepts.
- o In coordination with the Phase I program manager, efforts will focus on improving traceability and more fully explaining essential system functions, critical system characteristics, and critical test issues.
- o Defining more clearly the T&E approach using simulations and tests and provide detail to the SDS level T&E program based on the approach.
- o Refining resource requirements based on the assessment of the facility base with particular emphasis on long-lead requirements.

The T&E Directorate will participate in the establishment of the SDS OTO to ensure that its requirements are considered in the SDI T&E program and that the proper priorities are established. The T&E Directorate also plans to:

- o Sponsor a special study to determine the requirements and feasibility of establishing a space test range for SDI T&E.
- o Initiate a multiyear contract for T&E engineering and technical assistance for the T&E Directorate and other SDIO offices as necessary.
- o Begin a detailed review and assessment of SDS and element test plans developed to execute the T&E program defined in the TEMP.

APPENDIX A
SDI AND THE ALLIES

APPENDIX A

SDI AND THE ALLIES

This appendix responds to the Congressional requirement to include in the annual report on the Strategic Defense Initiative (SDI) "the status of consultations with other member nations of the North Atlantic Treaty Organization, Japan, and other appropriate allies concerning research being conducted in the Strategic Defense Initiative program."

OVERVIEW

When President Reagan first announced the SDI in March 1983, he emphasized that the program would be designed to enhance allied as well as U.S. security. In accordance with that mandate, SDIO is examining technologies and concepts for defense against all ballistic missiles, no matter what their range or armament. The program strengthens the U.S. commitment to the defense of NATO and other allies and enhances our common security.

The U.S. government has been engaged in close and continuing consultations with its allies on the SDI since its inception. The United States also conducts ongoing consultations with the allies on exchanges with the U.S.S.R. that bear on the SDI Program at the Defense and Space Talks in Geneva and at other high-level meetings. Those consultations will continue throughout the SDI Program. Furthermore, the United States will consult closely with its allies regarding any future decision to deploy defenses against ballistic missiles.

Contacts with the allies on the SDI go well beyond consultation. In March 1985, then Defense Secretary Weinberger invited the NATO allies, as well as Australia, Israel, Japan, and South Korea, to participate directly in SDI research. Pursuant to that invitation, several Memorandums of Understanding (MOUs) on participation in SDI research have been signed with the allies and a number of allied firms and research institutions are performing SDI research.

CONSULTATIONS WITH ALLIES ON THE SDI

Consultations with friends and allies on the SDI broadened and deepened throughout 1987. As in past years, such discussions are a regular feature of numerous bilateral and multilateral meetings

with allied officials at all levels, both in Washington and abroad. A brief summary of some of the more noteworthy contacts follows.

President Reagan, former Defense Secretary Weinberger, Defense Secretary Carlucci, and Secretary of State Shultz have discussed the program in virtually all of their bilateral meetings on security matters with their allied counterparts. Mr. Weinberger, Secretary Carlucci, and Secretary Shultz also consulted with NATO defense and foreign ministers on the SDI and SDI-related arms control issues at the ministerial meetings of the NATO Nuclear Planning Group (NPG) (March and November 1987), Defense Planning Committee (May and December 1987), and North Atlantic Council (June and December 1987). Lt. Gen. Abrahamson, USAF, Director of the SDIO, provided the NPG Ministers with a program status report during their November 1987 meeting.

In addition, U.S. officials consulted extensively with allied leaders, both bilaterally and at NATO, on the results of high-level meetings with the Soviet Union at which SDI was discussed, including the December 1987 summit in Washington, DC, and after each round of the Defense and Space Talks in Geneva. Furthermore, government and industry personnel from several allied countries have visited the United States for detailed technical discussions on the SDI Program and tours of SDI research facilities. SDI is also sponsoring periodic advance planning briefings to acquaint government and industry representatives from selected allied nations, as well as U.S. industry, with SDI programs, initiatives, missions, and future acquisition plans.

ALLIED PARTICIPATION IN SDI RESEARCH

In March 1985, then Defense Secretary Weinberger invited 18 nations to participate in the SDI research program so that the SDI and Western security as a whole could be strengthened by taking advantage of allied excellence in research areas relevant to SDI. Allied participation in SDI research--brought about through technical merit and rigorous competition--is of great benefit to the United States as well as to the participating nations. It allows us to accomplish the objectives of the SDI as quickly as possible with work of the highest quality and at the lowest possible cost.

The United States has signed MOUs on participation in SDI research with the governments of the United Kingdom (December 1985), Federal Republic of Germany (March 1986), Israel (May 1986), Italy (September 1986), and Japan (July 1987). The MOUs are not related to specific projects, but rather

are designed to facilitate allied participation in SDI research, insofar as that is permitted under U.S. laws, regulations, and international obligations, including the ABM Treaty.

All SDI contracts are awarded strictly on the basis of technical merit and cost, in accordance with the procurement practices mandated by the Congress. Until the current fiscal year, two provisions in particular governed the award of SDI contracts to foreign firms. The Bayh Amendment to the Fiscal Year 1973 Department of Defense Appropriations Act provides that no DOD R&D contracts may be awarded to foreign firms if a U.S. entity is equally competent to carry out the work and is willing to do so at lower cost. In addition, the Defense Appropriations Acts for Fiscal Years 1986 and 1987 prohibited any set-asides of funds for SDI research contracts to foreign firms and stated that U.S. firms should receive SDI contracts unless such awards would be likely to degrade research results.

Long-standing laws and policies governing rights to research results developed under U.S. contracts ensure that the U.S. technology base receives the benefits of all SDI research, whether performed by a domestic or foreign contractor. In conformance with these laws and policies, the U.S. government will receive rights to use the technology developed under SDI contracts. Contractor rights to use the results of their SDI research depend on security considerations and the specific conditions of each contract. These ground rules for cooperation are fully reflected in each of the MOUs the United States has signed on participation in SDI research.

During the past year, the Congress enacted new legislation regarding allied participation in the SDI Program. The new legislation, introduced by Senator Glenn and Representative AuCoin with an amendment by Senators Nunn, Quayle, and Warner, prohibits the award of new SDI contracts to allied firms unless: (1) the Secretary of Defense certifies to the Congress, in writing, that the work cannot be competently performed by a U.S. firm at equal or lower cost; or (2) the work is to be performed in the United States; or (3) an allied government or firm funds a substantial portion of the total cost; or (4) the contract had been signed prior to the date of the legislation; or (5) the contract is exclusively for research, development, test, or evaluation in connection with antitactical ballistic missile (ATBM) systems. Such provisions shall not apply to the award of subcontracts. (In addition to the summary of allied participation in the SDI that is presented here, the Secretary of Defense will provide another annual report to the Congress to comply with the certification requirements in the Glenn-AuCoin Amendment.)

The following is a summary of major SDI contracts and subcontracts awarded to allied firms and research establishments between October 1985 and March 1988.

- o United Kingdom: \$43.4 million. Optical and electron computing, ion sources for particle beams, electromagnetic railgun technology, optical logic arrays, meteorological environment, test bed, and theater defense architecture.
- o Federal Republic of Germany: \$46.5 million. Pointing and tracking, optics, free electron laser technology, lethality and target hardening, electron laser technology, and theater defense architecture.
- o Israel: \$11.6 million. Electrical and chemical propulsion, short-wave chemical lasers, and theater defense architecture.
- o Italy: \$7.5 million. Cryogenic induction, millimeter-wave radar seeker, and theater defense architecture.
- o France: \$6.2 million. Free electron laser technology, sensors, and theater defense architecture.
- o Canada: \$1.07 million. Power system materials, particle accelerators, platforms, and theater defense architecture.
- o Belgium: \$94,000. Theater defense architecture.
- o Netherlands: \$40,000. Theater defense architecture.

In addition, the SDIO concluded in July 1987 a Memorandum of Agreement with the Netherlands Organization for Applied Scientific Research to conduct cooperative research on electromagnetic launchers, power supplies, switches, and advanced materials. The Netherlands Organization for Applied Scientific Research is an authorized agent which performs defense research for the Netherlands Ministry of Defence. The total value of the effort is \$12 million, with the Netherlands contributing \$7 million and the United States \$5 million. This project falls under the Quayle Amendment to the FY 1987 Defense Authorization Bill which specifies monies for cooperative research

with allies in the SDI Program on antitactical ballistic missile research. Electromagnetic launch technology, the object of this cooperative project, holds promise for a variety of defense applications of interest to the U.S. and Netherlands governments, including extended air defense, ship defense against missile attack, and other conventional defense purposes, as well as strategic defense against ballistic missiles.

DEFENSE AGAINST SHORTER-RANGE BALLISTIC MISSILES

The United States, NATO, and Israel are actively addressing the need for antitactical missile (ATM) defenses in light of the tactical missile threat faced by our allies and U.S. forces overseas. NATO is engaged in a number of studies to further define the threat and to determine what measures should be undertaken to meet that threat.

As described in Appendix F, SDIO funded \$70 million in FY 1987 for research on Theater Missile Defense concepts and technologies. Approximately \$100 million will be funded by SDIO in FY 1988. Such ATBM efforts particularly via cooperative arrangements have been supported by the Congress in both FY 1987 and FY 1988.

In its ATBM efforts, SDIO has worked very closely with the U.S. Army. The U.S. Army, which has been designated as the lead service for DOD's overall ATM program, continues to organize overall support for the ATM. At the same time, the SDI continues to examine technologies and concepts for active defenses against ballistic missiles of all ranges and armaments, including those shorter-range systems which directly threaten our friends and allies. The Army's Strategic Defense Command (SDC) has been designated as the SDI executive agent for the management of this theater defense portion of the SDI Program. The advances in technology achieved in the SDI Program will be made available to the Army's ATM program through the SDC.

SDI research awards for theater defense architecture studies were granted in 1986 to the governments of the United Kingdom and Israel, and to seven multinational contractor teams. The awards to the seven multinational contractor teams were for the first phase of theater missile defense architecture studies (TMDAS). The contracting teams completed that first phase work in July 1987, and competed for longer-term second phase contracts to develop detailed system requirements and specifications for potential theater defenses against ballistic missiles. Five of the teams led by Messerschmitt-Boelkow-Blohm (West Germany); CoSyDe, a consortium formed by Aerospatiale and

Thomson CSF (France); SNIA-BPD (Italy); LTV Corporation, and Hughes Aircraft Company (United States)--were awarded second-phase contracts in July 1987. Together these five teams comprise 43 companies, including two Israeli and 24 European firms.

The multinational nature of this effort reflects the long and fruitful tradition of close cooperation among allied governments and firms and expresses the depth of the U.S. commitment to the common defense. It will ensure that the best possible work will be done to the benefit of all the parties concerned. The theater architecture studies being pursued under the SDI will contribute importantly to our collective thinking on the vital issue of ensuring NATO's and other allies' security against the threat of Soviet shorter-range missiles over the near and longer term.

APPENDIX B
SOVIET STRATEGIC DEFENSE PROGRAMS AND
SOVIET RESPONSE TO SDI

APPENDIX B
SOVIET STRATEGIC DEFENSE PROGRAMS AND
SOVIET RESPONSE TO SDI

SOVIET STRATEGIC DEFENSE PROGRAMS

Since World War II, the Soviets have pursued wide-ranging strategic defense programs in a clear and determined effort to, in conjunction with the use of offensive forces, blunt the effect of any attack on the U.S.S.R. The Soviet emphasis strategic defense is firmly grounded in Soviet military doctrine and strategy. Soviet strategic defense forces play a role equal to that of offensive forces.

During the past decade alone, the Soviets allocated resources equivalent to approximately \$400 billion to both strategic offensive and active and passive defensive programs in almost equal amounts--about \$20 billion per year for each program. In the event of nuclear war, Soviet offensive forces are to:

- o Destroy or neutralize as much of the enemy's nuclear assets as possible on the ground or at sea before they are launched; and
- o Destroy or disrupt enemy nuclear-associated command, control, and communications.

Soviet defensive efforts, designed to enhance the credibility of offensive forces, are to:

- o Intercept and destroy surviving retaliatory weapons--aircraft and missiles--before they reach their targets; and
- o Protect the Party, state, military forces, industrial infrastructure, and essential working population with active and passive defense measures.

In the Soviet view, the U.S.S.R. could best achieve its aims in any nuclear war if it attacked first, destroying much of the U.S. and allied capability for retaliation. Defensive measures, both active and passive, would in turn prevent those enemy forces that survived a Soviet first-strike from destroying critical targets in the U.S.S.R.

Ballistic Missile Defense

Traditional ABM Technologies

Soviet efforts to attain a viable strategic defense against ballistic missiles have resulted in the world's only operational ABM system and a large and expanding research and development program.

Starting about 1978, the Soviets have been expanding and modernizing the ABM defenses at Moscow. The new Moscow ABM system will be a two-layer defense composed of silo-based, long-range, modified GALOSH interceptors; silo-based, probably nuclear-armed GAZELLE high-acceleration endoatmospheric interceptors (designed to engage reentry vehicles within the atmosphere); and associated engagement, guidance, and battle management radar systems, including the new PILL BOX large phased-array radar (LPAR) at Pushkino north of Moscow. This modernization will bring Moscow's ABM defenses up to 100 operational ABM launchers, the limit permitted by the 1972 ABM Treaty. That system could become fully operational in the late 1980s.

The Soviet system for detection and tracking of ballistic missile attacks consists of three layers -- a launch detection satellite network, two over-the-horizon radars directed at U.S. ICBM fields, and two networks of large ballistic missile detection and tracking radars.

The current Soviet ICBM launch-detection satellite network and two over-the-horizon radars can provide as much as 30 minutes' tactical warning and can determine the general origin of the missile.

The current layer of ballistic missile detection and tracking radars consists of 11 large HEN HOUSE radars at 6 locations on the periphery of the U.S.S.R. These radars can confirm the warning from the satellite and over-the-horizon radar systems, characterize the size of an attack, and provide target-tracking data in support of antiballistic missile forces. Although the Soviet Union continues to maintain and upgrade this older network of ballistic missile detection and tracking systems, including launch-detection satellites and over-the-horizon radars, it is deploying a new series of large radars.

The Soviets are constructing a network of nine new large phased-array radars that can track more ballistic missiles with greater accuracy than the existing network. Most of these duplicate or supplement the coverage of the earlier HEN HOUSE network but with greatly enhanced capability.

The addition of three radars, discovered in 1986, in the western U.S.S.R. will form almost a complete circle of LPAR coverage around the U.S.S.R. The entire network could become fully operational in the mid 1990s. One of these radars, the LPAR near Krasnoyarsk in Siberia, will close the final gap in the Soviet ballistic missile radar coverage. The Krasnoyarsk radar violates the 1972 ABM Treaty because it is not located on the periphery of the Soviet Union or pointed outward, as required by the Treaty for early warning radars.

The growing network of large phased-array radars is of particular concern when linked with other Soviet ABM efforts. These radars take years to construct and their existence could allow the Soviet Union to move quickly to deploy a nationwide ABM defense. The degree of redundancy being built into their LPAR network is useful for early warning but has much greater utility for ballistic missile defenses.

During the 1970s, the Soviets began development of an ABM system that would allow them to construct individual ABM sites in months rather than the years required for more traditional ABM systems. Its development and testing represents a potential violation of the ABM Treaty's prohibition against the development of a mobile land-based ABM system or components. By using components of this ABM system along with the LPARs, the Soviets could strengthen the defenses of Moscow and defend targets in the western U.S.S.R. and east of the Urals.

In addition, the Soviet Union has conducted tests that have involved in ABM-related activities. The large number, and consistency over time, of incidents plus Soviet failure to accommodate fully U.S. concerns, indicate the U.S.S.R. probably has violated the Treaty's prohibition on testing. Additionally, two new surface-to-air missile systems may have the potential to intercept some types of strategic ballistic missiles. Both systems are expected to have widespread deployment. The technical capabilities of these systems highlight the problem that improving technology is blurring the distinction between permitted air defenses and prohibited ABM systems.

Taken together, all of the Soviet Union's ABM and ABM-related activities are more significant and more ominous than any one considered individually. Cumulatively, they suggest that the U.S.S.R. may be preparing an ABM defense of its national territory. Such a defense could provide an important degree of protection and would fill the only missing element in their defenses.

Advanced ABM Technologies

In the late 1960s, the U.S.S.R. initiated a substantial research program into advanced technologies applicable to ballistic missile defense systems. This effort covers many of the same technologies currently being explored for the U.S. SDI but involves a much greater investment of plant space, capital, and manpower. The Soviet emphasis on the necessity of research into defenses against ballistic missiles was demonstrated by then Minister of Defense Grechko shortly after the signing of the ABM Treaty in 1972, when he told the Soviet Presidium that the Treaty "places no limitations whatsoever on the conducting of research and experimental work directed towards solving the problem of defending the country from nuclear missile strikes."

Kinetic Energy Weapons

The Soviets have research programs under way on kinetic energy weapons, which use the high-speed collision of a small object with the target as the kill mechanism. In the 1960s, the U.S.S.R. developed an experimental "gun" that could shoot streams of particles of a heavy metal, such as tungsten or molybdenum, at speeds of nearly 25 kilometers per second in air and more than 60 kilometers per second in a vacuum.

Long-range, space-based kinetic energy weapons for defense against ballistic missiles probably could not be developed until at least the mid 1990s. However, the Soviets could deploy in the near term a short-range, space-based system for space station defense or for close-in attack by a maneuvering satellite. Current Soviet guidance and control systems are probably adequate for effective kinetic energy weapons use against some objects in space, such as satellites.

Laser Weapons

The U.S.S.R.'s laser program is considerably larger than U.S. efforts and involves over 10,000 scientists and engineers as well as more than a half-dozen major research and development facilities and test ranges. Much of this research takes place at the Sary-Shagan Missile Test Center, where ABM testing also is conducted. At Sary-Shagan alone, the Soviets are estimated to have lasers for air defense and two lasers probably capable of damaging some components of satellites in orbit, one of which could be used in feasibility testing for ballistic missile defense applications. The Soviet laser weapons program would cost roughly \$1 billion a year in the United States.

Scientists in the U.S.S.R. have been exploring several types of lasers that may prove useful for weapons applications--the gas-dynamic, electric discharge, chemical, x-ray, free electron, excimer, and argonne-ion laser. They have achieved impressive output power levels with some of these lasers.

The Soviets appear generally capable of supplying the prime power, energy storage, and auxiliary components for their laser and other directed-energy weapons programs. They have probably been developing optical systems necessary for laser weapons to track and attack their targets. They produced a 1.2-meter segmented mirror for an astrophysical telescope in 1978 and claimed that this reflector was a prototype for a 25-meter mirror. A large mirror is considered necessary for a long-range, space-based laser weapon system.

The Soviets could have prototypes for ground-based lasers for defense against ballistic missiles by the late 1980s and could begin testing components for a large-scale deployment system in the early 1990s. The remaining difficulties in fielding an operational laser system will require more development time. An operational ground-based laser for defense against ballistic missiles probably could not be deployed until the late 1990s or after the year 2000. If technological developments prove successful, the Soviets might be able to deploy a space-based laser system for defense against ballistic missiles after the year 2000. The Soviets' efforts to develop high-energy air defense laser weapons are likely to lead to ground-based deployments in the early 1990s and to naval deployments in the mid 1990s.

Particle Beam Weapons

Since the late 1960s, the Soviets have been exploring the feasibility of using particle beams for a space-based weapon system. They may be able to test a prototype space-based particle beam weapon intended to disrupt the electronics of satellites in the 1990s. An operational system designed to destroy satellites could follow later, and application of a particle beam weapon capable of destroying missile boosters or warheads would require several additional years of research and development.

Soviet efforts in particle beams, particularly ion sources and radio-frequency accelerators for particle beams, are impressive. In fact, a significant contribution to U.S. understanding of how particle beams could be made into practical weapons was derived from Soviet research published in the late 1960s and early 1970s.

Radio-Frequency Weapons

The U.S.S.R. has conducted research in the use of strong radio-frequency (high-power microwave) signals that have the potential to interfere with or destroy critical electronic components of ballistic missile warheads or satellites. The Soviets could test a ground-based, radio-frequency weapon capable of damaging satellites in the 1990s.

Antisatellite Operations

The Soviets continue to maintain the world's only operational ASAT system. It is launched into an orbit similar to that of the target satellite and, when it gets close enough, destroys the satellite by exploding a conventional warhead. The Soviet co-orbital antisatellite interceptor is reasonably capable of performing its missions, and thus it is a distinct threat to U.S. low-altitude satellites. At their Tyuratam Space Complex the Soviets have two launch pads with storage of interceptors and launch vehicles nearby.

During the next 10 years, the Soviets are likely to retain their current ASAT-capable systems while moving aggressively ahead in developing and deploying new ASAT systems. Their large-scale research and development efforts in laser, particle beam, radio-frequency, and kinetic energy technologies may also soon provide them with significant ASAT capabilities.

The development of a space-based laser ASAT that can disable several satellites is probably a high-priority Soviet objective. The Soviets may deploy space-based lasers for antisatellite purposes in the 1990s, if their technological developments prove successful. Space-based laser ASATs could be launched on demand, or maintained in orbit, thereby reducing the time required to attack a target. This option would decrease the warning time available to the target needed to attempt countermeasures. The Soviets are also developing an airborne laser whose missions could include ASAT.

Computer and Sensor Technology

Advanced technology weapons programs--including potential advanced defenses against ballistic missiles, aircraft, cruise missiles, and ASATs--are dependent on remote sensor and computer

technologies, areas in which the West currently leads the Soviet Union. The Soviets are devoting considerable resources to acquiring Western know-how and to improving their abilities and expertise in these technologies. An important part of that effort involves the increasing exploitation of open and clandestine access to Western technology. For example, the Soviets operate a well-funded program through third parties for the illegal purchase of U.S. high-technology computers, test and calibration equipment and sensors.

Despite these efforts the Soviets remain an average of 10 years behind the West in civil and industrial technology applications of computers, although, military applications may be somewhat less far behind. The Soviets are also at least 10 years behind in sensor applications, especially with very sensitive infrared sensors employing large focal plane detector arrays. These type sensors form the backbone of SDI tracking, pointing, and discrimination capabilities and, also, drive some of the more stressing computer requirements.

These limitations undoubtedly prevent the Soviets from deploying defenses with the level of sophistication and capability envisioned for SDI. Nevertheless, the Soviets could take an approach, using their strengths in weapon technologies such as missiles, radar and command guidance, space launch capabilities, and even high-powered directed energy devices, and deploy systems which operate at shorter range and against corresponding smaller portions of the threat. While this would overcome some of their limitations and could have the appearance of a formidable defense, it would necessitate greater proliferation, greater reliance on ground-based and terminal defenses, and probably would still present the Soviets with difficulties in performing discrimination and in overcoming the complexities of managing the coordination of many platforms and facilities.

Air Defense

The U.S.S.R. continues to modernize and expand what is already the most extensive strategic air defense network in the world. The mission is to be carried out by a strong pre-positioned national air defense force established in peacetime according to a unified concept and plan. The leadership appears to be in constant search for the optimum organizational structure of the air defense assets.

Major organizational changes instituted in 1980 transferred control of air defense aircraft, SAMs, and radars from national air defense authorities to local military district commanders. This change was

probably implemented to provide battlefield commanders with greater flexibility. Even after reorganizing, the Soviets appeared to be dissatisfied with their air defense organizational structure.

More recent shifts are apparently resubordinating surface-to-air missiles and aircraft back to the national air defense forces. The rationale may involve a desire for greater centralized control over weapons rather than the flexibility of the local commander in making certain decisions.

The Soviets have deployed a large number of strategic air defense systems with capabilities against aircraft flying at medium and high altitudes. They are now in the midst of a major effort to improve their capabilities against aircraft and cruise missiles that operate at low altitudes.

This effort includes upgrading their early warning and surveillance systems; deployment of more efficient data-transmission systems; as well as development and initial deployment of new aircraft, associated air-to-air missiles, SAMs, and airborne warning and control system (AWACS) aircraft.

Currently, the Soviets have more than 9,000 strategic SAM launchers, some with multiple launch capability, and some 10,000 air defense radars. Approximately 2,250 air defense forces interceptor aircraft are dedicated to strategic defense. An additional 2,100 interceptors assigned to Soviet Air Forces could be drawn upon for strategic defense missions. Collectively, these assets present a formidable air defense barrier.

Passive Defenses

A key element of Soviet military doctrine calls for passive defense to act in conjunction with active defense to ensure wartime operations and survival. The Soviets have undertaken a major program to harden military assets to make them more resistant to attack. Included in this program are their ICBM silos, launch facilities, and some command-and-control centers. Additionally, the U.S.S.R. has greatly emphasized mobility as a means of enhancing the survivability of military assets.

The Soviets provide their Party and government leaders with hardened alternate command posts located well away from urban centers--in addition to many deep underground bunkers and blast shelters in Soviet cities. This comprehensive and redundant network, patterned after a network designed for the Soviet Armed Forces, provides more than 1,500 hardened alternate facilities for more than 175,000 key Party and government personnel throughout the U.S.S.R.

By planning for economic survival, the Soviets hope to reconstitute vital production programs using those industrial components that could be redirected or salvaged after an attack. Reserves of vital material are maintained, many in hardened underground structures. Redundant industrial facilities are in active production. Industrial and other economic facilities are equipped with blast shelters for the work force, and detailed procedures have been developed for the relocation of selected production facilities.

FACTORS AFFECTING SOVIET RESPONSE TO SDI

Soviet actions in response to the SDI Program are important considerations in evaluating the overall contributions of SDI to U.S. security. Soviet responses are frequently hypothesized in debating the effect a strategic defense system would have on strategic stability and in arguing whether the Soviets could deploy effective countermeasures. Sometimes these hypothetical responses are put forth without adequate consideration of actual Soviet capabilities and perspectives. To avoid this pitfall, the SDIO maintains close ties with the U.S. intelligence community in order to better define Soviet capabilities and potential responses. In addition, SDIO maintains a Red-Blue Team effort wherein one group of innovative thinkers adopts a Soviet mindset (Red Team) and develops excursions to the baseline intelligence community estimates, then another group (Blue Team) develops potential U.S. counters. In these ways SDIO maintains a balanced program with prudent hedges against realistic Soviet capabilities.

It is important to maintain an appreciation of how various factors affect the likelihood of potential Soviet responses. Soviet responses will primarily be shaped by their perception of how the U.S. SDI Program will affect their strategies and programs. Secondly, strategic defenses have always played a major role in the Soviet's own military strategy. Thus, a close look at the extent of Soviet strategic defense programs will therefore help to convey the importance the Soviets attach to the fact that the United States is working to initiate its own strategic defenses. The Soviets own technological and economic strengths and weaknesses will enforce hard trade-offs among their many potential responses to the U.S. SDI Program. Finally, Soviet perceptions of the scope and nature of SDI, the political support it retains, as well as the likelihood of its success, will affect the nature and timing of their responses. For example, the Soviets are not likely to reshape their military forces, at great cost in time and money unless they believe that SDI will come to fruition. The degree to which the Soviets develop countermeasures will depend upon the effectiveness of counter-countermeasures.

Impact on Soviet Strategy and Programs

The Soviets clearly perceive SDI as a technical, political, economic, and military threat. It represents a major shift in U.S. defense policy aimed directly at negating the centerpiece of Soviet military might, their Strategic Rocket Forces (SRF). The importance the SRF plays in Soviet military strategy is signaled by its status as their premier service, a status it has retained since being elevated to the level of a separate armed service in 1959. Soviet writings indicate that the Strategic Rocket Forces "are the main and decisive means of achieving the goals of war since they can solve in the shortest period of time the tasks of demolishing the military economic potential of an aggressor, of destroying his strategic means of nuclear missile attack, and of crushing the main (military) groupings."¹ The Soviets have labored long, and have paid an enormous economic price to achieve ballistic missile forces adequate in size and quality to accomplish those objectives. An SDS of even modest capability would severely affect Soviet force planning which would entail a setback of many years. An SDS would also directly erode the nuclear ballistic missile capability of the Soviet Union, a capability they feel is necessary to ensure their ability to influence the course of world events toward their desired ends. Consequently, the Soviets will continue efforts to influence or entice the United States into stopping the SDI program.

The Soviets further perceive SDS as a major push by the United States which will widen the technological gap between themselves and the West. As a consequence, the Soviets may be expected to accelerate efforts both to acquire new technologies and to introduce those new technologies into military systems.

Considering the range of responses the Soviets must consider in attempting to preserve their present strategies, they probably perceive that SDI will impose a severe additional burden to their economy. To the extent the Soviets can influence, i.e., slow the pace of SDI, they will ease this burden.

At this time, the Soviets probably believe the United States is committed to continuing SDI in some form. Prudence dictates that they also assume that the SDI Program will, eventually, lead to deployments. They apparently have a good understanding of the elements the United States is considering for a strategic

¹ A.S. Zheltov, ed., *V. I. Lenin i Sovetskiye Vooruzhennyye Sily* [V. I. Lenin and the Soviet Armed Forces] (Moscow: Voenizdat, 1980), p. 317. Cited in *The Armed Forces of the USSR*, page 150, by Harriet Fast Scott and William F. Scott, Westview Press, 1984, as a typical Soviet statement regarding the role of the Strategic Rocket Forces.

defense system and generally how they will function. This is commensurate with the extent of publication on the subject in the United States. However, they probably have considerable uncertainty regarding the degree of commitment the United States will sustain, the consequent pace of SDI, and with respect to the extent, effectiveness, and timing of defenses the United States is likely to deploy. This uncertainty multiplies the complexity of Soviet decisions for timing of responses and for trade-offs with other programs.

The Role of Strategic Defense in Soviet Military Strategy

The Soviets have a long history in the pursuit of strategic defense. They established their strategic air defense forces the "PVO Strany" (National Air Defense; now "Voiska PVO" or "VPVO," Forces for Air Defense) in 1948, and they upgraded its status to be comparable to that of other services in 1954. It is actually ranked third in precedence after the Strategic Rocket Forces and Ground Forces and ahead of the Air Forces and Navy. Although originally created to respond to air attack, it has officially acquired the responsibility for defending the Soviet Union against ballistic missiles and satellites as well (since at least the 1950s) despite retaining the words "Air Defense" in the name. Official Soviet writings lay out these responsibilities explicitly and they have not been changed or otherwise de-emphasized despite periods in the United States when strategic defense systems were in disfavor and the United States adopted a strategy of deterrence based primarily on offensive forces. The VPVO, in every respect, is and remains, a separate armed service for "Strategic Defense."

Soviet pursuit of strategic defense, through the VPVO, has been dogged: an anti-aircraft defense totally out of proportion to anything in the West; ABM defenses at Moscow which are currently being revitalized with a new two-tiered ABM system; antisatellite capabilities such as the co-orbital system and the direct ascent capability of the GALOSH (ABM interceptor for the Moscow System); and continuous and pervasive R&D effort to allow successive upgrades to existing systems, follow-on systems, and to develop systems based on new technologies such as kinetic energy and beam weapons. In addition to these efforts, the Soviet Union has maintained an extensive passive defense program, including a civil defense program. Formally instituted within the Ministry of Defense under a Deputy Minister, civil defense has been implemented on an immense scale indicative of its status as a vital element in Soviet defensive strategy. These are not merely technology programs, rather they represent an unceasing devotion toward realizing a strategy which prescribes the means to survive a nuclear war and dominate in the aftermath.

Technological Constraints

Despite outspending the United States in research and development, the Soviets remain behind in many key technology areas. The Soviet leadership itself is very pragmatic about these technological deficiencies in relation to the West. Even their most optimistic predictions do not call for attaining technical ascendancy over the West before the 21st century. Nevertheless, they are working to improve their indigenous capabilities to catch up with and surpass those of the West in basic weapons technologies. The Soviets seek to accomplish this goal by investing heavily in their own R&D base; General Secretary Gorbachev's program for economic reform calls for priorities in key high technology sectors of industry. The Soviets augment their indigenous capability by aggressively obtaining the best possible technology from any source and applying it to their military effort as quickly as possible--often much faster than their Western counterparts.

The Soviets' most noticeable weakness is in computers (hardware and software), sensors (particularly focal plane detector arrays), micro-miniaturization, and electronics. Extrapolation suggests that they are weakest in tracking, pointing, guidance and control, and battle management tasks. They are in a far better position regarding kill mechanisms and heavy machine manufacturing necessary for propulsion or structures. Manufacturing high-technology items lies at the core of Soviet technological weaknesses. The Soviets can probably fabricate one or two of anything in the West. Their problem is that they cannot mass produce such items. Thus they will be able to demonstrate a better mission capability than their systems actually possess under combat conditions.

These weaknesses put the Soviets at a disadvantage in responding to the challenge of a U.S. strategic defense system. Many potential active and passive countermeasures to an SDS capability will require a refinement in technology over what the Soviets currently employ. While the Soviets can conceivably produce large inventories of direct-ascent antisatellite missiles, they will have to have a significantly more sophisticated guidance and homing capability than what they have currently demonstrated.

Economic Constraints

The Soviets have made a huge commitment of the nation's best resources to sustain their military buildup over the past two decades. Enormous expenditures for military programs have been a major factor behind slowing economic growth rates. The most valuable and productive resources

were channeled to the Soviet military programs at the expense of living standards and investment in industries essential for economic growth. The Soviet military effort now consumes 15 to 17 percent of their gross national product. As a result of this increased commitment to defense, the defense industrial ministries absorb almost 60 percent of the output of the vital machine building branch of industry.

These problems have been in the making for some time, and Soviet leaders from the Brezhnev period forward have acknowledged their existence. Gorbachev characterized the Soviet economy as having reached a "pre-crisis" stage, necessitating "in depth, truly revolutionary transformations." Accordingly, Gorbachev has introduced or is attempting to introduce the most far-reaching economic reforms to date, which include the boldest attempt yet at decentralized economic decision making, and extensive plans for industrial modernization.

Given SDI, the Soviets are faced with a dilemma; they are unlikely to be able to substantially increase military spending in response to SDI while fulfilling the goals of their industrial modernization program. The Soviets must carefully measure and weigh their response options. There are a wide range of potential options which the Soviets can take in attempting to nullify the effects of a U.S. strategic defense system; e.g., modifications to their offensive forces, additions to their offensive forces, expanding their own defenses, or developing the means to attack SDS elements directly. On the other hand, the Soviets have already been repressing their economy with ever expanding defense requirements. Any change will likely entail an additional economic burden, whether from the inefficiencies of changing established programs or from starting new efforts. Yet, faced with a U.S. SDS, they will respond in some manner. The Soviets therefore, have some difficult choices. They cannot institute all countermeasures which have been put forth and which are technologically possible. They must pick and choose, and their schedule for implementation will probably be delayed from what we project is possible.

As a final point, in assessing the additional economic burdens, it is necessary to separate efforts already programmed in response to the Soviet's internal military requirements from totally new requirements directed specifically at responding to the U.S. SDI Program, and to identify programs in which progress has been paced by technology rather than funding restrictions. For example, the Soviets have had a long-standing requirement for antisatellite systems, and have pursued several paths toward achieving this capability. While SDI may precipitate a requirement for greater ASAT

capacity, the progress in these efforts may be driven more by technological constraints than by funding.

Programmatic Constraints

The Soviet acquisition process and the Soviet Five-Year Plan budgeting process will influence the Soviet's ability to field responsive threats and countermeasures to SDI.

Two categories of responsive threats which can be considered are modifications and new systems. A modification is a change done to an existing system which results in some improvement in system capability. In this context it is meant primarily as a change in the payload or possibly some subcomponent of the propulsion system, with the basic system characteristics remaining unchanged. A new system is either a follow-on to an existing system or a completely new design. In either case a new system would involve extensive changes in design, materials, technology, subsystems and deployment mode resulting in some new or significantly improved technical capability or mission.

THREAT JUDGMENTS

While hopefully SDI would eventually convince the Soviets to abandon their war-fighting strategy, which relies heavily on the use of ballistic missiles to produce the decisive edge, we do not expect them to make such a drastic change in the near future. Until the Soviets are convinced the United States will succeed with effective defenses, they will undoubtedly seek to maintain their counterforce mission.

The degree to which they will succeed in penetrating the defense depends on a variety of constraints and conditions, not all under their control. For example, many characteristics of the SDS are not yet fully defined and the United States has options to respond depending on what Soviet actions are observed. Therefore, to have a response in place by the time the United States could potentially begin deployment, the Soviets must make commitments to system specifications based on incomplete information. Recognizing these uncertainties, estimates of a range of Soviet responses consistent with Soviet practices and constraints have been made.

It is important to recognize the uncertainty associated with predicting specific Soviet responses and countermeasures. Part of the problem are uncertainties associated with intelligence data. It also

reflects the uncertainty the Soviets will have in devising effective countermeasures. Generic countermeasures are easy to conceive, but they invariably involve trade-offs with system performance which can only be fully appreciated after very careful study, and eventually with attempts at designing and testing.

The purpose of the SDIO Countermeasures Program is to provide technical evaluations of potential countermeasures and to ensure that countermeasures are taken into account by SDI system designers and technology developers. During the past year, seven technical Red-Blue Team analyses were conducted to assist in improving understanding of countermeasures by both SDI system concept and technology developers. A Strategic Red Team (SRT) analysis was also conducted to examine counters to SDI from a Soviet perspective, considering political, military, doctrinal, and economic factors. The High Endoatmospheric Defense System (HEDS) analysis addressed the terminal defense region. The Ground-Based Midcourse Interceptor (GBMI) analysis addressed the midcourse region, and the Space-Based Interceptor (SBI) analysis addressed the boost and post-boost phases of the overall strategic defense engagement. The Architecture Red-Blue analysis considered the entire engagement region, and examined how an offensive force planner might attempt to balance countermeasures over the entire engagement. An Alternative Architectures evaluation was conducted over a 6-month period to assess the impacts of potential countermeasures on possible near-term architecture constructs. Having completed the Architectures and Alternative Architectures evaluation, an Innovative Architectures evaluation was initiated to explore the best path for the phased growth of an SDS. The Ground-Based Laser (GBL) Red-Blue Team analysis was started recently to evaluate possible countermeasures to a free electron laser.

Summary of Red-Blue Team Countermeasures

Based on the sum of the technical Red-Blue analyses to date, a set of critical countermeasures has been designated for special emphasis in FY 1988. Special analyses will be conducted to define in greater detail the technical credibility, effectiveness, economic factors, and schedule for each of the countermeasures.

The SDIO countermeasure analysis process has resulted in an improved understanding of countermeasures and countermeasure responses. New ideas for countermeasures and countermeasure responses were identified, evaluated, and are being considered in both technology and system design.

Significant results from initial analyses have been identified, and requirements have been developed for additional analysis by the Red and Blue Teams. Current efforts have resulted in defense system designs that are more robust to possible Soviet countermeasures, and it is expected that the future analyses will produce additional significant modifications to the defense system designs.

Although there are uncertainties, we must anticipate Soviet programs across a broad front that includes technologies both to counter SDS and to improve Soviet ballistic missile defense capabilities. The methodology and organizational structure which SDIO has developed seeks to ensure that most likely all potential responses are evaluated throughout the technical evolution of the SDI. A Red-Team function has been established to see that countermeasures are taken into account in all aspects of the program. This interactive projection and evaluation of potential countermeasures is designed to assure that the SDS system architectures and technology programs are sufficiently robust to achieve mission objective. By demonstrating the U.S. ability to develop and deploy such robust defenses, the SDI Program will create powerful incentives for the Soviets to enter into an agreement with the United States to reduce and ultimately eliminate ballistic missiles in transition to a mutual deployment of ballistic missile defenses.

Strategic Red Team

The Strategic Red Team (SRT) continued its analyses during the past year. The SRT was constituted to conduct a comprehensive appraisal of Soviet political, military, doctrinal, and economic factors influencing Soviet responses to SDI and to assess the likelihood of and the timeframe for the Soviets adopting specific technical countermeasures. The Team examined five major policy questions during the past year. These included consideration of Soviet perceptions of apparent U.S. goals for SDI; Soviet concerns about SDI technology; the potential for countermeasures demonstrations; the possibility of a violent response to an initial SDS deployment; and a broader look at likely Soviet responses, as a function of time, to a U.S. decision to concentrate on an early deployment of a strategic defense system.

Regarding Soviet perceptions of apparent U.S. goals for SDI, the SRT found that U.S. strategic defense systems do not need to be perfect or even near perfect to cause Soviet defense planners great concern. Also, near-term U.S. options are probably of more concern to Soviet decision makers

now than far-term options even though the latter may have a much greater impact on offense capabilities.

Addressing Soviet concerns about SDI technology, the Team assessed that from a Soviet perspective, SDI is seen as a symptom of a fundamental challenge to Soviet military-economic and industrial capability. A major expansion in scale and scope of high technology inputs needed to counter SDS could find the Soviet industrial base sorely wanting.

The SRT found that the most violent Soviet options for responding to initial SDI deployment are the least likely to appeal to Soviet decision makers. Any violent reaction would likely entail selected harassment of some of SDS space-based assets. General war and direct military action entail very high risks and go against Soviet predilections deeply ingrained toward lower risk solutions and a desire to control events. A plausible set of responses would focus in the near term on political actions intended to "roll back" the U.S. decision or, at worst, delay implementation. At the same time, R&D decisions would be taken about the development of technical countermeasures. In the long term, Soviet responses would probably continue to focus on political actions to restrain/contain the U.S. strategic defense system deployment. The Soviets would also focus on technical countermeasures.

Other Countermeasures Analysis

Much thought and analysis go into concerns for countermeasures. From the beginning, we have recognized that any U.S. strategic defense system must be survivable and must be resilient to the effects of countermeasures. Therefore, concern for potential Soviet countermeasures has, from the start, been instituted into all technology programs and studies of potential SDI architectures.

A broad survivability technology base and a number of passive and active protection concepts have been developed and evaluated. An optimum mix of active and passive measures will be used to counter evolving defense suppression threats. Trade-offs among factors such as increased weight, cost, and numbers have been made with the goal of maintaining mission effectiveness. While not yet validated by the Intelligence Community, additional defense suppression threats are being addressed as excursions to the baseline threat. Our simulations of defensive survivability against a defense suppression threat indicate little degradation of operational effectiveness.

THIS PAGE INTENTIONALLY LEFT BLANK

APPENDIX C
SDI COMPLIANCE WITH THE ABM TREATY

APPENDIX C

SDI COMPLIANCE WITH THE ABM TREATY

INTRODUCTION

This appendix addresses the portion of Section 231 of the FY 1988-1989 National Defense Authorization Act which requests: "A statement of the compliance of the planned SDI development and testing program with existing arms control agreements, including the Antiballistic Missile [ABM] Treaty."¹

The 1972 ABM Treaty is an agreement that addresses the development, testing, and deployment of different types of ABM systems and components. It should be noted that nowhere does the ABM Treaty use the word "research." Neither the United States nor the Soviet delegation to the SALT I negotiations chose to place limitations on research, and the ABM Treaty makes no attempt to do so. The United States made clear during the ABM Treaty negotiations that development commences with the initiation of field testing of a prototype ABM system or component. The United States has traditionally distinguished "research" from "development" as outlined by Harold Brown in a 1971 statement to the Soviet SALT I delegation. Research includes, but is not limited to, conceptual design and laboratory testing. Development follows research and precedes full-scale testing of systems and components designed for actual deployment. Development of a weapon system is usually associated with the construction and testing of one or more prototypes of the system or its major components. However, the construction of a prototype cannot necessarily be verified by national technical means (NTM) of verification. Therefore in large part because of these verification difficulties, the ABM Treaty prohibition on the development of sea, air, space, or mobile land-based ABM systems, or components for such systems, applies when a prototype of such a system or its components enters the field testing stage.

The ABM Treaty regulates the development, testing, and deployment of ABM systems whose components were defined in the 1972 Treaty as consisting of ABM interceptor missiles, ABM launchers, and ABM radars. Systems and components based on other physical principles (OPP) are

1

Treaty Between the United States of America and the Union of the Soviet Socialist Republics on the Limitation of Anti-Ballistic Missile Systems (signed at Moscow, May 26, 1972; entered into force October 3, 1972).

addressed only in Agreed Statement D to the Treaty as "ABM systems based on other physical principles and including components capable of substituting for ABM interceptor missiles, ABM launchers, or ABM radars." In order to fulfill the Treaty's basic obligation not to deploy ABM systems or components except as provided in Article III, this agreed statement prohibits the deployment of systems or components based on OPP, but does not proscribe the development and testing of such systems, regardless of basing mode. The SDI Program will continue to be conducted in a manner that fully complies with all U.S. obligations under the ABM Treaty.

Research and certain development and testing of defensive systems are not only permitted by the ABM Treaty, but were anticipated at the time the Treaty was negotiated and signed. Both the United States and the U.S.S.R supported this position in testimony to their respective legislative bodies. When the Treaty was before the U.S. Senate for advice and consent to ratification, Defense Secretary Melvin Laird advocated, in his testimony, that the United States "vigorously pursue a comprehensive ABM technology program." In a statement before the Presidium of the Supreme Soviet, Marshall Grechko said the ABM Treaty "places no limitations whatsoever on the conducting of research and experimental work directed toward solving the problem of defending the country from nuclear missile strikes."

EXISTING COMPLIANCE PROCESS FOR SDI

DOD has in place an effective compliance process (established in 1972, after the signing of the SALT I agreements) under which key offices in DOD are responsible for overseeing SDI compliance with all U.S. arms control commitments. Under this process the SDI Organization (SDIO) and armed services ensure that the implementing program offices adhere to DOD compliance directives and seek guidance from offices charged with oversight responsibility.

Specific responsibilities are assigned by DOD Directive 5100.70, 9 January 1973, Implementation of SAL Agreements. The Under Secretary of Defense for Acquisition, USD(A), ensures that all DOD programs are in compliance with U.S. strategic arms control obligations. The service secretaries, chairman of the Joint Chiefs of Staff (JCS), and agency directors ensure the internal compliance of their respective organizations. The DOD General Counsel provides advice and assistance with respect to the implementation of the compliance process and interpretation of arms control agreements.

DOD Instruction S-5100.72 establishes general instructions, guidelines, and procedures for ensuring the continued compliance of all DOD programs with existing arms control agreements. Under these procedures, questions of interpretation of specific agreements are to be referred to the USD(A) for resolution on a case-by-case basis. No project or program which reasonably raises a compliance issue can enter into the testing, prototype construction, or deployment phase without prior clearance from the USD(A). If such a compliance issue is in doubt, USD(A) approval shall be sought. In consultation with the DOD General Counsel, Office of the Assistant Secretary of Defense for International Security Policy, and the JCS, the USD(A) applies the provisions of the agreements, as appropriate. Military departments and DOD agencies, including SDIO, certify internal compliance quarterly and establish internal procedures and offices to monitor and ensure internal compliance.

In 1985, the United States began discussions with allied governments regarding technical cooperation on SDI research. To date, the United States has concluded bilateral SDI research Memorandums of Understanding with the United Kingdom, Federal Republic of Germany, Israel, Italy, and Japan. All such agreements will be implemented in a manner consistent with U.S. international obligations, including the ABM Treaty. The United States has established guidelines to ensure that all exchanges of data and research activities are conducted in full compliance with the ABM Treaty obligations, not to transfer to other states ABM systems or components limited by the Treaty, nor to provide technical descriptions or blue prints specially worked out for the construction of such systems or components.

SDI EXPERIMENTS

All SDI field tests must be approved for ABM Treaty compliance through the DOD compliance process. The following major experiments have been approved and are to be conducted during the remainder of FY 1988 and FY 1989: The Alpha Large Optics Demonstration Experiment (LODE)/Large Advanced Mirror Program (LAMP)/chemical laser ground-based test program, the SKYLITE test program which utilizes the Mid Infrared Chemical Laser and the SEALITE Beam Director, the Laser Atmospheric Compensation Experiment (LACE) and Relay Mirror Experiment (RME) space tracking and pointing experiments, the Airborne Optical Adjunct (AOA) Infrared Experiment, the continuation of the SATKA Integrated Experiments, JANUS, ground-based hypervelocity railgun experiments, and the first Kinetic Kill Vehicle Integrated Technology Experiment (KITE) tests for the High-Endoatmospheric Defense Interceptor (HEDI) program.

The following major experiments have been approved for later years and subject, in some cases, to test limitations or review of a more completely defined experiment: the Starlab tracking and pointing experiment, the ground-based free electron laser, the neutral particle beam technology integration experiment known as BEAR, the ground-based test in the space-based interceptor (SBI) Program, HEDI and ERIS ground-based interceptor tests, the Ground-Based Radar (GBR-X) Experiment formerly called the Terminal Imaging Radar, an airborne laser experiment (ALE) now in the planning stages which adds a laser range-finder to the AOA platform, and the Ground-Based Surveillance and Tracking System (GSTS) formerly called the Probe.

The Zenith Star space-based laser experiment is currently under compliance review. The Boost Surveillance and Tracking System (BSTS) experiment has been reviewed in the past but will require additional review as it becomes more fully defined.

In addition, the following data collection experiments or programs which have not been considered as major experiments continue to be approved: Queen Match, CIRRIS IA, Spirit, three Color, Excede, Optical Airborne Measurement Program (OAMP), and Infrared Background Signature Survey (IBSS).

Currently, no experiment has been approved which would not fall within the categories used in Appendix D to the 1987 Report to Congress on the SDI. Changes to previously approved experiments or new experiments resulting from the restructuring of the SDI Program require compliance review.

APPENDIX D
SDI ORGANIZATION AND COMPTROLLERSHIP

APPENDIX D

SDI ORGANIZATION AND COMPTROLLERSHIP

This appendix describes the development of the Strategic Defense Initiative Organization (SDIO), its accomplishments, activities, plans, and details regarding funding of programs and projects.

ORGANIZATION DEVELOPMENT

Following the signing of the official SDIO Charter in February 1986, a newer, streamlined organization was adopted in July 1986. This new structure was adaptable to both urgent near-term requirements and long-range programs. Therefore, when a first-phase Strategic Defense System was given authorization to proceed into the demonstration and validation phase, a Test and Evaluation Directorate was quickly added to the Organization. Manpower adjustments along with other minor refinements were made within current and projected manpower authorizations. The current SDIO organizational chart is shown at Figure D-1.

SIGNIFICANT ACCOMPLISHMENTS

To stay abreast of the tremendous technological progress and expanding role of the Organization, the Comptroller concentrated on refining systems, adapting and developing procedures to remain responsive to goals of the SDI, and identifying initiatives that will better serve a Phase I SDS while continuing support for development of less advanced technologies.

Table D-1 shows the annual appropriated program levels with comparisons of obligation and expenditure rates among the agencies using research, development, test, and evaluation funds. Highlights for FY 1987 are as follows:

- o Of over 2,500 SDIO contracts let, over 95 percent of the planned work was completed.

- o SDIO obligations were higher than those of agencies with similar research programs for the same period.

- o SDIO expenditures were also higher than those of agencies with similar research programs for the same period.
- o Of the funds appropriated for SDIO, 97 percent were obligated and 60 percent were expended.

**FIGURE D-1
Current Organizational Structure of the SDIO**

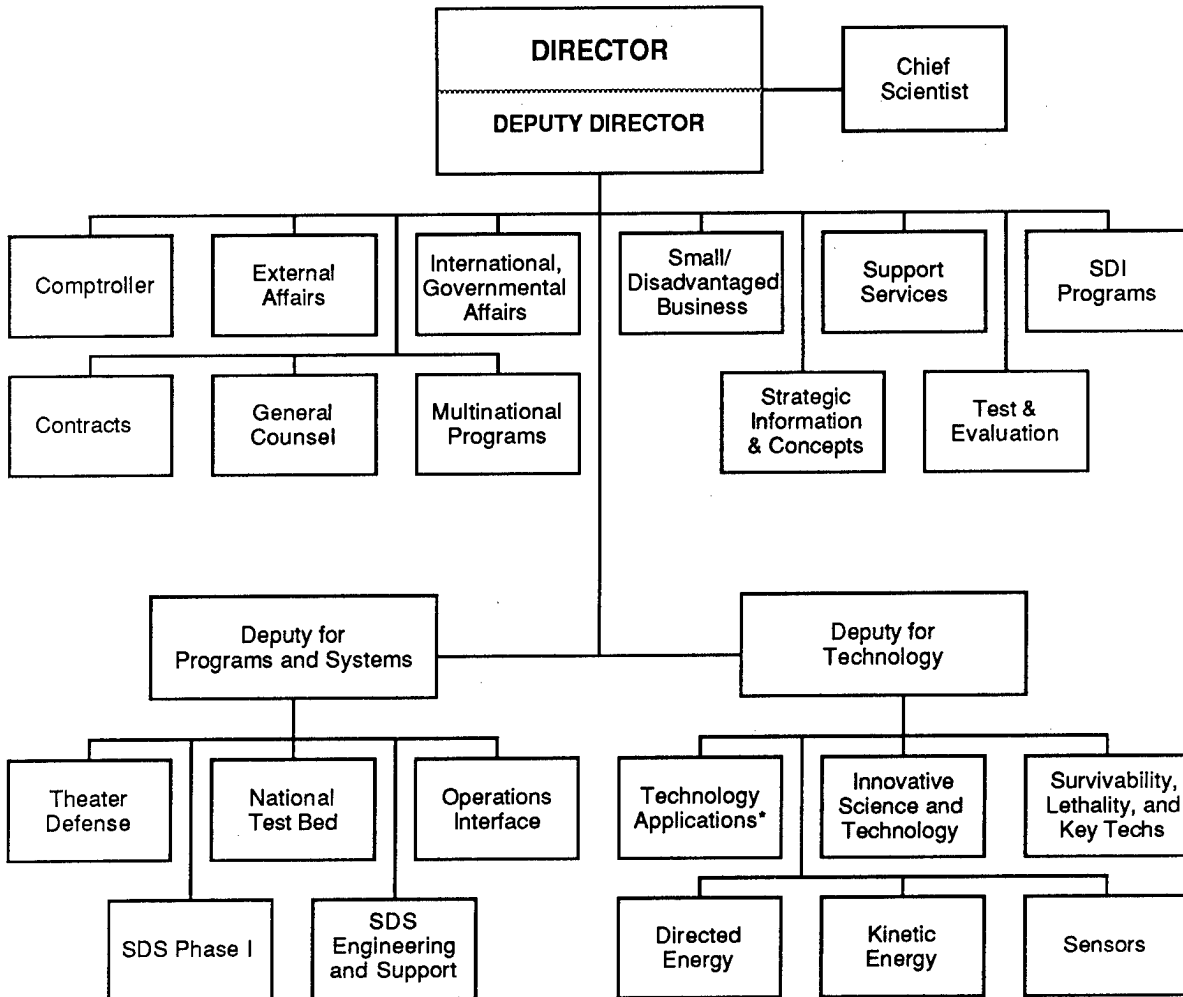

* More information on the SDI Technology Applications Program is in Appendix E.

TABLE D-1
Fiscal Obligation and Expenditure Comparisons Within DOD*
(Fiscal Year 1987)

Requests	Annual Program	Obligations Expressed as a Percent						
		Mar	Apr	May	Jun	Jul	Aug	Sep
Total Army R&D	\$ 4.6 B	59	63	70	75	80	85	94
Total Navy R&D	\$ 9.3 B	71	76	82	85	88	91	95
Total AF R&D	\$15.1 B	52	61	66	71	75	79	88
SDIO	\$ 3.3 B	68	74	81	87	91	93	97
DARPA	\$.8 B	38	50	63	68	75	75	87
Expenditures Expressed as a Percent								
Total Army R&D	\$ 4.6 B	17	22	22	26	37	41	52
Total Navy R&D	\$ 9.3 B	19	26	31	35	44	51	59
Total AF R&D	\$15.1 B	33	24	30	34	43	52	51
SDIO	\$ 3.3 B	16	22	29	35	42	48	60
DARPA	\$.8 B	13	18	25	30	38	38	44

* As of April 1988.

Details regarding funding of programs and projects for the Strategic Defense Initiative are provided in Table D-2.

The reductions that are shown have a devastating effect on the achievement of goals, because the major portion of SDIO's research program resources is used for contractual services. These services are funded incrementally each fiscal year to ensure continuation of uninterrupted services. The contractual services are primarily for technical research which began in prior years. Any omissions or delays not only create undesirable gaps in effort with attendant loss in program momentum, but also result in unsound fiscal practices. Obligation plans are developed to ensure continuation of uninterrupted services and a procedure which permits orderly commitments and obligations in a fashion that produces fiscal accountability and derives the most benefit from the planned research technology and from that already realized. Deviations that result from omissions or delays destroy not only the technical feasibility of our intentions but also a planned and orderly fiscal performance.

TABLE D-2
SDI FY 1989 Amended Budget Submission Project List

	FY86	FY87	FY88 Request	FY88 APPN	Change	FY89 Request	FY89 ABS	Change
Surveillance, Acquisition, Tracking, and Kill Assessment								
Radar Discrimination and Data Coll	18.926	12.110	21.754	16.267	-5.487	33.634	22.000	-11.634
Optical Discrimination and Data	106.488	93.493	84.611	99.355	14.744	77.676	122.000	44.324
Microwave Radar Tech	27.485	24.541	30.760	18.565	-12.195	36.959	25.000	-11.959
Laser Radar Tech	68.350	87.238	142.763	90.645	-52.118	172.254	110.000	-62.254
Passive Sensor Tech	74.269	71.723	90.195	60.963	-29.232	95.795	90.000	-5.795
Signal Processing Tech	85.799	91.621	129.546	71.478	-58.068	140.737	95.000	-45.737
Interactive Disc Tech	6.300	15.650	36.495	22.093	-14.402	59.831	20.000	-39.831
Boost Dem/Val	73.161	127.050	246.513	200.993	-45.520	334.399	179.000	-155.399
Midcourse Dem/Val	43.716	39.575	184.615	28.416	-156.199	234.901	90.000	-144.901
Midcourse Experiment	122.711	109.839	100.056	114.180	14.124	136.457	84.000	-52.457
Terminal Dem/Val	28.746	24.700	112.653	37.244	-75.409	132.258	73.000	-59.258
SATKA Support	103.274	118.240	233.219	97.701	-135.518	301.858	106.800	-195.058
Shuttle Recovery Support Programs	0.000	13.600	0.000	0.000	0.000	0.000	0.000	0.000
TOTAL SATKA	843.956	922.986	1492.680	955.523	-537.157	1859.530	1124.625	-734.905
Directed Energy Weapons								
CL Technology	125.318	86.961	86.600	108.500	21.900	96.000	261.000	165.000
FEL Technology	143.861	184.253	212.000	155.500	-56.500	266.000	229.000	-37.000
NPB Technology	83.573	144.703	200.000	102.600	-97.400	250.000	120.000	-130.000
ATP-FC Technology	247.953	239.740	254.500	248.580	-5.920	276.550	220.000	-56.550
MIRACL/T	18.650	36.744	27.400	20.000	-7.400	10.000	0.000	-10.000
CDT/Emerging Tech	142.954	97.459	210.179	159.880	-50.299	202.618	150.200	-52.418
Support Programs	33.720	63.271	113.001	37.266	-75.735	144.652	49.694	-94.958
TOTAL DEW	796.029	853.131	1103.680	832.326	-271.354	1245.820	1029.894	-215.926
Kinetic Energy Weapons								
Space-Based Interceptor Dev	135.162	118.768	296.279	204.750	-91.529	350.499	330.000	-20.499
Exoatmospheric Interceptor Dev	61.525	104.474	209.800	137.750	-163.579	294.100	202.000	-92.100
Endoatmospheric Interceptor Dev	76.689	100.095	226.000	112.100	-113.900	228.300	150.000	-78.300
Miniature Projectiles Tech	55.358	72.861	99.359	66.650	-32.709	130.633	77.000	-53.633
Test and Evaluation	198.655	239.099	100.797	162.120	61.323	43.000	31.000	-12.000
Technology Support	28.603	43.927	75.899	56.850	-19.049	78.211	84.900	6.689
Support Programs	40.050	43.269	66.596	51.329	-15.267	74.907	61.394	-13.513
TOTAL KEW	596.042	722.493	1074.730	791.549	-283.181	1199.650	936.294	-263.356
Systems Analysis and Battle Management								
SDS Phase I Engineering	0.000	0.000	0.300	27.500	27.200	0.400	74.500	74.100
SDS Engineering and Support	74.213	88.880	117.272	111.000	-6.272	119.817	135.000	15.183
Theater Defense	1.700	33.417	40.387	41.500	1.113	50.684	31.400	-19.284
BM/C3 Technology	68.133	83.165	119.251	70.900	-48.351	131.432	106.000	-25.432
BM/C3 Experimental Systems	23.053	67.954	165.096	99.100	-65.996	195.708	114.000	-81.708
National Test Bed	11.722	46.529	110.800	87.000	-23.800	207.183	115.000	-92.183
Support Programs	33.477	65.845	74.234	66.156	-8.078	82.286	63.994	-18.292
TOTAL SA/BM	212.348	385.790	627.340	503.156	-124.184	787.510	639.894	-147.616
Survivability, Lethality, and Key Technology								
Systems Survivability	44.957	58.693	93.339	100.205	6.866	97.461	175.400	77.939
Lethality and Target Hardening	80.279	76.380	101.606	74.741	-26.865	97.582	98.000	0.418
Power and Power Conditioning	46.572	83.887	156.550	98.318	-58.232	185.395	182.000	-3.395
Space Transportation and Support	18.759	82.586	429.840	80.000	-349.840	601.285	200.000	-401.285
Materials and Structures	2.083	13.821	22.307	26.136	3.829	40.149	54.000	-13.851
Support Programs	21.352	59.933	96.721	69.270	-27.001	140.317	81.014	-59.303
TOTAL SLKT	214.002	375.300	900.363	448.670	-451.693	1162.189	790.414	-371.775
Management Headquarters								
	12.772	20.025	22.000	19.776	-2.224	27.330	24.790	-2.540
TOTAL RDT&E RESOURCES	2675.149	3279.725	5220.793	3551.000	-1669.793	6282.029	4545.911	-1736.118
Military Construction								
	3.080	10.300	125.195	59.195	-66.000	18.000	90.500	+72.500
TOTAL DEPARTMENT OF DEFENSE	2678.229	3290.025	5345.988	3610.195	-1735.793	6300.029	4636.411	-1663.618
DOE SDI Program								
	284.900	360.300	569.100	353.800	-215.300	390.300	402.000	11.700
TOTAL SDI PROGRAM DOD/DOE	2963.100	3650.300	5915.100	3964.000	-1951.100	6690.300	5083.400	-1651.900
NASA ALS								
	0.000	38.000	0.000	70.000	70.000	0.000	—	—

* NDEW efforts only.

APPENDIX E
SDI TECHNOLOGY APPLICATIONS PROGRAM

APPENDIX E

SDI TECHNOLOGY APPLICATIONS PROGRAM

Historically, both the Department of Defense (DOD) and the National Aeronautics and Space Administration (NASA) significantly advanced the state of the art in science and technology and spurred the U.S. economy by technology transfer. Through the various military service research and development agencies, NASA centers, and federal laboratories, significant advances in technology and new inventions were transferred from military and space programs to the private sector. These advances are represented in many standard consumer items today and will be present in many new products that will be available in the future.

CONGRESSIONAL AND PRESIDENTIAL ACTION

Within the past year, a number of legislative provisions have focused on the intent of Congress on improving the domestic technology transfer process. The 99th Congress initiated this process by amending the 1980 Stevenson Wylder Technology Innovation Act to encourage the transfer of federal technology to the U.S. economy. The new amendment of Public Law 99-502 provides incentives for innovators in federal laboratories and agreements between laboratories and the private sector, and incorporates other provisions designed to enhance the process of transferring federal technology to the U.S. economy. The importance of this legislation was emphasized by the President in his 10 April 1987 Executive Order on "Facilitating Access to Science and Technology."

The National Defense Authorization Act of FY 1987 contained a provision to modify Public Law 99-145, Section 1457, providing direction to the Secretary of Defense to "encourage, to the extent consistent with national security objectives, the transfer of technology between laboratories and research centers of the Department of Defense and other federal agencies, state and local governments, colleges and universities, and private persons in cases that are likely to result in the maximum domestic use of such technology" and to "examine and implement methods, in addition to the encouragement referred to [above] ... that are consistent with national security objectives and to enable Department of Defense personnel to promote technology transfer."

The National Defense Authorization Act for FY 1987 also contained specific language regarding "Coordination and Communication of Defense Research Activities" that directed, "The Secretary of

Defense shall promote, monitor, and evaluate programs for the communication and exchange of technological data among the Defense research facilities, combatant commands, and other organizations that are involved in developing for the Department of Defense the technological requirements for new items for use by combat forces and among Defense research facilities, and other offices, agencies, and bureaus in the Department that are involved in related technological matters.

In view of the unprecedented advances in technology being derived from Strategic Defense Initiative (SDI) research, the SDIO Office of Technology Applications, formerly Civil Applications, was established in 1986 to develop and implement a technology transfer program designed to make SDI technology available to other DOD and federal agencies as well as to business and research interests in the American private sector. Unclassified information regarding new technologies is being made available to qualified American corporations and small businesses, universities, and entrepreneurs. Assistance in identifying the sources of new SDI technology to negotiate property rights and patent matters is also provided. Activities and programs are being conducted in conjunction and cooperation with other federal, state, and local government agencies; federal laboratories; universities; and the private sector.

SDIO TECHNOLOGY APPLICATIONS INFORMATION SYSTEM (TAIS)

The Office of Technology Applications developed a Technology Applications Information System and is using voluntary scientific and technical advisers from across the country to assist in the identification of SDI technology with spin-off potential. TAIS currently has over 300 unclassified synopses of technology innovations for review by researchers and developers in the DOD, federal agencies, and the private sector. The principal purpose of the system is to enable technology clients to contact inventors and researchers so that business arrangements, license agreements, and royalty arrangements can be expedited for the development of emerging technologies. More than just a data base, TAIS serves as a technology problem referral system to a network of over 70 technical advisers throughout the country and at universities, federal laboratories, private research institutes, large corporations, and professional associations. It also provides the small businessman or researcher with referrals to all of the federal- and state-funded technology transfer agencies, from NASA, the federal laboratories, other federal and state agencies, and other sources of federal information. TAIS is accessible by computer modem for use by an American corporation or citizen who has completed a Militarily Critical Technical Data Agreement and has been certified as eligible for access by the Defense Logistics Agency under the provisions of DOD Directive 5230.25.

Consistent with the multinational nature of the SDI research effort, the SDIO will respond to specific requests from allied firms and research institutions for unclassified information regarding individual technologies in accordance with the Memorandums of Understanding and Data Exchange Agreements signed between the DOD and allied signatories.

SDIO VOLUNTARY ADVISORY COMMITTEES AND PANELS

The Technology Applications program includes as an integral part of its operations advisory committees and panels of recognized experts whose members serve without remuneration except for reimbursement of travel and per diem under invitational travel orders when travel is necessary. The organization of these panels and committees follow.

Federal Applications Committee

A Federal Applications Committee is established as a subcommittee of the SDIO Advisory Committee to: (1) assist in a top-level review of classified, as well as unclassified, technologies for potential applications to other military and federal applications and (2) provide guidance on the overall approach and progress of the program. This senior advisory committee, which consists primarily of retired flag officers, meets on a semiannual basis and is assisted by representatives from the military departments and other federal agencies.

Civil Applications Committee

A Civil Applications Committee is established as a subcommittee of the SDIO Advisory Committee. The committee consists of senior government, civil, and industry leaders supported by recognized experts in specific technical fields. The committee assists in a top-level review of the technology transfer process considering SDI technologies for potential applications in the public and private sector and provides guidance on the overall approach and progress of the program. This senior advisory committee meets on a semiannual basis and is assisted by four technology applications panels as described below.

Technology Applications Panels

Four technology applications panels are established to: (1) assist in reformatting technology information into synopses that are meaningful to scientific and technical personnel outside the Department of Defense, (2) identify potential applications of the technology, and (3) review technology problem statements submitted by technology clients. Panels have been established in the following generic technology areas:

- o Biomedical applications
- o Electronics, communications, and computer applications
- o Power generation, storage, and transmission applications
- o Materials and industrial process applications.

Volunteer members of the technology applications panels include representatives from universities, private research institutes, federal laboratories, industry, government agencies and professional and industrial organizations. A number of the members hold patents and are nationally known leaders and inventors in their respective fields. The technology applications panels meet on a regular basis to review technology efforts. Panel members use the modem-accessible data base on a continuing basis to review technology information and communicate with other panel members and advisers in the process of screening SDI technologies for spin-offs.

PROMISING DOMESTIC SDI SPIN-OFFS

The Technology Applications Program identifies promising unions of technology and domestic applications deemed to have a high payoff potential in the near term and seeks to promote promising programs by encouraging successful partnerships among entrepreneurs, inventors, and venture capitalists. Figure E-1 provides a synopsis of some of these spin-offs. Some of the current activities in this area follow.

- o **Sol-Gel Derived Bioglass:** A bio-active material with the capability of replacing or repairing human bone and soft tissue. SDI research at the University of Florida in materials processing technology for rapid fabrication of optical devices led to a spin-off material with the appropriate chemical properties that make it bio-compatible with

spin-off material with the appropriate chemical properties that make it bio-compatible with human tissue. Extension of this technology is expected in a host of new applications for new types of bio-compatible prostheses for bone segments, inner ear ossicle bone replacements, dental implants, and numerous surgical applications.

**FIGURE E-1
Potential SDI Technology Spin-offs**

Materials and Structures	Electro-Optics
Lightweight Structural Materials Lightweight Structures Tribological System Materials Thermal Management System Materials Power Management System Materials Optical Materials	Advanced Signal Processing Radar and Ladar Focal Plane Arrays Guidance, Navigation, and Control Windows for High-Velocity Vehicles in Atmosphere Mirrors Cryocooling
Power Systems	Propulsion
Non-nuclear Nuclear Power Conditioning	Solid Liquid Altitude and Velocity Control
Data Processing	Kinetic Energy Technologies
Software Hardware	Electromagnetic Launchers (rail gun and reconnection gun) Rocket-Propelled Kinetic Energy Weapons
Manufacturing Technologies, Integration, and Automation	Directed Energy Technologies
Computer-Integrated Manufacturing Robotics and Numerical Control CAD/CAM Simulations	Acquisition, Tracking, and Pointing Lasers Discrimination Neutral Particle Beam Applications

- o **Bioglass Application for Helping Diabetics:** In the first meeting of the SDIO BioMedical Applications Panel, it was determined that this new material promises a

dramatic improvement with another new biomedical innovation--the Programmable, Implantable Medication System (PIMS). PIMS uses satellite telemetry technology and NASA Mars Viking Lander technology to automatically dispense insulin for diabetics. The inventor of the PIMS, Mr. Fischell of The Johns Hopkins University Applied Physics Laboratory, is a member of the SDIO BioMedical Technology Applications Panel.

- o **Diamond Crystal Coating Technology:** Developed under the SDI Diamond Technology Initiative Program for the coating and protection of mirrors, electronics, and other devices in space, this new process for depositing thin layers of diamond crystal on surfaces has numerous potential applications:
 - Protection of eyeglasses, windows, and mirrored surfaces
 - Surface hardening of cutting, grinding, and manufacturing tools and machinery
 - Acoustical speaker applications
 - Manufacture of microminiature surgical instruments from microcircuit technology, coated with diamond crystal to produce super-sharp microsurgical instruments for surgery.

- o **SPOCK Supercomputer:** The Georgia Technology Research Institute (GTRI), under contract to the Army Strategic Defense Command, developed a Very Large Scale Integrated Circuit (VLSIC) computer technology which combines hardware, computer code, and semiconductor devices for guidance and control simulations of SDI ground-based interceptors. This technology, known as Special Purpose Operational Computing Kernel (SPOCK), was licensed to Advanced Cybernetic Technology, Inc., in Rockville, MD, for commercial computer applications. The arrangement provides for a 5-percent royalty GTRI and a 1.3 percent royalty to the government on all sales.

o **High-Speed, Fault-Tolerant Computer Applications in Medicine:**

- High-speed computer processors and programs of the SDI Gallium Arsenide Million Instructions Per Second (MIPS) program are being made available to the medical community through the Mayo Clinic to enhance the study of model molecular structures essential in the derivation of new designer drugs.
- Computers used today in operating rooms may fail with potentially fatal consequences. Applications of the SDI gallium arsenide advanced on-board signal processor provides computing technology designed to degrade gracefully without total shutdown. Applications are being explored by the Mayo Clinic.

o **Applications to Eye Surgery:**

- SDI technology for optical tracking of ballistic missiles and warheads has potential application for tracking the rapid random movements of the eye to enhance diabetes-related eye surgery with lasers.
- SDI-developed, computer-based integrated system of diagnostic lasers could measure aberrations in the cornea through an aberration differencing analysis program. The program is being studied to plastically deform the cornea to allow a reshaping process (thermal keratoplasty) that may drastically improve poor vision. This process is a dramatic technological extension of the currently used, but controversial, radial keratotomy process that originated in the Soviet Union.

- o **New Materials for Automotive and Aerospace Applications:** Methods for extending material properties by means of a carbon fiber matrix/carbon fiber coating technology originally investigated under an SDI Small Business Innovative Research (SBIR) contract are being evaluated for use in a number of automotive and turbine engine applications. Evaluations in progress include applications of the high-temperature carbon fiber ceramic materials for automobile gasoline and diesel engine components (e.g., turbosuperchargers) as well as jet engine turbine blades. The Office of Technology Applications, working through the American Automobile

Manufacturers Association, initiated a number of investigations by several American car manufacturers and several aircraft engine companies. One contractor requested the small business contractor to provide test samples for engine components, and another is negotiating to procure 12.5 million ceramic cam follower rollers for 2.2-liter and 2.4-liter 4-cylinder overhead cam engines for the 1989 model year. Test samples for a suspension component have also been required. Components in advanced engines are being investigated for introduction in 1992. The process for turbine blade applications is also being investigated, and an agreement has been signed for a proprietary aircraft engine application. An automobile manufacturer is investigating component applications for their low-heat rejection, adiabatic diesel engine now in development.

- o **Applications of Pulse Power Transmission Technology to Oil Well Drilling:** Research originally completed under SDI contract for the transmission of high-energy pulsed power by a small business in New Mexico is now being extended under a grant from the Department of Energy (DOE) to applications for fracturing rock strata in oil well drilling.
- o **Superconducting Magnetic Energy Storage (SMES) System:** SDIO, in cooperation with DOE and the Electrical Power Research Institute, is beginning a 5-year effort to build a SMES system. The program has the dual objectives of demonstrating the feasibility of using SMES technology to provide SDI ground power and using the same technology to provide load leveling for commercial electrical utilities. Thus, civilian use of this SDI-developed technology will be not a byproduct but an integral part of the concept from inception. It is only through SDI's critical role as a "catalyst" that exploitation and early electrical utility application of this technology is being made possible.
- o **Safer Methods for Food Preservation:** DOE is currently negotiating an agreement with the Lawrence Livermore National Laboratory to use the linear accelerator technology developed under the SDI Program as the principal source for implementing a large-scale food irradiation program. The program may be used in six states (Hawaii, Alaska, Oklahoma, Florida, Washington, and New Jersey). This

technology provides a much safer (non-nuclear) source to irradiate food so that meats, fruits, and vegetables can be stored for prolonged periods without spoilage.

- o **New Instrumentation for Entomologists:** The laser doppler radar technology developed under SDI contract at Oak Ridge National Laboratory was packaged into a small prototype device which can be used to detect and discriminate the presence of various species of insects. This device could provide an entirely new and more effective analysis tool for entomologists. The Department of Agriculture is currently working with the inventor regarding applications of this technology.

- o **Highway Bridge Safety Analysis:** A potential application for both the neutral particle beam (NPB) associated radio frequency quadripole (RFQ) linear accelerator (linac) work at LANL and the laser doppler radar technology at Oak Ridge National Laboratory is the inspection and analysis of potentially dangerous bridge structures in the national highway system. SDIO is working with the Department of Transportation on these potential applications.

- o **NPB Medical and Industrial Spin-offs:** Linear accelerator technology developed in response to SDI requirements for a source for NPB technology at Los Alamos National Laboratory lent itself to spin-off applications for both medical and industrial applications. The key element of the technology is an RFQ linac. Originally a Soviet concept proposed in 1970, the first RFQ was tested at Los Alamos in 1980. Competition efforts on NPB requirements led to the invention of the "precision segment" RFQ linac which is now the baseline design for the initial stage of the accelerator in the SDI NPB Integrated Space Experiment. Related supporting technologies (ion injector, RF power source, vacuum pumping system, water cooling system, mechanical structures, instrumentation, and controls) have also been pushed by NPB requirements resulting in smaller, lighter, rugged, and more efficient and reliable systems.

- o **Production of Radioisotopes for Medical Diagnosis:** The RFQ design has been incorporated into a compact proton linac to produce medical radioisotopes for positron emission tomography via an SBIR grant from the National Cancer Institute. These isotopes are principally used in study and diagnosis of brain and heart

disease. The new technology has produced a smaller, lighter (easier to shield), less complex, more energy efficient, and safer source than other methods. Commercial production is expected by 1989. Additional medical needs are being assessed for other radioisotopes created by this new technology.

- o **Cancer Therapy Applications:** Loma Linda University Hospital in southern California has selected the SDI-derived RFQ linac device for use in their ion therapy cancer treatment facility now under construction. Currently under contract for this facility, it is anticipated that 3 to 5 more facilities will be built using this technology over the next 5 to 10 years.
- o **Semiconductor Manufacture Enhancements:** The NPB RFQ linac technology can be applied to an ion implantation device used for doping semiconductor materials with high-energy ions of boron, phosphorus, and arsenic being designed. Manufacturing devices will be built at user facilities under license agreements.
- o **Oil Well Logging and Mineral Surveys:** The RFQ linac's compact size lends itself to applications in the fabrication of survey tools for oil well logging operations where it can be used in a well shaft without the danger of contaminating an oil field with dropped radioisotopes which is prevalent in the current procedure. The instrumentation could also be used to assay mineral content in mining operations.
- o **Non-Destructive Inspection (NDI) Technology:** Neutron radiography has been used for many years to examine metallic parts, such as munitions and aircraft structures, for corrosion and internal damage. The compact RFQ linac is especially useful with a new generation of NDI equipment because of its small size and portability potential. The technology could be used to detect defects in solid rocket motors.
- o **Detection Devices for Explosives and Other Illegal Substances:** The NPB RFQ linac technology is applicable for use as a neutron source for non-destructive testing and detection. A proposal is under consideration by the Federal Aviation Administration (FAA) for a high explosive detector for use at airports. SDIO is working with appropriate offices in the State Department, Department of Justice,

Customs, CIA, and Coast Guard regarding this technology for applications to counterespionage, counterterrorism, antisabotage, and law enforcement applications.

- o **Nuclear Waste Disposal:** The RFQ linac may have the potential to be used in a process to change the nuclear structure of nuclear waste material, permitting it to decay on a more rapid basis and rendering it harmless sooner.

- o **Enhancement of Gemstones:** Linacs derived from SDI technology are being considered for deepening the color of gemstones, which enhances their value. Similar techniques are being applied to the hardening of plastics and other materials for electronic circuit testing and other industrial uses.

- o **TAIS:** This SDIO-designed technology applications information system is the principal information management tool of the SDIO technology transfer program. The system has a unique architecture and capability to integrate and correlate technology, requirements, and resources on a common denominator technology architecture. Because of its unique features and capabilities, the New York State Science and Technology Foundation is investigating the system for use as the state-wide resource directory for the state of New York. The state of Oklahoma has expressed a similiar interest. The Federal Laboratory Consortium is considering application of a mature system and software for the national laboratories' technology transfer system.

- o **Other Spin-offs:** Just a few examples of other devices and processes that were identified by the technology applications panels include:
 - Microminiature, gas-powered refrigerator devices with applications to food preservation, industrial processing, materials manufacture, and superconductors

 - Photolithographic processes for micro-fluidic devices with applications in industry, medicine, and aerodynamics

- High-power density alkaline fuel cells which can use ambient air in lieu of exotic fuels and are adaptable to long-term power needs at remote sites or for backup systems
- Monolithic solid oxide fuel cells with no moving parts that can use gasoline, jet fuel, and methane gas with efficiencies twice that of conventional automobile engines
- Multilayer ceramic processing techniques that can combine the characteristics of electrical, thermal, and mechanically active properties in one material
- Supercapacitors with over 20 times the capacitance or energy storage capability of current technology
- Attentive associative memory software which permits a high degree of artificial intelligence self-programming capability for computers
- Cryogenic alternators which provide a 40-percent increase in power output per unit of weight and are more simple, reliable, and inexpensive than current devices
- High-power superbatteries which may be spun off to lightweight, more powerful uses in the auto industry, powered wheelchairs for handicapped, etc.
- Superconductor materials with applications to superfast computers, low-power electronics and appliances, and transportation systems
- Hypercube parallel processing techniques for high-speed, large-scale computing problems such as FAA air traffic control applications
- Advanced thermoelectric cell for conversion of heat to electrical power.

While many of these technologies are in the prototype or developmental stage, they promise to significantly advance the technology base in many application areas.

THE MEDICAL FREE ELECTRON LASER (FEL) PROGRAM

SDI FEL technology has a significant potential for applications in medical research. At the direction of the Congress, the Medical FEL program was initiated within SDIO to establish FEL research facilities and conduct biomedical and materials research.

In accordance with the intent of Congress, regional Medical FEL (MFEL) centers are being established at Stanford University, California; University of California at Santa Barbara; Brookhaven National Laboratory, New York; National Bureau of Standards (NBS), Maryland; and Vanderbilt University, Tennessee.

The MFEL program draws upon the resources and expertise of 20 universities, 2 national laboratories, 2 commercial laboratories, and 1 teaching hospital to explore the following areas:

- o Preclinical medical research, such as surgical applications, therapy, and the diagnosis of disease, is being pursued at the Massachusetts General Hospital, the University of Utah, Northwestern University, Baylor Medical Research Foundation, the University of California at Irvine, and the Uniformed Services University of the Health Sciences.
- o Biophysics research into medical laser applications at the cellular level are being conducted at the University of Michigan, Purdue, Princeton, the University of Texas, Jackson Laboratories (Maine), Physical Science, Inc. (Massachusetts), Baylor Medical Research Foundation, and the Uniformed Services University of the Health Sciences.
- o Materials science is being investigated at Brown University, State University of New York at Buffalo, University of Utah, and Stanford, Vanderbilt, Princeton, and Southern Methodist universities.

Research efforts and accomplishments of the MFEL program to date include:

- o Significant progress in the identification of over 35 photoactive materials to enhance the use of lasers for photodynamic therapy in the treatment of cancer.

- o A process has been developed and is in use at several hospitals to fragment kidney stones using a pulsed laser.
- o Progress in the bone marrow therapy of leukemia and treatment of lymphoma has been enhanced through the use of a photoactive dye which, when retained by malignant tissue, destroys cancerous cells when exposed to visible laser irradiation without harming normal healthy cells.
- o The spread of Chagas disease, a parasite-borne infectious disease prevalent in Central and South America, has been abated by the application of a laser-induced photodynamic process which has the potential to eradicate the parasitic organism from over 5 percent of the blood supply in these Latin American countries.
- o The mutant strains of malaria which took over a million lives around the world last year have been found to be changed by the use of one of the photoactive dyes in such a way as to make them again susceptible to the malaria medication.
- o A process combining laser angioplasty and balloon angioplasty is under development by the Uniformed Services University of the Health Sciences to enhance the laser angioplasty process in terms of effectiveness and safety.
- o The entire family of viruses, including herpes, measles, and AIDS, has been found susceptible to laser-induced photodynamic processes in the presence of absorbed hematoporphyrin derivatives exposed to laser light. From the research, a process is evolving to cleanse the blood supply of the AIDS virus in blood bank applications. Work is continuing to extend and improve the process using the capabilities of the free electron laser.

APPENDIX F
SDI TECHNOLOGY AND OTHER
DEFENSIVE MISSIONS

APPENDIX F

SDI TECHNOLOGY AND DEFENSIVE MISSIONS

I. INTRODUCTION

In accordance with Section 233 of the FY 1988 Defense Authorization Act, this appendix will update the report on the contribution of mature SDI technologies to other defensive missions provided to Congress on 4 May 1987 as specified in Section 215 of the FY 1987 Defense Authorization Act. The focus of the requirements is on the identification and use of mature SDI technologies for strategic defense, and in support of the improvement of other defensive systems. The status of those technologies and their potential contributions to defense against strategic ballistic missiles and the issue of access to space are addressed in the body of this report.

II. POTENTIAL SDI CONTRIBUTIONS TO OTHER MILITARY MISSIONS

DRB IMPLEMENTATION REVIEW STUDY--MILITARY APPLICATIONS

Because the technologies under research and development for the SDI Program also have numerous applications to other military systems, the SDIO Director proposed that DOD formally establish a process of identifying the near-term programs and long-range requirements in each military service to identify technology outputs from SDI research that may be used in other systems and long-range requirements. At the request of the Defense Resources Board (DRB), in conjunction with its 1987 Policy Implementation Review, a short-term study group consisting of representatives from the military services and other defense agencies was established to provide recommendations for implementation of "Service Adoption/Utilization of SDI-Related Technologies."

Significant near-term military missions whose performance might be aided by the application of technologies developed under the SDI Program include strategic and tactical air defense, maritime defense, access to space, and conventional missions such as anti-armor.

Provided with resource material that identified the baseline technology developments of the SDI Program, the DRB Implementation Review Group conducted a top-level review of approximately 80 near-term SDI programs identified as having potential spin-offs and established a plan for a working

panel to conduct a thorough review of the programs for potential spin-offs (see Figure F-1). The programs initially identified include those technology developments that are a part of the Air Defense Initiative (ADI) Program as well as the Balanced Technology Initiative (BTI) Program. While these programs are separate and complementary, there is great potential for sharing common technological developments for utilization in and across a number of systems. The sharing of technology may be as macro as dual utilization of platforms in space or may extend to the use of common subsystems. Carrying the process further, components developed under one program may directly (or with modification) be efficiently used in another. New materials, processes, computer hardware and software, power systems, etc., may find multiple uses in space systems as well as conventional airborne, land-based, or naval systems.

JOINT SDI-DEFENSE TECHNOLOGY APPLICATIONS INITIATIVE

On 16 October 1987, the DRB reviewed and approved the SDI recommendation to establish a standing Joint SDI-Defense Technology Applications panel to review non-SDI defense programs which can benefit from SDI technologies and recommend areas for implementation. The panel is to be under the leadership of the Assistant Secretary of Defense for Research and Technology and will consist of representatives from SDIO, the Office of the Under Secretary of Defense for Acquisition (USD(A)), the military services, the Office of the Joint Chiefs of Staff (OJCS), the Defense Advanced Research Projects Agency (DARPA), and other agencies. Both developers and users will be represented in service memberships. The panel will proceed according to a five-phase plan.

In Phase One the services will identify near-term programs as well as long-range requirements with a potential for utilization of SDI technology. These programs would be characterized in terms of their status (developmental, production, preplanned product improvement [P³I], etc.).

Phase Two will be an effort to characterize the identified programs in terms of the principal technology challenges associated with each program (components, sensors, electronics, hardware/software, etc.) and those technology challenges defined as precisely as possible in terms of their design goals and other requirements such as reliability and interoperability, etc. Each technology goal or deficiency will then be categorized and cataloged to interface with SDI technology output.

**FIGURE F-1
Potential SDI Military Spinbacks**

Air Defense Initiative Programs
Air Defense Surveillance Technology Air Defense Battle Management Technology Cruise Missile Engagement Systems Technology Other Classified Programs
Balanced Technology Initiative Programs
SMART Weapon Technology Reconnaissance Surveillance Target Acquisition, BM/C3 Technology Armor/Anti-armor Technology High-Power Microwave Technology Special Technology Opportunities
Tactical Defense Programs
Tactical Air Defense Tactical Missile Tactical Fire Support Tactical Target Acquisition, Surveillance, and Reconnaissance Tactical C3 and Electronic Warfare
Strategic Forces Modernization Programs
Strategic Air Defense Strategic Space Defense Strategic Sensors
Science and Technology Areas and Programs
Military Systems Electronic Devices Computers and Software Industrial and Manufacturing Advanced Materials and Structures Environmental and Life Sciences Defense-Wide Communications and Information
Space Systems Programs
Space Transportation and Support Study National Aerospace Plane Expendable Launch Vehicles

Phase Three will be a process to cross-match service technology goals with SDI efforts using a computer-based matching scheme that uses the SDIO Technology Applications Information System (TAIS). The TAIS is a technology innovation information management and referral system that uses the Militarily Critical Technologies List (MCTL) as an indexing method. SDIO will upgrade the TAIS capability to enable a selection and matching capability among defense technologies, resources, and requirements. The output will associate SDI-related research and development (R&D) with the service programs and interrelate all similar efforts and agencies involved in the R&D across all the services. This will provide visibility and focus in each technology area for the next phase. Details of the TAIS are provided in Appendix E of this report.

Phase Four involves the review of specific technology efforts by panels of the primary researchers and developers in each service and in SDIO to enable a comprehensive review of each identified technology area. This will form a productive environment in which to share technology advancements as well as appropriate components, innovations, processes, new materials, etc., with the user communities. As a result, dual use of technologies may be enhanced and may form the basis for large-scale concepts such as the sharing of space platforms for dual missions, or perhaps the establishment of standardized modular interfaces for dual-use space system integration, or system enhancements and updates to meet evolving threats and mission requirements. On a smaller scale, subsystems and components may be identified with a variety of dual uses. Technology successes could take the place of lagging developments and enable acceleration of schedules and upgrades of other programs with deficiencies or technology deficits. Long-range plans and schedules could also be better integrated to accommodate technology goals across DOD. Beneficiaries of the process would include program managers, Defense Acquisition Board (DAB) committees, the Defense Science Board (DSB) task forces, and various specialized service panels and joint committees.

In Phase Five, the Joint SDI-Defense Technology Applications Initiative Panel will be formed as a resource for a number of potential beneficiaries and serve the acquisition process. The principal beneficiaries are to be the individual service program managers who need ready access to state-of-the-art technology solutions. Operational commands and elements can use the results of the reviews to keep informed of technologies and to suggest new arenas for their application. Because the applications panel will be looking across the spectrum of strategic, conventional, and C³I systems and requirements for potential applications (to include a significant investment in test and evaluation resources), the Panel will report to the Assistant Secretary of Defense for Research and Technology, thus serving all of the appropriate DAB committees to include the Science and Technology Committee,

the Strategic Systems Committee, the Conventional Systems Committee, the C³I Committee, and the Test and Evaluation Committee. To function effectively as a technology transfer initiative, the panel has been directed by the Deputy Secretary of Defense to work outside the resources arena and not be given any authority or be directly associated with any mechanism to redistribute resources. Funding levels associated with any program will not be a subject for review.

Subsequent to this initial effort, and depending on its outcome and utility, the Joint SDI-Defense Technology Applications Initiative Panel may reconvene for a continuation of the process for FY 1989 or the approach may be institutionalized throughout the DOD as a technology transfer, transition, and integration program.

III. DEFENSE AGAINST TACTICAL MISSILES

Deputy Secretary of Defense Taft in January 1987 directed an integrated DOD program of which SDIO is one component. This direction accorded priority to antitactical missile (ATM) solutions for the short-range ballistic missile (SRBM) threat against NATO; established a balanced program of passive measures, active defense, and counterforce options supported by an integrated BM/C³ system; and designated the Army as lead service for the ATM program. This direction further required that a near-term and far-term program be structured. SDIO has been directed to continue research into defense against ballistic missiles of all ranges and to continue the far-term concept definition effort now under way. As discussed in Section 3.0, requirements for tactical ballistic missile defenses for our allies is not obviated by the INF Treaty.

Memorandums of Agreement to implement the directions of Deputy Secretary Taft have been agreed to by SDIO and the Army and by their respective executive agencies, the Strategic Defense Command (SDC) and the Army Material Command. The U.S. Army's SDC has been designated as the SDI executive agent for managing the tactical missile defense portion of the SDI Program.

Although allied and U.S. Army ATM efforts are separate from the SDI research program, they remain closely coordinated. Furthermore, the United States fully expects that technologies and concepts under examination for SDI can make a substantial contribution to theater defenses. The Memorandum of Understanding (MOU) being completed by the Army and SDIO will facilitate this sharing of technology. It is also anticipated that conventional forces in general will benefit greatly from advances and achievements in SDI research.

The first bilateral allied architecture study between the United States and the United Kingdom began in September 1986. Scheduled for completion in May 1988, its purpose is to recommend theater architecture concepts and identify the associated technology requirements. In considering the primary threat of theater ballistic missiles, as well as the threat from air-breathing missiles, the study will define general requirements for theater missile defense from a British perspective. An additional component of the study, which began in December 1986, addresses implementation concepts for battle management/command and control, and communication (BM/C³) systems to support theater architecture-derived needs. Funded at \$5 million in 1987, the U.K. architecture study will receive \$3.3 million in FY 1988.

The U.K. architecture study was supported by numerous bilateral meetings and contacts in 1987. Bimonthly meetings, alternating sites between the United States and the United Kingdom, addressed progress in the study and outlined future plans. Regional defense experts from government and industry reviewed technological issues and architecture considerations to assist various aspects of the study.

The study, scheduled to be completed over 22 months, is divided into 4 phases. Phase I was completed in November 1986 and, among other results, generated a "foundation" architecture based on U.K. assets, initial threat, and two scenarios of engagement. Phase II of the study, completed in May 1987, generated new architectures drawing on examinations of component options and assessments of the foundation architectures. In Phase III, completed in late 1987, the U.K. architecture team generated follow-on architectures based on assessments of Phase II architectures, conducted seven far-term technology studies, and explored threat and mission issues.

By the end of Phase III, the U.K. architecture team, in close cooperation with U.S. government-industry specialists, concluded that an effective European theater missile defense must be multitiered and fully responsive to threats.

In late 1987, the U.K. architecture study entered its fourth and final phase. Scheduled to be completed in May 1988, Phase IV will assess the architectures generated in Phase III. After further assessment of these optimum architectures, the U.K. team will propose an evolutionary architecture and supporting technology and development plan with suggested areas for further study.

The second bilateral architecture study, between the United States and Israel, focusing on the Middle East theater, began in December 1986. The study examines possible weapons systems to counter the near-term threat from SRBMs. The study is also identifying technology issues and candidate architectures applicable to other theaters where the threat from SRBMs exists. The first phase of the study was completed in November 1987, with a follow-on effort anticipated to end in June 1988.

The purpose of the Israeli program (commonly known as the "Mid East Architecture Study") is to develop architectures for defense against tactical ballistic missiles. The program was to be executed within 12 months in 2 defined stages. The first (Task I) addressed defense system architectures for the near term and the second (Task II) defense system architectures for the long term. The program started on November 4, 1986. The total cost of the 1-year effort is \$5 million.

During Phase I, the Israelis conducted a study of five different defense system architecture configurations for the near-term defense of the state of Israel against various threats. There was no significant cost difference among the alternative architectures. A total life-cycle cost of \$2 billion was estimated. For the long-term requirement (Task II), the threat was increased.

Another major area of allied participation in theater defenses is the Theater Missile Defense Architecture Studies (TMDAS). In December 1986, then Defense Secretary Weinberger announced the first TMDAS contracts, awarded to seven consortia of American and European firms. These architecture studies are aimed at clearly identifying the functional requirements for a theater missile defense against theater ballistic missiles.

Phase I of TMDAS was launched in January 1987. The 7 multinational teams--4 U.S.-led and 3 European-led--were each given 6 months and \$2 million to perform a concept definition study to identify theater defense architectures. The teams also identified and conducted a detailed analysis of the functions and parameters for TMD of the Central European region. After the second IPR in June, the teams submitted Phase I final reports which outlined the preferred near-term candidate architectures, characterized their performance, and identified critical issues.

In the fall of 1987, five of the seven teams were selected, based on the technical merit of the final report, to pursue the year long Phase II effort of exploring near-term theater missile defense architectures for Europe.

During Phase II, each team will define system and subsystem requirements and develop detailed system specifications in addition to developing deployment costs and a technology plan for resolving critical technology issues. System interoperability among theater defense system elements and BM/C³ requirements will also be addressed. Each of the contracts contains an option for a Phase IIb to analyze the far-term requirements of theater missile defenses and to design the architectures to meet those requirements.

EXTENDED AIR DEFENSE TEST BED (EADTB) PROGRAM

The objective of the EADTB program is to develop a theater test bed capability to support the validation of an integrated BM/C³ architecture, algorithms, and doctrine as well as the hardware and software associated with BM/C³. To achieve this goal, the EADTB program will include the following three efforts:

- o Identifying and specifying the requirements for a theater test bed

- o Designing, developing, and implementing a test bed and a theater test facility to support a theater architecture trade-off analysis and to assess the effectiveness of SDI theater architectures

- o Identifying the interface requirements between the EADTB and the SDI NTB.

Initial work on the EADTB program was performed in early 1987. The United Kingdom delivered the initial requirements definition study of a U.K. test bed to the U.S. Army SDC in the third quarter of FY 1987.

COMBINED ALLIED DEFENSE EFFORT (CADE)

The technical objective of the Combined Allied Defense Effort (CADE) is to conduct tests and evaluate U.S. and allied systems, subsystems, and components from Invite, Show, and Test (IS&T) and other projects to recommend currently available technologies for an interim theater missile defense capability. CADE will also recommend follow-on subsystems and components for further evaluation.

In early 1987, the CADE contractor requirements were defined and a Request for Proposals was issued. In September, a 5-year contract was awarded to provide other theater missile defense support in addition to the CADE objectives. The most significant technical accomplishment during 1987 was the definition of the threat application for CADE.

Plans for CADE during 1988 include selecting viable candidates for testing, developing baseline test capabilities, and integrating SDIO work packages such as innovative science and technology and Extended Range Interceptor (ERINT) technology.

IS&T

IS&T is a program in which U.S. and allied contractors are invited to submit existing hardware, or minor modifications to existing hardware, for test and evaluation in an interim theater missile defense against SRBMs. IS&T will provide these items to be tested as part of the CADE.

During Phase I, 16 IST proposals were received in 1987. Five winners were selected in late 1987. Thirteen proposals are anticipated for Phase II evaluation with awards scheduled to be made in March 1988. Proposals for test articles include kill mechanisms, seekers, cueing radars, fire control radars, optical sensors cued on remotely piloted vehicles, and communications.

IS&T plans in 1988 call for the selected hardware items to be included in CADE tests to develop an evolutionary theater missile defense capability.

WAR GAMING

The purpose of the war gaming activity is to develop insights into the use of TMD in Western Europe and its impact on NATO planning. It is intended that the war gaming will go beyond war fighting and address strategic issues, in particular, deterrence and the degree of coupling between CONUS defense in space and theater defenses to provide a true global defense intended to achieve the U.S. goal of ballistic missile obsolescence. The war gaming activity is also providing parametric studies of the performance of candidate TMD systems in European warfare scenarios.

IV. AIR DEFENSE

The air defense mission encompasses surveillance, warning, interception, and identification or negation of unknown aircraft that penetrate the air defense identification zone. Systems that contribute to that mission in the continental United States include the Joint Surveillance System network of Air Force and Federal Aviation Administration (FAA) radars, North American Warning System of radars across Alaska and Canada, Airborne Warning and Control System (AWACS) aircraft, and those fighter-interceptors on continuous alert. These systems will be augmented by the Over-The-Horizon Backscatter (OTH-B) radar network, which is scheduled to be operational in the early 1990s. The technical promise of SDI could significantly improve air defense mission efficiency and effectiveness, especially against future threats.

Tactical air defense in a theater of operations includes sensor systems such as AWACS and mobile ground-based radar systems. These provide early warning and engagement control of Air Force air defense and Army anti-aircraft surface-to-air missile (SAM) systems such as Patriot and Hawk. This leads to a highly decentralized command and control environment, constrained by limitations in current battle management, command and control, and communications (BM/C³) systems.

North American air defense assets operate as a system, with one type of surveillance asset compensating for the deficiencies of others. Improvements in sensor range, data processing, and operating efficiency would greatly facilitate the air defense mission.

Because aircraft can be diverted to many possible targets, it is difficult to discern the character of an air-breathing attack. However, broad patterns of mass raids can be revealed if information from multiple sensors can be assimilated simultaneously. Advances in survivable communications and distributed computation could significantly improve raid recognition, attack assessment, and efficient assignment of interceptors.

Theater air defense operations depend on limited sensor and BM/C³ architectures, which are in turn affected by electronic countermeasures and raid size. The addition of adjunct sensors using a variety of physical principles would ensure sustained operation and preclude a simplified development of countermeasures. Robust BM/C³ and data processing systems are needed to ensure that adequate theater air defense operations are maintained.

The air defense surveillance mission could obtain substantial benefit from a variety of SDI efforts. Space-based sensors could detect aircraft activity and contribute information for attack assessment. SDI electrical power programs could provide long-term energy sources for unattended ground-based radar systems. Battle management and communications systems within the SDI Program could facilitate sensor data fusion and attack assessment. At the global level, SDI computational technologies and simulation display advances could help integrate threat information necessary to respond to combined attacks. Sensor, kinetic energy weapons, and battle management technologies pursued in the SDI Program would all be applicable to the strategic air defense mission.

Theater air defense operations would also benefit from the development of SDI technologies. For example, the extension of air defense systems to a more robust antitactical and anticruise missile role could be derived from SDI experiments; early warning attack assessment functions would benefit from sensor developments; missile lethality enhancements could be based on improved lethality/vulnerability analyses; and command, control, and data processing shortcomings could be improved as a result of the software development and signal data processing work being accomplished for SDI.

As currently envisioned, many of the SDI technologies discussed above could be phased into air defense systems. Their integration into air defenses will require continual monitoring of SDI research advances to apply technologies appropriately. The Air Defense Initiative is examining, inter alia, the contributions of SDI technologies to improved air defense.

V. MARITIME OPERATIONS

The global maritime operations of U.S. naval units and fleets in peacetime and wartime are critically dependent on surveillance, communications, and the ability to intercept hostile forces beyond the range at which they can actively threaten fleet units. The U.S. Navy is confronted by a Soviet maritime threat of growing size and sophistication, a multi-dimensional force that possesses demonstrated capability for surveillance, track, and attack from space, air, surface, and subsurface platforms. Existing Navy defenses involve multiple layers and redundant systems, much in the manner proposed for a layered strategic defense against ballistic missiles.

Massive raids of Soviet land-based bombers (each bomber carrying numbers of sophisticated antiship missiles [ASMs]) present an especially serious threat to the surface fleet. The bombers must

be intercepted before they launch their ASMs from standoff ranges. In the near term, the SDI first-generation surveillance satellite could significantly extend the range for detection of bombers and would augment naval airborne early warning radars to support timely launch of sea-based fighters and long-range shipboard anti-aircraft missiles. Technology spinoffs from the HEDI program could contribute to the development of a long-range, ship-based missile for intercepting bombers before they reach ASM launch range and for suppression of Soviet standoff jammer aircraft.

Spin-offs from advances in communications, multiprocessors, intelligence interfacing and software, now under development by SDI to meet the demanding BM/C³ needs of a global SDS, should greatly benefit fleet operations in both the near and the far term. For example, the battle management software developed to track and intercept thousands of ballistic missiles and RVs should be readily adaptable to the Navy's less stressing requirements to perform similar operations involving lesser numbers of seaborne and airborne friendly and hostile objects. Further, SDI software development tools employing artificial intelligence and knowledge-based technology should markedly reduce the cost and time required to develop and manufacture secure and fault-free software for tactical use.

In the longer term, it is expected that the Soviet bomber ASM launch range and jamming capability will increase. The SDI optical sensor technology employed in the second-generation surveillance satellite, if applied in naval aircraft and air-defense missiles, could help fleet defenses keep pace with advances in the bomber threat. The SDI space-based radar would provide a valuable multispectral surveillance mix with optical sensor satellites. Spinoffs from the SDI hypervelocity gun and laser technology could result in highly effective ship-based weapons for defense against an anticipated new generation of Soviet antiship cruise missiles. For example, a rapid-fire electromagnetic gun (rail gun) that propels a low-cost guided projectile at a velocity of 5 to 10 km/sec over a long range would be very attractive for defending against Soviet ASMs launched from bombers, ships, or submarines. Applications of SDI laser weapon technology (excimer, free electron, and chemical) could provide the sure quick-kill defensive capability needed to counter even the most advanced Soviet ASMs. Advances made in developing high-power microwave technologies for SDI purposes has potential application for seaborne tactical weapons.

VI. CONVENTIONAL FORCES

For conventional ground force operations in a European general war, the Soviets have deployed a vast array of weapons to provide massive firepower. This array includes tanks, mobile artillery, and armored personnel carriers as well as sophisticated attack helicopters. These weapons are designed to provide the mobility and firepower necessary to overwhelm NATO forces without resort to nuclear weapons.

As a counter to this Soviet-Warsaw Pact capability, conventional NATO forces require an infusion of new technologies to provide improved capabilities in the areas of fire power, fire control, C³, and improved power supplies to enhance the mobile operations of advanced weapons.

The SDIO is developing a range of advanced technologies which could be used in developing advanced weapons and support or control systems for conventional forces. These include, for example:

- o Lightweight, rapid-fire hypervelocity gun technologies that could provide significant improvements in anti-armor, anti-aircraft, and fleet defense operations. These kinds of systems could be capable of rapid, lethal response to conventional attack, especially when coupled with low-cost guided hypervelocity projectiles. These technologies may provide the synergy needed to develop an effective long-range deterrent to conventional threat systems.
- o The development of high-power density power supplies that could provide a significant benefit to the modern conventional force, especially command and control and support elements. The technical improvements being made in communications, battle management, and resource allocation also are generating greater demands on the design of effective power supply systems that can provide sufficient power with low noise and/or thermal signatures. Lightweight, quiet power systems would contribute to the reduced signature of critical units and thus enhance survivability while meeting power needs.
- o The ability to engage more than one target at a time that is being developed through advances in computer aided/controlled multi-target fire control systems. This would enhance the battle management functions of all forces and enhance their efficiency in the use of resources.

Recent experiments have demonstrated technologies related to hypervelocity weapons development and have demonstrated rapid-fire operations, launch efficiencies, projectile mass fires, and electronic switch operations. Within several months, launch energies will probably be increased to levels approaching artillery shell muzzle energies.

In another critical area, the SDI Program is developing technologies to automate the collection, fusion, and processing of massive amounts of intelligence data on a near real-time basis. The application of expert systems will further facilitate processing the data to allow force structures to be categorized and tracked. These developments can ensure the timeliness and availability of reliable intelligence to keep pace with increased application of heliborne and mobile forces on a battlefield. As discussed in Appendix A, the SDIO and the Netherlands Organization for Applied Scientific Research are engaged in a cooperative research project on electromagnetic launchers, power supplies, switches, and advanced materials.

VII. SPACE DEFENSE

The defense of U.S., allied, and military space assets has become increasingly important as the Soviets maintain their present co-orbital interceptor, develop large-scale directed energy facilities with satellite-attacking capability and potential ASAT capability, and maintain a potential direct ascent interceptor capability with the deployed ABM interceptor, the probable nuclear-armed Galosh. The SDIO is fully committed to researching systems that will remain effective in the face of these dedicated efforts to defeat them. We are funding major investments in the technologies needed to enhance the survivability of space- and ground-based elements of any future ballistic missile defense system.

This section summarizes SDI contributions to provide sufficient warning and tracking information to support satellite survivability as well as a means to defend, evade, or counterattack against U.S. military satellites. Particularly relevant are SDI technologies being developed for eventual Space Surveillance and Tracking System (SSTS), space-based interceptor (SBI), Exoatmospheric Reentry Vehicle Interceptor System (ERIS), and ground-based laser (GBL) systems, as well as for responsive or random maneuver and nuclear, fragment, and laser hardening of space platforms.

PROGRAM STATUS AND KEY TECHNOLOGIES

The problem of space defense comprises three areas:

- o Space surveillance and tracking
- o Space defense weapons
- o Space system survivability.

Currently, the Space Detection and Tracking System (SPADATS) sensor network operated by NORAD and the U.S. Space Command gives the United States the ability to locate and maintain track files on satellites. This network includes radars and visible/infrared systems. Space Object Identification uses radars and optical means to locate and track low orbit satellites. The SDI Program offers a wide range of sensor, radar, and laser technologies that have potential application for improvements in this area. In the long term, interceptors or other means of active self defense are likely to be required (ground-launched or other interceptors could be used). For example, an SBI positioned near the defended platform would draw on the technology in the current SBI program. Laser weapons currently under consideration potentially represent a longer-term alternative with lower marginal cost per shot.

The current threat posed to U.S. low orbit satellites by the operational Soviet co-orbital fragmentation interceptor is of immediate concern. Maneuvering is one possible countermeasure. A Soviet direct ascent nuclear ASAT targeted against a low orbit U.S. satellite requires development of a self-defense capability.

A third category of space defense technologies involves assuring space system survivability through passive and active countermeasures. The United States has worked over the last decade on hardening satellite systems. Because we must anticipate operations in a future wartime environment with advanced technology defense suppression threats, the SDI Program has invested in survivability technology aimed at protection levels far above current levels. Passive countermeasures research includes ablative and radiation shielding, mass shielding, and hardened chip technology. Active countermeasures will also be considered.

FUTURE PLANS

SDI is proceeding with the technology elements of the SDS as discussed, in coordination with other DOD elements. Major demonstrations are planned to show engineering feasibility for selected items such as the SBI and ERIS interceptors, the GBR-X, and selected countermeasures techniques. Details on the future plans are described in Section 4.0 of this report.

VIII. TACTICAL WARNING AND ATTACK ASSESSMENT

Tactical warning and attack assessment (TW/AA) is the crucial information required by decision makers to respond adequately to a ballistic missile attack. This function is essential for a deterrence policy based on offensive retaliation, defensive capability, or a combination of both. TW/AA for strategic defenses will be accomplished using the complete suite of SDI sensors tied into BM/C³ systems. These sensors would complement existing and planned systems. For a multitiered SDI system, early warning and initial attack assessment would occur in the boost phase. However, later tiers--post-boost, midcourse, and terminal--would provide additional sensor information on ballistic missiles or their deployed RVs. This SDI surveillance and tracking capability will also enhance our current offensive-based deterrence posture. TW/AA functions are important in all aspects of defensive operations. The sensors being developed in support of SDI goals could provide similar support to conventional defense elements, aid in the proper assessment of information, and help develop appropriate warning.

TW/AA functions related to phased missile defense and survivable C³ are described in the following paragraphs.

Boost Phase. Initial TW/AA will be provided during the boost phase by the Boost Surveillance and Tracking System (BSTS). This new satellite system will provide significantly more survivability and better performance than the current system capabilities. BSTS will detect the launch of ballistic missiles and provide rapid alert to the National Command Authority.

Post-Boost Phase. The post-boost phase occurs as the post-boost vehicle (PBV) leaves the atmosphere and begins deploying its RVs and decoys. The BSTS tracks this deployment. The battle

management would use this information to prepare subsequent tiers for their defensive roles. This information could also aid in the timely management of offensive strategic forces.

Tracking using the SSTS would begin during this phase. This system would track the RVs and other objects using advanced sensors. Using stereo processing in conjunction with other SSTS satellites, this system would be able to track objects with improved accuracy compared to single satellite performance. Information for attack assessment would then be more accurate and would begin to include the number of RVs as well as their target locations.

Midcourse Phase. Objects deployed from the PBV travel ballistically through space. SSTS satellites, which would begin tracking in the post-boost phase, would provide increasingly accurate attack assessment to subsequent tiers as threat objects progressed along their trajectory. During the later part of the midcourse phase, the Ground-Based Surveillance and Tracking System (GSTS), formerly called the Probe, would start to track the threat cloud. The GSTS would provide backup for the SSTS utilizing stereo processing. The Airborne Optical System (AOS) would track threat objects during the late midcourse and as they reenter the atmosphere.

Terminal Phase. As the objects reentered the atmosphere, the AOS could also provide greater accuracy and final attack assessment. It would alert and cue the terminal radars, which would provide final attack assessment of the surviving RVs that must be destroyed by endoatmospheric interceptors.

Survivable C³. In order for each tier's suite of sensors to provide continuous early warning and attack assessment, survivable C³ systems must be built. Systems contemplated by SDI complement C³ systems already in place and being upgraded by the Air Force. SDI would build upon these existing systems to provide continuous C³ functioning via highly survivable communications links. Command and control nodes would be proliferated on various weapons and sensors platforms, thereby reducing the vulnerability of the complete system. To provide highly survivable communication links, directional links would be used. Because of their directional nature, these links would be highly resistant to jamming. Both ground- and space-based nodes would be linked through existing and improved C³ facilities. SDI will provide the technology to implement most of these improvements into existing C³ systems even if the decision is made not to deploy strategic defenses.

PROGRAM STATUS

Experiments which will support development of SDI early warning and attack assessment concepts are described in Sections 3.0 and 4.0 of this report. Appendix C provides details on the compliance of SDI experiments with the ABM Treaty. These experiments include the BSTS, SSTS, AOS, GSTS, and Ground-Based Radar Experiment (GBR-X).

FUTURE PROGRAMS AND COSTS

Future tactical warning and attack assessment programs include the BSTS, SSTS, AOA, GSTS, and GBR-X.

BSTS. A system based on the BSTS experiment is scheduled to begin full-scale development in FY 1989. Cost of the deployed system is yet to be determined.

SSTS. Experimental costs are estimated at \$2.2 billion. The initial operational capability and cost of the deployed system will depend on the number of satellites and their complexity.

AOS. The AOS experiment will provide the basis for an airborne surveillance system. The cost of the AOS experiment is estimated at \$550 million. System costs are yet to be determined.

GBR-X. The GBR-X will provide the basis for an SDI ground-based radar. The experimental costs are estimated to be \$325 million.

TW/AA. This program provides valuable potential for an effective network of surveillance assets that would serve the United States in a variety of strategic, tactical, and conventional roles.

IX. APPLICATIONS FOR DETECTING ACCIDENTAL LAUNCH

Phase I of the SDS, as currently envisioned, would provide a capability for global protection against an attack by a limited number of nuclear missiles accidentally launched against the United States or its allies by the Soviet Union or other countries. Although an accidental launch of one or a few missiles from the Soviet Union is unlikely, the possibility cannot be entirely discounted. The

potential benefits of a more limited deployment designed to meet the threat of accidental or unauthorized launch is currently being considered by DOD.

THIS PAGE INTENTIONALLY LEFT BLANK

APPENDIX G
IMPLICATIONS OF NO ABM TREATY
RESTRICTIONS ON THE SDI PROGRAM

**SEC. 233. REPORT ON HOW ABSENCE OF THE ABM TREATY WOULD AFFECT
STRATEGIC OFFENSIVE AND DEFENSIVE PROGRAMS**

(a) *Report on No ABM Treaty Limitations.*--The Secretary of Defense shall submit to Congress a report concerning what the effect would be on strategic offensive and defensive programs of the United States if there were no limitations on strategic defensive systems in force under the 1972 ABM Treaty.

(b) *Matters To Be Included.*--The report shall include the following:

(1) *An analysis of the ramifications of there being no limitation in force under the 1972 ABM Treaty on development under the Strategic Defense Initiative (SDI) program of strategic defenses, including comprehensive strategic defense systems and more limited defenses designed to protect vital military and command and control assets of the United States.*

(2) *A comparison (based on the analysis made under paragraph (1)) of the research and development programs that could be pursued under the SDI program under the limitations applicable under the restrictive interpretation of such treaty, and under a case in which there were no such limitations, including a comparative analysis of*

(A) *the overall cost of such research and development programs;*

(B) *the schedule of such research and development programs;*
and

(C) *the level of confidence attained in such research and development programs with respect to supporting a decision to commence full-scale engineering development under such programs in the early-to-mid 1990s.*

(3) *A list of options for the SDI program, assuming that there are no limitations in force under the 1972 ABM Treaty, that meet one or more of the following objectives:*

(A) *Reduction of overall development cost.*

(B) *Advancement of the schedule for making a decision to commence full-scale engineering development.*

(C) Increase in the level of confidence in the results of the research by the original scheduled date for the commencement of full-scale development.

(4) An analysis of how rapidly, in the absence of limitations under the 1972 ABM Treaty, the Soviet Union could deploy a nationwide anti-ballistic missile defense of military and non-military targets and the consequences of such a deployment. The analysis should include an assessment of the following:

(A) The effect of such deployment on the confidence of the United States that, should deterrence that depends increasingly on defensive forces fail, the planned strategic nuclear forces of the United States would be sufficient to hold assets that the leaders of the Soviet Union value at risk following a first strike by the Soviet Union against the United States.

(B) The changes that must be made to the strategic offensive forces of the United States to hold assets that the leaders of the Soviet Union value at risk in the presence of strategic defenses. The analysis should include both the cost of those changes and the time period scale over which they could be accomplished.

(C) The consistency of the required changes to United States strategic offensive forces of the United States described under subparagraph (B) with the current United States negotiating position in the Strategic Arms Reduction (START) negotiations.

(D) The degree to which crisis stability would be affected during the transition period between the appearance of nationwide anti-ballistic missile defenses by both the United States and the Soviet Union and the completion of the changes that the United States would make to its strategic offensive forces in response to such defenses by the Soviet Union.

(5) An analysis of the effect on deterrence of nuclear conflict if both the United States and Soviet Union deploy strategic defenses of comparable capability, considering both less capable and highly capable strategic defenses, as well as appropriate transition issues (including the effect on deterrence of the potential vulnerability of strategic defenses).

THIS PAGE INTENTIONALLY LEFT BLANK

APPENDIX G
IMPLICATIONS OF NO ABM TREATY RESTRICTIONS
ON THE SDI PROGRAM

INTRODUCTION

On May 19, 1987, the Department of Defense (DOD), pursuant to Sec. 217 of the FY 1987 DOD Authorization, released to the Congress a report on the implications for the SDI Program of adopting the broad interpretation of the ABM Treaty. Entitled "A Report to the Congress on the Antiballistic Missile Treaty," this report included a comparison of a broad interpretation program with a program structured to remain consistent with the restrictive interpretation. The conclusions rendered at that time remain largely valid and will be referred to, as appropriate, in this report. However, budget reductions have resulted in certain programmatic changes since the report was issued. Where appropriate, this report will note where those changes alter the conclusions of last year's report.

Because most of the technologies being pursued under the SDI Program are clearly, or are assumed to be, based on "other physical principles (OPP)" and, therefore, not subject to testing or development restrictions under the broad interpretation, there are essentially no programmatic differences between what could be done under the broad interpretation and what could be done if there were no limitations in force under the ABM Treaty. The only major difference would lie in the area of deployment: under both the broad and the narrow interpretation, no deployments of OPP systems would be permitted. With no ABM Treaty limitations in force, of course, there would be no restriction on deployment.

As in last year's report, the following assumptions are made:

- o The President's objective, to demonstrate the feasibility of comprehensive defense for both the United States and its allies in order to support a decision as soon as possible on whether to deploy effective defenses remains unchanged;
- o A balance will be maintained in the program between mature and less developed technology; and

- o Advanced kinetic energy weapons (KEWs) are technologies "based on other physical principles" and, therefore, can be fully tested and developed under the broad interpretation of the ABM Treaty, even if space-based.

PROGRAM COST

The overall cost of the SDI program--up to full-scale development (FSD) of Phase I SDS elements--described in last year's report, which was structured to be consistent with the restrictive interpretation of the ABM Treaty, was approximately \$3 billion more than the program structured to be consistent with the broad interpretation. (See 1987 DOD Report to Congress on the ABM Treaty for a fuller discussion.) No savings beyond those of the broad interpretation would result if no ABM Treaty limits were enforced.

PROGRAM SCHEDULE

As noted in last year's report, under the restrictive interpretation of the ABM Treaty, the SDI program would be ready to enter FSD for an initial SDS (assuming the United States withdrew from the ABM Treaty two years earlier). After a four-year FSD period, deployments could begin. Under the broad interpretation, the program could enter into FSD and, following withdrawal from the ABM Treaty, the United States could begin to deploy a Phase I Strategic Defense System (SDS). (See May 19, 1987 DOD Report to Congress on the ABM Treaty for details.) It should be noted that the schedule described for the broad interpretation could be met under the restrictive interpretation, if additional funding were provided, and if a lower level of confidence in defense system feasibility prior to a decision to enter FSD were acceptable programmatically and politically.

If no ABM Treaty limits were enforced, the FSD and deployment schedule would be the same as for the broad interpretation, except that, in the absence of Treaty limits, it would not be necessary to withdraw from the Treaty to deploy. This assessment assumes that the Congress would be willing politically (it is not a legal issue) to permit the establishment of production facilities as well as the actual production of strategic defense weapons and sensors for test purposes during FSD and prior to deployment. If this did not prove to be the case, then under the broad interpretation the United States would have to withdraw from the ABM Treaty at some point during FSD to permit a deployment.

The dates above assume full funding for SDI, as identified in the FY 1988-1989 budget request. However, since the 1987 report to Congress on this subject was issued, the Congress has reduced the DOD portion of the FY 1988 SDI budget by \$1.6 billion, to \$3.6 billion. In addition, as a result of the requirement to make significant cuts in the DOD budget, the Administration has reduced planned funding for the SDI program for FY 1989 and beyond. These budget cuts will have the effect of moving the dates when full-scale engineering and development could commence one to two years farther into the future, if the same confidence levels envisioned in last year's report are to be achieved.

CONFIDENCE LEVEL

Confidence in technical feasibility is a measure of the opinion of technical experts and decisionmakers that a defense system, consisting of a given set of defensive technologies, will be effective in achieving a specified mission against a specific Soviet threat. Thus, the rate of increase in confidence and the level of confidence are determined by changes in defensive technologies, mission, and threat.

Under the broad interpretation, technical confidence in defense feasibility would increase faster and would reach a higher level when critical national decisions on whether to alter fundamentally the ABM Treaty regime would have to be made.

During the pre-FSD phase of a broad interpretation program, system exploration experiments would be conducted (system exploration experiments combine state-of-the-art sensors, weapons and battle management technologies to address fundamental system integration issues early in the program). These experiments could identify unexpected technical issues which then would be addressed and resolved in later technology validation experiments. Because these system exploration experiments could be conducted under a broad interpretation program, but not under a restrictive program, and because an early understanding of how components of a defensive system interact has a critical impact on the rate of increase in confidence, a broad interpretation program would result in a faster rate of growth in confidence than a restrictive interpretation program.

By contrast, during the pre-FSD phase of a restrictive interpretation program, technology and system validation issues involving mobile ABM technologies would have to be addressed through simulations and non-ABM-capable experiments. While this activity would increase confidence, the rate of increase would be less than could be achieved under a program consistent

with the broad interpretation. Under the restrictive interpretation, ABM-capable system validation and technology validation experiments needed to provide the additional confidence that would be desired for an FSD decision, could be conducted only after the ABM Treaty regime had been fundamentally altered.

Under a program in which no ABM Treaty limits are recognized, confidence in the feasibility of defenses incorporating devices based on "other physical principles" would increase at the same rate as a program pursued under the broad interpretation.

STRATEGIC DEFENSE SYSTEM OPTIONS

The removal of limitations under the ABM Treaty would provide no programmatic benefits in developing SDS options beyond those provided by the broad interpretation. The May 19, 1987 Report to Congress on the ABM Treaty provides programmatic details of an SDI program that could be pursued under the broad interpretation of the ABM Treaty. This program would maximize cost reduction, provide the shortest path to an informed FSD decision, and maximize the level of confidence in defense feasibility.

OPERATIONAL IMPLICATIONS OF U.S. AND SOVIET DEFENSE SYSTEM DEPLOYMENTS

Soviet Deployment of Near-Term, Nationwide Strategic Defenses

If the United States maintains an effective SDI research and technology program, it is less likely that the U.S.S.R. will opt to deploy a near-term, nationwide defense to attempt to gain a unilateral military advantage over the United States, even if the ABM Treaty ceased to exist. This assessment stems from the judgement that Soviet ballistic missile defense decisions are based less on what is permitted by the ABM Treaty than what is in its national security interest. For the Soviets, the main consideration is the impact a nationwide ABM deployment would have on their strategic position, taking into account U.S. response options.

If the United States had not pursued the SDI program in 1983 and had it continued to accord ABM research a low priority, the prospects for a Soviet unilateral deployment of defenses would have been increased. Because the United States would not have had useful strategic defense options to field in response to the Soviet deployment, and because in the West offensive force proliferation would be unlikely to be politically viable, a nationwide deployment of traditional defenses could have altered the strategic balance in the Soviet favor, and, thus, might have been

appealing to the U.S.S.R. However, with SDI, the United States will have effective options which can be deployed to counter the effects of any Soviet deployments. This capability undermines the payoff to the Soviets of a near-term defense system deployment.

Nevertheless, if the Soviet Union were to decide today to deploy a near-term nationwide defense against ballistic missiles, the initial stages of such a defense would necessarily incorporate traditional ABM technologies (although improvements to such a defense system could incorporate OPP technologies in the 1990's). These technologies would consist of ground-based, nuclear-armed, exoatmospheric and endoatmospheric interceptors, such as the upgraded GALOSH and the GAZELLE being deployed around Moscow. It also would consist of the large network of ground-based radars that the U.S.S.R. is deploying around the Soviet Union. In addition, the Soviet Union has developed a rapidly deployable ABM system, consisting of the GAZELLE interceptor and the FLAT TWIN and PAWN SHOP radars. These technologies would be deployed in addition to the SA-10 and SA-12 air defense systems which are already being deployed for air and tactical ballistic missile defense purposes, but which may have the potential to intercept some types of strategic ballistic missiles.

If the Soviets wished to deploy a near-term nationwide ABM defense, they may not wish to commence deployments until they could complete the upgrade of the Moscow ABM system and a larger portion of the large phased-array radar (LPAR) network now under construction. Soviet ABM deployments could reach a few hundred interceptor launchers in the early to mid 1990s and perhaps a few thousand interceptor launchers after the year 2000.

Defense coverage could include more than 100 ABM sites. Owing to the limitations of a traditional ABM system, and the importance of surviving military forces to Soviet doctrine, an early Soviet nationwide ABM defense would not be expected to provide more than incidental coverage to non-military or military-related assets. It is also assumed that the Soviet Union would not actively defend ICBM silos, although some silos would receive some protection by virtue of their collocation with other defended assets. This assumption is based on Soviet strategic military doctrine which, in the event nuclear war with the West appears likely, calls for preemptive nuclear strikes on U.S. and allied nuclear retaliatory forces. Soviet fixed ICBMs would constitute the main force of such an attack. Much, although not all, of the remaining ICBM force would consist of mobile SS-24s and SS-25s, which are less vulnerable to prompt retaliation than fixed missile silos. Any Soviet fixed ICBMs not used preemptively would likely be launched on tactical warning.

Implications for Deterrence of U.S. and Soviet Nationwide Defenses

In the event the United States and the Soviet Union deploy strategic defenses, the means by which the United States achieves deterrence will necessarily change. Today, the United States achieves deterrence by maintaining the ability to hold at risk the full range of high-value Soviet assets so that an effective, credible, and flexible response can be made, regardless of the nature of the Soviet attack. These assets consist of Soviet strategic forces (ICBM silos and launch facilities, bomber bases, SSBN ports, nuclear weapons storage sites), command, control, and communications (C³) facilities (including political and military leadership bunkers), conventional military forces, and war-supporting industries.

Prompt hard-target capability, such as is provided today by some land-based missiles, is required to retaliate effectively against ICBM silos and launch facilities and some C³ facilities. Other prompt, but non-hard-target-capable ballistic missiles, especially those currently deployed aboard submarines, are important in retaliating rapidly against such "soft" assets as bomber bases and SSBN ports, (although if hostilities followed several hours or days of force generation, it would not be necessary to attack them promptly, since most of the bombers and submarines would no longer be present). In time of war, such a prompt-response capability would permit the United States to begin to disrupt Soviet war plans and activities within the first hour of hostilities. Other less time-urgent assets in the Soviet Union, such as conventional forces and some C³ facilities can be covered by bomber and cruise missile forces.

With ballistic missile defenses deployed by both the United States and the Soviet Union these targeting priorities would change. Soviet ICBM silos, missile launch control facilities, and SSBN ports would no longer be a priority target for U.S. ballistic missile forces. By attacking land- and sea-based ballistic missiles in flight, ABM defenses can substitute for the counter silo and counter SSBN port mission of U.S. ICBMs and SLBMs. In this sense the only difference between defense and offense is that the defense destroys missiles in flight while the offense destroys them (as well as anything that is collocated) on Soviet territory. To the extent appropriate, ICBM silos and SSBN ports can be destroyed later by air-breathing assets.

Many of those few assets that could not be countered by defenses, but which one might wish to destroy in a time-urgent manner (some C³ facilities and bomber bases), could be dealt with by concentrating available ballistic missile forces on this narrow category of Soviet assets. If Soviet defenses had sufficient effectiveness to prevent even this tactic from succeeding (and assuming a U.S. defense of equal effectiveness), destroying these assets promptly would not be necessary.

Under these conditions, the rate with which U.S. and Soviet strategic military options could be executed would be reduced sufficiently to permit slower flying bombers and cruise missiles to be used against these assets.

The fact that the military utility of the U.S. strategic missile force would be reduced by Soviet defenses need not present a deterrence problem for the United States provided the utility of the Soviet ballistic missile force is similarly reduced. The U.S. requirement for prompt retaliatory capability is closely related to the degree to which Soviet strategic forces can support rapid attack options. If Soviet strategic forces can enforce a rapid operational pace in time of war, effective deterrence requires that the United States have forces that can match this pace. As Soviet rapid attack options are reduced, the burden of military operations would shift to less rapid attack options, reducing the pace of conflict. This, in turn, would reduce U.S. dependence on rapid retaliatory capability. Consequently, a Soviet ability to deny the United States a rapid retaliatory capability would not be detrimental to deterrence if U.S. defenses obviated the need for such capability.

Assets that even today do not require prompt retaliation (e.g., some C³ facilities, nuclear weapon storage sites, conventional military forces, war-supporting industries) would not require it in a strategic environment where ballistic missile defenses play a crucial role.

In view of the above, if the United States began to deploy effective defenses against Soviet ballistic missiles as or before the Soviet Union was able to field an extensive defense capability (this is possible if the SDI program is given full budgetary support), it would not be necessary to make extensive modifications to U.S. strategic ballistic missile forces. The development and deployment by the United States of countermeasures to Soviet ballistic missile defenses would be required only if the United States could not maintain a balance in U.S. and Soviet strategic capability by means of strategic defense. This would only be the case if effective defenses prove to be infeasible or if the SDI program receives insufficient funding to permit the United States to exploit effective defense options in a timely manner.

Of course, as dependence on ballistic missiles is reduced, the U.S. strategic force structure would begin to shift in the direction of greater dependence on air-breathing systems (i.e., bombers and cruise missiles) in order to maintain adequate coverage of the Soviet target base. The precise cost and duration of this force restructuring cannot be determined at this time, since it depends significantly on the overall effectiveness of Soviet ballistic missile and air defenses. Nevertheless, since Advanced Technology Bomber and Advanced Cruise Missile production lines would already

be operating to satisfy Strategic Modernization Program requirements, the cost and duration of this restructuring could be minimized. Over a more extended period, existing SSBNs might be converted to carry long-range, sea-launched cruise missiles. These changes in the U.S. strategic force structure could be accommodated within the limits of START by reducing deployed U.S. ballistic missiles.

Crisis Stability in a Transition to Defense

Crisis stability is a concept which seeks to define the degree to which the existing balance of forces between two or more adversarial nations can increase or decrease incentives to go to war during a severe international crisis. During such a crisis, nations assess the possibility that it could lead to conflict and the possible outcome of such a conflict. If the balance of forces is such that one or more of these nations believe that the outcome of conflict--should it come--would be very favorable to them if they strike first, but that the outcome would be very unfavorable to them if they do not, then the incentives for the nations involved to initiate hostilities would be relatively high. Under such conditions, the likelihood that an international crisis would lead to armed conflict would be equally high. This situation is characteristic of crisis instability. Conversely, if the balance of forces is such that it makes little difference to the outcome of a conflict whether a nation strikes first or second, a high degree of crisis stability is said to prevail. Under these circumstances, the likelihood of a crisis resulting in conflict is reduced significantly.

By reducing the military benefit that the Soviet Union might realize by a first strike, and the costs to the United States of such an attack, effective U.S. defenses could decrease significantly incentives to attack and, therefore, increase significantly crisis stability. In addition, if the United States restructures its offensive forces during the defense transition at roughly the same pace as the Soviet Union, no destabilizing imbalance in effective offensive capability would emerge. Since the United States traditionally has placed a greater priority on air-breathing forces (which would be the core of any offensive force restructuring) than the Soviet Union, and since the United States would have bomber and cruise missile programs in production in the 1990s, regardless of any decision to deploy ballistic missile defenses, maintaining an offensive balance would not be stressful for the United States.

Survivability of any deployed ballistic missile defense system is essential to stability. Consequently, one of the essential criteria of any deployed U.S. defense against ballistic missiles is that it be able to sustain direct attacks against it without losing its ability to satisfy its intended mission. By definition, therefore, any defense system that would be deployed by the United States

would not be susceptible to rapid attack and degradation of mission capability and, thus, would not raise an issue of stability or deterrence effectiveness, either during the transition period or after the defense system is fully deployed.

THIS PAGE INTENTIONALLY LEFT BLANK.

ACRONYMS/GLOSSARY

LIST OF ACRONYMS

ABE	Army Background Experiment
ABM	Antiballistic Missile
ADCOM	(U.S.) Aerospace Defense Command
ADI	Air Defense Initiative
AGT	Above Ground Test
AJ	Antijam
ALE	Airborne Laser Experiment
ALS	Advanced Launch System
AMOS	Air Force Maui Optical Station
AMTL	Army Materials Technology Laboratory
ANMCC	Alternate National Military Command Center
AOA	Airborne Optical Adjunct
AOS	Airborne Optical System
AOSP	Advanced On-board Signal Processor
ARPANET	DARPA Communications Network
ASAT	Antisatellite
ASM	Antisimulation Antiship Missile
ASPIRIS	Advanced Signal Processing for IR Sensors
ATA	Advanced Test Accelerator
ATB	Allied Test Bed
ATBM	Antitactical Ballistic Missile
ATM	Antitactical Missile
ATP	Acquisition, Tracking, and Pointing

ATP-FC	Acquisition, Tracking, and Pointing - Fire Control
AWACS	Airborne Warning and Control System
BCD	Baseline Concept Document
BCS	Beam Control System
BEAR	Beam Experiment Aboard Rocket
BGV	Boost Glide Vehicle
BIB	Blocked Impurity Band
BM/C ³	Battle Management/Command and Control, and Communications
BMD	Ballistic Missile Defense
BMT	Ballistic Missile Threat
BSTS	Boost Surveillance and Tracking System
BTI	Balanced Technology Initiative
C ³	Command and Control, and Communications
CAD	Computer-Aided Design
CADE	Combined Allied Defense Effort
CAM	Computer-Aided Manufacturing
CDI	Conventional Defense Initiative
CDR	Critical Design Review
CIM	Computer-Integrated Manufacturing
CINC	Commander-in-Chief
CINCSAC	Commander-in-Chief, Strategic Air Command
CINCLANT	Commander-in-Chief, Atlantic
CM	Countermeasures
CMEST	Cruise Missile Engagement Systems Technology
CMOS	Complementary Metal Oxide Semiconductor

COEA	Cost and Operational Effectiveness Analysis
CONUS	Continental United States
CRO	Chemical Release Observation
CSO	Closely Spaced Object
CSS	Cooperating Space System
CTV	Control Test Vehicle
CV	Carrier Vehicle
CWDD	Continuous Wave Deuterium Demonstrator
DAASAT	Direct Ascent Antisatellite
DAB	Defense Acquisition Board
DANASAT	Direct Ascent Nuclear Antisatellite
DARPA	Defense Advanced Research Projects Agency
DASO	Demonstration and Shakedown Operation
DEFCON	Defense Condition
Dem/Val	Demonstration/Validation
DE	Directed Energy
DEW	Directed Energy Weapon(s)
DIA	Defense Intelligence Agency
DIPS	Dynamic Isotope Power System
DNA	Defense Nuclear Agency
DOD	Department of Defense
DOE	Department of Energy
DOT&E	Director, Operational Test and Evaluation
DRB	Defense Resources Board
DSAT	Defense Satellite
DSP	Defense Support Program

DST	Defense Suppression Threat
DTST	Defense Technologies Study Team
EADTB	Extended Air Defense Test Bed
EADTP	Extended Air Defense Test Program
ECCM	Electronic Counter-Countermeasures
ECM	Electronic Countermeasures
EHF	Extremely High Frequency
EIAP	Environmental Impact Analysis Program
EIS	Environmental Impact Statement
ELSI	Enhanced Longwave Spectrometer Imager
EMG	Electromagnetic Gun
EML	Electromagnetic Launcher
EMP	Electromagnetic Pulse
ENSS	Experimental Network Surveillance System
EPA	Environmental Protection Agency
ERINT	Extended Range Interceptor
ERIS	Exoatmospheric Reentry Vehicle Intercept System
ESD	Electronic Systems Division
EV	Experimental Version
EW	Electronic Warfare
EW/AA	Early Warning and Attack Assessment
FAA	Federal Aviation Administration
FBB	Fast Burn Booster
FEL	Free Electron Laser
FET	Field Effect Transistor

FLAGE	Flexible Lightweight Agile Guided Experiment
FOC	Full Operating Capability
FOT&E	Follow-on Test and Evaluation
FOV	Field of View
FPA	Focal Plane Array
FSD	Full-Scale Development
FTV	Functional Test Vehicle
FY	Fiscal Year
FYP	Five-Year Plan
GBFEL	Ground-Based Free Electron Laser
GBL	Ground-Based Laser
GBMI	Ground-Based Midcourse Interceptor
GBR	Ground-Based Radar
GES	Ground Engineering System
GRTC	Georgia Research and Technical Corporation
GSTS	Ground-Based Surveillance and Tracking Systems
GTA	Ground Test Accelerator
GVSC	Generic VHSIC Spaceborne Computer
HEDI	High Endoatmospheric Defense Interceptor
HEL	High-Energy Laser
HELSTF	High-Energy Laser Systems Test Facility
HEMP	High-Altitude Electromagnetic Pulse
HOE	Homing Overlay Experiment
HPM	High-Power Microwave
HTS	High Temperature Superconducting
HVG	Hypervelocity Gun

HWIL	Hardware-in-the-Loop
HYWAYS	Hybrids With Advanced Yield for Surveillance
IAT	Integrated Assembly Test
IBC	Impurity Band Conduction
IBSS	Infrared Background Signature Survey
ICBM	Intercontinental Ballistic Missile
ID	Interactive Discrimination
IED	Intrinsic Event Discrimination
IFOV	Instantaneous Field of View
ILS	Integrated Logistics and Support
IMU	Inertial Measurement Unit
IOC	Initial Operating Capability
IR	Infrared
IRBM	Intermediate-Range Ballistic Missile
IRR	Interim Requirements Review
ISE	Integrated Space Experiment
IST	Innovative Science and Technology
IS&T	Invite, Show, and Test
IWCD	Integrated Wavefront Control Demonstration
JCS	Joint Chiefs of Staff
JSTPS	Joint Strategic Target Planning Staff
KBSF	Knowledge Based Sensor Fusion
KDS	Kwajalein Discrimination System
KE	Kinetic Energy
KEW	Kinetic Energy Weapon(s)

KITE	KKV Integrated Technology Experiment
KKV	Kinetic Kill Vehicle
KMR	Kwajalein Missile Range
LACE	Laser Atmospheric Compensation Experiment
LAMP	Large Advanced Mirror Program
LANL	Los Alamos National Laboratory
LASE	LIDAR Acquisition and Sizing Experiment
LASERCOM	Laser Communications
LDS	Lexington Discrimination System
LEAP	Lightweight Exoatmospheric Advanced Projectile
LEO	Low Earth Orbit
LIDAR	Light Detection and Ranging
Linac	Linear Accelerator
LLNL	Lawrence Livermore National Laboratory
LNA	Low Noise Amplifier
LOC	Lines of Code
LODE	Laser Optics Demonstration Experiment
LPAR	Large Phased-Array Radar
LRINF	Longer-Range Intermediate Nuclear Forces
LSA	Logistics Support Analysis
LTH	Lethality and Target Hardening
LWIR	Long-Wavelength Infrared
MaRV	Maneuvering Reentry Vehicle
MCSS	Midcourse Sensor Study
MCTR	Missile Control Technology Regime
MFEL	Medical Free Electron Laser

MHD	Magneto-Hydrodynamics
MILSAT	Military Satellite
MIPS	Million Instructions Per Second
MIRV	Multiple Independently Targetable Reentry Vehicle
MODIL	Manufacturing, Operations, Development, and Integration Lab
MOSHED	Multiplanar Organic Scintillator High-Energy Detector
MOU	Memorandum of Understanding
MRBM	Medium-Range Ballistic Missile
MRDA	Mission Requirements and Definition Analysis
MS	Milestone
MT	Megaton
MV	Miniature Vehicle
MWIR	Medium Wavelength Infrared
NASA	National Aeronautics and Space Administration
NASP	National Aerospace Plane
NATO	North Atlantic Treaty Organization
NBS	National Bureau of Standards
NCA	National Command Authority
NCDCS	Narrow Band Coherent Data Collection System
NDEW	Nuclear Directed Energy Weapon
NDI	Non-Destructive Inspection
NHMT	Nuclear-Hardened Mosaic Technology
NMCC	National Military Command Center
NNK	Non-Nuclear Kill
NORAD	North American Aerospace Defense (Command)

NPB	Neutral Particle Beam
NPG	Nuclear Planning Group
NRL	Naval Research Laboratory
NSA	National Security Agency
NSDD	National Security Decision Directive
NSSC	National Space Surveillance Center
NTB	National Test Bed
NTF	National Test Facility
OAMP	Optical Airborne Measurements Program
OJCS	Organization of the Joint Chiefs of Staff
OMT	Other Military Targets
OSD	Office of the Secretary of Defense
OSDR	Office of the Secretary of Defense Research
OTH	Over-The-Horizon
OTO	Operational Test Organization
OUSDRE	Office of the Under Secretary of Defense for Research and Engineering
PACOSS	Passive and Active Controls of Space Structures
PAR	Phased-Array Radar
PATHS	Precursor Above the Horizon Sensor
PBV	Post-Boost Vehicle
PDR	Preliminary Design Review
PE	Program Element
PEO	Program Executive Officer
PFC	Prototype Flight Cryocooler
P3I	Preplanned Product Improvement
PIMS	Programmable Implantable Medication System

POM	Program Objective Memorandum
PPBS	Programming, Planning, and Budgeting System
RB	Reentry Body
RCS	Radar Cross Section
R&D	Research and Development
RDT&E	Research, Development, Test, and Evaluation
RF	Radio Frequency
RFP	Request for Proposal
RFQ	Radio Frequency Quadripole
RME	Relay Mirror Experiment
RTIM	Radar Technology Identification Methodology
RV	Reentry Vehicle
SA/BM	Systems Analysis/Battle Management
SALT	Strategic Arms Limitation Talks
SAM	Surface-to-Air Missile
SAMS	Space Assemblance and Maintenance Study
SAMTO	Space and Missile Test Organization (USAF)
SATKA	Surveillance, Acquisition, Tracking, and Kill Assessment
SBES	Space-Based Experimental System
SBI	Space-Based Interceptor
SBIR	Small Business Innovative Research
SBL	Space-Based Laser
SBNPB	Space-Based Neutral Particle Beam
SBNPBW	Space-Based Nuclear Particle Beam Weapon
SBPB	Space-Based Particle Beam

SBR	Space-Based Radar
SCP	System Concept Paper
SDC	Strategic Defense Command (USA)
SDI	Strategic Defense Initiative
SDIAE	SDI Acquisition Executive
SDIO	Strategic Defense Initiative Organization
SDR	System Design Review
SDS	Strategic Defense System
SEER	Sensor Experimental Evaluation and Review
SEO	Survivability Enhancement Option
SE&I	Systems Engineering and Integration
SIE	SATKA Integrated Experiments
SIOP	Single Integrated Operations Plan
SLBD	Sealite Beam Director
SLBM	Submarine Launched Ballistic Missile
SLKT	Survivability, Lethality, and Key Technologies
SMES	Superconducting Magnetic Energy Storage
SNF	Strategic Nuclear Forces
SOI	Silicon-on-Insulator
SOS	Silicon-on-Sapphire
SPACECOM	Space Command (USAF)
SPADATS	Space Detection and Tracking System
SPADOC	Space Defense Operations Center
SPAS	Space Power Architecture Study
SPEAR	Space Power Experiments Aboard Rockets
SPO	System Program Office

SPOCK	Special Purpose Operating Computer Kernel
SRBM	Short-Range Ballistic Missile
SRF	Strategic Rocket Forces
SRINF	Short-Range Intermediate Nuclear Forces
SRR	System Requirements Review
SRT	Strategic Red Team
SSBN	Ballistic Missile Submarine (Nuclear)
SSN	Ballistic Missile Submarine
SSPM	Solid-State Photomultiplier
SSTS	Space Surveillance and Tracking System
S&T	Science and Technology
STA	Significant Technical Accomplishments
STAS	Space Transportation Architecture Study
STM	Significant Technical Milestone
SWIR	Short Wave Infrared
TAD	Tactical Air Defense
TAIS	Technology Applications Information System
TBM	Theater Ballistic Missile
TCE	Three Color Experiment
TDSSPA	Technology Development for Solid State Phased Arrays
T&E	Test and Evaluation
TEMP	Test and Evaluation Master Plan
TEWG	Test and Evaluation Working Group
TIE	Technology Integration Experiment
TIR	Terminal Imaging Radar

TMD	Theater Missile Defense
TMDAS	Theater Missile Defense Architecture Studies
TOM	Threat Object Map
T/R	Transmit/Receive
TVE	Technology Validation Experiment
TW/AA	Tactical Warning/Attack Assessment
TWT	Traveling Wave Tube
USAAE	U.S. Army Acquisition Executive
USAKA	U.S. Army Kwajalein Atoll
UV	Ultraviolet
VHSI	Very High Speed Integrated
VLOS	Vertical Line of Sight
VLSI	Very Large Scale Integration
VLSIC	Very Large Scale Integrated Circuit
VUE	Visible Light/Ultraviolet Experiment
WSMR	White Sands Missile Range
XRL	X-Ray Laser
YESKD	(Soviet) Unified System of Design Documentation

THIS PAGE INTENTIONALLY LEFT BLANK

GLOSSARY

Acquisition - The process of searching for and detecting a potentially threatening object in space. An acquisition sensor is designed to search a large area of space and to distinguish potential targets from other objects against the background of space.

Algorithms - Rules and procedures for solving a problem.

Antiballistic Missile System - A missile system designed to intercept and destroy a strategic offensive ballistic missile or its reentry vehicles.

Antisatellite Weapon - A weapon designed to destroy satellites in space. The weapon may be launched from the ground or an aircraft or be based in space. The target may be destroyed by nuclear or conventional explosion, collision at high speed, or directed energy beam.

Architecture - Description of all functional activities to be performed to achieve the desired level of defense, the system elements needed to perform the functions, and the allocation of performance levels among those system elements.

Ballistic Missile - A remotely piloted vehicle propelled into space by rocket engines. Thrust is terminated at a predesignated time after which the missile's reentry vehicles are released and follow free-falling trajectories toward their ground targets under the influence of gravity. Much of a reentry vehicle's trajectory will be above the atmosphere.

Battle Management - Management system featuring assets to perform the computations to direct target selection and fire control, perform kill assessments, provide command and control, facilitate communication, and assist a variety of military users in the accurate determination of their positions.

Boost Phase - The first phase of a ballistic missile trajectory during which it is being powered by its engines. During this phase, which usually lasts 3 to 5 minutes for an ICBM, the missile reaches an altitude of about 200 km whereupon powered flight ends and the missile begins to dispense its reentry vehicles. The other phases of missile flight, including midcourse and reentry, take up to the remainder of an ICBM's flight time of 25 to 30 minutes.

Booster - The rocket that propels the payload to accelerate it from the earth's surface into a ballistic trajectory, during which no additional force is applied to the payload.

Brightness - The unit used to measure source intensity. To determine the amount of energy per unit area on a target, both source brightness and source-target separation distance must be specified.

Bus - Also referred to as a post-boost vehicle, it is the platform on which the warheads of a single missile are carried.

Carrier Vehicle - A space platform whose principal function is to house the space-based interceptors in a protective environment prior to use. It provides fire control solution, initiation of interceptor guidance systems, and launch commands, and supports and controls intercept.

Chaff - Strips of frequency-cut metal foil, wire, or metallized glass fiber used to reflect electromagnetic energy, usually dropped from an aircraft or expelled from shells or rockets as a radar countermeasure.

Chemical Laser - A laser in which a chemical action is used to produce pulses of intense light.

Communication - Communication between two or more ground sites, between satellites, or between a satellite and a ground site.

Decoy - A device constructed to simulate a nuclear-weapon-carrying warhead. The replica is less costly, much less massive, and can be deployed in large numbers to complicate efforts to read defense strategies.

Directed Energy - Energy in the form of atomic particles, pellets, or focused electromagnetic beams that can be sent long distances at, or nearly at, the speed of light.

Directed Energy Weapon - A weapon that employs a tightly focused and precisely directed beam of very intense energy, either in the form of light (a laser) or in the form of atomic particles traveling at velocities at or close to the speed of light (a particle beam weapon). (See also Laser and Particle Beam Weapon.)

Discrimination - The process of observing a set of attacking objects and differentiating between decoys or other non-threatening objects and actual threat objects.

Electromagnetic Gun - A gun in which the projectile is accelerated by electromagnetic forces rather than by an explosion as in a conventional gun.

Endoatmospheric - Within the earth's atmosphere, generally considered to be at altitudes below 100 km.

Engagement Time - The amount of time that a weapon platform takes to negate a given target. This includes not only firing at the target, but all other necessary weapon functions involved that are unique to that particular target.

Excimer Laser - A laser in which emission is stimulated when a gas is shocked with electrical energy and the excited medium emits light when returning to a ground state.

Exoatmospheric - Outside the earth's atmosphere, generally considered to be at altitudes above 100 km.

Fluence - The amount of energy per unit area on target. (It should be specified whether this is incident or absorbed fluence.)

Gamma Ray - Electromagnetic radiation resulting from nuclear transitions.

Hardening - Measures which may be employed to render military assets less vulnerable.

Hypervelocity Gun - A gun that can accelerate projectiles to 5 km per second or more; for example, an electromagnetic or rail gun.

Imaging - The process of identifying an object by obtaining a high-quality image of it.

Interception - The act of destroying a target.

Intercontinental Ballistic Missile - A land-based ballistic missile with a range of 3,000 to 8,000 nautical miles.

Intermediate-Range Ballistic Missile - A land-based ballistic missile with a range of 2,500 to 3,000 nautical miles. The range is less than that of an ICBM but greater than that of a short- or medium-range ballistic missile. Types of IRBMs currently deployed include the Soviet SS-20.

Kinetic Energy - The energy from the motion of an object.

Kinetic Energy Weapon - A weapon that uses a nonexplosive projectile moving at very high speed to destroy a target on impact. The projectile may include homing sensors and on-board rockets to improve its accuracy, or it may follow a preset trajectory (as with a shell launched from a gun).

Laser - (Light Amplification by the Stimulated Emission of Radiation) A device for producing an intense beam of coherent light. The beam of light is amplified when photons (quanta of light) strike excited atoms or molecules. These atoms or molecules are thereby stimulated to emit new photons (in a cascade or chain reaction) which have the same wavelength and are moving in phase and in the same direction as the original photon. A laser weapon may destroy a target by heating, melting, or vaporizing its surface.

Layered Defense - A defense that consists of several sets of weapons that operate at different phases in the trajectory of a ballistic missile. Thus, there could be a first layer (e.g., boost phase) of defense with remaining targets passed on to succeeding layers (e.g., midcourse, terminal).

Leakage - The percentage of warheads that get through a defensive system intact and operational.

Lethality - State of effectiveness of an amount of energy or other beam characteristic required to eliminate the military usefulness of enemy targets by causing serious degradation (mission kill) or destruction (observable kill) of a target system.

Midcourse Phase - That portion of the trajectory of a ballistic missile between the boost phase and the reentry phase. During this phase of the missile trajectory, the missile releases its warheads, and decoys and is no longer a single object, but a swarm of RVs, decoys, and debris falling freely along preset trajectories in space.

Multiple Independently Targetable Reentry Vehicle - A package of two or more reentry vehicles which can be carried by a single ballistic missile and guided to separate targets. MIRVed missiles employ a warhead-dispensing mechanism called a post-boost vehicle to target and release the warheads.

Neutral Particle Beam - An energetic beam of neutral atoms (no net electric charge). A particle accelerator accelerates the particles to nearly the speed of light.

Non-nuclear Kill - A kill that does not involve a nuclear detonation.

Particle Beam - A stream of atoms or subatomic particles (electrons, protons, or neutrons) accelerated to nearly the speed of light.

Particle Beam Weapon - A weapon that relies on the technology of particle accelerators (atom-smashers) to emit beams of charged or neutral particles which travel near the speed of light. Such a beam could theoretically destroy a target by several means, e.g., electronics upset, electronics damage, softening/melting of materials, sensor damage, and initiation of high explosives. (Stable propagation of particle beams in the atmosphere has never been demonstrated.)

Penetration Aid - A device, or group of devices, that accompanies a reentry vehicle during its flight to spoof or misdirect defenses and thereby allow the RV to reach its target.

Passive Sensor - A sensor that only detects radiation naturally emitted (infrared radiation) or reflected (sunlight) from a target.

Post-Boost Phase - The portion of a rocket trajectory following the boost phase and preceding the reentry phase.

Post-Boost Vehicle - The portion of a rocket payload that carries the multiple warheads and has maneuvering capability to place each warhead on its final trajectory to a target. (Also referred to as a "bus.")

Rail Gun - A weapon using electromagnetic launching to fire hypervelocity projectiles. Such projectile launchers will have very high muzzle velocities, thereby reducing the lead angle required to shoot down fast objects, lessening windage effects, and flattening trajectories in the atmosphere.

Reentry Vehicle - The part of a ballistic missile that carries the nuclear warhead to its target. The RV is designed to reenter the earth's atmosphere in the terminal portion of its trajectory and proceed to its target.

Responsive Threat - A threat which has been upgraded in quality or quantity or with added protective countermeasures in response to a projected capability of defeating (all or part of) the threat.

Sensor - A device for measuring some physically observable phenomenon.

Signature - The characteristic pattern of the target displayed by detection and identification equipment.

Surveillance - An observation procedure that includes tactical observations, strategic warning, and meteorological assessments, by optical, infrared, radar, and radiometric sensors on space-borne and terrestrial platforms.

Survivability - The capability of a system to avoid or withstand hostile environments without suffering irreversible impairment of its ability to accomplish its designated mission.

Terminal Phase - The final phase of a ballistic missile trajectory during which warheads and penetration aids reenter the atmosphere. This phase follows the end of the midcourse phase and continues until impact or arrival of the missile in the vicinity of the target.

Tracking and Pointing - Once a target is detected, it must be followed or "tracked." When the target is successfully tracked, a weapon is "pointed" at the target. Tracking and pointing are frequently integrated operations.

Vulnerability - The characteristics of a space system which cause it to suffer a definite degradation (reduced capability to perform the designated mission) as a result of having been subjected to hostile environments. Vulnerability usually addresses a single space-system segment or element thereof. Of particular interest is the lowest level at which degradation effects, if any, are acceptable.

THIS PAGE INTENTIONALLY LEFT BLANK

INDEX

INDEX

- ABE (Army Background Experiment), 4.3-22
- ABM Treaty, 1-3, 1-5, B-2, 2-1, 2-2, A-3, B-3—B-4
 - Agreed Statement D, C-2
 - allied research agreements, C-3
 - compliance process, C-2—C-3
 - components based on OPP, C-1—C-2
 - deployment of LPARs, 1-3
 - implications of no restrictions on SDI, G-1—G-10
 - provisions, C-1—C-2
 - research and development distinction, C-1
 - SDI compliance, C-1—C-4
- Abrahamson, Lt. Gen., A-2
- accidental launch, detecting of, F-19
- acquisition
 - definition, xxiv
 - test objectives, 5-1
- acquisition, tracking, and pointing (ATP)
 - ground-based lasers, technology issues, 4.3-15
 - program delays, 4.3-25
 - Starlab experiment, 4.3-9
 - technical issues, 4.3-11
 - for X-ray lasers and NDEW concepts, 4.3-27
- acquisition, tracking, pointing, and fire control (ATP-FC) technology
 - accomplishments, 4.3-23—4.3-24
 - funding cuts, 4.3-29
 - future plans, 4.3-24—4.3-25
 - project description, 4.3-22—4.3-23, 4.3-30
 - space relay technology development, 4.3-23, 4.3-24
 - technology base, 4.3-22—4.3-23
- Advanced Cruise Missile, G-7
- Advanced Cybernetic Technology, Inc., E-6
- Advanced Launch System (ALS), 4.4-25
 - concept definition study, 4.4-26
 - core engine development, 4.4-26—4.4-27
 - initial launch capability (ILC), 4.4-26
 - Technology Fair, 4.4-26
- Advanced On-board Signal Processor (AOSP), 4.1-5
- Advanced Technology Bomber, G-7
- Advanced Technology Validation (ATV), 4.2-8—4.2-9, 4.2-10
- advisory committees and panels, E-3—E-4
- aerospace industry, technology applications, E-7—E-8
- Aerospatiale (France), A-5
- air-breathing systems, G-7—G-8
- air defense
 - mission description, F-10
 - radar systems, F-10
 - Soviet network and organizational structure, 1-3, B-7—B-8
 - surveillance benefits from SDI, F-11
 - theater operations, benefits from SDI, F-11
- Air Defense Initiative (ADI), F-2, F-11
 - SDI spinbacks, F-3
- Air Force Office of Scientific Research, 4.5-2
- Airborne Laser Experiment (ALE), C-4, 4.1-13
- Airborne Optical Adjunct (AOA), 4.1-17—4.1-18, 4.1-26
 - illustration, 4.1-12
- Infrared Experiment, C-3
- program accomplishments, 4.1-11—4.1-12
- signal and data processors, 4.1-12—4.1-13
- Airborne Optical System (AOS), F-17
 - costs, F-18
 - functions, 2-5
- Airborne Warning and Control System (AWACS), F-10
- ALE. See Airborne Laser Experiment
- algorithms, definition, xxiv
- alliance relationships, 1-7, 2-1
 - antitactical missile projects, F-5
 - consultations, A-1—A-2
 - defense against shorter-range ballistic missiles, A-5—A-6
 - kinetic energy projects, 4.2-20—4.2-21
 - overview, A-1
 - participation in theater defenses, 3-19, F-7—F-8
 - programs, 1-4
 - research participation, C-3, A-2—A-5
- Allied Test Bed (ATB), 3-8
- Alpha hydrogen fluoride (HF) laser, 4.3-9
 - program accomplishments, 4.3-4—4.3-5
- ALS. See Advanced Launch System
- American Automobile Manufacturers Association, E-7
- Antiballistic Missile (ABM) Treaty. See ABM Treaty
- antiballistic missile system
 - definition, xxiv
 - Soviet Union, 1-3, B-2—B-4, G-5
- antiship missiles (ASMs), F-12
- antitactical ballistic missile (ATBM), A-5
- antitactical missile (ATM) defenses, A-5—A-6, F-5—F-8
- AOA. See Airborne Optical Adjunct
- AOS. See Airborne Optical System
- AOSP (Advanced On-board Signal Processor), 4.1-5

architecture concept, definition, xxiv, 3-7
 architecture studies
 BM/C3, 3-11, 3-12
 follow-on phases, 3-8
 United States and Israel, F-7
 United States and United Kingdom, F-6—F-7
 ARCJET tests, 4.2-11
 Argonne National Laboratory, 4.3-20
 ARIES II booster, 4.2-9
 arms control
 interpretation of agreements, C-2
 objectives of, 1-5
 arms control treaties, 1-7
 phased introduction of ballistic missile defense systems, 1-5—1-6
 Soviet noncompliance, 1-2, 1-3, 1-4
 U.S. monitoring issues, 1-4
 Army Background Experiment (ABE), 4.3-22
 Army Material Command, F-5
 Army Research Office, 4.5-2
 Army Strategic Defense Command, E-6
 Arrow missile (Israel), 4.2-21, 4.2-22
 ATB (Allied Test Bed), 3-8
 ATBM. See antitactical ballistic missile
 ATM. See antitactical missile
 atomic layer epitaxy, 4.5-2
 ATP. See Acquisition, Tracking, and Pointing
 ATP-FC. See Acquisition, Tracking, Pointing, and Fire Control technology
 ATV (Advanced Technology Validation), 4.2-8—4.2-9, 4.2-10
 Australia, A-1
 automotive industry, technology applications, E-7—E-8

 Balanced Technology Initiative (BTI), F-2, 4.5-4
 SDI spinbacks, F-3
 ballistic missile, definition, xxiv
 ballistic missile boosters, 4.3-2
 ballistic missile defense, 1-5—1-6
 deployment, implications for deterrence, G-6—G-8
 research projects, 4.5-1
 submarines, 1-2
 technological advances, 1-1
 weapons reduction objectives, 1-5
 ballistic missile defense, Soviet, 1-2, B-2—B-9
 ABM technologies, B-2—B-3
 advanced ABM technologies, B-4
 air defense, B-7—B-8
 computer and sensor technology, B-6—B-7
 detection and tracking radars, 1-3
 kinetic energy weapons, B-4
 laser weapons, B-4—B-5
 particle beam weapons, B-5
 passive defenses, B-8—B-9
 radio-frequency weapons, B-6
 submarines, 1-2
 ballistic missile submarine (nuclear), G-8
 Baseline Concept Description (BCD), 3-11, 3-12
 Battelle National Laboratory, 4.4-13
 battle management
 and air defense, F-11
 definition, xxiv
 ERIS project, 4.2-7
 SBI project, 4.2-2
 spin-offs for conventional forces, F-13—F-14
 Battle Management/Command and Control, and Communications. See BM/C3
 BCD (Baseline Concept Description), 3-11, 3-12
 BCS. See Beam Control System
 beam control concepts, 4.3-9
 directed energy weapons (DEW) technology research, 4.3-4
 Beam Control System (BCS), 4.3-16
 components, 4.3-19
 ground segment experiment, 4.3-15
 Beam Experiment Aboard Rocket (BEAR), 4.3-18, 4.3-19, 4.3-22, C-4
 BEAR. See Beam Experiment Aboard Rocket
 Belgium, research contracts, A-4
 bioglass applications for diabetics, E-5—E-6
 Biomedical Applications Panel, E-5
 BM/C3, 3-2, 4.1-11, 4.2-7, F-5
 Dem/Val phase, 3-4
 development schedule and confidence level, 3-11, 3-12
 Experimental Systems Project, 3-10—3-13
 Experimental Version (EV) plans, 3-13
 functions, 2-4
 funding impacts, 3-23
 support of theater architecture, F-6
 system responsibilities, 3-4
 Technology Project, 3-14—3-19
 testing and evaluation, 5-5—5-6
 BM/C3 Experimental Systems Project
 accomplishments, 3-12—3-13
 description, 3-10—3-11
 future plans, 3-13
 BM/C3 Technology Project
 accomplishments, 3-15—3-17
 Battle Management Algorithms task, 3-14, 3-15, 3-17—3-18
 Communications task, 3-15, 3-17
 description, 3-14—3-15
 future plans, 3-17—3-19
 Network Concepts task, 3-14, 3-16, 3-18
 Processors task, 3-14—3-15, 3-16, 3-18
 Software Engineering task, 3-15, 3-17, 3-19

boost phase. See also sensors for the boost phase
 definition, xxiv
 detection of ballistic missiles, 4.5-5
 and ground-based laser program, 4.3-14 – 4.3-15
 NPB intercept capability, 4.3-18
 and space-based lasers, 4.3-1
 TW/AA functions, F-17
 Boost Surveillance and Tracking System (BSTS), 4.1-2, F-17, F-18
 concept description, 3-2
 Dem/Val phase, 3-2 – 3-3, 4.1-2
 functions, 2-4
 measurement data collection and analysis, 4.1-3 – 4.1-4
 program schedule and confidence level, 4.1-9
 scanning and staring concepts, 4.1-2 – 4.1-3
 supporting technology, 4.1-4 – 4.1-8
 boosters, 4.2-2
 definition, xxiv
 disabling of, 2-4
 brightness, definition, xxiv
 Brillouin scattering, 4.3-9
 Brookhaven National Laboratory, 4.3-20, 4.4-13, 4.4-15, E-13
 Brown, Harold, C-1
 BSTS. See Boost Surveillance and Tracking System
 budget. See also funding
 impact of reductions, 2-5 – 2-7
 project list submission FY 1989, D-4
 requests vs. appropriations, 1985-1988, 2-6
 bus, definition, xxiv

 C3 Committee, F-5
 C3 survivability, F-17 – F-18
 CADE. See Combined Allied Defense Effort
 Canada, research contracts, A-4
 capacitors for space applications, 4.5-5
 Carlucci, U.S. Secretary of Defense, A-2
 carrier vehicle, definition, xxiv
 carrier vehicle (CV) sensors, 2-4
 CCB (Configuration Control Board), 3-21
 CDR (Concept Design Review), 4.4-26
 CDR (Critical Design Review), 4.1-4
 CDTI. See Concept Definition and Technology Integration (CDTI) Studies
 CDTI/Emerging Technologies
 accomplishments, 4.3-28
 future plans, 4.3-28 – 4.3-29
 project description, 4.3-26 – 4.3-28
 chaff, definition, xxiv
 Challenger, 4.3-25
 charged particle beams (CPBs), 4.3-26, 4.3-28

 DELPHI concept, 4.3-27
 CHECKMATE, 4.5-4
 chemical laser technology
 accomplishments, 4.3-4 – 4.3-9
 future plans, 4.3-9 – 4.3-11
 integration with space-based laser program, 4.3-9
 project description, 4.3-3 – 4.3-4
 chemical lasers, F-13
 definition, xxiv
 CIRRI IA, 4.1-19, C-4
 Civil Applications Committee, E-3
 civil defenses, Soviet, B-11
 Cobra Dane, 4.1-20
 Cobra Eye, 4.1-14
 Cobra Judy, 4.1-20
 Combined Allied Defense Effort (CADE), 4.2-20, F-9
 communications. See also BM/C3
 and air defense, F-11
 and conventional forces, F-13
 definition, xxv
 compliance process for SDI, C-2 – C-4
 computerization
 IST Office research, 4, 4.5-1, 5-2
 medical applications, E-6 – E-7
 Soviet Union technology, B-6 – B-7
 SPOCK supercomputer, E-6
 Concept Definition and Technology Integration (CDTI) Studies, 4.3-18, 4.3-26, 4.3-27 – 4.3-29.
 See also CDTI/Emerging Technologies
 Concept Design Review (CDR), 4.4-26
 confidence level
 definition, G-3
 implications of no ABM Treaty restrictions, G-3 – G-4
 Configuration Control Board (CCB), 3-21
 Congress, F-1, 1-5
 budget issues, 2-5, 2-7
 SDI annual report requirements, A-1
 technology transfer provisions, E-1
 Connection Machine, 3-16
 Consolidated Space Operations Center (CSOC), Falcon AFS, 3-9
 Continental U.S. (CONUS) readiness review, 4.1-22, F-10
 continuous wave (CW) laser lethality, 4.4-18
 Continuous Wave Deuterium Demonstrator (CWDD), 4.3-18, 4.3-22
 configuration, 4.3-18
 contracts, SDI research, A-3
 foreign firms, A-3, A-4 – A-5
 Glenn-AuCoin Amendment, A-3
 Quayle Amendment, A-4

CONUS. See Continental U.S. (CONUS)
 readiness review
 conventional forces, 1-7
 SDI technologies for, F-13 – F-14
 Conventional Systems Committee, F-5
 CoSyDe (France), A-5
 countermeasures
 analysis programs, B-15 – B-17
 Red-Blue Team analyses, B-15 – B-16
 Soviet, B-13, B-14 – B-15, B-16, B-17
 against Soviet co-orbital fragmentation
 interceptor, F-15
 space system survivability, F-16
 Countermeasures Program
 purpose of, B-15
 crisis stability concept, G-8 – G-9
 Critical Design Review (CDR), 4.1-4
 cryogenics, 4.1-7
 Space Surveillance and Tracking System,
 4.1-16, 4.1-19
 CWDD. See Continuous Wave Deuterium
 Demonstrator

 DAB. See Defense Acquisition Board
 DARPA. See Defense Advanced Research
 Projects Agency
 DASO (Demonstration and Shakedown
 Operation), 4.2-19 – 4.2-20
 data collection and processing
 boost phase sensors, 4.1-3 – 4.1-4
 late midcourse/terminal sensors, 4.1-21
 midcourse phase sensors, 4.1-14
 technology spin-offs, E-5
 DCDS (Distributed Computer Design System),
 3-15
 decoys, F-17
 definition, xxv
 Defense Acquisition Board (DAB), 2-3, 3-3, F-4,
 4.2-4, 4.4-26
 Dem/Val phase recommendation, 3-1
 Defense Advanced Research Projects Agency
 (DARPA), 3-17
 Strategic Computing Program, 3-16, 3-19
 defense against tactical missiles. See
 antitactical missile (ATM) defenses
 Defense and Space Talks (Geneva), A-1, A-2
 Defense Authorization Act, FY 1987, Section
 217, G-1
 Defense Authorization Act, FY 1988, Section
 233, F-1, G-i – G-iii
 Defense Logistics Agency, E-2
 Defense Nuclear Agency, 4.1-24, 4.5-2
 Defense Planning Committee (NATO), A-2
 Defense Resources Board (DRB), F-1
 Defense Science Board (DSB), F-4

 defense suppression threat (DST), 4.4-1, 4.4-3,
 4.4-6
 scenarios, 4.4-4 – 4.4-5
 DELPHI concept, 4.3-27
 Delta 180/181, 4.1-19, 4.2-4, 4.2-20, 4.3-25, 5-2
 Dem/Val
 compliance with ABM Treaty, 2-2
 Defense Acquisition Board recommendation,
 3-1
 management approach to, 3-1
 purpose of, 2-3, 3-2
 of SDS Phase 1, 3-2
 Test and Evaluation strategy objectives, 5-1
 Demonstration and Shakedown Operation
 (DASO), 4.2-19 – 4.2-20
 demonstration and validation. See Dem/Val
 Department of Agriculture, E-9
 Department of Defense Appropriations Act
 Bayh Amendment to FY 1973, A-3
 Department of Defense (DOD), E-1, 2-3, 4.4-25,
 4.5-2
 Directive 5100.70, C-2
 Directive 5230.25, E-2
 Instruction S-5100.72, C-3
 technology responsibilities, 4.3-27, 4.3-28
 test resources, 5-7
 Department of Energy (DOE), 4.4-22, 4.5-2
 power concept development efforts, 4.4-20
 SMES system program, E-8
 technology responsibilities, 4.3-27, 4.3-28
 Department of Transportation (DOT), E-9
 deployment phase, 5-1
 deployment schedule and ABM Treaty, G-2
 Deputy for Programs and Systems, 3-2
 deterrence with no ABM Treaty restrictions,
 G-6 – G-8
 DEWs. See directed energy weapons
 diamond crystal coating technology
 applications, E-6
 diamond epitaxy, 4.5-2, 4.5-5
 Diamond Technology Initiative Program, E-6
 diamond-turned beam capacitor, 4.3-4, 4.3-5
 directed energy, 2-3, 4.3-2, 4.3-26, 4.5-1
 definition, xxv
 summary of programs, 4.3-29 – 4.3-30
 technology spin-offs, E-5
 Directed Energy Weapons (DEW) Technology
 Program, 4.3 – 4.3-30
 acquisition, tracking, pointing, and fire control
 technology, 4.3-22 – 4.3-25
 CDTI/emerging technologies, 4.3-26 – 4.3-29
 chemical laser technology, 4.3-3 – 4.3-11
 free electron laser (FEL) technology,
 4.3-11 – 4.3-16
 funding impacts, 4.3-29

MIRACL/SKYLITE program, 4.3-25 – 4.3-26
 neutral particle beam (NPB) technology program, 4.3-17 – 4.3-22
 program overview, 4.3-1 – 4.3-3
 technical objectives, 4.3-3 – 4.3-29
 directed energy weapons (DEWs), 4.1-2, 4.4-13
 definition, xxv
 Soviet capabilities, B-5
 Director, Operational Test and Evaluation (DOT&E), 5-3
 discrimination, definition, xxv
 Distributed Computer Design System (DCDS), 3-15
 DOD. See Department of Defense
 DOE. See Department of Energy
 domestic applications of technology. See spin-offs
 DOT&E (Director, Operational Test and Evaluation), 5-3
 DRB Implementation Review Group, F-1 – F-2
 DST. See defense suppression threat

Edwards AFB, 4.2-6
 Electric Power Research Institute (EPRI), 4.4-22, E-8
 electro-optics, technology spin-offs, E-5
 electromagnetic gun, 4.5-5, F-13
 definition, xxv
 U.K. technology, 4.2-21
 electromagnetic launcher (EML), 2-7, 4.2-18, 4.5-4, F-14
 CHECKMATE facility, 4.5-4
 technology, A-4 – A-5
 THUNDERBOLT program, 4.5-4 – 4.5-5
 Electron Propagation On Channels (EPOCH) facility, 4.3-28
 electronics materials research, 4.5-2
 ELSI. See Enhanced Longwave Spectrometer/Imager
 EML. See electromagnetic launcher
 encryption use, Soviet Union, 1-4
 endoatmospheric, definition, xxv
 engagement time, definition, xxv
 Enhanced Longwave Spectrometer/Imager (ELSI), 4.1-24
 ENSS. See Experimental Network Surveillance System
 entomology, technology applications, E-9
 Environmental Impact Statement (EIS) for Kwajalein Atoll, 3-7 – 3-8
 EPOCH (Electron Propagation On Channels) facility, 4.3-28
 ERINT (Extended Range Interceptor), 4.2-20, 4.2-21, F-9
 ERIS. See Exoatmospheric Reentry Vehicle Interceptor System
 European Space Tribology Laboratory, 4.4-29
 evaluation programs. See Test and Evaluation Program
 Excede, C-4
 excimer lasers, 4.3-26 – 4.3-27, 4.3-28, F-13
 definition, xxv
 exoatmospheric, definition, xxv
 exoatmospheric pop-up antenna (Italy), 4.2-21
 Exoatmospheric Reentry Vehicle Interceptor System (ERIS), 4.1-9, 4.1-11, 4.1-22, 4.3-2, 4.4-34
 accomplishments, 4.2-7 – 4.2-8
 Dem/Val, 3-4, 4.2-8 – 4.2-10
 functional test vehicle (FTV) program, 4.2-7, 4.2-8
 functions, 2-4, 4.2-7
 funding impacts, 4.2-23
 future plans, 4.2 – 4.2-10
 project description, 3-4, 4.2-7
 system confidence, 4.2-9
 technology developments, 4.2-7, 4.2-8
 tests, 4.2-7 – 4.2-8
 Experimental Network Surveillance System (ENSS), 4.1-24
 experimental versions (EVs), 3-13
 experiments
 Airborne Laser Experiment (ALE), C-4, 4.1-13
 Airborne Optical Adjunct (AOA), 4.1-11 – 4.1-13, 4.1-17 – 4.1-18, C-3
 CIRRI IA, C-4, 4.1-19
 Delta, 4.1-19
 Infrared Background Signature Survey, 4.1-19
 JANUS, C-3
 Kinetic Kill Vehicle Integrated Technology Experiment (KITE), C-3
 Laser Atmospheric Compensation Experiment (LACE), C-3
 LOD/LAMP/chemical laser ground-based, C-3
 Optical Aircraft Measurement Program, C-4, 4.1-14, 4.1-26
 Relay Mirror Experiment (RME), C-3, 4.3-15, 4.3-22, 4.3-25
 SATKA Integrated Experiments, C-3, 4.1-24 – 4.1-25, 5-2
 SKYLITE test program, C-3
 Spirit, C-4, 4.1-13, 4.1-19
 Extended Air Defense Test Bed (EADTB) Program, F-8 – F-9
 Extended Range Interceptor (ERINT), 4.2-20, 4.2-21, F-9
 Federal Applications Committee, E-3

Federal Aviation Administration, E-10
 Federal Laboratory Consortium, E-11
 Federal Republic of Germany, A-2
 research contracts, A-4
 SDI research, C-3
 Federally Funded Research and Development Centers (FFRDCs), 3-5
 FEL. See free electron laser technology
 Field of View (FOV), 4.3-25
 field of view (FOV) antennas, 4.1-22
 Fire Control Test Bed, 4.3-24
 Firepond Radar, 4.1-13
 FLAGE (Flexible Lightweight Agile Guided Experiment), 4.2-20, 4.2-21
 FLAT TWIN radars, G-5
 Fletcher Study, 4-1
 Flexible Lightweight Agile Guided Experiment (FLAGE), 4.2-20, 4.2-21
 flight tests of ERIS, 3-4
 fluence, definition, xxv
 Focal Plane Array (FPA), 4.1-5—4.1-6, 4.1-7
 for the Airborne Optical Adjunct, 4.1-12, 4.1-18
 follow-on phases. See SDS follow-on phases
 Follow-on T&E (FOT&E), 5-6
 food irradiation program, E-8
 FOT&E (Follow-on T&E), 5-6
 FOV (Field of View), 4.3-25
 FPA. See Focal Plane Array
 France, 1-4
 research contracts, A-4
 free electron laser (FEL) technology, 4.3-30, F-13
 accomplishments, 4.3-12—4.3-14
 beam generators for space basing, 4.3-11
 future plans, 4.3-14—4.3-16
 project description, 4.3-11—4.3-12
 FSD. See full-scale development
 full-scale development (FSD), 2-3, 2-4, 5-1
 effect of no ABM Treaty restrictions, G-2
 ground-based laser technology for, 4.3-11—4.3-12
 Phase 1 SDS, 2-2, 2-3
 system survivability, 4.4-6
 testing, 5-6
 functional test vehicle (FTV) program, 4.2-7, 4.2-8, 4.2-9
 funding. See also budget
 ATP-FC technology, 4.3-29
 directed energy weapons technology, 4.3-29
 Ground Test Accelerator, 4.3-29
 impact of budget reductions, 2-5—2-7
 implications for schedule, G-3
 Innovative Science and Technology Office, 4.3-26, 4.5-1
 KEW program, 4.2-23
 neutral particle beam (NPB) technology, 4.3-29
 programs and projects, D-3—D-4, 3-23
 SATKA programs, 4.1-25—4.1-26
 Soviet economic constraints, B-12—B-14
 Space-Based Surveillance and Tracking System (SSTS) program, 2-7, 4.1-25—4.1-26
 Theatre Missile Defense Program, A-5

 gain generator assembly, 4.3-5, 4.3-6
 Gallium Arsenide, E-7
 GALOSH, B-2, G-5, B-11, F-14
 gamma ray, definition, xxv
 GAZELLE high-acceleration endoatmospheric interceptors, B-2, G-5
 GBFEL (Ground-Based Free Electron Laser), C-4, 4.3-12, 4.4-22
 GBFEL TIE (Ground-Based Free Electron Laser Technology Integration Experiment), 4.3-15, 4.3-25, 4.3-29
 GBL. See ground-based laser
 GBMI (Ground-Based Midcourse Interceptor), B-15
 GBR. See ground-based radar
 GBR-X. See Ground-Based Radar Experiment (GBR-X)
 Generic VHSIC Spaceborne Computer (GVSC) project, 4.1-4—4.1-5
 Georgia Technology Research Institute (GTHR), E-6
 GES. See SP-100 Ground Engineering System
 Glenn-AuCoin Amendment, A-3
 Gorbachev, Soviet General Secretary, 3-19, B-12, B-13
 Great Britain. See United Kingdom
 Grechko, Marshall, C-2
 Ground-Based Free Electron Laser (GBFEL), C-4, 4.3-12, 4.4-22
 Ground-Based Free Electron Laser Technology Integration Experiment (GBFEL TIE), 4.3-15, 4.3-25, 4.3-29
 ground-based laser (GBL), 4.3-9
 acquisition, tracking, and pointing capability, 4.3-2—4.3-3
 concept description, 4.3-2
 confidence, 4.3-16
 Dem/Val phase, 4.3-15, 4.3-30
 excimer laser technology, 4.3-26—4.3-27
 and FEL technology, 4.3-11—4.3-16
 functions, 2-5
 risk reduction and supporting technology, 4.3-15
 Soviet Union, B-5
 space structures, 4.4-31

Ground-Based Midcourse Interceptor (GBMI), B-15
 Ground-Based Radar Experiment (GBR-X), 4.19–4.1-20, 4.1-22–4.1-23, C-4
 costs, F-18
 Dem/Val, 4.1-22–4.1-23
 discrimination and electronic countermeasures, 4.1-22–4.1-23
 system confidence, 4.1-23
 ground-based radar (GBR), 3-3
 functions, 2-5
 GBR-X. See Ground-Based Radar Experiment (GBR-X)
 for midcourse discrimination, 4.1-11
 midcourse phase support, 4.1-8
 objectives in midcourse/terminal phases, 4.1-19
 proposed technology enhancements, 4.1-23
 Soviet Union, G-5

 Ground-Based Surveillance and Tracking Systems (GSTS), C-4, 3-3, 4.1-8, F-17
 functions, 2-4, 4.1-11
 interactions with other SDS elements, 4.1-11
 surveillance role, 4.1-11
 system confidence, 4.1-18
 technical validation experiment, 4.1-17, 4.1-26
 Ground Power Study (GPS), 4.4-35
 Ground Test Accelerator (GTA), 4.3-18, 4.3-19, 4.3-21, 4.3-22
 design philosophy, 4.3-18
 funding implications, 4.3-29
 ground tests
 of ERIS, 3-4
 for evaluation, 5-1
 for High Endoatmospheric Defense Interceptor (HEDI), 4.2-12
 of SBI components, 4.2-6
 GSTS. See Ground-Based Surveillance and Tracking Systems
 GTA. See Ground Test Accelerator
 GVSC. See Generic VHSIC Spaceborne Computer project

 hardening, definition, xxv
 HAVE JEEP VII program, 4.1-14
 Hawk, F-10
 HEDI. See High Endoatmospheric Defense Interceptor
 HEL (high-energy laser) system, 4.3-25
 HELSTF (High-Energy Laser Systems Test Facility), 4.4-13, 4.4-16
 HEN HOUSE radars, B-2
 HICAMP, 4.3-24
 high-brightness electron beams, 4.3-13

 High Endoatmospheric Defense Interceptor (HEDI), C-3, 4.1-11, 4.4-18
 accomplishments, 4.2-10–4.2-11
 Dem/Val flights, 4.2-13
 functions, 2-5, 4.2-10
 funding impacts, 4.2-23
 future plans, 4.2-11–4.2-13
 project description, 4.2-10
 spin-offs for maritime operations, F-12
 system confidence, 4.2-12
 technology issues, 4.2-11
 tests, 4.2-10–4.2-11
 High Endoatmospheric Defense System (HEDS), B-15
 high-energy laser (HEL) system, 4.3-25
 High-Energy Laser Systems Test Facility (HELSTF), 4.4-13, 4.4-16
 High Temperature Superconducting (HTS) project, 4.4-29, 4.4-34
 highway bridges, technology applications, E-9
 Holloman AFB, New Mexico, 4.2-12
 hover test capability of SBI, 4.2-6
 Hughes Aircraft Company (United States), A-6
 HVG. See hypervelocity gun
 Hybrids With Advanced Yield for Surveillance (HYWAYS) project, 4.1-15, 4.1-18
 hydrogen fluoride (HF) chemical laser, 4.3-3
 hypervelocity gun (HVG), 4.2-14–4.2-17, 4.2-18, F-12
 definition, xxv
 demonstration (Israel), 4.2-21
 functions, 2-5
 funding impacts, 4.2-23
 research program (U.S.-Netherlands), 4.2-21
 hypervelocity weapons, spin-offs for conventional forces, F-13, F-14
 HYWAYS. See Hybrids With Advanced Yield for Surveillance

 IBSS. See Infrared Background Signature Survey
 ICBMs. See intercontinental ballistic missiles
 ID. See interactive discrimination
 IED (intrinsic event discrimination) concept, 4.1-15
 imaging, definition, xxv
 induction linac free electron laser, 4.3-12, 4.3-13
 industry, NPB technology spin-offs, E-9–E-11
 INF Treaty, 3-19, F-5
 Infrared Background Signature Survey (IBSS), 4.1-4, 4.1-19, C-4
 Innovative Science and Technology (IST) Office, 4-1
 accomplishments, 4.5-2–4.5-4
 future plans, 4.5-4–4.5-5

program funding, 4.3-26, 4.5-1
 program overview, 4.5-1
 research program management, 4.5-1 – 4.5-2
 technical objectives, 4.5-1 – 4.5-2
 Integrated Space Experiment, E-9
 Integrated Space Experiment (ISE), 4.3-29
 Integrated Technology Validation (ITV), 4.2-9, 4.2-10
 integration testing, 5-2
 interactive discrimination (ID)
 ground-based laser potential, 4.3-11
 NPB technology, 4.3-17, 4.3-18
 space-based lasers, 4.3-1 – 4.3-2
 interception, definition, xxv
 intercontinental ballistic missiles (ICBMs), 1-2, 3-2, 3-19
 boost-phase intercept of, 3-12, 4, 4.3-11
 definition, xxv
 midcourse phase intercepts, 4.2-7, 4.2-10
 sensor detection, 4.1-2
 Soviet capability, 1-2, 1-3, G-5
 intermediate-range ballistic missiles, F-6
 definition, xxvi
 Intermediate-Range Nuclear Forces (INF) Treaty, 3-19, F-5
 Intrinsic Event Discrimination (IED) concept, 4.1-15
 Invite, Show, and Test (IS&T), 3-21, 4.2-20, 4.4-16, F-9 – F-10
 ion source technology, 4.3-19
 ISE (Integrated Space Experiment), 4.3-29
 Israel, 4.2-21, A-1, A-2, A-5
 architecture study, F-7
 research contracts, A-4, A-5
 SDI research, C-3
 IST. See Innovative Science and Technology (IST) Office
 IS&T. See Invite, Show, and Test
 Italy, 4.2-21, A-2
 research contracts, A-4
 SDI research, C-3
 JANUS missions, 4.2-20, C-3
 funding impacts, 4.2-23
 Japan, A-1, A-2
 SDI research, C-3
 JCS. See Joint Chiefs of Staff
 Johns Hopkins University Applied Physics Laboratory, E-6
 Joint Chiefs of Staff (JCS), 3-21, 3-22, 4.2-2, 4.4-1, C-2
 operational requirements, Phase I SDS, 1-9
 Joint Operational Requirements and Operational Concepts, 5-7
 Joint SDI-Defense Technology Applications Initiative, F-2, F-4 – F-5
 formation and responsibilities of panel, F-4 – F-5
 membership, F-2
 Joint SDI-Defense Technology Applications initiative
 plan description, F-2, F-4 – F-5
 Joint Strategic Target Planning Staff (JSTPS), 3-22
 JSTPS (Joint Strategic Target Planning Staff), 3-22

 KDS. See Kwajalein Discrimination System
 KEW. See Kinetic Energy Weapons (KEW) Technology Program
 kill assessment, 2-4, 4.2-2, 4.2-7
 kill vehicle, 4.2-10
 kinetic energy, 4.5-1
 definition, xxvi
 technology spin-offs, E-5
 Kinetic Energy Weapons (KEW) Technology Program, 2-7, 4.2-1 – 4.2-24, 4.4-16
 Exoatmospheric Reentry Vehicle Interceptor System (ERIS), 4.2-7 – 4.2-10
 flight tests, 4.4-16
 funding impacts, 4.2-23
 High Endoatmospheric Defense Interceptor (HEDI), 4.2-10 – 4.2-13
 miniature projectiles, 4.2-13 – 4.2-18
 objectives, 4.2-1
 program overview, 4.2-1
 space-based interceptor (SBI), 4.2-2 – 4.2-6
 support project, 4.2-22 – 4.2-23
 technical objectives, 4.2-1 – 4.2-2
 technology support area, 4.2-20 – 4.2-22
 test and evaluation (T&E) effort, 4.2-18 – 4.2-20
 kinetic energy weapons (KEWs), 4.2-7, 4.4-13
 ABM Treaty provisions, G-2
 and air defense, F-11
 definition, xxvi
 Soviet Union, B-4
 Kinetic Kill Vehicle Integrated Technology Experiment (KITE), C-3, 4.2-12, 4.2-13
 kinetic kill vehicle (KKV), 2-7, 4.2-4
 kinetic shield designs, 4.4-5, 4.4-6
 KITE. See Kinetic Kill Vehicle Integrated Technology Experiment
 Knowledge Based Sensor Fusion system, 4.1-24
 Krasnoyarsk, Siberia, 1-3, B-3
 Kwajalein Atoll, 3-8, 4.1-14
 Kwajalein Discrimination System (KDS), 4.1-20 – 4.1-21
 Kwajalein Imaging System, 4.1-13

LACE (Laser Atmospheric Compensation Experiment), C-3, 4.3-16, 4.3-22, 4.3-25
 lidar, definition, xxvi
 LADD (Lens Antenna Deployment Demonstration), 4.1-14
 Laird, Melvin, C-2
 LAMP (Large Advanced Mirror Program), 3-5, 4, 4.3-4, C-3
 LANL. See Los Alamos National Laboratory
 Large Advanced Mirror Program (LAMP), 3-5, 4, 4.3-4, C-3
 Large Optics Demonstration Experiment (LODE), 4.3-4, C-3
 laboratory model tests, 4.3-7
 large phased-array radar (LPAR)
 Soviet Union, 1-3, B-2, B-3, G-5
 LASE. See LIDAR Acquisition and Sizing Experiment
 laser, definition, xxvi
 Laser Atmospheric Compensation Experiment (LACE), 4.3-16, 4.3-22, 4.3-25, C-3
 Laser Interferometer Detection and Ranging (LIDAR), 4.1-24
 laser radars, 4.1-11, 4.1-13, 4.1-16–4.1-17
 laser technology for maritime operations, F-13
 laser weapons
 Soviet Union, B-4–B-5
 for space defense, F-15
 launch requirements, analysis, 4.4-25
 launches, detection of, 2-4, 3-2
 Lawrence Livermore National Laboratory (LLNL), 4.3-20
 Advanced Test Accelerator, 4.3-12
 food irradiation program, E-8
 induction linac FEL experiments, 4.3-12
 layered defense, definition, xxvi
 LDS. See Lexington Discrimination System
 leakage, definition, xxvi
 legislation on allied participation, A-3
 Lens Antenna Deployment Demonstration (LADD), 4.1-14
 lethality, definition, xxvi
 Lethality and Target Hardening (LTH) project
 accomplishments, 4.4-13–4.4-15
 experiments and tests, 4.4-12–4.4-18
 funding impacts, 4.4-35
 future plans, 4.4-15–4.4-18
 high irradiance (Hi-I) testing, 4.4-15, 4.4-17
 lethality assessment document, 4.4-15
 objective, 4.4-2
 particle beam lethality, 4.4-18
 project description, 4.4-12–4.4-13
 Lexington Discrimination System (LDS), 4.1-20–4.1-21
 LIDAR Acquisition and Sizing Experiment (LASE), 4.1-24
 LIDAR (Laser Interferometer Detection and Ranging), 4.1-24
 Lightweight Exoatmospheric Advanced Projectile (LEAP), 4.2-6, 4.2-15, 4.2-16
 functions, 4.2-13
 projectile overview, 4.2-14, 4.2-17
 Limited Test Ban Treaty, 4.1-24
 Lincoln Laboratory, 4.3-14
 LOD. See Large Optics Demonstration Experiment
 lode beam expander, 4.3-4
 Logistics Support Analysis (LSA), 3-8
 Long-Wavelength Infrared (LWIR) sensors, 3-3, 4.1-11, 4.1-12
 Los Alamos National Laboratory (LANL), 4.3-14, 4.3-21
 Accelerator Test Stand, 4.3-19–4.3-20
 LPAR. See large phased-array radar
 LTV Corporation (United States), A-6
 LWIR sensors, 3-3, 4.1-11, 4.1-12

 manufacturing industry, technology spin-offs, E-5
 Manufacturing Operations Development and Integration Laboratory (MODIL), 3-7, 3-8
 maritime operations
 mission description, F-12
 surveillance, benefits from SDI, F-12
 Massachusetts Institute of Technology, Lincoln Laboratory Firepond facility, 4.1-17
 materials and structures
 high temperature superconducting materials, 4.4-34
 kinetic shield designs, 4.4-5–4.4-6
 large area, small device, and HTS components, 4.4-33
 lightweight materials for interceptor structures, 4.4-34
 for space applications, 4.5-1, 4.5-4
 technology spin-offs, E-5
 thermoplastic composites, 4.4-29
 tribomaterials, 4.4-33, 4.4-34
 Materials and Structures (M&S) project
 accomplishments, 4.4-28–4.4-29
 Dem/Val, 4.4-3
 demonstrations and experiments, 4.4-33
 funding impacts, 4.4-36
 future plans, 4.4-29–4.4-35
 objective, 4.4-2–4.4-3
 project confidence, 4.4-31, 4.4-32
 project description, 4.4-27–4.4-28
 technology issues, 4.4-27–4.4-28
 Mayo Clinic, E-7

MCSS. See Midcourse Sensor Study
 Medical Free Electron Laser program,
 E-13–E-14
 accomplishments, E-13–E-14
 research scope, E-13
 medicine
 cancer therapy applications, E-10
 computer applications in, E-6–E-7
 eye surgery, technology spin-offs, E-7
 Medical Free Electron Laser program,
 E-13–E-14
 radioisotopes for diagnoses, E9–E-10
 Memorandum of Understanding (MOU), A-1
 allied research, C-3, A-2–A-3
 technology sharing, F-5
 Memorandums of Agreement
 ATM program, F-5
 Messerschmitt-Boelkow-Blohm (Federal
 Republic of Germany), A-5
 MFEL. See Medical Free Electron Laser
 program
 microwave radars, 4.1-11, 4.1-14,
 4.1-16–4.1-17
 Mid East Architecture Study, F-7
 Mid Infrared Advanced Chemical Laser
 (MIRACL), 4.3-4, 4.3-29, 4.4-15
 accomplishments, 4.3-26
 future plans, 4.3-26
 project description, 4.3-25–4.3-26
 midcourse phase. See also sensors for the
 midcourse phase
 definition, xxvi
 GBL potential for interactive discrimination,
 4.3-11
 NPB systems, 4.3-17
 space-based particle beams, discrimination
 function, 4.3-2
 surveillance support, 4.3-3
 TW/AA functions, F-17
 Midcourse Sensor Study (MCSS), 3-3, 4.1-9,
 4.1-17, 4.1-22
 Milestone 1 (MS-1), 2-3, 3-7
 Directed Energy Weapons (DEW) Technology,
 4.3-29
 Milestone 11 (MS-11), 2-3, 3-23, 5-6
 Milestone Zero Review, 4.4-26
 Militarily Critical Technical Data Agreement, E-2
 Militarily Critical Technologies List (MCTL), F-4
 Military Airlift Command Air Weather Service,
 3-22
 military applications (other than SDI), F-1–F-19
 military missions, 1-6
 for strategic defense, 1-8
 Million Instructions Per Second (MIPS)
 program, E-7
 miniature projectile technology
 accomplishments, 4.2-15–4.2-16
 future plans, 4.2-16–4.2-18
 ground-based projectiles, 4.2-13
 project description, 4.2-13–4.2-15
 space-based projectiles, 4.2-13
 technology issues, 4.2-16–4.2-17
 tests, 4.2-17–4.2-18
 MIRACL. See Mid Infrared Advanced Chemical
 Laser
 MIRACL/SKYLITE program, 4.3-25–4.3-26,
 4.3-29
 Missile Technology Control Regime (MTCR),
 3-19
 MODIL. See Manufacturing Operations
 Development and Integration Laboratory
 MOSAIC Advanced Signal Processor, 3-17
 MOU. See Memorandum of Understanding
 multiple independently targetable reentry
 vehicle, definition, xxvi
 Narrow Band Coherent Data Collection System,
 4.1-24
 NASA. See National Aeronautics and Space
 Administration
 National Aeronautics and Space Administration
 (NASA), E-1, 4.4-25, 4.5-2
 Jet Propulsion Lab, 3-16
 Spacelab, 4.3-25
 National Bureau of Standards (NBS), Maryland,
 E-13
 National Cancer Institute, 4.3-21
 National Command Authority, F-17
 National Defense Authorization Act of FY
 1988-1989, C-1
 National Defense Authorization Act of FY 1987,
 E-1
 National Test Bed (NTB), 4.4-12, 5-5–5-6
 components, 5-5
 software/hardware testing, 4.4-10
 National Test Bed (NTB) Directorate
 accomplishments, 3-9
 funding impacts, 3-23
 future plans, 3-9–3-10
 project description, 3-8–3-9
 National Test Facility (NTF), 3-9, 4.1-24, 5-5
 National Tribology Centre (U.K.), 4.4-29
 NATO. See North Atlantic Treaty Organization
 Naval Research Laboratory (NRL), 4.4-13
 Naval Surface Weapons Center, 4.2-12
 NDEWs. See nuclear directed energy weapons
 NDI (Non-destructive Inspection technology),
 E-10
 Near-Term Systems Integration Test/Evaluation
 (NSITE) program, 3-6

Netherlands, 4.2-21
 research contracts, A-4
 Netherlands Organization for Applied Scientific Research, A-4 – A-5, F-14
 neutral particle beam (NPB), definition, xxvi
 neutral particle beam (NPB) technology, 4.4-18
 accomplishments, 4.3-19 – 4.3-21
 civilian applications, 4.3-21
 functional schematic of, 4.3-17
 funding cuts, 4.3-29
 future plans, 4.3-21 – 4.3-22
 NPB confidence, 4.3-20
 program issues, 4.3-12
 project description, 4.3-1 – 4.3-19
 space structures, 4.4-31
 spin-offs, E-9 – E-11
 system demonstrator, 4.4-22
 Nevada Test Site, 4.3-27
 New York State Science and Technology Foundation, E-11
 Non-destructive Inspection (NDI) technology, E-10
 non-nuclear kill, definition, xxvi
 NORAD (North American Aerospace Defense Command), F-15
 North American Aerospace Defense Command (NORAD), F-15
 North American Warning system, F-10
 North Atlantic Treaty Organization (NATO), A-1, 3-19, 3-20, F-5, F-10
 antitactical missile defenses, A-5
 Defense Planning Committee meetings, A-2
 North Atlantic Council meetings, A-2
 Nuclear Planning Group (NPG) meetings, A-2
 NPB. See neutral particle beam (NPB)
 technology
 NTF. See National Test Facility
 nuclear directed energy weapons (NDEWs), 4.3-26, 4.3-27, 4.3-28
 Soviet Union research, 4.3-2
 Nuclear Hardened Mosaic Technology project, 4.1-15
 Nuclear Planning Group (NPG) (NATO), A-2
 nuclear waste disposal, technology spin-offs, E-11

 Oak Ridge National Laboratory, 3-8, E-9
 OAMP. See Optical Airborne Measurements Program
 Office for Programs and Systems, 3-1 – 3-23
 BM/C3 program, 3-10 – 3-19
 National Test Bed Directorate, 3-8 – 3-10
 Operations Interface Directorate, 3-21 – 3-23
 SDS Engineering and Support Directorate, 3-6 – 3-8
 SDS Phase I Engineering Project Directorate, 3-2 – 3-5
 Theater Defense Directorate, 3-19 – 3-21
 Office of Naval Research, 4.5-2
 Office of the Joint Chiefs of Staff (OJCS), 3-22
 TEWG membership, 5-3
 Office of the Secretary of Defense, 5-6
 Operational Test Organization (OTO), 5-3, 5-6, 5-8
 Operations Interface Directorate
 accomplishments, 3-22
 functions, 3-21 – 3-22
 future plans, 3-22 – 3-23
 project description, 3-21 – 3-22
 Optical Airborne Measurement Program (OAMP), 4.1-14, 4.1-26, C-4
 optics research and technology, 4.3-3 – 4.3-4
 Be-on-Be program, 4.1-6
 benefits to maritime operations, F-12
 for boost phase sensors, 4.1-6, 4.1-7
 for midcourse phase sensors, 4.1-16, 4.1-18
 for radio-frequency FELs, 4.3-14
 replica mirror process, 4.1-6
 OTO. See Operational Test Organization
 Over-The-Horizon Backscatter (OTH-B), F-10

 PACOSS. See Passive and Active Controls of Space Structures
 particle beam weapons
 definition, xxvi
 Soviet Union, B-5
 particle beams
 definition, xxvi
 lethality, 4.4-16
 Soviet research, B-5
 Passive and Active Controls of Space Structures (PACOSS), 4.3-24, 4.4-28, 4.4-32
 dynamic test article (DTA), 4.4-30
 passive defenses, Soviet, 1-3, B-8 – B-9
 passive sensors, 4.1-8
 definition, xxvii
 PATHS. See Precursor Above-the-Horizon Sensor
 Patriot, F-10
 PAWN SHOP radars, G-5
 PBVs. See post-boost vehicles
 Peacekeeper, 1-2
 Pegasus orbital experiment, 4.3-18, 4.3-19, 4.3-22
 penetration aid, definition, xxvii
 Phase I SDS. See SDS Phase I
 Phase II SDS. See SDS Phase II
 Phase One Engineering Team (POET), 3-7, 3-22, 4.4-5
 Phase One Threat Specification (POTS), 4.4-5

phased development and deployment concept, 2-3–2-4
 phenomenology for SSTS/GSTS, 4.1-19
 PILL BOX large phased-array radar, Pushkino, B-2
 Plato 11 experiments, 4.4-15
 POET. See Phase One Engineering Team
 post-boost phase
 definition, xxvii
 space-based particle beams, discrimination function, 4.3-2
 TW/AA functions, F-17
 post-boost vehicles (PBVs), 3-3, 4.1-10, 4.2-2, F-17
 acquisition and tracking of, 2-4
 and space-based particle beams (SBPBs), 4.3-2
 POTS. See Phase One Threat Specification
 Power and Power Conditioning project, 4.4-2
 funding impacts, 4.4-35–4.4-36
 Power Architecture Studies (PAS), 4.4-19
 power systems, technology spinoffs, E-5
 Precursor Above-the-Horizon Sensor (PATHS), 4.1-15, 4.1-18
 Probe, 4.3-24, F-17. See also Ground-Based Surveillance and Tracking System (GSTS)
 Programmable, Implantable Medication System (PIMS), E-5–E-6
 propellants and propulsion, 4.5-1
 Israeli technology, 4.2-21
 technology spin-offs, E-5
 Public Law 99-145, Section 1457, E-1
 Public Law 99-502, E-1
 pulse power transmission technology, E-8
 Pushkino, U.S.S.R., B-2

 Quayle Amendment, A-4
 Queen Match, 4.1-26, C-4

 Radar Technology Identification Methodology (RTIM), 4.1-21
 radars. See also space-based radars
 ballistic missile defense, 1-3
 LPAR, Krasnoyarsk, 1-3
 radio frequency quadripole accelerators, 4.3-21
 radio frequency (RF) linac free electron laser, 4.3-13–4.3-14
 rail gun, F-13
 definition, xxvii
 Raman scattering, 4.3-14, 4.3-28
 Rapid Retargeting and Precision Pointing simulator, 4.3-24
 RDT&E. See Research, Development, Test, and Evaluation
 Reagan, U.S. President, 1-5, 1-9, 3-19, A-1, A-2
 Executive Order on technology transfer, E-1
 Red-Blue Team, countermeasures analyses, B-15–B-16
 reentry vehicles (RVs), 3-3, 4.1-10, 4.2-2, 4.2-7, 4.3-3, F-17
 acquisition and tracking of, 2-4
 definition, xxvii
 NPBs mass discrimination, 4.3-17
 regional defense, 3-21
 Relay Mirror Experiment (RME), C-3, 4.3-15, 4.3-22, 4.3-25
 REP III laser, 4.4-13, 4.4-16
 Request for Proposals (RFP), SDS Phase I, 3-5
 Research, Development, Test, and Evaluation (RDT&E), 3-2
 responsive threat, definition, xxvii
 RME. See Relay Mirror Experiment
 Roi-Namut island, 4.1-14
 Rotary Reciprocating Refrigerator, 4.1-16
 RTIM. See Radar Technology Identification Methodology
 RVs. See reentry vehicles

 SALT I, 1-2
 implementation of agreements, C-2
 mutual vulnerability foundation, 1-1
 negotiations, C-1, C-2
 SAMs. See surface-to-air missiles
 SAMS (Space Assembly and Maintenance Study), 3-8
 SAMTO (U.S. Air Force Space and Missile Test Organization), 5-6
 Sary-Shagan Missile Test Center, B-4
 satellites
 attack warning function, 4.3-3
 production and maintenance costs, 4.2-5
 SATKA. See Surveillance, Acquisition, Tracking, and Kill Assessment Program
 SATKA Integrated Experiment (SIE), 4.1-24–4.1-25, 5-2, C-3
 Control Center, 4.1-24, 4.1-25
 function, 4.1-24
 SBI. See space-based interceptor
 SBIR. See Small Business Innovation Research
 SBLs. See space-based lasers
 SBPBs. See space-based particle beams
 SBRs. See space-based radars
 Scanning LWIR Module (SLIM), 4.1-15
 SCENARIO, 4.1-24
 Science & Technology Agents (STAs), 4.5-2
 Science and Technology Areas and Programs, SDI spinbacks, F-3
 Science and Technology Committee, F-4–F-5
 SCOPA, 4.4-21

SDI Program
 costs, G-2
 goals, 2-1
 implications of no ABM Treaty restrictions, G-1 – G-9
 military objectives, 1-1, 1-4 – 1-5
 schedule, G-2 – G-3
 strategic context, 1-1 – 1-2
 structure, 2-2
 technical goals, 1-7, 4-1

SDIO. See Strategic Defense Initiative Organization

SDS
 criteria for effectiveness, 2-1 – 2-2
 follow-on phases. See SDS follow-on phases
 military effectiveness, 2-1
 Phase I. See SDS Phase I
 Phase II. See SDS Phase II
 program structure, 2-2
 survivability, 2-1 – 2-2

SDS Engineering and Support Directorate
 accomplishments, 3-7
 funding, 3-23
 future plans, 3-7 – 3-8
 project description, 3-6 – 3-7
 task areas, 3-6 – 3-7

SDS follow-on phases, 2-3, 2-4, 4.1-19, 5-7
 potential KEW technologies, 4.2-1
 proposed ERIS improvements, 4.2-7
 system survivability goals, 4.4-6
 and terminal phase sensors, 4.1-19

SDS Phase I, 1-9, 2-4, 4.2-2, 4.4-2
 accomplishments, 3-4 – 3-5
 concept of operations, 3-22
 Dem/Val activities, 2-3, 2-4
 ERIS, 4.2-7
 future plans, 3-5
 HEDI, 4.2-10
 and National Test Bed project, 3-2
 project description, 3-2 – 3-4
 survivability technology development areas, 4.4-6, 4.4-7 – 4.4-9, 4.4-10
 system survivability goals, 4.4-6

SDS Phase II, 4.4-2 – 4.4-3
 concept validation phase, 4.4-26
 survivability technologies, 4.4-12
 system survivability goals, 4.4-6

SDS Phase I Engineering Project Directorate
 funding, 3-23
 systems engineering and integration (SE&I) task, 3-5

Sealite beam director (SLBD), 4.3-25

Section 233 of Defense Authorization Act, F-1
 G-i – G-iii
 security, allied
 challenges to, 1-2 – 1-4
 SDI mandate, A-1
 security, U.S.
 challenges to, 1-2 – 1-4
 objectives, 1-6 – 1-7
 SDI mandate, A-1
 strategy and missions, 1-6 – 1-8

SEE (System Exploration Experiment), 5-2

SEER. See Sensor Experiment Evaluation and Review

Sensor Experiment Evaluation and Review (SEER), 4.1-15, 4.1-18

sensors
 active for midcourse phase, 4.1-11
 components of infrared, 4.1-15
 definition, xxvii
 functions in strategic defense system, 4.1-1
 passive, 4.1-8, 4.1-11, 4.1-21
 passive discrimination function, 4.1-26
 potential space experiment, 4.1-13
 research for locating launch paths, 4.5-3
 Soviet Union technology, B-6 – B-7
 threat characterization, 4.1-26

sensors for the boost phase
 accomplishments, 4.1-2 – 4.1-3
 future plans, 4.1-7 – 4.1-8
 measurements, 4.1-3 – 4.1-4
 project description, 4.1-2
 supporting technology, 4.1-4 – 4.1-7

sensors for the late midcourse/terminal phase
 accomplishments, 4.1-20
 future plans, 4.1-22 – 4.1-24
 measurements, 4.1-20 – 4.1-21
 project description, 4.1-19 – 4.1-20
 technologies, 4.1-21 – 4.1-22

sensors for the midcourse phase
 concept description, 3-3
 future plans, 4.1-17 – 4.1-19
 measurements programs, 4.1-14
 project description/accomplishments, 4.1-8 – 4.1-11
 supporting experiments, 4.1-11 – 4.1-14
 system developments for FSD decision, 4.1-17 – 4.1-19
 technology programs, 4.1-14 – 4.1-17

short-range ballistic missiles (SRBMs), 3-19, F-5, F-6
 interception, 4.2-22
 Soviet Union, 1-4
 Syrian-based Soviet, F-7
 short wavelength lasers, 4.5-3

Shultz, U.S. Secretary of State George, A-2

Shuttle Pallet Satellite (SPAS), 4.1-4

SIE. See SATKA Integrated Experiment

signature, definition, xxvii

silicon-on-insulator (SOI) technology, 4.1-14 – 4.1-15

simulations, 4.4-12

for evaluation, 5-1, 5-2

framework, 5-5

National Test Bed, 3-8 – 3-9

SKYLITE test program, C-3

SLBD (Sealite beam director), 4.3-25

SLBMs. See submarine-launched ballistic missiles

SLIM. See Scanning LWIR Module

SLKT. See Survivability, Lethality, and Key Technologies

Small Business Innovation Research (SBIR), 4.5-1

Phase I contracts, 4.5-2

Small Business Innovative Research (SBIR), E-7

SMES. See Superconducting Magnetic Energy Storage

SNIA-BPD (Italy), A-5 – A-6

sol-gel derived bioglass, E-4 – E-5

Sol-Gel (Solution-Gelatin) technology, 4.5-2 – 4.5-3

solid-state photomultiplier (SSPM), 4.1-16

Sounding Rocket Measurements Program, 4.1-14

South Korea, A-1

Soviet countermeasures, B-13, B-14 – B-15, B-17

Soviet Five-Year Plan, B-14

Soviet offensive strategy, 1-2

Soviet response to SDI, 1-2 – 1-4, B-9 – B-14

impact on Soviet strategy and programs, B-10 – B-11

potential offensive force responses, B-15 – B-17

Soviet SDI efforts, 1-2

Soviet strategic defense programs, 1-2 – 1-3, B-1 – B-9

defensive forces, functions, B-1

effects on U.S. deterrents, 1-2 – 1-3

offensive forces, functions, B-1

resources allocated to, B-1

role in military strategy, B-11 – B-14

VPVO, Forces for Air Defense, B-11

Soviet technological capabilities, B-12

Soviet Union, 1-1

co-orbital interceptor, F-14, F-15

defense system deployments, G-4 – G-5

economic constraints, B-12 – B-14

NDEWs research, 4.3-2

strategic forces, G-6

threat judgements, B-14 – B-15

Soviet-Warsaw Pact, F-13

SP-100 Ground Engineering System (GES), 4.4-19 – 4.4-20, 4.4-23

configuration, 4.4-20

Dem/Val testing, 4.4-21

funding impacts, 4.4-36

Space Active Vibration Isolation laboratory model, 4.3-24

Space Assembly and Maintenance Study (SAMS), 3-8

space assets, defense of, F-14

programs, status and technologies, F-15 – F-16

space-based interceptor (SBI), 3-2, 4.1-2, 4.1-9, 4.3-2, B-15

accomplishments, 4.2-4 – 4.2-5

concept description, 3-3

contracts, 4.2-2 – 4.2-4

Dem/Val phase, 3-3, 4.2-4

fire control sensors, 4.1-11

functions and requirements, 2-4, 4.2-2, 4.2-3

future plans, 4.2-5 – 4.2-6

interceptor and weapon platform issues, 4.2-4

orbital servicing of platforms, 4.2-2

platform, 4.1-8, 4.4-33

project description, 4.2-2 – 4.2-4

system confidence, 4.2-5, 4.2-6

technology issues, 4.2-4 – 4.2-5

space-based lasers (SBLs)

acquisition, tracking and pointing capability, 4.3-2 – 4.3-2

concept description, 4.3-1 – 4.3-2

confidence, 4.3-10

functions, 2-5

interactive discrimination (ID), 4.3-1 – 4.3-2

space structures, 4.4-31

technical issues, 4.3-10 – 4.3-11

Space-Based Neutral Particle Beam (NPB) Weapon, 2-5

space-based particle beams (SBPBs), 4.3-30

acquisition, tracking and pointing capabilities, 4.3-2 – 4.3-3

concept description, 4.3-2

kill mechanisms, 4.3-2

space-based radars (SBRs), F-12

for midcourse discrimination, 4.1-11

space-based sensors, 4.2-2. See also sensors and air defense, F-11

Space-Based Surveillance and Tracking System (SSTS), 3-3, 4.1-11, F-17

budget cuts, 2-7, 4.1-26

costs, F-18

functions, 2-4

surveillance role, 3-3

system confidence, 4.1-18

space-based weapon system, Soviet, B-5

space chamber/pressure recovery system, 4.3-5, 4.3-7

Space Detection and Tracking System (SPADATS), F-15

Space Object Identification, F-15

space platforms, 4.4-34

Space Power and Power Conditioning project

- accomplishments, 4.4-19–4.4-21
- baseload power confidence, 4.4-23, 4.4-24
- baseload power technology, 4.4-18–4.4-19, 4.4-21
- burst power confidence, 4.4-23, 4.4-24
- future plans, 4.4-21–4.4-24
- multimegawatt power technology, 4.4-19
- project description, 4.4-18–4.4-19
- pulse power and power conditioning, 4.4-19, 4.4-21
- requirements and analysis, 4.4-18
- survivable solar power systems, 4.4-21

Space Power Architecture Study (SPAS)

- funding impacts, 4.4-35

Space Power Experiments Aboard Rockets (SPEAR), 4.3-22, 4.5-5

space power research, 4.5-1, 4.5-3

- SPEAR experiment, 4.5-5

Space Shuttle, 4.1-4

Space Surveillance and Tracking System (SSTS), 4.1-8, 4.2-7

- concept illustration, 4.1-10
- midcourse surveillance and tracking, 4.1–4.1-10
- project capabilities, 4.1-10
- warning function, 4.1-10

Space Systems Programs, SDI spinbacks, F-3

Space Systems Test Capabilities Study, 5-6

space test range, 5-6, 5-8

space tests for SBIs, 4.2-4

Space Transportation and Support project, 4.4-2

Space Transportation Architecture Study (STAS), 4.4-25

Space Transportation project

- accomplishments, 4.4-25
- future plans, 4.4-26–4.4-27
- project description, 4.4-24–4.4-25

SPADATS. See Space Detection and Tracking System

SPEAR (Space Power Experiments Aboard Rockets), 4.3-22, 4.5-5

SPICE experiment, 4.4-32

spin-backs, F-2, F-3

spin-offs, E-11–E-12. See also technology applications program

- automotive and aerospace applications, E-7–E-8
- computerization, E-6
- detection devices for explosives, E-10–E-11
- entomological instrumentation, E-9
- food irradiation program, E-8
- medical applications, E-5–E-6, E-7
- military, F-2, F-3
- NPB technology, 4.3-21, E-9–E-11
- oil well drilling, E-8
- sol-gel derived bioglass, E-4–E-5
- synopsis of, E-5

Spirit, C-4, 4.1-13, 4.1-19

SPOCK (Special Purpose Operational Computing Kernel), E-6

SRBMs. See short-range ballistic missiles

SSPM (solid-state photomultiplier), 4.1-16

SSTS. See Space Surveillance and Tracking System

Stanford University, California, E-13

Starlab, C-4, 4.3-9, 4.3-15, 4.3-25, 4.3-29

STARS, 3-17

START (Strategic Arms Reduction negotiations), G-ii, G-8

STAs. See Science & Technology Agents

STAS (Space Transportation Architecture Study), 4.4-25

Stevenson Wydler Technology Innovation Act (1980), E-1

Strategic Air Command (SAC), 3-22

Strategic Arms Limitation Talks. See SALT I

Strategic Arms Reduction (START)

- negotiations, G-ii, G-8

Strategic Defense Command (SDC), A-5, F-5

Strategic Defense Initiative Organization (SDIO)

- accomplishments, D-1–D-2
- appropriated program levels, D-1, D-3
- development, D-1
- funding of programs and projects, D-3–D-4
- innovation support, 4-1
- IST office, 4.3-26
- Office of Technology Applications, E-2
- organizational structure, D-2
- program goal, 2-1
- program reductions, 2-5–2-7
- program structure and strategy, 2-1–2-7, 2-2–2-4
- SATKA Office, 4.3-19
- SLKT office, 4.3-21
- technology base and technology validation balance, 2-6, 2-7

Strategic Defense System. See SDS

Strategic Forces Modernization Programs, SDI

- spinbacks, F-3

Strategic Red Team (SRT), B-15

- countermeasures analysis, B-16–B-17

Strategic Rocket Forces (SRF), B-10, B-11

Strategic Systems Committee, F-5

submarine-launched ballistic missiles (SLBMs), 3-2, 3-19, 4.3-1
 boost-phase intercept of, 4.3-11, 4.3-12
 midcourse phase intercepts, 4.2-7, 4.2-10
 sensor detection, 4.1-2
 Soviet Union, 1-2
 United States, 1-2
 SUPER. See Survivable Solar Power Module
 Superconducting Magnetic Energy Storage (SMES), 4.4-22, E-8
 Support Project for KEW program
 accomplishments, 4.2-22 – 4.2-23
 advanced technology procurements, 4.2-23
 project description, 4.2-22
 surface-to-air missiles (SAMs), F-10
 Soviet Union, B-3, B-8
 Surveillance, Acquisition, Tracking, and Kill Assessment (SATKA) Program,
 4.1-1 – 4.1-27, 4.3-19. See also SATKA
 Integrated Experiment (SIE)
 concept description, 3-3
 functions of sensors, 4.1-1
 funding impacts, 4.1-25 – 4.1-26
 future plans, 4.1-23 – 4.1-24
 program overview, 4.1-1
 sensor projects, 4.1-2 – 4.1-24
 technical objectives, 4.1-1
 surveillance, definition, xxvii
 survivability, 2-1 – 2-2, 5-3 – 5-4
 definition, xxvii, 2-1 – 2-2
 space system, F-16
 weapon platform, 4.2-5
 Survivability, Lethality, and Key Technologies (SLKT) Program, 4.2-5, 4.3-21, 4.4-1 – 4.4-36
 funding impacts, 4.4-35 – 4.4-36
 Lethality and Target Hardening (LTH) project, 4.4-12 – 4.4-18
 Materials and Structures project, 4.4-27 – 4.4-35
 objectives, 4.4-1
 program overview, 4.4-1
 Space Power and Power Conditioning project, 4.4-18 – 4.4-24
 Space Transportation project, 4.4-24 – 4.4-27
 System Survivability Project (SDS), 4.4-3 – 4.4-12
 technical objectives, 4.4-1 – 4.4-3
 Survivable Solar Concentrator Photovoltaic Array (SCOPA), 4.4-2
 Survivable Solar Power Module (SUPER), 4.4-2, 4.4-23
 flight test, 4.4-23 – 4.4-24
 SUVAC, 4.4-16
 survivability enhancement options (SEOs), 4.4-3
 System Concept Paper (SCP), 3-7
 System Exploration Experiments (SEEs), 5-2
 System Program Office (SPO), 4.1-26, 4.4-6
 System Requirements Review (SRR), 4.4-11
 System Survivability project
 accomplishments, 4.4-4 – 4.4-5
 active and passive projects, FY 1989, 4.4-9 – 4.4-12
 active survivability measures program, 4.4-10 – 4.4-11
 aerospace contractors, 4.4-
 confidence level in selected approaches, 4.4-6, 4.4-7
 funding impacts, 4.4-35 – 4.4-36
 future plans, 4.4-6 – 4.4-13
 issues, 4.4-4
 nuclear mitigation software development, 4.4-10
 objectives, 4.4-1 – 4.4-2, 4.4-3, 4.4-6 – 4.4-7
 Phase II technology efforts, 4.4-12
 planned incremental hardenability project, 4.4-10
 planned technology improvements, 4.4-6 – 4.4-8
 project description, 4.4-3 – 4.4-4
 test, evaluation, and validation, 4.4-12, 4.4-14
 TMD survivability analysis, 4.4-11
 T/R. See Transmit/Receive module
 development
 Tactical Defense Programs, SDI spinbacks, F-3
 tactical warning and attack assessment (TW/AA), 4.1-7
 functions, F-16 – F-18
 future programs and costs, F-18
 sensor requirements, 4.1-2
 Taft, Deputy Secretary of Defense, F-5
 TAIS. See Technology Applications Information System
 Talon Gold, 4.3-23 – 4.3-24
 TDSSPA. See Technology Development for Solid-State Phased Arrays
 T&E. See Test and Evaluation Program
 technical feasibility, 5-3 – 5-4
 Technical Requirements Documents (TRDs), 4.4-5
 technical validation experiment (TVE)
 funding, 4.1-26
 for passive midcourse sensors, 4.1-17
 Technology Applications Information System (TAIS), E-11, F-4
 allied requests, E-3
 purpose and accessibility, E-2
 technology applications panels, E-4
 technology applications program, E-1 – E-14
 advisory committees, E-3

applications panels, E-4
 domestic spin-offs, E-4 – E-12
 legislative provisions, E-1 – E-2
 Medical Free Electron Laser program,
 E-13 – E-14
 Technology Applications Information System
 (TAIS), E-2 – E-3
 technology applications to defensive missions,
 F-1 – F-19
 technology base
 development, 2-2
 development, Phase I SDS, 2-3
 SATKA program, 4.1-27
 technology capabilities, Soviet, B-12
 Technology Development for Solid-State
 Phased Arrays (TDSSPA), 4.1-21
 technology developments, 4-1 – 4.5-5
 directed energy weapons (DEW) technology
 program, 4.3-1 – 4.3-30
 Innovative Science and Technology (IST)
 program, 4.5-1 – 4.5-5
 Program Elements, 4-1
 technology for boost-phase sensors
 Advanced On-board Signal Processor (AOSP),
 4.1-5, 4.1-8
 cryogenics, 4.1-7
 Focal Plane Array (FPA), 4.1-5 – 4.1-6
 Generic VHSIC Spaceborne Computer
 project, 4.1-4 – 4.1-5
 optics technology, 4.1-6
 radiation hardening, 4.1-5, 4.1-7, 4.1-8
 signal and data processing, 4.1-4 – 4.1-5,
 4.1-7 – 4.1-8
 technology for late midcourse/terminal phase
 sensors
 electronic countermeasure techniques, 4.1-22
 Radar Technology Identification Methodology,
 4.1-21
 TDSSPA project, 4.1-21
 Transmit/Receive module development,
 4.1-21 – 4.1-22
 technology for midcourse phase sensors
 cryogenics, 4.1-16
 IR FPAs, 4.1-15 – 4.1-16
 laser and microwave radars, 4.1-16 – 4.1-17
 optics, 4.1-16, 4.1-18
 signal and data processing, 4.1-14 – 4.1-17
 technical validation experiments (TVE), 4.1-17
 Technology Support Project for KEW program
 accomplishments, 4.2-21
 future plans, 4.2-21 – 4.2-22
 project description, 4.2-20 – 4.2-21
 technology transfer. See technology
 applications program
 TEMP. See Test and Evaluation Master
 Program
 terminal phase, 4.3-3. See also sensors for the
 late midcourse/terminal phase
 definition, xxvii
 TW/AA functions, F-17
 Test and Evaluation Committee, F-5
 Test and Evaluation Master Plan (TEMP), 3-7,
 5-1, 5-6
 methodology, 5-1 – 5-2, 5-7
 Test and Evaluation of KEW program
 accomplishments, 4.2-19 – 4.2-20
 future plans, 4.2-20
 project description, 4.2-18 – 4.2-19
 Test and Evaluation Program, 5-1 – 5-8
 accomplishments, 5-6 – 5-7
 approach, 5-3 – 5-6
 background, 5-1
 data collection program, 5-7
 Directorate, responsibilities, 5-1, 5-3, 5-8
 engineering and technical assistance
 contracts, 5-8
 facility requirements, 5-6
 future plans, 5-7 – 5-8
 management and responsibilities, 5-3
 methodology, 5-1 – 5-2
 relationship between simulation and testing,
 5-2
 strategy, 5-1 – 5-2
 system issues and test requirements, 5-4, 5-5
 Test and Evaluation Working Groups (TEWGs),
 5-7
 membership, 5-3, 5-4
 subcommittees, 5-4
 TEWGs. See Test and Evaluation Working
 Groups
 theater defense architecture, 4.2-21. See also
 architecture studies; theater missile defense
 Theater Defense Directorate
 accomplishments, 3-20 – 3-21
 funding, 3-23
 future plans, 3-21
 project description, 3-20
 responsibilities, 3-19
 theater missile defense (TMD), 3-19, F-5
 Central European region, F-7 – F-8
 IS&T program, F-9 – F-10
 kinetic energy program functions, 4.2-20
 U.S.-Israeli study, 3-20
 U.S.-U.K. program, 3-20
 use of war gaming, F-10
 Theater Missile Defense Architecture Studies
 (TMDAS), 3-20
 description, F-7 – F-8
 funding impact, 3-23

- research contracts, A-5 – A-6
- Theater Missile Defense (TMD) Survivability Analysis, 4.4-11
- Theatre Missile Defense Program, A-5
- Thomson CSF (France), A-5
- threat definitions, 4.4-5
- Three Color Experiment (TCE), C-4, 4.1-4
- Thunderbolt, 4.4-16, 4.5-4 – 4.5-5
- Titan, 4.3-25
 - dismantlement, 1-2
- TMD. See theater missile defense
- TMDAS. See Theater Missile Defense Architecture Studies
- tracking and pointing, definition, xxvii
- Transmit/Receive (T/R) module development, 4.1-21 – 4.1-22
- Troll accelerator, 4.3-28
- Turbo-Brayton, 4.1-16
- TVE. See technical validation experiment
- TW/AA. See tactical warning and attack assessment

- U.K. architecture study, description, F-6 – F-7
- Unified Space Command, 3-22, 3-23
- United Kingdom, 1-4, A-2, 4.2-21
 - architecture study, F-6 – F-7
 - EADTB Program, F-8
 - research contracts, A-4, A-5
 - SDI research, C-3
- University of California, E-13
- University of Florida, E-4 – E-5
- U.S. Air Force, 4.4-20 – 4.4-21
- U.S. Air Force Space and Missile Test Organization (SAMTO), 5-6
- U.S. Army

- antitactical missile program, A-5
- ATM program, F-5
- Strategic Defense Command, A-5
- U.S. Army Kwajalein Atoll (USAKA), 4.1-22, 4.1-23, 4.2-12, 4.2-13
- U.S. Navy, F-12
- U.S. Secretary of Defense, technology transfer obligations, E-1 – E-2
- U.S. Space Command, 3-23, F-15
 - TEWG membership, 5-3
- USAKA. See U.S. Army Kwajalein Atoll Using Command, 5-6
- U.S.S.R., See Soviet Union

- Vandenberg AFB, 4.1-24
- Vanderbilt University, Tennessee, E-13
- Very Large Scale Integrated Circuit (VLSIC), E-6
- Visible Light/Ultraviolet Experiment (VUE), 4.1-4
- vulnerability, definition, xxvii

- war gaming, 3-22, 3-23
 - purpose of, F-10
- Weinberger, Caspar, A-1, A-2, F-7
- White Sands Missile Range (WSMR), 4.2-12, 4.3-15, 4.3-16, 4.3-28, 4.3-29, 4.3-30, 4.4-13, 4.4-15, 4.4-16
- WSMR. See White Sands Missile Range

- X-ray, definition, xxviii
- X-ray laser program, 4.4-18

- Zenith Star, 4.3-4, 4.3-9, 4.3-15, 4.3-30, 4.4-33
 - space experiments, 4.3-11
- Zero-One Architecture Study, 3-11, 4.4-4