

VOLUME II
FLYING QUALITIES PHASE

CHAPTER 6
MANEUVERING FLIGHT

DISTRIBUTION STATEMENT R
Approved for public release
Distribution Unlimited

OCTOBER 1990

USAF TEST PILOT SCHOOL
EDWARDS AFB CA

19970117 033

DTIC QUALITY INSPECTED 1

6.1 INTRODUCTION

The method used to analyze maneuvering flight will be to determine a stick-fixed maneuver point (h_m) and stick-free maneuver point (h'_m). These are analogous to their counterparts in static stability, the stick-fixed and stick-free neutral points. The maneuver points will also be derived in terms of the neutral points, and their relationship to cg location will be shown.

6.2 DEFINITIONS

(Also see definitions for Chapter 5, Longitudinal Static Stability.)

Acceleration Sensitivity - The ratio n/α is used to determine allowable maneuvering stick force gradients. It is defined in MIL-STD-1797A as the "steady-state normal acceleration change per unit change in angle of attack for an incremental pitch control deflection at constant speed."

Centripetal Acceleration - The acceleration vector normal to the velocity vector that causes changes in direction (not magnitude) of the velocity vector.

Free Elevator Factor - $F = 1 - \tau C_{n_\alpha} / C_{n_\delta}$

A multiplier that accounts for the change in stability caused by freeing the elevator (allowing it to "float").

Pitch Damping - A stability derivative.

$$C_{m_q} = \frac{2U_0}{c} \cdot \frac{\partial C_m}{\partial Q}$$

Damping that is generated by a pitch rate.

Stick-Fixed Maneuver Margin - The distance in percent MAC between the cg and the stick-fixed maneuver point = $h_m - h$.

Stick-Fixed Maneuver Point - h_m The cg location where $d\delta_e/dn = 0$.

Stick-Free Maneuver Margin - The distance, in percent MAC, between the cg and the stick-free maneuver point = $h'_m - h$.

Stick-Free Maneuver Point - h'_m = The cg location where $dF_s/dn = 0$.

6.3 ANALYSIS OF MANEUVERING FLIGHT

Maneuvering flight will be analyzed much in the same manner used in determining a flight test relationship in longitudinal stability. For stick-fixed longitudinal stability, the flight test relationship was determined to be

$$\frac{d\delta_e}{dC_L} = - \frac{dC_m/dC_L}{C_{m_{\delta_e}}} \quad (5.69)$$

This equation gave the static longitudinal stability of the aircraft in terms that could easily be measured in a flight test.

In maneuvering flight, a similar stick-fixed equation relating to easily measurable flight test quantities is desirable. Where in longitudinal stability, the elevator deflection was related to lift coefficient or angle of attack, in maneuvering flight, elevator deflection will relate to load factor, n .

To determine this expression, we will start with the aircraft's basic equations of motion. As in longitudinal static stability, the six equations of motion are the basis for all analysis of aircraft stability and control. In maneuvering an aircraft, the same equations will hold true. Recalling the pitching moment

$$G_y = \dot{Q}I_y - PR(I_z - I_x) + (P^2 - R^2)I_{xz} \quad (4.3)$$

and the fact that in static stability analysis we have no roll rate, yaw rate, or pitch acceleration, Equation 4.3 reduces to

$$G_y = 0$$

There are five primary variables that cause external pitching moments on an aircraft:

$$M = f(U, \alpha, \dot{\alpha}, Q, \delta_e) \quad (6.1)$$

any or all of these variables change, there will be a change of total pitching moment that will equal the sum of the partial changes of all the variables. This is written as

$$\Delta M = \frac{\partial M}{\partial U} \Delta U + \frac{\partial M}{\partial \alpha} \Delta \alpha + \frac{\partial M}{\partial \dot{\alpha}} \Delta \dot{\alpha} + \frac{\partial M}{\partial Q} \Delta Q + \frac{\partial M}{\partial \delta_e} \Delta \delta_e \quad (6.2)$$

Since in maneuvering flight, ΔU and $\Delta \dot{\alpha}$ are zero, Equation 6.2 becomes

$$\Delta M = \frac{\partial M}{\partial \alpha} \Delta \alpha + \frac{\partial M}{\partial Q} \Delta Q + \frac{\partial M}{\partial \delta_e} \Delta \delta_e = 0 \quad (6.3)$$

and since $M = qSc C_m$, then

$$\frac{\partial M}{\partial \alpha} = qSc \frac{\partial C_m}{\partial \alpha} = qSc C_{m_\alpha} \quad (6.4)$$

$$\frac{\partial M}{\partial Q} = qSc \frac{\partial C_m}{\partial Q} \quad (6.5)$$

$$\frac{\partial M}{\partial \delta_e} = qSc \frac{\partial C_m}{\partial \delta_e} = qSc C_{m_{\delta_e}} \quad (6.6)$$

Substituting these values into Equation 6.3 and multiplying by $1/qSc$,

$$C_{m_\alpha} \Delta \alpha + \frac{\partial C_m}{\partial Q} \Delta Q + C_{m_{\delta_e}} \Delta \delta_e = 0 \quad (6.7)$$

The derivative $\partial C_m / \partial Q$ is carried instead of C_{m_q} since the compensating factor $c/2U_0$ is not used at this time. Solving for the change in elevator deflection $\Delta \delta_e$,

$$\Delta \delta_e = \frac{-C_{m_\alpha} \Delta \alpha - (\partial C_m / \partial Q) \Delta Q}{C_{m_{\delta_e}}} \quad (6.8)$$

The analysis of Equation 6.8 may be continued by substituting in values for $\Delta \alpha$ and ΔQ . The final equation obtained should be in the form of some

flight test relationship. Since maneuvering is related to load factor, the elevator deflection required to obtain different load factors will define the stick-fixed maneuver point. The immediate goal then is to determine the change in angle of attack, $\Delta\alpha$, and change in pitch rate, ΔQ , in terms of load factor, n .

6.4 THE PULL-UP MANEUVER

In the pull-up maneuver, the change in angle of attack of the aircraft, $\Delta\alpha$, may be related to the lift coefficient of the aircraft. In the pull-up with constant velocity, the angle of attack of the whole aircraft will be changed since the aircraft has to fly at a higher C_L to obtain the load factor required. The change in C_L required to maneuver at high load factors at a constant velocity comes from two sources: (1) load factor increase and (2) elevator deflection. Although often ignored because of its small value when compared to total C_L , the change in lift with elevator deflection $C_{L_\delta} \Delta\delta_e$ will be included for a more general analysis.

Referring to Figure 6.1, the aircraft is in equilibrium at some C_{L_0} corresponding to some α_0 before the elevator is deflected to initiate the pull-up. If the elevator is considered as a flap, its deflection will affect the lift curve as follows. When the elevator is deflected upward, the lift curve shifts downward and does not change slope. This says that a certain amount of lift is initially lost when the elevator is deflected upward. The loss in lift because of elevator deflection is designated $C_{L_\delta} \Delta\delta_e$. The increase in down-loading continues to pitch upward and increase its angle of attack until it reaches a new C_L and an equilibrium load factor.

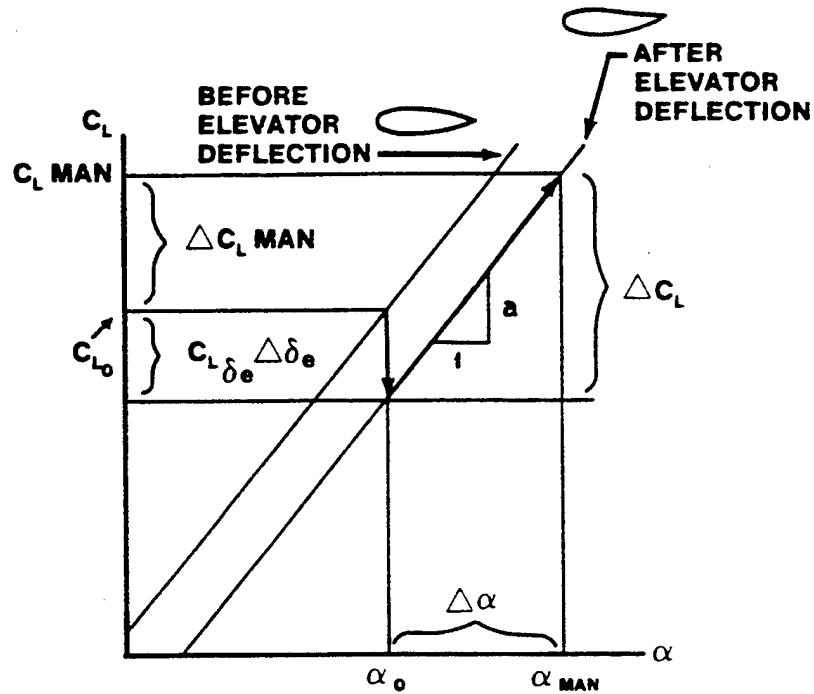

FIGURE 6.1. LIFT COEFFICIENT VERSUS ANGLE OF ATTACK

In other words, a pitch rate is initiated and α increases until a maneuvering lift coefficient $C_{L_{MAN}}$ is reached for the deflected elevator δ_e . The change in angle of attack is $\Delta\alpha$. The change in C_L has come partially from the deflected elevator and mainly from the pitching maneuver. The change in C_L due to the maneuver is from C_{L_0} to $C_{L_{MAN}}$. Since it did not change the lift curve, and including the change in lift caused by elevator deflection, the expression for $\Delta\alpha$ becomes

$$C_L = a\alpha \quad (6.9)$$

$$\Delta C_L = a\Delta\alpha$$

$$\Delta C_L = \Delta C_{L_{MAN}} - C_{L_{\delta_e}} \Delta\delta_e = a\Delta\alpha \quad (6.10)$$

$$\Delta\alpha = \frac{1}{a} \left(\Delta C_{L_{MAN}} - C_{L_{\delta_e}} \Delta\delta_e \right) \quad (6.11)$$

To put Equation 6.11 in terms of load factor, $\Delta C_{L_{MAN}}$ must be defined. This is the change in lift coefficient from the initial condition to the final maneuvering condition. This change can occur from one g flight to some other load factor or it can start at two or three g's and progress to some new load factor. If C_L is at one g then

$$C_L = \frac{W}{qS} \quad (6.12)$$

and

$$C_{L_0} = \frac{n_0 W}{qS} \quad (6.13)$$

where n_0 is the initial load factor. Similarly,

$$C_{L_{MAN}} = \frac{nW}{qS} \quad (6.14)$$

where n is the maneuvering load factor.

$$\Delta C_{L_{MAN}} = C_{L_{MAN}} - C_{L_0} = \frac{nW}{qS} - \frac{n_0 W}{qS} = C_L (n - n_0) = C_L \Delta n \quad (6.15)$$

Finally substituting Equation 6.15 into Equation 6.11

$$\Delta\alpha = \frac{1}{a} \left(C_L \Delta n - C_{L_{\delta_e}} \Delta\delta_e \right) \quad (6.16)$$

Equation 6.16 is now ready for substitution into Equation 6.8.

An expression for ΔQ in Equation 6.8 will be derived using the pull-up maneuver analysis.

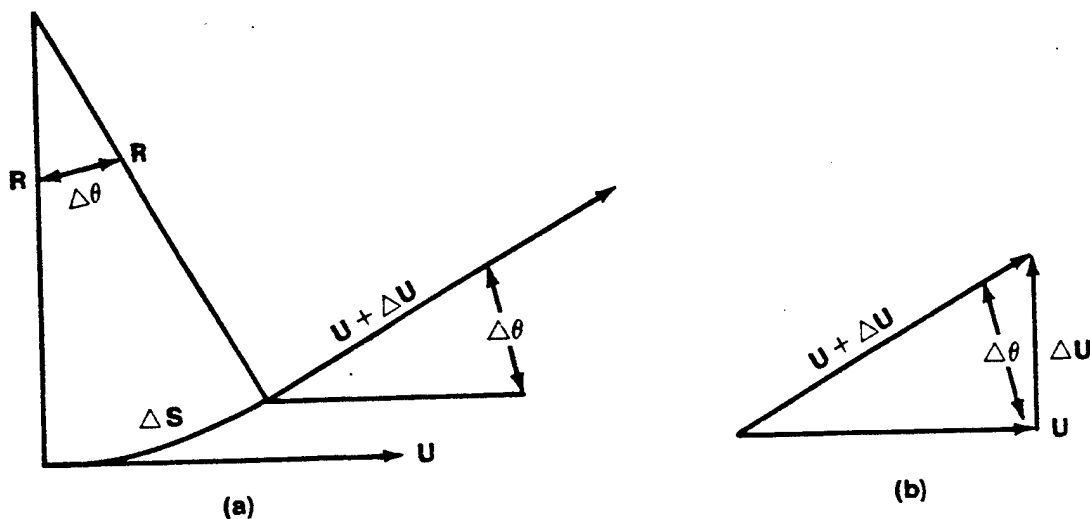

FIGURE 6.2. CURVILINEAR MOTION

Referring to Figure 6.2(a)

$$\Delta\theta = \frac{\Delta S}{R} \quad (6.17)$$

$$\frac{d\theta}{dt} = \lim_{\Delta t \rightarrow 0} \frac{\Delta\theta}{\Delta t} = \lim_{\Delta t \rightarrow 0} \frac{\Delta S}{\Delta t} \frac{1}{R} \quad (6.18)$$

$$\frac{d\theta}{dt} = \frac{U}{R} = \Omega \quad (6.19)$$

From Figure 6.2(b)

$$\frac{\Delta U}{U} = \Delta\theta \quad (\text{small angles where } \tan \theta \approx \theta) \quad (6.20)$$

$$\frac{dU}{dt} = \lim_{\Delta t \rightarrow 0} \frac{\Delta U}{\Delta t} \frac{1}{U} = \frac{1}{U} \frac{dU}{dt} \quad (6.21)$$

Combining Equations 6.21 and 6.19

$$\frac{dU}{dt} = \frac{U^2}{R} \quad (6.22)$$

which may be recognized as the equation for the centripetal acceleration of a particle moving in a circle of radius R at constant velocity U . The force (or change in lift, ΔL) required to achieve this centripetal acceleration can be derived from ($F = ma$). Thus,

$$\Delta L = \frac{w}{g} \Delta a = \frac{w}{g} \left[\frac{U^2}{R} - \frac{U_0^2}{R_0} \right] \quad (6.23)$$

The change in lift can be seen in Figure 6.3 to be

$$\Delta L = nW - n_0W = W(n - n_0) \quad (6.24)$$

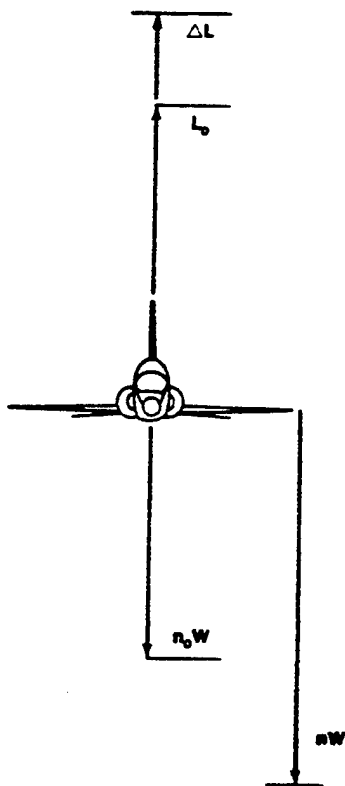

FIGURE 6.3. WINGS LEVEL PULL-UP

Again, the change may take place from any original load factor and is not limited to the straight and level flight condition ($n_0 = 1$). Therefore, for a constant velocity maneuver at U_0 , Equations 6.23 and 6.24 give

$$W (n - n_0) = \frac{WU_0}{g} \left(\frac{U_0}{R} - \frac{U_0}{R_0} \right) \quad (6.25)$$

Using Equation 6.19 and the definition of ΔQ

$$\frac{U_0}{R} - \frac{U_0}{R_0} = Q - Q_0 = \Delta Q \quad (6.26)$$

Equation 6.25 can be written

$$\Delta Q = \frac{g}{U_0} (n - n_0) = \frac{g}{U_0} \Delta n \quad (6.27)$$

Now Equations 6.27 and 6.16 may be substituted into Equation 6.8.

$$\Delta \delta_e = \frac{-C_{m_\alpha} \frac{1}{a} (C_L \Delta n - C_{L_{\delta_e}} \Delta \delta_e)}{C_{m_{\delta_e}}} - \frac{\frac{\partial C_m}{\partial Q} \frac{g}{U_0} \Delta n}{C_{m_{\delta_e}}} \quad (6.28)$$

From longitudinal static stability,

$$C_{m_\alpha} = a (h - h_n) \quad (6.29)$$

Also to help further in reducing the equation to its simplest terms,

$$U_0^2 = \frac{2W}{\rho S C_L} \quad (6.30)$$

and

$$\frac{\partial C_m}{\partial Q} = \frac{c}{2U_0} C_{m_q} \quad (6.31)$$

Substituting Equations 6.31, 6.30, and 6.29 into Equation 6.28 results in

$$\frac{\Delta\delta_e}{\Delta n} = \frac{aC_L}{C_{m_\alpha} C_{L_{\delta_e}} - C_{m_{\delta_e}}} a \left(h - h_n + \frac{\rho S C}{4m} C_{m_q} \right) \quad (6.32)$$

Equation 6.32 is now in the form that will define the stick-fixed maneuver point for the pull-up. The definition of the maneuver point, h_m , is the cg position at which the elevator deflection per g goes to zero. Taking the limit of Equation 6.32,

$$\lim_{\Delta n \rightarrow 0} \frac{\Delta\delta_e}{\Delta n} = \frac{d\delta_e}{dn} \quad (6.33)$$

or

$$\frac{d\delta_e}{dn} = \frac{aC_L}{C_{m_\alpha} C_{L_{\delta_e}} - C_{m_{\delta_e}}} a \left(h - h_n + \frac{\rho S C}{4m} C_{m_q} \right) \quad (6.34)$$

Setting Equation 6.34 equal to zero will give the cg position at the maneuver point $h = h_m$

$$h_m = h_n - \frac{\rho S C}{4m} C_{m_q} \quad (6.35)$$

Solving Equation 6.35 for h_n and substituting into Equation 6.34,

$$\frac{d\delta_e}{dn} = \frac{a C_L}{C_{m_\alpha} C_{L_{\delta_e}} - C_{m_{\delta_e}}} a (h - h_m) \quad (6.36)$$

where we now define $h_m - h$ as the stick-fixed maneuver margin.

The significant points to be made about Equation 6.36 are:

1. The derivative $d\delta_e/dn$ varies with the maneuver margin. The more forward the cg, the more elevator will be required to obtain the limit load factor. That is, as the cg moves forward, more elevator deflection is necessary to obtain a given load factor.

2. The higher the C_L , the more elevator will be required to obtain the limit load factor. That is, at low speeds (high C_L) more elevator deflection is necessary to obtain a given load factor than is required to obtain the same load factor at a higher speed (lower C_L).
3. The derivative $d\delta_e/dn$ should be linear with respect to cg at a constant C_L (Figure 6.4).

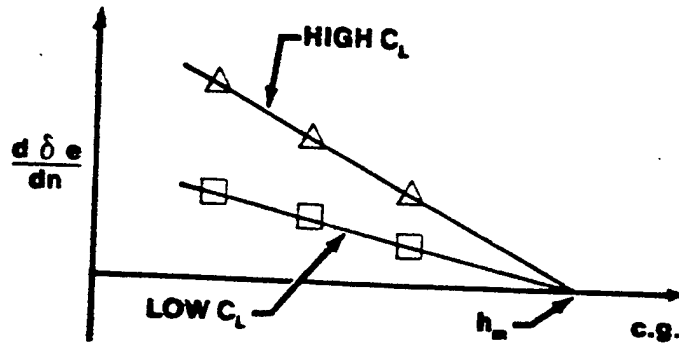

FIGURE 6.4. ELEVATOR DEFLECTION PER G

Another approach to solving for the maneuver point h_m is to return to the original stability equation from longitudinal static stability.

$$\frac{dC_n}{dC_L} = h - \frac{x_{ac}}{c} + \frac{dC_n}{dC_{L_{fus}}} - \frac{a_t}{a_w} v_H \eta_t \left(1 - \frac{d\epsilon}{d\alpha}\right) \quad (5.43)$$

The effect of pitch damping on aircraft stability will be determined and added to Equation 5.43. Recalling the relationship

$$\frac{\partial C_n}{\partial Q} = \frac{c}{2U_0} C_{n_q} \quad (6.31)$$

from equations of motion, Equation 6.37 can be written

$$\Delta C_n = \frac{c}{2U_0} C_{n_q} \Delta Q \quad (6.37)$$

Substituting the value obtained for ΔQ from Equation 6.27

$$\Delta C_m = \frac{cg}{2U_0^2} C_{m_q} \Delta n \quad (6.38)$$

Substituting

$$\Delta n = \frac{\Delta C_{L_{MAN}}}{C_L}$$

from Equation 6.15 and Equation 6.12

$$C_L = \frac{W}{qS} \quad (6.12)$$

into Equation 6.38 gives

$$\Delta C_m = \frac{\rho S c}{4m} C_{m_q} \Delta C_{L_{MAN}} \quad (6.39)$$

$$\lim_{\Delta C_{L_{MAN}} \rightarrow 0} \frac{\Delta C_m}{\Delta C_{L_{MAN}}} = \frac{dC_m}{dC_{L_{Pitch}}} = \frac{\rho S c}{4m} C_{m_q} \quad (6.40)$$

Damping

This term may now be added to Equation 5.43. If the sign of C_{m_q} is negative, then the term is a stabilizing contribution to the stability equation. C_{m_q} will be analyzed further.

$$\frac{dC_m}{dC_L} = h - \frac{X_{ac}}{c} + \frac{dC_m}{dC_{L_{FUS}}} - \frac{a_t}{a_w} v_H \eta_t \left(1 - \frac{d\varepsilon}{d\alpha} \right) + \frac{\rho S c}{4m} C_{m_q} \quad (6.41)$$

The maneuver point is found by setting dC_m/dC_L equal to zero and solving for the cg position where this occurs.

$$h_m = \frac{X_{ac}}{c} - \frac{dC_m}{dC_{L_{FUS}}} + \frac{a_t}{a_w} v_H \eta_t \left(1 - \frac{d\varepsilon}{d\alpha} \right) - \frac{\rho S c}{4m} C_{m_q} \quad (6.42)$$

The first three terms on the right side of Equation 6.42 may be identified as the expression for the neutral point h_n . If this substitution is made in Equation 6.42, Equation 6.35 is again obtained.

$$h_m = h_n - \frac{\rho S c}{4m} C_{m_q} \quad (6.35)$$

The derivative C_{m_q} found in Equations 6.34 and 6.35 needs to be examined before proceeding with further discussion.

The damping that comes from the pitch rate established in a pull-up comes from the wing, tail, and fuselage components. The tail is the largest contributor to the pitch damping because of the long moment arm. For this reason, it is usually used to derive the value of C_{m_q} . Sometimes an empirical value of 10% is added to account for damping of the rest of the aircraft, but often the value for the tail alone is used to estimate the derivative. The effect of the tail may be calculated from Figure 6.5.

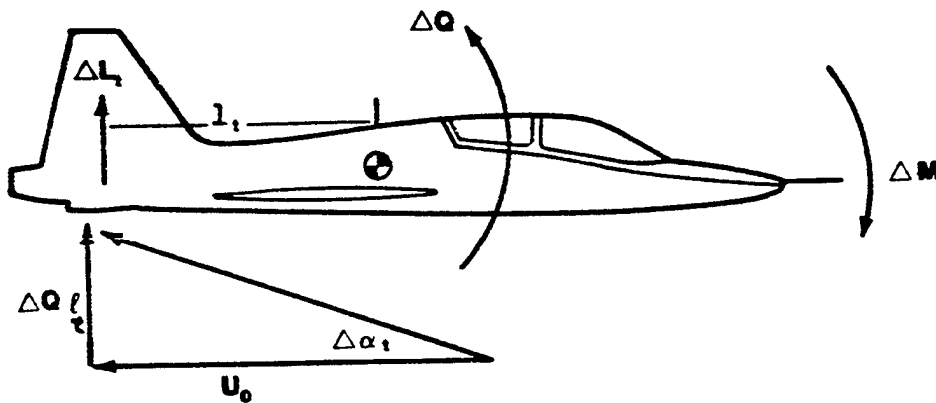

FIGURE 6.5. PITCH DAMPING

The pitching moment effect on the aircraft from the downward moving horizontal stabilizer is

$$\Delta M = -l_t \Delta L_t = q_w S_w c_w \Delta C_m \quad (6.43)$$

where

$$\Delta L_t = q_t S_t \Delta C_{L_t} \quad (6.44)$$

Solving for ΔC_m ,

$$\Delta C_m = - \left(\frac{q_t}{q_w} \right) \frac{l_t S_t}{c_w S_w} \Delta C_{L_t} \quad (6.45)$$

The combination $l_t S_t / c_w S_w$ can be recognized as the tail volume coefficient, V_H . The term q_t / q_w is the tail efficiency factor, η_t . Equation 6.45 may then be written

$$\Delta C_m = - V_H \eta_t \Delta C_{L_t} \quad (6.46)$$

which can be further refined to

$$\Delta C_m = - V_H \eta_t a_t \Delta \alpha_t \quad (6.47)$$

From Figure 6.5, the change in angle of attack at the tail caused by the pitch rate will be

$$\Delta \alpha_t = \tan^{-1} \frac{\Delta Q l_t}{U_0} \approx \Delta Q \frac{l_t}{U_0} \quad (6.48)$$

Substituting Equation 6.48 into 6.47

$$\Delta C_m = - a_t V_H \eta_t \frac{l_t}{U_0} \Delta Q \quad (6.49)$$

Taking the limit of Equation 6.49 gives

$$\frac{\partial C_m}{\partial Q} = - a_t V_H \eta_t \frac{l_t}{U_0} \quad (6.50)$$

Equation 6.50 shows that the damping expression $\partial C_m / \partial Q$ is an inverse function of airspeed (i.e., this term is greater at lower speeds). Solving for C_{m_q} using Equation 6.31

$$C_{m_q} = \frac{2U_0}{c} \frac{\partial C_m}{\partial Q} = -2a_t V_H \eta_t \frac{l_t}{c} \quad (6.51)$$

The damping derivative is not a function of airspeed, but rather a value determined by design considerations only (subsonic flight). The pitch damping derivative may be increased by increasing S_t or l_t .

When this value for C_{m_q} is substituted into Equation 6.35

$$h_m = h_n + \frac{\rho S a_t \eta_t l_t V_H}{2m} \quad (6.52)$$

The following conclusions are apparent from Equation 6.52:

1. The maneuver point should always be behind the neutral point. This is verified since the addition of a pitch rate increases the stability of the aircraft (C_{m_q} is negative in Equation 6.41.) Therefore, the stability margin should increase.
2. Aircraft geometry is influential in locating the maneuver point aft of the neutral point.
3. As altitude increases, the distance between the neutral point and maneuver point decreases.
4. As weight decreases at any given altitude, the maneuver point moves further behind the neutral point and the maneuver stability margin increases.
5. The largest variation between maneuver point and neutral point occurs with a light aircraft flying at sea level.

6.5 AIRCRAFT BENDING

Before the pull-up analysis is completed, one more subject should be covered. One of the assumptions made early in the equations of motion course was that the aircraft was a rigid body. In reality, all aircraft bend when a load is applied. The bigger the aircraft, the more they bend. The effect of the aircraft bending is shown in Figure 6.6.

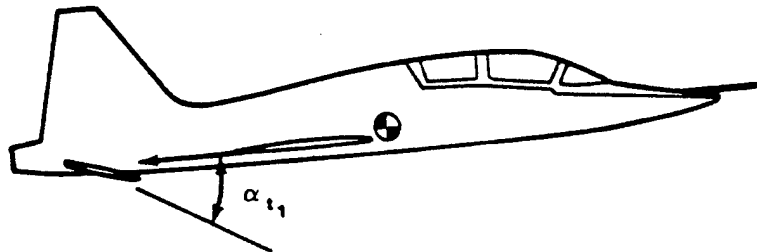

RIGID AIRCRAFT UNDER HIGH LOAD FACTOR

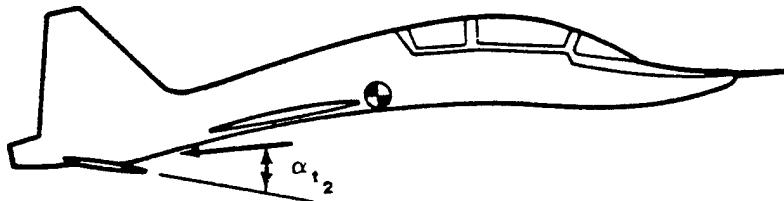

NONRIGID AIRCRAFT UNDER HIGH LOAD FACTOR

FIGURE 6.6. AIRCRAFT BENDING

As the non-rigid aircraft bends, the angle of attack, α_t of the horizontal stabilizer decreases. In order to keep the aircraft at the same overall angle of attack, the original angle of attack of the tail must be reestablished. This requires an increase in the elevator (slab) deflection or an additional $\Delta\delta_e$ per load factor.

6.6 THE TURN MANEUVER

The subject of maneuvering in pull-ups has already been presented. While it is the easiest method for a test pilot to perform, it is also the most time

consuming. Therefore, most maneuvering data is collected by turning. There are several methods used to collect data in a turn.

In order to analyze the maneuvering turn, Equation 6.8 is recalled

$$\Delta \delta_e = \frac{-C_{n_\alpha} \Delta \alpha - (\partial C_{n_\alpha} / \partial Q) \Delta Q}{C_{n_{\delta_e}}} \quad (6.8)$$

The expression for $\Delta \alpha$ in Equation 6.16 derived for the pull-up maneuver, is also applicable to the turning maneuver.

$$\Delta \alpha = \frac{1}{a} \left(C_L \Delta n - C_{L_{\delta_e}} \Delta \delta_e \right) \quad (6.16)$$

Such is not the case for the ΔQ expression in Equation 6.8. Another expression (other than Equation 6.27) for ΔQ pertaining to the turn maneuver, must be developed.

Referring to Figure 6.7, the lift vector will be balanced by the weight and centripetal acceleration. One component ($L \cos \phi$) balances the weight and the other ($L \sin \phi$) results in the centripetal acceleration.

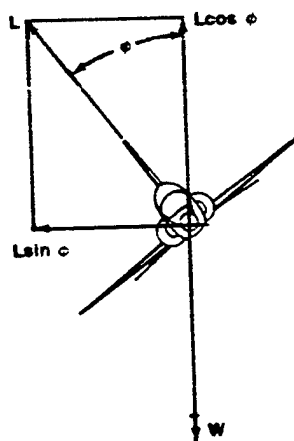

FIGURE 6.7. FORCES IN THE TURN MANEUVER

$$L \sin \phi = \frac{W U^2}{g R} \quad (6.53)$$

For a level turn,

$$L \cos \phi = W \quad (6.54)$$

$$n = L/W = \frac{1}{\cos \phi} \quad (6.55)$$

Now, dividing Equation 6.53 by Equation 6.54 and rearranging terms

$$\frac{U}{R} = \frac{g \sin \phi}{U \cos \phi} \quad (6.56)$$

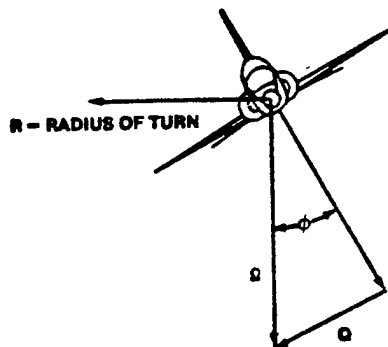

FIGURE 6.8. AIRCRAFT IN THE TURN MANEUVER

Referring to Figure 6.8 where pitch rate is represented by a vector along the wings and yaw rate a vector vertically through the center of gravity, the following relationships can be derived.

$$\Omega = \frac{U}{R} \quad (6.57)$$

$$Q = \Omega \sin \phi \quad (6.58)$$

$$Q = \frac{U}{R} \sin \phi \quad (6.59)$$

Substituting Equation 6.56 into Equation 6.59

$$Q = \frac{g \sin^2 \phi}{U \cos \phi} \quad (6.60)$$

From trigonometry,

$$Q = \frac{g}{U} \frac{1 - \cos^2 \phi}{\cos \phi} \quad (6.61)$$

$$Q = \frac{g}{U} \left(\frac{1}{\cos \phi} - \cos \phi \right) \quad (6.62)$$

Substituting Equation 6.55 into Equation 6.62 gives

$$Q = \frac{g}{U} \left(n - \frac{1}{n} \right) \quad (6.63)$$

When maneuvering from initial conditions of n_0 to n , the ΔQ equation becomes,

$$\Delta Q = Q - Q_0 = \frac{g}{U_0} \left(n - \frac{1}{n} \right) - \frac{g}{U_0} \left(n_0 - \frac{1}{n_0} \right) \quad (6.64)$$

$$\Delta Q = \frac{g}{U_0} (n - n_0) \left(1 + \frac{1}{nn_0} \right) \quad (6.65)$$

The general expression for ΔQ in Equation 6.65 and the value of $\Delta \alpha$ in Equation 6.16 may now be substituted into Equation 6.8 to determine $\Delta \delta_e$.

$$\Delta \delta_e = -C_{m_\alpha} \frac{1}{a} \frac{\left(C_{L_\Delta n} \Delta n - C_{L_{\delta_e}} \Delta \delta_e \right) \frac{\partial C_m}{\partial Q} \frac{g}{U_0} (\Delta n) \left(1 + \frac{1}{nn_0} \right)}{C_{m_{\delta_e}} \quad C_{m_{\delta_e}}} \quad (6.66)$$

Substituting Equation 6.31

$$\frac{\partial C_m}{\partial Q} = \frac{c}{2U_0} C_{m_q} \quad (6.31)$$

into Equation 6.66 and rearranging gives

$$\Delta \delta_e = \frac{C_{m_\alpha} C_L \Delta n + C_{m_q} a \frac{cg}{2U_0^2} (\Delta n) \left(1 + \frac{1}{nn_0}\right)}{C_{m_\alpha} C_{L_{\delta_e}} - C_{m_{\delta_e}} a} \quad (6.67)$$

Now, from longitudinal static stability,

$$C_{m_\alpha} = a (h - h_n)$$

and

$$U_0^2 = \frac{2W}{\rho S C_L}$$

Using these relationships, Equation 6.67 can be written

$$\frac{\Delta \delta_e}{\Delta n} = \frac{a C_L}{C_{m_\alpha} C_{L_{\delta_e}} - C_{m_{\delta_e}} a} \left[(h - h_n) + \frac{\rho S C}{4m} C_{m_q} \left(1 + \frac{1}{nn_0}\right) \right] \quad (6.68)$$

Taking the limit of $\Delta \delta_e / \Delta n$ as $\Delta n \rightarrow 0$ in Equation 6.68

$$\frac{d\delta_e}{dn} = \frac{a C_L}{C_{m_\alpha} C_{L_{\delta_e}} - C_{m_{\delta_e}} a} \left[(h - h_n) + \frac{\rho S C}{4m} C_{m_q} \left(1 + \frac{1}{n^2}\right) \right] \quad (6.69)$$

The maneuver point is determined by setting $d\delta_e/dn$ equal to zero and solving for the cg position at this point.

$$h_m = h_n - \frac{\rho S C}{4m} C_{m_q} \left(1 + \frac{1}{n^2}\right) \quad (6.70)$$

The maneuver point in a turn differs from the pull-up by the factor $\left(1 + 1/n^2\right)$. This means that at high load factors the turn and pull-up maneuver points will be very nearly the same. If Equation 6.70 is solved for h_n and substituted back into Equation 6.69 the result is

$$\frac{d\delta_e}{dn} = \frac{aC_L}{C_{m_\alpha} C_{L_{\delta_e}} - C_{m_{\delta_e}}} a (h - h_m) \quad (6.71)$$

The term $d\delta_e/dn$ is not the same for both pull-up and turn since h_m in Equation 6.71 for turns includes the factor $(1 + 1/n^2)$ and is different from the h_m found for the pull-up maneuver. The conclusions reached for Equations 6.36 and 6.52 apply to Equations 6.71 and 6.72 as well.

$$h_m = h_n + \frac{\rho S a_t \eta_t l_t V_H}{2m} (1 + 1/n^2) \quad (6.72)$$

6.7 SUMMARY

Before looking further into the stick-free maneuverability case, it would be well to review the development in the preceding paragraphs and relate it to the results of Chapter 5.

The basic approach to longitudinal stability was centered around finding a value for dC_m/dC_L . It was found that a negative value for this derivative meant that the aircraft was statically stable. The derivative was analyzed for the stick-fixed case first and then the stick-free case. The cg position where this derivative was zero was defined as the neutral point. Static margin was defined as the difference between the neutral point and the cg location. The stick-free case was determined by

$$\left. \frac{dC_m}{dC_L} \right|_{\text{Stick-Free Aircraft}} = \left. \frac{dC_m}{dC_L} \right|_{\text{Stick-Fixed Aircraft}} + \Delta \left. \frac{dC_m}{dC_L} \right|_{\text{Effect of Free Elev}} \quad (5.82)$$

The free elevator case was merely the basic stability of the aircraft with the effect of freeing the elevator added to it.

When the maneuvering case was introduced, it was shown that there was a new derivative to be discussed, but the basic stability of the aircraft would not change - only the effect of pitch rate was added to it.

$$\left. \frac{dC_m}{dC_L} \right|_{\text{Stick-Fixed Aircraft Pitching}} = \left. \frac{dC_m}{dC_L} \right|_{\text{Stick-Fixed Aircraft}} + \Delta \left. \frac{dC_m}{dC_L} \right|_{\text{Effect of the Pitch Rate}} \quad (6.73)$$

For the stick-free case, the following must be true,

$$\left. \frac{dC_m}{dC_L} \right|_{\text{Stick-Free Aircraft Pitching}} = \left. \frac{dC_m}{dC_L} \right|_{\text{Stick-Fixed Aircraft}} + \Delta \left. \frac{dC_m}{dC_L} \right|_{\text{Effect of Free Elev}} + \Delta \left. \frac{dC_m}{dC_L} \right|_{\text{Effect of Pitch Rate}} \quad (6.74)$$

$$\left. \frac{dC_m}{dC_L} \right|_{\text{Stick-Free Aircraft Pitching}} = \left. \frac{dC_m}{dC_L} \right|_{\text{Stick-Free Aircraft}} + \Delta \left. \frac{dC_m}{dC_L} \right|_{\text{Effect of Pitch Rate}} \quad (6.75)$$

NOTE: This "Effect of Pitch Rate" term is not necessarily the same as the corresponding term in Equation 6.73.

6.8. STICK-FREE MANEUVERING

The first analysis of stick-free maneuvering requires a review of longitudinal static stability. It was determined in Chapter 5 that the effect of freeing the elevator was to multiply the tail term by the free elevator factor F which equaled $1 - \tau C_{h_\alpha} / C_{h_\delta}$. Consequently, in the maneuvering case, to find the stick-free maneuver point the tail effect of stick-fixed maneuvering must be multiplied by this free elevator factor. Recalling Equation 6.42 from the stick-fixed maneuvering discussion,

$$h_m = \frac{X_{ac}}{c} - \frac{dC_m}{dC_L}_{FUS} + \frac{a_t}{a_w} v_H \eta_t \left(1 - \frac{d\varepsilon}{d\alpha} \right) - \frac{\rho S c}{4m} C_{m_q} \quad (6.42)$$

Multiplying the tail terms by F,

$$h'_m = \frac{X_{ac}}{c} - \frac{dC_m}{dC_{LFUS}} + \frac{a_t}{a_w} V_H \eta_t \left(1 - \frac{d\epsilon}{d\alpha} \right) F - \frac{\rho S c}{4m} C_{m_q} F \quad (6.76)$$

The first three terms on the right are the expression for stick-free neutral point, h'_n .

Thus,

$$h'_m = h'_n - \frac{\rho S c}{4m} C_{m_q} F \quad (6.77)$$

This is the stick-free maneuver point in terms of the stick-free neutral point for the pull-up case. It may be extended to the turn case by using the term for the pitch rate of the tail in a turn.

$$h'_m = h'_n - \frac{\rho S c}{4m} C_{m_q} F \left(1 + \frac{1}{n^2} \right) \quad (6.78)$$

These equations do not give a flight test relationship, so it is necessary to derive one from stick forces, as was done in longitudinal static stability. The method used will be to relate the stick-force-per-g to the stick-free maneuver point. Starting with the relationship of stick force, gearing, and hinge moment that was derived in Chapter 5,

$$F_s = -GH_e \quad (5.91)$$

$$H_e = q S_e c_e C_h \quad (5.92)$$

$$F_s = -Gq S_e c_e C_h \quad (5.93)$$

The change in stick-force for a change in load factor becomes,

$$\frac{\Delta F_s}{\Delta n} = -Gq S_e c_e \frac{\Delta C_h}{\Delta n} \quad (6.79)$$

where

$$\Delta C_n = C_{n_\alpha} \Delta \alpha_t + C_{n_\delta} \Delta \delta_e \quad (6.80)$$

6.8.1 Stick-Free Pull-up Maneuver

ΔC_n must be written in terms of load factor and substituted back into Equation 6.79. This will require defining $\Delta \alpha_t$ and $\Delta \delta_e$ in terms of load factor. The change in angle of attack of the tail comes partly from the change in angle of attack due to downwash from the wing and partly from the pitch rate.

$$\Delta \alpha_t = \Delta \alpha \left(1 - \frac{d\varepsilon}{d\alpha} \right) + \Delta Q \frac{l_t}{U_0} \quad (6.81)$$

Where $\Delta \alpha$ and ΔQ in the above equation are

$$\Delta \alpha = \frac{1}{a} \left(C_L \Delta n - C_{L_{\delta_e}} \Delta \delta_e \right) \quad (6.16)$$

$$\Delta Q = \frac{g}{U_0} \Delta n \quad (6.27)$$

Recall that

$$\frac{\Delta \delta_e}{\Delta n} = \frac{a C_L}{C_{m_\alpha} C_{L_{\delta_e}} - C_{m_{\delta_e}} a} (h - h_m) \quad (6.36)$$

Assuming $C_{L_{\delta_e}}$ is small enough to ignore, Equations 6.81 and 6.36 can be written

$$\Delta \alpha_t = \frac{C_L}{a} \left(1 - \frac{d\varepsilon}{d\alpha} \right) \Delta n + \frac{g}{U_0^2} l_t \Delta n \quad (6.82)$$

$$\frac{\Delta \delta_e}{\Delta n} = - \frac{C_L}{C_{m_{\delta_e}}} (h - h_m) \quad (6.83)$$

Substituting Equations 6.82 and 6.83 into Equation 6.80, gives Equation 6.84

$$\frac{\Delta C_h}{\Delta n} = C_{h_\alpha} \frac{C_L}{a} \left(1 - \frac{d\varepsilon}{d\alpha}\right) + C_{h_\alpha} g \frac{l_t}{U_0^2} - C_{h_\delta} \frac{C_L}{C_{m_{\delta_e}}} (h - h_m) \quad (6.84)$$

Substituting,

$$U_0^2 = 2W/\rho S C_L \quad (6.30)$$

and the definition of control power,

$$C_{m_{\delta_e}} = - a_t V_H \eta_t \tau \quad (6.50)$$

into Equation 6.84 and factoring gives

$$\frac{\Delta C_h}{\Delta n} = - \frac{C_{h_\delta} C_L}{C_{m_{\delta_e}}} \left[\frac{C_{h_\alpha}}{C_{h_\delta} a} \left(1 - \frac{d\varepsilon}{d\alpha}\right) a_t V_H \eta_t \tau + \frac{C_{h_\alpha}}{C_{h_\delta}} \frac{\rho S l_t}{2m} a_t V_H \eta_t \tau + (h - h_m) \right] \quad (6.85)$$

From longitudinal stability,

$$h_n - h'_n = \frac{C_{h_\alpha}}{C_{h_\delta}} \frac{a_t}{a} V_H \eta_t \tau \left(1 - \frac{d\varepsilon}{d\alpha}\right) \quad (6.86)$$

Substituting Equations 6.86, 6.51, and 6.87 into Equation 6.85 gives Equation 6.88

$$C_{m_q} = - 2a_t V_H \eta_t \frac{l_t}{c} \quad (6.51)$$

$$F = 1 - \tau \frac{C_{h_\alpha}}{C_{h_\delta}} \quad (6.87)$$

$$\frac{\Delta C_h}{\Delta n} = \frac{C_{h\delta} C_L}{C_{m\delta_e}} \left[(h'_n - h_n) + (1 - F) \frac{\rho S c}{4m} C_{m_q} - h + h_m \right] \quad (6.88)$$

But

$$h_m = h_n - \frac{\rho S c}{4m} C_{m_q} \quad (6.35)$$

Therefore

$$\frac{\Delta C_h}{\Delta n} = - \frac{C_{h\delta} C_L}{C_{m\delta_e}} \left[h - h'_n + \frac{\rho S c}{4m} C_{m_q} F \right] \quad (6.89)$$

Substituting Equation 6.89 back into Equation 6.79 and taking the limit gives

$$\frac{dF_s}{dn} = G q S_e c_e \frac{C_{h\delta} C_L}{C_{m\delta_e}} \left[h - h'_n + \frac{\rho S c}{4m} C_{m_q} F \right] \quad (6.90)$$

Defining the stick-free maneuver point h'_m as the cg position where dF_s/dn is equal to zero, Equation 6.90 reduces to

$$h'_m = h'_n - \frac{\rho S c}{4m} C_{m_q} F \quad (6.77)$$

which was previously derived. Equation 6.90 can then be rewritten

$$\frac{dF_s}{dn} = G q S_e c_e \frac{C_{h\delta} C_L}{C_{m\delta_e}} (h - h'_m) \quad (6.91)$$

Equation 6.12 can be substituted into Equation 6.91

$$C_L = \frac{W}{qS} \quad (6.12)$$

which gives the final stick-force-per-g equation

$$\frac{dF_s}{dn} = G S_e c_e C_{h\delta} \left(\frac{W}{S} \right) \left(\frac{1}{C_{m\delta_e}} \right) (h - h'_m) \quad (6.92)$$

6.8.2 Stick-Free Turn Maneuver

The procedures set for determining the dF_s/dn equation and an expression for the stick-free maneuver point for the turning maneuver is practically identical to the pull-up case. For the turn condition, ΔQ is now

$$\Delta Q = \frac{g}{U_0} \Delta n \left(1 + \frac{1}{nn_0} \right) \quad (6.93)$$

The change in angle of attack of the tail, $\Delta\alpha_t$ becomes

$$\Delta\alpha_t = \frac{C_L}{a} \left(1 - \frac{d\varepsilon}{d\alpha} \right) \Delta n + \frac{gl_t}{U_0^2} \Delta n \left(1 + \frac{1}{nn_0} \right) \quad (6.94)$$

and

$$\frac{\Delta\delta_e}{\Delta n} = \frac{-C_L}{C_{m_{\delta_e}}} \left[h - h'_n + \frac{\rho SC}{4m} C_{m_q} \left(1 + \frac{1}{nn_0} \right) \right] \quad (6.95)$$

Substituting Equations 6.94 and 6.95 into Equation 6.80 and performing the same factoring and substitutions as in the pull-up case

$$\frac{\Delta C_h}{\Delta n} = - \frac{C_{h_{\delta}} C_L}{C_{m_{\delta_e}}} \left[h - h'_n + \frac{\rho SC}{4m} C_{m_q} F \left(1 + \frac{1}{nn_0} \right) \right] \quad (6.96)$$

Substituting Equation 6.96 into Equation 6.79 and taking the limit as $\Delta n \rightarrow 0$,

$$\frac{dF_s}{dn} = GqS_e c_e \frac{C_{h_{\delta}} C_L}{C_{m_{\delta_e}}} \left[h - h'_n + \frac{\rho SC}{4m} C_{m_q} F \left(1 + \frac{1}{n^2} \right) \right] \quad (6.97)$$

Solving for the stick-free maneuver point,

$$h'_m = h'_n - \frac{\rho SC}{4m} C_{m_q} F \left(1 + \frac{1}{n^2} \right) \quad (6.98)$$

Further substitution puts Equation 6.97 into the following form:

$$\frac{dF_s}{dn} = G \left(S_e c_e C_{h_{\delta}} \right) \left(\frac{W}{S} \right) \left(\frac{1}{C_{m_{\delta}}} \right) (h - h'_m) \quad (6.99)$$

Again, the turning stick-force-per-g Equation 6.99 appears identical to the stick-free pull-up equation. However, the expression for the maneuver point h'_m is different.

The term in the first parenthesis represents the hinge moment of the elevator and the aircraft size. The second term in parenthesis is wing loading, and the third term in parenthesis is the reciprocal of elevator power. The last term is the negative value of the stick-free maneuver margin.

The following conclusions are drawn from this equation:

1. The stick-force-per-g appears to vary directly with the wing loading. However, weight also appears inversely in h'_m . Therefore, the full effect of weight cannot be truly analyzed since one effect could cancel the other.
2. Since airspeed does not appear in the equation, the stick-force-per-g will be the same at all airspeeds for a fixed cg.

$$h'_m = h'_n - \frac{\rho S c_e}{4m} C_{m_{\delta}} F \quad (6.77)$$

From Equation 6.77 come the following conclusions:

1. The difference between the stick-fixed and stick-free maneuver point is a function of the free elevator factor, F.
2. The stick-free maneuver point, h'_m , varies directly with altitude, becoming closer to the stick-free neutral point, the higher the aircraft flies.

The location of the stick-free maneuver point occurs where $dF_s/dn = 0$. It is difficult to fly an aircraft with this type gradient. Consequently, military specifications limit the minimum value of dF_s/dn to three pounds per g for a center stick, Level 1.

The forward cg may be limited by stick-force-per-g. The maximum value is limited by the type aircraft (bomber, fighter, or trainer), i.e., heavier gradients in bomber types and lighter ones in fighters.

6.9 EFFECTS OF BOBWEIGHTS AND DOWNSPRINGS

The effect of bobweights and downsprings on the stick-free maneuver point and stick-force gradients are of interest. The result of adding a spring or bobweight to the control system adds an incremental force to the system. The effect of the spring is different from the effect of the bobweight. The spring exerts a constant force on the stick no matter what load factor is applied. The bobweight exerts a force on the stick proportional to the load factor.

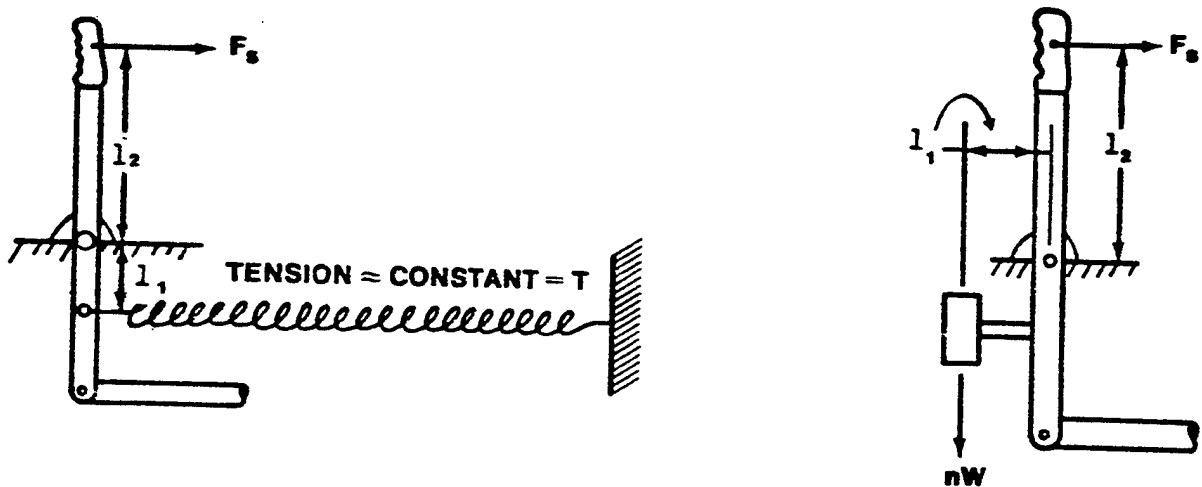

FIGURE 6.9. DOWNSPRING AND BOBWEIGHT

Adding incremental forces for the downspring and bobweight of Equation 5.93 gives

Downspring

$$F_s = -G q S_e c_e C_h + T \frac{l_1}{l_2} \quad (6.100)$$

Bobweight

$$F_s = -G q S_o c_o C_h + nW \frac{l_1}{I_2} \quad (6.101)$$

When the derivative is taken with respect to load factor, the effect on dF_s/dn of the spring is zero. The stick force gradient is not affected by the spring nor is the stick-free maneuver point changed.

Downspring

$$\frac{dF_s}{dn} = -G q S_o c_o \frac{dC_h}{dn} + 0 \quad (6.102)$$

For the bobweight, the stick-force gradient dF_s/dn is affected and

Bobweight

$$\frac{dF_s}{dn} = -G q S_o c_o \frac{dC_h}{dn} + W \frac{l_1}{I_2} \quad (6.103)$$

Consequently, the addition of the bobweight (positive) increases the stick force gradient, moves the stick-free maneuver point aft, and shifts the allowable cg spread aft (the minimum and maximum cg positions as specified by force gradients are moved aft). See Figure 6.10.

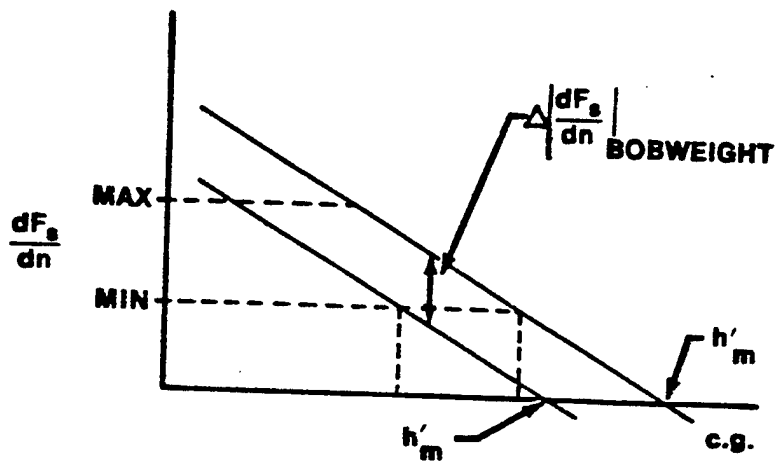

FIGURE 6.10. EFFECTS OF ADDING A BOBWEIGHT

Recall from Chapter 5, Longitudinal Static Stability, (Reference Figure 5.51), that upsprings and bobweights may be used to decrease stick forces. The bobweight may also decrease the stick force gradient. If a bobweight is used in this configuration, a downspring may be needed to counter-balance the bobweight for non-maneuvering (1g) flight conditions, i.e., to preserve the original speed stability before the bobweight was added.

6.10 AERODYNAMIC BALANCING

Aerodynamic balancing is used to affect the stick force gradient and stick-free maneuver point. Aerodynamic balancing or varying values of $C_{h\alpha}$ and $C_{h\delta}$ affects the following stick-free equations:

$$\frac{dF_s}{dn} = G \left(s_e c_e C_{h\delta} \right) \left(\frac{W}{S} \right) \left(\frac{1}{C_{m\delta e}} \right) (h - h'_m) \quad (6.99)$$

$$h'_m = h'_n - \frac{\rho S C}{4m} C_{m_q} F \quad (6.77)$$

$$F = 1 - \tau \frac{C_{h_\alpha}}{C_{h_\delta}} \quad (6.87)$$

Decreasing C_{h_δ} and/or increasing C_{h_α} by using such aerodynamic balancing devices as an overhang balance or a lagging balance tab, does the following:

1. The free elevator factor F decreases
2. The stick-free maneuver point h'_m moves forward
3. The maneuver margin term $(h - h'_m)$ decreases
4. The stick force gradient decreases
5. The forward and aft cg limits move forward

Increasing C_{h_δ} and/or decreasing C_{h_α} by using a convex trailing edge or a leading balance tab does the following:

1. The free elevator factor F increases
2. The stick-free maneuver point h'_m moves aft
3. The maneuver margin term $(h - h'_m)$ increases
4. The stick force gradient increases
5. The forward and aft cg limits move aft

6.11 CENTER OF GRAVITY RESTRICTIONS

The restrictions on the aircraft's center of gravity location may be examined by referring to the mean aerodynamic chord in Figure 6.11.

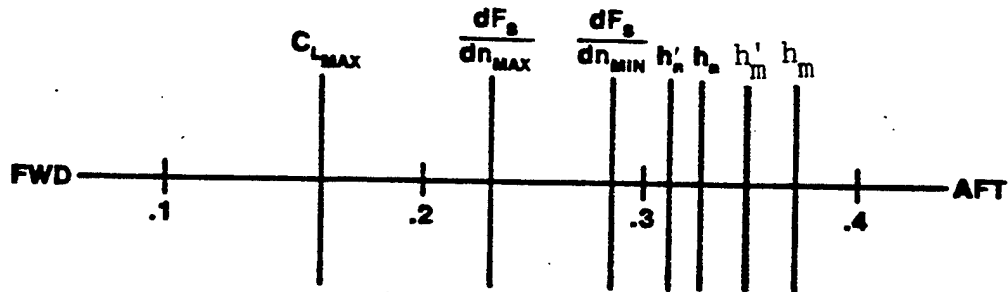

FIGURE 6.11. RESTRICTIONS TO CENTER OF GRAVITY LOCATIONS

The forward cg travel is normally limited by:

1. Maximum stick-force-per-g gradient, dF_s/dn ,
2. Elevator required to flare and land at $C_{L_{MAX}}$ in ground effect, or,
3. Elevator required to raise the nose for takeoff at the proper airspeed.

The aft cg travel is normally limited by:

1. Minimum stick-force-per-g, dF_s/dn , or,
2. Stick-free neutral point (power on), h'_n .

Additional considerations:

1. The stick-free neutral and maneuver points are located ahead of their respective stick-fixed points.
2. The stick-free maneuver point, h'_m , can be moved aft with a bobweight, but not with a downspring.

3. The desired aft cg location may be unsatisfactory because it lies aft of the cg position giving minimum stick force gradient. The requirement for a bobweight or a particular aerodynamic balancing then exists to increase the minimum stick force gradient aft of the desired aft cg position.

The equations which pertain to maneuvering flight are repeated below:

Pull-up, Stick-fixed

$$h_m = h_n - \frac{\rho S c}{4m} C_{m_q} \quad (6.35)$$

$$\frac{d\delta_e}{dn} = \frac{a C_L}{C_{m_\alpha} C_{L_{\delta_e}} - C_{m_{\delta_e}}} a (h - h_m) \quad (6.36)$$

Pull-up, Stick-free

$$h'_m = h'_n - \frac{\rho S c}{4m} C_{m_q} F \quad (6.77)$$

$$\frac{dF_s}{dn} = G S_e c_e C_{h_\delta} \frac{W}{S} \frac{1}{C_{m_{\delta_e}}} (h - h'_m) \quad (6.92)$$

$$\frac{dF_s}{dn} = -G q S_e c_e \frac{dC_h}{dn} + W \frac{1}{l_2} \quad (6.103)$$

Turn, Stick-fixed

$$h_m = h_n - \frac{\rho S c}{4m} C_{m_q} \left(1 + \frac{1}{n^2}\right) \quad (6.70)$$

$$\frac{d\delta_e}{dn} = \frac{a C_L}{C_{m_\alpha} C_{L_{\delta_e}} - C_{m_{\delta_e}}} a (h - h_m) \quad (6.71)$$

Turn, Stick-free

$$h'_m = h'_n - \frac{\rho S c}{4m} C_{m_q} F \left(1 + \frac{1}{n^2}\right) \quad (6.98)$$

$$\frac{dF_s}{dn} = G (S_c C_{h_s}) \left(\frac{W}{S}\right) \left(\frac{1}{C_{m_s}}\right) (h - h'_m) \quad (6.99)$$

6.12 MANEUVERING FLIGHT TESTS

The purpose of maneuvering flight is to determine the stick force versus load factor gradients and the forward and aft center of gravity limits for an aircraft in accelerated flight conditions.

To maneuver an aircraft longitudinally from its equilibrium condition, the pilot must apply a force, F_s , on the stick to deflect the elevator an increment, $\Delta\delta$. The requirements that must be met during longitudinal maneuvering are covered in MIL-STD-1797A paragraphs 4.2.7.2, 4.2.8.1, 4.2.8.2, 4.2.8.4 and 4.2.9.2.

6.12.1 Military Standard 1797A Requirements

MIL-STD-1797A specifies the allowable stick-force-per-g gradient during maneuvering flight. It also specifies that the force gradients be approximately linear with pull forces required to maintain or increase normal acceleration. The pilot must also have sufficient aircraft response without excessive cockpit control movement. These requirements and associated requirements of lesser importance provide the legitimate background for good aircraft handling qualities in maneuvering flight.

The backbone of any discussion of maneuvering flight is stick-force-per-g. The amount of force that the pilot must apply to maneuver his aircraft is an important parameter. If the force is very light, a pilot could overstress or overcontrol his aircraft with very little resistance from the aircraft. The T-38, for instance, has a 5 lb/g gradient at 25,000 feet, Mach 0.9, and 20% MAC cg position. With this condition, a ham-fisted pilot could pull 10 g's with only 50 pounds of force and bend or destroy the aircraft. The designer could prevent this possibility by making the pilot exert 100 lb/g to maneuver. This would be highly unsatisfactory for a fighter type aircraft, but perhaps about right for a cargo type aircraft. The mission and type of aircraft must therefore be considered in deciding upon acceptable stick-force-per-g. Furthermore, the force gradient at any normal load factor must be within 50% of the average gradient at the limit load factor. If it took 10

10 pounds to achieve a 4 g turn, it would be unacceptable for the pilot to reach the limit load factor of 7.33 g's with only a little additional force.

The position of the aircraft's cg is a critical factor in stick-force-per-g consideration. The fore and aft limits of cg position may therefore be established by maneuvering requirements.

6.12.2 Flight Test Methods

There are four general flight test methods for determining maneuvering flight characteristics such as stick force gradients, maneuver points, and permissible cg locations. The names given to these methods vary among test organizations, so make certain that everyone involved is speaking the same language when discussing a particular test method.

6.12.2.1 Stabilized g Method. This method requires holding a constant airspeed and varying the load factor. Establish a trim shot at the test altitude, note the power setting, and climb the aircraft to the upper limit of the altitude band (+2,000 feet). Reset trim power and roll the aircraft slowly into a 15° bank while lowering the nose slowly. At 15° of bank, the stick force required to maintain the condition is only slightly more than friction and breakout. Record data when the aircraft has been stabilized on an airspeed and bank angle. The attitude indicator should be used to establish the bank angle. Increase the bank angle to 30° and record data when stable. Obtain stabilized data points at 45° and 60° also.

Above 60° the bank angle should be increased so as to obtain 0.5 g increments in load factor. Stabilize at each 0.5 g increment, and record data. Terminate the test when heavy buffet or the limit load factor is reached. Above 2.0 g's only slight increases in bank angle are needed to obtain 0.5 g increments. Bank angle required can be approximated from the relationship $\cos \phi = 1/n$ (Figure 6.12).

Little altitude is lost at the lower bank angles up to approximately 60°, and thus more time may be spent stabilizing the aircraft. At 60° of bank and beyond, altitude is being lost rapidly; therefore every effort should be made to be on speed and well stabilized as rapidly as possible in order to stay within the allowable altitude block (test altitude $\pm 2,000$ feet). If the lower altitude limit is approached before reaching limit load factor, climb to the upper limit and continue the test. It is unnecessary to obtain data at precise values of target g since a good spread is all that is necessary. Realistically, data should be obtained within ± 0.2 g of target.

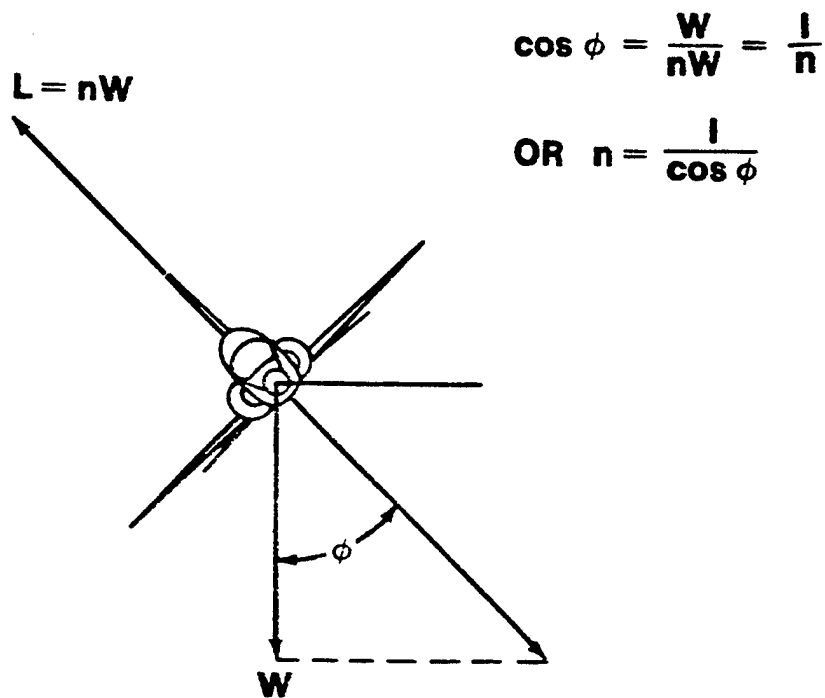

FIGURE 6.12. LOAD FACTOR VERSUS BANK ANGLE RELATIONSHIP

The method of holding airspeed constant within a specified altitude band is recommended where Mach is not of great importance. In regions where Mach may be a primary consideration, every effort should be made to hold Mach rather than airspeed, constant. If power has only a minor effect on the maneuvering stability and trim, altitude loss and the resulting Mach change may be minimized by adding power as load factor is increased. At times, constant Mach is held at the sacrifice of varying airspeed and altitude. For constant Mach tests, a sensitive Mach meter is required or a programmed airspeed/altitude schedule is flown. The stabilized g method is usually used for testing bomber and cargo aircraft and fighters in the power approach configuration.

6.12.2.2 Slowly Varying g Method. Trim the aircraft as before at the desired altitude. Note the power and fly to the upper limit of the altitude band (+2,000 feet). Reset power at the trimmed value and record data. Increase load factor and bank angle slowly holding airspeed constant until heavy buffet or limit load factor is reached. The rate of g onset should be approximately 0.2 g per second. Airspeed is of primary importance and should be held to within +2 knots of aim airspeed. Take care not to reverse stick forces during the maneuver.

If the airspeed varies excessively, or the lower altitude limit is approached, turn off the data recorder and repeat the test up to heavy buffet onset or limit load factor.

The greatest error made in this method is bank angle control when beyond 60° of bank. Excessive bank causes the aircraft to traverse the g increments too quickly to be able to accurately hold airspeed. Good bank control is important to obtain the proper g rate of 0.2 g per second. An error is induced in this method since the aircraft is in a descent rather than level flight. Stick forces to obtain a specific g will be less than in level flight. Fortunately, this error is in the conservative direction.

The slowly varying g method may be more applicable to fighter aircraft. Often a combination of the two methods is used in which the stabilized g method is followed up to 60° bank angle and then the slowly varying g method is used until heavy buffet or limit load factor is reached.

6.12.2.3 Constant g Method. Stabilize and trim at the desired altitude and maximum airspeed for the test. Establish a constant g turn. Record data and climb or descend to obtain a two to five knot per second airspeed bleed rate at the desired constant load factor. Normally climbs are used to obtain a bleed rate at low load factors and descents are used to obtain a bleed rate at high load factors. For high thrust-to-weight ratio aircraft at low altitudes, the maneuver may have to be initiated at reduced power to avoid rapidly traversing the altitude band. Maintaining the aim load factor is the primary requirement while establishing the bleed rate is secondary. Keep the aircraft within the altitude band of $\pm 2,000$ feet. Note the airspeed as the aircraft flies out of the altitude band. Return to the altitude band and start at an airspeed above the previously noted airspeed so that continuity of g and airspeed can be maintained. Note airspeed at buffet onset and the g break (when aim load factor can no longer be maintained). The buffet and stall flight envelope is determined or verified by this test method. Repeat the maneuver with 0.5 g increments at high altitudes and 1 g increments at low altitudes. This method does not define maneuver points or stick force gradients but is introduced for familiarization with different turn techniques. The primary use is to define stall/buffet boundaries and elevator deflections at different loadings.

6.12.2.4 Symmetrical Pull Up Method. Trim the aircraft at the desired test altitude and airspeed. Climb to an altitude above the test altitude using power as required. Reset trim power and push over into a dive. The dive angle and lead airspeed are functions of the target load factor.

Maneuver the aircraft to a lead point that will place it at a given constant load factor while passing through the test altitude at the test airspeed. Two methods may be used which yield the same results. The idea behind both methods is to minimize the number of variables.

a. Method A - Using a variable dive angle and fixed lead airspeed smoothly increase back pressure so that the airspeed stabilizes at trim airspeed. There is a specific dive angle which will allow you to stabilize the airspeed as you pass through 10° of dive.

b. Method B - Using a constant dive angle and adjusting lead airspeed, smoothly apply back pressure to establish the target g. If the proper lead airspeed is used, the airspeed will stabilize as the target g is established.

Using either method, the aircraft should pass through level flight ($\pm 10^\circ$ from horizontal) just as the airspeed reaches the trim airspeed with aim g loading and steady stick forces. Be sure to freeze the stick. Achieving the trim airspeed through level flight, $\pm 10^\circ$, and holding steady stick forces to give a steady pitch rate are of primary importance. The variation in altitude ($\pm 1,000$ feet) at the pull up is less important. The g loading need not be exact ($\pm 0.2g$) but must be steady. Record data as the aircraft passes through level flight $\pm 10^\circ$.

PROBLEMS

6.1. Given the following data, find the stick fixed maneuver point:

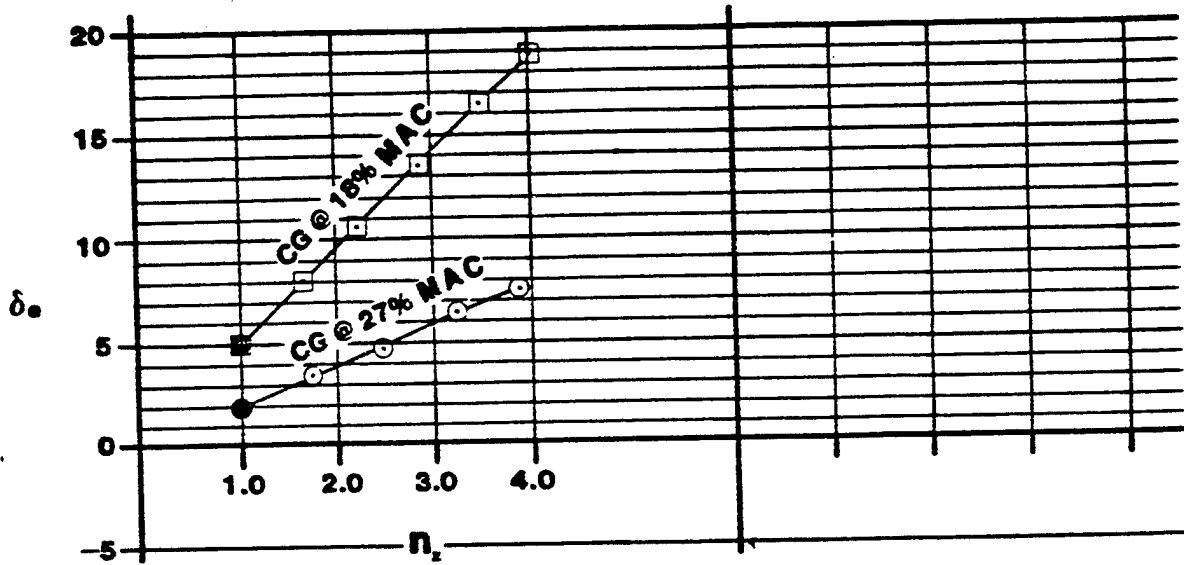

6.2. A. Compute C_{n_q} for the T-33A

$$l_T = 16.5 \text{ ft}$$

$$c = 6.7 \text{ ft}$$

$$\eta_T = 1.0$$

$$a_T = 3.5 \text{ RAD}^{-1}$$

$$S_T = 45.5 \text{ ft}^2$$

$$S = 235 \text{ ft}^2$$

B. Compute C_{n_q} for the F-4C

$$l_T = 21 \text{ ft}$$

$$c = 16.0 \text{ ft}$$

$$\eta_T = 1.0$$

$$a_T = 3.0 \text{ RAD}^{-1}$$

$$S_T = 96 \text{ ft}^2$$

$$S = 530 \text{ ft}^2$$

C. If C_{n_q} is in the range of -6.5 to -9 for most aircraft, which aircraft (T-33 or F-4C) would you anticipate might have maneuvering flight and dynamic damping problems?

D. How does C_{n_q} computed for the T-33A in 2.A on the last page compare to real wind tunnel data shown below?

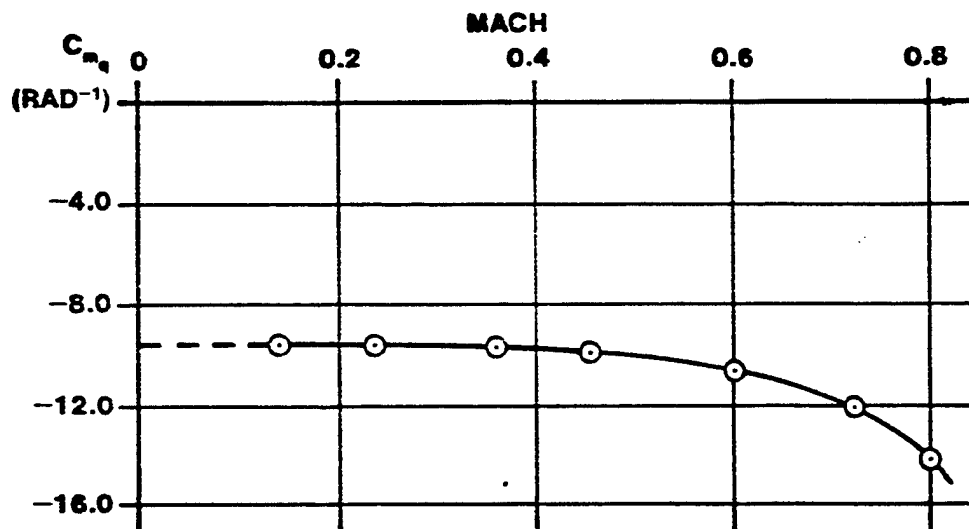

6.3. Given that an aircraft with a reversible flight control system has stick-fixed and stick-free neutral points of 30% and 28% respectively, the following is flight test data using the stabilized method (which is a technique involving stabilized turns).

$$\tau = -0.4$$

$$C_{h_\alpha} = .004$$

$$C_{h_\delta} = -.008$$

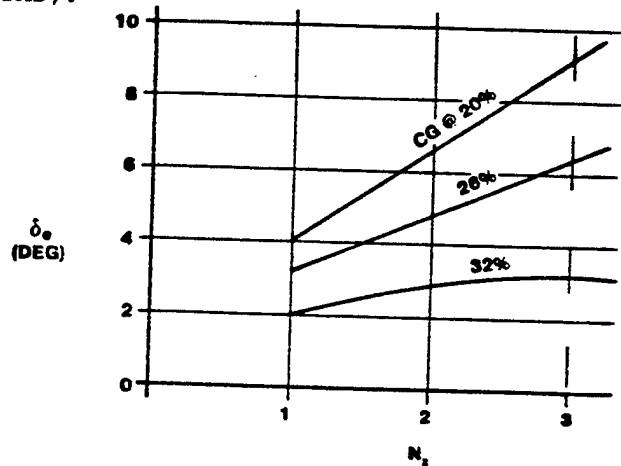

What is the value of the stick-free maneuver point at $n = 3$?

6.4. At the same trim and test point, a blue T-33 is in a stabilized 3 g pull up maneuver, and a red T-33 is in a stabilized 2 g steady turn maneuver. Both aircraft are standard T-33's (except for the color) and have identical gross weights. Which one has the higher-stick-force-per-g? Show why.

6.5. For a given set of conditions, an RF-4C had a stick force gradient as shown below. Compute the weight of the bobweight needed to increase this gradient to a minimum of five pounds per g.

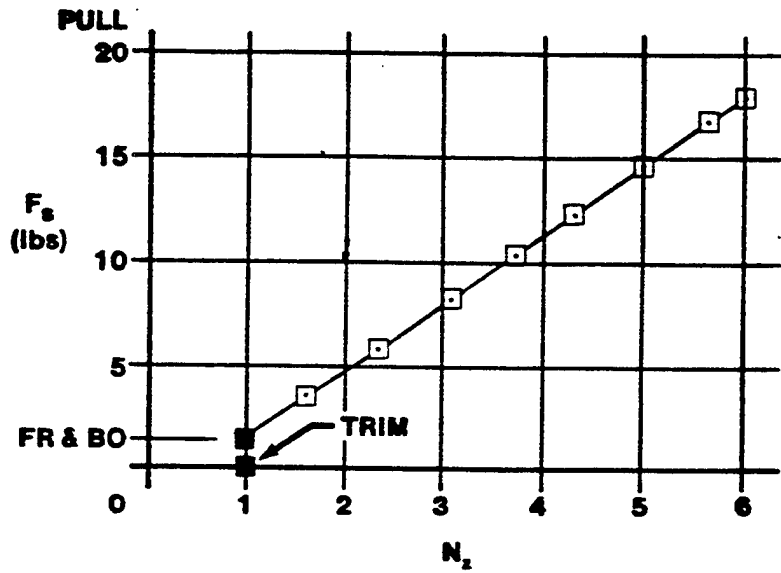
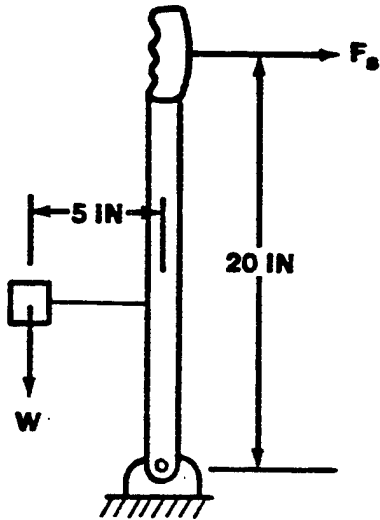

6.6. Given the transport aircraft data on this page, find the stick-fixed and stick-free maneuver points. What are the stick-fixed and stick-free maneuver margins? What is the friction and breakout force?

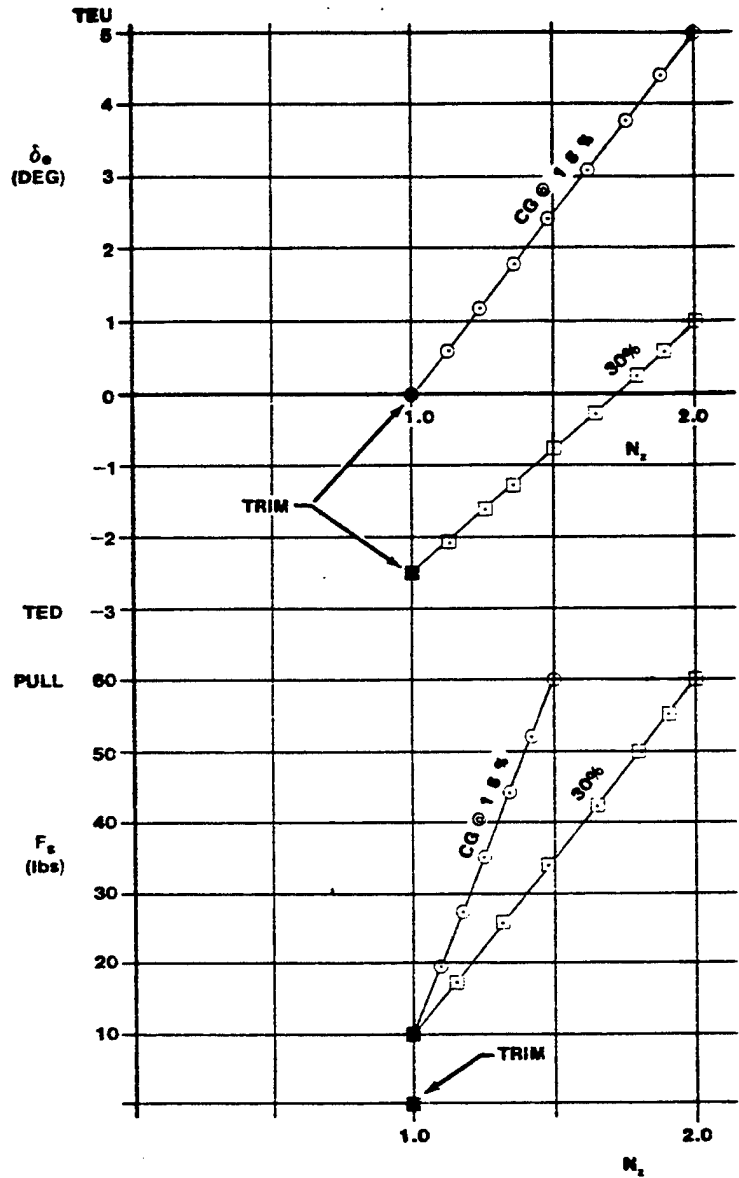

6.7. Given the flight test data at the end of this problem:

- A. Calculate the stick-free maneuver point.
- B. Calculate the stick-fixed maneuver point.
- C. If the minimum desired dF_s/dn is 3 lb/g, calculate the aft cg limit.
- D. Calculate the maneuver margin at the aft cg limit.
- E. If the stick-fixed neutral point was 48% MAC and given the following data, calculate an estimate for C_{n_q} . NOTE: C_{n_q} is very sensitive to h_n locations so an estimate of C_{n_q} calculated from aircraft geometry is probably as good, or better, than this flight test derived value. Density at test altitude, ρ , is 0.002 slugs/ft³.

$$S = 300 \text{ ft}^2$$

$$c = 7 \text{ ft}$$

$$W = 18,000 \text{ lbs}$$

- F. A new internal fuel tank arrangement is planned for the aircraft which will move the aircraft cg to 40% MAC. If a minimum stick-force-per-g of 3 lb/g is required at this new cg location, what size bobweight is required as a "fix"?

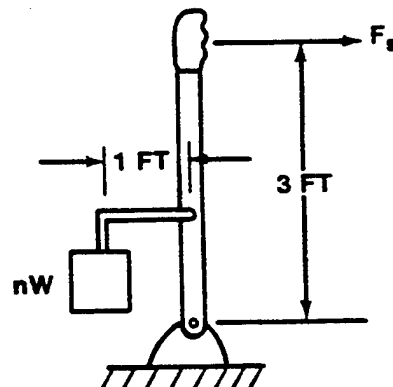

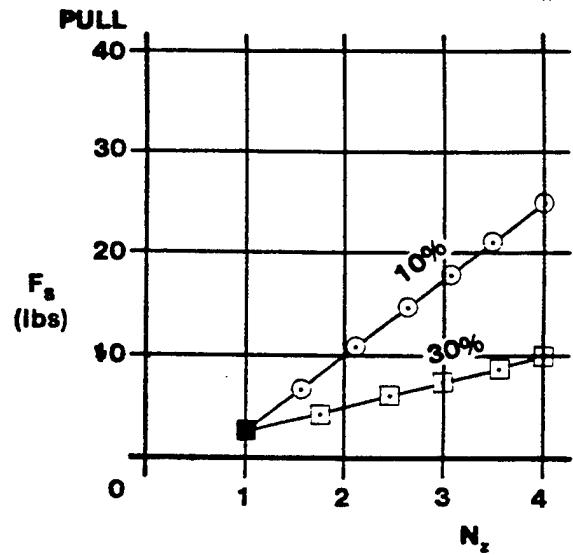
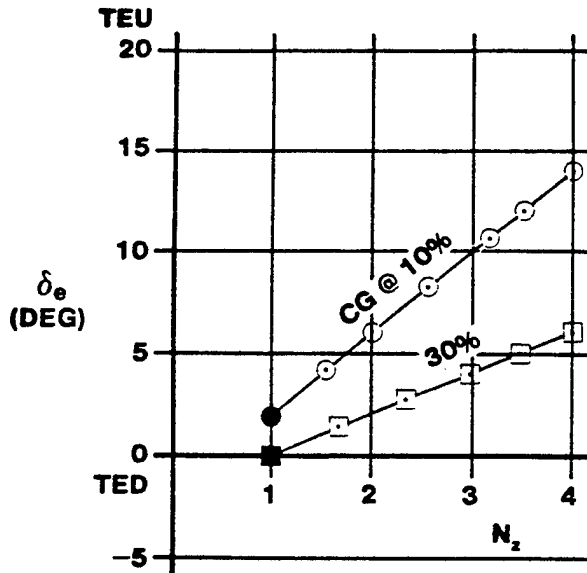

G. What downspring tension, T , is required to obtain the same minimum dF_s/dn determined in Part F.?

H. The forward cg limit is to remain at 10% MAC. What is the maximum stick-force-per-g the aircraft will have after bobweight installation?

6.8. An aircraft has a stick-force-per-g of one lb/g at a cg of 40% MAC. It is desired that the aircraft have a three lb/g maneuvering stick force gradient at the same cg without changing the aircraft's speed stability. You are given the choice of bobweight A or B, and/or springs C and D. Which bobweights and springs should be used and what should their sizes and tensions be?

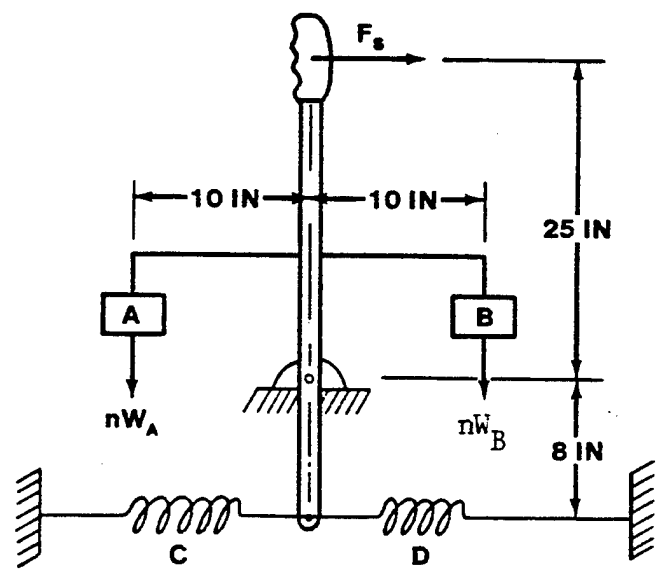

T_C AND T_D ARE CONSTANTS

6.9. Given the flight test data and MIL-STD-1797A requirements shown below:

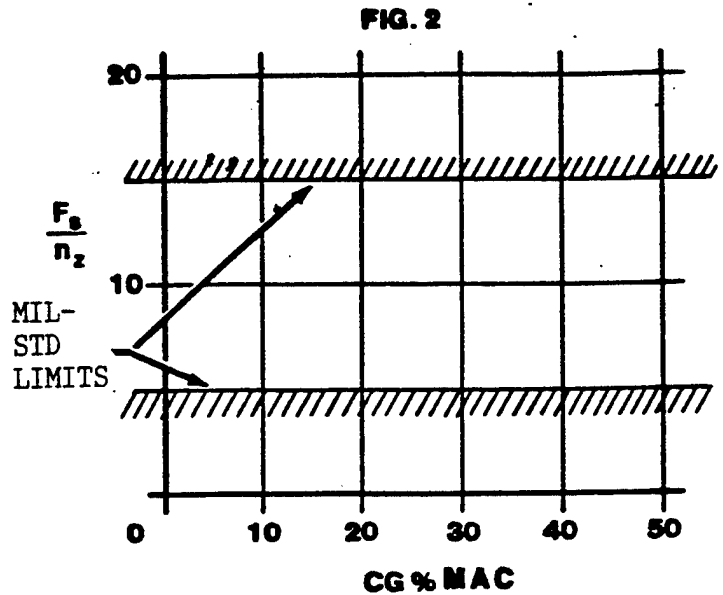
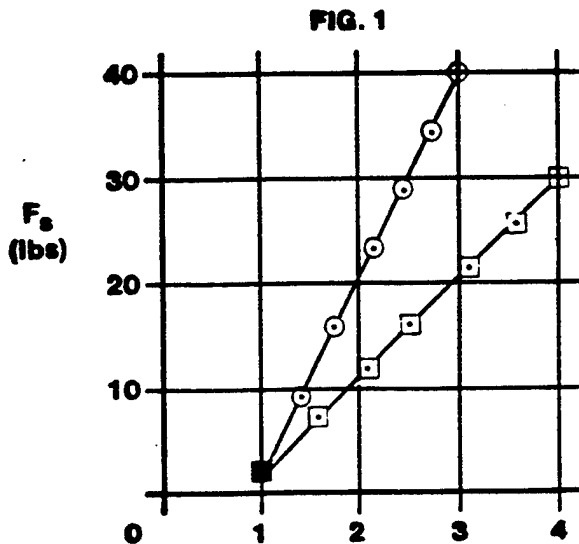

- One set of data on Figure 1 was taken at FWD cg (15% MAC) and the other at an AFT cg (30% MAC). Label the curves FWD and AFT properly.
- Determine the stick-free maneuver point.
- What is the AFT cg limit to meet the minimum MIL-STD stick force per g shown on Figure 2?
- What is the FWD cg limit to meet the maximum MIL-STD stick force per g?
- Given the control stick geometry shown below and choice of either bobweight A, bobweight B, or upspring C, which weight or spring and what size weight or spring is needed to just meet the maximum MIL-STD stick force per g requirement at cg of 15% MAC?

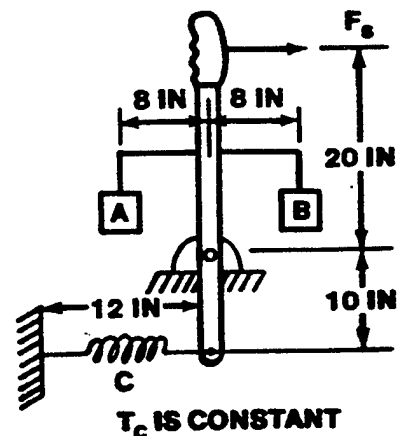

6.10. Read the question and circle the correct answer, true (T) or false (F).

- T F The maneuver point should always be behind the neutral point.
- T F C_{m_q} is always positive.
- T F Pitch rate decreases stability.
- T F The distance between the neutral point and the maneuver point is a function of aircraft geometry, altitude, and aircraft weight.
- T F The additional elevator requirement under aircraft bending gives an increase in stability.
- T F Maneuvering flight data can be collected in turns but not in pull-ups.
- T F Theory says that stick-force-per-g is the same at all airspeeds for a given cg.
- T F FWD cg position may be limited by a maximum value of dF_s/dn .
- T F Imposing a minimum value of dF_s/dn as the MIL-STD does prevents the permissible aircraft cg from being behind the maneuver point.
- T F The effect of either a spring or a bobweight is the same on stick-force-per-g.
- T F A downspring exerts a constant force on the stick independent of load factor.
- T F A bobweight exerts a constant force on the stick independent of load factor.
- T F A downspring effects maneuvering stick force gradient.
- T F A bobweight effects maneuvering stick force gradient.
- T F Aerodynamic balancing effects the stick-free maneuver point location.
- T F The stick-free maneuver point is normally ahead of the stick-fixed maneuver point (tail-to-the-rear aircraft).
- T F A downspring changes the location of the maneuver point.

- T F In "second order differential equation (mass-spring-damper) terms," $C_{m\alpha}$ is analogous to damping.
- T F Although both stick-fixed and stick-free neutral points can be defined, only a stick-free maneuver point exists.
- T F $C_{m\dot{q}}$ can be obtained from maneuvering flight tests.
- T F The wing is the largest contributor to pitch damping.
- T F $C_{m\dot{\alpha}}$ is commonly called "pitch damping" in informed aeronautical circles.
- T F In "second order differential equation (mass-spring-damper) terms," C_{mq} is analogous to the spring.
- T F In subsonic flight (no Mach effects) $\partial C_m / \partial Q$ is constant.
- T F In subsonic flight (no Mach effects), C_{mq} is a function of velocity.
- T F Maneuvering stick-force gradient data obtained from turning flight tests is identical to that obtained from pull-up flight tests.
- T F $\partial C_m / \partial Q$ and C_{mq} are identical.
- T F V_H is considered constant even though cg is allowed to vary.
- T F Increasing stability decreases maneuverability.
- T F $d\delta_e / dn$ is the same for both pull-up and turn maneuvers.
- T F Aerodynamic balancing does not effect dF_s / dn .
- T F FWD and AFT cg travel may be limited by maximum and minimum values of stick-force-per-g.
- T F Maneuvering stick-force gradient and stick force-per-g are the same.
- T F The same curve can be faired through maneuvering flight test data obtained by the pull-up and turn techniques.

ANSWERS

6.1. $h_m = 32.5\%$

6.2. A. $C_{m\dot{q}} = -8.2$ per rad for tail
 $C_{m\dot{q}} = -9.0$ per rad for aircraft

B. $C_{m\dot{q}} = -1.9$ per rad - tail

$C_{m\dot{q}} = -2.1$ per rad - aircraft

6.3. $h'_m = 0.296$

6.4. Red has higher dF_s/dn

6.5. $W = 6.8$ lb

6.6. $h_m = 0.65$

$h'_m = 0.45$

cg	Maneuver margin	
	Fixed	Free
15%	0.50	0.30
30%	0.35	0.15

Friction + Breakout = 10 lb

6.7. A. $h'_m = 0.40$

B. $h_m = 0.50$

C. Aft cg = 0.28

D. Man mar. fixed = 0.22

Man mar. free = 0.12

E. $C_{m_q} = -10.64$ per rad

F. $W = 9$ lb

G. Can't be done with spring.

H. $F_s/g = 10.5$ lb/g

6.8. $W_A = 5$ lb

Must be offset by $T_c = 6.25$ lb at $n = 1$

6.9. B. $h'_m = 0.45$

C. Aft lim = 37%

D. Fwd lim = 22%

E. $W_B = 10$ lb