

REPORT DOCUMENTATION PAGE

Form Approved
OMB No. 0704-0188

Public reporting burden for this collection of information is estimated to average 1 hour per response, including the time for reviewing instructions, searching existing data sources, gathering and maintaining the data needed, and completing and reviewing the collection of information. Send comments regarding this burden estimate or any other aspect of this collection of information, including suggestions for reducing this burden, to Washington Headquarters Services, Directorate for Information Operations and Reports, 1215 Jefferson Davis Highway, Suite 1204, Arlington, VA 22202-4302, and to the Office of Management and Budget, Paperwork Reduction Project (0704-0188), Washington, DC 20503.

1. AGENCY USE ONLY (Leave blank)		2. REPORT DATE September 1996	3. REPORT TYPE AND DATES COVERED Final October 1993 - September 1995	
4. TITLE AND SUBTITLE Engineered Systems for Handling Material and Product Between Processing Operations (Short Term Project STP #14)			5. FUNDING NUMBERS C-DLA 900-88-D-0383 PE-7811s PR-88003	
6. AUTHOR(S) T. Descovich, N. Litman and J. Luxhoj				
7. PERFORMING ORGANIZATION NAME(S) AND ADDRESS(ES) Rutgers, The State University of New Jersey The Center for Advanced Food Technology Cook College, NJ Agricultural Experiment Station New Brunswick, NJ 08903			8. PERFORMING ORGANIZATION REPORT NUMBER FTR 22.0	
9. SPONSORING/MONITORING AGENCY NAME(S) AND ADDRESS(ES) Defense Logistics Agency 8725 John J. Kingman Road Ft. Belvoir, VA 22060-6221			10. SPONSORING/MONITORING AGENCY REPORT NUMBER	
11. SUPPLEMENTARY NOTES				
12a. DISTRIBUTION / AVAILABILITY STATEMENT <div style="border: 1px solid black; padding: 5px; text-align: center;">DISTRIBUTION STATEMENT A Approved for public release; Distribution Unlimited</div>			12b. DISTRIBUTION CODE	
13. ABSTRACT (Maximum 200 words) The major equipment and steps in the production of combat rations have been individually addressed in the CRAMTD demonstration site, such as filling and seaming Tray Pack cans, filling and sealing MRE pouches and retorting for sterility. The introduction of materials and ingredients into the process, and movement between operations has been accomplished manually and expeditiously, but the methods and equipment used would not support normal production rates. Further, there was a need to optimize product safety and overall efficiency. This project covered documentation and analysis of current technology, and resulted in the development of integrated systems for moving product and material in and between specific process areas. A Hi-Speed Checkweigher, Pouch Inspection Conveyor, Brenner Retort Loader, Roll Hoist Machine, Intermittent Bucket Conveyor and Centralized Control Station were developed and demonstrated during the project. Non-Traditional Capital Investment Criteria (NCIC) studies were made of "Product Feeders", Retort Crate Loading" and a "Centralized Control Station".				
14. SUBJECT TERMS			15. NUMBER OF PAGES 147	
			16. PRICE CODE	
17. SECURITY CLASSIFICATION OF REPORT Unclassified	18. SECURITY CLASSIFICATION OF THIS PAGE Unclassified	19. SECURITY CLASSIFICATION OF ABSTRACT Unclassified	20. LIMITATION OF ABSTRACT UL	

19961220 096

DISCLAIMER NOTICE

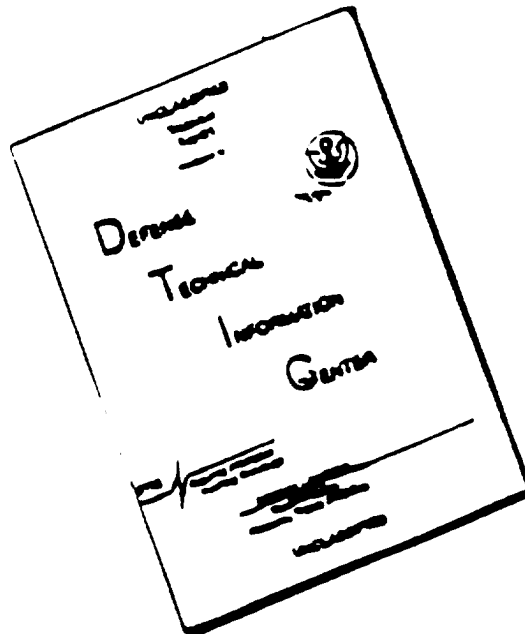

THIS DOCUMENT IS BEST
QUALITY AVAILABLE. THE COPY
FURNISHED TO DTIC CONTAINED
A SIGNIFICANT NUMBER OF
PAGES WHICH DO NOT
REPRODUCE LEGIBLY.

**COMBAT RATION
ADVANCED MANUFACTURING
TECHNOLOGY DEMONSTRATION
(CRAMTD)**

**"Engineered Systems for Handling Material and Product
Between Processing Operations"
Short Term Project (STP) #14**

**FINAL TECHNICAL REPORT
Results and Accomplishments (October 1993 through September 1995)
Report No. CRAMTD STP #14 - FTR22.0
CDRL Sequence A004
September 1996**

CRAMTD CONTRACT NO. DLA900-88-D-0383
CLIN 0004

Sponsored by:
DEFENSE LOGISTICS AGENCY
8725 John J. Kingman Road
Ft. Belvoir, VA 22060-6221

Contractor:
Rutgers, The State University of New Jersey
THE CENTER FOR ADVANCED FOOD TECHNOLOGY*
Cook College
N.J. Agricultural Experiment Station
New Brunswick, New Jersey 08903

Principal Investigators:
Theodore Descovich
Neal Litman
James Luxhoj

Dr. John F. Coburn
Program Director

TEL: 908-445-6132
FAX: 908-445-6145

19961220 096

Contents

1.0	CRAMTD STP #14	1
1.1	Introduction and Background	1
1.2	Results and Conclusions	1
1.3	Recommendations	2
2.0	Program Management	2
2.1	Progress Summary	2
2.1.1	Checkweigher	2
2.1.2	Inspection Conveyor and Rack Loading	3
2.1.3	Other Equipment	3
2.1.4	Centralized Control Station	3
3.0	Short Term Project Activities	4
3.1	STP Phase I Tasks	4
3.1.1	Establish System Design Requirements (Task 3.3.1.1)	4
3.1.2	Develop Conceptual Designs (Task 3.3.1.2)	4
3.1.3	Preliminary Engineering (Task 3.3.1.3)	4
3.1.4	Finalize Design/Recommendations (Task 3.3.1.4)	4
3.2	STP Phase II Tasks	5
3.2.1	Design Drawings, Specifications (Task 3.3.2.1)	5
3.2.2	Fabrication/Assembly (3.3.2.2)	5
3.2.3	Testing/Debugging (subcontractor) (Reference 3.3.2.3)	5
3.3	STP Phase III Tasks	5
3.3.1	Installation (3.3.3.1)	5
3.3.2	Testing/Evaluation (3.3.3.2)	5
4.0	Appendix	6
4.1	Projected Time & Events and Milestones	
4.2	Production Line Layout	
4.3	Revised Production Line Layout	
4.4	Hi-Speed Checkweigher	
4.4.1	Specifications	
4.4.2	Proposal	
4.4.3	Features	
4.5	Pouch Inspection Conveyors	
4.5.1	Specifications	
4.5.2	Proposal	
4.5.3	Layout Drawing	
4.6	Brenton Retort Loaders/Unloaders	
4.6.1	Specifications (Refer to Appendix 4.5.1)	
4.6.2	Proposal	
4.6.3	Layout Drawing	
4.7	Product Feeders	
4.8	Roll Hoist - Film Handling	
4.9	Econocorp Pouch Feeding Conveyor	
4.10	Centralized Control Station (CCS)	
4.10.1	Specifications	
4.10.2	Proposal	
4.10.3	Diagram	
4.11	Non-Traditional Capital Investment Criteria (NCIC) - Retort Loaders	
4.12	Non-Traditional Capital Investment Criteria (NCIC) - Product Feeders	
4.13	Non-Traditional Capital Investment Criteria (NCIC) - CCS	

1.0 CRAMTD STP #14

Results and Accomplishments

1.1 Introduction and Background

STP #14, "Engineered Systems for Handling Material and Products Between Processing Operations", was started October 1, 1993 based on the final proposal revision submitted dated June 22, 1992.

The major equipment and steps in the production of combat rations have been individually addressed in the CRAMTD demonstration site, such as filling and seaming Tray Pack cans, filling and sealing MRE pouches and retorting for sterility. Only small quantities of actual products have been made. The introduction of materials and ingredients into the process, and movement between operations has been accomplished manually and expeditiously, but the methods and equipment used would not support normal rates of production found in food plants. Further, there is a need to optimize on product safety and overall efficiency as in a real production environment. In the CRAMTD facility, the need exists to determine and introduce the most modern and cost effective transfer mechanisms, tools, and/or methods available. The methods and devices selected must be appropriate for demonstrating advanced processing within CRAMTD, and they should be useful and applicable to companies who produce packaged food such as combat rations for profit. This project is to cover the documentation and analysis of current technology, and result in the design and development of integrated systems for moving product and material in and between specific process areas.

1.2 Results and Conclusions

The Hi-Speed Checkweigher, Pouch Inspection Conveyors and Brenton Retort Loaders performed satisfactorily producing MRE Pouches at the "End of Contract Briefing" on June 19, 1996. The MRE Production Line during this demonstration was operated from the Centralized Control Station (Appendix 4.10) not only controlling remotely all major and minor equipment but also collecting production line data.

Non-Traditional Capital Investment Criteria (NCIC) studies were made on "Product Feeders", "Retort Crate Loading" and a "Centralized Control Station".

The NCIC study on Product Feeders (Appendix 4.12) examined the use of feeders that would automatically control the fill level as compared to manual feeding of the filling equipment. It concluded that it was economically justified, however, due to STP budget constraints it was not implemented.

The NCIC study on Retort Crate Loading (Appendix 4.11) compared manual loading (with the use of auxiliary equipment) of retort crates to semi-automatic loading. The NCIC revealed that due to anticipated costs of potential system downtime associated with the more technically sophisticated machine it was the preferred economic choice to use manual loading with assisted equipment.

The NCIC study on a Centralized Control Station (Appendix 4.13) compares the existing unit operations of the MRE Production Line whereby all start and stop operations are only accessible at the individual control panels of each piece of equipment to a Centralized Control Station (CCS). The NCIC study concluded that it was economical to design and install a CCS. The CCS controls all equipment on the MRE Pouch Line, indicates in real time where downtime occurred and allows for product recipes to be downloaded into the system.

1.3 Recommendations

It is recommended that MRE suppliers consider installing inspection conveyors and semi-automatic retort rack loaders at the discharge end of the new Multivac Horizontal Form-Fill Seal machines. The Non-Traditional Capital Investment Criteria (NCIC) Appendix 4.11 concluded that manual loading with the use of auxiliary lifting equipment was the preferred economic choice.

In the future if a two part filling system is used on the Multivac machines, it is recommended to include with the Solbern Filler a checkweigher with a servo feedback to achieve an accurate fill. Also, with this two part system, product feeders (Appendix 4.7) should be installed for the two fillers to maintain accuracy.

As more auxiliary equipment (robotic placeable and two part filling) is installed on the Multivac machines, consideration should be given to a Centralized Control Station.

2.0 Program Management

This STP was proposed as a three phase work activity as illustrated on the "CRAMTD STP #14 Time and Events and Milestones" (Appendix 4.1). The scope of this project was to:

Phase I. Process Review and Preliminary Engineering

Phase II. Subcontractor Fabrication, Testing and Assembly of Prototype Equipment

Phase III. Installation, Testing, Modifying and Demonstration Runs at CRAMTD

The timetable illustrated in the attached Appendix 4.1 reflects an extension of delivery to September 30, 1995.

2.1 Progress Summary

2.1.1 Checkweigher

A Checkweigher/Reject system was integrated with the Solbern tumble filler providing the fill accuracy of a scale filler but with better cost/benefit (NCIC) for product giveaway.

- Specifications were prepared for the checkweigher/reject system
- Requests for quotation sent to the following companies for checkweighing: Hi-Speed Checkweigher, Ramsey Technology, Barkley & Dexter and International Automation.

- Pre-bid conference for quotation on a checkweigher/reject system was held on January 12, 1994.
- Vendors were evaluated on the following criteria: delivery, cost, performance, engineering features, service and training. Hi-Speed Checkweigher was selected.

2.1.2 Inspection Conveyor and Rack Loading

The integrated Inspection Conveyor/Rack Loader couples the HFFS discharge with an improved inspection station and an operator assisted Retort Crate Loader.

- Equipment designs were developed for inspection conveyors and semi-automatic retort rack loading at the discharge of the MRE Pouch Line.
- Specifications were prepared for the Pouch Inspection Conveyor at the discharge of the MRE Line.
- Requests for quotation were sent to the following companies for Pouch Inspection Conveyor: Precision Automation, Enterprise Automation, Brenton Engineering and Conveyor Technology.
- Pre-bid conference for quotation on the Pouch Inspection Conveyor was held, Precision Automation met our specifications and was selected. They were the only bidder of the four to whom the RFP was sent and they did meet our specifications.
- Brenton Engineering was approved as a sole source subcontractor for two Semi-Automatic Retort Loading/Unloading Stations.

2.1.3 Other Equipment

Other equipment (film-roll Hoist and Bucket Conveyor) was acquired for safety and increased production capacity.

- A Roll Hoist Machine was purchased to handle the MRE top and bottom rolls on the Tiromat Form/Fill/Seal Machine.
- An Intermittent Motion Bucket Conveyor was purchased as sole source from Econocorp for automatically loading MRE pouches into an Econocorp Cartoner.

2.1.4 Centralized Control Station

A Centralized Control Station provides single-location control of unit operations and data-logging (subsystem status, fault conditions, record keeping, line component integration, quality control) thereby minimizing downtime and increasing production efficiency.

- Specifications were prepared for a Centralized Control Station for the MRE Horizontal Form/Fill/Seal Production Line.
- Requests for quotation sent to the following companies for a Centralized Control Station: Precision Automation, Delta Control Systems and Enterprise Automation.

- Precision Automation was selected based on our evaluation selection process.
- MRE Pouch Line demonstrated for the June 19, 1996 Final Contract Briefing. Demonstration included the Centralized Control Station, Checkweigher, Inspection Conveyors and Retort Loaders.

3.0 Short Term Project Activities

3.1 STP Phase I Tasks

3.1.1 Establish System Design Requirements (Task 3.3.1.1)

The system design requirements were established. The process areas where material handling and transfer of containers is required were identified (See Appendix 4.2 and 4.3).

3.1.2 Develop Conceptual Designs (Task 3.3.1.2)

Equipment designs were developed and budget estimates obtained on: inspection and retort loading conveyors, semi-automatic retort rack loading at the discharge of the MRE Pouch Line, checkweighers/servo system for the Solbern Filler, product feeders for the Solbern and FEMC Fillers and a liquid handling system using Croll-Reynolds vacuum cooling method.

3.1.3 Preliminary Engineering (Task 3.3.1.3)

Engineering meetings and plant visits were made with vendors to define machine specifications, fabrication time and costs on the equipment shown on Appendix 4.2. Based on a Croll-Reynolds tentative donation, tests were made at Lee Industries Pilot Plant in Pennsylvania (who has a Croll-Reynolds vacuum cooling unit) to determine the cooling rate required to cool beef stew gravy with this system. Flavor tests were also performed to ascertain if any flavor was lost due to vacuum. It was concluded that vacuum cooling had no significant effect on flavor.

Three Non-traditional Capital Investment Criteria (NCIC) studies were made: Retort Crate Loading (Appendix 4.11), Product Feeders (Appendix 4.12) and a Centralized Control Station for the MRE Production Line (Appendix 4.13).

3.1.4 Finalize Design/Recommendations (Task 3.3.1.4)

Design concepts were finalized and preliminary recommendations made as to what vendors to include in the pre-bid conferences. Ball park cost estimates and fabrication times were obtained. As a result of the NCIC studies it was decided to proceed with the Centralized Control Station and the Retort Loaders. While the product feeders (Appendix 4.7) were judged to be economical in the NCIC study, due to budget constraints it was decided to not proceed with their purchase. This was also the case with a liquid handling system.

3.2 STP Phase II Tasks

3.2.1 Design Drawings, Specifications (Task 3.3.2.1)

Specifications and layout drawings were completed for the following: Pouch Inspection Conveyors (Appendix 4.4.1), Brenton Retort Loaders/Unloaders (Appendix 4.5.1), Checkweigher/Reject System (Appendix 4.3.1), Roll Film Hoist (Appendix 4.8) and a Pouch Product Loading Conveyor (Appendix 4.9 into the cartoner and Inspection Conveyor after retorting).

3.2.2 Fabrication/Assembly (3.3.2.2)

Pre-bid Conferences and subcontract awards were made to the following companies: Hi-Speed Checkweigher Co. (Appendix 4.4) to checkweigh product in the small MRE transfer cup and the larger tray pack transfer cup and to Precision Automation for a pre-retort pouch inspection conveyor (see Appendix 4.5)

Brenton Engineering was approved as the sole source subcontractor for two Manual-Equipment assisted Retort Loading/Unloading Stations (Appendix 4.6) and Econocorp was also approved as the sole source subcontractor for an Intermittent Motion Conveyor (Appendix 4.9) to connect to the Econocorp cartoner. The conveyor will automatically load MRE Pouches into the Econocorp cartoner and is part of the post-retort inspection system.

A Roll Hoist Machine was purchased to handle the MRE top and bottom rolls on the Tiromat Form/Fill/Seal Machine. (Appendix 4.8).

A purchase order was issued for a MRE Centralized Control Station. This joint STP #14 - STP #16 System provides for control of the process line, material feeding and filling and collection of performance data (Appendix 4.10).

3.2.3 Testing/Debugging (subcontractor) (Reference 3.3.2.3)

Brenton Engineering tested and debugged the Retort Rack Loaders/Unloaders and Hi-Speed Checkweigher tested and debugged the Checkweigher/Reject System.

3.3 STP Phase III Tasks

3.3.1 Installation (3.3.3.1)

The Hi-Speed Checkweigher/Reject System, Econocorp Pouch Inspection Conveyor (after retorting), Pouch Inspection Conveyors (before retorting), Brenton Retort Loaders/Unloaders and the Centralized Control Station (CCS) were installed.

3.3.2 Testing/Evaluation (3.3.3.2)

The Hi-Speed Checkweigher/Reject System was tested and demonstrated at the March 8, 1995 Annual Contract Briefing Meeting weighing beef cubes discharging from the Solbern Filler.

The Econocorp Pouch Inspection Conveyor tests indicated that a pressing station before inserting the pouches into the carton was needed to prevent pouches jamming when entering the carton. Econocorp fabricated and installed a pressing station that corrected this problem.

At the June 19, 1996, Final Contract Briefing Meeting, the Centralized Control Station (CCS) operated the MRE Production Line which included the Tiromat HFFS machine, Solbern, FEMC, Oden Fillers and the Adept Robot. Further evaluation of the CCS will be made when a product for the MRE Line is identified for the civilian market.

4.0 Appendix

- 4.1 Projected Time & Events and Milestones
- 4.2 Production Line Layout
- 4.3 Revised Production Line Layout
- 4.4 Hi-Speed Checkweigher
 - 4.4.1 Specifications
 - 4.4.2 Proposal
 - 4.4.3 Features
- 4.5 Pouch Inspection Conveyors
 - 4.5.1 Specifications
 - 4.5.2 Proposal
 - 4.5.3 Layout Drawing
- 4.6 Brenton Retort Loaders/Unloaders
 - 4.6.1 Specifications (Refer to Appendix 4.5.1)
 - 4.6.2 Proposal
 - 4.6.3 Layout Drawing
- 4.7 Product Feeders
- 4.8 Roll Hoist - Film Handling
- 4.9 Econocorp Pouch Feeding Conveyor
- 4.10 Centralized Control Station (CCS)
 - 4.10.1 Specifications
 - 4.10.2 Proposal
 - 4.10.3 Diagram
- 4.11 Non-Traditional Capital Investment Criteria (NCIC) - Retort Loaders
- 4.12 Non-Traditional Capital Investment Criteria (NCIC) - Product Feeders
- 4.13 Non-Traditional Capital Investment Criteria (NCIC) - CCS

**Figure 1 - CRAMTD Short Term Project #14
Engineered Systems for Handling Material
Projected Time & Events and Milestones**

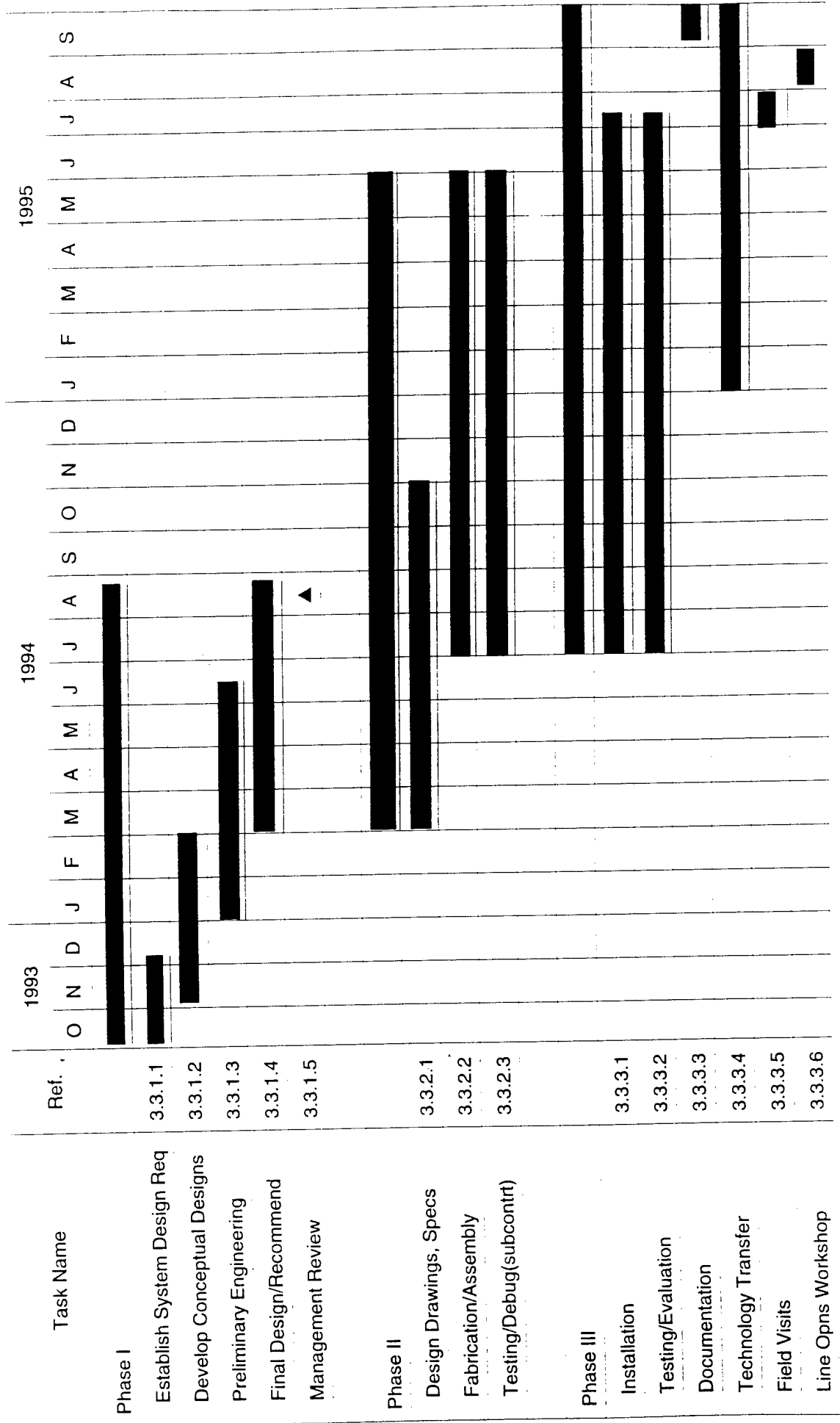

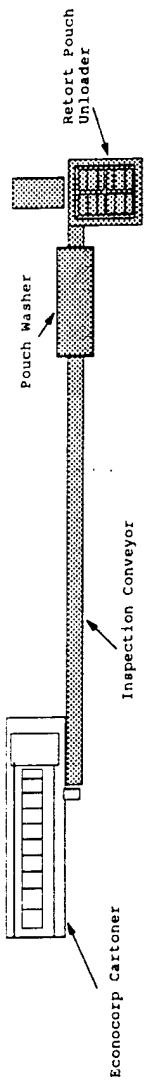

RETORT AREA

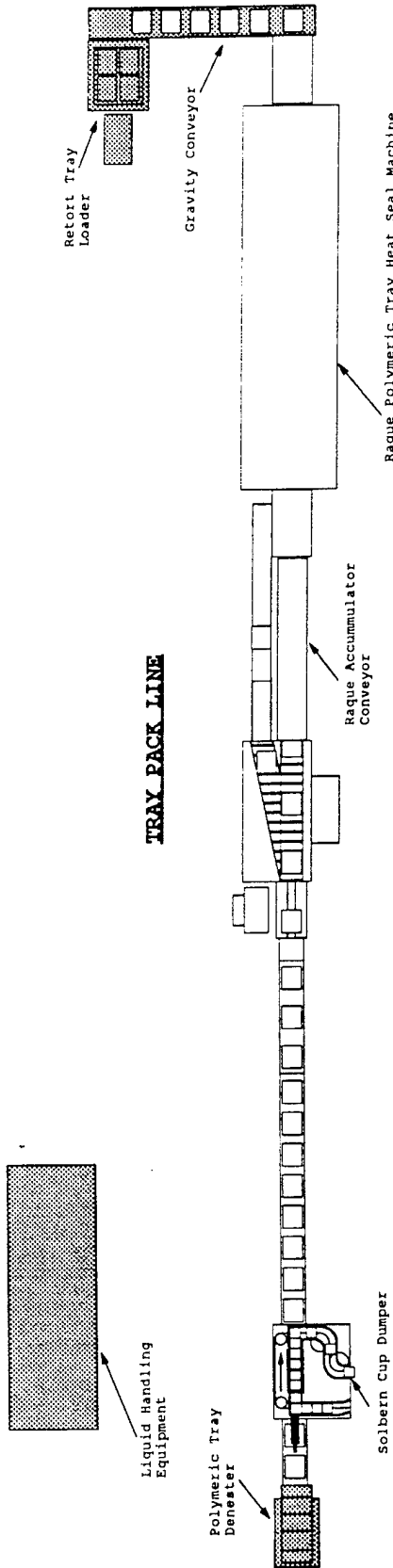

TRAY PACK LINE

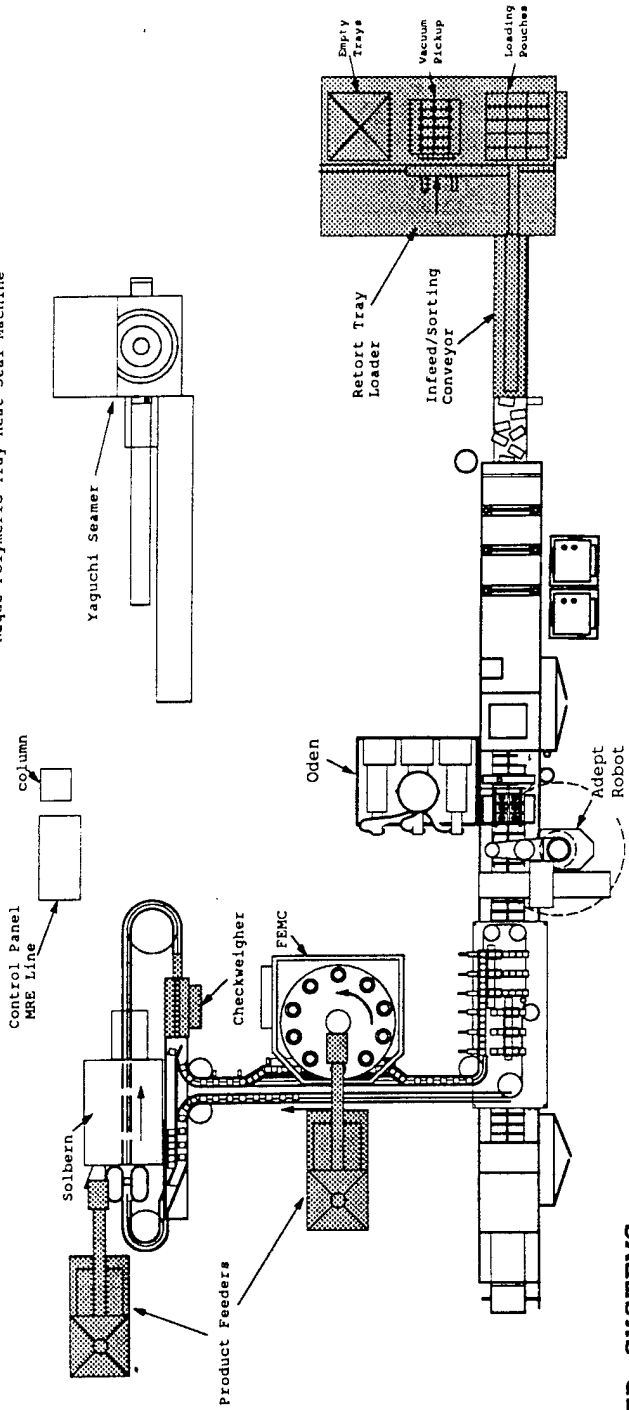

MRE POUCH LINE

STP #14 ENGINEERED SYSTEMS



Production Line Layout

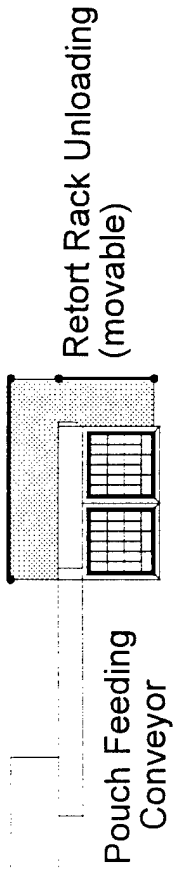

Cartoning/Inspection Line

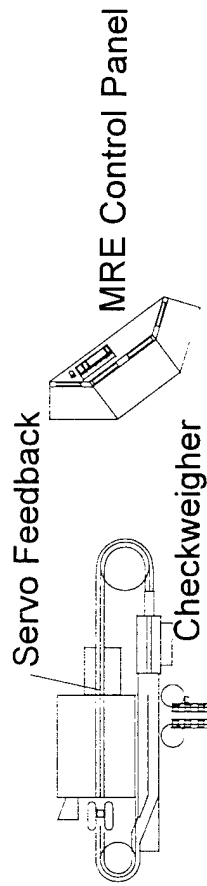
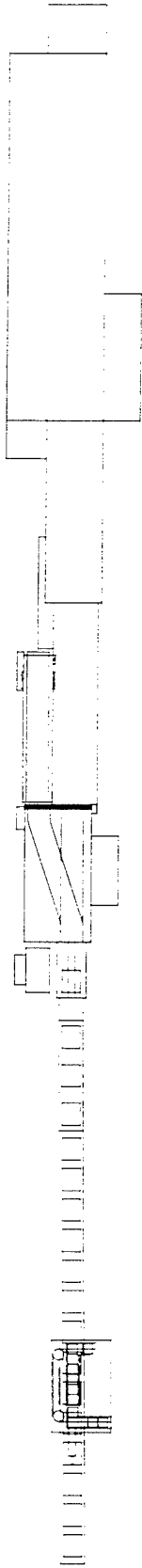

Roll Hoist - Film Handling

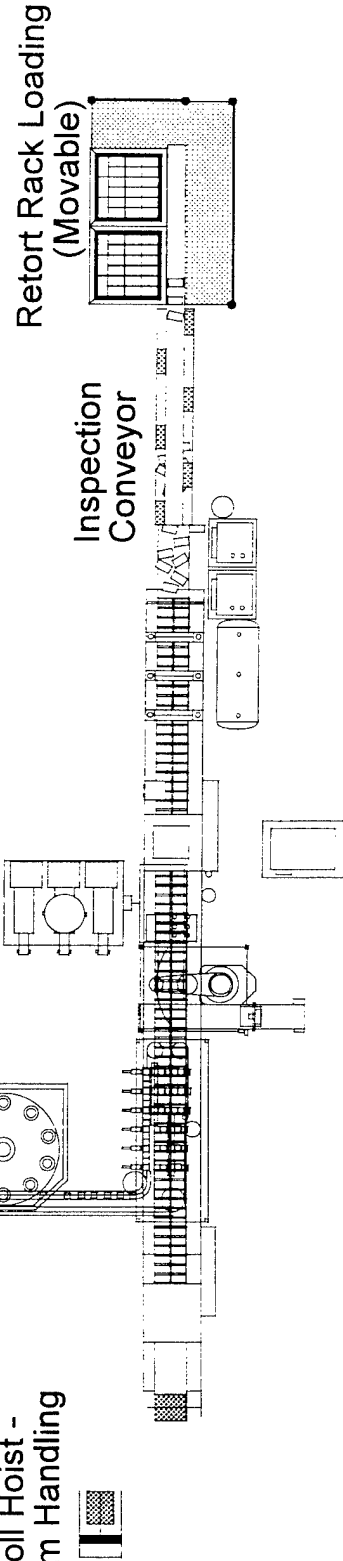

Dec. 22, 1993

RFP# 4-1-6-1

The State University of New Jersey
RUTGERS
Cook College - Center for Advanced Food Technology
CRAMTD Program
Specifications
for

Checkweigher for Volumetric Filling System

This specification covers the requirements for a checkweigher that will be used by the CRAMTD program under STP #14: Engineered Systems for Handling Material and Product Between Processing Operations. The CRAMTD program demonstration site uses equipment for research and development of new packaging methods and materials.

This specification consists of the following sections:

1. Performance Requirements
2. Package Information
3. Design Requirements
4. General
5. Acceptance
6. Shipping and Installation

1.0 Performance Requirements

1.1 Operational Duty. The system shall be designed for continuous operation with a Minimum Operating Efficiency of 98%. Minimum Operating Efficiency is percentage of time that equipment performs at the specified rate.

1.2 Primary Function. The checkweigher will work with a Solbern Tumble Filler. After filling, transfer cups will be weighed, a reject mechanism will move cups to a reject lane (accepts will continue in line). A servo device will provide control of filler volume adjustment. Statistical data will be collected, and transmitted to a production control system (PLC) or a PC.

1.3 Transfer Cups. The checkweigher will be designed for a large and small transfer cup (see Figure 1).

1.4 Production Rate. The checkweigher will weigh large and small cups at a minimum production rate of 75 and 150 cups per minute, respectively.

1.5 Weight Range. The checkweigher will be capable of weighing large and small cups at approximately 4 and 0.5 kilograms per cup.

1.6 Accuracy. Minimum accuracy is +/- 5.0 and 1.5 gram at 3 sigma standard deviation for the large and small cup, respectively.

2.0 Equipment Operation

2.1 Operator Control. Product setup for 5 weight zone classification, average weight, conveyor speed and cup tare. A lockout feature should prevent operators from changing the product setup or resetting statistical information. Zone lights should be provided.

2.2 Container Handling. Cups are transferred from the Solbern filler to the checkweigher (cups are back-to-back). The transfer cups will be spread with a speed up conveyor, then pass over the weigh cell. Rejected cups will be moved to a reject lane. Acceptable cups will then be transferred to the dumper conveyor, rejected cups will be transferred to a flat top conveyor on the Solbern filler. The vendor may mount the reject mechanism on both (large and small cup) dumpers. Cups may not rotate such that cup orientation can change, refer to Figure 1. The checkweigher is to fit within the existing Solbern equipment, Figure 2 is for reference only.

2.3 Container Reject. The checkweigher will include the reject mechanism. Containers that are below the lower weight set point or above the upper set point are to be rejected. Also, cups will be rejected when the Solbern filler signals a backup condition.

2.4 Feedback Control of Filler Volume. The checkweigher will provide servo position control of the Solbern filler volume control rail motor. The vendor is to define control algorithm used. A proportional-integral type control method or equivalent is desirable.

2.5 Data Collection. The checkweigher will collect weight data for the entire production or other selectable interval. The information should include the following; cup count by zone, average weight of accepted cups, average weight by zone, standard deviation, total weight of accepted cups, production rate of filler, and production rate of accepted cups.

2.6 Modes of Operation. The checkweigher should be capable of the following modes:

- a) Production - remote start/stop from Solbern filler, ready/not ready/running output to Solbern filler, download set points from PLC, transmit raw weight data and production statistics to PLC.
- b) Stand Alone - remote start/stop from Solbern filler, ready/not ready/running

indication to Solbern filler, set points from Operator Control Panel, statistics report to printer.

- c) Experimental - manual or remote start/stop, set points from Operator Control Panel, external control of servo motor, bypassing servo controller.

2.7 Communication. The checkweigher will be capable of communications to a personal computer, an Allen-Bradley 5 series PLC and a printer. The checkweigher should be capable of receiving product setup parameters and transmitting production data; weight of each cup and statistical information while running.

3.0 Design Requirements

3.1 Mechanical. Load cell, motor drives, reject mechanism and conveyors are to be defined in the proposal.

3.2 Compressed Air Supply. Up to 100 psi.

3.3 Electrical. Voltage: 120 or 208VAC. Equipment should meet NEMA 4 requirements for washdown.

3.4 Controls. The checkweigher will be operated from a free standing panel that can be located up to 15 feet from the load cell. The panel will permit product setup, display equipment status, statistic summaries and fault indications.

3.5 Construction. The checkweigher system must meet USDA requirements for food handling equipment. Exterior of equipment is to be stainless steel or metal covered with white epoxy paint. All components should be designed to operate in a typical washdown area. Product line for the large and small cup dumper is 55" and 42" above the floor, respectively. The frame or conveyors should not contact the Solbern filler and should resist vibration from nearby machinery.

3.6 Dimensions. Drawings of the equipment including location of utility connections are to be provided.

3.6 Cleanability. The equipment shall be designed for easy cleaning using hot water and typical detergents.

3.7 Safety. The vendor will provide equipment that is safe to operate. Safety guard, safety interlocks and emergency stop buttons are to be provided where required to prevent injury to operators.

4.0 General

4.1 Cost. The proposal submitted is to include the total cost F.O.B. Rutgers University,

Food Manufacturing Facility, Piscataway, NJ. Cost of equipment, recommended spare parts, accessories and crating should be quoted but clearly delineated from base bid.

4.2 Delivery Schedule. The vendor will specify the delivery schedule.

4.3 Service. The vendor will provide service as needed to fulfill requirements of the warranty and these specifications.

4.4 Manuals. A set of manuals documenting equipment, operational procedure, maintenance and cleaning procedure will be supplied.

4.5 Drawings, Photos. A layout drawing of this equipment shall be provided in both plan and elevation views. Additional drawings and photos shall be provided as needed.

4.6 Award. The criteria for selecting a proposal will be based on the evaluation of the CRAMTD staff:

- Delivery
- Performance
- Engineering Features
- Cost
- Service
- Training

4.7 Exceptions. The vendor may take exception to a part of this specification without being disqualified from consideration but is to clearly identify any exceptions taken.

4.8 Warranty. The vendor warrants the equipment performance specified herein for one year from the date of acceptance. The warranty includes all equipment and software supplied to be free from defects in materials and workmanship.

5.0 Acceptance

5.1 Acceptance Test. An Acceptance Test at Rutgers will be run to determine whether performance requirements have been met. The checkweigher system will operate for one hour at the guaranteed rate and accuracy specified by the vendor.

6.0 Shipping and Installation

6.1 The equipment will be shipped F.O.B., Rutgers University, Food Manufacturing Technology Facility, 120 New England Ave., Piscataway, NJ 08854.

6.2 The vendor will assemble and install equipment in full working order and provide training for operation and maintenance of the equipment.

Solbern Filler Transfer Cups

Tray Pack Transfer Cup

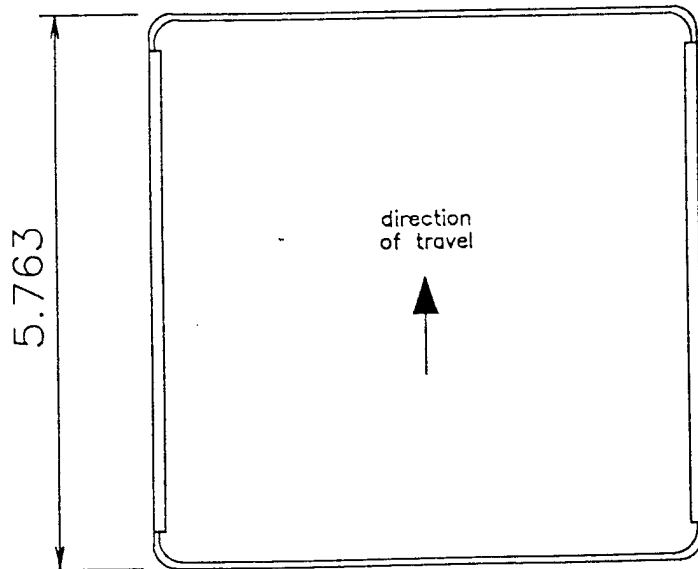
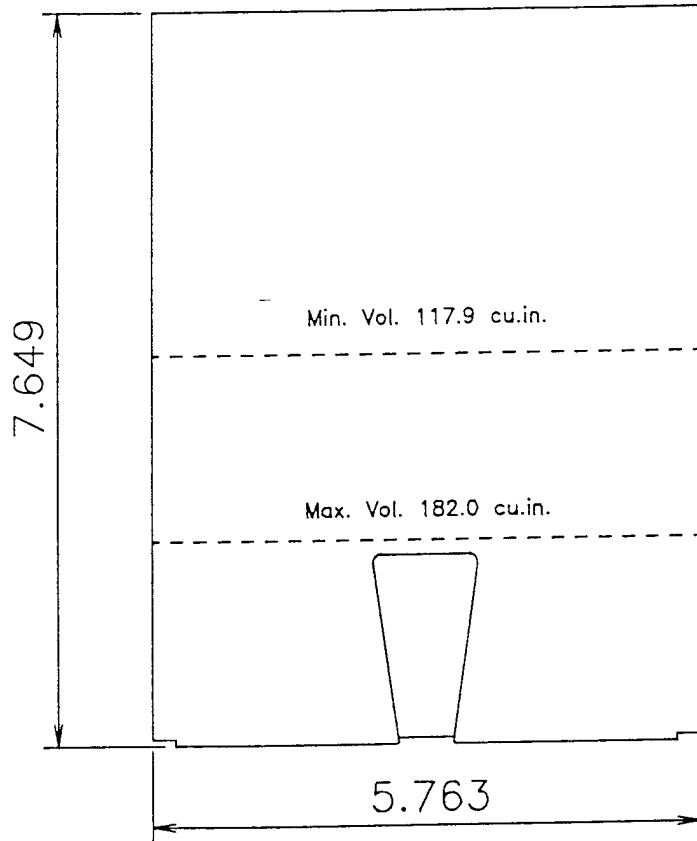

MRE Pouch Transfer Cup

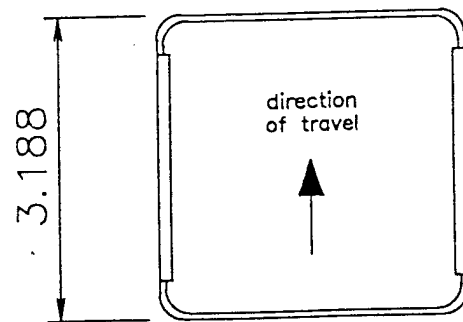
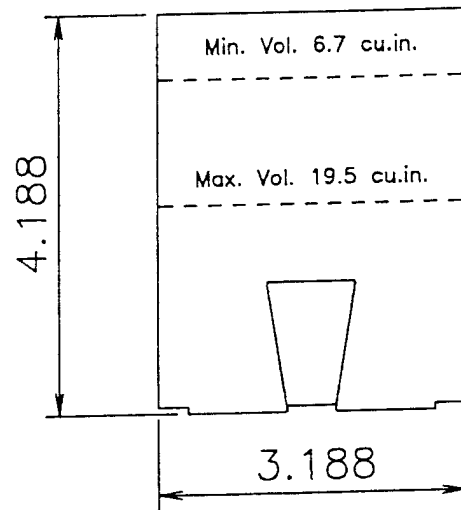

Scale: 1 in = 2 in

Figure 1

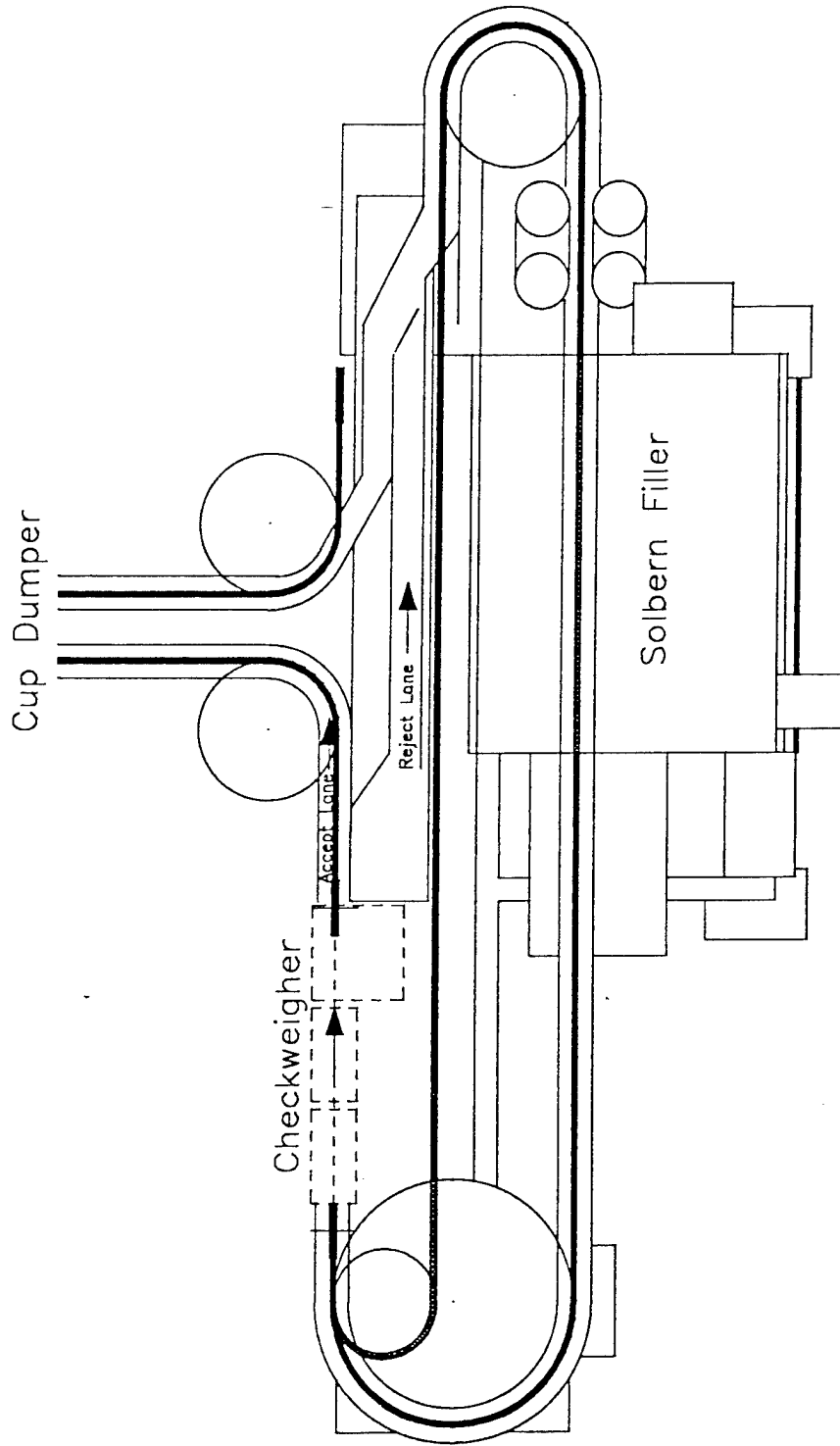

Figure 2

Scale: 1 in = 2 ft

Food Mfg. Technology Facility
120 New England Avenue
BUSCH Campus
EXT. 5-6130



Interdepartmental Communication

TO: M.Dunn
University Procurement & Contracting

FROM: T. Descovich *TD*
Combat Ration Advanced Manufacturing Technology
Demonstration (CRAMTD)

DATE: March 24, 1994

RE: **Short Term Project #14 - (STP#14) - Checkweigher**

The attached "Vendor Evaluations" of two checkweigher subcontractors documents our selection of Hi-Speed Checkweigher Co., Inc. as the subcontractor to design, manufacture and install a checkweigher after the Solbern Filling Machine according to RFP 4-1-6-1.

The proposals were evaluated based on performance, engineering features, cost, service, delivery and training. Based on these criteria Hi-Speed was selected. They were rated higher on engineering features and accuracy. A 25% educational discount was provided by Hi-Speed which gave them the lowest cost by a significant margin.

cc: J. Rossen
J. Coburn
N. Litman
R. Eggers
R. Bruins
A. Sigethy

		<u>VENDOR EVALUATIONS</u>		<u>RFP 4-1-6-1</u>	
<u>Evaluation Criteria</u>	<u>% Weight</u>	<u>Ramsey</u>	<u>Score</u>	<u>Hi-Speed</u>	<u>Score</u>
<u>Performance</u>	25	Accuracy +1.5-2 gm. 75/min. tray, 150/min. pouch	22	Accuracy +1-1.5 gm. 75/min. tray, 150/min pouch	25
<u>Engineering Features</u>	40	Single line display, no graphics Need 9" spacing into checkweigher No provision for conveyor height adjustment Air pusher rejector	25	Graphic display, multiple screens Will provide proper spacing Provision for conveyor height adjustment (1) Plow rejector, photogated	40
<u>Cost</u>	20	\$36,130.00	5	\$22,390.00(2)	20
<u>Service</u>	5	1 year guarantee	5	1 year guarantee	5
<u>Delivery</u>	5	10-12 weeks	5	12-14 weeks	3
<u>Training</u>	5	1-2 days cost estimate \$1000	4	1-2 days cost estimate \$750	5
TOTAL	100		66		98
	Note:	1. Includes \$4500.00 for height adjustment 2. Includes 25% education discount + no charge for options			

Q U O T A T I O N

Quote Number 22841 Rev
 Quotation Date 2/16/94
 Customer Name CENTER FOR ADVANCED FOOD TECH.
 Address 120 NORTHEAST AVENUE Customer Number
 PISCATAWAY, NJ
 Zip 08854 Contact: THEODORE DESCOVICH

Line	Qty	Part Number	Description	Price
1	1.0	CM6300SH-CM	CM6300 CHECKWEIGHER STWD W/CHECKMATE 3 Foot Stainless Steel Washdown Frame Hermetically Sealed Load Cell Designed for heavy-duty Applications #25 Heavy Duty Chain Transport CHECKMATE Control User-friendly Operator Controls 110 Volt Signal For Customer Supplied Product Rejection (Actual Price \$21141.00 Less 25% Educational Discount) And the following Price Options:	\$15855.75
2	2.0	M-ADDLNGTH	ADDITIONAL INCHES IN LENGTH Unit Length of 38" (Actual Price \$90.00 Less 25% Educational Discount)	\$67.50
3	1.0	R-PLOW	PLOW REJECTOR Remote Mounted To Customer's Takeaway Conveyor. Photogated Reject For Positive Reject Timing. (Actual Price of \$475.00 Less 25% Educational Dis- count)	\$356.25
4	1.0	E-230VSD4	230 VAC A.C. VARIABLE SPEED DRIVE NEMA4X (Actual Price \$2,150.00 Less 25% Educational Discount)	\$1612.50
5	1.0	CM-BIDEZW	BIDIRECTIONAL EZWAY OUTPUT PORT To Send Expanded Weight Data To PLC As Detailed In Section 2.5 of R.F.Q. And Receive Product Changes, Parameters *Note, This Communication Is Contingent Upon The Review of Input/Output Requirements of Customer PLC System. (\$500.00 Value)	\$0.00

Q U O T A T I O N

Quote Number 22841 Rev
 Quotation Date 2/16/94

Customer Name CENTER FOR ADVANCED FOOD TECH.
 Address 120 NORTHEAST AVENUE Customer Number
 PISCATAWAY, NJ

Zip 08854 Contact: THEODORE DESCOVICH

Line	Qty	Part Number	Description	Price
6	1.0	CM-FDBKCNT	FEEDBACK, TIMED CONTACT CLOSURE OUTPUT Feedback, Timed Contact Closure Output To Customer's Filler Per Item 2.4 (\$2,475.00 Value)	\$0.0
7	1.0	CM-5ZCNTRL	5 ZONE CONTROL AND LIGHTS (\$775.00 Value)	\$0.0
8	1.0	CM-SEROUT	SERIAL OUTPUT OPTION Send Net Weights Output or Reporting VIA RS232-C, RS422, or 20mA Current Loop. (\$500.00 Value)	\$0.0
9	1.0	CM-SQCSW	SQC SCREENS Includes Histogram, X-bar, Standard Deviation and Range Trending Charts (\$2,450.00 Value)	\$0.0
10	1.0	M-SPECMECH	SPECIAL MECHANICAL HARDWARE Special Mechanical Hardware Associated With 15" Height Adjustability. (Actual Price Of \$6,000.00 Less 25% Educational Discount)	\$4500.0

Prices Effective Through: 04/15/94
 Payment Terms: 1/3DP,Net30

Total Quote Amount: \$22392.00
 (ALL prices are in US\$)

Signed: *[Signature]*

Hi-Speed Checkweigher Co., Inc

Accepted by: _____ For: _____ Dated: _____
 (Customer)

CENTER FOR ADVANCED FOOD TECH.
Quotation No. 22841
February 16, 1994

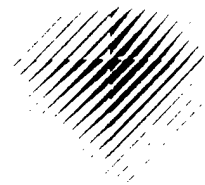

SPECIFICATIONS AND CONDITIONS

Product & Container - Metal cup/puck for MRE pouch line

<u>Length</u> (parallel to travel)	<u>Width</u>	<u>Height</u>	<u>Weight</u>	<u>Speed</u>	<u>Accuracy</u>
3.188"	3.188"	4.188"	1 pound	150 CPM	± 1 - 1.5 grams
5.763"	5.763"	7.649"	7 pounds	75 CPM	± 4.5 - 5 grams

Description of Operation - The customer will deliver the products to the infeed of the checkweigher in a uniform timed sequence with a minimum pitch of 15". The checkweigher will convey and weigh each product. After being weighed, the products will be forwarded to the customer's takeaway conveyor where off-weight products will be rejected via a remote mounted plow rejector.

The expected reject point accuracy will be as stated above at 3 sigma. Final preshipment accuracy tests will be recorded and included as part of the machine instruction book.

Product Timing - Product will be delivered to the infeed of the checkweigher in a uniform timed sequence by the customer with a minimum pitch of 15" (leading edge to leading edge of the products).

Construction and Finish - The checkweigher frame will have stainless steel structural members with stainless steel shafts and fasteners.

Conveyor height will be adjustable between 41" and 56". Please confirm this on your purchase order.

Two Instruction Manuals are provided with this equipment, at no additional charge. These manuals include a general description of the machine, operating instructions, a parts list, and pertinent wiring diagrams. Duplicate manuals are available at \$35 each, when ordered with the machine. The charge for manuals after machine shipment is \$50 each.

Utilities Required - 115 volts, A.C., 50/60 cycle, single phase for checkweigher control. Power should be from a clean source reasonably free of transients. 230 volts, A.C., 50/60 cycle, 3 phase input required for variable speed drive controller. The controller is equipped with a digital frequency display, soft touch keypad, with run/stop buttons.

Field Service - Service and equipment start-up is estimated at one day. Optional personnel training is estimated at one additional day. Please see attached Service Rates for additional information on service and installation. Service rates will receive 25% Educational discount.

CENTER FOR ADVANCED FOOD TECH.
Quotation No. 22841
February 16, 1994

Delivery - 12 to 14 weeks from receipt of purchase order, confirmed specifications, receipt of 1/3 down payment, and sufficient samples of test product, F.O.B., Ithaca, NY; freight collect. If approval drawings will be required, the delivery date will be extended the number of days the drawings are considered. The above prices are firm for 30 days. Delivery is firm for 30 days.

Terms of Payment - 1/3 of price shall be submitted with the order or paid upon receipt of the invoice accompanying Hi-Speed acknowledgment letter. Remaining 2/3 shall be due on receipt of the invoice and payable within 30 days after shipment.

BJB/jw

Enclosures

cc: Mr. Joe Poges - RYPAC PACKAGING MACHINERY (908) 879-7685
Mr. Phil Martyn - REGIONAL SALES MANAGER (609) 786-7506

APPENDIX D. THE FEEDBACK OPTION

(REVISION A4 - OCTOBER 14, 1992)

D.1 OVERVIEW

As a production line runs, package netweights may change gradually. For example, if a filler receives bulk product from a hopper, netweights may decrease gradually as the level in the hopper drops. The Feedback Option corrects automatically for such gradual netweight changes.

With the Feedback Option in use, CHECKMATE continuously monitors the short-term average weight of your products. The average is compared to the upper and lower limits of the DEADBAND (a range of acceptable netweights centered on the target weight). If the average weight drifts outside the deadband, CHECKMATE corrects the fill.

Proportional correction is used: the greater the error (difference between target weight and the short-term average), the longer the motor runs during each correction. When the option is set up correctly, a single correction should bring subsequent product to target weight.

After each correction, CHECKMATE waits until: (1) corrected product can travel from the filler to the checkweigher, and (2) the short-term average includes only corrected products. Then, the average is compared to the deadband limits and another correction is made if needed.

The filler can be operated manually if desired. If you have a MATEER-BURT NEOTRON(TM) BARTELT DX(TM), or HAYSSSEN(TM) filler, use the operator controls provided with it. For all other installations, HI-SPEED provides a remote control box. This includes controls for selecting automatic or manual operation and for increasing or decreasing the fill manually.

HI-SPEED checkweigher systems offer a number of different methods of providing proportional feedback control. This is usually based on statistical information gathered by the checkweigher.

D.1.1 FEEDBACK BY SERVO UP AND SERVO DOWN SIGNALS

If this method is used, two relay contact closures are provided. One set of contacts is called SERVO UP (make the packages heavier); the other set, SERVO DOWN (make the packages lighter).

These contacts are closed by the module for a time proportional to the amount of change necessary. That change is determined as the difference between the target weight and the average of the last N packages. The amount of time associated with that weight difference is governed by an operator entry -- "Weight / Second".

The module will normally limit a correction, however, to a maximum of 3 seconds with typical corrections within the range of 0.1 to 3.0 seconds.

For example, if the Weight / Second is 4.0 (grams/second), an average net product weight 2.0 grams heavier than target would result in a 0.5 second correction. A deviation of 4.0 grams would result in a 1.0 second correction and a deviation of 6.0 grams would give a correction of 1.5 seconds.

In some special applications, the upper limit on the servo time can be too restricting. For those instances, the limit can be raised to 30 seconds.

An operator panel with manual override pushbuttons, a servo on/off switch, and indicator lights is generally provided with the relay contact output option. Typically, the contact closures are used to automatically operate manual filler control pushbuttons or switch 120 VAC to the drive windings of a reversible motor (a servo motor) that controls a mechanical control -- a knob or a hand crank -- to control fill. For multi-head fillers, this is usually a "global" control which adjusts all heads equally.

D.1.2 FEEDBACK BY DIGITAL PULSE TRAIN

The second output configuration available provides digital pulse trains. Two outputs are provided: one for servo up, the other for servo down.

When a servo adjustment is necessary, a string of pulses is generated on the appropriate line. The number of pulses in the string is proportional to the amount of correction necessary.

The outputs are generally used to increment and decrement, respectively, a counter provided in the filler mechanism. These outputs are optoisolated. They can be configured to drive other optoisolators, or drive the filler input circuits directly, as needed.

In this case, no operator panel is provided. The 120 VAC Inhibit output is provided to allow the customer to drive an external indicator, if one is available. The "Weight / Second" entry becomes "Weight / 10 Pulses" for the servo calculations. Pulse duration is typically 5-10 ms, pulse period 15-30 ms.

D.1.3 FEEDBACK BY SERIAL MESSAGE STREAM

This output configuration uses the auxilliary port to send a serial message stream describing the necessary corrections to the filler. The format of the serial message stream is dependent upon the filler manufacturer. The feedback calculations are the same as described for the other configurations.

D.1.3.1 FEEDBACK BY HAYSSSEN^(TM) INTERFACE

This is the most common serial interface used with fillers. The definition of this interface includes:

1. RS-232 serial data transmission
2. Transmission parameters: 1200 baud, 7 data bits, 2 stop bits, and no parity. (NOTE: CHECKMATE Port C must be set to these values)
3. The character string transmitted. This is:

<STX><TARGET WT><ETB><DEVIATION><ETB><SAMPLE SIZE><ETX>

Where:

<STX> = ASCII 02_H

<TARGET WT> is the Feedback Target Weight. This is transmitted as five decimal digits without decimal point. The least significant digit represents 0.1 gram.

<ETB> = ASCII 17_H

<DEVIATION> is the difference in weight between the current sample and the target weight, for which a correction is needed. This is transmitted as four decimal digits, with leading + or - sign but without decimal point. The least significant digit represents 0.1 gram.

<SAMPLE SIZE> is the F1 value you have entered on the keyboard. This is transmitted as five decimal digits, without decimal point. The least significant digit represents 0.1 gram.

NOTE:

WHEN FEEDING BACK TO A HAYSSSEN FILLER,

1. ENTER THE SAME SAMPLE SIZE AND FEEDBACK TARGET WEIGHT AT BOTH THE HAYSSSEN CONTROL AND AT CHECKMATE.
2. AT THE CHECKMATE CONTROL, SET THE "Z" FACTOR TO ZERO. THIS PREVENTS THE TARGET WEIGHT FROM MOVING AS THE SHORT TERM STANDARD DEVIATION CHANGES WITH PRODUCTION.

D.1.4 FEEDBACK TARGET

The CHECKMATE calculates its "Feedback Target" based on the system target weight plus the standard deviation multiplied by a user-entered constant ('Z'). This is expressed as:

$$\begin{aligned} \text{(Feedback Target)} &= \text{System Target} \\ &\quad - (Z * \text{Feedback Standard Deviation}) \end{aligned}$$

As filler performance deteriorates, the standard deviation increases, and the target of the feedback system also increases. This forces the average weight of the packages high enough to keep most of the packages above the system target weight.

On the other hand, as the filler improves, the standard deviation decreases and brings the average weight of the packages closer to the system target weight.

In this way, your system can run very close to the actual target weight of the product as long as the filler performs as it should.

As the CHECKMATE calculates the Feedback Target Weight, that value is compared to a user-entered upper limit. If the calculated value exceeds this limit, then the system is presumed to be out of control. In this case, the Feedback Target Weight is set to the limit value instead of the calculated value.

CHECKMATE Feedback does its own average and standard deviation calculations. This allows for different sample sizes than the normal statistics.

D.2 OPERATING MODES

CHECKMATE can operate in either BLOCK mode or INDEPENDENT mode. The two operating modes can be distinguished by the timing of the servo decisions and the data upon which those decisions are based.

D.2.1 BLOCK MODE

In this mode:

1. CHECKMATE takes no action until it has collected F2 package weights and calculated the standard deviation of those packages.
2. With that information, CHECKMATE calculates a new Feedback Target weight. It then compares that target to the average of the last F1 package weights and makes a servo decision.

NOTE: You must choose and enter the sample sizes F1 and F2. They are entered when **SETTING UP FEEDBACK**, Page D-7.

3. If CHECKMATE finds no servo necessary, it immediately begins collecting data for another standard deviation calculation.

A servo is needed if:

$$\begin{aligned} \text{Average} < (\text{Feedback Target} - \text{Deadband Limit}) \\ \text{Or:} \\ \text{Average} > (\text{Feedback Target} + \text{Deadband Limit}) \end{aligned}$$

If a servo is needed, the needed correction is calculated and the servo is performed.

4. The system waits until the Inhibit Count of packages has passed, then begins collecting standard deviation data. Again, no action will be performed until that data is complete and a new Feedback Target is in place.

D.2.2 INDEPENDENT MODE

In this mode, the servo correction action is NOT tied to the calculation of the standard deviation.

1. As soon as an F1 average has been calculated and a feedback target is in place, a servo decision is made by comparing those two numbers. If no correction is necessary, CHECKMATE recalculates the average with each successive package and, again, makes a servo decision.
2. When a correction is necessary, the amount of correction is figured, and the servo is performed.
3. CHECKMATE waits for the Inhibit Count of packages, followed by F1 more packages.

After these have passed, CHECKMATE is ready for another servo. As each new package is weighed, CHECKMATE tests to see if a servo is needed.

D.2.2.1 CALCULATION OF STANDARD DEVIATION

At the same time as Steps 1-3 above, but asynchronously, CHECKMATE calculates new short term standard deviations:

1. As each successive group of F2 packages is weighed, a standard deviation is calculated.
2. From that data a new Feedback Target is set.
3. The new target is used immediately to decide if servo corrections are needed.

NOTE: THIS IS CALLED INDEPENDENT MODE BECAUSE THESE TWO FUNCTIONS (SERVO CORRECTION AND THE CALCULATION OF F2'S SHORT-TERM STANDARD DEVIATION) ARE NOT DIRECTLY DEPENDENT UPON ONE ANOTHER.

D.3 SETTING UP FEEDBACK

The CHECKMATE feedback system is set up through the menu command MENU-SETUP-FEEDBACK. Each product has its own feedback information allowing you to specify product-specific servoing control by the checkweigher.

The Feedback parameter entry facility is similar to other CHECKMATE entry functions in that it uses a 'pop-up' window with several data-entry fields. The screen is illustrated below. To enter the desired values, use the arrow keys to move the cursor to the appropriate field. Following entry of the desired field, press the ENTER key, or move the cursor to the next field. Once all values have been entered, press the CANCEL key to exit.

NOTE: CONSIDER ENTERING THE STATISTICAL LIMITS (MENU-SETUP STATISTICS). THESE LIMITS SPECIFY THE PACKAGE WEIGHT RANGE WHICH WILL BE CONSIDERED IN FEEDBACK CALCULATIONS.

D.3.1 THE SETUP-FEEDBACK MENU

-->> COMMANDS <<--							
1Product 2Statistics 3Communications 4Feedback 5Multihead Setup the FEEDBACK parameters							
0	0.00-9999.0	0	0.00	Label Weight	122.00	GMS.	
1 R	0.00-1999.0	0	0.00	Target Weight	122.00	GMS.	
2	1999.00-3999.0	0	0.00				
3	3999.						
4	5999.						
5 R	7999.						
Last Reze							
Last Clea							
Avg line							
>>>> Setup FEEDBACK <<<<							
Feedback Parameters:							
Upper Deadband Limit Offset (UDL): 25.000							
Lower Deadband Limit Offset (LDL): 25.000							
Z (std deviation multiplier): 0.00 (0-3.50)							
Feedback Target Weight upper limit: 9999.9							
Average Sample Size (F1): 100 (2-200)							
Std Dev Sample Size (F2): 100 (2-200)							
Inhibit Count: 5** Wt/Period: 0.000							
Mode: I (Independent / Block; use ON/OFF)							
HISTO-GRAM	XBAR CHARTS	WEIGHT SCREEN	FEED-BACK	IN-ACTIVE	IN-ACTIVE	IN-ACTIVE	PRINT SCREEN

D.3.1.1 DEFINITION OF MENU TERMS

UPPER DEAD BAND
LIMIT OFFSET

The heaviest weight, expressed as a deviation above target, for which no servo correction is needed.

LOWER DEAD BAND
LIMIT OFFSET

Similar to the UPPER DEADBAND LIMIT, except it represents the lightest weight (expressed as a deviation BELOW target) for which no servo correction is needed.

WEIGHT/PERIOD

The change in product weights caused by running the filler motor for one second. It must be measured for each filler WHILE RUNNING THE LINE WITH PRODUCT. If more than one product is run on a line, WEIGHT/PERIOD should be determined for each product.

THE INHIBIT COUNT

The Inhibit Count is the number of packages between consecutive servo corrections. It is the number of packages between the filler and the checkweigher. The system inhibits for this number plus the sample size F1 as described below.

AVERAGE SAMPLE SIZE
(F1)

Used in computing the short-term average weight. (Servo corrections are made if the average is outside of the DEAD BAND LIMITS.)

STD DEV SAMPLE SIZE
(F2)

Used in computing the short-term
standard deviation.

Z (Std Deviation
Multiplier)

Number of standard deviations between
target weight and feedback target.

FEEDBACK TARGET
WEIGHT UPPER LIMIT

This is the weight upon which (this
weight and above), the maximum
correction is applied. Think of this as
a limiting point for the correction
magnitude.

NOTE: If CHECKMATE always seems to be servoing, try increasing
the Inhibit Count or F1 value. When the Inhibit Count and the F1
value are summed, they should (in this case) cover a period of
time equal to the maximum servo time shown on the Feedback
Screen.

D.4 THE FEEDBACK DISPLAY SCREEN

The Feedback display (shown below) is very similar in appearance to the Histogram displays. In fact, the same increment and center are used (as setup in the statistics setup facility).

The purpose of this display is to give you a visual indication of the decisions being made regarding feedback calculations and servoing.

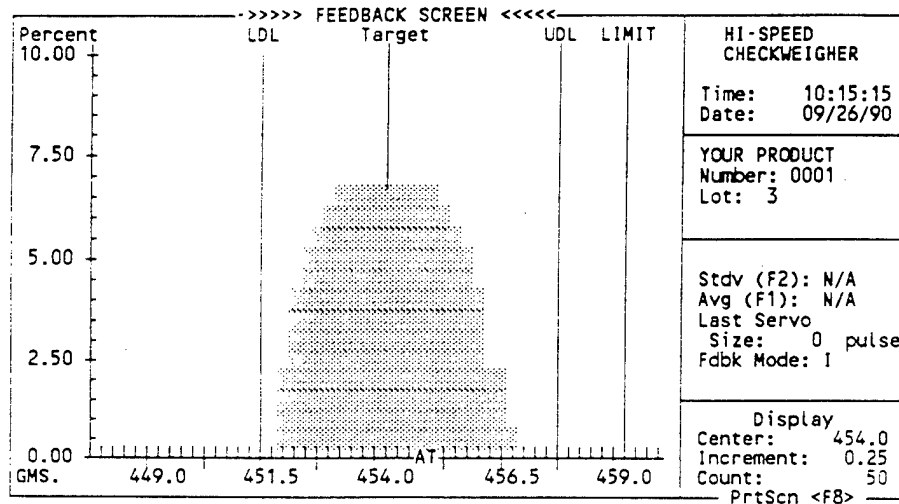

D.4.1 LABEL DEFINITIONS

- UDL: Upper deadband limit (user-set as relative to the calculated feedback target). This line shifts as the feedback target does.
- LDL: Lower deadband limit, as above.
- LIMIT: Upper limit for feedback target weight calculation.
- Target: System target weight (user-set).
- A (on X-axis): Currently calculated short-term average (N1). This indicator shifts as the production packages vary in weight.
- T (on X-axis): Currently calculated feedback target value. This indicator shifts as above, but in respect to the feedback target value.

CUSTOMER INFORMATION (By Sales)	
NAME AND/OR FOR ADV. FOOD NO. 18-33-940503	SALES OFFICE: ROCHESTER, NY
MODEL / CHEMIST-CM FOR ADV. FOOD TECH	ENGINEER: []
PACKAGE INFORMATION (By Sales)	
NO. OF METAL CUPS PER UNIT	NO. OF METAL CUPS PER UNIT
NO. OF METAL CUPS PER UNIT	NO. OF METAL CUPS PER UNIT
NO. OF METAL CUPS PER UNIT	NO. OF METAL CUPS PER UNIT
TRANSPORT INFORMATION (By Sales / Engineering)	
TYPE OF TRANSPORT	TYPE OF TRANSPORT
TYPE OF TRANSPORT	TYPE OF TRANSPORT
TYPE OF TRANSPORT	TYPE OF TRANSPORT
METAL DETECTOR SPECIFICATIONS	
TYPE OF METAL DETECTOR	TYPE OF METAL DETECTOR
TYPE OF METAL DETECTOR	TYPE OF METAL DETECTOR
TYPE OF METAL DETECTOR	TYPE OF METAL DETECTOR
UTILITIES INFORMATION (By Sales / Engineering)	
POWER SOURCE	POWER SOURCE
VOLTAJE	VOLTAJE
FREQUENCY	FREQUENCY
ENCLOSURE	ENCLOSURE
EXHAUST	EXHAUST
WATER	WATER
SEWER	SEWER
RECYCLE	RECYCLE
TYPE OF METAL DETECTOR	TYPE OF METAL DETECTOR
TYPE OF METAL DETECTOR	TYPE OF METAL DETECTOR
TYPE OF METAL DETECTOR	TYPE OF METAL DETECTOR

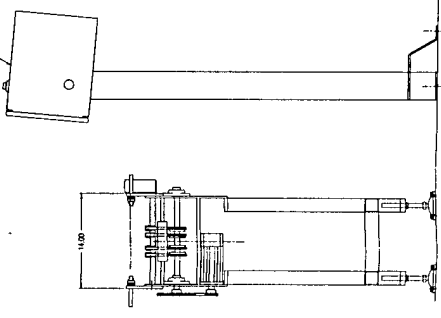
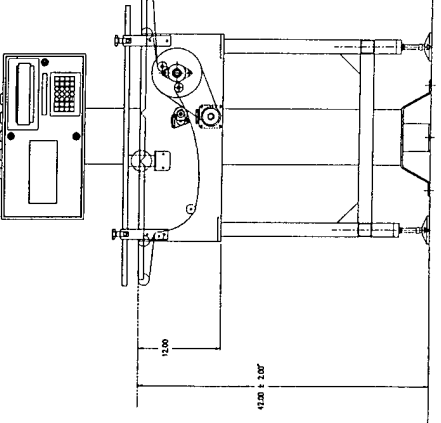
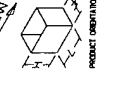
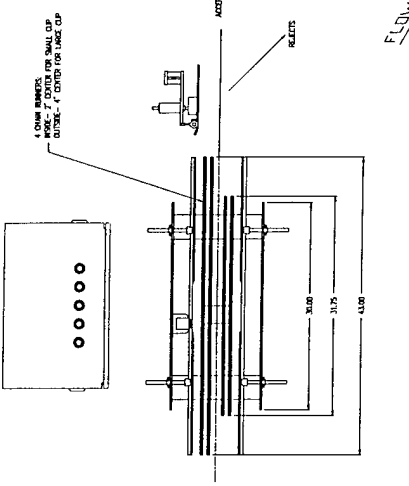
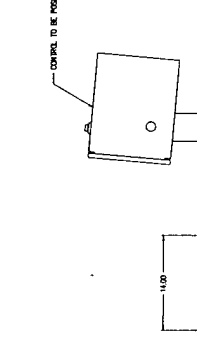
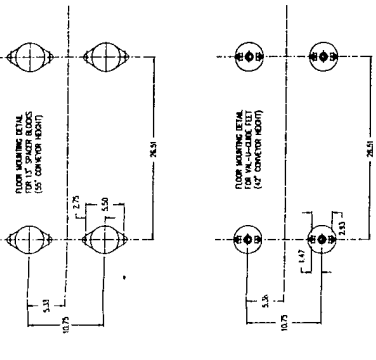

18-33-940503 1A.1

18-33-940503 1A.1

18-33-940503 1A.1

CHECKMATE™

Full statistics
at the line,
in real time.

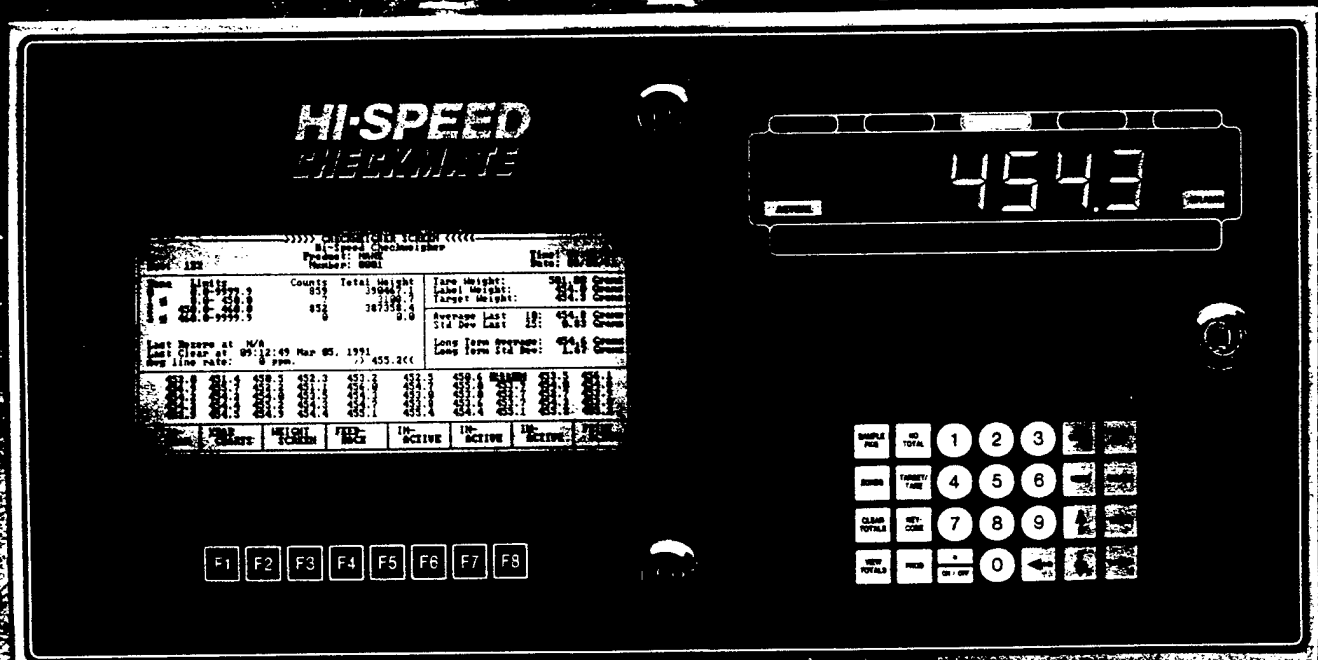

STP #14

CHECKMATE™

General Specifications

Checkmate Features:

- 50 product setup, (optional 100)
- 3 to 5 weight zones
- Handles in excess of 600 ppm
- Handles up to 6 concurrently serviced weigh platforms (optional)
- ACTP – built in automatic checkweigher test procedure
- User programmable Keycode password security (multi-level)
- Keyswitch security
- Large (1 1/8"), easily viewable digits
- Weights displayed in gross, net or deviation from target in ounces, grams, lbs., kilograms, or no units.
- Alphanumeric user display for data entry, display of production and set-up data
- Enhanced user friendliness by use of full size (200 x 640 LCD) display and menu selections
- Single key data access to many functions including soft keys for expanded flexibility
- Time of day/date calendar function

Enclosure:

- Dimensions: 12"H x 24"W x 15"D
- Cold rolled (NEMA 12) or stainless steel (NEMA 4X) (optional)
- Suitable for hazardous environments (optional)
- Washdown (optional)

Operating Environment:

- Temperature: 0° – 38°C / 32° – 100°F
- Humidity: 100% noncondensing
- Designed for continuous operation
- EMI, RFI, and ESD protected

Electrical:

- UL listed industrial control panel
- 115 VAC ± 10% – single phase, 50/60 Hz, fused for 1 amp (50 VA power rating)
- Other voltages available
- No microcomputer regulating transformer required

Self-Diagnostics:

- Auto memory test, A/D functional test, display check (all off and all on), power indicators, input-output indicators, I/O test.

Auto-Rezero:

- Rezeros automatically, instant or incremental for sustained accuracy

Technology:

- Single board microcomputer with 16 bit industry standard microprocessor and coprocessor for enhanced processing rates
- EPROM program memory
- Battery backup RAM memory for set-up data and long-term accumulated data
- 3 channel serial data output RS232, RS422, or current loop
- Bidirectional EZWAY communications link

Scale:

- Self-checking scale operation display indicates:
 - Good rezero
 - Needs rezero
 - Scale noise
 - Package spacing errors

Accuracy:

- Unsurpassed weight signal processing produces the purest weight signal possible with Hi-Speed's exclusive patented algorithms
- No potentiometer adjustments required
- Gain, filtering and timing automatically set and optimized for each product.

Checkmate Options

Rolling Statistics Sizes:

- N1 Average Size: 10-999
- N2 Std. Dev. Size: 25-999
- N3 Histogram Size: 50-999

Statistical Limits:

- Provides alternative range for processing statistics
- Fully user enterable, default = 0 - 9999.9

Multihead Statistics:

- 60 head capability
- N1 (Short term average) for each head: 10
- N2 (Short term std. dev.) for each head: 25
- Last 14 weights displayed for each head

Tare Gross:

- Dedicated bi-directional communication link
- Tare-Gross set-up screen
- Out-of-sync alarm and window

Floating Zone:

- Confirms correct piece counts on product where individual weights fluctuate with trackable product density variations.

Feedback:

- Dynamic control of servo activated fillers
- Control based on either independent or block mode statistical calculations
- Histogram-type display showing servo activity and product distribution
- Full user control over upper and lower deadband limits, z (standard deviation multiplier), feedback target weight upper limit, average sample size (F1), standard deviation sample size (F2), and weight for correction and optimizing feedback to minimize product giveaway as filler distribution improves
- Pulse train or timed output
- Remote operator panel optional for timed output

Printer:

- An 80 column parallel printer for full report generation and individual print screen capability via soft key access.

Serial Weight Output Capability:

- This option comes with a setup to print every weight, every N weights, or X weights every Y weights.

EZWAY Statistical Process Control Data Collection System:

- Unidirectional or bidirectional interface with Hi-Speed Controls for real-time production monitoring of all lines from a single location.

HI-SPEED CHECKWEIGHER, CO., INC.

5 Barr Road

Ithaca, New York 14850

1-800-836-0836 / 1-607-257-6000

Fax: 1-607-257-5232



HI-SPEED®

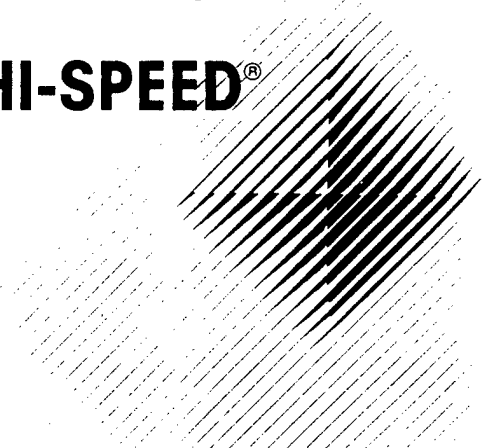

CHECKMATE

The Higher Intelligence

There isn't another checkweigher control available today that can out-perform Checkmate. Checkmate provides answers for those who want total information and center control of their processing and packaging lines.

Checkmate gives you the unsurpassed accuracy you expect from Hi-Speed technology plus complete statistics at the line as it happens — no off-line calculations, no delays.

There's no need to stop production to make adjustments either. Checkmate's full range of statistics allows you to make accurate filler adjustment decisions, and provides automatic feedback directly to the filler.

Checkmate's 50 product set-up provides instant access to all preprogrammed product parameters. Use Checkmate to support up to 6 independent scales within the same mainframe, or in close proximity. Checkmate's versatility and capabilities are adaptable to your application and will integrate with most Hi-Speed checkweighers.

To further enhance total statistical process control, Checkmate's full bidirectional communications capabilities allow interface with Hi-Speed's EZWAY Data Collection System.

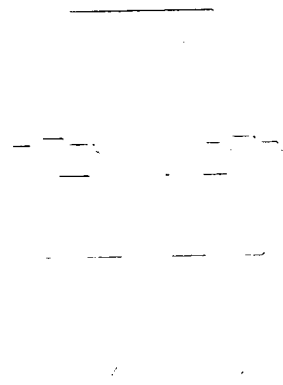

Checkmate, (shown with the Hi-Speed CM-60 Checkweigher) provides feedback to the filler.

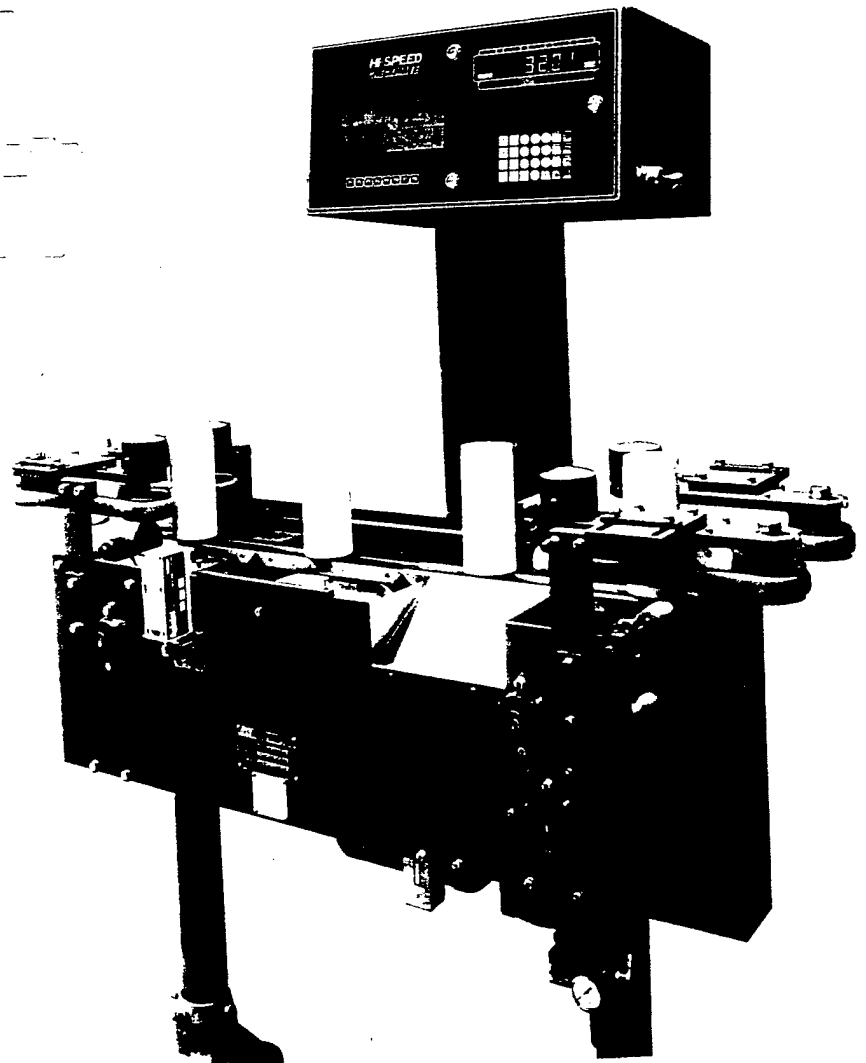

It's all at your fingertips with

CHECKMATE™

Easy to Program.

Input is handled through menu selection, direct key access, and soft keys. Checkmate communicates back to you in simple, direct language. Direct access keys are clearly labeled and color coded: yellow Set-Function keys provide single-stroke access to the most commonly used operator functions and red keys are Menu/Control keys. Keys are environmentally sealed and have alphanumeric capability.

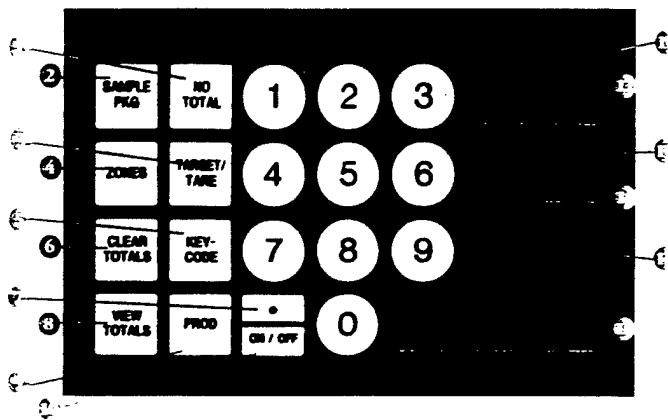

Checkmate's LCID display and 80 x 25 graphic display indicate acceptable weights as well as gross under and overweights. The special non-glare panel gives only the information you need, when you need it — no distracting additional prompts. The display shown below is fully illuminated for demonstration purposes.

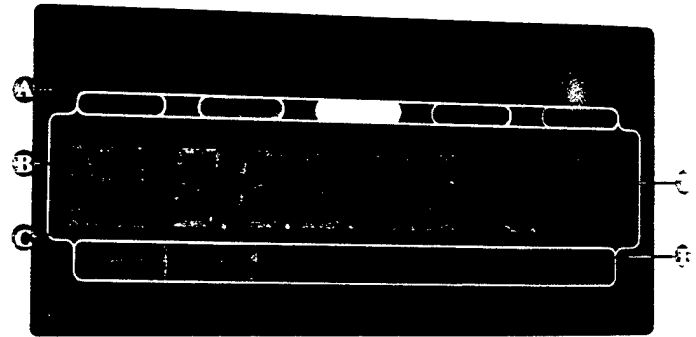

② No Total — turns off counters yet retains count information when you run a test package.

④ Sample Package — automatically ejects up to 25 packages and displays package weights for verification without stopping production.

⑥ Target/Tare — enter target weight and associated tare.

⑧ Zones — view and/or change current product set-point limits.

⑩ Key Code — provides 3 levels of security to facilitate or limit accessibility.

⑫ Clear Totals — zeros counts for selected product zones, and clears statistics.

⑭ Decimal — enter decimal point position.

① View Line Summary Screen — call up count and percentages by zone: accepts, underweights, overweights and total weight.

③ Product — instant recall of any of 50 products programmed.

⑤ On/Off — retractor status by zone and decimal point.

⑦ Calib. — operator prompted machine set-up.

⑨ Normal Display — shows current set-up limits on Checkweigher screen.

⑪ Menu — access to all functions.

⑬ Cancel — deletes last entry.

⑮ Cursor Keys — for scrolling through menu or viewing related screens within one category of information.

⑯ Enter — enters data into memory.

⑰ Zone Indicator Displays

- Zone 1 (Red) gross underweight
- Zone 2 (Yellow) just under
- Zone 3 (White) accept
- Zone 4 (Blue) just over
- Zone 5 (Green) overweight

⑱ Weight Mode Indicator

Deviation from Target or Actual weight readout mode.

⑲ 1 1/8" LCID Weight Display

Shows actual net weight of your product or variation as a plus or minus from target.

⑳ Weight Unit Indicator

Displays weights in grams, kilograms, ounces, or pounds.

㉑ System Status Indicators

- Sample Package (Orange) — automatically ejects package(s) from the line and displays the weight for operator verification.
- No Total (Orange) — indicates that the counters are "off" during set-up and calibration.
- Good Rezero (Green) — indicates that the scale is automatically rezeroed every time there is a gap of one or more packages in the production flow.
- Needs Rezero (Red) — immediately alerts the operator to excessive product build up on the scale or that automatic rezero is overdue.
- Package Spacing (Red) — alerts operator that packages are too close together for accurate weight.
- Scale Noise (Red) — alerts operator of excessive internal and/or external interference i.e., vibration, air currents, and unstable product transfer.

Easy to Read.

Checkweigher Screen

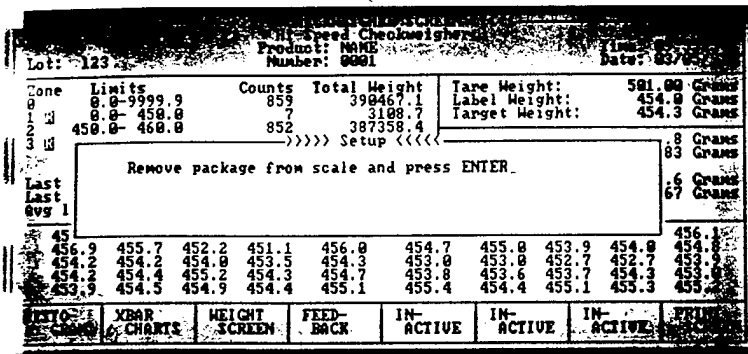

screens providing running statistics or graphic representations are accessed by direct keys or through menu selection. The sample screen above is the Checkweigher screen, also known as the Normal Display. It shows the checkweigher settings and production weights for a specific line (notice product name, lot number, and label weight display capability). The set-up values shown are for purpose of sample only (See front cover for full view Checkweigher screen). A small insert window gives the user step-by-step instructions for set-up and calibration. The window (shown above) is called up by pressing the "calibrate" key.

Soft Keypad



Each key of the soft keypad (F1-F8) is aligned below designated functions shown at the bottom of the checkweigher and Weights Screens. Other screens include: Histogram, XBAR, Summary, Statistics, Feedback, Screen Setup, Product setup, and Calibration parameters. Each screen may be accessed by a single stroke on the soft keypad. The software you select for your application will determine how many levels of information appear on each screen.

Easy to Understand.

XBAR Trend

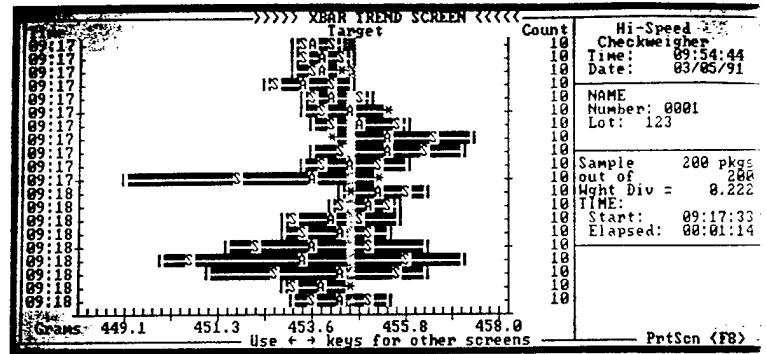

See averages, standard deviation and range as individual XBAR charts, as well as XBAR trend chart (composite display) instantly. No waiting for Q.C. reports or printouts. No time or product lost before appropriate line adjustments can be calculated and made. XBAR control chart sampling, based on time or count, is displayed showing user-entered control limits and interval data.

Weights

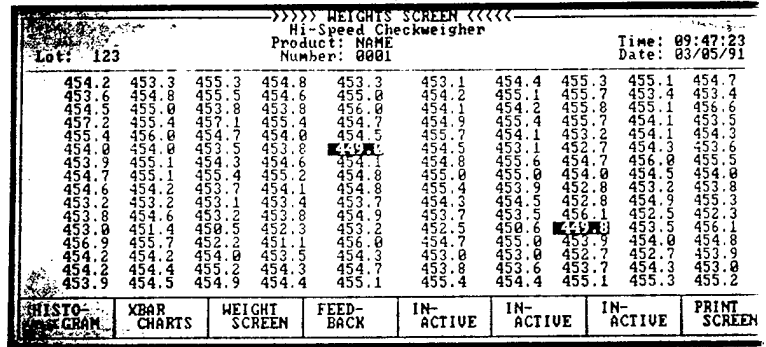

160 weights are displayed at one time. Rejected weights are highlighted, making it easy to see how the weights are running.

The software you select for your application will determine how many levels of information appear on each screen.

Concise, running statistics put you in complete control.

Feedback

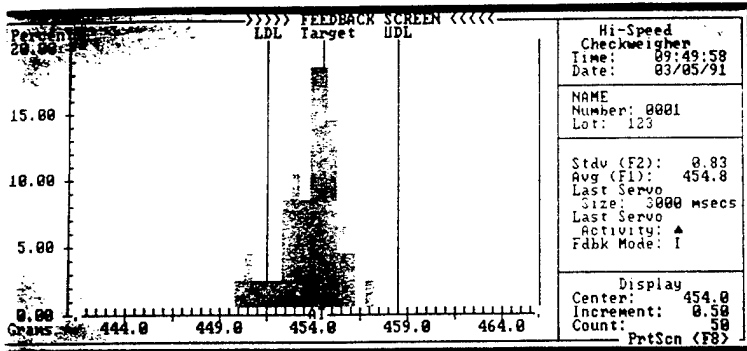

This screen provides a visual indication of decisions being made regarding feedback calculations and servoing. Feedback parameters are set and Feedback Target Weight is determined based on standard deviation, not just averages. No waiting for Statistical Process Control calculations and reports. Feedback to filler automatically, accurately, and instantly.

Histogram

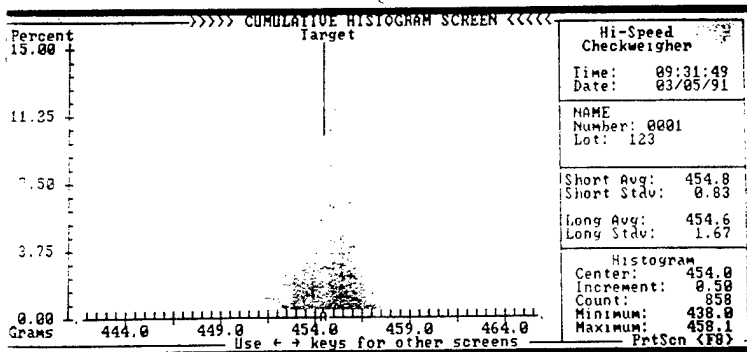

Easy to understand histograms show short term and cumulative product distribution instantly. Calculations are not necessary — there are no delays for information reaching the line.

Checkmate Basic

Checkweigher Statistics include:

- Package Counts by zone. Total Weight by zone. Averages, and Standard Deviation displayed on run and summary screens.
- Efficiencies and Distribution Percentages are shown on line summary screens.
- Rate Counter displayed on run screen.

Checkmate Screen Options:

- Histogram Package. Basic Checkweigher Statistics plus Graphic Histogram Representation of Short-term Product Distribution and Cumulative Product Distribution.
- XBAR Screens and Summaries SQC Package. XBAR screens and summaries: Basic Checkweigher Statistics plus Graphic XBAR representation of Averages, Standard Deviation, Range, and Trends (a composite of all three).
- Feedback Package. This includes the Histogram Package, feedback screen and filler interface.
- Multihead Statistics Package. Basic Checkweigher Statistics plus multihead screen.

Call: 1-800-836-0836

HI-SPEED CHECKWEIGHER, CO., INC.
 5 Barr Road
 Ithaca, New York 14850
 1-800-836-0836 / 1-607-257-6000
 Fax: 1-607-257-5232

HI-SPEED®

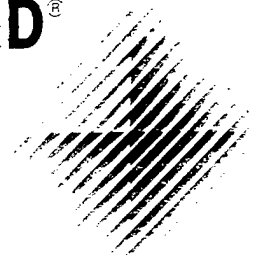

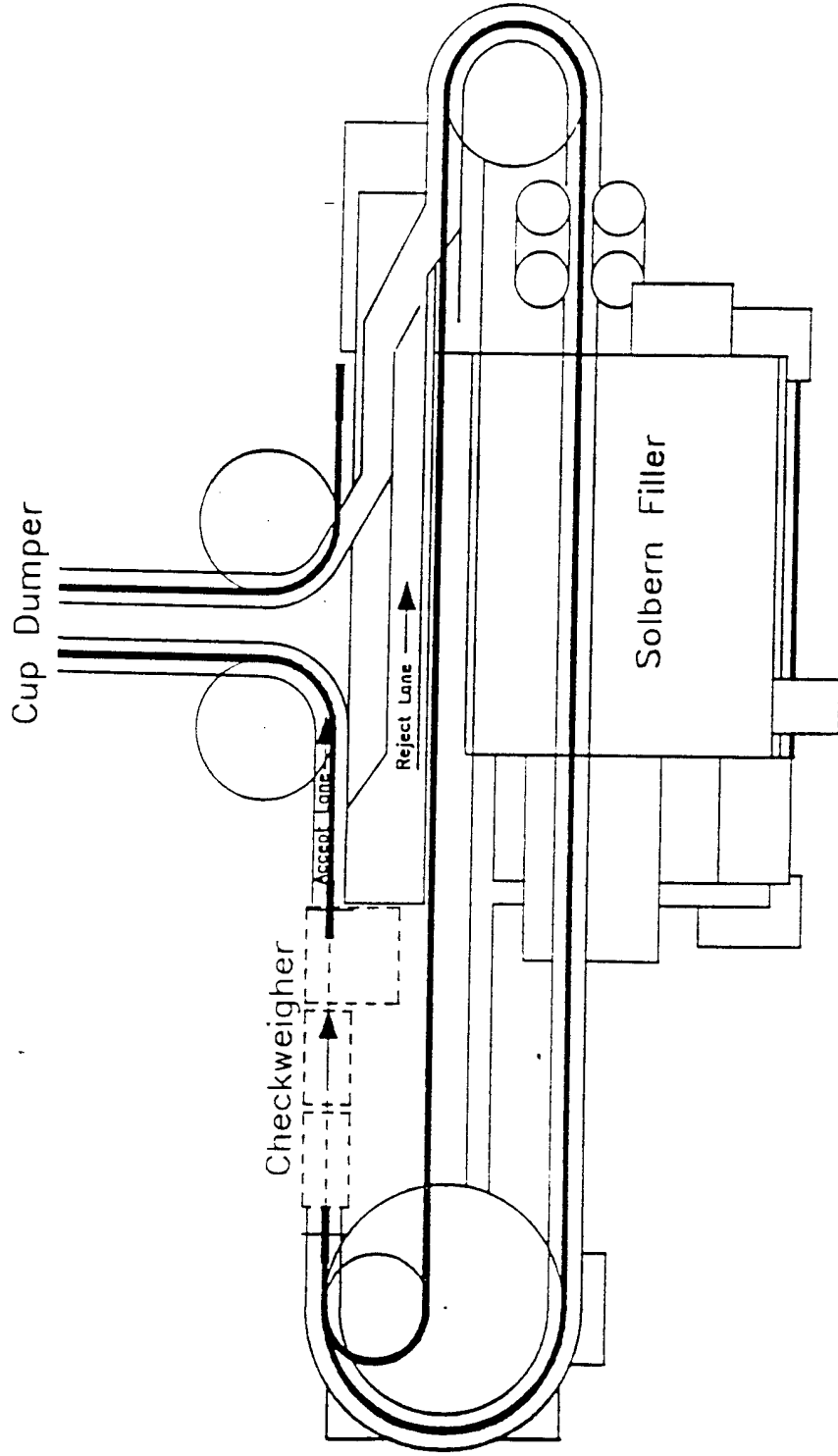

Solbern Checkweigher STP #14

August 24, 1994

RFP# 94-0611

The State University of New Jersey

RUTGERS

Cook College - Center for Advanced Food Technology

CRAMTD Program

Specifications

for

INSPECTION AND RETORT RACK LOADING STATION

This specification covers the requirements for a Inspection/Loading Station that will be used for the CRAMTD Program under STP #14 - Engineered Systems for Handling Material and Product Between Processing Operations. The CRAMTD program demonstration site uses equipment for research and development of new packaging methods and materials.

This specification consists of the following sections:

1. Performance Requirements
2. Product Information
3. Design Requirements
4. General
5. Acceptance
6. Shipping and Installation

August 24, 1994

1.0 Performance Requirements

1.1 Operational Duty. The system shall be designed for continuous operation with a Minimum Operating Efficiency of 98%. Minimum Operating Efficiency is percentage of time that equipment performs at the specified rate. This equipment will operate in a typical washdown area.

1.2 Primary Function. The station will convey food packages from a Tiromat Horizontal-Form-Fill-Seal packaging machine to an inspection area, where operators inspect, then place packages on a second conveyor. The packages move to retort rack loading equipment where operators place packages into retort racks. See Figure 1.

1.3 Production Rate. The system shall transport packages at a rate up to 100 per minute.

1.4 Material Handling. The packages will be transported without damage, scratching or dropping. MRE Pouches measuring approximately 8" by 4 3/4" by 3/4" thick leave the Tiromat packaging line loose in two lanes.

1.5 Operation. The station is to be able to operate either in the manual or automatic mode. When operated automatically, the station will run whenever the production line is running. In the manual mode it must be able to run independently of the Tiromat production line. The rate of the conveyors shall be adjustable using a variable speed drive to closely match the rate of the production line.

2.0 Equipment

2.1 Inspection Conveyor. A smooth belt conveyor with variable speed controller accessible to operators. The belt speed should range from 5-25 feet per minute. The motor should be located under the conveyor so that the inspection area is not reduced. The conveyor should have an end stop to hold pouches back from falling off.

August 24, 1994

2.2 Retort Rack Loading Conveyor. A smooth white belt conveyor with variable speed controller accessible to operators. The belt speed should range from 10-50 feet per minute. The motor should be located under the conveyor.

2.3 Reject Bins. Six reject bins attached to the Retort Loader Conveyor for placing defective pouches. The bins will be removable and be attachable to either side. See Figure 1.

2.4 Brenton Retort Loading/Unloading Stations. Two (2) Retort Loading/Unloading Stations will be provided by Rutgers. See Figure 2. The loaders will be modified as needed for integration with other functions. The loaders will retain portability capability. Sensors will automatically raise or lower racks to maintain height at the top of the retort cage. Sensors will indicate for the operator that a cage is full (OK to remove cage from loader) or empty (OK to remove cage from loader). Manual control will also be provided.

2.5 Loading Platform. A platform will be provided to elevate operators to a comfortable working height. The platform can be a grate or a non-skid plate. See Figure 1.

3.0 Design Requirements

3.1 Pneumatic service up to 100 psi. The vendor is to specify pneumatic requirements, if needed.

3.2 Dimensions. See Figure 1.

3.3 Construction. The station must meet USDA requirements for food handling equipment and be all stainless steel.

3.4 Electrical. Equipment should meet NEMA 4 requirements for washdown. The machine shall be wired for 120 or 208V.

3.5 Drawings. Drawings of the equipment are to be provided with the proposal.

August 24, 1994

3.6 Cleanability. The equipment shall be designed for easy cleaning.

3.7 Safety. The vendor will provide equipment that is safe to operate. Safety guards, safety interlocks and emergency stop buttons are to be provided where required to prevent injury to operators.

4.0 General

4.1 Cost. The proposal is to include the total cost F.O.B. Rutgers University, Food Manufacturing Technology Facility, Piscataway, NJ. Cost of optional equipment, recommended spare parts, accessories and crating should be quoted but clearly delineated from base bid.

4.2 Delivery Schedule. The vendor will specify the delivery schedule.

4.3 Service. The vendor will provide service as needed to fulfill requirements of the warranty and these specifications.

4.4 Manuals. A set of manuals that document equipment operational procedure, maintenance and cleaning procedure will be supplied.

4.5 Drawings, Photos. Drawings of the equipment shall be provided in both plan and elevation views. Additional drawings shall be provided for documentation as needed. Photos shall be provided as needed.

4.6 Award. The criteria for selecting a proposal will be based on the evaluation of the CRAMTD staff:

- Delivery
- Engineering Design and construction
- Cost
- Service
- Training

August 24, 1994

4.7 Exceptions. The vendor may take exception to a part of this specification without being disqualified from consideration but is to clearly identify any exceptions taken.

4.8 Warranty. The vendor warrants the equipment performance specified herein for one year from the date of acceptance. The warranty includes all equipment and software supplied to be free from defects in materials and workmanship.

6.0 Acceptance

6.1 Acceptance Test. An Acceptance Test at Rutgers will be run for up to one hour to determine whether performance requirements have been met.

7.0 Shipping and Installation

7.1 The equipment will be shipped F.O.B., Rutgers University, Food Manufacturing Technology Facility, 120 New England Ave, Piscataway, NJ 08903.

7.2 The vendor will assemble and install equipment in full working order and provide training to Rutgers personnel in the operation and maintenance of the equipment.

August 26, 1994

Vendors for Inspection and Retort Rack Loading Station

Precision Automation
P.O. box 49
Haddonfield, NJ 08033

(609) 428-7400

Enterprise Automation
549 East Third Street
Plainfield, NJ 07060

(908) 561-7774

Brenton Engineering Co.
Rt. 5, Box 178
Alexandria, MN 56308

(612) 852-7705

Conveyor Technology Incorporated
50 Williams Parkway
East Hanover, NJ 07936

(201) 884-0082



PRECISION AUTOMATION CO., INC.

Appendix 4.5.2

BOX 18
HADDONFIELD, NJ 08033
609-428-7400
FAX 609-428-1270

Rutgers - The State University

Piscataway, NJ

Inspection & Retort Rack Loading System



PRECISION AUTOMATION CO., INC.

BOX 18
HADDONFIELD, NJ 08033
609-428-7400
FAX 609-428-1270

October 11, 1994

Rutgers - The State University
University Procurement and Contracting
P.O. Box 6999
Piscataway, NJ 08855-6999

Attn: Mr. Michael Dunn

Ref: Your RFP 4-9-6-2
Our Quotation No. 94M-679

Dear Mr. Dunn:

Precision Automation Co., Inc. is pleased to provide this proposal for the Inspection and Retort Rack Loading Station per your above referenced RFP, specifications, and Addendum number 1 dated September 28, 1994. We reviewed the project requirements and site during the bidders conference on September 28, 1994, at your facility.

We are proposing to provide sanitary conveyors from Nedco. These conveyors are U.S.D.A. accepted, and have been used for many similar applications. The platforms, controls, wiring, system integration, and installation will be handled by our Cherry Hill, NJ facility. Our familiarity with this type of equipment and your entire project make Precision Automation Co., Inc. the ideal vendor.

The following pages provide a detailed description of the system being proposed. The literature and "photographs" of the conveyor will help illustrate the concept. If you have any questions or require additional information, please do not hesitate to contact us.

Sincerely,

PRECISION AUTOMATION CO., INC.

Mark J. Petri
Material Handling Manager

MJP:lah

TABLE OF CONTENTS

PAGE

Section I - TECHNICAL INFORMATION

A.	Scope of Work	3
B.	Product to Be Handled	3
C.	General Equipment Description	4
	1. Mechanical	
	2. Controls	
	3. Utilities Requirements	
	4. Installation/Start-Up	
	5. Training	5
D.	Description of Operation	6
E.	Specifications	6
F.	Documentation	7

Section II - COMMERCIAL DETAILS

A.	Pricing	8
B.	Schedule	8
C.	Shipping	8
D.	Payment Terms	8
E.	General Terms	9

Section III - COMPANY INTRODUCTION

A.	Company Profile	10
B.	Company Officials	11
C.	Services	11
D.	Partial Major Customer List	11
E.	Certification	12
F.	Affiliations	12

Appendix I	Contract Terms	
Appendix II	Service Schedule	
Appendix III	Literature	
Appendix IV	Drawings	

SECTION I - TECHNICAL INFORMATION

A. Scope of Work

1. By Precision Automation:

- * Supply Inspection Conveyor and Retort Rack Loader Conveyor as listed.
- * Supply Aluminum platforms per your drawing.
- * Supply Electrical Controls as listed.
- * Pre-Wire controls devices at our plant.
- * Deliver equipment to your facility, Piscataway, NJ.
- * Assembly and start-up of equipment.

2. By Others

- * Supply utilities for equipment operation as required.
- * Supply "Brenton" Retort Loading/Unloading Station.
- * Provide clear area and facilities for installation crew.

B. Product to be Handled

MRE pouch, Maximum rate is 100 per minute

8" x 4-3/4" x 3/4" thick.

C. General Equipment Description

1. Mechanical

<u>Item</u>	<u>Qty.</u>	<u>Description</u>
A	1	Inspection Conveyor. "Nedco" stainless steel slider bed belt conveyor, 19" wide belt x 9'0" long. 1/2 hp underslung end drive with variable speed maximum of 25 fpm. Elevation is 32" to top of belt (t.o.b.). Includes a removable plastic bin at discharge end (20" x 12" x 10" approximately).
B	1	Retort Rack Loading conveyor. "Nedco" stainless steel slider bed belt conveyor, 7" wide belt x 15'10" long. 1/2 hp underslung end drive with variable speed maximum of 50 fpm. Elevation is 45" to t.o.b. Includes retractable "catch plate" at discharge end and six (6) reject bins per drawing.
C	3 pcs.	Aluminum Diamond Plate Platform, 12" above floor with adjustable feet. Sizes: 24" x 36", 24" x 48", and 30" x 102". Diamond tread top plate lifts out for moving and cleaning.

2. Electrical Controls

D	1	Main Control Enclosure. NEMA 4, stainless steel box with two (2) Chassis-mount SCR motor controllers, master control relay, and cord with 3-prong plug for main 110V power supply. Includes door mounted "ON", "OFF" pushbuttons and potentiometer for speed control of item A. Mounted to conveyor near drive end.
E	1	Operator station. NEMA 4 enclosure with "Emergency Stop" pushbutton and potentiometer for speed control of item B. Mounted to conveyor near drive end.
F	1	Operator Station. NEMA 4 enclosure with "Emergency Stop" pushbutton. Mounted to conveyor near infeed end.

3. Utilities Requirements:

110V-1Ø-60Hz 20 amps electrical power.

Our equipment will be pre-wired with a standard 3-prong plug.

4. Installation/Start-Up

Our crew will unload, assemble, position, and level all supplied equipment. They will plug units in to your 110V supply and track both belts. The one hour acceptance test will be run at this time.

All work is by our non-union crews during regular working hours at prevailing wages.

5. Training

We have not provided a specific amount of time for training. Our installation supervisor can explain the operation during the installation. Refer to our enclosed "Service Schedule" for rates. It is difficult to estimate how much additional training your personnel would require for this basic system.

D. Description of Operation

Loose MRE pouches are discharged in two lanes from the existing Tiromat packaging line. The pouches transfer off of the Tiromat belt onto the inspection conveyor.

Operators on each side of the inspection conveyor inspect the pouches. They are then placed onto the upper level conveyor (Retort Rack Loading Conveyor) or into a reject bin. The pouches are conveyed to the retort rack loading area.

The belt speed of each conveyor is adjustable via the potentiometers for the D.C. controllers. The "ON/"OFF" pushbuttons start and stop both conveyors. There are two (2) Emergency stop push buttons per your request.

E. Specifications

"Nedco" Stainless Steel Sanitary Belt Conveyor

Drives: Underslung end type with 4" diameter pulley. Precision type self-aligning nickel plated bearings. C-faced motor/reducer combination drives pulley via a fully guarded chain transmission. Motors are 90V DC washdown type. Reducers are "TORQube" type, foot mounted.

Take-Up: End type with 4" diameter pulley. Bearings are nickel plated. Screw-type adjustment with quick release for cleaning slider bed type. 4" deep x 12 ga. formed box channel frame. Frames are 2" wider than belt.

Belt: White, USDA approved.

Supports: Sanitary Stainless Steel adjustable for elevations as listed.

Refer to enclosed literature for additional information.

F. Documentation

The equipment will be documented on our standard drawing media. The drawing package will include assembly drawings, detailed component drawings, electrical schematics, ladder logic diagrams, pneumatic schematics and a complete bill of material. Our standard operation/maintenance manual outlining the set-up, operation, trouble shooting and preventative maintenance procedures for the equipment will be provided as an option.

SECTION II - COMMERCIAL DETAILS

A. Pricing:

1. Price for above described equipment . . . \$27,850.00

B. Schedule:

Arrangement and schematic drawings for approval 3-4 weeks
ARO.

Equipment ready to ship approximately 8 weeks after drawing
approval.

Installation requires a day to be scheduled.

C. Shipping

The equipment is FOB: Your Facility, 120 New England Avenue,
Piscataway, New Jersey.

D. Payment Terms

Net 30 Days

E. GENERAL TERMS

1. Please review our "Contract Terms" found in Appendix I which are a part of this proposal.
2. Note the above prices do not include any state or local sales or use taxes. Licenses, permits or fees, if required, are the customer's responsibility.
3. This proposal is based on a straight time, 40 hours per week basis. Should overtime be requested by Customer, an appropriate extra charge will be required.
4. Equipment Operation - Purchaser shall use and shall require its employees to use all safety devices and guards on the equipment. Purchaser shall use safe operating procedures. Purchaser shall not remove or modify any such device or guard or warning sign. If purchaser fails to observe all of these obligations, purchaser agrees to indemnify and save Precision Automation Co., Inc. harmless from all liability incurred to persons injured directly by operating the Precision Automation Co., Inc. equipment.
5. Modifications or alterations to the equipment without the express written consent of the manufacturer is forbidden. Failure to obtain permission in writing voids any warranty, express or implied. It also relieves the manufacturer from all liability for said products.
6. All utilities are the responsibility of the Customer. 110V power supply receptacle is to be within five (5) feet of the control panels and/or machine connections for the system.

SECTION III - COMPANY INTRODUCTION

A. Company Profile

Incorporated in 1946

Mission Statement: Precision Automation Co., Inc. will provide high quality Automation Systems, Contract Machine Work, Fabrication, Assemblies and Controls to improve productivity in our customer's manufacturing and product handling processes.

Plant Locations: 1841 Old Cuthbert Road
Cherry Hill, NJ 08034
Phone: (609) 428-7400
Fax: (609) 428-1270

2120 Addmore Lane
Clarksville, IN 47129
Phone: (812) 283-7963
Fax: (812) 283-7992

3864 Lake Street
Macon, GA 31204
Phone: (912) 741-0918
Fax: (912) 741-4402

Plant Sizes: Cherry Hill, NJ - Approx. 40,000 sq. ft.
Clarksville, IN - Approx. 30,000 sq. ft.
Macon, GA - Approx. 10,000 sq. ft.

Total Number of Employees: Approximately 150

Total Annual Sales Volume: Approximately \$15 Million

Subsidiary: Altek Manufacturing
2120 Addmore Lane
Clarksville, IN 47129
Phone: (812) 284-9727
Fax: (812) 283-7992

B. Company Officials

G. Frederick Rexon, Sr. - President
Daniel J. Pisko - Executive Vice President
G. Frederick Rexon, Jr. - Vice President
Charles W. Bittner - Vice President/Engineering (New Jersey)
Warren G. Menaquale - Vice President/Sales (New Jersey)
Glen A. Morris - Vice President/General Manager (Indiana)
Robert Daily - Vice President (Indiana)
Mary Ann Huffman - Vice President (Indiana)

C. Services

- * System Engineering, Design and Project Management
- * Automation System Integration
- * Robotics/Flexible Automation Systems
- * Special Automated Machinery
- * Control Systems
- * Machine Vision Systems
- * Material Handling and Conveyor Systems
- * Die Handling Systems
- * Hatchery Automation Systems
- * Special Case Forming and Sealing Equipment
- * Palletized Stretch Wrap Machinery
- * Contract Machining, Fabrication, Assembly
- * Turnkey Contract Manufacturing
- * Equipment Installation and Start-Up

D. Partial Major Customer List

American Olean Tile Company
Armstrong World Industries
Brown & Williamson Tobacco Company
C & D Power Systems, Inc.
Certain Teed
Coca-Cola USA
E.I. DuPont de Nemours & Co., Inc.
Ford Motor Company
Gates Rubber Company
General Electric Company.
General Foods
Ingersoll-Dresser Pump
Johnson & Johnson
Kimble Glass Company
McNeil Consumer Products
Merck & Company
Philip Morris
Rockwell International
Rohm & Haas
Scott Paper Company
Sterling Winthrop
The Trane Company
Tyson Foods, Inc.

E. Certification

ASME Pressure Vessel Code Construction

F. Affiliations

"AAA" & "PVI" Systems Integrator

Adept Technology, Inc.
(SCARA Robots, Machine
Vision, Motion Control)

Systems Integrator

Kawasaki Robotics USA, Inc.
(Articulated Robot)

Systems Integrator

FMC, Packaging Systems Division
(Cartesian Coordinate Robot)

Systems Integrator

Bosch Group
(Automation Product)

Authorized Systems Integrator

Allen-Bradley Co.
(Controls, Motion Control
& Machine Vision)

Authorized Distributor

Ermanco, Inc.

Authorized Dealer

Webb Norfolk Conveyor
Div. of Jervis B. Webb Co.

Authorized Distributor

Automotion, Inc.

Authorized Systems Integrator

Buschman Conveyor Co.

Authorized Distributor

Automated Conveyor Systems, Inc.

Authorized Stocking Distributor

Richards-Wilcox Mfg. Co.

Authorized Distributor

Nedco Conveyor Co.

Authorized Dealer

New London Engineering, Inc.

Systems Integrator

Portec, Inc. - Flomaster Division

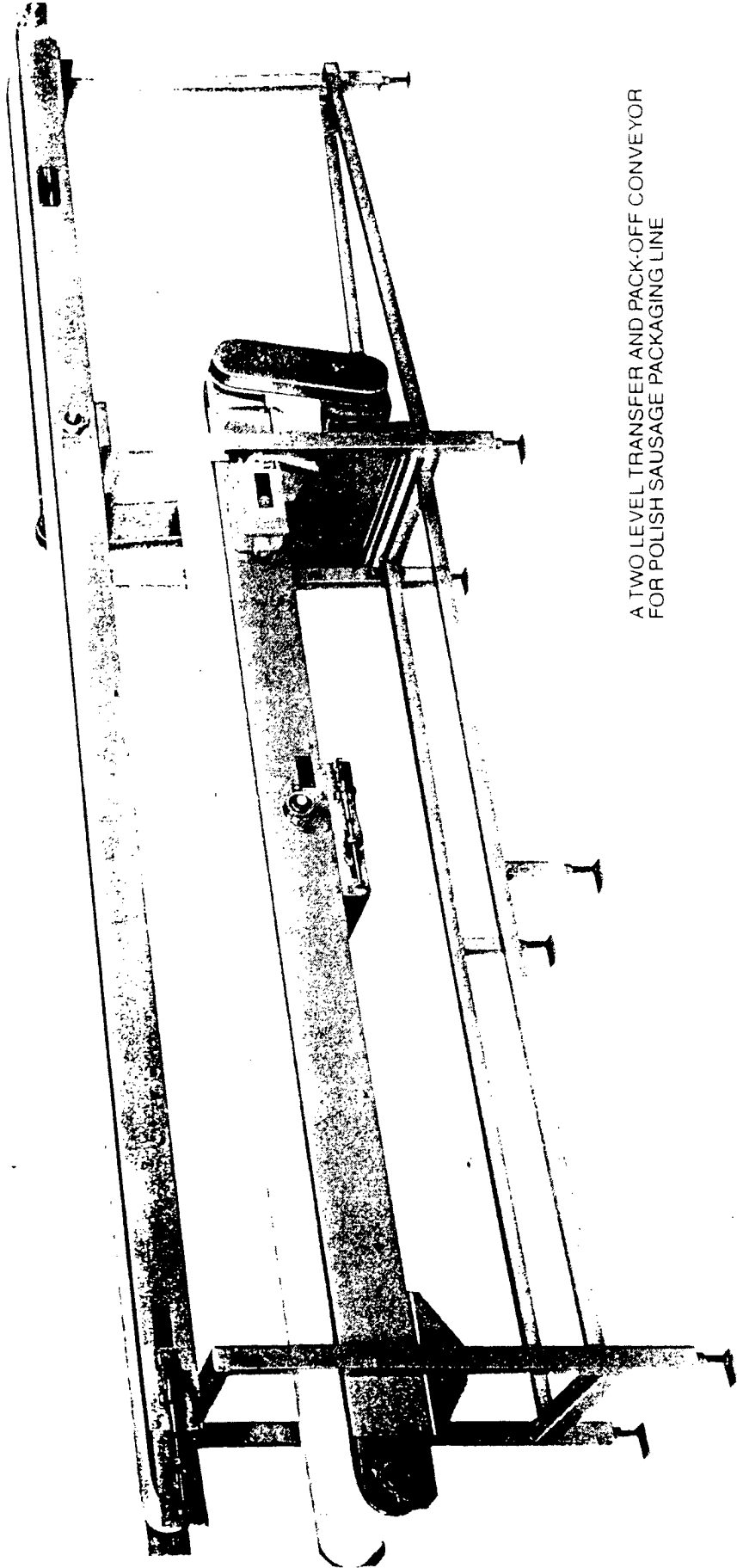

A TWO LEVEL TRANSFER AND PACK-OFF CONVEYOR
FOR POLISH SAUSAGE PACKAGING LINE

September 28, 1994

Brenton Engineering Company
Rt. 5, Box 178
Alexandria, MN 56308

RE: ADDENDUM #1 TO RFP# 4-9-6-2/INSPECTION AND RETORT LOADING STATION

Dear Contractor:

The information contained herein revises, supplements and/or supersedes the specific parts of the documents referred to as request for proposal number 4-9-6-2. Except as herein modified, all other provisions of the bid request shall remain in full force as originally set forth.

1. SECTION 2.1: Add; A plastic bin (20"W x 12"L x 10"D) will be provided at the conveyor discharge to catch pouches. Delete end stop.
2. SECTION 2.2: Add; A retractable plate at the conveyor discharge will be provided for catching pouches. An Emergency Stop will be provided near the discharge.
3. SECTION 2.5: Add; The platforms will be movable, and made of aluminum. The top surface will be raised diamond pattern.
4. Replace Figure 1 with the revised drawing dated 9/27/94 (attached).
5. All addenda received must be acknowledged by signing page 2, section 11 of the official bid document.

Sincerely,

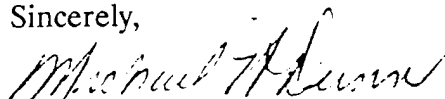

Michael H. Dunn
Acting Supervisory Buyer

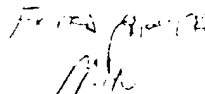

MD/kdl

atch: Figure 1, revised 9/27/94

c: T. Descovich
N. Litman
G. Thorn, Jr.

APPENDIX 2.5.3

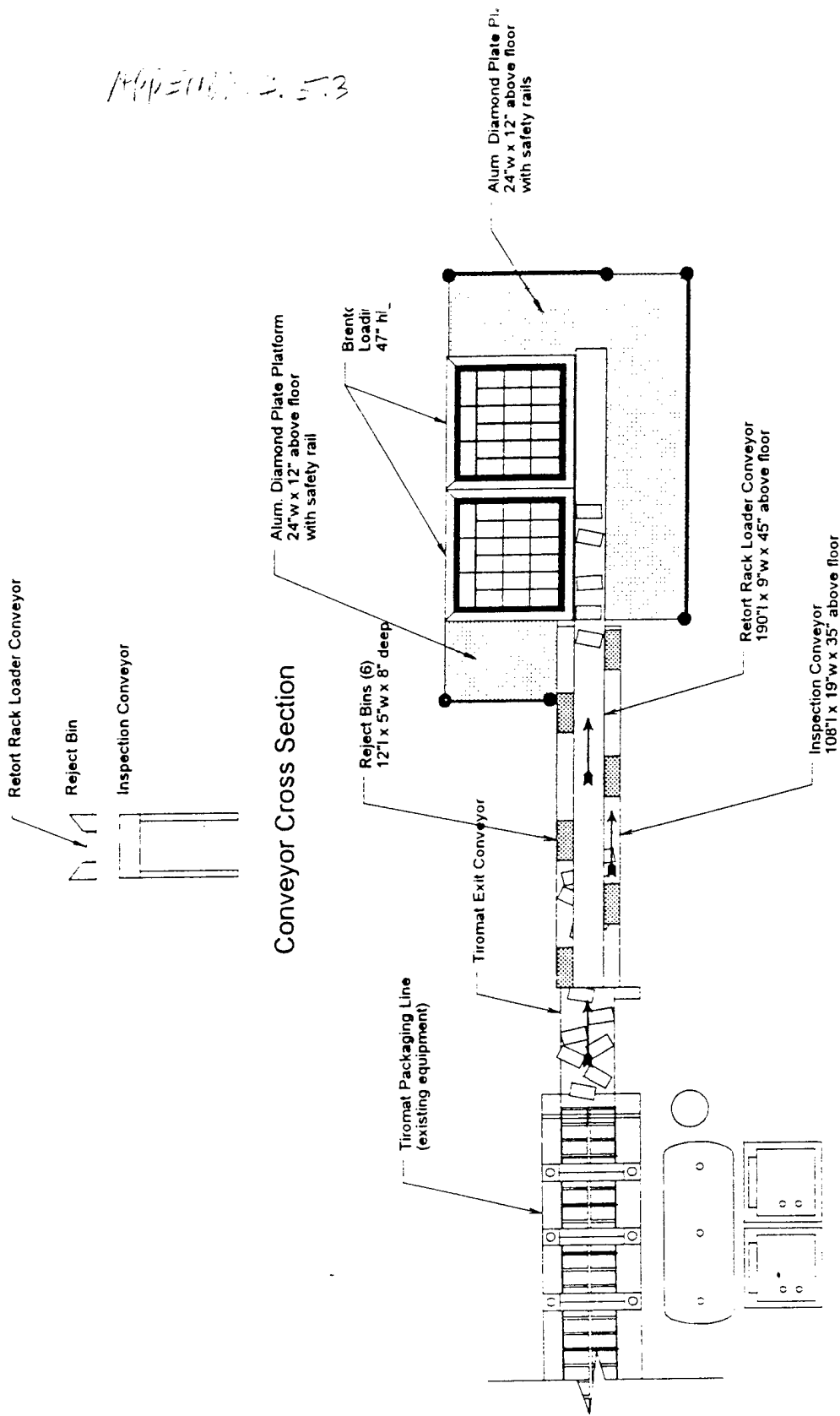

Pouch Inspection and Retort Loading Station

RLOAD2 revised 9/27/9.
Scale: 1/4" = 1'
Rutgers CRAMTD

Figure 1

QUOTATION

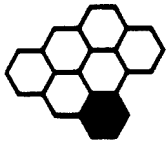

BRENTON
ENGINEERING COMPANY
"Expect Innovation"

4750 CO. RD. 13 N.E.
 ALEXANDRIA, MN 56308-9014
 (612) 852-7705
 (612) 852-7621 FAX

November 9, 1994

Mr Ted Descovich
 Rutgers Unniversity
 Food Service Building
 120 New England Avenue
 Piscataway, NJ 08855-6999

RE: Semi-Automatic Loader/Unloader

Dear Ted:

This is Brenton Engineering's quotation for two retort Loading/Unloading Stations to handle Stock 1300 cages and racks holding MRE pouches measuring 8.12" x 4.8" x .63" deep. Each station includes lift tables, self contained hydraulic system, photo eyes, two palm buttons, guards on three sides for hand loading. NEMA-4-120V, stations mounted on casters and all stainless construction.

The price for the above described stations is \$39,200, F.O.B. Rutgers University, Food Manufacturing Technology Facility, 120 New England Avenue, Piscataway, NJ 08854 (freight included).

At this time, delivery will be approximately four (4) months after receipt of your purchase order, including all specifications, product samples and down payment.

Terms:

- 30% down payment with purchase order
- 60% due prior to shipment
- 10% due within 30 days of acceptance

If you have any questions, or if I can be of further assistance, please do not hesitate to call me.

Sincerely,

BRENTON ENGINEERING COMPANY

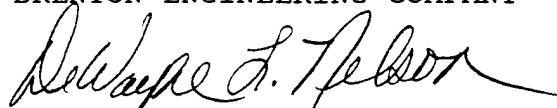
 DeWayne L. Nelson
 Sales Engineer

DLN

c: Norm Milligan / TechSystems, Inc.



RETORT • LOADING/UNLOADING STATION

RETORT BASKETS

Brenton Engineering Company offers a portable Loading/Unloading Station for your retort handling needs. This station incorporates a lift table to facilitate manual loading and unloading of retort baskets and can be custom built to meet your retort specifications and needs.

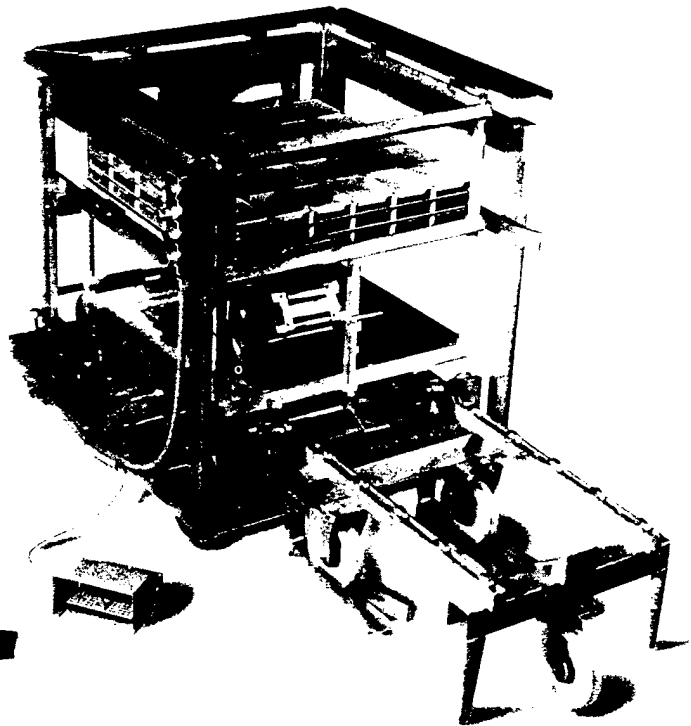
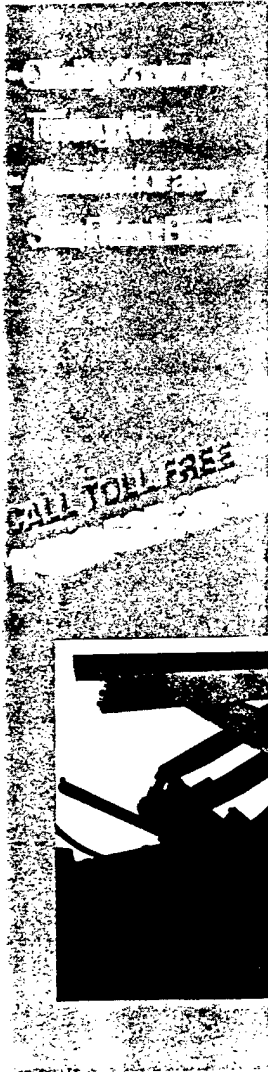

FEATURES/BENEFITS

- Fully portable
- All stainless steel construction
- Self-contained hydraulic system
- Simple to operate controls (options available)

Brenton Engineering Company
Rt. 5, Box 178 • Alexandria, MN 56308
(612) 852-7705 • Fax (612) 852-7621

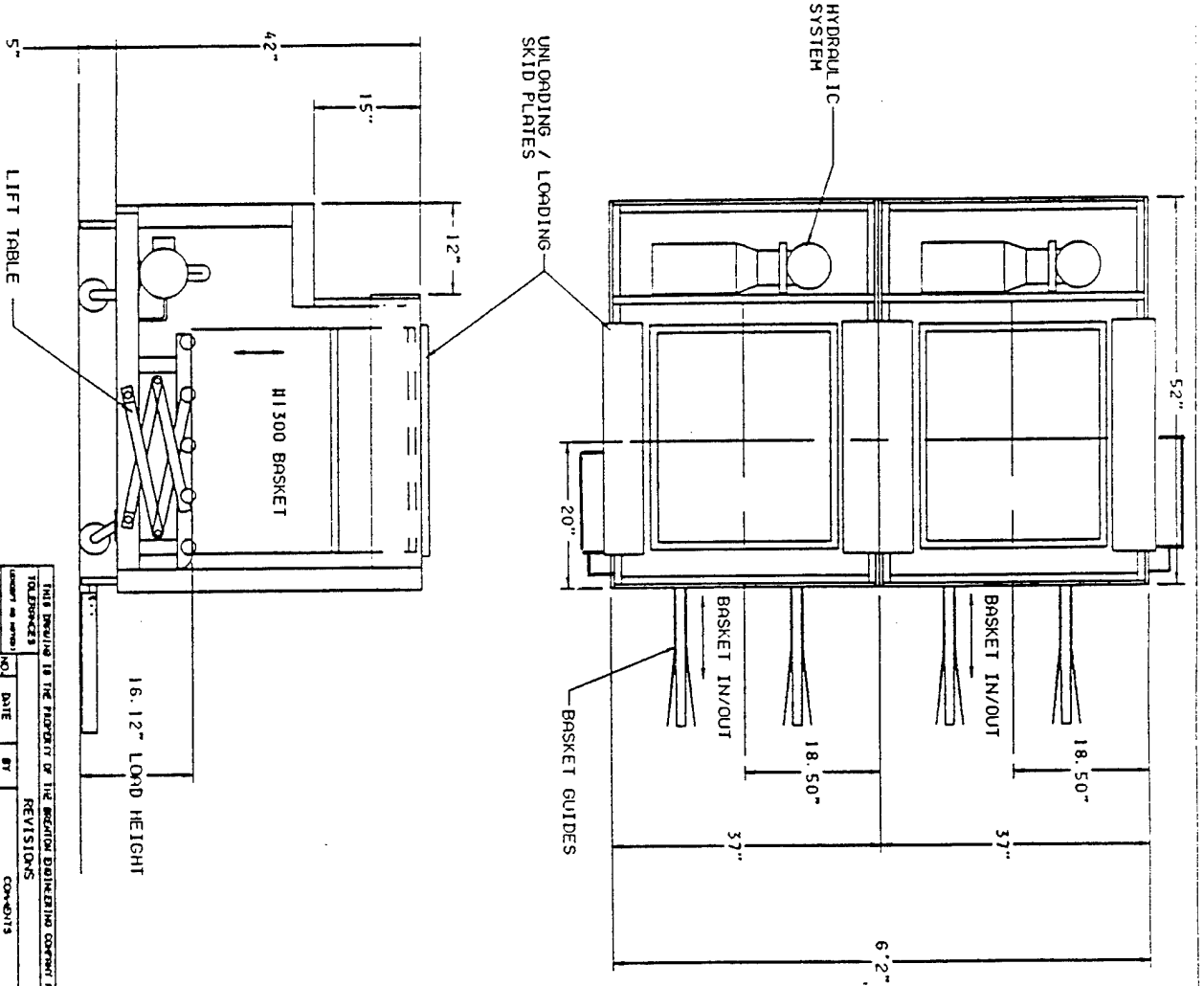

THIS DRAWING IS THE PROPERTY OF THE DESIGN ENGINEERING COMPANY AND IS NOT TO BE USED OR REPRODUCED WITHOUT THEIR PERMISSION.

TOLERANCES	NO.	DATE	BY	REVISIONS	COMMENTS
DECIMAL	1				
FRACTIONAL	2				
ANGULAR	3				
	4				
	5				

DESIGNED BY	DATE	PROJECT NO.	SCALE
PISTONWAY	GR		FP-2240C

BRENTON
 1750 COUNTY ROAD 11
 FARMINGTON, CT 06031
 TEL: 860-271-1111
 FAX: 860-271-1111

RUTGER'S UNIVERSITY
 RETORT LIFT STATION

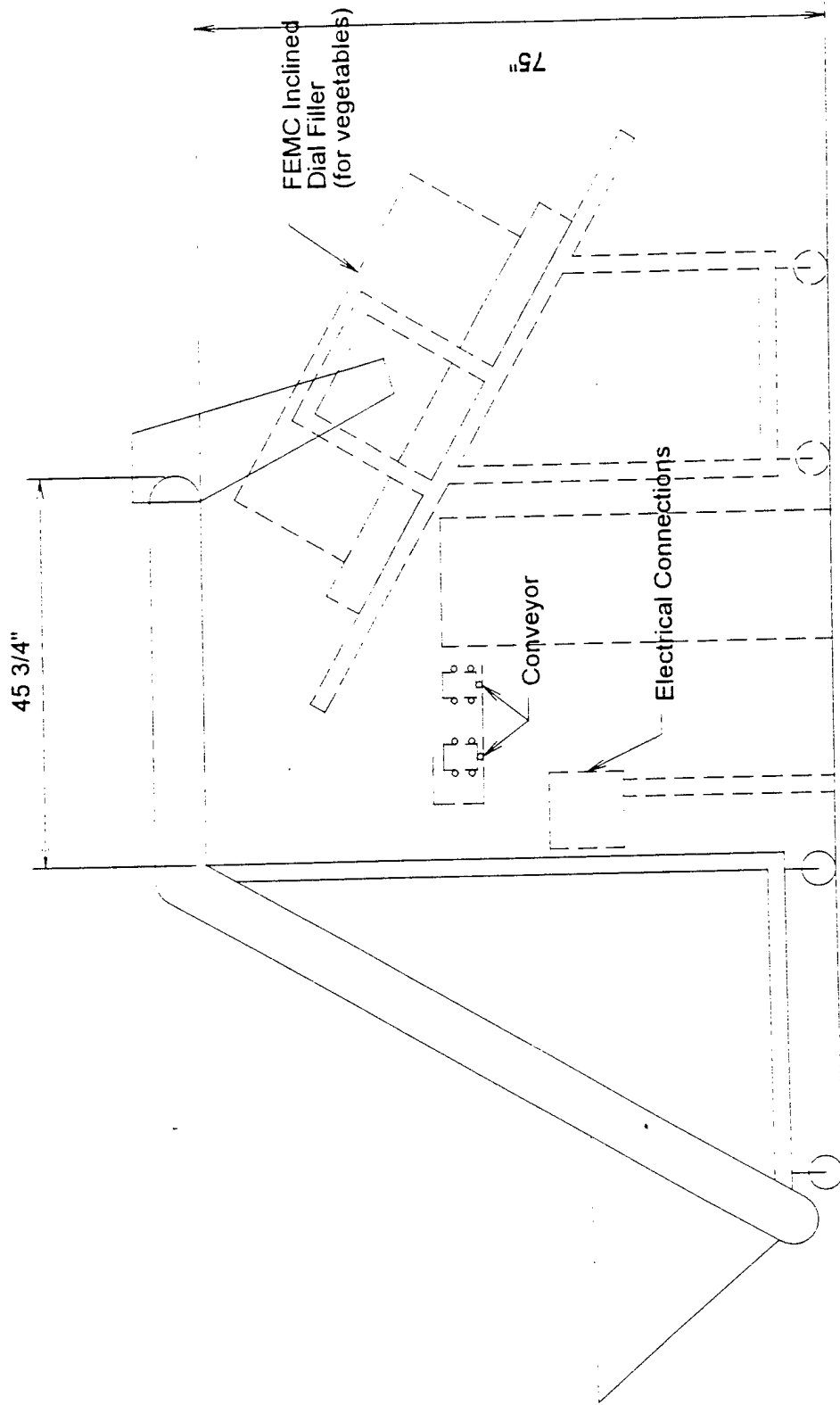

Rutgers - CRAMTD
FEEDER
Oct. 7, 1994

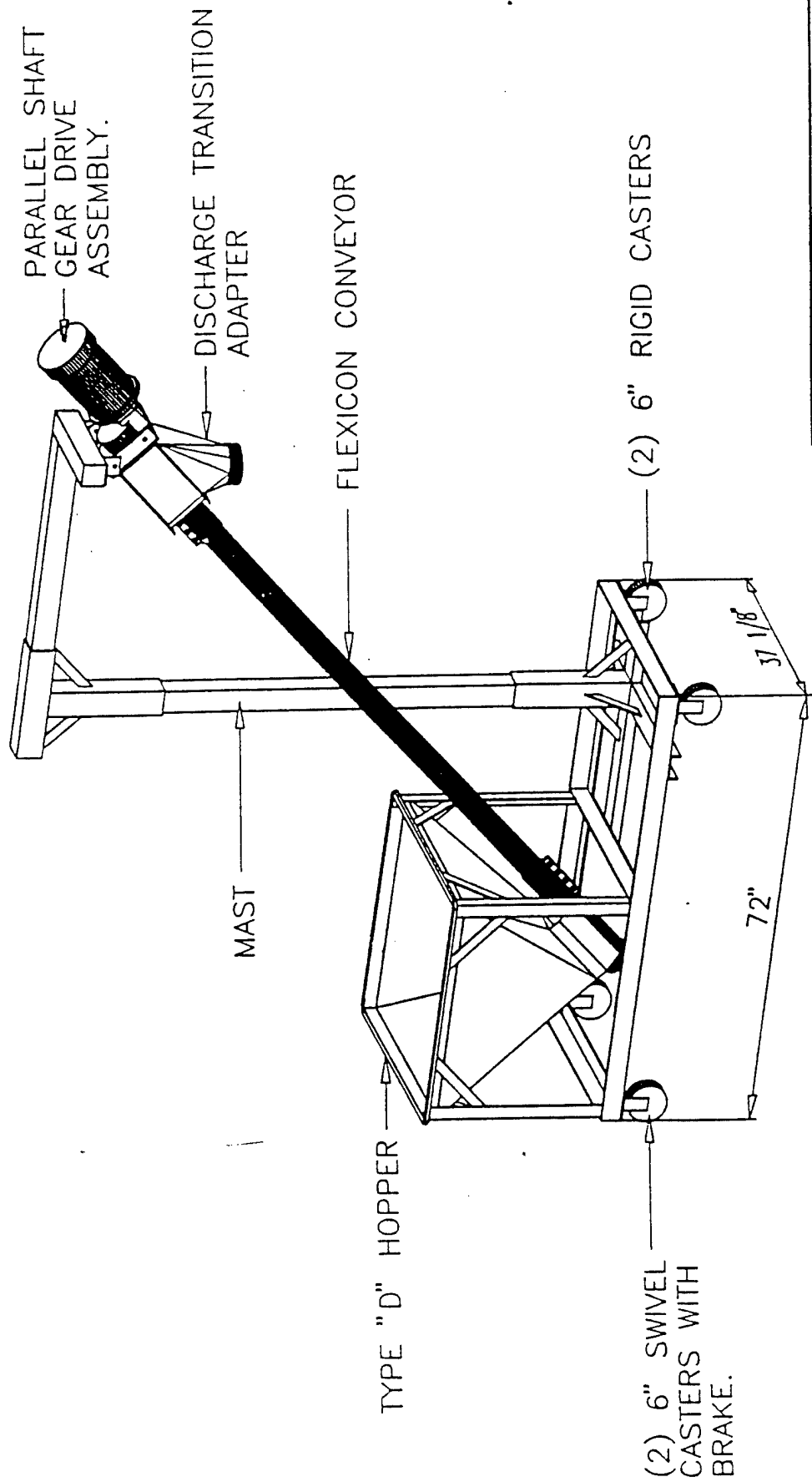

PARALLEL SHAFT
GEAR DRIVE
ASSEMBLY.

DISCHARGE TRANSITION
ADAPTER

FLEXICON CONVEYOR

MAST

TYPE "D" HOPPER

(2) 6" RIGID CASTERS

(2) 6" SWIVEL
CASTERS WITH
BRAKE.

37 1/8"

72"

INFORMATION SET FORTH IN THIS
DRAWING IS PROPRIETARY WITH
FLEXICON CORP. AND THIS DRAWING
SHALL NOT BE REPRODUCED, COPIED,
LOANED OR SUBMITTED TO OUTSIDE
PARTIES FOR EXAMINATION WITHOUT
THE CONSENT OF FLEXICON CORP.
EXCEPT FOR THE PURPOSE FOR
WHICH IT WAS SENT

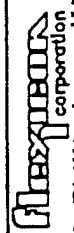

P.O. Box 5269 Phillipsburg, NJ 08865-5269
TEL: (608) 688-1700 FAX: (608) 688-4880

DRW. BY: D. CROUSE	REV. BY:	JOB NO.	QUOTE NO.
DATE: 2-24-92	TITLE:		
SCALE: 1" = 12"			
CUSTOMER:			
DWG. NO. D-501072	REV. 1	SHEET 1 OF 1	

PORTABLE FLEXICON CONVEYING SYSTEM

SOLBERN

Vibratory Infeed Conveyor

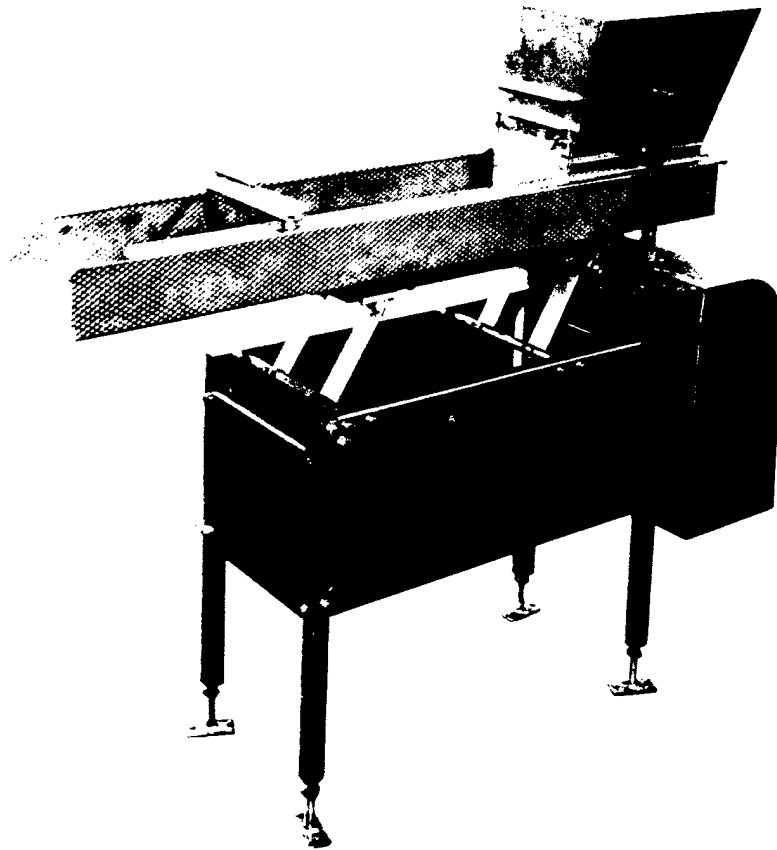

This vibratory conveyor was designed specifically to feed product to Solbern fillers. The machine is constructed entirely from stainless steel and other non-corrosive materials.

Conveyor motion is supplied via a motor-driven eccentric. Variable speed is standard on all machines.

For optimum filler efficiency, the "ON-OFF" function of this vibratory product infeed should be controlled by Solbern's product level control device in the filler drum.

OPTIONS

- 10" diameter hopper connection in place of rectangular
- Angle mounting for use with side belt drives
- Bias cut discharge to deliver fragile products evenly through drum
- Hinged Lexan trough cover with quick release latches
- Alternate trough attachments to remove fines, clumps or water from product

ROLL HOIST

"The Intelligent Machinery"

USES

- Lift Film
- Load Film
- Transport Film
- Change Tooling

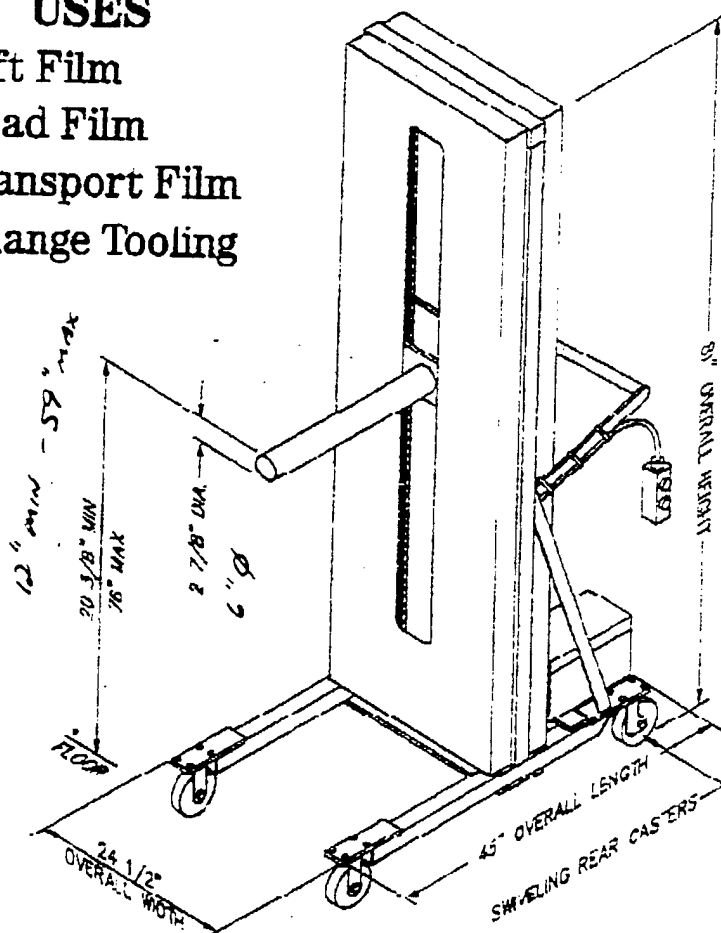

BENEFITS

- Reduce injury.
- All Stainless Steel Construction.
- Reduce damage to heavy fill rolls.
- Simplify and speed up time for die changeover.
- Simplify movement to and quick placement of film on machine.

SPECIFICATIONS

- 500 lb. capacity
- 8 hours use per charge
- 24 volt charging system
- (2) 12 volt deep cycle batteries
- Redundant lifting chains for added safety
- Self-locking wormgear

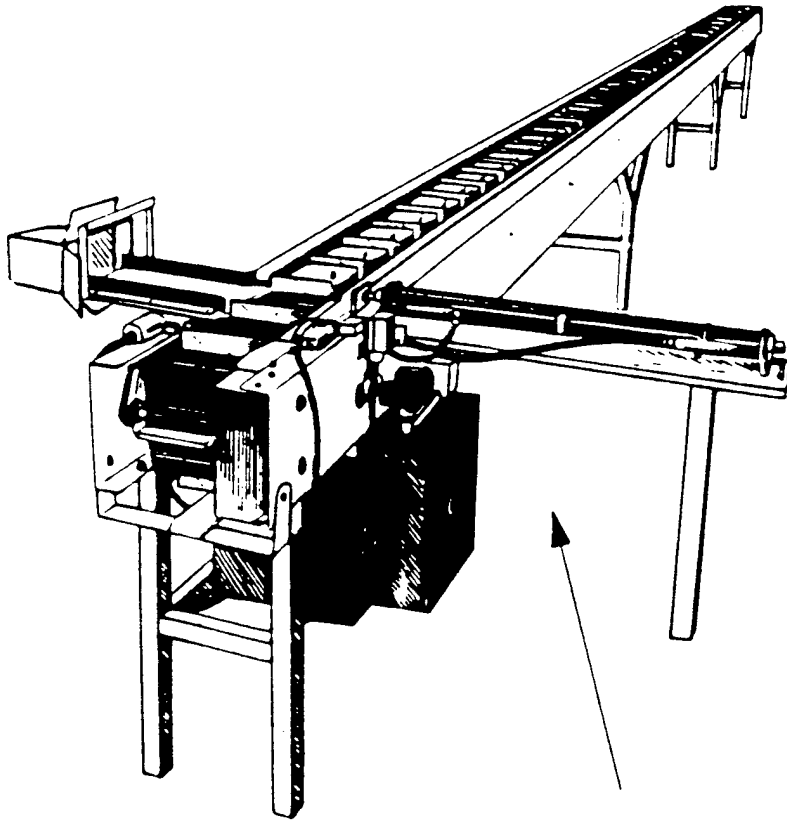

STP #14

Product Loading Conveyor

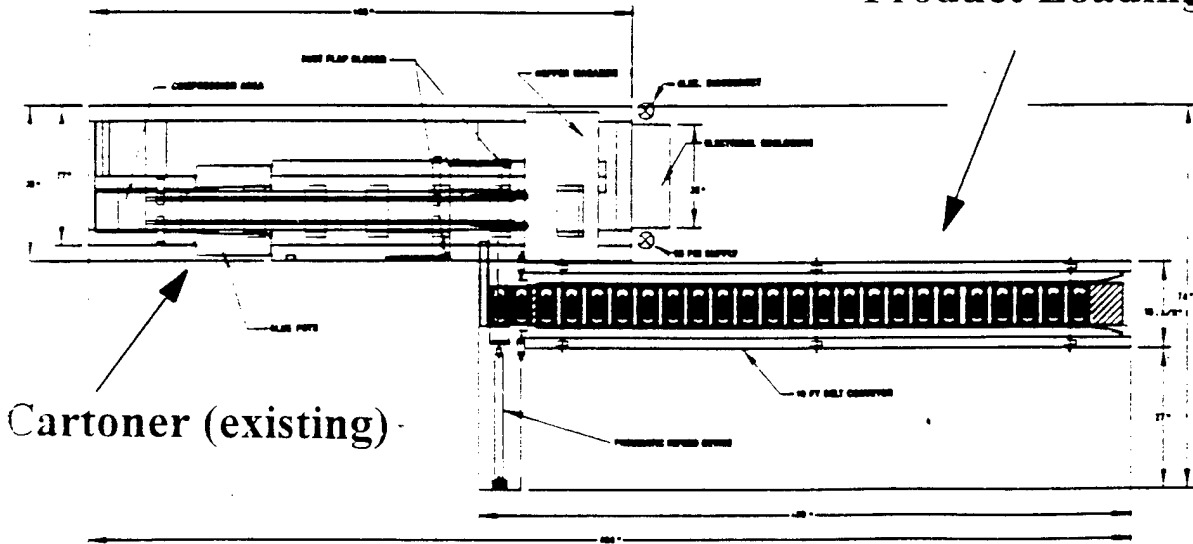

Cartoner (existing)

The State University of New Jersey
RUTGERS
Cook College - Center for Advanced Food Technology
CRAMTD Program

Specifications
For

Control System for Horizontal Form-Fill-Seal Production Line

This specification covers the requirements for a control system that will be used for the CRAMTD program under STP #16 - Implementation of Integrated Manufacturing. This specification includes control panel, PLC, wiring to existing machinery, installation of sensors, and software requirements for the PLC that will be used to coordinate machines on the horizontal form-fill-seal pouch line, while gathering information for data logging. Hereafter, this controller will be referred to as the "production line controller". The machines and their production line layout that are included in this specification are shown in Figure 1.

This specification consists of the following sections:

1. Performance requirements
2. Hardware requirements
3. Software requirements
4. Modes of Operation
5. Documentation requirements
6. General
7. Acceptance
8. Shipping and installation

1.0 Performance Requirements

1.1 Operational Duty. The equipment is to be capable of continuous operation in a typical food production environment. This equipment must operate in a typical wash down area and must withstand the use of non-caustic detergent, bleach and high pressure water cleaning. Cleaning time will be provided daily as required by regulatory agencies(i.e., FDA, USDA) or at least once per day.

1.2 Scan Time. The scan time of the production line controller shall be sufficient to handle all data logging functions and reporting functions to the scada node when the filler and checkweigher are operating at speeds up to 300 cups per minute and the form-fill-seal machine is operating at 110 pouches per minute. The relationship of the production line controller to the scada node and higher levels is shown in Figure 3.

2.0 Hardware Requirements

2.1 The controller hardware shall be a series 5 Allen Bradley PLC with a 5/12 processor or higher, based on the scan time and memory requirements to perform the control and data logging functions as described in section 1.2 and 3.0.

2.2 The control panel shall be a stainless steel floor mounted Nema 4 panel of approximate specifications and layout as shown in Figure 2. Hereafter, this will be referred to as "the panel". It shall have a flange mount main disconnect switch. The following components shall be mounted on the panel.

2.2.1 Control Switches

Push button start/stop contacts for the entire line.

Remote / Local select switches for the following subsystems: Solbern filler, FEMC filler, product feed fillers, checkweigher, Tiromat form-fill-seal machine, Adept robot, Oden filler, Videojet printers, and retort loader.

Selector switches that indicate which combination of three fillers are being used: Solbern dumper, Oden filler, Adept robot.

Interface for entering digital data and obtaining digital readout for set speeds of the following subsystems: Solbern shaker, drum, filler belt, and dumper belt.

2.2.2 Information displays

Digital readout of set speeds in 2.2.1, above.

Tiromat pouch production rate.

Inspection station reject count.

Retort rack loader rate and count.

Lamp on top of control cabinet to indicate status of line: red (stopped), green (running).

Digital readout of the product temperature data being collected by on-line sensors.

2.2.3 Pilot Lights

Product Feeders(2) - Power On (Ready), E-stop, Low Product Level.

Tiromat - Power On (Ready), Running, E-stop, Fault.

Solbern - Power On (Ready), Cycle Start, Pause, E-stop, Product Low Level, Dumper Jam, Dumper Starved.

FEMC - Power On (Ready), Product Low Level, E-stop, Low Speed, High Speed, Back Up Sensor.

Adept Robot - Arm Power, Program Running, Conveyor Start (On), Conveyor Stop, E-stop.

Videojets - Power On (Ready), Head, Print.

Retort Loader - Power On (Ready), E-stop, Pouch jam, No Pouch, No Rack.

Oden - Power On (Ready), Hopper Level, E-stop, Nozzle Fault.

Checkweigher - Power On (Ready), Fault.

Line Air Pressure Alarm
Vacuum Pressure Alarm

2.2.4 Terminal Displays

SMART Workstation and monitor, provided by Rutgers.

Adept Robot Workstation with Monitor and Mouse, provided by Rutgers.

Operator Interface with functions as described in sections 2.2.1, 2.2.2 and 2.2.3. Options quoted separately as follows:

- a) A CRT display indicating line status and faults.
- b) A touch screen panel view with a graphic display of the line, incorporating functions described in section 2.2.1, 2.2.2 and 2.2.3. Multiple screen levels or windows should display details for each machine.

View Node Operator Interface Workstation and Monitor as specified in Appendix A.

Contractor will provide a NEMA 4 Keyboard. It would be desirable if one keyboard could be used for all workstation interfaces.

2.3 All electrical wiring, connections, control boxes and components shall conform to NEMA 4 standards. Quick disconnects are to be used at all movable machinery. Wiring and conduits are to be off the floor, with a minimum number of drops from the ceiling.

2.4 The terminal CPU's will be mounted within the panel (SMART PDP11, Adept, view node operator interface as specified in Appendix A, and the PLC). All terminals shall have access to their computer disk drives through water tight doors.

2.5 Sensors and bar code scanners for on-line data acquisition shall be provided and installed by the contractor as per items 3.1.1.2, 3.1.3.2, 3.1.5.1, 3.1.6.2, 3.1.11.

3.0 Software Requirements

3.1 The following specifications refer to control and data logging requirements for the equipment shown in Figure 1. This equipment includes the Solbern filler, a checkweigher, FEMC filler, two product feed fillers, Tiromat form-fill-seal machine, Oden filler, Adept robot, Brenton Retort pouch loader, and Videojet printer.

3.1.1 Solbern Filler. The Solbern filler is programmed and operated by an Allen Bradley SLC 500 controller, model 02. It provides open loop control of the cup conveyor, cup transfer system, and the rotating filler drum. The following control functions should be available from the shop floor controller.

3.1.1.1 Production Line Control

Start / Stop: The Solbern filler should be started and stopped from the production line control panel. A return signal should be provided by the Solbern controller to indicate it is running.

Remote / Local operation: A Remote / Local switch should be provided on the production line control panel so that the Solbern filler can be operated under local control of the Solbern controller. When operating under remote control, the Solbern controller start button is overridden by the Solbern start button on the production line control panel. All control functions currently adjustable at the Solbern controller will be adjustable by remote input in the remote mode.

Checkweigher Conveyor: This conveyor should be placed under the control of the production line controller. This conveyor should start when the Solbern starts. Provision should be made to regulate the variable speed drive of this conveyor. If there is a high rejection rate from the Solbern because cups are being recycled empty, it should be possible to regulate this drive to a slower speed.

3.1.1.2 Data Logging

Line Stoppages: The production line controller shall record the source of all line stoppages such that this data can be collected by the scada node.

Low Product Level: The production line controller shall record the existence of a low product level from a sensor in the Solbern filler. This condition shall be used to replenish product from the product feed filler attending the Solbern.

Temperature Sensor: The contractor shall install a non-contact temperature sensor for acquiring the temperature of beef in the Solbern filler. Provision for collecting the data will be made in the production line PLC.

3.1.2 Checkweigher. The Checkweigher weighs filled cups coming from the Solbern filler and either accepts the fill weight or diverts the cup back to the filler because its weight is out of spec. The checkweigher controller also controls a stepper / servo motor that makes adjustments to the cup fill volume to compensate for out-of-spec weights. When downstream jams occur, the checkweigher controller passes cups back to the Solbern filler without recording weights. The checkweigher controller has an RS232 interface. The following functions should be available from the shop floor controller.

3.1.2.1 Production Line Control

Target Weights and Cutoffs: The production line controller shall be capable of downloading operational control data to the checkweigher controller. A download cycle shall be initiated by a computer communicating with the production line controller over data highway plus. Hereafter, this computer will be referred to as the "SCADA node". A download cycle shall consist of writing data to a set of registers of the production line controller. Data is then transferred over the RS232 port to the checkweigher. The contractor shall specify an appropriate handshake between the SCADA node and the production line PLC so that an acknowledgement is returned to the SCADA node when the operation is complete.

3.1.2.2 Data Logging

Weights: The checkweigher controller can transmit weights either individually or, on request, in blocks of size n. These options can be set in software. The production line controller should be able to set this function to either individual or block transmission. The production line controller should provide a set of registers to collect weight data and a corresponding set of registers to collect the time at which the weight was recorded and a corresponding bits that indicate the accept / reject zone in which the cup falls. A counter should provide the number of the last register beyond the base address that has been logged with a weight. The SCADA node will access weights by first enabling a bit that prevents new data logging from the checkweigher. The counter reading will then be taken. Starting from the base address, data will be read up to the current count. The cycle will end by resetting the counter and disabling the bit that inhibits data logging. The production line controller should be able to resume data logging at the weight sequentially following the last weight collected. The data logging will resume at the base addresses.

Count: The PLC shall maintain separate registers with the current count of filled cups that have been processed and the current count of filled cups that have been rejected. The total of these two registers indicate the total cups filled.

3.1.3 FEMC Filler. The FEMC filler provides continuous volumetric filling. The filling speed is controlled by a Danfoss variable speed drive and the cup height is controlled by an Electrocraft servo motor.

3.1.3.1 Production Line Control

Start / Stop: The FEMC filler should be started and stopped from the production line control panel. A return signal should be provided by the FEMC filler to indicate it is running.

Remote / Local operation: A remote / local switch should be provided so that the FEMC filler can be operated under local control. When operating under remote control, the start button on the FEMC controller is overridden by the start button on the production line control panel.

Control of cup height: Under remote control, cup height should be specified from the production line control panel. Adjustments via Electrocraft servo drive should be possible based on vegetable fill weight data as described in section 3.1.3.2.

3.1.3.2 Data Logging

Product Level: When the product level in the FEMC hopper is low alarm, a bit should be set in the production line controller.

Fault Condition: The production line controller should record the various failure conditions of the FEMC filler, including the motor drive failure.

Vegetable fill weights: FEMC fill weights are sampled and weighed on an off-line scale. This data shall be collected by the PLC and used to adjust FEMC cup height via servo control as described in section 3.1.3.1.

Temperature Sensor: The contractor shall install a non-contact temperature sensor above the main hopper for acquiring the vegetable temperature. Provision for logging the data will be made in the production line PLC.

Level Sensor: The contractor shall install an ultrasonic range sensor mounted above the FEMC main hopper. Provision for collecting the data shall be made in the production line PLC.

3.1.4 Product Feed Fillers. There are two bulk product feed fillers. One is servicing the Solbern filler and one is servicing the FEMC filler. In each case, low level sensors on the Solbern and FEMC detect the need for more material. The product feed fillers respond to a low level signal by conveying material into the Solbern or FEMC until a high level sensor is reached. At that point the conveyor is turned off until the low level sensor is encountered. This is a closed loop distributed control system and does not need to be integrated into the production line controller.

3.1.4.1 Production Line Control

Start / Stop: The product feed fillers should be started and stopped from the production line control panel. A return signal should be provided by the feed fillers to indicate they are on line.

3.1.4.2 Data Logging

Low product level: When the hoppers of the product feed fillers are low, a bit should be set in the production line controller. This will, in turn, turn on the low product pilot light. When material is brought from inventory and the hopper is replenished, this bit will be reset.

3.1.5 Oden Filler. The Oden filler consists of three rotary positive displacement pumps controlled by a digital controller encoder. There is no communication capability. Motion is controlled by a digital encoder coupled to a DC servo drive.

3.1.5.1 Production Line Control

On / Off Signal: When the Oden Filler is on, a return signal should be provided to the production line PLC to indicate it is on.

3.1.5.2 Data Logging

Temperature Sensor: The contractor shall install a non-contact temperature sensor for acquiring the gravy temperature. Provision for logging the data will be made in the production line PLC.

Level Sensor: An ultrasonic range sensor has been installed on the Oden filler. Gravy level data shall be logged by the production line PLC.

3.1.6 Tiromat Form-Fill-Seal Machine. The Tiromat is an intermittent motion form-fill-seal machine with four stations: Forming, Filling, Sealing, and Punching. The machine is controlled by an Allen Bradley PLC 2/17 controller that is programmed over RS232 using a proprietary software, the SMART system software. Once programmed, the PLC maintains functions within the control parameter setpoints. Under the configuration of Figure 1, programming of machine parameters shall be possible either from the SMART system or from the operator view node.

3.1.6.1 Production Line Control

Start / Stop: The Tiromat should be started and stopped from the production line control panel. A return signal should be provided by the Tiromat to indicate it is running.

Remote / Local operation: a remote / local switch should be provided so that the Tiromat can be operated under local control. When operating under remote control, the start button on the Tiromat is overridden by the start button on the production line control panel.

Program configuration and command bits: All program configuration and command bits currently programmed on the Tiromat controller should be capable of being programmed from the production line controller. A corresponding set of registers should be configured in the production line controller along with a software switch to download those registers to the Tiromat controller. A return signal from the Tiromat controller should indicate a successful data transfer. Setting registers in the production line controller and enabling the software switch for downloading will be done from the operator view node in the control panel via the SCADA node on Data Highway plus. Registers of the Tiromat controller are given in Appendix B.

3.1.6.2 Data Logging

Status bits / diagnostic bits / word assignments: All status and diagnostic bits, as well as measured data stored as integer or floating point variables, that exist in the Tiromat controller, should be duplicated in the production line controller. This data should be passed to the production line controller with the same frequency as currently exists when reporting data to the SMART system, which is approximately 1 Hz.

Production rate: A moving average of the production rate shall be calculated and stored in the production line controller. This calculation will be done every cycle and will be based on the previous five cycles.

Differential seal pressure: Two pressure transducers will be installed in the tiromat seal chamber, one on each side of the pouch film. Provision shall be made in the production

line controller for mapping the sensor data from the Tiromat controller during each operating cycle.

Seal plate temperature: Six temperature transducers will be installed on the seal plate of the Tiromat. Provision shall be made in the production line controller for mapping the sensor data from the Tiromat controller during each operating cycle.

Temperature Sensor: The contractor shall install a non-contact temperature sensor above the pouch just before the sealing operation.

3.1.7 Adept Pack-One Robot. The Adept robot, with drive and vision system, is controlled by a MC 68000 processor controller. RS 232 Serial ports are available for communication with the robot controller.

3.1.7.1 Production Line Control

Start / Stop: The robot subsystem should have start / stop control from the production line control panel. A return signal should be provided to indicate it is running.

Remote / Local Operation: A remote / local switch should be provided so that the robot subsystem can be operated under local control. When operating under remote control, the start button of the robot subsystem is overridden by the start button on the production line control panel.

3.1.7.2 Data Logging

Fault Conditions: All fault conditions should be sent to production line controller, where they are time stamped for data logging. Pilot light should go on when robot is the cause of error.

3.1.8 Videojet Printer. The Videojet printer has a serial communication port that allows a remote device to download text to be printed.

3.1.8.1 Production Control

Text transfer: The production line controller should be able to download text to be printed. Such text will be input to the production line controller from the control panel.

Remote operations: The operations of start, print, and head should be under the control of the production line controller.

3.1.8.2 Data Logging

Failure mode: Printer failure should be logged and time stamped. A pilot light should be provided to indicate printer failure.

3.1.9 Line Pressure and Vacuum

3.1.9.1 Production control

Pressure alarm settings: Provision should be made for mapping pressure and vacuum data from the Tiromat controller and setting alarm limits in the production line controller from the operator view node for line air pressure and line vacuum pressure.

3.1.9.2 Data Logging

Air supply pressure and vacuum supply pressure: Pressure transducers will be placed in the air supply line and the vacuum supply line. Provision shall be made in the production line controller to log the analog signals from these transducers. Alarm indicators are provided as in section 2.2.3.

3.1.10 Retort Rack Loader

3.1.10.1 Production Control

Start / Stop: The retort rack loader should be started and stopped from the production line controller. A return signal should be provided to indicate that it is running.

3.1.10.2 Data Logging

Fault conditions: The production line controller should record and time stamp fault conditions of the retort rack loader.

Counts: The production line controller should record the production counts for pouches loaded into the rack.

Cage Identification: The production line controller should take a bar code identification of the cage loaded into the retort rack and the time that the first pouch is loaded into the cage. The bar code scanner will be designed into the retort rack by Rutgers personnel.

Ancillary Equipment:

3.1.11 Radio Frequency Bar Code Transmitter / Receiver. For material tracking purposes, the production line controller should include a bar code scanner and radio frequency transmitter and receiver. Provision should be made in the controller for recording material lot numbers as material is loaded into filling equipment. Such information will be time stamped for tracking purposes.

3.1.12 Pouch Inspection Station. In order to track quality control problems, final pouch inspections will classify defects into 8 classes. Defective pouches will be inserted into a disposal chute based on defect type. Each chute will have a proximity sensor to record the passing of parts. The production line controller must keep count of the daily

X
2/20

counts passing each proximity sensor. The contractor shall make provision in the production line controller hardware and software for 8 digital inputs for this purpose.

4.0 Modes of Operation

This section contains a description of the required modes of operation of the control system. Each mode includes a description of the events or sequence of events that characterize that mode of operation.

4.1 Start Mode

- Check all machinery powered and ready.
- Product feeders on.
- Transfer pump on.
- Wait until product level OK: Solbern, FEMC, Oden.
- Dumper belt on.
- Checkweigher belt on.
- Wait until FEMC has cups (low level sensor activated).
- FEMC drive on.
- Solbern cycle start.
- Adept robot start.
- Robot conveyor start.
- Tiromat start.
- Retort loader and inspection conveyor on.
- Videojet head and printer on.

4.2 Stop Mode

- Tiromat stop.
- Wait until Tiromat cycle end.
- Feeders stop.
- FEMC drive stop.
- Solbern cycle stop.
- Checkweigher stop.
- Adept robot pause at end of cycle.
- Conveyors stop.
- Retort rack loader stop.
- Videojet head and print off.

4.3 Production Line Setup Mode

- Check power to all equipment.
- Load operating program parameters: Tiromat, Checkweigher, FEMC servo, Adept robot, Oden, Videojet printers.

4.4 Fault on Line Mode

Minor faults should be indicated on the control panel by change in color of the machine indicator.

Major faults should stop the line and be indicated on the control panel by change in color of the machine indicator. The following are major faults: a machine stops running, critical machine parameter out-of-tolerance per QC, filler out of product, dumper jam, retort loader jam.

4.5 Emergency Stop Mode

E-Stop all equipment: Tiromat, Solbern, FEMC, Adept robot, robot conveyor, Oden filler, product feeders, Transfer pump, retort rack loader, conveyors, checkweigher conveyor stop, Videojet head and print off.

4.6 Manual Operation Mode

Manual (local) operation of any machine can be selected at control panel. While machine is set to manual, the line can be run automatically; however, any machine faults except E- will not stop the line.

5.0 Documentation Requirements

5.1 Software documentation shall be provided as follows:

1. The ladder logic diagram for the shop floor controller program.
 2. A structured function chart that shows the modular design of the program.
- 5.2 Electrical drawings. Schematics shall be provided for all electrical wiring.
- 5.3 Layout drawings for control panel will be provided.
- 5.4 The contractor will supply manuals of operating procedures for all supplied equipment.
- 5.5 Contractor shall provide a spare parts list.

6.0 General

6.1 Cost. The proposal is to include total cost F.O.B. Rutgers University, CRAMTD building, 120 New England Avenue, Piscataway, NJ. Cost of optional equipment, recommended spare parts and accessories should be quoted but clearly delineated from the base bid.

6.2 Delivery Schedule. The vendor will specify engineering design, fabrication, testing and delivery schedule.

6.3 Service. The vendor will provide service as needed to fulfill requirements of the warranty and these specifications.

6.4 Award. The criteria for selecting a proposal will be based on the evaluation of the CRAMTD staff.

Delivery
Engineering features
Cost
Service
Training and support

6.5 Exceptions. The vendor is to clearly identify any exceptions taken from these specifications.

6.6 Warranty. The vendor warrants the equipment performance specified herein for one year from the date of acceptance.

7.0 Acceptance

Acceptance test. The equipment will be subject to an acceptance test to determine whether performance requirements have been met. The equipment will be tested for all functions as described herein.

8.0 Shipping and Installation

8.1 The equipment will be shipped F.O.B., Rutgers University, CRAMTD building, 120 New England Avenue, Piscataway, NJ.

8.2 The vendor will assemble and install equipment in full working order and provide training to Rutgers Personnel in the operation and maintenance of the equipment.

APPENDIX A

Computer Hardware Specification for the MRE Pouch Operator Interface Workstation

- 80486 DX2 66MHZ Processor
- 16 mb RAM
- 350 mb Hard Drive
- 3.5", 1.4mb Floppy Drive
- (2) Serial, (1) parallel Port
- SVGA Graphics card with 1mb Memory
- 19" SVGA Monitor
- MS DOS, Version 6.x
- Microsoft Windows for Workgroups 3.11
- Ethernet Card: SMC Ethernet Plus Elite COMBO, 16 bit with 3 connectors:
 - AUI (thick ethernet, 10Base-5)
 - BNC (thin ethernet, 10Base-2)
 - RJ45 (twisted pair 10Base-T)
- Note: 3COM with same specifications also acceptable.
- Microsoft Mouse

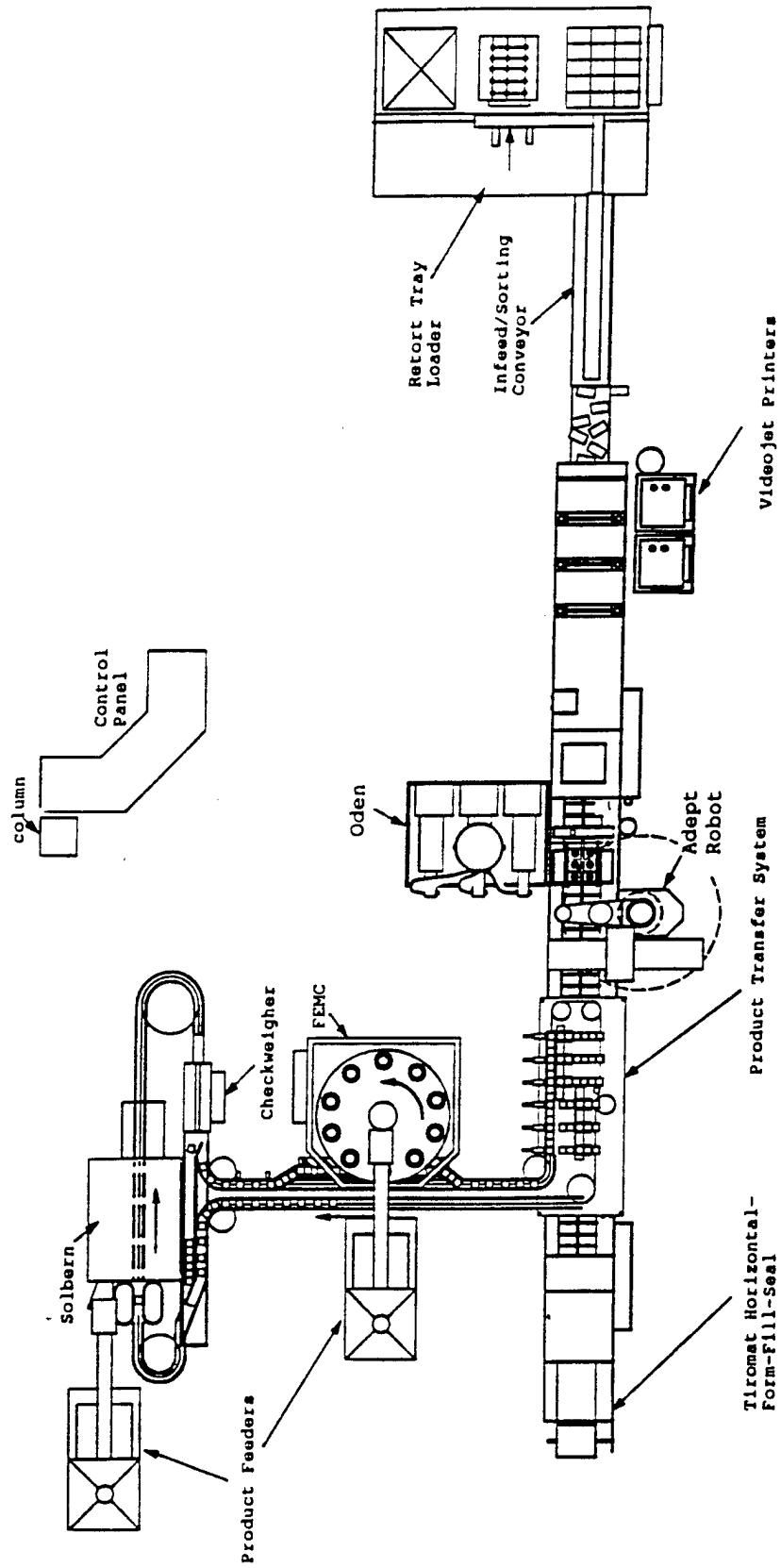

MRE POUCH LINE

FIGURE 1

Control Panel for H-F-F-S Line

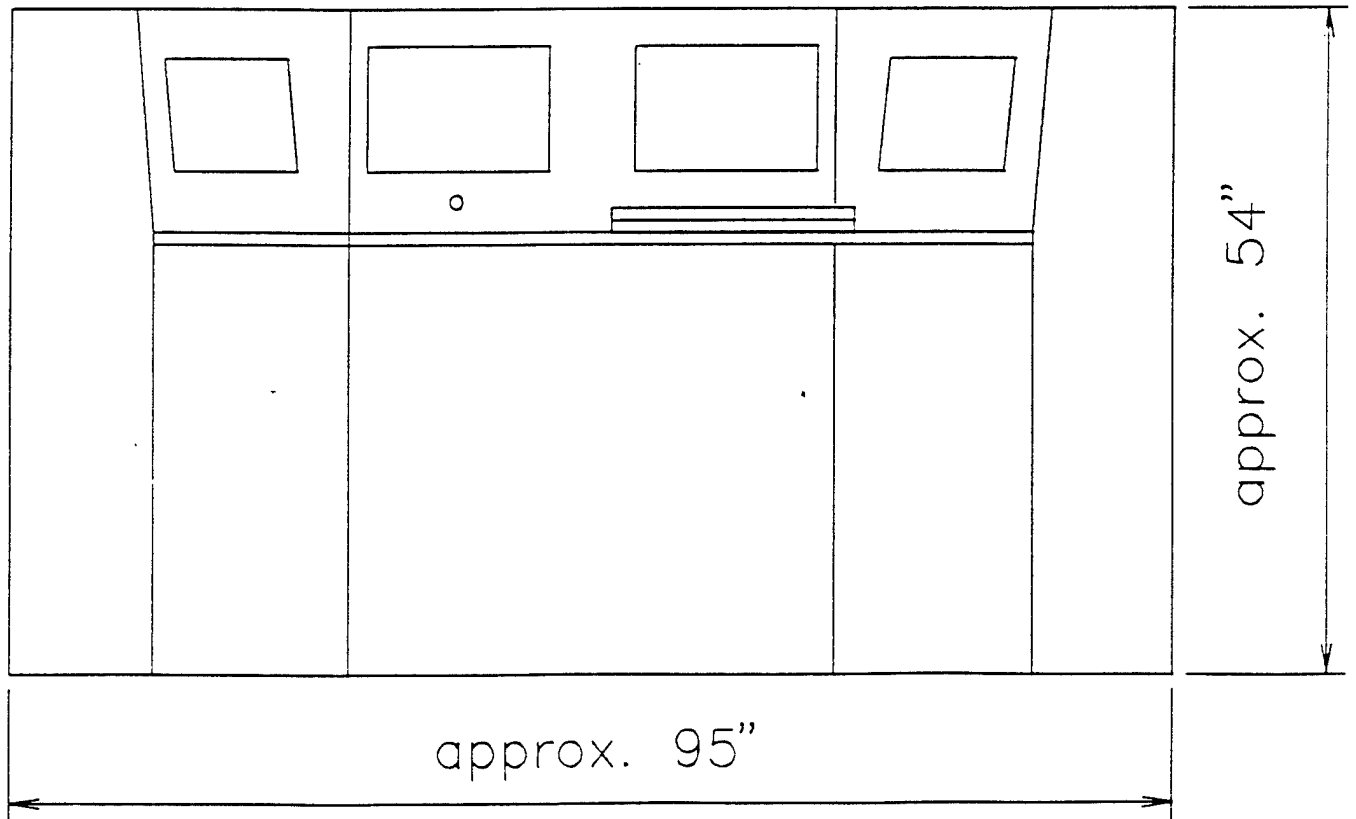
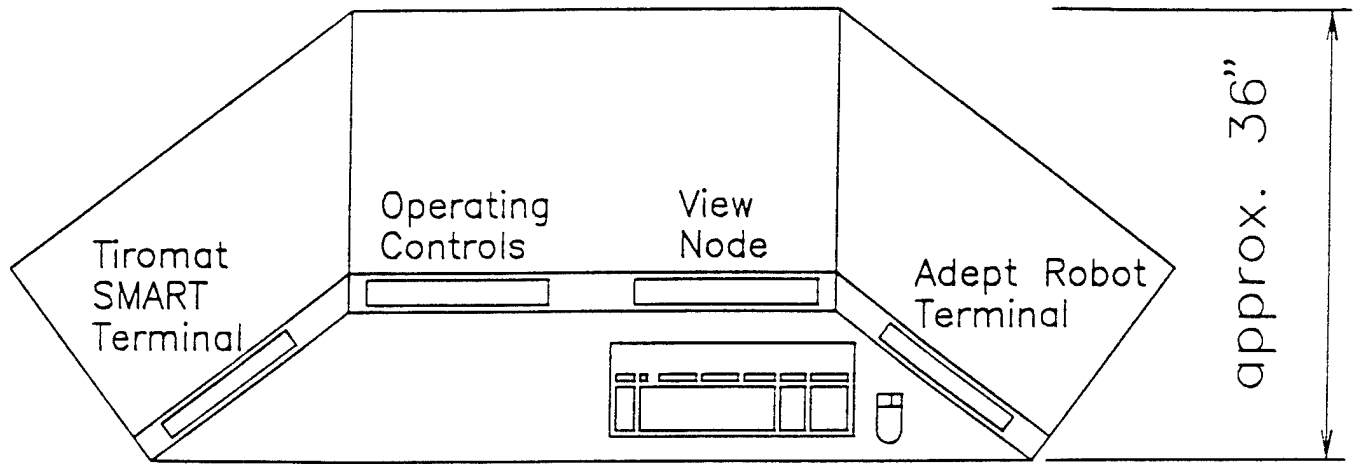
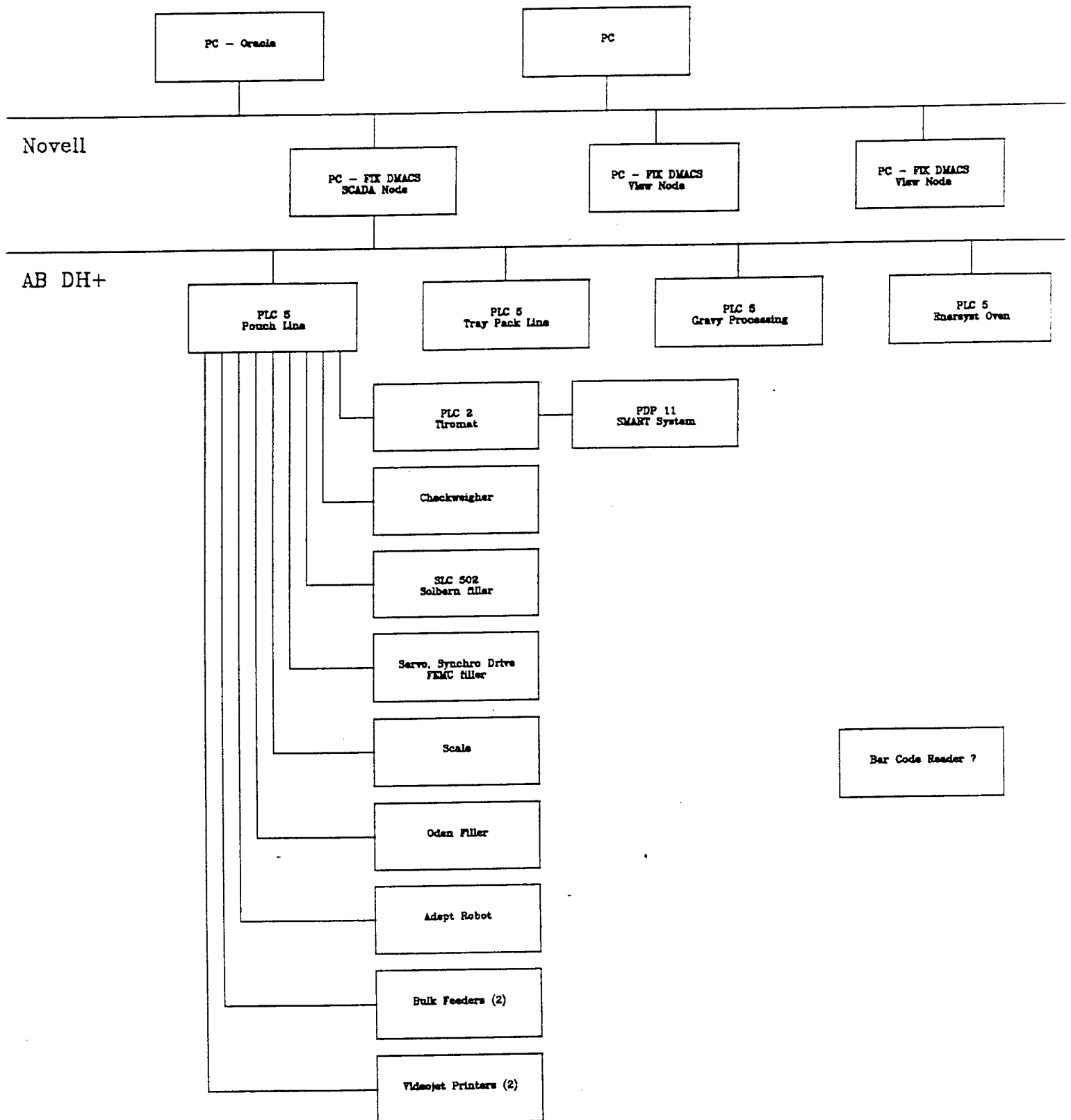

Figure 2

Figure 3

Integration of MRE Pouch Line





PRECISION AUTOMATION CO., INC.

BOX 18
HADDONFIELD, NJ 08033
609-428-7400
FAX 609-428-1270

Rutgers, The State University of NJ
University Procurement & Contracting
Admin. Services Annex Bldg./Rm. 101
Davidson Road/Busch Campus
P.O. Box 6999
Piscataway, NJ 08855-6999

Cook College - Center for Advanced Food Technology
CRAMTD Program

Proposal for a Control System for the
Horizontal Form - Fill - Seal Production Line

Rutgers RFP #4-3-3-2

Precision Automation Co., Inc. Proposal No. OD4-131

TABLE OF CONTENTS

PAGE

Section I - TECHNICAL INFORMATION

A.	Scope of Work	3 & 4
B.	General Equipment Description	5
	1. Controls	
C.	Description of Operation	5
D.	Documentation	6

Section II - COMMERCIAL DETAILS

A.	Pricing	7
B.	Schedule	7
C.	Shipping	7
D.	Payment Terms	7
E.	General Terms	8

Section III - COMPANY INTRODUCTION

A.	Company Profile	9
B.	Company Officials	10
C.	Services	10
D.	Partial Major Customer List	10
E.	Certification	11
F.	Affiliations	11

Appendix I	Contract Terms
Appendix II	Service Schedule
Appendix III	Literature

SECTION I - TECHNICAL INFORMATION

A. Scope of Work

1. Design Engineering: Controls

Our scope of work for this project will be broken down into three phases. Phase I will be the design of the control system hardware. Included in this Phase will be trips to your facility to gather discrete information concerning individual equipment requirements. Among this will be sensors, what type and their required locations and function, existing equipment interfaces, and a total understanding of system expectations. Also, during this phase the control panel will be designed using your figure #2 Concept Drawing as a guide. At the completion of this phase a complete set of control drawings will be delivered for your approval. These drawings will include the control panel layout, electrical schematics to show all sensors and interfaces with the control panel equipment, system line diagram to indicate how all of the equipment will interface, a pneumatic schematic, and line diagram. The design will also include a system map for software development, and a complete hardware bill of material for component procurement during Phase II.

2. Project Management

As for most of our system projects, a project manager will be assigned to this project from beginning to end. Their responsibility will be to interface with you and to arrange any meetings or correspondence. Also he will coordinate various phases of the project towards a smooth completion.

SECTION I - TECHNICAL INFORMATION

A. Scope of Work - Continued

3. Component Procurement & Equipment Fabrication

This will be Phase II of the project. During Phase II all equipment will be ordered and fabrication of the control panel will begin. The project manager will be interfacing during this phase to assure that time schedules are met. Also at the completion of the control panel fabrication, a systems hardware check-out will be performed prior to installation, to assure that all components are functional. During this phase overall software development will be implemented. Our past experience has shown that all hardware be designed into a system first and then, during the fabrication phase, the software development begin. This will allow the programmer to continue into installation with the software fresh in mind.

4. Installation/Supervision/Start-Up/Training

This is Phase III the final phase of the project. During this phase we will deliver all prefabricated components and integrate them with the existing equipment. This phase will require you to have all your equipment down to do our final wiring hook-ups. Also during this phase the developed software will be installed and de-bugged. At the completion of final wiring, and the software is de-bugged, start-up and training will begin. It is at this time that all final de-bug and acceptance will take place.

B. General Equipment Description

1. Controls

Equipment to be used in this system will start with a fabricated stainless steel control enclosure, NEMA 4 rated, which in concept will be similar to your Figure 2 drawing. This enclosure will house the production line controller which will be a PLC 5/25 Allen-Bradley processor. Also the enclosure will incorporate the Tiromat Smart Terminal, the View Node Station which will be supplied per Appendix A of your specification, and the Adept Robot Monitor, Keyboard, Mouse, and Operator Interface. For the operator controls, an Allen-Bradley Color Touch Screen Panel View Number 2711-TCI will be incorporated. This will allow for monitoring and control of all interfaced equipment. This enclosure will also be the central point of power for the individual equipment on the floor. This will allow for single point power distribution and also allow for E-Stop control and safe maintenance on the equipment.

Temperature sensors and fill level sensors will be incorporated along the system as required. Banner, Turck, and Omega will be the manufacture brands used. NEMA 4 Type stainless steel wireway will be used to interconnect all line equipment to the production line controller panel.

C. Description of Operation

The control enclosure will be the main operating system. From this point all information to run the system will be available. Any down load of information will be accomplished from this point. An operator will power-up the system from this single point and be able to view any and all functions. As per your specification 4.0, a start/stop mode of operation will be developed. This will allow for smooth start up and controlled stops when required. With the combination of the PLC 5 and the operator panel view, status of all equipment will be available. While the system is running, faults will be categorized and prioritized for either operator warning or system shutdown. In the event of either case, the operator will be able to determine the cause of the fault promptly. Also included per your specification, Section 3.1.6.1 Remote/Local operation from the production line controller will be permissible.

Within this description of operation, a few particular items have been discussed. Generally, your specifications will be followed as close as possible to achieve an efficient control system.

D. Documentation

The equipment will be documented on our standard drawing media. The drawing package will include electrical schematics, ladder logic diagrams, a structured function chart, pneumatic schematics and a complete bill of material. Our standard operation/maintenance manual outlining the set-up, operation, trouble shooting and preventative maintenance procedures for the equipment will be provided as well as a recommended spare parts list.

SECTION II - COMMERCIAL DETAILS

A. Pricing

As indicated previously our pricing structure is broken down in (3) Three Phases. The following is a breakdown of these Phases:

1. Phase I, Design Engineering
2. Phase II, Component Procurement and Equipment Fabrication
3. Phase III, Installation, Supervision, Start-Up, and Training.

Total \$165,000.00

B. Schedule

- Phase I - Approximately eight (8) weeks ARO.
- Phase II - Approximately 8-10 weeks from Phase I completion.
- Phase III - Approximately 4-6 weeks from start of installation.

C. Shipping

Equipment will be shipped via our truck direct to Rutgers University CRAMTD Building 120, New England Avenue, Piscataway, New Jersey.

D. Payment Terms

1. Progress payments are requested and are to be determined prior to award of contract.

PRECISION AUTOMATION COMPANY, INC.
 CHERRY HILL, N.J. CLARKSVILLE, IN. MACON, GA
 PHONE: 908-833-2200 FAX: 908-833-2201
 E-MAIL: SALES@PRECISIONAUTOMATION.COM

CUSTOMER: PUTIGERS
TITLE: MRE POUCH LINE CONTROL SYSTEM
DRAWING: MAIN CONTROL CENTER LAYOUT
DATE: 12-30-94

DESIGNED BY: Tony Miele
CHECKED BY: Tony Miele
DATE: 4-11-95

REV.: 0

REV.	DATE	BY	DESCRIPTION
A	6-24-96	TM	AS INSTALLED

TO CHANGE LINE USE DISCRETE SPECIFIED
 FINISH AND/OR PRACTICES
 AS SHOWN
 AS SHOWN

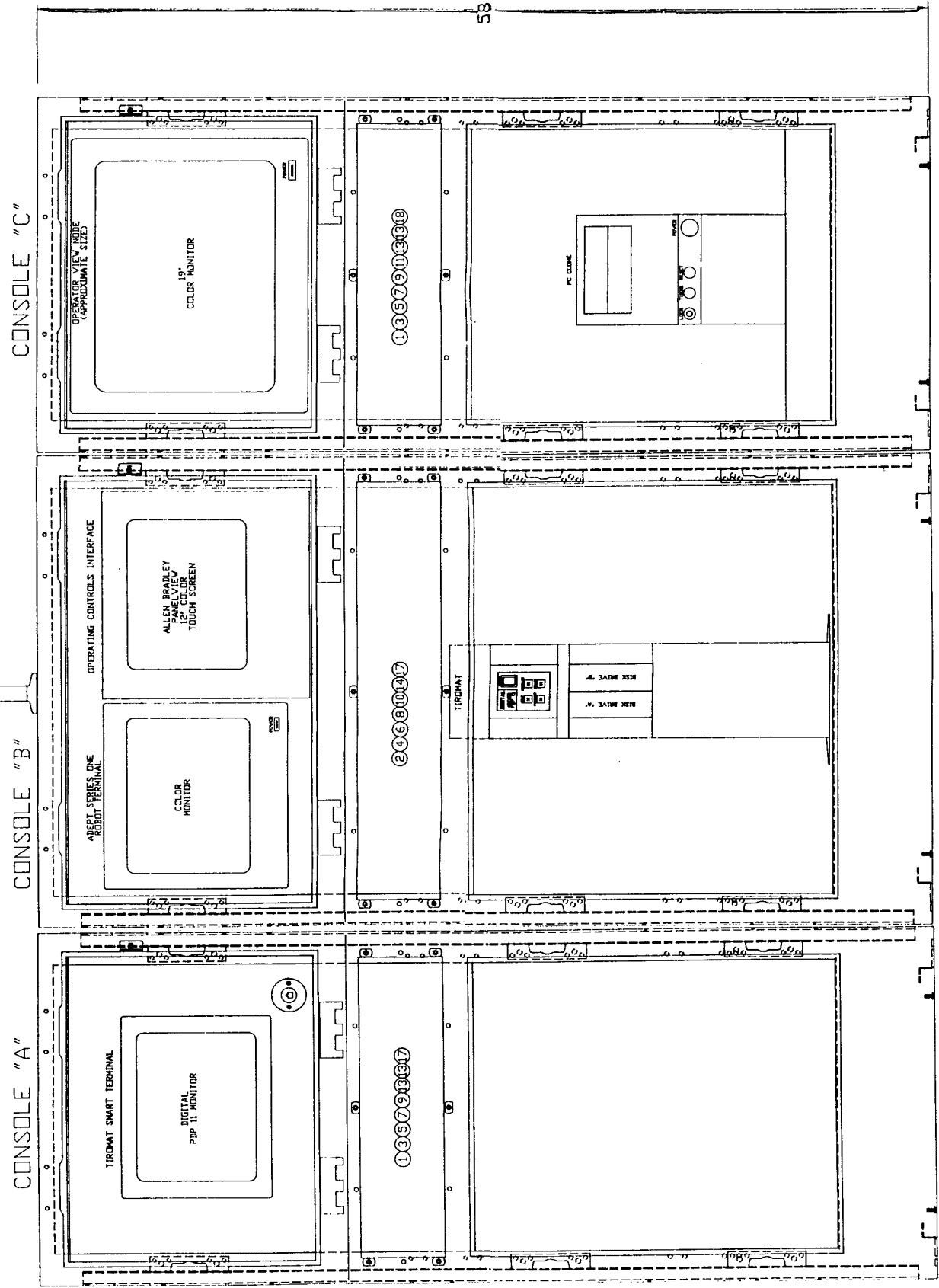
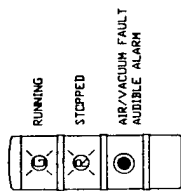

Integration of MRE Pouch Line

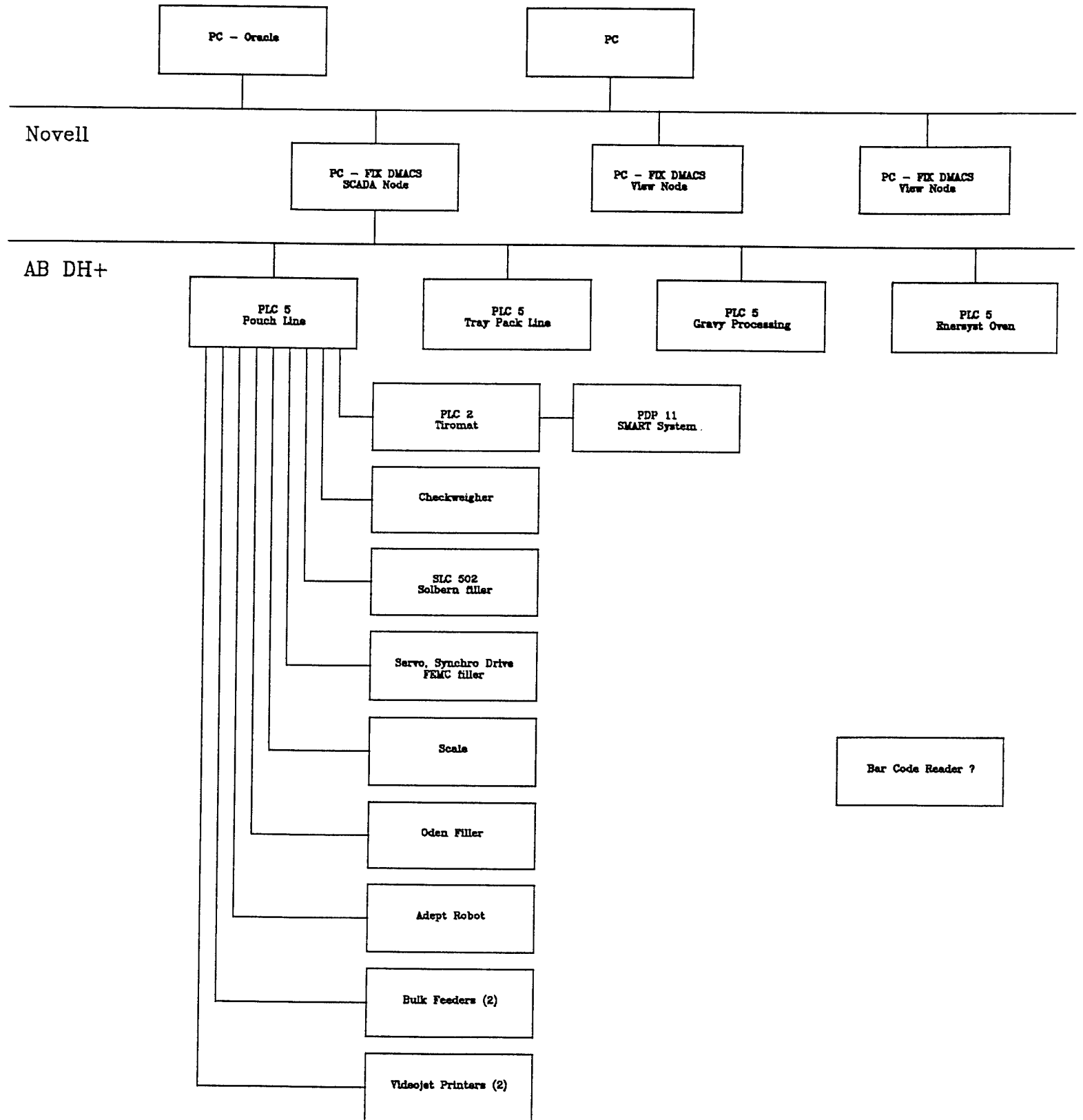

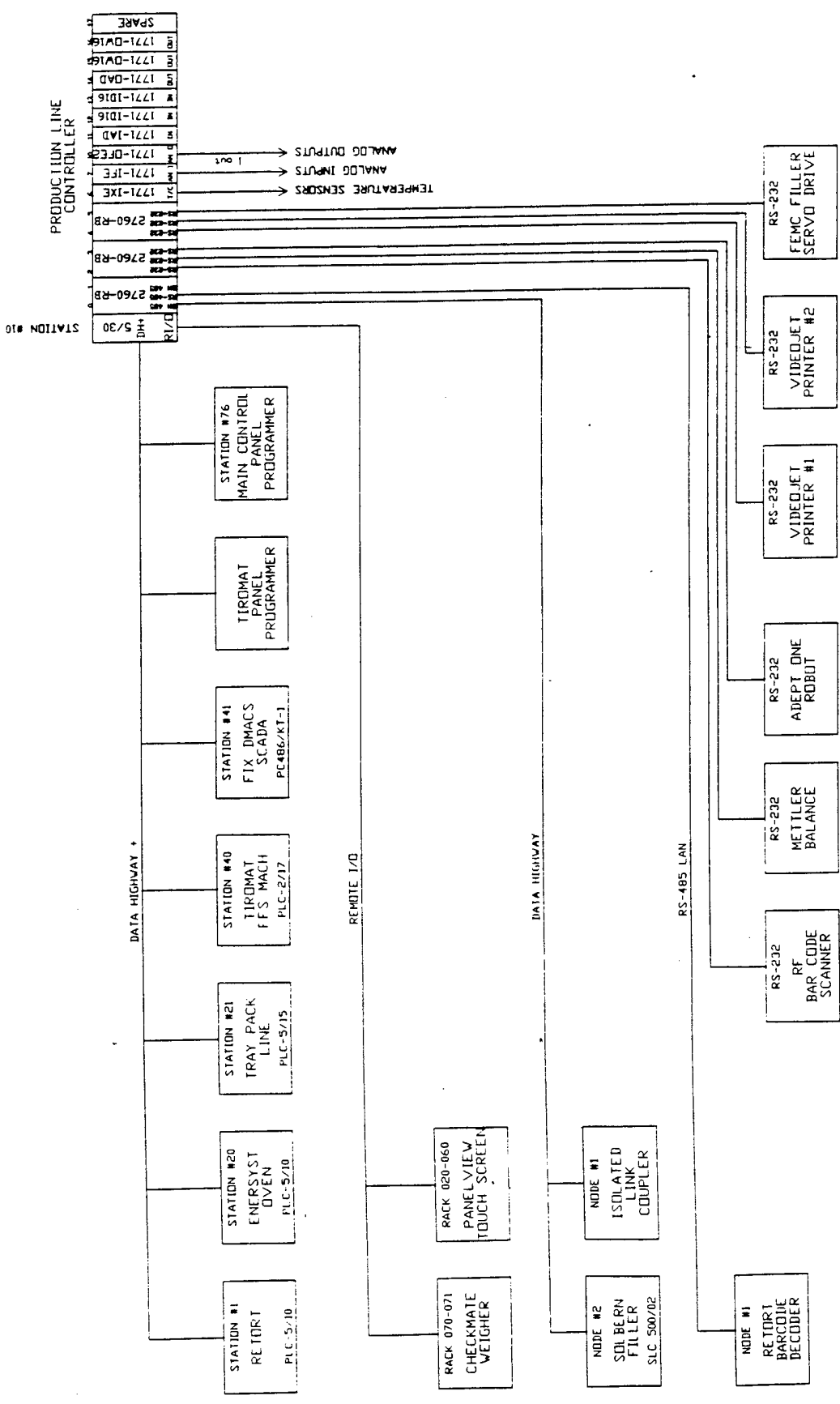

PRECISION AUTOMATION COMPANY, INC.
 CHERRY HILL, NJ CLARKSVILLE, IN MACON, GA

WORK BY:	Customer	RUTGERS UNIVERSITY	ISSUED BY:	Customer	MACON, GA
DESIGNED BY:	TONY MIELE		APPROVED BY:	TONY MIELE	
DATE:			DATE:	10/14/85	
REV:			REV:	1 OF 1	
DATE:			DATE:	NOV	
DESCRIPTION:	MRE POLY LINE CONTROL SYSTEM				
DESCRIPTION:	PLC COMMUNICATION BLOCK DIAGRAM				
FINISH	10/14/85		REV:		0
MOUSE	11/64		DATE:		
FRACIONS	37	1/85			
DECIMALS	4	14/75			

*NCIC Analysis of Engineered Systems for
Handling Material: Case Studies*

Technical Report

James T. Luxhoj, Ph.D.
Department of Industrial Engineering

Theodore Descovich
Neal Litman
Center for Advanced Food Technology

Rutgers University

August 1994

NCIC ANALYSIS OF ENGINEERED SYSTEMS FOR HANDLING MATERIAL:
CASE STUDIES

ABSTRACT

Multiattribute decision making models have been applied to manufacturing investment problems where both financial and non-financial criteria are deemed to be important to the problem domain. A software, termed the Non-traditional Capital Investment Criteria (NCIC), has been developed to facilitate the subjective assessment process of weighing the importance of hard-to-quantify decision attributes.

This report summarizes two applications of NCIC analyses for the CRAMTD demonstration site. The first case study focuses on an economic analysis of comparing manual loading of retort crates to semi-automatic loading. In this study, any annual benefits due to labor savings are significantly diminished due to the annual anticipated costs of potential system downtime associated with the more technically sophisticated machine. Thus, manual loading with the use of auxiliary lifting equipment was determined to be the preferred economic choice for the assumed decision scenario.

The second case study examines the use of product feeders for the horizontal form/fill/seal packaging line. The use of feeders that automatically control the fill level is compared to manual feeding of the filling equipment. Non-financial criteria, such as maintenance and sanitation, ergonomics, and line efficiency are considered. The economic analysis concludes that ergonomic considerations, such as worker safety and physical comfort, offset the costs associated with increased maintenance for the product feeders. Also, the incorporation of non-financial criteria serves to keep the payback period attractive.

Both case studies illustrate how multiattribute decision making models may be developed to better understand and economically evaluate the use of advanced technology for material handling systems.

NCIC ANALYSIS OF ENGINEERED SYSTEMS FOR HANDLING MATERIAL: CASE STUDIES

I. INTRODUCTION

The major equipment and steps in the production of combat rations have been individually addressed in the CRAMTD demonstration site, such as filling and seaming of tray pack cans, filling and sealing pouches, and retorting for sterility. Very small quantities of actual products have been made. So far, the introduction of materials and ingredients into the process, and movement between operations has been accomplished manually and expeditiously, but the methods and equipment used would not support normal rates of production found in food plants. Further, there is a need to optimize on product safety and overall efficiency as in a real production environment.

In the CRAMTD Phase II facility, to demonstrate a complete advanced technology production module, there is a need to determine the most modern and cost effective transfer mechanisms, tools, and/or methods available. The methods and devices selected must be appropriate for demonstrating advanced processing within the CRAMTD center, and they should be useful and applicable to companies who produce packaged food such as combat rations for profit.

II. NON-TRADITIONAL CAPITAL INVESTMENT CRITERIA (NCIC)

Boucher and MacStravic [1] have developed a methodology that combines easy-to-quantify and difficult-to-quantify benefits of new technology into a ranking of alternatives based on net present value. The methodology, termed non-traditional capital investment criteria (NCIC), has been implemented in a microcomputer software for routine evaluation of new technology projects. Boucher, et al. [2]

describe an NCIC application in a case study involving an evaluation of three candidate technologies for filling packaged food containers. In the case studies described herein, the application of this software for the evaluation of material handling equipment in the packaged food industry is discussed.

There are three steps in applying multiattribute decision processes for the justification of advanced technology. The first step is to design the framework of criteria that are important to consider. The second step is to weigh and evaluate the criteria. This will be described using data collected from the CRAMTD system design engineers. Finally, the evaluation of the decision maker's logical consistency is required.

III. CASE STUDY 1: RETORT CRATE LOADING

This case study considered two methods for loading pouches into crates for future retorting: manual and semi-automatic retort crate loading. The manual method requires that workers place the pouches from the conveyor into the crates positioned near the end of the Tiromat line. A basic loading station that incorporates a lift table to facilitate manual loading and unloading of crates is required for this option. A brief description of this loading station is provided in Appendix A. This method is considered as the baseline because it is the least technologically advanced method of loading crates. The manual method requires 6 inspectors, 3 handlers for loading the crates, and 1 handler for placing racks into the crates. Thus, a total of 10 workers is required in this scenario.

The alternative under consideration is to use a semi-automatic retort crate loading machine. A technical sheet describing this loader is also included in Appendix A. This machine is capable of loading and unloading retort crates at speeds of 100 to 400 units per minute depending on the container size. Based on the pouch dimensions, the infeed speed of the machine is 100 pouches per minute. A technical drawing of the semi-automatic retort crate loader with detailed specifications is illustrated in Figure 1.

With the second alternative, 6 inspectors are still required for the line as is the 1 handler for placing racks into crates. However, the 3 handlers for loading pouches into the crates are not required. Thus, a total of only 7 workers is needed with this method. Figure 2 displays a layout of the proposed CRAMTD line with semi-automatic retort crate loading. A layout with operator workstations is depicted in Figure 3.

In addition to the traditional labor cost savings to consider,

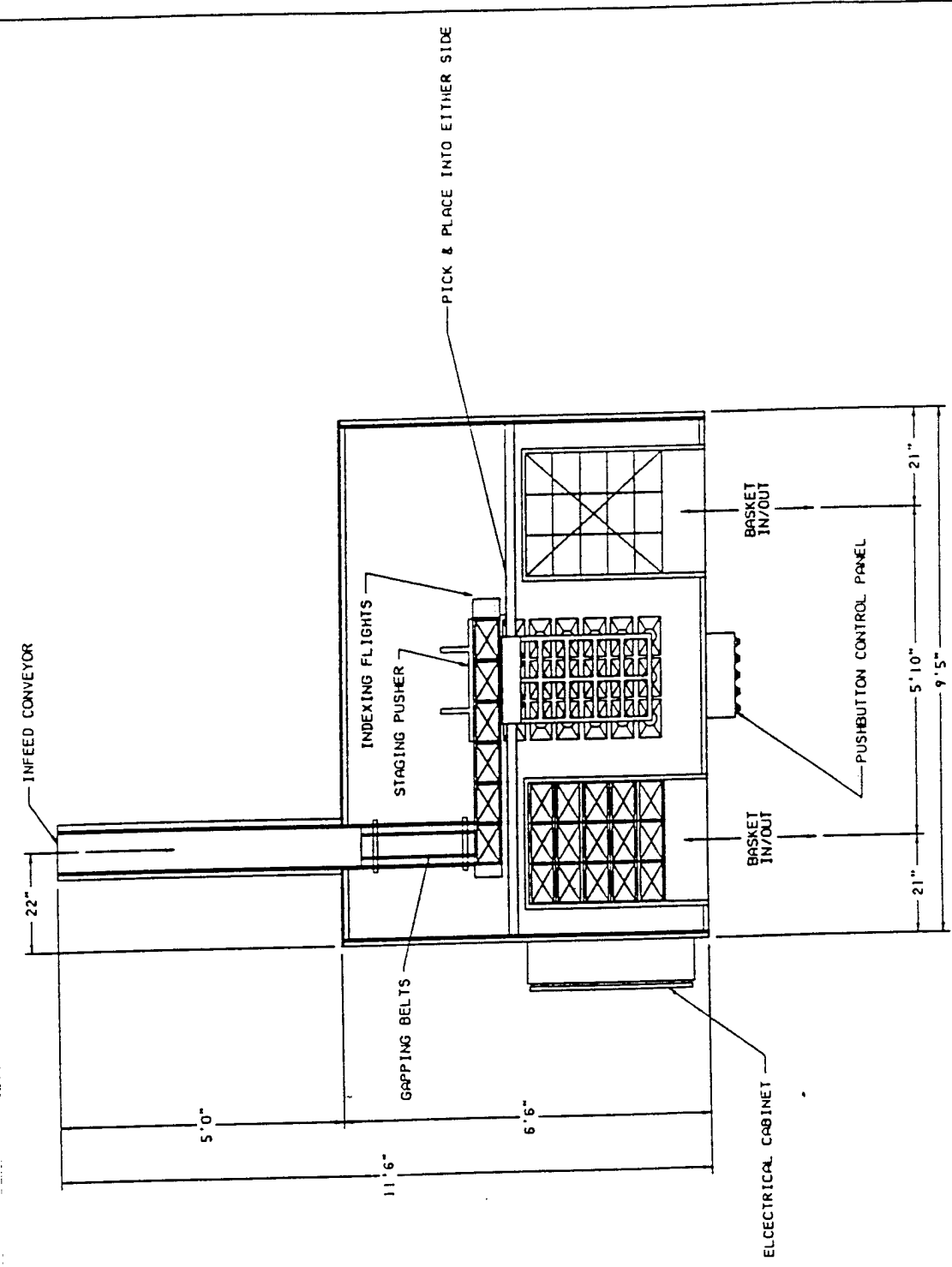

INFEED SPEED: UP TO 100 PPH
 INFEED HEIGHT: 40" ± 2"
 FLOOR CLEARANCE: 5" ± 2"
 NOTE: ALL DIMENSIONS ARE APPROXIMATE

THIS DRAWING IS THE PROPERTY OF THE DESIGN ENGINEERING COMPANY AND IS NOT TO BE USED OR REPRODUCED WITHOUT THEIR PERMISSION

BRENTON
 DESIGN ENGINEERING COMPANY
 1115 S. 10th St.
 Phoenix, Arizona 85006
 TEL. 352-1111

CENTER FOR ADVANCED FOOD TECHNOLOGY
 PROJECT: RETORT LOADER
 DRAWN BY: JKH
 CHECKED BY: JKH
 DATE: 1/18/81
 SCALE: 1/8" = 1'-0"

NO.	DATE	BY	REVISIONS
1			CONCEPTS
2			
3			
4			
5			

PROJECT NO. _____
 DRAWING NO. FP-1122C

Figure 1. Technical Drawing of Semi-Automatic Retort Crate Loader

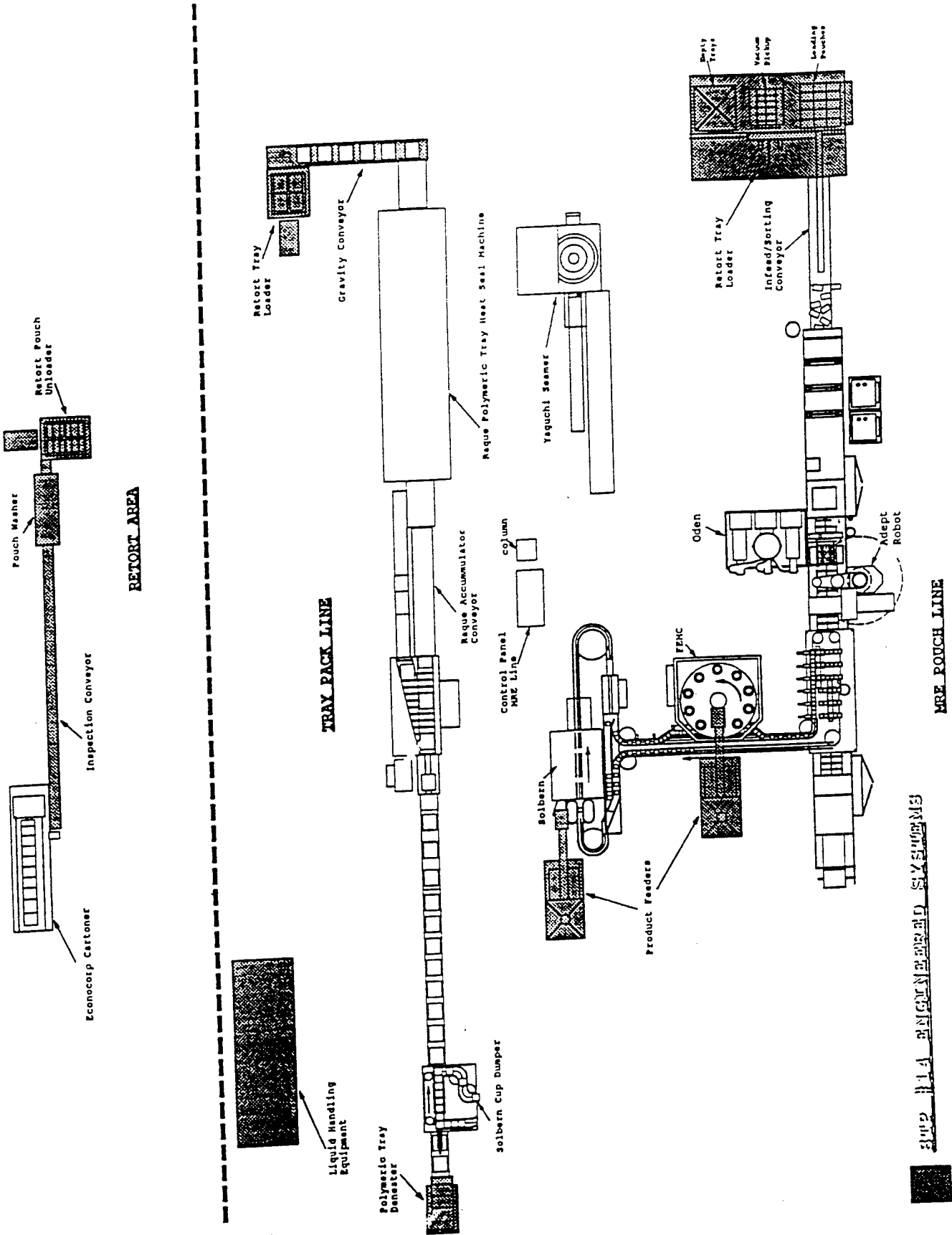
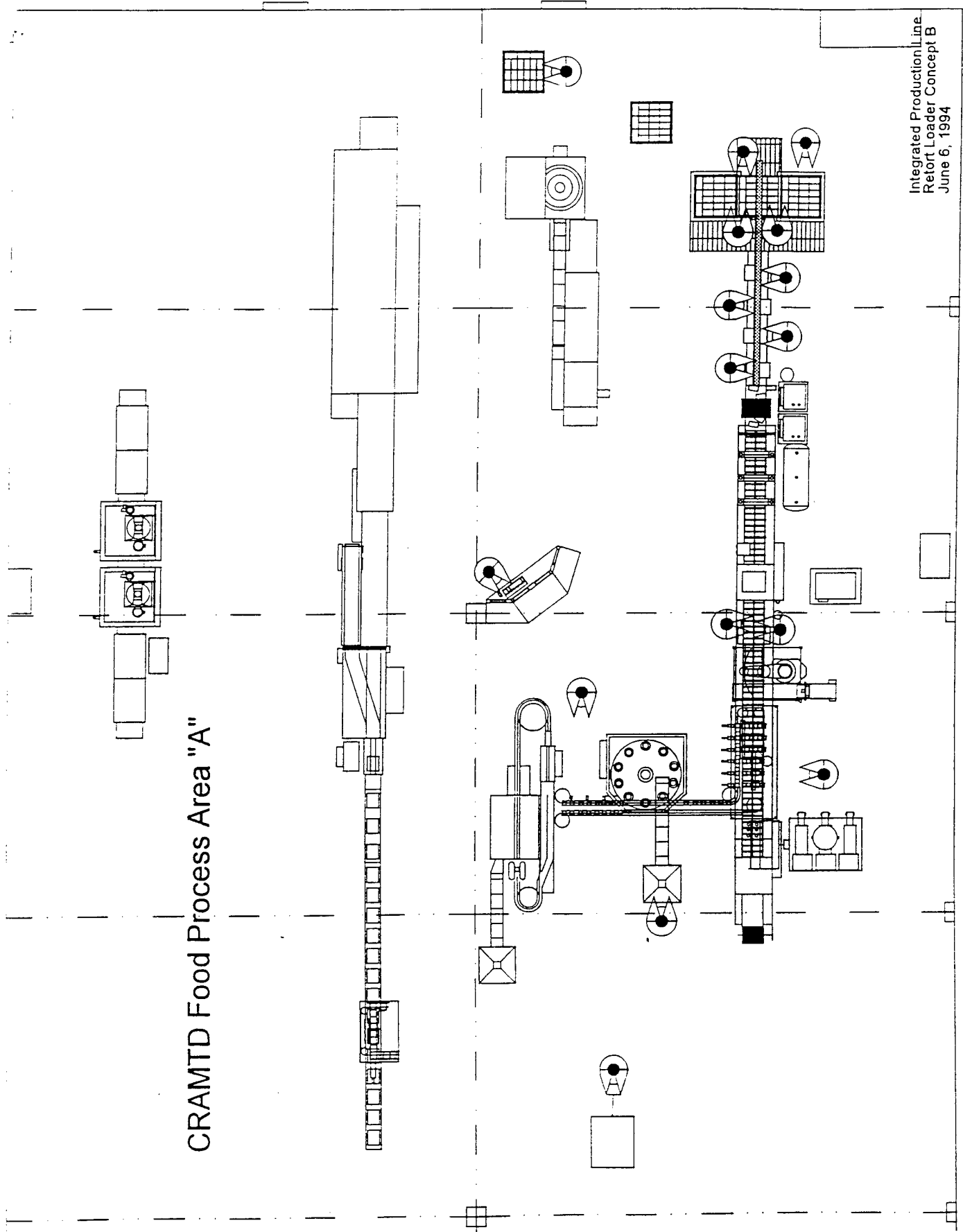

Figure 2. Proposed Engineered Systems for Material Handling

CRAMTD Food Process Area "A"



Integrated Production Line
Retort Loader Concept B
June 6, 1994

Figure 3. Operator Workstations for CRAMTD Process Area "A"

there are also some non-traditional factors, such as equipment reliability and maintenance, improved demand response and value of learning that are important. Therefore, an NCIC analysis of the two alternative methods was conducted with the CRAMTD system engineers.

3.1 Decision Scenario

At any time, there exists a set of technical alternatives for a particular manufacturing function. One alternative may be technically superior to all other alternatives on one or more technical criteria; however, it is usually not the case that one alternative is economically superior to all other alternatives. The preferred technology is determined by the context in which the technology is to be applied. In effect, it is not possible to choose the economically appropriate technology without describing a decision scenario.

In this decision scenario, the purchase of a semi-automatic retort crate loader is under consideration for a horizontal form/fill/seal packaging line. A flexible pouch that contains about 8 ounces of product is being produced. Current and projected contracts have established an annual volume of 4 million pouches, which is about 6 months of capacity for the line. The production rate is 102 pouches/minute. This line is dedicated to the production of Meals Ready to Eat (MREs) for the military. Civilian products are produced during the remaining 6 months.

In order to create the NCIC decision hierarchy it was necessary to obtain the testimony of experts knowledgeable about the technology, its benefits, and the particular circumstances of the decision scenario. A panel of two CRAMTD system engineers responsible for the design of the filling/packaging system was formed for this purpose. Henceforth, this panel will be referred to as the

Decision Maker (DM).

Figure 4 portrays the decision criteria that were considered important in this analysis by the CRAMTD system engineers. An NCIC analysis has four main criteria groupings: Annual Benefit, Material Conversion, Information Conversion, and Strategic. Under each category grouping there are sub-criteria. Thus, an NCIC decision hierarchy with three levels may be created.

The Annual Benefit category is used for traditional criteria, such as labor cost savings. Material conversion activities are the physical processes that convert raw material to delivered final product. Information conversion activities convert raw data into decisions. Strategic activities are more distant and less direct. The definitions of the individual sub-criteria are provided in Table 1.

In this case study, the DM excluded Information Conversion activities or the value of enhanced data acquisition, since this category grouping did not apply to either manual or semi-automatic retort crate loading.

3.2 Pairwise Comparisons

The second step in the NCIC process involves making pairwise comparisons among criteria. A meeting with the DM was separately scheduled to execute this step. The meeting lasted about 3 hours, during which the decision makers were asked to make pairwise comparisons among criteria within each alternative. In an NCIC analysis, comparisons of alternatives are always made relative to the baseline.

The Annual Benefit is the measurable dollar savings from labor. In this study, labor cost savings were calculated as follows:

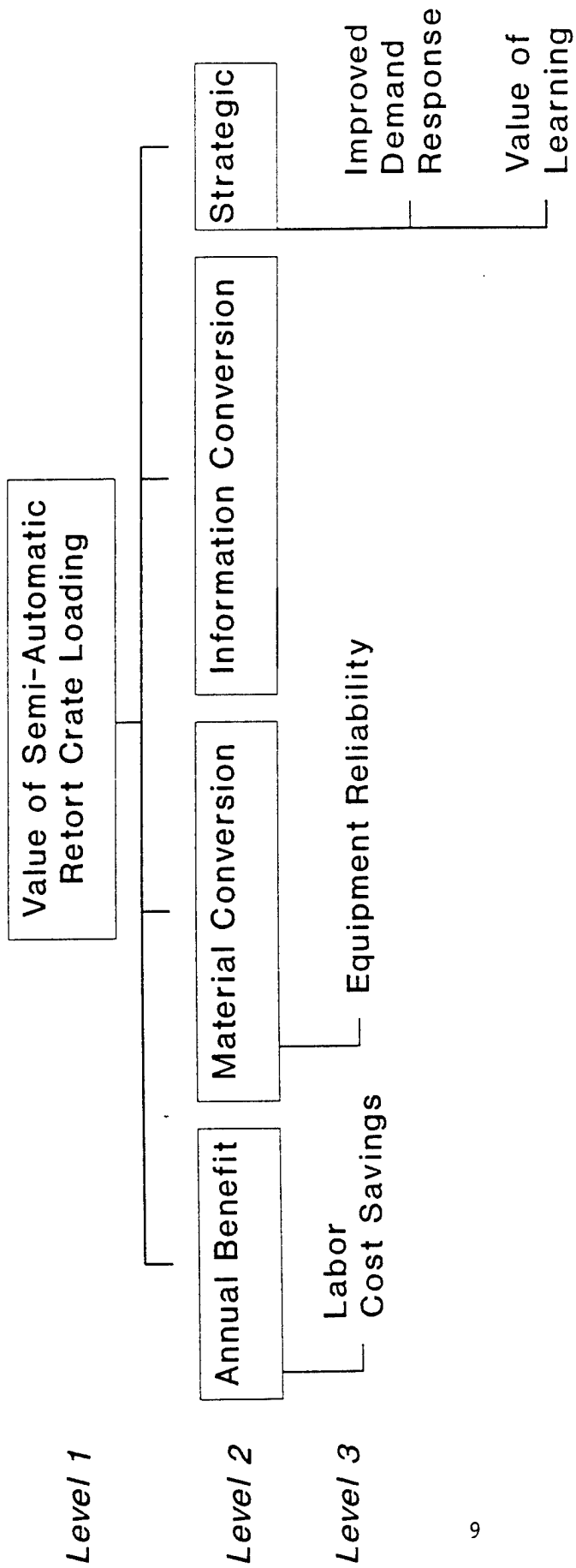

Figure 4. Evaluation Criteria for Semi-Automatic Retort Crate Loading

Table 1. Definitions of Evaluation Criteria for
Semi-Automatic Crate Loader

=====
Evaluation Criteria Definitions
=====

Criterion : Ability to Respond to Fluctuations in Demand
Short Name: Demand Response

The maximum level of production that can be achieved in the short run.

Criterion : Labor Cost Savings
Short Name: Labor Cost Savings

Annual cost savings due to reduced direct and indirect labor requirements.

Criterion : System Reliability
Short Name: Reliability

The uptime of the production system. This can be measured as the increase in hours of system availability. This attribute may be measurable in terms of Annual Benefits. If so, it should include the cost to repair and the cost of idle labor and other services during the time of repair.

Criterion : Value of Learning Experience with New Technology
Short Name: Value of Learning

When a new technology is implemented by a company, the engineers, managers, and workers become acquainted with using this technology. This puts the individuals in a position where they can more easily adopt future technologies that build on the technology currently being considered. There is a value to the company in so positioning itself. There is no recommended metric.

A. Manual Crate Loading

For manual crate loading, 10 workers are assumed (6 inspectors, 3 loaders, 1 rack handler) to achieve a production rate of 102 pouches/minute. It is further assumed that the line efficiency, on average, is approximately 70%. At a production volume of 4,000,000 pouches, there are:

$$\begin{array}{r} 4,000,000 \text{ pouches} \\ \hline (102 \text{ pouches/min}) \times (0.70) \end{array} = 934 \text{ hours.}$$

Thus, 934 hours x 10 workers = 9,340 worker-hours are required to achieve the desired production volume at the assumed production rate.

B. Semi-Automatic Crate Loading

For semi-automatic crate loading, 7 workers are assumed (6 inspectors, 1 rack handler) to achieve a production rate of 102 pouches/minute. The line efficiency is again assumed to be 70%. Thus, 934 hours x 7 workers = 6,538 worker-hours are required for semi-automatic crate loading.

Using an assumed labor rate of \$9.00/hr that includes fringe benefits, annual labor cost savings are calculated for semi-automatic crate loading with respect to the baseline case of manual crate loading. These annual labor cost savings are:

$$\text{Semi-Automatic Crate Loading: } (9,340 - 6,538 \text{ hr}) \times \$9.00/\text{hr} = \$25,218.$$

Therefore, the annual labor savings due to semi-automatic crate loading was approximated as \$25,000.

Table 2 displays the pairwise comparisons made by the DM for the Material Conversion and Strategic activities. In each comparison matrix, the category Annual Benefit is included. By including this category, the comparisons are linked to dollar values.

Table 2. Pairwise Comparison Matrices for Semi-Automatic Grate Loader

Material Conv.	A	B
A-Annual Benefit	1	1/4
B-Reliability	4	1
Consistency Ratio = 0.000		

Strategic	A	B	C
A-Annual Benefit	1	5	9
B-Demand Response	1/5	1	1
C-Value of Learning	1/9	1	1
Consistency Ratio = 0.033			

Consider the Material Conversion matrix. In this case, the annual benefit of \$25,000 in labor savings expected from using the semi-automatic crate loader is being traded off with the penalty (cost) associated with the potential increase in system reliability problems. Consider matrix cell B,A which compares a penalty with a benefit. Comparisons of this type involve questions such as: "By how much do you prefer not losing any system reliability that will result from replacing manual crate loading with semi-automatic crate loading to the annual benefit of \$25,000 due to the labor savings from semi-automatic crate loading?" The DM must supply a number from 1 to 9. This scale is adopted from the work by Saaty [3]. The answer of 4 in matrix cell B,A naturally infers a ratio of 1/4th for the complementary matrix cell (A,B). In this instance, the DM believes that not losing system reliability is 4 times more important than the anticipated labor savings.

When judgemental inconsistency is observed in NCIC, the DM must first reconsider the matrix of judgments. The consistency ratio (CR) is calculated using the maximum eigenvalue method introduced by Saaty [3] in the context of the Analytic Hierarchy Process (AHP). Saaty develops a concept of "tolerable inconsistency". He recommends a CR of 0.10 or less be considered consistent; a ratio greater than 0.10 shows inconsistencies. This is simply a guideline. This ratio is a check on the laws of transitivity. That is, if A is valued twice as high as B, and B is valued twice as high as C, then A must be valued four times as high as C. The consistency ratios for all comparison matrices in this case study were less than 0.10.

Table 3 presents a summary of the annual benefits for the semi-automatic crate loader by both criteria group summary and individual criteria.

Table 3. Annual Benefit Summary for
Semi-Automatic Crate Loader

Criteria Group Summary

	Alt. 1

Annual Benefit	25,000
Material Conv.	-100,000
Strategic	-732

Totals	-75,732

Annual Benefit of Individual Criteria

	Alt. 1

Labor Cost Saving	25,000
Reliability	-100,000
Demand Response	-4,109
Value of Learning	3,378

Totals	-75,732

3.3 Net Present Value

Table 4 displays the summary of the net present value (NPV) calculations for the semi-automatic retort crate loader. It must be remembered that all comparisons in NCIC are made with respect to the baseline. It is estimated that auxiliary lifting equipment costs for manual crate loading total \$40,000. The capital cost of the semi-automatic crate loader is estimated as \$150,000. Thus, with respect to the baseline, the total relative investment under consideration is \$110,000. Table 4 also summarizes the salvage value, discount rate, and marginal tax rate that were used in the economic analysis. A Modified Accelerated Capital Recovery System (MACRS) with a 7-year class life depreciation schedule was used for a planning horizon of 8 years.

3.4 Conclusions for Case Study 1

The NCIC analysis of the semi-automatic retort crate loader indicates that the manual method with auxiliary lifting equipment is the preferred economic choice. If only traditional annual benefits are considered, the semi-automatic crate loader option has a NPV of -\$781 compared to the baseline of manual crate loading. However, when both traditional and non-traditional criteria are considered, the NPV is -\$311,028. As Table 3 shows, the expected \$25,000 in labor savings due to the reduction in the total number of workers from using the semi-automatic method is significantly offset by the potential loss of system reliability. In this case study, the decision makers judged "uptime" or system availability to be very important. That is, they viewed the cost to repair and the cost of idle labor and other services during the repair time to be 4 times more important than the anticipated labor savings. By considering only traditional annual benefits, the simple

Table 4. Present Value Analysis for Semi-Automatic Crate Loader

=====
 Present Value Analysis Study Period: 8 years
 =====

PRESENT VALUE SUMMARY

	Alt. 1

Present Value of :	
Annual Benefit only	-781
Annual Benefit + NCIC	-311,028
 Payback Period Using :	
Annual Benefit only	4.40 years
Annual Benefit + NCIC	

PRESENT VALUE ANALYSIS DATA

	Alt. 1

Total Investment (\$)	110,000
Qualifying Property (%)	0.00
Investment Tax Credit (%)	0.00
 Salvage Value (\$)	15,000
 Discount Rate (%)	12.00
 Marginal Tax Rate (%) (State and Federal)	38.00

AMORTIZATION OF CAPITAL INVESTMENT

	Amount Depreciated	Depreciation Method	MACRS Class Life
	=====		
Semi-Auto Crate Load	110,000	MACRS	7

Model: CRATES

=====
Present Value Analysis (cont.) Study Period: 8 years
=====

DEPRECIATION SCHEDULE

YEAR	Alt. 1
-----	-----
1	15,719
2	26,939
3	19,239
4	13,739
5	9,823
6	9,812
7	9,823
8	4,906

payback period as shown in Table 4 is $\$110,000 / (\$25,000/\text{year}) = 4.4$ years which is the investment divided by the annual benefit. Since the annual benefit using the NCIC analysis is $-\$75,732$ (i.e. there are no benefits, only costs) the payback period is not appropriate.

Prior to the NCIC analysis in this case study, it may have appeared that traditional labor savings were attractive and sufficient to merit purchase of the semi-automatic retort crate loading equipment. A payback period of 4.4 years may seem reasonable. However, the consideration of non-traditional criteria, such as system reliability, demand response, and value of learning suggest that the semi-automatic crate loader is not the most cost effective system for the CRAMTD food factory as per the assumed decision scenario. Manual crate loading with the purchase of auxiliary lifting equipment is the preferred economic choice.

IV. CASE STUDY 2: PRODUCT FEEDERS

This case study considered the alternative of using automated feeders for the beef and vegetable product to manual feeding of the Solbern and FEMC filling machines. It was expected that the addition of product feeders would result in a labor savings of one worker. The CRAMTD system engineers were concerned that cost of maintenance and sanitation for the feeders would significantly lengthen the payback period. In addition, they believed that other non-traditional criteria, such as ergonomics, line efficiency, and maintaining accurate fill levels associated with the product feeders were important criteria, but were uncertain as to how these criteria might influence the economic choice. The proposed locations of the product feeders are illustrated in Figure 2.

As in the previous case study, two CRAMTD system engineers served as the panel of experts who were knowledgeable about the technology, its benefits, and the circumstances of the decision scenario. This panel is again referred to as the decision maker (DM).

4.1 NCIC Hierarchy and Decision Scenario

The NCIC decision hierarchy is displayed in Figure 5. The definitions of the evaluation criteria are provided below:

Equipment Maintainability - Ease of maintenance and sanitation.

Ergonomics - Consideration for worker safety and physical comfort.

Labor Cost Savings - Annual cost savings due to reduced direct and indirect labor requirements.

Line Efficiency - The ability of a product feeding system to maintain a high line efficiency.

Maintaining Accurate Fill Levels - The ability of a feeder to ensure an accurate level of buffer inventory of raw ingredients.

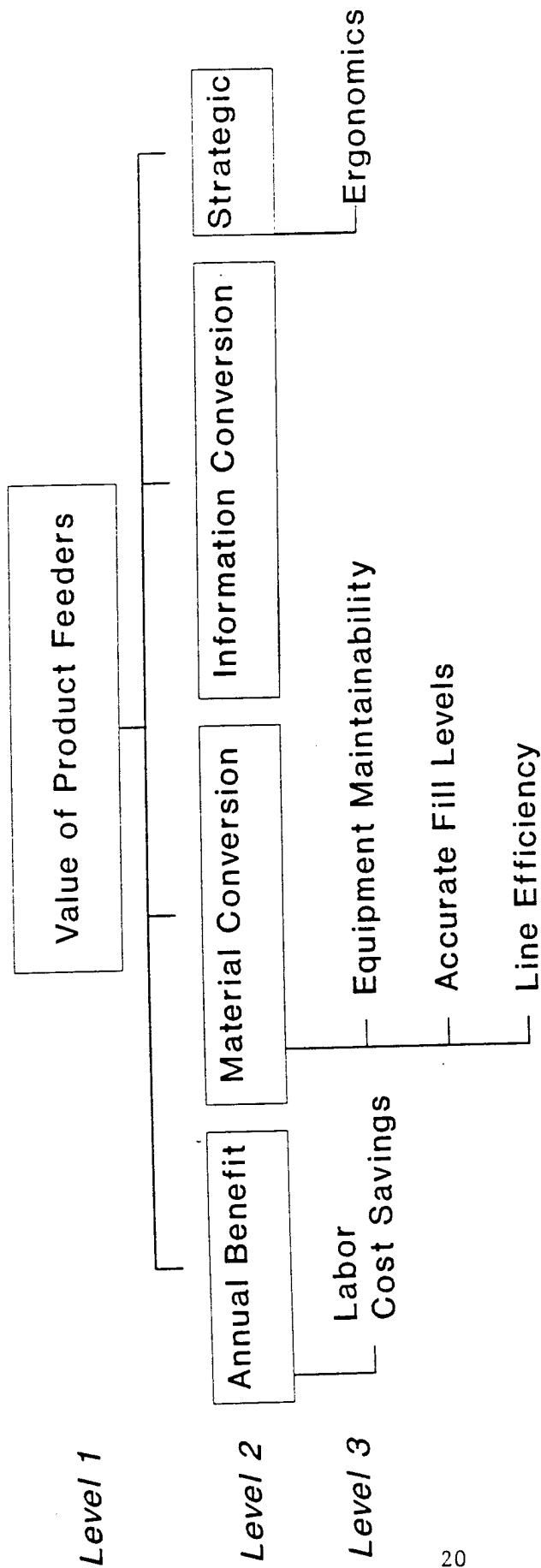

Figure 5. Evaluation Criteria for Product Feeders

In this decision scenario, the purchase of two product feeders is under consideration for a horizontal form/fill/seal packaging line. A flexible pouch that contains about 8 ounces of product is being produced. Current and projected contracts have established an annual volume of 4 million pouches which represent about 6 months of capacity for the line. Other civilian products may be produced on this line during the remaining 6 months.

4.2 Pairwise Comparisons

A meeting with the DM was scheduled to elicit the pairwise comparisons among criteria. This meeting lasted about 2 hours. In all NCIC analyses, comparisons of alternatives are always made with respect to the baseline. The baseline in this case study refers to manual feeding of the filling equipment, since this represents the lowest level of technical sophistication.

Table 5 displays the pairwise comparison matrices for Material Conversion and Strategic activities. As in the previous case study, the decision makers excluded the criteria group of Information Conversion activities, since enhanced data acquisition was not relevant to either alternative under consideration.

Compared to the baseline, it was approximated that the use of product feeders would result in a labor savings of one worker. The CRAMTD system engineers approximated this labor savings to be about \$25,000/yr which includes fringe benefits.

Note that in the Material Conversion matrix, the DM considered the Annual Benefit of \$25,000 to be four times, more important than equipment maintainability, and nine times more important than maintaining accurate fill levels. The DM also considered the Annual Benefit to be nine times more important than the efficiency of the line. The consistency ratios were all less than 0.10 which means

Table 5. Pairwise Comparison Matrices for Product Feeders

Material Conv.	A	B	C	D
A-Annual Benefit	1	4/1	9	9
B-Equipment Maint	1/4	1	4	7
C-Acc. Fill Levels	1/9	1/4	1	1
D-Line Efficiency	1/9	1/7	1	1
Consistency Ratio = 0.046				

Strategic	A	B
A-Annual Benefit	1	7
B-Ergonomicis	1/7	1
Consistency Ratio = 0.000		

that the DM was internally consistent in judgments.

Table 6 summarizes the annual benefits of using product feeders by criteria group and by individual criteria. Note that although equipment maintenance and sanitation associated with the product feeders result in an annual cost of \$9,630, this cost is essentially offset by the expected annual benefits of maintaining accurate fill levels, increased line efficiency, and ergonomic considerations.

4.3 Net Present Value

Table 7 summarizes the data used in the Net Present Value (NPV) calculations. Based solely on the traditional criterion of labor cost savings, the NPV of the annual benefits is \$47,830. If non-traditional criteria are included in the economic analysis, the expected NPV is \$42,717. A MACRS 5-year class life depreciation schedule was used with an 8 year planning horizon.

The investment for the two product feeders totals \$42,000, so the simple payback period when considering Annual Benefits only is calculated as $\$42,000 / \$25,000 = 1.68$ years. If the non-traditional criteria are included, the payback period is 1.80 years.

4.4 Conclusions from Case Study 2

The CRAMTD system engineers had originally surmised that the costs of maintenance and sanitation associated with the product feeders would significantly lengthen the payback period for this investment. In fact, based on the judgments provide by the DM, the annual maintenance costs were calculated as \$9,630 which reduce the Labor Cost Savings to \$15,370. Recalculating the payback period with this revised annual benefit gives 2.73 years which confirms the original conjecture of the CRAMTD system engineers.

However, the inclusion of non-traditional economic criteria, such as ergonomics, line efficiency, and the ability of the feeders

Table 6. Annual Benefit Summary for
Product Feeders

Criteria Group Summary

	Alt. 1

Annual Benefit	25,000
Material Conv.	-5,232
Strategic	3,571

Totals	23,340

Annual Benefit of Individual Criteria

	Alt. 1

Labor Cost Saving	25,000
Equipment Maint	-9,630
Acc. Fill Levels	2,324
Line Efficiency	2,074
Ergonomicis	3,571

Totals	23,340

Table 7. Present Value Analysis for Product Feeders

=====
 Present Value Analysis Study Period: 8 years
 =====

PRESENT VALUE SUMMARY

	Alt. 1

Present Value of :	
Annual Benefit only	47,830
Annual Benefit + NCIC	42,717
 Payback Period Using :	
Annual Benefit only	1.68 years
Annual Benefit + NCIC	1.80 years

PRESENT VALUE ANALYSIS DATA

	Alt. 1

Total Investment (\$)	42,000
Qualifying Property (%)	0.00
Investment Tax Credit (%)	0.00
 Salvalge Value (\$)	 4,200
Discount Rate (%)	12.00
Marginal Tax Rate (%) (State and Federal)	38.00

AMORTIZATION OF CAPITAL INVESTMENT

	Amount Depreciated	Depreciation Method	MACRS Class Life
	=====		
Feeders	42,000	MACRS	5

Model: FEEDERS

Present Value Analysis (cont.) Study Period: 8 years

DEPRECIATION SCHEDULE

YEAR	Alt. 1
1	8,400
2	13,440
3	8,064
4	4,838
5	4,838
6	2,419
7	0
8	0

to maintain accurate fill levels essentially offset the maintenance and sanitation costs. In particular, the ergonomic features of using product feeders, such as worker safety and physical comfort, resulted in an annual benefit of \$3,571 based on the pairwise comparisons by the decision makers for the given scenario. Thus, the payback period for the investment in the product feeders was only slightly lengthened from 1.68 years to 1.80 years. This case study illustrates the importance of considering non-traditional economic criteria in payback calculations.

V. CONCLUSIONS

Both case studies illustrate the application of multiattribute decision models to evaluate the investment in material handling equipment for advanced manufacturing systems. It appears that the NCIC methodology enhances the acceptability of applying multiattribute decision making to manufacturing investment problems that include non-financial criteria. The structured process of NCIC often leads to new insights regarding the economic appropriateness of advanced technology.

REFERENCES

- [1] Boucher, T.O., and MacStravic, "Multi-Attribute Evaluation Within a Present Worth Framework and its Relation to the Analytic Hierarchy Process," The Engineering Economist, Vol. 37, No. 1, 1991.
- [2] Boucher, T.O., Luxhoj, J.T., Descovich, T. and N. Litman, "Multicriteria Evaluation of Automated Filling Systems: A Case Study," Journal of Manufacturing Systems, Vol. 12, No. 5, 1993.
- [3] Saaty, T.L., The Analytic Hierarchy Process, New York: McGraw-Hill, 1980.

Appendix A

*Product Sheets for
Manual Crate Loading and
Semi-Automatic Crate Loading*

Auxiliary Lifting Equipment for Manual Method



**PRODUCT
INNOVATION
SHEET**

• **LOADING/UNLOADING STATION**

RETORT BASKETS

Brenton Engineering Company offers a portable Loading/Unloading Station for your retort handling needs. This station incorporates a lift table to facilitate manual loading and unloading of retort baskets and can be custom built to meet your retort specifications and needs.

- Quality Control & Testing Aid
- Available for any Size Retort Basket

1-800-535-2730

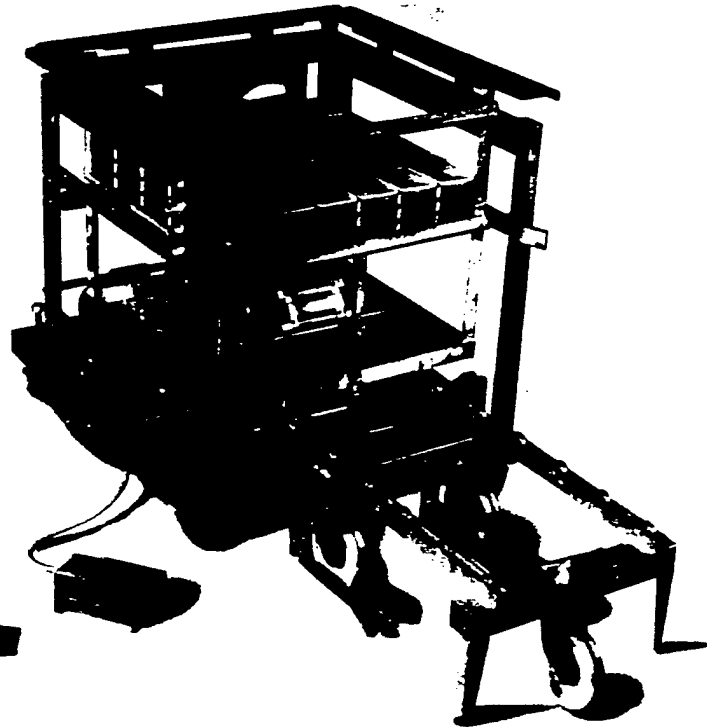

FEATURES/BENEFITS

- Fully portable
- All stainless steel construction
- Self-contained hydraulic system
- Simple to operate controls (options available)

Brenton Engineering Company
Rt. 5, Box 178 • Alexandria, MN 56308
(612) 852-7705 • Fax (612) 852-7621

Copyright © 1991 Brenton Engineering Company
Subsidiary of Continental Manufacturing, Inc.
150260/3-91/1M

“Expect Innovation”

Semi-Automatic Retort Crate Loader



**PRODUCT
INNOVATION
SHEET**

• **LOADER/UNLOADER**

RETORT BASKETS

Brenton Engineering Company offers a cost effective alternative to loading and unloading of retort baskets at speeds of 100 to 400 units per minute depending on container size. This semi-automatic method of retort handling integrates the "inspector"

in the production process resulting in improved quality control measures. Each project is custom built to meet your retort specifications and needs.

- Available for any Size Retort Basket
- Heavy-duty 1" x 3" Steel Frame

CALL TOLL FREE
1-800-535-2730

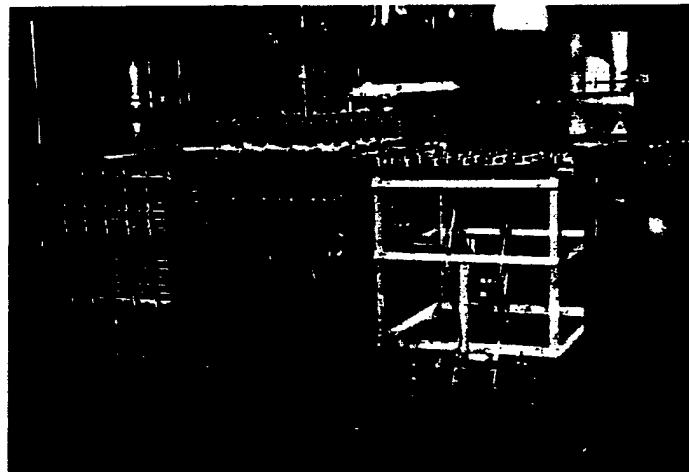

FEATURES/BENEFITS

- Semi-automatic design
- Speeds of 100 to 400 units per minute
- Cost-effective solution to retort handling
- Improves quality control capabilities

(see back for specifications)



"Expect Innovation"

1. Introduction

There have been many studies concerning the development and improvement of multicriteria decision models in the evaluation and justification of advanced manufacturing technologies. However, in the current literature, much less importance has been given to real world applications of these methodologies. In this paper the application of a decision model to a real problem in automation and computer integrated manufacturing (CIM) is described.

This case study is the second in a sequence of studies intended to illustrate the use of multicriteria decision models for analyzing investments at different levels of the factory CIM hierarchy, which is shown in Figure 1. We use a four level hierarchy: machine, cell or production line, shop floor, and plant level. At each level the information and control issues are different. Therefore, at each level one expects the investment criteria to be somewhat different.

LEVEL 4 - PLANT	ORDER PROCESSING PURCHASING AGGREGATE PRODUCTION PLANNING ACCOUNTING
LEVEL 3 - SHOP FLOOR	MATERIALS MANAGEMENT QUALITY MANAGEMENT SHOP FLOOR SCHEDULING
LEVEL 2 - WORK CELL/ PRODUCTION LINE	MATERIALS HANDLING PART SEQUENCING INSPECTION / STATISTICAL PROCESS CONTROL
LEVEL 1 - MACHINE	CNC MACHINE TOOLS ROBOTS PROGRAMMABLE CONTROLLERS

Figure 1 A Four Level Hierarchy of Factory Automation

At the *machine level* the focus is on the technologies that convert the input materials into finished product. Important criteria for investment include labor and material cost (yield) considerations as well as the flexibility of the manufacturing processes in responding to changing demand and product style. The CIM control issues are typically

limited to insuring that the sequence of machine operations corresponds to the program steps resident in the machine controller.

At the *production line or work cell level* the objective is to supervise the interactions between groups of related machines or processes. This level of the CIM hierarchy is not concerned with the operation of the machine or process itself, that is the responsibility of the machine control level. Examples of functional responsibilities at this level include control of materials handling among machines and the extracting of out-of-tolerance components or production lots as they are being processed.

At the *factory floor level* the objective is to supervise activities that affect groups of production lines or work cells. Important technologies include those for scheduling production among production lines and work cells and the management of common storage facilities, such as storage areas for raw materials and finished goods.

The *plant level* functions are less concerned with the daily operation of the factory and are more closely related to the business objectives of the firm. The important CIM technologies at this level are typically those associated purely with information management.

A previous case study by Boucher et al. [6] examined the use of multicriteria modeling at level 1, the machine level investment problem. In that study the decision problem involved the evaluation of two generic types of filling equipment used in packaged food manufacturing. The measurable cost savings were calculated for each alternative and the important difficult-to-quantify criteria in the justification of the investment alternatives were defined. The case study concluded that volumetric filling with in-line check weighing was the preferred solution for the specific decision scenerio studied. The chosen alternative was implemented.

In this paper we will examine an investment decision problem at level 2, the production line level of the hierarchy of Figure 1. This decision problem involves the procurement of a production line controller for coordinating machines along the production line, data logging of production information and integrating the production line to the factory level database for permanent storage of production information. The characteristics of the existing system and the proposal for a centralized controller will be discussed later.

The decision model applied to this case study is the Non-Traditional Capital Investment Criteria (NCIC) methodology developed by Boucher and MacStravic [5]. This method has been computerized in a software product by MacStravic and Boucher [11], which is commercially available through the Materials Handling Institute [12]. This is the same decision model that was applied in the previous case study [6]. It is a technique that is similar in some respects to Saaty's Analytic Hierarchy Process (AHP) [13], which has received some criticism in the literature (Watson [15], [16], Belton [2], Belton and Gear [3]). NCIC tries to overcome these criticisms by bringing the alternatives into the

decision at each step of the pairwise comparison process. Both AHP and NCIC start with subjective pairwise comparisons to rate criteria, and then calculate the importance of each criterion using the eigenvector approach. Maximum eigenvector is used in both models to check for logical consistency. However, unlike AHP, NCIC interprets the relative importance of each criterion in monetary terms. Moreover, NCIC provides additional checks on economic consistency and ranks alternatives with respect to their net present worth. More information on the use of multicriteria decision models in capital budgeting analysis can be found in Canada and Sullivan [7] and Falkner [9]. There are also applications of AHP to the evaluation of advanced manufacturing technologies in the literature (Arbel and Seidman [1], Chandra and Schall [8], and Wabalickis [14]).

All multicriteria decision analysis models generate solutions to problems by interpreting the results in terms of a ranking of alternatives ([4], [5], [6], [10], [13]). However, they all fail to justify their outcomes with respect to the sources of value imputed by the judgments of decision makers. It is as important as the result itself to be able to show the basis on which the chosen option is selected by the decision makers and where the benefits of that option are coming from. In this study, as in [6], we will address this issue.

In the following section the existing manufacturing system and the alternative under consideration will be explained as well as the decision scenario for the current problem. In section three we will elaborate on the framework of criteria that are important to consider in CIM justification. In the next section we explain the application of NCIC step by step with important criteria for the specific decision problem, pairwise comparisons, judgmental inconsistencies, computation of the criteria weights, calculation of net present worth and the post-audit. In the last section, we will show the justification of monetary values obtained through NCIC for some of the criteria.

2. The Alternatives under Consideration

The existing production line, for which a centralized controller is being considered, is shown in Figure 2. It is a food processing line that is used to fill ingredients into packages and to seal and label those packages. The food product in this case study is beef stew. The operation of the system is summarized below.

Raw material is manually moved into the production area and a paper record is made of the lot number, time and date when the material is placed into the product feeders, shown at the upper left of Figure 2. Federal government regulations for the food industry requires that the material lots be traceable to the production lots into which they go. This is required in the event of a product recall. For this decision scenario, the product is beef stew, the materials are beef, mixed vegetables, and gravy. The beef product feeder, which is a hopper with a conveyor, feeds the volumetric filler, shown at the top of Figure 2, which fills cups volumetrically. The transport system from the beef filler includes an in-line checkweigher that weighs the contents of the cup and recycles

cups back to the filler if they are outside the weight specification. This filling system was described in detail in [6].

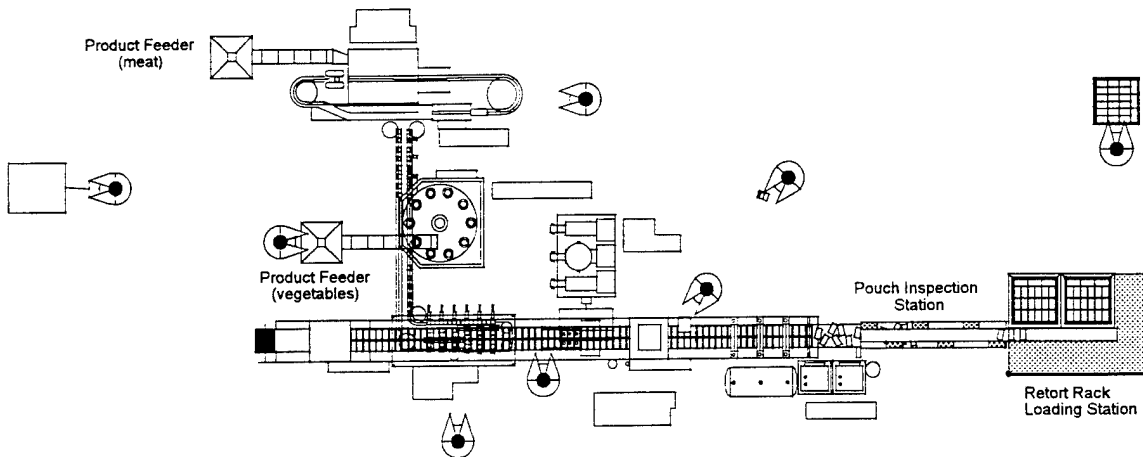

Figure 2 Polymer Pouch Filling and Packaging Line (Existing System)

Acceptable cups move onto the vegetable filler, where they receive a vegetable fill. When they arrive at the filling station of the packaging machine, they are moved into a cup dumper that overturns the cups into packages. Gravy is added to the package separately by the gravy filler, shown at the bottom left of Figure 2. Through this series of events an automatic fill is achieved.

The package is a polymer pouch, which is formed from roll stock on the packaging machine at the forming station, which is just prior to the cup dumper (filling) station. The packaging machine, which runs horizontally along the bottom of Figure 2, is a horizontal form-fill-seal (F/F/S) machine. The following steps are performed on that machine. After the materials are dumped into the package and gravy is automatically dispensed, the package is indexed forward through a vacuum and sealing station, where a top layer of polymer film is heat sealed under vacuum conditions to the package. At the next forward index, an Inkjet printer labels the package for product name and time of production and a slitter cuts the roll stock into individual packages. Finally, pouches are inspected and loaded into racks to be taken to the next operation.

The coordination of the cup filling and cup transport system with the packaging line is achieved using the Form-Fill-Seal (F/F/S) packaging machine controller. Each index of the F/F/S presents six pouches for filling. Upon completion of the index, a signal from the F/F/S controller to the product transfer system controller tells the cup dumper to fill the six pouches. A return signal from the product transfer system controller to the F/F/S controller tells the F/F/S that the fill is complete and an index of the F/F/S can begin. Start signals to the Inkjet printers and the gravy filler are also sent from the F/F/S

controller and a return signal is provided from the gravy filler when the six pouches are filled with gravy.

In this existing system, all the machinery along the filling and packaging line are controlled as unit operations. Both fillers, product feeders, the cup transfer system and the F/F/S have their own controllers. All start and stop operations are accessible at the control panel of the individual operation. Line stoppages that can occur within any of the subsystems are reported to the relevant subsystem controller. A subsystem stoppage causes the line to stop as the appropriate handshake is not exchanged to cause the F/F/S to continue with another index cycle.

The checkweigher at the exit of the meat filler provides a digital display of the most recent package weights. However, this data is not collected and permanently logged in the factory database. The only automatic data logging occurs on the F/F/S, which keeps a permanent record of certain events occurring during the sealing operation, such as seal temperature and pressure. This data is acquired by a stand alone computer terminal connected to its controller over an RS232 link.

The alternative to the current operation, which is being considered here, is the addition of a production line controller and a centralized control panel in order to centralize control of all of the unit operations along the line and to provide additional data logging capability.

In this new system, all the unit operation controllers will be reporting to a production line controller. It will be possible to operate the line centrally from the production line controller as well as locally using the controllers for each subsystem. Subsystem status information will be reported to the central controller by each subsystem controller. Information displays and readouts on the central control panel provide status of all subsystem operations, including fault conditions. Fault conditions and their downtime, which are monitored by the controller, will be kept as a permanent record by being loaded to the factory database. This data can be analyzed to identify recurring conditions that should be corrected. The central controller will be able to download information to the checkweigher, meat and vegetable fillers, F/F/S machine and Inkjet printer.

Sensors and bar code scanners will be installed for the purposes of quality control and tracking the packages and their material content. Instead of recording material lot numbers as a paper record, material lot information will be scanned into the database when material is introduced into production. Certain other quality assurance data will be collected electronically as opposed to a paper record.

3. Framework for Classifying Non-Traditional Capital Investment Criteria

The descriptions of the alternatives given above indicate that the solution to the decision problem under consideration should involve an economic analysis with both

measurable and difficult-to-quantify criteria. We will elaborate on the way to classify these criteria, which was explained by Boucher et al. in [6].

Properties of the production systems and the production technology should be reflected in the framework that will be used to define the criteria. A production system can be completely defined by three components : (1) the machine technology base, (2) the organization of production, and (3) the decision making support structure. The definitions for these components are given as follows : *Machine technology base* is the conversion process available to turn inputs into outputs, representing an upper limit, or boundary, on the potential technical efficiency of the production line. The *organization of production* defines the way the machines, workers and material are organized along the product flow. The efficiency of factory organization will affect the level of technical efficiency. For these two factors to operate effectively a *decision making support structure* is needed to determine , during any period of time, what products will be produced, how much will be produced, when materials will be ordered, what technical improvements will be made, and so on.

Technical change in a production system (as opposed to a product design) occurs through one or more of those three components mentioned above, a new machine technology, a new organization of production or a new decision making technique.

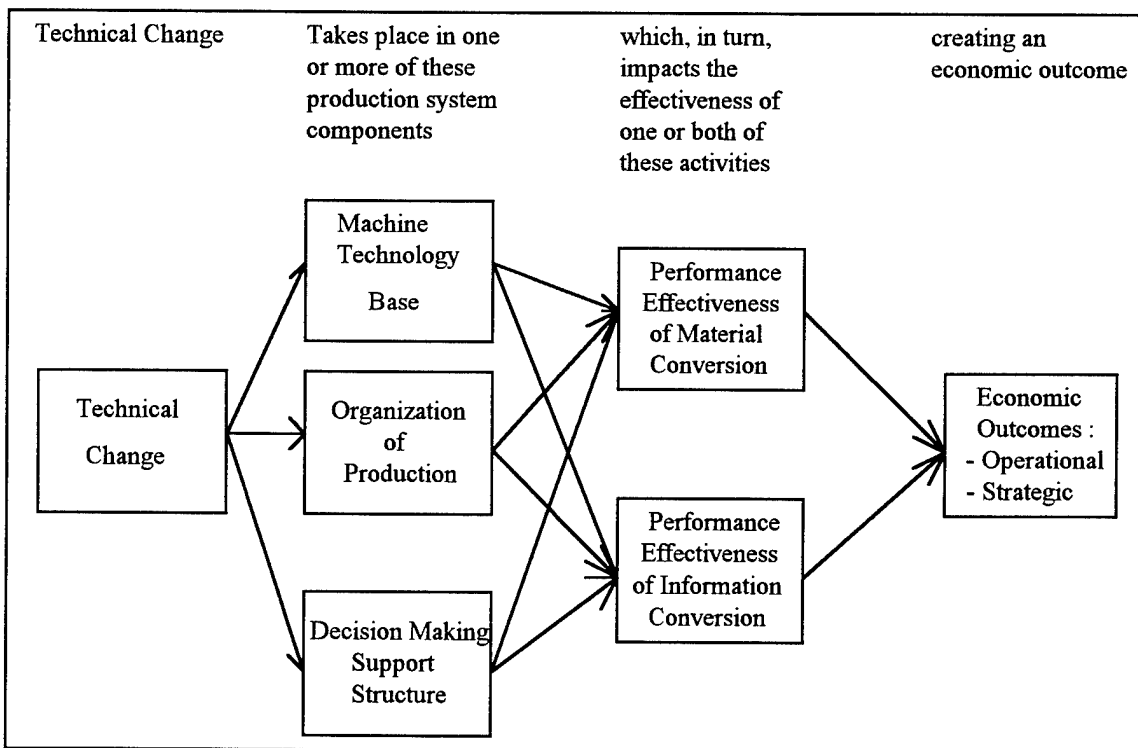

Figure 3 The Relationship Between Technical Change and Economic Performance

The cause-and-effect relationships underlying the framework are given in Figure 3. The left half of the figure points out the fact that a technical change takes place on one or more of the three components.

Continuing from the components of the system to the analysis of the impact of technical change, two major activities are defined : material conversion activities and information conversion activities. It is the efficiency of these two activities that are affected by the technical change that occurs in machine technology, organization of production, or decision support system. The process of converting raw material into products is covered by material conversion activities and the process of converting raw data into decisions is covered by information conversion activities. A technical change through one or more of the three components of the system affects the performance effectiveness of material conversion, information conversion, or both and may result in reduced cost, increased revenue or both.

The final results of the changes in the performance of these activities are the economic outcomes, which may be immediate and direct as in the case of labor efficiencies (operational), or distant and less direct, as in the case of improved market position from improved product quality (strategic).

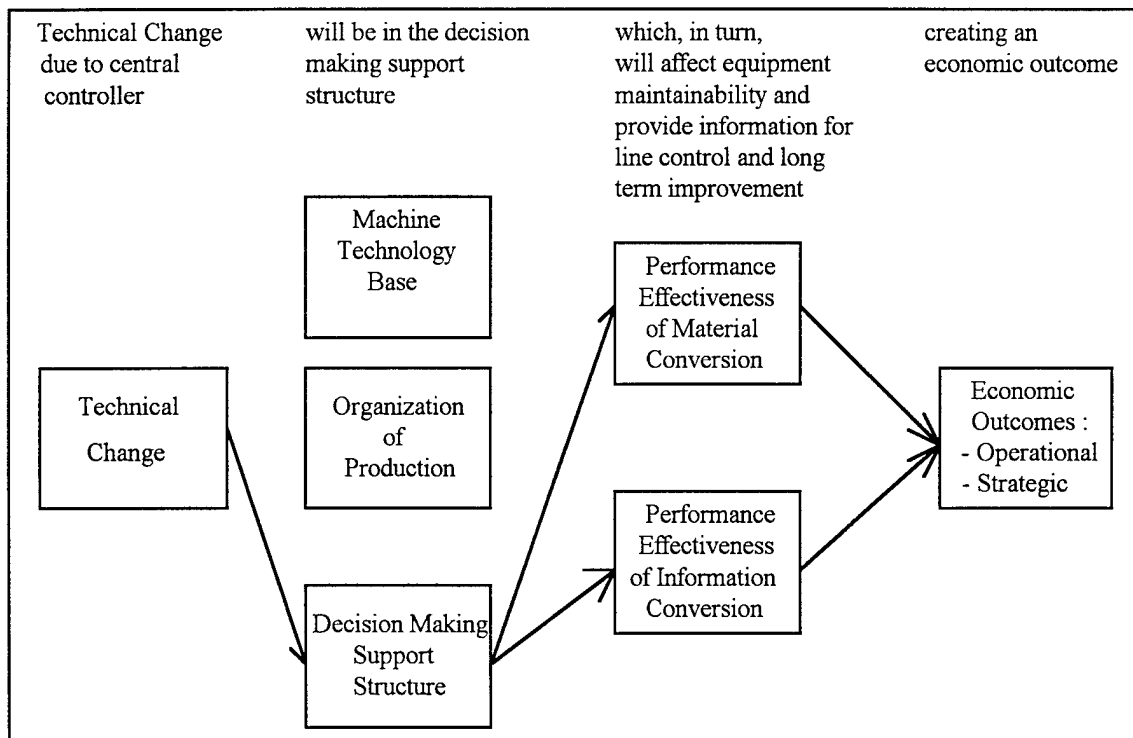

Figure 4 Framework for the Decision Problem of the Central Controller

In Figure 4 the situation for a central controller for data logging and integration from the shop floor to the factory database is shown. The technical change occurs in the decision making support structure, as the data logging capability of the controller will

provide opportunities for improved automatic real time decision making. The integration to the factory data base will enhance the capability for data analysis for long term process improvement. As a result, this technical change will have an impact on both material conversion activities and information conversion activities.

Using the above paradigm, the decision making framework for this problem can be constructed, incorporating both the traditional and the non-traditional criteria. This is done by bringing together the relevant experts on the technology and the operation of the production facility. Our panel was composed of three engineers with an average of 10 years experience in the food industry. Two engineers are responsible for the system design shown in Figure 2 and one engineer, a process engineer, is responsible for the design and implementation of quality control aspects of the production operation. Hereafter we will refer to this team of experts as the "decision maker".

The first step in the NCIC process is to have the decision maker define all the important performance criteria, measurable or not measurable, affecting material conversion and information conversion activities that may change as a result of the new investment and may have economic outcomes. Some of these criteria are given in Figure 5, which is a hierarchy in which the overall objectives of the decision problem appear at the top and the criteria for evaluation are classified below.

As shown in Figure 5, the overall objective is given at level 1; i.e., to determine the value of investing in a centralized controller. At level 2 we have the material conversion and information conversion activities which are subdivided into criteria at level 3. The objective is to compute the "value" of investing in the new alternative for the proposed technical change. The sum of the values of the effects of the changes in criteria performance will sum up to the overall value of the technical change.

It is important to make sure that the criteria are understood to have the same meaning among the decision makers. *Equipment Maintainability* under Material Conversion in Figure 5 refers to the fact that implementing the controller means adding a new component to the line that must be maintained and that could fail, causing a shutdown of the material conversion process. The decision makers considered this to be a net cost; i.e., it would have negative value to the central controller. Since it is not an easy cost to estimate, we need a good deal of engineering judgment to bring it into the computations.

Under Information Conversion, *Real Time Data for Operational Control* refers to the automatic data logging capability of the central controller, which will help in decreasing the line downtime and increasing efficiency by providing the operator with immediate identification of the sources of line stoppage. Under the current design, a fault that occurs in any of the subsystems will stop the line. The operator will then have to examine each subsystem to determine the cause of failure. The central controller will be programmed with a fault display that immediately directs the operator to the fault condition that must be cleared. The decision makers considered this to be a net benefit in

favor of investing in the controller. Since it is not an easy benefit to estimate, we need engineering judgment to bring it into the computation.

Real Time Data for Long Term Improvement focuses on the identification of areas of process improvement that will be achieved through studying the data collected and logged in the factory database. By having a time series of data on production and material usage to analyze, it may be possible to identify areas of improvement that will raise the overall yield of the process. This is in the general spirit of what is referred to as "continuous improvement" and "total quality management". Without having such data to analyze, it is less likely that one will find the sources for process improvement. Again, the decision makers considered this to be a net benefit in favor of investing in the central controller.

As in the previous case study [6], *Option for CIM* reflects the value of the degree to which a particular alternative provides a basis for continuing to a higher level of computer integration. Investment at some level of computer integration establishes a basis for higher levels of integration as per Figure 1. This has been compared to buying an option, which may have future value.

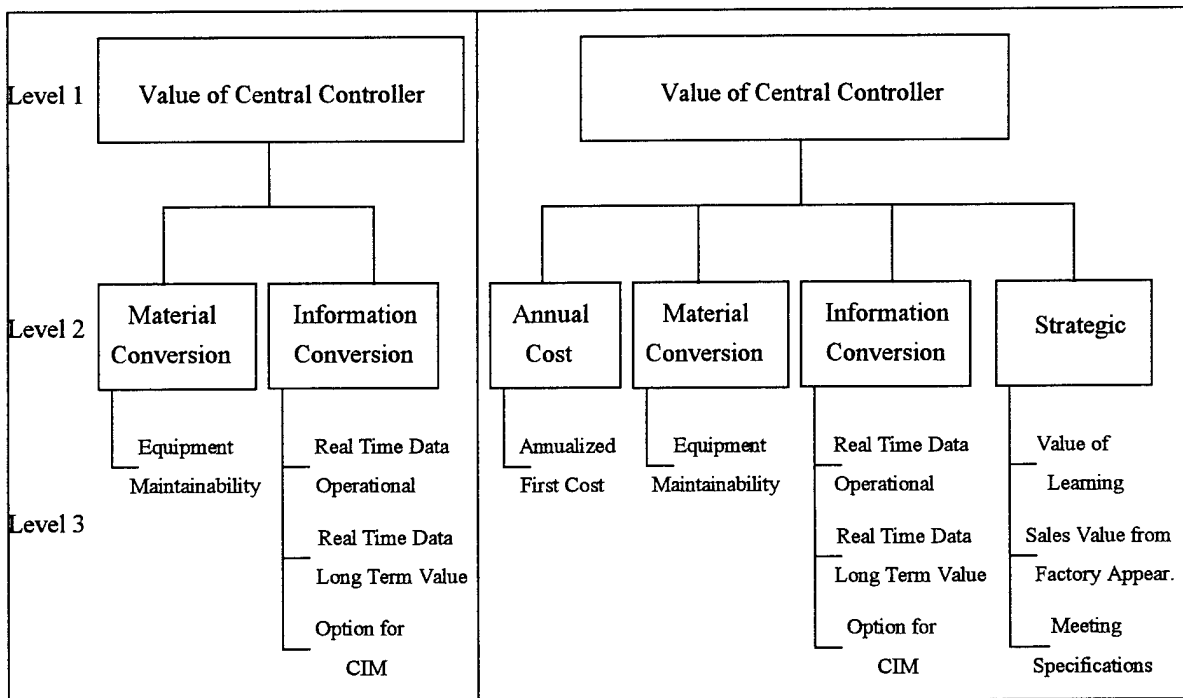

Figure 5
Examples of Criteria

Figure 6
Partial NCIC Decision-Making Framework

In Figure 5, none of the criteria are measured in monetary terms. For an NCIC analysis it is necessary to have a monetary value that all other criteria can be compared to. In this problem it is the annualized acquisition and installation cost of the central controller, which has been estimated to be equivalent to equal annual payments of

\$50,000, using a study period of 5 years. This is added into the hierarchy as a new criterion in Figure 6. There are no "Annual Cost Savings" determined to accrue from investment in the central controller that we were able to estimate directly at the outset.

There is one other major area in which important criteria exist; this is the "strategic competitive criteria" shown on the right of Figure 6. The three criteria that are considered here are (1) Value of Learning (a new technology), (2) Sales Value from Factory Appearance and (3) Meeting Specifications. These criteria have economic value as they form the basis of competition in the industry and determine the long-term survivability of the firm in its market. These criteria are defined in the Appendix

It is important to define the appropriate set of criteria for the decision making process. The reader can verify that this set of criteria is very different than those used in the previous case study [6], excepting a few common criteria. Although both problems deal with automation and computer integrated manufacturing for the same production line, because the alternatives under consideration are different, the criteria that determine the decision are different. The criteria are decision scenario specific and should be selected with care.

The inability to quantify the economic value of difficult-to-measure (non-traditional) criteria can lead to the situation where a superior investment is not given any serious consideration. In the following sections we will demonstrate the application of NCIC to the current decision problem, which will overcome these deficiencies of the traditional financial analysis in measuring economic value.

4. Application of NCIC

4.1. Establishing Criteria

The procedure for applying NCIC is similar in some respects to AHP and consists of four steps :

1. Identifying the evaluation criteria and the investment alternatives.
2. Making pairwise comparisons to determine the relative importance of criteria for each alternative.
3. Evaluating judgmental inconsistencies from the pairwise comparison process.
4. Computing the present worth of each investment based on the value of traditional and non-traditional criteria.

The final decision on the list of criteria and the categories was made after two group sessions with the decision makers. Figure 7 represents the hierarchy for the decision problem and illustrates all the criteria. In this decision problem there is only one hierarchy, in contrast to [6] in which there are two hierarchies. The distinction here is that we are evaluating an incremental change to an existing system. Hence, the incremental

investment in the central controller and the control panel as a new option is the basis for the hierarchy. The definitions of the criteria in the hierarchy are given in Appendix 1.

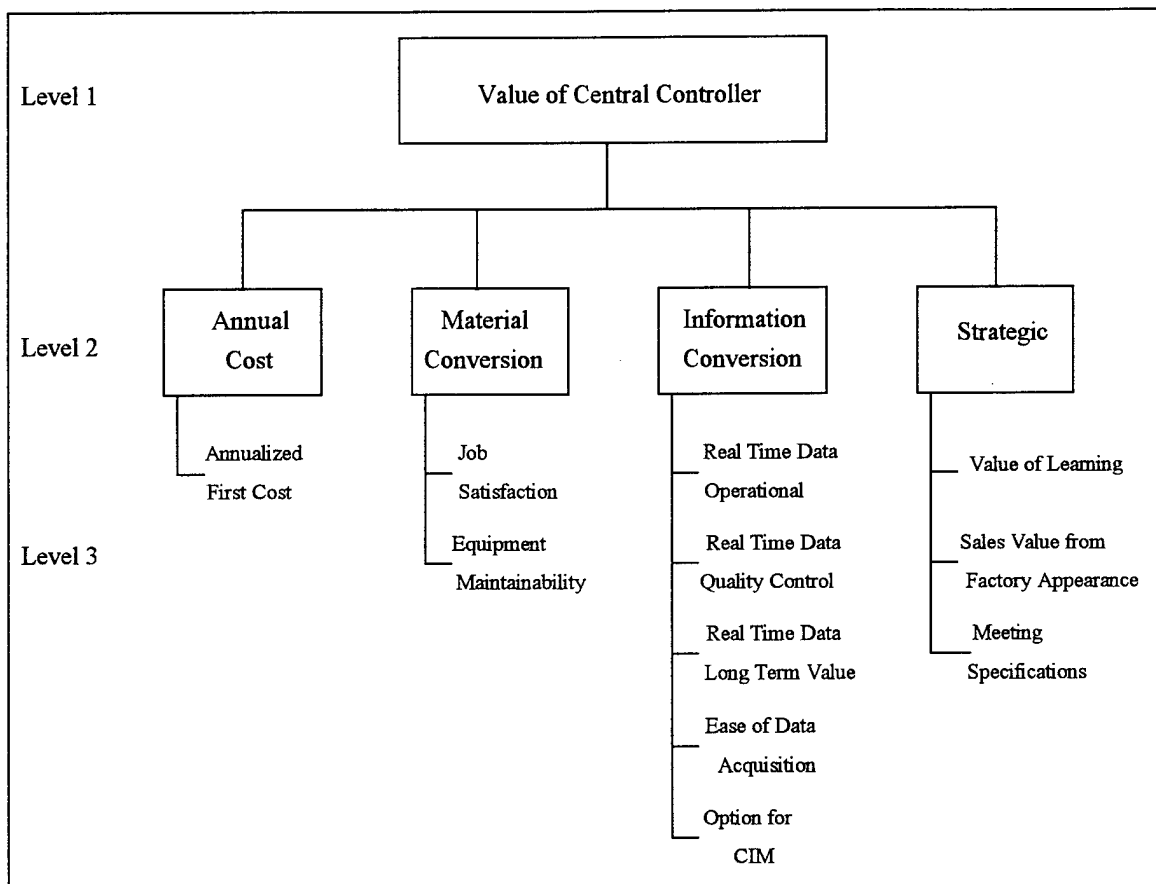

Figure 7 Decision Hierarchy showing the Evaluation Criteria for the Central Controller

It is important in multicriteria analysis to make sure that the criteria are independent. It is necessary to inform the decision makers that this independence must be strictly maintained in applying value to each criterion. Therefore, we shall discuss the distinction between the criteria involving the value of Data in Real Time; i.e., the first three criteria under Information Conversion. As previously discussed, *Real Time Data-Operational* refers to the immediate warning to the operator about actual or potential line stoppages and their causes. This will eliminate unnecessary line downtime by taking preventive measures and immediate action, and will be considered in Real Time Data for Operational Control. However, *Real Time Data for Quality Control* captures the benefit of being able to more accurately control product quality through control of the process by having real time electronic data collection on quality parameters. Finally, *Real Time Data for Long Term Improvement* represents the benefits of the incremental investment that will be provided through studying the behavior of the system over the long run, and hence improving yield by identifying areas for process improvement and implementing such improvements. These three areas turn out to be the most significant justification for the central controller.

4.2. Pairwise Comparisons

Having defined all the criteria and constructed the hierarchy, the decision makers were asked to make pairwise comparisons among the criteria within each category for the specific decision scenario. The procedure was completed in a single session that lasted 3 hours. The result is given in Figure 8.

In Figure 8, the pairwise comparisons among the criteria for the three categories can be seen. In addition to the criteria in a category, Annual Cost is included in all pairwise comparisons matrices in order to interpret the results in monetary terms.

In any pairwise comparisons matrix, three types of comparisons are possible: comparison of two benefit criteria, comparison of a benefit criterion with a cost criterion and comparison of two cost criteria. The first matrix consists of the last two types of comparisons whereas the other two consists of the first two types of comparisons. These comparisons will be explained next.

In the comparisons matrix for Material Conversion, Annual Cost, which is the measurable dollar value of the annualized acquisition and installation cost, is compared to Job Satisfaction whose benefit comes from less absenteeism and labor turnover due to the satisfaction of the workers from the use of sophisticated equipment. The question asked to the decision makers for this comparison was "By how much do you prefer not losing \$50,000 a year in paying for the cost of the controller to the decrease in absenteeism and labor turnover due to the increased job satisfaction of the workers?" The number of 7 given by the decision makers indicate that the annual cost of \$50,000 is seven time more important than the benefits of Job Satisfaction.

The comparison of Annual Cost to Equipment Maintainability in the same matrix is an example of the comparison of two cost criteria. In this case the annual cost of \$50,000 is compared to the increased cost of equipment maintainability due to additional equipment in the production line. The question is formed as "What is the relative importance of not losing \$50,000 a year to pay for the controller to not spending extra money on increased cost of equipment maintainability?" A value of 9 shows that annual cost is nine times more important than the increased cost of equipment maintenance. In other words, the decision makers were not expecting a high increase in the cost to maintain the production line.

For the comparison of two benefit criteria one may look at the comparison of Real Time Data for Operational Control versus Real Time Data for Quality Control. The question directed to the decision makers was "By how much do you prefer the benefits that will be provided through Real Time Data for Operational Control to the benefits that will come from Real Time Data for Quality Control?" The answer of the decision makers was a 9 meaning the benefit due to higher line efficiency is nine times more important than the benefit of automatically monitoring and electronic entry of product quality data.

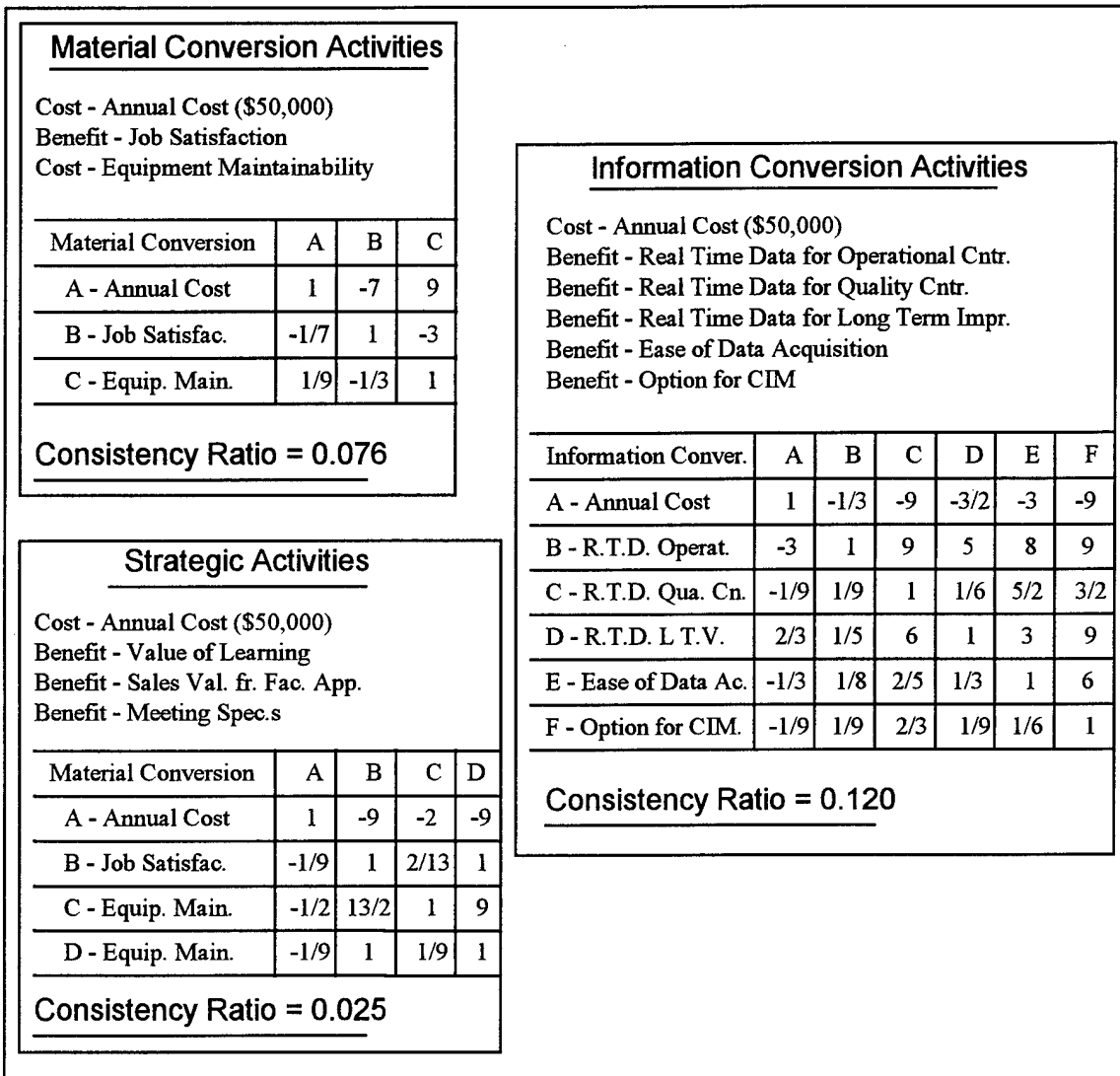

Figure 8 Pairwise Comparisons Matrices for Each Category

The scale that was used is the one-to-nine scale developed by Saaty [13]. When a number for any ij^{th} comparison was given, the reciprocal of the number was entered in the complementary matrix cell (ji^{th} entry). However, in Saaty's one-to-nine scale only integer numbers were used to represent preferences. The consistency ratios are computed by dividing the consistency index of a matrix by the random index for a matrix of the given size, where the random indices are the consistency ratios of the randomly generated reciprocal matrices whose entries are selected from integers 1 to 9 (and their reciprocals). Therefore, the consistency ratio developed by Saaty depends on the assumption of integer valued preferences. The decision makers in this case study insisted on using rational numbers to represent their preferences, in order to achieve a consensus. We did not round their figures to the nearest integer. We carried out the calculations based on their exact numbers and computed the consistency ratios based on the random indices developed by

Saaty [13]. Hence, except for the pairwise comparisons matrix of Material Conversion Activities, the consistency ratios are only approximations.

For the comparisons involving one benefit and one cost criterion, a negative sign is placed in front of the number provided by the decision makers. When the criteria are of the same type, both benefit or both cost, the number was used as it is (positive). For the details of this procedure the reader may refer to [6].

While conducting the pairwise comparisons process, the decision makers were first asked to choose the most important criterion and then compare it with the next important one, as it is easier to provide a number between 1 and 9 instead of a number between 1/9 and 1.

4.3. Judgmental Inconsistency

While conducting the pairwise comparisons process, the answers provided by the decision makers were constantly checked for inconsistency due to violating the laws of transitivity. This law can be explained as follows : if A is preferred to B three times and B is preferred to C twice, then A should be preferred to C six times. Saaty has introduced the concept of a consistency ratio, which is calculated by the use of the maximum eigenvector method for the decision analysis model of the Analytic Hierarchy Process [13]. He suggests that a consistency ratio of 0.1 or less is a tolerable amount, whereas a matrix with a value greater than that should be considered inconsistent. The consistency ratios for the pairwise comparisons matrices are given below the charts in Figure 8.

When faced with an inconsistent pairwise comparisons matrix, the decision makers should be given every opportunity to resolve the problem by reevaluating their answers. If, on the other hand, inconsistencies can not be resolved during reevaluation, the data should be used as it is in further calculations. Inconsistencies do not create problems in the upcoming steps of the solution procedure.

Another type of consistency check which is referred to as the check on returns to scale is specific to NCIC. With that procedure it is possible to check the economic consistency of the final monetary output as long as there are at least two alternatives being evaluated. Because we have just one alternative, the incremental investment, in our analysis, this additional check does not apply. The reader may refer to [5] for the details of this consistency check , and [6] for an application.

4.4. Computing the Criteria Weights

The next step in the solution process is the computation of the relative weights of the criteria, W_k 's. The eigenvector method, the procedure developed by Saaty [13], is used for this calculation.

Using the relative weights, a computation is made to convert them into monetary units as follows. Let :

W_k = the relative value (weight) of criterion k,
 AB_k = the annual benefit (or cost) of criterion k,
 AB_0 = the annualized acquisition and installation cost of the addition equipment.

Then,

$$AB_k = AB_0 (W_k / W_0)$$

where W_0 is the relative weight of annual cost criterion.

After having calculated the annual benefit (or cost) of each criterion using the above equation, the sum of all the dollar values for the criteria will give the Total Annual Benefit of the incremental investment. Hence, the difficult-to-quantify criteria will be taken into consideration in the decision process. Let :

TAB = Total Annual Benefit for the incremental investment,

$$TAB = \sum_k AB_k$$

The above equations have been applied to the case study and the annual weights for the criteria given in Table 1 have been calculated.

Table 1 Annual Benefit (Cost) of Individual Criteria

Criterion	Incremental Investment in Central Controller
Annual Cost	- \$ 50,000
Job Satisfaction	11,000
Equipment Maintainability	- 5,000
Real Time Data for Oper. Control	91,000
Real Time Data for Quality Control	11,000
Real Time Data for Long Term Improv.	38,000
Ease of Data Acquisition	14,000
Option for CIM	5,000
Value of Learning	5,000
Sales Value from Factory Appearance	29,000
Meeting Specifications	5,000
Total	154,000

The results of Table 1 are summarized and Annual Benefit (or Cost) for each criteria group are given in Table 2.

Table 2 Annual Benefit (Cost) by Criteria Group

Criteria Group	Incremental Investment in Central Controller
Annual Cost	- \$ 50,000
Material Conversion	6,000
Information Conversion	159,000
Strategic	39,000
Total	154,000

An observation that can be made from the above data is that the value of Information Conversion plays the dominant role in the final decision. Moreover, it is the values of Real Time Data for Operational Control and Real Time Data for Long Term Improvement that have the most significant effects. The result in Table 2 favors making the incremental investment in the central controller. However, it is the values of the criteria that are difficult to directly quantify in monetary terms that determine the result of the comparison and conclude that it is profitable to invest. In arriving at this conclusion, the decision makers have valued Real Time Data for Operational Control at \$91,000, almost twice as high as the annualized cost of the equipment; in other words the benefit of increased Operational Control due to having data in real time, increased line efficiency, is expected to more than compensate for the cost of the equipment. This is a very strong statement and should be questioned. The same question arises for Real Time Data for Long Term Improvement. The value of \$38,000 due to increased yield should be evaluated as well. NCIC considers such an evaluation process as a way to close the loop on expert judgment. We shall address this issue in Section 5.

4.5. Computing the Net Present Worth

Once the total annual benefit for the investment has been calculated the net present worth can be computed. The total annual benefit for the incremental investment is found as \$154,000. Using this figure with the tax and discount rates, time horizon and the depreciation schedule as given in Table 3, the net present worth is calculated. In the calculation of the depreciation amounts, straight-line depreciation was used.

Table 3 Net Present Worth Calculation

Present Worth Analysis	
Marginal Tax Rate (%) (State and Federal)	38%
Discount Rate (%)	15%
Time Horizon (years)	5 years
Depreciation Amounts	
Year 1	\$33,000
2	33,000
3	33,000
4	33,000
5	33,000
Total Initial Investment	\$165,000
Net Present Worth	\$301,000

5. Post-Auditing the Analysis

5.1 Comparison to Holistic Judgment

The analysis has been completed and a conclusion has been reached. The next step is to test the validity of the outcome. The purpose of this step of the process is to evaluate the reasonableness of the results. We refer to this as the post-audit phase of NCIC.

Table 4. Final outcomes for NCIC and the holistic rank order.

Criteria	NCIC		Holistic
	\$ value	rank	rank
Job Satisfaction	\$11,000	5.5	7.5
R.T.D. for Operation. Cntrl	91,000	1	1
R.T.D. for Quality Control	11,000	5.5	4
R.T.D. Long Term Imp.	38,000	2	2
Ease of Data Acquisition	14,000	4	3
Option for CIM	5,000	8	6
Value of Learning	5,000	8	7.5
Sales Value from Fac. App.	29,000	3	5
Meeting Specifications	5,000	8	9

It is a fact that individuals find holistic rank order preference judgments fairly easy to make. Difficulties arise when individuals are asked for cardinality relationships, as in NCIC (and also in AHP). When the evaluation procedure was completed and before the results were shown to the participants, the decision makers were asked to rank the benefits criteria in the order of importance with respect to their perceived contribution to making the system with the central controller better than the existing system. The resulting

holistic rank order is given in Table 4 along with the rank of the NCIC results. Holistic rank ordering was performed only for the benefits criteria for the ease of computation. When the decision makers felt that two criteria were about equal, they were allowed to share the ranking (e.g., Job Satisfaction and Value of Learning).

The outcome is not surprising. In general, the criteria that are rated as most important in NCIC are ranked high in the post-audit and vice versa. In order to find the degree of relationship between the two rankings, Spearman's coefficient of rank correlation among the two sets of data was computed. The result came out to be 0.859 which is quite satisfactory.

Another way to evaluate the reasonableness of the outcome is to try to justify the dollar values attached to criteria as a result of the NCIC analysis, by finding out how much of an improvement is required for the criteria performance in order to justify the dollar amount. This will be the purpose of the next section.

5.2 Justification of the Dollar Values

In NCIC, an important part of a decision analysis problem is an attempt to test the reasonableness of the result. In order to prove the strength of the model being applied, the final results, whether in monetary terms or not, should be linked to actual production line data. Only in this way will a management be convinced of the validity of the result. This requires a detailed analysis of the cost structure of the production system. To demonstrate this point we have selected the two criteria that had the strongest influence in the final outcome : Real Time Data for Operational Control (\$91,000) and Real Time Data for Long Term Improvement (\$38,000).

A cost model was developed by STP 20 in spreadsheet format that would allow the user to evaluate the impact on the total production cost arising from changes in line operating efficiency and material yield. Depending on the production scenario, two types of changes in the production cost are possible due to eliminating line downtime. In the first case, we have assumed a fixed amount of production (7,109,000 units; full capacity of the existing system) for both systems (with and without the controller). It was found that a change in the efficiency, while keeping the production constant, affects operating labor, direct supervisory and clerical labor, utility, and quality control costs. A 10% increase in the efficiency of the filling equipment (accepted as a reasonable assumption by the decision makers) was shown to yield a decrease of \$61,000 in the total production cost. On the other hand, in the second production scenario, it was assumed that the total capacity of the system would be used and all units would be sold. In this case, as a result of a 10% increase in the efficiency of the filling equipment, production capacity increased by 889,000 units leading to \$222,000 in increased profit (assuming a contribution margin of \$0.25). However, the total cost of production also increased by \$44,000. Therefore, the net benefit of the increased capacity was calculated as \$178,000. This implies that whichever production scenario is undertaken after implementing the controller, a 10% increase in operating line efficiency will lead to an annual benefit between [\$61,000,

\$178,000]. Hence, we can conclude that an annual benefit of \$91,000 as calculated by NCIC is a reasonable amount. The details of the above computations are given in Appendix 2.

The \$38,000 attached to Real Time Data-Long Term Value was expected to occur from continuous improvements in process yield over time. This would be achieved by statistically analyzing data on product output from ingredients of different vendors as well as the performance of equipment under varying conditions. It was found that an increase in the yield of filling equipment and/or horizontal F/F/S machine affected only the raw material and the packaging costs, and did not result in any increased capacity. Using the product cost structure spreadsheet, it was computed that an improvement in yield (of the filling equipment and horizontal F/F/S machine) of the order of 1% would decrease the total production cost by \$45,000 which would justify the judgmental value of \$38,000 that came from the NCIC analysis. Details of the computations are given in Appendix 2. This was considered a reasonable expectation by the decision makers.

In summary, this phase of the post audit confirmed that the original judgmental values were not out-of-line with real possibilities. It also provided "performance improvement targets" for plant operating personnel after the controller is installed. We shall say more about this in the next section.

5.3 Performance Targets as Management Contracts

In the approach we have outlined thusfar, engineers and other decision makers in the business unit are allowed to apply their intuitive judgment about the impact of a new technology investment on important performance and strategic criteria. These judgments are then converted to monetary units through the NCIC process. Once the important sources of value are identified, their reasonableness is tested by trying to model the performance improvement as a cost driver. This can be done using a production cost model. If the outcome of that evaluation shows the NCIC estimates to be unreasonable, a modification is called for. If the NCIC estimates seem reasonable, they may be accepted by the business unit and submitted as the justification for the investment. However, the process should not end there.

A shortcoming of many capital budgeting processes is the lack of follow-up on reexamining an investment decision based on its outcome verses its original justification. If a business unit supports an investment based on a predicted outcome, its capability for such judgment should be examined based on actual outcomes. Within the philosophy of the NCIC approach, we view the accepted performance targets as a kind of contractual obligation of those supporting the investment. In this case study these performance targets are quite specific: 10% less downtime and 1% improvement in yield. Hence, it is fairly straightforward to reexamine an investment decision of this type after the new technology investment has had its effect.

6.0 Summary

This case study was undertaken to illustrate the NCIC methodology applied to a problem in computer integrated manufacturing. The main objective of NCIC is to provide a decision-making process that includes difficult-to-quantify criteria in the analysis while addressing the typical requirements of the corporate capital budgeting process, which is to provide justification in terms of corporate financial goals.

The case study analysis of a production line controller identified criteria appropriate to a decision in which improved information was the primary benefit. For this decision scenario, the benefits of improved real time operational control (\$91,000) and the long term benefits of information for continuous improvement (\$38,000) were the dominant criteria. The analysis showed that the benefits outweighed the cost. Using a product cost structure spreadsheet and reasonable possibilities of improvement in the criteria, \$91,000 was shown to fall within the range of expected benefit value due to less line downtime, and \$38,000 was shown to be an acceptable level of annual benefit for increased yield. It was concluded that the estimates of benefit value obtained as a result of NCIC analysis were not out-of-line with reasonable possibilities.

References :

1. Arbel, A. and A. Seidmann, "Performance Evaluation of Flexible Manufacturing Systems," *IEEE Transactions on Systems, Man and Cybernetics*, Vol. SMC-14, No. 4, 1984, p.606.
2. Belton, V., "A Comparison of the Analytic Hierarchy Process and a simple Multi-Attribute Value Function," *European Journal of Operational Research*, Vol. 26, 1986, p.7.
3. Belton, V. and T. Gear, "On a Short-coming of Saaty's Method of Analytic Hierarchies," *Omega*, Vol. 11, No. 3, 1983, p.228.
4. Boender C.G.E., J.G. de Graan and F.A. Lootsma, "Multicriteria Decision Analysis with Fuzzy Pairwise Comparisons," *Fuzzy Sets and Systems*, Vol. 19, 1989, pp.133-143.
5. Boucher, T.O. and E.L. MacStravic, " Multi-Attribute Evaluation Within a Present Worth Framework and its Relation to Analytic Hierarchy Process," *The Engineering Economist*, Vol. 37, No. 1, 1991, p.1.
6. Boucher, T.O., J.T. Luxhoj, T. Descovich, and N. Litman, "Multicriteria Evaluation of Automated Filling Systems : A Case Study," *Journal of Manufacturing Systems*, Vol. 12, No. 5, 1993, p.357.
7. Canada, J.R. and W.G. Sullivan, *Economic and Multiattribute Evaluation of Advanced Manufacturing Systems*, Prentice Hall, 1989.
8. Chandra, J. and S.O. Schall, "Economic Justification of Flexible Manufacturing Using the Leontief Input-Output Model," *The Engineering Economist*, Vol. 34, No. 1, 1988, p.27.
9. Falkner, C.H. and S. Benhajla, "Multiattribute Decision Models in the Justification of CIM Systems," *The Engineering Economist*, Vol. 35, No. 2, 1990, p.91.
10. van Laarhoven, P.J.M. and W. Pedrycz, "A Fuzzy extension of Saaty's Priority Theory," *Fuzzy Sets and Systems*, Vol. 11, 1983, pp.229-241.
11. MacStravic, E.L. and T.O. Boucher, *Users Manual : NCIC Decision Support Software for Investment in Advanced Manufacturing Technology*, Piscataway, NJ : Rutgers University Center for Advanced Food Technology, August 1991.
12. NCIC, *Decision Support Software for Investment in Integrated Automation and Advanced Systems, Users Manual*, Version 4.0, Integrated Systems and Control Council, Materials Handling Institute.
13. Saaty, T.L., *The Analytic Hierarchy Process*, 1980, McGraw-Hill.
14. Wabalickis, R.N., "Justification of FMS with the Analytic Hierarchy Process," *Journal of Manufacturing Systems*, Vol. 7, No. 3, 1988, p.175.
15. Watson, S.R. and A.N.S. Freeling, "Assessing Attribute Weights," *Omega*, Vol. 10, No. 6, 1982, p.582.
16. Watson, S.R. and A.N.S. Freeling, " Comment on : Assessing Attribute Weights by Ratios," *Omega*, Vol. 11, No. 1, 1983, p.13.

Appendix 1 - Criteria Definitions

The non-traditional criteria that are used in the NCIC analysis of the investment in the central controller are:

Category : Annual Cost :

Annual Cost : Annualized acquisition and installation cost of the central controller converted to equal annual payments of \$50,000 using a study period of 5 years.

Category : Material Conversion :

Job Satisfaction : This criterion refers to the fact that having sophisticated equipment at the shop floor improves worker satisfaction, shows the worker that the management cares about them and hence causes less absenteeism and labor turnover. (⇒ Benefit)

Equipment Maintainability : is the cost to maintain the equipment. Although equipment manufacturers provide some guidelines on preventive maintenance, the actual cost of maintenance and part replacement is somewhat speculative and a good deal of engineering judgment is called for. (⇒ Cost)

Category : Information Conversion :

Real Time Data for Operational Control : Automatic collection and immediate warning of the operator about potential line stoppages and cause of actual line stoppages will eliminate unnecessary line downtime by taking preventive measures and immediate action. (⇒ Benefit)

Real Time Data for Quality Control : focuses on the advantage of having electronic data collection on quality parameters in order to make immediate correction to the process. (⇒ Benefit)

Real Time Data for Long Term Improvement : By the automatic data logging capability, the data can be held and analyzed for studying the behavior of the system over the long run and, hence, improve yield and identify the areas of process improvement (⇒ Benefit)

Ease of Data Acquisition : refers to the improvement in the ability to acquire data automatically, including the efficiencies in staff for gathering data (⇒ Benefit)

Option for CIM : reflects the value of the degree to which a particular alternative provides a basis for continuing to a higher level of computer integration. (⇒ Benefit)

Category : Strategic :

Value of Learning : The implementation of a new technology makes it easier to adopt future technologies that build on the current one, for engineers, managers and workers. (⇒ Benefit)

Sales Value from Factory Appearance : This criterion reflects the increase in the sales value as a result of the impressed customers due to a more advanced shop floor. (⇒ Benefit)

Meeting Specifications : is defined as the percentage of conforming units. It brings in the potential for increased business arising from meeting all contract specifications, including product specifications and delivery dates.

Appendix 2 - Justification of NCIC Outcomes

Benefit due to Real Time Data for Operational Control :

	Existing System	A	B
Operating Labor	\$655,000	\$612,000	\$689,000
Direct Supervisory and Clerical Labor	\$98,000	\$92,000	\$103,000
Utilities	\$60,000	\$54,000	\$60,000
Quality Control	\$98,000	\$92,000	\$103,000
Total	\$911,000	\$850,000	\$955,000
Units Produced	7,109,000	7,109,000	7,998,000

where

column A contains data relating to 10% increase in the efficiency of the filling equipment under fixed amount of production.

column B contains data relating to 10% increase in the efficiency of the filling equipment and using full capacity.

Benefit due to Real Time Data for Long Term Improvement :

	Existing System	A
Raw Material Cost	\$3,815,000	\$3,777,000
Pouch Packaging Cost	\$653,000	\$646,000
Total Cost	\$4,468,000	\$4,423,000
Units Produced	7,109,000	7,109,000

where

column A contains data relating to 1% increase in the yields of filling equipment and horizontal F/F/S machine.