



NAVAL FACILITIES ENGINEERING SERVICE CENTER
Port Hueneme, California 93043-4370

Contract Report
CR 96.012

**U.S. NAVY AMPHIBIOUS CARGO BEACHING LIGHTER
MODULE DESIGN AND DEVELOPMENT -- FINAL REPORT**

An Investigation Conducted by

M.J. Plackett and Associates
9515 Woodworth Avenue
Gig Harbor, WA

19961126 015

DTIC QUALITY INSPECTED 4

October 1996

DISCLAIMER NOTICE



**THIS DOCUMENT IS BEST
QUALITY AVAILABLE. THE
COPY FURNISHED TO DTIC
CONTAINED A SIGNIFICANT
NUMBER OF PAGES WHICH DO
NOT REPRODUCE LEGIBLY.**

REPORT DOCUMENTATION PAGE			Form Approved OMB No. 0704-018	
Public reporting burden for this collection of information is estimated to average 1 hour per response, including the time for reviewing instructions, searching existing data sources, gathering and maintaining the data needed, and completing and reviewing the collection of information. Send comments regarding this burden estimate or any other aspect of this collection information, including suggestions for reducing this burden, to Washington Headquarters Services, Directorate for Information and Reports, 1215 Jefferson Davis Highway, Suite 1204, Arlington, VA 22202-4302, and to the Office of Management and Budget, Paperwork Reduction Project (0704-0188), Washington, DC 20503.				
1. AGENCY USE ONLY (Leave blank)		2. REPORT DATE October 1996		3. REPORT TYPE AND DATES COVERED May 1995 to Feb 1996
4. TITLE AND SUBTITLE U.S. Navy Amphibious Cargo Beaching Lighter Module Design and Development - Final Report			5. FUNDING NUMBERS PE - 62233N Contract No. N47408-95-C-0201	
6. AUTHOR(S) M.J. Plackett & Associates Gig Harbor, WA				
7. PERFORMING ORGANIZATION NAME(S) AND ADDRESS(ES) Naval Facilities Engineering Service Center Port Hueneme CA 93043-4370			8. PERFORMING ORGANIZATION REPORT NUMBER CR 96.012	
9. SPONSORING/MONITORING AGENCY NAME(S) AND ADDRESSES Office of Naval Research Arlington VA 22217-5000			10. SPONSORING/MONITORING AGENCY REPORT NUMBER	
11. SUPPLEMENTARY NOTES				
12a. DISTRIBUTION/AVAILABILITY STATEMENT Approved for public release; distribution is unlimited.			12b. DISTRIBUTION CODE	
13. ABSTRACT (Maximum 200 words) This report documents a conceptual design effort for the Amphibious Cargo Beaching (ACB) Lighter, a modular barge system which is being developed to replace the Navy Lighter (NL) pontoon causeway system. The ACB Lighter will be rapidly deployed from an auxiliary crane ship and be assembled and operated in sea conditions through sea state three to support Joint Logistics Over the Shore (JLOTS) operations. The focus of this study was on the overall system design requirements, operational goals, objectives and constraining factors. The many constraints upon the size, weight and structural design of modular platforms must be addressed at the outset of design. This report discusses these problems and identifies the primary design criteria. Conceptual designs of a monolithic module as well as an intermodal module concept, the Tri-Module, are presented. These concepts are evaluated against manufacturing cost, maintainability, reliability and interoperability considerations. Continued development of the Tri-Module concept has been recommended.				
14. SUBJECT TERMS Amphibious Cargo Beaching (ACB) Lighter, Navy Lighter (NL), Joint Logistics Over the Shore (JLOTS), pontoons, barges, causeways, lighters			15. NUMBER OF PAGES 161	
			16. PRICE CODE	
17. SECURITY CLASSIFICATION OF REPORT Unclassified	18. SECURITY CLASSIFICATION OF THIS PAGE Unclassified	19. SECURITY CLASSIFICATION OF ABSTRACT Unclassified	20. LIMITATION OF ABSTRACT UL	

SUMMARY

The design concept of an Amphibious Cargo Beaching (ACB) Lighter to support Joint-Logistics-Over-The-Shore (JLOTS) operations is discussed relative to the design considerations and constraints of a modular lighterage system that is required to be rapidly deployed by an auxiliary crane ship and be assembled and operated in elevated sea state conditions up to SS3. To achieve this, it is required to have significantly higher freeboard than the current Navy and Army lighterage to improve its seakeeping capability and prevent waves from washing over its deck. The ACB Lighter module must be capable of being assembled into platforms of a variety of configurations using tugs and vessels in the current U. S. Navy and Army military sealift inventory. These platforms include a modular causeway, a lighter capable of being beached to unload cargo and a RO/RO discharge platform that can be moored to various Military Sealift Command (MSC) ships. The ACB Lighter must also be capable of interfacing with current amphibious lighterage including the Navy NL and the Army's Modular Causeway Section (MCS) systems.

The focus of this study is on the overall system design requirements, operational goals, objectives and constraining factors. The study analyzes the premise for the baseline approach which is a monolithic structure approximately 40-feet long by 24-feet wide by 8-feet high that can be stowed in or on a container ship using the method now used for Seasheds. An important design constraint is for the overall weight of the ACB Lighter to be under 30 long tons, commensurate with the limitations of ISO container handling equipment. The need to assemble the ACB Lighter under elevated sea state conditions dictates special attention be paid to the module-to-module interconnect devices. These have not yet been defined as they are the subject of a separate parallel investigation being conducted by NFESC. A preliminary structural and weight analysis of the ACB Lighter module indicates that to meet the weight goal an expensive structural approach, involving the use of lightweight composites and/or aluminum deck surfaces, would be necessary. The study addresses important manufacturing cost, maintainability, reliability and interoperability considerations along with rationale for the selection of various design criteria and suggests an alternative design concept called the Tri-Module.

A Tri-Module concept is presented along with a preliminary structural analysis, weight estimate, and Rough Order of Magnitude (ROM) cost estimate. The Tri-Module concept shows promise and should be further explored particularly with reference to inter modal transport and manufacturing considerations. Also, the ACB Lighter interface with existing Navy and Army lighterage and the beach requires that special ramps be developed. Further studies of these issues and the expansion of the Tri-Module ACB Lighter concept are recommended.

CONTENTS

Summary	i.
1. Introduction	1
2. ACB Lighter - Design Constraints, Goals and Objectives	1
2.1 Fabrication and Delivery	3
2.2 Storage Dockside	4
2.3 Loading Aboard Containership	4
2.4 Shipping	4
2.5 Deployment From Container Ship	5
2.6 Module-to-Module Interconnect	6
2.7 Modular Platform Assembled	6
2.8 Mission Operations	6
2.9 Module Disconnect	7
2.10 Recovery to Containership	8
2.11 Unloading to Dockside, Inspection and Repair and Storage	8
3. Module Concepts	9
3.1 Current Lighterage Systems and Operational Experience	9
3.2 ACB Lighter Module - Design Rationale	11
3.3 Weight Analysis and Structural Design Considerations	14
3.4 ACB Lighter - Module Design Approach	20
3.5 ACB Lighter Modules - Over 30 long tons	22
3.6 Tri-Module Structural Analysis and Weight Analysis	26
4. Manufacturing Assessment	26
4.1 General Fabrication Considerations	27
4.2 Survey of Manufacturers and Fabricators	28
4.3 Cost Analysis	29
5. Comparison of Monolithic and Tri-Module concepts	31
5.1 Tri-Module Fabrication and Delivery	31
5.2 Tri-Module Storage Dockside or Inland	32
5.3 Loading Tri-Module ACB Lighter Aboard Containerships and Shipping	32
5.4 Tri-Module Recovery to Containership and/or Inter-Modal Transportation	33
5.5 Tri-Modual Unloading to Dockside, Inspection, Repair and Storage	34

CONTENTS (Continued)

- 6. Conclusions and Recommendations 34
 - 6.1 Monolithic Module ACB Lighter Design Conclusions and Recommendations 34
 - 6.2 Tri-Module ACB Lighter Design Conclusions and Recommendations 35
 - 6.3 General Conclusions and Recommendations 36
- 7. References 37

FIGURES

- 2-1 The Total System Utilization Cycle of the ACB Lighterage Platforms 3
- 2-2 Plan View of Conceptual ACB Lighter Showing ISO Fitting Locations 5
- 3-1 Two Beach-End Ramps can be Coupled Together for Handling and Stowage in the Same Manner as a 40-foot ISO Container 11
- 3-2 ACB Lighter Connector Spheres Must Be Aligned With NL/MCS Flexor Receptacles 13
- 3-3 Narrower Beam, Shallower Depth and Thinner Plating Lead to a Lighter Weight Structure 16
- 3-4 ACB Lighter deck layout with 32 x 60 - inch frame spacing 17
- 3-5 ACB Lighter deck layout with 48 x 96 - inch frame spacing 18
- 3-6. Deck Panels May be Assembled from Interlocking Extruded Sections 19
- 3-7 ACB Lighter Module Conceptual Design 20
- 3-8 Initial ACB Lighter Tri-Module Concept 23
- 3-9 Tri-Module Removable Corner Fittings include ISO corners 24
- 3-10 Tri-Module Fender Corner Fitting Replaces ISO Corner Fitting When Deployed 24
- 3-11 ACB Lighter Tri-Module Concept With Simplified Center Unit and Interchangeable Port and Starboard Units Housing Module-to-Module Connectors 25

TABLES

3-1	Comparison of Major Features of Lighterage Systems	10
3-2	Weight Summary of Module Configurations	18
4-1	Cost Analysis	31

APPENDICES

- A Structural Analysis - Monolithic Module Design
- B Weight Estimates - Monolithic and Tri-Module Design
- C Structural Analysis & Weight Estimate - Tri-Module Design
- D Manufacturers Contacted

1. INTRODUCTION

This Final Report presents the results of design studies related to the development of an Amphibious Cargo Beaching (ACB) Lighter conducted by M. J. Plackett & Associates (MJP&A) under Contract Number N47408-95-C-0201 for the Naval Facilities Engineering Service Center (NFESC), Port Hueneme, California from May through December 1995. The need to develop an improved modular lighterage platform capable of being safely assembled and operated in elevated sea state conditions has been recognized for many years. Current modular platforms such as the U.S. Navy's Lighterage (NL) and U.S. Army's Modular Causeway Section (MCS) have very limited performance capabilities in elevated sea state conditions and cannot be easily assembled in the field of operations. Major difficulties and delays in delivering Logistics-Over-The-Shore (LOTS) occur when transferring cargo from ships at sea using current lighterage platforms when high winds, waves or other extreme environmental conditions occur. Among the greatest difficulties are the effects of wave action. Wave action makes it very difficult to unload and assemble modular lighterage. Even when empty, freeboard is only about three feet and when loaded, is less than two feet. Waves often sweep across the decks of current lighterage. Waves or surf near the beach make it difficult to beach an NL or MCS ferry. They also make it difficult to install or operate floating causeways or to install an elevated causeway that allows the use of deeper draft landing craft. Using larger modules that can be assembled at sea to form more seaworthy lighterage is an obvious approach. However, there are many constraints upon the size, weight and structural design of such modular platforms that must be addressed at the outset of design. This report discusses these problems and identifies the primary design criteria that have been derived from these studies along with conceptual designs of ACB Lighter modules. A manufacturing assessment is also included related to the conceptual designs suggested.

2. ACB LIGHTER - DESIGN CONSTRAINTS, GOALS AND OBJECTIVES

The basic premise for the design of the ACB Lighter is that current lighterage available to the U.S. Navy and U. S. Army for LOTS missions cannot meet rapid logistics deployment requirements when elevated sea states occur. A system is required that can be transported by current military and/or commercial containerships to the field of operations and be deployed and assembled in elevated sea state conditions up to and including sea state three. The ACB Lighter concept calls for the largest possible modular unit that can be handled by conventional ISO container lifting and handling facilities. Larger and deeper units offer significant advantages for seakeeping and simplify the handling, storage and ship transportation capability (i.e. by directly meeting the ISO container handling requirement). The development of an ACB Lighter module conceptual design for this program is constrained by several key factors. These are briefly identified below:

- a) To stay within the lifting capacity of current ship cranes and other ISO container handling equipment the total weight of an ACB Lighter module with all fixtures and fittings installed must not exceed 30 long tons.
- b) The height of the module should be of the order of seven to eight feet to gain the maximum freeboard and to minimize the occurrence of waves sweeping the decks when operating in elevated sea states.
- c) The length of the module shall be 40 feet and the width shall be 24 feet so that it will fit in triple adjacent container cells and deck spaces of container ships.
- d) The connector fittings for both the rigid and flexible connectors should be removable from the primary structure as complete units such that they could be replaced with an alternate system.
- e) The module deck loading requirement will be based upon the tire contact of a RTCH carrying a 50,000 lb payload when the total weight, mainly distributed between the front wheels, is 150,000 lb. That is, 75,000 lb per tire.
- f) Each module shall be compartmented with appropriate bulkheads to meet basic damage stability criteria with one compartment damaged.
- g) The modules shall be designed with ISO fittings top and bottom placed about the center of the unit such that it conforms to the lifting and stacking capabilities of a standard 40 ft x 8 ft x 8 ft container.
- h) The ACB Lighter, formed when several modules are connected together, must be provided with the means to directly interface with current NLS and MCS'. This includes ramps to allow RO/RO transition between the different deck levels. This may require special adapter units that would provide direct connections with current Flexor receivers.
- i) A special ACB Lighter beach end ramp is required that would provide unloading/loading capabilities for vehicles including long units such as the 140-ton mobile crane.

A review of the above requirements and constraints reveals several areas of concern related to staying within the weight limitations to meet the ISO container handling specifications while concurrently meeting the structural and operational requirements. These areas are addressed under Section 3.3 of this report.

Lessons learned from past experience with existing modular lighterage systems used by both the U.S. Navy and U.S. Army highlight the need to develop a total system design approach for the ship-to-shore logistics transfer to be successful. Figure 2-1 presents an illustration of the 'Total System Utilization Cycle' of the ACB Lighter. The sequential order of the diagram of Figure 2-1 is used as a guide. It is emphasized that the requirements are not prioritized but are merely stated as a guide to identify areas that must be addressed.

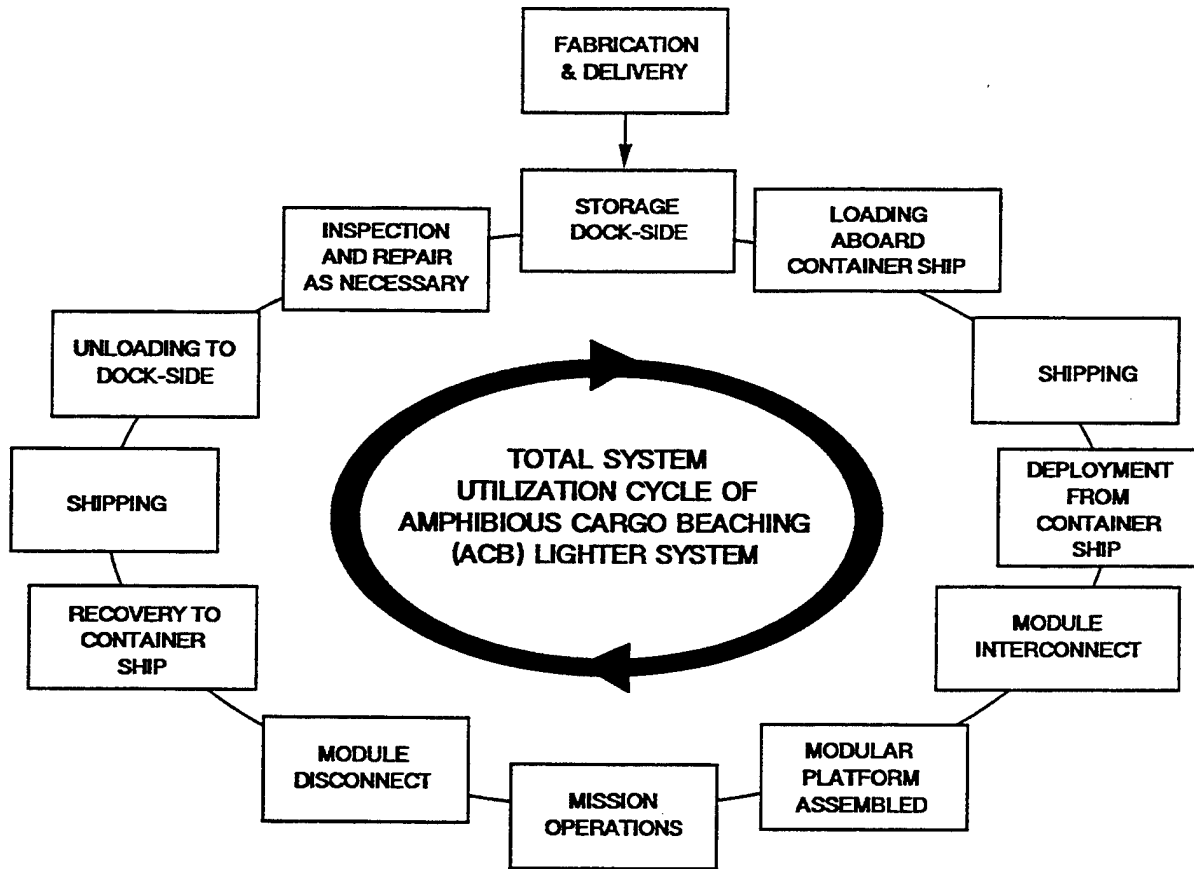

Figure 2-1. The Total System Utilization Cycle of the ACB Lighterage Platforms

Each facet of the utilization cycle requires specific analysis as it relates to the design and development of the ACB Lighter concept. For example, shipping requirements (i.e. containerships) impose specific constraints on both the physical and structural design of the modules. Similarly, ship loading and off-loading equipment requires that the modules have precisely located ISO-compatible fittings and be within the weight limitations of the designated lifting facilities. With regard to the mission and operational requirements, there are both primary and secondary considerations. Primary mission considerations involves analysis of the operational envelope, propulsion methods and deck loading profiles while secondary considerations require analysis of the cargo tie-down locations and strength, non-slip deck coatings to enhance personnel safety and on-board locker storage facilities etc. The primary considerations related to the ACB Lighter life cycle support are briefly addressed in the following paragraphs.

2.1 Fabrication and Delivery

Logically, it will be required that completed modules will be delivered for storage near a container port facility for loading on container ships when needed. If the module

fabricator is located remote from the designated storage facility, transportation of complete modules will be a problem. One approach would be to fabricate the modules as single structures at a shore-side facility, launch them and tow them directly to a designated Government unloading/storage facilities or to a container ship facility for loading directly aboard containerhips for subsequent delivery to a designated Government unloading/storage facilities. An alternative would be to design the modules so that they can be built in smaller sections (e.g. three longitudinal sections approximately 40-ft x 8-ft x 8-ft) that will be readily transportable by road or rail and then to complete their assembly at, or close to, the storage site.

2.2 Storage Dockside

The ACB Lighter may spend a large percentage of its life stored (stacked) on dry land local to a container ship loading and off-loading facility. Corrosion resistance and preventive maintenance must be considered relative to long-term storage dockside to ensure that the modules are kept in a state of operational readiness. The storage methods must therefore reflect the need for inspection access and the ability to perform any periodic maintenance tasks that may be called for.

2.3 Loading Aboard Containership

The design of the ACB Lighter will be based upon total containership compatibility including the ISO container loading/off-loading dockside and ship facilities. This requirement has a significant impact on the structural design of the modules which must be adequate to meet load transfer from the structure through the ISO fittings during hoisting and intermediate transport between storage and the container ship. The proposed study will look at the basic structural requirements of the modules to be container facility compatible. The problems associated with loading ACB Lighter modules aboard container ships will be similar to loading U.S. Navy's Seasheds. Like the SEASHED, the overall size of the modules precludes the use of conventional ISO container land transport equipment such as forklifts to move the modules from their storage areas to the port container loading facilities. Consideration must therefore be given to providing methods of lifting/transporting the modules to and from their storage areas to facilitate rapid deployment. This may involve the development of special rigs or pallets to transport the modules overland to and from the loading dock.

2.4 Shipping

Once loaded aboard a containership, ACB Lighter modules will be stacked in a similar manner to Seashed modules. In this configuration the load transfer from one module to the next and through to the ship structure must be through the ISO fittings located at either end of the modules as shown in Figure 2-2.

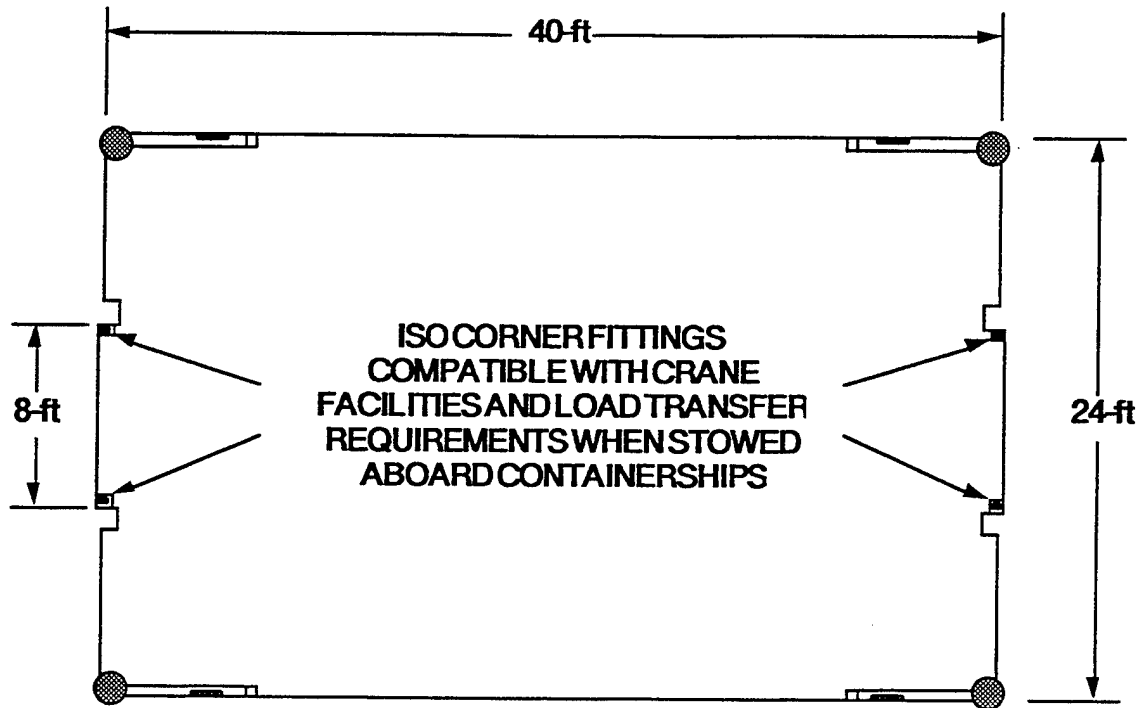

Figure 2-2. Plan View of Conceptual ACB Lighter Showing ISO Fitting Locations

This loading requirement is an important factor that must be taken into consideration relative to the structural design of the modules to ensure that adequate load transfer between stacked modules and the ship structure is maintained.

2.5 Deployment From Container Ship

The ability to load and unload modules from sealift ships and to safely assemble them into basic platforms in a seaway in the minimum of time are the keys to success of the concept. If the modules cannot be unloaded and assembled then they cannot perform any useful tasks. The ACB Lighter concept will enable the U.S. Navy to deploy modular sections rapidly from container ships using existing assets. Unlike the ISOLOG modules that must either be assembled on-deck before deploying overboard or assembled alongside to form a section, ACB Lighter modules will be designed so that they may be lifted in one operation from the hold into the sea to be assembled alongside or cast off to an awaiting tender to be taken away for assembly or to be moored. The overall weight and balance of the ACB Lighter modules must be carefully monitored and controlled during the manufacturing process to ensure that they remain within the design tolerances.

2.6 Module-to-Module Interconnect

Connection concepts for Ocean Barge Modules were studied in depth during 1993 and 1994 under a series of studies conducted under contract for, and in-house by Code L65 of the Naval Civil Engineering Laboratory (NCEL), Port Hueneme, California. Data generated during these studies has been made available to potential contractors and has been used as a starting point for this program study. Separate studies related to the connection of ACB Lighter modules in a sea state have been conducted by NFESC including a series of model tests in a wave tank to demonstrate various connectors and locking mechanisms. The emphasis for this study relating to the interconnect process is directed towards the physical components of the interconnect mechanisms in terms of materials and fabrication requirements. The structural requirements of various interconnect concepts are evaluated as they relate to support structure and stress concentrations within the body of the ACB Lighter modules.

A key feature of the module-to-module interconnect process is the ability to provide adequate fendering between modules. Several fender concepts have been proposed in the course of previous studies including both passive and active (e.g. inflated) systems. Fender types, materials and attachment concepts are also addressed as part of this study.

2.7 Modular Platform Assembled

When assembled, the ACB Lighter may be in any one of several mission configurations. For example the ACB Lighter may be configured as a ferry or a floating causeway to transfer material to a beachhead or it may be used as an interface platform to enable vehicles to be driven off RO/RO ships. The stability and safety of the various ACB Lighter modular platform configurations under various damage situations (e.g. one or more modules flooded or partially flooded) must be evaluated relative to the requirements for specific watertight compartments in the individual modules.

Each platform configuration may require special ancillary features to be added. A guard rail system that can be quickly erected around the periphery of a given platform configuration would be an important feature to enhance personnel safety. This would require special fittings be made available in the deck. Storage of the safety guard rail system on the ACB Lighter must also be addressed. Different platform configurations have varying impacts on the ACB Lighter design requirements.

2.8 Mission Operations

Optimization of a particular cargo throughput operation will be dependent upon many factors including payload type, ship-to-shore distance, weather conditions and availability of other equipment and personnel. Types and weights of payloads to be supported, such as 20-foot MILVANs as opposed to 40-foot containers, heavy vehicles

or low density payloads will dictate platform configuration. For instance, to use existing equipment, such as the Rough Terrain Container Handler (RTCH), to unload 40-foot containers at the beach, it will be advantageous to have a double-wide configuration so that containers can be loaded athwart ships. Different payloads will also require different tie-down arrangements.

Providing an array of "cloverleaf" tie-down anchorage points is the most common approach but other systems such as a universal cargo nets are possibilities. However, even cargo nets must be attached to something. 'Cloverleaves' have been incorporated in structures, such as early ISOLOGs, but if built-in flush, they fill with water and unless fitted with drains will eventually rust through. If built above deck so that they can be made to drain easily, they form obstructions. Using quarter-turn tubes along the edges of modules provides versatility as different types of fittings including cloverleaves and D-rings can readily be installed. A limitation is that if the anchorages are used for say deck rails for added safety when operating in a seaway, they cannot be used to secure the cargo. A fitting that combines a deck stanchion with a tie-down may be possible. A disadvantage to quarter-turn tube anchorages is that there will always be a temptation to use fittings as mooring bits which can be dangerous as the bolt-on attachments are of limited strength. The tubes themselves have considerable strength and can be used without fittings to attach lines such as those commonly used to attach fenders, but are not very suitable for attaching larger lines.

The best solution will be to incorporate strong mooring/towing bits into the structure, provide permanent, flush but drained tie-downs close to the perimeter of each module and provide special drained sockets for deck stanchions and safety rails.

Having established general platform beam and length requirements, consideration will be given to the need to employ rigid or flexible connectors. For platforms that are to be self-propelled or towed, special hull shaping features such as raked bows and stern will be required. Incorporating raked ends will have an impact on the transport configuration of the modules as a raked end would not be compatible with storage in ships container cells. Some means of converting from a raked end to a rectangular end is required.

2.9 Module Disconnect

When the mission is completed the ACB Lighter will be broken down into basic modules for recovery and shipping. The process of uncoupling the ACB Lighter modules must also be addressed with regard to the procedures and requirements for logistic support equipment (e.g. warping tugs, temporary mooring facilities etc.) and personnel requirements. Once disconnected, individual modules must be taken under control and either moored or be taken under tow for eventual recovery.

2.10 Recovery to Containership

Recovery of ACB Lighter modules at sea via crane to a containership presents a broad array of potential problems not the least of which is the relative motions of the modules adjacent to the ship and the difficulty of attaching the ISO-compatible hoisting mechanisms. If any modules have been damaged and/or are partially flooded, it may be necessary to provide means of de-watering them before they can be lifted. Damage may have to be repaired (at least temporarily) before modules can be lifted particularly if the structural integrity of any lift fitting has been compromised. It may be expedient to include in the design provision for a secondary set of lifting fixtures (such as the central lift rings fitted to ISOLOG modules). Flooded compartments may be self draining when partially lifted. Because damage is a distinct possibility, an Operational Procedure that includes checks and/or inspection prior to recovery operations will be essential to safe recovery. A temporary repair kit may also be a valuable item to be considered as part of the overall logistic support process.

2.11 Unloading to Dockside, Inspection and Repair and Storage

Unloading will require the use of container handling equipment as for loading. Special provisions may have to be made if lift fittings have been damaged. Post mission inspection and repair will most conveniently be conducted at a site close to the unloading facility. Inspection should be preceded by a thorough cleaning. Repair requirements should be carefully identified. Some damage may have already been identified and documented prior to shipment. Temporary repairs may also have been made. The ACB Lighter module design should allow for repair without the need for extensive tooling, fixtures or equipment, but a basic module checking facility that enables a module to be lifted and rotated will be desirable.

Structural repair may cause distortion which will require that key interface dimensions, including ISO corner dimensions, be checked and adjusted if necessary before repairs are completed. NL s are repaired by Construction Battalion (CB) crews. They have the skills and equipment to weld mild steel. Since NLs are permanently assembled, any distortions due to repair are of no consequence whereas if MCS modules are repaired, distortions may prevent the locking system from being operated and sections from being disassembled or assembled.

The design of the ACB as a series of three discreet watertight modules (Tri-Module) that can be separated when damaged beyond reasonable repair and replaced with new modules is a concept that has been investigated as part of these design studies. The concept includes removable corner struts that incorporate ISO fittings. It has been assumed that the connector system will be designed as separable units so that if they are damaged they will be removed and replaced as complete units. This has an associated weight penalty but with the Tri-Module concept this could be acceptable.

As a final check, a leak test will be made by pressurizing the module and brushing all joints with a soap solution. Detailed repair and preventative maintenance procedures will also need to be prepared that will include such items as repainting and interlock mechanism greasing

Once cleaned, inspected, repaired and repainted the modules should be returned to a land-based facility for long term storage. In-storage preventative maintenance procedures should then be continued as previously described.

3. MODULE CONCEPTS

This section describes MJP&A's ACB Lighter module concepts and the basic design requirements, considerations and constraints. A discussion of the current lighterage available for the LOTS mission and the rationale for the ACB lighter module design approaches are covered in some depth under MJP&A's report entitled Ocean Module Barge Connection Systems Development (Reference 1). The background is briefly revisited here prior to describing the design approach.

3.1 Current Lighterage Systems and Operational Experience

There are two primary lighterage systems used for LOTS operations. These are the U.S. Navy Lighter (NL) and the U.S. Army's Modular Causeway Sections (MCS) System. The U.S. Navy's long established Lighter system is based upon a number of sections that are pre-assembled from 5-foot by 5-foot by 7-foot welded steel cans. A causeway section has cans arranged in three rows giving a beam of 21 feet, 3 inches. Special angled cans are fitted at each end to form a raked bow and stern. Special tension/compression members, called Flexors, and shear connectors are used to join sections together. The sections can be carried as side loads on specially modified ships, such as Landing Ship, Tank (LST) or as deck cargo if there is space to fit their approximately 90-foot length. The significant number of LSTs that were available earlier are rapidly dwindling as they are now obsolete and have nearly all been decommissioned. With the aid of large cranes they can be unloaded directly into the sea and put into service immediately. An advantage of the Navy Lighter (NL) is that they are delivered as a self-contained unit to the field of operations and once launched, are ready for operations. However, a major disadvantage is the size and weight of the Navy Lighter (NL) which require transport ships that are outfitted with special storage and handling facilities dedicated to securing them during ocean transit and deploying and recovering them in the field of operations. Also, when loaded the Navy Lighter (NL) has freeboard of less than two feet allowing even moderate height waves to sweep across the deck.

The U.S. Army's MCS system is based upon 40-foot long by 8-foot wide by 4.5-foot deep modules that are ISO-compatible and meet all container handling restrictions and

limitations. They have to be connected together, either on-deck or alongside in almost calm water to form causeway sections. Two nominally 20-foot long end rakes are usually combined with each 40-foot rectangular module to form an 80-foot long string. These two end rakes are connected nose-to-nose on top of the 40-foot module to form an ISOPAK which is also ISO-container compatible. Three strings connected side-to-side form an 80-foot long by 24-foot wide by 4.5-foot deep causeway section. The end rakes have Flexors and shear connections, of the same design as the Navy Lighter (NL), incorporated in their structure so that they can be connected directly with Navy Lighter (NL) pontoons. A major advantage of the MCS system is its compatibility with ISO container ships and handling facilities. The MCS sections can be shipped on any military or commercial containership and be deployed using conventional container handling equipment. However, there are two significant weaknesses of the system. The first is the difficulty in connecting the modules and the lengthy assembly time required when handled on the deck of a ship. The MCS modules can more easily and quickly be assembled while floating but only in almost calm conditions. The second weakness is the low freeboard when loaded which, like the Navy Lighter (NL), is less than two feet. The major features of the current systems and the desired features of the ACB Lighter are compared in Table 3-1 below.

TABLE 3-1. Comparison of Major Features of Lighterage Systems

Characteristic	NAVY LIGHTER (NL)	MCS	ACB
Length, feet	90	80 (20+40+20)	120 (40+40+40)
Beam, feet	21.3	24 (8+8+8)	24
Depth, feet	5	4.5	7 - 8
Weight, long tons	70	66 (22+22+22)	90 (30+30+30)
Fits in ISO container cells	NO	YES	YES (Triple wide only)
Lift as a container	NO	YES	YES*
Assemble in 3-foot waves	No assembly needed	NO	YES (Primary design objective)
Operation in greater than 3-foot waves	POOR (Waves break over deck)	POOR (Waves break over deck)	GOOD (Greater freeboard keeps decks drier)
Manageability and Maintainability	VERY POOR (Difficult to handle and access)	GOOD (Easy to handle and access)	FAIR (Special handling, but good access)

* Providing the ACB can be built within the 30-long ton weight limit.

3.2 ACB Lighter Module - Design Rationale

It has not been the objective of this study to trade-off individual advantages and disadvantages of one system approach over another such as having large modules that do not require time consuming assembly versus the difficulty in handling, stowing, storing, and maintaining larger and heavier modules. In brief, experience has shown that Navy Lighter (NL)s are too big and the MCS' are too small. Like most systems that are heavily constrained by external factors the design approach for the ACB Lighter has to be a compromise.

The 24-foot beam of the ACB Lighter module provides a much more stable platform during assembly than the 8-foot beam of a single Army MCS ISOLOG module or string of center module with its end rakes attached.

Two ACB Lighters joined side-by-side to form a 48-foot wide lighter would provide a very stable load-carrying platform, but it is also important to have greater freeboard than that of an Navy Lighter (NL) section or an MCS. Waves sweep over the decks of Navy Lighter (NL)s and MCS' making them very dangerous for personnel. Another foot of freeboard would be an improvement, two feet would be very significant and three feet would be even more comforting. However, the greater the module height, the longer the ramp that will be needed to be able to drive vehicles from an ACB Lighter onto the beach or to either an Navy Lighter (NL) or MCS. If 10° is the maximum allowable break angle for transition of critical vehicles, and 40 feet is the longest ramp that could be made ISO-compatible, then, the maximum height would be 7 feet. If 7 feet is selected as the optimum ACB Lighter module depth, a 10° angled beach ramp would be 40 feet long, and a 2-foot high transition ramp for use with Navy Lighter (NL) or MCS would need to be at least 11-1/2 feet long. Two beach end ramps could be fastened together with standard twist-lock connectors then handled and stowed as a single 40-foot module fitted with standard ISO corner fittings. The ramps could be just 8 feet wide so that they could be handled in coupled pairs as containers. This concept is illustrated in Figure 3-1 below.

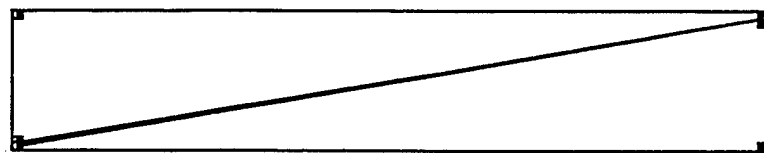

Figure 3-1 Two Beach-End Ramps can be Coupled Together for Handling and Stowage in the Same Manner as a 40-foot ISO Container

Once retrieved from their storage location, each coupled pair of beach ramps could be separated into two independent ramps by lifting the upper unit by one end and rotating it 180° . Three modules could then be joined side-by-side to form a 24-foot wide ramp.

It may be possible to incorporate ACB Lighter to NL/MCS transition ramps within the same package, but it may not be desirable as it becomes restrictive to the design and use of each of the types of ramp. The small ramps could be made just 8 feet wide and stowed on a flat-rack. Handling would not be a problem as they would be comparatively light. A lifting ring, built into their deck at their center-of-gravity would be the simplest arrangement. There would be no point in fitting ISO corner fittings as they would not be compatible except in width. Means of securing them to the decks of the Navy Lighter (NL)s or MCS' should be included in their design.

To make ACB Lighters inter-operable with Navy Lighter (NL)s or MCS', there must either be receptacles compatible with the Flexors used with those systems, or ball type fittings that might be used in pulling together and aligning ACB Lighters. The connectors must be compatible with the flared entrance to the Flexor receptacles. Flexors cannot resist the shear loads at section interfaces. Separate shear connectors are employed with Navy Lighter (NL)s and MCS'. If Flexors are used to couple ACB Lighters to Navy Lighter (NL)/MCS', then shear connectors must also be used. The shear connectors are inherently incompatible with the requirement of having nothing extending beyond the end faces of ISO-compatible modules. The ISOLOG system avoided this issue by incorporating the Flexors and shear connectors in rake ends that could be coupled end-to-end and combined with center modules to form ISOPAKs. For the ACB Lighter, it would seem that one feasible approach would be to make a ball-type coupling compatible with the Flexor receptacles. The ball can be made to resist all of the shear loads. However, the Flexor receptacles are rectangular rather than square. Therefore, only one vertical edge of each box can be used. The spacing of the ball fittings should be such that the centerlines of the balls should be offset from the edge of the boxes by an amount equal to half the height of the box. Then one ball would resist all the lateral shear load in one direction against the edge of one box and the other ball would resist all of the lateral shear load in the opposite direction against the opposite edge of the other box. Either the inner edge or the outer edge of the Flexor boxes could be selected depending upon other constraints placed on the position of the ball fittings. The height of the centerline of the ball should be made to coincide with the height of the centerline of the Flexor box when modules are floating in seawater. This concept is illustrated in Figure 3-2 below. Note that the ACB Lighter may have a deeper draft than the Navy Lighter (NL) or MCS. A ramp must be added to make up for the difference in deck heights.

The concept of ACB Lighters is based on stowage of modules in side-by-side container cells or on deck and handling them with container-handling equipment. This requires that the modules be 40 feet long with rectangular ends fitted with ISO container corner fittings. For modules to be towed effectively, it is important that the ends of a string of modules be cut back at an angle or raked. Such raked ends can either be achieved by

adding on a raked end, or taking away a portion of the module. ISOLOG modules solve the problem by joining half-length raked modules nose-to-nose and supporting them by placing them on top of a square ended center section. The complete assembly, called an ISOPAK, can be handled as an ISO container as its weight and dimensions meet all requirements. For ACB lighterage, the basic module alone will weigh at least 30 long tons.

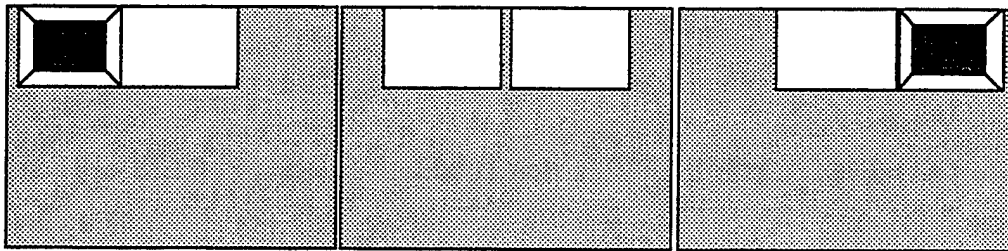

End View of Navy Lighter (NL) Showing Flexor Receptacles

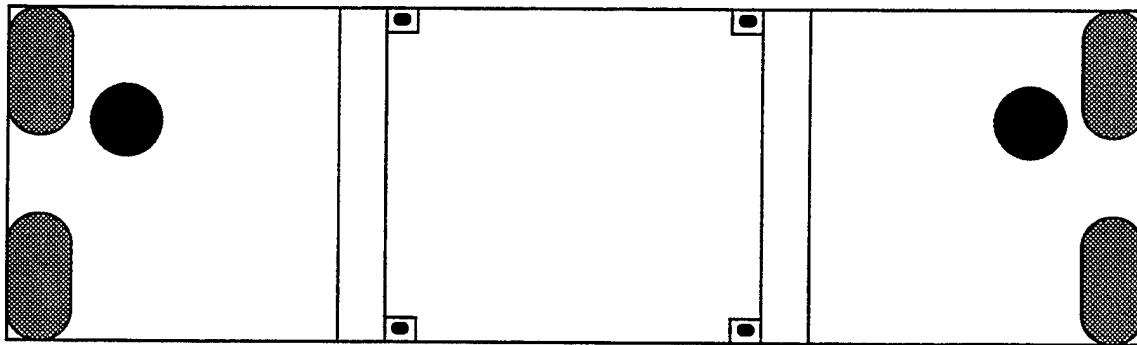

End View of ACB Showing Connectors

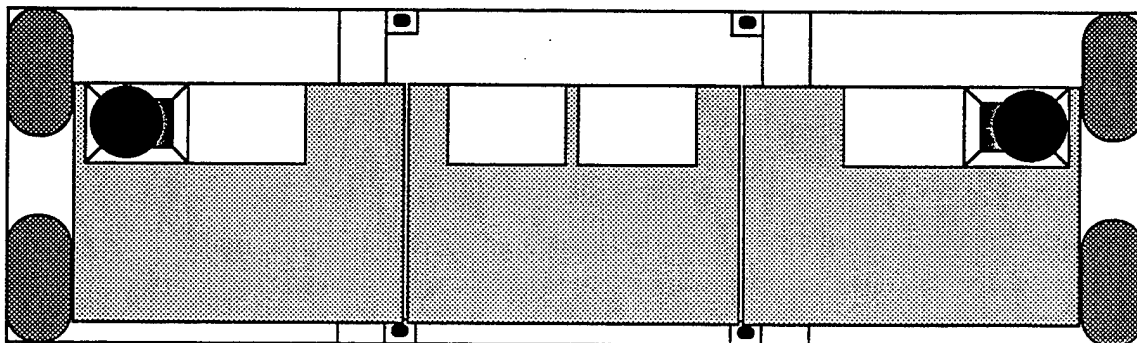

Figure 3-2. ACB Lighter Connector Can Be Made Compatible With Navy Lighter (NL) MCS Flexor Receptacles

Two half length rake end units could be fitted nose-to-nose to comply with dimensional constraints, but if they are to comply with the weight limitation, they would have to have some form of structurally adequate connector that would allow the pair of modules to be handled as a 40-foot container. When lifting the pair of rake ends by their outer corners, the middle will tend to sag. This can be avoided by fitting cables along the bottom edges to carry tension loads. The top edges must take the corresponding compressive loads. The cables must be detached to separate the pair of end rakes before they can be fitted to the center module. Because of their asymmetric shape and construction, the units will not float level and at the same draft as the center modules. The connection system must be able to tolerate this condition and provide means of bringing the modules together and applying the loads necessary to bring them into proper alignment. The connector system must also allow modules to be progressively slackened until the individual components are floating in equilibrium before they are separated. If any of the modules are damaged and compartments are even partially flooded, they will not float at normal trim or draft and means must be provided to allow them to be separated progressively.

An alternative to 20-foot rake ends is to have modules that are 40-feet long with rake ends built-in. The problem then is that they cannot be placed anywhere designed to accept loads only through ISO corner fittings. They could be stacked one upon another or upon rectangular ended ACB modules but these would have to have special load bearing supports built in that could transfer loads to their ends. The points of contact on the bottom of one rake and the top of another rake or rectangular ended module could be similar to the bottom and top of ISO corners. Then twist locks could be used to lock the modules together and prevent them from moving relative to one another. There are several potential difficulties with this method. The first is that the leading edge of the ramp is the edge most subject to wear and damage as this is the point of contact when the rake end beaches. It will be prone to snag and fill up with mud or gravel. Another potential problem is that it will be difficult to operate twist locks in such locations which are several feet in from the edges of the modules. Robishaw Engineering, Inc. built prototype end rakes of this type for their ISOLOG series of modules. The tops of the rake ends had normal ISO corners for lifting and removable struts, to carry stacking loads, that fitted into sockets and were braced against the bottom edge of the rake ends. Two rake ends will be needed per lighter. Stacking loads become more and more of a problem if sets of three ACB modules are stacked to the height limits of containership cells. The bottom unit, which must have rectangular ends, must be able to transfer the offset load of the complete stack of modules above it.

3.3 Weight Analysis and Structural Design Considerations

A major constraint to developing larger modules for the ACB Lighter is that their weight must not exceed 30 long tons (67,200 pounds) as most components and equipment

associated with ISO containers are limited to that value. If the module weight exceeds 30 long tons then the following applies:

- a) The modules should not be fitted with ISO corners because the unit exceeds the safe working loads of the handling equipment.
- b) If the modules weigh more than 30 LT each they will exceed the safe working limits of cables, corner twist-locks, and the corners themselves.
- c) If the modules exceed the 30 long ton limit, special lifting equipment must be provided which would increase the costs and limit the capabilities of the system dramatically. For example, a module in excess of 30 LT would require two T-ACS cranes on one pedestal to be paired, that is, work in parallel with special slings and fittings attached directly to the combined crane hook.
- d) ISO Container handling equipment at bases, ports or other facilities could not be used.

This is not to say that a large module fitted with two sets of ISO corners could not be lifted by utilizing two separate cranes or other lifting devices each fitted with ISO-compatible lifting equipment, but it is considered that this would be a very undesirable and costly design approach.

A Feasibility Design Study of an ACB Lighter was completed by The Design Branch ESC124 of NFESC. This study showed that it was feasible to construct a 40 foot long by 25 foot wide by 8 feet deep welded structure of high strength steel that would resist known deck loads and weigh less than 67,200 pounds. The estimated weight was actually 67,014 pounds. However, this estimate does not account for any form of connector system. It also does not include any allowance for lifting fittings, deck fittings, mooring or anchoring provisions or other special fittings, access hatches, storage spaces or any form of paint such as normally required for corrosion protection and non-slip deck coatings. It is estimated that approximately 15% of the 67,200 pounds or nearly 10,080 pounds will be taken up by these other needs. However, the NFESC study does provide a starting point for defining a structural approach and identifying weight components.

The structure evaluated by NFESC had four transverse bulkhead trusses with large section members reinforced with 1/2-inch plate. Top and bottom longitudinal beams were at 30-inch centers. If the structure is made a little narrower, say 24 feet, and shallower weight could be saved. A simple analysis has been made by taking the same structural design and reducing dimensions. The results are illustrated in Figure 3-3, below.

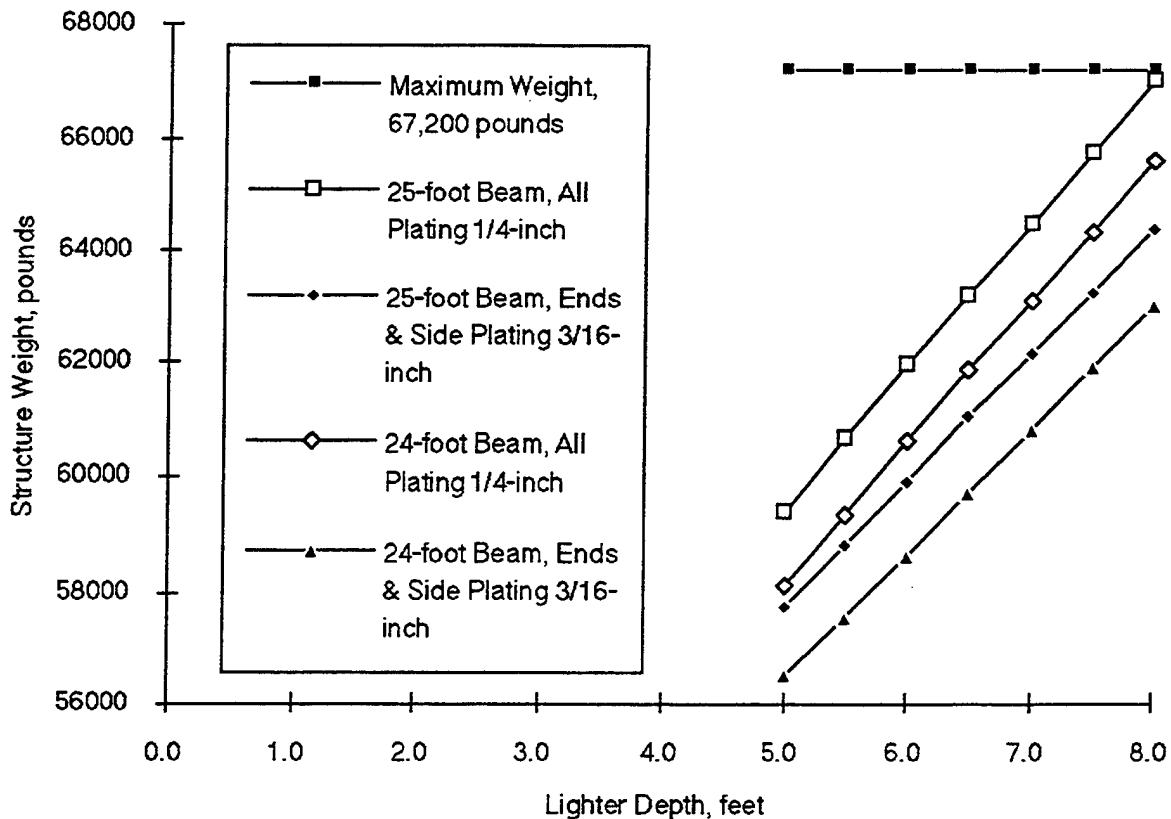

Figure 3-3 Narrower Beam, Shallower Depth and Thinner Plating Lead to a Lighter Weight Structure

The effect of reducing plating thickness on the sides and ends has also been estimated. The deck has to resist the heavy loading of Rough Terrain Container Handling (RTCH) vehicles carrying containers along the deck. When handling containers in heavy weather, corner impacts occur when landing containers on deck by crane. It is not recommended that the deck be of lighter gauge than 1/4-inch steel plate or of an aluminum or composite structure with comparable properties. Similarly, the bottom plating is subject to heavy impacts when beaching, especially if there are any unseen underwater obstructions or rocks and also when the lighter is subjected to the motion effects caused by operating in the surf zone. The sides and ends are not prone to damage by cargo handling, but are susceptible to damage when coming alongside ships, platforms, piers or other structures, especially when not properly fendered. Joining lighters together to form ferries or platforms may lead to damage if the connector system has not been designed to take up the relative motions in a controlled, progressive manner. The potential for weight saving by reducing the thickness of the side and plating from 1/4-inch to 3/16-inch is, at most, 2000 pounds.

The most obvious way to reduce weight is to design a more efficient structure. If more structural members are employed at closer spacing, they can be of lighter scantlings. Unfortunately, more structural elements and joints means greater expense in manufacture (see Manufacturing Assessment Section 4, below). A brief structural analysis has been conducted to identify the primary loading of the structure and provide sufficient data for selecting plate thickness and show the effects of alternative structural arrangements. This analysis is included as Appendix A to this report.

To gain a more detailed understanding of the weight distribution within the ACB Lighter module a preliminary weight analysis model has been developed which presents a basic breakdown of the module weight by component or group. The model is based upon a geometric assessment of the components required for various structural configurations. The selection of plate thicknesses and reinforcing member dimensions were derived from the structural analysis (see Appendix A) and a review of commonly available high-strength steel plates and extrusions. Tables were developed for module configurations with 8-foot, 7-foot and 6-foot deck heights. Two basic internal structure frame spacing configurations were evaluated. These were a nominal frame spacing of 60-inch by 32-inch (see Fig 3-4) and a 96-inch by 48-inch frame spacing (see Figure 3-5). The tables are presented as Appendix B to this report.

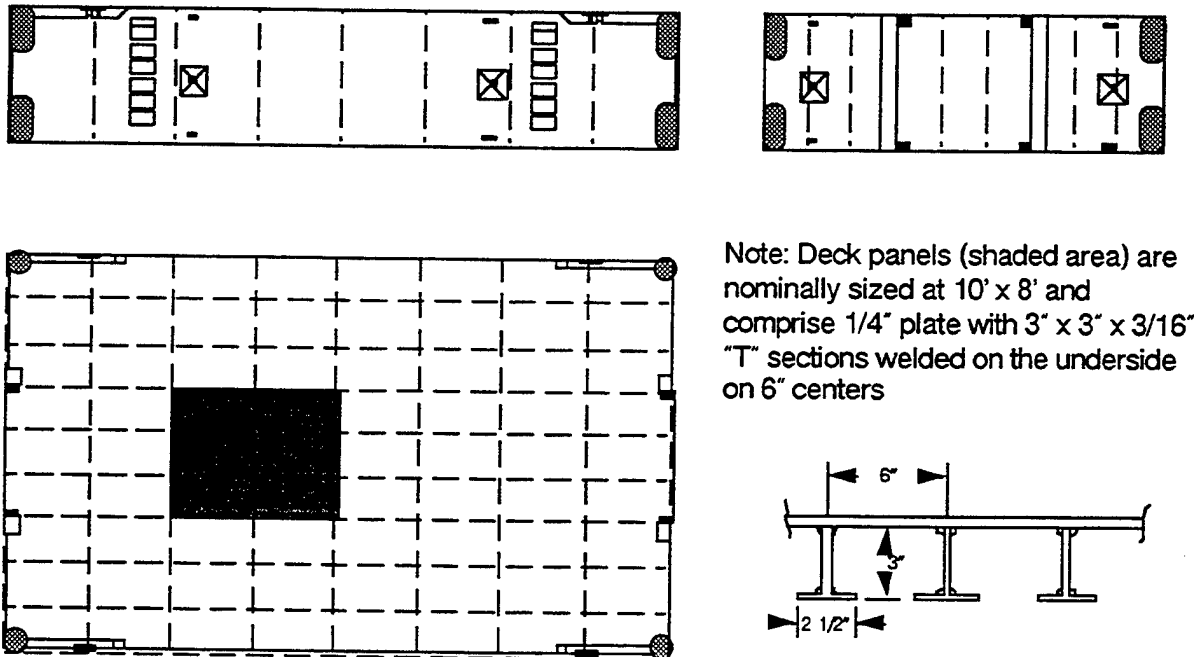

Figure 3-4. ACB Lighter deck layout with 32 x 60-inch frame spacing

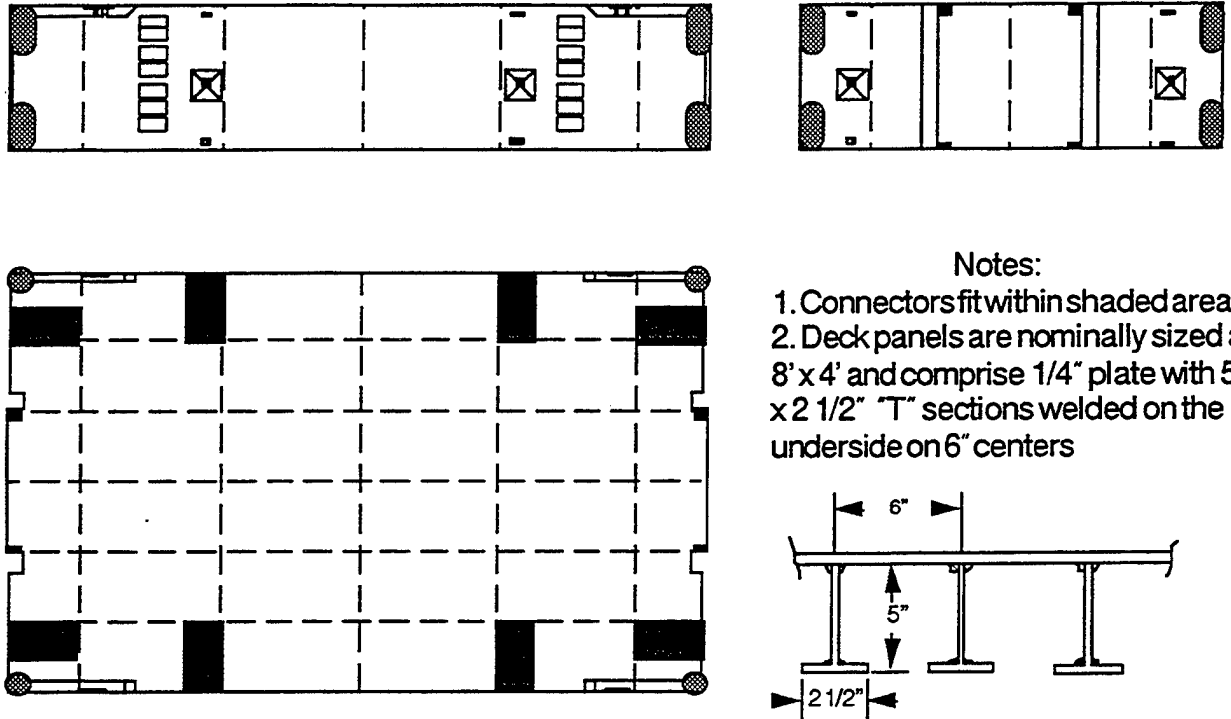

Figure 3-5. ACB Lighter deck layout with 48 x 96-inch frame spacing

A summary of the significant parameters of the various configurations studied are presented in Table 3-2 below.

Table 3-2. Weight Summary of Module Configurations

Ref. Table Number	Module Height	Watertight Bulkheads	Frame Spacing	Estimated Module Wt.
1	8 ft	Transverse	60" x 32"	34.67 LT
2	6 ft	Longitudinal	60" x 32"	31.77 LT
3	8 ft	Longitudinal	60" x 32"	35.10 LT
4	6 ft	Transverse	96" x 48"	29.35 LT
5	7 ft	Transverse	96" x 48"	31.77 LT
6	8 ft	Transverse	96" x 48"	33.25 LT

A review of the tables presented in Appendix B shows that even with minimizing plate thicknesses and reducing the interior structure to the minimum practical the overall weight of the module is unacceptable (i.e. exceeds 30 LT) for the 8 ft and 7 ft high deck models. The effect of running the watertight bulkheads transversely as opposed to

longitudinally improved the weight only marginally (ref. Tables 1 & 3). Longitudinal bulkheads would be preferred as they would minimize the free surface effects on roll stability should the hull be damaged. Roll stability would be more critical than pitch stability

Changing the frame spacing from 60-inch by 32-inch to 96-inch by 48-inch lowered the weight somewhat (ref. Tables 1 & 6) but not significantly. Progressively reducing the height of the module (ref. Tables 4, 5 & 6) was also studied and showed about a 4.5% to 7% weight reduction per foot of reduced height. The components contributing the most significant percentage of weight to the overall structure are the stiffened top and bottom decks which account for over 50% of the total weight. As discussed in the analysis (see appendix A) the deck loading of 5,000 lbs/ft² is the driving factor requiring an array of closely spaced stiffeners to resist the load. The study indicates that a more drastic reduction in the deck weight is required to bring the overall weight under the 30 LT requirement.

Fabricating the top deck panels from extruded aluminum sections could significantly reduce the weight while meeting the deck loading requirements. Two forms of interlocking sections are illustrated in Figure 3-6 below.

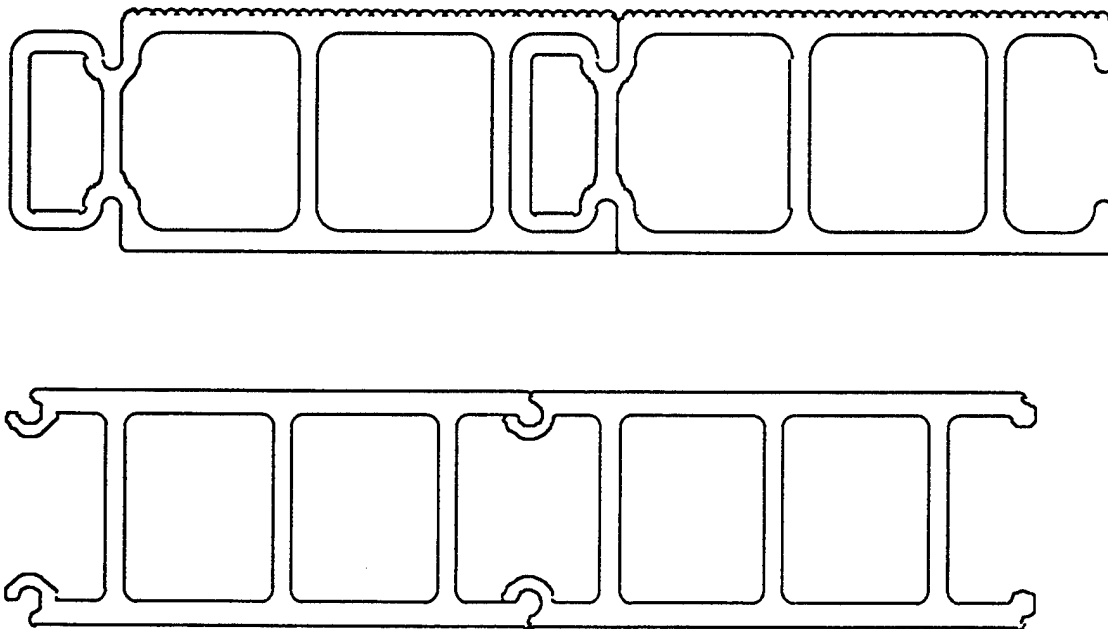

Figure 3-6. Deck Panels May be Assembled from Interlocking Extruded Sections

Extruded Aluminum sections can be interlocked together to form rectangular deck panels that would be attached to the longitudinal and transverse steel frame structure

with fasteners (see Section 3.4 below). Table 7 in Appendix B shows the weight reduction possible using aluminum top deck paneling instead of steel. With the exception of the top deck paneling the remainder of the structure would be of welded high-strength steel. This configuration shows promise of being under the weight limit of 30 LT. The approach of using extruded aluminum panels for the top deck structure is further discussed in Section 3.4 below.

3.4 ACB Lighter - Module Design Approach

The preceding paragraphs have identified the goals, objectives and constraints of the ACB Lighter and presented a design rationale. Figure 3-7 presents a conceptual design showing the key external features of the ACB Lighter module.

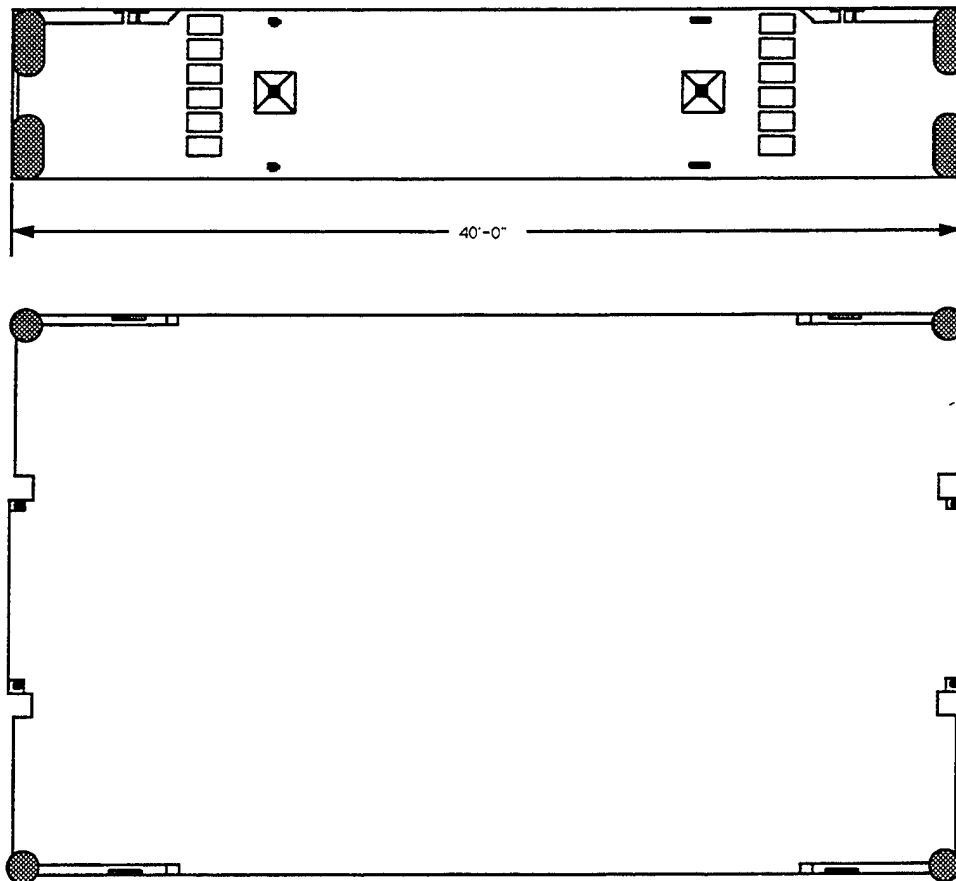

Figure 3-7. ACB Lighter Module Conceptual Design

The module connectors required for assembling modules into a platform is the subject of separate and parallel studies being conducted by NFESC. For the purposes of this conceptual design baseline a generic connector concept has been used that meets the following criteria:

- a) The connector concept is similar to systems that have been tested at model and full scale by NFESC.
- b) The connector provides a direct interface capability with the Flexor connection ports currently installed on the Navy Lighter (NL) and MCS systems.
- c) The connector system is designed to use the "Progressive Restraint" method for joining modules together in the open sea.

The ACB Lighter Module conceptual design incorporates the following features:

- 1) A 40-ft x 24-ft x 7-ft deep, steel box structure with connector fitting ports located on both ends and sides. The connector ports are universal in concept in that they allow various types of connector devices to be employed. The location of the connector ports allows direct interface with both the Navy Lighter (NL) and MCS platforms via special fittings based upon the Flexor type connector with shear resistance incorporated.
- 2) The ACB lighter is a welded, high-strength steel fabrication with provisions for a lightweight extruded aluminum panel deck structure that is attached to the internal frame supports in convenient sections. The extruded aluminum panels are interlocking and are designed for ease of removal and replacement in 8-ft x 4-ft sections. The internal structure consists of longitudinal and transverse steel frames modeled on the Warren Girder principal (see Appendix A) to minimize weight. The module is compartmented with transverse bulkheads into three watertight compartments. The total module weight is estimated at 29.39 LT (see Table 7 appendix B).
- 3) The ACB Lighter Module has ISO container lift corner fittings installed at the appropriate locations on the center section of the module on both top deck and wet deck.

The proposed design has several features that require further explanation. They are:

- **7 ft vs. 8 ft Deck Height** - Both the results of the weight analysis and consideration of the interface with the beach ramp, Navy Lighter (NL) and MCS systems suggest reducing the deck height from the 8-feet to 7-feet. Reducing the nominal module height by 12 1/2% will not reduce the sea keeping ability in the sea state 3 regime appreciably and offers the significant benefits discussed above.
- **Aluminum Top Deck Paneling vs. Steel** - The reason for selecting aluminum rather than steel for the top deck are directly related to weight reduction as demonstrated in the weights analysis (Section 3.3 above). Other types of deck structure using Glass Reinforced Plastics (GRP) composites can also be investigated. However, it is anticipated that the cost and long term durability factors will exclude these composites from consideration. Extruded aluminum decking has been used on various Navy craft including the prototype Amphibious Assault Landing Craft (AALC) JEFF(B). However, combining aluminum with steel can present significant corrosion problems due to electrolysis. These problems

can be overcome with special treatments of the aluminum and isolation of the aluminum panels from the steel structure with special sealing compounds.

3.5 ACB Lighter Modules - Over 30 long tons

During the conduct of this study it was realized that meeting the 30 LT weight limit would require a drastic revision of the design approach such as changing to an all aluminum construction or a composite structure of some sort. This approach would not be desirable for many obvious reasons including, but not limited to, high acquisition cost, operational reliability and repairability considerations. Therefore the consequences of not meeting the desired weight limit were considered.

As previously stated, the primary reason for maintaining the 30 LT weight limit was to make the ACB Lighter directly compatible with ISO container handling equipment. There are essentially three modes when the ACB Lighter requires handling as an ISO container. The first is for lifting and transporting the modules from storage to the dockside position prior to loading aboard a ship via crane. The second is the physical lifting of the modules aboard ship, which in the case of a T-ACS would entail using the onboard cranes. The third mode is the deployment and/or recovery of the modules at sea offshore.

Handling a heavy weight ACB Lighter (i.e. greater than 30 LT) aboard the T-ACS would not create a significant problem. With the two cranes on a single pedestal combined, lift capability is 60 long tons. A simple 4-part sling would be suitable for lifting modules from container cells or from on-deck locations, and would also be most convenient for retrieving modules from the water alongside. The greatest disadvantage would be that the module would not be compatible with any ISO container handling equipment. With such a large module, i.e. 40 feet x 24 feet x 8 feet, even if it were within the 30-long ton weight limit, it would not be compatible with most lifting equipment (e.g. could not be lifted by a RTCH) and would not conform to inter-modal transportation requirements.

To overcome these difficulties another ACB concept has been proposed. In this concept, the ACB Lighter module would be made up from three separate modules. Each module would be 40 feet long by 8 feet wide and 8 feet high as shown in Figure 3-8 below.

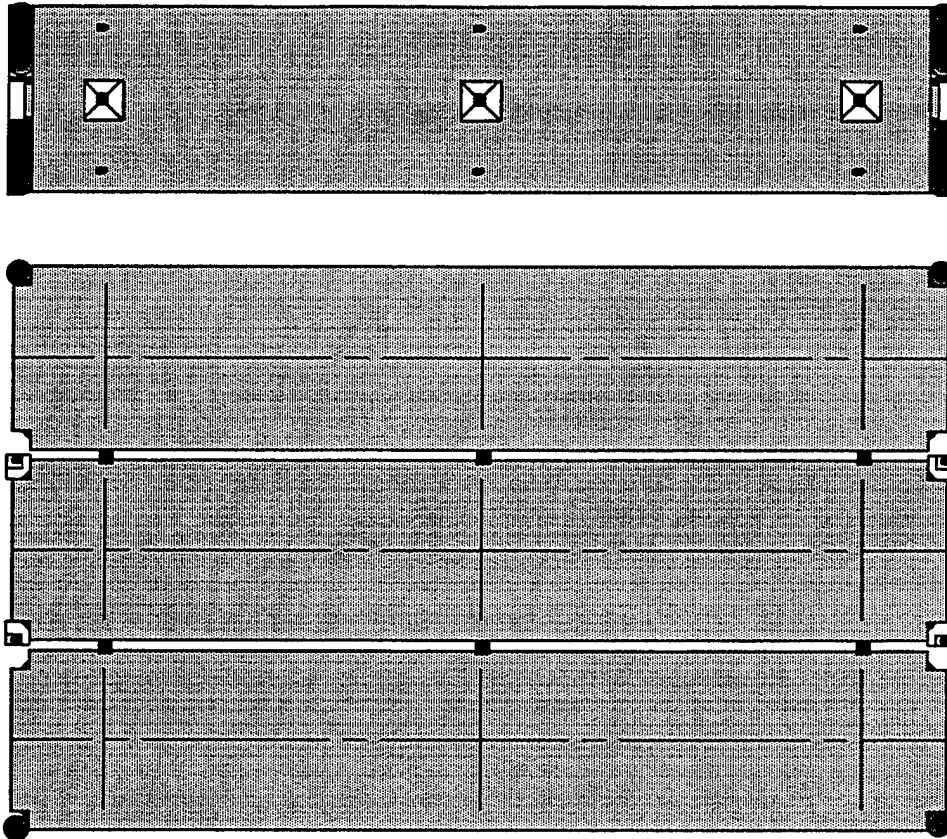

Figure 3-8. Initial ACB Lighter Tri-Module Concept

As individual 40-foot by 8-foot by 8-foot units, with corner fittings attached, they would be ISO-compatible and could be handled and transported as containers. This includes being handled by standard container handling equipment such as the RTCH. When connected together dockside to form a Tri-Module, the ISO corners would be retained on center module, which would react stacking loads. The inner ISO corners of the outer modules would be removed, see Figure 3-9, to allow clearance for the container guides in adjacent container cells and the outer ISO corner units of the outer modules would be replaced with fenders as in Figure 3-10. The Tri-Module would then be lifted aboard using a special lifting harness attached to designated deck fittings and stowed using the T-ACS crane. Alternatively, equivalent dockside cranes could be employed to load Tri-Modules on other containerships.

Initially it was thought that the three modules could be identical and each be capable of accepting ISO corner fittings or fenders in their four corners. Upon further consideration, it is now thought that outboard modules only would incorporate the connector assemblies and be attached to a simpler center module. The center module can incorporate permanent ISO corners and would carry all the stacking loads when the Tri-Modules are stowed in container cells or on deck. The outboard modules would still

have removable corner fittings and be able to accept fenders in their outboard corners. This concept is shown in Figure 3-11, below.

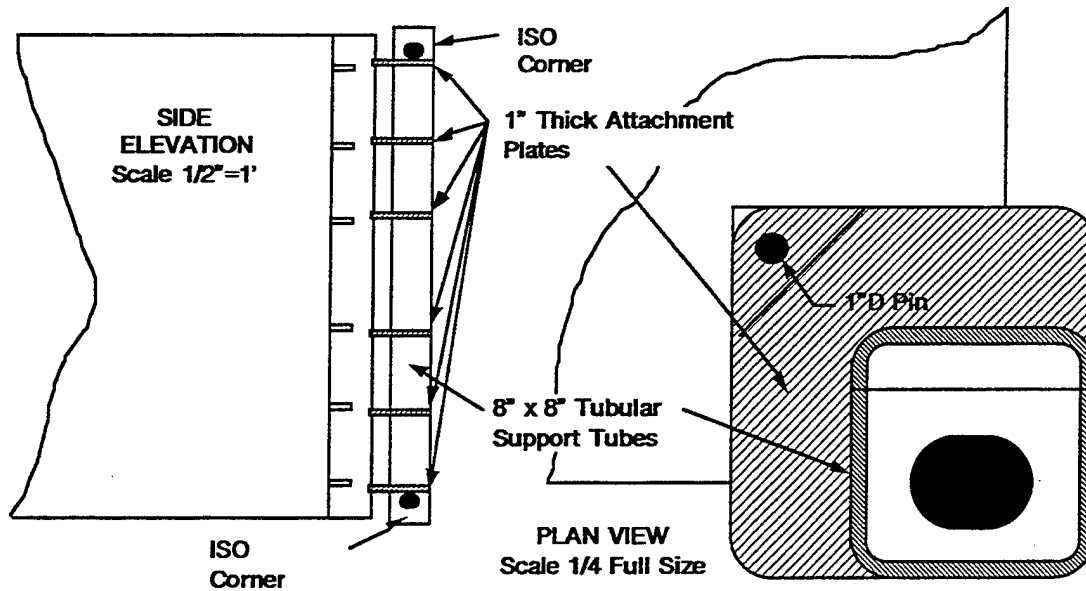

Figure 3-9 Tri-Module Removable Corner Fittings include ISO corners

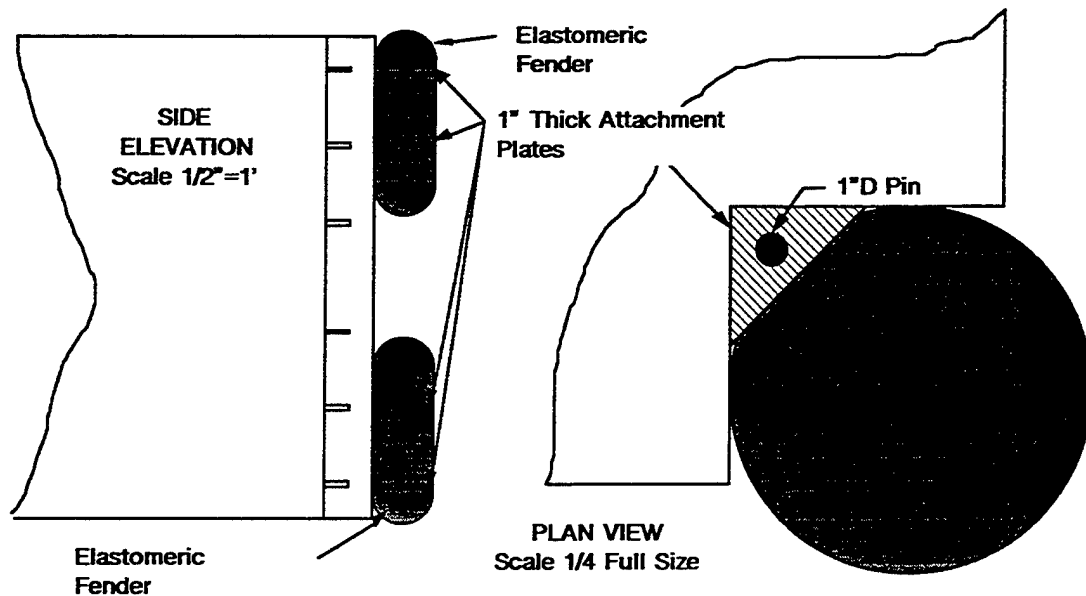

Figure 3-10. Tri-Module Fender Corner Fitting Replaces ISO Corner Fitting When Deployed

This arrangement is more compatible with having built-in mooring bits at its extremities and eliminates other unnecessary structure in the center module. The center module could conveniently be provided with storage lockers for the ISO corners, fenders and connector parts. This concept will allow for the simplest of mechanical joining systems for their connection under controlled conditions on the dock prior to loading on ships. The connectors must not be undone when the Tri-Modules are floating as individual modules will not float level and could not readily be connected. However, it would be feasible to disconnect them on the beach should it be necessary to conduct repairs or prepare the Tri-Module units for inter-modal transport.

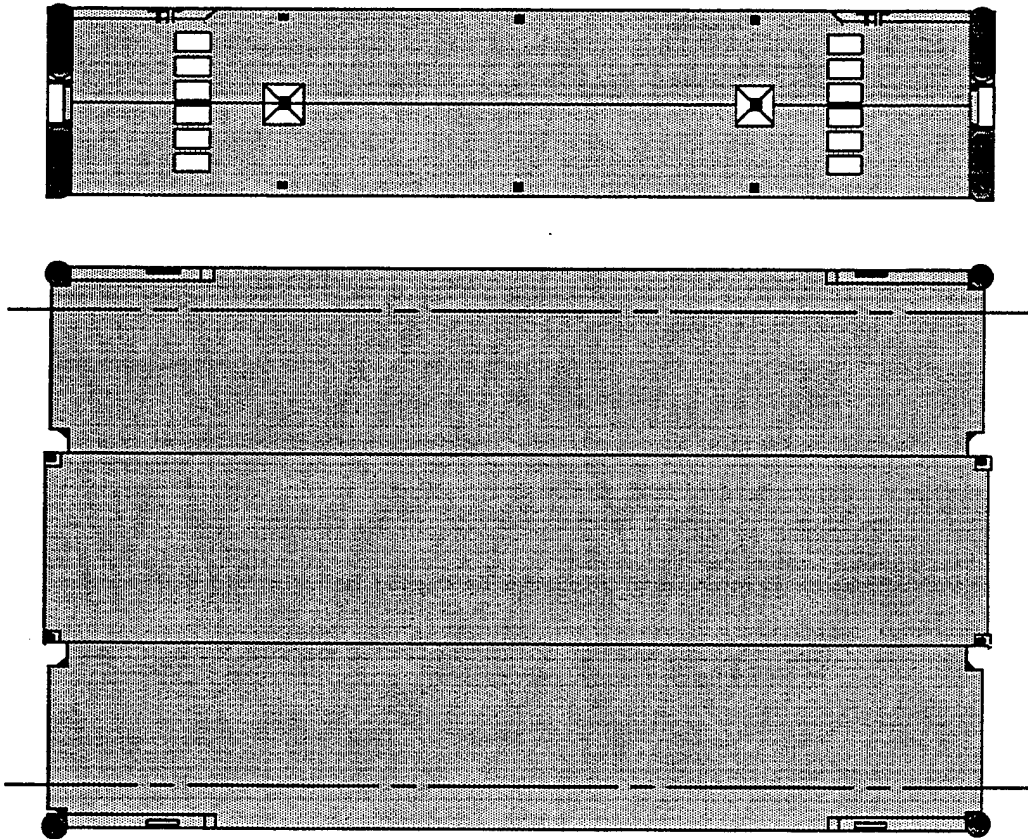

Figure 3-11 ACB Lighter Tri-Module Concept With Simplified Center Unit and Interchangeable Port and Starboard Units Housing Module-to-Module Connectors

It has been assumed that the centerlines of the connection system devices will be ten feet from the center of the Tri-Module. That is, twenty feet apart both on the ends and the sides. Major transverse frames will be needed to transfer connector loads from module to module. At the interface between center and outer modules, there would be a greater number of simple connections at the top and bottom edges at intervals that would distribute loads more evenly. These connectors would be capable of being

tightened, like nuts and bolts so that there can be wide tolerances and easy assembly. When tightened, there would be no slack or relative movement between modules.

3.6 Tri-Module Structural Analysis and Weight Analysis

The Tri-Module concept was developed as an alternate configuration to the single 40-foot x 24-foot x 8-foot structure because of the problems associated with meeting the maximum weight limit of 30-LT. Further, the Tri-Module offered a solution to the inter-modal transportation of the ACB Lighter and made manufacturing inland (as opposed to marine shipbuilders for the large 40-foot x 24-foot x 8-foot structure) a viable option. A conceptual design of the Tri-Module (see paragraph 3.5 above) has been prepared and a basic internal structure developed for the purposes of analyzing the weight and developing a baseline structural analysis. The estimated weights of an inner and of two outer modules that will be connected together to form a Tri-Module, are shown in Appendix B (ref. Tables 8 & 9) . The weight estimates are comparable with the other weight estimates in that they were calculated using the same general assumptions but with appropriate geometrical factors. The structural analysis and a more specific weight analysis for the Tri-Module concept is presented in Appendix C.

From the structural analysis of the Tri-Module, frames will be required at 5-foot spacing to support the deck loads. However, the final arrangement will have to be modified to suit the connector system when that design information is available. The weight analysis indicates that the inner Tri-Module unit (i.e. without the module to module connectors) would weigh in the region of 13.50 LT and the outboard units (i.e. with connectors) would weigh approximately 15 LT. This would present a total weight of about 43.5 LT for the Tri-Module using mild steel throughout. As each Tri-Module unit is well below the 30 LT limit they can be treated as ISO container units using all available ISO compatible Handling equipment.

4. MANUFACTURING ASSESSMENT

As part of this study MJP&A were tasked to conduct a manufacturing assessment of the ACB lighter system. This included evaluating the possibility of fabricating the modules at inland facilities (i.e. not local to the coast and/or navigable waterways) and transporting prefabricated components of the modules overland for final assembly adjacent to a coastal waterway. The following paragraphs discuss the overall fabrication considerations and results of the evaluation.

4.1 General Fabrication Considerations

The manufacture of large rectangular welded steel boxes with internal frames and stringers is within the capabilities of many shipbuilders and steel fabricators. However, the use of the lightest possible gauges of high strength steel and being particularly sensitive to weight control and maintaining consistent high quality welds is not quite as common. Maintaining close tolerances of crucial dimensions, location of ISO corners and connector fittings for example, will call for special tooling. Expensive jigs and tooling can only be cost effective if a considerable number of modules are to be built. If close tolerance fittings are held in place by means of jigs, care must be taken to allow for distortions that occur with welding. It would therefore be more expedient to add close tolerance fittings after the majority of welding has been completed and the various distortions have already occurred.

Transporting very large assemblies the size of the complete ACB Lighter module by rail or over highways will not be possible or practical unless it is over very short distances through specially cleared areas. If the module were prefabricated as three container size units, they could be transported without difficulty from anywhere within CONUS. However permanently joining the sections together to form a single final module will require special tooling jigs on-site adjacent to a navigable waterway. Aligning and joining all key structural members, achieving watertight integrity, and controlling distortions to meet overall dimensional requirements and be within tolerances will require careful planning and management procedures. Prefabrication of major portions of the structure, such as extruded aluminum panels for the top deck and stiffened plates for the bottom surfaces, leads to more consistent results and potentially lower costs. Prefabrication of major components and/or subassemblies allows remote production at potentially lower cost inland facilities even if final assembly must be completed at a waterside facility. Transportation by rail or road of forty-foot long prefabricated sections of an ACB Lighter would be possible however, the transportation and handling costs would have to be figured into the overall cost trade-offs versus fabrication in a conventional shipyard.

If the Tri-Module concept is adopted, each of the three modules would be ISO-compatible and could be transported by truck, train or ship anywhere in country or abroad. Having full inter-modal capabilities would be an obvious advantage during manufacture as well as during operations. The individual modules can be completely finished at the manufacturers including pressure testing to ensure water tightness and painting to prevent corrosion. Joining the center and two outer modules together dockside should be relatively straightforward with the simplest of connection systems. The Tri-Modules could be assembled on dunnage allowing access to connectors along the underside as well as from the deck. A simple cover plate that is bolted directly to protruding flanges with threaded holes would be extremely simple to manufacture and

install. The plates could be in relatively short lengths so that they are easy to lift into position, and easy to remove or replace if they become damaged. With this method, some means of pulling the modules together must be provided so that the bolt holes could be aligned. Alternatively, exposed angles that can be directly bolted together would be easier to use as the bolts would automatically pull the modules together into close contact. A combination of the two methods may be the best method where bolts and cover plates are both used. The bolts could be installed at the frame stations and be used to pull the modules together and take a major proportion of the loads. Then the cover plates could be fitted to provide a smooth continuous surface on the top and bottom and protect the bolts. These cover plates would transfer loads from deck plate to deck plate. External flanges with holes would not compromise the modules watertight integrity and would be easy to repair.

4.2 Survey of Manufacturers and Fabricators

A manufacturing assessment of the ACB Lighter was conducted by MJP&A using the anticipated life cycle of the system (as discussed in Sections 2.1 through 2.11 above) as the basis for developing a preliminary manufacturing requirement. As part of this study MJP&A personnel have been contacting shipyards and large steel and aluminum fabricators throughout the USA. A list of the companies and personnel contacted up to this report date is presented in Appendix D. Several of these companies have provided literature and information to MJP&A regarding their respective capabilities and facilities. There are essentially two groups of fabricators that have been contacted. The first group consists of shipyards and boat builders who have the necessary capabilities, facilities background and experience to fabricate steel barge modules. The second group consists of inland fabricators of large steel and aluminum structures. MJP&A focused primarily on the conventional shipyards and boat builders for information. These companies have the most experience building barge type structures and meeting Navy ship building specifications and requirements. However, shipyards and boatyards do not necessarily have the experience of building multiple large, identical units to close tolerance specifications. Maintaining very tight weight budgets is another area where shipyards do not have very good reputations.

In the latest phase of the study attention has been directed towards inland fabricators who have experience and specialize in large steel structure fabrication and use large tooling jigs and fixtures to ensure close tolerances are maintained. A local manufacturer, L&M Welding, Inc. of Corvallis, Oregon conducted a ROM cost estimate of a Tri-Module unit based upon the preliminary sketches and structural details presented in Appendix C. This estimate did not include the module-to-module interconnect fittings or allowances for any special deck fittings or other equipment. Also, the estimate did not take into account special tooling, jigs and fixtures. The L&M

estimate (see letter included under Appendix D) has been used to develop a preliminary cost model for the ACB Lighter as discussed in the following paragraphs.

4.3 Cost Analysis

The basis for a Rough-Order-of-Magnitude (ROM) costing for the ACB Lighter system has been developed. At this stage of the design evolution there are, understandably, many unknowns. Many cost models already exist that can be used to determine costs of manufacturing ships which are generally based on a Ships Weight Breakdown Structure (SWBS). However, a ships hull, Group 100, is not very applicable because few of the components are typical of ships. Frames will all be similar, bottom, side and deck plating will all be flat rather than curved and watertight bulkheads will be simply plated frames. There will be no machinery foundations. There will be extensive internal structure to support the connector system, deck fittings, mooring bits and the ISO corners.

Cost of building the ACB Lighter modules is dependent on many variables including detail design, building tolerances including weight, amount of tooling needed, selection of materials, finish required, quantity ordered, delivery rate required, and delivery locations. Some of these factors are independent and some are very interdependent. By adopting the Tri-Module concept, the manufacturing process can be moved inland so that they can be built at potentially lower cost without the penalty of completing final manufacture at a waterside manufacturing facility. Connection of the three modules to form the complete ACB can be achieved dockside with a minimum of facilities.

There are several general cost trends that can be summarized as follows:

- 1) Highest prices will result from the selection of very complex designs requiring extensive tooling because of tight tolerances especially weight, that call for the use of high strength-to-weight materials needing special manufacturing processes.
- 2) Lowest prices will result from very simple designs that require close tolerances on few parts without special attention to weight or process control.

Costs will be reduced if an order can be placed for a large number of modules to be delivered to a local base as completed, over an extended period of time, such as five or more years. Advantages will be obtained by buying materials at the best quantity discounts. Benefits will also be obtained by maintaining a select crew working at a sustained rate so that production sequences and learning may be optimized. An optimum production rate may be achieved after an initial set-up period of a few weeks,

then approximately a week for the first module, reducing time to one day per module after about a month, then with whatever adjustments in schedule, tooling and workers that may be necessary, an increase to two modules per day after about six months. Once this optimum manufacturing rate has been reached, it could be further increased by adding a second shift to make use of any special tooling that limits the production rate, or by investing in more tooling and a larger team of workers. This all supposes that appropriate space is available together with all back-up supporting services, supervision, quality control, management, etc. and without any limitations imposed by outside suppliers or subcontractors.

A simple cost model would have as its base the cost of the selected material. Mild steel plate and standard sections, already cut to size or shape, typically cost less than 50¢/lb. High strength steel costs about double that or nearly \$1/lb. Aluminum alloy plates and extrusions cost even more depending upon the alloy selected. Similarly, welding costs are similar in proportion to the material costs. Mild steel is the cheapest to weld and requires the least of special procedures. To weld an aluminum structure requires careful sequencing to account for the high shrinkage rates and critical welds must often be X-rayed to confirm their integrity. Cost of tooling may well be of the order of the cost of module, thus doubling the cost of the first module but becoming less and less significant if it can be amortized over many modules. Some long continuous seams will be appropriate to machine welding, but since much of the welding will be manual, costs will be reduced as production continues due to learning. That is, unless production is only short term or interrupted such that there is little continuity of effort.

A considerable number of special fittings must be included, not the least of which will be the connectors. There will also be the ISO corner fittings, mooring bits and deck tie-downs. The cost of these items can be regarded as a constant almost regardless of how and where the modules are built. Cost of preparing the structure for painting and applying the paint is a significant cost and very dependent upon the design and material selection. Typical mild steel construction requires sand-blasting to a near white finish before primer and paint can be applied if it is to provide any sort of lasting protection. It will be virtually impossible to properly clean surfaces that are in contact with one another making them inaccessible.

Table 4-1, below, gives rough order of magnitude costs for a notional 100,000 lb Tri-Module in terms of material, labor and other costs with variations for a number of the factors described above.

Table 4-1. Module ROM Production Costs

Item or Factor	Material	Labor	Other	Total
Mild Steel, Optimum Production	\$50,000	\$100,000	\$50,000	\$200,000
High-Strength Steel	\$100,000	\$200,000	\$50,000	\$350,000
Aluminum	\$150,000	\$300,000	\$100,000	\$550,000
Complex Design	+10 - 50%	+10 - 50%	+10 - 50%	+10 - 50%
Low vol/interrupted production	+10 - 20 %	+50 - 100%	+25 - 50%	+25 - 50%

5. COMPARISON OF MONOLITHIC AND TRI-MODULE CONCEPTS

The approach during the first phase of this study was to focus on defining the primary requirements and constraining factors related to the ACB Lighter modules and to develop a design concept about those issues. The original baseline approach was to develop a monolithic module approximately 40-foot x 24-foot x 8-foot weighing no more than 30 LT. From the work accomplished in the area of weights and structural analysis (see paragraph 3.3 above) it was apparent that, even with a very careful detail design and a comprehensive weight budgeting program, it would be unlikely that an end product could be achieved for a monolithic module that would remain within the 30 LT limit and also be fabricated within a reasonable cost while meeting reliability, operability and reparability criteria. Furthermore, there were significant problems related to overland transport because of the size of the monolithic modules. Because of these problems an alternate approach which would exceed the weight budget but meet the other requirements was developed and called the Tri-Module concept.

In Section 2 above a set of baseline design criteria and the 'Total System Utilization Cycle' (see Figure 2-1 page 3) was used to develop a basis for the ACB Lighter module design approach. The Tri-Module concept departs from this approach in that it exceeds the 30 LT weight limitation. However, the Tri-Module offers significant advantages over the monolithic module approach when compared with other criteria in the 'Total System Utilization Cycle'. These advantages are summarized in the following paragraphs.

5.1 Tri-Module Fabrication and Delivery

Each Tri-Module unit is designed within a 40-foot x 8-foot x 8-foot envelope and will be fitted with ISO compatible corner fittings thereby making them road and rail transportable using international standard handling and transport equipment. The manufacturing assessment (see Section 4 above) shows that a monolithic ACB Lighter module (i.e. 40-foot x 24-foot x 8-foot) for all practical purposes would have to be fabricated at a shore-side facility with coastal access. The problems of building such a large module inland and then trying to transport it as either a monolithic module or in sections that would be final welded at a shore-side facility are significant and would add

considerably to the overall cost of the system. Alternately, the Tri-Module units can be manufactured anywhere and are not limited for overland transportation. This allows a much broader and versatile group of manufacturers to bid the fabrication of the ACB Lighter system and will improve overall cost competitiveness.

5.2 Tri-Module Storage Dockside or Inland

The Tri-Module can be stored dockside as an assembled 40-foot x 24-foot x 8-foot ACB Lighter module or it can be stored at any convenient inland location as separate 40-foot x 8-foot x 8-foot Tri-Module units. As an 40-foot x 24-foot x 8-foot ACB Lighter module the Tri-Module is ready for immediate deployment requiring only access and transportation from the storage site to the ship for loading aboard. However, the Tri-Module ACB Lighter broken down into separate 40-foot x 8-foot x 8-foot units can be stored at any convenient location worldwide and does not require special transportation access to the dockside (i.e. does not need a clear access allowing a 24-foot wide monolithic ACB Lighter module to be transported from storage to dockside). This factor is significant in that it opens the possibility of reducing the overall number of ACB Lighter modules that would be required to fulfill world wide missions. For example, to meet both Pacific and Atlantic theater requirements perhaps a total of one hundred 40-foot x 24-foot x 8-foot ACB Lighter modules would be required with 30 located dockside and 20 located aboard ships on each coast. However, if the 40-foot x 8-foot x 8-foot Tri-Module units are stored at a suitable inland location midway between the Atlantic and Pacific ports then a total of 70 ACB Lighter modules may be all that is required to meet mission requirements (albeit with a slightly increased deployment time to allow for the transportation overland to the dockside). *Please note that the above figures are for example purposes only and do not reflect actual mission requirements.*

Another advantage of storing Tri-Module units separately is the ease of access for inspection, maintenance and repair while stored. Furthermore, storing the Tri-Module units inland away from the salt water environment should increase their overall service life significantly (e.g. storage in dry, arid climates such as parts of Arizona, Texas, New Mexico etc.,)

5.3 Loading Tri-Module ACB Lighter Aboard Containerships and Shipping

The assembled 40-foot x 24-foot x 8-foot Tri-Module ACB Lighter will weigh approximately 45 LT thereby exceeding the 30 LT lifting limitation and the use of ISO fittings and handling equipment. The logistics of handling the Tri-Module ACB Lighter configuration would be as follows:

- 1) Tri-Module 40-foot x 8-foot x 8-foot units are delivered to the dockside aboard standard truck or rail transportation using ISO fittings for all securing, handling and intermediate management.

- 2) The Tri-Module units consisting of one center unit and two outboard units are located within close proximity to each other on wooden dunnage alongside the ship and within reach of the ships crane (or dockside crane if they are to be used for loading the ACB Lighter Modules). The Tri-Module units would be placed on the dunnage to allow access to the interconnect fittings between the units.
- 3) The special ISO corner fittings (see Fig 3-9 above) are removed from the two outboard Tri-Module units and the corner fender units are installed on the four external corners (see Fig 3-10 above)
- 4) Using the ships crane and/or shore-side handling facilities, the Tri-Module units are maneuvered together and secured at top, bottom and ends (note: the attachment method details of the Tri-Modules is beyond the scope of this current study and should be studied further to develop a simple, reliable and structurally acceptable connection).
- 5) When the three Tri-Module units are secured the ACB Lighter module is ready for hoisting aboard the containership. If a T-ACS crane ship is used then the pedestal crane booms should be arranged to work in pairs to meet the approximate 45 LT lifting requirement. A special custom spreader bar or hoisting sling would be required and would be attached to the center Tri-Module unit section for lifting. (note: the ISO fittings could not be used for this lift because their structural limitations would be exceeded. Special lifting points would have to be provided)
- 6) The ACB Lighter module is stowed aboard the containership using three adjacent cells in the same manner as the Seashed modules or on hatch tops (see paragraph 2.4 and Figure 2-2 above).
- 7) The same spreader bar (i.e. step 5 above) would be used for the ACB Lighter module deployment from the ship to the sea (reference Section 2.5 above).

The continuation of the 'Total System Utilization Cycle' from deployment to module-to-module interconnect, platform assembly and mission operations as related to the Tri-Module concept is essentially the same as discussed in Sections 2.6 through 2.10 above for the monolithic ACB Lighter module concept.

5.4 Tri-Module Recovery to Containership and/or Inter-Modal Transportation

In Section 2.10 above, the recovery of the of the ACB Lighter module following a mission was discussed along with damage considerations and inspection requirements prior to lifting. It was noted that if a monolithic module were flooded in any compartment it would exceed the 30 LT lifting requirement and may require a special lifting rig to remove it from the water (i.e. to avoid exceeding ISO fitting capabilities). As the Tri-Module ACB Lighter module is naturally compartmented damage would be typically isolated to an individual ACB Tri-Module unit. It is possible that an ACB Lighter Tri-Module could be repaired in the field by removing the damaged unit and replacing it with another unit. Furthermore, the special lifting rig or spreader bar discussed in

Section 5.3 above could be sized to accommodate overweight lifts that may be encountered due to damage.

Another important characteristic of the Tri-Module ACB Lighter concept is the inter-modal, overland transport capability from one theater of operations to another. The Tri-Module ACB Lighter could be beached, disassembled into ISO transportable units and transported overland via truck or train to another theater of operations and there re-assembled. This would not be possible with a monolithic 40-foot x 24-foot x 8-foot ACB Lighter module. The inter-modal transportability of the Tri-Module units is a significant feature which broadens the usage of the platform and provides logistics planners with a wider array of options.

5.5 Tri-Modual Unloading to Dockside, Inspection, Repair and Storage

Following a mission deployment the Tri-Module ACB Lighter module would be unloaded dockside and disassembled using the reverse procedures described in Section 5.3 above. The outboard 40-foot x 8-foot x 8-foot Tri-Module units would have their fender fittings removed and their ISO corner fittings re-installed and would be ready for transport to a suitable location for careful inspection and repair as necessary. Again, the advantages of the 40-foot x 8-foot x 8-foot Tri-Module would be realized with access to a broad range of repair facilities not necessarily located on the coast. The Tri-Module units would then be returned to their designated storage facility until required.

6. CONCLUSIONS AND RECOMMENDATIONS

The previous paragraphs have explored the design rationale, requirements and constraints of the U. S. Navy ACB Lighter system. Essentially two design concepts have been developed and evaluated, a monolithic 40-foot x 24-foot x 8-foot ACB Lighter module and a Tri-Module concept consisting of an assembly of three 40-foot x 8-foot x 8-foot units. Also the requirement for a beaching ramp and an intermediate ramp to access current Navy Lighterage (NL) and Army MCS' from and to the ACB Lighter is common to both the monolithic and Tri-Module approach.

There are therefore three sets of conclusions which relate to the ACB Lighter designs studied here. The first set relate to the monolithic ACB Lighter module which must remain below the 30 LT weight limit. The second set of conclusions relate to the Tri-Module approach which exceeds the 30 LT weight limit when configured as a 40-foot x 24-foot x 8-foot ACB Lighter module but meets a broad array of other objectives. The third set are general observations common to both systems. They are therefore treated under appropriate headings below.

6.1 Monolithic Module ACB Lighter Design Conclusions and Recommendations.

A monolithic ACB Lighter module designed to meet the 30 LT weight limitation will require a special, structure combining high-strength steel components with an aluminum

or lightweight composite deck structure. The weights analysis has shown that weight is the critical factor which drives the design approach. The selection of materials and manufacturing processes is therefore driven by this factor and consequently drives not only the fabrication costs but life cycle costs in general, particularly maintenance and repair. The desire to be able to manufacture the ACB Lighter inland creates a significant problem because of its size. Methods of fabricating the modules in sections and then transporting them to a coastal access site for final assembly and commission were considered and found to be impractical. Modular fabrication presents further problems related to assembly tolerances and drives costs higher because of the increased jig and tooling requirements. The monolithic ACB lighter approach is therefore not recommended. However, if such a configuration ultimately proves to be essential to meet mission requirements then the following design approach is indicated:

- 1) The ACB Lighter module should be configured within overall dimensions of 40 feet x 24 feet x 7 feet high. The 7-foot height is preferred over the 8-foot for two reasons. a) The reduction from an 8-foot to 7-foot deck height reduces the overall module weight and b) The ideal interface with a 10 degree slope beaching ramp can be packaged in a 40-foot x 8-foot x 7-foot configuration.
- 2) The preliminary selection of an extruded aluminum deck panel as opposed to high strength steel is not the preferred solution and requires further in-depth analysis. It is recommended that a more detailed weight analysis be conducted along with a structural analysis using a CAD/CAE/CAM model of various steel structures with reduced stiffeners and internal frame sizes. The weights of external components such as connectors, fenders, lifting eyes, deck tie downs and their supporting structure etc., should also be examined in more detail. This study should be conducted in parallel with an in depth fabrication analysis to ensure that such structure can be built reliably and within justifiable cost.

6.2 Tri-Module ACB Lighter Design Conclusions and Recommendations.

During the second portion of the study, the effects of the ACB Lighter weighing in excess of 30 LT were considered and an alternative approach developed. In this approach, a special center module was joined to two outer modules to form a Tri-Module. Each Tri-Module unit could be handled as a 40-foot x 8-foot x 8-foot ISO compatible unit. Although the assembled Tri-Module would weigh more than 30 LT, it could still be lifted by the cranes on T-ACS, loaded aboard containerhips and off-loaded directly into the sea. Before joining or separating the Tri-Module ACB Lighter dockside or at some other site, the Tri-Module units would be adapted with simple corner fittings to be fully ISO-compatible. The adoption of the Tri-Module concept will bring about several advantages the major one being that Tri-Modules could be handled

and transported as ISO containers. Use of the Tri-Module concept will produce cost savings during all stages of manufacture, use, maintenance and repair.

The final recommendations are:

- 1) Conduct further design studies of the Tri-Module concept with particular emphasis on the manufacturing approach to reduce cost.
- 2) Complete the design of the connector system and integrate it into the design of the Tri-Module.
- 3) Conduct further analysis of the inter-modal transportation requirements to determine if the Tri-Module approach to the ACB Lighter allows reduction in the required inventory while still meeting worldwide mission requirements.
- 4) Design, build and evaluate a prototype Tri-Module and incorporate lessons learned into a final design for production.

6.3 General Conclusions and Recommendations

The module-to-module interconnect hardware is essentially common to both the Monolithic and Tri-Modular design configurations discussed previously. However, this study has been conducted with only very preliminary details available of the module-to-module interconnect hardware configuration. As the module-to-module interconnect fittings are critical to the overall design these items must be defined and incorporated in more detail if further study is to be useful. For example the weights analysis conducted here incorporates a 'best guess' of the module-to-module connector weights and should be updated as design information becomes available. Furthermore, the primary load paths through these connectors will dictate the internal structural design of the modules to a large extent. There are some preliminary conclusions that apply to the connector system which are as follows:

- 1) The module-to-module connector system should be designed to the maximum extent practical as independent, removable units that are bolted rather than welded to the ACB Lighter module. This will allow for ease of maintenance and repair and also allow for different types of connector to be used and or adapters to connect to existing systems.
- 2) The module-to-module connector system should be designed to directly interface with the existing connector systems used on the Navy Lighter (NL) and MCS systems. This does not mean using the current Flexor fitting but rather a custom designed connector which provides both shear and tensile restraint that fits in the current receiver ports on the Navy Lighter (NL)s and MCS'.

The need for special raked end modules for hydrodynamic considerations and access ramps for beaching and interfacing with existing Navy and Army platforms has not been dealt with in any depth under this study. The following recommendations are based upon observations and experience with similar systems:

- 3) The raked end modules for the ACB Lighter should be modeled on the same principal as the MCS system. This allows nose-to-nose storage within the 40-foot x 24-foot x 8-foot configuration. However, this design requires further study and analysis related to the overall weight and handling requirements in the storage configuration.
- 4) Special ramps are required to provide interoperability between the ACB Lighter and the Navy Lighter (NL)s and Army MCS'. These ramps should be as simple to deploy as possible and meet the overall transportation requirements of the ACB Lighter system (i.e. ISO-compatibility). It is anticipated that these ramps will only be required during the transition period from use of Navy Lighter (NL)s and MCS to the exclusive use of ACB Lighters.
- 5) Special ramps are required for beach transitions to and from the ACB Lighter. These ramps will require further conceptual design analysis to determine how they are to be transported, deployed and managed in the field. The nominal ramp break angle of approximately 12° to accommodate on and off-loading RO/RO equipment and the nominal 8-foot height of the ACB Lighter module are determining factors governing the design of this item.

7. REFERENCES

1. Final Report - Ocean Module Barge Connection Systems Development, Volume 1 - Conceptual Design and Operating Procedures, September 1993. Contract N47408-93-C-7346. Prepared for Naval Civil Engineering Laboratory (NCEL), Port Hueneme, California by M. J. Plackett & Associates.

APPENDIX A

Structural Analysis - Monolithic Module Design

DESIGN REQUIREMENTS

The ACB Lighter consists of a rectangular box, 40 feet long by 25 feet wide by 8 feet deep. It is required to be compatible with existing Navy and Army pontoons, transportable in existing container ships, capable of handling existing vehicular traffic and of being lifted by container-handling equipment that can only handle loads up to 30 long tons (67,200 lb).

DESIGN LOADS

The most severe deck load is assumed to be the wheel load of a loaded Rough Terrain Container Handler (RTCH). This load is 75,000 lb on each of two wheels spread over an area 2-foot square. (equivalent to a pressure of 130 psi); the wheels are assumed to be 10 feet apart in any orientation. These loads can be applied anywhere on the deck when the ACB lighter is either floating or stranded, when it is assumed to be supported by two diagonally opposite corners.

The bottom structure is assumed to be capable of resisting a hydrostatic pressure equivalent to 8 feet of water (equivalent to 3.56 psi). 8 feet is about twice the draft of the ACB lighter when its total loaded weight is 250,000 lb. The sides are expected to withstand appropriate hydrostatic pressures and normal service handling loads.

CONCEPTUAL STRUCTURAL DESIGN

Preliminary analyses have shown that the 30 long-ton weight limitation will be very difficult to achieve so that every effort must be concentrated on developing as light a structure as possible. It was realized that the Navy would be very unwilling to accept material other than steel or a deck plating thickness less than 1/4-inch. These factors were taken as basic ground rules. It was assumed that side and bottom plating thicknesses of 3/16-inch could be used. It was also assumed that the steel used for all structural members would have an allowable stress of 50,000 psi.

Structural Layout

It was initially assumed that the basic internal structure of the lighter would consist of two longitudinal frames, 8.33 feet apart, and four transverse frames, eight feet apart. This layout was maintained throughout the analysis. It was subsequently found to be advantageous to include three vertical stanchions in each transverse frame, as sketched in Section A, so that the basic deck-panel size was approximately 8-foot by 4-foot throughout.

Plating Design

Initial calculations showed that 1/4-inch deck plate would require stiffeners no more than 6 inches apart to support the required 130 psi tire pressure load (Section A.1). 1/8-inch deck plate would require a 3.5-inch stiffener spacing.

In Section A.II a novel type of sandwich plating was investigated. A suitable size for the 8-foot by 4-foot deck panel consisted of two 1/8-inch plates separated and supported by a "Warren Girder" arrangement of 1/8-inch plate. The total sandwich depth was 3.5 inches. It was found, however, that this configuration showed no particular advantages over a more conventional skin and stiffener arrangement, and, in fact, had disadvantages in complexity and cost of manufacture and the vulnerability of the 1/8-inch deck skin.

A more conventional alternative design is shown in section A.III. This configuration consisted of 1/4-inch plate supported by 5-inch by 2-inch T-stiffeners spaced 6 inches apart. This design had the same strength and weight as the sandwich structure and had the advantage of 1/4-inch thick skin and more conventional and cheaper construction. This plating-stiffener combination was therefore adopted for all subsequent analyses. The bottom plating was found to require the same size of stiffeners for, although the design pressure for the bottom was much lower, the area of application of this pressure was very much larger.

Bulkhead Design

Both longitudinal and transverse bulkheads were designed as Warren-Girder type trusses (Section A.IV). The design load was assumed to occur when one RTCH wheel was centered approximately over each of two adjacent bulkhead intersections. Such loads were assumed to be supported equally by longitudinal and transverse trusses. The horizontal truss members at the deck and bottom have to support all of the plating loads transmitted through the stiffeners.

Sizes selected for the truss components are as follows:

Diagonal truss members	Standard I	3 x 1.64 x 0.17"
Transverse deck beams	Standard I	7 x 3.66 x 0.25"
Longitudinal deck beams	T	5 x 2.50 x 0.25"
Trans. & Long. bottom beams	T	5 x 2.50 x 0.25"
Stanchions	Standard I	3 x 1.64 x 0.17"
Box corners	Standard L	4 x 4 x 0.25"
Deck plating		1/4"
Bottom & side plating		3/16"
Deck & bottom stiffeners (6" spacing)	T	5 x 2 x 0.25"

WEIGHTS

A preliminary weight estimate is shown in section A.V. Total basic structural weight estimate is 61,321 lb. When an allowance of 9,450 lb is added to this, for fittings, connectors, welding etc., the total weight becomes 70,711 lb. This total weight is 3,511 lb over the target weight limit of 67,200 lb. To achieve this weight target a careful review of every aspect of this structural analysis will be required. One promising modification, that has already been discussed, is to reduce the depth of the lighter from 8 feet to 7 feet or even 6 feet.

The use of aluminum alloy could also result in considerable weight reduction. As an example a very brief analysis of an alternative, aluminum-alloy deck structure is shown in section A.VII. A deck thickness of 0.26 inches is used, supported by 5-inch by 6-inch by 0.26-inch T-stiffeners, spaced 6 inches apart. It is envisaged that this deck would be comprised of a number of extruded planks each at least 8 feet long, one foot wide and 6 inches deep. This deck would have the same strength properties as the steel deck presented in section A.III, but would weigh 10,184 lb, instead of the 20,400 lb for the steel version. A mixed steel and aluminum structure would, however, complicate the attachment of the deck to the supporting trusses which would almost certainly negate some of the weight advantage.

DESIGN DETAILS

Typical truss intersections are sketched in Section A.VI. At the water-tight bulkheads the I-section members can be replaced by two back-to-back channel members.

APPENDIX A: AMPHIBIOUS CARGO BEACHING LIGHTER (ACBL)

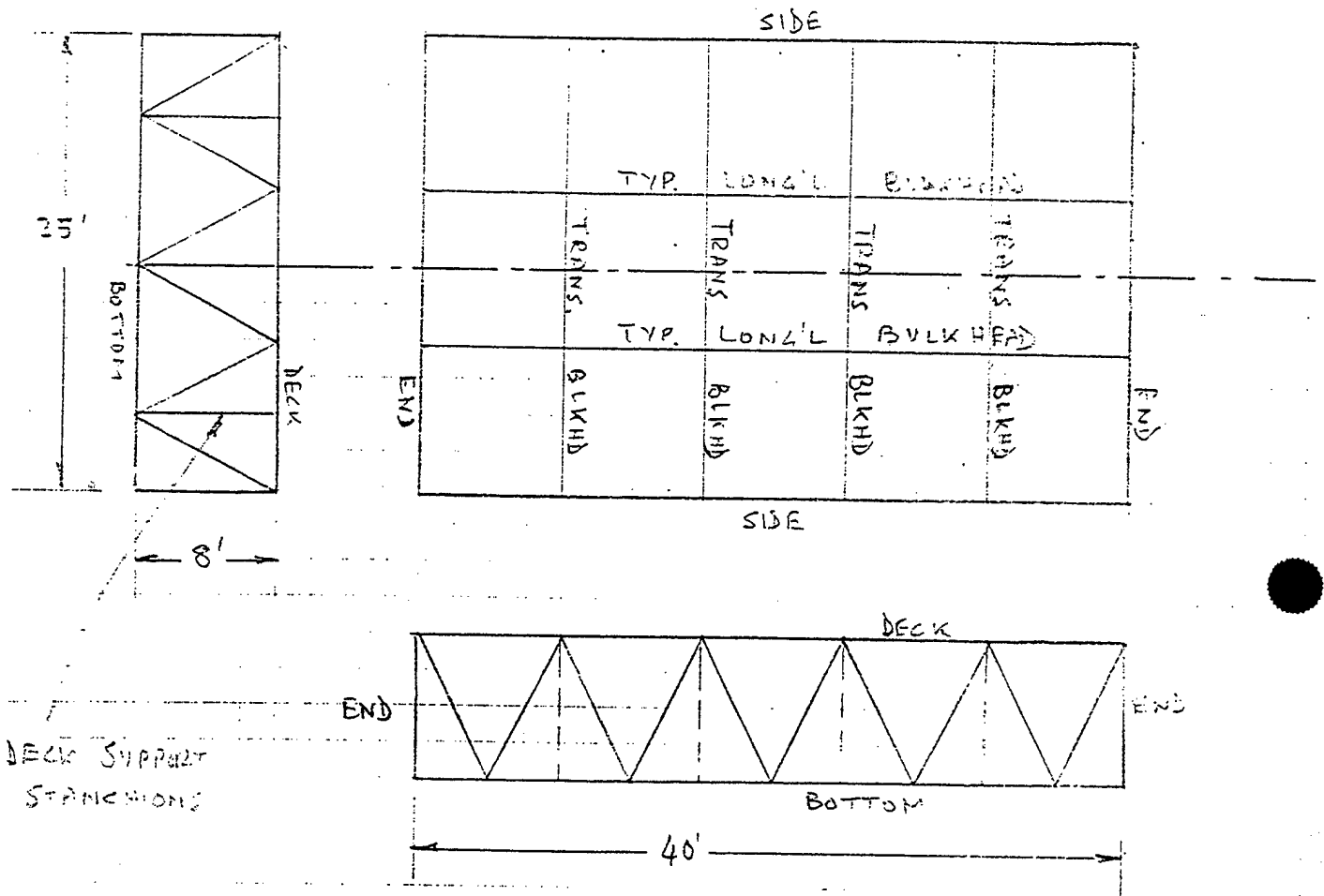

A.I. PLATING LOADS

DESIGN CASE IS 75000 lb TIRE LOAD (RTCH + SK LOAD)
ON 2x2 ft AREA
= 18,750 psf

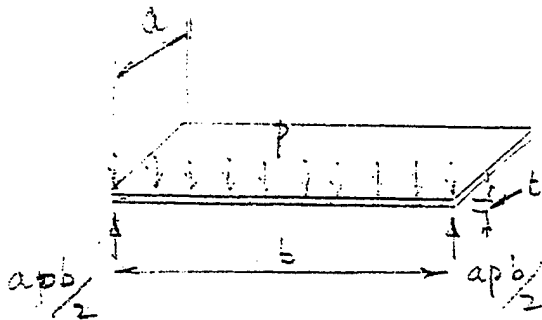

$$M_{\max} = \frac{pab^2}{12} \quad (\text{FOR FIXED ENDS})$$

$$I = \frac{at^3}{12}$$

$$Z = \frac{at^2}{6}$$

$$f_{\max} = \frac{M}{Z}$$

$$= \frac{pb^2}{2t^2}$$

$$\text{or } \frac{b_{\max}}{t} = \sqrt{\frac{2Zf_{\max}}{p}}$$

Thus if $p = 18,750$ psf = 130 psi and $f_{\max} = 50,000$ ksi

$$\frac{b_{\max}}{t} = \sqrt{\frac{2 \times 50,000}{130}}$$

$$= 27.7$$

Thus for $t = \frac{1}{16}'' \quad \frac{1}{8}'' \quad \frac{3}{16}'' \quad \frac{1}{4}'' \quad \frac{3}{8}''$

$b_{\max} = 1.73'' \quad 3.46'' \quad 5.20'' \quad 6.93'' \quad 10.4''$

A. II. SANDWICH PLATING

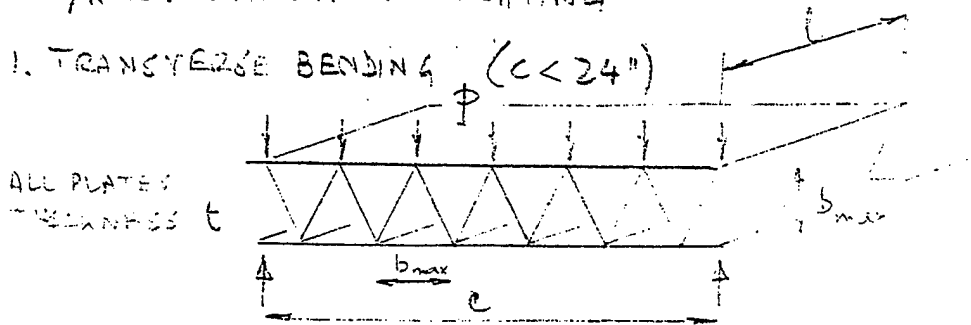
1. TRANSVERSE BENDING ($c < 24"$)

To determine max. width, c_{max} .

$$p = 130 \text{ psi (over 2 FT max. width)}$$

$$M = \frac{p c^2}{12} \text{ (FIXED ENDS)}$$

$$I = t b_{max}^2 / 2$$

$$S = t b_{max}$$

$$f = \frac{M}{S}$$

$$= \frac{p c^2}{12 t b_{max}}$$

$$c_{max} = \sqrt{12 f t b_{max} / p} \quad \text{but } t b_{max} = 27.7 t^2$$

$$= \sqrt{600,000 / 130} \sqrt{27.7} t$$

$$= 358 t$$

Thus for $t = 1/16"$ $1/8"$ $3/16"$ $1/4"$ $3/8"$

$$c_{max} = 22.3 \quad (44.7) \quad (67.0) \quad (89.4") \quad (134.4")$$

ANSWERS NOT VALID IF $c_{max} > 24"$

(SEE NEXT PAGE)

2. TRANSVERSE BENDING $c > 24"$

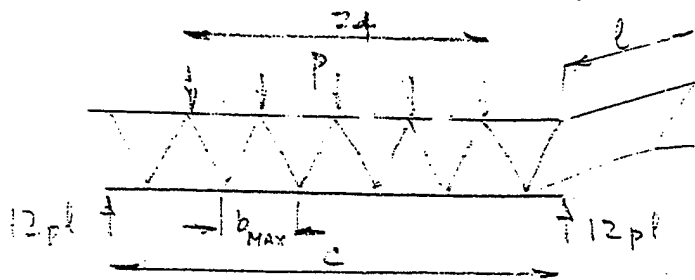

$$M = \frac{2}{3}(6plc - 72p^2l) \text{ approx (INCH UNITS)}$$

$$= 4pl(c - 12)$$

$$I = tb_{max}^2 / 2 =$$

$$Z = tb_{max}$$

$$f = M / Z$$

$$= 4p(c - 12) / tb_{max}$$

$$c_{max} = f tb_{max} / 4p + 12$$

$$= \frac{50,000 \times 27.7 t^2}{520} + 12$$

$$= 2663 t^2 + 12$$

Thus for $t = 1/16" \quad 1/8" \quad 3/16" \quad 1/4" \quad 3/8"$

$$c_{max} = (27.4) \quad 53.6" \quad 93.6" \quad 178" \quad 374"$$

NOT VALID AS $c < c_{max} < 24"$

3. LONGITUDINAL BENDING

TO DETERMINE MAX. LENGTH l_{max}

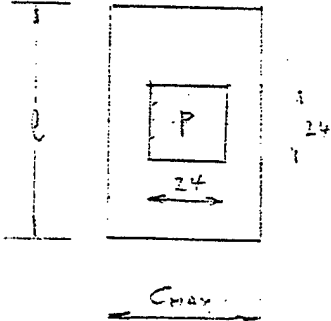

$$M = \frac{2}{3} 388 p (l/2 - 6) \text{ (approx) (For } C_{MAX} > 24 \text{)}$$

$$I = C_{MAX} t \frac{b_{MAX}^2}{2} + n b_{MAX}^3 t / 12$$

n = number of webs

$$= 2 C_{MAX} / b_{MAX}$$

$$b_{MAX} = 27.7 t$$

Thus $I = 383.6 t^3 C_{MAX} + 2 C_{MAX} 27.7^2 t^3 / 12$

$$= C_{MAX} t^3 (383.6 + 127.9)$$

$$= 511.5 C_{MAX} t^3$$

$$S = 2 I / b_{MAX}$$

$$= 511.5 C_{MAX} t^2 \times 2 / 27.7$$

$$= 36.93 C_{MAX} t^2$$

$$f = M / S$$

$$= 96 p (l - 12) / 36.93 C_{MAX} t^2$$

$$l_{MAX} = f_{MAX} C_{MAX} t^2 / 2.6 p + 12$$

$$= 148 C_{MAX} t^2 + 12$$

Thus for $t = 1/16" \quad 1/8" \quad 3/16" \quad 1/4" \quad 3/8"$

$C_{MAX} = (22.4) \quad 53.6 \quad 93.6 \quad 178 \quad 374"$

$l_{MAX} = (24.95) \quad 136" \quad 499" \quad 1359" \quad 7796"$

SELECTED FOR DESIGN

8' X 4' PAAEBS

$I_{LONG} = 53.5 \text{ in}^4 \quad 315.6 \quad 1423.6 \quad 12588 \text{ in}^4$

AIII ALTERNATIVE PLATE / STRINGER DECK

I. DECK PLATING

I FOR SANDWICH ($\frac{1}{8}$ " THICK PLATE) = 53.5 IN^4
 = 30.6 IN^3
 WEIGHT = $20.4 \text{ LB / sq. ft.}$

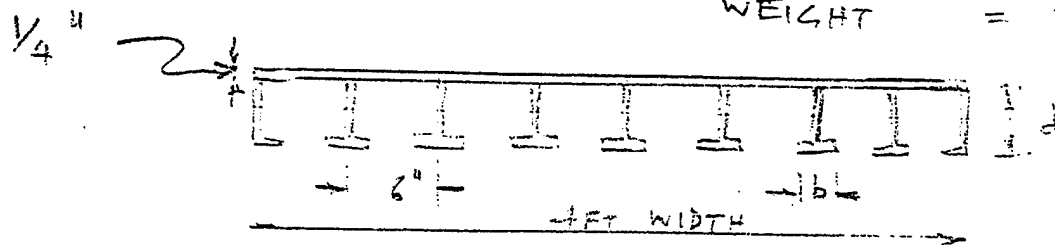

WEIGHT OF $\frac{1}{4}$ " PLATING = $10.2 \text{ LB / sq. ft.}$
 = 40.8 LB / ft.

WEIGHT GOAL FOR 8T STIFFENERS = $5.1 \text{ LB / ft. EACH}$

Z GOAL FOR EACH STIFFENER / SKIN COMBINATION = $30.6 / 8$
 = 3.825 IN^3

ASSUME FLANGE $\frac{1}{4}$ " THICK, DEPTH d
 WEB $\frac{3}{16}$ " THICK, WIDTH b
 EFFECTIVE SKIN WIDTH = FLANGE WIDTH

TO MEET WEIGHT GOAL:

$b + \frac{3}{4}d = 6.0$

$I = \frac{2}{4} b \left(\frac{d}{2}\right)^2 + \frac{d^3}{12} \frac{3}{16} = \frac{d^2}{8} (b + \frac{d}{8})$
 $= \frac{d^2}{8} (6 - \frac{3}{4}d + \frac{d}{8})$
 $= \frac{d^2}{8} (6 - \frac{5}{8}d)$

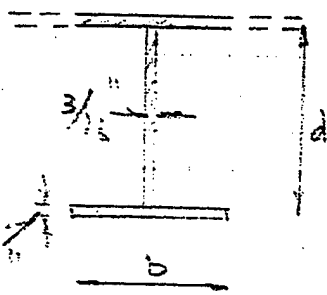

GOAL = 3.825 IN^3

$d =$	3"	4"	5"	6"	8"
-------	----	----	----	----	----

$I =$	4.64	7.0	8.98	10.125	8 IN^4
-------	------	-----	------	--------	------------------

$Z = 2I/d =$	3.09	3.5	3.59	3.375	2 IN^3
--------------	------	-----	------	-------	------------------

$R-10$	3.75"	3"	2.25"	1.5"	0"
--------	-------	----	-------	------	----

THUS USE $d = 5"$ $b = 2.5"$ AND ACCEPT

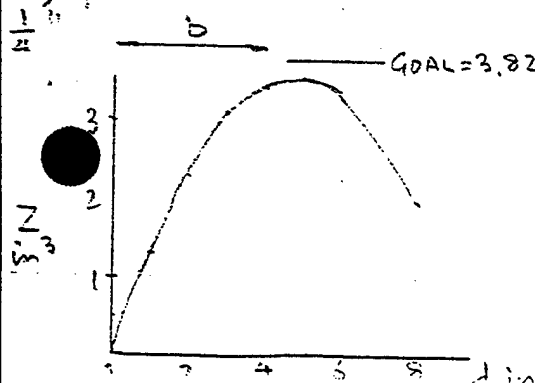

Z. BOTTOM PLATING

LOADING: HYDROSTATIC PRESSURE = 8 FT x 64
 = 512 psf = 3.56 psf

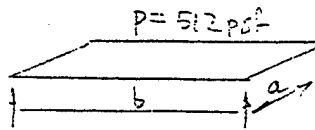

FROM SECTION I

$$\frac{b_{\max}}{t} = \sqrt{\frac{2 f_{\max}}{P}}$$

$$= \sqrt{\frac{2 \times 50,000}{3.56}}$$

$$\text{for } t = \frac{3}{16} \quad b_{\max} = 31.4 \text{ in}$$

ASSUME STRINGER SPACING OF 6 in

BOTTOM STRINGERS:

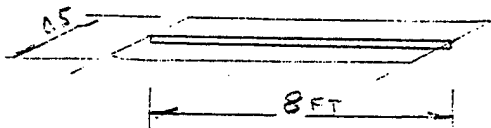

ASSUME STRINGER SPAN = 8 FT

SUPPORTS AREA 8 x 0.5

$$\text{LOAD / LINE } w = 6 \times 3.56$$

$$= 21.4 \text{ lb/in}$$

$$M = w l^2$$

$$= 21.4 \times 96^2$$

$$= 196,853 \text{ lb-in}$$

$$Z_{\min} = M / f_{\max}$$

$$= \frac{196,853}{50,000}$$

$$= 3.94 \text{ in}^3$$

USE STRINGERS T 5" x 2" ($\frac{1}{4}$ " FLANGE $\frac{3}{16}$ " WEB)
 (SAME AS DECK)

ALSO USE T 5" x 2" x $\frac{1}{4}$ / $\frac{3}{16}$
 A-11
 FOR BOTTOM TRUSS MEMBERS (5.1 lb/ft)

A.IV TRUSS ANALYSIS

I. TRANSVERSE BULKHEADS

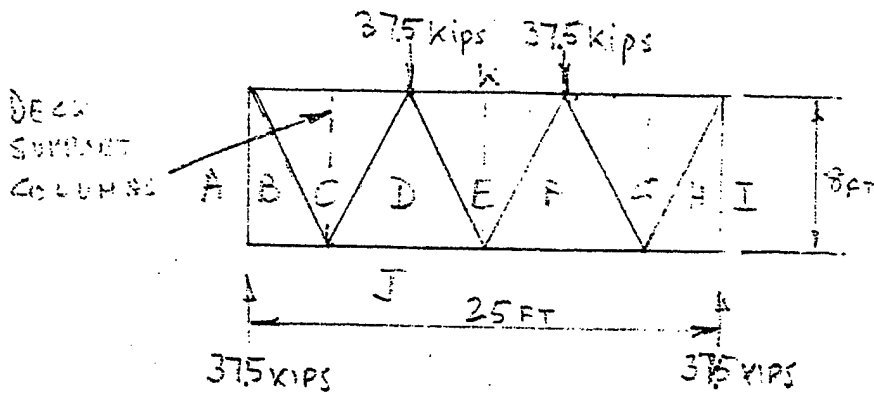

Worst Case Load

= ONE RTCH TIRE
OVER MEMBERS
CDE & EFG
(AS SKETCHED)

ASSUME 1/2 OF EACH
WHEEL LOAD IS TAKEN
BY LONGITRUSSES.

REDUCED BY LOADS
AT BOTTOM EDGES
MAX. LOAD IN ALL
DIAGONALS = ±42.5 kips

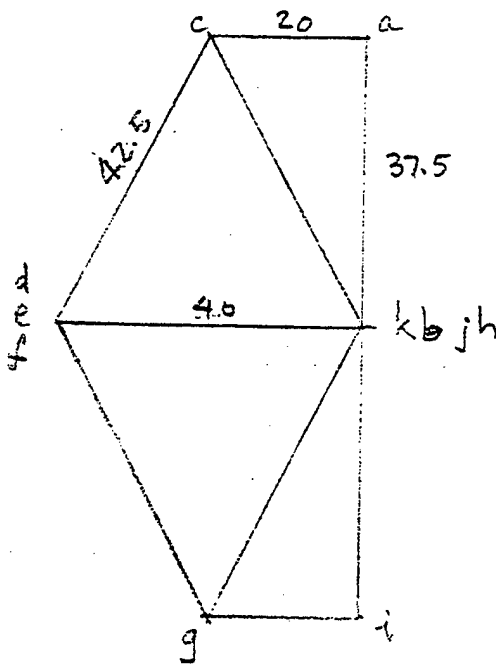

CRITICAL COLUMN LOAD:

$$P_c = n \pi^2 EI / l^2$$

$$n = 4 \text{ (BOTH ENDS FIXED)}$$

$$E = 29 \times 10^3 \text{ ksi}$$

$$l = 108''$$

$$P_c = 97.7 I \text{ kips}$$

$$\text{THUS } I_{\text{MIN}} = 42.5 / 97.7$$

$$= A-12$$

$$= 0.435 \text{ in}^4$$

2. LONGITUDINAL TRUSSES

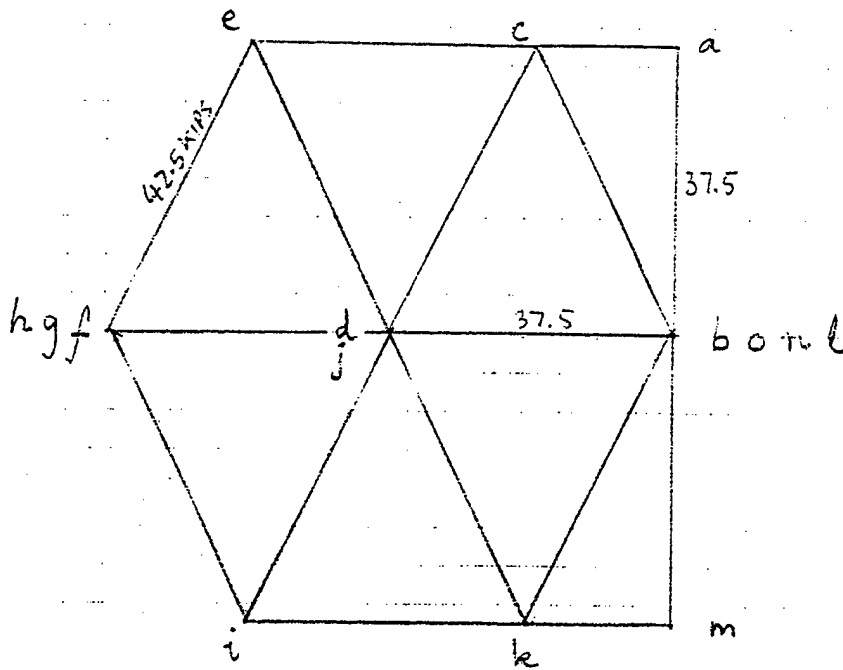
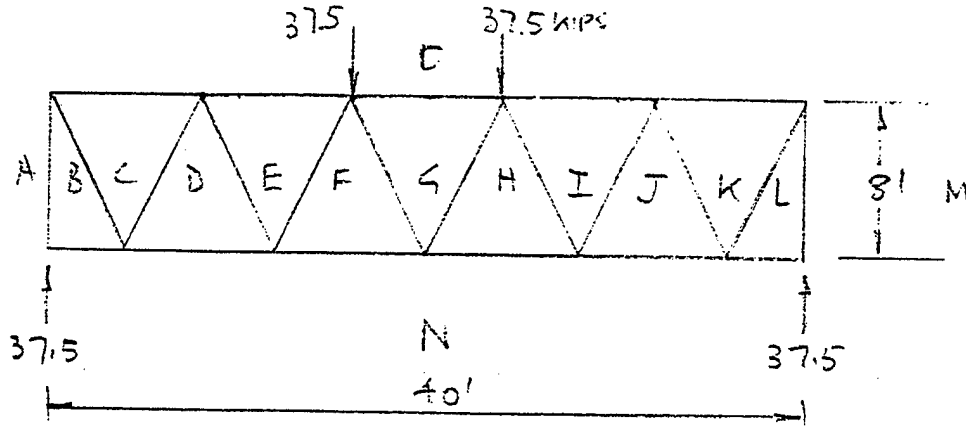

MAX. LOAD IN ALL DIAGONALS
= ±42.5 kips

MAX. LOAD IN HORIZONTALS
= 75 kips (OG, FN, M)

CRITICAL COLUMN LOADS:

$$OG: P_c = \frac{\pi^2 EI}{l^2} \quad l = 96''$$

$$= 124 I \quad P_c = 75 \text{ kips}$$

Thus $I_{MIN} = 0.60 \text{ m}^4$

A.V STRUCTURAL DESIGN

1. DECK - USE $1/4"$ PLATE, \perp $5" \times 2\frac{1}{2}" \times \frac{1}{4}"$ STIFFENERS
PANELS $96" \times 50" \times 5.25$ DEEP.

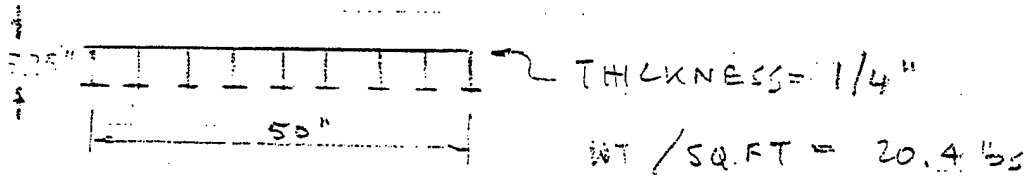
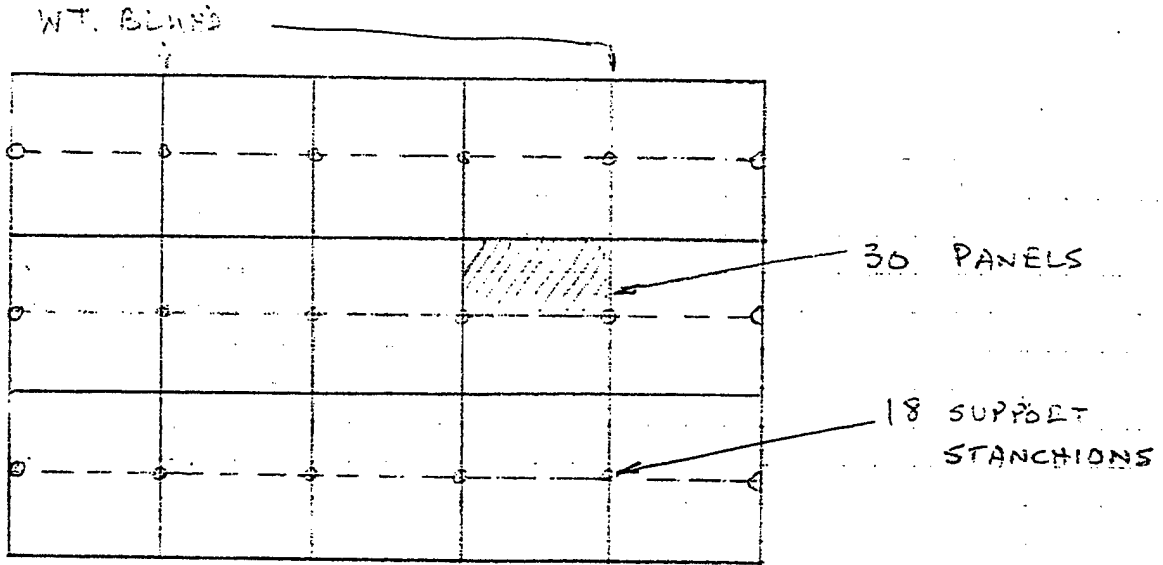

2. SIDE & BOTTOM PLATING

ASSUME $3/16"$ PLATE

WT/SQ.FT = 7.65 lbs

3. WATER TIGHT BULKHEADS

ASSUME $1/8"$ PLATE

WT/SQ.FT = 5.1 lbs

4. TRUSS MEMBERS

FOR ALL TRANSVERSE TRUSS MEMBERS: (EXCEPT DECK MEMBERS)

USE 3" x 1.64" x 0.17" STANDARD I (OR EQUIV)

$$A = 1.64 \text{ in}^2$$

$$I = 2.5 \text{ in}^4$$

$$\frac{I}{\text{MAX}} = 0.43 \text{ in}^4$$

$$\frac{I}{\text{MIN}} = 0.43 \text{ in}^4$$

$$\text{WT} = 5.7 \text{ lb/ft}$$

FOR LONGITUDINAL TRUSS DIAGONALS

USE 3" x 1.64" x 0.17" STANDARD I

FOR LONGITUDINAL TRUSS HORIZONTALS *

USE 3" x 2.17" x 0.300" STANDARD I

$$A = 2.17 \text{ in}^2$$

$$I = 2.9 \text{ in}^4$$

$$\frac{I}{\text{MAX}} = 0.59 \text{ in}^4$$

$$\frac{I}{\text{MIN}} = 0.59 \text{ in}^4$$

$$\text{WT} = 7.5 \text{ lb/ft}$$

FOR ALL BOX CORNERS #

USE 4 x 4 x 1/4" ANGLES (OR EQUIV)

$$A = 1.94 \text{ in}^2$$

$$I = 3.0 \text{ in}^4$$

$$\frac{I}{\text{MAX}} = 0.8 \text{ in}^4$$

$$\frac{I}{\text{MIN}} = 0.8 \text{ in}^4$$

$$\text{WT} = 6.6 \text{ lb/ft}$$

A-15

* FOR LONGITUDINAL DECK MEMBERS USE 5" x 2.5" x .25"

TRANSVERSE DECK BEAMS

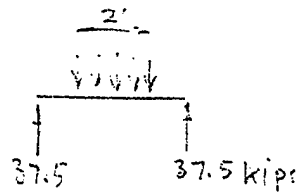
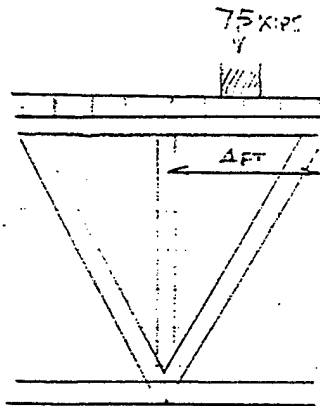

WORST LOAD = 75 kips ON CENTERED 2'
OF 4 FT BEAM

$$\begin{aligned}
 M_{\text{MAX}} &= \frac{2}{3} (37.5 \times 2 - 37.5 \times 0.5) \quad (\text{approx for fixed ends}) \\
 &= 37.5 \text{ kip}\cdot\text{in} \\
 &= 450 \text{ kip}\cdot\text{in}
 \end{aligned}$$

$$f_{\text{MA}} = 50 \text{ ksi}$$

$$\begin{aligned}
 Z_{\text{MIN}} &= 450 / 50 \text{ in}^3 \\
 &= 9 \text{ in}^3
 \end{aligned}$$

USE STANDARD I BEAM 7" x 3.66" x 0.25"

$$\text{WEIGHT} = 15.3 \text{ lb/ft.}$$

A.V WEIGHTS

PLATING: DECK 25 x 40 x 20.4 = 20,400 (INCLUDES DECK STRINGERS)

BOTTOM ENDS 25 x 40 } 20.4 x 7.65 = 15,600

SIDES 2 x 8 x 25 }

BOTTOM STIFFENERS 45 x 40 x 5.1 = 9,180

WT. BLK 40S 2 x 8 x 25 x 5.1 = 2,040

ALLOWANCE FOR END AND JOE STIFFENERS 5,000

TOTAL PLATING 52,220

BOX CORNERS (4 x 40 + 4 x 8 + 4 x 25) x 6.6 = 1,927

TRUSSES:

LONG'L BOTTOM BEAMS 2 x 40 x 5.1 = 408

TRANS. DECK BEAMS 4 x 35 x 15.3 = 1530

TRANS. BOTTOM BEAMS 4 x 25 x 5.1 = 510

DIAGONALS (10 x 4 + 6 x 6) x 9 x 5.7 = 3390

TOTAL TRUSSES = 6347 (EXC. CORNERS)

DECK SUPPORT STANCHIONS:

15 x 8 x 5.7 = 821 821 lb

TOTAL BASIC STRUCTURE 61,321

DOES NOT INCLUDE:

ALLOWANCE FOR WELDING
GUSSET PLATES ETC.
HATCHES
MARINE FITTINGS

(CHEATS, TIE DOWNS, LIFTING POINTS ETC.)
INTER-PLATFORM CONNECTORS
PAINT

ESTIMATE } 9450

TOTAL 70,771

A. VI JOINT DETAILS

1. UPPER INTERSECTION OF LONG'L & TRANS. FRAMES

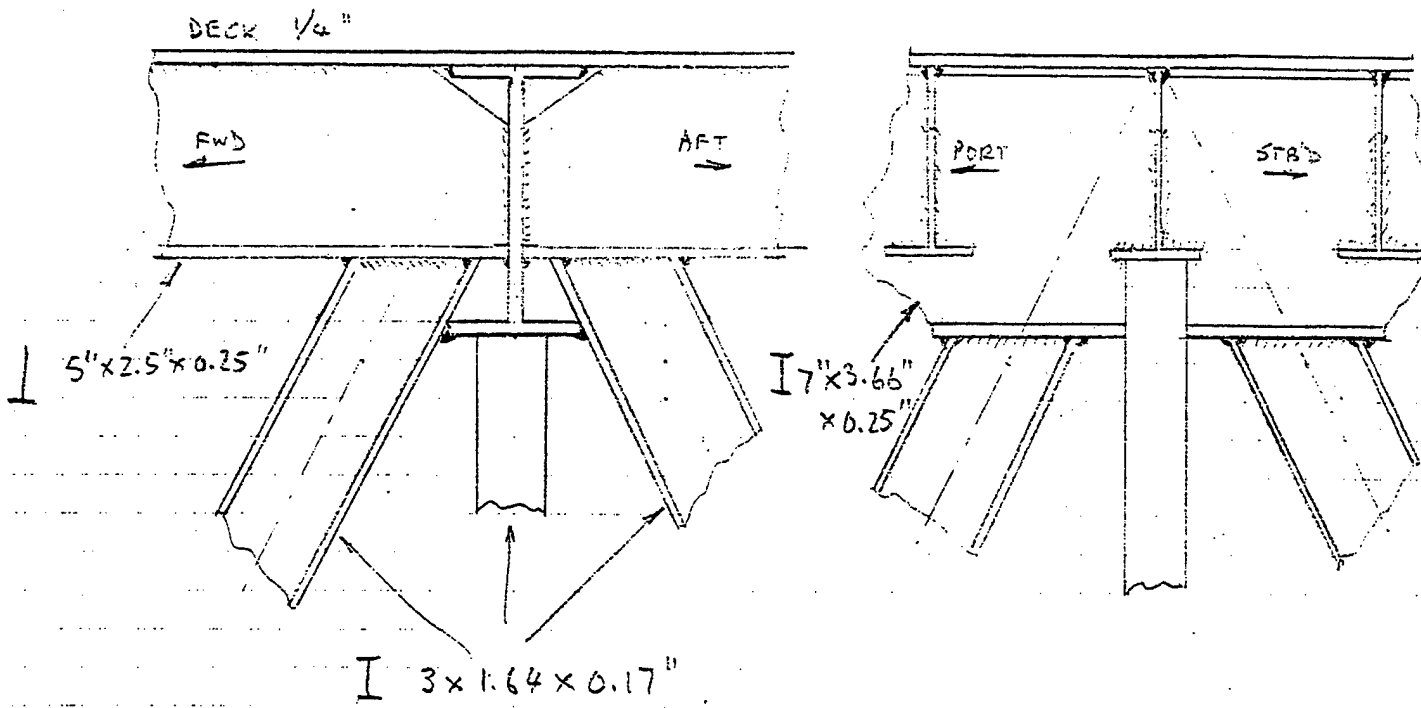

2. AT WATER-TIGHT BULKHEADS REPLACE I BY II :

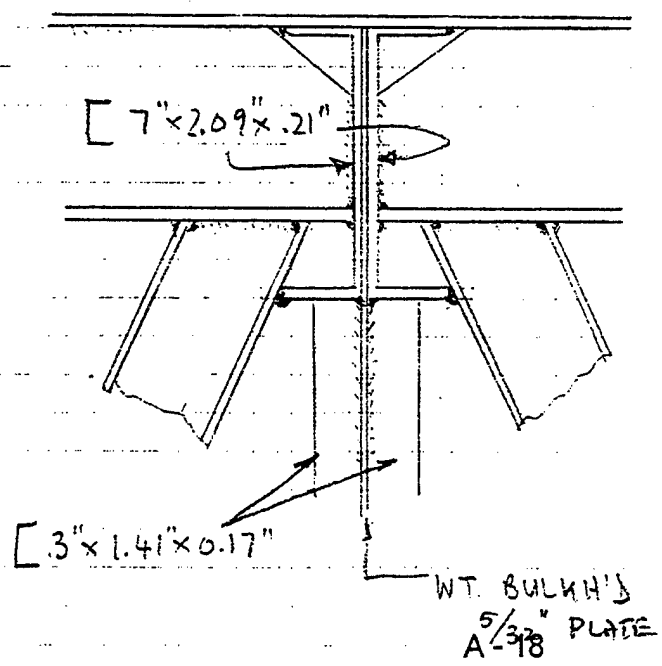

3. LOWER INTERSECTION OF TRANS. & LONG'L FRAMES

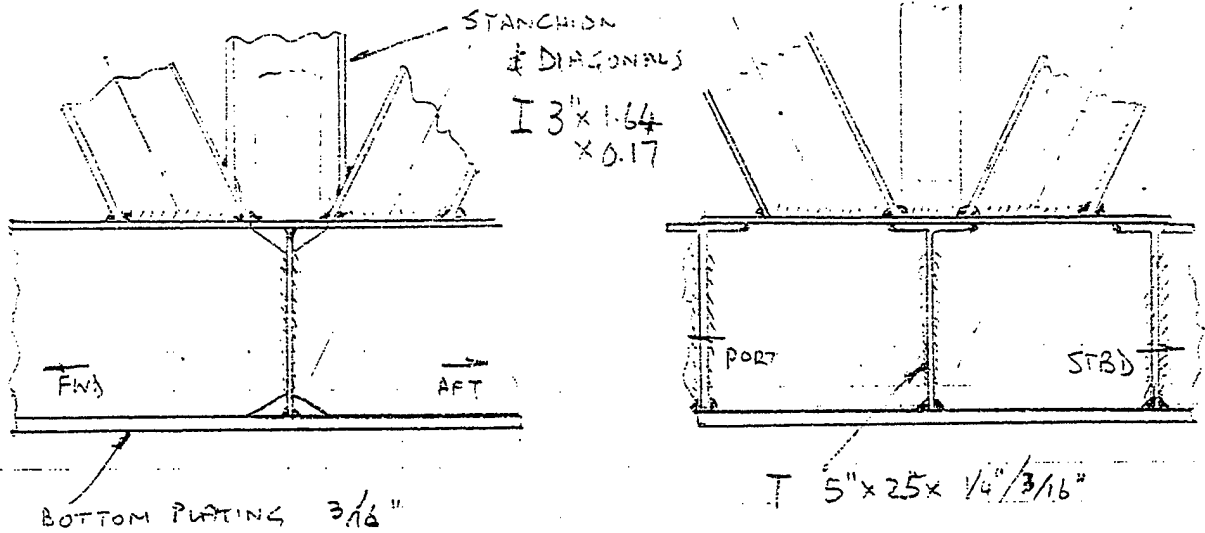

NOTE. FOR WATER-TIGHT TRANSVERSE BULKHEAD USE
TREATMENT SIMILAR TO THAT IN VI .1

A.VII ALTERNATIVE DECK OF EXTRUDED ALUMINUM

FROM A.III

IF ALUMINUM DECK IS TO REPLACE STEEL

① PLATING THICKNESS SHOULD BE
ADEQUATE FOR 130 PSI/SQ IN
6 INCH WIDTH (b)

② SECTION MODULUS FOR 8 FT SPAN
AND 4 FT WIDTH = $\frac{30.6 \times 50}{35}$
= 43.7 in^3

③ ALUMINUM YIELD STRESS = 35,000 PSI

④ ALUMINUM DENSITY = 0.1 lb/in³

FROM A.I

$$\frac{b_{max}}{t} = \sqrt{\frac{2 \times P}{\sigma}} = \sqrt{\frac{2 \times 35000}{130}}$$

$$= 23.2$$

if $b_{max} = 6"$ $t = \frac{6}{23.2}$
 $= 0.26 \text{ in}$

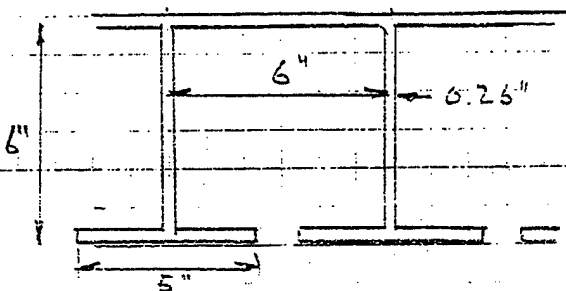

ASSUME 8 STIFFENERS

$$I = \frac{tw^d^3}{4} + \frac{d^3t}{12}$$

$$= \frac{td^2}{4} \left(w + \frac{d}{3} \right)$$

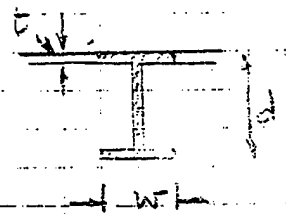

$$Z = \frac{2I}{d} = \frac{td}{2} \left(w + \frac{d}{3} \right)$$

if $Z = 5.46 \text{ in}^3$, $d = 6"$ and $t = 0.26"$

$$w = \frac{2Z}{td} - \frac{d}{3} = 5"$$

X SECT AREA PER 6" WIDTH
= $(6 + 6 + 5) \times 0.26$
= 4.42 in^2

WEIGHT OF 8 X A-20 PANEL = $4.42 \times 8 \times 96 \times 0.10$
= 339.5 lb

WEIGHT OF 21 X A-20 PANEL = 1212.1 lb

APPENDIX B
Weight Analysis

The weights of a number of ACB Lighter module configurations have been analysed on a comparative basis using some common general assumptions but with specific variations in such things as plating thicknesses and frame spacing. The results are shown in the Tables below.

TABLE 1. WEIGHT BREAKDOWN OF 40' X 24' X 8' HIGH ACB LIGHTER

Component	Type/ Comments	Units Reqd.	FEET			Steel Ft Cubed	% used	Total Wt lbs	% of Total Wt
			Length	Width	Ht				
1 Top Skin	(With stiffeners	1	40	24	1	20.00	100.00%	9,792	12.61%
2 Bottom Skin	@ 6" spacing)	1	40	24	1	20.00	100.00%	9,792	12.61%
3 Side Skin	3/16"	2	40	1	8	10.00	100.00%	4,896	6.30%
4 End Skin	3/16"	2	24	1	8	6.00	100.00%	2,938	3.78%
5 Top Skin Stiffeners "T" section	5"X2 1/2"X3/16"	44	40	0.625	1	17.19	100.00%	8,415	10.84%
6 Bottom Skin Stiffeners "T" section	5"X2 1/2"X3/16"	44	40	0.625	1	17.19	100.00%	8,415	10.84%
7 Longitudinal Frames	5/32"	8	40	1	8	33.33	40.00%	6,528	8.41%
8 Watertight bulkheads (Transverse)	5/32"	2	24	1	8	5.00	100.00%	2,448	3.15%
9 Transverse Frames	5/32"	5	24	1	8	12.50	40.00%	2,448	3.15%
10 Reinforce angle (vertical)	3"X3"X3/16"	168	1	0.5	8	10.50	100.00%	5,141	6.62%
11 Reinforce angle (horizontal)	3"X3"X3/16"	168	5	0.5	1	6.56	100.00%	3,213	4.14%
12 Reinforce angle (lateral)	3"X3"X3/16"	168	2.67	0.5	1	3.50	100.00%	1,716	2.21%
13 Reinforce angle (diagonal)	3"X3"X3/16"	35	9.43	0.5	1	2.58	100.00%	1,262	1.63%
14 ISO Corner fittings									
15 Deck Fittings								200	0.26%
16 Support structure for Connectors								750	0.97%
17 Paint and miscell., fittings								1,000	1.29%
18 Welding bead allowance								1,000	1.29%
19 Connector Hardware								1,200	1.55%
20 Fenders								5,000	6.44%
21 Stowed Items								1,000	1.29%
Weight Steel - lbs per cubic foot =	489.6							500	0.64%

Items in this section are best guesses

FRAME SPACING = 60" X 32"
(Transverse Watertight Bulkheads)

Total (lbs)=	77,654
Long Tons=	34.67

TABLE 2. WEIGHT BREAKDOWN OF 40' X 24' X 6' HIGH ACB LIGHTER

Component	Type/ Comments	Units Rqrd.	FEET			Steel Ft Cubed	% used	Total Wt lbs	% of Total Wt
			Length	Width	Ht				
1 Top Skin	(With stiffeners	1	40	24	1	20.00	100.00%	9,792	13.76%
2 Bottom Skin	@ 6" spacing)	1	40	24	1	20.00	100.00%	9,792	13.76%
3 Side Skin	3/16"	2	40	1	6	7.50	100.00%	3,672	5.16%
4 End Skin	3/16"	2	24	1	6	4.50	100.00%	2,203	3.10%
5 Top Skin Stiffeners "T" section	5"X2 1/2"X3/16"	44	40	0.625	1	17.19	100.00%	8,415	11.82%
6 Bottom Skin Stiffeners "T" section	5"X2 1/2"X3/16"	44	40	0.625	1	17.19	100.00%	8,415	11.82%
7 Longitudinal Frames	5/32"	6	40	1	6	18.75	40.00%	3,672	5.16%
8 Watertight bulkheads (longitudinal)	5/32"	2	40	1	6	6.25	100.00%	3,060	4.30%
9 Transverse Frames	5/32"	7	24	1	6	13.13	40.00%	2,570	3.61%
10 Reinforce angle (vertical)	3"X3"X3/16"	168	1	0.5	6	7.88	100.00%	3,856	5.42%
11 Reinforce angle (horizontal)	3"X3"X3/16"	168	5	0.5	1	6.56	100.00%	3,213	4.51%
12 Reinforce angle (lateral)	3"X3"X3/16"	168	2.67	0.5	1	3.50	100.00%	1,716	2.41%
13 Reinforce angle (diagonal)	3"X3"X3/16"	35	7.8	0.5	1	2.13	100.00%	1,044	1.47%
14 ISO Corner fittings								200	0.28%
15 Deck Fittings								750	1.05%
16 Support structure for Connectors								750	1.05%
17 Paint and miscell., fittings								750	1.05%
18 Welding bead allowance								1,300	1.83%
19 Connector Hardware								4,500	6.32%
20 Fenders								1,000	1.41%
21 Stowed Items								500	0.70%

Items in this section are best guesses

FRAME SPACING = 60" X 32"
(Longitudinal Watertight Bulkheads)

Weight Steel - lbs per cubic foot =	489.6	
Steel Plate Thickness	5/32" =	0.013021
	3/16" =	0.015625
	1/4" =	0.020834
	5/16" =	0.026042
	3/8" =	0.03125

Total (lbs) =	71,171
Long Tons =	31.77

TABLE 3. WEIGHT BREAKDOWN OF 40' X 24' X 8' HIGH ACB LIGHTER

Component	Type/ Comments	Units Reqd.	FEET			Steel Ft Cubed	% used	Total Wt lbs	% of Total Wt
			Length	Width	Ht				
1 Top Skin	(With stiffeners @ 6" spacing)	1	40	24	1	20.00	100.00%	9,792	12.45%
2 Bottom Skin		1	40	24	1	20.00	100.00%	9,792	12.45%
3 Side Skin		2	40	1	8	10.00	100.00%	4,896	6.23%
4 End Skin		2	24	1	8	6.00	100.00%	2,938	3.74%
5 Top Skin Stiffeners "T" section	5"X2 1/2"X3/16"	44	40	0.625	1	17.19	100.00%	8,415	10.70%
6 Bottom Skin Stiffeners "T" section	5"X2 1/2"X3/16"	44	40	0.625	1	17.19	100.00%	8,415	10.70%
7 Longitudinal Frames	5/32"	6	40	1	8	25.00	40.00%	4,896	6.23%
8 Watertight bulkheads (Longitudinal)	5/32"	2	40	1	8	8.33	100.00%	4,080	5.19%
9 Transverse Frames	5/32"	7	24	1	8	17.50	40.00%	3,427	4.36%
10 Reinforce angle (vertical)	3"X3"X3/16"	168	1	0.5	8	10.50	100.00%	5,141	6.54%
11 Reinforce angle (horizontal)	3"X3"X3/16"	168	5	0.5	1	6.56	100.00%	3,213	4.09%
12 Reinforce angle (lateral)	3"X3"X3/16"	168	2.67	0.5	1	3.50	100.00%	1,716	2.18%
13 Reinforce angle (diagonal)	3"X3"X3/16"	35	9.43	0.5	1	2.58	100.00%	1,262	1.61%
14 ISO Corner fittings								200	0.25%
15 Deck Fittings								750	0.95%
16 Support structure for Connectors								1,000	1.27%
17 Paint and miscell., fittings								1,000	1.27%
18 Welding bead allowance								1,200	1.53%
19 Connector Hardware								5,000	6.36%
20 Fenders								1,000	1.27%
21 Stowed Items								500	0.64%

Items in this section are best guesses

FRAME SPACING = 60" X 32"
(Longitudinal Watertight Bulkheads)

Total (lbs)=	78,634
Long Tons=	35.10

TABLE 4. WEIGHT BREAKDOWN OF 40' X 24' X 6' HIGH ACB LIGHTER

Component	Type/ Comments	Units Rqrd.	FEET			Steel Ft Cubed	% used	Total Wt lbs	% of Total Wt
			Length	Width	Ht				
1 Top Skin	(With stiffeners @ 6" spacing)	1	40	24	1	20.00	100.00%	9,792	14.89%
2 Bottom Skin	3/16"	1	40	24	1	20.00	100.00%	9,792	14.89%
3 Side Skin	3/16"	2	40	1	6	7.50	100.00%	3,672	5.58%
4 End Skin	3/16"	2	24	1	6	4.50	100.00%	2,203	3.35%
5 Top Skin Stiffeners "T" section	5"X2 1/2"X3/16"	44	40	0.625	1	17.19	100.00%	8,415	12.80%
6 Bottom Skin Stiffeners "T" section	5"X2 1/2"X3/16"	44	40	0.625	1	17.19	100.00%	8,415	12.80%
7 Longitudinal Frames	5/32"	5	40	1	6	15.63	40.00%	3,060	4.65%
8 Watertight bulkheads (transverse)	5/32"	2	24	1	6	3.75	100.00%	1,836	2.79%
9 Transverse Frames	5/32"	3	24	1	6	5.63	40.00%	1,102	1.68%
10 Reinforce angle (vertical)	3"X3"X3/16"	144	1	0.5	6	6.75	100.00%	3,305	5.03%
11 Reinforce angle (horizontal)	3"X3"X3/16"	120	5	0.5	1	4.69	100.00%	2,295	3.49%
12 Reinforce angle (lateral)	3"X3"X3/16"	144	2.67	0.5	1	3.00	100.00%	1,471	2.24%
13 Reinforce angle (diagonal)	3"X3"X3/16"	35	7.8	0.5	1	2.13	100.00%	1,044	1.59%
14 ISO Corner fittings								200	0.30%
15 Deck Fittings								750	1.14%
16 Support structure for Connectors								750	1.14%
17 Paint and miscell., fittings								750	1.14%
18 Welding bead allowance								900	1.37%
19 Connector Hardware								4,500	6.84%
20 Fenders								1,000	1.52%
21 Stowed Items								500	0.76%

Items in this section are best guesses

FRAME SPACING = 96" X 48"
(Transverse Watertight Bulkheads)

Total (lbs)=	65,752
Long Tons=	29.35

Weight Steel - lbs per cubic foot =	489.6	
Steel Plate Thickness	5/32" =	0.013021 ft
	3/16" =	0.015625 ft
	1/4" =	0.020834 ft
	5/16" =	0.026042 ft
	3/8" =	0.03125 ft

TABLE 5. WEIGHT BREAKDOWN OF 40' X 24' X 7' HIGH ACB LIGHTER

Component	Type/ Comments	Units Rqrd.	FEET			Steel Ft Cubed	% used	Total Wt lbs	% of Total Wt
			Length	Width	Ht				
1 Top Skin	(With stiffeners @ 6" spacing)	1	40	24	1	20.00	100.00%	9,792	13.76%
2 Bottom Skin		1	40	24	1	20.00	100.00%	9,792	13.76%
3 Side Skin	3/16"	2	40	1	7	8.75	100.00%	4,284	6.02%
4 End Skin	3/16"	2	24	1	7	5.25	100.00%	2,570	3.61%
5 Top Skin Stiffeners "T" section	5"X2 1/2"X3/16"	44	40	0.625	1	17.19	100.00%	8,415	11.83%
6 Bottom Skin Stiffeners "T" section	5"X2 1/2"X3/16"	44	40	0.625	1	17.19	100.00%	8,415	11.83%
7 Longitudinal Frames	5/32"	5	40	1	7	18.23	40.00%	3,570	5.02%
8 Watertight bulkheads (Transverse)	5/32"	2	24	1	7	4.38	100.00%	2,142	3.01%
9 Transverse Frames	5/32"	3	24	1	7	6.56	40.00%	1,285	1.81%
10 Reinforce angle (vertical)	3"X3"X3/16"	144	1	0.5	7	7.88	100.00%	3,856	5.42%
11 Reinforce angle (horizontal)	3"X3"X3/16"	120	7	0.5	1	6.56	100.00%	3,213	4.52%
12 Reinforce angle (lateral)	3"X3"X3/16"	144	4	0.5	1	4.50	100.00%	2,203	3.10%
13 Reinforce angle (diagonal)	3"X3"X3/16"	35	10.6	0.5	1	2.90	100.00%	1,419	1.99%
14 ISO Corner fittings								200	0.28%
15 Deck Fittings								750	1.05%
16 Support structure for Connectors								900	1.26%
17 Paint and miscell., fittings								900	1.26%
18 Welding bead allowance								950	1.34%
19 Connector Hardware								5,000	7.03%
20 Fenders								1,000	1.41%
21 Stowed Items								500	0.70%

Items in this section are best guesses

FRAME SPACING = 96" X 48"
(Transverse Watertight Bulkheads)

Total (lbs)=	71,157
Long Tons=	31.77

Weight Steel - lbs per cubic foot =	489.6	
Steel Plate Thickness	5/32" =	ft
	3/16" =	ft
	1/4" =	ft
	5/16" =	ft
	3/8" =	ft

TABLE 6. WEIGHT BREAKDOWN OF 40' X 24' X 8' HIGH ACB LIGHTER

Component	Type/ Comments	Units Rqrd.	FEET			Steel Ft Cubed	% used	Total Wt lbs	% of Total Wt
			Length	Width	Ht				
1 Top Skin	(With stiffeners @ 6" spacing)	1	40	24	1	20.00	100.00%	9,792	13.15%
2 Bottom Skin	3/16"	1	40	24	1	20.00	100.00%	9,792	13.15%
3 Side Skin	3/16"	2	40	1	8	10.00	100.00%	4,896	6.57%
4 End Skin	3/16"	2	24	1	8	6.00	100.00%	2,938	3.94%
5 Top Skin Stiffeners "T" section	5"X2 1/2"X3/16"	44	40	0.625	1	17.19	100.00%	8,415	11.30%
6 Bottom Skin Stiffeners "T" section	5"X2 1/2"X3/16"	44	40	0.625	1	17.19	100.00%	8,415	11.30%
7 Longitudinal Frames	5/32"	5	40	1	8	20.83	40.00%	4,080	5.48%
8 Watertight bulkheads (Transverse)	5/32"	2	24	1	8	5.00	100.00%	2,448	3.29%
9 Transverse Frames	5/32"	3	24	1	8	7.50	40.00%	1,469	1.97%
10 Reinforce angle (vertical)	3"X3"X3/16"	144	1	0.5	8	9.00	100.00%	4,406	5.92%
11 Reinforce angle (horizontal)	3"X3"X3/16"	120	8	0.5	1	7.50	100.00%	3,672	4.93%
12 Reinforce angle (lateral)	3"X3"X3/16"	144	4	0.5	1	4.50	100.00%	2,203	2.96%
13 Reinforce angle (diagonal)	3"X3"X3/16"	35	11.3	0.5	1	3.09	100.00%	1,513	2.03%
14 ISO Corner fittings								200	0.27%
15 Deck Fittings								750	1.01%
16 Support structure for Connectors								1,000	1.34%
17 Paint and miscell., fittings								1,000	1.34%
18 Welding bead allowance								1,000	1.34%
19 Connector Hardware								5,000	6.71%
20 Fenders								1,000	1.34%
21 Stowed Items								500	0.67%

Items in this section are best guesses

FRAME SPACING = 96" X 48"
(Transverse Watertight Bulkheads)

Total (lbs) =	74,490
Long Tons =	33.25

TABLE 7. WEIGHT BREAKDOWN OF 40' X 24' X 7' HIGH ACB LIGHTER

Component	Type/ Comments	Units Rqrd.	FEET			Steel Ft Cubed	% used	Total Wt lbs	% of Total Wt
			Length	Width	Ht				
1 Aluminum Deck Panels	Extruded Panels		40	24					
2 Bottom Skin	"T"- 6" spng)	1	40	24	1	20.00	10,186	14.31%	
3 Side Skin	3/16"	2	40	1	7	8.75	9,792	13.76%	
4 End Skin	3/16"	2	24	1	7	5.25	4,284	6.02%	
5 Top Skin Stiffeners "T" section	NOT USED						2,570	3.61%	
6 Bottom Skin Stiffeners "T" section	5"X2 1/2"X3/16"	44	40	0.625	1	17.19			
7 Longitudinal Frames	5/32"	5	40	1	7	18.23	8,415	11.83%	
8 Watertight bulkheads (Transverse)	5/32"	2	24	1	7	4.38	3,570	5.02%	
9 Transverse Frames	5/32"	3	24	1	7	6.56	2,142	3.01%	
10 Reinforce angle (vertical)	3"X3"X3/16"	144	1	0.5	7	7.88	1,285	1.81%	
11 Reinforce angle (horizontal)	3"X3"X3/16"	120	7	0.5	1	6.56	3,856	5.42%	
12 Reinforce angle (lateral)	3"X3"X3/16"	144	4	0.5	1	4.50	3,213	4.52%	
13 Reinforce angle (diagonal)	3"X3"X3/16"	35	10.6	0.5	1	2.90	2,203	3.10%	
14 ISO Corner fittings							1,419	1.99%	
15 Deck Fittings							200	0.28%	
16 Support structure for Connectors							2,500	3.51%	
17 Paint and miscell., fittings							900	1.26%	
18 Welding bead allowance							2,000	2.81%	
19 Connector Hardware							800	1.12%	
20 Fenders							5,000	7.03%	
21 Stowed Items							1,000	1.41%	
Weight Steel - lbs per cubic foot = 489.6							500	0.70%	

(Note increased weight estimate to allow for hardware to secure aluminum panels)

(Note increased weight estimate to allow for special deck coating)

Items in this section are best guesses

FRAME SPACING = 96" X 48"
(Transverse Watertight Bulkheads)
(ALUMINUM DECK PANELS)

Total (lbs)=	65,835
Long Tons=	29.39

TABLE 8 OUTER. WEIGHT BREAKDOWN OF 40' X 8' X 8' HIGH OUTER TRI-MODULE

Component	Type/ Comments	Units Rqrd.	FEET			Steel Ft Cubed	% used	Total Wt lbs	% of Total Wt
			Length	Width	Ht				
1 Top Skin	(With stiffeners @ 6" spacing)	1	40	8	1	6.67	100.00%	3,264	4.38%
2 Bottom Skin	1/4"	1	40	8	1	6.67	100.00%	3,264	4.38%
3 Side Skin	1/4"	2	40	1	8	13.33	100.00%	6,528	8.76%
4 End Skin	1/4"	2	8	1	8	2.67	100.00%	1,306	1.75%
5 Top Skin Stiffeners "T" section	5"X2 1/2"X1/4"	12	40	0.625	1	6.25	100.00%	3,060	4.11%
6 Bottom Skin Stiffeners "T" section	5"X2 1/2"X1/4"	12	40	0.625	1	6.25	100.00%	3,060	4.11%
7 Longitudinal Frames	3/16"	1	40	1	8	5.00	40.00%	979	1.31%
8 Watertight bulkheads (Transverse)	3/16"	2	8	1	8	2.00	100.00%	979	1.31%
9 Transverse Frames	3/16"	3	8	1	8	3.00	40.00%	588	0.79%
10 Reinforce angle (vertical)	3"X3"X1/4"	48	1	0.5	8	4.00	100.00%	1,958	2.63%
11 Reinforce angle (horizontal)	3"X3"X1/4"	40	8	0.5	1	3.33	100.00%	1,632	2.19%
12 Reinforce angle (lateral)	3"X3"X1/4"	48	4	0.5	1	2.00	100.00%	979	1.31%
13 Reinforce angle (diagonal)	3"X3"X1/4"	12	11.3	0.5	1	1.41	100.00%	692	0.93%
14 ISO Corner fittings									
15 Deck Fittings									
16 Support structure for Connectors									
17 Paint and miscell., fittings									
18 Welding bead allowance									
19 Connector Hardware									
20 Fenders									
21 Stowed items									
Weight Steel - lbs per cubic foot =	489.6								
Steel Plate Thickness	5/32" =	0.013021							
	3/16" =	0.015625							
	1/4" =	0.020834							
	5/16" =	0.026042							
	3/8" =	0.03125							

Items in this section are best guesses

FRAME SPACING = 96" X 48"
(Transverse Watertight Bulkheads)

Total (lbs) =	32,990
Long Tons =	14.73

TABLE 9 CENTER. WEIGHT BREAKDOWN OF 40' X 8' X 8' HIGH CENTER TRI-MODULE

Component	Type/ Comments	Units Rqrd.	FEET			Thickness	Steel Ft Cubed	% used	Total Wt lbs	% of Total Wt
			Length	Width	Ht					
1 Top Skin	(With stiffeners @ 6" spacing)	1	40	8	1	0.020834	6.67	100.00%	3,264	4.38%
2 Bottom Skin	1/4"	1	40	8	1	0.020834	6.67	100.00%	3,264	4.38%
3 Side Skin	1/4"	2	40	1	8	0.020834	13.33	100.00%	6,528	8.76%
4 End Skin	1/4"	2	8	1	8	0.020834	2.67	100.00%	1,306	1.75%
5 Top Skin Stiffeners "T" section	5"X2 1/2"X3/16"	12	40	0.625	1	0.020834	6.25	100.00%	3,060	4.11%
6 Bottom Skin Stiffeners "T" section	5"X2 1/2"X3/16"	12	40	0.625	1	0.020834	6.25	100.00%	3,060	4.11%
7 Longitudinal Frames	3/16"	1	40	1	8	0.015625	5.00	40.00%	979	1.31%
8 Watertight bulkheads (Transverse)	3/16"	2	8	1	8	0.015625	2.00	100.00%	979	1.31%
9 Transverse Frames	3/16"	3	8	1	8	0.015625	3.00	40.00%	588	0.79%
10 Reinforce angle (vertical)	3"X3"X1/4"	48	1	0.5	8	0.020834	4.00	100.00%	1,958	2.63%
11 Reinforce angle (horizontal)	3"X3"X1/4"	40	8	0.5	1	0.020834	3.33	100.00%	1,632	2.19%
12 Reinforce angle (lateral)	3"X3"X1/4"	48	4	0.5	1	0.020834	2.00	100.00%	979	1.31%
13 Reinforce angle (diagonal)	3"X3"X1/4"	12	11.3	0.5	1	0.020834	1.41	100.00%	692	0.93%
14 ISO Corner fittings									100	0.13%
15 Deck Fittings									200	0.27%
16 Support structure for Connectors									0	0.00%
17 Paint and miscell., fittings									350	0.47%
18 Welding bead allowance									350	0.47%
19 Connector Hardware									0	0.00%
20 Fenders									0	0.00%
21 Stowed items									500	0.67%

Items in this section are best guesses

FRAME SPACING = 96" X 48"
(Transverse Watertight Bulkheads)

Total (lbs) = 29,790
Long Tons = 13.30

Total (lbs) = 95,769
Long Tons = 42.75

FOR TWO OUTER AND ONE CENTER MODULES

APPENDIX C

Structural & Weight Analysis - Tri-Module Design

DESIGN REQUIREMENTS

The ACB lighter consists of three rectangular boxes, called Tri-Modules, each 40 feet long by 8 feet wide by 8 feet deep. It is required to be compatible with existing Navy and Army pontoons, transportable in existing container ships and capable of handling existing vehicular traffic.

DESIGN LOADS

The most severe deck load is assumed to be the wheel load of a loaded Rough Terrain Container Handler (RTCH). This load is 75,000 lb on each of two wheels spread over an area 2-foot square. (equivalent to a pressure of 130 psi); the wheels are assumed to be 10 feet apart in any orientation. These loads can be applied anywhere on the deck when the ACB lighter is either floating or stranded, when it is assumed to be supported by two diagonally opposite corners.

The bottom structure is assumed to be capable of resisting a hydrostatic pressure equivalent to 8 feet of water (equivalent to 3.56 psi). 8 feet is about twice the draft of the ACB lighter when its total loaded weight is 250,000 lb. The bottom must also be capable of withstanding the loads due to grounding. It has been assumed, conservatively that these grounding loads could be similar in magnitude and arrangement to the RTCH wheel loads which turn out to be much more severe than the hydrostatic pressure. The bottom has been designed in exactly the same way as the deck. The sides are expected to withstand appropriate hydrostatic pressures and normal service handling loads.

CONCEPTUAL STRUCTURAL DESIGN

To achieve a low cost design and for ease of manufacture it was decided to use mild steel for all structural components and to use 1/4 inch plating throughout. These factors were taken as basic ground rules. It was also assumed that the steel used for all structural members would have an allowable stress of 30,000 psi.

Structural Layout

It was assumed that the basic internal structure of the lighter would consist of a longitudinally stiffened deck, supported by a number of transverse frames. Longitudinal bending would be resisted by two longitudinal trusses which would be located at each side of the box. This layout was maintained throughout the analysis. It was subsequently found to be advantageous to include one vertical stanchion and two diagonal braces in each transverse frame, as sketched in Appendix A.3.3.5.

Plating Design

Initial calculations showed that 1/4" deck plate would require stiffeners no more than 6" apart to support the required 130 psi tire pressure load (Section A.3).

Frame Design

A brief analysis (A.3.3.4) indicated that a transverse frame spacing of 5 feet would result in the minimum total weight for deck, stiffeners and frames, so this spacing was adopted. The longitudinal trusses (A.4) were designed to suit this frame spacing and were assumed to be built into the sides of the box. The design load was assumed to occur when one RTCH wheel was centered approximately over each of two adjacent bulkhead intersections. The horizontal frame beams at the deck and bottom have to support all of the plating loads transmitted through the stiffeners.

Sizes selected for the truss components are as follows:

Diagonal truss members	Standard channel	4 x 1.72 x 0.32"
Transverse beams	Standard I	10 x 4.66 x 0.31"
Longitudinal beams	Standard channel	4 x 1.72 x 0.32"
Trans. & Long. bottom beams	T	5 x 2.50 x 0.25"
Verticals	Standard channel	4 x 1.72x 0.32"
Deck plating		1/4"
Bottom & side plating		1/4"
Deck & bottom stiffeners (6" spacing)	T	4 x 2.7 x 0.25"

WEIGHTS

A preliminary weight estimate is shown in section A.5. Total basic structural weight estimate is 31699 lb. No allowance has been made for fittings, connectors, welding etc.

DESIGN DETAILS

Typical truss intersections are sketched in section A.6. At the water-tight bulkheads the I-section members can be replaced by two back-to-back channel members.

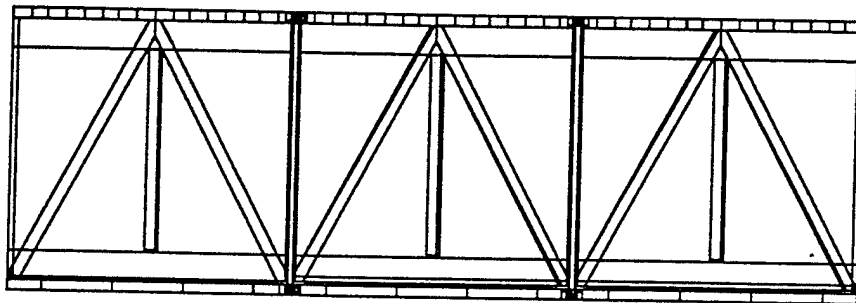

APPENDIX A
TRIMODULE CONCEPT

A.1 DESIGN LOAD CASES:

1.1 FLOATING

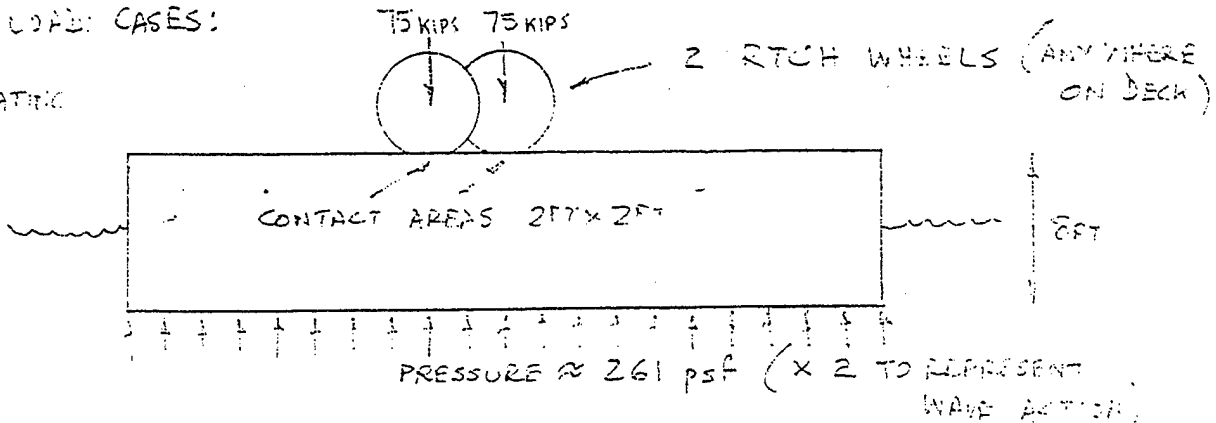

1.2 GROUNDED

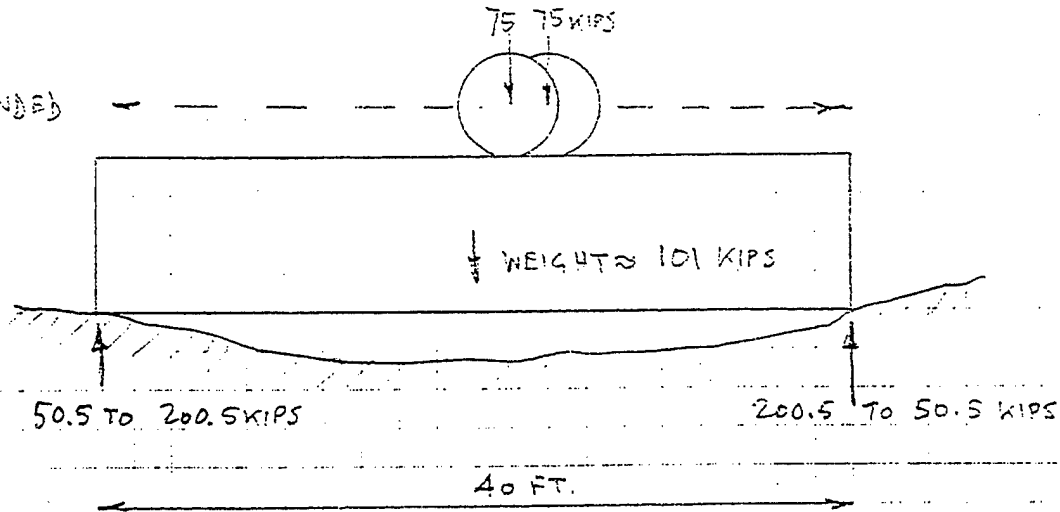

A.2 DESIGN PRESSURES:

DECK PRESSURE = 18,750 psf OVER TWO 2X2 FT. AREAS 8 FT. APART.

BOTTOM PRESSURE } = 522 psf OVER WHOLE AREA.
SIDE PRESSURE }
END PRESSURE }

A.3 PLATING / STIFFENER DESIGN

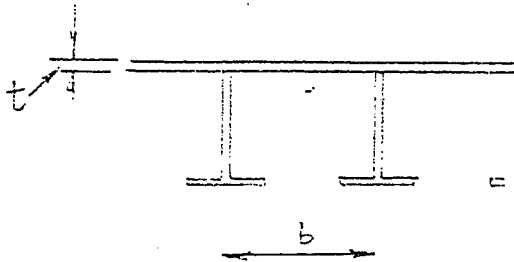

FROM PREVIOUS WORK IN REF 1*

$$b_{MAX} = t \sqrt{2 \frac{f_{MAX}}{P_{MAX}}}$$

 P_{MAX} = DESIGN PRESSURE

 f_{MAX} = ALLOWABLE STRESS

 b_{MAX} = MAX. STIFFENER SPACING

3.1 DECK PLATING

ASSUME $f_{MAX} = 30,000$ psi (MILD STEEL)

$$P_{MAX} = 18750 \text{ psf} = 130 \text{ psi}$$

$$b_{MAX} / t = 21.48$$

THUS FOR $t = \frac{3}{16} \quad \frac{1}{4} \quad \frac{5}{16} \quad \frac{3}{8}$ IN.

$$b_{MAX} = 4.0 \quad 5.4 \quad 6.7 \quad 8.1 \text{ IN.}$$

3.2. BOTTOM PLATING

$$P_{MAX} = 522 \text{ psf} = 3.625 \text{ psi}$$

$$b_{MAX} / t = 129$$

THUS FOR $t = \frac{3}{16} \quad \frac{1}{4} \quad \frac{5}{16} \quad \frac{3}{8}$ IN.

$$b_{MAX} = 24 \quad 32 \quad 40 \quad 48 \text{ IN.}$$

A. 3.3. DECK STIFFENERS AND FRAMES

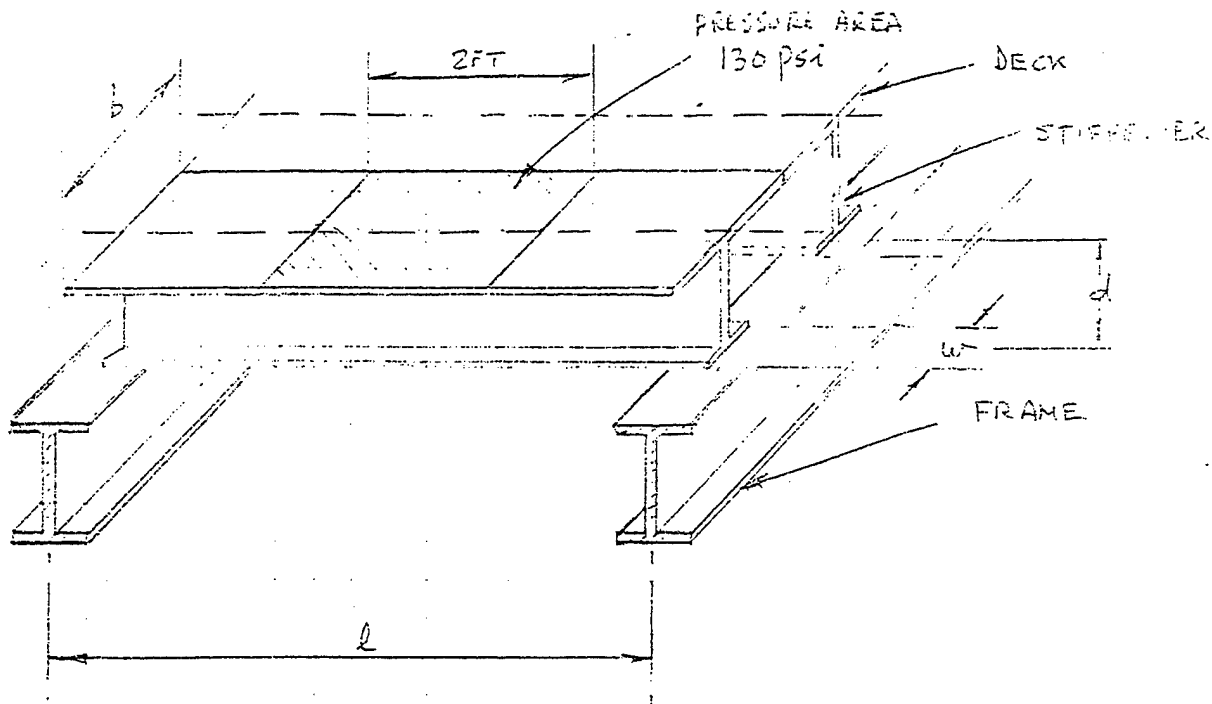

LOAD ON STIFFENER = $130 \times 24 \times b(\text{in}) = 3120b \text{ lb}$

MAX. BENDING MT $M \approx 390 b l \text{ in. lb}$ (FOR "FIXED" ENDS)

MAX. BENDING STRESS $f = M / Z$

SECTION MODULUS $Z = M / f$
 $= 390 b l / 30,000$
 $= b l / 77$

and $t = \begin{matrix} 3/16 & 1/4 & 5/16 & 3/8 \text{ in} \end{matrix}$

$b = \begin{matrix} 4.0 & 5.4 & 6.7 & 8.1 \text{ in} \end{matrix}$

if $l = 96 \text{ in}$ REQUIRES $Z = \begin{matrix} 5.0 & 6.7 & 8.4 & 10.1 \text{ in}^3 \end{matrix}$

$84 \text{ in} = \begin{matrix} 4.37 & 5.86 & 6.35 & 8.84 \text{ in}^3 \end{matrix}$

$72 \text{ in} = \begin{matrix} 3.75 & 5.02 & 6.3 & 7.57 \text{ in}^3 \end{matrix}$

$60 \text{ in} \text{ C-6} = \begin{matrix} 3.12 & 4.19 & 5.05 & 6.31 \text{ in}^3 \end{matrix}$

$48 \text{ in} = \begin{matrix} 2.5 & 3.35 & 4.2 & 5.05 \text{ in}^3 \end{matrix}$

A.3.3.1 STIFFENER SECTION PROPERTIES

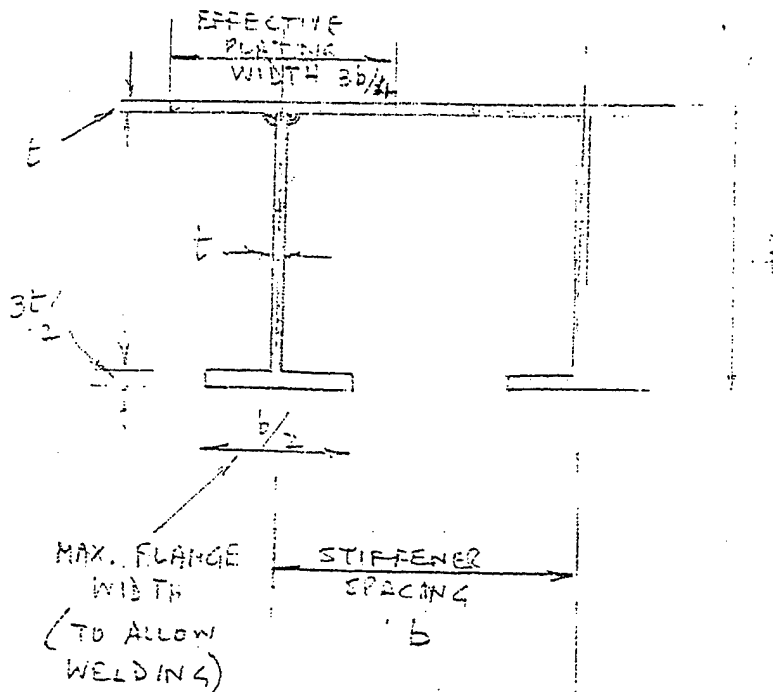

$$\text{X-SECT. AREA OF T STIFFENER} = td + (3bt/2) \cdot (b/2)$$

$$A_s = t(d + 3b/4) \quad \text{in}^2$$

$$\text{MOMENT OF INERTIA OF T-STIFFENER + PLATE} = 2 \cdot (3bt/4) \cdot (d/2)^2 + td^3/12$$

$$I = \frac{td^2}{12} (4.5b + d) \quad \text{in}^4$$

$$\text{SECTION MODULUS OF T-STIFFENER + PLATE } Z = \frac{td}{6} (4.5b + d) \quad \text{in}^3$$

$$\text{AND } d = \frac{-4.5b \pm \sqrt{(4.5b)^2 + 24Z/t}}{2}$$

$$\text{NUMBER OF STIFFENERS PER FOOT WIDTH } n = 12/b$$

$$\text{TOTAL X-SECT AREA PER FOOT WIDTH } A_T = nA_s + 12b \quad \text{in}^2$$

TOTAL WEIGHT OF DECK (40' x 8') PLUS STIFFENERS

$$W_T = (A_T/3) \times 10.2 \times 8 \times 40 \quad \text{LB}$$

$$C-7 = 1088 A_T \quad \text{LB}$$

(WEIGHT OF $1/4"$ PLATE = 10.2 LB/SQ.FT.)

A.3.3.2 DECK PLATING THICKNESS SELECTION

FROM FORMULAE IN 5.3.1.:

$t =$	$3/16$	$1/4$	$5/16$	$3/8$	in
$b =$	4.0	5.4	6.7	8.1	in
For $L=96''$ $\bar{E} =$	5.0	6.7	8.4	10.1	in ³
$d =$	5.52	5.41	5.34	5.295	in
$A_S =$	1.785	3.335	3.02	3.776	in ²
$A_T =$	7.605	2.26	9.15	10.09	in ²
$W_T =$	8274	8987	9955	10,978	LB

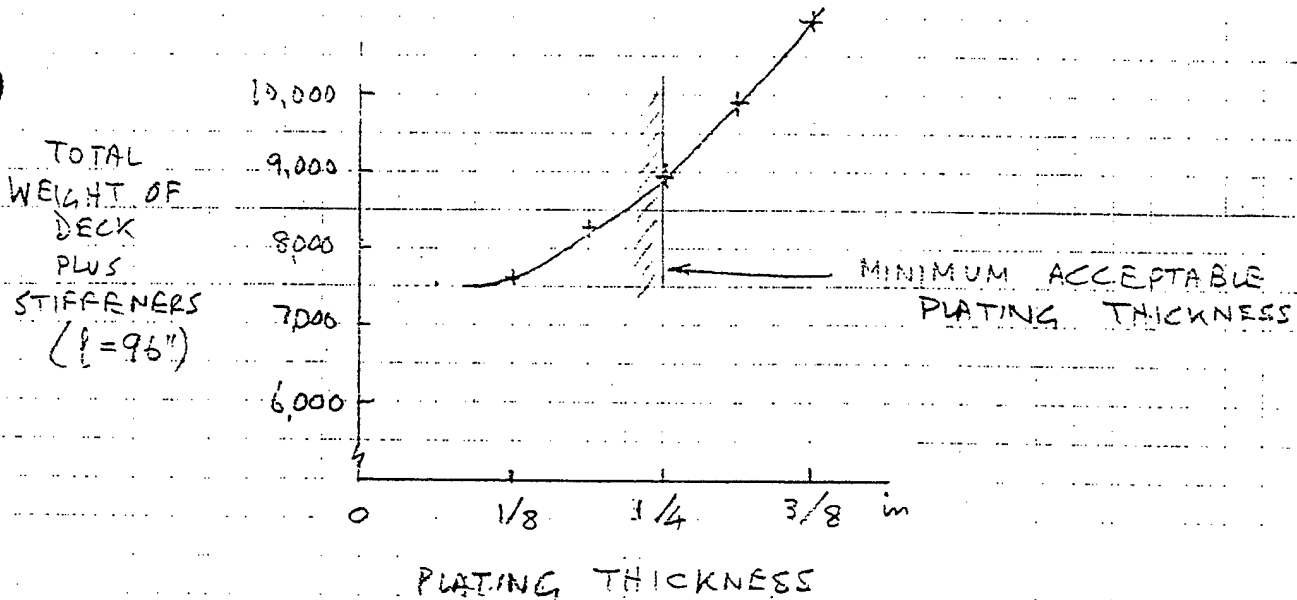

THUS RECOMMENDED PLATING THICKNESS IS $1/4''$

STIFFENER SPACING $b = 6''$

STIFFENER WEB DEPTH $d = 5.5''$
WEB THICKNESS $= 1/4''$

FLANGE WIDTH $= 3''$

FLANGE THICKNESS $= 3/8''$

A.3.3.3 FRAME DESIGN

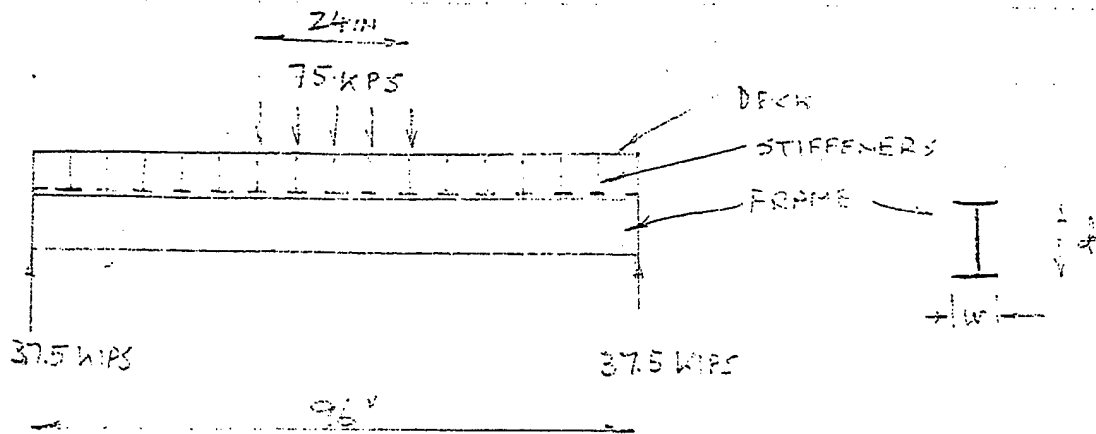

WORST CASE BENDING MOMENT $M = 37.5 \times (48 - 6)$
 (ENDS ARE ASSUMED FREE) $= 1575 \text{ KIPS} \cdot \text{in}$

REQUIRED SECTION MODULUS $Z = M / f$
 $= 1575 / 30 \text{ in}^3$
 $= 52.5 \text{ in}^3$

USE STANDARD I SECTION $15 \times 5.5 \times 0.41$
 $d \quad w \quad t$
 WEIGHT $= 42.9 \text{ lb/ft}$
 $= 343.2 \text{ lb (8ft)}$

ALTERNATE DESIGN: REDUCE SPAN TO 48" (USING BRACES)

(ASSUMING FREE ENDS) $M = 37.5 \times (24 - 6)$
 $= 675 \text{ KIPS} \cdot \text{in}$

$Z = 675 / 30 = 22.5 \text{ in}^3$

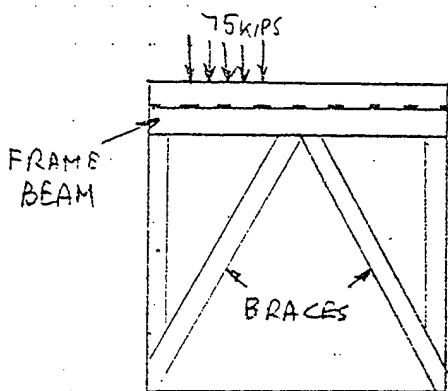

USE STANDARD I $10 \times 4.66 \times 0.31$
 WEIGHT $= 8 \times 25.4 = 203.2 \text{ lb}$

MAX. LOAD IN EACH BRACE $= 37.5 / \cos 30^\circ = 43.3 \text{ kips}$

FROM REF. 1, USE STANDARD I $3 \times 1.64 \times 0.17$
 WEIGHT OF 2 BRACES $= 5.7 \times 8 \times 2 = 91.2 \text{ lb}$
 WEIGHT OF FRAME BEAM + BRACES $= 203.2 + 91.2 = 294.4 \text{ lb}$

RECOMMENDATION: USE ALTERNATE DESIGN.

A. 3.3.4 FRAME SPACING / STIFFENER SELECTION:

ASSUME PLATING THICKNESS = $\frac{1}{4}$ " (SEE 3.3)
 $b = 5.4$ in

FRAME SPACING	$L =$	48	60	72	84	96	in
Z (DECK PLATING + STIFFENER)	=	3.35	4.19	5.02	5.86	6.7	in ³
STIFFENER DEPTH	$d =$	2.95	3.60	4.22	4.83	5.41	in
STIFFENER X SECT AREA	$A_s =$	1.75	1.91	2.07	2.22	2.365	in ²
TOTAL PLATE + STIFR AREA/FT	$A_T =$	6.885	7.24	7.59	7.93	8.25	in ²
TOTAL WT. PLATE + STIFRS	$W_T =$	7491	7886	8260	8625	8987	lb
NUMBER OF FRAMES	$N =$	11	9	7.7	6.71	6	
WT. OF FRAMES, PLTG + STIFNRS	=	10730	10536	10518	10602	10744	lb

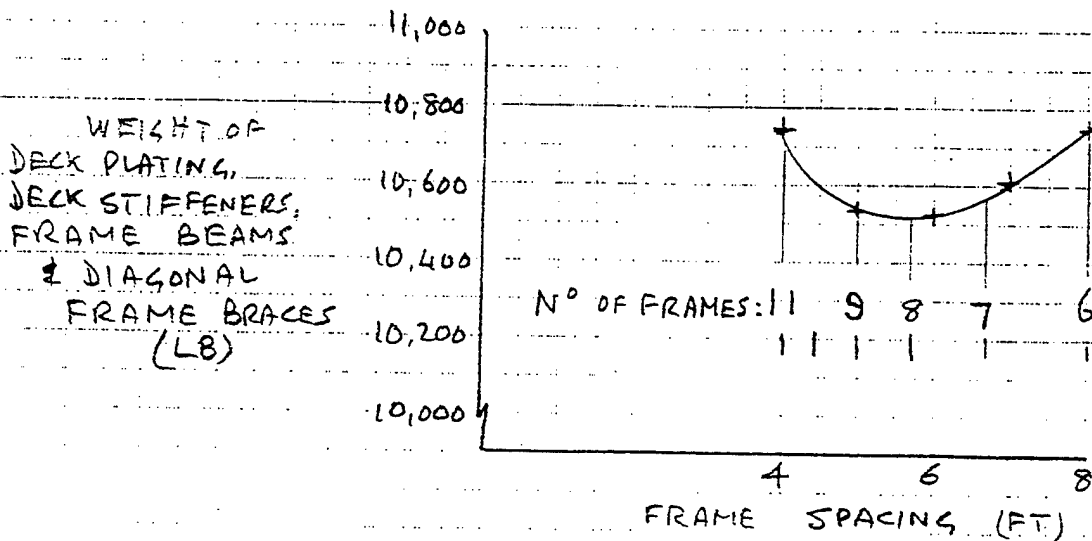

RECOMMENDATION: ASSUME 9 FRAMES AT 6 FT SPACE.

STIFFENERS: $d = 3.6$ in

C-10 $w = 2.7$ in

WEB THICKNESS $t = \frac{1}{4}$ in

A.3.3.5 BOTTOM PLATING / STIFFENERS / FRAME BEAMS

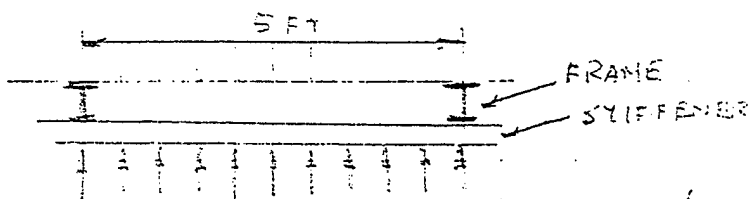
DESIGN PRESSURE $p = 5.00$ PSFFRAME SPACING $l = 5$ FTPLATING THICKNESS $t = 0.25$ inMAX. STIFFENER SPACING $s = 32$ in ASSUME $h = 24$ in

$$\text{LOAD} = 1044 \text{ lb/ft} = 87 \text{ lb/in}$$

MAX BM. ON ONE STIFFENER

$$M = \frac{wl^2}{12} \quad (\text{FIXED END})$$

$$= 87 \times 60^2 / 12$$

$$= 26,100 \text{ lb in}$$

REQUIRED SECTION MODULUS

$$Z = M / f$$

$$= 0.87 \text{ in}^3$$

RECOMMENDATION:

PRESSURE LOAD IS INSIGNIFICANT COMPARED WITH LOADS CAUSED BY GROUNDING, WHICH CAN BE SIMILAR IN MAGNITUDE TO WHEEL LOADS ON DECK. THEREFORE BUILD BOTTOM IN SAME WAY AS DECK.

ENDS AND WATER TIGHT BULKHEADS
SIDES WILL REQUIRE NO REINFORCEMENT

BEYOND THAT PROVIDED BY TRUSS MEMBERS.

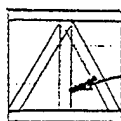

(NOTE: FRAMES WILL REQUIRE EXTRA VERTICAL BRACE TO SUPPORT BOTTOM FRAME BEAM)

A. 4. LONGITUDINAL TRUSSES

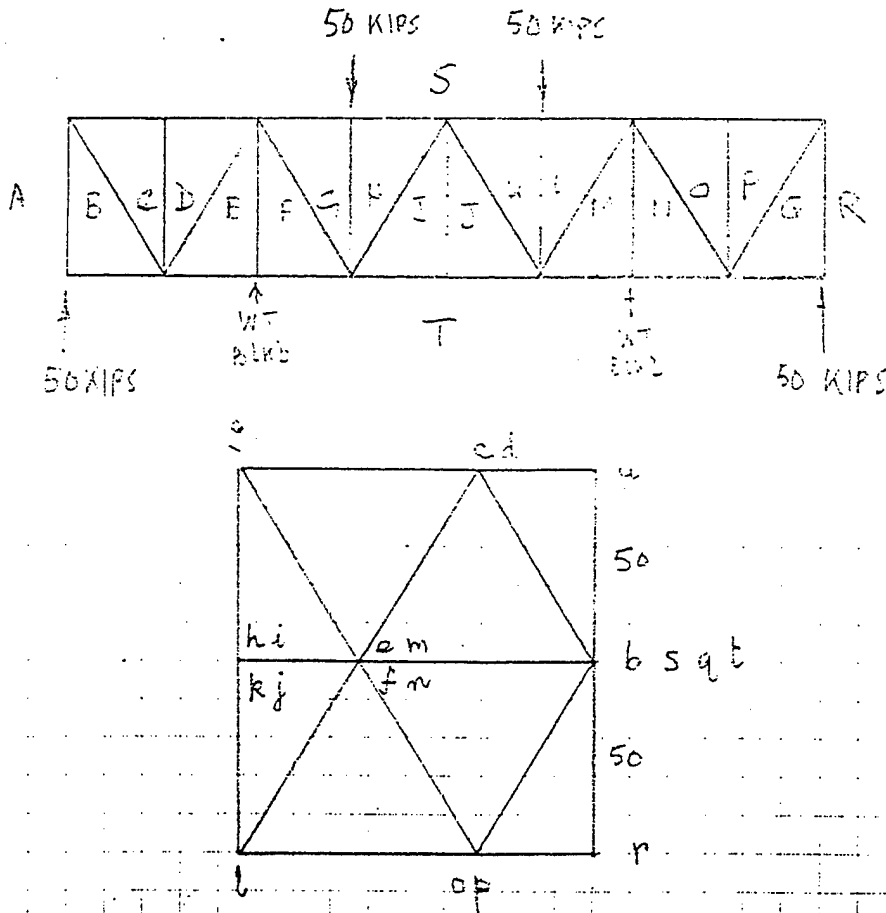

WHEEL LOAD
 ASSUME 2/3 OF
 WHEEL LOADS
 TAKEN BY ONE
 SIDE TRUSS,
 1/3 BY OTHER SIDE

MAX. LOAD IN ALL DIAGONALS = ± 59 KIPS

MAX. LOAD IN HORIZONTALS = ± 62.5 KIPS

MAX. LOAD IN VERTICALS (D, G, ETC) = 50 KIPS

CRITICAL COLUMN LOADS (DIAGONALS & VERTICALS)

$$P_c = n \pi^2 EI / L^2 \quad (E = 30 \times 10^6 \text{ psi})$$

$$= 124 \text{ I}_{yy} \text{ FOR } L = 96''$$

THUS $I_{MIN} = 0.48$ FOR $P_c = 59 \text{ KIPS}$ (DIAGONALS)

$= 0.40$ FOR $P_c = 50 \text{ KIPS}$ (VERTICALS)

FOR HORIZONTALS } USE
 DIAGONALS }
 & VERTICALS }

C-12

4" x 1.72 x 0.32 7.25 lb/ft
 A = 2.12 in²
 I_{yy} = 0.45 in⁴

(BUT WILL BE GREATER WITH SUPPORT FROM SKI)

A.5 WEIGHTS

ITEM	TYPE	DIMENSIONS	UNIT WEIGHT	SIZE	NUMBER	WEIGHT, LB
DECK	PLATE	1/4"	10.2 lb/sq.ft	8x40ft ²	1	3264
STIFFER	I	4.0x1/4x27x3/8	6.84 lb/ft	40ft	15	4106
FRAME BEAM	I	10x4.66x0.31	25.4 lb/ft	8ft	9	1829
FRAMING EDGE	I	3x1.64x0.31	5.7 lb/ft	8	27	1231
BOTTOM	PLATE	1/4"	10.2 lb/sq.ft	8x40	1	3264
BM STR	T	4.0x1/4x27x3/8	6.84 lb/ft	40ft	15	4106
BM FR. BEAM	I	10x4.66x0.31	25.4 lb/ft	8ft	9	1829
SIDES	PLATE	1/4"	10.2 lb/sq.ft	8x40	2	6528
ENDS	PLATE	1/4"	10.2 lb/sq.ft	8x8	2	1306

LONG TRUSSES:

HORIZONTALS	[4 x 1.72 x 0.32	7.5 lb/ft	40ft	4	11200
VERTICALS	[4 x 1.72 x 0.32	7.5 lb/ft	5.7ft	18	776
DIAGONALS	[4 x 1.72 x 0.32	7.5 lb/ft	8ft	16	960

WATER TIGHT BULKHEADS:

2'	PLATE	1/4"	10.2 lb/sq.ft	8x8	2	1306
----	-------	------	---------------	-----	---	------

TOTAL WEIGHT OF BASIC STRUCTURE 31,699 LB

A. 6.

JOINT DETAILS

6.1 DECK / SIDE INTERSECTION WITH DIAGONALS

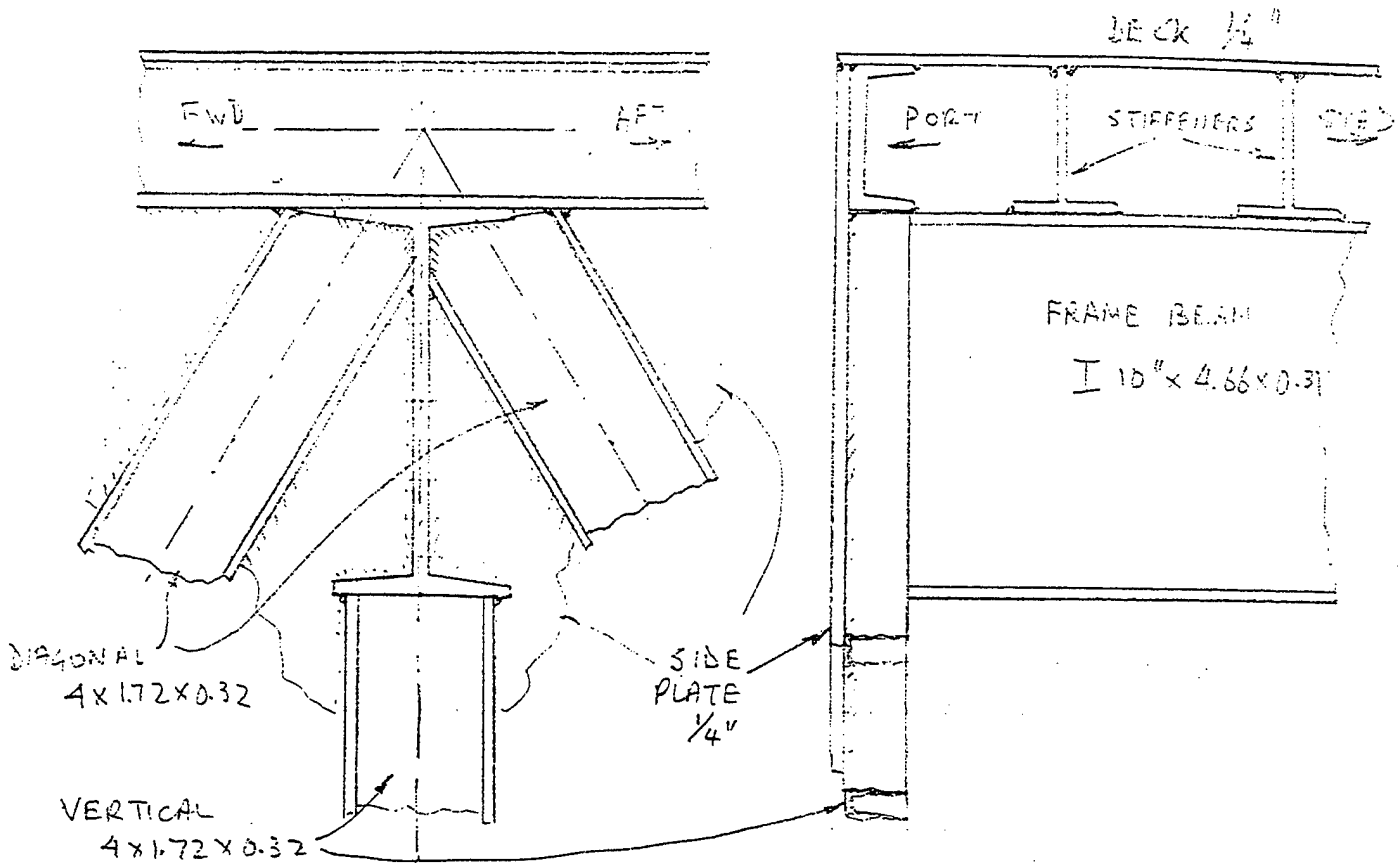

DECK 1/4"
PORT STIFFENERS (STAR)
FRAME BEAM
I 10" x 4.66 x 0.31

SCALE 1:5

6.2 AT WATER TIGHT BULKHEAD

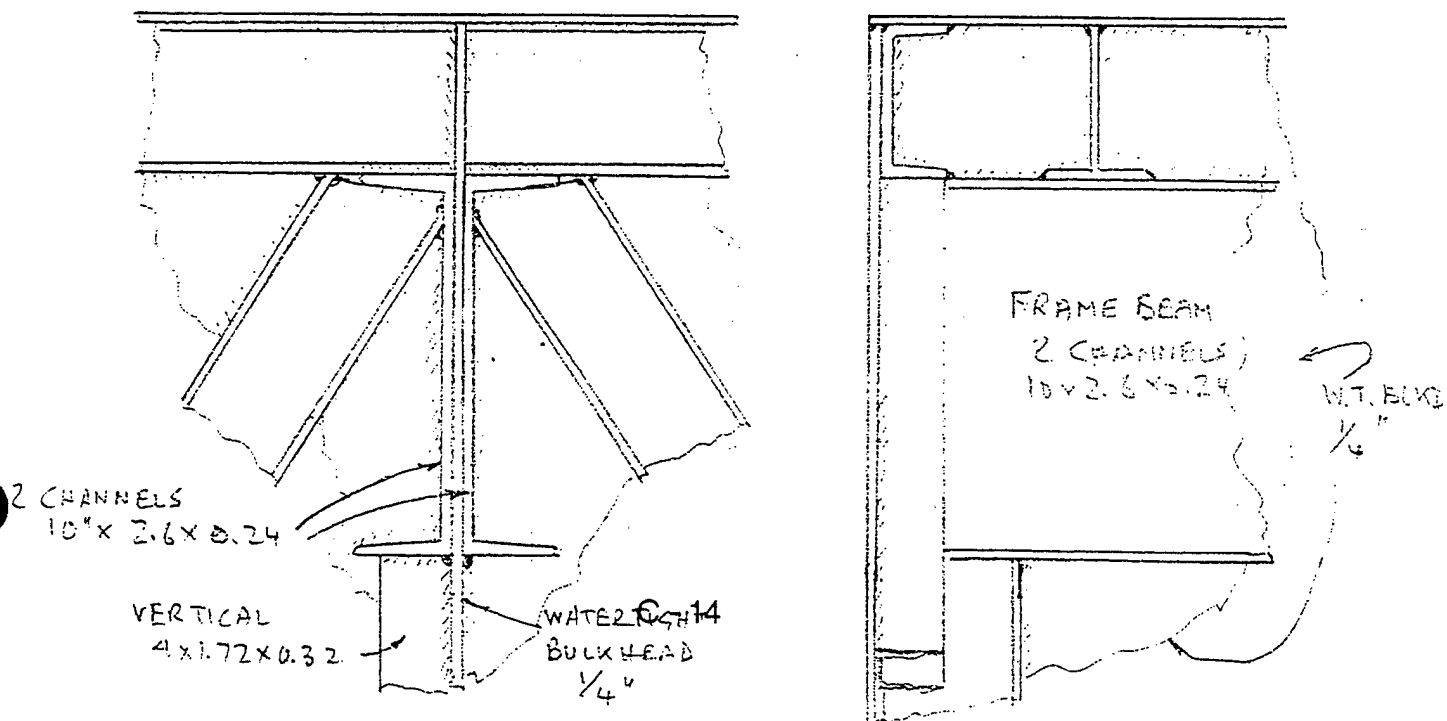

FRAME BEAM
2 CHANNELS
10 x 2.6 x 0.24

W.T. BULK
1/4"

A.6.3. END CORNERS

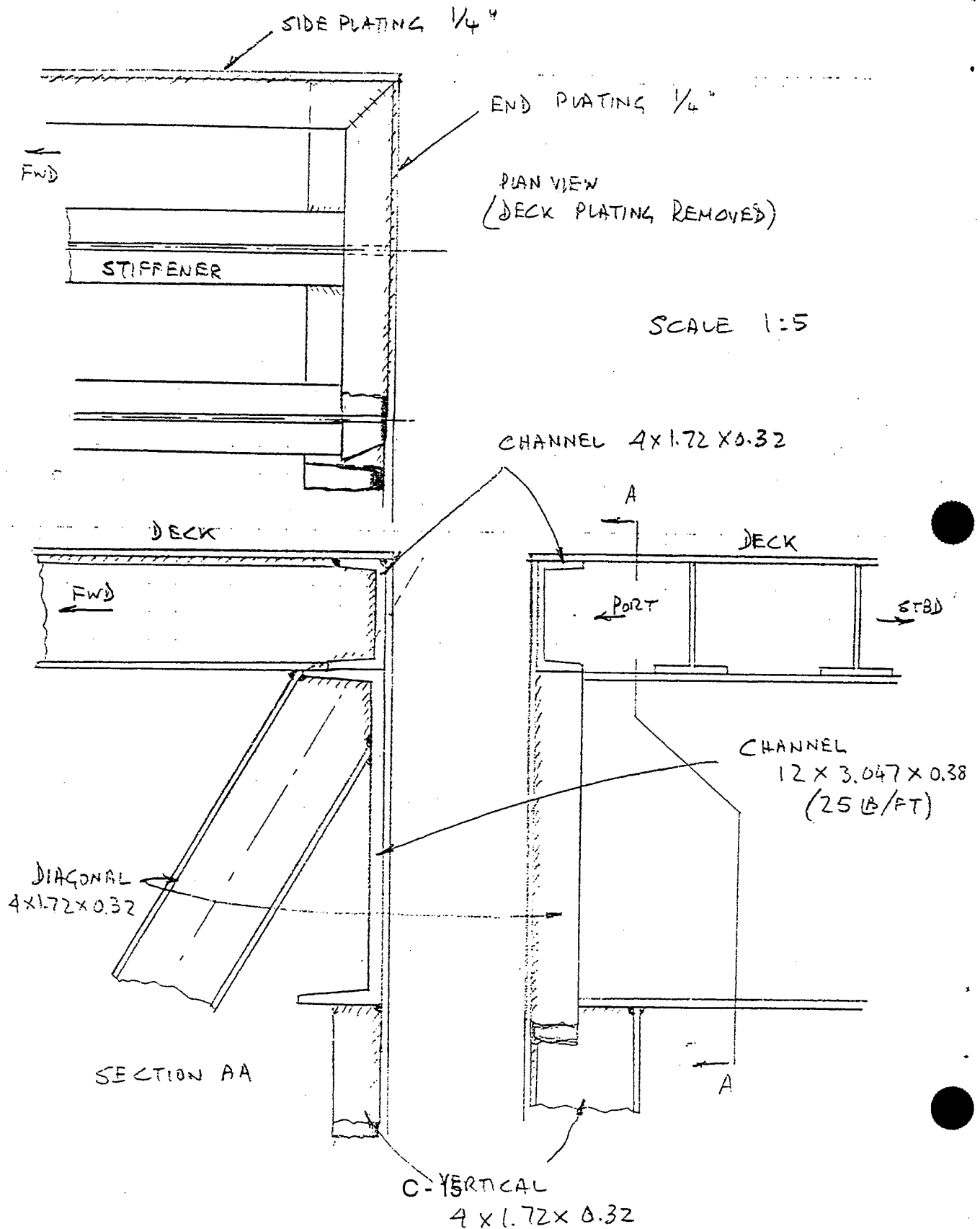

APPENDIX D
Manufacturers Contacted

Don Morrison - Manager of Civil & Structural Engineering

Chicago Bridge & Iron Technical Services Company

Tel (815) 439 6000 FAX (815) 439 6010

Chicago Bridge & Iron Technical Services Company

1501 North Division Street

Plainfield, Illinois 60544-8929

Dennis Sanguy - Director of Programs

Bollinger Shipyards, Inc.

Tel (504) 532 2554 FAX (504) 532 7295

Scott Theriot - Sales Mngr

Bollinger Shipyards, Inc.

P.O. Box 250

(8365, Hwy 308)

Lockport, Louisiana 70374

06/05/95 Spoke with Dennis Sanguy - send infor to him

06/06/95 FAXED info

Alan Powell - Director of Business Development

Peterson Builders, Inc.

Tel (414) 743 5574 FAX (414) 743 4784

Peterson Builders, Inc.

101, Pennsylvania Street

Sturgeon Bay, Wisconsin 54235

06/05/95 Spoke with Denise (secty)

06/06/95 FAXED info

Peter Anderson - Director of Marketing

Marinette Marine

Tel (715) 735 9341 FAX (715) 735 3516

Marinette Marine Corporation

1600, Ely Street

Marinette, Wisconsin 54143

06/05/95 Spoke with Beth Hermansen

06/06/95 FAXED Info

Neil Raj Vice President Government Programs

Trinity Marine Group

Tel (601) 896 0029 FAX (601) 897 4828

Sid Mizell - Sales Mngr

Trinity Marine Group

P. O. Box 3029

(13085, Seaway Rd.)

Gulfport, MS 39505

06/05/95 Spoke with Neil Raj

06/06/95 FAXED Info

Edward Doherty - President

Atlantic Marine, Inc.

Tel (904) 251 1510 FAX (904) 251 3500

Don Moore - Director of Business Planning

Helen Schirah Advertizing Coordinator 251 1790

Atlantic Marine, Inc.

8500, Heckscher Drive

Jacksonville, Florida 32226

06/07/95 Spoke with Helen Schirah

06/07/95 FAXED Info

Charles E. Burrell - Sales Manager.

Leevac Shipyards, Inc.

Tel (318) 824 2210 FAX (318) 824 2970

Leevac Shipyards, Inc.

Hwy 90 East

Jennings, Louisiana 70546

06/05/95 Spoke with Chris (secty)

06/06/95 FAXED Info

Frank G. Terrell Jr. - Marketing and Sales

Bender Shipbuilding & Repair Company Inc.

Tel (334) 431 8000 FAX (334) 432 2260

Bender Shipbuilding & Repair Company Inc.

265, South Waterstreet

Mobile, Alabama 36603

06/05/95 Spoke with Linda Lewis (secty)

06/06/95 FAXED Info

Terry Jenkins - Vice President

Gianotti Corp.

Tel (206) 272 0108 FAX (206) 272 4952

Gianotti Corporation
401, Alexandria Ave.,
Bldng 9588
Tacoma, WA 98421

06/01/95 Spoke with Terry Jenkins

06/06/95 FAXED Info

Gulf Shores Shipyard, Inc. Alabama

Robert Beal - Vice President

Oregon Ironworks, Inc.

Tel (503) 653 6300 FAX (503) 794 2405

Oregon Ironworks, Inc.
9700, S.E. Lawnfield Road
Clackamas, Oregon 97015

Doug Taylor - General Manager

Sundial Marine

Tel (503) 222 0268 FAX (503) 669 8595

Sundial Marine
5605, N.E. Sundial Road
Troutdale, Oregon 97060

06/01/95 Spoke with Linda (secty)

06/06/95 FAXED Info

Marco, Seattle, WA

Lakeshore Builders,

Derek Birkenfield - Sales Manager

Jered Brown Brothers, Brunswick, GA

Tel (912) 262 2000 FAX (912) 262 2051

Bruce Wright - Sales ext. 260

Jered Brown Brothers
1608, Newcastle Street
Brunswick, Georgia 31521

06/01/95 Spoke with secty.

06/06/95 FAXED Info

L & M WELDING, INC.

10 October 1995

Michael Plackett
M.J. Plackett & Associates
9515 Woodworth Avenue,
Gig Harbor, WA 98332

Subject: Tri-Module Fabrication

Dear Mike,

Further to our discussions, I would like to make the following points regarding the fabrication of Tri-Modules.

- a) Welding in mild steel will be considerably easier and cheaper than in higher strength steels. For the purpose of your requested estimates, without a good deal more information, I cannot make a detailed analysis of which sections and plate sizes of high strength steel could be substituted for the mild steel sections and plates that you have identified. I have therefore assumed that the same size materials would be used. This will make the high strength steel estimate a little conservative. The estimates are only to be taken as budgetary estimates. Firm prices can be developed once the design is fully defined.
- b) Normal manufacturing tolerances on a 40-foot long box without any special jigs or tooling would be of the order of $\pm 1/4$ -inch. With extra care this could be improved to something of the order of $\pm 1/8$ -inch. Anything better than that would probably need some form of tooling. With your concept of removable corners, we could jig build those and ensure that the corners were held to within $1/16$ -inch and the holes for the attachment pins could be jig drilled after all welding is completed to achieve an even higher accuracy and consistency to ensure interchangeability. Then, when the box is finished it could be set up on a reference plane and the mating corner gussets could be machined in place to a corresponding accuracy. Finally, the holes for the attaching pins could be jig drilled so that when the ISO corner units are attached, they would be within the required ISO standards for containers.
- c) A similar approach could possibly be used to locate the connector fittings. I can't say for sure because you haven't given us much information on those yet, and close tolerances may not even be required.

L & M WELDING, INC.

2

- d) Note that the estimates have not included any allowance for interfacing with the connector fittings as they have not yet been defined. Similarly, no allowances have been made for built-in lockers or storage facilities, access hatches, deck fittings, foundations for potentially highly loaded mooring bits, hold-down fittings or any other as yet undefined additional items. It would appear necessary to include additional lifting points in the modules in order to lift them once they have been joined together. It is apparent that the assembled Tri-Module could not be lifted by the ISO corner fittings on the center module only. Additional internal structure will be needed to support other lifting points.
- e) Application of protective coatings normally requires thorough preparatory cleaning, usually by sand-blasting to a white metal finish. This will be difficult to achieve inside the boxes. High strength steels have higher corrosion resistance which may well offset their higher cost.
- f) My best cost estimate is for a 1 off prototype, a production series would obviously be a good deal lower in price. Once again this is only a budgetary estimate and we will need a good deal more information before we can give you a firm quote. For mild steel construction my estimated price would be \$76,667 and for high strength steel \$95,000.

If you need any more information please call me.

Sincerely



Milton Hultberg - Vice President and General Manager

L&M Welding, Inc.