



**US Army Corps  
of Engineers**

Waterways Experiment  
Station

Technical Report ITL-94-9  
December 1994

# Reliability Analysis for Deep-Seated Stability of Pile Foundations

by *William M. Isenhower, University of Arizona*

19961118 167

DTIC QUALITY INSPECTED 1

Approved For Public Release; Distribution Is Unlimited

Prepared for Headquarters, U.S. Army Corps of Engineers

The contents of this report are not to be used for advertising, publication, or promotional purposes. Citation of trade names does not constitute an official endorsement or approval of the use of such commercial products.



PRINTED ON RECYCLED PAPER

Technical Report ITL-94-9  
December 1994

# Reliability Analysis for Deep-Seated Stability of Pile Foundations

by William M. Isenhower

Department of Civil Engineering and Engineering Mechanics  
University of Arizona  
Tucson, AZ 85721

Final report

Approved for public release; distribution is unlimited

Prepared for U.S. Army Corps of Engineers  
Washington, DC 20314-1000

Under Contract No. DAAL03-91-C-0034  
TCN Number 92-185  
Scientific Services Program

Monitored by U.S. Army Engineer Waterways Experiment Station  
3909 Halls Ferry Road, Vicksburg, MS 39180-6199



**US Army Corps  
of Engineers**  
Waterways Experiment  
Station

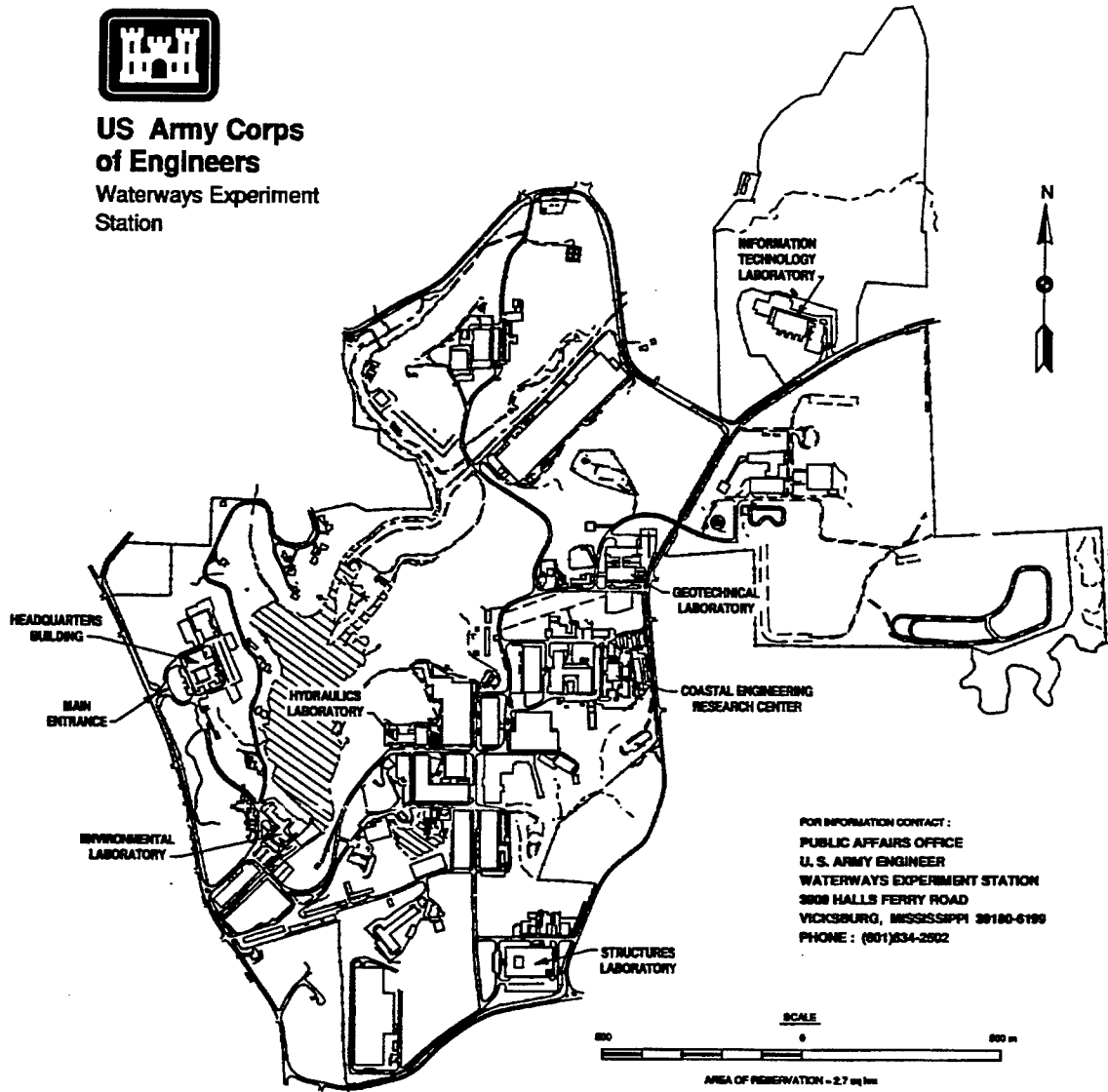

FOR INFORMATION CONTACT :  
PUBLIC AFFAIRS OFFICE  
U. S. ARMY ENGINEER  
WATERWAYS EXPERIMENT STATION  
3808 HALLS FERRY ROAD  
VICKSBURG, MISSISSIPPI 39180-6198  
PHONE : (601)634-2922

**Waterways Experiment Station Cataloging-in-Publication Data**

Isenhower, William M.

Reliability analysis for deep-seated stability of pile foundations / by William M. Isenhower ; prepared for U.S. Army Corps of Engineers ; monitored by U.S. Army Engineer Waterways Experiment Station..

61 p. : ill. ; 28 cm. -- (Technical report ; ITL-94-9)

Includes bibliographic references.

1. Accelerated life testing -- Reliability. 2. Piling (Civil engineering) -- Analysis. 3. Foundations -- Stability. 4. Reliability -- Testing. I. United States. Army. Corps of Engineers. II. U.S. Army Engineer Waterways Experiment Station. III. Information Technology Laboratory (U.S. Army Engineer Waterways Experiment Station) IV. Title. V. Series: Technical report (U.S. Army Engineer Waterways Experiment Station) ; ITL-94-9. TA7 W34 no.ITL-94-9

# Contents

---

Preface . . . . .	vi
Conversion Factors, Non-SI to SI Units of Measurement . . . . .	vii
1—Introduction . . . . .	1
2—Deterministic Design for Deep Stability of Pile Foundations . . . . .	3
Introduction . . . . .	3
Definition of Deep-Seated Stability . . . . .	3
Reese and Wang Procedure . . . . .	4
Evaluation of Lateral Loading of Piles . . . . .	6
Lateral forces from stability analyses . . . . .	6
Lateral displacements from finite element analyses . . . . .	11
Foundation Analysis by Other Methods . . . . .	12
Tschebotarioff . . . . .	12
Methods using plastic deformations . . . . .	13
Oakland and Chameau . . . . .	15
Conclusions . . . . .	15
3—Procedures for Reliability Analysis . . . . .	16
Introduction . . . . .	16
Sources of Uncertainty . . . . .	16
Modes of Failure . . . . .	17
Initiating Events . . . . .	20
System Reliability . . . . .	20
Prediction of Probability of Failure and Reliability Index . . . . .	21
Fundamentals . . . . .	21
Analysis of variance . . . . .	22
Reliability index . . . . .	22
Target reliability indices . . . . .	24
Choice of methods for determination of risk . . . . .	25
Evaluation Criteria . . . . .	26
Historical calibration . . . . .	27
Design code calibration . . . . .	29
Cost-utility evaluation . . . . .	29
Conclusions . . . . .	31

4—Computational Procedures and Issues . . . . .	32
Introduction . . . . .	32
Computational Procedures . . . . .	32
Computational Issues . . . . .	34
Interslice forces and displacements . . . . .	34
Foundation analysis . . . . .	38
Probabilistic characterization of soil properties . . . . .	38
Interaction of closely spaced piles . . . . .	38
Example Problem . . . . .	40
Conclusions . . . . .	46
5—Conclusions and Recommendations . . . . .	48
Conclusions . . . . .	48
Recommendations for Further Work . . . . .	49
References . . . . .	51

Form 298

## List of Figures

---

Figure 1. Interslice force function geometry . . . . .	9
Figure 2. Interslice force ratio, $\psi$ , at midslope versus depth factor, $D_f$ . . . . .	9
Figure 3. Values of $c$ versus slope angle . . . . .	10
Figure 4. Values of $n$ versus tangent of slope angle . . . . .	10
Figure 5. Forces acting on pile foundation . . . . .	12
Figure 6. Mode 1 failure mechanism . . . . .	18
Figure 7. Mode 2 failure mechanism . . . . .	18
Figure 8. Log-normal distribution of capacity divided by demand . . . . .	23
Figure 9. Reliability of major drilling and production platforms in the Gulf of Mexico subjected to hurricanes during the period 1950 through 1981 . . . . .	27
Figure 10. Hazard function versus time . . . . .	28
Figure 11. Historical relationship of risks and consequences for engineered structures . . . . .	29

Figure 12. Reliability index as function of cost ratio and present value function . . . . .	31
Figure 13. Example structure . . . . .	35
Figure 14. Finite element mesh for example analysis . . . . .	36
Figure 15. Normal effective stress on slip surface . . . . .	36
Figure 16. Shearing stress on slip surface . . . . .	37
Figure 17. Description of pile geometry for interaction analysis . . . . .	39
Figure 18. Example problem . . . . .	40
Figure 19. Mean horizontal displacements plus and minus one standard deviation calculated using Taylor's series expansion . . . . .	41

## List of Tables

---

Table 1. Probability of Failure versus Reliability Index . . . . .	23
Table 2. Target Reliability Indices . . . . .	24
Table 3. Modes of Failure and Prediction Methods . . . . .	26
Table 4. Reliability Indices for Bending Stress . . . . .	42
Table 5. Distribution of Variance in Bending Stress Due to Layer 1 . . . . .	43
Table 6. Distribution of Variance in Bending Stress Due to Layer 2 . . . . .	43
Table 7. Distribution of Variance in Bending Stress Due to Layer 3 . . . . .	43
Table 8. Reliability Indices for Bearing Capacity . . . . .	44
Table 9. Distribution of Variance in Bearing Capacity Due to Layer 1 . . . . .	45
Table 10. Distribution of Variance in Bearing Capacity Due to Layer 2 . . . . .	46
Table 11. Distribution of Variance in Bearing Capacity Due to Layer 3 . . . . .	47

# Preface

---

Preparation of this report was sponsored by the U.S. Army Engineer Waterways Experiment Station (WES) under the auspices of the U.S. Army Research Office Scientific Services Program administered by Battelle (TCN Number: 92-185, Delivery Order 252, Contract Number DAAL03-91-C-0034), and funded under the Civil Works Risk Analysis for Water Resource Investments R&D Program. This report summarizes work performed for WES as part of a study titled "Condition Evaluation of Navigation Structures." The work was performed by Professor William M. Isenhower of the University of Arizona at WES. The WES Technical Monitors on the project were Drs. Reed L. Mosher, Chief, Structural Mechanics Division, Structures Laboratory, and Mary Ann Leggett, Computer-Aided Engineering Division (CAED), Information Technology Laboratory (ITL), WES. All work was accomplished under the general supervision of Mr. H. Wayne Jones, Acting Chief, CAED, and Dr. N. Radhakrishnan, Director, ITL.

At the time of publication of this report, Director of WES was Dr. Robert W. Whalin. Commander was COL Bruce K. Howard, EN.

*The contents of this report are not to be used for advertising, publication, or promotional purposes. Citation of trade names does not constitute an official endorsement or approval or the use of such commercial products.*



# Conversion Factors, Non-SI to SI Units of Measurement

---

Non-SI units of measurement used in this report can be converted to SI units as follows:

<b>Multiply</b>	<b>By</b>	<b>To Obtain</b>
degrees (angle)	0.1745329	radians
feet	0.3048	meters
pounds (force) per square foot	47.88026	pascals

# 1 Introduction

---

Over 40 percent of inland navigation structures are more than 50 years old and demands for rehabilitation of these structures are increasing. Because limited funds are available, rehabilitation funds must be invested in a manner that maximizes the benefits to the public (Leggett and Mosher 1993). Thus, current conditions, usage, and economic impact of navigation structures must be considered in allocating funds for rehabilitation.

The objective of the study reported herein was to develop techniques for making reliability assessments of pile-supported navigation structures. These techniques are needed by the U.S. Army Corps of Engineers to:

- Assess the reliability of structures based on their current conditions.
- Provide a consistent uniform method for prioritizing rehabilitation expenditures.
- Initiate definition of detailed engineering studies to estimate the remaining service life of structures.

The procedure developed by Reese and Wang (1991) for the analysis of deep-seated stability of pile groups is examined in Chapter 2 of this study. The Reese and Wang procedure is a pile group analysis modified to account for soils moving around the foundation piles. The key to successful application of the Reese and Wang procedure is to accurately assess soil displacement profiles due to soil instability near the foundation piles. Three analytical techniques to assess soil forces or displacements for use in the Reese and Wang method were examined. These techniques were the finite element method and Spencer's (1967) method and the Morgenstern and Price (1965, 1967) method of slope stability analysis. In addition, several other methods for estimating lateral forces on piles by moving soils were reviewed.

Procedures used for reliability analysis are introduced in Chapter 3. Of particular interest to this study is the Taylor's series expansion technique for assessing variance. In addition, the definition of reliability indices is introduced and evaluation criteria for reliability analyses are presented.

Computational procedures and issues related to the deterministic analysis are introduced in Chapter 4. The relative accuracies of Spencer's procedure and the finite element method are compared for evaluation of

soil stresses and displacements. The finite element method was found to be the more accurate and is recommended for use in practice. An example problem is given to illustrate how reliability analyses can be made using a Taylor's series expansion of the Reese and Wang procedure. This example found that the structure could have relatively low reliability indices in one mode of performance and higher reliability indices in other modes.

## **2 Deterministic Design for Deep Stability of Pile Foundations**

---

### **Introduction**

Procedures used to analyze the deep-seated stability of pile foundations are discussed in this chapter in which the focus is the procedure developed by Reese and Wang (1991). The procedural steps are briefly reviewed, and application of the procedure in practice is examined. As part of this examination, two methods of evaluating lateral loading forces are discussed. These methods are limiting-equilibrium slope stability analyses and nonlinear finite element analyses. Lastly, previously developed methods for assessment of deep-seated stability are reviewed.

### **Definition of Deep-Seated Stability**

The problem of interest in this chapter is the analysis of deep-seated lateral stability and settlement of pile-supported structures. This problem is discussed in "Design of Pile Foundations" (Headquarters, U.S. Army Corps of Engineers 1991). The suggested method of solution of this problem follows.

Pile-supported structures should be analyzed based on the axial and lateral resistance of the piles alone. Additional axial or lateral resistance from contact between the base slab and the foundation material should be neglected for the following reasons. Scour of the riverbed frequently removes material from around the slab. Vibration of the structure typically causes densification of the foundation material and creates voids between the base slab and foundation material. Also, consolidation or piping of the foundation material can create voids beneath the structure.

The soil mass surrounding a pile group foundation must be stable without relying on the resistance of the pile foundation. Deep-seated stability of the soil mass should be analyzed neglecting the piles. Potential problems of inducing a deep seated failure due to excess pore water pressures

generated during pile driving or liquefaction due to an earthquake should be recognized and accounted for in design. The probable failure mechanism for piles penetrating a deep seated weak zone is due to formation of plastic hinges in the piles after experiencing large lateral displacements. Movement in the weak zone will induce bending in the piles. A second mechanism is a shear failure of the piles which can only occur if the piles penetrate a thin, weak zone which is confined by relatively rigid strata.

The "Design of Pile Foundations" manual does not provide additional information on how to perform an analysis of deep-seated lateral stability and settlement. The following sections discuss several methods suggested for solution of this problem.

## Reese and Wang Procedure

A procedure to analyze the behavior of deep-seated stability of pile groups was developed by Reese and Wang (1991) for the U.S. Army Engineer Waterways Experiment Station (WES). This procedure was implemented in computer program LOCKDAM, which analyzes the deep-seated stability of pile groups using the  $p$ - $y$  method.

The following assumptions are made in the Reese and Wang procedure.

1. The soil layers below the slip surface are not displaced and any piles penetrating below the slip surface will provide support to the structure against deep-seated stability.
2. The pile cap and piles can be modeled as a two-dimensional arrangement.
3. The pile cap does not deform under loading, but can rotate and translate under load.
4. The load-transfer relationships for lateral loading and axial loading on the piles are independent.

The input data for the LOCKDAM program include foundation geometry, structural properties, soil properties, structural loading, and estimated movements of soil above the slip surface. LOCKDAM is capable of internally calculating both lateral and axial load-transfer relationships from input soil properties or of using relationships input by the user.

The foundation piles are modeled as beam-columns. Equilibrium of lateral forces acting on the piles is satisfied by solving the beam-column equation

$$EI y'''' + Qy'' + W = p(y) \quad (1)$$

where

$$EI = \text{bending stiffness of the pile}$$

$y''$  and  $y''''$  = second and fourth partial derivatives of lateral displacement  $y$  with depth

$Q$  = axial load or thrust in the pile

$W$  = distributed lateral load intensity (force per unit length) acting on the side of the pile

$p$  = mobilized soil resistance as a function of  $y$

The way in which the distributed lateral load intensity  $W$  is handled by LOCKDAM is the feature that differentiates this program from a conventional  $p$ - $y$  analysis program.

Three coordinate systems are defined in the Reese and Wang procedure. One is the structural coordinate system. The origin of this coordinate system is at the point where the structural loadings are applied (at coordinate 0, 0). The locations of all piles in the group must be input relative to the structural coordinate system. A second set of coordinate systems are defined at the top of each pile. These coordinate systems are called the "member" coordinate systems, and the axes of these systems are parallel to the structural coordinate axes. The third set of coordinate systems are the "local" coordinate systems. The origins of the local coordinate systems are coincident with the origins of the member coordinate systems, but the axes are rotated so that one axis is parallel to the axis of the pile.

Group behavior is analyzed using a modified stiffness method. The following steps are used in the analysis:

1. Impose an initial displacement on the pile cap.
2. Compute the corresponding pile-top displacements.
3. Compute the pile reaction for the given pile-top displacements.
4. Sum the pile forces and moments.
5. Compute the difference between the applied load and the pile reactions to obtain the force-correction vector.
6. Impose a virtual displacement to obtain the stiffness matrix.
7. Invert the stiffness matrix to obtain the flexibility matrix.
8. Multiply the stiffness matrix by the force-correction vector to obtain the displacement-correction vector.
9. Correct the pile-cap displacement by adding the displacement-correction vector to the initial displacement used in step 1.
10. Repeat steps 2 through 9 until the displacement-correction vector becomes small and convergence is achieved.

One noteworthy feature of the LOCKDAM program is the incorporation of reduction factors for pile-soil-pile interaction. These factors are used to model the "shadowing" effects in pile groups. These reduction

factors have been developed empirically from load tests on pile groups and are discussed in detail in reports by Reese and Wang.

## **Evaluation of Lateral Loading of Piles**

The Reese and Wang procedure requires evaluation of either soil movements above the slip plane or lateral load intensity distributed on the piles. Two methods for evaluating lateral loading for this procedure have been suggested. One method is to estimate lateral forces in the slide mass from interslice forces calculated in a slope stability analysis using either Spencer's method or the Morgenstern and Price method. The second method is to use a finite element analysis to evaluate in situ stresses. The use of these two methods is discussed in the following sections.

### **Lateral forces from stability analyses**

Slope stability analyses require various assumptions to obtain a statically determinate problem. Usually the assumptions are made considering the equations of static equilibrium and the locations of external forces acting on vertical slices of soil in the sliding mass. Two methods of slope stability analysis that satisfy all equations of static equilibrium (sum of forces in vertical and horizontal directions and sum of moments) are the Spencer (1967) method and the Morgenstern and Price (1965, 1967) method. The assumption made in Spencer's method is that the thrust angles of all interslice forces are equal. This angle is unknown and is solved for as part of the solution. In contrast, in the Morgenstern and Price method the interslice thrust force angle is assumed to vary across the slide mass in some described manner. The following is a discussion of these two methods.

One implementation of Spencer's method is computer program UTEXAS3. This program was developed for the Corps of Engineers by Professor Stephen G. Wright of The University of Texas at Austin. UTEXAS3 is a general-purpose computer program for calculation of two-dimensional slope stability for circular and noncircular slip surfaces (Edriss and Wright 1992). Slope reinforcement from geotextiles, geogrid, and tieback anchors can be modeled using reinforcement lines and point forces acting on or in the slope. These forces and reinforcement lines were originally intended for the modeling of earth slope reinforcement, but may be tried for the modeling of pile foundations embedded in the slope because the program allows input of both axial and shear strengths for the reinforcement lines. In addition, the program user may specify whether reinforcement forces can act at either the vertical boundaries of a slice as well as to the base or only to the base of the slice. This feature allows the program user to model the reinforcement due to pile foundations in a slide mass.

The output information on lateral thrust forces from UTEXAS3 lists the  $x$  and  $y$  coordinates of the bottom corner of the slice, the lateral thrust force, the vertical location of the lateral thrust force expressed as a fraction

of the height of slice, and the inclination of the lateral thrust force. The user must manually resolve the lateral thrust data into an equivalent horizontal force distribution at the location of the piles to be used as input to program LOCKDAM.

UTEXAS3 cannot perform a soil-structure interaction analysis to evaluate the shear forces and bending moments in the foundation piles. Wright<sup>1</sup> recommends that one first perform a series of soil-structure interaction analyses using program LOCKDAM (Reese and Wang 1991) to determine the allowable axial and shear loading at a selected depth of slip surface such that the foundation piles are not overstressed. If the soil profile is stratified and a layer of weak soil controls the location of the slip surface, then the depth of the slip surface may be determined by the lower elevation of the weak layer. The consequence of this behavior is that one cannot use the full axial and shear capacities of a pile as input for a reinforcing line in UTEXAS3. Instead, the program user must reduce the axial and shear capacities at the location of the slip surface so that the piles are not overstressed at another location.

Another potential problem in using this approach is the distribution of forces among the piles in the group. Experimental measurements have found that piles in a group can carry substantially different lateral loads depending on the location of the pile in the group and the direction of loading. No general theory can successfully describe this distribution of loads, so empirical evaluation of load distribution is required. One question to be answered before using the empirical distributions is how similar the load distributions on a pile group are for the two cases of lateral loading on the foundation and lateral loading of piles by a sliding earth mass. Without any experimental evidence to prove otherwise, it is speculated that the load distributions are substantially the same with the leading row of piles carrying the largest load.

However, in a limiting-equilibrium slope stability analysis, all soil layers and soil reinforcing elements are assumed to have identical factors of safety. In the situation discussed above, the loading is divided unevenly among the piles in the group; therefore, the actual factor of safety will vary among the piles. Thus, a limiting-equilibrium analysis should not be used to evaluate stresses in the piles. Instead, the designing engineer should recognize that the factor of safety obtained using a limiting-equilibrium analysis is simply a ratio of the available shear strength of soil to the strength required to just maintain equilibrium. It is not a factor of safety in the traditional structural design perspective, which is the ratio of available strength to applied loading. The following example illustrates this point.

Consider a simple slope with an external vertical loading acting on a slab near the crest. Assume that the limiting-equilibrium factor of safety for this slope is 1.5. Now increase the load applied to the slab until failure occurs. In many situations, the vertical load may be increased on the order of 600 percent before a failure occurs. One might not predict this sixfold increase on the basis of the initial value of the factor of safety be-

---

<sup>1</sup> Personal communication, June 1992, Stephen G. Wright, University of Texas at Austin.



cause one has confused the limiting-equilibrium factor of safety with a structural factor of safety that is the ratio of the available strength to the applied loading.

An alternative to Spencer's method is the Morgenstern and Price method. Rahardjo, Fredlund, and Fan (1992) compared interslice forces obtained using various interslice functions in a Morgenstern and Price analysis with the forces obtained from a linear elastic finite element analysis. They report that approximately equal interslice forces can be obtained when a bell-shaped interslice function is used. This is an improvement over Spencer's method, but requires substantially more effort on the part of the user to develop the interslice function for the problem at hand. The form of the interslice function is

$$f(x) = \psi e^{-(c^n \eta^n)/2} \quad (2)$$

where

$\psi$  = the maximum value of interslice side force ratio at mid-slope

$c$  = a variable defining the inflection points for each slope angle

$n$  = a power specifying the flatness or sharpness of curvature of the function

$\eta$  = the dimensionless position relative to the middle of the slope

$e$  = the base of Napierian logarithms, 2.7182818284

The definition of the dimensionless distance  $\eta$  from the center of the slope to the inflection points is shown in Figure 1. The factor  $\psi$  is related to the average inclination of the slope and a depth factor  $D_f$  for the slip surface being analyzed.

$$\psi = e^{[D_i + D_s(D_f - 1.0)]} \quad (3)$$

where

$D_f$  = depth factor, as defined in Figure 2

$D_i$  = natural logarithm of the intercept on vertical axis of Figure 2 when  $D_f = 1.0$

$D_s$  = slope of the  $D_f$  versus  $\psi$  relationship for a specific slope angle

The values of  $c$  and  $n$  are shown as functions of slope angle in Figures 3 and 4.

The above relationships for  $y$  and  $f(x)$  have been programmed in computer program PC-SLOPE (GEO-SLOPE International, Ltd. 1989) for analysis of slope stability using the Morgenstern and Price method. In

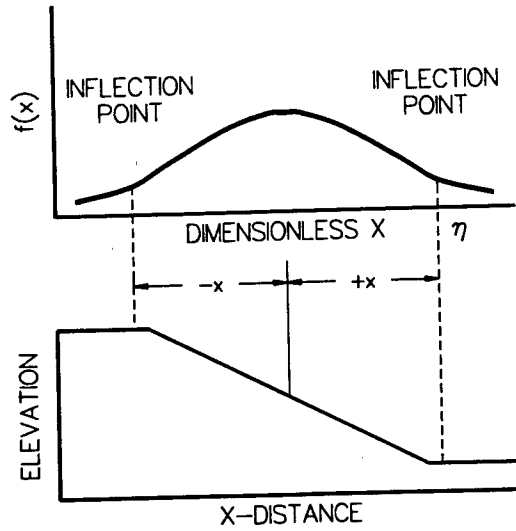

Figure 1. Interslice force function geometry

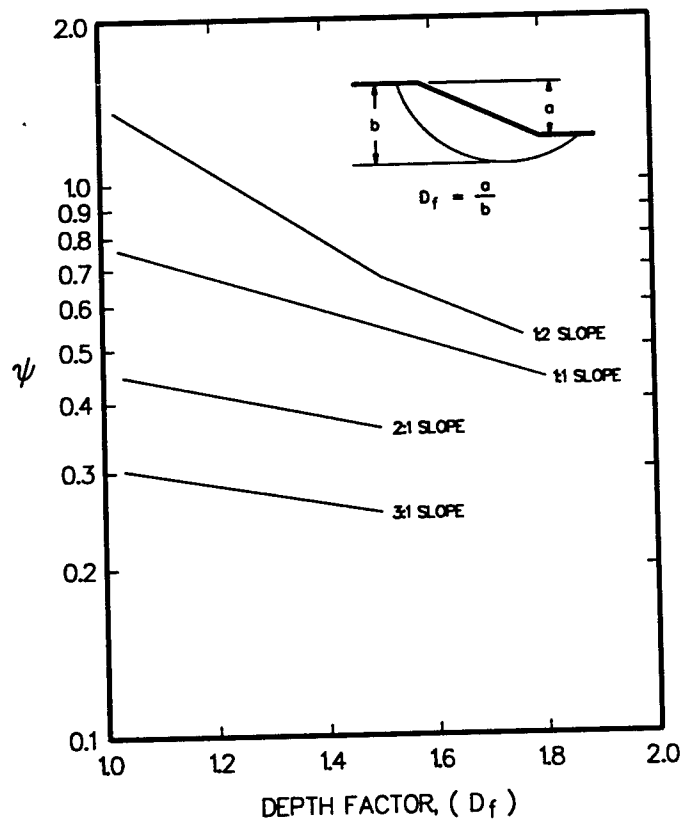

Figure 2. Interslice force ratio  $\psi$  at midslope versus depth factor  $D_f$ .

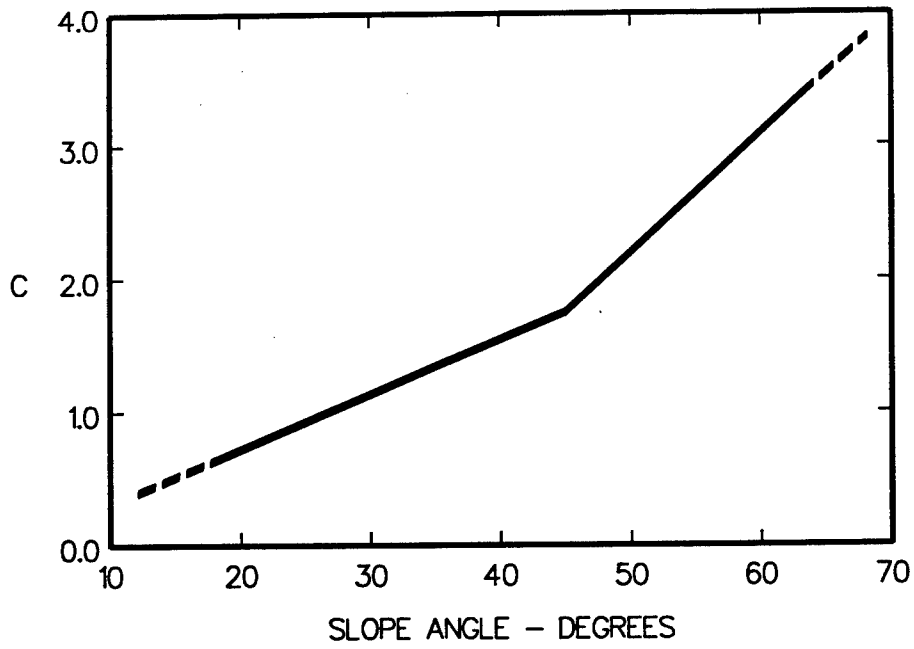

Figure 3. Values of  $c$  versus slope angle

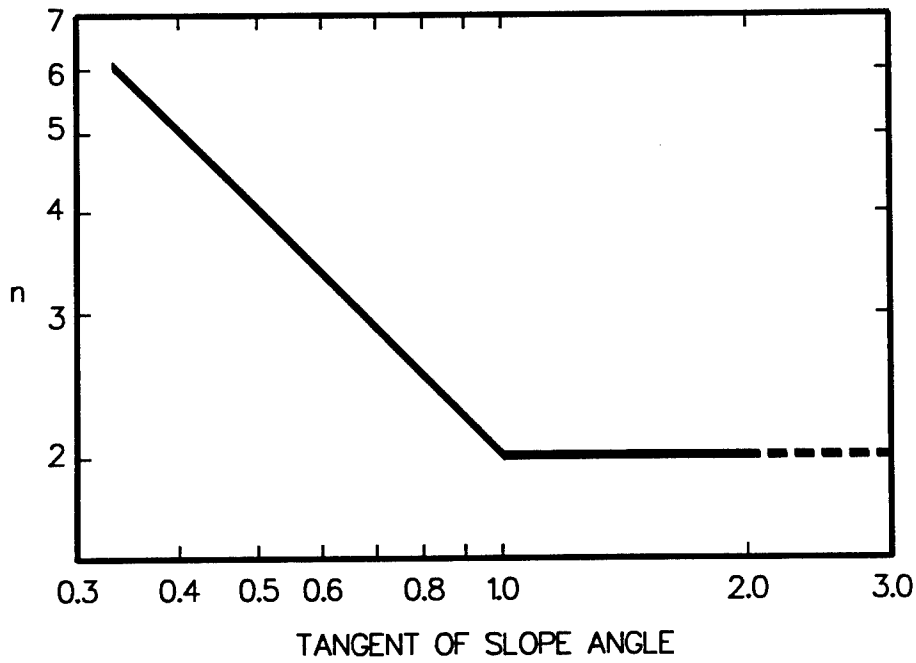

Figure 4. Values of  $n$  versus tangent of slope angle

this implementation, the input data is the average slope inclination of the slope defined by the location of the crest and toe of the slope.

In summary, two methods of estimating lateral soil forces using slope stability are available. Use of Spencer's method, as implemented in UTEXAS3, is relatively simple for the user because output of interslice forces is automatically performed by the program. However, the accuracy of this method may be in some doubt. In contrast, use of the Morgenstern and Price method may lead to relatively accurate computations of interslice thrust forces if an appropriate interslice force ratio function  $\gamma$  is used. The interslice force function discussed in this section is based on a comparison to stresses calculated in a linear elastic finite element analysis. Consequently, use of this function should be restricted to situations where the soil in the slope behaves in an approximately elastic manner. This is usually restricted to slopes with factors of safety well above 1.0.

### **Lateral displacements from finite element analyses**

Lateral displacements of soil moving around pile foundations can be estimated using the finite element method. The principal advantage of using the finite element method is the ability to model construction and loading of the structure in a rational manner. Typical finite element programs for geotechnical analysis can model stage construction of fill placement, excavation, application of surface loading, and application of seepage forces. Additional refinements are the use of interface elements between soil and structural materials and use of beam elements to model piles. Computer program SOILSTRUCT (Filz, Clough, and Duncan 1990) is a finite element analysis program with these features. Both two- and three-dimensional versions of this program are available.

Output information from finite element programs typically includes displacements and stresses relative to the coordinate axes. The user must carefully examine finite element displacement values when preparing lateral displacement values for program LOCKDAM. A finite element analysis will compute displacements for all elements in the problem. This includes elements below the slip surface. Therefore, the user must compute the displacements of the element in the sliding mass relative to the elements below the sliding mass. This is necessary because the piles supported in the elements below the sliding mass can be considered to move as a rigid body with the supporting elements.

The amount of effort required to use a finite element program is significantly higher than that for using a slope stability analysis program like UTEXAS3. The extra work is spent in developing the finite element grid, evaluating constitutive model parameters, and selecting an appropriate number of construction steps. Additional effort is required by the user when gravity turn-on and seepage analyses are combined because evaluation of pore water pressures due to seepage requires an additional analytical procedure. Usually, a hand-drawn flow net is adequate for initial calculations, but a finite element or finite difference seepage analysis may be required for problems with complex properties. This additional effort

is well spent because the accuracy of the results is much improved due to accurate modeling of the problem.

## Foundation Analysis by Other Methods

### Tschebotarioff (1973)

Tschebotarioff (1973) discussed a simple method to model the lateral loading of foundation piles by layers of soft soil undergoing shearing deformations. The problem discussed by Tschebotarioff is shown in Figure 5. The assumed distribution of lateral load intensity (load per unit length) is shown in the figure. The maximum load intensity  $p_H$  is calculated from

$$p_H = 2bK_0\gamma H' = 0.8b\gamma H' \quad (4)$$

where

$b$  = width of the pile

$K_0$  = coefficient of earth pressure at rest (assumed to equal 0.4)

$\gamma H'$  = weight of difference  $H'$  in height of fill at the toe and heel of the abutment

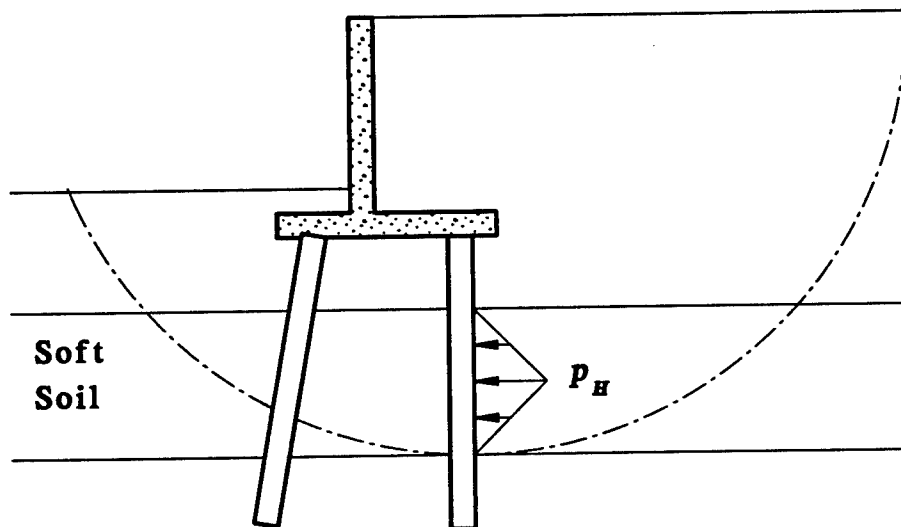

Figure 5. Forces acting on pile foundation (after Tschebotarioff (1973))

On the basis of one case history, Tschebotarioff (1962) modified Equation 4 to

$$p_H = K_0 \sigma_z b \quad (5)$$

where  $\sigma_z$  is the increment of vertical stress at midlayer of the soft soil. This stress includes the stress due to the weight of the backfill.

Equation 5 is based on the assumption that the coefficient of earth pressure at rest is equal to 0.4. The angle of internal friction calculated for this value using Jaky's formula for normally consolidated soils is 36.9 deg. This assumed friction angle is unrealistically high for a soft soil. A more reasonable value for a soft clay might be on the order of 25 deg. In this case, the coefficient of earth pressure at rest is equal to 0.577, which is 44 percent higher than the value assumed by Tschebotarioff.

One factor not considered by Tschebotarioff is the group interaction of the pile foundations and the moving soil mass. The reports by Reese and Wang have discussed this behavior in substantial detail. Particular attention must be paid to the spacing of the piles both perpendicular to and in the direction of soil mass movement. Reese and Wang note that relatively little experimental data are available for laterally loaded pile groups. So conclusions as to how to predict loading on individual piles in a group should be used with some caution.

### **Methods using plastic deformations**

Ito and Matsui (1975a, b) developed a procedure to calculate the lateral force per unit length acting on a row of piles located in a sliding mass. The input variables for this procedure are the cohesion  $c$ , friction angle  $\phi$ , unit weight  $\gamma$ , depth  $z$ , the center-to-center spacing of piles  $D_1$ , and the clear spacing between piles  $D_2$ .

$$\begin{aligned}
p(z) = & cD_1 \left( \frac{D_1}{D_2} \right)^{\sqrt{N_\phi} \tan \phi + N_\phi - 1} \\
& \times \left[ \frac{1}{N_\phi \tan \phi} \left\{ \exp \left( \frac{D_1 - D_2}{D_2} N_\phi \tan \phi \tan \left( \frac{\pi}{8} + \frac{\phi}{4} \right) - 2 \sqrt{N_\phi} \tan \phi - 1 \right) \right\} \right. \\
& \left. + \frac{2 \tan \phi + 2 \sqrt{N_\phi} + N_\phi^{-1/2}}{\sqrt{N_\phi} \tan \phi + N_\phi - 1} \right] \quad (6) \\
& - c \left\{ D_1 \frac{2 \tan \phi + 2 \sqrt{N_\phi} + N_\phi^{-1/2}}{\sqrt{N_\phi} \tan \phi + N_\phi - 1} - 2D_2 N_\phi^{-1/2} \right\} \\
& + \frac{\gamma z}{N_\phi} \left\{ D_1 \left( \frac{D_1}{D_2} \right)^{\sqrt{N_\phi} \tan \phi + N_\phi - 1} \exp \left( \frac{D_1 - D_2}{D_2} N_\phi \tan \phi \tan \left( \frac{\pi}{8} + \frac{\phi}{4} \right) \right) \right\}
\end{aligned}$$

where  $N_\phi = \tan^2(\pi/4 + \phi/2)$ . For purely cohesive soils,  $p(z)$  is calculated using

$$p(z) = c \left[ D_1 \left( 3 \log \frac{D_1}{D_2} + \frac{D_1 - D_2}{D_2} \tan \frac{\pi}{8} \right) - 2(D_1 - D_2) \right] + \gamma z (D_1 - D_2) \quad (7)$$

DeBeer and Carpentier (1977) have criticized Equation 6 because it predicts an infinite force acting on the pile when  $D_2 = 0$ . This case is analogous to the force acting on a wall. It is obvious that such a result is invalid because the forces acting on a row of piles cannot be larger than the force required for equilibrium of the soil mass. At the other extreme, when  $D_2 = \infty$ , DeBeer and Carpentier (1977) state that the force acting on the pile should become a minimum and be independent of the value of  $\phi$ . Again, they state that Equation 6 does not conform to reality. Neither of these two criticisms were rebutted in Ito and Matsui's (1977a, b) closure to the discussion.

Ito, Matsui, and Hong (1981) conducted a series of experiments to verify the accuracy of Equation 6. They found that the computed values of  $p(z)$  were only about 60 percent of the measured ultimate force. They interpreted their results to mean that their equation predicted the stress at which soil begins to yield. Therefore, an adjustment factor of 1.6 should be introduced to Equation 6 to compute the ultimate soil resistance.

$$p_{ult} = 1.6p(z) \quad (8)$$

## Oakland and Chameau

Oakland and Chameau (1989) reported the results of a study in which three-dimensional finite element analyses were used to evaluate pile-reinforced slopes. This study used 8-node linear isoparametric brick elements with the capability of adding mid-side nodes to obtain a 20-node isoparametric brick element. Second-order Gauss quadrature was used to integrate the element shape function to obtain the element stiffness. The pier elements were spar elements with four degrees of freedom. Slip elements were used at the interface of the piers and soil to prevent tensile stresses. The constitutive model used was the Duncan-Chang (1970) model extended to three-dimensional shearing. Both variable modulus combined with constant Poisson's ratio and constant modulus combined with variable Poisson's ratios were used. Initial stresses in the soil were obtained using a gravity turn-on analysis.

Oakland and Chameau (1989) found that the relative contributions to shear strength of soil of the cohesive and frictional components could substantially affect the results obtained from the analysis. For soils that are primarily cohesive, use of piles could increase the resistance to slope instability. In this case, it was found that locating piles in a zone where horizontal movements in a slope without piles were maximum yielded the greatest improvement in slope stability.

In contrast, when the soil is primarily frictional the change in resistance to instability depends on the movement of soil and the location of the piles. If the soil movement in a slope without piles is in the direction of unloading the slip surface, then the presence of piles may increase normal stresses thereby increasing stability. If the movement of soil tends to load the slip surface, then the presence of piles may actually lower resistance to instability because vertical loading may be carried by the piles rather than the normal stresses on the slip surface. In summary, for frictional soils in particular, the complete soil-structure interaction problem should be analyzed to assess the influence of piles on slope stability.

## Conclusions

Procedures used for deterministic analysis and design of pile groups subjected to deep-seated lateral loading were reviewed in this chapter. The general approach to follow in analysis is to first analyze the structure without foundation piles to assess the in situ stresses and displacements likely to load the foundation. Next, the performance of the foundation is assessed taking these soil displacements into account.



# 3 Procedures for Reliability Analysis

---

## Introduction

Procedures used in reliability analyses are discussed in this chapter. The first half of this chapter discusses the sources of uncertainty affecting lock structures along with potential modes of failure and the events capable of initiating failure. The second half of this chapter discusses techniques used in reliability analyses and the criteria used to evaluate the results of reliability analyses.

## Sources of Uncertainty

An analysis of deep-seated stability of pile-supported structures involves the estimation of soil movements loading the foundation and estimation of the resulting deflections, bending moments, and shearing forces in the piles. The sources of uncertainty in the analysis are:

1. The nonlinear stress-strain behavior and shear strength of soil.
2. The accuracy of the estimation of the lateral soil forces acting on the foundation.
3. The nonlinear load-transfer relationships of the soil loading and supporting the foundation.
4. The accuracy of the estimation of the response of the pile foundation.
5. The structural properties and as-built geometry of the pile foundation.

This chapter is concerned with items 1 and 2. Items 3, 4, and 5 are outside the scope of this study.

The uncertainty in soil properties is the first of the two components of uncertainty considered in this study. Christian, Ladd, and Baecher (1992) discuss the sources of uncertainty in soil properties. They discuss a

procedure to analyze laboratory and field data to separate the uncertainty into real spatial variation in soil properties, random testing errors, statistical errors in the mean, and bias in testing procedures. Application of these techniques can be quite useful in producing effective designs. However, it should be noted that application of these techniques requires a considerable amount of laboratory and field data. This amount of data is available only for large projects, so application of these techniques to small projects with just a few soil borings is not possible. This does not mean that in these situations one cannot use probabilistic methods to characterize the uncertainty in soil properties. Instead, one may use the procedures presented later in this chapter.

The second source of uncertainty considered in this study is the lateral earth forces acting on the foundation.

## **Modes of Failure**

Five modes of failure are identified with the performance of pile-supported structures. These modes are:

- 1a. Shearing failure of piles resisting mass instability near the structure.
- 1b. Bending failure of piles resisting mass instability near the structure.
- 2a. Shearing failure of piles resisting sliding of the structure on the surface of the soil.
- 2b. Bending failure of piles resisting sliding of the structure on the soil.
3. Bearing capacity failure of foundation under vertical loading resulting in excessive vertical movements.
4. Excessive settlement of foundation under long-term loading conditions.
5. Overturning of the structure due to overload conditions.

Modes 1a and 1b are failure of the piles resulting from mass instability of the upper soils near the structure as shown in Figure 6. These modes are associated with one another, and, depending on the design, one mode may not occur without the other. These modes can occur when the soil supporting the structure is relatively weak in supporting lateral loading.

Modes 2a and 2b are failure of the piles resulting from sliding of the lock structure on the ground surface as shown in Figure 7. These modes are the result of overloading of piles founded in soils strong enough that the structural capacity of the piles is the weakest part of the foundation system.

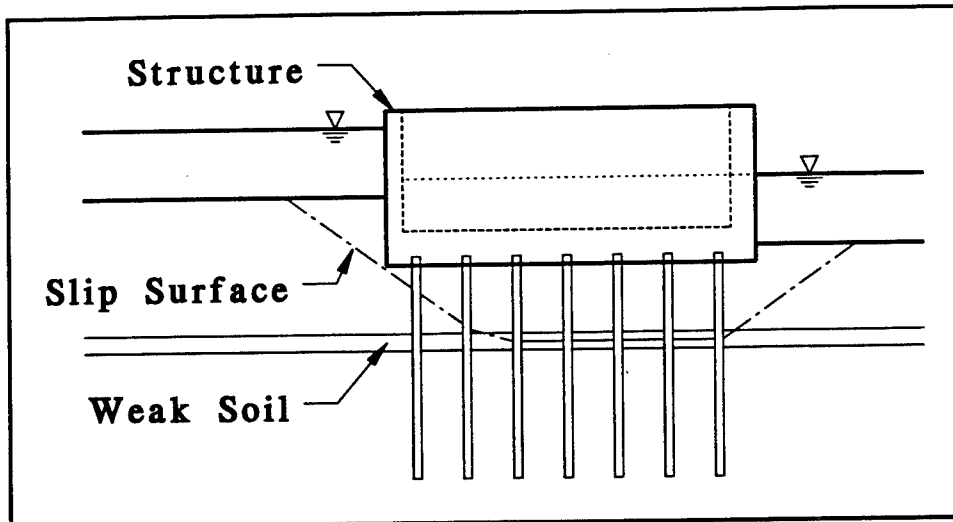

Figure 6. Mode 1 failure mechanism

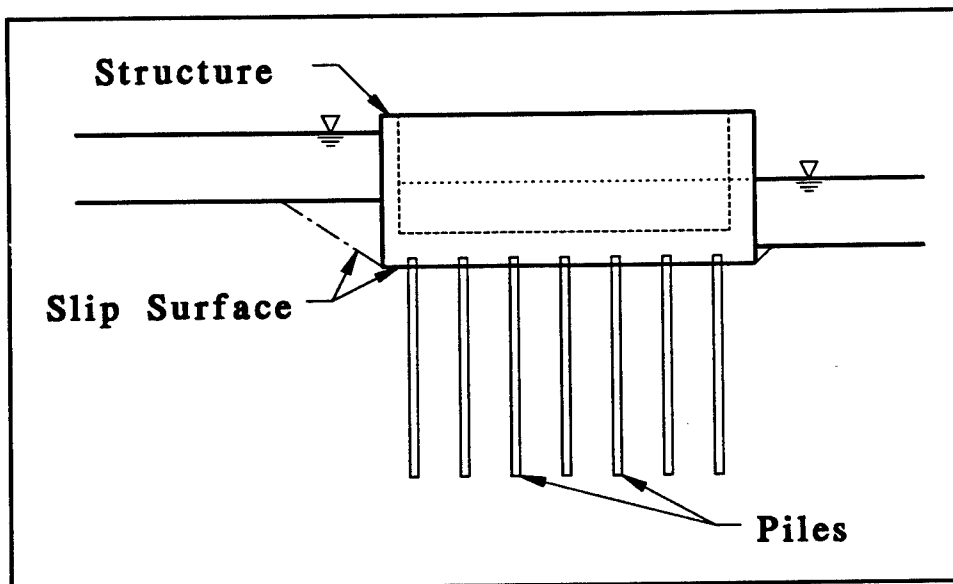

Figure 7. Mode 2 failure mechanism

Modes 1 and 2 are related but are not analyzed in similar manners. Modes 1a and 1b require an analysis of a failure surface passing through the soil and piles under the lock. The shape of this failure surface may be circular or noncircular. Modes 2a and 2b result from overloading the piles in lateral loading. Overstressing of the pile in bending at the pile head can occur when the piles are supported in strong soils and the pile head is restrained against rotation by its connection to the lock structure. Overstressing of the pile in shear can occur when undersize piles are used because the actual magnitude of lateral loading was underestimated for one reason or another. Both conditions can be minimized if piles are battered to increase axial loading and decrease lateral loading.

Mode 3 is due to a bearing capacity failure of the foundation. The probability of this mode of failure is remote because the foundation is designed to avoid this type of failure. In addition, calculation of bearing capacity is conservative because the interaction of the pile foundations and bottom of the structure acting as a mat usually is not considered.

Mode 4 is related to the long-term settlement and movement of the lock structure. In general, movement of the lock can result from three mechanisms: shear deformation, consolidation, and creep of the soils supporting the structure.

Movements of structures due to shear deformation result from loading the soil that supports the structure. Movements due to shear deformation occur when loading on a structure exceeds the bearing capacity of the foundation, but can also occur for loads below the bearing capacity of the foundation when conditions permit.

Movements due to consolidation can result from both the initial loading of the soils supporting the structure and subsequent cyclic loading during operation of the structure. The effect of alternate loading and unloading of a structure is to progressively overconsolidate the foundation soils. This results in volume change of the supporting soils and the consequent settlement of the structure. This also results in increased bearing capacity of the foundation because the foundation soils increase in strength with consolidation. The magnitudes of these volume changes vary with the nature of the soil supporting the structure. Typically, long-term settlements are of more concern for structures founded on friction piles. In contrast, structures founded on piles end-bearing in strong soils seldom undergo consolidation settlements.

Movements due to creep also depend on the nature of the soil. If the soils are highly plastic, are relatively low in permeability, and exhibit a decrease in volume during shearing, then "partially undrained" creep may occur. The sequences of events resulting in partially undrained creep are as follows. The soil is loaded in shear and positive pore water pressures are generated. The positive pore water pressures lower effective stress in the soil by an amount equal to the excess pore water pressure. As the effective stress is lowered, the available shearing strength of the soil is lowered correspondingly and the shearing deformations in the soil increase because the applied shearing stress is unchanged by the generation of pore water pressures. If this process continues until the applied shear stress exceeds the available shear strength, then failure will occur. This is sometimes called "creep rupture." The rate at which the positive pore water pressures are dissipated is the key to the occurrence of partially undrained creep. Creep will occur if the dissipation of positive pore water pressures is slower than the generation of additional positive excess positive pore water pressures.

Mode 5 is related to the overall stability of the lock structure under various loading conditions. Examples of different loading conditions include loading by differential levels of water during routine operation, impact loading by ice and other floating debris, and impact loading by river traffic. Commonly, the most dangerous condition is when the lock is fully drained for maintenance work. In this condition, the lock is in its lightest

condition and its buoyancy may be large enough to cause loading of the foundation in tension. In addition, the sliding resistance of the structure on the ground surface (not including pile resistance) is minimal for this condition.

## **Initiating Events**

The preceding discussion of failure modes of pile-supported locks did not include a discussion of the events initiating failure. The events, listed in order from most likely to least likely, thought to be most likely to induce failures of a pile-supported lock structure are:

1. Overloading by flood loading.
2. Erosion and scour of foundation soils.
3. Structural deterioration and resulting failure.
4. Overloading during maintenance.

These events are ranked in a realistic order of decreasing risk and increasing confidence in design to handle these conditions. For example, draining of a lock structure for maintenance is anticipated and evaluated during design. The high degree of confidence for this event results from the fact that the structural loadings during maintenance can be evaluated with relatively little uncertainty. In contrast, the occurrence and magnitude of loading due to flooding cannot be predicted nearly as accurately. Similar conditions exist for erosion and scour effects.

## **System Reliability**

Six modes of failure were identified for pile-supported lock foundations. Each of these modes has an individual probability of failure, and the calculation of these probabilities is a major problem in itself. However, the overall reliability of the lock foundation system will be a function of all modes of failure. Thus, the system reliability can be calculated only after the probabilities of failure of the individual modes of failure have been calculated.

The system reliability of multicomponent systems is a function of redundancy of the system. The analysis of reliability depends on the nature of the system. Different approaches are taken when all members in the system are active as opposed to when some members are passive under normal loadings.

# Prediction of Probability of Failure and Reliability Index

## Fundamentals

The following material is presented to introduce various factors used in later sections. The expected value  $E$  is the mean value obtained if all possible values of a random variable  $x$  were averaged by the number in the population  $N$ .

$$E[x] = \mu_x = \frac{\sum x}{N} \quad (9)$$

The variance  $\sigma_x^2$  of the random variable  $x$  is the expected value of the square of the differences between the data values and the mean.

$$\sigma_x^2 = V[x] = E[(x_i - \mu_x)^2] = \frac{\sum [(x_i - \mu_x)^2]}{N-1} \quad (10)$$

Usually, the denominator  $N - 1$  is used to obtain an unbiased estimate of the variance when sample values are used. If values are available from the total population, then  $N - 1$  is replaced by  $N$ .

The standard deviation is the square root of the variance.

$$\sigma_x = \sqrt{\sigma_x^2} \quad (11)$$

The coefficient of variation is the standard deviation divided by the expected value and is usually expressed as a percentage.

$$V_x = \frac{\sigma_x}{E[x]} \times 100\% \quad (12)$$

The covariance is an expression of the correlation between two random variables. If two variables are correlated, then the value of one variable depends on the other. The covariance measures how two variables vary together. For two random variables  $x$  and  $y$  the covariance  $\sigma_{xy}$  is

$$\sigma_{xy} = \frac{1}{N} \sum_{i=1}^N (x_i - \mu_x)(y_i - \mu_y) \quad (13)$$

The correlation coefficient is a nondimensional measure of the degree of correlation, ranging from  $-1$  to  $+1$ , with  $0$  indicating no correlation. The correlation coefficient  $\rho_{xy}$  is calculated using

$$\rho_{xy} = \frac{\sigma_{xy}}{\sigma_x \sigma_y} \quad (14)$$

### Analysis of variance

An analysis of variance based on a Taylor's series expansion was used in this study. One advantage of this type of analysis is that deterministic analyses can be used to produce the variance of systems with multiple variates. Harr (1987) discusses the case of systems with two correlated variates. The general case for multiple, correlated variates is presented by Hahn and Shapiro (1967). For the general case of a function of multiple, correlated variates,  $F(x_1 \dots x_n)$

$$V[F(x)] = \sum_{i=1}^n \left( \frac{\partial F}{\partial x_i} V[x_i] \right) + 2 \sum_{i=1}^{n-1} \sum_{i+1}^n \left( \frac{\partial F}{\partial x_i} \right) \left( \frac{\partial F}{\partial x_j} \right) E\{[x_i - E(x_j)][x_j - E(x_j)]\} \quad (15)$$

or

$$V[F(x)] = \sum_{i=1}^n \left( \frac{\partial F}{\partial x_i} V[x_i] \right) + 2 \sum_{i=1}^{n-1} \sum_{i+1}^n \left( \frac{\partial F}{\partial x_i} \right) \left( \frac{\partial F}{\partial x_j} \right) \rho_{ij} \quad (16)$$

where  $\rho_{ij}$  is the covariance between variables  $x_i$  and  $x_j$ . The above expressions for variance have been truncated, thereby omitting terms containing high-order derivatives. For problems with uncorrelated variates, the variance is calculated by setting  $\rho_{ij}$  to zero.

### Reliability index

All civil engineers are familiar with the use of the factor of safety as a design criterion. For a typical structural application, the factor of safety  $F$  is defined as

$$F = \frac{C}{D} \quad (17)$$

where  $D$  is the loading or demand on the structure and  $C$  is the resistance or structural capacity.

The reliability index is calculated using the statistical descriptions of loading (demand) and resistance (capacity) of a structure. The reliability index  $\beta$  for capacity and demand that are normally distributed and uncorrelated is calculated using

$$\beta = \frac{C - D}{\sqrt{\sigma_D^2 + \sigma_C^2}} \quad (18)$$

where  $\sigma_C$  and  $\sigma_D$  are the standard deviations of the capacity and demand. The reliability index is a mathematical description of the difference between the mean factor of safety and a factor of safety equal to 1.0 in terms of the standard deviation of the factor of safety as shown in Figure 8.

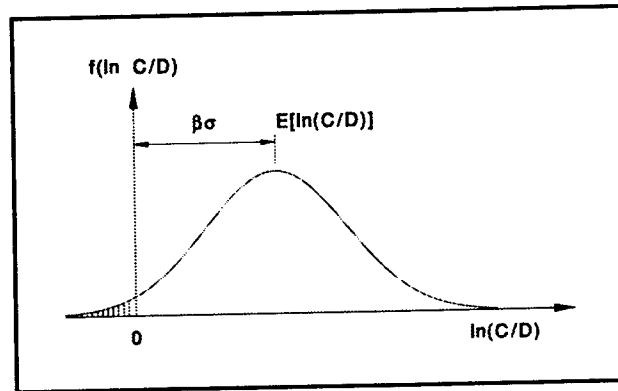

Figure 8. Log-normal distribution of capacity divided by demand

If capacity and demand are correlated, the reliability index is calculated using

$$\beta = \frac{C - D}{\sqrt{\sigma_C^2 + \sigma_D^2 - 2\rho\sigma_C\sigma_D}} \quad (19)$$

where  $\rho$  is the correlation between the capacity and demand.

Probability of failure can be calculated from the reliability index by using tables of standardized normal variates. The probability of failure versus  $\beta$  for normally distributed and uncorrelated capacity and demand is presented in Table 1.

Often capacity and demand are positively correlated, though they are generally assumed in engineering design to be uncorrelated. Harr (1987) states that the assumption of zero correlation violates the objective of engineering design. Harr's rationale is that one designs stronger structures to support higher loads and that it is standard practice to restrict loading on structures known to be substandard. Harr states that good engineering practice demands a positive correlation and that the value of  $\rho$  is probably around +0.75. The implications of the positive correlation are significant.

Table 1 Probability of Failure Versus Reliability Index	
$P_f$	$\beta$
0.10	1.28
0.01	2.33
0.001	3.10
0.0001	3.72
0.00001	4.25

In many situations, capacity, demand, and the resulting factor of safety are log normally distributed. This is a logical consequence of the factor of safety being the product of two numbers (Benjamin and Cornell 1970). The reliability index for log normally distributed capacity and demand is calculated using



$$\beta = \frac{E[\ln|C/D|]}{\sigma_{\ln(C/D)}} = \frac{\ln \left| \frac{E[C/D]}{\sqrt{1+V_{C/D}^2}} \right|}{\sqrt{\ln|1+V_{C/D}^2|}} \quad (20)$$

or, alternatively from

$$\beta = \frac{\ln \left| \frac{E[C]}{E[D]} \right|}{\sqrt{V_C^2 + V_D^2}} \quad (21)$$

where  $V_C$  and  $V_D$  are the coefficients of variation of the logarithms of capacity and demand.

### Target reliability indices

The Corps of Engineers has adopted the use of reliability indices to be a relative measure of the condition of structures for providing a qualitative estimate of structural performance. Target values of  $\beta$  developed from a wide base of experience are presented in Table 2. Values in this table were developed on the basis of events and not on an annual basis. Thus, an item used many times in daily operation requires a  $\beta$  value on the order of 7 to 8 for satisfactory performance because the number of events for that item is so large. In contrast, rarely occurring events may only require a  $\beta$  value in the range of 3 to 4 for satisfactory performance.

<b>Expected Performance Level</b>	<b><math>\beta</math></b>	<b>Probability of Unsatisfactory Performance</b>	<b>Potential Consequences</b>
High	5	0.0000003	Normal maintenance
Good	4	0.00003	Maintenance with traffic maintained
Above average	3	0.001	Shut down for repairs
Below average	2.5	0.006	Frequent outages for repairs
Poor	2.0	0.023	Frequent and extended outages for repairs
Unsatisfactory	1.5	0.07	Extensive rehabilitation required
Hazardous	1.0	0.16	Emergency

<sup>1</sup> From ETL 1110-2-532, 1 May 1992.

## Choice of methods for determination of risk

The choice of method used to predict the probability of failure of an individual mode of failure will depend on the amount and quality of knowledge available on the accuracy of design calculations. The choice of methods used for the determination of the reliability of a civil engineering structure can appear to be haphazard at first inspection. This is because the methods chosen will vary depending on the amount of information available for the analysis. In general, three approaches are available for establishment of probability.

One method is the a priori basis for calculating probability.<sup>1</sup> In this method, estimates of the statistical properties of various components are made and probabilistic estimates are calculated. The validity of this method depends on the reasonableness of the underlying assumptions made by the engineer regarding the individual components of the design. Often, this is the only method available when building a new structure where no history of similar structures is available.

A second method is an empirical approach utilizing past performance of similar structures. This approach must depend on the compilation of a large amount of observational data and the analysis of the relative frequency of different types of observed behaviors, both successes and failures. When data are limited, this method may be of little use, but when data are plentiful, this method can provide key insight into important factors involved. The key to successful application of this method is to ensure that the database is unbiased and complete. This is necessary so that all successes, as well as all failures, are utilized when a new design is compared to old designs contained in the database. Often, successful designs are left out of performance databases because they do not attract attention.

The third basis for the determination of probability is the combination of the first two methods. Here one combines one's intuition, reasonable assumptions, and available observational data to make an educated judgment of probability (Ang & Tang 1975). The tool used to combine the first two methods is Bayes' theorem. This method is often effective in improving the confidence in the results of the risk analysis.

An example of insight gained from examination of available information is the following. After Hurricane Camille in August 1969, designing engineers of offshore platforms realized that potential wave heights in the Gulf of Mexico were much higher than previously thought. This fact caused concern about the safety of the approximately 10,000 offshore oil production platforms constructed in the Gulf since the late 1940's. None of the foundations of the platforms had been designed with such large wave heights in mind. It was observed that if the platforms had not been safe, many more platform failures than the two of Hurricane Camille should have occurred (the platform failures of Hurricane Camille were structural failures not foundation failures). Since so few platforms had

---

<sup>1</sup> A priori is a Latin term for "from the former." When used in this sense, a priori means based on hypothesis rather than experiment.

failed, obviously the foundations possessed capacity in addition to that calculated using standard design methods. Several factors were considered. The two factors of greatest importance were the rate of loading effects and structural redundancy. Rate of loading effects could account for an increase of capacity of 3 to 10 percent per log cycle of loading rate. Structural redundancy can arise from temporary structures left in place and nonstructural elements capable of carrying load. The temporary structures left in place were the mud mats that support a platform jacket before the foundation piles are driven and grouted in the jacket legs. The nonstructural components are members like well conductor casing that are able to resist some lateral loading.

The point of the above discussion is to note that any estimate of the probability of failure of a complex structure will be in error if components of load or capacity are left out of the analysis. Christian, Ladd, and Baecher(1992) state that many reliability analyses provide only lower-bound estimates of reliability because of conservatism in the analysis. If we can be confident that all factors contributing to loading on the structure are included, then our estimate of the reliability of the structure will be a lower estimate of the reliability, as illustrated by the example above. However, if significant factors contributing to loading are omitted, then the conservatism of any estimate of reliability is in doubt.

Six modes of failure for pile-supported lock structures have been identified. Recommendations for the method used for prediction of probability of failure are presented in Table 3.

<b>Table 3 Modes of Failure and Prediction Methods</b>	
<b>Mode of Failure</b>	<b>Probability Prediction Method</b>
Performance failure of piles in shear resisting mass instability	a priori, local load test if available
Structural failure of piles in shear resisting sliding	a priori, local load test if available
Structural failure of piles in bending	a priori, local load test if available
Bearing capacity failure of foundation	Past performance based on American Petroleum Institute and Federal Highway Administration load test databases, local load test if available
Excessive settlement under long-term loading	a priori
Overturning	a priori

## Evaluation Criteria

Bea (1990) describes three basic approaches for evaluating the reliability of coastal and offshore structures. The three approaches are (1) historical

calibration, (2) design code calibration, and (3) cost-utility evaluation. These approaches will be presented and their acceptability for lock structures will be discussed.

### Historical calibration

Historical calibrations are based on what has happened to similar structures in the past when exposed to similar environments. Calibrations of this type should be considered from two perspectives. One perspective is the historical record of all similar structures taken as a group. The other perspective is the typical behavior of a structure over the useful lifetime of the structure.

The first perspective is illustrated in Figure 9. This figure shows the percentage of failures per year of offshore oil production platforms in the Gulf of Mexico. The rate of failure for these structures was high in the early days of offshore development and then decreased with time as designing engineers became more experienced.

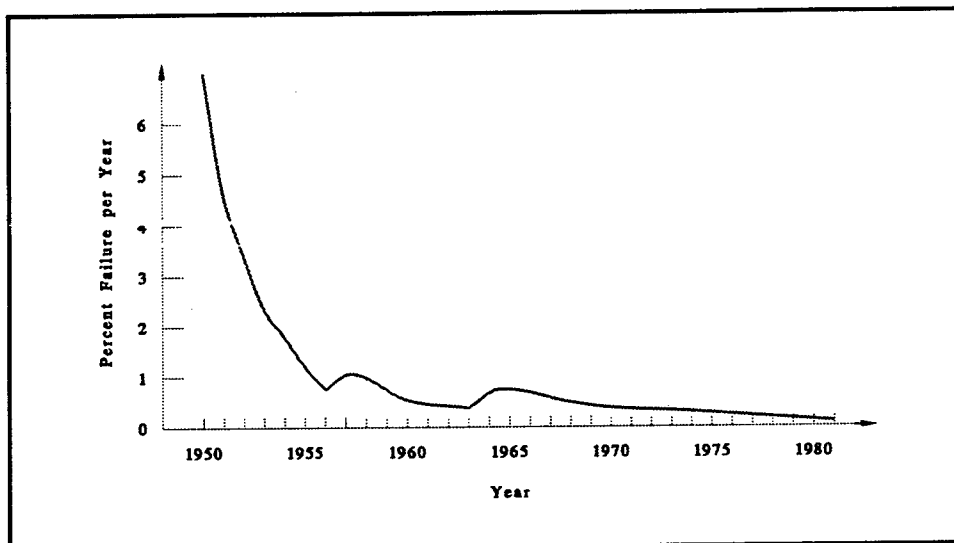

Figure 9. Reliability of major drilling and production platforms in the Gulf of Mexico subjected to hurricanes during the period 1950 through 1981 (from Bea (1990))

Harr (1987) has discussed the second perspective of historical calibration, the behavior of a single item over its useful lifetime. Harr categorizes the structure as having three periods of behavior as shown in Figure 10. The first period is the “breaking-in” period, during which structures fail primarily due to construction defects, flawed construction materials, or unsatisfactory design. The rate of failure during this period can be reduced through adequate quality control and inspection during construction. The rate of failure during the breaking-in period decreases with time because the structures most likely to fail undergo failure first. The second period is the “chance-failure” period during which failures occur randomly. The rate of failure during the chance-failure period is relatively constant. The

third period is the “wearing out” period in which structures have exceeded their useful life and the failure rate increases with time.

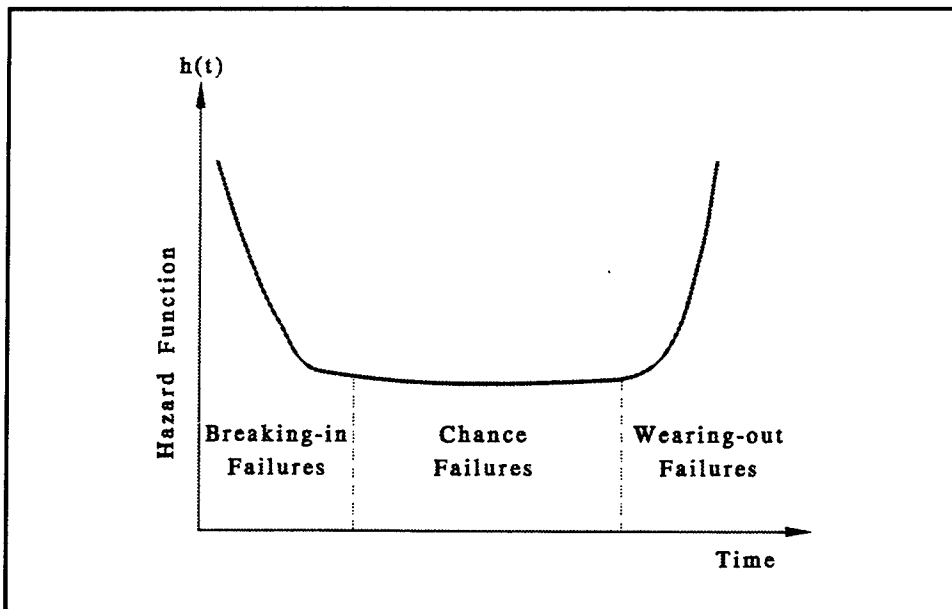

Figure 10. Hazard function versus time (after Harr (1987))

The adequacy of historical calibration depends on the quantity of the history used to make judgments. Historical calibration works well for offshore structures because the number of structures is large, over 10,000 structures in the Gulf of Mexico alone. In contrast, the number of lock structures maintained by the Corps of Engineers is much smaller, approximately 300. This small number of structures does not provide as extensive a history as other types of structures, so extrapolation of historical performance to lock structures is less well founded than for other structures that are more numerous.

A second way to view historical performance is illustrated in Figure 11. This figure was originally presented by Whitman (1984) and later modified by Bea (1990). The relationship between the rates of failure and failure consequences for many types of engineered structures is shown in 1984 U.S. dollars in this figure. The failure rates are due to all causes, both operational causes and environmental causes. Bea comments “The data indicate that over time and with experience, the industries and societies concerned have developed an acceptable or tolerable balance between failure consequences and reliability; as the failure consequences increase, there is an increase in the acceptable or tolerable reliability.” In other words, the acceptable probability of failure goes down as the cost of failure increases. The two lines for marginally acceptable and acceptable probability of failure  $P_f$  as a function of total cost of failure  $C_F$  are expressed as:

$$P_f(\text{acceptable}) = 10^{-0.74 \log C_F + 1.12} \quad (22)$$

$$P_f(\text{marginal}) = 10^{-0.6 \log C_F + 0.95} \quad (23)$$

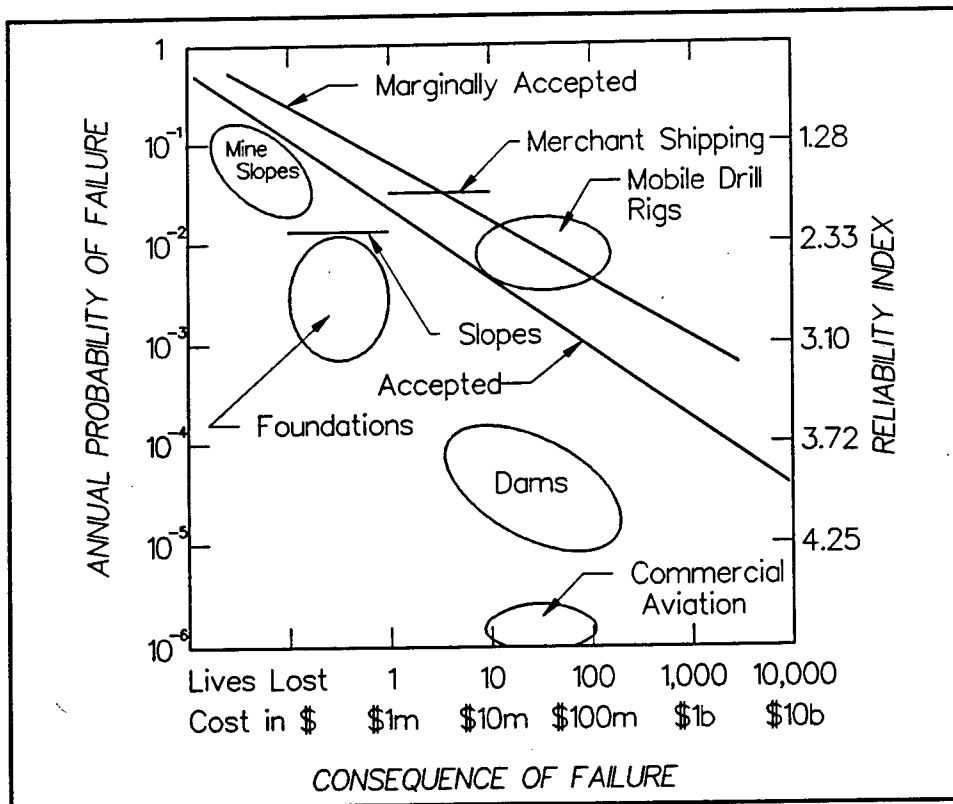

Figure 11. Historical relationship of risks and consequences for engineered structures (from Bea (1990) and Whitman (1984))

### Design code calibration

Calibration of design codes is based on evaluations of the reliability of structures resulting from application of the code used during design. Once the level of reliability of currently accepted codes is determined, new analyses of proposed code changes are made to achieve the desired levels of reliability. The desired levels of reliability are typically the same as those of the current code, but can be adjusted if required. Bea notes that almost all offshore design codes based on probabilistic methods have been based on this approach. Results of calibration analyses must be carefully analyzed whenever the results will be used for other structures.

### Cost-utility evaluation

The principal criteria used in cost-utility evaluations is that the best design results in the highest utility or highest cost efficiency. One common cost-utility evaluation is based on lowest total cost  $C_t$ , expressed as

$$C_t = C_i + C_f \quad (24)$$

where  $C_i$  is the initial cost and  $C_f$  is the future cost of operation, maintenance, and extraordinary cost due to risk.

In evaluation of expected costs  $C_E$  one can use

$$C_E = CP \quad (25)$$

where the cost  $C$  is the cost of some identifiable event and  $P$  is the probability of encountering that event. The cost  $C$  in the future is discounted to a present value by the present value function,  $F_{PV}$

$$F_{PV} = \frac{1 - (1+i)^{-L}}{i} \quad (26)$$

where  $i$  is the discount rate and  $L$  is the useful life of the structure. If a structure is considered to be permanent, the present value function is

$$F_{PV} = \frac{1}{i} \quad (27)$$

In design and operation, the owner must judge when it becomes uneconomical to invest in a structure to reduce expected costs. This point is reached when the marginal cost of investment exceeds the marginal savings in expected cost.

The expected cost for an event or alternative is the average cost per decision that would be realized over a series of trials is the cost decision makers use for consistent decision-making procedures. The use of expected values for decision making is a design and operational strategy with the objective of attaining highest utility possible.

The costs can be approximated as a linear function of the logarithm of probability of failure as shown in Figure 11. Thus,

$$C_i = C_0 + C \log_{10} |P_f| \quad (28)$$

where  $C_0$  is the cost versus  $P_f$  intercept and  $C$  is the slope per log cycle of the cost curve. By substituting Equation 28 and Equation 26 or 27 into Equation 25, differentiating, and setting equal to zero, one obtains the point of zero slope  $P_{f0}$ .

$$P_{f0} = \frac{0.435}{F_{PV} C_R} \quad (29)$$

where  $C_R$  is the cost ratio. The cost ratio is the ratio of expected cost to the cost needed to decrease the annual likelihood of loss by a factor of 10. The results of an evaluation of  $C_R$  and  $F_{PV}$  are shown in Figure 12 in terms of an optimum reliability index  $\beta$  that produces the lowest total cost.

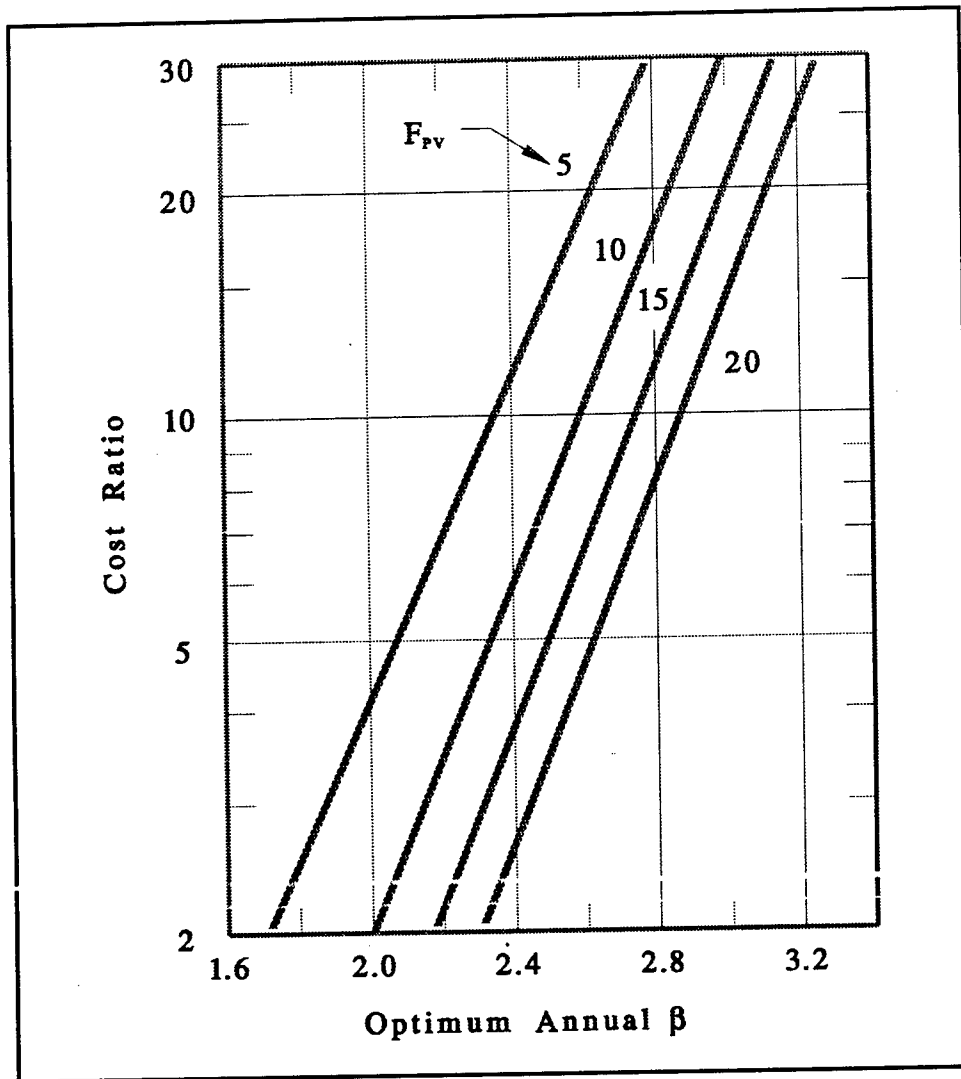

Figure 12. Reliability index as function of cost ratio and present value function (from Bea (1990))

## Conclusions

An introduction to techniques used in reliability analyses was presented in this chapter. A reliability analysis should include identification of the sources of uncertainty, modes of failure, and events that can initiate conditions leading to failure. The analysis then proceeds for selected combinations of the above factors by analyzing the expected variance in performance of the structure being considered and calculating the reliability index. Next, the reliability index is compared to a target reliability index to determine whether corrective measures are needed. If corrective measures are needed, the procedures discussed in the section titled "Evaluation Criteria" (pages 26-31) may be considered for evaluating the efficacy of varying rehabilitation strategies.



# 4 Computational Procedures and Issues

---

## Introduction

The subject of this chapter is a discussion of the computational procedures used for the reliability analysis of the deep stability of pile foundations. These procedures are an adaptation of the deterministic procedures presented in Chapter 2 and the reliability procedures presented in Chapter 3.

## Computational Procedures

The computational procedures used for the reliability analysis of deep-seated stability of pile foundations are an application of reliability-based design techniques to the deterministic procedure developed by Reese and Wang (1991). The computations are performed in the following order:

1. Identify the initiating event for which the reliability analysis is being performed. The initiating event should correspond to a clearly identifiable case of loading for the structure, i.e., routine operational conditions, flood conditions, etc.
2. Collect data describing soil profiles and shear strength of soil appropriate for the initiating event chosen in step 1. Careful attention should be given to selection of soil properties used for drained or undrained analyses.
3. Evaluate and characterize soil properties in terms of mean values, standard deviations, and covariances.
4. Perform a seepage analysis to establish the magnitude of pore water pressures under the structure. For simple geometries, a hand-drawn flow net may be acceptable for this purpose. For problems with complicated geometries or soils with anisotropic permeabilities, a computer analysis using either the finite element method or finite difference method is preferred.

5. Locate the position of the potential sliding surface assuming no piles are present by using a slope stability analysis program like UTEXAS3. Pay particular attention to whether the sliding surface is reasonable for the problem being considered. Examine the location of the thrust line through the sliding mass and the magnitude of stresses and pore water pressures acting on the slip surface. If required, use a tension crack to eliminate negative effective stresses at the head of the slide. Also examine the inclination of the slip surface at the toe of the slide, keeping in mind that steeply inclined slip surfaces through cohesionless materials can lead to computational errors. Once the critical slip surface has been located using the central values of the soil properties, repeat the analysis using the plus and minus standard deviation values. Calculate variance of  $F$  using the Taylor's series expansions for the partial derivatives of  $F$  with respect to the random variables and Equation 15 or 16. The reliability index of  $F$  is calculated using Equation 20. Note that this estimate of reliability index for the UTEXAS3 analysis is for a limiting equilibrium factor of safety and should not be compared to reliability indices from structural analyses where the factor of safety is calculated as the ratio of strength to load.
6. Analyze the movement of the soils by means of a plane strain finite element analysis using SOILSTRUCT. The distributed forces acting on a pile by moving soil will depend on the relative movement of the pile and soil. Repeat the finite element analysis using the central values of the Duncan and Chang (1970) model parameters  $K$ ,  $n$ ,  $K_b$ , and  $m$  plus or minus one standard deviation for each soil type. This is a total of eight analyses for each soil type in addition to one analysis using the central values for all layers.
7. Analyze the variance of performance of the structure foundations in moving soil using LOCKDAM in a Taylor's series expansion. Include the constitutive parameters for soil used in step 6 as random variables by using the soil displacement profiles generated by SOILSTRUCT in step 6. Other random variables are the shear strength parameters of the soil layers that will affect axial and lateral load transfer relationships. Treat all geometry and soil layer elevations as nonrandom variables. The total number of runs of LOCKDAM required are one run using mean values plus eight runs per soil layer for the Duncan-Chang model parameters plus two runs per random variable included in the LOCKDAM data.
8. Compute variances of a chosen performance variable such as factors of safety for bending stress or axial bearing capacity using the results from LOCKDAM in a Taylor's series expansion. In general, one should examine the factor of safety against overstressing the piles in bending and the factor of safety of the piles in bearing capacity.

9. If the factor of safety obtained using UTEXAS3 in step 5 is low, one may recompute the stability of the structure with the piles in place using the forces in the piles found in step 8.

This procedure is a modification of the original Reese and Wang (1991) procedure. The principal differences are the use of the finite element method to estimate soil displacement profiles and the use of Taylor's series expansions to assess variances of pile response. The following sections discuss several computational issues and an example analysis.

## Computational Issues

The critical step for the LOCKDAM analysis is to determine the amount of movement of the moving soil relative to lateral pile movement. A limit equilibrium procedure for calculation of slope stability by Spencer's method cannot provide this information because the actual stresses on the slip surface are not the factored shear strengths assumed in limit equilibrium analyses. However, a reasonable estimate for these distributed forces may be obtained by the Morgenstern and Price method if an appropriate interslice function is used. These factors and other issues are discussed in this section.

### Interslice forces and displacements

The deterministic analysis procedure developed by Reese and Wang requires that lateral loading of the foundation piles be input as either lateral displacements or as lateral distributed forces in the zone of sliding. Several techniques were discussed in Chapter 2 for calculation of lateral stresses and displacements. The recommended technique is to perform finite element analyses to assess displacements of soil near the foundation. Alternative techniques are to use methods to calculate internal forces in the zone of moving soil. The alternatives were to use limit equilibrium slope stability analysis programs to calculate interslice forces or other methods based on empirical techniques.

When choosing a method for calculation of lateral forces or displacements for use in the Reese and Wang procedure, the primary concern is to obtain realistic numbers. The finite element method is believed to be the best method to use for this purpose. It is recognized that limit equilibrium slope stability procedures like Spencer's method and the Morgenstern and Price method are easier to use because less effort is required for data preparation. However, the accuracy of a limit equilibrium procedure for assessing in situ stresses is uncertain. The following is a description of one comparison of interslice forces obtained using UTEXAS3 and a finite element analysis performed using SOILSTRUCT.

The soil profile and structure used in this study are shown in Figure 13. This figure is a cross section perpendicular to the axis of a lock structure. The loading of the structure results from the unequal water levels on the two sides of the structure and seepage forces in the foundation soils.

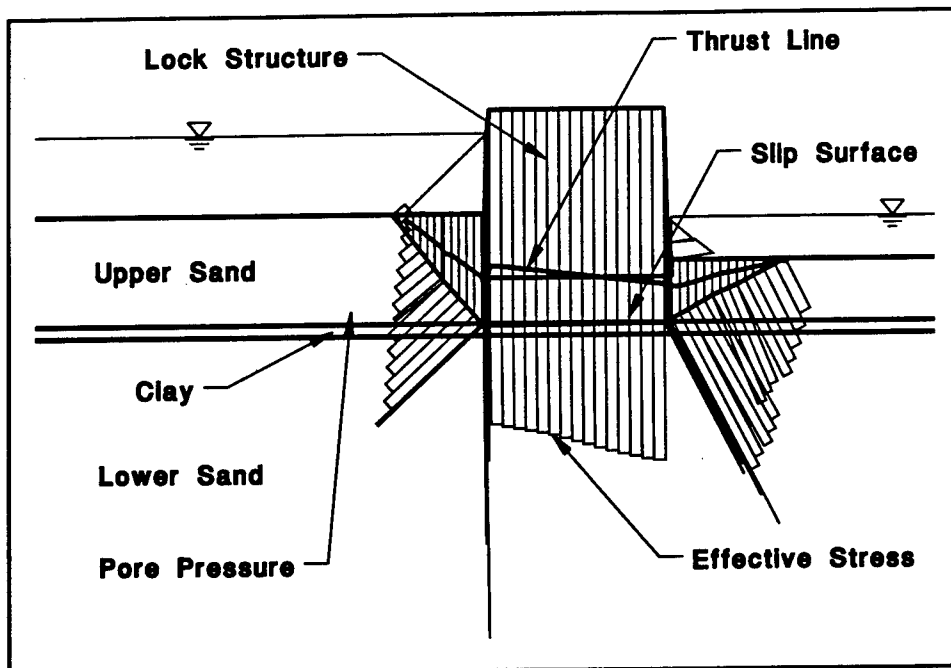

Figure 13. Example structure

This structure and soil profile were analyzed using UTEXAS3 with the noncircular failure surface search mode enabled. Spencer's method was used for the stability calculations. Nine points were used for the starting surface. The final critical surface was that shown in Figure 13. Note that this critical surface could have been modeled reasonably accurately using only four points. The factor of safety for this surface was 1.4. Also shown in this figure are graphical descriptions of effective stress, shear stress, and pore water pressure on the base of each slice. The lateral thrust force line is also shown in the figure.

The same soil profile and structure were analyzed again by the finite element method. The program used was SOILSTRUCT. Nine construction steps were used to model gravity turn-on and a tenth step was used for the application of surface and seepage loadings. Seepage forces were modeled by inputting pore water pressures under the structure. These pore water pressures were obtained from a hand-drawn flow net. The finite element grid and the critical slip surface obtained using Spencer's method are shown in Figure 14. The grid was composed of 200 elements and 236 nodal points. The execution time for SOILSTRUCT was approximately four minutes on an IBM PC compatible personal computer using an 80386 microprocessor and 80387 mathematical coprocessor running at 20 MHz. Hand preparation of the data for the finite element grid and material properties took approximately one week, but this time can be substantially reduced as experience is gained in using SOILSTRUCT. It should be noted that the documentation for SOILSTRUCT gives no guidance with regard to selection of the number of iterations and substeps to be used. It is recommended that a new user consult with an experienced user when first using SOILSTRUCT.

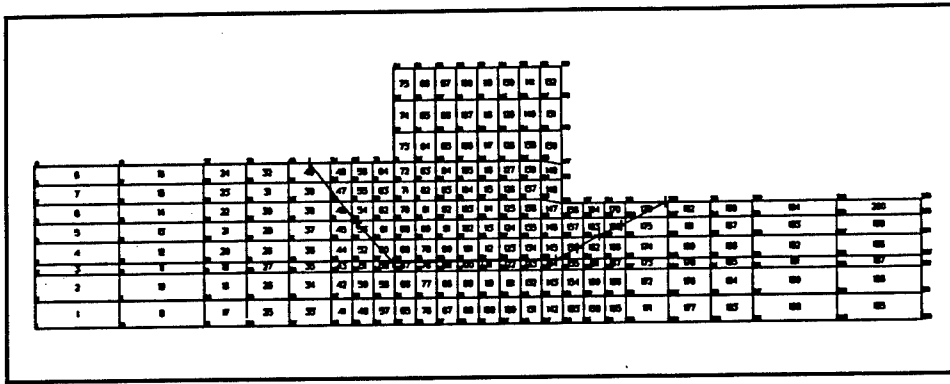

Figure 14. Finite element mesh for example analysis

Comparisons of normal effective stress and shear stress on the critical slip calculated with UTEXAS3 and SOILSTRUCT are shown in Figures 15 and 16, respectively. These stresses are plotted versus the element numbers through which the critical surface passes going from left to right. In general, the comparison is poor. It should be noted that the numbers from UTEXAS3 are for the base of the slice and the numbers from SOILSTRUCT are for the center-point of the element, so the numbers are not from identical locations. The poor comparison of stresses on the critical surface is not unexpected because of the fundamental differences in the two analyses.

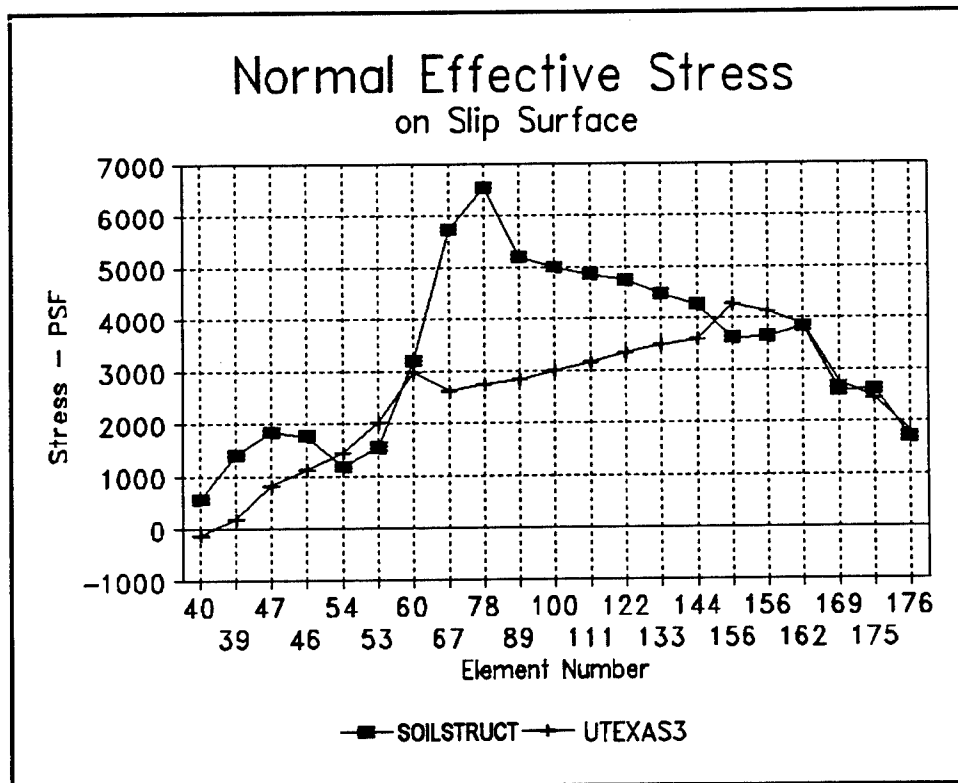

Figure 15. Normal effective stress on slip surface

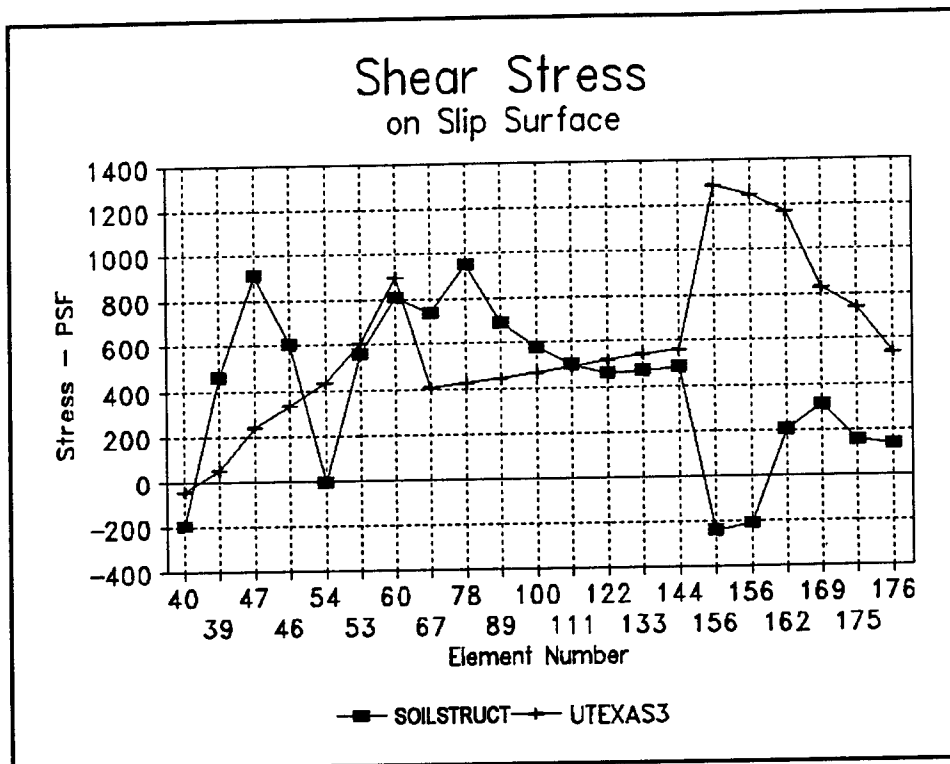

Figure 16. Shearing stress on slip surface

No comparisons of results obtained from the Morgenstern and Price method and the finite element method were made because no program for this method was available for use. It is anticipated on the basis of the study of Rahardjo, Fredlund, and Fan (1992), discussed in Chapter 2, that a better comparison would be found in cases of homogeneous slopes in overconsolidated clays with high factors of safety because the soil would behave in a somewhat elastic manner. A good comparison would not be expected for stratified soils or slopes with low factors of safety because the assumption of linear elastic behavior would be in error.

The recommended approach is to evaluate soil displacements for input into LOCKDAM using SOILSTRUCT or a similar program. This approach allows the user to introduce the effects of nonlinear soil properties and construction operations in a rational manner.

One limitation of the LOCKDAM program is that only one soil displacement profile is input for all piles analyzed by the program. Examination of output from SOILSTRUCT shows that soil displacements vary from one side of the structure to the other. Consequently, the user must select a representative soil displacement profile to be used for input to LOCKDAM. For the example problem discussed below, the soil displacement profile along the centerline of the structure was used. One additional adjustment to be made is the normalization of soil displacements to zero at the lower depths of the piles below the potential sliding surface. This is required because LOCKDAM was written using the assumption that soil displacements are zero below the slip surface.

## Foundation analysis

The procedure for reliability analysis of the pile group uses a Taylor's series expansion to calculate variance in structural response of the foundation members. The random variables in this analysis are the material properties of the soil. For this study, all geometric data and structural material properties were considered to be nonrandom. This may be considered an unrealistic reduction of the number of random variables because the randomness of soil layering is omitted. This compromise is made because for many practical problems insufficient data are available to characterize the spatial variability in soil layering.

## Probabilistic characterization of soil properties

The randomness of soil properties can be characterized in several levels of refinement. The simplest characterization is to use only the mean value of the property for a soil layer. Next, one may include the standard deviation of the property for each soil layer and the covariance of one property with another property for the same layer. Inclusion of covariance can minimize calculated variance when the covariance is negative as is the case with correlations between cohesion and friction angle for partially saturated clay soils.

## Interaction of closely spaced piles

The effects of closely spaced piles can be included in a LOCKDAM analysis. This requires that the user calculate the interaction factors for the pile group as functions of the group geometry. The interaction factors will depend on the relative position and spacing of piles in the group and the direction of loading. Reese and Wang recommend the following equations be used to calculate the interaction factors.

The interaction factor for an individual pile is the product of the interaction factors between a particular pile and every other pile in the group. For two piles in a row perpendicular to the direction of loading, the interaction factor  $\beta_{row}$  is calculated using

$$\beta_{row} = 0.5292 \left( \frac{s}{b} \right)^{0.5659} \quad \text{for } 1 \leq \frac{s}{b} \leq 3.28 \quad (30a)$$

$$\beta_{row} = 1.0 \quad \text{for } \frac{s}{b} \geq 3.28 \quad (30b)$$

where  $s$  is the center-to-center pile spacing and  $b$  is the pile diameter. For two piles in a line, the interaction factor for the leading pile is calculated using

$$\beta_{lead} = 0.7309 \left( \frac{s}{b} \right)^{0.1951} \quad \text{for } 1 \leq \frac{s}{b} \leq 3.37 \quad (31a)$$

$$\beta_{lead} = 1.0 \text{ for } \frac{s}{b} \geq 3.37 \quad (31b)$$

For two piles in a line, the interaction factor for the trailing pile is calculated using

$$\beta_{trail} = 0.5791 \left( \frac{s}{b} \right)^{0.3251} \text{ for } 1 \leq \frac{s}{b} \leq 5.37 \quad (32a)$$

$$\beta_{trail} = 1.0 \text{ for } \frac{s}{b} \geq 5.37 \quad (32b)$$

For two piles skewed relative to one another (i.e. not directly in a line or row), the interaction factor is calculated using

$$\beta_{skew} = \sqrt{\beta_{row}^2 \cos^2 \theta + \beta_{in-line}^2 \sin^2 \theta} \quad (33)$$

where  $\beta_{in-line}$  is the leading or trailing interaction factor and  $\theta$  is the angle between the direction of loading and the line connecting the two piles in question. Note that  $\beta_{row}$  and  $\beta_{in-line}$  are calculated on the basis of the in-line and perpendicular separation distances as shown in Figure 17. After all interaction factors in the  $n$ -pile group are calculated for the  $k^{\text{th}}$  pile, the pile interaction reduction factor is calculated using

$$\beta_k = \beta_{1k} \beta_{2k} \beta_{3k} \dots \beta_{nk} \quad (34)$$

where  $\beta_{1k}$  denotes the appropriate interaction factor between the first and  $k^{\text{th}}$  piles and so on. The interaction factor between the  $k^{\text{th}}$  pile and itself is omitted from Equation 34.

The interaction factors calculated using Equations 30 through 34 were based on tests of vertical piles without a pile cap in contact with the ground surface. The applicability of these interaction factors to battered piles or to pile groups where the pile cap has significant interaction with the ground is uncertain.

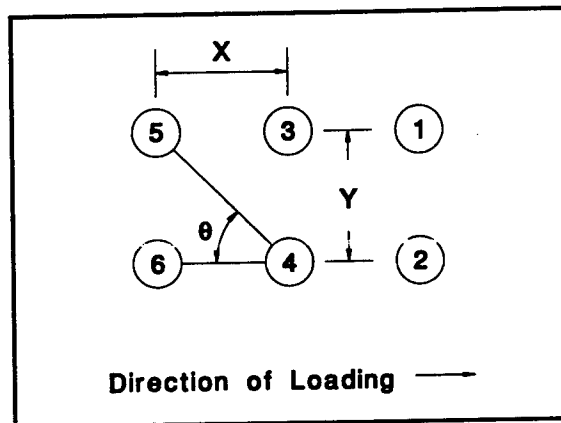

Figure 17. Description of pile geometry for interaction analysis



## Example Problem

An example problem will be used to illustrate the synthesis of methods used for reliability analysis of pile foundations. The problem considered is based on a similar problem analyzed by Reese and Wang (1991) and is shown in Figure 18. This problem is a navigation structure supported by battered foundation piles. The cross section shown represents a 10-ft section of the structure with two rows of battered piles. Please note that the piles do not interfere with one another because all piles in a row are battered in one direction.

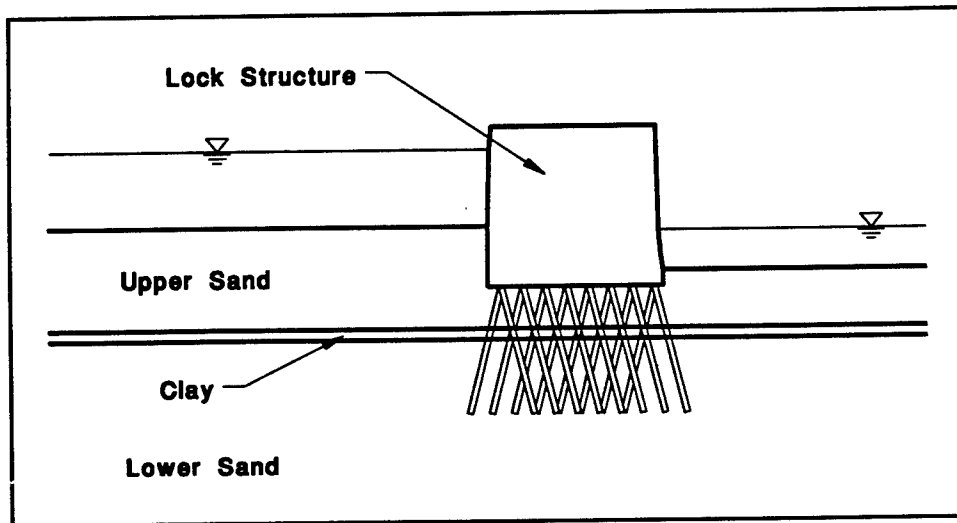

Figure 18. Example problem

The soil beneath this structure is modeled using three soil layers. The upper and lower soil layers had properties representative of medium and loose sands. The middle layer was representative of a silt under fully drained conditions.

Model parameters for the Duncan and Chang constitutive relationship were obtained for typical soils from Duncan et al. (1978). Standard deviations for the model parameters were obtained from Monte Carlo simulations using the curve-fitting procedure included in Duncan et al. (1978). Several simulations were performed to examine the statistical behavior of the model parameters. Both  $K$  and  $K_b$  were found to be log normally distributed, and  $n$  and  $m$  were found to be normally distributed. The Monte Carlo simulation used a normally distributed random number generation procedure to generate numbers for principal stress difference and axial strain. Typically 250,000 iterations were used per simulation.

Twenty-five two-stage finite element analyses were performed using SOILSTRUCT. The first stage of an analysis applied the first nine construction steps and stopped the program after writing a program data file. The second stage of the analysis applied the seepage forces and external water loadings acting on the structure. This required the editing of the program data file to insert the data for pore water pressures and external

loading. Thus, a total of 50 individual runs of the finite element program were made for this problem.

The output of SOILSTRUCT was examined to determine the profiles of soil displacement under the structure. A graph showing the distribution of soil displacements is shown in Figure 19. Please note that this figure does not include the effects of the piles supporting the structure. This figure is presented to illustrate the pattern of soil displacements under the structure.

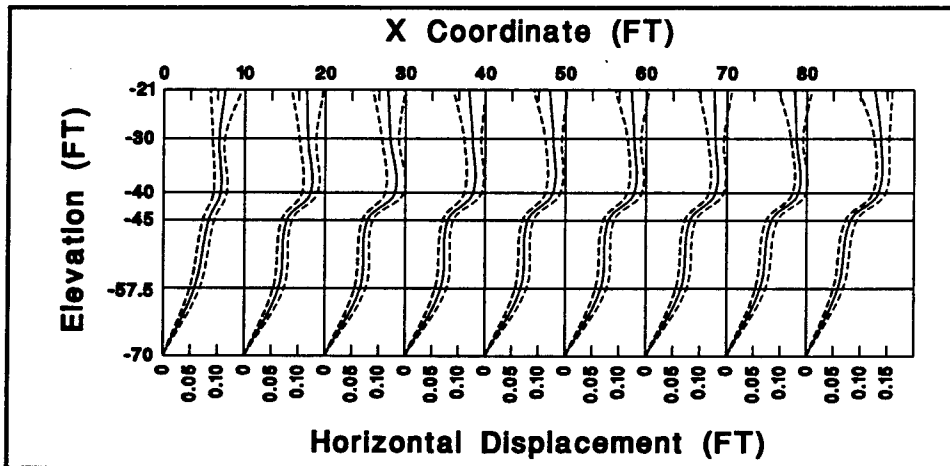

Figure 19. Mean horizontal displacements plus and minus one standard deviation calculated using Taylor's series expansion

The soil displacements calculated using the finite element method were adjusted before input into LOCKDAM to reflect a zero movement of the soil near the pile tips. This adjustment is necessary due to the assumption taken in programming that the soil displacements below the slip surface are zero. The procedure used for this adjustment was to take the horizontal soil displacements under the center line of the structure and to subtract the horizontal displacement at el -57.5 ft from the horizontal displacements above el -57.5 ft. This was done for all 25 two-stage finite element analyses.

These soil displacement profiles represented the mean value case and the plus and minus standard deviation cases for the four Duncan-Chang parameters for the three soil layers. These soil profiles were combined with soil strength and structural data to assemble the first 25 data files for LOCKDAM. The last six data files for LOCKDAM were developed by entering plus and minus one standard deviation of  $\tan(\phi)$ . The standard deviations of  $\tan(\phi)$  were based on a coefficient of variation of 0.12 for sands obtained from Harr (1987).

During the initial runs of LOCKDAM, convergence could not be obtained for several data sets because the foundation piles would fail in bearing capacity. Thus, the number and size of piles had to be increased over those used by Reese and Wang. The final foundation configuration used had 16 piles battered 14 deg. Each pile was a 30-in.-diam, 60-ft concrete-filled pipe pile. This configuration was necessary to obtain a pile that had adequate bearing capacity and adequate bending stiffness.

The output from LOCKDAM was examined using a Taylor's series expansion to evaluate variance in the factors of safety against bearing capacity and overstressing the piles in bending. The reliability indices for the 16 piles are shown in Table 4 along with the factor of safety in bending and the standard deviation in the factor of safety in bending. The reliability indices were calculated using Equation 21 for log normally distributed variates. This analysis found that the log-normal reliability indices for bending stress fell into the average category as defined by Table 2.

Pile Number	$F_B$	$s_B$	$\beta_{log-norm}$
1	2.47406	0.755700	2.88371
2	2.57769	0.743363	3.20881
3	2.45416	0.743121	2.88306
4	2.55211	0.742666	3.14363
5	2.47219	0.744041	2.92649
6	2.52880	0.746404	3.06546
7	2.49083	0.746001	2.96723
8	2.50941	0.747765	3.00858
9	2.50994	0.747491	3.01112
10	2.49032	0.746064	2.96561
11	2.52933	0.745380	3.07130
12	2.47151	0.744083	2.92454
13	2.55337	0.742109	3.14948
14	2.45566	0.751081	2.85470
15	2.57880	0.743058	3.21315
16	2.48413	0.755254	2.91157

One advantage of a reliability analysis is that one may determine where the uncertainty in performance may arise. The distribution of variance in bending stress for the three layers of soil is shown in Tables 5 to 7. These tables show the decimal fraction of variance due to each of the 15 random variables considered in this reliability analysis. These numbers were calculated by taking the variance due each random variable summed in the Taylor's series expansion and dividing by the total variance for the pile in question. Thus, the sum of decimal fractions in the corresponding rows of these tables is 1.0. These tables have been shortened because the maximum moment in each pair of piles is at the top of the piles. Thus, the bending stresses in piles 1 and 2 are equal because the pile rotations and pile-head displacements are equal for these two piles. This condition is due to the fixed-head boundary condition used in this analysis, which brings about equal pile response because both piles undergo the same rotation. If either free-head or rotationally restrained pile-head conditions had been assumed, pile response would have been different for each pile.

<b>Table 5 Distribution of Variance in Bending Stress Due to Layer 1</b>					
Pile	$K$	$n$	$K_b$	$m$	Tan( $\phi$ )
1, 2	0.14809	0.00215	0.00215	0.00000	0.32227
3, 4	0.14439	0.00212	0.00212	0.00000	0.32706
5, 6	0.14094	0.00205	0.00151	0.00000	0.33187
7, 8	0.11791	0.00163	0.00163	0.00000	0.36720
9, 10	0.17189	0.00269	0.00269	0.00000	0.26858
11, 12	0.15502	0.00242	0.00242	0.00000	0.29978
13, 14	0.15576	0.00234	0.00234	0.00000	0.30364
15, 16	0.15231	0.00232	0.00232	0.00001	0.30915

<b>Table 6 Distribution of Variance in Bending Stress Due to Layer 2</b>					
Pile	$K$	$n$	$K_b$	$m$	Tan( $\phi$ )
1, 2	0.00001	0.00361	0.00394	0.00019	0.00861
3, 4	0.00000	0.00331	0.00331	0.00013	0.00849
5, 6	0.00000	0.00339	0.00339	0.00017	0.00943
7, 8	0.00000	0.00367	0.00367	0.00041	0.01020
9, 10	0.00000	0.00477	0.00477	0.00030	0.00477
11, 12	0.00000	0.00458	0.00378	0.00015	0.00742
13, 14	0.00000	0.00355	0.00401	0.00022	0.00733
15, 16	0.00000	0.00378	0.00412	0.00018	0.00778

<b>Table 7 Distribution of Variance in Bending Stress Due to Layer 3</b>					
Pile	$K$	$n$	$K_b$	$m$	Tan( $\phi$ )
1, 2	0.03147	0.16760	0.09178	0.02506	0.19308
3, 4	0.03117	0.16867	0.08963	0.02476	0.19483
5, 6	0.03054	0.16629	0.09255	0.02413	0.19373
7, 8	0.03305	0.16320	0.07997	0.01999	0.19747
9, 10	0.03611	0.15786	0.10773	0.03611	0.20173
11, 12	0.03406	0.16989	0.09461	0.02967	0.19619
13, 14	0.03194	0.16773	0.09550	0.02933	0.19630
15, 16	0.03208	0.16946	0.09450	0.02747	0.19454

One interesting finding of the analysis of variance is the relatively small influence of layer 2 on bending stress. This is logical because the stronger soils above and below layer 2 are capable of developing greater load transfer and thereby carry most of the loading.

As mentioned above, the size and number of piles supporting the structure in this problem had to be increased over those used by Reese and Wang to obtain convergence of all cases of loading used in the Taylor's series expansion. The cause of the convergence problem was failure of the piles in bearing capacity. The reliability indices for the factor of safety against bearing capacity are presented in Table 8. These values of reliability index for bearing capacity cover a much wider range of values than those for bending stress presented in Table 4.

Pile Number	$F_{BC}$	$\sigma_{BC}$	$\beta_{log-norm}$
1	1.71689	0.164472	5.60746
2	1.02238	0.015496	1.45293
3	1.18806	0.032113	6.36286
4	1.02611	0.023943	1.09313
5	1.14552	0.037486	4.13642
6	1.04105	0.052945	0.76605
7	1.10593	0.054900	2.00465
8	1.07606	0.066884	1.14945
9	1.06898	0.065527	1.05852
10	1.11351	0.053972	2.19533
11	1.03441	0.046475	0.73099
12	1.15366	0.036219	4.53844
13	1.02537	0.020489	1.24413
14	1.21592	0.094691	2.47539
15	1.02165	0.014317	1.52151
16	1.97962	0.399797	3.31556

The wide variation in reliability indices for bearing capacity is related to the difference in loading of the piles. The even-numbered piles are battered with the pile head toward the direction of loading. Therefore, the even-numbered piles left of the center line are loaded more heavily than the odd-numbered piles left of center line and the reverse is true to the right of center line. The factors of safety are between 1.02 and 1.22 for all piles except piles 1 and 16. The factors of safety are approximately equal for piles that are opposite one another with respect to the center line of the structure. Axial capacities and load-settlement curves for the piles were calculated internally by LOCKDAM. The algorithm used gave substantially the same load-settlement behavior in tension and in compres-

The load-settlement analysis does not include the effects of residual driving stresses and cyclic degradation.

The lowest reliability indices for bearing capacity for piles in compression are of approximately the same magnitude as the lowest for piles in tension. These values are misleadingly low because the bearing capacity of the structure acting as a large footing has been ignored. This is a limitation for LOCKDAM which was written assuming that the pile cap connecting the piles together is not in contact with the ground surface.

The distribution of variance in bearing capacity is presented in Tables 9 through 11. The distribution of variance in bearing capacity is quite different than for the case of bending stress shown in Tables 5 through 7. Layer 1 generates the largest fraction of variance in bearing capacity. Note how little the properties associated with layer 2 contribute to overall variance.

Pile	$K$	$n$	$K_b$	$m$	$\text{Tan}(\phi)$
1	0.02726	0.00055	0.00053	0.00000	0.72147
2	0.39300	0.00169	0.00158	0.00000	0.21987
3	0.77377	0.00088	0.00081	0.00000	0.05698
4	0.69291	0.00052	0.00048	0.00000	0.10784
5	0.17880	0.00269	0.00250	0.00000	0.25975
6	0.33678	0.00588	0.00542	0.00000	0.14210
7	0.17376	0.00261	0.00241	0.00000	0.27433
8	0.17798	0.00259	0.00238	0.00000	0.24192
9	0.19631	0.00292	0.00270	0.00000	0.20497
10	0.16499	0.00239	0.00220	0.00000	0.28937
11	0.37066	0.00810	0.00657	0.00000	0.13264
12	0.16518	0.00235	0.00216	0.00000	0.28262
13	0.74032	0.00076	0.00071	0.00000	0.09202
14	0.41455	0.00580	0.00516	0.00000	0.09026
15	0.27687	0.00211	0.00196	0.00000	0.25764
16	0.08955	0.00220	0.00222	0.00000	0.48645

Pile	$K$	$n$	$K_b$	$m$	$\text{Tan}(\phi)$
1	0.00000	0.00098	0.00129	0.00005	0.00815
2	0.00000	0.00262	0.00271	0.00012	0.00580
3	0.00000	0.00131	0.00129	0.00006	0.00180
4	0.00000	0.00080	0.00083	0.00004	0.00179
5	0.00000	0.00412	0.00417	0.00019	0.00715
6	0.00000	0.00912	0.00941	0.00042	0.00025
7	0.00000	0.00401	0.00409	0.00018	0.00733
8	0.00000	0.00401	0.00413	0.00018	0.00862
9	0.00000	0.00451	0.00462	0.00021	0.00838
10	0.00000	0.00370	0.00380	0.00017	0.00826
11	0.00000	0.01254	0.01286	0.00057	0.00032
12	0.00000	0.00362	0.00371	0.00016	0.00865
13	0.00000	0.00117	0.00121	0.00005	0.00237
14	0.00000	0.00887	0.00883	0.00040	0.00027
15	0.00000	0.00324	0.00335	0.00015	0.00661
16	0.00000	0.00347	0.00385	0.00016	0.00468

## Conclusions

This chapter reviewed the computational procedure developed by Reese and Wang and discussed how this procedure can be used in a reliability assessment using the Taylor's series expansion technique. It was concluded that the best procedure to evaluate lateral soil displacements for input into the Reese and Wang procedure is the finite element method.

The reliability analysis demonstrated by this example problem shows how the Taylor's series expansion technique can be applied to complicated soil-structure interaction problems. In this analysis, parameters affecting performance were identified. Parameters known with certainty were assigned fixed values. All other parameters were considered to be random and were characterized by their means and standard deviations. For this problem, two computer programs were used; SOILSTRUCT and LOCKDAM. The random model parameters in SOILSTRUCT were included in LOCKDAM by using as input the soil displacement profiles generated by SOILSTRUCT. Thus, multiple runs of both programs were required to

<b>Pile</b>	<b>K</b>	<b>n</b>	<b>K<sub>b</sub></b>	<b>m</b>	<b>Tan(φ)</b>
1	0.02260	0.09215	0.04058	0.00849	0.07591
2	0.02266	0.12193	0.06714	0.01888	0.14200
3	0.00858	0.05057	0.02985	0.00925	0.06486
4	0.00694	0.06973	0.04115	0.00576	0.07121
5	0.03162	0.17245	0.09909	0.02958	0.20787
6	0.06443	0.12578	0.10980	0.06399	0.12661
7	0.03217	0.17061	0.09777	0.02897	0.20175
8	0.03427	0.18209	0.10155	0.02845	0.21183
9	0.03693	0.19245	0.11045	0.03270	0.20284
10	0.03149	0.17173	0.09455	0.2597	0.20137
11	0.05287	0.12195	0.10415	0.05281	0.12398
12	0.03054	0.17449	0.09404	0.02481	0.20767
13	0.00982	0.05237	0.02932	0.00852	0.06137
14	0.05915	0.11931	0.10337	0.05460	0.12943
15	0.02736	0.14551	0.08143	0.02363	0.17015
16	0.03538	0.12868	0.08227	0.03369	0.12740

evaluate variance in the performance factors considered in the reliability analysis.

The reliability analysis demonstrated that several performance factors must be considered because the reliability indices can be different for each. For the example problem, the critical performance factor was the factor of safety against bearing capacity.



# 5 Conclusions and Recommendations

---

## Conclusions

Techniques for making reliability assessments of pile-supported navigation structures subjected to deep-seated instability were examined in this study. The primary emphasis of this report was to review the procedure for deterministic analysis developed by Reese and Wang (1991), to introduce reliability techniques applicable to the Reese and Wang procedure, and to demonstrate a reliability assessment of a navigation structure using an example problem.

The key to successful application of the Reese and Wang procedure is an accurate evaluation of lateral soil displacements. Several procedures for estimating lateral soil displacement and lateral soil forces were evaluated. The finite element method was found to be best for this purpose.

Application of the Taylor's series expansion technique for reliability assessments to complicated soil-structure interaction problems is feasible. This process begins by identifying and quantifying parameters that affect performance. Parameters that are known with reasonable certainty are assigned fixed values and the others are considered to be random variables. The Taylor's series expansion technique requires values for mean and standard deviation of each random variable considered in the analysis. These values are input into the deterministic analysis procedure, varying each random variable in turn by plus or minus one standard deviation. Next, partial derivatives of the performance function in question (usually a factor of safety applied to stress, deformation, or bearing capacity) with respect to each random variable are evaluated, and variance of the performance function is calculated using Equation 15 and the log-normally distributed reliability index is calculated using Equation 20. The reliability index is used as a relative measure of reliability of a structure to perform in an acceptable manner. Reliability indices can be used in a risk model for making investment decisions.

The example problem presented in Chapter 4 demonstrated the general procedure for using a Taylor's series expansion of a soil-structure interaction analysis to evaluate reliability. Considerable time and effort are required to use the current versions of the computer programs in making a

reliability analysis. The amount of time and effort required of the user can be reduced by modifying the program to read multiple data files. However, an experienced user can get a better appreciation for the problem by examining the output files from each computer analysis and can make appropriate modifications to data as required.

## Recommendations for Further Work

In the course of this study, several areas were found where future research and development are warranted. These areas are divided among program development, analytical research, and investigations of case histories. The following items are suggested for consideration.

The following suggestions pertain to the analysis program LOCKDAM:

- Improve execution messages to the screen and output files.
- Add input of separate soil displacement profiles for different piles.
- Improve error messages to the screen and output files.

The following suggestions pertain to the data preparation program LOCKDATA:

- Improve the on-line help system.
- Add internal generation of  $p$  and  $y$  multipliers for closely spaced piles.

The following suggestions pertain to the graphics program LOCKPLOT:

- Add generation of DXF graphics files for input into CADD programs.
- Eliminate input errors when reading graphics data written in double precision format.

The following topics are suggested for analytical research:

- Investigate the effects of including interaction of the pile cap and ground surface.
- Investigate the effects of seepage by considering problems with sheet pile cut-off walls.
- Investigate the effects of interface elements between the soil and structure in finite element analyses.

The following suggestions are for case history development:

- Evaluate one or more actual structures using the procedures developed for this study.

- Convene a review team of experts in deep foundations and navigation structures to evaluate the findings of the case history investigation and reliability assessment. Ask the review team to make recommendations for typical structural loading and typical pile loading.

As experience is gained with reliability assessments, much of the work involved in compiling data for calculation of reliability indices will become routine for many applications. Much effort can be saved by modifying computer programs to write the summary data on which reliability calculations are based in a standardized format for input into a single program to be used for many applications.

## References

---

- Ang, A. H-S., and Tang, W. H. (1975). *Probability concepts in engineering planning and design; Volume I, basic principles*. Wiley, New York, 409 p.
- Bea, R. G. (1990). *Reliability based design criteria for coastal and ocean structures*, Institution of Engineers, Australia, 221 p.
- Benjamin, J. R., and Cornell, C. A. (1970). *Probability, statistics, and decision for civil engineers*. McGraw Hill, New York, 684 p.
- Christian, J. T., Ladd, C. C., and Baecher, G. B. (1992). "Reliability and probability in stability analysis," *Proceedings, Specialty Conference on Stability and Performance of Slopes and Embankments*, American Society of Civil Engineers, Berkeley, 1071-111.
- DeBeer, E., and Carpentier, R. (1977). Discussion of "Methods to estimate lateral force acting on stabilizing piles," *Soils and Foundations* 17 (2), 68-82.
- Duncan, J. M., Byrne, P., Wong, K. S., and Mabry, P. (1978). "Strength, stress-strain, and bulk modulus parameters for finite element analyses of stresses and movements in soil masses," Report No. UCB/GT/78-02, University of California, Berkeley.
- Duncan, J. M., and Chang, C-Y. (1970). "Nonlinear analysis of stress and strain in soils," *Journal of the Soil Mechanics and Foundations Division*, American Society of Civil Engineers, 96 (5), 1629-53.
- Edriss, E. V., and Wright, S. G. (1992). "User's guide: UTEXAS3 slope stability package," Instruction Report GL-87-1, U.S. Army Engineer Waterways Experiment Station, Vicksburg, MS.
- Filz, G., Clough, G. W., and Duncan, J. M. (1990). "Draft user's manual for program SOILSTRUCT (Isotropic) plane strain with beam element," Department of Civil Engineering, Virginia Tech, Blacksburg, VA.
- GOESLOPE International, Ltd. (1989). "PC-SLOPE user's manual," Calgary, Alberta, Canada.

- Hahn, G. J., and Shapiro, S. S. (1967). *Statistical models in engineering*. Wiley, 355 p.
- Harr, M. E. (1987). *Reliability-based design in civil engineering*, McGraw-Hill, 291 p.
- Headquarters, U.S. Army Corps of Engineers. (1991). "Design of pile foundations," Engineer Manual EM 1110-2-2906, Washington, DC.
- Ito, T., and Matsui, T. (1975a). "Methods to estimate lateral force acting on stabilizing piles," *Soils and Foundations* 15 (4), 43-59.
- Ito, T., and Matsui, T. (1975b). Closure to "Methods to estimate lateral force acting on stabilizing piles," *Soils and Foundations* 18 (2), 41-44.
- Ito, T., Matsui, T., and Hong, W. P. (1981). "Design method for stabilizing piles against landslide - one row of piles," *Soils and Foundations* 21 (2).
- Leggett, M. A., and Mosher, R. L. (1993). "Reliability-based assessment of navigation structures," *Proceedings, 5<sup>th</sup> Intl. Conf. On Computing in Civil and Building Engineering*, American Society of Civil Engineers, 881-90.
- Morgenstern, N. R., and Price, V. E. (1965). "The analysis of the stability of general slip surfaces," *Géotechnique*, 15 (1), 79-93.
- \_\_\_\_\_. (1967). "A numerical method for solving the equations of stability of general slip surfaces," *The Computer Journal* 9 (4), 388-93.
- Oakland, M. W., and Chameau, J.-L. (1989). "Analysis of drilled piers used for slope stabilization," *Transportation Research Record* 1219, 21-32.
- Rahardjo, H., Fredlund, D. G., and Fan, K. K. (1992). "Interslice force functions for limit equilibrium analysis," *Proceedings, Specialty Conference on Stability and Performance of Slopes and Embankments*. American Society of Civil Engineers, Berkeley, 325-41.
- Reese, L. C., and Wang, S-T. (1991). "Study of the stability of pile foundations for lock structures, phase three report," Report to U.S. Army Engineer Waterways Experiment Station, prepared under contract DACW39-88-C-0084.
- Spencer, E. (1967). "A method of analysis of the stability of embankments assuming parallel interslice forces," *Géotechnique* 17 (1), 11-26.
- Tschebotarioff, G. P. (1962). "Retaining structures." *Foundation engineering*, G. A. Leonards, McGraw-Hill, Chapter 5.
- \_\_\_\_\_. (1973). *Foundations, retaining and earth structures*. 2nd ed., McGraw-Hill, 642 pp.

U.S. Army Corps of Engineers. (1992). "Reliability assessment of navigation structures," Engineer Technical Letter 1110-2-0-532, Washington, DC.

Whitman, R. V. (1984). "Evaluating calculated risk in geotechnical engineering," *Journal of Geotechnical Engineering*, American Society of Civil Engineers, 110 (2), 145-88.

# REPORT DOCUMENTATION PAGE

Form Approved  
OMB No. 0704-0188

Public reporting burden for this collection of information is estimated to average 1 hour per response, including the time for reviewing instructions, searching existing data sources, gathering and maintaining the data needed, and completing and reviewing the collection of information. Send comments regarding this burden estimate or any other aspect of this collection of information, including suggestions for reducing this burden, to Washington Headquarters Services, Directorate for Information Operations and Reports, 1215 Jefferson Davis Highway, Suite 1204, Arlington, VA 22202-4302, and to the Office of Management and Budget, Paperwork Reduction Project (0704-0188), Washington, DC 20503.

1. AGENCY USE ONLY (Leave blank)		2. REPORT DATE December 1994	3. REPORT TYPE AND DATES COVERED Final report	
4. TITLE AND SUBTITLE Reliability Analysis for Deep-Seated Stability of Pile Foundations			5. FUNDING NUMBERS	
6. AUTHOR(S) William M. Isenhower				
7. PERFORMING ORGANIZATION NAME(S) AND ADDRESS(ES) Department of Civil Engineering and Engineering Mechanics University of Arizona Tucson, AZ 85721			8. PERFORMING ORGANIZATION REPORT NUMBER	
9. SPONSORING/MONITORING AGENCY NAME(S) AND ADDRESS(ES) U.S. Army Engineer Waterways Experiment Station 3909 Halls Ferry Road, Vicksburg, MS 39180-6199; U.S. Army Corps of Engineers, Washington, DC 20314			10. SPONSORING/MONITORING AGENCY REPORT NUMBER Technical Report ITL-94-9	
11. SUPPLEMENTARY NOTES Available from National Technical Information Service, 5285 Port Royal Road, Springfield, VA 22161.				
12a. DISTRIBUTION/AVAILABILITY STATEMENT Approved for public release; distribution is unlimited			12b. DISTRIBUTION CODE	
13. ABSTRACT (Maximum 200 words)  Over 40 percent of inland navigation structures are more than 50 years old and demands for rehabilitation of these structures are increasing. Reliability assessments are used to assess the reliability of structures in their current conditions, to estimate the remaining service life of structures, and to provide a consistent method for prioritizing rehabilitation expenditures. Factors affecting the structures were identified and examined. The finite element method was found to be the best technique for assessing lateral soil displacement profiles for input into the Reese and Wang pile group analysis method. Techniques used for reliability analyses were introduced. The reliability index is used as a relative measure of reliability of a structure to perform in an acceptable manner. A reliability assessment of a navigation structure was demonstrated by an example problem.				
14. SUBJECT TERMS Foundations Piles			Reliability Slope stability	15. NUMBER OF PAGES 61
				16. PRICE CODE
17. SECURITY CLASSIFICATION OF REPORT UNCLASSIFIED	18. SECURITY CLASSIFICATION OF THIS PAGE UNCLASSIFIED	19. SECURITY CLASSIFICATION OF ABSTRACT	20. LIMITATION OF ABSTRACT	