

# REPORT DOCUMENTATION PAGE

Form Approved  
OMB No. 0704-0188

Public reporting burden for this collection of information is estimated to average 1 hour per response, including the time for reviewing instructions, searching existing data sources, gathering and maintaining the data needed, and completing and reviewing the collection of information. Send comments regarding this burden estimate or any other aspect of this collection of information, including suggestions for reducing this burden, to Washington Headquarters Services, Directorate for Information Operations and Reports, 1215 Jefferson Davis Highway, Suite 1204, Arlington, VA 22202-4302, and to the Office of Management and Budget, Paperwork Reduction Project (0704-0188), Washington, DC 20503.

1. AGENCY USE ONLY (Leave blank)		2. REPORT DATE	3. REPORT TYPE AND DATES COVERED FINAL 01 May 93 To 30 Apr 96	
4. TITLE AND SUBTITLE POLYMER FIBERS FOR NONLINEAR OPTICS			5. FUNDING NUMBERS F49620-93-1-0255 61102F 2303/CS	
6. AUTHOR(S) Prof. Mark G. Kuzyk				
7. PERFORMING ORGANIZATION NAME(S) AND ADDRESS(ES) Dept of Physics Washington State University Pullman WA 99164-2814			AFOSR-TR-96 0516	
9. SPONSORING / MONITORING AGENCY NAME(S) AND ADDRESS(ES) AFOSR/NL 110 Duncan Ave Room B115 Bolling AFB DC 20332-8080 Dr Charles Y-C. Lee			10. SPONSORING / MONITORING AGENCY REPORT NUMBER  19961028 002	
11. SUPPLEMENTARY NOTES				
12a. DISTRIBUTION / AVAILABILITY STATEMENT  Approved for public release; distribution unlimited.			12b. DISTRIBUTION CODE	
13. ABSTRACT (Maximum 200 words) The goal of our research is to assess the possibility of making an ultrafast all-optical switching device. This require the preliminaries of doing materials processing, materials characterization, and making all-device component structures such as single mode fibrers. With these in hand, a demonstration all-optical switching device can be made. Such a device would be the first step towards ultrafast switching systems for the information highway and all-optical computing applications. Our work is motivated by the demonstration of an all-optical switch in a silica optical fiber. While this device displays all essential switching functions, the small materials nonlinearity requrees fibers oflkm lengths, resulting in long latency periods. Because we have the ability to make polymer fibers with optical nonlinearities that are three orders of magnitude larger, we can make sub-meter length devices. As an ongoing process, have continually improved the fiber drawing process, have characterized crucial material properties, and have improved on designs of optical switches that take advantage of the polymer fiber's nonlinearity. We have demonstrated the fabrication of fibers with cores that are less than 10um in diameter, have shown that these can support single mode light-guiding (required for optimum device operation), and that they do not depolarize light; an important property for devices that require polarization preserving fibers. The Sagnac interferometer experiment had been used to measure the switching efficiency in a single mode polymer fiber and a true all-optical switching device has been built and has given evidence of all-optical switching.				
14. SUBJECT TERMS			15. NUMBER OF PAGES	
			16. PRICE CODE	
17. SECURITY CLASSIFICATION OF REPORT (U)	18. SECURITY CLASSIFICATION OF THIS PAGE (U)	19. SECURITY CLASSIFICATION OF ABSTRACT (U)	20. LIMITATION OF ABSTRACT (U)	

# Polymer Fibers for Nonlinear Optics

Mark G. Kuzyk

Department of Physics, Washington State University, Pullman, WA 99164-2814

October 1, 1996

GRANT # F496209310255

FINAL REPORT TO AFOSR

REPORT PERIOD: 01 May 93 - 01 May 96

**ABSTRACT** The goal of our research is to assess the possibility of making an ultrafast all-optical switching device. This requires the preliminaries of doing materials processing, materials characterization, and making all-device component structures such as single mode fibers. With these in hand, a demonstration all-optical switching device can be made. Such a device would be the first step towards ultrafast switching systems for the information highway and all-optical computing applications. Our work is motivated by the demonstration of an all-optical switch in a silica optical fiber. While this device displays all essential switching functions, the small material nonlinearity requires fibers of 1km lengths, resulting in long latency periods. Because we have the ability to make polymer fibers with optical nonlinearities that are three orders of magnitude larger, we can make sub-meter-length devices. As an ongoing process, have continually improved the fiber drawing process, have characterized crucial material properties, and have improved on designs of optical switches that take advantage of the polymer fiber's nonlinearity. We have demonstrated the fabrication of fibers with cores that are less than  $10\mu m$  in diameter, have shown that these can support single mode light-guiding (required for optimum device operation), and that they do not depolarize light: an important property for devices that require polarization preserving fibers. The Sagnac interferometer experiment had been used to measure the switching efficiency in a single mode polymer fiber and a true all-optical switching device has been built and has given evidence of all-optical switching.

The project goal is to assess the possibility of making an all-optical switch in a polymer optical fiber. To this end, we have:

- Demonstrated that the polarization state of light is preserved in a single mode polymer fiber waveguide.
- Measured optical loss in a single-mode fiber.
- Analyzed the guiding modes to determine the refractive index profile of a single-mode core.

08 OCT 1996

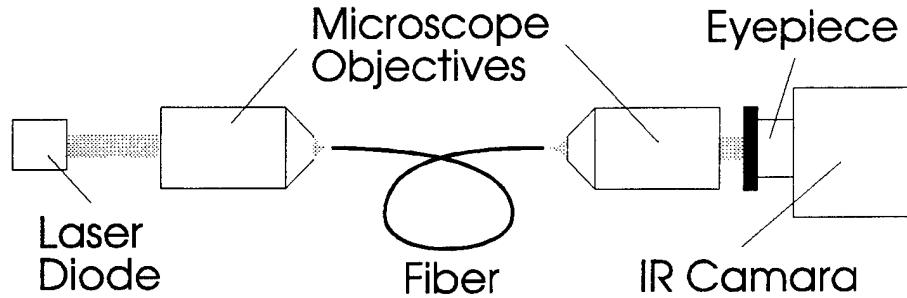

Figure 1: Mode imaging system.

- Performed optical damage studies.
- Measured the switching efficiency of a single mode fiber.
- Measured stimulated Brillouin from a single-mode fiber and determined it has no adverse effect on switching.
- Applied quadratic electroabsorption studies to help elucidate the nature of excited states in squaraine dyes which are the medium of switching.
- Evaluated the 2 photon absorption figure of merit and found candidate molecules that should be appropriate for switching devices.
- Fabricated dual-core fibers and observed light hopping between fibers
- Built an all-optical switch and seen evidence of all-optical switching in both the Sagnac and directional coupler geometries.

Details of these results are described below.

A single-mode waveguide is required for making devices because of the inherent high bandwidth, and its ideal geometry for efficient interferometric switching. It is therefore important to establish that our fiber waveguides are single-mode. To do so, we built an infra red optical imaging system (Figure 1). A collimated IR laser beam is launched into a microscope objective. The light is focused into the core of the fiber which is mounted on a high precision xyz-translation and rotation fiber mount. Note that for maximum coupling, the numerical aperture of the objective and fiber are matched. The exiting light is imaged with a microscope objective and eyepiece to an infrared camera. The signal from the camera is digitized by a frame grabber and sent to a Gateway computer for analysis.

The intensity distribution of the light leaving the fiber end in a single-mode core appears as a bright symmetric spot. The intensity profile through the brightest spot is the square of the zeroth-order Bessel function in the core and the square of the zeroth-order modified Bessel Function in the cladding when the guide is single-mode. Figure 2a shows a digitized image of the light exiting a typical ISQ-core PMMA fiber. The core is about  $8\mu\text{m}$  in diameter and the dye concentration is 0.1% by weight. The bright spot in the center is the guided mode. The bright scattered light that is observed in the cladding is a speckle pattern from the cladding mode. Note that the contrast on the image was set to maximize the scattered light in the cladding so that it would be visible. In a

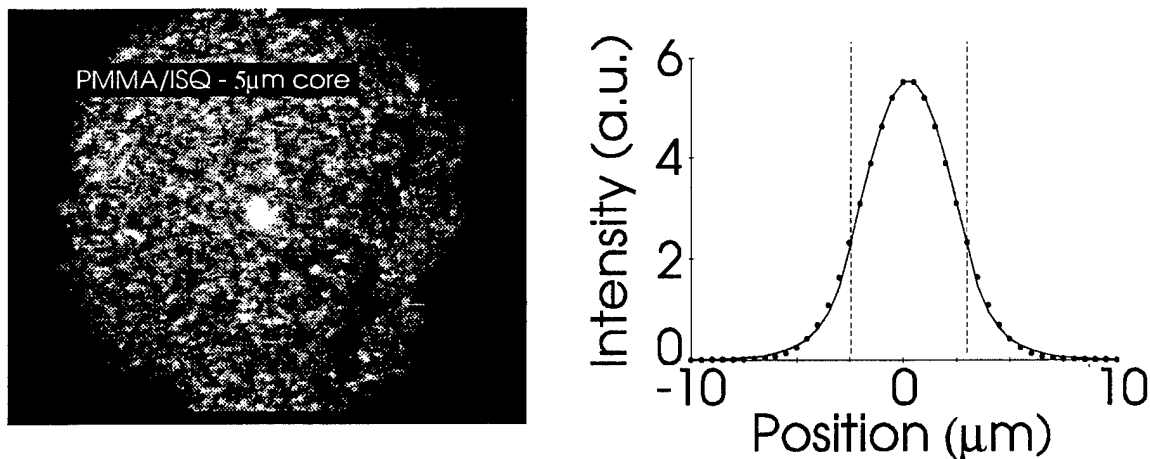

Figure 2: a) Image of fiber end when guiding light in the core at  $1.3\mu m$ . b) cross-section of light intensity (points) and fit to theory for a single-mode guide (curve).

more accurate representation of the fiber end, the cladding would be much darker. Note the dark line that runs almost vertically on the right side of the cladding. Under an optical microscope, this dark region is a groove that was formed when the fiber end was cut.

Figure 2b shows the intensity profile through the fiber center. A fit to the zeroth-order Bessel function shows that the fiber is indeed single-mode. The two vertical lines represent the position of the core-cladding interface. The fit parameters imply that the fiber core is  $5.5\mu m$  in diameter and that the refractive index difference between core and cladding is  $\Delta n = 0.0036$ . These numbers compare favorably with the core diameter of  $8\mu m$  that is determined from the core-to-cladding diameter ratio and a measure of the fiber's outside diameter.

We have also attempted to measure the loss in a single-mode fiber using the cut-and-measure technique. Because the light intensity leaving the fiber is a sensitive function of the quality of the fiber end, there are large cut-to-cut variations in the amount of light that leaves the fiber end. Measurements of the loss in the single-mode PMMA/ISQ guide at  $1.06\mu m$  range from 0.1dB/cm to 0.6dB/cm, compared with Kaino's result of about 0.1dB/cm in neat PMMA. Because the lowest loss values show that the intrinsic loss of the doped polymer is 0.1dB/cm, the higher values in some of the fibers implies that extrinsic sources such as scattering are responsible. It is significant, however, that the intrinsic loss in the doped fiber is the same as the neat fiber because it clearly shows that the dye's contribution to optical loss is much smaller than the polymer's loss.

In many applications, it is important for the polarization of the light beam to be unaffected by the waveguide. This is true for the device that we propose to build, and for the nonlinear Sagnac experiment used to characterize the intensity dependent refractive index of a fiber. Figure 3 shows an experiment that measures the degree of light depolarization in a single-mode fiber. We applied this experiment to ISQ/PMMA-core single-mode guides. A polarized laser beam is launched into the end of the fiber core with a microscope objective. After over tens of centimeters of propagation, the exiting light is imaged onto a detector with a microscope object. A second polarizer is used as an analyzer of the polarization state of the light. When the analyzer angle is perpendicular to the polarization of the light incident to the fiber, the detected intensity will be zero if the light is not depolarized in the fiber. Similarly, if the analyzer is aligned along the polarization

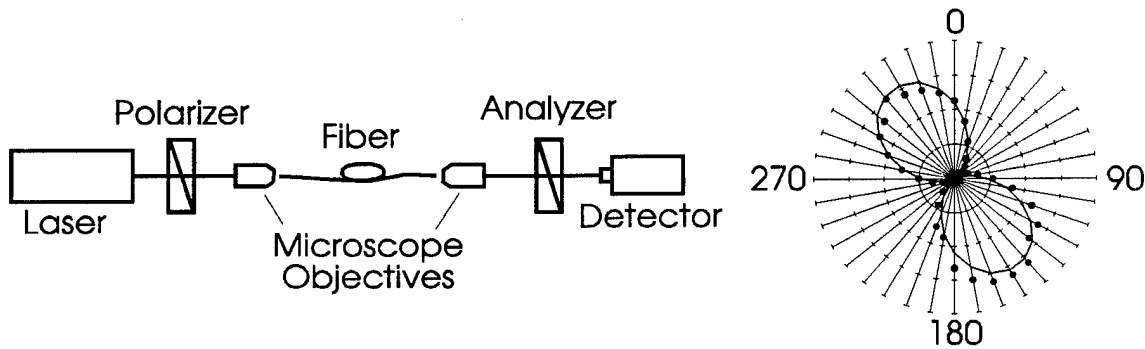

Figure 3: a) Experiment to measure fiber's effect on light polarization and b) polar plot of intensity at the detector as a function of analyzer angle (points). Solid curve is theory for no depolarization.

direction, the maximum intensity is observed.

The right-hand side of Figure 3 shows a polar plot (solid curve) of the theoretical prediction of the angular dependence of the intensity for a beam of light that is polarized at about  $45^\circ$ . The measured data points agree with the theory. This implies that the light remains polarized over tens of centimeters of propagation. The degree of depolarization can be estimated by the amount of light that makes it to the detector when the polarizer and analyzer are crossed (set  $90^\circ$  from each other). We find that the degree of depolarization is less than 5%. We have found that the degree of depolarization is much higher for multimode fibers, or in fibers that are weakly single-mode.

We have designed and built a Sagnac interferometer that can be used to measure the intensity dependent refractive index of either a fiber waveguide or a bulk material. This experimental geometry is very similar to our device design, so it serves two purposes: it enables the nonlinear-optical characterization of materials and gives us experience in building an all-optical switch. Figure 4 show the experimental setup.

The measurement procedure involves the simultaneous measurement of the interferometer contrast and signal using two separate lockin amplifiers that are interfaced to a computer. One lock-in amplifier is synchronized with the frequency ( $\Omega$ ) of light modulation due to the spinning half wave plate. The light intensity leaving the interferometer is then measured as a function of quartz wedge position. This determines the contrast of the interferometer. We call the amplitude of this interferogram  $I_\Omega$ . The second lockin measures the intensity at twice the modulation frequency. (described later). We call the amplitude of the large set of peaks  $I_{max}^{2\Omega}$ , and the smaller peaks  $I_{min}^{2\Omega}$ . The real and imaginary parts of the intensity dependent refractive index,  $n_{1111}^{(2)}$ , are proportional to the average peak height of the  $2\Omega$  interferogram, and the difference in peak heights in the  $2\Omega$  interferogram. The absolute intensity dependent refractive index is proportional to the ratio of the  $2\Omega$  intensity to the amplitude of the  $\Omega$  interferogram, and inversely proportional to the absolute peak intensity. The absolute intensity is determined by measuring the average power of the laser and taking into account both the temporal and spatial profile of the beam.

Figure 5 shows the light intensity at  $\Omega$  and  $2\Omega$  for a 25cm long single-mode ISQ/PMMA fiber of  $16\mu\text{m}$  diameter core,  $290\mu\text{m}$  cladding diameter, and 0.1% dye concentration. The light is launched into the fiber with a 20x microscope objective.

The switching efficiency of the fiber is proportional to the intensity dependent refractive index,

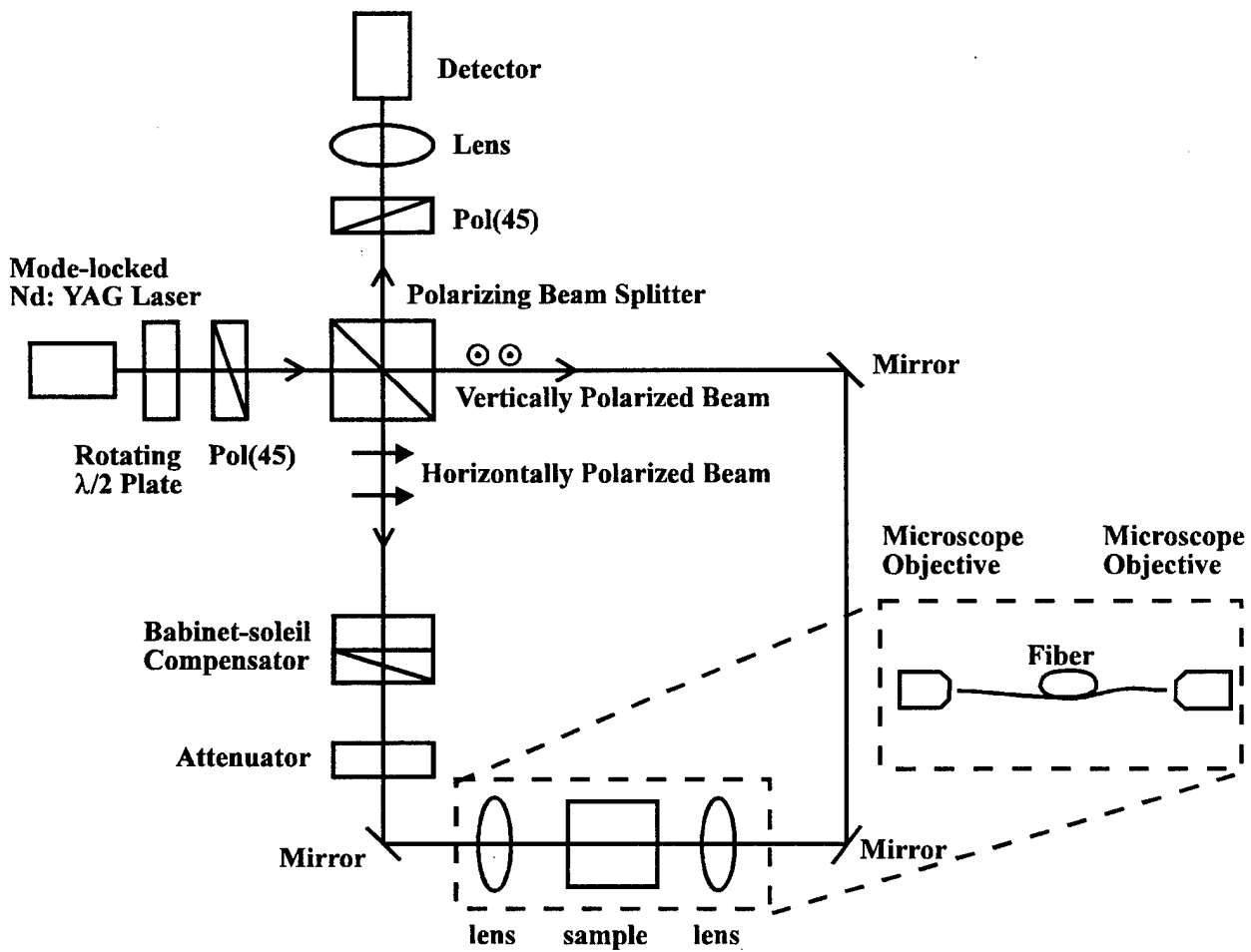

Figure 4: Sagnac interferometer configuration used to measure the intensity dependent refractive index.

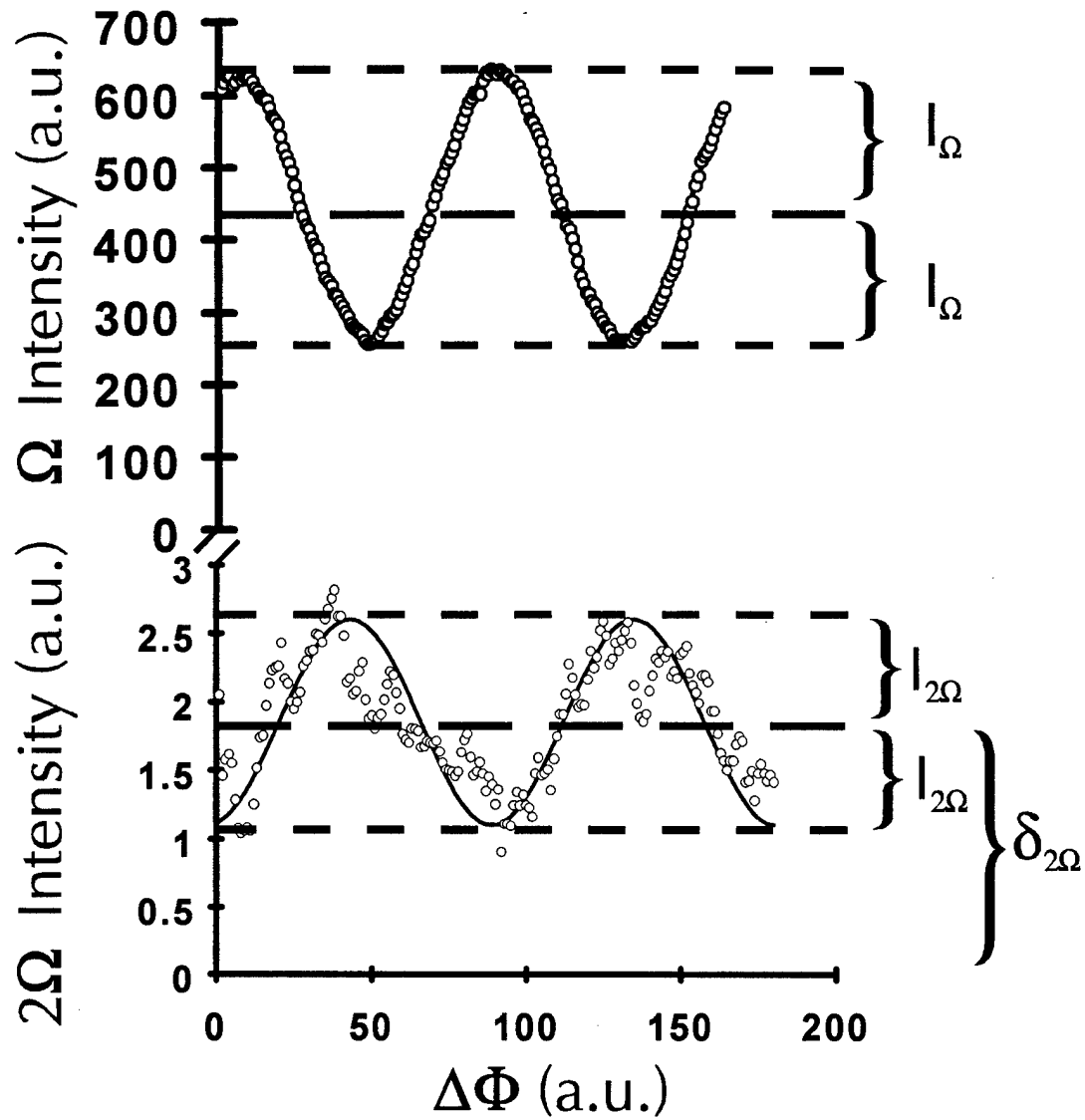

Figure 5: Intensity of light at frequency  $\Omega$  (top) and frequency  $2\Omega$  (bottom) as a function of phase difference between the two counterpropagating light beams for a single-mode ISQ/PMMA fiber.

light intensity, and propagation length. The polymer fiber is thus well suited for high switching efficiency because the brightest part of the light is confined to the core over the fiber's length  $L$ . A typical single-mode core diameter is on the order of  $10\mu\text{m}$  so that a laser source of 1W power, when exciting a guided mode, results in an intensity in the core of about  $1 \times 10^6 \text{W}/\text{cm}^2$ . The first step-index fiber was made with an ISQ-doped poly(methyl methacrylate) polymer (PMMA) (about 1% by weight dye) and a PMMA cladding. It is useful to consider what we have learned about the switching efficiencies of single-mode polymer optical fiber. For a peak intensity of about  $5 \times 10^5 \text{W}/\text{cm}^2$ , the phase shift that we have observed in our fiber is about  $\pi/200$ . This yields a switching efficiency of  $4.4 \times 10^{-9} \text{cm}^2 \cdot \text{W}^{-1} \cdot \text{cm}^{-1}$ . We have observed that even 'dirty fibers' (those that are made from undistilled monomer) have a damage threshold of about  $4 \times 10^8 \text{W}/\text{cm}^2$  and can easily sustain long term exposure of about  $8 \times 10^7 \text{W}/\text{cm}^2$ . We expect to observe 100% switching efficiency near the short-term damage threshold intensity for a fiber with an effective length of 7cm. At the long-term damage threshold, we would expect an efficiency of 35%. The efficiencies can be greatly increased if the effective fiber length is increased. With a decrease of loss by a factor of three, the resulting increased effective length to 21cm would make all-optical switching possible below the long term damage threshold. With improvements in material cleanliness, the damage threshold should also be greatly increased, leading to a reliable switch. Indeed, clean PMMA has been observed to have a long term damage threshold above  $1\text{GW}/\text{cm}^2$ . The only other issue that may need to be addressed is the two-photon absorption figure of merit. Choice of the appropriate dye should solve this problem as preliminary measurements have shown.

We have also studied the nature of excited states of squaraines with quadratic electroabsorption and have investigated the effect of stimulated Brillouin scattering processes (in single mode cores) on switching device performance. Two interesting results are suggested. First, it appears that the third-order susceptibility of the dye-doped fiber core is a factor of 20 larger than expected based on the quadratic electroabsorption results. Optical absorption spectroscopy of the core shows features that are reminiscent of a J aggregate spectrum. We thus believe that the dyes are partially aggregated in the core-making process. Because light scattering experiments show no evidence of aggregation, the aggregates must be much smaller than the wavelength of light. The conclusion is that the small aggregates do not result in substantial loss but result in a larger third-order susceptibility. The Brillouin studies, on the other hand, show that there is no significant contribution of stimulated scattering to the all-optical switching measurements. These two findings make us optimistic that all-optical switching technology is possible in polymer optical fibers.

We have also been studying wave propagation in dual core fibers as a prelude to making a directional coupler that can be used for either passive splitting or active switching. Figure 6 shows the light exiting from such a fiber and is measured with the imaging system shown in Figure 1. The output of the camera can be sent to a digital oscilloscope to digitize one scan line. Figure 7 shows the intensity profile through the center of the two cores as measured with the oscilloscope. It is clear that the intensity profiles overlap in the region between the cores so that the two modes are coupled. As light propagates down this fiber, energy should therefore be exchanged between the cores. The propagation length over which all the light from one core couples into the second core is called the coupling length. The coupling length depends on the separation between the cores, the diameter of each core and the refractive index difference between core and cladding.

The coupling length of a dual core fiber is determined by measuring the intensity inside each core as a function of distance along the fiber axis. Because the light is trapped inside the two cores, a direct measurement is not possible. We have therefore use the cut-and-measure technique: the



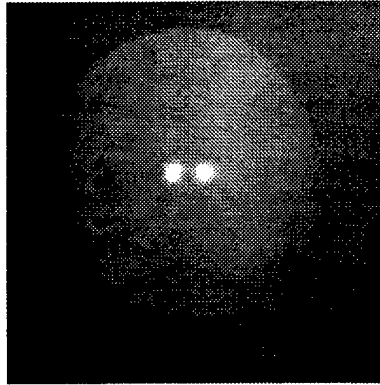

Figure 6: Intensity of light in a cross-section of a dual core fiber.

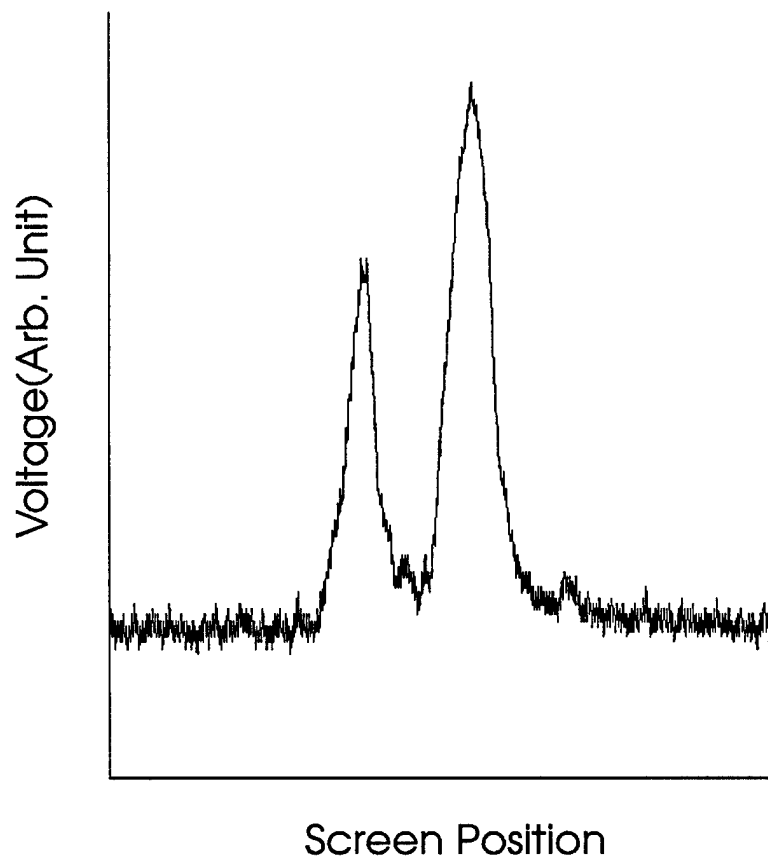

Figure 7: Intensity profile in a dual core fiber.

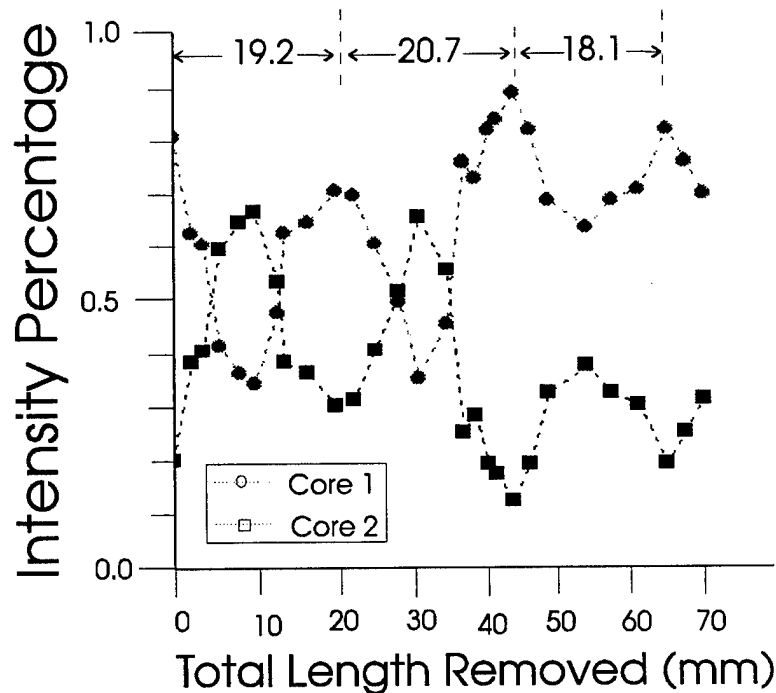

Figure 8: Intensity in each core of a dual core fiber as a function of fiber length.

mode profile is measured, a small piece of fiber snipped off, the end repolished and the light profile from the remaining length of fiber remeasured. Figure 8 shows a plot of the intensity in each core as a function of length of fiber removed. For each length, the two intensities are normalized so they add to unity. The coupling length so determined is found to be about 20mm and is close to the expected value for a single mode guide.

Each of the two curves in Figure 8 clearly do not go to zero intensity. This behavior is predicted for dual core waveguides that are asymmetric; that is, when the waveguide diameters are not equal, not parallel, or have different refractive indices. This is not unexpected in our first generation of dual core fiber. Of significance is that fact that coupling is observed. Because the coupling length depends on the refractive index and the core material has a large  $n_2$ , switching between cores at the output end of the fiber should be observable as a function of incident intensity. We have seen switching in such a coupler but these results have not yet been reproduced.

To summarize our cumulative research findings and results:

1. We have developed a process to make 5-10 $\mu$ m fiber waveguides made with PMMA/ISQ and PMMA/DR1 dye-doped polymer.
2. We have demonstrated that the guided mode is single-mode for a 8 $\mu$ m core at doping levels greater than 0.07% ISQ by weight.
3. We have optimized the coupling efficiency into the single-mode fiber.
4. We have found several methods for cleaving/polishing the fiber ends for better coupling.

5. We have measured the loss in the multimode PMMA/ISQ and PMMA/DR1 fiber to be equal to the neat PMMA loss (0.3dB/cm at 1.3 $\mu$ m and 0.1dB/cm at 1064nm).
6. We have measured the loss in a single-mode PMMA/ISQ fiber to be between 0.1dB/cm and 0.6dB/cm at 1.06 $\mu$ m.
7. We have determined that single-mode fibers depolarize light by less than 5%.
8. We have measured the intensity dependent refractive index in a single-mode fiber using a new Sagnac measurement developed at WSU. This experiment has also been applied to measure both the absolute real and imaginary part of the intensity dependent refractive index in nitrobenzene (a standard liquid).
9. We have found that the stimulated Brillouin scattering background signal in dye-doped polymer fiber is well below the minimum required for making a practical switch.
10. We have observed a damage threshold that is almost two orders of magnitude smaller than for neat PMMA and that it is fiber dependent.
11. We have studied the nature of excited states in squaraine dyes, and how these states contribute to the nonlinear-optical response.
12. We have successfully fabricated dual core fibers that guide light.
13. We have demonstrated a fiber directional coupler.
14. We have demonstrated all-optical switching in both a directional coupler and Sagnac geometry.

#### PERSONNEL SUPPORTED:

##### Graduate Students:

- Todd Brown
- Dennis Garvey
- Robert Kruhlak
- Qin Li (Completed Master degree in Physics)
- Karen Mathis (Completed Master degree in Physics)
- Constantina Poga (Completed Ph.D. degree in Physics)
- Zhongcai Zhou (Completed Master degree in Physics)

##### Undergraduate Students:

- Mark Dayton
- Jeffrey Tostenrude
- Richard Wolber
- Philip Young

#### PAPERS AND PRESENTATIONS

- D. W. Garvey, Q. Lin, M. G. Kuzyk, C. W. Dirk, and S. Martinez, "Sagnac interferometric intensity-dependent refractive-index measurements of polymer optical fiber," *Optics Letters* **21**, 435 (1996).
- D. W. Garvey, K. Zimmerman, P. Young, J. Tostenrude, J. S. Townsend, Z. Zhou, M. Lobel, M. Dayton, R. Wittorf, M. G. Kuzyk, J. Sounick, and C. W. Dirk, "Single-mode nonlinear-optical polymer fiber," *Journal of the Optical Society of America* **13**, 2017 (1996).
- D. W. Garvey, M. G. Kuzyk, C. W. Dirk, S. Martinez, H. Selnau Jr., P. Craig and L. Green, "Progress towards making an all-optical switch in Polymer Optical Fibers," *Nonlinear Optics* **15**, 104 (1996).
- C. Poga, T. M. Brown, M. G. Kuzyk, and C. W. Dirk, "Characterization of the excited states of a squaraine molecule with quadratic electroabsorption spectroscopy," *J. Opt. Soc. Am. B* **11**, 80 (1994).
- D. W. Garvey, R. Kruhlak, M. G. Kuzyk, C. W. Dirk, S. Martinez, H. Selnau, Jr., P. Craig, and L. Green "Characterization of Switching Properties of a Single-Mode Polymer Optical Fiber," in *Nonlinear Optical Properties of Organic Materials VII*, SPIE Proceedings **2527**, San Diego (1995).
- K. S. Mathis, M. G. Kuzyk, C. W. Dirk, S. Martinez, H. Selnau, Jr., P. Craig, and L. Green "Excited State Characterization of Squaraine Dye-Doped Polymers," in *Nonlinear Optical Properties of Organic Materials VII*, SPIE Proceedings **2527**, San Diego (1995).
- M. G. Kuzyk, "All-Optical Materials and Devices," in *Science and Technology of Organic Thin Films for Waveguiding Nonlinear Optics - Advances in Nonlinear Optics* **3**, F. Kajzar and J. D. Swalen, eds. Gordon and Breach, pp. 759-821. (invited)
- M. G. Kuzyk, Q. Li, D. J. Welker, S. Zhou, and C. W. Dirk, "All-Optical and Photomechanical Devices in Polymer Optical Fiber," SPIE OELASE'94 **2143**, (1994) (invited)
- M. G. Kuzyk, Q. Li, M. Lobel, D. J. Welker, P. Young, S. Zhou, and C. W. Dirk, "Intensity-Induced Phase Shift Phenomena in Polymer Optical Fibers," 4th IKETANI International Conference on Optically Nonlinear Organic Materials and Applications, Technical Digest, 153 (Hawaii,1994) (invited)
- M. G. Kuzyk, Q. Li, D. J. Welker, S. Zhou, and C. W. Dirk, "Applying Third-Order Field Mechanisms to a New Class of Devices," Proceedings of the First International Conference on Organic Nonlinear Optics, p76, Val Thorens, France (1994) (invited)

## INTERACTIONS

We have interacted with other researchers supported by AFOSR in areas of common interest. We have collaborated with Prof. Singer of Case Western Reserve University who has characterized the excited state character of our squaraine dyes (those used in fiber cores), and with Prof. Dirk of Univ. of Texas at El Paso, who has supplied chromophores and polymer processing information.

We have been approached by Melles-Griot (an optical component supplier) who have inquired about selling our single mode fiber. We are also interacting with Sentel Technologies who are interested in photomechanical applications of our fibers.