



U.S. Army Environmental Center
Environmental Technology Division
Edgewood Area
Aberdeen Proving Ground, Maryland

EVALUATION OF A
TRANSPORTABLE
HOT GAS
DECONTAMINATION
SYSTEM FOR THE
DECONTAMINATION
OF EXPLOSIVES-
CONTAMINATED
DEBRIS & PIPING

DTIC QUALITY INSPECTED

19961017 117

DISTRIBUTION STATEMENT A
Approved for public release;
Distribution Unlimited

VALIDATION TEST REPORT
VOLUME I



DISCLAIMER NOTICE

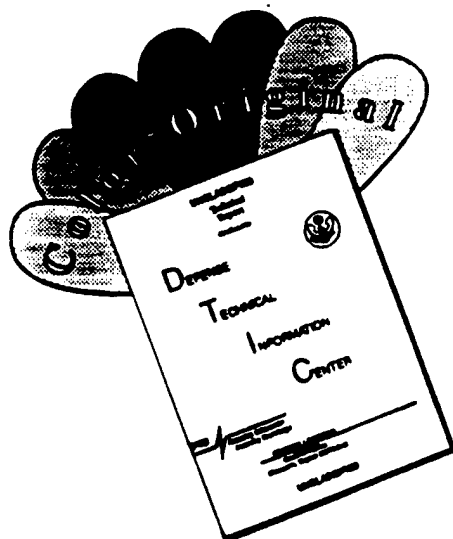

THIS DOCUMENT IS BEST QUALITY AVAILABLE. THE COPY FURNISHED TO DTIC CONTAINED A SIGNIFICANT NUMBER OF COLOR PAGES WHICH DO NOT REPRODUCE LEGIBLY ON BLACK AND WHITE MICROFICHE.

**VALIDATION TEST REPORT
FOR THE
TRANSPORTABLE HOT-GAS DECONTAMINATION SYSTEM
USED TO SUPPORT THE DECONTAMINATION OF
EXPLOSIVES-CONTAMINATED PIPING AND DEBRIS**

VOLUME I

Contract No. DACA 31-91-D-0079
Task Order 12

Prepared for

**U.S. ARMY ENVIRONMENTAL CENTER (USAEC)
SFIM-AEC-ETD
Edgewood Area
Aberdeen Proving Ground, MD 21010-5401**

September 1996

Prepared by

**ROY F. WESTON, INC.
1 Weston Way
West Chester, Pennsylvania 19380-1499**

REPORT DOCUMENTATION PAGE		Form Approved OMB No. 0704-0188	
Public reporting burden for this collection of information is estimated to average 1 hour per response, including the time for reviewing instructions, searching existing data sources, gathering and maintaining the data needed, and completing and reviewing the collection of information. Send comments regarding this burden estimate or any other aspect of this collection of information, including suggestions for reducing this burden to Washington Headquarters Services, Directorate for Information Operations and Reports, 1215 Jefferson Davis Highway, Suite 1204, Arlington, VA 22202-4302, and to the Office of Management and Budget, Paperwork Reduction Project (0704-0188), Washington, DC 20503.			
1. AGENCY USE ONLY (Leave blank)	2. REPORT DATE September 1996	3. REPORT TYPE AND DATES COVERED Operations and Maintenance Manual	
4. TITLE AND SUBTITLE		5. FUNDING NUMBERS DACA31-91-D-0079 Delivery Order #12	
6. AUTHOR(S) Roy F. Weston, Inc.		8. PERFORMING ORGANIZATION REPORT NUMBER N/A	
7. PERFORMING ORGANIZATION NAME(S) AND ADDRESS(ES) Roy F. Weston, Inc. 1 Weston Way West Chester, PA 19380-1499		10. SPONSORING/MONITORING AGENCY REPORT NUMBER	
9. SPONSORING/MONITORING AGENCY NAME(S) AND ADDRESS(ES) U.S. Army Environmental Center Environmental Technology Division Edgewood Area Aberdeen Proving Ground, MD 21010-5401		11. SUPPLEMENTARY NOTES	
12a. DISTRIBUTION/AVAILABILITY STATEMENT Unlimited Distribution/Availability		12b. DISTRIBUTION CODE	
13. ABSTRACT (Maximum 200 words) In 1994 the United States Army Environmental Center contracted Roy F. Weston, Inc. to design, procure, demonstrate, and validate transportable hot-gas decontamination (HGD) equipment. The HGD equipment was delivered in March 1995, demonstrated in December 1995, and validated between January and March 1996. This report documents the validation testing of the transportable HGD system for the decontamination of explosives-contaminated materials and debris. The purpose of validation testing was to demonstrate the effectiveness of the HGD process, and to define an optimum set of operating conditions that would then be used to support future real-world applications. A description of the validated equipment, details of the validation testing and analysis, operations logs, and the data and results related to emissions testing are provided as part of this document.			
14. SUBJECT TERMS Hot-Gas Decontamination Explosives Validation Tests Emission Tests		15. NUMBER OF PAGES Text - 199 Appendices A-D - 321 Appendices E-L - 557	
		16. PRICE CODE	
17. SECURITY CLASSIFICATION OF REPORT Unclassified	18. SECURITY CLASSIFICATION OF THIS PAGE Unclassified	19. SECURITY CLASSIFICATION OF ABSTRACT Unclassified	20. LIMITATION OF ABSTRACT None

NSN 7540-01-280-5500

Standard Form 298 (Rev 2-89)
Prescribed by ANSI Sta Z39-18
Z98-102

MATERIAL INSPECTION AND RECEIVING REPORT		1. PROC. INSTRUMENT IDEN. (CONTRACT)		(ORDER) NO.	6. INVOICE	7. PAGE	OF
		DACA 31-91-D-0079		0012		1	1
				8. ACCEPTANCE POINT			
2. SHIPMENT NO. A003	3. DATE SHIPPED 02 October 1996	4. B/L TCN	5. DISCOUNT TERMS				
9. PRIME CONTRACTOR Roy F. Weston, Inc. 1 Weston Way West Chester, PA 19380-1499		CODE 2M 222	10. ADMINISTERED BY DCMAO Philadelphia Attn: DFAS - c/o Cont. Mgmt Liaison P.O. Box 7699 Philadelphia, PA 19101-7699			CODE 539 15A	
11. SHIPPED FROM (if other than 9) See block 9		CODE	FOB:	12. PAYMENT WILL BE MADE BY DFAS Columbus Center Attn: DFAS All American Division P.O. Box 182137 Columbus, OH 43218-2137			CODE SC 1014
13. SHIPPED TO Commander SFIM - AEC - ETD (Kanas) Bldg E4430 Edgewood Area Aberdeen Proving Ground, MD 21010-5401		CODE CETHAM	14. MARKED FOR			CODE	
15. ITEM NO.	16. STOCK/PART NO.	DESCRIPTION	17. QUANTITY SHIP/REC'D*	18. UNIT	19. UNIT PRICE	20. AMOUNT	
A003		(Indicate number of shipping containers - type of container - container number.) Validation Test Report for the Transportable Hot-Gas Decontamination System Used To Support the Decontamination of Explosives-Contaminated Piping and Debris	10				
21. PROCUREMENT QUALITY ASSURANCE				22. RECEIVER'S USE			
A. ORIGIN <input type="checkbox"/> PQA <input type="checkbox"/> ACCEPTANCE of listed items has been made by me or under my supervision and they conform to contract, except as noted herein or on supporting documents.		B. DESTINATION <input type="checkbox"/> PQA <input type="checkbox"/> ACCEPTANCE of listed items has been made by me or under my supervision and they conform to contract, except as noted herein or on supporting documents.		Quantities shown in column 17 were received in apparent good condition except as noted.			
DATE SIGNATURE OF AUTH GOVT REP		DATE SIGNATURE OF AUTH GOVT REP		DATE RECEIVED		SIGNATURE OF AUTH GOVT REP	
TYPED NAME AND OFFICE		TYPED NAME AND OFFICE		TYPED NAME AND OFFICE			
				* If quantity received by the Government is the same as quantity shipped, indicated by (✓) mark, if different, enter actual quantity received below quantity shipped and encircle.			
23. CONTRACTOR USE ONLY WESTON has submitted the Contract Data Requirements listed as sequence number A003 on form DD1423, as set forth in the basic contract for Delivery Order #12.							
<p style="text-align: center;"><i>Signature for Mike Cosmos</i></p> <p>Michael G. Cosmos, Program Manager/Project Director</p>							

TABLE OF CONTENTS

VOLUME I—HGD VALIDATION TEST REPORT

Title	Page
1. EXECUTIVE SUMMARY	1-1
2. INTRODUCTION	2-1
2.1 TECHNOLOGY BACKGROUND.....	2-1
2.2 TECHNOLOGY HISTORY.....	2-1
3. EQUIPMENT AND SYSTEM DESCRIPTION	3-1
3.1 SITE LOCATION AND LAYOUT.....	3-1
3.1.1 Site Location.....	3-1
3.1.2 Site Layout.....	3-1
3.2 SYSTEM AND EQUIPMENT DESCRIPTION.....	3-5
3.2.1 System Description.....	3-5
3.2.2 Equipment Description.....	3-7
4. PURPOSE AND OBJECTIVES OF VALIDATION TESTING	4-1
5. VALIDATION TEST PLAN	5-1
5.1 VALIDATION TEST PLAN.....	5-1
5.2 VALIDATION TEST MATERIALS.....	5-6
5.3 EXPLOSIVES SPIKING.....	5-8
5.4 TREATMENT CRITERIA.....	5-9
5.5 DEVIATIONS FROM THE TEST PLAN.....	5-15
5.5.1 Changes in Soak Times and Ramp Rates.....	5-15
5.5.2 Increasing Number of Test Runs.....	5-16
5.5.3 Asbestos Testing.....	5-16
5.5.4 Changes to Spiking Procedures.....	5-17
6. EQUIPMENT OPERATIONS DURING VALIDATION TESTING	6-1
6.1 GENERAL OPERATIONS INFORMATION.....	6-1
6.1.1 Furnace Ramp.....	6-1
6.1.2 Treatment Temperature.....	6-2
6.1.3 Soak Time.....	6-2
6.1.4 Thermal Oxidizer Temperature.....	6-2
6.1.5 System Draft.....	6-2
6.1.6 Material Loading.....	6-2

TABLE OF CONTENTS

Title	Page
6.1.7 Thermocouple Placement	6-3
6.2 OPERATIONAL DATA	6-3
6.2.1 Validation Test 1	6-3
6.2.2 Validation Test 2	6-5
6.2.3 Validation Test 3	6-7
6.2.4 Validation Test 4	6-9
6.2.5 Validation Test 5	6-11
6.2.6 Validation Test 6	6-13
6.2.7 Validation Test 7	6-15
6.2.8 Validation Test 8	6-18
6.2.9 Validation Test 9	6-19
6.2.10 Validation Test 10.....	6-21
6.2.11 Validation Test 11.....	6-23
6.2.12 Validation Test 12.....	6-25
6.2.13 Validation Test 13.....	6-27
6.2.14 Validation Test 14.....	6-29
6.2.15 Validation Test 15.....	6-31
6.2.16 Validation Test 16A.....	6-33
6.2.17 Validation Tests 16B and 16C.....	6-35
6.3 DEVIATIONS FROM THE TEST PLAN.....	6-38
6.3.1 Data Logging.....	6-38
6.3.2 Treatment Duration (Soak Cycle).....	6-38
6.3.3 Oxidizer Residence Time.....	6-38
7. SOURCE EMISSIONS SAMPLING, ANALYSIS, AND RESULTS.....	7-1
7.1 OVERVIEW—SOURCE EMISSIONS TESTING PROGRAM.....	7-1
7.2 SOURCE EMISSIONS REGULATORY PERFORMANCE STANDARDS	7-2
7.3 SOURCE EMISSIONS TEST RESULTS AND DISCUSSION	7-2
7.3.1 Particulate, Hydrochloric Acid, and Chlorine.....	7-2
7.3.2 Explosives	7-3
7.3.3 Semivolatile Organic Compounds.....	7-13
7.3.4 Dioxins and Furans	7-23
7.3.5 Volatile Organic Compounds	7-24
7.3.6 Metals.....	7-24
7.3.7 Continuous Emissions Monitoring.....	7-60
7.4 DEVIATIONS FROM THE TEST PLAN.....	7-63
7.4.1 Sampling.....	7-63
7.4.2 Sample Handling and Analysis.....	7-64

TABLE OF CONTENTS

Title	Page
8. AIR SAMPLING: ANALYSIS AND RESULTS	8-1
8.1 TIME-INTEGRATED AMBIENT AIR SAMPLING RESULTS	8-1
8.1.1 TNT, RDX, and Tetryl Sampling—Perimeter and Personal	8-1
8.1.2 Total Particulate Monitoring—Perimeter.....	8-3
8.1.3 Asbestos Monitoring—Perimeter and Personal.....	8-3
8.2 REAL-TIME AIR SAMPLING MONITORING	8-4
8.2.1 Explosive Vapors.....	8-4
8.2.2 Dust Monitoring	8-4
8.3 QUALITY ASSURANCE/QUALITY CONTROL.....	8-5
8.3.1 Explosives	8-5
8.3.2 Asbestos Analysis	8-5
9. DISCUSSION OF RESULTS	9-1
9.1 TREATMENT CRITERIA.....	9-1
9.2 DISCUSSION OF LEVEL 1 RESULTS	9-2
9.3 DISCUSSION OF LEVEL 2 RESULTS	9-4
9.4 DISCUSSION OF LEVEL 3 RESULTS	9-6
9.5 TRENDS OBSERVED THROUGHOUT VALIDATION TESTING.....	9-12
9.6 RECOMMENDED TREATMENT TIME AND TEMPERATURE.....	9-13
9.7 NO _x EMISSIONS TRENDS IN THE INTERCONNECTION DUCT	9-13
9.8 ASBESTOS-CONTAMINATED MATERIALS.....	9-16
10. SYSTEM COST	10-1
10.1 CAPITAL EQUIPMENT COSTS	10-1
10.2 INSTALLATION AND STARTUP COSTS.....	10-2
10.2.1 Site Preparation	10-2
10.2.2 Transportation and Mobilization to Site	10-2
10.2.3 System Shakedown and Startup	10-3
10.2.4 Procurement and Installation Schedule	10-3
10.3 OPERATING COSTS	10-3
11. RECOMMENDATIONS	11-1
11.1 CONCLUSIONS.....	11-1
11.1.1 Validation Test Results	11-1

TABLE OF CONTENTS

Title	Page
11.1.2 Source Emissions Test Results	11-2
11.1.3 Continuous Emissions Monitoring Results.....	11-2
11.1.4 Regulatory Approval Requirements.....	11-4
11.2 RECOMMENDATIONS.....	11-4

VOLUME II—APPENDICES A-D

Appendix A—Sampling and Analytical Methods Used During Validation Testing

Appendix B—Validation Test Spiking Logs

Appendix C—Post-Treatment Sampling for Explosives

- **Analytical Results for Furnace Runs 1-17**

- **Analytical Results for Duplicate Samples Taken During Test Runs 3-15**

Appendix D—Post-Treatment Sampling Explosives Worksheets

VOLUME III—APPENDICES E-L

Appendix E—Control Room Logs for Furnace Runs 1-18

Appendix F—Hourly Datalogs for Furnace Runs 1-18

Appendix G—Summary of Data Sheets for Test Runs 1-15

Appendix H—Source Emissions Data Summary Sheets for Test Runs 1-3

Appendix I—Source Emissions Laboratory Analytical Data Reports Without Raw Data

Appendix J—Results of Ambient Air Monitoring for Explosives

Appendix K—Ambient Air Monitoring Results for Asbestos

Appendix L—NO_x Emissions Trends in the Furnace Exit Gases for Test Runs 1-15

LIST OF FIGURES

Title	Page
Figure 2-1 HGD Study Sites	2-3
Figure 2-2 Transportable HGD System General Arrangement.....	2-5
Figure 3-1 Location of ALAAP in Alabama	3-2
Figure 3-2 Location of the HGD Site at ALAAP.....	3-3
Figure 3-3 HGD Site Layout	3-4
Figure 3-4 HGD System Overview.....	3-6
Figure 3-5 Interconnection Wiring Diagram.....	3-11
Figure 3-6 HGD System Process & Instrumentation Diagram.....	3-12
Figure 3-7 HGD Data Logging and Monitoring System	3-20
Figure 3-8 HGD Propane Delivery System	3-26
Figure 5-1 Decision Tree To Establish Optimal Treatment Times and Temperatures for the Decontamination of Explosives.....	5-4
Figure 5-2 General Load and Thermocouple Placement.....	5-14
Figure 9-1 Steel Material Temperature	9-9
Figure 9-2 Clay Material Temperature	9-10
Figure 9-3 Concrete Material Temperature	9-11
Figure 9-4 Post-Treatment Explosives Residual Analysis (Wipe Samples).....	9-14
Figure 9-5 Post-Treatment Explosives Residual Analysis (Solid Samples).....	9-15
Figure 10-1 HGD System Project Schedule	10-4

LIST OF TABLES

Title	Page
Table 1-1 Validation Test Matrix	1-3
Table 1-2 Transportable HGD System Equipment Emissions Results	1-5
Table 3-1 HGD System Interlocks	3-14
Table 3-2 Summary of Continuous Emission Monitoring (CEM) Equipment	3-18
Table 3-3 Sample Extraction and Conditioning Equipment	3-19
Table 5-1 Validation Test Matrix	5-2
Table 5-2 Typical Spiked Load	5-3
Table 5-3 Quantity and Type of Wastes Treated During the HGD Treatability Study	5-10
Table 6-1 Test Run 1: Furnace Operating Times	6-4
Table 6-2 Test Run 1: Furnace Material Load Data	6-4
Table 6-3 Test Run 2: Furnace Operating Times	6-6
Table 6-4 Test Run 2: Furnace Material Load Data	6-7
Table 6-5 Test Run 3: Furnace Operating Times	6-8
Table 6-6 Test Run 3: Furnace Material Load Data	6-9
Table 6-7 Test Run 4: Furnace Operating Times	6-10
Table 6-8 Test Run 4: Furnace Material Load Data	6-11
Table 6-9 Test Run 5: Furnace Operating Times	6-12
Table 6-10 Test Run 5: Furnace Material Load Data	6-13

LIST OF TABLES

Title	Page
Table 6-11 Test Run 6: Furnace Operating Times.....	6-14
Table 6-12 Test Run 6: Furnace Material Load Data.....	6-15
Table 6-13 Test Run 7: Furnace Operating Times.....	6-16
Table 6-14 Test Run 7: Furnace Material Load Data.....	6-17
Table 6-15 Test Run 8: Furnace Operating Times.....	6-18
Table 6-16 Test Run 8: Furnace Material Load Data.....	6-19
Table 6-17 Test Run 9: Furnace Operating Times.....	6-20
Table 6-18 Test Run 9: Furnace Material Load Data.....	6-21
Table 6-19 Test Run 10: Furnace Operating Times.....	6-22
Table 6-20 Test Run 10: Furnace Material Load Data.....	6-23
Table 6-21 Test Run 11: Furnace Operating Times.....	6-24
Table 6-22 Test Run 11: Furnace Material Load Data.....	6-25
Table 6-23 Test Run 12: Furnace Operating Times.....	6-26
Table 6-24 Test Run 12: Furnace Material Load Data.....	6-27
Table 6-25 Test Run 13: Furnace Operating Times.....	6-28
Table 6-26 Test Run 13: Furnace Material Load Data.....	6-29
Table 6-27 Test Run 14: Furnace Operating Times.....	6-30
Table 6-28 Test Run 14: Furnace Material Load Data.....	6-31

LIST OF TABLES

Title	Page
Table 6-29 Test Run 15: Furnace Operating Times.....	6-32
Table 6-30 Test Run 15: Furnace Material Load Data.....	6-33
Table 6-31 Test Run 16A: Furnace Operating Times.....	6-34
Table 6-32 Test Run 16A: Furnace Material Load Data.....	6-35
Table 6-33 Test Run 16B: Furnace Operating Times.....	6-36
Table 6-34 Test Run 16C: Furnace Operating Times.....	6-36
Table 6-35 Test Run 16B: Furnace Material Load Data.....	6-37
Table 6-36 Test Run 16C: Furnace Material Load Data.....	6-37
Table 7-1 Summary of Particulate, HCl, and Cl ₂ Emissions at the Thermal Oxidizer Discharge.....	7-3
Table 7-2 Particulate, HCl, and Cl ₂ Test Data and Test Results at the Thermal Oxidizer Discharge.....	7-4
Table 7-3 Summary of Explosives Emissions at Furnace Discharge and Thermal Oxidizer Discharge.....	7-6
Table 7-4 Explosive Compounds Test Data and Test Results at the Furnace Discharge.....	7-7
Table 7-5 Explosive Compounds Test Data and Test Results at the Thermal Oxidizer Discharge.....	7-10
Table 7-6 Calculated Explosives Removal Efficiencies (%).....	7-14
Table 7-7 Summary of SVOCs Detected at the Thermal Oxidizer Discharge.....	7-15
Table 7-8 SVOC Test Data and Test Results at the Thermal Oxidizer Discharge.....	7-16
Table 7-9 Dioxin and Furan Emissions at the Thermal Oxidizer Discharge.....	7-25
Table 7-10 Dioxin and Furan Test Data and Test Results at the Thermal Oxidizer Discharge.....	7-26

LIST OF TABLES

Title	Page
Table 7-11 Summary of VOC Emissions Detected at the Thermal Oxidizer Discharge	7-34
Table 7-12 VOC Test Data and Test Results—Thermal Oxidizer Discharge Stack (Test T1)	7-35
Table 7-13 VOC Test Data and Test Results—Thermal Oxidizer Discharge Stack (Test T2)	7-41
Table 7-14 VOC Test Data and Test Results—Thermal Oxidizer Discharge Stack (Test T3)	7-47
Table 7-15 Summary of Metals Emissions at the Thermal Oxidizer Discharge	7-54
Table 7-16 Summary of Hexavalent Chromium at the Thermal Oxidizer Discharge.....	7-55
Table 7-17 Metals Test Data and Test Results at the Thermal Oxidizer Discharge	7-56
Table 7-18 Hexavalent Chromium Test Data and Test Results at the Thermal Oxidizer Discharge	7-59
Table 7-19 Summary of CEM Data for Validation Tests T1, T2, and T3	7-61
Table 7-20 Summary of CEM Mass Emission Rates.....	7-62
Table 8-1 Time-Integrated Results for Explosives.....	8-2
Table 8-2 Asbestos Results from HGD Furnace Run 17C of 18 March 1996	8-3
Table 9-1 Level 1 Acceptance Criterion.....	9-3
Table 9-2 Level 2 Acceptance Criterion.....	9-5
Table 9-3 Level 3 Acceptance Criterion.....	9-7
Table 11-1 Transportable HGD System Equipment Emissions Results.....	11-3
Table 11-2 Permit/Approval Requirements	11-4

LIST OF ABBREVIATIONS AND ACRONYMS

ALAAP	Alabama Army Ammunition Plant
ADEM	Alabama Department of Environmental Management
AMC	Army Materiel Command
AR	Army Regulation
BIF	Boiler and Industrial Furnace
Btu	British thermal unit
CEM	continuous emissions monitoring
CERCLA	Comprehensive Environmental Response, Compensation, and Liability Act
cfm	cubic feet per minute
CFR	Code of Federal Regulations
CGI	combustible gas indicator
Cl ₂	chlorine
cm ³	cubic centimeters
CO	carbon monoxide
CO ₂	carbon dioxide
Cr ⁺⁶	hexavalent chromium
DACU	Data Acquisition and Control Unit
DC	direct current
DRE	destruction and removal efficiency
DNT	dinitrotoluene
DNB	dinitrobenzene
EPA	U.S. Environmental Protection Agency
° F	degrees Fahrenheit
ft	feet
GC	gas chromatography
gr/dscf	grains per dry standard cubic foot
HGD	hot-gas decontamination
HMK	ooahydro-1,3,5,7-tetranitro-1,3,5,7-tetrazocine
HPLC	high-performance liquid chromatography
HWAAP	Hawthorne Army Ammunition Plant
HCl	hydrochloric acid
HRGC	high-resolution gas chromatography

LIST OF ABBREVIATIONS AND ACRONYMS

HGD	hot-gas decontamination
Hz	hertz
I/O	input/output
I.D.	induced draft
i.d.	inside diameter
IET	instantaneous electronic trip
in. w.c.	inch water column
IRI	Industrial Risk Insurers
kVA	kilovolt ampere
lb	pounds
lb/hr	pounds per hour
LEL	lower explosive limit
LRMS	low-resolution mass spectrometry
MMBtu/hr	million British thermal units/hour
mA	milliampere
MS	mass spectroscopy
MiniRAM	miniature Real-Time Aerosol Monitor
$\mu\text{g/dscm}$	micrograms per dry standard cubic meter
mg/m^3	milligrams per cubic meter
mV	millivolt
N/A	not available
NB	nitrobenzene
NA	not applicable
NFPA	National Fire Protection Association
ng TEQ/dscm	nanograms toxic equivalents per dry standard cubic meter
ng/dscm	nanograms per dry standard cubic meter
NEC	National Electrical Code
NIST	National Institute of Standards and Technology
NO	nitrogen oxide
NO_x	nitrous oxides
O_2	oxygen
O&M	Operations and Maintenance
P&ID	process and instrumentation diagram
PC	personal computer
PCV	pressure control valve
PIC	pressure indicating controller

PID	photoionization detector
pph	pounds per hour
ppm	parts per million
ppb	parts per billion
ppm/v	parts per million per volume
PIC	products of incomplete combustion
PEL	permissible exposure limit
psi	pounds per square inch
psig	pounds per square inch gauge
PS&BD	power supply and base driver
PT	pressure transmitter
RCRA	Resource Conservation and Recovery Act
RDX	cyclotrimethylenenitramine
RE	removal efficiency
RFW	Roy F. Weston, Inc.
SHSO	Site Health and Safety Officer
SIC	speed indicating controller
SO ₂	sulfur dioxide
SVOC	semivolatile organic compound
TCV	temperature control valve
TE	temperature element or thermocouple
tetryl	trinitrophenyl methylnitramine
TEQ	toxic equivalent
THC	total hydrocarbons
TIC	temperature indicating controller
TIR	temperature indicating recorder
TIT	temperature indicating transmitter
TNB	trinitrobenzene
TNT	2,4,6-trinitrotoluene
TSCA	Toxic Substances Control Act
TT	temperature transmitter
TVA	Tennessee Valley Authority
TWA	time-weighted average
TY	temperature transducer
UPS	uninterruptible power supply
USAEC	U.S. Army Environmental Center

LIST OF ABBREVIATIONS AND ACRONYMS

USATHAMA	U.S. Army Toxic and Hazardous Materials Agency
UV	ultraviolet
VAC	volts alternating current
VFD	variable frequency drive
VOC	volatile organic compound
VOST	volatile organic sampling train
w.c.	water column
WESTON®	Roy F. Weston, Inc.

1. EXECUTIVE SUMMARY

The U.S. Army Environmental Center (USAEC, formerly USATHAMA) has been conducting laboratory investigations and pilot-scale studies of the hot-gas decontamination (HGD) process since 1978. The results from these investigations and studies verified the effectiveness of the HGD technology in treating chemical agents and explosives; however, post-test recommendations indicated that improved system efficiencies and process optimization could be achieved using equipment specifically designed for the HGD concept.

Starting with these recommendations as a baseline, USAEC contracted Roy F. Weston, Inc. (WESTON®) to design and procure HGD equipment that could meet the following criteria:

- Design a system that could be procured easily from commercial sources. "Custom" equipment designs were discouraged.
- Size and design equipment that could be easily transported from site to site.
- Design system equipment that could be operated locally at the equipment or remotely from a remote control area to ensure operator safety.
- Design furnace equipment that minimized air infiltration and provided good heat distribution throughout the furnace load.
- Provide system equipment capable of reaching treatment temperatures quickly, and capable of maintaining treatment temperatures over long soak periods once operations began.
- Provide system equipment capable of repeatable system operations over a series of furnace runs.

The resultant transportable equipment design was delivered to USAEC's HGD site, at the Alabama Army Ammunition Plant (ALAAP) located in Alpine, Alabama, for demonstration and validation testing. The delivered HGD equipment consisted of:

- HGD Furnace.
- Interconnection Duct.
- Induced Draft Fan.
- Thermal Oxidizer.
- 24-Foot Stack with 8-Foot Extension.
- Data Logging and Monitoring System.
- Remote Control System.

Once site preparation was completed, and system utilities to support HGD system operations were installed, a 1-week demonstration test, using clean, noncontaminated debris, was conducted between 4 and 8 December 1995. The demonstration test program was successful. System trials proved the HGD system equipment to be fully functional and capable of maintaining anticipated treatment temperatures. In addition, the demonstration tests identified a number of system enhancements, modifications, and repairs that would improve system operations during upcoming validation tests. After receiving permission from USAEC, the suggested repairs and modifications were made to the HGD equipment by WESTON. Completed modifications were verified operable and system operations were reconfirmed. The HGD system equipment was available for validation testing with explosives-contaminated materials.

Validation testing of the HGD equipment was conducted by WESTON between 4 January and 15 March 1996. The purpose of the validation testing was to evaluate the operability of the HGD equipment and to determine:

- The effectiveness of the HGD process on various explosives-contaminated items such as metal, clay pipe, concrete block, and contaminated debris.
- The removal efficiency (RE) of the HGD process using clean metal, clean clay pipe, and clean debris (cinder block) spiked with 2,4,6-trinitrotoluene (TNT), cyclotrimethylenenitramine (RDX), and 2,4,6-trinitrophenylmethylnitramine (tetryl).
- The time and temperature relationships for the decontamination of explosives on metal, clay, and block surfaces.
- The optimum treatment time and temperature required for the complete destruction and removal of explosives and their breakdown compounds.
- Gather air emissions data on the HGD process to support future permitting of the process and equipment.

To meet these objectives, a series of 15 validation test runs were planned. Eighteen were actually conducted, as illustrated by the validation test matrix included as Table 1-1. Treatment temperatures ranged from 300 °F to 650 °F, and soak times ranged from 0 to 12 hours, depending on the test run. Ramp rates to treatment temperature varied from 50 °F/hour to 300 °F/hour. A combination of clean metal pipe, clean clay pipe, and clean concrete block spiked with an explosives-paste mixture that contained either TNT, RDX, or tetryl was placed in the furnace during each test run. An explosives-spike mixture contained only one explosive type and was not mixed with other explosives-spike mixtures on the same test plate. Twelve of the test runs, as indicated by the "D" in Table 1-1, also treated contaminated debris from the ongoing ALAAP remediation effort.

Table 1-1

Validation Test Matrix

Temperature	300 °F	400 °F	500 °F	550 °F	600 °F
No Soak					Tests 9 (D), 16A, 16B, 16C
1-Hour Soak	Test 12 (D)	Test 11 (D)	Test 13 (D)	Test 10 (D)	Tests 7 (D), 14 (D), 15 (D)
2-Hour Soak			Test 8 (D)		Test 6 (D)
4-Hour Soak			Test 3 (E)		Test 5 (D)
6-Hour Soak		Test 2 (E)	Test 4 (D)		
12-Hour Soak			Test 1 (E)		

(D) Indicates contaminated debris was also treated in addition to spiked test plates.

(E) Indicates furnace discharge gas and stack emissions testing was conducted during these test runs.

Confirmatory sampling and analysis was conducted before treatment to verify the absence of explosives prior to spiking, and after treatment to verify decontamination and identify breakdown compounds, if any, that remained on the treated contaminated materials after processing.

As noted by "E" on the validation test matrix above, an emissions testing program was conducted during the first three validation test runs to support future permitting efforts of the HGD process, and to determine, if possible, the thermal oxidizer's destruction and removal efficiency (DRE). The HGD system stack emissions were sampled for:

- Carbon monoxide (CO).
- Carbon dioxide (CO₂).
- Total hydrocarbons (THC).
- Nitrous oxides (NO_x).
- Sulfur dioxide (SO₂).
- Particulate.
- Explosives.
- Volatile and semivolatile organics.
- Metals.
- Hexavalent chromium (Cr⁺⁶).
- Hydrochloric acid (HCl) and chlorine gas (Cl₂).
- Dioxins and furans.

Explosives emissions samples were also taken from the interconnection duct between the furnace exit and thermal oxidizer unit to support DRE calculations.

Stack emissions were also monitored during all test runs by a Continuous Emissions Monitoring (CEM) system for CO₂, CO, THC, NO_x, SO₂, and O₂. To gather more information regarding furnace exit-gas constituents, the CEM system also monitored THC and NO_x at the furnace exit by placing a separate sample probe in the interconnection duct.

The validation test of the transportable HGD system was a success. Results indicate the following:

- The optimum operating conditions for removing TNT, RDX, tetryl, and their breakdown constituents to levels below method detection levels are **250 °F/hour ramp to 600 °F treatment temperature with a 1-hour soak.**
- The bulk of explosives decontamination occurs during the furnace ramp period, as indicated by the NO_x levels at the furnace exit.
- Post-treatment testing consistently indicates removal efficiencies for TNT, RDX, and tetryl of 99.999%, based on an initial quantity of 1 pound of total explosives.
- The HGD process effectively processes explosives-contaminated debris to microgram quantities or less.
- The transportable HGD system is a controlled and fully instrumented process that has demonstrated its repeatability, test after test.

Results from stack emissions testing during the first three validation test runs are summarized by the two points below and the information presented in Table 1-2.

- No detectable explosives contamination was observed in the stack emissions from the HGD system, thereby demonstrating the effectiveness of the thermal oxidizer in destroying explosives contained in the furnace exit gases.
- Sampling and analysis of volatile and semivolatile organic compounds (VOCs and SVOCs) was conducted to identify products of incomplete combustion (PICs) and explosives breakdown compounds. Results indicate:
 - Only acetone, which was used to make the explosives-spike mixtures, was found in detectable quantities.
 - Samples were analyzed for SVOC target compound list compounds; however, only nontarget SVOCs were identified.

Table 1-2

Transportable HGD System Equipment Emissions Results

Hazardous Air Pollutant	Existing Standard (as of June 1996)	Test Run Average
Total hydrocarbons (ppm/v)	12	<1.0
Carbon monoxide (ppm/v)	100	<1.0
Sulfur dioxide (ppm/v)	30	0.69
Nitrous oxides (ppm/v)	180	52.78
Particulate (gr/dscf at 7% O ₂)	<0.08	0.0004
Hexavalent chromium (µg/dscm)	NA	12.18
Low volatility metals (µg/dscm) (antimony, arsenic, beryllium, chromium)	210 (currently) 62 (proposed)	15.03
Semivolatile metals (µg/dscm) (lead and cadmium)	270 (currently) 62 (proposed)	2.33
Hydrochloric acid, HCl (lb/hr)	4.0	1.56 x 10 ⁻³
Chlorine, Cl ₂ (ppm/v)	NA	0.08
Total HCl and Cl ₂ (ppm/v)	280 (currently) 67 (proposed)	0.36
Mercury (µg/dscm)	50	0.04
Dioxins/furans (ng TEQ/dscm)	0.2	0.03

Notes:

lb/hr - pounds/hour.

ppm/v - parts per million per volume.

gr/dscf - grains per dry standard cubic foot.

µg/dscm - micrograms per dry standard cubic meter.

ng TEQ/dscm - nanograms toxic equivalents per dry standard cubic meter.

NA - not applicable.

CEM data collected during all test runs indicate the following:

- Total hydrocarbons (THC), sulfur dioxide (SO₂), nitrous oxides (NO_x), carbon monoxide (CO), and carbon dioxide (CO₂) emissions, measured by the CEM system, were significantly below the accepted permitting limits.
- NO_x levels monitored in the furnace exit-gas duct indicated increased NO_x activity during ramp-up periods and a return to baseline NO_x levels after the furnace chamber temperature reached approximately 400 °F.

2. INTRODUCTION

2.1 TECHNOLOGY BACKGROUND

For many years, the U.S. Army (the Army) has engaged in a wide variety of activities involving the handling and disposal of explosives materials at various Army installations. Past operations at these installations have included manufacture, storage, testing, and disposal of explosives that have resulted in the contamination of process-related equipment, sewers, piping, and enclosed structures at the installations.

Demilitarization of explosives-contaminated process equipment and structures has proven to be both difficult and expensive for the Army. Currently acceptable methods for decontamination of explosives-contaminated materials include 3X treatment methods such as steam cleaning and power washing, and 5X treatment methods that involve heating contaminated materials to a minimum temperature of 1,000 °F for 15 minutes. Unfortunately, many of these treatment methods have proven to be ineffective for demilitarization, or result in complete destruction and loss of equipment and/or structures.

To address these decontamination issues, the U.S. Army Environmental Center (USAEC, formerly U.S. Army Toxic and Hazardous Materials Agency or USATHAMA) began conducting bench-scale studies in the late 1970s to evaluate the effectiveness of the HGD technology on agent-contaminated materials and structures.

2.2 TECHNOLOGY HISTORY

Based on promising laboratory work with chemical warfare agents in the late 1970s, a pilot-scale study using agent-spiked samples was conducted at Dugway Proving Ground, Utah.¹ This controlled pilot-scale study successfully demonstrated the ability of the HGD process to decontaminate agent from a concrete and steel structure.

To further evaluate the HGD process on agent, USAEC selected a mustard thaw pit (constructed with concrete) at Rocky Mountain Arsenal for a field

¹ *Pilot Plant Testing of HGD Building Decontamination Process; Task Order 1. Report No. AMXTH-TE-CR-87130. Prepared by Battelle Columbus Division. 30 October 1987.*

demonstration of the HGD process in 1994.² Three tanks (two 2,600-gallon tanks and one 250-gallon tank) were also left in the thaw pit during the field demonstration to test the effectiveness of the HGD process in decontaminating process equipment. Mustard agent was successfully decontaminated from the concrete pit, contaminated steel tanks, and process off-gases. This field demonstration, once again, proved the effectiveness of the HGD process.

Based on the successful pilot-study results at Dugway, USAEC decided to investigate the effectiveness of the HGD process on explosives-contaminated materials. Pilot-scale tests using the HGD process to treat explosives contamination were conducted at the Cornhusker Army Ammunition Plant.³ Results from the Cornhusker tests indicated the HGD process seemed to be effective at treating explosives-contaminated materials, but more studies were needed. To verify this finding, USAEC contracted for additional HGD studies to be conducted at Hawthorne Army Ammunition Plant (HWAAP).^{4,5} The HWAAP studies used an existing flash chamber modified for the HGD process. The following two studies were conducted:

- Explosives-contaminated machinery, piping, and metal debris, such as shell casings, were treated in one study conducted by WESTON in 1989.
- Explosives contained within munitions, such as ship mines, depth bombs, and 106-mm and 5-inch projectiles, were treated in a second series of tests conducted by the Tennessee Valley Authority (TVA) in 1994.

The results from these studies verified the effectiveness of the HGD process in treating explosives-contaminated materials, but indicated that equipment enhancements would be required to optimize the process. A map indicating the test sites discussed and the technology history is provided as Figure 2-1.

Based on engineering data gathered during the HWAAP pilot studies, WESTON, under contract to USAEC, was requested to supply process equipment designed specifically for the decontamination of explosives-contaminated materials

² *Final Technical Report, Field Demonstration of the HGD Decontamination System.* Report No. SFIM-AEC-ET-CR-95011. Prepared by Battelle Pacific Northwest Laboratories, Parsons Engineering Science, Inc., and Battelle Columbus Operations. February 1995.

³ *Pilot Plant Testing of Caustic Spray HGD Building Decontamination Process; Task Order 5.* Report No. AMXTH-TE-CR-87112. Prepared by Arthur D. Little, Inc. August 1987.

⁴ *Task Order 2; Pilot Test of HGD Decontamination of Explosives-Contaminated Equipment at Hawthorne Army Ammunition Plant (HWAAP), Hawthorne, Nevada.* Report No. CETHA-TE-CR-90036. Prepared by Roy F. Weston, Inc. July 1990.

⁵ *Demonstration Results of HGD Decontamination for Explosives at Hawthorne Army Depot.* Report No. SFIM-AEC-ET-CR-95031. Prepared by the Tennessee Valley Authority Environmental Research Center. September 1995.

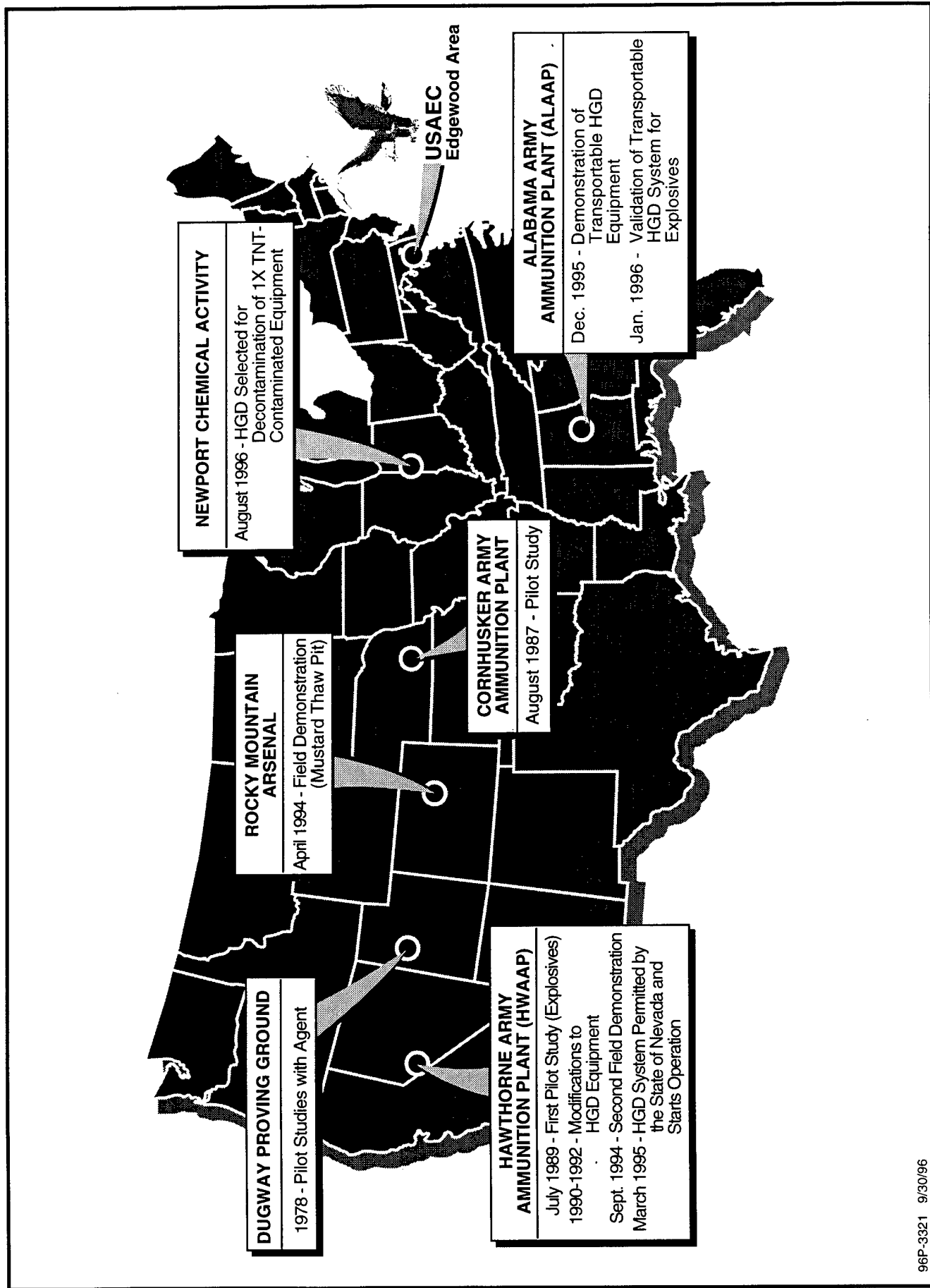

FIGURE 2-1 HGD STUDY SITES

96P-3321 9/30/96

by the HGD process. The equipment had to be transportable and easily procured through commercial sources. The finished equipment was delivered to the Alabama Army Ammunition Plant (ALAAP) for demonstration tests using clean, noncontaminated debris, and validation testing using explosives-contaminated piping and debris.

The HGD system equipment, which was delivered to USAEC's ALAAP hot-gas site, is shown in Figure 2-2 and consists of four basic elements: the HGD decontamination furnace, the induced draft (I.D.) fan, the thermal oxidizer, and the system stack.

The purpose of this Validation Test Report is to document the results of the test program that was conducted between 4 January and 15 March 1996 at ALAAP to validate the transportable HGD equipment. This report is organized as follows:

- Section 1: Executive Summary
- Section 2: Introduction
- Section 3: Equipment and System Description
- Section 4: Purpose and Objectives of Validation Testing
- Section 5: Validation Test Plan
- Section 6: Equipment Operations During Validation Testing
- Section 7: Source Emissions Sampling: Analysis and Results
- Section 8: Air Sampling: Analysis and Results
- Section 9: Discussion of Validation Test Results
- Section 10: System Costs
- Section 11: Conclusions and Recommendations

The test report appendices, which are presented in Volumes II and III, include:

- Appendix A: Sampling and Analytical Methods Used During Validation Testing
- Appendix B: Validation Test Spiking Logs
- Appendix C: Post-Treatment Sampling for Explosives
 - Analytical Results for Furnace Runs 1-17
 - Analytical Results for Duplicate Samples Taken During Test Runs 3-15
- Appendix D: Post-Treatment Sampling Explosives Worksheets
- Appendix E: Control Room Logs for Furnace Runs 1-18
- Appendix F: Hourly Datalogs for Furnace Runs 1-18
- Appendix G: Summary of Data Sheets for Test Runs 1-15
- Appendix H: Source Emissions Data Summary Sheets for Test Runs 1-3

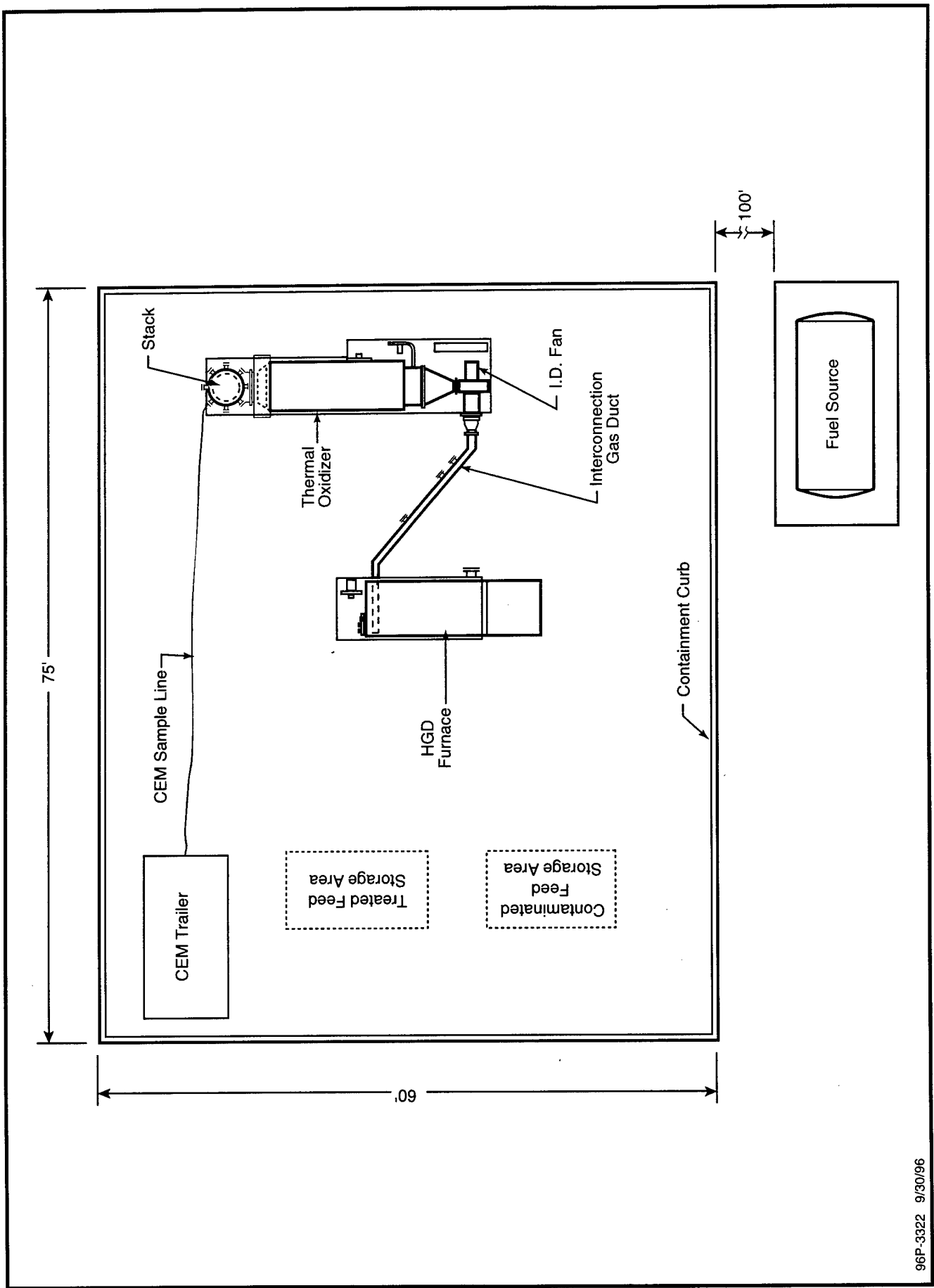

FIGURE 2-2 TRANSPORTABLE HGD SYSTEM GENERAL ARRANGEMENT

96P-3322 9/30/96

- Appendix I: Source Emissions Laboratory Analytical Data Reports Without Raw Data
- Appendix J: Results of Ambient Air Monitoring for Explosives
- Appendix K: Ambient Air Monitoring Results for Asbestos
- Appendix L: NO_x Emissions Trends in the Furnace Exit Gases for Test Runs 1-15

To assist the reader in reviewing this document, a list of abbreviations and acronyms has been included following the Table of Contents.

3.

EQUIPMENT AND SYSTEM DESCRIPTION

This section of the test report provides a brief description of the HGD site location, details regarding the site layout at ALAAP, and descriptions of the transportable HGD equipment that was used to support validation testing. A more detailed description of the transportable HGD equipment can be found in the system-specific Operations and Maintenance Manual, which WESTON prepared for USAEC as part of Contract DACA31-91-E-0079, Delivery Order 12.

3.1 SITE LOCATION AND LAYOUT

3.1.1 Site Location

ALAAP was selected by USAEC as the site for the demonstration and validation testing of the HGD equipment. The ALAAP site is located in central Alabama, in Talladega County, 4 miles from Childersburg, and 40 miles southeast of Birmingham. ALAAP is located near a junction of the Talladega Creek and the Coosa River. Figure 3-1 illustrates the location of ALAAP in Alabama, and Figure 3-2 indicates the approximate location of the HGD site at ALAAP. Throughout this document, references will be made to the existing remediation effort at ALAAP, or references to the Soils Stockpile and Red Water Ditch efforts. These areas are located within Area B, which is shown in Figure 3-2.

3.1.2 Site Layout

Because of an existing remediation effort being conducted at ALAAP at the same time validation testing of the HGD system was scheduled, and because explosives-contaminated materials would be processed by the HGD equipment during validation testing, two factors affected the location of the unit:

- The selected HGD site location could not interfere with the existing site remediation efforts at ALAAP.
- The selected HGD site had to meet quantity-distance requirements associated with the storage and use of explosives, as defined by AMC-R-385-100 and AR 385-64.

In accordance with AMC-R-385-100 and AR 385-64, the HGD system equipment was located a minimum of 670 feet from any manned location (e.g., control area and building) and a minimum of 350 feet from a railroad or active road way. The borrow, or main road, indicated in Figure 3-3 is located directly in front of the control area and was considered an active roadway. The selected site layout,

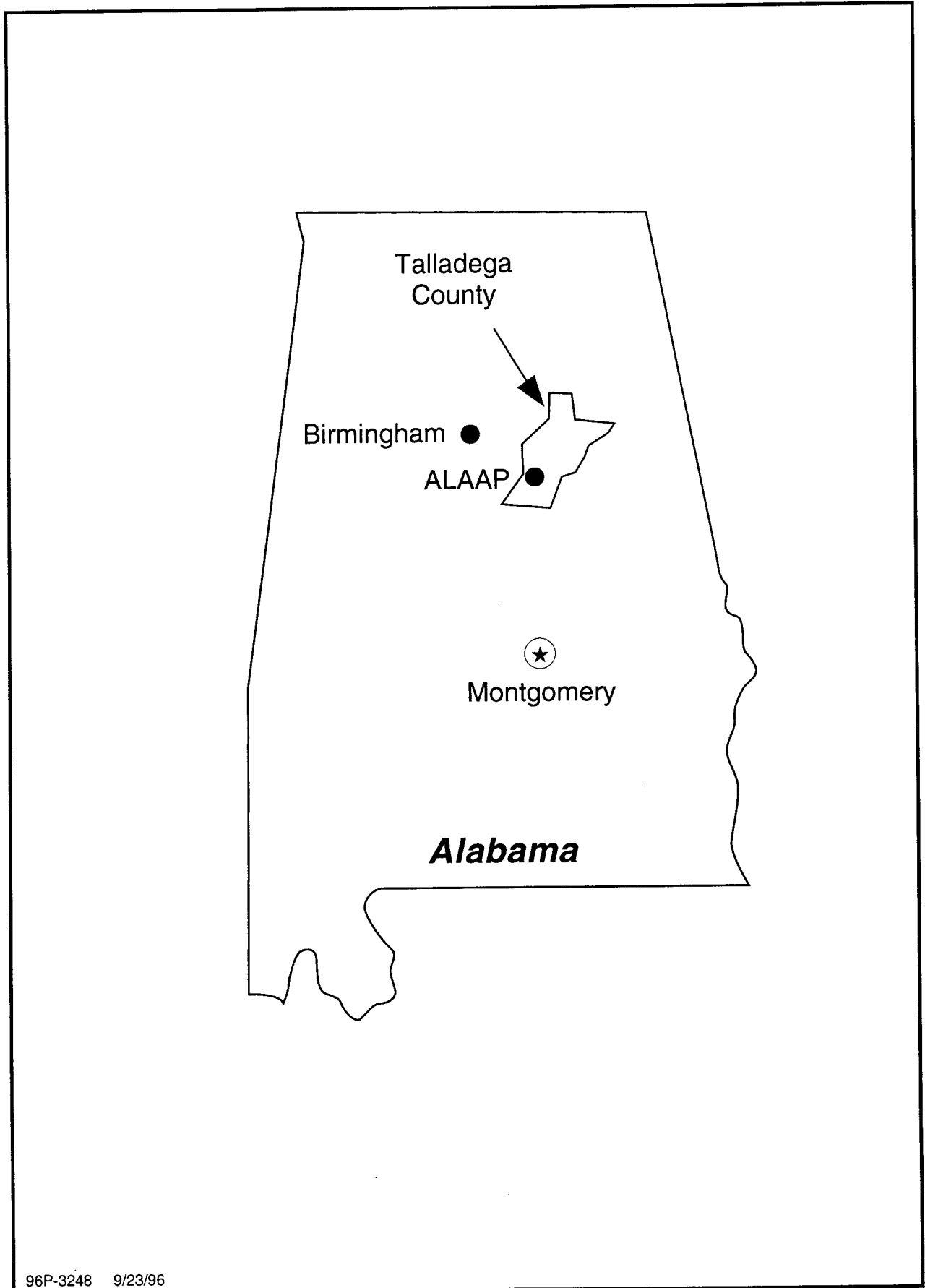

96P-3248 9/23/96

FIGURE 3-1 LOCATION OF ALAAP IN ALABAMA

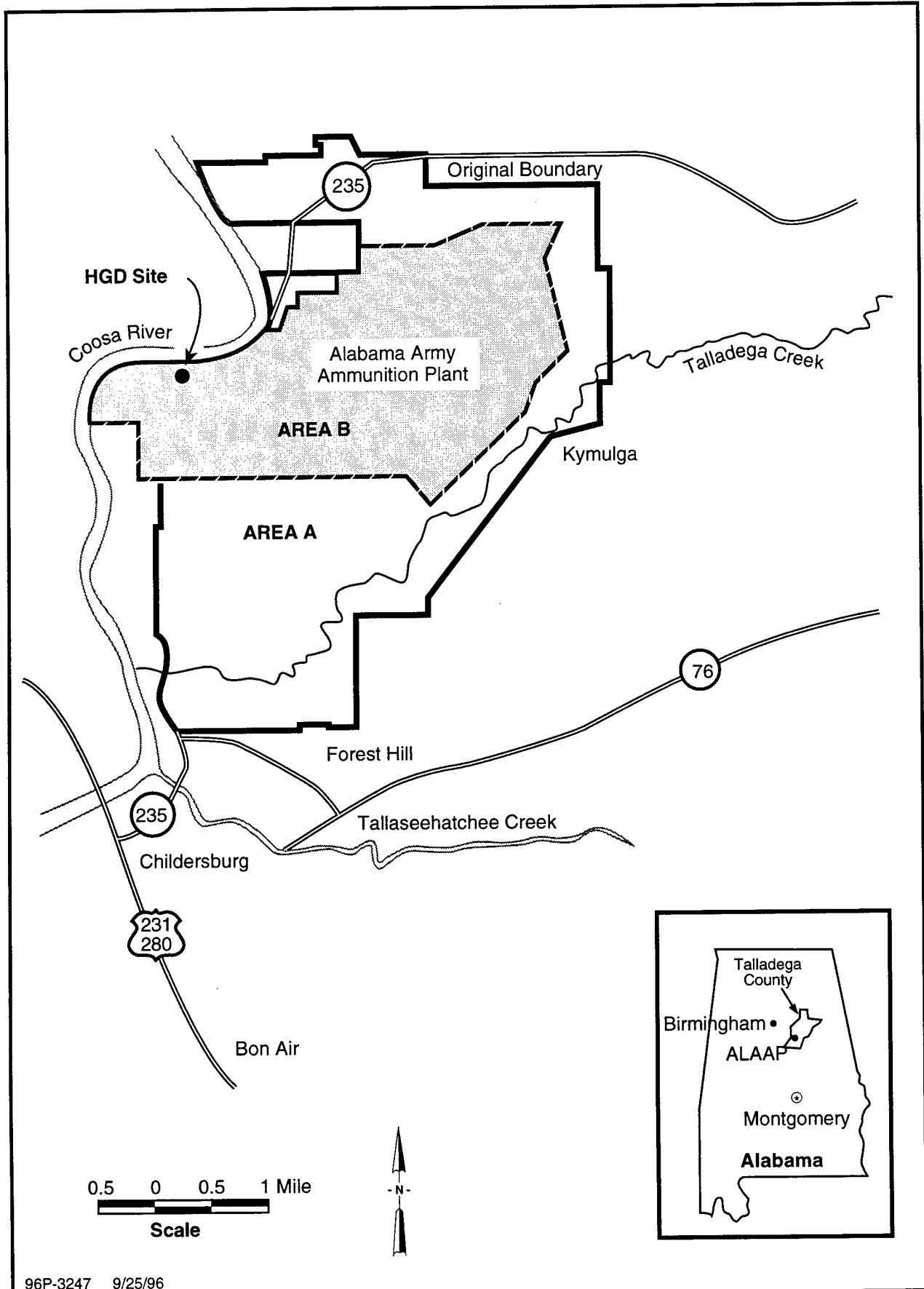

96P-3247 9/25/96

FIGURE 3-2 LOCATION OF THE HGD SITE AT ALAAP

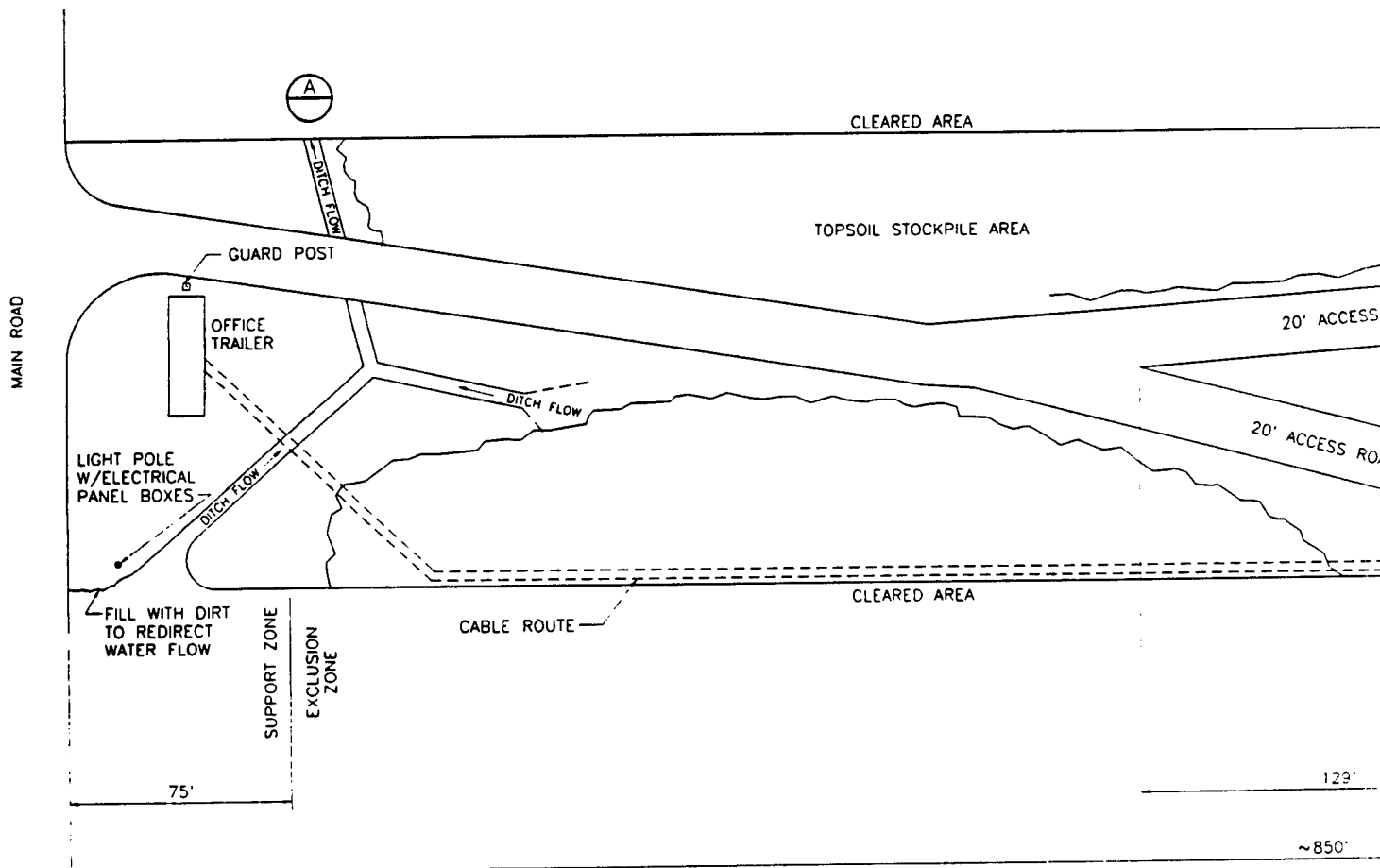
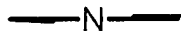

10-01-10-000
 10-01-10-000
 10-01-10-000

NO.	DATE	REVISION	NO.	DATE	REVISION
1	10/1/10	SHOWN WITH MODIFICATIONS FOR TESTING			
2	10/1/10	SHOWN WITH TRAILERS AND AS CONSTRUCTED			
		INITIAL SITE LAYOUT			

U
 DELIVERY OF

WEST CHESTER

①

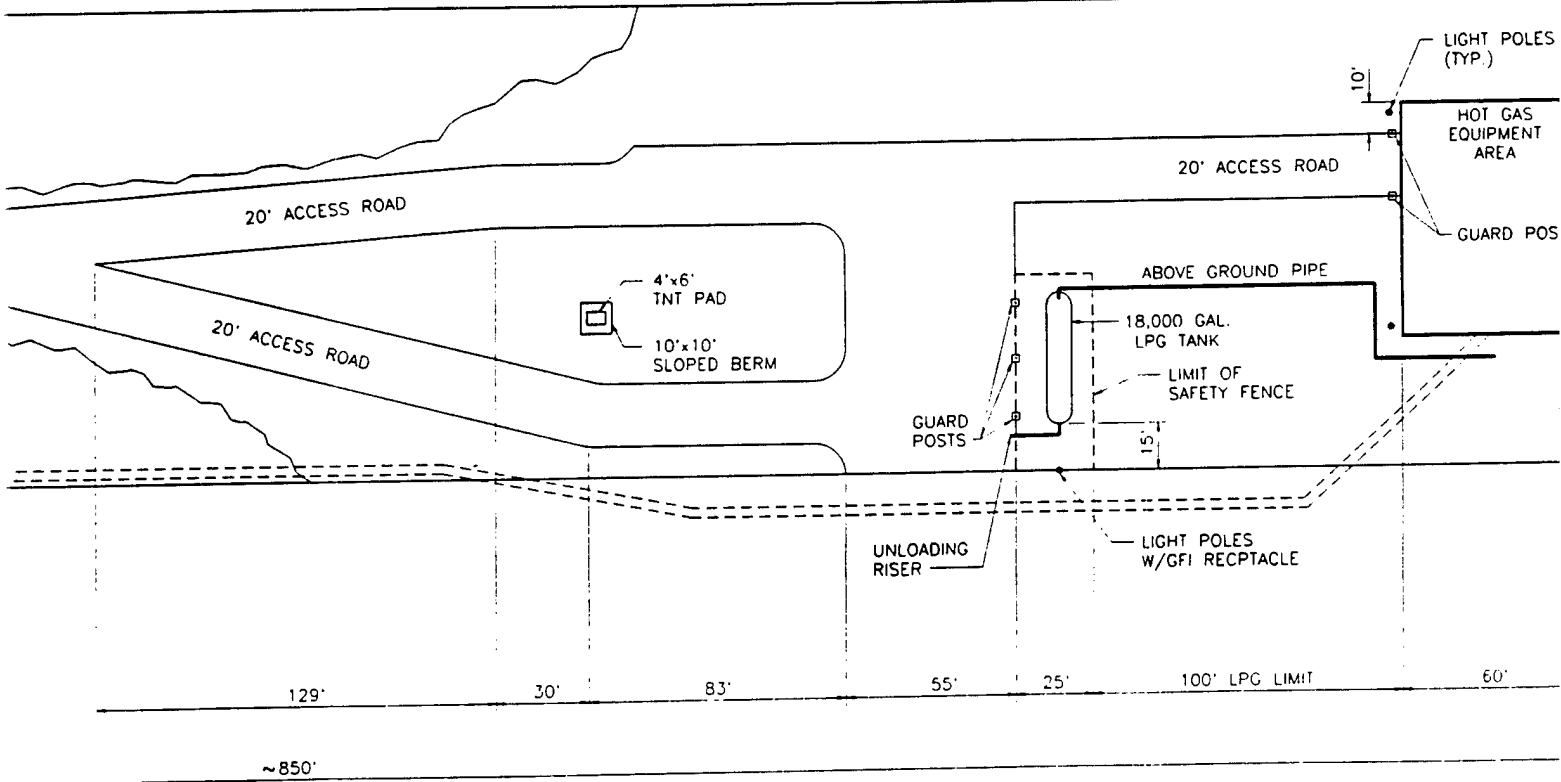

USACE DELIVERY ORDER #10& #12  <small>WEST CHESTER MANAGING DESIGNERS/CONSULTANTS PENNSYLVANIA</small>	CHECKED	DATE	CLIENT APPROVALS	DATE	FIGURE 3-3 HGD DRAWN DATE 6/21/04 SCALE 1" = 30' P.O. NO. 00001-01
	DES. ENG.				
	PROJ. ENG.				
	PROJ. MGR.				
APPROVED					
APPROVED					

2

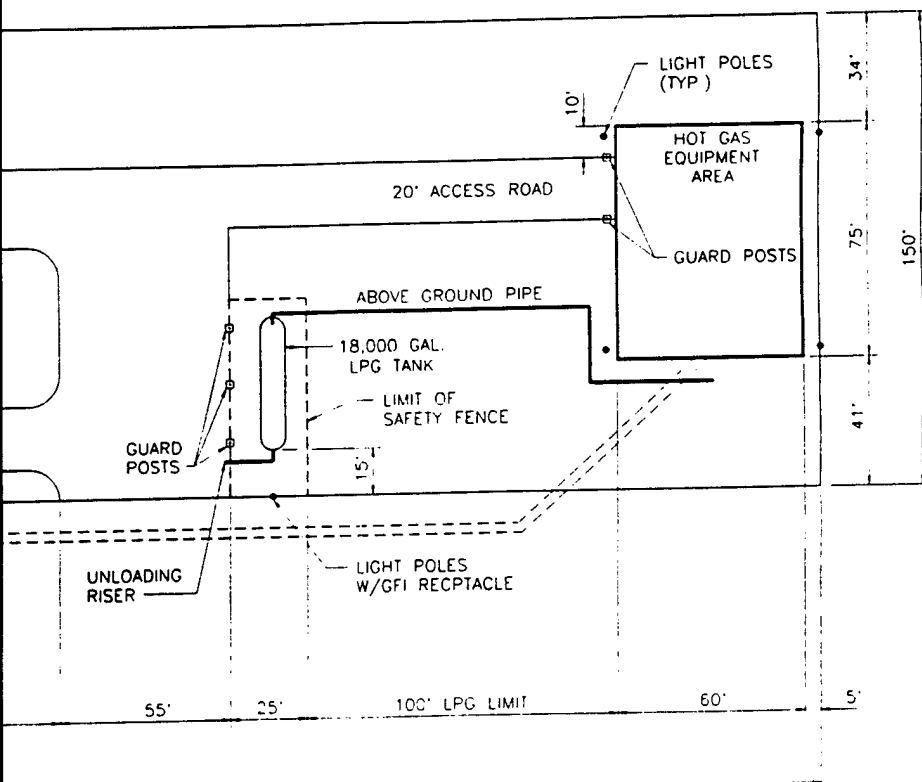

FIGURE 3-3 HGD SITE LAYOUT

DATE	CLIENT APPROVALS	DATE
11/1/05		

DRAWN	DATE	REV. NO.	REV.
	6/21/05	C100	3
SCALE	1" = 30'		



shown in Figure 3-3, highlights the location of the HGD equipment relative to the control area, propane supply tank, and main site access road. The control area and main access road to the site were situated 750 feet away from the HGD process equipment.

3.2 SYSTEM AND EQUIPMENT DESCRIPTION

The HGD process equipment used to complete validation testing was designed, specified, and procured by WESTON under contract to USAEC. The HGD equipment consists of:

- HGD Furnace.
- Interconnection Duct.
- Induced Draft (I.D.) Fan.
- Thermal Oxidizer.
- 24-Foot Stack with 8-Foot Stack Extension.
- Data Logging and Monitoring System.
- Remote Control System.
- Continuous Emissions Monitoring (CEM) System.¹

As discussed in Subsection 3.1.2, the furnace, thermal oxidizer, and CEM system equipment were located on a concrete equipment pad located 750 feet from the remote control area. A general arrangement drawing showing the placement of the HGD equipment on the equipment pad is provided in Figure 2-2.

3.2.1 System Description

The transportable HGD system is a batch process that is controlled and monitored remotely from a remote control area. After charging the furnace and securing the furnace door, the decontamination process can be started. As illustrated in Figure 3-4, once the furnace has started, a heated air stream is introduced into the loaded furnace chamber. The furnace chamber and explosives-contaminated materials contained within the furnace chamber are heated to a target treatment temperature that is specified by the operator, but cannot exceed 700 °F.² Treatment temperatures during the validation tests ranged between 300 °F and 600 °F. Contaminated exit-gases from the furnace chamber are drawn from the furnace via an interconnection duct and directed to a thermal oxidizer by the system I.D. fan. The thermal oxidizer is maintained at a minimum temperature of 1,800 °F to

¹ The CEM system was a rental unit. Although integral to system operations, it is not part of the system equipment delivered to USAEC as part of Contract DACA 31-91-D-0079, Delivery Order 10.

² The furnace equipment is capable of maintaining treatment temperatures up to 1,200 °F; however, a 700 °F limit has been imposed on the furnace operating system to protect the I.D. fan.

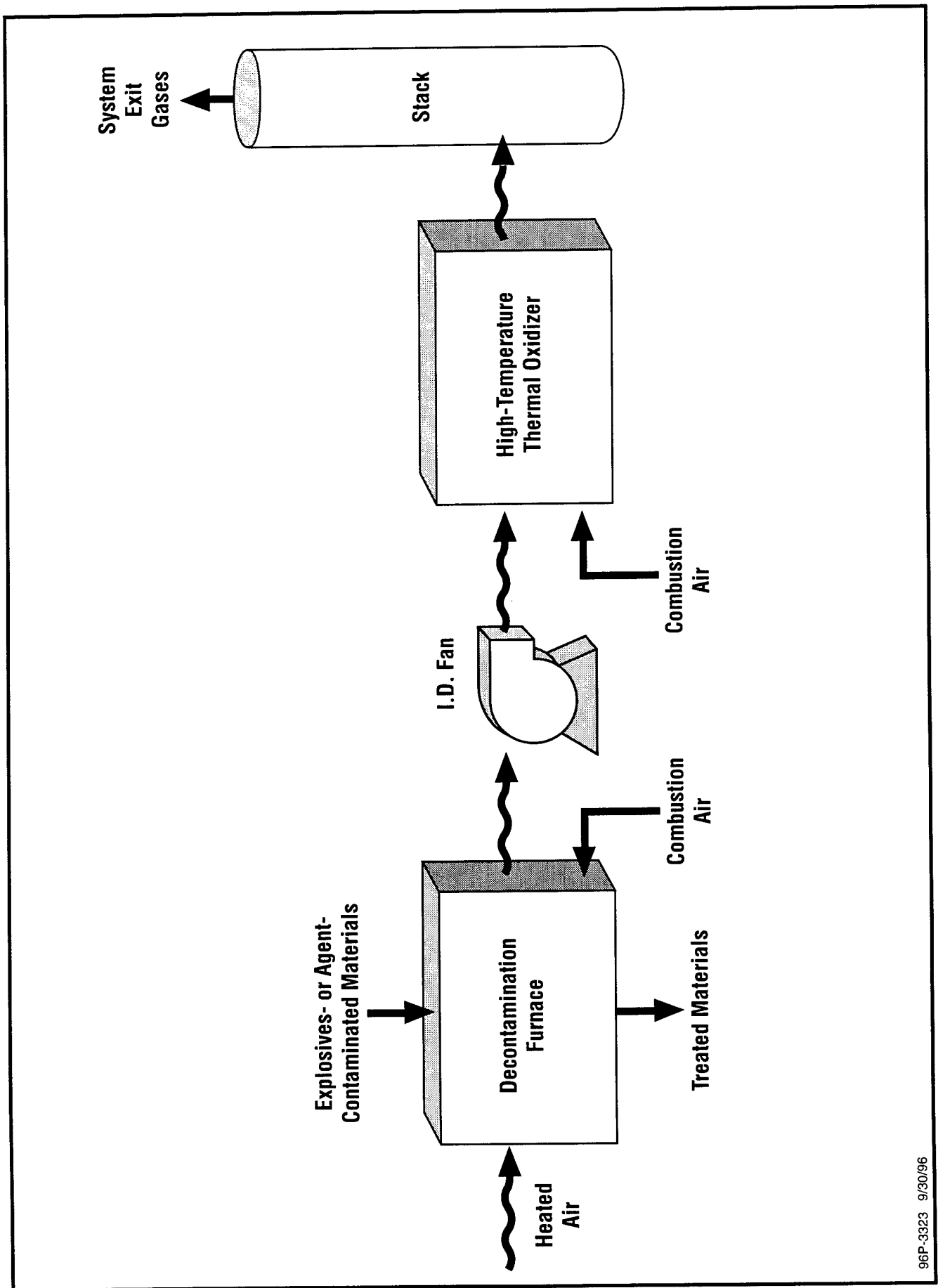

FIGURE 3-4 HGD SYSTEM OVERVIEW

96P-3323 9/30/96

ensure complete destruction of the contaminants contained in the furnace exit-gases. Treated gases are discharged to the atmosphere via the thermal oxidizer stack after a minimum retention time of 2 seconds in the thermal oxidizer.

A CEM system was used throughout the validation testing to monitor stack and furnace exit-gas emissions during processing. Two separate sample probes were used. The first was placed in the system exhaust stack to monitor the oxidizer's exit-gas stream, the second probe was located in the interconnection duct, between the furnace exit and I.D. fan inlet, to monitor nitrous oxides (NO_x) and total hydrocarbons (THC) contained in the furnace exit-gases.

3.2.2 Equipment Description

A brief description of the process equipment, remote control, and data logging and monitoring systems that WESTON supplied to USAEC as part of Contract DACA31-91-D-0079, Delivery Order 10, is provided in Subsections 3.2.2.1, 3.2.2.2, and 3.2.2.3.

3.2.2.1 HGD Furnace

The HGD furnace was supplied and manufactured by L&L Special Furnace Co., Inc., of Aston, Pennsylvania. The furnace is a gas-fired, box-type furnace with integrated ceramic-fiber lining. The furnace system includes:

- Furnace Chamber.
- Burner and Gas Train.
- Burner Control System.
- Burner Combustion Air Blower.
- Remote Control Panel.

All of these components, except for the remote control panel, are skid-mounted for easy transportability. The furnace skid is approximately 16 feet long by 8 feet wide. The remote control panel is shipped separately and located in a remote control area at least 670 feet from the process equipment.

The furnace is heated by a high-velocity, nozzle-mix Eclipse Burner equipped with an ultraviolet (UV) sensor and Industrial Risk Insurers (IRI) class gas safety system. The pilot and burner flames are monitored by a pilot and flame scanner system. Once all system interlocks are confirmed and the pilot flame is established, the main fuel valves automatically open and the main flame is lit. The burner flame is acknowledged through the flame scanner. Failure to detect a flame signal once operations begin results in an automatic shutdown of gas flow to the furnace.

Fuel flow to the furnace is controlled automatically based on the furnace chamber temperature. Combustion air to the burner is set at a fixed rate that maintains excess capacity to promote treatment temperatures between 300 °F and 700 °F. The furnace is

propane-fired and rated for a total heat release of 1 million British thermal units (MMBtu) per hour.

Although the primary means of furnace monitoring and control is accomplished through the remote control panel, a local control panel, mounted on the furnace skid, allows the furnace to be started and stopped locally. During treatment of explosives-contaminated materials, all system control is accomplished remotely from the remote control panels.

All materials treated by the transportable HGD system equipment must be manually loaded and unloaded; however, before loading materials into the furnace, the materials are first placed onto racks and weighed. A full load consists of 3,000 pounds (lb) contaminated materials containing no more than 1 lb total explosives contamination. A total of two racks comprise a complete furnace load. Racks are loaded into the furnace using a forklift.

Because the furnace is manually loaded, the furnace has been equipped with a number of safety features, including:

- A burner outlet cage.
- A kick-out door.
- Door switch ZAO-208.

The protective cage is located inside the furnace, at the top of furnace chamber. Its location prevents the placement or stacking of materials directly in front of the burner flame, and it prevents materials from being placed in areas that would come in direct contact with the burner flame. The kick-out door, which is located within the main furnace door, is provided to allow an escape from the furnace should personnel accidentally be locked in the furnace. Door switch ZAO-208 is associated with the main furnace door and supports an interlock condition that prevents system startup unless the switch indicates the furnace door is closed.

Temperature of the furnace exit-gases is monitored by three separate thermocouples: TE-200, TE-201, and TE-202. Thermocouple TE-200 is connected to a temperature transmitter (TT-200), which transmits the temperature signal to a Honeywell UDC 5000 temperature controller (TIC-200). Temperature controller TIC-200 maintains the desired furnace temperature by automatically adjusting fuel flow to the burner. Thermocouple TE-201 is connected to a Honeywell UDC 2000 high-limit controller (TIS-201), which contains a high-temperature switch (TSH-201A) that provides independent over-temperature control for the furnace. Thermocouple TE-202 is associated with temperature transmitter (TT-202), which transmits the temperature signal to a Honeywell DR4500A circular chart recorder (TIR-202) located on the furnace remote control panel.

The temperature of the furnace load during treatment is monitored by five thermocouples (TE/TT-203 through TE/TT-207), which are connected to the data logging and monitoring system through a jack panel located on the furnace skid. The jack panel has room for up to 12 load thermocouples, but only 5 thermocouples and their associated transmitters were used to support validation testing.

3.2.2.2 Thermal Oxidizer, I.D. Fan, and Stack

The thermal oxidizer system was furnished by Arrtech Environmental Systems, Inc., of Tulsa, Oklahoma. The thermal oxidizer is propane-fired and rated for a total heat release of 2.75 MMBtu/hr. The thermal oxidizer system consists of the following elements:

- I.D. Fan.
- Thermal Oxidizer Combustion Chamber.
- Burner and Gas Train.
- Air Pre-Mix System.
- 24-Foot Exhaust Stack with an 8-Foot Extension.
- Remote Control Panel.

The thermal oxidizer has a horizontal combustion chamber and is skid-mounted for transportability. The thermal oxidizer skid is approximately 29 feet long by 7.5 feet wide. The thermal oxidizer was nominally designed to thermally treat approximately 3,400 pounds per hour (lb/hr) of contaminated furnace exit-gases at a treatment temperature of 1,800 °F for a minimum residence time of 2 seconds. The maximum capacity of the thermal oxidizer is equal to the maximum capacity of the I.D. fan, which is equivalent to 4,758 lb/hr at 70 °F.

Furnace exit-gases are directed into the oxidizer combustion chamber via the I.D. fan. The I.D. fan is a centrifugal-type fan manufactured by Chicago Blower and rated for 2,250 cubic feet per minute (cfm) at 650 °F. The I.D. fan has been sized to maintain a 0.5 inch water column (in. w.c.) of negative pressure (draft) to prevent fugitive emissions at the furnace and force the furnace exit-gas stream through the thermal oxidizer combustion chamber and out the exhaust stack. The I.D. fan inlet is interconnected to the furnace chamber via an interconnection duct.

The oxidizer combustion chamber is constructed of carbon steel and lined with a ceramic-fiber refractory blanket. A turbulator is located halfway down the combustion chamber length to increase turbulent flow within the combustion chamber. The burner assembly consists of a Maxon Air Flow Model LV5 propane gas manifold burner with an HG-4 mixer. The pilot and burner flames are monitored by a UV pilot and flame scanner system. Once all system interlocks are confirmed and a pilot flame is established, the main fuel valves will automatically open and the main burner will be ignited. The burner flame is acknowledged through the system flame scanner. Failure to detect a flame signal once the main flame has ignited will result in an automatic shutdown of gas flow to the thermal oxidizer.

The Maxon burner is designed to use oxygen from the furnace exit-gas stream for combustion; however, in order to maintain excess oxygen levels in the combustion zone of the thermal oxidizer at all times, a completely separate combustion air fan has been supplied with the thermal oxidizer burner to provide pre-mix air to the burner's mixer. Temperature indicating transmitter TIT-131 monitors the combustion chamber exit-gas temperature and modulates the fuel flow to the oxidizer burner through the fuel gas control valve.

The system stack, which is located at the discharge end of the thermal oxidizer, is approximately 24 feet high with a 29-inch inside diameter (i.d.). The stack is shipped on its side, separate from the thermal oxidizer skid. The stack is outfitted with four 4-inch i.d. test ports for emissions sampling and one 4-inch i.d. CEM port for continuous emissions monitoring of the HGD system exit-gases. An 8-foot stack extension, containing four additional 4-inch i.d. test ports, has been provided to allow a full suite of emissions tests to be conducted simultaneously during validation test runs 1, 2, and 3. The stack extension is not required for operations, but may be required at future sites by permitting requirements.

3.2.2.3 Remote Control Systems

The furnace and thermal oxidizer systems each have a local control panel mounted on their respective equipment skids, and a remote control panel located in the remote control area. All HGD equipment (except the CEM system) can be started and stopped either locally or remotely; however, system control can only be accomplished from the equipment-specific remote control panels that are located in the control area.

The CEM system that was used to support validation testing at ALAAP was a leased unit that had its own self-contained control and monitoring system; therefore, the CEM system could be controlled only through its own local control system. However, by linking the CEM's monitoring system into the HGD's data logging and monitoring system (via a data transmission cable and two RS485 I/O cards), the control area operator was able to monitor and log CEM parameters, such as NO_x and CO levels at the stack, during HGD operations.

Figure 3-5 illustrates the interconnection points for both control- and monitoring-related cables associated with the transportable HGD equipment.

Figure 3-6 provides the process and instrumentation diagram (P&ID) for the transportable HGD equipment. The P&ID, which represents the system overview, provides a schematic representative of the following information regarding the HGD equipment:

- General Equipment Layout.
- Process Flow and Connections.
- Process Instrumentation.
- Process Alarms.
- System Interlocks.
- Process Parameters Monitored by the Data Logging System.
- Instrument Equipment Tags.
- General Utility Requirements.

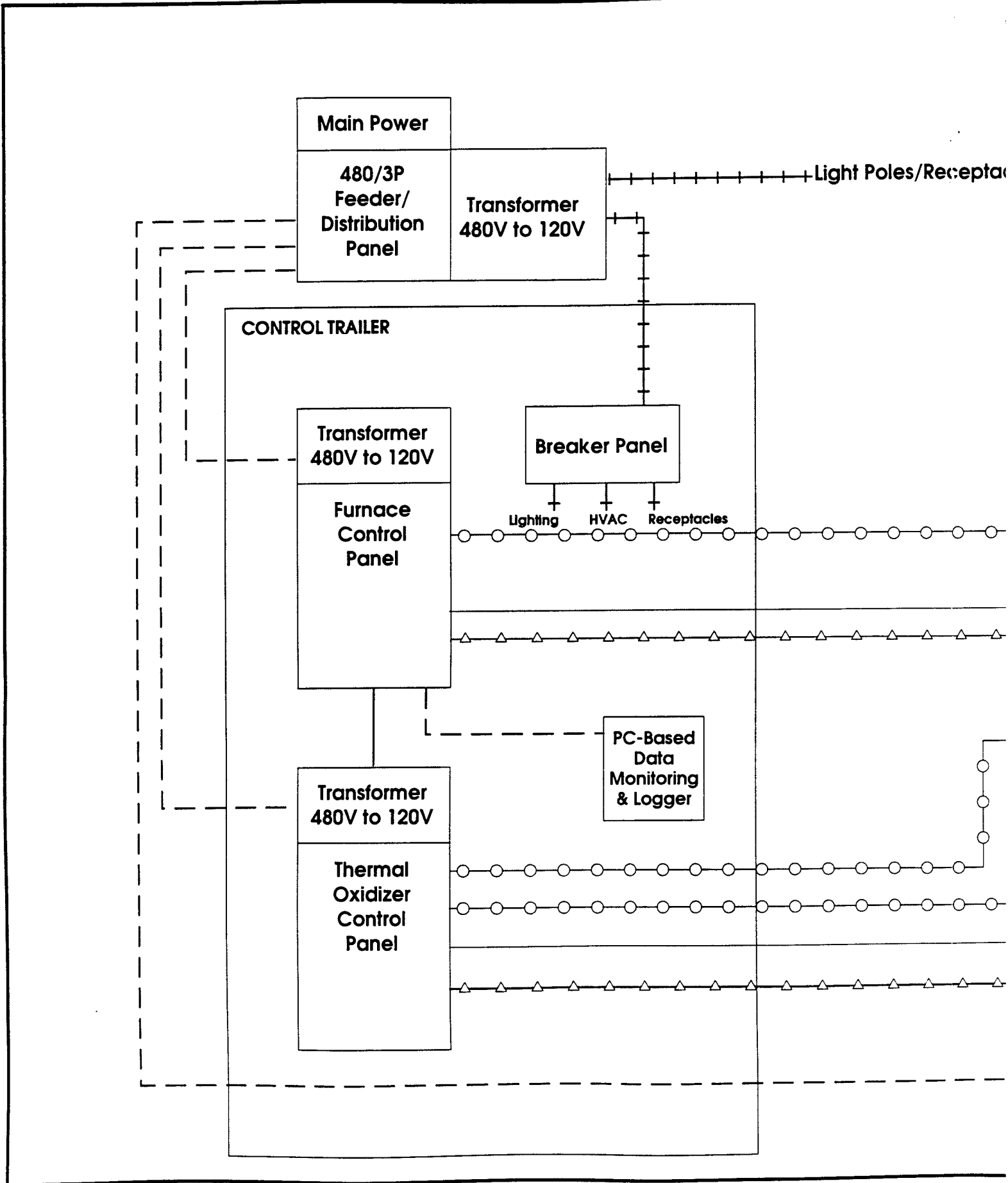

1

LEGEND

	4-20 mA
	480V Po
	480V Su
	120V Po
	RS232/4
	120V Po

Light Poles/Receptacles

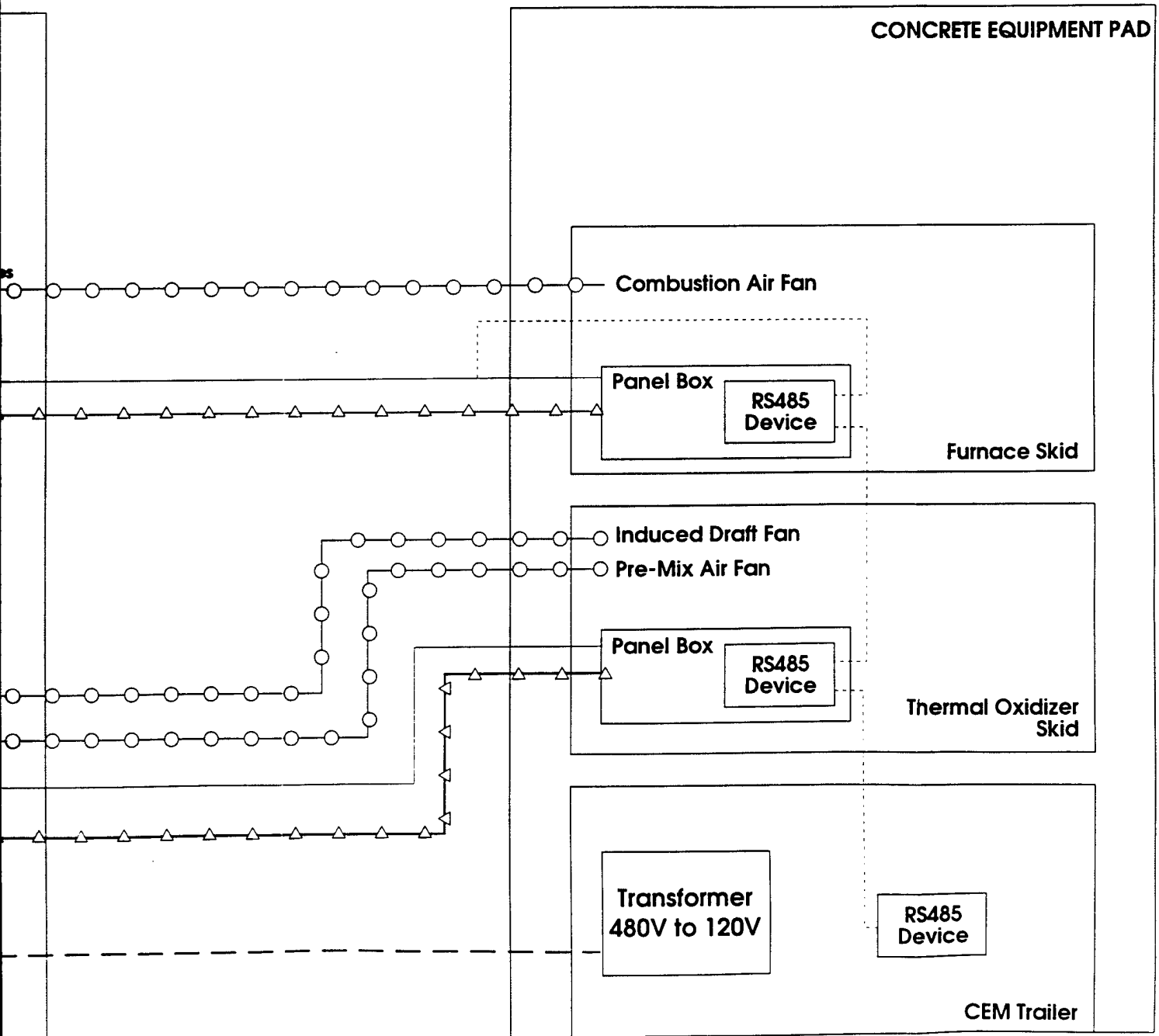

2

FIGURE 3-5 INTERCONNECTION W

LEGEND

- 4-20 mA, Discrete I/Os
- 480V Power for Motors
- 480V Supplied Power
- +++++ 120V Power
- RS232/485
- △—△—△—△—△— 120V Power for Control

CONCRETE EQUIPMENT PAD

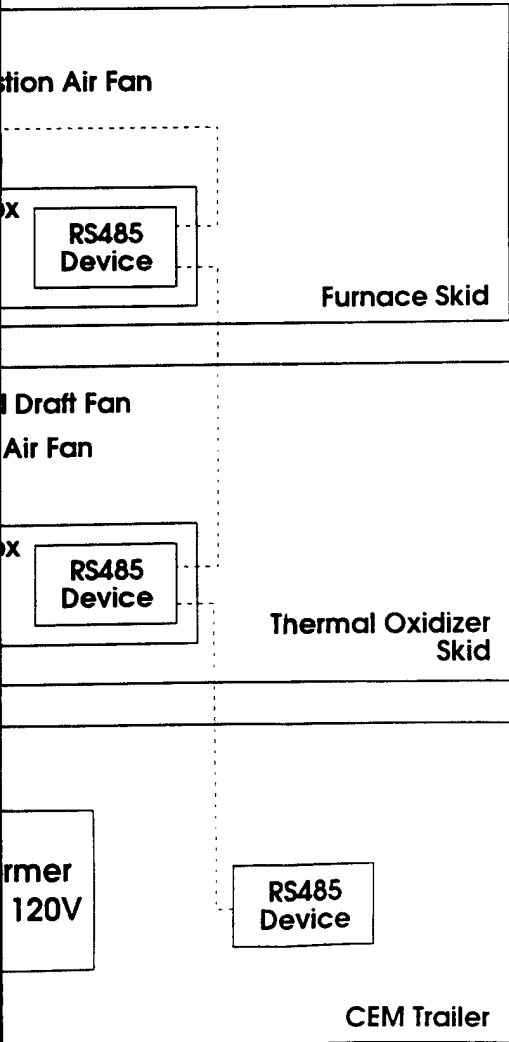
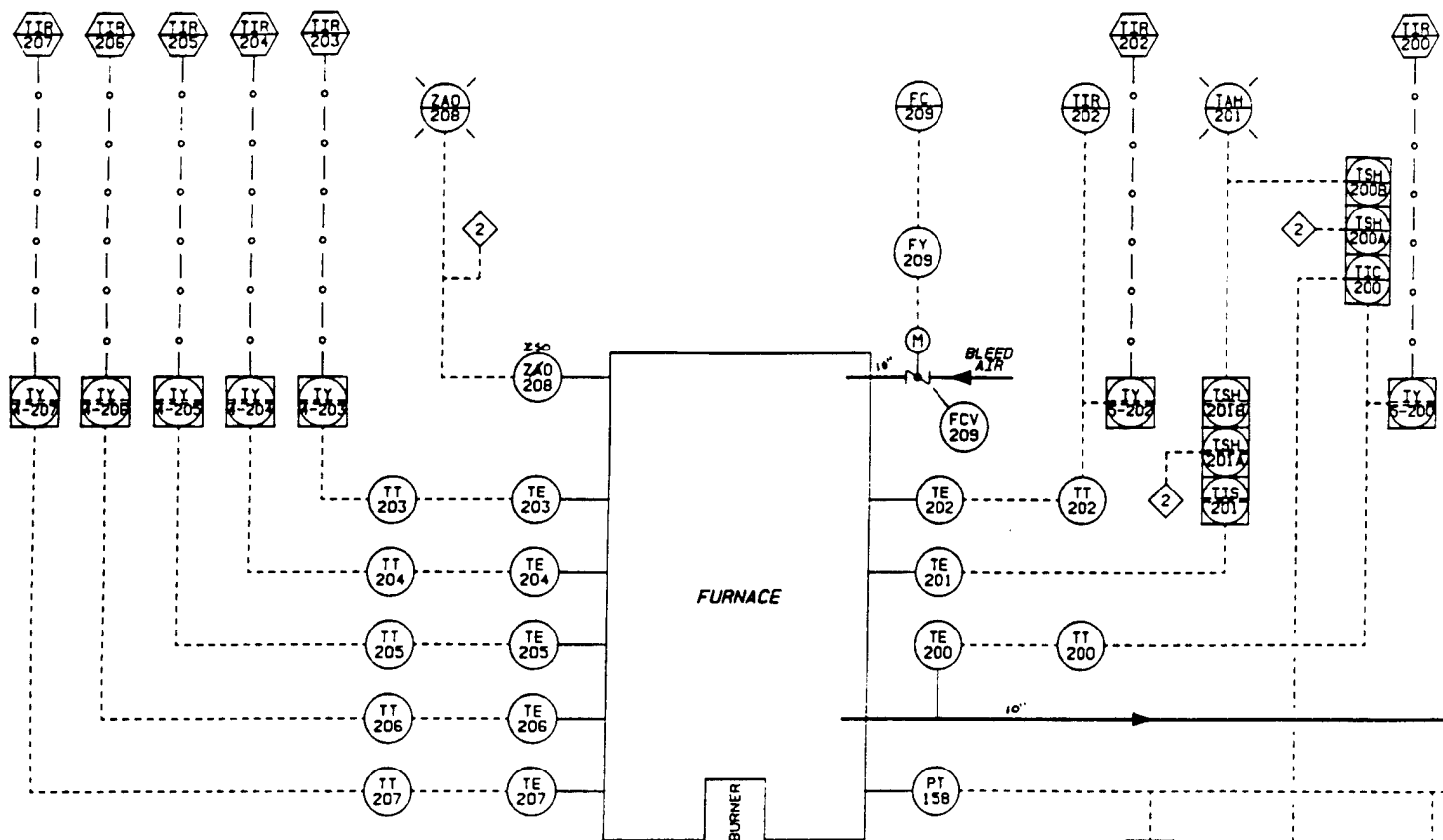

FIGURE 3-5 INTERCONNECTION WIRING DIAGRAM

3



- FIELD/SKID MOUNTED DEVICE
- ◐ AUXILLIARY/LOCAL PANEL/CEM ACCESSIBLE TO OPERATOR
- ◑ AUXILLIARY/LOCAL PANEL/CEM INDICATOR LIGHT
- ◒ AUXILLIARY/LOCAL PANEL/CEM INACCESSIBLE TO OPERATOR
- ◓ AUXILLIARY/LOCAL PANEL/CEM SHARED FUNCTION
- REMOTE PANEL DEVICE ACCESSIBLE TO OPERATOR
- ◐ REMOTE PANEL DEVICE SHARED FUNCTION
- ◑ REMOTE PANEL INDICATOR LIGHT
- ◒ REMOTE PANEL DEVICE INACCESSIBLE TO OPERATOR
- ◓ REMOTE PANEL DEVICE SHARED FUNCTION
- ◔ COMPUTER FUNCTION/ GRAPHICS/DATALOG

COMB. AIR BLOWER
19,980 SCFH
28" W.C.
3600 RPM, 2 HP

NO	DATE	APPR	REVISION
2	01/08/00	CAP	"AS-BUILT" FINAL EQUIPMENT CONFIGURATION
1	07/17/00	CAP	UPDATED PER L&L AND ARRTech REVISED SUBMITTALS
-	1	CAP	DRAFT

DELIVERY ORI
HOT-GAS DE



WEI CHESTER

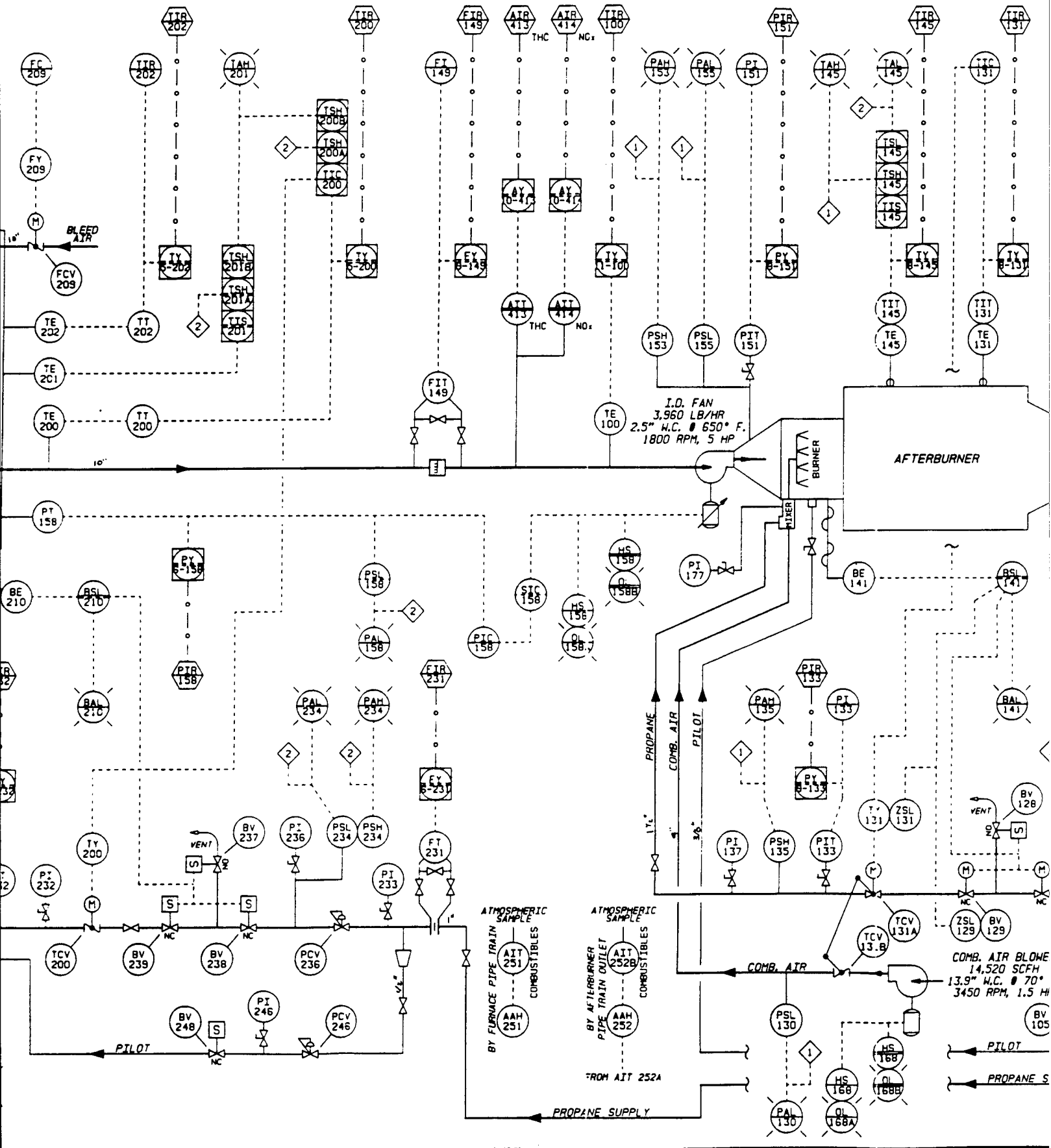

**DELIVERY ORDERS #10 & #12
HOT-GAS DECON SYSTEM**

CHECKED: <i>Chabala</i>	DATE: 6/12/90	CLIENT APPROVALS:	
DES. ENG.			
PROJ. ENG.			
PROJ. MGR.			
APPROVED:			
APPROVED:			

FIGURE

MENT CONFIGURATION

RTTECH REVISED SUBMITALS



WEST CHESTER

PLANNING

OWNER: R. D. AIT

SCALE:

NON

2

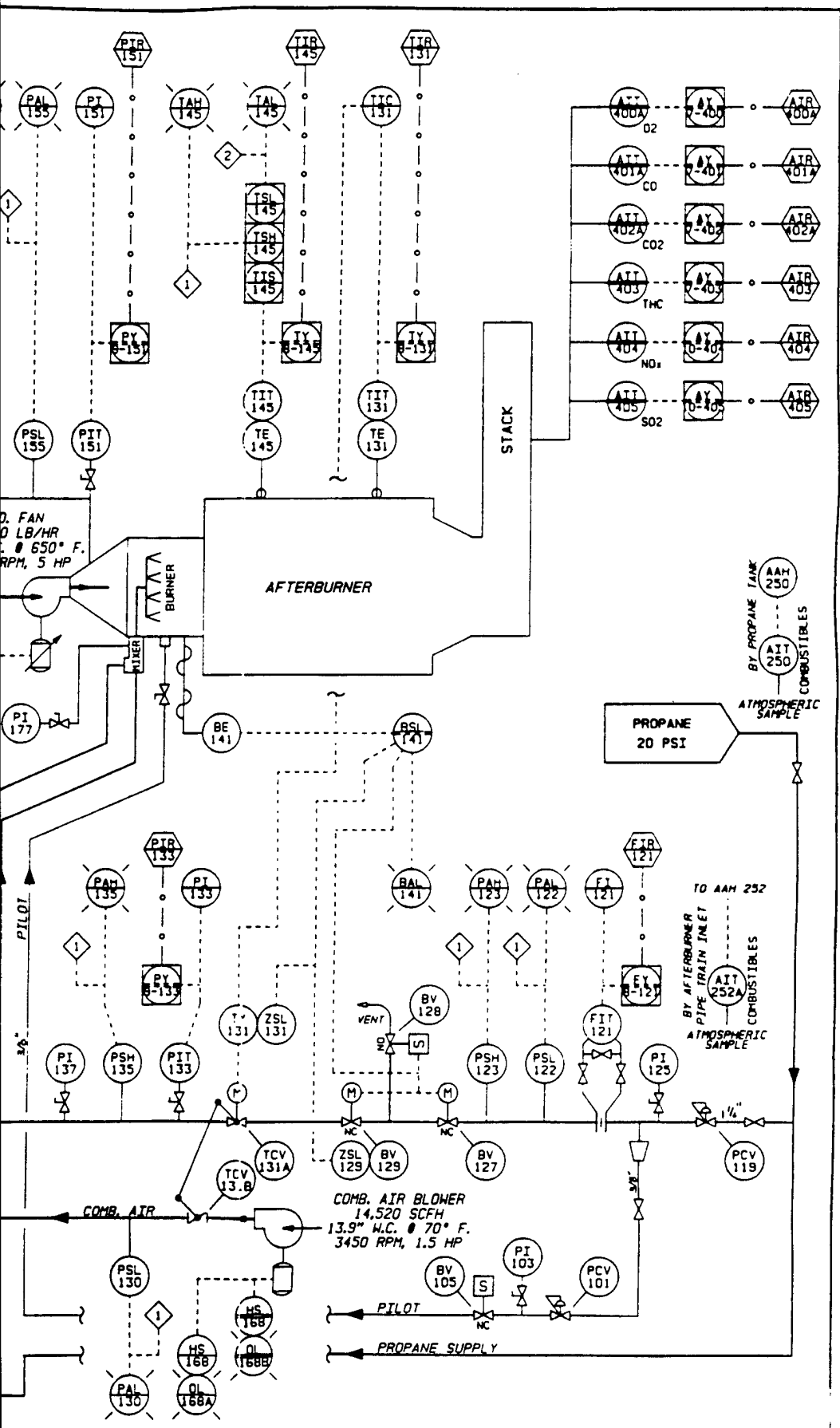

FIGURE 3-6 HGD SYSTEM PROCESS & INSTRUMENTATION DIAGRAM

CLIENT APPROVALS	DATE

OWNER: R DAILY	DATE: 2/2/95	DWG. NO: 1002	REV. NO: 2
SCALE: NONE	W.D. NO: 0228'-012'-010'		

3

The P&ID will be referred throughout the remaining discussions in Section 3. The P&ID is particularly helpful when discussing specific instruments and/or control loops associated with the HGD equipment.

Both furnace and thermal oxidizer systems are equipped with individual temperature and burner controls that are located in their respective remote control panels. The amount of gas flow to each burner is controlled remotely, by the furnace chamber or thermal oxidizer chamber temperature set-points, which are resident in the equipment-specific controllers. These temperature set-points are operator-determined and may be changed or adjusted, as necessary, during the operation of the HGD equipment to support successful decontamination operations.

The I.D. fan is equipped with a remote-controlled, variable-frequency drive (VFD), which is located in the thermal oxidizer's remote control panel. The VFD allows the operator to vary the speed of the I.D. fan from the remote control area, as necessary, to maintain draft through the system. During both the demonstration and validation test periods, the HGD system was operated at a draft of 0.5 w.c.

NOTE: A draft must be maintained to prevent fugitive emissions in the furnace and guarantee that all process gases are directed to and treated by the thermal oxidizer prior to exiting the exhaust stack.

3.2.2.4 System Interlocks

Although each of the HGD equipment controls has been designed to allow for independent operation of each piece of equipment, system interlocks have been programmed and hard-wired to create interdependency between the system equipment, and to prevent startup or continued operation of the HGD equipment for either safety or operational reasons. A summary of the HGD system interlocks is provided in Table 3-1.

Table 3-1 is a guideline. It reflects the final, optimized system operating conditions used to complete validation testing of the transportable HGD equipment at ALAAP. If the same transportable HGD system equipment is used at a different site, the values and parameters noted in Table 3-1 could change because of permitting requirements, changes in contaminant loading, and/or changes in treatment temperatures and system flows.

3.2.2.5 Continuous Emissions Monitoring System

The function of the CEM system during validation testing of the transportable HGD equipment was to monitor the gaseous emissions leaving the stack, and to monitor process exit-gases exiting the HGD furnace during process operations. This sampling was accomplished by using two separate sample probes. One probe

Table 3-1

HGD System Interlocks

Equipment	Parameter	Tag Number	Interlock Trigger	Consequence	
Furnace	Furnace Door	ZSO-208	Door switch indicates "OPEN"	Inability to start the furnace burner. System shutdown.	
	Draft "LOW"	PSL-158	≤ -0.5 inch w.c. after 180-second delay	Inability to start the furnace burner. Gas flow to the burner will be cut off if the furnace burner is operational.	
	Furnace Over-Temperature ^a	TSH-200A	>650 °F	Gas flow to the furnace burner will be cut off. The furnace burner cannot be restarted until the furnace exit-gas temperature is below 650 °F.	
	Furnace Over-Temperature ^b Chamber High-Limit	TSH-201A	>1,000 °F ^c	Gas flow to the furnace burner will be cut off. The furnace burner cannot be restarted until the furnace exit-gas temperature is below 650 °F.	
	Thermal Oxidizer On-Line	CR-124 on electrical drawings	Thermal oxidizer exit-line	Inability to start the furnace burner. Gas flow to the burner will be cut off, if the furnace burner is operational.	
	Thermal Oxidizer Temperature-Low	TSL-145	< 1,750 °F after 180-second delay	Inability to start the furnace burner. If the furnace burner was operational, gas flow to the furnace burner will be cut off as a result of the thermal oxidizer shutting off.	
	Thermal Oxidizer Temperature-High	TSH-145	> 1,900 °F after 180-second delay	Inability to start the furnace burner. If the furnace burner was operational, gas flow to the furnace burner will be cut off as a result of the thermal oxidizer shutting off.	
	Furnace Burner and Pilot	Gas Pressure High/Low	PSH-234 PSL-234	High Pressure: > 28 inches Low Pressure: < 4 inches	Inability to start the furnace burner. If the furnace burner was operational, gas flow to the furnace burner will be cut off.
		Pilot Flame	BSL-210	Loss of pilot flame during the trial for ignition period	Inability to start the furnace burner's main flame. Gas flow to the pilot will be cut off. Interrupted pilot.

Table 3-1

HGD System Interlocks
(Continued)

Equipment	Parameter	Tag Number	Interlock Trigger	Consequence
Furnace Burner and Pilot (continued)	Burner Flame	BSL-210	Loss of burner flame	Gas flow to the furnace burner will be cut off.
	Inability to Purge ^d	BSL-210	Inability to purge	Inability to start the furnace burner.
	Furnace Combustion Air Fan	PSL-224 (IM-1 on electrical drawings)	< 15 inches or fan motor starter indicates "OFF"	Inability to start the furnace burner. If the furnace burner is operational, gas flow to the furnace burner will be cut off.
Thermal Oxidizer	I.D. Fan Operation	SIC-158, (internal relay OR-1)	I.D. fan operation switch indicates "OFF"	Assuming the combustor and furnace burner are operational, gas flow to the furnace and combustor burners will be cut off.
	I.D. Fan Pressure Low	MS-168 on electrical drawings	Fan motor starter indicates "OFF"	Inability to start the combustor burner. Assuming the combustor and furnace burner are operational, gas flow to the furnace and combustor burners will be cut off.
	Furnace Combustion Air Fan Operation	IM-2 on electrical drawings	Fan motor starter is "OFF" (de-energized)	Inability to start the combustor burner. Assuming the combustor and furnace burner are operational, gas flow to the furnace and combustor burners will be cut off.
Thermal Oxidizer Burner and Pilot	I.D. Fan Discharge Pressure High/Low	PSH-153 PSL-155	High Pressure: > 5 inches Low Pressure: < 0.35 inch for longer than 15 seconds	Inability to start the combustor burner. Assuming the combustor and furnace burners are operational, gas flow to the combustor and furnace burner will be cut off.
	Thermal Oxidizer Temperature High	TSH-145	Temperature > 1,900 °F	Gas flow to the combustor and furnace burner will be cut off.
	Fuel Pressure High/Low	PSH-123 ^e PSH-135 ^f PSL-122	High Pressure ^d : > 5.5 psi High Pressure ^f : > 4.0 psi Low Pressure: < 2 psi	Inability to start combustor burner. Gas flow to the combustor and furnace burners will be cut off, assuming the combustor and furnace burner are operational.

Table 3-1

HGD System Interlocks
(Continued)

Equipment	Parameter	Tag Number	Interlock Trigger	Consequence
Thermal Oxidizer Burner and Pilot (continued)	Air Pressure Low	PSL-130	< 7 inches	Inability to start combustor burner. Gas flow to the combustor and furnace burners will be cut off, assuming the combustor and furnace burners are operational.
	Pilot Flame	BSL-141	Loss of pilot flame during the trial for ignition period	Inability to start the combustor's main burner flame. Gas flow to the combustor pilot will be cut off.
	Burner Flame	BSL-141	Loss of burner flame	Gas flow to the combustor and furnace burners will be cut off, assuming the furnace and combustor burners are operational.
	Inability to Purge	BSL-141	Inability to purge	Inability to start the combustor burner.
	Low-Fire Start	ZSL-131	Valve actuator TY-131 not in the "CLOSED" position	Inability to start the combustor burner.
	Low-Fire Start	ZSC-129	Burner safety valve BV-129 not "CLOSED"	Inability to start the combustor burner.

^aProvided to protect the furnace equipment.

^bProvided to protect the I.D. fan and other equipment and instrumentation located downstream of the furnace exit.

^cThis value represents the final settings used during system validation testing. This value has been set higher than the expected furnace operating temperatures to accommodate the temperature spikes that occur during the explosive's flashing activities, which occur in the furnace chamber during processing of explosives-contaminated materials.

^dPurge is an internal equipment timing event in the flame safety. There is no external hardware to the flame-safety that indicates proof-of-purge.

^ePSH-123 is regulated gas pressure (the normal National Fire Protection Association [NFPA] interlock).

^fPSH-135 is gas pressure associated with the combustor mixer.

was located at the stack, and the other probe was located at the interconnection duct.

Two completely redundant, fully operational sampling systems were provided to ensure continuous monitoring during process operations. The redundant system is supplied as an on-line backup to replace the primary system in the event of system calibration or analyzer failure. The CEM system was located in its own trailer on the equipment pad next to the furnace (see Figure 2-2). A summary of the analyzers supplied with this system and the manufacturer's performance specifications for each analyzer is presented in Table 3-2. A summary of the sample extraction and conditioning equipment provided with the CEM system is presented in Table 3-3.

Process compounds that were continuously monitored at the stack by the CEM system during validation testing were:

- Carbon monoxide.
- Carbon dioxide.
- Oxygen.
- Oxides of nitrogen.
- Total hydrocarbons.
- Sulfur dioxide.

The process compounds that were continuously monitored at the HGD furnace exit duct during validation testing were:

- Total hydrocarbons.
- Oxides of nitrogen.

3.2.2.6 Data Logging and Monitoring System

To allow for data acquisition and monitoring capabilities during process operations, WESTON designed the HGD system's data logging and monitoring system around a PC-based, RS-485 communications network using commercially available components. As shown in Figure 3-7, a data transmission cable daisy-chains between the RS-485 I/O communication interface cards in the control area PC and the RS-485 I/O modules located at the CEM and at each of the local and equipment remote control panels.

The data logging and monitoring system was provided with the HGD system equipment to perform the following functions:

- Log critical HGD operating parameters (on a regular basis during system operations) for future use and data reduction.
- Provide real-time, on-screen monitoring of process critical operating parameters for use by the control area operators.

**Table 3-2
Summary of Continuous Emission Monitoring (CEM) Equipment**

CEM Specifications	Parameter					
	O ₂	CO ₂	CO	NO _x	THC	SO ₂
Number of CEMs	2	2	2	2	2	1 ^b
Manufacturer model number	Servomex 1400	Infrared IR-730	Thermo Electron 48	Thermo Electron 10 AR	J.U.M. Engineers VE7	Bovar 721
Principle of operation	Paramagnetic	Nondispersive infrared absorption	Gas correlation filter infrared absorption	Chemiluminescence	Flame ionization detector	Nondispersive ultraviolet
Range	0-25%	0-20%	0-500 ppm	0-250 ppm	0-100 ppm	
Accuracy	+ 0.5%	+ 0.2%	+ 2.5 ppm	+ 2.5 ppm	+ 1.0 ppm	
Analyzer stability over 24 hours (percent span) ^a	2.0%	1.0%	1.0%	1.0%	1.0%	

^aSince the system is calibrated daily and the ambient temperature is maintained on-line at all times, this drift will be negligible.

^bEach analyzer is dedicated to a sample point, no spare analyzer is provided.

Table 3-3

Sample Extraction and Conditioning Equipment

Item	Description	Performance Parameters	Locations
Sample probe and cooling section	Inconel tubing with 316 stainless-steel fittings	Reduce gas temperature < 400 °F.	Sample port in thermal oxidizer exhaust stack (CO, CO ₂ , O ₂ , and NO _x , SO ₂ , THC). Sample port in furnace exhaust to duct (NO _x only).
Sample box	Carbon steel box with ceramic insulation and fitting connections for calibration gas introduction	Maintains sample temperature at ≥ 300 °F.	Insulated closure adjacent to the sample port at the thermal oxidizer exhaust stack.
Sample line	Heated Teflon TFA tubing.	Maintain sample temperature at ≥ 300 °F.	Between sample location and CEM trailer, as required.
Main thermal oxidizer exhaust sample (for CO, CO ₂ , NO _x , SO ₂ , and O ₂) conditioning system and auxiliary furnace exhaust sample (NO _x only)	Heated filter, pump, mechanical refrigeration chiller, condensate trap, coalescing filter, pressure regulator, and flow meters. Teflon and stainless-steel construction.	Exit dew point at ≥ 38 °F; removal of particulate > 0.3 micron.	In CEM trailer; draws wet sample directly from heated sample line; delivers cool, dry conditioned sample directly to CO, CO ₂ , NO _x , SO ₂ , and O ₂ analyzers.
THC sample conditioning system, thermal oxidizer exhaust	Heated fine filter.	Removal of particulate >0.3 micron.	Internal to THC analyzer; draws sample directly from heated sample line.

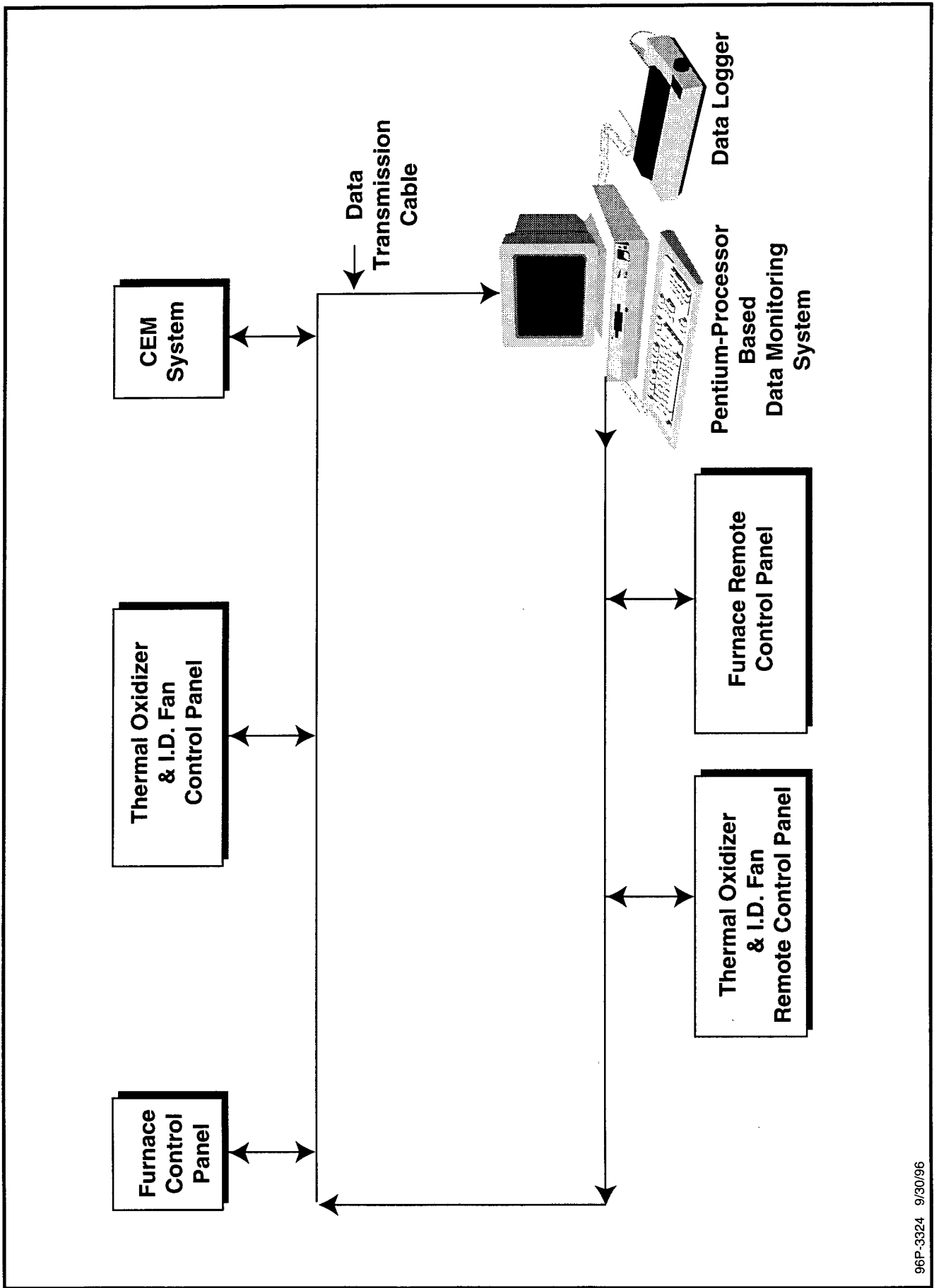

FIGURE 3-7 HGD DATA LOGGING AND MONITORING SYSTEM

96P-3324 9/30/96

- Provide real-time, on-screen trending of process critical operating parameters for use by the control area operators.

The data acquisition and monitoring system (data logger) used to support validation testing is a Windows-based, icon-driven data acquisition and control software program called *GENIE*, which was supplied by American Advantech Corporation of Sunnyvale, California. *GENIE* was configured by WESTON to support the data logging and monitoring³ needs of the transportable HGD system. Customized displays that mimic actual HGD equipment profiles were used to support real-time trending and monitoring of process operating parameters. These screens also were designed and programmed by WESTON.

As noted previously, the CEM system has its own independent, self-contained data acquisition and control system. Unfortunately, that system does not allow the remote control area operators to monitor CEM-related process parameters. To solve this problem, two RS485 I/O cards were installed in the CEM's control system. These cards allowed the transfer of CEM data to the HGD data logging and monitoring system. CEM-related parameters that are logged and monitored by the HGD data logger include:

- Nitrous oxides, NO_x (AIT-414 at the interconnection duct).
- Total hydrocarbons, THC (AIT-413 at the interconnection duct).
- Carbon dioxide, CO₂ (AIT-402A).
- Carbon monoxide, CO (AIT-401A).
- Oxygen, O₂ (AIT-400A).
- Nitrous oxides, NO_x (AIT-404).
- Sulfur dioxide, SO₂ (AIT-405).
- Total hydrocarbons, THC (AIT-403).

These parameters were also logged by the CEM's data logging system.

HGD furnace operating parameters that were logged and monitored by the HGD data logger include:

- Furnace Chamber Thermocouples #1 through #5, TT-203 through TT- 207.
- Furnace Temperature Control, TT-200.
- Furnace Temperature Recorder, TT-202.
- Furnace Exit-Gas Temperature, TE-100.⁴

³ *GENIE* can also be configured to **control**, as well as monitor, HGD process operating parameters. The *GENIE* program was not configured to control the HGD system equipment because this function was already being done by the equipment-specific control panels located in the remote control area.

⁴ TE-100 was removed from the furnace exit-gas location during the validation test period and relocated to the I.D. fan inlet. By moving the temperature element location, an equipment-specific interlock designed to protect the I.D. fan from excessive heat from the furnace was added to the control system. Temperature control thermocouple TT-200 was relocated to the furnace exit duct location formerly occupied by TE-100.

- Furnace Exit-Gas Flow, FIT-149.
- Combustion Air Flow, FT-221.
- Fuel Gas Pressure, PT-232.
- Combustion Air Pressure, PT-222.
- Fuel Gas Flow, FT-231.
- Furnace Chamber Draft Pressure, PT-158.

Thermal oxidizer-related parameters monitored and logged by the HGD data logger system include:

- Fuel Flow, FIT-121.
- Fuel Pressure, PIT-133.
- I.D. Fan Discharge Pressure, PIT-151.
- Combustion Chamber High Limit Temperature, TIT-145.
- Combustion Chamber Temperature Control, TIT-131.

Real-time trending allows the operator to monitor specific process parameters during system operations as they occur. Because the data are presented in a graphical form, the operator is often able to anticipate system upsets before they occur. If done correctly, trending can also enhance the operator's understanding of the relationship of certain system operating behaviors, such as the relationship between furnace NO_x emissions and treatment temperature. Real-time trending was programmed for the following parameters:

At the Interconnection Duct:

- Nitrous oxides, AIT-414.
- Total hydrocarbons, AIT-413.

At the Stack Exit:

- Carbon dioxide, AIT-402A.
- Carbon monoxide, AIT-401A.
- Oxygen, AIT-400.
- Nitrous oxides, AIT-404.
- Sulfur dioxide, AIT-405.
- Total hydrocarbons, AIT-403.

At the Furnace and Thermal Oxidizer:

- Thermocouples #1 through #5, TIT-203 through TIT-207.
- Furnace Exit Temperature, TIT-201.
- Furnace Control Temperature, TIT-202.
- Combustion Chamber Temperature, TIT-145.
- Combustion Chamber Temperature (Control), TIT-131.

3.2.2.7 System Utilities

As a minimum, the following utilities are required to support HGD system operations:

- Electrical power.
- Fuel.
- Telephone service.
- Water supply (optional).

Details regarding these items are presented in the following paragraphs.

Electrical Power

A 75-kVA service supplied 480VAC, 3-phase, 60-hertz, 90-amp service to the main distribution panel at the HGD site. That service was further broken into a service for the control area and a service for the HGD equipment pad. Service to the equipment pad was broken down as follows:

- Furnace: 480VAC/3-phase/60-hertz/10-amp service.
- Thermal Oxidizer: 480VAC/3-phase/60-hertz/30-amp service.
- CEM System: 480VAC/1-phase/60-hertz.

Service to the control area and site lighting was supplied as indicated:

- Site Lighting: 480VAC/1-phase/60-hertz.
- Remote Control Area: 240VAC/1-phase/60-hertz (37.5 kVA).

The 240VAC service to the control area is fed through a 220/120VAC transformer that supplies 120VAC power for computers, battery charges, etc.

Eight-hundred-foot-long power cables were used to connect between the main transformer and the remote services located on or near the equipment pad. These cables were purchased for the project and were transferred with the HGD system equipment when the HGD equipment was demobilized from ALAAP.

A battery backup unit or uninterruptible power supply (UPS) was located in the remote control area to provide approximately 20 minutes of power-loss protection to the data logger and remote control panels during brownouts, blackouts, and temporary localized power failures. The UPS contains an automatic load transfer switch that provides power from DC batteries when line voltage fails. Once line power is restored, the UPS will automatically revert to battery charging mode (standby). The battery charger automatically cuts off charge to the batteries when the batteries are fully charged. The UPS also provided voltage regulation to protect the data logging and monitoring equipment from electrical surges.

Propane

A propane delivery system, which is illustrated in Figure 3-8, was installed at the HGD site to support the HGD furnace and thermal oxidizer fuel requirements. The propane delivery system was leased from a local propane supplier and included the following major equipment items:

- One 18,000-gallon water capacity propane storage tank.
- One propane transport loading station.

To comply with National Fire Protection Association (NFPA) guidelines, the propane tank was located at least 100 feet from the HGD process equipment (see Figure 3-3).

Liquid propane was delivered to the site and stored in the propane tank. Vaporization of the liquid propane into a gaseous state was provided by the natural evaporation that occurred within the tank. The natural evaporation creates a head pressure in the tank that served as the supply pressure for the propane gas to the furnace and thermal oxidizer. The outlet pressure at the tank was regulated to 24 pounds per square inch gauge (psig), which, after pressure losses in the piping, provided 20 psig to the furnace and thermal oxidizer. The pressure was then reduced individually at the furnace and thermal oxidizer fuel trains by each system's main gas-reducing regulators. The furnace's main gas-reducing regulator (PCV-236) was set for 22 in. w.c. The thermal oxidizer's main gas-reducing regulator (PCV-119) was set for 5.0 psig.

Telephone Service

Telephone service to the site was required to support project communications and site safety. Telephone service lines were installed at the HGD site at the same time the site electricity was installed. Actual installation of the telephone service was completed by the local phone company. Five telephone lines were installed, but only three lines were actually placed in-service. One of the three lines was used for the site fax machine.

Water Supply

A water supply was not required for process operations. To support validation testing, water was transported to the HGD site via tanker truck. Water was used for general site cleanup and dust control.

Rain runoff that collected in the equipment pad sump was pumped into a temporary holding tank located on the equipment pad. The holding tank was periodically emptied and the contents treated by the wastewater treatment plant associated with the ALAAP remediation effort. Sites that have a storm runoff or sewer system in place would not require the holding tank arrangement.

Miscellaneous Utilities Support

In addition to electric, telephone, water, and fuel, services such as rental of a portable toilet unit, garbage pickup, and delivery of drinking water were required to support the HGD system operations. These services were procured from local vendors on a monthly basis.

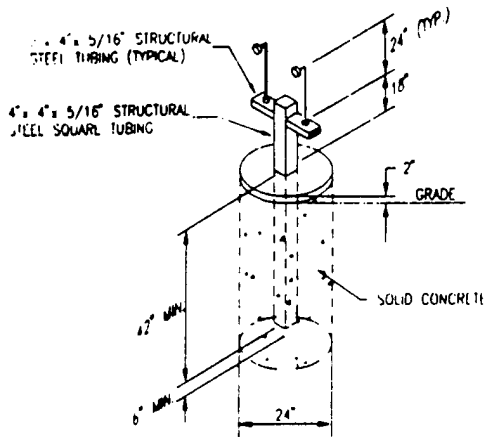

**BREAKAWAY
STANCHION DETAIL**

SCALE NONE

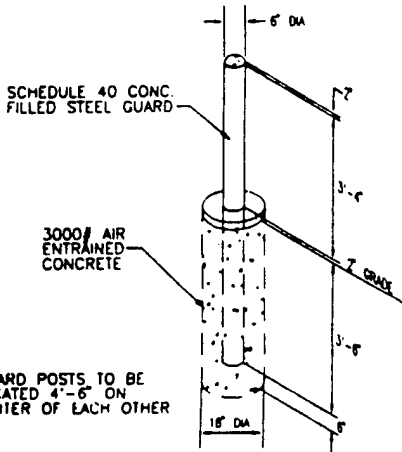

**TYP. 6" DIAMETER
GUARD POST DETAIL**

SCALE NONE

NOTE: CUSTOMER TO SUPPLY & INSTALL
GUARD POSTS IF REQUIRED

NOTE: GUARD POSTS TO BE
LOCATED 4'-6" ON
CENTER OF EACH OTHER

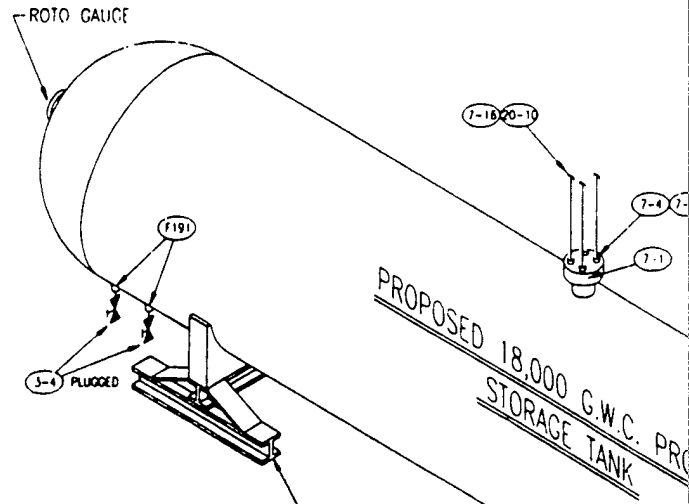

TANK SKID SUPPORT

SEE WOOD CRIBBING DETAIL

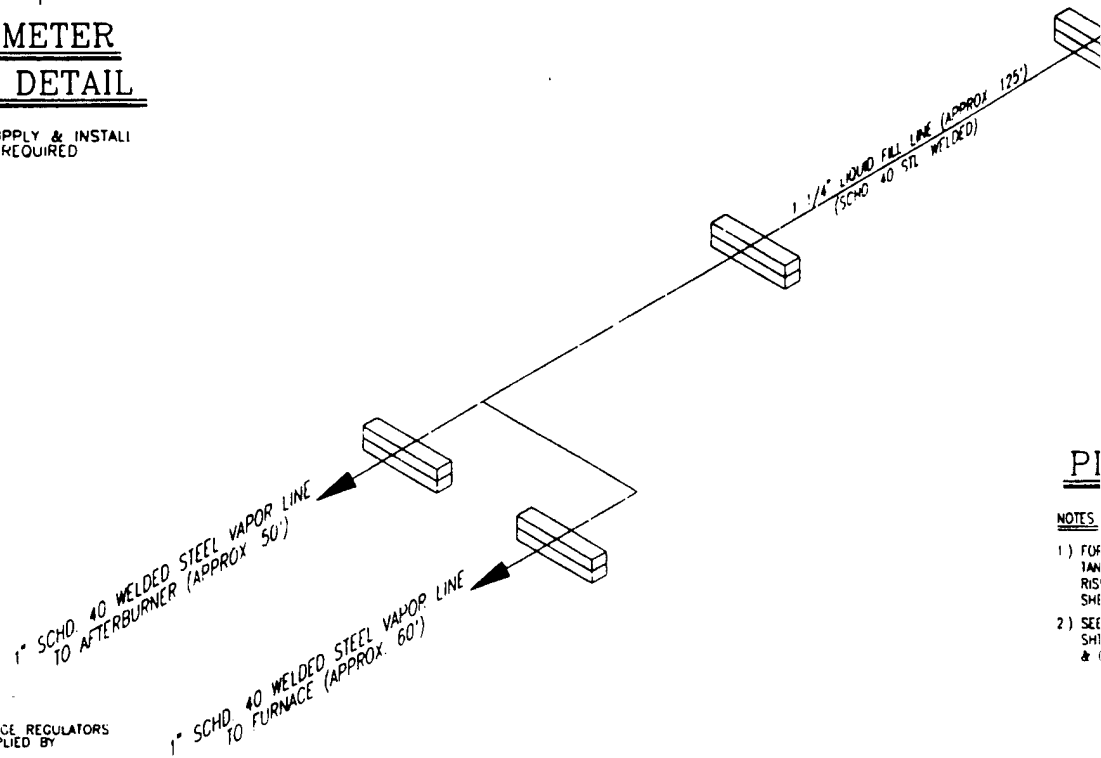

NOTE: SECOND STAGE REGULATORS
TO BE SUPPLIED BY
CUSTOMER

PI

NOTES

- 1) FOR TAN R/S SHE
- 2) SEE SHI & (

①

(8) 8" x 8" x 10" WOOD CRIBBING
(16 REQUIRED)

STEEL TANK SKID
I-BEAM CONSTRUCTION
(2 SETS REQUIRED)

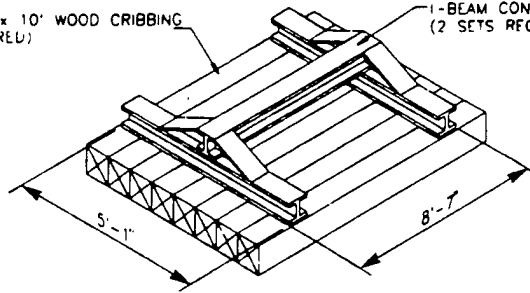

WOOD CRIBBING DETAIL

SCALE NONE

PROPOSED 18,000 G.W.C. PROPANE STORAGE TANK

RT

TI
UNLO
SEE BR

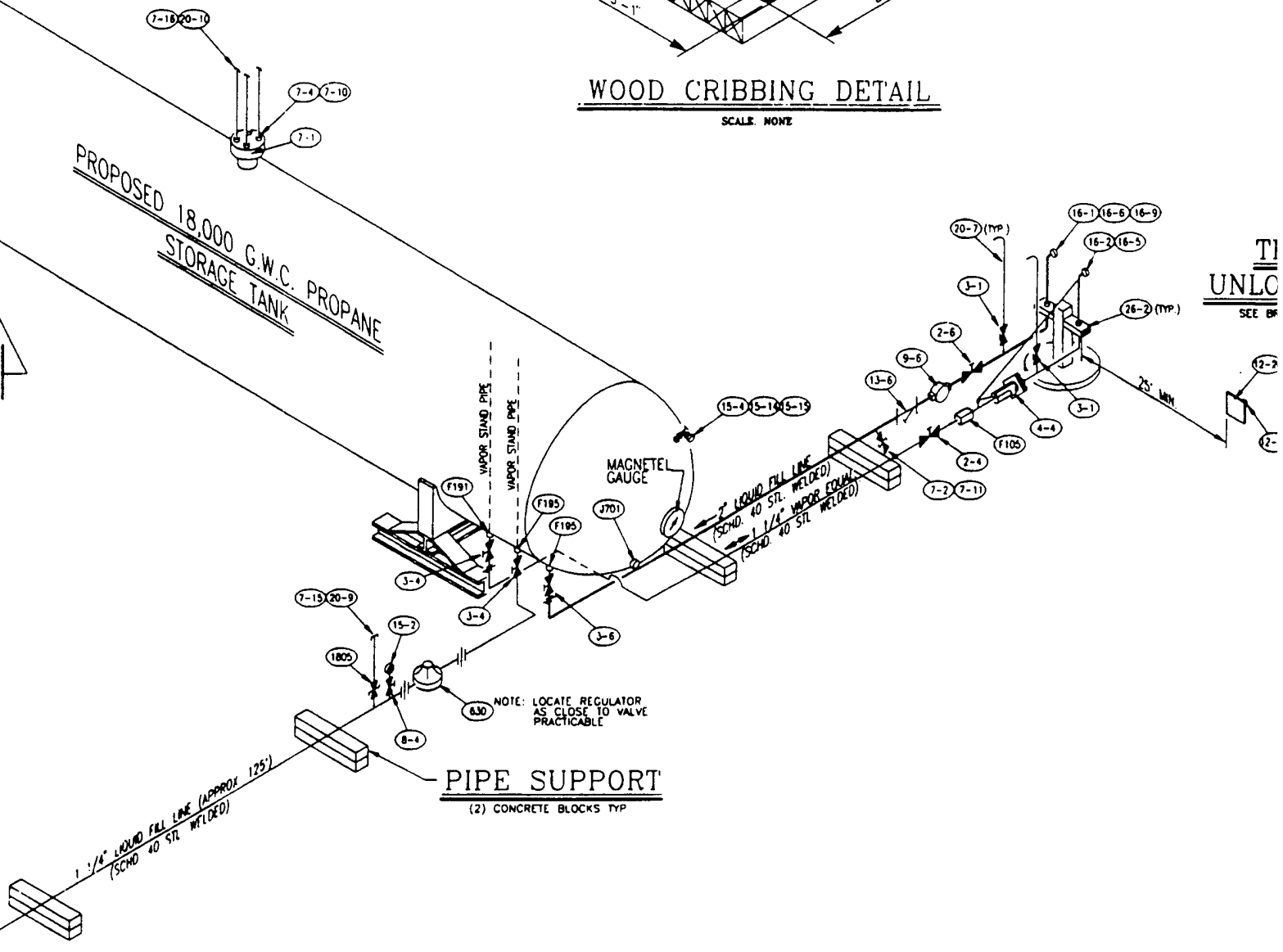

PIPING DIAGRAM

SCALE NONE

NOTES

- 1) FOR ACTUAL LOCATION OF PROPANE STORAGE TANK, VAPORIZERS & TRANSPORT UNLOADING RISER SEE SITE PLAN DRAWING NO 9508-112 SHEET 1 OF 3
- 2) SEE BILL OF MATERIALS DRWG NO 9508-112 SH. 3 OF 3 FOR ALL MATERIAL SPECIFICATIONS & GENERAL NOTES

FIGURE 3-8 HGD PROPANE DELIVERY SYSTEM

2

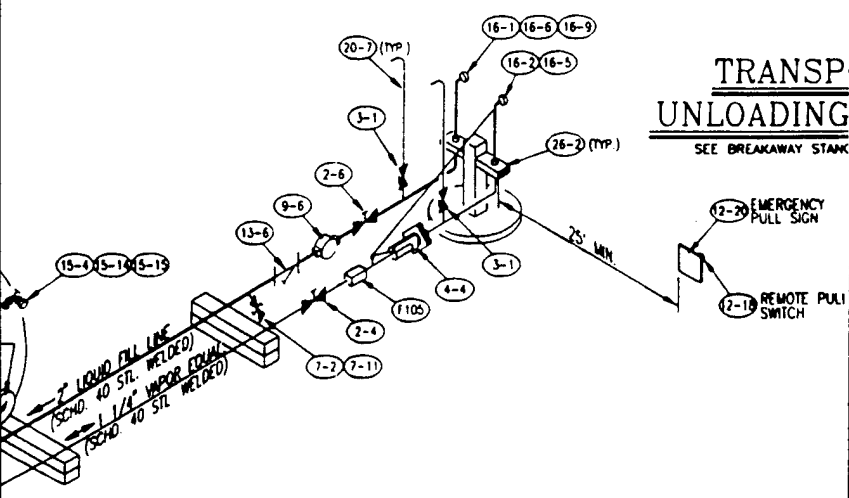
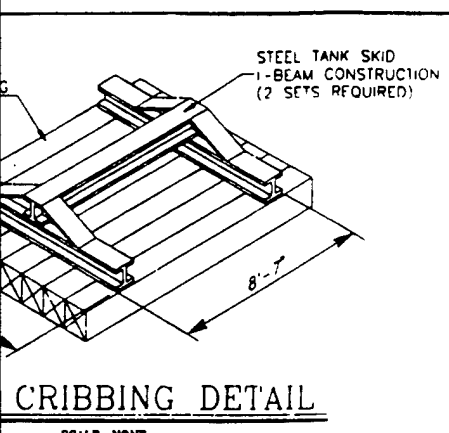

SUBURBAN PROPANE - WHIPPANY, N.J.		DATE: 2-27-95	SCALE: 1/2" = 1'
DRAWN BY: YAPAOVA		CREATED:	
PROJECT: PIPING DIAGRAM		PROJECT NO. 9508-112	
CLIENT: ROY WESTON, INC. - WEST CHESTER, PA		SHEET 2 of 3	
LOCATION: ALABAMA ARMY AMMUNITION PLANT - ALPINE, AL		DWG. NO. 9508-112	

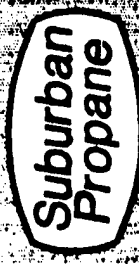

FIGURE 3-8 HGD PROPANE DELIVERY SYSTEM

4.

PURPOSE AND OBJECTIVES OF VALIDATION TESTING

Although the pilot-scale studies contracted by USAEC have shown the HGD process to be effective in treating explosives- and agent-contaminated materials, potential users still have questions regarding the technology. Of primary concern are the following:

- Is the technology ready for full-scale application?
- Can processing times be reduced?
- What are the costs associated with full-scale application?

To address these concerns, USAEC contracted WESTON to conduct validation testing of the transportable HGD equipment that had recently been demonstrated at ALAAP in December 1995. The objectives of the validation tests were as follows:

- Determine the effectiveness (or destruction and removal efficiency [DRE]) of the HGD process on various explosives-contaminated materials, including metal, clay, and concrete that had been spiked with TNT, RDX, and tetryl.
- Determine the time/temperature relationships for the decontamination of TNT, RDX, and tetryl from metal, clay, and concrete surfaces.
- Determine the effectiveness of the HGD process on explosives-contaminated debris and piping that had been excavated from another remediation effort at ALAAP.
- Define the optimum process conditions required for the complete destruction and removal of TNT, RDX, and tetryl and their breakdown compounds.
- Gather gas emissions data from the HGD process to support future permitting of the process and equipment.
- Verify the occurrence of the increased NO_x activity during processing and, if possible, identify the relationship between NO_x in the system exit-gases and decontamination activities in the furnace.
- Define the effect of the HGD process on asbestos-containing materials such as transite siding or pipe insulation.

PURPOSE AND OBJECTIVES OF VALIDATION TESTING

Starting with these objectives, a comprehensive test plan¹ was developed to meet the treatability study requirements contained in Sections 335-14-2-.01(4)(e) and 335-14-2-.01(4)(f), Division 14 of the Alabama Department of Environmental Management (ADEM) Administrative Code. The Treatability Study Test Plan described all HGD system testing at ALAAP; therefore, details regarding both the demonstration and validation test programs were included in the approval document.

The completed test plan was reviewed and approved by both USAEC and ADEM. Permission to conduct the treatability study was received from ADEM in a letter dated 21 August 1995. A successful demonstration test program and a series of equipment modifications to improve HGD system operability were completed in December 1995. The validation test program was begun on 4 January 1996. The approved Treatability Study Test Plan established the following criteria for successful validation testing:

- Identification of a range of temperatures and soak times indicating that the HGD process can successfully decontaminate explosives-contaminated piping and debris.
- Successful decontamination is demonstrated when post-treatment analysis of treated piping and debris indicates explosives in quantities below detection limits.
- Analytical results from stack testing indicate the thermal oxidizer has successfully destroyed (less than detection limits) any explosives compounds that might be contained in the HGD system exit-gas stream as a result of the HGD treatment process.

¹ Draft Treatability Study Test Plan for the Evaluation of a Transportable Hot Gas Decontamination System for the Decontamination of Explosives-Contaminated Piping and Debris. Revision 2. Prepared by Roy F. Weston, Inc. January 1996.

5. VALIDATION TEST PLAN

This section presents an overview of the Validation Test Plan, which was included in Revision 2 of the Treatability Study Test Plan, dated January 1996, and approved by both the Alabama Department of Environmental Management and USAEC. This section will also provide details regarding the test materials used during processing, spike mixtures, sampling methods used to support pre- and post-treatment testing, treatment criteria, and deviations from the test plan.

5.1 VALIDATION TEST PLAN

Since the demonstration test of the HGD had successfully optimized HGD equipment operations, the mission of the validation test program was simplified and the test objectives can be summarized as follows:

- Demonstrate the effectiveness of the transportable HGD system on TNT, RDX, and tetryl.
- Determine optimum operating conditions for the successful decontamination of TNT, RDX, and tetryl by the HGD system.
- Collect emissions data to support future permitting.

The validation test program is defined by a series of 18 validation test runs (1 through 15, 16A, 16B, and 16C), as illustrated by the test matrix presented in Table 5-1. As noted in Table 5-1, test run treatment temperatures ranged from 300 °F to 600 °F, and furnace soak times ranged from 0 to 12 hours, depending on the test run. A furnace ramp rate of 50 °F/hour was used for the first three test runs, but was steadily increased as the test program progressed to rates of 300 °F/hour.

All validation test runs were limited to a total maximum load of 3,000 lb of contaminated materials containing no more than 1 lb total explosives. A combination of contaminated piping and debris and clean spiked piping and block was loaded into the HGD furnace for most test runs. For test runs 1, 2, and 3, only clean piping and concrete block spiked with either TNT, RDX, or tetryl was placed in the HGD furnace for treatment. For test runs 4 through 15, a combination of contaminated debris from ALAAP (noted by a "(D)" in Table 5-1) and spiked piping and block was placed in each furnace run. For test runs 16A, 16B, and 16C, 3,000 lb of contaminated debris and spiked piping and block were placed in the furnace for treatment; however, only one type of explosives spike was used per test run. Test run 16A treated 1 lb TNT, 16B treated 1 lb tetryl, and 16C treated 1 lb RDX.

Table 5-1
Validation Test Matrix

Treatment Temperature	300 °F	400 °F	500 °F	550 °F	600 °F
No Soak					Tests 9 (D), 16A, 16B, 16C
1-hour Soak	Test 12 (D)	Test 11 (D)	Test 13 (D)	Test 10 (D)	Tests 7 (D), 14 (D), 15 (D)
2-hour Soak			Test 8 (D)		Test 6 (D)
4-hour Soak			Test 3 (E)		Test 5 (D)
6-hour Soak		Test 2 (E)	Test 4 (D)		
12-hour Soak			Test 1 (E)		

(D) Indicates contaminated debris was also treated in addition to spiked test plates.

(E) Indicates furnace discharge gas and stack emissions testing was conducted during these test runs.

Furnace ramp rates to treatment temperatures varied from 50 °F/hour for test runs 1, 2, and 3 to 300 °F/hr for test runs 16A, 16B, and 16C.

Nine test specimens and five furnace wall plates were spiked as noted in Table 5-2 and placed inside the furnace for each validation test run. The nine test specimens included three steel test plates, three clay saucers, and three 3" x 3" pieces of concrete block. The five furnace wall plates were used to verify that even decontamination occurred throughout the furnace chamber during processing. Four of the furnace wall plates are located on the furnace side walls (two each side), and one wall plate is located on the inside furnace door. Unlike the nine test specimens, all 5 wall plates were spiked with the same explosives-spike mixture for a given test run. For example, wall plates were spiked with TNT during test 1, RDX during test 2, tetryl during test 3, TNT during test 4, etc. This pattern was continued through and including validation test run 16C. Additional details regarding furnace loading and spiking practices during the validation test program are provided in Subsections 5.2 and 5.3. Changes to spiking procedures from the approved plan are discussed in Subsection 5.5.4.

Table 5-2

Typical Spiked Load

Test Specimens and Wall Plates	Spike Explosives		
	TNT	RDX	Tetryl
Steel (3 total)	1	1	1
Clay (3 total)	1	1	1
Concrete Block (3 total)	1	1	1
Furnace Wall Plates (5 total)			
- Left front	1		
- Left back	1		
- Right front	1		
- Right back	1		
- Furnace door	1		

Confirmatory sampling and analysis was conducted both before and after each validation test run. Pre-treatment sampling was performed to verify that furnace test plates and specimens were free of contamination prior to spiking and to confirm that the contaminated debris was indeed contaminated. Post-treatment sampling was performed to verify decontamination and identify breakdown compounds, if any, that remained on both the spiked and contaminated materials.

Because one of the objectives of this test program was to define optimum treatment conditions, the results of post-treatment analysis were used to determine the operating conditions for the next validation test run, as illustrated by the decision tree provided in Figure 5-1. Additional details regarding the sampling are

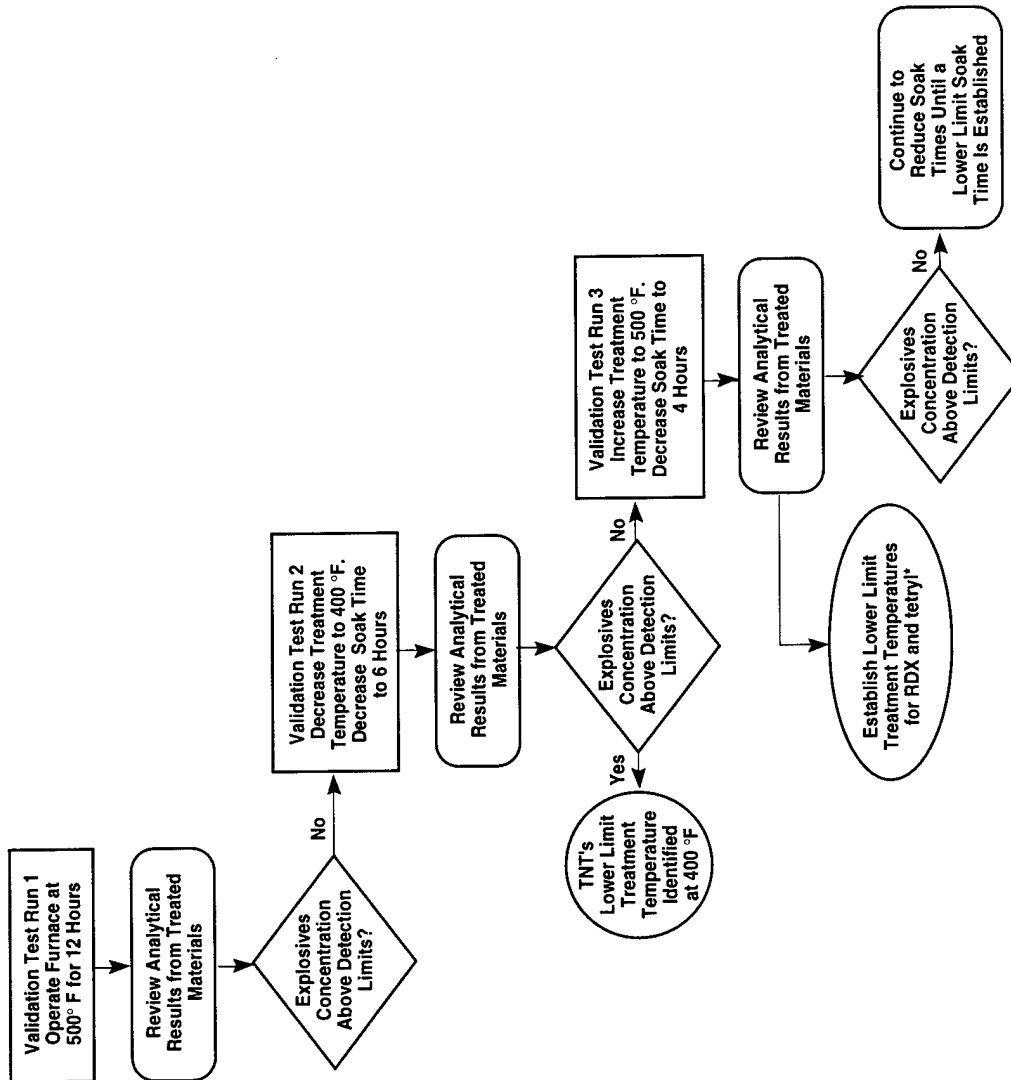

* The lower limit treatment temperature can be established by maintaining a soak time and continuing to decrease treatment temperature until an explosives concentration above detection limits occurs.

FIGURE 5-1 DECISION TREE TO ESTABLISH OPTIMAL TREATMENT TIMES AND TEMPERATURES FOR THE DECONTAMINATION OF EXPLOSIVES

provided in Subsection 5.4. By keeping track of the successes and failures over the life of the validation test runs, WESTON was able to determine a time/temperature relationship associated with the decontamination of TNT-, RDX-, and tetryl-contaminated materials. The results of these tests are discussed in detail in Section 9 of this Validation Test Report.

To support future operations and permitting efforts associated with the HGD system, a rigorous emissions testing program was conducted during test runs 1, 2, and 3, as noted by the "(E)" in Table 5-1. During test runs 1, 2, and 3, the HGD process emissions were sampled for:

- Carbon monoxide (CO).
- Carbon dioxide (CO₂).
- Oxygen.
- Total hydrocarbons (THC).
- Nitrous oxides (NO_x).
- Sulfur dioxide (SO₂).
- Particulates.
- Explosives:
 - 2,4,6-trinitrotoluene (2,4,6-TNT).
 - Hexahydro-1,3,5-trinitro-s-triazine (RDX).
 - 1,3-Dinitrobenzene (1,3-DNB).
 - 2,4-Dinitrotoluene (2,4-DNT).
 - 2,6-Dinitrotoluene (2,6-DNT).
 - 2,4,6-Trinitrophenylmethylnitramine (tetryl).
 - Octahydro-1,3,5,7 tetranitro-1,3,5,7-tetrazocine (HMX).
 - Nitrobenzene (NB).
 - 1,3,5-Trinitrobenzene (1,3,5-TNB).
- Volatile organic compounds (VOCs).
- Semivolatile organic compounds (SVOCs).
- Metals.
- Hexavalent chromium (Cr⁺⁶).
- Hydrochloric acid (HCl).
- Chlorine gas (Cl₂).
- Dioxins/furans.

In addition to the emissions sampling conducted at the stack, explosives, NO_x, THC, CO₂, and O₂ samples were taken at the thermal oxidizer's inlet. When used in combination with the data from the stack, the destruction and removal efficiency (DRE) of the thermal oxidizer can be calculated.

DRE is a measurement of the ability of the thermal oxidizer to destroy the explosives contamination contained in the furnace exit-gases. In previous HGD studies, determining the oxidizer DRE has proven difficult because of the inability to continuously sample oxidizer influent and effluent streams during a complete test run, and the inherent shortcomings of the DRE calculation (i.e., if detectable levels of explosives are not present in the samples, the detection limits of the

analysis are used in the DRE calculation). The results of the emissions testing and DRE calculation are discussed in detail in Section 7 of this Validation Test Report.

In addition to emissions testing conducted during validation test runs 1, 2, and 3, continuous emissions monitoring of the stack gases was conducted during all test runs. The CEM system used to complete this monitoring was an extractive-type system located on the equipment pad, next to the HGD furnace. To support sampling at both the stack and interconnection duct, two separate probes were used. The first probe was located in the system stack and monitored CO₂, CO, THC, NO_x, SO₂, and O₂. The second probe was placed in the interconnection duct between the furnace exit and thermal oxidizer inlet to monitor THC and NO_x. The results of the CEM monitoring are discussed in Section 7 of this Validation Test Report.

Results from the HGD study conducted at Hawthorne Army Ammunition Plant (HWAAP) in 1990 indicated short duration NO_x spikes at the system stack during processing of explosives-contaminated materials. The explosives treated at HWAAP were nitrogen based; therefore, it was suspected that if the phenomenon were repeatable, then perhaps NO_x levels in the process exit-gases could be used as an indicator of complete explosives decontamination within the furnace. Thus, a final objective of this validation test program was to monitor the NO_x levels in the furnace exit-gases to verify that the NO_x activity observed at HWAAP was real, and secondly to define, if possible, the relationship between NO_x levels in the process exit-gases and decontamination of the materials contained in the HGD furnace. To support this effort, NO_x readings detected by the second CEM probe were forwarded to the HGD system data logger for monitoring and trending. The observations made regarding NO_x as a result of this probe are discussed in both Sections 7 and 9 of this Validation Test Report.

5.2 VALIDATION TEST MATERIALS

Contaminated debris and clean materials that would be used to support testing were stored in designated areas on the HGD equipment pad, as indicated in Figure 2-2. As materials were used, site personnel moved the materials both by hand and forklift in accordance with the handling procedures provided in Appendix R of the Site Health and Safety Plan.¹

Contaminated materials that were loaded into the HGD furnace for processing during validation testing included the following:

- Clean metal piping of various diameters and three metal test plates spiked with TNT, RDX, or tetryl.

¹ Final Site Safety and Health Plan (SSHP) for Evaluation of a Transportable Hot-Gas Decontamination System for Decontamination of Excavated Explosives-Contaminated Piping. Prepared by Roy F. Weston, Inc. Revision 3. January 1996.

- Clean clay piping of various diameters and three clay saucers spiked with TNT, RDX, or tetryl.
- Clean concrete block and three block saucers spiked with TNT, RDX, or tetryl.
- Five clean metal furnace test plates spiked with either TNT, RDX, or tetryl.
- Contaminated piping and debris from the Soils Stockpile and Red Water Ditch areas of ALAAP.
- Pieces of transite siding taken from the Soils Stockpile Area of ALAAP (Test 17C only).

Because of hearth limitations in the furnace chamber, all validation test runs were limited to a total load of 3,000 lb contaminated materials, containing no more than 1 lb of total explosives contamination. In addition, the total amount of hazardous waste that could be treated during the validation test program was 11,023 lb, in accordance with the requirements of ADEM Administrative Code, Division 14, Chapter 335-14-2.01(4)(e) and (4)(f), dated 5 January 1995. These requirements state:

"the quantity of as received hazardous waste stored at the facility for the purpose of evaluation in treatability studies does not exceed 5,000 kg (11,023 lbs), the total of which can include 5,000 kg of media contaminated with non-acute hazardous waste, 2,500 kg (5,511 lbs) of media contaminated with acute hazardous waste, 1,000 kg (2,204 lbs) of non-acute hazardous wastes other than contaminated media, and 1 kg of acute hazardous waste."

Consequently, no more than 11,023 lb of contaminated debris from the Soils Stockpile or Red Water Ditch Areas of the ALAAP was treated by the HGD process during the term of the validation test program. All materials taken from the ALAAP remediation had been prescreened for the presence of explosives. Sampling of these materials, by the ALAAP remediation effort, had indicated the debris could be contaminated with the following compounds:

- 2,4,6-DNT
- 2,4-DNT
- 2,6-DNT
- 1,3,5-TNB
- 1,3-DNB
- Lead
- Tetryl

Since contamination was certain but not assured, WESTON performed pre-screening of the contaminated debris prior to placing it in the HGD furnace for processing. Prescreening procedures included taking a minimum of three wipe samples from randomly selected debris in accordance with the EPA wipe sampling technique. The three wipes were then composited and analyzed in accordance with Modified Method 8330 for explosives. The results of these wipe samples are discussed in Section 9 of this Validation Test Report.

Once contaminated debris was identified for treatment, the contaminated debris and piping were loaded into test racks, weighed, and then placed into the furnace

for treatment in accordance with the loading procedure provided as Exhibit 5-1 (located at the end of this section).

As noted earlier, only clean piping (metal and clay), concrete block, and test specimens and furnace wall plates spiked with known quantities of TNT, RDX, and tetryl were placed in the HGD furnace for test runs 1, 2, and 3. This procedure was followed for tests 1, 2, and 3 in order to process a known amount of explosives through the HGD system during emissions testing. This value would be used to support DRE calculations.

After completing emissions sampling, test runs 4 through 15 processed a combination of contaminated debris (noted by a "(D)" on Table 5-1), spiked metal and clay test specimens, spiked concrete block, spiked furnace wall plates, and clean piping and block. During the last three test runs (16A, 16B, and 16C), only clean materials spiked with 1 lb of either TNT, RDX, or tetryl was placed in the HGD furnace for treatment. These test runs were conducted to see if a distinctive set of NO_x peaks could be associated with each explosive type treated. Test 16A treated only TNT; 16B, only tetryl; and 16C, only RDX.

5.3 EXPLOSIVES SPIKING

To support explosives spiking throughout the validation test program, WESTON procured TNT, RDX, and tetryl from an explosives supply house. All spike explosives were stored in an explosives-storage box rated for up to 50 lb explosives. Two storage boxes were purchased so that TNT and tetryl could be stored separately from the RDX. The explosives-storage boxes were located approximately 150 feet from the HGD equipment pad and approximately 400 feet from the remote control area as indicated in Figure 3-3. The siting of the storage boxes took into consideration Hazard Analysis concerns and the quantity distance requirements found in Army Materiel Command regulation AMC-R-385-100 and Army Regulation (AR) 385-64.

TNT, RDX, and tetryl-spiked test plates and specimens were treated in all test runs, except test runs 16A, 16B, and 16C when only one of the explosives types was treated. Although different explosives were treated in the same test runs, explosives were never mixed together or placed on the same test plate or specimen. No explosives spiking was conducted during furnace run 17C, when only asbestos-containing transite siding was processed by the HGD furnace.

For all the validation test runs, five furnace wall plates and 9 specimens were spiked as noted in Table 5-2 and in accordance with the spiking procedure provided in Exhibit 5-2 (provided at the end of this section). All spiking activities (including mixing spike) were conducted outdoors, in a designated area, adjacent to the HGD furnace. Three separate explosives-spike mixtures were prepared. A spike mixture consisted of the explosive plus acetone. Just enough acetone was added to allow easy handling to avoid cross-contamination of the explosives spikes. Each spike mixture was maintained separately and applied separately to the wall plates and specimens. Because acetone was used to prepare the explosives-spike mixtures, all mixtures were prepared just prior to the actual

spiking operation to prevent the mixture from drying prior to application. All test plates had been confirmed clean prior to spiking. Refer to Subsection 5.5.4.

After all wall plates and specimens had been spiked, the test specimens were randomly placed throughout the furnace load. Clay saucers were placed inside clay pipe, metal test plates were placed inside metal pipe, and the block specimens were placed with the other block. The five furnace wall plates were placed in each wall plate receptacle located on the side walls and door of the furnace chamber. A listing of the quantity of spike and contaminated debris that was placed in each validation test run is presented in Table 5-3. After loading the furnace, material load thermocouples TE-203, TE-204, TE-205, TE-206, and TE-207 were placed throughout the load, as noted in Figure 5-2, to monitor the temperature of the load during processing. Once the thermocouples were attached to their respective locations, the furnace door was secured, the HGD equipment pad cleared of all personnel, and the HGD system started. The average of these five thermocouples was used to determine when the furnace chamber had reached treatment temperature.

5.4 TREATMENT CRITERIA

Following a completed test run, materials were left in the furnace chamber to cool. Once the materials had cooled, the furnace door was opened and post-treatment sampling began to sample for residual explosives concentrations on the treated test materials. All post-treatment sampling was conducted using a combination of wipes and solid samples to confirm the effectiveness of the selected treatment temperature and soak time. All samples were analyzed for the explosives listed below in accordance with modified Method 8330:

- 2,4,6-trinitrotoluene (2,4,6-TNT).
- Hexahydro-1,3,5-trinitro-s-triazine (RDX).
- 1,3-Dinitrobenzene (1,3-DNB).
- 2,4-Dinitrotoluene (2,4-DNT).
- 2,6-Dinitrotoluene (2,6-DNT).
- 2,4,6-Trinitrophenylmethylnitramine (tetryl).
- Octahydro-1,3,5,7 tetranitro-1,3,5,7-tetrazocine (HMX).
- Nitrobenzene (NB).
- 1,3,5-Trinitrobenzene (1,3,5-TNB).

Wipe samples were taken from all furnace wall plates, and all block, clay, and steel test specimens. In addition to wipe samples concrete block and clay specimens were also crushed and ground into powder. The powder was then analyzed for explosives in accordance with Method 8330.

For contaminated debris, wipe samples were taken from three randomly selected metal surfaces. The three wipes were then composited and analyzed in accordance with Method 8330. For debris, three randomly selected pieces were taken, crushed, composited, and analyzed for explosives in accordance with Method 8330.

Table 5-3

Quantity and Type of Wastes Treated During the HGD Treatability Study

Date	Validation Test Number	Type of Wastes	Quantity of Spike Placed in Furnace for Treatment	Quantity of Explosives-Contaminated Piping and Debris Placed in Furnace for Treatment
31 January 1996	1	Clean Spiked Metal Pipe Clean Spiked Clay Pipe Clean Spiked Cinder Block	0.29 lb TNT 0.10 lb tetryl 0.12 lb RDX	NA
2 February 1996	2	Clean Spiked Metal Pipe Clean Spiked Clay Pipe Clean Spiked Cinder Block	0.10 lb TNT 0.17 lb tetryl 0.40 lb RDX	NA
3 February 1996	3	Clean Spiked Metal Pipe Clean Spiked Clay Pipe Clean Spiked Cinder Block	0.10 lb TNT 0.34 lb tetryl 0.13 lb RDX	NA
6-7 February 1996	4	Clean Spiked Metal Pipe Clean Spiked Clay Pipe Clean Spiked Cinder Block	0.20 lb TNT 0.07 lb tetryl 0.07 lb RDX	NA
		Contaminated Piping & Debris	NA	490 lb steel <u>365 lb rock</u> 855 lb total
8 February 1996	5	Clean Spiked Metal Pipe Clean Spiked Clay Pipe Clean Spiked Cinder Block	0.07 lb TNT 0.08 lb tetryl 0.18 lb RDX	NA
		Contaminated Piping & Debris	NA	477 lb steel <u>367 lb rock</u> 844 lb total
12 February 1996	6	Clean Spiked Metal Pipe Clean Spiked Clay Pipe Clean Spiked Cinder Block	0.07 lb TNT 0.18 lb tetryl 0.06 lb RDX	NA
		Contaminated Piping & Debris	NA	445 lb steel <u>367 lb rock</u> 812 lb total

Table 5-3

**Quantity and Type of Wastes Treated During the HGD Treatability Study
(Continued)**

Date	Validation Test Number	Type of Wastes	Quantity of Spike Placed in Furnace for Treatment	Quantity of Explosives-Contaminated Piping and Debris Placed in Furnace for Treatment
13 February 1996	7	Clean Spiked Metal Pipe Clean Spiked Clay Pipe Clean Spiked Cinder Block	0.18 lb TNT 0.07 lb tetryl 0.08 lb RDX	NA
		Contaminated Piping & Debris	NA	440 lb steel 367 lb rock 807 lb total
15 February 1996	8	Clean Spiked Metal Pipe Clean Spiked Clay Pipe Clean Spiked Cinder Block	0.06 lb TNT 0.07 lb tetryl 0.17 lb RDX	NA
		Contaminated Piping & Debris	NA	424 lb steel 367 lb rock 791 lb total
19 February 1996	9	Clean Spiked Metal Pipe Clean Spiked Clay Pipe Clean Spiked Cinder Block	0.07 lb TNT 0.21 lb tetryl 0.12 lb RDX	NA
		Contaminated Piping & Debris	NA	467 lb steel 367 lb rock 834 lb total
20 February 1996	10	Clean Spiked Metal Pipe Clean Spiked Clay Pipe Clean Spiked Cinder Block	0.18 lb TNT 0.07 lb tetryl 0.06 lb RDX	NA
		Contaminated Piping & Debris	NA	400 lb steel 367 lb rock 767 lb total
22 February 1996	11	Clean Spiked Metal Pipe Clean Spiked Clay Pipe Clean Spiked Cinder Block	0.05 lb TNT 0.06 lb tetryl 0.21 lb RDX	NA
		Contaminated Piping & Debris	NA	433 lb steel 367 lb rock 00 lb total

Table 5-3

**Quantity and Type of Wastes Treated During the HGD Treatability Study
(Continued)**

Date	Validation Test Number	Type of Wastes	Quantity of Spike Placed in Furnace for Treatment	Quantity of Explosives-Contaminated Piping and Debris Placed in Furnace for Treatment
26 February 1996	12	Clean Spiked Metal Pipe Clean Spiked Clay Pipe Clean Spiked Cinder Block	0.08 lb TNT 0.16 lb tetryl 0.07 lb RDX	NA
		Contaminated Piping & Debris	NA	436 lb steel <u>367 lb rock</u> 803 lb total
26 February 1996	13	Clean Spiked Metal Pipe Clean Spiked Clay Pipe Clean Spiked Cinder Block	0.18 lb TNT 0.08 lb tetryl 0.07 lb RDX	NA
		Contaminated Piping & Debris	NA	409 lb steel <u>367 lb rock</u> 76 lb total
27 February 1996	14	Clean Spiked Metal Pipe Clean Spiked Clay Pipe Clean Spiked Cinder Block	0.09 lb TNT 0.09 lb tetryl 0.22 lb RDX	NA
		Contaminated Piping & Debris	NA	394 lb steel <u>367 lb rock</u> 761 lb total
1 March 1996	15	Clean Spiked Metal Pipe Clean Spiked Clay Pipe Clean Spiked Cinder Block	0.06 lb TNT 0.17 lb tetryl 0.09 lb RDX	NA
		Contaminated Piping & Debris	NA	363 lb steel <u>367 lb rock</u> 30 lb total
6 March 1996	16-A	Clean Spiked Metal Pipe Clean Spiked Clay Pipe Clean Spiked Cinder Block	0.21 lb TNT	NA
6 March 1996	16-B	Clean Spiked Metal Pipe Clean Spiked Clay Pipe Clean Spiked Cinder Block	0.24 lb tetryl	NA

Table 5-3

**Quantity and Type of Wastes Treated During the HGD Treatability Study
(Continued)**

Date	Validation Test Number	Type of Wastes	Quantity of Spike Placed in Furnace for Treatment	Quantity of Explosives-Contaminated Piping and Debris Placed in Furnace for Treatment
7 March 1996	16-C	Clean Spiked Metal Pipe Clean Spiked Clay Pipe Clean Spiked Cinder Block	0.21 lb RDX	NA
7 March 1996	16-D	Clean Metal Pipe Clean Clay Pipe Clean Cinder Block	0 lb TNT 0 lb tetryl 0 lb RDX	NA
8 March 1996	17-A	NA	0.677 lb TNT ^a	708 lb rock ^b
8 March 1996	17-B	NA	0.654 lb tetryl ^a	708 lb rock ^c 794 lb steel ^b
11 March 1996	17-C	NA	1.126 lb RDX ^a 1 lb transite siding ^c	708 lb rock ^d 794 lb steel ^d

^a This weight includes the weight of acetone used to mix explosives paste.

^b Materials from Tests 11 and 15 that were retreated to destroy small traces of residual explosives contamination.

^c Contents remained in furnace from Test 17-A.

^d Contents remained in furnace from Test 17-B.

^e Transite siding was taken from the ALAAP remediation site contaminated debris stockpile. It is assumed to have been contaminated. The transite siding was not spiked.

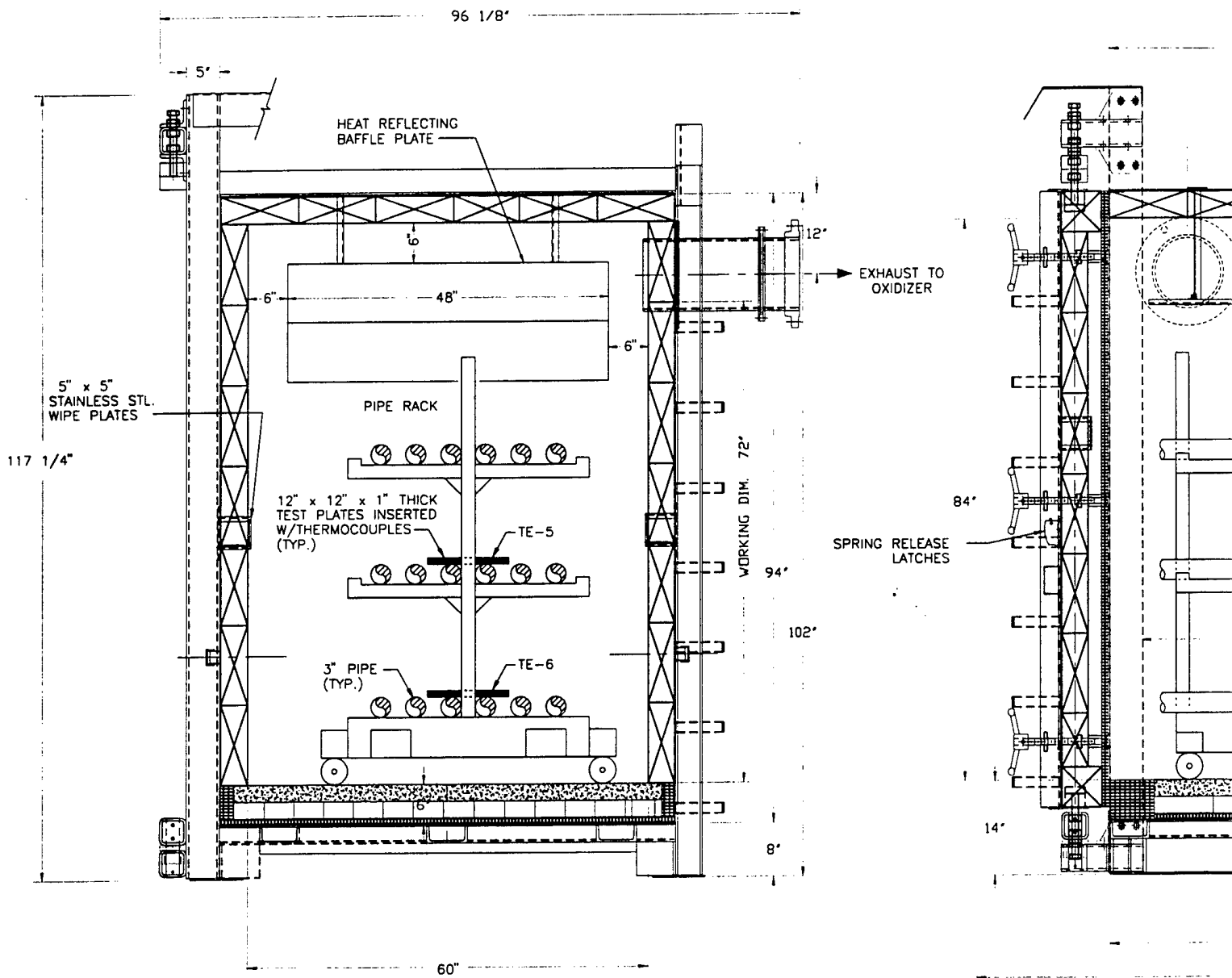

FRONT VIEW

JUNE 70
 FILE NO.

NO.	DATE	APPR.	REVISION	NO.	DATE	APPR.	REVISION

HOT-GAS DECON
 SYSTEM



WEST CHESTER

(1)

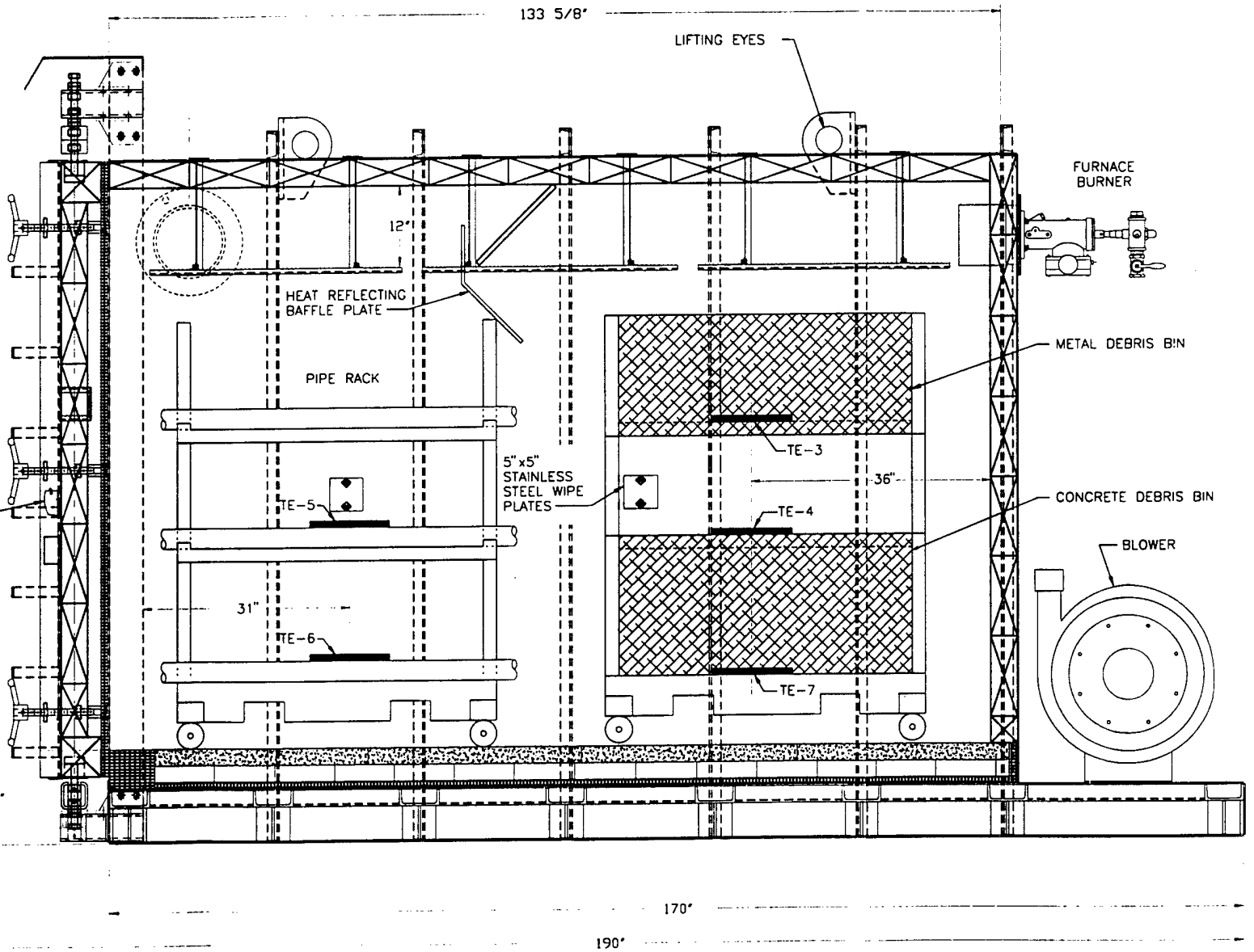

SIDE VIEW/SECTION

HOT-GAS DECONTAMINATION SYSTEM



CHECKED	DATE	CLIENT APPROVALS	DATE
DES. ENG.			
PRD. J. ENG.			
PRD. J. MGR.			
APPROVED			
APPROVED			

FIGURE 5-2 GENERAL LOAD AN THERMOCOUPLE PLACEMENT

DRAWN	A.B.H.	DATE	6/19/96	DWG. NO.	FIGURE 4-4
SCALE	NONE	V.D. NO.	02218-12-10	SHEET	1 OF 1

2

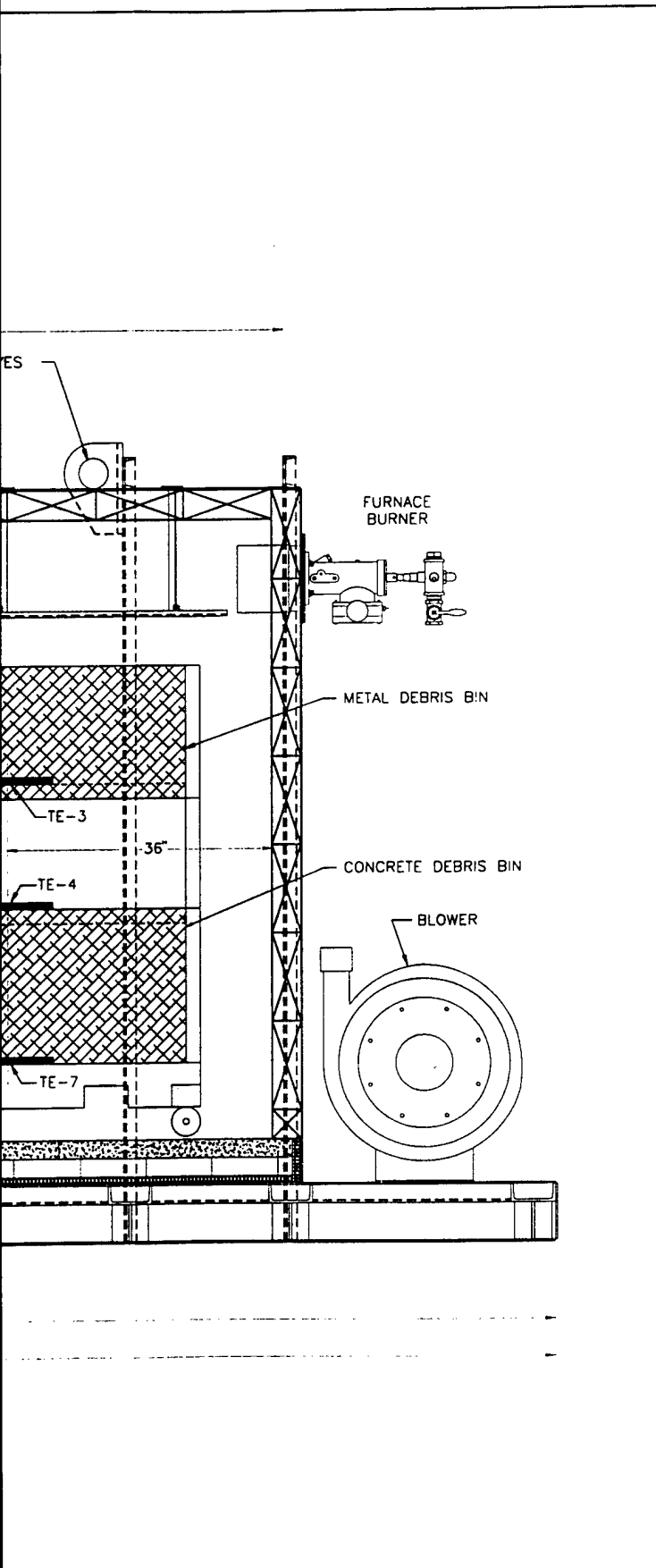

FIGURE 5-2 GENERAL LOAD AND THERMOCOUPLE PLACEMENT

DRAWN	A.B.H.	DATE	6/19/96	DWG NO	FIGURE 4-4	REV NO	1
SCALE	NONE	WD NO	02218-12-10	SHT	1	OF	1

3

Once the post-treatment analytical results became available, the data were examined to identify success or failure. Initially, a test run was considered successful if at least 99.99% removal of the spike compounds was achieved for each test plate or specimen; however, as testing progressed, it became obvious that more stringent criteria would be required to optimize treatment conditions. Therefore, WESTON established a three-tier acceptance criteria to determine the effectiveness of the HGD process.

- **Acceptance Level 1:** Post-treatment analysis indicates 99.999% or better removal of spike explosives from the test plate or specimen.
- **Acceptance Level 2:** Post-treatment results indicate the removal of all spike explosives, regardless of removal efficiency. The presence of either TNT, RDX, or tetryl would fail a test plate or specimen.

Note: A sample that passed Level 1 could fail this acceptance level because of trace quantities of spike explosives.

- **Acceptance Level 3:** Post-treatment results cannot indicate traces of either the spike explosive or explosives-breakdown compounds.

This criterion is the toughest to meet. Specimens that pass Levels 1 or 2 could fail this acceptance level because of trace levels of explosives-breakdown compounds, such as 1,3-DNT.

By using the three-level acceptance approach, it was possible to determine a time/temperature relationship associated with the decontamination of TNT-, RDX-, and tetryl-contaminated materials. For a complete discussion of the test results, refer to Section 9 of this Validation Test Report.

5.5 DEVIATIONS FROM THE TEST PLAN

5.5.1 Changes in Soak Times and Ramp Rates

Previous testing at HWAAP using the HGD process indicated that a slow ramp (50 °F/ hour) to treatment temperature, followed by soak periods in excess of 12 hours, would be necessary to effectively decontaminate materials contaminated with TNT, RDX, and tetryl. Based on these data, validation test runs with the transportable HGD system were planned with soak times of 4, 6, 12, 18, and 24 hours. The ramp rate to treatment temperature was not to exceed 50 °F/hour.

Because many system improvements had been made to the transportable HGD system over the unit tested at HWAAP, test run 1 was conducted using a 50°F/hour ramp to a treatment temperature of 500 °F for a 12-hour soak. Post-treatment sampling indicated no explosives or explosives-breakdown compounds present on the treated materials; therefore test run 2 was conducted using a 400 °F treatment temperature and a 6-hour soak. Post-treatment analysis from test run 2 indicated incomplete destruction and removal of TNT from some of the TNT-

contaminated test specimens, but complete destruction of RDX- and tetryl-contaminated test specimens. Based on these results, test run 3 was conducted using a 50 °F/hour ramp, 500 °F treatment temperature, and a 4- hour soak. Post-treatment testing indicated at least 99.999% removal efficiency for TNT-contaminated test specimens and complete destruction of the RDX- and tetryl-contaminated test specimens.

Based on the results from test runs 1, 2, and 3, USAEC and WESTON determined to eliminate all tests with soak times longer than 4 hours and concentrate on:

- Defining the shortest allowable ramp as allowed by the constraints of the equipment design (i.e., increasing the ramp rate from 50 °F/hr to possibly 300 °F/hr) and test results.
- Defining the lowest possible treatment temperature that would effectively decontaminate TNT, RDX, tetryl, and/or their breakdown compounds.
- Establishing the minimum required soak time at treatment temperature to ensure complete destruction of explosives contaminants and their breakdown compounds.

5.5.2 Increasing Number of Test Runs

Originally, fifteen 4-day test runs over a test period of 9 weeks were planned for the validation test program; however, the transportable HGD system efficiencies were significantly better than those of HGD systems used in previous studies. As a result, WESTON was able to conduct a complete test run, including pre- and post-treatment analysis, loading, cooldown, and unloading, in 2 days or less. On-line system availability was close to 100%.

To take advantage of the extra time at the end of test run 15, three additional test runs (16A, 16B, and 16C) were conducted. Each test run treated only one type of contaminant (TNT, RDX or tetryl) in an attempt to define characteristic NO_x spikes during the ramp period for each explosives type. Because the previous 15 test runs had indicated that all NO_x activity associated with the decontamination process occurred during the ramp between approximately 300 °F to 500 °F, the additional tests were run using a 300 °F/hour ramp, 600 °F treatment temperature, and no soak period. The results of these test runs are discussed in Section 9.

5.5.3 Asbestos Testing

WESTON was requested by USAEC to define the effects, if any, that the HGD process would have on asbestos-containing materials such as transite siding and pipe insulation. Asbestos-containing pipe insulation could not be located. Transite siding, however, was obtained from the ongoing ALAAP remediation effort. It was agreed that a small quantity of asbestos-containing transite siding would be placed in the last HGD furnace run to evaluate the condition of the transite siding after treatment by the HGD process. Personal air sampling was conducted during this

test to evaluate worker safety. The results of the personal air monitoring are discussed in Section 8 and the observations noted after furnace run 17C are discussed in Section 9.

5.5.4 Changes to Spiking Procedures

When the treatability study test plan was originally generated, WESTON had planned that all of the clean material (clay pipe, concrete block, metal pipe, and furnace wall plates) placed in the furnace load would be spiked with one of the explosives-spike mixtures (TNT, RDX, or tetryl). It was assumed the spike mixtures, once formulated, would have a viscous consistency similar to toothpaste. The spike mixtures did not have a viscous consistency, but a consistency more like a liquid/solid slurry similar to undissolved sugar at the bottom of a coffee cup. This was not conducive to spiking circular surfaces such as metal or clay piping.

To overcome this obstacle, test plates and specimens were prepared for each test run. The word "specimens" will be used to describe the pieces of concrete block and clay saucers that were used to support spiking. Test plates were used to support metals and furnace wall plate spiking. Each test plate was approximately 2 inches square with a welded bead around the edge to prevent spike mixtures from sliding or melting off the plate during treatment. Spike explosives were placed on the test plate, in a smooth, even layer, and then placed in the furnace, inside the metal pipe that made up part of the furnace load. Spike was applied to the furnace wall plates in the same manner and placed in the permanent wall plate fixtures located on the furnace side walls and door. After processing, the metal plates were removed from the pipes and furnace wall locations for analysis. Wipe samples were taken from each plate and analyzed for explosives in accordance with Method 8330. Metal plates that were verified clean were then used to support follow-on tests after a thorough rinse and cleaning with acetone. Wipe samples of the clean plates were taken and analyzed to verify cleanliness prior to reuse.

To support spiking and subsequent analysis of concrete block, clean block was broken into approximately 3-inch square chunks. The spike mixture was then placed on the block specimens and placed in the furnace with the other concrete block. Following processing, a wipe sample was taken from the block and the treated specimen was ground into a powder. The powder was then sampled in accordance with Method 8830 of the nine target explosives identified in Subsection 5.4.

To duplicate the clay pipe, clay saucers approximately 2 inches in diameter were purchased from a local garden supply store. The explosives-spike mixtures were placed in the saucer and then smoothed evenly over the saucer bottom. The spiked clay saucer was then placed in the furnace load, in the inside of a clay pipe that made up part of the furnace load. Following processing, a wipe sample of the saucer was taken, and the saucer was then ground into a powder. The powder was analyzed in accordance with Method 8830 for the nine target explosives identified in Subsection 5.4.

EXHIBIT 5-1

Exhibit 5-1

Furnace Loading And Unloading Procedures

Furnace Loading Procedure

1. Identify the contaminated materials to be treated by the HGD process.
2. Don the required personal protective gear as required by the site-specific health and safety plan.
3. Verify all loose dirt and debris contained on the contaminated materials or in the material internals has been removed, as best as practicable.
4. Place the contaminated materials to be treated by the transportable HGD process onto the treatment racks. A maximum of three treatment racks can be loaded into the furnace for any given batch. However, two loaded racks normally provide the maximum allowable treatment weight.

Do not mix clean materials with contaminated materials.

Contaminated piping and plate are normally placed on the upper shelves of the treatment racks, and debris is placed in a basket on the lower shelves of the treatment racks.

5. Weigh the loaded treatment rack and record the weight. The transportable HGD furnace is designed to treat a **maximum of 3,000¹ of contaminated materials**. If explosives are included in the contaminated load, **no more than 1 lb of total explosives²** can be placed into the furnace for a given batch.
6. Using a forklift, place weighed treatment racks into the furnace chamber. The operator will be required to slide the racks into place once the forklift places the racks onto the furnace hearth.
7. Place the load thermocouples throughout the load. Five thermocouples with transmitters were used to support validation testing; however, up to 12 load thermocouples can be used to monitor the load temperature during processing.
8. Once the load thermocouples are placed, verify that all personnel are clear of the furnace chamber and close and secure the furnace door. Check with the control area operator to verify that the furnace door contact (ZSO-208) indicates the door is closed.

¹ The furnace load limitation is based on the strength of the refractory floor and the required thermal input to heat up the load. The 3,000 lb includes the weight of the materials plus the weight of the racks or fixtures used to hold the materials in the furnace.

² The total explosive limit was imposed by permitting limitations established by the State of Alabama. The standard design and construction of the furnace allows processing of more than 1 lb of total explosives; however, proper explosion rating calculations must be performed by qualified personnel before increasing the explosives load limitation of the furnace beyond 1 lb.

9. The HGD system equipment may be started in accordance with the procedures outlined in Subsections 3.1.2 and 3.1.3.

Furnace Unloading Procedure

1. Verify that the temperature in the HGD furnace is below 150 °F.
2. Don the required personal protective gear as required by the site-specific health and safety plan.
3. Open the HGD furnace door and swing the door away from the furnace entrance. Secure the furnace door in the open position. Allow the furnace contents to cool further, if necessary.
4. Remove the treatment racks from the HGD furnace.
5. Perform post-treatment sampling, if required.
6. Remove the processed materials from the treatment racks and place the processed materials in a segregated storage area until confirmed clean by post-treatment analysis.
7. Transfer clean treated materials to the clean storage area once the treated materials have been verified clean. Clean materials may be reused, disposed of as scrap, or landfilled in accordance with the site-specific work plan.

Materials that have not been verified clean by post-treatment analysis must be retreated. These materials should be returned to the contaminated stockpile area for retreatment.

EXHIBIT 5-2

Exhibit 5-2**Spiking Procedure For Validation Tests 1-3****Pre-Spike**

1. Using an acetone-soaked wipe, clean all furnace test plates and specimen plates to remove dirt, grease, and other debris.
2. Take wipe samples of all test plates using an acetonitrile-soaked wipe (20 wipes per sample area). Place wipe sample in glass sample jar and label. Place each cleaned and sampled test plate in its own Ziploc bag. Label bag "Waiting for Verification Clean." As test plates are verified clean, place in "Verified Clean" box for use in future test runs.

Spike

1. Collect **one wipe for a field blank**. Place in glass sample jar and identify.
2. Collect **one solid field blank**. Select one piece only of either unspiked concrete block or clay pipe. Prepare in same manner as matrix samples, but ensure sampling materials are decontaminated (i.e., grinder). Place in glass sample jar and identify.
3. Collect three "clean" metal test plates from the "verified clean" group.
4. Record sample plate identification, e.g., "A."
5. Weight the unspiked, clean test plates. Record weight.
6. Transfer explosives to mixing containers, as indicated below.
 - Container 1: 60 grams of RDX for cinder block, clay pipe, and metal pipe. Approximately 20 grams per test item.
 - Container 2: 60 grams of tetryl for cinder block, clay pipe, and metal pipe. Approximately 20 grams per test item.
 - Container 3: 45 grams of TNT for cinder block, clay pipe, and metal pipe. Approximately 15 grams per test item.
 - Container 4:
 - Test Run 1: 75 grams of TNT for five furnace wall plates. Approximately 15 grams per test plate.
 - Test Run 2: 100 grams of tetryl for five furnace wall test plates. Approximately 20 grams per test plate.

- Test Run 3: 100 grams of RDX for five furnace wall test plates. Approximately 20 grams per test plate.
- 7. Add acetone to explosives as necessary, to form a workable mixture.
- 8. Transfer explosives-solvent mixture to test plates using rubber spatula, wooden spoon, or toothbrush. Spread mixtures evenly across the test plates and specimens.
- 9. Allow acetone to evaporate from spike mixes.
- 10. Weigh dried test plates. Record weight.
- 11. Place dried and weighed test plates in metal pipe, clay pipe, or cinder block throughout the furnace load. Record locations on pre-startup log (see Exhibit 5-3).
- 12. Rinse application tools and empty containers with acetone. Collect rinsate in cake pan with dried explosives.
- 13. Allow acetone in rinsate to evaporate. Once evaporated, place cake pan in furnace for treatment.

Post-Treatment Sampling

- 14. After treatment, lightly spray cake pans with water before removing from furnace and placing on spike stand. Remove test plates from the test materials. Do not remove test plates from furnace walls.
- 15. Weight each treated test plate and record weight.
- 16. Using an acetonitrile-soaked wipe, sample the treated test plates, including the five furnace wall plates, using a back and forth motion (20 swipes). Place wipe in glass sample jar. Label.
- 17. After taking wipe samples, place concrete and clay specimens in separate Ziploc bags. These samples will be ground, composited, and analyzed for explosives in accordance with modified Method 8330, which is provided as Appendix A of this Validation Test Report.

Validation Tests 4-15

Follow steps 1-17 above; however, randomly wipe sample at least three pieces of treated contaminated debris using an acetonitrile-soaked wipe for each piece. Use a back and forth motion (20 swipes). Place the wipes in a glass sample jar. Label.

These samples will be composited and analyzed for explosives in accordance with modified Method 8330.

EXHIBIT 5-3

Exhibit 5-3 Startup and Operations Checklist

PRE - STARTUP (1 of 3)

Date: _____
Time: _____

Test Number: _____

Ramp-Up Time _____

Soak Time: _____

Soak Temp: _____

MECHANICAL

Initial each item.

- Inspection doors/manways are SECURED
- Gas valves OPEN
- View/inspection ports CLOSED

Verify that all valves, doors, inspection ports, manways, etc. have been returned to a position capable of sustaining system operations.

ELECTRICAL

Initial each item.

- All lockout/tagouts (1-5) are ACCOUNTED for.
- Furnace and thermal oxidizer control breakers are ON.
- Verify that emergency stop pushbuttons are NOT ENGAGED.
- BUMP motors and switch to AUTO.

_____ Furnace Combustion Blower (M-220)
_____ Thermal Oxidizer Combustion Blower (M-130)
_____ Thermal Oxidizer I.D. Fan (M-158)

Verify that field selector switches are in "AUTO" after all motors have been "BUMPED" to verify operations.

- Calibrate CEM*

_____ Interconnection Duct NO_x
_____ Interconnection Duct THC

_____ Stack's NO_x
_____ Stack's SO₂
_____ Stack's THC
_____ Stack's CO
_____ Stack's O₂
_____ Stack's CO

Tank Values	Recorded Values	Adjustment (Y/N)

* Verify that all regulators on Calibration Gas Tanks are **CLOSED**.

- Data logger/computer is ON

_____ Record Time (Computer Clock)
_____ Record Ambient Air Temperature (TIT-300)
_____ Ambient Humidity (call weather service at 205-666-3010)
_____ record every 6 hours on data log sheet

Exhibit 5-3 Startup and Operations Checklist (Continued)

LOADING/UNLOADING (2 of 3)

Date: _____
Time: _____

Test Number: _____
Ramp-Up Rate: _____
Soak Time: _____
Soak Temp: _____

FIELD ACTIVITIES

Initial each item.

Load furnace with materials and thermocouples

For each rack/bin, provide a description in terms of contents, appearance, moisture, etc.

_____ *Rack A's Characteristics.*

Initial Wt. (lb)	Final Wt. (lb)	<u>Test Materials</u>	Initial Wt. (lb)	Final Wt. (lb)
_____	_____		_____	_____
_____	_____		_____	_____

Take Pictures

Verify that pipe is chucked with wooden chucks prior to loading to prevent pipes from rolling into each other.

_____ *Rack B's Characteristics.*

Initial Wt. (lb)	Final Wt. (lb)	<u>Test Materials</u>	Initial Wt. (lb)	Final Wt. (lb)
_____	_____		_____	_____
_____	_____		_____	_____
_____	_____		_____	_____

Take Pictures

*SP-Spiked Steel Pipe, SC-Spiked Clay Pipe, SD-Spiked Cinder Blocks
CP-Contaminated Steel Pipe, CC-Cont. Clay Pipe, CD-Cont. Debris
Total weight of the two racks must be less than 3,000 lb*

No more than 1 lb of total explosives will be loaded into the furnace during any one batch/load

Mark locations of thermocouples

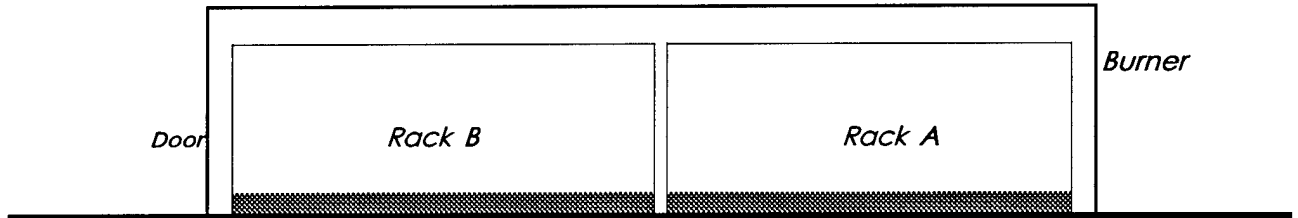

Roll calls and close furnace door (signatures required)

*Verify that all site personnel are accounted for.
Have each person initial this checklist.
Close and secure furnace door.*

Secure equipment pad and access road with chain links

SEE NEXT PAGE FOR THERMAL OXIDIZER and FURNACE STARTUP SEQUENCE

Exhibit 5-3 Startup and Operations Checklist (Continued)

STARTUP (3 of 3)

Date: _____

Time: _____

Test Number: _____

Ramp-Up Time: _____

Soak Time: _____

Soak Temp: _____

THERMAL OXIDIZER STARTUP

Initial and record time for each item.

- Start "I.D. Fan." Adjust fan speed to maintain a system draft < -0.5 in. w.c.
- Start "Pre-Mix AIR BLOWER." Adjust fan speed to maintain < -0.5 in. w.c.
- Start "OXIDIZER" (Burner). Adjust fan speed to maintain < -0.5 in. w.c.

*Once the burner has started, the control system will initiate a purge sequence.
The pilot will then attempt to light the burner at low fire.*

- Start "DATA LOGGER" pushbuttons on the computer.
- Heat up burner to 1,800 °F. Adjust I.D. fan speed to maintain < -0.5 in. w.c.

@ 600 °F: _____ :Time
 @ 1,200 °F: _____ :Time
 @ 1,800 °F: _____ :Time

*Once the burner is operating at low fire, the control will be released to the operator.
The operator must adjust gas flow and I.D. fan speed to maintain temperature at 1,800 °F
and system draft at < -0.5 in. w.c.*

FURNACE STARTUP

Initial and record time for each item.

- Turn furnace key to "BLOWER" position. Adjust I.D. fan speed to maintain < -0.5 in. w.c.
- Verify that "INTERLOCK OK" light is energized. Turn furnace key to "BURNER" position.

*Once the burner has started, the control system will initiate a purge sequence.
The pilot will then attempt to light the burner in low fire.*

- Ramp up furnace temperature to SOAK temperature. Maintain ramp-up rate. Adjust I.D. fan and temperatures.
Record furnace temperatures during ramp-up on hourly datalog sheet.

Once the burner is operating at low fire, the burner control will be released to the operator. The operator must adjust I.D. fan speed to maintain < -0.5 in. w.c., thermal oxidizer temperature at 1,800 °F, and furnace temperature at SOAK temperature.

- Manually Log Operating Parameters.

Use the Hourly Datalog to record all operating parameters at hourly intervals. SOAK times and temperatures may vary from test to test.

COOLDOWN

Initial and record time for each item.

- Turn furnace key to "BLOWER" after lowering furnace temperature to 200 °F.
- STOP "OXIDIZER" and "AIR BLOWER."
- STOP computer data logger when all thermocouples indicate < 150 °F.

FOLLOW THE FURNACE UNLOADING PROCEDURES PRESENTED AS EXHIBIT 5-1 IN SECTION 5 OF THE VALIDATION TEST REPORT.

6. EQUIPMENT OPERATIONS DURING VALIDATION TESTING

After successfully completing system shakedown and demonstration testing, validation testing of the transportable HGD equipment began on 4 January 1996 and continued through 15 March 1996. The first test run was begun on 31 January 1996. A total of 18 tests were conducted. Control variables were changed from test to test to evaluate their effects on response variables, such as final contaminant concentrations and stack emissions. This section presents the operating parameters for each test run and summarizes the data from each test run.

6.1 GENERAL OPERATIONS INFORMATION

Subsections 6.1.1 through 6.1.7 present details regarding equipment operations and procedures that were common to all validation test runs.

Among the system control variables, the three noted below define the HGD treatment process:

- Furnace Ramp Rate to Treatment Temperature.
- Material Treatment Temperature (Soak Temperature).
- Treatment Time (Soak Cycle).

These three variables were changed from test to test to evaluate their effect on system response variables and overall performance of the HGD process.

6.1.1 Furnace Ramp

The ramp rate is the rate, in degrees per hour, that the temperature of the furnace combustion chamber was elevated. The ramp rate is adjusted by temperature controller TIC-200. The ramp rate was programmed into TIC-200 by the operator prior to starting each test run.

Once initiated, the controller ramps the furnace chamber temperature to the final set-point and then maintains the temperature at the established set-point for treatment and soak. The treatment or soak temperature set-point is also programmed by the operator for each test run. The combustion chamber set-point is always set 50 °F above the target material treatment temperature.

6.1.2 Treatment Temperature

The treatment temperature is defined as the target material temperature for the load to reach and sustain for a designated soak period. Five material load thermocouple readings were combined into an average material load temperature to accommodate different heatup rates. When the thermocouple average reached treatment temperature, the soak cycle was started.

6.1.3 Soak Time

The soak time is defined as the duration that the material load was held at the treatment temperature. The soak time included only the time in which the average material load was at or above treatment temperature. If an unusual event caused a furnace shutdown, the soak time was suspended, and then restarted when the average material load temperature returned to the target treatment temperature. In some tests, no soak period was used, and only the effects of heatup on decontamination were evaluated.

At the completion of a soak cycle, the furnace burner was immediately placed in the low-fire position, and the furnace burner was turned off. This procedure normally took 2 to 5 minutes. The material load was then allowed to cool using ambient air from the combustion blower and bleed-air duct.

6.1.4 Thermal Oxidizer Temperature

Following heatup, the temperature of the thermal oxidizer was maintained at an established set-point to ensure destruction of contaminants in the furnace exit-gases.

The average oxidizer temperature for each individual test ranged from 1,800 °F to 1,830 °F. The average heatup time for the thermal oxidizer was 36 minutes, with individual times ranging from 15 minutes to 1 hour.

6.1.5 System Draft

An induced draft fan was used to create a negative system draft. The average system draft pressure throughout the validation tests was -0.04 in. w.c. Individual test averages ranged from -0.20 in. w.c. to -0.60 in. w.c.

6.1.6 Material Loading

All test runs were performed using similar mass loads. The furnace loads consisted of two material racks that were loaded with noncontaminated, spiked test materials and contaminated debris from an ongoing remediation project at ALAAP. The loaded material racks were placed in the furnace chamber in the

same position for each of the test runs. The pre-treatment and post-treatment weights of the materials and racks were recorded for each test run.

6.1.7 Thermocouple Placement

Five material load thermocouples were used to sense the temperature of the material load. These thermocouples were placed in the furnace and positioned throughout the material load as indicated in Figure 5-2. The thermocouples were held in fixed positions and placed in the same general locations for all test runs. Some thermocouples were located a few inches above the explosives spike material to provide an indicator of decontamination. The exact locations of the thermocouples and spike specimens were recorded for each test run in the operator logs that are included in Appendix F to the Validation Test Report.

6.2 OPERATIONAL DATA

A summary of data gathered and observations made during each test run is provided in this subsection. More detailed operational information is provided in Appendices E, F, and G as noted below:

- Appendix E: Control Room Log Book.
- Appendix F: Hourly Control Room Logs, Operations Check Sheets, and Furnace Temperature Recorder Charts.
- Appendix G: Summary Data Sheets for Test Runs 1-15.

The control variable settings for the first test run were selected by WESTON in accordance with the approved Validation Test Plan, information gained during demonstration testing, and known chemical and thermal properties of the explosives to be treated. Thereafter, analytical results from each test run were used to determine operating conditions for the following test run.

6.2.1 Validation Test 1

Validation test 1 was started at 16:34 on 31 January 1996 and was completed at 13:54 on 1 February 1996. The selected operating conditions are noted below and Table 6-1 summarizes the furnace operating times.

Treatment Temperature:	500 °F
Heatup (Ramp) Rate:	50 °F/hour
Material Soak Time:	12 hours

EQUIPMENT OPERATIONS DURING VALIDATION TESTING

Table 6-1

Test Run 1: Furnace Operating Times

	Start Time	Stop Time	Total Time
Furnace Burner	16:34	13:54	21:20
Ramp 1: 35-200 °F	16:34	18:22	1:48
Ramp 2: 200-550 °F	18:22	1:32	7:10
Total Ramp Time			8:58
Soak	1:32	13:48	12:16
Total Process Time			21:14

The average material temperature during the soak for test run 1, as measured by the five load thermocouples, was 513 °F. The highest thermocouple reading was 520 °F; the lowest, 502 °F. As noted in Table 6-1, the soak time lasted 12 hours and 16 minutes; however, on one occasion during the soak, the low I.D. fan discharge pressure interlock caused the thermal oxidizer and burner to shut off. The shutdown occurred because the I.D. fan was being operated too close to the I.D. fan interlock set-point. The oxidizer was relit, the burner was relit, and the soak resumed once the average of the load thermocouples reached 500 °F. A little further into the soak, the oxidizer burner and furnace shut down again because of a high temperature interlock. The soak time was stopped, the oxidizer relit, the furnace relit, and soak time was resumed once the average of the load thermocouples reached 500 °F.

Table 6-2 summarizes of the material load placed in the furnace during test run 1. Contaminated debris from the ALAAP remediation effort was not processed in this test run.

Table 6-2

Test Run 1: Furnace Material Load Data

Material Type	Independent Variables			Control Variables		Response Variables		
	Rack A Weight (lb)	Rack B Weight (lb)	Total Weight (lb)	Quantity Spike (grams)	Explosive Type	Material Weight (lb)	Final Wipe Contaminant Conc. (µg)	Final Ground Contaminant Conc. (µg)
Rack	460	460	920	N/A	N/A	920	N/A	N/A
Steel Pipe	1,049		1,049	0.29	TNT	1,049	14.0	N/A
Clay Pipe	521		521	0.10	Tetryl	520	0.00	N/A
Cinder Block	480		480	0.12	RDX	477	N/A	0.00
TOTALS	2,510	460	2,970	0.64		2,966	14.00	0.00

Unusual Events/Changes/Observations for Test Run 1

1. Toward the end of ramp 1, when the furnace chamber temperature was <200 °F, the oxidizer burner shut down. The shutdown was caused because the over-temperature set-point on the furnace control was set too low. The set-point did not allow for normal process temperature variances. This set-point was increased following test run 1 to accommodate variations in process temperature.
2. Approximately 2 hours into the soak period, material load thermocouples TE-203 and TE-204 were switched (using the data-logger program from the control room) to verify the accuracy of TT-204. TT-204 was suspected of reading low; however, the temperature readings after the switch indicated the transmitter calibrations were appropriate. Therefore, the thermocouples were switched back. Although the transmitter calibration was verified, the operation of the thermocouple could not be verified until HGD operations stopped. Post-test investigations found that TE 204 was not operating properly; it had shorted. The effect of a short in a thermocouple is that it causes a biased reading; therefore, datalog readings for TE-204 during test run 1 were inaccurate. TE-204 was not included in the summary data sheet for test run 1.
3. The NO_x analyzer located in the interconnection duct appeared to be operating erratically during test run 1. Post-test investigation indicated that there was a clog in the sample line; therefore, the integrity of NO_x readings throughout test run 1 are suspect.
4. Emissions testing in accordance with the Treatability Study Test Plan was conducted during this test run.

6.2.2 Validation Test 2

Validation test 2 was started at 11:09 on 2 February 1996 and was completed at 23:21 on 2 February 1996. Results from test run 1 indicated complete decontamination of the spiked test materials; therefore, a lower treatment temperature and shorter soak time were selected for test run 2. The selected operating conditions are noted below, and Table 6-3 summarizes the furnace operating times for test run 2.

Treatment Temperature:	400 °F
Heatup (Ramp) Rate:	50 °F/hour
Material Soak Time:	6 hours

Table 6-3

Test Run 2: Furnace Operating Times

	Start Time	Stop Time	Total Time
Oxidizer Burner	11:09	23:21	12:12
Furnace Burner	11:29	23:03	11:34
Ramp 1: 35-200 °F	11:29	13:00	1:13
Ramp 2: 200-450 °F	13:00	17:00	4:00
Total Ramp Time			5:31
Soak	17:00	23:00	6:00
Total Process Time			11:31

The average material temperature during the material soak for test run 2, as measured by the 5 load thermocouples, was 408 °F. The highest thermocouple reading was 418 °F; the lowest, 401 °F. As noted in Table 6-3, the soak time lasted 6 hours. Unlike test run 1, there were no equipment shutdowns during the soak period.

A summary of the material load placed in the furnace during test run 2 is provided in Table 6-4. Contaminated debris from the ALAAP remediation effort was not processed in this test run.

Unusual Events/Changes/Observations from Test Run 2

1. TE-205 appeared to be reading low during the ramp period, therefore, thermocouple TE-205 was unplugged to check for a short, and to check the transmitter. No problems were found with either the thermocouple or transmitter. TE-205 was plugged back in after approximately 12 minutes.

Unplugging TE-205 had no effect on the process, but caused the thermocouple to fail high, which causes the transmitter and data log temperatures to indicate 1,200 °F during the unplugged period. Approximately 12 minutes of data for TE-205 was affected.

2. About an hour before the ramp period ended, draft pressure transmitter PT-158 began indicating a positive pressure within the furnace chamber. This type of condition normally shuts down the furnace; however, draft pressure measured at the interconnection duct during this period indicated -0.70 in. w.c. Field investigations indicated that ice had formed in the low side of the draft transmitter, thus causing a false positive pressure indication. After clearing the ice plug, the furnace draft reading returned to negative. The rest of the test proceeded without event.

EQUIPMENT OPERATIONS DURING VALIDATION TESTING

3. Emissions testing in accordance with the Treatability Study Test Plan was conducted during this test run.

Table 6-4

Test Run 2: Furnace Material Load Data

Material Type	Independent Variables			Control Variables		Response Variables	
	Rack A Weight (lb)	Rack B Weight (lb)	Total Weight ^b (lb)	Quantity Spike (grams)	Explosive Type	Final Wipe Contaminant Conc. (µg)	Final Ground Contaminant Conc. (µg)
Rack	460	460	920	N/A	N/A	N/A	N/A
Steel Pipe			1,049	14.50	TNT	7784.00	N/A
				30.60	Tetryl	0.00	N/A
				24.20	RDX	0.00	N/A
Clay Pipe			521	15.50	TNT	0.00	79.80
				19/30	Tetryl	2.80	0.80
				20.00	RDX	0.00	0.00
Cinder Block			480	13.10	TNT	N/A	7.10
				27.00	Tetryl	N/A	7.40
				19.40	RDX	N/A	0.00
Furnace Wall Plates			N/A	116.20	RDX	0.00	N/A
TOTALS	SCALE NOT OPERABLE^a		2,970	299.80		7,786.80	95.10

^aThe load cell in the scale was not functional during this test; however, no more than 3,000 lb of material was placed in the furnace load.

^bThe weight in this column is approximate. The load used for test run 2 was similar to the furnace test load for test run 1.

6.2.3 Validation Test 3

Validation test 3 was started at 07:28 on 4 February 1996 and was completed at 23:23 on 4 February 1996. Treatment temperatures of 400 °F in test run 2 failed to successfully decontaminate TNT-spiked metal test plates; therefore, the treatment temperature for test run 3 was increased. The selected operating conditions are noted below and Table 6-5 summarizes the furnace operating times for test run 3.

EQUIPMENT OPERATIONS DURING VALIDATION TESTING

Treatment Temperature: 500 °F
 Heatup (Ramp) Rate: 50 °F/hour
 Material Soak Time: 4 hours

Table 6-5

Test Run 3: Furnace Operating Times

	Start Time	Stop Time	Total Time
Oxidizer Burner	7:28	23:23	15:55
Furnace Burner	8:12		14:53
Ramp 1: 35-200 °F	8:12		4:48
Ramp 2: 200-550 °F	13:00		5:42
Total Ramp Time			10:42
Soak	18:54	22:54	4:00
Total Process Time			14:42

The average material load temperature during the material soak for test run 3, as measured by the 5 load thermocouples was 510 °F. The highest thermocouple reading was 543 °F; the lowest, 457 °F. As noted in Table 6-5, the total soak time for this test run was 4 hours. There were no equipment shutdowns during the soak or ramp periods. A summary of the material load placed in test run 3 is provided in Table 6-6. Contaminated debris from the ALAAP remediation effort was not processed in this test run.

Unusual Events/Changes/Observations from Test Run 3

1. Cold weather experienced during this test run caused difficulties in lighting the furnace burner. The first attempt to light the furnace burner was not successful. Minor adjustments were made to the furnace burner, and the burner was lit and remained on-line throughout testing. This problem had no effect on the test run.
2. Material thermocouple TE-203 experienced a temperature spike of 756 °F during the ramp period. Thermocouple TE-203 was located next to a TNT-spiked steel test plate. Residual left on the test plate after processing is noted in Table 6-6.
3. Emissions testing was conducted during this test run.

Table 6-6

Test Run 3: Furnace Material Load Data

Material Type	Independent Variables			Control Variables		Response Variables	
	Rack A Weight (lb)	Rack B Weight (lb)	Total Weight ^b (lb)	Quantity Spike (grams)	Explosive Type	Final Wipe Contaminant Conc. (µg)	Final Ground Contaminant Conc. (µg)
Rack	460	460	920	N/A	N/A	N/A	N/A
Steel Pipe			1,049	12.60	TNT	105.00	715.00 ^c
				16.60	Tetryl	0.00	N/A
				17.80	RDX	0.00	N/A
Clay Pipe			521	14.90	TNT	0.00	
				22.50	Tetryl	0.00	0.00
				17.80	RDX	0.00	0.00
Cinder Block			480	15.80	TNT	N/A	0.00
				24.20	Tetryl	N/A	0.90
				22.00	RDX	N/A	0.00
Furnace Wall Plates			N/A	89.50	Tetryl	3.80	N/A
TOTALS	SCALE NOT OPERABLE^a		2,970	253.70		108.80	715.90

^aThe load cell in the scale was not functional during this test; however, no more than 3,000 lb material was placed in the furnace load.

^bThis weight is approximate. The load used for test run 3 was similar to the furnace test load for test run 1.

^cThis value reflects a residual explosives concentration, which remained on the TNT-spiked steel test plate. The residue was removed, ground into a powder, and analyzed in accordance with Method 8330.

6.2.4 Validation Test 4

Validation test 4 was started at 21:00 on 6 February 1996 and was completed at 15:45 on 7 February 1996. Emissions testing was completed with the conclusion of test run 3. Results from test run 3 indicated traces (0.9 µg to 3.8 µg) of explosives-breakdown compounds on tetryl-contaminated block and furnace wall plates; therefore, the treatment temperature used during test run 3 was maintained, but the soak time was increased from 4 to 6 hours. The selected operating conditions for test run 4 are noted below, and Table 6-7 summarizes the furnace

EQUIPMENT OPERATIONS DURING VALIDATION TESTING

operating times for test run 4. The furnace ramp rate was also increased from 50 °F/hr in test run 1, 2, and 3, to 75 °/hr in test run 4.

Treatment Temperature: 500 °F
 Heatup (Ramp) Rate: 75 °F/hour
 Material Soak Time: 6 hours

Table 6-7

Test Run 4: Furnace Operating Times

	Start Time	Stop Time	Total Time
Oxidizer Burner	21:00	15:45	18:45
Furnace Burner	2:17	15:00	12:43
Ramp 1: 35-200 °F	2:17	2:47	0:30
Ramp 2: 200-550 °F	2:47	8:00	5:13
Total Ramp Time			5:43
Soak	8:00	14:20	6:20
Total Process Time			12:03

The average material load temperature during the material soak for test run 4, as measured by the five load thermocouples, was 516 °F. The highest thermocouple reading was 577 °F; the lowest, 450 °F. Thermocouple TE-206 experienced a 892 °F temperature spike during the ramp.

There were no equipment shutdowns during soak or ramp times, and the cold-weather-related problems encountered during test run 3 were not a problem during this test run.

A summary of the material load placed in the furnace during test run 4 is provided in Table 6-8. This is the first test run where contaminated debris from the remediation effort was placed in the furnace for processing.

Unusual Events/Changes/Observations from Test Run 4

Material thermocouple TE-206, which was placed in a metal pipe with an RDX-spiked metal test plate, experienced a temperature spike of 892 °F during the ramp period. Unlike test run 3, where a similar event yielded residue on the test plate after treatment, no RDX residue was found on the RDX-spiked test plate. Wipe samples from the test plate indicated no traces of explosives or explosives-breakdown compounds.

Table 6-8

Test Run 4: Furnace Material Load Data

Material Type	Independent Variables			Control Variables		Response Variables	
	Rack A Weight (lb)	Rack B Weight (lb)	Total Weight (lb)	Quantity Spike (grams)	Explosive Type	Final Wipe Contaminant Conc. (µg)	Final Ground Contaminant Conc. (µg)
Rack	600	430	1,030	N/A	N/A	N/A	N/A
Steel Pipe	121	20	361	10.40	TNT	0.00	N/A
				9.30	Tetryl	0.00	N/A
				11.00	RDX	0.00	N/A
Clay Pipe		205	205	10.00	TNT	0.00	0.90
				10.10	Tetryl	0.00	0.00
				10.70	RDX	0.00	0.00
Cinder Block		672	672	10.00	TNT	N/A	0.00
				11.50	Tetryl	N/A	0.90
				10.25	RDX	N/A	0.00
Contaminated Steel Debris	369	---	369	---	---	7.00	N/A
Contaminated Rock Debris	365	---	365	---	---	N/A	0.00
Furnace Wall Plates			N/A	51.80	TNT	45.00	N/A
TOTALS	1,455	1,547	3,002	145.05		52.00	1.80

6.2.5 Validation Test 5

Validation test 5 was started at 23:00 on 7 February 1996 and was completed at 10:34 on 8 February 1996. Results from test run 4 indicated acceptable results; therefore, both the treatment temperature and soak times were varied. The selected operating conditions for test run 5 are noted below.

Treatment Temperature: 600 °F
 Heatup (Ramp) Rate: 75 °F/hour
 Material Soak Time: 4 hours

Table 6-9 summarizes the furnace operating times.

Table 6-9

Test Run 5: Furnace Operating Times

	Start Time	Stop Time	Total Time
Oxidizer Burner	23:00	10:34	11:34
Furnace Burner	23:22	10:30	11:08
Ramp 1: 35-200 °F	23:22	23:52	0:30
Ramp 2: 200-650 °F	23:52	4:05	4:13
Total Ramp Time			4:43
Soak	4:05	8:10	4:05
Total Process Time			8:48

The average material temperature during the material soak period for test run 5, as measured by the five load thermocouples, was 614 °F. The highest thermocouple reading was 662 °F; the lowest, 556 °F. Material thermocouples TE-203 and TE-207 experienced spikes during the ramp of 803 °F and 726 °F, respectively.

There were no equipment shutdowns during the soak or ramp periods, and the startup-related problems encountered in test run 3 were no longer an issue.

Table 6-10 summarizes the material load placed in the furnace during test run 5. Contaminated debris from the ALAAP remediation effort was placed in the furnace during this test run for processing.

Unusual Events/Changes/Observations from Test Run 5

1. Material thermocouple TE-203, which was placed next to an RDX-spiked metal test plate, experienced a temperature spike of 803 °F during the ramp period.
2. Material thermocouple TE-207, which was placed next to an RDX-spiked furnace wall plate, experienced a temperature spike of 726 °F during the ramp period.

Table 6-10

Test Run 5: Furnace Material Load Data

Material Type	Independent Variables			Control Variables		Response Variables	
	Rack A Weight (lb)	Rack B Weight (lb)	Total Weight (lb)	Quantity Spike (grams)	Explosive Type	Final Wipe Contaminant Conc. (µg)	Final Ground Contaminant Conc. (µg)
Rack	600	430	1,030	N/A	N/A	N/A	N/A
Steel Pipe	1,453	1,496	2,949	10.10	TNT	0.00	N/A
				14.80	Tetryl	0.00	N/A
				10.70	RDX	0.00	N/A
Clay Pipe		1,252	1,252	10.50	TNT	0.00	0.00
				9.50	Tetryl	0.00	0.00
				10.10	RDX	0.00	0.00
Cinder Block		1,048	1,048	10.10	TNT	N/A	0.00
				9.80	Tetryl	N/A	0.00
				11.80	RDX	N/A	0.00
Steel Debris	1,351	---	1,351	N/A	---	2.60	N/A
Rock Debris	976	---	976	N/A	---	N/A	0.00
Furnace Wall Plates			N/A	48.50	RDX	0.00	N/A
TOTALS	4,380	4,226	8,606	145.90		2.60	0.00

6.2.6 Validation Test 6

Validation Test 6 was started at 08:02 on 12 February 1996 and was completed at 17:40 on 12 February 1996. Post-treatment testing from test run 5 indicated all materials were decontaminated successfully. Based on these results, the operating conditions for test run 6 were selected as noted below.

Treatment Temperature: 600 °F
 Heatup (Ramp) Rate: 75 °F/hour
 Material Soak Time: 2 hours

Treatment temperatures and ramp times for test run 6 remained constant from test run 5. Only the soak time was reduced. Table 6-11 summarizes the operating times for test run 6.

Table 6-11

Test Run 6: Furnace Operating Times

	Start Time	Stop Time	Total Time
Oxidizer Burner	8:02	17:40	9:38
Furnace Burner	9:57	16:52	6:55
Ramp 1: 35-200 °F	0:00	0:00	0:00
Ramp 2: 200-650 °F	9:57	14:50	4:53
Total Ramp Time			4:53
Soak	14:50	16:50	2:00
Total Process Time			6:53

The average material temperature of the load during the soak period for test run 6 was 608 °F. The highest temperature recorded was 659 °F; the lowest, 543 °F. During the ramp period, thermocouple TT-205 began to malfunction. The malfunction lasted 9 minutes and did not appear to affect the average load material temperature during the ramp period. The entire ramp period lasted 4 hours and 54 minutes, versus a 9-minute malfunction.

There were no equipment shutdowns during either the ramp or soak periods for this test run. Table 6-12 summarizes the material load placed in the furnace during test run 6.

Unusual Events/Changes/Observations from Test Run 6

Thermocouple TT-205 malfunctioned during the ramp because of a bad wiring connection at the thermocouple junction box, which is located on the furnace skid. The wiring connection was repaired and the test run continued. As noted in earlier test run discussions, the effect of a failed thermocouple is for the thermocouple temperature to fail high. Therefore, the data logger indicates a material temperature of 1,200 °F for the failed thermocouple (TT-205). Because TT-205 was repaired in less than 10 minutes, the effect of the thermocouple failure was minimal to the overall test run or ramp time.

EQUIPMENT OPERATIONS DURING VALIDATION TESTING

Table 6-12

Test Run 6: Furnace Material Load Data

Material Type	Independent Variables			Control Variables		Response Variables	
	Rack A Weight (lb)	Rack B Weight (lb)	Total Weight (lb)	Quantity Spike (grams)	Explosive Type	Final Wipe Contaminant Conc. (µg)	Final Ground Contaminant Conc. (µg)
Rack	600	430	1,030	N/A	N/A	N/A	N/A
Steel Pipe	78	240	318	9.30	TNT	0.00	0.00
				10.60	Tetryl	0.00	0.00
				8.80	RDX	0.00	0.00
Clay Pipe		205	205	10.70	TNT	0.00	1.10
				8.70	Tetryl	0.00	0.00
				11.00	RDX	0.00	0.00
Cinder Block	89	611	700	9.90	TNT	0.00	0.00
				9.40	Tetryl	0.00	0.00
				9.00	RDX	0.00	0.00
Contaminated Steel Debris	367	---	367	N/A	---	0.00	N/A
Contaminated Rock Debris	367	---	367	N/A	---	N/A	0.00
Furnace Wall Plates			N/A	53.40	Tetryl	0.00	0.00
TOTALS	1,501	1,486	2,987	140.80		0.00	1.10

6.2.7 Validation Test 7

Validation test 7 was started at 16:15 on 13 February 1996 and was completed at 00:43 on 14 February 1996. Post-treatment testing from test run 6 indicated that all contaminated and spiked materials placed in the furnace were successfully decontaminated using a 2-hour soak, 75 °F/hour ramp, and 600 °F treatment temperature. Based on these results, operating conditions for test run 7 were selected as noted below.

Treatment Temperature: 600 °F
 Heatup (Ramp) Rate: 100 °F/hour
 Material Soak Time: 1 hour

The treatment temperature was maintained at 600 °F from test run 6, but the ramp time was increased from 75 °F/hour, to 100 °F/hour, and the soak time was

EQUIPMENT OPERATIONS DURING VALIDATION TESTING

reduced from 2 hours to 1 hour. Table 6-13 summarizes the operating times for test run 7.

Table 6-13

Test Run 7: Furnace Operating Times

	Start Time	Stop Time	Total Time
Oxidizer Burner	16:15	0:43	8:28
Furnace Burner	16:26	0:19	7:53
Total Ramp Time	16:26	21:13	4:47
Soak	21:13	22:18	1:05
Total Process Time			5:52

Starting with test run 7, the furnace ramp was controlled automatically by furnace temperature controller TIC-200, once the furnace chamber temperature reached 100 °F. Table 6-13 differs from the previous test run tables in that only a "Total Ramp Time" is shown, not "Ramp 1" and "Ramp 2", where ramp 2 was controlled manually by the operator.

The average material temperature achieved by the furnace load during the soak period was 605 °F, as determined by the average of the five load thermocouples. The highest temperature was 681 °F; the lowest 494 °F. A low oxidizer temperature interlock (<1,750 °F) was experienced during the ramp period. This caused both the oxidizer and furnace burners to shut off; however, both systems were restarted quickly and no net effect was caused to the test run.

Table 6-14 provides a summary of the material load placed in the furnace during test run 7.

Unusual Events/Changes/Observations from Test Run 7

The calibration range on the high limit controller TIS-145 and temperature transmitter TIT-145, located on the oxidizer, was changed prior to the start of test run 7 to accommodate a higher combustion chamber temperature reading and high limit set-point. The oxidizer was on-line, in a holding pattern at 1,650 °F, while the controller and transmitter were recalibrated.

EQUIPMENT OPERATIONS DURING VALIDATION TESTING

Table 6-14

Test Run 7: Furnace Material Load Data

Material Type	Independent Variables			Control Variables		Response Variables	
	Rack A Weight (lb)	Rack B Weight (lb)	Total Weight (lb)	Quantity Spike (grams)	Explosive Type	Final Wipe Contaminant Conc. (µg)	Final Ground Contaminant Conc. (µg)
Rack	600	430	1,030	N/A	N/A	N/A	N/A
Steel Pipe	73	240	313	10.20	TNT	0.00	N/A
				10.50	Tetryl	0.00	N/A
				10.70	RDX	0.00	N/A
Clay Pipe	---	205	205	10.20	TNT	0.00	1.10 RDX*
				9.70	Tetryl	0.00	0.00
				13.10	RDX	0.00	0.00
Cinder Block	93	626	719	9.90	TNT	N/A	0.00
				11.20	Tetryl	N/A	0.00
				10.90	RDX	N/A	0.00
Contaminated Steel Debris	367	---	367	N/A	---	0.00	N/A
Contaminated Rock Debris	367	---	367	N/A	---	N/A	0.00
Furnace Wall Plates			N/A	50.30	TNT	0.00	N/A
TOTALS	1,500	1,501	3,001	146.70		0.00	0.00

*Because this was a TNT-spiked test specimen, it is suspected the RDX was caused by cross contamination.

Even though the controller and transmitter calibration changes were made prior to testing, the ranges in the data-logging program were not changed until after the test run. As a result, all datalog readings collected for transmitter TIT-145 during test run 7 were incorrect. Because TIT-131 and TIT-145 are essentially the same measurement, and they sense the same temperature in the oxidizer combustion chamber, the temperature reading from TIT-131 was used to monitor the process. The correction factor calculation for the TIT-145 data is as follows:

$$\text{TIT-145}_{\text{corrected}} = \left[\frac{\text{TIT-145}_{\text{logged value}}}{1850 \text{ } ^\circ\text{F}} \right] \times 2000 \text{ } ^\circ\text{F}$$

Although the datalog for TIT-131 was affected, no effect on testing or equipment operations occurred because the controller was reading the correct temperature. Control room logs, kept by the operators, reflect the controller temperature, not the incorrect transmitter temperature.

6.2.8 Validation Test 8

Validation test run 8 was started at 12:05 on 15 February 1996 and was completed at 18:54 on 15 February 1996. Post-treatment analysis from test run 7 indicated that all contaminated debris and spiked materials placed in the furnace were successfully decontaminated using a 100 °F/hour ramp, 600 °F/hour treatment time, and a 1-hour soak. Based on these results, the operating conditions for test run 8 were selected and are noted below.

Treatment Temperature: 500 °F
 Heatup (Ramp) Rate: 100 °F/hour
 Material Soak Time: 2 hours

For test run 8, the treatment temperature was lowered from 600 °F to 500 °F. The ramp rate remains constant at 100 °F/hour, and the material soak time was increased from 1 hour to 2 hours to compensate for the drop in treatment temperature. Table 6-15 summarizes the operating times for test run 8.

Table 6-15

Test Run 8: Furnace Operating Times

	Start Time	Stop Time	Total Time
Oxidizer Burner	12:05	18:54	6:49
Furnace Burner	12:30	18:18	5:48
Total Ramp Time	12:30	16:15	3:45
Soak	16:15	18:15	2:00
Total Process Time			5:45

The average material temperature achieved by the furnace load during the soak period was 507 °F, as determined by the average of the five load thermocouples. The highest material temperature detected was 567 °F; the lowest, 440 °F. Material thermocouple TE-207, which was placed near a furnace wall plate spiked with RDX, experienced a temperature spike of 873 °F during the ramp period.

A summary of the material load placed in the furnace during test run 8 is provided in Table 6-16.

EQUIPMENT OPERATIONS DURING VALIDATION TESTING

Table 6-16

Test Run 8: Furnace Material Load Data

Material Type	Independent Variables			Control Variables		Response Variables	
	Rack A Weight (lb)	Rack B Weight (lb)	Total Weight (lb)	Quantity Spike (grams)	Explosive Type	Final Wipe Contaminant Conc. (µg)	Final Ground Contaminant Conc. (µg)
Rack	600	430	1,030	N/A	N/A	N/A	N/A
Steel Pipe	57	240	297	10.40	TNT	7.90	N/A
				10.90	Tetryl	0.00	N/A
				9.20	RDX	0.00	N/A
Clay Pipe	---	205	205	10.00	TNT	0.00	3.10
				10.40	Tetryl	0.00	0.00
				9.80	RDX	0.00	0.00
Cinder Block	109	626	735	9.80	TNT	N/A	0.70
				9.60	Tetryl	N/A	0.50
				9.60	RDX	N/A	0.00
Contaminated Steel Debris	367	---	367	N/A	---	0.00	N/A
Contaminated Rock Debris	367	---	367	N/A	---	N/A	1.70
Furnace Wall Plates			N/A	47.20	TNT	0.00	N/A
TOTALS	1,500	1,501	3,001	136.90		7.90	4.30

Unusual Events/Changes/Observations from Test Run 8

Except for the temperature spike associated with TE-207, no unusual or irregular events occurred during this test run.

6.2.9 Validation Test 9

Validation test run 9 was started at 12:00 on 19 February 1996 and was completed at 20:03 on 19 February 1996. Post-treatment analysis from test run 8 indicated trace levels of explosives-breakdown compounds on three of the TNT-spiked test specimens and one of the tetryl-spiked specimens. Overall, the test was considered successful and conditions for test run 9 were selected as noted below.

EQUIPMENT OPERATIONS DURING VALIDATION TESTING

Treatment Temperature: 600 °F
 Heatup (Ramp) Rate: 100 °F/hour
 Material Soak Time: None

For test run 9, the furnace treatment temperature was raised from 500 °F to 600 °F, the ramp remained constant at 100 °F/hour, but no soak time was used. Table 6-17 summarizes the operating times for test run 9.

Table 6-17

Test Run 9: Furnace Operating Times

	Start Time	Stop Time	Total Time
Oxidizer Burner	12:00	20:03	8:03
Furnace Burner	12:50	19:18	6:28
Total Ramp Time	12:50	19:08	6:18
Soak	19:08	19:08	0:00
Total Process Time			6:21

The average material temperature achieved by the furnace load during the soak period was 561 °F, as determined by the average of the five load thermocouples. The highest material temperature detected was 624 °F; the lowest, 480 °F. A short shutdown occurred during the ramp due to the high temperature interlock associated with the oxidizer. The oxidizer and furnace burners were restarted within 30 minutes, and the test run was resumed. A summary of the material load placed in the furnace during test run 9 is provided in Table 6-18.

Unusual Events/Changes/Observations from Test Run 9

1. Unused TNT from test run 1 was used to spike this test run. The TNT had crystallized during the storage period between test runs 1 and 9.
2. During the ramp period, the oxidizer burner shut off because of the high temperature interlock associated with the oxidizer chamber. This tripped the high limit set-point in the oxidizer controller and also shut off the furnace burner. The oxidizer burner was relit within 10 minutes and the furnace was relit a few minutes later. The ramp program was restarted approximately 30 minutes after the oxidizer shutdown.
3. Material thermocouple TE-207, which is associated with a tetryl-spiked furnace wall plate, experienced a temperature spike of 775 °F during the ramp period.

EQUIPMENT OPERATIONS DURING VALIDATION TESTING

Table 6-18

Test Run 9: Furnace Material Load Data

Material Type	Independent Variables			Control Variables		Response Variables	
	Rack A Weight (lb)	Rack B Weight (lb)	Total Weight (lb)	Quantity Spike (grams)	Explosive Type	Final Wipe Contaminant Conc. (µg)	Final Ground Contaminant Conc. (µg)
Rack	600	430	1,030	N/A	N/A	N/A	N/A
Steel Pipe	100	240	340	10.30	TNT	0.00	N/A
				11.30	Tetryl	0.00	N/A
				13.00	RDX	0.00	N/A
Clay Pipe		205	205	10.40	TNT	0.00	0.00
				11.40	Tetryl	0.00	0.00
				15.20	RDX	0.00	0.00
Cinder Block	66	626	692	10.20	TNT	N/A	0.00
				12.10	Tetryl	N/A	0.00
				10.80	RDX	N/A	0.00
Contaminated Steel Debris	367	---	367	N/A	---	0.00	N/A
Contaminated Rock Debris	367	---	367	N/A	---	N/A	3.60
Furnace Wall Plates			N/A	59.40	Tetryl	0.00	N/A
TOTALS	1,500	1,501	3,001	164.10		0.00	3.60

6.2.10 Validation Test 10

Validation test run 10 was started at 18:49 on 20 February 1996 and was completed at 01:20 on 21 February 1996. Post-treatment analysis from test run 9 indicated complete decontamination of all spiked test materials and trace levels (3.6 µg) of explosives on the porous, contaminated debris. Overall, 600 °F with a zero soak was effective; therefore, test run 10 was conducted using the operating conditions noted below.

Treatment Temperature: 550 °F
 Heatup (Ramp) Rate: 150 °F/hour
 Material Soak Time: 1 hour

In test run 10, the treatment temperature was lowered from 600 °F to 550 °F, the ramp rate was increased from 100 °F/hour to 150 °F/hour, and the soak time was

EQUIPMENT OPERATIONS DURING VALIDATION TESTING

increased from zero to 1 hour to compensate for the decrease in treatment temperature. Table 6-18 summarizes the operating times for test run 10.

Table 6-19**Test Run 10: Furnace Operating Times**

	Start Time	Stop Time	Total Time
Oxidizer Burner	18:49	1:20	6:31
Furnace Burner	19:52	0:41	4:49
Total Ramp Time	19:52	23:38	3:46
Soak	23:38	0:38	1:00
Total Process Time			4:46

The average material temperature achieved by the furnace load during the soak period was 559 °F, as determined by the average of the five load thermocouples. The highest material temperature was 642 °F; the lowest, 465 °F. A summary of the material load placed in the furnace during test run 10 is provided in Table 6-20.

Unusual Events/Changes/Observations from Test Run 10

No unusual events, changes, or observations occurred during test run 10.

Table 6-20

Test Run 10: Furnace Material Load Data

Material Type	Independent Variables			Control Variables		Response Variables	
	Rack A Weight (lb)	Rack B Weight (lb)	Total Weight (lb)	Quantity Spike (grams)	Explosive Type	Final Wipe Contaminant Conc. (µg)	Final Ground Contaminant Conc. (µg)
Rack	600	430	1,030	N/A	N/A	N/A	N/A
Steel Pipe	33	240	273	9.90	TNT	0.00	N/A
				10.80	Tetryl	0.00	N/A
				9.10	RDX	0.00	N/A
Clay Pipe		250	250	10.10	TNT	0.00	0.00
				9.70	Tetryl	0.00	0.00
				9.40	RDX	0.00	0.00
Cinder Block	133	629	759	10.10	TNT	N/A	0.50
				9.50	Tetryl	N/A	0.00
				9.00	RDX	N/A	0.00
Contaminated Steel Debris	367	---	367	N/A	---	0.00	N/A
Contaminated Rock Debris	367	---	367	N/A	---	N/A	0.00
Furnace Wall Plates			N/A	49.80	TNT	0.00	N/A
TOTALS	1,500	1,501	3,001	137.40		0.00	0.50

6.2.11 Validation Test 11

Validation test run 11 was started at 10:00 on 22 February 1996 and was completed at 14:30 on 22 February 1996. Post-treatment analysis from test run 10 indicated complete decontamination of all spiked test specimens, spiked furnace wall plates, and contaminated debris with the exception of trace (0.5 µg) explosives-breakdown compounds on a TNT-spiked block specimen. Overall, a 550 °F treatment temperature with a 150 °F/hour ramp, and 1-hour soak performed flawlessly; therefore, the conditions for test run 11 were selected in an attempt to fail test plates so that a lower limit treatment temperature could be defined. Up until this test run, most failures were related to TNT-spiked materials, not RDX or tetryl. The test conditions for test run 11 are noted below.

EQUIPMENT OPERATIONS DURING VALIDATION TESTING

Treatment Temperature: 400 °F
 Heatup (Ramp) Rate: 150 °F/hour
 Material Soak Time: 1 hour

In test run 11, the treatment temperature was lowered from 550 °F to 400 °F, but the ramps and soak times remained the same at 150 °F/hour and a 1-hour soak. Table 6-20 summarizes the operating times for test run 11.

Table 6-21

Test Run 11: Furnace Operating Times

	Start Time	Stop Time	Total Time
Oxidizer Burner	10:00	14:30	4:30
Furnace Burner	10:47	13:33	2:46
Total Ramp Time	10:47	12:28	1:41
Soak	12:28	13:28	1:00
Total Process Time			2:41

The average material temperature achieved by the furnace load during the soak period was 415 °F, as measured by the average of the five load thermocouples. The highest material temperature reached was 491 °F; the lowest, 299 °F. Material thermocouple TE-207, which was located next to an RDX-spiked furnace wall plate, indicated a 732 °F temperature spike during the ramp.

A summary of the material load placed in the furnace during test run 11 is provided in Table 6-22.

Unusual Events/Changes/Observations from Test 11

No unusual events, changes, or observations were observed during test run 11, except for the temperature spike associated with TE-207.

Table 6-22

Test Run 11: Furnace Material Load Data

Material Type	Independent Variables			Control Variables		Response Variables	
	Rack A Weight (lb)	Rack B Weight (lb)	Total Weight (lb)	Quantity Spike (grams)	Explosive Type	Final Wipe Contaminant Conc. (μg)	Final Ground Contaminant Conc. (μg)
Rack	600	430	1,030	N/A	N/A	N/A	N/A
Steel Pipe	66	240	306	9.90	TNT	22.00	N/A
				9.80	Tetryl	0.00	N/A
				11.20	RDX	0.00	N/A
Clay Pipe		205	205	10.00	TNT	0.00	7,235.00
				11.60	Tetryl	3.20	0.00
				14.50	RDX	0.00	0.00
Cinder Block	100	627	727	4.20	TNT	N/A	37,629.00
				4.70	Tetryl	N/A	134.00
				12.50	RDX	N/A	0.00
Contaminated Steel Debris	367	---	367	N/A	---	4.70	N/A
Contaminated Rock Debris	367	---	367	N/A	---	N/A	4.30
Furnace Wall Plates			N/A	58.90	RDX	19.10	N/A
TOTALS	1,500	1,502	3,002	147.30		49.0	45,002.30

6.2.12 Validation Test 12

Validation test run 12 was started at 11:50 on 26 February 1996 and was completed at 18:40 on 26 February 1996. Post-treatment analysis from test run 11 finally achieved what appeared to be gross failures. Test run 11 failed to decontaminate TNT-spiked porous materials, such as concrete and clay, and the RDX-spiked furnace wall plates, which had failed for trace levels (7.1 and 12 μg of RDX); and the contaminated debris still indicated levels of explosives-breakdown compounds.

Despite the results from test run 11, there still had not been gross failures related to either RDX or tetryl. For this reason, treatment conditions for test run 12 were selected as noted below.

EQUIPMENT OPERATIONS DURING VALIDATION TESTING

Treatment Temperature: 300 °F
 Heatup (Ramp) Rate: 200 °F/hour
 Material Soak Time: 1 hour

This treatment temperature is 100 °F below the treatment temperature for test run 11. The ramp rate was increased from 150 °F/hour to 200 °F/hour, but the soak time remained at 1 hour. Table 6-23 summarizes the operating times for test run 12.

Table 6-23

Test Run 12: Furnace Operating Times

	Start Time	Stop Time	Total Time
Oxidizer Burner	11:50	18:40	6:50
Furnace Burner	12:50	16:00	3:10
Total Ramp Time	12:50	14:58	2:08
Soak	14:58	15:58	1:00
Total Process Time			3:08

The average material temperature achieved by the furnace load during the soak period was 316 °F, as measured by the average of the five load thermocouples. The highest material temperature reached was 386 °F; the lowest, 206 °F. A summary of the material load placed in the furnace during test run 12 is provided in Table 6-24.

Unusual Events/Changes/Observations from Test Run 12

In order to collect temperature feedback on the furnace exit-gas temperature, TE-100 was moved prior to starting test run 12. The new thermocouple location is approximately 10 inches from the furnace shell. A Type K thermocouple was used, and the ADAM module was reprogrammed and calibrated to support data logging and monitoring.

Table 6-24

Test Run 12: Furnace Material Load Data

Material Type	Independent Variables			Control Variables		Response Variables	
	Rack A Weight (lb)	Rack B Weight (lb)	Total Weight (lb)	Quantity Spike (grams)	Explosive Type	Final Wipe Contaminant Conc. (µg)	Final Ground Contaminant Conc. (µg)
Rack	600	430	1,030	N/A	N/A	N/A	N/A
Steel Pipe	69	204	309	10.70	TNT	TNT still visible ^a	N/A
				9.90	Tetryl	0/00	N/A
				9.30	RDX	RDX still visible ^a	N/A
Clay Pipe	---	204	204	6.40	TNT	490.00 ^b	33048.00 ^b
				8.10	Tetryl	0.00	0.00
				12.00	RDX	---	RDX still visible ^a
Cinder Block	97	---	97	17.40	TNT	N/A	14566.00 ^b
				5.30	Tetryl	N/A	0.00
				10.10	RDX	N/A	RDX still visible ^a
Contaminated Steel Debris	367	626	993	N/A	---	0.00	N/A
Contaminated Rock Debris	367	---	367	N/A	---	N/A	0.00
Furnace Wall Plates			N/A	50.40	Tetryl	5.50	N/A
TOTALS	1,500	1,500	3,000	139.60		495.50	47614.00

^aThe treatment temperature (300 °F) for this test run was so low that TNT and RDX remained on many of the spiked specimens. The explosives appeared as though they had never been processed. These samples were rerun in a separate furnace run to complete decontamination.

^bThe samples were reprocessed with the test plates discussed in Note a.

6.2.13 Validation Test 13

Validation test 12 was started at 08:06 on 27 February 1996 and was completed at 13:15 on 27 February 1996. Results from test run 12 finally established a lower-level treatment temperature for RDX. Even though TNT had failed in higher temperature (400 °F) test runs, this is the first time "untreated" TNT remained on the spiked test plates and specimens. Based on these data, the remaining validation test runs were conducted using higher treatment temperatures.

EQUIPMENT OPERATIONS DURING VALIDATION TESTING

Test conditions for test run 12 were defined as noted below.

Treatment Temperature: 500 °F
 Heatup (Ramp) Rate: 200 °F/hour
 Material Soak Time: 1 hour

A table summarizing the operating times for test run 13 is provided in Table 6-25.

Table 6-25

Test Run 13: Furnace Operating Times

	Start Time	Stop Time	Total Time
Oxidizer Burner	8:06	13:15	5:09
Furnace Burner	8:39	11:56	3:17
Total Ramp Time	8:39	10:51	2:12
Soak	10:51	11:53	1:02
Total Process Time			3:14

The average material temperature achieved by the furnace load, as determined by the average of the five load thermocouples, was 511 °F. The highest material temperature detected was 608 °F; the lowest, 415 °F. Material thermocouple TE-203, which is located next to an RDX-spiked clay test specimen, had a temperature excursion of 1,023 °F during the ramp.

A summary of the material load placed in the furnace during test run 13 is provided in Table 6-26.

Unusual Events/Changes/Observations from Test Run 13

A few minutes into the soak, the oxidizer control temperature began to malfunction. Temperature controller TIC-131, which controls the oxidizer temperature, was placed into MANUAL. This allowed the operator to control the oxidizer temperature while the malfunction was being investigated. Starting with the thermocouple and working backward through the loop, it was discovered that TIT-131 (which is a Smart programmable transmitter) had lost its calibration values. TIT-131 was reprogrammed and calibrated; however, after 15 minutes of operation the transmitter failed again. Test run 13 was completed by operating TIC-131 in MANUAL. Further investigation, following test run 13, determined the problem to be an internal problem with the transmitter.

Table 6-26

Test Run 13: Furnace Material Load Data

Material Type	Independent Variables			Control Variables		Response Variables	
	Rack A Weight (lb)	Rack B Weight (lb)	Total Weight (lb)	Quantity Spike (grams)	Explosive Type	Final Wipe Contaminant Conc. (µg)	Final Ground Contaminant Conc. (µg)
Rack	600	430	1,030	N/A	N/A	N/A	N/A
Steel Pipe	42	204	282	11.10	TNT	0.00	N/A
				11.80	Tetryl	0.00	N/A
				11.40	RDX	0.00	N/A
Clay Pipe	---	204	204	11.70	TNT	0.00	0.00
				11.00	Tetryl	0.00	0.00
				10.00	RDX	0.00	0.00
Cinder Block	124	626	750	10.60	TNT	N/A	14.40
				13.70	Tetryl	N/A	0.00
				10.60	RDX	N/A	0.00
Contaminated Steel Debris	367	---	367	N/A	---	0.00	N/A
Contaminated Rock Debris	367	---	367	N/A	---	N/A	6.90
Furnace Wall Plates			N/A	50.50	TNT	14.70	66.00
TOTALS	1,500	1,500	3,000	152.40		14.70	87.30

6.2.14 Validation Test 14

Validation test 14 was started at 11:40 on 28 February 1996 and was completed at 16:16 on 28 February 1996. Results from test run 13 were good. All spiked and contaminated materials placed in the furnace were decontaminated except for a 66 µg hit of explosives-breakdown compounds found on a TNT-spiked furnace plate, and a 14.4 µg hit of explosives-breakdown compounds from a TNT-spiked block specimen. Based on these results, test conditions for test run 14 were defined as noted below.

Treatment Temperature: 600 °F
 Heatup (Ramp) Rate: 300 °F/hour
 Material Soak Time: 1 hour

This was the first test run that used a 300 °F/hour ramp. A summary of the operating times for test run 14 are provided in Table 6-27.

Table 6-27

Test Run 14: Furnace Operating Times

	Start Time	Stop Time	Total Time
Oxidizer Burner	on-line	16:16	N/A
Furnace Burner	11:40	15:25	3:45
Total Ramp Time	11:40	14:19	2:39
Soak	14:18	15:21	1:03
Total Process Time			3:41

The average material thermocouple temperature achieved by the furnace load, as determined by the five load thermocouples, was 587 °F. The highest material temperature recorded was 703 °F; the lowest, 458 °F. Material thermocouple TE-207, which was located next to an RDX-spiked furnace wall plate, experienced a temperature spike of 924 °F during ramp.

A summary of the material load placed in the furnace during test run 14 is provided in Table 6-28.

Unusual Events/Changes/Observation from Test Run 14

1. Due to the failure of TIT-131 in test run 13, data from TIT-131 was still invalid for test run 14. A replacement transmitter was ordered, but had not arrived in time to support test run 14.
2. Toward the end of the ramp period, the furnace burner shut off due to a high temperature interlock. Shortly thereafter, the oxidizer burner shut off because of the low I.D. fan discharge pressure interlock, which was triggered by a momentary low pressure caused when the furnace burner was reignited. This event repeated itself several times, before the burner successfully reignited and stayed lit. See Note 3 below.
3. The ramp rate for test run 14 was programmed for 300 °F/hour. This faster ramp rate did not allow enough time for the heat from the chamber to soak into the material load; therefore, when the chamber temperature reached 600 °F, the average material load temperature was lagging more than previously experienced in other test runs. As a result, the burner was required to fire harder once it reached treatment temperature (600 °F), and the operating temperatures inside the chamber increased to between 650 °F and 700 °F, which exceeded the set-point the furnace's high limit over-temperature interlock.

EQUIPMENT OPERATIONS DURING VALIDATION TESTING

Table 6-28

Test Run 14: Furnace Material Load Data

Material Type	Independent Variables			Control Variables		Response Variables	
	Rack A Weight (lb)	Rack B Weight (lb)	Total Weight (lb)	Quantity Spike (grams)	Explosive Type	Final Wipe Contaminant Conc. (µg)	Final Ground Contaminant Conc. (µg)
Rack	600	430	1,030	N/A	N/A	N/A	N/A
Steel Pipe	27	240	267	10.60	TNT	0.00	N/A
				9.80	Tetryl	0.00	N/A
				9.60	RDX	0.00	N/A
Clay Pipe		204	204	11.00	TNT	0.00	0.00
				10.60	Tetryl	0.00	0.00
				12.40	RDX	0.00	0.00
Cinder Block	139	629	765	10.10	TNT	N/A	0.00
				10.60	Tetryl	N/A	0.00
				11.90	RDX	N/A	0.00
Contaminated Steel Debris	367		367	N/A	---	0.00	N/A
Contaminated Rock Debris	367		367	N/A	---	N/A	0.00
Furnace Wall Plates			N/A	52.90	RDX	0.00	0.00
TOTALS	1,500	1,500	3,000	149.50		0.00	0.00

6.2.15 Validation Test 15

Validation test 15 was started at 08:05 on 1 March 1996 and was completed at 12:38 on 1 March 1996. All spiked wall plates and test specimens were completely decontaminated by the operating conditions set for test run 14. Those same conditions were repeated for test run 15, as noted below.

Treatment Temperature: 600 °F
 Heatup (Ramp) Rate: 300 °F/hour
 Material Soak Time: 1 hour

A summary of the operating times for test run 15 is provided in Table 6-29.

Table 6-29

Test Run 15: Furnace Operating Times

	Start Time	Stop Time	Total Time
Oxidizer Burner	8:05	12:38	4:33
Furnace Burner	8:46	11:55	3:09
Total Ramp Time	8:46	10:52	2:06
Soak	10:52	11:52	1:00
Total Process Time			3:06

The average material temperature reached by the furnace load, as determined by the five load thermocouples, was 612 °F. This is slightly higher than the average material load temperature for test run 14. The highest material temperature recorded was 710 °F; the lowest, 555 °F. This was approximately 100 °F higher than observed in test run 14. Material thermocouple TE-207, which was located next to a tetryl-spiked furnace wall plate, indicated a temperature excursion of 830 °F during ramp.

A summary of the material load placed in the furnace during test run 15 is provided in Table 6-30.

Unusual Events/Changes/Observations from Test Run 15

Toward the end of the soak, the furnace burner was shut off due to an over-temperature interlock. As in test run 14, the ramp rate for this test run was programmed for 300 °F/hour. This faster ramp rate did not allow enough time for the heat from the chamber to soak into the material load; therefore, when the chamber temperature reached 600 °F, the average material load temperature was approximately 100 °F lower. As a result, the furnace burner was required to fire harder once it reached treatment temperature (600 °F), and the operating temperatures inside the chamber increased to between 650 and 700° F, which exceeded the furnace's set-point for high limit over-temperature interlock.

Table 6-30

Test Run 15: Furnace Material Load Data

Material Type	Independent Variables			Control Variables		Response Variables	
	Rack A Weight (lb)	Rack B Weight (lb)	Total Weight (lb)	Quantity Spike (grams)	Explosive Type	Final Wipe Contaminant Conc. (μg)	Final Ground Contaminant Conc. (μg)
Rack	600	430	1,030	N/A	N/A	N/A	N/A
Steel Pipe	---	240	240	9.90	TNT	0.00	N/A
				9.20	Tetryl	0.00	N/A
				9.80	RDX	0.00	N/A
Clay Pipe	---	204	204	10.20	TNT	0.00	0.00
				11.30	Tetryl	0.00	0.00
				9.80	RDX	0.00	0.00
Cinder Block	170	626	796	7.00	TNT	N/A	0.00
				8.80	Tetryl	N/A	0.00
				10.50	RDX	N/A	0.00
Contaminated Steel Debris	363	---	363	N/A		0.00	N/A
Contaminated Rock Debris	367	---	367	N/A		N/A	1.20
Furnace Wall Plates			N/A	47.10	Tetryl	0.00	0.00
TOTALS	1,500	1,500	3,000	133.60		0.00	1.20

6.2.16 Validation Test 16A

Validation test 16A was started at 15:07 on 6 March 1996 and was completed at 17:47 on 6 March 1996. With the exception of trace (1.2 μg) explosives-breakdown compounds found on the contaminated debris, all spiked materials in test run 15 were completely decontaminated. Test run 16A was conducted with only TNT-spiked materials. As noted below, the treatment temperature and ramp were the same as those used in test run 15; however, the soak was decreased to zero.

Treatment Temperature: 600° F
 Heatup (Ramp) Rate: 300°/hour
 Material Soak Time: None

A summary of operating times for test run 16A is provided in Table 6-31.

Table 6-31

Test Run 16A: Furnace Operating Times

	Start Time	Stop Time	Total Time
Oxidizer Burner	15:07	17:47	2:40
Furnace Burner	15:31	17:20	1:49
Total Ramp Time	15:31	17:10	1:39
Soak	17:10	17:10	0:00
Total Process Time			1:39

A summary of the material load placed in test run 16A is provided in Table 6-32. Contaminated debris from ALAAP was not treated in this test run.

Unusual Events/Changes/Observations from Test Run 16A

The following process control/measurement changes were made prior to starting test run 16A:

1. To avoid the furnace shutdowns experienced in test runs 14 and 15 (while using a 300 °F/hour ramp), furnace control thermocouple TE-200 was moved from the furnace chamber to the furnace exit duct. By moving the thermocouple location, control of the combustion chamber would now be based on furnace exit-gas temperature, not furnace chamber temperature.
2. Thermocouple TE-100, which had measured the furnace exit-gas temperature, was moved to the I.D. fan inlet duct to measure the I.D. fan inlet gas temperature.
3. The stack NO_x analyzer's sample tubing was moved to the interconnection duct sample line, and the NO_x analyzer was set up to measure nitrogen oxide (NO) instead of NO_x.

Table 6-32

Test Run 16A: Furnace Material Load Data

Material Type	Independent Variables			Control Variables		Response Variables	
	Rack A Weight (lb)	Rack B Weight (lb)	Total Weight (lb)	Quantity Spike (grams)	Explosive Type	Final Wipe Contaminant Conc. (µg)	Final Ground Contaminant Conc. (µg)
Rack	600	430	1,030	N/A	N/A	N/A	N/A
Steel Pipe	---	240	240	11.70	TNT	0.00	N/A
				10.20	TNT	0.00	N/A
Clay Pipe	---	240	204	11.10	TNT	N/A	0.00
				11.30	TNT	N/A	0.00
Cinder Block	900	680	1580	10.20	TNT	N/A	7962.00
				9.40		N/A	6302.00
Furnace Wall Plates			N/A	52.60	TNT	71.00	N/A
TOTALS	1,500	1,554	3,054	116.50		71.00	14264.00

6.2.17 Validation Tests 16B and 16C

Validation test 16B was conducted using only tetryl-spiked materials, and was started at 22:06 on 6 March 1996 and completed at 00:30 on 7 March 1996. Validation test run 16C was conducted using only RDX-spiked materials and was started at 13:06 on 7 March 1996 and completed at 15:38 on 7 March 1996. Results from test run 16A indicated a 300 °F/hour ramp to treatment temperature (600 °F) with a zero soak period was not sufficient to treat TNT-contaminated materials. However, these conditions remained unchanged for test runs 16B and 16C as noted below.

Treatment Temperature: 600° F
 Heatup (Ramp) Rate: 300°F/hour
 Material Soak Time: None

Summaries of operating times for test runs 16B and 16C are provided in Tables 6-33 and 6-34, respectively.

EQUIPMENT OPERATIONS DURING VALIDATION TESTING

Table 6-33

Test Run 16B: Furnace Operating Times

	Start Time	Stop Time	Total Time
Oxidizer Burner	22:06	0:30	2:24
Furnace Burner	22:30	23:54	1:24
Total Ramp Time	22:30	23:51	1:21
Soak	23:51	23:51	0:00
Total Process Time			1:21

Table 6-34

Test Run 16C: Furnace Operating Times

	Start Time	Stop Time	Total Time
Oxidizer Burner	13:06	15:38	2:32
Furnace Burner	13:21	15:02	1:41
Total Ramp Time	13:21	14:53	1:32
Soak	14:53	14:53	0:00
Total Process Time			1:32

Contaminated debris from ALAAP was not placed in test runs 16B or 16C. Summaries of the materials placed in the furnace during test runs 16B and 16C are provided in Tables 6-35 and 6-36, respectively.

EQUIPMENT OPERATIONS DURING VALIDATION TESTING

Table 6-35

Test Run 16B: Furnace Material Load Data

Material Type	Independent Variables			Control Variables		Response Variables	
	Rack A Weight (lb)	Rack B Weight (lb)	Total Weight (lb)	Quantity Spike (grams)	Explosive Type	Final Wipe Contaminant Conc. (µg)	Final Ground Contaminant Conc. (µg)
Rack	600	430	1,030	N/A	N/A	N/A	N/A
Steel Pipe		240	240	11.70	Tetryl	0.00	N/A
				12.50	Tetryl	0.00	N/A
Clay Pipe		204	204	12.90	Tetryl	N/A	0.60
				11.50	Tetryl	N/A	0.00
Cinder Block	900	633	1533	12.10	Tetryl	N/A	191.00
				12.00	Tetryl	N/A	162.00
Furnace Wall Plates			N/A	62.00	Tetryl	16.00	N/A
TOTALS	1,500	1,507	3,007	134.70		16.00	353.60

Table 6-36

Test Run 16C: Furnace Material Load Data

Material Type	Independent Variables			Control Variables		Response Variables	
	Rack A Weight (lb)	Rack B Weight (lb)	Total Weight (lb)	Quantity Spike (grams)	Explosive Type	Final Wipe Contaminant Conc. (µg)	Final Ground Contaminant Conc. (µg)
Rack	600	430	1,030	N/A	N/A	N/A	N/A
Steel Pipe		240	240	10.60	RDX	0.00	N/A
			0	8.90	RDX	0.00	N/A
Clay Pipe		204	204	11.60	RDX	N/A	0.00
			0	11.10	RDX	N/A	0.00
Cinder Block	900	626	1526	10.00	RDX	N/A	0.00
				13.60	RDX	N/A	1.30
Furnace Wall Plates				53.70	RDX	7.40	N/A
TOTALS	1,500	1,500	3,000	119.50		7.40	1.30

Unusual Events/Changes/Observation from Test Runs 16B and 16C

No unusual events occurred during either test run 16B or 16C.

6.3 DEVIATIONS FROM THE TEST PLAN

6.3.1 Data Logging

The flame signals of the furnace and oxidizer were not monitored by the data logging system, because the flame safety system on both the furnace and oxidizer did not have the ability to provide a signal for datalog monitoring and because it is very difficult to transmit a flame signal over long distances (i.e., 800 ft from equipment to control area). Both flame signals were monitored locally.

6.3.2 Treatment Duration (Soak Cycle)

The Validation Test Plan stated that the soak would begin once the furnace chamber reached the desired steady-state treatment temperature for a particular test run; however, the soak actually began when the average of the five material load thermocouples reached the target treatment temperature for a particular test run.

6.3.3 Oxidizer Residence Time

The Validation Test Plan stated that the oxidizer gas residence time would be monitored; however, the temperature of the furnace exit-gas (which is needed to calculate the residence time) was not measured. In addition, the data-logging system was not set up to perform the necessary calculations, even though the program would be able to perform the calculation if given the necessary inputs from the process. Consequently, residence time was not calculated or recorded.

7.

SOURCE EMISSIONS SAMPLING, ANALYSIS, AND RESULTS

7.1 OVERVIEW—SOURCE EMISSIONS TESTING PROGRAM

Stacking testing was conducted at the thermal oxidizer inlet and outlet during three test runs (validation tests T1, T2, and T3) to determine system emissions and thermal oxidizer destruction removal efficiencies (DREs). Stack testing was conducted for the following parameters:

Parameter	Test Location	
	Furnace Discharge (Thermal Oxidizer Inlet)	Thermal Oxidizer Discharge
Explosives	X	X
Oxides of nitrogen (NO _x)	X	X
Total hydrocarbons (THC)	X	X
Carbon dioxide (CO ₂) and Oxygen (O ₂)	X	X
Particulates		X
Hydrochloric acid (HCl)		X
Chlorine (Cl ₂)		X
Semivolatile organic compounds (SVOCs)		X
Dioxins/furans		X
Volatile organic compounds (VOCs)		X
Metals		X
Carbon monoxide (CO)		X
Sulfur dioxide (SO ₂)		X

Detailed summary tables of the test data and test results, along with discussions of results for the source emissions measured at the furnace discharge (thermal oxidizer inlet) and thermal oxidizer discharge, are presented in this section.

Detailed descriptions of all sampling and analytical methods are provided in Appendix A. Raw test data, equipment calibration records, and example calculations are provided in Appendix H. Source emissions laboratory analytical reports are included in Appendix I.

7.2 SOURCE EMISSIONS REGULATORY PERFORMANCE STANDARDS

The HGD process is classified by federal and state regulatory agencies as a thermal treatment system; therefore, federal regulatory performance standards for thermal treatment systems processing hazardous and toxic waste as outlined in Chapter 40 of the Code of Federal Regulations (40 CFR) must be followed to support future permitting.

The transportable HGD system was designed to meet all applicable regulatory performance standards contained in the following sections of 40 CFR:

- Resource Conservation and Recovery Act (RCRA) incinerator standards specified in 40 CFR, Part 264, Subpart O.
- Miscellaneous Unit standards specified in 40 CFR, Part 264, Subpart X.
- Boiler and Industrial Furnace (BIF) standards specified in 40 CFR, Part 266, Subpart H.
- Toxic Substances Control Act (TSCA) incinerator standards specified in 40 CFR, Part 761.70(b).

When appropriate, a comparison of test results to the applicable performance standard is included in each subsection in which source emission results are discussed. Source emission testing performed during the validation test program demonstrated the transportable HGD system satisfies the applicable performance standards.

7.3 SOURCE EMISSIONS TEST RESULTS AND DISCUSSION

7.3.1 Particulate, Hydrochloric Acid, and Chlorine

Particulate, hydrochloric acid (HCl), and chlorine (Cl₂) emissions at the thermal oxidizer's discharge were sampled during validation tests T1, T2, and T3 using EPA Method 0050. The filterable particulate analysis was performed using EPA Method 5; HCl and Cl₂ determinations were performed using EPA Method 9057 (ion chromatography) procedures.

A summary of the particulate, HCl, and Cl₂ emission results is provided in Table 7-1. Detailed test data and test results are presented in Table 7-2.

Table 7-1

Summary of Particulate, HCl, and Cl₂ Emissions at the Thermal Oxidizer Discharge

Test Run No.: Date: Time:	T1 31 Jan 96 1834-0103	T2 2 Feb 96 1407-2011	T3 4 Feb 96 1408-2026	Average
Particulate, gr/dscf at 7% O ₂	4.52E-04	2.22E-04	6.56E-04	4.40E-04
HCl (ppm/v)	0.31	0.27	0.27	0.28
lb/hr	1.77E-03	1.50E-03	1.40E-03	1.56E-03
Cl ₂ (ppm/v)	0.019	0.098	0.109	0.08

gr/dscf = grains per dry standard cubic foot.
ppm/v = parts per million by volume.

As shown in Table 7-1, particulate emissions for test runs T1, T2, and T3 were 4.52×10^{-4} , 2.22×10^{-4} , and 6.56×10^{-4} gr/dscf at 7% O₂, respectively. The average particulate concentration was 4.4×10^{-4} gr/dscf at 7% O₂. Measured particulate emissions were two orders of magnitude below the current standard of 0.08 gr/dscf at 7% O₂.

HCl mass rates for tests T1, T2, and T3 were 1.77×10^{-3} , 1.50×10^{-3} , and 1.40×10^{-3} lb/hr, respectively. The average HCl mass rate was 1.56×10^{-3} lb/hr. The measured HCl emissions are well below the existing mass rate standard of 4.0 lb/hr.

Cl₂ emissions for tests T1, T2, and T3 were 0.019, 0.098, and 0.109 ppm/v, respectively. The average Cl₂ concentration was 0.08 ppm/v. No regulatory limit currently exists for Cl₂ alone; however, the total HCl and Cl₂ concentrations are well below the existing and proposed total chlorine standard of 280 ppm/v and 67 ppm/v, respectively.

7.3.2 Explosives

Explosives emissions were measured simultaneously at the furnace discharge (thermal oxidizer inlet) and thermal oxidizer discharge. Samples were collected using EPA Method 0010 procedures and were analyzed by EPA Method 8330 using high-performance liquid chromatography (HPLC).

Table 7-2

Particulate, HCl, and Cl₂ Test Data and Test Results at the Thermal Oxidizer Discharge

TEST DATA	T1	T2	T3
Test run number			
Test location	AFTERBURNER DISCHARGE		
Test date	01-31-96	02-02-96	02-04-96
Test time period	1834-0103	1407-2011	1408-2026
SAMPLING DATA			
Sampling duration, min.	320.0	320.0	320.0
Nozzle diameter, in.	0.620	0.620	0.620
Cross sectional nozzle area, sq.ft.	0.002097	0.002097	0.002097
Barometric pressure, in. Hg	29.73	29.59	30.28
Avg. orifice press. diff., in H ₂ O	0.71	0.69	0.56
Avg. dry gas meter temp., deg F	56	49	44
Avg. abs. dry gas meter temp., deg. R	516	509	504
Total liquid collected by train, ml	294.0	285.1	244.9
Std. vol. of H ₂ O vapor coll., cu.ft.	13.8	13.4	11.5
Dry gas meter calibration factor	1.0020	1.0020	1.0020
Sample vol. at meter cond., dcf	146.538	145.049	128.758
Sample vol. at std. cond., dscf (1)	149.429	149.381	136.963
Percent of isokinetic sampling	103.0	105.0	103.7
STACK GAS STREAM COMPOSITION DATA			
CO ₂ , % by volume, dry basis	5.7	5.8	6.1
O ₂ , % by volume, dry basis	12.1	11.9	11.9
CO, % by volume, dry basis	0.0	0.0	0.0
N ₂ , % by volume, dry basis	82.2	82.3	82.0
Molecular wt. of dry gas, lb/lb mole	29.4	29.4	29.5
H ₂ O vapor in gas stream, prop. by vol.	0.085	0.082	0.078
Mole fraction of dry gas	0.915	0.918	0.922
Molecular wt. of wet gas, lb/lb mole	28.4	28.5	28.6
GAS STREAM VELOCITY AND VOLUMETRIC FLOW DATA			
Static pressure, in. H ₂ O	-0.10	-0.10	-0.10
Static pressure, in. Hg	-0.007	-0.007	-0.007
Absolute pressure, in. Hg	29.72	29.58	30.27
Avg. temperature, deg. F	1675	1655	1643
Avg. absolute temperature, deg.R	2135	2115	2103
Pitot tube coefficient	0.84	0.84	0.84
Total number of traverse points	16	16	16
Avg. gas stream velocity, ft./sec.	16.0	15.6	14.0
Stack/duct cross sectional area, sq.ft.	4.59	4.59	4.59
Avg. gas stream volumetric flow, wacf/min.	4410	4300	3860
Avg. gas stream volumetric flow, dscf/min.	990	970	900
LABORATORY REPORT DATA			
Total Particulate, g	0.0028	0.0014	0.0038
Total HCl, mg	2.016	1.738	1.608
Total Cl ₂ , mg	0.234	1.216	1.242
PARTICULATE EMISSIONS			
Concentration, gr/dscf	2.89E-04	1.45E-04	4.28E-04
Concentration, gr/dscf @ 7% O ₂	4.52E-04	2.22E-04	6.56E-04
Concentration, gr/dscf @ 12% CO ₂	6.05E-04	2.98E-04	8.41E-04
Mass rate, lbs/hr	0.002	0.001	0.003
HCl EMISSIONS			
Concentration, lbs/dscf	2.97E-08	2.56E-08	2.59E-08
Concentration, ppm/v	0.31	0.27	0.27
Mass rate, lbs/hr	1.77E-03	1.50E-03	1.40E-03
Cl₂ EMISSIONS			
Concentration, lbs/dscf	3.45E-09	1.79E-08	2.00E-08
Concentration, ppm/v	0.019	0.098	0.109
Mass rate, lbs/hr	2.06E-04	1.05E-03	1.08E-03

(1) Standard conditions = 68 deg. F. (20 deg. C.) and 29.92 in Hg (760 mmHg)

SOURCE EMISSIONS SAMPLING, ANALYSIS, AND RESULTS

During each of the three validation test runs (T1, T2, and T3), the following explosives were sampled at both the furnace and thermal oxidizer discharges:

- Octahydro-1,3,5,7-tetranitro-1,3,5,7-tetrazocine (HMX).
- Hexahydro-1,3,5-trinitro-s-triazine (RDX).
- 1,3,5-Trinitrobenzene (1,3,5-TNB).
- 1,3-Dinitrobenzene (1,3-DNB).
- Nitrobenzene (NB).
- 2,4,6-Trinitrophenylmethylnitramine (tetryl).
- 2,4,6-Trinitrotoluene (TNT).
- 2,6-Dinitrotoluene (2,6-DNT).
- 2,4-Dinitrotoluene (2,4-DNT).

Sampling for explosives at both test locations was initiated once the furnace temperature reached approximately 250 °F. The decision to start testing at this temperature was based on previous studies from HWAAP indicating that no significant decomposition or exit-gassing of explosives occurred below 250 °F. Testing at both locations was conducted over a 6- to 7-hour period during each test run. During validation test T1 (12-hour soak time) in addition to the testing conducted at the 250 °F point, an additional 3 hours of explosives sampling was performed at the furnace discharge test location at the approximate test midpoint. The purpose of this midsoak test was to determine whether any explosives were being emitted from the furnace after 4 hours of the soak period.

Table 7-3 summarizes the measured explosives concentrations from the furnace discharge and thermal oxidizer discharge. Detailed test data and test results are provided in Tables 7-4 and 7-5.

Measurable quantities of TNT, tetryl, and RDX (which were introduced as spike to the furnace prior to each validation test) were detected at the furnace discharge location. In addition, smaller quantities of 1,3,5-TNB, 1,3-DNB, 2,6-DNT, and 2,4-DNT also were measured in the furnace discharge gas stream. No HMX or NB was detected in the furnace discharge gas stream during any of the three validation test runs.

The summary of explosive compounds measured at the thermal oxidizer discharge indicates that no explosives were measured at concentrations above method detection limits during any of the three validation tests. The absence of detectable explosives concentrations demonstrates the effectiveness of the thermal oxidizer in destroying explosives discharged from the furnace.

During test T1 midsoak period, small quantities of RDX, 1,3,5-TNB, and TNT were measured at the furnace discharge location. The concentrations of these explosives measured during the midsoak test period, when compared to the concentrations measured during the initial T1 test period, indicate that virtually all explosives were exit-gassed during the heatup period and initial 4 hours of soak time.

Table 7-3

Summary of Explosive Emissions at Furnace Discharge and Thermal Oxidizer Discharge

Sampling Location: Test Run No.:	Explosive Compound											
	Furnace Discharge			T1			T2			T3		
	T1	T2	T3	T1	T2	T3	T1	T2	T3	T1	T2	T3
Date:	31 Jan 96	2 Feb 96	4 Feb 96	31 Jan 96	2 Feb 96	4 Feb 96	31 Jan 96	2 Feb 96	4 Feb 96	31 Jan 96	2 Feb 96	4 Feb 96
Time:	1832-0122	1405-2100	1406-2106	1834-0110	1406-2100	1406-2106	1834-0110	1406-2031	1409-2036	1834-0110	1406-2031	1409-2036
Explosive Compound (ppb/v)												
HMX	ND	ND	ND	ND	ND	ND	ND	ND	ND	ND	ND	ND
RDX	24.23	54.30	23.20	ND	54.30	23.20	ND	ND	ND	ND	ND	ND
Trinitrobenzene (1,3,5-TNB)	11.49	11.38	9.98	0.30	11.38	9.98	ND	ND	ND	ND	ND	ND
Dinitrobenzene (1,3-DNB)	0.24	0.23	0.60	ND	0.23	0.60	ND	ND	ND	ND	ND	ND
Nitrobenzene (NB)	ND	ND	ND	ND	ND	ND	ND	ND	ND	ND	ND	ND
Tetyl	3.16	2.99	1.90	ND	2.99	1.90	ND	ND	ND	ND	ND	ND
2,4,6-Trinitrotoluene (TNT)	707.18	192.26	193.24	5.33	192.26	193.24	ND	ND	ND	ND	ND	ND
2,6-Dinitrotoluene (2,6-DNT)	ND	0.48	ND	ND	0.48	ND	ND	ND	ND	ND	ND	ND
2,4-Dinitrotoluene (2,4-DNT)	1.20	ND	ND	ND	ND	ND	ND	ND	ND	ND	ND	ND

ND = Analyte not detected above detection limit value; detection limits are provided in Appendix I.
 Midsoak = This sample was taken between hours 4 and 7 of the 12-hour soak period of T1.

Table 7-4

Explosive Compounds Test Data and Test Results at the Furnace Discharge

TEST DATA	T1	T1 (MID-SOAK)	T2	T3
	FURNACE DISCHARGE			
Run number				
Location				
Date	01-31-96	02-01-96	02-02-96	02-04-96
Time period	1832-0122	0644-1005	1405-2100	1406-2106
SAMPLING DATA				
Sampling duration, min.	410.0	180.0	415.0	420.0
Nozzle diameter, in.	0.311	0.311	0.275	0.275
Cross sectional nozzle area, sq.ft.	0.000528	0.000528	0.000412	0.000412
Barometric pressure, in. Hg	29.73	29.76	29.59	30.28
Avg. orifice press. diff., in H ₂ O	1.85	1.17	0.77	0.69
Avg. dry gas meter temp., deg F	57	59	45	40
Avg. abs. dry gas meter temp., deg. R	517	519	505	500
Total liquid collected by train, ml	187.7	67.5	108.8	106.6
Std. vol. of H ₂ O vapor coll., cu.ft.	8.8	3.2	5.1	5.0
Dry gas meter calibration factor	1.0060	1.0060	1.0060	1.0060
Sample vol. at meter cond., dcf	288.854	104.276	194.617	179.138
Sample vol. at std. cond., dscf (1)	296.360	106.493	202.829	192.896
Percent of isokinetic sampling	99.7	101.4	102.5	101.0
GAS STREAM COMPOSITION DATA				
CO ₂ , % by volume, dry basis	1.3	1.5	0.2	1.5
O ₂ , % by volume, dry basis	19.8	19.3	19.1	19.4
CO, % by volume dry basis	0.0	0.0	0.0	0.0
N ₂ , % by volume, dry basis	79.0	79.2	80.7	79.1
Molecular wt. of dry gas, lb/lb mole	28.99	29.01	28.80	29.02
H ₂ O vapor in gas stream, prop. by vol.	0.029	0.029	0.025	0.025
Mole fraction of dry gas	0.971	0.971	0.975	0.975
Molecular wt. of wet gas, lb/lb mole	28.7	28.7	28.5	28.7
GAS STREAM VELOCITY AND VOLUMETRIC FLOW DATA				
Static pressure, in. H ₂ O	-0.78	-1.00	-0.70	-0.90
Static pressure, in. Hg	-0.057	-0.074	-0.051	-0.066
Absolute pressure, in. Hg	29.67	29.69	29.54	30.21
Avg. temperature, deg. F	291	475	356	403
Avg. absolute temperature, deg.R	751	935	816	863
Pitot tube coefficient	0.99	0.99	0.99	0.99
Total number of traverse points	1	1	1	1
Avg. gas stream velocity, ft./sec.	33.8	33.9	31.0	30.5
Stack/duct cross sectional area, sq.ft.	0.492	0.492	0.492	0.492
Avg. gas stream volumetric flow, wacf/min.	1000	1000	910	900
Avg. gas stream volumetric flow, dscf/min.	680	540	570	540

(1) Standard conditions = 68 °F (20 °C) and 29.92 inches Hg (760 mm Hg)

Table 7-4

**Explosive Compounds Test Data and Test Results
at the Furnace Discharge
(Continued)**

TEST DATA	FURNACE DISCHARGE							
	T1	T1 (MID-SOAK)	T2	T3				
Run number								
Location								
Date	01-31-96	02-01-96	02-02-96	02-04-96				
Time period	1832-0122	0644-1005	1405-2100	1406-2106				
EXPLOSIVES LABORATORY REPORT DATA, ug								
HMX	ND<	462.0	ND<	28.60	ND<	462.0	ND<	462.0
RDX		1878.0		1.80		2880.0		1170.0
Trinitrobenzene (1,3,5-TNB)		854.0		8.00		579.0		483.0
Dinitrobenzene (1,3-DNB)		14.0	ND<	6.72		9.4		23.0
Nitrobenzene (NB)	ND<	109.2	ND<	6.72	ND<	109.2	ND<	109.2
Tetryl		316.0	ND<	19.40		205.0		124.0
2,4,6-Trinitrotoluene (TNT)		56000.0		151.60		10420.0		9960.0
2,6-Dinitrotoluene (2,6-DNT)	ND<	105.0	ND<	6.50		21.0	ND<	105.0
2,4-Dinitrotoluene (2,4-DNT)		76.0	ND<	6.50	ND<	105.0	ND<	105.0
EXPLOSIVES CONCENTRATIONS, ug/dscm								
HMX	ND<	55.0	ND<	9.5	ND<	80.4	ND<	84.6
RDX		223.8		0.6		501.4		214.2
Trinitrobenzene (1,3,5-TNB)		101.8		2.7		100.8		88.4
Dinitrobenzene (1,3-DNB)		1.7	ND<	2.2		1.6		4.2
Nitrobenzene (NB)	ND<	13.0	ND<	2.2	ND<	19.0	ND<	20.0
Tetryl		37.7	ND<	6.4		35.7		22.7
2,4,6-Trinitrotoluene (TNT)		6672.3		50.3		1814.0		1823.2
2,6-Dinitrotoluene (2,6-DNT)	ND<	12.5	ND<	2.2		3.7	ND<	19.2
2,4-Dinitrotoluene (2,4-DNT)		9.1	ND<	2.2	ND<	18.3	ND<	19.2
EXPLOSIVES CONCENTRATIONS, lb/dscf								
HMX	ND<	3.44E-09	ND<	5.92E-10	ND<	5.02E-09	ND<	5.28E-09
RDX		1.40E-08		3.73E-11		3.13E-08		1.34E-08
Trinitrobenzene (1,3,5-TNB)		6.35E-09		1.66E-10		6.29E-09		5.52E-09
Dinitrobenzene (1,3-DNB)		1.04E-10	ND<	1.39E-10		1.02E-10		2.63E-10
Nitrobenzene (NB)	ND<	8.12E-10	ND<	1.39E-10	ND<	1.19E-09	ND<	1.25E-09
Tetryl		2.35E-09	ND<	4.02E-10		2.23E-09		1.42E-09
2,4,6-Trinitrotoluene (TNT)		4.17E-07		3.14E-09		1.13E-07		1.14E-07
2,6-Dinitrotoluene (2,6-DNT)	ND<	7.81E-10	ND<	1.35E-10		2.28E-10	ND<	1.20E-09
2,4-Dinitrotoluene (2,4-DNT)		5.65E-10	ND<	1.35E-10	ND<	1.14E-09	ND<	1.20E-09

ND< = Analyte detection limit value.

NA = Sample was not analyzed for these compounds.

Table 7-4

Explosive Compounds Test Data and Test Results
at the Furnace Discharge
(Continued)

TEST DATA	T1	T1 (MID-SOAK)	T2	T3
Run number				
Location				
Date	01-31-96	02-01-96	02-02-96	02-04-96
Time period	1832-0122	0644-1005	1405-2100	1406-2106
FURNACE DISCHARGE				
EXPLOSIVES EMISSION RATES, lb/hr				
HMX	ND< 1.39E-04	ND< 1.93E-05	ND< 1.64E-04	ND< 1.80E-04
RDX	5.67E-04	1.22E-06	1.02E-03	4.56E-04
Trinitrobenzene (1,3,5-TNB)	2.58E-04	5.41E-06	2.05E-04	1.88E-04
Dinitrobenzene (1,3-DNB)	4.23E-06	ND< 4.54E-06	3.34E-06	8.97E-06
Nitrobenzene (NB)	ND< 3.30E-05	ND< 4.54E-06	ND< 3.88E-05	ND< 4.26E-05
Tetryl	9.54E-05	ND< 1.31E-05	7.27E-05	4.84E-05
2,4,6-Trinitrotoluene (TNT)	1.69E-02	1.02E-04	3.70E-03	3.89E-03
2,6-Dinitrotoluene (2,6-DNT)	ND< 3.17E-05	ND< 4.39E-06	7.45E-06	ND< 4.10E-05
2,4-Dinitrotoluene (2,4-DNT)	2.29E-05	ND< 4.39E-06	ND< 3.73E-05	ND< 4.10E-05
EXPLOSIVES CONCENTRATIONS, ppb/v				
HMX	ND< 4.47	ND< 0.77	ND< 6.53	ND< 6.87
RDX	24.23	0.06	54.30	23.20
Trinitrobenzene (1,3,5-TNB)	11.49	0.30	11.38	9.98
Dinitrobenzene (1,3-DNB)	0.24	ND< 0.32	0.23	0.60
Nitrobenzene (NB)	ND< 2.54	ND< 0.44	ND< 3.72	ND< 3.91
Tetryl	3.16	ND< 0.54	2.99	1.90
2,4,6-Trinitrotoluene (TNT)	707.18	5.33	192.26	193.24
2,6-Dinitrotoluene (2,6-DNT)	ND< 1.65	ND< 0.28	0.48	ND< 2.54
2,4-Dinitrotoluene (2,4-DNT)	1.20	ND< 0.28	ND< 2.41	ND< 2.54
EXPLOSIVES EMISSION RATES, g/sec				
HMX	ND< 1.76E-05	ND< 2.44E-06	ND< 2.07E-05	ND< 2.27E-05
RDX	7.14E-05	1.53E-07	1.29E-04	5.75E-05
Trinitrobenzene (1,3,5-TNB)	3.25E-05	6.81E-07	2.59E-05	2.37E-05
Dinitrobenzene (1,3-DNB)	5.32E-07	ND< 5.72E-07	4.20E-07	1.13E-06
Nitrobenzene (NB)	ND< 4.15E-06	ND< 5.72E-07	ND< 4.88E-06	ND< 5.37E-06
Tetryl	1.20E-05	ND< 1.65E-06	9.17E-06	6.10E-06
2,4,6-Trinitrotoluene (TNT)	2.13E-03	1.29E-05	4.66E-04	4.90E-04
2,6-Dinitrotoluene (2,6-DNT)	ND< 3.99E-06	ND< 5.54E-07	9.39E-07	ND< 5.16E-06
2,4-Dinitrotoluene (2,4-DNT)	2.89E-06	ND< 5.54E-07	ND< 4.69E-06	ND< 5.16E-06
SUMMARY OF DIESEL RANGE ORGANICS TEST RESULTS (1)				
Laboratory Report Data, ug	15400	NA	NA	NA
Concentration, ug/dscm	1834.9	NA	NA	NA
Concentration, lb/dscf	1.15E-07	NA	NA	NA
Concentration, ppb/v (2)	310.25	NA	NA	NA
Emission Rate, lb/hr	4.65E-03	NA	NA	NA
Emission Rate, g/sec	5.86E-04	NA	NA	NA

ND< = Analyte detection limit value.

NA = Sample was not analyzed for these compounds.

(1) The diesel range organic analysis was performed on T1 sample only.

(2) The reported ppb/v concentrations for these compounds is calculated using the molecular weight of decane.

Table 7-5

Explosive Compounds Test Data and Test Results at the Thermal Oxidizer Discharge

TEST DATA	T1	T2	T3
Run number			
Location		AFTERBURNER DISCHARGE	
Date	01-31-96	02-02-96	02-04-96
Time period	1834-0110	1406-2031	1409-2036
SAMPLING DATA			
Sampling duration, min.	360.0	360.0	360.0
Nozzle diameter, in.	0.622	0.622	0.622
Cross sectional nozzle area, sq.ft.	0.002110	0.002110	0.002110
Barometric pressure, in. Hg	29.73	29.59	30.28
Avg. orifice press. diff., in H ₂ O	0.86	0.80	0.62
Avg. dry gas meter temp., deg F	53	43	38
Avg. abs. dry gas meter temp., deg. R	513	503	498
Total liquid collected by train, ml	343.2	326.0	231.4
Std. vol. of H ₂ O vapor coll., cu.ft.	16.2	15.3	10.9
Dry gas meter calibration factor	1.0050	1.0050	1.0050
Sample vol. at meter cond., dcf	176.562	171.137	145.923
Sample vol. at std. cond., dscf (1)	181.864	178.670	157.476
Percent of isokinetic sampling	99.5	101.8	97.8
GAS STREAM COMPOSITION DATA			
CO ₂ , % by volume, dry basis	5.7	5.8	6.1
O ₂ , % by volume, dry basis	12.1	11.9	11.9
CO, % by volume dry basis	0.0	0.0	0.0
N ₂ , % by volume, dry basis	82.2	82.3	82.0
Molecular wt. of dry gas, lb/lb mole	29.40	29.41	29.45
H ₂ O vapor in gas stream, prop. by vol.	0.082	0.079	0.065
Mole fraction of dry gas	0.918	0.921	0.935
Molecular wt. of wet gas, lb/lb mole	28.5	28.5	28.7
GAS STREAM VELOCITY AND VOLUMETRIC FLOW DATA			
Static pressure, in. H ₂ O	-0.10	-0.10	-0.10
Static pressure, in. Hg	-0.007	-0.007	-0.007
Absolute pressure, in. Hg	29.72	29.58	30.27
Avg. temperature, deg. F	1560	1515	1510
Avg. absolute temperature, deg.R	2020	1975	1970
Pitot tube coefficient	0.84	0.84	0.84
Total number of traverse points	12	12	12
Avg. gas stream velocity, ft./sec.	16.8	15.8	13.9
Stack/duct cross sectional area, sq.ft.	4.587	4.587	4.587
Avg. gas stream volumetric flow, wacf/min.	4630	4360	3840
Avg. gas stream volumetric flow, dscf/min.	1100	1060	970

(1) Standard conditions = 68 °F (20 °C) and 29.92 inches Hg (760 mm Hg)

Table 7-5

**Explosive Compounds Test Data and Test Results
at the Thermal Oxidizer Discharge
(Continued)**

TEST DATA	AFTERBURNER DISCHARGE					
	T1	T2	T3			
Run number						
Location						
Date	01-31-96	02-02-96	02-04-96			
Time period	1834-0110	1406-2031	1409-2036			
EXPLOSIVES LABORATORY REPORT DATA, ug						
HMX	ND<	26.40	ND<	28.60	ND<	28.60
RDX	ND<	12.00	ND<	13.00	ND<	13.00
Trinitrobenzene (1,3,5-TNB)	ND<	6.00	ND<	6.50	ND<	6.50
Dinitrobenzene (1,3-DNB)	ND<	6.24	ND<	6.72	ND<	6.72
Nitrobenzene (NB)	ND<	6.24	ND<	6.72	ND<	6.72
Tetryl	ND<	18.00	ND<	19.40	ND<	19.40
2,4,6-Trinitrotoluene (TNT)	ND<	6.00	ND<	6.50	ND<	6.50
2,6-Dinitrotoluene (2,6-DNT)	ND<	6.00	ND<	6.50	ND<	6.50
2,4-Dinitrotoluene (2,4-DNT)	ND<	6.00	ND<	6.50	ND<	6.50
EXPLOSIVES CONCENTRATIONS, ug/dscm						
HMX	ND<	5.13	ND<	5.65	ND<	6.41
RDX	ND<	2.33	ND<	2.57	ND<	2.91
Trinitrobenzene (1,3,5-TNB)	ND<	1.16	ND<	1.28	ND<	1.46
Dinitrobenzene (1,3-DNB)	ND<	1.21	ND<	1.33	ND<	1.51
Nitrobenzene (NB)	ND<	1.21	ND<	1.33	ND<	1.51
Tetryl	ND<	3.49	ND<	3.83	ND<	4.35
2,4,6-Trinitrotoluene (TNT)	ND<	1.16	ND<	1.28	ND<	1.46
2,6-Dinitrotoluene (2,6-DNT)	ND<	1.16	ND<	1.28	ND<	1.46
2,4-Dinitrotoluene (2,4-DNT)	ND<	1.16	ND<	1.28	ND<	1.46
EXPLOSIVES CONCENTRATIONS, lb/dscf						
HMX	ND<	3.20E-10	ND<	3.53E-10	ND<	4.00E-10
RDX	ND<	1.45E-10	ND<	1.60E-10	ND<	1.82E-10
Trinitrobenzene (1,3,5-TNB)	ND<	7.27E-11	ND<	8.02E-11	ND<	9.10E-11
Dinitrobenzene (1,3-DNB)	ND<	7.56E-11	ND<	8.29E-11	ND<	9.41E-11
Nitrobenzene (NB)	ND<	7.56E-11	ND<	8.29E-11	ND<	9.41E-11
Tetryl	ND<	2.18E-10	ND<	2.39E-10	ND<	2.72E-10
2,4,6-Trinitrotoluene (TNT)	ND<	7.27E-11	ND<	8.02E-11	ND<	9.10E-11
2,6-Dinitrotoluene (2,6-DNT)	ND<	7.27E-11	ND<	8.02E-11	ND<	9.10E-11
2,4-Dinitrotoluene (2,4-DNT)	ND<	7.27E-11	ND<	8.02E-11	ND<	9.10E-11

ND< = Analyte detection limit value.

Table 7-5

Explosive Compounds Test Data and Test Results
at the Thermal Oxidizer Discharge
(Continued)

TEST DATA	AFTERBURNER DISCHARGE		
	T1	T2	T3
Run number			
Location			
Date	01-31-96	02-02-96	02-04-96
Time period	1834-0110	1406-2031	1409-2036
EXPLOSIVES EMISSION RATES, lb/hr			
HMX	ND< 2.12E-05	ND< 2.25E-05	ND< 2.34E-05
RDX	ND< 9.63E-06	ND< 1.02E-05	ND< 1.06E-05
Trinitrobenzene (1,3,5-TNB)	ND< 4.82E-06	ND< 5.10E-06	ND< 5.31E-06
Dinitrobenzene (1,3-DNB)	ND< 5.01E-06	ND< 5.28E-06	ND< 5.49E-06
Nitrobenzene (NB)	ND< 5.01E-06	ND< 5.28E-06	ND< 5.49E-06
Tetryl	ND< 1.44E-05	ND< 1.52E-05	ND< 1.59E-05
2,4,6-Trinitrotoluene (TNT)	ND< 4.82E-06	ND< 5.10E-06	ND< 5.31E-06
2,6-Dinitrotoluene (2,6-DNT)	ND< 4.82E-06	ND< 5.10E-06	ND< 5.31E-06
2,4-Dinitrotoluene (2,4-DNT)	ND< 4.82E-06	ND< 5.10E-06	ND< 5.31E-06
EXPLOSIVES CONCENTRATIONS, ppb/v			
HMX	ND< 0.42	ND< 0.46	ND< 0.52
RDX	ND< 0.25	ND< 0.28	ND< 0.32
Trinitrobenzene (1,3,5-TNB)	ND< 0.13	ND< 0.15	ND< 0.16
Dinitrobenzene (1,3-DNB)	ND< 0.17	ND< 0.19	ND< 0.22
Nitrobenzene (NB)	ND< 0.24	ND< 0.26	ND< 0.29
Tetryl	ND< 0.29	ND< 0.32	ND< 0.36
2,4,6-Trinitrotoluene (TNT)	ND< 0.12	ND< 0.14	ND< 0.15
2,6-Dinitrotoluene (2,6-DNT)	ND< 0.15	ND< 0.17	ND< 0.19
2,4-Dinitrotoluene (2,4-DNT)	ND< 0.15	ND< 0.17	ND< 0.19
EXPLOSIVES EMISSION RATES, g/sec			
HMX	ND< 2.67E-06	ND< 2.83E-06	ND< 2.95E-06
RDX	ND< 1.21E-06	ND< 1.29E-06	ND< 1.34E-06
Trinitrobenzene (1,3,5-TNB)	ND< 6.07E-07	ND< 6.43E-07	ND< 6.69E-07
Dinitrobenzene (1,3-DNB)	ND< 6.31E-07	ND< 6.65E-07	ND< 6.92E-07
Nitrobenzene (NB)	ND< 6.31E-07	ND< 6.65E-07	ND< 6.92E-07
Tetryl	ND< 1.82E-06	ND< 1.92E-06	ND< 2.00E-06
2,4,6-Trinitrotoluene (TNT)	ND< 6.07E-07	ND< 6.43E-07	ND< 6.69E-07
2,6-Dinitrotoluene (2,6-DNT)	ND< 6.07E-07	ND< 6.43E-07	ND< 6.69E-07
2,4-Dinitrotoluene (2,4-DNT)	ND< 6.07E-07	ND< 6.43E-07	ND< 6.69E-07

ND< = Analyte detection limit value.

7.3.2.1 Explosives Removal Efficiencies

Table 7-6 presents the calculated removal efficiencies (REs) for TNT, tetryl, and RDX. The overall system RE is based on the total quantities of TNT, tetryl, and RDX introduced to the furnace (converted to lb/hr based on the total test time) and the thermal oxidizer discharge mass rate (lb/hr) determined for each explosive. The thermal oxidizer RE is based on the explosive mass rates determined at the furnace discharge and thermal oxidizer discharge. All RE values are reported as greater because no explosives were measured at concentrations above the method detection limit at the thermal oxidizer discharge.

Overall System Removal Efficiency

As shown in Table 7-6, a >99.99% RE was demonstrated for TNT during test T1. The remaining RE values ranged from >99.79% (T1 for tetryl) to >99.97% (T2 for RDX). The overall system RE is dependent on the amount of explosive material introduced to the furnace prior to each test. Because of health and safety concerns, the quantities of explosives were kept to a minimum, thus limiting the ability to consistently demonstrate >99.99% RE. An additional low bias is introduced into the RE calculation by assuming that RE is constant throughout the entire test period. In actuality, the explosives removal varies over time and with temperature. The conversion of the total mass of explosives to a lb/hr mass rate (based on total test time) for the purpose of calculating overall RE introduces a low bias and understates the actual RE.

Thermal Oxidizer Removal Efficiency

As shown in Table 7-6, the thermal oxidizer RE ranged from > 67.15% to 99.97%. These seemingly low REs do not necessarily reflect poor thermal oxidizer performance, but reflect the inherent bias in the RE calculation when discharge concentrations are below detection limits. The thermal oxidizer RE is a function of the mass rates of explosives measured at the furnace discharge and thermal oxidizer discharge. A significant amount of TNT, tetryl, and RDX decomposed prior to the thermal oxidizer discharge test location. The calculated thermal oxidizer RE values are not a true indicator of the thermal oxidizer's ability to remove explosives, but are based on the actual amount of explosives measured at the thermal oxidizer inlet. As shown in Table 7-3, no detectable concentrations were determined to be present at the thermal oxidizer discharge.

7.3.3 Semivolatile Organic Compounds

A summary of the SVOCs detected in the thermal oxidizer discharge gas stream is presented in Table 7-7. Detailed test data and test results are provided in Table 7-8.

**Table 7-6
Calculated Explosives Removal Efficiencies (%)**

	Overall HGD System Removal Efficiency ^a			Thermal Oxidizer Efficiency ^b		
	T1	T2	T3	T1	T2	T3
Date: Time:	31 Jan 96 1832-0122	2 Feb 96 1405-2100	4 Feb 96 1406-2036	31 Jan 96 1832-0122	4 Feb 96 1406-2036	4 Feb 96 1406-2036
2,4,6-Trinitrotoluene (TNT)	>99.997	>99.95	>99.94	>99.97	>99.86	>99.86
Tetryl	>99.79	>99.92	>99.94	>84.91	>79.09	>67.15
RDX	>99.88	>99.97	>99.91	>98.30	>99.00	>97.68

^aBased on total explosives introduced to furnace converted to lb/hr (using total test times) and thermal oxidizer discharge mass rate determinations for each explosive.

^bThermal oxidizer removal efficiency based on the following:

$$DRE = \frac{C_1 - C_2}{C_1} \times 100$$

Where:

- DRE = Afterburner explosive (TNT, RDX, tetryl) destruction and removal efficiency (expressed as a percent)
- C₁ = Mass of explosive (TNT, RDX, tetryl) per unit time entering the afterburner (i.e., flash chamber discharge gas)
- C₂ = Mass of explosive (TNT, RDX, tetryl) per unit time discharging from the afterburner

NOTE: All removal efficiencies are reported as greater than because no explosives were measured at concentrations above the method detection limits at the thermal oxidizer discharge.

Table 7-7

Summary of SVOCs Detected at the Thermal Oxidizer Discharge

Test Run No.: Date: Time:	SVOC Emissions at Thermal Oxidizer Discharge (ppb/v)		
	T1 31 Jan 96 1834-0110	T2 2 Feb 96 1406-2031	T3 4 Feb 96 1409-2036
Parameter			
Diethylphthalate	0.168 J	0.73 J	ND
Pentachlorophenol	0.05 J	0.25 J	ND
Di-n-butylphthalate	0.08 J	ND	ND
Benzo(a)anthracene	ND	0.06 J	ND
Chrysene	ND	0.04 J	ND
bis(2-Ethylhexyl)phthalate	0.28 JB	0.13 JB	0.15 JB
Di-n-octylphthalate	ND	0.02 J	ND

J = Detected in samples in quantities less than the detection limits.

B = Detected in field blank in quantities greater than the samples; therefore, sample values are not blank.

ND = Nondetect, indicates values less than detection limits; detection limits are provided in Appendix I.

Table 7-8

SVOC Test Data and Test Results at the Thermal Oxidizer Discharge

TEST DATA	T1	T2	T3
Run number			
Location		AFTERBURNER DISCHARGE	
Date	01-31-96	02-02-96	02-04-96
Time period	1834-0110	1406-2031	1409-2036
SAMPLING DATA			
Sampling duration, min.	360.0	360.0	360.0
Nozzle diameter, in.	0.622	0.622	0.622
Cross sectional nozzle area, sq.ft.	0.002110	0.002110	0.002110
Barometric pressure, in. Hg	29.73	29.59	30.28
Avg. orifice press. diff., in. H ₂ O	0.86	0.80	0.62
Avg. dry gas meter temp., deg. F	53	43	38
Avg. abs. dry gas meter temp., deg. R	513	503	498
Total liquid collected by train, ml	343.2	326.0	231.4
Std. vol. of H ₂ O vapor coll., cu.ft.	16.2	15.3	10.9
Dry gas meter calibration factor	1.0050	1.0050	1.0050
Sample vol. at meter cond., dcf	176.562	171.137	145.923
Sample vol. at std. cond., dscf (1)	181.864	178.670	157.476
Percent of isokinetic sampling	99.5	101.8	97.8
GAS STREAM COMPOSITION DATA			
CO ₂ , % by volume, dry basis	5.7	5.8	6.1
O ₂ , % by volume, dry basis	12.1	11.9	11.9
CO, % by volume, dry basis	0.0	0.0	0.0
N ₂ , % by volume, dry basis	82.2	82.3	82.0
Molecular wt. of dry gas, lb/lb mole	29.40	29.41	29.45
H ₂ O vapor in gas stream, prop. by vol.	0.082	0.079	0.065
Mole fraction of dry gas	0.918	0.921	0.935
Molecular wt. of wet gas, lb/lb mole	28.5	28.5	28.7
GAS STREAM VELOCITY AND VOLUMETRIC FLOW DATA			
Static pressure, in. H ₂ O	-0.10	-0.10	-0.10
Static pressure, in. Hg	-0.007	-0.007	-0.007
Absolute pressure, in. Hg	29.72	29.58	30.27
Avg. temperature, deg. F	1560	1515	1510
Avg. absolute temperature, deg. R	2020	1975	1970
Pitot tube coefficient	0.84	0.84	0.84
Total number of traverse points	12	12	12
Avg. gas stream velocity, ft./sec.	16.8	15.8	13.9
Stack/duct cross sectional area, sq.ft.	4.587	4.587	4.587
Avg. gas stream volumetric flow, wacf/min.	4630	4360	3840
Avg. gas stream volumetric flow, dscf/min.	1100	1060	970

(1) Standard conditions = 68 °F (20 °C) and 29.92 inches Hg (760 mm Hg)

Table 7-8

SVOC Test Data and Test Results at the Thermal Oxidizer Discharge (Continued)

TEST DATA	AFTERBURNER DISCHARGE					
	T1	T2	T3			
Run number						
Location						
Date	01-31-96	02-02-96	02-04-96			
Time period	1834-0110	1406-2031	1409-2036			
SEMI-VOLATILE ORGANICS LABORATORY REPORT DATA, ug						
Phenol	ND<	300	ND<	300	ND<	300
Bis (2-chloroethyl) ether	ND<	300	ND<	300	ND<	300
2-Chlorophenol	ND<	300	ND<	300	ND<	300
1,3-Dichlorobenzene	ND<	300	ND<	300	ND<	300
1,4-Dichlorobenzene	ND<	300	ND<	300	ND<	300
Benzyl Alcohol	ND<	300	ND<	300	ND<	300
1,2-Dichlorobenzene	ND<	300	ND<	300	ND<	300
2-Methylphenol	ND<	300	ND<	300	ND<	300
bis (2-Chloroisopropyl) ether	ND<	300	ND<	300	ND<	300
4-Methylphenol	ND<	300	ND<	300	ND<	300
n-Nitroso-di-n-propylamine	ND<	300	ND<	300	ND<	300
Hexachloroethane	ND<	300	ND<	300	ND<	300
Nitrobenzene	ND<	300	ND<	300	ND<	300
Isophorone	ND<	300	ND<	300	ND<	300
2-Nitrophenol	ND<	300	ND<	300	ND<	300
2,4-Dimethylphenol	ND<	300	ND<	300	ND<	300
Benzoic acid	ND<	1440	ND<	1440	ND<	1440
Bis (2-chloroethoxy)-methane	ND<	300	ND<	300	ND<	300
2,4-Dichlorophenol	ND<	300	ND<	300	ND<	300
1,2,4-Trichlorobenzene	ND<	300	ND<	300	ND<	300
Naphthalene	ND<	300	ND<	300	ND<	300
4-Chloroaniline	ND<	300	ND<	300	ND<	300
Hexachlorobutadiene	ND<	300	ND<	300	ND<	300
4-chloro-3-methylphenol	ND<	300	ND<	300	ND<	300
2-Methylnaphthalene	ND<	300	ND<	300	ND<	300
Hexachlorocyclopentadiene	ND<	300	ND<	300	ND<	300
2,4,6-Trichlorophenol	ND<	300	ND<	300	ND<	300
2,4,5-Trichlorophenol	ND<	1440	ND<	1440	ND<	1440
2-Chloronaphthalene	ND<	300	ND<	300	ND<	300
2-Nitroaniline	ND<	1440	ND<	1440	ND<	1440
Dimethylphthalate	ND<	300	ND<	300	ND<	300
Acenaphthylene	ND<	300	ND<	300	ND<	300
2,6-Dinitrotoluene	ND<	300	ND<	300	ND<	300
3-Nitroaniline	ND<	1440	ND<	1440	ND<	1440
Acenaphthene	ND<	300	ND<	300	ND<	300
2,4-Dinitrophenol	ND<	1440	ND<	1440	ND<	1440
4-Nitrophenol	ND<	1440	ND<	1440	ND<	1440
Dibenzofuran	ND<	300	ND<	300	ND<	300
2,4-Dinitrotoluene	ND<	300	ND<	300	ND<	300
Diethylphthalate		8 J		34 J		300
4-Chlorophenyl-phenyl ether	ND<	300	ND<	300	ND<	300
Fluorene	ND<	300	ND<	300	ND<	300
4-Nitroaniline	ND<	1440	ND<	1440	ND<	1440
4,6-Dinitro-2-methylphenol	ND<	1440	ND<	1440	ND<	1440
n-Nitrosodiphenylamine	ND<	300	ND<	300	ND<	300
4-Bromophenyl-phenyl ether	ND<	300	ND<	300	ND<	300
Hexachlorobenzene	ND<	300	ND<	300	ND<	300
Pentachlorophenol		3 J		14 J		1440
Phenanthrene	ND<	300	ND<	300	ND<	300
Anthracene	ND<	300	ND<	300	ND<	300
Di-n-butylphthalate		5 J				300
Fluoranthene	ND<	300	ND<	300	ND<	300
Pyrene	ND<	300	ND<	300	ND<	300
Butylbenzylphthalate	ND<	300	ND<	300	ND<	300
3,3'-Dichlorobenzidine	ND<	600	ND<	600	ND<	600
Benzo(a)anthracene	ND<	300		3 J		300
Chrysene	ND<	300		2 J		300
bis(2-Ethylhexyl)phthalate		23 JB		11 JB		11 JB
Di-n-octylphthalate	ND<	300		2 J		300
Benzo(b)fluoranthene	ND<	300	ND<	300	ND<	300
Benzo(k)fluoranthene	ND<	300	ND<	300	ND<	300
Benzo(a)pyrene	ND<	300	ND<	300	ND<	300
Indeno(1,2,3-cd)pyrene	ND<	300	ND<	300	ND<	300
Dibenzo(a,h)anthracene	ND<	300	ND<	300	ND<	300
Benzo(g,h,i)perylene	ND<	300	ND<	300	ND<	300
Carbazole	ND<	300	ND<	300	ND<	300
Diesel Range Organics ⁽¹⁾	ND<	6000	NA	NA	ND<	NA

"ND<(....)" = Analyte detection limit value.

B=Detected in the field blank in quantities greater than the sample, therefore sample values are not blank corrected.

J=Detected in the samples in quantities less than the calibration detection limit.

(1) Diesel range organics analysis performed on T1 sample only.

Table 7-8

SVOC Test Data and Test Results at the Thermal Oxidizer Discharge (Continued)

TEST DATA	AFTERBURNER DISCHARGE					
	Run number	T1	T2	T3		
	Location	01-31-96	02-02-96	02-04-96		
	Date	1834-0110	1406-2031	1409-2036		
Time period						
SEMIVOLATILE ORGANICS CONCENTRATIONS, ug/dscm						
Phenol	ND<	58.25	ND<	59.29	ND<	67.27
Bis (2-chloroethyl) ether	ND<	58.25	ND<	59.29	ND<	67.27
2-Chlorophenol	ND<	58.25	ND<	59.29	ND<	67.27
1,3-Dichlorobenzene	ND<	58.25	ND<	59.29	ND<	67.27
1,4-Dichlorobenzene	ND<	58.25	ND<	59.29	ND<	67.27
Benzyl Alcohol	ND<	58.25	ND<	59.29	ND<	67.27
1,2-Dichlorobenzene	ND<	58.25	ND<	59.29	ND<	67.27
2-Methylphenol	ND<	58.25	ND<	59.29	ND<	67.27
bis (2-Chloroisopropyl) ether	ND<	58.25	ND<	59.29	ND<	67.27
4-Methylphenol	ND<	58.25	ND<	59.29	ND<	67.27
n-Nitroso-di-n-propylamine	ND<	58.25	ND<	59.29	ND<	67.27
Hexachloroethane	ND<	58.25	ND<	59.29	ND<	67.27
Nitrobenzene	ND<	58.25	ND<	59.29	ND<	67.27
Isophorone	ND<	58.25	ND<	59.29	ND<	67.27
2-Nitrophenol	ND<	58.25	ND<	59.29	ND<	67.27
2,4-Dimethylphenol	ND<	58.25	ND<	59.29	ND<	67.27
Benzoic acid	ND<	279.59	ND<	284.59	ND<	322.89
Bis (2-chloroethoxy)-methane	ND<	58.25	ND<	59.29	ND<	67.27
2,4-Dichlorophenol	ND<	58.25	ND<	59.29	ND<	67.27
1,2,4-Trichlorobenzene	ND<	58.25	ND<	59.29	ND<	67.27
Naphthalene	ND<	58.25	ND<	59.29	ND<	67.27
4-Chloroaniline	ND<	58.25	ND<	59.29	ND<	67.27
Hexachlorobutadiene	ND<	58.25	ND<	59.29	ND<	67.27
4-chloro-3-methylphenol	ND<	58.25	ND<	59.29	ND<	67.27
2-Methylnaphthalene	ND<	58.25	ND<	59.29	ND<	67.27
Hexachlorocyclopentadiene	ND<	58.25	ND<	59.29	ND<	67.27
2,4,6-Trichlorophenol	ND<	58.25	ND<	59.29	ND<	67.27
2,4,5-Trichlorophenol	ND<	279.59	ND<	284.59	ND<	322.89
2-Chloronaphthalene	ND<	58.25	ND<	59.29	ND<	67.27
2-Nitroaniline	ND<	279.59	ND<	284.59	ND<	322.89
Dimethylphthalate	ND<	58.25	ND<	59.29	ND<	67.27
Acenaphthylene	ND<	58.25	ND<	59.29	ND<	67.27
2,6-Dinitrotoluene	ND<	58.25	ND<	59.29	ND<	67.27
3-Nitroaniline	ND<	279.59	ND<	284.59	ND<	322.89
Acenaphthene	ND<	58.25	ND<	59.29	ND<	67.27
2,4-Dinitrophenol	ND<	279.59	ND<	284.59	ND<	322.89
4-Nitrophenol	ND<	279.59	ND<	284.59	ND<	322.89
Dibenzo furan	ND<	58.25	ND<	59.29	ND<	67.27
2,4-Dinitrotoluene	ND<	58.25	ND<	59.29	ND<	67.27
Diethylphthalate	ND<	1.55 J	ND<	6.72 J	ND<	67.27
4-Chlorophenyl-phenyl ether	ND<	58.25	ND<	59.29	ND<	67.27
Fluorene	ND<	58.25	ND<	59.29	ND<	67.27
4-Nitroaniline	ND<	279.59	ND<	284.59	ND<	322.89
4,6-Dinitro-2-methylphenol	ND<	279.59	ND<	284.59	ND<	322.89
n-Nitrosodiphenylamine	ND<	58.25	ND<	59.29	ND<	67.27
4-Bromophenyl-phenyl ether	ND<	58.25	ND<	59.29	ND<	67.27
Hexachlorobenzene	ND<	58.25	ND<	59.29	ND<	67.27
Pentachlorophenol	ND<	0.58 J	ND<	2.77 J	ND<	322.89
Phenanthrene	ND<	58.25	ND<	59.29	ND<	67.27
Anthracene	ND<	58.25	ND<	59.29	ND<	67.27
Di-n-butylphthalate	ND<	0.97 J	ND<	59.29	ND<	67.27
Fluoranthene	ND<	58.25	ND<	59.29	ND<	67.27
Pyrene	ND<	58.25	ND<	59.29	ND<	67.27
Butylbenzylphthalate	ND<	58.25	ND<	59.29	ND<	67.27
3,3'-Dichlorobenzidine	ND<	116.50	ND<	118.58	ND<	134.54
Benzo(a)anthracene	ND<	58.25	ND<	0.59 J	ND<	67.27
Chrysene	ND<	58.25	ND<	0.40 J	ND<	67.27
bis(2-Ethylhexyl)phthalate	ND<	4.47 JB	ND<	2.17 JB	ND<	2.47 JB
Di-n-octylphthalate	ND<	58.25	ND<	0.40 J	ND<	67.27
Benzo(b)fluoranthene	ND<	58.25	ND<	59.29	ND<	67.27
Benzo(k)fluoranthene	ND<	58.25	ND<	59.29	ND<	67.27
Benzo(a)pyrene	ND<	58.25	ND<	59.29	ND<	67.27
Indeno(1,2,3-cd)pyrene	ND<	58.25	ND<	59.29	ND<	67.27
Dibenzo(a,h)anthracene	ND<	58.25	ND<	59.29	ND<	67.27
Benzo(g,h,i)perylene	ND<	58.25	ND<	59.29	ND<	67.27
Carbazole	ND<	58.25	ND<	59.29	ND<	67.27
Diesel Range Organics ⁽¹⁾	ND<	1164.96	ND<	NA	ND<	NA

"ND<(...)" = Analyte detection limit value.

B=Detected in the field blank in quantities greater than the sample, therefore sample values are not blank corrected.

J=Detected in the samples in quantities less than the calibration detection limit.

(1) Diesel range organics analysis performed on T1 sample only.

Table 7-8

SVOC Test Data and Test Results at the Thermal Oxidizer Discharge (Continued)

TEST DATA	AFTERBURNER DISCHARGE		
	T1	T2	T3
Run number	01-31-96	02-02-96	02-04-96
Location	1834-0110	1406-2031	1409-2036
Date			
Time period			
SEMIVOLATILE ORGANICS CONCENTRATIONS, lb/dscf			
Phenol	ND< 3.64E-09	ND< 3.70E-09	ND< 4.20E-09
Bis (2-chloroethyl) ether	ND< 3.64E-09	ND< 3.70E-09	ND< 4.20E-09
2-Chlorophenol	ND< 3.64E-09	ND< 3.70E-09	ND< 4.20E-09
1,3-Dichlorobenzene	ND< 3.64E-09	ND< 3.70E-09	ND< 4.20E-09
1,4-Dichlorobenzene	ND< 3.64E-09	ND< 3.70E-09	ND< 4.20E-09
Benzyl Alcohol	ND< 3.64E-09	ND< 3.70E-09	ND< 4.20E-09
1,2-Dichlorobenzene	ND< 3.64E-09	ND< 3.70E-09	ND< 4.20E-09
2-Methylphenol	ND< 3.64E-09	ND< 3.70E-09	ND< 4.20E-09
bis (2-Chloroisopropyl) ether	ND< 3.64E-09	ND< 3.70E-09	ND< 4.20E-09
4-Methylphenol	ND< 3.64E-09	ND< 3.70E-09	ND< 4.20E-09
n-Nitroso-di-n-propylamine	ND< 3.64E-09	ND< 3.70E-09	ND< 4.20E-09
Hexachloroethane	ND< 3.64E-09	ND< 3.70E-09	ND< 4.20E-09
Nitrobenzene	ND< 3.64E-09	ND< 3.70E-09	ND< 4.20E-09
Isophorone	ND< 3.64E-09	ND< 3.70E-09	ND< 4.20E-09
2-Nitrophenol	ND< 3.64E-09	ND< 3.70E-09	ND< 4.20E-09
2,4-Dimethylphenol	ND< 3.64E-09	ND< 3.70E-09	ND< 4.20E-09
Benzoic acid	ND< 1.75E-08	ND< 1.78E-08	ND< 2.02E-08
Bis (2-chloroethoxy)-methane	ND< 3.64E-09	ND< 3.70E-09	ND< 4.20E-09
2,4-Dichlorophenol	ND< 3.64E-09	ND< 3.70E-09	ND< 4.20E-09
1,2,4-Trichlorobenzene	ND< 3.64E-09	ND< 3.70E-09	ND< 4.20E-09
Naphthalene	ND< 3.64E-09	ND< 3.70E-09	ND< 4.20E-09
4-Chloroaniline	ND< 3.64E-09	ND< 3.70E-09	ND< 4.20E-09
Hexachlorobutadiene	ND< 3.64E-09	ND< 3.70E-09	ND< 4.20E-09
4-chloro-3-methylphenol	ND< 3.64E-09	ND< 3.70E-09	ND< 4.20E-09
2-Methylnaphthalene	ND< 3.64E-09	ND< 3.70E-09	ND< 4.20E-09
Hexachlorocyclopentadiene	ND< 3.64E-09	ND< 3.70E-09	ND< 4.20E-09
2,4,6-Trichlorophenol	ND< 3.64E-09	ND< 3.70E-09	ND< 4.20E-09
2,4,5-Trichlorophenol	ND< 1.75E-08	ND< 1.78E-08	ND< 2.02E-08
2-Chloronaphthalene	ND< 3.64E-09	ND< 3.70E-09	ND< 4.20E-09
2-Nitroaniline	ND< 1.75E-08	ND< 1.78E-08	ND< 2.02E-08
Dimethylphthalate	ND< 3.64E-09	ND< 3.70E-09	ND< 4.20E-09
Acenaphthylene	ND< 3.64E-09	ND< 3.70E-09	ND< 4.20E-09
2,6-Dinitrotoluene	ND< 3.64E-09	ND< 3.70E-09	ND< 4.20E-09
3-Nitroaniline	ND< 1.75E-08	ND< 1.78E-08	ND< 2.02E-08
Acenaphthene	ND< 3.64E-09	ND< 3.70E-09	ND< 4.20E-09
2,4-Dimethylphenol	ND< 1.75E-08	ND< 1.78E-08	ND< 2.02E-08
4-Nitrophenol	ND< 1.75E-08	ND< 1.78E-08	ND< 2.02E-08
Dibenzofuran	ND< 3.64E-09	ND< 3.70E-09	ND< 4.20E-09
2,4-Dinitrotoluene	ND< 3.64E-09	ND< 3.70E-09	ND< 4.20E-09
Diethylphthalate	9.70E-11 J	4.20E-10 J	ND< 4.20E-09
4-Chlorophenyl-phenyl ether	ND< 3.64E-09	ND< 3.70E-09	ND< 4.20E-09
Fluorene	ND< 3.64E-09	ND< 3.70E-09	ND< 4.20E-09
4-Nitroaniline	ND< 1.75E-08	ND< 1.78E-08	ND< 2.02E-08
4,6-Dinitro-2-methylphenol	ND< 1.75E-08	ND< 1.78E-08	ND< 2.02E-08
n-Nitrosodiphenylamine	ND< 3.64E-09	ND< 3.70E-09	ND< 4.20E-09
4-Bromophenyl-phenyl ether	ND< 3.64E-09	ND< 3.70E-09	ND< 4.20E-09
Hexachlorobenzene	ND< 3.64E-09	ND< 3.70E-09	ND< 4.20E-09
Pentachlorophenol	3.64E-11 J	1.73E-10 J	ND< 2.02E-08
Phenanthrene	ND< 3.64E-09	ND< 3.70E-09	ND< 4.20E-09
Anthracene	ND< 3.64E-09	ND< 3.70E-09	ND< 4.20E-09
Di-n-butylphthalate	6.06E-11 J	ND< 3.70E-09	ND< 4.20E-09
Fluoranthene	ND< 3.64E-09	ND< 3.70E-09	ND< 4.20E-09
Pyrene	ND< 3.64E-09	ND< 3.70E-09	ND< 4.20E-09
Butylbenzylphthalate	ND< 3.64E-09	ND< 3.70E-09	ND< 4.20E-09
3,3'-Dichlorobenzidine	ND< 7.27E-09	ND< 7.40E-09	ND< 8.40E-09
Benzo(a)anthracene	ND< 3.64E-09	3.70E-11 J	ND< 4.20E-09
Chrysene	ND< 3.64E-09	2.47E-11 J	ND< 4.20E-09
bis(2-Ethylhexyl)phthalate	2.79E-10 JB	1.36E-10 JB	1.54E-10 JB
Di-n-octylphthalate	ND< 3.64E-09	2.47E-11 J	ND< 4.20E-09
Benzo(b)fluoranthene	ND< 3.64E-09	ND< 3.70E-09	ND< 4.20E-09
Benzo(k)fluoranthene	ND< 3.64E-09	ND< 3.70E-09	ND< 4.20E-09
Benzo(a)pyrene	ND< 3.64E-09	ND< 3.70E-09	ND< 4.20E-09
Indeno(1,2,3-cd)pyrene	ND< 3.64E-09	ND< 3.70E-09	ND< 4.20E-09
Dibenzo(a,h)anthracene	ND< 3.64E-09	ND< 3.70E-09	ND< 4.20E-09
Benzo(g,h,i)perylene	ND< 3.64E-09	ND< 3.70E-09	ND< 4.20E-09
Carbazole	ND< 3.64E-09	ND< 3.70E-09	ND< 4.20E-09
Diesel Range Organics ⁽¹⁾	ND< 7.27E-08	NA	NA

"ND<(...)" = Analyte detection limit value.

B=Detected in the field blank in quantities greater than the sample, therefore sample values are not blank corrected.

J=Detected in the samples in quantities less than the calibration detection limit.

(1) Diesel range organics analysis performed on T1 sample only.

Table 7-8

SVOC Test Data and Test Results at the Thermal Oxidizer Discharge (Continued)

TEST DATA	AFTERBURNER DISCHARGE		
	T1	T2	T3
Run number			
Location			
Date	01-31-96	02-02-96	02-04-96
Time period	1834-0110	1406-2031	1409-2036
SEMIVOLATILE ORGANICS EMISSION RESULTS, lb/hr			
Phenol	ND< 2.41E-04	ND< 2.36E-04	ND< 2.45E-04
Bis (2-chloroethyl) ether	ND< 2.41E-04	ND< 2.36E-04	ND< 2.45E-04
2-Chlorophenol	ND< 2.41E-04	ND< 2.36E-04	ND< 2.45E-04
1,3-Dichlorobenzene	ND< 2.41E-04	ND< 2.36E-04	ND< 2.45E-04
1,4-Dichlorobenzene	ND< 2.41E-04	ND< 2.36E-04	ND< 2.45E-04
Benzyl Alcohol	ND< 2.41E-04	ND< 2.36E-04	ND< 2.45E-04
1,2-Dichlorobenzene	ND< 2.41E-04	ND< 2.36E-04	ND< 2.45E-04
2-Methylphenol	ND< 2.41E-04	ND< 2.36E-04	ND< 2.45E-04
bis (2-Chloroisopropyl) ether	ND< 2.41E-04	ND< 2.36E-04	ND< 2.45E-04
4-Methylphenol	ND< 2.41E-04	ND< 2.36E-04	ND< 2.45E-04
n-Nitroso-di-n-propylamine	ND< 2.41E-04	ND< 2.36E-04	ND< 2.45E-04
Hexachloroethane	ND< 2.41E-04	ND< 2.36E-04	ND< 2.45E-04
Nitrobenzene	ND< 2.41E-04	ND< 2.36E-04	ND< 2.45E-04
Isophorone	ND< 2.41E-04	ND< 2.36E-04	ND< 2.45E-04
2-Nitrophenol	ND< 2.41E-04	ND< 2.36E-04	ND< 2.45E-04
2,4-Dimethylphenol	ND< 2.41E-04	ND< 2.36E-04	ND< 2.45E-04
Benzoic acid	ND< 1.16E-03	ND< 1.13E-03	ND< 1.18E-03
Bis (2-chloroethoxy)-methane	ND< 2.41E-04	ND< 2.36E-04	ND< 2.45E-04
2,4-Dichlorophenol	ND< 2.41E-04	ND< 2.36E-04	ND< 2.45E-04
1,2,4-Trichlorobenzene	ND< 2.41E-04	ND< 2.36E-04	ND< 2.45E-04
Naphthalene	ND< 2.41E-04	ND< 2.36E-04	ND< 2.45E-04
4-Chloroaniline	ND< 2.41E-04	ND< 2.36E-04	ND< 2.45E-04
Hexachlorobutadiene	ND< 2.41E-04	ND< 2.36E-04	ND< 2.45E-04
4-chloro-3-methylphenol	ND< 2.41E-04	ND< 2.36E-04	ND< 2.45E-04
2-Methylnaphthalene	ND< 2.41E-04	ND< 2.36E-04	ND< 2.45E-04
Hexachlorocyclopentadiene	ND< 2.41E-04	ND< 2.36E-04	ND< 2.45E-04
2,4,6-Trichlorophenol	ND< 2.41E-04	ND< 2.36E-04	ND< 2.45E-04
2,4,5-Trichlorophenol	ND< 1.16E-03	ND< 1.13E-03	ND< 1.18E-03
2-Chloronaphthalene	ND< 2.41E-04	ND< 2.36E-04	ND< 2.45E-04
2-Nitroaniline	ND< 1.16E-03	ND< 1.13E-03	ND< 1.18E-03
Dimethylphthalate	ND< 2.41E-04	ND< 2.36E-04	ND< 2.45E-04
Acenaphthylene	ND< 2.41E-04	ND< 2.36E-04	ND< 2.45E-04
2,6-Dinitrotoluene	ND< 2.41E-04	ND< 2.36E-04	ND< 2.45E-04
3-Nitroaniline	ND< 1.16E-03	ND< 1.13E-03	ND< 1.18E-03
Acenaphthene	ND< 2.41E-04	ND< 2.36E-04	ND< 2.45E-04
2,4-Dinitrophenol	ND< 1.16E-03	ND< 1.13E-03	ND< 1.18E-03
4-Nitrophenol	ND< 1.16E-03	ND< 1.13E-03	ND< 1.18E-03
Dibenzofuran	ND< 2.41E-04	ND< 2.36E-04	ND< 2.45E-04
2,4-Dinitrotoluene	ND< 2.41E-04	ND< 2.36E-04	ND< 2.45E-04
Diethylphthalate	6.42E-06 J	2.67E-05 J	ND< 2.45E-04
4-Chlorophenyl-phenyl ether	ND< 2.41E-04	ND< 2.36E-04	ND< 2.45E-04
Fluorene	ND< 2.41E-04	ND< 2.36E-04	ND< 2.45E-04
4-Nitroaniline	ND< 1.16E-03	ND< 1.13E-03	ND< 1.18E-03
4,6-Dinitro-2-methylphenol	ND< 1.16E-03	ND< 1.13E-03	ND< 1.18E-03
n-Nitrosodiphenylamine	ND< 2.41E-04	ND< 2.36E-04	ND< 2.45E-04
4-Bromophenyl-phenyl ether	ND< 2.41E-04	ND< 2.36E-04	ND< 2.45E-04
Hexachlorobenzene	ND< 2.41E-04	ND< 2.36E-04	ND< 2.45E-04
Pentachlorophenol	2.41E-06 J	1.10E-05 J	ND< 1.18E-03
Phenanthrene	ND< 2.41E-04	ND< 2.36E-04	ND< 2.45E-04
Anthracene	ND< 2.41E-04	ND< 2.36E-04	ND< 2.45E-04
Di-n-butylphthalate	4.01E-06 J	ND< 2.36E-04	ND< 2.45E-04
Fluoranthene	ND< 2.41E-04	ND< 2.36E-04	ND< 2.45E-04
Pyrene	ND< 2.41E-04	ND< 2.36E-04	ND< 2.45E-04
Butylbenzylphthalate	ND< 2.41E-04	ND< 2.36E-04	ND< 2.45E-04
3,3'-Dichlorobenzidine	ND< 4.82E-04	ND< 4.71E-04	ND< 4.90E-04
Benzo(a)anthracene	ND< 2.41E-04	2.36E-06 J	ND< 2.45E-04
Chrysene	ND< 2.41E-04	1.57E-06 J	ND< 2.45E-04
bis(2-Ethylhexyl)phthalate	1.85E-05 JB	8.64E-06 JB	8.99E-06 JB
Di-n-octylphthalate	ND< 2.41E-04	1.57E-06 J	ND< 2.45E-04
Benzo(b)fluoranthene	ND< 2.41E-04	ND< 2.36E-04	ND< 2.45E-04
Benzo(k)fluoranthene	ND< 2.41E-04	ND< 2.36E-04	ND< 2.45E-04
Benzo(a)pyrene	ND< 2.41E-04	ND< 2.36E-04	ND< 2.45E-04
Indeno(1,2,3-cd)pyrene	ND< 2.41E-04	ND< 2.36E-04	ND< 2.45E-04
Dibenzo(a,h)anthracene	ND< 2.41E-04	ND< 2.36E-04	ND< 2.45E-04
Benzo(g,h,i)perylene	ND< 2.41E-04	ND< 2.36E-04	ND< 2.45E-04
Carbazole	ND< 2.41E-04	ND< 2.36E-04	ND< 2.45E-04
Diesel Range Organics ⁽¹⁾	ND< 4.82E-03	NA	NA

"ND<(....)" = Analyte detection limit value.

B=Detected in the field blank in quantities greater than the sample, therefore sample values are not blank corrected.

J=Detected in the samples in quantities less than the calibration detection limit.

(1) Diesel range organics analysis performed on T1 sample only.

Table 7-8

SVOC Test Data and Test Results at the Thermal Oxidizer Discharge (Continued)

TEST DATA	AFTERBURNER DISCHARGE					
		T1	T2		T3	
	Run number	01-31-96	02-02-96	02-04-96		
	Location	1834-0110	1406-2031	1409-2036		
Date						
Time period						
SEMIVOLATILE ORGANICS CONCENTRATIONS, ppb/v						
Phenol	ND<	14.89	ND<	15.16	ND<	17.20
Bis (2-chloroethyl) ether	ND<	9.80	ND<	9.97	ND<	11.32
2-Chlorophenol	ND<	10.90	ND<	11.10	ND<	12.59
1,3-Dichlorobenzene	ND<	9.53	ND<	9.70	ND<	11.01
1,4-Dichlorobenzene	ND<	9.53	ND<	9.70	ND<	11.01
Benzyl Alcohol	ND<	12.959	ND<	13.19	ND<	14.966
1,2-Dichlorobenzene	ND<	9.53	ND<	9.70	ND<	11.01
2-Methylphenol	ND<	12.96	ND<	13.19	ND<	14.97
bis (2-Chloroisopropyl) ether	ND<	8.24	ND<	8.39	ND<	9.52
4-Methylphenol	ND<	12.96	ND<	13.19	ND<	14.97
n-Nitroso-di-n-propylamine	ND<	10.76	ND<	10.95	ND<	12.43
Hexachloroethane	ND<	5.92	ND<	6.03	ND<	6.84
Nitrobenzene	ND<	11.38	ND<	11.59	ND<	13.15
Isophorone	ND<	10.14	ND<	10.32	ND<	11.71
2-Nitrophenol	ND<	10.07	ND<	10.25	ND<	11.63
2,4-Dimethylphenol	ND<	11.47	ND<	11.67	ND<	13.25
Benzoic acid	ND<	55.08	ND<	56.07	ND<	63.61
Bis (2-chloroethoxy)-methane	ND<	8.10	ND<	8.24	ND<	9.35
2,4-Dichlorophenol	ND<	8.60	ND<	8.75	ND<	9.93
1,2,4-Trichlorobenzene	ND<	7.72	ND<	7.86	ND<	8.92
Naphthalene	ND<	10.93	ND<	11.128	ND<	12.626
4-Chloroaniline	ND<	10.98	ND<	11.18	ND<	12.69
Hexachlorobutadiene	ND<	5.37	ND<	5.47	ND<	6.21
4-chloro-3-methylphenol	ND<	9.83	ND<	10.00	ND<	11.35
2-Methylnaphthalene	ND<	9.855	ND<	10.031	ND<	11.381
Hexachlorocyclopentadiene	ND<	5.14	ND<	5.23	ND<	5.93
2,4,6-Trichlorophenol	ND<	7.10	ND<	7.22	ND<	8.20
2,4,5-Trichlorophenol	ND<	34.07	ND<	34.68	ND<	39.34
2-Chloronaphthalene	ND<	8.62	ND<	8.77	ND<	9.95
2-Nitroaniline	ND<	48.70	ND<	49.57	ND<	56.24
Dimethylphthalate	ND<	7.22	ND<	7.35	ND<	8.33
Acenaphthylene	ND<	9.21	ND<	9.37	ND<	10.63
2,6-Dinitrotoluene	ND<	7.69	ND<	7.83	ND<	8.89
3-Nitroaniline	ND<	48.70	ND<	49.57	ND<	56.24
Acenaphthene	ND<	9.09	ND<	9.25	ND<	10.49
2,4-Dinitrophenol	ND<	36.53	ND<	37.19	ND<	42.19
4-Nitrophenol	ND<	48.35	ND<	49.22	ND<	55.84
4-Nitrophenol	ND<	8.33	ND<	8.48	ND<	9.62
Dibenzofuran	ND<	7.69	ND<	7.83	ND<	8.89
2,4-Dinitrotoluene	ND<	0.168 J	ND<	0.73 J	ND<	7.28
Diethylphthalate	ND<	6.87	ND<	6.99	ND<	7.93
4-Chlorophenyl-phenyl ether	ND<	8.43	ND<	8.58	ND<	9.74
Fluorene	ND<	48.70	ND<	49.57	ND<	56.24
4-Nitroaniline	ND<	33.96	ND<	34.56	ND<	39.21
4,6-Dinitro-2-methylphenol	ND<	7.07	ND<	7.20	ND<	8.16
n-Nitrosodiphenylamine	ND<	5.65	ND<	5.75	ND<	6.53
4-Bromophenyl-phenyl ether	ND<	4.92	ND<	5.01	ND<	5.68
Hexachlorobenzene	ND<	0.05 J	ND<	0.25 J	ND<	29.17
Pentachlorophenol	ND<	7.862	ND<	8.00	ND<	9.08
Phenanthrene	ND<	7.86	ND<	8.00	ND<	9.08
Anthracene	ND<	0.08 J	ND<	5.12	ND<	5.81
Di-n-butylphthalate	ND<	6.929	ND<	7.05	ND<	8.00
Fluoranthene	ND<	6.93	ND<	7.05	ND<	8.00
Pyrene	ND<	4.486	ND<	4.566	ND<	5.1808
Butylbenzylphthalate	ND<	11.07	ND<	11.27	ND<	12.79
3,3'-Dichlorobenzidine	ND<	6.14	ND<	0.06 J	ND<	7.09
Benzo(a)anthracene	ND<	6.14	ND<	0.04 J	ND<	7.09
Chrysene	ND<	0.28 JB	ND<	0.13 JB	ND<	0.15 JB
bis(2-Ethylhexyl)phthalate	ND<	3.59	ND<	0.02 J	ND<	4.14
Di-n-octylphthalate	ND<	5.55	ND<	5.65	ND<	6.41
Benzo(b)fluoranthene	ND<	5.55	ND<	5.65	ND<	6.41
Benzo(k)fluoranthene	ND<	5.55	ND<	5.65	ND<	6.41
Benzo(a)pyrene	ND<	5.07	ND<	5.16	ND<	5.86
Indeno(1,2,3-cd)pyrene	ND<	5.03	ND<	5.12	ND<	5.81
Dibenzo(a,h)anthracene	ND<	5.07	ND<	5.16	ND<	5.86
Benzo(g,h,i)perylene	ND<	8.38	ND<	8.53	ND<	9.68
Carbazole	ND<	196.98	ND<	NA	ND<	NA
Diesel Range Organics ⁽¹⁾	ND<		ND<		ND<	

"ND<(....)" = Analyte detection limit value.

B=Detected in the field blank in quantities greater than the sample, therefore sample values are not blank corrected.

J=Detected in the samples in quantities less than the calibration detection limit.

(1) Diesel range organics analysis performed on T1 sample only.

Table 7-8

SVOC Test Data and Test Results at the Thermal Oxidizer Discharge (Continued)

TEST DATA	AFTERBURNER DISCHARGE		
	T1	T2	T3
Run number			
Location			
Date	01-31-96	02-02-96	02-04-96
Time period	1834-0110	1406-2031	1409-2036
SEMIVOLATILE ORGANICS EMISSION RESULTS, g/sec			
Phenol	ND< 3.03E-05	ND< 2.97E-05	ND< 3.09E-05
Bis (2-chloroethyl) ether	ND< 3.03E-05	ND< 2.97E-05	ND< 3.09E-05
2-Chlorophenol	ND< 3.03E-05	ND< 2.97E-05	ND< 3.09E-05
1,3-Dichlorobenzene	ND< 3.03E-05	ND< 2.97E-05	ND< 3.09E-05
1,4-Dichlorobenzene	ND< 3.03E-05	ND< 2.97E-05	ND< 3.09E-05
Benzyl Alcohol	ND< 3.03E-05	ND< 2.97E-05	ND< 3.09E-05
1,2-Dichlorobenzene	ND< 3.03E-05	ND< 2.97E-05	ND< 3.09E-05
2-Methylphenol	ND< 3.03E-05	ND< 2.97E-05	ND< 3.09E-05
bis (2-Chloroisopropyl) ether	ND< 3.03E-05	ND< 2.97E-05	ND< 3.09E-05
4-Methylphenol	ND< 3.03E-05	ND< 2.97E-05	ND< 3.09E-05
n-Nitroso-di-n-propylamine	ND< 3.03E-05	ND< 2.97E-05	ND< 3.09E-05
Hexachloroethane	ND< 3.03E-05	ND< 2.97E-05	ND< 3.09E-05
Nitrobenzene	ND< 3.03E-05	ND< 2.97E-05	ND< 3.09E-05
Isophorone	ND< 3.03E-05	ND< 2.97E-05	ND< 3.09E-05
2-Nitrophenol	ND< 3.03E-05	ND< 2.97E-05	ND< 3.09E-05
2,4-Dimethylphenol	ND< 3.03E-05	ND< 2.97E-05	ND< 3.09E-05
Benzoic acid	ND< 1.46E-04	ND< 1.42E-04	ND< 1.48E-04
Bis (2-chloroethoxy)-methane	ND< 3.03E-05	ND< 2.97E-05	ND< 3.09E-05
2,4-Dichlorophenol	ND< 3.03E-05	ND< 2.97E-05	ND< 3.09E-05
1,2,4-Trichlorobenzene	ND< 3.03E-05	ND< 2.97E-05	ND< 3.09E-05
Naphthalene	ND< 3.03E-05	ND< 2.97E-05	ND< 3.09E-05
4-Chloroaniline	ND< 3.03E-05	ND< 2.97E-05	ND< 3.09E-05
Hexachlorobutadiene	ND< 3.03E-05	ND< 2.97E-05	ND< 3.09E-05
4-chloro-3-methylphenol	ND< 3.03E-05	ND< 2.97E-05	ND< 3.09E-05
2-Methylnaphthalene	ND< 3.03E-05	ND< 2.97E-05	ND< 3.09E-05
Hexachlorocyclopentadiene	ND< 3.03E-05	ND< 2.97E-05	ND< 3.09E-05
2,4,6-Trichlorophenol	ND< 1.46E-04	ND< 1.42E-04	ND< 1.48E-04
2,4,5-Trichlorophenol	ND< 3.03E-05	ND< 2.97E-05	ND< 3.09E-05
2-Chloronaphthalene	ND< 1.46E-04	ND< 1.42E-04	ND< 1.48E-04
2-Nitroaniline	ND< 3.03E-05	ND< 2.97E-05	ND< 3.09E-05
Dimethylphthalate	ND< 3.03E-05	ND< 2.97E-05	ND< 3.09E-05
Acenaphthylene	ND< 3.03E-05	ND< 2.97E-05	ND< 3.09E-05
2,6-Dimethyltoluene	ND< 3.03E-05	ND< 2.97E-05	ND< 3.09E-05
3-Nitroaniline	ND< 1.46E-04	ND< 1.42E-04	ND< 1.48E-04
Acenaphthene	ND< 3.03E-05	ND< 2.97E-05	ND< 3.09E-05
2,4-Dinitrophenol	ND< 1.46E-04	ND< 1.42E-04	ND< 1.48E-04
4-Nitrophenol	ND< 1.46E-04	ND< 1.42E-04	ND< 1.48E-04
Dibenzofuran	ND< 3.03E-05	ND< 2.97E-05	ND< 3.09E-05
2,4-Dimethyltoluene	ND< 3.03E-05	ND< 2.97E-05	ND< 3.09E-05
Diethylphthalate	8.09E-07 J	3.36E-06 J	ND< 3.09E-05
4-Chlorophenyl-phenyl ether	ND< 3.03E-05	ND< 2.97E-05	ND< 3.09E-05
Fluorene	ND< 3.03E-05	ND< 2.97E-05	ND< 3.09E-05
4-Nitroaniline	ND< 1.46E-04	ND< 1.42E-04	ND< 1.48E-04
4,6-Dinitro-2-methylphenol	ND< 1.46E-04	ND< 1.42E-04	ND< 1.48E-04
n-Nitrosodiphenylamine	ND< 3.03E-05	ND< 2.97E-05	ND< 3.09E-05
4-Bromophenyl-phenyl ether	ND< 3.03E-05	ND< 2.97E-05	ND< 3.09E-05
Hexachlorobenzene	ND< 3.03E-05	ND< 2.97E-05	ND< 3.09E-05
Pentachlorophenol	3.03E-07 J	1.38E-06 J	ND< 1.48E-04
Phenanthrene	ND< 3.03E-05	ND< 2.97E-05	ND< 3.09E-05
Anthracene	ND< 3.03E-05	ND< 2.97E-05	ND< 3.09E-05
Di-n-butylphthalate	5.06E-07 J	ND< 2.97E-05	ND< 3.09E-05
Fluoranthene	ND< 3.03E-05	ND< 2.97E-05	ND< 3.09E-05
Pyrene	ND< 3.03E-05	ND< 2.97E-05	ND< 3.09E-05
Butylbenzylphthalate	ND< 3.03E-05	ND< 2.97E-05	ND< 3.09E-05
3,3'-Dichlorobenzidine	ND< 6.07E-05	ND< 5.94E-05	ND< 6.18E-05
Benzo(a)anthracene	ND< 3.03E-05	2.97E-07 J	ND< 3.09E-05
Chrysene	ND< 3.03E-05	1.98E-07 J	ND< 3.09E-05
bis(2-Ethylhexyl)phthalate	2.33E-06 JB	1.09E-06 JB	1.13E-06 JB
Di-n-octylphthalate	ND< 3.03E-05	1.98E-07 J	ND< 3.09E-05
Benzo(b)fluoranthene	ND< 3.03E-05	ND< 2.97E-05	ND< 3.09E-05
Benzo(k)fluoranthene	ND< 3.03E-05	ND< 2.97E-05	ND< 3.09E-05
Benzo(a)pyrene	ND< 3.03E-05	ND< 2.97E-05	ND< 3.09E-05
Indeno(1,2,3-cd)pyrene	ND< 3.03E-05	ND< 2.97E-05	ND< 3.09E-05
Dibenzo(a,h)anthracene	ND< 3.03E-05	ND< 2.97E-05	ND< 3.09E-05
Benzo(g,h,i)perylene	ND< 3.03E-05	ND< 2.97E-05	ND< 3.09E-05
Carbazole	ND< 3.03E-05	ND< 2.97E-05	ND< 3.09E-05
Diesel Range Organics ⁽¹⁾	ND< 6.07E-04	NA	NA

"ND<(....)" = Analyte detection limit value.

B=Detected in the field blank in quantities greater than the sample, therefore sample values are not blank corrected.

J=Detected in the samples in quantities less than the calibration detection limit.

(1) Diesel range organics analysis performed on T1 sample only.

SVOCs were sampled during all three validation test runs and performed at the thermal oxidizer discharge stack using the EPA Method 0010 (explosives) test train. Analysis was conducted using EPA Method 8270 procedures by high-resolution gas chromatography (HRGC) with low-resolution mass spectrometry (LRMS). With few exceptions, all SVOCs for tests T1, T2, and T3 were reported as detection limit values.

Because of the multiple extracts required for the analysis of explosives, the detection limit values for SVOCs were higher than expected. As a result, WESTON elected to also analyze the EPA Method 23 (dioxin/furan) sample extracts for SVOCs. Sample extracts for tests T1 and T2 and the field blank sample were analyzed for SVOCs using EPA 8270 procedures. The test T3 sample extract was totally consumed during dioxin/furan analyses; therefore, SVOC analysis of the EPA Method 23 test T3 sample could not be performed.

Table 7-8 presents the SVOC analytical results of the T1, T2, and field blank samples obtained from the EPA Method 23 test train, and SVOC results obtained from the EPA Method 0010 test train for test runs T1, T2, and T3. As indicated, the results of the additional analysis provided significantly lower SVOC detection limits. The majority of detected SVOCs were also measured in the field blank sample at concentrations equal to or exceeding those detected in the T1 and T2 samples, indicating that the low concentrations of SVOCs present may be the result of contamination and not the result of source emissions.

It should be noted that WESTON elected to analyze the EPA Method 23 extracts for SVOCs in order to obtain lower detection limits. Although the SVOC analytical results obtained from analysis of the EPA Method 0010 samples show higher detection limits, the results are considered valid. In addition, although no SVOC surrogate standards were added to the Method 23 samples prior to extraction and analysis, the acceptable dioxin/furan surrogate recoveries provide an indication that the SVOC results obtained from the EPA Method 23 sample extracts are representative.

In addition to the EPA Method 8270 SVOC analysis of the thermal oxidizer discharge samples, a portion of the test T1 Method 0010 sample collected at the furnace discharge and thermal oxidizer discharge was also analyzed for C₇-C₁₇ (diesel range) hydrocarbons using EPA Method 8015 analytical procedures. The results of the C₇-C₁₇ hydrocarbon analysis of the furnace discharge sample is presented in Table 7-4 (Summary of Explosive Compounds Test Data and Test Results). The C₇-C₁₇ analytical results for the thermal oxidizer discharge are provided in Table 7-8 with the other SVOC results.

7.3.4 Dioxins and Furans

Thermal oxidizer discharge stack sampling using an EPA Method 23 sampling train was performed to determine emission concentrations and mass rates of polychlorinated dibenzo-p-dioxins (PCDDs) and dibenzofurans (PCDFs).

A summary of the dioxin/furan toxic equivalent (TEQ) emission concentrations is presented in Table 7-9. Detailed dioxin/furan test data and test results are provided in Table 7-10. The measured dioxin/furan 2,3,7,8-TCDD TEQ emission concentrations for tests T1, T2, and T3 were 0.0395, 0.0221, and 0.0309 ng/dscm. These emissions are well below the regulatory standard of 0.2 ng/dscm TEQ.

7.3.5 Volatile Organic Compounds

During validation test runs T1, T2 and T3, VOCs were measured at the thermal oxidizer discharge stack using an EPA Method 0030 volatile organic sampling train (VOST). Samples were analyzed by EPA Methods 5040 and 8240 (with gas chromatography [GC] and mass spectrometry [MS]).

A summary of the detected VOCs is presented in Table 7-11. The detailed VOST test data and test results are presented in Tables 7-12, 7-13, and 7-14 for tests T1, T2, and T3, respectively. Of the 10 VOCs that were consistently detected in the thermal oxidizer discharge gas stream, bromomethane, methylene chloride, benzene, and toluene were also detected in VOST blank samples. The reported values for these compounds, although very low, may not be truly representative of source emissions and may be the result of contamination because some of these compounds are common laboratory solvents.

7.3.6 Metals

Metals testing was performed at the thermal oxidizer discharge stack using EPA Method 29 sampling and analytical procedures. The metals determined during each of the three validation tests included:

- Antimony (Sb)
- Arsenic (As)
- Barium (Ba)
- Beryllium (Be)
- Cadmium (Cd)
- Lead (Pb)
- Mercury (Hg)
- Nickel (Ni)
- Selenium (Se)
- Silver (Ag)
- Thallium (Tl)

A separate test train was used to determine concentrations of hexavalent chromium (Cr^{+6}) at thermal oxidizer discharge during tests T1, T2, and T3. Sampling and analysis for Cr^{+6} was performed using the procedures outlined in Determination of Hexavalent Chromium Emissions from Stationary Sources (EPA 40 CFR, Part 266, Appendix IX).

Table 7-9

Dioxin and Furan Emissions
at the Thermal Oxidizer Discharge

Test Run No.:	T1	T2	T3
Date:	31 Jan 96	2 Feb 96	4 Feb 96
Parameter	1834-0121	1405-2038	1410-2045
1,2,3,4,7,8-HxCDD	2.54E-03	1.23E-03	1.32E-03
1,2,3,6,7,8-HxCDD	2.93E-03	1.02E-03	1.54E-03
1,2,3,7,8,9-HxCDD	6.45E-03	2.25E-03	3.95E-03
1,2,3,4,6,7,8-HpCDD	2.35E-03	6.96E-04	1.60E-03
OCDD	6.06E-04	2.25E-04	4.39E-04
2,3,7,8-TCDF	ND	2.05E-04	2.20E-04
1,2,3,7,8-PeCDF	ND	1.02E-04	2.20E-04
2,3,4,7,8-PeCDF	ND	3.07E-03	2.20E-03
1,2,3,4,7,8-HxCDF	3.91E-04	8.19E-04	1.32E-03
1,2,3,6,7,8-HxCDF	1.96E-04	4.09E-04	6.59E-04
2,3,4,6,7,8-HxCDF	3.91E-04	6.14E-04	6.59E-04
1,2,3,7,8,9-HxCDF	ND	ND	ND
1,2,3,4,6,7,8-HpCDF	9.78E-05	1.64E-04	2.20E-04
1,2,3,4,7,8,9-HpCDF	1.96E-05	2.05E-05	4.39E-05
OCDF	1.56E-05	1.02E-05	1.10E-05
Detected Total 2,3,7,8-TCDD Equivalents	0.0395	0.0221	0.0309

Calculated total 2,3,7,8-TCDD equivalents based on detected values only.

ND = Non-detect, indicates values less than detection limits; detection limits are provided in Appendix I.

Table 7-10

Dioxin and Furan Test Data and Test Results
at the Thermal Oxidizer Discharge

TEST DATA	T1	T2	T3
	AFTERBURNER DISCHARGE		
Test run number	01-31-96	02-02-96	02-04-96
Test location	1834-0121	1405-2038	1410-2045
Test date			
Test time period			
SAMPLING DATA			
Sampling duration, min.	360.0	360.0	360.0
Nozzle diameter, in.	0.620	0.620	0.620
Cross sectional nozzle area, sq.ft.	0.002097	0.002097	0.002097
Barometric pressure, in. Hg	29.73	29.59	30.28
Avg. orifice press. diff., in H ₂ O	0.83	0.77	0.65
Avg. dry gas meter temp., deg. F	49	50	49
Avg. abs. dry gas meter temp., deg. R	509	510	509
Total liquid collected by train, ml	341.1	299.4	252.8
Std. vol. of H ₂ O vapor coll., cu.ft.	16.1	14.1	11.9
Dry gas meter calibration factor	0.993	0.993	0.993
Sample vol. at meter cond., dcf	176.066	169.257	153.896
Sample vol. at std. cond., dscf (1)	180.526	172.471	160.738
Percent of isokinetic sampling	100.6	102.1	99.5
GAS STREAM COMPOSITION DATA			
CO ₂ , % by volume, dry basis	5.7	5.8	6.1
O ₂ , % by volume, dry basis	12.1	11.9	11.9
CO, % by volume dry basis	0.0	0.0	0.0
N ₂ , % by volume, dry basis	82.2	82.3	82.0
Molecular wt. of dry gas, lb/lb mole	29.40	29.41	29.45
H ₂ O vapor in gas stream, prop. by vol.	0.082	0.076	0.069
Mole fraction of dry gas	0.918	0.924	0.931
Molecular wt. of wet gas, lb/lb mole	28.5	28.5	28.7
GAS STREAM VELOCITY AND VOLUMETRIC FLOW DATA			
Static pressure, in. H ₂ O	-0.10	-0.10	-0.10
Static pressure, in. Hg	-0.007	-0.007	-0.007
Absolute pressure, in. Hg	29.72	29.58	30.27
Avg. temperature, deg. F	1541	1517	1509
Avg. absolute temperature, deg.R	2001	1977	1969
Pitot tube coefficient	0.84	0.84	0.84
Total number of traverse points	12	12	12
Avg. gas stream velocity, ft./sec.	16.5	15.3	14.1
Stack/duct cross sectional area, sq.ft.	4.59	4.59	4.59
Avg. gas stream volumetric flow, wacf/min.	4530	4210	3890
Avg. gas stream volumetric flow, dscf/min.	1090	1030	980

(1) Standard conditions = 68 degrees F. (20 deg. C.) and 29.92 in Hg (760 mm Hg)

Table 7-10

**Dioxin and Furan Test Data and Test Results
at the Thermal Oxidizer Discharge
(Continued)**

TEST DATA				
Test run number	T1	T2	T3	
	AFTERBURNER DISCHARGE			
Test location				
Test date	01-31-96	02-02-96	02-04-96	
Test time period	1834-0121	1405-2038	1410-2045	
TOXICITY EQUIVALENCY EMISSIONS (I-TEFs/89), ng/dscm				
2,3,7,8-TCDD	7.82E-03	4.09E-03	4.39E-03	
1,2,3,7,8-PeCDD	1.56E-02	7.17E-03	1.21E-02	
1,2,3,4,7,8-HxCDD	2.54E-03	1.23E-03	1.32E-03	
1,2,3,6,7,8-HxCDD	2.93E-03	1.02E-03	1.54E-03	
1,2,3,7,8,9-HxCDD	6.45E-03	2.25E-03	3.95E-03	
1,2,3,4,6,7,8-HpCDD	2.35E-03	6.96E-04	1.60E-03	
Total TCDD	0 ⁽³⁾	0 ⁽³⁾	0 ⁽³⁾	
Total PeCDD	0 ⁽³⁾	0 ⁽³⁾	0 ⁽³⁾	
Total HxCDD	0 ⁽³⁾	0 ⁽³⁾	0 ⁽³⁾	
Total HpCDD	0 ⁽³⁾	0 ⁽³⁾	0 ⁽³⁾	
OCDD	6.06E-04	2.25E-04	4.39E-04	
2,3,7,8-TCDF	ND<	1.37E-04	2.05E-04	
1,2,3,7,8-PeCDF	ND<	1.96E-04	1.02E-04	
2,3,4,7,8-PeCDF	ND<	1.96E-03	3.07E-03	
1,2,3,4,7,8-HxCDF		3.91E-04	8.19E-04	
1,2,3,6,7,8-HxCDF		1.96E-04	4.09E-04	
2,3,4,6,7,8-HxCDF		3.91E-04	6.14E-04	
1,2,3,7,8,9-HxCDF	ND<	1.96E-04	ND<	
1,2,3,4,6,7,8-HpCDF		9.78E-05	1.64E-04	
1,2,3,4,7,8,9-HpCDF		1.96E-05	2.05E-05	
Total TCDF	0 ⁽³⁾	0 ⁽³⁾	0 ⁽³⁾	
Total PeCDF	0 ⁽³⁾	0 ⁽³⁾	0 ⁽³⁾	
Total HxCDF	0 ⁽³⁾	0 ⁽³⁾	0 ⁽³⁾	
Total HpCDF	0 ⁽³⁾	0 ⁽³⁾	0 ⁽³⁾	
OCDF	1.56E-05	1.02E-05	1.10E-05	
TOTAL 2,3,7,8-TCDD EQUIVALENTS, ng/dscm⁽¹⁾	≤ 4.20E-02	≤ 2.25E-02	≤ 3.11E-02	
DETECTED TOXICITY EQUIVALENCY EMISSIONS (I-TEFs/89), ng/dscm				
2,3,7,8-TCDD	7.82E-03	4.09E-03	4.39E-03	
1,2,3,7,8-PeCDD	1.56E-02	7.17E-03	1.21E-02	
1,2,3,4,7,8-HxCDD	2.54E-03	1.23E-03	1.32E-03	
1,2,3,6,7,8-HxCDD	2.93E-03	1.02E-03	1.54E-03	
1,2,3,7,8,9-HxCDD	6.45E-03	2.25E-03	3.95E-03	
1,2,3,4,6,7,8-HpCDD	2.35E-03	6.96E-04	1.60E-03	
OCDD	6.06E-04	2.25E-04	4.39E-04	
2,3,7,8-TCDF	ND	2.05E-04	2.20E-04	
1,2,3,7,8-PeCDF	ND	1.02E-04	2.20E-04	
2,3,4,7,8-PeCDF	ND	3.07E-03	2.20E-03	
1,2,3,4,7,8-HxCDF	3.91E-04	8.19E-04	1.32E-03	
1,2,3,6,7,8-HxCDF	1.96E-04	4.09E-04	6.59E-04	
2,3,4,6,7,8-HxCDF	3.91E-04	6.14E-04	6.59E-04	
1,2,3,7,8,9-HxCDF	ND	ND	ND	
1,2,3,4,6,7,8-HpCDF	9.78E-05	1.64E-04	2.20E-04	
1,2,3,4,7,8,9-HpCDF	1.96E-05	2.05E-05	4.39E-05	
OCDF	1.56E-05	1.02E-05	1.10E-05	
DETECTED TOTAL 2,3,7,8-TCDD EQUIVALENTS, ng/dscm⁽²⁾	3.95E-02	2.21E-02	3.09E-02	

(1) Calculated Total 2,3,7,8-TCDD equivalents based on all detected and non-detected values.

(2) Calculated Total 2,3,7,8-TCDD equivalents based on detected values only.

(3) Zero value denotes no toxic equivalency.

Table 7-10

Dioxin and Furan Test Data and Test Results
at the Thermal Oxidizer Discharge
(Continued)

TEST DATA				
Test run number	T1	T2	T3	
	AFTERBURNER DISCHARGE			
Test location				
Test date	01-31-96	02-02-96	02-04-96	
Test time period	1834-0121	1405-2038	1410-2045	
TOXICITY EQUIVALENCY EMISSIONS (I-TEFs/89), lb/hr				
2,3,7,8-TCDD	3.20E-11	1.58E-11	1.62E-11	
1,2,3,7,8-PeCDD	6.39E-11	2.76E-11	4.44E-11	
1,2,3,4,7,8-HxCDD	1.04E-11	4.73E-12	4.85E-12	
1,2,3,6,7,8-HxCDD	1.20E-11	3.94E-12	5.66E-12	
1,2,3,7,8,9-HxCDD	2.64E-11	8.67E-12	1.45E-11	
1,2,3,4,6,7,8-HpCDD	9.59E-12	2.68E-12	5.90E-12	
Total TCDD	0 ⁽³⁾	0 ⁽³⁾	0 ⁽³⁾	
Total PeCDD	0 ⁽³⁾	0 ⁽³⁾	0 ⁽³⁾	
Total HxCDD	0 ⁽³⁾	0 ⁽³⁾	0 ⁽³⁾	
Total HpCDD	0 ⁽³⁾	0 ⁽³⁾	0 ⁽³⁾	
OCDD	2.48E-12	8.67E-13	1.62E-12	
2,3,7,8-TCDF	ND< 5.59E-13	7.88E-13	8.08E-13	
1,2,3,7,8-PeCDF	ND< 7.99E-13	3.94E-13	8.08E-13	
2,3,4,7,8-PeCDF	ND< 7.99E-12	1.18E-11	8.08E-12	
1,2,3,4,7,8-HxCDF	1.60E-12	3.15E-12	4.85E-12	
1,2,3,6,7,8-HxCDF	7.99E-13	1.58E-12	2.42E-12	
2,3,4,6,7,8-HxCDF	1.60E-12	2.36E-12	2.42E-12	
1,2,3,7,8,9-HxCDF	ND< 7.99E-13	ND< 1.58E-12	ND<	8.08E-13
1,2,3,4,6,7,8-HpCDF	3.99E-13	6.30E-13	8.08E-13	
1,2,3,4,7,8,9-HpCDF	7.99E-14	7.88E-14	1.62E-13	
Total TCDF	0 ⁽³⁾	0 ⁽³⁾	0 ⁽³⁾	
Total PeCDF	0 ⁽³⁾	0 ⁽³⁾	0 ⁽³⁾	
Total HxCDF	0 ⁽³⁾	0 ⁽³⁾	0 ⁽³⁾	
Total HpCDF	0 ⁽³⁾	0 ⁽³⁾	0 ⁽³⁾	
OCDF	6.39E-14	3.94E-14	4.04E-14	
TOTAL 2,3,7,8-TCDD EQUIVALENTS, lb/hr⁽¹⁾	≤ 1.71E-10	≤ 8.66E-11	≤ 1.14E-10	
DETECTED TOXICITY EQUIVALENCY EMISSIONS (I-TEFs/89), lb/hr				
2,3,7,8-TCDD	3.20E-11	1.58E-11	1.62E-11	
1,2,3,7,8-PeCDD	6.39E-11	2.76E-11	4.44E-11	
1,2,3,4,7,8-HxCDD	1.04E-11	4.73E-12	4.85E-12	
1,2,3,6,7,8-HxCDD	1.20E-11	3.94E-12	5.66E-12	
1,2,3,7,8,9-HxCDD	2.64E-11	8.67E-12	1.45E-11	
1,2,3,4,6,7,8-HpCDD	9.59E-12	2.68E-12	5.90E-12	
OCDD	2.48E-12	8.67E-13	1.62E-12	
2,3,7,8-TCDF	ND	7.88E-13	8.08E-13	
1,2,3,7,8-PeCDF	ND	3.94E-13	8.08E-13	
2,3,4,7,8-PeCDF	ND	1.18E-11	8.08E-12	
1,2,3,4,7,8-HxCDF	1.60E-12	3.15E-12	4.85E-12	
1,2,3,6,7,8-HxCDF	7.99E-13	1.58E-12	2.42E-12	
2,3,4,6,7,8-HxCDF	1.60E-12	2.36E-12	2.42E-12	
1,2,3,7,8,9-HxCDF	ND	ND	ND	
1,2,3,4,6,7,8-HpCDF	3.99E-13	6.30E-13	8.08E-13	
1,2,3,4,7,8,9-HpCDF	7.99E-14	7.88E-14	1.62E-13	
OCDF	6.39E-14	3.94E-14	4.04E-14	
DETECTED TOTAL 2,3,7,8-TCDD EQUIVALENTS, lb/hr⁽²⁾	1.61E-10	8.50E-11	1.14E-10	

(1) Calculated Total 2,3,7,8-TCDD equivalents based on all detected and non-detected values.

(2) Calculated Total 2,3,7,8-TCDD equivalents based on detected values only.

(3) Zero value denotes no toxic equivalency.

Table 7-10

Dioxin and Furan Test Data and Test Results
at the Thermal Oxidizer Discharge
(Continued)

TEST DATA		T1	T2	T3
Test run number			AFTERBURNER DISCHARGE	
Test location				
Test date		01-31-96	02-02-96	02-04-96
Test time period		1834-0121	1405-2038	1410-2045
DIOXIN LABORATORY REPORT DATA, ng				
2,3,7,8-TCDD		0.040	0.020	0.020
1,2,3,7,8-PeCDD		0.160	0.070	0.110
1,2,3,4,7,8-HxCDD		0.130	0.060	0.060
1,2,3,6,7,8-HxCDD		0.150	0.050	0.070
1,2,3,7,8,9-HxCDD		0.330	0.110	0.180
1,2,3,4,6,7,8-HpCDD		1.200	0.340	0.730
Total TCDD		0.840	0.360	0.260
Total PeCDD		1.900	0.790	1.300
Total HxCDD		2.600	0.960	1.400
Total HpCDD		2.800	0.750	1.900
OCDD		3.100	1.100	2.000
Total PCDD		11.240	3.960	6.860
DIOXIN CONCENTRATION, ppb/v mole wt.				
2,3,7,8-TCDD	321.9744	5.85E-07	3.06E-07	3.28E-07
1,2,3,7,8-PeCDD	356.4195	2.11E-06	9.67E-07	1.63E-06
1,2,3,4,7,8-HxCDD	390.8646	1.57E-06	7.56E-07	8.11E-07
1,2,3,6,7,8-HxCDD	390.8646	1.81E-06	6.39E-07	9.47E-07
1,2,3,7,8,9-HxCDD	390.8646	3.97E-06	1.39E-06	2.43E-06
1,2,3,4,6,7,8-HpCDD	425.3097	1.33E-05	3.94E-06	9.07E-06
Total TCDD	321.9744	1.23E-05	5.51E-06	4.27E-06
Total PeCDD	356.4195	2.51E-05	1.09E-05	1.93E-05
Total HxCDD	390.8646	3.13E-05	1.21E-05	1.89E-05
Total HpCDD	425.3097	3.10E-05	8.69E-06	2.36E-05
OCDD	459.7548	3.17E-05	1.18E-05	2.30E-05
Total PCDD	321.9744	1.64E-04	6.06E-05	1.13E-04
DIOXIN EMISSIONS, lb/dscf				
2,3,7,8-TCDD		4.88E-16	2.56E-16	2.74E-16
1,2,3,7,8-PeCDD		1.95E-15	8.95E-16	1.51E-15
1,2,3,4,7,8-HxCDD		1.59E-15	7.67E-16	8.23E-16
1,2,3,6,7,8-HxCDD		1.83E-15	6.39E-16	9.60E-16
1,2,3,7,8,9-HxCDD		4.03E-15	1.41E-15	2.47E-15
1,2,3,4,6,7,8-HpCDD		1.47E-14	4.35E-15	1.00E-14
Total TCDD		1.03E-14	4.60E-15	3.57E-15
Total PeCDD		2.32E-14	1.01E-14	1.78E-14
Total HxCDD		3.18E-14	1.23E-14	1.92E-14
Total HpCDD		3.42E-14	9.59E-15	2.61E-14
OCDD		3.79E-14	1.41E-14	2.74E-14
Total PCDD		1.37E-13	5.06E-14	9.41E-14

Table 7-10

Dioxin and Furan Test Data and Test Results
at the Thermal Oxidizer Discharge
(Continued)

TEST DATA	AFTERBURNER DISCHARGE		
	T1	T2	T3
Test run number	01-31-96	02-02-96	02-04-96
Test location	1834-0121	1405-2038	1410-2045
Test date			
Test time period			
DIOXIN CONCENTRATION, ng/dscm			
2,3,7,8-TCDD	7.82E-03	4.09E-03	4.39E-03
1,2,3,7,8-PeCDD	3.13E-02	1.43E-02	2.42E-02
1,2,3,4,7,8-HxCDD	2.54E-02	1.23E-02	1.32E-02
1,2,3,6,7,8-HxCDD	2.93E-02	1.02E-02	1.54E-02
1,2,3,7,8,9-HxCDD	6.45E-02	2.25E-02	3.95E-02
1,2,3,4,6,7,8-HpCDD	2.35E-01	6.96E-02	1.60E-01
Total TCDD	1.64E-01	7.37E-02	5.71E-02
Total PeCDD	3.72E-01	1.62E-01	2.86E-01
Total HxCDD	5.09E-01	1.97E-01	3.08E-01
Total HpCDD	5.48E-01	1.54E-01	4.17E-01
OCDD	6.06E-01	2.25E-01	4.39E-01
Total PCDD	2.20E+00	8.11E-01	1.51E+00
DIOXIN EMISSIONS, lb/hr			
2,3,7,8-TCDD	3.20E-11	1.58E-11	1.62E-11
1,2,3,7,8-PeCDD	1.28E-10	5.52E-11	8.89E-11
1,2,3,4,7,8-HxCDD	1.04E-10	4.73E-11	4.85E-11
1,2,3,6,7,8-HxCDD	1.20E-10	3.94E-11	5.66E-11
1,2,3,7,8,9-HxCDD	2.64E-10	8.67E-11	1.45E-10
1,2,3,4,6,7,8-HpCDD	9.59E-10	2.68E-10	5.90E-10
Total TCDD	6.71E-10	2.84E-10	2.10E-10
Total PeCDD	1.52E-09	6.22E-10	1.05E-09
Total HxCDD	2.08E-09	7.56E-10	1.13E-09
Total HpCDD	2.24E-09	5.91E-10	1.54E-09
OCDD	2.48E-09	8.67E-10	1.62E-09
Total PCDD	8.98E-09	3.12E-09	5.54E-09

Table 7-10

Dioxin and Furan Test Data and Test Results
at the Thermal Oxidizer Discharge
(Continued)

TEST DATA	T1	T2	T3
Test run number			
Test location	AFTERBURNER DISCHARGE		
Test date	01-31-96	02-02-96	02-04-96
Test time period	1834-0121	1405-2038	1410-2045

FURAN LABORATORY REPORT DATA, ng

2,3,7,8-TCDF	ND<	0.007	0.010	0.010
1,2,3,7,8-PeCDF	ND<	0.020	0.010	0.020
2,3,4,7,8-PeCDF	ND<	0.020	0.030	0.020
1,2,3,4,7,8-HxCDF		0.020	0.040	0.060
1,2,3,6,7,8-HxCDF		0.010	0.020	0.030
2,3,4,6,7,8-HxCDF		0.020	0.030	0.030
1,2,3,7,8,9-HxCDF	ND<	0.010	ND<	ND<
1,2,3,4,6,7,8-HpCDF		0.050	0.080	0.100
1,2,3,4,7,8,9-HpCDF		0.010	0.010	0.020
Total TCDF		0.040	0.140	0.350
Total PeCDF		0.130	0.280	0.320
Total HxCDF		0.160	0.200	0.280
Total HpCDF		0.130	0.160	0.180
OCDF		0.080	0.050	0.050
Total PCDF		0.540	0.830	1.180

FURAN CONCENTRATION, ppb/v

mole wt

2,3,7,8-TCDF	305.9750	ND<	1.08E-07	1.61E-07	1.73E-07
1,2,3,7,8-PeCDF	340.4201	ND<	2.76E-07	1.45E-07	3.11E-07
2,3,4,7,8-PeCDF	340.4201	ND<	2.76E-07	4.34E-07	3.11E-07
1,2,3,4,7,8-HxCDF	374.8652		2.51E-07	5.26E-07	8.46E-07
1,2,3,6,7,8-HxCDF	374.8652		1.26E-07	2.63E-07	4.23E-07
2,3,4,6,7,8-HxCDF	374.8652		2.51E-07	3.94E-07	4.23E-07
1,2,3,7,8,9-HxCDF	374.8652	ND<	1.26E-07	ND<	ND<
1,2,3,4,6,7,8-HpCDF	409.3103		5.75E-07	9.63E-07	1.41E-07
1,2,3,4,7,8,9-HpCDF	409.3103		1.15E-07	1.20E-07	1.29E-06
Total TCDF	305.9750		6.15E-07	2.25E-06	6.05E-06
Total PeCDF	340.4201		1.80E-06	4.05E-06	4.97E-06
Total HxCDF	374.8652		2.01E-06	2.63E-06	3.95E-06
Total HpCDF	409.3103		1.49E-06	1.93E-06	2.32E-06
OCDF	443.7554		8.48E-07	5.55E-07	5.96E-07
Total PCDF	305.9750		8.31E-06	1.34E-05	2.04E-05

FURAN EMISSIONS, lb/dscf

2,3,7,8-TCDF	ND<	8.55E-17	1.28E-16	1.37E-16
1,2,3,7,8-PeCDF	ND<	2.44E-16	1.28E-16	2.74E-16
2,3,4,7,8-PeCDF	ND<	2.44E-16	3.83E-16	2.74E-16
1,2,3,4,7,8-HxCDF		2.44E-16	5.11E-16	8.23E-16
1,2,3,6,7,8-HxCDF		1.22E-16	2.56E-16	4.11E-16
2,3,4,6,7,8-HxCDF		2.44E-16	3.83E-16	4.11E-16
1,2,3,7,8,9-HxCDF	ND<	1.22E-16	2.56E-16	ND<
1,2,3,4,6,7,8-HpCDF		6.11E-16	1.02E-15	1.37E-15
1,2,3,4,7,8,9-HpCDF		1.22E-16	1.28E-16	2.74E-16
Total TCDF		4.88E-16	1.79E-15	4.80E-15
Total PeCDF		1.59E-15	3.58E-15	4.39E-15
Total HxCDF		1.95E-15	2.56E-15	3.84E-15
Total HpCDF		1.59E-15	2.05E-15	2.47E-15
OCDF		9.77E-16	6.39E-16	6.86E-16
Total PCDF		6.59E-15	1.06E-14	1.62E-14

Table 7-10

Dioxin and Furan Test Data and Test Results
at the Thermal Oxidizer Discharge
(Continued)

TEST DATA	AFTERBURNER DISCHARGE		
	T1	T2	T3
Test run number			
Test location			
Test date	01-31-96	02-02-96	02-04-96
Test time period	1834-0121	1405-2038	1410-2045
FURAN CONCENTRATIONS, ng/dscm			
2,3,7,8-TCDF	ND< 1.37E-03	2.05E-03	2.20E-03
1,2,3,7,8-PeCDF	ND< 3.91E-03	2.05E-03	4.39E-03
2,3,4,7,8-PeCDF	ND< 3.91E-03	6.14E-03	4.39E-03
1,2,3,4,7,8-HxCDF	3.91E-03	8.19E-03	1.32E-02
1,2,3,6,7,8-HxCDF	1.96E-03	4.09E-03	6.59E-03
2,3,4,6,7,8-HxCDF	3.91E-03	6.14E-03	6.59E-03
1,2,3,7,8,9-HxCDF	ND< 1.96E-03	ND< 4.09E-03	ND< 2.20E-03
1,2,3,4,6,7,8-HpCDF	9.78E-03	1.64E-02	2.20E-02
1,2,3,4,7,8,9-HpCDF	1.96E-03	2.05E-03	4.39E-03
Total TCDF	7.82E-03	2.87E-02	7.69E-02
Total PeCDF	2.54E-02	5.73E-02	7.03E-02
Total HxCDF	3.13E-02	4.09E-02	6.15E-02
Total HpCDF	2.54E-02	3.28E-02	3.95E-02
OCDF	1.56E-02	1.02E-02	1.10E-02
Total PCDF	1.06E-01	1.70E-01	2.59E-01
FURAN EMISSIONS, lb/hr			
2,3,7,8-TCDF	ND< 5.59E-12	7.88E-12	8.08E-12
1,2,3,7,8-PeCDF	ND< 1.60E-11	7.88E-12	1.62E-11
2,3,4,7,8-PeCDF	ND< 1.60E-11	2.36E-11	1.62E-11
1,2,3,4,7,8-HxCDF	1.60E-11	3.15E-11	4.85E-11
1,2,3,6,7,8-HxCDF	7.99E-12	1.58E-11	2.42E-11
2,3,4,6,7,8-HxCDF	1.60E-11	2.36E-11	2.42E-11
1,2,3,7,8,9-HxCDF	ND< 7.99E-12	ND< 1.58E-11	ND< 8.08E-12
1,2,3,4,6,7,8-HpCDF	3.99E-11	6.30E-11	8.08E-11
1,2,3,4,7,8,9-HpCDF	7.99E-12	7.88E-12	1.62E-11
Total TCDF	3.20E-11	1.10E-10	2.83E-10
Total PeCDF	1.04E-10	2.21E-10	2.59E-10
Total HxCDF	1.28E-10	1.58E-10	2.26E-10
Total HpCDF	1.04E-10	1.26E-10	1.45E-10
OCDF	6.39E-11	3.94E-11	4.04E-11
Total PCDF	4.31E-10	6.54E-10	9.53E-10

Table 7-10

Dioxin and Furan Test Data and Test Results
at the Thermal Oxidizer Discharge
(Continued)

TOXICITY EQUIVALENCY FACTORS (I-TEFs/89)

2,3,7,8-TCDD	1	1	1
1,2,3,7,8-PeCDD	0.5	0.5	0.5
1,2,3,4,7,8-HxCDD	0.1	0.1	0.1
1,2,3,6,7,8-HxCDD	0.1	0.1	0.1
1,2,3,7,8,9-HxCDD	0.1	0.1	0.1
1,2,3,4,6,7,8-HpCDD	0.01	0.01	0.01
Total TCDD	0	0	0
Total PeCDD	0	0	0
Total HxCDD	0	0	0
Total HpCDD	0	0	0
OCDD	0.001	0.001	0.001
2,3,7,8-TCDF	0.1	0.1	0.1
1,2,3,7,8-PeCDF	0.05	0.05	0.05
2,3,4,7,8-PeCDF	0.5	0.5	0.5
1,2,3,4,7,8-HxCDF	0.1	0.1	0.1
1,2,3,6,7,8-HxCDF	0.1	0.1	0.1
2,3,4,6,7,8-HxCDF	0.1	0.1	0.1
1,2,3,7,8,9-HxCDF	0.1	0.1	0.1
1,2,3,4,6,7,8-HpCDF	0.01	0.01	0.01
1,2,3,4,7,8,9-HpCDF	0.01	0.01	0.01
Total TCDF	0	0	0
Total PeCDF	0	0	0
Total HxCDF	0	0	0
Total HpCDF	0	0	0
OCDF	0.001	0.001	0.001

Table 7-11

Summary of VOC Emissions
Detected at the Thermal Oxidizer Discharge

Test Run No.:	Emissions of VOCs at Thermal Oxidizer Discharge (ppm/v)			
	T1	T2	T3	Average
	Date:	2 Feb 96	4 Feb 96	
	Time:	1846-2322	1419-2005	1418-1950
Parameter*				
Chloromethane (methyl chloride)	6.78E-02	1.59E-02	3.03E-02	3.80E-02
Bromomethane (methyl bromide)	3.18E-03	1.22E-03	2.04E-03	2.15E-03
Methylene chloride	9.84E-04	9.55E-04	1.19E-03	1.04E-03
Acetone	1.45E-01	7.98E-02	3.99E-02	8.82E-02
Carbon disulfide	ND	3.18E-04	2.10E-04	1.76E-04
Chloroform	1.82E-04	1.80E-04	1.14E-04	1.59E-04
Benzene	9.70E-04	2.72E-04	3.78E-04	5.40E-04
Toluene	4.72E-04	1.07E-04	1.22E-04	2.34E-04
Styrene	1.14E-04	4.37E-04	4.28E-04	3.26E-04
Xylenes (total)	2.76E-04	2.85E-04	2.01E-04	2.54E-04

* Detection limit values are included in the overall average.

ND = Indicates values less than detection limits; detection limits are provided in Appendix I.

Table 7-12

VOC Test Data and Test Results—Thermal Oxidizer Discharge Stack (Test T1)

TEST DATA:

	1	1	1	1
Test run number				
Test location	OUTLET	OUTLET	OUTLET	OUTLET
Test date	01-31-96	01-31-96	01-31-96	01-31-96
Test time	1846-1926	2052-2132	2153-2233	2242-2322
Test tube pair	1	3	4	5

SAMPLING DATA:

	1	1	1	1
Duration, minutes	40.00	40.00	40.00	40.00
Average dry gas meter press. in. H ₂ O	1.39	1.40	1.40	1.30
Average dry gas meter temp. deg. C	9.81	11.12	11.00	11.00
Average dry gas meter temp. deg. F	49.66	52.02	51.80	51.80
Average absolute meter temp. deg. R	519.66	517.02	517.80	517.80
Actual sample volume, liters	21.440	22.693	21.385	20.763
Meter box calibration, Y	1.0060	1.0060	1.0060	1.0060
Barometric pressure, in. Hg	29.73	29.73	29.73	29.73
Sample volume, dscf	0.7865	0.8287	0.7812	0.7583
Volumetric flow rate, dscf/min ⁽¹⁾	1000	1000	1000	1000

LABORATORY DATA, ng:

	M.W.	1	1	1	1
Chloromethane (Methyl Chloride)	50.49	1000.000	2200.000 E	5500.000 E	3900.000 E
Bromomethane (Methyl Bromide)	94.95	81.000 JB	530.000	120.000	400.000
Vinyl Chloride	62.50	100.000 U	100.000 U	100.000 U	100.000 U
Chloroethane (Ethyl Chloride)	64.52	100.000 U	100.000 U	100.000 U	100.000 U
Methylene chloride	84.93	99.463 JB	86.257 JB	68.239 JB	57.264 JB
Acetone	58.09	24667.707 E	1682.057	2265.912	2568.114
Carbon Disulfide	76.13	50.000 U	50.000 U	50.000 U	50.000 U
1,1-Dichloroethene	96.94	50.000 U	50.000 U	50.000 U	50.000 U
1,1-Dichloroethane	98.96	50.000 U	50.000 U	50.000 U	50.000 U
1,2-Dichloroethene (trans)	96.94	50.000 U	50.000 U	50.000 U	50.000 U
Chloroform	119.37	20.078 J	21.154 J	19.943 J	19.359 J
1,2-Dichloroethane (EDC)	98.96	50.000 U	50.000 U	50.000 U	50.000 U
2-Butanone (MEK)	72.12	1000.000 U	1000.000 U	1000.000 U	1000.000 U
1,1,1-Trichloroethane (TCA)	133.40	50.000 U	50.000 U	50.000 U	50.000 U
Carbon Tetrachloride	153.81	50.000 U	50.000 U	50.000 U	50.000 U
Vinyl acetate	86.09	200.000 U	200.000 U	200.000 U	200.000 U
Bromodichloromethane	163.83	50.000 U	50.000 U	50.000 U	50.000 U
1,2-Dichloropropane	112.99	50.000 U	50.000 U	50.000 U	50.000 U
cis-1,3-Dichloropropene	110.98	50.000 U	50.000 U	50.000 U	50.000 U
Dichloroethene (TCE)	131.38	50.000 U	50.000 U	50.000 U	50.000 U
Dibromochloromethane	208.29	50.000 U	50.000 U	50.000 U	50.000 U
1,1,2-Trichloroethane	133.40	50.000 U	50.000 U	50.000 U	50.000 U
Benzene	78.12	99.000 JB	46.000 JB	68.000 JB	67.000 JB
trans-1,3-Dichloropropene	110.98	50.000 U	50.000 U	50.000 U	50.000 U
Bromoform	252.75	50.000 U	50.000 U	50.000 U	50.000 U
4-Methyl-2-Pentanone (MIBK)	100.18	1000.000 U	1000.000 U	1000.000 U	1000.000 U
2-Hexanone	100.18	1000.000 U	1000.000 U	1000.000 U	1000.000 U
Tetrachloroethene (PCE)	165.82	50.000 U	50.000 U	50.000 U	50.000 U
1,1,2,2-Tetrachloroethane	167.84	50.000 U	50.000 U	50.000 U	50.000 U
Toluene	92.15	50.000 JB	32.000 JB	44.000 JB	35.000 JB
Chlorobenzene	112.56	50.000 U	50.000 U	50.000 U	50.000 U
Ethylbenzene	106.18	50.000 U	50.000 U	50.000 U	50.000 U
Styrene	104.16	17.000 J	6.000 J	12.000 J	9.000 J
Xylenes (total)	106.18	38.000	13.000 J	28.000	29.000 J
2-Chloroethyl vinyl ether	106.55	200.000 U	200.000 U	200.000 U	200.000 U

U = detection limit value.

J = Estimated value below the detection limit.

E = Estimated value above the detection limit.

B = Compound also detected on blank. Reported values are not blank corrected.

(1) Volumetric flow rate based on average of Particulate/HCl and MMTL tests flow measurements.

NOTE: Data from test tube pairs 2 and 6 not available due to instrument failure during analysis.

Table 7-12

VOC Test Data and Test Results—Thermal Oxidizer Discharge Stack (Test T1) (Continued)

TEST DATA:

	1	1	1	1	1
Test run number	OUTLET	OUTLET	OUTLET	OUTLET	OUTLET
Test location	01-31-96	01-31-96	01-31-96	01-31-96	
Test date	1846-1926	2052-2132	2153-2233	2242-2322	
Test time	1	3	4	5	AVERAGE (2)
Test tube pair					

VOST EMISSIONS (lbs/dscf):

Chloromethane (Methyl Chloride)	2.80E-09	5.85E-09 E	1.55E-08 E	1.13E-08 E	8.88E-09
Bromomethane (Methyl Bromide)	2.27E-10 JB	1.41E-09	3.39E-10	1.16E-09	7.85E-10
Vinyl Chloride	< 2.80E-10	< 2.66E-10	< 2.82E-10	< 2.91E-10	< 2.80E-10
Chloroethane (Ethyl Chloride)	< 2.80E-10	< 2.66E-10	< 2.82E-10	< 2.91E-10	< 2.80E-10
Methylene chloride	2.79E-10 JB	2.29E-10 JB	1.93E-10 JB	1.66E-10 JB	2.17E-10
Acetone	6.91E-08 E	4.48E-09	6.39E-09	7.47E-09	2.19E-08
Carbon Disulfide	< 1.40E-10	< 1.33E-10	< 1.41E-10	< 1.45E-10	< 1.40E-10
1,1-Dichloroethene	< 1.40E-10	< 1.33E-10	< 1.41E-10	< 1.45E-10	< 1.40E-10
1,1-Dichloroethane	< 1.40E-10	< 1.33E-10	< 1.41E-10	< 1.45E-10	< 1.40E-10
1,2-Dichloroethene (trans)	< 1.40E-10	< 1.33E-10	< 1.41E-10	< 1.45E-10	< 1.40E-10
Chloroform	5.63E-11 J	5.63E-11 J	5.63E-11 J	5.63E-11 J	5.63E-11
1,2-Dichloroethane (EDC)	< 1.40E-10	< 1.33E-10	< 1.41E-10	< 1.45E-10	< 1.40E-10
2-Butanone (MEK)	< 2.80E-09	< 2.66E-09	< 2.82E-09	< 2.91E-09	< 2.80E-09
1,1,1-Trichloroethane (TCA)	< 1.40E-10	< 1.33E-10	< 1.41E-10	< 1.45E-10	< 1.40E-10
Carbon Tetrachloride	< 1.40E-10	< 1.33E-10	< 1.41E-10	< 1.45E-10	< 1.40E-10
Vinyl acetate	< 5.61E-10	< 5.32E-10	< 5.64E-10	< 5.81E-10	< 5.60E-10
Bromodichloromethane	< 1.40E-10	< 1.33E-10	< 1.41E-10	< 1.45E-10	< 1.40E-10
1,2-Dichloropropane	< 1.40E-10	< 1.33E-10	< 1.41E-10	< 1.45E-10	< 1.40E-10
cis-1,3-Dichloropropene	< 1.40E-10	< 1.33E-10	< 1.41E-10	< 1.45E-10	< 1.40E-10
Trichloroethene (TCE)	< 1.40E-10	< 1.33E-10	< 1.41E-10	< 1.45E-10	< 1.40E-10
Dibromochloromethane	< 1.40E-10	< 1.33E-10	< 1.41E-10	< 1.45E-10	< 1.40E-10
1,1,2-Trichloroethane	< 1.40E-10	< 1.33E-10	< 1.41E-10	< 1.45E-10	< 1.40E-10
Benzene	2.78E-10 JB	1.22E-10 JB	1.92E-10 JB	1.95E-10 JB	1.97E-10
trans-1,3-Dichloropropene	< 1.40E-10	< 1.33E-10	< 1.41E-10	< 1.45E-10	< 1.40E-10
Bromoform	< 1.40E-10	< 1.33E-10	< 1.41E-10	< 1.45E-10	< 1.40E-10
4-Methyl-2-Pentanone (MIBK)	< 2.80E-09	< 2.66E-09	< 2.82E-09	< 2.91E-09	< 2.80E-09
2-Hexanone	< 2.80E-09	< 2.66E-09	< 2.82E-09	< 2.91E-09	< 2.80E-09
Tetrachloroethene (PCE)	< 1.40E-10	< 1.33E-10	< 1.41E-10	< 1.45E-10	< 1.40E-10
1,1,2,2-Tetrachloroethane	< 1.40E-10	< 1.33E-10	< 1.41E-10	< 1.45E-10	< 1.40E-10
Toluene	1.40E-10 JB	8.51E-11 JB	1.24E-10 JB	1.02E-10 JB	1.13E-10
Chlorobenzene	< 1.40E-10	< 1.33E-10	< 1.41E-10	< 1.45E-10	< 1.40E-10
Ethylbenzene	< 1.40E-10	< 1.33E-10	< 1.41E-10	< 1.45E-10	< 1.40E-10
Styrene	4.77E-11 J	1.60E-11 J	3.39E-11 J	2.62E-11 J	3.09E-11
Xylenes (total)	1.07E-10	3.46E-11 J	7.90E-11	8.43E-11 J	7.61E-11
2-Chloroethyl vinyl ether	< 5.61E-10	< 5.32E-10	< 5.64E-10	< 5.81E-10	< 5.60E-10

B = Compound also detected in blank. Reported values are not blank corrected.

J = Estimated value below the detection limit.

E = Estimated value above the detection limit.

(2) Detection limit values included in overall average.

Table 7-12

VOC Test Data and Test Results—Thermal Oxidizer Discharge Stack (Test T1)
(Continued)

TEST DATA:

Test run number	1	1	1	1	1
Test location	OUTLET	OUTLET	OUTLET	OUTLET	OUTLET
Test date	01-31-96	01-31-96	01-31-96	01-31-96	
Test time	1846-1926	2052-2132	2153-2233	2242-2322	
Test tube pair	1	3	4	5	AVERAGE (2)

VOST EMISSIONS (ug/dscm):

Chloromethane (Methyl Chloride)	4.49E+01	9.37E+01 E	2.49E+02 E	1.82E+02 E	1.42E+02
Bromomethane (Methyl Bromide)	3.64E+00 JB	2.26E+01	5.42E+00	1.86E+01	1.26E+01
Vinyl Chloride	< 4.49E+00	< 4.26E+00	< 4.52E+00	< 4.66E+00	< 4.48E+00
Chloroethane (Ethyl Chloride)	< 4.49E+00	< 4.26E+00	< 4.52E+00	< 4.66E+00	< 4.48E+00
Methylene chloride	4.47E+00 JB	3.68E+00 JB	3.08E+00 JB	2.67E+00 JB	3.47E+00
Acetone	1.11E+03 E	7.17E+01	1.02E+02	1.20E+02	3.50E+02
Carbon Disulfide	< 2.24E+00	< 2.13E+00	< 2.26E+00	< 2.33E+00	< 2.24E+00
1,1-Dichloroethene	< 2.24E+00	< 2.13E+00	< 2.26E+00	< 2.33E+00	< 2.24E+00
1,1-Dichloroethane	< 2.24E+00	< 2.13E+00	< 2.26E+00	< 2.33E+00	< 2.24E+00
1,2-Dichloroethene (trans)	< 2.24E+00	< 2.13E+00	< 2.26E+00	< 2.33E+00	< 2.24E+00
Chloroform	9.01E-01 J	9.01E-01 J	9.01E-01 J	9.01E-01 J	9.01E-01
1,2-Dichloroethane (EDC)	< 2.24E+00	< 2.13E+00	< 2.26E+00	< 2.33E+00	< 2.24E+00
2-Butanone (MEK)	< 4.49E+01	< 4.26E+01	< 4.52E+01	< 4.66E+01	< 4.48E+01
1,1,1-Trichloroethane (TCA)	< 2.24E+00	< 2.13E+00	< 2.26E+00	< 2.33E+00	< 2.24E+00
Carbon Tetrachloride	< 2.24E+00	< 2.13E+00	< 2.26E+00	< 2.33E+00	< 2.24E+00
Vinyl acetate	< 8.98E+00	< 8.52E+00	< 9.04E+00	< 9.31E+00	< 8.96E+00
Bromodichloromethane	< 2.24E+00	< 2.13E+00	< 2.26E+00	< 2.33E+00	< 2.24E+00
1,2-Dichloropropane	< 2.24E+00	< 2.13E+00	< 2.26E+00	< 2.33E+00	< 2.24E+00
cis-1,3-Dichloropropene	< 2.24E+00	< 2.13E+00	< 2.26E+00	< 2.33E+00	< 2.24E+00
Trichloroethene (TCE)	< 2.24E+00	< 2.13E+00	< 2.26E+00	< 2.33E+00	< 2.24E+00
Dibromochloromethane	< 2.24E+00	< 2.13E+00	< 2.26E+00	< 2.33E+00	< 2.24E+00
1,1,2-Trichloroethane	< 2.24E+00	< 2.13E+00	< 2.26E+00	< 2.33E+00	< 2.24E+00
Benzene	4.44E+00 JB	1.96E+00 JB	3.07E+00 JB	3.12E+00 JB	3.15E+00
trans-1,3-Dichloropropene	< 2.24E+00	< 2.13E+00	< 2.26E+00	< 2.33E+00	< 2.24E+00
Bromoform	< 2.24E+00	< 2.13E+00	< 2.26E+00	< 2.33E+00	< 2.24E+00
4-Methyl-2-Pentanone (MIBK)	< 4.49E+01	< 4.26E+01	< 4.52E+01	< 4.66E+01	< 4.48E+01
2-Hexanone	< 4.49E+01	< 4.26E+01	< 4.52E+01	< 4.66E+01	< 4.48E+01
Tetrachloroethene (PCE)	< 2.24E+00	< 2.13E+00	< 2.26E+00	< 2.33E+00	< 2.24E+00
1,1,2,2-Tetrachloroethane	< 2.24E+00	< 2.13E+00	< 2.26E+00	< 2.33E+00	< 2.24E+00
Toluene	2.24E+00 JB	1.36E+00 JB	1.99E+00 JB	1.63E+00 JB	1.81E+00
Chlorobenzene	< 2.24E+00	< 2.13E+00	< 2.26E+00	< 2.33E+00	< 2.24E+00
Ethylbenzene	< 2.24E+00	< 2.13E+00	< 2.26E+00	< 2.33E+00	< 2.24E+00
Styrene	7.63E-01 J	2.56E-01 J	5.42E-01 J	4.19E-01 J	4.95E-01
Xylenes (total)	1.71E+00	5.54E-01 J	1.27E+00	1.35E+00 J	1.22E+00
2-Chloroethyl vinyl ether	< 8.98E+00	< 8.52E+00	< 9.04E+00	< 9.31E+00	< 8.96E+00

B = Compound also detected in blank. Reported values are not blank corrected.

J = Estimated value below the detection limit.

E = Estimated value above the detection limit.

(2) Detection limit values included in overall average.

Table 7-12

VOC Test Data and Test Results—Thermal Oxidizer Discharge Stack (Test T1)
(Continued)

TEST DATA:

Test run number	1	1	1	1	1
Test location	OUTLET	OUTLET	OUTLET	OUTLET	OUTLET
Test date	01-31-96	01-31-96	01-31-96	01-31-96	
Test time	1846-1926	2052-2132	2153-2233	2242-2322	
Test tube pair	1	3	4	5	AVERAGE (2)

VOST EMISSIONS (ppm/v):

Chloromethane (Methyl Chloride)	2.14E-02	4.47E-02 E	1.18E-01 E	8.65E-02 E	6.78E-02
Bromomethane (Methyl Bromide)	9.21E-04 JB	5.72E-03	1.37E-03	4.72E-03	3.18E-03
Vinyl Chloride	< 1.73E-03	< 1.64E-03	< 1.74E-03	< 1.79E-03	< 1.73E-03
Chloroethane (Ethyl Chloride)	< 1.67E-03	< 1.59E-03	< 1.69E-03	< 1.74E-03	< 1.67E-03
Methylene chloride	1.27E-03 JB	1.04E-03 JB	8.74E-04 JB	7.55E-04 JB	9.84E-04
Acetone	4.59E-01 E	2.97E-02	4.24E-02	4.95E-02	1.45E-01
Carbon Disulfide	< 7.09E-04	< 6.73E-04	< 7.14E-04	< 7.36E-04	< 7.08E-04
1,1-Dichloroethene	< 5.57E-04	< 5.29E-04	< 5.61E-04	< 5.78E-04	< 5.56E-04
1,1-Dichloroethane	< 5.46E-04	< 5.18E-04	< 5.49E-04	< 5.66E-04	< 5.45E-04
1,2-Dichloroethene (trans)	< 5.57E-04	< 5.29E-04	< 5.61E-04	< 5.78E-04	< 5.56E-04
Chloroform	1.82E-04 J	1.82E-04 J	1.82E-04 J	1.82E-04 J	1.82E-04
1,2-Dichloroethane (EDC)	< 5.46E-04	< 5.18E-04	< 5.49E-04	< 5.66E-04	< 5.45E-04
2-Butanone (MEK)	< 1.50E-02	< 1.42E-02	< 1.51E-02	< 1.55E-02	< 1.50E-02
1,1,1-Trichloroethane (TCA)	< 4.05E-04	< 3.84E-04	< 4.08E-04	< 4.20E-04	< 4.04E-04
Carbon Tetrachloride	< 3.51E-04	< 3.33E-04	< 3.54E-04	< 3.64E-04	< 3.51E-04
Vinyl acetate	< 2.51E-03	< 2.38E-03	< 2.53E-03	< 2.60E-03	< 2.51E-03
Bromodichloromethane	< 3.30E-04	< 3.13E-04	< 3.32E-04	< 3.42E-04	< 3.29E-04
1,2-Dichloropropane	< 4.78E-04	< 4.54E-04	< 4.81E-04	< 4.96E-04	< 4.77E-04
cis-1,3-Dichloropropene	< 4.87E-04	< 4.62E-04	< 4.90E-04	< 5.05E-04	< 4.86E-04
Trichloroethene (TCE)	< 4.11E-04	< 3.90E-04	< 4.14E-04	< 4.26E-04	< 4.10E-04
Dibromochloromethane	< 2.59E-04	< 2.46E-04	< 2.61E-04	< 2.69E-04	< 2.59E-04
1,1,2-Trichloroethane	< 4.05E-04	< 3.84E-04	< 4.08E-04	< 4.20E-04	< 4.04E-04
Benzene	1.37E-03 JB	6.04E-04 JB	9.47E-04 JB	9.61E-04 JB	9.70E-04
trans-1,3-Dichloropropene	< 4.87E-04	< 4.62E-04	< 4.90E-04	< 5.05E-04	< 4.86E-04
Bromoform	< 2.14E-04	< 2.03E-04	< 2.15E-04	< 2.22E-04	< 2.13E-04
4-Methyl-2-Pentanone (MIBK)	< 1.08E-02	< 1.02E-02	< 1.09E-02	< 1.12E-02	< 1.08E-02
2-Hexanone	< 1.08E-02	< 1.02E-02	< 1.09E-02	< 1.12E-02	< 1.08E-02
Tetrachloroethene (PCE)	< 3.26E-04	< 3.09E-04	< 3.28E-04	< 3.38E-04	< 3.25E-04
1,1,2,2-Tetrachloroethane	< 3.22E-04	< 3.05E-04	< 3.24E-04	< 3.34E-04	< 3.21E-04
Toluene	5.86E-04 JB	3.56E-04 JB	5.19E-04 JB	4.26E-04 JB	4.72E-04
Chlorobenzene	< 4.80E-04	< 4.55E-04	< 4.83E-04	< 4.98E-04	< 4.79E-04
Ethylbenzene	< 5.09E-04	< 4.83E-04	< 5.12E-04	< 5.28E-04	< 5.08E-04
Styrene	1.76E-04 J	5.91E-05 J	1.25E-04 J	9.68E-05 J	1.14E-04
Xylenes (total)	3.87E-04	1.26E-04 J	2.87E-04	3.06E-04 J	2.76E-04
2-Chloroethyl vinyl ether	< 2.03E-03	< 1.92E-03	< 2.04E-03	< 2.10E-03	< 2.02E-03

B = Compound also detected in blank. Reported values are not blank corrected.

J = Estimated value below the detection limit.

E = Estimated value above the detection limit.

(2) Detection limit values included in overall average.

Table 7-12

VOC Test Data and Test Results—Thermal Oxidizer Discharge Stack (Test T1)
(Continued)

TEST DATA:

Test run number	1	1	1	1	1
Test location	OUTLET	OUTLET	OUTLET	OUTLET	OUTLET
Test date	01-31-96	01-31-96	01-31-96	01-31-96	
Test time	1846-1926	2052-2132	2153-2233	2242-2322	
Test tube pair	1	3	4	5	AVERAGE (2)

VOST EMISSIONS (lb/hr):

Chloromethane (Methyl Chloride)	1.68E-04	3.51E-04 E	9.31E-04 E	6.80E-04 E	5.33E-04
Bromomethane (Methyl Bromide)	1.36E-05 JB	8.46E-05	2.03E-05	6.98E-05	4.71E-05
Vinyl Chloride	< 1.68E-05	< 1.60E-05	< 1.69E-05	< 1.74E-05	< 1.68E-05
Chloroethane (Ethyl Chloride)	< 1.68E-05	< 1.60E-05	< 1.69E-05	< 1.74E-05	< 1.68E-05
Methylene chloride	1.67E-05 JB	1.38E-05 JB	1.16E-05 JB	9.99E-06 JB	1.30E-05
Acetone	4.15E-03 E	2.69E-04	3.84E-04	4.48E-04	1.31E-03
Carbon Disulfide	< 8.41E-06	< 7.98E-06	< 8.47E-06	< 8.72E-06	< 8.39E-06
1,1-Dichloroethene	< 8.41E-06	< 7.98E-06	< 8.47E-06	< 8.72E-06	< 8.39E-06
1,1-Dichloroethane	< 8.41E-06	< 7.98E-06	< 8.47E-06	< 8.72E-06	< 8.39E-06
1,2-Dichloroethene (trans)	< 8.41E-06	< 7.98E-06	< 8.47E-06	< 8.72E-06	< 8.39E-06
Chloroform	3.38E-06 J	3.38E-06 J	3.38E-06 J	3.38E-06 J	3.38E-06
1,2-Dichloroethane (EDC)	< 8.41E-06	< 7.98E-06	< 8.47E-06	< 8.72E-06	< 8.39E-06
2-Butanone (MEK)	< 1.68E-04	< 1.60E-04	< 1.69E-04	< 1.74E-04	< 1.68E-04
1,1,1-Trichloroethane (TCA)	< 8.41E-06	< 7.98E-06	< 8.47E-06	< 8.72E-06	< 8.39E-06
Carbon Tetrachloride	< 8.41E-06	< 7.98E-06	< 8.47E-06	< 8.72E-06	< 8.39E-06
Vinyl acetate	< 3.36E-05	< 3.19E-05	< 3.39E-05	< 3.49E-05	< 3.36E-05
Bromodichloromethane	< 8.41E-06	< 7.98E-06	< 8.47E-06	< 8.72E-06	< 8.39E-06
1,2-Dichloropropane	< 8.41E-06	< 7.98E-06	< 8.47E-06	< 8.72E-06	< 8.39E-06
cis-1,3-Dichloropropene	< 8.41E-06	< 7.98E-06	< 8.47E-06	< 8.72E-06	< 8.39E-06
Trichloroethene (TCE)	< 8.41E-06	< 7.98E-06	< 8.47E-06	< 8.72E-06	< 8.39E-06
Dibromochloromethane	< 8.41E-06	< 7.98E-06	< 8.47E-06	< 8.72E-06	< 8.39E-06
1,1,2-Trichloroethane	< 8.41E-06	< 7.98E-06	< 8.47E-06	< 8.72E-06	< 8.39E-06
Benzene	1.67E-05 JB	7.34E-06 JB	1.15E-05 JB	1.17E-05 JB	1.18E-05
trans-1,3-Dichloropropene	< 8.41E-06	< 7.98E-06	< 8.47E-06	< 8.72E-06	< 8.39E-06
Bromoform	< 8.41E-06	< 7.98E-06	< 8.47E-06	< 8.72E-06	< 8.39E-06
4-Methyl-2-Pentanone (MIBK)	< 1.68E-04	< 1.60E-04	< 1.69E-04	< 1.74E-04	< 1.68E-04
2-Hexanone	< 1.68E-04	< 1.60E-04	< 1.69E-04	< 1.74E-04	< 1.68E-04
Tetrachloroethene (PCE)	< 8.41E-06	< 7.98E-06	< 8.47E-06	< 8.72E-06	< 8.39E-06
1,1,2,2-Tetrachloroethane	< 8.41E-06	< 7.98E-06	< 8.47E-06	< 8.72E-06	< 8.39E-06
Toluene	8.41E-06 JB	5.11E-06 JB	7.45E-06 JB	6.11E-06 JB	6.77E-06
Chlorobenzene	< 8.41E-06	< 7.98E-06	< 8.47E-06	< 8.72E-06	< 8.39E-06
Ethylbenzene	< 8.41E-06	< 7.98E-06	< 8.47E-06	< 8.72E-06	< 8.39E-06
Styrene	2.86E-06 J	9.58E-07 J	2.03E-06 J	1.57E-06 J	1.85E-06
Xylenes (total)	6.39E-06	2.08E-06 J	4.74E-06	5.06E-06 J	4.57E-06
2-Chloroethyl vinyl ether	< 3.36E-05	< 3.19E-05	< 3.39E-05	< 3.49E-05	< 3.36E-05

B = Compound also detected in blank. Reported values are not blank corrected.

J = Estimated value below the detection limit.

E = Estimated value above the detection limit.

(2) Detection limit values included in overall average.

Table 7-12

VOC Test Data and Test Results—Thermal Oxidizer Discharge Stack (Test T1) (Continued)

TEST DATA:					
Test run number	1	1	1	1	1
Test location	OUTLET	OUTLET	OUTLET	OUTLET	OUTLET
Test date	01-31-96	01-31-96	01-31-96	01-31-96	
Test time	1846-1926	2052-2132	2153-2233	2242-2322	
Test tube pair	1	3	4	5	AVERAGE (2)
VOST EMISSIONS (g/sec):					
Chloromethane (Methyl Chloride)	2.12E-05	4.42E-05 E	1.17E-04 E	8.57E-05 E	6.71E-05
Bromomethane (Methyl Bromide)	1.72E-06 JB	1.07E-05	2.56E-06	8.79E-06	5.93E-06
Vinyl Chloride	< 2.12E-06	< 2.01E-06	< 2.13E-06	< 2.20E-06	< 2.12E-06
Chloroethane (Ethyl Chloride)	< 2.12E-06	< 2.01E-06	< 2.13E-06	< 2.20E-06	< 2.12E-06
Methylene chloride	2.11E-06 JB	1.73E-06 JB	1.46E-06 JB	1.26E-06 JB	1.64E-06
Acetone	5.23E-04 E	3.38E-05	4.83E-05	5.64E-05	1.65E-04
Carbon Disulfide	< 1.06E-06	< 1.01E-06	< 1.07E-06	< 1.10E-06	< 1.06E-06
1,1-Dichloroethane	< 1.06E-06	< 1.01E-06	< 1.07E-06	< 1.10E-06	< 1.06E-06
1,1-Dichloroethane	< 1.06E-06	< 1.01E-06	< 1.07E-06	< 1.10E-06	< 1.06E-06
1,2-Dichloroethane (trans)	< 1.06E-06	< 1.01E-06	< 1.07E-06	< 1.10E-06	< 1.06E-06
Chloroform	4.25E-07 J	4.25E-07 J	4.25E-07 J	4.25E-07 J	4.25E-07
1,2-Dichloroethane (EDC)	< 1.06E-06	< 1.01E-06	< 1.07E-06	< 1.10E-06	< 1.06E-06
2-Butanone (MEK)	< 2.12E-05	< 2.01E-05	< 2.13E-05	< 2.20E-05	< 2.12E-05
1,1,1-Trichloroethane (TCA)	< 1.06E-06	< 1.01E-06	< 1.07E-06	< 1.10E-06	< 1.06E-06
Carbon Tetrachloride	< 1.06E-06	< 1.01E-06	< 1.07E-06	< 1.10E-06	< 1.06E-06
Vinyl acetate	< 4.24E-06	< 4.02E-06	< 4.27E-06	< 4.40E-06	< 4.23E-06
Bromodichloromethane	< 1.06E-06	< 1.01E-06	< 1.07E-06	< 1.10E-06	< 1.06E-06
1,2-Dichloropropane	< 1.06E-06	< 1.01E-06	< 1.07E-06	< 1.10E-06	< 1.06E-06
cis-1,3-Dichloropropene	< 1.06E-06	< 1.01E-06	< 1.07E-06	< 1.10E-06	< 1.06E-06
Trichloroethene (TCE)	< 1.06E-06	< 1.01E-06	< 1.07E-06	< 1.10E-06	< 1.06E-06
Dibromochloromethane	< 1.06E-06	< 1.01E-06	< 1.07E-06	< 1.10E-06	< 1.06E-06
1,1,2-Trichloroethane	< 1.06E-06	< 1.01E-06	< 1.07E-06	< 1.10E-06	< 1.06E-06
Benzene	2.10E-06 JB	9.25E-07 JB	1.45E-06 JB	1.47E-06 JB	1.49E-06
trans-1,3-Dichloropropene	< 1.06E-06	< 1.01E-06	< 1.07E-06	< 1.10E-06	< 1.06E-06
Bromoform	< 1.06E-06	< 1.01E-06	< 1.07E-06	< 1.10E-06	< 1.06E-06
4-Methyl-2-Pentanone (MIBK)	< 2.12E-05	< 2.01E-05	< 2.13E-05	< 2.20E-05	< 2.12E-05
2-Hexanone	< 2.12E-05	< 2.01E-05	< 2.13E-05	< 2.20E-05	< 2.12E-05
Tetrachloroethene (PCE)	< 1.06E-06	< 1.01E-06	< 1.07E-06	< 1.10E-06	< 1.06E-06
1,1,2,2-Tetrachloroethane	< 1.06E-06	< 1.01E-06	< 1.07E-06	< 1.10E-06	< 1.06E-06
Toluene	1.06E-06 JB	6.44E-07 JB	9.39E-07 JB	7.69E-07 JB	8.53E-07
Chlorobenzene	< 1.06E-06	< 1.01E-06	< 1.07E-06	< 1.10E-06	< 1.06E-06
Ethylbenzene	< 1.06E-06	< 1.01E-06	< 1.07E-06	< 1.10E-06	< 1.06E-06
Styrene	3.60E-07 J	1.21E-07 J	2.56E-07 J	1.98E-07 J	2.34E-07
Xylenes (total)	8.05E-07	2.61E-07 J	5.97E-07	6.37E-07 J	5.75E-07
2-Chloroethyl vinyl ether	< 4.24E-06	< 4.02E-06	< 4.27E-06	< 4.40E-06	< 4.23E-06

B = Compound also detected in blank. Reported values are not blank corrected.

J = Estimated value below the detection limit.

E = Estimated value above the detection limit.

(2) Detection limit values included in overall average.

Table 7-13

VOC Test Data and Test Results—Thermal Oxidizer Discharge Stack (Test T2)

TEST DATA:

Test run number	2	2	2	2	2	2
Test location	OUTLET	OUTLET	OUTLET	OUTLET	OUTLET	OUTLET
Test date	02-02-96	02-02-96	02-02-96	02-02-96	02-02-96	02-02-96
Test time	1419-1459	1542-1622	1628-1708	1730-1810	1825-1914	1925-2005
Test tube pair	1	2	3	4	5	6

SAMPLING DATA:

	40.00	40.00	40.00	40.00	40.00	40.00
Duration, minutes	40.00	40.00	40.00	40.00	40.00	40.00
Average dry gas meter press. in. H ₂ O	1.40	1.40	1.40	1.40	1.40	1.44
Average dry gas meter temp. deg. C	7.63	9.00	9.44	10.00	10.00	10.00
Average dry gas meter temp. deg. F	45.73	48.20	48.99	50.00	50.00	50.00
Average absolute meter temp. deg. R	505.73	508.20	508.99	510.00	510.00	510.00
Actual sample volume, liters	21.930	21.491	21.148	21.265	21.755	22.222
Meter box calibration, Y	1.0060	1.0060	1.0060	1.0060	1.0060	1.0060
Barometric pressure, in. Hg	29.59	29.59	29.59	29.59	29.59	29.59
Sample volume, dscf	0.8069	0.7869	0.7732	0.7759	0.7938	0.8109
Volumetric flow rate, dscf/min (1)	975	975	975	975	975	975

LABORATORY DATA, ng

	M.W.							
Chloromethane (Methyl Chloride)	50.49	260.000	2000.000	E	760.000	390.000	360.000	690.000
Bromomethane (Methyl Bromide)	94.95	68.000	180.000		93.000	85.000	73.000	150.000
Vinyl Chloride	62.50	100.000 U	100.000 U		100.000 U	100.000 U	100.000 U	100.000 U
Chloroethane (Ethyl Chloride)	64.52	100.000 U	100.000 U		100.000 U	100.000 U	100.000 U	100.000 U
Methylene chloride	84.93	52.597 JB	76.260 JB		94.028 JB	90.074 JB	63.376 JB	75.664 JB
Acetone	58.09	3517.553	9312.164		2648.453 J	3579.191 J	3314.012	3518.628
Carbon Disulfide	76.13	8.000 J	50.000 U		50.000 U	7.000 J	9.000 J	10.000 J
1,1-Dichloroethene	96.94	50.000 U	50.000 U		50.000 U	50.000 U	50.000 U	50.000 U
1,1-Dichloroethane	98.96	50.000 U	50.000 U		50.000 U	50.000 U	50.000 U	50.000 U
1,2-Dichloroethene (trans)	96.94	50.000 U	50.000 U		50.000 U	50.000 U	50.000 U	50.000 U
Chloroform	119.37	20.396 J	19.890 J		19.542 J	19.612 J	20.064 J	20.496 J
1,2-Dichloroethane (EDC)	98.96	50.000 U	50.000 U		50.000 U	50.000 U	50.000 U	50.000 U
2-Butanone (MEK)	72.12	1000.000 U	1000.000 U		1000.000 U	1000.000 U	1000.000 U	1000.000 U
1,1,1-Trichloroethane (TCA)	133.40	50.000 U	50.000 U		50.000 U	50.000 U	50.000 U	50.000 U
Carbon Tetrachloride	153.81	50.000 U	50.000 U		50.000 U	50.000 U	50.000 U	50.000 U
Vinyl acetate	86.09	200.000 U	200.000 U		200.000 U	200.000 U	200.000 U	200.000 U
Bromodichloromethane	163.83	50.000 U	50.000 U		50.000 U	50.000 U	50.000 U	50.000 U
1,2-Dichloropropane	112.99	50.000 U	50.000 U		50.000 U	50.000 U	50.000 U	50.000 U
cis-1,3-Dichloropropene	110.98	50.000 U	50.000 U		50.000 U	50.000 U	50.000 U	50.000 U
Trichloroethene (TCE)	131.38	50.000 U	50.000 U		50.000 U	50.000 U	50.000 U	50.000 U
Dibromochloromethane	208.29	50.000 U	50.000 U		50.000 U	50.000 U	50.000 U	50.000 U
1,1,2-Trichloroethane	133.40	50.000 U	50.000 U		50.000 U	50.000 U	50.000 U	50.000 U
Benzene	78.12	24.000 JB	17.000 JB		10.000 JB	30.000 JB	18.000 JB	20.000 JB
trans-1,3-Dichloropropene	110.98	50.000 U	50.000 U		50.000 U	50.000 U	50.000 U	50.000 U
Bromoform	252.75	50.000 U	50.000 U		50.000 U	50.000 U	50.000 U	50.000 U
4-Methyl-2-Pentanone (MIBK)	100.18	1000.000 U	1000.000 U		1000.000 U	1000.000 U	1000.000 U	1000.000 U
2-Hexanone	100.18	1000.000 U	1000.000 U		1000.000 U	1000.000 U	1000.000 U	1000.000 U
Tetrachloroethene (PCE)	165.82	50.000 U	50.000 U		50.000 U	50.000 U	50.000 U	50.000 U
1,1,2,2-Tetrachloroethane	167.84	50.000 U	50.000 U		50.000 U	50.000 U	50.000 U	50.000 U
Toluene	92.15	10.000 J	12.000 J		5.000 J	14.000 J	7.000 J	7.000 J
Chlorobenzene	112.56	50.000 U	50.000 U		50.000 U	50.000 U	50.000 U	50.000 U
Ethylbenzene	106.18	50.000 U	50.000 U		50.000 U	50.000 U	50.000 U	50.000 U
Styrene	104.16	50.000 U	50.000 U		50.000 U	5.000 J	50.000 U	50.000 U
Xylenes (total)	106.18	6.000 J	5.000 J		50.000 U	8.000 J	50.000 U	50.000 U
2-Chloroethyl vinyl ether	106.55	200.000 U	200.000 U		200.000 U	200.000 U	200.000 U	200.000 U

U = detection limit value.

J = Estimated value below the detection limit.

E = Estimated value above the detection limit.

B = Compound also detected in blank. Reported values are not blank corrected.

(1) Volumetric flow rate based on average of Particulate/HCl and MMTL tests flow measurements.

Table 7-13

VOC Test Data and Test Results—Thermal Oxidizer Discharge Stack (Test T2)
(Continued)

TEST DATA:							
Test run number	2	2	2	2	2	2	2
Test location	OUTLET	OUTLET	OUTLET	OUTLET	OUTLET	OUTLET	OUTLET
Test date	02-02-96	02-02-96	02-02-96	02-02-96	02-02-96	02-02-96	02-02-96
Test time	1419-1459	1542-1622	1628-1708	1730-1810	1825-1914	1925-2005	
Test tube pair	1	2	3	4	5	6	AVERAGE ⁽²⁾
VOST EMISSIONS (lbs/dscf):							
Chloromethane	7.10E-10	5.60E-09 E	2.17E-09	1.11E-09	1.00E-09	1.88E-09	2.08E-09
Bromomethane (Methyl Bromide)	1.80E-10	5.04E-10	2.65E-10	2.42E-10	2.03E-10	4.08E-10	3.01E-10
Vinyl Chloride	< 2.73E-10	< 2.80E-10	< 2.85E-10	< 2.84E-10	< 2.78E-10	< 2.72E-10	< 2.79E-10
Chloroethane (Ethyl Chloride)	< 2.73E-10	< 2.80E-10	< 2.85E-10	< 2.84E-10	< 2.78E-10	< 2.72E-10	< 2.79E-10
Methylene chloride	1.44E-10 JB	2.14E-10 JB	2.68E-10 JB	2.56E-10 JB	1.76E-10 JB	2.06E-10 JB	2.11E-10
Acetone	9.61E-09	2.61E-08	7.55E-09 J	1.02E-08 J	9.20E-09	9.57E-09	1.20E-08
Carbon Disulfide	2.19E-11 J	< 1.40E-10	< 1.43E-10	1.99E-11 J	2.50E-11 J	2.72E-11 J	< 6.28E-11
1,1-Dichloroethene	< 1.37E-10	< 1.40E-10	< 1.43E-10	< 1.42E-10	< 1.39E-10	< 1.36E-10	< 1.39E-10
1,1-Dichloroethane	< 1.37E-10	< 1.40E-10	< 1.43E-10	< 1.42E-10	< 1.39E-10	< 1.36E-10	< 1.39E-10
1,2-Dichloroethane (trans)	< 1.37E-10	< 1.40E-10	< 1.43E-10	< 1.42E-10	< 1.39E-10	< 1.36E-10	< 1.39E-10
Chloroform	5.57E-11 J	5.57E-11 J	5.57E-11 J	5.57E-11 J	5.57E-11 J	5.57E-11 J	5.57E-11
1,2-Dichloroethane (EDC)	< 1.37E-10	< 1.40E-10	< 1.43E-10	< 1.42E-10	< 1.39E-10	< 1.36E-10	< 1.39E-10
2-Butanone (MEK)	< 2.73E-09	< 2.80E-09	< 2.85E-09	< 2.84E-09	< 2.78E-09	< 2.72E-09	< 2.79E-09
1,1,1-Trichloroethane (TCA)	< 1.37E-10	< 1.40E-10	< 1.43E-10	< 1.42E-10	< 1.39E-10	< 1.36E-10	< 1.39E-10
Carbon Tetrachloride	< 1.37E-10	< 1.40E-10	< 1.43E-10	< 1.42E-10	< 1.39E-10	< 1.36E-10	< 1.39E-10
Vinyl acetate	< 5.46E-10	< 5.60E-10	< 5.70E-10	< 5.68E-10	< 5.55E-10	< 5.44E-10	< 5.57E-10
Bromodichloromethane	< 1.37E-10	< 1.40E-10	< 1.43E-10	< 1.42E-10	< 1.39E-10	< 1.36E-10	< 1.39E-10
1,2-Dichloropropane	< 1.37E-10	< 1.40E-10	< 1.43E-10	< 1.42E-10	< 1.39E-10	< 1.36E-10	< 1.39E-10
cis-1,3-Dichloropropene	< 1.37E-10	< 1.40E-10	< 1.43E-10	< 1.42E-10	< 1.39E-10	< 1.36E-10	< 1.39E-10
Trichloroethene (TCE)	< 1.37E-10	< 1.40E-10	< 1.43E-10	< 1.42E-10	< 1.39E-10	< 1.36E-10	< 1.39E-10
Dibromochloromethane	< 1.37E-10	< 1.40E-10	< 1.43E-10	< 1.42E-10	< 1.39E-10	< 1.36E-10	< 1.39E-10
1,1,2-Trichloroethane	< 1.37E-10	< 1.40E-10	< 1.43E-10	< 1.42E-10	< 1.39E-10	< 1.36E-10	< 1.39E-10
Benzene	6.56E-11 JB	4.76E-11 JB	2.85E-11 JB	8.52E-11 JB	5.00E-11 JB	5.44E-11 JB	5.52E-11
trans-1,3-Dichloropropane	< 1.37E-10	< 1.40E-10	< 1.43E-10	< 1.42E-10	< 1.39E-10	< 1.36E-10	< 1.39E-10
Bromoform	< 1.37E-10	< 1.40E-10	< 1.43E-10	< 1.42E-10	< 1.39E-10	< 1.36E-10	< 1.39E-10
4-Methyl-2-Pentanone (MIBK)	< 2.73E-09	< 2.80E-09	< 2.85E-09	< 2.84E-09	< 2.78E-09	< 2.72E-09	< 2.79E-09
2-Hexanone	< 2.73E-09	< 2.80E-09	< 2.85E-09	< 2.84E-09	< 2.78E-09	< 2.72E-09	< 2.79E-09
Tetrachloroethene (PCE)	< 1.37E-10	< 1.40E-10	< 1.43E-10	< 1.42E-10	< 1.39E-10	< 1.36E-10	< 1.39E-10
1,1,2,2-Tetrachloroethane	< 1.37E-10	< 1.40E-10	< 1.43E-10	< 1.42E-10	< 1.39E-10	< 1.36E-10	< 1.39E-10
Toluene	2.73E-11 J	3.36E-11 J	1.43E-11 J	3.98E-11 J	1.94E-11 J	1.90E-11 J	2.56E-11
Chlorobenzene	< 1.37E-10	< 1.40E-10	< 1.43E-10	< 1.42E-10	< 1.39E-10	< 1.36E-10	< 1.39E-10
Ethylbenzene	< 1.37E-10	< 1.40E-10	< 1.43E-10	< 1.42E-10	< 1.39E-10	< 1.36E-10	< 1.39E-10
Styrene	< 1.37E-10	< 1.40E-10	< 1.43E-10	1.42E-11 J	< 1.39E-10	< 1.36E-10	< 1.18E-10
Xylenes (total)	1.64E-11 J	1.40E-11 J	< 1.43E-10	2.27E-11 J	< 1.39E-10	< 1.36E-10	7.84E-11
2-Chloroethyl vinyl ether	< 5.46E-10	< 5.60E-10	< 5.70E-10	< 5.68E-10	< 5.55E-10	< 5.44E-10	< 5.57E-10

B = Compound also detected in blank. Reported values are not blank corrected.

J = Estimated value below the detection limit.

E = Estimated value above the detection limit.

(2) Detection limit values included in overall average.

Table 7-13

VOC Test Data and Test Results—Thermal Oxidizer Discharge Stack (Test T2)
(Continued)

TEST DATA:

Test run number	2	2	2	2	2	2	2
Test location	OUTLET	OUTLET	OUTLET	OUTLET	OUTLET	OUTLET	OUTLET
Test date	02-02-96	02-02-96	02-02-96	02-02-96	02-02-96	02-02-96	02-02-96
Test time	1419-1459	1542-1622	1628-1708	1730-1810	1825-1914	1925-2005	
Test tube pair	1	2	3	4	5	6	AVERAGE ⁽²⁾

VOST EMISSIONS (ug/dscm):

Chloromethane (Methyl Chloride)	1.14E+01	8.97E+01 E	3.47E+01	1.77E+01	1.60E+01	3.00E+01	3.33E+01
Bromomethane (Methyl Bromide)	2.98E+00	8.08E+00	4.25E+00	3.87E+00	3.25E+00	6.53E+00	4.82E+00
Vinyl Chloride	< 4.38E+00	< 4.49E+00	< 4.57E+00	< 4.55E+00	< 4.45E+00	< 4.35E+00	< 4.46E+00
Chloroethane (Ethyl Chloride)	< 4.38E+00	< 4.49E+00	< 4.57E+00	< 4.55E+00	< 4.45E+00	< 4.35E+00	< 4.46E+00
Methylene chloride	2.30E+00 JB	3.42E+00 JB	4.29E+00 JB	4.10E+00 JB	2.82E+00 JB	3.29E+00 JB	3.37E+00
Acetone	1.54E+02	4.18E+02	1.21E+02 J	1.63E+02 J	1.47E+02	1.53E+02	1.93E+02
Carbon Disulfide	3.50E-01 J	< 2.24E+00	< 2.28E+00	3.19E-01 J	4.00E-01 J	4.35E-01 J	< 1.01E+00
1,1-Dichloroethene	< 2.19E+00	< 2.24E+00	< 2.28E+00	< 2.28E+00	< 2.22E+00	< 2.18E+00	< 2.23E+00
1,1-Dichloroethane	< 2.19E+00	< 2.24E+00	< 2.28E+00	< 2.28E+00	< 2.22E+00	< 2.18E+00	< 2.23E+00
1,2-Dichloroethene (trans)	< 2.19E+00	< 2.24E+00	< 2.28E+00	< 2.28E+00	< 2.22E+00	< 2.18E+00	< 2.23E+00
Chloroform	8.92E-01 J	8.92E-01 J	8.92E-01 J	8.92E-01 J	8.92E-01 J	8.92E-01 J	8.92E-01
1,2-Dichloroethane (EDC)	< 2.19E+00	< 2.24E+00	< 2.28E+00	< 2.28E+00	< 2.22E+00	< 2.18E+00	< 2.23E+00
2-Butanone (MEK)	< 4.38E+01	< 4.49E+01	< 4.57E+01	< 4.55E+01	< 4.45E+01	< 4.35E+01	< 4.46E+01
1,1,1-Trichloroethane (TCA)	< 2.19E+00	< 2.24E+00	< 2.28E+00	< 2.28E+00	< 2.22E+00	< 2.18E+00	< 2.23E+00
Carbon Tetrachloride	< 2.19E+00	< 2.24E+00	< 2.28E+00	< 2.28E+00	< 2.22E+00	< 2.18E+00	< 2.23E+00
Vinyl acetate	< 8.75E+00	< 8.97E+00	< 9.13E+00	< 9.10E+00	< 8.90E+00	< 8.71E+00	< 8.93E+00
Bromodichloromethane	< 2.19E+00	< 2.24E+00	< 2.28E+00	< 2.28E+00	< 2.22E+00	< 2.18E+00	< 2.23E+00
1,2-Dichloropropane	< 2.19E+00	< 2.24E+00	< 2.28E+00	< 2.28E+00	< 2.22E+00	< 2.18E+00	< 2.23E+00
cis-1,3-Dichloropropane	< 2.19E+00	< 2.24E+00	< 2.28E+00	< 2.28E+00	< 2.22E+00	< 2.18E+00	< 2.23E+00
Trichloroethene (TCE)	< 2.19E+00	< 2.24E+00	< 2.28E+00	< 2.28E+00	< 2.22E+00	< 2.18E+00	< 2.23E+00
Dibromochloromethane	< 2.19E+00	< 2.24E+00	< 2.28E+00	< 2.28E+00	< 2.22E+00	< 2.18E+00	< 2.23E+00
1,1,2-Trichloroethane	< 2.19E+00	< 2.24E+00	< 2.28E+00	< 2.28E+00	< 2.22E+00	< 2.18E+00	< 2.23E+00
Benzene	1.05E+00 JB	7.63E-01 JB	4.57E-01 JB	1.37E+00 JB	8.01E-01 JB	8.71E-01 JB	8.84E-01
trans-1,3-Dichloropropane	< 2.19E+00	< 2.24E+00	< 2.28E+00	< 2.28E+00	< 2.22E+00	< 2.18E+00	< 2.23E+00
Bromoform	< 2.19E+00	< 2.24E+00	< 2.28E+00	< 2.28E+00	< 2.22E+00	< 2.18E+00	< 2.23E+00
4-Methyl-2-Pentanone (MIBK)	< 4.38E+01	< 4.49E+01	< 4.57E+01	< 4.55E+01	< 4.45E+01	< 4.35E+01	< 4.46E+01
2-Hexanone	< 4.38E+01	< 4.49E+01	< 4.57E+01	< 4.55E+01	< 4.45E+01	< 4.35E+01	< 4.46E+01
Tetrachloroethene (PCE)	< 2.19E+00	< 2.24E+00	< 2.28E+00	< 2.28E+00	< 2.22E+00	< 2.18E+00	< 2.23E+00
1,1,2,2-Tetrachloroethane	< 2.19E+00	< 2.24E+00	< 2.28E+00	< 2.28E+00	< 2.22E+00	< 2.18E+00	< 2.23E+00
Toluene	4.38E-01 J	5.38E-01 J	2.28E-01 J	6.37E-01 J	3.11E-01 J	3.05E-01 J	4.10E-01
Chlorobenzene	< 2.19E+00	< 2.24E+00	< 2.28E+00	< 2.28E+00	< 2.22E+00	< 2.18E+00	< 2.23E+00
Ethylbenzene	< 2.19E+00	< 2.24E+00	< 2.28E+00	< 2.28E+00	< 2.22E+00	< 2.18E+00	< 2.23E+00
Styrene	< 2.19E+00	< 2.24E+00	< 2.28E+00	2.28E-01 J	< 2.22E+00	< 2.18E+00	< 1.89E+00
Xylenes (total)	2.63E-01 J	2.24E-01 J	< 2.28E+00	3.64E-01 J	< 2.22E+00	< 2.18E+00	1.26E+00
2-Chloroethyl vinyl ether	< 8.75E+00	< 8.97E+00	< 9.13E+00	< 9.10E+00	< 8.90E+00	< 8.71E+00	< 8.93E+00

B = Compound also detected in blank. Reported values are not blank corrected.

J = Estimated value below the detection limit.

E = Estimated value above the detection limit.

(2) Detection limit values included in overall average.

Table 7-13

VOC Test Data and Test Results—Thermal Oxidizer Discharge Stack (Test T2)
(Continued)

TEST DATA:	2	2	2	2	2	2	2
Test run number							
Test location	OUTLET	OUTLET	OUTLET	OUTLET	OUTLET	OUTLET	OUTLET
Test date	02-02-96	02-02-96	02-02-96	02-02-96	02-02-96	02-02-96	02-02-96
Test time	1419-1459	1542-1622	1628-1708	1730-1810	1825-1914	1925-2005	
Test tube pair	1	2	3	4	5	6	AVERAGE ⁽²⁾
VOST EMISSIONS (ppm/v):							
Chloromethane (Methyl Chloride)	5.42E-03	4.28E-02 E	1.65E-02	8.46E-03	7.63E-03	1.43E-02	1.59E-02
Bromomethane (Methyl Bromide)	7.54E-04	2.05E-03	1.08E-03	9.80E-04	8.23E-04	1.66E-03	1.22E-03
Vinyl Chloride	< 1.68E-03	< 1.73E-03	< 1.76E-03	< 1.75E-03	< 1.71E-03	< 1.68E-03	< 1.72E-03
Chloroethane (Ethyl Chloride)	< 1.63E-03	< 1.67E-03	< 1.70E-03	< 1.70E-03	< 1.66E-03	< 1.62E-03	< 1.66E-03
Methylene chloride	6.52E-04 JB	9.69E-04 B	1.22E-03 JB	1.16E-03 JB	7.99E-04 JB	9.33E-04 JB	9.55E-04
Acetone	6.38E-02	1.73E-01	5.01E-02 J	6.75E-02 J	6.11E-02	6.35E-02	7.98E-02
Carbon Disulfide	1.11E-04 J	< 7.09E-04	< 7.22E-04	1.01E-04 J	1.27E-04 J	1.38E-04 J	< 3.18E-04
1,1-Dichloroethane	< 5.43E-04	< 5.57E-04	< 5.67E-04	< 5.65E-04	< 5.52E-04	< 5.40E-04	< 5.54E-04
1,1-Dichloroethane	< 5.32E-04	< 5.45E-04	< 5.55E-04	< 5.53E-04	< 5.41E-04	< 5.29E-04	< 5.43E-04
1,2-Dichloroethane (trans)	< 5.43E-04	< 5.57E-04	< 5.67E-04	< 5.65E-04	< 5.52E-04	< 5.40E-04	< 5.54E-04
Chloroform	1.80E-04 J	1.80E-04 B	1.80E-04 J	1.80E-04 J	1.80E-04 J	1.80E-04 J	1.80E-04
1,2-Dichloroethane (EDC)	< 5.32E-04	< 5.45E-04	< 5.55E-04	< 5.53E-04	< 5.41E-04	< 5.29E-04	< 5.43E-04
2-Butanone (MEK)	< 1.46E-02	< 1.50E-02	< 1.52E-02	< 1.52E-02	< 1.48E-02	< 1.45E-02	< 1.49E-02
1,1,1-Trichloroethane (TCA)	< 3.95E-04	< 4.05E-04	< 4.12E-04	< 4.10E-04	< 4.01E-04	< 3.93E-04	< 4.03E-04
Carbon Tetrachloride	< 3.42E-04	< 3.51E-04	< 3.57E-04	< 3.56E-04	< 3.48E-04	< 3.41E-04	< 3.49E-04
Vinyl acetate	< 2.45E-03	< 2.51E-03	< 2.55E-03	< 2.54E-03	< 2.49E-03	< 2.43E-03	< 2.50E-03
Bromodichloromethane	< 3.21E-04	< 3.29E-04	< 3.35E-04	< 3.34E-04	< 3.27E-04	< 3.20E-04	< 3.28E-04
1,2-Dichloropropane	< 4.66E-04	< 4.78E-04	< 4.86E-04	< 4.85E-04	< 4.74E-04	< 4.64E-04	< 4.75E-04
cis-1,3-Dichloropropene	< 4.74E-04	< 4.86E-04	< 4.95E-04	< 4.93E-04	< 4.82E-04	< 4.72E-04	< 4.84E-04
Trichloroethene (TCE)	< 4.01E-04	< 4.11E-04	< 4.18E-04	< 4.17E-04	< 4.07E-04	< 3.99E-04	< 4.09E-04
Dibromochloromethane	< 2.53E-04	< 2.59E-04	< 2.64E-04	< 2.63E-04	< 2.57E-04	< 2.51E-04	< 2.58E-04
1,1,2-Trichloroethane	< 3.95E-04	< 4.05E-04	< 4.12E-04	< 4.10E-04	< 4.01E-04	< 3.93E-04	< 4.03E-04
Benzene	3.23E-04 JB	2.35E-04 B	1.41E-04 JB	4.20E-04 JB	2.47E-04 JB	2.68E-04 JB	2.72E-04
trans-1,3-Dichloropropene	< 4.74E-04	< 4.86E-04	< 4.95E-04	< 4.93E-04	< 4.82E-04	< 4.72E-04	< 4.84E-04
Bromoform	< 2.08E-04	< 2.14E-04	< 2.17E-04	< 2.17E-04	< 2.12E-04	< 2.07E-04	< 2.12E-04
4-Methyl-2-Pentanone (MIBK)	< 1.05E-02	< 1.08E-02	< 1.10E-02	< 1.09E-02	< 1.07E-02	< 1.05E-02	< 1.07E-02
2-Hexanone	< 1.05E-02	< 1.08E-02	< 1.10E-02	< 1.09E-02	< 1.07E-02	< 1.05E-02	< 1.07E-02
Tetrachloroethene (PCE)	< 3.17E-04	< 3.26E-04	< 3.31E-04	< 3.30E-04	< 3.23E-04	< 3.16E-04	< 3.24E-04
1,1,2,2-Tetrachloroethane	< 3.14E-04	< 3.22E-04	< 3.27E-04	< 3.26E-04	< 3.19E-04	< 3.12E-04	< 3.20E-04
Toluene	1.14E-04 J	1.41E-04 B	5.96E-05 J	1.66E-04 J	8.13E-05 J	7.96E-05 J	1.07E-04
Chlorobenzene	< 4.68E-04	< 4.80E-04	< 4.88E-04	< 4.86E-04	< 4.75E-04	< 4.65E-04	< 4.77E-04
Ethylbenzene	< 4.96E-04	< 5.08E-04	< 5.17E-04	< 5.16E-04	< 5.04E-04	< 4.93E-04	< 5.06E-04
Styrene	< 5.05E-04	< 5.18E-04	< 5.27E-04	< 5.26E-05 J	< 5.14E-04	< 5.03E-04	< 4.37E-04
Xylenes (total)	5.95E-05 J	5.08E-05 B	< 5.17E-04	8.25E-05 J	< 5.04E-04	< 4.93E-04	< 2.85E-04
2-Chloroethyl vinyl ether	< 1.98E-03	< 2.03E-03	< 2.06E-03	< 2.06E-03	< 2.01E-03	< 1.97E-03	< 2.02E-03

B = Compound also detected in blank. Reported values are not blank corrected.
 J = Estimated value below the detection limit.
 E = Estimated value above the detection limit.
 (2) Detection limit values included in overall average.

Table 7-13

VOC Test Data and Test Results—Thermal Oxidizer Discharge Stack (Test T2)
(Continued)

TEST DATA:	2	2	2	2	2	2	2
Test run number	2	2	2	2	2	2	2
Test location	OUTLET	OUTLET	OUTLET	OUTLET	OUTLET	OUTLET	OUTLET
Test date	02-02-96	02-02-96	02-02-96	02-02-96	02-02-96	02-02-96	02-02-96
Test time	1419-1459	1542-1622	1628-1708	1730-1810	1825-1914	1925-2005	
Test tube pair	1	2	3	4	5	6	AVERAGE ⁽²⁾
VOST EMISSIONS (lb/hr):							
Chloromethane (Methyl Chloride)	4.16E-05	3.28E-04 E	1.27E-04	6.48E-05	5.85E-05	1.10E-04	1.22E-04
Bromomethane (Methyl Bromide)	1.09E-05	2.95E-05	1.55E-05	1.41E-05	1.19E-05	2.39E-05	1.76E-05
Vinyl Chloride	< 1.60E-05	< 1.64E-05	< 1.67E-05	< 1.66E-05	< 1.62E-05	< 1.59E-05	< 1.63E-05
Chloroethane (Ethyl Chloride)	< 1.60E-05	< 1.64E-05	< 1.67E-05	< 1.66E-05	< 1.62E-05	< 1.59E-05	< 1.63E-05
Methylene chloride	8.41E-06 JB	1.25E-05 JB	1.57E-05 JB	1.50E-05 JB	1.03E-05 JB	1.20E-05 JB	1.23E-05
Acetone	5.62E-04	1.53E-03	4.42E-04 J	5.95E-04 J	5.38E-04	5.60E-04	7.04E-04
Carbon Disulfide	1.28E-06 J	< 8.19E-06	< 8.34E-06	1.16E-06 J	1.46E-06 J	1.59E-06 J	< 3.67E-06
1,1-Dichloroethane	< 7.99E-06	< 8.19E-06	< 8.34E-06	< 8.31E-06	< 8.12E-06	< 7.95E-06	< 8.15E-06
1,1-Dichloroethane	< 7.99E-06	< 8.19E-06	< 8.34E-06	< 8.31E-06	< 8.12E-06	< 7.95E-06	< 8.15E-06
1,2-Dichloroethane (trans)	< 7.99E-06	< 8.19E-06	< 8.34E-06	< 8.31E-06	< 8.12E-06	< 7.95E-06	< 8.15E-06
Chloroform	3.26E-06 J	3.26E-06 J	3.26E-06 J	3.26E-06 J	3.26E-06 J	3.26E-06 J	3.26E-06
1,2-Dichloroethane (EDC)	< 7.99E-06	< 8.19E-06	< 8.34E-06	< 8.31E-06	< 8.12E-06	< 7.95E-06	< 8.15E-06
2-Butanone (MEK)	< 1.60E-04	< 1.64E-04	< 1.67E-04	< 1.66E-04	< 1.62E-04	< 1.59E-04	< 1.63E-04
1,1,1-Trichloroethane (TCA)	< 7.99E-06	< 8.19E-06	< 8.34E-06	< 8.31E-06	< 8.12E-06	< 7.95E-06	< 8.15E-06
Carbon Tetrachloride	< 7.99E-06	< 8.19E-06	< 8.34E-06	< 8.31E-06	< 8.12E-06	< 7.95E-06	< 8.15E-06
Vinylacetate	< 3.20E-05	< 3.28E-05	< 3.34E-05	< 3.32E-05	< 3.25E-05	< 3.18E-05	< 3.26E-05
Bromodichloromethane	< 7.99E-06	< 8.19E-06	< 8.34E-06	< 8.31E-06	< 8.12E-06	< 7.95E-06	< 8.15E-06
1,2-Dichloropropane	< 7.99E-06	< 8.19E-06	< 8.34E-06	< 8.31E-06	< 8.12E-06	< 7.95E-06	< 8.15E-06
cis-1,3-Dichloropropane	< 7.99E-06	< 8.19E-06	< 8.34E-06	< 8.31E-06	< 8.12E-06	< 7.95E-06	< 8.15E-06
Trichloroethene (TCE)	< 7.99E-06	< 8.19E-06	< 8.34E-06	< 8.31E-06	< 8.12E-06	< 7.95E-06	< 8.15E-06
Dibromochloromethane	< 7.99E-06	< 8.19E-06	< 8.34E-06	< 8.31E-06	< 8.12E-06	< 7.95E-06	< 8.15E-06
1,1,2-Trichloroethane	< 7.99E-06	< 8.19E-06	< 8.34E-06	< 8.31E-06	< 8.12E-06	< 7.95E-06	< 8.15E-06
Benzene	3.84E-06 JB	2.79E-06 JB	1.67E-06 JB	4.99E-06 JB	2.92E-06 JB	3.18E-06 JB	3.23E-06
trans-1,3-Dichloropropane	< 7.99E-06	< 8.19E-06	< 8.34E-06	< 8.31E-06	< 8.12E-06	< 7.95E-06	< 8.15E-06
Bromoform	< 7.99E-06	< 8.19E-06	< 8.34E-06	< 8.31E-06	< 8.12E-06	< 7.95E-06	< 8.15E-06
4-Methyl-2-Pentanone (MIBK)	< 1.60E-04	< 1.64E-04	< 1.67E-04	< 1.66E-04	< 1.62E-04	< 1.59E-04	< 1.63E-04
2-Hexanone	< 1.60E-04	< 1.64E-04	< 1.67E-04	< 1.66E-04	< 1.62E-04	< 1.59E-04	< 1.63E-04
Tetrachloroethene (PCE)	< 7.99E-06	< 8.19E-06	< 8.34E-06	< 8.31E-06	< 8.12E-06	< 7.95E-06	< 8.15E-06
1,1,2,2-Tetrachloroethane	< 7.99E-06	< 8.19E-06	< 8.34E-06	< 8.31E-06	< 8.12E-06	< 7.95E-06	< 8.15E-06
Toluene	1.60E-06 J	1.97E-06 J	8.34E-07 J	2.33E-06 J	1.14E-06 J	1.11E-06 J	1.50E-06
Chlorobenzene	< 7.99E-06	< 8.19E-06	< 8.34E-06	< 8.31E-06	< 8.12E-06	< 7.95E-06	< 8.15E-06
Ethylbenzene	< 7.99E-06	< 8.19E-06	< 8.34E-06	< 8.31E-06	< 8.12E-06	< 7.95E-06	< 8.15E-06
Styrene	< 7.99E-06	< 8.19E-06	< 8.34E-06	8.31E-07 J	< 8.12E-06	< 7.95E-06	< 6.91E-06
Xylenes (total)	9.59E-07 J	8.19E-07 J	< 8.34E-06	1.33E-06 J	< 8.12E-06	< 7.95E-06	< 4.59E-06
2-Chloroethyl vinyl ether	< 3.20E-05	< 3.28E-05	< 3.34E-05	< 3.32E-05	< 3.25E-05	< 3.18E-05	< 3.26E-05

B = Compound also detected in blank. Reported values are not blank corrected.
 J = Estimated value below the detection limit.
 E = Estimated value above the detection limit.
 (2) Detection limit values included in overall average.

Table 7-13

VOC Test Data and Test Results—Thermal Oxidizer Discharge Stack (Test T2)
(Continued)

TEST DATA:							
Test run number	2	2	2	2	2	2	2
Test location	OUTLET	OUTLET	OUTLET	OUTLET	OUTLET	OUTLET	OUTLET
Test date	02-02-96	02-02-96	02-02-96	02-02-96	02-02-96	02-02-96	02-02-96
Test time	1419-1459	1542-1622	1628-1708	1730-1810	1825-1914	1925-2006	
Test tube pair	1	2	3	4	5	6	AVERAGE ⁽²⁾
VOC EMISSIONS (g/sec):							
Chloromethane (Methyl Chloride)	5.24E-06	4.13E-05 E	1.60E-05	8.17E-06	7.37E-06	1.38E-05	1.53E-05
Bromomethane (Methyl Bromide)	1.37E-06	3.72E-06	1.95E-06	1.78E-06	1.49E-06	3.01E-06	2.22E-06
Vinyl Chloride	< 2.01E-06	< 2.06E-06	< 2.10E-06	< 2.09E-06	< 2.05E-06	< 2.00E-06	< 2.05E-06
Chloroethane (Ethyl Chloride)	< 2.01E-06	< 2.06E-06	< 2.10E-06	< 2.09E-06	< 2.05E-06	< 2.00E-06	< 2.05E-06
Methylene chloride	1.06E-06 JB	1.57E-06 JB	1.98E-06 JB	1.89E-06 JB	1.30E-06 JB	1.52E-06 JB	1.55E-06
Acetone	7.08E-05	1.92E-04	5.57E-05 J	7.50E-05 J	6.78E-05	7.05E-05	8.87E-05
Carbon Disulfide	1.61E-07 J	< 1.03E-06	< 1.05E-06	1.47E-07 J	1.84E-07 J	2.00E-07 J	4.63E-07
1,1-Dichloroethane	< 1.01E-06	< 1.03E-06	< 1.05E-06	< 1.05E-06	< 1.02E-06	< 1.00E-06	< 1.03E-06
1,1-Dichloroethane	< 1.01E-06	< 1.03E-06	< 1.05E-06	< 1.05E-06	< 1.02E-06	< 1.00E-06	< 1.03E-06
1,2-Dichloroethane (trans)	< 1.01E-06	< 1.03E-06	< 1.05E-06	< 1.05E-06	< 1.02E-06	< 1.00E-06	< 1.03E-06
Chloroform	4.11E-07 J	4.11E-07 J	4.11E-07 J	4.11E-07 J	4.11E-07 J	4.11E-07 J	4.11E-07
1,2-Dichloroethane (EDC)	< 1.01E-06	< 1.03E-06	< 1.05E-06	< 1.05E-06	< 1.02E-06	< 1.00E-06	< 1.03E-06
2-Butanone (MEK)	< 2.01E-05	< 2.06E-05	< 2.10E-05	< 2.09E-05	< 2.05E-05	< 2.00E-05	< 2.05E-05
1,1,1-Trichloroethane (TCA)	< 1.01E-06	< 1.03E-06	< 1.05E-06	< 1.05E-06	< 1.02E-06	< 1.00E-06	< 1.03E-06
Carbon Tetrachloride	< 1.01E-06	< 1.03E-06	< 1.05E-06	< 1.05E-06	< 1.02E-06	< 1.00E-06	< 1.03E-06
Vinyl acetate	< 4.03E-06	< 4.13E-06	< 4.20E-06	< 4.19E-06	< 4.09E-06	< 4.01E-06	< 4.11E-06
Bromodichloromethane	< 1.01E-06	< 1.03E-06	< 1.05E-06	< 1.05E-06	< 1.02E-06	< 1.00E-06	< 1.03E-06
1,2-Dichloropropane	< 1.01E-06	< 1.03E-06	< 1.05E-06	< 1.05E-06	< 1.02E-06	< 1.00E-06	< 1.03E-06
cis-1,3-Dichloropropene	< 1.01E-06	< 1.03E-06	< 1.05E-06	< 1.05E-06	< 1.02E-06	< 1.00E-06	< 1.03E-06
Trichloroethene (TCE)	< 1.01E-06	< 1.03E-06	< 1.05E-06	< 1.05E-06	< 1.02E-06	< 1.00E-06	< 1.03E-06
Dibromochloroethane	< 1.01E-06	< 1.03E-06	< 1.05E-06	< 1.05E-06	< 1.02E-06	< 1.00E-06	< 1.03E-06
1,1,2-Trichloroethane	< 1.01E-06	< 1.03E-06	< 1.05E-06	< 1.05E-06	< 1.02E-06	< 1.00E-06	< 1.03E-06
Benzene	4.83E-07 JB	3.51E-07 JB	2.10E-07 JB	6.28E-07 JB	3.68E-07 JB	4.01E-07 JB	4.07E-07
trans-1,3-Dichloropropene	< 1.01E-06	< 1.03E-06	< 1.05E-06	< 1.05E-06	< 1.02E-06	< 1.00E-06	< 1.03E-06
Bromoform	< 1.01E-06	< 1.03E-06	< 1.05E-06	< 1.05E-06	< 1.02E-06	< 1.00E-06	< 1.03E-06
4-Methyl-2-Pentanone (MIBK)	< 2.01E-05	< 2.06E-05	< 2.10E-05	< 2.09E-05	< 2.05E-05	< 2.00E-05	< 2.05E-05
2-Hexanone	< 2.01E-05	< 2.06E-05	< 2.10E-05	< 2.09E-05	< 2.05E-05	< 2.00E-05	< 2.05E-05
Tetrachloroethene (PCE)	< 1.01E-06	< 1.03E-06	< 1.05E-06	< 1.05E-06	< 1.02E-06	< 1.00E-06	< 1.03E-06
1,1,2,2-Tetrachloroethane	< 1.01E-06	< 1.03E-06	< 1.05E-06	< 1.05E-06	< 1.02E-06	< 1.00E-06	< 1.03E-06
Toluene	2.01E-07 J	2.48E-07 J	1.05E-07 J	2.93E-07 J	1.43E-07 J	1.40E-07 J	1.89E-07
Chlorobenzene	< 1.01E-06	< 1.03E-06	< 1.05E-06	< 1.05E-06	< 1.02E-06	< 1.00E-06	< 1.03E-06
Ethylbenzene	< 1.01E-06	< 1.03E-06	< 1.05E-06	< 1.05E-06	< 1.02E-06	< 1.00E-06	< 1.03E-06
Styrene	< 1.01E-06	< 1.03E-06	< 1.05E-06	1.05E-07 J	< 1.02E-06	< 1.00E-06	8.70E-07
Xylenes (total)	1.21E-07 J	1.03E-07 J	< 1.05E-06	1.68E-07 J	< 1.02E-06	< 1.00E-06	5.78E-07
2-Chloroethyl vinyl ether	< 4.03E-06	< 4.13E-06	< 4.20E-06	< 4.19E-06	< 4.09E-06	< 4.01E-06	< 4.11E-06

B = Compound also detected in blank. Reported values are not blank corrected.
 J = Estimated value below the detection limit.
 E = Estimated value above the detection limit.
 (2) Detection limit values included in overall average.

Table 7-14

VOC Test Data and Test Results—Thermal Oxidizer Discharge Stack (Test T3)

TEST DATA:

	3	3	3	3	3	3
Test run number						
Test location	OUTLET	OUTLET	OUTLET	OUTLET	OUTLET	OUTLET
Test date	02-04-96	02-04-96	02-04-96	02-04-96	02-04-96	02-04-96
Test time	1418-1458	1503-1543	1600-1640	1652-1750	1802-1842	1910-1950
Test tube pair	1	2	3	4	5	6

SAMPLING DATA:

	3	3	3	3	3	3
Duration, minutes	40.00	40.00	40.00	40.00	40.00	40.00
Average dry gas meter press. in. H ₂ O	1.50	1.50	1.48	1.49	1.50	1.50
Average dry gas meter temp. deg. C	5.94	5.88	5.94	6.38	7.44	6.81
Average dry gas meter temp. deg. F	42.69	42.58	42.69	43.48	45.39	44.26
Average absolute meter temp. deg. R	502.69	502.58	502.69	503.48	505.39	504.26
Actual sample volume, liters	21.420	22.233	20.770	22.441	22.218	23.278
Meter box calibration, Y	1.0060	1.0060	1.0060	1.0060	1.0060	1.0060
Barometric pressure, in. Hg	30.28	30.28	30.28	30.28	30.28	30.28
Sample volume, dscf	0.8116	0.8425	0.7869	0.8489	0.8373	0.8792
Volumetric flow rate, dscf/min (1)	950	950	950	950	950	950

LABORATORY DATA, ng

	M.W.	3	3	3	3	3	3
Chloromethane (Methyl Chloride)	50.49	520.000 J	431.000	730.000	330.000	4600.000 E	2500.000 E
Bromomethane (Methyl Bromide)	94.95	136.000 JB	237.000 B	78.000	87.000	260.000	360.000
Vinyl Chloride	62.50	100.000 U	100.000 U	100.000 U	100.000 U	100.000 U	100.000 U
Chloroethane (Ethyl Chloride)	64.52	100.000 U	100.000 U	100.000 U	100.000 U	100.000 U	100.000 U
Methylene chloride	84.93	138.905 B	90.390 B	75.723 JB	78.694 JB	114.139 JB	95.148 B
Acetone	58.09	2710.608	2512.393	1553.266 J	3146.852 J	2188.704	1548.178
Carbon Disulfide	76.13	11.000 J	13.000 J	7.000 J	7.000 J	50.000 U	6.000 J
1,1-Dichloroethene	96.94	50.000 U	50.000 U	50.000 U	50.000 U	50.000 U	50.000 U
1,1-Dichloroethane	98.96	50.000 U	50.000 U	50.000 U	50.000 U	50.000 U	50.000 U
1,2-Dichloroethene (trans)	96.94	50.000 U	50.000 U	50.000 U	50.000 U	50.000 U	50.000 U
Chloroform	119.37	12.968 J	13.463 J	12.574 J	13.565 J	13.380 J	14.049 J
1,2-Dichloroethane (EDC)	98.96	50.000 U	50.000 U	50.000 U	50.000 U	50.000 U	50.000 U
2-Butanone (MEK)	72.12	1000.000 U	1000.000 U	1000.000 U	1000.000 U	1000.000 U	1000.000 U
1,1,1-Trichloroethane (TCA)	133.40	50.000 U	50.000 U	50.000 U	50.000 U	50.000 U	50.000 U
Carbon Tetrachloride	153.81	50.000 U	50.000 U	50.000 U	50.000 U	50.000 U	50.000 U
Vinyl acetate	86.09	200.000 U	200.000 U	200.000 U	200.000 U	200.000 U	200.000 U
Bromodichloromethane	163.83	50.000 U	50.000 U	50.000 U	50.000 U	50.000 U	50.000 U
1,2-Dichloropropane	112.99	50.000 U	50.000 U	50.000 U	50.000 U	50.000 U	50.000 U
cis-1,3-Dichloropropene	110.98	50.000 U	50.000 U	50.000 U	50.000 U	50.000 U	50.000 U
Trichloroethene (TCE)	131.38	50.000 U	50.000 U	50.000 U	50.000 U	50.000 U	50.000 U
Dibromochloromethane	208.29	50.000 U	50.000 U	50.000 U	50.000 U	50.000 U	50.000 U
1,1,2-Trichloroethane	133.40	50.000 U	50.000 U	50.000 U	50.000 U	50.000 U	50.000 U
Benzene	78.12	28.000 JB	61.000 JB	23.000 JB	25.000 JB	19.000 JB	18.000 JB
trans-1,3-Dichloropropene	110.98	50.000 U	50.000 U	50.000 U	50.000 U	50.000 U	50.000 U
Bromoform	252.75	50.000 U	50.000 U	50.000 U	50.000 U	50.000 U	50.000 U
4-Methyl-2-Pentanone (MIBK)	100.18	1000.000 U	1000.000 U	1000.000 U	1000.000 U	1000.000 U	1000.000 U
2-Hexanone	100.18	1000.000 U	1000.000 U	1000.000 U	1000.000 U	1000.000 U	1000.000 U
Tetrachloroethene (PCE)	165.82	50.000 U	50.000 U	50.000 U	50.000 U	50.000 U	50.000 U
1,1,2,2-Tetrachloroethane	167.84	50.000 U	50.000 U	50.000 U	50.000 U	50.000 U	50.000 U
Toluene	92.15	11.000 J	25.000	10.000 J	8.000 J	7.000 J	5.000 J
Chlorobenzene	112.56	50.000 U	50.000 U	50.000 U	50.000 U	50.000 U	50.000 U
Ethylbenzene	106.18	50.000 U	50.000 U	50.000 U	50.000 U	50.000 U	50.000 U
Styrene	104.16	50.000 U	12.000 J	50.000 U	50.000 U	50.000 U	50.000 U
Xylenes (total)	106.18	10.000 J	9.000 J	50.000 U	3.000 J	3.000 J	50.000 U
2-Chloroethyl vinyl ether	106.55	200.000 U	200.000 U	200.000 U	200.000 U	200.000 U	200.000 U

U = detection limit value.

J = Estimated value below the detection limit.

E = Estimated value above the detection limit.

B = Compound also detected in blank. Reported values are not blank corrected.

(1) Volumetric flow rate based on average of Particulate/HCl and MMTL tests flow measurements.

Table 7-14

VOC Test Data and Test Results—Thermal Oxidizer Discharge Stack (Test T3)
(Continued)

TEST DATA:	3	3	3	3	3	3	3
Test run number							
Test location	OUTLET	OUTLET	OUTLET	OUTLET	OUTLET	OUTLET	OUTLET
Test date	02-04-96	02-04-96	02-04-96	02-04-96	02-04-96	02-04-96	02-04-96
Test time	1418-1458	1503-1543	1600-1640	1652-1750	1802-1842	1910-1950	
Test tube pair	1	2	3	4	5	6	AVERAGE (2)
VOST EMISSIONS (lbs/dscf):							
Chloromethane (Methyl Chloride)	1.41E-09 J	1.13E-09	2.05E-09	8.57E-10	1.21E-08 E	6.27E-09 E	3.97E-09
Bromomethane (Methyl Bromide)	3.69E-10 JB	6.20E-10 B	2.19E-10	2.26E-10	6.85E-10	9.03E-10	5.04E-10
Vinyl Chloride	< 2.72E-10	< 2.62E-10	< 2.80E-10	< 2.60E-10	< 2.63E-10	< 2.51E-10	< 2.65E-10
Chloroethane (Ethyl Chloride)	< 2.72E-10	< 2.62E-10	< 2.80E-10	< 2.60E-10	< 2.63E-10	< 2.51E-10	< 2.65E-10
Methylene chloride	3.77E-10 B	2.37E-10 B	2.12E-10 JB	2.04E-10 JB	3.01E-10 JB	2.39E-10 B	2.62E-10
Acetone	7.36E-09	6.57E-09	4.35E-09 J	8.17E-09 J	5.76E-09	3.88E-09	6.02E-09
Carbon Disulfide	2.99E-11 J	3.40E-11 J	1.90E-11 J	1.82E-11 J	< 1.32E-10	1.50E-11 J	< 4.14E-11
1,1-Dichloroethane	< 1.36E-10	< 1.31E-10	< 1.40E-10	< 1.30E-10	< 1.32E-10	< 1.25E-10	< 1.32E-10
1,1-Dichloroethane	< 1.36E-10	< 1.31E-10	< 1.40E-10	< 1.30E-10	< 1.32E-10	< 1.25E-10	< 1.32E-10
1,2-Dichloroethane (trans)	< 1.36E-10	< 1.31E-10	< 1.40E-10	< 1.30E-10	< 1.32E-10	< 1.25E-10	< 1.32E-10
Chloroform	3.52E-11 J	3.52E-11 J	3.52E-11 J	3.52E-11 J	3.52E-11 J	3.52E-11 J	3.52E-11
1,2-Dichloroethane (EDC)	< 1.36E-10	< 1.31E-10	< 1.40E-10	< 1.30E-10	< 1.32E-10	< 1.25E-10	< 1.32E-10
2-Butanone (MEK)	< 2.72E-09	< 2.62E-09	< 2.80E-09	< 2.60E-09	< 2.63E-09	< 2.51E-09	< 2.65E-09
1,1,1-Trichloroethane (TCA)	< 1.36E-10	< 1.31E-10	< 1.40E-10	< 1.30E-10	< 1.32E-10	< 1.25E-10	< 1.32E-10
Carbon Tetrachloride	< 1.36E-10	< 1.31E-10	< 1.40E-10	< 1.30E-10	< 1.32E-10	< 1.25E-10	< 1.32E-10
Vinyl acetate	< 5.43E-10	< 5.23E-10	< 5.60E-10	< 5.19E-10	< 5.27E-10	< 5.01E-10	< 5.29E-10
Bromodichloromethane	< 1.36E-10	< 1.31E-10	< 1.40E-10	< 1.30E-10	< 1.32E-10	< 1.25E-10	< 1.32E-10
1,2-Dichloropropane	< 1.36E-10	< 1.31E-10	< 1.40E-10	< 1.30E-10	< 1.32E-10	< 1.25E-10	< 1.32E-10
cis-1,3-Dichloropropane	< 1.36E-10	< 1.31E-10	< 1.40E-10	< 1.30E-10	< 1.32E-10	< 1.25E-10	< 1.32E-10
Trichloroethene (TCE)	< 1.36E-10	< 1.31E-10	< 1.40E-10	< 1.30E-10	< 1.32E-10	< 1.25E-10	< 1.32E-10
Dibromodichloroethane	< 1.36E-10	< 1.31E-10	< 1.40E-10	< 1.30E-10	< 1.32E-10	< 1.25E-10	< 1.32E-10
1,1,2-Trichloroethane	< 1.36E-10	< 1.31E-10	< 1.40E-10	< 1.30E-10	< 1.32E-10	< 1.25E-10	< 1.32E-10
Benzene	7.61E-11 JB	1.60E-10 JB	6.44E-11 JB	6.49E-11 JB	5.00E-11 JB	4.51E-11 JB	7.67E-11
trans-1,3-Dichloropropane	< 1.36E-10	< 1.31E-10	< 1.40E-10	< 1.30E-10	< 1.32E-10	< 1.25E-10	< 1.32E-10
Bromoform	< 1.36E-10	< 1.31E-10	< 1.40E-10	< 1.30E-10	< 1.32E-10	< 1.25E-10	< 1.32E-10
4-Methyl-2-Pentanone (MIBK)	< 2.72E-09	< 2.62E-09	< 2.80E-09	< 2.60E-09	< 2.63E-09	< 2.51E-09	< 2.65E-09
2-Hexanone	< 2.72E-09	< 2.62E-09	< 2.80E-09	< 2.60E-09	< 2.63E-09	< 2.51E-09	< 2.65E-09
Tetrachloroethene (PCE)	< 1.36E-10	< 1.31E-10	< 1.40E-10	< 1.30E-10	< 1.32E-10	< 1.25E-10	< 1.32E-10
1,1,2,2-Tetrachloroethane	< 1.36E-10	< 1.31E-10	< 1.40E-10	< 1.30E-10	< 1.32E-10	< 1.25E-10	< 1.32E-10
Toluene	2.99E-11 J	6.54E-11	2.80E-11 J	2.08E-11 J	1.84E-11 J	1.25E-11 J	2.92E-11
Chlorobenzene	< 1.36E-10	< 1.31E-10	< 1.40E-10	< 1.30E-10	< 1.32E-10	< 1.25E-10	< 1.32E-10
Ethylbenzene	< 1.36E-10	< 1.31E-10	< 1.40E-10	< 1.30E-10	< 1.32E-10	< 1.25E-10	< 1.32E-10
Styrene	< 1.36E-10	3.14E-11 J	< 1.40E-10	< 1.30E-10	< 1.32E-10	< 1.25E-10	< 1.16E-10
Xylenes (total)	2.72E-11 J	2.35E-11 J	< 1.40E-10	7.79E-12 J	7.90E-12 J	< 1.25E-10	5.53E-11
2-Chloroethyl vinyl ether	< 5.43E-10	< 5.23E-10	< 5.60E-10	< 5.19E-10	< 5.27E-10	< 5.01E-10	< 5.29E-10

B = Compound also detected in blank. Reported values are not blank corrected.
 J = Estimated value below the detection limit.
 E = Estimated value above the detection limit.
 (2) Detection limit values included in overall average.

Table 7-14

VOC Test Data and Test Results—Thermal Oxidizer Discharge Stack (Test T3)
(Continued)

TEST DATA:							
Test run number	3	3	3	3	3	3	3
Test location	OUTLET	OUTLET	OUTLET	OUTLET	OUTLET	OUTLET	OUTLET
Test date	02-04-96	02-04-96	02-04-96	02-04-96	02-04-96	02-04-96	02-04-96
Test time	1418-1458	1503-1543	1600-1640	1652-1750	1802-1842	1910-1950	
Test tube pair	1	2	3	4	5	6	AVERAGE ⁽²⁾
VOST EMISSIONS (ug/dscm):							
Chloromethane (Methyl Chloride)	2.26E+01 J	1.81E+01	3.28E+01	1.37E+01	1.94E+02 E	1.00E+02 E	6.36E+01
Bromomethane (Methyl Bromide)	5.92E+00 JB	9.93E+00 B	3.50E+00	3.62E+00	1.10E+01	1.45E+01	8.07E+00
Vinyl Chloride	< 4.35E+00	< 4.19E+00	< 4.49E+00	< 4.16E+00	< 4.22E+00	< 4.02E+00	< 4.24E+00
Chloroethane (Ethyl Chloride)	< 4.35E+00	< 4.19E+00	< 4.49E+00	< 4.16E+00	< 4.22E+00	< 4.02E+00	< 4.24E+00
Methylene chloride	6.04E+00 B	3.79E+00 B	3.40E+00 JB	3.27E+00 JB	4.81E+00 JB	3.82E+00 B	4.19E+00
Acetone	1.18E+02	1.05E+02	6.97E+01 J	1.31E+02 J	9.23E+01	6.22E+01	9.64E+01
Carbon Disulfide	4.79E-01 J	5.45E-01 J	3.14E-01 J	2.91E-01 J	< 2.11E+00	< 2.01E+00	< 6.63E-01
1,1-Dichloroethane	< 2.18E+00	< 2.10E+00	< 2.24E+00	< 2.08E+00	< 2.11E+00	< 2.01E+00	< 2.12E+00
1,1-Dichloroethane	< 2.18E+00	< 2.10E+00	< 2.24E+00	< 2.08E+00	< 2.11E+00	< 2.01E+00	< 2.12E+00
1,2-Dichloroethane (trans)	< 2.18E+00	< 2.10E+00	< 2.24E+00	< 2.08E+00	< 2.11E+00	< 2.01E+00	< 2.12E+00
Chloroform	5.64E-01 J	5.64E-01 J	5.64E-01 J	5.64E-01 J	5.64E-01 J	5.64E-01 J	5.64E-01
1,2-Dichloroethane (EDC)	< 2.18E+00	< 2.10E+00	< 2.24E+00	< 2.08E+00	< 2.11E+00	< 2.01E+00	< 2.12E+00
2-Butanone (MEK)	< 4.35E+01	< 4.19E+01	< 4.49E+01	< 4.16E+01	< 4.22E+01	< 4.02E+01	< 4.24E+01
1,1,1-Trichloroethane (TCA)	< 2.18E+00	< 2.10E+00	< 2.24E+00	< 2.08E+00	< 2.11E+00	< 2.01E+00	< 2.12E+00
Carbon Tetrachloride	< 2.18E+00	< 2.10E+00	< 2.24E+00	< 2.08E+00	< 2.11E+00	< 2.01E+00	< 2.12E+00
Vinyl acetate	< 8.70E+00	< 8.38E+00	< 8.97E+00	< 8.32E+00	< 8.43E+00	< 8.03E+00	< 8.47E+00
Bromodichloromethane	< 2.18E+00	< 2.10E+00	< 2.24E+00	< 2.08E+00	< 2.11E+00	< 2.01E+00	< 2.12E+00
1,2-Dichloropropane	< 2.18E+00	< 2.10E+00	< 2.24E+00	< 2.08E+00	< 2.11E+00	< 2.01E+00	< 2.12E+00
cis-1,3-Dichloropropene	< 2.18E+00	< 2.10E+00	< 2.24E+00	< 2.08E+00	< 2.11E+00	< 2.01E+00	< 2.12E+00
Trichloroethene (TCE)	< 2.18E+00	< 2.10E+00	< 2.24E+00	< 2.08E+00	< 2.11E+00	< 2.01E+00	< 2.12E+00
Dibromochloromethane	< 2.18E+00	< 2.10E+00	< 2.24E+00	< 2.08E+00	< 2.11E+00	< 2.01E+00	< 2.12E+00
1,1,2-Trichloroethane	< 2.18E+00	< 2.10E+00	< 2.24E+00	< 2.08E+00	< 2.11E+00	< 2.01E+00	< 2.12E+00
Benzene	1.22E+00 JB	2.56E+00 JB	1.03E+00 JB	1.04E+00 JB	8.01E-01 JB	7.23E-01 JB	1.23E+00
trans-1,3-Dichloropropene	< 2.18E+00	< 2.10E+00	< 2.24E+00	< 2.08E+00	< 2.11E+00	< 2.01E+00	< 2.12E+00
Bromoform	< 2.18E+00	< 2.10E+00	< 2.24E+00	< 2.08E+00	< 2.11E+00	< 2.01E+00	< 2.12E+00
4-Methyl-2-Pentanone (MIBK)	< 4.35E+01	< 4.19E+01	< 4.49E+01	< 4.16E+01	< 4.22E+01	< 4.02E+01	< 4.24E+01
2-Hexanone	< 4.35E+01	< 4.19E+01	< 4.49E+01	< 4.16E+01	< 4.22E+01	< 4.02E+01	< 4.24E+01
Tetrachloroethene (PCE)	< 2.18E+00	< 2.10E+00	< 2.24E+00	< 2.08E+00	< 2.11E+00	< 2.01E+00	< 2.12E+00
1,1,2,2-Tetrachloroethane	< 2.18E+00	< 2.10E+00	< 2.24E+00	< 2.08E+00	< 2.11E+00	< 2.01E+00	< 2.12E+00
Toluene	4.79E-01 J	1.05E+00	4.49E-01 J	3.33E-01 J	2.95E-01 J	2.01E-01 J	4.67E-01
Chlorobenzene	< 2.18E+00	< 2.10E+00	< 2.24E+00	< 2.08E+00	< 2.11E+00	< 2.01E+00	< 2.12E+00
Ethylbenzene	< 2.18E+00	< 2.10E+00	< 2.24E+00	< 2.08E+00	< 2.11E+00	< 2.01E+00	< 2.12E+00
Styrene	< 2.18E+00	< 5.03E-01 J	< 2.24E+00	< 2.08E+00	< 2.11E+00	< 2.01E+00	< 1.85E+00
Xylenes (total)	4.35E-01 J	3.77E-01 J	< 2.24E+00	1.25E-01 J	1.27E-01 J	< 2.01E+00	< 8.86E-01
2-Chloroethyl vinyl ether	< 8.70E+00	< 8.38E+00	< 8.97E+00	< 8.32E+00	< 8.43E+00	< 8.03E+00	< 8.47E+00

B = Compound also detected in blank. Reported values are not blank corrected.

J = Estimated value below the detection limit.

E = Estimated value above the detection limit.

(2) Detection limit values included in overall average.

Table 7-14

VOC Test Data and Test Results—Thermal Oxidizer Discharge Stack (Test T3)
(Continued)

TEST DATA:	3	3	3	3	3	3	3
Test run number	3	3	3	3	3	3	3
Test location	OUTLET	OUTLET	OUTLET	OUTLET	OUTLET	OUTLET	OUTLET
Test date	02-04-96	02-04-96	02-04-96	02-04-96	02-04-96	02-04-96	02-04-96
Test time	1418-1458	1503-1543	1600-1640	1652-1750	1802-1842	1910-1950	
Test tube pair	1	2	3	4	5	6	AVERAGE ⁽²⁾
VOST EMISSIONS (ppm/v):							
Chloromethane (Methyl Chloride)	1.08E-02 J	8.61E-03	1.56E-02	6.54E-03	9.24E-02 E	4.78E-02 E	3.03E-02
Bromomethane (Methyl Bromide)	1.50E-03 JB	2.52E-03 B	8.87E-04	9.17E-04	2.78E-03	3.66E-03	2.04E-03
Vinyl Chloride	< 1.67E-03	< 1.61E-03	< 1.73E-03	< 1.60E-03	< 1.62E-03	< 1.55E-03	< 1.63E-03
Chloroethane (Ethyl Chloride)	< 1.62E-03	< 1.56E-03	< 1.67E-03	< 1.55E-03	< 1.57E-03	< 1.50E-03	< 1.58E-03
Methylene chloride	1.71E-03 B	1.07E-03 B	9.63E-04 JB	9.27E-04 JB	1.36E-03 JB	1.08E-03 B	1.19E-03
Acetone	4.88E-02	4.36E-02	2.89E-02 J	5.42E-02 J	3.82E-02	2.58E-02	3.99E-02
Carbon Disulfide	1.51E-04 J	1.72E-04 B	9.93E-05 J	9.20E-05 J	< 6.66E-04	7.62E-05 J	< 2.10E-04
1,1-Dichloroethane	< 5.40E-04	< 5.20E-04	< 5.57E-04	< 5.16E-04	< 5.23E-04	< 4.98E-04	< 5.26E-04
1,1-Dichloroethane	< 5.29E-04	< 5.09E-04	< 5.45E-04	< 5.06E-04	< 5.13E-04	< 4.88E-04	< 5.15E-04
1,2-Dichloroethane (trans)	< 5.40E-04	< 5.20E-04	< 5.57E-04	< 5.16E-04	< 5.23E-04	< 4.98E-04	< 5.26E-04
Chloroform	1.14E-04 J	1.14E-04 B	1.14E-04 J	1.14E-04 J	1.14E-04 J	1.14E-04 J	1.14E-04
1,2-Dichloroethane (EDC)	< 5.29E-04	< 5.09E-04	< 5.45E-04	< 5.06E-04	< 5.13E-04	< 4.88E-04	< 5.15E-04
2-Butanone (MEK)	< 1.45E-02	< 1.40E-02	< 1.50E-02	< 1.39E-02	< 1.41E-02	< 1.34E-02	< 1.41E-02
1,1,1-Trichloroethane (TCA)	< 3.92E-04	< 3.78E-04	< 4.05E-04	< 3.75E-04	< 3.80E-04	< 3.62E-04	< 3.82E-04
Carbon Tetrachloride	< 3.40E-04	< 3.28E-04	< 3.51E-04	< 3.25E-04	< 3.30E-04	< 3.14E-04	< 3.31E-04
Vinyl acetate	< 2.43E-03	< 2.34E-03	< 2.51E-03	< 2.32E-03	< 2.36E-03	< 2.24E-03	< 2.37E-03
Bromodichloromethane	< 3.19E-04	< 3.08E-04	< 3.29E-04	< 3.05E-04	< 3.10E-04	< 2.95E-04	< 3.11E-04
1,2-Dichloropropane	< 4.63E-04	< 4.46E-04	< 4.78E-04	< 4.43E-04	< 4.49E-04	< 4.28E-04	< 4.51E-04
cis-1,3-Dichloropropene	< 4.72E-04	< 4.54E-04	< 4.86E-04	< 4.51E-04	< 4.57E-04	< 4.35E-04	< 4.59E-04
Trichloroethene (TCE)	< 3.98E-04	< 3.84E-04	< 4.11E-04	< 3.81E-04	< 3.86E-04	< 3.68E-04	< 3.88E-04
Dibromodichloromethane	< 2.51E-04	< 2.42E-04	< 2.59E-04	< 2.40E-04	< 2.44E-04	< 2.32E-04	< 2.45E-04
1,1,2-Trichloroethane	< 3.92E-04	< 3.78E-04	< 4.05E-04	< 3.75E-04	< 3.80E-04	< 3.62E-04	< 3.82E-04
Benzene	3.75E-04 JB	7.87E-04 B	3.18E-04 JB	3.20E-04 JB	2.47E-04 JB	2.23E-04 JB	3.78E-04
trans-1,3-Dichloropropene	< 4.72E-04	< 4.54E-04	< 4.86E-04	< 4.51E-04	< 4.57E-04	< 4.35E-04	< 4.59E-04
Bromoform	< 2.07E-04	< 1.99E-04	< 2.14E-04	< 1.98E-04	< 2.01E-04	< 1.91E-04	< 2.02E-04
4-Methyl-2-Pentanone (MIBK)	< 1.04E-02	< 1.01E-02	< 1.08E-02	< 9.99E-03	< 1.01E-02	< 9.65E-03	< 1.02E-02
2-Hexanone	< 1.04E-02	< 1.01E-02	< 1.08E-02	< 9.99E-03	< 1.01E-02	< 9.65E-03	< 1.02E-02
Tetrachloroethene (PCE)	< 3.16E-04	< 3.04E-04	< 3.26E-04	< 3.02E-04	< 3.06E-04	< 2.91E-04	< 3.07E-04
1,1,2,2-Tetrachloroethane	< 3.12E-04	< 3.00E-04	< 3.22E-04	< 2.98E-04	< 3.02E-04	< 2.88E-04	< 3.04E-04
Toluene	1.25E-04 J	2.74E-04	1.17E-04 J	8.69E-05 J	7.71E-05 J	5.24E-05 J	1.22E-04
Chlorobenzene	< 4.65E-04	< 4.48E-04	< 4.80E-04	< 4.45E-04	< 4.51E-04	< 4.29E-04	< 4.53E-04
Ethylbenzene	< 4.93E-04	< 4.75E-04	< 5.08E-04	< 4.71E-04	< 4.78E-04	< 4.55E-04	< 4.80E-04
Styrene	< 5.02E-04	1.16E-04 B	< 5.18E-04	< 4.80E-04	< 4.87E-04	< 4.64E-04	< 4.28E-04
Xylenes (total)	9.86E-05 J	8.55E-05 B	< 5.08E-04	2.83E-05 J	2.87E-05 J	< 4.55E-04	2.01E-04
2-Chloroethyl vinyl ether	< 1.96E-03	< 1.89E-03	< 2.03E-03	< 1.88E-03	< 1.90E-03	< 1.81E-03	< 1.91E-03

B = Compound not detected in blank. Reported values are not blank corrected.
 J = Estimated value below the detection limit.
 E = Estimated value above the detection limit.
 (2) Detection limit values included in overall average.

Table 7-14

VOC Test Data and Test Results—Thermal Oxidizer Discharge Stack (Test T3)
(Continued)

TEST DATA:	3	3	3	3	3	3	3
Test run number	OUTLET	OUTLET	OUTLET	OUTLET	OUTLET	OUTLET	OUTLET
Test location	02-04-96	02-04-96	02-04-96	02-04-96	02-04-96	02-04-96	02-04-96
Test date	1418-1458	1503-1543	1600-1640	1652-1750	1802-1842	1910-1950	
Test time	1	2	3	4	5	6	AVERAGE ⁽²⁾
Test tube pair							
VOST EMISSIONS (lb/hr):							
Chloromethane (Methyl Chloride)	8.05E-05 J	6.43E-05	1.17E-04	4.89E-05	6.90E-04 E	3.57E-04 E	2.26E-04
Bromomethane (Methyl Bromide)	2.11E-05 JB	3.53E-05 B	1.25E-05	1.29E-05	3.90E-05	5.15E-05	2.87E-05
Vinyl Chloride	< 1.55E-05	< 1.49E-05	< 1.60E-05	< 1.48E-05	< 1.50E-05	< 1.43E-05	< 1.51E-05
Chloroethane (Ethyl Chloride)	< 1.55E-05	< 1.49E-05	< 1.60E-05	< 1.48E-05	< 1.50E-05	< 1.43E-05	< 1.51E-05
Methylene chloride	2.15E-05 B	1.35E-05 B	1.21E-05 JB	1.16E-05 JB	1.71E-05 JB	1.36E-05 B	1.49E-05
Acetone	4.20E-04	3.75E-04	2.48E-04 J	4.66E-04 J	3.28E-04	2.21E-04	3.43E-04
Carbon Disulfide	1.70E-06 J	1.94E-06 J	1.12E-06 J	1.04E-06 J	< 7.50E-06	8.58E-07 J	< 2.36E-06
1,1-Dichloroethene	< 7.74E-06	< 7.46E-06	< 7.98E-06	< 7.40E-06	< 7.50E-06	< 7.15E-06	< 7.54E-06
1,1-Dichloroethane	< 7.74E-06	< 7.46E-06	< 7.98E-06	< 7.40E-06	< 7.50E-06	< 7.15E-06	< 7.54E-06
1,2-Dichloroethene (trans)	< 7.74E-06	< 7.46E-06	< 7.98E-06	< 7.40E-06	< 7.50E-06	< 7.15E-06	< 7.54E-06
Chloroform	2.01E-06 J	2.01E-06 J	2.01E-06 J	2.01E-06 J	2.01E-06 J	2.01E-06 J	2.01E-06
1,2-Dichloroethane (EDC)	< 7.74E-06	< 7.46E-06	< 7.98E-06	< 7.40E-06	< 7.50E-06	< 7.15E-06	< 7.54E-06
2-Butanone (MEK)	< 1.55E-04	< 1.49E-04	< 1.60E-04	< 1.48E-04	< 1.50E-04	< 1.43E-04	< 1.51E-04
1,1,1-Trichloroethane (TCA)	< 7.74E-06	< 7.46E-06	< 7.98E-06	< 7.40E-06	< 7.50E-06	< 7.15E-06	< 7.54E-06
Carbon Tetrachloride	< 7.74E-06	< 7.46E-06	< 7.98E-06	< 7.40E-06	< 7.50E-06	< 7.15E-06	< 7.54E-06
Vinyl acetate	< 3.10E-05	< 2.98E-05	< 3.19E-05	< 2.96E-05	< 3.00E-05	< 2.86E-05	< 3.02E-05
Bromodichloromethane	< 7.74E-06	< 7.46E-06	< 7.98E-06	< 7.40E-06	< 7.50E-06	< 7.15E-06	< 7.54E-06
1,2-Dichloropropane	< 7.74E-06	< 7.46E-06	< 7.98E-06	< 7.40E-06	< 7.50E-06	< 7.15E-06	< 7.54E-06
cis-1,3-Dichloropropene	< 7.74E-06	< 7.46E-06	< 7.98E-06	< 7.40E-06	< 7.50E-06	< 7.15E-06	< 7.54E-06
Trichloroethene (TCE)	< 7.74E-06	< 7.46E-06	< 7.98E-06	< 7.40E-06	< 7.50E-06	< 7.15E-06	< 7.54E-06
Dibromochloromethane	< 7.74E-06	< 7.46E-06	< 7.98E-06	< 7.40E-06	< 7.50E-06	< 7.15E-06	< 7.54E-06
1,1,2-Trichloroethane	< 7.74E-06	< 7.46E-06	< 7.98E-06	< 7.40E-06	< 7.50E-06	< 7.15E-06	< 7.54E-06
Benzene	4.34E-06 JB	9.10E-06 JB	3.67E-06 JB	3.70E-06 JB	2.85E-06 JB	2.57E-06 JB	4.37E-06
trans-1,3-Dichloropropene	< 7.74E-06	< 7.46E-06	< 7.98E-06	< 7.40E-06	< 7.50E-06	< 7.15E-06	< 7.54E-06
Bromoform	< 7.74E-06	< 7.46E-06	< 7.98E-06	< 7.40E-06	< 7.50E-06	< 7.15E-06	< 7.54E-06
4-Methyl-2-Pentanone (MIBK)	< 1.55E-04	< 1.49E-04	< 1.60E-04	< 1.48E-04	< 1.50E-04	< 1.43E-04	< 1.51E-04
2-Hexanone	< 1.55E-04	< 1.49E-04	< 1.60E-04	< 1.48E-04	< 1.50E-04	< 1.43E-04	< 1.51E-04
Tetrachloroethene (PCE)	< 7.74E-06	< 7.46E-06	< 7.98E-06	< 7.40E-06	< 7.50E-06	< 7.15E-06	< 7.54E-06
1,1,2,2-Tetrachloroethane	< 7.74E-06	< 7.46E-06	< 7.98E-06	< 7.40E-06	< 7.50E-06	< 7.15E-06	< 7.54E-06
Toluene	1.70E-06 J	3.73E-06	1.60E-06 J	1.18E-06 J	1.05E-06 J	7.15E-07 J	1.66E-06
Chlorobenzene	< 7.74E-06	< 7.46E-06	< 7.98E-06	< 7.40E-06	< 7.50E-06	< 7.15E-06	< 7.54E-06
Ethylbenzene	< 7.74E-06	< 7.46E-06	< 7.98E-06	< 7.40E-06	< 7.50E-06	< 7.15E-06	< 7.54E-06
Styrene	< 7.74E-06	1.79E-06 J	< 7.98E-06	< 7.40E-06	< 7.50E-06	< 7.15E-06	< 6.59E-06
Xylenes (total)	1.55E-06 J	1.34E-06 J	< 7.98E-06	4.44E-07 J	4.50E-07 J	< 7.15E-06	< 3.15E-06
2-Chloroethyl vinyl ether	< 3.10E-05	< 2.98E-05	< 3.19E-05	< 2.96E-05	< 3.00E-05	< 2.86E-05	< 3.02E-05

B = Compound also detected in blank. Reported values are not blank corrected.
 J = Estimated value below the detection limit.
 E = Estimated value above the detection limit.
 (2) Detection limit values included in overall average.

Table 7-14

VOC Test Data and Test Results—Thermal Oxidizer Discharge Stack (Test T3)
(Continued)

TEST DATA:	3	3	3	3	3	3	3
Test run number							
Test location	OUTLET	OUTLET	OUTLET	OUTLET	OUTLET	OUTLET	OUTLET
Test date	02-04-96	02-04-96	02-04-96	02-04-96	02-04-96	02-04-96	02-04-96
Test time	1418-1458	1503-1543	1600-1640	1652-1750	1802-1842	1910-1950	
Test tube pair	1	2	3	4	5	6	AVERAGE ⁽²⁾
VOST EMISSIONS (g/sec):							
Chloromethane (Methyl Chloride)	1.01E-05 J	8.10E-06	1.47E-05	6.16E-06	8.70E-05 E	4.50E-05 E	2.85E-05
Bromomethane (Methyl Bromide)	2.65E-06 JB	4.45E-06 B	1.57E-06	1.62E-06	4.92E-06	6.48E-06	3.62E-06
Vinyl Chloride	< 1.95E-06	< 1.88E-06	< 2.01E-06	< 1.87E-06	< 1.89E-06	< 1.80E-06	< 1.90E-06
Chloroethane (Ethyl Chloride)	< 1.95E-06	< 1.88E-06	< 2.01E-06	< 1.87E-06	< 1.89E-06	< 1.80E-06	< 1.90E-06
Methylene chloride	2.71E-06 B	1.70E-06 B	1.52E-06 JB	1.47E-06 JB	2.11E-06 JB	1.71E-06 B	1.88E-06
Acetone	5.29E-05	4.72E-05	3.13E-05 J	5.87E-05 J	4.14E-05	2.79E-05	4.32E-05
Carbon Disulfide	2.15E-07 J	2.44E-07 J	1.41E-07 J	1.31E-07 J	< 9.45E-07	1.08E-07 J	< 2.97E-07
1,1-Dichloroethane	< 9.75E-07	< 9.40E-07	< 1.01E-06	< 9.33E-07	< 9.45E-07	< 9.00E-07	< 9.50E-07
1,1-Dichloroethane	< 9.75E-07	< 9.40E-07	< 1.01E-06	< 9.33E-07	< 9.45E-07	< 9.00E-07	< 9.50E-07
1,2-Dichloroethane (trans)	< 9.75E-07	< 9.40E-07	< 1.01E-06	< 9.33E-07	< 9.45E-07	< 9.00E-07	< 9.50E-07
Chloroform	2.53E-07 J	2.53E-07 J	2.53E-07 J	2.53E-07 J	2.53E-07 J	2.53E-07 J	2.53E-07
1,2-Dichloroethane (EDC)	< 9.75E-07	< 9.40E-07	< 1.01E-06	< 9.33E-07	< 9.45E-07	< 9.00E-07	< 9.50E-07
2-Butanone (MEK)	< 1.95E-05	< 1.88E-05	< 2.01E-05	< 1.87E-05	< 1.89E-05	< 1.80E-05	< 1.90E-05
1,1,1-Trichloroethane (TCA)	< 9.75E-07	< 9.40E-07	< 1.01E-06	< 9.33E-07	< 9.45E-07	< 9.00E-07	< 9.50E-07
Carbon Tetrachloride	< 9.75E-07	< 9.40E-07	< 1.01E-06	< 9.33E-07	< 9.45E-07	< 9.00E-07	< 9.50E-07
Vinyl acetate	< 3.90E-06	< 3.76E-06	< 4.02E-06	< 3.73E-06	< 3.78E-06	< 3.60E-06	< 3.80E-06
Bromodichloromethane	< 9.75E-07	< 9.40E-07	< 1.01E-06	< 9.33E-07	< 9.45E-07	< 9.00E-07	< 9.50E-07
1,2-Dichloropropane	< 9.75E-07	< 9.40E-07	< 1.01E-06	< 9.33E-07	< 9.45E-07	< 9.00E-07	< 9.50E-07
cis-1,3-Dichloropropene	< 9.75E-07	< 9.40E-07	< 1.01E-06	< 9.33E-07	< 9.45E-07	< 9.00E-07	< 9.50E-07
Trichloroethene (TCE)	< 9.75E-07	< 9.40E-07	< 1.01E-06	< 9.33E-07	< 9.45E-07	< 9.00E-07	< 9.50E-07
Dibromodichloromethane	< 9.75E-07	< 9.40E-07	< 1.01E-06	< 9.33E-07	< 9.45E-07	< 9.00E-07	< 9.50E-07
1,1,2-Trichloroethane	< 9.75E-07	< 9.40E-07	< 1.01E-06	< 9.33E-07	< 9.45E-07	< 9.00E-07	< 9.50E-07
Benzene	5.46E-07 JB	1.15E-06 JB	4.63E-07 JB	4.66E-07 JB	3.59E-07 JB	3.24E-07 JB	5.51E-07
trans-1,3-Dichloropropane	< 9.75E-07	< 9.40E-07	< 1.01E-06	< 9.33E-07	< 9.45E-07	< 9.00E-07	< 9.50E-07
Bromoform	< 9.75E-07	< 9.40E-07	< 1.01E-06	< 9.33E-07	< 9.45E-07	< 9.00E-07	< 9.50E-07
4-Methyl-2-Pentanone (MIBK)	< 1.95E-05	< 1.88E-05	< 2.01E-05	< 1.87E-05	< 1.89E-05	< 1.80E-05	< 1.90E-05
2-Hexanone	< 1.95E-05	< 1.88E-05	< 2.01E-05	< 1.87E-05	< 1.89E-05	< 1.80E-05	< 1.90E-05
Tetrachloroethene (PCE)	< 9.75E-07	< 9.40E-07	< 1.01E-06	< 9.33E-07	< 9.45E-07	< 9.00E-07	< 9.50E-07
1,1,2,2-Tetrachloroethane	< 9.75E-07	< 9.40E-07	< 1.01E-06	< 9.33E-07	< 9.45E-07	< 9.00E-07	< 9.50E-07
Toluene	2.15E-07 J	4.70E-07	2.01E-07 J	1.49E-07 J	1.32E-07 J	9.00E-08 J	2.10E-07
Chlorobenzene	< 9.75E-07	< 9.40E-07	< 1.01E-06	< 9.33E-07	< 9.45E-07	< 9.00E-07	< 9.50E-07
Ethylbenzene	< 9.75E-07	< 9.40E-07	< 1.01E-06	< 9.33E-07	< 9.45E-07	< 9.00E-07	< 9.50E-07
Styrene	< 9.75E-07	2.26E-07 J	< 1.01E-06	< 9.33E-07	< 9.45E-07	< 9.00E-07	< 8.31E-07
Xylenes (total)	1.95E-07 J	1.69E-07 J	< 1.01E-06	5.60E-08 J	5.67E-08 J	< 9.00E-07	< 3.97E-07
2-Chloromethyl vinyl ether	< 3.90E-06	< 3.76E-06	< 4.02E-06	< 3.73E-06	< 3.78E-06	< 3.60E-06	< 3.80E-06

B = Compound also detected in blank. Reported values are not blank corrected.
 J = Estimated value below the detection limit.
 E = Estimated value above the detection limit.
 (2) Detection limit values included in overall average.

SOURCE EMISSIONS SAMPLING, ANALYSIS, AND RESULTS

Summaries of the metals and Cr⁺⁶ test results are presented in Tables 7-15 and 7-16, respectively. Detailed metals and Cr⁺⁶ test data and test results are presented in Tables 7-17 and 7-18, respectively. Of the 12 target metals, nonmeasurable quantities above the method detection limits were reported for arsenic, selenium, silver, and thallium. Of the remaining eight metals, barium, chromium, lead, mercury, and nickel were present in measurable quantities in all three validation test samples. Chromium was detected at the highest concentration, with a reported average mass rate of 3.9×10^{-5} lb/hr.

For each validation test run, the measured Cr⁺⁶ concentration result obtained from the EPA Cr⁺⁶ sampling train was 12% higher (on average) than the total chromium concentration determined from the EPA Method 29 sampling train. The ratio of Cr⁺⁶ to total chromium is typically less than 10%, based on data obtained from typical combustion sources.

The Cr⁺⁶ sampling train has been validated by EPA for use on sources with stack temperatures of less than 300 °F. During this test program, the sample train was modified to allow for sampling at elevated temperature (>1,500 °F) at the thermal oxidizer discharge test location. The modifications involved the use of a quartz nozzle, quartz probe, and a quartz tube inside the sample probe (near the back of nozzle) to recirculate the potassium hydroxide (KOH) impinger solution. A water-cooled jacket was used to cool the quartz probe. The remaining train components followed the reference method. None of these modifications are thought to have affected the collection of representative Cr⁺⁶ results. The data suggest that there may have been conversion of trivalent chromium to Cr⁺⁶.

Discussions with EPA indicated that the elevated temperature would not influence conversion of trivalent chromium to Cr⁺⁶. The presence of lime, however, coupled with the high temperature and excess oxygen, may contribute to the conversion. It should be noted that cement blocks were used to support clay pipe inside the furnace during each validation test run. There was a possibility that lime dust generated from the cement block entered the system. Although the chance of these minute quantities of lime dust causing the conversion from trivalent chromium to Cr⁺⁶ is small, it must be considered. Future studies of the HGD system may warrant additional evaluation of total chromium and Cr⁺⁶ sampling.

Metals emissions for mercury; low-volatility metals (Sb, As, Be, and Cr); and semivolatile metals (Pb and Cd) were significantly below the existing metals standards.

Table 7-15

Summary of Metals Emissions at the Thermal Oxidizer Discharge

Test Run No.:	Metals Emissions Rate (lb/hr)			
	T1	T2	T3	Average
	Date:	Date:	Date:	
Time:	31 Jan 96 1834-0103	2 Feb 96 1406-2011	4 Feb 96 1415-2026	
Parameter				
Antimony	4.11E-06	9.54E-07	<1.11E-05	5.39E-06
Arsenic	<7.50E-06	<7.38E-06	<7.46E-06	<7.45E-06
Barium	2.16E-05	2.78E-07	2.16E-07	7.36E-06
Beryllium	1.96E-08	<2.40E-08	<2.45E-08	<2.27E-06
Cadmium	1.57E-06	7.57E-07	<6.87E-07	1.00E-06
Chromium	4.28E-05	4.27E-05	3.13E-05	3.89E-05
Lead	1.70E-05	3.55E-06	2.45E-06	7.67E-06
Mercury	1.37E-07	2.35E-07	2.95E-08	1.33E-07
Nickel	1.03E-05	1.22E-05	2.55E-06	8.35E-06
Selenium	<8.68E-06	<8.53E-06	<8.64E-06	<8.55E-06
Silver	<2.20E-06	<2.16E-06	<2.20E-06	<2.18E-06
Thallium	<7.65E-06	<7.48E-06	<7.66E-06	<2.59E-06

< = Indicates the analyte was detected at values less than the detection limit indicated.

Table 7-16

Summary of Hexavalent Chromium at Thermal Oxidizer Discharge

Test Run No.:	T1	T2	T3	
Date:	31 Jan 96	2 Feb 96	4 Feb 96	
Time:	1837-0127	1404-2043	1416-2050	
Emission Rate (lb/hr)				Average
Hexavalent chromium	5.10E-05	5.29E-05	3.85E-05	4.24E-05

Notes: The hexavalent chromium values reported may not be truly representative.

The hexavalent chromium values exceed the total chromium values obtained using the multimetals test train.

The hexavalent chromium test train has not been validated by EPA for use on sources > 300 °F.

Table 7-17

Metals Test Data and Test Results at the Thermal Oxidizer Discharge

TEST DATA

	T1	T2	T3
Test run number			
Test location	AFTERBURNER DISCHARGE		
Test date	01-31-96	02-02-96	02-04-96
Test time period	1834-0103	1406-2011	1415-2026

SAMPLING DATA

Sampling duration, min.	320.0	320.0	320.0
Nozzle diameter, in.	0.586	0.586	0.586
Cross sectional nozzle area, sq.ft.	0.001873	0.001873	0.001873
Barometric pressure, in. Hg	29.73	29.59	30.28
Avg. orifice press. diff., in H ₂ O	0.60	0.57	0.46
Avg. dry gas meter temp., deg F	53	43	44
Avg. abs. dry gas meter temp., deg. R	513	503	504
Total liquid collected by train, ml	262.6	255.9	196.1
Std. vol. of H ₂ O vapor coll., cu.ft.	12.4	12.0	9.2
Dry gas meter calibration factor	0.9958	0.9958	0.9939
Sample vol. at meter cond., dcf	133.154	130.320	118.896
Sample vol. at std. cond., dscf ⁽¹⁾	135.801	134.777	125.265
Percent of isokinetic sampling	103.3	105.6	103.1

GAS STREAM COMPOSITION DATA

CO ₂ , % by volume, dry basis	5.7	5.8	6.1
O ₂ , % by volume, dry basis	12.1	11.9	11.9
N ₂ , % by volume, dry basis	82.2	82.3	82.0
Molecular wt. of dry gas, lb/lb mole	29.4	29.4	29.5
H ₂ O vapor in gas stream, prop. by vol.	0.083	0.082	0.069
Mole fraction of dry gas	0.917	0.918	0.931
Molecular wt. of wet gas, lb/lb mole	28.4	28.5	28.7

GAS STREAM VELOCITY AND VOLUMETRIC FLOW DATA

Static pressure, in. Hg	-0.10	-0.10	-0.10
Absolute pressure, in. Hg	29.72	29.58	30.27
Avg. temperature, deg. F	1681	1646	1638
Avg. absolute temperature, deg.R	2141	2106	2098
Pitot tube coefficient	0.84	0.84	0.84
Total number of traverse points	16	16	16
Avg. gas stream velocity, ft./sec.	16.3	15.6	14.3
Stack/duct cross sectional area, sq.ft.	4.59	4.59	4.59
Avg. gas stream volumetric flow, wacf/min.	4480	4290	3920
Avg. gas stream volumetric flow, dscf/min ⁽¹⁾	1010	980	930

⁽¹⁾ Standard conditions = 68 deg. F. (20 deg. C.) and 29.92 in Hg (760 mm Hg)

Table 7-17

**Metals Test Data and Test Results at Thermal Oxidizer Discharge
(Continued)**

TEST DATA

	T1	T2	T3
Test run number			
Test location	AFTERBURNER DISCHARGE		
Test date	01-31-96	02-02-96	02-04-96
Test time period	1834-0103	1406-2011	1415-2026

METALS LABORATORY REPORT DATA, ug

Antimony (Sb)	4.20	1.00	< 11.30
Arsenic (As)	< 7.65	< 7.70	< 7.60
Barium (Ba)	22.04	0.29	0.22
Beryllium (Be)	0.02	< 0.03	< 0.03
Cadmium (Cd)	1.60	0.79	< 0.70
Chromium (Cr)	43.70	44.52	31.89
Lead (Pb)	17.30	3.70	2.50
Mercury (Hg)	0.14	0.25	0.03
Nickel (Ni)	10.53	12.70	2.60
Selenium (Se)	< 8.85	< 8.90	< 8.80
Silver (Ag)	< 2.25	< 2.25	< 2.24
Thallium (Tl)	< 7.80	< 7.80	< 7.80

METALS CONCENTRATIONS, ug/dscm ⁽¹⁾

Antimony (Sb)	1.09E+00	2.61E-01	< 3.19E+00
Arsenic (As)	< 1.99E+00	< 2.02E+00	< 2.14E+00
Barium (Ba)	5.73E+00	7.60E-02	6.20E-02
Beryllium (Be)	5.20E-03	< 6.55E-03	< 7.05E-03
Cadmium (Cd)	4.16E-01	2.07E-01	< 1.97E-01
Chromium (Cr)	1.14E+01	1.17E+01	8.99E+00
Lead (Pb)	4.50E+00	9.70E-01	7.05E-01
Mercury (Hg)	3.64E-02	6.42E-02	8.46E-03
Nickel (Ni)	2.74E+00	3.33E+00	7.33E-01
Selenium (Se)	< 2.30E+00	< 2.33E+00	< 2.48E+00
Silver (Ag)	< 5.84E-01	< 5.90E-01	< 6.32E-01
Thallium (Tl)	< 2.03E+00	< 2.04E+00	< 2.20E+00

METALS CONCENTRATIONS, lb/dscf ⁽¹⁾

Antimony (Sb)	6.81E-11	1.63E-11	< 1.99E-10
Arsenic (As)	< 1.24E-10	< 1.26E-10	< 1.34E-10
Barium (Ba)	3.58E-10	4.74E-12	3.87E-12
Beryllium (Be)	3.25E-13	< 4.09E-13	< 4.40E-13
Cadmium (Cd)	2.60E-11	1.29E-11	< 1.23E-11
Chromium (Cr)	7.09E-10	7.28E-10	5.61E-10
Lead (Pb)	2.81E-10	6.05E-11	4.40E-11
Mercury (Hg)	2.27E-12	4.01E-12	5.28E-13
Nickel (Ni)	1.71E-10	2.08E-10	4.58E-11
Selenium (Se)	< 1.44E-10	< 1.46E-10	< 1.55E-10
Silver (Ag)	< 3.64E-11	< 3.68E-11	< 3.94E-11
Thallium (Tl)	< 1.27E-10	< 1.28E-10	< 1.37E-10

⁽¹⁾ Standard conditions = 68 deg. F. (20 deg. C.) and 29.92 in Hg (760 mm Hg)

Table 7-17

**Metals Test Data and Test Results at Thermal Oxidizer Discharge
(Continued)**

TEST DATA			
	T1	T2	T3
Test run number			
Test location	AFTERBURNER DISCHARGE		
Test date	01-31-96	02-02-96	02-04-96
Test time period	1834-0103	1406-2011	1415-2026
METALS MASS EMISSION RATES, lb/hr			
Antimony (Sb)	4.11E-06	9.54E-07	< 1.11E-05
Arsenic (As)	< 7.50E-06	< 7.38E-06	< 7.46E-06
Barium (Ba)	2.16E-05	2.78E-07	2.16E-07
Beryllium (Be)	1.96E-08	< 2.40E-08	< 2.45E-08
Cadmium (Cd)	1.57E-06	7.57E-07	< 6.87E-07
Chromium (Cr)	4.28E-05	4.27E-05	3.13E-05
Lead (Pb)	1.70E-05	3.55E-06	2.45E-06
Mercury (Hg)	1.37E-07	2.35E-07	2.95E-08
Nickel (Ni)	1.03E-05	1.22E-05	2.55E-06
Selenium (Se)	< 8.68E-06	< 8.53E-06	< 8.64E-06
Silver (Ag)	< 2.20E-06	< 2.16E-06	< 2.20E-06
Thallium (Tl)	< 7.65E-06	< 7.48E-06	< 7.66E-06

Table 7-18

Hexavalent Chromium Test Data and Test Results at the Thermal Oxidizer Discharge

TEST DATA:	T1	T2	T3
Test run number			
Test location	AFTERBURNER DISCHARGE		
Test date	01-31-96	02-02-96	02-04-96
Test time period	1837-0127	1404-2043	1416-2050
SAMPLING DATA:			
Sampling duration, min.	360.0	360.0	360.0
Nozzle diameter, in.	0.586	0.586	0.586
Barometric pressure, in. Hg	29.73	29.59	30.28
Avg. orifice press. diff., in H ₂ O	0.53	0.52	0.45
Avg. dry gas meter temp., deg F	53.11	49.00	44.17
Avg. abs. dry gas meter temp., deg. R	513	509	504
Total liquid collected by train, ml	288.9	276.5	229.5
Std. vol. of H ₂ O vapor coll., cu.ft.	13.6	13.0	10.8
Dry gas meter calibration factor	1.002	1.002	1.002
Sample vol. at meter cond., dcf	158.264	157.762	145.159
Sample vol. at std. cond., dscf ⁽¹⁾	162.292	162.313	154.262
Percent of isokinetic sampling	104.0	104.2	106.1
GAS STREAM COMPOSITION DATA:			
CO ₂ , % by volume, dry basis	5.7	5.8	6.1
O ₂ , % by volume, dry basis	12.1	11.9	11.9
CO, % by volume, dry basis	0.0	0.0	0.0
N ₂ , % by volume, dry basis	82.2	82.3	82.0
Molecular wt. of dry gas, lb/lb mole	29.4	29.4	29.5
H ₂ O vapor in gas stream, prop. by vol.	0.077	0.074	0.065
Mole fraction of dry gas	0.923	0.926	0.935
Molecular wt. of wet gas, lb/lb mole	28.5	28.6	28.7
GAS STREAM VELOCITY AND VOLUMETRIC FLOW DATA:			
Static pressure, in. H ₂ O	-0.10	-0.10	-0.10
Static pressure, in. Hg	-0.007	-0.007	-0.007
Absolute pressure, in. Hg	29.72	29.58	30.27
Avg. temperature, deg. F	1546	1513	1493
Avg. absolute temperature, deg.R	2006	1973	1953
Pitot tube coefficient	0.84	0.84	0.84
Total number of traverse points	12	12	12
Avg. gas stream velocity, ft./sec.	16.0	15.7	14.1
Stack/duct cross sectional area, sq.ft.	4.59	4.59	4.59
Avg. gas stream volumetric flow, wacf/min.	4400	4330	3870
Avg. gas stream volumetric flow, dscf/min. ⁽¹⁾	1060	1060	990
LABORATORY REPORT DATA ⁽²⁾			
Hexavalent Chromium (Cr ⁺⁶), ug	58.94	61.19	45.37
HEXAVALENT CHROMIUM EMISSIONS			
Concentration, lb/dscf	8.01E-10	8.31E-10	6.48E-10
Concentration, ug/dscm	12.83	13.31	10.39
Mass emission rate, lb/hr	5.10E-05	5.29E-05	3.85E-05

(1) Standard conditions = 68 deg. F. (20 deg. C.) and 29.92 in Hg (760 mm Hg)

(2) Per EPA Cr⁺⁶ method the laboratory results are blank corrected. A blank KOH value of 2.4 ug. per liter was used.

NOTE: The Cr⁺⁶ values reported above may not be truly representative. The Cr⁺⁶ values exceed the total chromium values obtained using the multi-metals test train. The Cr⁺⁶ test train has not been validated by EPA for use on sources exceeding 300° F.

7.3.7 Continuous Emissions Monitoring

Continuous emissions monitoring (CEM) testing of the furnace discharge and thermal oxidizer discharge gas streams was performed during all 15 validation test runs. The CEM parameters measured at each test location and the associated EPA reference methods are provided as follows:

Sample Location	CEM Parameter	EPA Reference Method
Furnace Discharge	NO _x	7E
	THC	25A
Thermal Oxidizer Discharge	NO _x	7E
	THC	25A
	CO	10
	SO ₂	6C
	O ₂ and CO ₂	3A

Table 7-19 presents the minimum, maximum, and average concentrations of NO_x, THC, SO₂, and CO determined for each location during tests T1, T2, and T3. Table 7-20 presents the mass emission rates for NO_x, THC, SO₂, and CO. The mass rates are calculated using average volumetric flow rates measured by the isokinetic sampling trains during tests T1, T2, and T3.

Appendix G presents summaries of CEM test results obtained during all 15 validation test runs. A graphical presentation of the CEM concentrations measured during each validation test also is provided.

A review of the data shows that the highest emissions are attributed to NO_x measured at the thermal oxidizer discharge. The NO_x emissions at the thermal oxidizer discharge are the result of propane combustion and the associated high temperature of the thermal oxidizer. The NO_x trends clearly show a rise in NO_x concentrations following thermal oxidizer startup, a leveling off during the ramp and soak periods, and then a decline during the cooldown period. Concentrations averaged 30 to 60 ppm/v during each test period, with peaks observed over 100 ppm/v.

Table 7-19
Summary of CEM Data for Validation Tests T1, T2, and T3

Test Run No.	Test Date	Test Period	Furnace Discharge Duct				Thermal Oxidizer Discharge Stack						
			NO _x	THC	CO	THC	CO	THC	NO _x	SO ₂	O ₂	CO	
			Concentration (ppm/v)				Concentration (ppm/v)						
T1	1/31/96- 2/1/96	1831-0122	Minimum	0.65	7.25	-1.00	0.31	0.03	-5.00	11.23	5.38		
T1			Maximum	0.95	20.19	-0.50	1.24	166.03	-0.50	12.63	6.62		
T1			Average	0.82	12.25	-0.51	0.73	35.39	-1.77	12.05	5.74		
T1			Standard deviation	0.07	3.11	0.07	0.15	19.11	0.48	0.28	0.17		
T2	2/2/96	1404-2043	Minimum	1.03	37.15	-1.00	-0.23	49.13	0.00	10.90	5.36		
T2			Maximum	42.53	64.23	0.00	2.34	98.80	5.00	12.73	6.48		
T2			Average	1.95	49.23	-0.47	0.92	59.62	2.35	11.87	5.82		
T2			Standard deviation	1.57	7.17	0.15	0.67	6.03	1.41	0.39	0.25		
T3	2/4/96	1408-2049	Minimum	2.45	4.54	-0.50	-5.07	41.70	1.00	9.73	5.00		
T3			Maximum	117.65	100.00	0.50	6.49	177.13	2.50	13.55	7.48		
T3			Average	4.22	77.73	0.15	1.22	63.32	1.48	11.86	6.11		
T3			Standard deviation	4.85	22.25	0.23	5.05	8.10	0.36	0.51	0.33		

Table 7-20

Summary of CEM Mass Emission Rates

Test Run No.	Test Date	Test Period	Furnace Discharge Duct				Thermal Oxidizer Discharge Stack							
			NO _x		THC ^a		NO _x		THC ^a		SO ₂		CO	
			Concentration (ppm/v)	Mass Rate (lb/hr) ^b	Concentration (ppm/v)	Mass Rate (lb/hr) ^b	Concentration (ppm/v)	Mass Rate (lb/hr) ^b	Concentration (ppm/v)	Mass Rate (lb/hr) ^b	Concentration (ppm/v)	Mass Rate (lb/hr) ^b	Concentration (ppm/v)	Mass Rate (lb/hr)
T1	1/31/96 - 2/1/96	1831-0122	<1.0	$<4.9 \times 10^{-3}$	12.6	0.059	35.4	0.27	<1	$<7.2 \times 10^{-3}$	<1	<0.01	<1	<0.004
T2	2/2/96	1404-2043	1.9	7.8×10^{-3}	50.7	0.19	59.6	0.44	<1	$<6.8 \times 10^{-3}$	2.4	0.02	<1	<0.004
T3	2/4/96	1408-2049	4.2	1.6×10^{-2}	79.7	0.29	63.3	0.43	1.3	8.6×10^{-3}	1.5	0.01	<1	<0.004

^aTotal hydrocarbon concentrations and mass rates are calculated on a dry weight basis (as propane).

^bMass rates calculated using volumetric airflows measured on the isokinetic sampling trains.

The NO_x levels measured at the furnace discharge are directly related to decomposition and exit-gassing of the explosives, with some NO_x generated by natural gas combustion in the furnace. The NO_x levels were typically less than 5 ppm/v, with periodic spikes as high as 120 ppm/v. The THC levels measured at the furnace discharge are also related to the decomposition of explosives and are believed to be the result of solvent (acetone) volatilization. During explosives introduction to the furnace, the acetone was mixed with the explosive materials to form a paste to facilitate application. The THC analyzer was calibrated in the 0 to 100 ppm range. Readings periodically went off scale (>100 ppm/v). Typically, THC concentrations ranged between 20 to 80 ppm/v.

The THC, CO, and SO₂ concentrations measured at the thermal oxidizer discharge were generally low (<1 to 5 ppm on average). Periodic spikes of THC and CO were observed during some of the validation tests. The average CO levels determined at the thermal oxidizer discharge were well below the existing standard of 100 ppm/v. THCs were below the standard of 12 ppm/v. No applicable standard exists for NO_x.

7.4 DEVIATIONS FROM THE TEST PLAN

During validation testing, the sampling and analytical procedures followed those outlined in Section 6 of Revision 2 to the Treatability Study Test Plan.¹ Any modifications to sampling and analytical procedures are noted in the following subsection.

7.4.1 Sampling

An additional explosives sample using EPA Method 0010 sampling procedures was obtained at the furnace discharge/thermal oxidizer inlet test location during test T1. The purpose of this additional test was to measure furnace discharge explosive emissions at the midpoint of the 12-hour soak period. Discussions regarding the additional test are provided in Subsection 7.3.2.

During explosives testing at the thermal oxidizer discharge location, some traverse point sampling times were modified to avoid port changes during critical furnace temperature periods when the potential for explosive exit-gassing was increased. As a result, sampling was extended approximately 10 to 15 minutes prior to port change. The sample duration for the next port was adjusted to offset the time difference. This occurred at least once during each of tests T1, T2, and T3 and is not believed to have impacted the representativeness of the explosive results. Although the sample times for some points were changed, no traverse points were missed as a result of the sampling point time adjustments.

¹ Treatability Study Test Plan for the Evaluation of a Transportable Hot-Gas Decontamination System for the Decontamination of Explosives-Contaminated Piping and Debris. Revision 2. Dated January 1996. Prepared by Roy F. Weston, Inc.

No sampling problems were noted during validation test T1, T2, or T3. All test train leak checks, sample volumes, train operating parameters, and isokinetic results met the reference method acceptance criteria.

7.4.2 Sample Handling and Analysis

The EPA Method 29 back-half (impinger portion) nitric acid/hydrogen peroxide sample collected during validation test T1 was broken; therefore, the sample was lost prior to analysis. Because most detected metals were collected in the front-half (filterable particulate) fraction of the EPA Method 29 test train, the loss of this sample fraction is not believed to have significantly affected the overall results for test T1. The reported back-half catch fraction results for arsenic, beryllium, cadmium, mercury, lead, silver, antimony, selenium, and thallium for test T1 were calculated using the average detection limit values obtained for tests T2 and T3. Barium, chromium, and nickel were detected in the test T2 and T3 back-half samples. The T1 results for these three metals were calculated based on the ratio of back-half to front-half concentrations for tests T2 and T3. The average ratio was then applied to the T1 test front-half values to obtain the T1 test back-half values for barium, chromium, and nickel.

During VOC sampling, a total of six individual VOST tube pair samples were collected in conjunction with each test run. For validation test T1, the VOST tube pair 2 and 6 results are not available; the samples were lost during analysis as a result of instrument failure. The VOC results for test T1 are based on the remaining four tube pair results. Use of the four tube pair results provides representative VOC data for test T1.

SVOCs were quantified for all three validation test runs using the EPA Method 0010 test train. With few exceptions, SVOCs were measured below detection limit values. Because of multiple extracts analyzed for explosives using the EPA Method 0010 test train, the detection limit values for SVOCs were higher than anticipated. As a result, WESTON elected to also analyze the EPA Method 23 (dioxin/furan) sample extracts for tests T1 and T2 and the field blank sample for SVOCs. The test T3 sample extract was totally consumed during dioxin/furan analysis; therefore, SVOC analysis of the EPA Method 23 test T3 sample could not be performed.

Discussions regarding the additional SVOC analytical results are provided in Subsection 7.3.3.

No other sample handling or analytical problems were noted during any of the validation test periods (T1, T2, and T3).

8.

AIR SAMPLING: ANALYSIS AND RESULTS

The primary goal of an air monitoring program is to collect data that quantifies personal exposures, thereby ensuring worker safety. To support the validation testing of the HGD equipment, WESTON designed a monitoring program that would provide data of sufficient quality that worker exposures to explosives-contamination during validation test activities could be evaluated.

Time-integrated air sampling was conducted during the first three validation test runs to quantify concentrations of airborne TNT, RDX, and tetryl¹ and during the last validation test run (17C) for asbestos. During all spiking and materials loading operations, airborne explosive vapors and dust were measured using real-time monitoring.

The following subsections present a description of the monitoring equipment, monitoring procedures, number and types of samples, and the quality assurance (QA) procedures used to support the air sampling and monitoring program at the HGD site. Results of the air sampling and monitoring program conducted at the ALAAP HGD site are discussed in this section. Analytical results for integrated samples for explosives and asbestos are provided in Appendices J and K, respectively.

8.1 TIME-INTEGRATED AMBIENT AIR SAMPLING RESULTS

8.1.1 TNT, RDX, and Tetryl Sampling—Perimeter and Personal

OSHA Method 44, the accepted personal sampling method for TNT, was used to support personal sampling for TNT, RDX, and tetryl. Note, however, that OSHA Method 44 has not been validated for RDX and tetryl.

Six sample sets were collected for explosives analysis between 29 January and 20 February 1996. The samples were sent to WESTON's laboratory in Lionville, Pennsylvania, and were analyzed for explosives in accordance with OSHA Method 44, modified for HPLC analysis. Results are summarized in Table 8-1. As shown in this table, no samples contained explosives concentrations above the detection limit. The absence of detectable levels of explosives indicates that no airborne explosives were present during the spiking, loading, and unloading

¹ Total particulate samples were collected, but the sample results and documentation, contained in the site trailer, were transferred with the HGD equipment to USAEC's designated trustee.

Table 8-1
Time-Integrated Results for Explosives

<i>Sample Date</i>	<i>RFW No.^a</i>	<i>Sample ID</i>	<i>Sample Type</i>	<i>Explosives Results</i>
29 Jan 96	001	EAED29JAN96-1	Air	Non-Detect ^b
	002	EPED29JAN96-1	Personal	Non-Detect
	003	EPIM29JAN96-1	Personal	Non-Detect
	004	EPIM29JAN96-1	Personal	Non-Detect
	005	EPIS29JAN96-1	Personal	Non-Detect
	006	EPIS29JAN96-2	Personal	Non-Detect
	007	EAEU29JAN96-1	Air	Non-Detect
	008	EAEU29JAN96-1	Air	Non-Detect
31 Jan 96	001	EPIS31JAN96-2	Personal	Non-Detect
	002	EPIS31JAN96-2	Personal	Non-Detect
	003	EPIM31JAN96-2	Personal	Non-Detect
	004	EPIM31JAN96-2	Personal	Non-Detect
	005	EAED31JAN96-2	Air	Non-Detect
	006	EAED31JAN96-2	Air	Non-Detect
	007	EAEU31JAN96-2	Air	Non-Detect
	008	EAEU31JAN96-2	Air	Non-Detect
6-7 Feb 96	001	TB06FEB97F	Trip	Non-Detect
	002	TB06FEB97B	Trip	Non-Detect
	003	BLO6FEB96F	Blank	Non-Detect
	004	BL06FEB96B	Personal	Non-Detect
	005	EPPM07FEB96F	Personal	Non-Detect
	006	EPPM07FEB96B	Personal	Non-Detect
	007	EPIM06FEB96-3F	Personal	Non-Detect
	008	EPIM06FEB96-3B	Personal	Non-Detect
	009	EPIS06FEB96-3F	Personal	Non-Detect
	010	EPIS06FEB96-3B	Personal	Non-Detect
	011	EAEU06FEB96-3F	Air	Non-Detect
	012	EAEU06FEB96-3B	Air	Non-Detect
	013	EAED06FEB96-3F	Air	Non-Detect
	014	EAED06FEB96-3B	Air	Non-Detect
	015	EPPS07FEB96F	Personal	Non-Detect
	016	EPPS07FEB96B	Personal	Non-Detect
12 Feb 96	004	XAED12FEB96-1	Air	Non-Detect
	005	XAEU12FEB96-1	Air	Non-Detect
15 Feb 96	006	XAEU15FEB96-2	Air	Non-Detect
	007	XAED15FEB96-2	Air	Non-Detect
20 Feb 96	002	XAEU20FEB96-3	Air	Non-Detect
	003	XAED20FEB96-3	Air	Non-Detect

^aRFW = Roy F. Weston, Inc.

^bDetection limits are provided in Appendix J.

activities associated with the operation of the HGD system. Based on these data, Level D personal protective equipment was determined to be adequate to protect workers from exposure to explosives during spiking, loading, and unloading activities. Because spiking is conducted using a solvent, it may be advisable to conduct personal sampling for VOCs during future operations. However, monitoring during spiking activities indicated that vapors from the acetone were well below the NIOSH-recommended exposure limit of 250 ppm.

8.1.2 Total Particulate Monitoring—Perimeter

Total particulate samples were collected around the perimeter of the HGD equipment pad in accordance with NIOSH Method 0500. Sample results and documentation are included with the health and safety files located in the control area and were transferred with the HGD equipment to USAEC's designated trustee.

8.1.3 Asbestos Monitoring—Perimeter and Personal

Perimeter and personal asbestos sampling was conducted on 18 March 1996 during test run 17C. The purpose of test run 17C was to determine the effect, if any, that the HGD process would have on asbestos-containing materials. For example, would the asbestos become friable after treatment at normal processing times and temperatures?

HGD personnel loaded 1 lb of asbestos-containing transite siding into the HGD furnace and treated the materials using a 250 °F/hour ramp and 600 °F treatment temperature for a 1-hour soak time. The asbestos sampling conducted during the loading and unloading activities and the subsequent analyses were conducted in accordance with NIOSH Method 7400, Phase Contrast Microscopy, which determines a total fibers count. Three investigative samples (one personal and two work area samples) and a field blank were collected. The results of the analysis are presented in Table 8-2.

Table 8-2

Asbestos Results from HGD Furnace Run 17C of 18 March 1996

WESTON Sample No.	Sample ID	Fibers/cc
DS013	USAEC/AAEU	0.005
DS014	USAEC/AAED	<0.003
DS015	USAEC/APIIS	<0.026
DS016	USAEC/AFIELD BLANK	---

The results presented in Table 8-2 indicate that the fiber counts are below the OSHA-permissible exposure limit (PEL) of 0.1 fibers/cc.

8.2 REAL-TIME AIR SAMPLING MONITORING

Real-time air sampling monitoring was conducted as part of the ambient air sampling program. A combination of permanently installed combustible gas indicators (CGIs), portable CGIs, and a Miniature Real-Time Aerosol Monitor (MiniRAM) was used during validation testing to monitor levels of explosive vapors and dust.

8.2.1 Explosive Vapors

8.2.1.1 Propane

A CGI, calibrated to detect propane fuel leaks, was permanently mounted at each of the following four equipment locations and operated continuously during all phases of the HGD equipment validation testing:

- Main propane supply valve to the equipment pad.
- Main fuel valve to the furnace fuel train.
- Main fuel valve to the thermal oxidizer fuel train.
- Thermal oxidizer burner.

Each CGI was tested regularly to verify functionality and was electrically operated and equipped with both audible and visual (blinking light) alarms. Each CGI was calibrated to alarm if the lower explosive limit (LEL) increased above 5,250 ppm ($\geq 25\%$ of the LEL for propane). No gas leaks were detected during the validation test operations.

8.2.1.2 Other than Propane

Monitoring for explosive gases or vapors other than propane was conducted using a portable CGI on an as-needed basis. Regular monitoring by the HGD staff indicated that explosive gases and vapors did not pose a problem during HGD equipment operations.

8.2.2 Dust Monitoring

A MiniRAM was used to monitor for dust in the HGD work area during validation testing. MiniRAM results obtained throughout validation testing indicated that dust levels at the HGD site, and especially in the HGD work areas used to perform loading, spiking, and processing activities, were below the

WESTON-recommended action level of 5.0 mg/m^3 and well below the time weighted-average (TWA) using an 8-hour average of 10 mg/m^3 .

8.3 QUALITY ASSURANCE/QUALITY CONTROL

Two types of blank samples (field and trip) were collected at the HGD site during air monitoring activities. The purpose of these samples was to measure the possible contamination introduced by field sampling procedures, sampling media, sampling equipment, or sample shipment. Field blanks are handled in the same manner as actual samples, undergoing the same preparation, installation in the sampler module, and cleanup procedures. The only difference between a field blank and an actual sample is that no air volume is drawn through the field blank. A trip blank is a sample that is handled similar to an actual sample, but is not exposed to the environment (i.e., it is kept in the shipping container). Each field blank was shipped to the field, and prepared and handled as were the other samples. Each field blank was then returned to the laboratory without drawing air through the sample.

8.3.1 Explosives

As indicated in Table 8-1, both the trip and field blanks for the explosives samples collected in accordance with OSHA Method 44 indicated non-detect; therefore, no contamination was introduced into the samples by field sampling procedures, sampling media, sampling equipment, or sample shipment.

8.3.2 Asbestos Analysis

For asbestos, one field blank was submitted with the three samples taken on 18 March 1996. The results of the asbestos field blank indicated that no fibers were present; therefore, no contamination was introduced into the sample by field sampling procedures, sampling media, sampling equipment, or sample shipment.

9.

DISCUSSION OF RESULTS

This section of the Validation Test Report will discuss the results of the post-treatment sampling and analysis conducted at the end of each validation test run. As noted in Section 5, wipe samples were taken from all test specimens and furnace wall plates in accordance with EPA wipe sampling techniques and analyzed in accordance with modified Method 8330. Concrete block, clay, and nonmetal contaminated debris samples were also ground into a powder and analyzed for explosives residuals. Method 8330 analysis uses an HPLC to analyze for the nine explosives and explosives-breakdown compounds noted below:

- Octahydro-1,3,5,7 tetranitro-1,3,5,7-tetrazocine (HMX).
- Hexahydro-1,3,5-trinitro-s-triazine (RDX).
- 1,3,5-Trinitrobenzene (1,3,5-TNB).
- 1,3-Dinitrobenzene (1,3-DNB).
- Nitrobenzene (NB).
- 2,4,6-Trinitrophenylmethylnitramine (tetryl).
- 2,4,6-Trinitrotoluene (2,4,6-TNT).
- 2,6-Dinitrotoluene (2,6-DNT).
- 2,4-Dinitrotoluene (2,4-DNT).

9.1 TREATMENT CRITERIA

At the start of validation testing, an extremely simple pass/fail criterion was established: any test specimen or furnace wall plate able to meet 99.99% removal of the initial spike explosives quantity was considered a pass. Samples that could not meet this criterion failed. Unfortunately, as testing progressed, it became obvious that more stringent acceptance criteria would be needed if the resulting data were to clearly indicate the optimal operating conditions for decontamination of TNT, RDX, and tetryl. Three levels of acceptance criteria were established and used throughout the validation test program. These acceptance criteria are described as follows:

- **Acceptance Level 1:** To pass this acceptance criterion, post-treatment analysis must indicate 99.999% or better removal efficiency (RE) of the spike explosives. Residual levels of explosives or explosives-breakdown compounds are acceptable.
- **Acceptance Level 2:** To pass this acceptance criterion, post-treatment results must indicate the removal of all spike-explosives compounds. The presence of TNT, RDX, or tetryl residuals caused test specimens and furnace wall plates to fail regardless of detection level.

NOTE: A sample that passed the Level 1 criterion could fail this level if trace levels of TNT, RDX, or tetryl existed.

Acceptance Level 3: To pass this acceptance level, the post-treatment sample must be completely free of explosives and explosives-breakdown compounds. This was the most difficult criterion to meet. Test specimens and furnace wall plates that passed Level 1 and Level 2 criteria could fail this acceptance level if trace levels of explosives-breakdown compounds existed, such as 1,3-DNT.

9.2 DISCUSSION OF LEVEL 1 RESULTS

Table 9-1 provides a test matrix indicating the results of validation tests 1 through 16C, using the Level 1 acceptance criterion. Green boxes indicate that the test specimen or furnace wall plate met or exceeded the established 99.999% RE criterion. White boxes indicate a failure. Level 1 was the easiest acceptance criterion to meet. Contaminated debris from the ALAAP remediation area was not considered for this acceptance level because initial contamination levels were unknown, and an RE could not be established.

Level 1 results indicate that at treatment temperatures between 500 °F and 600 °F, the HGD process can successfully decontaminate explosives-contaminated debris to at least 99.999% RE. In most cases the REs were actually a magnitude higher (i.e., 99.9999%). At 600 °F, all test plates and specimens passed the Level 1 criterion with no soak time at all. Zero soak time tests were not conducted at 500 °F; therefore, Table 9-1 indicates that at 500 °F, a 1-hr soak time was required to meet the 99.999% RE criterion. At 400 °F, with a 6-hr soak, tetryl and RDX can pass the 99.999% RE, but one of the TNT-spiked metal specimens failed to meet the treatment criterion even though a 6-hr soak was used. At 400 °F, and 1-hr soak, the TNT-spiked metal specimen passed the 99.999% criterion, but the TNT-spiked clay and block specimens did not. The tetryl-contaminated block that failed this same test contained 134 µg of tetryl after processing.

The most interesting results at this acceptance level are the results from test runs 16A, 16B, and 16C. These test runs used a 300 °F/hr ramp to 600 °F. At 600 °F, the furnace was shut off, and there was no soak time at treatment temperature. Only one type of explosive was placed in each furnace run: TNT in 16A, tetryl in 16B, and RDX in 16C. For each of these test runs, the furnace operated approximately 2 hr to reach treatment temperature and was then shut down. As indicated in Table 9-1, all of the TNT-contaminated block samples failed. A similar event occurred in test run 16C for tetryl-contaminated block; however, all of the RDX-contaminated specimens and test plates treated in test run 16C passed. Clearly, the combination of fast ramp and no soak time affects the ability of the process to decontaminate explosives-contaminated materials.

In general, the results of the Level 1 acceptance criterion suggest certain treatment trends that do not become obvious until a Level 3 acceptance criterion is applied to

Table 9-1
Level 1 Acceptance

	300°F				400°F				500°F				550°F			
No Soak																
1 hr Soak	Test #12: 3 hr 8 min				Test #11: 2 hr 41 min				Test #13: 3 hr 14 min				Test #10: 4 hr 46 min			
	TN-S	TN-C	TN-B	FP-Te	TN-S	TN-C	TN-B	FP-R	TN-S	TN-C	TN-B	FP-TN	TN-S	TN-C	TN-B	FP-TN
	R-S	R-C	R-B	Dup	R-S	R-C	R-B	Dup	R-S	R-C	R-B	Dup	R-S	R-C	R-B	Dup
	Te-S	Te-C	Te-B		Te-S	Te-C	Te-B		Te-S	Te-C	Te-B		Te-S	Te-C	Te-B	
2 hr Soak									Test #8: 5 hr 48 min							
									TN-S	TN-C	TN-B	FP-R				
									R-S	R-C	R-B	Dup				
									Te-S	Te-C	Te-B					
4 hr Soak									Test #3: 13hr 42 min							
									TN-S	TN-C	TN-B	FP-Te				
									R-S	R-C	R-B	Dup-Te				
									Te-S	Te-C	Te-B					
6 hr Soak					Test #2: 11hr 30 min				Test #4: 12 hr 43 min							
					TN-S	TN-C	TN-B	FP-R	TN-S	TN-C	TN-B	FP-TN				
					R-S	R-C	R-B		R-S	R-C	R-B					
					Te-S	Te-C	Te-B		Te-S	Te-C	Te-B					
12 hr Soak									Test #1: 20 hr 47 min							
									TN-S	TN-C	TN-B	FP-TN				
									R-S	R-C	R-B					
									Te-S	Te-C	Te-B					

KEY:

B- Block TN - TNT FP - Furnace Plates
 C- Clay Te- Tetryl Dup - Duplicated Test Plate & Analysis
 S- Steel R - RDX

50° F/hr ramp: Tests 1,2, & 3
 75° F/hr ramp: Tests 4, 5 & 6
 100° F/hr ramp: Tests 7, 8 & 9

150° F/hr ramp: Tests 10 & 11
 200° F/hr ramp: Test 12
 200° F/ramp: Test 13
 300° F/hr ramp: Test 14, 15, 16A, 16B, & 16C



**Table 9-1
Level 1 Acceptance Criterion**

		550°F				600°F				600°F				600°F				600°F	
						Test #9: 6hr 15 min				Test 16A				Test 16B:				Te	
						TN-S	TN-C	TN-B	FP-Te	TN-S	TN-C	TN-B	FP-TN	Te-S	Te-C	Te-B	FP-Te	R-S	R-C
						R-S	R-C	R-B	Dup	TN-S	TN-C	TN-B		Te-S	Te-C	Te-B		R-S	R-C
						Te-S	Te-C	Te-B		TN-S	TN-C	TN-B		Te-S	Te-C	Te-B		R-S	R-C
hr 14 min		Test #10: 4 hr 46 min				Test #7: 7 hr 53 min				Test #14: 3 hr 20 min				Test #15: 3 hr 3 min					
TN-B	FP-TN	TN-S	TN-C	TN-B	FP-TN	TN-S	TN-C	TN-B	FP-TN	TN-S	TN-C	TN-B	FP-R	TN-S	TN-C	TN-B	FP-Te		
R-B	Dup	R-S	R-C	R-B	Dup	R-S	R-C	R-B	Dup-Te	R-S	R-C	R-B	Dup	R-S	R-C	R-B	Dup		
Te-B		Te-S	Te-C	Te-B		Te-S	Te-C	Te-B		Te-S	Te-C	Te-B		Te-S	Te-C	Te-B			
hr 48 min						Test #6: 7 hr 43 min													
TN-B	FP-R					TN-S	TN-C	TN-B	FP-Te										
R-B	Dup					R-S	R-C	R-B	Dup-Te										
Te-B						Te-S	Te-C	Te-B											
hr 42 min						Test #5: 11 hr 8 min													
TN-B	FP-Te					TN-S	TN-C	TN-B	FP-R										
R-B	Dup-Te					R-S	R-C	R-B	Dup-Te										
Te-B						Te-S	Te-C	Te-B											
hr 43 min																			
TN-B	FP-TN																		
R-B																			
Te-B																			
hr 47 min																			
TN-B	FP-TN																		
R-B																			
Te-B																			

LEVEL 1 Acceptance Criterion:

- >99.999% Explosives Removal Efficiency must be Achieved

Pass

Fail

- b: Tests 10 & 11
- b: Test 12
- Test 13
- b: Test 14, 15, 16A, 16B, & 16C

2

00°F			600°F				600°F			
Test 16A			Test 16B:				Test 16C:			
N-C	TN-B	FP-TN	Te-S	Te-C	Te-B	FP-Te	R-S	R-C	R-B	FP-R
N-C	TN-B		Te-S	Te-C	Te-B		R-S	R-C	R-B	
N-C	TN-B		Te-S	Te-C	Te-B		R-S	R-C	R-b	
#14: 3 hr 20 min			Test #15 3 hr 3 min							
N-C	TN-B	FP-R	TN-S	TN-C	TN-B	FP-Te				
R-C	R-B	Dup	R-S	R-C	R-B	Dup				
Te-C	Te-B		Te-S	Te-C	Te-B					

Criterion:
 Solids Removal Efficiency must be Achieved

3

the data. One of those trends is that TNT is more difficult to successfully decontaminate than either RDX or tetryl. A second trend that becomes more obvious as more stringent acceptance criteria are applied, is that metals-contaminated test plates and debris are easier to decontaminate than porous materials (clay, block, and nonmetal debris) contaminated with the same explosive and treated for the same treatment temperatures and times.

9.3 DISCUSSION OF LEVEL 2 RESULTS

Table 9-2 provides a test matrix indicating the results of validation tests meeting the acceptance criterion defined by Level 2. White blocks indicate those test specimens that failed to meet the established criterion: no explosives hits. Therefore, any post-treatment sample that indicated residual levels of TNT, RDX, or tetryl failed to meet the Level 2 criterion. In some instances, test specimens and wall plates that had passed the Level 1 criterion did not pass the Level 2 criterion. As noted in Level 1 discussions, contaminated debris from the ALAAP remediation area was not considered in this acceptance level because initial contamination levels were unknown and REs could not be calculated.

Applying Level 2 acceptance criterion, the data presented in Table 9-2 indicate that spike explosives were successfully decontaminated at treatment temperatures of 550 °F and 600 °F, regardless of soak time. Successful decontamination means no trace of the original spike explosives and meeting at least 99.999% RE.

Note the failure of a TNT-contaminated block in test run 16A, whereas a TNT-contaminated block passed under similar treatment circumstances in test run 9. Although the REs for the samples from test 16A ranged between 99.999% and 99.93%, residual levels of TNT detected after treatment were between 6,302 and 10,000 µg. Although the actual cause of the failure is unknown, it is likely that the TNT-contaminated block never reached a temperature hot enough to vaporize the contaminant. During all validation test runs, treatment temperature was based on the average of the five material thermocouples distributed throughout the load. Because this test run had a zero soak time, when the five-thermocouple average indicated 600 °F, the furnace was shut off. There was no soak period, which allows materials within the load to equalize at temperatures closer to the thermocouple average. The system datalog for test run 16A indicated that the highest surface temperature reached by the concrete blocks contained in the furnace load was only 394 °F, whereas the metal pipe in the same load reached treatment temperatures between 565 and 710 °F. Discussion in Subsection 9.4 will highlight the importance of reaching material temperatures in excess of 500 °F.

Table 9-2 also indicates that spike explosives were successfully decontaminated to the Level 2 criterion (no trace of the original spike explosives and meets or exceeds 99.999% RE) at treatment temperatures of 500 °F, provided that the soak time was greater than or equal to 2 hr. Test 13, which was also conducted at 500 °F, but with a 1-hr soak, failed to meet the Level 2 criterion because of a 66-µg hit of TNT found in the ash residual left behind the TNT-spiked furnace wall plate located in the left rear of the furnace.

Table 9
Level 2 Acceptan

	300°F				400°F				500°F				550°F			
No Soak																
1 hr Soak	Test #12: 3hr 8 min				Test #11: 2 hr 41 min				Test #13: 3 hr 14 min				Test #10: 4 hr 46 min			
	TN-S	TN-C	TN-B	FP-Te	TN-S	TN-C	TN-B	FP-R	TN-S	TN-C	TN-B	FP-TN	TN-S	TN-C	TN-B	FP-
	R-S	R-C	R-B	Dup-Te	R-S	R-C	R-B	Dup-Te	R-S	R-C	R-B	Dup-Te	R-S	R-C	R-B	Dup
2 hr Soak									Test #8: 5 hr 48 min							
									TN-S	TN-C	TN-B	FP-R				
									R-S	R-C	R-B	Dup-Te				
4 hr Soak									Test #3: 13hr 42 min							
									TN-S	TN-C	TN-B	FP-Te				
									R-S	R-C	R-B	Dup-Te				
6 hr Soak					Test #2: 11hr 30 min				Test #4: 12 hr 43 min							
					TN-S	TN-C	TN-B	FP-R	TN-S	TN-C	TN-B	FP-TN				
					R-S	R-C	R-B	Dup-Te	R-S	R-C	R-B	Dup-Te				
12 hr Soak									Test #1: 20 hr 47 min							
									TN-S	TN-C	TN-B	FP-TN				
									R-S	R-C	R-B					

KEY:

B- Block	TN - TNT	FP - Furnace Plates	50° F/hr ramp: Tests 1, 2, & 3
C- Clay	Te- Tetryl	Dup - Duplicated Test Plate & Analysis	75° F/hr ramp: Tests 4, 5, & 6
S- Steel	R - RDX		100° F/hr ramp: Tests 7, 8 & 9
			150° F/hr ramp: Tests 10 & 11
			200° F/hr ramp: Tests 12 & 13
			300° F/hr ramp: Tests 14, 15, 1



**Table 9-2
Level 2 Acceptance Criterion**

550°F						600°F				600°F				600°F				600°F			
						Test #9: 6hr 15 min				Test 16 A:				Test 16B				Te			
						TN-S	TN-C	TN-B	FP-Te	TN-S	TN-C	TN-B	FP-TN	Te-S	Te-C	Te-B	FP-Te	R-S	R-C		
						R-S	R-C	R-B	Dup	TN-S	TN-C	TN-B		Te-S	Te-C	Te-B		R-S	R-C		
						Te-S	Te-C	Te-B		TN-S	TN-C	TN-B		Te-S	Te-C	Te-B		R-S	R-C		
hr 14 min						Test #10: 4 hr 46 min				Test #7: 7 hr 53 min				Test #14: 3 hr 20 min				Test #15: 3 hr 3 min			
TN-B	FP-TN	TN-S	TN-C	TN-B	FP-TN	TN-S	TN-C	TN-B	FP-TN	TN-S	TN-C	TN-B	FP-R	TN-S	TN-C	TN-B	FP-Te				
R-B	Dup-Te	R-S	R-C	R-B	Dup-Te	R-S	R-C	R-B	Dup-Te	R-S	R-C	R-B	Dup-Te	R-S	R-C	R-B	Dup-Te				
Te-B		Te-S	Te-C	Te-B		Te-S	Te-C	Te-B		Te-S	Te-C	Te-B		Te-S	Te-C	Te-B					
hr 48 min						Test #6: 7 hr 43 min															
TN-B	FP-R					TN-S	TN-C	TN-B	FP-Te												
R-B	Dup-Te					R-S	R-C	R-B	Dup-Te												
Te-B						Te-S	Te-C	Te-B													
hr 42 min						Test #5: 11 hr 8 min															
TN-B	FP-Te					TN-S	TN-C	TN-B	FP-R												
R-B	Dup-Te					R-S	R-C	R-B	Dup-Te												
Te-B						Te-S	Te-C	Te-B													
hr 43 min																					
TN-B	FP-TN																				
R-B	Dup-Te																				
Te-B																					
hr 47 min																					
TN-B	FP-TN																				
R-B																					
Te-B																					

- 50° F/hr ramp: Tests 1, 2, & 3
- 75° F/hr ramp: Tests 4, 5, & 6
- 100° F/hr ramp: Tests 7, 8 & 9
- 150° F/hr ramp: Tests 10 & 11
- 200° F/hr ramp: Tests 12 & 13
- 300° F/hr ramp: Tests 14, 15, 16A, 16B, & 16C

LEVEL 2 Acceptance Criterion:

- Any explosives hit (TNT, RDX, or Tetryl) regardless of removal efficiency or quantity found constitutes a failure

 Pass

 Fail

0°F			600°F				600°F			
Test 16 A:			Test 16B				Test 16 C			
C	TN-B	FP-TN	Te-S	Te-C	Te-B	FP-Te	R-S	R-C	R-B	FP-R
C	TN-B		Te-S	Te-C	Te-B		R-S	R-C	R-B	
C	TN-B		Te-S	Te-C	Te-B		R-S	R-C	R-b	
14: 3 hr 20 min			Test #15: 3 hr 3 min							
C	TN-B	FP-R	TN-S	TN-C	TN-B	FP-Te				
C	R-B	Dup-Te	R-S	R-C	R-B	Dup-Te				
C	Te-B		Te-S	Te-C	Te-B					

Passance Criterion:
 No traces of TNT, RDX, or Teteryl regardless of removal quantity found constitutes a failure

3

As noted earlier, TNT was the most difficult of the explosives to decontaminate. At treatment temperatures below 600 °F, TNT usually left behind a residue. The residue typically had a shiny, glass-like appearance. It was very light in weight, and in most cases formed a thin layer crust that would collapse into an ash when touched on the test plates. The residual was sampled, whenever encountered, by removing the ash from the test specimen and grinding the residue into a powder, before sampling the ground powder in accordance with Method 8330.

In general, results evaluated to the Level 2 criterion narrowed the selection of optimal treatment temperatures, but not sufficiently to discern a clear treatment temperature and soak period. Level 2 results indicated the HGD process was capable of decontaminating the explosives contaminants of concern over a fairly wide range of treatment temperatures (500 °F to 600 °F) and soak times (0 to 12 hr). As with Level 1, TNT still proved to be the most difficult explosive to treat, and nonporous surfaces were easier to treat than materials such as concrete and clay.

9.4 DISCUSSION OF LEVEL 3 RESULTS

Table 9-3 provides a test matrix indicating the results of validation testing using the most stringent acceptance criterion, Level 3. The white blocks indicate a test specimen or furnace wall plate failed to meet the acceptance criteria established by Level 3. To pass the Level 3 criterion, a test specimen or furnace wall plate cannot contain any detectable level of spike explosives (TNT, RDX, or tetryl) or any detectable level of explosives-breakdown compounds (HMX, 1,3,5-TNB, 1,3-DNB, NB, 2,6-DNT, or 2,4-DNT) regardless of RE. Contaminated debris was not considered for this criterion because initial concentration levels are unknown and RE could not be established.

Using the Level 3 acceptance criterion narrowed the range of acceptable treatment temperatures and soak times considerably. As indicated by Table 9-3, only treatment temperatures of 600 °F with at least 1-hr soak times (test runs 6, 7, and 14) are capable of decontaminating explosives-contaminated materials to levels where neither the spike explosives nor their breakdown compounds are detected. These test runs also successfully decontaminated the contaminated debris. Test 15, which was run at 600 °F, 300 °F/hr ramp, and no soak, failed to completely decontaminate the contaminated debris because of traces of 1,3,5-TNB and 2,4,6-TNT (0.5 µg and 0.7 g, respectively) found in a randomly selected nonmetal debris sample. Although this level of contamination is clearly nonreactive, these concentrations may not be low enough to pass a locally imposed treatment criterion.

In contrast to test runs 6, 7, and 14, test runs 9, 16A, 16B, and 16C were conducted with a 600 °F treatment temperature and no soak, and were only partially successful. Although test 9 failed to completely decontaminate contaminated debris for trace levels of 1,3,5-TNB and 2,4,6-TNT (1.4 µg and 2.2 µg, respectively), tests 16A and 16B failed to successfully decontaminate concrete blocks that had been spiked with TNT or tetryl. Test 16A treated only TNT-contaminated samples, and test 16B only tetryl-contaminated samples. Post-

Table 9-
Level 3 Acceptanc

	300°F				400°F				500°F				550°F			
No Soak																
1 hr Soak	Test #12: 3 hr 8 min				Test #11: 2 hr 41 min				Test #13: 3 hr 14 min				TEST #10: 4 hr 46 min			
	TN-S	TN-C	TN-B	FP-Te	TN-S	TN-C	TN-B	FP-R	TN-S	TN-C	TN-B	FP-TN	TN-S	TN-C	TN-B	FP-
	R-S	R-C	R-B	Dup-Te	R-S	R-C	R-B	Dup	R-S	R-C	R-B	Dup	R-S	R-C	R-B	Du
	Te-S	Te-C	Te-B	Cont	Te-S	Te-C	Te-B	Cont	Te-S	Te-C	Te-B	Cont	Te-S	Te-C	Te-B	Co
2 hr Soak									Test #8: 5 hr 48 min							
									TN-S	TN-C	TN-B	FP-R				
									R-S	R-C	R-B	Dup				
									Te-S	Te-C	Te-B	Cont				
4 hr Soak									Test #3: 13hr 42 min							
									TN-S	TN-C	TN-B	FP-Te				
									R-S	R-C	R-B	Dup-Te				
									Te-S	Te-C	Te-B					
6 hr Soak					Test #2: 11hr 30 min				Test #4: 12 hr 43 min							
					TN-S	TN-C	TN-B	FP-R	TN-S	TN-C	TN-B	FP-TN				
					R-S	R-C	R-B		R-S	R-C	R-B	Dup-Te				
					Te-S	Te-C	Te-B		Te-S	Te-C	Te-B	Cont				
12 hr Soak									Test #1: 20 hr 47 min							
									TN-S	TN-C	TN-B	FP-TN				
									R-S	R-C	R-B					
									Te-S	Te-C	Te-B					

KEY:

B- Block	TN - TNT	FP - Furnace Plates	50° F/hr Ramp: Tests 1,
C- Clay	Te- Tetryl	Dup - Duplicated Test Plate & Analysis	75° F/hr Ramp: Tests 4,
S- Steel	R - RDX	Cont - Contaminated Debris After Treatment	100° F/hr Ramp: Tests 7,
			150° F/hr Ramp: Tests 11
			200° F/hr Ramp: Tests 13
			300° F/hr Ramp: Tests 14



**Table 9-3
Level 3 Acceptance Criterion**

500°F			550°F				600°F				600°F				600°F				
							Test #9: 6hr 15 min				Test 16 A:				Test 16B				
							TN-S	TN-C	TN-B	FP-Te	TN-S	TN-C	TN-B	FP-TN	Te-S	Te-C	Te-B	FP-Te	R-S
							R-S	R-C	R-B	Dup	TN-S	TN-C	TN-B		Te-S	Te-C	Te-B		R-S
							Te-S	Te-C	Te-B	Cont	TN-S	TN-C	TN-B		Te-S	Te-C	Te-B		R-S
Test #13: 3 hr 14 min			TEST #10: 4 hr 46 min				Test #7: 7 hr 53 min				Test #14: 3 hr 20 min				Test #15: 3 hr 3 min				
TN-C	TN-B	FP-TN	TN-S	TN-C	TN-B	FP-TN	TN-S	TN-C	TN-B	FP-TN	TN-S	TN-C	TN-B	FP-R	TN-S	TN-C	TN-B	FP-Te	
R-C	R-B	Dup	R-S	R-C	R-B	Dup	R-S	R-C	R-B	Dup	R-S	R-C	R-B	Dup	R-S	R-C	R-B	Dup	
Te-C	Te-B	Cont	Te-S	Te-C	Te-B	Cont	Te-S	Te-C	Te-B	Cont	Te-S	Te-C	Te-B	Cont	Te-S	Te-C	Te-B	Cont	
Test #8: 5 hr 48 min							Test #6: 7 hr 43 min												
TN-C	TN-B	FP-R					TN-S	TN-C	TN-B	FP-Te									
R-C	R-B	Dup					R-S	R-C	R-B	Dup-Te									
Te-C	Te-B	Cont					Te-S	Te-C	Te-B	Cont									
Test #3: 13hr 42 min							Test #5: 11 hr 8 min												
TN-C	TN-B	FP-Te					TN-S	TN-C	TN-B	FP-R									
R-C	R-B	Dup-Te					R-S	R-C	R-B	Dup-Te									
Te-C	Te-B						Te-S	Te-C	Te-B	Cont									
Test #4: 12 hr 43 min																			
TN-C	TN-B	FP-TN																	
R-C	R-B	Dup-Te																	
Te-C	Te-B	Cont																	
Test #1: 20 hr 47 min																			
TN-C	TN-B	FP-TN																	
R-C	R-B																		
Te-C	Te-B																		

Analysis
Treatment

- 50° F/hr Ramp: Tests 1, 2 & 3
- 75° F/hr Ramp: Tests 4, 5, & 6
- 100° F/hr Ramp: Tests 7, 8, & 9
- 150° F/hr Ramp: Tests 10 & 11
- 200° F/hr Ramp: Tests 12 & 13
- 300° F/hr Ramp: Tests 14, 15, 16A, 16B, & 16C

LEVEL 3 Acceptance Criterion:

- Any hit for explosives or explosives breakdown components of removal efficiency or quantity found, constitutes a failure

 Pass

 Fail

2

600°F				600°F				600°F			
Test 16 A:				Test 16B				Test 16 C			
TN-S	TN-C	TN-B	FP-TN	Te-S	Te-C	Te-B	FP-Te	R-S	R-C	R-B	FP-R
TN-S	TN-C	TN-B		Te-S	Te-C	Te-B		R-S	R-C	R-B	
TN-s	TN-C	TN-B		Te-S	Te-C	Te-B		R-S	R-C	R-b	
Test #14: 3 hr 20 min				Test #15: 3 hr 3 min							
TN-S	TN-C	TN-B	FP-R	TN-S	TN-C	TN-B	FP-Te				
R-S	R-C	R-B	Dup	R-S	R-C	R-B	Dup				
Te-S	Te-C	Te-B	Cont	Te-S	Te-C	Te-B	Cont				

LEVEL 3 Acceptance Criterion:

Any hit for explosives or explosives breakdown compound, regardless of removal efficiency or quantity found, constitutes a failure

Pass

Fail

3

treatment samples of TNT-spiked blocks from test 16A contained levels as high as 7,962 μg 2,4,6-TNT and 10,000 μg of 2,4-DNT. Post-treatment samples of tetryl-spiked blocks taken after test 16B contained levels of 1,3,5-TNB from 0.6 to 191 μg . In tests 16B and 16C (RDX only), some of the furnace test plates failed to meet the treatment criterion.

These failures point to the importance of ramp times and treatment temperature in decontaminating explosives-contaminated materials. In each test load, spiked steel pipe, spiked clay plates, spiked concrete blocks, and five furnace wall plates were treated. Precontaminated debris (metal valving, pieces of clay and metal piping, and chunks of concrete) from the remediation effort were placed with similar items in the furnace. Like the other test runs, five thermocouples were placed throughout the furnace load to track material temperatures during the test runs. The average of the five thermocouples was used to determine when the furnace had reached treatment temperature. When the average thermocouple value, as tracked by the data logger, was equal to 600 $^{\circ}\text{F}$, the soak period started. In the case of a zero soak time, the test run was completed and the furnace burner was shut off. Figures 9-1, 9-2, and 9-3 provide a comparison of metal, clay, and block temperatures at the end of the test ramp to 600 $^{\circ}\text{F}$ and at the end of soak times for tests 7, 9, 14, 15, 16A, and 16B. Tests 7 and 9 were performed with a slow ramp rate of 100 $^{\circ}\text{F}/\text{hr}$ to 600 $^{\circ}\text{F}$ treatment temperature. Tests 14, 15, 16A, and 16B used the fastest ramp rate to 600 $^{\circ}\text{F}$ (i.e., 300 $^{\circ}\text{F}/\text{hr}$); however, tests 16A and 16B did not use a soak period. Tests 14 and 15 ramped at 300 $^{\circ}\text{F}/\text{hr}$ but were maintained at 600 $^{\circ}\text{F}$ for 1 hr before shutting down the furnace burner.

For tests 7, 9, 14, 15, 16A, and 16B, all metal test specimens and furnace wall plates were successfully decontaminated regardless of the original spike contaminant. Figure 9-1 indicates that a common material temperature of 565 $^{\circ}\text{F}$ was reached by the metal specimens in as little as 1 hr and as long as 5 hr and 15 minutes, depending on ramp times and specimen location within the furnace. This figure also illustrates that the time to reach a required temperature for decontamination is not important; however, having the material reach the decontamination temperature is important for complete decontamination to occur.

In the case of spiked clay specimens, Figure 9-2 indicates that a common treatment temperature of 571 $^{\circ}\text{F}$ was reached by the clay specimens in as little as 1 hr and 5 minutes, and as long as 4 hr and 35 minutes, depending on ramp times and location within the furnace. Like Figure 9-1, this figure illustrates that the time to reach the decontamination temperature is not as important as the ability of the contaminated material to reach that temperature. The clay specimen failure indicated in Table 9-3 for test run 16B occurred because of a concentration of 0.6 μg 1,3,5-TNT.

Figure 9-3 was prepared for the block specimens treated in test runs 7, 9, 14, 15, 16A, and 16B. In tests 16A and 16B, the HGD process failed to treat block specimens contaminated with TNT and tetryl. Figure 9-3 shows that the concrete block in test run 16A never reached 400 $^{\circ}\text{F}$ and block in test run 16B barely reached an average temperature of 450 $^{\circ}\text{F}$. As noted in Table 9-3, these tests failed to decontaminate the spiked block. For test runs 7, 9, 14, and 15, however,

Figure 9-1 STEEL MATERIAL TEMPERATURE

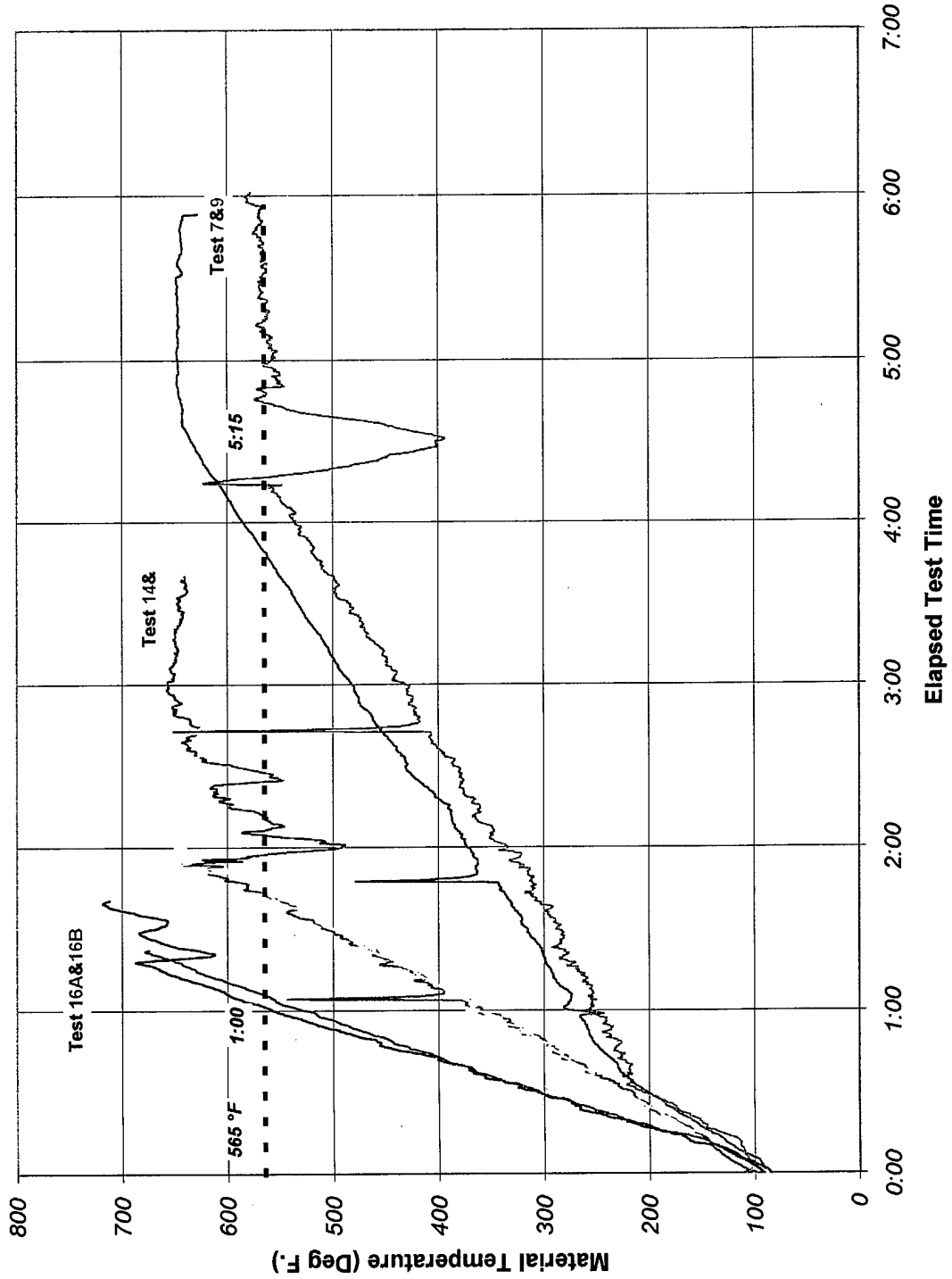

Figure 9-2 CLAY MATERIAL TEMPERATURE

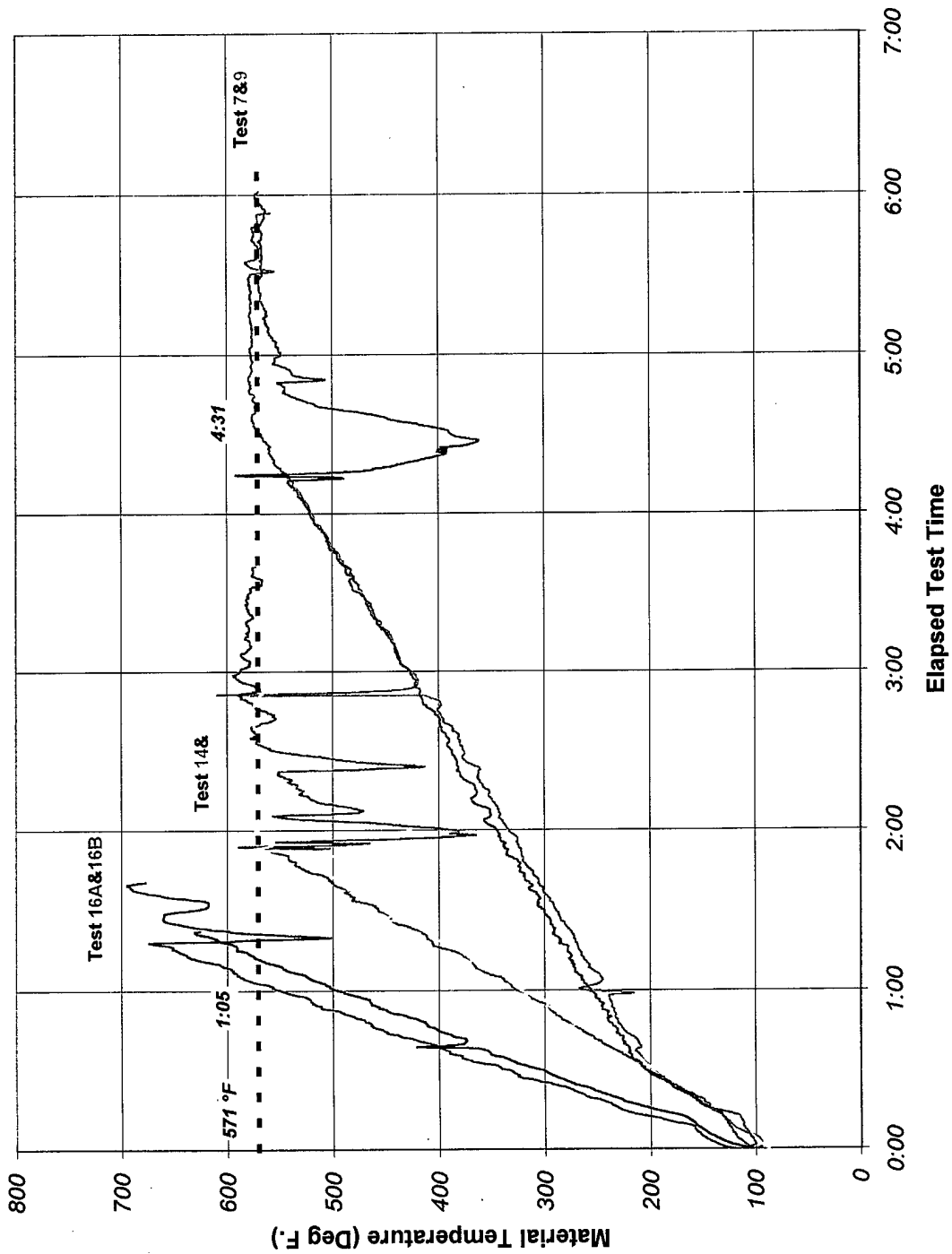

Figure 9-3 CONCRETE MATERIAL TEMPERATURE

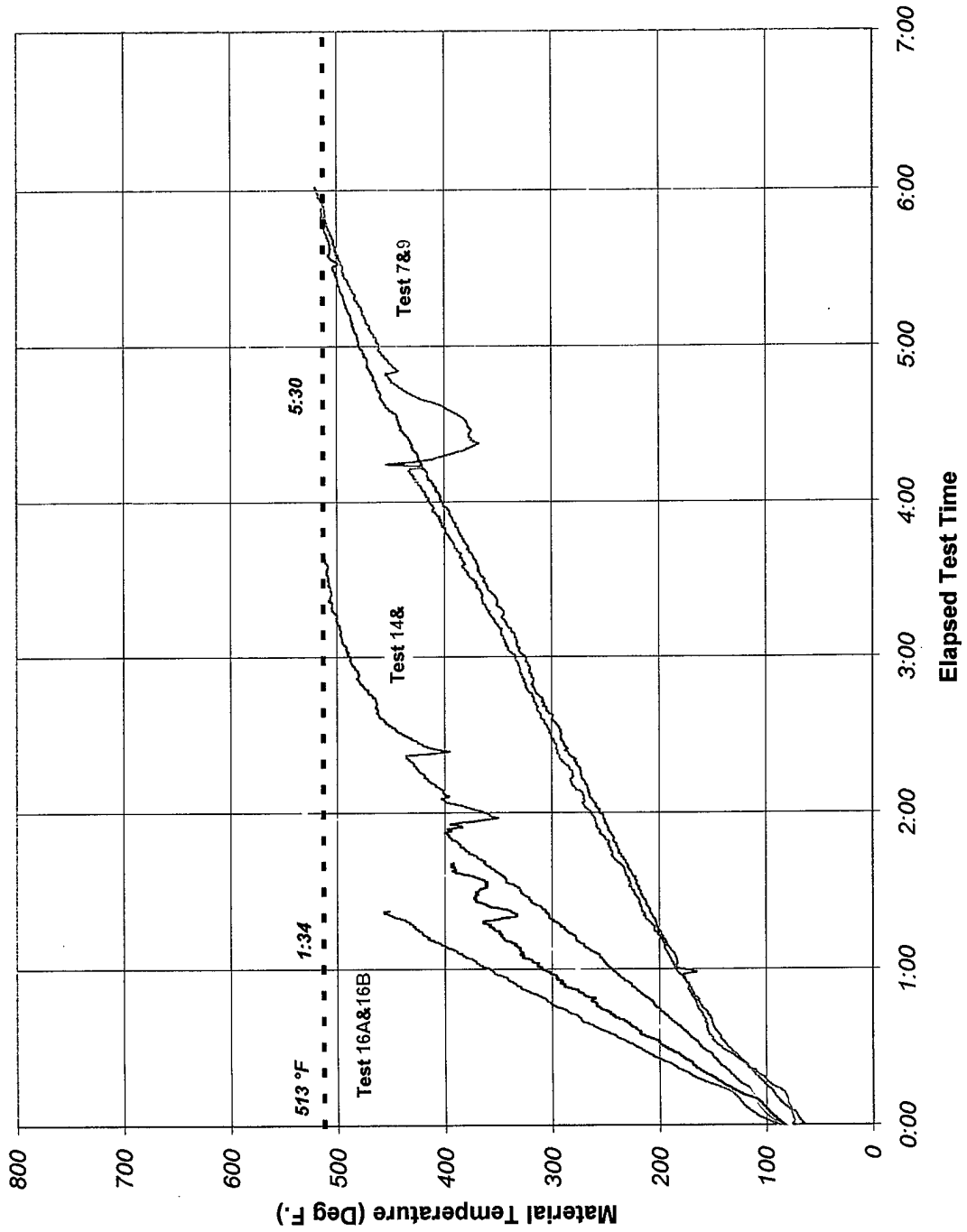

Figure 9-3 shows the average material temperature did reach at least 500 °F before the test was ended and all spiked materials were successfully decontaminated.

Based on the information provided in this figure, one can conclude that contaminated materials in test runs 16A and 16B could have passed the Level 3 criterion if the test runs had used a soak period, slower ramp to 600 °F, or a combination of both.

From the graphs presented in Figures 9-1, 9-2, and 9-3, the evidence indicates contaminated materials that are allowed, by virtue of ramp to treatment temperature and soak at treatment, to reach temperatures between 500 °F and 565 °F, are able to successfully pass the Level 3 criterion. In other words, post-treatment sampling of these materials indicates complete decontamination of TNT, RDX, and tetryl and their breakdown compounds. An examination of the same data for the lower temperature test runs indicates that contaminated materials that do not reach at least 500 °F do not meet the criterion for complete decontamination.

These figures seem to indicate that soak and ramp are unimportant as long as the contaminated load is able to achieve the minimum required temperature for complete decontamination during the furnace run. However, from an operational standpoint, WESTON found that 300 °F/hr ramps were too fast. With a 300 °F/hour ramp, the furnace chamber temperature reaches treatment temperature (600 °F) much sooner than the load temperature reaches treatment temperature; therefore, the furnace burner over-fires during the lag period needed for the material load temperature to catch up to the furnace chamber temperature. Therefore, a 250 °F/hr ramp to treatment temperature is more desirable, and allows better process control of the furnace burner. Finally, Figures 9-1, 9-2, and 9-3 illustrate the inherent disadvantages to processing materials having distinctly different material types in the same furnace load. For instance, if only metal were processed in a batch load instead of metal and block, the temperature differential problems highlighted in Figures 9-1 through 9-3 could be avoided.

9.5 TRENDS OBSERVED THROUGHOUT VALIDATION TESTING

Throughout testing, regardless of test conditions, TNT was the most difficult explosives compound and RDX the easiest compound to decontaminate. Test 2 was conducted at 300 °F to define a temperature that **did not** successfully treat RDX.

Nonporous materials (metal) were easier to decontaminate than porous materials such as clay or concrete block; however, once materials reached treatment temperatures of at least 500 °F, the likelihood of successful decontamination was excellent.

A review of post-treatment sampling results indicates that many of the residual contamination levels that caused specimens and wall plates to fail the Level 3

criterion are quite small. However, the question becomes: "Are the residual levels low enough to pass standard accepted treatment criteria for explosives?"

To provide a comparison of the residual contamination levels found during validation testing to an accepted treatment criterion, WESTON converted the residual levels of contaminants found on the post-treatment wipes and ground samples to a concentration ($\mu\text{g/g}$ for ground samples and $\mu\text{g/in.}^2$ for wipe samples). The resultant concentrations were graphed against the pretreatment concentration of spike explosives and then compared against a 99.99% removal requirement (see Figures 9-4 and 9-5). In the case of the solid samples (concrete block, clay, and contaminated debris), the final concentration was also compared against a 1-ppm treatment criterion for explosives, which WESTON was required to meet prior to backfilling explosives-contaminated soils at ALAAP. Figure 9-4 illustrates that all wipe samples, except for those taken following test 3 (which was conducted at 300 °F), are able to successfully pass the 99.99% removal criterion. Figure 9-5 indicates that all but one of the solid samples that passed the 99.99% removal criterion were able to pass the 1-ppm backfill criterion. The solid samples that did not meet the 99.99% removal criterion had not reached temperatures sufficiently hot enough (at least 500 °F) to completely decontaminate the spike explosives.

9.6 RECOMMENDED TREATMENT TIME AND TEMPERATURE

After reviewing the post-treatment sampling results with USAEC, it was determined that the optimal conditions necessary to ensure complete decontamination of explosives-contaminated materials placed in the transportable HGD system would be a **250 °F/hr ramp to a 600 °F treatment temperature for a 1-hr soak**. This set of conditions has been proven to decontaminate furnace loads containing metal and clay piping, concrete block, and contaminated debris containing no more than 1 lb. TNT, RDX, and tetryl combined.

The efficiency of all thermal processes will vary, depending on the contaminant to be treated, material loading, contaminant type, and local regulatory requirements for cleanup. A close examination of the data gathered during validation testing with the HGD system at ALAAP indicates that successful decontamination of TNT, RDX, and tetryl was achieved at operating temperatures that are much lower than the optimal conditions selected for the decontamination of a furnace load containing a variety of material types and contaminants. Therefore, it is strongly recommended that future users of the transportable HGD system conduct a treatability study on their specific wastes and contaminants of concern to verify that the treatment temperatures, soak and ramp times, and general system operating conditions (e.g., interlocks and alarm points) defined by these validation tests are adequate for decontamination.

9.7 NO_x EMISSIONS TRENDS IN THE INTERCONNECTION DUCT

During earlier HGD studies, high-level intermittent NO_x spikes had been observed at the stack. The spikes were of short duration (1 to 2 seconds) and occurred once

Figure 9-4 POST TREATMENT EXPLOSIVES RESIDUAL ANALYSIS (WIPE SAMPLES)

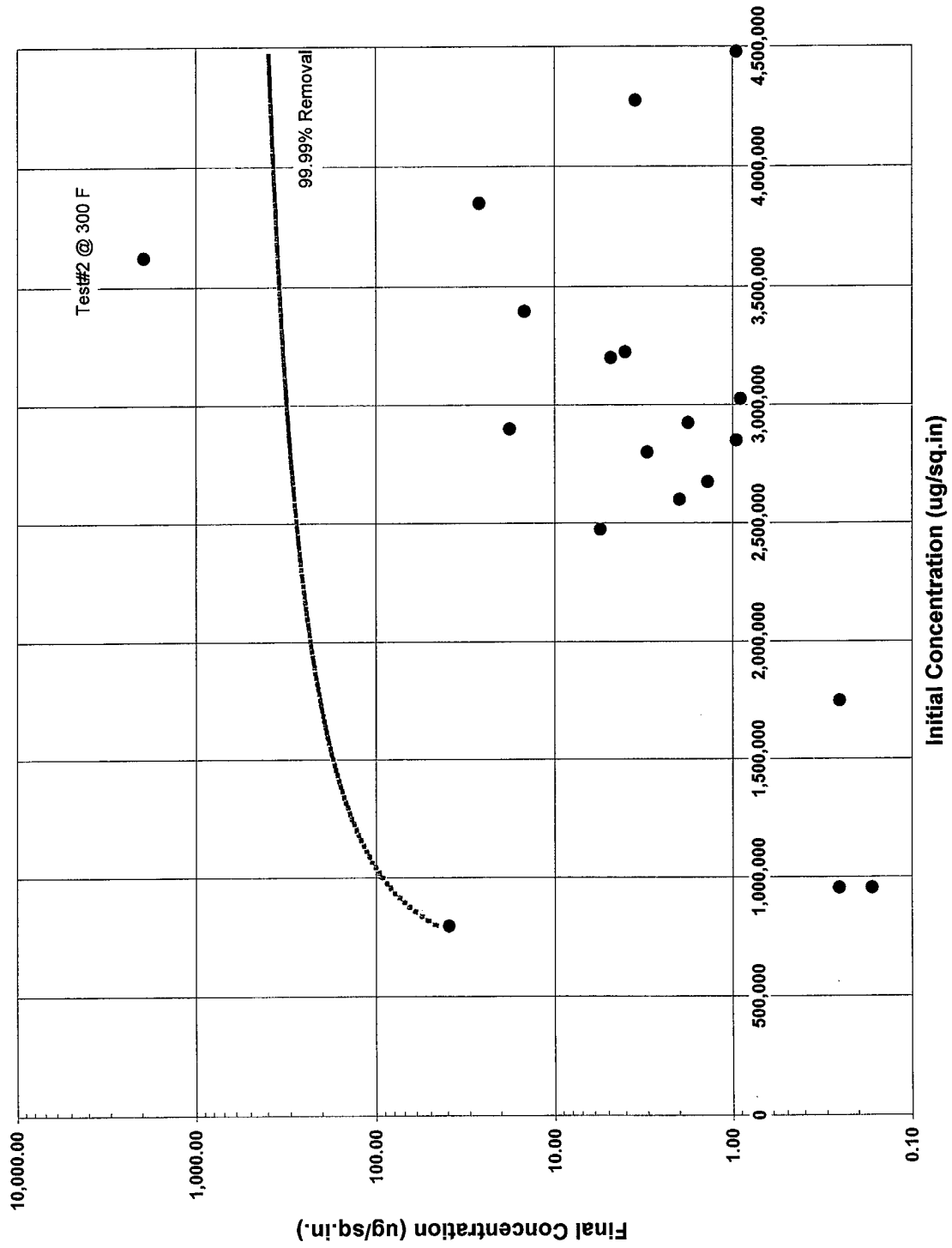
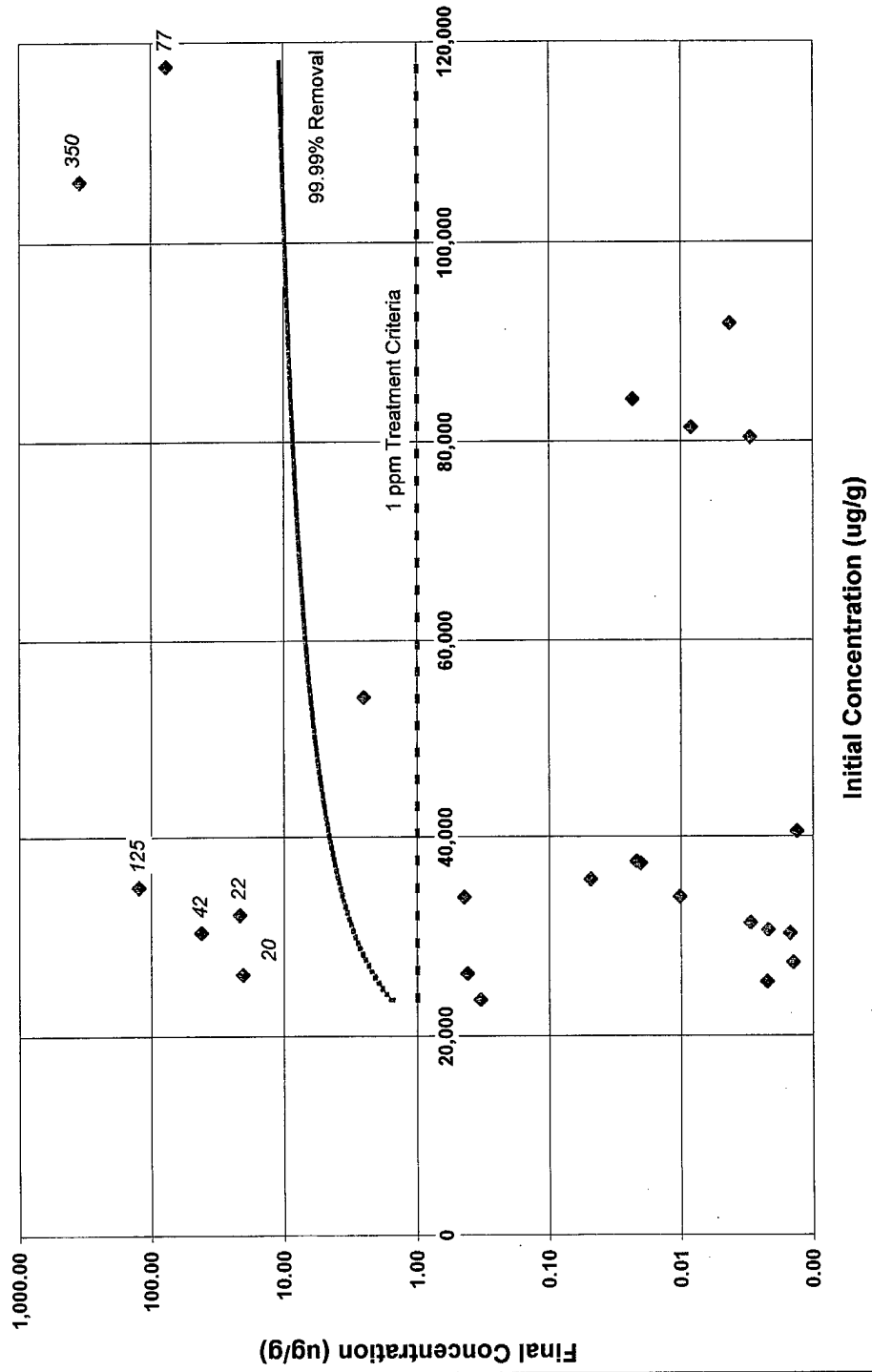

Figure 9-5 POST TREATMENT EXPLOSIVES RESIDUAL ANALYSIS (SOLID SAMPLES)



or twice during the entire length of a furnace run. Because the explosives that would be treated by the transportable HGD system were nitrogen-based, the phenomenon seemed worth investigating. To verify the spiking NO_x was indeed real, a second CEM probe, separate from the stack probe, was installed in the interconnection duct between the furnace exit and thermal oxidizer inlet. The data gathered by the CEM system were sent to the control area datalog and displayed on the system's real-time trending screen. A copy of the NO_x trends at the furnace exit for each test run is provided in Appendix L of this test report.

Once a furnace run started it did not take long before the CEM data collected from the interconnection duct probe showed increased NO_x activity well above baseline levels. This activity would begin at approximately 300 °F, during the ramp period, and continue until the average material load reached about 400 °F. After this point the NO_x would return to baseline. This same trend was not seen at the stack. NO_x measured at the stack indicated NO_x concentrations rise during thermal oxidizer startup, as expected, and then level off during furnace ramp and soak periods. As expected, NO_x at the stack tapers off during cooldown. This clearly shows that stack NO_x was a direct result of propane combustion and the high temperatures at the thermal oxidizer exit. Closer inspection of the NO_x data from all the validation test runs indicates that NO_x levels at the furnace exit are essentially at nondetect levels, except during pre- and post-ramp periods and stack NO_x seemed to directly correlate to the thermal oxidizer and not decontamination activities in the furnace. The increased NO_x activity at the furnace exit during ramp periods seems to be an indication of bulk decontamination taking place; however, there are no data from this test program to support this theory.

9.8 ASBESTOS-CONTAMINATED MATERIALS

In the process of decommissioning explosives manufacturing facilities, the Army encounters many buildings that have been constructed using transite siding or contain asbestos-insulated piping, and much of this asbestos-containing material is also explosives-contaminated. Therefore, one of the final objectives of the validation test was to place asbestos-containing materials into the HGD furnace and evaluate the effect of processing on the asbestos-contaminated materials.

There was a concern that the asbestos-containing materials would break down and become friable as a result of treatment. Transite siding was obtained from the ongoing remediation activities at ALAAP. On 11 March 1996, approximately 1 lb. of asbestos-containing transite siding was placed in the HGD furnace. No other materials were placed in the furnace with the transite. The HGD furnace was operated with a 300 °F/hr ramp, a treatment temperature of 600 °F, and a 2-hr soak at 600 °F prior to shutting down the furnace.

Once the system cooled, the furnace door was opened and the processed transite was visually inspected to identify its condition. The operators donned air sampling cartridges during all handling procedures to determine if any asbestos had become airborne during processing or final handling. The visual inspection of the transite indicated no noticeable effect on the transite. The asbestos contained in the transite had not become friable, and the siding itself was intact and showed no signs of

structural breakdown. The results of the personal air monitoring indicated fiber counts less than detection limits for two samples. One sample had a fiber count of 0.005 fibers/cc versus the detection limit of 0.003 fibers/cc.

Based on these limited data, it appears that explosives-contaminated transite could be processed by the HGD process, without concern that the material would become friable during processing. However, additional studies to evaluate the effects of the HGD process with different types of asbestos-containing materials, such as asbestos-containing pipe insulation, and longer soak times at treatment temperatures is strongly recommended.

10. SYSTEM COST

The total costs associated with the transportable HGD system can be broken down into the following cost items, and are further detailed in Subsections 10.1 through 10.3:

- Capital equipment costs.
- Installation and startup costs.
- Operating costs.

10.1 CAPITAL EQUIPMENT COSTS

All capital equipment costs provided in this subsection are based on the skid-mounted, transportable HGD system that was procured for USAEC in fiscal 1995. All instrumentation and electrical systems supplied with the transportable HGD equipment were capable of remote and local operations, and qualified to operate in National Electrical Code (NEC) and NFPA Class 1, Division 2, Group D environments.

Furnace \$156,000

Includes furnace, 1 million Btu/hr gas-fired burner, burner controls, combustion air blower, and local and remote control panels.

Thermal Oxidizer \$180,000

Includes 2.75 million Btu/hr gas-fired thermal oxidizer, stack, air pre-mix system, and local and remote control panels.

Interconnection Duct \$5,500

Includes materials and fabrication costs.

I.D. Fan \$9,000

Centrifugal-type rated for 2,250 cfm at 650 °F (700 °F maximum operating temperature) remote-controlled variable frequency drive.

Miscellaneous Equipment \$35,000

Power and instrument cables, computers, software, treatment racks, uninterruptable power supply.

Continuous Emission Monitoring System (Optional) \$286,000

Extractive-type, redundant system for monitoring O₂, CO, CO₂, THC, SO₂, and NO_x. System meets 40 CFR 60, Appendix A and B requirements.

Control Trailer (Optional) \$18,000

8 feet by 40 feet with office space and restroom.

10.2 INSTALLATION AND STARTUP COSTS

Installation costs will vary from site to site and from job to job because of local conditions, labor costs, and equipment transportation costs. Items that should be considered in estimating installation costs are identified in Subsections 10.2.1 through 10.2.4.

10.2.1 Site Preparation

Site preparation costs can be expected to vary, depending on the location and condition of the site to be used. Site preparation items can also have a significant impact on installation costs, especially if a selected site is undeveloped. Site preparation items that may be required prior to mobilization of the HGD equipment to the selected site include the following:

- Site clearing and grubbing.
- Site grading.
- Installation of static control, lightning protection grid, and grounding grid.
- Equipment pad installation.
- Installation of site lighting.
- Installation of an electrical service.
- Installation of telephone service.
- Installation of a fuel source.
- Installation of water service.
- Installation of sanitary sewer system.
- Installation of fire protection.

10.2.2 Transportation and Mobilization to Site

The transportable HGD system is mobilized using three low-boy-style trailers (one each for the furnace, the thermal oxidizer, and the stack and miscellaneous equipment). A low-boy style trailer would be required for either the CEM or the control trailer should they be required to support operations. The skid-mounted equipment can be removed from the trailers, by a crane or heavy forklift, and placed on an equipment pad, as required for operations. A 1-day crane or heavy forklift rental is adequate to support this operation.

10.2.3 System Shakedown and Startup

System shakedown to verify electrical connections, instrument calibrations, and general system operating integrity should be performed prior to actual treatment of contaminated materials by the HGD system equipment. Shakedown operations include:

- Installation of interconnecting instrument and control cabling.
- Instrument calibration and checkouts.
- System functionality testing.

Cost associated with system shakedown and startup is approximately \$18,000 (assuming three people for 10 days).

10.2.4 Procurement and Installation Schedule

A generic project schedule to procure and install a transportable HGD system is illustrated in Figure 10-1. This schedule is based on the actual project schedule to procure and install the transportable HGD system at ALAAP. Please note schedule task durations may vary, depending on project or site-specific requirements.

10.3 OPERATING COSTS

The pricing listed below is based on one transportable HGD system operated at ALAAP between December 1995 and March 1996. Costs are expected to vary from site to site, depending on the costs of labor and utilities and the selected operating conditions. A day assumes 24-hour operation.

Electricity:	\$100/day
Propane:	\$725/day
Propane delivery system equipment (15,000 GWC storage tank):	\$40/day
CEM calibration gases:	\$60/day
Incidentals and miscellaneous parts:	\$60/day
Labor (assume 2 workers: 1 operator and 1 shift supervisor):	\$5,200/day

To increase production, additional furnaces can be installed and connected to one common thermal oxidizer, provided the capacity of the thermal oxidizer is adequate. Operation of the multiple furnace arrangement would be staggered so that as one furnace is heating up and operating, the second furnace would be

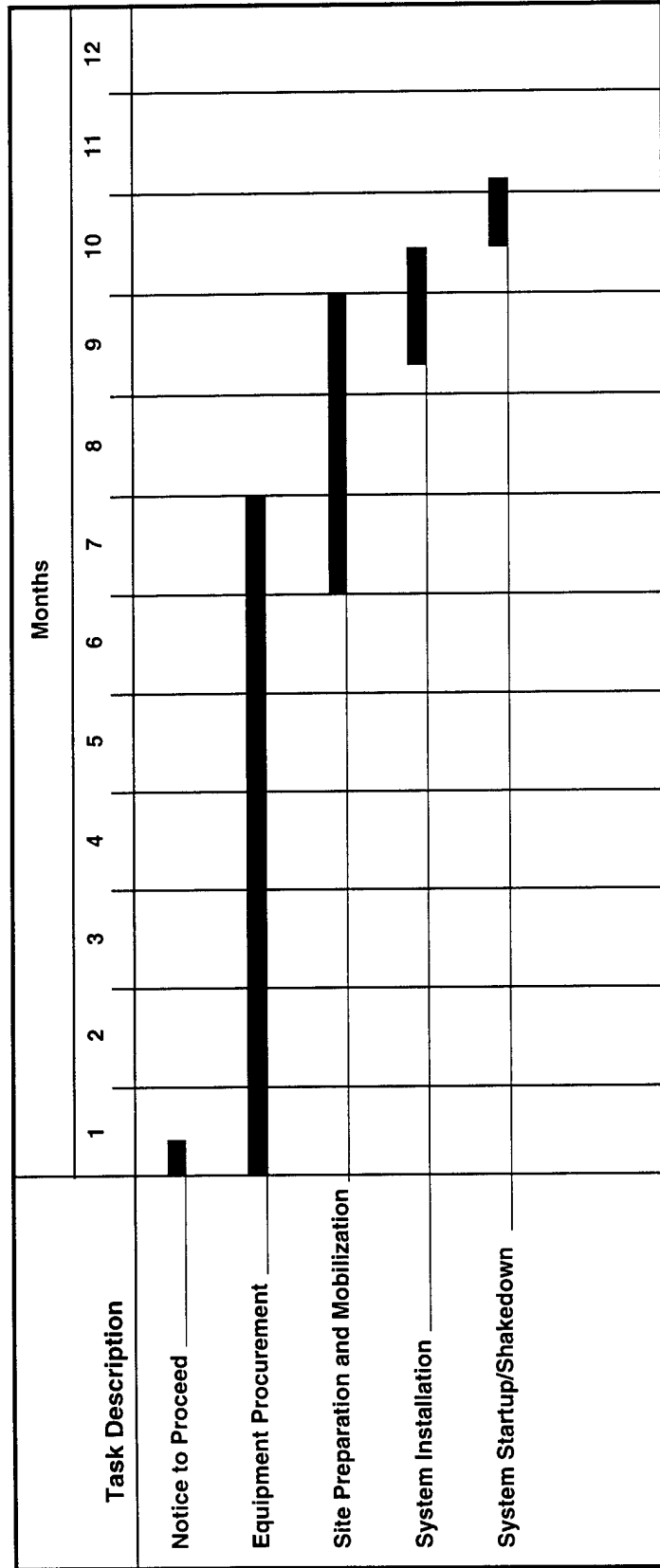

96P-3208-1 9/30/96

FIGURE 10-1 HGD SYSTEM PROJECT SCHEDULE

loaded with the next batch of material to be treated. The estimated incremental increase in operating cost for each additional furnace is as follows:

Electricity:	\$100/day
Propane:	\$725/day
Incidentals and miscellaneous parts:	\$20/day
Labor (assume one more operator for each additional furnace):	\$2,600/day

Note: Additional propane delivery system equipment and CEM calibration gases are not required for each additional furnace installed.

11. RECOMMENDATIONS

11.1 CONCLUSIONS

The validation test program conducted by WESTON at ALAAP was a success. Eighteen test runs were conducted. Each test run processed approximately 3,000 lb of TNT-, RDX-, and tetryl-contaminated metal, clay, and concrete block, as well as contaminated debris from an ongoing remediation project at ALAAP. No more than 1 lb of total explosives was processed in any test run.

11.1.1 Validation Test Results

The validation test program demonstrated the soundness of the transportable HGD equipment design and the efficacy of the HGD process to remove and destroy explosives residues, such as TNT, RDX, and tetryl from metal, clay, and concrete materials and debris. Results of the validation test program indicate the following:

- The optimum operating conditions for achieving complete removal of TNT, RDX, tetryl, and their breakdown constituents to levels below method detection levels are:
 - 250 °F/hr ramp rate to treatment temperature.
 - 600 °F treatment temperature.
 - 1-hour soak at treatment temperature.
- The bulk of explosives decontamination seems to occur during the furnace ramp period, as indicated by NO_x levels monitored in the interconnection duct between the furnace exit and thermal oxidizer inlet. Sampling conducted for explosives at the furnace exit during the soak periods associated with tests 1, 2, and 3 detected small quantities of explosives during the soak periods.
- Post-treatment sampling and analysis consistently indicated removal efficiencies for TNT, RDX, and tetryl of 99.999%, based on an initial quantity of total explosives contamination.
- The removal efficiency (RE) of the thermal oxidizer ranged from >67.15% to 99.97%. The low REs, however, do not reflect poor oxidizer efficiency. No detectable explosives concentrations were detected at the thermal oxidizer's discharge. These REs reflect the inherent bias in the RE calculation when discharger concentrations are below detection limits.
- The HGD process effectively processes explosives-contaminated debris to microgram quantities or less.

- The transportable HGD process is a controlled and fully instrumented process that has demonstrated its repeatability, test after test.
- Asbestos-containing transite siding did not become friable or show signs of structural breakdown after processing with a 300 °F/hr ramp and a treatment temperature of 600 °F.

11.1.2 Source Emissions Test Results

Stack emission data were collected during validation test runs 1, 2, and 3. Continuous Emissions Monitoring (CEM) data were collected during all test runs. Emissions results are summarized in Table 11-1 and in the following statements:

- No detectable explosives contamination was determined to be present in the thermal oxidizer's discharge stream.
- Sampling and analysis of volatile and semivolatile organic compounds (VOCs and SVOCs) was conducted to identify Products of Incomplete Combustion (PICs) and explosives breakdown compounds. Results indicate the following:
 - Only acetone, which was used to make the explosives-spike mixtures, was found in significant quantities.
 - Samples were analyzed for SVOC Target Compound List (TCL) compounds; however, only nontarget SVOCs were identified.

11.1.3 Continuous Emissions Monitoring Results

- Total hydrocarbons, sulfur dioxide, nitrous oxides, carbon monoxide, and carbon dioxide emissions, measured by the CEM system, were significantly below the limits usually associated with permitting.
- NO_x levels monitored in the furnace exit gas duct (thermal oxidizer inlet) indicated increased NO_x activity during ramp-up periods and a return to baseline NO_x levels after the furnace chamber temperature reached approximately 400 °F.
- NO_x emissions at the stack are slightly higher than expected, and are suspected to be a result of propane combustion and the high operating temperature (approximately 1,800 °F) of the thermal oxidizer.

Table 11-1

Transportable HGD System Equipment Emissions Results

Hazardous Air Pollutant	Existing Standard (as of June 1996)	Test Run Average
Total hydrocarbons (ppm/v)	12	<1.0
Carbon monoxide (ppm/v)	100	<1.0
Sulfur dioxide (ppm/v)	30	0.69
Nitrous oxides (ppm/v)	180	52.78
Particulate (gr/dscf at 7% O ₂)	<0.08	0.0004
Hexavalent chromium (µg/dscm)	NA	12.18
Low volatility metals (µg/dscm) (antimony, arsenic, beryllium, chromium)	210 (currently) 62 (proposed)	15.03
Semivolatile metals (µg/dscm) (lead and cadmium)	270 (currently) 62 (proposed)	2.33
Hydrochloric acid, HCl (lb/hr)	4.0	1.56 x 10 ⁻³
Chlorine, Cl ₂ (ppm/v)	NA	0.08
Total HCl and Cl ₂ (ppm/v)	280 (currently) 67 (proposed)	0.36
Mercury (µg/dscm)	50	0.04
Dioxins/furans (ng TEQ/dscm)	0.2	0.03

Notes:

lb/hr - pounds/hour.

ppm/v - parts per million per volume.

gr/dscf - grains per dry standard cubic foot.

µg/dscm - micrograms per dry standard cubic meter.

ng TEQ/dscm - nanograms toxic equivalents per dry standard cubic meter.

NA - not applicable.

11.1.4 Regulatory Approval Requirements

Future users of the transportable HGD system should expect to apply for an operating permit, granted by federal and state regulatory agencies, prior to starting HGD operations at their facility. Federal and state regulatory agencies should be contacted to verify permit/approval requirements prior to equipment mobilization. Based on WESTON's experience, requirements for approval will depend primarily on the following:

- Classification of the site with regard to the Comprehensive Environmental Response, Compensation, and Liability Act (CERCLA).
- The type of contaminants to be treated (RCRA, TSCA, or nonhazardous).
- Levels of contaminants (high concentrations of contaminants may trigger air emissions limitations, which vary throughout the country).

Anticipated permit/approval requirements, in relation to waste type, are presented in Table 11-2.

Table 11-2

Permit/Approval Requirements

Type of Waste	CERCLA Site	Non-CERCLA Site
RCRA	Part B Permit	Part B Substantive Technical Information Requirements
	State Air Permit	State Air Permit Substantive Technical Information Requirements
TSCA	TSCA Permit	TSCA Permit Substantive Technical Information Requirements
	State Air Permit	State Air Permit Substantive Technical Information Requirements
Nonhazardous	State Air Permit	State Air Permit Substantive Technical Information Requirements

11.2 RECOMMENDATIONS

Over the life of the validation test program at ALAAP, a number of observations were made regarding future operations and testing of the transportable HGD equipment. Those observations and associated recommendations are as follows:

1. NO_x levels measured at the furnace exit indicated an increase in NO_x above baseline during the ramp-up periods for each validation test run. Once the ramp period was completed, increased NO_x activities steadied and levels returned to baseline. Based on this observation, WESTON recommends

- conducting additional testing to determine whether NO_x levels at the furnace exit can be used as an indicator of completed decontamination.
2. Test runs 1, 2, and 3 used 50 °F/hr ramps and soak times in excess of 4 hr, thereby resulting in total test times of 21.1, 11.3, and 14.5 hr long, respectively. Stack testing did not begin until furnace temperatures were equal to 250 °F, and initial explosives-spike quantities were sufficiently small to limit the ability to demonstrate >99.99% RE consistently. As a result of these facts, actual system REs could not be calculated. Future emissions testing should be conducted to determine the actual RE for the thermal oxidizer.
 3. If test items or contaminants to be treated during future operations are significantly different from those treated during this validation test, further testing (sampling and analysis) should be conducted to verify optimum operating conditions.
 4. If explosives or propellant compounds other than TNT, RDX, or tetryl are to be treated by the HGD system, additional source emissions testing should be conducted to determine the associated REs.
 5. Several indications of flashing, melting, or boiling events occurring in the furnace chamber during processing were observed by the equipment operators during post-treatment sampling. Although post-treatment analysis can confirm decontamination, there is currently no way to observe the actual decontamination process. A remote-controlled, water-cooled camera installed inside the furnace chamber would allow the equipment operators to observe the decontamination process as it is occurring.
 6. Validation testing at ALAAP limited the total explosives load to 1 pound. This quantity was artificially selected to ensure both operator safety and equipment integrity. Before validation testing began, it was thought that system pressures might be affected by the vaporization and/or flashing that occurs during decontamination. System pressures, however, remained constant throughout processing, despite evidence that flashing or boiling might have occurred. Although the maximum load of 3,000 lb cannot be increased because of furnace design limitations, it is strongly suggested that USAEC define the explosives load for this HGD system. Additional explosives loading would also support future RE calculations.
 7. During the course of conducting this treatability study, WESTON has received several inquiries from government agencies interested in using HGD for treating contaminants other than explosives; i.e., propellants and PCBs. For this reason, WESTON suggests that USAEC consider testing to investigate the effectiveness of the HGD technology on other contaminants such as propellants and PCBs.