

UNCLASSIFIED

MTA-50

Subject Category: INSTRUMENTATION

UNITED STATES ATOMIC ENERGY COMMISSION

A SPOT-SENSITIVE HIGH ENERGY BEAM
MONITOR

By
S. Siegel

DTIC QUALITY INSPECTED R

May 7, 1953

Livermore Research Laboratory
California Research and Development Company
Livermore, California

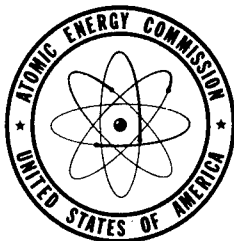

Technical Information Service, Oak Ridge, Tennessee

19961016 344

UNCLASSIFIED

DISTRIBUTION STATEMENT B

Approved for public release
Distribution Unlimited

Date Declassified: December 6, 1955.

This report was prepared as a scientific account of Government-sponsored work. Neither the United States, nor the Commission, nor any person acting on behalf of the Commission makes any warranty or representation, express or implied, with respect to the accuracy, completeness, or usefulness of the information contained in this report, or that the use of any information, apparatus, method, or process disclosed in this report may not infringe privately owned rights. The Commission assumes no liability with respect to the use of, or from damages resulting from the use of, any information, apparatus, method, or process disclosed in this report.

This report has been reproduced directly from the best available copy.

Issuance of this document does not constitute authority for declassification of classified material of the same or similar content and title by the same authors.

Printed in USA, Price 20 cents. Available from the Office of Technical Services, Department of Commerce, Washington 25, D. C.

A SPOT-SENSITIVE HIGH ENERGY BEAM MONITOR

By

S. Siegel

May 7, 1953

LIVERMORE RESEARCH LABORATORY

OF THE U. S. ATOMIC ENERGY COMMISSION

OPERATED BY

CALIFORNIA RESEARCH & DEVELOPMENT COMPANY

LIVERMORE, CALIFORNIA

CONTRACT NO. AT(11-1)-74

ABSTRACT

An instrument is described which can be used to measure the beam intensity (current per unit area) at different points within a large high energy nuclear beam. A small collimated portion of the beam is allowed to impinge on the end of a heat conducting rod and the thermal gradient measured along this rod is proportional to the entering current. Measurements can be made over areas as small as a one sixteenth of an inch diameter circular hole.

The instrument was tested in the experimental ion source at Livermore using a 50 kilovolt proton beam. Beam profiles are given for 120 and 85 milliamper beams.

A more efficient design is also described which may be used to determine beam profiles in the Mark I linear accelerator, and other high energy machines.

A SPOT-SENSITIVE HIGH ENERGY BEAM MONITOR

INTRODUCTION

Considerable work has been done in the development of instruments and equipment for quantitatively measuring high energy, charged particle beams. At the present time, three important methods have found wide usage. One method allows the beam to pass through a thin foil or a wire grid and the induced radioactivity in the foil or grid is an index of the total beam current. In this type of experiment, it is possible to cut up the radioactive foil into regular sections and monitor each section individually. From these measurements, a curve showing the beam intensity at any given position can be drawn. A second approach utilizes a collector plate to completely stop the beam and then the electrical current is measured with an ammeter placed between the collector plate and ground. In a third method, the total power of the beam is measured by stopping it in a water cooled target and then measuring the differential temperature between inlet and outlet water and also measuring the flow rate of the water. The beam current can then be calculated by dividing the total power dissipated in the water by the voltage of the beam particles.

Each method discussed has demonstrated considerable merit and one type of measurement may be more useful in one application than another. However, there is also an inherent inaccuracy, functional restriction or limitation in applicability in the use of each method. In the measurement of electrical charge, the accuracy is seriously limited by secondary electron emission from the collector plate and ionization of the surrounding atmosphere if the collector plate is not maintained in vacuo. The radioactivation technique offers good accuracy but the interpretation of the data takes time and it is not possible to get instantaneous readings during the course of the exposure. The third method has poor sensitivity (i. e. a small change in the differential temperature of the inlet and outlet water is equivalent to a significant change in the beam current). Furthermore, only the total current can be measured in this manner; it is not possible to get a beam profile. In the last two methods, insertion of test samples made of electrically insulating material or of other target equipment, makes interpretation of the measurement difficult or impossible.

At the present time, another method is being developed at the California Research & Development Company in which the beam is passed through a toroid coil. The current induced in the coil is proportional to the

total beam current. However, the necessary integrating circuits have not yet been satisfactorily developed and the toroid is not able to distinguish between beam particles and secondary charges going in the opposite direction.

In the MTA project, a need has arisen for an instrument which can provide instantaneous accurate measurements of beam flux and which can be used in conjunction with other target assemblies and test samples of all types of materials. This instrument would be used in measuring radiation dosage rate and integrated exposure of radiation received by test specimens which will be exposed in the beam of the Mark I accelerator at Livermore for determining radiation effects on materials properties. Such an instrument could be used in determining the profile of any nuclear beam but it will be particularly useful in this accelerator because of the unusually large beam diameter and because of the large difference between peak current intensity and average current intensity.

This report describes an instrument which may find such universal application. The principle used by this device is simple and the design was suggested by similar work carried out at the NEPA Project in 1951.

DESIGN AND OPERATING CHARACTERISTICS

The beam monitor (see Figure 1) consists of a graphite plate which permits selection of a small collimated portion of the beam. This portion impinges on one end of the heat conductor. The energy generated there is conducted to the water-cooled chamber below. By measuring the thermal gradient along a known length of the heat conductor and knowing its diameter and thermal conductivity, the total flow of heat energy which is equal to the product of the beam current and the energy of the particles can be calculated. The beam energy of high energy accelerators is usually known with good accuracy, so that the current can be calculated directly. By varying the position of the instrument within the beam, the beam intensity can be obtained at different points. The dimensions of the conductor, the material of which it is made and the size of the beam collimating slot can all be adjusted so that the thermal gradient produced is large enough to be read with sufficient accuracy and still not approach temperatures high enough for radiation losses from the heat conductor to be significant. The sensitive element of this instrument is surrounded by a chamber containing circulating cooling water to make the walls more efficient in absorbing spurious radiations.

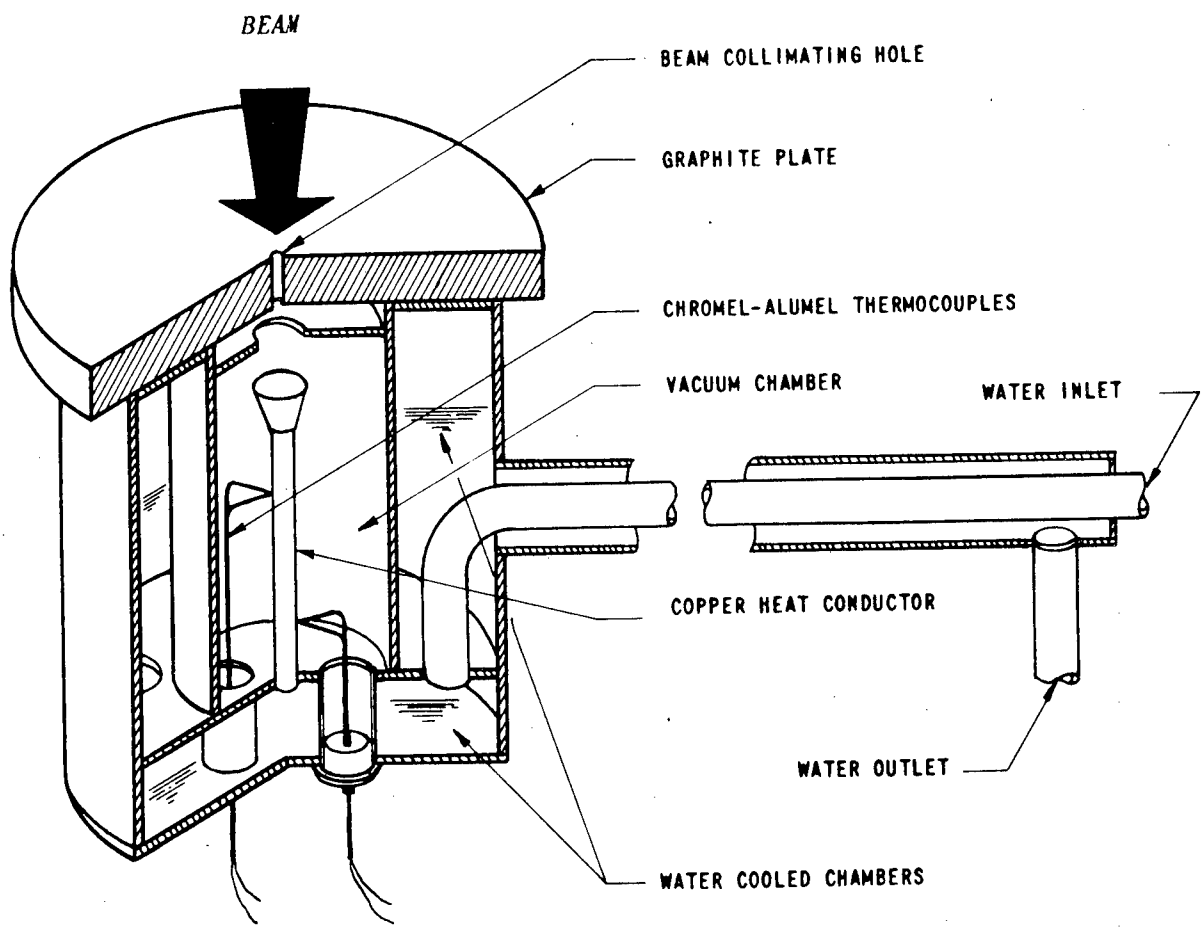

FIGURE 1
SPOT SENSITIVE BEAM MONITOR
(Design for Preliminary Test)

In order to obtain maximum sensitivity and maximum accuracy with the use of this instrument, it is necessary to have some previous information about the size and intensity of the beam to be measured. With this information, the size of the beam collimating hole can be reduced so that (1) the resolution of the instrument is high (2) the temperature of the heat conductor does not rise to a level where radiation losses are significant and (3) the head of the heat conductor is not melted. However, the size of this hole must be large enough so that sufficient heat will be generated in the heat conductor to obtain thermal electro-motive forces from the two thermocouples which are large enough to be measured with sufficient accuracy. Chromel-alumel thermocouples were used in the first experiments; however copper-constantan couples will be used in the later designs because of their better characteristics at the operating temperatures.

The first instrument was designed for measuring the beam of the experimental ion source at CR&D in Livermore. The characteristics of this beam were given as follows: approximately four inches in diameter, up to 400 milliamperes of total current and as high as 80 kilovolts of beam energy. Arbitrarily assuming 10:1 as the ratio of peak current intensity to average current intensity, the maximum power flux, ϕ , is calculated.

$$\phi = \frac{80,000 \text{ (volts)} \times 0.4 \text{ (amperes)}}{\pi(2)^2} \times 10 = 25 \text{ kw/in}^2 \quad (1)$$

This flux was too high for the instrument of simplest design so that the initial experiments were run with a 50 kilovolt beam and current of 85 and 120 milliamperes. Under these conditions, the maximum power flux is

$$\phi = \frac{50,000 \times .12}{\pi(2)^2} \times 10 = 4.75 \text{ kw/in}^2 \quad (2)$$

A 1/16 inch diameter collimating hole was considered capable of providing adequate resolution and the maximum power through this hole is

$$q = 4.75 \text{ kw/in}^2 \times \pi (1/32)^2 \text{ in}^2 = 15 \text{ watts} \quad (3)$$

The temperature gradient between the two thermocouples approximately 0.6 inches apart, along the copper rod 1/8 inch in diameter, is obtained from the conventional equation for heat conduction:

$$\Delta T = \frac{q l}{k A} = \frac{15 (.239) \times .6 (2.54)}{92 \times \frac{\pi (2.54)^2}{(16)^2}} = 75^{\circ}\text{C} \quad (4)$$

A similar calculation shows the temperature of the end of the rod, neglecting the local heating effects of the beam, to be 200°C above the temperature of the cooling water. This maximum temperature is appreciably lower than the temperature at which radiation losses from the heat conductor become significant but allowance must be made for the additional increase in temperature arising from heat radiated to the copper heat conductor by the graphite plate. In actual operation, the temperature of this plate approached 1000°C. A special experiment was performed to evaluate the heat contribution from this source. In a subsequent design (see Figure 3) the sensitive element is more effectively shielded from the graphite plate by a water-cooled chamber. This reduces the radiation received from the graphite plate resulting in less correction for this factor and undoubtedly greater overall accuracy of the instrument.

EXPERIMENTAL WORK

After checking the instrument for water-tightness and vacuum tightness, it was assembled with a Wilson seal on a mounting flange. The Wilson seal supports the instrument by the 1/2 inch diameter water-cooled tubing and allows the apparatus to be moved inward and outward along the axis of the tubing. This permitted making a traverse of the beam. The assembly was mounted on the experimental ion source, the water connections were made and the thermocouple wires were connected to a Leeds and Northrup potentiometer, Model Number 8662, after passing through electrically insulating vacuum seals in the flange. A stable 50 kilovolt beam was obtained and the experiment was begun with the beam monitor in the completely withdrawn position. Measurements of position were obtained visually by reading a scale mounted on the sliding water-cooled tubing. In order to permit calculations of the radiant heat absorbed by the heat conductor from the graphite plate, the average temperature of latter was measured with a Leeds and Northrup optical pyrometer, Catalog Number 8622-C. Subsequently, a similar experiment was performed using a graphite plate with no collimating hole and the temperatures of the thermocouples were observed for particular temperatures of the graphite plate. From these measurements, the contribution of heat by radiation from the graphite was determined.

The beam monitor was inserted toward the center of the beam in increments of 0.5 inches and later in increments of 0.25 inches. In each position, the output of the thermocouples was read frequently until thermal equilibrium between the heat conductor and its environment was established. Only the readings at equilibrium conditions are recorded. A total of three runs was made, all at different levels of total beam current. In the first two runs, the instrument was inserted up to the approximate center line of the beams; in the third run, it was passed entirely through the beam in order to obtain a complete profile. Unfortunately, the operation of the beam on the day this last experiment was done was unstable and the measurements obtained were unreliable and therefore are not shown. During this last experiment, the water-cooled tubing was protected from the direct beam by a length of graphite plate fastened to it.

In Tables 1 and 2 are listed the temperatures of the thermocouples during the actual runs, the temperature rises measured with the solid graphite plate, the corrected temperature gradient across the two thermocouples, the calculated heat flow and the beam intensity in milliamperes per square centimeter. The corrected temperature gradient was obtained by subtracting the differences between initially measured temperature and δT , the temperature rise during the "blank" run, of T. C. #2 from similar differences of T. C. #1. This calculation assumes (1) that the thermal conductivity does not change significantly over the temperature range of the two readings and (2) that the millivolt output in this range is linear with respect to temperature. These are well within reasonable error.

The precision of the final results was affected to some degree by the relative inaccuracy of the pyrometer readings. These readings could not be improved because of random discolorations in the plate glass window through which the measurements were made. However, absolute readings of the pyrometer are not essential because only measurements of thermocouple output for given pyrometer readings were compared. In the later design of the monitor, however, the necessary correction factors will be reduced to a minimum by more effective thermal shielding.

DISCUSSION OF RESULTS

The dependence of beam intensity in milliamperes per square centimeter as a function of position in the beam is shown in Figure 2 for the 120 and 85 milliamperere beams. In both cases, the beam was a 50 kilovolt proton beam.

TABLE I

RUN #1 - 120 MILLIAMPERE BEAM

POSITION INCHES	TEMP.	T.C. #1	TEMP.	T.C. #2	CORRECTED ΔT °C	q WATTS	BEAM INTENSITY ma/cm ²
	EXP'T °C	δT (BLANK)* °C	EXP'T °C	δT (BLANK)* °C			
0.0	18	--	18	--	0	0	0
0.5	18	--	18	--	0	0	0
1.0	18	--	18	--	0	0	0
1.5	20	--	18	--	0	0	0
2.0	30	12	20	3	1	0.21	0.212
2.25	39	22	23	10	4	0.84	0.850
2.5	51	25	32	12	6	1.26	1.27
2.75	70	28	38	12	16	3.36	3.40
3.0	85	29	45	13	24	5.05	5.10
3.25	106	32	54	13	33	6.94	7.01
3.5	115	34	61	14	34	7.15	7.23

*IN THIS RUN, NO ACTUAL READINGS OF GRAPHITE TEMPERATURE WERE MADE BUT THE VALUES LISTED WERE OBTAINED BY COMPARING AND INTERPOLATING THE DATA FROM TABLE II.

TABLE II
RUN #2 - 85 MILLIAMPERE BEAM

POSITION INCHES	TEMP.	T.C. #1	TEMP.	T.C. #2	CORRECTED ΔT °C	q WATTS	BEAM INTENSITY ma/cm ²
	EXP'T °C	δT (BLANK) °C	EXP'T °C	δT (BLANK) °C			
0.5	13	--	13	--	0	0	0.000
1.0	16	--	14	--	2	0.42	0.425
1.5	19	4	15	0	0	0.00	0.000
2.0	30	12	20	3	1	0.21	0.212
2.25	39	22	24	10	3	0.63	0.637
2.5	48	25	28	11	6	1.26	1.27
2.75	59	27	33	12	11	2.31	2.34
3.0	73	28	40	12	16	3.36	3.40
3.25	87	29	47	13	24	5.05	5.10
3.5	105	32	55	13	31	6.52	6.59

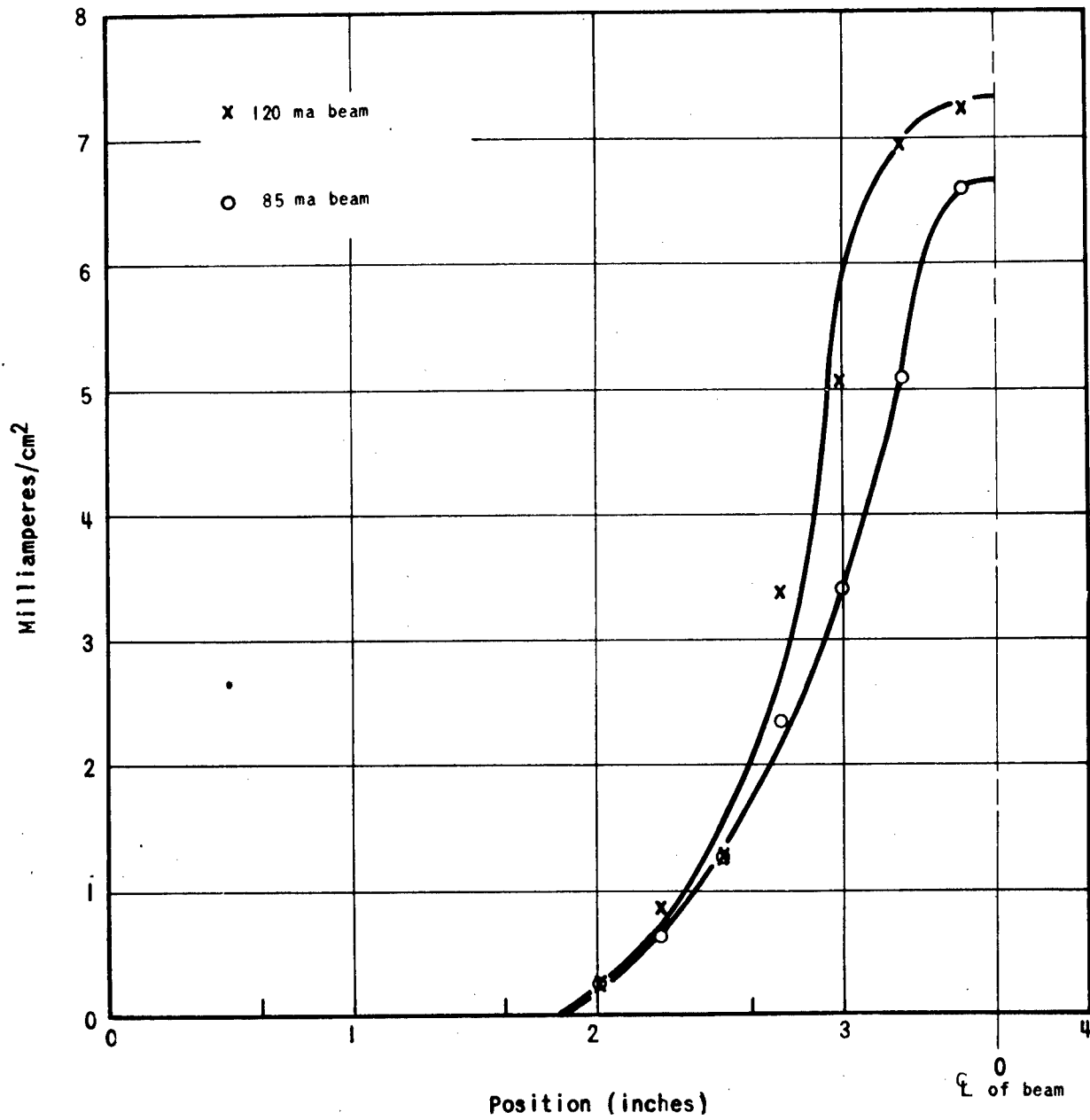

FIGURE 2
BEAM PROFILES OF 120 ma AND 85 ma BEAMS

Assuming circular symmetry of the beam, a graphical integration of the two curves in Figure 2 yielded 127 ma and 99 ma respectively for the total current in each case. This is in fairly good agreement with the values of 120 ma and 85 ma as measured by the Faraday cup on the experimental ion source. It is important to note that the values as measured with the spot sensitive beam monitor are within the probable error of the values as measured by the Faraday cup. Actually, it is quite probable that the Faraday cup measurement is less accurate than the beam monitor measurement because of uncalculable errors associated with the former method such as secondary electron emission.

Examination of the experimental data shows that the successful operation of this instrument has been demonstrated. The resolution was at least as good as 1/8" and simple changes in design will greatly improve this. Most of the error was introduced by the correction factors which originated from temperature measurements made with the optical pyrometer. This source of error will be reduced in a later experiment by providing a better thermal radiation shield between the heat conductor and the hot graphite plate.

FUTURE WORK

It should be emphasized that the design of the first instrument described in this report was not a final design but one which could be easily, quickly and inexpensively fabricated. It was built primarily to check the performance and sensitivity of an instrument utilizing this principle.

A later, more efficient design has been completed which can be used to monitor the beam of the Mark I accelerator and is shown in Figure 3. When accelerator operations permit, beam profiles will be measured on the precessed and unprecessed beams. The necessary facilities for carrying out these investigations are already available.

The instrument shown in Figure 3 is provided with auxiliary equipment so that all operation can be performed from a remote position outside of the accelerator shielding. Controls for accurately positioning it in the beam and instruments for indicating position at a remote operating station are available. The important changes that were incorporated into the beam sensitive monitor are the water cooled chamber located between the long heat conducting rod and the graphite plate, the relocation of the thermocouple wire leads so that the entire instrument can pass through one opening in the vacuum system, the elimination of water cooling

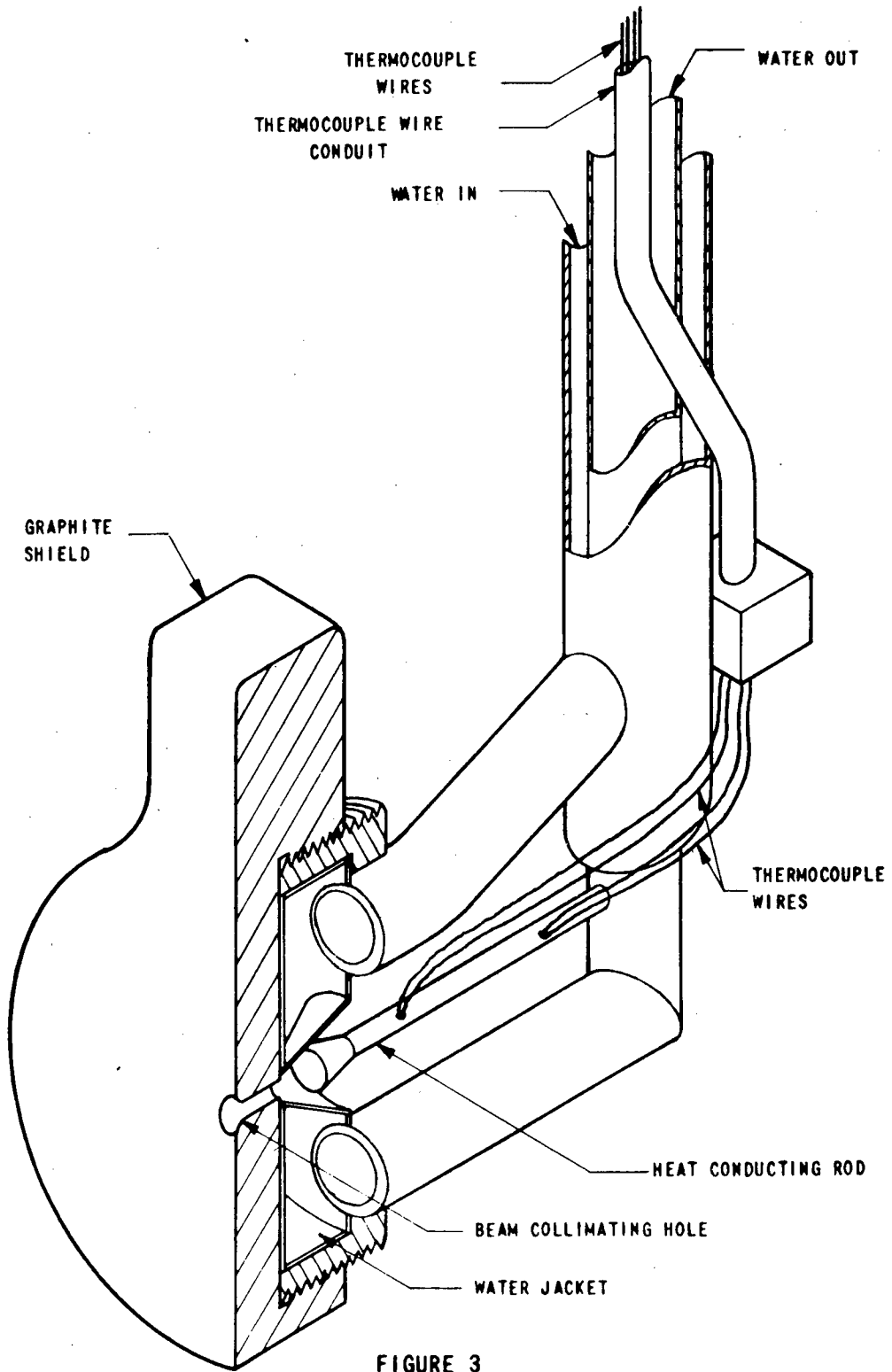

FIGURE 3
SPOT SENSITIVE BEAM MONITOR
MARK I ACCELERATOR DESIGN

around the side walls which introduced fabrication difficulties and more reliable method of mounting the graphite plate to the main assembly.

It is very simple and relatively inexpensive to design a similar piece of equipment for monitoring any high energy beam.

ACKNOWLEDGEMENT

The author is grateful to W. E. Browning and H. Thomas of the Irradiation Experiments Group and to W. A. Lamb and the other personnel associated with the experimental ion source who participated in this project for their invaluable help and their cooperative spirit.