



**US Army Corps
of Engineers**

Waterways Experiment
Station

Miscellaneous Paper EL-96-5
August 1996

Remote Downstream Monitoring of Savannah River Hydropower Releases

by *John W. Lemons, Michael C. Vorwerk,
Computer Sciences Corporation*

William E. Jabour, Joe H. Carroll, WES

DTIC QUALITY INSPECTED 4

DTIC QUALITY INSPECTED 4

Approved For Public Release; Distribution Is Unlimited

19961008 116

Prepared for U.S. Army Engineer District, Savannah

The contents of this report are not to be used for advertising, publication, or promotional purposes. Citation of trade names does not constitute an official endorsement or approval of the use of such commercial products.



PRINTED ON RECYCLED PAPER

Remote Downstream Monitoring of Savannah River Hydropower Releases

by John W. Lemons, Michael C. Vorwerk

Computer Sciences Corporation
3402 Wisconsin Avenue, Suite 3
Vicksburg, MS 39180

William E. Jabour, Joe H. Carroll

U.S. Army Corps of Engineers
Waterways Experiment Station
3909 Halls Ferry Road
Vicksburg, MS 39180-6199

Final report

Approved for public release; distribution is unlimited



**US Army Corps
of Engineers**
Waterways Experiment
Station

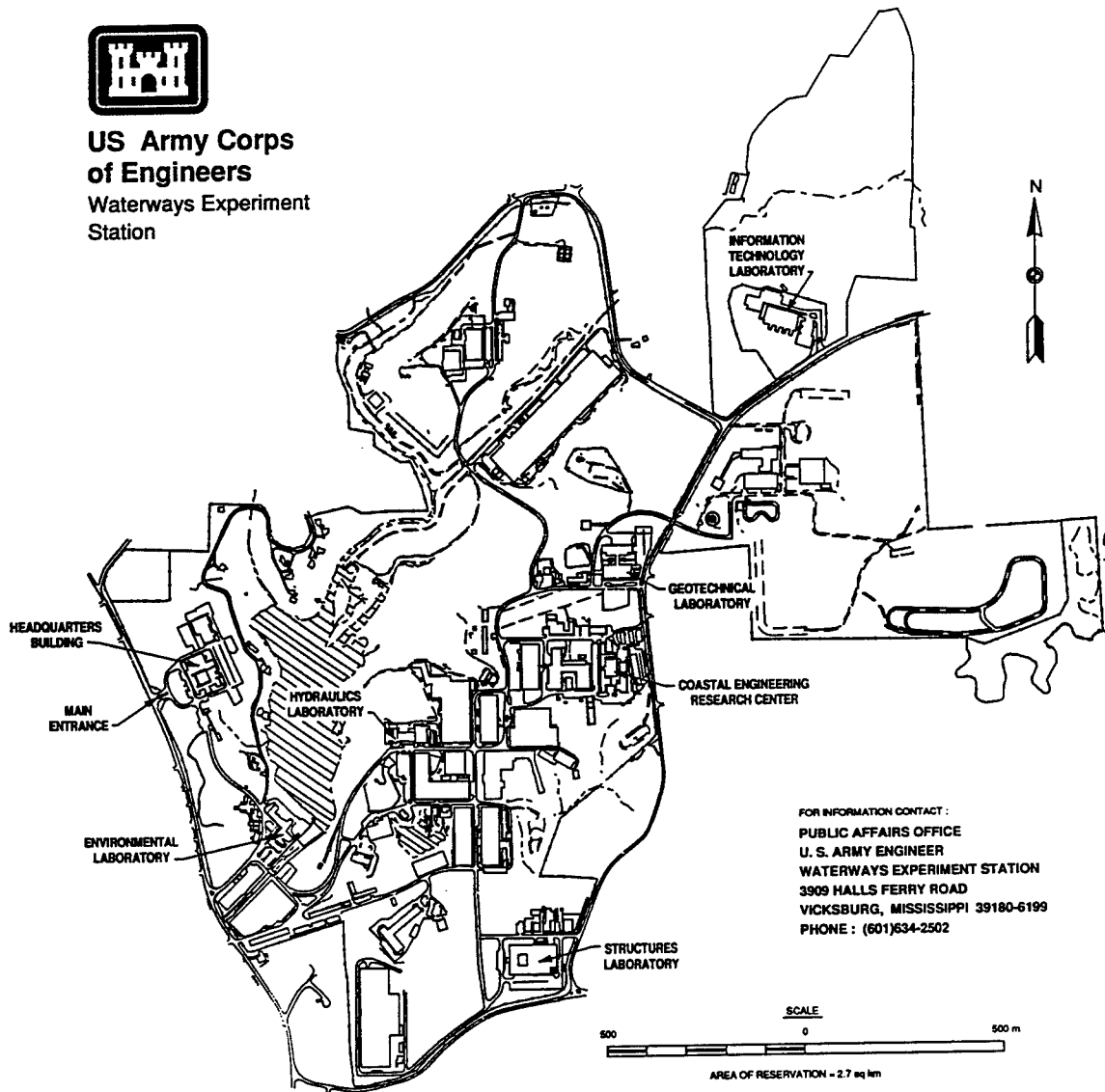

FOR INFORMATION CONTACT:
PUBLIC AFFAIRS OFFICE
U. S. ARMY ENGINEER
WATERWAYS EXPERIMENT STATION
3909 HALLS FERRY ROAD
VICKSBURG, MISSISSIPPI 39180-6199
PHONE: (601)634-2502

Waterways Experiment Station Cataloging-in-Publication Data

Remote downstream monitoring of Savannah River hydropower releases / by John W. Lemons ... [et al.] ; prepared for U.S. Army Engineer District, Savannah.
50 p. : ill. ; 28 cm. -- (Miscellaneous paper ; EL-96-5)
Includes bibliographic references.

1. Water quality monitoring stations -- Georgia. 2. Water quality monitoring stations -- South Carolina. 3. Richard B. Russell Lake (Ga. and S.C.) 4. J. Strom Thurmond Dam (S.C.) 5. Hartwell Lake (S.C. and Ga.) I. Lemons, John W. II. United States. Army. Corps of Engineers. Savannah District. III. U.S. Army Engineer Waterways Experiment Station. IV. Environmental Laboratory (U.S. Army Engineer Waterways Experiment Station) V. Series: Miscellaneous paper (U.S. Army Engineer Waterways Experiment Station) ; EL-96-5. TA7 W34m no.EL-96-5

Contents

Preface	v
Conversion Factors, Non-SI to SI Units of Measurement	vi
Summary	vii
1—Introduction	1
2—Monitoring System Development	5
3—Hartwell and J. Strom Thurmond Monitoring Systems	12
4—Richard B. Russell Monitoring System	14
5—Communication with Remote Monitors	19
6—Monitor Maintenance and Calibration	21
7—Data Storage and Handling	24
8—Discussion	26
References	28
Appendix A: Procedure for Winkler Titration for Determining Dissolved Oxygen Concentration	A1
Appendix B: Standard Operating Procedures for Savannah River Remote Water Quality Monitors	B1
Appendix C: Pumped Storage Monitoring at RBR	C1

SF 298

List of Figures

Figure 1.	Savannah River, indicating locations of three CE reservoirs . . .	2
Figure 2.	Location of HW monitor	6
Figure 3.	Original location of RBR downstream monitor	6
Figure 4.	Location of JST monitor	7
Figure 5.	Schematic diagram of H2O variability comparison	7
Figure 6.	Plot of results from H2O variability comparison	8
Figure 7.	Plot of H2O DO probe drift assessment data	9
Figure 8.	Schematic diagram of H2O monitoring systems at HW and JST	15
Figure 9.	Cross-sectional view of RBR Dam	15
Figure 10.	Lateral DO concentrations in front of RBR Dam, 16 May, 17 July, and 28 August 1994.	16
Figure 11.	Schematic diagram of piping gallery monitoring system at RBR Dam	18
Figure 12.	Savannah River monitor calibration log sheet	22
Figure 13.	Example of linking monitor data with other hydropower data	27

Preface

The work described herein was conducted by the U.S. Army Engineer Waterways Experiment Station (WES), Vicksburg, MS, for the U.S. Army Engineer District, Savannah.

The report was prepared by Messrs. John W. Lemons and Michael C. Vorwerk, Computer Sciences Corporation, Vicksburg, MS, and William E. Jabour and Joe H. Carroll, Environmental Processes and Effects Division (EPED), Environmental Laboratory (EL), WES. The authors gratefully acknowledge the support and assistance of personnel associated with WES's Trotters Shoals Limnological Research Facility, Calhoun Falls, SC. Special appreciation is extended to Meses. Deborah Patterson and Jennifer Moore, Computer Sciences Corporation, for their assistance in the editing and formatting of this report.

The work was performed under the general supervision of Dr. Richard E. Price, Acting Chief, Ecosystem Processes and Effects Branch, EPED; Mr. Donald L. Robey, Chief, EPED; and Dr. John W. Keeley, Director, EL.

At the time of publication of this report, Director of WES was Dr. Robert W. Whalin. Commander was COL Bruce K. Howard, EN.

This report should be cited as follows:

Lemons, J. W., Vorwerk, M. C., Jabour, W. E., and Carroll, J. H. (1996). "Remote downstream monitoring of Savannah River hydropower releases," Miscellaneous Paper EL-96-5, U.S. Army Engineer Waterways Experiment Station, Vicksburg, MS.

The contents of this report are not to be used for advertising, publication, or promotional purposes. Citation of trade names does not constitute an official endorsement or approval of the use of such commercial products.

Conversion Factors, Non-SI to SI Units of Measurement

Non-SI units of measurement used in this report can be converted to SI units as follows:

Multiply	By	To Obtain
cubic feet	0.02831685	cubic meters
feet	0.3048	meters
pounds (force) per square inch	6.894757	kilopascals
tons (2,000 pounds, mass)	907.1847	kilograms

Summary

Increased concerns over the water quality associated with hydropower releases have created the need for accurate and reliable release water quality monitoring techniques. Remote, automated monitors afford the best method for collecting the data needed to make informed decisions concerning hydropower operation. The Savannah District of the U.S. Army Corps of Engineers has installed and maintained remote, unattended monitors at the dams of the three Savannah River reservoirs, Hartwell (HW), Richard B. Russell (RBR), and J. Strom Thurmond (JST). The installations presently being used provide access to real-time data as well as a continuous record of the water quality of the Savannah River impoundments' releases. All work was performed by the staff of the Trotters Shoals Limnological Research Facility (TSLRF) under the direction of the Savannah District.

The monitors collect temperature, dissolved oxygen, and specific conductance data that are utilized in various decision-making processes. These data are used in determining optimum operation levels for an oxygen-injection system in the RBR forebay, maintaining a trout fishery below HW in the RBR headwater, monitoring pumped storage operation at RBR, and evaluating the water quality exiting the three impoundments and entering the Savannah River below JST.

The remote monitoring installations below HW and JST consist of submersible pumps and pipelines that pipe water from their tailwaters to water quality sondes. The RBR monitor is located within the RBR Dam piping gallery. Because of the lacustrine characteristics of the RBR tailwater, a downstream monitor at this site was determined to be less representative of the actual dam release as a result of entrainment of JST surface water (Vorwerk and Carroll 1994). The sondes at each site are connected to computers that communicate with the sondes, store water quality data, and provide a means of remotely communicating with the monitors via modems.

Maintenance schedules for the remote monitors include bi-weekly calibrations for dissolved oxygen and bi-monthly cleaning and servicing (if necessary) of the sondes' sensors. Calibration and maintenance procedures are relatively simple to perform and can be done in the field. Variability between sondes was determined to be within the manufacturer's specifications (temperature ± 0.15 °C, dissolved oxygen ± 0.2 mg/l, and specific conductance

± 1 percent of range) allowing for rotational sonde deployments that significantly reduce downtime and enhance data collection. Data are downloaded monthly and imported into the TSLRF database. These data are linked with operational data from the respective dams such that the resultant data set contains water quality data exclusively for release periods that may then be utilized for resource management.

The remote, water quality monitors at HW, RBR, and JST provide access to real-time, as well as continuous, water quality data for the release waters from each dam. The three monitors are less expensive, easier to maintain, and are more resistant to data loss than previous remote installations because of their automation. The water quality sondes are more easily calibrated and serviced so that outside technical assistance is infrequently required, which effectively reduces monitor downtime. The intention is for these systems, as well as their precursors, to serve as models of remote, automated monitoring systems that may be implemented elsewhere in future installations.

1 Introduction

In light of increasing concerns over the water quality associated with hydroelectric projects, an accurate and reliable system for remotely monitoring hydropower releases is urgently needed. The following report describes the remote downstream monitoring systems in place at Richard B. Russell (RBR), Hartwell (HW), and J. Strom Thurmond (JST) reservoirs. These three U.S. Army Corps of Engineers (CE) impoundments are located on the Savannah River along the Georgia-South Carolina border (Figure 1). All work was performed by the staff of the Trotters Shoals Limnological Research Facility (TSLRF), a field laboratory of the U.S. Army Engineer Waterways Experiment Station (WES), under contract to the U.S. Army Engineer District, Savannah.

The RBR Dam was completed in December of 1983. It impounds an area of 10,785 ha (26,650 acres) between the HW and JST reservoirs on the Savannah River. To document the effects of HW Dam releases on newly impounded RBR Lake and the effects of RBR Dam releases on JST Lake, intensive water quality studies were conducted. These studies included the installation of remote downstream monitors in the tailrace of each reservoir (Figures 2-4).

An agreement between the Savannah District and the State resource agencies of South Carolina and Georgia mandated a minimum dissolved-oxygen (DO) concentration of 6.0 mg/l in the RBR release water. An oxygen-injection system was installed in the forebay of RBR to increase the DO concentrations in the deep, oxygen-poor waters during critical summer months when hypolimnetic DO concentrations typically decrease to less than 1.0 mg/l. To increase RBR Dam release DO concentrations to the required 6.0 mg/l, injection rates of up to 100 tons¹ of oxygen per day at a cost of approximately \$100 per ton (1994), or approximately \$10,000 per day, are required. Adjustments to the system's injection rate are based on data gathered by the remote water quality monitoring system. Thus, accurate data concerning release water DO concentrations are needed to make informed operational decisions so that the minimum 6.0-mg/l release DO concentration

¹ A table of factors for converting non-SI units of measurement to SI units is presented on page vi.

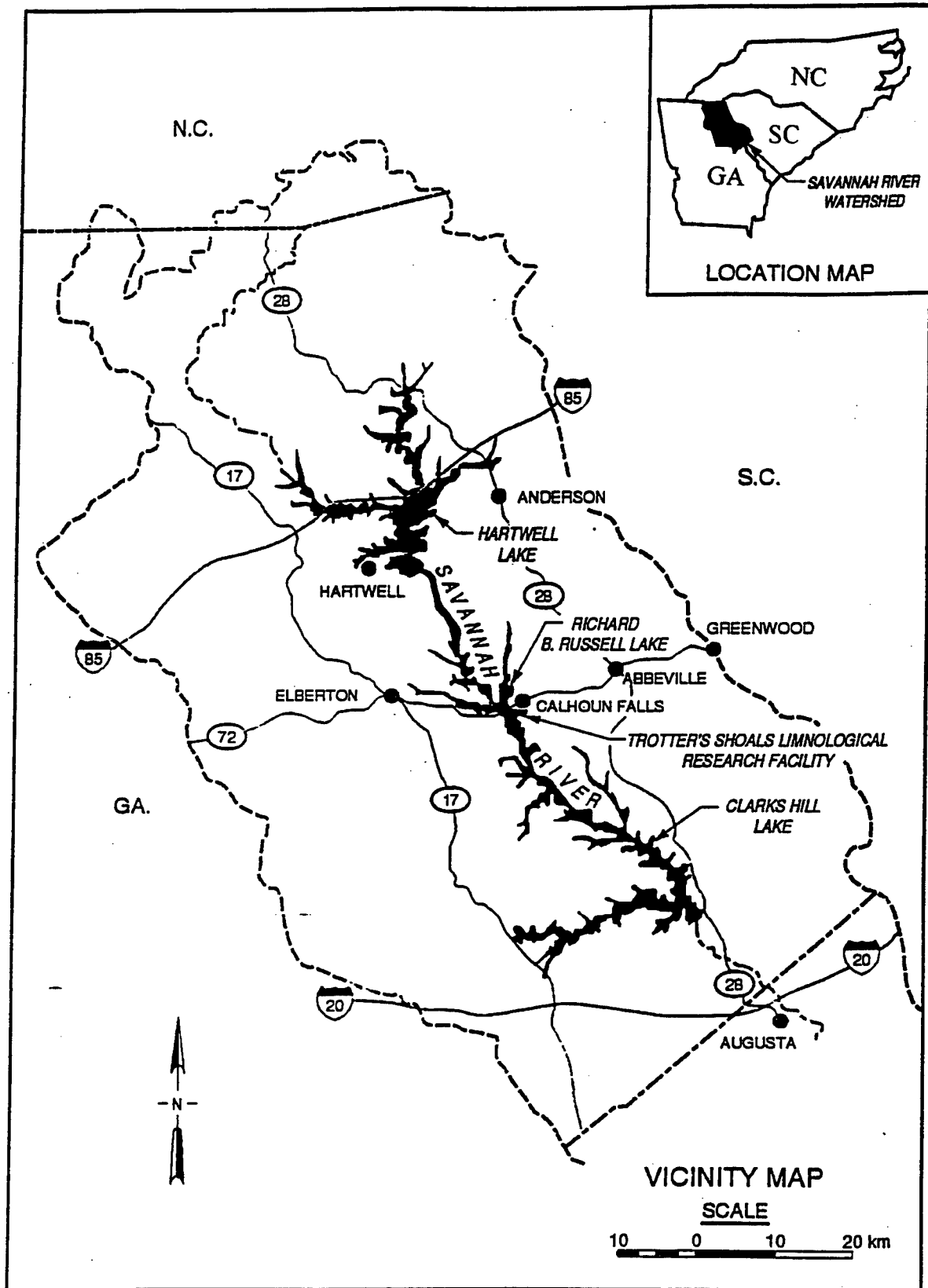

Figure 1. Savannah River, indicating locations of three CE reservoirs

is maintained while minimizing the cost in supplemental oxygen resulting from excessive injection rates. Additionally, monitor data are utilized for measuring the water quality of the pump jet during pumped storage tests at RBR, maintaining a trout fishery below HW Dam, and monitoring the water quality of releases entering the Savannah River below JST Dam.

Initial monitor installations consisted of Schneider Instruments RM-25 monitors (SIM) installed downstream of each dam and supplied with water from the tailwaters via submersible pumps and pipelines. The sample interval was factory-set at 1 hr and could not be changed by the operator. Data were stored into a buffer in two forms: a daily log containing data for the previous 24 hr, and a weekly log containing data for the previous 7 days. Data were downloaded daily and weekly via modem. The SIMs were maintained and calibrated according to Schneider Instruments' guidelines: DO concentration was calibrated using the azide modification of the Winkler titration (American Public Health Association 1992), and calibrations for pH and specific conductance were accomplished using known standards (Schneider Instruments Company 1981).

The SIM system presented various problems in the areas of calibration, maintenance, and data storage. Sensor adjustments required knowledge of basic electronics because of the complex nature of sensor calibrations. Probes demanded frequent replacement (sensor life being approximately 3 months), and the SIM required frequent calibration visits to ensure data accuracy because of sensor drift. The complexity of the SIM's sensors limited the number of qualified personnel capable of carrying out calibration and troubleshooting procedures. Monthly problems with the SIM's electronics, often the result of lightning, required the services of an electrical technician for repair.

Another major limitation of the SIM was the manner in which data were stored. The SIM's buffer contained space for about 170 readings (1 week at the factory-set, 1-hr interval). Once the buffer was filled, incoming data were written over the oldest data in the buffer. This meant that if the download time was missed (e.g., because of communication failure, lightning damage, and operator absence), the oldest data in the file were lost and could not be recovered, resulting in large gaps in the overall data set.

Because of these problems with the SIM, the decision was made to pursue alternate methods for remote monitoring. To ensure the installation of an adequate system, certain guidelines were developed prior to implementation. To meet these guidelines, the system must perform as follows:

- a. Provide accurate data that were reflective of the dam release waters.
- b. Be relatively easy to maintain so highly skilled technicians would not be required.
- c. Store data in a manner that would minimize the risk of data loss and be presented in a manner that was compatible with the TSLRF database.

- d.* Provide remote access to real-time data.
- e.* Be economical to install and maintain.
- f.* Be serviced in a timely manner if manufacturer repair was required.

2 Monitoring System Development

Recent advancements in water quality instrumentation have led to the development of compact water quality sondes that are capable of accurately measuring and recording a wide variety of water quality parameters. The Hydrolab Corporation of Austin, TX, is one such supplier that manufactures water quality sondes, with or without internal logging capabilities, that can monitor a wide variety of water quality parameters. Previous experience with these instruments used in in situ and remote logging applications proved them accurate and reliable while relatively inexpensive and easy to maintain. The sonde's small size allows for ease in transportation and deployment so that special events, e.g., pumped storage tests at RBR, can be monitored and necessary repairs carried out offsite. Sensors can be serviced by the operator, and DO sensor life expectancy is over 6 months under constant operation (Hydrolab Corporation 1991a, personal experience).

The sondes' compact size makes it possible to send them to the manufacturer for repairs. The turnaround time for factory repairs is typically less than 1 month; by utilizing two sondes in a rotational deployment regime, data loss because of sonde downtime is virtually eliminated. To determine the possible variability between two sondes utilized in such a rotation, the following experiment was conducted: two sondes were piped to identical water supplies in the RBR piping gallery (Figure 5). Both were calibrated for DO via 100-percent saturated air (Hydrolab Corporation 1991) and specific conductance via a known standard (American Public Health Association 1992). The sondes were then programmed to record data at a 30-min interval and deployed for 1 week. The results from this experiment are depicted in Figure 6. Variance was within the tolerances set by Hydrolab (DO ± 0.2 mg/l with Standard membrane, ± 0.5 mg/l with LoFlow (Hydrolab Corporation) membrane, temperature ± 0.15 °C, and specific conductance ± 1 percent of range. The LoFlow and Standard membranes are discussed in Chapter 6.)

Through careful review of calibration logs for the Savannah River remote downstream monitors, evaluations of the DO sensor drift experienced by an H2O over time were performed. By comparing the DO concentration of the H2O to the DO concentration determined by a Winkler titration (American Public Health Association 1992), an approximate measure of the drift

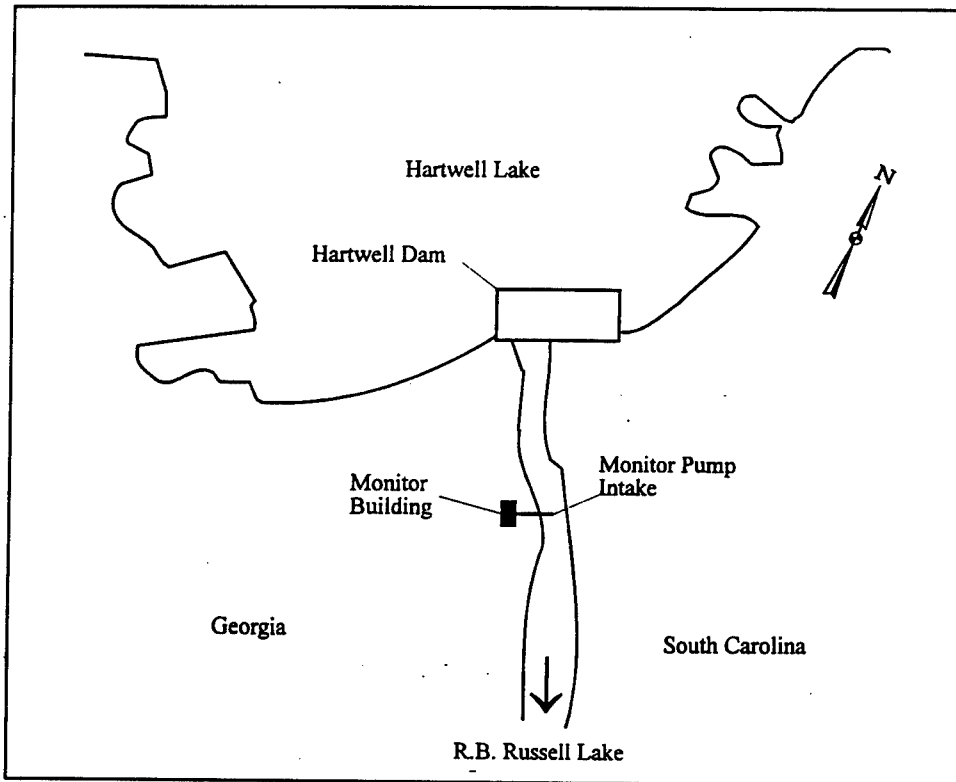

Figure 2. Location of HW monitor

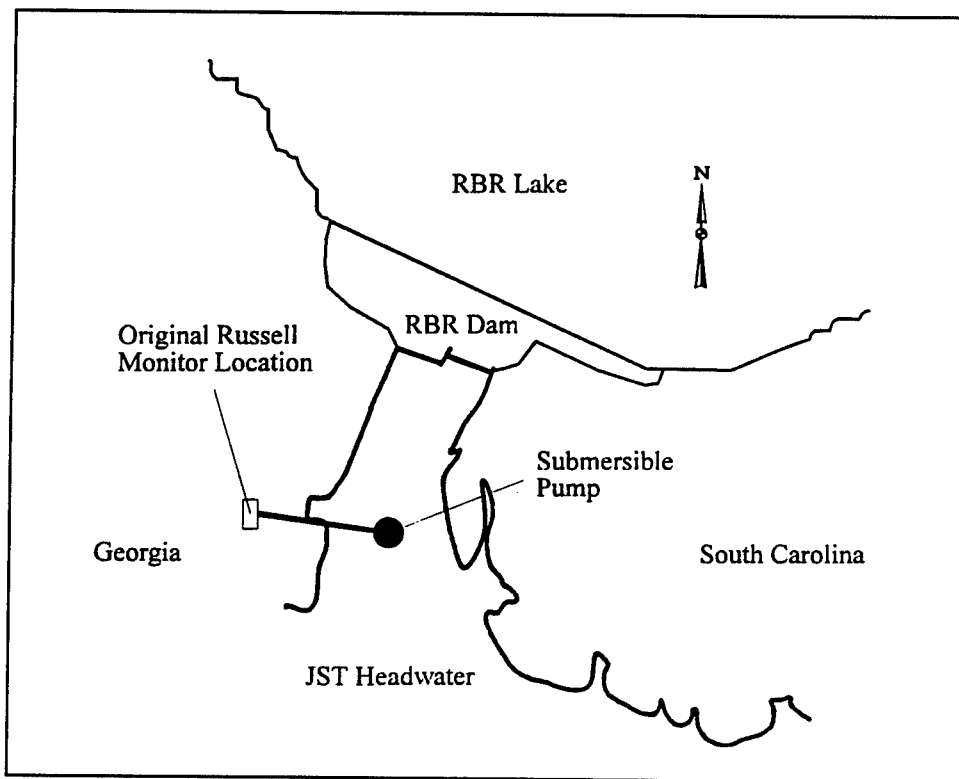

Figure 3. Original location of RBR downstream monitor

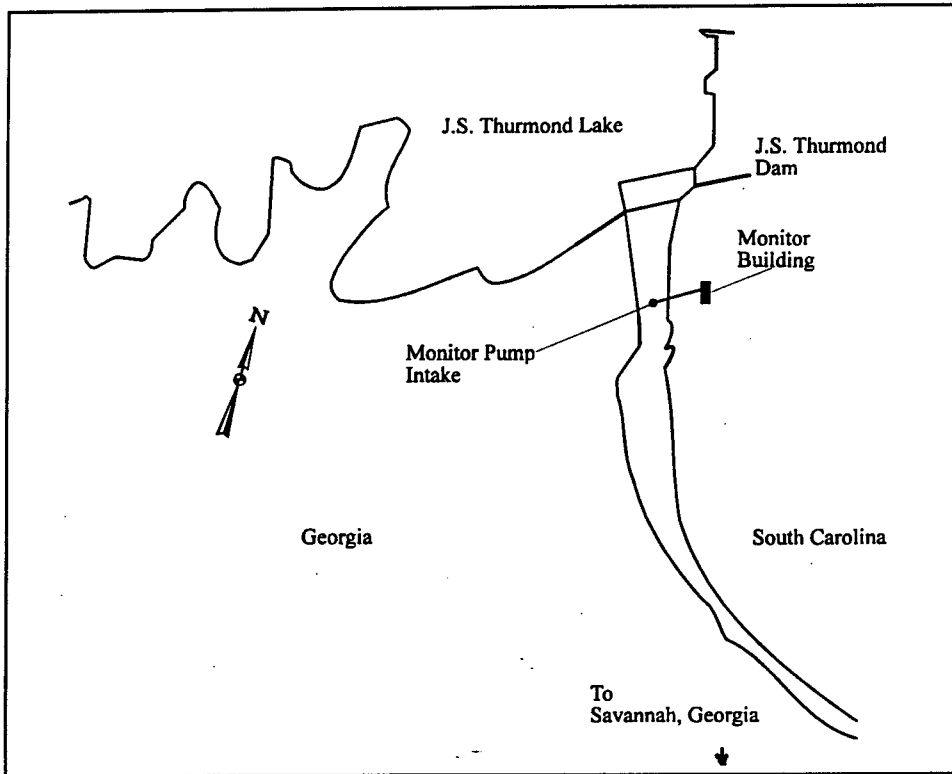

Figure 4. Location of JST monitor

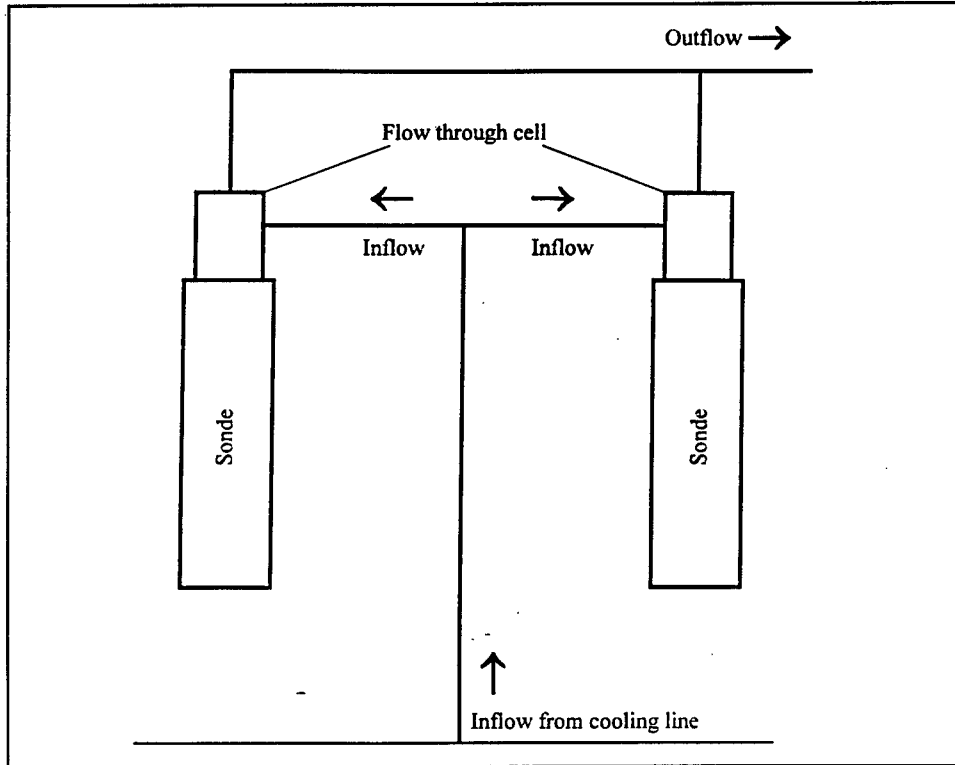

Figure 5. Schematic diagram of H₂O variability comparison

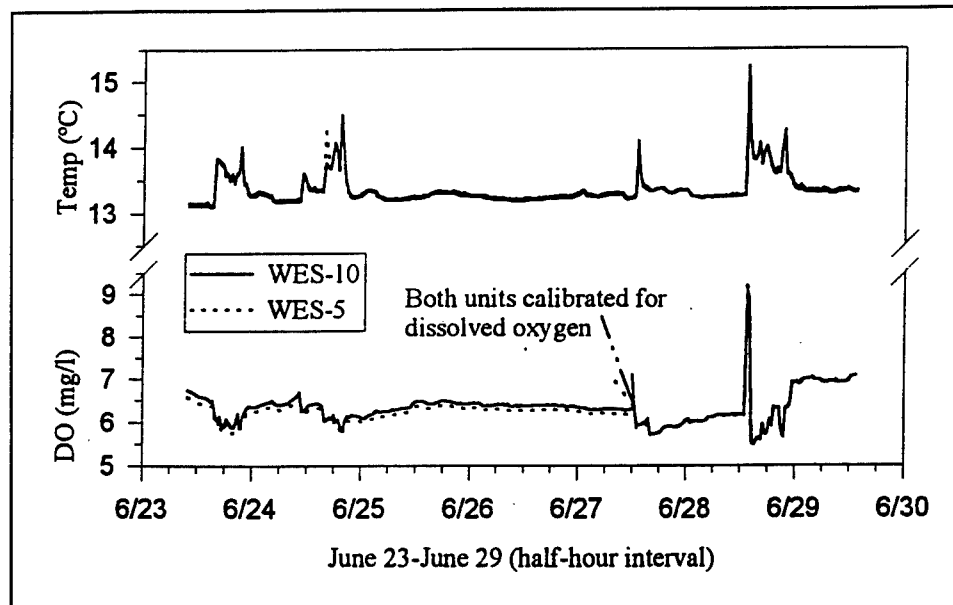

Figure 6. Plot of results from H2O variability comparison

experienced by the H20's DO sensor was obtained. By using data from consecutive calibration visits that required no adjustment to the sonde's DO concentration, it was determined that deployments of up to 1 month without recalibration were possible. Using these data, a calibration regimen was designed that involved calibration checks every 2 weeks during winter months and weekly during summer months when biofouling of the DO sensor was more pronounced. Biofouling results from biological growth on the DO probe that artificially raises or lowers the measured DO concentrations depending on the processes, i.e., photosynthesis or respiration, that are occurring at that time. Representative results of these comparisons are presented in Figure 7.

Communication with the data transmitter may be accomplished using the Scout 2 display unit, the Surveyor 3 Display Logger (both manufactured by the Hydrolab Corporation), or a personal computer (PC) that uses any communications software that supports the following H20 requirements: 1,200 bps, 8 data bits, no parity, and one stop bit. PC to H20 communication has been established using Procomm Plus (Datastorm Technologies, Inc., Columbia, MO), Crosstalk (Digital Communications Associates, Inc., Alpharetta, GA), pcAnywhere for DOS, and pcAnywhere for Windows (Symantec Corporation, Cupertino, CA); however, experience proved these programs to be more complex than communications with the H20 required. Furthermore, none of the aforementioned packages had a suitable means for logging data.

To overcome the logging limitations presented by established software packages, a BASIC computer program tailored to the specific needs of the monitoring system was developed. A PC with the BASIC data collection

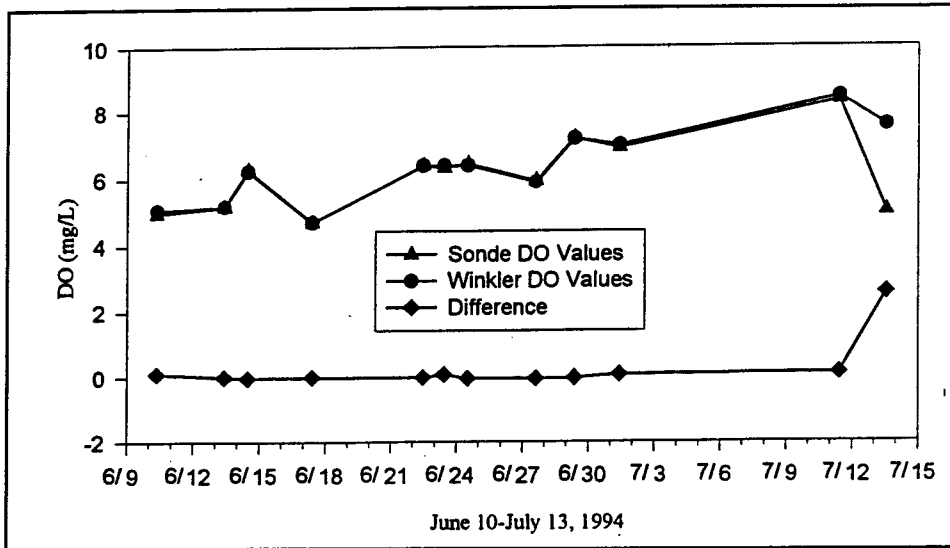

Figure 7. Plot of H2O DO probe drift assessment data

program was preferable to the internal logging option available from Hydrolab because of the PC's increased memory capability, the additional flexibility afforded by the program in terms of data displays and data management, and the reduced expense of the PC versus the Hydrolab sondes capable of internal logging. A description of the data collection program and data handling procedures appears later in this report in Chapters 5 and 7, respectively.

The conversion from the SIM to the Hydrolab H20 began in the spring of 1993. The equipment and installation costs, as of 1994, of the Savannah River remote monitoring systems are summarized in Tables 1 and 2, and detailed descriptions of the hardware configurations for each monitor are included in Chapters 3 and 4.

Table 1
1994 Equipment and Costs for Hartwell and Thurmond Monitors

Hydrolab H2O multiparameter water quality sonde with sensors for temperature, dissolved oxygen, and specific conductance	\$2,600
Personal computer with modem	\$3,000
Flow-through cell	\$200
Computer/H2O interface cable	\$85
H2O to 12-V battery cable	\$65
12-V deep-cycle battery	\$30
1-amp trickle charger	\$20
Uninterruptible power supply (UPS)	\$150
Surge protector power strip	\$20
Lightning arrestor for outside phone line	\$10
Ring stand for H2O	\$25
Hoses and plumbing	\$25
Tailwater submersible pump and pipeline	\$200
Assorted connections and phone lines	\$10
Labor	\$1,000
Total	\$7,440

Table 2 1994 Equipment and Costs for RBR Monitor	
Hydrolab H2O multiparameter water quality sonde with sensors for temperature, dissolved oxygen, and specific conductance	\$2,600
Personal computer with modem	\$3,000
Computer/H2O interface cable	\$85
H2O to 12-V battery cable	\$65
12-V deep-cycle battery	\$30
1-amp trickle charger	\$20
Uninterruptible power supply (UPS)	\$150
Surge protector power strip	\$20
Lightning arrestor for outside phone line	\$10
Manifold plumbing and mixing chamber	\$2,500
Solenoid switches, connections, and galvanized conduit for computer/H2O RS-232	\$3,100
Shielded phone line	\$70
Labor	\$5,800
Total	\$17,450

3 Hartwell and J. Strom Thurmond Monitoring Systems

The riverine conditions of both the HW and JST tailwaters are thought to lead to complete mixing of release water from each turbine, while "plug flow" of the dams' discharge is thought to prevent the entrainment of the lower lakes' headwaters. Therefore, water sampled from the tailrace below HW and JST dams, following the commencement of generation, should adequately represent each dam's release. The systems were designed to draw sample water directly from the tailraces using existing SIM plumbing at these locations. The necessary equipment for the installation of the HW and JST monitors is listed in Table 1. The monitor configurations were identical at HW and JST and are displayed in Figure 8.

Water is supplied to the sondes via flow-through cells (with a pressure limit of 15 psi) and hoses. The water supply is divided between an inflow hose and a pressure relief hose to prevent inadvertent clogging of the hoses that could result in pressure buildup within the cells with the potential for damage to the sondes' sensors. The data transmitters in use are Hydrolab H20s equipped with sensors for temperature, DO, and specific conductance. Flows from the sondes' outlet hoses are maintained at approximately 0.1 l/sec and are therefore insufficient for the standard 1-mil Teflon membrane, which requires flows of at least 0.3 l/sec (Hydrolab Corporation 1991b). While the flows may be increased to levels sufficient for the standard membrane, its increased sensitivity to biofouling is a concern. The sondes' DO probes are equipped with LoFlow membranes, which demonstrate less sensitivity to fouling and low flows than the standard membrane (Hydrolab Corporation 1991b). Data at each site are recorded hourly.

The sondes are connected to the PC serial ports via RS-232 connectors obtained from Hydrolab. Power for the sondes is supplied by 12-V deep-cycle batteries that are continuously charged by 1-amp trickle chargers (trickle chargers eliminate the need for regular transportation of the batteries for recharging).

Power for the PCs and the trickle chargers is supplied externally and is routed through surge protectors and backup power supplies (UPS). Power surges are common around hydropower projects, and inexpensive surge protectors are required to prevent expensive equipment damage. The UPSs provide temporary power sources for the PCs in the event of brief power outages. Because the sondes are powered by deep-cycle batteries and immune to external power loss, it is only necessary to power the PCs with the UPSs (the PC monitors, modems, etc., are not connected to the UPS). This configuration extends the duration of the backup power available and allows the UPSs to operate the PCs for approximately 15 min in the absence of external power. This is enough to survive most power outages, which are brief, and relieves the PCs from repeated rebooting.

Because of the frequent occurrence of lightning (particularly in the summer months), lightning arrestors are installed between the external phone lines and the modems. Like the power surge protectors, the lightning arrestors provide inexpensive protection against expensive equipment damage. Lightning arrestors do not afford complete protection, however, and the cost of occasional modem replacement must be factored into the monitors' maintenance expenses.

4 Richard B. Russell Monitoring System

Because of the lacustrine nature of the RBR tailwater, entrainment of JST Lake's headwaters by the RBR monitor occurred at the original downstream SIM installation. Mixing of the RBR releases with JST surface water led to erroneous temperature and DO data. Subsequent studies determined that water more representative of the actual release could be sampled directly from the cooling line of each turbine (Vorwerk and Carroll 1994).

Sample water was withdrawn from the spiral case (Figure 9) just upstream of the turbines and conveyed to a sonde utilizing a flow-through cell configuration similar to the HW and JST monitors. This provided a means of monitoring water more representative of the release without entraining JST water. Monitoring a single unit with a single sonde was not ideal because of two assumptions of such a design:

- a. Homogeneity across the penstock withdrawal zone such that water sampled from any of the releasing turbines is identical to water released from other turbines.
- b. The monitored turbine will be used throughout every generation cycle yielding water quality data for the entire period of release.

During winter months when the water column is completely mixed, the water across the withdrawal zone is isothermal with DO concentrations greater than 6.0 mg/l throughout the entire water column. However, during stratified periods, when DO concentration is of primary concern, the penstock withdrawal zone is heterogeneous with varying DO concentrations observed laterally across the dam. This variability across the penstock withdrawal zone is displayed in Figure 10. The patterns of temperature and DO concentration distribution in front of Units 1-4 are believed to be the result of a "withdrawal zone effect." This effect likely resulted from increased usage of these units for conventional generation creating variable stratification patterns across the face of the RBR Dam depending on the frequency and duration of conventional generation and the turbines used.

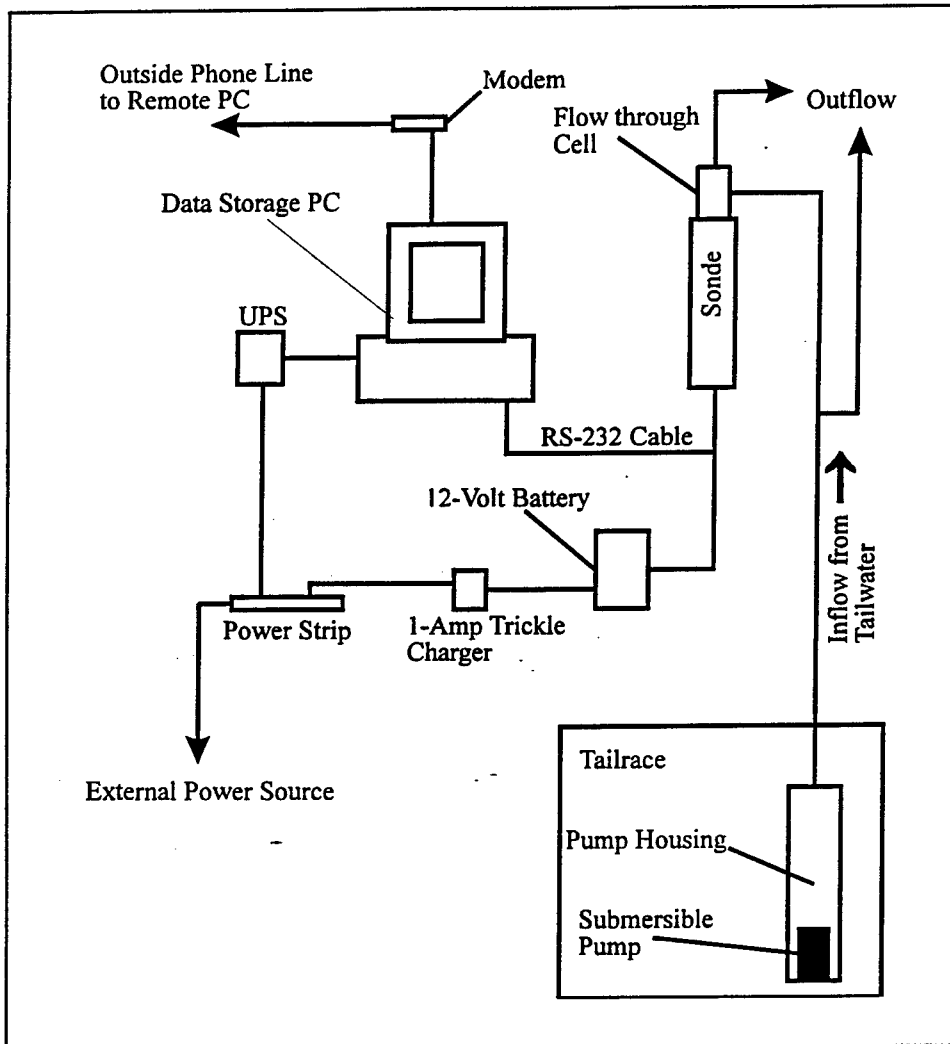

Figure 8. Schematic diagram of H₂O monitoring systems at HW and JST

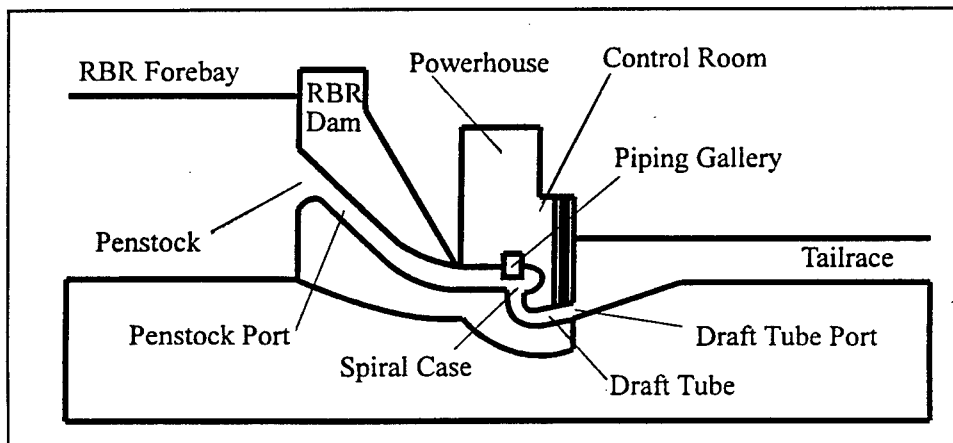

Figure 9. Cross-sectional view of RBR Dam

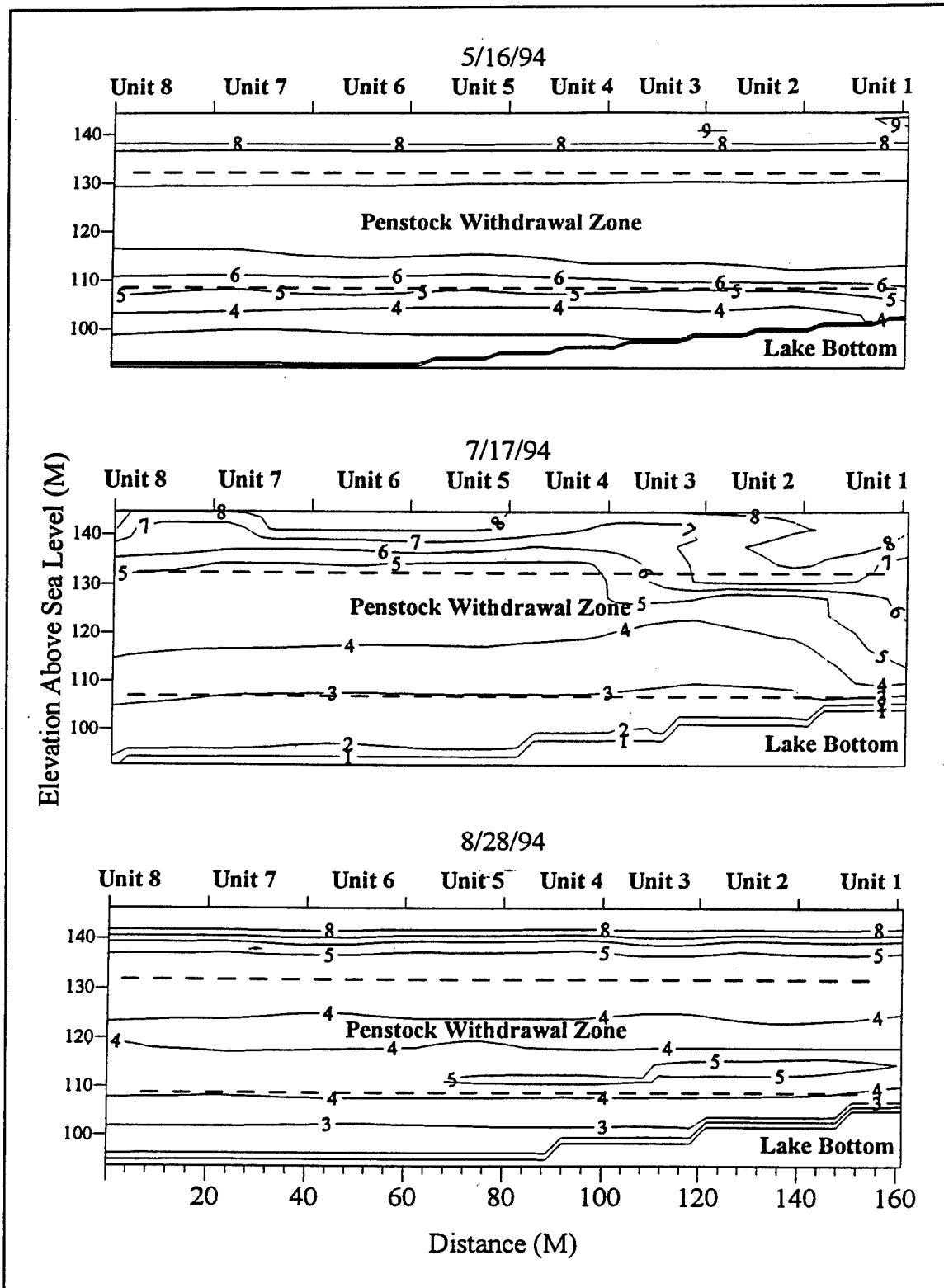

Figure 10. Lateral DO concentrations in front of RBR Dam, 16 May, 17 July, and 28 August 1994

In addition to the stratification across the penstock withdrawal zone, variation in the operation schedules for conventional generation, i.e., the duration and frequency of operation with each unit, means that one-unit, within-dam monitoring provides an incomplete representation of the dam's releases. Since no single unit is operated throughout the entire cycle for every generation period, a means of monitoring each unit was necessary.

Piping sample water from the cooling line of each unit into a centralized mixing chamber, makes it possible to monitor the entire generation period with a single sonde. The mixing chamber is analogous to a riverine tailwater in that it serves to mix the release water from the turbines, thereby providing a means of sampling representative water from a single location.

Certain considerations had to be addressed to ensure accurate water quality data from a mixing chamber system sampling water from the cooling lines. Because of the constant flow of water through the lines regardless of unit operation, water from operating turbines would be mixed with water from nonoperating turbines leading to nonrepresentative release water quality data. To overcome the problem of sampling a release/nonrelease water mixture, solenoid switches were installed to control valves on the pipes from the cooling lines to the mixing chamber. The solenoid switches are linked to the turbine's operational controls so the valves pass water while the turbines are operating and close during nonoperation. The mixing chamber serves the dual purpose of thoroughly mixing the sample water as well as maintaining a water supply when the turbines are not operating to prevent drying of the DO probe's membrane.

Care was taken during installation of the plumbing from the turbine cooling lines to the mixing chamber to minimize potential changes in the sample water. Because of the mixing chamber's central location within the piping gallery (PG), the shortest sample distance is from Unit 4, and the greatest distance is from Unit 8. Distances range from about 5 to 300 ft. The pipes were insulated to prevent warming of the sampled water and carefully sealed to prevent the introduction of ambient oxygen. The manual valves that control flow from the cooling lines were adjusted to deliver equal flow, thus compensating for the variation of delivery distances for the samples. This installation allows water from generating turbines to be measured while preventing the mixing of nonrelease water from nonoperating turbines so that the entire release is monitored.

The sample water flow rate from the cooling lines to the mixing chamber is uniform, meaning that water flow is constant and independent of the discharge rates of the turbines. This implies that if different units were simultaneously operating at different levels, the water sampled from the mixing chamber may not be representative of the actual release.

A comparison of the 1993 discharge levels for Turbines 1-4 yielded a mean difference of 50 ft³/sec. This demonstrated that the turbines were operated at virtually identical rates and that sample withdrawal proportionality is not a

concern at this time; however, if future operation demonstrates variability in the rate of discharge, provisions may need to be implemented to ensure a sample withdrawal that is proportional to the volume of water being released through each turbine.

Because of the concern for optimum operation of the RBR forebay oxygen injection system, it was decided that the dam operators needed easier access to real time data gathered by the remote monitor. To accommodate this need, the remote monitor's PC was relocated to the RBR control room (Figure 9).

A 500-ft shielded phone cable is used to transmit data between the H20's RS-232 connector in the PG and the PC's serial port located in the control room. The custom cable allows the 12-V battery to be located adjacent to the sonde, which eliminates the voltage drop that would be experienced if the power source were located in the control room, as would be the case with a custom-built cable from Hydrolab. Appropriate adapters were soldered onto both cable ends. The cable was run from the piping gallery to the control room through 1-in.-diam, galvanized conduit to prevent electrical noise, background interference resulting from normal powerplant operation, from affecting H20-to-computer communications.

The computer and modem are connected to a UPS, surge protector, etc., identical to the configurations at HW and JST. A complete equipment list with current (1994) costs is included in Table 2. The monitor installation at RBR is displayed in Figure 11.

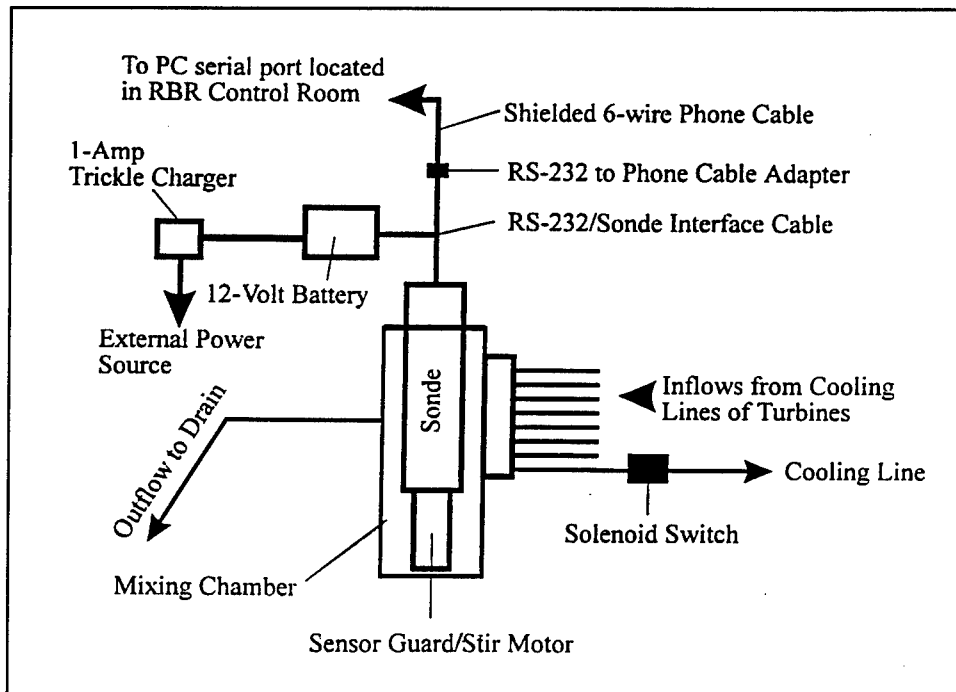

Figure 11. Schematic diagram of piping gallery monitoring system at RBR Dam

5 Communication with Remote Monitors

Initially, communication between the PC and the sonde was established using the commercial software package Awremote (Symantec, Cupertino, CA); however, this program had no suitable method for logging data. Additionally, the PC had no means of automatically reinitiating communication with the sonde. These problems prompted the search for a more suitable means of data logging.

A BASIC computer program was developed for H20-to-PC communication and data storage. A BASIC program was preferable to commercial communications software because most marketed software packages tend to be more complex than H20 communications require. In addition, many commercial communications software packages typically logged data into open-ended buffers. In this type of buffer, the data remain in the PC's volatile memory and are not stored in the nonvolatile memory until the buffer is full or until the file is manually closed. Power loss to the system before the data are committed to the nonvolatile memory results in the loss of all data stored in the buffer. Such power outages resulted in the loss of several days of data using the recording feature of Awremote.

To prevent extensive data loss, the BASIC program places each line of data directly into the PC's nonvolatile memory. The data logging program is also configured to begin communicating with the H20 upon start-up of the PC. An initialization file configured by the operator provides the reservoir, station, sampling interval, a file name to which data is to be stored, the PC communications port for the sonde, the communication rate for the sonde, the upper and lower bounds for measured parameters, and the passwords required to access the program. Direct communication with the sonde for calibration et al. is possible by activating the program's direct communications mode via "hot keys." The use of hot keys (e.g., <CTRL> + <T> to access the program's direct communications mode) and passwords prevents unwanted tampering with data collection. A detailed report on the development of the BASIC remote monitoring software is forthcoming.

The pcAnywhere communications program Awhost (Symantec, Cupertino, CA) is used for monitor PC ("host") to outside ("remote") communications.

Awhost is configured to begin operating upon the monitor computer's start-up. The program automatically resets the modem and tells the host PC to wait for a call. By utilizing software that automatically begins operation when the computer boots up and stores data directly into the host PC's nonvolatile memory, power loss to the system results in fewer and smaller data gaps that are restricted to down periods.

6 Monitor Maintenance and Calibration

Routine calibration of the water quality sondes is imperative. Data generated by the remote monitors are limited by the accuracy of the calibrations. Detailed logs recording all calibration changes are maintained so that any necessary corrections to the final data set can be performed (Figure 12). The calibration log also serves as a source of data validation. Questions that arise concerning the accuracy of the monitor data are frequently answered through examination of the calibration records. As a backup, calibration changes are also recorded in the monitors' computer files via direct communication as described in Chapter 5.

Maintenance and calibration schedules vary depending on the characteristics of the sample location and the season. Since DO probes exhibit a greater degree of drift than other water quality parameters and DO concentrations are the primary measure of release water quality for the three Savannah River dams, calibration frequency is based on examination of the degree and rapidity of drift observed in the sonde's DO sensor. Experience demonstrated that calibrations might hold for periods of up to 1 month without exhibiting significant drift (Figure 7); however, calibrations are performed every 2 weeks during winter months and weekly during summer months when bio-fouling of the DO sensor is more pronounced and data accuracy more critical.

Calibrations for DO are accomplished using two methods: (a) calibration to 100-percent saturated air (Hydrolab Corporation 1991) and (b) calibration to a Winkler titration (American Public Health Association 1992). The Winkler titration is the preferred method since it yields DO values for the sample water in milligrams per liter (ppm). The titrations are performed onsite, but the samples may be fixed with sulfamic acid and the titrations performed offsite with calibration changes being entered remotely via modem. Onsite calibration is better, however, as it reduces the risk of sample contamination and allows potential calibration problems to be addressed immediately. Step-by-step instructions for DO calibration using the azide modification of the Winkler titration and dry chemicals are presented in Appendix A.

The sondes are thoroughly serviced offsite every 2 months. Bi-monthly servicing consists of complete cleaning of the sonde's probes and replacement

Monitor: CH HW RBR Other:

Generation? Y N

Arrival Time:
Departure Time:

Hydrolab Unit: WES ___ H2O DS3
Date deployed:

Initial Readings:
Temp: ___ °C SpCond: ___ μS
DO: ___ mg/l Bat Volt: ___ V

Replacement Unit: WES ___ H2O DS3

Final Readings:
Temp: ___ °C SpCond: ___ μS
DO: ___ mg/l Bat Volt: ___ V

Comments:

Bottle #	H2O DO	Begin	End	Total	Difference
Average of 2 closest titrations = DO mg/l					

Figure 12. Savannah River monitor calibration log sheet

of the DO electrolyte and membrane. The sonde is then allowed to operate overnight before recalibration. This is an important step because it allows the new DO membrane to relax to its final shape so that a stable DO reading may be obtained for calibration. Calibrations entered before the membrane has relaxed to calibration shape are not reliable, as relaxation of the DO membrane leads to extreme drift in DO measurements making stable readings nearly impossible.

The sonde is calibrated offsite for DO and specific conductance using 100-percent saturated air and a known standard, respectively, prior to redeployment. The DO calibration is then verified onsite by comparing the sonde's readings to a Winkler titration. When the DO probe employs a

LoFlow membrane, all measurements are automatically compensated by an optimization factor of 2.5 percent. This optimization factor compensates for the LoFlow membrane's -6-percent error because of flow, for flows above approximately 1 in. per minute (Hydrolab Corporation 1991) so that accurate field measurements may be achieved. As a result of this optimization factor, calibration changes input to an H2O yield primary readings approximately 0.20 mg/l higher than the entered calibration. For example, if a Winkler titration yielded a DO concentration of 6.0 mg/l and this value were input to the sonde, an immediate measurement would yield a DO value of 6.2 mg/l. Subsequent readings should agree with subsequent Winkler titrations. The benefit of the LoFlow membrane is its decreased sensitivity to biofouling of the DO probe, which is a major concern during the highly productive summer months.

If low sample flow and fouling are not a problem, the Standard 1-mil Teflon membrane may be used. The life expectancy of the DO probe is somewhat reduced with the Standard membrane (the average life span of a DO sensor under constant operation is about 6 months); however, frequent changing of the membrane (every 2 weeks or more) will lengthen the life expectancy (Hydrolab Corporation 1991). Use of the Standard DO membrane decreases the sonde's response time. This is useful when there is concern over rapid changes in DO or if a small sampling interval is desired. If the power supply for the sonde is unlimited and deployment requirements permit, a stir motor may be attached to the sonde that significantly reduces growth on the DO sensor (personal communication with Hydrolab representative and personal experience). Such a configuration is used at RBR during summer months while the oxygen injection system is in operation and data are sampled on a 10-min interval.

Care should be taken when changing the type of membrane on the sonde because of the LoFlow optimization factor the H2O employs when equipped with the LoFlow DO membrane. The sonde must be configured for the proper membrane type (Standard or LoFlow) on the DO sensor via the H2O operating menu (Hydrolab Corporation). The LoFlow optimizing factor may be enabled or disabled in this fashion as the situation dictates.

Monthly maintenance also includes replacement of any damaged or worn-out probes. Difficulty with DO calibration (assuming the membrane has been allowed to relax to its calibration shape) indicates that the probe requires replacement. The DO probes are checked by taking measurements while the DO cavity is completely empty of electrolyte (Hydrolab Corporation 1991). The DO readings in this situation should be nearly zero. If the reading are significantly higher than zero, the probe is replaced. The silver triangle (anode) in the DO cavity typically darkens as the probe ages and oxidizes. A black anode is a sign the probe needs replacing, but the zero electrolyte test should be performed as an absolute determination. The DO probe was replaced with little difficulty in less than an hour by a qualified technician. The 1994 replacement cost for a DO/specific conductivity probe was \$425.

7 Data Storage and Handling

Data are stored in comma delimited ASCII text files that are downloaded monthly. Data files consist of both a continuous log and daily files that can be printed to a disk or to a printer. Library files are created that list all of the files that should be stored on the PC. (See Appendix B for more on the operation of the logging program.) Archive data sets are maintained both onsite and offsite as backup files. The raw data files are edited using a DOS text editor to remove computer characters and calibration communications that may confuse spreadsheet programs used for data analyses.

The edited data files are imported into a spreadsheet program for easier manipulation. Dissolved oxygen measurements are corrected, if necessary, by factoring in calibration changes. Sensor drift is assumed to be linear; therefore, DO readings are corrected by assuming a constant rate of drift between calibration visits. By allowing that the initial visit represented zero drift, the slope of DO sensor drift versus time (based on the sampling interval) is determined for the period between the initial visit (V_{T_0}) and the second calibration visit (V_{T_i}). Compensated DO readings are obtained by multiplying each time by this compensation factor and adding (or subtracting) this value to each DO reading to be corrected. The compensation factor is calculated using the following formula:

$$(C_{T_i} - C_{T_0}) / (T_i - T_0) = \Delta C / \Delta T = \text{calibration change}$$

where

C_{T_i} = calibration at second visit

C_{T_0} = calibration at initial visit

T_i = time of second visit

T_0 = time of initial visit

ΔC = change in concentration

ΔT = change in time

The corrected data are then linked to the operational data sets for each dam. Since the original management concern was for the water quality attributable to the dams' "releases" and the monitoring systems were designed to address this concern, the data reflect the dams' release water quality only during operating cycles, i.e., periods of release. Data gathered during other periods represent the bottom tailwater conditions at HW and JST and the standing water in the wet-well at RBR. Compilation of the monitor and hydraulic data results in a final water quality database representative of each dam's release.

8 Discussion

Remote, automated monitors provide the best method for unattended logging of release water quality data associated with hydropower production. Various systems for remote monitoring were tested at the three Savannah River projects. The products of this research are the present installations that provide access to real-time data and a continuous data set used for completing many objectives.

The replacement of the SIM-based monitoring system with the Hydrolab sonde-based system resulted in a less expensive, more user friendly monitoring configuration that allows greater flexibility in data storage and data handling. Less servicing is required, and the simplicity of the system allows more individuals to perform monitor calibration and service procedures without extensive technical training.

The system presently in use was less expensive to install, operate, and maintain than the previous system, while sacrificing none of the original system's accuracy. The data logging program protects the monitors from major data losses and creates a nearly "hands off" system, freeing the operators' time for other duties. Less lab-to-monitor communications are required to ensure the system's operation, and automatic start-up of logging with the booting of the computer means that visits to the monitor to reinitiate sonde-to-PC communication are practically eliminated.

Initial installation costs were quickly offset by the value of the data gathered by the monitors. Data collected are used to maximize the operational efficiency of the RBR forebay oxygen injection system and to monitor the quality of water being released from the Savannah River impoundments. Additionally, remote, unattended logging techniques are employed for monitoring pumped storage testing at RBR and other studies as needs arise (see Appendix C for more on pumped storage monitoring).

By employing the latest monitoring technology and addressing the individual needs of each impoundment, an inexpensive, low maintenance, and reliable system for monitoring dam releases has been developed. The data generated by the remote monitors are easily imported into spreadsheet and database programs, e.g., Microsoft Excel (Microsoft Corporation, Redmond, WA) and Borland Paradox (Borland International Inc., Scotts Valley, CA),

allowing easier consolidation of the monitor data sets with the dams' hydraulic data sets, oxygen injection data, in situ data, et al. for interpretation (Figure 13). The systems presently used attempt to address and correct many of the problems that have been encountered with previous remote installations. These systems, by incorporating programs that automatically initiate communication with the sondes and remote access software, provide actual automated data collection. The result is a comprehensive sampling system that requires minimal supervision, provides accurate data, and frees resource managers for other duties.

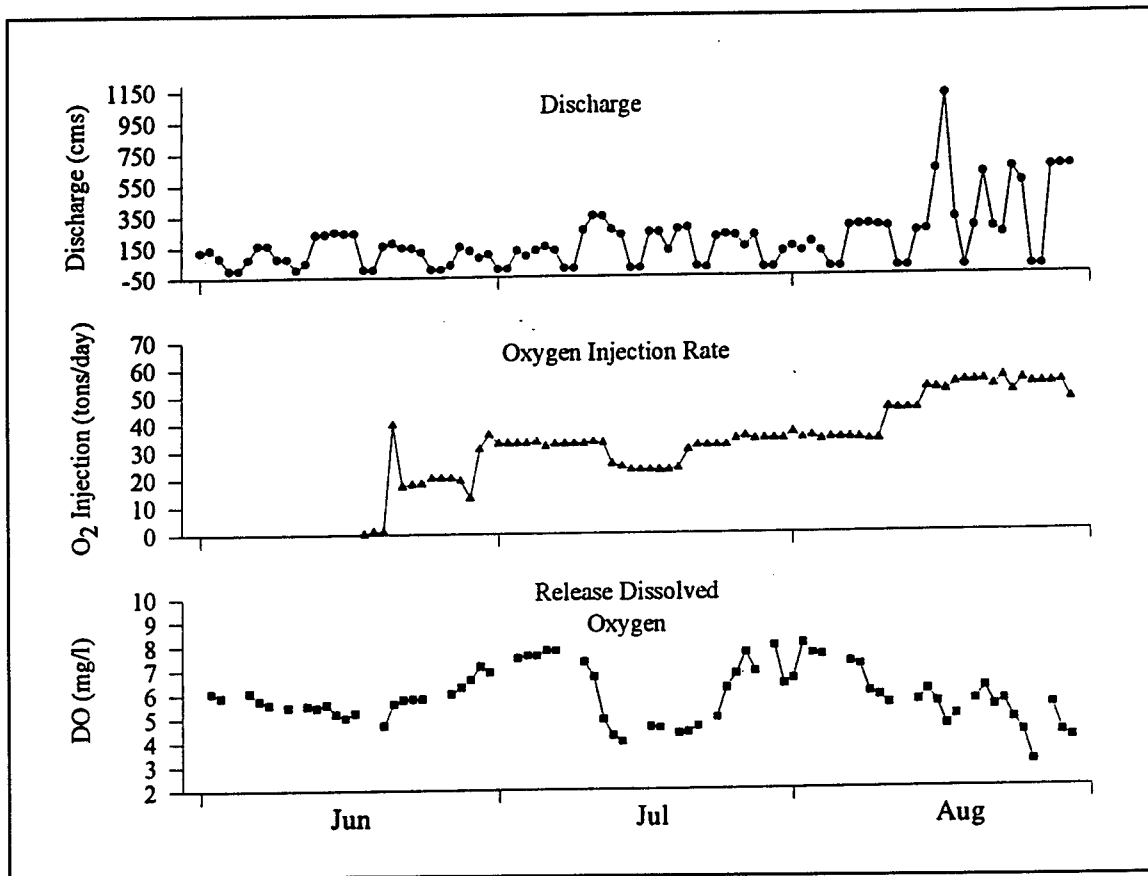

Figure 13. Example of linking monitor data with other hydropower data

References

- American Public Health Association. (1992). *Standard methods for the examination of water and wastewater*. 19th ed., American Public Health Association, Washington, DC.
- Hydrolab Corporation. (1991a). *Datasonde 3 multiparameter water quality monitoring instruments operating manual*. Austin, TX.
- _____. (1991b). *H2O multiparameter water quality data transmitter operating manual*. Austin, TX.
- _____. (1991c). *Surveyor 3 multiparameter water quality monitoring instruments operating manual*. Austin, TX.
- Schneider Instrument Company. (1981). *Operation and service manual for Model RM25 Robot Monitor*. Cincinnati, OH.
- Vorwerk, M. C., and Carroll, J. H. (1994). "Implications of reservoir release and tailwater monitor placement," *Lake and Reservoir Management* 9(1), 170-172.

Appendix A

Procedure for Winkler Titration for Determining Dissolved Oxygen Concentration (Ameri- can Public Health Association 1992)

Calibrations for dissolved oxygen (DO) are determined by performing the azide modification of the Winkler Titration. The equipment and reagents required are listed below along with the appropriate Hach Company catalog numbers and costs (1993-94 Hach Company catalog) for ordering supplies.

Equipment

- 1 25-ml burette
- 2 300-ml BOD bottles
- 1 500-ml Erlenmeyer flask
- 1 burette stand
- 1 12-in. section of 1/4-in.-O.D. tubing with appropriate adapter to fit H2O outflow hose

Reagents	Cat #	Cost(93-94)
Manganous Sulfate powder pillows	1071-68	3.50/25
Alkaline Iodide-Azide reagent powder pillows	1072-68	3.60/25
Sulfamic Acid powder pillows	1073-99	15.25/100
0.0375N Sodium Thiosulfate standard solution	24094-53	17.80/ℓ
Starch Indicator Solution	349/53	8.25/ℓ
DO Reagent Pack (Includes all reagents and indicators for 100 tests)*	23514-00	59.15/pkg.

Procedure

- a. The precalibration readings of the sonde should be recorded prior to taking samples (calibration log, Figure 12), as these readings will be used to determine the amount (if any) of correction to the data set that is required.
- b. To collect the sample water, attach the tubing to the outflow hose leading from the sonde's flow-through cell (in the RBR piping gallery, samples should be taken from the mixing chamber outflow) and extend it to the bottom of a 300-ml BOD bottle. Allow the bottle to overflow several volumes worth while taking DO concentration readings from the sonde until a stable DO reading (within 0.1 mg/l) is achieved. Stable readings are more easily obtained during periods of nongeneration since there is less actual variation in the sample.
- c. Add the contents of one manganous sulfate powder pillow followed by one alkaline iodide-azide powder pillow (the reagents should be added in this order) being careful not to introduce ambient oxygen to the sample water through excess agitation of the bottle.
- d. Stopper the bottle and shake well until the reagents are thoroughly mixed.
- e. Allow floc to settle approximately three-fourths to one-half distance from the bottom of the bottle (typically 10 to 15 min).
- f. Add the contents of one sulfamic acid powder pillow, again being careful not to introduce oxygen to the sample, and shake until thoroughly mixed.
- g. Pour sample into the Erlenmeyer flask and titrate with 0.0375N sodium thiosulfate solution until titrant (sample) is pale yellow (straw) in color.
- h. Add a few drops of the starch indicator so the sample turns blue in color.
- i. Continue to titrate with 0.0375N sodium thiosulfate until the sample solution becomes clear.
- j. Record the amount of titrant required to obtain a clear sample. This value (in milliliters) is equivalent to the DO concentration in milligrams per liter (or ppm).
- k. Repeat Steps *b-j*. It is faster to perform calibrations if two BOD bottles are used so both samples may be prepared simultaneously.
- l. Calculate the difference between the Winkler and H₂O DO concentrations to determine the amount of correction to the sonde that is

necessary. Take a current measurement from the sonde and add (or subtract) the Winkler/H₂O difference to this measurement.

- m. Record any adjustments, including the date and technician, in both the calibration log and the computer file.

Records of calibration visits should be maintained for the purpose of data validation and determination of a calibration regimen, i.e., frequency of calibration, parameters of primary calibration concern resulting from drift, etc. Some features that should be included in a calibration log include the date and time of the visit, the technician performing the calibrations, the status of the dam's operation (i.e., releasing or not releasing water), the sonde's precalibration and postcalibration measurements, and the Winkler titration values obtained during the visit. If more than one water quality sonde is employed for monitoring, i.e., in a rotational deployment or in concert, an identity should be given, e.g., WES-1, and recorded. Such information is useful in determining the amount of sensor drift that may be expected, the variability between sondes, and as an indicator that sensors need replacing or repairing.

- * Reagent pack includes 0.0250 N sodium thiosulfate and must be used with 200-ml sample. If 300-ml samples are used, the Winkler DO concentration value must be multiplied by a correction factor of 0.667 to represent the actual DO concentration.

Appendix B

Standard Operating Procedures for Savannah River Remote Water Quality Monitors

Equipment Setup

The monitors at Hartwell (HW) and J. S. Thurmond (JST) are housed in buildings located just downstream of the respective dams. Because of complications with the original downstream location, the monitor at R. B. Russell (RBR) is located within the dam in the piping gallery (PG), and the computer (PC) used for communication is located in the RBR control room (CR). The PC and H2O at RBR are connected by a custom RS-232-to-H2O cable.

The equipment configurations at the HW and JST monitors are identical, and the following description applies to both systems. Water is sampled from the tailwaters via submersible pumps and pipelines and is supplied to the H2Os via hoses and flow-through cells. Excess pressure is alleviated by dividing the flows to the H2Os between the inflow hoses to the flow-through cells and the pressure relief hoses. Flows to the H2Os are maintained at approximately 120 ml/sec. The H2Os are mounted to laboratory ring stands with the sensors pointing up to allow inadvertent air bubbles that could adversely affect dissolved oxygen (DO) measurements to be carried away from the probes (Figure 8).

The H2Os are equipped with sensors for temperature, DO (DO probes utilize LoFlow membranes), specific conductance, and battery voltage. The H2Os are connected to computers (PCs) and 12-V deep-cycle batteries via RS-232 cables. The computers are equipped with modems allowing outside communications for transferring files and obtaining status reports on monitor operation.

Sample water at RBR is supplied to a centrally located mixing chamber in the PG. The mixing chamber is connected to the cooling lines of the turbines via hoses, and the sample flows are controlled by solenoid switches located

behind and above each unit's cooling line. The switches control the sample such that water flows to the mixing chamber only from turbines engaged in conventional generation or pumped storage operation. For the switches to operate properly, they must be "ON" (switched up); proper operation is easily determined during periods of no generation by the absence of flowing water through the mixing chamber.

The H2O at RBR has the same sensor configuration as those at HW and JST. The DO probe is equipped with a LoFlow membrane during winter months when the oxygen injection system is not operating and with a Standard membrane during summer months when the system is operating. A weighted sensor guard is attached to the H2O in place of a flow-through cell when it employs a LoFlow membrane, and a stir motor is attached when the H2O employs a Standard membrane. The stir motor ensures adequate flow across the Standard membrane and reduces the effects of sensor fouling.

Communication

The PCs at all three monitor locations utilize a BASIC program for communicating with the H2Os and Awhost (Symantec, Cupertino, CA) for outside (remote) communication. Communication is established in the same manner for all three monitor locations as described below.

PC to H2O

The executable program and an initialization file are placed in the same directory on the PC's hard drive, e.g., "MONITOR." Awhost is installed following the manufacturer's guidelines. The initialization file is a comma delimited ASCII text file containing information concerning the reservoir, station, sampling interval (minutes), data log file name, serial port (COM port) for communication with the H2O, communication (baud) rate, floppy drive to be used for local file downloading, upper and lower bounds for temperature and DO, enabling or disabling of the drivesave option, and the main and print passwords. These values are determined and entered by the operator using a DOS text editor in a comma delimited format. The initialization file is accessed by the logging program each time it starts and provides it with the necessary information for communicating with the H2O and initiating logging. Following is an example of an initialization file for RBR, Station 050, that stores data into a file called MONIDATA.DAT in the directory "H2O" and samples on a 60-min interval. Communication with the H2O in the following example is established through COM 2 at 1200 baud. Drive A is used for file downloading to floppy disk. The upper bound for temperature is 40 °C, and the lower bound is 10 °C. The upper bound for DO is 15 mg/l, and the lower bound is 5 mg/l. The drivesave option is enabled (Drivesave instructs the computer to "rest" at 10-sec intervals between readings and should be enabled as a general rule), the main password is "DATA", and the print

password is "PRINT". The headers displayed by the program are shown in bold print and the values entered by the operator are shown in *italics*:

```
RES STATION INTERVAL(MIN)
DATAFILE COMPORT BAUD
FLOPPYDRIVE UBTEMP LBTEMP
UBDO LBDO DRIVESAVE(Y/N)
MAINPASS PRINTPASS
RB,050,60,C:\H20\MONIDATA.DAT,2,1200,
A,40,10,15,5,Y, DATA,PRINT
```

The PC's autoexec.bat file is edited so that the path statement includes the directory containing the executable and initialization files for the data collection program and the directory containing Awhost (AW in the example). The last two lines of the autotexec.bat file should be edited to include the commands to begin the operation of Awhost and the BASIC data collection program, respectively. An example of a possible autoexec.bat file follows displaying the additions made by the operator shown in boldface for a logging program called "MONISAV5" that is stored in a directory called "MONITOR".

```
@ECHO OFF
PROMPT $P$G
C:\POWER.MAN\PM.EXE
C:\DOS\SMARTDRV.EXE
SET MOUSE=C:\MSMOUSE
C:\MSMOUSE\MOUSE
PATH C:\MONITOR;C:\DOS;C:\WIN;C:\AW;C:\NC
SET TEMP=C:\TEMP
AHOST -M=A
MONISAV5
```

The last two lines of the file instruct the PC to start Awhost and the data collection program upon booting. Each line of data is placed into the operator specified file. In addition, daily files are created, named by date, and stored in the same directory as the logging program.

Direct communication with the H20 is accomplished through the use of "hot" keys, which are operated as follows:

- a. To take real-time measurements, simultaneously press the <CTRL> and <M> keys. This will give one line of data consisting of the current readings, although there may be a few seconds delay between the pressing of the keys and the display of the measurement.
- b. To access the Hydrolab menu for entering new calibrations, changing parameter variables, etc., simultaneously press the <CTRL> and <T> keys.

- c. To print files to floppy disk or to a serial printer, simultaneously press the <CTRL> and <P> keys. You will be instructed by the program regarding the procedure for printing to each.
- d. To end logging, simultaneously press the <CTRL> and <Q> keys.

You will be prompted for the main password anytime that actions interfere with routine logging. The print password will be necessary for printing hard copies of files or to floppy disk. You will also be prompted to enter your initials when modifying logging operation so that records of changes may be maintained.

Remote access

Follow Awremote (Symantec, Cupertino, CA) guidelines for establishing remote access to the monitor PCs. You will be prompted for a remote access password that is established when setting up Awhost. This password may be configured to automatically be given to the host PC by Awremote upon initiating communications. The present phone numbers for accessing the Savannah River monitors are listed below:

RBR: 706-213-7400

HW: 706-376-8114

JST: 803-333-2583

Calibration

Use the following procedure for routine calibration of the remote monitors at HW, RBR, and JST.

Calibration (Every 2 weeks)

- a. Thoroughly clean growth from the DO and temperature probes with a paper towel being careful not to damage the DO membrane.
- b. Attach tubing to flow-through cell outflow hose at HW and JST (or to wet-well outflow hose at RBR) and fill two 300-ml BOD bottles while taking DO measurements from H2O as outlined in Appendix A.*
- c. Take measurements until DO reading stabilizes (stable to 0.1 mg/l).
- d. Measurements are taken as follows:
 - (1) <CTRL> + <T>, to access direct communication mode.

- (2) <spacebar>.
 - (3) <M>.
- e. Perform Winkler titrations following procedure outlined in Appendix A.
- f. Compare H2O DO reading to the value obtained from the Winkler titration.
- g. If the H2O's DO concentration varies by more than ± 0.2 mg/l from the Winkler value, calculate the difference between the two values and add or subtract that amount from a current H2O DO measurement. For example, if the DO concentration as measured by the H2O was 0.4 mg/l less than concentration obtained from the Winkler titration and the current H2O concentration was 10.45 mg/l, then the H2O should be calibrated to 10.85 mg/l. Calibrations are entered as follows from the direct communications menu:
- (1) <spacebar>.
 - (2) <C>.
 - (3) <O>. Display will read "Std:".
 - (4) Enter "760" for the barometric pressure followed by <enter>, display will read "Std:".
 - (5) Enter corrected DO value (10.85 mg/l in the preceding example) followed by <enter>.
 - (6) The DO reading from the H2O should now read 0.2 mg/l higher than the Winkler value. †
- h. Leave message indicating calibration changes using the following procedure:
- (1) <spacebar>.
 - (2) <C>.
 - (3) <M>, display will read "Msg:".
 - (4) Enter message followed by initials, e.g., 'Calibration for Unit 4 changed by 0.20 mg/l on 10/29/94. JWL' followed by <enter>.

- i.* Record any messages, e.g., problems with calibration and excessive drift in DO readings, in the "Comments" section of the calibration log (Figure 12).
- ** When taking samples from the wet-well at RBR during nongeneration periods, it will be necessary to turn off (switch "down") the solenoid switch from one of the cooling lines to achieve sample flow. It is important to remember to close the drain and then switch the solenoid "on" (up) before leaving so that the sample flows are automatically regulated.
- †* The LoFlow membrane has a compensation factor of 2.5 percent for all DO measurements. This means that a DO concentration of 10.85 mg/l would initially read 11.05 mg/l by the H20, which effectively optimizes the membrane's error because of flow. When the Standard membrane and stir motor are utilized at RBR, no compensation factor is needed; entered values should be accepted literally by the H20. See Standard versus LoFlow membranes in the H20 Operator's Manual for more information.

Maintenance

Maintenance (Every 2 months)

- a.* Thoroughly clean growth from DO and temperature sensors.
- b.* Remove black O-ring and DO membrane.
- c.* Empty DO electrolyte and rinse DO probe cavity twice with fresh electrolyte (2M potassium chloride).
- d.* Fill DO probe cavity with fresh electrolyte until a meniscus (curved upper surface) is visible rising above sensor.
- e.* Carefully place new LoFlow membrane over DO sensor making certain no air bubbles are trapped under it. This is easiest accomplished by clamping H20 in a ring clamp (or between knees) and bending membrane so that curved portion is gently lowered on the sensor, being careful not to stretch the membrane. The ends are then gently released.
- f.* Gently lay O-ring so that it is centered over the sensor.
- g.* Place thumbs over O-ring and point fingers down side of H20 that faces away from the body.
- h.* With one smooth motion, snap O-ring into place.

- i.* Shake H2O until certain that the sensor is free of air bubbles. (If bubbles are present, repeat Steps *a-h.*)
- j.* Record date of servicing and membrane type on the H2O's label.
- k.* Allow at least 1 hr before recalibrating. (If possible, allow unit to operate overnight before recalibration.)

If during weekly calibrations, the H2O becomes difficult to calibrate or if visible damage to the membrane is observed, change the membrane following procedure outlined above. The preceding information is included as a supplement to the Hydrolab H2O Operating Manual. The H2O Operating Manual should be referenced if any problems are encountered.

Appendix C

Pumped Storage Monitoring at RBR

Introduction

In addition to monitoring dam release water quality, data were collected for pumped storage testing at RBR Dam. Pumped storage (pumpback) operation involves reversing conventional generation turbines so that downstream water is pumped into the forebay during nonpeak hours when power requirements are low. This stored water is then discharged by way of conventional generation during peak hours when power requirements are higher. In accordance with requirements outlined by the Savannah District and the State resource agencies of Georgia and South Carolina, testing of the viability of routine pumpback operation is being conducted in four phases. Testing includes monitoring the water quality of the pump jet (the water pumped from downstream to the forebay, i.e., the pump back release) of each pumpback turbine for every testing cycle.

Methods

Hydrolab Corporation water quality sondes are used to record pump jet temperatures, dissolved oxygen (DO) concentrations, and specific conductances for each test with temperature and DO concentrations being the major water quality indicators (specific conductance served primarily as a compensation factor for DO concentration measurements (Hydrolab Corporation 1991a).¹ Because data are desired for each individual unit and testing is conducted with varying combinations of the four pumpback turbines, it was decided that a single, permanent pumped storage monitor was unfeasible for the testing phase of pumpback operation.

¹ References cited in this appendix are located at the end of the main text.

Instead of a permanent monitor installation for pumpback testing, sondes with the capacity for internal data logging (Hydrolab Datasonde 3) or sondes without logging capacities in concert with display data loggers (Hydrolab H20 and Surveyor 3, respectively) are deployed for each test. The use of the sondes allows greater flexibility in designing deployment regimens so that each unit is individually monitored. This allows changes in testing schedules, typically the result of problems with the pump back turbines, to be addressed and yields continuous data sets of pump jet temperatures and DO concentrations for each turbine.

The water quality sondes are connected to the cooling lines of the tested turbines via hoses and flow-through cells similar to the hose-to-pump configurations of the remote downstream monitors at HW and JST dams (Figure 8). The sondes' DO probes are outfitted with LoFlow membranes because of the lower flow requirements imposed by the pressure constraints (≤ 15 psi) of the flow-through cells. LoFlow membranes are less sensitive to reduced flows and biofouling than Standard membranes, but require increased response times. Since computers are not used during data collection, the sondes' sensors remain inactive between measurements (connection of a sonde to the serial port of a computer maintains a state of sensor readiness). Hydrolab guidelines recommend allowing at least 5 min of warm-up time before taking DO measurements if a computer is not used for sonde communication and a "warm-up" option is included to accommodate this (Hydrolab Corporation 1991). Experience indicates, however, that warm-up periods of 20 min or longer are often necessary for accurate DO measurements. By installing two internal 3.5-V polarizing batteries, the sensors remain "hot" so that the response time of the LoFlow membrane approximates that of the Standard membrane (response time for the Standard membrane is virtually instantaneous). Polarizing batteries are installed prior to deployment and are removed at the conclusion of each monitoring cycle, which extends the life of the DO probes.

The sondes are powered by internal battery packs that have the capacity to hold 10 AA batteries. The internal battery packs typically power the sondes for periods of at least 1 month. Deployment duration is usually less than 1 week, and adequate power is provided by the internal battery packs so that additional external power is unnecessary. The Datasonde 3 sondes and Surveyor 3 display loggers are outfitted with the expanded memory option, available from Hydrolab, and are capable of up to 70,000 readings with all parameters enabled (Hydrolab Corporation 1991). By enabling only the parameters of concern (temperature, DO concentration, specific conductance, and battery voltage), readings taken at a 10-min interval for 1 week (the typical length of deployments for pumpback monitoring) are well within the memory constraints of the sondes.

The sondes are calibrated for DO and specific conductance prior to deployment using 100-percent saturated air and a known standard, respectively (Hydrolab Corporation 1991). Follow-up DO calibrations are performed using the azide-modification of the Winkler titration outlined in Appendix A upon initial deployment of the instrument as a corroboration of the air

calibration. Winkler calibrations are conducted for data verification midway through testing and again upon the conclusion of testing and prior to data retrieval. Logs of all calibration changes are maintained (Figure 12) so that the appropriate adjustments may be factored into the final data set. Deployments in excess of 2 weeks require maintenance of the sondes' sensors as described in Appendix B. Specific conductance was determined to express little or no drift and was of lesser concern as a water quality indicator; thus, follow-up calibrations for specific conductance were deemed unnecessary.

The sondes are programmed to record data at intervals ranging from 1 min to 1 hr, with 10 min being the most commonly used interval. Upon completion of the testing cycle, data are retrieved via computer in an ASCII text format. These data are revised to reflect calibration adjustments and linked to hydrologic data so that only data pertaining to the periods of pumpback operation are included before their incorporation into the final database for interpretation.

Results and Discussion

The use of water quality sondes for pumpjet monitoring makes it possible to adapt to the changing conditions of pumped storage testing. It is not uncommon for problems with the pumpback units to necessitate testing delays and/or schedule modifications incorporating different turbines. When situations dictate the modification of pumpjet monitoring to include a different unit, sonde relocation is a simple procedure requiring only the reconnection of the inflow hose from the cooling line of the unit to be tested to the sonde.

Pumpjet monitoring provides valuable data that are utilized by water quality and fisheries biologists in both determining the impacts of short-term pumpback operation and predicting the long-term effects attributable to routine pumped storage application. Remote monitoring allows for the identification of weekly and seasonal trends resulting from pumpback that can then be used in conjunction with additional data concerning flow rates, fish counts, etc., in evaluating the expected physical and biological impacts of continuous pumpback operation. The use of automated remote loggers serves as an invaluable tool in the assessment of the short-term implications of pumpback operation and the validation of projected long-term water quality impacts of sustained operation.

REPORT DOCUMENTATION PAGE

Form Approved
OMB No. 0704-0188

Public reporting burden for this collection of information is estimated to average 1 hour per response, including the time for reviewing instructions, searching existing data sources, gathering and maintaining the data needed, and completing and reviewing the collection of information. Send comments regarding this burden estimate or any other aspect of this collection of information, including suggestions for reducing this burden, to Washington Headquarters Services, Directorate for Information Operations and Reports, 1215 Jefferson Davis Highway, Suite 1204, Arlington, VA 22202-4302, and to the Office of Management and Budget, Paperwork Reduction Project (0704-0188), Washington, DC 20503.

1. AGENCY USE ONLY (Leave blank)		2. REPORT DATE August 1996	3. REPORT TYPE AND DATES COVERED Final report	
4. TITLE AND SUBTITLE Remote Downstream Monitoring of Savannah River Hydropower Releases			5. FUNDING NUMBERS	
6. AUTHOR(S) John W. Lemons, Michael C. Vorwerk, William E. Jabour, Joe H. Carroll				
7. PERFORMING ORGANIZATION NAME(S) AND ADDRESS(ES) Computer Sciences Corporation 3402 Wisconsin Avenue, Suite 3 Vicksburg, MS 39180; U.S. Army Engineer Waterways Experiment Station 3909 Halls Ferry Road, Vicksburg, MS 39180-6199			8. PERFORMING ORGANIZATION REPORT NUMBER Miscellaneous Paper EL-96-5	
9. SPONSORING/MONITORING AGENCY NAME(S) AND ADDRESS(ES) U.S. Army Engineer District, Savannah P.O. Box 889 Savannah, GA 31402-0889			10. SPONSORING/MONITORING AGENCY REPORT NUMBER	
11. SUPPLEMENTARY NOTES Available from National Technical Information Service, 5285 Port Royal Road, Springfield, VA 22161.				
12a. DISTRIBUTION / AVAILABILITY STATEMENT Approved for public release; distribution is unlimited.			12b. DISTRIBUTION CODE	
13. ABSTRACT (Maximum 200 words) Increased concerns over the water quality associated with hydropower releases have prompted a greater need for accurate and reliable tailrace monitoring techniques. Remote automated monitors afford the best method for continuous, unattended logging of release waters. The U.S. Army Corps of Engineers has installed and maintained remote monitors below three Savannah River reservoirs, Hartwell, Richard B. Russell, and J. Strom Thurmond. Data obtained from the monitors are utilized for operation of an oxygen-injection system, maintenance of a trout fishery, monitoring pumped storage testing, and evaluation of the water quality entering the Savannah River downstream of the three impoundments. Each monitor provides real-time information and continuous data records of water quality that are stored onsite and remotely accessible via modem. Maintenance schedules include bi-weekly calibrations combined with bi-monthly servicing. Although no single system design is universally appropriate, by careful consideration of the monitoring objectives, site characteristics, parameters of concern, and available funding, aspects of these monitoring systems may be adapted to meet the specific needs of other sites.				
14. SUBJECT TERMS Dam Dissolved oxygen Hydropower			15. NUMBER OF PAGES 50	
Remote monitor Reservoir Water quality			16. PRICE CODE	
17. SECURITY CLASSIFICATION OF REPORT UNCLASSIFIED	18. SECURITY CLASSIFICATION OF THIS PAGE UNCLASSIFIED	19. SECURITY CLASSIFICATION OF ABSTRACT	20. LIMITATION OF ABSTRACT	