

MDDC - 1297
(LADC - 333)

05282
05282

UNITED STATES ATOMIC ENERGY COMMISSION

MODEL 100 COUNTING-RATE METER

by

James Gallagher
Matthew Sands

LIBRARY OF CONGRESS
SCIENCE & TECHNOLOGY PROJECT
TECHNICAL INFORMATION SECTION

9
MAR 30 1949

19961016 385

DTIC QUALITY INSPECTED 2

Los Alamos Scientific Laboratory

This document is reproduced as a project report and is without editorial preparation. The manuscript has been submitted to The Review of Scientific Instruments for possible publication.

FILE COPY
TECHNICAL INFORMATION SECTION

Date of Manuscript: October 7, 1946
Date Declassified: September 12, 1947

Issuance of this document does not constitute authority for declassification of classified copies of the same or similar content and title and by the same authors.

Technical Information Branch, Oak Ridge, Tennessee
AEC, Oak Ridge, Tenn., 3-8-49--850-A3387

Copy #
54

Printed in U.S.A.
~~PRICE \$1.00~~

DISTRIBUTION STATEMENT A
Approved for public release;
Distribution Unlimited

DISCLAIMER NOTICE

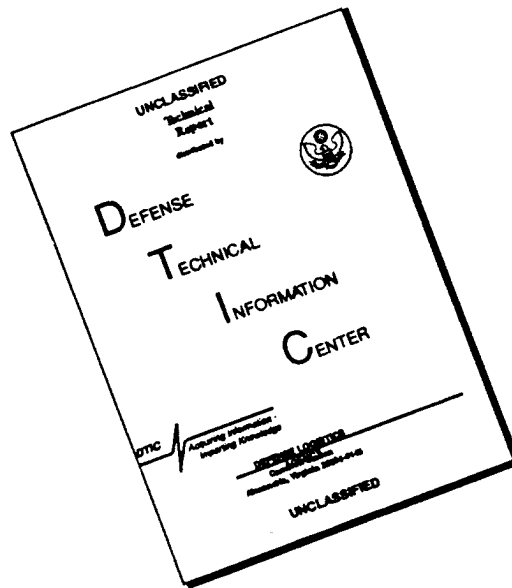

THIS DOCUMENT IS BEST QUALITY AVAILABLE. THE COPY FURNISHED TO DTIC CONTAINED A SIGNIFICANT NUMBER OF PAGES WHICH DO NOT REPRODUCE LEGIBLY.

MODEL 100 COUNTING-RATE METER

By James Gallagher and Matthew Sands

ABSTRACT

A counting-rate meter is described which provides for the operation of a pen-writing device so that a continuous and permanent record of radiation intensity can be obtained. A control of the "averaging time" or electrical damping is provided, so that the time necessary for the instrument to reach equilibrium need be no longer than that required for the desired statistical accuracy. This control is calibrated in terms of the statistical probable error in any given instantaneous indication. The instrument also contains a limit device which may be used to operate an alarm system.

INTRODUCTION

In the operation of a sustained but variable source of high-energy radiation, it is convenient to have a continuously indicating instrument for monitoring the strength of the source. Ionization chambers with sensitive DC amplifiers have been used for this purpose, but they cannot differentiate between the various types of radiation which may be present. A counting-rate meter, on the other hand, which indicates continuously the average rate of occurrence of electrical pulses, can be used, in combination with a pulse amplifier and a suitable detector, for monitoring a neutron intensity, for instance, without being affected by gamma rays which may be present. The counting-rate meter described in this article has been used for many months as part of the control and monitoring equipment of a slow neutron chain reactor. The instrument is, however, suitable for use as a counting device in the more conventional pulse-detection techniques.

Several electronic counting-rate meters have been described previously,^{1,2} and the statistical theory of the operation of such instruments has been worked out in detail.³ The instrument described here possesses some properties not found in the earlier instruments and has an essentially different type of circuit.

The Model 100 Counting-Rate Meter was designed specifically to provide for the operation of a pen-writing device, so that a continuous and permanent record of the radiation intensity could be obtained. Five sensitivity ranges are provided, so that full-scale deflections are obtained on a one-milliampere meter for counting rates from 2,000 to 50,000 counts per minute. A control of the "averaging time" or electrical damping is also provided, so that the time necessary for the instrument to reach equilibrium need be no longer than that required for the desired statistical accuracy. This control is calibrated in terms of the statistical probable error in any given instantaneous indication. The range of relative probable errors from 1 to 15 per cent is covered in five steps. The probable error and sensitivity controls are independent. The instrument contains, in addition, a limit device which operates when the counting rate exceeds some chosen value and which can be used in connection with an automatic control or alarm system. A power supply is included for operation from the 115-volt alternating-current mains.

DISCUSSION

A block diagram of the instrument is given in Figure 1. Pulses, normally from an amplifier, are applied to the input terminal. An amplitude discriminator selects for counting only those pulses larger than some chosen value. The discriminator provides pulses of uniform amplitude, which trigger a pulse shaper, or, in reality, a circuit which generates signals suitable for operating the pulse counter. The counter produces a slowly varying potential whose instantaneous value is proportional to the average rate of occurrence of the input pulses. The constant of proportionality between the pulse rate and the derived potential, i.e., the sensitivity, is adjustable, as is the averaging time. A vacuum-tube voltmeter produces a current, proportional to the derived potential, for operating indicating and recording meters. A safety circuit operates from the output of the counter when the counting rate exceeds some specified value.

The discriminator, pulse shaper, vacuum-tube voltmeter, and safety circuits are adaptations of well-known circuits. The pulse counter, which is the heart of the instrument, will, however, be discussed in detail.

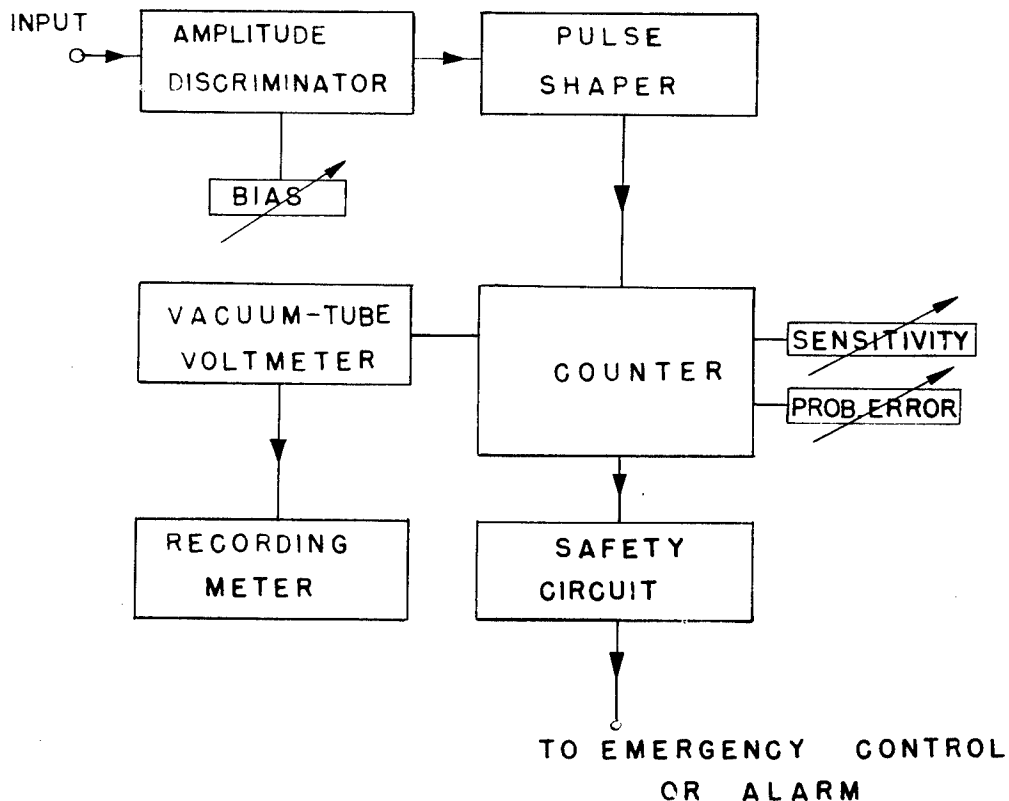

Figure 1.

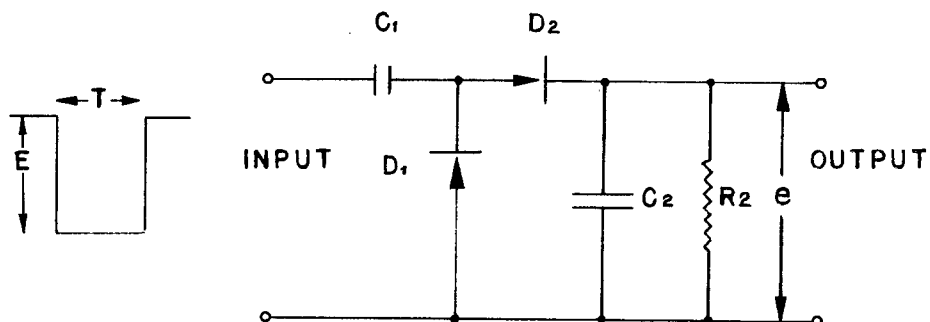

Figure 2.

The Pulse Counter

A simplified diagram of the pulse counter is given in Figure 2. For the purpose of this discussion, the diodes D_1 and D_2 are assumed to be ideal unilateral elements. The input signal consists of a negative rectangular pulse of amplitude E and of duration T . One such signal appears for each pulse which is to be counted. At the leading edge of the input signal the capacitor C_1 is charged to a potential E through the diode D_1 and is discharged through the diode D_2 at the end of the signal.* The amplitude, E , is assumed to be the same for all signals. The duration, T , need not be exactly the same for all signals, provided that it obeys the inequality

$$1/n \gg T > 5 R_1 C_1, \quad (1)$$

where n is the average counting rate and R_1 is the internal resistance of the input-signal source. If the following inequalities hold,

$$C_2 \gg C_1 \quad (2)$$

and

$$E \gg e \quad (3)$$

where e is the instantaneous value of the output potential, then each input pulse causes a charge

$$q_0 = C_1 E \quad (4)$$

to be deposited on the capacitor C_2 . The capacitor C_2 is discharged continuously through the resistance R_2 . Under equilibrium conditions, the average current through R_2 will be

$$nq_0 = nC_1 E \quad (5)$$

and the average value of the output potential will be given by

$$\bar{e} = nC_1 ER_2 \quad (6)$$

Since the vacuum-tube voltmeter indicates the instantaneous value of the output potential of the counter, the average indication is proportional to the average counting rate n . The sensitivity of the instrument, defined as the counting rate required for full-scale deflection of the meter, is conveniently controlled by switching in various values of R_2 .

* Diode circuits of this kind have long been used in electronic peak voltmeters and, more recently, as counting devices in radar circuits.

When randomly occurring pulses are being counted, the potential at the output of the pulse counter will be continually varying in accordance with statistical fluctuations in the counting rate. It can be shown, however, that the instantaneous value of e is a measure of the true average counting rate n , with a probable error which depends on the time constant R_2C_2 . It can also be shown that the relative probable error, for a given average output potential e , depends only on the capacitance C_2 .

It is evident that the output potential resulting from a single input pulse at the time T_1 will be

$$e = \frac{q_0}{C_2} e^{-(t-t_1)/(R_2C_2)} = \frac{C_1 E}{C_2} e^{-(t-t_1)/(R_2C_2)} \quad (7)$$

Application of Campbell's theorem⁴ to this result yields for the mean square deviation from the mean for random events*

$$\sigma^2 = (\overline{e^2} - \bar{e}^2) = \frac{n C_1^2 E^2 R_2}{2 C_2} \quad (8)$$

Substitution of equation 6 in equation 8 gives us the relative statistical deviation

$$\frac{\sigma}{e} = \frac{1}{(2nR_2C_2)^{1/2}} \quad (9)$$

which is the relation obtained by Schiff.⁵ Further use of equation 6, however, gives us

$$\frac{\sigma}{e} = \left(\frac{C_1 E}{2eC_2} \right)^{1/2} \quad (10)$$

which is independent of R_2 for a given value of \bar{e} . This allows us to choose the fractional statistical error in any given instantaneous indication of the instrument by a suitable choice of C_2 . Any variation in R_2 will change the counting rate at which this indication occurs, but the fractional deviation will be the same. It will be remembered that the sensitivity of the instrument is independent of C_2 , so that we have independent controls over the sensitivity and the statistical error. The most probable fractional error is

$$0.67 \frac{\sigma}{e} = 0.67 \left(\frac{C_1 E}{2eC_2} \right)^{1/2} \quad (11)$$

The Complete Circuit

The circuit diagram of the complete Model 100 Counting-Rate Meter is given in Figure 3. The diagram shows the power supply used, as well as the elements indicated in Figure 1. The tubes T-1 and T-2 with their associated components comprise an amplitude discriminator which will accept only positive pulses and whose bias setting can be varied continuously from 0 to 100 volts. The operation of this circuit is described in a paper on the Model 200 Pulse Counter. The positive pulses from the discriminator trigger the pulse shaper, Tube T-4, via the triode T-3a. A push-button switch in the cathode circuit of T-3a allows its bias to be increased momentarily, so that the pulse shaper is not triggered. This effectively disconnects the input to the counter, so that the zero adjustment of the vacuum-tube voltmeter can be checked. The pulse shaper is a trigger circuit which produces for each triggering pulse a rectangular signal of 15-microsecond duration and about 100-volt amplitude.

* It should be mentioned that the signals which are obtained from a chain-reacting system do not in general conform to the usual criterion for randomness. In these cases the fluctuations are somewhat greater than is predicted by the present discussion.

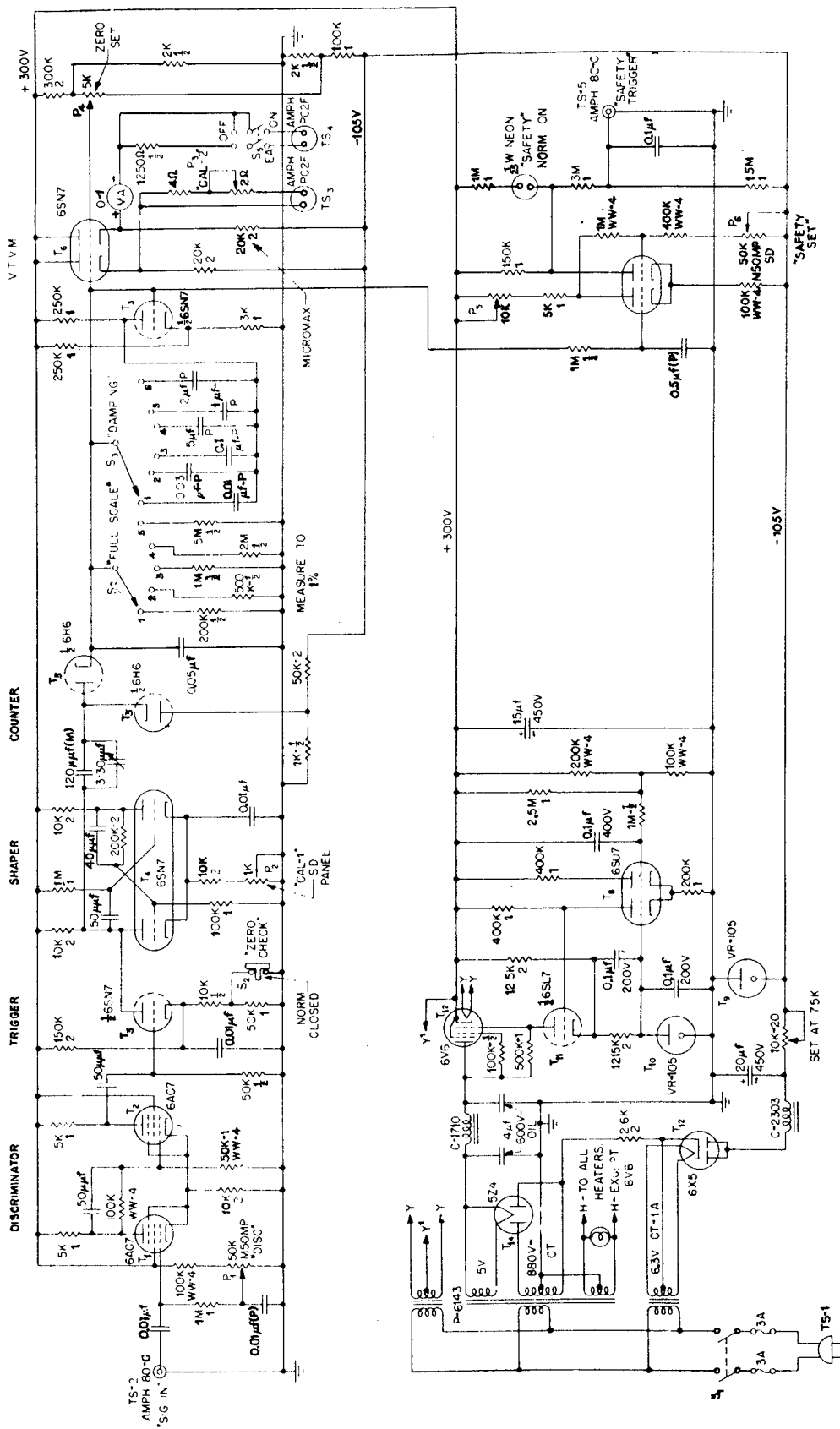

NOTES - 54.

POS	FULL SCALE CTS/MIN	POS	PROB ERROR %
1	2000	1	20
2	5000	2	10
3	10000	3	6
4	20000	4	8
5	50000	5	2
		6	15

Figure 3.

Circuits of this type, sometimes called delay multivibrators or univibrators, are discussed in the literature.⁵ The variable resistor, P_2 , in the cathode circuit of the pulse shaper serves as a fine adjustment on the amplitude, E , of the output signal, and is used as a means of calibration in accordance with equation 6. The degeneration in the cathode circuit of the pulse shaper maintains the value of E reasonably constant. The pulse shaper can be triggered by each of two pulses, separated by 20 microsecond's or more.

The pulse-counter circuit is essentially the same as that shown in Figure 2. Since electronic diodes are used which have an appreciably low resistance with zero anode potential, it was found necessary to supply a "back" bias of about three volts to achieve linearity. This does not make any essential change in the considerations of the previous section. The capacitance C_1 has been made variable so that an initial rough calibration can be made to compensate for the variations in the wiring capacitances of the individual instruments. Various values for the resistance R_2 can be selected by means of the switch SW_2 . The values shown give full-scale indications for 2,000, 5,000, 10,000, 20,000, and 50,000 counts per minute. The range of the instrument can easily be extended to lower rates by increasing the value of the capacitance C_1 and the time T . Extensions to higher rates involve more drastic alterations of the circuit. The capacitance C_2 consists of two parts, a real capacitance ($0.05 \mu f$) directly across the output of the counter and a virtual capacitance which consists of the capacitors selected by the switch SW_3 in combination with an amplifier based on the tube, T-3b. This amplifier has a voltage gain from grid to plate of 13 times and effectively "multiplies" the capacitances by this factor.* With the circuit components shown, values of 1.0, 1.5, 2.0, 5, 10, and 15 per cent can be selected for the probable error in half-scale deflection of the indicators. Actually, at the highest counting rates, an upper limit to the statistical error is set by the mechanical damping of the indicating meters.

The vacuum-tube voltmeter circuit based on T-6 is of a conventional type, in which case of centering and stability against heater-temperature variations are obtained by the use of a symmetric arrangement. The circuit will operate simultaneously a 0-1 milliamperere recording meter,[†] a Micromax Recorder[‡] (0-5 millivolts), and an ordinary panel-type meter (50 ohms). The voltmeter circuit provides a current of one milliamperere for an input potential of two volts, and is quite linear up to that value. Variation of the zero position of the vacuum-tube voltmeter with changes in the value of R_2 may occur unless a tube with reasonably low grid current is selected.

The vacuum-tube voltmeter and the counter circuit are calibrated as a unit. Sine waves at a frequency of 167 cycles per second (and amplitude greater than ten volts) are introduced at the input of the counting-rate meter. The discriminator bias is set near zero, and the range switch is set at the 10,000 counts per minute position. The meter is set to read zero while depressing the "Zero Check" switch. The switch is released and the recording current meter is brought to full-scale deflection by manipulation of the "Cal. 1" control. (If the range of the control is not sufficient, a readjustment of C_1 can be made.) After this, the Micromax Recorder can be brought to full scale by an adjustment of the "Cal. 2" resistor. No further calibration is necessary. The other ranges will be correct within the accuracy to which the resistors used for R_2 were measured.

The safety circuit, based on the tube T-7, is a Schmitt trigger circuit.⁷ It has the property that it will be triggered to a new state when the input signal rises to some positive potential (with respect to ground), say 2.5 volts, and will return to its original state when the potential falls to some lower value, say 1.5 volts. The "Safety Set" control (P_6) enables the circuit to be adjusted so that it will trigger when the output of the counter circuit becomes greater than that required for full-scale deflection of the indicators. The control P_5 determines the potential at which the circuit returns to its original state, and is normally adjusted so that this occurs only when the meter reads some value on-scale.

* Actually by 14. See, for instance, a discussion of the Miller effect.⁶

† Esterline-Angus Co. (internal resistance 1250 ohms).

‡ Leeds and Northrup.

The output of the trigger circuit is normally at -20 volts, but when triggered rises to + 25 volts. These values were chosen so that the output of the circuit could be connected directly to the grid of a thyratron in an automatic alarm device. The neon lamp, which indicates the state of the safety circuit, is normally on, and is extinguished when the circuit is triggered. It should be emphasized here that a counting-rate meter is not to be recommended as a safety device without other instruments. The nature of a pulse amplifier is usually such that it will block if the source intensity suddenly increases by a large factor. Under these conditions the counting-rate meter will fail to operate. An ionization chamber used with a DC amplifier does not exhibit this undesirable property.

The diagram of Figure 3 shows also the stabilized positive and negative supplies which are used to operate the counting-rate meter. It would be possible to modify most of the circuit so that a negative supply would not be required. In view of the added complication, and because of the bias requirement for the output of the safety circuit, this was not thought advisable. The present arrangement also insures operation of the external safety devices if the power to the counting-rate meter is interrupted.

ACKNOWLEDGMENT

The authors are indebted to R. J. Watts whose efforts made possible the appearance of this report at this time.

REFERENCES

1. Gingrich, N. S., R. D. Evans, and H. E. Edgerton, Rev. Sci. Inst. 7:450 (1936).
2. Evans, R. D., and R. L. Alder, Rev. Sci. Inst. 10:332 (1939).
3. Schiff, L. I., and R. D. Evans, Rev. Sci. Inst. 7:456 (1936).
4. Campbell, N. R., Proc. Camb. Phil. Soc. 15:117 (1909).
5. Reich, H. J., Theory and Applications of Electron Tubes, second edition, p 359, McGraw-Hill Book Company, New York, 1944.
6. Radiotron Designers Handbook, third edition, ch 7, Amalgamated Wireless Valve Co., Publisher, Sydney, New South Wales.
7. Schmitt, O. H., Jour. Sci. Inst. 15:24 (1938).

END OF DOCUMENT