

MDDC - 832

UNITED STATES ATOMIC ENERGY COMMISSION

# PRELIMINARY REPORT ON THE HIGINBOTHAM SCALER

by  
Ernest Wakefield

Argonne National Laboratory

**DISTRIBUTION STATEMENT A**  
Approved for public release  
Distribution Unlimited

DTIC QUALITY INSPECTED 2

Date of Manuscript: April 26, 1944  
Date Declassified: March 9, 1947

Issuance of this document does not constitute authority for declassification of classified copies of the same or similar content and title and by the same author.

Technical Information Branch, Oak Ridge, Tennessee  
AEC, Oak Ridge, Tenn., 5-20-49--850-A4931

Printed in U.S.A.  
PRICE 3 CENTS

19961015 161

STI  
ORDER FILE COPY  
ASTIA FILE COPY  
ATI No. 194848  
OCT 20 1951

1.15

## PRELIMINARY REPORT ON THE HIGINBOTHAM SCALER

By Ernest Wakefield

### SUMMARY

Because of the interest in the Higinbotham scaler, its operation is described and some test data is presented together with the circuit diagram. A typical parts list is included. This circuit, particularly the input, is subject to change as experience is gained.

Tests indicate that the circuit parameters of a Higinbotham circuit are wide. This conclusion is based on tests of two scalers made by Wendell Bradley's group and tested largely through the efforts of Stanley Cooper. Further work is envisaged and will be reported on in due course.

John Simpson reports that a Higinbotham has been driven at 800 K.C. He achieved this with a special input circuit and a regular pulse. In the early stages he was also careful about stray capacitances. An oscilloscope was used as a recorder.

### CIRCUIT OPERATION

#### Description of Scaling Action in the Higinbotham Circuit

The reset button being pressed places a positive potential on the right hand grid of each 6SN7 (as shown in the diagram). This causes all the right hand triodes to conduct, hence lowering their plate potentials. This cuts off the left triode and also depresses the potential on the left plate of the preceding connecting diode. The scaler is now ready to receive pulses.

A negative pulse being applied to the input trigger pair causes the first plate to go positive. This pulse is transferred to the grid of the second tube of the trigger pair causing this latter plate to go negative. As the left plate of the diode is at a lower potential than the right, the latter conducts with this negative pulse. This drops the potential of the diode plate and a negative pulse is transmitted to the grid of the triode which has been conducting current. This action decreases the current flow through this tube causing its plate to become more positive, which transmits a positive pulse to the grid of the paired triode. The plate of this triode drops in potential, which lowers the plate potential of the preceding diode, which has just conducted. This action also lowers the grid potential of the triode pair which had just decreased its passage of current further cutting off this tube. It can be seen that a positive pulse is transmitted to the next diode stage, but has no effect since it decreases the plate-cathode potential which is already too low for the diode to conduct.

The next negative pulse out of the input circuit causes the left diode to fire, because its plate potential is higher than the adjoining one. This transmits a negative pulse to the grid of the left triode which is carrying current, decreasing this flow. The plate, rising in potential, puts a positive pulse on the grid of the adjacent triode which conducts. The plate, dropping in potential as a result, places a negative pulse on the cathode of the following diode. Hence, for two negative pulses applied to the scaling stage only one has gone on.

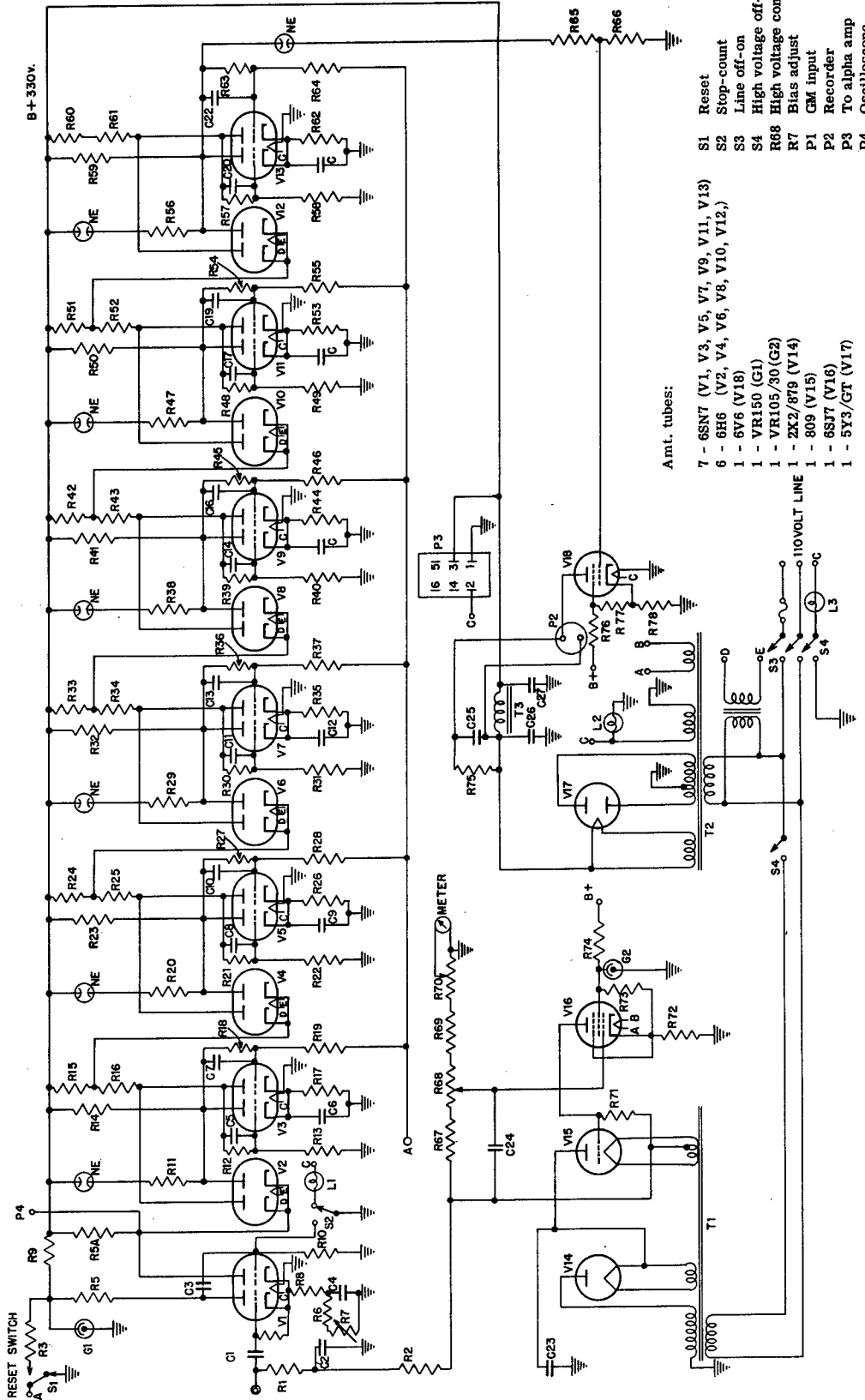

- Amt. tubes:
- 7 - 6SN7 (V1, V3, V5, V7, V9, V11, V13)
  - 6 - 6H6 (V2, V4, V6, V8, V10, V12,)
  - 1 - 6V6 (V18)
  - 1 - VR150 (G1)
  - 1 - VR105/30 (G2)
  - 1 - 2K2/8T9 (V14)
  - 1 - 809 (V15)
  - 1 - 6ST7 (V16)
  - 1 - 5Y3/GT (V17)
- S1 Reset
  - S2 Stop-count
  - S3 Line off-on
  - S4 High voltage off-on
  - R68 High voltage control
  - R7 Bias adjust
  - P1 GM input
  - P2 Recorder
  - P3 To alpha amp
  - P4 Oscilloscope

Figure 1. Circuit diagram Higginbotham scaler.

The appliance of two negative pulses to the last stage causes a positive pulse to be emitted. This places a firing voltage across the neon coupling lamp, which now passes current. This increases the potential across R66 which makes the grid of the output tube, a 6V6, more positive. This tube becomes conducting and draws current through the recorder. To decrease the reluctance of the magnetic circuit (in the Wizard recorder) iron arms rotate operating a pawl and gear registering a count. To reduce the back voltage and hasten operation of the recorder a 200,000 ohm resistor in parallel with a .06 mfd, 600 volt condenser is placed in parallel with the recorder.

The low voltage supply is conventional.

Operation of the Regulated High Voltage Supply

One end of the secondary of the high voltage transformer is grounded and the other is connected to the plate of a 2x2 half-wave rectifier tube. The cathode of this, which is at a potential of about 1600 volts, is connected to the plate of an 809 triode, which is also connected to a 2 mfd filter condenser to ground. The 809 acts as a variable resistance in the high voltage circuit and is controlled by the 6SJ7 in the manner given in the next paragraph.

Suppose the high voltage at the cathode of the 809 becomes too high. More current then passes through the bleeder resistances R67, R68, R69 and R70 to ground. From potentiometer R68 the control grid of the 6SJ7 becomes more positive with respect to the cathode permitting more current to pass through this tube. This lowers the potential on the plate of the 6SJ7, which in turn lowers the grid potential on the 809. As this effectively increases the resistance of the 809, less current is supplied to the high voltage supply and hence the voltage decreases. A decrease in voltage gives the opposite effect.

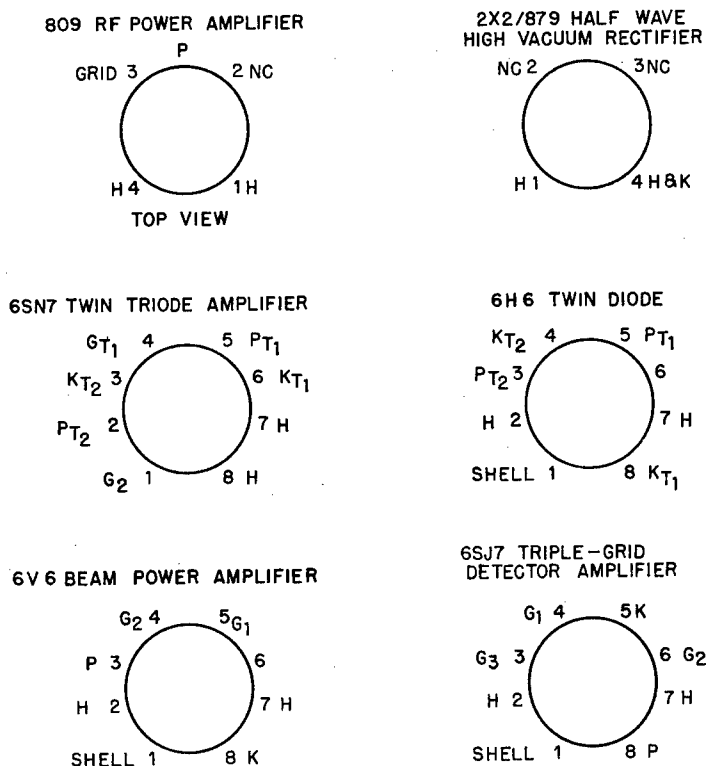

Figure 2. Several of the tubes in the Higinbotham scaler.

Table 1. Parameter tolerances.

Parameter	Actual value	First stage	Second stage	Third stage	Fourth stage	Fifth stage	Sixth stage
R11	1.0 megohm			91,000-6.0 meg. plus			
R12 or R18	0.2 megohm		180,000-225,000 †	180,000-225,000 †			
R13	0.1 megohm			160,000----- †			
R14	20,000 ohms		12,000-26,000	75,000-150,000			75,000-155,000
R15*	5,000 ohms	3,400-26,600	2,800-21,800	9,000-30,000			12,000-32,000
R16*	15,000 ohms	5,500-18,000	6,400-22,000	3,000-21,000	3,600-19,200	3,500-26,800	12,000-28,000
R17	10,000 ohms			6,500-21,000	4,700-20,800	5,400-27,000	R60 plus R61
R19	0.1 megohm			6,000-25,000			6,000-20,000
C6	.01 $\mu$ f			89,000-180,000			86,000-180,000
C7	50 $\mu$ f		37-50,000 $\mu$ $\mu$ f	80-800,000 $\mu$ $\mu$ f			80-110,000 $\mu$ $\mu$ f
			x42-15,000 $\mu$ $\mu$ f				plus

\* This row ran at 23,000 c/m. † 9,000 c/m. ‡ 23,000 c/m. Numbers not marked — 16,000 c/m.

Condenser C24 is inserted between the cathode of the 809 and the control grid of the 6SJ7 to control and reduce effects of transients or ripple.

#### TEST RESULTS

##### Method of Determining Tolerances of Parameters

On one stage at a time each parameter was varied until the scaling on that stage failed. In this way, maximum and minimum resistance and capacitance values were found. These parameters were individually soldered in for stages 3 and 6. As these results check with the results of clipping the parameters in, the values of several elements in the first, second, fourth, and fifth stages were found in this manner. These are shown in Table 1. The counting rate is also given in each instance.

## PARTS LIST

V14	2x2/879	R16	15,000 ohms, 2 watts
V15	809	R17	10,000 ohms, 3 watts
V16	6SJ7	R18	0.2 megohm, 1 watt
V17	5Y3GT	R19	0.1 megohm, 1 watt
V18	6V6	R65	1 megohm, 0.5 watt
L1	Stop Count Indicator Lamp, 6v	R66	0.5 megohm, 0.5 watt
L2	Power Supply Indicator Lamp, 6v	R71	5 megohms, 2 watts
L3	High Voltage Supply Indicator Lamp, 6v	R72	50,000 ohms
R1	1 megohm, 2 watts	R74	30,000 ohms
R2	1 megohm, 2 watts	R 75	200,000 ohms, 2 watts
R3	2 megohms, 0.5 watt	R76	5,000 ohms, 20 watts
R4	0.1 megohm, 1 watt	R77	5,000 ohms, 20 watts
R5	24,000 ohms, 1 watt	R78	2,000 ohms, 10 watts
R5A	5,000 ohms, 1 watt	C1	75 $\mu\mu\text{f}$ , 5,000 volts
R6	3,300 ohms, 1 watt	C2	.05 $\mu\text{f}$ , 2,000 volts
R7	5,000 ohms, 4 watts wire-wound potentiometer	C3	50 $\mu\mu\text{f}$
R8	1,000 ohms, 1 watt	C4	10 $\mu\text{f}$
R9	15,000 ohms, 10 watts	C5	50 $\mu\mu\text{f}$
R10	0.1 megohm, 1 watt	C6	0.01 $\mu\text{f}$
R11	1 megohm, 0.5 watt	C7	50 $\mu\mu\text{f}$
R12	0.2 megohm, 1 watt	C25	.06 $\mu\text{f}$ , 600 volts DC
R13	0.1 megohm, 1 watt	C26	20 $\mu\text{f}$ , 450 volts DC
R14	20,000 ohms, 2 watts	C27	20 $\mu\text{f}$ , 450 volts DC
R15	5,000 ohms, 1 watt		

This is not a complete list of the resistors and capacitors used in this unit. However, the values here given for the first scaling stage are typical of all six scaling stages.

END OF DOCUMENT