

FEAP-UG-96/04

August 1996

MP GL-96-25

**USER'S GUIDE**

## User's Guide: Automated Railroad Track Inspection

by

**J. Todd Weatherford**  
U.S. Army Engineer Waterways Experiment Station  
Vicksburg, MS 39180-6199

*Approved For Public Release; Distribution Is Unlimited*

19961011 061

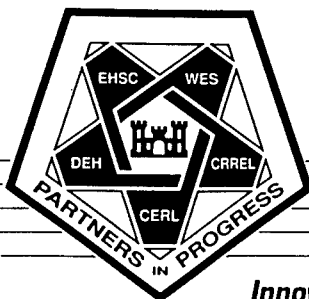

U.S. Army Center for Public Works  
Alexandria, VA 22310-3860

*Innovative Ideas for the Operation, Maintenance, & Repair of Army Facilities*

DTIC QUALITY INSPECTED 1

Destroy this report when no longer needed. Do not return  
it to the originator.

The findings in this report are not to be construed as an official  
Department of the Army position unless so designated  
by other authorized documents.

The contents of this report are not to be used for  
advertising, publication, or promotional purposes.  
Citation of trade names does not constitute an  
official endorsement or approval of the use of  
such commercial products.

# REPORT DOCUMENTATION PAGE

Form Approved  
OMB No. 0704-0188

Public reporting burden for this collection of information is estimated to average 1 hour per response, including the time for reviewing instructions, searching existing data sources, gathering and maintaining the data needed, and completing and reviewing the collection of information. Send comments regarding this burden estimate or any other aspect of this collection of information, including suggestions for reducing this burden, to Washington Headquarters Services, Directorate for Information Operations and Reports, 1215 Jefferson Davis Highway, Suite 1204, Arlington, VA 22202-4302, and to the Office of Management and Budget, Paperwork Reduction Project (0704-0188), Washington, DC 20503.

<b>1. AGENCY USE ONLY (Leave blank)</b>		<b>2. REPORT DATE</b> August 1996	<b>3. REPORT TYPE AND DATES COVERED</b> Final report	
<b>4. TITLE AND SUBTITLE</b> User's Guide: Automated Railroad Track Inspection			<b>5. FUNDING NUMBERS</b>	
<b>6. AUTHOR(S)</b> J. Todd Weatherford				
<b>7. PERFORMING ORGANIZATION NAME(S) AND ADDRESS(ES)</b> U.S. Army Engineer Waterways Experiment Station 3909 Halls Ferry Road, Vicksburg, MS 39180-6199			<b>8. PERFORMING ORGANIZATION REPORT NUMBER</b> Miscellaneous Paper GL-96-25	
<b>9. SPONSORING/MONITORING AGENCY NAME(S) AND ADDRESS(ES)</b> U.S. Army Center for Public Works 7701 Telegraph Road Alexandria, VA 22315-3862			<b>10. SPONSORING/MONITORING AGENCY REPORT NUMBER</b> FEAP-UG-96/04	
<b>11. SUPPLEMENTARY NOTES</b> Available from National Technical Information Service, 5285 Port Royal Road, Springfield, VA 22161.				
<b>12a. DISTRIBUTION/AVAILABILITY STATEMENT</b> Approved for public release; distribution is unlimited.			<b>12b. DISTRIBUTION CODE</b>	
<b>13. ABSTRACT (Maximum 200 words)</b> Automated railroad track inspection can be used to supplement a track inspector's walking inspection for a comprehensive railroad track evaluation. A track geometry vehicle can automatically measure track geometry parameters such as gauge, crosslevel, superelevation, alignment, profile, warp, and curvature. The measurements can be compared to maintenance standards and used to make a defect listing or exception report. An internal rail defect vehicle uses ultrasonic testing equipment to detect internal rail flaws such as transverse fissures and vertical or horizontal split heads. These internal rail flaws are typically not visible to the naked eye and can lead to a rail break and cause a train derailment. This report includes discussions of the description, application, benefits, limitations, costs and recommended uses for automated railroad track inspection. Model specifications for automated track geometry inspection and internal rail defect testing are also provided in the appendix of this report.				
<b>14. SUBJECT TERMS</b> Automated railroad track inspection Defect report Exception and testing reports High-rail test vehicle			<b>15. NUMBER OF PAGES</b> 38	
			<b>16. PRICE CODE</b>	
<b>17. SECURITY CLASSIFICATION OF REPORT</b> UNCLASSIFIED	<b>18. SECURITY CLASSIFICATION OF THIS PAGE</b> UNCLASSIFIED	<b>19. SECURITY CLASSIFICATION OF ABSTRACT</b>	<b>20. LIMITATION OF ABSTRACT</b>	

# DISCLAIMER NOTICE

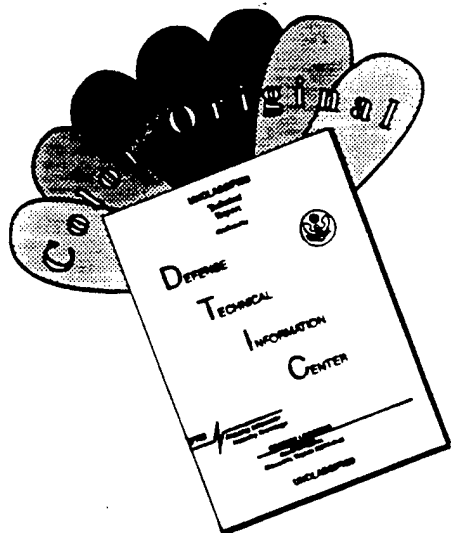

THIS DOCUMENT IS BEST QUALITY AVAILABLE. THE COPY FURNISHED TO DTIC CONTAINED A SIGNIFICANT NUMBER OF COLOR PAGES WHICH DO NOT REPRODUCE LEGIBLY ON BLACK AND WHITE MICROFICHE.

# Contents

---

1—EXECUTIVE SUMMARY .....	1
Description .....	1
Application .....	1
Benefits .....	1
Limitations .....	1
Costs .....	1
Recommendation for Use .....	2
Points of Contact .....	2
2—PREACQUISITION .....	3
Description of Automated Railroad Track Inspection .....	3
Application .....	4
Benefits .....	6
Limitations .....	6
Life-Cycle Costs .....	6
FEAP Demonstration/Implementation Sites .....	7
3—ACQUISITION/PROCUREMENT .....	8
Potential Funding Sources .....	8
Technology Components and Sources .....	9
Procurement Documents .....	9
Procurement Scheduling .....	9
4—POSTACQUISITION .....	10
Initial Implementation .....	10
Operation and Maintenance .....	11
Service and Support Requirements .....	11
Performance Monitoring .....	11
REFERENCES .....	12
APPENDIX A: SPECIFICATIONS .....	A1
Automated Track Geometry Inspection .....	A3
Internal Rail Defect Testing .....	A12
APPENDIX B: FEAP AD FLIER .....	B1

# 1 Executive Summary

---

## Description

In the past, track walkers armed with various manual tools were the primary means of assessing railroad track conditions to determine required maintenance. Today, track inspection is automated with both full-size, track-bound test cars and smaller, truck-mounted high-rail test vehicles. The smaller truck-mounted vehicles are the best suited for testing at most Army installations.

## Application

Automated railroad track inspection can be used to complete a comprehensive railroad track evaluation. A track geometry vehicle can automatically measure track geometry parameters and compare these measurements to maintenance standards and make a defect listing or exception report. An internal rail defect vehicle uses ultrasonic testing equipment to detect internal rail flaws which are typically not visible to the naked eye and can lead to a rail break and cause a train derailment.

## Benefits

The exception and testing reports provided by a comprehensive railroad track evaluation will allow installation personnel to prioritize track maintenance activities based on the type, severity, and location of the track deficiencies. Cost effective maintenance can be scheduled before problem track areas reach the point where major repairs or rehabilitation are necessary. In addition, costly or dangerous derailments can be avoided. Such efforts will prevent operating restrictions, or track closures in day-to-day operations or, more importantly, during mobilization.

## Limitations

There are no distinct limitations to using track geometry testing or internal rail defect testing at military installations. Planning and coordination should be performed prior to the contractor arriving on site to reduce the number of delays in testing.

## Costs

The 1995 cost associated with track geometry testing has a base price of approximately \$11,000 which includes mobilizations, 2 days of testing, and all related expenses. Each additional day of on-site testing is billed at \$3000 per day. The number of miles of track tested with a high-rail type vehicle varies

with the track condition and amount of railroad traffic. The average testing speed for a military installation is 3 to 4 miles per hour.

The 1995 cost associated with internal rail defect testing is approximately \$2,500 per eight-hour day. The number of miles of track tested per day will vary with track condition, number of defects, and amount of railroad traffic. The average testing speed for a military installation is 2 to 3 miles per hour.

## **Recommendation for Use**

Automated railroad track inspection is recommended for use on military railroads. The exception and testing reports will allow personnel to prioritize track maintenance based on the type, severity, and location of the track defects. Cost effective maintenance can be scheduled and executed before major problems arise. These efforts will help ensure the railroad track's ability to effectively sustain both day-to-day and mobilization operations.

## **Points of contact**

Points of contact regarding this technology are:

### **Technical:**

Director  
US Army Engineer Waterways Experiment Station  
ATTN: CEWES-GP-N (Mr. Todd Weatherford)  
3909 Halls Ferry Road  
Vicksburg, MS 39180-6199  
Telephone: (601) 634-2223  
Facsimile: (601) 634-3020

### **US Army Center for Public Works:**

Commander  
US Army Center for Public Works  
ATTN: CECPW-ER (Mr. Mike Dean)  
7701 Telegraph Road  
Alexandria, VA 22310-3862  
Telephone: (703) 806-5995  
Facsimile: (703) 806-5219

## 2 PREACQUISITION

### Description of Automated Railroad Track Inspection

Today, railroad track inspection has become automated with both full-size, track-bound test cars and smaller, truck-mounted high-rail test vehicles. These automated vehicles do not replace track inspectors, but instead they supplement the visual inspection performed by the inspector. Railroad track can be tested at rates of 2 to 4 miles per hour with these systems which automatically record the data.

The track geometry test vehicles can automatically measure physical parameters such as gage, crosslevel, superelevation, alinement, profile, warp and curvature. Figure 1 illustrates these track geometry parameters. An on-board computer system records the data, compares the measurements to maintenance standards, and prints the results in real time on a continuous strip chart in addition to making a defect listing or exception report.

The internal rail defect test vehicle uses ultrasonic testing equipment to detect internal rail flaws such as transverse fissures, vertical split heads, horizontal split heads, head/web separations, and bolt hole cracks. Figure 2 illustrates these rail defects. These defects are typically not visible to the naked eye and can lead to a rail break. The ultrasonic equipment can detect these internal defects before the rail breaks and causes a derailment.

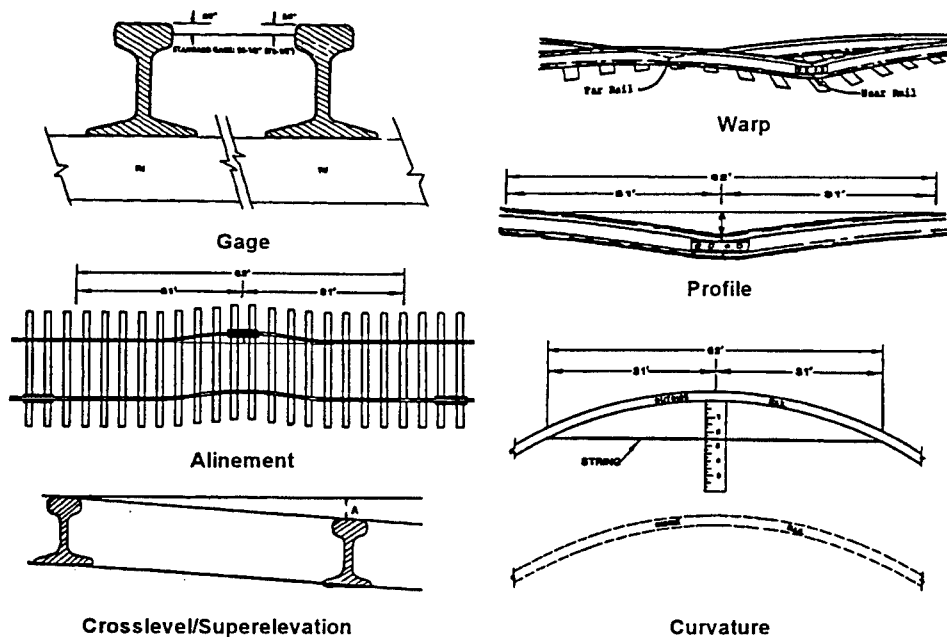

Figure 1. Track Geometry Parameters



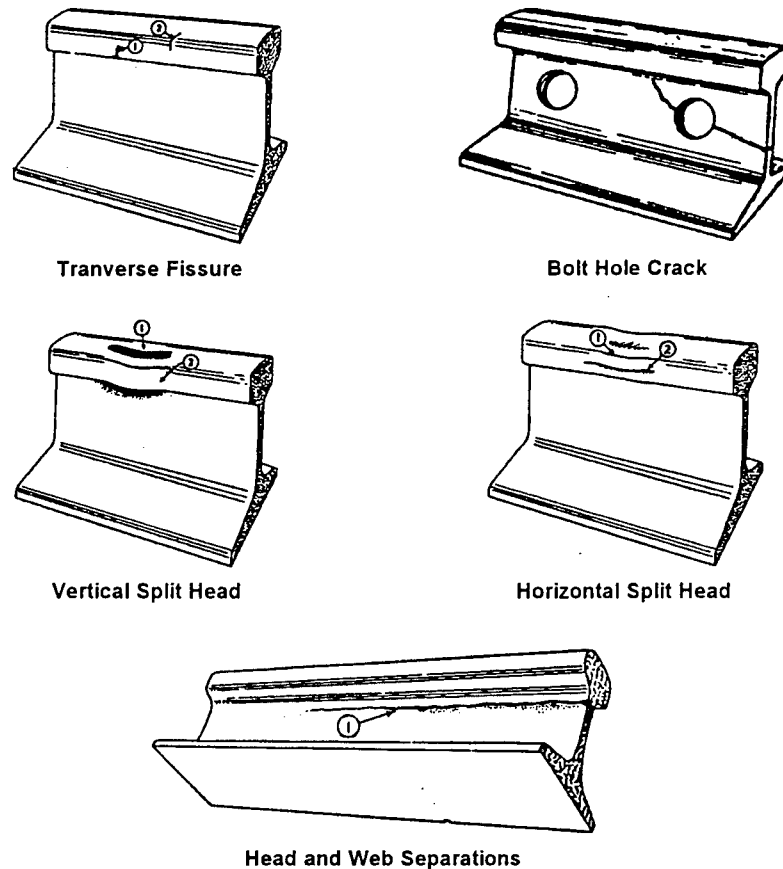

Figure 2. Rail Defects

## Application

Automated railroad track inspection can be used to supplement a track inspector's walking inspection for a comprehensive railroad track evaluation. A track geometry vehicle (Photo 1) can automatically measure track geometry parameters such as gage, crosslevel, superelevation, alinement, profile, warp and curvature. The measurements can be compared to maintenance standards and used to make a defect listing or exception report.

An internal rail defect vehicle (Photo 2) uses ultrasonic testing equipment to detect internal rail flaws such as transverse fissures and vertical or horizontal split heads. Internal rail flaws are typically not visible to the naked eye and have progressed to a dangerous state if the rail flaw is visible. If left in track, these rail defects can lead to a rail break and cause a train derailment.

A comprehensive railroad track evaluation will allow installation personnel to prioritize track maintenance activities. First, any repairs needed to avoid potential costly or dangerous derailments can be performed. Then cost effective maintenance can be performed before problem track areas reach the point where major repairs or rehabilitation are necessary. Properly executed, routine maintenance will allow day-to-day or mobilization operations to proceed without operating restrictions or track closures. Railroad tracks that receive minimal maintenance become dangerous to operate over and will eventually require expensive, major rehabilitation.



Photo 1. High-rail Track Geometry Vehicle



Photo 2. High-rail Internal Rail Defect Vehicle

## **Benefits**

A comprehensive railroad track evaluation is best accomplished through a visual inspection by a track inspector supplemented by exception and testing reports from track geometry testing and internal rail defect testing. The track inspector will always be required and cannot be replaced by automated inspection techniques.

The combined inspection data from visual and automated inspection allows maintenance personnel to plan and prioritize maintenance based on the type, severity and location of the track deficiencies. Track maintenance can be effectively planned before problem track areas require major track repairs or rehabilitation.

Effective track maintenance will lead to uninterrupted train operations due to operating restrictions or track closures. Day-to-day and mobilization operations can be sustained and the occurrence of costly and dangerous train derailments will be reduced.

Due to maintenance personnel cutbacks at the Army installations, installations may resort to using automated railroad track inspection as a means to accomplish part of their required inspections.

## **Limitations**

There are no distinct limitations to using automated railroad track inspection at Army Installations. Internal rail defect testing is required for all active Army railroads by AR 420-72 at intervals defined in Chapter 7 of Army TM 5-628, Railroad Track Standards.

Track geometry testing may not be as feasible at installations with small quantities of track (i.e. 10 miles of track or less) where track inspectors can more easily monitor on track conditions through visual inspections. The installations which have especially large quantities of track (i.e. 40 miles of track or more) can significantly improve their maintenance program by using track geometry testing.

## **Life-Cycle Costs**

With automated railroad track inspection being a testing service which generates a defect report, it is difficult to assign life-cycle costs to this technology. Benefits that are obtained through the use of the exception and testing reports are better maintenance planning and use of maintenance funds. These reports may indicate areas of track which are still in full compliance but on the borderline of becoming problem areas. These areas may require additional maintenance which will prevent costly problems from arising.

One significant benefit which arises from the use of automated railroad track inspection is a reduced number of derailments. Derailments, no matter how small or large, are always dangerous and costly. There is great potential for personnel to be injured in both the derailment and during the rerailling of the train. Even the most minor train derailment can cost a minimum of \$1000 to correct. This includes the non-operation time of the train and crew, time of the track maintenance crew and cost of repairs to the track and possibly the train.

## **FEAP Demonstration/Implementation Sites**

In 1986, all 78 miles of active railroad track at Tooele Army Depot, Utah, were evaluated. This included track geometry, rail flaw and track deflection testing and visual inspection. For 70 miles of track, track geometry testing took 4 days at a cost of \$171 per mile, and rail defect testing took 5 days at \$160 per mile. As one of the first Army sites to use automated railroad track inspection equipment, this site found this technology extremely beneficial to its maintenance program and very suitable for use at Army installations.

# 3 ACQUISITION/PROCUREMENT

---

## Potential Funding Sources

Typically, installations fund the implementation of pavements and railroads technologies from their annual budgets. However, the installation's annual budget is usually underfunded and the pavements and railroads projects do not compete well with other high visibility or high interest type projects. As a result, it is prudent to seek out additional funding sources when the project merits the action. Listed below are some sources commonly pursued to fund projects.

- a. *Productivity program.* See AR 5-4, Department of the Army Productivity Improvement Program for guidance to determine if the project qualifies for this type of funding.
- b. *Facilities Engineering Applications Program (FEAP).* In the past, a number of pavement and railroad maintenance projects located at various installations were funded with FEAP demonstration funds. At that time, emphasis was placed on demonstrating new technologies to the Directorate of Public Works (DPW) community. Now that these technologies have been demonstrated, the installations will be responsible for funding their projects through other sources. However, emphasis concerning the direction of FEAP may change in the future; therefore one should not rule out FEAP as a source of funding.
- c. *Special programs.* Examples of these are as follows:
  - (1) FORSCOM mobilization plan which may include rehabilitation of railroads and rehabilitation or enlargement of parking areas and the reinforcement of bridges.
  - (2) Safety program which may include the repair of unsafe/deteriorated railroads at crossings and in ammunition storage areas.
  - (3) Security upgrade which may include the repair or enlargement of fencing (may apply where railroads through gates are being reconstructed).
- d. *Reimbursable customer.* Examples of this source are roads to special function areas such as family housing or schools and airfield pavements required to support logistical operations.
- e. *Special requests for MACOMS.*

- f. *Year end funds.* This type of funding should be coordinated with the MACOMS to ensure that the funds will not be lost after a contract is advertised.
- g. *Operations and Maintenance Army.* These are the normal funds used for funding pavement and railroad projects.

## Technology Components and Sources

Components of the technology which must be procured for track geometry testing or internal rail defect testing are specifications and a testing contractor to perform the work. There are several commercial contractors available to perform track geometry testing or internal rail defect testing.

## Procurement Documents

A standard guide specification is not available for track geometry testing or internal rail defect testing. Specifications should at least include the quantity and location of track to be tested, a general site map for track layout, contractor equipment requirements for testing, and reporting requirements for the contractor. Appendix A presents general specifications for automated track geometry inspection and internal rail defect testing. These specifications can be used as examples.

## Procurement Scheduling

Depending on the time of the year, lead times for track testing may vary from a few days to several months. If the track testing is time critical, a contract should be executed as quickly as possible so that the contractor can coordinate testing schedules. The mainline, commercial railroads are the primary customers of track testing contractors and therefore a considerable portion of the testing contractor's schedule is usually devoted to these commercial railroads due to the enormous amount of track they have to be tested.

If the track testing is not time critical, the contractors may provide a better cost for testing if the testing can be scheduled where it best fits into an existing schedule and doesn't have to meet a specific timetable.

## 4 POSTACQUISITION

---

### Initial Implementation

#### Equipment

Railroad track testing is performed by contractors who own track geometry testing and internal rail defect testing equipment. This equipment ranges in size from small push or pull type carts to truck-mounted high-rail test vehicles, and large track-bound test cars. The truck-mount high-rail test vehicles have been found to be best suited for testing at most Army installations. The large, track-bound test cars are best suited for testing on the larger, mainline railroads. The small push type equipment for internal rail defect testing may be an option for testing small amounts of trackage, especially when justified by economics or if there is a long waiting period for a high-rail testing vehicle.

#### Materials

There are no special material requirements for track geometry testing. Internal rail defect testing does require approximately 100 gallons of water per day to act as a couplant (provides path for ultrasonic signal) between the roller search units on the testing carriage and the rail. It is reasonable and customary for the railroad owner that is being tested to provide the contractor with water for wetting the rail and a location for equipment storage.

#### Personnel

The contractor is responsible for providing personnel who are fully qualified to operate the testing vehicle and accomplish the required testing. There should be one person from the installation's railroad organization (preferably the track maintenance foreman or other experienced person) designated to ride the test car at all times during the testing. This Government representative has the responsibility of coordinating the movement of the test car with the installation railroad operations (train crew or dispatcher), guiding the test car operators during testing operations, providing the correct track name or identification to the contractor personnel, providing switching as needed, being observant for track conditions that need maintenance/repair and noting the location of these items for later investigation. If a defect is serious enough to warrant restricting operations or closing a section of track, the representative should notify the proper personnel.

Once a contract for testing has been awarded, the steps in performing the testing are:

- a. Prior to the arrival of the testing contractor, a track name or identification should be established for each track on the installation. Each track identification should be unique and have a definite beginning (usually at the switch point) and ending point. For long tracks that do not have mileposts, station markers, or some other means of referencing location along the track, it is helpful to establish reference markers at a specified intervals along the track. Typical intervals for placing markers are 1 mile (mileposts) or every 1,000-ft if 100-ft stations are used on the track.
- b. Upon arrival of the contractor and coordination between the contractor and installation personnel, testing can be accomplished as is required by the contract.
- c. Upon completion of testing, the contractor shall provide the installation with copies of the exception and testing report if performing track geometry testing or rail defect report if performing internal rail defect testing. For track geometry testing, the exception report shall be generated by comparing all measurements and calculations to the Department of the Army Railroad Track Standards for track geometry as given in Chapter 12 of technical manual TM 5-628 and noting where these measurements and calculations do not meet full compliance. For internal rail defect testing, the rail defect report shall list the exact location, type, and size of each rail defect found.

## **Operation and Maintenance**

There is no operation and maintenance of these services required by the installation. The testing reports generated by these testing services can be used by the installation to better plan and execute maintenance on the railroad track.

## **Service and Support Requirements**

No special services or support are required to implement or maintain this technology.

## **Performance Monitoring**

There are no means of monitoring the performance of automated railroad track inspections as there is with a new pavement. Automated railroad track inspections yield test reports which show the track condition at the time of testing. However, these test reports can indicate areas of track which may require operating restrictions and monitoring of track conditions until track repairs can be made.



# REFERENCES

---

Headquarters, Departments of the Army and the Air Force. (1991). "Railroad Track Standards," Technical Manual TM 5-628/AFR 91-44, Washington, DC.

US Army Engineer Waterways Experiment Station. (1991). "Automated Railroad Track Inspection," Video, 16 min, 15 sec., Vicksburg, MS.

# **APPENDIX A SPECIFICATIONS**

---

# AUTOMATED TRACK GEOMETRY INSPECTION (A)

## General

1. The contractor shall furnish all services, personnel, equipment, supplies, accessories, and travel necessary to test for geometric deviations in track using automated track geometry inspection equipment.

- a. The contractor shall perform testing on the quantity of rail specified (B) at the locations listed below.

.....

.....

- b. A general site map showing the tracks to be tested is attached. (C)
- c. The testing equipment shall measure gage, crosslevel (superelevation), left alinement, right alinement, left profile, right profile, and warp (twist) at 1-foot intervals along the track as specified in paragraph 3. The testing equipment shall have on-board data processing capability to collect, process, record, and produce real-time output of the track geometry data. The equipment shall also have the on-board capability to compare the measured parameters to preset standards and produce an exception report.
- d. The contractor shall furnish the Government a listing by location of all track geometry deviations, as specified in paragraph 4.
- e. The contractor shall coordinate all testing and movement of equipment with the Government, as specified in paragraph 2.
- f. The contractor shall abide by all Government security rules and regulations when on the installation.

## Government Responsibilities

2. The Government will be responsible for coordination of the test vehicle (D,E) movements with the installation railroad. An installation railroad employee will be provided to serve as a guide for the test vehicle and provide necessary coordination with the railroad operations.

- a. The Government will provide the contractor a location for equipment storage if needed. (F)
- b. The Government will be responsible for providing the necessary identification passes and access to secure areas. (G)

### Work to be performed by the contractor

3. Within 10 days of receipt of the signed contract, the contractor shall (G) furnish the Government a description of the equipment to be used, a work plan, and a schedule for performance of the work. [At least 14 calendar days prior to the start of testing, the contractor shall submit a list of personnel with their social security numbers and a list of equipment with an identification number to Contracting Officer. This information is required for the Government to issue identification passes to contractor personnel prior to beginning of work.]

- a. Results of testing [for each installation] shall be furnished to the Contracting Officer [and to the Government representative at each installation] upon completion of the testing [at each installation]. Testing and reports [for all locations] shall be completed for Government use not later than .....
- b. Track geometry deviations to be measured and reported shall be as follows:
  - (1) Gage shall be measured and reported as the distance between the heads of the rails at right angles to the rails in a plane 5/8-in. below the top of the rail head. Both wide and narrow gage exceptions shall be reported. The accuracy of the gage measurement shall be within plus/minus 1/16-in. of the actual track gage.
  - (2) If the inspection equipment measures gage at the rail head instead of 5/8-in. below the top of the rail head, the amount of any lip of wear present on the gage side of the rail shall be taken into account. This shall be done by manually measuring the lip on the rail at a minimum of three locations per track segment and correcting the measured gage reading.
  - (3) Crosslevel/superelevation shall be measured and reported as the difference in elevation between the top surfaces of the left and right rails measured at right angles to the rails. The accuracy of the crosslevel/superelevation measurements shall be within plus/minus 1/16-in. of the actual track crosslevel/superelevation.
  - (4) Alinement. Both left rail and right rail alinement shall be measured and reported. Alinement shall be reported as the

deviation at the mid-offset of a 62-ft chord. The accuracy of the alinement measurements shall be within plus/minus 1/16-in. of the actual track alinement.

- (5) Profile. Both left rail and right rail profile shall be measured and reported. Profile shall be reported as the deviation at the mid-offset of a 62-ft. chord. The accuracy of the profile measurements shall be within plus/minus 1/16-in. of the actual track profile.
  - (6) Warp (Twist). Warp or twist shall be calculated from the crosslevel measurements and reported as the difference in crosslevel between any two points less than or equal to 62-ft. apart.
  - (7) Landmarks such as mileposts, turnouts, curves, road crossings, and bridges shall be recorded and reported to provide reference points in locating deviations.
- c. If the measured geometric deviations appear suspect, or if there are visual indications of excessive track geometry deviations, the location will be noted and a manual, on-the-ground verification measurement will be made at that location. The manual verification will be made using conventional track inspection techniques and will include any visual evidence of movement under load.

### **Evaluation Parameters and Deviation Reporting**

4. The track geometry shall be measured and compared to the Department of the Army Railroad Track Standards for track geometry as given in Chapter 12 of technical manual TM 5-628.

- a. The maximum limits for track geometry deviation for the four Army track condition levels are given in Table 1. The deviation limits for each of the four track condition levels shall be input into the track geometry equipment's data processing system prior to the start of the testing and shall be used for all data analysis and exception reporting. (H,I)
- b. The measured/calculated data shall be output in the form of a continuous strip chart and in a geometry exception report. An exception is defined as a track geometry measurement that exceeds

the minimum or maximum requirements for a given track condition level.

- (1) The continuous strip chart shall display a continuous plot of all the parameters measured along with the location of mileposts and other landmarks.
- (2) The geometry exception report shall be a written report consisting of a detailed exception report which contains as a minimum the track segment number, the exception parameter name, the exception beginning and ending locations, the exception length in feet, the maximum (or minimum) value of the exception threshold (track condition level) used, and the type of track (i.e. tangent or curve).

Table 1. Limits for Track Geometry Deviations

<u>Parameter</u>	<u>Track Condition Level</u>			
	<u>Full Compliance</u>	<u>Restricted Operations</u>		
		<u>10 mph</u>	<u>5 mph</u>	<u>No Operation</u>
Wide Gage	57.50-in.	57.75-in.	58.00-in.	Over 58.00-in.
Narrow Gage (minimum)	56.00-in.	56.00-in.	56.00-in.	Under 56.00-in.
Crosslevel	1.50-in.	2.50-in.	3.00-in.	Over 3.00-in.
Warp	1.75-in.	2.50-in.	3.00-in.	Over 3.00-in.
Alinement	2.00-in.	4.00-in.	5.00-in.	Over 5.00-in.
Profile	2.50-in.	2.75-in.	3.00-in.	Over 3.00-in.

- c. During the testing operations, the measured track geometry data shall be compared to the limits established for the full compliance track condition level. Strip charts and exception reports shall be output during the testing operation using the full compliance track condition level.
- d. If the testing equipment has the capability of outputting the exception class and highest allowable track class (condition level) that the exception will meet, each of the track condition levels listed in Table 1 shall be input into the system, and the exception class and highest allowable condition level that the exception will (I)

meet shall be output in the exception report. If the system will only output this track class as a number, the following identification system shall be used.

<u>Track Condition Level</u>	<u>Track Class</u>
Full Compliance	3
10 mph	2
5 mph	1
No Operation	0

- e. A minimum of three copies of the strip charts and three copies of the exception reports shall be provided to the Contracting Officer at the conclusion of the tests.
- [f. In addition to the strip charts and exception reports required in (J) paragraph 4.e, data obtained during the track geometry testing shall be provided on a floppy disk(s) for input into a magnetic system. The processed track geometry data shall be provided in an ASCII file on a MSDOS readable, [5-1/4-in., 360-kilobyte, double-sided, double density][5-1/4-in., 1.2-megabyte, double-sided, high-density][3-1/2-in., high density] floppy disk. The data file shall be built with all the track geometry data for one specific track location on one line of the data file. For a specific point on the track, each data element in the file shall be separated with a blank space. The track geometry data shall be presented in engineering units in the format shown in Table 2.]

Table 2. Data Format for Microcomputer Track Geometry Files

---

Data taken at 1-ft intervals along track.  
 One test location per line of data.  
 Each data element separated by 1 blank space.  
 Format:

TRACK MP FEET GAGE XLEV LTAL RTAL LTPR RTPR SUPER  
 CURVE

where:

TRACK = Track name or identification  
 MP = Milepost  
 FEET = Number of feet past milepost  
 GAGE = Gage in inches

XLEV = Crosslevel in inches  
LTAL = Left alinement in inches  
RTAL = Right alinement in inches  
LTPR = Left profile in inches  
RTPR = Right profile in inches  
SUPER = Superelevation in inches (given only for curves)  
CURVE = Curve indicator. Tangent = 1, Curve =1

---

### **Testing Equipment and Personnel**

5. The testing equipment shall be sufficient to provide the test results and degree of accuracy required in these specifications.

- a. The testing equipment shall be capable of making measurements of gage, crosslevel or superelevation, left and right alinement, and left and right profile at intervals along the track not to exceed 1 foot. The test vehicle shall have: (1) a total vehicle weight of at least 25,000-lb when on the track with sufficient load to apply a minimum load of 500-lb to the measuring axles during testing; (2) on-board data processing capability to collect, process, record, and produce real-time output of measured data; and (3) the on-board capability to compare the measured parameters to preset standards and produce an exception report.
- b. The use of a high-rail type detection vehicle is preferred to ensure rapid completion of the testing and to facilitate coordination with the installation's railroad operations.
- c. The contractor shall submit information completely describing the characteristics and capabilities of the detection vehicle prior to its delivery to the site. Approval of the equipment by the Contracting Officer shall not relieve the contractor of his responsibility to meet the requirements of the specifications contained herein.
- d. Operating personnel shall be fully qualified to operate the testing equipment in an effective manner.

### **Quality Control**

6. The contractor shall maintain calibration checks in accordance with the manufacturer's recommendations on all testing equipment to assure accurate test results. A calibration check shall be performed on the equipment prior to each day's testing. This check shall consist of a comparison of manual



measurements taken at the loading axles under the testing equipment with measurements taken by the testing equipment. Measurements not meeting the requirements in paragraph 3 shall be corrected prior to the start of testing.

## Safety

7. The contractor shall abide by all Government rules and regulations (K) pertaining to safety and security while on the Government installation.
  - a. The maximum operating speed on Government track shall be 25 mph, unless otherwise restricted by the installation's railroad operating rules. The maximum operating speed shall be set by the on-board Government pilot consistent with the installation's railroad operation and shall not exceed 25 mph.

## GENERAL NOTES

1. This guide specification is to be used in the preparation of project specifications. It will not be made a part of a contract merely by reference; pertinent portion will be copied verbatim into the contract documents. Edit and modify this guide specification to meet project requirements.
2. The capital letters in the right-hand margins indicate that there is a technical note pertaining to that portion of the guide specification. It is intended that the letters in the margins be deleted before typing the project specifications.
3. Where numbers, symbols, words, phrases, clauses, or sentences in this specification are enclosed in brackets [ ], a choice or modification must be made; delete inapplicable portions(s) carefully. Where blank spaces occur in sentences, insert the appropriate data. Where entire paragraphs are not applicable, they should be deleted completely, and the subsequent paragraphs renumbered as appropriate.

## TECHNICAL NOTES

- A. This specification is for use in obtaining track geometry testing services for military railroad track. Track geometry testing services are available from several different contractors. These contractors use mobile equipment to test for the presence of track geometry defects. Once defects are located, the location, type, extent, and length of the defect are recorded on an exception report and strip chart inside the test vehicle. This specification has been prepared specifying automated track geometry testing using a high-rail type of test vehicle as this method has been shown

to provide good test results and optimum mobility of test equipment on military track.

- B. Paragraph 1.a. Insert the location(s) of the installation where the testing is to be performed, the nearest city or town, and the state. Also list the quantity of track to be tested. For example:

Fort Stewart, Hinesville, GA --- Approx. 17.2 track miles

If several installations are to be tested under one contract, list all of the installations to be tested.

- C. Paragraph 1.b. Provide a general site map or drawing of the tracks to be tested. This map should show the general layout of the track to be tested along with a vicinity map indicating highway access to the installation. It is desirable for the Government representative aboard the test car to have scaled maps or drawings of the installation track to provide a means of identifying the tracks and marking the location of defects for future reference.
- D. Paragraph 2. Prior to the arrival of the testing contractor, a track name or identification should be established for each track on the installation. Each track identification should be unique and have a definite beginning (usually at the switch point) and ending point. For long tracks that do not have mileposts, station markers, or some other means of referencing location along the track, it is helpful to establish reference markers at a specified interval along the track. Typical intervals for placing markers are 1 mile (mileposts) or every 1,000-ft if 100-ft stations are used on the track.
- E. Paragraph 2. There should be one person from the installation's railroad organization (preferably the track maintenance foreman or other experienced person) designated to ride the test car at all times during the testing. This Government representative has the responsibility of coordinating the movement of the test car with the installation railroad operations (train crew or dispatcher), guiding the test car operators during testing operations, providing the correct track name or identification to the contractor personnel, providing switching as needed, being observant for track conditions that need maintenance/repair and noting the location of these items for later investigation, and notifying the proper personnel should a defect be serious enough to warrant restricting speed over or closing a section of track.
- F. Paragraph 2.a. It is reasonable and customary for the railroad that is being tested to provide the contractor with a location for equipment storage during the track testing. This may or may not be needed by the contractor.
- G. Paragraphs 2.b. and 3. Delete bracketed sentences if there is no security requirement for identification passes. Modify bracketed sections as necessary to meet local security requirements.
- H. Paragraph 4.a. Table 1 lists the maximum limits for track deviations (minimum limits for narrow gage). These are the values that the

contractor should input into the testing equipment's system. In applying this table to inspection results, the following example is offered using wide gage reading. For gage measurements between 56.5-in. and 57.5-in., the track is at the "full compliance" condition level indication full compliance with the Army Railroad Track Standards. Gage measurements greater than 57.5-in. but less than or equal to 57.75-in. places the track in the "10 mph" condition level and results in operations being restricted to a maximum of 10 mph. Measurements greater than 57.75-in. up to 58.0-in. place the track in the "5 mph" condition level and require a 5 mph operating restriction. Gage measurements greater than 58.0-in. place the track in the "no operation" track condition level and require that the track be closed to operations as specified in TM 5-628, Railroad Track Standards.

- I. Paragraphs 4.a and 4.d. The term "track class" as used in the track geometry exception reports should not be confused with the class of track designated in the Federal Railroad Administration (FRA) Track Safety Standards. Most of the track geometry test equipment is configured to report results in terms of both company and FRA safety standards. With the adoption of the U.S. Army Railroad Track Standards, the FRA Track Safety Standards are no longer applicable to Army railroad track. When configuring the test equipment for track geometry testing on Army track, the contractor should eliminate the FRA standards from his data processing equipment and install the deviation limits for each track condition level from the Army standards as listed in Table 1.
- J. Paragraph 4.f. Certain contractors have the ability to convert the test data into a file compatible with RAILER and other railroad maintenance management systems. This paragraph should be retained if the data is to be used in a management system. Otherwise, delete this paragraph.
- K. Paragraph 7. Additional safety and security rules and regulations may be applicable at various installations. These rules and regulations should be included in this paragraph or outlined to the contractor prior to the start of testing.

# INTERNAL RAIL DEFECT TESTING

(A)

## General

1. The contractor shall furnish all services, personnel, equipment, supplies, accessories, and travel necessary to test for geometric deviations in track using automated track geometry inspection equipment.

- a. The contractor shall perform testing on the quantity of rail specified (B) at the locations listed below.

.....  
.....

- b. A general site map showing the tracks to be tested is attached. (C)
- c. The testing apparatus shall detect: (1) rail head defects and rail web defects inside and outside the joint bar area, (2) centrally located transverse defects in the rail head and elsewhere in the rail, (3) bolt hole cracks and head and web separations, and (4) vertical/longitudinal defects in the head or web as specified in paragraph 3.
- d. The contractor shall furnish the Government a listing by location of all rails determined to be defective by the testing operators, as specified by paragraph 4.
- e. The contractor shall coordinate all testing and movement of equipment with the Government, as specified by paragraph 2.
- f. The contractor shall abide by all Government safety and security rules and regulations when on the installation.

## Government Responsibilities

2. The Government will be responsible for the coordination of the test vehicle movements with the installation railroad. An installation railroad employee will be provided to serve as a guide for the test vehicle and provide necessary coordination with the railroad operations. (D,E)

- a. The Government will provide the contractor with a location for equipment storage and water for wetting the rail as needed. (F)
- [b. The Government will be responsible for providing the necessary identification passes and access to secure areas.] (G)

## Work to be performed by the contractor

3. Within 10 days of receipt of the signed contract, the contractor shall (G) furnish the Government a description of the equipment to be used, a work plan, and a schedule for performance for the work. [At least 14 calendar days prior to the start of testing, the contractor shall submit a list of personnel with their titles and social security numbers along with a list of equipment including equipment identification numbers to the Contracting Officer. This information is required for the Government to issue identification passes to contractor personnel prior to the beginning of work.]

- a. Results of testing [for each installation] shall be furnished to the Contracting Officer [and to the Government representative at each installation] upon completion of the testing [at each installation]. Testing and reports [for all locations] shall be completed for Government use no later than .....
- b. The minimum degree of defect detection shall be as follows:
  - (1) Transverse fissures or other centrally located transverse defects approximately 10 percent of the cross-sectional area of the rail head.
  - (2) Detail fractures representing approximately 15 percent of the cross-sectional area of the rail head and not masked from above by the shallow horizontal separation sometimes associated with shells.
  - (3) Engine burn fractures or transverse separations developing from thermal cracks underneath driver burns representing approximately 20 percent of the cross-sectional area of the rail head.
  - (4) Horizontal split head at least 2-in. in length extending at least halfway through the rail head and located 1/2-in. or more below the running surface of the rail.
  - (5) Vertical split head so oriented as to interrupt an ultrasonic signal transmitted centrally through the rail section from above.
  - (6) Head and web separations and split webs outside the joint bar limits at least 2-in. in length and progressing entirely through the rail web.

- (7) Joint defects (bolt hole cracks and head and web separations inside the joint bar limits) at least 2-in. in length and progressing entirely through the rail web.
- (8) Defective welds (plant or field) with centrally located transverse defects, voids, or inclusions in the rail head representing approximately 10 percent of the cross-sectional area of the rail head; transverse head defects not centrally located representing approximately 15 percent of the cross-sectional area of the rail head; and web defects on a generally horizontal plane at a rail weld approximately 2-in. in length or longer with penetration more than half way through the rail web.

#### **Verification, Marking, and Reporting Defective Rails**

4. Upon detecting a rail defect, the contractor shall examine the defect to determine the size, severity, and exact location of the defect. Visual verification shall be made of cracked-out transverse defects, longitudinal defects, and web and base defects outside the joint bar limits. Defects detected in previous inspections that have been protected with joint bars or otherwise not removed from track shall be examined to determine the size and severity of the defect and the rail reported defective.

- a. Defective rails shall be marked on the rail, on the detector recording, and on the defective rail report as to location type of defect, estimated size, and identification number.
- b. The location of the defect shall be identified on the rail using a high visibility point. The identification number, defect type, and estimated size shall be marked on the rail using a [lumber crayon] [or] paint marker for rapid future identification of the defect. (H)
- c. A test car movement report and a defective rail report shall be submitted daily to the Government. A final summary of test results and operation shall be furnished to the Government at the conclusion of the test.
  - (1) The test car movement report shall be a written report describing fully the movement and location of the test vehicle along the rail for each testing day.

- (2) The defective rail report shall be a daily written report that accurately describes the size, severity, and exact location of each detected defect. Location of defects shall be referenced by measuring the distance between reference points [mileposts] along the track and the defect.
- (3) The final summary of the test results and operation shall be a written report that accurately summarizes the results of all phases of the test operation and the results.

### **Testing Equipment and Personnel**

5. The testing equipment shall be sufficient to provide the test results and degree of accuracy required in these specifications.
  - a. The use of a high-rail type detection vehicle is preferred to ensure rapid completion of testing and to facilitate coordination with the installation's railroad operations.
  - b. The contractor shall submit information completely describing the characteristics and capabilities of the detection vehicle prior to its delivery to the site. Approval of the equipment by the Contracting Officer's Representative shall not relieve the contractor of his responsibility to meet the requirements of the specifications contained herein.
  - c. Operating personnel shall be fully qualified to operate the testing equipment in an effective manner.

### **Quality Control**

6. The contractor shall maintain calibration checks in accordance with the manufacturer's recommendations on all testing equipment to assure accurate test results.

### **Safety and Security**

7. The contractor shall abide by all Government rules and regulations (I) pertaining to safety and security while on the Government installation.
  - a. The maximum operating speed on Government track shall be 25 mph, unless otherwise restricted by the installation's railroad operating rules. The maximum operating speed shall be set by the

on-board Government pilot consistent with the installation's railroad operation and shall no exceed 25 mph.

## GENERAL NOTES

1. This guide specification is to be used in the preparation of project specifications. It will not be made a part of a contract merely by reference; pertinent portion will be copied verbatim into the contract documents. Edit and modify this guide specification to meet project requirements.
2. The capital letters in the right-hand margins indicate that there is a technical note pertaining to that portion of the guide specification. It is intended that the letters in the margins be deleted before typing the project specifications.
3. Where numbers, symbols, words, phrases, clauses, or sentences in this specification are enclosed in brackets [ ], a choice or modification must be made; delete inapplicable portions(s) carefully. Where blank spaces occur in sentences, insert the appropriate data. Where entire paragraphs are not applicable, they should be deleted completely, and the subsequent paragraphs renumbered as appropriate.

## TECHNICAL NOTES

- A. This specification is for use in obtaining rail defect testing services for military railroad track. Rail defect testing services are available from several different contractors. These contractors use mobile equipment to test the rail for the presence of internal defects. Once defects are located, the location, type, and size of the defect are marked on the defective rail and on a defect report inside the test vehicle. Methods normally used for rail defect testing include both magnetic induction and ultrasonic testing. This specification has been prepared specifying ultrasonic testing as this method has been shown to provide good test results and optimum mobility of test equipment on military track.
- B. Paragraph 1.a. Insert the location(s) of the installation where the testing is to be performed, the nearest city or town, and the state. Also list the quantity of track to be tested. For example:

Fort Stewart, Hinesville, GA --- Approx. 17.2 track miles

If several installations are to be tested under one contract, list all of the installations to be tested.
- C. Paragraph 1.b. Provide a general site map or drawing of the tracks to be tested. This map should show the general layout of the track to be tested along with a vicinity map indicating highway access to the installation. It



is desirable for the Government representative aboard the test car to have scaled maps or drawings of the installation track to provide a means of identifying the tracks and marking the location of defects for future reference.

- D. Paragraph 2. Prior to the arrival of the testing contractor, a track name or identification should be established for each track on the installation. Each track identification should be unique and have a definite beginning (usually at the switch point) and ending point. For long tracks that do not have mileposts, station markers, or some other means of referencing location along the track, it is helpful to establish reference markers at a specified interval along the track. Typical intervals for placing markers are 1 mile (mileposts) or every 1,000-ft if 100-ft stations are used on the track.
- E. Paragraph 2. There should be one person from the installation's railroad organization (preferably the track maintenance foreman or other experienced person) designated to ride the test car at all times during the testing. This Government representative has the responsibility of coordinating the movement of the test car with the installation railroad operations (train crew or dispatcher), guiding the test car operators during testing operations, providing the correct track name or identification to the contractor personnel, providing switching as needed, being observant for conditions in the rail, joints, or other track components that need maintenance/repair and noting the location of these items for later investigation; and notifying the proper personnel should a defect be serious enough to warrant restricting speed over or closing a section of track.
- F. Paragraph 2.a. It is reasonable and customary for the railroad that is being tested to provide the contractor with a location for equipment storage and water for wetting the rail. These may or may not be needed by the contractor.
- G. Paragraphs 2.b. and 3. Delete bracketed sentences if there is no security requirement for identification passes. Modify bracketed sections as necessary to meet local security requirements.
- H. Paragraph 4.b. The defect identification should be written on the rail using a permanent paint marker (paint pen) if any length of time is expected between the rail defect testing and the correction of the defective condition. Lumber crayon provides a temporary marking but will fade with time and weather.
- I. Paragraph 7. Additional safety and security rules and regulations may be applicable at various installations. These rules and regulations should be included in this paragraph or outlined to the contractor prior to the start of testing.

**APPENDIX B**  
**AD FLIER**

---

## Automated Railroad Track Inspection



**Left:** Rail defect testing with a truck-mounted high-rail test vehicle.

**Above:** A three-inch bolt hole crack located by a rail defect testing car. The defect is marked with paint for repair.

**PROBLEM:** Identifying railroad track deficiencies and locations where maintenance is required.

**TECHNOLOGY:** Automated and visual techniques for railroad track inspection, including:

- Track-bound or truck-mounted high-rail test vehicles for testing track geometry
- Internal rail flaw testing
- Track deflection testing
- Visual inspection

**DEMO SITES:** Tooele Army Depot, UT – FY86

**BENEFITS:**

- Identifies problem areas requiring maintenance
- Allows for more cost effective repairs
- Prevents track closures or operating restrictions
- Improves track safety

**Description of Technology.** In the past, track walkers armed with various manual tools were the primary means of assessing railroad track conditions to determine required maintenance. Today, track inspection is automated with both full-size, track-bound test cars and smaller, truck-mounted high-rail test vehicles. The smaller truck-mounted vehicles are the best suited for testing at most Army installations.

Test vehicles can automatically measure track geometry parameters such as gage, cross level, superelevation, alignment, profile, warp and curvature. An on-board computer system records the data, compares the measurements to maintenance standards, and prints the results in real time on a continuous strip chart in addition to making a defect listing or exception report.

Using ultrasonic testing equipment mounted in a high-rail test vehicle is the best way to detect internal rail flaws such as transverse fissures and vertical or horizontal split heads. The ultrasonic equipment can detect internal rail flaws that are not visible to the naked eye before the rail breaks and causes a derailment.

Since much of the Army's railroad track is lightweight rail with fair to poor support conditions, track deflection testing should be conducted using a locomotive or loaded car with a known wheel load for the testing. Structural analysis based on track deflection testing will determine the structural capacity of the track and provide engineering data for the design of any required repairs.

Visual inspection of turnouts, road and rail crossings, drainage structures and the roadway completes the comprehensive track evaluation program.

**Details of Demonstration..** In 1986, all 78 miles of active railroad track at Tooele Army Depot, UT, were evaluated. This included track geometry, rail flaw and track deflection testing and visual inspection. For 70 miles of track, track geometry testing took 4 days at a cost of \$171/mile, and rail flaw testing took 5 days at \$160/mile. Waterways Experiment Station (WES) personnel conducted track deflection tests during a 6-day period which covered 31 miles of track at a total cost of \$3,375.

**Benefits of Technology.** The exception and testing reports provided by a comprehensive railroad track evaluation will allow personnel to prioritize track maintenance activities based on the type, severity and location of the track deficiencies. Cost effective maintenance can be scheduled before problem track areas reach the point where major repairs or rehabilitation are necessary. In addition, costly or dangerous derailments can be avoided. Such efforts will prevent operating restrictions, or track closures in day-to-day operations or, more importantly, during mobilization.

**Point of Contact.** Mr. David M. Coleman, U.S. Army Engineer Waterways Experiment Station, 3909 Halls Ferry Road, Vicksburg, MS 39180-6199, (601) 634-2223. Mr. Scott Thompson, CEHSC-FB-P, U.S. Army Engineering and Housing Support Center, Building 358, Fort Belvoir, VA 22060-5516, COMM 202-355-3582.