

---

---

**COMBAT RATION  
ADVANCED MANUFACTURING  
TECHNOLOGY DEMONSTRATION  
(CRAMTD)**

**"Machine Vision Inspection - Pouch Seal Areas"**  
Short Term Project (STP) #63

**FINAL TECHNICAL REPORT**  
Results and Accomplishments (October 1995 through June 1996)  
Report No. CRAMTD STP #63 - FTR21.0  
CDRL Sequence A004  
August 1996

CRAMTD CONTRACT NO. SPO300-95-Z107  
CLIN 0002

Sponsored by:  
DEFENSE LOGISTICS AGENCY  
8725 John J. Kingman Road  
Ft. Belvoir, VA 22060-6221

Contractor:  
Rutgers, The State University of New Jersey  
THE CENTER FOR ADVANCED FOOD TECHNOLOGY\*  
Cook College  
N.J. Agricultural Experiment Station  
New Brunswick, New Jersey 08903

Principal Investigators: .  
Neal Litman  
Stanley Dunn

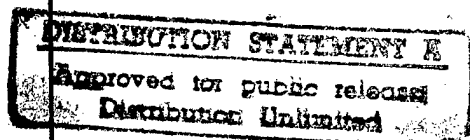

Dr. John F. Coburn  
Program Director

TEL: 908-445-6132  
FAX: 908-445-6145

19961008 031

\*A New Jersey Commission on Science and Technology Center

DTIC QUALITY INSPECTED 1

# DISCLAIMER NOTICE

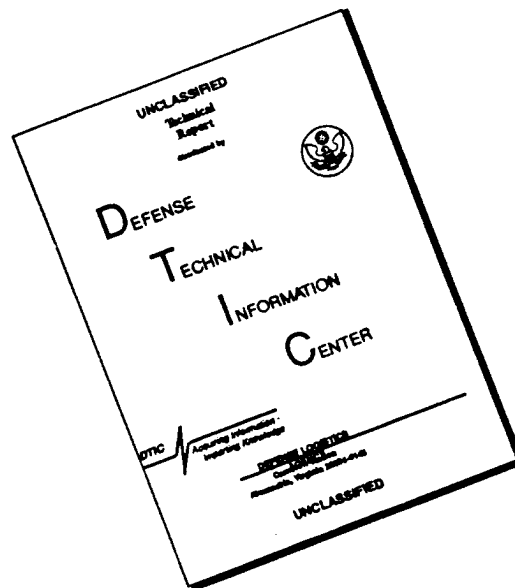

**THIS DOCUMENT IS BEST QUALITY AVAILABLE. THE COPY FURNISHED TO DTIC CONTAINED A SIGNIFICANT NUMBER OF PAGES WHICH DO NOT REPRODUCE LEGIBLY.**

# REPORT DOCUMENTATION PAGE

Form Approved  
OMB No. 0704-0188

Public reporting burden for this collection of information is estimated to average 1 hour per response, including the time for reviewing instructions, searching existing data sources, gathering and maintaining the data needed, and completing and reviewing the collection of information. Send comments regarding this burden estimate or any other aspect of this collection of information, including suggestions for reducing this burden, to Washington Headquarters Services, Directorate for Information Operations and Reports, 1215 Jefferson Davis Highway, Suite 1204, Arlington, VA 22202-4302, and to the Office of Management and Budget, Paperwork Reduction Project (0704-0188), Washington, DC 20503.

<b>1. AGENCY USE ONLY (Leave blank)</b>		<b>2. REPORT DATE</b> August 1996	<b>3. REPORT TYPE AND DATES COVERED</b> Final Oct. 1995 - Jun 1996	
<b>4. TITLE AND SUBTITLE</b> Machine Vision Inspection - Pouch Seal Area (Short Term Project) STP#63			<b>5. FUNDING NUMBERS</b> C-SP0300-95-Z107 PE-7811s PR-88003	
<b>6. AUTHOR(S)</b>  N. Litman and S. Dunn				
<b>7. PERFORMING ORGANIZATION NAME(S) AND ADDRESS(ES)</b> Rutgers, The State University of New Jersey The Center for Advanced Food Technology Cook College, NJ Agricultural Experiment Station New Brunswick, NJ 08903			<b>8. PERFORMING ORGANIZATION REPORT NUMBER</b>  FTR 21.0	
<b>9. SPONSORING/MONITORING AGENCY NAME(S) AND ADDRESS(ES)</b> Defense Logistics Agency 8725 John J. Kingman Road Ft. Belvoir, VA 22060-6221			<b>10. SPONSORING/MONITORING AGENCY REPORT NUMBER</b>	
<b>11. SUPPLEMENTARY NOTES</b>				
<b>12a. DISTRIBUTION/AVAILABILITY STATEMENT</b>			<b>12b. DISTRIBUTION CODE</b>	
<b>13. ABSTRACT (Maximum 200 words)</b>  A preventative element within the process of Horizontal Form-Fill-Seal (HFFS) MRE pouch production is needed to avoid defects due to seal area contamination. In the proposed concept, a machine vision camera is positioned above the formed pouch after the filling operation and just prior to placement of the upper lidstock/sealing station. A seal would be acceptable if there were no product or other contaminant found on any of the four seal areas and the seal process (seal time, temperature, and pressure) was under control. Controlled lab experiments were conducted on MRE pouches produced on the HFFS which showed that common contaminants are detected with sensitivities of 95-100% and without false positives (specificity of 100%). The worst system performance was found for water (sensitivity 93%, specificity 100%). Based on the laboratory results, a single camera, single pouch, prototype machine vision inspection system was specified, designed, constructed and installed on the CRAMTD HFFS line. The plant-floor system is an enclosed unit constructed by Precision Automation, Cherry Hill, NJ and incorporating an Allen-Bradley Color CVIM module.				
<b>14. SUBJECT TERMS</b>			<b>15. NUMBER OF PAGES</b> 48	
			<b>16. PRICE CODE</b>	
<b>17. SECURITY CLASSIFICATION OF REPORT</b> Unclassified	<b>18. SECURITY CLASSIFICATION OF THIS PAGE</b> Unclassified	<b>19. SECURITY CLASSIFICATION OF ABSTRACT</b> Unclassified	<b>20. LIMITATION OF ABSTRACT</b> UL	

# Contents

---

1.0	CRAMTD STP #63 .....	1
1.1	Introduction and Background .....	1
1.2	Results and Conclusions .....	1
1.3	Recommendations .....	2
2.0	Program Management .....	3
2.1	Progress Summary .....	3
3.0	Short Term Project Activities .....	4
3.1	STP Phase I Tasks .....	4
3.1.1	Problem Specification, Requirements Analysis and System Definition (Task 4.3.1.1) .....	4
3.1.2	Laboratory Model (Task 4.3.1.2) .....	4
3.2	STP Phase II Tasks .....	5
3.2.1	Production Prototype System (Task 4.3.2.1) .....	5
3.2.2	Installation on Line (4.3.2.2) .....	5
3.2.3	Performance Testing (Reference 4.3.2.3) .....	5
4.0	Appendix .....	6
4.1	Figure 1 Program Plan and Schedule: CRAMTD CSTP #63 Machine Vision Inspection - Pouch Seal Areas	
4.2	Specification for Vision Inspection System for HFFS Packaging Line	
4.3	Precision Automation Proposal for Vision Inspection System, OD6-8009	
4.4	Memo: Justification for Purchase of Vision Inspection System	
4.5	Product Data: Allen-Bradley Color CVIM, Bulletin 5370	
4.6	Drawing of Machine Vision Inspection System	

# 1.0 CRAMTD STP #63

## Results and Accomplishments

---

### 1.1 Introduction and Background

At present time, two 100% inspections are conducted of each MRE pouch, pre- and post-retort, typically requiring 12 inspectors per line to inspect for surface defects and defective seals. A defective seal is not limited to current leakers but also includes poor seals which result in later leaks. Even with this investment of manpower, the USDA still rejects for bad seals approximately 2% of the lots offered for acceptance. Besides the high rejection rate, the in-process inspections are carried out at the production line pace, limiting the inspecting time to any individual pouch. Secondly, human performance is variable and degrades with time. Thirdly, the Horizontal Form-Fill-Seal (HFFS) pouch with four produced seals increases the exposure to seal contamination when compared to the one produced seal from preformed vertical filling. Also, human inspection is limited to the visible defects and neglects the quality of the seal. Finally, all of these inspections address detection after the defect already exists.

A preventative element within the process is needed to avoid defects from escaping inspection and causing lot rejection. Such a method exists, as demonstrated in Short Term Project #11, a machine vision system for inspection of the exposed sealing surface of the HFFS pouch. In the proposed concept, a system camera is positioned above the formed pouch (looking down), after the filling operation and just prior to placement of the upper lidstock/sealing station. Such an approach must be demonstrated to process MRE pouches at the 120 per minute rate. A seal would be acceptable if there were no product or other contaminant found on any of the four side seal areas and the seal process was under control. HFFS machines have automated controls that monitor the critical sealing parameters; seal time, temperature and pressure to assure seal consistency.

The objective of this project was to demonstrate a single camera, single pouch, prototype machine vision inspection system installed on the CRAMTD HFFS line. The purpose of developing the prototype is to determine inspection criteria, physical constraints and assess system performance on the CRAMTD production line.

### 1.2 Results and Conclusions

One of the results of STP 11 was that color could be used as a feature for automatic inspection of pouches. Whereas the tests conducted as part of STP 11 were for pouch surfaces, we first had to show in this work that the same principle could be applied to the internal surface of the HFFS pouch.

The laboratory tests demonstrated that the same principle could be used and with promising detection accuracy. It is common to think of color represented by red, green and blue; televisions and computer monitors operate by representing color this way. However, this may not be the best representation for contaminants on seal areas. We found in this work that color saturation - the "amount" or "degree" of color present is a significant feature.

The internal surface of the HFFS pouch is nearly white (i.e., there is no saturation) and reflects all color. Any contaminant present (which has some color) will change the saturation. Thus, a location on the HFFS where there is a sudden change in saturation is likely to be due to the presence of a contaminant. Since some changes are due to contours or impressions of the web from forming the pouch which may appear as noise in the image, a threshold can be set to eliminate potential false positive defects.

We found that this simple imaging principle works satisfactorily in both laboratory tests and in controlled experiments in the pilot plant. Our results (see Section 3.0) show that common contaminants are detected with great accuracy (sensitivity) without false positives (high specificity). The worst system performance was found for water, but this is to be expected since the amount of color change from water to HFFS seal is very small. Even so, water was detected 93% of the time.

This laboratory work allowed us to establish a specification and criteria for a commercial system to work in the pilot plant. Of the three competing technologies considered, we chose the Allen Bradley system since it was the only one of the three that had color imaging technology and could perform the necessary computation fast enough to satisfy the 120 pouch per minute transfer rate. In the Allen Bradley system the images are processed and a decision is made in 42 milliseconds.

It is conceivable that the other systems may be able to detect the contaminants with the similar detection accuracy, but one or more other specification criteria may not be met. For example, it is possible that monochrome, i.e., black and white cameras may be used in conjunction with color filters to capture color information. This approach is more costly and will increase the computation time necessary. Using black and white cameras alone is not likely to be as robust as color since many other factors (noise, dust, or shadows, for example) can confound the presence of true contaminant changes.

Consequently, we selected a system in which we could implement directly the principles demonstrated in our laboratory studies. We have successfully demonstrated that the detection system works in both off line and on line tests in the pilot plant.

These results demonstrate practical feasibility of using machine vision technology to automatically detect the presence of contaminants on seal areas of HFFS pouches. The state of the art is at a point now where there is machine vision hardware and software available to implement complex imaging techniques in practically useful ways, that are robust (insensitive to small variation) and low cost. These results suggest that seal area contaminants can be detected during HFFS line operation.

### **1.3 Recommendations**

- Upgrade the prototype system with components to enable inspection of the complete HFFS web (all pouches). This will require adding vision processor/camera/lighting components to the existing enclosure.
- Develop automated pouch removal from HFFS machines. This will benefit labor cost and reduce operator error.

- Integrate system with Multivac HFFS lines. Develop integrated controls with Multivac PLC and communication links for Information System and/or data collection.
- Demonstrate complete system at vendor facilities.

## **2.0 Program Management**

---

This STP was proposed as a two phase work activity as illustrated on the “CRAMTD STP #63 Program Plan and Schedule” (Appendix 4.1). The scope of this project was to:

- Phase I.** Continue the preliminary experiments reported in STP #11 so that data acquisition and analysis software be added to the hardware breadboard.
- Phase II.** Integrate a prototype inspection system with the CRAMTD horizontal form-fill-seal machine and conduct performance testing and demonstration.

During Phase I the seal inspection problem was to be precisely defined along with the constraints of on-line performance and functional requirements. Using a laboratory model, the inspection software will be developed and a proof of concept tested.

Phase II is devoted to acquisition of a plant floor prototype machine vision inspection system including special image processing hardware, camera, lighting and other components. The phase ends with the demonstration of the prototype on the horizontal form/fill/seal line. The work activity and status are illustrated on the attached figure 1 CRAMTD STP #63, “Machine Vision Inspection - Pouch Seal Areas,” Time and Event Milestones (Appendix 4.1).

### **2.1 Progress Summary**

- Laboratory experiments performed on 4 contaminants: water, gravy, grease from Hot Dogs or Ham slices and slivers of meat from Hot Dogs or Ham Slices were used to establish required vision system resolution.
- Accuracy for a laboratory color imaging system was determined for several types of seal contaminants.
- Vision system equipment suppliers and system integrators were contacted. Initial discussions were held with several of the vendors.
- Developed specifications for Vision Inspection System for HFFS.
- Visited three machine vision vendors.
- Evaluated proposals from Precision Automation, Parish Automation and Packaging Technologies & Inspection (PTI).
- Selected proposal from Precision Automation. Purchase Order placed for system.
- Demonstrated prototype component-system at CRAMTD End of Contract Briefing.

## 3.0 Short Term Project Activities

---

### 3.1 STP Phase I Tasks

#### 3.1.1 Problem Specification, Requirements Analysis and System Definition (Task 4.3.1.1)

A number of machine vision system vendors and system integrators were contacted; Acuity Imaging, Perceptics, Intec, Allen-Bradley, Precision Automation, Dolan Jenner, PTI Visi-Pack, Parish Automation, Thermedics Detection, Kodak, Kalish, Sharp and PPT Vision. Initial meetings were held with Parish Automation and Precision Automation.

Work was accomplished to establish performance requirements to be used in developing the equipment specifications. Experiments were conducted to determine the amount of contamination that is detectable and the corresponding required resolution. Contaminants considered were; water, gravy grease and fragments of meat.

#### 3.1.2 Laboratory Model (Task 4.3.1.2)

Controlled laboratory experiments were conducted on individual pouches produced on the Tiromat H-F-F-S machine. The inspection consisted of analysis of all 4 side seals by color spectrum. Sensitivity and specificity are used to characterize accuracy of vision systems. Sensitivity is the percentage of true defects labeled as such, specificity is the percentage of clean pouches labeled correctly.

Results based on the collective set of 50 samples of each class, with different size defects in each class, are as follow:

<u>Defect</u>	<u>Sensitivity</u>	<u>Specificity</u>
Beef Stew	100%	100%
Beef Stew + Gravy	100%	100%
Beef Stew Gravy	97%	100%
Ham pieces	99%	100%
Ham Grease	97%	100%
Frankfurters	99%	100%
Frankfurter Grease	95%	100%
Water	93%	100%

Examples of processed vision system images can be viewed at the CRAMTD Website;  
<http://pfmis.rutgers.edu>

Experiments were made on the polymeric half steam table tray to determine whether a vision system could also be used to inspect the tray seal area. This presents a greater challenge, since the surface is reflective. The problem was mostly solved by color compensation methods developed in STP #11. The performance was comparable to the MRE inspection results with degradation noted for water contamination where the sensitivity was 89%.



## **3.2 STP Phase II Tasks**

### **3.2.1 Production Prototype System (Task 4.3.2.1)**

System specifications were developed from the experiments performed in Phase I, and from discussions with vision system vendors (Appendix 4.2).

Proposals based on our specifications were received from Precision Automation, Parish Automation and Packaging Technologies & Inspection. These proposals were evaluated on a technical basis.

Demonstration tests were made on four vision systems;

- Allen-Bradley CVIM-2 monochrome (Precision Automation)
- Allen-Bradley Color CVIM (Precision Automation)
- Acuity Power Vision 60 monochrome (PTI)
- PC/Sharp GPB-2 Image Processor monochrome (Parish Automation)

These tests showed the A-B Color CVIM system was best able to reject "noise" and correctly identify real contamination. All systems had the same video resolution and therefore the ability to detect small flaws.

Precision Automation's proposal (Appendix 4.3) was selected because the proposed Allen-Bradley color processor was considered superior (see Appendix 4.4 for Letter of Justification). The high performance dedicated processor has less reliance on image processing algorithms and programming which improves robustness and detection accuracy of the system. The cost of the system was \$53,000 which included all hardware, software, installation and training. The system can accommodate a second vision processor that increases the field of view for complete web inspection of either Tiromat or Multivac HFFS lines at an estimated cost of \$30,000. A description of the vision processor is provided in Appendix 4.5.

### **3.2.2 Installation on Line (4.3.2.2)**

Meetings were held with Precision Automation to discuss design details of the contracted vision inspection system which included; fiber optic strobe lighting and a unitized console.

Final drawings of the vision inspection system were received from Precision Automation and approved. A drawing of the system is shown in Appendix 4.6. The prototype component-system was returned to Precision Automation, following preliminary testing at the CRAMTD Demonstration Site, in order to be integrated into a suitable, plant-floor, enclosure.

### **3.2.3 Performance Testing (Reference 4.3.2.3)**

The prototype component-system was successfully demonstrated during the June 19, 1996 End of Contract Briefing by representatives of Precision Automation and Allen-Bradley. Performance testing and ongoing demonstration will resume when the plant-floor enclosed system is returned (scheduled for late July 1996).

## 4.0 Appendix

---

- 4.1 Figure 1 Program Plan and Schedule: CRAMTD CSTP #63 Machine Vision Inspection - Pouch Seal Areas
- 4.2 Specification for Vision Inspection System for HFFS Packaging Line
- 4.3 Precision Automation Proposal for Vision Inspection System, OD6-8009
- 4.4 Memo: Justification for Purchase of Vision Inspection System
- 4.5 Product Data: Allen-Bradley Color CVIM, Bulletin 5370
- 4.6 Drawing of Machine Vision Inspection System

**Figure 1 - CRAMTD Candidate Short Term Project #63  
Machine Vision Inspection - Pouch Seal Areas  
Program Plan and Schedule**

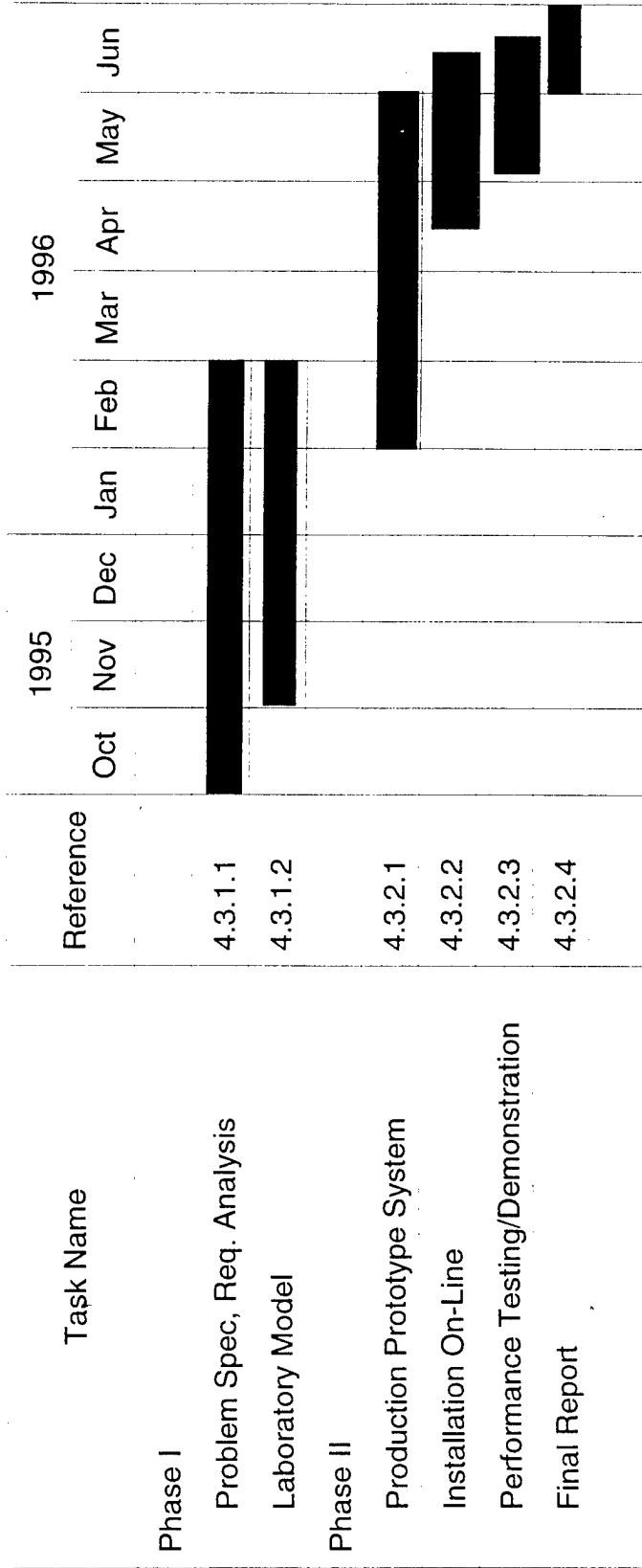

Printed: 07/19/96



March 13, 1996

## Specification for Vision Inspection System for H-F-F-S Packaging Line

### 1.0 Application

Inspect seal areas of packages for one lane of a horizontal-form-fill seal production line for contamination.

### 2.0 Production Requirements

2.1 Production Line: Tiromat 3000 horizontal form-fill-seal packaging line forming MRE pouches in a 2 lane by 3 row index. The film surface is polypropylene over aluminum foil. Tiromat total cycle time is 3.5 seconds, having a dwell of approximately 2.5 seconds. The inspection will be located immediately preceding the sealing station and occupy the smallest possible area.

2.2 Area to inspect: The vision inspection system will inspect the seal areas of each pouch including adjacent web areas (between pouches and at the transport chain clips). The system will be required to inspect one lane (three pouches of per index). Note: due to forming, the seal area is not perfectly flat or smooth.

2.3 Defects/Objects to be identified: Water droplets, gravy droplets or smears, solid pieces (meat or vegetables). Defects are 1.5mm in diameter or larger.

### 3.0 Performance Requirements

Accuracy/Reliability: The system will identify 75% of defects from 1.5 to 3.0mm in diameter and 98% of defects greater than 3.0mm in diameter. The vision system will not reject "good" pouches.

### 4.0 Integration

4.1 Package identification: defective pouches will be identified with indicator lights mounted at the Tiromat discharge conveyor.

4.2 Data Collection: The vision system will collect and display results of each image and overall production statistics (number of packages inspected, rejected, location of defects). Statistical (summary) and operational (system status and faults) data will also be transmitted to supervisory PLC and displayed at the MRE Line control panel.

4.3 Physical Requirements: The vision system will be operated in a washdown environment (any components that are easily moved from line need only be splash proof), compliance with USDA is required, operating power will be 120V.

## **5.0 Operator Interface**

The vision system will be operated at a movable control panel. Programming, control and status display will be at this station.

## **6.0 Project Scope**

6.1 Vision system hardware and software: Vision processor, camera(s), lens, cables and wiring, monitor, input devices.

6.2 Lighting: reflectors, baffles, hood, light, ballast and fiberoptic cables(as needed),

6.3 Support: frame to mount camera and lighting to Tiromat. This fixture should be removable to facilitate production line cleaning.

6.4 Enclosure: cabinets for processor (on wheels) and camera (as needed).

6.5 Programming: vision system calibration and application specific software, Supervisory PLC and remote operator control panel.

6.6 Installation: delivery of equipment to Rutgers, wiring to PLC and any other necessary devices, assembly of hardware components, testing and calibration.

6.7 Acceptance Test: demonstrate performance requirements have been met.

6.8 Training: instruction for use and maintaining equipment.

6.9 Documentation/Manuals: drawings, software and manuals

## **7.0 Future Applications**

The vision system will be capable of being used for other applications such as different packaging materials, package configurations (i.e. package size, additional lanes) or packaging lines (traypacks).

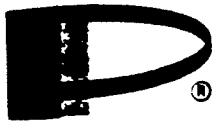

**PRECISION AUTOMATION CO., INC.**

BOX 18  
HADDONFIELD, NJ 08033  
609-428-7400  
FAX 609-428-1270

CAFT/Food Mfg. Tech. Facility  
Rutgers, the State University of NJ  
Vision Inspection System  
OD6-8009



# PRECISION AUTOMATION CO., INC.

BOX 18  
HADDONFIELD, NJ 08033  
609-428-7400  
FAX 609-428-1270

March 21, 1996

OD6-8009

CAFT/Food Manufacturing Technology Facility  
Rutgers, The State University of New Jersey  
120 New England Avenue  
Piscataway, NJ 08854

Attn: Mr. Neal Litman

Ref: Vision Inspection System

The following is in response to a request for a design and implementation proposal for the vision inspection system project.

This proposal has been prepared after a careful review of all the project requirements. An approach has been developed utilizing extensive machine and control system integration experience. As a result, we believe that this approach will lead to a successful project which will be on target, on time and on budget.

Thank you for this opportunity to provide this proposal. We are looking forward to meeting with you to review this proposal in detail and providing our services on this and future projects.

Very truly yours,

Jack Tarman

Copy To:

1. PAC File
2. JET File

**PROPOSAL NO. OD6-8009 Rev. 0**  
**March 21, 1996**

**Proposal for**

**CAFT/Food Manufacturing Technology Facility**  
**Rutgers, The State University of New Jersey**  
**Vision Inspection System**

**Design/Build**

**TABLE OF CONTENTS**

<b>BASIS OF PROPOSAL:</b> .....	<b>3</b>
<b>CLIENT SPECIFICATIONS AND GOALS:</b> .....	<b>3</b>
<b>PROPOSED SCOPE:</b> .....	<b>4</b>
<b>PROJECT MANAGEMENT:</b> .....	<b>4</b>
<b>DESIGN AND ENGINEERING:</b> .....	<b>4</b>
<b>EQUIPMENT:</b> .....	<b>5</b>
<b>SIMULATION TESTING:</b> .....	<b>5</b>
<b>SHIPPING AND PREPARATION:</b> .....	<b>5</b>
<b>INSTALLATION:</b> .....	<b>5</b>
<b>FIELD SERVICE:</b> .....	<b>6</b>
<b>COMMERCIAL:</b> .....	<b>7</b>
<b>PRICING:</b> .....	<b>7</b>
<b>PAYMENT TERMS:</b> .....	<b>7</b>
<b>NOTES:</b> .....	<b>7</b>
<b>SCHEDULE:</b> .....	<b>8</b>
<b>APPENDIX I - CONTRACT TERMS:</b> .....	<b>9</b>



## **Basis of Proposal:**

### ***Client Specifications and Goals:***

The following information has been provided to Precision Automation and forms the basis of this proposal:

- I. General Requirements.
  - A. Inspect seal areas of packages for contamination.
    1. One lane of horizontal-form-fill seal production line.
  - B. Rate of production is up to 110 pouches/min.
  - C. Performance:
    1. 75% of defects from 1.5 to 3.0mm in diameter will be identified.
    2. 98% of defects greater than 3.0mm in diameter will be identified.
    3. "Good" pouches will not be rejected.
  - D. Defective pouches are to be identified utilizing indicator lights mounted at the Tiromat discharge conveyor.
- II. Type of Proposal.
  - A. This proposal is a complete Design/Build/Install.
  - B. Pricing is provided as a budget price estimate for the defined scope.
- III. Customer specifications. Dwgs, Etc.
  - A. Specification for Vision Inspection System for H-F-F-S Packaging Line dated 3/13/96.

## **Proposed Scope:**

### ***Project Management:***

The goal of this service is to coordinate all project execution activities to insure quality, schedule and budget while addressing and minimizing risk. The following tasks and deliverables are included:

- I. Conduct a project kick off meeting with the client, sales and engineering representatives.
- II. Maintain and manage client communications including:
  - A. Client reviews and approvals.
  - B. All required commercial issues including:
    1. Documents (Purchase order, etc.)
    2. Billings
    3. Shipping instructions and schedule.
    4. Change order requirements and documents.
  - C. Technical issues not resolved by engineering.

### ***Design and Engineering:***

The goal of this service is to provide a system that will perform in accordance with the project requirements and client expectations within the technical constraints. The following tasks and deliverables are included:

- I. Camera & Lighting Specification, B/M.
- II. Control console design, specification and B/M.
- III. Annunciator panel design, specification and B/M.
- IV. Software Development
  - A. Provide Color CVIM application set up & configuration.
  - B. Modify existing PLC code for CVIM.PLC Communication.
  - C. Modify panelview code to display CVIM accept/reject data.
  - D. Modify existing PLC code to provide data base for SCADA system.
- V. Documentation
  - A. The equipment will be documented on our standard drawing media. The drawing package will include:
    1. Assembly drawings
    2. Detailed component drawings
    3. Electrical schematics
    4. Ladder logic diagrams
    5. Complete bill of material
  - B. Our standard operation/maintenance manual outlining the set-up, operation, trouble shooting and preventative maintenance procedures for the equipment will be provided as an option.
- VI. Simulation testing plan.

**Equipment:**

The goal of this service is to provide an assembly of equipment that will be in accordance with the design and engineering specifications. The following tasks and deliverables are included:

- I. Sensors:
  - A. (1) AB Color Camera
    - 1. With 12.5mm Lens C-Mount
    - 2. With Camera Cable
- II. (1) Portable control console assembly consisting of:
  - A. (1) Stainless Steel console enclosure.
  - B. (1) Main circuit breaker - 1 pole, 120V
  - C. (1) AB Color CVIM.
  - D. (1) AB Vision Platform.
  - E. (1) Monitor, 14" Color.
  - F. (1) RGB to VGA Converter.
  - G. (1) 24V DC Power Supply.
  - H. (1) Light Pen.
  - I. (1) AB 16 pt I/O Module.
- III. (1) Annunciator Panel consisting of the following:
  - A. (1) Stainless Steel Enclosure.
  - B. (6) Indicator lights.
- IV. (1) Strobe lighting assembly.

**Simulation Testing:**

The goal of this service is to verify that all equipment and assemblies perform in accordance with the project requirements and engineering specifications as well as substantially reduce risks prior to on site installation and testing. The following tasks and deliverables are included:

- I. Shop simulation test set up.
- II. S/W installation and pretest.
- III. Client witness testing.

**Shipping and Preparation:**

The goal of this service is to insure that all equipment will arrive on site, on time, in good condition. The following tasks and deliverables are included:

- I. Equipment wrapping and crating where required.
- II. Transportation to the site via motor frt. collect transportation (FOB shipping point).

**Installation:**

Since the proper installation and adjustment of the sensors is critical to the success of the project, installation services have been included in this proposal. Also, recognizing that

there are many unknown variables beyond the control of Precision Automation Co. the following is the intended scope that is included in this proposal:

- I. **Mechanical Installation:**
  - A. Furnish mounting brackets for supplied camera.
  - B. Provide mounting of supplied camera with mounting brackets.
  - C. Furnish mounting brackets for supplied lighting equipment.
  - D. Provide mounting of supplied lighting equipment with mounting brackets.
  - E. Provide mounting of supplied annunciator panel.
- II. **Electrical Installation:**
  - A. Power supply (115V) within 10 ft. of system console to be provided by customer.
  - B. Provide wiring from camera to system console. (Portable cords)
  - C. Provide wiring from power supply (115V) to system console. (Portable cord)
  - D. Provide wiring from system console to lighting equipment. (Portable cord)
  - E. Provide remote I/O wiring from system console to PLC cabinet. (Portable cord)
  - F. Provide wiring from annunciator panel to the PLC panel. Spare space in existing conduit runs will be utilized.
- III. An allowance for installation services is included in this proposal as follows. (Addl services are available - see commercial section for rate schedule)
  - A. On site engineer - 40 hr regular time.
  - B. Installation mechanic/electrician - 40 hr regular time.
  - C. Electrical installation materials (conduit, sealtite, boxes, etc.) may not be required and are not included. If required, these materials may be furnished by customer.

**Field Service:**

The goal of this service is to verify that all equipment and assemblies perform in accordance with the project requirements and engineering specifications as well as to confirm proper installation and functionality for the client's process. The following tasks and deliverables are included:

- I. **Mechanical**
  - A. Final adjustment and alignment of supplied machine mounted equipment.
- II. **Electrical**
  - A. Field wiring verification.
  - B. Power up functional test.
  - C. System commissioning.
  - D. Post commissioning f/u & fine tuning.
  - E. All documentation upgraded to "As Installed".
- III. An allowance for start-up services is included in this proposal as follows. (Addl services are available - see commercial section for rate schedule)
  - A. On site engineer - 20 hr regular time.

**Commercial:**

**Pricing:**

Budget Estimate Pricing for project scope as outlined above:

- I. **Total (ESTIMATED) Price** **\$ 53,000.**
  
- II. Field Service and/or Start-Up assistance as additional scope to the above is available upon request and the following is our current rates:
  - A. Regular hours including portal to portal travel time.
    - 1. Up to 8Hrs/Day \$ 60.00/Hr
    - 2. Plus actual travel and living expenses.
  - B. Weekday overtime hours/or Saturday including portal to portal travel time.
    - 1. Over 8Hrs/Day or Saturday \$ 70.00/Hr
    - 2. Plus actual travel and living expenses.
  - C. Sunday or holiday hours including portal to portal travel time.
    - 1. Anytime \$ 80.00/Hr
    - 2. Plus actual travel and living expenses.

**Payment Terms:**

- I. Milestone payment schedule - to be determined.
- II. Travel and living expenses for Project Management/Engineering/Installation/Field Service are not included and will be billed as actual expenses with net 30 payment terms

**Notes:**

- I. General Terms:
  - A. Please Review our "Contract Terms: found in Appendix 1 which are a part of this proposal.
  - B. Note the above prices do not include any state or local sales or use taxes. Licenses, permits or fees, if required, are the customer's responsibility.
  - C. This proposal is based on a straight time. 40 hours per week basis. Should overtime be requested by Customer, an appropriate extra charge will be required.
  - D. This proposal includes an acceptance run-off at the Precision Automation Co., Inc. plant witnessed by the customer.
  - E. The customer shall have a competent technical support staff to operate and maintain the equipment in their facility.
  - F. Equipment Operation - Purchaser shall use and shall require its employees to use all safety devices and guards on the equipment. Purchaser shall use safe operating procedures. Purchaser shall not remove or modify any such device or guard or warning sign. If purchaser fails to observe any or all of these obligations, purchaser agrees to indemnify and save Precision

- Automation Co., Inc. harmless from all liability incurred to persons injured directly by operating the Precision Automation Co., Inc. equipment.
- G. Modifications or alterations to the equipment without the express written consent of the manufacturer is forbidden. Failure to obtain permission in writing voids any warranty, expressed or implied. It also relieves the manufacturer from all liability for said products.
  - H. *If required* - Customer supplied parts shall be to agreed specifications. Precision Automation Co., Inc. cannot be held responsible for equipment operation using out of tolerance components.
  - I. *If installation is included* - All Utilities are the responsibility of the Customer. Utilities are to be within five (5) feet of the control panels and/or machine connections for the system.

**Schedule:**

Schedule details are to be developed in conjunction with client needs. All pricing is based on the following approximate schedule:

- I. Order placement is anticipated within 30 days.
- II. Four week lead time is required to procure vision equipment.
- III. Shipment is estimated to be six weeks after receipt of vision equipment.

**Appendix I - Contract Terms:**

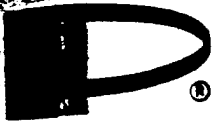

**CONTRACT TERMS**

1. **PRICES** - F.O.B., as specified. All applicable taxes will be added to the price of the equipment and paid by the Purchaser.
2. **SHIPMENT** - Delivery time specified has been calculated pursuant to the nature of the work required and the experience of Precision Automation Co., Inc. in furnishing the equipment of the kind desired by Purchaser; however, any order must be accepted by us with the understanding that delivery time is our best estimate but is not a guaranteed date. Estimate of time of delivery shall date from our acceptance of written purchase order and receipt of full manufacturing details.
3. **TITLE** - Seller retains title to this equipment until full payment is made. Buyer agrees to protect Seller by maintaining full insurance in the amount of the purchase price, as Seller's interest may appear.
4. **WARRANTY** - Seller warrants equipment of its own manufacture to be free from defects in materials and workmanship. This warranty extends only to the original Buyer and is limited to repair or replacement F.O.B. Seller's factory of any original part or component manufactured by Seller which is found by Seller to have been defective at the time of shipment, provided written claim has been received from Buyer within three (3) months of shipment. With respect to equipment, materials, parts and accessories manufactured by others, Seller will undertake to obtain for Buyer the full benefit of the manufacturer's warranties. Seller will not be liable for any loss of profit, loss by reason of plant shutdown, non-operation or increased expense of operation, loss of product or materials, or other special or consequential loss or damage of any nature, and all claims for such loss or damage are expressly waived by Buyer. Buyer hereby agrees to indemnify and save Seller harmless from any and all liability, loss or damage, expense, causes of action, suits, claims or judgments arising from injury to person or property resulting from the use, operation, delivery, or transportation of the equipment. Buyer expressly agrees to indemnify Seller against and hold Seller harmless from any and all claims and causes of action arising out of or relating to any actual or alleged negligent acts of Seller or arising out of or related to any strict liability in tort imposed upon Seller for placing the equipment in the stream of commerce, having any defect or claimed defect. **THIS WARRANTY IS IN LIEU OF ALL OTHER WARRANTIES, EXPRESS OR IMPLIED.**
5. **CANCELLATION** - Cancellation of orders placed and accepted can be made only with our written consent and upon terms which will indemnify us against loss or damages.
6. **APPROVAL** - This Proposal is subject to change without notice. Any order given shall not constitute a binding contract until order has been received at the office of Precision Automation Co., Inc. and accepted by it in writing.
7. **CONFIDENTIAL** - Technical data and layouts supplied by Seller in connection herewith are confidential pending Buyer's acceptance of this Proposal, and may not be used without written consent of Seller.
8. **OSHA LAWS** - The Williams-Steiger Occupational Safety and Health Act of 1970 (OSHA) and like state and local laws and all regulations issued under such laws, are designated to assure a safe place to work and apply primarily to the employer, not the equipment manufacturer. Seller will work with Buyer to find technically feasible answers to possible compliance problems; however, because compliance is significantly affected by many factors over which Seller has little control (such as installation, plant layout, building acoustics, materials processed, processing procedures and supervision and training of employees), Seller does not represent or warrant that equipment sold by it complies with OSHA or any like state or local law or regulation, and the cost of modifications and responsibility for compliance are the Buyer's responsibility.



THE STATE UNIVERSITY OF NEW JERSEY  
**RUTGERS**

Food Mfg. Technology Facility  
120 New England Avenue  
BUSCH Campus  
EXT. 5-6130

Interdepartmental Communication

TO: Mike Dunn  
Purchasing Dept.

FROM: Neal Litman



DATE: April 10, 1996

RE: Justification For Purchase of Vision Inspection System

This memo is to request purchase of a Vision Inspection System for H-F-F-S Packaging Line from Precision Automation Co., Inc. The system specification and Precision Automation proposal is attached with the Purchase Order.

The primary task of Short Term Project #63 Phase II is the installation and integration of a Production Prototype Vision Inspection System on our H-F-F-S production line, see Attachment A. Our selection is based on a comprehensive research effort under STP #63:

- Feasibility study (under STP #11)
- Problem definition and development of system specifications
- Contact potential equipment suppliers; Acuity Imaging, Perceptics, Intec, Allen-Bradley, Precision Automation, Dolan Jenner, PTI Visi-Pack, Parish Automation, Thermedics Detection, Kodak, Kalish, Sharp and PPT Vision)
- Laboratory and in-plant testing with prototype components from Parish Automation/Sharp, Precision Automation/Allen-Bradley and PTI/Acuity Imaging. The other companies were unable to meet our project requirements or declined to test.
- Proposal review and negotiation for best value and features

Of the three systems considered, the Parish and PTI systems were based on PC platforms using monochrome imaging and the Precision system was based on a dedicated vision processor with color imaging. The Parish system required 4 cameras per pouch (not practical for production), the PTI system used 2 cameras for 3 pouches and Precision required 1 camera for all 3 pouches. The Parish and PTI systems are more complicated and rely significantly on image processing algorithms and programming, which limit the robustness of the system, they are more sensitive to errors or variation in the production environment.

Our previous work, as well as work reported in the literature, suggest that color is a significant feature to use for our task. The Precision Automation/Allen-Bradley system is based on the A-B Color CVIM vision module. The processor is compatible with the existing production line control system and thereby minimizes integration time and cost.

Therefore, the Precision system is the only one of the three that meets our requirements and needs. We consider Precision to be the only supplier that has an appropriate vision system.

#### Attachments

cc: J. Coburn  
T. Descovich  
S. Dunn  
K. Danner



ALLEN-BRADLEY

## Bulletin 5370 Color CVIM™ Configurable Vision Input Module

(Catalog No. 5370-CVIMC)

### Product Data

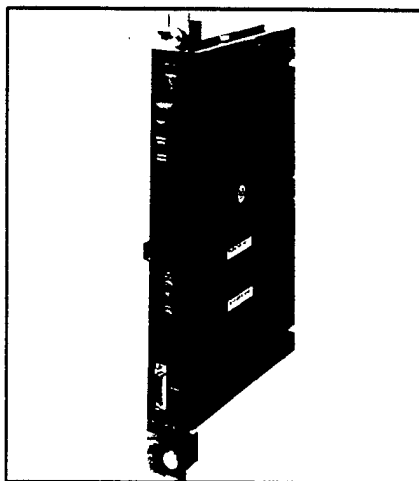

92T 510-7

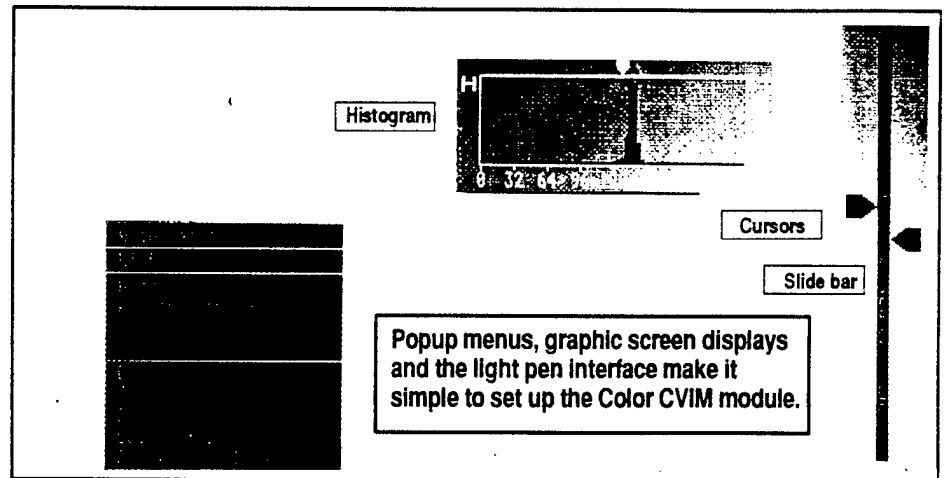

**Description.** The Color Configurable Vision Inspection Module (CVIM) is part of the growing family of machine vision products from Allen-Bradley. Based on the successful CVIM module platform, the Color CVIM module retains many of the familiar CVIM features, including a wide selection of powerful vision analysis tools, easy setup, flexibility, and affordable price.

Add to that even more new features, like high-speed contour analysis, *plus the dramatic dimension of color-based inspection*, and the result is the Color CVIM module – a very sophisticated yet easy-to-use vision system.

Figure 1. Gray-scale vs. Color Imaging in Machine Vision

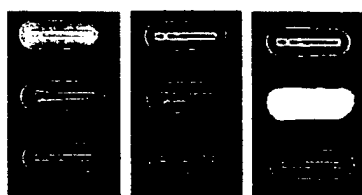

A

B

C

The first column (A) of Figure 1 shows how three differently colored capsules might appear in a gray-scale image. Distinguishing among the three types of capsules using a gray-scale image would be difficult, if not impossible. It is easy to distinguish among the capsules when viewed in color (column B). Finally, when configured to identify all objects of a particular color (red in column C), the Color CVIM module highlights the red capsule in bright white so it stands out for further evaluation.

And because the Color CVIM module is part of an *integrated system* wholly supported by a single vendor, you can put it to work without the time and effort associated with untested hardware combinations and customized software.

## Machine Vision Inspection

The Color CVIM module delivers exceptional value because it is loaded with the capabilities you need to take the next big step in making machine vision work for you. Based on 85 years of factory automation experience, the Color CVIM module is yet another tool you can use to:

- **Increase production** without compromising the quality of your product. The Color CVIM module will never get tired, bored, or distracted, and its electronic eyesight works hundreds of times faster than any human eye. Now you can boost your throughput *and* maintain high quality.
- **Improve effectiveness of automation** with a clear, straightforward *system* approach that saves you time and development effort. We designed the Color CVIM module with an emphasis on easy integration into even the most complex automated manufacturing environments. A powerful base feature set, a wide variety of hardware and software options, and flexible input and output capabilities provide the flexibility you need to make the Color CVIM module work for *you* the way *you* want.
- **Improved product quality** resulting from 100% inspection of your product as it comes off the assembly line. The system follows the parameters *you* set. Have you ever tried to concentrate on a moving workstream for more than a few seconds at a time? Then you already know it is impossible for any human inspector to perform well for more than a minute or two at a time, much less a full shift. Yet the Color CVIM module never even blinks without your permission.
- **Improved implementation of Statistical Process Control** thanks to the specialized statistical management functions built into the Color CVIM module. The system makes it easy to gather the data you need for even the most comprehensive SPC application.
- **Reduced rework and scrap** because nothing gets any further along the production line than it should. Problems identified early avoid more serious problems later on. If a part or product fails, then you can take corrective action before it reaches your customer.
- **Reduced labor costs** thanks to machine vision's unmatched stamina and friendly user interface. With the Color CVIM module on the job, your people can spend their time doing more challenging-and productive-tasks.
- **Reduced training time means greater productivity.** The proven Color CVIM module user interface is easy to learn and use. Your people can spend more time working and less time training.
- **Lower installation and set-up cost** because the Color CVIM module is a *complete system solution* that you can put to work right now. You never have to fight that nagging feeling that your installation is a pilot project, and that you will spend the next two years "working out the bugs."

## Color Inspection!

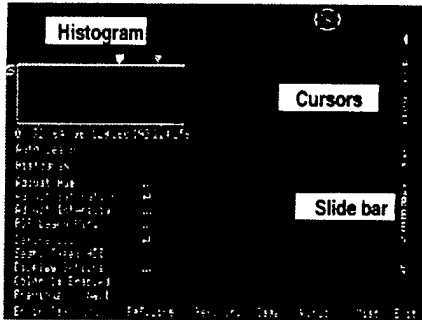

Figure 2. Logical screen layout and light pen interface make it easy to understand what you are doing at any time.

Most ordinary inspection systems rely on the brightness contrast in a gray-scale or binary image to detect and evaluate product features. But all too often gray-scale imaging will not suffice.

The Color CVIM module can identify and inspect product features according to their color, and make easy work of counting, sorting, gaging, and otherwise inspecting product characteristics that would be impractical, or impossible to inspect with typical gray-scale or binary image capabilities alone.

With the Color CVIM module you can apply vision inspection technology where you could never use it before.

**Both HSI and RGB Segmentation.** With the Color CVIM module you can define up to 32 different colors (and/or select from 6 different gray-scale image types). In addition, the Color CVIM module gives you the flexibility to define those colors in either of two different color definition (or "segmentation") schemes-HSI or RGB.

The default color segmentation scheme used by the Color CVIM module is the HSI method. It is based on a measure of hue, saturation, and intensity in the light reaching the camera sensor. The alternate RGB method measures the actual content of each of the three primary colors – red, green, and blue.

You can think of the HSI segmentation as corresponding to the color, saturation, and brightness adjustments on the front of your home television set. The RGB segmentation is more like the red, blue, and green electron guns at the back of the picture tube itself.

Is there a difference? In most cases, the HSI method is preferable because, with it, the *intensity* (I) threshold can be expanded to allow for greater variation in lighting brightness from inspection to inspection (or within a single inspection image) without degrading the color separation results. RGB segmentation can work better if the color *saturation* is low. That is, if the color is very light or very dark, or has a significant amount of gray content.

The Color CVIM module's custom very large scale integration (VLSI) technology helps convert RGB images to HSI images while maintaining optimum inspection speeds.

In the end, the flexibility of being able to choose either HSI or RGB color segmentation helps the Color CVIM module provide outstanding service under the widest possible range of light and color conditions.

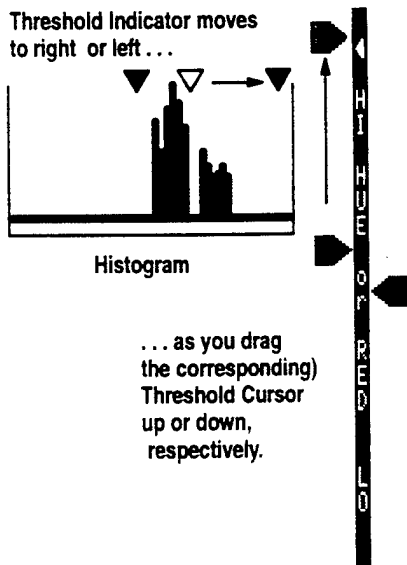

Figure 3. Easy adjustment of color definitions right on screen.

**Color Auto Learn for Easy Setup.** The Color CVIM module lets you easily and quickly identify a color so the system can memorize it for later use. You need no special expertise or training to do so. Just move the color "learn" window over a sample of the color you want to teach. The Color CVIM module provides all the tools you need to accurately – and almost instantly – define a color *right on screen*.

**Color Definition Adjustment.** For even greater control, you can fine tune the newly "learned" color to meet your exact needs. The Color CVIM module's logical on-screen menus and natural-feeling light pen make it easy. For example, to change a key threshold value, just drag a cursor up or down a slide bar on the screen. See Figure 3 for an example of the threshold adjustment interface.

**Color ID and Color Match.** Sometimes you need to know the exact color of an inspection target. The color ID capability of the Color CVIM module allows you to compare a target with each of up to 32 colors you define, and report which of those colors it is.

When counting or sorting colored objects, for example, you might want to know which objects are pink and which are blue. With color ID you can easily instruct the system to send pink objects in one direction, and blue objects in another.

In other situations you might want to evaluate the overall color makeup of your target. Color matching gives you a way to do just that. Color matching allows you to view a target and decide which of up to 32 predefined colors predominate in the target field.

For example, suppose a firm sells a family of similar products. The packaging looks similar for each product, differing most obviously by color. One package is blue, another orange, a third purple, and one is green. It would be difficult to monitor this labeling operation with gray-scale imaging, but with the Color CVIM module and color matching it would be easy to identify the most prominent color on each passing package.

Refer to Figure 4 for an example showing the differences between color ID and color match.

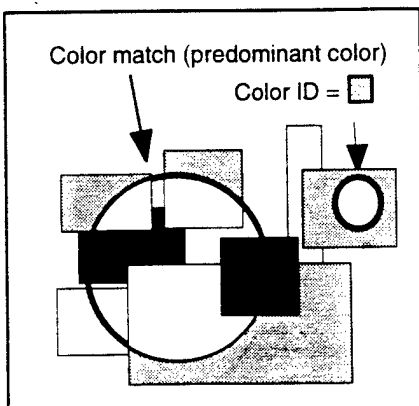

Figure 4. Color ID and Color Match in circular windows.

## **Extensive Image Filtering Capabilities**

In addition to letting you adjust the thresholds for your defined colors, the Color CVIM module features a number of additional threshold controls and filters you can use to perfect your inspection setup. These include:

- Filtering designed to remove unwanted visual “noise” from the path of gages or reference lines.
- For color window inspections, the Color CVIM module lets you apply up to six levels of noise filtering, using any combination of eight different filtering functions.
- Gray-scale threshold controls you can use to optimize reference edges on gages or reference lines on gray-scale images.
- Additional window controls you can use to optimize gradient images for edge inspections.

Each of these specialized tools helps provide the best possible image for inspection, and helps assure fast, certain setup and outstanding performance.

## **Automatic Light Reference Adjustment**

The Color CVIM module can automatically adjust to the color content of an image to optimize its color detection capabilities during inspection. With automatic light reference adjustment, you can automatically set the color light sensing thresholds. Doing so allows the system to work within a wider range of color separations, and helps assure the most precise possible results.

## **Contour Analysis to Help Define a Target**

Not only can you detect objects by color, but with the Color CVIM module you can use a wide range of dimensional criteria to narrow your selection even further. Contour analysis lets you set value ranges for up to 10 physical parameters that help define an inspection target. Possible criteria include perimeter, area, minimum radius, maximum radius, angle of orientation, “oriented” length and height, or object location.

You will find contour analysis especially valuable for product flaw detection, sorting, and discriminant part counting. As with color segmentation, the ability to perform contour analysis depends largely upon Allen-Bradley’s custom VLSI chips expertise.

For example, a packer might use contour analysis to help grade fruit into categories based on color, size, and shape. The Color CVIM module could help sort the fruit, and also continuously collect statistical information about it to perform additional analysis.

## Plus the Complete Array of Familiar CVIM module Features

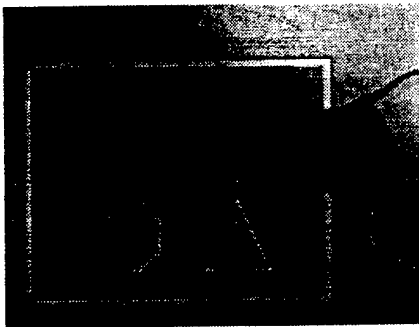

Figure 5. Logical, easy-to-learn user interface.

With all its exciting new color vision capabilities, the Color CVIM module comes fully equipped with the same inspection tools that made the original CVIM module so popular. A brief overview of some of them appears below.

### Proven User Interface

Easy-to-use, and proven in the industrial market, the Color CVIM module user interface features a logical pop-up menu structure so uncluttered that it allows you to replace the entire keyboard with a simple light pen. Everything happens on screen – with no hidden surprises. And the Color CVIM module stores all application parameters in non-volatile memory so you can use (or change) them any time.

### Pre-Inspection Adjustment Tools

**Light Probe.** In the real world things never stop changing. Which is why the Color CVIM module provides a light probe that can automatically adjust your system *in real time* to compensate for variations in brightness and color composition from inspection to inspection. And, if light levels fall outside an acceptable range *defined by you*, the Color CVIM module will let you know. The light probe helps compensate – automatically – for normal fluctuations in lighting intensity to avoid false rejects.

**Object Calibration.** Object calibration makes it possible to calibrate a camera image to “real-world” units such as inches or centimeters in order to provide more meaningful measurement results. Once calibrated, range limits can be entered in real-world units (e.g.  $\pm 0.05$  in.).

**Reference Tools.** You can only inspect an object after you know its location and orientation. The Color CVIM module provides all the tools you need to automatically compensate for normally anticipated variations in positioning – even including rotation – within your work stream. The full complement of reference line and reference window tools provided with the Color CVIM module help move machine vision out of the lab and onto the plant floor.



## Vision Analysis Tools

Your goal is to identify defective product before it gets out the door. Our goal is to provide the tools that can help you do that. With the Color CVIM module you can do multiple on-line inspections of every item that passes through your operation. If quality with a "Big Q" is what you want, then the inspection and analysis talents of the Color CVIM module can help get you there.

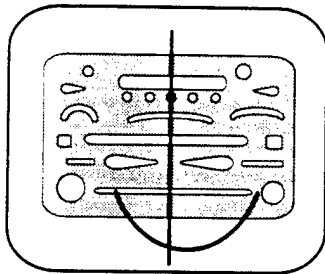

Figure 6. Linear gage counts edges to confirm existence of openings; circular gage measures angle of orientation.

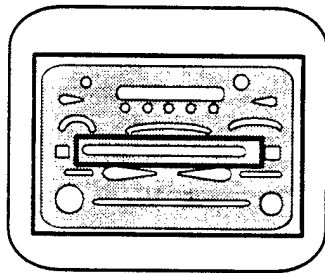

Figure 7. Rectangular window counts openings in plate.

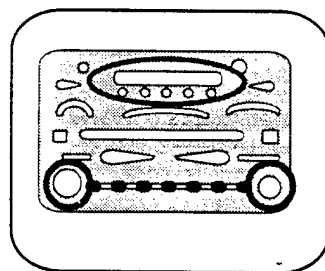

Figure 8. Large elliptical window counts openings; circles check orientation of workpiece.

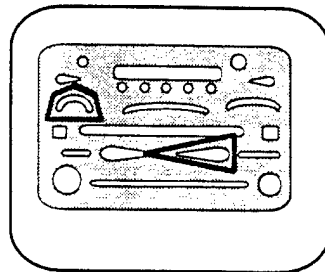

Figure 9. Polygonal windows count white pixels to assure smooth edge and complete removal of scrap.

**Gages.** With the Color CVIM module you can define up to 64 different gages in an almost unlimited variety of shapes and sizes. Gages can be linear in any direction, or in the form of an arc. You can adjust their lengths as well as their widths, and simply place them on a sample image with the light pen. You can easily configure each gage to perform its own special task.

You can use gages to count pixels, objects, or edges, or to measure linear distances, arc distances, angles, or other spatial relationships.

**Windows.** Windows, like gages, can be assigned to perform any of several inspection and analysis operations. Some possibilities include:

- Confirming the presence of a part.
- Checking for correct assembly.
- Checking for defects.
- Confirming the presence of a specified number of features.
- Verifying features against a gray-scale template.

The Color CVIM module lets you define up to 48 windows in an unlimited variety of sizes and shapes (including rectangular, elliptical, or polygonal). You can use those windows to accomplish many different tasks. Here are just a few:

- Compare objects to a target *you define* and count those that are similar in size and shape.
- Measure area by counting either black or white pixels in a high contrast binary image.
- Detect surface flaws and scratches by identifying gradients and edges within a window.
- Check luminance by comparing the average gray-scale value of a window's contents with criteria *you determine*.

## Product Data

### Color CVIM

##	USAGE	Set. Usage
1	Master Range ...	<input type="checkbox"/> Not Used
		<input type="checkbox"/> Module Busy
		<input type="checkbox"/> Trigger Nak
		<input type="checkbox"/> Data Valid
		<input type="checkbox"/> Strobe
		<input checked="" type="checkbox"/> Results
8	Results ↵	
9	Not Used ...	
10	Not Used ...	
11	Not Used ...	
12	Not Used ...	
13	Not Used ...	
14	Not Used ...	
	Duration Qns ...	

Figure 10. Easy-to-understand Results page.

## Range Limits and Discrete Outputs

Each vision tool you define returns a specific value at the end of every inspection cycle. In most cases an acceptable result can fall within a range of values instead of equaling an exact ideal.

For that reason, the Color CVIM module lets you set your own tolerance limits for gage, window, and light probe operations. In most cases you can set upper and lower limits representing both warnings and outright failures for each inspection. The Color CVIM module even displays warnings and failures in different colors to help you immediately recognize them when they occur.

You can also establish a central reference value based on your technical specifications for an ideal component, on a “nominal” value obtained with the Color CVIM module’s learn function, or on a “mean” value derived from trial inspections.

With the Color CVIM module you have as much flexibility in responding to inspection results as you do in gathering them. You can configure each of 14 discrete output lines to carry the signals you need to convey inspection results, control, and status information *as required* (see Figure 10). And with the Color CVIM module’s clear setup and status reporting features you always know the exact status of each output.

## Configuration Aids

**Trial Run Statistics in Learn Mode.** With the Color CVIM module’s flexible setup options, you never need go into full production with an inspection setup until you know for sure the application works the way you want it to.

“Learn” mode lets you gather statistical information on a limited sample of your actual production process. The system monitors the trial run and compiles statistics for each analysis tool. Statistics available include minimum, maximum, mean, and standard deviation. Together they make it easy to fine-tune your application for maximum performance.

In addition, these statistics are also available to the host controller via any of the communication interfaces.

**Inspection Time Analysis.** With the Color CVIM module's analysis function you can instantly compute the cycle time required for a given inspection configuration. You can then evaluate the timing realities of your own application in light of that analysis.

During analysis, the Color CVIM module processes all enabled tools, and then reports the time it takes to process those tools. For even greater flexibility, you can even perform continuous analysis on a series of image acquisitions. Inspection time analysis enables you to easily confirm that the processing time required for a given configuration matches your production speed.

**Registration.** Shifted parts could easily confuse some vision products. But Allen-Bradley's Color CVIM module provides registration functions which can accommodate normally expected variation in workpiece position. With them your system can automatically reposition (or "register") gages and windows if their target changes position.

These features prove especially valuable as you continue to fine-tune your machine vision system application over time. With them you can make adjustments "on the fly," with a minimum of time and effort.

**Halt or Freeze Options.** What happens when the Color CVIM module detects a part that fails to meet your acceptance criteria? These options are available to capture the failed inspection for analysis:

- **Go on reject.** You can use the system primarily as a statistical tool to report and record the failure, then continue the inspection without interruption.
- **Halt on reject.** You can have the system freeze the rejected image on screen, and then stop the inspection process. You can take whatever action is necessary, then resume normal operations with a touch of the light pen.
- **Freeze display.** You can also freeze the rejected image on the screen while continuing the inspection process. Freeze display options include freezing on next inspection, on first reject, or on all rejects.

With the Color CVIM module you can choose whichever option best suits your needs.

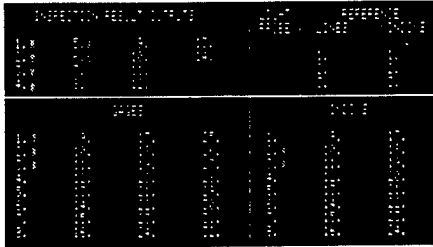

Figure 11. I/O status display in convenient table form. Shows the status of all analysis tools and configured outputs in real time.

The image shows a terminal-style display with a table of results data. The title is 'RESULTS SUMMARY'. The table has columns for 'Tool Name', 'Pass/Fail', 'Min. Val.', 'Max. Val.', 'Warning Limit', and 'Fail Limit'. The data is presented in a clear, tabular format.

Tool Name	Pass/Fail	Min. Val.	Max. Val.	Warning Limit	Fail Limit
Probe	Pass	210.000	215.000	212.000	215.000
Probe	Fail	210.000	215.000	212.000	215.000
Probe	Pass	210.000	215.000	212.000	215.000
Probe	Fail	210.000	215.000	212.000	215.000
Probe	Pass	210.000	215.000	212.000	215.000
Probe	Fail	210.000	215.000	212.000	215.000

Figure 12. Results data display lets you review valuable results data collected during production. All data appears in a neat table for easy interpretation.

## Runtime Displays

The Color CVIM module offers an assortment of display options you can use to help make the inspection process meet your exact needs. As with most of the advanced features built into the system, you can switch from one display to another at any time. The Color CVIM module continuously updates these displays, usually after each inspection cycle. You can see examples of two typical displays at the left, and a more complete summary of runtime display options below.

- **Image Only.** Selecting this option tells the Color CVIM module you want to see only the camera image (along with the Run Mode menu) during Run mode.
- **Failed Tools.** This option tells the Color CVIM module to display only the inspection tools (gages or windows) that fail their inspection task and create a “reject” or “fail” condition. Tools (gages and windows) appear on screen (in red) only during the particular inspection cycle in which they fail.
- **All Tools.** When selected, all tools instructs the Color CVIM module to display all enabled tools during every inspection cycle. A tool’s color depends on its status at the end of an inspection cycle. A tool that passes its inspection task appears in *green*; a tools that exceeds a warning limit appears in *yellow*; a tool that fails appears in *red*.
- **I/O Page.** This choice results in display of the I/O page panel, which shows the “pass/fail” condition of each enabled tool and discrete output status for which you have assigned a “master range” or “results” value.
- **Results Page.** This selection causes the Color CVIM module to display the inspection results values, range limit settings, and other data relating to the currently enabled tools.
- **State Page 1.** Choose this option to display statistics for the light probe, gages, and windows while the Color CVIM module operates in “learn mode.”
- **State Page 2.** Choose this option to display statistics on reference windows while the Color CVIM module operates in “learn mode.”

The Color CVIM module is well-equipped to perform complex inspection and analysis tasks and keep you informed of its findings in a form that best meets your needs. The result is a great combination of flexibility and power under your complete control.

**Configured to Meet Your Needs  
Today and In the Future**

The Color CVIM module offers a wide range of configuration possibilities designed to meet your production needs today *and* tomorrow. Flexibility and adaptability mean you can use the system's stand-alone capabilities now, and expand its capabilities later. Allen-Bradley offers a full line of PLC™ and other automation equipment to help you fully integrate machine vision capability into your manufacturing process.

**Stand-Alone With Discrete I/O**

In stand-alone mode, all module communications and inspection results are handled by front panel I/O on the CVIM module itself. All the advantages of on-line inspection without additional hardware or software.

Figure 13  
Typical Configuration

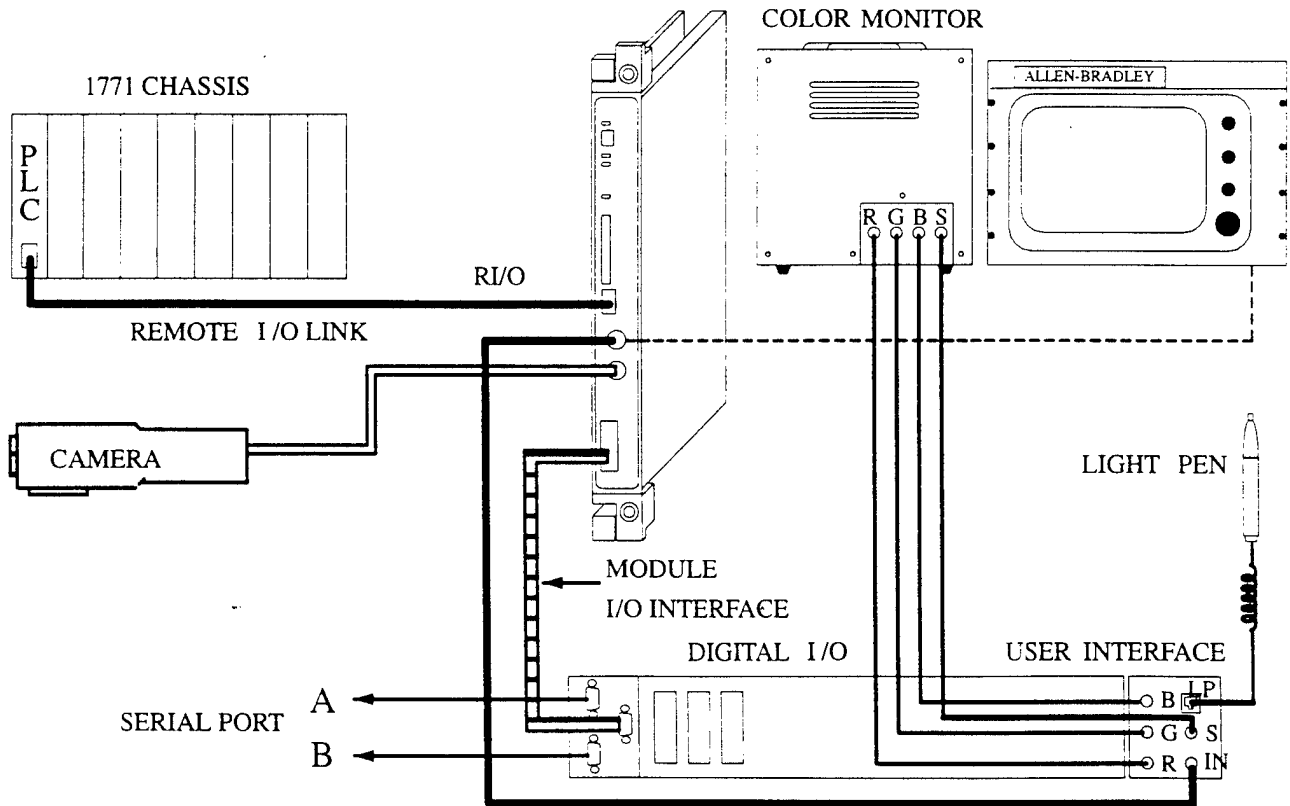

**Color CVIM module with PLC-2, PLC-3, or PLC-5**

You can boost the functionality of the basic Color CVIM module by connecting it with any Allen-Bradley PLC™ through the Color CVIM module's remote I/O port designed especially for communications with a PLC.

As a host controller, the PLC uses 256 points of discrete I/O to control module operations and handle even complex results data. The PLC can access Color CVIM module data and results data using block transfer communications.

### **RS-232 Communications for Maximum Flexibility**

The Color CVIM module's two RS-232 serial ports allow it to communicate with any host device capable of using industry-standard RS-232 serial communications techniques.

### **Color CVIM module With 5000 Series Pyramid Integrator™ System**

Allen-Bradley's powerful, expandable Pyramid Integrator was designed to provide seamless, network compatible integration of control and information processing on your plant floor – and beyond. And it is fully compatible with the Color CVIM module. Just install the Color CVIM module in the Pyramid Integrator rack (with our PLC-5/250 and Micro VAX™ modules) and you, too, can discover the advantages of complete integration.

The PLC-5/250 and Micro VAX information processors can continually monitor the Color CVIM module's inspection results, and direct corrective action back up the production line as necessary. Or the Pyramid Integrator itself can reconfigure the Color CVIM module to adapt to changing situations.

The CVIM module has a shared memory area which stores all results data for easy access by the Pyramid Integrator. Configuration data is easily transferred between the Color CVIM module and other processors in the Pyramid Integrator chassis using PLC-5/250 message transfer communications.

It all adds up to an integrated system that can transfer real-time vision data from a PLC controller to a higher level processor for total information management and factory automation. And, because that system uses Allen-Bradley's standard Application Programming Interface (API), you avoid spending months writing the code to make it work.

## The Speed of Advanced VLSI Technology

VLSI stands for Very Large Scale Integration, and refers to advanced engineering and manufacturing techniques resulting in integrated circuits containing many, many times more components than standard integrated circuits. A VLSI chip is, in effect, a powerful integrated circuit made up of many simpler integrated circuits.

### Higher Throughput

Did you know that one of the critical factors affecting the speed of an integrated circuit is the distance each digital signal must travel during processing? Delay caused by signal travel can have a profound effect on performance even at the microscopic level on which those devices operate.

But simply stuffing more circuitry into a given area does little good if it comes at the cost of reliability. And that is where Allen-Bradley's experience and dedication to quality yield real benefits. Our VLSI chips perform well by every measure.

Well-designed, carefully manufactured VLSI chips offer dramatic performance improvements over comparable software techniques wherever they are used. And each Color CVIM module contains *five* VLSI chips, each one doing its part to help the system work faster and more dependably.

### ACE Chip

The Advanced Contour Extraction (ACE) chip uses VLSI technology to enable the Color CVIM module to derive a number of measurements at much higher speeds than were previously possible. The ACE chip makes it practical to use measurements of area, centroid location, and perimeter as real-time inspection criteria.

### SCOP Chip

The Color CVIM module's ability to work with either HSI or RGB is due, in large part, to the unprecedented power of the VLSI SCOP chip used for image processing. Its purpose is to convert incoming RGB images into HSI images, to improve segmentation. And thanks to the high processing speeds possible only with VLSI, the Color CVIM module offers this added flexibility with no penalty in performance.

## Typical Applications

The benefits of on-line, real-time inspections offer quick returns wherever they are used. And with the Color CVIM module you can now use machine vision in completely new ways to enjoy:

- Increased production line speed.
- Improved quality.
- More effective utilization of capacity.
- Improved statistical reporting.
- Reduced rework and scrap.
- Reduced labor costs.
- Reduced training costs.

Even better, you will be up and running faster with the Color CVIM module because it is part of a complete, integrated *family* of products from Allen-Bradley dedicated to making machine vision work and work well. While systems pasted together with components from multiple manufacturers may eventually work, they can require tremendous commitments of time and energy just to establish a successful interface. You can avoid many of those issues by choosing the Color CVIM module.

Listed below are some areas where the Color CVIM module can prove especially useful. This list is not comprehensive, but it should give you some ideas about how you might apply the power of color inspections in your own situation.

- Food/food packaging industry.
  - Sorting for ripeness, size, or shape
  - Monitoring degree of cooking
  - Detecting leaks or smears
  - Detecting spoilage
- Pharmaceutical industry
  - Sorting and inspecting tablets, capsules, etc.
  - Inspecting blister packs
- Miscellaneous manufacturing
  - Verifying assembly of color-coded components
  - Identifying electronic components
  - Identifying textile defects
  - Monitoring color registration/alignment
  - Sorting by shade of color
  - Detecting flaws, blemishes, or inconsistencies
  - Inspecting wiring harnesses, connectors, and fuse blocks



## Pharmaceutical Industry Applications

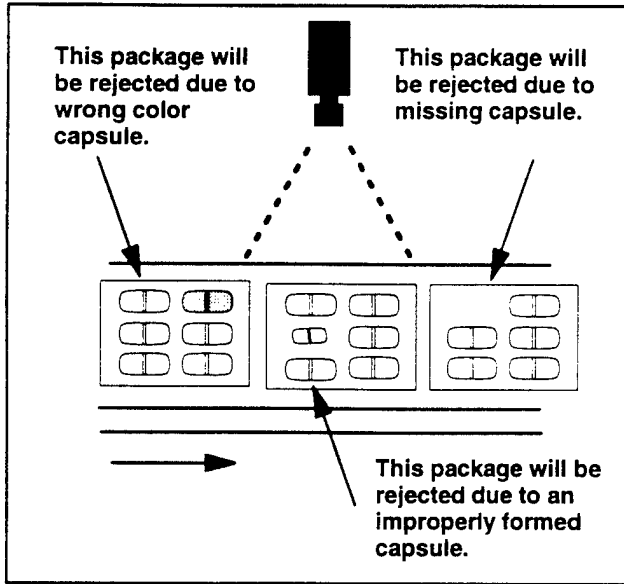

**Problem:** A pharmaceutical plant needed to inspect 100% of the blister packs of capsules before these packs were inserted into individual packages. Inspection must detect missing capsules, verify the presence of variable dosage capsules (required as part of the course of treatment) by their color, and detect improperly formed tablets.

**Solution:** A camera for the Color CVIM module has been mounted above the packaging line. When a photo electric switch detects the leading edge of a package the strobe light and camera are triggered.

At production line speeds, the system verifies that each blister contains a capsule of the correct color. In addition, the Color CVIM module confirms that no capsules are missing or defective.

## Cosmetics Industry Applications

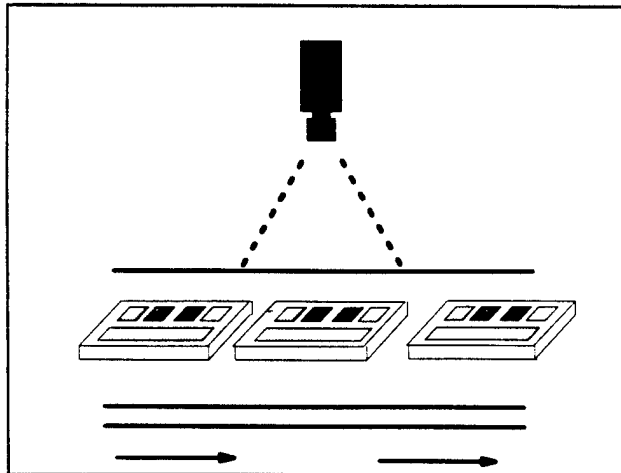

**Problem:** A cosmetic company wants to be absolutely certain that every makeup case coming off its assembly line contains the correct assortment of colors. Manual inspection would be prohibitively expensive because it would force the line to run too slowly or require too many employees dedicated solely to inspection. And gray-scale inspection simply can't do the job.

**Solution:** A single camera mounted over the line captures an image for inspection by the Color CVIM module, which confirms complete and correct assembly of each compact.

The manufacturer has all but eliminated quality issues related to the assembly of its makeup products.

## Textile Industry Applications

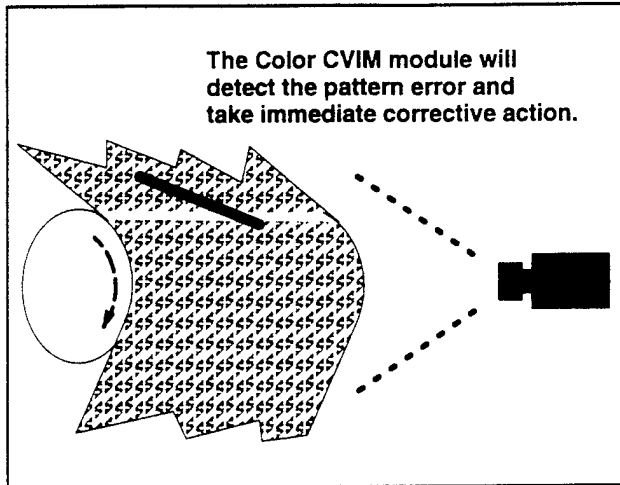

**Problem:** A textile mill wanted to eliminate weaving defects from its product. Manual inspection proved impossible because of the speed of the passing material, and gray-scale inspection could not be depended upon to differentiate a defect from a normal pattern.

**Solution:** A Color CVIM module analyzes the material passing under its lens, and constantly monitors the consistency of its color and pattern. Any variation results in an automatic shutdown and an audible alarm. The system also watches for spots or other blemishes, as well.

Now even minute errors in the mill's production can be spotted in time to take corrective action and avoid delivery of low quality goods.

## Miscellaneous Manufacturing Applications

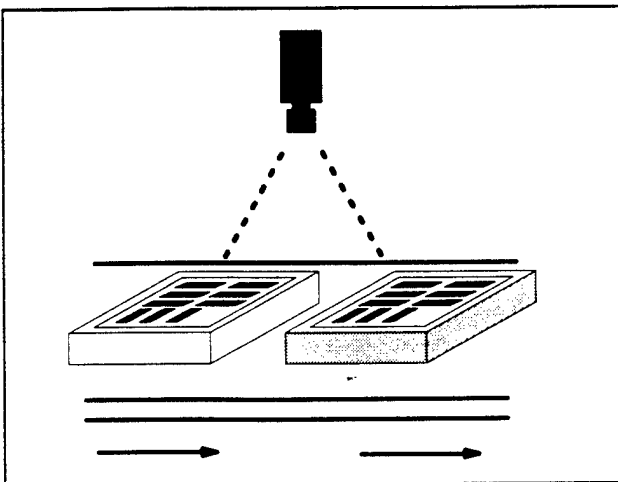

**Problem:** A major automotive parts manufacturer wants to inspect, and sort color-coded fuse blocks as they come off the assembly line. Once accepted, the manufacturer wanted each part directed to a separate bin of similar parts intended for a specific model car.

**Solution:** A Color CVIM module now monitors production, and sorts usable parts by color as they pass underneath its lens.

The application of color machine vision technology allows this manufacturer to operate at a much higher production rate while actually increasing the quality of its shipments.

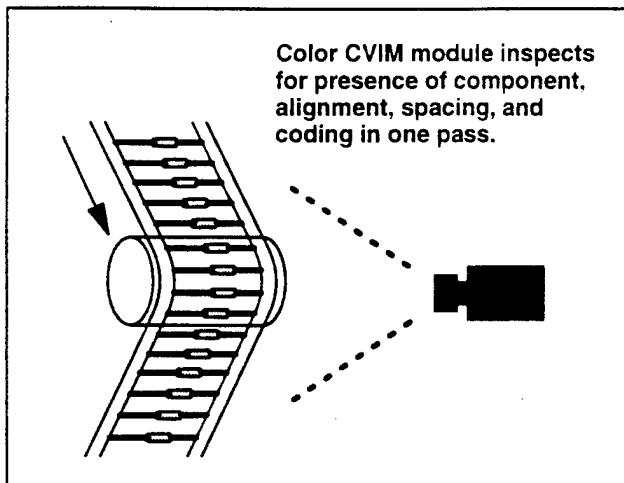

**Problem:** An electronics component manufacturer wanted to monitor production of resistor strips destined for use in automated assembly equipment. The company wanted to make sure there were no gaps in the strip, check for correct color coding, and confirm acceptable alignment of each resistor. Throughput was much too fast to allow manual inspection of more than a tiny sample of production, and gray-scale imaging could not guarantee correct interpretation of the color coding on each resistor.

**Solution:** Color CVIM module directly views each resistor and checks it for all required criteria. The result has been a significant improvement in overall quality, and better utilization of available labor.

## Optional PAKs

### Color MATH-PAK™

Color MATH-PAK (Cat. No. 5370-CMPK) allows the results of various inspection parameters to be combined mathematically to make an overall pass/fail decision. It is a licensed software product, and is distributed on a memory card. The software is permanently installed into the Color CVIM module's program memory in minutes. Firmware revision A02 or greater is required to support Color MATH-PAK. Refer to Pub. No. 5370-920 for more information.

### Color USER-PAK™

Color USER-PAK allows modification of setup and runtime user interfaces. Through Color USER-PAK, the system can be configured with a mouse or trackball to:

- implement password security
- delete unnecessary menu items
- activate "copy and paste" functions for gages and windows
- customize serial communication
- generate custom Runtime displays

Color USER-PAK is a licensed software product, and is distributed on a memory card. The software is permanently installed into the Color CVIM module's program memory in minutes. Firmware revision A03A or greater is required to support Color USER-PAK. Refer to Pub. No. 5370-923 for more information.

## Vision System Peripherals

The Color CVIM module, like all Allen-Bradley machine vision products, is supported by a full line of peripheral products and accessories, including cameras, optics, monitors, power supplies, lighting, and cables. Contact your local Allen-Bradley distributor for more information.

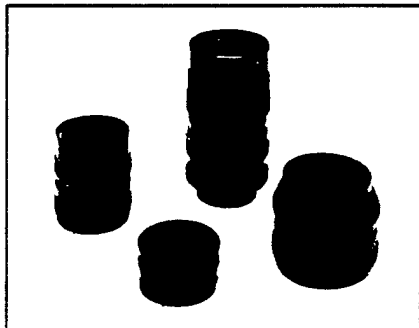

90-011-3

Figure 14. A complete selection of high quality lenses.

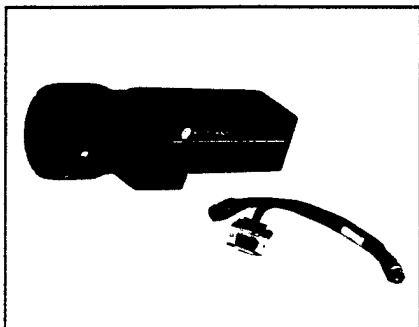

92-510-1

Figure 15. Camera, lens and cable.

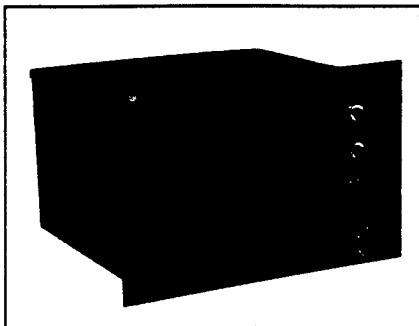

85C-341-1

Figure 16. 2801- N8 Color Monitor.

### Lenses

A selection of CCTV optics – ranging in focal length from 12.5mm to 105mm – delivers the versatility you need to meet your own unique machine vision application. These high quality lenses always give you a clear perspective on your work. Refer to Machine Vision Lenses, Optics, and Accessories (Allen-Bradley Publication 2801-2.6) for more information.

### Cameras and Cables

The standard camera designed for use with the Color CVIM module (Catalog Number 2801-YJC) is a single CCD chip RGB camera that uses a primary color/vertical stripe filter to provide excellent color reproduction and resolution. The camera provides 512H x 512V image resolution in strobed or non-strobed operation, and can operate in a shuttered (512H x 256V) or non-shuttered (512H x 512V) mode.

Each camera comes equipped with a Y-adapter cable for connection to the Color CVIM module in standard Allen-Bradley cable lengths of 5, 10, or 25 meters.

This camera accepts standard two-thirds inch C-mount lenses, and can accept bayonet mount lenses with an optional Lens Mount Adapter (Catalog Number 2801-N2).

For additional information on cameras, cables, and accessories, please refer to Machine Video Cameras and Accessories (Allen-Bradley Publication 2801-2.3) and Machine Vision Lights and Fiber Optic Guides (Allen-Bradley Publication 2801-2.1).

### Monitor

The Color CVIM module uses the 13-inch diagonal Allen-Bradley 2801-N8 (90 to 132 VAC, 50/60 Hz) or 2801-N8V (195 to 265 VAC, 50/60 Hz) color monitor for both display and configuration (via the light pen assembly). Depending on your needs, this industrially rugged NEMA Type 12 monitor can be mounted in a rack or standard enclosure.

## Outstanding Support In Many Accessible Forms

At Allen-Bradley, "customer support" means experienced representatives at Sales/Support offices in key cities throughout the world – and an entire company division dedicated to nothing else. That support takes many forms including, but not limited to:

- Field engineering.
- Field service.
- Technical training.
- Product warranty.
- Maintenance support agreements.
- Technical telephone support.
- On-line diagnostics.
- Parts repair and exchange.

With our unique technological know-how, we can offer you the understanding, knowledge, and experience you need to meet your machine vision goals. Plus, the expertise of Allen-Bradley's authorized systems integrators is available to offer specific application solutions and services.

### A Practical Approach to Training

Despite their friendly interface and ease-of-use, it still takes specialized skills to get the most benefit from today's sophisticated machine vision products. We have made it easy to get those skills. When you purchase a Color CVIM module you can be sure you can get the training you need to make your system work the way it should.

You can even get additional advanced training at Allen-Bradley training centers world-wide. You can even make special arrangements for training at or near your own site. Contact your local Allen-Bradley sales office for complete information.

### Documentation

You will also find the Color CVIM module supported by complete, informative, and *usable* documentation that has been prepared from the ground up to support the Color CVIM module and all its related equipment in the way you actually use it.

## Specifications

The Bulletin 5370 Color CVIM™ from Allen-Bradley brings the power and flexibility of fully configurable color vision to a wide range of inspection tasks impractical, or even impossible, with gray-scale vision technology.

The Color CVIM is part of a growing family of vision products from Allen-Bradley, and builds upon on a history of over 85 years of successful integrated factory automation experience. Contact your local Allen-Bradley sales office for more information.

Specifications Summary	
Form Factor	Allen-Bradley Pyramid Integrator
Power Requirements	+5 Volts DC draws 5.5 Amps +12 Volts DC draws 60 Milliamps -12 Volts DC draws 80 Milliamps
Operator Interface	Menu driven, Light pen activated
I/O Communications	Remote I/O to PLC™ Serial I/O to RS-232 device Discrete I/O for stand-alone applications
Environment	
Temperature	0°C to 60°C Operational 40°C to 85°C Storage
Relative Humidity	5% to 95% (non-condensing)
Color Segmentation	HSI or RGB
Cameras	Allen-Bradley Bulletin 2801-YJC Three-chip color CCD cameras
Shipping Weight	4 lbs (1.8 kg)



**ALLEN-BRADLEY**  
A ROCKWELL INTERNATIONAL COMPANY

A subsidiary of Rockwell International, one of the world's largest technology companies, Allen-Bradley meets today's automation challenges with over 85 years of practical plant floor experience. More than 13,000 employees throughout the world design, manufacture and apply a wide range of control and automation products and supporting services to help our customers continuously improve quality, productivity and time to market. These products and services not only control individual machines, but also integrate the manufacturing process while providing access to vital plant floor data that can be used to support decision-making throughout the enterprise. \*

With offices in major cities worldwide.

### WORLD HEADQUARTERS

Allen-Bradley  
1201 South Second Street  
Milwaukee, WI 53204 USA  
Tel:(414) 382-2000  
Telex:43 11 016  
FAX:(414)382-4444

### EUROPE/MIDDLE EAST/ AFRICA HEADQUARTERS

Allen-Bradley Europe B.V.  
Amsterdamseweg 15  
1422 AC Uithoorn  
The Netherlands  
Tel:(31) 2975/43500  
Telex:(844) 18042  
FAX:(31) 2975/60222

### ASIA/PACIFIC HEADQUARTERS

Allen-Bradley (Hong Kong) Limited  
Room 1006, Block B, Sea View Estate  
2-8 Watson Road  
Hong Kong  
Tel:(852)887-4788  
Telex:(780) 64347  
FAX:(852)510-9436

### CANADA HEADQUARTERS

Allen-Bradley Canada Limited  
135 Dundas Street  
Cambridge, Ontario N1R 5X1  
Canada  
Tel:(519)623-1810  
FAX:(519)623-8930

### LATIN AMERICA HEADQUARTERS

Allen-Bradley  
1201 South Second Street  
Milwaukee, WI 53204 USA  
Tel:(414)382-2000  
Telex:43 11 016  
FAX:(414)382-2400

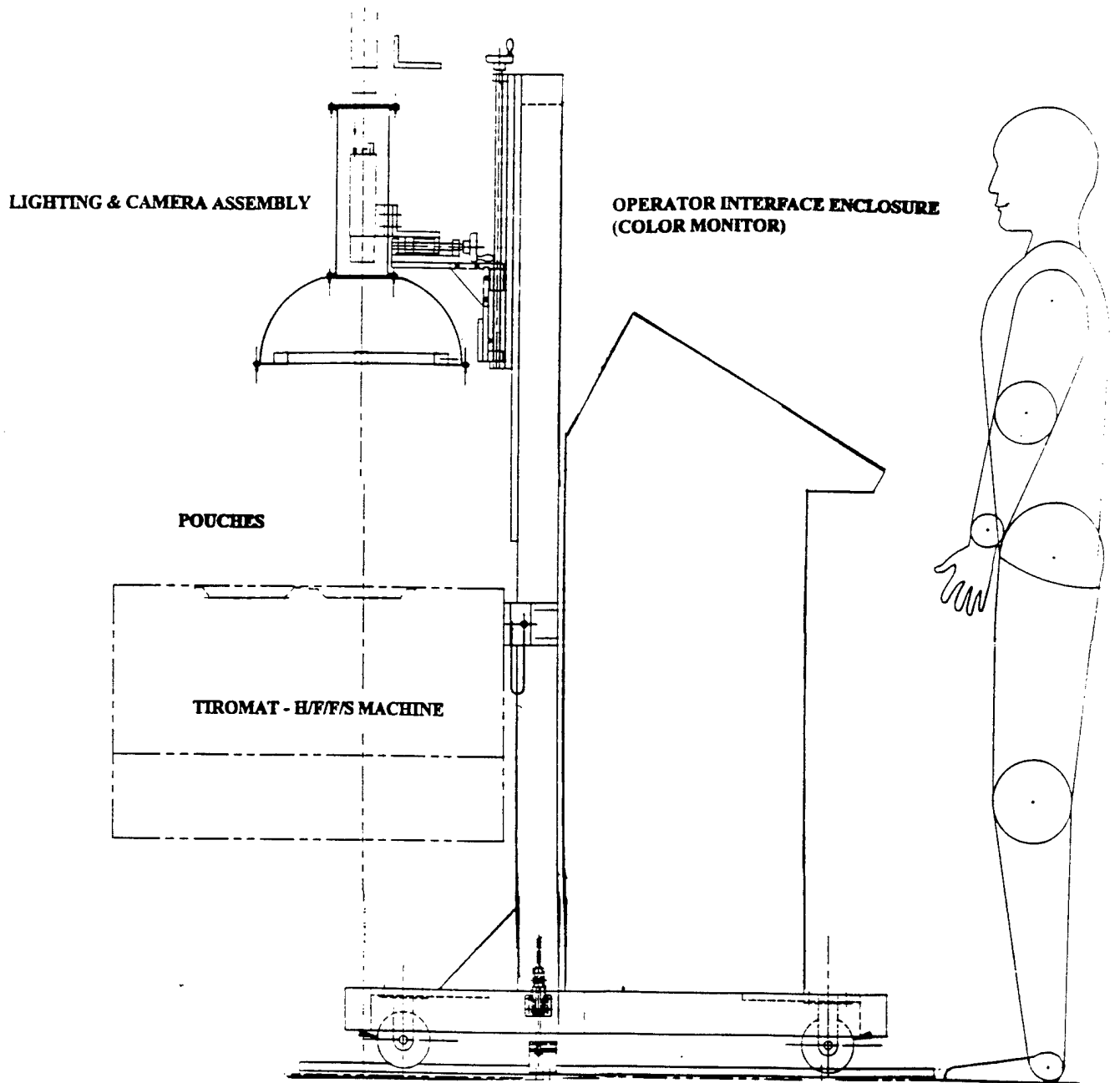

**MACHINE VISION INSPECTION**