



**US Army Corps  
of Engineers**

Construction Engineering  
Research Laboratories

USACERL Technical Report 96/77  
July 1996

# Investigation of Preapproved Underground Heat Distribution Systems

by  
Charles P. Marsh, Nicholas M. Demetroulis, and James V. Carnahan

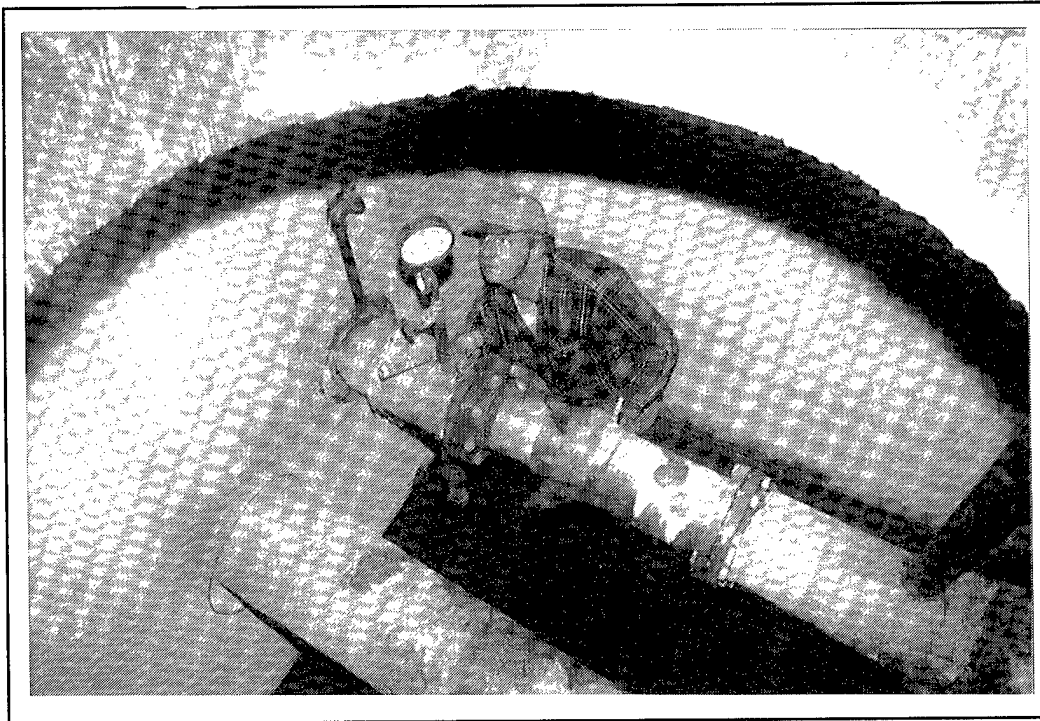

19961008 083

The Department of Defense maintains and operates approximately 6,000 mi of steam and hot water heat distribution system piping, mostly underground. Even a small decrease in heat transmission efficiency could waste large amounts of energy, natural resources, and lead to increased greenhouse gas production.

USACERL investigated and evaluated the physical condition and general performance of drainable-dryable heat distribution systems installed since 1981.

Inspections covered 35 heat distribution systems at 15 locations. Manhole inspections were performed and air pressure tests were successfully conducted on 5.18 mi of conduits. Many systems were not installed in

accordance with criteria. Drains and vents were generally found to be dry; however, water or evidence of water in the manholes was common. Using a stringent standard of no more than a 1.0 psi drop in pressure after 30 min, 59 percent of the steel conduits passed while only 7 percent of the fiberglass reinforced plastic (FRP) conduits passed. With a more lenient standard of no more than a 5.0 psi drop in pressure after 30 min, 73 percent of the steel conduits passed while only 24 percent of the FRP conduits passed. In the more lenient case, normalizing to length, the failure rate of FRP-cased conduits was 4.82 times that of steel conduits.

**DTIC QUALITY INSPECTED 3**

The contents of this report are not to be used for advertising, publication, or promotional purposes. Citation of trade names does not constitute an official endorsement or approval of the use of such commercial products. The findings of this report are not to be construed as an official Department of the Army position, unless so designated by other authorized documents.

***DESTROY THIS REPORT WHEN IT IS NO LONGER NEEDED***

***DO NOT RETURN IT TO THE ORIGINATOR***

## USER EVALUATION OF REPORT

REFERENCE: USACERL Technical Report 96/77, *Investigation of Preapproved Underground Heat Distribution Systems*

Please take a few minutes to answer the questions below, tear out this sheet, and return it to USACERL. As user of this report, your customer comments will provide USACERL with information essential for improving future reports.

1. Does this report satisfy a need? (Comment on purpose, related project, or other area of interest for which report will be used.)

---

---

---

2. How, specifically, is the report being used? (Information source, design data or procedure, management procedure, source of ideas, etc.)

---

---

3. Has the information in this report led to any quantitative savings as far as manhours/contract dollars saved, operating costs avoided, efficiencies achieved, etc.? If so, please elaborate.

---

---

4. What is your evaluation of this report in the following areas?

a. Presentation: \_\_\_\_\_

b. Completeness: \_\_\_\_\_

c. Easy to Understand: \_\_\_\_\_

d. Easy to Implement: \_\_\_\_\_

e. Adequate Reference Material: \_\_\_\_\_

f. Relates to Area of Interest: \_\_\_\_\_

g. Did the report meet your expectations? \_\_\_\_\_

h. Does the report raise unanswered questions? \_\_\_\_\_

i. General Comments. (Indicate what you think should be changed to make this report and future reports of this type more responsive to your needs, more usable, improve readability, etc.)

---

---

---

---

---

---

---

5. If you would like to be contacted by the personnel who prepared this report to raise specific questions or discuss the topic, please fill in the following information.

Name: \_\_\_\_\_

Telephone Number: \_\_\_\_\_

Organization Address: \_\_\_\_\_

\_\_\_\_\_

\_\_\_\_\_

6. Please mail the completed form to:

Department of the Army  
CONSTRUCTION ENGINEERING RESEARCH LABORATORIES  
ATTN: CECER-TR-I  
P.O. Box 9005  
Champaign, IL 61826-9005

# REPORT DOCUMENTATION PAGE

Form Approved  
OMB No. 0704-0188

Public reporting burden for this collection of information is estimated to average 1 hour per response, including the time for reviewing instructions, searching existing data sources, gathering and maintaining the data needed, and completing and reviewing the collection of information. Send comments regarding this burden estimate or any other aspect of this collection of information, including suggestions for reducing this burden, to Washington Headquarters Services, Directorate for Information Operations and Reports, 1215 Jefferson Davis Highway, Suite 1204, Arlington, VA 22202-4302, and to the Office of Management and Budget, Paperwork Reduction Project (0704-0188), Washington, DC 20503.

1. AGENCY USE ONLY (Leave Blank)		2. REPORT DATE July 1996	3. REPORT TYPE AND DATES COVERED Final	
4. TITLE AND SUBTITLE Investigation of Preapproved Underground Heat Distribution Systems			5. FUNDING NUMBERS LA0MCAMX4370001, RP3417MCZ370001, RZ3357MSM370001, and RE4836MEO370001	
6. AUTHOR(S) Charles P. Marsh, Nicholas M. Demetroulis, and James V. Carnahan				
7. PERFORMING ORGANIZATION NAME(S) AND ADDRESS(ES) U.S. Army Construction Engineering Research Laboratories (USACERL) P.O. Box 9005 Champaign, IL 61826-9005			8. PERFORMING ORGANIZATION REPORT NUMBER  TR 96/77	
9. SPONSORING / MONITORING AGENCY NAME(S) AND ADDRESS(ES) Headquarters, U.S. Army Corps of Engineers (HQUSACE) ATTN: CEMP-ET 20 Massachusetts Avenue, NW. Washington, DC 20314-1000			10. SPONSORING / MONITORING AGENCY REPORT NUMBER	
11. SUPPLEMENTARY NOTES Copies are available from the National Technical Information Service, 5285 Port Royal Road, Springfield, VA 22161.				
12a. DISTRIBUTION / AVAILABILITY STATEMENT  Approved for public release; distribution is unlimited.			12b. DISTRIBUTION CODE	
13. ABSTRACT (Maximum 200 words)  The Department of Defense maintains and operates approximately 6,000 mi of steam and hot water heat distribution system piping, mostly underground. Even a small decrease in heat transmission efficiency could waste large amounts of energy, natural resources, and lead to increased greenhouse gas production.  USACERL investigated and evaluated the physical condition and general performance of drainable-dryable heat distribution systems installed since 1981.  Inspections covered 35 heat distribution systems at 15 locations. Manhole inspections were performed and air pressure tests were successfully conducted on 5.18 mi of conduits. Many systems were not installed in accordance with criteria. Drains and vents were generally found to be dry; however, water or evidence of water in the manholes was common. Using a stringent standard of no more than a 1.0 psi drop in pressure after 30 min, 59 percent of the steel conduits passed while only 7 percent of the fiberglass reinforced plastic (FRP) conduits passed. With a more lenient standard of no more than a 5.0 psi drop in pressure after 30 min, 73 percent of the steel conduits passed while only 24 percent of the FRP conduits passed. In the more lenient case, normalizing to length, the failure rate of FRP-cased conduits was 4.82 times that of steel conduits.				
14. SUBJECT TERMS underground heat distribution systems energy efficient design criteria			15. NUMBER OF PAGES 144	
			16. PRICE CODE	
17. SECURITY CLASSIFICATION OF REPORT Unclassified	18. SECURITY CLASSIFICATION OF THIS PAGE Unclassified	19. SECURITY CLASSIFICATION OF ABSTRACT Unclassified	20. LIMITATION OF ABSTRACT SAR	

## Foreword

This study was conducted for the Federal Agency Committee of Underground Heat Distribution Systems (FAC) under funding provided by the Office of the Chief of Engineers (OCE), Army (LA0MCAMX4370001), Navy (RP3417MCZ370001), Air Force (RZ3357MSM370001), and the Veterans Administration (RE4836MEO370001). The technical monitor was Dale Otterness, CEMP-ET.

The work was performed by the Materials Science and Technology Division (FL-M) of the Facilities Technology Laboratory (FL), U.S. Army Construction Engineering Research Laboratories (USACERL). The USACERL principal investigator was Charles P. Marsh. The cooperation and assistance of the manufacturers were greatly appreciated. Also, base personnel were consistently helpful during the inspections. Above and beyond their regular duties, their efforts served to greatly improve the quality and scope of this study. The efforts of Stephen Reynolds, FL-M, in preparation of this report are also acknowledged. Ellen G. Segan is Acting Chief, CECER-FL-M and Donald F. Fournier is Acting Operations Chief, CECER-FL. The USACERL technical editor was Linda L. Wheatley, Technical Resources Center.

COL James T. Scott is Commander of USACERL, and Dr. Michael J. O'Connor is Director.

# Contents

SF 298 .....	1
Foreword .....	2
List of Tables and Figures .....	5
<b>1 Introduction</b> .....	<b>11</b>
Background .....	11
Objectives .....	12
Approach .....	12
Mode of Technology Transfer .....	13
<b>2 General Approach and Methodology</b> .....	<b>14</b>
Site Selection .....	14
Survey Method .....	15
<b>3 Summary of Results</b> .....	<b>17</b>
Installation Experience .....	17
Moisture and Steaming .....	17
Conduit Air Pressure Tests .....	18
Statistical Analysis .....	20
General Observations .....	22
<b>4 Conclusions and Recommendations</b> .....	<b>26</b>
References .....	28
<b>Appendix A:</b> Results of Conduit Air Pressure Tests .....	<b>29</b>
<b>Appendix B:</b> Statistical Analysis of Survey Data .....	<b>38</b>
<b>Appendix C:</b> Detailed Site Inspection Reports for Aberdeen Proving Grounds, Baltimore, MD .....	<b>45</b>
<b>Appendix D:</b> Detailed Site Inspection Reports for Wright-Patterson Air Force Base, Dayton, OH .....	<b>52</b>
<b>Appendix E:</b> Detailed Site Inspection Reports for Veterans Administration Medical Center, Bedford, MA .....	<b>62</b>

<b>Appendix F:</b>	Detailed Site Inspection Reports for U.S. Military Academy, West Point, NY .....	70
<b>Appendix G:</b>	Detailed Site Inspection Reports for Fort Riley, Manhattan, KS .....	75
<b>Appendix H:</b>	Detailed Site Inspection Reports for Patrick Air Force Base, Satellite Beach, FL .....	81
<b>Appendix I:</b>	Detailed Site Inspection Reports for Jacksonville Naval Air Station, Jacksonville, FL .....	85
<b>Appendix J:</b>	Detailed Site Inspection Reports for Mayport Naval Station, Jacksonville, FL .....	92
<b>Appendix K:</b>	Detailed Site Inspection Reports for Charleston Naval Shipyard, Charleston, SC .....	96
<b>Appendix L:</b>	Detailed Site Inspection Reports for Charleston Air Force Base, Charleston, SC .....	100
<b>Appendix M:</b>	Detailed Site Inspection Reports for Grissom Air Force Base, Kokomo, IN .....	109
<b>Appendix N:</b>	Detailed Site Inspection Reports for Norfolk Naval Station, Norfolk, VA ...	120
<b>Appendix O:</b>	Detailed Site Inspection Reports for Fort Lewis, Olympia, WA .....	125
<b>Appendix P:</b>	Detailed Site Inspection Reports for San Diego Naval Facilities, San Diego, CA .....	134
<b>Distribution</b>		



## List of Tables and Figures

### Tables

1	Inspection sites .....	14
2	Overall distribution by casing material of conduits tested .....	18
3	The Pass/Fail distribution by casing material using Standard I: no more than a 1.0 psi drop after 30 minutes .....	19
4	The Pass/Fail distribution by casing material using Standard II: no more than a 5.0 psi drop after 30 minutes .....	19
5	The Pass/Fail distribution by casing material without gland seals using Standard I: no more than a 1 .....	19
6	The Pass/Fail distribution by casing material with gland seals using Standard I: no more than a 1.0 psi drop after 30 minutes .....	19
7	The Pass/Fail distribution by casing material without gland seals using Standard II: no more than a 5.0 psi drop after 30 minutes .....	19
8	The Pass/Fail distribution by casing material with gland seals using Standard II: no more than a 5.0 psi drop after 30 minutes .....	20
9	Failure rates and associated 95% confidence intervals (CI) for all FRP and steel conduits (Standard I) .....	21
10	Failure rates and associated 95% confidence intervals (CI) for all FRP and steel conduits (Standard II) .....	21
11	Failure rates (failures/mile) for "old" and "new" steel and FRP systems (Standard I) .....	21
12	Failure rates (failures/mile) for "old" and "new" steel and FRP systems (Standard II) .....	21
A1	Conduit air pressure test results for System #1 at Aberdeen Proving Grounds in Baltimore, MD .....	29

A2	Conduit air pressure test results for System #2 at Aberdeen Proving Grounds in Baltimore, MD .....	29
A3	Conduit air pressure test results for System #3 at Wright-Patterson Air Force Base (AFB) in Dayton, OH .....	29
A4	Conduit air pressure test results for System #4 at Wright-Patterson AFB in Dayton, OH .....	29
A5	Conduit air pressure test results for System #5 at Wright-Patterson AFB in Dayton, OH .....	30
A6	Conduit air pressure test results for System #6 at Wright-Patterson AFB in Dayton, OH .....	30
A7	Conduit air pressure test results for System #7 at Wright-Patterson AFB in Dayton, OH .....	30
A8	Conduit air pressure test results for System #8 at Veterans Administration Facility in Bedford, MA .....	30
A9	Conduit air pressure test results for System #9 at VA Facility in Bedford, MA .....	31
A10	Conduit air pressure test results for System #10 at U.S. Military Academy at West Point, NY .....	31
A12	Conduit air pressure test results for System #12 at Fort Riley in Manhattan, KS .....	31
A13	Conduit air pressure test results for System #13 at Patrick AFB in Satellite Beach, FL .....	32
A14	Conduit air pressure test results for System #14 at Jacksonville Naval Air Station (NAS) in Jacksonville, FL .....	32
A15	Conduit air pressure test results for System #15 (road crossing) at Jacksonville NAS in Jacksonville, FL .....	32
A16	Conduit air pressure test results for System #16 (road crossing) at Jacksonville NAS in Jacksonville, FL .....	32
A17	Conduit air pressure test results for System #17 at Jacksonville NAS in Jacksonville, FL .....	32

A18	Conduit air pressure test results for System #18 at Jacksonville NAS in Jacksonville, FL .....	33
A19	Conduit air pressure test results for System #19 at Jacksonville NAS in Jacksonville, FL .....	33
A20	Conduit air pressure test results for System #20 at Mayport Naval Station in Jacksonville, FL .....	33
A21	Conduit air pressure test results for System #21 at Mayport Naval Station in Jacksonville, FL .....	33
A22	Conduit air pressure test results for System #22 (exposed to coastal atmosphere in concrete trench along a pier) at Charleston Naval Shipyard in Charleston, SC .....	33
A23	Conduit air pressure test results for System #23 at Charleston Air Force Base in Charleston, SC (Manufacturer D) .....	34
A24	Conduit air pressure test results for System #23 at Charleston AFB in Charleston, SC (Manufacturer A) .....	34
A25	Conduit air pressure test results for System #24 at Grissom Air Force Base in Kokomo, IN .....	35
A26	Conduit air pressure test results for System #25 at Grissom AFB in Kokomo, IN .....	35
A27	Conduit air pressure test results for System #26 at Grissom AFB in Kokomo, IN .....	35
A28	Conduit air pressure test results for System #27 at Norfolk Naval Station in Norfolk, VA .....	36
A29	Conduit air pressure test results for System #28 at Norfolk Naval Station in Norfolk, VA .....	36
A30	Conduit air pressure test results for System #29 at Fort Lewis in Olympia, WA .....	36
A31	Conduit air pressure test results for System #30 at Fort Lewis in Olympia, WA .....	36
A32	Conduit air pressure test results for System #31 at Fort Lewis in Olympia, WA .....	36

A33	Conduit air pressure test results for System #32 at Fort Lewis in Olympia, WA .....	37
A34	Conduit air pressure test results for System #33 at Fort Lewis in Olympia, WA .....	37
A36	Conduit air pressure test results for System #35 at San Diego Naval Station in San Diego, CA .....	37
B1	Failure rates versus length weighted average age .....	40
B2	Number of failures versus length and length-weighted average age .....	41
B3	Failure rates for manufacturers of FRP conduit pipe .....	42
B4	Failure rates for manufacturers of steel conduit pipe .....	43
B5	Failure rates for FRP conduit pipe .....	44
B6	Failure rates for steel conduit pipe .....	44
D1	Pipe and conduit diameters and conduit casing temperatures as measured in the equipment room of Building 167 .....	54
 <b>Figures</b>		
1a	Failure rates vs. age (Standard I) .....	22
1b	Failure rates vs. age (Standard II) .....	23
B1	Failure rates versus length-weighted average age for four sequential time periods .....	40
B2	Number of failures versus lengths .....	42
C1	Schematic drawing of System 1 at Aberdeen Proving Grounds, MD .....	47
C2	Schematic drawing of System 2 at Aberdeen Proving Grounds, MD .....	50
D1	Schematic diagram of System 3 at Wright-Patterson AFB, OH .....	53
D2	Schematic diagram of System 4 at Wright-Patterson AFB, OH .....	55
D3	Schematic diagram of System 5 at Wright-Patterson AFB, OH .....	56

D4	Schematic diagram of System 4 at Wright-Patterson AFB, OH	59
D5	Schematic diagram of System 7 at Wright-Patterson AFB, OH	59
E1	Schematic diagram of System 8 at VA-Bedford, MA	63
E2	Schematic diagram of System 9 at VA-Bedford, MA	67
F1	Schematic diagram of System 10 at USMA, West Point, NY	71
F2	Schematic diagram of System 11 at USMA, West Point, NY	74
G1	Schematic diagram of System 12 at Fort Riley, KS	76
H1	Schematic diagram of System 13 at Patrick AFB, FL	82
I1	Schematic diagram of System 14 at Jacksonville NAS, FL	86
I2	Schematic diagram of System 15 at Jacksonville NAS, FL	88
I3	Schematic diagram of System 16 at Jacksonville NAS, FL	89
I4	Schematic diagram of System 17 at Jacksonville NAS, FL	89
I5	Schematic diagram of System 18 at Jacksonville NAS, FL	90
I6	Schematic diagram of System 19 at Jacksonville NAS, FL	91
J1	Schematic diagram of System 20 at Mayport Naval Station, FL	93
J2	Schematic diagram of System 21 at Mayport Naval Station, FL	95
K1	Schematic diagram of System 22 at Charleston Ship Yard, SC	98
L1	Schematic diagram of System 23 at Charleston AFB, SC	102
M1	Schematic diagram of System 24 at Grissom AFB, IN	110
M2	Schematic diagram of System 25 at Grissom AFB, IN	113
M3	Schematic diagram of System 26 at Grissom AFB, IN	118
N1	Schematic diagram of System 27 at Norfolk Naval Station, VA	122
N2	Schematic diagram of System 28 at Norfolk Naval Station, VA	123

---

O1	Schematic diagram of System 29 at Fort Lewis, WA .....	127
O2	Schematic diagram of System 30 at Fort Lewis, WA .....	128
O3	Schematic diagram of System 31 at Fort Lewis, WA .....	129
O4	Schematic diagram of System 32 at Fort Lewis, WA .....	132
O5	Schematic diagram of System 33 at Fort Lewis, WA .....	133
P1	Schematic diagram of System 34 at San Diego Naval Training Center, CA .....	136
P2	Schematic diagram of System 35 at San Diego Naval Station, CA .....	140

# 1 Introduction

## Background

The Department of Defense (DOD) currently owns, maintains, and operates approximately 6,000 miles of steam and high temperature hot water heat distribution system piping. The majority of this piping is underground. The replacement cost in 1993 dollars for all of these systems would be well over \$8 billion. Given the extent of these systems, even a small decrease in heat transmission efficiency can lead to large amounts of wasted energy, natural resources, and increased production of greenhouse gases.

The number of new installations of underground heat distribution systems increased in the late 1940s and early 1950s. The associated unacceptable failure and premature replacement rates of these systems attracted the attention of construction agencies. To address the problem, a National Academy of Sciences (NAS) Federal Construction Council (FCC) Task Force performed a series of studies. Based on these studies, the first Tri-Service Specification (Corps of Engineers 1963) was developed and made mandatory both for new construction and for maintaining existing systems. The specification established criteria for design, construction, maintenance, and operation of underground heat distribution systems. Also established were requirements for site classification. Class A sites are where water in the soil will be expected to influence the performance or expected life of the system. Class B sites are those where water in the soil is not expected to influence the performance or expected life of the system.

In 1969, the FCC concluded that the Tri-Service Specification appeared to be too inflexible and prevented the development of new types of systems. Updating the specification led to the development of Federal Construction Guide Specification (FCGS) 15705 (NAS-FCC 1976). The requirements for Class A systems remained relatively unchanged, but the requirements were revised to introduce a "systems approach" where the system supplier is held responsible for design and construction. One major change as a result of the new criteria is the granting of Letters of Acceptability to preapproved, drainable-dryable systems employing fiberglass reinforced plastic (FRP) conduit casings. Previously, only systems with coated steel casings were allowed. Because of industry resistance and unfamiliarity with new test procedures, the implementation of FCGS 15705 criteria was delayed more than 5

years, and the "systems approach" and new site classification requirements were not implemented until 1981. Relatively minor changes and revisions of FCGS 15705 caused its replacement by the specific agencies' guide specifications. Corps of Engineers Guide Specification (CEGS) 02695 (May 1991) is the latest basic version of the Engineer's guide specification.

At the Federal Agency Committee (FAC) member agencies' request, this investigation was undertaken by the U.S. Army Construction Engineering Research Laboratories (USACERL) to objectively investigate and evaluate drainable-dryable systems installed and operated since the new FAC criteria were implemented in 1981.

The only previous study of these systems (Segan and Chen 1984) evaluated the effectiveness of those systems installed in accordance with the 1963 Tri-Service Specification. This evaluation was done by excavating different types of systems known to be experiencing problems. Before 1993, no systematic evaluation of the effectiveness of the latest criteria change of 1981 had been performed.

## Objectives

The objectives of this investigation were to inspect and evaluate the physical condition and general performance of underground heat distribution systems installed in compliance with the 1981 FAC criteria. Another objective of this investigation was to obtain a representative and statistically significant sampling of all of the drainable/dryable systems currently in use at FAC member agency sites within the continental United States.

## Approach

The inspection teams evaluated 35 systems on 15 different DOD and Department of Veterans Affairs (VA) installations. The inspections were accomplished by:

- a. Air pressure testing of casings.
- b. Visually inspecting for indications of flooded manholes, steaming or moisture at conduit end plate vents/drains, and excessive heat loss.
- c. Gathering other data, either observed or from the experience of base personnel, pertinent to system condition.



d. Where a system fault is identified, attempting to identify the possible cause or causes without system excavation.

Appendix A gives the results of all conduit pressure tests, and Appendix B gives the statistical analysis of inspection data.

### **Mode of Technology Transfer**

It is recommended that the information in this report be used to revise CEGS 02695, *Preapproved Underground Heat Distribution Systems* (May 1991), Technical Manual 5-810-17, *Heating and Cooling Distribution Systems* (May 1994), and equivalent criteria in the FAC member agencies.

## 2 General Approach and Methodology

### Site Selection

The first step of site selection was to request from each prequalified manufacturer a list of all systems installed on VA and DOD installations from 1981 to the present. The information requested included: location, year installed, and the approximate size of the project in linear feet. All but one preapproved manufacturer responded with information. The submissions from the participating manufacturers totaled more than 800 projects.

Site selection first involved identifying sites with projects from multiple manufacturers. This criterion assured efficient use of funds and allocated resources. Every effort was made to examine piping from each of the preapproved manufacturers. Final site selection was greatly influenced by the available projects lists which were shorter from some manufacturers than from others.

**Table 1. Inspection sites.**

1	Aberdeen Proving Grounds - Baltimore, MD
2	Wright-Patterson Air Force Base - Dayton, OH
3	Veterans Administration Facility - Bedford, MA
4	United States Marine Academy - West Point,
5	Fort Riley - Manhattan, KS
6	Patrick Air Force Base - Satellite Beach, FL
7	Jacksonville Naval Air Station - Jacksonville, FL
8	Mayport Naval Station - Jacksonville, FL
9	Charleston Naval Shipyard - Charleston, SC
10	Charleston Air Force Base - Charleston, SC
11	Grissom Air Force Base - Kokomo, IN
12	Norfolk Naval Station - Norfolk, VA
13	Fort Lewis - Olympia, WA
14	Naval Training Center - San Diego, CA
15	San Diego Naval Station - San Diego, CA

A secondary criterion was to select an assortment of sites from the various agencies so that sites were distributed throughout the continental United States. This selection ensured that a variety of site conditions would be sampled and would include possible differences in the approach to maintenance between the DOD and VA services. Generally, sites previously visited by members of the FAC and its advisors were not selected to avoid known problem sites and help assure a representative sampling. Table 1 lists the sites visited grouped by area. A typical site inspection in an area involved a three-man team working a full week.

## Survey Method

The typical area investigation began by contacting the appropriate installation personnel and design/construction agent at least 2 weeks in advance of the planned inspection. Once a date was set, the inspection team notified the designated manufacturer's representative, who in turn notified the other manufacturers should they wish to be present at an inspection. Before an inspection, all available information on construction projects was telefaxed to the site to aid base personnel in locating drawings of specific projects. In addition, assistance from the installation and the use of an air compressor were arranged.

When the inspection team arrived at an installation, an initial meeting was generally held with representatives from both maintenance and engineering. At this meeting, the purpose of the inspections was explained and the collection of installation experience with the preapproved systems was begun. In particular, questions were asked concerning experience with leaks and repairs in preapproved underground heat distribution systems installed since 1981. The accumulation of experiences with the preapproved systems continued throughout the inspection.

After the initial meeting, dated drawings of construction projects were obtained and the manufacturers of the installed systems positively identified. The time required for this step of the process varied considerably at each installation. For some projects, no drawings could be found. For others, the project had been designed but not built. For each segment inspected, however, a positive identification of both the project's manufacturer and the year installed was made without fail.

From this pool of potential projects, a few were chosen as showing the best potential to have conduits that could be pressure tested. Often at this stage, drawings indicated that water shed caps were installed, especially in equipment rooms. Because system segments with water shed caps are hot sealed, their installation often precluded projects from further consideration.

The next stage of the inspection involved locating the system segments chosen for inspection and assessing the specific aspects of what would be needed to perform air pressure tests. Initially the method used was to randomly choose a conduit section with the intention of then performing an air pressure test on that section. In practice, except for some of the larger systems inspected, this proved to be an unworkable methodology. A number of factors often affected accessibility or the ability to pressurize a conduit casing. These factors included: water shed caps, excessive steaming, flooded manholes, buried take offs, absence of manhole ladders, and obstructions at the vents or drains. Therefore, the choice of system segments often involved those

segments in locations more conducive to an inspection, at least at the time of the team's visit.

On some of the larger projects inspected, it was possible to randomly select the system segments to be air tested. This selection was done by numbering the segments sequentially and dividing the list in half. With a flip of a coin, one half of the list was selected. This process was repeated with the remainder of the list until a single segment was chosen. For the cases where an odd number of segments were involved, the top or bottom part of the list contained more segments depending on whether it was an even or odd day, respectively. This process was used whenever possible.

Depending on the number available, as many as four conduits were sequentially pressurized and under test at any one time. The initial pressure of 15 psi was used before valving off the sealed conduit. Generally, the pressure tests lasted at least 30 min. Initially, longer periods were used, but to maximize the number of conduit air pressure tests, a minimum of 30 min was judged to be a good indication of conduit soundness. Occasionally conduits were left under test over lunch or overnight as noted in the detailed site inspection reports (Appendices C through P). The air pressure test is intended as a measure of soundness of the conduit against water infiltration. If a conduit can hold air pressure, then it is assured of not allowing the infiltration of ground water into the annular space, which can lead to excess heat loss, system damage, and carrier pipe failures.

In addition to conduit air pressure tests, the vents and drains were checked for moisture, and detailed manhole\* inspections were performed. Any other pertinent information concerning the condition of the system being inspected was also noted.

---

\* The procedure for inspection is detailed in Demetroulis, Nicholas M., Vincent F. Hock, Ellen G. Segan, *Guidance for Manhole Rehabilitation in Army Underground Heat Distribution Systems*, USACERL Technical Report M-91/01/ADA233709 (March 1991).

## 3 Summary of Results

### Installation Experience

When asked about their experience with major failures and needed repairs for pre-approved systems installed since 1981, installation personnel usually replied that no repairs had been needed. This reply, however, was found to be an unreliable indication of actual experience. In two instances, major failures (in the form of carrier pipe leaks) were found after installation personnel indicated no problems with the systems.

The first major failure involved a sealed steam conduit at Grissom Air Force Base (AFB) that was produced by Manufacturer C and pressurized to approximately 75 psi. Other conduits at this site were said to be acting as the carrier "pipe," but this pipe was previously unknown. Upon valving off the steam supply, the casing temperature dropped from the initial 320 °F, indicating an internal carrier pipe break.

The second major failure was found in a system supplied by Manufacturer G at Fort Lewis. The cost for the location and repair of this major failure was documented as \$14,234. It should be noted that the system was not repaired to preapproved system standards. A section of carrier pipe was replaced and then covered with cellular glass insulation with a mastic coating. The preferred repair would have been to use an approved insulation (which depends on site classification) such as mineral wool or calcium silicate as well as the same conduit casing material as originally installed.

In addition to these major failures, personnel at Charleston AFB indicated that many steam pipe failures had occurred that primarily involved both factory and field welds. Extensive excavations had been required to locate and repair these failures, but the cost data for locating and repairing the pipe failures were not available.

### Moisture and Steaming

In the course of the inspections, numerous vents and drains were checked for evidence of moisture or steam. With nine exceptions, these features were found to be dry at the time of the inspections. However, evidence of water in manholes often was seen in standing water, water marks, or degraded insulation with deposits of mud on the

pipng. The systems inspected at Navy sites had exceptional problems with water infiltration in manholes. It was not uncommon to have difficulty in finding any systems on Navy installations that even afforded access for pressure testing because of water in the manholes. By the nature of the Navy mission, the installations must be located in areas with high water tables. This abundance of subsurface water often leads to excessive steaming in the manholes, and in at least two instances, Navy installation manholes were observed to be full of boiling water. Also at Navy installations, condensate return systems were often not operational or were absent. One installation indicated that this apparent deficiency was because of the requirement for clean steam used to service ships.

### Conduit Air Pressure Tests

In some instances, conduit segments could not be pressure tested because of water shed caps, untightenable gland seals, manhole flooding, and excessive steaming. A total of 97 conduit pressure tests were successfully attempted. Of these, 51 tests were on systems with steel casings and 46 were on systems with fiberglass-reinforced plastic (FRP) casings (Table 2). To gauge the performance of conduit casings, two standards of pass/fail are defined. Standard I allows for no more than a 1.0 psi drop in pressure 30 min after initial pressurization. Standard II allows for no more than a 5.0 psi drop in pressure 30 min after initial pressurization.

**Table 2. Overall distribution by casing material of conduits tested.**

Total testable with steel casings	51
Total testable with FRP casings	46
Total casings tested	97

By Standard I, the FRP-cased conduits performed very poorly (Table 3). If the more lenient Standard II is adopted instead, the performance of the conduit segments with FRP casings improves dramatically but still lags substantially behind that of the steel cased systems (Table 4). On several occasions, the sealed conduits could not be pressurized to 15 psi. This failure occurred seven times for steel and 13 times for FRP conduits. In addition, five out of nine conduits that evidenced water or steaming were pressure tested. Using Standard I, four conduits failed and one passed. When Standard II was used, one conduit failed and four passed.

For every conduit air pressure test performed any gland seals present were tightened so as to have minimal or no leakage. If seals could not be tightened, the air test was considered invalid and not included in the analysis. It is, however, still of interest to note the relative performance of both steel and FRP conduits both with, and without, gland seals. Tables 5 through 8 show the conduit air pressure test results separated by whether gland seals were present. Note that even in the absence of gland seals, steel conduits performed significantly better than FRP conduits.

**Table 3. The Pass/Fail distribution by casing material using Standard I: no more than a 1.0 psi drop after 30 minutes.**

Standard I	Steel casings	FRP casings
Pass	30 (59%)	3 (7%)
Fail	21 (41%)	43 (93%)
Total	51 (100%)	46 (100%)

**Table 4. The Pass/Fail distribution by casing material using Standard II: no more than a 5.0 psi drop after 30 minutes.**

Standard II	Steel casings	FRP casings
Pass	37 (73%)	11 (24%)
Fail	14 (27%)	35 (76%)
Total	51 (100%)	46 (100%)

**Table 5. The Pass/Fail distribution by casing material without gland seals using Standard I: no more than a 1.**

Standard I: WITHOUT gland seals	Steel casings	FRP casings
Pass	29 (74.4%)	3 (14.3%)
Fail	10 (25.6%)	18 (85.7%)
Totals	39 (100.0%)	21 (100.0%)

**Table 6. The Pass/Fail distribution by casing material with gland seals using Standard I: no more than a 1.0 psi drop after 30 minutes.**

Standard I: WITH gland seals	Steel casings	FRP casings
Pass	1 (8.3%)	0 (0%)
Fail	11 (91.7%)	25 (100%)
Totals	12 (100%)	25 (100%)

**Table 7. The Pass/Fail distribution by casing material without gland seals using Standard II: no more than a 5.0 psi drop after 30 minutes.**

Standard II: WITHOUT gland seals	Steel casings	FRP casings
Pass	32 (82.1%)	7 (33.3%)
Fail	7 (17.9%)	14 (66.7%)
Totals	39 (100%)	21 (100%)

**Table 8. The Pass/Fail distribution by casing material with gland seals using Standard II: no more than a 5.0 psi drop after 30 minutes.**

<b>Standard II: WITH gland seals</b>	<b>Steel casings</b>	<b>FRP casings</b>
Pass	4 (33.3%)	4 (16.0%)
Fail	8 (66.7%)	21 (84.0%)
Totals	12 (100%)	25 (100%)

## Statistical Analysis

For purposes of statistical analysis, the failure rate is assumed to be Poisson in space and not time. This is based on the expectation that longer pipe systems tend to have more failures. For completeness this assumption was tested and shown to be valid (Appendix B). Failure data and associated 95 percent confidence intervals (CIs) are shown in Table 9 (Standard I) and Table 10 (Standard II). These calculations group all the conduits together and do not consider the age of the piping systems. The results of the statistical analysis indicate that steel conduits have a significantly lower failure rate than FRP conduits. The analysis also considered the effects of type of service, different piping manufacturers, and age on the failure rates. Appendix B shows that none of these factors were found to have a significant effect.

To investigate the relationship between system age and failure rate, two methods were used. First, the piping was divided into "old" systems (installed during 1981 to 1987) and "new" systems (installed from 1988 to the present). Failure data for Standards I and II (listed in Tables 11 and 12, respectively) show the failure rate for FRP conduit systems is significantly greater than the rate for steel conduits.

An alternate failure rate that accounts for the differing age of the conduits can be calculated by dividing the failures per mile by the length weighted average age of the conduit segments (Table B1 of Appendix B). No CIs have been calculated for these failure rates because the dependence on time is, arguably, not Poisson.

However, plotting the results in Tables 11 and 12 may show the general time dependence of the failure rates (Figures 1a and 1b). Accounting for the confidence intervals, the time dependence of the failure rates are not pronounced. The failure rate for FRP conduits appears to decrease slightly as the systems get older. The failure rate for steel appears to increase marginally. However, it would be difficult to call these trends statistically significant.



**Table 9. Failure rates and associated 95% confidence intervals (CI) for all FRP and steel conduits (Standard I).**

Conduit Type	Steel	FRP
Number testable	51	46
Number of failures	21	43
Length (miles)	3.413	1.768
Failure rate (failures/mile)	6.153	24.32
95 % CI	(3.81, 9.41)	(17.6, 32.7)
average age (years)	7.13	5.11

**Table 10. Failure rates and associated 95% confidence intervals (CI) for all FRP and steel conduits (Standard II).**

Conduit Type	Steel	FRP
Number testable	51	46
Number of failures	14	35
Length (miles)	3.413	1.768
Failure rate (failures/mile)	4.102	19.79
95 % CI	(2.24, 6.88)	(13.8, 27.5)
average age (years)	7.13	5.11

**Table 11. Failure rates (failures/mile) for "old" and "new" steel and FRP systems (Standard I).**

Conduit Type	OLD		NEW	
	Steel	FRP	Steel	FRP
Number of failures	16	23	5	20
Length (miles)	2.131	0.8864	1.281	0.8820
Failure rate	7.51	25.9	3.90	22.7
95 % CI	(4.29, 12.2)	(16.4, 38.9)	(1.27, 9.11)	(13.8, 35.0)
average age (years)	9.33	6.96	3.48	3.26

**Table 12. Failure rates (failures/mile) for "old" and "new" steel and FRP systems (Standard II).**

Conduit Type	OLD		NEW	
	Steel	FRP	Steel	FRP
Number of failures	10	18	4	17
Length (miles)	2.131	0.8864	1.281	0.8820
Failure rate	4.69	20.3	3.12	19.3
95 % CI	(2.25, 8.63)	(12.0, 32.1)	(.851, 7.99)	(11.2, 30.9)
average age (years)	9.33	6.96	3.48	3.26

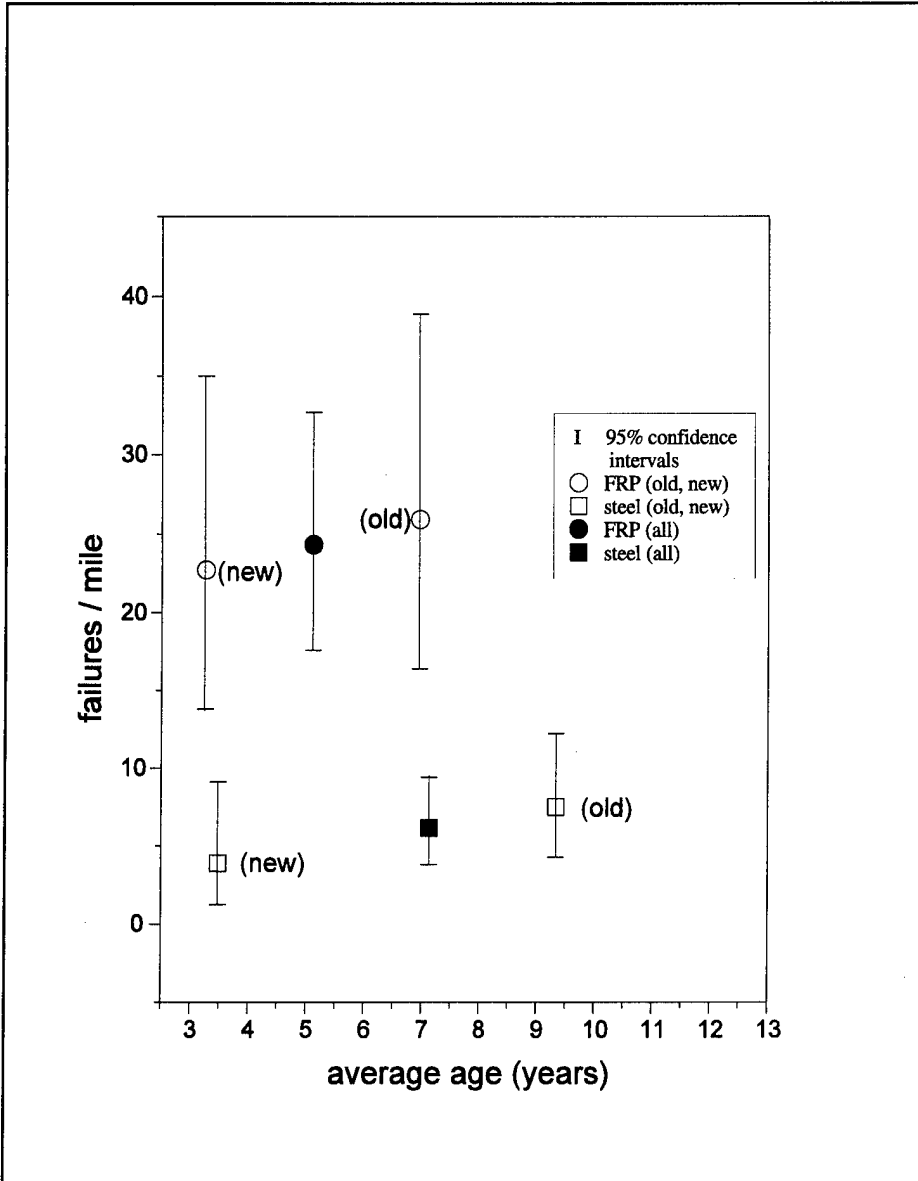

Figure 1a. Failure rates vs. age (Standard I).

## General Observations

Often the heat distribution systems inspected had been installed improperly. Of the conduits successfully pressure tested, 10 instances of steam and steel condensate lines within a common conduit were found. This practice is not allowed because the condensate line typically fails first and soon causes a steam line break, which interrupts service. Another disallowed practice found was the use of buried connections or take-offs constructed outside of a manhole. To save money on additions to the system, manholes are sometimes not used, requiring the contractor to connect both the carrier and conduit piping and then backfill. In practice, this connection is difficult to fabricate in the field and often leads to unsound conduits that allow ground water

infiltration. In addition, investigators found several cases of runs between manholes well in excess of the maximum allowed distance of 500 ft. These long runs make leak detection difficult and expensive because of the number of excavations needed. Long piping runs also lead to either excessive burial depth or improper slope.

Within the manholes, various problems were found that were contrary to the concept behind the preapproved drainable and dryable design. This concept, for normal operation, includes both an open vent and a closed drain on both ends of the protective conduit. The drain is meant to be temporarily removable to inspect for water in the conduit. When the conduit drains were checked during this study, the threaded plug was often found to be missing or was unremovable due to corrosion. Criteria specifies the use of either a brass or bronze plug, but a steel plug often is used, which corrodes

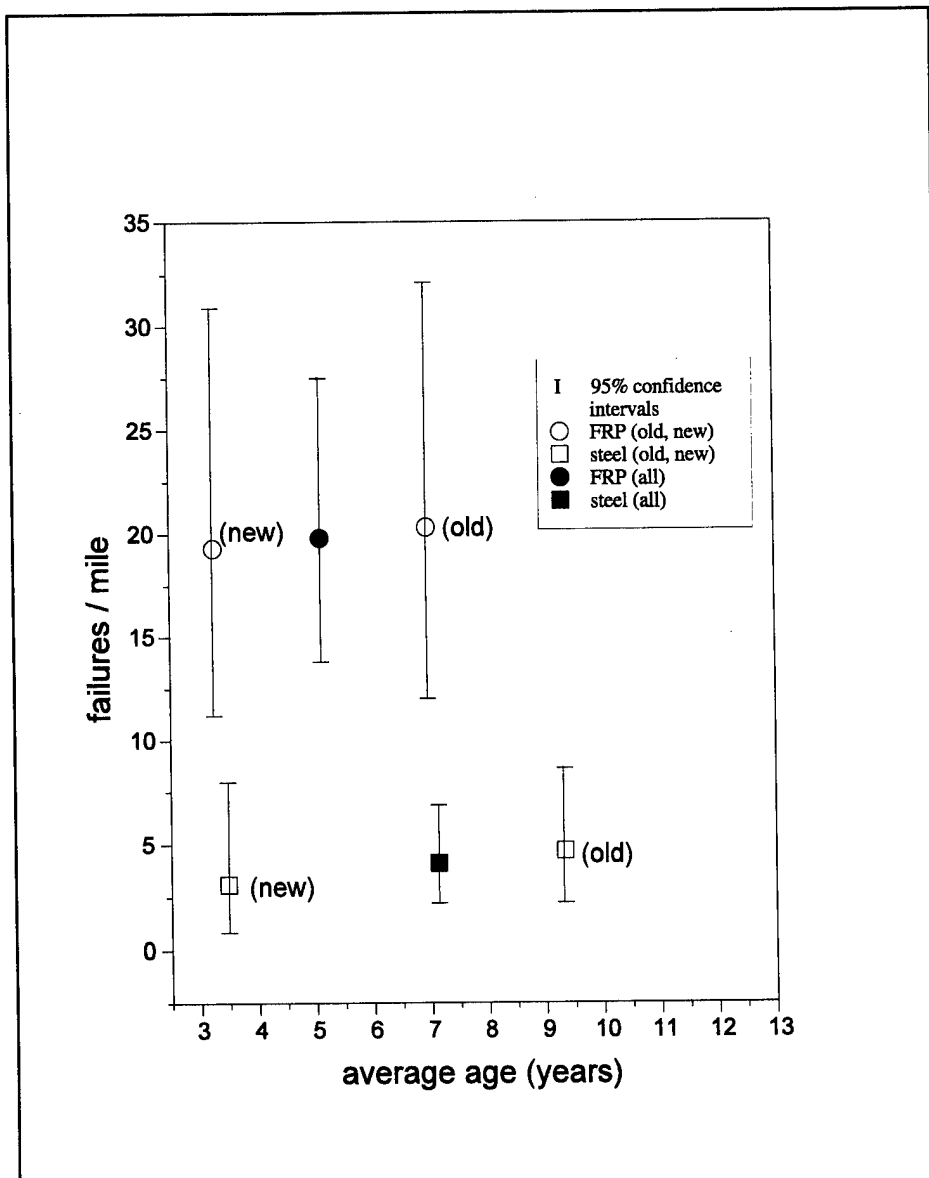

Figure 1b. Failure rates vs. age (Standard II).

shut over time. Investigators found a related problem with access to conduit drain plugs often being difficult or impossible. At one installation, the manhole wall penetration sleeves extended so far into the manhole that they completely obstructed the removal of the drain plug.

Almost all the gland seals required tightening. Nuts around the gland seal often were not even hand tight, and occasionally a nut was missing. The state of the gland seals made their effectiveness minimal as a barrier to the ingress of water from the manhole into the conduit. Some manufacturers of preapproved FRP conduit systems appeared to prefer the widespread use of gland seals for a partial thermal break between the FRP and the carrier pipe. A suggested counter example was found at the VA Hospital in Bedford, MA, where Manufacture F's system did not use gland seals. In a few instances during conduit air pressure tests of this piping, leaks were observed at the FRP to steel transition at the end plate assemblies.

Two safety issues were identified that could be *extremely hazardous* for maintenance personnel. The dangerous practice of plugging the conduit vents was found in a few cases, which precludes the use of vent steaming to indicate water infiltration into the conduit. Besides being a safety issue, this practice of using the conduit as the carrier pipe will also lead to excessive heat loss.

Another safety issue encountered was the production of ammonia from wet insulation. In one case, after depressurizing the conduit casing, the ammonia present prevented entry into the manhole. Ammonia was present on another occasion involving a sealed conduit. In confined spaces, such as manholes, the presence of ammonia could lead to the very dangerous displacement of oxygen.

Although not the main focus of this study, the field experience gathered from installation personnel was uniformly negative concerning condensate *carrier* lines made of FRP. Charleston AFB, Fort Lewis, and Grissom AFB all had major failures with FRP piping. Personnel from each of these installations stated that they would not install FRP again if given a choice. Grissom AFB was replacing sections of failed piping with systems using steel carrier pipe. The typical mode of failure was said to be a steam trap failing in the open position. On one occasion, the concrete anchor blocks settled during a small earthquake at Grissom AFB and sheared the FRP condensate piping in two.

On two occasions, investigators had the opportunity to examine the manholes associated with a water spread limiting (WSL) system. An integral part of these systems is a polymeric end seal used to isolate successive conduit sections between manholes and at the manhole penetration. In all instances, the end seal is in contact with the

hot carrier piping and is essential to limit the spread of any potential carrier pipe or casing leak. In both manholes examined, failed end seals were found. One seal appeared to be deformed from the heat of a steaming manhole and was observed hanging on uninsulated carrier piping. Another seal was in place but had formed large cracks where the end seal was in contact with the carrier pipe. The need for further investigation of field experience with both FRP condensate carrier piping and WSL systems is strongly indicated.

At two different sites, a "delta loop" thermostatic steam trap was said to work effectively on drip legs for extended periods of time. With the potential of substantially reducing both steam losses and maintenance requirements, further investigation of this steam trap design is indicated.

## 4 Conclusions and Recommendations

After air pressure tests of conduits, visual inspections of manholes, and compilation of installation experience with underground heat distribution systems, the following conclusions and recommendations are made:

1. The use of FRP conduit casings should be disallowed on Class A sites. Preapproved heat distribution systems are used on Class A sites where ground water may be expected above the top of the piping. The fact that the FRP conduits performed significantly worse at holding air pressure compared to the steel conduits makes them a poor defense against water infiltration.
2. The use of water shed caps should be prohibited. Water shed caps make air pressure testing of any associated conduit segments difficult. Pressure tests are useful for quality assurance during construction and later as a diagnostic maintenance tool.
3. Various methods should be investigated to assure better compliance with existing criteria. The purpose of construction criteria and preapproved product brochures is to assure the installation of a reliable, energy efficient and long lived heat distribution system. Many years of collective experience with these systems has shown that deviation from these criteria will lead to excess heat loss and premature failure of the system. In many instances, investigators found design and construction errors contrary to existing criteria. These discrepancies included: steam and condensate lines in a common conduit, excessive length of runs between manholes, buried connections without a manhole, inaccessible and occasionally open drains, and plugged vents.
4. Given the avoidable maintenance for them and the frequently occurring path for water infiltration into the conduit, it is recommended that the use of gland seals be restricted and allowed only with special justification. The original intent of allowing gland seals was to account for the rare occasion when thermal expansion could not be accommodated in any other way than to allow expansion into the manhole. Normally, through the use of elbows, "Zee" bends, and expansion loops, the use of gland seals can be avoided in a piping design. Virtually all gland seals encountered during these inspections required tightening before conduit air pressure testing, and many seals could not be fully tightened. In addition, the use of gland seals adds the recurring maintenance task of gasket replacement in order for the system to continue to function as designed.

5. Guidance and funding should be provided to establish preventative maintenance programs for underground heat distribution system manholes with special emphasis on the sump pumps. The presence of ground water in manholes for at least some time during service was almost universal. Even those manholes without standing water almost always showed evidence of having had water in them at one time. Water marks, deposits of mud on the piping, slumped or completely missing insulation, and stains on the manhole walls all pointed to prior water infiltration. Even when sump pumps were present, they were often inoperative or in need of adjustment. Severe system degradation and excess heat loss will result from ground water collecting unchecked in manholes.

6. The source of ammonia should be verified and steps should be taken to avoid its production. Upon releasing the air pressure on a 16-in. diameter conduit that terminated in two risers, the smell of ammonia was detected. When the air pressure was released on a 1,120-ft long 14-in. diameter conduit, the gas collected in the manhole. The smell was so severe it prevented entry into the manhole. In a confined space, a workman could easily be overcome, representing a very real hazard to maintenance personnel.

7. All sealed conduits should be vented (with any associated repairs), and the use of plugs in conduit vents should be strictly prohibited. The purpose of the conduit vent is to serve as a "tattle tale" sign of water infiltration into the conduit by venting steam. If steaming vents are observed, the system should be repaired rather than just sealing the conduit vents. Conduit piping is not designed to withstand carrier pressure and could explode if plugged. The greatest hazard is to maintenance personnel who may unwittingly open a pressurized conduit. In addition, this practice causes a significantly higher heat loss by exposing a much larger and uninsulated "carrier" pipe to the thermal sink of the ground.

8. The moisture absorption characteristics and the related effects on insulating properties of calcium silicate insulation should be investigated. A conduit with this type of insulation was installed in a humid environment. When the conduit was opened, a considerable amount of water was drained. The observing manufacturer's representative indicated that this was entirely a result of moisture retained in the insulation. Though only a single instance of this absorption was observed, the ramifications could be far reaching. The presence of moisture in insulation invariably decreases the insulating ability drastically. It is possible that all current and future systems installed with this type of insulation actually lose significantly more heat than expected.

## References

- Bain, L.J., *Statistical Analysis of Reliability and Life-Testing Models* (Marcel Dekker, New York, 1978).
- Hahn, G.J., and W.Q. Meeker, *Statistical Intervals* (John Wiley and Sons, New York, 1991).
- Heat Distribution Systems Outside of Buildings*, CE-301.21 (U.S. Army Corps of Engineers [HQUSACE], April 1967).
- Hogg, R.V., and A.T. Craig, *Introduction to Mathematical Statistics* (The MacMillan Co., Toronto, 1970).
- Heating and Cooling Distribution Systems*, Technical Manual 5-810-17 (Headquarters, Department of the Army, 10 May 1994).
- Mann, N.R., R.E. Schafer, and N.D. Singpurwalla *Methods for Statistical Analysis of Reliability and Life-Data* (John Wiley and Sons, New York, 1974).
- Preapproved Underground Heat Distribution Systems*, Corps of Engineers Guide Specification 02695 (USACE, May 1991).
- Underground Heat Distribution Systems (Prefabricated or Pre-Engineered Type)*, Federal Construction Guide Specification 15705 (NAS-FCC, April 1976).
- Segan, E.G., and C-P. Chen, *Investigation of Tri-Service Heat Distribution Systems*, Technical Report M-347/ADA145181 (U.S. Army Construction Engineering Research Laboratory, June 1984).



## Appendix A: Results of Conduit Air Pressure Tests

**Table A1. Conduit air pressure test results for System #1 at Aberdeen Proving Grounds in Baltimore, MD.**

MFR	Year	Conduit Diameter (in.)	Length of Run (ft)	Type of Service	Initial Pressure (psi)	Pressure at 30 Minutes (psi)
D(s)	1989	13	150	Stm+Con	8.0	0.0

Water shed caps were used exclusively in equipment rooms.  
Note: "(s)" indicates a steel conduit.

**Table A2. Conduit air pressure test results for System #2 at Aberdeen Proving Grounds in Baltimore, MD.**

MFR	Year	Conduit Diameter (in.)	Length of Run (ft)	Type of Service	Initial Pressure (psi)	Pressure at 30 Minutes (psi)
G(p)	1988	16	220	Steam	17.0	0.0

Many of the manholes were full of water.  
Note: "(p)" indicates an FRP conduit.

**Table A3. Conduit air pressure test results for System #3 at Wright-Patterson Air Force Base (AFB) in Dayton, OH.**

MFR	Year	Conduit Diameter (in.)	Length of Run (ft)	Type of Service	Initial Pressure (psi)	Pressure at 30 Minutes (psi)
B(s)	1988	6	167	Cond.	15.0	15.0
B(s)	1988	10	381	Steam	2.5	0.0
B(s)	1988	6	381	Cond.	16.0	10.5
B(s)	1988	10	167	Steam	15.0	15.0

**Table A4. Conduit air pressure test results for System #4 at Wright-Patterson AFB in Dayton, OH.**

MFR	Year	Conduit Diameter (in.)	Length of Run (ft)	Type of Service	Initial Pressure (psi)	Pressure at 30 Minutes (psi)
C(s)	1990	16	600	Stm+Con	15.0	15.0

**Table A5. Conduit air pressure test results for System #5 at Wright-Patterson AFB in Dayton, OH.**

MFR	Year	Conduit Diameter (in.)	Length of Run (ft)	Type of Service	Initial Pressure (psi)	Pressure at 30 Minutes (psi)
G(p)	1989	10	110	Cond.	Untestable (vent weld)	
G(p)	1989	13	110	Steam	Untestable (vent weld)	
G(p)	1989	7	135	Cond.	16.0	12.1

The steam conduits contained polyester resin and the condensate conduits used the newer vinyl ester resin.

**Table A6. Conduit air pressure test results for System #6 at Wright-Patterson AFB in Dayton, OH.**

MFR	Year	Conduit Diameter (in.)	Length of Run (ft)	Type of Service	Initial Pressure (psi)	Pressure at 30 Minutes (psi)
D(s)	1983	10	470	Steam	15.25	15.0

**Table A7. Conduit air pressure test results for System #7 at Wright-Patterson AFB in Dayton, OH.**

MFR	Year	Conduit Diameter (in.)	Length of Run (ft)	Type of Service	Initial Pressure (psi)	Pressure at 30 Minutes (psi)
A(s)	1989	No pressure tests due to rain				

**Table A8. Conduit air pressure test results for System #8 at Veterans Administration Facility in Bedford, MA.**

MFR	Year	Conduit Diameter (in.)	Length of Run (ft)	Type of Service	Initial Pressure (psi)	Pressure at 30 Minutes (psi)
F(p)	1987	5	150	Cond.	15.5	13.4
F(p)	1987	6	90	Cond.	14.5	14.5
F(p)	1987	9	90	Steam	3.0	0.0
F(p)	1987	6	300	Cond.	15.0	1.0
F(p)	1987	5	30	Cond.	16.5	1.0
F(p)	1987	9	210	Steam	4.0	1.0
F(p)	1987	9	300	Steam	5.1	0.0

**Table A9. Conduit air pressure test results for System #9 at VA Facility in Bedford, MA.**

MFR	Year	Conduit Diameter (in.)	Length of Run (ft)	Type of Service	Initial Pressure (psi)	Pressure at 30 Minutes (psi)
G(p)	1988	6	30	Steam	7.0	0.0
G(p)	1988	4	30	Cond.	15.0	13.2
G(p)	1988	9	110	Steam	15.5	0.0
G(p)	1988	14	70	Steam	1.0	0.0
G(p)	1988	8	70	Cond.	7.0	1.0

**Table A10. Conduit air pressure test results for System #10 at U.S. Military Academy at West Point, NY.**

MFR	Year	Conduit Diameter (in.)	Length of Run (ft)	Type of Service	Initial Pressure (psi)	Pressure at 30 Minutes (psi)
E(p)	1983	10	400	Cond.	16.0	0.0
E(p)	1983	13	350	Steam	1.0	0.0

**Table A11. Conduit air pressure test results for System #11 at U.S. Military Academy at West Point, NY.**

MFR	Year	Conduit Diameter (in.)	Length of Run (ft)	Type of Service	Initial Pressure (psi)	Pressure at 30 Minutes (psi)
C(s)	1990	16	860	Steam	Untestable (water shed cap)	

Note: The length of this run is excessive.

**Table A12. Conduit air pressure test results for System #12 at Fort Riley in Manhattan, KS.**

MFR	Year	Conduit Diameter (in.)	Length of Run (ft)	Type of Service	Initial Pressure (psi)	Pressure at 30 Minutes (psi)
A(s)	1984	14	120	Stm+Con	15.0	15.0
A(s)	1984	14	70	Stm+Con	Untestable (gland seals)	
A(s)	1984	15	20	Stm+Con	Untestable (gland seals)	
A(s)	1984	17	25	Stm+Con	Untestable (gland seals)	
A(s)	1984	14	36	Stm+Con	1.0	0.0
A(s)	1984	17	216	Stm+Con	1.0	0.0

Note: System #12 is part of the FEAP demonstration program and as a result receives expert inspection and recommendations in addition to standard procedures.

**Table A13. Conduit air pressure test results for System #13 at Patrick AFB in Satellite Beach, FL.**

MFR	Year	Conduit Diameter (in.)	Length of Run (ft)	Type of Service	Initial Pressure (psi)	Pressure at 30 Minutes (psi)
F(p)	1984	13	150	Steam	3.0	0.0
F(p)	1984	9	150	Cond.	15.5	0.0

Note: A number of conduit terminations in this system used water shed caps of various designs or had ends open to the weather. This precluded additional pressure tests.

**Table A14. Conduit air pressure test results for System #14 at Jacksonville Naval Air Station (NAS) in Jacksonville, FL.**

MFR	Year	Conduit Diameter (in.)	Length of Run (ft)	Type of Service	Initial Pressure (psi)	Pressure at 30 Minutes (psi)
A(s)	1982	8	220	Cond.	16.0	15.8
A(s)	1982	11	220	Steam	15.0	10.9

**Table A15. Conduit air pressure test results for System #15 (road crossing) at Jacksonville NAS in Jacksonville, FL.**

MFR	Year	Conduit Diameter (in.)	Length of Run (ft)	Type of Service	Initial Pressure (psi)	Pressure at 30 Minutes (psi)
A(s)	1986	20	40	Steam	Untestable (water shed cap)	

**Table A16. Conduit air pressure test results for System #16 (road crossing) at Jacksonville NAS in Jacksonville, FL.**

MFR	Year	Conduit Diameter (in.)	Length of Run (ft)	Type of Service	Initial Pressure (psi)	Pressure at 30 Minutes (psi)
C(s)	1990	20	40	Steam	Untestable (water shed cap)	

**Table A17. Conduit air pressure test results for System #17 at Jacksonville NAS in Jacksonville, FL.**

MFR	Year	Conduit Diameter (in.)	Length of Run (ft)	Type of Service	Initial Pressure (psi)	Pressure at 30 Minutes (psi)
C(s)	1990	Untestable (water shed cap)				

**Table A18. Conduit air pressure test results for System #18 at Jacksonville NAS in Jacksonville, FL.**

MFR	Year	Conduit Diameter (in.)	Length of Run (ft)	Type of Service	Initial Pressure (psi)	Pressure at 30 Minutes (psi)
B(s)	1989	Untestable (water shed cap)				

**Table A19. Conduit air pressure test results for System #19 at Jacksonville NAS in Jacksonville, FL.**

MFR	Year	Conduit Diameter (in.)	Length of Run (ft)	Type of Service	Initial Pressure (psi)	Pressure at 30 Minutes (psi)
B(s)	Untestable (water shed cap)					

**Table A20. Conduit air pressure test results for System #20 at Mayport Naval Station in Jacksonville, FL.**

MFR	Year	Conduit Diameter (in.)	Length of Run (ft)	Type of Service	Initial Pressure (psi)	Pressure at 30 Minutes (psi)
B(s)	Untestable (too hot)					
Note: Excessive steaming, leaks, and high temperatures prevented entry into any of the 11 manholes. One run between manholes was approximately 1,200 ft.						

**Table A21. Conduit air pressure test results for System #21 at Mayport Naval Station in Jacksonville, FL.**

MFR	Year	Conduit Diameter (in.)	Length of Run (ft)	Type of Service	Initial Pressure (psi)	Pressure at 30 Minutes (psi)
B(s)	Untestable (too hot)					
Note: All nine manholes were too hot for entry. No access ladders or means for ventilation had been installed.						

**Table A22. Conduit air pressure test results for System #22 (exposed to coastal atmosphere in concrete trench along a pier) at Charleston Naval Shipyard in Charleston, SC.**

MFR	Year	Conduit Diameter (in.)	Length of Run (ft)	Type of Service	Initial Pressure (psi)	Pressure at 30 Minutes (psi)
D(s)	1984	18	226	Steam	15.0	9.3
D(s)	1984	18	158	Steam	15.5	12.6
D(s)	1984	18	142	Steam	15.5	1.3
Note: No other drainable/dryable systems installed since 1981 could be found.						

**Table A23. Conduit air pressure test results for System #23 at Charleston Air Force Base in Charleston, SC (Manufacturer D).**

MFR	Year	Conduit Diameter (in.)	Length of Run (ft)	Type of Service	Initial Pressure (psi)	Pressure at 30 Minutes (psi)
C-D	1988	Underground tie in (inconclusive)				
D(s)	1982	14	130	Steam	15.5	5.4
D(s)	1985	10	270	Steam	15.8	15.5
D(s)	1985	6	270	Cond.	17.0	16.9
D(s)	1985	11	150	Steam	16.0	16.0
D(s)	1985	7	150	Cond.	15.6	14.5
D(s)	1983	Untestable (vent unsealable)				
D(s)	1985	10	40	Steam	16.0	0.0

**Table A24. Conduit air pressure test results for System #23 at Charleston AFB in Charleston, SC (Manufacturer A).**

MFR	Year	Conduit Diameter (in.)	Length of Run (ft.)	Type of Service	Initial Pressure (psi)	Pressure at 30 Minutes (psi)
A(s)	1982	14	106	Steam	15.5	14.5
A(s)	1985	6	290	Steam	15.0	15.0
A(s)	1992	6	135	Steam	16.0	8.6
A(s)	1992	6	135	Cond.	16.0	15.9
A(s)	1986	11	540	Steam	16.0	16.0
A(s)	1982	11	125	Steam	15.5	15.5
A(s)	1982	11	165	Steam	17.6	17.1
A(s)	1982	20	320	Steam	15.0	14.4
A(s)	1982	10	300	Steam	16.0	2.0
A(s)	1982	10	250	Steam	16.0	15.8
A(s)	1987	15	200	Steam	17.0	16.0
A(s)	1987	10	180	Steam	16.0	16.0
A(s)	1987	14	250	Steam	16.0	16.0

Table A25. Conduit air pressure test results for System #24 at Grissom Air Force Base in Kokomo, IN.

MFR	Year	Conduit Diameter (in.)	Length of Run (ft.)	Type of Service	Initial Pressure (psi)	Pressure at 30 Minutes (psi)
C(s)	1989	11	20	Steam	Untestable (leaking flange)	
C(s)	1989	7	400	Cond.	15.5	15.5
C(s)	1989	12	600	Steam	15.0	14.2
C(s)	1989	7	600	Cond.	15.5	12.5
C(s)	1989	12	400	Steam	Untestable (carrier leak)	

Note: A steam leak in progress was found and many of the vents had been plugged.

Table A26. Conduit air pressure test results for System #25 at Grissom AFB in Kokomo, IN.

MFR	Year	Conduit Diameter (in.)	Length of Run (ft)	Type of Service	Initial Pressure (psi)	Pressure at 30 Minutes (psi)
G(p)	1987	8	300	Cond.	16.0	15.0
G(p)	1987	14	300	Steam	15.0	0.0
G(p)	1987	12	200	Steam	16.0	10.3
G(p)	1987	6	45	Steam	16.0	10.5
G(p)	1987	4	45	Cond.	15.0	11.0
G(p)	1987	6	150	Cond.	15.0	12.0
G(p)	1987	11	150	Steam	4.0	0.0
G(p)	1987	10	120	Steam	16.0	10.0
G(p)	1987	6	120	Cond.	14.0	11.0
G(p)	1987	8	45	Steam	16.0	14.0
G(p)	1987	5	45	Cond.	14.0	5.5
G(p)	1987	6	180	Cond.	14.0	13.0
G(p)	1987	10	180	Steam	16.0	0.0

Table A27. Conduit air pressure test results for System #26 at Grissom AFB in Kokomo, IN.

MFR	Year	Conduit Diameter (in.)	Length of Run (ft)	Type of Service	Initial Pressure (psi)	Pressure at 30 Minutes (psi)
A(s)	1981	16	480	Steam	15.0	12.2
A(s)	1981	10	480	Cond.	14.0	14.0
A(s)	1981	20	400	Steam	15.8	15.8
A(s)	1981	12	400	Cond.	14.0	14.0
A(s)	1981	14	300	Steam	15.0	14.2
A(s)	1981	6	400	Cond.	15.0	15.0

**Table A28. Conduit air pressure test results for System #27 at Norfolk Naval Station in Norfolk, VA.**

MFR	Year	Conduit Diameter (in.)	Length of Run (ft.)	Type of Service	Initial Pressure (psi)	Pressure at 30 Minutes (psi)
A(s)	1987	12	200	Steam	5.0	0.0

**Table A29. Conduit air pressure test results for System #28 at Norfolk Naval Station in Norfolk, VA.**

MFR	Year	Conduit Diameter (in.)	Length of Run (ft)	Type of Service	Initial Pressure (psi)	Pressure at 30 Minutes (psi)
D(s)	1984	20	170	Steam	15.0	12.3
D(s)	1984	22	200	Steam	5.0	3.0

**Table A30. Conduit air pressure test results for System #29 at Fort Lewis in Olympia, WA.**

MFR	Year	Conduit Diameter (in.)	Length of Run (ft)	Type of Service	Initial Pressure (psi)	Pressure at 30 Minutes (psi)
Untestable (water spread limiting design)						
Note: Only one of many steam conduit terminations in a manhole was sealed and that one was cracked in two places near the carrier pipe.						

**Table A31. Conduit air pressure test results for System #30 at Fort Lewis in Olympia, WA.**

MFR	Year	Conduit Diameter (in.)	Length of Run (ft)	Type of Service	Initial Pressure (psi)	Pressure at 30 Minutes (psi)
D(s)	1986	14	1,120	HW-S&R	5.0	3.0
Note: A potential safety hazard in the form of ammonia gas was encountered. The length of this run is excessive.						

**Table A32. Conduit air pressure test results for System #31 at Fort Lewis in Olympia, WA.**

MFR	Year	Conduit Diameter (in.)	Length of Run (ft)	Type of Service	Initial Pressure (psi)	Pressure at 30 Minutes (psi)
G(p)	1986	12	290	HW-S	15.0	0.0
G(p)	1986	12	290	HW-R	15.0	1.0
G(p)	1986	12	260	HW-R	Untestable (corrosion hole)	
G(p)	1986	12	260	HW-S	Untestable (corrosion hole)	



Table A33. Conduit air pressure test results for System #32 at Fort Lewis in Olympia, WA.

MFR	Year	Conduit Diameter (in.)	Length of Run (ft)	Type of Service	Initial Pressure (psi)	Pressure at 30 Minutes (psi)
I(s)	1984	11	500	HW-S	15.0	15.0
I(s)	1984	11	500	HW-R	15.0	15.0

Table A34. Conduit air pressure test results for System #33 at Fort Lewis in Olympia, WA.

MFR	Year	Conduit Diameter (in.)	Length of Run (ft)	Type of Service	Initial Pressure (psi)	Pressure at 30 Minutes (psi)
B(s)	1985	14	180	HW-S&R	15.0 (minor gland seal leak)	13.50

Table A35. Conduit air pressure test results for System #34 at Naval Training Center in San Diego, CA.

MFR	Year	Conduit Diameter (in.)	Length of Run (ft)	Type of Service	Initial Pressure (psi)	Pressure at 30 Minutes (psi)
G(p)	1990	9	30	Steam	15.0	5.5
G(p)	1990	6	30	Cond.	15.0	3.7
G(p)	1990	13	500	Steam	15.0	2.0
G(p)	1990	7	500	Cond.	15.0	11.5
G(p)	1990	13	620	Steam	5.0	0.0
G(p)	1990	7	620	Cond.	7.0	0.0
G(p)	1990	9	30	Steam	15.0	0.0
G(p)	1990	6	30	Cond.	15.0	0.0
G(p)	1990	9	54	Steam	Untestable (obstruction)	
G(p)	1990	6	54	Cond.	15.0	3.0
G(p)	1990	13	525	Steam	16.5	2.0
G(p)	1990	7	525	Cond.	15.0	0.0
G(p)	1990	13	264	Steam	4.0	0.0
G(p)	1990	7	264	Cond.	4.0	0.0

Table A36. Conduit air pressure test results for System #35 at San Diego Naval Station in San Diego, CA.

MFR	Year	Conduit Diameter (in.)	Length of Run (ft)	Type of Service	Initial Pressure (psi)	Pressure at 30 Minutes (psi)
B(s)	1990	28	2,900	Steam	3.0	0.0

Note: The length of this run is excessive.

## Appendix B: Statistical Analysis of Survey Data

### Summary

The purpose of this analysis was to determine the statistical significance of the conduit air pressure test results. In addition, the effects of the system's age, conduit material, manufacturer, and type of service were analyzed to determine their significance. The data set assembled from the survey was sufficiently populated to make a number of statements with confidence. The results of the analysis indicate that steel conduits had a significantly lower failure rate (failures per mile) than fiberglass-reinforced plastic (FRP) conduits. Once categorized by material, differences in failure rates for different manufacturers and different usages were not generally significant. In addition, once categorized by material, the differences in failure rates for systems of varying ages were not significant. For the systems investigated (1 to 12 years old), the observed failure rates show no statistically significant trends with age.

### Background

The failure mechanism is assumed to be Poisson with the measure being miles of pipe. The basic concept for choosing this measure is the expectation that longer pipe systems tend to have more failures, when all other factors are equal. This concept was statistically validated during the analysis. If, instead, a binomial model had been used, each inspected pipe section would have the same probability of passing a pressure test, regardless of the section's length; an unsatisfactory conceptual approach.

It is tempting to characterize the failure process as being nonstationary (having, for example, an increasing failure rate with age). However, the data from the survey do not support this hypothesis, since failure rates were found to have no significant age trends for systems up to 12 years in age. Incidentally, a variety of Poisson processes would have been able to accommodate such a finding, since nonstationary Poisson models would have been developed (Mann, Schafer, and Singpurwalla 1974; Bain 1978).

For purposes of this analysis, pipe segments found to be untestable were eliminated from the data set. Two standards for failure of the conduit air pressure test were used in subsequent analyses: no more than 1.0 psi drop in pressure in 30 minutes (Standard I) and no more than 5.0 psi drop in pressure in 30 minutes (Standard II).

### **Influence of Material Type, System Age and Length**

At first the potential effect of the age of the systems was ignored and failure rates (numbers of failures per mile) for steel and FRP systems were calculated using both standards for pressure test failure. Using the approach given by Hahn and Meeker (1991), 95 percent confidence intervals (CIs) were calculated for these rates. In addition, the length-weighted average age of each system as calculated and provided in Tables 5 and 6 (Chapter 3, **Summary of Results**) show the observed failure rates for steel systems were much lower than those observed for FRP systems, regardless of which standard for failure was used. In fact, steel conduits have a failure rate that is 21 to 25 percent of that observed for FRP. The CIs are far from overlapping, so there is little doubt of the significance of these findings. It is noted that these CIs are not quite symmetric about the estimated failure rate and will become more asymmetric when the observed number of failures in a sample becomes small.

Conceivably, some part of the failure rate differences between FRP and steel conduits might be attributed to differences in the ages of the systems being compared. Several analyses of the relationship between failure rate and system age were performed. In the first analysis, the failure rates are compared for "old" systems installed in 1987 or earlier and "new" systems installed in 1988 to the present (Tables 7 and 8). In a second analysis discussed later in this chapter (Tables B1 and B2), failure rates are regressed on the length weighted age of the systems. These tables show that the CIs for the failure rates for old and new systems overlap significantly, whereas those for steel and FRP do not. Therefore conduit material, rather than age, is shown to have the more pronounced and significant effect on the observed differences in failure rates, as presented in Figures 1a and 1b.

To be more certain that age has no statistically detectable relationship with the observed failure rates, the data presented in Table B1 and Figure B1 were categorized into 3-yr age intervals; finer classification would have produced some observed zero failure rates for some intervals. Both Standards I and II were used to define failure of the pressure test.

Table B1. Failure rates versus length weighted average age.

Year installed	Steel			FRP		
	Avg. age (years)	Fail rate		Avg. age (years)	Fail rate	
		I	II		I	II
1981-83	11.40	4.53	2.26	10.00	14.10	14.10
1984-86	8.13	10.10	6.42	7.68	24.00	24.00
1987-89	4.78	5.99	4.49	5.78	34.10	24.20
1990-92	2.87	2.59	2.59	3.00	17.20	15.80

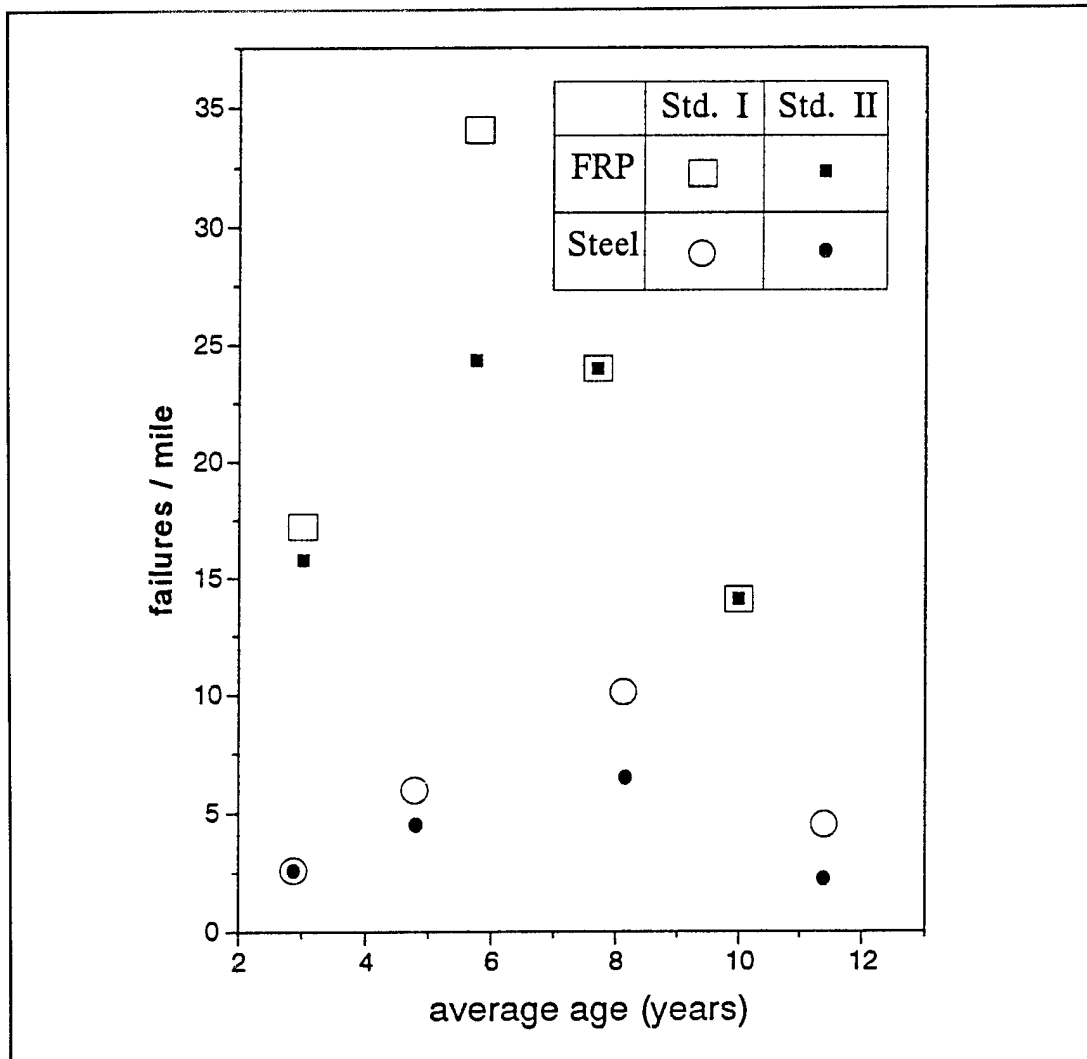

Figure B1. Failure rates versus length-weighted average age for four sequential time periods.

The Pearson correlation coefficient between failure rate and age was found to be quite small ( $R^2 \leq 0.1$ ). A generalized linear model was fit to the data, attempting to explain variation in failure rates with material type (represented by an indicator variable) and

system age. The result was that system age was not statistically significant. The data were then categorized by material, and the failure rate was regressed on age for each group; as expected, the same result was found. One conclusion of this analysis is that the failure rate shows no statistically significant increasing trend with age. Based on the data collected, the failure rates may be assumed to be constant with age. In addition, survey data from systems of different ages (but not different material) may be aggregated to increase sample size for further analyses. The same results were found for either failure standard. In Figure B1, systems that are 6 to 8 years old appear to have relatively higher failure rates. If sample sizes were larger, a failure rate model that is not monotonic in age might be pursued to determine if this is a real effect or not. Following in a similar vein, the numbers of failures (rather than failure rates) were regressed on material type, system age, and system length. The data are presented in Table B2 and Figure B2.

Again, age was not found to be significant. However, both material type and system length were significant (at a 5 percent level) explanatory variables with  $R^2 = 0.76$  and  $R^2 = 0.85$  for the regressions using failure Standards I and II, respectively. This analysis validates the original intuitive assumption that the number of failures tends to increase with system length. It also validates the failure rate (number of failures per mile of system) as a useful measure of performance.

### Influence of the Manufacturer

After the failure rate data have been categorized according to material, the observed differences for different manufacturers were investigated. Based on the findings in the previous section, systems of different ages were aggregated to improve the sample size; failure rates and CIs were then calculated. The results are given in Table B3 for FRP conduit systems and Table B4 for steel conduit systems.

**Table B2. Number of failures versus length and length-weighted average age.**

Time frame	Steel				FRP			
	Age (years)	Length (mi)	Failures		Age (years)	Length (mi)	Failures	
			I	II			I	II
1981-83	11.40	0.88	4	2	10.00	0.14	2	2
1984-86	8.13	1.09	11	7	7.68	0.17	4	4
1987-89	4.78	0.67	4	3	5.78	0.70	24	17
1990-92	2.87	0.77	2	2	3.00	0.76	13	12.00

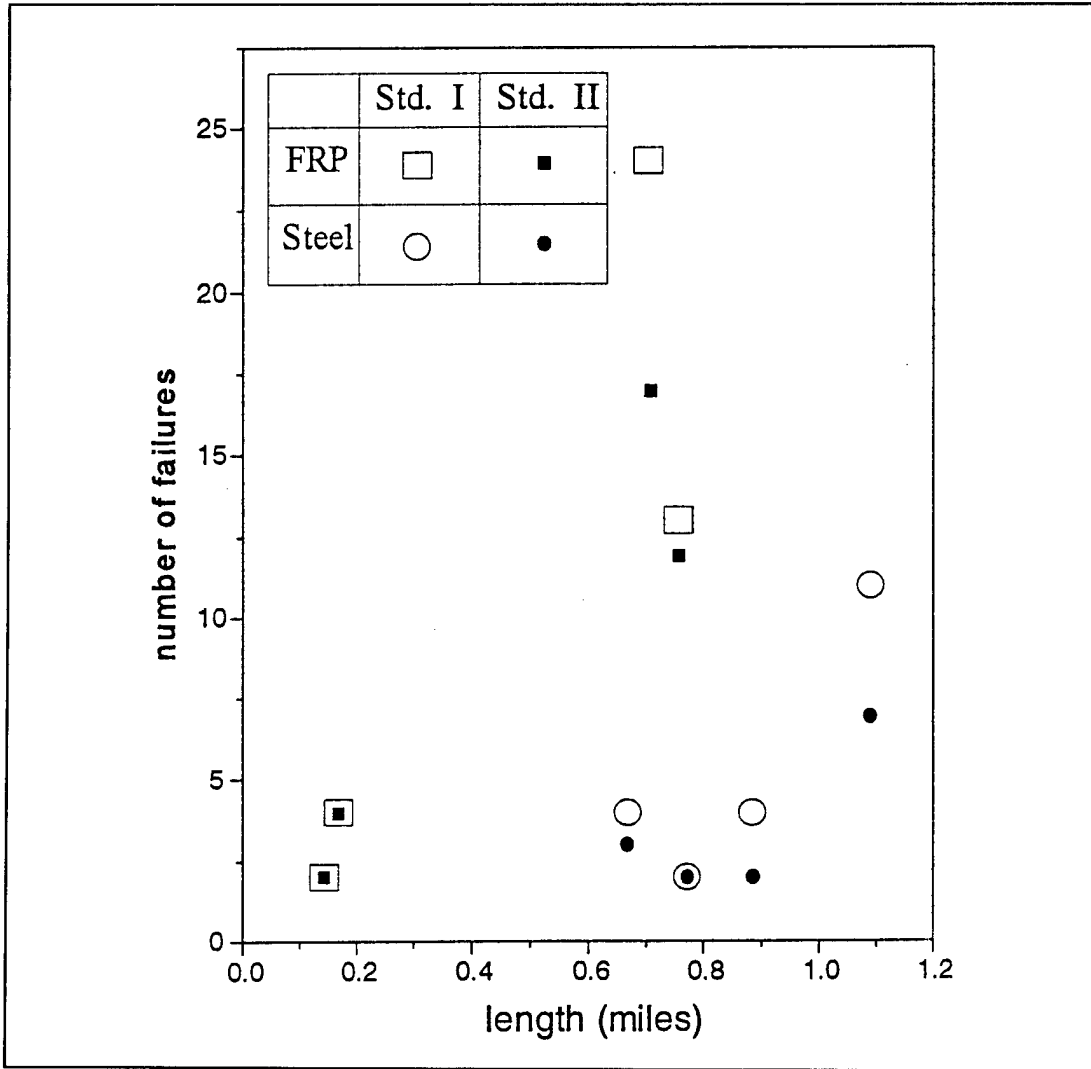

Figure B2. Number of failures versus lengths.

Table B3. Failure rates for manufacturers of FRP conduit pipe.

Manufacturer	Standard I		Standard II	
	Failures/mi	Failure rate (CI)	Failures/mi	Failure rate (CI)
E	2/0.142	14.1 (1.70, 50.9)	2/0.142	14.1 (1.70, 50.9)
F	8/0.278	28.7 (12.4, 56.6)	7/0.278	25.1 (10.1, 51.8)
G	33/1.35	24.5 (16.8, 34.4)	26/1.35	19.3 (12.6, 28.3)

Table B4. Failure rates for manufacturers of steel conduit pipe.

Manufacturer	Standard I		Standard II	
	Failures/mi	Failure rate (CI)	Failures/mi	Failure rate (CI)
A	7/1.29	5.44 (2.19, 11.2)	5/1.29	3.87 (1.26, 9.07)
B	3/0.242	12.4 (2.56, 36.6)	2/0.242	8.27 (1.00, 29.9)
C	1/0.417	2.40 (0.61, 13.4)	0/0.242	0 (0, 8.85)
D	9/0.691	13.0 (5.95, 24.7)	6/0.691	8.68 (3.19, 18.9)

Although the failure rate for Manufacturer E appears smaller than the others, the CIs indicate the effect of the small sample size on the variability of this estimate. Based on the overlapping CIs from these data, it would be difficult to conclude with any confidence that failure rates for FRP conduit piping differ significantly by manufacturer. In addition, a standard contingency table test for independence (Hogg 1970) was run on these data with the same result: the number of failures per mile was independent of the manufacturer. A minor weakness of this latter test is that all inspected pipe are treated equally, regardless of their length.

The same result can be observed in the data for steel conduit systems. Although failure rates differ by steel conduit piping manufacturers, the CIs for these failure rate estimates overlap substantially. In some cases, the small observed numbers of failures have produced very wide CIs, making discrimination difficult. As with the FRP data above, a standard contingency table test for independence was run on these data. For Standard II, the number of failures per mile was found to be independent of the manufacturer. For Standard I, the failure rate for Manufacturer D was somewhat larger than would be expected at a 5 percent level of significance.

## Influence of Use

Once again, the data were categorized according to material and aggregated across system ages. The differences in failure rates for different usages (steam, condensate, steam and condensate) were examined. The methods of analyses paralleled those in the previous section. Table B5 gives the results for FRP conduit systems, and Table B6 gives the results for steel conduit systems.

Table B5. Failure rates for FRP conduit pipe.

Usage	Standard I		Standard II	
	Failures/mi	Failure rate (CI)	Failures/mi	Failure rate (CI)
condensate	19/0.799	23.8 (14.3, 37.1)	12/0.799	15.0 (7.76, 26.2)
steam	22/0.860	25.5 (16.1, 38.8)	21/0.860	24.4 (16.9, 37.3)

Table B6. Failure rates for steel conduit pipe.

Usage	Standard I		Standard II	
	Failures/mi	Failure rate (CI)	Failures/mi	Failure rate (CI)
condensate	3/0.682	4.40 (0.906, 12.9)	1/0.682	1.47 (0.004, 8.17)
steam	13/1.30	10.0 (5.33, 17.1)	9/1.30	6.92 (3.17, 13.1)
both	3/0.213	14.1 (2.91, 41.3)	3/0.213	14.1 (2.91, 41.3)

Because of the substantial overlap of the CIs, it would be difficult to confidently ascribe differences in failure rates to the different usage of the pipe. The standard contingency table test for independence gave the same result: the number of failures was independent of the use of the piping.

The same results can be observed in the data for steel conduit systems. Although failure rates differ by piping usage, the CIs for these failure rate estimates overlap substantially. In some cases, the small observed numbers of failures have produced very wide CIs, making discrimination difficult. As above, a standard contingency table test for independence was run on these data and the number of failures were found to be independent of the use of the pipe.



## Appendix C: Detailed Site Inspection Reports for Aberdeen Proving Grounds, Baltimore, MD

1. Date of Survey: 9 through 12 March 1993.

2. Survey Team and Observers:

Dr. Charles Marsh - USACERL

N.M. Demetroulis - NMD & Associates

H.D. Musselman - USAEHSC (now USACPW)

Dennis Vevang - USAEHSC (now USACPW)

Chris Dilks - USACERL

3. General Observations

a. Heating Medium—The heat distribution systems for the Aberdeen area are primarily low (15 psi) and medium (40 psi) pressure steam supplied from several unmanned boiler plants throughout the installation. Additional high pressure steam from an off-base incinerator is reduced to system operating pressure and supplements the installation's production capacity. The amount of steam supplied by the incinerator is variable and requires reserve capacity be kept on line at the main boiler plant.

b. Manhole Construction—Manholes generally consist of prefabricated concrete upper and lower sections. The lower section consists of floor and side walls and is set in place at an elevation that accommodates the depth of the distribution piping. The top section is set on the walls of the bottom section and the joint sealed with a bitumastic material. Access is provided by a 30-in.-diameter tube to grade. Manholes were vented with 6-in.-diameter steel piping extending above grade.

c. Manhole Internals

(1) Wall penetrations consist of slightly oversized holes through which the conduits extend. The joint around the conduit pipe is caulked and cemented on the interior surface of the walls. No metallic wall sleeves nor link seals were observed.

(2) The newer manholes had electric driven sump pumps. The discharge piping, in most cases, was routed through the 6-in. manhole ventilation pipe.

(3) Internal piping, valves, and fittings were generally insulated and covered with aluminum or plastic casing. The 1-in. conduit vent piping is extended to terminate just below the intake of the higher 6-in. manhole vent pipe.

#### 4. Detailed Inspection of System #1

This system consists of piping from Manufacturer D and has a steel conduit (Figure C1). The project was "E.M. Barracks Complex" (Order No. A317616V, Drawing No. D-18744) and was installed in 1984. Base personnel stated that cathodic protection had been installed with the system, but it was later removed during the installation of chilled water lines.

a. Boiler Plant (Building 4312)—Building 4312 houses two Scotch-Marine, oil-fired boilers, each rated at 5,230,000 Btu/hr. One boiler was operating at 35 psi. The 6-in. supply line and the 4-in. condensate return line were contained in separate conduits. These lines exited the plant below grade from an 8-ft-deep pit. The manhole had no sump pump and about 8 in. of standing water. Both conduits had open vent holes but no vent piping. No steaming was observed. The conduit end plates were slightly corroded.

b. Manhole 1—The sump pump was not functional. Internal piping in contact with standing water produced general steaming. None of the conduit vents were observed to be steaming. The end plates had minor corrosion.

c. Manhole 3—This manhole serves Building 4313. No steaming was observed at conduit vents. Standing water was present in the manhole. The access ladder was loose and should be reattached to the manhole wall.

d. Manhole 4—The manhole was dry. No steaming was observed at conduit vents. Drain plugs were removed, and no water or moisture was observed.

e. Manhole 5—The sump pump was functional, and the manhole was dry. Drain plugs were removed, and no signs of moisture were observed. The casing portion of the end plate sections were badly corroded. The access ladder was in poor condition.

f. Manhole 6—This manhole serves Building 4317. The sump pump was operational, and the manhole was dry. No steaming was observed at conduit vents. In this manhole, the steam supply and condensate return lines transition from

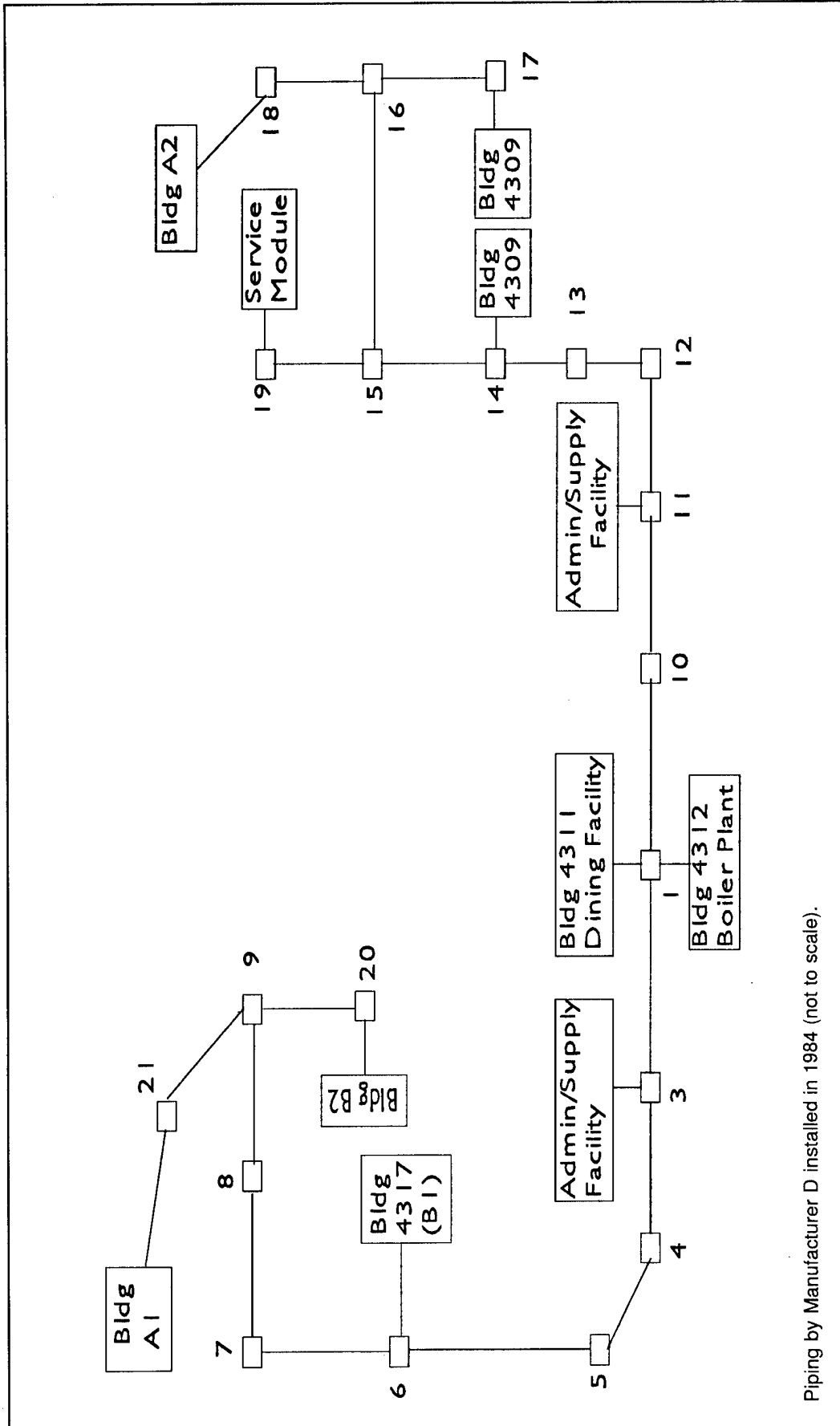

Piping by Manufacturer D installed in 1984 (not to scale).

Figure C1. Schematic drawing of System 1 at Aberdeen Proving Grounds, MD.

separate conduits to a single, common conduit that services Manhole 7. The access ladder is corroded and has a rung missing.

g. Manhole 7—The sump pump was functional, and the manhole was relatively dry. However, a leak in the discharge pipe sprays water back into the manhole. The drain plug to the conduit from Manhole 6 was removed, and mud was in the bottom of the conduit. The access ladder needed repair.

h. Manhole 8—The sump pump discharge line sprayed water back into the manhole. The sump pump was not functional until the line was unclogged.

i. Manhole 9—The sump pump did not operate, but the manhole was dry. No steaming was observed at conduit vents. Conduit drain plugs were removed, and no water or moisture was observed.

j. Manhole 20—This manhole serves Building B-2. The sump pump was not functioning, but the manhole was dry. Dampness was noted in one conduit drain coming from Manhole 9.

k. Manhole 21—This manhole serves Building 4316. The sump pump was not functioning, and approximately 8 in. of standing water was present.

l. Manhole 10—This manhole serves the Administrative Supply Facility. After adjusting the float mechanism, the sump pump operated. Water marks on the walls indicated that the manhole had previously been flooded above the distribution piping. About 6 in. of standing water was present. Much of the insulation was missing from the internal piping.

m. Manhole 11—This manhole serves the Administrative Supply Facility. The sump pump was not functioning and about 7 in. of standing water was present. Water marks on the walls indicated previous excessive flooding. The conduit end plates were heavily corroded.

n. Manhole 12—The sump pump had no float mechanism and was not operational. The manhole contained about 3 in. of standing water. Deposits of dirt on the piping were evidence of previous serious flooding. Most of the internal piping was not insulated. As a result, the piping did not rest in the intended hanging supports as designed. The end plates were severely corroded, and some water had entered through a crack in the manhole wall.

o. Manhole 13—The sump pump was operating almost continuously because the water that was discharged flowed back into the manhole, causing standing water. The piping was no longer insulated.

p. Manhole 14—This manhole serves Building 4309. The switch on the sump pump was not functioning, and about 5 in. of standing water was present. Water has entered through a crack in the manhole wall. Water marks and deposits indicated previous severe flooding. The insulating on the piping was badly damaged. The conduit end plates were in fair condition.

q. Manhole 15—The sump pump was not operational. Water was leaking into the manhole from wall cracks and a chilled water piping penetration. The caulking at the wall penetration was dry and deteriorated.

r. Manhole 16—The conduits were badly corroded, as was the sump pump discharge pipe. Water seeped into the manhole at a chilled water pipe penetration.

s. Manhole 17—This manhole serves Building 4307. This manhole was filled with water to within 3 ft of grade and could not be inspected.

t. Manhole 18—This manhole serves Building A-2. There was slight water leakage into the manhole from wall cracks and chilled water piping penetrations.

u. Manhole 19—This manhole serves the Service Module Building. This manhole was filled with water to within 5 ft of grade and could not be inspected.

v. Pressure Test—A conduit pressure test was conducted between Manholes 6 and 7. The conduit diameter was 13 in. and contained both steam and condensate piping. The length of the conduit was about 150 ft. Using a 100 CFM compressor, the air pressure within the conduit was increased to about 8 psi. Both manholes were checked to ensure no leakage at the end plates. Upon closing the valve to the compressor, the conduit lost pressure within a few minutes. No steaming vents were observed.

## 5. Detailed Inspection of System #2

This system consists of piping from Manufacturer G and has an FRP conduit (Figure C2). The project was "Replace Underground Steam and Condensate Piping From Boiler Plant (Bldg. 3062) to Bldgs. 3071, 3072, 3073, 3074, 3144, 3147 & 3148" (Drawing No. A38972) and was dated 1988.

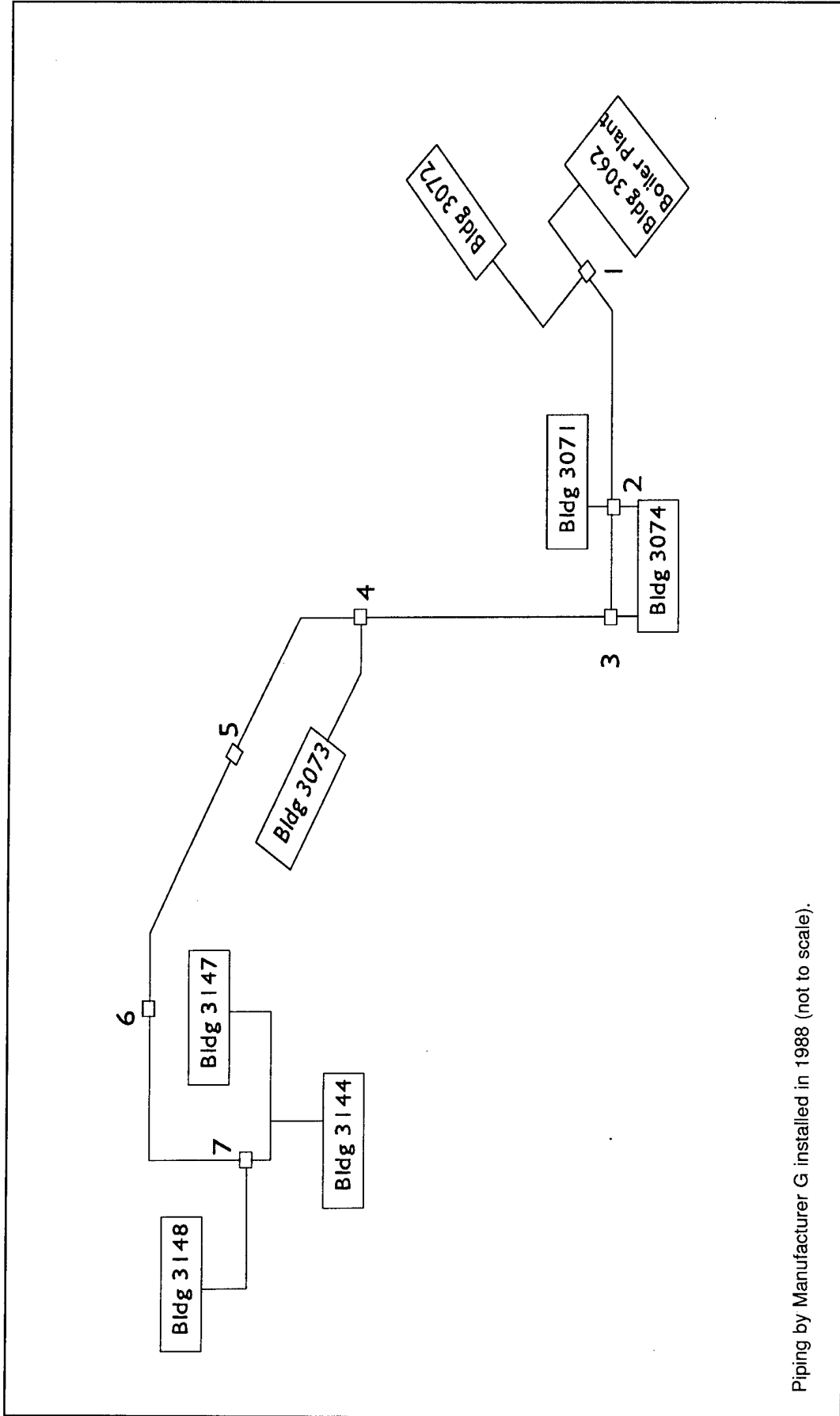

Piping by Manufacturer G installed in 1988 (not to scale).

Figure C2. Schematic drawing of System 2 at Aberdeen Proving Grounds, MD.

a. Boiler Plant (Building 3062)—This boiler plant contains two oil-fired boilers, each rated at 12,552,000 Btu/hr. The operating steam pressure was 15 psi. No vents were installed on the conduits leaving the building.

b. Manhole 1—This manhole serves Building 3022. No steaming was observed from the conduit vents. Drain plugs were removed, and no water or moisture was observed. The manhole was dry and in excellent condition.

c. Manhole 2—This manhole serves Building 3071. Slight steaming was observed from the steam line conduit vent to Building 3071. Approximately 2 qt (1.89 L) of water was drained from the same conduit. It was unknown if the leak was in the conduit or the carrier pipe. The building equipment room was inaccessible. The other seven vents and drains were dry.

d. Manhole 3—This manhole serves Building 3074. The sump pump was operating erratically, and some standing water was present. The manhole internals appeared to be in good shape.

e. Manhole 4—This manhole serves Building 3073. Standing water was observed within 1 ft of grade. The submerged piping caused heavy steaming and prevented further inspection. Maintenance personnel began to pump out the manhole but later indicated that their hose and dewatering pump could not handle the high temperature of the water.

f. Manhole 5—This manhole was filled with water and could not be entered for inspection. Standing surface water was observed near this manhole.

g. Manhole 6—This manhole was filled with water and could not be entered for inspection.

h. Manhole 7—This manhole serves Buildings 3148, 3147, and 3144. The manhole was filled with water and could not be entered for inspection.

i. Pressure Test—A conduit pressure test was conducted between Manholes 1 and 2. The length of the 16-in.-diameter conduit between manholes was about 220 ft. The steam line conduit pressure was originally raised to 16 psi. It was noted that significant leakage then occurred at the gland seals at both ends of the conduit. The gland seals were tightened until leakage was only minor, although it was not possible to entirely seal the conduit. The pressure then was raised to 17 psi. When the compressor was valved off, a rapid decrease in pressure was observed. The rate of this decrease was judged to be far in excess of that caused by the minor gland seal leakage.

## Appendix D: Detailed Site Inspection Reports for Wright-Patterson Air Force Base, Dayton, OH

1. Date of Survey: 28 March through 2 April 1993.
2. Survey Team and Observers:

Dr. Charles Marsh - USACERL  
N.M. Demetroulis - NMD & Associates  
H.D. Musselman - NMD & Associates  
V. Meyer - CE-MRD  
C. Dilks - USACERL  
R. Couch - RicWil, Inc.

3. General Observations:

The basic system design involves generation of high temperature water (450 °F) in the central plant and the distribution of this heating medium to satellite plants for the generation of steam at 100 to 125 psi. Steam is delivered to individual buildings through above ground or buried conduit systems.

4. Detailed Inspection of System #3

This system consists of piping from Manufacturer B and has a steel conduit (Figure D1). The work was done under Project No. 149-7 dated 27 December 1988 entitled "Replace Steam Supply and Return Line." The contract was for the replacement of high- and low-pressure condensate return lines and steam lines between two manholes and Buildings 167 and 189. The lines connecting Building 127 to the system were not part of this contract. The system drawings show a cathodic protection system containing 12 sacrificial magnesium anodes.

- a. Equipment Room - Building 189—Steam and condensate lines were contained in individual conduits. The steam conduit casing did not extend through the wall into



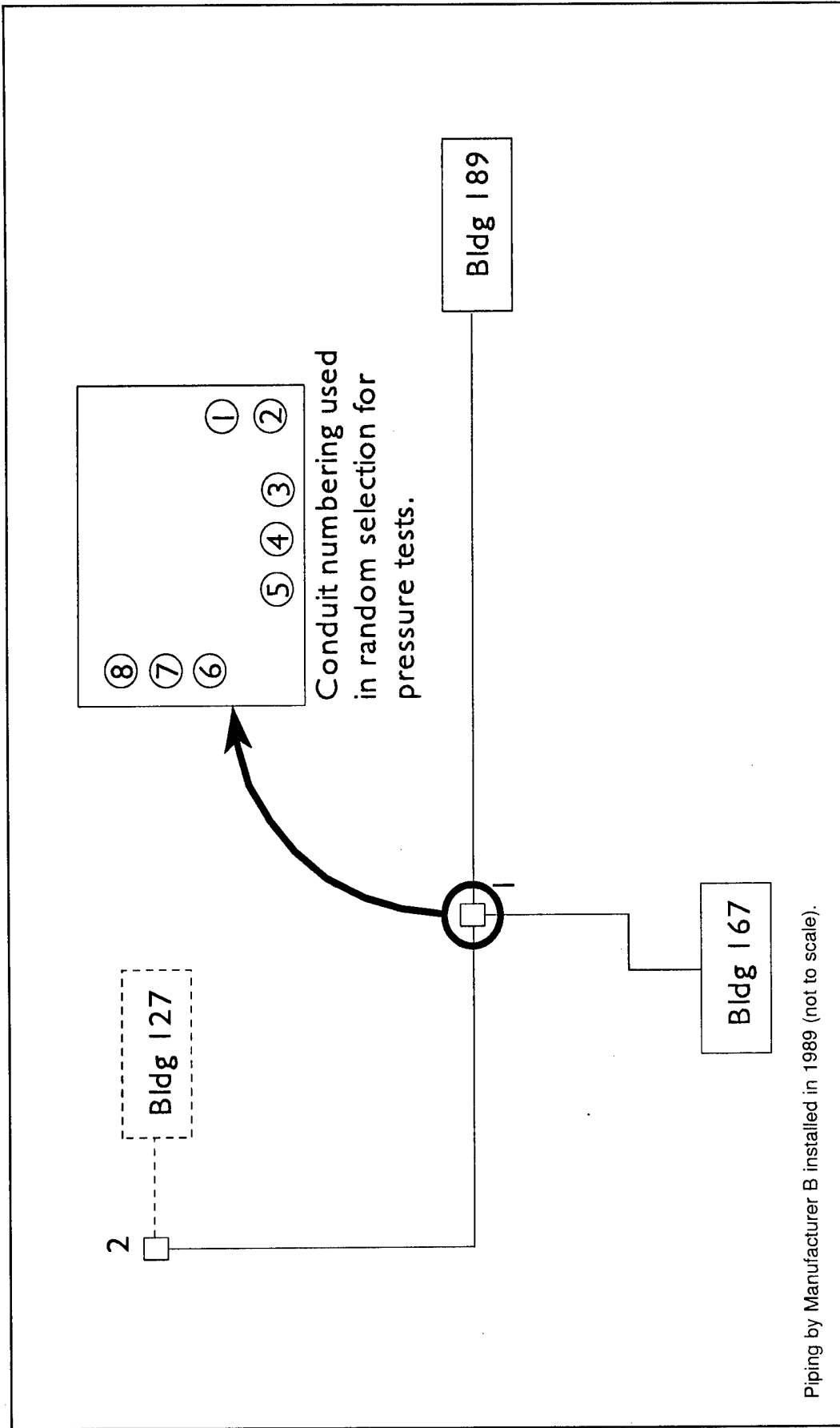

Figure D1. Schematic diagram of System 3 at Wright-Patterson AFB, OH.

the equipment room as normally required. End plates appeared to be zinc coated and were in excellent condition. Vent and drain openings on both conduits were plugged.

b. Equipment Room - Building 167—The steam line, high-pressure return line, and low-pressure return line were all contained in individual conduits. Conduits were buried about 4 ft below grade at the building. Table D1 lists the piping and conduit diameters and the conduit casing temperatures.

**Table D1. Pipe and conduit diameters and conduit casing temperatures as measured in the equipment room of Building 167.**

	Pipe Diameter (in.)	Conduit Diameter (in.)	Conduit Temperature (°F)
steam line	3	10	195
LP return	2	8	145
HP return	1.5	6	140

Drain plugs were removed from the end plates. The return line casings showed no evidence of moisture, but the steam line casing contained an accumulation of rust at the bottom of the conduit. Stains on the interior walls of the building indicated some water leakage through the caulked wall penetrations.

c. Manhole 1—This manhole was 7 ft × 7 ft × 8 ft deep and contained eight conduit entries: two to Building 189, three to Building 167, and three to Manhole 2. For identification, conduits were numbered from 1 to 8 in a clockwise direction starting at the runs to Building 189. All conduit vents were dry with the exception of the steam line running to Manhole 2, which was steaming slightly. The sump pump pit was filled with debris, but the pump operated properly after the float mechanism was cleared. Some water seepage into the manhole was observed from the electrical conduit wall penetration. Steam conduit casing temperatures were measured and found to be in the range of 170 to 200 °F. Condensate return casing temperatures were in the range of 100 to 130 °F. Drain plugs on the conduits to Building 189 were removed, and no moisture was observed. A heavy water mark was observed on the manhole walls about 6 in. from the floor, indicating previous minor flooding.

d. Manhole 2—This manhole was 8 ft × 7 ft × 8 ft deep. All piping in this manhole was uninsulated. The vent and drain openings on conduits from Manhole 1 were plugged. The steam and condensate lines to Building 127 (not part of this contract) were uninsulated for the entire length of the run and were contained in a single conduit casing that had no end plate assembly.

### e. Pressure Tests

(1) Conduit No. 5 - Manhole 2 to Building 167—This 3-in. high-pressure condensate return line was 167 ft in length. The conduit was pressurized to 16 psi at 12:40 PM. Pressure dropped to 15.5 psi at 12:45 PM. A slight leak was noted at the conduit vent plug in the equipment room. The conduit vent plug was tightened and pressure stabilized at 15 psi at 12:50 PM. No pressure drop occurred, and the test was concluded at 2:20 PM.

(2) Conduit No. 7 - Manhole 1 to Manhole 2—This 6-in. steam line had a length of 381 ft. Pressure was applied starting at 1:37 PM. The conduit vent and drain plugs were checked to ensure that no leakage occurred. The pressure could not be raised above 2.5 psi, indicating a major casing failure.

(3) Conduit No. 8 - Manhole 1 to Manhole 2—This conduit contained a 5-in. condensate return line that was 381 ft in length. The pressure was increased to 17 psi at 1:47 PM. The drain plugs were tightened at both manholes and pressure stabilized at 16 psi at 1:56 PM. The pressure dropped gradually to 7 psi at 2:45 PM, indicating a loss of about 1 psi per 5-min interval.

(4) Conduit No. 3 - Manhole 1 to Building 167—This 167-ft-long conduit housed a 3-in. steam line. The conduit air pressure was increased to 15 psi at 2:24 PM. No pressure drop was observed. The test was terminated at 3:45 PM.

### 5. Detailed Inspection of System #4

This system consists of piping from Manufacturer C and has a steel conduit (Figure D2). It was installed in 1990 under contract No. F33601-89-CW027. The project consists of steam and condensate lines contained in a single conduit. It ties into an

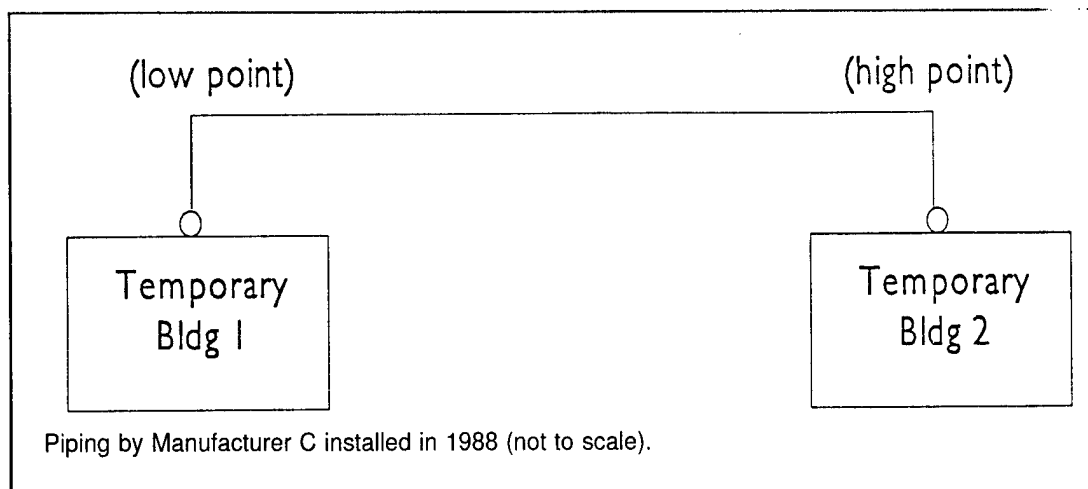

Figure D2. Schematic diagram of System 4 at Wright-Patterson AFB, OH.

overhead system, feeds two temporary buildings along "L" street and extends approximately 600 ft. On the lower half of the system, the route of the conduit and expansion loops were clearly defined by dried grass over the buried conduit.

a. Conduit Risers—This system had no manholes. Two vertical conduit risers extend about 1 ft above grade at each building. The piping then enters the equipment rooms through the exterior walls of the buildings. The 16-in.-diameter conduit contained a 2-in. steam line and a 1-in. condensate return. Both the conduit vent and drain openings on the end plates were tightly plugged. Upon opening one of the plugs, air under pressure surged from the opening. The faint odor of ammonia was present, which indicated some deterioration of the insulation. Piping at one of the vertical risers was not properly centered. No provision appeared to have been made for draining the conduit at the lower riser should water ever enter the conduit.

b. Pressure Test—The conduit was pressurized to 15 psi at 9:45 AM. No pressure drop was noted, and the test was concluded at 11:30 AM.

#### 6. Detailed Inspection of System #5

This system consists of piping from Manufacturer G and has an FRP conduit (Figure D3). Drawing WP-43-7 for the project was dated May 1989. The contract involved replacing condensate lines using new vinyl ester resin conduits and steam lines

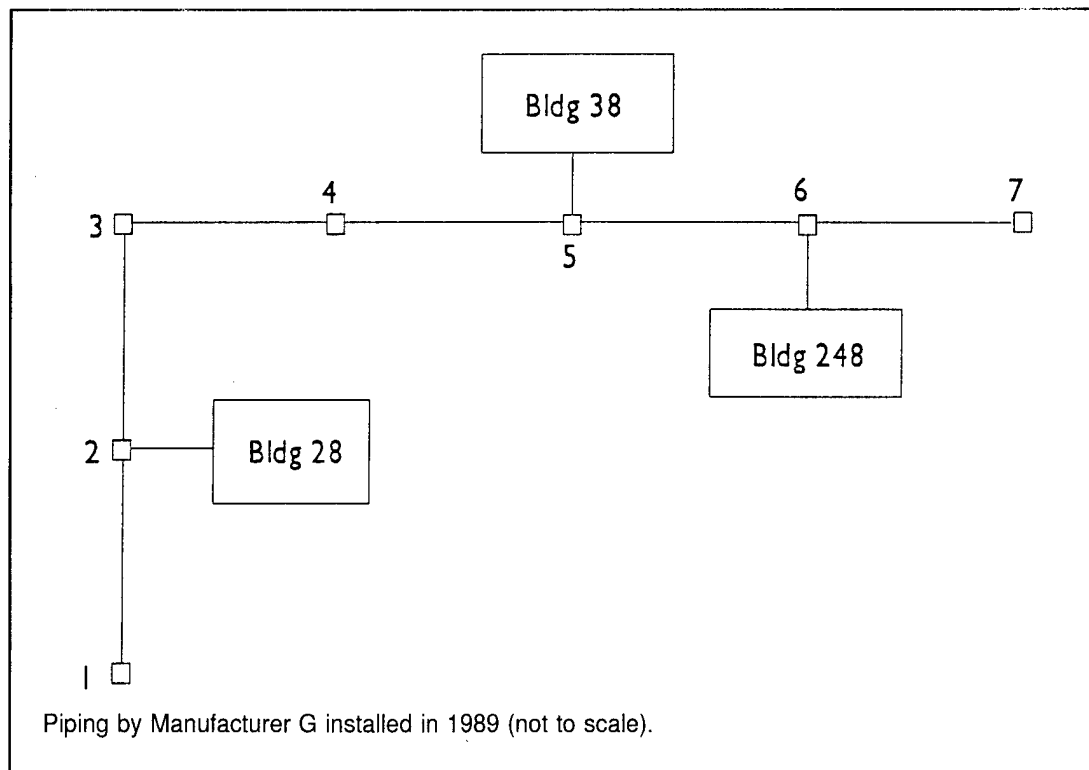

Figure D3. Schematic diagram of System 5 at Wright-Patterson AFB, OH.

encased in conduits of the old polyester resin. The "L"-shaped system runs parallel to Buildings 28 and 38. It then makes a right angle to run along the end of Building 28. Manholes 6 and 7 were in a construction zone and were inaccessible.

a. Manhole 2—This manhole was in the street and contained about 8 in. of water. No access ladder was available, and the manhole could not be entered for inspection.

b. Manhole 3—This manhole was in the street and appeared to be approximately 12 ft deep. No access ladder was available, and some water was present. One conduit vent was accessible from the 30-in.-diameter opening.

c. Manhole 4—This manhole was 7 ft × 7 ft × 8 ft deep and had a raised concrete top with a 3 ft × 3 ft steel access hatch. A second 2 ft × 2 ft access was under an unattached roof ventilator that needed lubrication. The manhole ladder was corroded and should be replaced. None of the conduit vents in the manhole were steaming. All conduit end plates contained gland seals. No sump pump was in the manhole. Three conduit drains were opened, and no moisture was evident.

d. Manhole 5—This manhole was 9 ft × 9 ft × 6 ft deep and had a raised concrete top with a steel plate access hatch. The manhole contained no sump pump, and the manhole floor was damp. None of the conduit vents in the manhole were steaming. The pipe insulation and covering were in good condition. No moisture was observed when four drain plugs were removed.

e. Pressure Tests

(1) 4-In. Condensate - Manhole 3 to Manhole 4—The conduit diameter for this test was 10 in., and the distance between manholes was about 110 ft. The conduit was pressurized to 17 psi at 11:13 AM. The pressure dropped rapidly after the compressor was shut off. Inspection showed that the gland seal in Manhole 3 was leaking. In addition, the conduit vent pipe connection at the end plate in Manhole 4 was only partially welded and could not hold pressure.

(2) 6-In. Steam - Manhole 4 to Manhole 5—The 13-in.-diameter conduit for this test was about 135 ft in length. The conduit was pressurized to 15 psi at 11:22 AM. The pressure dropped off rapidly when the compressor was shut off. Inspection showed that the gland seal was leaking in Manhole 5 and that air was escaping from a poorly welded conduit vent connection to the end plate in Manhole 4.

(3) 2-In. Condensate - Manhole 4 to Manhole 5—The conduit diameter for this test was 7 in., and the distance between manholes was about 135 ft. The conduit was pressurized to 17 psi at 11:47 AM. The pressure dropped rapidly from a leak at the gland seal in Manhole 4. The gland seal was tightened and the conduit pressurized to 16 psi at 11:55 AM. The gland seals were inspected to ensure that no further leakage occurred. Pressure readings of 14.5 psi at 12:05 PM and 8.5 psi at 1:20 PM indicated a slow but steady loss of pressure.

7. Detailed Inspection of System #6—This system consists of piping from Manufacturer D and has a steel conduit (Figure D4). The 1983 contract was "Replacement of Condensate Lines." The project consists of a straight run of about 470 ft between two manholes. Manhole 2 was near the corner of Estrabrook and Chidlaw streets. This system was a back-up in the event of a failure and was not in operation when inspected.

a. Manhole 1—This manhole was 10 ft × 7 ft × 7 ft deep. It had a solid concrete top with a 3 ft × 3 ft access hatch. The manhole contained no sump pump. The manhole ladder was deteriorated and should be replaced. The piping consisted of a 2-in.-diameter line in a 6-in. conduit and a 4-in. line in a 10-in. conduit. In addition there was a large steam line (not part of this contract). The vents and drains on both condensate conduits were plugged. The end plates and gland seals were in fair condition. The gland seal followers used a single large nut for tightening. The manhole contained ADSCO slip type expansion joints.

b. Manhole 2—This manhole was 12 ft × 9 ft × 10 ft deep with a solid concrete top accessed through a 30-in. tube and a 3 ft × 3 ft access hatch. No sump pumps or manhole vents had been installed. About 2 ft of water and silt were on the manhole floor. The steam trap assembly was under water. The conduit vent holes were open with no vent piping. The drain openings were plugged. Caulking at wall penetrations was dry and deteriorated. The end plates and gland seals were in fair condition. The gland seal followers used a single large nut for tightening.

c. Pressure Test—The 2-in. line conduit could not be tested because of interference from welded moment guides at both ends of the conduit. The 10-in. conduit was pressurized to 15.25 psi at 9:58 AM. A pressure of 14.5 psi was observed at 11:30 AM when the test was terminated, indicating a slight leakage. This slight drop in air pressure was probably due to incomplete sealing at the gland seals.

8. Detailed Inspection of System #7—This system consists of piping from Manufacturer A and has a steel conduit (Figure D5). The 1989 project was designated WP 54-8, FAC. 07199, and PCF1939. The piping was at the base of a long sloping hill.

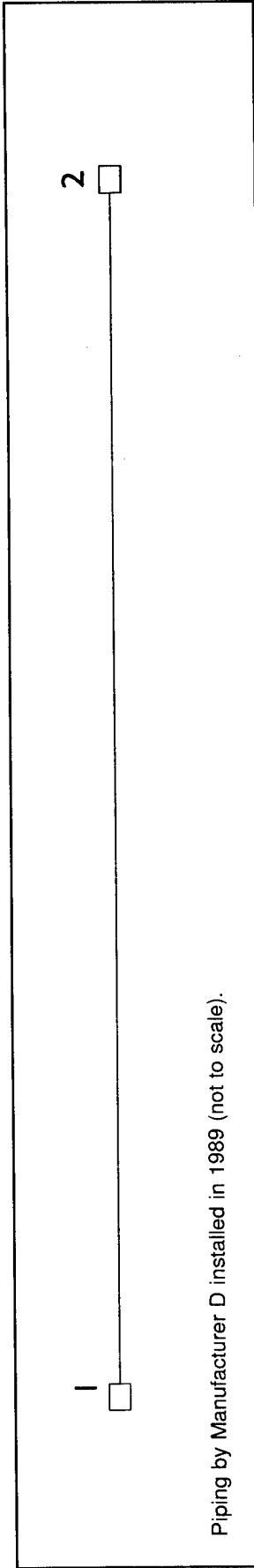

Piping by Manufacturer D installed in 1989 (not to scale).

Figure D4. Schematic diagram of System 4 at Wright-Patterson AFB, OH.

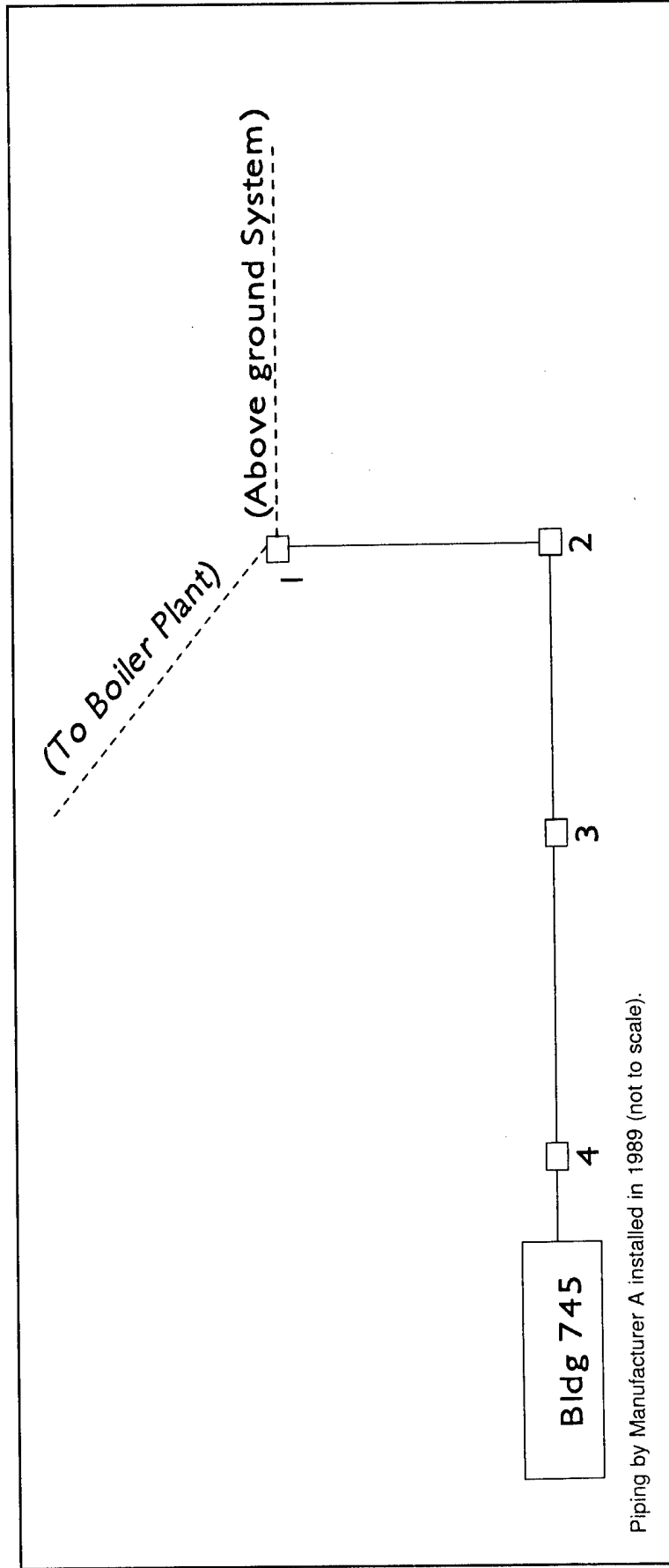

Piping by Manufacturer A installed in 1989 (not to scale).

Figure D5. Schematic diagram of System 7 at Wright-Patterson AFB, OH.

The system was fed from the boiler plant (Building 770), has four manholes, and serves Building 745. Rain precluded pressure testing.

a. Manhole 1—A concrete tunnel housed piping from the boiler plant (not part of this contract) into this manhole. No steaming was observed from the three conduit vent pipes associated with this project. The manhole was locked and could not be entered for inspection.

b. Manhole 2—This manhole was 9 ft × 13 ft × 9 ft deep and had a solid concrete top with a 3 ft × 3 ft access hatch. Coming from Manhole 1 was an 11-in. steam line in a 21-in. conduit, a 3-in. condensate line in an 8-in. conduit, and a 4-in. condensate line. All three conduits were vented and no steaming was observed. The piping transitions to an above ground system that continues up a hill. Continuing on to Manhole 3 was a 5-in. steam line in a 12-in. conduit and a 3-in. condensate line in an 8-in. conduit. Both conduits were vented and no steaming was observed. All conduits were cemented in and none of the drain plugs could be removed. Water was entering the manhole through both the West and South walls. The sump pump was operational. A small stream flowed approximately 10 ft North of the manhole.

c. Manhole 3—This manhole was 9 ft × 13 ft × 9 ft deep and had a solid concrete top with a 3 ft × 3 ft access hatch and a 2 ft × 2 ft access tunnel that extended about 3 ft above the concrete top. Water was penetrating the manhole wall at the base of the ladder, causing the bottom of one side to rust away. The ladder should be replaced. The manhole contained a little water and mud. The sump pump was operational and was discharged to a small stream about 40 ft away. The three conduit vent pipes from Manhole 3 were observed to not be steaming. Feeding Manhole 4 was a 5-in. steam line in a 12-in. conduit and a 3-in. condensate line in an 8-in. conduit. These two conduit vents were also dry and not steaming. All conduit penetrations are cemented in. A water line was evident about 3 ft from the floor on the manhole wall. The insulation appeared to be in good shape. The drain plug on the condensate line going to Manhole 4 was removed and the conduit was dry. The other drain plugs could not be removed. The steam conduit temperature was 175 °F, and the condensate conduit temperature was 90 °F.

d. Manhole 4—This manhole was 5 ft × 5 ft × 5 ft deep and was in a parking lot just outside of Building 745. Access was by a 2 ft × 2 ft square hatch. There was no ladder, and the manhole was not vented. Three conduit vent pipes vent into the manhole, and no steaming was observed. The conduit vent pipe for the condensate line to Manhole 3 had entirely corroded off, but no steaming was observed at the conduit vent hole. All metal surfaces in the manhole were heavily corroded. About 4 in. of water was in the manhole, and both the condensate pipe and the steam conduit were



in water. All drain plugs were under water and no attempt was made to remove them. There was no sump pump. An electrical outlet was present but did not have power. The conduits were cemented into the manhole wall. Water was coming into the manhole at the penetrations. There were gland seals on both lines going to Building 745.

e. Boiler Plant Information

(1) Boiler Plant 770—This boiler plant contained three coal fired IBW boilers, each of which was rated at 150,000 lb/hr. They produced 400 psi steam, which was then reduced to 125 psi for distribution. The peak load on the plant was about 275,000 lb/hr, and the minimum load was about 50,000 lb/hr. Approximately 50 to 60 percent of the condensate was returned. The condensate pH was usually in the range of 7.5 to 8.2. Water quality testing was done by plant personnel and was checked once a day. The chemical feed ratio was also adjusted once a day. Morpholine and Cyclohexamine was injected at one feed point. Sodium Zeolite Softener and condensate polishers are also used. The dearator tank was observed to be working. The boiler operators did notice an increase in steam demand after heavy rains.

(2) Boiler Plant 1240—This boiler plant contained three 1973 coal fired IBW boilers, each of which was rated at 130,000 MBtu/hr. They produced high temperature hot water at 450 °F and 360 psi. The peak load on the plant was about 250,000 MBtu/hr and the minimum load was about 40,000 MBtu/hr. The system flow was approximately 5,000 gpm and the makeup was 5,000 gal/day. Water quality testing was done by plant personnel and was checked once a day. The chemical feed ratio was also adjusted once a day. The pH generally measured in the range of 8 to 9.5. Sodium sulfite, caustic soda, and tamol were used.

## Appendix E: Detailed Site Inspection Reports for Veterans Administration Medical Center, Bedford, MA

1. Date of Survey: 21 through 25 April 1993.
2. Survey Team and Observers:

Dr. Charles Marsh - USACERL  
N.M. Demetroulis - NMD & Associates  
H.D. Musselman - NMD & Associates  
P. Phillips - U.S. PolyCon, Inc.

3. General Observations:

Both systems inspected at this site consist of an inner heat carrying pipe covered with insulation and surrounded by an air space contained within an FRP casing. Metallic end plates containing vents and drains are attached to the FRP conduits by bonding the casing to the end plate assembly. None of the manholes had sump pumps or any means for continuous ventilation. Conduit wall penetrations were sealed using a caulking material between the casing and the concrete wall and were an avoidable maintenance item. The use of a wall penetration sleeve with a welded water stop ring along with a link seal avoids the need to recaulk after every wall penetration. The operating steam pressure was 100 psi.

4. Detailed Inspection of System #8

This system consists of piping from Manufacturer F and has an FRP conduit (Figure E1). It was installed in 1987. The design done by Trimont Engineering Co. was "Replacement Steam Distribution System - Phase III" (Project No. 518-83-112, Project No. 013-01). The project serves six buildings in a residential complex.

a. Manhole 5—This manhole was round with a 6-ft diameter, was 9-ft deep, and was a solid concrete top design with a 30-in. manhole cover. No sump pump or means for ventilation were provided, and the manhole contained 3 in. of standing water. A

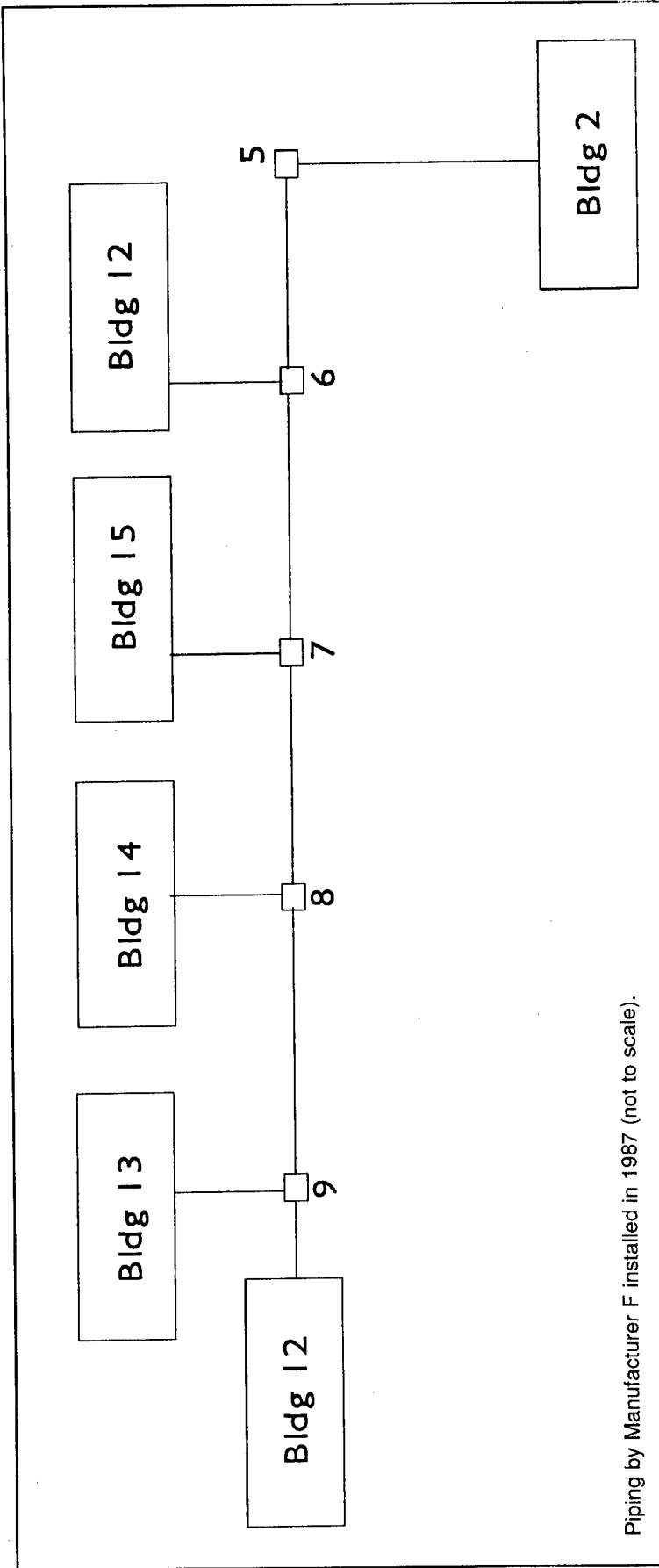

Piping by Manufacturer F installed in 1987 (not to scale).

Figure E1. Schematic diagram of System 8 at VA-Bedford, MA.

water line on the manhole wall indicated previous flooding above the piping. Both vent and drain openings were plugged. A submerged trap assembly produced some steaming. The bottom ladder rung was about 3 ft above the manhole floor. The wall penetrations were caulked. Where the FRP casing was bonded to the end plate assembly, the color had changed to a dark orange or tan. The steam conduit temperature was 185 °F.

b. Manhole 6—This manhole was round with a 6-ft-diameter, was 7.5-ft deep, and was a solid concrete top design with a 30-in. manhole cover. No sump pump or means for ventilation were provided. The floor of the manhole was damp, but no water was standing. Both vent and drain openings were plugged. The color of the FRP casing was much lighter than that in Manhole 5. Insulation was needed on 3 ft of steam line and 5 ft of condensate line. The drains were checked, and some water dripped out of the condensate conduit going to Manhole 7. One ladder rung was loose, and heavy water marks were on the manhole wall at piping level. The steam conduit temperature was 210 °F and the condensate conduit temperature was 180 °F.

c. Manhole 7—This manhole was round with a 6-ft-diameter, was 8-ft deep, and was a solid concrete top design with a 30-in. manhole cover. No sump pump or means for ventilation were provided, and 30 in. of standing water was present. The wall penetrations were caulked. Conduit vent pipes were installed on the steam line to Manhole 8 and the condensate line to Manhole 6.

d. Manhole 8—This manhole was round with a 6-ft-diameter, was 5-ft deep, and was a solid concrete top design with a 30-in. manhole cover. No sump pump or means for ventilation were provided. The manhole had a damp floor but no standing water. All conduit vents and drains were plugged. The drains were checked, and no moisture was found. Approximately 8 ft of condensate piping needed to be insulated. The wall penetrations were caulked. The color of the FRP casing was lighter than in previous manholes.

e. Manhole 9—This manhole was round with a 6-ft diameter, was 6-ft deep, and was a solid concrete top design with a 30-in. manhole cover. No sump pump or means for ventilation were provided, and the manhole contained 5 in. of standing water. All conduit vents and drains were plugged. The drains to Building 12 were dry. Six ft of condensate piping needed to be insulated. The steam and condensate conduit temperatures to Building 12 were 190 °F and 140 °F, respectively. The wall penetrations were caulked.

f. Pressure Tests—A total of seven conduit air pressure tests were performed. Two conduits maintained pressure at approximately 15 psi. The remaining five conduits failed to hold pressure.

(1) Manhole 8 to Manhole 7—The condensate conduit diameter was 5 in., and the condensate line was 1 in. The conduit run was 150 ft. The conduit pressure was increased to 15.5 psi at 1:05 PM and dropped to 15 psi in 1 minute. Soaping showed very minor leakage at the drain plug in Manhole 7. At 2:17 PM the pressure had dropped to 10.5 psi, and the test was terminated.

(2) Manhole 8 to Manhole 9—The condensate conduit diameter was 6 in., and the condensate line was 2 in. The conduit run was 90 ft. The conduit temperature was 155 °F. The conduit was pressurized to 17.5 psi at 11:32 AM and dropped to 15 psi at 11:40 AM. During this time, drain plugs in both manholes were tightened to stop slight leakage. The pressure settled at 14.5 psi with no further drop noted. The test was terminated at 2:18 PM.

(3) Manhole 8 to Manhole 9—The steam conduit diameter was 9 in., and the steam line was 2.5 in. The conduit run was 90 ft. The conduit temperature was 197 °F. Pressure was applied to the conduit at 1:29 PM but could not be raised above 3 psi. When the compressor was valved off, the pressure dropped immediately to zero. A loose bond appeared to exist between the end plate assembly and the FRP conduit in both manholes. The test was terminated at 1:52 PM.

(4) Manhole 6 to Manhole 5—The condensate conduit diameter was 6 in., and the condensate line was 2 in. The conduit run was 300 ft. The conduit pressure was raised to 15 psi at 3:00 PM. The compressor was valved off, and the pressure dropped to 10 psi within 1 minute. The end plate assemblies in both manholes were soaped and no leaks were found. The conduit was repressurized to 15 psi at 3:17 PM. After the compressor was valved off, the pressure dropped to 1 psi in 5 minutes.

(5) Manhole 6 to Building 16—The condensate conduit diameter was 5 in. and the condensate line was 1 in. The conduit run was 30 ft. A gland seal was used in the building equipment room. Pressure was applied several times to the conduit to locate and contain leaks at the gland seal, the manhole drain plug, and the gauge assembly. After sealing all leaks, the conduit was pressurized to 16.5 psi at 1:26 PM. After the compressor was valved off, the pressure dropped to 10 psi in 4 min, and to 5 psi during the next 7 min.

(6) Manhole 6 to Manhole 7—The steam conduit diameter was 9 in. and the steam line was 2.5 in. The conduit run was 210 ft. Pressure was applied at 2:10 PM

but could not be raised above 4 psi. Both end plate assemblies were soaped and no leakage was found at the vents and drains. However, some bubbles were observed coming from the junction of the FRP casing and the end plate assembly. The compressor was valved off at 2:18 PM, and the pressure dropped from 4 psi to 1 psi in 1 minute.

(7) Manhole 6 to Manhole 5—The steam conduit diameter was 9 in. and the steam line was 2.5 in. The conduit run was 300 ft. Pressure was applied and the conduit pressure could not be raised above 5.5 psi. Both end plate assemblies were soaped and no leaks were found at the vents, drains, or the bond between the casing and the end plate assembly. However, a small leak was found at a weld between the end plate and the metal ring of the end plate assembly. The pressure was again raised to 5.5 psi at 2:47 PM. The compressor was valved off at 3:12 PM, and the pressure dropped to 1 psi within 4 minutes.

#### 5. Detailed Inspection of System #9

This system consists of piping from Manufacturer G and had an FRP conduit (Figure E2) and was installed in 1988. The design done by Trimont Engineering Co. was "Replacement Steam Distribution System - Phase II" (Project No. 518-81-140, Project No. 013-02). The project serves 13 administrative and support buildings. Most of the conduit sections that ran from manholes to buildings could not be pressure tested because conduit terminations at buildings were located in inaccessible crawl spaces. All of the terminations employed gland seals. Each gland seal represents an avoidable maintenance item both for periodic tightening and gasket replacement. The use of gland seals was intended for rare occasions where pipe movement at the end plate was unavoidable. Usually this situation can be avoided by proper anchor and expansion loop location. This allows the end plate to be welded directly to the heat carrying pipe assuring a positive and continuous seal.

a. Manhole 1—This manhole was round with an 8-ft diameter, was 11-ft deep, and was a solid concrete top design with a steel access cover. No sump pump or means for ventilation were provided. One ladder rung was missing. A drip type leak was observed at the condensate conduit coming from Building 19, and 4 in. of standing water was present in the manhole. None of the ten casing vents was steaming. All conduit penetrations were caulked and all end plate assemblies contained gland seals.

b. Manhole 2—This manhole was 4 ft x 5 ft x 4 ft deep and was a solid concrete top design with a steel access cover. No sump pump or means for ventilation were provided. The manhole was dry, and no steaming was observed from four conduit

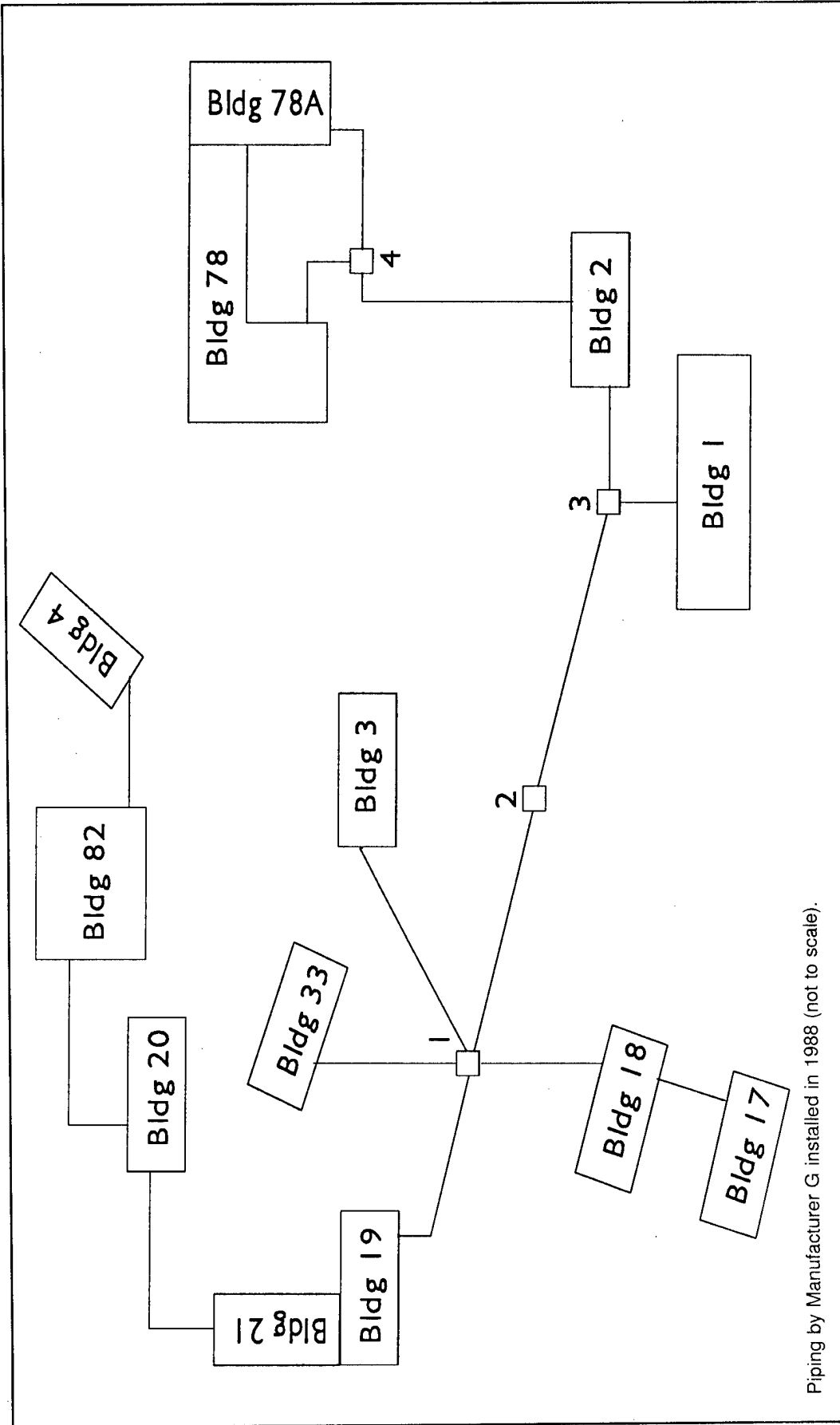

Piping by Manufacturer G installed in 1988 (not to scale).

Figure E2. Schematic diagram of System 9 at VA-Bedford, MA.

vents. All conduit penetrations were caulked and all end plate assemblies contained gland seals.

c. Manhole 3—This manhole was round with a 7-ft-diameter, was 9-ft deep, was in a parking area, and had a 30-in. manhole cover. No sump pump or means for ventilation were provided, and 8 in. of standing water was present. No steaming was observed from six conduit vents. All conduit penetrations were caulked and all end plate assemblies contained gland seals. Approximately 6 ft of piping was missing insulation.

d. Manhole 4—This manhole was 7-ft deep, had a concrete top, was in a parking area, and had a 30-in. manhole cover. No sump pump or means for ventilation were provided, and 2 ft of standing water was present. The manhole was steaming heavily and could not be entered for inspection.

e. Pressure Tests—A total of five conduit air pressure tests were performed. One conduit was able to maintain pressure at approximately 15 psi. Three conduits failed to maintain pressure, and one conduit was untestable. The primary difficulty was the inability to tighten the gland seals sufficiently to prevent air leakage.

(1) Manhole 3 to Building 1—The steam conduit diameter was 6 in. and the carrier pipe was 1.5 in. The conduit run was 30 ft. The steam pipe temperature was 305 °F and the conduit temperature was 120 °F. Some slight peeling of the bond to the end plate assembly was observed. The bonding material was very dry and brittle. Pressure was applied to the conduit at 9:45 AM. Some leakage was noted at both gland seals, and they were tightened. Pressure was applied again at 9:55 AM but could not be increased above 7 psi. Some minor leakage at the gland seals was still noted. When the compressor was valved off, the pressure dropped to zero in approximately 1 minute.

(2) Manhole 3 to Building 1—The condensate conduit diameter was 4 in. and the condensate line was 3/4 in. The conduit run was 30 ft. After tightening the gland seals, pressure was increased to 15 psi and the compressor valved off at 10:16 AM. The pressure dropped to 10 psi by 11:40 AM. A very slight leak was noted at the gland seal in the manhole.

(3) Manhole 1 to Building 3—The steam conduit diameter was 9 in. and the carrier pipe was 3 in. The conduit run was 110 ft. The conduit entered Building 3 below grade in an equipment room pit that was 8 ft × 7 ft × 6 ft deep. The gland seals were tightened and the conduit pressure was raised to 15.5 psi at 12:30 PM. The gland seal at the building entry was soaped and minor bubbling was noted. While being



pressurized, some water was forced out the gland seal in the manhole, producing steam. The conduit vent continued to show no signs of steaming. The pressure in the conduit dropped as follows:

12:35 PM — 10 psi  
12:40 PM — 6 psi  
12:42 PM — 5 psi  
12:45 PM — 3 psi

(4) Building 82 to transition near Building 20—An above ground system transitioned to go under a road and enter Building 82. End plate assemblies with plugged vents and drains were noted at the transition. The steam conduit diameter was 14 in. and the carrier pipe was 8 in. The conduit run was 70 ft. The equipment room pit in Building 82 was 5 ft x 6 ft x 10 ft deep and contained about 2 ft of standing water. No sump pump was present, but the conduit penetrations were above the water level. Some associated piping had insulation sitting in the water, causing the water to wick upward approximately 14 ft. This caused the protective jackets to be hot to the touch. The gland seal was tightened. As pressure was applied, the gland seals were soaped and showed no leakage. The conduit could not be pressurized during compressor operation from 9:47 AM to 10:07 AM.

(5) Building 82 to transition near Building 20—The condensate conduit diameter was 8 in. and the condensate line was 3 in. The conduit run was 70 ft. The equipment room pit in Building 82 was as previously described. The gland seal was tightened. As the conduit was pressurized, minor bubbles formed at the building penetration at the gland seal. Pressure was applied from 10:35 to 10:45 AM but could not be raised above 7 psi. When the compressor was valved off, the pressure dropped to 1 psi within 2 minutes.

## Appendix F: Detailed Site Inspection Reports for U.S. Military Academy, West Point, NY

1. Date of Survey: 26 through 29 April 1993.
2. Survey Team and Observers:

Dr. Charles Marsh - USACERL  
N.M. Demetroulis - NMD & Associates  
H.D. Musselman - NMD & Associates  
K.A. Jalovec - Ricwil, Inc.

3. General Observations:

This site overlooks the Hudson River but is well above the water level. The steam system operating pressure is 85 psi.

4. Detailed Inspection of System #10

This system was installed in 1983, consists of piping from Manufacturer E, and has an FRP conduit (Figure F1). The project was "West Point" (Project No. DACA-51-82-C-0084) and services the Thayer Hotel. The piping consists of steam and condensate piping in separate conduits.

a. Manhole 1—This manhole was 18 ft × 12 ft × 8 ft deep, was of the solid concrete top design, and had two 3 ft × 2 ft steel plate access hatches. The manhole was served by a steam ejector type sump pump. Steaming was observed from a 6-in. manhole vent pipe. This steaming was caused by a 1-in. discharge line from pressure regulating station relief valves being routed out of the vent pipe. The manhole was dry. Wall penetrations consisted of neatly drilled holes in the manhole walls for the installation of link seals between the conduit casings and the concrete. No conduit vents or drains were observable on runs from Manhole 2 because the end plate assemblies were buried outside of the manhole.

b. Manhole 2—This manhole was 6 ft × 9 ft × 8 ft deep, was of the solid concrete top design, and had a 3-ft-diameter steel manhole cover and an 18-in. steel covered

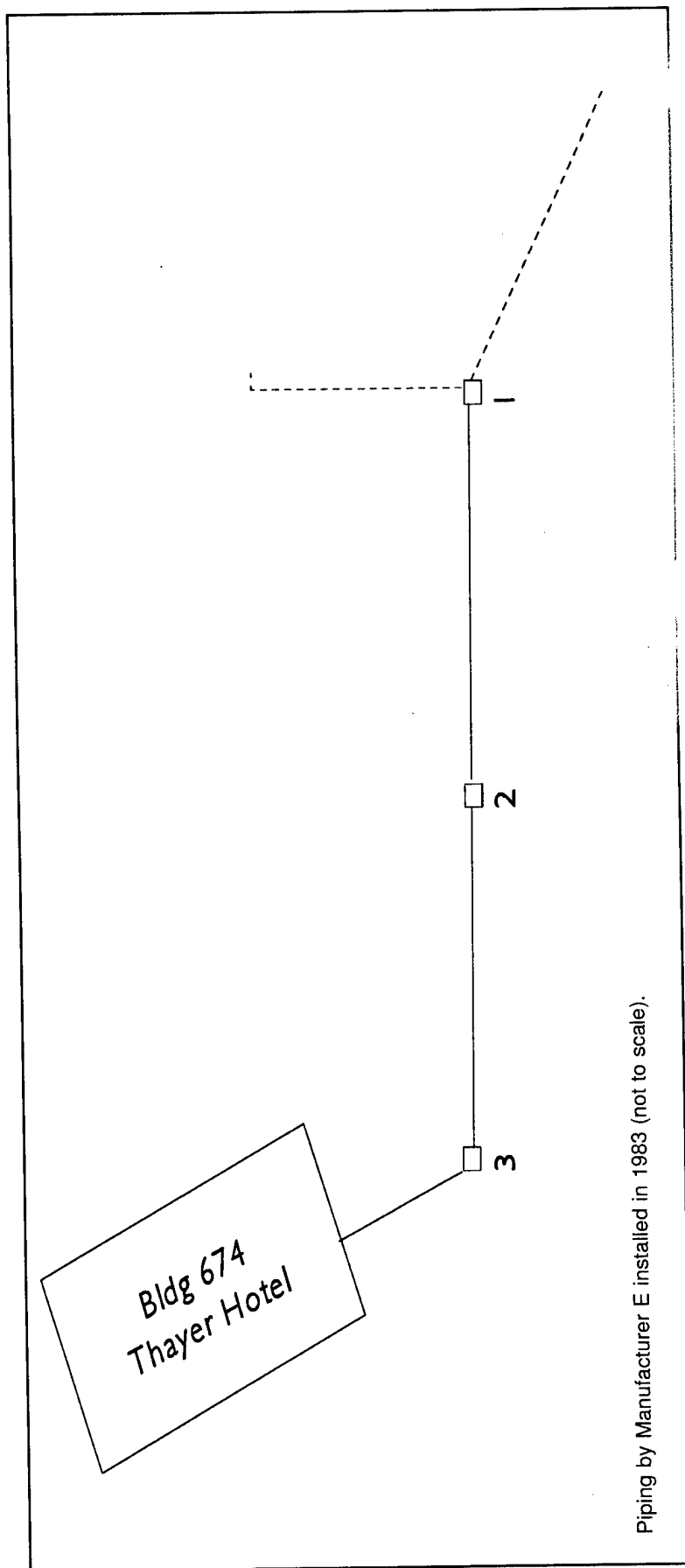

Piping by Manufacturer E installed in 1983 (not to scale).

Figure F1. Schematic diagram of System 10 at USMA, West Point, NY.

inspection port. No sump pump or means for ventilation were provided, and 3 in. of standing water was present. Link seals were used between the end plates and the heat carrying pipes. The conduit vents and drains were 3/4-in.-diameter instead of the required 1 in. The drains were fitted with check valves that did not function properly in this application after a time. None of the five conduit vents were observed to be steaming. Three drains were checked and were dry.

c. Manhole 3—This manhole was 7 ft × 9 ft × 7 ft deep, was of the solid concrete top design, and had a 3-ft steel access cover. The condensate conduit passed directly through the manhole without end plate assemblies. The 6-in. steam line had a slip type expansion joint. No sump pump or means for ventilation were provided, and 4 in. of standing water was present. The steam conduit vent pipe from Manhole 2 was installed flush with the vertical face of the manhole wall and could not be removed for pressure testing. The steam conduit to the Thayer Hotel also could not be pressure tested. Neither vent pipe was steaming. While attempting to remove the heavily corroded vent pipe in the equipment room, the pipe broke and could not be sealed for pressure testing.

d. Pressure Tests

(1) Manhole 2 to Thayer Hotel—The condensate conduit was routed through Manhole 3 with no end plates installed. Therefore, the conduit was continuous from Manhole 2 to the hotel equipment room. The conduit diameter was 10 in. and the condensate line was 3 in. The temperature of the condensate line was 180 °F. The conduit run was about 400 ft. Pressure was applied at 2:45 PM and had risen to 10 psi by 3:00 PM. Leakage was noted and a carrier-pipe link seal was found. The link seal bolts were tightened and the system repressurized. Operations were halted by severe thunderstorms, but the pressure gauge was left in place. The next morning the pressure gauge read zero. A pressure of 15 psi was achieved at 8:37 AM. The compressor was valved off and the pressure dropped to 10 psi in 1 minute. Link seals at the equipment room and the manhole were tightened and soaped to ensure no leakage. At 9:08 AM a pressure of 16 psi was applied. The pressure in the conduit dropped as follows:

9:10 AM — 16.0 psi  
9:11 AM — 10.0 psi  
9:12 AM — 6.75 psi  
9:13 AM — 5.25 psi  
9:14 AM — 4.0 psi  
9:15 AM — 3.0 psi  
9:16 AM — 2.5 psi

(2) Manhole 2 to Manhole 1—The steam conduit diameter was 13 in. and the condensate line was 6 in. The conduit run was 350 ft. Pressure was applied at 9:37 AM, but no rise in conduit pressure was noted after 10 min. The conduit link seal in Manhole 2 was tightened, but the other end plate was not accessible. USMA personnel indicated that an anchor was located a short distance outside of Manhole 1 during construction, and end plates were installed on the conduits immediately after the anchor. The piping from the end plates to Manhole 1 was then filled with powder type insulation. It was not possible to examine the end plate link seals without excavation.

## 2. Detailed Inspection of System #11

This system consists of piping from Manufacturer C and has a steel conduit (Figure F2). Installed in 1990, the system extends approximately 860 ft between Buildings 845 and 900 with no intermediate manholes. The steam line is contained in a steel conduit. The condensate line is an insulated plastic pipe contained in a plastic conduit. The conduits penetrate Building 900 below grade into a large crawl space. Outside Building 845, the piping transitions to above ground without a manhole. The steam conduit uses a water shed cap, and the condensate conduit has a shrink sleeve.

a. Building 900 Entry—The building wall penetrations for both conduits used metal sleeves and link seals. The condensate conduit terminated with a shrink sleeve, while the steam conduit ended with a standard end plate with a gland seal. The vent from the steel conduit ran back through the wall to the exterior of the building.

b. Building 845 Entry—Both the plastic cased condensate line and the steel cased steam line rose vertically outside the building. The casings terminated about 5 ft above grade and insulated piping continued to the roof of the building. The condensate conduit riser was sealed with a shrink sleeve, while the steel conduit had a rain cap instead of a welded end plate. The unwelded rain cap prevented a pressure test of the system. The dielectric isolation flange assembly was about 1 ft above the rain cap. Both steam and condensate pipe and casings were in excellent condition with no rusting or plastic deterioration.

c. Cathodic Protection—The steel conduit had an installed cathodic protection system consisting of buried zinc anodes. The isolating flange assembly was found to lack the necessary dielectric washers and bolt sleeves needed to achieve electrical isolation. A test station was located about 10 ft from the riser at Building 845. The pipe potential was found to be -0.66V, which was insufficient and above the standard of -0.85V. An anode potential reading of 1.86V indicated plenty of remaining anode life.

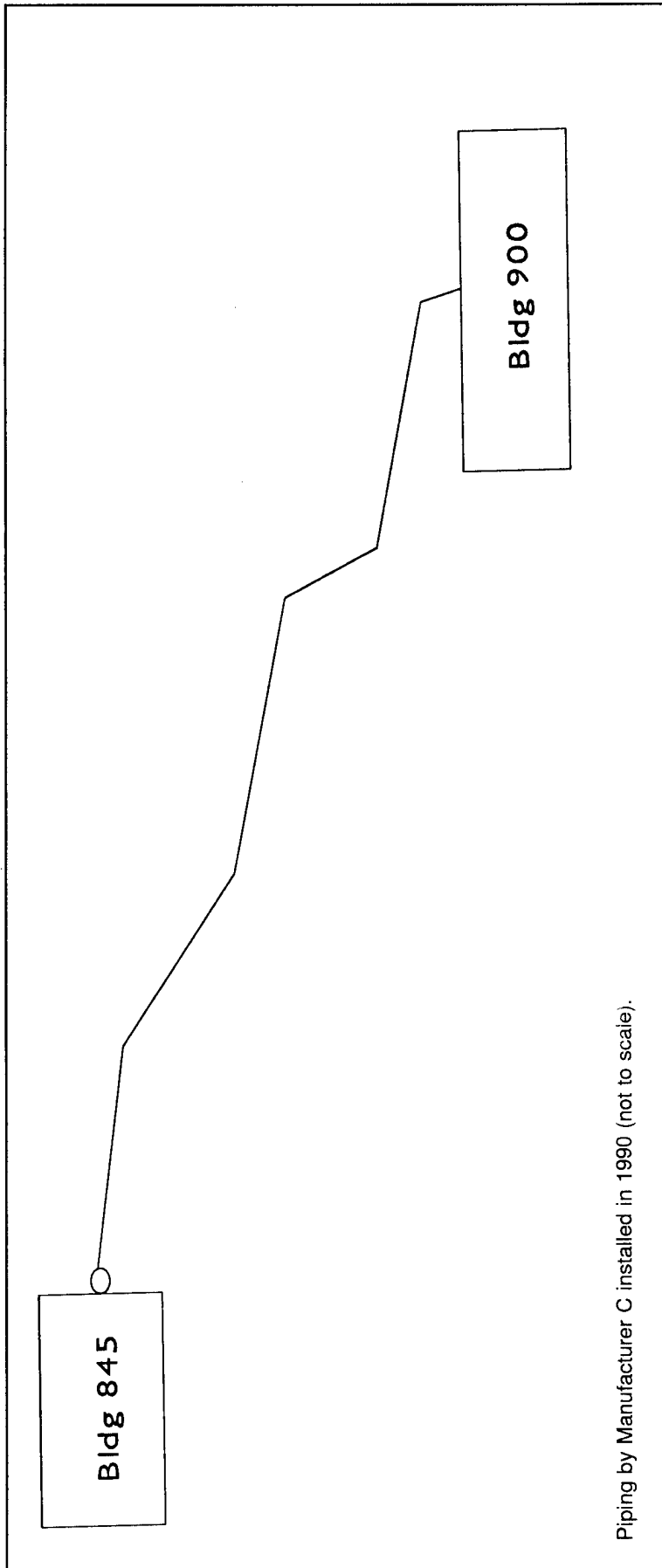

Piping by Manufacturer C installed in 1990 (not to scale).

Figure F2. Schematic diagram of System 11 at USMA, West Point, NY.

## Appendix G: Detailed Site Inspection Reports for Fort Riley, Manhattan, KS

1. Date of Survey: 3 through 8 April 1993.
2. Survey Team and Observers:

N.M. Demetroulis - NMD & Associates  
H.D. Musselman - NMD & Associates  
K. Jevons - Fort Riley  
K. Jones - Fort Riley  
M. Cessor - E-4, US Army

3. General Observations:

The heat distribution systems at Fort Riley, KS generally operate at about 100 psi. The terrain is mainly flat.

4. Detailed Inspection of System #12

This system consists of piping from Manufacturer A and has a steel conduit (Figure G1). The piping was installed in 1984 and is in the Custer Hill area. Approximately 95 percent of the piping contains both steam and condensate in a common conduit. Cathodic protection has been provided, but many of the isolating flange gasket kits are incomplete. The manhole penetrations for the conduit are sealed only with caulking material.

a. Manhole 3—This manhole was 6 ft × 6 ft × 13 ft deep and was a raised top design with steel plate covers. The transition from a shallow trench system in one wall was made to buried conduits to the other three walls. Each conduit contains both steam and condensate piping. The end plate of the conduit from Manhole 4 was recessed into the manhole wall. All end plates showed minor general corrosion. The manhole was dry, and the sump pump was functioning properly. No evidence of water or steam in the conduits was found.

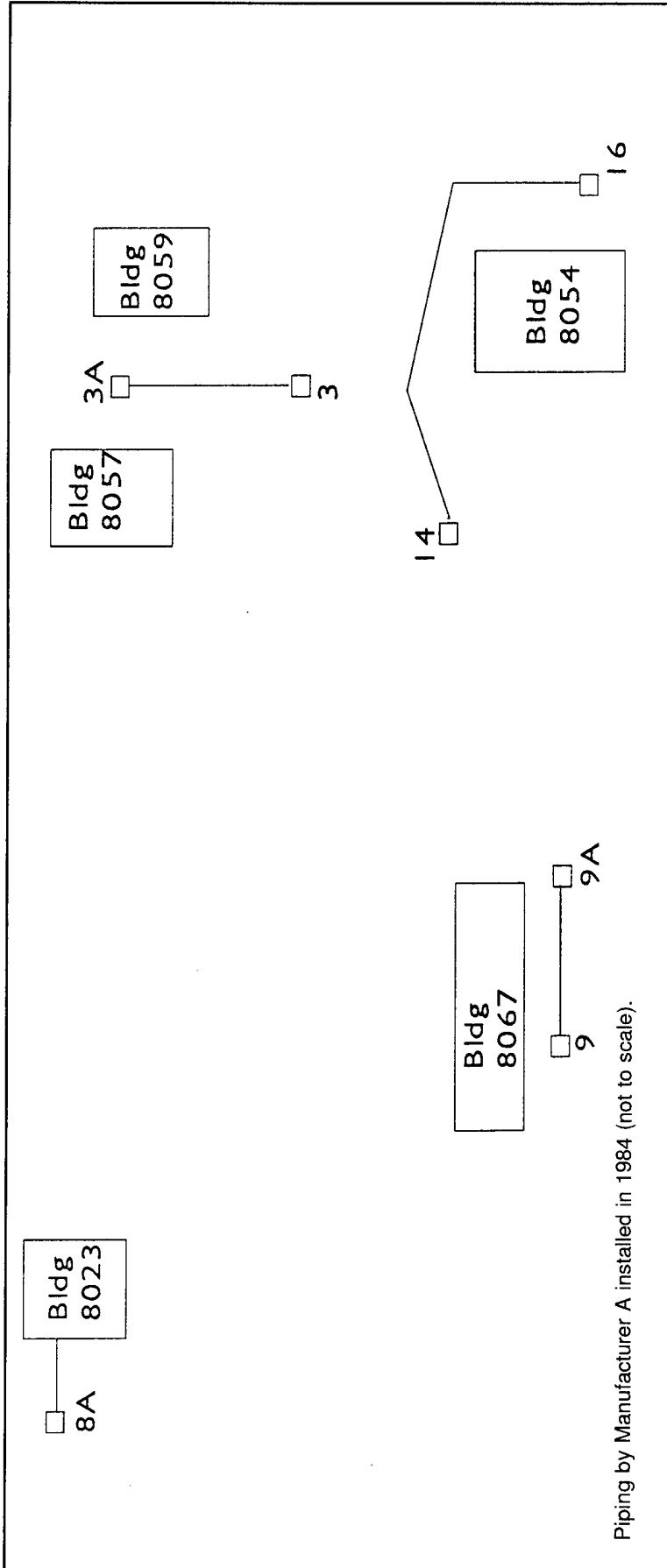

Figure G1. Schematic diagram of System 12 at Fort Riley, KS.



b. Manhole 3A—This manhole was 6 ft × 6 ft × 9 ft deep and was a raised top design with steel plate covers. All three conduits contained both steam and condensate lines. Each manhole penetration was sealed with caulking material that was badly deteriorated. The manhole was dry, and the sump pump was functioning properly. The dielectric isolation kits on the flanged take offs to Buildings 8057 and 8059 were incomplete. The isolating washers on the flange bolts were missing though steel washers were present.

c. Manhole 4—This manhole was 6 ft × 6 ft × 7 ft deep, was in a parking area, and was a solid concrete top design with a 36-in. manhole cover. This manhole had no sump pump and about 10 in. of standing water. The lowest manhole piping was about 2.5 ft above the water. The conduit penetrations were recessed into the manhole walls and the caulking was badly deteriorated. No steaming was observed from the conduit vents.

d. Manhole 5—This manhole was 6 ft × 6 ft × 7 ft deep, was in a parking area, and was a solid concrete top design with a 36-in. manhole cover. This manhole had no sump pump and about 4 in. of standing water. The lowest manhole piping was about 3 ft above the water. Some general corrosion was observed on the conduit end plates.

e. Manhole 6—This manhole was 6 ft × 6 ft × 7 ft deep, was in a parking area, and was a solid concrete top design with a 36-in. manhole cover. This manhole had no sump pump. The lowest manhole piping was about 3 ft above the water. Some general corrosion was observed on the conduit end plates.

f. Manhole 3B and 3C—These manholes were 6 ft × 6 ft × 8 ft deep and were raised top designs with steel plate covers. Both manholes were dry, and the sump pumps were functioning properly. The manhole internals are in good condition, and no steam or water was observed in the conduits.

g. Manhole 3D—This manhole was 6 ft × 6 ft × 11 ft deep and was a raised design with an open grate top. The manhole was dry, and the internals were in good condition. No steam or water was observed in the conduits.

h. Manhole 15—This manhole was in a driveway and was a concrete top design with a 36-in. steel manhole cover. This manhole had no sump pump and 40 in. of standing water. The lowest manhole piping was 1.5 ft above the water.

i. Manhole 15A—This manhole was 6 ft × 6 ft × 7 ft deep, was in a driveway, and had a solid steel plate top that was flush with grade. The sump pump was functioning properly, and the manhole was dry. A leak existed at an isolation flange

gasket on the line feeding Building 8054. No conduit vent steaming was observed. The conduit drains were dry.

j. Manholes 15B and 15C—These manholes were 6 ft × 6 ft × 7 ft deep and had solid steel plate tops that were flush with grade. The sump pumps were functioning properly, and the manholes were dry. No conduit vent steaming was observed. The conduit drains were dry. In Manhole 15B, some water was entering the manhole at an old wall penetration.

k. Manhole 7—This manhole was 6 ft × 6 ft × 10 ft deep and was a raised top design with a steel plate cover. The manhole was dry. This was a transition manhole with two shallow trench entries and one conduit entry. A slight leak existed at an isolating flange gasket.

l. Manhole 8—This manhole was 6 ft × 6 ft × 9 ft deep, was in a driveway, and had a solid steel plate cover at grade. The manhole was dry, and the internals were in good condition. The manhole had one shallow trench entry and two conduit entries.

m. Manhole 8A—This manhole was 6 ft × 6 ft × 8 ft deep and had a solid steel plate cover at grade. The sump pump was functioning properly, and the internals were in good condition. An old wall penetration was leaking slightly.

n. Manhole 9—This manhole was 6 ft × 6 ft × 8 ft deep and was a raised top design with a steel plate cover. Two conduit entries and one small shallow trench fed a building. The sump pump was functioning properly, and the manhole was dry. No conduit vent steaming was observed. The conduit drains were dry.

o. Manholes 9A and 9B—These manholes were 6 ft × 6 ft × 8 ft deep and were raised top designs with steel plate covers. Both sump pumps were functioning properly, and the manholes were dry. Manhole 9A contained a leaking steam trap. No conduit vent steaming was observed. The conduit drains were dry.

p. Manhole 10—This manhole was 6 ft × 6 ft × 8 ft deep and had a concrete top at grade with a 36-in. manhole cover. This manhole had no sump pump and some standing water. General minor corrosion was observed on conduit end plates. A valve packing leak was repaired by tightening the bolts. No conduit vent steaming was observed.

q. Manholes 10C and 11A—These manholes were 6 ft × 6 ft × 10 ft deep and were raised top designs with steel plate covers. Both sump pumps were functioning properly, and the manholes were dry. No conduit vent steaming was observed.

r. Manhole 14—This manhole was 6 ft × 6 ft × 15 ft deep, had walls about 1 ft above grade, and had an open grate steel cover. The sump pump was functioning properly, and the manhole was dry. No conduit vent steaming was observed. The manhole internals were in good condition.

s. Manhole 16—This manhole was in a parking area and was a raised top design with a steel plate cover. The manhole was dry, and no conduit vent steaming was observed. Bolts on a leaking flange joint were tightened, which caused the disintegration of the dielectric materials. Upon inspection, the material was found to be extremely brittle.

t. Pressure Tests—Conduit air pressure tests were conducted wherever practical. A total of six pressure tests were performed with one conduit being able to hold a pressure of 15 psi for 1 hour. The most noticeable cause of air leakage was the inability to sufficiently tighten the gland seals. As a result, a gland seal in Manhole 3A was dismantled. The sealing material appeared to have the consistency of a high asbestos content gasket material. This material was backed by a thin plastic piece that was cracked, brittle, and had little flexibility or strength.

(1) Manhole 3 to Manhole 3A—The conduit diameter was 14 in. and the conduit length was 120 ft. No conduit vent steaming was observed. The conduit drains were dry. The pressure was raised to 15 psi at 1:35 PM. No pressure drop was observed and the test was terminated at 2:35 PM.

(2) Manhole 3A to Building 8057—The conduit diameter was 15 in., and the conduit length was 70 ft. No conduit vent steaming was observed. The conduit drains were dry. Leakage at the gland seals prevented the conduit from being pressurized. Both gland seals could not be sufficiently tightened to hold pressure.

(3) Manhole 3A to Building 8059—The conduit diameter was 15 in., and the conduit length was 20 ft. No conduit vent steaming was observed. The conduit drains were dry. Leakage at the gland seals prevented the conduit from being pressurized. Both gland seals could not be sufficiently tightened to hold pressure.

(4) Manhole 8A to Building 8023—The conduit diameter was 17 in., and the conduit length was 25 ft. No conduit vent steaming was observed. The conduit drains were dry. Leakage at the gland seals prevented the conduit from being pressurized. Both gland seals could not be sufficiently tightened to hold pressure.

(5) Manhole 9 to Manhole 9A—The conduit diameter was 14 in., and the conduit length was 36 ft. No conduit vent steaming was observed. The conduit drains

were dry. In this case, both end plate openings were able to be plugged tight. As air pressure was increased, no conduit pressure build-up was observed.

(6) Manhole 14 to Manhole 16—The conduit diameter was 17 in., and the conduit length was 216 ft. No conduit vent steaming was observed. The conduit drains were dry. In this case, both end plate openings were able to be sealed tight. As the air pressure was increased, the conduit pressure could not be raised above 1 psi.

## Appendix H: Detailed Site Inspection Reports for Patrick Air Force Base, Satellite Beach, FL

1. Date of Survey: 23 through 25 May 1993.

2. Survey Team and Observers:

Dr. Charles Marsh - USACERL  
N.M. Demetroulis - NMD & Associates  
H.D. Musselman - NMD & Associates  
C.R. Reed - Ric-Wil, Inc.  
P. Patrone - Ric-Wil, Inc.

3. General Observations:

In most cases the use of rain caps in lieu of end plate assemblies prevented pressure testing of the casings. At the time of the inspection, the system was not in operation. The boiler plant contains three Superior boilers, each rated at 12,075 lb/hr at an operating pressure of 100 psi.

4. Detailed Inspection of System #13

This system consists of piping from Manufacturer F and has an FRP conduit (Figure H1). The 1984 project was designed in-house by the Engineering and Construction Branch - 6550 Civil Engineer Squadron as project No. PA 84-0047, "Repair Steam Lines Base Wide." Minor additional repairs were made in 1991 under project No. SXJT 89-0047, "Repair Underground Steam Mains" (Drawing No. F89CE-9631). The piping inspected was not installed in accordance with the manufacturer's brochure.

Most of the distribution system at Patrick AFB is above ground with buried systems used primarily at street crossings, parking areas, and service to administrative facilities. Generally, manholes were not installed in making the transition from above ground to buried conduits. This results in a "U" type configuration for conduits at street crossings with conduit risers on each side of the street. This design does not

permit drainage of water that may enter the casing and will lead to rapid deterioration of the system. The lack of standard end plate assemblies on the risers further complicates maintenance operations because pressure tests on the buried sections cannot be performed to determine the soundness of the casing.

a. Street Crossing North of Boiler Plant—This buried conduit section was about 60-ft long with risers on each end connecting to the above ground system. The supply and return lines were 6 in. and 3 in., respectively. The steam conduit riser was covered with a loose fitting 1/4-in. steel plate while the condensate riser was open. Insulation in the conduit risers appeared to be foam glass. Maintenance personnel indicated that a trap leak on the north riser required unearthing a portion of the conduit system to mount the trap assembly at a higher elevation. Neither of these conduits could be pressure tested.

b. Along East Face of Building 312—Here the system was above ground except for burial of condensate lines at doorways and for an extended run of 160 ft to a condensate return station. The condensate conduit risers were not sealed and appear to contain urethane foam insulation. No conduit sections could be pressure tested.

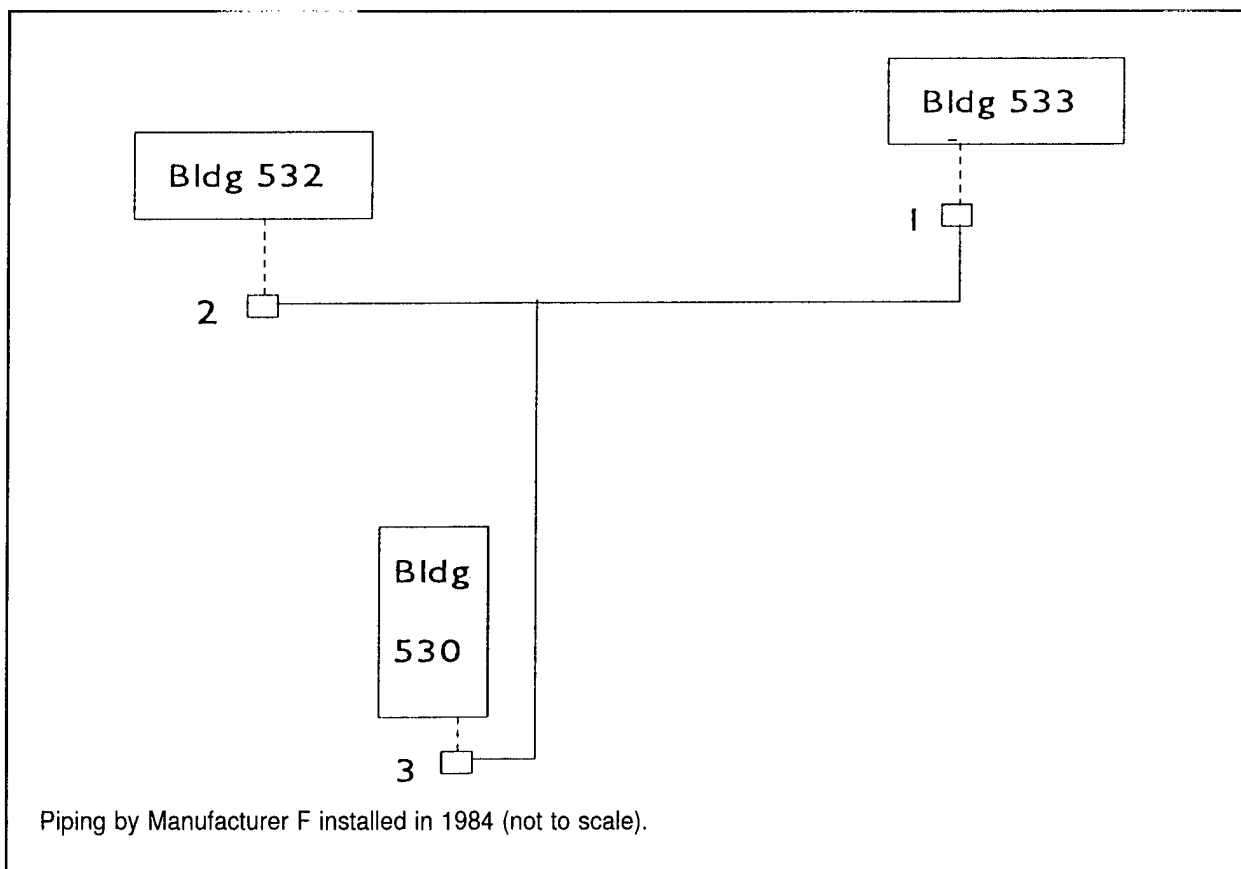

Figure H1. Schematic diagram of System 13 at Patrick AFB, FL.

c. Building 330 to Building 400—The system transitioned from above ground to below ground without a manhole at the southeast corner of Building 330 and then ran east underground to Building 400. The riser at Building 400 was an old metallic conduit indicating that a connection was made underground with the FRP-cased system. Underground connections, especially a change in conduit material without a manhole, were not in accordance with the applicable brochure. The steam supply line was 6 in. and the condensate return was 3 in. The condensate riser southeast of Building 330 consisted of a standard end plate assembly with vent and drain openings on the casing portion of the assembly. One opening was plugged and the other was open. The steam riser was covered with a loose steel plate. The risers at Building 400 were of FRP conduit and contained end plate assemblies that were severely corroded through. The FRP material on the end plate assemblies was loose and very brittle. It was evident that the conduit runs could not hold air pressure.

d. Southeast Corner of Building 546—This manhole was 9 ft × 9 ft × 5 ft deep, had a steam jet sump pump, and had about 1 ft of standing water. One half of the manhole had a solid concrete top and the other half had removable steel plates. The conduit end plates were severely corroded. In this manhole, the above ground system transitioned to buried conduits that ran across the street to another manhole. An underground tee-takeoff ran parallel to the street to feed Buildings 556 and 557. The risers at Buildings 556 and 557 had rain caps or were open with exposed foam glass insulation. These conduits could not be pressure tested.

e. Risers at Building 558—The FRP casing was extended beyond the ends of the conduits and bonded to the heat carrying pipes. There were no conduit vents or drains, and the condensate line was badly corroded at the juncture of the pipe and casing material. These conduits could not be pressure tested.

f. Manhole Northeast of Building 559—This manhole was 8 ft × 8 ft × 7 ft deep and had a top consisting of half concrete and half removable steel plates. One 6-in. goose neck manhole vent was welded to the steel plate top. About 1 ft of standing water was present. The steam jet sump pump was not operating because the system was not in operation.

g. Manhole North of Building 562—This manhole was 4 ft × 4 ft × 4 ft deep and housed the transition from buried conduits to an above ground system. The manhole top consisted of removable steel plates with no manhole vents. The condensate conduit end plate assembly was embedded in the manhole wall, restricting access to vent and drain openings. The steam conduit vent was plugged and the drain plug had broken off from corrosion. The piping in the manhole was heavily corroded.

h. Conduit Risers at Building 533—The sets of conduits rose from buried sections into 2 ft × 2 ft × 2 ft deep concrete boxes with removable steel plate covers. The conduit casings within the boxes were partially deteriorated. No end plate assemblies were used on the conduit risers.

i. Manholes for Buildings 530 and 533—These three manholes were approximately 8 ft × 8 ft × 6 ft deep and each had two 6-in. manhole vents. The tops were half concrete and half removable steel plates. About 1 ft of standing water was pumped out of each manhole in order to perform pressure tests. Steam jet sump pumps were installed but were not operational because the system was shut down. Vent and drain openings were located on the casing rather than on the end plates. Considerable corrosion of the end plates and other manhole internals was evident.

j. Pressure Tests—Only two conduit sections were suitable for pressure testing. Three manholes were involved in these pressure tests. Air pressure was applied from Manhole 2 east of Building 530. One run extended under a road to the Manhole 1 west of Building 533. A buried connection was made to the conduit section immediately outside of Manhole 2 and extended to Manhole 3 west of Building 530. The design and configuration of the buried connection could not be determined.

(1) Steam Conduit—The distance from Manhole 2 to Manhole 1 was 150 ft; from Manhole 2 to Manhole 3, 225 ft. The conduit tested was 13 in. and contained a 6-in. steam line. Air pressure was applied from Manhole 2 at 3:10 PM. After 10 minutes, the pressure would not rise above 2 psi. Conduit casings, drain plugs, and vents at Manholes 1 and 3 were soaped, but no leakage was found. After the system was valved off from the compressor, the pressure immediately dropped to zero.

(2) Condensate Conduit—The condensate conduit was 9 in. and contained a 3-in. return line. Air pressure was applied at Manhole 2 at 3:29 PM. A leak was noted in the connection to the gauge assembly, which was tightened. Air pressure was again applied at 3:37 PM and rose to 15.5 psi. The system was then valved off and the pressure dropped to 10 psi within 1 minute. Soaping indicated a leak at the vent pipe connection in Manhole 2, which was sealed. Air pressure was applied again at 3:55 PM. When the system was valved off, the pressure again dropped from 15 psi to 10 psi within 1 minute. The test was terminated. During part of this test, the drain plug in Manhole 3 was left open, and it was found that the tee connection take-off at Manhole 2 may have been capped with an end plate. If this was the case, then the pressure test results for both steam and condensate conduits would apply only to the runs between Manhole 1 and Manhole 2.



## Appendix I: Detailed Site Inspection Reports for Jacksonville Naval Air Station, Jacksonville, FL

1. Date of Survey: 26 through 28 May 1993.
2. Survey Team and Observers:

Dr. Charles Marsh - USACERL  
N.M. Demetroulis - NMD & Associates  
H.D. Musselman - NMD & Associates

3. General Observations:

The system was operating at 125 psi at the time of the inspection. The systems inspected were not installed in accordance with the manufacturer's brochure.

4. Detailed Inspection of System #14

This system consists of piping from Manufacturer A and has a steel conduit (Figure I1). The project, designed in 1982 by Architect-Engineer Evans and Hammond of Jacksonville, FL, was "Replacement of Steam Condensate Lines," Construction Contract N62427-2514 (Spec. 06-82-2514). This system is above ground except for street crossings and for service to Buildings 11, 845, and 855. Manholes were not provided at street crossing segments.

a. Transition Southeast of Building —Two side-by-side manholes are at the point where the above ground system transitions to below ground. Manhole A (7 ft x 7 ft x 5 ft deep) appeared to be part of an older system that was in use prior to 1983. The manhole top was covered with removable steel plates with no manhole vents. The manhole contained no sump pump and was dry. A 6-in. steam line and a 4-in. condensate line exited the manhole through a buried concrete trench. Maintenance personnel indicated that the 4-in. line has been abandoned and that the 6-in. line was being used for condensate return. The temperature of the 6-in. line was 170 °F. There

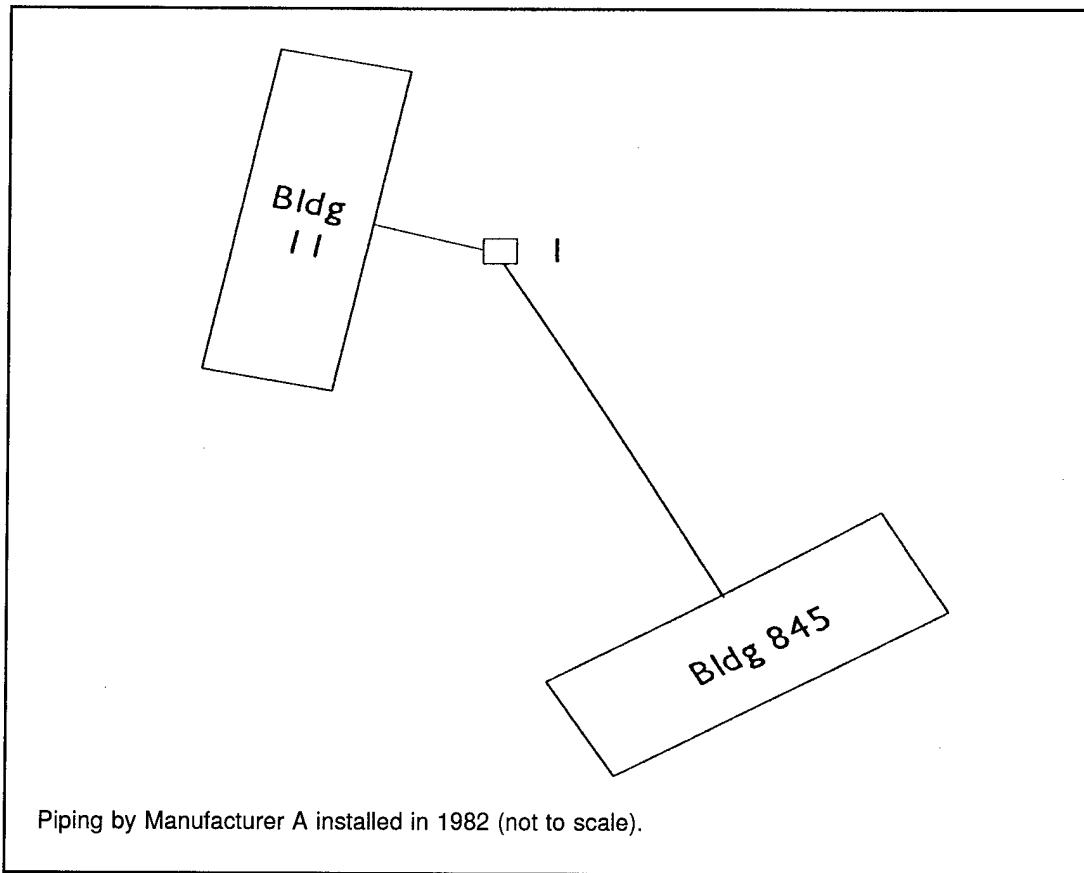

Figure I1. Schematic diagram of System 14 at Jacksonville NAS, FL.

was evidence that a poured type insulation was used in conjunction with the buried concrete trench.

Manhole B (9 ft × 7 ft × 6 ft deep) was built more recently and was a solid concrete top with a 2 ft × 2 ft aluminum plate covered access opening. Manhole ventilation was provided by an 8-in. goose neck vent pipe. A link seal was used on the manhole wall penetration for the steam conduit.

b. Manhole Southeast of Building 10—This manhole was 10 ft × 8 ft × 14 ft deep and had a solid concrete top with a 2 ft × 2 ft aluminum plate covered access opening. Ventilation was provided by one 8-in. goose neck pipe. An electric sump pump was installed but was not functioning. The manhole contained 1 ft of standing water. Steaming and high temperature prevented manhole entry.

c. Manhole Northeast of Building 11—This manhole was 7 ft × 7 ft × 6 ft deep and had a solid concrete top with a 36-in.-diameter access opening with a steel manhole cover. Two 8-in. goose neck pipes provide manhole ventilation. The manhole was dry and had an electric sump pump. Both the conduit drains and vents were

plugged, and the wall penetrations were cemented and caulked. About 8 ft of steam piping was not insulated.

d. Equipment Room Pit - Building 845—This pit was 9 ft × 7 ft × 6 ft deep and had a solid concrete top with a 36-in.-diameter access opening with a steel plate cover. The pit was dry and contained an electric sump pump. No steam or moisture was evident from conduit vents or drains. The 3-in. steam supply had a 12-in. conduit while the 1-1/2-in. return line had an 8-in. conduit. The wall penetrations were cemented and caulked.

e. Pressure Tests—The two conduits tested were the steam supply and condensate return running from the manhole northeast of Building 11 to the equipment room in Building 845. The length of this run was 220 ft.

(1) Condensate Line—The 1-1/2-in. condensate return line was contained in an 8-in. conduit. No steaming or moisture was evident at the conduit vents and drains. The conduit was sealed and pressurized to 16 psi at 3:45 PM. At 4:15 PM the pressure had stabilized at 15.8 psi, and the test was concluded.

(2) Steam Line—The 3-in. steam line was contained in an 11-in. conduit. No steaming or moisture was evident from the conduit vent and drain openings. The conduit was sealed and pressurized to 15 psi at 5:01 PM. A slight leak detected at the plugged vent in the manhole at Building 11 could not be completely sealed. Pressure drop in the conduit was as follows:

5:01 PM — 15.0 psi  
5:11 PM — 14.0 psi  
5:21 PM — 12.8 psi  
5:31 PM — 10.9 psi  
5:41 PM — 8.0 psi

The slow rate of decrease in air pressure was likely due to the leak at the plugged vent. The casing itself appeared sound.

##### 5. Detailed Inspection of System #15

This system consists of a single road crossing with piping from Manufacturer A and has a steel conduit (Figure I2). Installed in 1986, the project is under Birmingham Avenue near the intersection with Mustin Street. Risers on both sides of the street are fitted with loose water shed caps that precluded pressure testing.

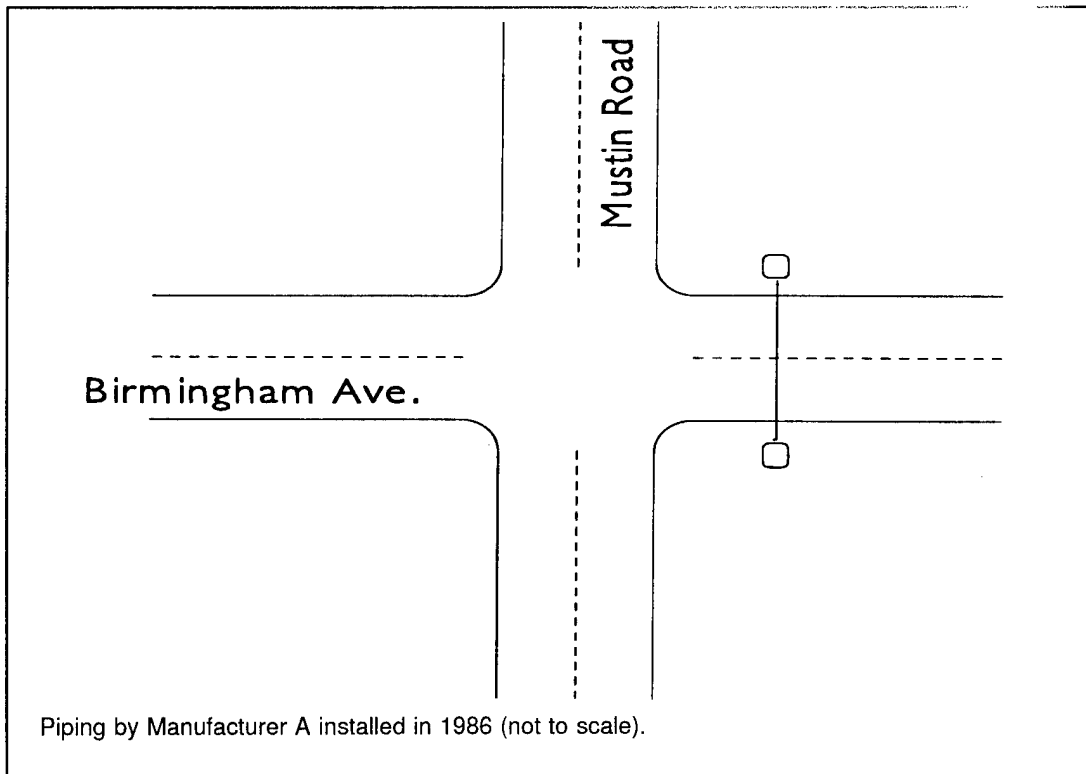

Figure I2. Schematic diagram of System 15 at Jacksonville NAS, FL.

#### 6. Detailed Inspection of System #16

This system consists of a single road crossing with piping from Manufacturer C and has a steel conduit (Figure I3). Installed in 1990, the project is under Mustin Street near the intersection with Birmingham Avenue. A cathodic protection test station was near this project, but no isolating flanges had been installed. Risers on both sides of the street are fitted with loose water shed caps that precluded pressure testing.

#### 7. Detailed Inspection of System #17

This system consists of piping from Manufacturer C that has a steel conduit (Figure I4). It was installed in 1990.

a. Transition North of Building 711—The above ground distribution system was routed under Building 711 and transitioned to buried conduits supplied by Manufacturer C on the north side of the building. No manhole was used in this transition. Both separate conduits had water shed caps installed.

b. Manhole Southeast of Building 855—This manhole was 5 ft × 7 ft × 4 ft deep and had a solid concrete top with a 36-in.-diameter access opening with a steel manhole cover. This manhole had no sump pump, and some water had accumulated.

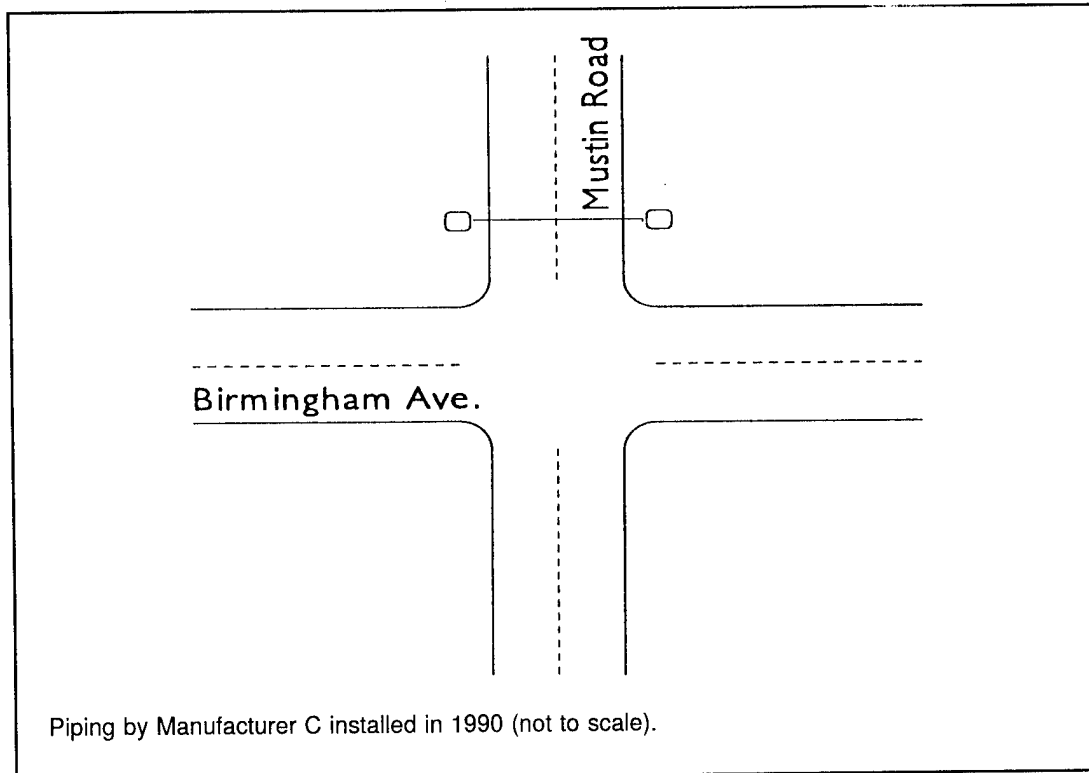

Figure 13. Schematic diagram of System 16 at Jacksonville NAS, FL.

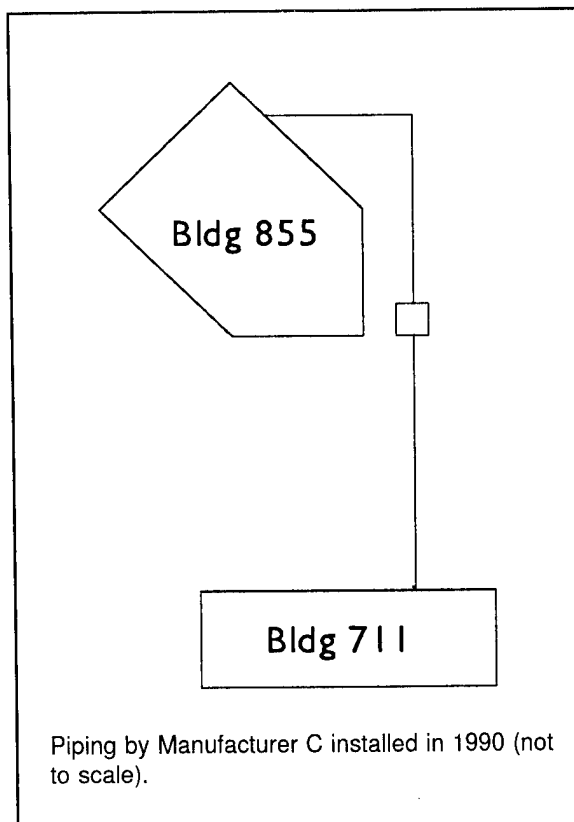

Figure 14. Schematic diagram of System 17 at Jacksonville NAS, FL.

The conduit wall penetrations were cemented and caulked. A valve stem leak was found on the steam line. The steam conduit diameter was 12 in. and the condensate conduit was 10 in. On both conduits, both the drains and the vents were plugged. The manhole could not be entered because of steaming and high temperature.

c. Equipment Room - Building 855— Both conduits extended vertically in the equipment room about 4 ft above the floor. Plugs and open vent piping were evident on both. No steaming was observed. A valve stem on the condensate line was leaking and missing a handle. Both the steam and condensate lines were missing insulation.

### 8. Detailed Inspection of System #18

This system consisted of piping from Manufacturer B and had a steel conduit (Figure I5). Installed in 1989, the project began after a transition from an above ground system to buried conduits. This was done without a manhole. The risers are located near the intersection of Jason and Saratoga streets and appear to be coated with fiberglass reinforced asphalt or bitumen. The coating is embossed with the name "Fostercoat." The exposed coating showed signs of deterioration and was moderately brittle. Both risers had loose water shed caps installed that do not allow pressure testing. A cathodic protection test station was located near the risers, but no dielectric flanges had been installed. The buried conduits serve Building 798.

### 9. Detailed Inspection of System #19

This system consists of piping from Manufacturer B and has a steel conduit (Figure I6). It consists of a transition from above ground to below ground without a manhole. A single conduit containing both steam and condensate piping crosses Birmingham street and feeds Building 789. The riser had a loose water shed cap and the "Fostercoat" coating had some minor deterioration. The equipment room pit is 4 ft x 4 ft x 12 ft deep and has an electric sump pump. Gland seals were used at the end plates for both the steam and condensate piping. The single conduit drain was

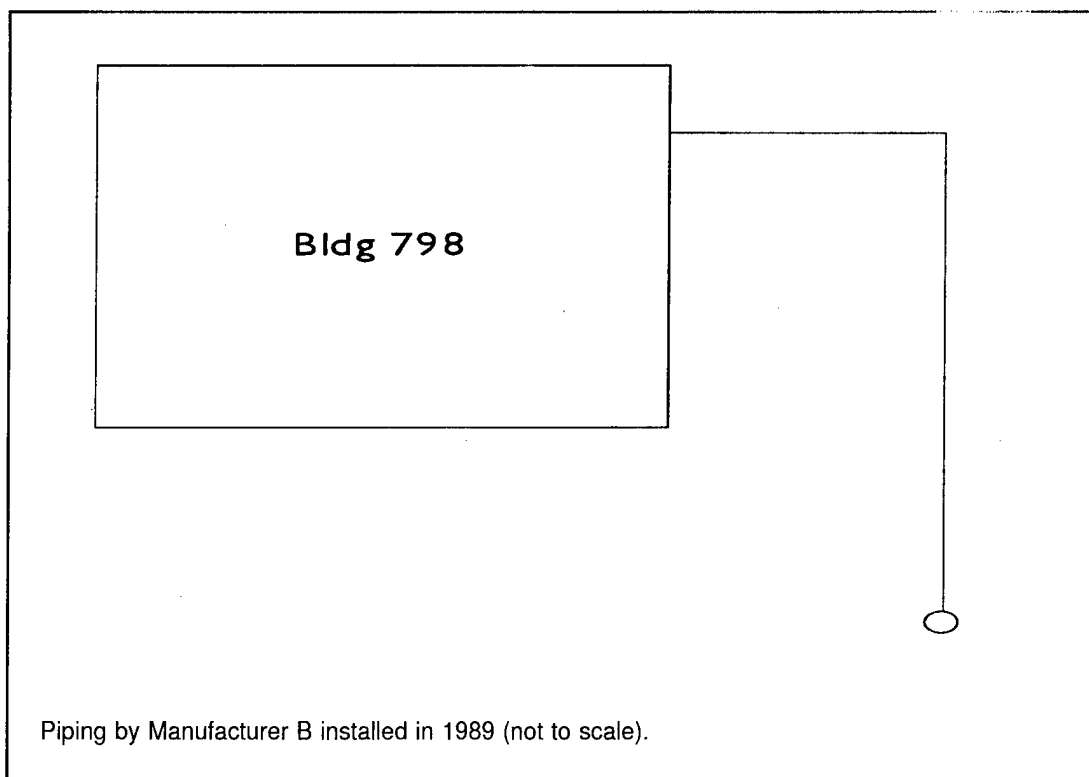
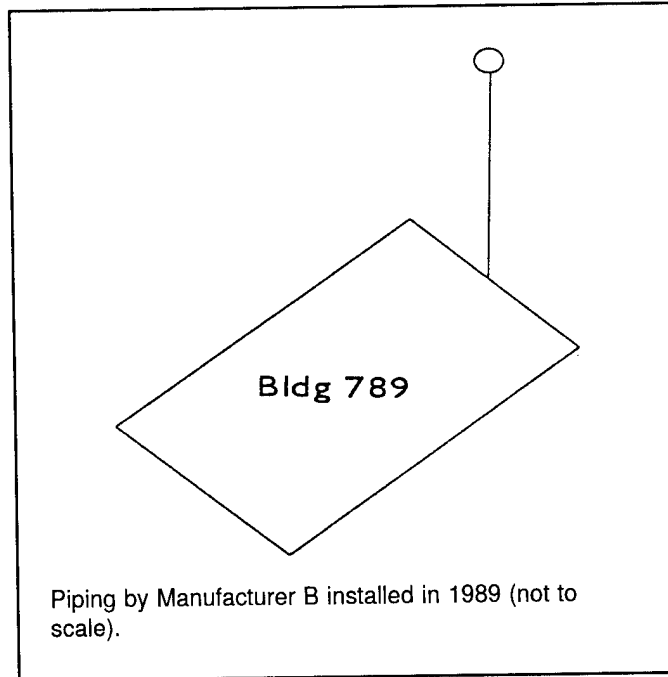

Figure I5. Schematic diagram of System 18 at Jacksonville NAS, FL.

plugged, but the vent was recessed into the pit wall and was full of concrete. The wall penetration was cemented and caulked, but slight water infiltration was noted. Some water seepage was also evident at an old wall penetration. A pressure test could not be performed because of the rain cap.



**Figure I6. Schematic diagram of System 19 at Jacksonville NAS, FL.**

## Appendix J: Detailed Site Inspection Reports for Mayport Naval Station, Jacksonville, FL

1. Date of Survey: 28 May 1993.

2. Survey Team and Observers:

Dr. Charles Marsh - USACERL

N.M. Demetroulis - NMD & Associates

H.D. Musselman - NMD & Associates

3. General Observations:

The system was operational at the time of inspection. The plant produces 180 psi steam in order to deliver 160 psi steam at the piers. In most cases, the condensate is dumped and not returned to the plant, so only steam supply piping was inspected. Because of steaming and high temperatures, none of the manholes could be entered to perform pressure tests.

4. Detailed Inspection of System #20

This system (installed in 1983) consists of piping from Manufacturer B and has a steel conduit (Figure J1). Excessive steaming, leaks and high temperatures prevented any pressure tests being done.

a. Manhole 1—This manhole was 8 ft × 5 ft × 10 ft deep and was northwest of Building 7. The manhole had removable heavy steel plate tops with no manhole vents. No entry ladder was installed. Water in the manhole indicated that the steam jet sump pump was not operational. The 6-in. steam line was contained in a 13-in. conduit. A gland seal was installed at the conduit end plate. The manhole was extremely hot and could not be entered.

b. Manhole 2—This manhole was essentially identical to Manhole 1.



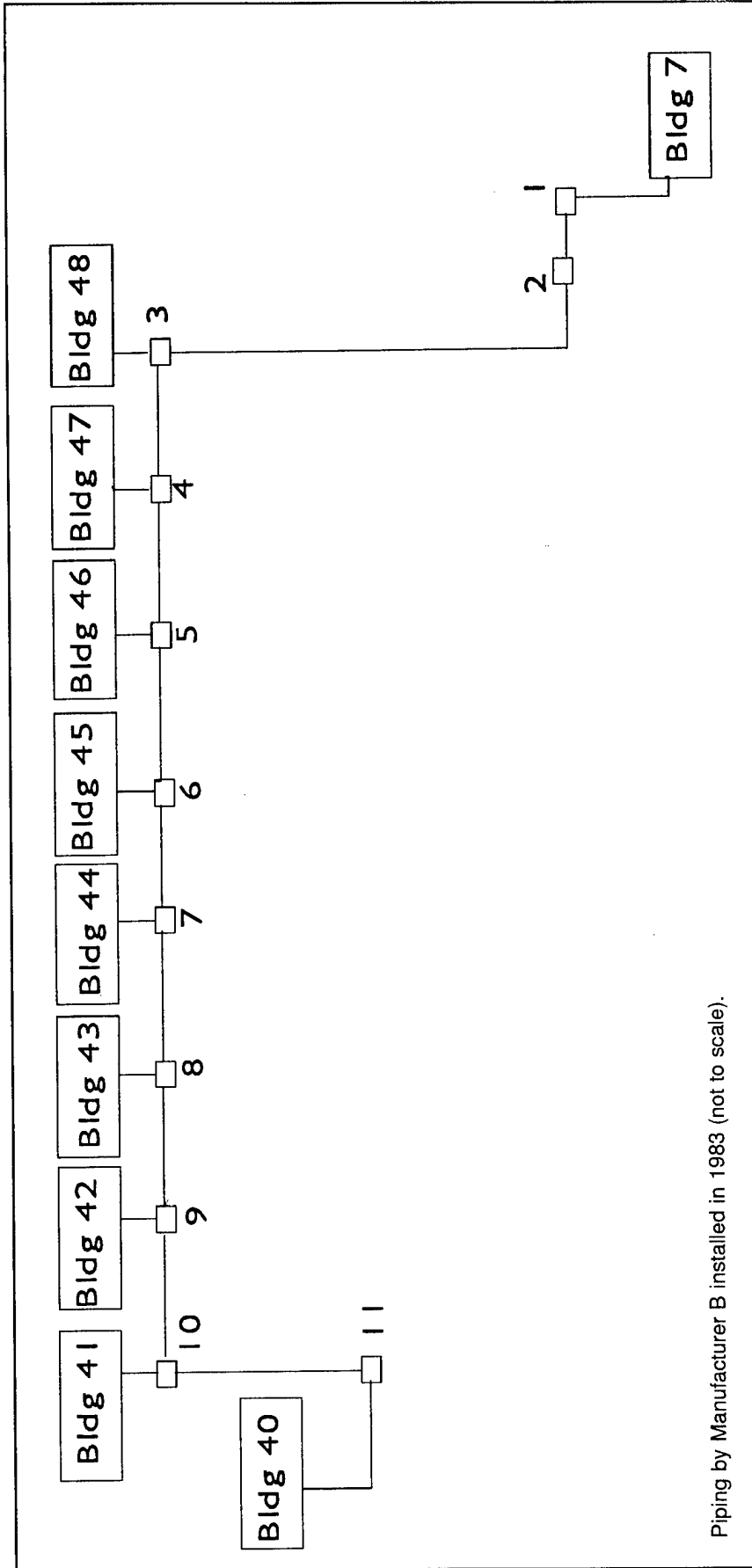

Piping by Manufacturer B installed in 1983 (not to scale).

Figure J1. Schematic diagram of System 20 at Mayport Naval Station, FL.

c. Manhole 3—The conduit run from Manhole 2 was approximately 1,200 ft under a street and a large paved area. The manhole top consisted of two heavy steel plates with no vent pipes located below grade. The manhole walls did not extend above grade and surface water tended to collect in the depression. The manhole was steaming heavily and could not be opened for inspection.

d. Manholes 4 Through 10—These manholes were installed in a line approximately 150 ft apart and serve HSL Buildings 40 through 48. All of the manholes were about 6 ft × 6 ft and 5- to 7-ft deep. Each had removable heavy steel tops with no manhole vent piping. No access ladders were installed and sump pumps, if present, were not operational. All of the manholes were steaming heavily and severe corrosion was observed at conduit end plates, casings, and other manhole internals. Essentially no pipe insulation remained on any of the piping. Manholes 5 and 7 had leaks in the steam piping or fittings. In Manhole 6, water had covered the supply piping and was boiling vigorously. At Manhole 9, the conduit casing had corroded through completely leaving the conduit open for water intrusion.

e. Manhole 11—This manhole was south of HSL Building 40 and was 6 ft × 6 ft × 7 ft deep. Ground water in the manhole was well above the steam piping and was boiling vigorously. The manhole could not be entered for inspection.

##### 5. Detailed Inspection of System #21

Installed in 1983, this system consists of piping from Manufacturer B and has a steel conduit (Figure J2). A series of nine manholes serves a pier located about 800 ft north of Building 46. No condensate return piping was used. All manholes were of similar construction and design. The manholes were 6 ft × 6 ft × 10 ft deep, and most had one 6-in. manhole vent pipe. Each had solid concrete tops with 30-in.-diameter access with steel covers. No access ladders had been installed. Manhole wall penetrations were cemented and caulked. Gland seals were installed at the conduit end plates. The 8-in. steam line was contained in a 15-in. conduit. Light to very heavy steaming in all but the last manhole prevented entry for inspection. Steam escaping at a fitting was noted in Manhole 8. The last manhole at the end of the pier, Manhole 9, had no steaming but was still too hot to enter. A cathodic protection test station was found near the last manhole, but no dielectric flange connections had been installed.

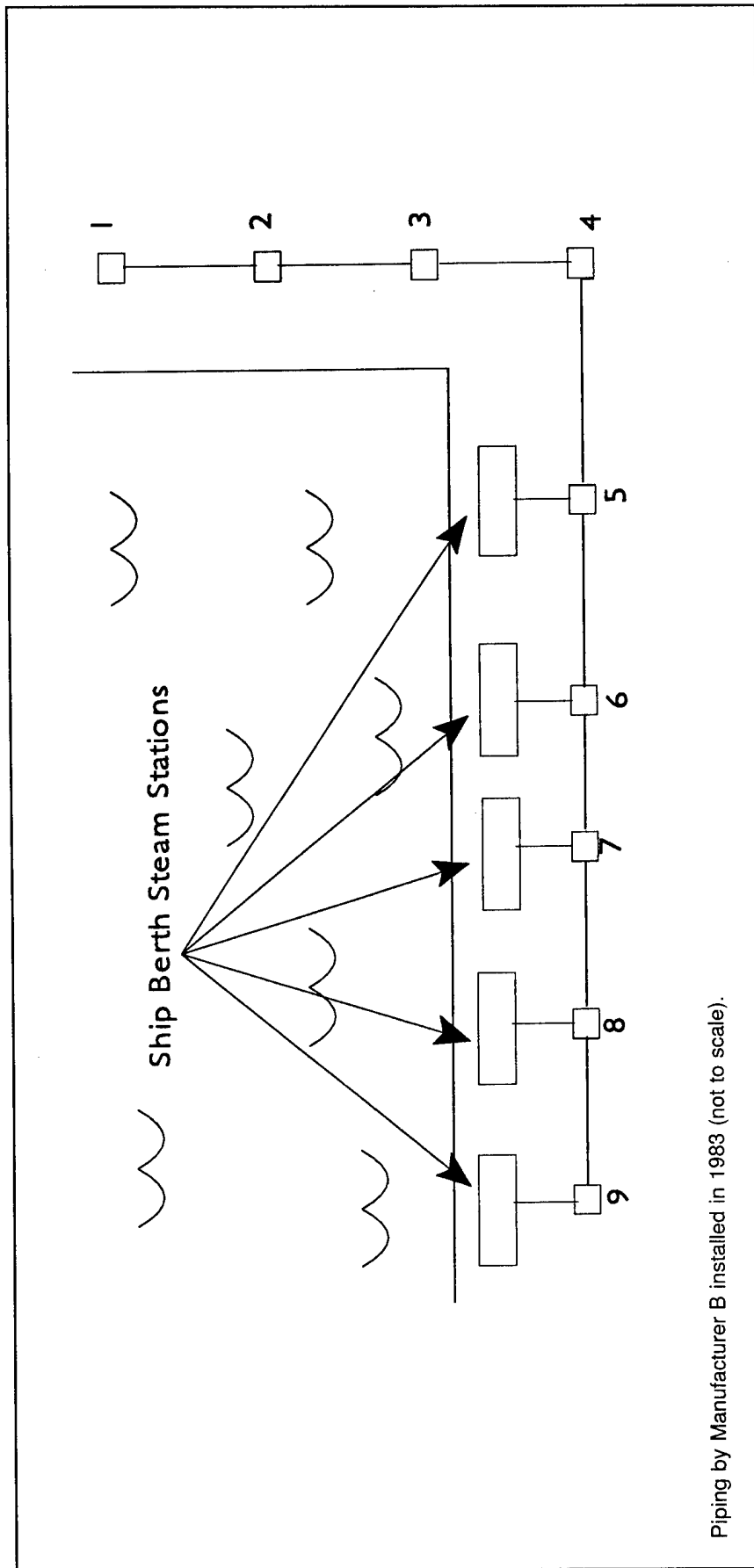

Piping by Manufacturer B installed in 1983 (not to scale).

Figure J2. Schematic diagram of System 21 at Mayport Naval Station, FL.

## Appendix K: Detailed Site Inspection Reports for Charleston Naval Shipyard, Charleston, SC

1. Date of Survey: 21 through 22 June 1993.
2. Survey Team and Industry Observers:

Dr. Charles Marsh - USACERL  
C. Dilks - USACERL  
N.M. Demetroulis - NMD & Associates  
H.D. Musselman - NMD & Associates  
R. Couch - RicWil, Inc.  
P.H. Russom - RicWil, Inc.

3. General Observations:

This facility is served by a central plant that provides electric power, compressed air, potable water, and steam. The electric power is generated by three 1,250 KW diesel generators and one 5,000 KW steam turbine generator for a combined total capacity of 8,750 KW. The total compressed air capacity is 25,000 CFM provided by four electric 5,000 CFM compressors and one steam driven 5,000 CFM compressor. The water purification unit can provide as much as 15,000 gallons per day. The total steam generating capacity was listed as 360,000 pounds per hour at 400 psi.

The steam system was operational at the time of inspection. The steam pressure is reduced to 150 psi for distribution to the ship servicing piers and other base facilities. Condensate lines are not installed for most of the system, which results in high water make-up requirements for the central plant. Most of the distribution system at the Charleston Naval Shipyard is above ground, and where transitions are made to below ground sections, loose fitting rain caps were used. On extended underground runs, the manholes were full of water and the resultant violent boiling and steaming prevented access for inspection and pressure testing. As a result, no direct buried conduit sections were found that could be pressure tested.

The older piers at this facility are supplied by steam lines suspended under the pier and exposed to the atmosphere. The insulation and aluminum casings used appear identical to that used for above ground systems. At the time of the inspection, the under pier steam supply piping was 5 to 8 ft above the surface of the water.

The newest pier, Pier Z, is supplied by a steam line within a steel cased conduit installed along with other utilities in a concrete trench under the pier. The trench is 12-ft wide, 4-ft deep and is covered with concrete slabs except where take-offs are provided for servicing ships. At those points, heavy open grate steel tops are installed for inspection and access. Although this is not a typical application for conduit systems, it was decided to pressure test a few randomly selected conduit sections.

#### 4. Detailed Inspection of System #22

This system consists of piping from Manufacturer D and has a steel conduit (Figure K1). Installed in 1984, this project was "Naval Shipyard Pier 'Z' Berthing Pier," order number A418142 (Drawing No. D-18987). Beginning at the southwest point of the pier, 19 conduit sections are in a concrete trench along the pier perimeter. The 8-in. steam line is contained in an 18-in. conduit. Contract drawings indicate 3-1/2-in. of calcium silicate insulation. No steaming was evident at conduit vents.

a. Pressure Test of Conduit Section 18—This conduit section was 226 ft long. Air pressure was initially applied at 3:00 PM. Significant air leakage occurred at both gland seals. One gland seal was effectively tightened, while the other seal had a broken bolt and a second bolt that could not be reached. Some leakage remained at the latter gland seal. The conduit was again pressurized and valved off at 3:12 PM. The pressure readings and times observed were:

3:12 PM — 15.0 psi  
3:17 PM — 14.2 psi  
3:22 PM — 13.1 psi  
3:27 PM — 12.3 psi  
3:32 PM — 11.5 psi  
3:37 PM — 10.0 psi  
3:42 PM — 9.3 psi  
3:47 PM — 8.1 psi

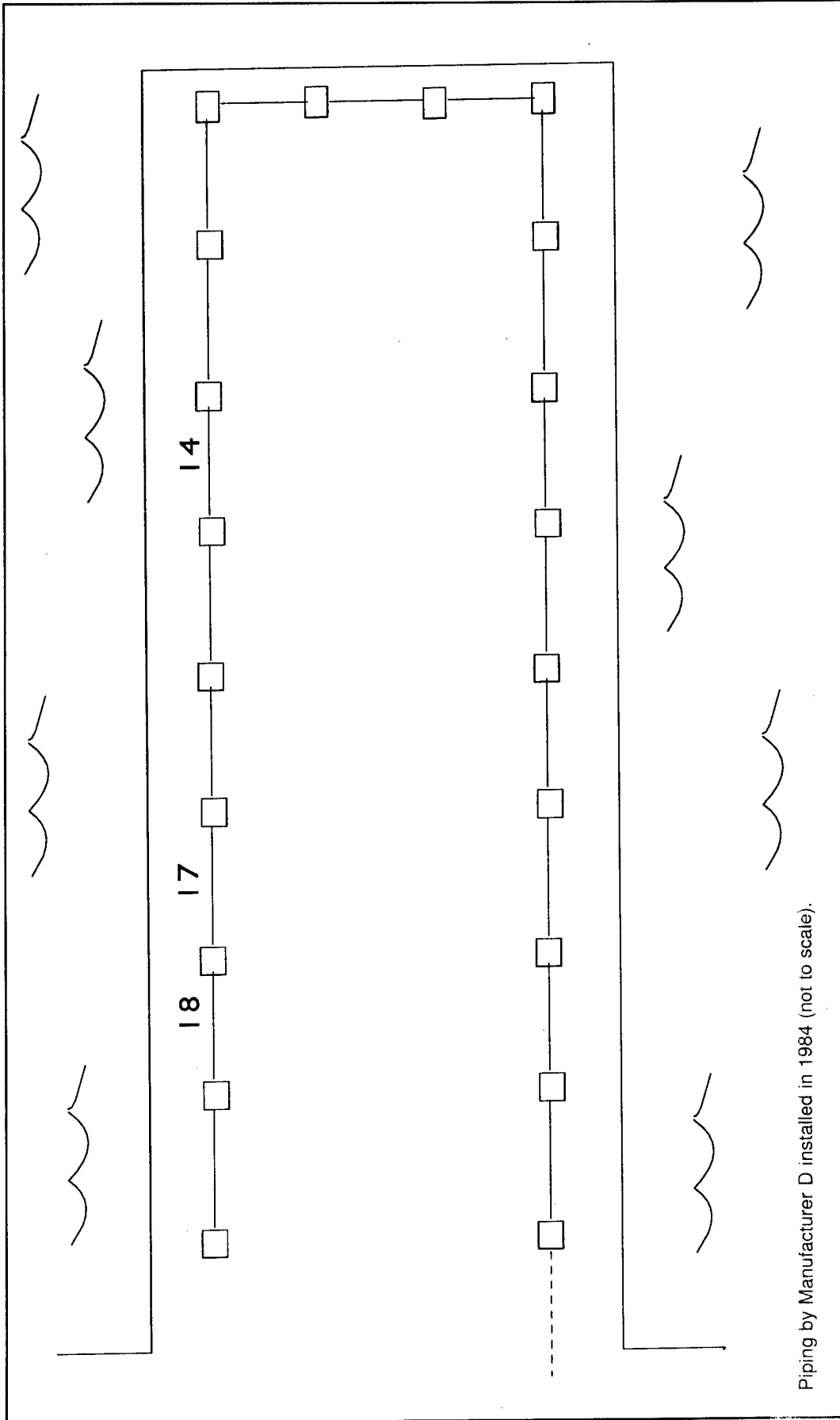

Piping by Manufacturer D installed in 1984 (not to scale).

Figure K1. Schematic diagram of System 22 at Charleston Ship Yard, SC.

b. Pressure Test of Conduit Section 17—This conduit section was 158 ft long. The conduit and end plate coatings were in excellent condition. No steaming or moisture occurred at the vent and drain at the higher elevation. At the lower elevation, a large quantity of water was drained from the conduit. The manufacturer's representative theorized that this moisture had been absorbed by the calcium silicate insulation, was later driven off when the system was energized, and then condensed in the conduit casing. The conduit was pressurized to 15.5 psi and valved off at 9:27 AM. The pressure readings and times observed were:

9:27 AM — 15.5 psi

9:37 AM — 15.0 psi

9:42 AM — 14.0 psi

9:57 AM — 12.6 psi

After the pressure test, the lower drain plug was opened. The escaping air carried with it a significant amount of water that had not been fully drained from the casing.

c. Pressure Test of Conduit Section 14—This conduit section was 142 ft long. Some cracking and spalling of the casing coating exposed uncoated fiberglass. Considerable peeling of the coating was evident at the welded juncture of the end plate and the casing. The manufacturer's representatives indicated that this was believed to be a field patch rather than a factory fabricated section. A water mark on the concrete trench wall indicated that this section was submerged for some time. The conduit was initially pressurized at 10:15 AM but could not hold pressure because of leaks at the gland seals. The seals could not be completely tightened and air could be heard escaping during the test. The pressure readings and times observed were:

10:35 AM — 15.5 psi

10:40 AM — 12.5 psi

10:45 AM — 9.8 psi

10:50 AM — 7.5 psi

10:55 AM — 6.0 psi

## Appendix L: Detailed Site Inspection Reports for Charleston Air Force Base, Charleston, SC

1. Date of Survey: 23 through 25 June 1993.
2. Survey Team and Industry Observers:

Dr. Charles Marsh - USACERL  
C. Dilks - USACERL  
N.M. Demetroulis - NMD & Associates  
H.D. Musselman - NMD & Associates  
R. Couch - RicWil, Inc.  
P.H. Russom - RicWil, Inc.

3. General Observations:

The facility is served by a central plant containing three Combustion Engineering steam boilers. Each boiler is rated at 50,000 lb/hr and operates at 110 psi. The plant was not in operation during the period of the inspection. The distribution system consists of about 100,000 ft of piping. Most of the condensate return lines are made of FRP. Of the 62 manholes in the system, 22 have electric sump pumps, and the remainder have steam ejector sump pumps. Base personnel indicated that most of the smaller projects were done "in-house" and, with the exception of Manufacturer D, manufacturers did not provide representatives to inspect and assist in conduit installation.

The base has had numerous steam pipe failures, primarily involving both factory and field welds. Extensive excavations were required to locate and repair the leaks. Base personnel did not have the cost figures for locating and repairing these pipe failures. In addition, base personnel indicated that they have had numerous failures with FRP condensate return lines and are trying to prohibit their use.



#### 4. Detailed Inspection of System #23

The excellent assistance on this base allowed for a large number of conduits to be air pressure tested. In this one instance the system is considered to consist of piping supplied by Manufacturer A, Manufacturer D, and Manufacturer C (Figure L1).

a. Pressure Test 1—This conduit, installed in 1988, was supplied by Manufacturer C and had a steel conduit. The total run was about 350 ft. This new system was spliced into an old system (Manufacturer D) as a means of repairing a failed system. The design of the buried interface could not be determined. No air pressure build up was observed when compressed air was applied. Aside from the fact that a buried connection was made, no conclusions could be drawn from this test.

b. Pressure Test 2—This conduit, installed in the early 1980s, was supplied by Manufacturer D and had a steel conduit. The conduit length was 130 ft and extended from a manhole northeast of Building 176 (Manhole A) under Bates street to Manhole B. Manhole A was a prefabricated steel design, 8 ft in diameter and 11-ft deep. The top contains a 30-in. access hatch. The manhole was dry and served by an electric sump pump. Manhole B was 12 ft × 12 ft × 12 ft deep and was concrete with walls extending 4.5 ft above grade. About 5 ft of standing water was removed with a portable pump because the installed steam ejector type sump pump did not function when the system was off. Some water entry was noted at the conduit wall penetration. The 6-in. steam line was contained in a 14-in. conduit. The pressure readings and times observed were:

9:37 AM — 15.5 psi  
9:42 AM — 14.0 psi  
9:47 AM — 12.1 psi  
9:52 AM — 10.4 psi  
9:57 AM — 8.9 psi  
10:02 AM — 7.5 psi

c. Pressure Test 3—This conduit was installed in the middle 1980s, was supplied by Manufacturer A, and had a steel conduit. The conduit was 106 ft long and extended from Manhole B, described above, to a prefabricated steel manhole, Manhole C, 9 ft in diameter and 12-ft deep. The steel manhole was dry and contained an electric sump pump. The 6-in. line was contained in a 14-in. conduit, which was pressurized to 15.5 and valved off. The pressure readings and times observed were:

10:13 AM — 15.5 psi  
10:18 AM — 15.0 psi

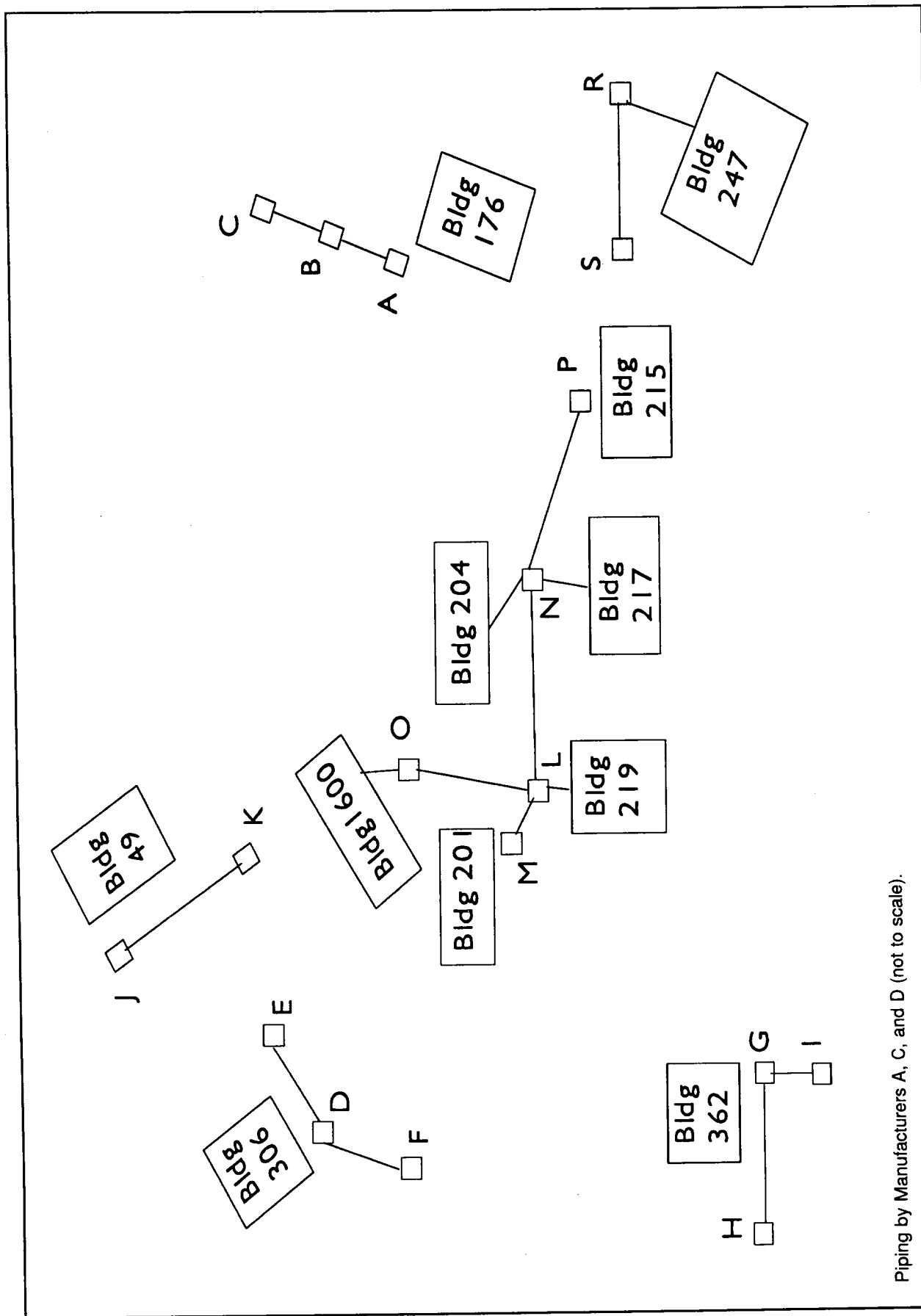

Piping by Manufacturers A, C, and D (not to scale).

Figure L1. Schematic diagram of System 23 at Charleston AFB, SC.

10:23 AM — 15.0 psi  
10:28 AM — 14.8 psi  
10:33 AM — 14.7 psi  
10:38 AM — 14.6 psi  
10:43 AM — 14.5 psi

d. Pressure Test 4—This conduit was installed in 1985, was supplied by Manufacturer A, and had a steel conduit. The conduit length was 290 ft and extended from Manhole D at the southwest corner of Building 306 running parallel to the building and connecting with Manhole E. The 2-in. steam line was contained in a 6-in. conduit. Both manholes were of prefabricated steel design, 6 ft in diameter and 6-ft deep. Both manholes had electric sump pumps. Manhole D was dry and Manhole E contained some mud and a heavy water mark on the wall above the internal piping. The steam conduit was pressured to 15 psi at 11:20 AM. No pressure drop was noted at 1:35 PM, and the test was terminated. A cathodic protection test station was located near Manhole D.

e. Pressure Test 5—This conduit was installed in 1985, was supplied by Manufacturer A, and had a steel conduit. The conduit length was 325 ft and ran south from Manhole D (previously described) to Manhole F. The 2-1/2-in. carrier line was contained in an 8-in. conduit. Manhole F was in a parking area and was 9 ft × 9 ft × 8 ft deep. The concrete top contained a 30-in. square access hatch. This manhole was dry and was served by an electric sump pump. The wall penetration was cemented and caulked. The drain plug was missing from the conduit end plate. The conduit was pressurized to 15.5 psi at 11:25 AM, and no pressure drop was evident at 1:40 PM.

f. Pressure Tests 6 and 7—This conduit was installed in 1992, was supplied by Manufacturer A, and had a steel conduit. This section ran underground from the equipment room of Building 543 to transition risers and then to an above ground system. The length of the conduit was 135 ft. Both steam and condensate risers at the transition extended about 1 ft above grade and were capped with standard pressure-testable end plates. Both conduits were 6 in. in diameter and entered the equipment room in a pit 4 ft × 5 ft × 9 ft deep. The steam line end plate contained a gland seal, while the condensate line end plate did not.

(1) Pressure Test 6 (Steam Conduit)—Some air leakage was observed at the equipment room gland seal, which could not be tightened. A pressure of 16 psi was applied at 2:10 PM. The pressure readings and times observed were:

2:10 PM — 16.0 psi  
2:15 PM — 15.5 psi

2:20 PM — 14.0 psi  
2:25 PM — 12.5 psi  
2:30 PM — 11.0 psi  
2:35 PM — 9.7 psi  
2:40 PM — 8.6 psi  
2:45 PM — 7.0 psi  
2:50 PM — 6.7 psi  
2:55 PM — 5.9 psi

(2) Pressure Test 7 (Condensate Conduit)—The conduit was pressurized to 16 psi at 2:25 PM. The pressure readings and times observed were:

2:25 PM — 16.0 psi  
2:30 PM — 16.0 psi  
2:35 PM — 16.0 psi  
2:40 PM — 15.9 psi  
2:45 PM — 15.9 psi  
2:50 PM — 15.9 psi  
2:53 PM — 15.9 psi

g. Pressure Tests 8 and 9—This conduit was installed in 1985, was supplied by Manufacturer D, and had a steel conduit. The run was 270 ft long and ran from Manhole G at the southwest of Building 362 to Manhole H. The steam and condensate lines were contained in separate conduits. Manhole G was 9 ft × 8 ft × 7 ft deep, was of the solid concrete top design, and had a 30-in.-diameter access. Manhole H was very similar to Manhole G, and both had electric sump pumps. The 3-in. steam line was contained in a 10-in. conduit while the 2-in. condensate line was housed in a 6-in. conduit.

(1) Pressure Test 8 (Steam Conduit)—The conduit was pressurized to 15.8 psi at 3:30 PM. The pressure readings and times observed were:

3:30 PM — 15.8 psi  
3:36 PM — 15.5 psi  
3:42 PM — 15.5 psi  
3:47 PM — 15.5 psi  
3:55 PM — 15.5 psi  
4:05 PM — 15.5 psi

The casing was kept under pressure until 8:37 AM the next morning. At this time the pressure had dropped to 6.5 psi.

(2) Pressure Test 9 (Condensate Conduit)—The casing was pressurized to 17 psi at 4:05 PM and was kept under pressure overnight. At 8:37 AM the pressure had dropped to 12 psi. Upon opening the conduit drain valve, a large quantity of water flowed from the interior of the casing. The casing pressure drop was not very large, indicating a condensate pipe leak.

h. Pressure Tests 10 and 11—This conduit was installed in 1985, was supplied by Manufacturer D, and had a steel conduit. This section ran from Manhole G 150 ft southwest to Manhole I. Manhole I was 8 ft × 8 ft × 11 ft deep and was made of concrete. Both manholes were dry. The 3-in. steam line was contained in an 11-in. conduit and the 1-1/4-in. condensate pipe was inside a 7-in. conduit. The condensate conduit drain plug was removed, and minor water dripping occurred.

(1) Pressure Test 10 (Steam Conduit)—The casing was pressurized to 16 psi at 9:00 AM. No drop in pressure was evident at 9:35 AM, and the test was terminated.

(2) Pressure Test 11 (Condensate Conduit)—The casing was pressurized to 15.6 psi at 9:05 AM. The pressure readings and times observed were:

9:05 AM — 15.6 psi  
9:10 AM — 15.4 psi  
9:15 AM — 15.4 psi  
9:20 AM — 15.2 psi  
9:25 AM — 15.0 psi  
9:30 AM — 14.8 psi  
9:35 AM — 14.5 psi

i. Pressure Test 12—This conduit was installed in 1983, was supplied by Manufacturer D, and had a steel conduit. This run extended 140 ft from manholes at two corners of Building 49. Both steam and condensate pipes are enclosed in a single conduit. The system could not be tested because severe corrosion at an end plate vent prevented the sealing of the conduit.

j. Pressure Test 13—This conduit was installed in 1986, was supplied by Manufacturer A, and had a steel conduit. This section ran from a manhole at the corner of Building 49 (Manhole J) parallel to the length of the building to Manhole K. The distance between manholes was 540 ft. Both manholes were of a prefabricated steel design 8 ft in diameter and 7-ft deep. About 6 in. of standing water was observed in Manhole K. The steam conduit casing diameter was 11 in. The condensate line was FRP. There is a cathodic protection test station near Manhole J. The steam conduit

was pressurized to 16 psi at 10:09 AM. No pressure drop was indicated, and the test was terminated at 10:39 AM.

k. Pressure Test 14—This conduit was installed in 1985, was supplied by Manufacturer D, and had a steel conduit. This run extends 40 ft from the equipment room of Building 1600 to the concrete Manhole O, which was 8 ft × 8 ft × 6 ft deep. Manhole O was dry and contained an electric sump pump. The 2-1/2-in. steam line was housed in a 10-in. conduit. The casing was pressurized to 16 psi at 11:00 AM. The pressure readings and times observed were:

11:00 AM — 16.0 psi  
11:02 AM — 14.0 psi  
11:03 AM — 12.0 psi  
11:04 AM — 8.0 psi  
11:06 AM — 6.0 psi  
11:09 AM — 2.0 psi

l. Pressure Test 15—This conduit was installed in 1982, was supplied by Manufacturer A, and had a steel conduit. This section ran from the equipment room of Building 219 to the central Manhole L, which was 10 ft × 10 ft × 11 ft deep and had concrete walls that extended 3 ft above grade. The solid concrete top had a 30-in. access hatch. The manhole was dry and was served by an electric sump pump. The 3-in. steam line was contained in an 11-in. conduit. The casing was pressurized to 15.5 psi at 1:57 PM. No pressure drop was observed and the test was terminated at 2:41 PM.

m. Pressure Test 16—This conduit was installed in 1982, was supplied by Manufacturer A, and had a steel conduit. This section extended 165 ft from Manhole L to Manhole M immediately outside of Building 201. Manhole M was concrete with dimensions of 8 ft × 8 ft × 7 ft deep and contained a steam ejector sump pump. One foot of standing water was removed with a portable pump unit. The 3-in. steam line was contained in an 11-in. conduit, which was pressurized to 17.6 psi at 2:12 PM. The pressure readings and times observed were:

2:12 PM — 17.6 psi  
2:17 PM — 17.5 psi  
2:22 PM — 17.4 psi  
2:27 PM — 17.2 psi  
2:32 PM — 17.2 psi  
2:37 PM — 17.2 psi  
2:42 PM — 17.1 psi

n. Pressure Test 17—This conduit was installed in 1982, was supplied by Manufacturer A, and had a steel conduit. This section was 320 ft long and ran from Manhole L to Manhole N, which feeds Buildings 204 and 217. Manhole N was 10 ft × 10 ft × 8 ft deep and had a steam ejector sump pump. The manhole was of concrete construction and had to have considerable water removed with a portable pump. The 8-in. steam line was contained in a 20-in. conduit, which was pressurized to 15 psi at 2:45 PM. The pressure readings and times observed were:

2:45 PM — 15.0 psi  
2:50 PM — 14.8 psi  
2:55 PM — 14.6 psi  
3:00 PM — 14.5 psi  
3:05 PM — 14.5 psi  
3:10 PM — 14.5 psi  
3:15 PM — 14.4 psi

o. Pressure Test 18—This conduit was installed in 1982, was supplied by Manufacturer A, and had a steel conduit. This section extended 300 ft from Manhole N to Building 204. The 3-in. line was contained in a 10-in. conduit. The conduit was pressurized to 16 psi at 4:10 PM. The pressure readings and times observed were:

4:10 PM — 16.0 psi  
4:20 PM — 7.0 psi  
4:30 PM — 4.0 psi

The pressurized conduit was left overnight and the reading the next morning at 8:40 AM was 2 psi.

p. Pressure Test 19—This conduit was installed in 1982, was supplied by Manufacturer A, and had a steel conduit. This section ran 250 ft from Manhole N to Building 217. The 3-in. line was contained in a 10-in. conduit, which was pressurized to 16 psi at 4:15 PM. The pressure readings and times observed were:

4:15 PM — 16.0 psi  
4:25 PM — 15.9 psi  
4:30 PM — 15.9 psi

The pressurized conduit was left overnight, and the reading the next morning at 8:45 AM was 15.0 psi.

q. Pressure Test 20—This conduit was installed in 1987, was supplied by Manufacturer A, and had a steel conduit. This section ran 200 ft from Manhole N at the corner of Building 214 to Manhole P at the corner of Building 215. The 8-in. steam line was contained in a 15-in. conduit. Both manholes were of concrete construction measuring 9 ft × 9 ft × 8 ft deep. Water was entering Manhole N through a conduit wall penetration, and the access ladder was not attached to the wall. Both manholes were served by steam jet sump pumps. Both manholes had to be pumped out with a portable pump. The casing was pressurized to 17 psi at 9:18 AM. The pressure readings and times observed were:

9:18 AM — 17.0 psi  
9:23 AM — 17.0 psi  
9:28 AM — 17.0 psi  
9:33 AM — 16.0 psi  
9:38 AM — 16.0 psi  
9:43 AM — 16.0 psi  
9:48 AM — 16.0 psi

r. Pressure Test 21—This conduit was installed in 1987, was supplied by Manufacturer A, and had a steel conduit. This section ran 180 ft from primary Manhole R to the equipment room of Building 247. The 4-in. steam line was contained in a 10-in. conduit. Manhole A was 9 ft × 9 ft × 6 ft deep, of concrete construction, and had walls that extended 2 ft above grade. The manhole was dry and had an electric sump pump. The conduit was pressurized to 16 psi at 10:12 AM. At 10:42 AM no pressure loss had been observed, and the test was terminated.

s. Pressure Test 22—This conduit was installed in 1987, was supplied by Manufacturer A, and had a steel conduit. This section ran 250 ft from Manhole R to Manhole S. Manhole R was similar to Manhole S with the exception of having a concrete top that was flush with grade. The 6-in. steam line was contained in a 14-in. conduit. The conduit was pressurized to 16 psi at 10:27 AM. At 10:57 AM no pressure loss had been observed, and the test was terminated.



## Appendix M: Detailed Site Inspection Reports for Grissom Air Force Base, Kokomo, IN

1. Date of Survey: 12 through 16 July 1993.
2. Survey Team and Industry Observers:

Dr. Charles Marsh - USACERL  
N.M. Demetroulis - NMD & Associates  
H.D. Musselman - NMD & Associates  
J. Williams - Grissom AFB  
L.J. Stonitsch - Rovanco Corp.

3. General Observations:

The facility is served by a central plant containing five steam generating boilers. Four of the boilers are rated at 40,000 lb/hr, and one boiler is rated at 60,000 lb/hr. The maximum pressure rating on all of the boilers is 160 psi. However, during the inspection the system was operating at 100 psi. The plant is in the process of being converted from coal fired to combination gas and oil in order to meet environmental standards.

This is the first installation where we found an automatic conduit failure alarm/monitoring system that was proposed by some manufacturers years ago. This system was to sound an alarm when a pre-established pressure within the casing fluctuated due either to a casing failure or a leak in the heat carrying pipe. The Grissom AFB system consisted of plastic tubing connecting one or more of the casing vent pipes to a sensor box mounted on the manhole wall. No instances were found where this system was functional. Base personnel indicated that the maintenance requirements for the system were such that the concept was not feasible.

In one manhole, conduits were found of the water-spread limiting type currently approved for Federal construction projects. In these conduits, each section is sealed with a plastic material bonded to the nonmetallic casing and to the heat carrying pipe.

On the steam conduit casings, the plastic end seal had fallen off the conduit and appeared to be in a deteriorated and charred condition. It is apparent that the plastic material is not capable of withstanding high temperatures over an extended time period. The manufacturer should be required to establish and verify maximum allowable temperature conditions for its use. Until this is done, it is recommended that the use of this system be limited to applications below 250 °F.

Maintenance personnel indicated that they had problems for many years with premature trap failures. After considerable trial and error, they now feel they have found a trap which provides longevity and reliability and significantly reduces maintenance requirements. The trap is manufactured by Richards Industries of Cincinnati, Ohio under the trade name "Best-O-Bell." This trap should be examined to determine the design and materials features responsible for its performance with a view toward revising current procurement specifications.

#### 4. Detailed Inspection of System #24

This system consists of piping from Manufacturer C and has a steel conduit (Figure M1). It was installed in 1989.

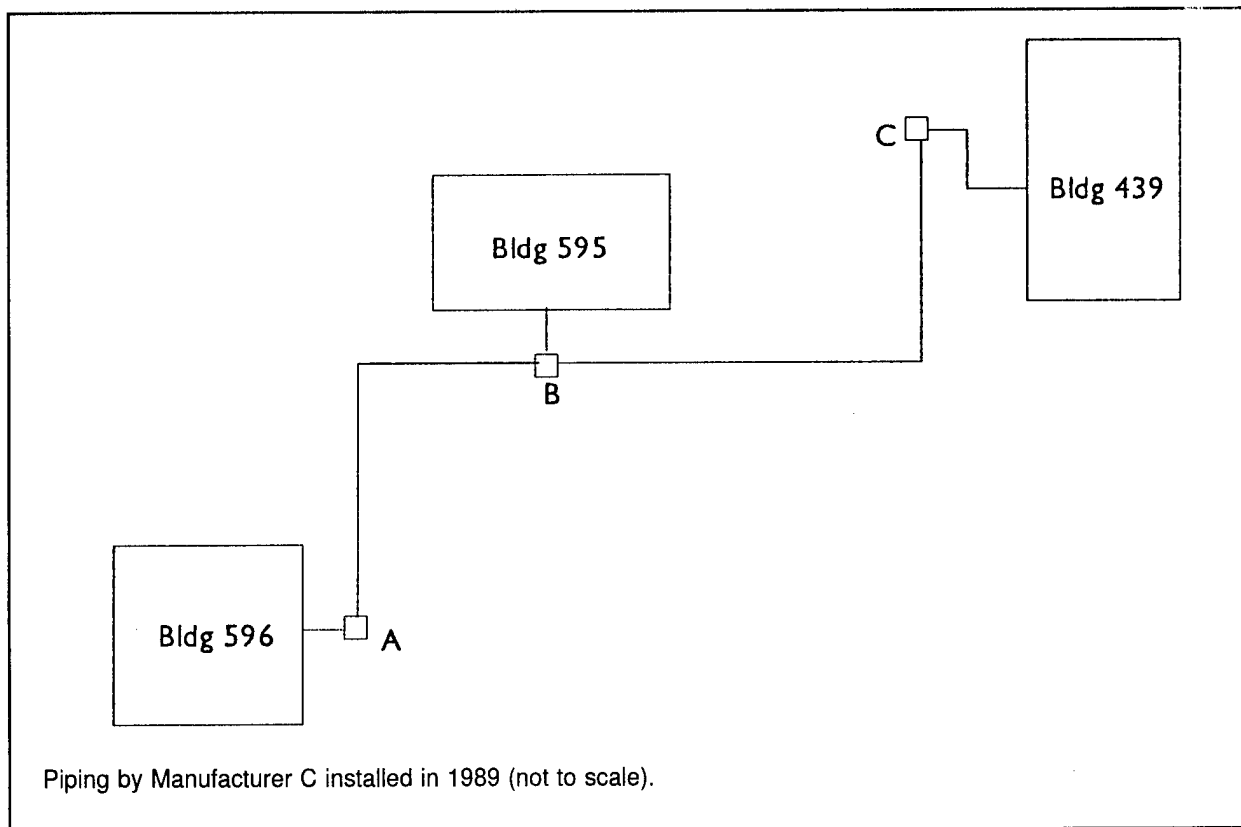

Figure M1. Schematic diagram of System 24 at Grissom AFB, IN.

a. Pressure Test 1— This section extended 20 ft from Manhole A to a pit in the equipment room of Bldg. 596. The concrete manhole was 5.5 ft × 5.5 ft × 6 ft deep, extended slightly above grade and had a solid aluminum plate cover. No access ladder was present and a steam valve gasket had a slight leak. Six in. of water in the manhole was drained after adjusting the float mechanism on the sump pump. The conduit wall penetrations were caulked and cemented. No vapor was evident at the steam line casing vent, but a light dripping was noted at the drain opening. Gland seals were installed at the end plates both at the manhole and the building pit. Building pit dimensions were 4 ft × 4 ft × 5 ft deep. The steam line casing was 10-3/4 in. in diameter and contained a 3-in. pipe.

Pressure was applied to the casing at 10:00 AM to 15 psi. Pressure immediately dropped when the line was valved off due to leakage at the gland seals. The gland seal at the manhole was tightened and the system repressurized with the same results because of a gland seal leak at the building pit. This pit could not be entered because of a leaking flange gasket on the steam line. At this point the pressure test was abandoned.

b. Pressure Tests 2 and 3—This section extended from Manhole A, as described above, to Manhole B—a distance of 400 ft. Manhole B was 5.5 ft × 5.5 ft × 7 ft deep and contained about 6 in. of water. Manhole B had no entry ladder, and the electric sump pump was not operable. Manhole B had a solid plate aluminum top and the wall penetrations were caulked and cemented. The steam line casing was 12 in. in diameter containing a 3-in. steam line, and the condensate line casing was 7 in. in diameter with a 1-1/2-in. return line.

(1) Pressure Test 2 (Condensate Return)—Pressure was applied to the condensate return line casing to 15.5 psi at 10:34 AM. No pressure drop had occurred by 11:14 AM when the test was terminated.

(2) Pressure Test 3 (Steam Supply)—The steam line casing vent was plugged. While opening the vent, steaming was observed, and the plug was retightened. The conduit temperature was 320 °F, which indicates an internal pipe leak. Assuming a 320 °F steam temperature, the conduit casing was pressurized to at least 75 psi. This section was valved off for about an hour and the casing temperature dropped to 270 °F. Upon reactivation, the casing temperature again rose. No attempt was made to pressurize this conduit.

c. Pressure Tests 4 and 5—This section ran from Manhole B, as described above, to Manhole C—a distance of 600 ft. Manhole C was 10 ft × 5 ft × 7 ft deep and had a top of solid aluminum plates. Wall penetrations were caulked and cemented.

Water in the manhole was pumped out after adjusting the sump pump float mechanism. No gland seals were on the conduit end plates. No steaming or moisture was noted when vent and drain plugs were removed from end plates. Steam line casing was 12 in. in diameter with a 3-in. steam pipe, and the condensate casing was 7 in. in diameter with a 1-1/2-in. condensate line.

(1) Pressure Test 4 (Steam Supply)—Pressure test readings on steam line conduit casing were as follows:

12:15 PM — 15.0 psi  
12:20 PM — 14.8 psi  
12:25 PM — 14.5 psi  
2:25 PM — 13.6 psi

(2) Pressure Test 5 (Condensate Return)—Pressure test readings on condensate line conduit casing were as follows:

2:29 PM — 15.5 psi  
2:34 PM — 14.5 psi  
2:39 PM — 14.0 psi  
2:54 PM — 13.0 pis  
2:59 PM — 12.5 psi  
3:17 PM — 12.0 psi

## 5. Detailed Inspection of System #25

This system consists of piping from Manufacturer G and has an FRP casing (Figure M2). It was installed in 1987.

a. Pressure Tests 1 and 2—This section ran 300 ft from Manhole C, as described above, to Manhole D. Manhole D was similar to Manhole C in dimension and construction. The steam casing diameter was 14 in. with an 8-in. steam main. The condensate casing was 8 in. in diameter with a 4-in. return line. No gland seals were on end plates. No steaming was seen at the vents and no moisture at the conduit drains.

(1) Condensate Return—Pressure test readings on condensate line conduit casing were as follows:

3:12 PM — 16.0 psi  
3:17 PM — 15.0 psi

3:22 PM — 15.0 psi  
 3:27 PM — 15.0 psi  
 3:32 PM — 15.0 psi  
 3:37 PM — 15.0 psi  
 3:42 PM — 15.0 psi

(2) Steam Supply—Pressure test readings on steam line conduit casing were as follows:

2:58 PM — 15.0 psi  
 3:04 PM — 6.0 psi  
 3:09 PM — 3.0 psi  
 3:17 PM — 0.0 psi

b. Pressure Test 3—Conduits extend 200 ft from Manhole E at northwest corner of Bldg. 427 to Manhole F feeding Bldgs. 421 and 420. Both manholes were concrete with solid plate aluminum covers and caulked and cemented conduit wall penetrations. Manhole E was 10 ft × 5 ft × 10 ft deep, and Manhole F was 10 ft × 5 ft × 8 ft deep. Manhole E had a leak at the steam water ejector. No gland seals were present

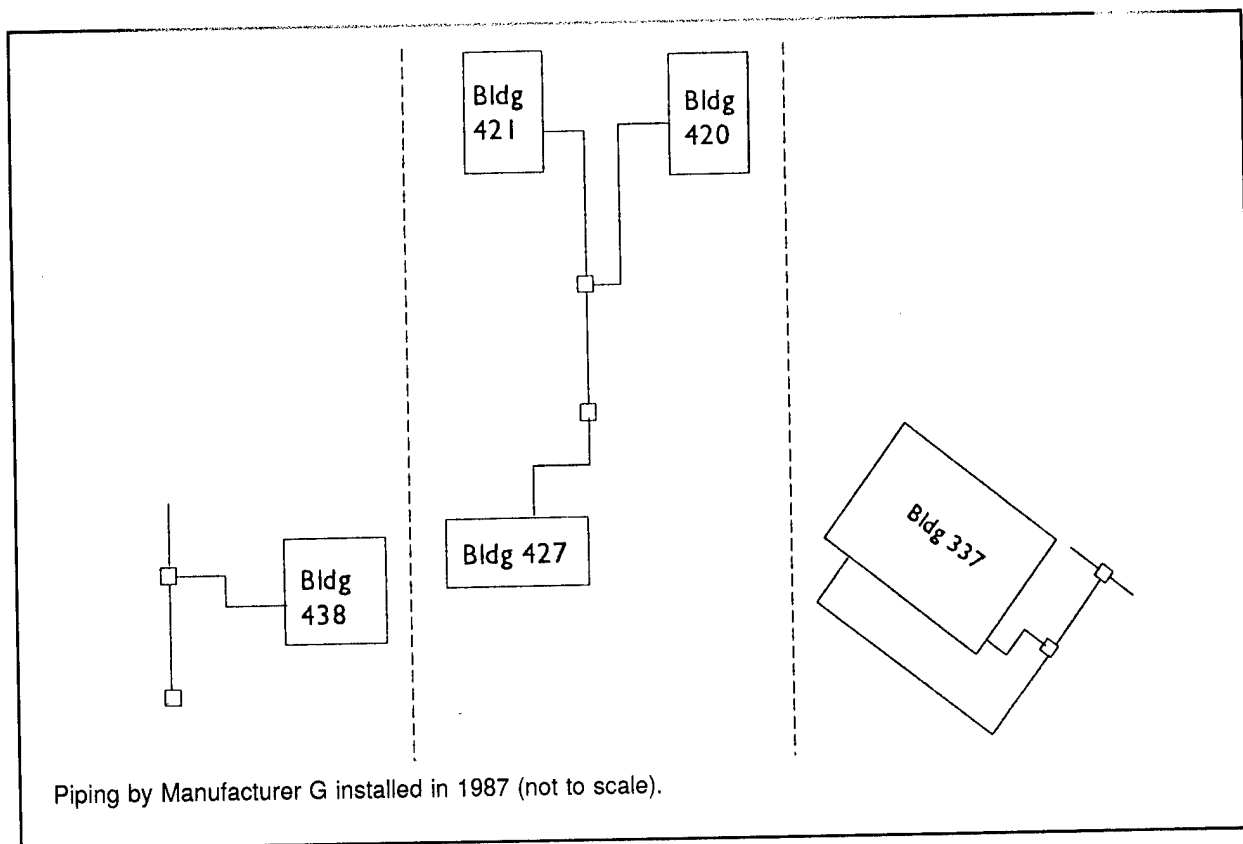

Figure M2. Schematic diagram of System 25 at Grissom AFB, IN.

at conduit end plates. The 12-in.-diameter steam supply casing contained a 3-in. steam pipe and the 6-in.-diameter condensate casing enclosed a 1-1/2-in. return line.

Pressure test readings on steam line conduit casing were as follows:

10:15 AM — 16.0 psi  
10:25 AM — 14.5 psi  
10:30 AM — 13.0 psi  
10:35 AM — 12.0 psi  
10:55 AM — 8.5 psi  
11:00 AM — 7.0 psi  
11:10 AM — 6.0 psi

c. Pressure Tests 4 and 5—Conduits extended from Manhole F, described above, to Bldg. 421, a distance of 45 ft. Conduit casings rose through the floor of the building equipment room and were sealed with end plates. A 6-in.-diameter steam conduit contained a 2-in. supply pipe. The 4-in.-diameter condensate casing contained a 1-in. return line.

(1) Steam Supply—Pressure test readings on steam line conduit casings were as follows:

9:40 AM — 16.0 psi  
9:45 AM — 15.0 psi  
9:50 AM — 14.0 psi  
9:55 AM — 12.5 psi  
10:00 AM — 12.0 psi  
10:05 AM — 11.0 psi  
10:15 AM — 10.0 psi  
10:25 AM — 9.0 psi

(2) Condensate Return—Pressure test readings on condensate conduit casing were as follows:

9:33 AM — 15.0 psi  
9:38 AM — 14.0 psi  
9:43 AM — 13.5 psi  
9:48 AM — 13.0 psi  
9:53 AM — 12.5 psi  
9:58 AM — 12.0 psi  
10:03 AM — 11.0 psi

10:15 AM — 10.8 psi

10:20 AM — 9.0 psi

10:25 AM — 8.0 psi

d. Pressure Tests 6 and 7—Conduits ran from Manhole F, as described above, to Bldg. 420—a distance of 150 ft. Conduits rose in the building equipment room and had end plates. The 11-in. steam conduit casing contained a 3-in. supply pipe, and the 6-in. condensate casing had a 1-1/2-in. return line.

(1) Condensate Return—Pressure test readings on condensate conduit casing were as follows:

9:45 AM — 15.0 psi

9:50 AM — 15.0 psi

9:55 AM — 14.2 psi

10:00 AM — 13.0 psi

10:15 AM — 12.0 psi

10:25 AM — 11.0 psi

10:30 AM — 10.0 psi

10:55 AM — 8.0 psi

11:10 AM — 7.5 psi

(2) Steam Supply—A pressure test of the steam conduit casing was attempted, but pressure above 4 psi was unachievable. After application of pressure for over 15 min, the test was terminated.

e. Pressure Tests 8 and 9—This conduit run extended 120 ft north from Manhole G, just west of the chapel, to Manhole H. Both manholes were 10 ft x 5 ft x 7 ft deep and contained no water. The 10-in.-diameter steam conduit casing contained a 3-in. steam line. The condensate casing diameter is 6 in. with a 1-1/2-in. return line. Gland seals were installed at the end plates in Manhole G. Gland seals were tightened before application of pressure. No steaming occurred at conduit vents or moisture at drains.

(1) Steam Supply—Pressure readings for test of steam conduit casing were as follows:

1:40 PM — 16.0 psi

1:45 PM — 15.0 psi

1:50 PM — 13.8 psi

1:55 PM — 12.8 psi

2:00 PM — 12.0 psi

2:10 PM — 10.0 psi

Pinhole leaks were observed where the end plate was welded to the metal end plate assembly.

(2) Condensate Return—Pressure readings for test of the condensate conduit casing were as follows:

1:50 PM — 14.0 psi

1:55 PM — 14.0 psi

2:00 PM — 13.0 psi

2:10 PM — 12.0 psi

2:15 PM — 12.0 psi

2:20 PM — 11.0 psi

2:25 PM — 11.0 psi

f. Pressure Tests 10 and 11—Conduits extended 45 ft from Manhole G, described above, to the equipment room in the chapel. The 8-in.-diameter steam supply conduit contained a 1-1/2-in. steam line, and the condensate conduit is 5 in. in diameter containing a 1-in. return line. Some water dripped from the conduit drain of the steam supply casing.

(1) Steam Supply—Pressure readings for test of the steam conduit casing were as follows:

1:52 PM — 16.0 psi

1:55 PM — 15.5 psi

2:00 PM — 15.0 psi

2:10 PM — 14.5 psi

2:15 PM — 14.0 psi

2:20 PM — 14.0 psi

2:30 PM — 14.0 psi

(2) Condensate Return—Pressure readings for test of the condensate conduit casing were as follows:

1:55 PM — 14.0 psi

1:57 PM — 12.0 psi

2:00 PM — 9.5 psi

2:10 PM — 6.0 psi



2:15 PM — 6.0 psi  
2:20 PM — 5.5 psi  
2:30 PM — 5.5 psi

g. Pressure Tests 12 and 13—Conduits extended from Manhole G to the chapel annex—a distance of 180 ft. Steam conduit casing diameter was 10 in. containing a 3-in. steam line. The condensate line conduit casing is 6 in. in diameter and contains a 1-1/2-in. return line. No steaming occurred at casing vents or water at end plate drains.

(1) Pressure Test 12 (Condensate Return)—Pressure readings for test of the condensate conduit casing were as follows:

2:35 PM — 14.0 psi  
2:40 PM — 14.0 psi  
2:45 PM — 14.0 psi  
2:50 PM — 13.5 psi  
2:55 PM — 13.5 psi  
3:00 PM — 13.0 psi  
3:05 PM — 13.0 psi

(2) Pressure Test 13 (Steam Supply)—Pressure readings for test of the steam conduit casing were as follows:

2:40 PM — 16.0 psi  
2:45 PM — 7.0 psi  
2:50 PM — 0.0 psi

## 6. Detailed Inspection of System #26

This system consists of piping from Manufacturer A and has a steel conduit (Figure M3). It was installed in 1981.

a. Pressure Tests 1 and 2—Conduits ran from Manhole I to Manhole J—a distance of 480 ft. Manhole I was at the southwest corner of the intersection of Hoosier Boulevard and Constellation Street. Manhole I is 5 ft × 10 ft × 7 ft deep with top at grade. Half of the top was open grate and half was solid aluminum plate. The sump pump discharge line was plugged so the manhole was dewatered with a portable pump. The condensate piping was badly corroded and had a pinhole leak, and a valve gasket had a minor leak. Manhole J was 10 ft × 10 ft × 7 ft deep and had a solid aluminum top. The steam conduit casing was 16 in. in diameter and contained an 8-

in. steam line. The condensate line casing was 10 in. in diameter and held a 4-in. return line.

(1) Pressure Test 1 (Steam Supply)—Pressure readings for test of the steam conduit casing were as follows:

11:13 AM — 15.0 psi  
 11:18 AM — 15.0 psi  
 11:23 AM — 14.8 psi  
 11:28 AM — 14.0 psi  
 11:33 AM — 13.5 psi  
 11:38 AM — 12.8 psi  
 11:43 AM — 12.2 psi  
 11:48 AM — 11.8 psi

(2) Pressure Test 2 (Condensate Return)—The condensate conduit casing was pressurized to 14.0 psi at 10:10 AM and exhibited no pressure loss through 10:40 AM, when the test was terminated.

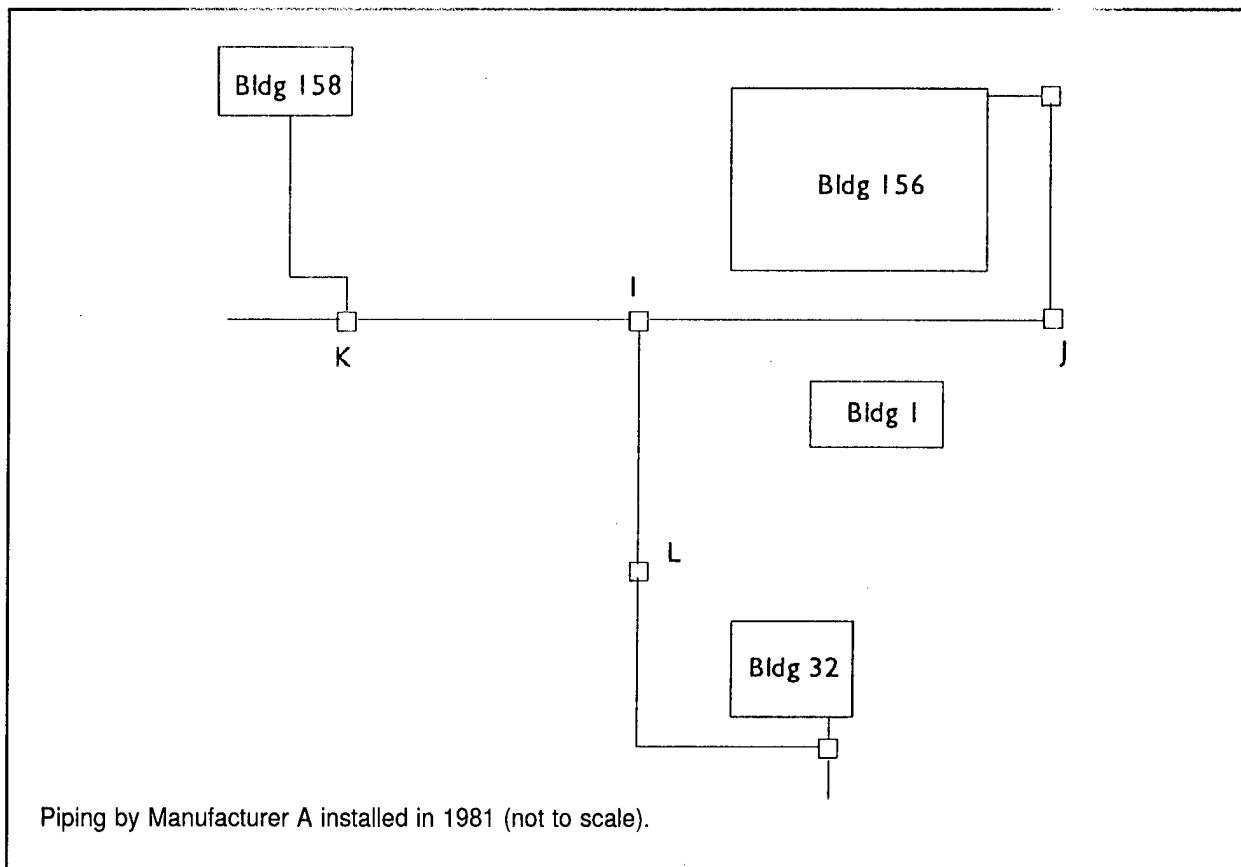

Figure M3. Schematic diagram of System 26 at Grissom AFB, IN.

b. Pressure Test 3—Conduits extended from Manhole I, described above, to Manhole K—a distance of 400 ft. Manhole K was 5 ft × 10 ft × 7 ft deep with an open grate top. Water was pumped out of the manhole after adjustment of the sump pump float mechanism. There was heavy water infiltration into the manhole at a conduit wall penetration. The 20-in.-diameter steam conduit casing contained a 10-in. steam pipe. The 12-in.-diameter condensate conduit casing contained a 4-in. return line.

The steam line casing was pressurized to 15.8 psi and the condensate casing to 14.0 psi. Both conduits held these pressures for over 35 minutes before the test was terminated.

c. Pressure Tests 4 and 5—Conduits ran from Manhole I, described above, to Manhole L—a distance of 300 ft. Manhole L was 5 ft × 10 ft × 7 ft deep with an open grate top. The steam conduit casing was 14-in. in diameter and held a 6-in. steam line. The 6-in.-diameter condensate conduit casing had a 2-in. return line.

(1) Pressure Test 4 (Steam Supply)—Test pressures for the steam line conduit casing were as follows:

11:27 AM — 15.0 psi  
11:32 AM — 14.8 psi  
11:37 AM — 14.5 psi  
11:42 AM — 14.4 psi  
11:47 AM — 14.3 psi  
11:52 AM — 14.3 psi  
11:57 AM — 14.2 psi  
12:02 PM — 14.2 psi

(2) Pressure Test 5 (Condensate Return)—The condensate line conduit casing was pressurized to 15 psi at 11:38 AM and held that pressure for over 30 min without variation. The test was then terminated.

## Appendix N: Detailed Site Inspection Reports for Norfolk Naval Station, Norfolk, VA

1. Date of Survey: 9 through 12 August 1993.
2. Survey Team and Observers:

Dr. Charles Marsh - USACERL  
N.M. Demetroulis - NMD & Associates  
H.D. Musselman - NMD & Associates  
D. Otterness - OCE  
L. Davidson - NAVFAC  
V.P. Meyer - CEMRD  
Dennis Vevang - CECPW  
T. Harris - NAVFAC  
C. Dilks - USACERL  
G. Phetteplace - CRREL  
Quaiser Toor - ACSIM

The inspection personnel and the observers also attended the Annual Research Review Workshop on underground heat distribution systems held 11 August 1993 and the Federal Agency Committee meeting held 12 August 1993, both held at the Norfolk Naval Base.

3. General Observations:

- a. System Characteristics—The facility is served by five central heating plants located at load centers throughout the base. Plant operating pressures range from 275 to 340 psi. Steam pressure is reduced to a range of 125 to 150 psi through pressure reducing stations for distribution to ship servicing piers and other base facilities.

Because of the severe requirements for clean steam for ship servicing, condensate is not returned to the plants, so there are no condensate return lines. This results in 100 percent water make-up at the central plants. The station contains about 37 miles of

heat distribution piping of which more than half is above ground. The system was in operation during our inspection.

b. Conduit Test Section Selection—The availability of conduit sections that could be tested was limited by the requirement that only systems installed since 1981 or later were to be pressure tested. Of those available for testing, safe entry into many of the manholes was not possible due to extremely high internal temperatures. Manholes were of the solid concrete top type with no ventilation and usually contained water in contact with the heat carrying pipe. Other manholes contained sections of uninsulated pipe and/or steam leaks at steam jet sump pumps. Where manholes could be entered, it was necessary to provide ventilation and cooling with large portable fans. The base safety office required that the manhole interior be checked for adequate oxygen supply and for the possible presence of flammable gas, carbon monoxide, and other toxic gases. The omission of end plates at vertical risers in building equipment rooms further reduced the number of sections that could be pressure tested. As a result, only three conduit sections were pressure tested at this facility.

c. New Design—The Naval Base was in the process of completing a design for construction of a new slab-on-grade concrete trench system for heat distribution. This design includes options for cast-in-place construction or installation of prefabricated concrete sections. Design personnel were advised of installation problems associated with the prefabricated section concept experienced at Forts Jackson and Riley. In both cases, contractors abandoned efforts to install prefabricated sections and reverted to cast-in-place construction. In the event the contractor proposes the use of prefabricated concrete sections, the base should arrange for close inspection during construction and ensure that the lids fit properly to keep surface water out of the trenches.

The use of raised top manholes (Omaha design) with segmented aluminum plate covers and side wall vent openings was further recommended. This design is highly preferred by maintenance personnel at other installations and is particularly applicable in this system where distribution temperatures are high.

Copies of the drawings and specifications for the Norfolk design were obtained from design personnel for use in the development of a standard design for concrete trench slab-on-grade systems.

#### 4. Detailed Inspection of System #27

This system consists of piping from Manufacturer A and has a steel conduit (Figure N1). It was installed in 1987.

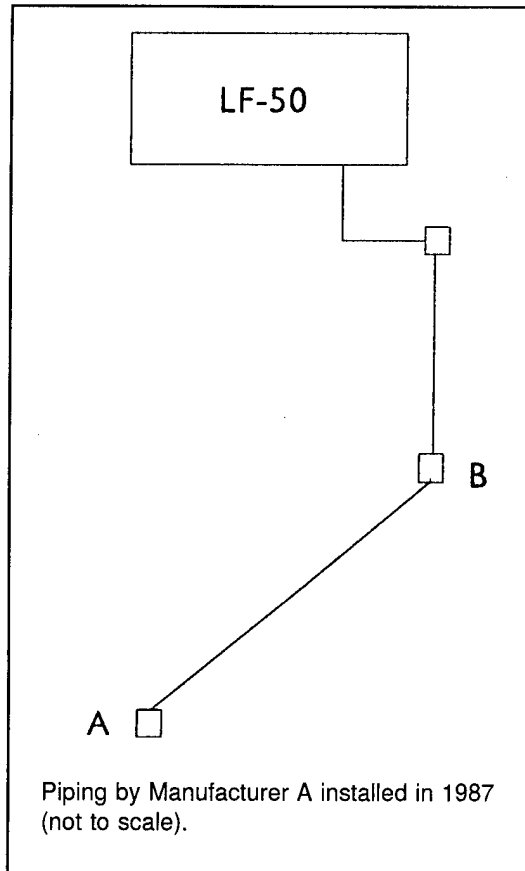

**Figure N1. Schematic diagram of System 27 at Norfolk Naval Station, VA.**

**Pressure Test**—This conduit section extended from Manhole A at the intersection of Toway and Avionics streets under Toway northward to Manhole B south of Building LF-50. The distance between manholes was 200 ft. Manhole A was in a parking area and was constructed of concrete with a solid concrete top flush with the pavement. The top contained 36-in.- and 24-in.-diameter access holes with steel plate covers. No manhole ventilation was provided. Manhole dimensions were 12 ft × 8 ft × 7 ft deep. A slight steam leak was present at the steam ejector sump pump. The heat carrying pipe had no insulation. Wall penetrations were caulked and cemented. Manhole B was concrete with walls extending about 1 ft above grade. The solid concrete top contained two access openings and two 6-in. vent pipes. Manhole dimensions were 9 ft × 12 ft × 8 ft deep. Some minor leakage was observed at the

steam ejector pump, but the manhole was dry. Manhole A was drained of water with a portable pump, and both manholes were cooled with portable fans. The conduit casing was 12-in. in diameter and contained a 3-in. steam line. A gland seal had been installed at the conduit entry in Manhole B. Pressure was applied to the conduit at 11:59 AM, but the pressure would not rise above 5 psi. Pressure readings were as follows:

11:59 AM — 5.0 psi  
 12:00 PM — 3.6 psi  
 12:01 PM — 3.0 psi  
 12:02 PM — 2.6 psi  
 12:03 PM — 2.0 psi  
 12:04 PM — 1.7 psi

##### 5. Detailed Inspection of System #28

This system consists of piping from Manufacturer D and has a steel conduit (Figure N2). It was installed in 1984.

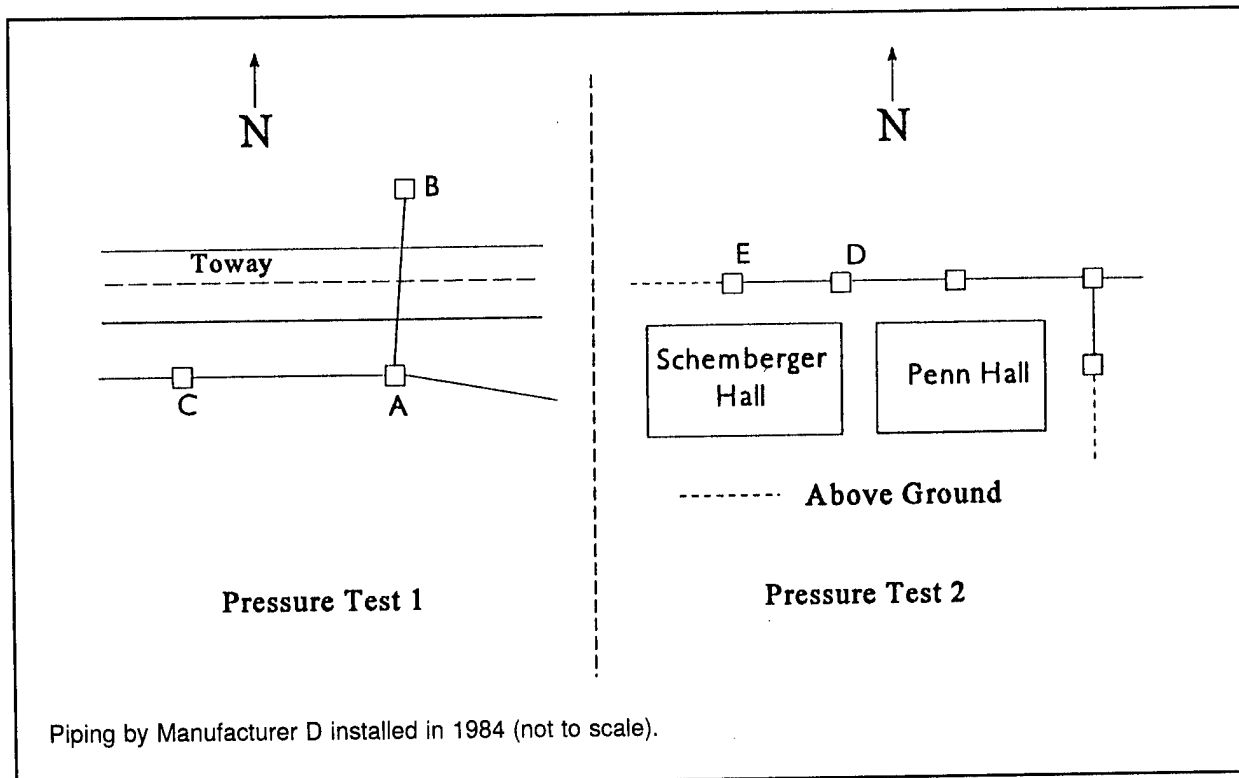

Figure N2. Schematic diagram of System 28 at Norfolk Naval Station, VA.

a. Pressure Test 1—This conduit section extended from Manhole A, described above, westward 170 ft to Manhole C. Manhole C was concrete with a concrete top flush with the parking lot pavement. The top had two access openings but no vent pipes. Manhole dimensions were 6 ft x 12 ft x 7 ft deep. Water was pumped out of this manhole and a portable fan was used to cool the manhole before entry. A gland seal was installed on the supply line at the manhole entry. The gland seal was tightened before pressure was applied to the conduit. One of the flanges on the dielectric flange assembly had been removed so the system was no longer electrically isolated. The conduit casing was 20-in. in diameter and contained a 12-in. steam line. Pressure to 15.0 psi was applied to the casing at 10:33 AM. Pressure readings were as follows:

10:33 AM — 15.0 psi  
 10:38 AM — 15.0 psi  
 10:43 AM — 14.5 psi  
 10:48 AM — 14.0 psi  
 10:53 AM — 13.5 psi  
 10:58 AM — 12.6 psi  
 11:03 AM — 12.3 psi  
 11:08 AM — 12.0 psi

b. Pressure Test 2—This conduit section extended about 200 ft westward from Manhole D northeast of Schemberger Hall to Manhole E. Manhole E was a transition manhole where the distribution line dropped from above ground to a direct buried system. The manhole was concrete with a solid concrete top at grade. The top contains two access openings but no manhole vents. Manhole dimensions were 7 ft x 7 ft x 7 ft deep. Six-in. of water was pumped from the manhole with a portable pump. The dielectric flange assembly was installed with steel washers instead of proper insulating material. Manhole D was concrete with solid concrete top containing two access openings. Manhole dimensions were 12 ft x 7 ft x 7 ft deep. A steam jet sump pump was operating properly, and the manhole was dry. No steaming or moisture were noted at the conduit vent or drain. Before entry, both manholes were cooled by use of portable fans. This run was clearly outlined by dead grass immediately above the conduit between manholes. The conduit casing was 22-in. in diameter and contained a 14-in. steam line. Pressure was applied to the conduit, but the pressure would not rise above 5.0 psi. Pressure readings were as follows:

3:56 PM — 5.0 psi

4:01 PM — 5.0 psi

4:06 PM — 5.0 psi

4:11 PM — 4.0 psi

4:16 PM — 4.0 psi

4:21 PM — 3.5 psi

4:26 PM — 3.0 psi



## Appendix O: Detailed Site Inspection Reports for Fort Lewis, Olympia, WA

1. Date of Survey: 29 August through 4 September 1993.
2. Survey Team and Observers:

Dr. C. Marsh - USACERL  
N.M. Demetroulis - NMD & Associates  
H.D. Musselman - NMD & Associates  
D. Vevang - CECPW  
C. Keller - Fort Lewis DPW  
L.J. Stonitsch - Rovanco Corp.

3. General Observations:

Fort Lewis is served by two boiler plants that are interconnected to provide for maintenance and operation flexibility. Boilers are gas fired or combination oil and gas fired, and one plant includes an incinerator. Most of the base is heated with hot water at 260 °F, with a smaller area supplied with steam at 125 psi. Make-up water for the plants was estimated at 2,500 gallons per day.

The terrain at the base is relatively flat with a low water table. The soil is a dark, reddish-brown loam with minor sand inclusion. The soil contains a high percentage of smooth rocks (approximately 50 percent by volume) ranging from 1/4 to 4 in. in diameter.

Fort Lewis personnel indicated they have had no problems with pipe failures in the walk-through tunnels and the concrete trench portions of the system but have experienced some flange gasket leaks, particularly at expansion joints. Major failures have occurred in the FRP condensate return lines in the steam portion of the system. These lines have been replaced with steel piping as failures have occurred.

#### 4. Detailed Inspection of System #29

This system is a 125 psi steam system with fiberglass return piping and was installed in 1984 (Figure O1). The steam supply uses a water-spread limiting system in which each section is sealed so that water cannot enter an adjoining section in the event of a pipe failure. The sections are joined with specially fabricated couplings with elastomeric rings that also serve as expansion-contraction joints. In Manhole 1, one of the conduits contained an end sleeve consisting of a rubberized plastic material bonded to the outer casing and extending to the heat carrying pipe. This material had dried out and cracked in two places and was very brittle in the area of the heat carrying pipe. This seal was not found on the ends of conduits at any of the other manholes. The lack of end seals exposes conduit insulation to water in the event of manhole flooding. Manholes inspected were as follows:

a. Manhole 1—Located 200 ft west of Bldg. 3985, Manhole 1 was constructed of precast concrete sections with top slab at grade containing a 30-in.-diameter access opening. Manhole dimensions are 8 ft × 6 ft × 7 ft deep. Manhole ventilation was provided by two 6-in. vent pipes. The manhole was dry and contained a sump and french drain.

b. Manhole 2—Located just north of Bldg. 3985, this manhole's construction and design was identical to Manhole 1. Manhole 2 contained 1-1/2 ft of water. Water marks on walls indicated that water was entering through conduit wall penetrations that are caulked and cemented.

c. Manhole 3—Located 200 ft north of Manhole 1, this manhole was buried 2 ft below grade and was accessed through a 30-in.-diameter tube extending from grade to the manhole top. Manhole dimensions were 4 ft in diameter and 5 ft deep. Caulking at conduit wall penetrations was badly deteriorated.

d. Manhole 4—Located 300 ft north of Manhole 3, this manhole was buried 4 ft below grade and was accessed through a 30-in.-diameter tube extending from grade to the manhole top. Manhole dimensions were 6 ft × 8 ft × 7 ft deep. Manhole ventilation was provided by two 6-in. vent pipes. The manhole was dry and contained a sump and french drain.

e. Manhole 5—Located 600 ft north Manhole 4, this manhole was constructed of prefabricated concrete sections with concrete top at grade. Ventilation was provided by two 6-in. vent pipes. Manhole was dry and contained a sump and french drain. Manhole dimensions were 6 ft × 8 ft × 7 ft deep.

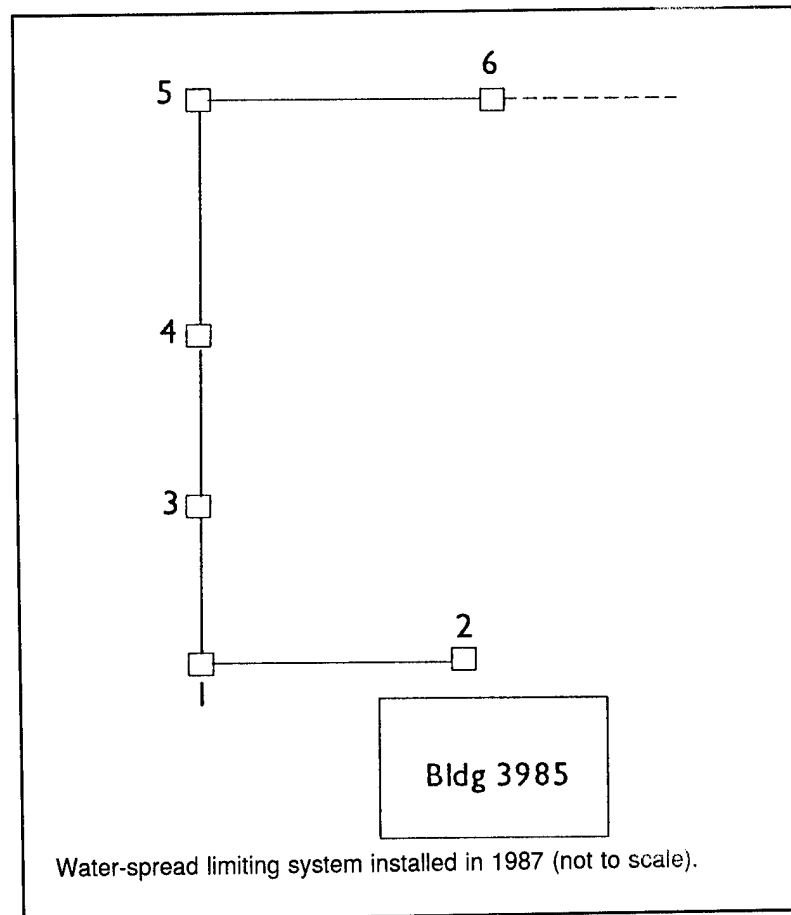

Figure O1. Schematic diagram of System 29 at Fort Lewis, WA.

f. Manhole 6—Located 300 ft east of Manhole 5, this manhole was concrete with top at grade containing two 6-in. ventilation pipes. Manhole dimensions were 5 ft x 7 ft x 8 ft deep. The water-spread limiting system ended at this manhole with the conduit extending 2 ft into the manhole with no end seal. The manhole was dry with a gravity drain. Exit from this manhole was with a steel-cased conduit that continues to Manhole 7 located 100 ft east of Manhole 6. Manhole 7 provides for transition from buried conduit to concrete trench.

#### 5. Detailed Inspection of System #30

This system consists of piping from Manufacturer D and has a steel conduit (Figure O2). It was installed in 1986. This section of conduit extended from Manhole 8 (just west of Bldg. 3165B) to the Special Forces Group Complex building. The length of this run was 1120 ft. Manhole 8 was concrete with top at grade containing a 30-in.-diameter access opening. The manhole had no vent piping. The conduit enters the manhole through the wall sleeve with caulking between the sleeve and the casing. Both the drain and vent openings at the end plate assembly were plugged. The

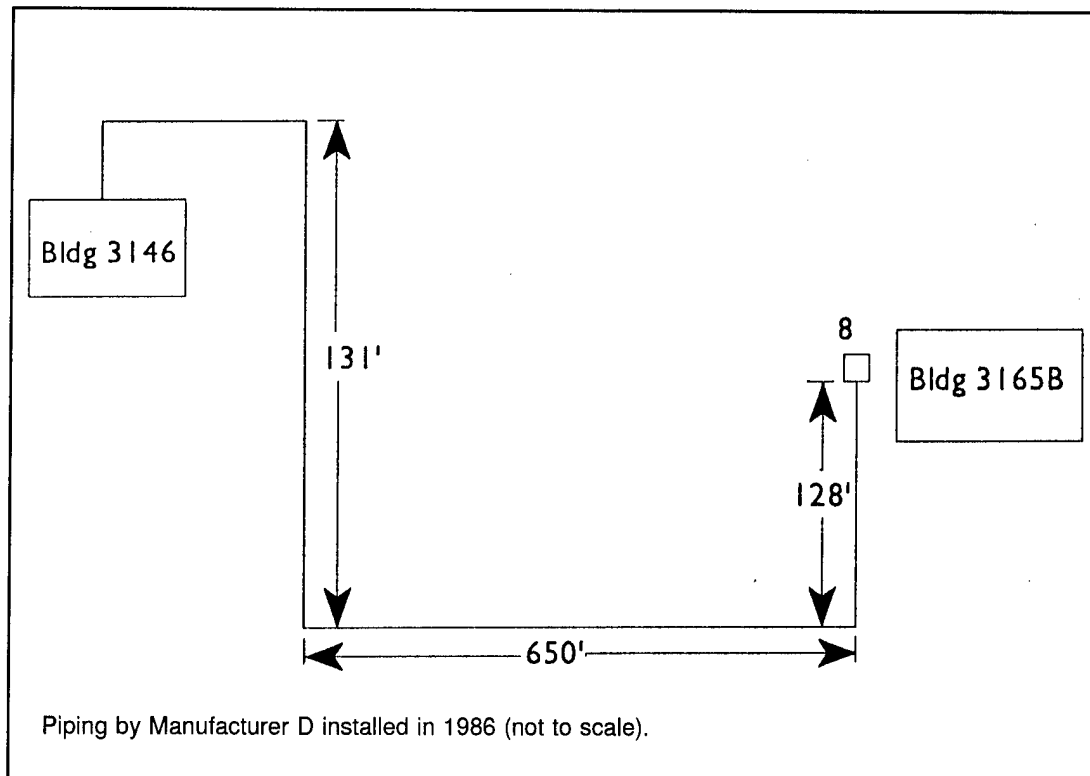

Figure O2. Schematic diagram of System 30 at Fort Lewis, WA.

conduit rose through the floor at the equipment room of Bldg. 3146, terminating with a standard end plate. Both vent and drain openings at the end plate were also plugged, which sealed the conduit run.

Pressure test—This section was part of the hot water system operating at 260 °F. Both supply and return lines were contained in a single conduit casing. Both pipes were 3-in. in diameter and the casing diameter was 14-in. The conduit was pressurized to 15 psi at 1:40 PM. Pressure readings were as follows:

1:40 PM — 15.0 psi  
 1:45 PM — 15.0 psi  
 1:50 PM — 15.0 psi  
 1:55 PM — 15.0 psi  
 2:00 PM — 14.8 psi  
 2:05 PM — 14.5 psi  
 2:10 PM — 14.1 psi  
 2:15 PM — 14.0 psi  
 2:20 PM — 13.8 psi  
 2:25 PM — 13.6 psi  
 2:30 PM — 13.5 psi  
 2:35 PM — 13.3 psi

2:40 PM — 13.1 psi  
2:45 PM — 13.1 psi  
2:50 PM — 13.0 psi

Upon completion of this test, the vent plug was removed from the conduit end plate at Manhole 8. An extremely strong odor of ammonia was evident in the air escaping from the conduit. This odor was similar to that detected at another facility with a sealed conduit section. As a matter of safety, this phenomenon should be further examined to ensure that maintenance personnel are not at risk.

#### 6. Detailed Inspection of System #31

Installed in 1986, this system consists of piping from Manufacturer G and has an FRP conduit (Figure O3). The piping design consists of an inner heat carrying pipe covered with insulation, an air space, and an FRP casing. Metallic end plate assemblies are bonded to the FRP conduit casing and contains vent and drain openings at the end plates. The heating medium is hot water operating at 260 °F.

Base personnel indicated that a major pipe leak was found in this system. The estimated cost for locating and repairing the leak was \$16,814 and the actual documented cost was \$14,234. However, it should be noted that the repair did not involve an "in-kind" replacement of the damaged system. Repair was accomplished by cutting out the failed section of conduit and installing a new carrier pipe covered with cellular glass insulation with a mastic coating. Cellular glass is not considered satisfactory for heat distribution system applications because of its brittleness, lack of shear strength, and its tendency to disintegrate under shock and vibration loads.

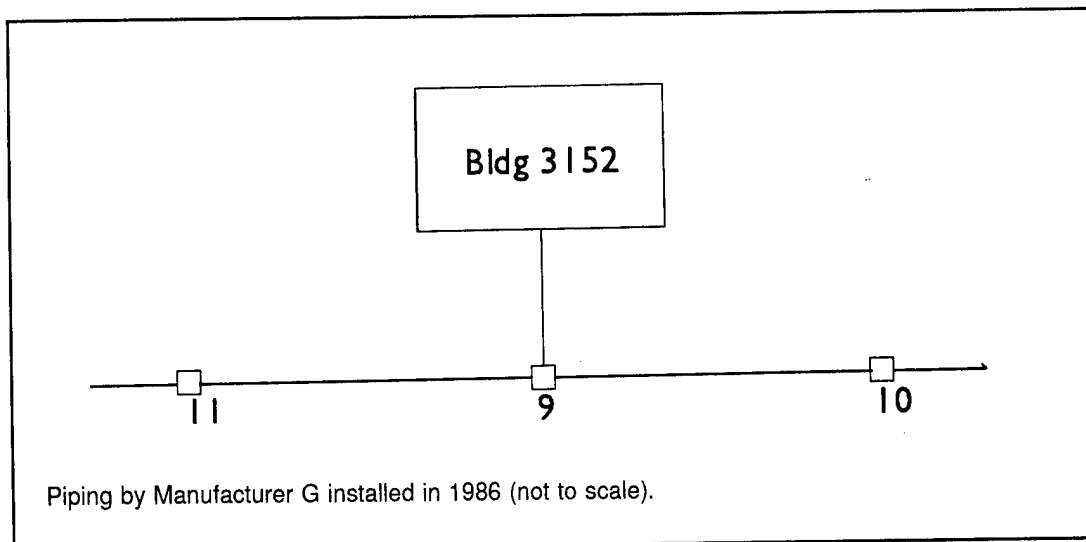

Figure O3. Schematic diagram of System 31 at Fort Lewis, WA.

This type of repair disrupts the continuity of the conduit air space, which is needed to drain the conduit and dry the insulation in the event of future failures.

In reviewing the contract documents, it was noted that drawings indicated that both the drain and vent openings at the conduit end plates were to be plugged. This is not in accordance with current criteria. In the case of a heat carrying pipe failure, the sealed conduit casing would be subject to the full system operating pressure and would present an *extreme safety hazard* to maintenance personnel. Care should be taken to ensure that future designs show a 1-in. goose-necked open vent pipe attached to the conduit vent opening. Conduit systems that have the drain and the vent openings plugged should be modified so that the vent opening is connected to a 1-in. goose-necked open vent.

a. Pressure tests

(1) Manhole 9 to Manhole 10—Two separate conduit casings were involved (supply and return), each 290 ft in length. Each casing was 12-in. in diameter containing a 6-in. inner pipe. Pressure readings follow.

<i>Supply Line</i>	<i>Return Line</i>
10:48 AM — 5.0 psi	10:43 AM — 15.0 psi
10:50 AM — 9.5 psi	10:45 AM — 13.0 psi
10:53 AM — 6.5 psi	10:50 AM — 10.0 psi
10:55 AM — 3.0 psi	10:53 AM — 8.0 psi
10:58 AM — 0.5 psi	10:55 AM — 6.0 psi
	10:58 AM — 5.0 psi
	11:03 AM — 3.5 psi
	11:05 AM — 2.0 psi

(2) Manhole 9 to Manhole 11—The length of each of the conduit casings was 260 ft. Conduit casings were 12 in. in diameter. Neither the supply line nor the return line casing could be pressure tested. On the supply line casing, corrosion had eaten through the bottom of the end plate; and on the return line casing, the same condition had occurred at the vent pipe connection to the end plate.

b. Manhole inspections:

(1) Manhole 9—This manhole was directly south of Bldg. 3152 (Boiler Plant). Piping from the boiler plant to the manhole was contained in a concrete trench. Manufacturer G buried conduit then extends from Manhole 9 to Manholes 10 and 11. The

manhole was concrete with top at grade. Access was through a 36-in. square aluminum plate covered opening. Manhole dimensions were 13 ft × 20 ft × 10 ft deep. The manhole was ventilated by two 6-in. capped pipe vents. The manhole sump connected to a french drain, and the manhole was dry at the time of inspection. Caulking at wall penetrations was in very poor condition.

(2) Manhole 10—This manhole was 290 ft east of Manhole 9. The manhole was concrete with top at grade. Access was through a 36-in. square aluminum plate covered opening. Two 6-in. pipes provide manhole ventilation. The manhole was dry and was connected to a french drain. Conduit vents protruded through the manhole top. Caulking at wall penetrations was in very poor condition.

## 7. Detailed Inspection of System #32

This system consists of piping from Manufacturer I and has a steel conduit (Figure O4). It was installed in 1984. The heating medium is hot water operating at 260 °F.

### a. Conduit pressure tests:

(1) Manhole 12 to Manhole 13—Two conduit casings (supply and return) were tested, each 500 ft in length. Both casings were 11 in. in diameter and contained a 4-in. water line. The casings were pressurized to 15.0 psi from 1:45 to 1:55 PM. The conduits were valved off, and neither showed any drop in pressure for 1 hour.

### b. Manhole Inspections:

(1) Manhole 12—This manhole was north of Bldg. 3238 and was concrete with concrete top at grade and dimensions of 7 ft × 7 ft × 8 ft deep. Manhole ventilation was provided by two capped 6-in. vent pipes. The manhole was dry at the time of inspection, and conduit wall penetrations were caulked and cemented. Access was through a 30-in.-diameter opening with a steel manhole cover.

(2) Manhole 13—This manhole was 500 ft west of Manhole 12. Construction was concrete with concrete top at grade containing a 3-ft square access opening with solid aluminum cover. Ventilation is provided by two capped 6-in. vent pipes. The manhole was dry at the time of inspection, and conduit wall penetrations were caulked and cemented.

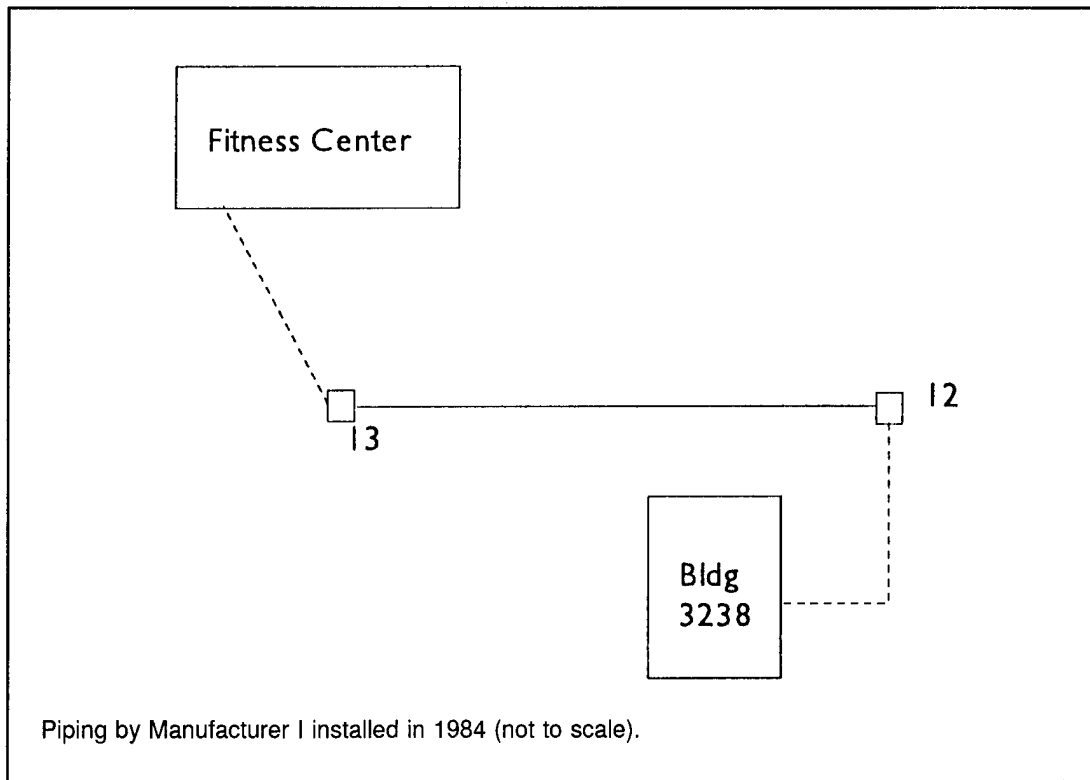

Figure O4. Schematic diagram of System 32 at Fort Lewis, WA.

#### 8. Detailed Inspection of System #33

This system consists of piping from Manufacturer B and has a steel conduit (Figure O5). It was installed in 1985.

##### a. Conduit pressure test:

(1) Manhole 12 to equipment room of Bldg. 3238—This run consisted of a single conduit casing enclosing both the supply and return piping. The conduit casing was 14-in. in diameter and each of the internal pipes were 4 in. Each of the 4-in. pipes have a gland seal at the end plate in the equipment room. The length of the conduit run is 180 ft. One of the gland seals in the equipment room could not be completely tightened and leaked slightly during the test. Pressure readings were as follows:

2:42 PM — 15.0 psi  
 2:47 PM — 15.0 psi  
 2:52 PM — 14.5 psi  
 2:57 PM — 14.2 psi  
 3:02 PM — 14.1 psi  
 3:07 PM — 14.0 psi



3:12 PM — 13.5 psi

3:17 PM — 13.3 psi

3:22 PM — 13.1 psi

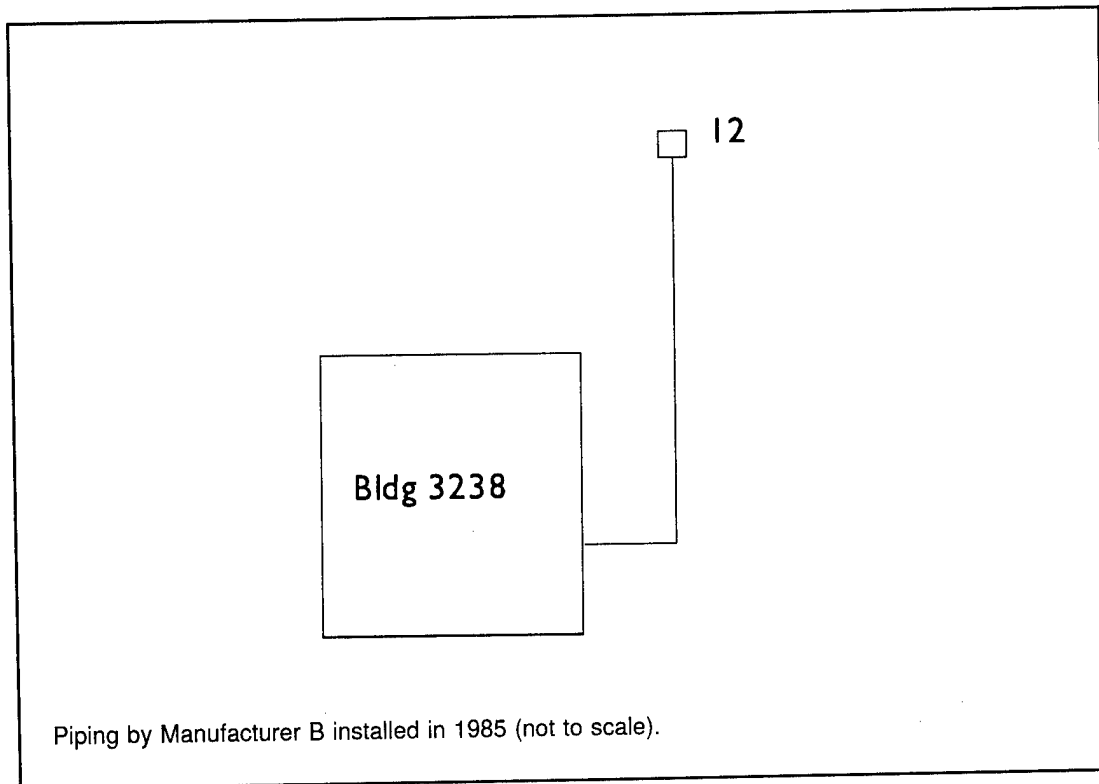

**Figure O5. Schematic diagram of System 33 at Fort Lewis, WA.**

## Appendix P: Detailed Site Inspection Reports for San Diego Naval Facilities, San Diego, CA

1. Date of Survey: 6 through 10 September 1993.
2. Survey Team and Observers:

Dr. C. Marsh - USACERL  
N.M. Demetroulis - NMD & Associates  
H.D. Musselman - NMD & Associates  
Juan Serratos - Naval Training Center Public Works

3. General Observations:

All but one of the conduit runs inspected were located at the Naval Training Center. The exception was an extremely long run installed at the Naval Station.

Buildings at the Training Center are primarily educational, administrative, and troop housing and are served by a steam system with condensate return lines. The steam operating pressure is 60 psi. In some instances in these systems, valve and trap stations were installed above ground rather than in typical buried manholes. These involved conduit risers extending through a concrete slab and then dropping back underground after passing through required valves and trap assemblies. These above ground piping and auxiliaries were covered by a steel enclosure about 5-ft high with louvered side panels for ventilation. As a method of referral these will be called Riser Stations.

The Naval Station is an industrial facility with piers to service and maintain ships. The heating medium is steam at 150 psi with no condensate return. Several manholes along the line serving the piers were opened but could not be entered because of steaming and high temperatures. Maintenance personnel stated that this was most likely due to the use of french drains rather than sump pumps for water removal. The conduit run that was pressure tested at this facility was selected because of its extreme length (over 3,000 ft). The current criteria requires that manholes be installed at intervals not to exceed 500 ft.

In discussions regarding cathodic protection, maintenance personnel indicated very satisfactory performance of silicone glass gaskets and washers at dielectric flange connections. Failure of other materials had been a significant problem at previous inspection sites. Material samples and specifications of the silicone glass product were obtained for future evaluation at USACERL.

#### 4. Detailed Inspection of System #34

This system consists of piping from Manufacturer G and has an FRP conduit (Figure P1). It was installed in 1990 at the Naval Training Station.

a. Pressure tests - Manhole A to Bldg. 304—The supply and return conduits extended 30 ft from Manhole A to risers just outside of Bldg. 304. Manhole A was directly south of the building and had a raised, fabricated metallic top extending about 18-in. above grade. The top had louvered side panels for ventilation. The manhole was concrete with dimensions of 12 ft x 7 ft x 8 ft deep and was served by a steam jet sump pump located in a corner pit. Conduit wall penetrations were caulked and cemented. The steam line had a small flange gasket leak. Gland seals were installed on the piping both in the manhole and at the building risers. All gland seal nuts were loose and had to be tightened before pressure testing. The steam conduit casing was 9 in. in diameter and contained a 3-in. pipe. The condensate conduit casing was 6 in. in diameter with a 2-in. return line.

##### *Steam Conduit*

9:55 AM — 15.0 psi  
 10:00 AM — 12.8 psi  
 10:05 AM — 11.2 psi  
 10:10 AM — 10.0 psi  
 10:20 AM — 8.8 psi  
 10:30 AM — 7.0 psi  
 10:40 AM — 6.0 psi  
 10:50 AM — 5.0 psi

##### *Condensate Conduit*

10:00 AM — 15.0 psi  
 10:05 AM — 7.5 psi  
 (Leak at vent - Repressurized)  
 10:23 AM — 15.0 psi  
 10:28 AM — 12.0 psi  
 10:33 AM — 9.5 psi  
 10:38 AM — 7.7 psi  
 10:43 AM — 6.2 psi  
 10:53 AM — 3.7 psi

b. Pressure tests - Manhole A to Manhole B—Conduits ran 500 ft east from Manhole A to Manhole B. An underground take-off between the manholes extends to risers outside the building. Manhole B is concrete with concrete top at grade.

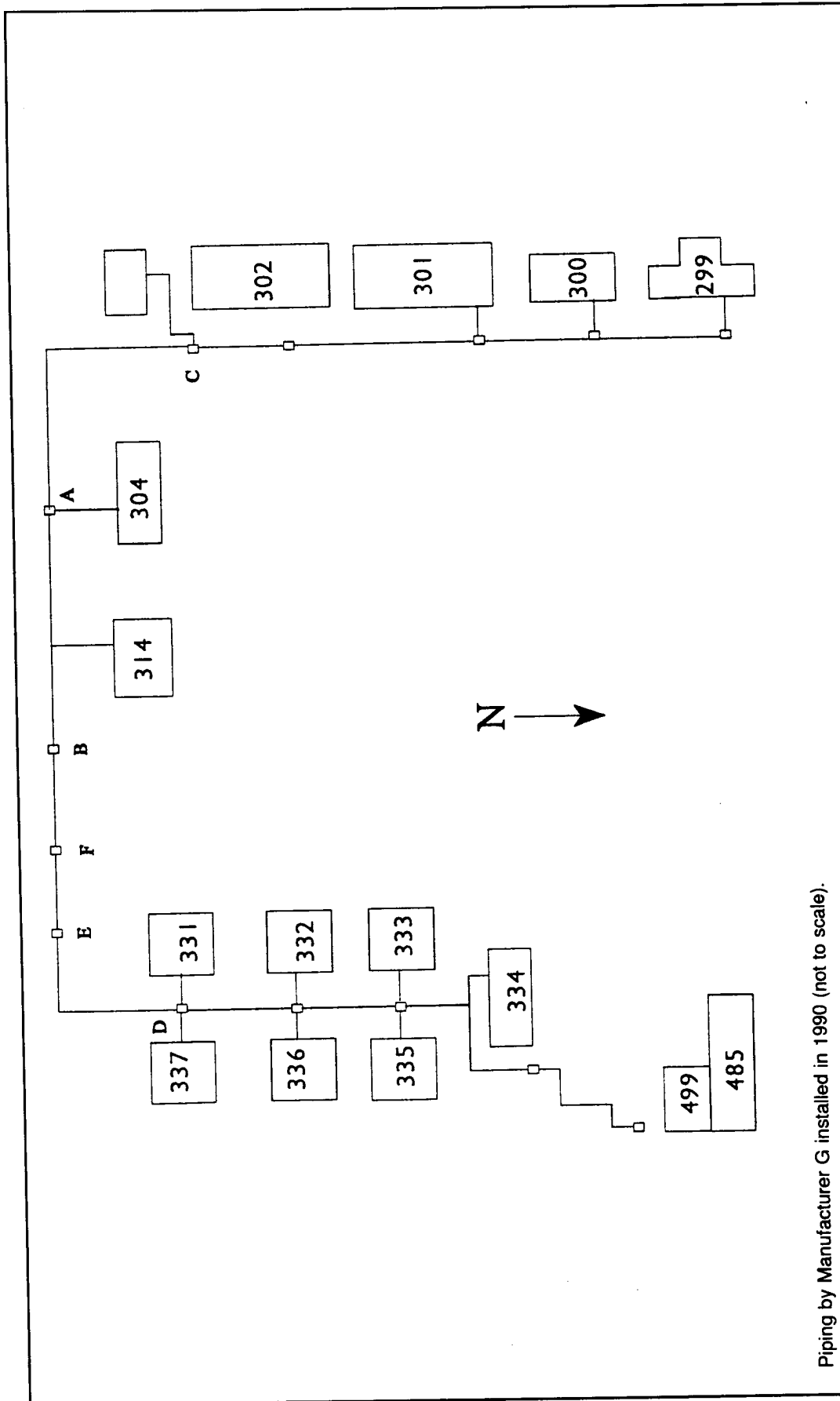

Piping by Manufacturer G installed in 1990 (not to scale).

Figure P1. Schematic diagram of System 34 at San Diego Naval Training Center, CA.

Manhole B dimensions were 9 ft x 10 ft x 9 ft deep with no manhole vents. Manhole B contained about 1 in. of water and was served by a steam jet sump pump. Conduit wall penetrations were caulked and cemented at both manholes. Gland seals were installed at all conduit end plates, and all gland seal nuts had to be tightened. The steam conduit casing temperature at Manhole A was 135 °F. Casing test pressures were as follows:

<i>Steam Conduit</i>	<i>Condensate Conduit</i>
11:10 AM — 15.0 psi	10:55 AM — 15.0 psi
11:15 AM — 11.5 psi	11:00 AM — 14.0 psi
11:20 AM — 9.5 psi	11:10 AM — 13.0 psi
11:25 AM — 8.0 psi	11:15 AM — 12.3 psi
11:30 AM — 6.0 psi	11:20 AM — 12.0 psi
11:35 AM — 3.5 psi	11:25 AM — 11.5 psi
11:40 AM — 2.0 psi	11:30 AM — 10.5 psi
	11:35 AM — 10.0 psi
	11:40 AM — 9.5 psi

c. Pressure test—Manhole A to Manhole C—Conduits extended from Manhole A to Riser Station C, a distance of 620 ft. Riser Station C was 270 ft west and 350 ft north of Manhole A. The steam line conduit was 13 in. in diameter with a 6-in. heat carrying pipe. The condensate conduit casing was 7 in. in diameter with a 3-in. return line. All conduit end plates had gland seals. Attempts to pressure test these conduits resulted in the following:

*Steam Conduit:* The casing would not hold pressure above 5 psi. Gland seals were inspected to ensure that there were no leaks. Pressure dropped rapidly to zero when the compressor was valved off.

*Condensate Conduit:* The casing would not hold pressure above 7 psi. A very slight air leak was noted at the Manhole A gland seal, which could not be tightened. Pressure dropped rapidly to zero when the compressor was valved off.

d. Pressure test—Manhole D to Bldg. 337—Conduits extended from Manhole D to risers outside of Bldg. 337, a distance of 30 ft. All conduit end plates contained gland seals. Manhole D was in a paved area between Bldgs. 337 and 331, was of prefabricated steel, and was 12 ft in diameter and 9-ft deep. The manhole top was concrete at grade with no ventilation provisions. Conduit wall penetrations were through metal sleeves, which were caulked. Caulking material was in poor condition.

The manhole contained a steam jet sump pump. Though it was dry, the interior manhole temperature was very high. Pressure test results were as follows:

*Steam Conduit:* The drain plug at the end plate in Manhole D had not been installed and, because of interferences, a plug or cap could not be installed to seal the casing. Therefore, a pressure test of this section could not be accomplished.

*Condensate Conduit:* The casing was pressurized to 15.0 psi at 1:16 PM but, after being valved off, dropped to 3 psi within 2 minutes. After ensuring that the gland seals were tight, two more attempts to pressurize were made with the same results.

e. Pressure tests - Manhole D to Manhole E—This run extended from Manhole D to Manhole E, a distance of 525 ft. Manhole E was 225 ft south and 300 ft west of Manhole D. Manhole E was concrete with a concrete slab top just above grade. Manhole dimensions were 9 ft x 10 ft x 6 ft deep. No manhole vents were provided. The manhole contained a steam jet sump pump and was dry at the time of inspection. Wall penetrations were caulked and cemented. Gland seals were installed at end plates in both manholes. The steam conduit casing was 13 in. in diameter with a 6-in. heat carrying pipe. The condensate casing is 7 in. in diameter with a 3-in. return line. Pressure test readings were as follows:

<i>Steam Conduit</i>	<i>Condensate Conduit</i>
10:40 AM — 16.5 psi	9:23 AM — 15.0 psi
10:42 AM — 14.0 psi	9:24 AM — 13.5 psi
10:44 AM — 12.0 psi	9:25 AM — 12.0 psi
10:49 AM — 9.5 psi	9:26 AM — 10.0 psi
10:53 AM — 7.0 psi	9:27 AM — 9.0 psi
11:05 AM — 3.0 psi	9:29 AM — 7.0 psi
11:08 AM — 2.0 psi	9:32 AM — 4.0 psi
9:38 AM — 0.0 psi	

f. Pressure test—Manhole E to Riser Station F—These sections extended from Manhole E to Riser Station F, a distance of 264 ft. Riser Station F was directly west of Manhole E. The steam line casing was 13 in. in diameter with a 6-in. supply pipe. The condensate line casing was 7 in. in diameter with a 3-in. return pipe. Gland seals were installed at all end plates.

Neither of the casings was able to hold pressure above 4 psi, and when valved off the pressure immediately dropped to zero.

#### 5. Detailed Inspection of System #35

This system consists of piping from Manufacturer B and has a steel conduit (Figure P2). It was installed in 1990 at the Naval Station. This system only had steam supply piping since the condensate is not returned to the plant.

**Pressure test**—This segment extended 2,900 ft from Manhole A (located southeast of Bldg. 3322) to Manhole B (located at the corner of Vesta and Ward streets). The steam pipe was 16 in. enclosed in a conduit casing 28 in. in diameter.

Manhole A was concrete with segmented solid steel plate top flush with grade in parking area. Manhole dimensions were 6 ft × 6 ft × 4 ft deep. The manhole was dry and contained a french drain. Wall penetration design involved the use of a steel sleeve in the manhole wall and a link seal between the sleeve and the conduit casing. The end plate assembly contained a gland seal.

Manhole B was in the street and the top contained two 36-in. slotted manhole covers that provide both access and ventilation. The manhole was concrete, and the dimensions are 18 ft × 12 ft × 7 ft deep. The manhole was dry and was served by a steam jet sump pump. The wall penetration was the same as in Manhole A described above. The conduit end plate was standard with no gland seal.

Pressure was applied to the casing at 1:25 PM, and it slowly rose to 3 psi but would not rise further. The gland seal and gauge and compressor connections were thoroughly checked for leakage and were found to be sound. The compressor was operated for an additional 50 minutes, but no additional increase in pressure was evident. When the conduit casing was sealed by valving off the compressor, the pressure immediately dropped to zero.

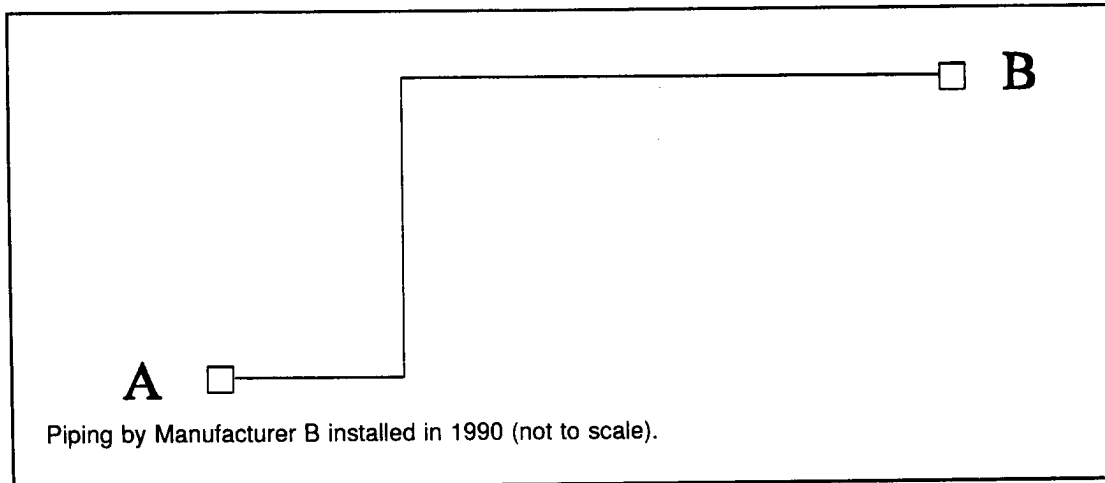

**Figure P2. Schematic diagram of System 35 at San Diego Naval Station, CA.**



## USACERL DISTRIBUTION

Chief of Engineers  
 ATTN: CEHEC-IM-LH (2)  
 ATTN: CEHEC-IM-LP (2)  
 ATTN: CECG  
 ATTN: CECC-P  
 ATTN: CECC-R  
 ATTN: CECW  
 ATTN: CECW-O  
 ATTN: CECW-P  
 ATTN: CECW-PR  
 ATTN: CEMP  
 ATTN: CEMP-E  
 ATTN: CEMP-ET  
 ATTN: CEMP-C  
 ATTN: CEMP-M  
 ATTN: CEMP-R  
 ATTN: CERD-C  
 ATTN: CERD-ZA  
 ATTN: CERD-L  
 ATTN: CERD-M  
 ATTN: CERM  
 ATTN: DAEN-ZC  
 ATTN: DAIM-FDP

CECPW 22310-3882  
 ATTN: CECPW-E  
 ATTN: CECPW-FT  
 ATTN: CECPW-ZC

US Army Engr District  
 ATTN: Library (40)

US Army Engr Division  
 ATTN: Library (11)

US Army Europe  
 ATTN: AEAEN-EH 09014  
 ATTN: AEAEN-ODCS 09014  
 29th Area Support Group  
 ATTN: AEUSG-K-E 09054  
 100th Area Support Group  
 ATTN: AETT-SG-DPW 09114  
 222d BSB Unit #23746  
 ATTN: AETV-BHR-E 09034  
 235th BSB Unit #28614  
 ATTN: AETV-WG-AM 09177  
 293d BSB Unit #29901  
 ATTN: AEUSG-MA-E 09086  
 409th Support Battalion (Base)  
 ATTN: AETG-DPW 09114  
 412th Base Support Battalion 09630  
 ATTN: Unit 31401  
 221st Base Support Battalion  
 ATTN: Unit 29623 09096  
 CMTC Hohenfels 09173  
 ATTN: AETTH-SB-DPW  
 Mainz Germany 09185  
 ATTN: AETV-MNZ-E  
 21st Support Command  
 ATTN: DPW (9)  
 SETAF  
 ATTN: AESE-EN-D 09613  
 ATTN: AESE-EN 09630  
 Supreme Allied Command  
 ATTN: ACSGEB 09703  
 ATTN: SHIH/ENGR 09705

INSCOM  
 ATTN: IALOG-I 22060  
 ATTN: IAV-DPW 22186

USA TACOM 48397-5000  
 ATTN: AMSTA-XE

Defense Distribution Region East  
 ATTN: ASCE-WI 17070-5001

Defense Distribution Region West  
 ATTN: ASCW-WG 95296-0100

HQ XVIII Airborne Corps 28307  
 ATTN: AFZA-DPW-EE

4th Infantry Div (MECH) 80913-5000  
 ATTN: AFZC-FE

US Army Materiel Command (AMC)  
 Alexandria, VA 22333-0001  
 ATTN: AMCEN-F  
 Installations: (20)

FORSCOM  
 Forts Gillem & McPherson 30330  
 ATTN: FCEN  
 Installations: (20)

6th Infantry Division (Light)  
 ATTN: APVR-DE 99505  
 ATTN: APVR-WF-DE 99703

TRADOC  
 Fort Monroe 23851  
 ATTN: ATBO-G  
 Installations: (20)

Fort Belvoir 22060  
 ATTN: CETEC-IM-T  
 ATTN: CETEC-ES 22315-3803  
 ATTN: Water Resources Support Ctr

USA Natick RD&E Center 01760  
 ATTN: STRNC-DT  
 ATTN: AMSSC-S-IMI

US Army Materials Tech Lab  
 ATTN: SLCMT-DPW 02172

USARPAC 96858  
 ATTN: DPW  
 ATTN: APEN-A

SHAPE 09705  
 ATTN: Infrastructure Branch LANDA

Area Engineer, AEDC-Area Office  
 Arnold Air Force Station, TN 37389

HQ USEUCOM 09128  
 ATTN: ECJ4-LIE

AMMRC 02172  
 ATTN: DRXMR-AF  
 ATTN: DRXMR-WE

CEWES 39180  
 ATTN: Library

CECRL 03755  
 ATTN: Library

USA AMCOM  
 ATTN: Facilities Engr 21719  
 ATTN: AMSMC-EH 61299  
 ATTN: Facilities Engr (3) 85613

USAARMC 40121  
 ATTN: ATZIC-EHA

Military Traffic Mgmt Command  
 ATTN: MTEA-GB-EHP 07002  
 ATTN: MT-LOF 22041-5000  
 ATTN: MTE-SU-FE 28461  
 ATTN: MTW-IE 94626

Fort Leonard Wood 65473  
 ATTN: ATSE-DAC-LB (3)  
 ATTN: ATZT  
 ATTN: ATSE-CFLO  
 ATTN: ATSE-DAC-FL  
 ATTN: Australian Liaison Office

Military Dist of WASH  
 Fort McNair  
 ATTN: ANEN-IS 20319

USA Engr Activity, Capital Area  
 ATTN: Library 22211

US Army ARDEC 07806-5000  
 ATTN: AMSTA-AR-IMC

Engr Societies Library  
 ATTN: Acquisitions 10017

Defense Nuclear Agency  
 ATTN: NADS 20305

Defense Logistics Agency  
 ATTN: MMDIS 22060-6221

National Guard Bureau 20310  
 ATTN: NGB-ARI

US Military Academy 10996  
 ATTN: MAEN-A  
 ATTN: Facilities Engineer  
 ATTN: Geography & Envr Engrg

Naval Facilities Engr Command  
 ATTN: Facilities Engr Command (8)  
 ATTN: Division Offices (11)  
 ATTN: Public Works Center (8)  
 ATTN: Naval Constr Battalion Ctr 93043  
 ATTN: Naval Facilities Engr Service Center 93043-4328

8th US Army Korea  
 ATTN: DPW (11)

USA Japan (USARJ)  
 ATTN: APAJ-EN-ES 96343  
 ATTN: HONSHU 96343  
 ATTN: DPW-Okinawa 96376

416th Engineer Command 60623  
 ATTN: Gibson USAR Ctr

US Army MEDCOM  
 ATTN: MCFA 78234-6000  
 Fitzsimons Army Medical Center 80045-5000  
 ATTN: MCHG-PW  
 Fort Detrick 21702-5000  
 ATTN: MCHS-IS  
 Fort Sam Houston 78234-5000  
 ATTN: MCFA-PW  
 Walter Reed Army Medical Center 20007-5001  
 ATTN: MCHL-PW

Tyndall AFB 32403  
 ATTN: HQAFCEA/CES  
 ATTN: Engrg & Srvc Lab

USA TSARCOM 63120  
 ATTN: STSAS-F

American Public Works Assoc. 64104-1806

US Army CHPPM  
 ATTN: MCHB-DE 21010

US Gov't Printing Office 20401  
 ATTN: Rec Sec/Deposit Sec (2)

Nat'l Institute of Standards & Tech  
 ATTN: Library 20899

Defense General Supply Center  
 ATTN: DGSC-WI 23297-5000

Defense Construction Supply Center  
 ATTN: DCSC-WI 43216-5000

Defense Tech Info Center 22060-6218  
 ATTN: DTIC-O (2)