

**ARI Contractor Report 96-56**

---

**Close Air Support Mission Battle Task Performance  
Measurement System: The Air-Ground Training  
Feedback System for Close Air Support**

**James T. Root**

**BDM Federal, Inc.**

19960919 012

This report is published to meet legal and contractual requirements and may not  
meet ARI's scientific or professional standards for publication.

**August 1996**

**United States Army Research Institute for the Behavioral and Social Sciences**

Approved for public release; distribution is unlimited

DMIC QUALITY INSPECTED 1

# U.S. ARMY RESEARCH INSTITUTE FOR THE BEHAVIORAL AND SOCIAL SCIENCES

A Field Operating Agency Under the Jurisdiction  
of the Deputy Chief of Staff for Personnel

EDGAR M. JOHNSON  
Director

---

## NOTICES

**DISTRIBUTION:** This report has been cleared for release to the Defense Technical Information Center (DTIC) to comply with regulatory requirements. It has been given no primary distribution other than to DTIC and will be available only through DTIC or the National Technical Information Service (NTIS).

**FINAL DISPOSITION:** This report may be destroyed when it is no longer needed. Please do not return it to the U.S. Army Research Institute for the Behavioral and Social Sciences.

**NOTE:** The views, opinions and findings in this report are those of the author(s) and should not be construed as an official Department of the Army position, policy, or decision, unless so designated by other authorized documents.

# REPORT DOCUMENTATION PAGE

Form Approved  
OMB No. 0704-0188

Public reporting burden for this collection of information is estimated to average 1 hour per response, including the time for reviewing instructions, searching existing data sources, gathering and maintaining the data needed, and completing and reviewing the collection of information. Send comments regarding this burden estimate or any other aspect of this collection of information, including suggestions for reducing this burden, to Washington Headquarters Services, Directorate for Information Operations and Reports, 1215 Jefferson Davis Highway, Suite 1204, Arlington, VA 22202-4302, and to the Office of Management and Budget, Paperwork Reduction Project (0704-0188), Washington DC 20503.

1. AGENCY USE ONLY (Leave blank)	2. REPORT DATE August 1996	3. REPORT TYPE AND DATES COVERED Interim Report 07/17/92 - 10/16/94	
4. TITLE AND SUBTITLE Close Air Support Mission Battle Task Performance Measurement System: The Air-Ground Training Feedback System for Close Air Support		5. FUNDING NUMBERS MDA903-92-D-0075-0006 3414 CO3 665803 D730	
6. AUTHOR(S) Jim T. Root <i>Gene</i>			
7. PERFORMING ORGANIZATION NAME(S) AND ADDRESS(ES) BDM FEDERAL INC. DOD CENTER MONTEREY BAY 400 GIGLING ROAD SEASIDE, CA 93955		8. PERFORMING ORGANIZATION REPORT NUMBER	
9. SPONSORING/MONITORING AGENCY NAME(S) AND ADDRESS(ES) U.S. ARMY RESEARCH INSTITUTE FOR THE BEHAVIORAL AND SOCIAL SCIENCES 5001 EISENHOWER AVENUE ALEXANDRIA, VA 22333-5600		10. SPONSORING/MONITORING AGENCY REPORT NUMBER  Contractor Report 96-56	
11. SUPPLEMENTARY NOTES The COR is Michael R. McCluskey. This report is published to meet legal and contractual requirements and may not meet ARI's scientific or professional standards for publication.			
12a. DISTRIBUTION/AVAILABILITY STATEMENT APPROVED FOR PUBLIC RELEASE; DISTRIBUTION IS UNLIMITED.		12b. DISTRIBUTION CODE	
13. ABSTRACT (Maximum 200 words) This study and subsequent development of an Air-Ground Training Feedback System (AGTFS) was to explore the application of CAS in actual combat situations. This allows the examination of doctrine, as well as appropriate tactics, techniques, and procedures that would normally be used in such an environment. In absence of war, however, the "laboratory" for the study became the U.S. Army's Combat Training Centers. These are the only locations in which ground and air forces are in place and able to routinely conduct joint training in a realistic battlefield environment. By identifying and isolating the various constraints and limitations within this arena, it is possible to draw appropriate lessons and conclusions about the level of integration between ground and air forces and the degree of effectiveness of JCAS. During the development of the AGTFS a number of issues emerged that are fundamental to JCAS operational readiness. These are initially addressed as they apply to doctrine, organization, training, material, and leadership (DOTML). Additional analysis will provide for the basis of appropriate remedies and recommendations.			
14. SUBJECT TERMS Close Air Support (CAS), Joint Close Air Support (JCAS), Air Liaison Officer (ALO), Air Component Tasks, Ground Maneuver Tasks, Integrated Task List		15. NUMBER OF PAGES	
		16. PRICE CODE	
17. SECURITY CLASSIFICATION OF REPORT UNCLASSIFIED	18. SECURITY CLASSIFICATION OF THIS PAGE UNCLASSIFIED	19. SECURITY CLASSIFICATION OF ABSTRACT UNCLASSIFIED	20. LIMITATION OF ABSTRACT  UNLIMITED

CONTRACT #: MDA 903-92-D-0075  
DELIVERABLE #: 0006-04-0009  
AUGUST 31, 1994

**CLOSE AIR SUPPORT MISSION BATTLE TASK PERFORMANCE  
MEASUREMENT SYSTEM:  
THE AIR-GROUND TRAINING FEEDBACK SYSTEM FOR CLOSE  
AIR SUPPORT**

Jim T. Root  
*BDM Federal*

Submitted by: Mr. Michael R. McCluskey, Acting Chief  
Unit-Collective Training Research Unit  
and Jack Hiller, Director  
Training Research Laboratory

Mr. Michael R. McCluskey, Contracting Office's Representative



August 1, 1994

U.S. Army Research Institute

## Table of Contents

I. INTRODUCTION .....	1
II. THE SYSTEM MODEL .....	2
III. PROCESS MEASURES .....	4
Air Component Tasks .....	4
Ground Maneuver Tasks .....	6
Integrated Task List .....	6
IV. OUTCOME MEASURES .....	8
Lethality and Survivability .....	9
Contribution .....	9
Instrumentation: .....	9
V. THE DATABASE .....	10
Data Collection .....	10
Data Manipulation: .....	10
Data Access .....	11
VI. EMERGING ISSUES .....	12
Doctrine .....	12
Organization: .....	12
Materiel .....	12
Leadership .....	12
Training .....	13
VII. CONCLUSION .....	14
VIII. REFERENCES .....	15

## List of Figures

Figure 1: Schematic organization of the battle task and outcome measurement model for the Air-ground training feedback system. ....	2
Figure 2: The mission Flow Chart for TACP and AFAC critical task sequencing and linkage. ....	5
Figure 3: Schematic of the task linkage network for close air support battle tasks for air and ground support. ....	7
Figure 4: The outcome measurement model and essential assessment elements. ....	8

## I. INTRODUCTION

The goal of the training feedback system was to develop a methodology to systematically identify and define operational aspects of joint close air support (JCAS) to enhance the overall application of JCAS and to reduce the incidence of fratricide. The study was designed to develop performance measures for the processes necessary to employ JCAS and an outcome assessment of the effectiveness of JCAS. These measures may be used to examine doctrinal, organizational, training, materiel, and leadership issues concerning JCAS. They may also be used to provide feedback on training status to units in all services. The detailed examination of processes and outcomes needed to develop these measures was also intended to identify systemic problems within each service and between services that lead to degraded performance of JCAS. Identifying these problems was intended to be the first step in addressing and resolving them.

This study and subsequent development of an Air-Ground Training Feedback System was to explore the application of CAS in actual combat situations. This allows the examination of doctrine, as well as appropriate tactics, techniques, and procedures that would normally be used in such an environment. In the absence of war, however, the "laboratory" for the study became the U.S. Army's Combat Training Centers. These are the only locations in which ground and air forces are in place and able to routinely conduct joint training in a realistic battlefield environment. By identifying and isolating the various constraints and limitations within this arena, it is possible to draw appropriate lessons and conclusions about the level of integration between ground and air forces and the degree of effectiveness of JCAS.

## II. THE SYSTEM MODEL

The conceptual approach to the Air-Ground Training Feedback System is illustrated in the system model shown in Figure 1. The model (Keesling, 1992) depicts two primary components: process measures and outcome measures. Outcome measures are designed to identify *what happened* by keying on a variety of effectiveness factors such as battle damage assessments and specific CAS contributions to the overall battle. Process measures focus on the *why it happened* aspects of the close air support mission. To do this, the process measures address critical events and actions that must be accomplished to ensure the effective application of CAS. Logically, if the process tasks are done correctly, the level of CAS effectiveness should be enhanced.

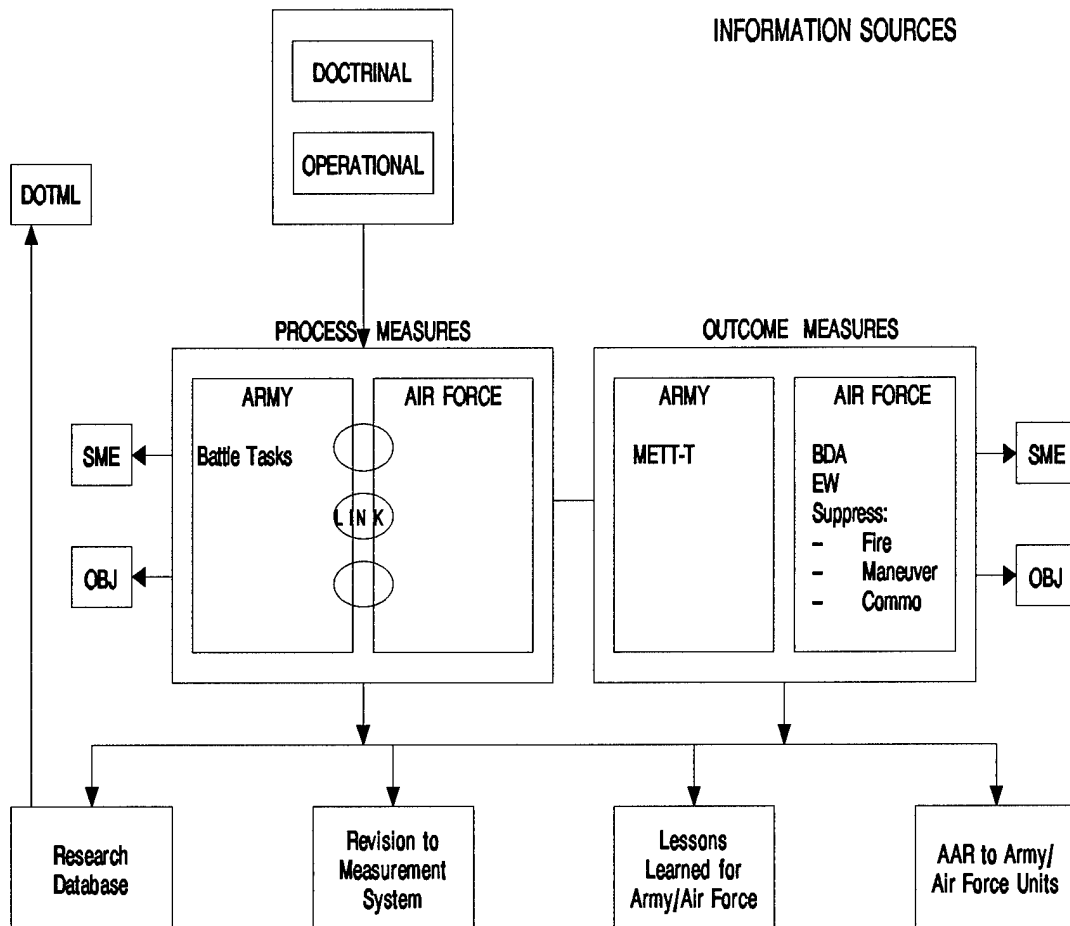

**Figure 1: Schematic organization of the battle task and outcome measurement model for the Air-ground training feedback system.**

Another feature of the model is a feedback mechanism which is designed to synthesize the process and outcome assessments into an easily accessible framework. This allows for immediate training feedback to units at the Combat Training Centers and provides a framework to assist in home station training. It also allows for more detailed and focused evaluation of systemic issues which can be summarized into lessons learned for the entire CAS community. Finally, a research database of this information can be used to examine the need for, and the effects of, changes in doctrine, organization, training, material, and leadership. As new equipment becomes available, or doctrine is modified to adjust to new threats, or responsibility for certain tasks is passed to different players, the research database containing historical performance information can be used to help guide the changes and determine the impact on CAS operations.



### III. PROCESS MEASURES

There are three primary elements of air-ground operations (Root, 1994): The ground maneuver forces, the air liaison team attached to the ground force, and the air forces themselves. For purposes of this study, the ground forces are defined as a maneuver brigade with its normal attachments. The air liaison team consists of an Air Liaison Officer (ALO) and Enlisted Tactical Air Controllers (ETAC) and is collectively known as the TACP (Tactical Air Control Party). The air forces include the attack aircraft which are directly controlled by a Forward Air Controller (FAC), which, if airborne, is called an AFAC (Air Forward Air Controller). Each of these components has a variety of actions, or tasks, which they must accomplish to effectively apply CAS.

**Air Component Tasks:** Air component tasks were derived from both doctrinal and operational sources. Doctrinal sources included a myriad of primary source documents and interviews with school training cadre. Interviews with unit personnel and field training site cadre (Army, Air Force, and Marines) provided the primary sources for operational aspects of CAS. Both sources provided volumes of information on CAS operations specifically and how CAS was linked to broader issues such as airspace management and the employment of air defense assets. Based on this information, air component tasks were organized into two lists - one for the TACP and one for AFAC.

The TACP consists of an ALO and ETAC personnel who are attached to a ground maneuver unit and functions as part of the fire support battlefield operating system. The TACP mission is to integrate CAS with other fire support assets which, in turn, should be synchronized with the ground force scheme of maneuver. To ensure effective integration, the TACP must fully understand the ground tactical situation (friendly and enemy) and what part fire support is expected to play in the battle. In addition, because of the unique vantage point aircraft pilots have of the battlefield, the ALO must be cognizant of unit intelligence requirements and be prepared to disseminate and exploit new information generated by CAS aircraft. In short, to ensure that CAS is used to its full potential as a force multiplier, the ALO and his team must become an integral part of the ground force staff.

The direct control of the attack aircraft is done by a FAC who can either be on the ground (GFAC - normally a member of the TACP), or in the air (AFAC). In this study, the actions by an AFAC are addressed so that the complete spectrum of critical events for all controlling elements is included. The AFAC is responsible for acquiring enough information to effectively control and direct attack aircraft. This information is generally provided by the TACP. The AFAC, in turn, provides the TACP with critical combat information he acquires himself or from other pilots.

Two task lists (one each for the AFAC and TACP) were developed based on the specific actions required of each element as determined from the source documents and interviews (Root, 1993a). The tasks within each list were grouped by the phase of the mission when they would logically occur - plan, prepare, and execute. Tasks were then sequenced within each phase to reflect their place in the event flow and linked to each other to indicate interaction or dependency. The TACP task flow chart followed a straightforward pattern with tasks occurring in concert with the ground maneuver mission flow of plan, prepare, and execute.

The AFAC task flow charts showed a somewhat different pattern. The AFAC receives its initial planning guidance and intelligence estimate from its squadron intelligence officer or GLO (Ground Liaison Officer) usually prior to take off and certainly prior to arriving in the brigade sector. The information in the initial briefing is broad and typically covers a corps or division area of operations. Once on station over the brigade sector, the AFAC relies on the TACP to update the information given at the squadron and provide additional specific mission guidance. As a result, the AFAC planning phase is split into two segments: pre-flight and on-station. Preparation tasks are done rapidly and are generally designed to confirm critical information and actions. The execution phase is conducted by a Forward Air Controller, which can be the AFAC, if there is one on station, or a ground FAC (GFAC), who is a member of the TACP. In either case, the tasks and the task sequence for the execution phase are the same for the TACP and the AFAC.

Essentially, TACP personnel who have participated in the staff planning and preparation, have the most detailed knowledge of the mission. That knowledge is synthesized and briefed to the AFAC, who then passes critical elements of information to the attack aircraft. The attack aircraft physically strike the designated targets and relay combat information back through the AFAC to the TACP. The information flow and interaction between the TACP and AFAC is continuous throughout the mission. The task sequence for the TACP and AFAC is graphically depicted in Figure 2.

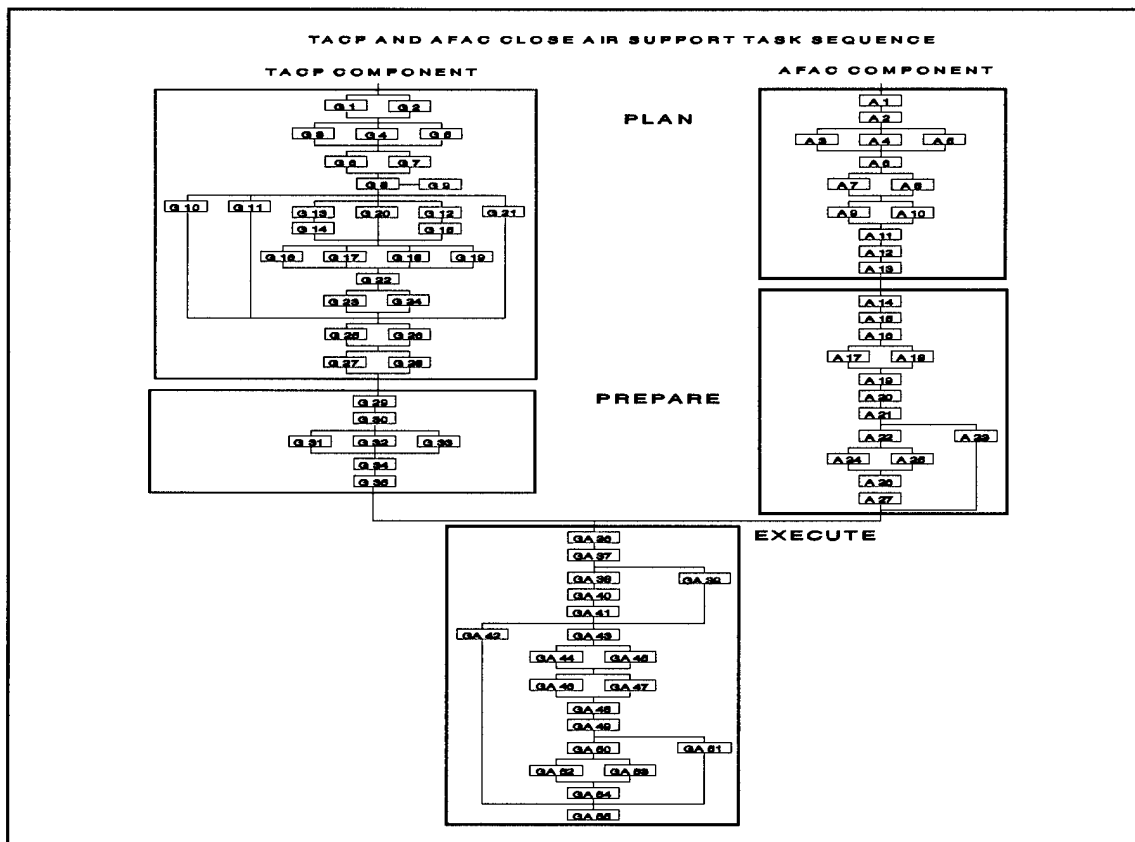

**Figure 2: The mission Flow Chart for TACP and AFAC critical task sequencing and linkage.**

**Ground Maneuver Tasks:** Ground maneuver tasks were developed to identify those actions by the ground maneuver forces that directly influence the application and effectiveness of CAS. Within the battlefield operating systems (BOSs), CAS is considered a functional part of the fire support system. However, the successful utilization of CAS requires the close integration with other BOSs for information and coordination.

The Combined Arms Battle Tasks (Lewman, 1994) were developed to identify critical combat tasks for ground maneuver forces. As such, they provided a useful basis for development of ground maneuver tasks as they relate to CAS. While they did provide a firm foundation and defined the scope and magnitude of ground maneuver tasks, many of these tasks were too broad for the narrow focus of this study. Even so, a candidate task list was prepared with the intention of expanding the elements of information within each task as CAS specific measures were developed.

A deductive approach was then followed in which TACP tasks were used as the start point from which to derive appropriate ground maneuver tasks. Briefly stated, the TACP must receive and give information, as well as coordinate with someone, so the process became that of identifying the appropriate information and personnel in the ground maneuver unit and identifying tasks they must perform to enable the TACP to perform its tasks.

The candidate tasks derived from the Combined Arms Battle Tasks were aligned with the requirements from the TACP task list. The process then became one of filling in the blanks and discarding redundant and extraneous elements of information. In cases where there were still gaps, or the task measures of performance were inadequate, Army training documents (mission training plans and field manuals) were used to assist in fleshing out the tasks. Finally, the ground maneuver task list was reviewed for completeness, correctness, and the degree of integration with the TACP tasks.

**Integrated Task List:** The final step in the development of the process measures was the integration of the ground maneuver, TACP, and AFAC tasks (See Root, 1994). This was done by linking the individual tasks identified in each list to supporting and dependent tasks in the other lists. This process expanded the horizontal task sequence and linkage and resulted in a tiered or stacked vertical linkage with the TACH serving as the integrating agent between the ground maneuver force and the AFAC. Figure 3 depicts the overall relationships between the three task lists.

The integration of all task lists provides the capability of backing through the task linkages from the air to the TACH to the ground maneuver component to clearly identify which, if any, links in the event chain are weak. As an example, if the ground maneuver fire support plan is flawed, it is unlikely that the CAS execution will be entirely effective. Another important aspect of this three-dimensional linkage is that it is possible to identify potential by-pass linkages and secondary sources in the event of a disconnect between normal circuits. This information could also help identify predictive events which could serve as alert indicators and allow for corrective action before the process became completely unravelled. Finally, the task linkages provide a clear picture of the magnitude of the effort and the scope of players and information necessary for the effective application of close air support assets.

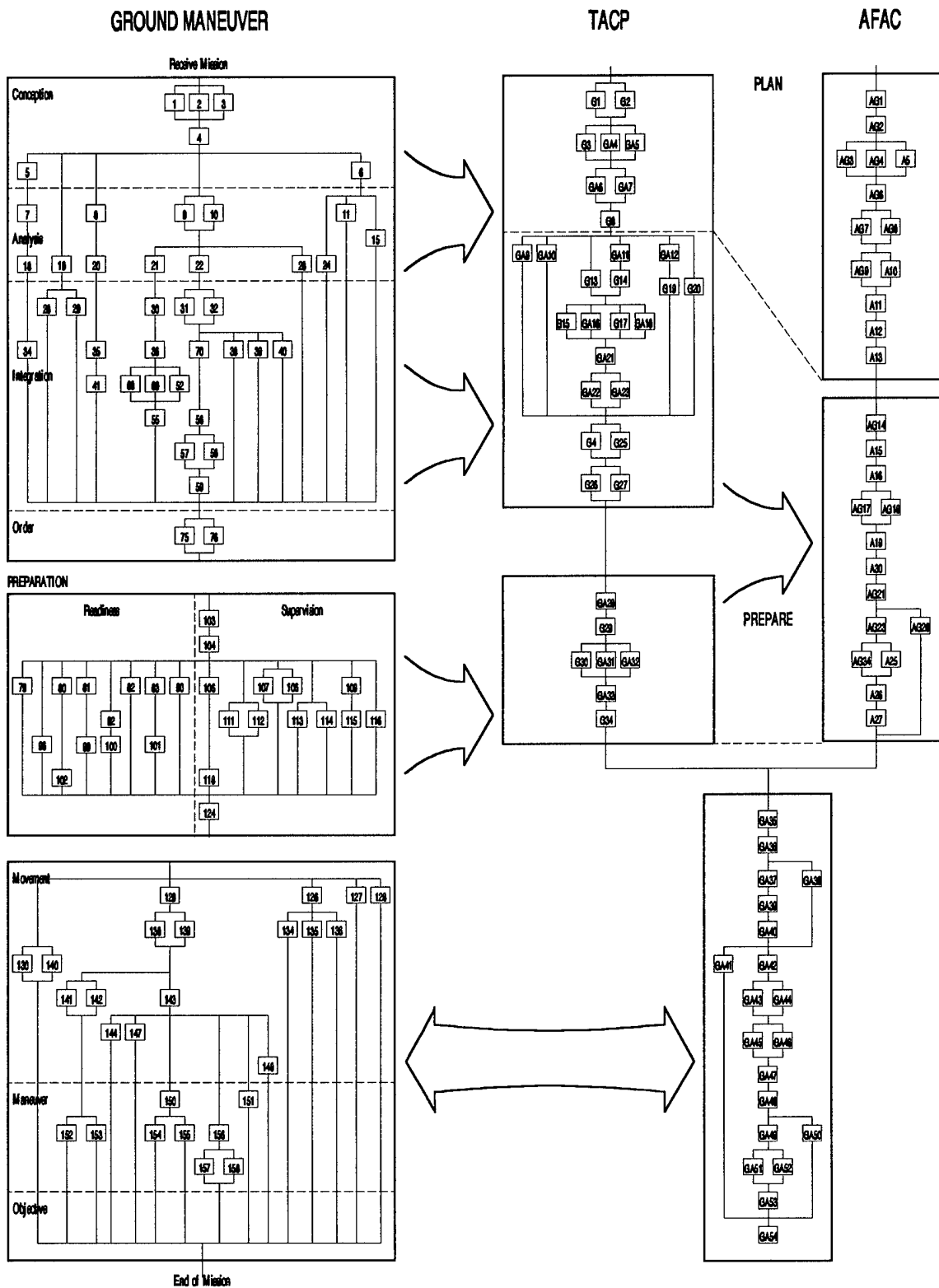

Figure 3: Schematic of the task linkage network for close air support battle tasks for air and ground support.

#### IV. OUTCOME MEASURES

Outcome measures were developed to provide a specific assessment of CAS effectiveness on a mission by mission basis (Jarrett, 1994). While the empirical data derived from CTC player instrumentation would provide the foundation for assessments, both objective and subjective measures are used. These assessments only focus on global, end-of-mission factors which address a final level of effectiveness. The data requirements are designed to identify specifically *what happened* in three areas: Lethality, Survivability, and Contribution. Figure 4 depicts the measurable elements for the outcome assessment.

CAS OUTCOME COMPILATION			
Rotation: _____	Mission: _____		
DTG: _____	Team: _____		
<b>Lethality Component</b>			
A: # of Weapons Used _____			
B: # of Vehicles Killed _____			
	B/A= _____	x 25 =	_____
<b>Survivability Component</b>			
A: # of Aircraft Starting Mission _____			
B: # of Aircraft at the End of Mission _____			
	B/A= _____	x 25 =	_____
<b>Contribution Component**</b>			
Mission: Yes _____	No _____	_____ x 13 =	_____
Enemy: Yes _____	No _____	_____ x 10 =	_____
Troops: Yes _____	No _____	_____ x 10 =	_____
Terrain (Tactics): Yes _____	No _____	_____ x 07 =	_____
Time: Yes _____	No _____	_____ x 10 =	_____
**A Yes = 1, a No = 0		Total =	_____

**Figure 4: The outcome measurement model and essential assessment elements.**

**Lethality and Survivability:** Lethality and Survivability are empirical measures that assess the number of enemy forces lost to CAS and the number of friendly aircraft lost to enemy ground fires. (There is not any air-to-air combat at the CTC's.) This is a straightforward battle damage assessment (BDA) that gives a very broad overview of CAS effectiveness. It does not attempt to determine why, or how, and more critically it does not address a number of more subtle factors that are part of mission success.

**Contribution:** Since comparisons of friendly and enemy BDA is such a one dimensional measure of what happened, it was necessary to develop a modifying measurement, called contribution. The Contribution factor is designed to serve as a refinement of the casualty exchange ratio derived from the Lethality and Survivability measures. Contribution is framed by the factors of METT-T (Mission, Enemy, friendly Troops, Terrain, and Time) which have been modified to meet the measurement criteria necessary for the CAS outcome assessment. These measures provide a mix of empirical and subjective data and address a number of critical outcomes that give a more comprehensive picture of what happened.

The Mission factor determines whether CAS accomplished the mission assigned to it. Enemy determines whether the correct targets (those that correspond to and support the ground maneuver plan.) were attacked. Troops addresses the fratricide issue. Terrain seeks to identify whether the proper tactics were used by the attack aircraft. Finally, the Time factor addresses CAS synchronization with the ground maneuver force.

**Instrumentation:** While all the Combat Training Centers are instrumented, the level of instrumentation varies greatly among them. The National Training Center (NTC) has the most advanced facility and has instrumentation modules on personnel, ground vehicles, and aircraft (rotary and fixed wing). The NTC Training Analysis and Feedback (TAF) computer system is able not only to capture real time dispositions of all engaged forces, but can also observe both ground-ground engagements and air-ground engagements as they occur. This capability allows for empirical data collection, particularly in regard to outcome measures such as lethality and survivability assessments. In addition, since the location of forces can be continuously monitored, the TAF can become the primary data source for several elements of the contribution measures such as incidents of fratricide and air tactics. As other CTC's and field training sites acquire similar instrumentation, it will be possible to duplicate data which can now only be empirically derived from the NTC.

## V. THE DATABASE

The CAS database (Butterfield, 1994) was designed to provide a central collection point for CAS data derived from Combat Training Center-Air Warrior training missions. Since the CTC's (and to some extent the Marine Air-Ground Training Center at Twentynine Palms) offer the only situations in which there are both ground maneuver and air forces routinely present, their training rotations provide the best picture of how actual operations are conducted. Process measures can be collected from all field training sites, but due to instrumentation limitations empirical outcome data can only be collected from the NTC. Until it undergoes an instrumentation upgrade, the JRTC (Joint Readiness Training Center) can only provide subjective outcome assessments. The Marine Air-Ground Training Center conducts its training in a live fire environment which clearly satisfies any questions about where the munitions fell and what they hit. However, the training is conducted in such a manner that the actual use of CAS is more of a firepower demonstration designed to reinforce techniques and procedures to the ground forces and underscore close air support's potential as a force multiplier.

Two automated data collection structures to supplement the paper instruments were explored. The first provided text in the form of a task checklist and a computer generated graphic presentation of task assessments using task sequence and linkage charts. A prototype was developed and was well received but proved too technically ambitious for practical use. A second prototype was developed using the checklists only and proved to be adequate as a field collection and storage device.

**Data Collection:** Data collection can be accomplished by using either a paper based system or an electronic collection instrument (ECI). Regardless of the collection device, key observer/controllers (OC's) are required to collect the data. The ground maneuver package should be completed by a designated OC at the unit TOC (Tactical Operations Center). The TACH package should be completed by an Air Warrior (AW) OC with that element. The AFAC package should be completed by the AFAC in concert with AW cadre.

At the NTC, outcome measures are derived from Air Warrior I cadre positioned at the computer based AWMDS (Air Warrior Measurement and Debriefing System) located at the TAF Division Tactical Operations Center (DTOC). Decisions are made in concert with the AWI cadre who are also observing the AWMDS at Nellis AFB and who have access to aircraft gun camera tapes that can be used to reconcile discrepancies in the instrumentation.

Accumulated data is then entered, either physically from paper instruments or by electronic download from ECI's, into a single mission file in a central desk top computer. Once all rotational missions have been completed, the rotation files can be entered into a central database maintained at the Army Research Institute Field Unit, Presidio of Monterey (ARI-POM).

**Data Manipulation:** Data manipulation for report purposes can be conducted at any stage after the information has been entered into a central computer. To facilitate this requirement, a number of report templates have been developed to allow organization of the data into mission, rotation, and trendline formats. In addition, it is possible to extract focus elements, such as all planning tasks in general or, more specifically, TACH planning tasks. This level of flexibility

is critical in providing the capability to exploit training points as they emerge immediately following a mission or in identifying systemic issues and trends over multiple rotations.

**Data Access:** The ability to easily access the data in a readily usable form is the final critical aspect of this product. This function is designed to accommodate three time frames: Direct access, cumulative, and long range. Direct access is focused on the capability of producing immediate training assessments in support of after action reviews (AARs) conducted after each mission. Cumulative data gathered and tabulated over the course of a rotation can be presented back to a unit in a variety of report formats at intervals during the exercise or at the conclusion of the rotation. These reports can be structured to provide an overall training assessment and demonstrate trends during the rotation. Once printed, these reports can be part of a unit's take home package and facilitate home station training while the CTC experience is still fresh.

Most important, however, is the long term accumulation of data which can be used not only to increase the readiness level of the individual exercise units, but to enhance the operational capabilities of the total force. Data can be used to more clearly define systemic issues and provide a focus for the type and scope of potential remedies. In addition, the database can serve as a tracking mechanism to verify whether installed enhancements are having the desired impact.



## VI. EMERGING ISSUES

The Air-Ground Training Feedback System (AGTFS) is designed to assess joint operational processes and identify critical readiness shortfalls in the joint close air support arena. During the course of this study a number of systemic issues emerged (Vermilyea, 1994) that are fundamental to effective JCAS operations. The U.S. Army term DOTML (doctrine, organization, training, materiel, and leadership) identifies the major factors that influence operational readiness and provides a framework for exploiting the information gained from the AGTFS and other joint training and operational assessments. Some of these emerging issues are outlined below.

**Doctrine:** Joint doctrine represents the foundation upon which the synchronization of forces is established. In addition to identifying the appropriate JCAS tactics, techniques, and procedures, it establishes a common language and defines the routine coordination processes among the affected maneuver and supporting arms. However, there are some fundamental disconnects in this area. Some are as basic as language where similar positions are called by different names in each service. The difference between ground force targeting priorities and air priorities are still another issue. The planning cycle ensures appropriate synchronization and utilization of CAS with other supporting arms such as indirect fires and rotary wing assets. However, the Air Tasking Order (ATO) is out of synch with the ground force tactical planning sequence.

**Organization:** Maneuver units are designed to facilitate team and task force configurations that incorporate a variety of attached supporting arms which can greatly increase the unit's combat power. This addition of dedicated personnel in habitual attachments is assumed. However, ensuring the compatibility between organizations, particularly in the joint arena, is an ongoing challenge. The alignment of organizations and units so they can best support joint operations needs review. A determination of what works, and how well, in an operational environment is critical to the development of an appropriate structure that is both comprehensive and flexible enough to meet the demands of joint CAS application. The role of a junior officer as the Air Mission Commander during JAAT operations needs a second look.

**Materiel:** Technological advances in areas such as IFF (Identification Friend or Foe) designators, lasers, and radios can both streamline the process or provide immediate incompatibility between services. These items plus a number of other inter and intra service infrastructure requirements need constant monitoring. The adequacy of ordnance and training munitions needs review. Physical constraints such as training ranges and airspace can distract from realistic tactics, techniques, and procedures that must be employed in real world operations.

**Leadership:** Leadership is responsible for orchestrating the integration of the doctrine, materiel, and organization and creating the necessary synergy among the myriad of service and branch commands. There is an inherent unity of command problem at the operational and tactical level and command relationships, responsibilities, and staffing levels in the habitual special staff areas that impact on JCAS utilization need review. The command emphasis on close air support as a force multiplier and the allocation of resources is different across services.

**Training:** Training is conducted at three levels: Individual, unit, and collective/joint. The direction and scope of individual and unit training tends to be stovepiped by branch and service. Collective/joint training can provide the necessary integrated training, but there is clearly not enough of it. This lack of training and cumulative lack of synergy in doctrine, organization, materiel, and leadership is manifested at the CTC's by frequent misunderstandings, lack of synchronization, inappropriate utilization of CAS assets, and fratricide.

## VII. CONCLUSION

This examination of close air support provides a framework for a detailed analysis of JCAS operational readiness and a basis for a quantifiable justification for potential fixes and remedies for systemic issues. There are two main elements of the project: The Air-Ground Training Feedback System, which directly addresses operational readiness aspects, and the identification of systemic issues, which provides some insight into resourcing factors that inhibit the successful utilization of JCAS.

The foundation of this project is the Air-Ground Training Feedback System which has three primary components: The process measures identify the required sequence of actions necessary for the successful application of close air support. The outcome measures provide the criteria for an performance effectiveness assessment. The database structure provides a tool for organizing and synthesizing the information acquired from the process and outcome measures into useable formats for training feedback and analysis of trends and new developments.

During the development of the AGTFS a number of issues emerged that are fundamental to JCAS operational readiness. These are initially addressed as they apply to doctrine, organization, training, materiel, and leadership (DOTML). Additional analysis will allow for a more detailed examination of each issue and provide the basis for the development of appropriate remedies and recommendations.

## VIII. REFERENCES

- Butterfield, D. (1994). Design Plan for Collection, Storage, and Access of Close Air Support Performance Data, (in progress), Presidio of Monterey, CA: Army Research Institute.
- Jarrett, P. (1994). Outcome Measures for the Air-Ground Training Feedback System, Research Product, Presidio of Monterey, CA: Army Research Institute.
- Keesling, J. W. (1992). A Measurement Model Supporting the Air-Ground Training Feedback System, Research Product, Presidio of Monterey, CA: Army Research Institute.
- Lewman, T. J. (ed.) (1994). Combined Arms Battle Tasks (Coordinating Draft): Battalion Task Force Deliberate Attack, Research Product, Presidio of Monterey, CA: Army Research Institute.
- Lewman, T. J. (ed.) (1994). Combined Arms Battle Tasks (Coordinating Draft): Battalion Task Force Defend, Research Product, Presidio of Monterey, CA: Army Research Institute.
- Root, J. T. (1992). Analysis of an Interservice Exercise Measurement and Feedback System, Research Product, Presidio of Monterey, CA: Army Research Institute.
- Root, J. T., Creen, M. J. (1993a). List of Doctrinally Based Tasks for the Close Air Support System, Research Product, Presidio of Monterey, CA: Army Research Institute.
- Root, J. T. (1993b). List of Brigade Critical Combat Tasks for the Air-Ground Training Feedback System, Research Product, Presidio of Monterey, CA: Army Research Institute.
- Root, J. T. (1994). Integrated Task List for the Air-Ground Training Feedback System, Research Product, Presidio of Monterey, CA: Army Research Institute.
- Vermilyea, C. L. (1994). Joint Close Air Support (JCAS): An Assessment. Research Product, Presidio of Monterey, CA: Army Research Institute.