



**Research Product 96-07**

**Task Analysis for Coordinate,  
Synchronize, and Integrate Fire Support  
as Accomplished by a  
Brigade Combat Team**

**Bartholomew J. McIlroy, Jr., and William J. Mullen III**  
BDM Federal, Inc.

**J. Douglas Dressel and Franklin L. Moses**  
U.S. Army Research Institute

19960926 107

**August 1996**

**Advanced Training Methods Research Unit**

**U.S. Army Research Institute for the Behavioral and Social Sciences**

**DTIC QUALITY INSPECTED 3**

Approved for public release; distribution is unlimited.

# **U.S. ARMY RESEARCH INSTITUTE FOR THE BEHAVIORAL AND SOCIAL SCIENCES**

**A Field Operating Agency Under the Jurisdiction  
of the Deputy Chief of Staff for Personnel**

**EDGAR M. JOHNSON  
Director**

---

Research accomplished under contract  
for the Department of the Army

BDM Federal, Inc.

Technical review by

James Love, LTC (USA, ret.)  
Douglas Mcpherson (ARI)

## **NOTICES**

**FINAL DISPOSITION:** This Research Product may be destroyed when it is no longer needed.  
Please do not return it to the U.S. Army Research Institute for the Behavioral and Social Sciences.

**NOTE:** This Research Product is not to be construed as an official Department of the Army  
position, unless so designated by other authorized documents.

## REPORT DOCUMENTATION PAGE

1. REPORT DATE (dd-mm-yy) August 1996		2. REPORT TYPE Final		3. DATES COVERED (from... to) May 1994-Feb 1996	
4. TITLE AND SUBTITLE  Task Analysis for Coordinate, Synchronize, and Integrate Fire Support as Accomplished by a Brigade Combat Team				5a. CONTRACT OR GRANT NUMBER MDA 903-92-D-0075,DO25	
				5b. PROGRAM ELEMENT NUMBER 06027885A	
6. AUTHOR(S)  McIlroy, Bartholomew J. Jr. (BDM) ; Mullen, William J. III (BDM) Dressel, Douglas J. (ARI); and Moses, Franklin L. (ARI)				5c. PROJECT NUMBER 62785	
				5d. TASK NUMBER A791	
				5e. WORK UNIT NUMBER 2122	
7. PERFORMING ORGANIZATION NAME(S) AND ADDRESS(ES) BDM Federal, Inc. DoD Center Monterey Bay 400 Gigling Road Seaside, CA 93955-6771				8. PERFORMING ORGANIZATION REPORT NUMBER	
9. SPONSORING/MONITORING AGENCY NAME(S) AND ADDRESS(ES) U.S. Army Research Institute for the Behavioral and Social Sciences 5001 Eisenhower Avenue ATTN: PERI-IR Alexandria, VA 22333-5600				10. MONITOR ACRONYM ARI	
				11. MONITOR REPORT NUMBER Research Product 96-07	
12. DISTRIBUTION/AVAILABILITY STATEMENT Approved for public release; distribution is unlimited.					
13. SUPPLEMENTARY NOTES					
14. ABSTRACT ( <i>Maximum 200 words</i> ):  This Research Product provides a detailed description of fire support as accomplished by a Brigade Combat Team. It is one in a series that describes the tasks, performers, and outcomes for the combat function of Coordinate, Synchronize, and Integrate Fire Support. Assessment criteria are provided for reports in this series except for the current one at Brigade level. Other reports focus on fire support at the echelons of Division, Corps, and to related functions at Corps as a Joint Task Force.  This series of Research Products are intended as resource documents for military and civilian trainers to assist in the design and evaluation of single service and joint training. Doctrinal writers may use these descriptions as a basis for modifying current doctrine or for the formulation of future doctrine.					
15. SUBJECT TERMS Military training                      Groups/Teams                      Brigade                      Fire support Training methods                      Functions                      Assessment                      Synchronization					
SECURITY CLASSIFICATION OF			19. LIMITATION OF ABSTRACT  Unlimited	20. NUMBER OF PAGES  350	21. RESPONSIBLE PERSON (Name and Telephone Number)  Franklin L. Moses 703-617-5948
16. REPORT Unclassified	17. ABSTRACT Unclassified	18. THIS PAGE Unclassified			

**Research Product 96-07**

**Task Analysis for Coordinate, Synchronize,  
and Integrate Fire Support as  
Accomplished by a  
Brigade Combat Team**

**Bartholomew J. McIlroy, Jr., and William J. Mullen III**  
BDM Federal, Inc.

**J. Douglas Dressel and Franklin L. Moses**  
U.S. Army Research Institute

**Advanced Training Methods Research Unit**  
**Robert J. Seidel, Chief**

U.S. Army Research Institute for the Behavioral and Social Sciences  
5001 Eisenhower Avenue, Alexandria, Virginia 22333-5600

Office, Deputy Chief of Staff for Personnel  
Department of the Army

**August 1996**

---

**Army Project Number**  
20262785A791

**Education and Training**  
**Technology**

Approved for public release; distribution is unlimited.

## FOREWORD

---

One of the goals for the U.S. Army Research Institute for the Behavioral and Social Sciences (ARI) is to facilitate the training of Army units by designing strategies and methods which successfully incorporate emerging technologies such as distributed simulations. Part of meeting this goal is to have comprehensive descriptions of what needs to be trained. The coordination, synchronization, and integration of fire support presents particular training challenges and benefits. Fire support can overwhelm an enemy force before friendly troops are put into harm's way.

This work is the first in a series of reports which describe the complex procedure and performance of fire support at different echelons. The depiction of this combat force multiplier can be used by civilian and military trainers when assessing unit performance or developing enhanced training. ARI is using this work in its research on the effective use of distributed simulation for multi-Service and Joint training in support of ground operations.

ZITA M. SIMUTIS  
Deputy Director  
Science and Technology

EDGAR M. JOHNSON  
Director

**TASK ANALYSIS FOR  
COORDINATE, SYNCHRONIZE, AND INTEGRATE FIRE SUPPORT  
AS ACCOMPLISHED BY A BRIGADE COMBAT TEAM**

CONTENTS

---

	Page
INTRODUCTION .....	1
CCF TA COMPONENTS OVERVIEW .....	1-1
PURPOSE AND OUTCOMES OF CCF 15 .....	2-1
FLOW CHARTS BY BATTLE PHASE (PLAN, PREPARE, EXECUTE) .....	3-1
OTHER CCFs WHICH INTERACT WITH CCF 15 .....	4-1
CCF 15 KEY PARTICIPANTS BY TASK .....	5-1
KEY INPUTS AND OUTPUTS TO CCF 15 .....	6-1
TASK LIST SUMMARY .....	7-1
PLANNING TASK LIST .....	8-1
PREPARATION TASK LIST .....	9-1
EXECUTION TASK LIST .....	10-1
TASK LIST ENDNOTES .....	11-1
CALL LESSONS LEARNED RELEVANT TO CCF 15 .....	12-1
LESSONS LEARNED INTEGRATED INTO CCF 15 TASK LIST .....	13-1
CRITICAL TASKS AND OTHER LINKAGES .....	14-1
REFERENCES .....	15-1
APPENDIX A        INDEX OF CRITICAL COMBAT FUNCTIONS (CCF) .....	A-1
APPENDIX B        STRUCTURE OF CRITICAL COMBAT FUNCTIONS .....	B-1
APPENDIX C        LIST OF ABBREVIATIONS AND ACRONYMS.....	C-1

# TASK ANALYSIS FOR COORDINATE, SYNCHRONIZE, AND INTEGRATE FIRE SUPPORT AS ACCOMPLISHED BY A BRIGADE COMBAT TEAM

## Introduction

This Task Analysis (TA) of Coordinate, Synchronize, and Integrate Fire Support as performed by a Brigade Combat Team (BCT), is a continuation of an ongoing research program at the U.S. Army Research Institute for the Behavioral and Social Sciences (ARI). This research program is to support Army development of brigade training strategies through the use of functions derived from the Battlefield Operating Systems (BOS). This analysis reflects tasks, products, participants, and processes in a sequence and relationship necessary to employ all aspects of indirect fire support available and under the control of a BCT (Light or Heavy).

Given the task-based nature of Army training, the tools for identifying, structuring, and organizing tasks critical for combat effectiveness are essential to realizing goals of Army training for the 21st century. Providing such tools has been a continuing effort in structuring planning and assessment of collective training. Army Training and Evaluation Program Mission Training Plans (ARTEP MTPs), which list tasks by mission, represent one approach to provide that structure. A complementary approach has emerged in the use of functional areas.

Several initiatives have considered tasks in relation to functional areas rather than missions. One such approach was adopted at the Combat Training Centers (CTCs). The specific approach developed in the mid-1970s used BOSs as the framework for after action reviews (AARs) and take home packages. The BOSs are seven functional areas which encompass tactical operations.

In addition, to enhance the utility of the BOS structure, the U.S. Army Training and Doctrine Command (TRADOC) developed the Blueprint of the Battlefield. That work used the BOS structure as a framework to describe the tactical level of war in terms of operating systems, functions, and generic tasks. While the functional hierarchy in the Blueprint of the Battlefield provided finer granularity than the BOS, the Blueprint of the Battlefield did not represent battlefield processes, critical sequences of events, procedural steps, and many of the tasks that must be accomplished.

This research product is part of an effort to improve further the functional structure for planning and assessing collective training through the identification and analysis of Critical Combat Functions (CCFs), an ARI research term, defined as follows:

**CRITICAL COMBAT FUNCTIONS:** *The integration [i.e., interrelationship] among participants and tasks that represents a force multiplier with a definable outcome*

Like the Blueprint of the Battlefield, the CCFs focus on functions (activities and processes that occur over time) while retaining granularity that supports task-based training. The CCF analyses extend the Blueprint of the Battlefield in two ways:

- Identify relationships among BOSs, tasks, echelons, and people required to achieve identified outcomes, thus improving representation of battlefield processes and sequences of events.
- Provide explicit ties to tasks derived from ARTEP MTPs and doctrine, tactics, techniques, and procedures described in doctrinal manuals, applied at CTCs, or identified by experienced

field commanders, thus improving representation of procedural steps and tasks that must be accomplished.

Task analyses (TAs) of CCFs have been conducted at a level of detail that supports a functional approach to training. The functional approach uses battlefield functions performed by units as the basis for assessing proficiency and planning training. The CCF TAs provide content and a framework to apply the functional approach to training.

This CCF TA builds on previous work in the development of a CCF TA for a heavy Battalion Task Force (Bn TF), as well as existing doctrinal publications and information relevant to the function of Coordinating, Synchronizing, and Integrating Fire Support.

This CCF TA identifies the tasks that the brigade commander, the brigade staff, key officers and non-commissioned officers (NCOs), and all subordinate and supporting elements of the brigade must perform to coordinate, synchronize, and integrate fire support. Sources of fire support available to the BCT are field artillery (FA); mortars; close air support (CAS) as provided by U.S. Air Force (USAF), U.S. Navy (USN), and U.S. Marine Corps (USMC) aircraft; naval surface fires provided by USN ships; and non-lethal fires provided by electronic warfare (EW) systems. Also included in this task analysis are planning, preparation, and execution considerations for the employment of USAF Air Liaison Officer (ALO) elements and USN Air/Naval Gunfire Liaison Company (ANGLICO) elements for the terminal control of CAS aircraft, as well as ANGLICO elements for the execution of naval surface fires.

This CCF TA does not address: (a) FA tasks associated directly with actions taken by the FA battalion or the firing batteries, (b) tasks taken by USAF personnel or units to physically prepare CAS aircraft for a mission or those tasks taken by CAS aircraft pilots to deliver their ordnance on targets, (c) tasks taken by USN and USMC personnel or units to physically prepare naval surface fires for the mission, or (d) tasks taken by Army personnel or units external to the brigade for the conduct of support missions (e.g., non-lethal fires).

The battle phases PLAN, PREPARE, and EXECUTE relate to the entire brigade vice phasing solely for this particular CCF.

The processes outlined in this task analysis are never initiated from a standing start due to the continuous nature of the battlefield. However, for the purposes of analysis and for portrayal of the CCF, the task analysis begins with actions to sustain and protect the BCT during the Planning Phase and upon the receipt of the Division Warning Order (WARNO).

This analysis addresses the actions and coordination activities initiated by the brigade commander and brigade targeting team to develop a fire support plan. This includes all available fire support systems which support the brigade commander's intent and concept of the operation (Planning Phase). This analysis continues through the brigade's preparation for battle by detailing modifications of and refinements to the fire support plan and actions taken by the brigade commander, the brigade targeting team, and subordinate fire support leaders to ensure that units and systems are prepared to implement the fire support plan (Preparation Phase). The analysis culminates with the synchronized and integrated employment of indirect fire support during the conduct of the battle and consolidation/reorganization following the battle (Execution Phase).



The fire support plan is developed to provide the information necessary to understand how fire support will be used to support the operation. In order to provide this level of understanding, the fire support plan cannot be contained in a single document; this plan is defined and demonstrated in multiple products. The term "fire support plan" as used in this CCF TA is inclusive of the following products:

1. Fire support estimate.
2. Paragraph 3a(2) of the Brigade operations order (OPORD), Concept of the Operation for Fires.
3. Paragraph 3c(1) of the Brigade OPORD, Tasks to Fire Support Units.
4. Fire Support Annex to the Brigade OPORD.
5. Field Artillery Support Plan (as produced by the DS FA Battalion).
6. Fire Support Execution Matrix.
7. Target List and target overlays.
8. Target Acquisition Plan.
9. High Pay-off Target List.
10. Attack Guidance Matrix.
11. Air Tasking Order.

This list is not all-inclusive. The doctrinal references used to develop this list of products which describe the fire support plan are FM 6-20, Fire Support in the AirLand Battle; FM 6-20-40, Tactics, Techniques, and Procedures for Fire Support for Brigade Operations (Heavy); and FM 101-5, Command and Control for Commanders and Staff (Final Draft).

The primary focus is the performance and application of the targeting process at the BCT. The targeting process requires the Brigade Commander to implement measures and processes to decide, detect, deliver, and assess targeting as an integral part of his decision cycle from the receipt of the mission from the division through the execution of the brigade Operations Order (OPORD). Each part of the targeting process occurs both simultaneously and sequentially.

The targeting process performed at the BCT is not as formal as it is at higher headquarters. The brigade battle is essentially the division-close battle and is shaped by targeting actions at higher levels. However, the organization of the brigade staff, the detection and attack systems under brigade control, and the brigade's access to intelligence and information from division and other sources require the application of the targeting process to all missions. The Brigade Targeting Team performs three functions: (a) synchronize operations; (b) recommend targets to acquire and attack, including most efficient and available assets to detect and attack targets; and (c) identify combat

combat assessment requirements. The targeting process is conducted to enable fire support to disrupt, delay, destroy, or limit enemy capabilities which could interfere with the brigade's mission. Although the targeting process may involve them, attack helicopters or other direct fire weapons systems are considered maneuver systems and are not included in this task analysis.

Ongoing work on CCF TAs at the brigade echelon has been integrated where necessary, such as planning tasks established for CCF 18 (Plan for Combat Operations), preparation tasks established for CCF 19 (Direct and Lead Units During Preparation for the Battle), and execution tasks established for CCF 20 (Direct and Lead Units in Execution of Battle). The tasks established for CCFs 18, 19, and 20 have been developed for "Innovative Tools and Techniques for Brigade and Below Staff Training" (ITTBBST), a separate ARI research program is in progress. Plan, Prepare, and Execute procedures and processes critical to each battle phase and which directly contribute to the coordination, synchronization, and integration of fire support have been further outlined and included in this CCF TA.

The level of detail and the tasks were selected by the analyst as relevant to a brigade training strategy. Compliance with branch training strategies and proficiency at ARTEP MTP tasks and sub-tasks are recognized to be the responsibility of the brigade commander and subordinate commanders.

In this analysis, an effort was made to use specific task and sub-task titles derived directly from the appropriate ARTEP MTPs. Those task and sub-task titles not taken from the ARTEP MTP are derived titles that may apply to (a) only part of a sub-task or other element of the ARTEP MTP; (b) multiple sub-tasks from different, but related, tasks; or (c) tasks that are not directly stated in the ARTEP MTP, but are implied by other tasks or by requirements in an applicable Field Manual (FM) or related doctrine. Additionally, tasks identified by subject matter experts (SMEs) from TRADOC schools and U.S. Army Forces Command (FORSCOM) during interviews have been integrated into this task analysis.

The text of the task has been reworded as needed to describe what was being performed in the task as well as the individual(s) performing the task. Task references are shown in brackets [...] after each task or task element. For tasks derived from ARTEP MTPs, the task number is specified and modified to reflect the sub-task or standard contained in the task. (Example Task: 71-3-3003 from ARTEP 71-3-MTP (p. 5-73); the derived task 71-3-3003/1c is stated as "Recommends adjustments to the plan as required.")

Three appendices are included in this task analysis. Appendix A provides a listing of the thirty-nine (39) CCFs grouped by BOS. This is a complete listing of all CCF applicable to tactical echelon units that have been identified to date. Not all the CCFs listed would be performed by BCTs. Appendix B provides the definition and focus of each CCF. Appendix C is a listing of the abbreviations and acronyms used in this report.

The analysis of this brigade function primarily is to support training development. Training developers may use it to design new and modify existing training programs which support doctrine, emerging technologies, changes in organization, and reduced resources and training environments. Unit commanders may use this CCF to assess training effectiveness, develop training plans, and execute training. Other possible users of this CCF are force developers, materiel developers, and doctrine developers.

## CCF TA Components Overview

The purpose of this section is to present a brief overview of the fourteen (14) components of this TA. Each component is listed with a description of its purpose.

Purpose and Outcomes of CCF 15: The overall end result which the CCF is supposed to accomplish, termed the purpose, is identified. This component also identifies the end states or bottom line results necessary to achieve the purpose, termed outcomes. As a consequence, this component of the analysis defines the end states that performance of the tasks must accomplish.

Flow Charts by Battle Phase (Plan, Prepare, Execute): This graphical description portrays the sequence of CCF tasks within the framework of tactical battle phases. This component describes the flow of tasks during each battle phase, the vertical task linkages (to higher and lower echelon units), and horizontal linkages to other CCFs for the echelon being analyzed. It also depicts information flow which affects the tasks.

Other CCFs Which Interact with CCF15: Tasks performed in other CCFs or by other units are described as they relate (i.e., are linked) to the tasks of the CCF being analyzed. These descriptions provide verbal details of the relationships portrayed graphically by the Flow Chart. The purpose of this component is to allow the user to incorporate related tasks and participants into a training exercise for this CCF. Tasks which link to this analysis have been extracted for CCFs or units for which TAs have been accomplished and extrapolated for TAs which have not yet been developed.

CCF15 Key Participants by Task: The participants required to perform the tasks are identified. Identification is based on the appropriate echelon/type unit TO&E. It includes special staff members who are critical for task accomplishment.

Key Inputs and Outputs to CCF15: The critical information required and generated by participants to successfully accomplish the CCF is identified. Where information results from the performance of the CCF tasks, CCF information output is identified. One CCF's information output normally is provided as another CCF's input. Critical input and output are organized by the specific part of the doctrinal product or means used to communicate it. The source of critical information is specific only to the CCF echelon and function being analyzed, and is not intended to reflect all the information the product may contain. The linkages of inputs and outputs to specific tasks are depicted in the Flow Charts component.

Task List Summary: The tasks which are required to achieve the purpose of the CCF are listed and organized by battle phase.

Planning, Preparation, and Execution Task Lists: Tasks and supporting tasks necessary to perform the function are listed by battle phase. Normally, the task identifies the primary participants responsible for performing the tasks. The tasks have been extracted from the appropriate ARTEP MTPs, echelon and functional area field manuals (FMs), and proponent school special texts. The specific sources of references for each task and sub-task are shown in brackets [ ] following the task.

Task List Endnotes: These notes provide ancillary information and guidance keyed to specific tasks. Endnotes are indicated by superscript numbers in the Task Lists.

CALL Lessons Learned Relevant to CCF15: These are extracts from the Center for Army Lessons Learned (CALL) bulletins which provide insights into the performance of CCF15 tasks.

Lessons Learned Integrated into CCF15 Task List: The lessons learned extracted from the CALL publications relevant to performing this CCF are identified. They are organized and listed by the appropriate task from the Task List component. The purpose of this component is to provide the user with recent tactics, techniques, and procedures (TTP) associated with the performance of the tasks in this CCF.

Critical Tasks and Other Linkages: Critical individual or collective tasks (i.e., gate tasks) which CCF participants must be able to perform prior to engaging in the identified CCF tasks are listed so that the training can be conducted efficiently and safely.

References: Lists the sources of information from which this CCF task analysis is derived. The source's title and publication date are provided for users to locate the doctrinal source material for further detail and context.

## Purpose and Outcomes of CCF 15

This component identifies what the CCF is supposed to accomplish overall, which we term as the purpose. This component also identifies the end states or bottom line results necessary to achieve the purpose, which we term outcomes. As a consequence, this component of the analysis defines the end states that performance of the tasks will accomplish.

### PURPOSE

The synchronization and integration of lethal and non-lethal indirect fires in accordance with the Brigade Commander's concept and intent.

### OUTCOMES

1. The brigade commander and brigade staff integrate all lethal and non-lethal indirect fire systems in support of the brigade scheme of maneuver.
2. Fire support systems and personnel are positioned to acquire, process, execute, and assess indirect fires.
3. The brigade staff coordinates indirect fires with supporting fire support headquarters and units.
4. Brigade indirect fires are synchronized to support the brigade scheme of maneuver and to achieve the brigade commander's intent.
5. Indirect fires result in no fratricide to ground forces or to attack systems.

## FLOW CHARTS BY BATTLE PHASE (PLAN, PREPARE, EXECUTE)

This component illustrates Critical Combat Function (CCF) tasks as they are sequenced within the framework of tactical battle phases (e.g., Planning, Preparation, Execution). The purpose of this component is (1) to indicate the flow of tasks during each battle phase, (2) to show vertical task linkages (to higher and lower echelon units) and horizontal task linkages (to other CCF tasks for the echelon being analyzed), and (3) to depict information input and output which affects each task. Although the sequencing of tasks throughout each battle phase is intended to reflect the flow of tasks, tasks may be performed concurrently or may overlap with preceding or subsequent tasks.

Each echelon is labeled on the left of the flow chart. A horizontal line depicts the flow of tasks by sequence, reading left to right. The horizontal line for the echelon being analyzed is bolder than all other echelon horizontal lines.

Each task box contains a major task paraphrased from the CCF Task List. On the inside and upper left corner of each task box is placed the appropriate Task number from the Task List. The linkages of tasks, both vertical and horizontal, are depicted with lines. Arrowheads are placed on the linking lines to reflect the relevance of the linkage. Examples follow:

Figure 1 illustrates the Bn TF task providing input or otherwise supporting the Bde task.

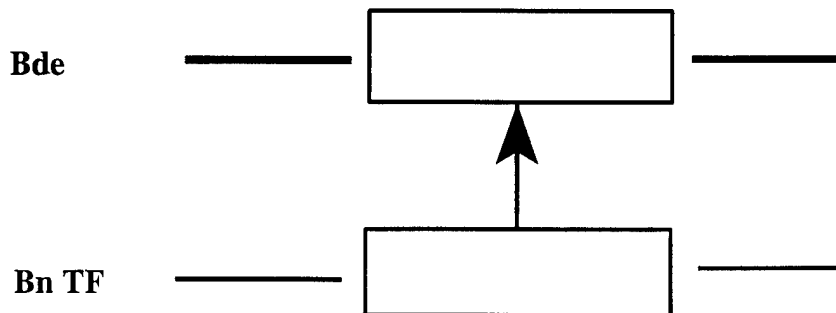

Figure 1.

Figure 2 illustrates the brigade task providing input or otherwise supporting the Bn TF task.

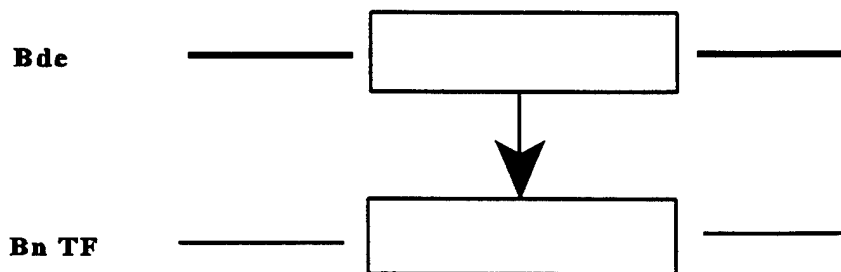

Figure 2.

Figure 3 illustrates both brigade and Bn TF tasks providing input or otherwise exchanging information which both tasks require.

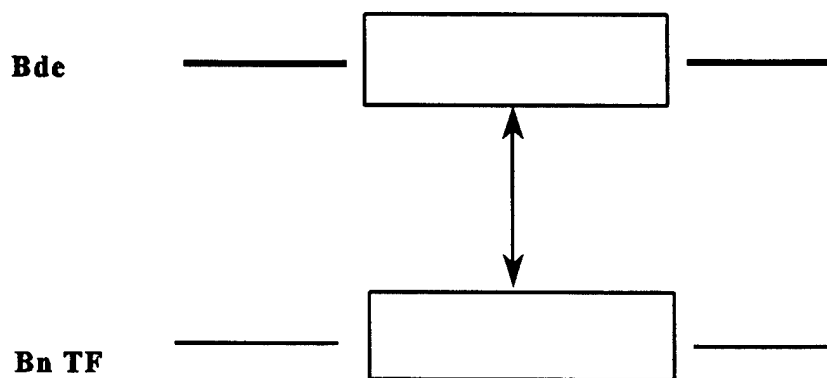

Figure 3.

Lines with no arrowheads reflect an inter-relationship between two or more tasks.

The relevant Input and Output letters listed in the Key Inputs and Outputs component are listed to the outside upper right of the task box. Each relevant task is depicted with input information which is required to perform the task and output information which is produced as a result of performing the task. Input and Output information is listed in the Key Inputs and Outputs component of the CCF analysis.

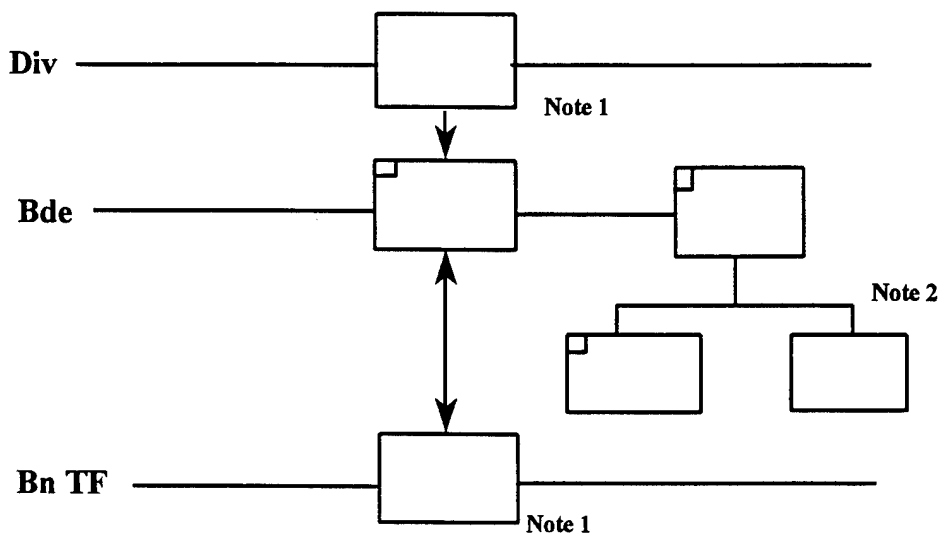

Figure 4.

Note 1: Task linkage to other units

Note 2: Task linkage to other CCF (same echelon)

Task linkages to other CCFs/Units are reflected on the flow charts. The task's text is placed in a box without a task number. In the case of a task from another unit (echelon), it is shown on that unit's (echelon's) horizontal line. Its relationship to the brigade task is illustrated as described in Figures 1 through 3. In the case of a task from another CCF, for the same echelon as the CCF being performed, the task is depicted on the same CCF echelon horizontal line, and its relationship to the brigade task is indicated.



# TASK FLOW PLAN

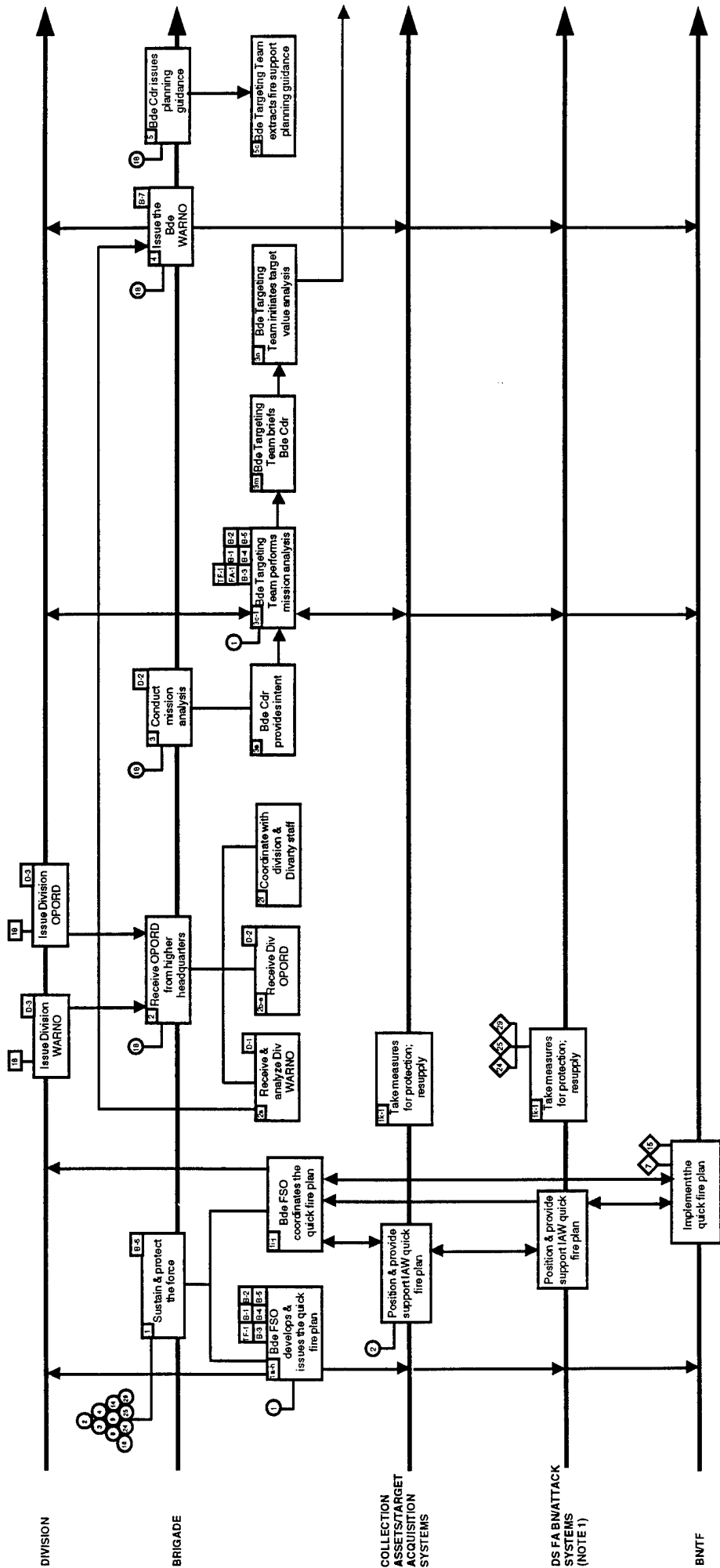

- = Division CCF
- = BCT CCF
- ◇ = BN TF CCF

Note 1: Attack systems are FA cannons, CAS aircraft, USN ships providing naval surface fires, and EW systems

# TASK FLOW PLAN (Continued)

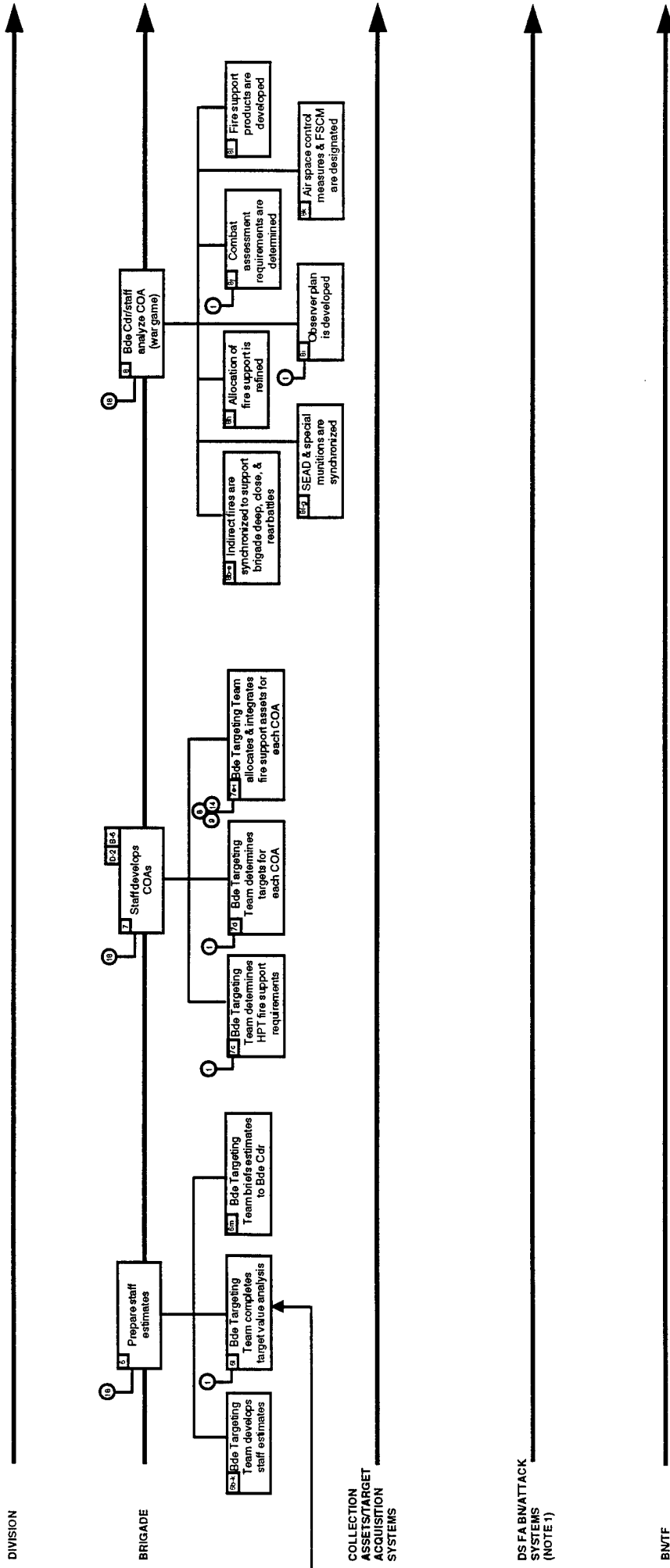

Note 1: Attack systems are FA cannons, CAS aircraft, USN ships providing naval surface fires, and EW systems

# TASK FLOW PLAN (Continued)

Brigade CCF 15 - Coordinate, Synchronize and Integrate Fire Support

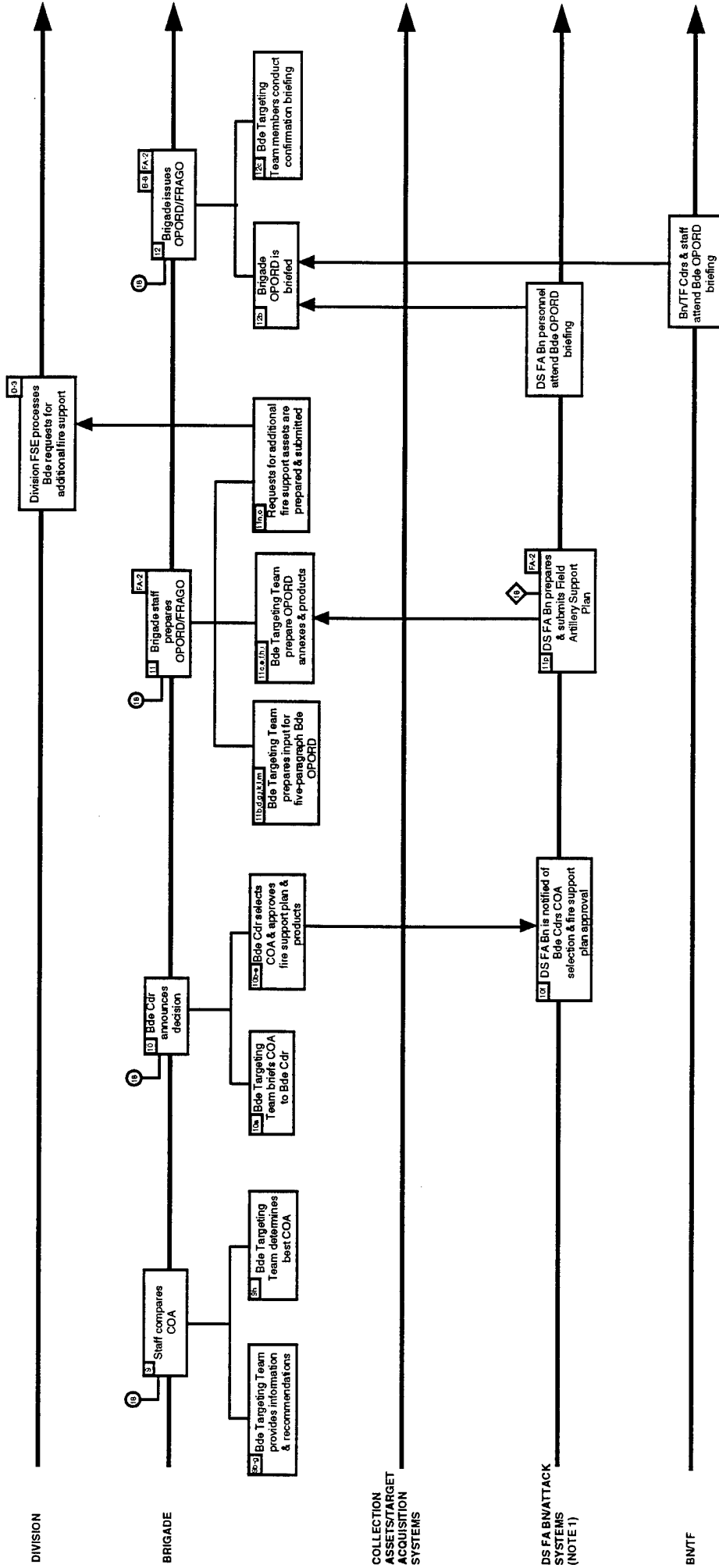

- = Division CCF
- = BCT CCF
- ◇ = BN TF CCF

Note 1: Attack systems are FA cannons, CAS aircraft, USN ships providing naval surface fires, and EW systems



# TASK FLOW PREPARE (Continued)

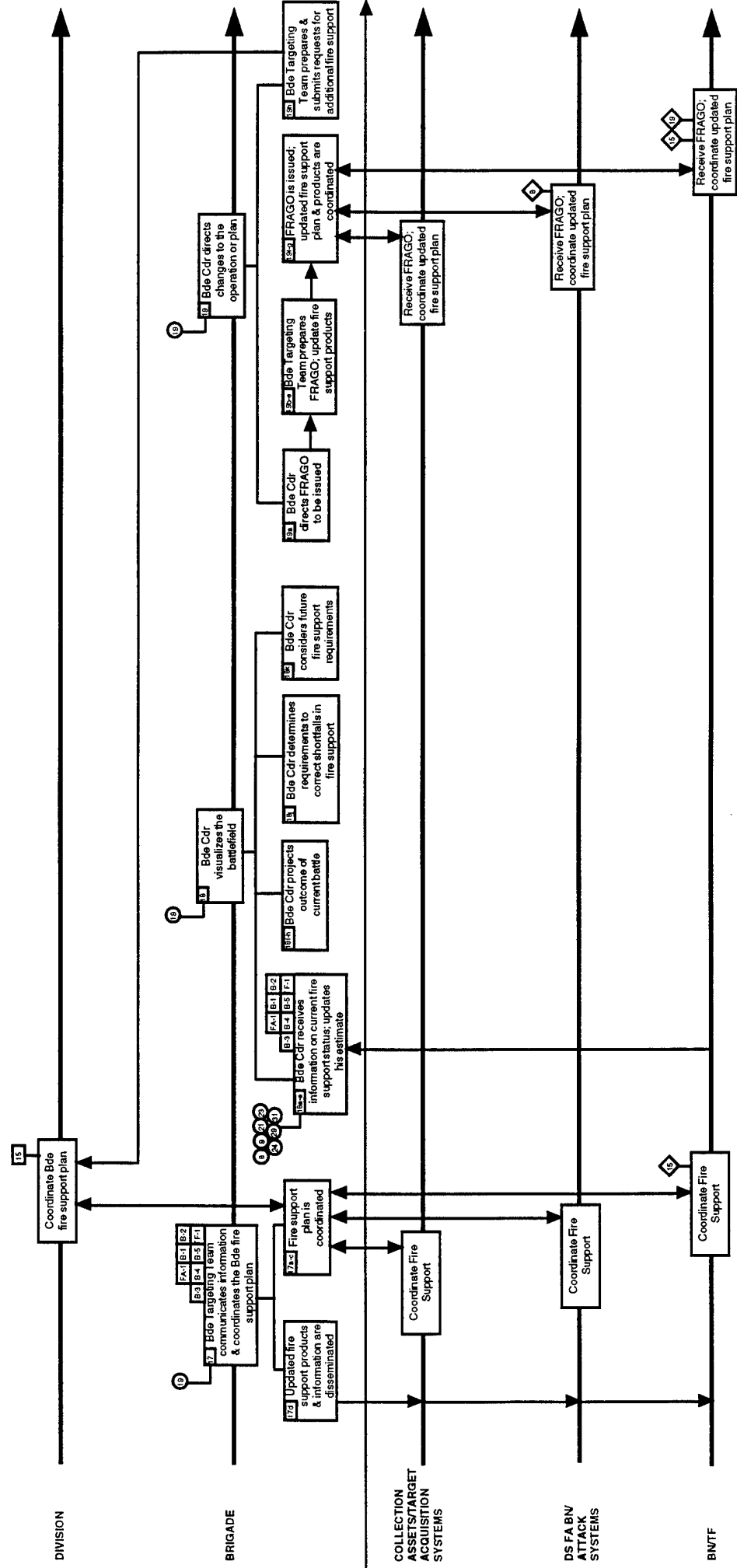

- = Division CCF
- = BCT CCF
- ◇ = BN TF CCF

# TASK FLOW PREPARE (Continued)

Brigade CCF 15 - Coordinate, Synchronize and Integrate Fire Support

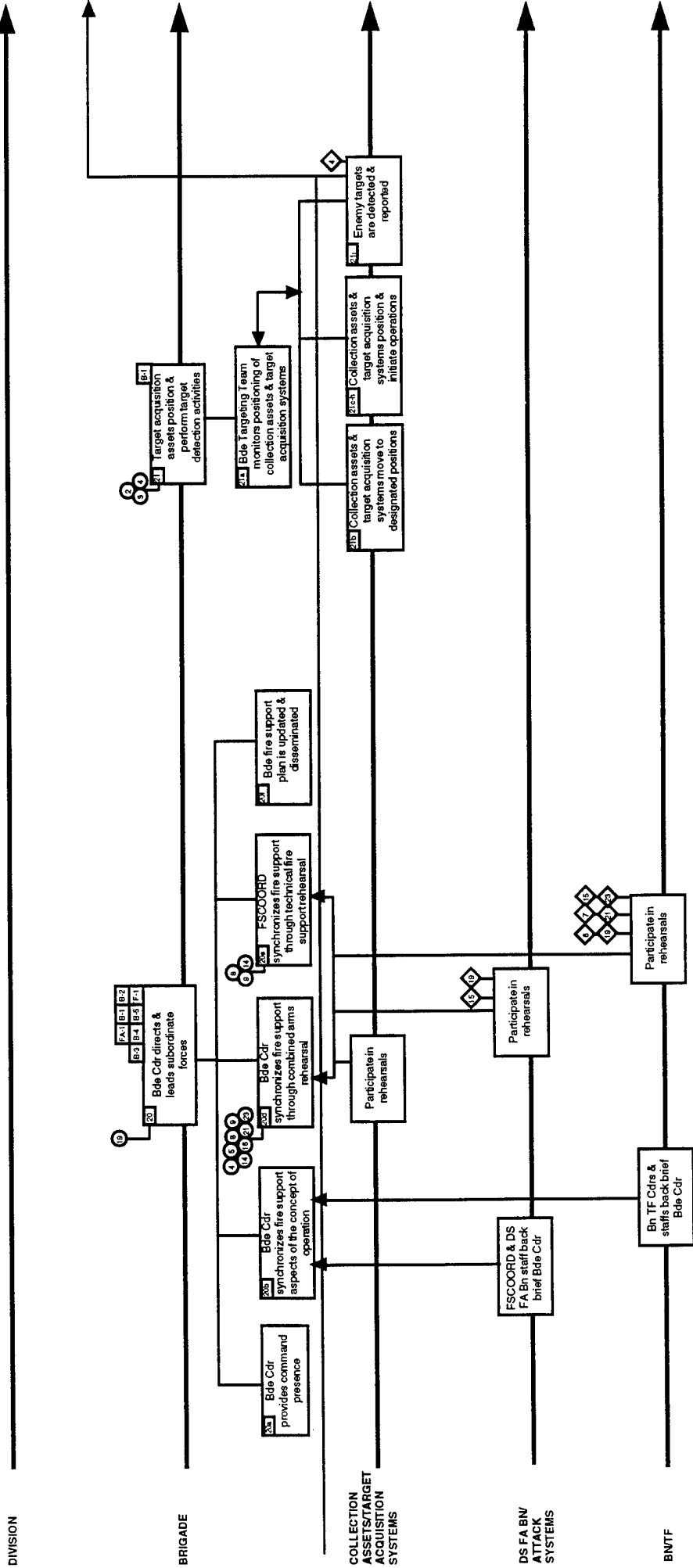

# TASK FLOW EXECUTE

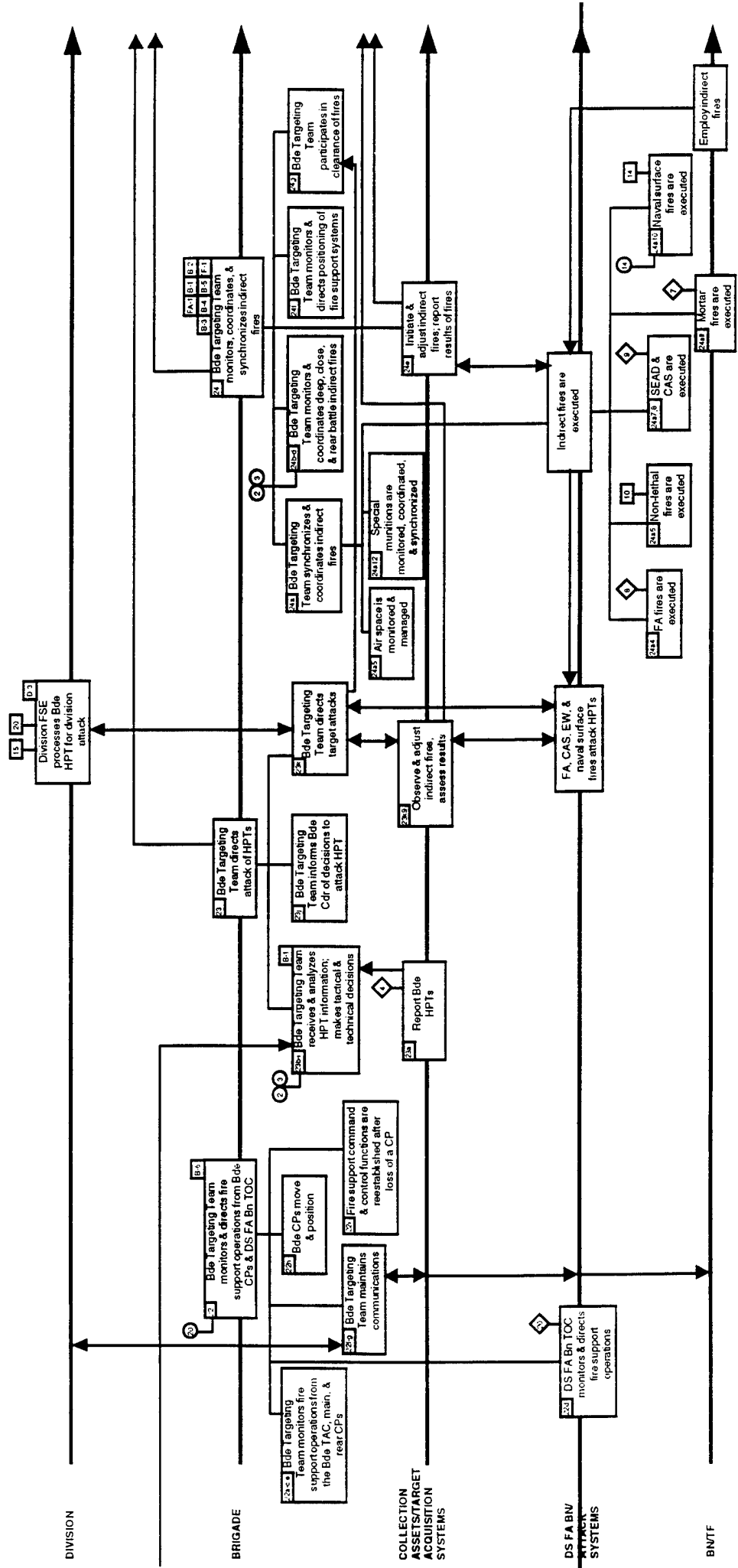

- = Division CCF
- = BCT CCF
- ◇ = BN II CCF

# TASK FLOW EXECUTE (Continued)

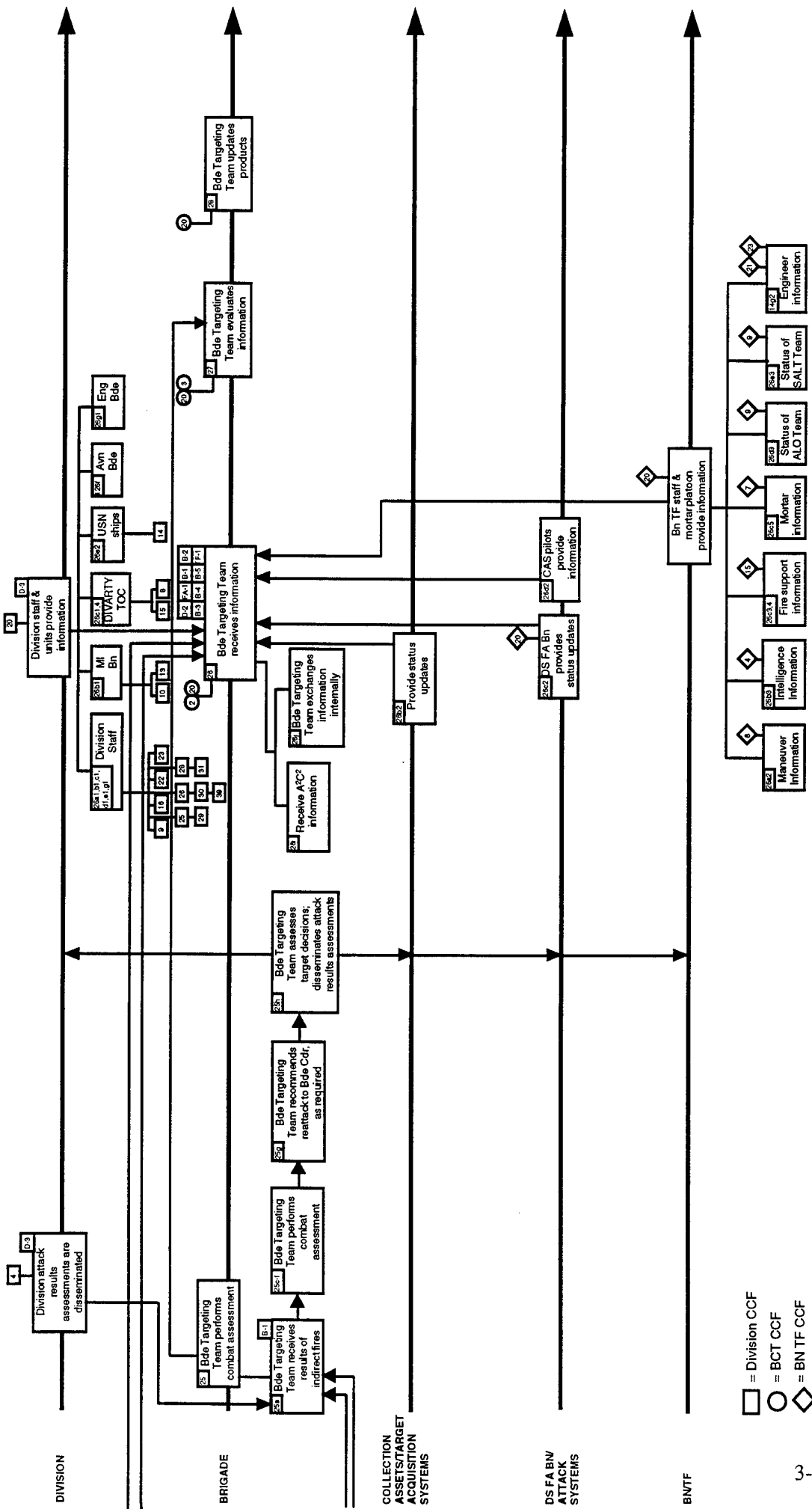

= Division CCF  
 = BCT CCF  
 = BN TF CCF



# TASK FLOW EXECUTE (Continued)

Brigade CCF 15 - Coordinate, Synchronize and Integrate Fire Support

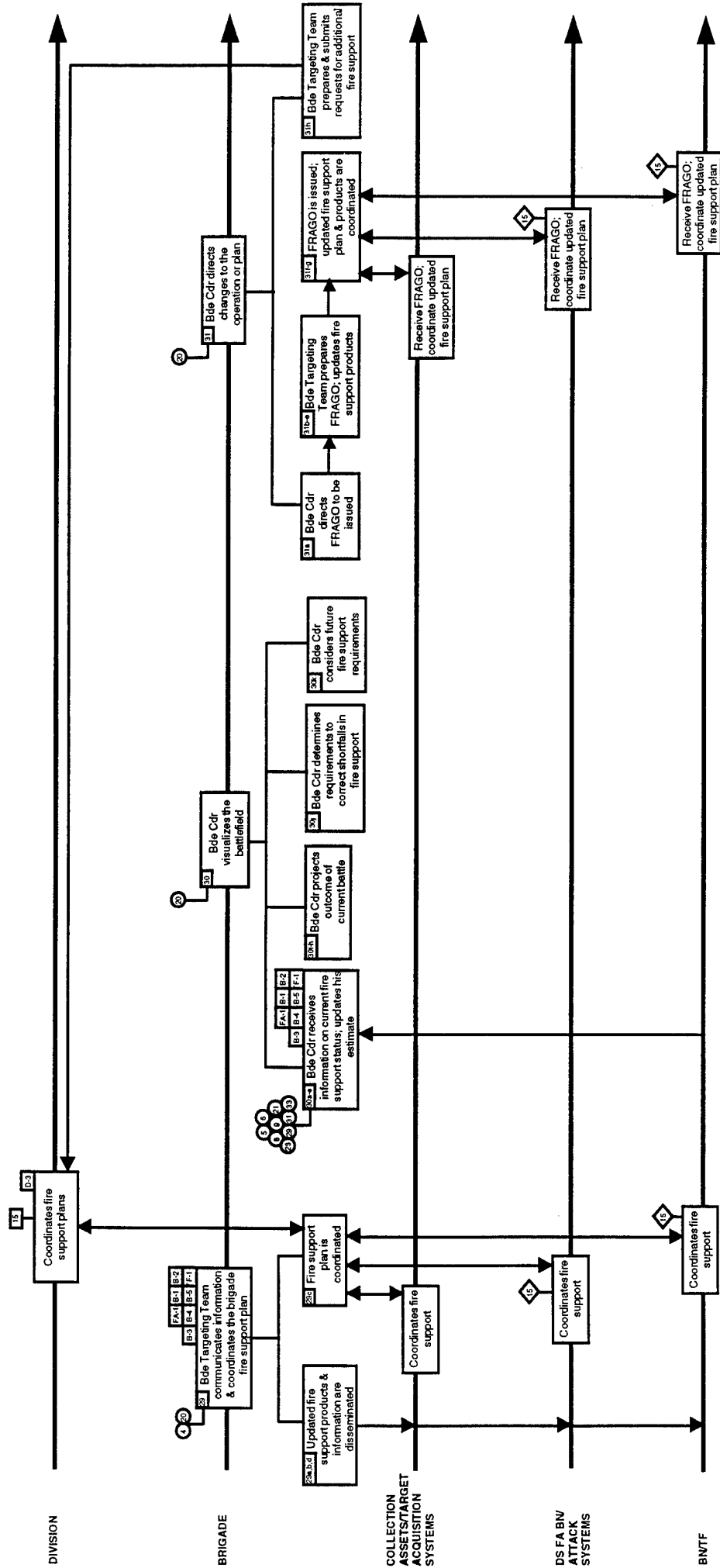

- = Division CCF
- = BCT CCF
- ◇ = BN TF CCF

# TASK FLOW EXECUTE (Continued)

Brigade CCF 15 - Coordinate, Synchronize and Integrate Fire Support

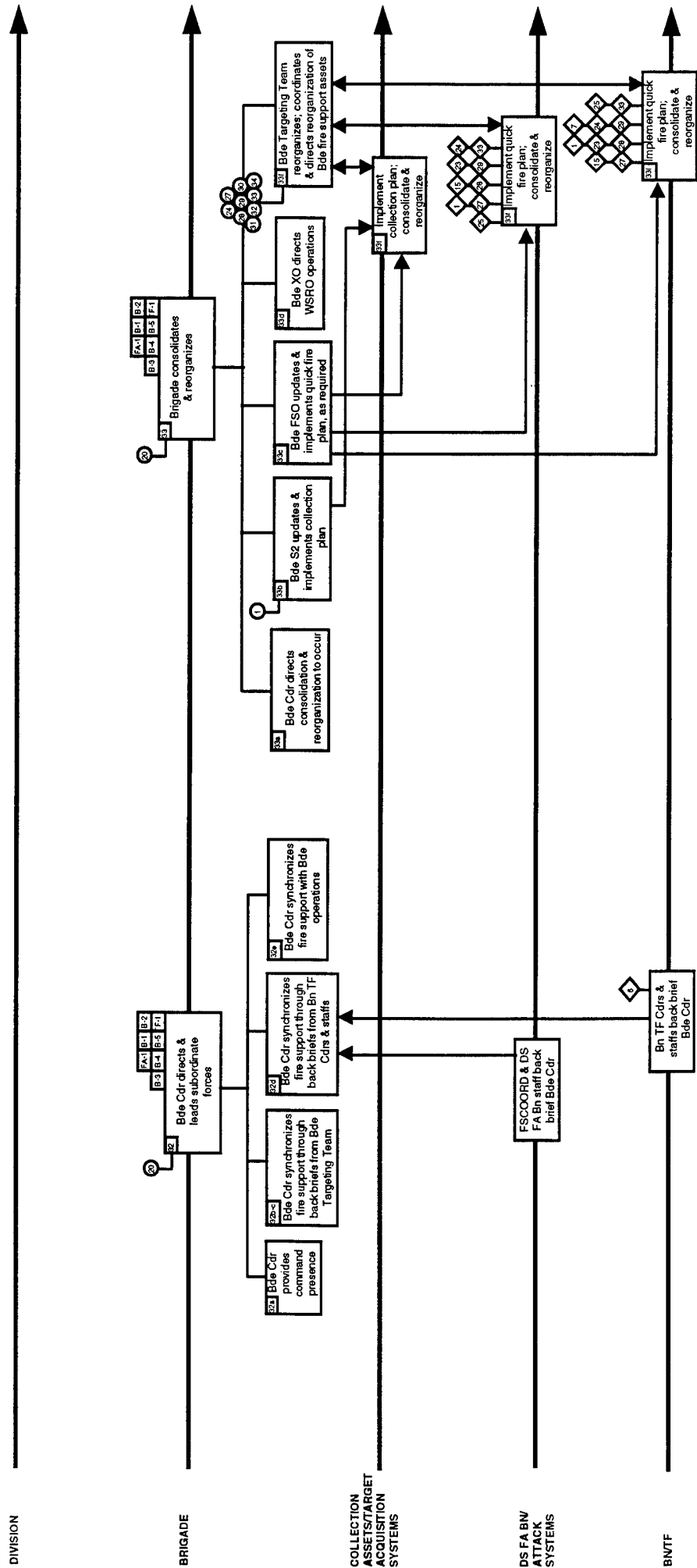

- = Division CCF
- = BCT CCF
- ◇ = BN TF CCF

## Other CCFs which Interact with CCF 15

This section describes other CCFs which are relevant to Brigade CCF 15 by echelon. The first echelon described is other brigade CCFs which interact with Brigade CCF 15. The second echelon described is division CCFs which interact with Brigade CCF 15. The last echelon described is battalion task force (Bn TF) CCFs which interact with Brigade CCF 15.

### CCFs WHICH INTERACT WITH CCF 15

<u>CCF</u>	<u>TITLE</u>	<u>LOGIC</u>
1	Conduct Intelligence Planning	<p><u>BCT CCF:</u></p> <p>The intelligence plan develops the knowledge of weather, enemy, terrain, and other aspects of the battlefield environment necessary to position acquisition systems and to identify suitable targets for indirect fires. Military intelligence (MI) assets involved in information gathering and target attack, by intelligence and electronic warfare (IEW) and other non-lethal means, are integrated into the intelligence plan. The brigade fire support officer (FSO), ALO, ANGLICO, and Aviation Liaison Officer (LNO) participate in the intelligence preparation of the battlefield (IPB) process.</p> <p><u>Bn TF CCF:</u></p> <p>Brigade tasks Bn TF units to observe brigade named area of interest (NAIs), targeted areas of interest (TAIs), and decision points (DPs); observations are integrated into Bn TF reconnaissance and surveillance (R&amp;S) plans. Brigade commander's critical information requirements (CCIR) and information requirements (IRs) are incorporated into Bn TF information collection plans and operations.</p>
2	Collect Information	<p><u>BCT CCF:</u></p> <p>Information relative to the implementation and refinement of the fire support plan is collected from internal brigade sources, the DS FA Battalion through its interface with division artillery (DIVARTY), LNOs (USAF, USN, USMC) through their interface with their Services, the DS MI Company through its interface with the Division MI Battalion, and from the division headquarters. Collected information sets the framework for target analysis by the brigade targeting team to accomplish the detect and assess functions of fire support. Enemy activities detected by</p>

CCF TITLE

LOGIC

brigade units and systems during security operations are assessed to determine their importance as indicators of possible enemy operations and intentions.

3 Process Information

BCT CCF:

Fire support planners are integrated into information processing systems to refine and modify the indirect fire support plan. Analyzed information, and its transition into intelligence, is used by the brigade targeting team to accomplish the decide, detect, and assess functions of fire support.

4 Disseminate Intelligence

BCT CCF:

Analyzed and processed intelligence is disseminated throughout the brigade and all supporting fire support headquarters. Intelligence is used to modify and refine the fire support plan and to provide responsive indirect fires as needed. Intelligence is disseminated to lower, higher, supporting, and adjacent units and headquarters to support target development, refinement, and acquisition.

Division CCF:

Division sources [e.g., Intelligence, General Staff (G2), All Source Analysis System (ASAS), DIVARTY] provide the brigade commander and brigade staff with intelligence. Intelligence is used by the brigade staff and the brigade targeting team to support the detect, decide, and assess functions of fire support.

Bn TF CCF:

Subordinate brigade units provide the brigade staff with intelligence collected from their assets during R&S operations; intelligence is used by the brigade staff and the brigade targeting team to detect brigade targets.

5 Conduct Tactical Movement

BCT CCF:

Indirect fires are integrated and utilized to support brigade movement. Fire support assets conduct movement to and

CCF TITLE

LOGIC

occupy positions from which to acquire, process, execute, and assess indirect fire support. Air movement of indirect fire units and systems is performed to support the scheme of maneuver and the brigade commander's intent. Movement of indirect fire systems is integrated and deconflicted with other BCT elements.

- 6 Engage the Enemy  
with Direct Fire and  
Maneuver

BCT CCF:

Indirect fire assets under brigade control are positioned to provide indirect fires. Target acquisition assets, observers, and brigade leaders detect targets for attack by indirect fire systems and request, process, execute, and assess target attack. Indirect fires are integrated and synchronized to support the execution of the brigade's maneuver and direct fires. Indirect fires are provided to support attack helicopter operations controlled by the brigade.

Bn TF CCF:

Brigade subordinate Bn TFs integrate indirect fires to support their maneuver and direct fires. The brigade commander and brigade staff monitor Bn TF tactical operations to ensure that indirect fires are prioritized and executed to support brigade main and supporting efforts; the brigade commander and brigade staff integrate and synchronize indirect fires for the brigade-deep battle to set the conditions for the brigade and subordinate Bn TF close battles.

- 7 Employ Mortars

Bn TF CCF:

A source of fire support employed by the brigade's Bn TFs; may be employed to support major brigade operations (e.g., river crossing, obstacle breach, air-head/beach-head entry), requiring close coordination and integration between the brigade staff and commanders and staff of subordinate Bn TFs.

- 8 Employ Field Artillery

BCT CCF:

A source of fire support, to be integrated and synchronized with brigade maneuver and direct fires. Priorities are established for artillery support, terrain management, movement of artillery systems within the brigade area, and positioning of batteries and radars. The fire support

CCF TITLE

LOGIC

coordinator (FSCoord) provides direction to the DS FA battalion to ensure compliance with the brigade scheme of maneuver and the brigade commander's intent.

Division CCF:

A source of fire support; division FA units and systems are prioritized to support the division scheme of maneuver and division commander's intent; FA systems (guns, radars, acquisition systems) retained under division control are provided to the brigade as required in a general support (GS) or GS-reinforcing (GS(R)) role. The brigade staff and DS FA battalion commander and staff maintain status updates on division fire support assets to provide the brigade commander and brigade staff with recommendations on their employment and availability; brigade FA targets which exceed the brigade DS FA fire support capability are integrated into the division's FA fire support plan.

Bn TF CCF:

A source of fire support. For maneuver Bn TFs, FA fires are integrated, synchronized, and executed to support their maneuver. For the DS FA Bn, BCT and Bn TF fire support plans are processed and technical data is computed. Firing batteries and fire direction centers (FDCs) are positioned to provide fires and designated support. Fire support plans are executed and refined to ensure that FA fires are responsive to the BCT and Bn TFs.

9 Employ Close Air Support

BCT CCF:

Sources of fire support provided by USAF, USN, and/or USMC units; these are integrated and synchronized with brigade maneuver and direct fires. LNOs from separate services are integrated into the brigade staff during all phases of the battle to ensure that CAS achieves the brigade commander's intent and supports the brigade scheme of maneuver.

Division CCF:

Sources of fire support; division allocation of and priorities for support from USAF, USN, and/or USMC LNO teams and aircraft to the brigade are established. Division CAS is

**CCF TITLE**

**LOGIC**

integrated and synchronized with brigade maneuver and direct fires. LNOs from separate services are integrated into the brigade staff during all phases of the battle. Brigade targets for CAS are provided to the division staff for integration into the division CAS plan. Suppression of enemy air defenses (SEAD) fires are provided as required in support of division-level CAS and battlefield air interdiction (BAI) operations.

**Bn TF CCF:**

Sources of fire support provided by USAF, USN, and/or USMC units, to be integrated and synchronized with Bn TF maneuver and direct fires. LNOs from separate services are integrated into the Bn TF staff during all phases of the battle to ensure that CAS achieves the Bn TF commander's intent and supports the Bn TF scheme of maneuver.

10 Conduct Electronic  
Collection and  
Jamming

**Division CCF:**

A source of non-lethal fire support. The brigade commander and brigade staff integrate and synchronize collection and jamming assets under division control to support brigade fire support and information collection activities.

13 Conduct Counter  
Target Acquisition  
Operations

**Division CCF:**

A source of fire support; the brigade commander and brigade staff integrate and synchronize assets under division control to suppress or degrade enemy direct observation, optics, radar, sensors, electronic DF equipment, and imaging systems in support of the brigade commander's intent and the brigade scheme of maneuver.

14 Employ Naval  
Surface Fires

**BCT CCF:**

A source of fire support, to be integrated and synchronized with brigade maneuver and direct fires; augmentation by USN ANGLICO team and/or USMC supporting arms liaison team (SALT), when available, is integrated into the brigade staff during all phases of the battle to ensure that naval surface fires achieve the brigade commander's intent and support the brigade scheme of maneuver.

CCF TITLE

LOGIC

Division CCF:

A source of fire support; division allocation of and priorities for support from USN ships and distribution of USN and/or USMC LNO teams to the brigade are established. Division naval surface fires are integrated and synchronized with brigade maneuver and direct fires; LNOs from separate services are integrated into the brigade staff during all phases of the battle. Brigade targets for naval ships GS to the brigade are provided to the division staff for integration into the division naval surface fires plan.

- 15 Coordinate,  
Synchronize, and  
Integrate Fire Support

Division CCF:

The brigade commander and brigade staff coordinate brigade fire support requirements with the division fire support element (FSE) and DIVARTY staff. Brigade fire support is synchronized and integrated to support the division commander's intent and the division scheme of maneuver.

BN TF CCF:

The brigade commander and staff coordinate brigade fire support requirements with Bn TF FSOs and FSEs; Bn TFs integrate and execute the brigade fire support plan.

- 16 Take Active Air  
Defense Measures

BCT CCF:

Indirect fires and fire support assets are positioned and employed to bring fires against known and suspected enemy air defense systems, forward air control assets, and attack helicopters. Units and systems providing indirect fire support to the brigade employ active defense measures to repel enemy air attacks while retaining the ability to provide responsive fire support to the brigade. Air defense artillery (ADA) units in support of the brigade provide air defense to high priority assets and activities.

Division CCF:

The brigade commander and brigade staff integrate divisional air defense assets operating in the brigade's area of operations to provide active air defense support (as available) to fire support systems and units providing support to the brigade.



CCF TITLE

LOGIC

18 Plan for Combat Operations

BCT CCF:

Fire support assets and indirect fires are integrated and synchronized with the brigade scheme of maneuver, direct fire plans, and the brigade commander's intent.

Division CCF:

The division scheme of maneuver and the division commander's intent focus brigade operations. Fire support assets and indirect fires in support of and available to the brigade are determined and prioritized in the division plan. The division plan establishes support relationships and allocates target acquisition and fire support systems to the brigade.

Bn TF CCF:

Fire support assets and indirect fires available to brigade subordinate units are integrated and synchronized with the Bn TF maneuver plan, direct fire plan, and Bn TF commander's intent. Bn TF plans are developed to accomplish the brigade commander's intent.

19 Direct and Lead Units in Preparation for Battle

BCT CCF:

Indirect fire support assets under brigade control are positioned and rehearsed. The indirect fire support plan is modified and refined based on rehearsals, updated intelligence, and changes to the brigade maneuver and direct fire plans. Indirect fires and fire support assets which process and control indirect fires are utilized to support brigade security operations. The brigade commander and brigade staff adjust the tactical plan based on updated intelligence and other information, which results in changes to the fire support plan.

Division CCF:

Indirect fire support assets under brigade control are rehearsed, including the acquisition, processing, execution, and assessment of indirect fires against division targets. The brigade indirect fire support plan is modified and refined based on division rehearsals, intelligence, and changes to the division scheme of maneuver. Indirect fires and assets which

CCF TITLE

LOGIC

process and control indirect fires are utilized to support brigade security operations which accomplish division-imposed missions. Preparation status of division units and fire support systems is monitored by the brigade commander and brigade staff to determine their availability to the brigade. The brigade commander and brigade staff provide updates and status reports to the division commander and division staff on the brigade's preparation activities.

Bn TF CCF:

Indirect fire support assets under Bn TF control are positioned and rehearsed. The indirect fire support plan is modified and refined based on rehearsals, intelligence, and changes to the maneuver and direct fire plan. Indirect fires and assets which process and control indirect fires are utilized to support security operations. The preparation status of brigade units is monitored by the brigade commander and brigade staff to ensure that the brigade can accomplish the mission and achieve the brigade commander's intent. Bn TF rehearsals and rehearsal results serve as the basis for brigade rehearsals and modifications to the brigade plan.

20 Direct and Lead Units  
in Execution of Battle

BCT CCF:

Indirect fires and fire support assets are integrated and synchronized with brigade maneuver and direct fires through positive command and control. The brigade commander, with support from the brigade staff, adjusts the tactical plan based on updated intelligence and other information, resulting in changes to the fire support plan. Indirect fires are delivered and their results are assessed to ensure that the brigade commander's intent is achieved.

Division CCF:

Division-deep indirect fires and cross-forward line of own troops (FLOT) operations are assessed to determine their effectiveness in shaping the battlefield for the brigade-deep and close battles. Updates from the division commander, division staff, and DIVARTY are used by the brigade commander and brigade staff to determine the success of the division's fight and to determine the availability of divisional lethal and non-lethal fire support to support the brigade. The brigade commander and brigade staff provide updates and

CCF TITLE

LOGIC

status reports to the division commander and division staff on the brigade's activities during mission execution. Division consolidation, reorganization, and reconstitution plans are implemented by the brigade.

Bn TF CCF:

Indirect fires and fire support assets are integrated and synchronized with Bn TF maneuver and direct fires through positive command and control. Bn TF commanders and staffs provide status updates to the brigade commander and brigade staff on their progress and activities to accomplish assigned missions. The brigade commander and brigade staff monitor, plan, and direct brigade actions to ensure that priorities for indirect fire support and all other types of support are being met in support of brigade units and to achieve the brigade commander's intent.

21 Overcome Obstacles

BCT CCF:

Indirect fire support assets under brigade control retain freedom of movement as they bypass or overcome obstacles. Indirect fires are used to suppress and destroy enemy forces overwatching obstacles or in support of enemy obstacles and to obscure breaching activities by brigade units.

Bn TF CCF:

Indirect fire support assets under Bn TF control are positioned to acquire, process, execute, and assess indirect fires in support of breaching operations. Indirect fires are used to suppress and destroy enemy forces overwatching obstacles and to obscure movement of friendly forces and breaching of obstacles. The brigade commander and brigade staff monitor, plan, and direct brigade units and indirect fire support to ensure that indirect fires support the brigade's and Bn TF schemes of maneuver and commanders' intents.

22 Enhance Movement

Division CCF:

Division activities to construct or repair roads, trails, and airfields, as well as coordination with host nation agencies to acquire support to enhance the movement of division units and equipment, are monitored by the brigade commander and brigade staff to determine relevancy to brigade operations and

CCF TITLE

LOGIC

the movement of brigade fire support units in the brigade's battle space. The brigade staff provides recommendations to and coordinates with the division staff for the enhancement of roads, trails, and airfields necessary to support the brigade's scheme of maneuver.

23 Provide Counter-mobility

BCT CCF:

Scatterable mines delivered by fire support assets (artillery, Air Force, Navy, Marine Corps) are integrated into fire support planning and preparation. The brigade engineer coordinates with the brigade FSO and LNOs of units providing scatterable mines to ensure that placement of scatterable mines is in accordance with the obstacle plan. Fire support and target acquisition assets are positioned to initiate employment of scatterable mines; to assess the effectiveness of scatterable mines; and to acquire, process, execute, and assess indirect fires in support of obstacles emplaced by brigade units.

Division CCF:

Division-directed obstacles are integrated into the brigade obstacle plans; division obstacles are emplaced, observed, and covered by observation and fires by brigade units. Division guidance (e.g., quantities, duration) and allocation of scatterable mines establish the criteria for employment by the brigade. FA units providing support to the brigade's DS FA battalion and USN, USAF, and USMC aircraft supporting the division are integrated into the brigade countermobility plan and are employed to emplace scatterable mines.

Bn TF CCF:

Scatterable mines are integrated and employed to support Bn TF schemes of maneuver and the brigade commander's intent and brigade's scheme of maneuver; brigade indirect fire support assets and systems are employed to emplace scatterable mines in support of Bn TF operations.

CCF   TITLE

LOGIC

24   Enhance Physical  
      Protection

BCT CCF:

Indirect fire support assets under brigade control are included in the planning and construction of defensive positions. Fire support assets are protected from enemy and friendly fires.

Bn TF CCF:

Indirect fire support assets under Bn TF control are included in the planning for and construction of survivability and defensive positions. Brigade fire support personnel and systems operating in Bn TF areas of operation may be included in Bn TF construction plans. Brigade fire support assets operating in Bn TF areas of operation are provided protection from enemy direct fires.

25   Provide Operations  
      Security

BCT CCF:

Indirect fires and fire support systems and assets under brigade control are positioned to acquire, process, execute, and assess indirect fires in support of brigade security operations. Fire support assets adhere to operational security (OPSEC) requirements and measures to deny the enemy information on friendly forces' plans and intentions.

Division CCF:

Division OPSEC requirements and measures are implemented by the brigade headquarters and brigade units; division-directed security operations are executed by brigade units and are supported by indirect fire support personnel and systems; division security operations being performed by non-brigade units are monitored by the brigade commander and brigade staff to assess their impact on brigade operations and plans.

Bn TF CCF:

Indirect fires and fire support assets under TF control which acquire, process, execute, and assess indirect fires are provided to support Bn TF security operations, and these contribute to brigade security operations. Indirect fire systems and fire support assets which process, coordinate, and control indirect fires are conducted in such a way as to deny the enemy information on friendly forces' plans and intentions. Brigade fire support personnel and systems

**CCF TITLE**

**LOGIC**

operating in Bn TF areas of operation are included in Bn TF OPSEC plans.

26 Conduct Deception Operations

**Division CCF:**

Division deception operations and measures are implemented by the brigade, including the use of available brigade indirect fires. The brigade commander and brigade staff monitor the status of brigade actions to accomplish deception goals to ensure that the division deception plan is successful. The brigade staff assesses the deception effort to determine tactical advantages gained by the brigade.

27 Provide NBC Defense

**BCT CCF:**

Supporting indirect fire support units, personnel, and systems are integrated into the brigade nuclear, biological, and chemical (NBC) defense and decontamination plan. Fire support personnel react to NBC attack and perform individual, hasty, and deliberate NBC decontamination following NBC attack.

**Bn TF CCF:**

Brigade fire support personnel and systems may be included in decontamination plans of Bn TFs. Brigade fire support personnel and systems operating in Bn TF areas of operations are provided decontamination support as required.

28 Provide Transport Services

**BCT CCF:**

Brigade transportation assets are planned for and provided to support movement of fire support personnel, ammunition, and equipment during all battle phases. Brigade staff and DS FA battalion staff identify transportation requirements and request augmentation from division and higher sources as required.

**Division CCF:**

Division transportation plans and operations are monitored by the brigade staff to ensure that required ammunition and equipment are transported to brigade units. The brigade staff exercises control of brigade main supply routes (MSRs)/alternate supply routes (ASRs) to ensure that ground transportation assets are able to navigate through the brigade's

CCF TITLE

LOGIC

area of operations. The brigade requests and coordinates the use of division air assets and USAF aircraft for the transportation of brigade supplies, equipment, and personnel.

Bn TF CCF:

Bn TF transportation assets may be used to transport fire support personnel, equipment, and supplies for brigade units.

29 Conduct Supply Operations

BCT CCF:

Continuous, responsive resupply of brigade fire support assets is performed. Brigade Supply/Logistics Officer (S4), Forward Support Battalion (FSB) staff, and DS FA battalion combat service support (CSS) staff plan and prioritize logistical support of fire support units under brigade control. Brigade S4, FSB staff, and DS FA battalion CSS staff perform coordination with division CSS staff and logistics agencies to requisition and receive ammunition (by mix and type of munitions) and all other classes of supply to support fire support assets under brigade control.

Division CCF:

Division supply priorities, supply restrictions controlled supply rate (CSR), and distribution plans establish planning criteria in terms of possible constraints. The brigade staff monitors division supply operations to ensure that brigade units receive required supplies.

Bn TF CCF:

Bn TF CSS operations may be required to provide limited supplies [i.e., petroleum, oils, and lubricants (POL), small arms ammunition] to brigade fire support assets operating in Bn TF areas of operation.

30 Provide Personnel Services

BCT CCF:

Brigade Personnel Officer (S1) and Personnel and Administration Center (PAC) monitor distribution and fill of trained fire support personnel for all brigade units. Brigade S1 and the brigade staff coordinate with the DS FA battalion and DIVARTY for replacement personnel with fire support military qualification standards (MQS)/military occupational

**CCF TITLE**

**LOGIC**

skill (MOS) supporting the brigade staff, DS FA battalion, and brigade subordinate units. The Brigade S1 and PAC coordinate with USAF, USN, and/or USMC headquarters for replacement of fire support personnel supporting the brigade staff and brigade subordinate units.

**Division CCF:**

The brigade operates within the division personnel management system to request replacements to fill brigade fire support personnel requirements which cannot be met by the DS FA battalion or other fire support headquarters supporting the brigade. Critical grade and MOS requirements are managed to ensure that the division personnel system provides qualified personnel to fill brigade vacancies.

31 Maintain Weapons  
Systems and  
Equipment

**BCT CCF:**

Fire support and specific mission essential equipment [e.g., fire-support team vehicles (FIST-Vs), combat observation lasing teams (COLTs), digital and voice communications equipment, etc.] are repaired and replaced by DS FA battalion maintenance assets operating in the Brigade Support Area (BSA) and Division Support Area (DSA). Maintenance of fire support equipment and systems belonging to the DS FA battalion, USAF, USN, and USMC units is conducted to maintain operational readiness (OR) rates required for the mission. Maintenance priorities are established for fire support equipment and systems.

**Division CCF:**

Division maintenance priorities are implemented by the brigade. Brigade fire support systems (i.e., tubes, radars, lasers, communications systems) which cannot be repaired by FSB maintenance assets are repaired by division or higher maintenance units.

32 Provide Health  
Services

**BCT CCF:**

Brigade Surgeon and the FSB Medical Company provide medical services to the DS FA battalion and other (USAF, USN, USMC) fire support personnel operating in support of the brigade. DS FA battalion and fire support personnel conduct preventive medicine.



**CCF   TITLE**

**LOGIC**

33    Treat and Evacuate  
      Battlefield Casualties

**BCT CCF:**

The brigade staff integrates the DS FA battalion and other (USAF, USN, USMC) fire support personnel into plans for the treatment and evacuation of casualties to the FSB Medical Company. Medical treatment and services are provided to fire support personnel supporting the brigade.

**Bn TF CCF:**

Bn TF medical personnel and vehicles may provide medical support to brigade fire support personnel operating in Bn TF areas of operation.

34    Conduct Enemy  
      Prisoners of War  
      (EPW) Operations

**BCT CCF:**

The brigade staff integrates the DS FA battalion and supporting fire support units into enemy prisoners of war (EPW) plans in order to establish EPW control throughout the entire brigade area of operations. EPW operations are conducted to ensure that EPWs do not interfere with the movement, positioning, and employment of indirect fire systems and units in support of the brigade.

35    Conduct Civil Affairs  
      Operations

**Division CCF:**

Division civil affairs (CA) requirements and measures are implemented by the brigade. Divisional and non-divisional CA units operating in the brigade area of operations provide support to the brigade for the movement and positioning of fire support systems, as well as recommendations to the brigade commander and brigade staff on the use of indirect fires and the impact of indirect fires on the civil authorities and population.

39    Provide Field  
      Services

**Division CCF:**

Division CSS assets are allocated to the brigade to provide support beyond the capability of the FSB. Division CSS units providing field services support to the brigade operate in the brigade area of operations.

## CCF 15 Key Participants by Task

For the purposes of this task analysis, the term "Brigade Targeting Team" will be used to describe those members of the brigade staff involved in the coordination, synchronization, and integration of fire support. If the brigade commander is available, he joins the Brigade Targeting Team. See Endnote 9 to the Task List for doctrinal references on Brigade Targeting Team members.

### Brigade Targeting Team:

- Brigade FSCoord (i.e., the DS FA Battalion Commander)
- Brigade Executive Officer
- Brigade Operations and Training Officer (S3)
- Brigade S3 Air
- Brigade Intelligence Officer, (S2)
- Brigade battlefield information control center (BICC) Officer
- DS MI Company Commander
- Brigade Targeting Officer
- Brigade Engineer Officer (e.g., DS Engineer Brigade Commander)
- Brigade FSO
- Brigade ALO
- Brigade ANGLICO (when assigned)
- Army Aviation LNO (when assigned)
- AD LNO
- Brigade Chemical Officer
- DS FA Battalion S3
- DS FA Battalion S2

FMs 6-20-10, 6-20-40, and 6-20-50 are the doctrinal sources used to determine the composition of the Brigade Targeting Team. Endnote 4 to the Planning Task List provides a complete description of the sources (e.g., FM, page number) used to determine the composition. For purposes of this task analysis, the term "ad-hoc fire support team" is used to describe that element organized to operate from the Brigade Rear CP. See Task 8e, Task 13c, and Endnote 17 to the Task List for doctrinal references.

## TASKS

## KEY PARTICIPANTS

### PLANNING TASKS

1. Sustain and Protect the Force During Planning

Brigade Commander, Brigade FSCoord, Brigade S3, Brigade S3 Air, Brigade FSO, Brigade FSE, Brigade ALO, Brigade ANGLICO, Brigade Aviation LNO, Brigade S4, Bn TF Commanders, Bn TF S3s, Bn TF FSOs, Bn TF Mortar Platoon Leaders, DS

## TASKS

## KEY PARTICIPANTS

- |   |   |
|---|---|
|   | FA Battalion Executive Officer (XO), DS FA Battalion S3, DS FA Battalion S4, Division FSE, Division G4, DIVARTY TOC, DIVARTY S4, FSB Commander  |
| 2. Receive Order from Higher Headquarters               | Division Commander, Division G3, Division ALO, Division ANGLICO, DIVARTY Commander, DIVARTY S3, Division FSE, Brigade Commander, Brigade FSCoord, Brigade S3, Brigade FSO, Brigade S2, Brigade ALO, Brigade ANGLICO |
| 3. Conduct Mission Analysis                             | Brigade Commander, Brigade Targeting Team, Brigade S4, Brigade Signal Officer, Division FSE, DIVARTY Targeting Element  |
| 4. Issue the Warning Order                              | Brigade Commander, Brigade FSCoord, Brigade XO, Brigade S3, Brigade FSO, Brigade ALO, Brigade ANGLICO, Brigade Aviation LNO, Bn TF Commanders   |
| 5. Brigade Commander Issues Planning Guidance           | Brigade Commander, Brigade Targeting Team   |
| 6. Prepare Staff Estimates                              | Brigade Targeting Team, Brigade Signal Officer, Brigade S4  |
| 7. Staff Develops Courses of Action                     | Brigade Targeting Team  |
| 8. Staff/Commander Analyze Courses of Action (War Game) | Brigade Commander, Brigade Targeting Team   |
| 9. Staff Compares Courses of Action                     | Brigade Commander, Brigade Targeting Team   |
| 10. Brigade Commander Announces Decision                | Brigade Commander, Brigade Targeting Team, DS FA Battalion S3   |
| 11. Brigade Staff Prepares OPORD/FRAGO                  | Brigade Targeting Team, Brigade S4, DS FA Battalion S3  |
| 12. Brigade Issues the OPORD/FRAGO                      | Brigade Commander, Brigade Targeting Team, Brigade S4, Brigade Signal Officer, Brigade FSCoord, DS FA Battalion staff, Bn TF Commanders and staffs, FSB.  |

## TASKS

## KEY PARTICIPANTS

Commander and staff, separate company commanders, DS Engineer Battalion Commander and staff, Operational Control (OPCON) Army Aviation unit commander and staff, staffs from adjacent units, Brigade LNOs to other units, LNOs to the brigade from other units.

### **PREPARATION TASKS**

- |   |  |
|---|--|
| 13. The Brigade Targeting Team Organizes Operations   | Brigade Commander, Brigade Targeting to Monitor, Plan, and Direct Fire Support Team, Brigade FSE, ad-hoc fire support team in the Brigade Rear CP, Brigade Fire Support NCO, DS FA battalion staff   |
| 14. The Brigade Targeting Team Acquires Information   | Brigade Targeting Team, Division operations staff, Division intelligence section, Division FSE, DIVARTY tactical operations center (TOC), Corps Air Support Operations Center (ASOC), Aviation Brigade S3, commanders of OPCON aviation units, MI Battalion S3, Bn TF FSOs, Bn TF S2s, Bn TF ALOs, Bn TF SALT officers, Bn TF Engineers, Bn TF S4s, DS FA Battalion S3, DS FA Battalion S4s, Engineer Battalion S3, FSB S3, leaders of target acquisition systems and collection assets, air space users |
| 15. The Brigade Targeting Team Evaluates Information  | Brigade Targeting Team   |
| 16. The Brigade Targeting Team Updates Products   | Brigade Targeting Team, Brigade Signal Officer   |
| 17. The Brigade Targeting Team Communicates Information and Coordinates the Brigade Fire Support Plan | Brigade Targeting Team, Division G2, DIVARTY Commander, Division ALO, Division ANGLICO, DIVARTY S3, MI Battalion S3, Aviation Brigade S3, DS Battalion S3, FSOs of adjacent units, Bn TF FSOs, Bn TF S2s, Bn TF ALOs, Bn TF SALT officers  |
| 18. The Brigade Commander Visualizes the Battlefield  | Brigade Commander, Brigade Targeting Team, Bn TF Commanders  |

## TASKS

19. The Brigade Commander Directs Changes to the Operation or Plan
20. The Brigade Commander Directs and Leads Subordinate Forces
21. Target Acquisition Assets Position and Perform Target Detection Activities

## KEY PARTICIPANTS

Brigade Commander, Brigade Targeting Team, Bn TF Commanders, Bn TF S3s, Bn TF FSOs, Division G3, DIVARTY G3

Brigade Commander, Brigade Targeting Team, Bn TF Commanders and staffs, DS FA battalion staff, commanders and operators of DS FA battalion fire support systems involved in the fire support technical rehearsal as designated, Bn TF FSOs, Bn TF ALOs, Bn TF SALT officers, Bn TF Mortar Platoon Leaders, leaders and operators of target acquisition systems and collection assets

Brigade FSO, Brigade S2, Brigade Targeting Officer, Brigade FSCoord, fire support observers, target acquisition systems and collection assets

## EXECUTION TASKS

22. The Brigade Targeting Team Monitors and Directs Fire Support Operations from Brigade CPs and the DS FA Battalion TOC
23. The Brigade Targeting Team Directs the Employment of Indirect Fires Against Brigade high priority targets (HPTs)
24. The Brigade Targeting Team Monitors, Coordinates, and Synchronizes the Employment of Indirect Fires
25. The Brigade Targeting Team Receives the Results of Target Attacks and Performs Combat Assessment

Brigade Commander, Brigade Targeting Team, Brigade FSE, ad-hoc fire support team in the Brigade Rear Command Post (CP), Brigade fire support NCO, DS FA battalion staff

Brigade Commander, Brigade Targeting Team, Division FSE, CAS pilots, USN Fire Direction Centers (FDCs) on ships, DS FA Battalion S3, target acquisition systems and collection assets

Brigade Targeting Team, Bn TF FSOs, leader of ad-hoc fire support team in the Brigade Rear CP, DS FA Battalion S3, target acquisition systems, fire support observers, collection assets

Brigade S3, Brigade S2, Brigade Targeting Officer, other Brigade Targeting Team members as required, DS FA Battalion S3, DIVARTY Targeting Element, Bn TF S2, Bn TF FSO, target acquisition systems and collection assets

## TASKS

26. The Brigade Targeting Team Acquires Information
27. The Brigade Targeting Team Evaluates Information
28. The Brigade Targeting Team Updates Products
29. The Brigade Targeting Team Communicates Information and Coordinates the Brigade Fire Support Plan
30. The Brigade Commander Visualizes the Battlefield
31. The Brigade Commander Directs Changes to the Operation or Plan
32. The Brigade Commander Directs and Leads Subordinate Forces
33. The Brigade Consolidates and Reorganizes

## KEY PARTICIPANTS

- Brigade Targeting Team, Division operations staff, Division intelligence section, Division FSE, DIVARTY TOC, Corps ASOC, Aviation Brigade S3, commanders of OPCON aviation units, MI Battalion S3, Bn TF FSOs, Bn TF S2s, Bn TF ALOs, Bn TF SALT officers, Bn TF Engineers, Bn TF S4s, DS FA Battalion S3, DS FA Battalion S4, Engineer Battalion S3, FSB S3, leaders of target acquisition systems and collection assets, air space users
- Brigade Targeting Team
- Brigade Targeting Team, Brigade Signal Officer
- Brigade Targeting Team, Division G2, DIVARTY Commander, Division ALO, Division ANGLICO, DIVARTY S3, MI Battalion S3, Aviation Brigade S3, DS FA Battalion S3, FSOs of adjacent units, Bn TF FSOs, Bn TF S2s, Bn TF ALOs, Bn TF SALT officers
- Brigade Commander, Brigade Targeting Team, Bn TF Commanders
- Brigade Commander, Brigade Targeting Team, Bn TF Commander, Bn TF S3s, Bn TF FSOs, Division G3, DIVARTY G3
- Brigade Commander, Brigade Targeting Team, Bn TF Commanders and staffs, DS FA Battalion staff, commanders and operators of DS FA battalion fire support systems, Bn TF FSOs, Bn TF ALOs, Bn TF SALT officers, Bn TF Mortar Platoon Leaders, leaders and operators of target acquisition systems and collection assets
- Brigade Commander, Brigade Targeting Team, Bn TF Commanders

## Key Inputs and Outputs to CCF 15

This component identifies critical input information, organized by the doctrinal product or means used to communicate it, required by participants to successfully accomplish the CCF. Where information results from the performance of the CCF tasks, CCF information output will be identified. A CCF's information output normally becomes another CCF's input. The purpose of this component is to identify information required to drive a training exercise for this CCF and to help establish standards for measuring the performance of CCF tasks resulting in information output.

### KEY INPUTS

#### D-1 DIVISION WARNO

1. Mission, intent, and CCIR of Division (or Corps for Separate Brigades) Commander.
2. Graphics (e.g., fire support, maneuver, obstacles, airspace coordination area (ACA)).
3. Type of fire support munitions available, including CSR and required supply rate (RSR).
4. Enemy situation.
5. Assets available for collection of information and intelligence.
6. Projected task organization and support relationship for fire support units and target acquisition assets.

#### D-2 DIVISION OPORD/FRAGMENTARY ORDER (FRAGO)

1. Task organization.
  - a. FA battalions, batteries, target acquisition assets.
  - b. Collection assets.
  - c. USAF ALO elements.
  - d. USN ANGLICO elements.
2. Situation paragraph.
  - a. Division Commander's CCIR, Division IR.
  - b. Enemy courses of action (COAs) and timelines.
  - c. Weather and terrain.
  - d. Enemy fire support capabilities (lethal, non-lethal).
  - e. Enemy ADA capability.
  - f. Enemy air corridors.
3. Mission paragraph.
4. Execution paragraph.
  - a. Division Commander's Intent.
  - b. Concept of the Operation.
    - 1) Scheme of maneuver.
    - 2) Fires paragraph.
    - 3) Counter-air operations.
    - 4) Intelligence and Division Joint Targeting Board Information.
    - 5) Electronic Warfare operations.
    - 6) Deception operations.

- 7) Battle handover from division to brigade.
  - 8) Brigade Area of Operations (AO), Area of Interest (AI).
  - 9) Division Main Effort, Supporting Efforts.
  - c. Tasks to division units.
    - 1) Fire support.
      - a) Air support and CAS allocations.
      - b) Chemical support.
      - c) FA support.
      - d) Naval surface fire support.
      - e) Fire support instructions, including Fire Support Coordinating Measures (FSCM).
    - 2) Air defense and ADA coverage.
    - 3) NBC defense.
    - 4) Combat engineer and engineering support.
    - 5) IEW support.
    - 6) Military police (MP) support.
    - 7) Aviation support (attack, observation/target acquisition/cargo).
    - 8) Directed obstacles.
  - d. Coordinating instructions.
    - 1) Army Airspace Command and Control (A2C2) guidance and instructions (air corridors).
    - 2) Rules of engagement.
    - 3) Risk assessment.
    - 4) Timelines [e.g., mission, turn in of requests for Air Tasking Order (ATO) input and additional fire support].
    - 5) Air defense warning system, weapons control status.
5. Service Support.
    - a. CSR/RSR.
    - b. Priorities (by all classes).
    - c. Supply distribution.
  6. Command and Signal.
    - a. Division signal nodes, locations, networks.
    - b. Locations for Division Commander, Command Group, CPs.
  7. Annexes.
    - a. Intelligence Annex.
      - 1) Event template/matrix.
      - 2) Information/Intelligence Collection Plan.
    - b. Fire Support Annex.
      - 1) High Payoff Target List (HPTL).
      - 2) Fire Support Execution Matrix (FSEM).
      - 3) Restrictions on use of radars.
      - 4) Target lists.
      - 5) Schedules of fire.
      - 6) Target attack guidance, spread sheets, target sheets.
      - 7) Defeat criteria.
      - 8) Priorities for control of fire support.
      - 9) Fires in the brigade zone planned by division.



- 10) USAF ALO and USN/USMC ANGLICO element task organization.
  - 11) Ammunition allocation of special munitions [e.g., precision guided munitions (PGM), family of scatterable mines (FASCAM)].
  - 12) Ammunition constraints (e.g., CSR, RSR).
  - 13) Artillery units tasked as GS and reinforcing to the brigade.
  - 14) Allocation of meteorological support assets.
  - 15) Division target data.
  - 16) Allocation of survey support.
  - 17) Allocation of radar support.
  - 18) Division Radar Zones.
  - 19) Division counter fires plan.
- c. Logistics Annex.
- 1) Locations of division and higher CSS nodes and routes.
  - 2) Brigade requirements to provide CSS to divisional units in Brigade AO.
- d. Graphics.
- 1) NAI.
  - 2) TAI.
  - 3) Maneuver.
  - 4) Modified Combined Obstacle Overlay (MCOO).
  - 5) FSCM.
- e. Decision Support Template (DST).
- f. ATO
- 1) Identification of headquarters responsible for publication of ATO.
  - 2) Submission time lines for pre-planned requests.
  - 3) Air assets available (USAF, USN, USMC, Allied).
- g. Army Aviation Annex
- h. Mobility, Countermobility, Survivability Annex
- i. A2C2 Annex.
- 1) Division commander's airspace priorities.
  - 2) Battle space the brigade is responsible for.
    - a) Vertical limits.
    - b) Left and right limits.
    - c) Front and rear limits.
  - 3) Airspace users.
    - a) Army aviation.
    - b) USAF.
    - c) USN.
    - d) USMC.
    - e) Remotely piloted vehicles (RPVs) and unmanned aerial vehicles (UAVs).
    - f) Fire support.
    - g) ADA.
  - 4) Requirements for the users of airspace.
    - a) Combat.
    - b) Combat support (CS).
    - c) CSS.
  - 5) Positive and procedural A2C2 control measures imposed by division.
  - 6) Division A2C2 guidance.

- a) Flight rules.
- b) Airspace control order issuing times and headquarters.
- c) High-use areas.
- d) Division EW operations which will affect airspace users.
- e) Forward arming and refuel point (FARP) locations.
- f) Airfield locations and operations.
- g) Navigation aids (NAVAIDs) locations, including operating times.

**D-3 DIVISION TACTICAL STANDING OPERATING PROCEDURES (TSOP)**

1. Composition of Division Targeting Team.
2. Division targeting process.
3. Time requirements for submission of reports and requests.
4. LNO procedures and responsibilities.
5. Target numbering system.
6. Orders process (including products developed).
7. War Game procedures.
8. Laser pulse repetition frequency code distribution.
9. CP organization and operation.
10. A2C2 operations.
11. Communication system distribution and operation [local area network (LAN), wide area network (WAN)].
12. Attachment and detachment procedures.
13. Division deep battle operations.
14. Division intelligence and information dissemination procedures and systems.
15. Division rehearsal procedures.
16. Fratricide countermeasures and clearance of fires procedures.

**FA-1 DS FA BATTALION SITUATION REPORTS (SITREPS)**

1. Fire support systems available.
2. Current and projected status (e.g. cannons, ammunition, FDCs, radars).
3. Current FA unit/systems locations.
4. Number, type, and status of FA units supporting the DS FA battalion.
5. Munitions capabilities.
  - a) Ammunition locations.
  - b) Quantity, by type [(e.g. PGM, FASCAM, rocket assisted projectile (RAP))].
  - c) Fuse and charge.
6. Status on movement plans, terrain requirements, and position requirements for fire support assets.
7. Observer and observer location requirements.
8. Status of division-directed missions and allocation/positions of division assets in the brigade sector.
9. Transportation requirements.
10. Communications requirements.
11. Status of digital systems.
12. Status of position azimuth determining system (PADS).

13. Target attack systems capabilities.
14. Jamming requirements.
15. Rear area fire support capability (assets available to provide support, areas requiring support).

#### **B-1 INTELLIGENCE SITREPS**

1. Enemy artillery capabilities (e.g., ranges, system types, systems capabilities).
2. Enemy NBC capabilities.
3. Enemy air defense capabilities.
4. Location and composition of enemy obstacles.
5. Enemy air routes.
6. Enemy air assets availability.
7. Known and suspected enemy locations.
8. Enemy order of battle (OB) (e.g., size, type, strength) for enemy units the brigade is expected to encounter.
9. Terrain analysis of battle space (mobility corridors, avenues of approach).
10. Templates (Situation, Event).
11. Weather.
12. Brigade information collection systems/sensors availability.

#### **B-2 CAS SITREPS**

1. Joint suppression of enemy air defense (J-SEAD) requirements.
2. Information for CAS support.
  - a) Mission number.
  - b) Aircraft call sign.
  - c) Number and type of aircraft.
  - d) Time on target.
  - e) When aircraft will arrive at initial points (IPs).
  - f) How long aircraft will remain on-station.
  - g) Sortie allocation.
  - h) Air priority of effort in brigade AO.
3. Aircraft and munitions capabilities (e.g., LANTERN equipped, AC-130).
4. CAS times, reaction times (strip alert, push CAS).
5. Target distance from friendly troops.
6. Ingress and egress routes, IPs.
7. Airborne forward air controller (AFAC) requirements.

#### **B-3 ANGLICO SITREPS**

1. Allocation and status of naval surface fire support.
2. Range, gun-target line requirements.
3. Responsiveness of naval surface fires.
4. Munitions availability.
5. Constraints and limitations for naval surface fires.
6. Availability and capabilities of USN and USMC aircraft.

**B-4 ARMY AVIATION SITREPS**

1. Attack helicopter support relationship and status (DS, GS, attached, OPCON).
2. Attack helicopter roles, missions.
3. Ingress and egress routes.
4. Status of non-brigade aviation operations in the brigade AO.
5. SEAD requirements.
6. Observer requirements.
7. Availability of utility and observer helicopters.
8. Aircraft/aircrew availability.
9. Aircraft capabilities (e.g., night capable, laser capable).
10. Refuel/rearm requirements.
11. Crew rest status of pilots.

**B-5 BRIGADE CSS SITREPS**

1. Current and projected classes of supply status for fire support units.
2. Current and projected maintenance status of fire support and collection systems.
3. Class V availability and resupply status.
4. Task organization of CSS assets to fire support units.
5. Transportation assets and capabilities to support fire support units.
6. RSR, CSR.
7. Status of MSR/ASR.
8. Status and locations of CSS nodes.

**B-6 BRIGADE TACTICAL STANDING OPERATING PROCEDURES (TSOP)**

1. Succession of command.
2. CP organization and operation .
3. Orders process (including products developed).
4. War Game procedures.
5. LNO procedures and responsibilities.
6. Alarms and warning procedures.
7. Fixed call signs and code words.
8. Road march procedures.
9. Assembly area operations.
10. OPSEC and security operations.
11. A2C2 operations.
12. Communication system distribution and operations (LAN, WAN).
13. Time requirements for submission of reports and requests.
14. Target numbering system.
15. Laser pulse repetition frequency code distribution.
16. Attachment and detachment procedures.
17. Logistics operations.
18. Brigade targeting team activities and targeting process.
19. Information management procedures (e.g., dissemination, logs and journals).
20. Brigade rehearsal procedures.

21. Fratricide countermeasures and clearance of fires procedures.
22. CP standard operating procedures (SOPs).

**TF-1      BN TF SITREPS**

1. Subordinate unit's target refinements.
2. Final protective fires (FPF) requests.
3. Fire support coordination measures.
4. Target Lists.
5. FSEM.
6. R&S plans.
7. Observer plan.
8. Bn TF commander's intent.
9. Bn TF commander's concept for fires.
10. Bn TF OPORD/FRAGO.
11. Clearance of fires plan.

## KEY OUTPUTS

### B-7 BRIGADE WARNO

NOTE: Multiple WARNOs will be issued prior to the issuance of the brigade OPORD. The initial WARNO will be issued after receipt of the division OPORD/FRAGO, with subsequent WARNOs issued as planning is performed by the brigade commander and staff.

1. Task organization changes.
2. Movement to be accomplished (e.g., to effect task organization, reposition forces on the battlefield).
3. Detail requisition and transportation requirements for equipment, units, and supplies.
4. Initiation of security operations.
5. Information to support R&S operations.

### B-8 BRIGADE OPORD/FRAGO

1. Task organization.
  - a. FA batteries and target acquisition assets.
  - b. Collection assets.
  - c. USAF ALO elements.
  - d. USN ANGLICO elements.
2. Situation paragraph.
  - a. Brigade Commander's CCIR, Division IR.
  - b. Enemy COAs and time lines.
  - c. Weather and terrain.
  - d. Enemy fire support capabilities (lethal, non-lethal).
  - e. Enemy ADA capability.
  - f. Enemy air corridors.
3. Mission paragraph.
4. Execution paragraph.
  - a. Brigade Commander's Intent.
  - b. Concept of the Operation.
    - 1) Scheme of maneuver.
    - 2) Fires paragraph.
    - 3) Counter-air operations.
    - 4) Intelligence.
    - 5) Electronic warfare operations.
    - 6) Deception operations.
    - 7) Battle handover from division to brigade.
    - 8) Brigade AO, AI.
    - 9) Brigade main effort, supporting efforts.
  - c. Tasks to brigade units.
    - 1) Fire support.
      - a) Air support and CAS allocations.
      - b) Chemical support.

- c) FA support.
      - d) Naval surface fire support.
      - e) Fire support instructions, including FSCM.
      - f) Bn TF fire support.
    - 2) Air defense and ADA coverage.
    - 3) NBC defense.
    - 4) Combat engineer and engineering support.
    - 5) IEW support.
    - 6) MP support.
    - 7) Aviation support (attack, observation/target acquisition/cargo).
    - 8) Directed obstacles.
  - d. Coordinating instructions.
    - 1) A2C2 guidance and instructions (air corridors).
    - 2) Rules of engagement.
    - 3) Risk assessment.
    - 4) Timelines (e.g., mission, turn in of requests for ATO input and additional fire support).
    - 5) Air defense warning system, weapons control status.
5. Service Support.
  - a. CSR/RSR.
  - b. Priorities (by all classes).
  - c. Supply distribution.
6. Command and Signal.
  - a. Brigade signal nodes, locations, networks.
  - b. Locations for brigade commander, Command Group, CPs.
7. Annexes.
  - a. Intelligence Annex.
    - 1) Event template/matrix.
    - 2) R & S and Collection Plans.
    - 3) High Value Targets (HVT).
    - 4) HPT.
    - 5) NAIs/TAIs.
    - 6) Allocation of collection assets.
    - 7) External collection systems supporting the brigade (e.g., division, corps).
    - 8) IR.
  - b. Fire Support Annex.
    - 1) HPTL.
    - 2) FSEM.
    - 3) Restrictions on use of radars.
    - 4) Target lists.
    - 5) Schedules of fire.
    - 6) Target attack guidance, spread sheets, target sheets.
    - 7) Defeat criteria.
    - 8) Priorities for control of fire support.
    - 9) Fires in the brigade zone planned by division.
    - 10) USAF ALO and USN/USMC ANGLICO element task organization.
    - 11) Ammunition allocation of special munitions (e.g., PGM, FASCAM).

- 12) Ammunition constraints (e.g., CSR, RSR).
- 13) Artillery units tasked as GS and reinforcing to the brigade.
- 14) Allocation of meteorological support assets.
- 15) Brigade target data.
- 16) Allocation of survey support.
- 17) Allocation of radar support.
- 18) Brigade radar zones; radar operations.
- 19) Brigade counter fires plan.
- 20) Clearance of fire plan.
- 21) Fire support observer plan.
  - a) FA observer and target acquisition Observer Plan.
  - b) Observer responsibility for targets.
  - c) Method of fire control (e.g., voice, digital).
  - d) Allocation of observers and target acquisition systems.
  - e) Target damage assessment requirements.
- c. Logistics Annex.
  - 1) Locations of brigade and division CSS nodes and routes.
  - 2) Distribution times and schedules.
- d. Graphics.
  - 1) NAI.
  - 2) TAI.
  - 3) Maneuver.
  - 4) MCOO.
  - 5) FSCM.
- e. DST.
- f. ATO and CAS plan.
  - 1) Mission number (from ATO).
  - 2) Control of CAS [(e.g. ALO, AFAC, enlisted terminal attack controller (ETAC), ANGLICO, SALT, other)].
  - 3) CAS ordnance.
  - 4) SEAD plan.
  - 5) Weather restrictions.
  - 6) CAS times (IP, time on target).
  - 7) Weapons' effects on targets.
  - 8) Command, control, communications.
  - 9) Ingress and egress routes.
- g. Army Aviation Annex.
- h. Mobility, Countermobility, Survivability Annex.
  - 1) Brigade obstacle plan.
  - 2) Obstacle intent.
  - 3) FA FASCAM requirements.
- i. A2C2 Annex.
  - 1) Brigade commander's airspace priorities.
  - 2) Battle space for which the brigade is responsible.
    - a) Vertical limits.
    - b) Left and right limits.
    - c) Front and rear limits.



- 3) Airspace users.
  - a) Army aviation.
  - b) USAF.
  - c) USN.
  - d) USMC.
  - e) RPVs and UAVs.
  - f) Fire support.
  - g) ADA.
- 4) Requirements for the users of airspace.
  - a) Combat.
  - b) CS.
  - c) CSS.
- 5) Positive and procedural A2C2 control measures imposed by division.
- 6) Brigade A2C2 guidance.
  - a) Flight rules.
  - b) Airspace control order issuing times and headquarters.
  - c) High-use areas.
  - d) Brigade EW operations which will affect airspace users.
  - e) FARP locations.
  - f) Airfield locations and operations.
  - g) NAVAIDs locations, including operating times.

**FA-2      DS FA BATTALION FIRE SUPPORT PLAN**

1. Desired effects on targets (suppress, neutralize, destroy).
2. Order and timing of target engagement.
3. Duration of fires.
4. Priority targets.
5. Units with priority of fires.
6. Allocation of fire support assets.
7. Munitions mix.
8. Shell-fuse combinations.
9. Survey plan.
10. Position Areas (PAs) for DS and supporting FA battalion assets (e.g., firing batteries, radars, FDCs).
11. Declination stations.
12. Movement plan for FA units.
13. Special ammunition allocation.
14. Employment plan and missions for reinforcing artillery units.
15. DS and supporting FA battalion's scheme of maneuver.
16. Radar cueing schedule.
17. Survey plan.
18. Radar plan.

## Task List Summary

This component provides a summary of the major tasks contained in the Planning, Preparation, and Execution Task Lists. The purpose of this component is to provide a quick reference to the tasks in order to assist users in locating the major tasks which may address a specific area of interest. Doctrinal references are included at the end of each major tasks and are shown in brackets, e.g. [...]. The doctrinal publication number is included as the reference; see the appropriate task lists to identify the doctrinal source page numbers or chapters. Author notes/tasks are shown as [AN]. Field notes/tasks identified by FORSCOM and/or TRADOC SMEs are preceded by FN; i.e., tasks identified by National Training Center observer/controllers (NTC OCs) are shown as [FN-NTC]. See the 'Reference' portion of this task analysis for reference titles and publication dates.

### PLANNING PHASE

1. **Sustain and Protect the Force During Planning** [FM 6-20; FM 6-20-1; FM 6-20-2; FM 6-20-40; FM 6-20-50; FN-BCTP]
2. **Receive Order From Higher Headquarters** [FM 6-20-1; FM 6-20-2; FM 6-20-10; FM 6-20-30; FM 6-20-40; FM 6-20-50; FM 101-5; FN-NTC; FN-JRTC; FN-BCTP; FN-AR Sch]
3. **Conduct Mission Analysis** [ARTEP 71-3-MTP; FM 1-111; FM 3-7; FM 3-50; FM 3-101; FM 5-100; FM 5-101; FM 5-102; FM 6-20-1; FM 6-20-2; FM 6-20-10; FM 6-20-30; FM 6-20-40; FM 6-20-50; FM 11-41; FM 11-50; FM 34-8; FM 34-130; FM 71-3; FM 71-100; FM 71-123; FM 101-5; MCM 3-3; FN-NTC; FN-JRTC; FN-FA Sch; FN-BCTP; FN-BCBST; FN-AR Sch; FN-3/24 ID; FN-194 AR]
4. **Issue the Warning Order (WARNO)** [ARTEP 71-3-MTP; FM 101-5; FN-JRTC; FN-IN Sch]
5. **Brigade Commander Issues Planning Guidance** [ARTEP 71-3-MTP; FM 6-20-10; FM 6-20-40; FM 6-20-50; FM 71-3; FM 101-5; FN-NTC; FN-JRTC; FN-IN Sch; FN-FA Sch; FN-CGSC; FN-BCTP; FN-BCBST; FN-3/24 ID; FN-III Corps; FN-194 AR; Battle Command Battle Lab "Battle Command"]
6. **Prepare Staff Estimates** [ARTEP 71-3-MTP; FM 1-111; FM 5-100; FM 6-20; FM 6-20-1; FM 6-20-10; FM 6-20-40; FM 6-20-50; FM 11-41; FM 34-1; FM 71-123; FM 90-7; FM 101-5; NWP 3-09.11M; FN-NTC; FN-JRTC; FN-CGSC; FN-FA Sch; FN-AR Sch; FN-IN Sch; FN-III Corps; FN-3/24 ID; FN-194 AR]
7. **Staff Develops Courses of Action** [ARTEP 71-3-MTP; FM 6-20-10; FM 6-20-40; FM 6-20-50; FM 34-1; FM 34-80; FM 34-130; FM 101-5; NWP 3-09.11M; FN-NTC; FN-IN Sch; FN-FA Sch; FN-AR Sch; FN-CGSC; FN-BCTP; FN-III Corps; FN-3/82 ABN; FN-194 AR; FN-3/24 ID]

## PLANNING PHASE Continued

8. **Staff/Commander Analyze Courses of Action (War Game)** [ARTEP 6-115-20-MTP; ARTEP 71-3-MTP; FM 6-20; FM 6-20-10; FM 6-20-40; FM 6-20-50; FM 34-2; FM 34-8; FM 34-130; FM 90-7; FM 100-5; FM 101-5; NWP 3-09.11M; FN-NTC; FN-JRTC; FN-FA Sch; FN-AR Sch; FN-IN Sch; FN-BCTP; FN-BCBST; FN-3/24 ID]
9. **Staff Compares Courses of Action** [ARTEP 6-115-20-MTP; ARTEP 71-3-MTP; FM 6-20-10; FM 6-20-40; FM 6-20-50; FM 34-2; FM 34-8; FM 34-130; FM 101-5; FN-NTC; FN-JRTC; FN-3/24 ID]
10. **Brigade Commander Announces Decision** [FM 6-20-10; FM 6-20-40; FM 6-20-50; FM 34-2; FM 34-8; FM 34-130; FM 101-5; FN-JRTC; FN-AR Sch; FN-3/24 ID]
11. **Brigade Staff Prepares OPORD/FRAGO** [ARTEP 71-3-MTP; FM 6-20-10; FM 6-20-40; FM 6-20-50; FM 34-2; FM 34-130; FM 101-5; FN-NTC; FN-JRTC; FN-AR Sch; FN-FA Sch; FN-BCBST; FN-CGSC; FN-IN Sch; FN-3/24 ID; FN-194 AR]
12. **Brigade Issues the OPORD/FRAGO** [FM 101-5; FN-NTC; FN-JRTC; FN-AR Sch; FN-194 AR]

## PREPARATION PHASE

13. **The Brigade Targeting Team Organizes to Monitor, Plan, and Direct Fire Support Operations** [ARTEP 6-115-20-MTP; ARTEP 71-3-MTP; FM 6-20; FM 6-20-1; FM 6-20-40; FM 6-20-50; FM 71-3; FM 71-123; FM 101-5]
14. **The Brigade Targeting Team Acquires Information** [ARTEP 6-115-20-MTP; ARTEP 71-3-MTP; FM 1-111; FM 5-100; FM 5-102; FM 6-20-30; FM 6-20-40; FM 6-20-50; FM 71-3; FM 71-100; FM 101-5; NWP 3-09.11M; FN-JRTC; FN-AR Sch; FN-FA Sch; FN-IN Sch; FN-CGSC; FN-194]
15. **The Brigade Targeting Team Evaluates Information** [ARTEP 6-115-MTP; ARTEP 71-3-MTP; FM 6-20-40; FM 6-20-50; FM 101-5; FN-NTC]
16. **The Brigade Targeting Team Updates Products** [ARTEP 6-115-20-MTP; ARTEP 71-3-MTP; FM 6-20-40; FM 6-20-50; FM 34-130; FM 101-5; FN-NTC; FN-FA Sch; FN-AR Sch; FN-CGSC; FN-3/24 ID]
17. **The Brigade Targeting Team Communicates Information and Coordinates the Brigade Fire Support Plan** [ARTEP 6-115-20-MTP; ARTEP 71-3-MTP; FM 6-20-40; FM 6-20-50; FM 34-130; FM 71-3; FM 101-5; FN-NTC; FN-JRTC; FN-CGSC; FN-3/24 ID; FN-194 AR]

## PREPARATION PHASE Continued

18. **The Brigade Commander Visualizes the Battlefield** [ARTEP 6-115-20-MTP; ARTEP 71-3-MTP; FM 1-111; FM 6-20-10; FM 6-20-40; FM 6-20-50; FM 34-130; FM 71-3; FM 101-5; NWP 3-09.11M; FN-NTC; FN-JRTC; FN-CGSC; FN-FA Sch; FN-3/24 ID; FN-194 AR; Battle Command Battle Lab "Battle Command"]
19. **The Brigade Commander Directs Changes to the Operation or Plan** [ARTEP 6-115-20-MTP; ARTEP 71-3-MTP; FM 6-20-40; FM 6-20-50; FM 34-130; FM 101-5; FN-CGSC; FN-3/24 ID]
20. **The Brigade Commander Directs and Leads Subordinate Forces** [ARTEP 6-115-20-MTP; ARTEP 71-3-MTP; FM 1-111; FM 5-102; FM 6-20; FM 6-20-1; FM 6-20-2; FM 6-20-10; FM 6-20-40; FM 6-20-50; FM 34-2; FM 34-130; FM 71-2; FM 71-3; FM 71-123; FM 101-5; FN-NTC; FN-JRTC; FN-AR Sch; FN-IN Sch; FN-FA Sch; Battle Command Battle Lab "Battle Command"]
21. **Target Acquisition Assets Position and Perform Target Detection Activities** [ARTEP 6-115-20-MTP; ARTEP 71-3-MTP; FM 6-20-1; FM 6-20-10; FM 6-20-40; FM 6-20-50; FM 6-30; FM 6-121; FM 34-2; FM 34-130]

## EXECUTION PHASE

22. **The Brigade Targeting Team Monitors and Directs Fire Support Operations from Brigade CPs and the DS FA Battalion TOC** [ARTEP 6-115-MTP; ARTEP 6-115-20-MTP; ARTEP 71-3-MTP; FM 6-20; FM 6-20-1; FM 6-20-40; FM 6-20-50; FM 71-3; FM 71-123; FM 101-5; FN-NTC; FN-JRTC; FN-FA Sch]
23. **The Brigade Targeting Team Directs the Employment of Indirect Fires Against Brigade HPTs** [ARTEP 71-3-MTP; FM 6-20-1; FM 6-20-10; FM 34-130; FN-NTC; FN-JRTC; FN-CGSC]
24. **The Brigade Targeting Team Monitors, Coordinates, and Synchronizes the Employment of Indirect Fires** [ARTEP 71-3-MTP; FM 6-20; FM 6-20-10; FM 6-20-40; FM 6-20-50; FM 6-30; FM 34-1; FM 34-2; FM 34-80; FM 34-130; FM 90-14; FM 101-5; FM 100-5; NWP 3-09.11M; FN-NTC; FN-JRTC; FN-IN Sch; FN-AR Sch; FN-FA Sch; FN-BCTP; FN-194 AR]
25. **The Brigade Targeting Team Receives the Results of Target Attacks and Performs Combat Assessments** [ARTEP 71-3-MTP; FM 6-20-10; FM 6-20-40; FM 6-20-50; FN-NTC; FN-CGSC; FN-III Corps]
26. **The Brigade Targeting Team Acquires Information** [ARTEP 6-115-20-MTP; ARTEP 71-3-MTP; FM 1-111; FM 5-100; FM 5-102; FM 6-20-30; FM 6-20-40; FM 6-20-50; FM 71-3; FM 71-100; FM 101-5; NWP 3-09.11M; FN-JRTC; FN-AR Sch; FN-FA Sch; FN-IN Sch; FN-CGSC; FN-194]

## EXECUTION PHASE Continued

27. **The Brigade Targeting Team Evaluates Information** [ARTEP 6-115-MTP; ARTEP 71-3-MTP; FM 6-20-40; FM 6-20-50; FM 101-5; FN-NTC]
28. **The Brigade Targeting Team Updates Products** [ARTEP 6-115-20-MTP; ARTEP 71-3-MTP; FM 6-20-40; FM 6-20-50; FM 34-130; FM 101-5; FN-NTC; FN-FA Sch; FN-AR Sch; FN-CGSC; FN-3/24 ID]
29. **The Brigade Targeting Team Communicates Information and Coordinates the Brigade Fire Support Plan** [ARTEP 6-115-20-MTP; ARTEP 71-3-MTP; FM 6-20-40; FM 6-20-50; FM 34-130; FM 71-3; FM 101-5; FN-NTC; FN-JRTC; FN-CGSC; FN-3/24 ID; FN-194 AR]
30. **The Brigade Commander Visualizes the Battlefield** [ARTEP 6-115-20-MTP; ARTEP 71-3-MTP; FM 1-111; FM 6-20-10; FM 6-20-40; FM 6-20-50; FM 34-130; FM 71-3; FM 101-5; NWP 3-09.11M; FN-NTC; FN-JRTC; FN-CGSC; FN-FA Sch; FN-3/24 ID; FN-194 AR; Battle Command Battle Lab "Battle Command"]
31. **The Brigade Commander Directs Changes to the Operation or Plan** [ARTEP 6-115-20-MTP; ARTEP 71-3-MTP; FM 6-20-40; FM 6-20-50; FM 34-130; FM 101-5; FN-CGSC; FN-3/24 ID]
32. **The Brigade Commander Directs and Leads Subordinate Forces** [ARTEP 6-115-20-MTP; ARTEP 71-3-MTP; FM 1-111; FM 5-102; FM 6-20; FM 6-20-1; FM 6-20-2; FM 6-20-10; FM 6-20-40; FM 6-20-50; FM 34-2; FM 34-130; FM 71-2; FM 71-3; FM 71-123; FM 101-5; FN-NTC; FN-JRTC; FN-AR Sch; FN-IN Sch; FN-FA Sch; Battle Command Battle Lab "Battle Command"]
33. **The Brigade Consolidates and Reorganizes** [ARTEP 71-3-MTP; FM 6-20-1; FM 6-20-10; FM 34-2; FM 71-3]

## Planning Task List

These tasks provide required detail to describe the brigade commander and brigade targeting team roles in the Deliberate Decision Making Process (DDMP). The tasks listed below (in bold) are taken from the Task Analysis for Brigade CCF 18 (Plan for Combat Operations). Sub-tasks included under each of the Brigade CCF 18 planning tasks reflect those tasks which are critical to Coordinate, Synchronize, and Integrate Fire Support. See Brigade CCF 18 for brigade planning tasks dealing with all other non-fire support tasks. References are shown in brackets [...] after each task or task element. Tasks are either taken directly from an ARTEP MTP task or sub-task or are derived from portions of sub-tasks, implied tasks, or requirements specified in the ARTEP MTPs, applicable FMs, or other related documents. Author-generated tasks are indicated as [AN]. Field notes/tasks from FORSCOM and/or TRADOC SMEs are identified with their source, e.g., [FN-NTC]. Endnotes, which provide ancillary information about tasks, are indicated by a numerical annotation in superscript (e.g., <sup>1</sup>).

The quick fire planning process is included under Task 1. This process is fully described under Task 1 in the context of providing fires to protect the brigade while the brigade planning process is ongoing. If the brigade has just completed a mission, the existing fire support plan for that previous mission is continued and refined as required. If this is the case, the quick fire planning process will not necessarily be performed, unless that previous mission fire support plan is determined to be inadequate.

These tasks describe the DECIDE function of the targeting process which occurs during the brigade planning battle phase.

### 1. **Sustain and Protect the Force During Planning**

- a. The brigade Fire Support Officer (FSO), with support from the brigade Fire Support Element (FSE), initiates quick fire planning to ensure that brigade units are protected during the planning process [FM 6-20-40, p. 2-13].<sup>1</sup>
  - 1) The brigade FSO develops the quick fire plan, with support provided by the brigade staff [FM 6-20-40, p. 2-13; FM 6-20-50, p. 2-13].
  - 2) Existing fire support plans are used as the starting point for performing quick fire planning [AN].
  - 3) The existing fire support plan is modified and refined based on the brigade commander's intent, guidance, and METT-T [AN].
  - 4) If there is no existing fire support plan, the brigade FSO and brigade FSE develop a new fire support plan [AN].
- b. The brigade commander provides fire support guidance to the brigade FSO to focus quick fire planning. Guidance includes [FM 6-20-40, p. 2-14; FM 6-20-50, p. 2-13]:

- 1) Targets (division directed, brigade) to be included in the brigade quick fire target list [FM 6-20-40, p. 2-14; FM 6-20-50, p. 2-13].
  - 2) Desired effects on targets [FM 6-20-40, p. 2-14; FM 6-20-50, p. 2-13].
  - 3) Order and timing of target engagement [FM 6-20-40, p. 2-14; FM 6-20-50, p. 2-13].
  - 4) Duration of fires [FM 6-20-40, p. 2-14; FM 6-20-50, p. 2-13].
  - 5) H-hour [FM 6-20-40, p. 2-14; FM 6-20-50, p. 2-13].
  - 6) Priority of fires [FM 6-20-40, p. 2-14; FM 6-20-50, p. 2-13].
  - 7) Priority for targeting [FM 6-20-40, p. 2-14; FM 6-20-50, p. 2-13].
  - 8) Priority for execution [FM 6-20-40, p. 2-14; FM 6-20-50, p. 2-13].
  - 9) Estimated rate of movement (brigade units, enemy) [FM 6-20-40, p. 2-14; FM 6-20-50, p. 2-13].
  - 10) Need for target adjustment [FM 6-20-40, p. 2-14; FM 6-20-50, p. 2-13].
  - 11) Concept of the operation (including objective and defensive positions, maneuver control measures, and obstacles) [FM 6-20-40, p. 2-14; FM 6-20-50, p. 2-13].
- c. The brigade FSO determines fire support assets available [FM 6-20-40, p. 2-14; FM 6-20-50, p. 2-14].
- 1) The brigade Fire Support Coordinator (FSCOORD), Direct Support (DS) FA battalion XO, and DS FA battalion S3 identify status and availability of firing units [FM 6-20-40, p. 2-14; FM 6-20-50, p. 2-14].
  - 2) Bn TF commanders identify status and availability of their Bn TF mortar platoons [FM 6-20-40, p. 2-14; FM 6-20-50, p. 2-14].
  - 3) The brigade ALO and brigade ANGLICO review the Air Tasking Order (ATO) and identify availability of USAF, USN, and USMC CAS aircraft. They determine [FM 6-20-40, p. 2-14; FM 6-20-50, p. 2-14]:
    - a) Planned CAS missions available to the brigade [AN].
    - b) CAS missions under division control assigned to other missions which may be available to the brigade [AN].
    - c) Uncommitted CAS (e.g., CAS on strip alert) [AN].

- 4) The brigade ANGLICO identifies the status and availability of naval surface fires from USN ships in a DS or General Support (GS) support relationship [FM 6-20-40, p. 2-14; FM 6-20-50, p. 2-14].
- 5) The brigade S3/Air, with the brigade aviation Liaison Officer (LNO), identifies the status and availability of Army aviation assets [AN]:
  - a) Aerial observer and target acquisition systems [AN].
  - b) Lift (to transport: ground observers, collection assets, FA CL V) [AN].
- d. The brigade FSO prepares the quick fire plan based on the brigade scheme of maneuver, brigade commander's guidance, and assets available [FM 6-20-40, p. 2-14; FM 6-20-50, p. 2-14; BCTP].
  - 1) The brigade FSO designates targets [FM 6-20-40, p. 2-14; FM 6-20-50, p. 2-14; BCTP].
  - 2) The brigade FSO allocates fire support assets available to engage planned targets and retains some fire support systems under brigade control [FM 6-20-40, p. 2-14; FM 6-20-50, p. 2-13; FN-BCBST].
  - 3) The brigade FSO prescribes the method of target attack for each target; options include [AN]:
    - a) Attack by a specific system (e.g., FA, EW, CAS, naval surface fires) [AN].
    - b) Attack by multiple systems [AN].
  - 4) The brigade FSO prescribes munitions mix [FM 6-20-40, p. 2-14; FM 6-20-50, p. 2-14].
  - 5) The brigade FSO prescribes shell-fuse combinations [FM 6-20-40, p. 2-14; FM 6-20-50, p. 2-14].
  - 6) The brigade FSO prescribes duration of fires for each target [FM 6-20-40, p. 2-14; FM 6-20-50, p. 2-14].
  - 7) The brigade FSO determines time to fire requirements [FM 6-20-40, p. 2-14; FM 6-20-50, p. 2-14].
  - 8) The brigade FSO prepares quick fire plan documents, which include [AN]:
    - a) Schedule of fires [FM 6-20-40, p. 2-14; FM 6-20-50, p. 2-13].
    - b) Target overlays [FM 6-20-40, p. 2-14; FM 6-20-50, p. 2-13, 2-15].



- c) Fire Support Execution Matrix (FSEM) [FM 6-20-40, p. 2-14; FM 6-20-50, p. 2-13, 2-15].
- e. The brigade FSO deconflicts terrain requirements for fire support assets through coordination with the brigade S3 and Bn TF S3s [AN].
- f. The brigade FSCOORD, if available, reviews the quick fire plan and, as required, provides direction to the brigade FSO regarding modifications [AN].
- g. The brigade FSO briefs the quick fire plan to the brigade commander for approval [FM 6-20-40, p. 2-14; FM 6-20-50, p. 2-15].
- h. The brigade FSO disseminates the approved quick fire plan (and its products) to [FM 6-20-40, p. 2-14; FM 6-20-50, p. 2-13, 2-15]:
  - 1) The brigade staff [FM 6-20-40, p. 2-14; FM 6-20-50, p. 2-13, 2-15].
  - 2) The brigade ALO, brigade ANGLICO, and brigade aviation LNO (who disseminate the quick fire plan to their parent headquarters) [FM 6-20-40, p. 2-14; FM 6-20-50, p. 2-13, 2-15].
  - 3) The brigade FSCOORD and DS FA battalion S3 [FM 6-20-40, p. 2-14; FM 6-20-50, p. 2-13, 2-15].
  - 4) Bn TF commanders, S3s, and FSOs [FM 6-20-40, p. 2-14; FM 6-20-50, p. 2-13, 2-15].
  - 5) The division FSE [FM 6-20-40, p. 2-14; FM 6-20-50, p. 2-13, 2-15].
  - 6) Division Artillery (DIVARTY) TOC (i.e., Operations Element, Fire Control Center, Targeting Element) [FM 6-20-40, p. 2-14; FM 6-20-50, p. 2-13, 2-15; FM 6-20-1, p. 1-11].
- i. The brigade FSO coordinates the quick fire plan with Bn TF FSOs, FISTs, and all elements which will implement the quick fire plan, which includes [FM 6-20-40, p. 2-14; FM 6-20-50, p. 2-15]:
  - 1) Positions to be occupied by FSOs and/or observers during the operation [FM 6-20-40, p. 2-15; FM 6-20-50, p. 2-15].
  - 2) Designation of FSO or observer responsible for initiating the fire plan or initiating the fire request on specific targets [FM 6-20-40, p. 2-15; FM 6-20-50, p. 2-15].
  - 3) Fire support headquarters to be contacted for requesting fires [FM 6-20-40, p. 2-15; FM 6-20-50, p. 2-15].

- 4) When fires will be initiated against planned targets [FM 6-20-40, p. 2-15; FM 6-20-50, p. 2-15].
  - 5) Communications nets to be used for requesting and controlling indirect fires [FM 6-20-40, p. 2-15; FM 6-20-50, p. 2-15].
  - 6) Designation of units which have priority of fires [FM 6-20-40, p. 2-15; FM 6-20-50, p. 2-15].
  - 7) Designation of units which have responsibility for priority targets [FM 6-20-40, p. 2-15; FM 6-20-50, p. 2-15].
  - 8) Process for modifying the quick fire plan during execution [FM 6-20-40, p. 2-15; FM 6-20-50, p. 2-15].
  - 9) Fire support systems available to attack unplanned targets [FM 6-20-40, p. 2-15; FM 6-20-50, p. 2-15].
- j. The brigade FSO informs the brigade commander when brigade units and units providing fire support to the brigade are ready to execute the quick fire plan [FM 6-20-40, p. 2-15; FM 6-20-50, p. 2-15].
- k. The brigade S3, brigade FSO, and brigade FSCoord monitor, plan, and direct activities to ensure that fire support units and systems are protected [FM 6-20, p. 3-4].
- 1) Positions are constructed to protect fire support systems, supplies, equipment, and personnel [FM 6-20, p. 3-4].
  - 2) OPSEC measures are employed to ensure that fire personnel, equipment, and systems are difficult to locate, strike, or destroy [FM 6-20, p. 3-4].
  - 3) Fire support systems and units are task organized to protect critical assets [FN-BCBST].
- i. The brigade FSO, with the brigade S4, monitors, plans, and directs activities to sustain brigade units providing fire support during the brigade planning phase [AN].
- 1) The brigade S4 ensures that brigade fire support assets receive required CSS support; fire support assets are [FM 6-20, p. 3-4]:
    - a) DS FA battalion [AN].
    - b) Brigade ALO, ETACs, and TACPs [AN].
    - c) Brigade ANGLICO elements [AN].
    - d) Brigade aviation [AN].

- 2) The brigade FSO and brigade S4 coordinate CSS support for fire support assets with [FM 6-20, p. 3-4]:
  - a) FSB commander and S3 [FM 6-20, p. 3-4].
  - b) The division G4 [FM 6-20, p. 3-4].
  - c) DS FA battalion XO, S3, and S4 [FM 6-20, p. 3-4].
  - d) DIVARTY S4 and A/L section [FM 6-20, p. 3-4; FM 6-20-2, p. 1-12].
- 3) The brigade S4 and brigade FSO ensure that the DS FA battalion is resupplied with sufficient quantities of CL V to support missions specified in the quick fire plan [AN].
- 4) Weapons systems and all other fire support equipment are maintained [FM 6-20, p. 3-4].

2. **Receive Order From Higher Headquarters**

- a. The brigade receives the division WARNO; the brigade commander, brigade S3, brigade S2, brigade FSO, and brigade FSCOORD analyze the division WARNO and determine [FN-JRTC]:
  - 1) Corps and division missions [FM 101-5, p. 4-38; FN-JRTC; FN-BCBST].
  - 2) Corps and division commanders' intent [FN-JRTC; FN-BCBST].
  - 3) Division CCIR [FN-JRTC].
  - 4) Graphics (e.g., maneuver, fire support, SIT TEMP, obstacles) [FN-JRTC].
  - 5) Fire support available to the brigade, including [FN-JRTC]:
    - a) Target acquisition systems [AN].
    - b) Attack systems (e.g., artillery, CAS, IEW, naval surface fires) [AN].
    - c) Munitions constraints, including Control Supply Rate (CSR) [FN-JRTC].
  - 6) Enemy situation [FN-JRTC].
  - 7) Collection assets dedicated to acquire intelligence and targeting information [FN-JRTC].
  - 8) Brigade and division task organization [FM 101-5, p. H-31].

- 9) Time, location, and brigade representation requirements for the division order [AN].
- b. The brigade commander selects brigade targeting team officers and other brigade fire support leaders to attend the division OPORD/FRAGO briefing; officers and leaders may include:<sup>2</sup>
  - 1) Brigade FSCoord [FM 6-20-1, p. 3-7; FN-NTC; FN-JRTC; FN-AR Sch].
  - 2) Brigade S3 [FM 6-20-1, p. 3-7; FN-NTC].
  - 3) Brigade FSO [FM 6-20-40, p. 2-13; FM 6-20-50, p. 2-13; FN-NTC; FN-JRTC; FN-AR Sch].
  - 4) Brigade S2 [FM 6-20-1, p. 3-7; FN-NTC].
  - 5) Brigade ALO [AN].
  - 6) Brigade ANGLICO [AN].
- c. The brigade commander receives the division OPORD/FRAGO; options for the issuance of the division OPORD/FRAGO include [FM 6-20-40, Ch 2; FM 6-20-50, Ch 2; FM 6-20-10, Ch 2]:
  - 1) Formal briefing by the division commander and division staff [AN].
  - 2) Briefings by the division commander, division G3, and selected division staff [AN].
  - 3) Electronic means (via radio or digital systems) [AN].
  - 4) Delivery by LNOs or messengers [AN].
- d. The brigade commander conducts a confirmation briefing with the division commander to ensure his understanding of [FM 101-5, p. 4-59]:
  - 1) Division commander's intent [FN-AR Sch].
  - 2) Division scheme of maneuver [AN].
  - 3) Directed brigade missions and tasks [AN].
  - 4) Division commander's Critical Information Requirements (CCIR) [AN].
  - 5) Brigade missions and specified tasks [AN].
- e. The brigade commander receives a copy of the division order with supporting documents and products [FN-CGSC].

- f. The brigade FSCoord, brigade FSO, brigade ALO, and brigade ANGLICO meet with the DIVARTY commander, DIVARTY S3, representative from the division Fire Support Element (FSE), division ALO, and division ANGLICO to receive fire support information, which includes [FM 6-20-40, p. 2-1, 2-12; FM 6-20-50, p. 2-1, 2-12; FM 6-20-10, p. 2-3; FM 6-20-2, p. 1-13; FN-JRTC]:
- 1) Division and DIVARTY commanders' [FN-JRTC; FN-AR Sch]:
    - a) Intents and guidance for fire support [FM 6-20-40, p. 2-2; FM 6-20-50, p. 2-2; FN-JRTC; FN-AR Sch].
    - b) Target attack guidance [FN-JRTC; FN-AR Sch].
    - c) Defeat criteria [FN-JRTC; FN-AR Sch].
    - d) Priorities for fire support [FN-JRTC; FN-AR Sch].
  - 2) Mission of DIVARTY and missions of FA units retained under division control [FN-JRTC; FN-AR Sch].
  - 3) Identification of the force artillery commander, including [FN-JRTC]:
    - a) Force artillery structure and assets [FN-JRTC].
    - b) Fire support systems and assets phased into theater and projected availability times [FN-JRTC].
  - 4) Submission timelines for input to ATO and ATO publication timelines [FN-JRTC].
  - 5) Identification of information requirements from brigade ANGLICO to USN ships and USMC headquarters and disposition of ANGLICO units in the division AO [FM 6-20-30, p. 2-13; FN-JRTC].
  - 6) Division attack helicopter cross-FLOT operations, including effects on the brigade mission and utilization of brigade air space [FN-JRTC].
  - 7) CL V considerations for all DS, GS, and reinforcing artillery units, including [FM 6-20-40, p. 2-3; FM 6-20-50, p. 2-3; FN-JRTC; FN-BCTP; FN-AR Sch]:
    - a) Allocation of special munitions (e.g. PGM, FASCAM) [FM 6-20-40, p. 2-3; FM 6-20-50, p. 2-3; FN-JRTC; FN-BCTP; FN-AR Sch].
    - b) Constraints (e.g. CSR) [FM 6-20-40, p. 2-3; FM 6-20-50, p. 2-3; FN-JRTC; FN-BCTP; FN-AR Sch].

- 8) Allocation of division meteorological support assets; weather forecasts during the mission [FN-JRTC; FN-BCTP].
- 9) Division permissive fire support coordinating measures, which include [FM 6-20-40, p. 2-2; FM 6-20-50, p. 2-2; FM 6-20-30, p. 4-23, F-2]:
  - a) Coordinated Fire Line (CFL) [FM 6-20-30, p. 4-23, F-2].
  - b) Fire Support Coordination Line (FSCL) [FM 6-20-30, p. 4-23, F-3].
  - c) Free-Fire Areas (FFA) [FM 6-20-30, p. 4-23, F-4].
- 10) Division restrictive fire support coordinating measures, which include [FM 6-20-40, p. 2-2; FM 6-20-50, p. 2-2; FM 6-20-30, p. 4-23, F-5]:
  - a) Restrictive Fire Line (RFL) [FM 6-20-30, p. 4-23, F-5].
  - b) Airspace Coordination Areas (ACA) [FM 6-20-30, p. 4-23, F-5].
  - c) No-Fire Areas (NFA) [FM 6-20-30, p. 4-23, F-6].
  - d) Restrictive Fire Areas (RFA) [FM 6-20-30, p. 4-23, F-7].
- 11) Zones of fire designated for division FA units and USN ships providing naval surface fires [FM 6-20-30, p. 4-23, F-2].
- 12) Division targeting data from the division FSE and DIVARTY Targeting Element, which includes [AN]:
  - a) Division High Payoff Target (HPT) and directed brigade actions upon detection of division HPT (e.g., attack, report) [FN-JRTC].
  - b) Target Value Analysis (TVA) for the division AO [FM 6-20-40, p. 2-12; FM 6-20-50, p. 2-12].
  - c) Division Named Areas of Interest (NAI) and Target Areas of Interest (TAI) [FM 6-20-40, p. 2-12; FM 6-20-50, p. 2-12].
  - d) Fires in the brigade zone planned by division [FM 6-20-40, p. 2-13; FM 6-20-50, p. 2-13; BCTP].
- 13) Allocation of division survey assets to support the brigade [FN-BCTP].
- 14) Allocation of division radar assets to support the brigade [FN-BCTP].

### 3. Conduct Mission Analysis<sup>3</sup>

- a. The brigade commander provides his intent to the brigade staff to assist in staff mission analysis [FM 101-5, p. D-1].
  - 1) The brigade XO supervises the staff's mission analyses [FM 101-5, p. D-2; FN-NTC].
    - a) The brigade XO ensures that each brigade staff officer produces a complete and integrated mission analysis [FM 101-5, p. D-1; FN-NTC].
    - b) The brigade XO manages the mission analysis to ensure that all steps are conducted [FM 101-5, p. D-1; FN-NTC].<sup>4</sup>
  - 2) Each brigade staff officer is provided access to the division order and supporting products [FM 101-5, p. D-1; FN-JRTC; FN-AR Sch].
  - 3) Brigade staff identifies division-directed and higher headquarters-directed timelines for submission of requests for additional assets and information by using imposed time constraints to determine brigade cut-off times [FN-JRTC].
- b. The brigade S3 performs mission analysis [ARTEP 71-3-MTP, 71-3-3001; FM 6-20-10, p. 2-3; FN-3/24 ID].
  - 1) The brigade S3 determines the new brigade task organization (e.g., attachments and detachments); he identifies [AN]:
    - a) Effective times for attachment and detachment of units [AN].
    - b) The headquarters to which units are being detached, and their command relationship with the new headquarters [AN].
    - c) Requirements to bring the units to mission-ready status prior to detachment from the brigade [AN].
    - d) Operational status of units being attached to the brigade [AN].
    - e) Command relationship of attached units to the brigade [AN].
  - 2) The brigade S3, with the brigade S3/Air, brigade FSO, brigade ALO, brigade ANGLICO, brigade aviation LNO, and brigade AD LNO, extracts army airspace command and control (A2C2) information from the division order [ARTEP 71-3-MTP, 71-3-3013/1c; FN-BCBST].

- 3) The brigade S3 identifies locations and missions of non-brigade units operating in the brigade area of operations to determine:
  - a) Impact on brigade operations [AN].
  - b) Terrain and air space requirements [AN].
- 4) The brigade S3 identifies division requirements for the brigade to accept deep battle hand-over from the division [FM 6-20-30, p. 4-16; FN-FA Sch].<sup>5</sup>
- c. The brigade S2 performs mission analysis [ARTEP 71-3-MTP, 71-3-2001/1; FM 6-20-10, p. 1-6, 2-3].
  - 1) The brigade S2 updates the brigade IPB based on the new brigade mission [ARTEP 71-3-MTP, 71-3-2001/2; JRTC; 3/24 ID].
  - 2) The brigade S2 defines the battlefield environment [FM 34-130, p. 2-12].

Note: This task is initiated during the mission analysis and is continually refined.

- a) The brigade S2 identifies the limits of the brigade's Area of Operations (AO) and battle space [FM 34-130, p. 2-3; FN-FA Sch].
- b) The brigade S2, with the brigade commander and brigade S3, determine the extent of the brigade's AI [FM 101-5, p. C-6; ARTEP 71-3-MTP, 71-3-2001/1c; FM 34-8, p. 2-3; FM 34-130, p. 2-6; FN-FA Sch].<sup>6</sup>
- 3) The brigade S2 describes battlefield effects [FM 34-130, p. 2-7; FM 34-8, p. 2-3).

Note: This task is initiated during the mission analysis and is continually refined.

- a) The brigade S2 develops a terrain analysis for the Area of Interest (AI) [ARTEP 71-3-MTP, 71-3-2001/2b; FM 101-5, p. C-6]:
- b) The brigade S2 conducts a weather analysis [ARTEP 71-3-MTP, 71-3-2001/2c].
- 4) The brigade S2, with the brigade targeting officer, evaluates the threat [FM 34-130, p. 2-29; FM 34-8, p. 2-3; ARTEP 71-3-MTP, 71-3-2001/2d; FN-JRTC].

Note: This task is initiated during the mission analysis and is continually refined.

- a) The intelligence database is refined using Order of Battle (OB) factors [ARTEP 71-3-MTP, 71-3-2001/2d1; FM 34-8, p. 2-2; FN-3/24 ID].



- b) Threat doctrine and doctrinal patterns of operations are converted into a doctrinal template [FM 34-130, p. 2-30].
  - c) Enemy tactics, options, and capabilities are determined [FM 34-130, p. 2-30].
- 5) The brigade S2 determines enemy courses of action (COAs); the brigade S2 [FM 34-130, p. 2-39]:

Note: This task is initiated during the mission analysis and is continually refined.

- a) Identifies the full set of COAs available to the enemy, including likely objectives and desired end state [FM 34-130, p. 2-40].
  - b) Evaluates and prioritizes each enemy COA [FM 34-130, p. 2-40].
- 6) The brigade S2 develops the situation template (SIT TEMP), which depicts [ARTEP 71-3-MTP, 71-3-2001/2d3; FM 34-130, p. 2-45; FN-3/24 ID; FN-BCTP]:
- a) Expected enemy dispositions for a particular COA, including where the enemy might adopt branches or sequels [FM 34-130, p. 2-45].
  - b) Places where the enemy is vulnerable [FM 34-130, p. 2-45].
  - c) Dispositions for all the enemy's major assets and critical nodes [ARTEP 71-3-MTP, 71-3-2001/2d3a; FM 34-130, p. 2-45].
  - d) NAIs and TAIs [ARTEP 71-3-MTP, 71-3-2001/2d3c].
- 7) The brigade S2 and brigade targeting officer determine High Value Targets (HVT); the brigade S2 and brigade targeting officer [ARTEP 71-3-MTP, 71-3-2001/2d3b; FM 34-130, p. 2-33; FM 6-20-40, p. G-1; FM 6-20-50, p. K-1; FM 6-20-10, p. 2-3]:
- a) Evaluate the intelligence database and Doctrinal Templates to develop HVT [FM 34-130, p. 2-33].
  - b) Identify assets the enemy will consider are critical to their operations [FM 34-130, p. 2-33].
  - c) Determine how the enemy will react to the loss of each HVT, including the ability to substitute other assets and the selection of other courses of action [FM 34-130, p. 2-33].
  - d) Identify changes in each HVT's worth, by projected phases of the enemy operation [FM 34-130, p. 2-33].
  - e) Prioritize HVTs with regard to their relative worth to the enemy's operations [FM 34-130, p. 2-33].

- f) Group HVTs into categories for target development. Categories are [FM 34-130, p. 2-33; FM 6-20-40, p. G-3; FM 6-20-50, p. K-3]:
- (1) Command, control, and communications [FM 34-130, p. 2-33; FM 6-20-40, p. G-3; FM 6-20-50, p. K-3].
  - (2) Fire support (e.g., firing systems, target acquisition, ammunition, aircraft, fire direction control) [FM 34-130, p. 2-33; FM 6-20-40, p. G-3; FM 6-20-50, p. K-3].
  - (3) Maneuver [FM 34-130, p. 2-34; FM 6-20-40, p. G-3; FM 6-20-50, p. K-3].
  - (4) Air defense (e.g., radars, processing centers, firing units, headquarters) [FM 34-130, p. 2-34; FM 6-20-40, p. G-3; FM 6-20-50, p. K-3].
  - (5) Engineer [FM 34-130, p. 2-34; FM 6-20-40, p. G-3; FM 6-20-50, p. K-3].
  - (6) Reconnaissance, intelligence, surveillance, and target acquisition (RISTA) [FM 34-130, p. 2-34; FM 6-20-40, p. G-3; FM 6-20-50, p. K-3].
  - (7) NBC (e.g., support elements, weapons) [FM 34-130, p. 2-34; FM 6-20-40, p. G-3; FM 6-20-50, p. K-3].
  - (8) Radio electronic combat (REC) or EW assets [FM 34-130, p. 2-34; FM 6-20-40, p. G-3; FM 6-20-50, p. K-3].
  - (9) Bulk fuels (e.g., storage assets, refueling assets) [FM 34-130, p. 2-34; FM 6-20-40, p. G-3; FM 6-20-50, p. K-3].
  - (10) Ammunition storage sites and distribution points [FM 34-130, p. 2-34; FM 6-20-40, p. G-3; FM 6-20-50, p. K-3].
  - (11) Maintenance and repair units (e.g., collection points, mobile repair facilities) [FM 34-130, p. 2-34; FM 6-20-40, p. G-3; FM 6-20-50, p. K-3].
  - (12) Lift [FM 34-130, p. 2-34; FM 6-20-40, p. G-3; FM 6-20-50, p. K-3].
  - (13) Lines of communications (e.g., roads, bridges, railheads, transloading facilities, airfields, choke points) [FM 34-130, p. 2-34; FM 6-20-40, p. G-3; FM 6-20-50, p. K-3].
- g) Annotate HVTs on the SIT TEMP, including where and when they will appear [FM 34-130, p. 2-49; FN-NTC; FN-BCBST].

- h) Determine systems and methods to acquire HVTs based on where and when they will appear [FN-3/24 ID].
- 8) The brigade S2 develops the Event Template to determine when to collect information which indicates which course of action the enemy will use, and depicts NAIs and time-phase lines (TPLs) to collect enemy courses of action information [FM 6-20-10, p. A-8; FM 34-130, p. 2-50; FN-JRTC].
- 9) The brigade S2 develops the Event Matrix to provide indicators of enemy activity; the Event Matrix reflects [FM 34-130, p. 2-51].
  - a) Details on the type of activity expected at each NAI [FM 34-130, p. 2-51].
  - b) Times NAIs are expected to be active [FM 34-130, p. 2-51].
  - c) Relationship of NAIs to other battlefield events [FM 34-130, p. 2-51].
- 10) The brigade S2 evaluates the existing database and IPB products to determine information and intelligence gaps [FM 34-130, p. 2-3; FM 34-8, p. 2-2; 3/24 ID].
- 11) The brigade S2, brigade FSO, brigade targeting officer, and DS MI company commander determine initial collection requirements and capabilities [FM 34-130, p. 2-40].
  - a) Target acquisition assets and collection systems available to the brigade are identified; their status is determined [FM 6-20-10, p. B-1; FN-AR Sch; FN-3/24 ID].<sup>7</sup>
  - b) Division-directed collection requirements are identified [AN].
  - c) The Event Template and Event Matrix are used as the basis for [FM 34-130, p. 2-52]:
    - (1) Planning collection strategies [FM 34-130, p. 2-52].
    - (2) Synchronizing intelligence with friendly operations [FM 34-130, p. 2-52].
    - (3) Preparing the collection plan [FM 34-130, p. 2-52].
- d. The brigade FSO performs mission analysis [FM 6-20-1, p. 3-7; FM 6-20-10, p. 2-3; FN-JRTC; FN-NTC; FN-3/24 ID].
  - 1) The brigade FSO determines the task organization of FA assets, including duration of support, support relationship, and directed division missions [FM 6-20-2, p. B-3; FM 6-20-30, p. D-5; FM 6-20-40, p. 2-3; FM 6-20-50, p. 2-3; FN-NTC].
  - 2) The brigade FSO and brigade ALO determine CAS allocations available to the

brigade, including the responsible service (e.g., USAF, USN, USMC) and division-directed missions [FM 6-20-30, p. D-16; FN-NTC; FN-BCBST].

- 3) The brigade FSO and brigade ANGLICO determine allocation and support relationship (e.g., DS, GS) of naval surface fires, including division directed missions [FM 6-20-30, p. D-17].
- 4) The brigade FSO and brigade aviation LNO determine Army aviation assets allocated for observation, target acquisition, and lift support to the brigade, including division-directed missions [FM 1-111, p. 3-3; FN-NTC].
- 5) The brigade FSO, brigade S2, and DS MI company commander determine allocation of offensive EW systems, including division-directed missions [FM 6-20-30, p. D-18].
- 6) The brigade FSO determines allocation of division radar systems to the brigade, including division radar zones and directed missions [FM 6-20-2, p. B-14; FN-NTC].
- 7) The brigade FSO extracts [AN]:
  - a) Division-directed targets and obstacles [FM 6-20-40, p. 2-1, 2-13; FM 6-20-50, p. 2-1, 2-13; FN-NTC; FN-FA Sch].
  - b) SEAD requirements to support CAS and Army aviation missions in the brigade AO [FM 1-111, p. 3-3; NTC].
  - c) Division plans and requirements to provide fire support for rear area operations [FM 6-20-30, p. 4-19].
  - d) Division fire support coordinating measures [FM 6-20-30, p. D-11, F-1; FM 6-20-40, p. E-2; FN-NTC; FN-JRTC].
  - e) CSR for fire support systems [FM 6-20-40, p. 2-3; FN-NTC].
  - f) Division attack helicopter cross-FLOT operations in the brigade AO [FM 1-111, p. 3-3; FN-NTC].
  - g) Follow-on missions for fire support units supporting the brigade [FM 6-20-30, p. D-6; FN-NTC].
  - h) Locations and schemes of maneuver for non-brigade fire support units operating in the brigade's AO [FM 6-20-30, p. 2-11; FN-NTC; FN-FA Sch].
  - i) Division-deep battle plan and concept for transition from division-deep battle to brigade-deep and close battles [FM 71-100, p. 1-5; FM 6-20-30, p. 4-16, B-1].

- j) Division counter-preparation plan [FM 6-20-30, p. D-2].
- 8) The brigade FSO determines A2C2 requirements to resolve conflicts [ARTEP 71-3-MTP, 71-3-9002/3d2].
    - a) Identifies division-planned FA support fires and their effect on brigade air space [ARTEP 71-3-MTP, 71-3-9002/3d1].
    - b) Extracts locations of FA units under division control [ARTEP 71-3-MTP, 71-3-9002/3d1].
    - c) Determines effects of division-imposed fire support coordination measures on brigade air space [ARTEP 71-3-MTP, 71-3-9002/3d3].
- e. The brigade ALO performs mission analysis [FM 6-20-10, p. 2-3].
    - 1) The brigade ALO determines brigade allocation of CAS, including responsible service (USAF, USN, USMC) [FM 71-3, p. 7-8; MCM 3-3, Vol VIII, Ch 9; FM 6-20-40, p. A-8; FM 6-20-50, p. C-5; FN-194 AR].
    - 2) The brigade ALO determines task organization of ALOs and tactical command posts (TACPs) under division and brigade control [MCM 3-3, Vol VIII, Ch 8].
    - 3) The brigade ALO determines brigade responsibility to execute SEAD fires in support of division-directed CAS mission [AN].
    - 4) The brigade ALO identifies division preplanned CAS missions (e.g., CAS, IEW) [FM 71-3, p. 7-8; MCM 3-3, Vol VIII, Ch 9; FM 6-20-40, p. A-8; FM 6-20-50, p. C-5; FN-194 AR].
    - 5) The brigade ALO determines aircraft and munitions characteristics for aircraft allocated to support the brigade [ARTEP 71-3-MTP, 71-3-3004/2a; FM 71-3, p. 7-8; FM 6-20-40, p. A-8; FM 6-20-50, p. C-13].
    - 6) The brigade ALO determines cut-off times for submitting preplanned CAS requests to the division G3 as specified in the ATO [ARTEP 71-3-MTP, 71-3-3004/2c].
    - 7) The brigade ALO determines division A2C2 guidance and measures to deconflict airspace [AN].
      - a) Identifies division CAS mission and its effect on brigade air space [AN].
      - b) Determines effects of division-imposed fire support coordination measures on CAS support to the brigade [AN].
    - 8) The brigade ALO, with the brigade S2, determines [AN]:

- a) Enemy air defense capabilities [MCM 3-3, Vol VIII, Ch 2].
  - b) Division IEW operations which will affect the employment of high performance aircraft [MCM 3-3, Vol VIII, Ch 2].
- f. The brigade ANGLICO performs mission analysis [FM 6-20-10, p. 2-3].
- 1) The brigade ANGLICO determines support relationships (e.g., DS, GS) of USN ships to the brigade [FM 71-3, p. 7-14; FM 6-20-40, p. A-3; FM 6-20-50, p. C-26; FN-194 AR].
  - 2) The brigade ANGLICO and brigade ALO determine USN and USMC CAS allocation to the brigade [FM 6-20-40, p. A-3; FM 6-20-50, p. C-13].
  - 3) The brigade ANGLICO identifies task organization of ANGLICO and Naval gunfire officer (NGO) elements within the division [FM 71-3, p. 7-12].
  - 4) The brigade ANGLICO identifies division-directed naval surface fires and USN/USMC CAS mission to determine brigade responsibilities [FM 6-20-40, p. A-3; FM 6-20-50, p. C-13].
  - 5) The brigade ANGLICO identifies division A2C2 guidance and measures to deconflict airspace [AN].
    - a) Identifies division USN/USMC CAS mission and its effect on brigade air space [AN].
    - b) Identifies division naval surface fire missions and their effects on brigade air space [AN].
    - c) Determines effects of division-imposed fire support coordination measures on USN/USMC CAS and USN naval surface fire support to the brigade [AN].
- g. The brigade Army aviation LNO performs mission analysis [FM 6-20-10, p. 2-3].
- 1) The brigade aviation LNO identifies task organization of Army aviation assets in support of the brigade, including their roles [ARTEP 71-3-MTP, 71-3-7001/1a; FM 1-111, p. 2-33, 3-3]:
    - a) Helicopters providing observation and target acquisition [FM 1-111, p. 3-2].
    - b) Helicopters providing lift support [FM 1-111, p. 3-2].
  - 2) The brigade aviation LNO identifies [AN]:
    - a) Aircraft capabilities [FM 1-111, p. 3-2].

- b) Times and available operating hours aircraft will be available [FM 1-111, p. 3-2].
  - c) Locations from which aircraft will operate [FM 1-111, p. 3-2].
  - d) Support relationship (e.g., OPCON, DS, GS) [FM 6-20-40, p. A-33; FM 6-20-50, p. C-29].
  - e) Requirements to provide logistical support (e.g., CL III, FARP operations) of Army aviation units [AN].
- 3) The brigade aviation LNO identifies division-directed aviation employment guidance and plans which will affect brigade helicopter operations, including [ARTEP 71-3-MTP, 71-3-7001/1h]:
- a) Brigade support of SEAD operations [ARTEP 71-3-MTP, 71-3-7001/1h3; FM 1-111, p. 4-3].
  - b) Brigade support of division Joint Air Attack Team (JAAT) plans and guidance [FM 71-100, Ch 6; FM 1-111, p. G-1].
  - c) Division IEW operations in support of aviation operations [FM 1-111, p. 4-16].
- 4) The brigade aviation LNO determines division A2C2 guidance and measures to deconflict airspace, including [ARTEP 71-3-MTP, 71-3-7001/4a]:
- a) Air corridors for helicopters [FM 1-111, p. H-11; ARTEP 71-3-MTP, 71-3-7001/1h1].
  - b) Airspace coordination altitude for helicopters [ARTEP 71-3-MTP, 71-3-7001/2b7].
  - c) Division-imposed A2C2 rules and procedures for helicopter operations [FM 1-111, p. H-11; ARTEP 71-3-MTP, 71-3-7001/2b6].
  - d) Division Army aviation missions and their effect on brigade air space [AN].
  - e) Division-directed air space control measures and their effect on brigade air space users [FM 1-111, p. H-11; ARTEP 71-3-MTP, 71-3-7001/4i].
  - f) Potential conflicts with flight control measures generated by [ARTEP 71-3-MTP, 71-3-7001/4k]:
    - (1) FA unit locations and missions [ARTEP 71-3-MTP, 71-3-7001/4k].
    - (2) ADA unit locations and missions [ARTEP 71-3-MTP, 71-3-7001/4k].

- (3) Flight obstructions in the brigade's area of operations [ARTEP 71-3-MTP, 71-3-7001/4k].
- h. The Assistant Brigade Engineer (ABE) performs mission analysis [ARTEP 71-3-MTP, 71-3-8001; FM 6-20-10, p. 2-3].
  - 1) The ABE determines brigade allocation of FA-delivered FASCAM missions, including [FM 5-100, p. 24; FM 5-102, p. 57, 82]:
    - a) Division-desired FA FASCAM effects (e.g., on terrain, on enemy) [AN].
    - b) Division restrictions imposed on the employment of FA FASCAM [ARTEP 71-3-MTP, 71-3-8003/1d].
    - c) Terrain and weather effects on FA FASCAM employment [ARTEP 71-3-MTP, 71-3-8003/1e].
  - 2) The ABE determines division-directed obstacles which the brigade is responsible for emplacing and covering with indirect fires [FM 5-102, p. 55; FN-JRTC].
  - 3) The ABE, brigade FSO, and the brigade S2 [FM 5-101, p. 3-3]:
    - a) Assess division terrain analysis products to determine friendly and enemy mobility factors in the brigade AO and AI [FM 5-101, p. 3-3].
    - b) Determine enemy obstacles and restrictive terrain which will require suppression and obscuration by brigade fire support systems [FM 5-101, p. 3-3].
    - c) Identify enemy engineer capabilities and likely reactions to brigade FASCAM employment [ARTEP 71-3-MTP, 71-3-8003/1c].
    - d) Identify enemy mobility and countermobility assets (for HVT consideration) [FM 5-101, p. 3-3].
- i. The brigade AD LNO performs mission analysis and determines A2C2 information, which includes [ARTEP 71-3-MTP, 71-3-6002/1; FM 6-20-10, p. 2-3]:
  - 1) Identification of division-planned ADA fires and engagement areas to determine their effect on the use of brigade air space [ARTEP 71-3-MTP, 71-3-6002/1b].
  - 2) Determination of locations of ADA units under division control [AN]
  - 3) Determination of effects of division-imposed air defense control measures on brigade air space [AN].



- j. The brigade S4 performs mission analysis and determines [FM 71-123, p. 8-1; FM 6-20-10, p. 2-3; FN-3/24 ID]:
  - 1) Brigade allocation of CSS by class of supply for brigade fire support units, including FA and mortar CL V [FM 71-123, p. 8-3; FN-3/24 ID].
  - 2) Ground and air transportation assets supporting brigade fire support units [FM 71-123, p. 8-5; FN-3/24 ID].
  - 3) Locations of division CSS nodes and their operating times [FM 71-123, p. 8-1; FN-3/24 ID].
  - 4) Division maintenance priorities for fire support systems (as the basis for recommending brigade priorities), including [AN]:
    - a) FA tubes [AN].
    - b) COLTs and FIST-Vs [AN].
    - c) Radars [AN].
    - d) FA voice and digital communications systems [AN].
    - e) ALO and ANGLICO equipment [AN].
  - 5) Division personnel operations for replacement of trained fire support personnel [AN].
- k. The brigade Signal Officer (SO) performs mission analysis [ARTEP 71-3-MTP, 71-3-1101/1a; FM 6-20-10, p. 2-3].
  - 1) The brigade SO reviews the division communications area analysis for the brigade's AO to determine brigade's ability to communicate [FM 11-50, p. G-3; FM 11-41, p. C-1; FN-3/24 ID].
  - 2) The brigade SO identifies division and higher headquarters retrans sites and communications nodes [FM 11-41, p. 3-2, 4-1; FM 11-50, p. 2-6; FN-3/24 ID].
  - 3) The brigade SO determines brigade allocation of voice and digital communications frequencies [FM 11-41, p. 3-2, 4-2; FM 11-50, p. 1-9; ARTEP 71-3-MTP, 71-3-1102/2].
  - 4) The brigade SO, brigade S2, and DS MI company commander [ARTEP 71-3-MTP, 71-3-1007/1b]:
    - a) Identify enemy communications activities and their potential impact on the brigade (for HVT consideration) [ARTEP 71-3-MTP, 71-3-1007/1b1].

- b) Determine division meaconing, intrusion, jamming, and interference (MIJI) guidance [ARTEP 71-3-MTP, 71-3-1007/1b2].
    - c) Determine potential effect on enemy communications systems resulting from division-directed non-lethal attack [AN].
- l. The brigade chemical officer performs mission analysis [FM 6-20-10, p. 2-3].
  - 1) The brigade chemical officer determines [AN]:
    - a) Locations of division decontamination sites and decontamination units [FM 3-101, p. C-4].
    - b) Division-directed smoke and obscuration missions the brigade is responsible to execute [FM 3-7, p. 6-1; FM 3-50, p. 7].
  - 2) The brigade chemical officer reviews division Vulnerability Analysis to determine the NBC risk to the brigade [FM 3-7, p. 1-0, 3-3].
  - 3) The brigade chemical officer, brigade S2, and brigade targeting officer review division intelligence on enemy NBC capabilities and determine division actions to eliminate the enemy's ability to employ NBC (for brigade HVT consideration) [FM 3-101, p. C-1].
- m. The brigade staff prepares for and presents the results of mission analysis to the brigade commander [AN].
  - 1) The brigade S3, with input from the brigade staff, develops the brigade's restated mission [FM 101-5, p. D-7; FN-JRTC].
  - 2) The brigade staff briefs and provides information to the brigade commander on the results of its mission analysis [FM 6-20-10, p. 2-3; FM 101-5, p. 4-15, D-9; FM 71-3, p. 3-4].
  - 3) The brigade commander reviews the restated mission and [AN]:
    - a) As required, modifies the restated mission or approves the restated mission developed by the brigade staff<sup>6</sup> [FM 101-5, p. 4-15 D-7; FN-JRTC].
    - b) Revises, as required, his intent for mission [FN-JRTC].
    - c) Provides his guidance for fire support [FN-JRTC].
    - d) Provides specific guidance as to how the brigade will defeat the enemy [FN-JRTC].

- n. The brigade targeting team begins initial targeting for the new mission [FM 6-20-10, p. 2-3].<sup>9</sup>
- 1) The brigade targeting team maintains continuous coordination with division FSE and DIVARTY Targeting Element to receive updates on intelligence, targeting information, and targeting products [FM 6-20-40, p. 2-11; FM 6-20-50, p. 2-11; FN-BCTP; FN-JRTC].
  - 2) The brigade S2 provides the brigade targeting team HVTs grouped into categories for target development (see task 3c7f above for categories) [ARTEP 71-3-MTP, 71-3-2001/2d3b; FM 34-130, p. 2-33; FM 6-20-40, p. G-3; FM 6-20-50, p. K-3].
  - 3) The brigade FSO, brigade targeting Officer, and brigade S2 use the target sheets and spreadsheets provided by the division FSE and DIVARTY Targeting Element to perform TVA and develop TVA products [FM 6-20-40, p. G-6; FM 6-20-50, p. K-6].
  - 4) The brigade FSO, brigade targeting officer, and brigade S2 perform TVA and develop TVA tools; TVA tools are [ARTEP 71-3-MTP, 71-3-9003/1; FM 6-20-10, p. 2-3; FM 6-20-40, p. G-2; FM 6-20-50, p. K-2; FN-BCTP]:
    - a) Target sheets. The brigade FSO, brigade targeting officer, and brigade S2 develop brigade target sheets, which reflect [FM 6-20-40, p. G-6; FM 6-20-50, p. K-6]:
      - (1) Target category [FM 6-20-40, p. G-6; FM 6-20-50, p. K-6].
      - (2) Target function (e.g., specific operations and tasks that the target is expected to perform) [FM 6-20-40, p. G-7; FM 6-20-50, p. K-7].
      - (3) Target description (e.g., number and types of vehicles and equipment in position, approximate number of personnel associated with the target) [FM 6-20-40, p. G-7; FM 6-20-50, p. K-7].
      - (4) Target signature (e.g., signatures the target will emit, ranging from visual and electronic to auditory and IR) [FM 6-20-40, p. G-7; FM 6-20-50, p. K-7].
      - (5) Degradation effect (e.g., what happens to the parent unit or an associated unit when the target function is destroyed or rendered ineffective) [FM 6-20-40, p. G-7; FM 6-20-50, p. K-7].
      - (6) Graphic representation (e.g., reflecting how the target would be arrayed doctrinally on the battlefield) [FM 6-20-40, p. G-7; FM 6-20-50, p. K-7].
    - b) Spreadsheets. The brigade FSO, brigade targeting officer, and brigade S2 develop brigade spreadsheets to identify HVTs in relation to a type of enemy

operation; spreadsheets include [FM 6-20-10, p. 2-3; FM 6-20-40, p. G-2, G-13; FM 6-20-50, p. K-2; K-13]:

- (1) Relative value matrix, reflecting target categories [FM 6-20-40, p. G-2, G-3; FM 6-20-50, p. K-2, K-3; FM 34-130, p. 2-34].
- (2) Attack rationale (e.g., benefits to be derived by attacking targets of a particular category) [FM 6-20-40, p. G-2, G-4; FM 6-20-50, p. K-2, K-4].
- (3) Brigade HVTs [FM 6-20-40, p. G-2, G-4; FM 6-20-50, p. K-2, K-4].
- (4) Fall-back option (e.g., what the enemy will do if he fails to accomplish the mission) [FM 6-20-40, p. G-2, G-6; FM 6-20-50, p. K-2, K-6].

5) The brigade targeting team uses TVA products to [AN]:

- a) Determine HVT for each enemy course of action [FM 6-20-10, p. 2-3; FN-IN Sch].
- b) Describe a relative ranking of target categories [FM 6-20-10, p. 2-3].
- c) Translate HVTs into brigade HPTs (see task 61 below).

#### 4. **Issue the Warning Order (WARNO)**<sup>10</sup>

- a. The brigade FSCoord, brigade FSO, brigade ALO, brigade ANGLICO, and brigade aviation LNO provide recommendations to the brigade commander on aspects of fire support which should be included in brigade WARNOs [FM 101-5, p. H-13].
- b. Fire support information contained in WARNOs may include [AN]:
  - 1) Task organization changes of fire support assets [FN-JRTC].
  - 2) Positioning guidance for [FN-IN Sch]:
    - a) COLTS [FN-IN Sch].
    - b) FA firing batteries, FDCs, and radars [FN-IN Sch].
    - c) Brigade ALO elements (e.g., ETAC, TACP) [FN-IN Sch].
    - d) Brigade ANGLICO elements [FN-IN Sch].
    - e) Mortars (if required to support brigade operations) [FN-IN Sch].
  - 3) Guidance for the DS FA battalion on [FN-JRTC; FN-IN Sch]:

- a) Restrictions on or permission to perform reconnaissance of locations for fire support assets [FN-JRTC; FN-IN Sch].
- b) Types of fires that will be executed at locations being reconnoitered [FN-JRTC; FN-IN Sch].
- 4) Guidance to subordinate Bn TFs on CAS sorties available (to support Bn TF planning) [ARTEP 71-3-MTP, 71-3-3004/2b].
- c. The brigade commander issues or directs the brigade XO or brigade S3 to issue the WARNO [ARTEP 71-3-MTP, 71-3-3001/1f]
- d. All subordinate headquarters acknowledge receipt of the brigade WARNO [FM 101-5, p. H-14].

## 5. **Brigade Commander Issues Planning Guidance**

- a. The brigade FSCOORD assists the brigade commander in developing the brigade commander's guidance for fire support and CCIR [FN-FA Sch].
- b. The brigade commander issues planning guidance to the brigade staff, which includes [ARTEP 71-3-MTP, 71-3-0001/3; FM 101-5, p. 4-17; FM 6-20-40, p. 2-1, 2-3; FM 6-20-50, p. 2-1, 2-3; FM 6-20-10, p. 1-7; FN-CGSC]:
  - 1) Enemy courses of action (COA) [FM 101-5, p. 4-17].
  - 2) Restated mission [FM 101-5, p. 4-18].
  - 3) Intent (e.g., purpose, method, end state) [FM 101-5, p. 4-18; FM 71-3, p. 3-3; FN-JRTC; FN-IN Sch; FN-194 AR].
  - 4) Concept of the operation [FM 101-5, p. 4-18].
  - 5) Deception objective [FM 101-5, p. 4-21].
  - 6) Priorities for fires, resupply, and movement [FM 101-5, p. 4-22].
  - 7) Time plan [FM 101-5, p. 4-23].
  - 8) Type of brigade order to issue (e.g., FRAGO, oral, overlay, 5-paragraph) [FM 101-5, p. 4-24].
  - 9) Type of rehearsal to conduct [FM 101-5, p. 4-25].
  - 10) Type of planning process the brigade will use to develop the brigade order [FM 101-5, p. 4-7, 4-8; FN-IN Sch].

- 11) Commander's Critical Information Requirements (CCIR), by battle phase, which include [FM 101-5, p. 4-47; FN-NTC; FN-BCBST]:
    - a) Essential Elements of Friendly Information (EEFI) [BCBL "Battle Command," p. 21; FN-BCTP].
    - b) Friendly Force Information Requirements (FFIR) [BCBL "Battle Command," p. 21; FN-BCTP].
    - c) Priority Intelligence Requirements (PIR) [BCBL "Battle Command," p. 21; FN-BCTP].
    - d) Battle damage assessment (BDA) information requirements (addressed separately or as a component of PIR) [FN-CGSC].
- c. The brigade targeting team extracts fire support planning guidance [AN].
- 1) The brigade targeting team determines the brigade commander's attack criteria; attack criteria include [FM 6-20-40, p. G-1; FM 6-20-50, p. K-1; FN-BCBST; FN-FA Sch]:
    - a) Attack guidance, which describes [FM 6-20-40, p. G-1; FM 6-20-50, p. K-1]:
      - (1) How the brigade commander wants fire support resources to be used [FM 6-20-40, p. 2-3; FM 6-20-50, p. 2-3].
      - (2) Which subordinate units and brigade activities the brigade commander wants weighted with fire support [FM 6-20-40, p. 2-3; FM 6-20-50, p. 2-3].
      - (3) What targets the brigade commander wants to attack [FM 6-20-40, p. 2-3; FM 6-20-50, p. 2-3].
    - b) Desired effects and results of target attack (i.e., destroy, suppress, neutralize, jam, listen) [FM 6-20-40, p. 2-3, G-1; FM 6-20-50, p. 2-3, K-1; FN-IN Sch; FN-BCTP; FN-FA Sch; FN-3/24 ID].
    - c) Targets to include on the HPTL [FM 6-20-40, p. G-1; FM 6-20-50, p. K-1].
    - d) Attack priorities (e.g., which targets or types of targets to attack, when to attack them) [ARTEP 71-3-MTP, 71-3-9001/3b; FM 6-20-40, p. 2-3, G-1; FM 6-20-50, p. 2-3, K-1; FM 6-20-10, p. 5-4, 5-5; FN-JRTC; FN-IN Sch; FN-III Corps].
  - 2) The brigade targeting team determines the brigade commander's guidance and concept for brigade A2C2 [ARTEP 71-3-MTP, 71-3-3013/1e].
  - 3) The brigade targeting team determines the brigade commander's guidance on fire

support priorities and for the allocation of fire support assets; determines priorities and allocations to support [FM 6-20-10, p. 5-5; FN-NTC; FN-JRTC; FN-3/24 ID; FN-FA Sch):

- a) The brigade security/counter-reconnaissance battle [FN-NTC; FN-JRTC; FN-3/24 ID].
  - b) The brigade deep battle [AN].
  - c) The brigade close battle [FN-NTC; FN-JRTC; FN-3/24 ID].
  - d) The brigade rear battle [FN-NTC; FN-JRTC; FN-3/24 ID].
- 4) The brigade targeting team determines the brigade commander's concept for the method to be employed against targets (e.g., FA fires, naval surface fires, EW, CAS, or a combination of indirect fires) [FN-JRTC; FN-IN Sch].
  - 5) The brigade targeting team determines the brigade commander's guidance on the allocation of special munitions (e.g., FASCAM, smoke, illumination, precision-guided munitions) [FN-IN Sch; FN-FA Sch].
  - 6) The brigade targeting team determines fire support aspects of the brigade commander's CCIR, which include [FM 101-5, p. 4-47; FN-NTC; FN-BCBST]:
    - a) BDA requirements [FM 6-20-40, p. 2-3; FM 6-20-50, p. 2-3; FM 6-20-10, p. 5-5; FN-IN Sch].
    - b) Reduction of fire support capabilities below a certain level (e.g., status of fire support assets is degraded to a point that the brigade commander's intent and guidance for fire support cannot be met) [FN-NTC].
    - c) Information relative to achieving the brigade commander's attack criteria [FM 6-20-40, p. G-1; FM 6-20-50, p. K-1; FN-BCBST; FN-FA Sch].
    - d) Implementation of measures to collect CCIR [FN-JRTC; FN-BCTP].

## 6. **Prepare Staff Estimates**<sup>11</sup>

- a. brigade targeting team members disseminate and exchange information to develop staff estimates [FM 101-5, p. 3-85].
  - 1) Brigade targeting team members coordinate internally and with other members of the brigade staff to disseminate information, exchange information, and develop targeting data [FM 101-5, p. 3-85; FN-III Corps].
  - 2) Brigade targeting team members coordinate with external headquarters to

disseminate and exchange information [FM 6-20-40, Ch 2; FM 6-20-50, Ch 2; FN-3/24 ID]:

- a) The brigade S2 coordinates with the division G2, Bn TF S2s, DS FA battalion S2, and the divisional MI battalion S3 [AN].
  - b) The brigade FSO coordinates with the FSCoord, subordinate Bn TF FSOs, the DS FA battalion S3, the division FSE, and the DIVARTY TOC [FN-AR Sch].
  - c) The brigade ALO coordinates with the division ALO, Bn TF ALOs, and USAF headquarters [FN-AR Sch].
  - d) The brigade ANGLICO coordinates with the division ANGLICO, Bn TF SALT, and USN/USMC headquarters [AN].
  - e) The brigade aviation LNO coordinates with the aviation brigade S3 [FN-AR Sch].
  - f) The ABE coordinates with the DS engineer battalion commander and S3 [AN].
- b. The brigade S3 develops the Operations Estimate [ARTEP 71-3-MTP, 71-3-3001/2].
- 1) The brigade S3, with the brigade FSO, determines the locations and status of brigade units and fire support assets, to include [FM 101-5, p. C-8; FN-3/24 ID]:
    - a) Maneuver units (platoon size and larger) currently available and projected to be available during the mission [FN-3/24 ID].
    - b) Current task organization of brigade units and fire support assets [AN].
    - c) Status and dispositions of Bn TF mortar platoons (current, projected) [AN].
  - 2) The brigade S3 determines combat capabilities of brigade units [FM 101-5, p. C-8]:
    - a) Level of training [FM 101-5, p. C-8].
    - b) Effectiveness of command and control [FM 101-5, p. C-8].
    - c) Degree of mobility [FM 101-5, p. C-8].
    - d) Type of equipment [FM 101-5, p. C-8].
    - e) Limitations (e.g., equipment shortages, personnel shortages, physical condition of personnel) [FM 101-5, p. C-8].
  - 3) The brigade S3 determines locations, status, and mission of [FM 101-5, p. C-9]:



- a) Flank units [FM 101-5, p. C-9].
  - b) Supporting units [FM 101-5, p. C-9].
  - c) Uncommitted units under division control [FM 101-5, p. C-9].
- 4) The brigade S3 determines the status of fire support assets available to support the brigade's concept of the operations [FM 101-5, p. C-8].
- a) The brigade FSO provides the brigade S3 status of FA systems available to support the concept of the operation (see task 6d below).
  - b) The brigade ALO provides the brigade S3 with the status of USAF CAS and brigade ALO elements available to support the concept of the operation (see task 6e below).
  - c) The brigade ANGLICO provides the brigade S3 with the status of USN/USMC CAS, naval surface fires, and brigade ANGLICO elements available to support the concept of the operation (see task 6f below).
  - d) The brigade aviation LNO provides the brigade S3 with the status of Army aviation assets available to support the concept of the operation (see task 6g below).
  - e) The ALO provides information about air support (e.g., CAS, TAR) [FM 101-5, p. C-8].
  - f) The ANGLICO provides information about naval surface fires and USN/USMC air support [FM 101-5, p. C-8].
- 5) The brigade S3, with the brigade S3 Air, prepares A2C2 estimate based on the Operations Estimate's COAs [ARTEP 71-3-MTP, 71-3-3013/2].
- c. The brigade S2 develops the Intelligence estimate [ARTEP 71-3-MTP, 71-3-2001/5c].
- 1) The brigade S2, with the brigade FSO and brigade targeting officer, determines [FM 6-20, p. 3-7; FN-NTC; FN-JRTC; FN-194 AR]:
    - a) Effects of terrain and weather on friendly and enemy fire support capabilities [FN-NTC].
    - b) Enemy capabilities which may impact on employment of friendly fire support. Enemy capabilities include [FM 6-20, p. 3-7, 3-8; FN-NTC]:
      - (1) Smoke and other obscurants [FN-NTC].
      - (2) Persistent and non-persistent chemicals [FN-NTC].

- (3) ADA systems [FN-NTC].
  - (4) Illumination [FN-NTC].
  - (5) FASCAM [FN-NTC].
- c) Enemy artillery, rockets, and mortar capabilities, limitations, and employment based on terrain, enemy doctrine, and enemy organization [FM 6-20, p. 3-7, 3-8; FN-NTC; FN-AR Sch]:
- (1) Range of systems [FN-AR Sch].
  - (2) Types and capabilities of systems [FN-AR Sch].
  - (3) Number of weapons systems [AN].
  - (4) Locations of enemy indirect fire systems [AN].
- d) Enemy radar and IEW capabilities, limitations, and employment based on terrain, enemy doctrine, and enemy organization [FM 6-20, p. 3-7].
- 2) The brigade S2, with the brigade ALO, brigade ANGLICO, brigade aviation LNO, and brigade AD LNO, develops enemy air employment, capabilities, and limitations aspects of intelligence estimate [ARTEP 71-3-MTP, 71-3-7001/1f; FN-JRTC]
- a) Determines enemy ADA capabilities and ADA locations (for HPT consideration) [ARTEP 71-3-MTP, 71-3-3004/3e; FN-JRTC; FN-AR Sch].
  - b) Determines enemy EW capabilities and effects of EW on brigade CAS and air defense operations (for HPT consideration) [FN-AR Sch].
  - c) Identifies enemy air routes, air assets (e.g., fixed wing, helicopter), and recent enemy air activities which confirms or refutes enemy air avenues of approach and intentions [FN-JRTC].
  - d) Determine enemy counter-air capabilities to respond to brigade CAS, including [FN-194 AR]:
    - (1) Air-to-air capabilities [AN].
    - (2) Ground-to-air (e.g., missile and AAA) capabilities [AN].
    - (3) Air-to-ground (e.g., SEAD) capabilities [AN].
    - (4) Radar and command and control capabilities [AN].
- 3) The brigade S2, with the brigade ANGLICO, develops enemy naval employment,

capabilities, and limitations aspects of intelligence estimate [AN].

- a) Determines enemy naval surface assets [AN].
  - b) Determines enemy subsurface assets [AN].
  - c) Determines enemy naval air assets [AN].
- 4) The brigade S2, with the ABE, develops terrain and weather aspects of the intelligence estimate; the brigade S2 and ABE [AN]:
- a) Determine terrain and weather factors which impact on friendly and enemy engineer capabilities [FM 6-20, p. 3-7].
  - b) Determine terrain information for development of the MCOO [ARTEP 71-3-MTP, 71-3-8001/3d; FN-JRTC].
  - c) Perform terrain analysis of the brigade battle space to determine enemy [FN-JRTC]:
    - (1) Mobility corridors [FM 6-20-40, p. 2-9, 2-10; FM 6-20-50, p. 2-9, 2-10; FN-NTC].
    - (2) Avenues of approach [FM 101-5, p. C-7].
    - (3) Zones of entry for deep, close, and rear operations [FM 101-5, p. C-7].
    - (4) Key and decisive terrain [FM 101-5, p. C-7].
  - d) Determine locations, composition, and intent of enemy obstacles [FN-NTC; FN-JRTC; FN-AR Sch].
  - e) Identify enemy engineer activities which serve as indicators to enemy intentions [FN-JRTC].
- 5) The brigade S2, with the brigade chemical officer, determines enemy NBC capabilities (for HPT consideration) [FM 101-5, p. C-11; FN-AR Sch].
- 6) The brigade S2 integrates enemy information developed from his own estimate and information provided by other brigade staff officers to describe the enemy situation and capabilities [ARTEP 71-3-MTP, 71-3-2001/5c3].
- a) Known and suspected enemy locations are defined, including [FM 6-20-40, p. 2-2; FM 6-20-50, p. 2-2; FM 6-20-10, p. 1-7; FM 101-5, p. C-7]:
    - (1) Committed forces [FM 101-5, p. C-7].

- (2) Reinforcing forces [FM 101-5, p. C-7].
    - (3) Supporting forces [FM 101-5, p. C-7].
    - (4) Terrorist forces [FM 101-5, p. C-7].
  - b) Enemy order of battle is determined [FM 6-20-40, p. 2-2; FM 6-20-50, p. 2-2; FM 101-5, p. C-8; FN-NTC].
  - c) Size, type, and strength of enemy force expected to be encountered by the brigade is determined [FM 6-20-40, p. 2-2; FM 6-20-50, p. 2-2].
  - d) Enemy forces, activities, and capabilities in the brigade AI and areas adjacent to the brigade AO which may impact on brigade units or operations are determined [FM 101-5, p. C-8].
  - e) Current and projected weather and its potential effects on friendly and enemy intentions is determined [FM 101-5, p. C-10, C-31; FN-NTC].
  - f) Recent and on-going enemy activities are assessed to determine indicators of future enemy actions [FM 101-5, p. C-8].
- 7) The brigade S2 prepares a summary of known enemy weaknesses and peculiarities that would favorably or unfavorably influence the brigade's combat effectiveness for targeting considerations. Enemy vulnerabilities include [FM 101-5, p. C-8, C-11]:
- a) Personnel strength [FM 101-5, p. C-11].
  - b) Combat effectiveness [FM 101-5, p. C-11].
  - c) Combat service support capabilities [FM 101-5, p. C-11].
  - d) Conditions that may cause the enemy to commit his reserves [FM 101-5, p. C-11].
- 8) The brigade S2 depicts enemy dispositions and capabilities before, during, and after the brigade mission on the SIT TEMP [FM 101-5, p. C-8, C-10, C-33].
- 9) The brigade S2, with the brigade targeting officer and DS MI company commander, determines organic and attached collection assets available to acquire enemy assets; identifies collection asset [FM 6-20-40, p. 2-11; FM 6-20-50, p. 2-11; FM 6-20-10, p. 1-10; FN-NTC]:
- a) Availability [FN-NTC].
  - b) Capability [FN-NTC].

- c) Limitations [FN-NTC].
  - d) Ability to provide continuous updates [AN].
- 10) The brigade S2, with the brigade S3 and the DS MI company commander, determines systems and assets available for non-lethal attack [AN].
- a) Electronic Attack (EA) systems capable of employing directed energy and jamming support to disrupt, damage, destroy, and kill enemy forces are determined [FM 34-1, p. 2-21].
  - b) Electronic Warfare Support (ES) systems capable of intercepting, locating, and exploiting enemy radios, radars, and other emitters are determined [FM 34-1, p. 2-21].
- d. The brigade FSO develops the estimate [FM 6-20-40, p. 2-3; FM 6-20-50, p. 2-3; FM 6-20, p. 3-8].
- 1) The brigade FSO determines the locations and dispositions (current and projected) of fire support assets, including ranges to division and brigade targets [FM 6-20-1, p. 3-9; FM 6-20-40, p. 2-11, A-3; FM 6-20-50, p. 2-11; FN-FA Sch].
  - 2) The brigade FSO determines current and projected status of DS and supporting FA systems, including [FM 6-20, p. 3-8; FN-IN Sch]:
    - a) Tubes (by caliber, number) [FM 6-20-1, p. 3-7, A-3; FN-IN Sch].
    - b) Number of firing batteries [FN-NTC; FN-FA Sch].
    - c) Ammunition on hand [FM 6-20-1, p. 3-9; FN-IN Sch].
    - d) Fire Direction Centers (FDCs) [FM 6-20-1, Ch 3; FN-IN Sch].
    - e) Radars [FM 6-20-1, p. 3-9; FM 6-20-40, p. 2-11; FM 6-20-50, p. 2-11; FN-IN Sch; FN-NTC; FN-FA Sch].
    - f) FIST-Vs, COLTs, and other observer/target acquisition systems [FM 6-20-1, p. 3-9; FM 6-20-40, p. 2-11; FM 6-20-50, p. 2-11; FN-NTC; FN-FA Sch].
    - g) Digital communications systems [FN-FA Sch].
    - h) Position and Azimuth Determining System (PADS) [FN-FA Sch].
  - 3) The brigade FSO determines FA terrain requirements [AN].
    - a) The brigade FSO coordinates with the brigade FSCOORD and the DS FA

battalion S3 to determine FA terrain requirements. Requirements include [AN]:

- (1) Survey requirements for brigade needs (e.g., positions, TRPs) [FN-JRTC].
  - (2) Position areas (PAs) for firing batteries as identified by the DS FA battalion S3 [FN-JRTC].
  - (3) Terrain requirements for other FA units in GS or reinforcing support roles to the brigade [FN-JRTC].
  - (4) Declination station location and support to indirect fire systems [FN-JRTC].
  - (5) Radar positions [FN-JRTC].
  - (6) Routes for movement [AN].
- b) The brigade FSO coordinates with the brigade S3 to resolve [ARTEP 71-3-MTP, 71-3-9002/3c]:
- (1) Terrain requirements for FA assets DS to the brigade [ARTEP 71-3-MTP, 71-3-9002/3c1].
  - (2) Terrain requirements of DIVARTY and other higher headquarters FA assets not DS to the brigade but operating in the brigade sector [ARTEP 71-3-MTP, 71-3-9002/3c2].
- 4) The brigade FSO, with the brigade aviation LNO, determines status of aviation assets supporting the brigade by providing observer and target acquisition support; determines [FM 6-20, p. 3-8]:
- a) Command and support relationship (e.g., DS, GS, reinforcing) [FN-NTC; FN-FA Sch].
  - b) Aircraft and crew capability to operate in limited visibility and inclement weather [FN-FA Sch].
  - c) Crew rest status and requirements [FN-FA Sch].
- 5) The brigade FSO, through coordination with Bn TF commanders, S3s, and FSOs, determines mortar status, including [AN]:
- a) Locations and directed Bn TF missions [AN].
  - b) Number of mortar tubes and FDCs available (current, projected) [FN-NTC; FN-FA Sch].

- c) Ammunition status, by type (e.g., HE, smoke, illumination) [AN].
- 6) The brigade FSO, through coordination with the ABE, determines requirements for FA FASCAM [ARTEP 71-3-MTP, 71-3-9002/3b; FN-NTC].
- 7) The brigade FSO, through coordination with the brigade S2 and DS MI company commander, determines status, capabilities, and availability of EW assets to provide non-lethal fire support [FN-NTC].
- 8) The brigade FSO, through coordination with the brigade S4 and FSB S3, determines fire support requirements for protection of the FSB, brigade CSS nodes, and the brigade rear area [FN-NTC].
- 9) The brigade FSO, through coordination with the brigade ALO and brigade ANGLICO, determines status and requirements for CAS support (see task 6e below).
- 10) The brigade FSO, through coordination with the brigade ANGLICO, determines status and requirements for naval surface fires (see task 6f).
- 11) The brigade FSO develops the brigade fire support estimate. Information includes [FM 6-20, p. 3-8; FN-JRTC]:
  - a) Battlefield geometry (e.g., constraints, no fire areas, control of maneuver fires) [FN-JRTC].
  - b) Current and anticipated FA unit locations, including [FN-JRTC]:
    - (1) Movement and repositioning requirements [FN-JRTC].
    - (2) Positions for phasing FA systems movement [FN-JRTC].
    - (3) Time requirements for firing batteries to be in position [FN-JRTC].
    - (4) Security requirements during movement [FN-JRTC].
  - c) Availability of CL IV, V, and V special supply [FN-JRTC].
  - d) Requirements for observers and target acquisition systems, including position requirements [FN-JRTC].
  - e) Requirements for the registration of fires (with assistance from maneuver forces) [FN-JRTC].
  - f) Meteorology support requirements [FN-JRTC].

- g) Information from GS or reinforcing FA battalions/batteries, including [FM 6-20-40, p. A-3; FM 6-20-50, p. C-1]:
  - (1) Number and type of reinforcing battalions/batteries [FM 6-20-40, p. A-3; FM 6-20-50, p. C-3].
  - (2) MLRS batteries in general support role [FM 6-20-40, p. A-3].
- h) CSS and logistics requirements to support brigade fire support systems, including [AN]:
  - (1) CSR [FN-JRTC].
  - (2) Allocation of special munitions [FN-JRTC].
  - (3) Transportation requirements to move ammunition [FN-FA Sch].
  - (4) Ammunition on-hand and required [FN-FA Sch].
- 12) The brigade FSO develops the attack guidance, which includes [FM 6-20-10, p. 5-5]:
  - a) Brigade commander's attack criteria (see task 5c above).
  - b) Definitions of how, when, with what restrictions, and in what priority to attack different targets [FM 6-20-10, p. 5-10].
  - c) Guidance on [FM 6-20-10, p. 5-10]:
    - (1) Final protective fires (FPF) [FM 6-20-10, p. 5-10].
    - (2) Screening fires [FM 6-20-10, p. 5-10].
    - (3) Obscuration [FM 6-20-10, p. 5-10].
    - (4) Illumination [FM 6-20-10, p. 5-10].
    - (5) Positioning (e.g., firing units, observers) [FM 6-20-10, p. 5-10].
    - (6) Engagement method (e.g., FA, CAS, non-lethal, combination of fire support systems) [FM 6-20-10, p. 5-10].
    - (7) Counterfire targets [FM 6-20-10, p. 5-10; FN-III Corps].
    - (8) Critical times and locations firing units must meet to support each phase of the brigade operation [FM 6-20-10, p. 5-10].



- e. The brigade ALO, with the brigade ANGLICO, develops the estimate for employment of CAS (USAF, USN, USMC) [FM 6-20-40, p. A-8; FM 6-20-50, p. C-5; FM 6-20, p. 3-8; FN-JRTC]:
- 1) Operational status of the brigade ALO elements is determined [AN].
  - 2) SEAD requirements to support CAS are identified [FN-JRTC].
  - 3) Apportionment of CAS missions to the brigade, as derived from the ATO, is determined [FN-JRTC].
  - 4) Requirements (e.g., observers, communications, processing of requests) for targeting for CAS are identified [AN].
  - 5) Availability of precision guidance munitions (PGM) is determined [FN-JRTC].
  - 6) Availability of LANTERN-equipped aircraft is determined [FN-JRTC].
  - 7) Availability of AC-130 support and other special aircraft is determined [FN-JRTC].
  - 8) Time windows for planned CAS are determined [FN-JRTC].
  - 9) Submission times of changes to planned CAS and immediate CAS are identified [FN-III Corps]:
  - 10) Proximity of planned CAS targets to brigade units and personnel is determined [FN-JRTC].
  - 11) CAS aircraft reaction times (e.g., minutes, hours) for immediate CAS are determined (e.g., strip alert, push-CAS) [FN-JRTC].
  - 12) Position requirements for ALO and ANGLICO elements to provide terminal control of CAS aircraft are identified; availability and capability of alternate terminal control assets (e.g., FSOs, FOs) are determined [FN-JRTC].
  - 13) IPs, flight times from IPs to targets, ingress and egress routes, air corridors, and other control measures for CAS are identified [FN-FA Sch].
  - 14) Measures to receive battlefield information from CAS aircraft are determined. Sources include [AN]:
    - a) Overhead imagery [FN-AR Sch].
    - b) Aircraft performing tactical reconnaissance [FN-FA Sch)].
    - c) EC-130 aircraft [FN-AR Sch].

- d) PIREPs [FN-AR Sch].
- f. The brigade ANGLICO develops the estimate for employment of naval surface fires [FM 6-20, p. 3-8; FN-JRTC].
  - 1) Operational status of the brigade ANGLICO elements is determined [FM 71-3, p. 7-12; NWP 3-09.11M, p. 1-5].
  - 2) Capabilities of naval surface fires and ships are determined; capabilities are [FM 6-20-40, A-28; NWP 3-09.11M, p. 2-1]:
    - a) Variety of ammunition (on-hand, available) [FM 6-20-40, p. A-28; FM 6-20-50, p. C-26; FN-JRTC; NWP 3-09.11M, p. 2-1].
    - b) Ability to provide high and relatively flat trajectory due to muzzle velocity [FM 6-20-40, p. A-28; FM 6-20-50, p. C-26; NWP 3-09.11M, p. 2-1].
    - c) Ability to provide high rates of fire [FM 6-20-40, p. A-28; FM 6-20-50, p. C-26; NWP 3-09.11M, p. 2-1; FN-194 AR].
    - d) Small dispersion patterns (e.g, narrow deflection, long range) [FM 6-20-40, p. A-28; FM 6-20-50, p. C-26; NWP 3-09.11M, p. 2-1; FN-194 AR].
    - e) Mobile firing point due to mobility of the ship [FM 6-20-40, p. A-28; FM 6-20-50, p. C-26; NWP 3-09.11M, p. 2-1].
    - f) Availability of precision fire control equipment [FM 6-20-40, p. A-28; FM 6-20-50, p. C-26; NWP 3-09.11M, p. 2-1].
  - 3) Limitations of naval surface fires and ships are determined [FM 6-20-40, Appendix A; NWP 3-09.11M, p. 2-1]:
    - a) Changing gun-target line [FM 6-20-40, p. A-28; FM 6-20-50, p. C-26; NWP 3-09.11, p. 2-2; FN-JRTC; FN-194 AR].
    - b) Special communications requirements (compatibility with systems available to brigade units) [FM 6-20-40, p. A-28; FM 6-20-50, p. C-27; NWP 3-09.11M, p. 2-2].
    - c) Hydrography of waters [FM 6-20-40, p. A-29; FM 6-20-50, p. C-27; NWP 3-09.11M, p. 2-1].
    - d) Potential difficulties associated with maintaining accurate locations of ships [FM 6-20-40, p. A-29; FM 6-20-50, p. C-27; NWP 3-09.11, p. 2-1].
    - e) Weather and visibility effects on target acquisition and adjustments to fires [FM 6-20-40, p. A-29; FM 6-20-50, p. C-27; NWP 3-09.11M, p. 2-1].

- f) Enemy action (e.g., actions to counter enemy threats to ships performed concurrently with providing fire support) [FM 6-20-40, p. A-29; FM 6-20-50, p. C-27].
  - g) Magazine capacity and time delays imposed to reload ship magazines [FM 6-20-40, p. A-29; FM 6-20-50, p. C-27; NWP 3-09.11M, p. 2-2; FN-194 AR].
  - h) Range accuracy [NWP 3-09.11M, p. 2-2; FN-JRTC; FN-194 AR].
- 4) Number, types of ships, and support relationships (e.g., DS, GS) providing naval surface fire support are identified [FM 6-20-40, p. A-26; FM 6-20-50, p. C-24; NWP 3-09.11M, p. 2-2; FN-JRTC].
  - 5) Requirements for ships to go off-station for reload and turnaround time for reloading of ships are determined [NWP 3-09.11M, p. 3-13; FN-JRTC].
  - 6) Responsiveness (e.g., timeliness, accuracy) of naval surface fires to brigade fire support requests based on planned locations for ships is determined [FN-JRTC; FN-194 AR].
  - 7) Firing positions for ships are determined; ship positioning options (as directed in the division order) are [NWP 3-09.11M, p. 2-6; FN-194 AR]:
    - a) Fire support station (e.g., ship remains in exact locations) [NWP 3-09.11M, p. 2-7; FN-AR Sch; FN-194 AR].
    - b) Fire support area (e.g., ship moves in designated area) [NWP 3-09.11M, p. 2-7; FN-194 AR].
  - 8) Requirements for radar beacon employment are determined to allow ships to provide accurate naval surface fires [NWP 3-09.11M, p. 2-14].
- g. The brigade aviation LNO develops Army aviation estimate [FM 6-20-40, p. A-33; FM 6-20-50, p. C-29; FM 6-20, p. 3-8].
- 1) Aviation employment and mission requirements are determined, which include [AN]:
    - a) Coordination and adjustment of indirect fires when CAS and artillery are employed [FM 6-20-40, p. A-33; FM 6-20-50, p. C-29].
    - b) Command and control for the conduct of joint air attack team (JAAT) operations [FM 6-20-40, p. A-33; FM 6-20-50, p. C-29; FN-JRTC].
    - c) Lift support for soldiers, supplies, and equipment [AN].
  - 2) Aircraft and crew status are determined, including [AN]:

- a) Aircraft availability, including day and night capabilities [FN-JRTC].
  - b) Number of crews (AH-1, OH-58, UH-60) night-vision goggle (NVG) qualified [FN-JRTC].
  - c) Capabilities of aircraft [FM 1-111, p. 3-2; FN-JRTC].
  - d) Classes (CL) III and V availability and resupply rates [AN].
  - e) Requirements for refuel/rearm locations in the brigade area [AN].
- h. The ABE develops the engineer estimate [FM 5-100, p. 23; FM 6-20, p. 3-9].
- 1) FA FASCAM requirements are defined [FM 5-100, p. 104].
  - 2) Terrain information and the impact of weather on terrain and brigade units are determined [FM 5-100, p. 104].
  - 3) Priorities for mobility, survivability, and countermobility support to fire support systems and units are determined [AN].
  - 4) Brigade obstacle belts are determined [FM 90-7, p. 2-14].
- i. The brigade AD LNO develops the air defense estimate [FM 6-20, p. 3-9].
- 1) Priorities for air defense support of fire support units and systems are determined [FM 6-20, p. 3-9].
  - 2) Weapons control status and the early warning system are determined [FM 6-20, p. 3-10].
  - 3) Effects of ADA coverage and employment on brigade A2C2 are determined [AN].
- j. The brigade S4 develops the logistical estimate [FM 6-20, p. 3-8; FM 101-5, p. C-13].
- 1) CL V requirements for the DS FA battalion and subordinate mortar platoons are computed and determined, including CSR and RSR [FM 6-20, p. 3-8; FM 71-123, p. 8-3; FN-3/24 ID].
  - 2) Maintenance status (current, projected) of fire support units is determined [FM 71-123, p. 8-7; FN-3/24 ID].
  - 3) CSS and logistical status (current, projected) of fire support units are determined [FM 101-5, p. C-13].
  - 4) Distribution method for providing supplies and equipment to fire support units is determined [FM 101-5, p. C-13].

- 5) Personnel strength of fire support units is determined, including [FM 101-5, p. C-41];
    - a) Assigned and on-hand strength [FM 101-5, p. C-41].
    - b) Casualties factors [FM 101-5, p. C-41].
    - c) Replacement operations [FM 101-5, p. C-41].
    - d) Special MOS/MQS requirements [AN].
  - 6) Material and service requirements for fire support units are determined, including [FM 101-5, p. C-45]:
    - a) Maintenance [FM 101-5, p. C-45].
    - b) Supply [FM 101-5, p. C-45].
    - c) Services [FM 101-5, p. C-45].
    - d) Transportation [FM 101-5, p. C-45].
    - e) Labor [FM 101-5, p. C-45].
  - 7) Transportation requirements of fire support units are determined and compared with current and projected brigade transportation capability [FM 71-123, p. 8-5; FN-3/24 ID].
- k. The brigade SO develops the communications estimate [AN].
- 1) Current and projected status of brigade communications equipment [FM 11-41, p. 4-1; FN-3/24 ID].
  - 2) Communications requirements of fire support units are determined [AN].
- l. The brigade targeting team completes the TVA by producing a tentative HPTL [FM 6-20-10, p. 2-9; FM 6-20-40, p. G-12; FM 6-20-50, p. K-12].
- 1) All brigade targeting team members provide input and recommendations for HPT [AN].
  - 2) The brigade targeting team reviews previously developed HVTs and selects targets for inclusion on the HPTL; selection considerations are [FM 6-20-10, p. 2-9, A-13; FN-CGSC]:
    - a) Brigade commander's intent and attack guidance [FM 6-20-10, p. 2-9].

- b) Target value [FM 6-20-10, p. 2-9].
  - c) Sequence or the order in which targets will appear on the battlefield [FM 6-20-10, p. 2-9].
  - d) Ability of the brigade to detect, identify, classify, locate, and track targets in the brigade's AO and AI [FM 6-20-10, p. 2-9].
  - e) Availability of sensors and processing timeline constraints [FM 6-20-10, p. 2-9].
  - f) Degree of accuracy available from sensors and other target acquisition systems [FM 6-20-10, p. 2-9].
  - g) Ability of the brigade to engage targets with lethal and/or non-lethal fires [FM 6-20-10, p. 2-9].
  - h) Ability to suppress, neutralize, or destroy targets based on the attack guidance [FM 6-20-10, p. 2-9].
- 3) The brigade targeting team selects HPTs; HPTs which the brigade cannot acquire and attack are submitted to the division FSE as PIR [FM 6-20-10, p. A-13].
  - 4) The brigade targeting team selects HPTs for each phase of the brigade battle [FN-3/24 ID].
  - 5) The brigade S3 and brigade S2 begin development of the brigade R&S Plan and Collection Plan [FN-3/24 ID].
  - 6) The brigade S2 refines the SIT TEMP to reflect TAIs and NAIs based on HPT activity [ARTEP 71-3-MTP, 71-3-2001/2d3c; FN-3/24 ID].
  - 7) The brigade FSO, brigade S2, and brigade S3 produce the tentative HPTL [FM 6-20-10, p. 5-5].
- m. The brigade targeting team and brigade staff brief their estimates to the brigade commander; the brigade commander [AN]:
    - 1) Modifies, as required, and approves the HPTL as recommended by the brigade FSO, brigade S2, and brigade S3 [FM 6-20-10, p. 5-3].
    - 2) Modifies, as required, and approves the attack guidance as recommended by the brigade FSO [FM 6-20-10, p. 5-5].

## 7. Staff Develops Courses of Action<sup>12</sup>

**NOTE:** The tasks associated with the development of brigade courses of action are

contained in task 7 of Brigade CCF 18, Plan for Combat Operations. From the perspective of coordinate, synchronize, and integrate fire support, this task covers those actions performed by the brigade targeting team to develop fire support plans and requirements to support the courses of action.

- a. The brigade XO supervises the brigade staff in the development of courses of action [FM 101-5, p. E-4].<sup>13</sup>
- b. The brigade S3 leads the staff through course of action development; the brigade S3 [FM 101-5, p. 4-46, E-3]:
  - 1) Develops the brigade's scheme of maneuver for each COA [FN-194 AR].
  - 2) Develops friendly courses of action [ARTEP 71-3-MTP, 71-3-3001/2f; FM 101-5, p. 4-26].
  - 3) Provides courses of action to other coordinating and special staff sections [ARTEP 71-3-MTP, 71-3-3001/2g].
  - 4) Manages terrain and approves positioning of fire support assets [FM 6-20-40, p. 2-19; FM 6-20-50, p. 2-18; FN-FA Sch; FN-194 AR].
  - 5) Integrates fire support tasks and requirements developed by the brigade targeting team into brigade courses of actions [FN-194 AR].
- c. The brigade targeting team uses TVA products and the HPTL to develop fire support requirements for HPTs in each course of action [AN].<sup>14</sup>
  - 1) The brigade targeting team prioritizes HPTs on the HPTL for each course of action by assessing which HPTs, when rendered ineffective, will contribute to the success of the brigade's course of action [FM 6-20-10, p. 2-1].
  - 2) The brigade targeting team considers HPT locations as potential TAI and engagement areas during course of action development [FM 34-130, p. 2-49].
- d. The brigade targeting team determines targets for each course of action [FM 6-20-40, p. D-1; FM 6-20-50, p. F-1].
  - 1) The brigade targeting team determines shape, attitude, and characteristics of targets; characteristics are [AN]:
    - a) Point target [FM 6-20-40, p. D-3; FM 6-20-50, p. F-4].
    - b) Linear target [FM 6-20-40, p. D-3; FM 6-20-50, p. F-4].
    - c) Rectangular target [FM 6-20-40, p. D-4; FM 6-20-50, p. F-4].

- d) Circular target [FM 6-20-40, p. D-4; FM 6-20-50, p. F-4].
  - e) Target Reference Points (TRPs) [FM 6-20-40, p. D-4; FM 6-20-50, p. F-4].
- 2) The brigade targeting team identifies type targets for prearranged fires [FM 6-20-40, p. D-1; FM 6-20-50, p. F-1]:
    - a) Scheduled targets (e.g., targets which are attacked at a specific time) are designated [FM 6-20-40, p. D-1; FM 6-20-50, p. F-1].
    - b) On-call targets (e.g., targets which are attacked when requested) are designated [FM 6-20-40, p. D-1; FM 6-20-50, p. F-1].
    - c) Priority targets (e.g., targets which, when requested, are attacked immediately) are designated [FM 6-20-40, p. D-1; FM 6-20-50, p. F-1].
  - 3) The brigade targeting team identifies measures to engage targets of opportunity (e.g., targets to be attacked when acquired) [FM 6-20-40, p. D-1; FM 6-20-50, p. F-1].
  - 4) The brigade targeting team determines measures to attack division-directed targets [ARTEP 71-3-MTP, 71-3-9001/2d].
- e. The brigade targeting team, led by the brigade FSO, allocates and integrates FA fires and assets into each course of action [ARTEP 71-3-MTP, 71-3-9001/2a; FM 6-20-40, p. 2-5; FM 6-20-50, p. 2-5).
- 1) FA targets are developed to support the brigade scheme of maneuver [AN].
  - 2) Targets which require FA fires to be massed are determined to identify FA positioning requirements [FN-AR Sch].
  - 3) FA fires are planned to supplement and increase the effectiveness of direct fires for the brigade main effort or for critical brigade missions [FM 6-20-40, p. 2-5; FM 6-20-50, p. 2-5].
  - 4) FA ammunition type and quantity for each target identified are determined to ensure desired target effects can be achieved [FN-FA Sch].
  - 5) Position requirements for FA systems are identified based on [FM 6-20-40, Ch 3; FM 6-20-50, Ch 3]:
    - a) FA FPF requirements (e.g., size, duration) [FN-AR Sch].
    - b) FA obscuration/smoke requirements (e.g., size, duration) [FN-AR Sch].
    - c) Triggers lines or other events for the initiation and sustainment of FA fires [FN-FA Sch; FN-IN Sch].



- d) Target locations, to ensure FA firing positions can achieve required ranges [FN-BCTP].
  - e) Requirements to mass fires at critical times or critical events [FN-BCTP].
  - f) Implementing measures to minimize risk of FA units to enemy attack [FN-BCTP].
- 6) Positions for FA systems are selected based on priorities by FA unit, in order [FM 6-20-40, p. 2-19; FM 6-20-50, p. 2-18; FN-FA Sch]:
- a) DS FA battalion [FM 6-20-40, p. 2-19; FM 6-20-50, p. 2-18].
  - b) FA radars [FN-BCBST].
  - c) Reinforcing FA battalions [FM 6-20-40, p. 2-19; FM 6-20-50, p. 2-18].
  - d) Division GSR and GS FA units [FM 6-20-40, p. 2-19; FM 6-20-50, p. 2-18].
  - e) Corps GSR and GS FA units [FM 6-20-40, p. 2-19; FM 6-20-50, p. 2-18].
- 7) Movement requirements and routes for FA units are determined throughout all phases of the battle to ensure that required FA fires can be provided and synchronized with brigade maneuver [FN-BCTP; FN-IN Sch].<sup>15</sup>
- f. The brigade targeting team, led by the brigade ALO and brigade ANGLICO, allocates and integrates CAS (USAF, USN, USMC) and ALO/ANGLICO assets into each course of action [ARTEP 71-3-MTP, 71-3-3004/1a; FM 6-20-40, p. A-8; FM 6-20-50, p. C-6; FN-194 AR].
- 1) CAS aircraft routes, flight profiles, and attack headings are determined in order to [FM 6-20-40, p. A-15, A-26; FM 6-20-50, p. C-13, C-24; FN-AR Sch]:
- a) Identify A2C2 requirements (e.g., deconfliction time and space requirements between CAS and other indirect fires) [FM 6-20-40, p. A-16; FM 6-20-50, p. C-13; FN-AR Sch].
  - b) Ensure that CAS aircraft can accurately and effectively deliver munitions [FM 6-20-40, p. A-15; FM 6-20-50, p. C-13; FN-AR Sch].
  - c) Prevent engagement of CAS aircraft by enemy air defense systems [ARTEP 71-3-MTP, 71-3-3004/3e; FM 6-20-40, p. A-15; FM 6-20-50, p. C-13; FN-AR Sch].
  - d) Deconflict SEAD operations in support of CAS aircraft [ARTEP 71-3-MTP, 71-3-3004/3e; FM 6-20-40, p. A-15; FM 6-20-50, p. C-13; FN-AR Sch].

- e) Allow CAS aircraft to avoid terrain which restricts the use of CAS munitions or aircraft [FM 6-20-40, p. A-9; FM 6-20-50, p. C-7].
  - f) Reduce the effects of weather on CAS aircraft and munitions effects [FM 6-20-40, p. A-9; FM 6-20-50, p. C-7].
- 2) CAS targets are identified on known, suspected, and likely enemy locations [FM 6-20-40, p. A-8, A-26; FM 6-20-50, p. C-6, C-24].
    - a) Required munitions and weapons effects are determined based on targets to be engaged [FM 6-20-40, p. A-9; FM 6-20-50, p. C-7; FN-AR Sch].
    - b) BAI targets are determined [ARTEP 71-3-MTP, 71-3-3004/1b].
    - c) BDA requirements are determined, including methods to acquire them when targets are beyond the brigade's capability to observe [ARTEP 71-3-MTP, 71-3-3004/1e].
  - 3) Position requirements for terminal control of CAS aircraft by ground elements are identified [FM 6-20-40, p. A-15, A-26; FM 6-20-50, p. C-13, C-24]:
    - a) Brigade and Bn TF USAF ALOs and ETACs [FM 6-20-40, p. A-30; FM 6-20-50, p. C-28; FN-194 AR].
    - b) USN SALT and FCT [FM 6-20-40, p. A-30; FM 6-20-50, p. C-28].
    - c) Brigade, Bn TF, or company technical manual (Co/Tm) FSOs and forward observers (FOs) (as alternate controllers, depending on availability of communications equipment and qualified/trained personnel) [FM 6-20-40, p. A-30; FM 6-20-50, p. C-28].
  - 4) Requirements for AFACs as alternate or primary terminal controllers are determined [FM 6-20-40, p. A-30; FM 6-20-50, p. C-28].
  - 5) Command, control, and communications requirements between ground units and CAS aircraft are determined [FM 6-20-40, p. A-9; FM 6-20-50, p. C-7].
  - 6) Target acquisition and identification (e.g., marking) requirements are identified [FM 6-20-40, p. A-15; FM 6-20-50, p. C-13].
  - 7) Requirements for identification of ground forces and troop safety limits are determined to reduce the risk of fratricide [ARTEP 71-3-MTP, 71-3-3004/3f; FM 6-20-40, p. A-15; FM 6-20-50, p. C-13].
  - 8) Alternate fire support systems are identified to engage CAS targets in the event CAS aircraft are diverted to other higher priority targets [FM 6-20-40, p. A-8; FM 6-20-50, p. C-5].

- g. The brigade targeting team, led by the brigade ANGLICO, allocates and integrates naval surface fires and ANGLICO assets into each course of action [FN-194 AR].
- 1) Firing positions for ships (e.g., fire support area, fire support station) are identified to determine which targets are within range and can be engaged based on naval gun capabilities [NWP 3-09.11M, p. 2-7; FN-194 AR].
  - 2) Desired effects on targets for naval surface fires are determined; target effects are [NWP 3-09.11M, p. 2-4; FN-AR Sch; FN-194 AR]:
    - a) Destruction fire [NWP 3-09.11M, p. 2-4].
    - b) Neutralization fire [NWP 3-09.11M, p. 2-4].
    - c) Suppression fire [NWP 3-09.11M, p. 2-4].
    - d) Harassing fire [NWP 3-09.11M, p. 2-4].
    - e) Illumination fire [NWP 3-09.11M, p. 2-4].
    - f) Interdiction fire [NWP 3-09.11M, p. 2-4].
  - 3) Targets for naval surface fires are determined based on required tactical uses [NWP 3-09.11M, p. 2-6; FN-AR Sch; FN-194 AR]:
    - a) Close supporting fires [NWP 3-09.11M, p. 2-4].
    - b) Deep supporting fires [NWP 3-09.11M, p. 2-4].
    - c) Preparation fires [NWP 3-09.11M, p. 2-4].
    - d) Counterfire [NWP 3-09.11M, p. 2-4].
    - e) Reconnaissance fire [NWP 3-09.11, p. 2-4].
    - f) SEAD [NWP 3-09.11M, p. 2-4].
    - g) Defensive fire [NWP 3-09.11M, p. 2-4].
    - h) Protective fire [NWP 3-09.11M, p. 2-4].
    - i) Obscuration fire [NWP 3-09.11M, p. 2-4].
    - j) Screening fire [NWP 3-09.11M, p. 2-4].
    - k) Countermechanized fire [NWP 3-09.11M, p. 2-4].

- 4) Position requirements for brigade elements requesting and controlling naval surface fires are determined [FM 6-20-40, p. A-30; FM 6-20-50, p. C-28; NWP 3-09.11M, p. 1-9]:
    - a) Brigade ANGLICOs, SALTs, and FCTs [FM 6-20-40, p. A-30; FM 6-20-50, p. C-28].
    - b) Brigade, Bn TF, or Co/Tm FSOs and FOs (as alternates, depending on availability of communications equipment and qualified/trained personnel) [FM 6-20-40, p. A-30; FM 6-20-50, p. C-28].
  - 5) Command, control, and communications requirements between brigade ground elements and USN ships to request and adjust naval surface fires are determined [FM 6-20-40, p. A-29; FM 6-20-50, p. C-27; NWP 3-09.11M, p. 3-12; FN-III Corps].
- h. The brigade targeting team, led by the brigade FSO, allocates and integrates Bn TF mortar fires to support courses of action [FM 6-20-40, p. 3-22; FM 6-20-50, p. K-3; FN-FA Sch].
- 1) Requirements for use of Bn TF mortars are determined; missions for Bn TF mortars in support of brigade operations include [FN-FA Sch]:
    - a) Brigade breaching operations [FN-FA Sch].
    - b) Brigade river crossing [FN-FA Sch].
    - c) Brigade air-head or beach-head operations [FN-3/82 ABN].
  - 2) The employment of Bn TF mortars in support of brigade operations is planned as directed in the brigade commander's planning guidance, subject to approval by Bn TF commander's [FN-FA Sch].
  - 3) Targets and missions for Bn TF mortars are determined [AN].
  - 4) CL V requirements for mortars to provide required fires and achieve desired effects are determined [AN].
  - 5) Positions for Bn TF mortars are determined based on brigade mortar missions and targets [AN].
  - 6) Measures for Bn TF mortars to implement fires in support of brigade missions and targets are determined in order to ensure rapid return of mortar fires to support of Bn TFs [AN].
- i. The brigade targeting team, led by the brigade S3, allocates and integrates non-lethal fires and EW assets to support courses of action [FM 34-80, p. 2-65, 4-35].

- 1) Targets which are vulnerable to EW operations are determined; targets are [AN]:
  - a) Target acquisition systems [FM 34-80, p. 5-32].
  - b) UAV/RPVs [FN-NTC].
  - c) Tactical fire direction system (TACFIRE)-equivalent digital systems [FM 34-80, p. 5-23; FN-NTC].
  - d) Command posts and Command, Control, Communications and Information (C3I) systems [FM 34-80, p. 5-20].
  - e) Enemy counterfire systems [FM 34-80, p. 5-23, 5-32; FN-194 AR].
- 2) Desired effects (e.g., suppress, neutralize, or destroy) of EW attack are used as the basis to select targets [FM 34-1, p. 2-21; FN-FA Sch].
  - a) Targets to be disrupted, damaged, destroyed, and killed through electronic attack are selected [FM 34-1, p. 2-21; FN-AR Sch].
  - b) Targets to be intercepted, located, and exploited through electronic support are selected [FM 34-1, p. 2-21; FN-FA Sch].
- 3) Measures are identified to ensure that the employment of EW systems in target attack do not affect brigade friendly units, communications systems, and digital systems [FN-NTC].
- 4) Positions and routes for EW assets are identified which [FM 34-80, p. 5-1]:
  - a) Provide protection (e.g., cover, concealment, vicinity to maneuver units) to EW systems [FN 34-80, p. 5-5; FN-CGSC].
  - b) Allow communications from the brigade main CP to the EW system [FM 34-80, p. 5-5].
  - c) Provide LOS and range to targeted receivers, transmitters, and emitters [FM 34-80, p. 5-5].
  - d) Allow EW systems to move with and provide support to the brigade [FM 34-80, p. 5-20].
- 5) Command, control, and communications requirements for employment of non-lethal attack systems are determined [FM 34-80, p. 3-1, 3-12].
- j. The brigade targeting team designates types of planned fires [ARTEP 71-3-MTP, 71-3-9001/2b; FM 6-20-40, p. D-6; FM 6-20-50, p. F-6].

- 1) Groups of targets (e.g., two or more targets attack simultaneously) are designated [FM 6-20-40, p. D-6; FM 6-20-50, p. F-6; FN-3/24 IN].
  - 2) Series of targets (e.g., targets or groups of targets attacked in sequence) are designated [FM 6-20-40, p. D-6; FM 6-20-50, p. F-6].
  - 3) Program of targets (e.g., sequential attack of targets of a similar nature) are designated [FM 6-20-40, p. D-6; FM 6-20-50, p. F-7].
  - 4) Preparation fires (e.g., targets attacked preparatory to an assault) are designated [FM 6-20-40, p. D-6; FM 6-20-50, p. F-7; FN-3/24 ID; FN-BCTP].
  - 5) Counter-preparation fires (e.g., prearranged fires initiated when the threat of enemy attack is discovered) are designated [FM 6-20-40, p. D-7; FM 6-20-50, p. F-7; FN-3/24 IN].
- k. The brigade FSO prepares the initial target list worksheet based on the development of targets for each course of action [FM 6-20-40, p. D-5; FM 6-20-50, p. F-5].
- l. The brigade targeting team updates the HPTL to reflect HPTs developed for each course of action [FM 6-20-10, p. 2-1].

**8. Staff/Commander Analyze Courses of Action (War Game)<sup>16</sup>**

- a. The brigade commander and brigade staff prepare for and assemble to perform course of action analysis (war game) [AN].
- 1) The brigade commander (or brigade XO in the brigade commander's absence) directs the brigade staff in analyzing courses of actions [FM 101-5, p. F-3; FN-NTC].
  - 2) The brigade S3 [AN]:
    - a) Briefs courses of actions and leads the brigade staff in war gaming for each course of action [ARTEP 71-3-MTP, 71-3-3001/2h, 3001/3b; FM 101-5, p. F-3].
    - b) Integrates the fire support plan into the course of action analysis to ensure consonance with the brigade commander's guidance and is compatible with the scheme of maneuver [ARTEP 71-3-MTP, 71-3-3005/1].
  - 3) The brigade staff develops a synchronization matrix to record information and results of war gaming each course of action [FM 101-5, p. F-13; FN-JRTC].
  - 4) The brigade S2 role-plays the enemy and describes [FM 34-130, p. A-3; FM 34-8, p. 2-7; FN-JRTC]:

- a) Most likely enemy courses of action [ARTEP 71-3-MTP, 71-3-2001/3a; FM 34-130, p. A-3].
  - b) The location and activities of enemy HVTs and HPTs (with other members of the brigade targeting team), including when they are of importance to the enemy's course of action [FM 34-130, p. A-3; FN-BCBST].
  - c) Activities of collection assets monitoring enemy actions at NAIs and TAIs [FM 34-8, p. 2-9].
  - d) Actions to acquire PIR and IR [FM 34-8, p. 2-9].
  - e) Enemy actions to defeat: brigade maneuver, target acquisition operations, and the employment of brigade indirect fires [AN].
- 5) The brigade commander, brigade S3, and brigade FSO identify fire support goals for course of action analysis [FM 101-5, p. F-19; FN-FA Sch]:
- a) Synchronization of fire support with other BOSs [FM 101-5, p. F-15, F-20; FN-FA Sch].
  - b) Deconfliction of terrain requirements for fire support systems [FM 101-5, p. F-21; FN-AR Sch].
  - c) Identification of fire support requirements for branches and sequels [FM 101-5, p. F-3, F-20, F-24].
  - d) Designation of tasks and requirements for fire support units and systems [FM 101-5, p. F-19].
  - e) Identification of task organization requirements for fire support units and systems [FM 101-5, p. F-19; FN-JRTC].
  - f) Determination of the duration of the battle and fire support requirements to support the battle [FM 101-5, p. F-20].
  - g) Identification of additional requirements for fire support which exceed brigade capabilities, for development of requests to the division FSE [FM 101-5, p. F-20; FM 6-20-40, p. 2-5; FM 6-20-50, p. 2-5].
  - h) Command and control requirements for fire support units, fire support systems, and fire support tasks [FM 101-5, p. F-20].
  - i) Identification of requirements to modify CCIR [FM 101-5, p. F-20].
- b. The brigade targeting team synchronizes indirect fires to support the brigade deep battle [AN].

- 1) Times, locations, and events for deep battle handover between the division and the brigade are determined [FN-JRTC].
- 2) Lethal and nonlethal fires are planned and synchronized in the brigade deep battle to achieve the desired effects [FM 100-5, p. 6-14]:
  - a) Restrict the enemy commander's freedom of action [FM 100-5, p. 6-14].
  - b) Reduce and eliminate the enemy commander's ability to implement coherence and tempo in his command and control [FM 100-5, p. 6-14].
  - c) Attrit the enemy force or selected parts of it in order to ensure that brigade units involved in the close battle have sufficient combat power to accomplish designated missions [FM 100-5, p. 6-14].
  - d) Create opportunities and advantages the brigade can exploit [FM 6-20, p. 3-10].
- 3) Deep battle targets are selected [FM 6-20-40, p. 3-1; FM 6-20-50, p. 3-1]:
  - a) Enemy second-echelon forces [FM 6-20-40, p. 3-1; FM 6-20-50, p. 3-1].
  - b) Enemy C3 facilities [FM 6-20-40, p. 3-1; FM 6-20-50, p. 3-1; FM 6-20, p. 3-10].
  - c) Enemy reserves, counterattack forces, and follow-on forces [FM 6-20-40, p. 3-1; FM 6-20-50, p. 3-1].
  - d) Routes and avenues of approach which enemy second echelon, reserves, and follow-on forces will use to move into the brigade close battle area [FM 6-20-40, p. 3-1; FM 6-20-50, p. 3-1].
  - e) Enemy logistics sites [FM 6-20-40, p. 3-1; FM 6-20-50, p. 3-1].
- 4) Lethal and nonlethal fires are planned against specific targets based on [AN]:
  - a) The furthest range which brigade target acquisition assets can acquire and track enemy targets [FM 6-20, p. 3-11; FN-FA Sch].
  - b) Desired effects of target attack and the ability of each attack system to achieve the desired effects [AN].
  - c) Ability of lethal and nonlethal attack to range targets [FM 6-20, p. 3-11; FN-FA Sch].
- 5) Transition of lethal and nonlethal fires from brigade deep battle to brigade close battle support are synchronized [AN].



- a) Times, locations, and events are selected from which brigade subordinate units will accept close battle responsibilities [AN].
  - b) Locations, times, and events for the transition of fire support from the brigade deep battle to the brigade close battle are determined [FN-NTC].
    - (1) Sequence of transition from deep to close battle support for each fire support system (e.g., FA, CAS, EW) is determined [AN].
    - (2) Lethal and non-lethal attack systems are selected to be retained under brigade control for sustainment of the brigade deep battle [FM 100-5, p. 6-14].
  - c) Measures are determined to ensure that lethal and non-lethal fires can be employed in the brigade deep battle and brigade close battle simultaneously [FM 100-5, p. 6-14; FN-NTC].
- c. The brigade targeting team synchronizes indirect fires to support the brigade close battle [AN].
- 1) Lethal and non-lethal fires are synchronized to shape the brigade's close battle by [FM 6-20-40, p. 3-1; FM 6-20-50, p. 3-1]:
    - a) Disorganizing, delaying, weakening, and canalizing the enemy as they enter the brigade's close battle area [FM 6-20-40, p. 3-1; FM 6-20-50, p. 3-1].
    - b) Stripping away enemy reconnaissance, surveillance, and target acquisition (RSTA) elements [FM 6-20-40, p. 3-1; FM 6-20-50, p. 3-1; FM 6-20, p. 3-10].
    - c) Impairing the enemy command and control by causing him to button up; destroying vehicle optics and antennas [FM 6-20-40, p. 3-1; FM 6-20-50, p. 3-1].
  - 2) Lethal and non-lethal fires are planned and synchronized to support brigade R&S operations; desired effects of fires are [FM 6-20-40, p. 3-42; FM 6-20-50, p. 3-28]:
    - a) Suppress enemy forces by engaging brigade R&S forces [FM 6-20-40, p. 3-42; FM 6-20-50, p. 3-28].
    - b) Protect the movement and infiltration of R&S forces and target acquisition assets [FM 6-20-40, p. 3-42; FM 6-20-50, p. 3-28].
    - c) Inflict casualties and force enemy units to deploy early and reveal their main attack [FM 6-20-40, p. 3-42; FM 6-20-50, p. 3-28].
    - d) Reduce the enemy's capability to gain information by eliminating enemy

reconnaissance forces and intelligence-gathering assets [(FM 6-20-40, p. 3-42; FM 6-20-50, p. 3-28)].

- e) Deceive the enemy as to the location of brigade units [FM 6-20-40, p. 3-42; FM 6-20-50, p. 3-28].
  - f) Slow and canalize enemy movement to provide better targets for maneuver direct fire systems [FM 6-20-40, p. 3-42; FM 6-20-50, p. 3-28].
  - g) Suppress enemy direct and indirect fire weapons [FM 6-20-40, p. 3-42; FM 6-20-50, p. 3-28].
- 3) Lethal and non-lethal fires are planned and synchronized to support brigade offensive operations [FM 6-20-40, p. 3-2; FM 6-20-50, p. 3-2].
- a) Fires are planned for terrain that will be traversed by brigade units; desired effects are [FM 6-20-40, p. 3-2; FM 6-20-50, p. 3-2]:
    - (1) Suppress, neutralize, or destroy enemy OPs and target acquisition systems [FM 6-20-40, p. 3-2; FM 6-20-50, p. 3-2].
    - (2) Suppress, neutralize, or destroy enemy direct fire systems [FM 6-20-40, p. 3-2; FM 6-20-50, p. 3-2].
    - (3) Deny enemy attack helicopters' use of potential attack positions [FN-NTC].
    - (4) Suppress, neutralize, or destroy enemy elements that are to be bypassed [FM 6-20-40, p. 3-2; FM 6-20-50, p. 3-2].
  - b) Fires are planned on flanks. Desired effects are [FM 6-20-40, p. 3-2; FM 6-20-50, p. 3-2]:
    - (1) Protect brigade units during movement [FM 6-20-40, p. 3-2; FM 6-20-50, p. 3-2].
    - (2) Reduce the number of brigade units committed to flank security [FM 6-20-40, p. 3-2; FM 6-20-50, p. 3-2].
  - c) Fires are planned in front of, on, and beyond brigade objectives. Desired effects are [FM 6-20-40, p. 3-2; FM 6-20-50, p. 3-2]:
    - (1) Concentrate fires to suppress, neutralize, and destroy forward enemy elements [FM 6-20-40, p. 3-2; FM 6-20-50, p. 3-2].
    - (2) Create points of penetration into enemy defenses [FM 6-20-40, p. 3-2; FM 6-20-50, p. 3-2].

- (3) Suppress enemy forces which will respond to penetrations or breakthroughs of enemy positions [FM 6-20-40, p. 3-2; FM 6-20-50, p. 3-2].
  - (4) Assist brigade forces to maneuver to positions to provide direct fires against enemy forces in the defense [FM 6-20-40, p. 3-2; FM 6-20-50, p. 3-2].
- 4) Lethal and non-lethal fires are planned and synchronized to support brigade defensive operations [FM 6-20-40, p. 3-18; FM 6-20-50, p. 3-18].
- a) Fires are planned in the main battle area (MBA). Desired effects are [FM 6-20-40, p. 3-18; FM 6-20-50, p. 3-18]:
    - (1) Deny the enemy information about brigade units and intentions by reducing capabilities of enemy reconnaissance and intelligence-gathering elements [FM 6-20-40, p. 3-18; FM 6-20-50, p. 3-18].
    - (2) Inflict maximum enemy casualties at choke points and obstacles [FM 6-20-40, p. 3-18; FM 6-20-50, p. 3-18].
    - (3) Canalize the enemy, deny enemy use of terrain, and cause the enemy to deploy early and reveal the main attack [FM 6-20-40, p. 3-18; FM 6-20-50, p. 3-18].
    - (4) Delay, disrupt, suppress, and destroy enemy direct and indirect fire weapons throughout the brigade sector [FM 6-20-40, p. 3-18; FM 6-20-50, p. 3-18].
    - (5) Isolate forward enemy units from follow-on forces in the MBA to [FM 6-20-40, p. 3-18; FM 6-20-50, p. 3-18]:
      - (a) Separate enemy infantry from armor [FM 6-20-40, p. 3-18; FM 6-20-50, p. 3-18].
      - (b) Disrupt enemy attack tempo and activities [FM 6-20-40, p. 3-18; FM 6-20-50, p. 3-18].
  - b) Fires are planned to support disengagement of brigade elements. Desired effects are [FM 6-20-40, p. 3-19; FM 6-20-50, p. 3-19]:
    - (1) Increase tempo of battle to create opportunities to brigade units to disengage [FM 6-20-40, p. 3-19; FM 6-20-50, p. 3-20].
    - (2) Allow brigade units to withdraw from positions without being effectively hindered or delayed [FM 6-20-40, p. 3-19; FM 6-20-50, p. 3-20].

- (3) Support repositioning and movement of brigade units to other positions [FM 6-20-40, p. 3-19; FM 6-20-50, p. 3-20].
  - (4) Support brigade counterattack forces [AN].
- 5) Lethal and non-lethal fires are planned and synchronized to provide time and to assist brigade units in their consolidation (of objectives, of positions) and reorganization [FM 6-20-40, p. 3-1; FM 6-20-50, p. 3-1].
- d. The brigade targeting team, lead by the ABE, synchronizes indirect fires in support of mobility and counter-mobility operations [ARTEP 71-3-MTP, 71-3-8003/3a; FN-IN Sch].
- 1) Lethal and nonlethal fires are planned and synchronized to support brigade obstacle belts. Fires are synchronized to [FM 6-20-40, p. 3-18, 3-19; FM 6-20-50, p. 3-19; FM 90-7, p. 2-14]:
    - a) Disrupt enemy formations [FM 6-20-40, p. 3-18; FM 6-20-50, p. 3-19].
    - b) Separate attacking enemy echelons [FM 6-20-40, p. 3-18; FM 6-20-50, p. 3-19].
    - c) Force enemy to deploy into EAs [FM 6-20-40, p. 3-18, 3-19; FM 6-20-50, p. 3-19].
    - d) Maximize enemy casualties on enemy forces halted or bunched by brigade obstacles [FM 6-20-40, p. 3-18; FM 6-20-50, p. 3-19].
    - e) Hinder enemy breaching attempts by destroying breaching teams or equipment, including lane markers [FM 6-20-40, p. 3-19; FM 6-20-50, p. 3-19].
    - f) Hinder enemy attempts to bypass obstacles [FM 6-20-40, p. 3-19; FM 6-20-50, p. 3-19].
    - g) Destroy enemy piecemeal as he passes through the obstacle [FM 6-20-40, p. 3-19; FM 6-20-50, p. 3-19].
    - h) Support withdrawal of friendly elements [FM 6-20-40, p. 3-19; FM 6-20-50, p. 3-19].
  - 2) Indirect fires are planned such that they do not degrade or destroy brigade obstacles [FM 6-20-40, p. 3-19; FM 6-20-50, p. 3-19].
  - 3) FASCAM fires are synchronized (see task 8g1 below) [ARTEP 71-3-MTP, 71-3-8003/3a; FM 6-20-40, p. 3-19, H-1; FM 6-20-50, p. 3-19, I-1].

- 4) Lethal and non-lethal fires are planned and synchronized to support the brigade's mobility plan [ARTEP 71-3-MTP, 71-3-8005/2b1].
  - a) Movement of brigade units is screened by smoke or other obscurants [FM 6-20-40, p. 3-19; FM 6-20-50, p. I-17].
  - b) Enemy vision, OPs, target acquisition systems, and direct fire systems are obscured or rendered ineffective by lethal and non-lethal fires [FM 6-20-40, p. 3-19; FM 6-20-50, p. I-17].
  - c) Suppression and obscuration fires are provided in support of brigade obstacle breaching operations [FM 6-20-40, p. 3-19; FM 6-20-50, p. I-17].
  - d) Fire support assets implement measures to support deception plans; measures include [FM 6-20-40, p. 3-19; FM 6-20-50, p. I-17; FN-BCTP]:
    - (1) Employment of indirect fires to deceive the enemy about the brigade's scheme of maneuver [FN-BCTP].
    - (2) False transmissions on fire support nets [FN-BCTP].
    - (3) Movement of fire support units and assets to portray massing [FN-BCTP].
- e. The brigade targeting team synchronizes indirect fires to support the brigade rear battle [AN].
  - 1) Fire support assets are allocated to provide support to the rear battle and defense of brigade rear area units; fire support assets include [FM 6-20, p. 3-11; FN-NTC]:
    - a) FA [FM 6-20, p. 3-11].
    - b) Bn TF mortars [FM 6-20, p. 3-11].
    - c) CAS [FM 6-20, p. 3-11].
  - 2) Measures for the establishment of an ad-hoc fire support organization within the brigade rear are identified [FM 6-20, p. 3-11; FM 6-20-40, p. 2-5].<sup>17</sup>
  - 3) Enemy threat to the brigade rear is determined and classified (i.e., Level I, II, III) [ARTEP 71-3-MTP, 71-3-3008/3b].
  - 4) Fires are planned in the brigade rear area. Desired effects are [AN]:
    - a) Protect brigade units, installations, facilities, and lines of communications from enemy attack or sabotage and reestablish support capabilities [FM 6-20-40, p. 3-42]

- b) Deny the enemy information about brigade units and intentions by reducing capabilities of enemy reconnaissance and intelligence-gathering elements [FM 6-20-40, p. 3-18; FM 6-20-50, p. 3-18].
  - c) Inflict maximum casualties on enemy units operating in the brigade rear area [FM 6-20-40, p. 3-18; FM 6-20-50, p. 3-18].
- 5) Fires are planned to support disengagement of brigade elements [FM 6-20-40, p. 3-19; FM 6-20-50, p. 3-19].
- f. The brigade targeting team synchronizes indirect fires in support of brigade SEAD operations [AN].
- 1) Lethal and non-lethal fire support assets are allocated to provide SEAD and to mark SEAD targets [ARTEP 71-3-MTP, 71-3-3004/3e; FM 6-20-40, p. A-15, A-16; FM 6-20-50, p. C-13, C-14; FN-AR Sch; FN-BCTP].
  - 2) CAS aircraft routes, flight profiles, and attack headings are assessed to determined areas and locations requiring SEAD [FM 6-20-40, p. A-15, A-26; FM 6-20-50, p. C-13, C-24; FN-AR Sch].
  - 3) A2C2 measures are identified to deconflict time and space requirements between SEAD missions and CAS aircraft [FM 6-20-40, p. A-16; FM 6-20-50, p. C-13; FN-AR Sch].
  - 4) Enemy air defense weapons, radar, and communications nets are identified as SEAD targets [ARTEP 71-3-MTP, 71-3-3004/3e; FM 6-20-40, p. A-15; FM 6-20-50, p. C-13; FN-AR Sch].
  - 5) Command, control, and communications requirements for executing SEAD are determined [FM 6-20-40, p. A-9; FM 6-20-50, p. C-7].
  - 6) Division-directed joint suppression of enemy air defense (J-SEAD) requirements are integrated into the brigade SEAD [ARTEP 71-3-MTP, 71-3-3004/1a].
  - 7) Times and events for the employment of SEAD fires are determined. Options for the initiation of SEAD fires are [FN-NTC]:
    - a) When SEAD targets acquired [AN].
    - b) At designated times [FN-BCTP].
    - c) As developed in the directed program of fires [FN-BCBST].
- g. The brigade targeting team plans and synchronizes the employment of special munitions [FN-NTC].

- 1) FASCAM fires are determined and synchronized with other indirect fires [ARTEP 71-3-MTP, 71-3-8003/3a; FM 6-20-40, p. 3-19, H-1; FM 6-20-50, p. 3-19, I-1].
  - a) The ABE determines intent of FASCAM as basis for identifying which system to use for [FM 6-20-40, p. H-2; FM 6-20-50, p. I-2]:
    - (1) Interdiction or area denial [FM 6-20-40, p. H-2; FM 6-20-50, p. I-2].
    - (2) Obstacles [FM 6-20-40, p. H-2; FM 6-20-50, p. I-2].
    - (3) Obstacle augmentation [FM 6-20-40, p. H-2; FM 6-20-50, p. I-2].
    - (4) Targets of opportunity [FM 6-20-40, p. H-2; FM 6-20-50, p. I-2].
  - b) The ABE determines time of emplacement, duration of, and locations for FASCAM minefields [ARTEP 71-3-MTP, 71-3-8003/3a1, 8003/3a3, 8003/3a4; FM 6-20-40, p. H-1; FM 6-20-50, p. I-1; FN-IN Sch].
  - c) The brigade targeting team identifies the best fire support system to emplace FASCAM [ARTEP 71-3-MTP, 71-3-8003/3a2; FM 6-20-40, p. H-2; FM 6-20-50, p. I-1; FN-IN Sch]:
    - (1) FA [FM 6-20-40, p. H-2; FM 6-20-50, p. I-1; FM 90-7, p. 2-11; FN-IN Sch].
    - (2) USAF GATOR [FM 90-7, p. 2-11; FN-JRTC; FN-IN Sch].
    - (3) Army aviation VOLCANO [FM 90-7, p. 2-11; FN-JRTC; FN-IN Sch].
  - d) The brigade FSO determines FA FASCAM emplacement requirements [FM 6-20-40, p. H-2; FM 6-20-50, p. I-2; FN-IN Sch].
    - (1) Firing positions for batteries are identified [FN-IN Sch].
    - (2) Times for firing batteries to occupy firing positions and fire FASCAM are determined [FN-IN Sch].
    - (3) Locations, routes, and times for firing batteries to repositioning after firing FASCAM are determined [FN-IN Sch].
    - (4) Measures to resupply firing batteries after FASCAM missions are performed are determined [FN-IN Sch].
  - e) The brigade ALO and brigade ANGLICO determine emplacement requirements for USAF, USN, and USMC aircraft-delivered FASCAM [AN].

- f) The brigade aviation LNO determines emplacement requirements for Army aviation aircraft-delivered FASCAM [AN].
  - g) The brigade targeting team determines which indirect fire systems are available and will provide indirect fire support to replace systems dedicated to FASCAM missions [FN-IN Sch].
- 2) Obscurant fires are determined and synchronized with other indirect fires [FM 6-20-40, p. 3-19, H-17; FM 6-20-50, p. I-16].
- a) The brigade FSO and brigade S3 determine obscurant purpose (e.g., application) [FM 6-20-40, p. H-17; FM 6-20-50, p. I-16]:
    - (1) Obscuration (e.g., interfere with enemy observation) [FM 6-20-40, p. H-17; FM 6-20-50, p. I-16].
    - (2) Screening (e.g., degrade enemy observation and fires) [FM 6-20-40, p. H-17; FM 6-20-50, p. I-16].
    - (3) Marking and signaling (e.g., to communicate actions or mark positions) [FM 6-20-40, p. H-18; FM 6-20-50, p. I-17].
    - (4) Deception (e.g., confuse or mislead the enemy)[FM 6-20-40, p. H-18; FM 6-20-50, p. I-17].
  - b) The brigade FSO and brigade chemical officer determine factors affecting use of obscurants [FM 6-20-40, p. H-18; FM 6-20-50, p. I-17]:
    - (1) Atmospheric conditions [FM 6-20-40, p. H-18; FM 6-20-50, p. I-17].
    - (2) Characteristics and type of obscurant munitions required [FM 6-20-40, p. H-18; FM 6-20-50, p. I-17].
    - (3) Size of area to be obscured [FM 6-20-40, p. H-18; FM 6-20-50, p. I-17].
    - (4) Duration (e.g., time) obscurant is required [FM 6-20-40, p. H-18; FM 6-20-50, p. I-17].
  - c) The brigade FSO, brigade ANGLICO, and brigade chemical officer select systems to use to employ obscuration based on purpose and factors [FM 6-20-40, p. H-18; FM 6-20-50, p. I-17]:
    - 1) Bn TF mortars [FM 6-20-40, p. H-18; FM 6-20-50, p. I-17].
    - (2) FA cannons [FM 6-20-40, p. H-18; FM 6-20-50, p. I-17].
    - (3) USN guns [NWP 3-09.11M, p. 2-3]



- (4) Smoke platoon and smoke pots [FM 6-20-40, p. H-18; FM 6-20-50, p. I-17].
- d) The brigade FSO synchronizes the employment of obscurants to ensure that target acquisition systems, observers, and attack systems are not adversely affected [FM 6-20-40, p. H-18; FM 6-20-50, p. I-17].
- 3) Copperhead and other precision guided munitions (PGM) are planned and synchronized with other indirect fires [FM 6-20-40, p. H-22; FM 6-20-50, p. I-12].
  - a) The brigade FSO and brigade S3 select targets [FM 6-20-40, p. H-22; FM 6-20-50, p. H-21]:
    - (1) Command and control vehicles [FM 6-20-40, p. H-22; FM 6-20-50, p. H-21].
    - (2) Radars [FM 6-20-40, p. H-22; FM 6-20-50, p. H-21].
    - (3) Bridges [FM 6-20-40, p. H-22; FM 6-20-50, p. H-21].
    - (4) ADA assets [FM 6-20-40, p. H-22; FM 6-20-50, p. H-21].
    - (5) Other HPT [FM 6-20-40, p. H-22; FM 6-20-50, p. H-21].
  - b) The brigade FSO, brigade ALO, and brigade ANGLICO select the system to designate targets from [FM 6-20-40, Ch 3; FM 6-20-50, Ch 3]:
    - (1) FIST and FOs with ground/vehicle laser locator designator (G/VLLD) [FM 6-20-40, p. H-22; FM 6-20-50, p. I-20; FN-FA Sch].
    - (2) COLTs with G/VLLD [FM 6-20-40, p. H-22; FM 6-20-50, p. I-20; FN-FA Sch].
    - (3) ANGLICO and ALO elements with laser designators [FN-FA Sch].
    - (4) Army aviation assets, including OH-58Ds [FN-FA Sch].
    - (5) USAF, USN, and USMC aircraft [FN-FA Sch].
  - c) The brigade FSO determines Copperhead/PGM footprint to select positions for G/VLLD and other laser designators [FM 6-20-40, p. H-22; FM 6-20-50, p. H-21].
  - d) The brigade FSO, brigade ALO, and brigade ANGLICO select optional positions for systems tasked to designate target [FM 6-20-40, Ch 3; FM 6-20-50, Ch 3]:

- (1) Angle-T between designator-target-attack system of less than 800 mils [FM 6-20-40, p. H-24; FM 6-20-50, p. I-22; FN-FA Sch].
  - (2) Range of 3-5 km between ground designator and target [FM 6-20-40, p. H-24; FM 6-20-50, p. I-22; FN-FA Sch].
- e) The brigade FSO synchronizes the employment of Copperhead and other PGMs to ensure [AN]:
- (1) Target acquisition systems, observers, and attack systems are not adversely affected [AN].
  - (2) Lethal and non-lethal systems can be employed and sustained against other targets [AN].
- 4) Illumination fires are determined and synchronized with other indirect fires [FM 6-20-40, p. 3-19].
- a) The brigade FSO and brigade S3 determine illumination purposes, which are to FM 6-20-40, p. 3-19:
- (1) Silhouette enemy targets to enhance acquisition by fire support observers and support adjustment of indirect fires [FM 6-20-40, p. 3-19].
  - (2) Enhance target acquisition and engagement by direct fire systems [FM 6-20-40, p. 3-19].
  - (3) Confuse or mislead the enemy on brigade actions and intents [AN].
- b) The brigade FSO and brigade ANGLICO determine factors affecting the use of illumination [AN]:
- (1) Atmospheric and weather conditions [AN].
  - (2) Characteristics and type of illumination munitions required [AN].
  - (3) Size of area to be illuminated [AN].
  - (4) Duration (e.g., time) illumination is required [AN].
- c) The brigade FSO and brigade ANGLICO select systems to use to employ obscuration based on purpose and factors [FM 6-20-40, p. 3-19]:
- (1) Bn TF mortars [FM 6-20-40, p. 3-19].
  - (2) FA cannons [FM 6-20-40, p. 3-19].

- (3) USN guns [NWP 3-09.11M, p. 2-3]
- d) The brigade FSO synchronizes the employment of obscurants to ensure that target acquisition systems, observers, and attack systems are not adversely affected [FM 6-20-40, p. 3-19].
- h. The brigade targeting team refines the allocation of lethal and non-lethal systems and fires to support the brigade scheme of maneuver [AN].
  - 1) Locations for the impact of indirect fires are determined [FM 6-20-40, Ch 3; FM 6-20-50, Ch 3].
  - 2) Quantity and type of indirect fire munitions for target are identified to ensure target attack achieves the desired end state [FN-NTC; FN-IN Sch; FN-3/24 ID].
  - 3) Trigger points for the initiation of fires are selected [FM 6-20-40, Ch 3; FM 6-20-50, Ch 3; FN-NTC; FN-JRTC].
    - a) Processing time for each fire mission is determined [FM 6-20-40, Ch 3; FM 6-20-50, Ch 3]:
      - (1) Time required by observer to acquire and identify targets [FM 6-20-40, Ch 3; FM 6-20-50, Ch 3].
      - (2) Time required for observers to transmit calls for fire [FM 6-20-40, Ch 3; FM 6-20-50, Ch 3].
      - (3) Time required to clear fires [FM 6-20-40, Ch 3; FM 6-20-50, Ch 3].
      - (4) Time required for FDCs to process calls for fire [FM 6-20-40, Ch 3; FM 6-20-50, Ch 3].
      - (5) Time required for attack systems to fire [FM 6-20-40, Ch 3; FM 6-20-50, Ch 3].
      - (6) Time of flight for munitions designated for target attack [FM 6-20-40, Ch 3; FM 6-20-50, Ch 3].
    - b) Projected enemy rates of movement are identified in order to determine when fires must be initiated to ensure impact of fires at designated points of impact [FM 6-20-40, Ch 3; FM 6-20-50, Ch 3].
    - c) Easily identifiable points on the ground are selected for observers to initiate fires based on processing time requirements and enemy rates of movement [FM 6-20-40, Ch 3; FM 6-20-50, Ch 3].

- d) Primary and alternate trigger points for the initiation of fires are selected [FM 6-20-40, Ch 3; FM 6-20-50, Ch 3].
- 4) Priority of lethal and nonlethal fires are determined [FM 6-20-40, p. 2-5; FM 6-20-50, p. 2-5].
  - a) Priorities are designated based on the brigade commander's guidance; priorities are assigned to [FM 6-20-40, p. 2-3; FM 6-20-50, p. 2-3; FN-NTC]:
    - (1) The brigade deep battle [FM 100-5, p. 6-14].
    - (2) Brigade units performing security operations [FM 6-20-40, p. 3-18, 3-23; FM 6-20-50, p. 3-18, 3-27].
    - (3) The brigade close battle FM 6-20-40, p. 3-1; FM 6-20-50, p. 3-1]
    - (4) The brigade rear battle [FM 6-20, p. 3-11; FM 6-20-40, p. 3-42; FN-NTC]
    - (5) Weight the brigade main and supporting efforts [AN].
    - (6) Critical sectors or battle positions [FM 6-20-40, p. 2-5; FM 6-20-50, p. 2-5].
  - b) Requirements to adjust priorities for lethal and nonlethal fires to respond to enemy courses of actions, branches, and sequels are determined [FM 6-20-40, p. 2-5; FM 6-20-50, 2-3].
- 5) Position requirements for fire support systems are updated [FN-NTC].
  - a) Movement and position requirements for fire support systems are updated to ensure their movement does not inhibit the maneuver of combat units [FN-NTC].
  - b) Position areas (PAs) and gun target lines for artillery firing units are designated to ensure that fires do not inhibit the employment of CAS [FN-NTC].
  - c) Measures to ensure continuous fire support coverage while brigade units are moving are determined [AN].
  - d) Terrain requirements for indirect fire units and systems are updated [ARTEP 71-3-MTP, 71-3-9002/3c].
  - e) Periods when indirect fires and radar support will be reduced are determined and compensated for [AN].

- f) Positions are selected which allow indirect fire systems to survive [FM 6-20-10, p. 2-8].
- i. The brigade targeting team develops an Observer Plan which assigns responsibilities to target acquisition systems and observers for the employment of indirect fires against designated targets [FN-NTC; FN-IN Sch].<sup>18</sup>
  - 1) Locations for target acquisition systems and observers are determined to ensure continuous observation and coverage of [FM 6-20-10, p. 2-8; FN-NTC]:
    - a) Obstacles (friendly, enemy) [FM 6-20-40, p. 2-11; FM 6-20-50, p. 2-11].
    - b) Engagement areas [AN].
    - c) TAIs, NAIs, and DPs [FN-IN Sch].
    - d) Other areas where HPTs are expected [FN-NTC].
  - 2) Multiple observer positions are designated to allow observers to reposition as required while maintaining observation on designated areas and targets [FN-IN Sch; FN-FA Sch].
  - 3) Positions are selected which allow observers and target acquisitions systems to survive [FM 6-20-10, p. 2-8].
  - 4) Primary and back-up observers and target acquisition systems are designated to achieve redundancy and to ensure that indirect fires can be initiated and sustained [FM 6-20-40, p. 2-11; FM 6-20-50, p. 2-11; FN-NTC; FN-FA Sch].
  - 5) Primary and alternate communications systems, frequencies, and nets are identified to ensure that indirect fires can be initiated, sustained, and concluded [FM 6-20-40, p. 2-11; FM 6-20-50, p. 2-11; FN-FA Sch].
- j. The brigade targeting team determines Combat Assessment (CA) requirements to assess effects of target attack [FM 6-20-10, p. 1-8, 2-27, 2-29; FM 34-130, p. A-7].
  - 1) The brigade S2 determines measures to perform Battle Damage Assessment (BDA) [FM 6-20-10, p. 2-26].
    - a) Resources and assets available for acquiring BDA are determined [FM 6-20-10, p. 2-27].
    - b) Responsibilities of assets to provide BDA are clearly defined to resolve conflicts between providing BDA and other responsibilities (e.g., target development, target acquisition) [FM 6-20-10, p. 2-27].

- c) Measures and responsibilities are determined to perform the components of BDA [FM 6-20-10, p. 2-28]:
  - (1) Physical damage assessment [FM 6-20-10, p. 2-28].
  - (2) Functional damage assessment [FM 6-20-10, p. 2-28].
  - (3) Target system assessment [FM 6-20-10, p. 2-28].
- d) The brigade S2 translates BDA requirements into brigade PIRs [FM 6-20-10, p. 2-26].
- e) Measures to receive BDA from division sources are determined [FN-BCBST].
- 2) The brigade S3 determines measures to perform Munitions Effects Assessments (MEA); measures include [FM 6-20-10, p. 2-27]:
  - a) Determining the effectiveness of munitions, weapons systems, and tactics [FM 6-20-10, p. 2-27].
  - b) Determining the quantity of munitions fired on a specific target [FM 6-20-10, p. 2-27].
  - c) Establishing mechanisms to modify the brigade commanders' guidance on UBL, RSR, and CSR [FM 6-20-10, p. 2-27].
- 3) The brigade S2 and brigade S3 determine procedures for providing reattack recommendations to the brigade commander [FM 6-20-10, p. 2-29].
- k. The brigade targeting team designates airspace control measures and FSCM to support the synchronization of indirect fires [FM 6-20-40, p. E-1; FM 6-20-50, p. G-1].<sup>19</sup>
  - 1) The brigade targeting team designates permissive FSCM which are applicable to all fire support systems [FM 6-20-40, p. E-2; FM 6-20-50, p. G-2]:
    - a) Coordinated fire line (CFL) [ARTEP 71-3-MTP, 71-3-9001/3c3; ARTEP 6-115-20-MTP, 06-3-02-1130, 1190; FM 6-20-40, p. E-2; FM 6-20-50, p. G-2].
    - b) Fire Support Coordination Line (FSCL) [ARTEP 71-3-MTP, 71-3-9001/3c1; ARTEP 6-115-20-MTP, 06-3-02-1130, 1190; FM 6-20-40, p. E-3; FM 6-20-50, p. G-2].
    - c) Free-Fire Area (FFA) [FM 6-20-40, p. E-3; FM 6-20-50, p. G-3].
  - 2) The brigade targeting team designates restrictive FSCM which are applicable to all fire support systems [FM 6-20-40, E-4; FM 6-20-50, p. G-4]:

- a) Restrictive fire line (RFL) [ARTEP 71-3-MTP, 71-3-9001/3c2; ARTEP 6-115-20-MTP, 06-3-01-1130, 1190; FM 6-20-40, p. E-4; FM 6-20-50, p. G-4].
  - b) Restricted fires areas (RFAs) [ARTEP 71-3-MTP, 71-3-9001/3c5; ARTEP 6-115-20-MTP, 06-3-02-1130, 1190; FM 6-20-40, p. E-4; FM 6-20-50, p. G-2].
  - c) No-fire area (NFA) [ARTEP 71-3-MTP, 71-3-9001/3c4; ARTEP 6-115-20-MTP, 06-3-02-1130, 1190; FM 6-20-40, p. E-5; FM 6-20-50, p. G-4].
  - d) Airspace Coordination Area (ACA) (see task 8k4 below) [FM 6-20-40, p. E-5; FM 6-20-50, p. G-5].
  - e) Unit boundaries [FM 6-20-40, p. E-1; FM 6-20-50, p. G-1].
- 3) The brigade ANGLICO designates control measures applicable to naval surface fires, which are [FM 6-20-40, p. A-29; FM 6-20-50, p. C-27]:
- a) Zones of action [FM 6-20-40, p. A-29; FM 6-20-50, p. C-27; NWP 3-09.11M, p. 2-5].
  - b) Fire support areas [FM 6-20-40, p. A-29; FM 6-20-50, p. C-27; NWP 3-09.11M, p. 2-7].
  - c) Fire support stations [FM 6-20-40, p. A-29; FM 6-20-50, p. C-27; NWP 3-09.11M, p. 2-7].
- 4) The brigade targeting team develops air space management (e.g., A2C2) measures [ARTEP 71-3-MTP, 71-3-3012/2].
- a) Areas which will impact on aviation operations are identified [ARTEP 71-3-MTP, 71-3-3012/2b]:
    - (1) Locations for Army aviation units and FARPs [ARTEP 71-3-MTP, 71-3-3012/2b1].
    - (2) FA locations [ARTEP 71-3-MTP, 71-3-3012/2b2].
    - (3) RPV launch and recovery sites and flight paths [ARTEP 71-3-MTP, 71-3-3012/2b3].
    - (4) Instrument landing system positions, navigation aids (NAVAID) locations, flight coordination center (FCC) locations, and flight operations center (FOC) locations [ARTEP 71-3-MTP, 71-3-3012/2b4].
    - (5) NBC contaminated areas [ARTEP 71-3-MTP, 71-3-3012/2b5].

- (6) Friendly ADA locations, engagement zones, and ADA coverage areas [ARTEP 71-3-MTP, 71-3-3012/2b6].
- b) Aircraft identification procedures are designated which are compatible with air defense identification requirements [ARTEP 71-3-MTP, 71-3-3012/2g].
- c) ACAs are designated to provide separation between aircraft and indirect fires (and the effects of fires) by either time or space. ACAs describe [ARTEP 71-3-MTP, 71-3-9001/3c6; ARTEP 6-115-20-MTP, 06-3-02-1130, 1190; FM 6-20-40, p. A-16; FM 6-20-50, p. C-14]:
  - (1) Lateral separation [FM 6-20-40, p. A-16; FM 6-20-50, p. C-14].
  - (2) Altitude separation [FM 6-20-40, p. A-16; FM 6-20-50, p. C-14].
  - (3) Time separation [FM 6-20-40, p. A-16; FM 6-20-50, p. C-14].
  - (4) Altitude and lateral separation [FM 6-20-40, p. A-16; FM 6-20-50, p. C-14].
- d) Aircraft are provided sufficient maneuver space to counter enemy ADA systems [FM 6-20-40, p. A-16; FM 6-20-50, p. C-14].
- e) Routes which provide aircraft access to and egress from IPs to the target areas are identified [FM 6-20-40, p. A-16; FM 6-20-50, p. C-14].
- f) Reference points for aircraft that are easily identifiable from the air are designated [FM 6-20-40, p. A-16; FM 6-20-50, p. C-14].
- g) Low-level and minimum risk routes for CAS aircraft are identified [ARTEP 71-3-MTP, 71-3-3012/2e].
- h) Requirements for the employment of mortar, air defense, FA, and naval surface fires are deconflicted with aircraft requirements [FM 6-20-40, p. A-16; FM 6-20-50, p. C-14].
- i) Airspace control measures required by friendly air defense systems are designated. Control measures include [ARTEP 71-3-MTP, 71-3-6002/2]:
  - (1) Restricted operation areas (ROA) [ARTEP 71-3-MTP, 71-3-6002/2a].
  - (2) Standard-use Army aircraft flight routes [ARTEP 71-3-MTP, 71-3-6002/2b].
  - (3) Weapons-free zones [ARTEP 71-3-MTP, 71-3-6002/2c].
  - (4) Coordinating altitude [ARTEP 71-3-MTP, 71-3-6002/2g].



- 5) The brigade S3 consolidates airspace use requirements and [ARTEP 71-3-MTP, 71-3-3013/2a]:
  - a) Integrates requirements from all users [ARTEP 71-3-MTP, 71-3-3013/2a1].
  - b) Identifies conflicts between user requirements [ARTEP 71-3-MTP, 71-3-3013/2a2].
  - c) Determines the requirements to resolve conflict through additional control measures [ARTEP 71-3-MTP, 71-3-3013/2b].
- 4) The brigade S3 reviews FSCM to ensure that they support the brigade scheme of maneuver [ARTEP 71-3-MTP, 71-3-3005/1c].
1. The brigade targeting team develops and updates products based on results of course of action war gaming [ARTEP 71-3-MTP, 71-3-9003/1b1; FM 101-5, p. F-22; FM 6-20-10, p. 1-8; FM 34-130, p. A-4].
  - 1) The brigade S2, brigade S3, brigade targeting officer, and DS MI company commander develop the Sensor/Attack System Matrix [FM 6-20-10, p. 2-5; FN-BCBST].
    - a) Sensor ability to acquire specific HPTs for each critical event or phase of the battle is identified [FM 6-20-10, p. 2-5].
    - b) Attack system ability to attack specific HPTs for each critical event or phase of the battle is identified [FM 6-20-10, p. 2-5].
    - c) The brigade targeting team uses the Sensor/Attack System Matrix to [FM 6-20-10, p. 2-9]:
      - (1) Refine the tentative HPTL [FM 6-20-10, p. 2-9].
      - (2) Develop the Attack Guidance Matrix [FM 6-20-10, p. 2-9].
      - (3) Develop targeting information for the Intelligence Collection Plan [FM 6-20-10, p. 2-9].
  - 2) The brigade S3 refines the DST to depict [ARTEP 71-3-MTP, 71-3-2001/3c; FM 6-20-10, p. 1-8, A-8, A-10; FN-JRTC]:
    - a) NAIs (e.g., critical point or area where enemy activity, or lack of activity, will confirm or deny a potential course of action) [FM 6-20-10, p. A-8; FM 34-130, p. A-5]
    - b) TAIs (e.g., where HVTs and HPTs might be most vulnerable to attack) [FM 6-20-10, p. A-10; FM 34-130, p. A-5].

- c) DPs (e.g., events, areas, and points on the battlefield where the brigade commander is required to make tactical decisions) [FM 6-20-10, p. A-10; FM 34-130, p. A-5].
  - d) TPLs (e.g., estimated rate of offensive advance for friendly and enemy forces) [FM 6-20-10, p. A-10].
  - e) Avenues of approach and mobility corridors [FM 6-20-10, p. A-10].
  - f) Objectives [FM 6-20-10, p. A-10].
  - g) Current enemy situation (from the SIT MAP and SIT TEMP) [FM 6-20-10, p. A-10].
- 3) The brigade FSO, brigade targeting officer, and the brigade S2 develop Target Selection Standards (TSS) [FM 6-20-10, p. 1-8, 2-12].
- a) The brigade S2 and brigade targeting officer develop information for integration into the TSS; the brigade S2 and brigade targeting officer determine [FM 6-20-10, p. 2-13]:
    - (1) Reliability and accuracy of selected sensors [FM 6-20-10, p. 2-13].
    - (2) Target dwell time (e.g., the length of time a target is doctrinally expected to remain at its location) [FM 6-20-10, p. 2-13].
    - (3) Effects of weather and terrain on collection assets and on enemy equipment [FM 6-20-10, p. 2-13].
  - b) Criteria for determining whether enemy activity is a target are formulated [FM 6-20-10, p. 2-12; NWP 3-09.11M, p. 3-7].
  - c) Targets are divided into categories of known targets and suspected targets [FM 6-20-10, p. 2-12].
  - d) Target selection standards (TSSs) are based on enemy activity under considerations and available attack systems; TSSs reflect [FM 6-20-10, p. 2-12; NWP 3-09.11M, p. 3-7]:
    - (1) Attack system and target location accuracy [FM 6-20-10, p. 2-12].
    - (2) Size of enemy activity (e.g., point or area) [FM 6-20-10, p. 2-12].
    - (3) Status of enemy activity (e.g., moving or stationary) [FM 6-20-10, p. 2-12].
    - (4) Timeliness of information [FM 6-20-10, p. 2-12].

- e) HPTs that meet all TSS criteria are included on the AGM [FM 6-20-10, p. 2-13].
- 4) The brigade FSO and brigade S3 develop the AGM; the AGM describes how each target should be engaged in terms of [FM 6-20-10, p. 1-8, 2-14, 2-15; FM 34-130, p. A-7; FM 34-8, p. 2-10]:<sup>20</sup>
    - a) Effects of fire (e.g., harass, suppress, neutralize, or destroy) on the target [FM 6-20-10, p. 2-14].
    - b) Attack options (e.g., systems) to be used [FM 6-20-10, p. 2-14].
    - c) Timing for attack (e.g, immediate, as acquired, planned) [FM 6-20-40, p. G-14; FM 6-20-50, p. K-14].
    - d) Requirements for BDA [FM 6-20-10, p. 2-15].
  - 5) The brigade S2 develops the collection plan, which describes [ARTEP 71-3-MTP, 71-3-2001/3d; FM 6-20-10, p. 1-8, 2-2, 2-11; FM 34-2, p. 3-14; FN-JRTC]:
    - a) Collection assets responsible for acquiring, tracking, and determining BDA on HPTs [FM 34-2, p. 3-14; FM 6-20-10, p. 2-2, 2-11].
    - b) Synchronization of collection systems to provide coverage of the brigade AO [FM 6-20-10, p. 2-11].
    - c) The battlefield environment in terms of width, length, depth and altitude, time, and the electromagnetic spectrum [FM 6-20-10, p. 2-11].
    - d) Collection capabilities of higher and adjacent units [FM 6-20-10, p. 2-11].
  - 6) The brigade S2 and brigade targeting officer update the HPTL to reflect HPTs developed during the course of action analysis and war game [FM 6-20-10, p. 2-1; FM 34-130].

## 9. Staff Compares Courses of Action<sup>21</sup>

- a. Brigade commander or brigade XO directs the brigade staff in comparing courses of action [FM 101-5, p. F-3; FN-NTC].
  - 1) Each brigade staff officer uses his own criteria for comparing the brigade courses of actions in his own staff area of responsibility [FM 34-130, p. A-7; FM 101-5, p. F-36].
  - 2) Each brigade staff officer presents his findings to the rest of the brigade staff [FM 34-130, p. A-7; FM 101-5, p. F-36].

- b. The brigade FSO, brigade ALO, brigade ANGLICO, and brigade aviation LNO provide information and make recommendations [ARTEP 71-3-MTP, 71-3-9001/2a5; FN-NTC]:
- 1) Compare the employment of respective fire support systems in each course of action [ARTEP 71-3-MTP, 71-3-9001/2a5; FN-NTC].
  - 2) Evaluate the employment of respective fire support systems based on the brigade commander's intent and guidance for fire support [ARTEP 71-3-MTP, 71-3-9001/2a5; FN-NTC].
  - 3) Provide advice to the brigade commander and brigade staff to assist in COA comparison on [ARTEP 71-3-MTP, 71-3-9001/3a; ARTEP 6-115-20-MTP, 06-3-02-1130, 1190; FN-BCBST]:
    - a) Effects of CSR on fire support [ARTEP 71-3-MTP, 71-3-9001/3a1; ARTEP 6-115-20-MTP, 06-3-02-1130, 1190].
    - b) Location requirements for indirect fire units and systems [ARTEP 71-3-MTP, 71-3-9001/3a2; ARTEP 6-115-20-MTP, 06-3-02-1130, 1190].
    - c) Weapons capabilities/limitations [ARTEP 71-3-MTP, 71-3-9001/3a3; ARTEP 6-115-20-MTP, 06-3-02-1130, 1190].
    - d) Fire support missions and tasks as developed during course of action development and war gaming [ARTEP 71-3-MTP, 71-3-9001/3a4; ARTEP 6-115-20-MTP, 06-3-02-1130, 1190].
    - e) Measures to synchronize indirect fires [ARTEP 71-3-MTP, 71-3-9001/3a5; ARTEP 6-115-20-MTP, 06-3-02-1130, 1190].
  - 4) Provide information acquired through coordination with the DS FA battalion staff on the best course of action from the DS FA battalion perspective [FN-JRTC].
  - 5) Assist the brigade commander and brigade S3 in establishing targeting priorities [ARTEP 71-3-MTP, 71-3-9001/3; ARTEP 6-115-20-MTP, 06-3-02-1130, 1190].
  - 6) Advise the brigade commander and brigade S3 on the use of FSCM [ARTEP 71-3-MTP, 71-3-9001/3; ARTEP 6-115-20-MTP, 06-3-02-1130, 1190]:
- c. The brigade ALO advises the brigade commander on the capabilities and employment of air support and provides his recommendation on the best course of action in terms of USAF CAS [FM 6-20-40, p. A-11; FM 6-20-50, p. C-5].
- d. The brigade ANGLICO advises the brigade commander about the capabilities and employment of naval surface fires and USN/USMC air support and provides his recommendation on the best course of action in terms of naval surface fires and USN/USMC CAS [FM 6-20-40, p. A-27; FM 6-20-50, p. C-26].

- e. The brigade aviation LNO advises the brigade commander on the capabilities and employment of Army aviation assets providing support to the brigade fire support plan [ARTEP 71-3-MTP, 71-3-7001/1d, 7001/1e].
- f. The ABE provides advice and recommendations on the best course of action in terms of fire support for mobility and countermobility [ARTEP 71-3-MTP, 71-3-8003/2c].
- g. The brigade S2, brigade targeting officer, and brigade FSO advise the brigade commander on the availability, capabilities, and employment of target acquisition assets and non-lethal attack systems [ARTEP 71-3-MTP, 71-3-9001/3d; ARTEP 6-115-20-MTP, 06-3-02-1130, 1190].
- h. The brigade targeting team determines the single course of action, with its branches and sequels, which has the highest probability of success against the enemy's courses of actions [FM 6-20-40, p. 2-3; FM 6-20-50, p. 2-3; FM 34-130, p. A-7; FM 101-5, p. 4-28, F-34].
- i. The brigade targeting team completes fire support products supporting the selected course of action and prepares them for review and approval by the brigade commander; fire support products include [FM 101-5, p. F-36; FM 34-130, p. A-7; FM 6-20-40, p. 2-5; FM 6-20-50, p. 2-5]:
  - 1) Task organization of fire support units and systems (e.g., COLTS, mortars) including support relationships (e.g., OPCON, DS, GS) [FM 101-5, p. 4-35].
  - 2) HPTL [FM 6-20-10, p. 2-9; FM 6-20-40, p. G-12; FM 6-20-50, p. K-12; FM 34-130, p. A-5; FN-3/24 ID].
  - 3) FSCM [FM 6-20-40, p. E-1; FM 6-20-50, p. G-1].
  - 4) Collection plan [FM 6-20-10, p. 1-8, 2-2; FM 34-2, p. 3-14; FM 6-20-40, p. 2-11; FM 6-20-50, p. 2-11; FN-3/24 ID].
  - 5) DST (including TAIs, NAIs, DPs) [FM 6-20-10, p. A-8].
  - 6) AGM [FM 6-20-10, p. 1-8, 2-14; FM 34-130, p. A-7; FM 34-8, p. 2-10; FN-3/24 ID].
  - 7) BDA requirements [FM 6-20-10, p. 1-8, 2-27; FM 34-130, p. A-7; FN-3/24 ID].
  - 8) TSS [FM 6-20-10, p. 1-8, 2-12].
  - 9) Priorities for fires and support [FN-JRTC].
  - 10) Movement and positioning plans for target acquisition and target attack systems [FN-JRTC].

11) CCIR and IR [FM 101-5, p. 4-47].

- j. The brigade targeting team determines requirements for additional fire support assets and develops requests for the division to provide required support [FM 101-5, p. F-20; FM 6-20-40, p. 2-5; FM 6-20-50, p. 2-4].

**10. Brigade Commander Announces Decision**

- a. The brigade targeting team briefs the brigade commander [FM 101-5, p. 4-33].
  - 1) The brigade targeting team provides its recommendation for the course of action that can best achieve the brigade commander's intent, the brigade mission, and brigade commander's guidance for fire support [FM 101-5, p. 4-33].
  - 2) The selected course of action is briefed in its entirety, including all branches and sequels [FM 101-5, p. 4-33].
  - 3) Brigade targeting team members provide answers to questions or issues raised by the brigade commander [FM 101-5, p. 4-33].
- b. The brigade commander selects the course of action [FM 101-5, p. 4-34; FM 6-20-40, p. 2-5; FM 6-20-50, p. 2-5].
- c. The brigade commander converts his decision on the course of action into [FM 101-5, p. 4-34]:
  - 1) A clear and concise statement of his intent [FM 101-5, p. 4-34].
  - 2) A general scheme of fire support and the synchronization of fire support with maneuver [FM 101-5, p. 4-34].
- d. The brigade commander decides on the level of risk he is willing to accept for fire support based on recommendations provided by the brigade targeting team [FM 101-5, p. 4-35; FN-3/24 ID].
- e. The brigade commander approves the fire support plan and supporting documents, which include [AN]:
  - 1) Task organization of fire support units and systems (e.g., COLTS, mortars), including support relationships (e.g., OPCON, DS, GS) [FM 101-5, p. 4-35, H-30].
  - 2) HPTL [FM 6-20-10, p. 2-9; FM 6-20-40, p. G-12; FM 6-20-50, p. K-12; FM 34-130, p. A-5; 3/24 ID].
  - 3) FSCM [FM 6-20-40, p. E-1; FM 6-20-50, p. G-1].

- 4) Collection plan [FM 6-20-10, p. 1-8, 2-2; FM 34-2, p. 3-14; FM 6-20-40, p. 2-11; FM 6-20-50, p. 2-11; FN-3/24 ID].
  - 5) DST (including TAIs, NAIs, DPs) [FM 6-20-10, p. A-8].
  - 6) AGM [FM 6-20-10, p. 1-8, 2-14; FM 34-130, p. A-7; FM 34-8, p. 2-10; FN-3/24 ID].
  - 7) BDA requirements [FM 6-20-10, p. 1-8, 2-27; FM 34-130, p. A-7; FN-3/24 ID].
  - 8) TSS [FM 6-20-10, p. 1-8, 2-12].
  - 9) Priorities for fires and support [FN-JRTC].
  - 10) Movement and positioning plans for target acquisition and target attack systems [FN-JRTC].
  - 11) CCIR and IR [FM 101-5, p. 4-47].
  - 12) Requests to division for additional fire support [FM 101-5, p. F-20; FM 6-20-40, p. 2-5; FM 6-20-50, p. 2-5].
- f. The brigade FSO or brigade FSCOORD notifies the DS FA battalion S3 of the brigade commander's course of action selection and fire support decisions [FN-FA Sch].

#### 11. **Brigade Staff Prepares OPORD/FRAGO**

- a. The brigade XO supervises the staff in preparation of the OPORD [FM 101-5, p. H-1].
  - 1) The brigade XO ensures plans and products are in compliance with the brigade commander's intent and concept of the operation [FM 101-5, p. H-1].
  - 2) The brigade staff incorporates the approved course of action and its branches and sequels into the OPORD [FM 101-5, p. 4-37].
- b. The brigade FSO, brigade ALO, and brigade ANGLICO select fire support plan information for inclusion in the OPORD [FM 6-20-40, p. 2-5; FM 6-20-50, p. 2-5; FN-JRTC; FN-3/24 ID; FN-194 AR]:
  - 1) Priority of fires and how that priority will be executed [FM 6-20-40, p. 2-5; FM 6-20-50, p. 2-5; FN-FA Sch].
  - 2) Concept of planned fire support within the brigade AO for the deep, close, and rear battles [FM 6-20-40, p. 2-5; FM 6-20-50, p. 2-5; FM 101-5, p. H-123, H-128, H-155; FN-FA Sch].

- 3) Division targets the brigade is responsible to acquire and attack [FM 6-20-40, p. 2-5; FM 6-20-50, p. 2-5].
  - 4) Retransmission requirements for fire support communications [FM 6-20-40, p. 2-5; FM 6-20-50, p. 2-5; FN-FA Sch].
  - 5) Tasks to FA units and subordinate fire support elements, including command and support relationships [FM 6-20-40, p. C-7; FM 6-20-50, p. E-5; FM 101-5, p. H-123; FN-FA Sch; FN-BCBST].
  - 6) Fire support coordinating instructions [FM 6-20-40, p. C-8; FM 6-20-50, p. E-6; FM 101-5, p. H-72].
  - 7) BDA requirements [FM 6-20-10, p. 2-27].
  - 8) Task organization and support relationship for fire support assets [FM 101-5, p. H-123; FN-FA Sch].
  - 9) Air support plan, including JAAT and SEAD [FM 101-5, p. H-123; FN-FA Sch].
  - 10) FSCM [FM 101-5, p. H-128; FN-JRTC; FN-FA Sch].
  - 11) Time of execution of program fires relative to H-hour (e.g., counterfire, preparations, counter-preparations, SEAD) [FM 101-5, p. H-128].
  - 12) Special munitions (e.g., FASCAM, Copperhead, smoke, illumination) employment plan [FM 101-5, p. H-113; FN-JRTC; FN-FA Sch].
  - 13) Cut-off time for subordinate unit submission of fire support plan refinements [FN-JRTC].
- c. The brigade FSO prepares fire support products for inclusion in the OPORD [FM 6-20-40, p. 2-5; FM 6-20-50, p. 2-5; FN-3/24 ID; FN-194 AR].
- 1) FSCM graphics [FM 101-5, p. H-128; FN-JRTC; FN-FA Sch].
  - 2) Target lists [FM 6-20-40, p. 2-5, C-18; FM 6-20-50, p. 2-5, E-13; FN-NTC; FN-JRTC; FN-3/24 ID; FN-AR Sch; FN-FA Sch].
  - 3) AGM [FM 6-20-10, p. 2-16; FM 6-20-40, p. 2-5, C-8; FM 6-20-50, p. 2-5, E-6; FM 101-5, p. H-128; FN-NTC; FN-JRTC; FN-FA Sch].
  - 4) HPTL [FM 6-20-10, p. 2-16; FM 6-20-40, p. C-9; FM 101-5, p. H-128; FN-JRTC; FN-FA Sch].
  - 5) FSEM [FM 6-20-10, p. 5-11; FM 6-20-40, p. 2-16, C-16; FM 6-20-50, p. E-12; FM



101-5, p. H-173; FN-NTC; FN-JRTC; FN-3/24 ID; FN-BCBST; FN-FA Sch; FN-IN Sch).

- 6) TSS [FM 101-5, p. H-128].
  - 7) Target overlays [FM 6-20-40, p. 2-5; FM 6-20-50, p. 2-5; FN-NTC; FN-JRTC; FN-AR Sch; FN-FA Sch).
- d. The brigade S2 and DS MI company commander select intelligence information for inclusion in the OPORD and the collection plan [AN]:
- 1) Intelligence and Electronic Warfare paragraphs to the concept of the operation [FM 101-5, p. H-69].
  - 2) Tasks to intelligence units [FM 101-5, p. H-73].
  - 3) UAV use [FM 101-5, p. H-73].
  - 4) PIR [FM 101-5, p. H-105].
  - 5) Intelligence acquisition and surveillance plan and tasks (developed with the brigade targeting officer) [FM 6-20-40, p. 2-5; FM 6-20-50, p. 2-5; FM 101-5, p. H-106].
  - 6) Distribution plan for intelligence [FM 101-5, p. H-107].
  - 7) Concept for offensive EW support (e.g., listen only, jam only, jam based on time or event criteria) [FM 101-5, p. H-127; FN-JRTC].
- e. The brigade S2 and DS MI company commander prepare intelligence products for inclusion in the OPORD and the collection plan [AN]:
- 1) MCOO [FM 34-130, p. 2-22].
  - 2) SIT TEMP [FM 101-5, p. H-102; FN-3/24 ID].
  - 3) Event Template [FM 34-130, p. 2-50; FN-CGSC].
- f. The brigade S2, DS MI company commander, and brigade targeting officer produce the brigade collection plan for inclusion in the brigade order which reflects [FM 6-20-10, p. 1-8, 2-2; FM 34-2, p. 3-14]:
- 1) Tasking to collection assets to acquire particular PIRs or IRs [FM 34-2, p. 3-14; FM 6-20-10, p. 2-11].
  - 2) HPT designated as PIR [FM 6-20-10, p. 2-2].
  - 3) Methods for acquiring HPTs [FM 6-20-10, p. 2-2].

- 4) Coverage of the brigade AO to be provided by each collection system [FM 6-20-10, p. 2-2].
- 5) Description of the battlefield environment in terms of [FM 6-20-10, p. 2-20]:
  - a) Width [FM 6-20-10, p. 2-2].
  - b) Length [FM 6-20-10, p. 2-2].
  - c) Depth/altitude [FM 6-20-10, p. 2-2].
  - d) Time [FM 6-20-10, p. 2-2].
  - e) The electromagnetic spectrum [FM 6-20-10, p. 2-2].
  - f) BDA requirements for collection assets [FM 6-20-10, p. 2-27].
- g. The brigade S3, brigade ALO, brigade ANGLICO, brigade aviation LNO, and brigade AD LNO select CAS and A2C2 information for inclusion into the OPORD [AN]:
  - 1) The brigade commander's airspace priorities [ARTEP 71-3-MTP, 71-3-3013/3c].
  - 2) The A2C2 mission [ARTEP 71-3-MTP, 71-3-3013/3d; FM 101-5, p. H-133].
  - 3) Type of control required (e.g., positive, procedural) for each air space user, including the time and locations in which control measures are initiated [ARTEP 71-3-MTP, 71-3-3013/3f1].
  - 4) Flight rules [ARTEP 71-3-MTP, 71-3-3013/3g2].
  - 5) Airspace control order issuing times [ARTEP 71-3-MTP, 71-3-3013/3g3].
  - 6) High-use areas [ARTEP 71-3-MTP, 71-3-3013/3g4].
  - 7) Friendly EW operations which affect airspace users [ARTEP 71-3-MTP, 71-3-3013/3g5].
  - 8) FARP locations (active, preplanned) [ARTEP 71-3-MTP, 71-3-3013/3g6].
  - 9) Airfield locations and operations [ARTEP 71-3-MTP, 71-3-3013/3g7].
  - 10) NAVAIDs locations (active, preplanned, and time of operation [ARTEP 71-3-MTP, 71-3-3013/3g8].
  - 11) Flight operations center (FOC) and flight command center (FCC) location and operations [ARTEP 71-3-MTP, 71-3-3013/3g9].

- 12) Coordinating altitudes, routes, and corridors [FM 101-5, p. H-133].
  - 13) Tasks to USAF and ANGLICO elements providing target acquisition and terminal guidance support for CAS aircraft [FM 101-5, p. H-123; FN-FA Sch].
  - 14) Positions to be occupied by USAF and ANGLICO elements providing target acquisition and terminal guidance support for CAS aircraft [FM 101-5, p. H-123; FN-FA Sch].
  - 15) Weapons control status [FM 101-5, p. H-131].
  - 16) IFF measures and ROE [AN].
- h. The brigade S3, brigade ALO, and brigade ANGLICO prepare the A2C2 annex [ARTEP 71-3-MTP, 71-3-3012/2a, 3013/3]:
- 1) Delineates airspace subsectors in terms of [ARTEP 71-3-MTP, 71-3-3013/3a]:
    - a) Upper limits [ARTEP 71-3-MTP, 71-3-3013/3a1].
    - b) Left and right limits [ARTEP 71-3-MTP, 71-3-3013/3a2].
    - c) Front and rear limits [ARTEP 71-3-MTP, 71-3-3013/3a3].
  - 2) Describes authority to be exercised by each echelon concerning [ARTEP 71-3-MTP, 71-3-3013/3b]:
    - a) Army users [ARTEP 71-3-MTP, 71-3-3013/3b1].
    - b) Other service users [ARTEP 71-3-MTP, 71-3-3013/3b2].
    - c) Establishment of control measures [ARTEP 71-3-MTP, 71-3-3013/3b3].
    - d) Positive control and procedural control requirements [ARTEP 71-3-MTP, 71-3-3013/3b4].
- i. The brigade S3, brigade ALO, and brigade ANGLICO prepare the A2C2 utilization and situation overlay [ARTEP 71-3-MTP, 71-3-3013/3e, 3012/2d]:
- 1) A2C2 control measures and restrictions [ARTEP 71-3-MTP, 71-3-3012/2d1].
  - 2) ADA unit locations, weapons control status, and systems coverage [ARTEP 71-3-MTP, 71-3-3012/2d2; FM 101-5, p. H-133].
  - 3) Locations and coverage by indirect fire support systems [ARTEP 71-3-MTP, 71-3-3012/2d3].

- 4) Aviation unit and FARP locations (current and planned) [ARTEP 71-3-MTP, 71-3-3012/2d4].
- 5) Instrumented landing sites [ARTEP 71-3-MTP, 71-3-3012/2d5].
- j. The brigade ANGLICO selects naval surface fires and USN/USMC CAS information for inclusion in the OPORD [AN]:
  - 1) Tasks to brigade ANGLICO elements [FM 101-5, p. H-72].
  - 2) Concept for naval surface fires [FM 101-5, p. H-126].
- k. The brigade aviation LNO selects Army aviation information for inclusion in the OPORD [AN]:
  - 1) Army aviation tasks and missions supporting the brigade fire support plan [FM 101-5, p. H-118].
  - 2) Concept of operations for Army aviation assets supporting the brigade fire support plan [FM 101-5, p. H-119].
- l. The brigade S4 selects logistics information and products for inclusion in the OPORD [AN].
  - 1) Concept of logistical support [FM 101-5, p. H-75].
  - 2) Priorities for support [FM 101-5, p. H-76].
  - 3) CSR for fire support units under brigade control [FM 101-5, p. H-76].
  - 4) Distribution plans and schedules for supplies [AN].
  - 5) Transportation plan [AN].
  - 6) CSS overlay [AN].
- m. The brigade S3 consolidates information provided by the brigade targeting team and prepares the brigade OPORD [FM 101-5, p. H-11].
  - 1) The brigade S3 reviews the fire support plan to ensure it supports the brigade commander's intent and includes [ARTEP 71-3-MTP, 71-3-3005/2]:
    - a) Weighting the brigade main effort with fire support [ARTEP 71-3-MTP, 71-3-3005/2c2].
    - b) Application of all available fire support resources in support of the brigade scheme of maneuver [ARTEP 71-3-MTP, 71-3-3005/2c1].

- c) Designation of targets to attack with each fire support asset [ARTEP 71-3-MTP, 71-3-3005/2c3].
  - d) Priority and sequence for engaging targets [ARTEP 71-3-MTP, 71-3-3005/2c4].
  - e) Allocation of firing units [ARTEP 71-3-MTP, 71-3-3005/2c5].
- 2) The brigade S3 approves the "fires" paragraph portion to the OPORD and the brigade fire support plan prepared by the brigade FSO [ARTEP 71-3-MTP, 71-3-3005/1d, 3005/2a].
  - 3) The brigade S3 integrates the fire support plan into the OPORD as an annex [ARTEP 71-3-MTP, 71-3-3005/2].
  - 4) The brigade S3 integrates CCIR in the OPORD [FM 101-5, p. H-74, H-176; FN-CGSC].
  - 5) The brigade S3 prepares the operations overlay and DST for inclusion in the OPORD [FM 101-5, p. H-109, H-175].
- n. The brigade S3, brigade ALO, and brigade ANGLICO prepare preplanned CAS requests [ARTEP 71-3-MTP, 71-3-3004/3d, 3004/4].
- 1) Preplanned requests are complete and properly prepared; CAS information in requests include [ARTEP 71-3-MTP, 71-3-3004/4b; FM 6-20-40, p. A-8; FM 6-20-50, p. C-6]:
    - a) General information about planned schemes of maneuver [FM 6-20-40, p. A-8; FM 6-20-50, p. C-6].
    - b) Estimates of weapons effects needed by percentage [FM 6-20-40, p. A-8; FM 6-20-50, p. C-6].
    - c) Times required for CAS to support the scheme of maneuver [FM 6-20-40, p. A-8; FM 6-20-50, p. C-6; FN-BCBST].
    - d) Peak need times [FM 6-20-40, p. A-8; FM 6-20-50, p. C-6].
    - e) CAS targets (e.g., type, size, desired effects) and patterns of CAS attack [FM 6-20-40, p. A-8; FM 6-20-50, p. C-6; FN-BCBST].
    - f) CAS priorities [ARTEP 71-3-MTP, 71-3-3004/4d].
  - 2) Preplanned CAS requests are submitted to the division G3 by the NLT time specified in the division OPORD [ARTEP 71-3-MTP, 71-3-3004/4e].

- o. Requests for additional support are prepared and submitted [AN].
  - 1) The brigade S2 and DS MI company commander prepare requests for IEW support from the division and submits them to the division FSE and division G2 [FN-CGSC].
  - 2) The brigade S3, with the brigade targeting team, prepares and submits requests for additional fire support to the division FSE [FM 101-5, p. F-20; FM 6-20-40, p. 2-5; FM 6-20-50, p. 2-5].
- p. The brigade FSO and the brigade FSCOORD receive the FA Support Plan (FASP) provided by the DS FA battalion S3. The FASP is included in the brigade OPORD; FASP information includes [FM 6-20-40, p. C-20; FM 6-20-50, p. E-14]:
  - 1) Five-paragraph OPORD [FM 6-20-40, p. C-20; FM 6-20-50, p. E-14].
  - 2) FA support matrix [FM 6-20-40, p. C-24; FM 6-20-50, p. E-17].
  - 3) Target acquisition plan for FA target acquisition systems, including radar cueing schedule [FM 6-20-40, p. C-25; FN-FA Sch].
  - 4) Schedule of fires [FM 6-20-40, p. C-26].
  - 5) Firing positions and scheme of maneuver (as approved by the brigade S3) for the DS FA battalion and other FA battalions providing support to the brigade [FN-FA Sch; FN-IN Sch].
  - 6) DS FA battalion TOC locations [FN-FA Sch].
  - 7) FASCAM Minefield Safety Zone Report [FM 6-20-40, p. H-10; FM 6-20-50, p. H-10; FN-FA Sch; FN-IN Sch].

## 12. **Brigade Issues the OPORD/FRAGO**

- a. The brigade orders group assembles at the designated time and the brigade order is issued [FM 101-5, p. 4-59].
  - 1) The brigade order is issued within 1/3 of the time available to the brigade for planning and preparation; subordinate brigade units are provided 2/3 of available time to perform their own planning and preparation [FM 101-5, p. 4-23].
  - 2) Due to time constraints, the brigade commander may verbally issue the order, or the order may be issued through automated or digital systems [FM 101-5, p. 4-59; FN-194 AR].
  - 3) The brigade S3 is responsible for distributing the brigade order and supporting products to the brigade order briefing attendees [FM 101-5, p. 4-59; FN-NTC; FN-

AR Sch].

- b. The brigade fire support plan is briefed to the brigade orders group [FM 101-5, p. 4-59].
  - 1) The brigade S2 briefs the enemy situation and the collection plan [FM 101-5, p. 4-59].
  - 2) The brigade S3 briefs the brigade scheme of maneuver and A2C2 plan [FM 101-5, p. 4-59].
  - 3) The brigade FSO briefs the fire support plan and the employment of FA assets [FM 101-5, p. 4-59].
  - 4) The brigade ALO and brigade ANGLICO brief CAS support [FM 101-5, p. 4-59].
  - 5) The brigade ANGLICO briefs naval surface fires [FM 101-5, p. 4-59].
  - 6) The brigade AD LNO briefs air defense, weapons control status, and IFF measures [FM 101-5, p. 4-59].
  - 7) The brigade aviation LNO briefs Army aviation operations in support of the brigade fire support plan [FM 101-5, p. 4-59].
  - 8) The brigade engineer briefs M-S-CM [FM 101-5, p. 4-59].
- c. The brigade commander and brigade staff conduct confirmation briefings with subordinate commanders following the order issue [FM 101-5, p. 4-59; FN-JRTC].

## Preparation Task List

These tasks provide required detail to describe the brigade commander and brigade targeting team roles in monitoring and directing brigade fire support preparation activities, as well as required actions to perform and implement a deliberate or time-constrained decision making process, in the event that the brigade OPORD must be modified and refined. These tasks are structured to provide fire support tasks and information relevant to the function of "Direct and Lead Units in Preparation for Combat" as addressed in Brigade CCF 19. The tasks and task elements contained in this task list reflect those actions which are critical to Coordinate, Synchronize, and Integrate Fire Support. References are shown in brackets [...] after each task or task element. Tasks are either taken directly from an ARTEP MTP task or sub-task, or are derived from portions of sub-tasks, implied tasks, or requirements specified in the ARTEP MTPs, applicable FMs, or other related documents. Author-generated tasks are indicated as [AN]. Field notes/tasks from FORSCOM and/or TRADOC SMEs are identified with their source, e.g., [FN-NTC]. Endnotes, which provide ancillary information about tasks, are indicated by a numerical annotation in superscript (e.g., <sup>23</sup>).

These tasks describe the DETECT function of the targeting process, which occurs during the brigade preparation battle phase.

### 13. **The Brigade Targeting Team Organizes to Monitor, Plan, and Direct Fire Support Operations<sup>22</sup>**

- a. The brigade tactical CP (TAC) organizes [FM 71-3, p. 3-10, 3-20].<sup>23</sup>
  - 1) Brigade targeting team members manning the brigade TAC are [FM 6-20-40, p. 2-23; FM 6-20-50, p. 2-23; FM 71-3, p. 3-10, 3-20]:
    - a) Brigade commander [FM 71-3, p. 3-10, 3-20].
    - b) Brigade FSCOORD [FM 6-20-50, p. 2-23].
    - c) Brigade S3 [FM 71-3, p. 3-10, 3-20].
    - d) Brigade S2 or intelligence section representative [ARTEP 71-3-MTP, 71-3-2006/7; FM 71-3, p. 3-10, 3-20].
    - e) Brigade FSO [FM 71-3, p. 3-20; FM 6-20-40, p. 2-23; FM 6-20-50, p. 2-23].
    - f) The brigade ALO and/or brigade ANGLICO [FM 6-20-50, p. 2-23; FM 71-3, p. 3-11].
    - g) Other fire support personnel, as directed [FM 71-3, p. 3-20].
  - 2) Brigade targeting team members in the brigade TAC assist the brigade commander in directing and managing the preparation for and transition to the execution of the brigade close battle. Brigade targeting team members [FM 71-3, p. 3-10, 3-20]:



- a) Influence preparation for the battle through their personal presence (e.g., visits, inspections) as directed by the brigade commander [FM 71-3, p. 3-20].
  - b) Provide the brigade commander with critical information [FM 71-3, p. 3-10]
  - c) Develop and provide planning guidance to the brigade commander [FM 71-3, p. 3-20].
  - d) Synchronize and monitor ongoing combat, CS, and CSS activities in their areas of responsibilities and direct actions within their authority according to the brigade commander's intent [FM 71-3, p. 3-20; FM 101-5, p. 5-12].
  - e) Disseminate the brigade commander's decisions [FM 71-3, p. 3-10, 3-20].
  - f) Provide information to the main CP [FM 101-5, p. 5-12].
  - g) Monitor division and brigade deep and rear operations [FM 101-5, p. 5-12].
- 3) Brigade targeting team members in the brigade TAC monitor designated communications nets to manage and direct the implementation of the fire support plan, to acquire information and intelligence, and to monitor preparation activities of fire support units. Brigade targeting team members monitor [FM 71-123, p. 1-42, 3-12]:
- a) The division command net [FM 71-3, p. 3-12].
  - b) The division OI net [FM 71-3, p. 3-12].
  - c) The brigade command net [FM 71-3, p. 3-12].
  - d) The brigade OI net [FM 71-3, p. 3-12].
  - e) USAF, USN, USMC, and Army aviation coordination nets (FM, HF, UHF, VHF) [FM 71-3, p. 3-12].
  - f) Fire support nets [FM 71-3, p. 3-12].
- 4) The brigade FSO and brigade ALO organize to operate from the brigade TAC [AN].
- a) The brigade FSO and brigade ALO determine and acquire required communications systems and equipment [FM 6-20-50, p. 2-23, 2-24].<sup>24</sup>
  - b) The brigade FSO and brigade ALO determine what their information requirements will be while operating in the brigade TAC [FM 6-20-40, p. 2-23, 2-24; FM 6-20-50, p. 2-23].
  - c) The brigade FSO provides instructions to the brigade targeting officer and

brigade FSE members for the handling of fire support information that he and the brigade ALO will relay to the brigade FSE for action [FM 6-20-40, p. 2-23, 2-24; FM 6-20-50, p. 2-23].

- d) The brigade FSO determines communications networks and contingency plans in the event of breaks in communications contact between the brigade TAC and brigade main CP to ensure that flow of fire support information and guidance will be continuous [FM 6-20-40, p. 2-23; FM 6-20-50, p. 2-23].
- b. The brigade main CP organizes [FM 71-3, p. 3-20].<sup>25</sup>
- 1) Brigade targeting team members not selected to man the brigade TAC are positioned in the brigade main CP [FM 71-3, p. 3-10, 3-20]:
  - 2) The brigade FSE operates as a component of the brigade main CP [ARTEP 6-115-20-MTP, task 06-3-02-1300/2].
    - a) The brigade FSE maintains communications with all fire support elements [ARTEP 6-115-20-MTP, task 06-3-02-1300/2].
    - b) The brigade FSE maintains status of fire support assets and refinements to the fire support plan [ARTEP 6-115-20-MTP, task 06-3-02-1300/2].
  - 3) Brigade targeting team members in the brigade main CP assist the brigade commander in monitoring, planning, and directing brigade operations throughout the brigade AO. Brigade targeting team members [FM 71-3, p. 3-10, 3-20; FM 101-5, p. 5-13]:
    - a) Control preparation activities and transition to the close battle when the brigade TAC CP is not deployed, is displaced, is destroyed in battle, or has maintenance problems that reduce capabilities [FM 101-5, p. 5-13].
    - b) Synchronize combat, CS, and CSS activities in support of preparation activities and deep operations [FM 101-5, p. 5-13].
    - c) Provide the focal point for the development of intelligence [FM 101-5, p. 5-13].
    - d) Plan for future operations [FM 101-5, p. 5-13].
    - e) Monitor brigade activities throughout the brigade AO [FM 101-5, p. 5-13].
    - f) Provide situational information to division, adjacent, and subordinate headquarters [FM 101-5, p. 5-13].
  - 4) Brigade targeting team members in the brigade main CP monitor designated communications nets to manage and direct the implementation of the fire support plan, to acquire information and intelligence, and to monitor preparation activities

of fire support units. Brigade targeting team members monitor [FM 71-3, p. 3-15]:

- a) The division command net [FM 71-3, p. 3-15].
  - b) The division Operations and Intelligence (OI) Net [FM 71-3, p. 3-15].
  - c) The brigade command net [FM 71-3, p. 3-15].
  - d) The brigade OI net [FM 71-3, p. 3-15].
  - e) Brigade fire support nets [FM 71-3, p. 3-15].
  - f) Division fire support nets [FM 71-3, p. 3-15].
  - g) Engineer nets [FM 71-3, p. 3-15].
  - h) Division early warning nets and ADA battery nets [FM 71-3, p. 3-15].
  - i) USAF, USN, USMC, and Army aviation coordination nets (FM, HF, UHF, VHF) [FM 71-3, p. 3-15].
- c. The brigade rear CP organizes [FM 71-3, p. 3-20].<sup>26</sup>
- 1) The ad-hoc fire support team established by the brigade commander and brigade S3 operates from the brigade rear CP (see task 8e) [FM 6-20, p. 3-11; FM 6-20-40, p. 2-5].
  - 2) The ad-hoc fire support team in the brigade rear CP assists the brigade targeting team in monitoring, planning, and directing activities in support of the brigade fire support plan. Ad-hoc fire support team members [FM 101-5, p. 5-14]:
    - a) Synchronize preparation activities of fire support units in support of rear operations [FM 101-5, p. 5-14].
    - b) Manage and direct the implementation of indirect fires in support of rear area security operations [FM 101-5, p. 5-14].
    - c) Support terrain management activities for fire support units operating in the brigade rear area [FM 101-5, p. 5-14].
    - d) Manage and monitor the sustainment of brigade fire support units [FM 101-5, p. 5-14].
    - e) Monitor preparation activities of fire support units in the brigade AO [FM 101-5, p. 5-14].
    - f) Provide situation information to the brigade targeting team in the brigade main

CP [FM 101-5, p. 5-14].

- 3) The ad-hoc fire support team members in the brigade rear CP monitor designated communications nets to manage and direct the implementation of the fire support plan, to acquire information and intelligence, and to monitor preparation activities of fire support units. Ad-hoc fire support members monitor [FM 71-3, p. 3-17]:
  - a) The brigade command net [AN].
  - b) Brigade fire support nets [AN].
  - c) Brigade A/L nets [FM 71-3, p. 3-17].
  - d) Subordinate fire support unit A/L nets [ARTEP 71-3-MTP, 71-3-1012/2, 4004/1].
- d. The DS FA Battalion TOC organizes [AN].
  - 1) The DS FA battalion TOC supports the brigade commander, brigade FSCOORD, and the brigade targeting team in monitoring and directing preparation activities of brigade fire support units. The DS FA battalion TOC [FM 6-20-1, p. 3-1]:
    - a) Advises the brigade FSCOORD on the FA organization for combat, FA positioning, allocation of ammunition, and FA attack guidance [FM 6-20-1, p. 3-1].
    - b) Continuously assists in the targeting process [FM 6-20-1, p. 3-1].
    - c) Performs tactical fire direction activities in support of brigade preparation activities and for the protection of brigade units performing security and rear battle operations [FM 6-20-1, p. 3-1].
    - d) Monitors and controls preparation activities of cannon assets and FA target acquisition assets (e.g., organic, attached, reinforcing) [FM 6-20-1, p. 3-1].
    - e) Plans for future FA operations [FM 6-20-1, p. 3-1].
    - f) Performs alternate CP functions for reinforcing battalions [FM 6-20-1, p. 3-1].
  - 2) DS FA battalion staff members monitor designated communications nets to manage and direct the implementation of the fire support plan, to acquire information and intelligence, and to monitor preparation activities of fire support units. Staff members monitor [AN]:
    - a) DS FA battalion command net (voice) [FM 6-20-1, p. 6-13].<sup>27</sup>
    - b) DS FA battalion FDC net (voice and digital) [FM 6-20-1, p. 6-14].<sup>28</sup>

- c) DS FA battalion operations/fire net (voice and digital) [FM 6-20-1, p. 6-14].<sup>29</sup>
  - d) DS FA battalion A/L net (voice) [FM 6-20-1, p. 6-15].
  - e) DIVARTY/Force FA command net (voice) [FM 6-20-1, p. 6-15].
  - f) DIVARTY/Force FA operations/fire nets (voice and digital) [FM 6-20-1, p. 6-15].
  - g) DIVARTY/Force FA command/fire net [FM 6-20-1, p. 6-15].
  - h) Brigade OI net (voice) [FM 6-20-1, p. 6-16].
  - i) Brigade fire support net (voice) [FM 6-20-1, p. 6-16].
  - j) Reinforcing FA battalions operations/fire nets (voice and digital) [FM 6-20-1, p. 6-16].
  - k) DIVARTY/Force A/L net (voice) [FM 6-20-1, p. 6-16].
- e. Brigade CPs and the DS FA battalion TOC position to monitor, plan, and direct preparation activities and to support the transition from mission preparation to mission execution [AN].
- 1) Brigade CPs and the DS FA battalion TOC position in terrain which [FM 71-3, p. 3-21]:
    - a) Provides masking of physical signatures (e.g., visual, audio, radar) [FM 101-5, p. 5-4].
    - b) Provides masking of thermal signatures (e.g., heat-generating vehicles and equipment, lasers, electronic equipment, personnel) [FM 101-5, p. 5-4].
    - c) Provides masking of electronic signatures (e.g., radios, radars, electronic equipment, transmitters) [FM 101-5, p. 5-4].
    - d) Provides passive security (e.g., cover, concealment) [FM 71-3, p. 3-21; FM 101-5, p. 5-4].
    - e) Contains ground that is trafficable regardless of weather conditions [FM 71-3, p. 3-21].
    - f) Locates near existing road networks which are out of sight of enemy observation and which can be located by subordinate commanders and LNOs [FM 71-3, p. 3-21].
  - 2) Brigade CPs and the DS FA battalion TOC collocate with tactical units for mutual

support and local security [FM 71-3, p. 3-21].

- 3) Brigade CPs and the DS FA battalion TOC implement OPSEC measures [ARTEP 71-3-MTP, 71-3-1501/5, 2010, 2011, 3014; FM 71-3, p. 3-21; FM 101-5, p. 5-5].
- f. The brigade FSO briefs and directs the brigade targeting officer and brigade fire support NCO to coordinate, synchronize, and execute fire support from the brigade main CP [FM 6-20-40, p. 2-23; FM 6-20-50, p. 2-23].
- g. The brigade FSO ensures that the brigade targeting officer and the brigade FSE are prepared to [FM 6-20-40, p. 2-23; FM 6-20-50, p. 2-23]:
  - 1) Relay messages to the brigade FSO and brigade ALO [FM 6-20-50, p. 2-23].
  - 2) Perform retransmission for the brigade FSO and brigade ALO [FM 6-20-50, p. 2-23].
  - 3) Perform limited planning and coordination for current and future operations [FM 6-20-50, p. 2-23].
  - 4) Implement fire support guidance and instructions issued by the brigade commander through the brigade FSCOORD and brigade FSO [FM 6-20-40, p. 2-24].
  - 5) Accomplish all brigade FSO functions in the absence of the brigade FSO [FM 6-20-50, p. 2-23].
- h. The brigade targeting team determines categories of fire support information [FM 101-5, p. 6-4]:
  - 1) CCIR: critical information which directly affects the brigade mission and the brigade commander's decisions [FM 101-5, p. 6-6].
  - 2) Exceptional information: specific and vital information which signals the occurrence of one or more unpredictable, extraordinary events which directly affects the brigade mission and brigade commander's decision-making process [FM 101-5, p. 6-10].
  - 3) Routine information: standard, repetitive information essential for day-to-day operations within the brigade [FM 101-5, p. 6-5].
- I. The brigade targeting team uses automated systems for the transmission of fire support information, guidance, and instructions [FM 101-5, p. 6-20].
  - 1) Maneuver Control System (MCS) is used to integrate maneuver information with fire support, air defense, IEW, and CSS command and control information [FM 101-5, p. 6-22].
  - 2) Advanced Field Artillery Tactical Data System (AFATDS) is used to coordinate the

employment (e.g., planning, coordination, control) of all service and combined fire support assets [FM 101-5, p. 6-23].

- 3) Forward Area Air Defense Command, Control, Communications, and Intelligence System (FAADC2I) is used to collect, store, process, display, and disseminate critical, time-sensitive, air-situation and targeting information from forward area air defense systems (FAADS) [FM 101-5, p. 6-24].
- 4) All-Source Analysis System (ASAS) is used to [AN]:
  - a) Support IEW operations and technical control of MI assets [FM 101-5, p. 6-24].
  - b) Provide automated intelligence and information management by rapidly processing combat information and sensor reports from internal and external sources [FM 101-5, p. 6-24].
  - c) Produce fused, near-real-time, all-source information relative to the battlefield [FM 101-5, p. 6-24].
- j. The brigade targeting team uses communications systems for the transmission of fire support information, guidance, and instructions. Systems are [FM 101-5, p. 6-26; FM-JRTC]:
  - 1) Combat Net Radios (CNR) [FM 101-5, p. 6-26].<sup>30</sup>
  - 2) Area Common User (ACU)/Mobile Subscriber Equipment (MSE) [FM 101-5, p. 6-27].
  - 3) Data Distribution System (DDS) [FM 101-5, p. 6-27].
  - 4) Army Data Distribution System (ADDS) [FM 101-5, p. 6-28].
- k. The brigade targeting team organizes to retain the capability to provide updates and briefings to the brigade commander on [FM 101-5, p. J-18]:
  - 1) Status of mission preparation by fire support units and systems [FM 101-5, p. J-18].
  - 2) Implementation of the brigade fire support plan [FM 101-5, p. J-18].
  - 3) Status and dispositions of target acquisition and attach systems [FM 101-5, p. J-18].
- l. Brigade targeting team members in all brigade CPs maintain communications with [AN]:
  - 1) Bn TF FSOs, S2s, ALOs, ANGLICO elements, and FSEs [FM 6-20-50, p. 2-23].
  - 2) Division FSCoord, division FSE, and DIVARTY TOC [FM 6-20-50, p. 2-23].

- 3) DS FA battalion TOCs [FM 6-20-50, p. 2-23].
- 4) Division G2, MI battalion, and division collection and target acquisition assets [ARTEP 71-3-MTP, 71-3-2006/7].
- 5) Division G3 Air, division ALO, division ANGLICO, and corps ASOC [FM 6-20-40, p. A-9, A-11, A-26; FM 6-20-50, p. C-7, C-8, C-25; FM 71-3, p. 7-13].
- 6) USN ships providing naval surface fires [FM 71-3, p. 7-13; FM 6-20-40, p. A-29; FM 6-20-50, p. C-27].
- 7) Division air defense officer and ADA battalion S3 [FM 71-3, p. 7-21].
- 8) Aviation brigade S3 and commanders of aviation units supporting the brigade [FM 6-20-40, p. A-31; FM 6-20-50, p. C-29].

14. **The Brigade Targeting Team Acquires Information** <sup>31</sup>

- a. The brigade S3 receives information [ARTEP 71-3-MTP, 71-3-3003/1].
  - 1) The brigade S3 receives information from the division G3, division operations staff, and adjacent unit S3s. Information includes [AN]:
    - a) Status of division deception operations [FM 101-5, p. 6-45].
    - b) Division CP locations (current and proposed) [FM 101-5, p. 6-43].
    - c) Status of division deep operations [ARTEP 71-3-MTP, 71-3-2006/5b].
  - 2) The brigade S3 receives reports and updates from subordinate Bn TF S3s. Information includes [AN]:
    - a) Status of task organization and mission preparation by Bn TFs [ARTEP 71-3-MTP, 71-3-3003/1; FM 101-5, p. 6-44, 6-45, 6-47].
    - b) Status of Bn TF combat and combat support systems [FM 6-20-40, p. 2-18; FM 6-20-50, p. 2-18].
    - c) Dispositions and locations of Bn TF units [FM 6-20-40, p. 2-18; FM 6-20-50, p. 2-18; FM 101-5, p. 6-44].
    - d) Implementation of OPSEC operations and measures [ARTEP 71-3-MTP, 71-3-3014; FM 101-5, p. 6-45].
    - e) Adherence with brigade timelines [AN].
    - f) Bn TF CP locations (current and proposed) [FM 101-5, p. 6-43].





MTP, 71-3-2004/2].

- e) Updates on and status of pre-combat checks and inspections, including actions to correct deficiencies [AN].
- 3) The brigade S2 receives R&S plans and status of execution of R&S plans from Bn TF S2s [ARTEP 71-3-MTP, 71-3-2004/2, 2006/3c7]:
- a) Bn TF reconnaissance and patrol activity [FM 6-20-40, p. 2-22; FM 6-20-50, p. 2-22].
  - b) Movement and infiltration routes for Bn TF R&S and target acquisition assets [FM 6-20-40, p. 2-22; FM 6-20-50, p. 2-22].
  - c) Positions and locations of Bn TF R&S and target acquisition assets [FM 6-20-40, p. 2-22; FM 6-20-50, p. 2-22].
  - d) Reporting schedules of Bn TF assets performing R&S missions [ARTEP 71-3-MTP, 71-3-2004/2].
  - e) Status updates on Bn TF R&S and collection missions in progress [ARTEP 71-3-MTP, 71-3-2004/2].
- c. The brigade FSO receives information [AN].
- 1) The brigade FSO receives information from the division FSCoord, division FSE members, and DIVARTY TOC members. Information includes [FM 71-3, p. 7-4; FM 6-20-40, p. 2-18; FM 6-20-50, p. 2-18]:
    - a) Status of FA units providing GS or reinforcing fire support to the DS FA battalion, as required [FM 71-3, p. 7-4].
    - b) Changes to division target attack guidance and priorities for fire support [FM 6-20-40, p. 2-2; FM 6-20-50, p. 2-2; FN-JRTC; FN-AR Sch].
    - c) Changes and updates on division permissive and restrictive fire support coordinating measures [FM 6-20-40, 2-2; FM 6-20-50, p. 2-2; FM 6-20-30, p. 4-23, F-2].
    - d) Targeting data and updates on results of division deep attack operations [FM 6-20-40, p. 2-12; FM 6-20-50, p. 2-12; FM 6-20-30, p. 4-16, B-1; FM 71-100, p. 1-5].
    - e) Status on requests for augmentation to the brigade of additional FA fire support assets [FM 101-5, p. F-20; FM 6-20-40, p. 2-5; FM 6-20-50, p. 2-5].
  - 2) The brigade FSO receives information and status updates on the DS FA battalion

from the FSCOORD and the DS FA battalion S3 [ARTEP 71-3-MTP, 71-3-9002/1; ARTEP 6-115-20-MTP, 06-3-02-1130, 1190, 1390; FM 101-5, p. 6-49; FM 6-20-40, p. 2-18, 2-23; FM 6-20-50, p. 2-18, 2-22; FN-AR Sch]:

- a) Status of COLTs, including those task organized to subordinate units [FM 6-20-40, p. 2-19, 2-23; FM 6-20-50, p. 2-18, 2-22].
  - b) Status of AN/TRQ-36 radars [FM 101-5, p. 6-49; FM 6-20-40, p. 2-19; FM 6-20-50, p. 2-18].
  - c) Current and proposed locations of firing batteries and target acquisition systems [ARTEP 71-3-MTP, 71-3-9002/1; ARTEP 6-115-20-MTP, 06-3-02-1130, 1190; FM 6-20-40, p. 2-19; FM 6-20-50, p. 2-18].
  - d) Ammunition status of firing batteries [ARTEP 71-3-MTP, 71-3-9002/1; ARTEP 6-115-20-MTP, 06-3-02-1130, 1190; FM 6-20-40, p. 2-23; FM 6-20-50, p. 2-22].
  - e) Status of firing batteries and equipment [ARTEP 71-3-MTP, 71-3-9002/1; ARTEP 6-115-20-MTP, 06-3-02-1130, 1190; FM 101-5, p. 6-49; FM 6-20-40, p. 2-19; FM 6-20-50, p. 2-18].
  - f) Personnel status of fire support units [FM 101-5, p. 6-49].
  - g) Status of FA battalion CPs [FM 6-20-40, p. 2-19; FM 6-20-50, p. 2-18, 2-22].
  - h) Updates on and status of pre-combat checks and inspections, including actions to correct deficiencies [AN].
- 3) The brigade FSO receives from the Bn TF FSOs bottom-up refinements to the brigade fire support plan and products resulting from Bn TF fire support planning [ARTEP 71-3-MTP, 71-3-9003/10; ARTEP 6-115-20-MTP, 06-3-02-1130, 1190; FM 6-20-40, p. 2-8; FM 6-20-50, p. 2-8; FN-FA Sch]:
- a) Target lists [FM 6-20-40, Ch 2].
  - b) FSEM [FM 6-20-40, Ch 2].
  - c) Preparatory fires plan [ARTEP 71-3-MTP, 71-3-9003/10; ARTEP 6-115-20-MTP, 06-3-02-1130, 1190].
  - d) Counter-fire programs [ARTEP 71-3-MTP, 71-3-9003/10; ARTEP 6-115-20-MTP, 06-3-02-1130, 1190].
  - e) Priority targets [ARTEP 71-3-MTP, 71-3-9003/10; ARTEP 6-115-20-MTP, 06-3-02-1130, 1190].

- f) Counter-prep plan [ARTEP 71-3-MTP, 71-3-9003/10; ARTEP 6-115-20-MTP, 06-3-02-1130, 1190].
  - g) On-call targets [ARTEP 71-3-MTP, 71-3-9003/10; ARTEP 6-115-20-MTP, 06-3-02-1130, 1190].
  - h) Targets of opportunity and HPTs [ARTEP 71-3-MTP, 71-3-9003/10; ARTEP 6-115-20-MTP, 06-3-02-1130, 1190].
  - i) Final Protective Fires (FPF) requirements [FM 6-20-40, p. D-1; FM 6-20-50, p. F-1].
- 4) The brigade FSO receives status updates and information from Bn TF FSOs on their activities to implement the brigade and Bn TF fire support plans [AN]:
- a) Bn TF plans for positioning of fire support assets under their task organization [FM 6-20-40, p. 2-8; FM 6-20-50, p. 2-8; FN-FA Sch].
  - b) Bn TF R&S operations as they support the brigade and Bn TF fire support plans [FM 6-20-40, p. 2-8; FM 6-20-50, p. 2-8; FN-FA Sch].
  - c) Status of Bn TF Mortar Platoons, as required [FM 6-20-40, p. A-4; FM 6-20-50, p. C-3].
- d. The brigade ALO receives information [AN].
- 1) The brigade ALO, with the brigade ANGLICO, receives updates from the division ALO, division ANGLICO, division G3/Air, and corps ASOC [FM 6-20-40, p. A-9, A-11; FM 6-20-50, p. C-7, C-8; FN-CGSC]:
    - a) Updates and changes to the ATO for CAS missions scheduled for the next 24, 48, and 72 hours [FM 6-20-40, p. A-9, A-11; FM 6-20-50, p. C-7, C-8; FN-CGSC].
    - b) Status on requests for additional CAS support [FM 101-5, p. F-20; FM 6-20-40, p. 2-5; FM 6-20-50, p. 2-5].
  - 2) The brigade ALO receives information and updates from Bn TF ALOs, TACPs, and FACs [FM 6-20-40, p. A-9; FM 6-20-50, p. C-7]:
    - a) Operational status and task organization of Bn TF ALO assets [FM 101-5, p. H-123; FN-FA Sch].
    - b) Movement and positioning of Bn TF ALO elements [FM 101-5, p. H-123; FN-FA Sch].
    - c) Bn TF CAS target recommendations [ARTEP 71-3-MTP, 71-3-3004/4e; FM

6-20-40, p. A-8; FM 6-20-50, p. C-6].

- d) Bn TF air space requirements (see task 13j below) [ARTEP 71-3-MTP, 71-3-2013/3b].
  - e) Updates on and status of pre-combat checks and inspections, including actions to correct deficiencies [AN].
- e. The brigade ANGLICO receives information [AN].
- 1) The brigade ANGLICO, with the brigade ALO, receives updates from the division ALO, division ANGLICO, division G3/Air, and corps ASOC [FM 6-20-40, p. A-9, A-11, A-26; FM 6-20-50, p. C-7, C-8, C-25; FM 71-3, p. 7-13; FN-CGSC].
    - a) Updates and changes to the ATO for CAS missions scheduled for the next 24, 48, and 72 hours [FM 6-20-40, p. A-9, A-11; FM 6-20-50, p. C-7, C-8; FN-CGSC].
    - b) Status on requests for additional naval surface fire support [FM 101-5, p. F-20; FM 6-20-40, p. 2-5; FM 6-20-50, p. 2-5].
  - 2) The brigade ANGLICO receives information and updates from USN ships providing naval surface fire support to the brigade [FM 71-3, p. 7-13; FM 6-20-40, p. A-29; FM 6-20-50, p. C-27]:
    - a) Status on ammunition and capabilities of USN ships [FM 6-20-40, p. A-28; NWP 3-09.11M, p. 2-1].
    - b) Locations and positions of USN ships [NWP 3-09.11M, p. 2-6; FN-194 AR].
    - c) Changes to concept for naval surface fires [FM 101-5, p. H-126].
  - 3) The brigade ANGLICO receives information and updates from Bn TF SALT elements. Information includes [FM 6-20-40, p. A-27; FM 6-20-50, p. C-25]:
    - a) Operational status and task organization of Bn TF ANGLICO assets [FM 101-5, p. H-123; FM 71-3, p. 7-12; NWP 3-09.11M, p. 1-5; FN-FA Sch].
    - b) Movement and positioning of Bn TF ANGLICO elements [FM 101-5, p. H-123; FN-FA Sch].
    - c) Bn TF target recommendations for naval surface fires [ARTEP 71-3-MTP, 71-3-3004/4e; FM 6-20-40, p. A-8; FM 6-20-50, p. C-6].
    - d) Updates on and status of pre-combat checks and inspections, including actions to correct deficiencies [AN].

- f. The brigade aviation LNO receives information [AN].
- 1) The brigade aviation LNO receives information and updates from the aviation brigade S3 [ARTEP 71-3-MTP, 71-3-7001/2; FM 6-20-40, p. A-31; FM 6-20-50, p. C-29]:
    - a) Status of division Army aviation operations in the brigade AO [ARTEP 71-3-MTP, 71-3-7001/2; FM 6-20-40, p. A-31; FM 6-20-50, p. C-29].
    - b) Changes and updates on air space requirements for Army aviation assets (see task 13j below) [ARTEP 71-3-MTP, 71-3-7001/2; FM 6-20-40, p. A-31; FM 6-20-50, p. C-29].
    - c) Changes or additions to fire support requirements to support aviation brigade operations in the brigade AO [ARTEP 71-3-MTP, 71-3-7001/2].
  - 2) The brigade aviation LNO receives information and status updates from commanders of Army aviation units supporting the brigade fire support plan [FM 6-20-40, p. A-31; FM 6-20-50, p. C-29]:
    - a) Changes to aircraft capabilities and availability [FM 101-5, p. 6-49; FM 1-111, p. 3-2; FN-JRTC].
    - b) Changes and updates on air space requirements (see task 13j below) [ARTEP 71-3-MTP, 71-3-7001/1].
    - c) Changes to aircraft crew capabilities (e.g., crew rest, night vision goggles (NVG) qualified) [AN].
    - d) Status of resupply operations and establishment of FARPs [AN].
    - e) Updates on and status of pre-combat checks and inspections, including actions to correct deficiencies [AN].
- g. The ABE receives information [AN].
- 1) The ABE receives information and updates from the division engineer and engineer brigade S3 [FM 71-3, p. 7-14]:
    - a) Locations of enemy obstacles [ARTEP 71-3-MTP, 71-3-8005/1].
    - b) Changes to division-directed obstacles and FA FASCAM requirements [FM 5-100, p. 24; FM 5-102, p. 57, 82].
    - c) Updates on terra base products for the brigade AO [AN].
  - 2) The ABE receives information and updates from the engineer battalion commander,

engineer battalion S3, and engineer company commanders operating with Bn TFs [AN]:

- a) Exact locations for brigade obstacles after they are emplaced (to refine fire support plans) [ARTEP 71-3-MTP, 71-3-8005/1; FM 101-5, p. 6-46; FM 6-20-40, p. 3-18; FM 6-20-50, p. 3-19].
  - b) Locations and types of obstacles enemy forces have emplaced in the brigade AO, from engineer units performing obstacle reconnaissance [FM 6-20-40, p. 3-4; FM 6-20-50, p. 3-2].
  - c) Adherence to brigade timelines for the emplacement of obstacles [ARTEP 71-3-MTP, 71-3-8002/2; FM 101-5, p. 6-47].
  - d) Bn TF FA FASCAM targets [FM 6-20-40, p. H-2; FM 6-20-50, p. I-2; FN-IN Sch].
  - e) Updates on and status of pre-combat checks and inspections, including actions to correct deficiencies [AN].
- h. The brigade S4 receives information from the DS FA battalion S4, FSB S3, and Bn TF S4s relative to CSS operations in support of fire support units [AN]:
- 1) Casualties (e.g., battle, non-battle) of fire support personnel [FM 101-5, p. 6-46].
  - 2) Current status and projected maintenance status of FA cannons, Bn TF mortars, and non-lethal attack systems undergoing repair [ARTEP 71-3-MTP, 71-3-4003/2; FM 101-5, p. 6-46].
  - 3) Implementation and execution of weapons system replacement operations for lethal and non-lethal weapon systems [ARTEP 71-3-MTP, 71-3-4003/2].
  - 4) Status of requisition, acquisition, storage, and distribution of supplies for fire support units and assets [ARTEP 71-3-MTP, 71-3-4003/1].
  - 5) Status of CSR for fire support units and assets [ARTEP 71-3-MTP, 71-3-4003/1].
  - 6) Status of CL III supply points, CL V transfer points, and maintenance collection points [FM 101-5, p. 6-47].
  - 7) Transportation and movement information, including [ARTEP 71-3-MTP, 71-3-4005/2]:
    - a) Status of MSR, ASR, and other routes, including information relevant to enemy capabilities and action to interrupt use of MSR, ASR, and other routes [ARTEP 71-3-MTP, 71-3-4005/2; FM 101-5, p. 6-46].

- b) Routes, traffic control, and timetables for transportation of supplies and equipment to fire support systems and units [ARTEP 71-3-MTP, 71-3-4005/2].
  - c) Aerial resupply operations in support of fire support units and systems [ARTEP 71-3-MTP, 71-3-4005/2].
- i. The brigade S3, brigade S3/Air, brigade FSO, brigade ALO, brigade ANGLICO, brigade aviation LNO, and brigade ALO receive information to support monitoring of brigade air space [ARTEP 71-3-MTP, 71-3-3012/2, 7001/4]:
- 1) Routine reports and updates from air space users on their activities in the brigade air space [ARTEP 71-3-MTP, 71-3-3012/2, 7001/4].
  - 2) Reports on enemy aircraft, including locations for massing of enemy aircraft, from division intelligence and ADA assets [ARTEP 71-3-MTP, 71-3-3012/2; FM 101-5, p. 6-46].
  - 3) Priorities, restrictions, and control measures requirements, from air space users [ARTEP 71-3-MTP, 71-3-3012/2].
  - 4) Changes to air defense priorities, warnings, ROE, and weapons control status, from the division AD LNO and ADA battalion S3 [ARTEP 71-3-MTP, 71-3-3012/2, 6002/3].
  - 5) Status of airfields [ARTEP 71-3-MTP, 71-3-3012/2].
  - 6) Planned and ongoing artillery fires, from Bn TF FSOs [ARTEP 71-3-MTP, 71-3-3012/2].
  - 7) Changes to IFF/SIF procedures and standard use Army aircraft flight routes (SAAFR), from the division ALO and division G3 Air [ARTEP 71-3-MTP, 71-3-3012/2, 6002/4].
  - 8) Status of instrumented landing systems, NAVAIDs, FCCs, and FOCs [ARTEP 71-3-MTP, 71-3-3012/2].
  - 9) Friendly ECM activities, from the division G2 [ARTEP 71-3-MTP, 71-3-3012/2].
  - 10) Army aviation air space requirements (includes specially-equipped mission aircraft [SEMA]), from air space users [ARTEP 71-3-MTP, 71-3-3012/3].
  - 11) Status updates on brigade requests for additional air support (e.g., RPV, USAF/USN/USMC CAS and reconnaissance assets), from the division ALO, division ANGLICO, and division G3 Air [ARTEP 71-3-MTP, 71-3-3012/3].
  - 12) Changes to weather conditions and the effect of weather on ADA systems [ARTEP 71-3-MTP, 71-3-6002/3].



- 13) Changes to aircraft coordinating altitudes [ARTEP 71-3-MTP, 71-3-6002/3].
- 14) Positioning and status of friendly ADA units [ARTEP 71-3-MTP, 71-3-6002/3].
- j. Brigade targeting team members exchange information internally [FM 101-5, p. 3-84; FN-AR Sch].
  - 1) Copies of pertinent combat information reports [ARTEP 71-3-MTP, 71-3-2006/6].
  - 2) Information and intelligence relative to brigade HPT and activity at NAIs, TAIs, and DPs [ARTEP 71-3-MTP, 71-3-2006/7].
  - 3) Changes to the enemy situation [FM 6-20-40, p. 2-22; FM 6-20-50, p. 2-22].
  - 4) Locations and status of delivery units, radars, COLTS, and CPs [FM 6-20-40, p. 2-19; FM 6-20-50, p. 2-18, 2-22].
  - 5) Movement times and routes for fire support systems [FM 6-20-40, p. 2-19; FM 6-20-50, p. 2-18].
  - 6) Supply and resupply status of fire support systems [FM 6-20-40, p. 2-19; FM 6-20-50, p. 2-18].
  - 7) Information answering CCIR and IR [FM 101-5, p. 6-2].
  - 8) Changes to or additional guidance from the brigade commander relative to the brigade commander's intent and guidance for fire support [FM 6-20-40, p. 2-22; FM 6-20-50, p. 2-22].
  - 9) Changes to priorities of fire and priority targets [FM 6-20-40, p. 2-22; FM 6-20-50, p. 2-22].
  - 10) Implementation of FSCM [FM 6-20-40, p. 2-19; FM 6-20-50, p. 2-21].
  - 11) Bn TF fire support plans and products (e.g., FSEM, target list worksheets) [FM 6-20-40, p. 2-12; FM 6-20-50, p. 2-12].
  - 12) Changes to plans for brigade and division JAAT, CAS, and J-SEAD missions [ARTEP 71-3-MTP, 71-3-3007/2].
  - 13) Operational status of MI collectors and target acquisition systems operating in the brigade AO [ARTEP 71-3-MTP, 71-3-2004/2].

15. **The Brigade Targeting Team Evaluates Information**<sup>32</sup>

- a. The brigade S3 evaluates information to ensure that the brigade commander's intent and guidance for fire support are being achieved [FM 101-5, p. 6-45].

- b. The brigade S2, with the brigade targeting officer, evaluates information [AN].
  - 1) The validity and reliability of information provided by target acquisition and collection systems are determined [ARTEP 71-3-MTP, 71-3-2006/4].
    - a) Out-of-date information is identified; information is deleted or used to determine new information requirements [ARTEP 71-3-MTP, 71-3-2006/4].
    - b) Highly perishable information is identified and is quickly disseminated to the division G2 and DIVARTY Targeting Element and, as required, to brigade fire support systems for immediate attack if the attack criteria are satisfied [ARTEP 71-3-MTP, 71-3-2003/2, 2006/6].
  - 2) Changes to capabilities of collection system to acquire required information are assessed to determine requirements to change the collection plan [ARTEP 71-3-MTP, 71-3-2004/2].
  - 3) Information and intelligence are evaluated to determine if new enemy activities are in agreement with projected enemy COA [ARTEP 71-3-MTP, 71-3-2003/2].
  - 4) Information is assessed to determine likely enemy perception of brigade capabilities and COAs [ARTEP 71-3-MTP, 71-3-2003/1].
- c. The brigade FSO, brigade S3, brigade S2, and brigade targeting officer evaluate results of division deep battle operations [AN].
  - 1) BDA results on brigade HPTs included in division deep attack operations are evaluated to determine if desired effects have been achieved [ARTEP 71-3-MTP, 71-3-2006/4, 2006/5b].
  - 2) Enemy responses and reaction to loss of resources (brigade HPT) during division deep attack operations are identified to determine requirements to change the fire support plan [ARTEP 71-3-MTP, 71-3-2006/4, 2006/5b].
- d. The brigade FSO and ABE evaluate information to determine fire support requirements [AN].
  - 1) Locations of brigade obstacles are assessed in order to refine brigade target lists [ARTEP 71-3-MTP, 71-3-8005/1; FM 101-5, p. 6-46; FM 6-20-40, p. 3-25; FM 6-20-50, p. 3-19].
  - 2) Enemy obstacle information is assessed to determine refinements to fire support for brigade breaching operations [FM 6-20-40, p. 3-4; FM 6-20-50, p. 3-2].
  - 3) Changes to the enemy situation are identified to determine refinements to the FASCAM employment plan and FASCAM locations [FM 6-20-40, p. 3-3, 3-25; FM 6-20-50, p. 3-2, 3-19].

- 4) Changes to brigade and enemy avenues of approach and mobility corridors are identified to determine requirements to adjust the fire support plan [ARTEP 71-3-MTP, 71-3-8005].
- e. The brigade FSCoord and brigade FSO evaluate information provided by the DS FA battalion staff [AN].
- 1) Activities of the DS FA battalion are assessed to ensure that the DS FA battalion is implementing the brigade fire support plan [FM 6-20-40, p. 2-18; FM 6-20-50, p. 2-18].
  - 2) FA target acquisition radars and systems operations are evaluated to ensure that they are adhering to priorities for observation [ARTEP 6-115-MTP, 06-2-01-2513/1].
    - a) Radars and systems are positioned as directed [ARTEP 6-115-MTP, 06-2-01-2513/1].
    - b) Searches are executed in directed sectors in accordance with cueing guidance [ARTEP 6-115-MTP, 06-2-01-2513/1].
    - c) Coverage of the brigade AO is achieved as directed [ARTEP 6-115-MTP, 06-2-01-2513/1].
    - d) Brigade radar zones are integrated with division radar zones to ensure that no gaps in coverage exist [ARTEP 6-115-MTP, 06-2-01-2513/1].
- f. The brigade FSO, with the brigade targeting team, evaluates fire support plans and targets provided by Bn TF FSOs during bottom-up refinement of the fire support plan [FM 6-20-40, p. 2-8; FM 6-20-50, p. 2-8].
- 1) Duplicate targets are identified and are either deleted or modified [FM 6-20-40, p. 2-8; FM 6-20-50, p. 2-8].
  - 2) Targets that do not fit the brigade commander's intent and support the brigade scheme of maneuver are deleted [FM 6-20-40, p. 2-8; FM 6-20-50, p. 2-8].
  - 3) New targets identified and developed by Bn TF FSOs are added to target lists and to the fire support plan [FM 6-20-40, p. 2-13; FM 6-20-50, p. 2-13].
- g. The brigade S3, brigade S3/Air, brigade S2, brigade FSO, brigade ALO, brigade ANGLICO, and brigade aviation LNO evaluate reports and updates from air space users [ARTEP 71-3-MTP, 71-3-7001/4].
- 1) Intelligence reports are evaluated to determine enemy activities and dispositions [ARTEP 71-3-MTP, 71-3-7001/4].
  - 2) Requirements to adjust air space coordination measures and air space user schedules

are determined based on changes to brigade and user requirements [ARTEP 71-3-MTP, 71-3-7001/4].

- 3) Communications difficulties experienced by air space users are evaluated to determine required measures to correct communications problems [ARTEP 71-3-MTP, 71-3-7001/4].
- 4) Required changes to selective identification feature (SIF) and identification--friend or foe (IFF) lines and procedures are evaluated to ensure that the brigade fire support plan can be implemented [ARTEP 71-3-MTP, 71-3-6002/4].

## 16. **The Brigade Targeting Team Updates Products**

- a. The brigade targeting team continuously refines and updates the brigade fire support plans based on Bn TF bottom-up refinements and analysis of new information and intelligence [FM 6-20-40, p. 2-13; FM 6-20-50, p. 2-12; FN-NTC].
- b. The brigade S3, with the brigade S3 section, brigade SO, and brigade chemical officer, updates the DST, current SITMAPs and operational graphics, information displays, and journals to reflect [ARTEP 71-3-MTP, 71-3-3003/2; FM 101-5, p. 3-84, 6-47, I-1; FN-AR Sch]:
  - 1) Bn TF unit locations (to company-level sized units) [ARTEP 71-3-MTP, 71-3-3003/2; FN-BCBST].
  - 2) Bn TF task organization for combat [ARTEP 71-3-MTP, 71-3-3003/2].
  - 3) Bn TF activities and brigade commander's assessment of Bn TF activities to accomplish preparation tasks [ARTEP 71-3-MTP, 71-3-3003/2].
  - 4) Bn TF weapon status [ARTEP 71-3-MTP, 71-3-3003/2].
  - 5) Uncommitted Bn TF units and brigade reserve units locations, availability, and status [ARTEP 71-3-MTP, 71-3-3003/2].
  - 6) CAS sorties requested, approved, completed, and remaining [ARTEP 71-3-MTP, 71-3-3003/2].
  - 7) Recent and present significant activities [ARTEP 71-3-MTP, 71-3-3003/2].
  - 8) Brigade control measures [ARTEP 71-3-MTP, 71-3-3003/2].
  - 9) Enemy locations [ARTEP 71-3-MTP, 71-3-3003/2].
  - 10) A2C2 information, including joint and Army-specific measures and restrictions [ARTEP 71-3-MTP, 71-3-3012/3].

- 11) Frequencies and call signs for brigade units, division units, and adjacent units [FM 101-5, p. 6-43].
  - 12) CP locations (current and proposed) for the brigade, division, subordinate and supporting headquarters, and adjacent units [FM 101-5, p. 6-43].
  - 13) NBC threat status [FM 101-5, p. 6-46].
  - 14) Mission-oriented protective posture (MOPP) level [FM 101-5, p. 6-46].
  - 15) Support priorities for smoke, decontamination, and NBC reconnaissance [FM 101-5, p. 6-46].
  - 16) NBC overlays depicting NBC-contaminated areas and decontamination points [FM 101-5, p. 6-47].
  - 17) Assessments on vulnerability of the brigade units and personnel to enemy NBC attack [ARTEP 71-3-MTP, 71-3-3003/1].
- c. The brigade S2, with the brigade targeting officer, updates intelligence products [ARTEP 71-3-MTP, 71-3-2005/2; FM 101-5, p. 3-84, I-1; FN-AR Sch]:
- 1) Intelligence database and intelligence estimate [ARTEP 71-3-MTP, 71-3-2001/5].
  - 2) List of intelligence indicators [ARTEP 71-3-MTP, 71-3-2005/2].
  - 3) Intelligence workbook [ARTEP 71-3-MTP, 71-3-2005/2].
  - 4) PIR/IR/SIR [ARTEP 71-3-MTP, 71-3-2005/2].
  - 5) SITMAP [ARTEP 71-3-MTP, 71-3-2005/2, 2006/3].
  - 6) SIT TEMPs [ARTEP 71-3-MTP, 71-3-2006/3c9; FM 101-5, p. H-102; FN-24 ID].
  - 7) Event Templates [ARTEP 71-3-MTP, 71-3-2006/3c10; FM 34-130, p. 2-50; FN-CGSC].
  - 8) MCOO and enemy obstacle overlays (with ABE) [ARTEP 71-3-MTP, 71-3-2006/3c8; FM 34-130, p. 2-22].
  - 9) Brigade R&S and collection plan [ARTEP 71-3-MTP, 71-3-2001/4b].
- d. The brigade S2, with the brigade targeting officer, ensures updated intelligence products reflect [AN]:
- 1) Enemy strengths, capabilities, and vulnerabilities [ARTEP 71-3-MTP, 71-3-2003/1, 2005/2].

- 2) Analysis of the effects of weather on the operation [ARTEP 71-3-MTP, 71-3-2003/1, 2005/2].
  - 3) Analysis of the effect of terrain on the operation, including mobility corridors [ARTEP 71-3-MTP, 71-3-2003/1; 2005/2; FM 6-20-40, p. 2-22; FM 6-20-50, p. 2-22].
  - 4) Enemy history, training, tactics, and doctrine [ARTEP 71-3-MTP, 71-3-2003/1, 2005/2].
  - 5) Size, type, and strength of enemy force expected to be encountered [ARTEP 71-3-MTP, 71-3-2003/1; FM 6-20-40, p. 2-22; FM 6-20-50, p. 2-22].
  - 6) Disposition and activities of enemy forces, including known and suspected enemy locations [ARTEP 71-3-MTP, 71-3-2003/1, 2005/2; FM 6-20-40, p. 2-22; FM 6-20-50, p. 2-22].
  - 7) Personalities of key enemy personnel, if known [ARTEP 71-3-MTP, 71-3-2003/1, 2005/2].
  - 8) Enemy order of battle [FM 6-20-40, p. 2-22; FM 6-20-50, p. 2-22].
- e. The brigade FSO, with the brigade targeting team, updates fire support products [FM 101-5, p. 3-84, I-1; FN-AR Sch]:
- 1) SITMAPS [AN].
  - 2) Fire support overlays [FM 6-20-40, p. 2-13; FM 6-20-50, p. 2-13; FM 101-5, p. 6-47].
  - 3) Target lists [FM 6-20-40, p. 2-13; FM 6-20-50, p. 2-13].
  - 4) Fire support execution matrix (FSEM) [FM 6-20-40, p. 2-13; FM 6-20-50, p. 2-13].
  - 5) FSCM [FM 6-20-40, p. 2-13; FM 6-20-50, p. 2-13; FM 101-5, p. 6-47].
  - 6) Attack-guidance matrix (AGM) [FM 6-20-40, p. 2-13; FM 6-20-50, p. 2-13; FM 101-5, p. 6-47].
- f. The brigade FSO, with the brigade targeting team, ensures that the updated fire support products reflect [ARTEP 71-3-MTP, 71-3-9002/1; ARTEP 6-115-20-MTP, 06-3-02-1130, 1190]:
- 1) Movement, routes, and locations of brigade collection and target acquisition assets [FM 6-20-40, p. 2-22; FM 6-20-50, p. 2-22; FN-NTC].
  - 2) Current friendly and enemy situation [ARTEP 71-3-MTP, 71-3-9002/1; ARTEP 6-

115-20-MTP, 06-3-02-1130, 1190]:

- 3) Brigade, division, and Bn TF boundaries and maneuver control measures [ARTEP 71-3-MTP, 71-3-9002/1; ARTEP 6-115-20-MTP, 06-3-02-1130, 1190].
- 4) Locations of maneuver and artillery support elements [ARTEP 71-3-MTP, 71-3-9002/1; ARTEP 6-115-20-MTP, 06-3-02-1130, 1190].
- 5) Fire support coordinating measures [ARTEP 71-3-MTP, 71-3-9002/1; ARTEP 6-115-20-MTP, 06-3-02-1130, 1190].
- 6) Locations (actual, planned) for FA-delivered mines [ARTEP 71-3-MTP, 71-3-9002/1; ARTEP 6-115-20-MTP, 06-3-02-1130, 1190].
- 7) Priorities for fire support [FM 101-5, p. 6-45].
- 8) CAS missions [FM 101-5, p. 6-45].
- 9) Status and locations of Bn TF ALO and ANGLICO elements [AN].
- 10) Targeting priorities, categorized by brigade indirect fire weapons system (e.g., FA, CAS, USN ships, non-lethal systems, mortars) [FM 101-5, p. 6-45].
- 11) Status on HPT and enemy activity at TAIs, NAIs, DPs, and other brigade targets [FM 6-20-40, Ch 2; FM 101-5, p. 6-47].
- 12) Exact locations of obstacles (friendly, enemy) [FM 101-5, p. 6-47].
- 13) Execution of missions in support of brigade units during the mission preparation phase and implementation of measures to safeguard friendly forces from fratricide [ARTEP 71-3-MTP, 71-3-9002/1; ARTEP 6-115-20-MTP, 06-3-02-1130, 1190; FM 6-20-40, Ch 2].
- 14) Capabilities of indirect fire systems [ARTEP 71-3-MTP, 71-3-9002/1; ARTEP 6-115-20-MTP, 06-3-02-1130, 1190].
- 15) Ammunition status [ARTEP 71-3-MTP, 71-3-9002/1; ARTEP 6-115-20-MTP, 06-3-02-1130, 1190].
- 16) Equipment status [ARTEP 71-3-MTP, 71-3-9002/1; ARTEP 6-115-20-MTP, 06-3-02-1130, 1190].
- 17) Status on Bn TFs' submission of their bottom-up refinements to the brigade fire support plan [FN-FA Sch].
- 18) Receipt and allocation of additional FA, CAS, target acquisition, and survey assets from division [FM 101-5, p. F-20; FM 6-20-40, p. 2-5; FM 6-20-50, p. 2-5].

17. **The Brigade Targeting Team Communicates Information and Coordinates the Brigade Fire Support Plan**

- a. The brigade S3 and brigade S3 Air, with brigade targeting team members, communicate and coordinate brigade A2C2 information and requirements with the division G3, division G3 Air, division ALO, division ANGLICO, and Bn TF S3s. C2 information and requirements are coordinated [ARTEP 71-3-MTP, 71-3-7001/2]:
  - 1) Joint and Army-specific measures and restrictions [ARTEP 71-3-MTP, 71-3-3012/3].
  - 2) Early warning measures, procedures, and warnings [ARTEP 71-3-MTP, 71-3-7001/2].
  - 3) Friendly and enemy ADA unit locations [ARTEP 71-3-MTP, 71-3-7001/2].
  - 4) IFF/SIF procedures for Army aircraft, to include the location of the IFF/SIF line [ARTEP 71-3-MTP, 71-3-7001/2].
  - 5) Minimum risk routes [ARTEP 71-3-MTP, 71-3-7001/2].
  - 6) Airspace command and control rules and procedures [ARTEP 71-3-MTP, 71-3-7001/2].
  - 7) Coordinating altitudes [ARTEP 71-3-MTP, 71-3-7001/2].
  - 8) IPs, ingress, and egress flight routes [AN].
  - 9) Rules of engagement (weapons control status and hostile criteria) [ARTEP 71-3-MTP, 71-3-7001/2].
  - 10) Weather conditions and forecasts [ARTEP 71-3-MTP, 71-3-7001/2].
  - 11) NBC information [ARTEP 71-3-MTP, 71-3-7001/2].
- b. The brigade S2, with the brigade intelligence section and brigade targeting officer, communicates information to the division G2, the MI battalion S3, and Bn TF S2s to coordinate the brigade collection plan and non-lethal attack of brigade targets [AN].
  - 1) Division EW assets are updated on brigade HPTs requiring attack and desired effect of attack [FN-194 AR].
  - 2) Requests for additional information to fill gaps in intelligence are coordinated [ARTEP 71-3-MTP, 71-3-2002/1, 2003/2].
  - 3) Division, brigade, and Bn TF R&S plans are consolidated, deconflicted, and coordinated to ensure that the enemy and the brigade AO is under constant



observation and surveillance [ARTEP 71-3-MTP, 71-3-2002/1].

- 4) Acquisition of information supporting intelligence taskings is coordinated after analysis and evaluation [ARTEP 71-3-MTP, 71-3-2006/7].
- c. The brigade FSO, with the brigade ALO, brigade ANGLICO, and brigade aviation LNO, communicates information to the division FSCoord, division ALO, division ANGLICO, DIVARTY S3, aviation brigade S3, DS FA battalion S3, Bn TF FSOs, Bn TF ALOs, Bn TF SALT elements, and adjacent unit FSOs to coordinate the brigade fire support plan [AN].
- 1) Requests for additional fire support systems are coordinated and integrated into the brigade fire support plan when approved [ARTEP 6-115-20-MTP, 06-2-02-1000/3; FM 101-5, p. F-20; FM 6-20-40, p. 2-5; FM 6-20-50, p. 2-5; FN-JRTC].
  - 2) Quick Fire channels are confirmed [FN-JRTC].
  - 3) Division radar zones are coordinated to ensure synchronization and integration with brigade radar zones [ARTEP 6-115-MTP, 06-2-01-2513/1; FN-JRTC].
  - 4) Continuous updates on brigade dispositions, situation, and scheme of maneuver, including possible changes based on the analysis of new information, are exchanged to deter fratricide [FM 6-20-40, Ch 2; ARTEP 6-115-20-MTP, 06-3-02-1100/5].
  - 5) Division, brigade, and Bn TF FSCM are coordinated and integrated in fire support plans [FM 6-20-40, p. E-1; FM 6-20-50, p. G-1].
  - 6) Primary and alternate communications nets and frequencies are coordinated to counter enemy jamming [FM 6-20-40, Ch 2].
  - 7) Bn TF fire support plans are coordinated to ensure that they support the brigade fire support plan [ARTEP 71-3-MTP, 71-3-9003/1; ARTEP 6-115-20-MTP, 06-3-02-1130, 1190].
  - 8) The attack of brigade targets or other targets which could impact on brigade operations outside of the brigade AO are coordinated [ARTEP 6-115-20-MTP, 06-3-02-1300/2].
  - 9) Movement and position requirements for FA systems and target acquisition assets are coordinated to ensure they will not hinder division, brigade, and Bn TF schemes of maneuver [ARTEP 6-115-20-MTP, 06-2-02-1000/2; FM 6-20-40, Ch 3; FN-NTC].
  - 10) Movement and positioning requirements for Bn TF mortar platoons providing support to the brigade fire support plan are coordinated [ARTEP 6-115-20-MTP, 06-3-02-1390/3].

- 11) Targeting information and intelligence are continuously coordinated to facilitate target tracking and attack [ARTEP 6-115-20-MTP, 06-2-02-1000/4; ARTEP 71-3-MTP, 71-3-2006/4; FM 6-20-40, Ch 2].
  - 12) Preplanned and immediate CAS requirements are coordinated [FM 6-20-40, Ch 2].
  - 13) Employment of Army aviation aircraft in support of brigade fire support and target acquisition operations are coordinated [ARTEP 6-115-MTP, 06-1-02-2600/2].
- d. The brigade targeting team disseminates updated products to higher, adjacent, supporting, and supported headquarters [AN]:
- 1) Brigade DST [ARTEP 71-3-MTP, 71-3-3003/2; FM 101-5, p. 6-47].
  - 2) SITMAPS and maneuver overlays [ARTEP 71-3-MTP, 71-3-3003/2, 2005/2, 2006/3; FM 101-5, p. 6-47].
  - 3) Consolidated brigade R&S and collection plans and overlays [ARTEP 71-3-MTP, 71-3-2002/4b, 2002/1].
  - 4) List of intelligence indicators [ARTEP 71-3-MTP, 71-3-2005/2].
  - 5) Brigade CCIR and IR [ARTEP 71-3-MTP, 71-3-2005/2].
  - 6) SIT TEMPs [ARTEP 71-3-MTP, 71-3-, 2--3/2, 2006/3c9; FM 101-5, p. H-102; FN-3/24 ID].
  - 7) Event Templates [ARTEP 71-3-MTP, 71-3-2003/2, 2006/3c10; FM 34-130, p. 2-50; FN-CGSC].
  - 8) MCOO [ARTEP 71-3-MTP, 71-3-2006/3c8; FM 34-130, p. 2-22].
  - 9) Fire support overlays [FM 6-20-40, p. 2-13; FM 6-20-50, p. 2-13; FM 101-5, p. 6-47].
  - 10) Target lists [FM 6-20-40, p. 2-13; FM 6-20-50, p. 2-13].
  - 11) FSEM [FM 6-20-40, p. 2-13; FM 6-20-50, p. 2-13].
  - 12) FSCM [FM 6-20-40, p. 2-13; FM 6-20-50, p. 2-13; FM 101-5, p. 6-47].
  - 13) AGM [FM 6-20-40, p. 2-13; FM 6-20-50, p. 2-13; FM 101-5, p. 6-47].
- e. The brigade commander directs brigade targeting team members to perform visits and inspections [AN].
- 1) Brigade targeting team members visit and inspect fire support units, target

acquisition systems, and collection assets under brigade control to appraise the status of mission preparation and the implementation of the brigade fire support plan [FM 71-3, p. 3-5].

- 2) Brigade targeting team members visit the division FSE, DIVARTY TOC, adjacent brigade FSEs, and other headquarters as required to exchange brigade fire support plans and acquire information [FM 71-3, p. 3-5].

18. **The Brigade Commander Visualizes the Battlefield**

- a. The brigade commander continuously assesses preparations and updates his estimate of the current situation by receiving information [FM 101-5, p. 4-46].

- 1) The brigade commander receives information from his personal observations during inspections and visits to Bn TF units, CPs, division CPs, and CPs of adjacent units [FM 101-5, p. 6-8; FM 71-3, p. 3-3; BCBL "Battle Command," p. 10, 15].
- 2) The brigade commander receives answers to CCIR and other combat information from the brigade targeting team, the brigade staff, and subordinate leaders [FM 101-5, p. 6-2, 6-5, 3-84].
- 3) The brigade commander receives information from LNOs attached to other units and LNOs attached to the brigade [FM 101-5, p. L-1].<sup>33</sup>
- 4) The brigade commander receives information by eavesdropping on division nets and cross-talking with other commanders, division staff, and division command group on division nets [FM 101-5, p. I-4; FM 71-3, p. 3-3].

- b. The brigade commander continuously assesses the maneuver aspects of brigade plans and preparation activities; the brigade commander updates his estimate of the current situation [AN].

- 1) The brigade S3 provides updates to the brigade DST, DPs, NAIs, TAIs, and other maneuver control measures resulting from integration and synchronization of Bn TF scheme of maneuver [ARTEP 71-3-MTP, 71-3-3016/1].
- 2) The brigade S3 provides updates and adjustments to the brigade scheme of maneuver based on refinement of IPB products and the status of brigade maneuver units [ARTEP 71-3-MTP, 71-3-3003/1, 3003/3].
- 3) The brigade S3 provides updates on changes to the division commander's intent, guidance for fire support, and concept of the operations [AN].
- 4) The brigade S3 provides updates on the status of preparation by Bn TFs in terms of progress, completion, and adherence to brigade timelines [ARTEP 71-3-MTP, 71-3-3003/3].

- 5) The brigade S3 provides updates on the disposition and locations of brigade units [ARTEP 71-3-MTP, 71-3-3003/3].
  - 6) The brigade S3 provides updates on the current locations, activities, and intentions of adjacent units (left, right, front, rear, higher) [AN].
  - 7) The brigade S3 provides updates on current A2C2 operations and control measures [ARTEP 71-3-MTP, 71-3-3012/2a, 3013/3].
- c. The brigade commander continuously assesses intelligence and target acquisition aspects of brigade plans and preparation activities; the brigade commander updates his estimate of the current situation [AN].
- 1) The brigade S2 provides updates on the enemy's most likely course of action [ARTEP 71-3-MTP, 71-3-3003/3; FM 71-3, p. 2-3].
  - 2) The brigade S2 provides updates on enemy vulnerabilities [ARTEP 71-3-MTP, 71-3-3003/3].
  - 3) The brigade S2 provides updates on the confirmation of the enemy's order of battle [ARTEP 71-3-MTP, 71-3-3003/3].
  - 4) The brigade S2 provides updates on the enemy's intention to employ NBC and EW [ARTEP 71-3-MTP, 71-3-3003/3].
  - 5) The brigade S2 provides updated SIT TEMP and Event Templates to reflect the current enemy situation [ARTEP 71-3-MTP, 71-3-2006/3c9, 2006/3c10; FM 34-130, p. 2-50; FM 101-5, p. H-102; FN-3/24 ID; FN-CGSC].
  - 6) The brigade S2 provides the updated MCOO to reflect terrain conditions in the brigade AO [ARTEP 71-3-MTP, 71-3-2006/3c8; FM 34-130, p. 2-22].
  - 7) The brigade S2 provides the updated brigade-consolidated R&S plan and the status of implementation of consolidated R&S plan [ARTEP 71-3-MTP, 71-3-2004/2, 2006/3c7].
  - 8) The brigade S2 and brigade targeting officer provide current locations, status, and preparation activities of target acquisition and collection systems [ARTEP 71-3-MTP, 71-3-3003/3].
  - 9) The brigade S2 and brigade targeting officer provide updates on the implementation of the brigade collection plan, including CCIR information resulting from information collection activities [FM 6-20-40, p. 2-5; FM 6-20-50, p. 2-5].
  - 10) The brigade S2 and brigade targeting officer provide updates on the detection of brigade HPTs and enemy activities at DPs, NAIs, and TAIs [FM 6-20-10, p. 1-10].

- d. The brigade commander continuously assesses fire support aspects of brigade plans and preparation activities; the brigade commander updates his estimate of the current situation [AN].
- 1) The brigade S2 and brigade targeting officer provide results of division deep battle attack against division and brigade HPTs to the brigade commander, including BDA and the effects of target attack [ARTEP 71-3-MTP, 71-3-2006/4, 2006/5b].
  - 2) The brigade S2 provides information on enemy responses and reaction to the elimination of brigade HPT during division-deep attack operations to the brigade commander [ARTEP 71-3-MTP, 71-3-2006/4, 2006/5b].
  - 3) The brigade FSO provides status on submission of Bn TF fire support plans to the brigade commander in accordance with scheduled cut-off times [FM 6-20-10, p. 5-3; FM 6-20-40, p. 2-13; FM 6-20-50, p. 2-13].
  - 4) The brigade FSO provides updates to the brigade commander regarding refinements to the brigade fire support plan generated by bottom-up refinements from Bn TF fire support planning [ARTEP 71-3-MTP, 71-3-9003/10; ARTEP 6-115-20-MTP, 06-3-02-1130, 1190; FM 6-20-40, p. 2-8; FM 6-20-50, p. 2-8; FN-FA Sch].
  - 5) The brigade FSO, brigade ALO, and brigade ANGLICO provide to the brigade commander the current status on composition and task organization of brigade fire support assets [ARTEP 71-3-MTP, 71-3-3003/3].
  - 6) The brigade FSO provides information to the brigade commander regarding actions to synchronize and integrate lethal and non-lethal indirect fires with the brigade scheme of maneuver to achieve the brigade commander's intent [FM 71-3, p. 2-3].
  - 7) The brigade FSO provides information to the brigade commander regarding current locations, status, and preparation activities taken to implement the brigade fire support plan by DS FA battalion firing batteries and radars [ARTEP 6-115-20-MTP, 06-3-02-1100/3; ARTEP 71-3-MTP, 71-3-3003/3; FM 6-20-40, p. 2-18; FM 6-20-50, p. 2-18].
  - 8) The brigade ALO and brigade ANGLICO provide updates to the brigade commander concerning the ATO and current status on planned and immediate CAS missions over the next 24 to 78 hours [FM 6-20-40, p. A-9, A-11; FM 6-20-50, p. C-7, C-8; FN-NTC; FN-CGSC].
  - 9) The brigade ANGLICO provides updates to the brigade commander regarding the current status and capabilities of USN ships to provide naval surface fires [FM 71-3, p. 7-13; FM 6-20-40, p. A-28, A-29; FM 6-20-50, p. C-27; FM 101-5, p. H-126; NWP 3-09.11M, p. 2-1, 2-6; FN-194 AR].
  - 10) The brigade aviation LNO provides updates to the brigade commander on the current status and capabilities of Army aviation assets providing observation and

target acquisition support [ARTEP 71-3-MTP, 71-3-7001/1, 7001/2; FM 6-20-40, p. A-31; FM 6-20-50, p. C-29; FM 101-5, p. 6-49; FM 1-111, p. 3-2; FN-JRTC].

- 11) The brigade S2 and DS MI company commander provide updates to the brigade commander on the current status and capabilities of IEW assets providing non-lethal fires [ARTEP 71-3-MTP, 71-3-2004/2, 2006/3c7; FM 101-5, p. 6-47].
  - 12) The brigade FSO provides to the brigade commander the current status of brigade requests to the division for additional fire support [ARTEP 71-3-MTP, 71-3-3003/5].
- e. The brigade commander continuously updates his estimate of the current situation based on fire support information provided by the brigade targeting team [FM 101-5, p. 4-46].
- f. The brigade commander projects the outcome of the current battle to determine the feasibility of the OPORD to meet the assessed situation by comparing his current "running estimate" with his visualization of needed end states for fire support as stated in the base plan [[FM 6-20-10, p. 5-5; FM 6-20-40, p. 2-5; GM 6-20-50, p. 2-5; FM 101-5, p. 4-48].
- 1) The brigade commander determines if additional guidance to the brigade targeting team and subordinate units is required to achieve needed end states [FM 6-20-10, p. 5-5].
  - 2) The brigade commander determines if his visualization of the needed end states for indirect fires as stated in the base plan will still support the brigade mission [FM 6-20-10, p. 5-5].
  - 3) New information about enemy equipment and tactics is assessed [FM 6-20-10, p. 5-5; FM 6-20-40, p. 2-5; FM 6-20-50, p. 2-5].
  - 4) Changes in the brigade's fire support and target acquisition capabilities are assessed [FM 6-20-10, p. 5-5; FM 6-20-40, p. 2-5, 2-22; FM 6-20-50, p. 2-5, 2-22].
  - 5) Impact of division disapproval on brigade requests for additional fire support is assessed [ARTEP 71-3-MTP, 71-3-3003/5].
  - 6) Losses (e.g., to enemy action, maintenance) of fire support, target acquisition, and collection systems are assessed [FN-NTC].
  - 7) Peculiarities and weaknesses of Bn TF mission preparations and the implementation of the base fire support plan are assessed [ARTEP 71-3-MTP, 71-3-3003/3].
  - 8) Impact of failure by brigade units to complete fire support preparation activities in accordance with planned timelines is assessed [ARTEP 71-3-MTP, 71-3-3003/3].
  - 9) Impact of new fire support requirements which exceed brigade capabilities

identified through the analysis and evaluation of information and intelligence is assessed [FM 6-20-40, Ch 2].

- 10) The brigade's ability to engage the enemy simultaneously throughout the depth of the battlefield as planned is assessed [FM 71-3, p. 2-4].
- g. The brigade commander, with the brigade S2, projects the outcome of the current battle to determine the ability of collection plans to acquire and track brigade HPTs and other targets based on the assessed situation [FM 6-20-10, p. 1-10, 2-11].
- h. The brigade commander, with the brigade S3 and brigade FSO, projects the outcome of the current battle to determine requirements for additional fire support or target acquisition needed to achieve required end state for the current mission, and identifies [FN-BCBST]:
  - 1) Additional fire support attack systems (e.g., FA, CAS, naval surface fires, non-lethal) required to implement the base fire support plan [FM 6-20-40, p. 2-5; FM 6-20-50, p. 2-5].
  - 2) Additional target acquisition and collection systems required to implement the base fire support plan [FM 6-20-40, p. 2-5; FM 6-20-50, p. 2-5].
  - 3) Alternatives and options for changing the current distribution and missions of existing brigade target acquisition and attack systems assets to allow the base fire support plan to be implemented [FM 6-20-40, p. 2-5; FM 6-20-50, p. 2-5].
- i. The brigade targeting team assists the brigade commander in his assessment of the base fire support plan by continuously wargaming current mission branches and sequels based on new information and status of subordinate unit preparation [FM 101-5, p. 4-39; FM 6-20-10, p. 5-5; FM 6-20-40, p. 2-5; FM 6-20-50, p. 2-5].
- j. The brigade commander determines required actions to correct shortfalls in the base fire support plan or preparation activities based on his "running estimate" and his analysis of the base fire support plan. Options are [FM 6-20-10, p. 4-46, 5-5]:
  - 1) The brigade commander directs the brigade targeting team and Bn TFs to implement adjustments to preparation activities and the fire support plans based on his refined "running estimate," the brigade timeline, and his appraisal of the current state of preparations [AN].
  - 2) The brigade commander determines that the plan must be modified by a FRAGO (see task 19 below) [FM 101-5, p. 4-48].
    - a) The brigade commander determines whether sufficient time is available to develop, coordinate, and implement the new FRAGO [FM 101-5, p. 4-43].
    - b) The brigade commander assesses the impact of the new plan and task

organization changes on subordinate units ability to complete new preparation requirements [FM 101-5, p. 4-43].

- c) The brigade commander assesses the impact of FRAGO planning requirements on the brigade targeting team (e.g., detracting from monitoring and directing current brigade activities) [FM 101-5, p. 4-43].
- k. The brigade commander considers future requirements and actions based on his projection of the outcome of the current battle [FM 101-5, p. 4-46]
  - 1) The brigade targeting team refines the base fire support plan for existing contingency plans, branches, and sequels based on updated information, updated intelligence, and the status of brigade units in mission preparation [ARTEP 71-3-MTP, 71-3-3016/2; FM 6-20-40, p. 2-5; FM 6-20-50, p. 2-5].
  - 2) The brigade targeting team develops new fire support plans for new contingency plans, branches, and sequels based on guidance from the brigade commander [ARTEP 71-3-MTP, 71-3-3016/1].

19. **The Brigade Commander Directs Changes to the Operation or Plan**

- a. The brigade commander determines the decision-making process to be used to develop the FRAGO based on complexity, ambiguity of the situation, and time available [AN].
  - 1) If time permits, the brigade commander directs the brigade staff to use the DDMP to develop the FRAGO [FM 101-5, p. 4-7].<sup>34</sup>
  - 2) The brigade commander directs the brigade staff to use the time-constrained Decision Making Process (DMP) by employing the Concept, Planning, and/or preparation, Execution, and Assessment (CPEA) methodology [FM 101-5, p. 4-41].<sup>35</sup>
- b. The brigade XO implements the brigade commander's decisions and FRAGO guidance [ARTEP 71-3-MTP, 71-3-0001/8; FM 101-5, p. H-11].
- c. The brigade S3 prepares FRAGOs to change the existing plan and implement the brigade commander's new guidance and directions [ARTEP 71-3-MTP, 71-3-3010/1].
  - 1) The brigade S3 refines the plan as directed in the brigade commander's guidance [ARTEP 71-3-MTP, 71-3-3010/1].
  - 2) The brigade S3 coordinates the new plan with brigade staff members to synchronize maneuver with all other battlefield operating systems [ARTEP 71-3-MTP, 71-3-3010/1].
  - 3) The brigade S3 develops the FRAGO; the FRAGO [ARTEP 71-3-MTP, 71-3-3010/2]:



- a) Refers to the previous order [ARTEP 71-3-MTP, 71-3-3010/2].
  - b) Indicates changes to the task organization [ARTEP 71-3-MTP, 71-3-3010/2].
  - c) Includes a brief outline of the situation that generated the need for the FRAGO [ARTEP 71-3-MTP, 71-3-3010/2].
  - d) States the mission [ARTEP 71-3-MTP, 71-3-3010/2].
  - e) Provides brief and specific instructions for the conduct of the revised plan without loss of clarity [ARTEP 71-3-MTP, 71-3-3010/2].
- d. The brigade targeting team performs fire support planning to support the FRAGO. Planning options are [AN]:
- 1) The brigade targeting team uses fire support plans previously developed during the original plan COA development and revises them to support the FRAGO (see tasks 7-9 above) [FM 6-20-40, p. 2-3; FM 6-20-50, p. 2-3].
  - 2) The brigade targeting team uses the deliberate fire support planning process to develop an entirely new fire support plan when the brigade commander directs the DDMP process to be employed (see tasks 3-11 above) [FM 6-20-40, p. 2-3; FM 6-20-50, p. 2-3].
  - 3) The brigade targeting team uses the quick fire planning process to replace the existing fire support plan when the brigade commander directs the time-constrained DMP and CPEA methodology to be employed (see task 1 above) [FM 6-20-40, p. 2-13; FM 6-20-50, p. 2-13].
- e. The brigade targeting team prepares revised fire support plans and products [AN]:
- 1) Brigade DST [ARTEP 71-3-MTP, 71-3-3003/2; FM 101-5, p. 6-47].
  - 2) SITMAPS and maneuver overlays [ARTEP 71-3-MTP, 71-3-3003/2, 2005/2, 2006/3; FM 101-5, p. 6-47].
  - 3) Consolidated brigade R&S and collection plans and overlays [ARTEP 71-3-MTP, 71-3-2001/4b, 2002/1].
  - 4) List of intelligence indicators [ARTEP 71-3-MTP, 71-3-2005/2].
  - 5) Brigade CCIR and IR [ARTEP 71-3-MTP, 71-3-2005/2].
  - 6) SIT TEMPs [ARTEP 71-3-MTP, 71-3-, 2--3/2, 2006/3c9; FM 101-5, p. H-102; FN-3/24 ID].
  - 7) Event Templates [ARTEP 71-3-MTP, 71-3-2003/2, 2006/3c10; FM 34-130, p. 2-50;

FN-CGSC].

- 8) MCOO [ARTEP 71-3-MTP, 71-3-2006/3c8; FM 34-130, p. 2-22].
  - 9) Fire support overlays [FM 6-20-40, p. 2-13; FM 6-20-50, p. 2-13; FM 101-5, p. 6-47].
  - 10) Target lists [FM 6-20-40, p. 2-13; FM 6-20-50, p. 2-13].
  - 11) FSEM [FM 6-20-40, p. 2-13; FM 6-20-50, p. 2-13].
  - 12) FSCM [FM 6-20-40, p. 2-13; FM 6-20-50, p. 2-13; FM 101-5, p. 6-47].
  - 13) AGM [FM 6-20-40, p. 2-13; FM 6-20-50, p. 2-13; FM 101-5, p. 6-47].
- f. The brigade commander, brigade XO, or brigade S3 issues the FRAGO, with all accompanying products. Bn TF commanders and S3s, the division G3, DIVARTY S3, and all supporting and adjacent headquarters acknowledge receipt of the FRAGO [ARTEP 71-3-MTP, 71-3-3010/2b; FN-CGSC]
  - g. The brigade targeting team synchronizes the FRAGO by coordinating internally and with higher, adjacent, supporting, and subordinate units (see task 14-17 above) [ARTEP 6-115-20-MTP, 06-3-02-1100/4; FM 6-20-40, p. 2-5; FM 6-20-50, p. 2-5; FM 101-5, App B; FN-NTC].
  - h. The brigade targeting team prepares new requests for additional fire support and target acquisition assets to support the new base fire support; requests are submitted to the division G3 [FM 101-5, p. F-20; FM 6-20-40, p. 2-5; FM 6-20-50, p. 2-5].
20. **The Brigade Commander Directs and Leads Subordinate Forces**
- a. The brigade commander provides command presence by exercising the Battle Command elements of leadership and information assimilation; the brigade commander maintains unit cohesion and discipline [FM 101-5, p. 4-60; "Battle Command," p. 10, 15].
    - 1) The brigade commander checks and ensure that orders are executed and reinforces discipline by demanding compliance to standards and his guidance [FM 71-3, p. 3-3].
    - 2) The brigade commander observes subordinates for [AN]:
      - a) Indicators of shortfalls in performance or manner of performance, and takes corrective action as necessary [FM 101-5, p. 5-7; "Battle Command," p. 27].
      - b) Noteworthy performance so that he can recognize accomplishments [FM 101-5, p. 5-7; "Battle Command," p. 27].

- 3) The brigade commander displays a calm presence to subordinates while clearly delineating guidance, providing precise and simple orders and instructions [AN].
  - 4) The brigade commander maintains a moral presence ["Battle Command," p. 33, G-11].
  - 5) The brigade commander monitors subordinates and himself for degradation of mental and physical capability [FM 101-5, p. 5-7; "Battle Command," p. 27].
- b. The brigade commander synchronizes fire support aspects of the brigade concept of the operation [AN].
- 1) The brigade commander synchronizes the BOS to support the brigade mission and to achieve his intent [AN].
    - a) The brigade commander synchronizes all BOS activities across time, space, and purpose in relation to enemy actions and responses to brigade operations [FM 101-5, p. F-13].
    - b) The brigade commander uses the DST to ensure synchronization occurs to achieve the massed effects of available combat power [FM 101-5, p. F-13].
    - c) The brigade commander uses his own observations, his visualization of the battlefield, and information (e.g., CCIR) provided by the brigade staff and subordinate commanders to determine specific time factors for battlefield activities to calculate when to initiate fires, movement, or maneuver in order to synchronize their effects [AN].
    - d) The brigade commander achieves synchronization through the coordination of BOS, supporting and main efforts, fires (direct and indirect), echelons, and rear, close and deep battles to ensure that each complements the others at the times and places he chooses [Battle Command Techniques and Procedures, p. 2-25].
  - 2) The brigade commander synchronizes the collection plan and the concept of the operation with the brigade S2 and brigade targeting officer. Fire support aspects of the collection plan are [FM 6-20-10, p. 1-8, 2-2; FM 34-2, p. 3-14; FM 6-20-40, p. 2-11; FM 6-20-50, p. 2-11].<sup>36</sup>
    - a) Information supporting CCIR and IR [FM 34-2, p. 3-14; FM 6-20-10, p. 2-11; FM 101-5, p. 4-47].
    - b) Acquisition and tracking of brigade HPT [FM 6-20-10, p. 2-2].
    - c) Synchronization of collection operations for complete coverage of the brigade AO [FM 6-20-10, p. 2-2].

- d) BDA reports resulting from division-deep attack of division and brigade HPT [FM 6-20-10, p. 1-8, 2-27; FM 34-130, p. A-7].
- 3) The brigade commander synchronizes the fire support plan and the concept of the operation with the brigade targeting team. Fire support aspects for synchronization are [ARTEP 6-115-20-MTP, 06-3-02-1380/2; FM 101-5, p. 4-59, M-1]:<sup>37</sup>
- a) Available fire support, assigned missions, and status on requests for additional fire support [FM 101-5, p. F-20; FM 6-20-40, p. 2-5; FM 6-20-50, p. 2-5].
  - b) Fire support organization for combat and status of task organization [FM 6-20-2, p. B-3; FM 101-5, p. H-123].
  - c) Status and locations of FA and mortar firing systems, target acquisition systems, radars, and observers [ARTEP 6-115-20-MTP, 06-3-02-1100/5; FM 6-20-40, p. 2-22; FM 6-20-50, p. 2-22; FN-NTC].
  - d) Status of CAS support, including ALO and ANGLICO personnel and equipment [FM 71-3, p. 7-8; FM 6-20-40, p. A-8; FM 6-20-50, p. C-5].
  - e) Status of naval surface fires, including ANGLICO personnel and equipment [FM 6-20-40, p. A-3; FM 6-20-50, p. C-13].
  - f) Status of Army aviation support [FM 1-111, p. 2-33, 3-3; ARTEP 71-3-MTP, 71-3-7001/1].
  - g) Status of brigade indirect fires supporting brigade obstacles or brigade obstacle breaching plans [ARTEP 71-3-MTP, 71-3-8005/2b1; FM 6-20-40, p. 3-18, 3-19; FM 6-20-50, p. 3-19, I-17].
  - h) Status of non-lethal fires, as well as IEW personnel and equipment [FM 6-20-40, p. 2-12; FM 6-20-50, p. 2-11].
  - I) Quantities and duration of FA, naval, and mortar special munitions (e.g., illumination, FASCAM, Copperhead, smoke) and other munitions [FM 6-20-40, p. 3-19, H-1; FM 6-20-50, p. 3-19; I-1; FM 5-102, p. 82; FM 71-123, p. 8-3].
  - j) Status of HPTs and other brigade targets as reflected on the HPTL and target lists [ARTEP 71-3-MTP, 71-3-9001/3; ARTEP 6-115-20-MTP, 06-3-02-1130, 1190].
  - k) Status on refinements to the FSEM and FSCM [ARTEP 71-3-MTP, 71-3-9001/3; ARTEP 6-115-10-MTP, 06-3-02-1130, 1190; FM 101-5, p. H-128].
  - l) Status on A2C2 operations and control measures [ARTEP 71-3-MTP, 71-3-3012/2a, 3013/3].

- 4) The brigade commander synchronizes the fire support plan and the concept of the operation with subordinate unit commanders and their staffs. Fire support aspects for synchronization are [FM 101-5, p. 4-59, M-1]:<sup>38</sup>
  - a) Indirect fires to be fired in support of brigade targets (e.g., HPT, FASCAM, SEAD) [FM 71-2, p. 6-9].
  - b) Indirect fires in support of breaching operations [FM 71-2, p. 3-54].
  - c) Indirect fires in support of obstacles [FM 71-2, p. 4-16].
  - d) Employment of Bn TF mortars in support of the brigade fire support plan [FM 71-2, p. 6-16].
  - e) Indirect fires in support of the brigade rear battle [FM 6-20, p. 3-11; FN-NTC].
  - f) Actions to observe brigade NAIs and TAIs [FM 71-123, p. 2-51; FM 71-2, p. 1-8].
  - g) Actions to acquire brigade HPTs [FM 71-123, p. 2-51; FM 71-2, p. 1-8].
  - h) Measures to provide security for brigade collection assets operating in the Bn TF AOs [FM 71-123, p. 2-51; FM 71-2, p. 1-8].
  - I) Measures to collect CCIR and IR [FM 71-123, p. 2-51; FM 71-2, p. 1-8].
  - j) Measures to initiate the close battle as the brigade transitions from the deep battle to the close battle [AN].
- c. The brigade commander prepares for and conducts the combined arms rehearsal [AN].
  - 1) The brigade commander uses the DST, the base maneuver and fire support plans, IPB products, and the synchronization matrix as the framework to test and measure the brigade's ability to synchronize fire support and combat power [FM 71-3, p. 3-26; FN-JRTC; FN-AR Sch].
  - 2) During rehearsals, the brigade commander emphasizes [FN-IN Sch]:
    - a) Priorities he established for fire support (e.g., HPTs, brigade target series and groups, brigade units with priority) [FN-IN Sch].
    - b) Protection of observers [FN-IN Sch].
    - c) Methods to trigger fires [FN-IN Sch].
    - d) Measures to acquire BDA [AN].

- e) Ways in which fire support assets and capabilities are synchronized and integrated (through positioning, movement, and timing) with the scheme of maneuver [FN-BCBST].
- d. The brigade commander and brigade targeting team synchronize the fire support plan with the brigade scheme of maneuver and all battlefield operating systems during the brigade combined arms rehearsal [FM 101-5, p. M-1].
- 1) The brigade targeting team prepares for and conducts the combined arms rehearsal [AN].
    - a) The brigade commander, or his designated representative (e.g, brigade XO, brigade S3) directs the conduct of the rehearsal [FM 101-5, p. M-12; FM 71-3, p. 3-27].
    - b) The brigade S2 role-plays the enemy (actions and reactions) to test the brigade plan against an uncooperative enemy [FM 101-5, p. M-12].
    - c) The rehearsal is conducted in accordance with the rehearsal plan [FM 101-5, p. M-14].
    - d) Brigade targeting team members use existing products to record adjustments to the fire support plan or unresolved fire support issues [FM 101-5, p. M-12].
    - e) Whenever possible, all brigade targeting team members participate in the rehearsal [FM 6-20-40, p. 2-5; FM 6-20-50, p. 2-5].
    - f) Subordinate commanders (e.g., Bn TF, Co/Tm), FSOs (e.g., Bn TF, Co/Tm), S3s, S2s, and observers participate in the rehearsal, as directed [AN].
  - 2) Primary and alternate fire support communications nets are identified and confirmed [FM 6-20-40, p. 2-6; FM 6-20-50, p. 2-6; FM 6-20-1, p. 3-12].
  - 3) Alternate attack systems to be used in the engagement of specified targets are confirmed [FM 6-20-40, p. 2-6; FM 6-20-50, p. 2-6].
  - 4) Movement routes, positioning, timing, and employment of target acquisition, radars, and fire support observers are confirmed [FM 6-20-40, p. 2-6; FM 6-20-50, p. 2-6; FM 6-20-10, p. 5-14; FM 6-20-1, p. 3-12; FN-FA Sch]
  - 5) Movement routes, timings, and positioning of indirect fire weapons systems are confirmed [FM 6-20-40, p. 2-6; FM 6-20-50, p. 2-6; FM 6-20-1, p. 3-12].
  - 6) Target acquisition operations are synchronized to support the scheme of maneuver of brigade units [FM 6-20-10, p. 5-14; FM 6-20-40, p. 2-6; FM 6-20-50, p. 2-6].

- 7) The employment of lethal and non-lethal fires are synchronized with the brigade scheme of maneuver, the brigade commander's intent, and the brigade commander's attack guidance [FM 6-20-10, p. 5-14; FM 6-20-40, p. 2-6; FM 6-20-50, p. 2-6; FN-FA Sch].
- 8) Schedules of fire are rehearsed and confirmed [FM 6-20-40, p. 2-6; FM 6-20-50, p. 2-6].
- 9) Munition requirements (e.g., amounts, types) for target attack are confirmed to ensure that the desired effects (e.g., suppression, neutralization, destruction) are achievable [FM 6-20-40, p. 2-6; FM 6-20-50, p. 2-6].
- 10) Time factors (for fires and movement) relevant to the synchronization and integration of indirect fires with the brigade scheme of maneuver are confirmed [FM 6-20-40, p. 2-6; FM 6-20-50, p. 2-6].
- 11) FSCM synchronization with maneuver control measures are confirmed [FM 6-20-10, p. 5-14; FN-FA Sch].
- 12) Target acquisition, target tracking, and target attack procedures are rehearsed [FM 6-20-10, p. 5-14]:
  - a) Target locations are verified [FM 6-20-10, p. 5-14; FM 6-20-1, p. 3-12; FN-FA Sch].
  - b) Engagement criteria are confirmed [FM 6-20-10, p. 5-14; FM 6-20-1, p. 3-12; FN-FA Sch].
  - c) Rules of engagement (ROE) are confirmed [FM 6-20-10, p. 5-14].
  - d) Trigger points/events to initiate target attack are verified [FM 6-20-10, p. 5-14; FM 6-20-1, p. 3-12; FN-FA Sch].
  - e) Target priorities are verified [FM 6-20-1, p. 3-12].
  - f) Methods of engagement (e.g., time on target (TOT), on-order, when ready) are confirmed [FM 6-20-1, p. 3-12].
  - g) Attack guidance (e.g., shell-fuze combination, number of volleys, systems to fire) is verified [FM 6-20-1, p. 3-12].
- 13) Battle handover points (e.g., phase lines, terrain features, grid coordinates) for transition from the brigade battle to subordinate Bn TFs are confirmed [FM 6-20-10, p. 5-14].
- 14) Responsibilities and measures for the clearance of fires are confirmed [FM 6-20-10, p. 5-14].

- 15) Non-fire support personnel responsible for target acquisition and adjustment of indirect fires verify how they will execute the fire support plan and comply with the criteria for target engagement [AN].
- e. The brigade FSCOORD and brigade FSO conduct a technical fire support rehearsal to synchronize the fire support plan with the brigade scheme of maneuver and all battlefield operating systems [FM 6-20-40, p. 2-6; FM 6-20-50, p. 2-6; FM 6-20-1, p. 3-12].
    - 1) The brigade FSCOORD and brigade FSO use the brigade OPORD/FRAGO, the fire support plan, and the FSEM to direct the technical fire support rehearsal [FM 6-20-40, p. 2-6; FM 6-20-50, p. 2-6; FM 6-20-1, p. 3-12].
    - 2) The brigade commander and brigade FSO direct personnel to participate in the technical fire support rehearsal. Participants include [FM 6-20-40, p. 2-6; FM 6-20-50, p. 2-6; FM 6-20-1, p. 3-12]:
      - a) Brigade commander [FM 6-20-40, p. 2-6; FM 6-20-50, p. 2-6; FM 6-20-1, p. 3-12].
      - b) Brigade FSCOORD [FM 6-20-40, p. 2-6; FM 6-20-50, p. 2-6; FM 6-20-1, p. 3-12].
      - c) Brigade S3 [FM 6-20-40, p. 2-6; FM 6-20-50, p. 2-6; FM 6-20-1, p. 3-12].
      - d) Brigade S2, brigade targeting officer, and DS MI company commander [FM 6-20-40, p. 2-6; FM 6-20-50, p. 2-6; FM 6-20-1, p. 3-12; FN-BCBST].
      - e) Brigade FSO [FM 6-20-40, p. 2-6; FM 6-20-50, p. 2-6; FM 6-20-1, p. 3-12].
      - f) DS FA battalion staff, firing batteries, radars, and COLTS [FM 6-20-40, p. 2-6; FM 6-20-50, p. 2-6; FM 6-20-1, p. 3-12; FN-BCBST].
      - g) Brigade fire support LNOs (e.g., brigade ALO, brigade ANGLICO, brigade aviation LNO) [FM 6-20-40, p. 2-6; FM 6-20-50, p. 2-6; FM 6-20-1, p. 3-12].
      - h) Bn TF and Co/Tm FSOs and FOs [FM 6-20-40, p. 2-6; FM 6-20-50, p. 2-6; FM 6-20-1, p. 3-12].
      - i) Bn TF mortar platoon leaders [FM 6-20-1, p. 3-12].
      - j) Brigade chemical officer [FM 6-20-1, p. 3-12].
      - k) ABE and engineer battalion commander [FM 6-20-1, p. 3-12].
      - l) Army aviation pilots [FN-BCBST].



- 3) The brigade S3 and brigade FSCOORD describe the brigade scheme of maneuver in order to provide technical fire support plan rehearsal participants the framework to rehearse the fire support plan [FM 6-20-40, p. 2-6; FM 6-20-50, p. 2-6; FM 6-20-1, p. 3-12].
  - a) Brigade maneuver actions and enemy reactions are described as they will occur during the course of the battle [FM 6-20-40, p. 2-6; FM 6-20-50, p. 2-6; FM 6-20-1, p. 3-12].
  - b) Possible brigade maneuver initiatives are identified [FM 6-20-40, p. 2-6; FM 6-20-50, p. 2-6; FM 6-20-1, p. 3-12].
  - c) Possible brigade reactions to enemy initiatives are identified [FM 6-20-40, p. 2-6; FM 6-20-50, p. 2-6; FM 6-20-1, p. 3-12].
  - d) Maneuver control measures and the times they are initiated or deleted are depicted [FM 6-20-40, p. 2-6; FM 6-20-50, p. 2-6; FM 6-20-1, p. 3-12].
  - e) Significant events that are to occur in relation to time or phases of the brigade's operations are described [FM 6-20-40, p. 2-6; FM 6-20-50, p. 2-6; FM 6-20-1, p. 3-12].
- 4) At the appropriate time, the brigade, Bn TF and Co/Tm FSOs and FOs rehearse execution of their part of the fire support plan [FM 6-20-40, p. 2-6; FM 6-20-50, p. 2-6; FM 6-20-1, p. 3-12]:
  - a) Assigned targets are identified and calls for fire are initiated [FM 6-20-40, p. 2-6; FM 6-20-50, p. 2-6; FM 6-20-1, p. 3-12].
  - b) FSCM are placed into effect or deleted [FM 6-20-40, p. 2-6; FM 6-20-50, p. 2-6; FM 6-20-1, p. 3-12].
  - c) Reports and combat information are rendered [FM 6-20-40, p. 2-6; FM 6-20-50, p. 2-6; FM 6-20-1, p. 3-12].
  - d) Assigned missions are loaded into DMDs and made ready for transmission [FM 6-20-40, p. 2-6; FM 6-20-50, p. 2-6; FM 6-20-1, p. 3-12].
- 5) At the appropriate time, the brigade and Bn TF ALOs, ANGLICOs, and aviation LNOs rehearse execution of their part of the fire support plan [FM 6-20-40, p. 2-6; FM 6-20-50, p. 2-6; FM 6-20-1, p. 3-12]:
  - a) Airspace coordination procedures are monitored, initiated, and deleted [FM 6-20-40, p. 2-6; FM 6-20-50, p. 2-6; FM 6-20-1, p. 3-12].
  - b) Aircraft are notionally cleared to depart IPs [FM 6-20-40, p. 2-6; FM 6-20-50, p. 2-6; FM 6-20-1, p. 3-12].

- c) Calls for target marking are made [FM 6-20-40, p. 2-6; FM 6-20-50, p. 2-6; FM 6-20-1, p. 3-12].
  - d) SEAD fires are requested [FM 6-20-40, p. 2-6; FM 6-20-50, p. 2-6; FM 6-20-1, p. 3-12].
- 6) At the appropriate time, the DS FA battalion TOC members rehearse execution of their part of the fire support plan [FM 6-20-40, p. 2-6; FM 6-20-50, p. 2-6; FM 6-20-1, p. 3-12].
  - a) The DS FA battalion TOC monitors fire support actions to ensure compliance with the plan [FM 6-20-40, p. 2-6; FM 6-20-50, p. 2-6; FM 6-20-1, p. 3-12].
  - b) The DS FA battalion O&I section tracks displacement of attack and target acquisition systems [FM 6-20-40, p. 2-6; FM 6-20-50, p. 2-6; FM 6-20-1, p. 3-12].
- 7) At the appropriate time, FDCs (e.g., DS FA battalion, firing batteries, mortars) rehearse execution of their part of the fire support plan [FM 6-20-40, p. 2-6; FM 6-20-50, p. 2-6; FM 6-20-1, p. 3-12]:
  - a) Fire orders are issued [FM 6-20-40, p. 2-6; FM 6-20-50, p. 2-6; FM 6-20-1, p. 3-12].
  - b) Messages to observers are passed [FM 6-20-40, p. 2-6; FM 6-20-50, p. 2-6; FM 6-20-1, p. 3-12].
  - c) Fire commands are computed [FM 6-20-40, p. 2-6; FM 6-20-50, p. 2-6; FM 6-20-1, p. 3-12].
  - d) FSCMs are acknowledged [FM 6-20-40, p. 2-6; FM 6-20-50, p. 2-6; FM 6-20-1, p. 3-12].
  - e) Assigned missions are verified [FM 6-20-40, p. 2-6; FM 6-20-50, p. 2-6; FM 6-20-1, p. 3-12].
- 8) At the appropriate time, radars implement situational cues with the cueing agents and rehearse execution of their part of the fire support plan [FM 6-20-40, p. 2-6; FM 6-20-50, p. 2-6; FM 6-20-1, p. 3-12].
- f. The brigade targeting team refines the brigade fire support plan at the completion of all rehearsals [FM 101-5, p. M-15].
  - 1) Rehearsal participants conduct AARs to determine plan refinements [FM 101-5, p. M-15].

- 2) Changes made during the rehearsals are incorporated into existing fire support plans and documents [FM 101-5, p. M-15].
- 3) Changes are disseminated by FRAGO; copies of refined fire support products are issued (see task 19 above) [FM 101-5, p. M-15].
- 4) Key brigade leaders who did not participate in the rehearsal are briefed on rehearsal results and all refinements [FM 101-5, p. M-15].

**21. Target Acquisition Assets Position and Perform Target Detection Activities**

- a. Positioning of target acquisition assets is monitored [AN].
  - 1) The brigade FSO and brigade S2, with the DA FA battalion S2, ensure that sensors and ground surveillance radars attached to the brigade are properly positioned to enhance target acquisition capabilities [ARTEP 6-115-20-MTP, 06-3-02-1390/1; FN-BCBST].
  - 2) The brigade FSCoord and brigade FSO ensure COLTs and FA observers are positioned to support the brigade commander's intent and the brigade scheme of maneuver [FM 6-20-40, p. I-4; FM 6-20-50, p. J-4; FM 6-20-1, p. 5-3].
- b. Target acquisition systems and collection assets conduct movement to occupy designated positions [AN].

NOTE: This task deals with the insertion of target acquisition and collection assets beyond the brigade FLOT.

- 1) Target acquisition and collection systems communicate on and monitor designated communication nets [FN-BCBST].
- 2) Target acquisition and collection assets are inserted in accordance with the R&S and collection plans [AN].
  - a) Movement is conducted with subordinate units' Scout Platoons and other brigade reconnaissance elements, whenever possible [FM 6-30, p. 2-3].
  - b) Movement may be conducted by helicopter, mounted, or dismounted [AN].
- 3) Forward passage of lines is coordinated and performed, as required [AN].
- 4) Security is maintained throughout movement, and actions at danger areas are taken [AN].
- 5) Designated primary routes are used; alternate routes are used as required [AN].
- 6) Cover and concealment are maintained to reduce detection by the enemy [AN].

- 7) Reports are provided at designated times and locations to ensure the brigade S2, DS MI company commander, and brigade targeting officer can monitor progress and implement measures to reduce risk of fratricide [AN].
  - 8) Movement speed (e.g., mounted, dismounted) is based on equipment loads; care is taken to ensure necessary equipment is protected from damage [AN].
  - 9) Actions on enemy contact are performed in the event of detection by the enemy, and indirect fires are employed as required [AN].
  - 10) Recovery operations are implemented by the brigade in the event target acquisition and collection assets are compromised [AN].
- c. Brigade COLTs and FA observers occupy positions; positions [FM 6-20-40, p. I-4; FM 6-20-50, p. J-4]:
- 1) Provide ability to support the brigade commander's intent [FM 6-20-40, p. I-4; FM 6-20-50, p. J-4].
  - 2) Allow the collection of information in support of the collection plan [FM 6-20-40, p. I-4; FM 6-20-50, p. J-4].
  - 3) Comply with angle-T considerations based on their designated targets [FM 6-20-40, p. I-4; FM 6-20-50, p. J-4].
  - 4) Are at altitudes as close as possible to their expected targets to minimize vertical angle of attack factors [FM 6-20-40, p. I-4; FM 6-20-50, p. J-4].
  - 5) Allow survivability and concealment from the enemy [FM 6-20-40, p. I-4; FM 6-20-50, p. J-4; FM 6-30, p. 2-4].
  - 6) Are surveyed, if possible [FM 6-20-40, p. I-4; FM 6-20-50, p. J-4].
  - 7) Provide for communications (e.g., voice, digital) [FM 6-20-40, p. I-4; FM 6-20-50, p. J-4; FM 6-30, p. 2-5].
  - 8) Provide observation of designated areas [FM 6-30, p. 2-4]:
    - a) TRPs and planned targets [FM 6-30, p. 2-4].
    - b) NAIs [FM 6-20-10, p. A-8].
    - c) TAIs [FM 6-20-10, p. A-9].
    - d) DPs [FM 6-20-10, p. A-9].
    - e) TPL [FM 6-20-10, p. A-8].

- f) Obstacles (friendly, enemy) [AN].
  - g) HPTs [FM 6-20-10, p. 2-1].
  - h) Targets of opportunity [FM 6-20-10, p. 2-24].
- 9) Allow evaluation of target attack effects [FM 6-30, p. 2-4].
- d. Brigade COLTs and FA observers take appropriate actions to reduce environmental restrictions [FM 6-20-40, p. I-1; FM 6-20-50, p. J-1; FN-BCBST]:
- 1) Line of sight from COLTs and FA observers to targets [FM 6-20-40, p. I-2; FM 6-20-50, p. J-2; FN-BCBST].
  - 2) Visibility degradation, due to [FM 6-20-40, p. I-2; FM 6-20-50, p. J-2]:
    - a) Clouds [FM 6-20-40, p. I-2; FM 6-20-50, p. J-2].
    - b) Darkness [FM 6-20-40, p. I-2; FM 6-20-50, p. J-2].
    - c) Battlefield obscuration [FM 6-20-40, p. I-2; FM 6-20-50, p. J-2].
    - d) Concave targets [FM 6-20-40, p. I-2; FM 6-20-50, p. J-2].
    - e) Obstructions [FM 6-20-40, p. I-2; FM 6-20-50, p. J-2].
    - f) Temperature extremes [FM 6-20-40, p. I-2; FM 6-20-50, p. J-2].
    - g) Solar saturation [FM 6-20-40, p. I-2; FM 6-20-50, p. J-2].
- e. Brigade COLTs and FA observers with lasing devices perform an assessment of their sectors to ensure compliance with all safety measures [ARTEP 6-115-20-MTP, 06-3-02-1100/7].
- f. DS FA battalion Firefinder radars occupy positions and initiate operations [FM 6-20-1, p. 5-3].<sup>39</sup>
- 1) Radar systems occupy positions which [FM 6-20-1, p. 5-4]:
    - a) Mask physical and electronic signatures [FM 6-20-1, p. 5-4; FM 6-121, p. 4-12].
    - b) Provide physical security, including cover and concealment [FM 6-20-1, p. 5-4; FM 6-121, p. 4-14]:
    - c) Allow mobility for repositioning to avoid enemy detection [FM 6-121, p. 4-13].

- d) Allow avoidance of visual or IR detection [FM 6-121, p. 4-13].
  - e) Do not interfere with the operations of other radar systems [FM 6-121, p. 4-14].
  - f) Provide access for logistical resupply and support [FM 6-20-1, p. 5-4].
  - g) Provide electronic line of sight to assigned zones [FM 6-121, p. 4-13].
  - h) Have been surveyed [FM 6-121, p. 4-14].
  - I) Are located to range expected enemy positions based on desired probability of detection [FN-BCBST].
- 2) Radars implement scanning [AN].
- a) Radars scan assigned sectors and provide designated coverage [FM 6-20-1, p. 5-4; FM 6-121, p. 4-16].
  - b) Radars radiate as designated in the radar cueing guidance [FM 6-20-1, p. 5-4].
  - c) Radars adhere to time requirements for scans [FM 6-121, p. 4-16].
- g. Brigade COLTs, FA observers, and DS FA battalion radars report the accurate locations of their positions to the brigade FSCOORD, the DS FA battalion S2, and the DS FA battalion TOC [FM 6-30, p. 2-4; FM 6-121, p. E-1; FN-BCBST].
- h. Collection assets supporting target detection are positioned and initiate collection activities [AN].
- 1) Collection management is performed by the brigade S2, with support from the DS MI company commander and the brigade targeting officer [FM 34-2, p. 2-1; FM 6-20-10, p. 2-19].
    - a) Collection emphasis is placed on satisfying the brigade commander's PIR, IR, and support the targeting process [ARTEP 71-3-MTP, 71-3-2004/1].
    - b) Taskings to intelligence gathering assets are managed to ensure that updated information requirements are coordinated and met [ARTEP 71-3-MTP, 71-3-2004/1].
  - 2) Collection assets position as directed in the collection plan [FM 6-20-10, p. 2-11; FM 34-2, p. 3-14, A-1].
  - 3) Information received from brigade assets and division sources is received, analyzed, and evaluated [FM 34-2, p. 3-4].

- 4) Collection is performed to provide specific information requirements in support of the targeting process [FM 34-130, p. 1-9; FM 6-20-10, p. 2-19].
  - 5) The brigade FSO provides the brigade S2 with information collected by target acquisition systems and ensures that the brigade S2 is kept aware of the brigade FSE intelligence needs [FM 6-20-40, Ch 2].
- i. Target acquisition systems and collection assets detect brigade targets [AN].
- 1) Mobile HPTs are detected and tracked by target acquisition and collection systems to maintain a current target location [FM 6-20-10, p. 2-19].
  - 2) Target acquisition systems and collection assets immediately notify the brigade targeting team of the detection of brigade targets and suspected targets [FM 6-20-10, p. 2-19, 2-21].
  - 3) Target acquisition systems and collection assets provide the brigade targeting team with essential target information. Essential target information includes [AN]:
    - a) Reporting agency [FM 6-20-10, p. 2-21].
    - b) DTG of acquisition by the sensor [FM 6-20-10, p. 2-21].
    - c) Description of the activity [FM 6-20-10, p. 2-21].
    - d) Size of target [FM 6-20-10, p. 2-21].
    - e) Target location and altitude [FM 6-20-10, p. 2-21].
    - f) Target location error [FM 6-20-10, p. 2-21].
    - g) Dwell time [FM 6-20-10, p. 2-21].
    - h) Status (e.g., stationary, moving) [FM 6-20-10, p. 2-21].
  - 4) Brigade targets are tracked upon detection by the brigade S2, brigade targeting officer, and target acquisition and collection system [AN].
    - a) Priorities for tracking of brigade targets adhere to brigade commander's concept of the operation and targeting priorities [FM 6-20-10, p. 2-20].
    - b) Target tracking is executed through the collection plan [FM 6-20-10, p. 2-20].
  - 5) The brigade targeting team is notified of brigade targets detected by division assets and, when the brigade is capable of tracking the targets, accepts target handover from the division [FM 6-20-10, p. 2-20].

## Execution Task List

These tasks provide required detail to describe the brigade commander and brigade targeting team roles in monitoring and directing brigade fire support execution activities, as well as required actions to perform and implement a time-constrained decision-making process in the event the brigade OPORD must be modified and refined. These tasks are structured to provide fire support tasks and information relevant to the function of "Direct and Lead Units in Execution of Battle" as addressed in brigade CCF 20. The tasks and task elements contained in this task list reflect those actions which are critical to Coordinate, Synchronize, and Integrate Fire Support. References are shown in brackets [...] after each task or task element. Tasks are either taken directly from an ARTEP MTP task or sub-task, or are derived from portions of sub-tasks, implied tasks, or requirements specified in the ARTEP MTPs, applicable FMs, or other related documents. Author-generated tasks are indicated as [AN]. Field notes/tasks from FORSCOM and/or TRADOC SMEs are identified with their source, e.g., [FN-NTC]. Endnotes, which provide ancillary information about tasks, are indicated by a numerical annotation in superscript (e.g., <sup>40</sup>).

These tasks describe the DELIVER and ASSESS functions of the targeting process which occur during the brigade execution battle phase.

### 22. **The Brigade Targeting Team Monitors and Directs Fire Support Operations From Brigade CPs and the DS Battalion TOC** (see task 13 above)

- a. Selected members of the brigade targeting team operate from the brigade tactical CP (TAC)[FM 71-3, p. 3-10, 3-20].
  - 1) Brigade targeting team members in the brigade TAC assist the brigade commander in monitoring and directing the execution of the brigade fire support plan [FM 71-3, p. 3-10, 3-20].
  - 2) Brigade targeting team members in the brigade TAC monitor designated communications nets to manage and direct the execution of the fire support plan, to acquire information and intelligence, and to monitor execution activities of fire support units [FM 71-123, p. 1-42, 3-12].
- b. The brigade FSE and other members of the brigade targeting team not in the brigade TAC operate from the brigade main CP and monitor designated communications systems and nets [ARTEP 6-115-20-MTP, task 06-3-02-1300/2; FM 71-3, p. 3-15, 3-20].
- c. The ad-hoc fire support team established by the brigade commander and brigade S3 operates from the brigade rear CP and monitors designated communications systems and nets [FM 71-3, p. 3-20; FM 6-20, p. 3-11; FM 6-20-40, p. 2-5].
- d. The DS FA battalion TOC performs operations as planned and directs and monitors designated communications systems and nets [FM 6-20-1, p. 3-1, 6-14].



- e. The brigade targeting officer and brigade FSE coordinate, synchronize, and direct the execution of the brigade fire support plan as directed by the brigade FSO [FM 6-20-40, p. 2-23; FM 6-20-50, p. 2-23]:
  - 1) Relay messages to the brigade FSO and brigade ALO [FM 6-20-50, p. 2-23].
  - 2) Perform retransmission for the brigade FSO and brigade ALO [FM 6-20-50, p. 2-23].
  - 3) Perform limited planning and coordination for current and future operations [FM 6-20-50, p. 2-23].
  - 4) Implement fire support guidance and instructions issued by the brigade commander through the brigade FSCoord and brigade FSO [FM 6-20-40, p. 2-24].
- f. The brigade targeting team uses automated systems and communications systems for the transmission of fire support information, guidance, and instructions [FM 101-5, p. 6-20, 6-26; FN-JRTC].
- g. Brigade targeting team members in all brigade CPs maintain communications with [AN]:
  - 1) Bn TF FSOs, S2s, ALOs, ANGLICO elements, and FSEs [FM 6-20-50, p. 2-23].
  - 2) Division FSCoord, division FSE, and DIVARTY TOC [FM 6-20-50, p. 2-23].
  - 3) DS FA battalion TOCs [FM 6-20-50, p. 2-23].
  - 4) Division G2, MI battalion, and division collection and target acquisition assets [ARTEP 71-3-MTP, 71-3-2006/7].
  - 5) Division G3 Air, division ALO, division ANGLICO, corps ASOC, and AFACs [FM 6-20-40, p. A-9, A-11, A-26; FM 6-20-50, p. C-7, C-8, C-25; FM 71-3, p. 7-13].
  - 6) USN ships providing naval surface fires [FM 71-3, p. 7-13; FM 6-20-40, p. A-29; FM 6-20-50, p. C-27].
  - 7) Division air defense officer and ADA battalion S3 [FM 71-3, p. 7-21].
  - 8) Aviation brigade S3 and commanders of aviation units supporting the brigade [FM 6-20-40, p. A-31; FM 6-20-50, p. C-29].
- h. Brigade CPs and DS FA battalion TOC move and locate where they can monitor, plan, and direct the battle and execute the FS plan [FM 71-3, p. 3-21].
  - 1) Brigade CPs and the DS FA battalion TOC move and position on the battlefield as planned or as the tactical situation warrants to assist the brigade commander in exercising of command and control of the brigade [FM 71-3, p. 3-20].

- 2) Brigade CPs and the DS FA battalion TOC move by echelon to maintain survivability and to keep pace with the movement of brigade units [ARTEP 6-115-MTP, 06-2-02-5000/c; FM 71-3, p. 3-22, H-3; FM 6-20-1, p. 3-25; FN-NTC; FN-JRTC].
  - 3) Brigade CPs and the DS FA battalion TOC occupy positions which [AN]:
    - a) Provide masking of physical, thermal, and electronic signatures [FM 71-3, p. 3-21; FM 101-5, p. 5-4].
    - b) Provide cover and concealment [FM 71-3, p. 3-21; FM 101-5, p. 5-4].
    - c) Are collocated with or are near tactical units for mutual support and local security [FM 71-3, p. 3-21].
    - d) Near road networks which are trafficable regardless of weather conditions and are not within sight of enemy ground observation [FM 71-3, p. 3-21].
  - 4) The DS FA battalion TOC occupies locations to support the brigade; location considerations are [AN]:
    - a) Ability to effectively command, control, and communicate with firing batteries [ARTEP 6-115-MTP, 06-3-01-2110/1a].
    - b) Ability to maintain communications with brigade units, reinforcing FA unit, and DIVARTY [ARTEP 6-115-MTP, 06-3-01-2110/1b].
    - c) Proximity to brigade main CP [ARTEP 6-115-MTP, 06-3-01-2110/1c; FM 6-20-1, p. 3-25].
- I. Brigade CPs reestablish command and control functions after the loss of CPs of the brigade commander due to enemy action or other calamities [FM 101-5, p. 5-14].
- 1) Subordinate commanders and division headquarters are informed of loss and reestablishment of brigade CPs [AN].
  - 2) Succession of command is initiated as required due to the loss of brigade leaders [FM 71-3, p. H-2].
  - 3) The brigade main CP assumes operational control of the brigade battle when the brigade commander or brigade TAC is lost [FM 71-3, p. 3-12].
  - 4) The brigade FSO assumes temporary duties as the brigade FSCOORD until the DS FA battalion TOC designates a new FSCOORD [AN].

- 5) Brigade main CP functions are distributed between the brigade TAC and brigade rear CP when the brigade main CP is lost until the brigade main CP is reconstituted [FM 101-5, p. 5-14].
- 6) Brigade FSE functions are temporarily assumed by the DS FA battalion TOC or the FSEs of uncommitted Bn TFs until the brigade main CP is reconstituted [FN-FA Sch].
- 7) DS FA battalion TOC functions are temporarily assumed by the reinforcing FA battalion TOC (if available) or the brigade FSE until the DS FA battalion TOC is reconstituted [AN].

**23. The Brigade Targeting Team Directs the Employment of Indirect Fires Against Brigade HPTs**

- a. The brigade targeting team receives HPT target information from brigade and division target acquisition systems and collection assets (see task 21i) [FM 6-20-10, p. 2-19, 2-21].
  - 1) The brigade S2 and brigade targeting officer verify the enemy target as the HPT to be attacked [FM 6-20-10, p. 2-24].
  - 2) The brigade S2 and brigade targeting officer conduct a check on the reliability and accuracy of the information source [FM 6-20-10, p. 2-24].
- b. The brigade targeting team reviews the HPTL, DST, and AGM to confirm that the HPT meets the criteria for attack [ARTEP 71-3-MTP, 71-3-2001/3c; FM 6-20-10, p. 1-8, 2-9, 2-14, A-10, A-13; FM 34-130, p. A-7; FN-JRTC; FN-CGSC].
- c. The brigade targeting team determines the time of HPT attack [FM 6-20-10, p. 2-23].
  - 1) Planned targets are attacked when they are within the designated engagement areas or time frames and meet the attack criteria [FM 6-20-10, p. 2-24].
  - 2) High payoff targets of opportunity are evaluated to determine if and when they should be attacked [FM 6-20-10, p. 2-24].<sup>40</sup>
- d. The brigade targeting team verifies the desired effect and/or degree of damage required from HPT attack as stated in the brigade commander's intent and attack guidance [FM 6-20-10, p. 2-23].
- e. The brigade targeting team verifies that primary and alternate target acquisition system and fire support observers are positioned to observe the HPT and understand [FM 6-20-10, p. 2-25]:
  - 1) The required desired effects from HPT attack [FM 6-20-10, p. 2-25].

- 2) When observation is required [FM 6-20-10, p. 2-25].
  - 3) Required duration of effects on HPTs from attack [FM 6-20-10, p. 2-25].
- f. The brigade targeting team determines if the attack system(s) designated to attack planned HPTs is available and/or remains the optimum attack system at the time of engagement [FM 6-20-10, p. 2-23, 2-24, 2-25; FM 6-20-1, p. 4-1].
- 1) The brigade targeting team verifies that designated attack systems are in position, that they have the correct munitions, and that their fires can achieve the desired effects [FM 6-20-10, p. 2-25].
  - 2) If the designated attack system is not available, the brigade targeting team selects the most feasible attack system available which can achieve the attack's desired effects [FM 6-20-10, p. 2-25].
- g. The brigade targeting team considers which lethal and/or non-lethal attack system to employ against HPT targets of opportunity based on [ARTEP 71-3-MTP, 71-3-9003/2b4; FM 6-20-10, p. 2-25]:
- 1) The availability of each attack system [FM 6-20-10, p. 2-25].
  - 2) Which can best achieve the desired effects [FM 6-20-10, p. 2-25].
  - 3) The degree of risk for the attack system [FM 6-20-10, p. 2-25].
  - 4) Impact on the support of brigade units is if the attack system is directed to execute the HPT attack [FM 6-20-10, p. 2-25].
  - 5) Availability of required munitions [AN].
- h. The brigade targeting team reviews the brigade commander's attack guidance and AGM and makes technical decisions on the attack of HPTs [FM 6-20-10, p. 2-23].
- 1) The brigade targeting team confirms the number and type of munitions required for the HPT attack to achieve the desired effects [FM 6-20-10, p. 2-23; FM 6-20-1, p. 4-1].
  - 2) The brigade targeting team verifies the required response time for the attacking system (e.g., time required by the attack system to process and execute the attack [FM 6-20-10, p. 2-23].
  - 3) The brigade targeting team confirms and coordinates the method of HPT attack (e.g., type and number of attack system or systems to employ) depending on the attack system to be used [ARTEP 71-3-MTP, 71-3-9003/2b1; FM 6-20-1, p. 4-1; FM 6-20-10, p. 2-24].

- 4) The brigade FSO, brigade ALO, brigade ANGLICO, and brigade aviation LNO provide information on [FM 6-20-10, p. 2-26]:
  - a) Availability of their systems to attack the HPT [FM 6-20-10, p. 2-26].
  - b) Potential conflicts due to status of their systems in other activities (e.g., moving, engaging other targets) [FM 6-20-10, p. 2-26].
  - c) Munitions availability [FM 6-20-10, p. 2-26].
  - d) Range requirements for HPT attack [FM 6-20-10, p. 2-26].
- i. The brigade targeting team nominates brigade HPTs to the division FSE for immediate attack for HPTs that exceed brigade attack capabilities or if brigade attack systems are not available to execute the attack [FM 6-20-10, p. 2-25].
- j. The brigade targeting team informs the brigade commander of its recommendations to attack brigade HPTs [FM 6-20-10, p. 2-25].
- k. The brigade targeting team receives the brigade commander's approval for HPT attack [AN].
  - 1) HPTs which are not approved by the brigade commander for attack are tracked for future attack [FM 6-20-10, p. 2-25].
  - 2) The brigade FSO forwards target nominations to the division FSE and the division targeting team for attack [FM 6-20-10, p. 2-25].
  - 3) The brigade targeting team directs the attack system manager (e.g., brigade FSCoord, brigade ALO, brigade ANGLICO, DS MI company commander) to execute the attack [FM 6-20-10, p. 2-23, 2-24, 2-26].
  - 4) The attack system manager notifies the attack system (e.g., DS FA battalion S3, CAS pilots, FDCs in USN ships, DS MI company commander) to execute the attack [AN].
  - 5) The brigade targeting team coordinates the execution of HPT attacks involving multiple attack systems [FM 6-20-10, p. 2-25].
  - 6) The brigade targeting team coordinates with subordinate, adjacent, and higher headquarters to clear HPT attack fires (see task 24f below) [FM 6-20-10, p. 2-24].
  - 7) The brigade S2 and brigade targeting officer alert target acquisition assets and observers responsible for providing BDA of attack decisions and times [ARTEP 71-3-MTP, 71-3-9003/3a; FM 6-20-10, p. 2-24].

- 8) The attack system manager informs the brigade S2 and brigade targeting officer when target attack occurs [FM 6-20-10, p. 2-24].
  - 9) Target acquisition systems and fire support observers provide the brigade targeting team with the results of HPT attack (see task 25) [ARTEP 71-3-MTP, 71-3-9003/a; FM 6-20-10, p. 2-27; FN-NTC].
24. **The Brigade Targeting Team Monitors, Coordinates, and Synchronizes the Employment of Indirect Fires<sup>41</sup>**
- a. The brigade targeting team synchronizes and coordinates lethal and non-lethal fires based on events and times as required due to significant battlefield changes not previously anticipated [FM 6-20-10, p. 1-13, 2-23; FN-IN Sch].
    - 1) The brigade targeting team coordinates, synchronizes, and integrates fires as prescribed in [AN]:
      - a) DST [FM 6-20-10, p. A-8, A-10].
      - b) AGM [FM 6-20-10, p. 1-8, 2-14; FM 34-130, p. A-7].
      - c) TSS [FM 6-20-10, p. 1-8, 2-12].
      - d) Collection plan [FM 6-20-10, p. 1-8. 2-2; FM 34-2, p. 3-4].
      - e) FSEM [FM 6-20-10, p. 5-11; FM 6-20-40, p. 2-16; FM 6-20-50, p. E-12].
      - f) HPTL [FM 6-20-10, p. 5-11; FM 6-20-40, p. 2-16; FM 6-20-50, p. E-12].
      - g) Target overlays [FM 6-20-40, p. 2-5; FM 6-20-50, p. 2-5].
      - h) Target lists [FM 6-20-40, p. 2-5; FM 6-20-50, p. 2-5].
    - 2) The brigade targeting team continually assesses enemy actions, enemy responses to brigade direct and indirect fires, and losses to brigade fire support systems to ensure that the brigade commander's intent can be achieved [ARTEP 71-3-MTP, 71-3-2003/2].
      - a) Trigger points for the execution of indirect fires are refined based on enemy movement, positions, and actions [FM 6-20-40, Ch 3; FM 6-20-50, Ch 3; FN-NTC; FN JRTC].
      - b) Priorities of fires are continually assessed to ensure that indirect fires are provided to brigade units best able to accomplish the brigade commander's intent [FM 6-20-40, p. 2-3; FM 6-20-50, p. 2-3; FN-NTC].

- c) Locations of brigade target acquisition systems and fire support observers are assessed to ensure that indirect fires can be employed and results of fires can be observed [FM 6-20-10, p. 2-8].
  - d) The brigade targeting team prepares, submits, and coordinates additional fire support and target acquisition systems to counter unanticipated enemy activities and the loss (e.g., battle loss, maintenance) of fire support and target acquisition systems [FM 101-5, p. F-20; FM 6-20-40, p. 2-5; FM 6-20-50, p. 2-5].
  - e) The brigade targeting team implements and adjusts the fire support plan based on changes to the tactical situation and changes to the employment of attack systems [FM 6-20-40, p. E-1; FM 6-20-50, p. G-1].
- 3) As targets appear, the brigade FSCOORD, brigade S3, and brigade FSO task the appropriate attack systems to engage the targets in accordance with the brigade commander's attack guidance and target location requirements of attack systems [FM 6-20-10, p. 1-11].
  - 4) The brigade FSCOORD and brigade FSO monitor, coordinate, and synchronize the employment of FA fires [AN].
  - 5) The brigade S3 Air, through coordination with brigade targeting team members, manages brigade air space [ARTEP 71-3-MTP, 71-3-3012/2].
    - a) A2C2 measures are implemented and adjusted to control and manage the brigade's airspace and users of the airspace [ARTEP 71-3-MTP, 71-3-3012/2].
    - b) Indirect fires are deconflicted to ensure that FA, mortar, naval surface, and CAS fires can be employed against designated targets [ARTEP 71-3-MTP, 71-3-3013/2b].
  - 6) The brigade S3, brigade S2, and DS MI company commander monitor, coordinate, and synchronize the employment of EW assets and other non-lethal attack systems [FM 34-80, p. 2-65, 4-35].
    - a) Enemy systems are attacked and suppressed, neutralized, or destroyed through electronic attack [FM 6-20-40, p. 2-12; FM 6-20-50, p. 2-11; FM 34-1, p. 2-21; FN-AR Sch].
    - b) Enemy systems and transmissions are intercepted and located; the brigade S3 directs exploitation for intelligence collection purposes or attack [FM 34-1, p. 2-21].
    - c) EW and other non-lethal fires employed by brigade assets, division assets, CAS and Army aviation aircraft do not degrade brigade units, communications systems, and digital systems [FN-NTC].

- 7) The brigade FSO and brigade S2 monitor, coordinate, and synchronize the employment of lethal and non-lethal fires to provide SEAD [ARTEP 71-3-MTP, 71-3-3004/32; FM 6-20-40, p. A-15, A-16; FM 6-20-50, p. C-13, C-14; FN-AR Sch; FN-BCTP].
  - a) SEAD targets are engaged at designated times [ARTEP 71-3-MTP, 71-3-3004/3e; FM 6-20-40, p. A-15; FM 6-20-50, p. C-13; FN-AR Sch].
  - b) Desired effects of attack are achieved before CAS and Army aviation assets are employed [ARTEP 71-3-MTP, 71-3-3004/3e; FM 6-20-40, p. A-15; FM 6-20-50, p. C-13; FN-AR Sch].
- 8) The brigade S3 Air, brigade FSO, brigade ALO, and brigade ANGLICO monitor, coordinate, and synchronize the employment of CAS [ARTEP 71-3-MTP, 71-3-3004/1a; FM 6-20-40, p. A-8; FM 6-20-50, p. C-6].
  - a) Requests for immediate CAS are developed and submitted to the division G3 [ARTEP 71-3-MTP, 71-3-3009].
  - b) Brigade ALO and brigade ANGLICO elements responsible for terminal control of aircraft direct CAS attacks [FM 6-20-40, p. A-26; FM 6-20-50, p. C-13, C-24].
  - c) Requirements for the employment of alternate observers (e.g., brigade, Bn TF, or Co/Tm FSOs and FOs) to perform terminal control of CAS are coordinated with CAS aircraft and the division ALO or ANGLICO [FM 6-20-40, p. A-30; FM 6-20-50, p. C-28].
  - d) The brigade FSO identifies and coordinates the employment of other fire support assets in the event CAS attacks do not achieve the desired effects [FM 6-20-40, p. A-8; FM 6-20-50, p. C-5].
- 9) The brigade S3 Air, brigade FSO, brigade ALO, and brigade ANGLICO ensure that elements involved in terminal control of CAS aircraft provide CAS pilots with attack information [FM 6-20-40, p. A-12; FM 6-20-50, p. C-10]:
  - a) Updated target location and identification means [FM 6-20-40, p. A-12; FM 6-20-50, p. C-10].
  - b) Initiation of SEAD fires [FM 6-20-40, p. A-12; FM 6-20-50, p. C-10].
  - c) Attack restrictions [FM 6-20-40, p. A-12; FM 6-20-50, p. C-10].
  - d) Friendly air defense considerations [FM 6-20-40, p. A-12; FM 6-20-50, p. C-10].
  - e) Time factors for the attack [FM 6-20-40, p. A-12; FM 6-20-50, p. C-10].



- f) A2C2 measures implemented [FM 6-20-40, p. A-16; FM 6-20-50, p. C-13].
  - g) Nine-line mission briefing [FM 6-20-40, p. A-21; FM 6-20-50, p. C-19].
- 10) The brigade ANGLICO monitors, coordinates, and synchronizes the employment of naval surface fires to ensure that the desired effects are achieved [FM 6-20-40, p. A-30; FM 6-20-50, p. C-28; NWP 3-09.11M, p. 1-9].
  - 11) The brigade FSO monitors, coordinates, and synchronizes the employment of Bn TF mortars in brigade missions to ensure that the desired effects are achieved [FM 6-20-40, p. 3-22; FM 6-20-50, p. K-3; FN-FA Sch].
  - 12) The brigade FSO, through coordination with brigade targeting team members, monitors, coordinates, and synchronizes the employment of special munitions [AN].
    - a) Fire support observers and target acquisition assets are positioned to initiate calls and adjust special munitions fires, and to lase targets, and report effects of fires [FM 6-20-10, p. 2-8].
    - b) Locations for FA FASCAM are continually assessed based on enemy actions; FA FASCAM fires are employed on time and at designated locations to achieve the desired effects [ARTEP 71-3-MTP, 71-3-8003/3a; FM 6-20-40, p. 3-19, H-1; FM 6-20-50, p. I-2].
    - c) Obscurants are emplaced by indirect fire weapons systems at designated locations to achieve the desired effects [FM 6-20-40, p. 3-19, H-17; FM 6-20-50, p. I-16].
    - d) Precision-guided munitions are employed on designated targets to achieve the desired effects [FM 6-20-40, p. H-22; FM 6-20-50, p. I-12].
    - e) Illumination fires are employed to achieve desired effects [FM 6-20-40, p. 3-19].
- b. The brigade targeting team directs the employment of indirect fires to support the brigade-deep battle [ARTEP 71-3-MTP, 71-3-3008/2].
    - 1) The brigade targeting team monitors division-deep battle operations [FM 6-20, p. 3-11; FN-FA Sch].
      - a) The results of division-deep battle attacks on division and brigade HPTs are assessed to ensure that desired effects were achieved [FM 100-5, p. 6-14].
      - b) Division and brigade HPTs not attacked and HPTs which were attacked but whose desired effects have not been achieved are tracked and processed for future attack [FM 6-20-10, p. 2-25].

- c) The brigade S2 assesses information to confirm or refute the projected enemy's course of action and to determine enemy reactions to the loss of HPTs [ARTEP 71-3-MTP, 71-3-2003/2].
  - 2) The brigade targeting team directs the initiation of indirect fires at the designated locations for the transition from division to brigade-deep battles [FM 6-20, p. 3-11; FN-FA Sch].
  - 3) The brigade targeting team directs indirect fires against brigade HPTs (see task 22 above)[FM 6-20-10, p. 2-23, 2-24, 2-26].
  - 4) The brigade targeting team monitors and directs brigade-deep battle indirect fires to ensure that the desired effects have been achieved (see task 8b above) [FM 100-5, p. 6-14].
- c. The brigade targeting team monitors the employment of indirect fires by Bn TFs in the close battle [AN].
  - 1) The brigade targeting team ensures that indirect fires are placed on terrain and on the enemy to weigh the main effort and to support movement and maneuver of Bn TF and brigade units [FM 6-20-40, p. 3-2; FM 6-20-50, p. 3-2; FN-BCBST].
  - 2) The brigade targeting team ensures that indirect fires are placed on enemy forces [FM 6-20-40, p. 3-3; FM 6-20-50, p. 3-2].
  - 3) The brigade targeting team ensures that indirect fires are placed on brigade and Bn TF objectives to support attacking brigade units [FM 6-20-40, p. 3-3; FM 6-20-50, p. 3-2].
  - 4) The brigade targeting team ensures that indirect fires degrade enemy offensive operations by inflicting casualties, destroying equipment and weapons systems, separating forces and echelons, and forcing the enemy into planned brigade and Bn TF EAs [FM 6-20-40, p. 2-18; FM 6-20-50, p. 3-18].
  - 5) The brigade targeting team ensures that indirect fires support disengagement and repositioning of brigade and Bn TF units [FM 6-20-40, p. 3-19; FM 6-20-50, p. 3-19].
  - 6) The brigade targeting team ensures that indirect fires support mobility operations [ARTEP 71-3-MTP, 71-3-8003/3a; FN-IN Sch].
    - a) Brigade and Bn TF units are screened during movement [FM 6-20-40, p. 3-19; FM 6-20-50, p. I-17].
    - b) Suppression and obscuration fires are employed to support breaching operations [FM 6-20-40, p. 3-19; FM 6-20-50, p. I-17].

- 7) The brigade targeting team ensures that indirect fires support countermobility operations [ARTEP 71-3-MTP, 71-3-8003/3a; FN-IN Sch].
  - a) Indirect fires reinforce emplaced Bn TF and brigade obstacles and hinder enemy breaching or bypass operations [FM 6-20-40, p. 3-19; FM 6-20-50, p. 3-19].
  - b) Indirect fires do not degrade or destroy brigade or Bn TF obstacles [FM 6-20-40, p. 3-19; FM 6-20-50, p. 3-19].
  - c) Indirect fires force enemy units into brigade and Bn TF obstacles [FM 6-20-40, p. 3-19; FM 6-20-50, p. 3-19].
  - d) FASCAM is emplaced based on brigade and Bn TF plans [ARTEP 71-3-MTP, 71-3-3006/1b; FM 6-20-40, p. H-2; FM 6-20-50, p. I-2].
- 8) The brigade targeting team monitors the types of fires employed by Bn TFs to ensure that they are in accordance with the Bn TF and brigade schemes of maneuver and changing battlefield requirements [ARTEP 71-3-MTP, 71-3-9001/2b; FM 6-20-40, p. D-6; FM 6-20-50, p. F-6]:
  - a) Groups of targets [FM 6-20-40, p. D-6; FM 6-20-50, p. F-6].
  - b) Series of targets [FM 6-20-40, p. D-6; FM 6-20-50, p. F-6].
  - c) Program of targets [FM 6-20-40, p. D-6; FM 6-20-50, p. F-7].
  - d) Preparatory fires [FM 6-20-40, p. D-6; FM 6-20-50, p. F-7].
  - e) Counter-preparation fires [FM 6-20-40, p. D-7; FM 6-20-50, p. F-7].
- d. The brigade targeting team directs the employment of indirect fires to support the brigade rear battle [FM 6-20, p. 3-11; FM 90-14, p. 5-3; FN-NTC]
  - 1) The brigade S3 is notified of rear area threats by brigade units and determines methods to respond to the threat; he approves the use of indirect fires based on his assessment of the situation [FM 90-14, p. 5-2].
  - 2) The ad-hoc fire support team operating in the brigade rear CP coordinates with the brigade S3 and brigade FSO for the employment of indirect fires against rear area threats [FM 6-20, p. 3-11; FM 6-20-40, p. 2-5].
  - 3) The brigade FSO and brigade S3 ensure that the most appropriate indirect fire system is employed against the rear threat [FM 6-20, p. 3-11].
  - 4) The brigade FSO and brigade S3 monitor the employment of indirect fires as executed by the brigade rear ad-hoc fire support team [FM 90-14, p. 5-3].

- 5) The brigade ALO and brigade ANGLICO coordinate with the brigade rear ad-hoc fire support element to position observers to perform terminal control of CAS [FM 90-14, p. 5-3].
  - 6) The brigade FSO ensures that indirect fires employed in support of the brigade rear battle do not significantly degrade the employment of fires in support of the close battle [AN].
- e. Target acquisition systems and fire support observers provide the brigade targeting team with the results of HPT attack (see task 25) [ARTEP 71-3-MTP, 71-3-9003/a; FM 6-20-10, p. 2-27; FN-NTC].
- f. The brigade targeting team monitors and directs the positioning and repositioning of fire support systems during the battle [FM 6-20-40, p. 2-19; FM 6-20-50, p. 2-18; FN-FA Sch].
- 1) The brigade targeting team monitors the movement and positioning and repositioning of indirect fire systems and assets to facilitate the transition from the deep battle to the close battle [AN].
  - 2) The brigade targeting team monitors and, as required, coordinates with the DS FA battalion S3 to ensure that FA firing batteries and radars displace and reposition to maintain pace with brigade maneuver forces, provide required support, and avoid enemy counter-fires [FM 6-20-10, p. 2-8].
  - 3) The brigade S2, brigade FSO, brigade targeting officer, and DS MI company commander direct target acquisition systems and fire support observers to reposition as required to maintain observation of DPs, NAIs, TAIs, targets, and enemy actions [FM 6-20-10, p. 2-8].
  - 4) The brigade FSCoord, brigade S3, and brigade FSO monitor the movement and positioning of fire support assets to ensure that the movement of Bn TF unit combat systems are not inhibited [FN-NTC].
  - 5) The brigade S3 resolves terrain problems resulting from conflicts between fire support and maneuver requirements [ARTEP 71-3-MTP, 71-3-9002/3c].
  - 6) The brigade S3, brigade S2, and DS MI company commander monitor and coordinate the movement and repositioning of non-lethal attack systems [FM 34-80, p. 5-1].
- g. The brigade targeting team participates in the clearance of fires [FM 6-20-40, p. 2-19; FM 6-20-50, p. 2-19].<sup>42</sup>
- 1) Bn TF commanders and FSOs internally clear and approve their own indirect fires in their AO [FM 6-20-40, p. 2-19; FM 6-20-50, p. 2-19].

- 2) The brigade commander is responsible for clearing and approving fires when [FM 6-20-40, p. 2-19; FM 6-20-50, p. 2-19]:
  - a) Bn TFs request indirect fires outside their maneuver boundaries [AN].
  - b) Brigade units request indirect fires outside the brigade maneuver boundaries [AN].
  - c) Units adjacent to the brigade request indirect fires inside the brigade maneuver boundaries [AN].
  - d) Division and other units request fires inside the brigade maneuver boundaries [AN].
- 3) Brigade fire support observers and others calling for fires provide target information, including [AN]:
  - a) Precise target locations (e.g., lasers, surveyed TRPs) [FM 6-30, p. 3-1, 4-1; FN-FA Sch].
  - b) Positive identification of target [FM 6-30, p. 4-1; FN-FA Sch].
  - c) Locations of friendly forces in relation to target locations [FM 6-30, p. 4-4; FN-FA Sch].
- 4) The brigade FSCOORD, brigade FSO, and brigade FSE act as the brigade commander's agents for processing clearance of fires [FN-FA Sch].
  - a) The brigade FSCOORD and brigade S3 provide assistance, as required [FM 6-20-40, p. 2-19; FM 6-20-50, p. 2-19].
  - b) The brigade commander normally delegates authority to coordinate and clear fires within the brigade AO to the brigade FSO [FM 6-20-40, p. 2-19; FM 6-20-50, p. 2-19].
  - c) When fires or the effects of fires fall outside the brigade AO, the brigade commander and brigade FSO coordinate with the appropriate commander [FM 6-20-40, p. 2-19; FM 6-20-50, p. 2-19].
- 5) Brigade and Bn TF FSCOORDs and FSOs monitor calls for fire and, if friendly forces are not at risk, inform requesting headquarters that friendly forces are not at risk [FM 6-20-40, p. 2-19; FM 6-20-50, p. 2-19; FN-BCBST].
- 6) The brigade FSO coordinates with Bn TF FSOs in whose area targets lie to determine if their Bn TF soldiers are at risk to fires requested by division, adjacent brigade, and other brigade Bn TF FSOs [FN-FA Sch; FN-194 AR].

- a) Bn TF FSOs confirm dispositions and locations of friendly forces [FN-BCTP; FN-194 AR Sch].
  - b) Bn TF commanders approve the fire mission request after confirmation that friendly forces are not at risk [FM 6-20-40, p. 2-19; FM 6-20-50, p. 2-19].
  - c) The brigade FSO informs the brigade commander of the receipt of clearances of fires from Bn TF commanders [AN].
- 7) The brigade targeting team implements FSCM as required to prevent fratricide of friendly personnel from indirect fires [FM 6-20-40, p. E-1; FM 6-20-50, p. G-1].
  - 8) The brigade commander exercises final authority to approve (clear) fires and their effects within the brigade AO [FM 6-20-40, p. 2-19; FM 6-20-50, p. 2-19].
  - 9) The brigade FSCOORD or brigade FSO relay the brigade commander's clearance of fire missions to the headquarters requesting the fires [FN-BCTP; FN-194 AR].
  - 10) Observers requesting the fires maintain continuous observation of the target to ensure that friendly forces remain safe [FN-FA Sch].

**25. The Brigade Targeting Team Receives the Results of Target Attacks and Performs Combat Assessment**

- a. The brigade S2 and brigade targeting officer receive information on the results of target attack from [ARTEP 71-3-MTP, 71-3-9003/3a; FM 6-20-10, p. 2-27; FN-NTC]:
  - 1) Brigade target acquisition systems, collection assets, and fire support [ARTEP 71-3-MTP, 71-3-9003/3a; FM 6-20-10, p. 2-26, 2-27; FN-NTC].
  - 2) Adjacent unit S2s, the division G2, the DIVARTY targeting element, and higher target acquisition and collection assets [FM 6-20-10, p. 2-27; FN-III Corps].
  - 3) Bn TF S2s and FSOs [FM 6-20-10, p. 2-26, 2-27].
  - 4) Other brigade targeting team members resulting from their assessment of battlefield changes (i.e., the cessation of enemy fires from a specific location) [FM 6-20-10, p. 2-29].
- b. The brigade S2 and brigade targeting officer assess the reliability and credibility of the information source [FM 6-20-10, p. 2-27].
- c. The brigade S2 and brigade targeting officer assess information to determine Battle Damage Assessment (BDA) [FM 6-20-10, p. 2-26; FN-NTC].
  - 1) The brigade S2 and brigade targeting officer analyze target attack results to determine if the desired effects were achieved [FM 6-20-10, p. 2-27].

- 2) The brigade S2 and brigade targeting officer perform a physical damage assessment to determine the quantitative extent of physical damage to the target resulting from [FM 6-20-10, p. 2-28]:
  - a) Munitions blast [FM 6-20-10, p. 2-28].
  - b) Fragmentation [FM 6-20-10, p. 2-28].
  - c) Damage due to fire [FM 6-20-10, p. 2-28].
- 3) The brigade S2 and brigade targeting officer perform a functional damage assessment to determine the temporary effect on the target's ability to perform its mission [FM 6-20-10, p. 2-28].
- 4) The brigade S2 and brigade targeting officer perform a target system assessment to determine the permanent overall impact and effectiveness of the attack on the target system's capabilities [FM 6-20-10, p. 2-28].
- d. The brigade S3, with assistance from brigade targeting team members, assesses information to determine Munitions Effects Assessment (MEA) [FM 6-20-10, p. 2-27].
  - 1) The brigade S3 and brigade targeting team members assess MEA in terms of brigade weapon systems employed in the attack and munitions effectiveness [FM 6-20-10, p. 2-27].
  - 2) The brigade S3 uses the results to the MEA to determine and recommend changes to [FM 6-20-10, p. 2-27]:
    - a) Method of attack [FM 6-20-10, p. 2-27].
    - b) Tactics to be used by fire support systems to perform attacks [FM 6-20-10, p. 2-27].
    - c) Weapons systems to use in attacks [FM 6-20-10, p. 2-27].
    - d) Munitions to use in attacks [FM 6-20-10, p. 2-27].
    - e) Weapon delivery attack parameters and locations [FM 6-20-10, p. 2-27].
- e. The brigade targeting team uses the results of its assessments on target attack to determine [FM 6-20-10, p. 2-26]:
  - 1) Future enemy actions and intentions [FM 6-20-10, p. 2-26].
  - 2) Remaining enemy capabilities [FM 6-20-10, p. 2-26].
  - 3) Enemy combat effectiveness [FM 6-20-10, p. 2-26].

- 4) Likely enemy responses and reactions [ARTEP 71-3-MTP, 71-3-2006/4].
  - 5) Battlefield centers of gravity that the brigade can exploit [FM 6-20-10, p. 2-26].
  - 6) The ability of the brigade's fire support systems and targeting effort to achieve the brigade commander's intent and desired target effects [FM 6-20-10, p. 2-27; FM 6-20-40, p. A-3; FM 6-20-50, p. C-3].
  - 7) Range requirements from attack systems to designated targets [FM 6-20-40, p. A-3; FM 6-20-50, p. C-3].
- f. The brigade targeting team analyzes its assessments to determine reattack requirements [ARTEP 71-3-MTP, 71-3-2006/4, 9003/3; FM 6-20-10, p. 2-26].
- 1) Target detection and attack are repeated as required if initial target attack did not achieve the brigade commander's attack guidance [FM 6-20-10, p. 1-11].
  - 2) Reattack requirements are prioritized [FN-CGSC].
  - 3) Reattack recommendations consider the targeting objectives relative to [FM 6-20-10, p. 2-29]:
    - a) Targets selected for attack [FM 6-20-10, p. 2-29].
    - b) Target critical elements [FM 6-20-10, p. 2-29].
    - c) Fire support systems to perform the attack [FM 6-20-10, p. 2-29].
    - d) Enemy capabilities to counter attacks and to continue operations even with the loss of the target [FM 6-20-10, p. 2-29].
  - 4) Target reattack considerations include how the reattack will affect [AN]:
    - a) On-going and future brigade operations [ARTEP 71-3-MTP, 71-3-2006/4c].
    - b) Enemy actions (e.g., the enemy adopting a different or unanticipated course of action) [ARTEP 71-3-MTP, 71-3-2006/4d].
- g. The brigade FSCOORD, brigade S3, and brigade FSO provide their recommendations for target reattack to the brigade commander; the brigade commander decides whether or not to reattack the target [FN-NTC].
- h. The brigade targeting team reassesses previous targeting decisions based on the results of target attacks and its assessment of attack results and [FM 6-20-10, p. 1-11, 2-29]:
- 1) Adjusts targeting process on decisions based on its assessments [FM 6-20-10, p. 1-11,].



- 2) Provides its assessments to the division targeting team, the DS FA battalion S3, and Bn TF S2s [FN-CGSC].
- 3) Updates fire support products based on its assessments (see Task 28 below).

**26. The Brigade Targeting Team Acquires Information**

- a. The brigade S3 receives information [ARTEP 71-3-MTP, 71-3-3001/1].
  - 1) The brigade S3 receives information from the division G3, division Operations staff, and adjacent units' S3s. Information includes [AN]:
    - a) Status of division deception operations [FM 101-5, p. 6-45].
    - b) Division CP locations (current and proposed) [FM 101-5, p. 6-43].
    - c) Status of division-deep operations [ARTEP 71-3-MTP, 71-3-2006/5b].
    - d) Locations and activities of adjacent and other division units [ARTEP 71-3-MTP, 71-3-3003/2a, 3003/2c; FM 6-20-40, p. 2-18; FM 6-20-50, p. 2-18].
  - 2) The brigade S3 receives reports and updates from subordinate Bn TF S3s. Information includes [ARTEP 71-3-MTP, 71-3-3003/2; FM 6-20-40, p. 2-18; FM 6-20-50, p. 2-18]:
    - a) Assessments by Bn TF commanders on their ability to execute their missions and projections of enemy intentions and capabilities [ARTEP 71-3-MTP, 71-3-3003/2c].
    - b) Task organization status [ARTEP 71-3-MTP, 71-3-3003/1, 3003/2b; FM 101-5, p. 6-44, 6-45, 6-47].
    - c) Combat power and weapons status [ARTEP 71-3-MTP, 71-3-3003/2e; FM 6-20-40, p. 2-18; FM 6-20-50, p. 2-18].
    - d) Locations and activities of Bn TF units [ARTEP 71-3-MTP, 71-3-3003/2a, 3003/2c; FM 6-20-40, p. 2-18; FM 6-20-50, p. 2-18; FM 101-5, p. 6-44].
    - e) Adherence to brigade timelines for the execution of assigned tasks and mission [AN].
    - f) Bn TF CP locations (current and proposed) [FM 101-5, p. 6-43].
    - g) Status of fire support assets (e.g., target acquisition systems, firing batteries) [FM 101-5, p. 6-44].

- b. The brigade S2, brigade targeting officer, and DS MI company commander receive information [AN].
  - 1) The brigade S2 and brigade targeting officer receive information from the division G2, the division S2 section, and the MI battalion S3. Information includes [FM 71-3, p. 7-26]:
    - a) INTSUMS [ARTEP 71-3-MTP, 71-3-2006/2; FM 101-5, p. 6-45; FN-AR Sch].
    - b) Indicators and assessments on enemy capabilities, strengths and losses, intentions, and activities [ARTEP 71-3-MTP, 71-3-2006/2, 2006/3; FM 101-5, p. 6-45].
    - c) Weather forecasts [ARTEP 71-3-MTP, 71-3-2006/3c4; FM 101-5, p. 6-45].
    - d) Information from IEW assets supporting the brigade or operating in the brigade AO [ARTEP 71-3-MTP, 71-3-2004/2, 2006/3c7; FM 101-5, p. 6-47].
    - e) Brigade PIR, EEFI, IR, and CCIR information [ARTEP 71-3-MTP, 71-3-2006/3c2; FM 101-5, p. 6-34, 6-45].
    - f) COMINT, ELINT, and IMINT information [ARTEP 71-3-MTP, 71-3-2006/2; FM 101-5, p. 6-49].
    - g) Analysis on results of division-deep attack of division and selected brigade HPT [ARTEP 71-3-MTP, 71-3-2006/5b].
    - h) Status of non-brigade collection assets operating in the brigade AO [ARTEP 71-3-MTP, 71-3-2004/2e].
    - i) Status on requests for augmentation to the brigade of additional IEW assets [FM 101-5, p. F-20; FM 6-20-40, p. 2-5; FM 6-20-50, p. 2-5].
  - 2) The brigade S2, brigade targeting officer, and DS MI company commander receive information from brigade target acquisition and collection systems [ARTEP 71-3-MTP, 71-3-2004/2a, 2006/3c6, 2006/3c7; FM 101-5, p. 6-45]:
    - a) Locations and status of target acquisition and collection systems [ARTEP 71-3-MTP, 71-3-2004/2, 2006/4].
    - b) Enemy activities or lack of activity at NAIs and TAIs [ARTEP 71-3-MTP, 71-3-2006/4].
    - c) Locations and activities of HPT [ARTEP 71-3-MTP, 71-3-2003/2c, 2006/4].
    - d) Brigade PIR, EEFI, IR, and CCIR information [ARTEP 71-3-MTP, 71-3-2006/3c2; FM 101-5, p. 6-34, 6-45].

- 3) The brigade S2 receives information from Bn TF S2s [ARTEP 71-3-MTP, 71-3-2004/2, 2006/3c7; FN-JRTC]:
  - a) Status and locations of Bn TF reconnaissance units and target acquisition systems [FM 6-20-40, p. 2-22; FM 6-20-50, p. 2-22].
  - b) SALUTE reports from Bn TF units [ARTEP 71-3-MTP, 71-3-2006/2].
  - c) CCIR and IR [ARTEP 71-3-MTP, 71-3-2006/3; FM 101-5, p. 6-34].
  - d) Information on enemy strengths and losses from Bn TF fires [ARTEP 71-3-MTP, 71-3-2006/3].
  - e) Information on enemy actions and possible intentions [ARTEP 71-3-MTP, 71-3-2006/3].
  - f) Other information as designated in the R&S and collection plans [ARTEP 71-3-MTP, 71-3-2004/2, 2006/3].
- c. The brigade FSO receives information [AN].
  - 1) The brigade FSO receives information from the division FSCoord, division FSE members, and DIVARTY TOC members [FM 71-3, p. 7-4; FM 6-20-40, p. 2-18; FM 6-20-50, p. 2-18]:
    - a) Status and availability of FA units providing GS or reinforcing fire support to the DS FA battalion [FM 71-3, p. 7-4].
    - b) Changes to division target attack guidance and priorities for fire support [FM 6-20-40, p. 2-2; FM 6-20-50, p. 2-2; FN-JRTC; FN-AR Sch].
    - c) Changes and updates on division permissive and restrictive fire support coordinating measures [FM 6-20-40, 2-2; FM 6-20-50, p. 2-2; FM 6-20-30, p. 4-23, F-2].
    - d) Targeting data and updates on results of division-deep attack operations [FM 6-20-40, p. 2-12; FM 6-20-50, p. 2-12; FM 6-20-30, p. 4-16, B-1; FM 71-100, p. 1-5].
    - e) Status on requests for augmentation to the brigade of additional FA fire support assets [FM 101-5, p. F-20; FM 6-20-40, p. 2-5; FM 6-20-50, p. 2-5].
  - 2) The brigade FSO receives information and status updates on the DS FA battalion from the brigade FSCoord and the DS FA battalion S3 [ARTEP 71-3-MTP, 71-3-9002/1; ARTEP 6-115-20-MTP, 06-3-02-1130, 1190, 1390; FM 101-5, p. 6-49; FM 6-20-40, p. 2-18, 2-23; FM 6-20-50, p. 2-18, 2-22; FN-NTC; FN-AR Sch]:

- a) Status and positions of COLTs, including those task organized to subordinate units [FM 6-20-40, p. 2-19, 2-23; FM 6-20-50, p. 2-18, 2-22].
  - b) Status and positions of AN/TRQ-36 radars [FM 101-5, p. 6-49; FM 6-20-40, p. 2-19, 2-23; FM 6-20-50, p. 2-18, 2-22].
  - c) Status, to include equipment and current and projected locations of firing batteries, FDCs, and target acquisition systems [ARTEP 71-3-MTP, 71-3-9002/1; ARTEP 6-115-20-MTP, 06-3-02-1130, 1190; FM 6-20-40, p. 2-19, 2-23; FM 6-20-50, p. 2-18, 2-22; FM 101-5, p. 6-49].
  - d) Ammunition status of firing batteries [ARTEP 71-3-MTP, 71-3-9002/1; ARTEP 6-115-20-MTP, 06-3-02-1130, 1190; FM 6-20-40, p. 2-23; FM 6-20-50, p. 2-22].
  - e) Personnel status of fire support units [FM 101-5, p. 6-49].
  - f) Status and locations of FA battalion CPs [FM 6-20-40, p. 2-19; FM 6-20-50, p. 2-18, 2-22].
- 3) The brigade FSO receives information from the division FSE, adjacent unit FSOs, and Bn TF FSOs on changes to fire support plans and products resulting from friendly and enemy actions [ARTEP 71-3-MTP, 71-3-9003/10; ARTEP 6-115-20-MTP, 06-3-02-1130, 1190; FM 6-20-40, p. 2-8; FM 6-20-50, p. 2-8; FN-FA Sch]:
- a) Target lists [FM 6-20-40, Ch 2].
  - b) FSEM [FM 6-20-40, Ch 2].
  - c) Preparatory fires plan [ARTEP 71-3-MTP, 71-3-9003/10; ARTEP 6-115-20-MTP, 06-3-02-1130, 1190].
  - d) Counter-fire programs [ARTEP 71-3-MTP, 71-3-9003/10; ARTEP 6-115-20-MTP, 06-3-02-1130, 1190].
  - e) Priority targets [ARTEP 71-3-MTP, 71-3-9003/10; ARTEP 6-115-20-MTP, 06-3-02-1130, 1190].
  - f) Counter-prep plans [ARTEP 71-3-MTP, 71-3-9003/10; ARTEP 6-115-20-MTP, 06-3-02-1130, 1190].
  - g) On-call targets [ARTEP 71-3-MTP, 71-3-9003/10; ARTEP 6-115-20-MTP, 06-3-02-1130, 1190].
  - h) Targets of opportunity and HPTs [ARTEP 71-3-MTP, 71-3-9003/10; ARTEP 6-115-20-MTP, 06-3-02-1130, 1190].

- i) FPF requirements [FM 6-20-40, Ch 2].
- 4) The brigade FSO receives status updates and information from Bn TF FSOs on their activities to execute the brigade and Bn TF fire support plans [ARTEP 71-3-MTP, 71-3-9003/1; ARTEP 6-115-20-MTP, 06-3-02-1130, 1190]:
  - a) Positions and locations of Bn TF fire support assets [FM 6-20-40, p. 2-8; FM 6-20-50, p. 2-8; FN-FA Sch].
  - b) Bn TF R&S operations as they support the brigade and Bn TF fire support plans [FM 6-20-40, p. 2-8; FM 6-20-50, p. 2-8; FN-FA Sch].
- 5) The brigade FSO receives information from Bn TF mortar platoon leaders providing fires in support of the brigade fire support plan [FM 6-20-40, p. A-4; FM 6-20-50, p. C-3, C-5; ARTEP 6-115-20-MTP, 06-3-02-1390/3]:
  - a) Positions and displacement [FM 6-20-40, p. A-4; FM 6-20-50, p. C-5; ARTEP 6-115-20-MTP, 06-3-02-1390/3].
  - b) Coverage of and range to designated targets [FM 6-20-40, p. A-4; FM 6-20-50, p. C-5; ARTEP 6-115-20-MTP, 06-3-02-1390/3].
  - c) Status of mortar tubes, FDCs, and ammunition (by type) [FM 6-20-40, p. A-4; FM 6-20-50, p. C-5; ARTEP 6-115-20-MTP, 06-3-02-1390/3].
- d. The brigade ALO receives information [AN].
  - 1) The brigade ALO, with the brigade ANGLICO, receives updates from the division ALO, division ANGLICO, division G3/Air, and corps ASOC [FM 6-20-40, p. A-9, A-11; FM 6-20-50, p. C-7, C-8; FN-CGSC]:
    - a) Updates and changes to the ATO for planned CAS missions [FM 6-20-40, p. A-9, A-11; FM 6-20-50, p. C-7, C-8; FN-NTC; FN-JRTC; FN-CGSC].
    - b) Updates and status on brigade requests for immediate CAS [ARTEP 71-3-MTP, 71-3-3009; FN-NTC; FN-JRTC].
    - c) Status on requests for augmentation to the brigade of additional CAS assets [FM 101-5, p. F-20; FM 6-20-40, p. 2-5; FM 6-20-50, p. 2-5].
  - 2) The brigade ALO, with the brigade ANGLICO, receives updates from pilots in aircraft supporting the brigade [FM 6-20-40, p. A-12; FM 6-20-50, p. C-9].
    - a) Numbers and types of aircraft currently supporting the brigade [FM 6-20-40, p. A-12; FM 6-20-50, p. C-9].
    - b) Aircraft ordnance [FM 6-20-40, p. A-12; FM 6-20-50, p. C-9].

- c) Times when aircraft will be at Ips and time on target [FM 6-20-40, p. A-12; FM 6-20-50, p. C-9].
  - d) Times when SEAD will be required [FM 6-20-40, p. A-12; FM 6-20-50, p. C-10].
- 3) The brigade ALO receives information and updates from Bn TF ALOs, TACPs, and FACs [FM 6-20-40, p. A-9; FM 6-20-50, p. C-7]:
- a) Status and locations of Bn TF ALO assets [FM 101-5, p. H-123; FN-FA Sch].
  - b) CAS target recommendations [ARTEP 71-3-MTP, 71-3-3004/4e; FM 6-20-40, p. A-8; FM 6-20-50, p. C-6].
  - c) Air space requirements (see task 13j below) [ARTEP 71-3-MTP, 71-3-2013/3b].
  - d) Confirmation that laser designator systems and Bn TF ALO assets are prepared to perform terminal control of aircraft [FM 6-20-40, p. A-13; FM 6-20-50, p. C-11].
- e. The brigade ANGLICO receives information [AN].
- 1) The brigade ANGLICO, with the brigade ALO, receives updates from the division ALO, division ANGLICO, division G3/Air, and corps ASOC [FM 6-20-40, p. A-9, A-11, A-26; FM 6-20-50, p. C-7, C-8, C-25; FM 71-3, p. 7-13; FN-CGSC]:
- a) Updates and changes to the ATO for planned CAS missions [FM 6-20-40, p. A-9, A-11; FM 6-20-50, p. C-7, C-8; FN-NTC; FN-JRTC; FN-CGSC].
  - b) Updates and status on brigade requests for immediate CAS [ARTEP 71-3-MTP, 71-3-3009; FN-NTC; FN-JRTC].
  - c) Status on requests for augmentation to the brigade of additional naval surface fire assets [FM 101-5, p. F-20; FM 6-20-40, p. 2-5; FM 6-20-50, p. 2-5].
- 2) The brigade ANGLICO receives information and updates from USN ships providing naval surface fire support to the brigade [FM 71-3, p. 7-13; FM 6-20-40, p. A-29; FM 6-20-50, p. C-27]:
- a) Status on fires and capabilities of USN ships [FM 6-20-40, p. A-28; NWP 3-09.11M, p. 2-1].
  - b) Locations and status of USN ships [NWP 3-09.11M, p. 2-6; FM 6-20-40, p. A-28; FM 6-20-50, p. C-26; FN-194 AR].
  - c) Changes to concept for naval surface fires [FM 101-5, p. H-126].

- d) Ammunition status of ships providing support [FM 6-20-40, p. A-28; FM 6-20-50, p. C-26].
- 3) The brigade ANGLICO receives information and updates from Bn TF ANGLICO elements [FM 6-20-40, p. A-27; FM 6-20-50, p. C-25]:
- a) Status and locations of Bn TF ANGLICO assets [FM 101-5, p. H-123; FM 71-3, p. 7-12; NWP 3-09.11M, p. 1-5; FN-FA Sch].
  - b) Naval surface fire target recommendations [ARTEP 71-3-MTP, 71-3-3004/4e; FM 6-20-40, p. A-8; FM 6-20-50, p. C-6].
  - c) Confirmation that laser designator systems and Bn TF ANGLICO assets are prepared to perform terminal control of aircraft [FM 6-20-40, p. A-13; FM 6-20-50, p. C-11].
- f. The brigade aviation LNO receives information [AN].
- 1) The brigade aviation LNO receives information and updates from the aviation brigade S3 [ARTEP 71-3-MTP, 71-3-7001/2; FM 6-20-40, p. A-31; FM 6-20-50, p. C-29]:
- a) Status and activities of division Army aviation operations in the brigade AO [ARTEP 71-3-MTP, 71-3-7001/2; FM 6-20-40, p. A-31; FM 6-20-50, p. C-29].
  - b) Changes and updates on air space requirements for Army aviation assets [ARTEP 71-3-MTP, 71-3-7001/2; FM 6-20-40, p. A-31; FM 6-20-50, p. C-29].
  - c) Changes or additions to fire support requirements to support aviation brigade operations in the brigade AO [ARTEP 71-3-MTP, 71-3-7001/2].
- 2) The brigade aviation LNO receives information and status updates from Army aviation units supporting the brigade fire support plan [FM 6-20-40, p. A-31; FM 6-20-50, p. C-29]:
- a) Status of and locations of aircraft [ARTEP 6-115-MTP, 06-1-02-2600/2; FM 6-20-40, p. A-31; FM 6-20-50, p. C-29].
  - b) Changes to aircraft capabilities and availability [FM 101-5, p. 6-49; FM 1-111, p. 3-2; FN-JRTC].
  - c) Changes and updates on air space requirements [ARTEP 71-3-MTP, 71-3-7001/1].
  - d) Changes to aircraft crew capabilities (e.g., crew rest, NVG qualified) [AN].
  - e) Status of resupply operations and establishment of FARPs [AN].

- f) SEAD requirements to support aviation operations [FM 6-20-40, p. A-31; FM 6-20-50, p. C-29].
- g. The ABE receives information [AN].
  - 1) The ABE receives information and updates from the division engineer and engineer brigade S3 [FM 71-3, p. 7-14]:
    - a) Locations of enemy obstacles [ARTEP 71-3-MTP, 71-3-8005/1; FM 101-5, p. 6-47; FM 6-20-40, p. 3-4; FM 6-20-50, p. 3-2].
    - b) Changes to division-directed obstacles and FA FASCAM requirements [FM 5-100, p. 24; FM 5-102, p. 57, 82].
    - c) Updates on terra base products for the brigade AO [AN].
  - 2) The ABE receives information and updates from Bn TF engineer unit commander [AN]:
    - a) Updates on brigade locations [ARTEP 71-3-MTP, 71-3-8005/1; FM 101-5, p. 6-46; FM 6-20-40, p. 3-18; FM 6-20-50, p. 3-19].
    - b) Confirmation on locations and types of enemy obstacles [FM 6-20-40, p. 3-4; FM 6-20-50, p. 3-2].
    - c) Employment and effects of FA FASCAM, including requirements to change FASCAM locations due to unanticipated enemy activities [FM 6-20-40, p. 3-3, 3-25, H-2; FM 6-20-50, p. 3-2, 3-19, I-2; FN-IN Sch].
    - d) Employment and effects of indirect fire emplaced obscuration to protect brigade units and to support brigade breaching operations [FM 6-20-40, p. 3-25; FM 6-20-50, p. 3-19].
- h. The brigade S4 receives information from the DS FA battalion, FSB, and Bn TF S4s relative to CSS operations in support of fire support units [AN]:
  - 1) Casualties (e.g., battle, non-battle) of fire support personnel [FM 101-5, p. 6-46].
  - 2) Updates on equipment losses and status and projected status of FA cannons, Bn TF mortars, and non-lethal attack systems undergoing repair [ARTEP 71-3-MTP, 71-3-4003/2; FM 101-5, p. 6-46].
  - 3) Status on the implementation and execution of weapons system replacement operations for lethal and non-lethal weapon systems [ARTEP 71-3-MTP, 71-3-4003/2].



- 4) Status of requisition, acquisition, storage, and distribution of supplies for fire support units and assets [ARTEP 71-3-MTP, 71-3-4003/1].
- 5) Status of CSR for fire support units and assets [ARTEP 71-3-MTP, 71-3-4003/1].
- 6) Status of CL III supply points, CL V transfer points, and maintenance collection points [FM 101-5, p. 6-47].
- 7) Transportation and movement information, including [ARTEP 71-3-MTP, 71-3-4005/2]:
  - a) Status of MSR, ASR, and other routes, including information relevant to enemy capabilities and action to interrupt use of MSR, ASR, and other routes [ARTEP 71-3-MTP, 71-3-4005/2; FM 101-5, p. 6-46].
  - b) Routes, traffic control, and timetables for transportation of supplies and equipment to fire support systems and units [ARTEP 71-3-MTP, 71-3-4005/2].
  - c) Aerial resupply operations in support of fire support units and systems [ARTEP 71-3-MTP, 71-3-4005/2].
- i. The brigade S3, brigade S3 Air, brigade FSO, brigade ALO, brigade ANGLICO, brigade AD LNO, and brigade aviation LNO receive information to support their monitoring of brigade air space [ARTEP 71-3-MTP, 71-3-3012/2, 7001/4]:
  - 1) Routine reports and updates from air space users on their activities in the brigade air space [ARTEP 71-3-MTP, 71-3-3012/2, 7001/4].
  - 2) Reports on inbound enemy aircraft and changes to enemy air threat, from division intelligence and ADA assets [ARTEP 71-3-MTP, 71-3-3012/2, 7001/2; FM 101-5, p. 6-46].
  - 3) Priorities, restrictions, and control measures requirements, from air space users [ARTEP 71-3-MTP, 71-3-3012/2].
  - 4) Changes to air defense priorities, warnings, ROE, and weapons control status, from the division AD LNO and ADA battalion S3 [ARTEP 71-3-MTP, 71-3-3012/2, 6002/3].
  - 5) Status of airfields, from division ALOs [ARTEP 71-3-MTP, 71-3-3012/2].
  - 6) Planned and ongoing artillery fires, from Bn TF FSOs [ARTEP 71-3-MTP, 71-3-3012/2].
  - 7) Changes to IFF/SIF procedures and standard use Army aircraft flight routes (SAAFR), from the division ALO and division G3 Air [ARTEP 71-3-MTP, 71-3-3012/2, 6002/4].

- 8) Status of instrumented landing systems, NAVAIDs, FCCs, and FOCs [ARTEP 71-3-MTP, 71-3-3012/2].
  - 9) Friendly ECM activities, from the division G2 [ARTEP 71-3-MTP, 71-3-3012/2].
  - 10) Army aviation air space requirements (includes specially-equipped mission aircraft [SEMA]), from air space users [ARTEP 71-3-MTP, 71-3-3012/3].
  - 11) Status updates on brigade requests for additional air support (e.g., RPV, USAF/USN/USMC CAS and reconnaissance assets), from the division ALO, division ANGLICO, and division G3 Air [ARTEP 71-3-MTP, 71-3-3012/3].
  - 12) Changes to weather conditions and the effect of weather on ADA systems [ARTEP 71-3-MTP, 71-3-6002/3].
  - 13) Changes to aircraft coordinating altitudes [ARTEP 71-3-MTP, 71-3-6002/3].
  - 14) Locations, activities, and status of friendly ADA units [ARTEP 71-3-MTP, 71-3-6002/3, 7001/2].
- j. Brigade targeting team members exchange information internally [FM 101-5, p. 3-84; FN-AR Sch].
- 1) Copies of pertinent combat information reports are disseminated [ARTEP 71-3-MTP, 71-3-2006/6].
  - 2) Information and intelligence relative to brigade HPT and activity at NAIs, TAIs, and DPs are exchanged [ARTEP 71-3-MTP, 71-3-2006/7].
  - 3) Changes to the enemy activities and intentions are exchanged [FM 6-20-40, p. 2-22; FM 6-20-50, p. 2-22].
  - 4) Locations and status of delivery units, radars, COLTS, and CPs are disseminated [FM 6-20-40, p. 2-19; FM 6-20-50, p. 2-18, 2-22].
  - 5) Movement times and routes for fire support systems are disseminated [FM 6-20-40, p. 2-19; FM 6-20-50, p. 2-18].
  - 6) Supply and resupply status of fire support systems are exchanged [FM 6-20-40, p. 2-19; FM 6-20-50, p. 2-18].
  - 7) Information answering CCIR and IR is disseminated [FM 101-5, p. 6-2].
  - 8) Changes to or additional guidance from the brigade commander relative to the brigade commander's intent and guidance for fire support are disseminated [FM 6-20-40, p. 2-22; FM 6-20-50, p. 2-22].

- 9) Changes to priorities of fire and priority targets are disseminated [FM 6-20-40, p. 2-22; FM 6-20-50, p. 2-22].
  - 10) Implementation of FSCM are disseminated [FM 6-20-40, p. 2-19; FM 6-20-50, p. 2-21].
  - 11) Updates to Bn TF fire support plans and products are exchanged [FM 6-20-40, p. 2-12; FM 6-20-50, p. 2-12].
  - 12) Implementation of and changes to plans for brigade and division JAAT, CAS, and J-SEAD missions are disseminated [ARTEP 71-3-MTP, 71-3-3007/2].
  - 13) Operational status of MI collectors and target acquisition systems operating in the brigade AO is disseminated [ARTEP 71-3-MTP, 71-3-2004/2].
- k. Information received by the brigade targeting team members which satisfies the CCIR is immediately provided to the brigade commander [FM 101-5, p. 6-5].

**27. The Brigade Targeting Team Evaluates Information**

- a. The brigade S3 evaluates information [AN].
  - 1) Information is evaluated to ensure that the brigade commander's intent and guidance for fire support are being achieved [FM 101-5, p. 6-45].
  - 2) Information from adjacent units is evaluated to determine impact on brigade operations. Information includes [FM 101-5, p. 6-33]:
    - a) Status of units (e.g., locations, combat power) [FM 101-5, p. 6-33].
    - b) Activities being performed to achieve their missions or in response to unanticipated enemy actions [ARTEP 71-3-MTP, 71-3-3003/1; FM 101-5, p. 6-33].
    - c) Employment of fire support, including refinements to their fire support plans and assessments of target effects against enemy targets [ARTEP 71-3-MTP, 71-3-9003/10; ARTEP 6-115-20-MTP, 06-3-02-1130, 1190].
  - 3) Brigade combat power and fire support capabilities are evaluated to determine the brigade's ability to perform the mission as planned [FM 101-5, p. 6-33].
  - 4) Movement of brigade units is evaluated to ensure that brigade units are oriented on assigned objectives [FM 71-123, p. 3-21].
- b. The brigade S2 and brigade targeting officer evaluate information [AN].

- 1) Information is evaluated against the intelligence database to confirm or refute the intelligence estimate and enemy courses of action. Information evaluation determines [ARTEP 71-3-MTP, 71-3-2003/1, 2003/2; FM 101-5, p. 6-32; FN-BCTP]:
  - a) Enemy dispositions, on-going actions, and intentions [ARTEP 71-3-MTP, 71-3-2003/1; FM 101-5, p. 6-33].
  - b) Enemy capabilities [ARTEP 71-3-MTP, 71-3-2003/1; FM 101-5, p. 6-33].
  - c) Enemy vulnerabilities [FM 101-5, p. 6-33].
  - d) Effects of weather on terrain, enemy actions, and brigade operations [ARTEP 71-3-MTP, 71-3-2003/1].
  - e) Changes to terrain conditions [ARTEP 71-3-MTP, 71-3-2003/1].
  - f) Types of equipment the enemy is employing [ARTEP 71-3-MTP, 71-3-2003/1].
  - g) Consistency of enemy activity with previous indicators as depicted on the SIT TEMP and Event Templates [ARTEP 71-3-MTP, 71-3-2003/1; FN-BCTP].
  - h) Enemy perception of brigade capabilities and courses of action [ARTEP 71-3-MTP, 71-3-2003/1].
  - i) Enemy capability to conduct deception operations [ARTEP 71-3-MTP, 71-3-2003/1].
  - j) Enemy losses due to division and higher deep engagement, to determine remaining enemy capability and potential [FN-BCTP].
  - k) Dispersion of enemy formations [FM 6-20-40, Ch 3; FM 6-20-50, Ch 3].
  - l) Quantity, types, and locations of enemy artillery and mortar assets [FM 6-20-40, Ch 3; FM 6-20-50, Ch 3].
  - m) Locations of enemy command, control, and communications assets [FM 6-20-40, Ch 3; FM 6-20-50, Ch 3].
- 2) Information provided by target acquisition and collection systems is evaluated to determine its validity, reliability, and relevance to the targeting process. Assessment is performed to determine [ARTEP 71-3-MTP, 71-3-2006/4].
  - a) Timeliness and accuracy of information [ARTEP 71-3-MTP, 71-3-2006/4a, 2006/4b].

- b) Exact location of targets (six-digit coordinates) [ARTEP 71-3-MTP, 71-3-2006/4e].
  - c) Whether detected targets are HPTs [ARTEP 71-3-MTP, 71-3-2003/2c].
  - d) Whether information meets the criteria for a DP, decision line, or event [ARTEP 71-3-MTP, 71-3-2003/2i].
  - e) Times enemy formations will arrive at indirect fire trigger points based on movement speed [FM 6-20-40, Ch 3; FM 6-20-50, Ch 3].
- 3) Changes to capabilities of the collection system to acquire required information are assessed to determine requirements to change the collection plan [ARTEP 71-3-MTP, 71-3-2004/2].
  - 4) The likely enemy perception of brigade capabilities and COAs [ARTEP 71-3-MTP, 71-3-2003/1; FM 101-5, p. 6-33].
  - 5) Additional information requirements needed to fill gaps in intelligence [ARTEP 71-3-MTP, 71-3-2003/2k].
- c. The brigade FSO, brigade S3, brigade S2, and brigade targeting officer continuously evaluate the results of division and brigade deep battle operations [AN].
    - 1) BDA results on brigade HPTs included in division-deep attack operations are evaluated to determine if desired effects have been achieved [ARTEP 71-3-MTP, 71-3-2006/4, 2006/5b].
    - 2) Enemy responses and reaction to the elimination of brigade HPT during division-deep attack operations are identified to determine requirements to change the fire support plan [ARTEP 71-3-MTP, 71-3-2006/4, 2006/5b].
    - 3) See tasks 22 and 24 above.
  - d. The brigade FSO and ABE evaluate information to determine fire support requirements [AN].
    - 1) Changes to the locations of brigade obstacles, and enemy actions to reduce brigade obstacles, are assessed in order to refine brigade target lists [ARTEP 71-3-MTP, 71-3-8005/1; FM 101-5, p. 6-46; FM 6-20-40, p. 3-25; FM 6-20-50, p. 3-19].
    - 2) Information on the confirmation of enemy obstacle and brigade units activities to reduce or bypass enemy obstacles is assessed to determine refinements to fire support for breaching operations [FM 6-20-40, p. 3-4; FM 6-20-50, p. 3-2].

- 3) Changes to the enemy situation are identified to determine refinements to the FASCAM employment plan and FASCAM locations [FM 6-20-40, p. 3-3, 3-25; FM 6-20-50, p. 3-2, 3-19].
  - 4) Changes to brigade and enemy avenues of approach and mobility corridors are identified to determine requirements to adjust the fire support plan [ARTEP 71-3-MTP, 71-3-8005].
- e. The brigade FSCOORD and brigade FSO evaluate information provided by the DS FA battalion staff [AN].
- 1) Activities of the DS FA battalion are assessed to ensure that the DS FA battalion is executing the brigade fire support plan [FM 6-20-40, p. 2-18; FM 6-20-50, p. 2-18].
  - 2) FA target acquisition radars and systems operations are evaluated to ensure that they are adhering to priorities for observation [ARTEP 6-115-MTP, 06-2-01-2513/1].
    - a) Radars and systems are positioned as directed [ARTEP 6-115-MTP, 06-2-01-2513/1].
    - b) Searches are being executed in directed sectors [ARTEP 6-115-MTP, 06-2-01-2513/1].
    - c) Coverage of the brigade AO is being achieved as directed [ARTEP 6-115-MTP, 06-2-01-2513/1].
    - d) Brigade radar zones are integrated with division radar zones to ensure that no gaps in coverage exist [ARTEP 6-115-MTP, 06-2-01-2513/1].
- f. The brigade FSO and brigade targeting team evaluate fire support plans and targets provided by Bn TF FSOs during execution of their fire support plan [FM 6-20-40, p. 2-8; FM 6-20-50, p. 2-8].
- 1) Duplicate targets are identified and are either deleted or modified [FM 6-20-40, p. 2-8; FM 6-20-50, p. 2-8].
  - 2) Targets that do not fit the brigade commander's intent and support the brigade scheme of maneuver are deleted [FM 6-20-40, p. 2-8; FM 6-20-50, p. 2-8].
  - 3) New targets identified and developed by Bn TF FSOs are added to target lists and the fire support plan [FM 6-20-40, p. 2-13; FM 6-20-50, p. 2-13].
- g. The brigade S3, brigade S3 Air, brigade S2, brigade FSO, brigade ALO, brigade ANGLICO, and brigade aviation LNO evaluate reports and updates from air space users [ARTEP 71-3-MTP, 71-3-7001/4].

- 1) Intelligence reports are evaluated to determine enemy activities and dispositions [ARTEP 71-3-MTP, 71-3-7001/4].
  - 2) Requirements to adjust air space coordination measures and air space user schedules are determined based on changes to brigade and air space user requirements [ARTEP 71-3-MTP, 71-3-7001/4].
  - 3) Communications difficulties experienced by air space users are evaluated to determine required measures to correct communications problems [ARTEP 71-3-MTP, 71-3-7001/4].
  - 4) Required changes to SIF and IFF lines and procedures are evaluated to ensure that the brigade fire support plan can be implemented [ARTEP 71-3-MTP, 71-3-6002/4].
- h. Each brigade targeting team member identifies out-of-date information which is deleted or used to determine new information requirements [ARTEP 71-3-MTP, 71-3-2006/4].
  - i. The brigade S3, with brigade targeting team members, identifies highly perishable information and quickly disseminates it to higher and subordinate fire support headquarters for immediate attack (if the brigade commander's attack criteria is satisfied) [ARTEP 71-3-MTP, 71-3-2003/2, 2006/6].
  - j. See tasks 22- 24 above for brigade targeting team evaluations performed during the employment of indirect fires and assessments of attack results [AN].

**28. The Brigade Targeting Team Updates Products**

- a. The brigade targeting team continuously refines and updates the brigade fire support plans based on the results of fires and the analysis and evaluation of new information and intelligence [FM 6-20-40, p. 2-13; FM 6-20-50, p. 2-12; FN-NTC].
- b. The brigade S3, with the S3 section, brigade signal officer, brigade targeting team members, and brigade chemical officer, updates the DST, current SITMAPs and operational graphics, information displays, and journals to reflect [ARTEP 71-3-MTP, 71-3-3003/2, 2006/3; FM 101-5, p. 3-84, 6-43, 6-47, I-1; FN-AR Sch]:
  - 1) Locations of Bn TF units (down to Co/Tm level) [ARTEP 71-3-MTP, 71-3-3003/2].
  - 2) Combat power status of Bn TF systems [ARTEP 71-3-MTP, 71-3-3003/2; FM 101-5, p. 5-61].
  - 3) Bn TF activities and the brigade commander's assessment of the brigade's ability to accomplish the mission [ARTEP 71-3-MTP, 71-3-3003/2].
  - 4) Uncommitted Bn TF and brigade units, location, availability, and status [ARTEP 71-3-MTP, 71-3-3003/2].

- 5) CAS sorties requested, approved, completed, and available [ARTEP 71-3-MTP, 71-3-3003/2].
  - 6) Recent and present significant activities [ARTEP 71-3-MTP, 71-3-3003/2].
  - 7) Brigade control measures [ARTEP 71-3-MTP, 71-3-3003/2].
  - 8) Enemy locations [ARTEP 71-3-MTP, 71-3-3003/2].
  - 9) A2C2 information, including joint and Army specific measures and restrictions [ARTEP 71-3-MTP, 71-3-3012/3].
  - 10) Frequencies and call signs for brigade units, division units, and adjacent units [FM 101-5, p. 6-43].
  - 11) CP locations (current and proposed) for the brigade, division, subordinate and supporting headquarters, and adjacent units [FM 101-5, p. 6-43].
  - 12) NBC threat status [FM 101-5, p. 6-46].
  - 13) MOPP level [FM 101-5, p. 6-46].
  - 14) Support priorities for smoke, decontamination, and NBC reconnaissance [FM 101-5, p. 6-46].
  - 15) NBC overlays depicting NBC-contaminated areas and decontamination points [FM 101-5, p. 6-47].
  - 16) Assessments on vulnerability of the brigade units and personnel to enemy NBC attack [ARTEP 71-3-MTP, 71-3-3003/1].
- c. The brigade S2 and brigade targeting officer update intelligence products [ARTEP 71-3-MTP, 71-3-2005/2, 2006/3; FM 101-5, p. 3-84, I-1; FN-AR Sch]:
- 1) Intelligence database and intelligence estimate [ARTEP 71-3-MTP, 71-3-2001/5, 2006/2; FM 101-5, p. 4-4, 6-45].
  - 2) List of intelligence indicators [ARTEP 71-3-MTP, 71-3-2005/2].
  - 3) Intelligence workbook [ARTEP 71-3-MTP, 71-3-2005/2].
  - 4) PIR/IR/SIR [ARTEP 71-3-MTP, 71-3-2005/2; FM 101-5, p. 6-45].
  - 5) SITMAP [ARTEP 71-3-MTP, 71-3-2005/2, 2006/3].
  - 6) SIT TEMPs [ARTEP 71-3-MTP, 71-3-2006/3c9; FM 101-5, p. H-102; FM 71-123, p. 3-21; FN-24 ID].



- 7) Event Templates [ARTEP 71-3-MTP, 71-3-2006/3c10; FM 34-130, p. 2-50; FM 71-123, p. 3-21; FN-CGSC].
  - 8) MCOO and enemy obstacle overlays (with the ABE) [ARTEP 71-3-MTP, 71-3-2006/3c8; FM 34-130, p. 2-22; FM 101-5, p. 6-47].
  - 9) Brigade R&S, collection, and observer plans [ARTEP 71-3-MTP, 71-3-2001/4b; FN-BCBST].
- d. The brigade S2 and brigade targeting officer ensure that updated intelligence products contain [AN]:
- 1) Enemy strengths, capabilities, and vulnerabilities [ARTEP 71-3-MTP, 71-3-2003/1, 2005/2].
  - 2) Analysis of the effects of weather on the operation [ARTEP 71-3-MTP, 71-3-2003/1, 2005/2].
  - 3) Analysis of the effect of terrain on the operation, including mobility corridors [ARTEP 71-3-MTP, 71-3-2003/1; 2005/2; FM 6-20-40, p. 2-22; FM 6-20-50, p. 2-22].
  - 4) Enemy history, training, tactics, and doctrine [ARTEP 71-3-MTP, 71-3-2003/1, 2005/2].
  - 5) Size, type, and strength of enemy force encountered [ARTEP 71-3-MTP, 71-3-2003/1; FM 6-20-40, p. 2-22; FM 6-20-50, p. 2-22].
  - 6) Disposition of enemy forces, including known and suspected enemy locations [ARTEP 71-3-MTP, 71-3-2003/1, 2005/2; FM 6-20-40, p. 2-22; FM 6-20-50, p. 2-22].
  - 7) Personalities of key enemy personnel, if known [ARTEP 71-3-MTP, 71-3-2003/1, 2005/2].
  - 8) Enemy order of battle [FM 6-20-40, p. 2-22; FM 6-20-50, p. 2-22].
  - 9) Weather, including forecasts and effects [ARTEP 71-3-MTP, 71-3-2006/3c4; FM 101-5, p. 6-45].
  - 10) Status of IEW assets [ARTEP 71-3-MTP, 71-3-2006/3c7; FM 101-5, p. 6-47].
  - 11) COMINT, ELINT, and IMINT information [ARTEP 71-3-MTP, 71-3-2006/2; FM 101-5, p. 6-49].
  - 12) Locations of collection and target acquisition assets [FM 6-20-40, p. 2-22; FM 6-20-50, p. 2-22].

- 13) Operational status of MI collectors (e.g., attached, in support) [ARTEP 71-3-MTP, 71-3-2004/2].
- e. The brigade FSO and brigade targeting team update fire support products [FM 101-5, p. 3-84, I-1; FN-AR Sch]:
- 1) SITMAPS [AN].
  - 2) Fire support overlays [FM 6-20-40, p. 2-13; FM 6-20-50, p. 2-13; FM 101-5, p. 6-47].
  - 3) Target lists [FM 6-20-40, p. 2-13; FM 6-20-50, p. 2-13].
  - 4) FSEM [FM 6-20-40, p. 2-13; FM 6-20-50, p. 2-13].
  - 5) FSCM [FM 6-20-40, p. 2-13; FM 6-20-50, p. 2-13; FM 101-5, p. 6-47; FM 6-20-40, p. 2-13; FM 6-20-50, p. 2-13].
  - 6) AGM [FM 6-20-40, p. 2-13; FM 6-20-50, p. 2-13; FM 101-5, p. 6-47].
- f. The brigade FSO and brigade targeting team ensure that updated fire support products contain [ARTEP 71-3-MTP, 71-3-9002/1; ARTEP 6-115-20-MTP, 06-3-02-1130, 1190]:
- 1) Movement, routes, and locations of brigade collection and target acquisition assets [FM 6-20-40, p. 2-22; FM 6-20-50, p. 2-22; FN-NTC].
  - 2) Current friendly and enemy situation [ARTEP 71-3-MTP, 71-3-9002/1; ARTEP 6-115-20-MTP, 06-3-02-1130, 1190]:
  - 3) Brigade, division, and Bn TF boundaries and maneuver control measures [ARTEP 71-3-MTP, 71-3-9002/1; ARTEP 6-115-20-MTP, 06-3-02-1130, 1190].
  - 4) Locations of maneuver and artillery support elements [ARTEP 71-3-MTP, 71-3-9002/1; ARTEP 6-115-20-MTP, 06-3-02-1130, 1190].
  - 5) Fire support coordinating measures [ARTEP 71-3-MTP, 71-3-9002/1; ARTEP 6-115-20-MTP, 06-3-02-1130, 1190].
  - 6) Locations (actual, planned) for FA-delivered mines [ARTEP 71-3-MTP, 71-3-9002/1; ARTEP 6-115-20-MTP, 06-3-02-1130, 1190].
  - 7) Priorities for fire support [FM 101-5, p. 6-45].
  - 8) CAS missions [FM 101-5, p. 6-45].
  - 9) Status and locations of Bn TF ALO and ANGLICO elements [AN].

- 10) Targeting priorities, categorized by brigade indirect fire weapons system (e.g., FA, CAS, USN ships, non-lethal systems, mortars) [FM 101-5, p. 6-45].
- 11) Status on HPT and enemy activity at TAIs, NAIs, DPs, and other brigade targets [FM 6-20-40, Ch 2].[FM 101-5, p. 6-47].
- 12) Exact locations of obstacles [FM 101-5, p. 6-47].
- 13) Execution of missions in support of brigade units and implementation of measures to safeguard friendly forces from fratricide [ARTEP 71-3-MTP, 71-3-9002/1; ARTEP 6-115-20-MTP, 06-3-02-1130, 1190; FM 6-20-40, Ch 2].
- 14) Capabilities of indirect fire systems [ARTEP 71-3-MTP, 71-3-9002/1; ARTEP 6-115-20-MTP, 06-3-02-1130, 1190].
- 15) Ammunition status [ARTEP 71-3-MTP, 71-3-9002/1; ARTEP 6-115-20-MTP, 06-3-02-1130, 1190].
- 16) Equipment status [ARTEP 71-3-MTP, 71-3-9002/1; ARTEP 6-115-20-MTP, 06-3-02-1130, 1190].
- 17) Status on Bn TFs submission of the execution of their fire support plans [FN-FA Sch].
- 18) Receipt and allocation of additional FA, CAS, target acquisition and survey assets from division based on submitted requests [FM 101-5, p. F-20; FM 6-20-40, p. 2-5; FM 6-20-50, p. 2-5].

29. **The Brigade Targeting Team Communicates Information and Coordinates the Brigade Fire Support Plan**

- a. The brigade S3 coordinates and communicates information [AN].
  - 1) The brigade S3 immediately disseminates and implements guidance and directions from the brigade commander when it is received [FM 71-123, p. 3-35].
  - 2) The brigade S3 Air, with the brigade S3 and other brigade targeting team members, coordinates and disseminates A2C2 information and requirements [ARTEP 71-3-MTP, 71-3-7001/2]:
    - a). Joint and Army-specific measures and restrictions [ARTEP 71-3-MTP, 71-3-3012/3].
    - b). Early warning measures, procedures, and warnings [ARTEP 71-3-MTP, 71-3-7001/2].
    - c). Friendly and enemy ADA unit locations [ARTEP 71-3-MTP, 71-3-7001/2].

- d) IFF/SIF procedures for Army aircraft, to include the location of the IFF/SIF line [ARTEP 71-3-MTP, 71-3-7001/2].
  - e) Minimum risk routes [ARTEP 71-3-MTP, 71-3-7001/2].
  - f) Airspace command and control rules and procedures [ARTEP 71-3-MTP, 71-3-7001/2].
  - g) Coordinating altitudes [ARTEP 71-3-MTP, 71-3-7001/2].
  - h) IPs, ingress and egress flight routes [AN].
  - i) Rules of engagement (weapons control status and hostile criteria) [ARTEP 71-3-MTP, 71-3-7001/2].
  - j) Weather conditions and forecasts [ARTEP 71-3-MTP, 71-3-7001/2].
  - k) NBC information [ARTEP 71-3-MTP, 71-3-7001/2].
- b. The brigade S2, with the brigade targeting officer and S2 section, communicate information to the brigade commander, division G2, the MI battalion S3, and Bn TF S2s to coordinate the brigade collection plan and non-lethal attack of brigade targets [ARTEP 71-3-MTP, 71-3-2006/3, 2006/5c, 2006/6a, 2006/7e, 2006/7c; FM 71-123, p. 3-21, 3-35; FM 71-3, p. 4-4, 7-26].
- 1) Division EW assets are updated on brigade HPTs requiring attack and desired effect of attack [FN-194 AR].
  - 2) Requests for additional information to fill gaps in intelligence are coordinated [ARTEP 71-3-MTP, 71-3-2002/1, 2003/2].
  - 3) Information and information requirements from the division, brigade and Bn TF collection and R&S plans are coordinated to ensure that the enemy and the brigade AO are under constant observation and surveillance [ARTEP 71-3-MTP, 71-3-2002/1].
  - 4) Acquisition of information supporting intelligence taskings is coordinated after analysis and evaluation [ARTEP 71-3-MTP, 71-3-2006/7; FN-AR Sch].
  - 5) Information on acquisition and tracking of HPT is coordinated [ARTEP 71-3-MTP, 71-3-2006/4].
  - 6) Changes to the movement, positioning, and targeting to be performed by target acquisition systems to meet changing battlefield conditions are coordinated [ARTEP 6-115-20-MTP, 06-2-02-1000/2].

- c. The brigade FSO, with the brigade ALO, brigade ANGLICO, and brigade aviation LNO, communicates information to the division FSCoord, division ALO, division ANGLICO, DIVARTY S3, aviation brigade S3, DS FA battalion S3, Bn TF FSOs, and adjacent unit FSOs to coordinate the brigade fire support plan [FM 6-20-40, p. 2-18, A-3; FM 6-20-50, p. C-3; FM 71-3, p. 7-4; FM 101-5, p. L-6; FN-NTC; FN-AR Sch].
- 1) Requests for additional fire support systems are coordinated and integrated into the brigade fire support plan when approved [ARTEP 6-115-20-MTP, 06-2-02-1000/3; FM 101-5, p. F-20; FM 6-20-40, p. 2-5; FM 6-20-50, p. 2-5; FN-JRTC].
  - 2) Division radar zones are coordinated to ensure synchronization and integration with brigade radar zones [ARTEP 6-115-MTP, 06-2-01-2513/1; FN-JRTC].
  - 3) Continuous updates on brigade dispositions, situation, and scheme of maneuver, including possible changes based on the analysis of new information, are exchanged to deter fratricide [FM 6-20-40, Ch 2; ARTEP 6-115-20-MTP, 06-3-02-1100/5].
  - 4) Division, brigade, and Bn TF FSCM are coordinated and integrated in fire support plans [FM 6-20-40, p. E-1; FM 6-20-50, p. G-1].
  - 5) Primary and alternate communications nets and frequencies are coordinated and employed to counter enemy jamming [FM 6-20-40, Ch 2].
  - 6) Fires by Bn TFs are coordinated to ensure that they support the brigade fire support plan [ARTEP 71-3-MTP, 71-3-9003/1; ARTEP 6-115-20-MTP, 06-3-02-1130, 1190].
  - 7) The attack of brigade targets or other targets which could impact on brigade operations outside of the brigade AO is coordinated [ARTEP 6-115-20-MTP, 06-3-02-1300/2].
  - 8) Movement and position requirements for FA systems and target acquisition assets are coordinated to ensure that they will not hinder division, brigade, and Bn TF schemes of maneuver [ARTEP 6-115-20-MTP, 06-2-02-1000/2; FM 6-20-40, Ch 3; FN-NTC].
  - 9) Movement, positioning, and employment of Bn TF mortar platoons providing support to the brigade fire support plan are coordinated [ARTEP 6-115-20-MTP, 06-3-02-1390/3].
  - 10) Targeting information and intelligence are immediately coordinated to facilitate target tracking and attack [ARTEP 6-115-20-MTP, 06-2-02-1000/4; ARTEP 71-3-MTP, 71-3-2003/2f; 2006/4; FM 6-20-40, Ch 2].
  - 11) Preplanned and immediate CAS requirements are coordinated [FM 6-20-40, Ch 2].

- 12) Employment of Army aviation aircraft in support of brigade fire support and target acquisition operations are coordinated [ARTEP 6-115-MTP, 06-1-02-2600/2].
  - 13) Changes to the fire support plan are coordinated and disseminated as soon as approved [FM 6-20-40, p. 2-18; FM 6-20-50, p. 2-18; FN-NTC].
- d. The brigade targeting team disseminates updated products to higher, adjacent, supporting, and supported headquarters [AN]:
- 1) Brigade DST [ARTEP 71-3-MTP, 71-3-3003/2; FM 101-5, p. 6-47].
  - 2) SITMAPS and maneuver overlays [ARTEP 71-3-MTP, 71-3-3003/2, 2005/2, 2006/3; FM 101-5, p. 6-47].
  - 3) Updated brigade R&S and collection plans and overlays [ARTEP 71-3-MTP, 71-3-2001/4b, 2002/1].
  - 4) List of intelligence indicators [ARTEP 71-3-MTP, 71-3-2005/2].
  - 5) Brigade CCIR and IR [ARTEP 71-3-MTP, 71-3-2005/2].
  - 6) SIT TEMPs [ARTEP 71-3-MTP, 71-3-, 2--3/2, 2006/3c9; FM 101-5, p. H-102; FN-24 ID].
  - 7) Event Templates [ARTEP 71-3-MTP, 71-3-2003/2, 2006/3c10; FM 34-130, p. 2-50; FN-CGSC].
  - 8) MCOO [ARTEP 71-3-MTP, 71-3-2006/3c8; FM 34-130, p. 2-22].
  - 9) Fire support overlays [FM 6-20-40, p. 2-13; FM 6-20-50, p. 2-13; FM 101-5, p. 6-47].
  - 10) Target lists [FM 6-20-40, p. 2-13; FM 6-20-50, p. 2-13].
  - 11) FSEM [FM 6-20-40, p. 2-13; FM 6-20-50, p. 2-13].
  - 12) FSCM [FM 6-20-40, p. 2-13; FM 6-20-50, p. 2-13; FM 101-5, p. 6-47].
  - 13) AGM [FM 6-20-40, p. 2-13; FM 6-20-50, p. 2-13; FM 101-5, p. 6-47].
  - 14) A2C2 measures, as they are implemented and changed [ARTEP 71-3-MTP, 71-3-7001/4].

### 30. **The Brigade Commander Visualizes the Battlefield**

- a. The brigade commander continuously assesses mission execution and updates his

estimate of the current situation by receiving information on the current status of the fire support plan and the effects of indirect fires on the enemy [FM 101-5, p. 4-46].

- 1) The brigade commander considers information from his personal observations [FM 101-5, p. 6-8; FM 71-3, p. 3-3; "Battle Command," p. 10, 15].
  - 2) The brigade commander receives answers to CCIR and other combat information from the brigade targeting team, the brigade staff, and subordinate leaders [FM 101-5, p. 6-2, 6-5, 3-84, 4-47, 6-6].
  - 3) The brigade commander receives information from LNOs attached to other units and LNOs attached to the brigade [FM 101-5, p. L-1].
  - 4) The brigade commander receives information by eavesdropping on division nets and cross-talking with other commanders, division staff, and division command group on division nets [FM 101-5, p. I-4; FM 71-3, p. 3-3].
  - 5) The brigade commander receives status reports and situation updates from Bn TF commanders and their staffs on their abilities to employ indirect fires [FM 101-5, p. 3-84].
- b. The brigade commander continuously assesses the maneuver aspects of brigade plans and the execution of the brigade scheme of maneuver by brigade units; the brigade commander updates his estimate of the current situation [AN].
- 1) The brigade S3 provides updates to the brigade DST, DPs, NAIs, TAIs, and other maneuver control measures resulting from integration and synchronization of Bn TF scheme of maneuver [ARTEP 71-3-MTP, 71-3-3016/1].
  - 2) The brigade S3 provides updates and adjustments to the brigade scheme of maneuver based on reports from Bn TFs on their actions to accomplish their missions, refinements to IPB products, and the changing tactical situation [ARTEP 71-3-MTP, 71-3-3003/1, 3003/3].
  - 3) The brigade S3 provides updates on changes to the division commander's intent, guidance for fire support, and concept of the operations [AN].
  - 4) The brigade S3 provides updates on the status of Bn TFs in terms of mission progress, completion, and adherence to brigade timelines [ARTEP 71-3-MTP, 71-3-3003/3].
  - 5) The brigade S3 provides updates on the disposition and locations of brigade units and changes to their plans based on contact with the enemy and enemy responses [ARTEP 71-3-MTP, 71-3-3003/3].
  - 6) The brigade S3 provides updates on the current locations, activities, and intentions of adjacent units (left, right, front, rear, higher) [AN].

- 7) The brigade S3 provides updates on current A2C2 operations and control measures [ARTEP 71-3-MTP, 71-3-3012/2a, 3013/3].
- c. The brigade commander continuously assesses intelligence and target acquisition aspects of the mission execution; the brigade commander updates his estimate of the current situation [AN].
- 1) The brigade S2 provides updates on the enemy's most likely course of action based on analysis of on-going enemy actions [ARTEP 71-3-MTP, 71-3-3003/3; FM 71-3, p. 2-3].
  - 2) The brigade S2 provides updates on enemy vulnerabilities [ARTEP 71-3-MTP, 71-3-3003/3].
  - 3) The brigade S2 provides updates on the confirmation of the enemy's order of battle [ARTEP 71-3-MTP, 71-3-3003/3].
  - 4) The brigade S2 provides updates on the enemy's intention to employ NBC and EW [ARTEP 71-3-MTP, 71-3-3003/3].
  - 5) The brigade S2 provides updated SIT TEMP and Event Templates to reflect the current enemy situation [ARTEP 71-3-MTP, 71-3-2006/3c9, 2006/3c10; FM 34-130, p. 2-50; FM 101-5, p. H-102; FN-24 ID; FN-CGSC].
  - 6) The brigade S2 provides the updated MCOO to reflect terrain conditions in the brigade AO [ARTEP 71-3-MTP, 71-3-2006/3c8; FM 34-130, p. 2-22].
  - 7) The brigade S2 provides information generated by the execution of the brigade consolidated R&S and collection plans [ARTEP 71-3-MTP, 71-3-2004/2, 2006/3c7].
  - 8) The brigade S2 and brigade targeting officer provide current locations, status, and activities of target acquisition and collection systems [ARTEP 71-3-MTP, 71-3-3003/3].
  - 9) The brigade S2 and brigade targeting officer provide information and intelligence received from collection operations which satisfy CCIR [FM 6-20-40, p. 2-5; FM 6-20-50, p. 2-5].
  - 10) The brigade S2 and brigade targeting officer provide updates on enemy activities at DPs, NAIs, and TAIs [FM 6-20-10, p. 1-10].
- d. The brigade commander continuously assesses the results of the execution of the brigade fire support plan; the brigade commander updates his estimate of the current situation based on the information supplied to him [AN]:



- 1) The brigade S2 and brigade targeting officer provide results of division and brigade deep battle attack against brigade HPTs, including BDA and the effects of target attack [ARTEP 71-3-MTP, 71-3-2006/4, 2006/5b; FM 6-20-10, p. 1-10; FM 6-20-40, p. 3-23; FM 6-20-50, p. 3-18].
- 2) The brigade S2 provides information on enemy responses and reaction to the elimination of brigade HPT during division and brigade-deep attack operations [ARTEP 71-3-MTP, 71-3-2006/4, 2006/5b; FM 6-20-10, p. 1-10].
- 3) The brigade FSO provides status on Bn TF execution of its fire support plans [ARTEP 71-3-MTP, 71-3-3003/3; FM 6-20-10, p. 5-3; FM 6-20-40, p. 2-13; FM 6-20-50, p. 2-13].
- 4) The brigade FSO provides updates on refinements to the brigade fire support plan resulting from [ARTEP 71-3-MTP, 71-3-9003/10; ARTEP 6-115-20-MTP, 06-3-02-1130, 1190; FM 6-20-40, p. 2-8; FM 6-20-50, p. 2-8; FN-FA Sch]:
  - a) Changes to Bn TF fire support requirements [ARTEP 71-3-MTP, 71-3-3003/3; FM 6-20-10, p. 5-3; FM 6-20-40, p. 2-13; FM 6-20-50, p. 2-13].
  - b) Changes to projected enemy courses of action [ARTEP 71-3-MTP, 71-3-3003/3; FM 71-3, p. 2-3].
  - c) Changes generated by the attack of targets of opportunity [FM 6-20-40, p. F-1; FM 6-20-50, p. D-1].
  - d) Changes to the brigade's ability to employ fire support due to the loss of target acquisition systems and firing units [FM 6-20-40, p. 2-22; FM 6-20-50, p. 2-22].
- 5) The brigade FSO, brigade ALO, and brigade ANGLICO provide current status on composition and activities of brigade fire support assets [ARTEP 71-3-MTP, 71-3-3003/3].
- 6) The brigade FSO provides information concerning actions to synchronize and integrate lethal and non-lethal indirect fires with the brigade scheme of maneuver to achieve the brigade commander's intent [FM 71-3, p. 2-3].
- 7) The brigade FSO provides current locations, status, and preparation activities taken to execute the brigade fire support plan by DS FA battalion firing batteries and radars [ARTEP 6-115-20-MTP, 06-3-02-1100/3; ARTEP 71-3-MTP, 71-3-3003/3; FM 6-20-40, p. 2-18; FM 6-20-50, p. 2-18].
- 8) The brigade FSO, brigade ALO, and brigade ANGLICO provide changes to ammunition status of their fire support systems [FM 6-20-1, p. 2-4].

- 9) The brigade ALO and brigade ANGLICO provide updates on and changes to the ATO, current status on planned and immediate CAS missions, and results of CAS missions [FM 6-20-40, p. A-9, A-11, A-30; FM 6-20-50, p. C-7, C-8, C-28; FN-NTC; FN-CGSC].
  - 10) The brigade ANGLICO provides updates on and changes to the current status and results of naval surface fires [FM 71-3, p. 7-13; FM 6-20-40, p. A-28, A-29; FM 6-20-50, p. C-26, C-27; FM 101-5, p. H-126; NWP 3-09.11M, p. 2-1, 2-6; FN-194 AR].
  - 11) The brigade aviation LNO provides updates on the current status and activities of Army aviation assets providing observation and target acquisition support [ARTEP 71-3-MTP, 71-3-7001/1, 7001/2; FM 6-20-40, p. A-31; FM 6-20-50, p. C-29; FM 101-5, p. 6-49; FM 1-111, p. 3-2; FN-JRTC].
  - 12) The brigade S2 and DS MI company commander provide updates on the current status and activities of IEW assets providing non-lethal fires [ARTEP 71-3-MTP, 71-3-2004/2, 2006/3c7; FM 101-5, p. 6-47].
  - 13) The brigade FSO provides the current status of brigade requests to the division for additional fire support [ARTEP 71-3-MTP, 71-3-3003/5].
  - 14) The brigade FSO provides updates on changes to FSCM resulting from division guidance and input from subordinate units [FM 6-20-40, p. G-1; FM 6-20-50, p. E-1].
- e. The brigade commander continuously assesses the execution of indirect fires and the results of indirect fires on the enemy to determine if the brigade is engaging the enemy simultaneously throughout the depth of the battlefield as planned; the brigade commander updates his estimate of the current situation based on fire support information provided by the brigade targeting team [FM 101-5, p. 4-46; FM 71-3, p. 2-4].
- f. The brigade commander projects the outcome of the current battle to determine if the current OPORD meets the assessed situation by comparing his current "running estimate" with his visualization of needed end states for fire support as stated in the current OPORD [FM 6-20-10, p. 5-5; FM 6-20-40, p. 2-5; GM 6-20-50, p. 2-5; FM 101-5, p. 4-48].
- 1) The brigade commander determines if additional guidance to the brigade targeting team and subordinate units is required to achieve needed end states [FM 6-20-10, p. 5-5].
  - 2) The brigade commander determines if his visualization of the needed end states for indirect fires as stated in the current OPORD will still support the brigade mission [FM 6-20-10, p. 5-5].

- 3) New information about enemy equipment and tactics is assessed [FM 6-20-10, p. 5-5; FM 6-20-40, p. 2-5; FM 6-20-50, p. 2-5].
  - 4) Changes in the brigade's fire support and target acquisition capabilities are assessed [FM 6-20-10, p. 5-5; FM 6-20-40, p. 2-5, 2-22; FM 6-20-50, p. 2-5, 2-22].
  - 5) Impact of division disapproval on brigade requests for additional fire support is assessed [ARTEP 71-3-MTP, 71-3-3003/5].
  - 6) Losses (e.g., to enemy action, maintenance) of fire support, target acquisition, and collection systems are assessed [FN-NTC].
  - 7) Bn TF actions to execute its fire support plans are assessed [ARTEP 71-3-MTP, 71-3-3003/3].
  - 8) Impact of failure by brigade units to achieve the desired results their fire support plans and missions in accordance with planned timelines is determined [ARTEP 71-3-MTP, 71-3-3003/3].
  - 9) Impact of new fire support requirements which exceed brigade capabilities are identified through the analysis and evaluation of information and intelligence [FM 6-20-40, Ch 2].
  - 10) The brigade's ability to engage the enemy simultaneously throughout the depth of the battlefield as planned is assessed [FM 71-3, p. 2-4].
- g. The brigade commander determines the feasibility of collection plans' ability to acquire and track brigade HPTs and other targets based on the assessed situation [FM 6-20-10, p. 1-10, 2-11].
- h. The brigade commander projects the outcome of the current battle to determine requirements for additional fire support or target acquisition systems needed to achieve the required end state for the current mission [AN].
- 1) The brigade commander identifies additional fire support attack systems (e.g., FA, CAS, naval surface fires, non-lethal) required to execute the OPORD fire support plan [FM 6-20-40, p. 2-5; FM 6-20-50, p. 2-5].
  - 2) The brigade commander identifies additional target acquisition and collection systems required to implement the base fire support plan [FM 6-20-40, p. 2-5; FM 6-20-50, p. 2-5].
  - 3) The brigade commander identifies alternatives and options for changing the current distribution and missions of existing brigade target acquisition and attack systems assets to allow the OPORD fire support plan to be executed [FM 6-20-40, p. 2-5; FM 6-20-50, p. 2-5].

- i. The brigade targeting team assists the brigade commander in his assessment of the OPORD fire support plan by continuously wargaming current mission branches and sequels based on new information and status of Bn TF actions to execute and achieve its missions [FM 101-5, p. 4-39; FM 6-20-10, p. 5-5; FM 6-20-40, p. 2-5; FM 6-20-50, p. 2-5].
- j. The brigade commander determines required actions to correct shortfalls in the execution of the OPORD fire support plan or preparation activities based on his "running estimate" and his analysis of the base fire support plan. Options are [FM 6-20-10, p. 4-46, 5-5]:
  - 1) The brigade commander directs the brigade targeting team and Bn TFs to implement adjustments to the execution of their fire support plans based on his refined "running estimate," the brigade timeline, and his appraisal of the current situation [AN].
  - 2) The brigade commander determines the need to adjust his CCIR and IR as the situation changes and as he determines that different or additional information is critical to his decision making [FM 101-5, p. 6-9].
  - 3) The brigade commander determines that the OPORD must be modified by a FRAGO [FM 101-5, p. 4-48].
- k. The brigade commander considers future requirements and actions based on his projection of the outcome of the current battle [FM 101-5, p. 4-46]
  - 1) The brigade targeting team continuously refines the OPORD fire support plan for existing contingency plans, branches, and sequels based on updated information, updated intelligence, enemy actions, and the status of brigade units in executing their missions [ARTEP 71-3-MTP, 71-3-3016/2; FM 6-20-40, p. 2-5; FM 6-20-50, p. 2-5].
  - 2) The brigade targeting team develops new fire support plans for new contingency plans, branches, and sequels based on guidance from the brigade commander [ARTEP 71-3-MTP, 71-3-3016/1].

**31. The Brigade Commander Directs Changes to the Operation or Plan**

- a. The brigade commander uses the time-constrained Decision Making Process (DMP) by employing the Concept, Planning, and/or preparation, Execution, and Assessment (CPEA) methodology to develop the FRAGO [FM 101-5, p. 4-41].
- b. The brigade XO implements the brigade commander's decisions and FRAGO guidance [ARTEP 71-3-MTP, 71-3-0001/8; FM 101-5, p. H-11].
- c. The brigade S3 prepares FRAGOs to change the existing plan and implement the brigade commander's new guidance and directions [ARTEP 71-3-MTP, 71-3-3010/1].

- 1) The brigade S3 refines the plan as directed in the brigade commander's guidance [ARTEP 71-3-MTP, 71-3-3010/1].
- 2) The brigade S3 coordinates the FRAGO with brigade staff members to synchronize maneuvers with all other battlefield operating systems [ARTEP 71-3-MTP, 71-3-3010/1].
- 3) The brigade S3 develops the FRAGO [ARTEP 71-3-MTP, 71-3-3010/2]:
  - a) Refers to the previous base order [ARTEP 71-3-MTP, 71-3-3010/2].
  - b) Indicates changes to the task organization [ARTEP 71-3-MTP, 71-3-3010/2].
  - c) Includes a brief outline of the situation that generated the need for the FRAGO [ARTEP 71-3-MTP, 71-3-3010/2].
  - d) States the mission [ARTEP 71-3-MTP, 71-3-3010/2].
  - e) Provides brief and specific instructions for the conduct of the revised base plan without loss of clarity [ARTEP 71-3-MTP, 71-3-3010/2].
- d. The brigade targeting team performs the quick fire planning process to replace the existing fire support plan in order to support the new FRAGO, as required (see task 1a - I) [FM 6-20-40, p. 2-13; FM 6-20-50, p. 2-13].
- e. The brigade targeting team prepares revised base fire support plans and products [AN].
  - 1) Brigade DST [ARTEP 71-3-MTP, 71-3-3003/2; FM 101-5, p. 6-47].
  - 2) SITMAPS and maneuver overlays [ARTEP 71-3-MTP, 71-3-3003/2, 2005/2, 2006/3; FM 101-5, p. 6-47].
  - 3) Updated brigade R&S and collection plans and overlays [ARTEP 71-3-MTP, 71-3-2001/4b, 2002/1].
  - 4) List of intelligence indicators [ARTEP 71-3-MTP, 71-3-2005/2].
  - 5) Brigade CCIR and IR [ARTEP 71-3-MTP, 71-3-2005/2].
  - 6) SIT TEMPs [ARTEP 71-3-MTP, 71-3-, 2--3/2, 2006/3c9; FM 101-5, p. H-102; FN-24 ID].
  - 7) Event Templates [ARTEP 71-3-MTP, 71-3-2003/2, 2006/3c10; FM 34-130, p. 2-50; FN-CGSC].
  - 8) MCOO [ARTEP 71-3-MTP, 71-3-2006/3c8; FM 34-130, p. 2-22].

- 9) Fire support overlays [FM 6-20-40, p. 2-13; FM 6-20-50, p. 2-13; FM 101-5, p. 6-47].
  - 10) Target lists [FM 6-20-40, p. 2-13; FM 6-20-50, p. 2-13].
  - 11) FSEM [FM 6-20-40, p. 2-13; FM 6-20-50, p. 2-13].
  - 12) FSCM [FM 6-20-40, p. 2-13; FM 6-20-50, p. 2-13; FM 101-5, p. 6-47].
  - 13) AGM [FM 6-20-40, p. 2-13; FM 6-20-50, p. 2-13; FM 101-5, p. 6-47].
- f. The brigade commander, or the brigade XO or brigade S3, issues the FRAGO, with all accompanying products; Bn TF commanders and S3s, the division G3, and all supporting and adjacent headquarters acknowledge receipt of the FRAGO [ARTEP 71-3-MTP, 71-3-3010/2b; FN-CGSC].
  - g. The brigade targeting team synchronizes the FRAGO by coordinating internally and with higher, adjacent, supporting, and subordinate units (see task 14-17 above) [ARTEP 6-115-20-MTP, 06-3-02-1100/4; FM 6-20-40, p. 2-5; FM 6-20-50, p. 2-5; FM 101-5, App B; FN-NTC].
  - h. The brigade targeting team prepares new requests for additional fire support and target acquisition assets to support the new base fire support; requests are submitted to the division G3 [FM 101-5, p. F-20; FM 6-20-40, p. 2-5; FM 6-20-50, p. 2-5].

### 32. **The Brigade Commander Directs and Leads Subordinate Forces**

- a. The brigade commander provides command presence by exercising the Battle Command elements of leadership and information assimilation; the brigade commander maintains unit cohesion and discipline [FM 101-5, p. 4-60; "Battle Command," p. 10, 15].
  - 1) The brigade commander and brigade FSCOORD position themselves to [FM 71-3, p. 3-3]:
    - a) Observe and influence brigade maneuver and plan execution [FM 101-5, p. 1-5].
    - b) Synchronize fire support and other combat multipliers with maneuver execution [FM 101-5, p. 1-5].
    - c) Retain freedom to move; they do not become engaged in individual direct combat execution [FM 101-5, p. 1-5].
    - d) Survive on the battlefield [FM 101-5, p. 1-5].
    - e) Communicate with division, brigade CPs, adjacent units, and subordinate units [FM 101-5, p. 1-5].

- 2) The brigade commander keeps subordinate leaders informed of the situation and makes personal contact with brigade units and soldiers to:
  - a) Increase morale ["Battle Command," p. 11].
  - b) Maintain situational awareness [FM 101-5, p. 1-7; "Battle Command," p. 11].
  - c) Understand effects of battle on units and soldiers ["Battle Command," p. 11].
- 3) The brigade commander displays a calm presence to subordinates while clearly delineating guidance and providing precise and simple orders and instructions [AN].
- 4) The brigade commander monitors subordinates and self for degradation of mental and physical capability [FM 101-5, p. 5-7; "Battle Command," p. 27].
- 5) The brigade commander emphasizes cross-talk between subordinate commanders and supporting elements on the brigade command net or O&I net to [AN]:
  - a) Coordinate efforts [AN].
  - b) Ensure mutual support [AN].
  - c) Integrate and synchronize efforts [AN].
  - d) Prevent fratricide [AN].
  - e) Increase situational awareness [AN].
- b. The brigade commander synchronizes tactical operations and the collection plan by coordinating with the brigade S2 and brigade targeting officer. The brigade S2 and brigade targeting officer provide relevant information to the brigade commander on [FM 6-20-10, p. 1-8, 2-2; FM 34-2, p. 3-14; FM 6-20-40, p. 2-11; FM 6-20-50, p. 2-11]:
  - 1) Information supporting CCIR and IR [FM 34-2, p. 3-14; FM 6-20-10, p. 2-11; FM 101-5, p. 4-47].
  - 2) Acquisition and tracking of brigade HPT [FM 6-20-10, p. 2-2].
  - 3) Synchronization of collection operations for complete coverage of the brigade AO [FM 6-20-10, p. 2-2].
  - 4) BDA reports resulting from the indirect fire attack of brigade HPT [FM 6-20-10, p. 1-8, 2-27; FM 34-130, p. A-7].
- c. The brigade commander synchronizes tactical operations and the fire support plan by coordinating with the brigade targeting team; brigade targeting team members provide

relevant information to the brigade commander on [ARTEP 6-115-20-MTP, 06-3-02-1380/2; FM 101-5, p. 4-59, M-1]:

- 1) Available fire support, assigned missions, and status on requests for additional fire support [FM 101-5, p. F-20; FM 6-20-40, p. 2-5; FM 6-20-50, p. 2-5].
  - 2) Current status of task organization of fire support assets [FM 6-20-2, p. B-3; FM 101-5, p. H-123].
  - 3) Status and locations of FA and mortar firing systems, target acquisition systems, radars, and observers [ARTEP 6-115-20-MTP, 06-3-02-1100/5; FM 6-20-40, p. 2-22; FM 6-20-50, p. 2-22; FN-NTC].
  - 4) Status of CAS support, including ALO and ANGLICO personnel and equipment [FM 71-3, p. 7-8; FM 6-20-40, p. A-8; FM 6-20-50, p. C-5].
  - 5) Status of naval surface fires, including ANGLICO personnel and equipment [FM 6-20-40, p. A-3; FM 6-20-50, p. C-13].
  - 6) Status of Army aviation support [FM 1-111, p. 2-33, 3-3; ARTEP 71-3-MTP, 71-3-7001/1].
  - 7) Status of brigade indirect fires supporting brigade obstacles or brigade obstacle breaching operations [ARTEP 71-3-MTP, 71-3-8005/2b1; FM 6-20-40, p. 3-18, 3-19; FM 6-20-50, p. 3-19, I-17].
  - 8) Status of non-lethal fires and IEW personnel and equipment [FM 6-20-40, p. 2-12; FM 6-20-50, p. 2-11].
  - 9) Quantities and duration of FA, naval, and mortar special munitions (e.g., illumination, FASCAM, Copperhead, smoke) and other munitions [FM 6-20-40, p. 3-19, H-1; FM 6-20-50, p. 3-19; I-1; FM 5-102, p. 82; FM 71-123, p. 8-3].
  - 10) Status of HPTs and other brigade targets as reflected on the HPTL and target lists [ARTEP 71-3-MTP, 71-3-9001/3; ARTEP 6-115-20-MTP, 06-3-02-1130, 1190].
  - 11) Status on refinements to the FSEM and FSCM [ARTEP 71-3-MTP, 71-3-9001/3; ARTEP 6-115-10-MTP, 06-3-02-1130, 1190; FM 101-5, p. H-128].
  - 12) Status on A2C2 operations and control measures [ARTEP 71-3-MTP, 71-3-3012/2a, 3013/3].
- d. The brigade commander synchronizes tactical operations and the fire support plan by coordinating with subordinate unit commanders and their staffs; subordinate commanders and their staffs provide relevant information to the brigade commander on [FM 101-5, p. 4-59, M-1]:



- 1) Indirect fires fired and to be fired in support of brigade targets (e.g., HPT, FASCAM, SEAD) [FM 71-2, p. 6-9].
  - 2) Indirect fires in support of breaching operations [FM 71-2, p. 3-54].
  - 3) Indirect fires in support of obstacles [FM 71-2, p. 4-16].
  - 4) Employment of Bn TF mortars in support of the brigade fire support plan [FM 71-2, p. 6-16].
  - 5) Indirect fires in support of the brigade rear battle [FM 6-20, p. 3-11; FN-NTC].
  - 6) Actions to observation of brigade NAIs and TAIs [FM 71-123, p. 2-51; FM 71-2, p. 1-8].
  - 7) Actions to acquire brigade HPTs [FM 71-123, p. 2-51; FM 71-2, p. 1-8].
  - 8) Measures to provide security for brigade collection assets operating in the Bn TF AOs [FM 71-123, p. 2-51; FM 71-2, p. 1-8].
  - 9) Measures to collect CCIR and IR [FM 71-123, p. 2-51; FM 71-2, p. 1-8].
- e. The brigade commander synchronizes fire support with brigade operations [AN]. He:
- 1) Monitors and directs the maneuver of brigade combat forces and uses the DST as an aid to synchronize the brigade battle [FM 71-3, p. 3-27; FN-AR Sch].
  - 2) Monitors the execution of indirect fires to ensure synchronization with brigade maneuver and other combat multipliers by using the DST and FSEM as aids [FM 6-20-10, p. 5-14; FM 71-3, p. 3-26; FN-JRTC].
  - 3) Monitors subordinate unit actions; provides direction and guidance to subordinate unit commanders to ensure that [AN]:
    - a) They understand and are striving to achieve the brigade commander's intent [FM 101-5, p. M-8].
    - b) Are accomplishing assigned missions and tasks as described in their concept of the operation and plans [FM 101-5, p. M-8].
  - 4) Monitors actions by the brigade targeting team; provides direction and guidance to brigade targeting team members to ensure that [AN]:
    - a) Modifications and refinements to the fire support plan are completed, coordinated, and synchronized with maneuver [FM 101-5, p. 4-59, M-1].

- b) Fire support is being executed as planned and meets the brigade commander's intent, and that fires achieve the desired results [FM 6-20-40, p. 3-2, 3-18, 3-42; FM 6-20-50, p. 3-2, 3-18, 3-28].
  - c) Brigade HPT are attacked as planned [FM 6-20-10, p. 2-2].
  - d) Lethal and non-lethal fires are employed in support of brigade operations [FM 71-3, p. 2-4].
  - e) Time factors relevant to the concept of the operation are being followed [FM 6-20-40, p. 2-6; FM 6-20-50, p. 2-6].
  - f) FSCM are integrated with maneuver control measures [FM 6-20-10, p. 5-14; FN-FA Sch].
  - g) Battle handover is synchronized between [AN]:
    - (1) Division deep battle and brigade deep battle [FM 6-20-10, p. 5-14].
    - (2) Brigade deep battle and close battle (e.g., performed by subordinate Bn TFs) [FM 6-20-10, p. 5-14].
  - h) Fires are cleared to prevent fratricide [FM 6-20-10, p. 5-14].
  - D) Indirect fires are responsive and are synchronized with all of the brigade commander's resources for the battle [FM 6-20-40, p. 2-6; FM 6-20-50, p. 2-6].
- 5) Provides continuous guidance and direction to the brigade targeting team on fire support; directs changes to the fire support plan based on the tactical situation [AN].

**33. The Brigade Consolidates and Reorganizes<sup>43</sup>**

- a. The brigade commander issues appropriate orders and instructions to the brigade targeting team and Bn TF commanders to [AN]:
  - 1) Occupy new positions to consolidate terrain and objectives against enemy attacks and counterattacks [AN].
  - 2) Initiate planning and preparation activities to prepare for future missions [AN].
  - 3) Perform fire support planning to protect the brigade's transition between missions [AN].
- b. The brigade S2 refines the existing collection or, as required, prepares and implements new collection plans in order to observe DPs, NAIs, TAIs, and to regain and maintain contact with the enemy [FM 6-20-10, p. 1-8, 2-2; FM 34-2, p. 3-14].

- c. The brigade targeting team refines the existing fire support plan or, as required, performs quick fire planning (see task 1a-I ), to [AN]:
  - 1) Compensate for losses to target acquisition and attack systems [AN].
  - 2) Develop new targets based on enemy activities [AN].
- d. The brigade XO oversees fire support weapons system replacement operations and the reorganization and refit of fire support systems and target acquisition assets [ARTEP 71-3-MTP, 71-3-0002; FM 71-3, p. 8-23; FM 6-20-1, p. 7-25].
- e. The brigade commander directs that reorganization measures be initiated; reorganization options are [FM 71-3, p. 8-22; FM 6-20-1, p. 7-24]:
  - 1) Immediate reorganization: to temporarily restore degraded brigade units to minimum levels of effectiveness with assets internal to the brigade [FM 71-3, p. 8-22; FM 6-20-1, p. 7-24].
  - 2) Deliberate reorganization: to restore degraded brigade units from internal brigade assets and assets provided from division and higher sources [FM 71-3, p. 8-22; FM 6-20-1, p. 7-24].
- f. The brigade targeting team and brigade fire support elements perform reorganization [FM 6-20-1, p. 7-24].
  - 1) Key and critical fire support leaders and personnel are replaced and the chain of command is reestablished [AN].
  - 2) Casualties are treated and evacuated [AN].
  - 3) Inoperative fire support and target acquisitions equipment are recovered, repaired, returned to users, or evacuated [AN].
  - 4) Fire support units resupply and cross-level CL III and V to maintain basic loads [AN].
  - 5) Fire support personnel and equipment are redistributed as needed [AN].
  - 6) All fire support personnel and equipment are accounted for [AN].
  - 7) Bn TF FSOs and the DS FA battalion S3 submit status reports on reorganization activities to the FSCOORD and brigade FSO [AN].
  - 8) Fire support task organization is reconfigured, as required [AN].
- g. The brigade commander assesses the combat readiness of brigade fire support systems, assets, and units after reorganization is conducted [FM 71-3, p. 8-21].

- 1) The brigade commander performs the assessment considering [FM 71-3, p. 8-22]:
  - a) His own observations [FM 71-3, p. 8-22].
  - b) Condition and effectiveness of subordinate commanders and leaders [FM 71-3, p. 8-22].
  - c) Previous, current, and anticipated situations and missions [FM 71-3, p. 8-22].
  - d) Available combat, CS, and CSS personnel, equipment, and supplies [AN].
- 2) The brigade commander determines if fire support reorganization has rendered the brigade mission capable or if the brigade must perform regeneration [FM 71-3, p. 8-21].
- 3) The brigade commander notifies the division commander of his assessment; the division commander authorizes and directs regeneration of the brigade as required [FM 71-3, p. 8-22].

## Task List Endnotes

1. Quick fire planning is conducted to quickly prepare and execute fire support in anticipation of and/or during an operation [FM 6-20-40, p. 2-13; FM 6-20-50, p. 2-13].
2. Advantages of staff accompanying the brigade commander:
  - a. They receive division order and division commander's intent in person [FN-AR Sch].
  - b. Opportunity to coordinate with division counterpart [FN-AR Sch].
  - c. Opportunity to conduct early discussions with the brigade commander on his intent [FN-AR Sch].Disadvantages of staff members accompanying the commander [FN-AR Sch].
  - a. Primary staff members are taken away from performing other duties.
  - b. Commander should be able to gather staff information requirements.
  - c. Brigade FSCOORD could receive conflicting guidance from DIVARTY commander (e.g., guidance may conflict with brigade commander's guidance).
  - d. Brigade FSCOORD and brigade engineer/ABE are delayed in initiating parallel planning with their headquarters.
3. Brigade staff officers use their running estimates for mission analysis, as well as the division order and order products.
4. Mission analysis steps, in sequence, are [FM 101-5, p. D-1; FN-NTC]:
  - a. Understand the corps and division commanders' intents [FM 101-5, p. D-2; FN-NTC].
  - b. Review the brigade's battle space, task organization, and concept of the operation statements [FM 101-5, p. D-3; FN-NTC].
  - c. Identify specified and implied tasks [FM 101-5, p. D-3; FN-NTC].
  - d. Identify essential tasks [FM 101-5, p. D-3; FN-NTC].
  - e. Review available assets [FM 101-5, p. D-4; FN-NTC].
  - f. Determine limitations [FM 101-5, p. D-4; FN-NTC].
  - g. Determine broad command and control warfare (C2W) employment considerations [FM 101-5, p. D-4; NTC].
  - h. Determine acceptable risks [FM 101-5, p. D-5; FN-NTC].
  - i. Determine critical facts and assumptions [FM 101-5, p. D-5; FN-NTC].
  - j. Establish initial time analysis for all battle phases [FM 101-5, p. D-6; FN-NTC].
  - k. Develop the brigade's restated mission [FM 101-5, p. D-7; FN-NTC].
5. Deep battle for the brigade is determined by the depth at which the brigade is able to acquire information and intelligence, acquire targets, and attack targets [194 AR].
6. Development of the brigade's AI is performed to focus information collection so the brigade commander can anticipate events on the battlefield and make proactive decisions [FM 101-5, p. C-6].
7. Collection systems and target acquisition assets include:
  - a. Subordinate maneuver units [FM 6-20-10, p. B-1].
    - 1) Patrols [FM 6-20-10, p. B-1; FM 6-20-40, p. 2-11; FM 6-20-50, p. 2-11].

- 2) OPs [FM 6-20-10, p. B-1].
- 3) Scouts [FM 6-20-10, p. B-1; FM 6-20-40, p. 2-11; FM 6-20-50, p. 2-11].
- b. DS MI Company.
  - 1) Counterintelligence Team [FM 6-20-40, p. 2-12; FM 6-20-50, p. 2-11].
  - 2) Ground Surveillance Radars (GSR) and remotely employed sensors (REMS) Teams [FM 6-20-40, p. 2-11; FM 6-20-50, p. 2-11].
- c. DS FA battalion and DIVARTY assets [FM 6-20-10, p. B-3; FM 6-20-40, p. 2-11; FM 6-20-50, p. 2-11].
  - 1) FIST/FOs [FM 6-20-10, p. B-3].
  - 2) Radars (e.g., TPQ-26, TPQ-37) [FM 6-20-10, p. B-4; FM 6-20-40, p. 2-11; FM 6-20-50, p. 2-11; FN-3/24 ID].
  - 3) COLTs [FM 6-20-10, p. B-4; FM 6-20-40, p. 2-11; FM 6-20-50, p. 2-11].
- d. Division aviation/air assets [FM 6-20-10, p. B-1; FN-BCTP].
  - 1) UAV [FM 6-20-10, p. B-10; FN-BCTP].
  - 2) OH-58D and other Aerial Fire Support Observers (AFSOs) [FM 6-20-40, p. 2-11; FM 6-20-50, p. 2-11; FN-BCTP].
  - 3) EH-60 "Quickfix" [FM 6-20-10, p. B-10; FN-BCTP].
- e. Division MI Bn assets [FM 6-20-10, p. B-2].
  - 1) Signal Intelligence (SIGINT) [FM 6-20-10, p. B-2].
  - 2) IMINT [FM 6-20-10, p. B-2].
  - 3) Human Intelligence (HUMINT)[e.g., long range surveillance unit/company (LRSU/LRSC); psychological operations (PSYOPS), CA] [FM 6-20-10, p. B-3].
  - 4) TRQ-32 "Teammate" [FM 6-20-10, p. B-8; FN-BCTP].
  - 5) TLQ-17 "Trafficjam" [FM 6-20-10, p. B-8; FN-BCTP].
  - 6) TSQ-160 "Trailblazer" [FM 6-20-10, p. B-10; FN-BCTP].
- f. Division and higher ADA systems [FM 6-20-10, p. B-4].
- g. National assets [FM 6-20-10, p. B-4].
- h. Joint assets (e.g., USAF, USN, USMC) [FM 6-20-10, p. B-5].
  - 1) Pilot reports (PIREPs) [FM 6-20-10, p. B-5].
  - 2) Photo imagery [FM 6-20-10, p. B-5].
  - 3) InfraredIR imagery [FM 6-20-10, p. B-5].
  - 4) Side-looking airborne radar (SLAR) [FM 6-20-10, p. B-5].
  - 5) Low-light-level television [FM 6-20-10, p. B-5].
  - 6) Airborne warning and control system (AWACS) [FM 6-20-10, p. B-5].
  - 7) Joint surveillance and target attack radar system (JSTARS) [FM 6-20-10, p. B-5].
- I. Special Operations Forces (SOF) assets [FM 6-20-10, p. B-5].

8. The restated mission statement approved by the brigade commander is used by the brigade staff for course of action planning and war gaming. The restated mission statement may change during the course of those planning actions. The restated mission will become final when the brigade commander selects a course of action (task 10). The final restated mission is incorporated in the brigade OPORD (task 11) and is issued with the OPORD (task 12) [FM 101-5, p. D-7; FN-JRTC].

9. The brigade targeting team consists of:

- a. Brigade commander, as available [FM 6-20-10, p. 5-4; FM 6-60-40, Ch 2; FM 6-20-50, Ch 2].

- b. Brigade XO [FM 6-20-10, p. 5-4; FN-NTC; FN-IN Sch; FN-BCBST; FN-194 AR].
- c. Brigade S3 [FM 6-20-10, p. 1-13, 5-4; FM 6-20-40, Ch 2; FM 6-20-50, Ch 2; FN-NTC; FN-IN Sch; FN-BCBST; FN-194 AR; FN-AR Sch].
- d. Brigade S2 [FM 6-20-10, p. 1-13, 5-4; FM 6-20-40, Ch 2; FM 6-20-50, Ch 2; FN-NTC; FN-IN Sch; FN-3/24 ID; FN-AR Sch].
- e. DS MI company commander [FM 6-20-10, p. 1-13, 5-4; FM 6-20-40, Ch 2; FM 6-20-50, Ch 2; FN-NTC; FN-BCBST; FN-BCTP].
- f. Brigade targeting officer [FM 6-20-10, p. 5-4; FM 6-20-40, Ch 2; FM 6-20-50, Ch 2; FN-IN Sch; FN-3/24 ID].
- g. Brigade engineer officer [FM 6-20-10, p. 1-13, 5-4; FM 6-20-40, Ch 2; FM 6-20-50, Ch 2; FN-NTC; FN-IN Sch; FN-BCBST; FN-AR Sch; FN-194 AR].
- h. Brigade FSO [FM 6-20-10, p. 1-13, 5-4; FN-NTC; FN-IN Sch; FN-3/24 ID; FN-BCBST; FN-194 AR].
- i. Brigade ALO [FM 6-20-10, p. 1-13, 5-4; FN-NTC; FN-IN Sch; FN-3/24 ID; FN-AR Sch; FN-194 AR].
- j. Brigade BICC officer [FM 6-20-10, p. 1-13, 5-4; FN-NTC; FN-3/24 ID].
- k. ANGLICO (when assigned) [FM 6-20-10, p. 1-13, 5-4; FN-NTC; FN-3/24 ID].
- l. FSCOORD (when available) [FM 6-20-10, p. 5-4; FN-BCBST].
- m. Brigade S3/Air [FM 6-20-10, p. 5-4; FN-NTC; FN-BCBST; FN-194 AR].
- n. Army aviation LNO [FM 6-20-10, p. 1-13; FN-NTC; FN-JRTC; FN-IN Sch].
- o. AD LNO [FM 6-20-10, p. 1-13, 5-4; FN-NTC; FN-JRTC; FN-IN Sch; FN-AR Sch; FN-194 AR].
- p. Brigade chemical officer [FM 6-20-10, p. 1-13, 5-4; FN-NTC; FN-JRTC; FN-194 AR].
- q. DS FA battalion S3 and S2 [FM 6-20-10, p. 5-4].

Other brigade staff members who will provide assistance and information as required:

- a. SOF representatives (when assigned) [FN-IN Sch].
  - b. S-5 [FN-IN Sch].
  - c. Brigade signal officer [FN-JRTC].
  - d. Brigade S4 [FN-JRTC].
10. The brigade commander directs the brigade XO and brigade S3 to issue multiple WARNOs throughout the planning phase to disseminate new and updated information to brigade staff and subordinate Bn TF commanders and staff [FM 101-5, p. 4-55].
  11. Estimates are evaluations by each staff officer on how factors in each staff officer's field of interest will influence brigade courses of action. They include recommendations to other staff officers and to the commanders of brigade subordinate units [FM 101-5, p. C-1, 3-85].
  12. During course of action development, the brigade staff considers [FM 101-5, p. E-3]:
    - a. brigade mission [FM 101-5, p. E-3].
    - b. Brigade commander's intent and guidance [FM 101-5, p. E-3].
    - c. Task organization requirements [FM 101-5, p. E-4].
    - d. Brigade CCIR [FM 101-5, p. E-4].
    - e. Battlefield framework (BOS) [FM 101-5, p. E-4].

- f. Essential tasks [FM 101-5, p. E-4].
  - g. Effective use of command and control [FM 101-5, p. E-4].
  - h. CSS requirements [FM 101-5, p. E-4].
13. The brigade XO guides the brigade staff through course of action development steps for each course of action [FM 101-5, p. E-4]:
- a. Analyze relative combat power [FM 101-5, p. E-4].
  - b. Generate potential possibilities [FM 101-5, p. E-4].
  - c. Array initial forces [FM 101-5, p. E-4].
  - d. Develop schemes of maneuver [FM 101-5, p. E-4].
  - e. Determine command and control measures [FM 101-5, p. E-5].
  - f. Prepare course of action statements and sketches [FM 101-5, p. E-5].
14. The brigade targeting team applies the fire support planning principles when developing fire support for each course of action [ARTEP 71-3-MTP, 71-3-9001/2a5; FM 6-20, p. 3-5]:
- a. Plan early and continuously [FM 6-20, p. 3-5].
  - b. Exploit all available targeting assets [FM 6-20, p. 3-5].
  - c. Consider the use of all lethal/non-lethal attack means [FM 6-20, p. 3-5].
  - d. Use lowest echelon capable of furnishing effective support [FM 6-20, p. 3-5].
  - e. Use most effective means to acquire and attack targets [FM 6-20, p. 3-5].
  - f. Furnish type of support requested [FM 6-20, p. 3-5].
  - g. Avoid unnecessary duplication [FM 6-20, p. 3-5].
  - h. Consider airspace coordination [FM 6-20, p. 3-5].
  - i. Provide adequate support [FM 6-20, p. 3-5].
  - j. Provide rapid and effective coordination [FM 6-20, p. 3-5].
  - k. Integrate FSCM [FM 6-20, p. 3-5].
  - l. Provide for flexibility [FM 6-20, p. 3-5].
15. The FSCoord and DS FA battalion S3 provide updates to FA movement requirements resulting from their parallel planning [FN-194 AR].
16. War gaming by the DS FA battalion TOC is performed concurrently with the brigade staff war gaming. The brigade FSO exchanges information with the DS FA battalion staff to support war gaming by the brigade staff and the DS FA battalion staff [FN-IN Sch; FN-3/24 ID; FN-194 AR].
17. Fire support planning for the brigade rear area is the responsibility of the brigade S3. However, the FSB, as the major command organization operating in the brigade rear area, does not have the organizational structure or capability to plan fires in support of the BSA and brigade CCS nodes, or call for and adjust fires against rear area threats. The identification and establishment of an ad-hoc fire support planning and controlling element within the brigade rear, under the control of the FSB commander, can be based on the elements of the DS FA battalion occupying positions with the BSA (e.g. DS FA battalion Service Battery) [FN-NTC; FN-AR Sch].
18. Observer Plan should not be redundant with the Collection Plan. The Observer Plan is focused on the physical employment of indirect fires against targets once they are detected. Persons and systems included in the Observer Plan are responsible for detecting targets,



- calling for fires, adjusting fires, and providing BDA results from target attack [FN-NTC].
19. FSCM are computed using wartime minimum safe distances of the munitions to be fired. They are designed to be flexible to facilitate possible changes in the tactical situation [FM 6-20-40, p. E-1; FM 6-20-50, p. G-1].
  20. The brigade commander's guidance to disrupt, delay, damage or destroy the enemy is used as the basis for developing the AGM; the AGM presents the brigade commander's attack guidance for specific HPT [FM 6-20-10, p. 2-14; FM 6-20-40, p. G-14; FM 6-20-50, p. K-14].
  21. The brigade targeting team provides fire support information on course of action comparison and make recommendations on which course of action can best be supported [FM 34-130, p. A-3, A-7; FM 101-5, p. F-4, F-36].
  22. The brigade commander directs the brigade targeting team to man brigade CPs to enhance the exercise of command and control and implement the fire support plan [FM 101-5, p. 5-1].
  23. The brigade Command Group operates from the brigade TAC. The brigade TAC and brigade Command Group operate well forward in the brigade AO at critical locations determined by the brigade commander. The brigade TAC is organized and begins operations in accordance with the brigade commander's guidance. The brigade TAC initiates operations as late as possible to ensure that the brigade main CP retains the capability to operate 24 hours a day. [FM 71-3, p. 3-20].
  24. Communications equipment requirements are identified based on the type of TAC organized. Types of brigade TAC include aerial TAC, stationary TAC, and mobile TAC [FM 6-20-50, p. 2-23, 2-24].
  25. The brigade main CP is supervised by the brigade XO. The brigade main CP is located in the brigade AO, generally forward of the division main CP and behind Bn TFs main CPs [FM 71-3, p. 3-20].
  26. The brigade rear CP collocates with the FSB CP in the brigade rear and is supervised by the brigade S1. The brigade rear CP is responsible for coordinating administrative and logistics activities of the brigade [FM 71-3, p. 3-20].
  27. Fire support personnel, units, and systems operating on the DS FA battalion voice command net are [FM 6-20-1, p. 6-13]:
    - a. brigade FSCOORD [FM 6-20-1, p. 6-13].
    - b. DS FA battalion supply operations center (BSOC) [FM 6-20-1, p. 6-13].
    - c. DS FA battalion A/L operations center (ALOC) [FM 6-20-1, p. 6-13].
    - d. DS FA battalion RSO [FM 6-20-1, p. 6-13].
    - e. DS FA battalion BSO [FM 6-20-1, p. 6-13].
    - f. Firefinder radars [FM 6-20-1, p. 6-13].
    - g. Brigade FSE [FM 6-20-1, p. 6-13].
    - h. Reinforcing FA battalion TOCs [FM 6-20-1, p. 6-13].
    - i. DS FA battalion battery commanders and FDCs [FM 6-20-1, p. 6-13].

28. Fire support personnel, units, and systems operating on the DS FA battalion voice and digital FDC nets are [FM 6-20-1, p. 6-14]:
  - a. DS FA battery or platoon FDCs [FM 6-20-1, p. 6-14].
  - b. COLTs [FM 6-20-1, p. 6-14].
  - c. Maneuver Bn TF FSEs [FM 6-20-1, p. 6-14].
  - d. Brigade FISTs [FM 6-20-1, p. 6-14].
  - e. Firefinder radars [FM 6-20-1, p. 6-14].
29. Fire support personnel, units, and systems operating on the DS FA battalion voice and digital operations /fire nets are [FM 6-20-1, p. 6-14]:
  - a. Firefinder radars [FM 6-20-1, p. 6-14].
  - b. Brigade FSE [FM 6-20-1, p. 6-14].
  - c. Reinforcing FA battalion FDCs [FM 6-20-1, p. 6-14].
  - d. DS FA battalion FDCs [FM 6-20-1, p. 6-14].
30. CNR systems include:
  - a. Single-channel ground and airborne radio system SINCGARS) [FM 101-5, p. 6-27].
  - b. Improved high-frequency radio (IHFR) [FM 101-5, p. 6-27].
  - c. Tactical satellite systems, when available [FM 101-5, p. 6-27].
31. The brigade targeting team continuously acquires information internally (e.g., within the brigade staff) and externally (e.g., with division and DIVARTY staff, DS FA battalion, subordinate units, USAF/USN/USMC headquarters) to implement the brigade's fire support plan and to manage fire support assets [FN-JRTC].
32. Information is analyzed to determine if it satisfies CCIR, IR, DP, and HPT information requirements. Evaluation is performed to appraise the validity of the brigade fire support and collection plans and to determine requirements to refine plans [ARTEP 71-3-MTP, 71-3-2003/2].
33. Brigade LNOs assigned to other units, and LNOs assigned to the brigade, keep the brigade commander informed by providing [FM 101-5, p. L-1]:
  - a. Exceptional, CCIR, or routine information [FM 101-5, p. L-1].
  - b. Verification of information [FM 101-5, p. L-1].
  - c. Clarification of questions [FM 101-5, p. L-1].
  - d. Courier services, as required [FM 101-5, p. L-1].
34. The DDMP is generally used when sufficient time is available to conduct detailed planning and during periods when fighting is not intense. It may be used during the preparation battle phase if sufficient time and staff are available to perform a methodical estimate of the situation and to explore the full range of possible enemy and friendly COAs without detracting from staff actions to monitor and direct ongoing activities [FM 101-5, p. 4-7].
35. The time-constrained DMP employing the CPEA methodology is generally used during the preparation or execution battle phases of combat operations. The brigade commander has limited time. The brigade commander may personally develop the plan or, if time and conditions allow, may include selected members of the brigade staff to assist in planning [FM 101-5, p. 4-43, 4-52].

36. The brigade commander conducts back briefs with brigade staff and subordinate commanders during and after visits, inspections, and rehearsals. Back briefs are conducted to ensure understanding of the brigade concept of the operation and to disseminate information and changes which occur as a result of plan refinement during the rehearsal. During back briefs, the brigade staff and subordinate commanders [FM 101-5, p. M-8]:
  - a. Describe in detail how schemes of maneuver, indirect fires, and monitoring of the battle will be conducted [FM 101-5, p. M-8].
  - b. Describe how subordinate unit commanders' concept of the operation supports the brigade commander's intent and contributes to the brigade mission [FM 101-5, p. M-8].
  - c. Describe the level of preparation achieved, those preparation activities which still need to be completed, and how they will adhere to the mission timelines [FM 101-5, p. 4-25, M-8].
37. Ibid.
38. Ibid.
39. Normally, AN/TPQ-36 radars establish positions 3-6 km from the brigade FLOT and AN/TPQ-37 radars establish positions 8-12 km behind the brigade FLOT, as designated [FM 6-20-1, p. 5-3].
40. Target evaluation for HPT targets of opportunity is based on the brigade commander's attack guidance, target activity, dwell time of the target, and analysis on target attack payoff compared with the payoff of other targets currently being processed for engagement [FM 6-20-10, p. 2-24].
41. The synchronization and employment of indirect fires in support of the brigade scheme of maneuver is time-or-event driven as prescribed in the DST, Synchronization Matrix, and FSEM, or by significant battlefield changes not previously anticipated [FM 6-20-10, p. 1-13; FN-IN Sch].
42. Fire support observers and others calling for fires provide precise target locations (e.g., lasers, surveyed TRPs) and positive identification of each target. Observers maintain continuous observation of each target throughout target attack [FN-FA Sch].
43. Consolidation and reorganization is performed by subordinate Bn TFs. The brigade commander provides direction and priorities to subordinate units to facilitate the consolidation and reorganization process. Consolidation and reorganization, as it affects the brigade headquarters and brigade targeting team, consists of implementing guidance and decisions made by the brigade commander, monitoring subordinate unit status and activities, and reorganizing brigade CPs [AN].

## CALL Lessons Learned Relevant to CCF 15

### 1. NTC Commander's Memorandum – Nov 85

The fire support plan is far more than a target list or schedule of fires. It is an articulation of how supporting fires are to be employed with the other elements of combat power to accomplish the mission. The timing of maneuver and fires must be developed and then fully explained. "Priority of artillery fires to Team B. See target list." simply does not cut it.

Specific guidance from battalion concerning where, when, and what to shoot rather than an allocation of priorities to specific companies is often the most effective method of synchronizing fires with maneuver.

Given that there is never sufficient artillery to do all things, a centralized approach guards against the risk of firing a few rounds at a large number of low priority targets. The preferred solution is a lot of rounds on a few particularly critical targets.

... it is important to guard against the tendency to fire preplanned targets when the enemy is somewhere else. Adjustments from preplanned targets or grid missions must be used if that is what it takes to get the fire on the enemy.

A face-to-face meeting between brigade and task force FSOs and the DS Battalion S3 and FDO, where the concepts of operations and intents of the various maneuver commanders are discussed, pays rich dividends.

The fire support execution matrix, the linkage of targets to systems and the identification of specifically who is to shoot by phase of battle, is a very effective tool. Responsibility for each target to include identification on the ground, observation, execution, and adjustment as necessary is given to a specific unit, e.g., company team, scout platoon. Sufficient redundancy is required to guard against obscuration and casualties.

Communications between units, FSOs, and FDCs need to be thoroughly checked before the battle to include necessary corrective action. The locations of OPs, obstacles, and reference points require confirmation by resection or PADs to the maximum extent possible. Commanders, subordinate infantry and tank leaders, FOs, and others responsible for specific targets must be able to point them out on the ground. Trigger lines based upon projected enemy routes and movement rates must be clearly identified.

While FSOs and FOs play a big role, the effective integration of fire is a command responsibility and there clearly needs to be a lot of non-artillerymen calling for fire. All leaders must know the frequencies and how to make the system work.

TACFIRE tends to back up during battles and it is difficult to override the queuing sequence, in part because the FSO forward cannot monitor the fire nets. Non-TACFIRE nets can also become jammed with the stronger stations overriding. In either case, the likely consequence is

that fires will not be massed on the highest priority targets. Disciplined fire nets are obviously important. In addition, the establishment of a voice fire coordination net for the task force is recommended. On this net, the FSO passes instructions to company FSOs and his FSE, and he receives feedback on what is happening on fire direction nets. Unless the FSO has a net to receive information and pass instructions, he becomes just another FO.

Artillery illumination should be planned for all night operations, even when the primary concept calls for no illumination. Plans need to delineate specific conditions which will trigger the use of illumination and who will make the decision. Even when gunners can acquire targets with night sights, leaders often need illumination to facilitate command and control and fire distribution.

## 2. **NTC Lessons Learned Bulletin – Jan 86**

### **Fire Support Planning Timeline**

Even though fire planning is a continuous process, there must be a “drop dead” time for making changes to an existing fire plan. A good cut-off time is one hour prior to execution. Naturally, critical changes occur after the “drop dead” time, but adherence to this time allows everyone to make his final preparation.

### **Communication Between the Commander and FSO is an Art**

Communication between the commander and his FSO is critical. If there is a misunderstanding, it will probably not be obvious until the execution commences. The FSO must communicate his thoughts in a language the commander will understand. For example, the FSO should tell him how many minutes of smoke (HC) are available, not how many rounds; or that firing a preplanned 400m x 400m (medium) FASCAM minefield takes 7–12 minutes to fire, and with displacement to an alternate position this may result in the TF being unable to use its artillery for 45 minutes to one hour on other missions.

### **Maintaining Proficiency of the Basic Skills**

During the planning sequence, the TF FSO must develop a maneuver battalion voice fire support net and, in conjunction with the FA BN S3, a voice fire direction net to be utilized during emergencies. Once the dedicated voice nets are established, a unit must rehearse these techniques and procedures to ensure execution during the battle. The FSO must ensure that all leaders know what frequencies and call signs to use.

## 3. **NTC Lessons Learned Bulletin – Sep 86**

### **Rehearsing the Fire Plan**

The successful execution of a fire plan is directly proportional to the amount of prior planning and rehearsing. Units, as a whole, plan and coordinate fire plans well, but very few units take the time to rehearse them with the maneuver plans.

Rehearsing a fire plan is no different than wargaming a maneuver commander's concept of the operation. In fact, both require the same thought process and players. This thought process must ensure synchronization of fire support to enhance the maneuver commander's intent of fighting the battle. When rehearsing a fire plan, the following areas must be addressed:

- a. Who is responsible to initiate the mission and over what net?
- b. What is the redundancy in execution?
- c. Who clears fires?
- d. How is the maneuver commander made aware of the voids in fire support due to artillery units moving, mission processing times, etc.?
- e. What are the capabilities and limitations of field artillery?
- f. How many missions can be fired before artillery starts moving?
- g. How many targets of opportunity can be fired without interfering with the execution of the fire plan?

The maneuver commander walks through the concept of the operation and depicts (based on the fire plan) where and when he wants fire support. As the maneuver commander identifies a target:

- a. The person shooting it explains where and when he executes the mission, what net and call signs he uses, and what effect he anticipates on the target.
- b. The alternate shooter addresses the same question.

This rehearsal continues until the fire plan is completed. This tests whether the fire plan supports the task force commander's scheme of maneuver.

Other successful tactics, techniques, and procedures to execute fires are:

- a. Assign targets (high value targets, groups, series, etc.) to a commander for execution, not to the FSO. In most cases, the FSO is going to be colocated with the commander and will actually do the requesting and adjusting. The smarter maneuver commander ensures that his subordinates know how the fire plan is synchronized with the battle plan. A maneuver company commander, given the mission to fire group A1B at PL RED, will certainly be at the right place, at the right time to do just that. He will also probably ensure that his FSO has good communications with the FDC and that the mission goes as planned.
- b. Control the target of opportunity missions that are fired during the battle by the maneuver with close coordination with the FSO.

4. **NTC Commander's Comments – The CS Team – 1987**

Fire planning must be a continuous process to be successful. Decentralization (informal) planning, like centralized (formal) planning, is a product of the situation, the time available, and the echelon at which it occurs. Fire planning should be both formal and informal, regardless of the time available, to be executable and successful. A fire plan formulated and disseminated from a higher level to a lower level will allow the fire plan to be communicated to support the commander's concept, but feedback from the lower echelons is vital to refine the plan according to conditions that lower units meet.

5. **CALL, Vol 1: Heavy Forces – Fall 88**

**Fire Support Execution Matrix – A Valuable Tool**

Target lists that consist of quality targets and not quantity are more likely to succeed. These target lists must support the commander's concept.

**Location of FOs/FSOs**

Problem: Frequently cited as one of the problems facing units on the battlefield is disagreement over the location of fire support personnel relative to their supported maneuver commanders. Successful tactics, techniques, and procedures:

- a. The tactical requirement is for the FSO to be responsive to or, in some cases, under the control of the maneuver commander he supports. The key consideration is whether his location enables him to accomplish his mission. If his primary function during a battle is to be the commander's FO, he should be as close to the maneuver commander as possible while maintaining observation of the battalion area. If his mission is to fire a series or group of planned targets as part of the overall fire plan, the FSO must observe those targets at all times and remain responsive to the maneuver commander throughout the entire battle.
- b. Commanders and FSOs should work together to determine the best location for the observers. They share responsibility for positioning the observers where they can see the battlefield and contribute to the operation's success. The FO must select observation posts and movement routes to support the maneuver commander's scheme of maneuver. The FSO must apply the factors of METT-T to determine optimal positions for his observers.

6. **CALL, Non-Mechanized Forces – Spring 89**

**Fire Support Execution Matrix and Maneuver Commanders**

The fire support execution matrix is an excellent tool for the FSO to explain the fire support plan to the commander.

- a. Give copies of the fire support execution matrix to the Bn/Co commanders, platoon leaders, and platoon FOs.
- b. Brief the matrix to those individuals so they understand and visualize the fire support plan and can execute it if required.
- c. Use the fire support execution matrix to conduct a fire support rehearsal. The purpose of the rehearsal is to ensure that all personnel fully understand their mission and responsibilities in the fire support plan. Ideally, conduct this rehearsal with a maneuver rehearsal. If the commander does not understand the fire support plan, he will not use it. The fire support execution matrix and the rehearsal overcome this problem.
- d. Fire support fails when the FSO or the Fire Support Sergeant become casualties and their subordinates are unable to step in and accomplish the mission. Train your subordinates and then use them in providing effective fire support during periods of continuous operations.

7. **CALL 90-1, Fire Support for the Maneuver Commander – Feb 90**

**The Fire Support Process**

Effective fire support starts with, and is the responsibility of, the commander of the maneuver force. Before the battle staff or the fire support staff begins planning, the commander must first articulate his intent and guidance for the operation.

The maneuver commander's intent is the foundation that drives the process of planning, preparing, and executing the battle. The commander's guidance and intent provide the basis for collection of information, development of the scheme of maneuver and fire support, and integration of the combat power of the seven operating systems into a cohesive, synchronized force.

The preparation phase gives the commander and staff the opportunity to check and verify the plans against the commander's guidance, and to correct all deficiencies before the execution phase.

The execution phase of the fire support plan is the prosecution of the maneuver commander's intent. The fire support is the prosecution of the maneuver commander's battle plan.

**Fire Support Planning**

Fire support planning is conducted concurrently as the maneuver force conducts its battle planning, and determines how, when, and with what means targets will be attacked in support of the maneuver force.

The fire support plan includes how fire support elements will move and position



themselves, their tactical deception and survivability plans, the survey and target acquisition plans, and how the fires will be allocated to the maneuver force.

### **The Maneuver Commander is the Owner of the Fire Support Plan**

He must synchronize and concentrate all of his combat power at the critical time and place. Synchronizing and integrating the battlefield operating system is fundamental to success on the battlefield.

The maneuver commander is responsible for integrating fire support and the scheme of maneuver into the concept of operation.

### **Wargaming**

Upon receipt of the commander's guidance, the commander, FSO, maneuver S3, and staff set about to develop the operations order. A critical step in building the foundation for the operations order is wargaming of the mission by the commander and staff. Wargaming allows the maneuver commander to analyze and evaluate various courses of action to determine how best to defeat and destroy the enemy.

As the maneuver commander wargames the operation, the FSO provides the most current information for applying all elements to the fire support system. The FSO recommends options to the maneuver commander and courses of action on how to best apply the fire support system in concert with other operating systems. The maneuver commander provides the required target effects and the priorities for engaging targets and allocating targets.

Wargaming allows the maneuver commander to decide how fire support resources will be used, designates which subordinate echelons will be weighted with fire support, states what targets and target types to attack, and designates what fire support means to use. When the wargaming is complete, the FSO provides the maneuver commander with a fire support plan recommendation to ensure that the selected course of action as well as a positioning and movement plan to ensure that firing support elements are able to provide continuous support throughout the operation. The recommended fire support plan will also identify firing support logistical requirements and their impact on the battle.

The process of wargaming integrates the fire support target acquisition systems into the maneuver force battlefield intelligence collection plan (operations and ensures the task force uses the proper fire support means to engage targets).

### **Commander's Guidance**

Development of a successful fire support plan is dependent on the maneuver commander's guidance.

The maneuver commander must state the role that fire support plays in the overall operation.

The commander defines the areas where indirect fires are to be planned, engagement areas where fires must support maneuver, and any areas critical to the battlefield that require fire support.

### **Target Priorities**

The maneuver commander on today's battlefield faces more targets than he has weapons systems with which to attack them. To prevent the overloading of the fire support system with targets, a method of prioritizing targets is necessary.

Using the attack criteria established by the maneuver commander, the FSCOORD and the FSO must prioritize targets in relation to their impact on the battle. The highest priority targets are those that, if not defeated, can inhibit the execution of the maneuver commander's battle plan. The next priority of targets are those that may seriously interfere with the battle plan. The lowest priority targets are those that might seriously interfere with the battle plan later in the battle or disrupt future plans, and those targets that have limited impact on the plan or are very low payoff to the maneuver commander.

The maneuver commander reviews the recommendation of the FSO along with the available ammunition and delivery means and determines the desired effect by category or suppression, neutralization, or destruction.

### **Briefbacks**

The most effective method of ensuring that the commander's guidance is understood is for the FSO to briefback his understanding of the commander's fire support guidance to the maneuver commander. This ensures that the FSO understands how the maneuver commander sees how fire support will be used in the operation.

Only after the commander's guidance and intent are clearly defined and understood can the FSCOORD and the FSO conduct their planning, wargaming, and rehearsing of the operation with the commander and his battle staff.

### **Fire Support Plan Rehearsals**

Throughout the planning and preparation phases of the operation, the maneuver commander and the FSO continually work to focus and refine the plans that the organization is preparing to defeat the enemy. The final step in the development of the fire support plan is the combined arms rehearsal.

How the rehearsal looks is not as important as what it accomplishes. The rehearsal will be more effective if all of the battlefield operating systems are included. The maneuver commander and subordinate commanders, as well as the FSO, must rehearse the fire support plan at the same time as the maneuver plan.

A rehearsal is an effective tool for identifying and refining battle plans. The keys to an effective rehearsal are that:

- a. The positioning and movement plans of the artillery units are exercised.
- b. The target acquisition plan is verified.
- c. The fire support plan is validated with the scheme of maneuver, the commander's intent, and attack guidance.
- d. The obstacle/barrier plan of the maneuver force is part of the fire support plan.
- e. The fire and maneuver control measures for protecting and controlling aerial and ground forces do not disrupt the fire support plan and are not violated by the plan.
- f. Target grids and trigger points are verified.
- g. Redundant observers will initiate fires if the primary observer fails to execute.

The rehearsal provides the FSCoord and the FSO with an opportunity to identify gaps in the fire plan, potential engagement areas that were not found during the initial planning and wargaming process, and obstacles or barriers that are not covered with fires. The FSO should also use the rehearsal to identify targets that cannot be observed without the use of remote sensors.

The FSO must understand maneuver doctrine, tactics, techniques, and procedures for all battlefield operating systems. He must communicate the capabilities and limitations of fire support to the maneuver force commander and staff. The FSO must articulate the ability of the indirect fire systems to support each course of action to the maneuver commander; the maneuver commander must listen.

### **The Decision Support Template (DST)**

The wargaming process identifies the decision points for the commander. The DST graphically portrays the decision points and the options available to the commander if an action occurs. The DST provides the FSO with the critical information that is required to provide timely and accurate fires in support of the maneuver force.

### **Fire Support Execution Matrix**

The matrix, when linked to the maneuver execution matrix, provides both the fire support staff and the maneuver commander with a method of controlling indirect fire during the battle. Use of the matrix provides a system of controlling fires, a target list, and target numbers that are common throughout the force.

The fire support execution matrix, like the maneuver execution matrix, is event, not time driven. It works like a musical score to bring mortars, field artillery, rocket, and all fire

support systems in concert with the other operating systems on the battlefield at the needed time and place.

The FSO develops and distributes the fire support execution matrix to the key players on the battlefield. This includes maneuver commanders, staff officers, scouts, fire support personnel, mortar and artillery fire direction centers, and anyone in a position to call for indirect fire during the battle.

In a time sensitive operation, the fire support execution matrix can stand alone to portray graphically the support needed to achieve the commander's intent.

### **Top-Down Planning**

The FSCOORD or FSO do not have the luxury of time to develop a "bottom-up" fire support plan. Operational requirements do not allow the observers to develop, identify, and plan targets or fires in support of the maneuver force and forward them up through fire support channels for consolidation at each higher level.

The lack of available planning time requires the FSCOORD and FSO to conduct the planning for their subordinate units and to disseminate the plan down to the units for refinements, adjustments, and execution.

The key to effective employment of "top-down" fire planning is the redundant check of the plan before execution. This is not to imply that company FSOs should not be developing their own fire plan prior to receipt of the task force fire plan and target list. The company/team FSO should use his fire plan to provide the "bottom-up" refinements of the TF fire support plan and target list.

The most critical aspect of the refinement is the verification of target locations by the observer to ensure the accuracy of the fires. Using resection, intersection, or registration, the observers must verify the location of planned targets and coordination measures to ensure that the fire supports the intent of the maneuver force commander.

To achieve successful fire support, it is essential that every participant in the fire support system uses a common target list. A common target list allows the mortars, artillery, aviation, and maneuver to reference and call fires on the same set of targets.

### **Shorter Target Lists**

The FSO should use the S2's situation template to develop and refine the target list to include only targets that support the operation.

A target list with fewer targets is easier for the observer, commanders, and other key personnel in the fire support system to employ. With fewer targets observers are better able to shift fires from planned targets to new targets on the battlefield. The FSCOORD and FSO must insist that every target has a purpose and is tied to the scheme of maneuver and the commander's intent.

Shorter target lists accomplish several key things:

- a. The FSO can ensure that planned targets are based on the target engagement priorities established by the maneuver commander.
- b. The FSCOORD and FSO can quickly consolidate and disseminate the fire support plan and target list.
- c. The FSO can solve or eliminate duplication of targets.
- d. Executing a "shift from a planned target" is quicker than initiating a new call for fire.

8. **CALL 90-3 "The Stone Forest" – May 90**

Fire support must be integrated with the unit's scheme of maneuver and its surveillance and target acquisition efforts. The fire support system must be flexible enough to supply conventional fires without interruption as the tactical situation changes.

9. **CALL 90-5, Fire Support Lesson Learned – May 90**

**Planning Lessons Learned: Use Top-Down Fire Planning with Bottom-Up Refinement**

FOs and FSOs at lower levels must verify and refine the plan, their assigned targets, and positioning to ensure that they can execute fires needed to support to commander's intent.

**Execution Lesson Learned: A Fire Support Execution Matrix is an Essential Tool for Briefing and Executing the Fire Plan**

The fire support execution matrix is a concise, easy planning and executing tool that shows the many factors of a complex fire support plan. The matrix assists the FSO and maneuver commander in understanding how the fire plan supports the scheme of maneuver and the commander's intent.

The matrix explains the portion of the fire support plan each FSO, FO, and maneuver commander is responsible for executing. Not only does it describe what and who, it also describes when (by phase/event) where and how.

When approved by the maneuver commander, the matrix becomes the primary execution tool for the FSO, FO, and maneuver commanders. It is particularly useful in fixing responsibility for execution. It can use maneuver control measures such as target reference points or checkpoints to help integrate maneuver and fire.

The fire support execution matrix must be event driven, not based on time. This amplifies the importance of close cooperation between the FSO and the maneuver and artillery S2s. IPB reveals possible and likely enemy locations, avenues of approach, and provides the initial framework for developing the fire plan.

## **Planning Lesson Learned: The FSCOORD and FSO Must Explain Field Artillery Combat Power in Terms the Maneuver Commander Understands**

The FSCOORD and FSO must explain FA combat power, limitations and capabilities of the fire support system, and how artillery and mortars can best support the operation. The FSO must be able to state whether he can support the mission, and if not, why not. The FSCOORD and FSO must be able to express the capabilities and limitations of the fire support system in terms that the maneuver commander, his staff, and subordinate commanders understand:

- a. Minutes of smoke, not just number of smoke rounds available.
- b. Number of available RAAM/ADAM minefields by type, size, and density; the safety zone around each; the time to emplace each, not the number of rounds.
- c. Battalion volleys by type of ammunition, and what effects the maneuver commander can expect from each volley given specific targets description, not just the number of dual-purpose, improved, conventional munitions (DPICM) or high-explosive (HE) rounds available.
- d. Range and artillery area coverage based on the preponderance of the shell/fuze/charge combinations available, not just the maximum range of the system.
- e. The need for timely and accurate target locations.

The briefback is used at the end of the staff planning process. A briefback is used by the FSCOORD or FSO to tell the maneuver commander how fire support will accomplish the commander's stated and implied missions. It summarizes the FSCOORD's or FSO's mission analysis and concept of fire support. The briefback is an efficient way to advise the commander and assure him that his guidance has been met. The briefback must communicate essential information without overloading the commander with details he does not need:

- a. State objective; what fire support will accomplish for the commander's plan. This can be summarized in terms of fire support roles with a general characterization of desired effects on target.
- b. State essential tasks; identify the principal means the fire plan uses to achieve the objective. Summarize the high points of the plan, such as: number of targets; schedules; special missions such as FASCAM, smoke, or illumination.
- c. State constraints on the plan; identify factors impacting on the execution of fires such as; availability of ammunition, special missions such as FASCAM or smoke, communications requirements, and fire units' repositioning times.
- d. Summarize execution; review the fire support matrix. State: who is responsible for firing each target; what coordination is required; what support from the

maneuver force is necessary to accomplish the execution of the fire support plan.

- e. State objectives for contingencies and foreseeable future operations. Unless an unusual amount of time is available for the briefing, don't cover them in detail. These objectives are the first part of the planning guidance for subsequent operations.

### **Planning Lesson Learned: The FSCOORD and FSO Must Manage the Length of Target Lists Submitted for Formal Fire Planning**

Target lists should be short, with ten or twenty targets per battalion TF FSOs who insist every target has a purpose and is tied to the scheme of maneuver and the commander's intent end up with quality target lists, not "measle sheets."

FSOs should use situational templates from IPB to develop targets for target lists. Shorter, well-managed lists are best for several reasons:

- a. Reduces the processing time for TACFIRE.
- b. Firing units have more time to compute firing data for planned targets.
- c. FA battalion TOC will have time to determine when and if it will have to move fire units to range planned targets.
- d. Provides more time to ensure coordination across maneuver boundaries, if necessary.
- e. Permits more time to ensure that targets planned by the FSOs are based on the target engagement priorities established by the brigade/battalion commander in his intent.
- f. Facilitates reproduction and distribution of the fire support plan, as well as a realistic division of responsibility between maneuver and fire support for servicing the targets.

The number of targets planned to support any maneuver operation should be METT-T dependent.

### **Preparation Lesson Learned: Establish and Enforce a Cutoff Time for Submitting Routine Changes to the Target List**

A reasonable cutoff time is five hours to crossing the line of departure (LD) or anticipated beginning of defensive operations. Emergency and critically important changes identified prior to the start of an operation should be made if they will have an adverse effect on the operation. Changes that do not affect the outcome of the operation should not be made.

The effect of limiting the time for submitting changes is the same as controlling the number of planned targets: It gives more time to check data; better preparation for the mission; more time for dissemination of the fire plan; and more time to wargame and rehearse.

### **Preparation Lesson Learned: Never Pass Up an Opportunity to Rehearse**

Rehearsals are an integral part of the planning process. The rehearsal should both practice and test the plan. If at all possible, the fire support/artillery rehearsal should be conducted with the maneuver commander's rehearsal. A combined rehearsal will improve responsiveness of fires and synchronization of all the maneuver commander's battle resources.

At any level, the list of fire support participants in the maneuver commander's rehearsal should include all members of the fire support cell and all subordinate fire support element.

A rehearsal is a run-through of the operation that both practices and tests it enough to be executed. At the end of an effective rehearsal, everyone should know his responsibilities and the cues for action. The commander should also know if the plan is viable. A rehearsal presupposes a complete plan, that is, a plan complete enough to be executed. Completion is what distinguishes a plan under rehearsal from one being wargamed.

If planning is well organized, many plans and subplans can be rehearsed concurrently. When time is limited, pick out the plans that need attention and which can be checked and fixed in the time available.

If the maneuver commander does not conduct a combined rehearsal and if rehearsal time is available, the FSO should conduct a fire support rehearsal using the maneuver force OPORD, fire support plan, fire support execution matrix, and the field artillery support plan. A rehearsal conducted with fire support personnel only is still better than no rehearsal at all.

At a minimum, rehearse the following:

- a. Fire Support Plan: Verify target locations, trigger positions/lines, primary and backup observers/target executors, primary and backup communications channels, target engagement criteria, target priority, purpose, method of engagement, attack guidance, and fire support coordination measures.
- b. Target Acquisition Plan: Verify target priorities, queuing agents, queuing criteria, timeliness and accuracy requirements, who targets, what information is reported to whom, target selection standards, sectors or responsibility/zones of search, positioning/movement plans.
- c. Reconnaissance and Surveillance Plan: Same as those for Target Acquisition Plan.



- d. Communications-Electronics Plan: Verifies signal operations instructions (SOI) instructions, TACFIRE subscriber list, jamming procedures and requirements.

### **Preparation Lesson Learned: The FSCOORD/FSO Should be Where He Can Contribute Most to the Success of the Operation**

The battalion or company FSO facilitates fire support by accompanying the maneuver commander in all phases of planning. Every coordination meeting, orders briefing, or briefback the commander attends also requires the FSO's active participation. During execution, an FSO does not always have to stay beside the maneuver commander. The tactical requirement is responsiveness, not proximity.

The key consideration is not whether the FSO is located directly with or adjacent to his commander, but whether he can accomplish his mission within the commander's intent from wherever he locates. The FSO's primary roles are as a planner and executor. He must be where he can communicate with his fire supporters and effect changes in priorities, allocation of assets, and assist in the battle as directed by the maneuver commander.

If the maneuver commander assigns the FSO secondary missions as his primary or redundant shooter for a particular engagement, he should be as close to the commander as possible. If his mission is to fire a series or group of targets as part of the larger plan, he must position himself where he can observe his targets and still remain within communications distance of his commander.

### **Preparation Lesson Learned: The FSO and Forward Observers Must Verify the Location of Obstacles and Plan Fires on or Around Them**

FOs and FSOs must verify obstacle locations and plan fires on or around them. The countermobility effort is an integrated task in which the FSO supports the engineer. Neither planning nor execution of fires or obstacles can be done in a vacuum. Battlefield synchronization mandates that both the engineer and the FSO work together and advise each other on the respective capabilities and limitations. The FSO and engineer must integrate obstacles with the fire plan so the unit can attack enemy forces breaching or attempting to bypass friendly obstacles.

The FSO assigns targets planned on and around obstacles to an observer who can call for fire when the enemy reaches the obstacle. FSOs often plan targets around obstacles but fires are often ineffective due to observers not being able to see the obstacle, or the obstacle location was not verified after it was emplaced.

### **Position Forward Observers Where They Can See That Portion of the Battlefield for Which They are Responsible**

The maneuver commander and FSO must determine the best locations for their forward observers. The most frequently overlooked element of the indirect fire system is the location of the forward observer in relation to the targets.

If an FO has been given responsibility for initiating fire supporting of an obstacle, he must be positioned where he can both see the target and communicate with the delivery unit responsible for engaging those targets.

The maneuver commander's (Co, TF, or BDE) METT-T analysis must drive where observers will be positioned and what functions/responsibilities each has. Platoon FOs and COLTs can be assigned responsibility for target engagement or surveillance of a particular portion of the battlefield at BDE, TF, or Co level. It is incumbent upon the FSO to ensure that his forward observation parties are positioned to execute their responsibilities, regardless of who assigns the tasks.

Observers and fire support must maintain effective communications to deliver timely and accurate fires on the enemy. Digital equipment must have electronic line of sight in order to pass traffic. Positioning of observers and FSOs must consider their need both to see the battlefield and to communicate.

Position observers where they can see their targets and maintain communications with their indirect fire assets.

The forward observer, regardless of assigned tasks or where he is positioned, must be able to see the battlefield to get effective fires.

#### **Execution Lesson Learned: FSO Must be Aggressive**

FSOs, particularly at company level, must be aggressive!! This means they must plan in the absence of detailed guidance, supervise their subordinates, and above all, react to the changing situation on the battlefield. They cannot sit by passively, unable to observe or communicate, while they wait for their commander to tell them to move. They must take the initiative to bring fire on the enemy.

#### **Execution Lessons Learned: Forward Observers and FSOs Must Know Maneuver Boundaries and Other Control Measures**

FSOs and FOs must be familiar with maneuver boundaries to prevent firing across boundaries into another unit's area. FSOs must be aware of the limitations boundaries impose on their planning. Failure to pay attention to boundaries is the second most common cause of fratricides.

#### **Execution Lessons Learned: Know and Report the Location of the Maneuver Force**

The greatest unnecessary risk that confronts the soldier on the battlefield is fratricide. To minimize the risk it is essential that the location of friendly elements be kept current and that each target be checked to ensure that fires not be brought down upon friendly elements.

#### **Planning Lessons Learned: Copperhead and FASCAM Must be Planned Carefully and Used Against High Payoff Targets**

## **Copperhead**

Copperhead (CPHD) is a highly specialized munition that requires a great deal of planning for successful employment. When employed correctly, it can have a devastating effect on enemy formations. Units have their greatest success with Copperhead when they use it in preplanned areas against clearly defined high payoff targets.

## **FASCAM**

Frequently maneuver commanders must plan for the use of FASCAM. Although the term FASCAM includes a wide variety of delivery systems (tactical air, Army aviation, artillery, and ground emplaced), artillery delivered remote anti-armor (RAAM) and area denial artillery munitions (ADAM) are the most responsive to the needs of the maneuver commander. The artillery-delivered systems are also very effective in shaping the battlefield.

As with any obstacle system, the engineer is the staff proponent for planning the employment of FASCAM. The FSO and FSCoord must coordinate with the engineer in planning and coordinating FASCAM. The FSO can work out the inconsistencies between the planning and logistics estimates.

### **Execution Lessons Learned: Use Artillery Illumination to Facilitate Direct Fire Weapons at Night**

Whether the heavy maneuver TFs are modernized or non-modernized, they benefit from illumination. The widespread fear that illumination washes out thermal sights and other night vision devices appears wholly unfounded. Experience during live fire exercises shows that maneuver TFs fire more and more accurately when they use artillery illumination.

#### **10. CALL 93-4: Combat Training Centers (CTCs) Bulletin – Jul 93**

Fire support may be rehearsed with the subordinate battalion and company FSOs rehearsing their planned fire missions at the appropriate time and place. Enemy events and a general chronology of critical friendly events trigger actions at the rehearsal. The sequence should usually be enemy actions, acquisition of these actions, and friendly fire support actions.

Brigades must plan for fire support from the line of departure to actions on the objective. Successful units plan for smoke and suppressive fires to deny enemy observation during the movement to the objective. OPFOR observation posts (OPs) continually destroy considerable brigade combat power with indirect fire prior to the unit's arrival at the objective. Units generally do not completely suppress observed obstacles during breaching operations. During the assault on the objective, the execution of fire tends to become disconnected from the scheme of maneuver.

S2s and Fire Support Officers (FSOs) must be trained to develop the reconnaissance and surveillance plans and fire plan together. The S2 must template and develop NAIs for all OPs and command observation posts (COPs); obstacles; MRPs; potential reserve platoons and antitank ambushes. At the same time, the FSO must put the NAI into the fire plan as targets. Together, the S2 and FSO must track the results of reconnaissance to confirm, update, or deny their NAIs. The FSE must update targets based on reconnaissance. During movement, the brigade must plan to suppress direct fire and use smoke to screen themselves from known and suspected OPs that can affect their courses of action. All obstacles that affect the brigades movement and assault of the objective must be breached, and breached quickly; they require a corresponding fire support plan. Units must practice breach drills with fire support actions included. For obstacle breaches, units must learn to call for indirect suppressive fires on enemy overwatch positions and smoke to screen friendly positions. These fires must be called and in place before the unit leaves its last covered and concealed positions. For smoke, this may mean initiating the call as much as 10 minutes ahead of the unit's departing for the breach to ensure that the smoke screen is in place. Most units will not carry enough mortar smoke to do the job, so the use of field artillery smoke must be in the plan. The breaching of the obstacle will probably require 30 minutes of smoke if done correctly. For both the breaching of obstacles and the assault of the objectives, the brigade must develop graphic control measures that integrate the movement of forces and the delivery of fires. These graphics must be tied to specific locations on the ground where maneuver forces control the delivery and shifting of fires. Key control measures include limits of advance to designated locations (to shift across the objective). The leadership must understand the concept; must train leaders specifically on the call for fire to control the fire plan; and must identify SOPs for graphic control measures, radio procedures, and nets. The rehearsal of fires and maneuver on the objective must be reviewed by company commanders and platoon leaders.

11. **CALL 90-7, Winning in the Desert - Aug 90**

Illumination or smoke rounds can be used to reorient maneuver forces.

The fire support coordinator/FSO is responsible for planning and coordinating all fires in the maneuver area of operations, i.e., mortars, Air Force, Marine Corps, and Navy CAS, naval gunfire, and attack helicopters.

12. **CALL 90-8, Winning in the Desert II - Sept 90**

TOPIC: Use time and variable time-fuzed munitions to kill and point-detonating fuzed munitions to screen.

DISCUSSION: The Allies in North Africa and the Israelis found that point detonating fuzed munitions very often buried themselves in the sand prior to bursting, drastically reducing the casualty producing effect, but the bursts raised large clouds of dust/sand which effectively screened units' movements. The air bursting munitions were more effective casualty producers.

LESSON LEARNED: Artillery units must prepare to use point-detonating high-explosive

ammunition to screen unit movements when smoke/white phosphorus ammunition is depleted.

13. **CALL 92-4: Fratricide: Reducing Self-Inflicted Losses – Apr 92**

The RAND Study also investigated indirect fire and found fratricidal missions in 51 of 116 battles reviewed. On average, task forces fired 26.7 missions per battle (excluding smoke and illumination), with 33 percent achieving at least some suppression of forces on the ground. About one-tenth of these “effective” missions, or 3.6 percent of total missions was fratricidal. Of interest, there was only a small deviation between kinds of operations (offense vs. defense) and between units with and without TACFIRE. However, the difference between training in units was significant. The best task forces had fratricidal fire missions in only 25 percent of their battles, while some had friendly indirect fire in every battle. Unfortunately, these figures do not readily translate to casualty estimates for comparison with direct fire casualties.

A recent white paper on this subject from the U.S. Army Field Artillery School states “The Fire Support Element (FSE) at the maneuver headquarters initiating the request for fires is responsible for obtaining internal clearance (clearance from subordinate units) and, as necessary, clearance from adjacent units in whose areas the target lie.” The white paper further details the lack of TTP available to the FSCoord and maneuver commander. Although doctrinally acceptable within unit boundaries, passive control (silence is consent) greatly increases the potential for fratricide, due to the assumption of optimal communications and battle tracking. Combat Training Center (CTC) experiences show that there is no substitution for clearing fires through positive control and “eyes-on-target” observation at the lowest level.

Experience at Combat Maneuver Training Center (CMTC) shows that fratricide from friendly minefields is a major problem due to lack of coordination, failure to disseminate obstacle plan, and failure to accurately report obstacle locations back up the chain. — — — Solutions include training with scatterable minefields in command post exercises (CPXs) and field training exercises (FTXs), including minefield locations in your liaison officer (LO) checklist and development of a “flash” traffic format or quick report format similar to NBC reports. Note that any use of FASCAM (and possibly some use of dud-producing submunitions) requires appropriate reporting.

During Operation DESERT STORM, the combined dud rate of multiple engagements with improved conventional munitions [antipersonnel improved conventional munition (APICM), DPICM, cluster bomb units (CBUs)] caused obstacles and safety concerns for the maneuver commander. — — — Commanders can create Restricted Fire Areas (RFAs) where they anticipate subsequent maneuver to control this problem. Dud-producing missions would then require coordination with the maneuver headquarters.

## **Lessons Learned Integrated into CCF 15 Task List**

This component identifies the lessons learned extracted from the U.S. Army Center for Army Lessons Learned (CALL) publications relevant to performing this CCF. The lessons learned are organized and listed by the appropriate task in the CCF Task List. See Section 7 of this analysis for the detailed task list or, Section 6 for a summary list of the tasks. Where appropriate to address the absence of a task in an Army Training and Evaluation Program - Mission Training Plan (ARTEP-MTP), the lessons learned have been structured as tasks and are included in the detailed task list as sub-tasks. The purpose of the lessons learned component is to provide the user with the most recent tactics, techniques and procedures (TTP) associated with the performance of the tasks in this CCF.

### **PLANNING PHASE**

#### **1. Sustain and Protect the Force During Planning**

The FSCoord or FSO does not have the luxury of time to develop a "bottom-up" fire support plan. Operational requirements do not allow the observers to develop, identify, and plan targets or fires in support of the maneuver force and forward them up through fire support channels for consolidation at each higher level.

The lack of available planning time requires the FSCoord and FSO to conduct the planning for their subordinate units and to disseminate the plan down to the units for refinements, adjustments, and execution.

#### **2. Receive Order From Higher Headquarters**

#### **3. Conduct Mission Analysis**

#### **4. Issue the WARNO**

#### **5. Brigade Commander Issues Planning Guidance**

Specific guidance concerning where, when, and what to shoot rather than an allocation of priorities is often the most effective method of synchronizing fires with maneuver.

Effective fire support starts with, and is the responsibility of, the commander of the maneuver force. Before the battle staff or the fire support staff begins planning, the commander must first articulate his intent and guidance for the operation.

The maneuver commander's intent is the foundation that drives the process of planning, preparing, and executing the battle.

The commander's guidance and intent provide the basis for collection of information, the development of the scheme of maneuver and fire support, and the integration of the combat power of the seven operating systems into a cohesive, synchronized force.

Development of a successful fire support plan is dependent upon the maneuver commander's guidance.

The maneuver commander must state the role that fire support is to play in the overall operation.

The commander defines the areas where indirect fires are to be planned, engagement areas where fires must support maneuver, and any areas critical to the battlefield that require fire support.

The most effective method of ensuring that the commander's guidance is understood is for the FSO to briefback his understanding of the commander's fire support guidance to the maneuver commander. This ensures that the FSO understands how the maneuver commander sees the ways in which fire support will be used in the operation.

Only after the commander's guidance and intent is clearly defined and understood can the FSCoord and the FSO conduct their planning, wargaming, and rehearsing of the operation with the commander and his battle staff.

**6. Prepare Staff Estimates**

**7. Staff Develops Courses of Action**

Given that there is never sufficient artillery to do all things, a centralized approach guards against the risk of firing a few rounds at a large number of low priority targets. The preferred solution is to fire many rounds on a few particularly critical targets.

Artillery illumination should be planned for all night operations, even when the primary concept calls for no illumination. Plans need to delineate specific conditions which will trigger the use of illumination and who will make the decision. Even when gunners can acquire targets with night sights, leaders often need illumination to facilitate command and control and fire distribution.

During the planning sequence, the FSO must develop a maneuver battalion voice fire support net and, in conjunction with the FA BN S3, a voice fire direction net to be utilized during emergencies.

The FO must select observation posts and movement routes to support the maneuver commander's scheme of maneuver. The FSO must apply the factors of METT-T to determine the optimal positions for his observers.

Fire support planning is conducted concurrently as the maneuver force conducts its battle planning and determines how, when, and with what means targets will be attacked in support of the maneuver force.

The maneuver commander on today's battlefield faces more targets than he has weapons systems with which to attack them. To prevent the overloading of the fire support system with

targets, a method of prioritizing targets is necessary.

The FSO should use the S2's situation template to develop and refine the target list to include only targets which support the operation.

A target list with fewer targets is easier to employ for the observer, commanders, and other key personnel in the fire support system to employ. With fewer targets, observers are better able to shift fires from planned targets to new targets on the battlefield. The FSCOORD and FSO must insist that every target has a purpose and that it be tied to the scheme of maneuver and the commander's intent.

Shorter target lists accomplish several key things:

- a. The FSO can ensure that planned targets are based on the target engagement priorities established by the maneuver commander.
- b. The FSCOORD and FSO can quickly consolidate and disseminate the fire support plan and target list.
- c. The FSO can solve or eliminate duplication of targets.
- d. Executing a "shift from a planned target" is quicker than initiating a new call for fire.

Fire support must be integrated with the unit's scheme of maneuver and its surveillance and target acquisition efforts. The fire support system must be flexible enough to supply conventional fires without interruption as the tactical situation changes.

The fire support execution matrix is a concise, easy planning and executing tool that shows the many factors of a complex fire support plan. The matrix assists the FSO and maneuver commander in understanding how the fire plan supports the scheme of maneuver and the commander's intent.

The matrix explains the portion of the fire support plan each FSO, FO, and maneuver commander is responsible for executing. Not only does it describe what and who, it also describes when (by phase/event), where, and how.

The fire support execution matrix must be event driven, not based on time. This amplifies the importance of close cooperation between the FSO and the maneuver and artillery S2s. IPB reveals possible and likely enemy locations and avenues of approach. IPB provides the initial framework for developing the fire plan.

FSOs should use situational templates from IPB to develop targets for target lists. Shorter, well-managed lists are best for several reasons:

- a. Reduces the processing time for TACFIRE.



- b. Provides more time to firing units to compute firing data for planned targets.
- c. Provides time to FA battalion TOC to determine when and if it will have to move fire units to range planned targets.
- d. Provides more time to ensure coordination across maneuver boundaries, if necessary.
- e. Permits more time to ensure that targets planned by the FSOs are based on the target engagement priorities established by the brigade/battalion commander in his intent.
- f. Facilitates reproduction and distribution of the fire support plan, as well as a realistic division of responsibility between maneuver and fire support for servicing the targets.

The number of targets planned to support any maneuver operation should be METT-T dependent.

The FSO assigns targets planned on and around obstacles to an observer who can call for fire when the enemy reaches the obstacle. FSOs often plan targets around obstacles, but fires are often ineffective because observers were not able to see the obstacle or the obstacle location was not verified after it was emplaced.

The maneuver commander and FSO must determine the best locations for their forward observers. The most frequently overlooked element of the indirect fire system is the location of the forward observer in relation to the targets.

The maneuver commander's (Co, TF, or BDE) METT-T analysis must drive where observers will be positioned and what functions/responsibilities each has. Platoon FOs and COLTs can be assigned responsibility for target engagement or surveillance of a particular portion of the battlefield at BDE, TF, or Co level.

Position observers where they can see their targets and maintain communications with their indirect fire assets.

CPHD is a highly specialized munition that requires a great deal of planning for successful employment. When employed correctly, it can have a devastating effect on enemy formations. Units have their greatest success with Copperhead when they use it in preplanned areas against clearly defined high payoff targets.

Frequently, maneuver commanders must plan for the use of FASCAM. Although the term FASCAM includes a wide variety of delivery systems (tactical air, Army aviation, artillery, and ground emplaced), artillery-delivered RAAM and ADAM are the most responsive to the need of the maneuver commander. The artillery-delivered systems are also very effective in shaping the battlefield.

As with any obstacle system, the engineer is the staff proponent for planning the employment of FASCAM. The FSO and FSCoord must coordinate with the engineer in planning and coordinating FASCAM. The FSO can work out the inconsistencies between the planning and logistics estimates.

Whether the heavy maneuver TFs are modernized or non-modernized, they benefit from illumination. The widespread fear that illumination washes out thermal sights and other night vision devices appears wholly unfounded. Experience during live fire exercises shows that maneuver TFs fire more and more accurately when they use artillery illumination.

Brigades must plan for fire support from the line of departure to actions on the objective. Successful units plan for smoke and suppressive fires to deny enemy observation during the movement to the objective. OPFOR OPs continually destroy considerable brigade combat power with indirect fire prior to the unit's arrival at the objective. Units generally do not completely suppress observed obstacles during breaching operations. During the assault on the objective, the execution of fire tends to become disconnected from the scheme of maneuver.

S2s and FSOs must be trained to develop the reconnaissance and surveillance plans and fire plan together. The S2 must template and develop NAIs for all Ops and COPs, obstacles, MRPs, potential reserve platoons, and antitank ambushes. At the same time, the FSO must put the NAIs into the fire plan as targets.

During movement, the brigades must plan to suppress direct fire and use smoke to screen themselves from known and suspected OPs that can affect their courses of action. All obstacles that affect the brigade's movement and assault of the objective must be breached quickly; they require a corresponding fire support plan.

The breaching of the obstacle will probably require 30 minutes of smoke if done correctly.

For both the breaching of obstacles and the assault of the objectives, brigades must develop graphic control measures that integrate the movement of forces and the delivery of fires. These graphics must be tied to specific locations on the ground where maneuver forces control the delivery and shifting of fires. Key control measures include limits of advance to designated locations (to shift across the objective).

Illumination or smoke rounds can be used to reorient maneuver forces.

The fire support coordinator/FSO is responsible for planning and coordinating all fires in the maneuver area of operations, i.e., mortars, Air Force, Marine Corps, and Navy CAS, naval gunfire, and attack helicopters.

During Operation DESERT STORM, the combined dud rate of multiple engagements with improved conventional munitions (APICM, DPICM, CBU's) caused obstacles and safety concerns for the maneuver commander. --- Commanders can create RFAs where they anticipate subsequent maneuvers to control this problem. Dud-producing missions would then require coordination with the maneuver headquarters.

## 8. Staff/Commander Analyze Courses of Action (War Game)

Upon receipt of the commander's guidance, the commander, FSO, maneuver S3, and staff set about to develop the operations order. A critical step in building the foundation for the operations order is wargaming of the mission by the commander and staff. Wargaming allows the maneuver commander to analyze and evaluate various courses of action to determine how best to defeat and destroy the enemy.

As the maneuver commander wargames the operation, the FSO provides the most current information for applying all elements to the fire support system. The FSO recommends options to the maneuver commander and courses of action on how to best apply the fire support system in concert with other operating systems. The maneuver commander provides the required target effects and the priorities for engaging targets and allocating targets.

Wargaming allows the maneuver commander to decide how fire support resources will be used, designates which subordinate echelons will be weighted with fire support, states what targets and target types to attack, and designates what fire support means to use. When the wargaming is complete, the FSO provides the maneuver commander with a fire support plan recommendation to support the selected course of action as well as a positioning and movement plan to ensure firing support elements are able to provide continuous support throughout the operation. The recommended fire support plan will also identify firing support logistical requirements and their impact on the battle.

The process of wargaming integrates the fire support target acquisition systems into the maneuver force battlefield intelligence collection (operations and ensures that the task force uses the proper fire support means to engage targets).

The FSO must understand maneuver doctrine, tactics, techniques, and procedures for all battlefield operating systems. He must communicate the capabilities and limitations of fire support to the maneuver force commander and staff. The FSO must articulate the ability of the indirect fire systems to support each course of action to the maneuver commander; the maneuver commander must listen.

The wargaming process identifies the decision points for the commander. The DST graphically portrays the decision points and the options available to the commander if an action occurs. The DST provides the FSO with the critical information that is required to provide timely and accurate fires in support of the maneuver force.

The fire support execution matrix, like the maneuver execution matrix, is event, not time driven. It works like a musical score to bring mortars, field artillery, rocket, and all fire support systems in concert with the other operating systems on the battlefield at the needed time and place.

The countermobility effort is an integrated task in which the FSO supports the engineer. Neither planning nor execution of fires or obstacles can be done in a vacuum. Battlefield synchronization mandates that both the engineer and the FSO work together and advise each other on their respective capabilities and limitations. The FSO and engineer must integrate obstacles with the fire plan so the unit can attack enemy forces breaching or attempting to bypass friendly

obstacles.

9. **Staff Compares Courses of Action**

The FSO must understand maneuver doctrine, tactics, techniques, and procedures for all battlefield operating systems. He must communicate the capabilities and limitations of fire support to the maneuver force commander and staff. The FSO must articulate the ability of the indirect fire systems to support each course of action to the maneuver commander; the maneuver commander must listen.

10. **Brigade Commander Announces Decision**

Assign targets (high value targets, groups, series, etc.) to a commander for execution, not to the FSO. In most cases, the FSO is going to be colocated with the commander and will actually do the requesting and adjusting. The smarter maneuver commander ensures that his subordinates know how the fire plan is synchronized with the battle plan. A maneuver company commander, given the mission to fire group A1B at PL RED, will certainly be at the right place, at the right time to do just that. He will also probably ensure that his FSO has good communications with the FDC and that the mission goes as planned.

A fire plan formulated and disseminated from a higher to lower level, will allow the fire plan to be communicated to support the commander's concept, but feedback from the lower echelons is vital in order to refine the plan according to conditions that lower units meet.

Commanders and FSOs should work together to determine the best location for the observers. They share responsibility for positioning the observers where they can see the battlefield and contribute to the operation's success.

The fire support execution matrix is an excellent tool for the FSO to explain the fire support plan to the commander.

The maneuver commander is responsible for integrating fire support and the scheme of maneuver into the concept of operation.

The maneuver commander reviews the recommendation of the FSO along with the available ammunition and delivery means and determines the desired effect by category or suppression, neutralization, or destruction.

When approved by the maneuver commander, the matrix becomes the primary execution tool for the FSO, FO, and maneuver commanders. It is particularly useful in fixing responsibility for execution. It can use maneuver control measures such as target reference points or checkpoints to help integrate maneuver and fire.

The FSCOORD and FSO must explain FA combat power, limitations and capabilities of the fire support system, and how artillery and mortars can best support the operation. The FSO must be able to state whether he can support the mission, and if not, why not. The FSCOORD and FSO must be able to express the capabilities and limitations of the fire support system in terms

that the maneuver commander, his staff, and subordinate commanders, understand:

- a. Minutes of smoke, not just number of smoke rounds available.
- b. Number of available RAAM/ADAM minefields by type, size, and density. Safety zone around each; the time to emplace each, not the number of rounds.
- c. Battalion volleys by type of ammunition, and what effects the maneuver commander can expect from each volley given specific targets' description, not just the number of DPICM or HE rounds available.
- d. Range and artillery area coverage based on the preponderance of the shell/fuze/charge combinations available, not just the maximum range of the system.
- e. The need for timely and accurate target locations.

The briefback is used at the end of the staff planning process. A briefback is used by the FSCoord or FSO to tell the maneuver commander how fire support will accomplish the commander's stated and implied missions. It summarizes the FSCoord's or FSO's mission analysis and concept of fire support.

The briefback is an efficient way to advise the commander and assure him his guidance has been met. The briefback must communicate essential information without overloading the commander with details he does not need:

- a. State objective; what fire support will accomplish for the commander's plan. This can be summarized in terms of fire support roles with a general characterization of the desired effects on the target.
- b. State essential tasks; identify the principal means the fire plan uses to achieve the objective. Summarize the high points of the plan, such as number of targets; schedules; and special missions such as FASCAM, smoke, or illumination.
- c. State constraints on the plan; identify factors impacting on the execution of fires, such as availability of ammunition, special missions such as FASCAM or smoke, communications requirements, and fire units' repositioning times.
- d. Summarize execution; review the fire support matrix. State who is responsible for firing each target, what coordination is required, and what support from the maneuver force is necessary to accomplish the execution of the fire support plan.
- e. State objectives for contingencies and foreseeable future operations. Unless an unusual amount of time is available for the briefing, don't cover them in detail. These objectives are the first part of the planning guidance for subsequent operations.

The maneuver commander and FSO must determine the best locations for their forward

observers. The most frequently overlooked element of the indirect fire system is the location of the forward observer in relation to the targets.

#### 11. **Brigade Staff Prepares OPORD/FRAGO**

The fire support plan is far more than a target list or schedule of fires. It is an articulation of how supporting fires are to be employed with the other elements of combat power to accomplish the mission. The timing of maneuver and fires must be developed and then fully explained. "Priority of artillery fires to Team B. See target list." simply does not cut it.

The fire support execution matrix, which is the linkage of targets to systems and the identification of specifically who is to shoot by phase of battle, is a very effective tool. Responsibility for each target (to include identification on the ground, observation, execution, and adjustment as necessary) is given to a specific unit, e.g., company team, scout platoon. Sufficient redundancy is required to guard against obscuration and casualties.

Target lists that consist of quality targets and not quantity are more likely to succeed. These target lists must support the commander's concept.

The fire support plan includes how fire support elements will move and position themselves, their tactical deception and survivability plans, the survey and target acquisition plans, and how the fires will be allocated to the maneuver force.

The (fire support execution) matrix, when linked to the maneuver execution matrix, provides both the fire support staff, and the maneuver commander with a method of controlling indirect fire during the battle. Use of the matrix provides a system of controlling fires, a target list and target numbers that are common throughout the force.

To achieve successful fire support, it is essential that every participant in the fire support system uses a common target list. A common target list allows the mortars, artillery, aviation, and maneuver to reference and call fires on the same set of targets.

The matrix explains the portion of the fire support plan each FSO, FO, and maneuver commander is responsible for executing. Not only does it describe what and who, it also describes when (by phase/event), where, and how.

Target lists should be short, with ten or twenty targets per battalion TF. FSOs who insist every target has a purpose and is tied to the scheme of maneuver and the commander's intent end up with quality target lists, not "measle sheets."

#### 12. **Brigade Issues the OPORD/FRAGO**

Give copies of the fire support execution matrix to the Bn/Co commanders, platoon leaders, and platoon FOs.

Brief the (fire support execution) matrix to those individuals so they understand and visualize the fire support plan and can execute it if required.

The FSO develops and distributes the fire support execution matrix to the key players on the battlefield. This includes maneuver commanders, staff officers, scouts, fire support personnel, mortar and artillery fire direction centers, and anyone in a position to call for indirect fire during the battle.

The briefback is an efficient way to advise the commander and assure him his guidance has been met. The briefback must communicate essential information without overloading the commander with details he does not need:

- a. State objective; what fire support will accomplish for the commander's plan. This can be summarized in terms of fire support roles with a general characterization of desired effects on target.
- b. State essential tasks; identify the principal means the fire plan uses to achieve the objective. Summarize the high points of the plan, such as number of targets; schedules; and special missions such as FASCAM, smoke, or illumination.
- c. State constraints on the plan; identify factors impacting on the execution of fires such as the availability of ammunition, special missions such as FASCAM or smoke, communications requirements, and fire units' repositioning times.
- d. Summarize execution; review the fire support matrix. State who is responsible for firing each target, what coordination is required, and what support from the maneuver force is necessary to accomplish the execution of the fire support plan.
- e. State objectives for contingencies and foreseeable future operations. Unless an unusual amount of time is available for the briefing, don't cover them in detail. These objectives are the first part of the planning guidance for subsequent operations.

The battalion or company FSO facilitates fire support by accompanying the maneuver commander in all phases of planning. Every coordination meeting, orders briefing, or briefback the commander attends also requires the FSO's active participation.

## **PREPARATION PHASE**

### **13. The Brigade Targeting Team Organizes to Monitor, Plan, and Direct Fire Support Operations**

Communications between units, FSOs, and FDCs needs to be thoroughly checked before the battle. Necessary corrective action must be taken.

TACFIRE tends to back up during battles, and it is difficult to override the queuing sequence, in part because the FSO forward cannot monitor the fire nets. Non-TACFIRE nets can also become jammed with the stronger stations overriding. In either case, the likely consequence is that fires will not be massed on the highest priority targets. Disciplined fire nets are obviously important. In addition, the establishment of a voice fire coordination net for the task force is

recommended. On this net, the FSO passes instructions to company FSOs and his FSE, and he receives feedback on what is happening on fire direction nets. Unless the FSO has a net to receive information and pass instructions, he becomes just another FO.

The FSO must ensure that all leaders know what frequencies and call signs to use.

All leaders must know the frequencies and how to make the system work.

Observers and fire support personnel must maintain effective communications to deliver timely and accurate fires on the enemy. Digital equipment must have electronic line of sight in order to pass traffic. Positioning of observers and FSOs must consider their need both to see the battlefield and to communicate.

#### **14. The Brigade Targeting Team Acquires Information**

The key to effective employment of "top-down" fire planning is the redundant check of the plan before execution. This is not to imply that company FSOs should not be developing their own fire plans prior to receipt of the task force fire plan and target list. The company/team FSO should use his fire plan to provide the "bottom-up" refinements of the TF fire support plan and target list.

FOs and FSOs must verify obstacle locations and plan fires on or around them.

#### **15. The Brigade Targeting Team Evaluates Information**

The FSO should use the S2's situation template to develop and refine the target list to include only targets that support the operation.

The FSCOORD and FSO must insist that every target has a purpose and is tied to the scheme of maneuver and the commander's intent.

Fire planning must be a continuous process to be successful. Decentralization (informal) planning, like centralized (formal) planning, is a product of the situation, the time available, and the echelon at which it occurs. Fire planning should be both formal and informal, regardless of the time available, for it to be executable and successful.

A fire plan formulated and disseminated from a higher to a lower level will allow the fire plan to be communicated to support the commander's concept, but feedback from the lower echelons is vital to refine the plan according to conditions that lower units meet.

The fire support execution matrix (the linkage of targets to systems and the identification of specifically who is to shoot by phase of battle), is a very effective tool. Responsibility for each target (to include identification on the ground, observation, execution, and adjustment as necessary) is given to a specific unit, e.g., company team, scout platoon. Sufficient redundancy is required to guard against obscuration and casualties.

Target lists that consist of quality targets and not quantity are more likely to succeed. These



target lists must support the commander's concept.

The most critical aspect of the refinement is the verification of target locations by the observer to ensure the accuracy of the fires. Using resection, intersection, or registration, the observers must verify the location of planned targets and coordination measures to ensure the fire supports the intent of the maneuver force commander.

Together, the S2 and FSO must track the results of reconnaissance to confirm, update, or deny their NAIs. The FSE must update targets based on reconnaissance.

#### **16. The Brigade Targeting Team Updates Products**

A target list with fewer targets is easier for the observer, commanders, and other key personnel in the fire support system to employ. With fewer targets, observers are better able to shift fires from planned targets to new targets on the battlefield. The FSCoord and FSO must insist that every target has a purpose and is tied to the scheme of maneuver and the commander's intent.

Shorter target lists accomplish several key things:

- a. The FSO can ensure that planned targets are based on the target engagement priorities established by the maneuver commander.
- b. The FSCoord and FSO can quickly consolidate and disseminate the fire support plan and target list.
- c. The FSO can solve or eliminate duplication of targets.
- d. Executing a "shift from a planned target" is quicker than initiating a new call for fire.

The greatest unnecessary risk that confronts the soldier on the battlefield is fratricide. To minimize the risk, it is essential that the location of friendly elements be kept current and that each target be checked to ensure that fires not be brought down upon friendly elements.

Together, the S2 and FSO must track the results of reconnaissance to confirm, update, or deny their NAIs. The fire support element (FSE) must update targets based on reconnaissance.

#### **17. The Brigade Targeting Team Communicates Information and Coordinates the Brigade Fire Support Plan**

A face-to-face meeting between brigade and task force FSOs and the DS battalion S3 and FDO, where the concepts of operations and intents of the various maneuver commanders are discussed, pays rich dividends.

FOs and FSOs at lower levels must verify and refine the plan, their assigned targets, and positioning to ensure they can execute fires needed to support to commander's intent.

Position the observers in locations where they can see their targets and maintain communications with their indirect fire assets.

The fire support coordinator/FSO is responsible for planning and coordinating all fires in the maneuver area of operations; i.e., mortars, Air Force, Marine Corps, and Navy CAS, naval gunfire, and attack helicopters.

During Operation DESERT STORM, the combined dud rate of multiple engagements with improved conventional munitions (APICM, DPICM, CBU's) caused obstacles and safety concerns for the maneuver commander. -- -- Commanders can create RFAs where they anticipate subsequent maneuvers to control this problem. Dud-producing missions would then require coordination with the maneuver headquarters.

Fire planning must be a continuous process to be successful. Decentralization (informal) planning, like centralized (formal) planning, is a product of the situation, the time available, and the echelon at which it occurs. Fire planning should be both formal and informal, regardless of the time available, to be executable and successful. A fire plan formulated and disseminated from a higher to a lower level, will allow the fire plan to be communicated to support the commander's concept but feedback from the lower echelons is vital to refine the plan according to conditions that lower units meet.

Give copies of the fire support execution matrix to the Bn/Co commanders, platoon leaders, and platoon FOs.

Brief the (fire support execution) matrix to those individuals so they understand and visualize the fire support plan and can execute it if required.

Throughout the planning and preparation phases of the operation, the maneuver commander and the FSO continually work to focus and refine the plans that the organization is preparing to defeat the enemy.

Fire support must be integrated with the unit's scheme of maneuver and its surveillance and target acquisition efforts. The fire support system must be flexible enough to supply conventional fires without interruption as the tactical situation changes.

Brigades must plan for fire support from the line of departure to actions on the objective. Successful units plan for smoke and suppressive fires to deny enemy observation during the movement to the objective. OPFOR OPs continually destroy considerable brigade combat power with indirect fire prior to the unit's arrival at the objective. Units generally do not completely suppress observed obstacles during breaching operations. During the assault on the objective, the execution of fire tends to become disconnected from the scheme of maneuver.

#### **18. The Brigade Commander Visualizes the Battlefield**

Communication between the commander and his FSO is critical. If there is a misunderstanding, it will probably not be obvious until the execution commences. The FSO must communicate his thoughts in a language the commander will understand. For example, the FSO should tell him

how many minutes of smoke (HC) are available, not how many rounds; or that firing a preplanned 400m x 400m (medium) FASCAM minefield takes 7–12 minutes to fire, and with displacement to an alternate position this may result in the TF being unable to use its artillery for 45 minutes to one hour on other missions.

The preparation phase gives the commander and staff the opportunity to check and verify the plans against the commander's guidance and to correct all deficiencies before the execution phase.

The brigade commander must synchronize and concentrate all of his combat power at the critical time and place. Synchronizing and integrating the battlefield operating system is fundamental to success on the battlefield.

The FSCoord and FSO must explain FA combat power, limitations and capabilities of the fire support system and how artillery and mortars can best support the operation. The FSO must be able to state whether he can support the mission, and if not, why not. The FSCoord and FSO must be able to express the capabilities and limitations of the fire support system in terms that the maneuver commander, his staff, and subordinate commanders understand:

- a. Minutes of smoke, not just number of smoke rounds available.
- b. Number of available RAAM/ADAM minefields by type, size, and density; safety zone around each; and the time to emplace each, not the number of rounds.
- c. Battalion volleys by type of ammunition, and what effects the maneuver commander can expect from each volley given a specific target's description, not just the number of DPICM or HE rounds available.
- d. Range and artillery area coverage based on the preponderance of the shell/fuze/charge combinations available, not just the maximum range of the system.
- e. The need for timely and accurate target locations.

FSOs should use situational templates from IPB to develop targets for target lists. Shorter, well-managed lists are best for several reasons:

- a. Reduces the processing time for TACFIRE.
- b. Firing units have more time to compute firing data for planned targets.
- c. FA battalion TOC will have time to determine when and if it will have to move fire units to range planned targets.
- d. Provides more time to ensure coordination across maneuver boundaries, if necessary.
- e. Permits more time to ensure that targets planned by the FSOs are based on the

target engagement priorities established by the brigade/battalion commander in his intent.

- f. Facilitates reproduction and distribution of the fire support plan, as well as a realistic division of responsibility between maneuver and fire support for servicing the targets.

#### 19. **The Brigade Commander Directs Changes to the Operation or Plan**

Even though fire planning is a continuous process, there must be a "drop dead" time for making changes to an existing fire plan. A good cut-off time is one hour prior to execution. Naturally, critical changes occur after the "drop dead" time, but adherence to this time allows everyone to make his final preparation.

Brief the (fire support execution) matrix to those individuals so they understand and visualize the fire support plan and can execute it if required.

The maneuver commander's intent is the foundation that drives the process of planning, preparing, and executing the battle.

The FSO develops and distributes the fire support execution matrix to the key players on the battlefield. This includes maneuver commanders, staff officers, scouts, fire support personnel, mortar and artillery fire direction centers, and anyone in a position to call for indirect fire during the battle.

A reasonable cut-off time is five hours to crossing the LD or anticipated beginning of defensive operations. Emergency and critically important changes identified prior to the start of an operation should be made if they will have an adverse effect on the operation. Changes that do not affect the outcome of the operation should not be made.

The effect of limiting the time for submitting changes is the same as controlling the number of planned targets: It gives more time to check data, better preparation for the mission, more time for dissemination of the fire plan, and more time to wargame and rehearse.

#### 20. **The Brigade Commander Directs and Leads Subordinate Forces**

Commanders, subordinate infantry and tank leaders, FOs, and others responsible for specific targets must be able to point them out on the ground. Trigger lines based upon projected enemy routes and movement rates must be clearly identified.

Once the dedicated voice nets are established, a unit must rehearse these techniques and procedures to ensure execution during the battle.

The successful execution of a fire plan is directly proportional to the amount of prior planning and rehearsing. Units, as a whole, plan and coordinate fire plans well, but very few units take the time to rehearse them with the maneuver plans.

Rehearsing a fire plan is no different than wargaming a maneuver commander's concept of the operation. In fact, both require the same thought process and players. This thought process must ensure synchronization of fire support to enhance the maneuver commander's intent of fighting the battle. When rehearsing a fire plan, the following areas must be addressed:

- a. Who is responsible to initiate the mission and over what net?
- b. What is the redundancy in execution?
- c. Who clears fires?
- d. How is the maneuver commander made aware of the voids in fire support due to artillery units moving, mission processing times, etc.?
- e. What are the capabilities and limitations of field artillery?
- f. How many missions can be fired before artillery starts moving?
- g. How many targets of opportunity can be fired without interfering with the execution of the fire plan?

The maneuver commander walks through the concept of the operation and depicts (based on the fire plan) where and when he wants fire support. As the maneuver commander identifies a target:

- a. The person shooting it explains where and when he executes the mission, what net and call signs he uses, and what effect he anticipates on the target.
- b. The alternate shooter addresses the same question.

This rehearsal continues until the fire plan is completed. This tests whether the fire plan supports the task force commander's scheme of maneuver.

Use the fire support execution matrix to conduct a fire support rehearsal. The purpose of the rehearsal is to ensure that all personnel fully understand their mission and responsibilities in the fire support plan. Ideally, conduct this rehearsal with a maneuver rehearsal. If the commander does not understand the fire support plan, he will not use it. The fire support execution matrix and the rehearsal overcome this problem.

Throughout the planning and preparation phases of the operation, the maneuver commander and the FSO continually work to focus and refine the plans that the organization is preparing in order to defeat the enemy. The final step in the development of the fire support plan is the combined arms rehearsal.

How the rehearsal looks is not as important as what it accomplishes. The rehearsal will be more effective if all the battlefield operating systems are included. The maneuver commander and subordinate commanders, as well as the FSO, must rehearse the fire support plan at the same

time as the maneuver plan.

A rehearsal is an effective tool for identifying and refining battle plans. The keys to an effective rehearsal are that:

- a. The positioning and movement plans of the artillery units are exercised.
- b. The target acquisition plan is verified.
- c. The fire support plan is validated with the scheme of maneuver, the commander's intent, and attack guidance.
- d. The obstacle/barrier plan of the maneuver force is part of the fire support plan.
- e. The fire and maneuver control measures for protecting and controlling aerial and ground forces do not disrupt the fire support plan and are not violated by the plan.
- f. Target grids and trigger points are verified.
- g. Redundant observers will initiate fires if the primary observer fails to execute.

The rehearsal provides the FSCoord and the FSO with an opportunity to identify gaps in the fire plan, potential engagement areas that were not found during the initial planning and wargaming process, and obstacles or barriers that are not covered with fires. The FSO should also use the rehearsal to identify targets that cannot be observed without the use of remote sensors.

The FSO must understand maneuver doctrine, tactics, techniques, and procedures for all battlefield operating systems. He must communicate the capabilities and limitations of fire support to the maneuver force commander and staff. The FSO must articulate the ability of the indirect fire systems to support each course of action to the maneuver commander; the maneuver commander must listen.

Fire support must be integrated with the unit's scheme of maneuver and its surveillance and target acquisition efforts. The fire support system must be flexible enough to supply conventional fires without interruption as the tactical situation changes.

The briefback is an efficient way to advise the commander and assure him that his guidance has been met. The briefback must communicate essential information without overloading the commander with details he does not need:

- a. State objective; what fire support will accomplish for the commander's plan. This can be summarized in terms of fire support roles with a general characterization of desired effects on target.
- b. State essential tasks; identify the principal means the fire plan uses to achieve the

objective. Summarize the high points of the plan, such as number of targets; schedules; special missions such as FASCAM, smoke, or illumination.

- c. State constraints on the plan; identify factors impacting on the execution of fires, such as availability of ammunition, special missions such as FASCAM or smoke, communications requirements, and fire units' repositioning times.
- d. Summarize execution; review the fire support matrix. State who is responsible for firing each target, what coordination is required, and what support from the maneuver force is necessary to accomplish the execution of the fire support plan.
- e. State objectives for contingencies and foreseeable future operations. Unless an unusual amount of time is available for the briefing, don't cover them in detail. These objectives are the first part of the planning guidance for subsequent operations.

Rehearsals are an integral part of the planning process. The rehearsal should both practice and test the plan. If at all possible, the fire support/artillery rehearsal should be conducted with the maneuver commander's rehearsal. A combined rehearsal will improve responsiveness of fires and synchronization of all the maneuver commander's battle resources.

At any level, fire support participants in the maneuver commander's rehearsal should include all members of the fire support cell, and all subordinate fire support elements.

A rehearsal is a run-through of the operation that both practices and tests it enough to be executed. At the end of an effective rehearsal, everyone should know his responsibilities and the cues for action. The commander should also know if the plan is viable. A rehearsal presupposes a complete plan, that is, a plan complete enough to be executed. Completion is what distinguishes a plan under rehearsal from one being wargamed.

If planning is well organized, many plans and subplans can be rehearsed concurrently. When time is limited, select the plans that need attention and which can be checked and fixed in the time available.

If the maneuver commander does not conduct a combined rehearsal and rehearsal time is available, the FSO should conduct a fire support rehearsal using the maneuver force operation order OPORD, fire support plan, fire support execution matrix, and the field artillery support plan. A rehearsal conducted with only fire support personnel is still better than no rehearsal at all.

At a minimum, rehearse the following:

- a. Fire Support Plan: Verify target locations, trigger positions/lines, primary and backup observers/target executors, primary and backup communications channels, target engagement criteria, target priority, purpose, method of engagement, attack guidance, and fire support coordination measures.

- b. Target Acquisition Plan: Verify target priorities, queuing agents, queuing criteria, timeliness and accuracy requirements, who targets, what information is reported to whom, target selection standards, sectors or responsibility/zones of search, positioning/movement plans.
- c. Reconnaissance and Surveillance Plan: Same as those for Target Acquisition Plan.
- d. Communications-Electronics Plan: Verifies SOI instructions, TACFIRE subscriber list, jamming procedures and requirements.

Fire support may be rehearsed with the subordinate battalion and company FSOs rehearsing their planned fire missions at the appropriate time and place. Enemy events and a general chronology of critical friendly events trigger actions at the rehearsal. The sequence should usually be enemy actions, acquisition of these actions, and friendly fire support actions.

Brigades must plan for fire support from the line of departure to actions on the objective. Successful units plan for smoke and suppressive fires to deny enemy observation during the movement to the objective. OPFOR OPs continually destroy considerable brigade combat power with indirect fire prior to the unit's arrival at the objective. Units generally do not completely suppress observed obstacles during breaching operations. During the assault on the objective, the execution of fire tends to become disconnected from the scheme of maneuver.

Units must practice breach drills with fire support actions included.

The leadership must understand the concept; train leaders specifically on the call for fire to control the fire plan; and identify SOPs for graphic control measures, radio procedures, and nets. The rehearsal of fires and maneuver on the objective must be reviewed by company commanders and platoon leaders.

## 21. Target Acquisition Assets Position and Perform Target Acquisition Activities

The location of OPs, obstacles, and reference points require confirmation by resection or PADs to the maximum extent possible.

Commanders and FSOs should work together to determine the best location for the observers. They share the responsibility for positioning the observers where they can see the battlefield and contribute to the operation's success.

The FO must select observation posts and movement routes to support the maneuver commander's scheme of maneuver. The FSO must apply the factors of METT-T to determine optimal positions for his observers.

If an FO has been given responsibility for initiating fire supporting an obstacle, he must be positioned where he can both see the target and communicate with the delivery unit responsible for engaging those targets.



It is incumbent upon the FSO to ensure that his forward observation parties are positioned to execute their responsibilities, regardless of who assigns the tasks.

Observers and fire support must maintain effective communications to deliver timely and accurate fires on the enemy. Digital equipment must have electronic line of sight in order to pass traffic. Positioning of observers and FSOs must consider both their need to see the battlefield and to communicate.

Position observers where they can see their targets and maintain communications with their indirect fire assets.

The forward observer, regardless of assigned tasks or where he is positioned, must be able to see the battlefield to get effective fires.

FSOs and FOs must be familiar with maneuver boundaries to prevent firing across boundaries into another unit's area. FSOs must be aware of the limitations boundaries impose on their planning. Failure to pay attention to boundaries is the second most common cause of fratricides.

The most frequently overlooked element of the indirect fire system is the location of the forward observer in relation to the targets.

The maneuver commander's (Co, TF, or BDE) METT-T analysis must drive where observers will be positioned and what functions/responsibilities each has.

## **EXECUTION PHASE**

### **22. The Brigade Targeting Team Monitors and Directs Fire Support Operations from Brigade CPs and the DS FA Battalion TOC**

Communications between units, FSOs, and FDCs need to be thoroughly checked before the battle to include necessary corrective action.

TACFIRE tends to back up during battles and it is difficult to override the queuing sequence, in part because the FSO forward cannot monitor the fire nets. Non-TACFIRE nets can also become jammed with the stronger stations overriding. In either case, the likely consequence is that fires will not be massed on the highest priority targets. Having disciplined fire nets is obviously important. In addition, the establishment of a voice fire coordination net for the task force is recommended. On this net, the FSO passes instructions to company FSOs and to his FSE, and he receives feedback on what is happening on fire direction nets. Unless the FSO has a net to receive information and pass instructions, he becomes just another FO.

The FSO must ensure that all leaders know what frequencies and call signs to use.

All leaders must know the frequencies and how to make the system work.

During execution, an FSO does not always have to stay beside the maneuver commander. The tactical requirement is responsiveness, not proximity.

The key consideration is not whether the FSO is located directly with or adjacent to his commander, but whether he can accomplish his mission within the commander's intent from wherever he locates. The FSO's primary roles are as a planner and executor. He must be where he can communicate with his fire supporters, effect changes in priorities and allocation of assets, and assist in the battle as directed by the maneuver commander.

If the maneuver commander assigns the FSO secondary missions as his primary or redundant shooter for a particular engagement, he should be as close to the commander as possible. If his mission is to fire a series or group of targets as part of the larger plan, he must position himself where he can observe his targets and still remain within communications distance of this commander.

Observers and fire support personnel must maintain effective communications to deliver timely and accurate fires on the enemy. Digital equipment must have electronic line of sight in order to pass traffic. Positioning of observers and FSOs must consider both their need to see the battlefield and to communicate.

The tactical requirement is for the FSO to be responsive to or, in some cases, under the control of the maneuver commander he supports. The key consideration is whether his location enables him to accomplish his mission. If his primary function during a battle is to be the commander's FO, he should be as close to the maneuver commander as possible while maintaining observation of the battalion area. If his mission is to fire a series or group of planned targets as part of the overall fire plan, the FSO must observe those targets at all times and remain responsive to the maneuver commander throughout the entire battle.

23. **The Brigade Targeting Team Directs the Employment of Indirect Fires Against Brigade HPTs**

The maneuver commander on today's battlefield faces more targets than he has weapons systems to attack. To prevent the overloading of the fire support system with targets, a method of prioritizing targets is necessary.

Using the attack criteria established by the maneuver commander, the FSCoord and the FSO must prioritize targets in relation to their impact on the battle. The highest priority targets are those that, if not defeated, can inhibit the execution of the maneuver commander's battle plan. The next priority of targets are those that may seriously interfere with the battle plan. The lowest priority targets are those that might seriously interfere with the battle plan later in the battle or disrupt future plans, and those targets that have limited impact on the plan or are very low payoff to the maneuver commander.

Units have their greatest success with Copperhead when they use it in preplanned areas against clearly defined high payoff targets.

The fire support execution matrix, like the maneuver execution matrix, is event, not time, driven. It works like a musical score to bring mortars, field artillery, rocket, and all fire support systems in concert with the other operating systems on the battlefield at the needed time and place.

The (fire support execution) matrix, when linked to the maneuver execution matrix, provides both the fire support staff and the maneuver commander with a method of controlling indirect fire during the battle. Use of the matrix provides a system of controlling fires, a target list, and target numbers that are common throughout the force.

To achieve successful fire support, it is essential that every participant in the fire support system uses a common target list. A common target list allows the mortars, artillery, aviation, and maneuver to reference and call fires on the same set of targets.

The most critical aspect of the refinement is the verification of target locations by the observer to ensure the accuracy of the fires. Using resection, intersection, or registration, the observers must verify the location of planned targets and coordination measures to ensure that the fire supports the intent of the maneuver force commander.

The fire support execution matrix must be event driven, not based on time. This amplifies the importance of close cooperation between the FSO and the maneuver and artillery S2s. IPB reveals possible and likely enemy locations and avenues of approach, and provides the initial framework for developing the fire plan.

Together, the S2 and FSO must track the results of reconnaissance to confirm, update, or deny their NAIs. The FSE must update targets based on reconnaissance.

The execution phase of the fire support plan is the prosecution of the maneuver commander's intent. The fire support is the prosecution of the maneuver commander's battle plan.

24. **The Brigade Targeting Team Monitors, Coordinates, and Synchronizes the Employment of Indirect Fires**

Specific guidance concerning where, when, and what to shoot rather than an allocation of priorities is often the most effective method of synchronizing fires with maneuver.

The maneuver commander on today's battlefield faces more targets than he has weapons systems to attack. To prevent the overloading of the fire support system with targets, a method of prioritizing targets is necessary.

Using the attack criteria established by the maneuver commander, the FSCoord and the FSO must prioritize targets in relation to their impact on the battle. The highest priority targets are those that if not defeated can inhibit the execution of the maneuver commander's battle plan. The next priority of targets are those that may seriously interfere with the battle plan. The lowest priority targets are those that might seriously interfere with the battle plan later in the battle or disrupt future plans, and those targets that have limited impact on the plan or are very low payoff to the maneuver commander.

The fire support system must be flexible enough to supply conventional fires without interruption as the tactical situation changes.

Units have their greatest success with Copperhead when they use it in preplanned areas against clearly defined high payoff targets.

OPFOR observation posts (OPs) continually destroy considerable brigade combat power with indirect fire prior to the unit's arrival at the objective. Units generally do not completely suppress observed obstacles during breaching operations. During the assault on the objective, the execution of fire tends to become disconnected from the scheme of maneuver.

The breaching of the obstacle will probably require 30 minutes of smoke if done correctly.

Illumination or smoke rounds can be used to reorient maneuver forces.

The fire support execution matrix, like the maneuver execution matrix, is event, not time, driven. It works like a musical score to bring mortars, field artillery, rocket, and all fire support systems in concert with the other operating systems on the battlefield at the needed time and place.

The fire support execution matrix, when linked to the maneuver execution matrix, provides both the fire support staff and the maneuver commander with a method of controlling indirect fire during the battle. Use of the matrix provides a system of controlling fires, a target list, and target numbers that are common throughout the force.

To achieve successful fire support, it is essential that every participant in the fire support system uses a common target list. A common target list allows the mortars, artillery, aviation, and maneuver to reference and call fires on the same set of targets.

The most critical aspect of the refinement is the verification of target locations by the observer to ensure the accuracy of the fires. Using resection, intersection, or registration, the observers must verify the location of planned targets and coordination measures to ensure that the fire supports the intent of the maneuver force commander.

The fire support execution matrix must be event driven, not based on time. This amplifies the importance of close cooperation between the FSO and the maneuver and artillery S2s. IPB reveals possible and likely enemy locations and avenues of approach, and provides the initial framework for developing the fire plan.

The greatest unnecessary risk that confronts the soldier on the battlefield is fratricide. To minimize the risk it is essential that the location of friendly elements be kept current and that each target be checked to ensure that fires not be brought down upon friendly elements.

Together, the S2 and FSO must track the results of reconnaissance to confirm, update, or deny their NAIs. The FSE must update targets based on reconnaissance.

. . . it is important to guard against the tendency to fire preplanned targets when the enemy is somewhere else. Adjustments from preplanned targets or grid missions must be used if that is what it takes to get the fire on the enemy.

While FSOs and FOs play a big role, the effective integration of fire is a command responsibility, and there clearly needs to be many non-artillerymen calling for fire.

Control the target of opportunity missions that are fired during the battle by the maneuver with close coordination with the FSO.

Fire support fails when the FSO or the Fire Support Sergeant become casualties and their subordinates are unable to step in and accomplish the mission. Train your subordinates and then use them in providing effective fire support during periods of continuous operations.

The execution phase of the fire support plan is the prosecution of the maneuver commander's intent. The fire support is the prosecution of the maneuver commander's battle plan.

Fire support must be integrated with the unit's scheme of maneuver and its surveillance and target acquisition efforts. The fire support system must be flexible enough to supply conventional fires without interruption as the tactical situation changes.

FSOs, particularly at company level, must be aggressive!! This means they must plan in the absence of detailed guidance, supervise their subordinates, and above all, react to the changing situation on the battlefield. They cannot sit by passively, unable to observe or communicate, while they wait for their commander to tell them to move. They must take the initiative to bring fire on the enemy.

FSOs and FOs must be familiar with maneuver boundaries to prevent firing across boundaries into another unit's area. FSOs must be aware of the limitations boundaries impose on their planning. Failure to pay attention to boundaries is the second most common cause of fratricides.

Whether the heavy maneuver TFs are modernized or non-modernized, they benefit from illumination. The widespread fear that illumination washes out thermal sights and other night vision devices appears wholly unfounded. Experience during live fire exercises shows that maneuver TFs fire more and more accurately when they use artillery illumination.

For obstacle breaches, units must learn to call for indirect suppressive fires on enemy overwatch positions and smoke to screen friendly positions. These fires must be called and in place before the unit leaves its last covered and concealed positions. For smoke, this may mean initiating the call as much as 10 minutes ahead of the unit departing for the breach to ensure that the smoke screen is in place. Most units will not carry enough mortar smoke to do the job, so the use of field artillery smoke must be in the plan.

**TOPIC:** Use time and variable time-fuzed munitions to kill and point-detonating fuzed munitions to screen.

**DISCUSSION:** The Allies in North Africa and the Israelis found that point detonating fuzed munitions very often buried themselves in the sand prior to bursting, drastically reducing the casualty producing effect, but the bursts raised large clouds of dust/sand which effectively screened units' movements. The air bursting munitions were more effective casualty producers.

**LESSON LEARNED:** Artillery units must prepare to use point-detonating high-explosive ammunition to screen unit movements when smoke/white phosphorus ammunition is depleted.

A recent white paper on this subject from the U.S. Army Field Artillery School states "The Fire Support Element (FSE) at the maneuver headquarters initiating the request for fires is responsible for obtaining internal clearance (clearance from subordinate units) and, as necessary, clearance from adjacent units in whose areas the target lie." The white paper further details the lack of TTP available to the FSCoord and maneuver commander. Although doctrinally acceptable within unit boundaries, passive control (silence is consent) greatly increases the potential for fratricide, due to the assumption of optimal communications and battle tracking. CTC experiences shows that there is no substitution for clearing fires through positive control and "eyes-on-target" observation at the lowest level.

**25. The Brigade Targeting Team Receives the Results of Target Attacks and Performs Combat Assessments**

The most frequently overlooked element of the indirect fire system is location of the forward observer in relation to the targets.

Position observers where they can see their targets and maintain communications with their indirect fire assets.

The execution phase of the fire support plan is the prosecution of the maneuver commander's intent. The fire support is the prosecution of the maneuver commander's battle plan.

Together, the S2 and FSO must track the results of reconnaissance to confirm, update, or deny their NAIs. The FSE must update targets based on reconnaissance.

**26. The Brigade Targeting Team Acquires Information**

Fire support fails when the FSO or the Fire Support Sergeant become casualties and their subordinates are unable to step in and accomplish the mission. Train your subordinates and then use them in providing effective fire support during periods of continuous operations.

To achieve successful fire support, it is essential that every participant in the fire support system uses a common target list. A common target list allows the mortars, artillery, aviation, and maneuver to reference and call fires on the same set of targets.

Fire support must be integrated with the unit's scheme of maneuver and its surveillance and target acquisition efforts. The fire support system must be flexible enough to supply conventional fires without interruption as the tactical situation changes.

Observers and fire support must maintain effective communications to deliver timely and accurate fires on the enemy. Digital equipment must have electronic line of sight in order to pass traffic. Positioning of observers and FSOs must consider both their need to see the battlefield and to communicate.

## **27. The Brigade Targeting Team Evaluates Information**

The FSO should use the S2's situation template to develop and refine the target list to include only targets that support the operation.

The FSCoord and FSO must insist that every target has a purpose and be tied to the scheme of maneuver and the commander's intent.

To be successful, fire planning must be a continuous process. Decentralization (informal) planning, like centralized (formal) planning, is a product of the situation, the time available, and the echelon at which it occurs. Fire planning should be both formal and informal, regardless of the time available, to be executable and successful.

A fire plan formulated and disseminated from a higher to a lower level, will allow the fire plan to be communicated to support the commander's concept, but feedback from the lower echelons is vital to refine the plan according to conditions that lower units meet.

The fire support execution matrix (the linkage of targets to systems and the identification of specifically who is to shoot by phase of battle) is a very effective tool. Responsibility for each target to include identification on the ground, observation, execution, and adjustment as necessary is given to a specific unit, e.g., company team or scout platoon. Sufficient redundancy is required to guard against obscuration and casualties.

Target lists that consist of quality targets and not quantity are more likely to succeed. These target lists must support the commander's concept.

The FSO should use the S2's situation template to develop and refine the target list to include only targets that support the operation.

The maneuver commander's intent is the foundation that drives the process of planning, preparing, and executing the battle.

In a time-sensitive operation, the fire support execution matrix can stand alone to portray graphically the support needed to achieve the commander's intent.

FSOs and FOs must be familiar with maneuver boundaries to prevent firing across boundaries into another unit's area. FSOs must be aware of the limitations boundaries impose on their planning. Failure to pay attention to boundaries is the second most common cause of fratricides.

Together, the S2 and FSO must track the results of reconnaissance to confirm, update, or deny their NAIs. The FSE must update targets based on reconnaissance.

## **28. The Brigade Targeting Team Updates Products**

The greatest unnecessary risk that confronts the soldier on the battlefield is fratricide. To minimize the risk, it is essential that the location of friendly elements be kept current and that

each target be checked to ensure that fires not be brought down upon friendly elements.

Together, the S2 and FSO must track the results of reconnaissance to confirm, update, or deny their NAIs. The FSE must update targets based on reconnaissance.

29. **The Brigade Targeting Team Communicates Information and Coordinates the Brigade Fire Support Plan**

The maneuver commander reviews the recommendation of the FSO along with the available ammunition and delivery means and determines the desired effect by category or suppression, neutralization, or destruction.

The fire support coordinator/FSO is responsible for planning and coordinating all fires in the maneuver area of operations, i.e., mortars, Air Force, Marine Corps, and Navy CAS, naval gunfire, and attack helicopters.

Experience at CMTC shows that fratricide from friendly minefields is a major problem due to lack of coordination, failure to disseminate obstacle plan, and failure to accurately report obstacle locations back up the chain. --- Solutions include training with scatterable minefields in CPXs and FTXs, including minefield locations in your liaison officer's (LO) checklist; and development of a "flash" traffic format or quick report format similar to NBC reports. Note that any use of FASCAM (and possibly some use of dud-producing submunitions) requires appropriate reporting.

During Operation DESERT STORM, the combined dud rate of multiple engagements with improved conventional munitions (APICM, DPICM, CBU) caused obstacles and safety concerns for the maneuver commander. --- Commanders can create Restricted Fire Areas RFAs where they anticipate subsequent maneuvers to control this problem. Dud-producing missions would then require coordination with the maneuver headquarters.

The greatest unnecessary risk that confronts the soldier on the battlefield is fratricide. To minimize the risk, it is essential that the location of friendly elements be kept current and that each target be checked to ensure that fires not be brought down upon friendly elements.

30. **The Brigade Commander Visualizes the Battlefield**

Communication between the commander and his FSO is critical. If there is a misunderstanding, it will probably not be obvious until the execution commences. The FSO must communicate his thoughts in a language the commander will understand. For example, the FSO should tell him how many minutes of smoke (HC) are available, not how many rounds; or that firing a preplanned 400m x 400m (medium) FASCAM minefield takes 7-12 minutes to fire, and with displacement to an alternate position this may result in the TF being unable to use its artillery for 45 minutes to one hour on other missions.

The brigade commander must synchronize and concentrate all of his combat power at the critical time and place. Synchronizing and integrating the battlefield operating system is fundamental to success on the battlefield.



The FSCOORD and FSO must explain FA combat power, limitations and capabilities of the fire support system and how artillery and mortars can best support the operation. The FSO must be able to state whether he can support the mission, and if not, why not. The FSCOORD and FSO must be able to express the capabilities and limitations of the fire support system in terms that the maneuver commander, his staff, and subordinate commanders understand:

- a. Minutes of smoke, not just number of smoke rounds available.
- b. Number of available RAAM/ADAM minefields by type, size, and density; safety zone around each; and the time to emplace each, not the number of rounds.
- c. Battalion volleys by type of ammunition, and what effects the maneuver commander can expect from each volley given a specific target's description, not just the number of DPICM or HE rounds available.
- d. Range and artillery area coverage based on the preponderance of the shell/fuze/charge combinations available, not just the maximum range of the system.
- e. The need for timely and accurate target locations.

**31. The Brigade Commander Directs Changes to the Operation or Plan**

Fire planning must be a continuous process to be successful. Decentralization (informal) planning, like centralized (formal) planning, is a product of the situation, the time available, and the echelon at which it occurs. Fire planning should be both formal and informal, regardless of the time available, in order to be executable and successful. A fire plan formulated and disseminated from a higher to a lower level, will allow the fire plan to be communicated to support the commander's concept, but feedback from the lower echelons is vital to refine the plan according to conditions that lower units meet.

**32. The Brigade Commander Directs and Leads Subordinate Forces**

**33. Brigade Consolidates and Reorganizes**

## Critical Tasks and Other Linkages

This component links individual and, in some cases, collective tasks with the tasks identified in the task analysis. These individual and collective tasks identify a prerequisite level of tasks individuals and sections must perform to standard or be familiar with in order to perform the tasks listed in this task analysis.

### TASKS

1. Sustain and Protect the Force  
During Planning

### OTHER LINKAGES

#### Brigade FSO

- Prepare Target Lists and Scheduling Work Sheets (STP 6-13II-MQS, 01-2660.00-2011)
- Direct the Entry and Dissemination of FSCMs and FLOT with TACFIRE (STP 6-13II-MQS, 01-2770.01-0103)
- Direct the Reporting of Friendly Element Locations With TACFIRE (STP 6-13II-MQS, 01-2770.01-0104)
- Decide to Attack a Target (STP 6-13II-MQS, 01-2770.01-0106)
- Direct the Massing of FA and Mortar Fires with TACFIRE (STP 6-13II-MQS, 01-2770.01-0110)
- Direct the Evaluation and Dissemination of Intelligence Reports Using TACFIRE (STP 6-13II-MQS, 01-2770.01-0114)
- Direct the Establishment of a Fire Plan in the TACFIRE Computer (STP 6-13II-MQS, 01-2770.01-0115)
- Direct Processing of the Fire Support Request (STP 6-13II-MQS, 01-2770.01-0133)
- Coordinate Intelligence Collection/ Protection Plan (STP 6-13II-MQS, 01-2770.01-0136)
- Plan, Request, and Direct an Emergency CAS Mission (STP 6-13II-MQS, 01-2830.00-3031)
- Prepare and Submit a Quick Fire Plan (STP 6-13EII-MQS, 01-2840.00-2022)
- Advise the Maneuver Commander on the Fire Support Plan (STP 6-13EII-MQS, 01-2840.00-2024)
- Advise the Maneuver Commander on Fire Support Coordinating Measures (STP 6-13EII-MQS, 01-2840.00-2025)

## TASK

## OTHER LINKAGES

- Apply the Fire Support Coordinating Measures (STP 6-13II-MQS, 01-2840.00-2025)
- Coordinate and Request Fire Support From Observers (STP 6-13II-MQS, 01-2840.00-2026)
- Monitor and Coordinate Requests for Fire Support from Observers (STP 6-13EII-MQS, 01-2840.00-2026)
- Request and Coordinate Preplanned and Immediate CAS (STP 6-13II-MQS, 01-2840.00-2041)
- Recommend Fire Support Coordinating Measures, and Coordinate Fires (STP 6-13II-MQS, 01-2840.00-2042)
- Recommend the Employment of Mortars (STP 6-13EII-MQS, 01-2840.00-8502)
- Develop Fire Support Guidance to FIST (STP 6-13EII-MQS, 01-2840.00-9015)
- Verify Posting of Information on Fire Support Situation Map (STP 6-13EII-MQS, 01-2840.01-0001)
- Direct Establishment of Fire Support Communications (STP 6-13EII-MQS, 01-2840.01-0003)
- Prepare, Consolidate, and Submit Target Lists (STP 6-13EII-MQS, 01-2840.01-0006)
- Advise the Commander and Staff on the Mission, Capabilities, and Limitations of Available TA Assets (STP 6-13II-MQS, 01-2900.00-7021)
- Recommend Employment of Available TA Assets (STP 6-13II-MQS, 01-2900.00-7022)
- Coordinate Fire Support for a Maneuver Unit (STP 6-13II-MQS, 01-2999.93-0001)
- Recommend Fire Support Coordinating Measures (STP 6-13II-MQS, 01-2999.94-0101)
- Coordinate Employment of FA Target Acquisition Assets (STP 6-13II-MQS, 01-2999.94-0103)
- Coordinate Employment of FA Survey and Meteorological Assets (STP 6-13II-MQS, 01-2999.94-0107)

## TASK

## OTHER LINKAGES

- Supervise a Targeting Element (STP 6-13II-MQS, 01-2999.97-0400)
- Plan Employment of FA Target Acquisition Assets (STP 6-13II-MQS, 01-2999.97-0402)
- Recommend Employment of Weapons-Locating Radar Zones and Common Sensor Boundary (STP 6-13II-MQS, 03-2940.00-3204)
- Conduct Fire Support Employment (STP 6-13II-MQS, 04-3313.02-0001)

### Target Acquisition Systems/Observers

- Conduct Digital Communications With the DMD (STP 6-13II-MQS, 01-2660.00-2013)
- Engage a Moving Target with Indirect Fire (STP 6-13II-MQS, 01-2660.00-2016)
- Conduct Digital Communications With the FIST DMD (STP 6-13II-MQS, 01-2660.00-2017)
- Designate a Target Using the Laser Target Designator (STP 6-13II-MQS, 01-2740.00-1964)
- Request and Adjust Area Fire (STP 6-13F14-SM-TG, 061-283-1011)
- Conduct a Suppression Mission (STP 6-13F14-SM-TG, 061-283-1013)
- Conduct a Fire-for-Effect Mission (STP 6-13F14-SM-TG, 061-283-1015)
- Conduct an Immediate Smoke Mission (STP 6-13F14-SM-TG, 061-283-2021)
- Conduct a Quick Smoke Mission (STP 6-13F14-SM-TG, 061-283-2023)
- Prepare and Submit FO Target List (STP 6-13F14-SM-TG, 061-284-1001)
- Request Close Air Support (STP 6-13F14-SM-TG, 061-284-3030)
- Prepare a SITREP ( STP 21-24-SMCT, 071-332-5022)
- Adjust Indirect Fires (STP 21-24-SMCT, 061-283-6003)

## TASK

## OTHER LINKAGES

### Brigade S2/DS MI Company Commander

- Conduct Threat Evaluation (STP 34-34II-MQS, 01-3381.01-4014)
- Conduct Situation Development (STP 34-34II-MQS, 01-3381.01-4016)
- Conduct Target Development (STP 34-34II-MQS, 01-3381.01-4017)
- Participate in the Development of Intelligence Requirements (STP 34-34II-MQS, 01-3381.01-5001)
- Select Intelligence and Electronic Warfare Operational Sites (STP 34-34II-MQS, 01-3381.04-4005)
- Conduct IEWSE Operations (STP 34-34II-MQS, 01-3381.04-5003)
- Conduct Asset Management (STP 34-34II-MQS, 01-3381.06-4007)
- Conduct Electronic Warfare Operations (STP 34-34II-MQS, 01-3381.06-4008)
- Direct Asset Management (STP 34-34II-MQS, 01-3381.06-5001)
- Analyze Intelligence and Combat Information (STP 34-34II-MQS, 01-3381.39-4004)
- Disseminate Intelligence and Combat Information (STP 34-34II-MQS, 01-3381.39-4005)
- Conduct All-Source Intelligence Analysis (STP 34-34II-MQS, 01-3381.41-4014)
- Direct Collection Management Operations (STP 34-34II-MQS, 01-3381.44-5002)

### Aviation LNO

- Apply the Fundamentals of CAS (STP 1-15II-MQS, 01-1413.00-0123)
- Apply the Fundamentals of Fire Support Planning and Execution (STP 1-15II-MQS, 01-1413.00-0124)

### Infantry/Armor TOC Officers

- Perform Duties as a TOC Shift Officer (STP 7-11II-MQS, 01-3317.04-0006)

## TASK

## OTHER LINKAGES

### Brigade Engineer

- Develop an Obstacle Plan (STP 5-21II-MQS, 01-2240.20-1001)
- Advise Supported Units on Engineer Capabilities and Employment (STP 5-21II-MQS, 01-2250.10-1002)
- Direct the Employment of Engineers (STP 5-21II-MQS, 01-2250.20-1003)
- Establish Intelligence Production Requirements and Essential Elements of Terrain or Engineer Information (STP 5-21II-MQS, 01-2250.20-1004)
- Advise the Commander on the Use of Terrain for Combat Operations (STP 5-21II-MQS, 01-2250.20-1008)

### Brigade Signal Officer

- Employ Communications System of a Maneuver Brigade or Battalion (STP 11-25II-MQS, 01-5841.07-0001)
- Plan Communications Requirements in Support of Battlefield Functional Area (STP 11-25II-MQS, 01-5879.07-9001)

### Mortar Platoon

- Plan and Control Combat Operations (ARTEP 7-90-MTP, 7-3/4-1237)
- Prepare Mortar Fire Plans (STP 7-11C14-SM-TG, 071-074-0017)

2. Receive Order from Higher Headquarters

3. Conduct Mission Analysis

### Brigade FSO

- Interpret Threat Organization and Equipment (STP 6-13II-MQS, 01-2660.00-2004)
- Direct the Establishment of and Verify the Tactical Data Base (STP 6-13II-MQS, 01-2770.01-0102)

## TASK

## OTHER LINKAGES

- Supervise a Targeting Element (STP 6-13II-MQS, 01-2999.97-0400)

### Brigade S2/DS MI Company Commander

- Conduct Threat Evaluation (STP 34-34II-MQS, 01-3381.01-4014)
- Participate in the Development of Intelligence Requirements (STP 34-34II-MQS, 01-3381.01-5001)

### Aviation LNO

- Conduct IPB to support Aviation Operations at Battalion and Brigade Levels (STP 1-15II-MQS, 01-1414.00-0282)

### Brigade Engineer

- Establish Intelligence Production Requirements and Essential Elements of Terrain or Engineer Information (STP 5-21II-MQS, 01-2250.20-1004)
- Provide Input to IPB (STP 5-21II-MQS, 01-2250.20-1006)

### Brigade Signal Officer

- Determine Frequency Requirements at Corps Level and Below (STP 11-25II-MQS, 01-5701.07-0001)
- Determine Communications Requirements for Joint or Combined Operations (STP 11-25II-MQS, 01-5840.07-0001)

4. Issue the Warning Order (WARNO)

5. Brigade Commander Issues  
Planning Guidance

6. Prepare Staff Estimates

### Brigade FSO

- Produce an Attack Guidance Matrix (STP 6-13II-MQS, 01-2840.00-2038)

## TASK

## OTHER LINKAGES

- Evaluate the Information Obtained Through the IPB Process (STP 6-13II-MQS, 01-2840.00-4227)

### Brigade S2/DS MI Company Commander

- Conduct Threat Evaluation (STP 34-34II-MQS, 01-3381.01-4014)
- Direct the Intelligence Portion of the IPB Process (STP 34-34II-MQS, 01-3381.01-5002)
- Product Finished Intelligence Products from All-Source Information (STP 34-34II-MQS, 01-3381.41-5003)

### Brigade Engineer

- Prepare Engineer Estimates (STP 5-21II-MQS, 01-2250.20-1001)
- Evaluate Engineer Intelligence for Dissemination (STP 5-21II-MQS, 01-2250.20-1005)

## 7. Staff Develops Courses of Action

### Brigade FSO

- Develop a Fire Plan to Support an Offensive Operation (STP 6-13II-MQS, 01-2660.00-2008)
- Develop a Fire Support Plan to Support a Defensive Operation (STP 6-13II-MQS, 01-2660.00-2009)
- Direct the Establishment of and Verify Commander's Criteria (STP 6-13II-MQS, 01-2770.01-0105)
- Plan for Emplacement of Special Munitions (STP 6-13II-MQS, 01-2840.00-2040)
- Plan Fires for an Offense (STP 6-13EII-MQS, 01-2840.00-3002)
- Plan Fires for a Defense (STP 6-13EII-MQS, 01-2840.00-3003)
- Plan Field Artillery Fire Support of Maneuver Units (STP 6-13II-MQS, 01-2999.94-0100)
- Develop and Write a FA Support Plan (STP 6-13II-MQS, 01-2999.94-0104)



## TASK

## OTHER LINKAGES

- Plan Employment of FA Target Acquisition Assets (STP 6-13II-MQS, 01-2999.97-0402)
- Select and Occupy an Observation Post (STP 6-13F14-SM-TG, 061-283-2051)

### Brigade S2/DS MI Company Commander

- Participate in the Threat Integration Process (STP 34-34II-MQS, 01-3381.01-4015)
- Conduct Situation Development (STP 34-34II-MQS, 01-3381.01-4016)
- Conduct Target Development (STP 34-34II-MQS, 01-3381.01-4017)
- Participate in the Development of Intelligence Requirements (STP 34-34II-MQS, 01-3381.01-5001)
- Participate in the Development of the DST (STP 34-34II-MQS, 01-3381.01-5003)
- Select Intelligence and Electronic Warfare Operational Sites (STP 34-34II-MQS, 01-3381.04-4005)
- Develop an Intelligence and Electronic Warfare Scheme of Maneuver (STP 34-34II-MQS, 01-3381.04-5001)
- Plan Employment of Intelligence and Electronic Warfare Assets (STP 34-34II-MQS, 01-3381.04-5002)
- Conduct Asset Management (STP 34-34II-MQS, 01-3381.06-4007)
- Direct Asset Management (STP 34-34II-MQS, 01-3381.06-5001)

### Aviation LNO

- Apply the Fundamentals of CAS (STP 1-15II-MQS, 01-1413.00-0123)
- Apply the Fundamentals of Fire Support Planning and Execution (STP 1-15II-MQS, 01-1413.00-0124)
- Plan A2C2 Elements (STP 1-15II-MQS, 01-1414.00-0129)
- Plan SEAD (STP 1-15II-MQS, 01-1414.00-0146)

## TASK

## OTHER LINKAGES

### Infantry/Armor TOC Officers

- Plan Offensive Operations at the Battalion Level (STP 7-11II-MQS, 01-3317.04.0004)
- Plan Offensive Operations at the Battalion/Squadron Level (STP 17-12II-MQS, Composite Task)
- Plan Defensive Operations at the Battalion Level (STP 7-11II-MQS, 01-3317.04-0005)
- Plan Defensive Operations at the Battalion/Squadron Level (STP 17-12II-MQS, Composite Task)

### Brigade Engineer

- Develop an Obstacle Plan (STP 5-21II-MQS, 01-2240.20-1001)
- Advise Supported Units on Engineer Capabilities and Employment (STP 5-21II-MQS, 01-2250.10-1002)

### Brigade Signal Officer

- Plan Displacement of Communications Nodes (STP 11-25II-MQS, 01-5754.07-0002)
- Plan Communications Requirements in Support of Battlefield Functional Area (STP 11-25II-MQS, 01-5879.07-9001)

### 8. Staff/Commander Analyze Courses of Action (War Game)

### Brigade FSO

- Evaluate All Operations Connected With Planning, Preparation, and Actual Application of Fire on a Target (STP 6-13II-MQS, 01-2830.00-2339)
- Supervise a Targeting Element (STP 6-13II-MQS, 01-2999.97-0400)

### Brigade S2/DS MI Company Commander

- Participate in the Threat Integration Process (STP 34-34II-MQS, 01-3381.01-4015)

**TASK**

**OTHER LINKAGES**

9. Staff Compares Courses of Action

Brigade FSO

- Recommend Fire Support Coordinating Measures, and Coordinate Fires (STP 6-13II-MQS, 01-2840.00-2042)
- Recommend Changes to Attack Guidance (STP 6-13II-MQS, 01-2840.00-4226)
- Recommend the Employment of Mortars (STP 6-13EII-MQS, 01-2840.00-8502)
- Recommend Employment of Available TA Assets (STP 6-13II-MQS, 01-2900.00-7022)
- Recommend Fire Support Coordinating Measures (STP 6-13II-MQS, 01-2999.94-0101)
- Supervise a Targeting Element (STP 6-13II-MQS, 01-2999.97-0400)
- Recommend Employment of Weapons-Locating Radar Zones and Common Sensor Boundary (STP 6-13II-MQS, 03-2940.00-3204)

10. Brigade Commander Announces Decision

Brigade FSO

- Advise Maneuver Commander and FSCoord on TACFIRE Operations (STP 6-13II-MQS, 01-2770.01-0118)
- Advise the Maneuver Commander on the Employment of the COLT (STP 6-13EII-MQS, 01-2840.00-2021)
- Advise the Maneuver Commander on the FASP (STP 6-13EII-MQS, 01-2840.00-2023)
- Advise the Maneuver Commander on the Fire Support Plan (STP 6-13EII-MQS, 01-2840.00-2024)
- Advise the Maneuver Commander on Fire Support Coordinating Measures (STP 6-13EII-MQS, 01-2840.00-2025)
- Advise the Maneuver Commander on Employment of COLTs and Aerial Fire Support Teams (STP 6-13II-MQS, 01-2840.00-2039)

## TASK

## OTHER LINKAGES

- Advise Supported Maneuver Unit of Friendly and Enemy Fire Support Capabilities and Limitations (STP 6-13EII-MQS, 01-2840.00-3004)
- Inform Supported Maneuver Commander of the FA Tactical Mission and Corresponding Plan to Support the Scheme of Maneuver (STP 6-13EII-MQS, 01-2840.00-3042)
- Advise Maneuver Commander on the Capabilities and Limitations of Naval Gunfire (STP 6-13EII-MQS, 01-2840.00-4021)
- Advise Maneuver Commander on Employment of Available Fire Support Assets (STP 6-13II-MQS, 01-2999.94-0106)
- Advise the Commander on the Capabilities of Available Target Acquisition Assets (STP 6-13II-MQS, 01-3020.00-7002)

### Brigade Engineer

- Advise Supported Units on Engineer Capabilities and Employment (STP 5-21II-MQS, 01-2250.10-1002)
- Advise the Commander on the Use of Terrain for Combat Operations (STP 5-21II-MQS, 01-2250.20-1008)

### Brigade Signal Officer

- Determine Frequency Requirements at Corps Level and Below (STP 11-25II-MQS, 01-5701.07-0001)
- Determine Communications Requirements for Joint or Combined Operations (STP 11-25II-MQS, 01-5840.07-0001)

### All Fire Support Leaders

- Brief fire support plan refinements and modifications (no MTP/STP reference)

## TASK

### 11. Brigade Staff Prepares OPORD/ FRAGO

## OTHER LINKAGES

### Brigade FSO

- Prepare Target Lists and Scheduling Work Sheets (STP 6-13II-MQS, 01-2660.00-2011)
- Direct the Entry and Dissemination of FSCMs and FLOT with TACFIRE (STP 6-13II-MQS, 01-2770.01-0103)
- Direct the Establishment of a Fire Plan in the TACFIRE Computer (STP 6-13II-MQS, 01-2770.01-0115)
- Coordinate Intelligence Collection/Protection Plan (STP 6-13II-MQS, 01-2770.01-0136)
- Produce an Attack Guidance Matrix (STP 6-13II-MQS, 01-2840.00-2038)
- Request and Coordinate Preplanned and Immediate CAS (STP 6-13II-MQS, 01-2840.00-2041)
- Produce a High-Payoff Target Matrix (STP 6-13II-MQS, 01-2840.00-2044)
- Develop Fire Support Guidance to FIST (STP 6-13EII-MQS, 01-2840.00-9015)
- Prepare, Consolidate, and Submit Target Lists (STP 6-13EII-MQS, 01-2840.01-0006)
- Develop and Write a FA Support Plan (STP 6-13II-MQS, 01-2999.94-0104)
- Supervise a Targeting Element (STP 6-13II-MQS, 01-2999.97-0400)

### Brigade S2/DS MI Company Commander

- Develop an Intelligence and Electronic Warfare Scheme of Maneuver (STP 34-34II-MQS, 01-3381.04-5001)
- Prepare Intelligence Taskings (STP 34-34II-MQS, 01-3381.39-4002)
- Prepare the Intelligence Estimate (STP 34-34II-MQS, 01-3381.41-4004)

### Brigade Engineer

- Prepare Engineer Annexes (STP 5-21II-MQS, 01-2250.20-1002)

## TASK

## OTHER LINKAGES

### Brigade Signal Officer

- Determine Frequency Requirements at Corps Level and Below (STP 11-25II-MQS, 01-5701.07-0001)

### 12. Brigade Issues the OPORD/FRAGO

### Brigade FSO

- Coordinate Fire Support for a Maneuver Unit (STP 6-13II-MQS, 01-2999.93-0001)
- Brief the Fire Support Plan (no MTP/STP reference)

### All Maneuver Leaders

- Brief fire support plans to support tactical scheme of maneuver and direct fire plan (no MTP/STP reference)

### 13. The Brigade Targeting Team Organizes to Monitor, Plan, and Direct Fire Support Operations

### Brigade FSO

- Direct the Establishment of and Verify the Tactical Data Base (STP 6-13II-MQS, 01-2770.01-0102)
- Direct the Entry and Dissemination of FSCMs and FLOT with TACFIRE (STP 6-13II-MQS, 01-2770.01-0103)
- Supervise Brigade FSE in TACFIRE-Equipped Units (STP 6-13II-MQS, 01-2770.01-0140)
- Coordinate Digital Communications Requirements (STP 6-13II-MQS, 01-2770.01-0190)
- Direct Establishment of Fire Support Communications (STP 6-13EII-MQS, 01-2840.01-0003)
- Supervise a Targeting Element (STP 6-13II-MQS, 01-2999.97-0400)

### Infantry/Armor TOC Officers

- Perform Duties as a TOC Shift Officer (STP 7-11II-MQS, 01-3317.04-0006)

## TASK

14. The Brigade Targeting Team  
Acquires Information

15. The Brigade Targeting Team  
Evaluates Information

## OTHER LINKAGES

Brigade Signal Officer

- Employ Communications System of a Maneuver Brigade or Battalion (STP 11-25II-MQS, 01-5841.07-0001)
- Plan Displacement of Communications Nodes (STP 11-25II-MQS, 01-5754.07-0002)

Brigade FSO

- Direct the Reporting of Friendly Element Locations With TACFIRE (STP 6-13II-MQS, 01-2770.01-0104)

Target Acquisition Systems/Observers

- Conduct Digital Communications With the DMD (STP 6-13II-MQS, 01-2660.00-2013)
- Conduct Digital Communications With the FIST DMD (STP 6-13II-MQS, 01-2660.00-2017)

Mortar Platoon

- Plan and Control Combat Operations (ARTEP 7-90-MTP, 7-3/4-1237)
- Prepare Mortar Fire Plans (STP 7-11C14-SM-TG, 071-074-0017)

Brigade FSO

- Interpret Threat Organization and Equipment (STP 6-13II-MQS, 01-2660.00-2004)
- Direct the Evaluation and Dissemination of Intelligence Reports Using TACFIRE (STP 6-13II-MQS, 01-2770.01-0114)
- Apply the Fire Support Coordinating Measures (STP 6-13II-MQS, 01-2840.00-2025)
- Advise Supported Maneuver Unit of Friendly and Enemy Fire Support Capabilities and Limitations (STP 6-13EII-MQS, 01-2840.00-3004)

**TASK**

**OTHER LINKAGES**

- Evaluate the Information Obtained Through the IPB Process (STP 6-13II-MQS, 01-2840.00-4227)
- Advise the Commander and Staff on the Mission, Capabilities, and Limitations of Available TA Assets (STP 6-13II-MQS, 01-2900.00-7021)

**Brigade S2/DS MI Company Commander**

- Conduct Threat Evaluation (STP 34-34II-MQS, 01-3381.01-4014)
- Conduct Target Development (STP 34-34II-MQS, 01-3381.01-4017)
- Participate in the Development of Intelligence Requirements (STP 34-34II-MQS, 01-3381.01-5001)
- Analyze Intelligence and Combat Information (STP 34-34II-MQS, 01-3381.39-4004)
- Conduct All-Source Intelligence Analysis (STP 34-34II-MQS, 01-3381.41-4014)

16. The Brigade Targeting Team  
Updates Products

**Brigade FSO**

- Verify Posting of Information on Fire Support Situation Map (STP 6-13EII-MQS, 01-2840.01-0001)
- Review a Fire Support Capability Overlay (STP 6-13EII-MQS, 01-2840.01-0004)
- Prepare, Consolidate, and Submit Target Lists (STP 6-13EII-MQS, 01-2840.01-0006)

**Brigade S2/DS MI Company Commander**

- Prepare Intelligence Taskings (STP 34-34II-MQS, 01-3381.39-4002)
- Produce Finished Intelligence Products from All-Source Information (STP 34-34II-MQS, 01-3381.41-5003)

17. The Brigade Targeting Team  
Communicates Information and  
Coordinates the Brigade Fire  
Support Plan

**Brigade FSO**

- Direct the Evaluation and Dissemination of



## TASK

## OTHER LINKAGES

- Intelligence Reports Using TACFIRE (STP 6-13II-MQS, 01-2770.01-0114)
- Coordinate Intelligence Collection/Protection Plan (STP 6-13II-MQS, 01-2770.01-0136)
- Coordinate Digital Communications Requirements (STP 6-13II-MQS, 01-2770.01-0190)
- Apply the Fire Support Coordinating Measures (STP 6-13II-MQS, 01-2840.00-2025)
- Develop Fire Support Guidance to FIST (STP 6-13EII-MQS, 01-2840.00-9015)
- Coordinate Fire Support for a Maneuver Unit (STP 6-13II-MQS, 01-2999.93-0001)
- Coordinate Employment of FA Target Acquisition Assets (STP 6-13II-MQS, 01-2999.94-0103)
- Coordinate Employment of FA Survey and Meteorological Assets (STP 6-13II-MQS, 01-2999.94-0107)

### Target Acquisition Systems/Observers

- Conduct Digital Communications With the DMD (STP 6-13II-MQS, 01-2660.00-2013)
- Conduct Digital Communications With the FIST DMD (STP 6-13II-MQS, 01-2660.00-2017)

### Brigade S2/DS MI Company Commander

- Direct the Intelligence Portion of the IPB Process (STP 34-34II-MQS, 01-3381.01-5002)
- Conduct IEWSE Operations (STP 34-34II-MQS, 01-3381.04-5003)
- Conduct Asset Management (STP 34-34II-MQS, 01-3381.06-4007)
- Direct Asset Management (STP 34-34II-MQS, 01-3381.06-5001)
- Disseminate Intelligence and Combat Information (STP 34-34II-MQS, 01-3381.39-4005)

## TASK

## OTHER LINKAGES

- Direct Collection Management Operations (STP 34-34II-MQS, 01-3381.44-5002)

### Brigade Engineer

- Direct the Employment of Engineers (STP 5-21II-MQS, 01-2250.20-1003)
- Evaluate Engineer Intelligence for Dissemination (STP 5-21II-MQS, 01-2250.20-1005)

### Mortar Platoon

- Plan and Control Combat Operations (ARTEP 7-90-MTP, 7-3/4-1237)

### 18. The Brigade Commander Visualizes the Battlefield Brigade FSO

- Recommend Fire Support Coordinating Measures, and Coordinate Fires (STP 6-13II-MQS, 01-2840.00-2042)
- Recommend Changes to Attack Guidance (STP 6-13II-MQS, 01-2840.00-4226)
- Recommend the Employment of Mortars (STP 6-13EII-MQS, 01-2840.00-8502)
- Recommend Employment of Available TA Assets (STP 6-13II-MQS, 01-2900.00-7022)
- Recommend Fire Support Coordinating Measures (STP 6-13II-MQS, 01-2999.94-0101)
- Recommend Employment of Weapons-Locating Radar Zones and Common Sensor Boundary (STP 6-13II-MQS, 03-2940.00-3204)
- Advise Maneuver Commander and FSCoord on TACFIRE Operations (STP 6-13II-MQS, 01-2770.01-0118)
- Advise the Maneuver Commander on the Employment of the COLT (STP 6-13EII-MQS, 01-2840.00-2021)
- Advise the Maneuver Commander on the FASP (STP 6-13EII-MQS, 01-2840.00-2023)

## TASK

## OTHER LINKAGES

- Advise the Maneuver Commander on the Fire Support Plan (STP 6-13EII-MQS, 01-2840.00-2024)
- Advise the Maneuver Commander on Fire Support Coordinating Measures (STP 6-13EII-MQS, 01-2840.00-2025)
- Advise the Maneuver Commander on Employment of COLTs and Aerial Fire Support Teams (STP 6-13II-MQS, 01-2840.00-2039)
- Inform Supported Maneuver Commander of the FA Tactical Mission and Corresponding Plan to Support the Scheme of Maneuver (STP 6-13EII-MQS, 01-2840.00-3042)
- Advise Maneuver Commander on the Capabilities and Limitations of Naval Gunfire (STP 6-13EII-MQS, 01-2840.00-4021)
- Advise Maneuver Commander on Employment of Available Fire Support Assets (STP 6-13II-MQS, 01-2999.94-0106)
- Advise the Commander on the Capabilities of Available Target Acquisition Assets (STP 6-13II-MQS, 01-3020.00-7002)

### All Fire Support Leaders

- Brief fire support plan refinements and modifications (no MTP/STP reference)

### Brigade Engineer

- Advise Supported Units on Engineer Capabilities and Employment (STP 5-21II-MQS, 01-2250.10-1002)
- Advise the Commander on the Use of Terrain for Combat Operations (STP 5-21II-MQS, 01-2250.20-1008)

### All Maneuver Leaders

- Brief fire support plans to support tactical scheme of maneuver and direct fire plan (no MTP/STP reference)

**TASK**

**OTHER LINKAGES**

19. The Brigade Commander Directs Brigade FSO  
Changes to the Operations of Plan

- Prepare Target Lists and Scheduling Work Sheets (STP 6-13II-MQS, 01-2660.00-2011)
- Direct the Establishment of and Verify Commander's Criteria (STP 6-13II-MQS, 01-2770.01-0105)
- Prepare and Submit a Quick Fire Plan (STP 6-13EII-MQS, 01-2840.00-2022)
- Request and Coordinate Preplanned and Immediate CAS (STP 6-13II-MQS, 01-2840.00-2041)

Brigade S2/DS MI Company Commander

- Prepare Intelligence Taskings (STP 34-34II-MQS, 01-3381.39-4002)

All Fire Support Leaders

- Brief fire support plan refinements and modifications (no MTP/STP reference)

All Maneuver Leaders

- Brief fire support plans to support tactical scheme of maneuver and direct fire plan (no MTP/STP reference)

All TF Leaders

- Rehearse fire support with the combined arms rehearsals (no MTP/STP reference)

20. The Brigade Commander Directs Brigade FSO  
and Leads Subordinate Forces

- Brief the Fire Support Plan (no MTP/STP reference)

21. Target Acquisition Assets Position and Perform Target Acquisition Operations  
Brigade FSO

- Direct the Evaluation and Dissemination of Intelligence Reports Using TACFIRE (STP 6-13II-MQS, 01-2770.01-0114)

## TASK

## OTHER LINKAGES

- Direct Processing of the Fire Support Request (STP 6-13II-MQS, 01-2770.01-0133)
- Plan, Request, and Direct an Emergency CAS Mission (STP 6-13II-MQS, 01-2830.00-3031)
- Apply the Fire Support Coordinating Measures (STP 6-13II-MQS, 01-2840.00-2025)
- Coordinate and Request Fire Support From Observers (STP 6-13II-MQS, 01-2840.00-2026)
- Monitor and Coordinate Requests for Fire Support from Observers (STP 6-13EII-MQS, 01-2840.00-2026)
- Request and Coordinate Preplanned and Immediate CAS (STP 6-13II-MQS, 01-2840.00-2041)
- Coordinate Employment of FA Target Acquisition Assets (STP 6-13II-MQS, 01-2999.94-0103)
- Supervise a Targeting Element (STP 6-13II-MQS, 01-2999.97-0400)
- Conduct Fire Support Employment (STP 6-13II-MQS, 04-3313.02-0001)

### Target Acquisition Systems/Observers

- Conduct Digital Communications With the DMD (STP 6-13II-MQS, 01-2660.00-2013)
- Engage a Moving Target with Indirect Fire (STP 6-13II-MQS, 01-2660.00-2016)
- Conduct Digital Communications With the FIST DMD (STP 6-13II-MQS, 01-2660.00-2017)
- Designate a Target Using the Laser Target Designator (STP 6-13II-MQS, 01-2740.00-1964)
- Request and Adjust Area Fire (STP 6-13F14-SM-TG, 061-283-1011)
- Conduct a Suppression Mission (STP 6-13F14-SM-TG, 061-283-1013)
- Conduct a Fire-for-Effect Mission (STP 6-13F14-SM-TG, 061-283-1015)
- Conduct an Immediate Smoke Mission (STP 6-13F14-SM-TG, 061-283-2021)

## TASK

## OTHER LINKAGES

- Conduct a Quick Smoke Mission (STP 6-13F14-SM-TG, 061-283-2023)
- Select and Occupy an Observation Post (STP 6-13F14-SM-TG, 061-283-2051)
- Prepare and Submit FO Target List (STP 6-13F14-SM-TG, 061-284-1001)
- Request Close Air Support (STP 6-13F14-SM-TG, 061-284-3030)
- Prepare a SITREP ( STP 21-24-SMCT, 071-332-5022)
- Adjust Indirect Fires (STP 21-24-SMCT, 061-283-6003)

### Brigade S2/DS MI Company Commander

- Conduct Threat Evaluation (STP 34-34II-MQS, 01-3381.01-4014)
- Conduct Target Development (STP 34-34II-MQS, 01-3381.01-4017)
- Select Intelligence and Electronic Warfare Operational Sites (STP 34-34II-MQS, 01-3381.04-4005)
- Direct Collection Management Operations (STP 34-34II-MQS, 01-3381.44-5002)

22. The Brigade Targeting Team  
Monitors and Directs Fire Support  
Operations from Brigade CPs  
and the DS FA Battalion

### Brigade FSO

- Supervise a Targeting Element (STP 6-13II-MQS, 01-2999.97-0400)
- Direct the Establishment of and Verify the Tactical Data Base (STP 6-13II-MQS, 01-2770.01-0102)
- Supervise Brigade FSE in TACFIRE-Equipped Units (STP 6-13II-MQS, 01-2770.01-0140)
- Coordinate Digital Communications Requirements (STP 6-13II-MQS, 01-2770.01-0190)
- Direct Establishment of Fire Support Communications (STP 6-13EII-MQS, 01-2840.01-0003)

## TASK

## OTHER LINKAGES

### Target Acquisition Systems/Observers

- Conduct Digital Communications With the DMD (STP 6-13II-MQS, 01-2660.00-2013)
- Conduct Digital Communications With the FIST DMD (STP 6-13II-MQS, 01-2660.00-2017)

### Brigade S2/DS MI Company Commander

- Conduct Asset Management (STP 34-34II-MQS, 01-3381.06-4007)
- Direct Asset Management (STP 34-34II-MQS, 01-3381.06-5001)
- Direct Collection Management Operations (STP 34-34II-MQS, 01-3381.44-5002)

### Infantry/Armor TOC Officers

- Perform Duties as a TOC Shift Officer (STP 7-11II-MQS, 01-3317.04-0006)

### Brigade Signal Officer

- Employ Communications System of a Maneuver Brigade or Battalion (STP 11-25II-MQS, 01-5841.07-0001)
- Plan Displacement of Communications Nodes (STP 11-25II-MOQS, 01-5754.07-002)

23. The Brigade Targeting Team  
Directs the Employment of  
Indirect Fires Against Brigade  
HPTs

### Brigade FSO

- Decide to Attack a Target (STP 6-13II-MQS, 01-2770.01-0106)
- Direct the Massing of FA and Mortar Fires with TACFIRE (STP 6-13II-MQS, 01-2770.01-0110)
- Plan, Request, and Direct an Emergency CAS Mission (STP 6-13II-MQS, 01-2830.00-3031)
- Apply the Fire Support Coordinating Measures (STP 6-13II-MQS, 01-2840.00-2025)

## TASK

## OTHER LINKAGES

- Monitor and Coordinate Requests for Fire Support from Observers (STP 6-13EII-MQS, 01-2840.00-2026)
- Conduct Fire Support Employment (STP 6-13II-MQS, 04-3313.02-0001)
- Apply the Fire Support Coordinating Measures (STP 6-13II-MQS, 01-2840.00-2025)
- Review a Fire Support Capability Overlay (STP 6-13EII-MQS, 01-2840.01-0004)
- Coordinate Fire Support for a Maneuver Unit (STP 6-13II-MQS, 01-2999.93-0001)
- Coordinate Employment of FA Target Acquisition Assets (STP 6-13II-MQS, 01-2999.94-0103)

### Target Acquisition Systems/Observers

- Engage a Moving Target with Indirect Fire (STP 6-13II-MQS, 01-2660.00-2016)
- Designate a Target Using the Laser Target Designator (STP 6-13II-MQS, 01-2740.00-1964)
- Request and Adjust Area Fire (STP 6-13F14-SM-TG, 061-283-1011)
- Conduct a Suppression Mission (STP 6-13F14-SM-TG, 061-283-1013)
- Conduct a Fire-for-Effect Mission (STP 6-13F14-SM-TG, 061-283-1015)
- Conduct an Immediate Smoke Mission (STP 6-13F14-SM-TG, 061-283-2021)
- Conduct a Quick Smoke Mission (STP 6-13F14-SM-TG, 061-283-2023)
- Request Close Air Support (STP 6-13F14-SM-TG, 061-284-3030)
- Adjust Indirect Fires (STP 21-24-SMCT, 061-283-6003)

### Brigade S2/DS MI Company Commander

- Conduct Target Development (STP 34-34II-MQS, 01-3381.01-4017)
- Conduct IEWSE Operations (STP 34-34II-MQS, 01-3381.04-5003)



## TASK

## OTHER LINKAGES

- Conduct Electronic Warfare Operations (STP 34-34II-MQS, 01-3381.06-4008)

### Aviation LNO

- Apply the Fundamentals of CAS (STP 1-15II-MQS, 01-1413.00-0123)
- Apply the Fundamentals of Fire Support Planning and Execution (STP 1-15II-MQS, 01-1413.00-0124)

24. The Brigade Targeting Team Monitors, Coordinates, and Synchronizes the Employment of Indirect Fires

### Brigade FSO

- Decide to Attack a Target (STP 6-13II-MQS, 01-2770.01-0106)
- Direct the Massing of FA and Mortar Fires with TACFIRE (STP 6-13II-MQS, 01-2770.01-0110)
- Plan, Request, and Direct an Emergency CAS Mission (STP 6-13II-MQS, 01-2830.00-3031)
- Apply the Fire Support Coordinating Measures (STP 6-13II-MQS, 01-2840.00-2025)
- Monitor and Coordinate Requests for Fire Support from Observers (STP 6-13EII-MQS, 01-2840.00-2026)
- Conduct Fire Support Employment (STP 6-13II-MQS, 04-3313.02-0001)
- Apply the Fire Support Coordinating Measures (STP 6-13II-MQS, 01-2840.00-2025)
- Review a Fire Support Capability Overlay (STP 6-13EII-MQS, 01-2840.01-0004)
- Coordinate Fire Support for a Maneuver Unit (STP 6-13II-MQS, 01-2999.93-0001)
- Coordinate Employment of FA Target Acquisition Assets (STP 6-13II-MQS, 01-2999.94-0103)

### Target Acquisition Systems/Observers

- Engage a Moving Target with Indirect Fire (STP 6-13II-MQS, 01-2660.00-2016)

## TASK

## OTHER LINKAGES

- Designate a Target Using the Laser Target Designator (STP 6-13II-MQS, 01-2740.00-1964)
- Request and Adjust Area Fire (STP 6-13F14-SM-TG, 061-283-1011)
- Conduct a Suppression Mission (STP 6-13F14-SM-TG, 061-283-1013)
- Conduct a Fire-for-Effect Mission (STP 6-13F14-SM-TG, 061-283-1015)
- Conduct an Immediate Smoke Mission (STP 6-13F14-SM-TG, 061-283-2021)
- Conduct a Quick Smoke Mission (STP 6-13F14-SM-TG, 061-283-2023)
- Request Close Air Support (STP 6-13F14-SM-TG, 061-284-3030)
- Adjust Indirect Fires (STP 21-24-SMCT, 061-283-6003)

### Brigade S2/DS MI Company Commander

- Conduct Target Development (STP 34-34II-MQS, 01-3381.01-4017)
- Conduct IEWSE Operations (STP 34-34II-MQS, 01-3381.04-5003)
- Conduct Electronic Warfare Operations (STP 34-34II-MQS, 01-3381.06-4008)

### Aviation LNO

- Apply the Fundamentals of CAS (STP 1-15II-MQS, 01-1413.00-0123)
- Apply the Fundamentals of Fire Support Planning and Execution (STP 1-15II-MQS, 01-1413.00-0124)

### Mortar Platoon

- Plan and Control Combat Operations (ARTEP 7-90-MTP, 7-3/4-1237)

25. The Brigade Targeting Team  
Receives the Results of Target  
Attacks and Performs Combat  
Assessment

### Brigade FSO

- Decide to Attack a Target (STP 6-13II-MQS, 01-2770.01-0106)

## TASK

## OTHER LINKAGES

- Direct the Evaluation and Dissemination of Intelligence Reports Using TACFIRE (STP 6-13II-MQS, 01-2770.01-0114)
- Evaluate All Operations Connected With Planning, Preparation, and Actual Application of Fire on a Target (STP 6-13II-MQS, 01-2830.00-2339)
- Interpret Threat Organization and Equipment (STP 6-13II-MQS, 01-2660.00-2004)
- Direct the Evaluation and Dissemination of Intelligence Reports Using TACFIRE (STP 6-13II-MQS, 01-2770.01-0114)
- Coordinate Intelligence Collection/Protection Plan (STP 6-13II-MQS, 01-2770.01-0136)
- Supervise a Targeting Element (STP 6-13II-MQS, 01-2999.97-0400)

### Brigade S2/DS MI Company Commander

- Conduct Target Development (STP 34-34II-MQS, 01-3381.01-4017)
- Conduct Threat Evaluation (STP 34-34II-MQS, 01-3381.01-4014)
- Analyze Intelligence and Combat Information (STP 34-34II-MQS, 01-3381.39-4004)
- Conduct All-Source Intelligence Analysis (STP 34-34II-MQS, 01-3381.41-4014)

26. The Brigade Targeting Team  
Acquires Information

### Brigade FSO

- Direct Processing of the Fire Support Request (STP 6-13II-MQS, 01-2770.01-0133)
- Direct the Reporting of Friendly Element Locations With TACFIRE (STP 6-13II-MQS, 01-2770.01-0104)

### Target Acquisition Systems/Observers

- Conduct Digital Communications With the DMD (STP 6-13II-MQS, 01-2660.00-2013)
- Conduct Digital Communications With the FIST DMD (STP 6-13II-MQS, 01-2660.00-2017)

## TASK

## OTHER LINKAGES

- Prepare a SITREP ( STP 21-24-SMCT, 071-332-5022)

### Mortar Platoon

- Prepare Mortar Fire Plans (STP 7-11C14-SM-TG, 071-074-0017)

### 27. The Brigade Targeting Team Evaluates Information

### Brigade FSO

- Evaluate All Operations Connected With Planning, Preparation, and Actual Application of Fire on a Target (STP 6-13II-MQS, 01-2830.00-2339)
- Apply the Fire Support Coordinating Measures (STP 6-13II-MQS, 01-2840.00-2025)
- Interpret Threat Organization and Equipment (STP 6-13II-MQS, 01-2660.00-2004)
- Direct the Evaluation and Dissemination of Intelligence Reports Using TACFIRE (STP 6-13II-MQS, 01-2770.01-0114)
- Apply the Fire Support Coordinating Measures (STP 6-13II-MQS, 01-2840.00-2025)
- Review a Fire Support Capability Overlay (STP 6-13EII-MQS, 01-2840.01-0004)

### Brigade S2/DS MI Company Commander

- Conduct Threat Evaluation (STP 34-34II-MQS, 01-3381.01-4014)
- Participate in the Development of Intelligence Requirements (STP 34-34II-MQS, 01-3381.01-5001)
- Conduct Target Development (STP 34-34II-MQS, 01-3381.01-4017)
- Direct the Intelligence Portion of the IPB Process (STP 34-34II-MQS, 01-3381.01-5002)
- Analyze Intelligence and Combat Information (STP 34-34II-MQS, 01-3381.39-4004)
- Conduct All-Source Intelligence Analysis (STP 34-34II-MQS, 01-3381.41-4014)

## TASK

## OTHER LINKAGES

### Brigade Engineer

- Advise Supported Units on Engineer Capabilities and Employment (STP 5-21II-MQS, 01-2250.10-1002)
- Evaluate Engineer Intelligence for Dissemination (STP 5-21II-MQS, 01-2250.20-1005)

28. The Brigade Targeting Team  
Updates Products

### Brigade FSO

- Prepare and Submit a Quick Fire Plan (STP 6-13EII-MQS, 01-2840.00-2022)
- Prepare, Consolidate, and Submit Target Lists (STP 6-13EII-MQS, 01-2840.01-0006)
- Develop Fire Support Guidance to FIST (STP 6-13EII-MQS, 01-2840.00-9015)
- Verify Posting of Information on Fire Support Situation Map (STP 6-13EII-MQS, 01-2840.01-0001)

### Brigade S2/DS MI Company Commander

- Prepare Intelligence Taskings (STP 34-34II-MQS, 01-3381.39-4002)
- Produce Finished Intelligence Products from All-Source Information (STP 34-34II-MQS, 01-3381.41-5003)

29. The Brigade Targeting Team  
Communicates Information  
and Coordinates the Brigade  
Fire Support Plan

### Brigade FSO

- Direct the Entry and Dissemination of FSCMs and FLOT with TACFIRE (STP 6-13II-MQS, 01-2770.01-0103)
- Direct the Reporting of Friendly Element Locations With TACFIRE (STP 6-13II-MQS, 01-2770.01-0104)
- Direct the Massing of FA and Mortar Fires with TACFIRE (STP 6-13II-MQS, 01-2770.01-0110)
- Direct the Evaluation and Dissemination of Intelligence Reports Using TACFIRE (STP 6-13II-MQS, 01-2770.01-0114)

## TASK

## OTHER LINKAGES

- Plan, Request, and Direct an Emergency CAS Mission (STP 6-13II-MQS, 01-2830.00-3031)
- Prepare and Submit a Quick Fire Plan (STP 6-13EII-MQS, 01-2840.00-2022)
- Coordinate and Request Fire Support From Observers (STP 6-13II-MQS, 01-2840.00-2026)
- Monitor and Coordinate Requests for Fire Support from Observers (STP 6-13EII-MQS, 01-2840.00-2026)
- Request and Coordinate Preplanned and Immediate CAS (STP 6-13II-MQS, 01-2840.00-2041)
- Direct the Entry and Dissemination of FSCMs and FLOT with TACFIRE (STP 6-13II-MQS, 01-2770.01-0103)
- Coordinate Intelligence Collection/Protection Plan (STP 6-13II-MQS, 01-2770.01-0136)
- Request and Coordinate Preplanned and Immediate CAS (STP 6-13II-MQS, 01-2840.00-2041)
- Coordinate Fire Support for a Maneuver Unit (STP 6-13II-MQS, 01-2999.93-0001)
- Coordinate Employment of FA Target Acquisition Assets (STP 6-13II-MQS, 01-2999.94-0103)
- Coordinate Employment of FA Survey and Meteorological Assets (STP 6-13II-MQS, 01-2999.94-0107)

### Target Acquisition Systems/Operators

- Prepare a SITREP ( STP 21-24-SMCT, 071-332-5022)

### Brigade S2/DS MI Company Commander

- Disseminate Intelligence and Combat Information (STP 34-34II-MQS, 01-3381.39-4005)

30. The Brigade Commander Visualizes the Battlefield Brigade FSO

- Recommend Fire Support Coordinating

## TASK

## OTHER LINKAGES

- Measures, and Coordinate Fires (STP 6-13II-MQS, 01-2840.00-2042)
- Recommend Changes to Attack Guidance (STP 6-13II-MQS, 01-2840.00-4226)
- Evaluate the Information Obtained Through the IPB Process (STP 6-13II-MQS, 01-2840.00-4227)
- Recommend the Employment of Mortars (STP 6-13EII-MQS, 01-2840.00-8502)
- Recommend Employment of Available TA Assets (STP 6-13II-MQS, 01-2900.00-7022)
- Recommend Fire Support Coordinating Measures (STP 6-13II-MQS, 01-2999.94-0101)
- Recommend Employment of Weapons-Locating Radar Zones and Common Sensor Boundary (STP 6-13II-MQS, 03-2940.00-3204)
- Advise Maneuver Commander and FSCoord on TACFIRE Operations (STP 6-13II-MQS, 01-2770.01-0118)
- Advise the Maneuver Commander on the Employment of the COLT (STP 6-13EII-MQS, 01-2840.00-2021)
- Advise the Maneuver Commander on the FASP (STP 6-13EII-MQS, 01-2840.00-2023)
- Advise the Maneuver Commander on the Fire Support Plan (STP 6-13EII-MQS, 01-2840.00-2024)
- Advise the Maneuver Commander on Fire Support Coordinating Measures (STP 6-13EII-MQS, 01-2840.00-2025)
- Advise the Maneuver Commander on Employment of COLTs and Aerial Fire Support Teams (STP 6-13II-MQS, 01-2840.00-2039)
- Advise Supported Maneuver Unit of Friendly and Enemy Fire Support Capabilities and Limitations (STP 6-13EII-MQS, 01-2840.00-3004)
- Inform Supported Maneuver Commander of the FA Tactical Mission and Corresponding Plan to Support the Scheme of Maneuver (STP 6-13EII-MQS, 01-2840.00-3042)

## TASK

## OTHER LINKAGES

- Advise Maneuver Commander on the Capabilities and Limitations of Naval Gunfire (STP 6-13EII-MQS, 01-2840.00-4021)
- Advise the Commander and Staff on the Mission, Capabilities, and Limitations of Available TA Assets (STP 6-13II-MQS, 01-2900.00-7021)
- Advise Maneuver Commander on Employment of Available Fire Support Assets (STP 6-13II-MQS, 01-2999.94-0106)
- Advise the Commander on the Capabilities of Available Target Acquisition Assets (STP 6-13II-MQS, 01-3020.00-7002)

### All Fire Support Leaders

- Brief fire support plan refinements and modifications (no MTP/STP reference)

### Brigade Engineer

- Advise the Commander on the Use of Terrain for Combat Operations (STP 5-21II-MQS, 01-2250.20-1008)

### All Maneuver Leaders

- Brief fire support plans to support tactical scheme of maneuver and direct fire plan (no MTP/STP reference)

### 31. The Brigade Commander Directs Brigade FSO Changes to the Operation of Plan

- Prepare Target Lists and Scheduling Work Sheets (STP 6-13II-MQS, 01-2660.00-2011)
- Direct the Establishment of and Verify Commander's Criteria (STP 6-13II-MQS, 01-2770.01-0105)
- Prepare and Submit a Quick Fire Plan (STP 6-13EII-MQS, 01-2840.00-2022)
- Request and Coordinate Preplanned and Immediate CAS (STP 6-13II-MQS, 01-2840.00-2041)



**TASK**

**OTHER LINKAGES**

Brigade S2/DS MI Company Commander

- Prepare Intelligence Taskings (STP 34-34II-MQS, 01-3381.39-4002)

32. The Brigade Commander Directs and Leads Subordinate Forces

33. The Brigade Consolidates and Reorganizes

## References

This component identifies the references and sources used by the author to develop the CCF task list. This component provides users with sources for further information.

### ARTEPs

- 6-115-MTP            Mission Training Plan for Field Artillery Cannon Battalion Headquarters and Headquarters Battery; Headquarters, Headquarters and Service Battery; or Service Battery, November 90
- 6-115-20-MTP        Mission Training Plan for the Field Artillery Cannon Battalion Fire Support, January 90
- 71-3-MTP            Mission Training Plan for the Heavy Brigade Command Group and Staff, October 88

### EMs

- 1-111                Aviation Brigade, August 90
- 3-3                  Chemical and Biological Contamination Avoidance, November 92
- 3-7                  NBC Handbook, September 94
- 3-50                 Deliberate Smoke Operations, December 90
- 3-101                Chemical Staffs and Units, April 87
- 5-100                Engineer Combat Operations, November 88
- 5-101                Mobility, January 85
- 5-102                Countermobility, March 85
- 6-20                 Fire Support in the AirLand Battle, May 88
- 6-20-1              Tactics, Techniques, and Procedures for the Field Artillery Cannon Battalion, November 90
- 6-20-2              Tactics, Techniques, and Procedures for Corps Artillery, Division Artillery, and Field Artillery Brigade Headquarters, January 93

**Fms (Continued)**

- 6-20-10            Tactics, Techniques, and Procedures for the Targeting Process - FINAL DRAFT, February 95
- 6-20-20            Tactics, Techniques, and Procedures for Fire Support at Battalion Task Force and Below, December 91
- 6-20-30            Tactics, Techniques, and Procedures for Fire Support for Corps and Division Operations, October 89
- 6-20-40            Tactics, Techniques, and Procedures for Fire Support for Brigade Operations (Heavy), January 90
- 6-20-50            Tactics, Techniques, and Procedures for Fire Support for Brigade Operations (Light), January 90
- 6-30                Tactics, Techniques, and Procedures for Observed Fire, July 91
- 6-121              Field Artillery Target Acquisition, September 90
- 7-90                Tactical Employment of Mortars, October 92
- 11-41              Signal Support: Echelons Corps and Below, December 91
- 11-50              Combat Communications Within the Division (Heavy and Light), April 91
- 34-1                Intelligence and Electronic Warfare Operations, September 94
- 34-2                Collection Management, March 94
- 34-8                Combat Commanders Handbook on Intelligence, September 92
- 34-80              Brigade and Battalion Intelligence and Electronic Warfare Operations, April 86
- 34-130             Intelligence Preparation of the Battlefield, July 94
- 71-2                The Tank and Mechanized Infantry Battalion Task Force, September 88
- 71-3                The Armored and Mechanized Infantry Brigade - FINAL DRAFT, July 95
- 71-100             Division Operations, June 90
- 71-123             Tactics, Techniques and Procedures for Combined Arms Heavy Forces: Armored and Mechanized Infantry Brigade, Battalion/Task Force, and

Company Team, September 92

90-7 Combined Arms Obstacle Integration, September 94

90-14 Rear Battle, June 85

100-5 Operations, June 93

101-5 Command and Control for Commanders and Staff (Draft), July 92

**STPs**

1-15II-MQS Military Qualification Standards II, Aviation Branch (15), Company Grade Officer's and Aviation Commissioned Warrant Officer's Manual, March 92

5-21II-MQS Military Qualification Standards II, Engineer (21), Company Grade Officer's Manual, Mar 91

6-13F14-SM-TG Soldier's Manual and Trainer's Guide: 13F, Fire Support Specialist (SL 1/2/3/4), September 91

6-13II-MQS Military Qualification Standards II, Field Artillery Branch (13) Company Grade Officer's Manual, March 91

6-13EII-MQS Military Qualification Standards II, Field Artillery Branch-Cannon (13) Company Grade Officer's Manual, March 91

7-11II-MQS Military Qualification Standards II, Infantry Branch (11), Company Grade Officer's Manual, July 91

11-25II-MQS Military Qualification Standards II, Signal Corps (25), Company Grade Officer's Manual, August 91

17-12II-MQS Military Qualification Standards II, Armor Branch (13), Company Grade Officer's Manual, February 91

21II-MQS Military Qualification Standards II, Manual for Common Tasks for Lieutenants and Captains, January 91

21-24-SMCT Soldiers Manual of Common Tasks (SL 2-4), October 92

34-35II-MQS Military Qualification Standards II, Military Intelligence Branch (35), Company Grade Officer's Manual, September 91

## **Center for Army Lessons Learned (CALL) Publications**

NTC Commander's Memorandum, November 85

NTC Lessons Learned Bulletin, January 86

NTC Lessons Learned Bulletin, September 86

NTC Commander's Comments – The CS Team, 1987

CALL, Vol 1: Heavy Forces, Fall 88

CALL, Non-Mechanized Forces, Spring 89

CALL 90-1, Fire Support for the Maneuver Commander, February 90

CALL 90-3, "The Stone Forest", May 90

CALL 90-5, Fire Support Lesson Learned, May 90

CALL 93-4: Combat Training Centers (CTCs) Bulletin, July 93

CALL 90-7: Winning in the Desert, August 90

CALL 90-8: Winning in the Desert II, September 90

CALL 92-4: Fratricide Reducing Self-Inflicted Losses, April 92

## **Other Publications**

"BATTLE COMMAND: Leadership and Decision Making for War and Operations Other Than War", Battle Command Battle Laboratory, Fort Leavenworth, KS, April 94

"Battle Command Techniques and Procedures", Battle Command Battle Laboratory, Ft. Leavenworth, KS, April 95

Multi-Command Manual (MCM) 3-3, Vol VIII, "Mission Employment Tactics AFAC and TACP (Draft)"

NWP 3-09.11M, "Supporting Arms In Amphibious Operations", Department of the Navy, Officer of the Chief of Naval Operations and Headquarters, U.S. Marine Corps, PCN # 13900010900

## **Interviews with FORSCOM Units and Unit Staffs**

3rd Brigade, 24th Infantry Division (Mechanized), Ft. Benning, GA: 18-20 July 94; 24 May 95

**Interviews with FORSCOM Units and Unit Staffs (Continued)**

III Corps Artillery, Ft. Sill, OK: 22-24 August 94

194th Armored Brigade (Separate), Ft. Knox, KY: 10-13 July 94, 2-4 October 94

3rd Brigade, 82nd Airborne Division, Ft. Bragg, NC: 6 June 95

**Interviews with TRADOC Training Centers (Schools and Staffs)**

National Training Center (NTC) OCs, Ft. Irwin, CA: 18-20 April 94; 25-27 April 94; 29-30 August 94; 25-27 September 94; 24-25 October 94; 21-22 November 94; 19-20 December 94; 30-31 January 95

Joint Readiness Training Center (JRTC) OCs, Ft. Polk, LA: 10-13 July 94

U.S. Army Infantry Center and School, Ft. Benning, GA: 18-20 July 94; 25 May 95

U.S. Army Armor Center and School, Ft. Knox, KY: 10-13 July 94; 2-4 October 94; 1 June 95

U.S. Army Field Artillery Center and School, Ft. Sill, OK: 22-24 August 94; 7 June 95

Battle Command Battle Staff Trainer (BCBST), Ft. Leavenworth, KS: 9-12 August 94

Battle Command Training Program (BCTP) OCs, Ft. Leavenworth, KS: 9-12 August 94

Command and General Staff College (CGSC) Instructors, Ft. Leavenworth, KS: 9-12 August 94

## APPENDIX A

### Index of Critical Combat Functions (CCF)

This component lists the thirty nine (39) CCFs which have been identified as relevant to U.S. Army tactical echelon units. The purpose of this component is to depict the relationship between each BOS and the CCF it comprises.

<b>INTELLIGENCE</b>	(1)	Conduct Intelligence Planning
	(2)	Collect Information
	(3)	Process Information
	(4)	Disseminate Intelligence
<b>MANEUVER</b>	(5)	Conduct Tactical Movement
	(6)	Engage Enemy with Direct Fire and Maneuver
<b>AIR DEFENSE</b>	(16)	Take Active Air Defense Measures
	(17)	Take Passive Air Defense Measures
<b>FIRE SUPPORT</b>	(7)	Employ Mortars
	(8)	Employ Field Artillery
	(9)	Employ Close Air Support
	(10)	Conduct Electronic Collection and Jamming
	(11)	Conduct Battlefield PsyOps
	(12)	Employ Chemical Weapons
	(13)	Conduct Counter Target Acquisition Operations <sup>1</sup>
	(14)	Employ Naval Surface Fires
	(15)	Coordinate, Synchronize and Integrate Fire Support
<b>MOBILITY AND SURVIVABILITY</b>	(21)	Overcome Obstacles
	(22)	Enhance Movement
	(23)	Provide Countermobility
	(24)	Enhance Physical Protection
	(25)	Provide Operations Security
	(26)	Conduct Deception Operations
	(27)	Provide NBC Defense
<b>BATTLE COMMAND</b>	(18)	Plan for Combat Operations
	(19)	Direct and Lead Unit During Preparation for the Battle
	(20)	Direct and Lead Units in Execution of Battle

---

<sup>1</sup>Although US National Policy has renounced the use of chemical weapons, this CCF is retained because it is a function which could be performed by other nations.

## LOGISTICS

- (28) Provide Transport Services
- (29) Conduct Supply Operations
- (30) Provide Personnel Services
- (31) Maintain Weapons Systems and Equipment
- (32) Provide Health Services
- (33) Treat and Evacuate Battlefield Casualties
- (34) Conduct Enemy Prisoners of War (EPW) Operations
- (35) Conduct Law and Order Operations
- (36) Conduct Civil Affairs Operations
- (37) Provide Sustainment Engineering
- (38) Evacuate Non-combatants from Area of Operations
- (39) Provide Field Services



## APPENDIX B

### Structure of Critical Combat Functions

This component provides a description of each CCF and the BOS with which it is aligned. Included with each CCF definition is a listing of major doctrinal topics and aspects addressed by the CCF. These definitions provide the necessary framework required to understand the focus of each CCF. Under most circumstances, brigades will be involved in the accomplishment of some or all aspects of the CCF. The involvement can vary from extensive, wherein the CCF is a major focus, to minor, wherein the brigade only furnishes information. In the latter instances, the involvement may not be sufficient to warrant incorporation into a brigade's training plans, although the brigade's responsibilities are likely addressed in its SOP for tactical operations (TACSOP). CCF definitions were extracted from TRADOC Pam 350-7 "Blueprint of the Battlefield," as well as other doctrinal publications relevant to the applicable CCF or BOS.

**Critical Combat Function:** The integration [i.e., interrelationship] among participants and tasks that represent a force multiplier with a definable outcome.

1. **Intelligence BOS** - The ways and means of acquiring, analyzing, and using knowledge of the enemy, weather, and terrain required by a commander in planning, preparing, and conducting combat operations. These CCF are continuous throughout the planning, preparation, and execution phases of the battle.
  - a. **CCF (1) Conduct Intelligence Planning** - The development and coordination of information relative to the enemy, weather, and terrain prior to and during the development of the unit OPORD; the planning to collect information from battlefield sources and to acquire intelligence from other headquarters. Focus of this CCF is the IPB. This CCF addresses:
    - 1) R & S Plan.
    - 2) Integrated threat templates (e.g., doctrinal, event, input to DST).
    - 3) Terrain and weather analysis.
  - b. **CCF (2) Collect Information** - Obtaining information in any manner from BCT's elements and from sources outside the BCT (e.g., higher headquarters and adjacent units). This CCF includes the tasks associated with managing the processes and activities necessary to collect battlefield information which may eventually be used to provide intelligence relative to the enemy, terrain, and weather. This CCF addresses:
    - 1) Information collected as a result of the R & S Plan.
    - 2) Continuous information collection and acquisition from all sources.

c. **CCF (3) Process Information** - The conversion of information into intelligence through collation, evaluation, analysis, integration, and interpretation in a continual process. This CCF addresses:

- 1) Evaluation of threat information.
- 2) Evaluation of physical environment information.
- 3) Integration of intelligence information.
- 4) Development of enemy intentions.
- 5) Development of targeting information.
- 6) Preparation of intelligence reports.
- 7) Update of situational template.
- 8) Provision of battlefield area reports.

d. **CCF (4) Disseminate Intelligence** - Transmission of information by any means (verbal, written, electronic, etc.), from one person or place to another to provide timely dissemination of critical intelligence to all appropriate members of the combined arms team. This CCF addresses:

- 1) The sending of processed intelligence in a timely manner to those on the combined arms team who can, by its receipt, take appropriate actions to accomplish the mission. This includes intelligence on the enemy, terrain, and weather.
- 2) The sending of raw intelligence directly from those responsible for reconnaissance and surveillance to the commander should that raw intelligence be time sensitive (and not be subject to receipt and processing by intelligence analysts).
- 3) Dissemination of battlefield reports.

2. **Maneuver BOS** - The employment of direct fire weapons, platforms, and systems through movement and fire and maneuver to achieve a position of advantage in respect to enemy ground forces, in order to accomplish the mission. The direct fire weapons are tank guns, BFV 25mm, anti-tank guns and rockets, attack helicopter guns and rockets, small arms, crew-served weapons, and directed energy weapons systems.

a. **CCF (5) Conduct Tactical Movement** - Planning for and directing the positioning of direct fire weapons systems relative to the enemy to secure or retain positional advantage, making full use of terrain and formations. Tactical movement occurs when contact with the

enemy is likely or imminent but direct fire engagement has not yet occurred. Units supporting maneuver units are included. This CCF addresses:

- 1) Subordinate element OPORD preparation and dissemination.
  - 2) Preparation for movement.
  - 3) Movement, both mounted and dismounted, and on and off road.
  - 4) Closure of movement to tactical assembly area or tactical positions.
  - 5) Navigation.
  - 6) Air movement.
- b. **CCF (6) Engage Enemy with Direct Fire and Maneuver** - Planning for and directing elements in ground combat with the enemy using direct fire and/or close combat in order to destroy the enemy or cause him to withdraw. This CCF relates only to those direct fire weapons systems associated with the maneuver BOS. This CCF addresses:
- 1) Preparation of engagement areas.
  - 2) Rehearsals of battle plans.
  - 3) Prevention of fratricide.
  - 4) Conduct of close combat.
  - 5) Integration of direct fire with maneuver.
  - 6) Control of terrain.
  - 7) Consolidation and reorganization.
3. **Fire Support BOS** - The collective, coordinated, and synchronized use of target acquisition data, indirect fire weapons, armed aircraft (less attack helicopters) and other lethal and non-lethal means against ground targets in support of maneuver force operations and to achieve the commander's intent and scheme of maneuver. The fire support BOS addresses these weapons: mortars, field artillery, close air support, electronic measures, and naval surface fires.
- a. **CCF (7) Employ Mortars** - Planning for and employment of mortars by the maneuver unit to place fires on the enemy or terrain to support the commander's concept and intent.
  - b. **CCF (8) Employ Field Artillery** - Planning for and directing of indirect artillery fires to be placed on the enemy or terrain to support the commander's concept and intent. The fire support coordination tasks necessary to integrate the field artillery and the maneuver units

are the primary focus. This CCF does not address those field artillery tasks associated directly with those actions taken by the batteries of the artillery battalion in the conduct of their support mission such as FDC operations, gun operations, etc. This CCF addresses:

- 1) Fire support - maneuver unit rehearsals.
  - 2) FSE operations during the preparation and execution phases of the battle.
  - 3) Positioning and movement within the maneuver unit sector or zone.
  - 4) Indirect fire missions in support of maneuver commander's concept and intent.
- c. **CCF (9) Employ Close Air Support** - Planning for, requesting, and employing armed aircraft (less attack helicopters) in coordination with other fire support (lethal and non-lethal) against ground targets in support of the maneuver force commander's concept and intent. This CCF addresses:
- 1) Air-ground attack requests.
  - 2) Air space coordination and management.
  - 3) Air liaison officer, forward air controller; other Army fire support coordination officers, USN/USMC brigade team commander, SALT-O and FCT-O tasks that enable air-to-ground attacks.
- d. **CCF (10) Conduct Electronic Collection and Jamming** - Planning for and directing actions taken to deny the enemy effective command, control, and communications of his own tactical force in support of maneuver commander's concept and intent. This CCF includes jamming, deception, and collection.
- e. **CCF (11) Conduct Battlefield PsyOps** - Planning for and directing the conduct or support of psychological operations (when psychological operations units are available) as an integral part of combat operations to bring psychological pressure to bear on enemy forces and civilians under enemy control in the battle area, to assist in the achievement of tactical objectives in support of maneuver commander's concept and intent.
- f. **CCF (12) Employ Chemical Weapons** - Employing chemical agents or other means to degrade enemy capabilities in support of maneuver commander's concept and intent.<sup>1</sup>
- g. **CCF (13) Conduct Counter Target Acquisition Operations** - Planning for and directing the suppression (e.g., using smoke or dazzling illumination) to degrade enemy direct observation, optics, radar, sensors, electronic DF equipment, and imaging systems in

---

<sup>1</sup>Although US National Policy has renounced the use of chemical weapons, this CCF is retained because it is a function which could be performed by other nations.

support of maneuver commander's concept and intent.

- h. **CCF (14) Employ Naval Surface Fires** - Planning for and directing naval gunfire in support of the maneuver commander's concept and intent.
  - I. **CCF (15) Coordinate, Synchronize, and Integrate Fire Support** - Coordinating all fire support means in support of the maneuver commanders' concepts and intents. The CCF integrates CCF 7-14.
4. **Air Defense BOS** - The means and measures organic or assigned to the maneuver commander which, when employed successfully, will nullify or reduce the effectiveness of attack by hostile aircraft or missiles after they are airborne.
- a. **CCF (16) Take Active Air Defense Measures** - Planning for and directing the application of firepower to destroy enemy air targets. This CCF encompasses the coordinating tasks which enable the maneuver commander to successfully employ any attached or assigned air defense weapons system, as well as the tasks necessary to employ all organic weapons systems against enemy air targets. This CCF addresses:
    - 1) Employment of air defense artillery guns and missiles.
    - 2) Employment of maneuver unit weapons systems such as small arms, automatic weapons, Bradley fighting vehicle (BFV) 25 mm and tube-launched, optically- bracked, wire-guided missiles (TOW), and tank main gun against enemy air.
    - 3) Airspace management.
    - 4) Early warning.
  - b. **CCF (17) Take Passive Air Defense Measures** - Planning for and directing the protection of the maneuver force from enemy air by means other than weapons. This CCF addresses:
    - 1) Early warning.
    - 2) Dispersion.
    - 3) Deception.
5. **Battle Command BOS** - The ways and means a maneuver commander exercises authority and direction over organic and assigned combat power in the accomplishment of the mission.
- a. **CCF (18) Plan for Combat Operations** - The integration of all members of the combined arms team in the coordinated development of the maneuver unit operations order which will

guide the activities of the combined arms team in conducting combat operations to accomplish assigned missions. The product/outcome of this CCF is a briefed, understood OPORD. This CCF addresses:

- 1) Receipt and analysis of higher HQ OPORD.
  - 2) Issuance of warning order.
  - 3) Restated mission statement.
  - 4) Commander's estimate process/troop leading procedures.
  - 5) Commander's guidance.
  - 6) Mission analysis (includes course of action development).
  - 7) Decision brief to commander.
  - 8) Development of a synchronized OPORD.
  - 9) Reproduction and distribution of OPORD to all participants.
  - 10) Briefing of OPORD; understanding of order by participants.
  - 11) FRAGO planning and issue.
- b. **CCF (19) Direct and Lead Unit during Preparation for the Battle** - The ways and means to prepare the maneuver force for the battle so that the maneuver force is ready to support the maneuver commander's concept and intent. This CCF addresses:
- 1) Commander's actions and decisions.
  - 2) Directing preparation for the battle.
  - 3) Issuing orders.
  - 4) Communicating information.
  - 5) Confirmation briefs and backbriefs.
  - 6) Rehearsals.
  - 7) Maintaining and updating information and force status.
  - 8) Decisions to act or change ongoing actions.

- 9) Confirming IPB through the reconnaissance effort.
  - 10) Determining actions to implement decisions.
  - 11) Synchronizing preparation (e.g., management of time).
  - 12) TOC operations (e.g., staff integration).
  - 13) Second in command (2IC) responsibilities.
  - 14) Continuous and sustained operations.
  - 15) Communications (e.g., planning, installation and operation of system, management, site election).
- c. **CCF (20) Direct and Lead Units in Execution of Battle** - The ways and means to command and control the maneuver force's execution of the battle plan (engaging the enemy in battle) to accomplish the maneuver commander's concept and intent. This CCF addresses:
- 1) Commander's actions and decisions.
  - 2) Directing the conduct of the battle.
  - 3) Issuing orders.
  - 4) Information distribution.
  - 5) Synchronizing tactical operations (e.g., use of DST).
  - 6) TOC operations (includes CP displacement, security, survivability, battle tracking).
  - 7) Continuity of command (e.g., C2 redundancy).
  - 8) Second in command (2IC) responsibilities.
  - 9) Continuous and sustained operations.
  - 10) Consolidation and reorganization.
6. **Mobility and Survivability BOS** - The ways and means that permit freedom of movement, relative to the enemy, while retaining the force's ability to fulfill its primary mission, as well as the measures the force takes to remain viable and functional by protection from the effects of enemy weapons systems and natural occurrences.
- a. **CCF (21) Overcome Obstacles** - Planning for and directing actions to remove or clear/reduce natural and man-made obstacles.

- b. **CCF (22) Enhance movement** - Planning for and coordinating elements providing mobility for the maneuver unit in its area of operations. This CCF addresses:
  - 1) Construction and repair of combat roads and trails.\*
  - 2) Facilitating movement on routes. (This includes control of road traffic and control of refugees and stragglers.)\*
  - 3) Tracking status of routes.\*
  - 4) Host nation support.\*
- c. **CCF (23) Provide Countermobility** - Planning for and directing actions to delay, channel, or stop enemy offensive movement consistent with the commander's concept and intent by enhancing the effectiveness of friendly direct and indirect weapons systems.
- d. **CCF (24) Enhance Physical Protection** - Planning for and directing actions that provide protection of friendly forces on the battlefield by enhancing the physical protection of personnel, equipment and weapons systems, and supplies.
- e. **CCF (25) Provide Operations Security** - Planning for and directing action to deny information to the enemy about friendly capabilities and intentions by identifying, controlling, and protecting indicators associated with planning and conducting military operations. This CCF addresses:
  - 1) Analysis to determine key assets and threats to them.
  - 2) Monitoring of implementation of OPSEC measures.
  - 3) Physical security measures.
  - 4) Signal security.
  - 5) Electronic security.
- f. **CCF (26) Conduct Deception Operations** - Taking actions in accordance with the division's or corps' deception plan to mask the objectives of tactical operations in order to delay effective enemy reaction. This CCF addresses:
  - 1) Physical deception.
  - 2) Electronic deception.
- g. **CCF (27) Provide NBC Defense** - Planning for and directing actions to absorb, destroy, neutralize, make harmless or remove chemical or biological agents, or to remove radioactive

\*Normally accomplished by units supporting the division.



material. This CCF addresses:

- 1) Decontamination of individual soldiers and equipment.
- 2) Decontamination of weapon systems and supplies.
- 3) Hasty and deliberate decontamination.

7. **Logistics BOS** - The support, assistance, and service provided to sustain forces, primarily in the area of logistics, personnel services, and health services.

a. **CCF (28) Provide Transport Services** - Planning for and directing provision or coordination for transportation which will assure sustainment support operations in support of the maneuver commander. This CCF addresses:

- 1) Movement of cargo, equipment, and personnel by surface or air.
- 2) Loading, transloading, and unloading material and supplies.
- 3) Reporting status.

b. **CCF (29) Conduct Supply Operations** - Planning for and directing provision of the items necessary to equip, maintain, and operate the force during the preparation and execution phases of the battle. This CCF addresses:

- 1) Requesting, receiving, procuring, storing, protecting, relocating, and issuing supplies to the specific elements of the force.
- 2) Providing munitions to weapons systems.
- 3) Providing fuel and petroleum products to equipment and weapons systems.
- 4) Reporting status.

c. **CCF (30) Provide Personnel Services** - Planning for and directing all personnel-related matters to sustain the force. This CCF addresses:

- 1) Personnel administrative services.
  - a) Replacement, casualty reporting.
  - b) Awards and decorations.
  - c) Postal operations.
  - d) Promotions, reductions.

- 2) Financial services.
  - 3) Unit ministry team operations.
  - 4) Legal services.
  - 5) Public affairs services.
  - 6) Preservation of the force through safety.
  - 7) Management of stress.
  - 8) Reporting status.
- d. **CCF (31) Maintain Weapons Systems and Equipment** - Planning for and directing preservation and repair of weapons systems and equipment. This CCF includes the provision of repair parts and end items to all members of the combined arms team before, during and after the battle. Included also is doctrinal echeloning of maintenance (organization, DS, GS). This CCF addresses:
- 1) Recovery.
  - 2) Diagnosis, substitution, exchange, repair and return of equipment and weapons systems to the combined arms force.
  - 3) Reporting status.
- e. **CCF (32) Provide Health Services** -Planning for, directing and coordinating health services regardless of location, to promote, improve, conserve or restore the mental or physical well-being of individuals or groups. This CCF addresses:
- 1) Preventive medicine.
  - 2) Field sanitation.
  - 3) Mental health.
- f. **CCF (33) Treat and Evacuate Battlefield Casualties** - Planning for and directing the application of medical procedures on battlefield casualties beginning with "buddy aid" through treatment by trained medical personnel. The CCF includes movement of casualties from the forward edge of the battlefield back to division-level medical facilities. This CCF addresses:
- 1) Triage of battlefield casualties.

- 2) Treatment and movement of casualties to rear (medevac).
  - 3) Evacuation.
  - 4) Handling and processing the remains of soldiers who have died of wounds.
  - 5) Reporting status.
- g. **CCF (34) Conduct Enemy Prisoners of War (EPW) Operations** - Planning for and directing the collection, processing, evacuation, and safeguarding of enemy prisoners of war. This CCF addresses:
- 1) Collecting and evacuating EPW.
  - 2) Searching, segregating, safeguarding, silencing, and rapid rearward movement of EPW.
- h. **CCF (35) Conduct Law and Order Operations** - Enforcing laws and regulations and maintaining of unit and personnel discipline.
- i. **CCF (36) Conduct Civil Affairs Operations** - Planning for, directing, and/or coordinating assigned tasks to conduct activities which encompass the relationship between the military forces and civil authorities and the citizens in a friendly or occupied country or area when U.S. military forces are present.
- j. **CCF (37) Provide Sustainment Engineering** - Planning for and coordinating the actions of elements (when in the brigade area), providing repair and construction of facilities and lines of communication. This CCF addresses:
- 1) Rear area restoration.\*
  - 2) Construction and maintenance of lines of communication (roads, railroads, ports, airfields).\*
  - 3) Construction support:
    - a) Marshaling, distribution and storage facilities.\*
    - b) Pipelines.\*
    - c) Fixed facilities.\*
    - d) Well drilling.\*
    - e) Dismantlement of fortifications.\*

- k. **CCF (38) Evacuate Non-combatants from Area of Operations** - Planning for and directing the maneuver unit's participation in actions to use available military and host-nation resources for the evacuation of US forces, dependents, US government civilian employees, and private citizens (US and other). This CCF addresses:
- 1) Medical support.
  - 2) Transportation.
  - 3) Security.
  - 4) Preparation of temporary shelters.
  - 5) Operation of clothing exchange facilities.
  - 6) Operation of bathing facilities.
  - 7) Graves registration.
  - 8) Laundry.
  - 9) Feeding.
- l. **CCF (39) Provide Field Services** - Planning for and coordinating the provision of service logistics functions by CSS elements\*. This CCF addresses:
- 1) Clothing exchange.
  - 2) Bathing facilities.
  - 3) Graves registration.
  - 4) Laundry and clothes renovation.
  - 5) Bakeries.
  - 6) Feeding (rations supply, kitchens).
  - 7) Salvage.

\*Normally accomplished by units supporting the division.

## APPENDIX C

### List of Abbreviations and Acronyms

**A2C2:** Army Airspace Command and Control  
**ABE:** Assistant Brigade Engineer  
**ACA:** airspace coordination area  
**ACU:** area common user  
**AD:** air defense  
**ADA:** air defense artillery  
**ADAM:** area denial antipersonnel mine  
**ADDS:** Army data distribution system  
**AFAC:** airborne forward air controller  
**AFATDS:** Advanced Field Artillery Tactical Data System  
**AFSO:** aerial fire support observers  
**AGM:** attack-guidance matrix  
**AI:** air interdiction  
**ALO:** Air Liason Officer  
**ANGLICO:** Air/Naval Gunfire Liason Company  
**AO:** area of operations  
**APICM:** antipersonnel improved conventional munition  
**ARI:** Army Research Insitute for the Behavioral and Social Sciences  
**ARTEP:** Army Training and Evaluation Program  
**ASAS:** All Source Analysis System  
**ASOC:** Air Support Operations Center  
**ASR:** alternate supply route  
**ATO:** air tasking order

**BAI:** battlefield air interdiction  
**BCT:** Brigade Combat Team  
**BDA:** battle damage assessment  
**BFV:** Bradley Fighting Vehicle  
**BICC:** battlefield information control center  
**Bn TF:** Battalion Task Force  
**BOS:** battlefield operating system  
**BSA:** Brigade Support Area

**C3I:** command, control, communications, and intelligence  
**CA:** civil affairs  
**CA:** combat assessment  
**CALL:** Center for Army Lessons Learned  
**CAS:** close air support

**CBU:** cluster bomb unit  
**CCF:** Critical Combat Function  
**CCF 15:** Coordinate, Synchronize, and Integrate Fire Support  
**CCF 18:** Plan for Combat Operations  
**CCF 19:** Direct and Lead Units During Preparation for the Battle  
**CCF 20:** Direct and Lead Units in Execution of Battle  
**CCIR:** commander's critical information requirement  
**CFL:** coordinated fire line  
**CNR:** combat net radio  
**CMTC:** Combat Maneuver Training Center  
**Co:** company  
**COA:** course of action  
**COLT:** combat observation lasing team  
**COMINT:** communications intelligence  
**COP:** command operation procedures  
**CO/Tm:** company/team  
**CP:** command post  
**CPEA:** concept, planning and/or preparation, execution, and assessment  
**CPHD:** copperhead  
**CPX:** command post exercise  
**CS:** combat support  
**CSR:** controlled supply rate  
**CSS:** combat service support  
**CTC:** Combat Training Center

**DDMP:** deliberate decision-making process  
**DDS:** data distribution system  
**DIVARTY:** division artillery  
**DMP:** decision making process  
**DP:** decision point  
**DPICM:** dual-purpose, improved, conventional munitions  
**DS:** direct support  
**DSA:** division support area  
**DST:** decision support template  
**DTG:** data-time group

**EA:** engagement area  
**ECM:** electronic counter measures  
**EEFI:** essential elements of friendly information  
**ELINT:** electronic intelligence  
**EPW:** enemy prisoner(s) of war  
**ES:** electronic support  
**ETAC:** enlisted terminal attack controller

**EW:** electronic warfare

**FA:** field artillery

**FAADC:** Forward Area Air Defense Command, Control, Communications and Intelligence System

**FAADS:** forward area defense system

**FARP:** forward arming and refuel point

**FASCAM:** family of scatterable mines

**FASP:** field artillery support plan

**FCC:** flight command center

**FCT:** firepower control team

**FDC:** fire direction center

**FFA:** free fire areas

**FFIR:** friendly forces information requirements

**FIST:** fire support team

**FIST-V:** fire support team vehicle

**FLOT:** forward line of own troops

**FM:** field manual

**FO:** forward observer

**FOC:** flight operations center

**FORSCOM:** United States Army Forces Command

**FPF:** final protective fires

**FRAGO:** fragmentary order

**FSB:** Forward Support Battalion

**FSCL:** fire support coordination line

**FSCM:** fire support coordinating measures

**FSCOORD:** fire support coordinator

**FSE:** fire support element

**FSEM:** fire support execution matrix

**FSO:** fire support officer

**FTE:** field training exercise

**G2:** Intelligence, General Staff

**GS:** general support

**GS(R):** general support--reinforcing

**GSR:** ground surveillance radar

**G/VLLD:** ground/vehicle laser locator designator

**HC:** hydrogen chloride

**HE:** high-explosive

**HPT:** high payoff targets

**HPTL:** high payoff target list

**HUMINT:** human intelligence

**HVT:** high-value target

**IEW:** intelligence and electronic warfare

**IFF:** identification--friend or foe

**IMINT:** imagery intelligence

**INTSUMS:** intelligence summary

**IP:** initial point

**IPB:** intelligence preparation of the battlefield

**IR:** infrared

**ITTBBST:** Innovative Tools and Techniques for Brigade and Below Staff Training

**JAAT:** joint air attack team

**J-SEAD:** joint suppression of enemy air defense

**J-STARS:** joint surveillance and target attack radar system

**LAN:** local area network

**LD:** line of departure

**LNO:** liaison officer

**LO:** liaison officer

**LOS:** line of sight

**LRSU:** Long-Range Surveillance Unit

**MBA:** main battle area

**M/CM/S:** mobility/counter-mobility/survivability

**MCOO:** Modified Combined Obstacle Overlay

**MCS:** maneuver control system

**MEA:** munitions effect assessment

**METT-T:** mission, enemy, terrain, troops-time

**MI:** military intelligence

**MOPP:** mission-oriented protective posture

**MOS:** major operating system

**MP:** military police

**MQS:** military qualification standards

**MSE:** mobile subscriber equipment

**MSR:** main supply route

**MTP:** Mission Training Plan

**NAI:** named area of interest

**NAVAID:** navigation aid

**NBC:** nuclear, biological, and chemical

**NCO:** non-commissioned officer

**NFA:** no fire area



**NGO:** Naval Gunfire Officer  
**NLT:** no later than  
**NTC:** National Training Center  
**NVG:** night vision goggles

**OB:** order of battle  
**OC:** observer/controller  
**OI :** operations and intelligence  
**OPCON:** operational control  
**OPORD:** operations order  
**OPSEC:** operational security  
**OR:** operational readiness

**PA:** position area  
**PAC:** Personnel and Administration Center  
**PADS:** position azimuth determining system  
**PGM:** precision guided munitions  
**PIR:** priority intelligence requirements  
**PIREPS:** pilot reports  
**POC:** point of contact  
**POL:** petroleum, oils, and lubricants  
**PSYOPS:** psychological operations

**R&S:** reconnaissance and surveillance  
**RAAMS:** remote antiarmor mine system  
**RAP:** rocket assisted projectile  
**REC:** radio electronic combat  
**REMS:** remotely employed sensors  
**RFA:** restricted fire area  
**RFL:** restrictive fire line  
**RISTA:** reconnaissance, intelligence, surveillance and target acquisition  
**ROA:** restricted operations area  
**ROE:** rules of engagement  
**RPV:** remotely piloted vehicle  
**RSR:** required supply rate

**S1:** Adjutant/Personnel Officer, Brigade and Battalion Staff  
**S2:** Intelligence Officer, Brigade and Battalion Staff  
**S3:** Operations and Training Officer, Brigade and Battalion Staff  
**S4:** Supply/Logistics Officer, Brigade and Battalion Staff  
**SAAFR:** standard-use Army aircraft flight routes  
**SALT:** supporting arms liason team  
**SALUTE:** size, activity, location, unit, time, equipment

**SEAD:** suppression of enemy air defenses  
**SEMA:** Special Electronic Mission Aircraft  
**SIGINT:** signals intelligence  
**SIF:** selective identification feature  
**SITREPS:** situation reports  
**SIT TEMP:** situation template  
**SLAR:** side-looking laser radar  
**SME:** subject matter experts  
**SO:** signal officer  
**SOF:** special operations forces

**SOP:** standing operating procedures

**TA:** task analysis  
**TACFIRE:** tactical fire direction system  
**TACP:** tactical command post  
**TACSOP:** tactical standard operating procedures  
**TAI:** target area of interest  
**TM:** technical manual  
**TOC:** tactical operations center  
**TOT:** time on target  
**TOW:** tube-launched, optically tracked, wire-guided missile  
**TPL:** time-phase line  
**TRADOC:** Training and Doctrine Command  
**TRP:** target-reference point  
**TSS:** target selection standards  
**TTP:** tactics, techniques, and procedures  
**TVA:** target value analysis

**UAV:** unmanned aerial vehicle  
**UBL:** unit basic load  
**USAF:** United States Air Force  
**USMC:** United States Marine Corps  
**USN:** United States Navy

**WAN:** Wide Area Network  
**WARNO:** Division Warning Order

**XO:** Executive Officer