

**PEER REVIEW
COORDINATING DRAFT**

**TASK ANALYSIS
FOR**

**PROVIDE DECONTAMINATION
(CRITICAL COMBAT FUNCTION 27)**

AS ACCOMPLISHED BY A BATTALION TASK FORCE

Author: **DESMOND W. FLANIGAN**, *PRC, Inc.*

Submitted by Harold Wagner, Acting Chief
Unit-Collective Training Research Unit
and
Jack Hiller, Director
Training Systems Research Division
and
Mr. Michael R. McCluskey,
Contracting Officer's Technical Representative



U.S. Army Research Institute

Prime Contractor: **BDM Federal, Inc.**
W. J. Mullen, III

POC: Bartholomew J. McIlroy, Jr.,
BDM Federal Inc., (408) 372-3329

Program Director: **Thomas J. Lewman**
BDM Federal, Inc.

DTIC QUALITY INSPECTED 3

November 23, 1993

19960916 058

DISTRIBUTION STATEMENT A
Approved for public release;
Distribution Unlimited

**Task Analysis for Provide Decontamination
as Accomplished by a Battalion Task Force.
Critical Combat Function 27 (CCF 27)**

Desmond W. Flanigan

BDM Federal, Inc.

This report is published to meet legal and contractual requirements and may not meet ARI's scientific or professional standards for publication.

August 1996

United States Army Research Institute for the Behavioral and Social Sciences

Approved for public release; distribution is unlimited.

U.S. ARMY RESEARCH INSTITUTE FOR THE BEHAVIORAL AND SOCIAL SCIENCES

A Field Operating Agency Under the Jurisdiction
of the Deputy Chief of Staff for Personnel

EDGAR M. JOHNSON
Director

NOTICES

DISTRIBUTION: This report has been cleared for release to the Defense Technical Information Center (DTIC) to comply with regulatory requirements. It has been given no primary distribution other than to DTIC and will be available only through DTIC or the National Technical Information Service (NTIS).

FINAL DISPOSITION: This report may be destroyed when it is no longer needed. Please do not return it to the U.S. Army Research Institute for the Behavioral and Social Sciences.

NOTE: The views, opinions and findings in this report are those of the author(s) and should not be construed as an official Department of the Army position, policy, or decision, unless so designated by other authorized documents.

REPORT DOCUMENTATION PAGE

Form Approved
OMB No. 0704-0188

Public reporting burden for this collection of information is estimated to average 1 hour per response, including the time for reviewing instructions, searching existing data sources, gathering and maintaining the data needed, and completing and reviewing the collection of information. Send comments regarding this burden estimate or any other aspect of this collection of information, including suggestions for reducing this burden, to Washington Headquarters Services, Directorate for Information Operations and Reports, 1215 Jefferson Davis Highway, Suite 1204, Arlington, VA 22202-4302, and to the Office of Management and Budget, Paperwork Reduction Project (0704-0188), Washington DC 20503.

1. AGENCY USE ONLY (Leave blank)	2. REPORT DATE August 1996	3. REPORT TYPE AND DATES COVERED Interim Report 07/17/92 - 03/15/96	
4. TITLE AND SUBTITLE Task Analysis for Provide Decontamination as Accomplished by a Battalion Task Force Critical Combat Function ²⁷ (CCF 27)		5. FUNDING NUMBERS MDA903-92-D-0075-0005 3414 CO1 665803 D730	
6. AUTHOR(S) Desmond W. Flanigan			
7. PERFORMING ORGANIZATION NAME(S) AND ADDRESS(ES) BDM FEDERAL INC. DOD CENTER MONTEREY BAY 400 GIGLING ROAD SEASIDE, CA 93955		8. PERFORMING ORGANIZATION REPORT NUMBER	
9. SPONSORING/MONITORING AGENCY NAME(S) AND ADDRESS(ES) U.S. ARMY RESEARCH INSTITUTE FOR THE BEHAVIORAL AND SOCIAL SCIENCES 5001 EISENHOWER AVENUE ALEXANDRIA, VA 22333-5600		10. SPONSORING/MONITORING AGENCY REPORT NUMBER Contractor Report 96-45	
11. SUPPLEMENTARY NOTES The COR is Michael R. McCluskey. This report is published to meet legal and contractual requirements and may not meet ARI's scientific or professional standards for publication.			
12a. DISTRIBUTION/AVAILABILITY STATEMENT APPROVED FOR PUBLIC RELEASE; DISTRIBUTION IS UNLIMITED.		12b. DISTRIBUTION CODE	
13. ABSTRACT (Maximum 200 words) The purpose of CCF 27 is TF personnel, equipment and supplies, as well as, working areas needed to accomplish the mission are made safe. The TF is fully prepared for the tactical mission and can readily conduct decontamination activities without degrading its ability to accomplish the mission. The outcomes include: 1) Individual soldiers/operators perform basic decontamination to standard: Skin decontamination, Personal wipedown, Operators spray down. 2) Unit performs hasty decontamination to standard: MOOP gear exchange, Vehicle washdown, Site cleanup, Site marking, Report decon status. 3) Unit performs deliberate decontamination to standard: Coordination for decontamination, Detailed soldier decontamination, Site cleanup, Report decon status. 4) Contaminated units are restored to full combat potential with minimum delay.			
14. SUBJECT TERMS decontamination of individual soldiers and equipment, decontamination of weapon systems and supplies, hasty and deliberate decontamination		15. NUMBER OF PAGES	
		16. PRICE CODE	
17. SECURITY CLASSIFICATION OF REPORT UNCLASSIFIED	18. SECURITY CLASSIFICATION OF THIS PAGE UNCLASSIFIED	19. SECURITY CLASSIFICATION OF ABSTRACT UNCLASSIFIED	20. LIMITATION OF ABSTRACT UNLIMITED

INDEX

**CRITICAL COMBAT FUNCTION 27
PROVIDE DECONTAMINATION**

Preface----- ii

Index of Critical Combat Functions (CCF)----- 1

Structure of Critical Combat Functions-----2

Outcomes and Purpose of CCF 27----- 11

Flow Charts by Battle Phase (Plan)----- 12

Other CCF Which Interact with CCF 27----- 16

CCF 27 Key Participants by Task----- 19

Key Inputs and Outputs to CCF 27 ----- 23

Task List Summary for CCF 27----- 27

Planning Task List----- 30

Preparation Task List----- 33

Execution Task List----- 35

CALL Lessons Learned Relevant to CCF 27----- 42

Lessons Learned Integrated into CCF 27 Task List ----- 49

CCF 27 Critical Tasks and Other Linkages----- 57

References----- 60

PREFACE

This task analysis of **Provide Decontamination, Critical Combat Function 27 (CCF 27)**, is an intermediate product of the process of developing a training strategy for the CCF. The analysis reflects tasks, products, players and processes in sequence necessary to conduct decontamination operations in support of a heavy battalion task force and addresses all types of decontamination operations ranging from individual soldier and operator decon through deliberate personnel and equipment decontamination.

CRITICAL COMBAT FUNCTIONS: *The integration of related players and tasks that represent a source of combat power. The synchronization of critical combat functions provides maneuver commanders at any echelon with a definable outcome that materially affects the battle.*

The battle phases **PLAN, PREPARE, and EXECUTE** relate to the entire battalion task force (TF) battle vice phasing for this particular CCF.

This analysis identifies the tasks that the TF Commander, the TF staff, key officers and NCOs and all subordinate and supporting elements of the TF must perform. For analytical purposes, CCF is initiated with the receipt of a Brigade order (WO/FRAGO/OPORD). The analysis identifies tasks beginning with the receipt of the brigade OPORD order (Planning Phase), continues through the preparation of the task force for battle in an NBC environment (Preparation Phase), contamination and decontamination during the ensuing engagement (Execution Phase), and, following the engagement, culminates with the continued decontamination, reconstitution of the TF or its subordinate elements in preparation for a continuation or change of mission.

The analyst has described decontamination following contamination during the Execution Phase; contamination could occur in any or all of the phases of the battle (Plan, Prepare, Execute). Response to contamination will be as depicted in this analysis.

CCF 27, Provide Decontamination, has two primary outcomes: to permit a contaminated unit to continue operations with the minimum interruption, and to return the contaminated unit to full effectiveness as soon as possible. These outcomes are achieved through the decontamination of the individual soldiers and their equipment, and the decontamination of weapon systems and supplies.

This Task Analysis describes the critical tasks necessary to achieve these ends and incorporates the Army's doctrinal decontamination principals and processes. It identifies the affected subordinate and supporting TF elements, their responsibilities and capabilities, from the individual to the TF level. Appropriate coordination and communication responsibilities of/with higher and adjacent supporting elements are delineated.

The following critical processes are necessary for the successful execution CCF 27. These processes must be continuously monitored/ planned and directed by TF leaders and the TF staff: NBC Monitoring; MOPP analysis; wind/weather data collection and awareness; IPB (enemy NBC capabilities, delivery systems, requirements); and manage and monitor the NBC Warning and Reporting System (NBCWARS).

Leaders and staff must continuously evaluate METT-T in all phases of the mission. They must assess the impact of changes in METT-T on their particular area(s) of responsibility. (The monitor/ plan/ direct cycle by leaders and staff is repeated throughout all phases of the mission.)

The TF level tasks are derived from ARTEP 71-2-MTP. The supporting Co/Tm level tasks are derived from ARTEP 71-1-MTP. Based on the concept that the TF commander would focus

on the tasks for the entire TF, the analyst has sequenced similar and supporting tasks by placing the TF level task first, followed immediately by the subordinate or supporting element task (i.e. Co/Tm, separate platoon, DS unit). Since command and control facilities are primary and high payoff targets for enemy NBC attack, the analyst included the specific NBC operations tasks for CPs contained in ARTEP 71-2-MTP.

**INDEX OF
CRITICAL COMBAT FUNCTIONS**
Grouped By Battlefield Operating System (BOS)

INTELLIGENCE	(1)	Conduct Intelligence Planning
	(2)	Collect Information
	(3)	Process Information
	(4)	Disseminate Intelligence
MANEUVER	(5)	Conduct Tactical Movement
	(6)	Engage Enemy with Direct Fire and Maneuver
AIR DEFENSE	(16)	Take Active Air Defense Measures
	(17)	Take Passive Air Defense Measures
FIRE SUPPORT	(7)	Employ Mortars
	(8)	Employ Field Artillery
	(9)	Employ Close Air Support
	(10)	Conduct Electronic Collection and Jamming
	(11)	Conduct Battlefield PsyOps
	(12)	Employ Chemical Weapons
	(13)	Conduct Counter Target Acquisition Operations
	(14)	Employ Naval Gunfire
(15)	Coordinate, Synchronize and Integrate Fire Support	
MOBILITY AND SURVIVABILITY	(21)	Overcome Obstacles
	(22)	Enhance Movement
	(23)	Provide Countermobility
	(24)	Enhance Physical Protection
	(25)	Provide Operations Security
	(26)	Conduct Deception Operations
	(27)	Provide Decontamination
COMMAND AND CONTROL	(18)	Plan for Combat Operations
	(19)	Direct and Lead Unit During Preparation for the Battle
	(20)	Direct and Lead Units in Execution of Battle
COMBAT SERVICE SUPPORT	(28)	Provide Transport Services
	(29)	Conduct Supply Operations
	(30)	Provide Personnel Services
	(31)	Maintain Weapons Systems and Equipment
	(32)	Provide Health Services
	(33)	Treat and Evacuate Battlefield Casualties
	(34)	Conduct Enemy Prisoners of War (EPW) Operations
	(35)	Conduct Law and Order Operations
	(36)	Conduct Civil Affairs Operations
	(37)	Provide Sustainment Engineering
	(38)	Evacuate Non-combatants from Area of Operations
(39)	Provide Field Services	

STRUCTURE OF CRITICAL COMBAT FUNCTIONS RELEVANT TO BATTALION TASK FORCE OPERATIONS

CRITICAL COMBAT FUNCTION: *The integration of related players and tasks that represent a source of combat power. The synchronization of critical combat functions provides maneuver commanders at any echelon with a definable outcome that materially affects the battle.*

- I. **Intelligence BOS** — The ways and means of acquiring, analyzing and using knowledge of the enemy, weather and terrain required by a commander in planning, preparing and conducting combat operations. These CCF are continuous throughout the planning, preparation and execution phases of the battle.
 1. **CCF (1) Conduct Intelligence Planning** — The development and coordination of information relative to the enemy, weather and terrain prior to and during the development of the unit OPORD; the planning to collect information from battlefield sources and to acquire intelligence from other headquarters. Focus of this CCF is the Intelligence Preparation of the Battlefield (IPB). This CCF addresses:
 - a. Reconnaissance and Surveillance plan.
 - b. Integrated threat templates (doctrinal; event; input to DST).
 - c. Terrain and Weather analysis.
 2. **CCF (2) Collect Information** — Obtaining information in any manner from TF elements and from sources outside the TF (e.g., higher headquarters; adjacent units); this CCF includes the tasks associated with managing the processes and activities necessary to collect battlefield information which may eventually be used to provide intelligence relative to the enemy, terrain and weather. This CCF addresses:
 - a. Information collected as a result of R & S plan.
 - b. Continuous information collection and acquisition from all sources.
 3. **CCF (3) Process Information** — The conversion of information into intelligence through collation, evaluation, analysis, integration and interpretation in a continual process. This CCF addresses:
 - a. Evaluation of threat information.
 - b. Evaluation of physical environment information.
 - c. Integration of intelligence information.
 - d. Development of enemy intentions.
 - e. Development of targeting information.
 - f. Preparation of intelligence reports.
 - g. Update of situational template.
 - h. Provision of battlefield area reports.
 4. **CCF (4) Disseminate Intelligence** — Transmission of information by any means (verbal, written, electronic etc.), from one person or place to another to provide timely dissemination of critical intelligence to all appropriate members of the combined arms team. This CCF addresses:
 - a. The sending of processed intelligence in a timely manner to those on the combined arms team who can by its receipt, take appropriate actions to accomplish the mission. This includes intelligence on the enemy, terrain and weather.

- b. The sending of raw intelligence directly from those responsible for reconnaissance and surveillance to the commander should that raw intelligence be time sensitive (and not be subject to receipt and processing by intelligence analysts).
- c. Dissemination of battlefield reports.

II. **Maneuver BOS** — The employment of direct fire weapons, platforms and systems through movement and fire and maneuver to achieve a position of advantage in respect to enemy ground forces, in order to accomplish the mission. The direct fire weapons are: tank guns; BFV 25mm; anti-tank guns and rockets; attack helicopter guns and rockets; small arms; crew served weapons; directed energy weapons systems.

1. **CCF (5) Conduct Tactical Movement** — Position direct fire weapons systems relative to the enemy to secure or retain positional advantage making full use of terrain and formations. Tactical movement occurs when contact with the enemy is likely or imminent but direct fire engagement has not yet occurred. Units supporting maneuver units are included. This CCF addresses:

- a. Subordinate element OPORD preparation and dissemination.
- b. Preparation for movement.
- c. Movement, mounted and dismounted; on and off road.
- d. Closure of movement — tactical assembly area; tactical positions.
- e. Navigation.
- f. Force protection.
- g. Air movement.

2. **CCF (6) Engage Enemy with Direct Fire and Maneuver** — Entering into ground combat with the enemy using direct fire and/or close combat in order to destroy the enemy or cause him to withdraw. This CCF relates only to those direct fire weapons systems associated with the Maneuver BOS. This CCF is initiated with the OPORD at the completion of the planning phase of the battle and includes all tasks associated with subordinate echelon planning, preparation and execution of the battle. This CCF addresses:

- a. Subordinate element OPORD preparation and dissemination.
- b. Preparation of engagement areas.
- c. Rehearsals of battle plans.
- d. Pre-combat prepare to fire checks.
- e. Target acquisition.
- f. Fire control and distribution.
- g. Fratricide.
- h. Conduct close combat.
- i. Integration of direct fire with maneuver.
- j. Control of terrain.
- k. Prestocked ammunition.
- l. Resupply during operations.
- m. Maintenance during operations.
- n. Consolidation and reorganization.

III. **Fire Support BOS** — The collective, coordinated, and synchronized use of target acquisition data, indirect fire weapons, armed aircraft (less attack helicopters) and other lethal and non-lethal means against ground targets in support of maneuver force operations and to achieve the commanders intent and scheme of maneuver. The Fire Support BOS

addresses these weapons: mortars; field artillery; close air support; electronic measures; naval gunfire.

1. **CCF (7) Employ Mortars** — Employment of mortars by the maneuver unit to place fires on the enemy or terrain to support the commander's concept and intent. This CCF initiates with the receipt of an OPORD by the maneuver commander and address those tasks required during the preparation and execution phases of the battle. This CCF addresses:
 - a. Subordinate element OPORD preparation and dissemination.
 - b. Prepare to fire checks.
 - i. Rehearsals.
 - c. Pre-combat checks.
 - d. Development of order to fire.
 - e. Tactical movement.
 - f. FDC operations.
 - g. Target engagements with illumination, smoke, HE.
 - h. Sustainment operations.

2. **CCF (8) Employ Field Artillery** — The ways and means employed by the maneuver unit to cause indirect artillery fires to be placed on the enemy or terrain to support the commander's concept and intent. This CCF initiates upon receipt of an OPORD by the maneuver commander and includes tasks performed during the preparation and execution phases of the battle. The Fire Support Coordination tasks necessary to integrate the field artillery and the maneuver units are the primary focus. This CCF does not address those field artillery tasks associated directly with those actions taken by the batteries of the artillery battalion in the conduct of their support mission such as FDC operations, gun operations, etc. This CCF addresses:
 - a. Fire Support — Maneuver unit rehearsals.
 - b. FSE operations during the preparation and execution phase of the battle.
 - c. FSO and FIST operations in coordination with their maneuver commander.
 - d. Positioning and movement within the maneuver unit sector or zone.
 - e. Indirect fire missions in support of maneuver commander's concept and intent.
 - f. Sustainment operations.
 - g. Indirect fire planning as battlefield METT-T change.

3. **CCF (9) Employ Close Air Support** — Planning for, requesting and employing armed aircraft (less attack helicopters) in coordination with other fire support (lethal and non-lethal) against ground targets in support of the maneuver force commander's concept and intent. This CCF addresses:
 - a. Air-ground attack requests.
 - b. Air space coordination and management.
 - c. Air Liaison Officer, Forward Air Controller; other Army Fire Support Coordination Officer; USN/USMC Bde Team Commander, SALT-O and FCT-O tasks that enable air to ground attacks.

4. **CCF (10) Conduct Electronic Collection and Jamming** — Actions taken to deny the enemy effective command, control and communications of his own tactical force in support of maneuver commander's concept and intent. This CCS includes jamming, deception, and collection.

5. **CCF (11) Conduct Battlefield PsyOps** — Conduct psychological activities as an integral part of combat operations to bring psychological pressure to bear on enemy

forces and civilians under enemy control in the battle area, to assist in the achievement of tactical objectives in support of maneuver commander's concept and intent.

6. **CCF (12) Employ Chemical Weapons** — Employ chemical agents or other means to degrade enemy capabilities in support of maneuver commander's concept and intent.
 7. **CCF (13) Conduct Counter Target Acquisition Operations** — Suppress (e.g. using smoke or dazzling illumination) or degrade enemy direct observation, optics, radar, sensors, electronic DF equipment, and imaging systems in support of maneuver commander's concept and intent.
 8. **CCF (14) Employ Naval Gunfire** — The means and ends to provide naval gunfire in support of the maneuver commander's tactical operation.
 9. **CCF (15) Coordinate, Synchronize and Integrate Fire Support** — Coordination of all fire support means in support of the maneuver commanders concept and intent. This CCF addresses the preparation and execution of tasks necessary to integrate the fire support detailed in the OPORD. The CCF integrates CCF 7-14 in support of maneuver commander's concept and intent.
- IV. **Air Defense BOS** — The means and measures organic or assigned to the maneuver commander which when employed successfully will nullify or reduce the effectiveness of attack by hostile aircraft or missiles after they are airborne.
1. **CCF (16) Take Active Air Defense Measures** — Application of firepower to destroy enemy air targets. This CCF addresses the coordinating tasks which enable the maneuver commander to successfully employ any attached or assigned air defense weapons system as well as the tasks necessary to employ all organic weapons systems against enemy air targets. This CCF addresses:
 - a. Employment of Air Defense Artillery guns and missiles.
 - b. Employment of maneuver unit weapons systems such as small arms, automatic weapons, BFV 25 mm and TOW missiles, tank main gun against enemy air.
 - c. Airspace management.
 - d. Early warning.
 - e. Sustainment.
 2. **CCF (17) Take Passive Air Defense Measures** — The protection of the maneuver force from enemy air by means other than weapons. This CCF will focus on the preparation and execution phases of the battle. This CCF addresses:
 - a. Early warning.
 - b. Dispersion.
 - c. Cover and concealment.
 - d. Air watch.
 - e. Deception.
- V. **Command and Control BOS** — The way and means a maneuver commander exercises authority and direction over organic and assigned combat power in the accomplishment of the mission.

1. **CCF (18) Plan for Combat Operations** — The integration of all members of the combined arms team in the coordinated development of the maneuver unit Operations Order which will guide the activities of the combined arms team in conducting combat operations to accomplish assigned missions. The product/outcome of this CCF is a briefed, understood OPORD. This CCF addresses:
 - a. Receipt and analysis of higher HQ OPORD.
 - b. Issuance of Warning Order.
 - c. Restated mission statement.
 - d. Commander's estimate process/troop leading procedures.
 - e. Commander's guidance.
 - f. Mission analysis (includes course of action development).
 - g. Decision brief to commander.
 - h. Development of a synchronized OPORD.
 - i. Reproduction and distribution of OPORD to all participants.
 - j. Briefing of OPORD; understanding of order by participants.
 - k. FRAGO planning and issue.

2. **CCF (19) Direct and Lead Unit during Preparation for the Battle** — The ways and means to prepare combined arms task force for the battle so that the combined arms task force is ready to support the maneuver commander's concept and intent. This CCF addresses:
 - a. Commander's activities.
 - b. Communicating information.
 - c. Briefbacks and backbriefs.
 - d. Rehearsals.
 - e. Management of the means of communicating information.
 - f. Maintaining and updating information and force status.
 - g. Managing information distribution.
 - h. Decisions to act or change ongoing actions.
 - i. Confirming IPB through the reconnaissance effort.
 - j. Determining actions to implement decisions.
 - k. Providing command presence.
 - l. Maintaining unit discipline.
 - m. Synchronizing tactical operations (e.g., execution matrix DST).
 - n. TOC operations (e.g., staff integration and battle tracking).
 - o. Continuity of command.
 - p. Second in command (2IC responsibilities).
 - q. Continuous and sustained operations.
 - r. Communications (e.g., planning, installation and operation of system, management, site selection).

3. **CCF (20) Direct and Lead Units In Execution of Battle** — The ways and means to command and control in the combined arms task force execution of the battle plan (engaging the enemy in battle) to accomplish the maneuver commander's concept and intent. This CCF addresses:
 - a. Directing the conduct of the battle.
 - b. Issue orders.
 - c. Command presence.
 - d. Information distribution.
 - e. Decide on need for action or change.
 - f. Maintaining unit discipline.
 - g. Synchronizing tactical operations.

- h. TOC operations (includes CP displacement, security, survivability).
- i. Continuity of command (e.g., C2 redundancy).
- j. Second in command (2IC) responsibilities.
- k. Continuous and sustained operations.
- l. Consolidation and reorganization.

- VI. **Mobility and Survivability BOS** — The ways and means of the force that permit freedom of movement, relative to the enemy, while retaining the task force ability to fulfill its primary mission as well as the measures the force takes to remain viable and functional by protection from the effects of enemy weapons systems and natural occurrences.
1. **CCF (21) Overcome Obstacles** — Enabling the maneuver force to maintain its mobility by removing or clearing/reducing natural and man-made obstacles. This CCF will initiate after receipt of the OPORD and address subordinate echelon planning as well as task force preparation and execution tasks necessary to achieve the maneuver commander's concept and intent. This CCF addresses:
 - a. Breach obstacle. Clearing a path or lane for personnel and equipment through a battlefield obstacle.
 - b. Cross gaps. Passing through or over any battlefield terrain feature, wet or dry, that is too wide to be overcome by organic/self bridging.
 2. **CCF (22) Enhance movement** — Provision of adequate mobility for the maneuver unit in its area of operations. This CCF addresses:
 - a. Construction and repair of combat roads and trails.
 - b. Construction or repair of forward airfields.
 - c. Facilitating movement on routes. (This includes control of road traffic and control of refugees and stragglers.)
 - d. Tracking status of routes.
 - e. Host nation support.
 3. **CCF (23) Provide Countermobility** — Delaying, channeling, or stopping offensive movement by the enemy consistent with the commander's concept and intent by enhancing the effectiveness of friendly direct and indirect weapons systems. This CCF addresses:
 - a. Emplacement of mines and complex obstacles.
 - b. Digging tank ditches.
 - c. Creation of road craters with explosives.
 - d. Terrain enhancement.
 4. **CCF (24) Enhance Physical Protection** — Providing protection of friendly forces on the battlefield by enhancing the physical protection of personnel, equipment and weapons systems, and supplies. This CCF addresses:
 - a. Construction of fighting positions.
 - b. Preparation of protective positions.
 - c. Employment of protective equipment.
 5. **CCF (25) Provide Operations Security** — Denying information to the enemy about friendly capabilities and intentions by identifying, controlling, and protecting indicators associated with planning and conducting military operations. This CCF addresses:

- a. Analysis to determine key assets and threats to them.
 - b. Cover and concealment.
 - c. Camouflage.
 - d. Noise and light discipline.
 - e. Counter reconnaissance.
 - f. Smoke/obscurants.
 - g. Physical security measures.
 - h. Signal security.
 - i. Electronic security.
6. **CCF (26) Conduct Deception Operations** — Taking actions to mask the real objectives of tactical operations in order to delay effective enemy reaction. This CCF addresses:
- a. Physical deception.
 - b. Electronic deception.
7. **CCF (27) Provide Decontamination** — Making any person, object or area safe by absorbing, destroying, neutralizing, making harmless or removing chemical or biological agents, or by removing radioactive material. This CCF addresses:
- a. Decontamination of individual soldiers and equipment.
 - b. Decontamination of weapon systems and supplies.
 - c. Hasty and deliberate decontamination.
- VII. **Combat Service Support BOS** — The support, assistance and service provided to sustain forces, primarily in the area of logistics, personnel services and health services.
1. **CCF (28) Provide Transport Services** — Providing or coordinating for transportation which will assure sustainment support operations in support of the maneuver commander. Upon receipt of an OPORD, this CCF addresses preparation and execution tasks necessary to achieve transportation support of the maneuver force. This CCF addresses:
 - a. Movement of cargo, equipment and personnel by surface or air.
 - b. Loading, transloading and unloading material and supplies.
 2. **CCF (29) Conduct Supply Operations** — Providing the items necessary to equip, maintain and operate the force during the preparation and execution phases of the battle. This CCF addresses:
 - a. Requesting, receiving, procuring, storing, protecting, relocating and issuing supplies to the specific elements of the force.
 - b. Providing munitions to weapons systems.
 - c. Providing fuel and petroleum products to equipment and weapons systems.
 - d. Reporting status.
 3. **CCF (30) Provide Personnel Services** — Management and execution of all personnel-related matters to sustain the force. This CCF addresses:
 - a. Personnel Administrative Services.
 - 1) Replacement, casualty reporting.
 - 2) Awards and decorations.

- 3) Postal Operations.
 - 4) Promotions, reductions.
 - b. Financial services.
 - c. Unit Ministry team.
 - d. Legal.
 - e. Public Affairs.
 - f. Reporting personnel status.
 - g. Preservation of the force through safety.
 - h. Management of stress.
4. **CCF (31) Maintain Weapons Systems and Equipment** — Preservation and repair of weapons systems and equipment. This CCF includes the provision of repair parts and end items to all members of the combined arms team before, during and after the battle. Included also is doctrinal echeloning of maintenance (organization, DS, GS). This CCF addresses:
- a. Preventative Maintenance.
 - b. Recovery.
 - c. Diagnosis, substitution, exchange, repair and return of equipment and weapons systems to the combined arms force.
 - d. Reporting status.
5. **CCF (32) Provide Health Services** — Performance, provision or arrangement for health services regardless of location, to promote, improve, conserve or restore the mental or physical well-being of individuals or groups. This CCF addresses
- a. Preventive medicine.
 - b. Field sanitation.
6. **CCF (33) Treat and Evacuate Battlefield Casualties** — Application of medical procedures on battlefield casualties beginning with "buddy aid" through trained medical personnel. The CCF includes movement of casualties from the forward edge of the battlefield back to division-level medical facilities. This CCF addresses:
- a. Triage of battlefield casualties.
 - b. Treatment and movement of casualties to rear (medevac).
 - 1) Identification of levels of care and locations.
 - 2) Synchronization and coordination of movement of medical facilities to ensure continuity of care.
 - 3) Establishment and maintenance of communications with redundant means.
 - 4) Rehearsals.
 - 5) Resupply.
 - c. Evacuation:
 - 1) Ground ambulance.
 - 2) Aero medevac.
 - 3) Non-standard evacuation.
 - d. Handling and processing the remains of soldiers who have died of wounds.
 - e. Reporting status.
7. **CCF (34) Conduct Enemy Prisoners of War (EPW) Operations** — The collection, processing, evacuation and safeguarding of enemy prisoners of war. This CCF addresses:
- a. Collecting and evacuating EPW.
 - b. Searching, segregating, safeguarding, silencing, and rapid rearward movement of EPW.

8. **CCF (35) Conduct Law and Order Operations** — Enforcement of laws and regulations and maintenance of units and personnel discipline.
9. **CCF (36) Conduct Civil Affairs Operations** — Conduct of those phases of the activities of a tactical commander which embrace the relationship between the military forces and civil authorities, and the citizens in a friendly or occupied country or area when U.S. military forces are present.
10. **CCF (37) Provide Sustainment Engineering** — The repair and construction of facilities and lines of communication. This CCF addresses:
 - a. Rear area restoration.
 - b. Construction and maintenance of lines of communication (roads, railroads, ports, airfields).
 - c. Construction support:
 - 1) Marshaling, distribution and storage facilities.
 - 2) Pipelines.
 - 3) Fixed facilities.
 - 4) Drill wells.
 - 5) Dismantlement of fortifications.
11. **CCF (38) Evacuate Non-combatants from Area of Operations** — The use of available military and host-nation resources for the evacuation of US forces, dependents, US government civilian employees, and private citizens (US and other). This CCF addresses:
 - a. Medical support.
 - b. Transportation.
 - c. Security.
 - d. Preparation of temporary shelters.
 - e. Operation of clothing exchange facilities.
 - f. Operation of bathing facilities.
 - g. Graves registration.
 - h. Laundry.
 - i. Feeding.
12. **CCF (39) Provide Field Services** — Performance of service logistics functions by and for Army elements in the field. This CCF addresses:
 - a. Clothing exchange.
 - b. Bathing facilities.
 - c. Graves registration.
 - d. Laundry and clothes renovation.
 - e. Bakeries.
 - f. Feeding (rations supply, kitchens).
 - g. Salvage.

OUTCOMES AND PURPOSE OF CCF 27

OUTCOMES

1. Individual soldiers/operators perform basic skills decontamination to standard.
 - Skin decontamination
 - Personal wipedown
 - Operators spray down
2. Unit performs hasty decontamination to standard.
 - MOPP gear exchange
 - Vehicle washdown
 - Site cleanup
 - Site marking
 - Report decon status
3. Unit performs deliberate decontamination to standard.
 - Coordination for decontamination
 - Detailed soldier decontamination
 - Detailed equipment decontamination
 - Site cleanup
 - Report decon status
4. Contaminated units are restored to full combat potential with minimum delay.

PURPOSE

TF personnel, equipment, and supplies as well as working areas needed to accomplish the mission are made safe. The TF is fully prepared for the tactical mission and can readily conduct decontamination activities without degrading its ability to accomplish the mission.

TASK FLOW PLAN

CORPS/DIV

BDE

TF

CO/TM
PLATOONS

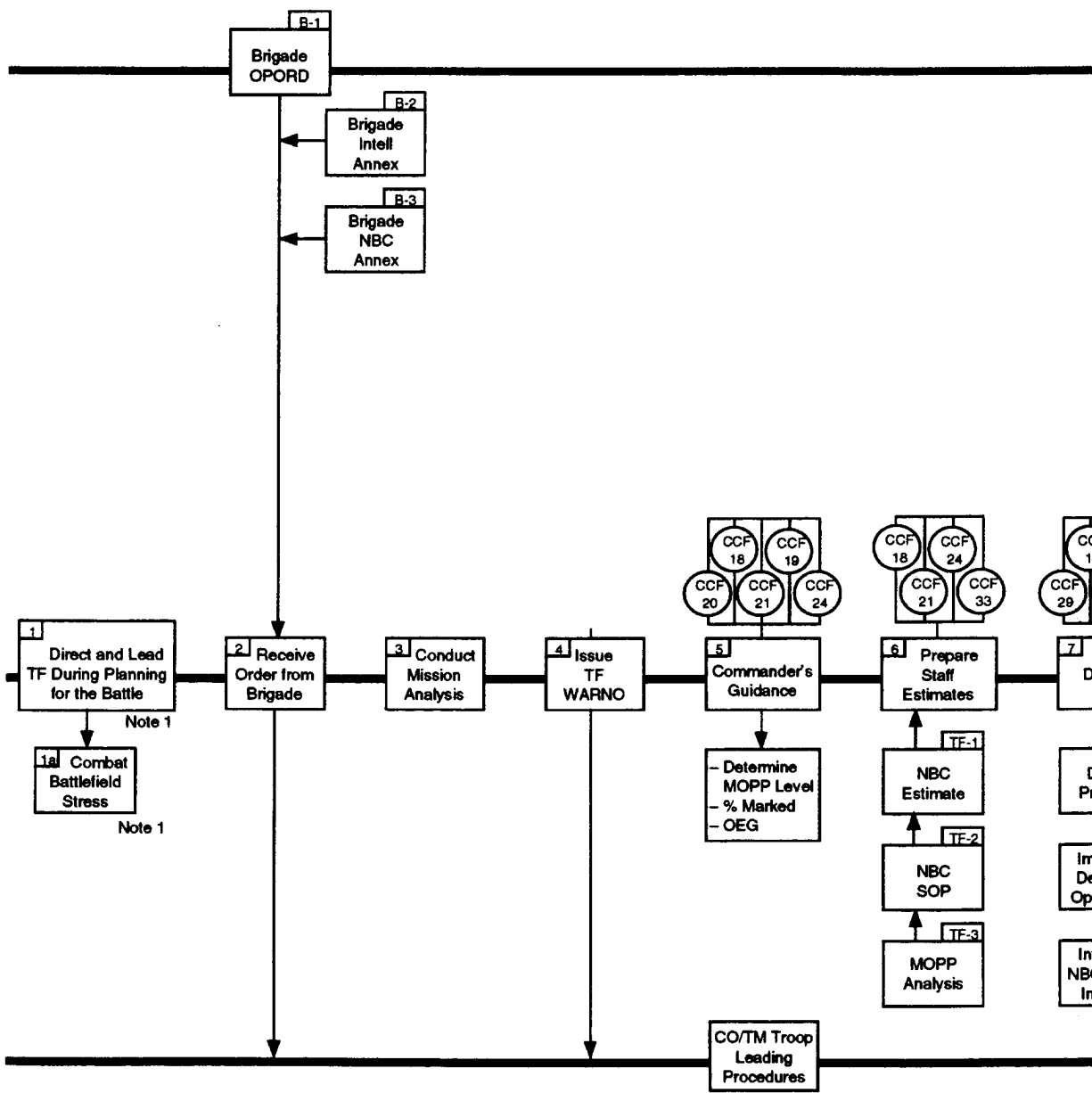

Note 1: Continuous Task CCF 18, 19, 20.

○ CCF □ (outside) Input or Output (inside) Task

TASK FLOW PLAN

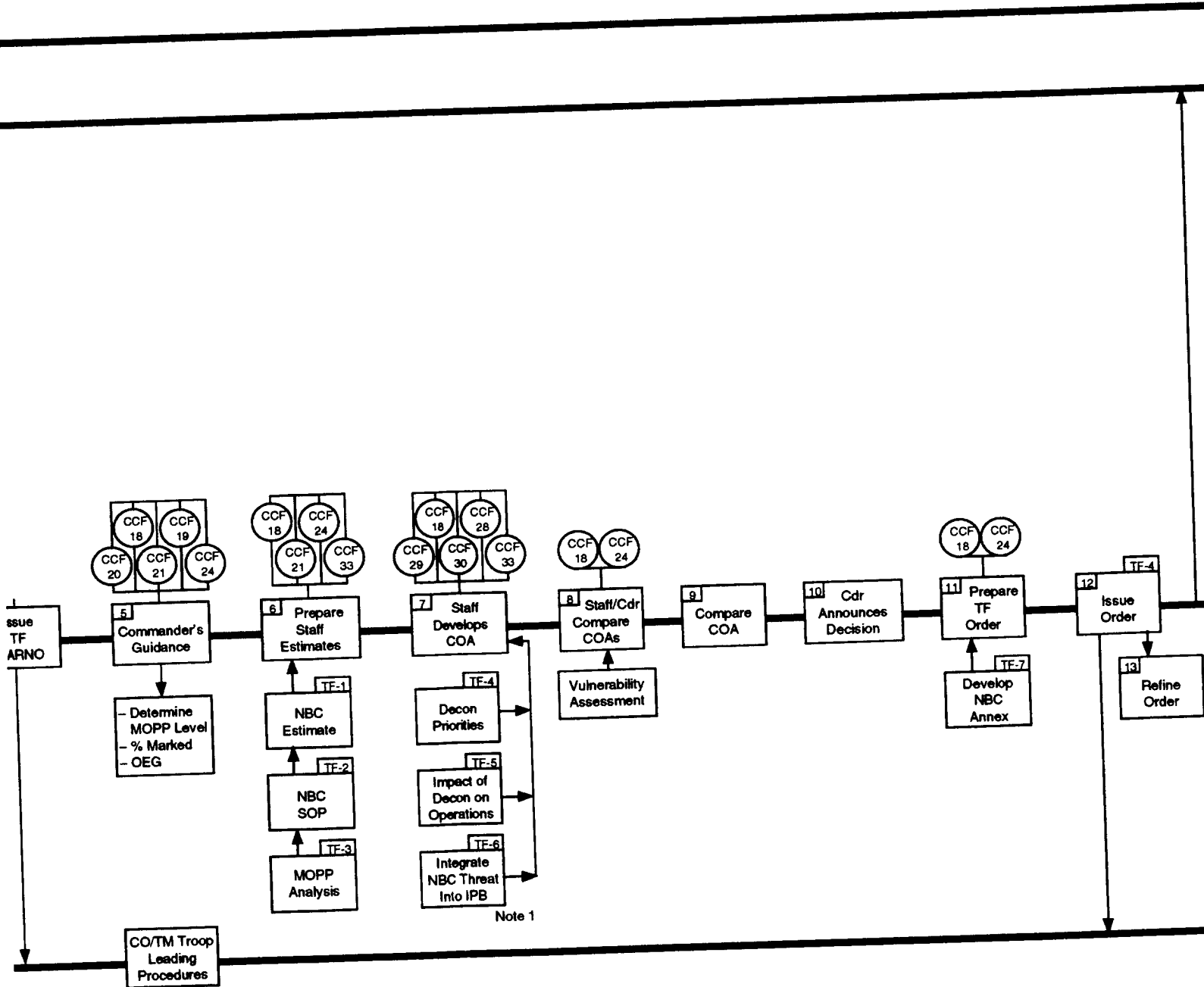

CCF 27 — Provide Decontamination

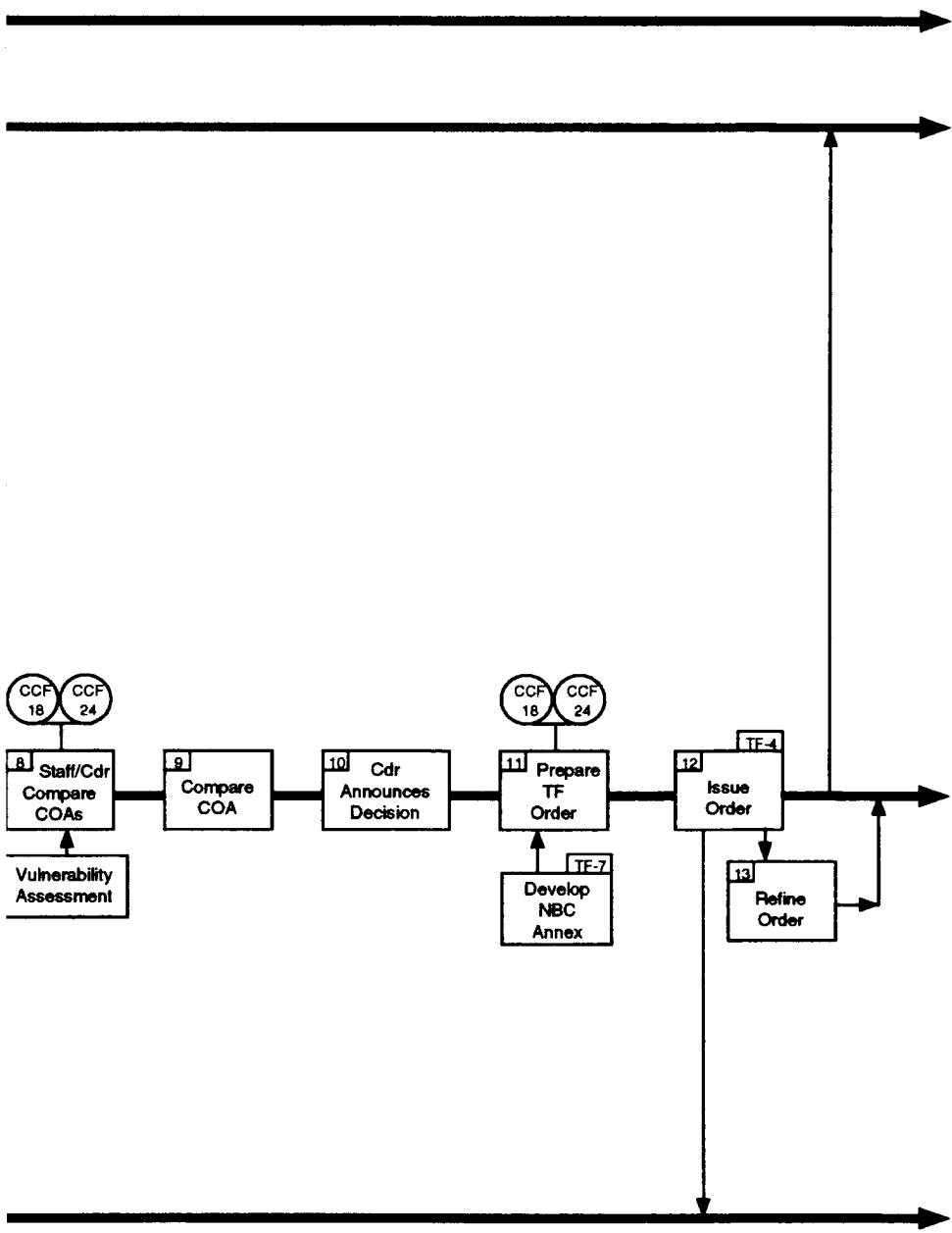

November 23, 1993

TASK FLOW PREPARE

CORPS/DIV

BDE

TF

CO/TM
PLATOONS

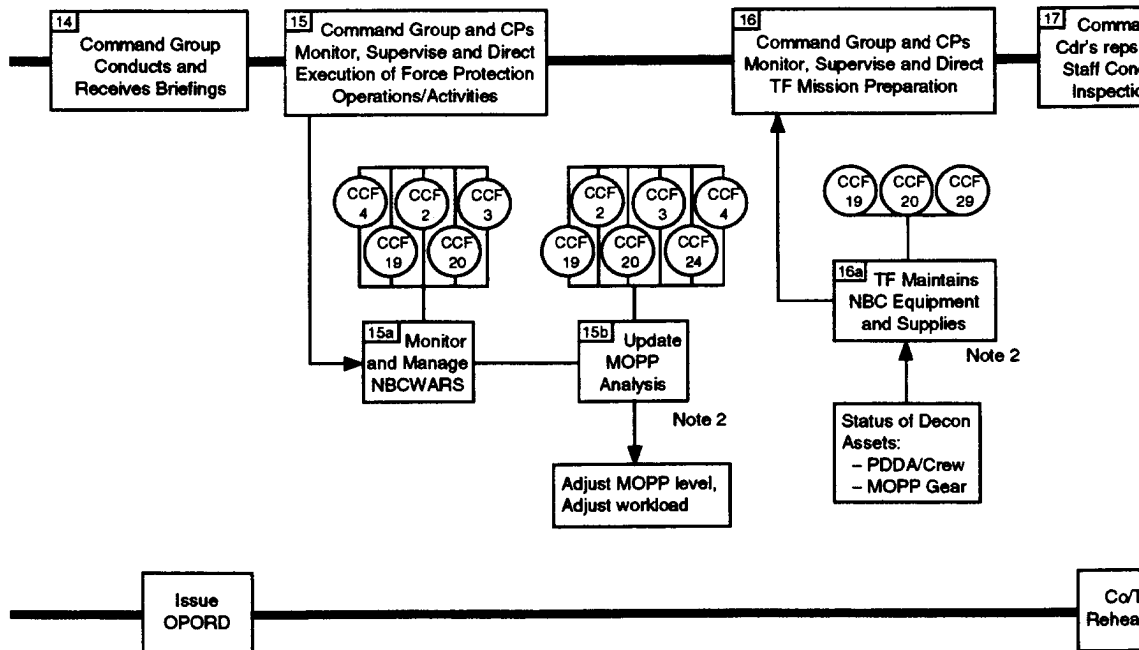

Note 2: Continuous Task - Integral task to CCF 19 and 20.

○ CCF □ (outside) Input or Output
 □ (inside) Task

TASK FLOW PREPARE

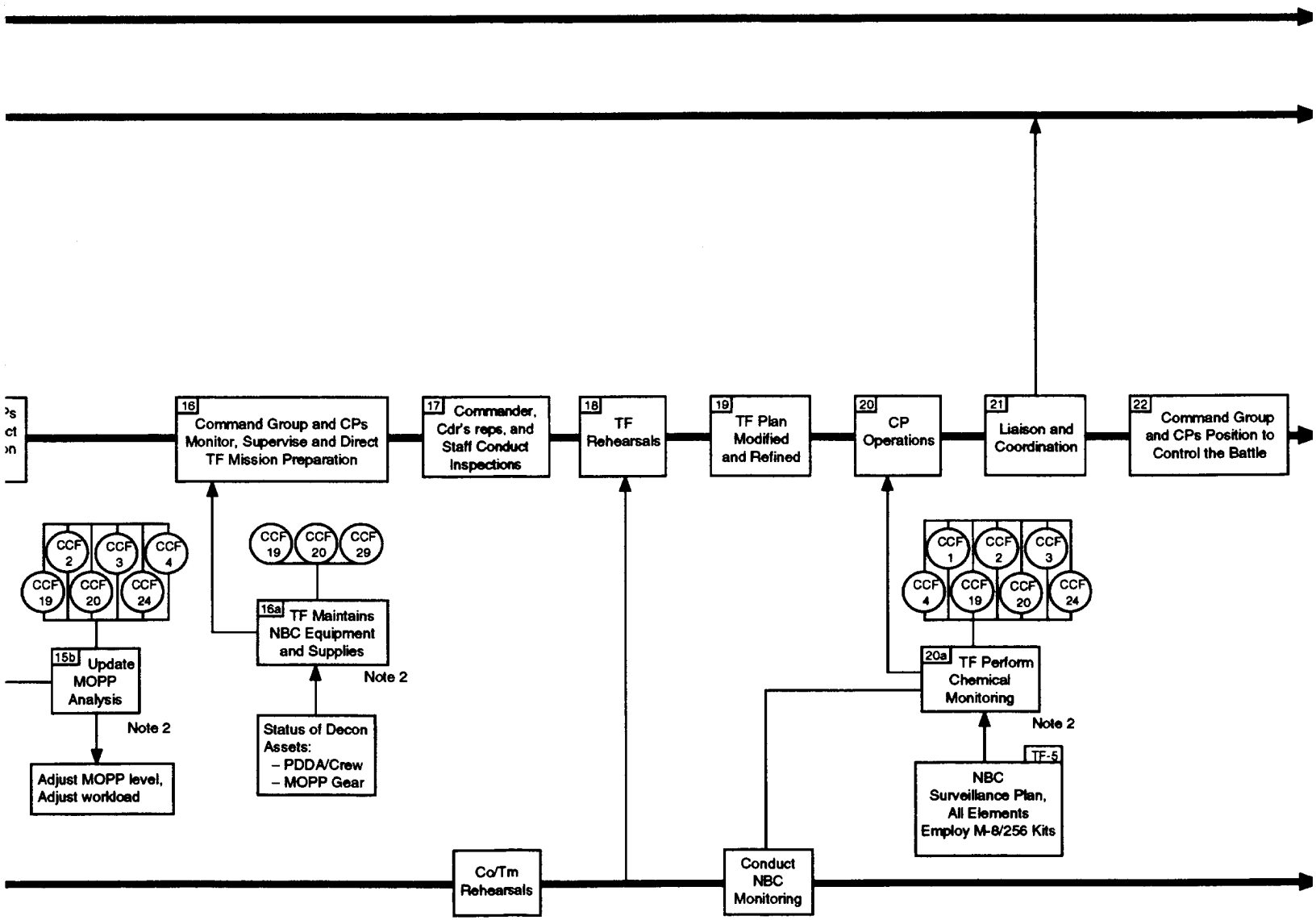

CORPS/DIV

BDE

TF

CO/TM
PLATOONS

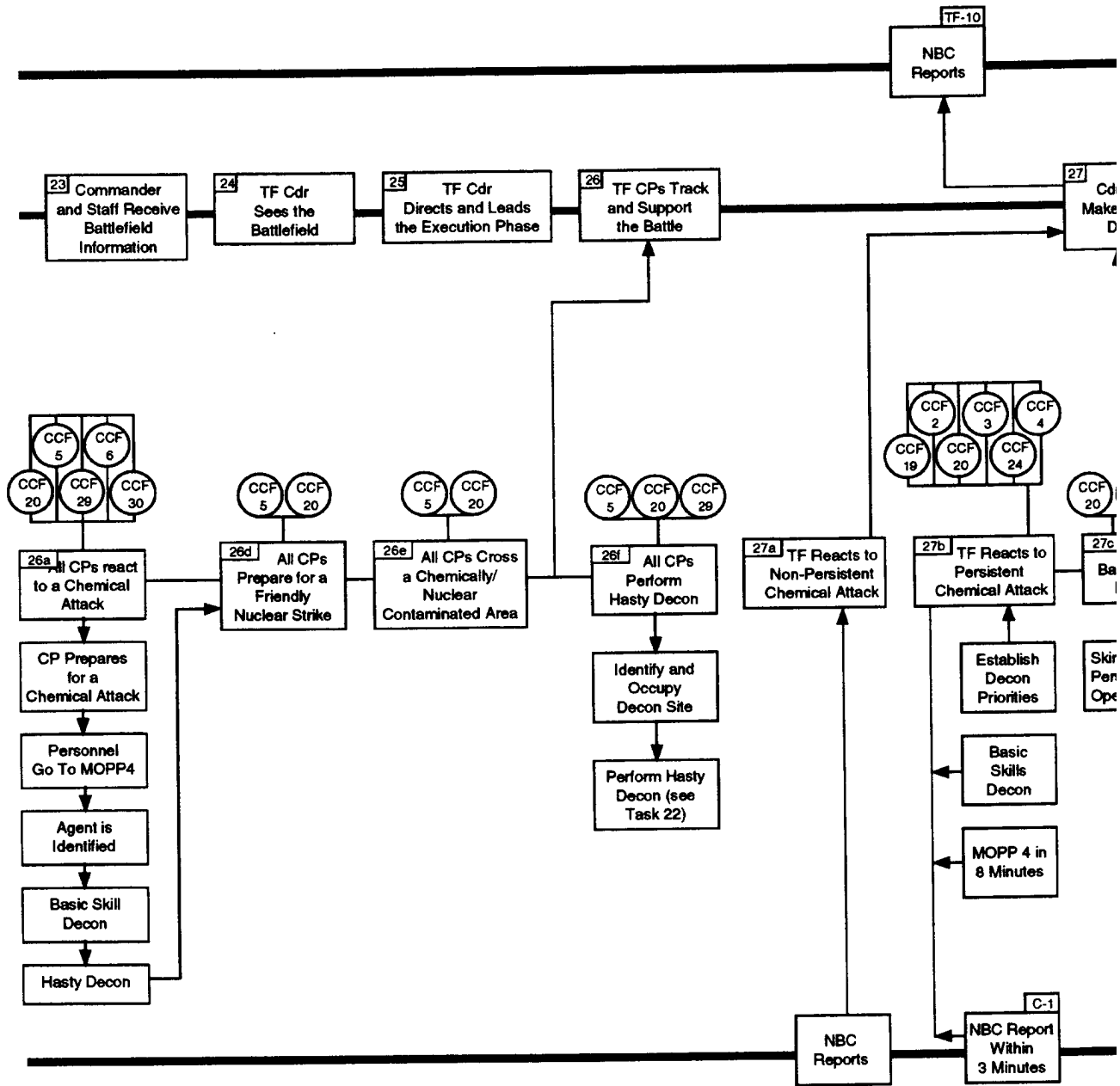

Note 3: This task uses two decon techniques: detailed
 Note 4: This task is normally performed on conjunction

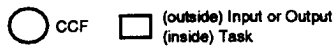

TASK FLOW EXECUTE

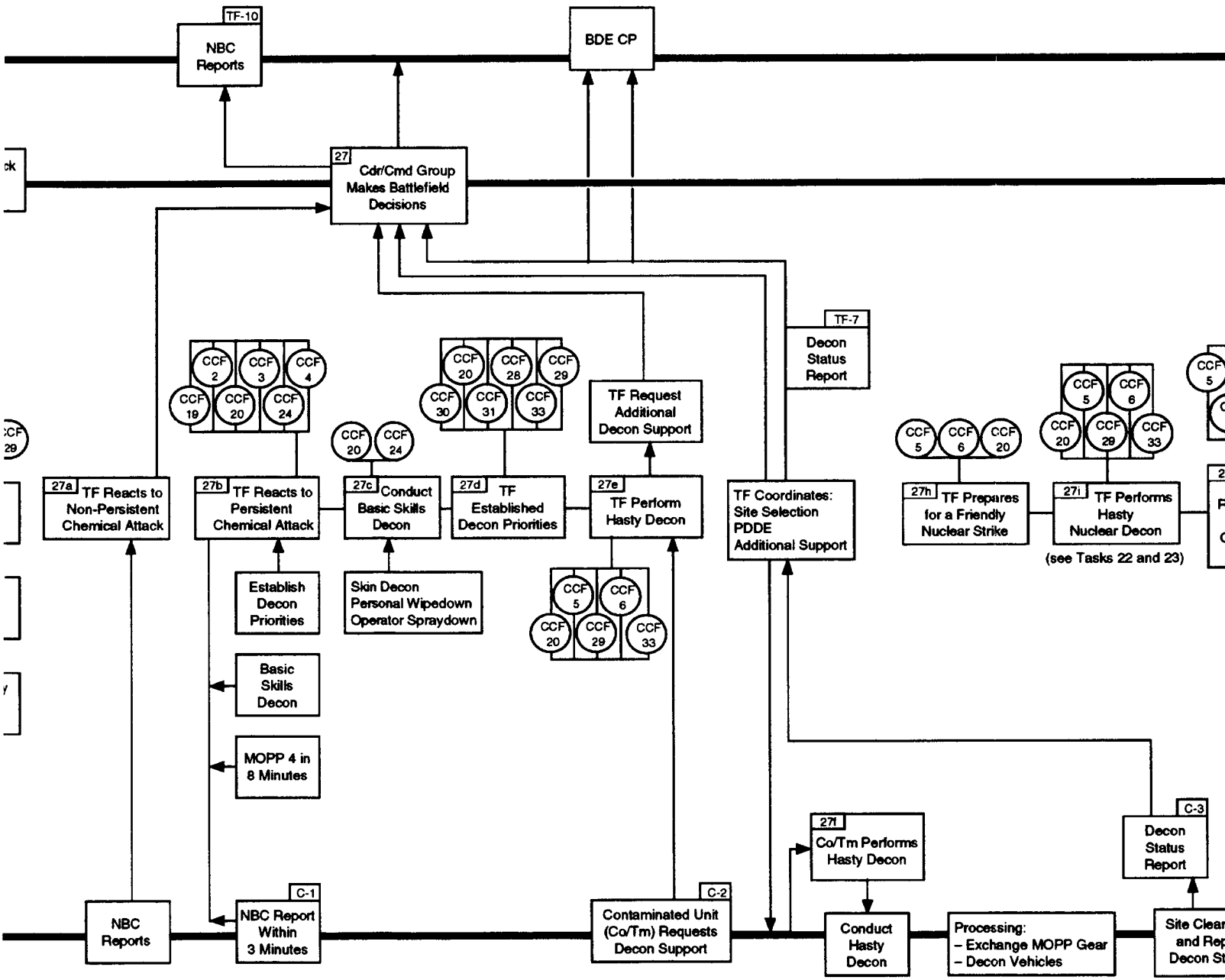

Note 3: This task uses two decon techniques: detailed troop and detailed equipment decon.
 Note 4: This task is normally performed on conjunction with reconstitution.

CCF 27 — Provide Decontamination

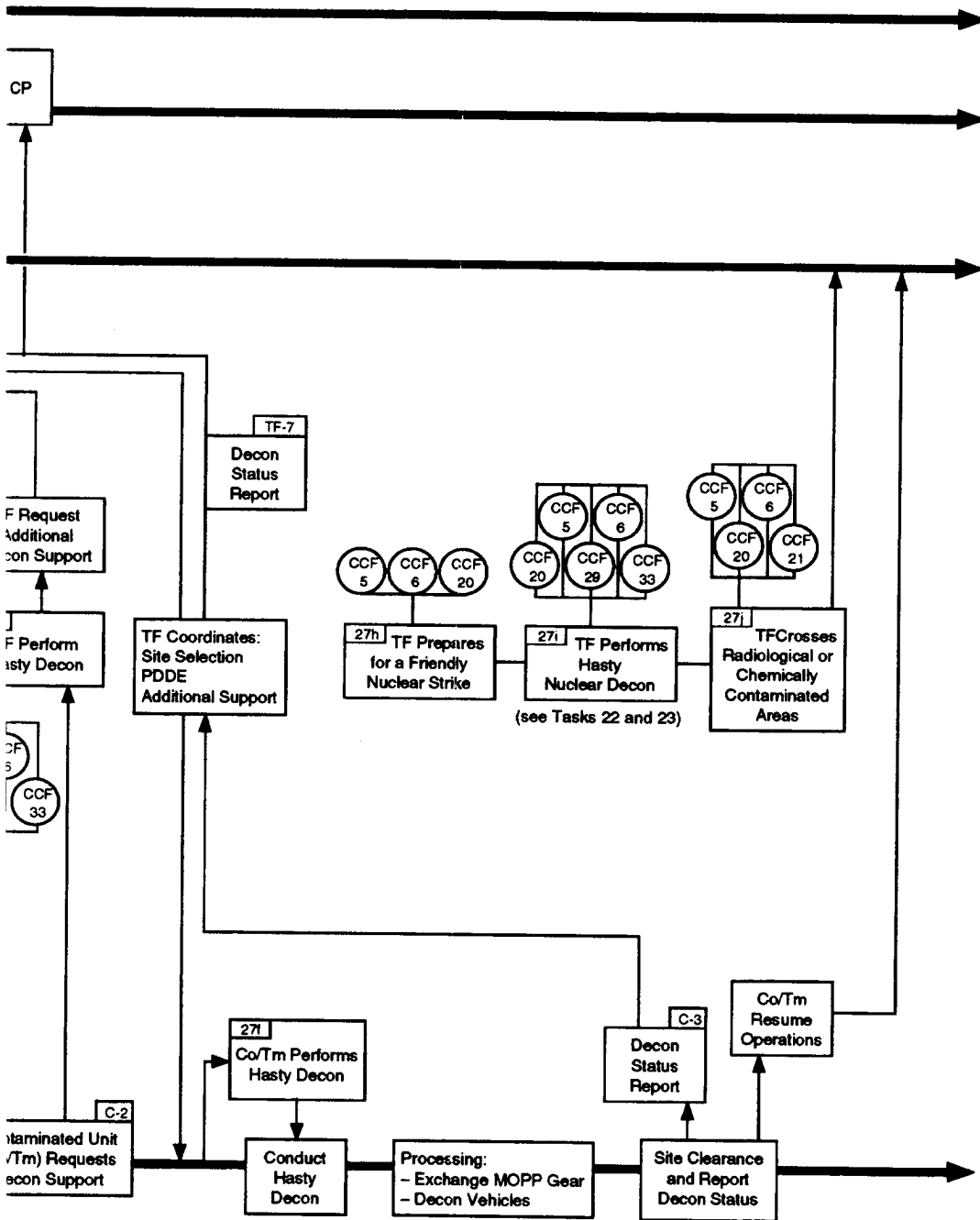

November 12, 1993

TAS EXECUTE

CORPS/DIV

BDE

TF

CO/TM PLATOONS

27g TF Performs Deliberate Decon

Notes 3/4

TF Coordinates with Bde and Co/Tm
 - Withdraw Contaminated Unit
 - Site Selection in BSA
 - Additional Decon Support

TF-7
 Decon Status Report

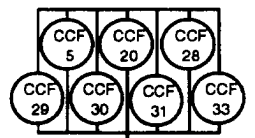

C-4
 Contaminated Unit (Co/Tm) Requests to Conduct Deliberate Decon

27g Co/Tm Performs Deliberate Decon

Note 5

Conduct Deliberate Decon

Conduct Detailed Troop Decon

Conduct Deliberate Equip Decon

○ CCF □ (outside) Input or Output (inside) Task

Note 5: This to
 Note 6: The to

TASK FLOW EXECUTE (Concluded)

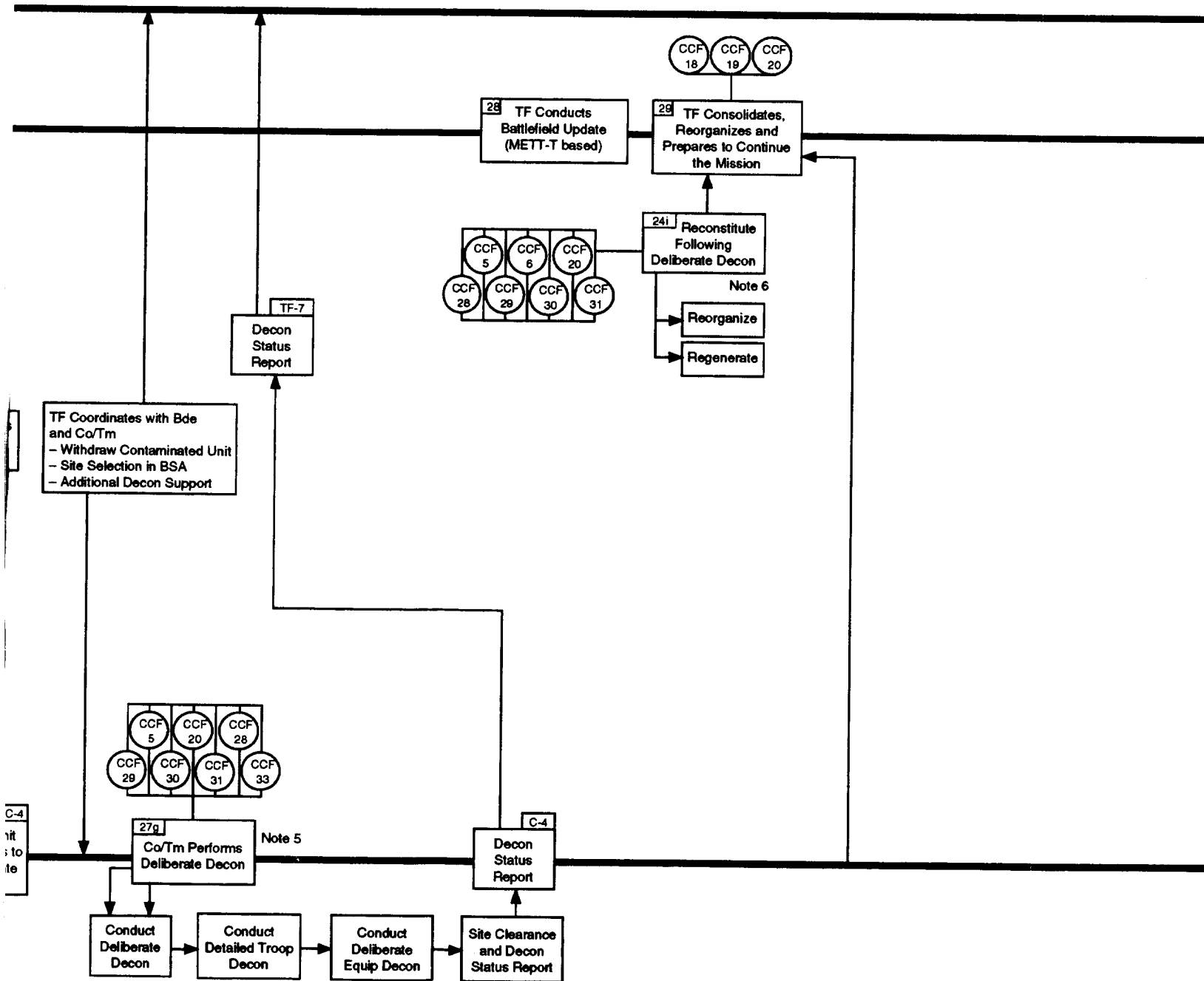

Note 5: This task is normally performed in conjunction with detailed troop decon.

Note 6: The following units assist in reconstitution after decon: BAS, FSB, Maintenance elements.

**K FLOW
(Concluded)**

CCF 27 — Provide Decontamination

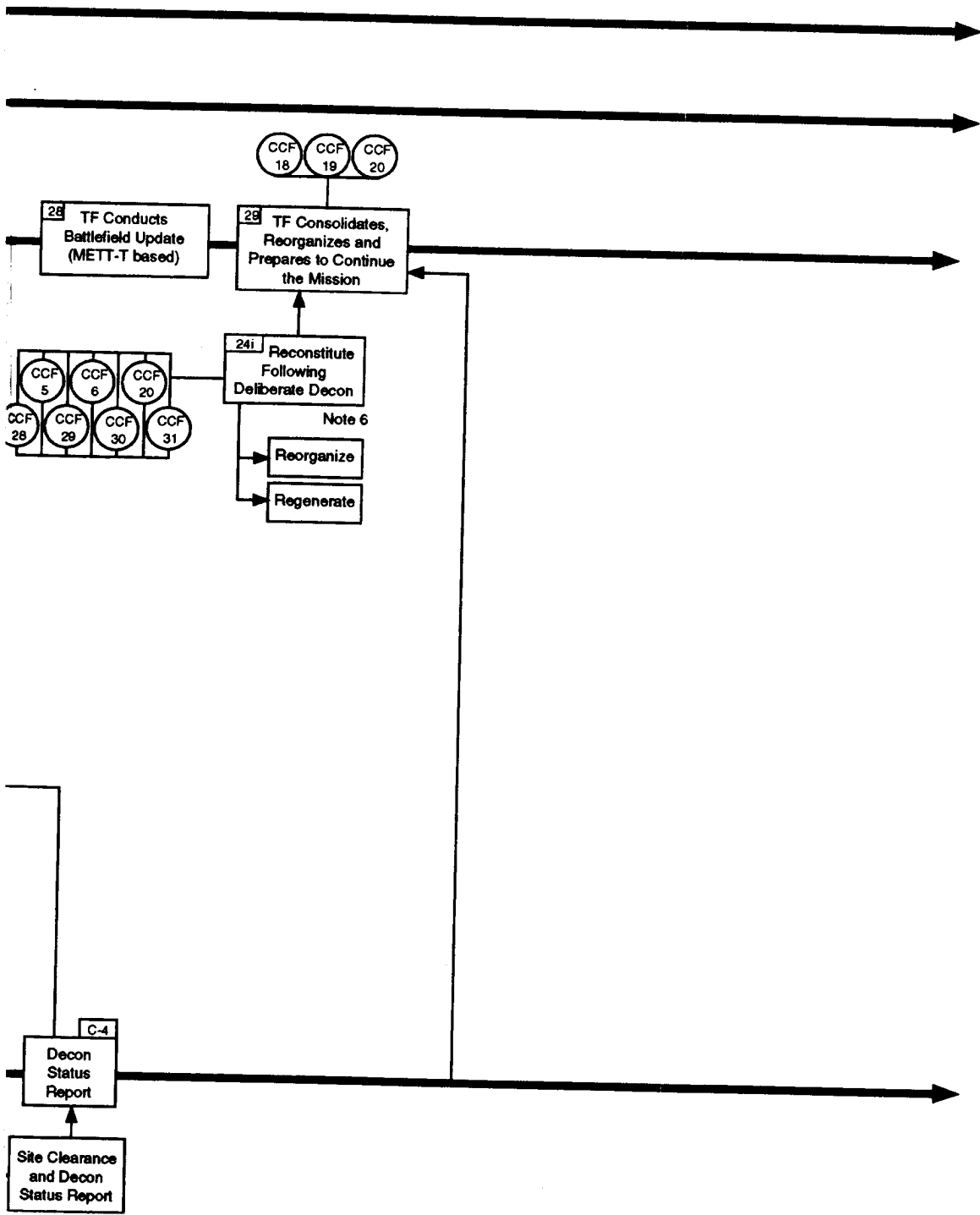

November 23, 1993

normally performed in conjunction with detailed troop decon.
g units assist in reconstitution after decon: BAS, FSB, Maintenance elements.

OTHER CCF WHICH INTERACT WITH CCF 27

<u>CCF #</u>	<u>TITLE</u>	<u>LOGIC</u>
CCF 1	Conduct Intelligence Planning	The IPB process must address the enemy's NBC capability, types of agents, intent and current status of contaminated areas. The TF NBC Section and the S2 must coordinate information gathering and continually share and update information concerning weather, terrain, and their effects on decontamination requirements. The NBC Officer coordinates NBC reconnaissance efforts of organic and supporting units.
CCF 2	Collect Information	The TF NBC Section manages and monitors the NBC Warning and Reporting System (NBCWARS), collecting information on enemy NBC attacks (weapon, system, agent, location, DTG)
CCF 3	Process Information	The TF NBC Section assists the S2 in analyzing and processing NBC data collected through NBCWARS
CCF 4	Disseminate Intelligence	The S2, assisted by the NBC Officer must keep the TF, adjacent and higher units aware of enemy NBC capabilities, indications of possible employment, and locations and status of contaminated areas.
CCF 5	Conduct Tactical Movement	The TF CMLO develops a picture of NBC hazards on the battlefield to assist maneuver planners and commanders when planning and executing the maneuver plan. The TF NBC Section and all unit NBC personnel must use the NBC Warning and Reporting System (NBCWARS) to immediately forward reports. Supporting decontamination units and organic decon teams must be positioned to support the maneuver plan. When an NBC attack occurs and/or when units must undergo decontamination, the maneuver plan is effected and must be modified.
CCF 6	Engage Enemy with Direct Fire and Maneuver	Commanders and all maneuver elements must be prepared to fight under NBC conditions. Reduction of combat power when a unit becomes contaminated has an immediate impact on the direct fire battle.

<u>CCF #</u>	<u>TITLE</u>	<u>LOGIC</u>
CCF 12	Employ Chemical Weapons	TF elements must be alerted to use of friendly chemical weapons to permit appropriate preparations (e.g. assigning MOPP level and masking requirements).
CCF 18	Plan for Combat Operations	The TF commander sets decontamination priorities (unit, equipment, time, location). The TF NBC Officer must participate in the planning process to integrate NBC operations into the TF OPORD (NBC Annex). He ensures the supporting Chemical unit's decontamination plan supports the TF commander's intent and is in sync with the maneuver plan/DST. Decon assets must be positioned to best support the plan; they should be reflected on the DST. The TF Command Post must plan for CP decontamination and continuous operations during all mission phases.
CCF 19	Direct and Lead Unit During Preparation for the Battle	Decontamination elements conduct PCIs, rehearse support plans, keep the TOC informed of status, and ensure all necessary decontamination preparation operations are completed. Unit NBC personnel conduct PCIs on individual and units system decontamination supplies and equipment. TF conducts continuous NBC monitoring, and assumes the appropriate MOPP level.
CCF 20	Direct and Lead Units in Execution of Battle	The TF conducts continuous NBC monitoring, and assumes the appropriate MOPP level. Decontamination units must be prepared to support the TF during and after battle by constantly monitoring the battle and pushing support forward. Individuals conduct basic skills decontamination; the commander must decide on decontamination methods, hasty or deliberate, based on mission, time, extent of contamination and previous plans.
CCF 21	Overcome Obstacles	Obstacles must be reconnoitered to determine if they are contaminated.
CCF 24	Enhance Physical Protection	NBC Defense is a balance of three principles: avoidance, protection, and decontamination. The extent to which the TF successfully avoids and is physically protected from contamination directly impacts on the need for, the type and extent of decontamination required following an NBC attack. Avoidance and protection are employed continuously when operating in a NBC environment.

CCF #	TITLE	LOGIC
CCF 28	Provide Transport Services	TF transportation assets may require decontamination. Decontamination resources will require transportation. Additional transportation assets may have to be requested by the TF.
CCF 29	Conduct Supply Operations	Decontamination activities require special supplies in large quantities. The NBC Officer must assist the TF S4 in determining consumption rates and resupply requirements for items like MOPP gear and decontaminants; in assessing the rate and extent of the unit's decontamination capability; and in determining available matter supply sources. Decisions must be made concerning the decontamination, destruction, or the emergency issue of contaminated supplies and equipment.
CCF 30	Provide Personnel Services	CMLO provides assistance and guidance on: procedures for handling mass NBC casualties and the disposal of NBC contaminated remains; personnel radiation exposure. CMLO provides radiation exposure status for subordinate units. CMLO requests NBC personnel to fill chemical positions or manages training of non-NBC personnel tasked from internal TF units.
CCF 31	Maintain Weapons Systems and Equipment	Maintenance planners must identify a contaminated vehicle holding area and plan for the decontamination and repair of vehicles and the decontamination of contaminated spare parts. When a unit undergoes detailed equipment decon, maintenance support is essential to return the unit to full operational capability.
CCF 32	Provide Health Services	Health services units and personnel must be kept informed of the battlefield NBC conditions and the need for patient decontamination.
CCF 33	Treat and Evacuate Battlefield Casualties	TF medical personnel must be kept informed of the battlefield NBC conditions and the need for patient decontamination. Patient decontamination is essential; personnel injured from chemical munitions must be triaged separately and decontaminated before medical treatment can be rendered.
CCF 39	Field Services	All units and personnel performing these functions must be kept informed of the NBC conditions and the requirement for decontamination, avoidance and protection (e.g clothing exchange, bathing facilities, mortuary activities).

CCF 27

KEY PARTICIPANTS BY TASK

<u>TASK</u>	<u>KEY PARTICIPANTS</u>
1. Direct and lead task force during planning for the battle	TF Cdr, S3, CMLO, Cdrs of subordinate and supporting units
2. Receive Brigade WO/OPORD	
3. Conduct mission analysis	TF Cdr, S3, CMLO, S2
4. Issue TF warning order	
5. Commander's guidance	TF Cdr, CMLO, TF S4
6. Prepare staff estimates	TF XO, S1, S2, S3, Engr, CMLO, NBC Sect, S4
7. Develop course of action	TF Cdr, XO, CMLO, S1/S4, S2, S3, Engr
8. Analyze COA	TF Cdr, XO, S3, S2, CMLO, Eng
9. Compare COA	TF Cdr, XO, S3, S2, CMLO, Eng
10. Commander's decision	
11. Prepare order	XO, S1, S2, S3, CMLO, NBC Sect, S4, Eng
12. Issue order	TF Cdr, S2, S3, CMLO, Eng, S1/S4, Co/Tm Cdrs, attached/supporting unit representatives
13. Refine order	TF Cdr, S3, CMLO
14. Command group conducts and receives briefings (backbriefs/briefbacks).	CMLO, S2, Eng
15. Command group and command post monitor, supervise and direct execution of force protection operations/activities.	XO, S3, S2, CMLO, Eng
CMLO monitors and manages the NBC Warning and Reporting System (NBCWARS).	TOC, CMLO, S1/4, CTCP, S2, S3, HHC Cdr, FTCP, Co/Tm CPs, assigned/attached/supporting elements
TF commander and staff update MOPP analysis to determine MOPP level and workload.	TF Cdr, S3, CMLO, Co/Tm Cdrs, Cdrs of assigned/attached/supporting elements

<u>TASK</u>	<u>KEY PARTICIPANTS</u>
16. Command group and command posts monitor, supervise and direct TF mission preparation.	TF Cdr, XO, S3, CMLO, S2, Eng
TF maintains NBC equipment and supplies.	CMLO, S4, Spt Plt Ldr, Co/Tm, assigned/attached/supporting elements
17. Commander, commander's representatives, and staff conduct inspections and visits.	CMLO, NBC Section
18. TF Rehearsals.	CMLO
19. TF plan modified and refined.	S2, CMLO, Eng
20. Command Post (TAC, TOC, CTCP) operations.	
TF performs chemical monitoring.	TOC, CMLO, NBC Section, subordinate and supporting unit NBC personnel (assigned and additional duty)
21. Liaison and coordination with higher, adjacent, supported and supporting elements.	
22. Command group and command posts position to control the battle.	
23. TF Command Posts locate where they can control the battle.	
24. TF commander sees the battlefield.	CMLO
25. TF commander directs and leads the execution phase.	TF Cdr, CMLO
26. TF Command Posts track and support the battle.	
All CPs react to a chemical attack.	TF Cdr, XO, TOC OIC, S1/4, CTCP, S2, S3, Engr, HHC Cdr, FTCP, CMLO, contaminated unit, Spt Plt, PDDE Crew, supporting decon unit
All CPs prepare for a friendly nuclear strike.	TF Cdr, XO, TOC OIC, S1/4, CTCP, S2, S3, Engr, HHC Cdr, FTCP, CMLO
All CPs cross a chemically/nuclear contaminated area.	TF Cdr, XO, TOC OIC, S1/4, CTCP, S2, S3, Engr, HHC Cdr, FTCP, CMLO

<u>TASK</u>	<u>KEY PARTICIPANTS</u>
All CPs perform hasty decontamination.	TF Cdr, XO, TOC OIC, S1/4, CTCP, S2, S3, TF Engr, HHC Commander, FTCP, CMLO, contaminated unit, Spt Plt, PDDE Crew, supporting decon unit
27. TF conducts the decision making process (accelerated)	
TF reacts to chemical attack	CMLO, NBC Section, S3, all elements
TF reacts to persistent chemical attack	TF Cdr, S1/4, S2, S3, CMLO, contaminated unit, Spt Plt, PDDE crew, supporting decon unit
Conduct basic skills decontamination	Individual soldiers, vehicle/equipment operators
TF Commander updates decontamination priorities (unit, equipment, location, time).	TF Cdr, S2, S3, Engr, CMLO, contaminated unit, Spt Plt, PDDE crew, supporting decon unit
TF performs hasty decontamination	TF Cdr, S1/4, S2, S3, Engr, CMLO, Co/Tm Cdr, contaminated unit, contaminated unit's supply section, Spt Plt, PDDE Crew, supporting decon unit
Co/Tm performs hasty decon.	TF Cdr, S1/S4, S2, S3, Engr, CMLO, Co/Tm Cdr, contaminated unit, contaminated unit's supply section, Spt Plt, PDDE Crew, supporting decon unit
TF performs deliberate chemical decontamination.	Bde Cdr (as appropriate), Bde S1/4, S2, S3, CMLO, TF Commander, S1/4, S3, S2, Engr, CMLO, contaminated unit, Spt Plt, PDDE Crew, Maint Plt, supporting decon unit
Co/Tm coordinates for detailed equipment decontamination (NB this task is normally performed in conjunction with a detailed troop decontamination).	TF Cdr, S1/4, S2, S3, TF Engr, CMLO, Co/Tm Cdr, contaminated unit, contaminated unit's supply section, TF Spt Plt, Maint Plt, supporting decon unit
Reconstitute following deliberate decontamination.	Bde Cdr and staff as appropriate, FSB, TF Cdr, S1/4, S2, S3, Engr, CMLO, Co/Tm Cdr
TF prepares for friendly nuclear strike.	TF Cdr, S1/4, S2, S3, Engr, CMLO, all Co/Tms, assigned/attached/supporting elements
TF performs hasty nuclear decontamination.	TF Cdr, S1/4, S2, S3, Engr, CMLO, Co/Tm Cdr, contaminated unit,

TASK

KEY PARTICIPANTS

TF crosses radiological or chemically contaminated areas.	contaminated unit's supply section, Spt Plt, PDDE Crew, supporting decon unit
28. TF conducts battlefield update (METT-T based)	TF Cdr, S1/4, S2, S3, Engr, CMLO, all Co/Tms, assigned/attached/supporting elements
29. TF consolidates and reorganizes.	CMLO, Scout Plt, subordinate and supporting chemical recon elements
Prepare to continue or change mission.	TF Cdr, S3, S2, CMLO, NBC Section
	TF Cdr, S1/4, S2, S3, Engr, CMLO, all Co/Tms, assigned/attached/supporting elements

**KEY INPUTS AND OUTPUTS TO CCF 27
(W/ CRITICAL INFORMATION)**

KEY INPUTS

B- 1 BRIGADE OPORD

- a. Commander's intent.
- b. Designation of routes, axes of advance, or defensive positions/sectors.
- c. Decision Support Template (DST).
- d. Task organization (including effective time).
- e. Rules of engagement and acceptable level of risk.
- f. Reporting requirements.
- g. Operational Exposure Guidance (OEG).
- h. Priorities (artillery, engineer, resupply, etc.)

B-2 BRIGADE INTELLIGENCE ANNEX

- a. Terrain analysis.
- b. Weather analysis.
- c. Enemy analysis and threat integration.
- d. Reconnaissance and surveillance plans and assets available.
- e. Collection plan and specific taskings.
- f. Priority Intelligence Requirements (PIRs).
- g. Named and Targeted Areas of Interest (NAIs and TAIs).
- h. Situation/events templates.
- i. Locations of identified/known contaminated areas.
- j. Suspected or probable contaminated area locations.

B-3 BRIGADE NBC ANNEX

- a. NBC threat assessment.
- b. Minimum NBC threat status and directed minimum MOPP levels.
- c. Decontamination operation locations.
- d. Attachment, availability, priority of support of chemical units (decon, recon).

TF- 1 TF NBC ESTIMATE

- a. Vulnerability assessment.
- b. Assesses readiness to operate in NBC environment.
- c. Integrates NBC tasks into overall concept of operation.
- d. Analyses aspects of weather, terrain, enemy and friendly forces from aspect of NBC defense(decon).
- e. Analyses of chemical units available to conduct decon: status, current operations, completion times for ongoing activities.
- f. Impact of decontamination on operations;
 - 1) Time required to conduct hasty/deliberate decon.
 - 2) Impact on DST.
 - 3) Additional resources needed to conduct hasty/deliberate decon.

TF- 2 TF TSOP

- a. Immediate action drills and procedures for decon.
- b. Setup and organization of decon sites.
- c. OPSEC requirements and procedures (physical, communications, camouflage, etc.).
- d. Passive and active air defense measures.
- e. Preparation for, response to and reporting of NBC operations/activities.
- f. Procedures for handling contaminated casualties.
- g. Procedures for handling contaminated equipment.
- h. Procedures for requesting hasty and deliberate decon
- i. MOPP levels and automatic masking criteria and procedures (MOPP/masking drills)
- j. Designation of alternate nets for follow-up reports or instructions.
- k. Passive and active NBC defense measures.
- l. Chemical protective equipment and supplies basic load (MOPP suits, filters, NAAK, decon set, DS2).
- m. Unmask procedures.

TF- 3 TF MOPP ANALYSIS

- a. Commander's guidance on MOPP level and workload.
- b. Commander's decision on subordinate unit commander's authority to modify MOPP guidance.
- c. Analysis of three situation factors:
 - 1) Mission factors.
 - 2) Environmental factors.
 - 3) Soldier factors.

TF- 4 TF OPORD

- a. Automatic masking criteria.
- b. MOPP level for the mission.
- c. Guidance on continuing the mission "dirty".
- d. OEG.

TF- 5 NBC ANNEX TO TF OPORD

- a. NBC threat assessment status.
- b. MOPP assessment and directed minimum MOPP levels.
- c. Identification of tentative decontamination sites and priority for decontamination.
- d. Location of known or suspected contaminated areas, and possible chemical areas.
- e. Availability and location of NBC defense and decontamination supplies/materiels (Class IIZ and VIIZ).
- f. Information on attached/supporting decontamination units.
 - 1) Chemical unit task organization and command relationship.
 - 2) Chemical unit locations/concept of operations.

KEY OUTPUTS**TF- 6 TF ADDITIONAL DECON SUPPORT REQUEST**

- a. Identification, and location of contaminated unit.
- b. Status of contaminated unit:
 - 1) Number of personnel requiring decon.
 - 2) Type and quantity of equipment requiring decon.
 - 3) Combat situation and mission status.
- c. Type of decon to be conducted (hasty/deliberate).
- d. Type agent involved.
- e. Location of decon site.
- f. Coordinating details (exchange SOIs, internal support, etc.).

T-7 TF DECON STATUS REPORT

- a. Contaminated unit:
 - 1) Personnel and equipment operational status.
 - 2) MOPP level required to continue operations.
- b. Decon Site:
 - 1) Time soldier and equipment decon sites are closed.
 - 2) Site marked with standard NBC markers.
 - 3) Site location reported through channels (posted as a contaminated area).

C- 1 CO/TM NBC REPORTS

- a. NBC 1 Report: Observers' Initial Report.
- b. NBC 4 Report: NBC hazards' location.

C- 2 CO/TM HASTY DECON SUPPORT REQUEST

- a. Identification of contaminated unit.
- b. Unit's current mission and status
- c. Extent of personnel and equipment contamination.
- d. Current MOPP level.
- e. Length of time in MOPP.
- f. Decon site location.
- g. Contaminating Agent.
- h. Requirements for additional NBC supplies/equipment (MOPP suits, decon kits, filters, NAAK kits, etc.).
- i. Number and status of contaminated casualties.

C-3 CO/TM DECON STATUS REPORTS

- a. Contaminated unit:
 - 1) Personnel and equipment operational status.
 - 2) MOPP level required to continue operations.

- b. Decon Site:
 - 1) Time soldier and equipment decon sites are closed.
 - 2) Site marked with standard NBC markers.
 - 3) Site location reported through channels (posted as a contaminated area).

C- 4 CO/TM DELIBERATE DECON SUPPORT REQUEST

- a. Identification of contaminated unit.
- b. Mission and status of contaminated unit:
 - 1) Number of personnel requiring decon.
 - 2) Type and quantity of equipment requiring decon.
 - 3) Combat situation and mission status.
 - 4) Current MOPP level and length of time in MOPP.
- c. Type of decon to be conducted (hasty/deliberate).
- d. Type of agent involved.
- e. Location of decon site.
- f. Coordinating details (exchange of SOIs, internal support, etc.).

PROVIDE DECONTAMINATION TASK LIST SUMMARY

The tasks identified in this list are those considered by analysts as critical to CCF 27. Tasks 1 through 12 listed below are the tasks that comprise CCF 18. They are reiterated here because there are planning subtasks that are critical to the planning of CCF 27. These subtasks are listed in the Planning Tasks List that follows this Summary List.

Planning

1. **Direct and Lead Task Force During Planning for the Battle** (ARTEP 71-2-MTP, Task 7-1-3001/5; ARTEP 71-1-MTP, Task 17-2-0101, 0701; FM 71-123, Chap 2; FM 71-1, Chap 2; FM 7-7J, Chap 2)
 - a. **Combat battlefield stress** (ARTEP 71-2-MTP, Task 7-1-3912; FMs 3-4 Chap 2; 22-9; FM 71-2, Chap. 7)
2. **Receive Brigade WO/OPORD** (ARTEP 71-2-MTP, Task 7-1-3901, 3904; FM 71-2; FM 101-5)
3. **Conduct mission analysis** (ARTEP 71-2-MTP, Task 7-1-3901, 3904; FM 71-2; FM 101-5)
4. **Issue TF warning order** (ARTEP 71-2-MTP, Task 7-1-3901, 3904; FM 71-2; FM 101-5)
5. **Commander's guidance** (ARTEP 71-2-MTP, Task 7-1-3901, 3904; FM 71-2; FM 101-5)
6. **Prepare staff estimates** (ARTEP 71-2-MTP, Task 7-1-3901, 3904; FMs 3-5, Chap 5/6; FM 3-100, App B; FM 71-2; FM 101-5; Commanders Battle Staff Handbook)
7. **Staff develops courses of action** (ARTEP 71-2-MTP, Task 7-1-3901, 3904; FM 3-100, Chap 10, 11, App B; FM 71-2; FM 101-5)
8. **Staff/CDR analyze COA** (ARTEP 71-2-MTP, Task 7-1-3901, 3904; FM 71-2; FM 101-5; Commanders Battle Staff Handbook)
9. **Staff compares COA** (ARTEP 71-2-MTP, Task 7-1-3901, 3904; FM 71-2; FM 101-5)
10. **Commander announces decision** (ARTEP 71-2-MTP, Task 7-1-3901, 3904; FM 71-2; FM 101-5)
11. **Prepare order** (ARTEP 71-2-MTP, Task 7-1-3901, 3904; FM 71-2; FM 101-5)
12. **Issue order** (ARTEP 71-2-MTP, Task 7-1-3901; FM 71-2; FM 101-5)
13. **Refine order** (ARTEP 71-2-MTP, Task 7-1-3901, 3904; FM 71-2; FM 101-5)

- Preparation**
14. **Command Group conducts and receive briefings (backbriefs/briefbacks)** (ARTEP 71-2-MTP, Task 7-1-3903/2; FM 71-2, Chap 2; FM 101-5, Chap 4)
 15. **Command Group and Command Posts monitor, supervise and direct execution of force protection operations/activities** (ARTEP 71-2-MTP, Task 7-1-3028/3, 3904/6, 3905/2, 3905/4)
 - a. CMLO monitors and manages the NBC Warning and Reporting System (NBCWARS) (ARTEP 71-2-MTP, Task 7-1-3910; FM 3-100, Chap 3; FM 3-3, Chap 2)
 - b. TF commander and staff update MOPP analysis to determine MOPP level and workload (ARTEP 71-2-MTP, Task 7-1-3910; FM 3-4, Chap 2, App A (performance degradation))
 16. **Command Group and Command Posts monitor, supervise and direct TF mission preparation** (ARTEP 71-2-MTP, Task 7-1-3001/5, 3901/9, 3901/10, 3904/12; FM 71-123, Chap 5)
 - a. TF maintains NBC equipment and supplies (ARTEP 71-2-MTP, Task 7-1-3910; FM 3-5, Chap 7; FM 3-100, Chap 8, 9; Commanders Battle Staff Handbook)
 17. **Commander, commander's representatives, and staff conduct inspections and visits** (ARTEP 71-2-MTP, Task 7-1-3903/2; FM 71-2, Chap 2)
 18. **TF Rehearsals** (FM 71-2, Chap 2; FM 71-123, Chap 2; FM 101-5, App M)
 19. **TF plan modified and refined** (ARTEP 71-2-MTP, Task 7-1-3901/8, 3904/12)
 20. **Command Post (TAC, TOC, CTCP) operations** (ARTEP 71-2-MTP, Task 7-1-3401, 3035, 3036, 3902/9, 3913)
 - a. TF performs chemical monitoring (ARTEP 71-2-MTP, Task 7-1-3910; FM 3-3, Chaps 2, 3)
 21. **Liaison and coordination with higher, adjacent, supported and supporting elements** (ARTEP 71-2-MTP, Task 7-1-3003/2, 3010/2, 3016/1, 3902/10)
 22. **Command Group and Command Posts position to control the battle** (ARTEP 71-2-MTP, Task 7-1-3901/11, 3902/11, 3903/1)
- Execution**
23. **TF Command Posts locate when they can control the battle** (ARTEP 71-2-MTP, Task 7-1-3902)
 24. **TF commander sees the battlefield** (ARTEP 71-2-MTP, Task 7-1-3901/11; FM 71-100, Chap 1)
 25. **TF commander directs and leads the execution phase** (ARTEP 71-2-MTP, Task 7-1-3901/12; FM 71-100, Chap 1)

26. **TF Command Posts track and support the battle** (ARTEP 71-2-MTP, Task 7-1-3903/3, 3904/14; FM 71-123, Chap 1)
- a. All CPs react to a chemical attack (ARTEP 71-2-MTP, Task 7-1-3029; FM 3-5, Chaps 3, 5, 6)
 - b. All CPs prepare for a friendly nuclear strike (ARTEP 71-2-MTP, Task 7-1-3030; FM 3-5, Chaps 3, 5, 6; FM 3-100, Chap 4)
 - c. All CPs cross a chemically/nuclear contaminated area (ARTEP 71-2-MTP, Task 7-1-3031; FM 3-5, Chaps, 3, 4, 5; FM 3-100, Chap 4)
 - d. All CPs perform hasty decontamination (ARTEP 71-2-MTP, Task 7-1-3032; FM 3-5, Chaps 3, 4, 5; FM 3-100, Chap 4)
27. **TF conducts the decision making process (accelerated)** (FM 71-123, Chap 1)
- a. TF reacts to chemical attack (ARTEP 71-2-MTP, Task 7-1-3910; FM 3-4; FM 3-5, Chap 5; FM 21-11)
 - b. TF reacts to persistent chemical attack (ARTEP 71-2-MTP, Task 7-1-3910; FM 3-5, Chap 6)
 - c. Conduct Basic Skills Decontamination (ARTEP 71-2-MTP, Task 7-1-3910; FM 3-5, Chap 4; FM 3-100, Chap 4)
 - d. TF commander updates decontamination priorities (unit, equipment, location, time) (ARTEP 71-2-MTP, Task 7-1-3910; FM 3-5, Chap 2; FM 3-100, Chap 4)
 - e. TF performs hasty decontamination (ARTEP 71-2-MTP, Task 7-1-3910; FM 3-5, Chap 5; FM 3-100, Chap 4; Commanders Battle Staff Handbook)
 - f. Co/Tm performs hasty decontamination (ARTEP 71-1-MTP, Task 30-2-C031; FM 3-5, Chap 5; FM 3-100, Chap 4)
 - g. TF performs deliberate chemical decontamination (ARTEP 71-2-MTP, Task 7-1-3910; FM 3-5, Chap 6; FM 3-100, Chap 4; Commanders Battle Staff Handbook)
 - h. Co/Tm coordinates for detailed equipment decontamination (This task is normally performed in conjunction with a detailed troop decontamination) (ARTEP 71-1-MTP, Task 30-2-C033; FM 71-1; FM 3-5, Chap 6; FM 3-100, Chap 4)
 - i. Reconstitute following deliberate decontamination (ARTEP 71-2-MTP, Task 7-1-3022; FM 71-3, Chap 7; FM 3-5, Chap 3)
 - j. TF prepares for friendly nuclear strike (ARTEP 71-2-MTP, Task 7-1-3910; FM 3-3)
 - k. TF performs hasty nuclear decontamination (ARTEP 71-2-MTP, Task 7-1-3910; FM 3-5, Chap 3)
 - l. TF crosses radiological or chemically contaminated areas (ARTEP 71-2-MTP, Task 7-1-3910; FM 3-5, Chap 3)
28. **TF conducts battlefield update (METT-T based)** (ARTEP 71-2-MTP, Task 7-1-3902/3, 3906/1, 3913/5)
29. **TF consolidates and reorganizes** (ARTEP 71-2-MTP, Task 7-1-3022, 3023)
- a. Prepare to continue or change mission (ARTEP 71-2-MTP, Task 7-1-3023; FM 71-2, Chaps 3, 4)

PROVIDE DECONTAMINATION PLANNING TASK LIST

See CCF 18 for a detailed analysis of the planning process and a listing of all planning tasks. Tasks 1 through 13 are tasks that comprise CCF 18. All planning tasks are reiterated here to retain the flow of the planning process and identify those planning tasks with subtasks that are critical to CCF 27. Task 13, was added as a critical planning task because of the extreme importance placed on monitoring the condition of all TF members when operating in an NBC and MOPP environment.

1. **Direct and Lead Task Force During Planning for the Battle** (ARTEP 71-2-MTP, Task 7-1-3001/5; ARTEP 71-1-MTP, Task 17-2-0101, 0701; FM 71-123, Chap 2; FM 71-1, Chap 2; FM 7-7J, Chap 2)
 - a. Combat battlefield stress (continuous task in coordination with task 15 below)
 - 1) Leaders execute leader actions.
 - 2) Keep soldiers informed.
 - 3) Issue orders to lowest possible level.
 - 4) Provide current situation information.
 - 5) Maintain a positive attitude.
 - 6) Quell and prevent rumors.
 - b. Be prepared to respond to NBC attack.
 - c. Operate in an NBC environment (as appropriate).
 - d. See: CCF 18, Plan for Combat Operations; CCF 19, Direct and Lead Units During Preparation for the Battle; CCF 20, Direct and Lead Units in Execution of the Battle; CCF 24, Enhance Physical Protection; CCF 29, Conduct Supply Operations.
2. **Receive Brigade WO/OPORD** (ARTEP 71-2-MTP, Task 7-1-3901, 3904; FM 71-2; FM 101-5)
3. **Conduct mission analysis** (ARTEP 71-2-MTP, Task 7-1-3901, 3904; FM 71-2; FM 101-5)
4. **Issue TF warning order** (ARTEP 71-2-MTP, Task 7-1-3901, 3904; FM 71-2; FM 101-5)
5. **Commander's guidance** (ARTEP 71-2-MTP, Task 7-1-3901, 3904; FM 71-2; FM 101-5)
 - a. CMLO advises and assists the commander to determine:
 - 1) MOPP level (continuous process see task 15 below).
 - 2) % soldiers to be masked (continuous process see task 15 below).
 - 3) Operational Exposure Guidance (continuous process see task 15 below).
 - b. S3 gives CMLO specific guidance for developing NBC plans to support the commander's intent and scheme of maneuver/concept of the operation.

- c. See: CCF 18, Plan for Combat Operations; CCF 19, Direct and Lead Units During Preparation for the Battle; CCF 20, Direct and Lead Units in Execution of the Battle; CCF 21, Overcome Obstacles; CCF 24, Enhance Physical Protection.
6. **Prepare staff estimates** (ARTEP 71-2-MTP, Task 7-1-3901, 3904; FM 3-5, Chap 5/6; FM 3-100, App B; FM 71-2; FM 101-5; Commanders Battle Staff Handbook)
- a. **CMLO:**
 - 1) Prepares NBC estimates and SOPs.
 - 2) Assess probability and impact OF NBC related-casualties.
 - 3) Monitor and report on status of NBC equipment and supplies.
 - 4) Completes MOPP analysis. MOPP analysis considers the three situational factors:
 - a) Mission factors:
 - The mission.
 - The likelihood of chemical agent employment.
 - Agents likely to be employed.
 - Likely targets.
 - Expected warning time for agent employment.
 - Additional protection available.
 - Physical and mental requirements of work needing to be accomplished.
 - Mission completion time.
 - Duration of the mission.
 - Adequate food and water available.
 - b) Environmental factors:
 - Ambient air temperature.
 - Humidity.
 - WBGT index reading.
 - Weather conditions (cloudy, sunny, windy, dry, night).
 - c) Soldier factors:
 - Soldiers well hydrated and nourished.
 - Soldiers well rested.
 - Soldiers heat acclimatized.
 - Soldiers physically fit and well trained.
 - Soldiers healthy.
 - 5) Recommend MOPP status.
 - 6) Predicts fallout and downwind vapor hazards.
 - 7) Incorporates information from the NBC Warning and Reporting System(NBCWARS).
 - b. See: CCF 18, Plan for Combat Operations; CCF 21, Overcome Obstacles; CCF 24, Enhance Physical Protection; CCF 33, Treat and Evacuate Battlefield Casualties.
7. **Staff develops courses of action** (ARTEP 71-2-MTP, Task 7-1-3901, 3904; FM 3-100, Chap 10, 11, App B; FM 71-2; FM 101-5)
- a. **CMLO develops NBC support for COA. Advises commander on:**
 - 1) Decontamination priorities.
 - 2) Impact of NBC contamination on operations.
 - 3) Resupply of chemical defense equipment.

- b. CMLO coordinates with TF staff:
 - 1) Integrates NBC threat analysis into IPB and NBC recon into the R&S plan.
 - 2) Maintains supply status and allocations of NBC defense stocks.
 - 3) Ensure field medical support is prepared for an NBC attack.
 - 4) Assists CSS elements in planning for decon:
 - a) Water
 - b) Decontaminants
 - c) Augmentees,
 - d) Transportation
 - e) Medical support.
 - 5) Incorporates information from the NBC Warning and Reporting System (NBCWARS).
 - c. See: CCF 18, Plan for Combat Operations; CCF 28, Provide Transport Services; CCF 29, Conduct Supply Operations; CCF 30, Provide Personnel Services.
8. **Staff/CDR analyze COA** (ARTEP 71-2-MTP, Task 7-1-3901, 3904; FM 71-2; FM 101-5; Commanders Battle Staff Handbook)
- a. Evaluate ability of NBC defense plan to support tactical operations.
 - b. Perform vulnerability assessments given the commander's acceptable loss criteria.
 - c. See: CCF 18, Plan for Combat Operations; CCF 24, Enhance Physical Protection.
9. **Staff compares COA** (ARTEP 71-2-MTP, Task 7-1-3901, 3904; FM 71-2; FM 101-5)
10. **Commander announces decision** (ARTEP 71-2-MTP, Task 7-1-3901, 3904; FM 71-2; FM 101-5)
11. **Prepare order** (ARTEP 71-2-MTP, Task 7-1-3901, 3904; FM 71-2; FM 101-5)
- a. Develop a Chemical Annex and NBC defense plan.
 - b. See: CCF 18, Plan for Combat Operations; CCF 24, Enhance Physical Protection
12. **Issue order** (ARTEP 71-2-MTP, Task 7-1-3901; FM 71-2; FM 101-5)
13. **Refine order** (ARTEP 71-2-MTP, Task 7-1-3901, 3904; FM 71-2; FM 101-5)

**PROVIDE DECONTAMINATION
PREPARATION TASK LIST**

14. **Command Group conducts and receive briefings** (backbriefs/briefbacks) (ARTEP 71-2-MTP, Task 7-1-3903; FM 71-2, Chap 2; FM 101-5, Chap 4)
15. **Command Group and Command Posts monitor, supervise and direct execution of force protection operations/activities** (ARTEP 71-2-MTP, Task 7-1-3028/3, 3904/6, 3905/2, 3905/4)
- a. CMLO monitors and manages NBCWARS (continuous task).
- 1) Collates, evaluates and distributes NBC contamination data.
 - 2) This process is continuous throughout all mission phases.
 - 3) Performed in coordination with task 16 below.
 - 4) See: CCF 19, Direct and Lead Units During Preparation for the Battle; CCF 20, Direct and Lead Units in Execution of the Battle; CCF 1, Conduct Intelligence Planning; CCF 2, Collect Information; CCF 3, Process Information; CCF 4, Disseminate Information.
- b. TF commander and staff update MOPP analysis to determine MOPP level and workload (continuous task).
- 1) MOPP level is adjusted based on threat, weather, tactical requirements and brigade commanders guidance.
 - 2) Commander considers situation factors (FM 3-4, Chap 2):
 - a) Mission.
 - b) Environment.
 - c) Soldiers.
 - 3) See: CCF 19, Direct and Lead Units During Preparation for the Battle; CCF 20, Direct and Lead Units in Execution of the Battle; CCF 2, Collect Information; CCF 3, Process Information; CCF 4, Disseminate Information; CCF 24, Enhance Physical Protection,
16. **Command Group and Command Posts monitor, supervise and direct TF mission preparation** (ARTEP 71-2-MTP, Task 7-1-3001/5, 3901/9, 3901/10, 3904/12; FM 71-123, Chap 5)
- a. TF maintains NBC equipment and supplies (continuous operations).
- 1) Sufficient supplies are on hand for basic skills and hasty decontamination and for 24 hour survival.
 - 2) Ensure PDDA is operational and operator is briefed on planned decontamination operations.
- b. See: CCF 19, Direct and Lead Units During Preparation for the Battle; CCF 20, Direct and Lead Units in Execution of the Battle; CCF 29, Conduct Supply Operations.
17. **Commander, commander's representatives, and staff conduct inspections and visits** (ARTEP 71-2-MTP, Task 7-1-3903/2; FM 71-2, Chap 2)

18. **TF Rehearsals** (FM 71-2, Chap 2; FM 71-123, Chap 2; FM 101-5, App M)
19. **TF plan modified and refined** (ARTEP 71-2-MTP, Task 7-1-3901/8, 3904/12)
20. **Command Post (TAC, TOC, CTCP) operations** (ARTEP 71-2-MTP, Task 7-1-3401, 3035, 3036, 3902/9, 3913)
 - a. TF performs chemical monitoring (continuous operations).
 - b. NBC and S3 section plan NBC surveillance.
 - c. All elements perform chemical monitoring.
 - d. Type agent and general area of contamination are correctly identified, reported and warning is disseminated.
 - e. Specific area of contamination is identified and marked.
 - f. See: CCF 19, Direct and Lead Units During Preparation for the Battle; CCF 20, Direct and Lead Units in Execution of the Battle; CCF 24, Enhance Physical Protection; CCF 1, Conduct Intelligence Planning; CCF 2, Collect Information; CCF 3, Process Information; CCF 4, Disseminate Information.
21. **Liaison and coordination with higher, adjacent, supported and supporting elements** (ARTEP 71-2-MTP, Task 7-1-3003/2, 3010/2, 3016/1, 3902/10)
22. **Command Group and Command Posts position to control the battle** (ARTEP 71-2-MTP, Task 7-1-3901/11, 3902/11, 3903/1)

**PROVIDE DECONTAMINATION
EXECUTION TASK LIST**

23. **TF Command Posts locate when they can control the battle** (ARTEP 71-2-MTP, Task 7-1-3902)
24. **TF commander sees the battlefield** (ARTEP 71-2-MTP, Task 7-1-3901/11; FM 71-100, Chap 1)
25. **TF commander directs and leads the execution phase** (ARTEP 71-2-MTP, Task 7-1-3901/12; FM 71-100, Chap 1)
26. **TF Command Posts track and support the battle** (ARTEP 71-2-MTP, Task 7-1-3903/3, 3904/14; FM 71-123, Chap 1)
 - a. All CPs react to a chemical attack.
 - 1) CP prepares for a chemical attack.
 - 2) ALL personnel are in MOPP gear.
 - 3) All water, supplies, rations and equipment are stored in vehicles or undercover.
 - 4) Chemical agent alarm is in operation upwind.
 - 5) Decon equipment is ready.
 - b. Personnel react by:
 - 1) Masking and going to MOPP 4.
 - 2) Agent is identified IAW FM 3-3.
 - 3) Personnel decontamination is completed in MOPP IAW STP 21-1-SMCT, Task 031-503-1007.
 - 4) Hasty decontamination is completed when situation allows.
 - 5) Basic skill decontamination is completed in 15 minutes.
 - 6) MOPP level is adjusted dependent on threat.
 - 7) See: CCF 20, Direct and Lead Units in Execution of the Battle; CCF 5, Conduct Tactical Movement; CCF 6, Engage Enemy with Direct Fire and Maneuver.
 - c. When hasty decon is performed:
 - 1) See: CCF 29, Conduct Supply Operations; CCF 33, Treat and Evacuate Battlefield Casualties.
 - d. All CPs prepare for a friendly nuclear strike.
 - 1) See: CCF 20, Direct and Lead Units in Execution of the Battle; CCF 5, Conduct Tactical Movement.
 - e. All TF CPs cross a chemically/nuclear contaminated area.

- 1) CP prepares to cross contaminated area.
 - 2) CP crosses the contaminated area.
 - 3) CP exits the contaminated area.
 - 4) See: CCF 20, Direct and Lead Units in Execution of the Battle; CCF 5, Conduct Tactical Movement.
- f. All CPs perform hasty decontamination.
- 1) CP OIC identifies time and site.
 - 2) CP occupies position and establishes local security.
 - 3) CP performs hasty decontamination.
 - 4) CP continue to collect chemical or nuclear contamination report and monitor detection devices.
 - 5) CP maintain a record of radiation dose received.
 - 6) CP report contamination level to TF.
 - 7) CP OIC reports to TF commander when hasty decontamination is complete.
 - 8) See: CCF 20, Direct and Lead Units in Execution of the Battle; CCF 5, Conduct Tactical Movement; CCF 29, Conduct Supply Operations; CCF 33, Treat and Evacuate Battlefield Casualties.
27. **Commander/Command Group makes battlefield decisions (accelerated)** (FM 71-123, Chap 1)
- a. TF reacts to chemical attack.
 - 1) If required all personnel are in MOPP4 within eight minutes.
 - 2) TF submits NBC report to brigade within three minutes and follow-up reports as required.
 - 3) Agent is identified.
 - 4) See: CCF 20, Direct and Lead Units in Execution of the Battle; CCF 2, Collect Information; CCF 3, Process Information; CCF 4, Disseminate Information; CCF 24, Enhance Physical Protection.
 - b. TF reacts to persistent chemical attack.
 - 1) All personnel in the area of the attack are in MOPP4 in eight minutes.
 - 2) All personnel in area of attack perform basic skills decontamination.
 - 3) TF submits NBC report to brigade within three minutes and follow-up reports as required.

- 4) Agent is identified.
- 5) Establish decontamination priorities.
- 6) All personnel in TF forward area are in MOPP4 within eight minutes and begin to conduct hasty decontamination within 20 minutes.
- 7) See: CCF 20, Direct and Lead Units in Execution of the Battle; CCF 2, Collect Information; CCF 3, Process Information; CCF 4, Disseminate Information; CCF 24, Enhance Physical Protection; CCF 33, Treat and Evacuate Battlefield Casualties.

c. Conduct Basic Skills Decontamination.

Note: Basic skills decon is performed automatically by the individual soldier on themselves and their equipment to survive and continue to fight.

- 1) Soldiers perform the following tasks:
 - a) Skin decontamination.
 - b) Personal wipedown.
 - c) Operators spraydown.
- 2) See: CCF 20, Direct and Lead Units in Execution of the Battle; CCF 24, Enhance Physical Protection.

d. TF commander updates decontamination priorities (unit, equipment, location, time).

- 1) CMLO coordinate with Bde S3 and recommend decontamination priorities to the brigade commander.
- 2) S4 coordinate with Bde XO and FSB staff for replacement of contaminated supplies and equipment operations.
- 3) See: CCF 20, Direct and Lead Units in Execution of the Battle; CCF 28, Provide Transport Services; CCF 29, Conduct Supply Operations; CCF 30, Provide Personnel Services; CCF 31, Maintain Weapons Systems and Equipment; CCF 33, Treat and Evacuate Battlefield Casualties.

e. TF Performs Hasty Decon (FM 3-5, Chap 3).

Note: Hasty decon uses two techniques: MOPP gear exchange and vehicle washdown. It is done in the unit's AO with support from TF PDDE crews or chemical company decon squads.

- 1) HASTY DECON Preparation.
 - a) Contaminated unit commander (Co/Tm, other assigned attached element) decides to conduct hasty decontamination and requests support from TF TOC.
 - b) TF TOC coordinates w/ PDDE decon crew.
 - c) TF TOC requests additional decontamination support from higher as needed.
 - d) Contaminated unit selects decontamination site.
 - e) Contaminated unit rendezvous with decon crew.
 - f) Site setup:
 - PDDE decon crew sets up hasty vehicle washdown area.
 - Co/Tm supply section drops off supplies (MOPP gear).

– Contaminated unit sets up MOPP gear exchange area.

- 2) HASTY DECON Execution. Decon activities include:
 - a) Site control and security.
 - b) Processing of contaminated personnel, equipment, and supplies.
 - c) Vehicle washdown.
 - d) MOPP gear exchange.
 - e) Unit mounts vehicles at the conclusion of decon and continues the mission.
- 3) HASTY DECON Site Clearance.
 - a) No cleanup required in vehicle washdown area (areas will be contaminated; could be a hazard to friendly forces).
 - b) TF PDDE crew cleans up MOPP gear exchange area only.
 - c) TF PDDE crew marks site and reports through NBCWRS.
- 4) See: CCF 20, Direct and Lead Units in Execution of the Battle; CCF 5, Conduct Tactical Movement; CCF 6, Engage Enemy with Direct Fire and Maneuver; CCF 29, Conduct Supply Operations; CCF 33, Treat and Evacuate Battlefield Casualties.

f. Co/Tm performs hasty decontamination (for tasks, guidance, see above).

- 1) Commander/XO/ISG select decontamination site.
- 2) Commander/XO/ISG request decontamination support from TF.
- 3) XO/ISG coordinate the decontamination site.
- 4) Co/Tm occupies decontamination site.
- 5) Co/Tm performs MOPP gear exchange.
- 6) Co/Tm performs vehicle decontamination.
- 7) Co/Tm resumes operations.
- 8) Cmdr reports decontamination status to TF CP.
- 9) See: CCF 20, Direct and Lead Units in Execution of the Battle; CCF 5, Conduct Tactical Movement; CCF 6, Engage Enemy with Direct Fire and Maneuver; CCF 29, Conduct Supply Operations.

g. TF performs deliberate chemical decontamination.

Note: Deliberate decon uses two techniques: detailed troop and detailed equipment decon. Generally, contaminated units of company and larger conduct deliberate decon supported by chemical decon units. Usually, companies do deliberate decon in the BSA, battalions in the DSA. Because it is so resource intensive, deliberate decon should be done as part of reconstitution operations.

- 1) DELIBERATE DECON Preparation.

- a) Contaminated unit commander (Co/Tm, other assigned/attached element) decides to conduct deliberate decontamination, contacts TF TOC and requests relief from mission.
 - b) TF commander makes decision to withdraw the company and coordinates with Bde TOC.
 - c) TF TOC shifts units to allow contaminated unit to withdraw and coordinates with decon units.
 - d) TF TOC requests additional decontamination support from higher as needed.
 - e) Chemical decon unit selects decontamination site.
- 2) DELIBERATE DECON Execution.
- a) Elements move to designated decontamination sites.
 - b) Contaminated Co/Tm establishes site control and security.
 - c) Chemical unit sets up and conducts equipment decon; assists contaminated unit with troop decon.
 - d) All elements perform deliberate decontamination as directed by the decontamination unit and IAW FM 3-5, Chaps 3 & 6. Conduct:
 - Detailed troop decontamination.
 - Detailed equipment decontamination.
- 3) DELIBERATE DECON Site Clearance.
- a) Cleanup of site conducted jointly by chemical unit and contaminated unit.
 - b) Marking and reporting performed by chemical unit.
 - c) See: CCF 20, Direct and Lead Units in Execution of the Battle; CCF 5, Conduct Tactical Movement; CCF 6, Engage Enemy with Direct Fire and Maneuver; CCF 28, Provide Transport Services; CCF 29, Conduct Supply Operations; CCF 30, Provide Personnel Services; CCF 31, Maintain Weapons Systems and Equipment; CCF 33, Treat and Evacuate Battlefield Casualties.
- 4) Co/Tm coordinates for detailed equipment decontamination.

Note: This task is normally performed in conjunction with a detailed troop decontamination.

- a) Commander plans detailed equipment decontamination:
 - Plans sequencing of platoons through decontamination.
 - Plans to provide personnel to assist site set up.
 - Plans for the resupply of equipment lost to decontamination procedures.
- b) Co/Tm organizes detailed equipment decontamination through TF TOC.
 - Coordinates with TF TOC and decontamination elements.
 - Sends advance party to rendezvous with decontamination elements.
 - Provides most of labor to set up, processing and cleanup.

- c) Unit prepares for and conducts decontamination:
 - Unit completes basic skills decontamination.
 - Unit arrives at staging area and prioritize vehicles per commander's guidance/TSOP.
 - Units process through decontamination site.
 - Co/Tm clears the site.
 - Chemical unit directs and supervises clearance.
 - Co/Tm provides necessary labor to assist in site clearance.
 - Company reorganizes and resumes operations.
 - Ensures complete decontamination of personnel.
 - Co/Tm reports decontamination complete and continues the mission.
 - d) See: CCF 20, Direct and Lead Units in Execution of the Battle; CCF 5, Conduct Tactical Movement; CCF 28, Provide Transport Services; CCF 29, Conduct Supply Operations; CCF 30, Provide Personnel Services; CCF 31, Maintain Weapons Systems and Equipment.
- 5) Reconstitute following deliberate decontamination.
- a) Develop command priorities to allocate resources.
 - b) Decide to Reorganize or Regenerate unit:
 - Reorganize:
 - Either immediate battlefield reorganization or deliberate reorganization.
 - Authorized by commander one echelon above.
 - Most expedient; limited to resources on hand.
 - Regenerate:
 - Either incremental or whole-unit.
 - Authorized by commander two echelons above.
 - Involves large-scale replacement of personnel, equipment, and supplies.
 - c) The following units assist in reconstitution after decon:
 - BAS: triage casualties at decon site.
 - FSB: provides one-stop shopping log support package to unit.
 - Maintenance: restores unit's equipment to full fighting capability.
 - d) See: CCF 20, Direct and Lead Units in Execution of the Battle; CCF 5, Conduct Tactical Movement; CCF 6, Engage Enemy with Direct Fire and Maneuver; CCF 28, Provide Transport Services; CCF 29, Conduct Supply Operations; CCF 30, Provide Personnel Services; CCF 31, Maintain Weapons Systems and Equipment; CCF 33, Treat and Evacuate Battlefield Casualties.
- h. TF prepares for friendly nuclear strike.
- 1) TF performs hasty nuclear decontamination.
 - 2) All elements conduct hasty decontamination IAW FM 3-5 (see task above).
 - 3) See: CCF 20, Direct and Lead Units in Execution of the Battle; CCF 5, Conduct Tactical Movement; CCF 6, Engage Enemy with Direct Fire and Maneuver; CCF 29, Conduct Supply Operations; CCF 33, Treat and Evacuate Battlefield Casualties.
- i. TF crosses radiological or chemically contaminated areas.

- 1) See: CCF 20, Direct and Lead Units in Execution of the Battle; CCF 21, Overcome Obstacles; CCF 5, Conduct Tactical Movement; CCF 6, Engage Enemy with Direct Fire and Maneuver.
 - j. TF performs hasty decontamination (see task 27e above).
28. **TF conducts battlefield update (METT-T)** (ARTEP 71-2-MTP, Task 7-1-3902/3, 3906/1, 3913/5)
29. **TF consolidates and reorganizes** (ARTEP 71-2-MTP, Task 7-1-3022, 3023)
- a. Prepare to continue or change mission.
 - b. CMLO coordinates with S1 for assignment of chemical personnel for the NBC Section.
 - c. See: CCF 18, Plan for Combat Operations; CCF 19, Direct and Lead Units During Preparation for the Battle; CCF 20, Direct and Lead Units in Execution of the Battle.

**CALL LESSONS LEARNED RELEVANT TO CCF 27
(EXTRACTS FROM LESSONS LEARNED BULLETINS)**

1. NTC Commanders Memorandum – Nov 85

Defensive Chemical Measures

Formal NBC reports should not be transmitted on battalion and company command nets due to their disruptive impact. The preferred procedure is for platoons and companies to send initial spot reports on the command net, followed by NBC reports on the admin/log net. Normally, the Co XO or NBC NCO makes the formal report. The TOC must temporarily switch a radio to admin/log or use one of the XO's radios if they have been remoted into the TOC.

MOPP posture decisions, to include when to unmask, must be made at battalion -- the first level with the staff to make a risk assessment. Just because the M-256 kit shows clear in a company area does not mean it is safe to begin unmasking.

The company NBC NCO must be forward with either the commander, XO, or FSO. He cannot perform his duties from the combat or field trains.

As best as can be determined in a training environment, our chemical defense equipment works well when used by units with discipline, knowledge, and motivation. The addition of NBC officers and NCOs at battalion and company levels has helped.

A systematic rather than a decentralized piecemeal integration of equipment is key. As an example, the company must plan the placement of its M-8 chemical alarms to provide coverage for alternative and supplementary as well as primary positions. Also, repositioning must occur as weather conditions change.

While effective operations in MOPP require intensive training in both combat and support tasks, units can perform far better than I previously imagined. The amount of CS used at NTC is such that most organizations adopt the chemical suit as their duty uniform, upgrading with mask, gloves, and boots as the situation dictates. Yet, even in the middle of the summer with temperatures well in excess of 110° F, defenses are successful, obstacles are breached, objectives are taken, and weapons are fired accurately. MOPP gear obviously degrades performance, but it is not a show stopper for well trained units.

Getting NBC warnings to elements not organic or attached to companies requires the use of all battalion nets, to include admin/log and mortar FDC. Each element in the task force area must monitor at least one battalion net, regardless of the support or command relationship.

2. Lessons Learned Bulletin – Jan 86

All CSS players focus on pushing their services forward without waiting for a unit request. An example of a push supply system is sending forward NBC filters and protective overgarments without a unit request after a chemical attack.

3. **Lessons Learned Bulletin – Feb 87**

Transmission of messages under the NBC Reporting System can be further reduced by:

Users fully understanding the intent of the system and why certain reports are essential. The system is designed as a means of disseminating intelligence; not to jam nets with an almost continuous flow of NBC reports to the exclusion of all other traffic.

Submitting only the essential line items of information.

Using alternate nets to submit lengthy reports. Uses the O&I net initially and pass follow-on information on a designated net (e.g., the admin-log net).

Developing clear, concise instructions in unit SOPs which specify the abbreviated reporting procedures.

4. **Lessons Learned Bulletin – May 87**

A recommended technique to preclude cluttering the command net is for only one NBC 1 reports to be forwarded: the first unit which transmits. All other stations quickly acknowledge the NBC 1 report and indicate whether or not they are also under attack. If a unit is being subjected to attack by an agent other than that indicated in the initial NBC 1 report that unit will also render the NBC 1 (chemical) report. The TF TOC is thus given the full extent of the chemical attack without the command net being cluttered with numerous NBC 1 (chemical) reports.

5. **Lessons Learned Bulletin – Compendium Fall 88: Volume I**

Blood agents break down mask filters, rendering them ineffective. S4's must have replacement filters planned for and repositioned for quick exchange in case of exposure.

All units, regardless of command relationship, operating in the task force sector should monitor at least one of the TF nets for NBC warnings. The TF should issue warnings on command, A/L and fire support nets to ensure the widest dissemination.

6. **Lessons Learned Bulletin – Nov 89**

RECONSTITUTION PLANNING

There are currently no FMs in the field that adequately address reconstitution planning requirements. TRADOC Pam 525-51, 4 April 1986, provides valuable broad guidance into reconstitution planning. CGSOC Student Text, 63-1, "AirLand Battle Sustainment Doctrine (Division and Corps)," addresses reconstitution planning in more detail and includes planning considerations for establishing a reconstitution program.

Detailed SOP Needed

In recent exercises, reconstitution efforts have generally been accomplished.

However, they have frequently been reactive in nature. They have usually been poorly planned and coordinated efforts, lacking in organization and efficiency.

Reconstitution Requirements

Reconstitution is a major mission for the CSS organization of a division/corps and it may be the most difficult mission they will be called on to accomplish.

7. **Lessons Learned Bulletin – Dec 91**

Logistic operations in an NBC environment are consistently weak. The BSA is routinely targeted and fired upon with persistent chemical agents at the CTCs. Unit reactions to this threat have been mixed. Some react and cope with the situation better than others, but none do very well. Sometimes only a small area of the BSA is targeted for the persistent nerve agent. Initially the BSA goes to MOPP level IV when attacked. From there operations begin to deteriorate. Units are not able to quickly determine the limits of the contamination and then cordon off the area to establish control of entrances and exists.

CSS units for the most part do not conduct NBC training at home station. When they do, it consists of going about their regular jobs in MOPP level IV for a predetermined period of time. SOPs are not developed that cover how the unit will react to a persistent chemical agent attack. It is well known that threat doctrine calls for possible use of persistent and nonpersistent agents throughout the Division Main Battle Area, yet our training to conduct sustained operations in this environment is woefully inadequate.

Require BDE S4 and FSB TOC to monitor availability of water for decontamination.

8. **CALL NEWSLETTER NO. 90-8, SEP 90: Winning in the Desert II**

TOPIC: Chemical Alarms

DISCUSSION: The M-8 chemical alarm detects nerve agents only. The Iraq army has and uses munitions filled with blister.

LESSON(S) LEARNED:

- a. Educate all users of the M-8 alarm.
- b. Immediately conduct a M-256 ticket test for each M-8 detection.
- c. Always expect rear area units, artillery positions, CPs and other fixed or semi-fixed units to sustain an attack of mixed agents.
- d. Use the nose as a very sensitive detector of mustard agent. Have soldiers immediately mask if they smell strange and unexplained odors on the battlefield once chemical attacks, using mustard, have been initiated (the nose is more sensitive to blister agents than most alarms.)

TOPIC: Wear rubber boots and gloves (MOPP gear) in desert warfare.

DISCUSSION: Wearing rubber gloves and boots in hot weather causes many problems.

LESSON(S) LEARNED:

- a. Do not wear rubber gloves and boots in desert warfare unless direct exposure to liquid mustard agent is imminent.
- b. Find clean areas to get relief from wearing rubber gloves and boots before softening of the hands and feet, as well as other associated medical problems set in.

TOPIC: Characteristics of Chemical Agents in Desert Climates.

DISCUSSION: Chemical agents dissipate rapidly in hot weather. Hot air convection currents carry agents upward and, therefore, minimize cloud travel and the threat of vapor hazards for ground troops. On the other hand, this creates a greater threat to pilots than they would face under a more moderate climate.

LESSON(S) LEARNED:

- a. Think of classic G-nerve agent persistency to be similar to that of water. It has little chemical similarity, but it does evaporate at about the same rate. Almost everyone can relate to how quickly water evaporates in most terrain and under climatic conditions. In very hot weather, like water, classic G-nerve agents last only minutes, but create a significant, short-lived vapor hazard. G-agent effects are immediate.
- b. Think of mustard agents as being delayed-acting (effects often coming 6-12 hrs after exposure) persistent chemical agents with the following rules of thumb. In the hot, daytime desert temperatures, mustard persistency will be about 6 hours or less if the mustard agent is exposed to the atmosphere (e.g., not buried). With winds of 4 mph or greater, the persistency is reduced to around 2 hours.
- c. Think of classic V-nerve agent persistency to be similar to that of liquid mercury, i.e., it hardly evaporates at all. It therefore is mainly a touch hazard with long persistency (its persistency is dependent on chemical reactions with the elements, not on evaporation.) V-agents, like mustard agents, are delayed acting because they must soak through clothing and the skin to be effective. Once in the blood stream, however, they are extremely fast acting and symptoms, to include death, will occur in seconds to minutes. Entry through wounds, cuts, etc., will produce immediate effect.
- d. During periods of active chemical warfare, have at least one helicopter pilot masked at all times.

TOPIC: Chemical Casualty Identification.

DISCUSSION: Soldiers may exhibit symptoms of exposure to chemical agents, but not be chemical casualties. Heat casualties suffering from exhaustion, heatstroke or sunstroke can exhibit symptoms similar to chemical casualties.

LESSON(S) LEARNED:

- a. Conduct awareness seminars, classes, briefings, etc.
- b. Suspect other-than-a-chemical casualty if no event on the battlefield or IPB analysis indicates a chemical attack or exposure was likely.

- c. Suspect other-than-a-chemical casualty if only one or a very few soldiers exhibit symptoms.

TOPIC: In most cases, overreaction to the chemical threat is worse than underreaction.

DISCUSSION: Wearing the MOPP suit in hot desert temperatures as a precautionary measure to impending chemical attacks can result in more casualties, including death, than a chemical attack would produce. Wearing MOPP gear and doing hard work, such as humping ammunition, digging in, or attacking, can quickly put soldiers at risk.

LESSON(S) LEARNED:

- a. Always operate at minimum MOPP levels. Accept risk in the chemical defense business just as with any other aspect of warfare. Expect a fair share of chemical casualties along with other conventional casualties.
- b. Remember, mission accomplishment is paramount, and risks must be taken if MOPP posture will prevent mission accomplishment.
- c. Don't win the chemical survival battle and lose the tactical battle.
- d. Don't become consumed with chemical survival and ignore other important tasks, missions, etc.

TOPIC: Leader Identification.

DISCUSSION: Leader's strength of character is lost when MOPP gear is donned. Everyone becomes automatons. Leadership becomes increasingly more difficult. Frustration quickly sets in, accompanied by irritation.

LESSON(S) LEARNED:

- a. Units must establish an SOP for identifying leaders. Leaders should find ways to be visible while wearing MOPP gear. For example, the chief of staff could always carry an ax handle or other trademark. Others should do similar things.
- b. Conduct entire-unit realistic training.
- c. Get adequate rest to better be able to cope with frustration and irritability.
- d. Accept degradation associated with wearing MOPP gear.

TOPIC: Delegation of Authority in a Chemical Environment.

DISCUSSION: Leaders have a tendency to not delegate authority while in MOPP gear and try to do too much themselves. Consequently, they become the first to fall out due to sheer exhaustion.

LESSON(S) LEARNED: Error on the side of overdelegation during periods where MOPP gear is worn. Let the number two man handle the action, as our doctrine requires, so the number one soldier can get uninterrupted rest.

TOPIC: Personal Hygiene.

DISCUSSION: Soldiers tend not to shave every day in a combat situation especially in a desert environment where water is a precious commodity. But if soldiers do not shave every day, they cannot get a good seal on their protective masks and are likely to become a casualty in the event of a chemical attack.

LESSON(S) LEARNED: Make it a command policy that every male soldier shave every day. Use of battery-powered electric razors can reduce water requirements.

TOPIC: Decontamination.

DISCUSSION: Deliberate decontamination is seldom a good idea in desert operations. The natural weathering due to hot temperatures, wind, and humidity, will normally reduce contamination to acceptable levels before a deliberate decontamination operation could be planned and executed.

LESSON(S) LEARNED: Conduct deliberate decontamination only as an exception to policy when operating in extremely hot temperatures. Ensure that the decision to conduct deliberate decontamination operations makes sense both tactically and technically.

TOPIC: False Alarms of the M-8 Detectors.

DISCUSSION: The M-8 Detectors will periodically malfunction producing a false alarm. Nothing can be done to prevent this. This problem will have to be accepted and dealt with on a case-by-case basis.

LESSON(S) LEARNED:

- a. Always array alarms, and , if only one activates, suspect a false alarm.
- b. Suspect a false alarm when no obvious chemical attacks have occurred.

TOPIC: Miosis.

DISCUSSION: Threshold concentrations of nerve agent vapors can quickly cause miosis (involuntary constriction of the pupil). This results in loss of visual acuity and depth perception. Effects can last minutes to hours depending on vapor concentration. This will cause serious problems for pilots, riflemen, and anyone else performing duties where visual acuity and depth perception are necessary for mission performance.

LESSON(S) LEARNED: Immediately close your eyes, hold your breath and don your mask when a chemical alarm sounds during an attack on your position.

TOPIC: Contaminated Casualties.

DISCUSSION: Contamination problems can be greatly reduced if the clothing is immediately removed from all chemical casualties. It is unlikely that chemical casualties will have significant quantities of liquid contaminants on their skin as most

will be present on their clothing. This will greatly facilitate moving chemical casualties through medical channels.

LESSON(S) LEARNED: Make it a requirement to immediately remove all clothing from chemical casualties. Cutting it off is recommended.

TOPIC: Chemical Protection in Hot Weather.

DISCUSSION: Light infantry and other combatants that require light loads and minimum heat burden can use ponchos for field-expedient, short-term MOPP gear. Ponchos were not designed for this, but common sense tells you that they will give short-term protection from any liquid. The MOPP suit is designed to give long-term protection from liquid agents. This involves some risk taking, but the risk is normally worth taking in the desert.

LESSON(S): The 5-percent allowance above authorized strength for certain sizes of NBC items may not match unit needs. Units must continually monitor the sizes and serviceability of NBC equipment. Use banana oil, and continually check serviceability. Turn in unserviceable NBC equipment.

**LESSONS LEARNED INTEGRATED
INTO CCF 27 TASK LIST**

PLANNING

1. Direct and lead TF during planning for the battle

Combat battlefield stress

TOPIC: Leader Identification

DISCUSSION: Leader's strength of character is lost when MOPP gear is donned. Everyone becomes automatons. Leadership becomes increasingly more difficult. Frustration quickly sets in, accompanied by irritation.

LESSON(S) LEARNED:

- a. Units must establish an SOP for identifying leaders. Leaders should find ways to be visible while wearing MOPP gear. For example, the chief of staff could always carry an ax handle or other trademark. Others should do similar things.
- b. Conduct entire-unit realistic training.
- c. Get adequate rest to better be able to cope with frustration and irritability.
- d. Accept degradation associated with wearing MOPP gear.

TOPIC: Delegation of Authority in a Chemical Environment.

DISCUSSION: Leaders have a tendency to not delegate authority while in MOPP gear and try to do too much themselves. Consequently, they become the first to fall out due to sheer exhaustion.

LESSON(S) LEARNED: Error on the side of overdelegation during periods where MOPP gear is worn. Let the number two man handle the action, as our doctrine requires, so the number one soldier can get uninterrupted rest.

2. **Receive Brigade WO/OPORD**
3. **Conduct mission analysis**
4. **Issue TF warning order**
5. **Commander's guidance**
6. **Prepare staff estimates**
7. **Staff develop courses of action**

8. **Staff/Commander analyze COA**
9. **Staff compare COA**
10. **Commander announces decision**
11. **Prepare order**
12. **Issue order**
13. **Refine order**

PREPARATION

14. **Command Group conducts and receives briefings (backbriefs/briefbacks)**
15. **Command Group and Command Posts monitor, supervise, and direct execution of force protection operations/activities**
 - a. **CMLO monitors and manages the NBC Warning and Reporting System (NBCWARS)**

Formal NBC reports should not be transmitted on battalion and company command nets due to their disruptive impact. The preferred procedure is for platoons and companies to send initial spot reports on the command net, followed by NBC reports on the admin/log net. Normally, the Co XO or NBC NCO makes the formal report. The TOC must temporarily switch a radio to admin/log or use one of the XO's radios if they have been remoted into the TOC.

Getting NBC warnings to elements not organic or attached to companies requires the use of all battalion nets, to include admin/log and mortar FDC. Each element in the task force area must monitor at least one battalion net, regardless of the support or command relationship.

Transmission of messages under the NBC Reporting System can be further reduced by:

- Users fully understanding the intent of the system and why certain reports are essential. The system is designed as a means of disseminating intelligence; not to jam nets with an almost continuous flow of NBC reports to the exclusion of all other traffic.
- Submitting only the essential line items of information.
- Using alternate nets to submit lengthy reports. Uses the O&I net initially and pass follow-on information on a designated net (e.g., the admin-log net).
- Developing clear, concise instructions in unit SOPs which specify the abbreviated reporting procedures.

A recommended technique to preclude cluttering the command net is for only one NBC 1 report to be forwarded: the first unit which transmits. All other stations quickly acknowledge the NBC 1 report and indicate whether or not they are also under attack. If a unit is being subjected to attack by an agent other than that indicated in the initial

NBC 1 report that unit will also render the NBC 1 (chemical) report. The TF TOC is thus given the full extent of the chemical attack without the command net being cluttered with numerous NBC 1 (chemical) reports.

All units, regardless of command relationship, operating in the task force sector should monitor at least one of the TF nets for NBC warnings. The TF should issue warnings on command, A/L and fire support nets to ensure the widest dissemination.

- b. TF commander and staff update MOPP analysis to determine MOPP level and workload

MOPP posture decisions, to include when to unmask, must be made at battalion -- the first level with the staff to make a risk assessment. Just because the M-256 kit shows clear in a company area does not mean it is safe to begin unmasking.

While effective operations in MOPP require intensive training in both combat and support tasks, units can perform far better than I previously imagined. The amount of CS used at NTC is such that most organizations adopt the chemical suit as their duty uniform, upgrading with mask, gloves, and boots as the situation dictates. Yet, even in the middle of the summer with temperatures well in excess of 110° F, defenses are successful, obstacles are breached, objectives are taken, and weapons are fired accurately. MOPP gear obviously degrades performance, but it is not a show stopper for well trained units.

TOPIC: Wear rubber boots and gloves (MOPP gear) in desert warfare.

DISCUSSION: Wearing rubber gloves and boots in hot weather causes many problems.

LESSON(S) LEARNED:

- a. Do not wear rubber gloves and boots in desert warfare unless direct exposure to liquid mustard agent is imminent.
- b. Find clean areas to get relief from wearing rubber gloves and boots before softening of the hands and feet, as well as other associated medical problems set in.

TOPIC: Characteristics of Chemical Agents in Desert Climates.

DISCUSSION: Chemical agents dissipate rapidly in hot weather. Hot air convection currents carry agents upward and, therefore, minimize cloud travel and the threat of vapor hazards for ground troops. On the other hand, this creates a greater threat to pilots than the would face under a more moderate climate.

LESSON(S) LEARNED:

- a. Think of classic G-nerve agent persistency to be similar to that of water. It has little chemical similarity, but it doe evaporate at about the same rate. Almost everyone can relate to how quickly water evaporates in most terrain and under climatic conditions. In very hot weather, like water, classic G-nerve agents last only minutes, but create a significant, short- lived vapor hazard. G-agent effects are immediate.

- b. Think of mustard agents as being delayed-acting (effects often coming 6-12 hrs after exposure) persistent chemical agents with the following rules of thumb. In the hot, daytime desert temperatures, mustard persistency will be about 6 hours or less if the mustard agent is exposed to the atmosphere (e.g., not buried). With winds of 4 mph or greater, the persistency is reduced to around 2 hours.
- c. Think of classic V-nerve agent persistency to be similar to that of liquid mercury, i.e., it hardly evaporates at all. It therefore is mainly a touch hazard with long persistency (its persistency is dependent on chemical reactions with the elements, not on evaporation.) V-agents, like mustard agents, are delayed acting because they must soak through clothing and the skin to be effective. Once in the blood stream, however, they are extremely fast acting and symptoms, to include death, will occur in seconds to minutes. Entry through wounds, cuts, etc., will produce immediate effect.
- d. During periods of active chemical warfare, have at least one helicopter pilot masked at all times.

TOPIC: Chemical Casualty Identification.

DISCUSSION: Soldiers may exhibit symptoms of exposure to chemical agents, but not e chemical casualties. Heat casualties suffering from exhaustion, heatstroke or sunstroke can exhibit symptoms similar to chemical casualties.

LESSONS) LEARNED:

- a. Conduct awareness seminars, classes, briefings, etc.
- b. Suspect other-than-a-chemical casualty if no event on the battlefield or IPB analysis indicates a chemical attack or exposure was likely.
- c. Suspect other-than-a-chemical casualty if only one or a very few soldiers exhibit symptoms.

TOPIC: In most cases, overreaction to the chemical threat is worse than underreaction.

DISCUSSION: Wearing the MOPP suit in hot desert temperatures as a precautionary measure to impending chemical attacks can result in more casualties, including death, than a chemical attack would produce. Wearing MOPP gear and doing hard work, such as humping ammunition, digging in, or attacking, can quickly put soldiers at risk.

LESSON(S) LEARNED:

- a. Always operate at minimum MOPP levels. Accept risk in the chemical defense business just as with any other aspect of warfare. Expect a fair share of chemical casualties along with other conventional casualties.
- b. Remember, mission accomplishment is paramount, and risks must be taken if MOPP posture will prevent mission accomplishment.
- c. Don't win the chemical survival battle and lose the tactical battle.

- d. Don't become consumed with chemical survival and ignore other important tasks, missions, etc.

TOPIC: Personal Hygiene.

DISCUSSION: Soldiers tend not to shave every day in a combat situation especially in a desert environment where water is a precious commodity. But if soldiers do not shave every day, they cannot get a good seal on their protective masks and are likely to become a casualty in the event of a chemical attack.

LESSON(S) LEARNED: Make it a command policy that every male soldier shave every day. Use of battery-powered electric razors can reduce water requirements.

16. Command Group and Command Posts monitor, supervise, and direct TF mission preparation

- a. TF maintains NBC equipment and supplies.

The 5-percent allowance above authorized strength for certain sizes of NBC items may not match unit needs.

Units must continually monitor the sizes and serviceability of NBC equipment. Use banana oil, and continually check serviceability. Turn in unserviceable NBC equipment.

Blood agents break down mask filters, rendering them ineffective. S4's must have replacement filters planned for and repositioned for quick exchange in case of exposure.

17. Commander, Commander's representatives, and staff conduct inspections and visits

18. TF rehearsals

19. TF plan modified and refined

20. Command Post (TAC, TOC, CTCP) operations

- a. TF performs chemical monitoring.

A systematic rather than a decentralized piecemeal integration of equipment is key. As an example, the company must plan the placement of its M-8 chemical alarms to provide coverage for alternative and supplementary as well as primary positions. Also, repositioning must occur as weather conditions change.

TOPIC: Chemical Alarms.

DISCUSSION: The M-8 chemical alarm detects nerve agents only. The Iraq army has and uses munitions filled with blister.

LESSON(S) LEARNED:

- a. Educate all users of the M-8 alarm.
- b. Immediately conduct a M-256 ticket test for each M-8 detection.
- c. Always expect rear area units, artillery positions, CPs and other fixed or semi-fixed units to sustain an attack of mixed agents.
- d. Use the nose as a very sensitive detector of mustard agent. Have soldiers immediately mask if they smell strange and unexplained odors on the battlefield once chemical attacks, using mustard, have been initiated (the nose is more sensitive to blister agents than most alarms).

TOPIC: False Alarms of the M-8 Detectors.

DISCUSSION: The M-8 Detectors will periodically malfunction producing a false alarm. Nothing can be done to prevent this. This problem will have to be accepted and dealt with on a case-by-case basis.

LESSON(S) LEARNED:

- a. Always array alarms, and , if only one activates, suspect a false alarm.
 - b. Suspect a false alarm when no obvious chemical attacks have occurred.
21. **Liaison and coordination with higher, adjacent, supported and supporting elements**
 22. **Command Group and Command Posts position to control the battle**

EXECUTION

23. **TF Command Posts locate when they can control the battle**
24. **TF Commander sees the battlefield**
25. **TF Commander directs and leads the execution phase**
26. **TF Command Posts track and support the battle**
27. **TF conducts the decision making process (accelerated)**

- b. TF reacts to persistent chemical attack.

All CSS players focus on pushing their services forward without waiting for a unit request. An example of a push supply system is sending forward NBC filters and protective overgarments without a unit request after a chemical attack.

Logistic operations in an NBC environment are consistently weak. The BSA is routinely targeted and fired upon with persistent chemical agents at the CTCs. Unit reactions to this threat have been mixed. Some react and cope with the situation better than others, but none do very well. Sometimes only a small area of the BSA is targeted for the persistent nerve agent. Initially the BSA goes to MOPP level IV when attacked. From there operations begin to deteriorate. Units are not able to quickly determine the limits of the contamination and then cordon off the area to establish control of entrances and exists.

CSS units for the most part do not conduct NBC training at home station. When they do, it consists of going about their regular jobs in MOPP level IV for a predetermined period of time. SOPs are not developed that cover how the unit will react to a persistent chemical agent attack. It is well known that threat doctrine calls for possible use of persistent and nonpersistent agents throughout the Division Main Battle Area, yet our training to conduct sustained operations in this environment is woefully inadequate.

- e. TF performs hasty decontamination.

Require BDE S4 and FSB TOC to monitor availability of water for decontamination.

- f. Co/Tm performs hasty decontamination.

The company NBC NCO must be forward with either the commander, XO, or FSO. He cannot perform his duties from the combat or field trains.

- g. TF performs deliberate chemical decontamination.

TOPIC: Decontamination.

DISCUSSION: Deliberate decontamination is seldom a good idea in desert operations. The natural weathering due to hot temperatures, wind, and humidity, will normally reduce contamination to acceptable levels before a deliberate decontamination operation could be planned and executed.

LESSON(S) LEARNED: Conduct deliberate decontamination only as an exception to policy when operating in extremely hot temperatures. Ensure that the decision to conduct deliberate decontamination operations makes sense both tactically and technically.

TOPIC: Contaminated Casualties.

DISCUSSION: Contamination problems can be greatly reduced if the clothing is immediately removed from all chemical casualties. It is unlikely that chemical casualties will have significant quantities of liquid contaminants on their skin as

most will be present on their clothing. This will greatly facilitate moving chemical casualties through medical channels.

LESSON(S) LEARNED: Make it a requirement to immediately remove all clothing from chemical casualties. Cutting it off is recommended.

- g. Reconstitute following deliberate decontamination.

Reconstitution Planning

There are currently no FMs in the field that adequately address reconstitution planning requirements. TRADOC Pam 525-51, 4 April 1986, provides valuable broad guidance into reconstitution planning. CGSOC Student Text, 63-1, "AirLand Battle Sustainment Doctrine (Division and Corps)," addresses reconstitution planning in more detail and includes planning considerations for establishing a reconstitution program.

Detailed SOP Needed

In recent exercises, reconstitution efforts have generally been accomplished. However, they have frequently been reactive in nature. They have usually been poorly planned and coordinated efforts, lacking in organization and efficiency.

Reconstitution Requirements

Reconstitution is a major mission for the CSS organization of a division/corps and it may be the most difficult mission they will be called on to accomplish.

- 28. **TF conducts battlefield update (METT-T based)**
- 29. **TF consolidates and reorganizes**

**CCF 27
CRITICAL TASKS AND OTHER LINKAGES**

<u>TASK</u>	<u>OTHER LINKAGES</u>
5. Commander's guidance	CMLO (STP 3-74II-MQS) Advise the Commander on NBC Threat (01-5090.02-2044)
6. Prepare staff estimates	CMLO (STP 3-74II-MQS) Advise Commander and Staff on Current NBC Situations (01-5060.02-2008) Assess Unit NBC Status (01-5060.02-2007) Prepare Chemical Vulnerability Analysis of Friendly Troop Dispositions (01-5060.01-2104) Advise the Commander on Chemical and Biological Agents and Their Effects (01-5090.02-2032) NBC NCOs/Section STP 3-54B2-SM Provide Technical Advise on Chemical Agents and Compounds (031-506-2002) STP 3-54B34-SM-TG Plan Decon Operations (031-506-3001) Plan Chem Survey (031-506-3003)
11. Prepare Order	CMLO (STP 3-74II-MQS) Prepare NBC Defense Annex to OPLAN or OPORD (03-5060.01-2107) NBC NCOs/Section (STP 3-54B2-SM) Prepare NBC Annex to Unit SOP (031-506-2032)
15a. CMLO monitors and manages the NBC Warning and Reporting System (NBCWARS)	CMLO (STP 3074II-MQS) Prepare and Disseminate a Chemical Downwind Message (01-5060.02-3099) NBC NCOs/Section (STP 3-54B34-SM-TG) Prepare STRIKEWARN/ CHEMWARN Message (031-506-3038) Prepare Effective Downwind Message (031-506-3045)

<u>TASK</u>	<u>OTHER LINKAGES</u>
	<p>Prepare Chemical Downwind Message (031-506-3067)</p> <p>Recommend Protective Measures for Friendly Troops in STRIKEWARN/ CHEMWARN Area (031-506-3065)</p>
15b. Update MOPP analysis to determine MOPP level and workload	<p>CMLO (STP 3-74II-MQS)</p> <p>Prepare Chemical Vulnerability Analysis of Friendly Troop Dispositions (01-5060.01-2104)</p> <p>NBC NCOs/Section (STP 3-54B2-SM)</p> <p>Advise Commander on MOPP (031-506-2053)</p>
16a. TF maintains NBC equipment and supplies	<p>CMLO (STP 3-74II-MQS)</p> <p>Establish Decontamination Material Requirements (01-5070.02-2019)</p>
20a. TF performs chemical monitoring	<p>CMLO (STP 3-74II-MQS)</p> <p>Supervise NBC Recon Operations (01-5060.02-2071)</p> <p>Supervise Chemical Survey Operations (01-5060.02-2093)</p>
27a. TF reacts to chemical attack	<p>CMLO (STP 3-74II-MQS)</p> <p>Supervise NBC Detection and Identification Operations (01-5060.02-20901)</p> <p>Direct Recon and Decon Team Operations at a Chemical Accident or Incident Site (01-5060.02-3072)</p> <p>NBC NCOs/Section (STP 3-54B2-SM)</p> <p>Prepare and Submit NBC 1 Reports (031-503-3005)</p> <p>ALL</p> <p>(STP 21-1 SMCT)</p> <p>Recognize and React to Chemical or Biological Hazard (031-503-1019)</p> <p>(STP 21-24-SMCT)</p> <p>Implement Mission-Oriented Protective Posture (031-503-3008)</p>

<u>TASK</u>	<u>OTHER LINKAGES</u>
27c. Conduct basic skills decontamination	ALL (STP 21-1-SMCT) Decon Your Skin and Personal Equipment (031-503-1007)
27d. TF commander updates decontamination priorities (unit, equipment, location, time)	CMLO (STP 3-74II-MQS) Recommend Decontamination Types and Procedures (01-5070.02-2010)
24e. TF performs hasty decontamination	NBC NCOs (STP 3-54B2-SM) Conduct Hasty Decontamination (031-507-2006) ALL (STP 21-24-SMCT) Supervise Hasty Decon (031-507-3003)
27f. Co/Tm performs hasty decontamination	NBC NCOs (STP 3-54B2-SM) Conduct Hasty Decontamination (031-507-2006) ALL (STP 21-24-SMCT) Supervise Hasty Decon (031-507-3003)
27g. TF performs deliberate decon	NBC NCOs/Section (STP 3-54B2-SM) Supervise Deliberate Equipment Decontamination (031-507-2013) Supervise Deliberate Troop Decontamination (031-507-2018)
27h. Co/Tm performs deliberate decon	NBC NCOs/Section (STP 3-54B2-SM) Supervise Deliberate Equipment Decontamination (031-507-2013) Supervise Deliberate Troop Decontamination (031-507-2018)
TF prepares for nuclear strike	CMLO (STP 3-74II-MQS) Supervise Maintenance of Unit Radiation Exposure Status (01-5050.02-2039)

**PROVIDE DOCUMENTATION
REFERENCES**

FMs

3-3	Chemical and Biological Contamination Avoidance, Nov 92
3-4	NBC Protection, May 92
3-5	NBC Decontamination, June 85
3-100	NBC Defense, Chemical Warfare, Smoke and Flame Operations, May 91
3-101	Chemical Staffs and Units, Apr 87
25-100	Training the Force, Nov 88
25-101	Battle Focused Training, Sept 90
63-2	Division Support Command: Armored, Infantry, and Mechanized Infantry Divisions, May 91
63-20	Forward Support Battalion, Feb 90
71-1	The Tank and Mechanized Infantry Company Team, Nov 88
71-2	The Tank and Mechanized Infantry Battalion Task Force, Sept 88
71-3	Armored and Mechanized Infantry Brigade, May 88
71-100	Division Operations, June 1990
71-123	Tactics, Techniques, and Procedures for Combined Arms Forces: Armored and Mechanized Infantry Brigade, Battalion/Task Force, and Company/Team, Sept 92
100-5	Operations, May 86
100-10	Combat Services Support, Feb 88
101-10-1/2	Staff Officers Field Manual, July 90

ARTEPs

08-058-30-MTP	MTP for the Medical Company, FSB, Jun 89
3-117-40-MTP	MTP for the Chemical Section and NBC Center, Oct 88
3-457-10-MTP	MTP for the Smoke/Decontamination Platoon, Sept 92
17-236-10-MTP	Task Force Maintenance Platoon, Dec 87
17-236-11-MTP	Task Force Support Platoon, Nov 87
17-236-12-MTP	Task Force Medical Platoon, Dec 87
71-1-MTP	The Tank and Mechanized Infantry Company Team MTP, Oct 88
71-2-MTP	The Tank and Mechanized Infantry Battalion TF MTP, Oct 88
71-3-MTP	Heavy Brigade Command Group and Staff, Oct 88
42-004-30-MTP	MTP for the Supply Company, FSB, Armor and Mechanized Divisions, Feb 89
43-009-30-MTP	MTP for the Maintenance Company, FSB, Armor and Mechanized Divisions, Feb 89
63-005-MTP	MTP for Battalion HQ, FSB, Heavy and Motorized Division, Oct 88

STPs

3-54B2-SM	Chemical Operations Specialist Soldiers Manual (Skill Level 2), Mar 92
3-5434-SM-TG	Chemical Operations Specialist Soldiers Manual (Skill Levels 3/4), Mar 92
21-1-SMC7	Soldier's Manual of Common Tasks (Skill Level 1), Oct 90
21-24-SMC7	Soldier's Manual of Command Tasks (Skill Levels 2-4), Oct 92

**CENTER FOR ARMY LESSONS LEARNED (CALL)
PUBLISHED LESSONS LEARNED**

NTC Commanders Memorandum - Nov 85
Lessons Learned Bulletin - Jan 86
Lessons Learned Bulletin - Feb 87
Lessons Learned Bulletin - Jul 87
Year of Training Newsletter - Fall 88
Lessons Learned Bulletin - Nov 89
Battlefield Logistics Newsletter - Dec 91
Newsletter NO. 90-8: Winning in the Desert II
Newsletter NO. 90-11: Getting to the Desert

RESEARCH PRODUCTS

Commander's Battle Staff Handbook, US ARI, Ft Benning Field Unit, May 1993