



AFCTN Report 94-109

AFCTB-ID
94-103



**Technical TO 31R2-2T-21 Publication
Transfer Using:**



**O'Neil & Associates' Data
Supporting:**

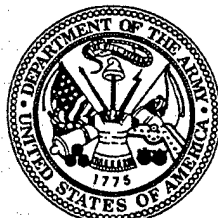

ESC/MSL's MILSTAR Program

(Contract #F19628-89-C-0131)



**MIL-STD-1840A
MIL-D-28000A (IGES)
MIL-M-28001B (SGML)
MIL-R-28002A (Raster)
MIL-D-28003 (CGM)**

Quick Short Test Report

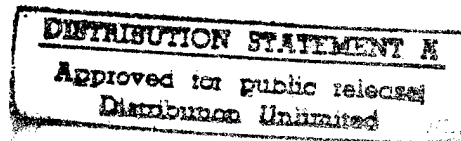

31 July 1994

19960822 123



Prepared for
Electronic Systems Center
Air Force CALS Program Office
HQ ESC/AV-2
4027 Colonel Glenn Hwy Suite 300
Dayton OH 45431-1672

DTIC QUALITY INSPECTED 3

Technical TO 31R2-2T-21 Publication Transfer

Using:

O'Neil & Associates' Data

Supporting:

ESC/MSL's MILSTAR Program

(Contract #F19628-89-C-0131)

MIL-STD-1840A

MIL-D-28000A (IGES)

MIL-M-28001B (SGML)

MIL-R-28002A (Raster)

MIL-D-28003 (CGM)

Quick Short Test Report

31 July 1994

Prepared By

Air Force CALS Test Bed
Wright-Patterson AFB, OH 45433

AFCTB Contact

Gary Lammers
(513) 427-2295

AFCTN Contact

Mel Lammers
(513) 427-2295

[DTIC QUALITY INSPECTED 3]

DISCLAIMER

This document was prepared as an account of the work sponsored by the Air Force. Neither the United States Government, the Air Force, nor any of their employees makes any warranty, expressed or implied, or assumes any legal liability or responsibility for the accuracy, completeness, or usefulness of any information, apparatus, product, or process disclosed, nor represents that its use would not infringe on privately owned rights. Reference herein to any specific commercial products, process, or service by trade name, trademark, manufacturer, or otherwise, does not necessarily constitute or imply its endorsement, recommendation, or favoring by the United States Government or the Air Force. The views and opinions of authors expressed herein do not necessarily state or reflect those of the United States Government or the Air Force, and shall not be used for advertising or product endorsement purposes.

Available to the public from the
National Technical Information Service
U.S. Department of Commerce
5285 Port Royal Road
Springfield, VA 22161

This report and those involved in its preparation do not endorse any product, process, or company stated herein. Use of these means by anyone does not imply certification by the Air Force CALS Test Network (AFCTN).

Air Force CALS Test Bed

Notification of Test Results

31 July 1994

This notice documents the results of an Air Force CALS Test Bed (AFCTB) Quick Short Test Report (QSTR) evaluation of data submitted by:

O'Neil & Associates, Inc.

Identified as follows:

Title:	Technical Publication T O 31R2-2T-21 Transfer
Program:	MILSTAR
Program Office:	ESC/MSL
Contract No.:	F19628-89-C-0131
QSTR No.:	AFCTB-ID 94-103

Received on the following media: **Three 9-Track Tapes**

The results of the QSTR evaluation are as follows:

MIL-STD-1840A Standard:	Pass
MIL-STD-1840A Media Format:	Pass
MIL-D-28000A IGES:	Pass
MIL-M-28001B SGML:	Pass
MIL-R-28002A Raster:	Pass
MIL-D-28003 CGM:	Pass

Formal results with associated disclaimer are documented and available from the AFCTB.

**Air Force CALS Test Bed
HQ ESC/AV-2P
4027 Colonel Glenn Highway, Suite 300
Dayton, OH 45431-1672
Phone: 513-257-3085 FAX: 513-257-5881**

Contents

1.	Introduction.....	1
1.1.	Background.....	1
1.2.	Purpose.....	2
2.	Test Parameters.....	3
3.	1840A Analysis.....	6
3.1.	External Packaging.....	6
3.2.	Transmission Envelope.....	6
3.2.1.	Tape Formats.....	6
3.2.2.	Declaration and Header Fields.....	6
4.	IGES Analysis.....	7
5.	SGML Analysis.....	10
6.	Raster Analysis.....	11
7.	CGM Analysis.....	12
8.	Conclusions and Recommendations.....	14
9.	Appendix A - Tapetool Report Logs.....	15
9.1.	Tape Catalog.....	15
9.2.	Tape Evaluation Log.....	16
9.3.	Tape File Set Validation Log.....	17
10.	Appendix B - Detailed IGES Analysis.....	18
10.1.	File D001Q027.....	18
10.1.1.	Parser/Verifer Log.....	18

10.2.	D001Q016.....	24
10.2.1.	Output CADLeaf.....	24
10.2.2.	Output IGESView.....	25
10.2.3.	Output iges2draw/IslandDraw.....	26
10.2.4.	Output IGESWorks.....	27
10.2.5.	Output X-Change.....	28
11.	Appendix C - Detailed SGML Analysis.....	29
11.1.	Exoterica Validator Parser.....	29
12.	Appendix D - Raster	30
12.1.	Output X-Change - R126.....	30
13.	Appendix E - Detailed CGM Analysis.....	31
13.1.	File D001C001.....	31
13.1.1.	Parser Log MetaCheck.....	31
13.1.2.	validcgm Log.....	33
13.1.3.	Output Cadleaf.....	34
13.1.4.	Output CALSView	35
13.1.5.	Output cgm2draw/IslandDraw.....	36
13.1.6.	Output Designer.....	37
13.1.7.	Output Freelance.....	38
13.1.8.	Output HiJaak Pro.....	39
13.1.9.	Output IslandDraw 4.0.....	40
13.1.10.	Output X-Change.....	41

1. Introduction

1.1 Background

The Department of Defense (DoD) Air Force Continuous Acquisition and Life-cycle Support (CALs) Test Network (AFCTN) is conducting tests of the military standard for the Automated Interchange of Technical Information, MIL-STD-1840A, and its companion suite of military specifications. The AFCTN is a DoD sponsored confederation of voluntary participants from industry and government managed by the Electronic Systems Center (ESC).

The primary objective of the AFCTN is to evaluate the effectiveness of the CALs standards for technical data interchange and to demonstrate the technical capabilities and operational suitability of those standards. Two general categories of tests are performed to evaluate the standards; formal and informal.

Formal tests are large and comprehensive, which follow a written test plan, require specific authorization from the DoD, and may take months to prepare, execute, and report.

Informal tests are quick and short, used by the AFCTN technical staff, to broaden the testing base. They include representative samples of the many systems and applications used by AFCTN participants. They also allow the AFCTN staff to gain feedback from many industry and government interpretations of the standards, to increase the base of participation in the CALs initiative, and respond to the many requests for help that come from participants. Participants take part voluntarily, benefit by receiving an evaluation of their latest implementation (interpretation) of the standards, interact with the AFCTN technical staff, gain experience using the standards, and develop increased confidence in them. The results of informal tests are reported in Quick Short Test Reports (QSTRs) that briefly summarize the standard(s) tested, the hardware and software used, the nature of the test, and the results.

1.2 Purpose

The purpose of the informal test, reported in this QSTR, was to analyze O'Neil & Associates' interpretation and use of the CALS standards in transferring technical publication data. O'Neil used its CALS Technical Data Interchange System to produce data, in accordance with the standards, and delivered it to the AFCTN technical staff on three 9-track magnetic tapes.

2. Test Parameters

Test Plan: AFCTB 94-103

Date of Evaluation: 31 July 1997

Evaluator: George Elwood
Air Force CALS Test Bed
DET 2 HQ ESC/AV-2P
4027 Colonel Glenn Hwy
Suite 300
Dayton OH 45431-1672

Data Originator: Larry C. McKinley
O'Neil & Associates, Inc.
425 North Findlay Street
Dayton OH 45404-2203
(513) 461-1852

Data Description: Technical Manual Test

- 1 Document Declaration file
- 4 Document Type Definitions (DTDs)
- 113 Initial Graphics Exchange Specification (IGES) files
- 1 Text/Standard Generalized Markup Language (SGML) file
- 14 Raster files
- 2 Computer Graphics Metafiles (CGMs)

Data Source System: 1840

HARDWARE

386 PC

SOFTWARE

AFCTN Tapetool v1.2.10

IGES

HARDWARE

Xerox 7650 Pro Imager
Xerox 6085 Workstation

SOFTWARE

Xerox Expert Drafting v5.0
Conversion of IGES files v5.1

Text/SGML

HARDWARE

386 PC

SOFTWARE

WordPerfect Intellitag v1.2
Exoterica Validator v1.1

Raster

HARDWARE

Xerox 7650 Pro Imager
6085 Workstation

SOFTWARE

Xerox XTI v2.2
Xerox XPI Image Conversion 2.6

CGM

HARDWARE

HP/Apollo 425T

SOFTWARE

Auto-trol S5000/CGM Converter 1.4

Evaluation Tools Used:

MIL-STD-1840A (TAPE)

SUN 3/280

AFCTN *Tapetool v1.2.10 UNIX*
XSoft *CAPS/CALS v40.4*

MIL-D-28000 (IGES)

HP 735

ArborText *iges2draw*
Carberry *CADLeaf Plus v3.1.2*
Island Software *IslandDraw v3.0*
InterCAP *X-Change*

SGI Indigo2

IGES Data Analysis (IDA) *CALSVIEW*

Sun SparcStation 2

Carberry *CADLeaf Plus v3.1*
IDA *Parser/Verifier v94*
IDA *IGESView*
International TechneGroup Incorporated
(ITI) *IGES/Works v1.3*

MIL-M-28001 (SGML)

PC 486/50

Exoterica *XGMLNormalizer v1.2e3.2*
Exoterica *Validator v2.0 ex1*
Public Domain *sgmls*

MIL-R-28002 (Raster)

HP 735

AFCTN *xrastb.hp*
InterCAP *X-Change v7.82*

SGI Indigo2

IDA *CALSVIEW*

SUN SparcStation 2

Carberry *CADLeaf Plus v3.1*
AFCTN *validg4*

PC 486

IDA *IGESVIEW Windows*
Inset Systems *HiJaak Pro*
Expert Graphics *RxHighlight v1.0*

MIL-D-28003 (CGM)

HP 735

InterCAP *X-Change v7.82*
ArborText *cgm2draw*
Island Software *IslandDraw v3.0*

SGI Indigo 2

IDA *CALSVIEW*

SUN SparcStation 2

Carberry *CADLeaf Plus v3.1*
Island Software *IslandDraw v4.0*

PC 486/50

Advanced Technology Center
(ATC) *MetaCheck R 2.10*
ATC *ForView*
Software Publishing Corporation
(SPC) *Harvard Graphics v3.05*
Inset Systems *HiJaak Pro*
Lotus *Freelance v2.01*
Micrografx *Designer v4.0*

Standards

Tested:

MIL-STD-1840A
MIL-D-28000A
MIL-M-28001B
MIL-R-28002A
MIL-D-28003

3. 1840A Analysis

3.1 External Packaging

The tapes were hand delivered to the Air Force CALS Test Bed (AFCTB) enclosed in boxes in accordance with ASTM D 3951.

The tapes were enclosed in a barrier bag as required by MIL-STD-1840A, para. 5.3.1.2. Inspection of the tape reels showed the labels indicating the recording density, as required by MIL-STD-1840A, para. 5.3.1. Attached to the tapes were packing lists showing all files recorded on the tapes.

3.2 Transmission Envelope

The 9-track tapes received by the AFCTB contained MIL-STD-1840A files. The files were named per the standard conventions.

3.2.1 Tape Formats

The tapes were run through the AFCTN *Tapetool v1.2.10* utility. No errors were encountered while evaluating the contents of the tape labels.

The physical structure of the tapes meets the CALS MIL-STD-1840A requirements.

3.2.2 Declaration and Header Fields

No errors were reported in the Document Declaration file and data file headers. This portion of the tapes meets the CALS MIL-STD-1840A requirements.

4. IGES Analysis

The tapes contained 113 IGES files. Because of the number of files submitted only six files (D001Q007, Q008, Q027, Q052, Q074, and Q108) were selected for detailed evaluation.

The AFCTB has several tools for viewing IGES files. These tools are not used to generate a pass/fail but to report how commercially available software can handle the files. Many of these products are used in the development of technical publications and are good indicators of usability. The use of these products is not an endorsement nor an indication of CALS capability. All operations were performed using the default settings.

These files were evaluated using IDA's *parser/verifier* set for CALS Class I. This utility reported all files tested meet the specification defined in MIL-D-28000A. While no CALS errors were reported, all files had basic IGES errors and/or warnings. These deficiencies were disjointed line segments, or disjointed arcs. When viewed in a technical publication these deficiencies were not apparent; however, when these areas were examined in detail they could be seen. In some cases these disjointed lines were thickened to hide the gaps and overlapping arcs.

Files Q009, Q010 and Q041 were noted as having a negative origin point. This requires the *Carberry Cadleaf* and the *ArborText iges2draw* utilities to be set using the bound data parameter.

Several other files were evaluated using this parser. While no CALS errors were reported, all files had basic IGES errors and/or warnings. These deficiencies were disjointed line segments, or disjointed arcs. When viewed in a technical publication these deficiencies would not be apparent; however, when these areas were examined in detail they could be seen. In some cases these disjointed lines were thickened to hide the gaps and overlapping arcs.

A more critical problem was the use of entity 230 (the sectioned areas used to make the arrowheads and circular connect points). All files displayed this property, and for the most part it did not cause a problem. However, in files Q014-22, Q041, and Q052 this entity displayed par-

tially unusable characteristics in several applications. The connect points were joined together resulting in sets of triangle shapes on the images.

It was also noted that the basic leader line was thickened. This made the arrowhead look different than the rest of the lines. The log file from IDA's *parser/verifier* for file Q027, is included in Appendix B, Section 10 of this report.

Each file was viewed by at least one software application. The required basic conformance statement was found in the start section of the files. Files Q008, Q027, Q041, Q052 Q074 and Q108 were selected for the detailed analysis provided below.

The files were converted using ArborText's *iges2draw* utility without a reported error. The resulting files were read into Island Software's *IslandDraw*, displayed and printed without a reported error. Files Q041 and Q052 displayed a sectioned area problem in the arrows.

According to Carolyn Holland of ArborText, "These problems could be the result of the source file not containing attributes required by the *iges2draw* utility."

All files were read and displayed using Carberry's *CADLeaf* software without a reported error. Files Q014-Q022, Q041 and Q052 displayed errors because of the use of entity 230. Note the added lines on the arrows, and their appearance.

The selected files were read and displayed using IDA's *CALSVIEW* with reported errors. Errors were noted in files Q014-Q022, Q041 and Q052 due to the use of the 230 entity.

The files were imported into ITI's *IGES/Works* without a reported error. On the evaluated files note the missing arrows and arrowheads created by using the 230 entity.

According to David Mattei of ITI, "The IGES files in these reports contains several Sectioned Area entities (IGES type 230). These entities are illegally defined in the IGES file. IGES requires that the curve defining the sectioned area be closed and the entities in these IGES files fail to meet this requirement. The Validation module in *IGES/Works* flags these entities as being invalid."

Version 2.0.0 of IGES/Works does not display these invalid Sectioned Area entities as you correctly state. In Version 2.0.2 of IGES/Works which is currently available, we have made a change to at least display the boundary of the sectioned area.... Even with this new approach to displaying these entities, the display still does not look completely correct. This is a result of the fact that the IGES entities violate the rules of IGES. Also please note that some of the other plots in the test report are not completely correct for the same reason."

The files were imported into InterCAP's *X-Change* without a reported error. Files Q008, Q027, Q052, Q074, and Q108 appeared to be correct.

The IGES files meet the CALS MIL-D-28000A specification. However, many of the files had errors due to the use of entity 230, to create the arrowheads and connect points. This caused some systems to display unusable files.

While the use of IGES files as a graphic is valid in CALS, the size of some of the files included was very large. This required both large amounts of memory for storage and publication work. The use of 2-d vector CGM files should be considered. As an example, file Q008 as an IGES file was 2.6M in size. This file was converted using different software tools available within the AFCTB. The file sizes varied between 156K to 396K.

5. SGML Analysis

The tapes contained one text and four DTD files. The basic DTD contained the graphic references and pointed to the basic ATOS DTD, which was named BSPEC. The BSPEC DTD pointed to two other subset DTDs; CALSFIGS (figure unique tags) and CALSTABS (table unique tags).

```
BASIC (G004) ----> BSPEC (G003)
                   |> CALSTABS (G005)
                   |> CALSFIGS (G006)
```

The AFCTB has several parsers available for evaluating submitted DTD and text files. These tools are not used to generate a pass/fail but to report how commercially available software can handle the files. These products are used in the development of technical publications and are good indicators of usability. The use of these products is not an endorsement nor an indication of CALS capability. All operations were performed using the default settings unless specified in the report. Changes to DTD or text files required by each system are not documented in the report.

The text and DTD files were evaluated using ArborText's *Adept* parser. No errors or warnings were issued for the DTD or text files.

The text and DTD files were evaluated using Exoterica's *Validator ex1* parser. No errors and two warnings were reported in the DTD and text files. The reported warnings were for mixed content models in the BSPEC DTD.

```
<!-- **Warning** in "i:\94103\BSPEC.DTD" (entity "%BSPEC"), line 600,
      used in "\xgml\94103.dtd", line 266:
      An element with mixed content should permit data characters ("#PCDATA")
      everywhere.
      The element being declared is "WARNING".
      <!ELEMENT warning - - (title?, (%txt; | para | list)+) >
      /\
```

The text and DTD files were tested using Exoterica's *XGML-Normalizer* parser. No errors or warnings were issued by this utility.

The text and DTD files were evaluated using the Public Domain *sgmls* parser. Many errors were issued by this program for graphic references which could not be found. These are not considered errors for this report.

The DTD and text files meet the CALS MIL-M-28001B specification.

6. Raster Analysis

The tapes contained 14 Raster files. These files were evaluated using the AFCTN *validg4* utility. This program reported that the files meet the CALS MIL-R-28002A specification.

The AFCTB has several tools for viewing Raster files. These tools are not used to generate a pass/fail but to report how commercially available software can handle the files. Many of these products are used in the development of technical publications and are good indicators of usability. The use of these products is not an endorsement nor an indication of CALS capability. All operations were performed using the default settings.

The files were read into the AFCTN *xrastb.sun4* viewing utility. No problems were encountered, but it was noted that some of the images were white on black. This made viewing difficult. For technical publications, graphic images are normally black on white.

The files were converted using ArborText's *g42tiff* utility without a reported error. The resulting file was read into Island Software's *IslandPaint* and displayed.

The files were read into Carberry's *CADLeaf* software and displayed without a reported error.

The files were read using IDA's *CALSVIEW* and displayed without a reported error.

The files were read and displayed using IDA's *IGESVIEW* and *IGESVIEW for Windows* without a reported error.

The files were read and displayed using Inset Systems' *HiJaak Pro* without a reported error.

The files were converted using Rosetta Technologies' *Prepare* without a reported error. The resulting files were read into Rosetta Technologies' *Preview* and displayed.

The files were imported into Expert Graphics' *RxHighlight* and displayed without a reported error.

The Raster files meet the CALS MIL-R-28002A specification.

7. CGM Analysis

The tape contained two CGM files. The AFCTB has several tools for viewing CGM files. These tools are not used to generate a pass/fail but to report how commercially available software can handle the files. Many of these products are used in the development of technical publications and are good indicators of usability. The use of these products is not an endorsement nor an indication of CALS capability. All operations were performed using the default settings.

The files were evaluated using ATC's *MetaCheck* with CALS options. No CALS or CGM errors or warnings were reported by this utility.

The CGM files were evaluated using the beta AFCTN *validcgm* utility. This utility reported no errors in either file.

The files were converted using ArborText's *cgm2draw* utility without a reported error. The resulting files were read into Island Software's *IslandDraw v3.1* and displayed. In file C001, the text font was noted in error with the word "CAUTION" extending beyond the symbol, toward the right.

The files were read into Carberry's *CADLeaf* software and displayed. File C001 had a problem with the text extending beyond the graphics to the right. The selection of the proportional text option of *CADLeaf* resulted in a correct display.

The files were read into IDA's *CALSVIEW*. File C001 had a problem with the text extending beyond the graphics to the right. The type font appeared to be wrong.

The files were imported into the Micrografx *Designer* without a reported error. File C001 displayed and printed correctly.

The files were read into ATC's *ForView* without a reported error. The text exceeded the length of the line to the right.

The files were imported into Lotus' *Freelance* and displayed. The text font in file C001 was incorrect. The text was displayed and printed in very small letters.

The files were imported into SPC's *Harvard Graphics v3.05* without a reported error. File C001 did not display the line between the text and the graphics. The text exceeded the length of the graphics to the right.

The files were read into Inset Systems' *HiJaak Pro* without a reported error. File C001 had a problem with the text extended beyond the length of the line between the graphics and the text.

The files were imported directly into Island Software's *IslandDraw v4.0* without a reported error. The image appeared to be correct although the text was not centered on the line.

The files were read into InterCAP's *X-Change*. The text font was in error, with text exceeding the length of the line toward the right.

The files were imported into Corel's *Ventura Publisher* without a reported error. File C001 had a noted problem with the text. The displayed and printed text was very small and located on the left side of the line.

While both CGM files were reported without error, most applications, in the AFCTB, had problems with the text in file C001. The text was normally too large and the words exceeded the length of the line to the right. The CGM files meet the CALS MIL-D-28003 specification.

8. Conclusions and Recommendations

The physical structure of the tapes had no reported errors or warnings. The CALS headers were correct. This portion of the tapes meets the requirements defined in MIL-STD-1840A.

The IGES files had no reported CALS errors. All files reported basic IGES errors and/or warnings; however, they are not critical for files used in technical publications. The IGES files meet the CALS MIL-D-28000A specification.

The DTD and text files meet the CALS MIL-M-28001B specification.

The Raster files meet the CALS MIL-R-28002A specification.

The CGM files meet the CALS MIL-D-28003 specification, although most applications had problems with the text font in file C001.

The tapes submitted by O'Neil & Associates, Inc. meet the CALS MIL-STD-1840A requirements.

9. Appendix A - Tapetool Report Logs

9.1 Tape Catalog

CALS Test Network Catalog Evaluation - Version 1.2; Release 10 (C)

Standards referenced:

MIL-STD-1840A (1987) - Automated Interchange of Technical Information

ANSI X3.27 (1987) - File Structure and labeling of Magnetic Tapes
for Information Interchange

ANSI X3.4 (1986) - Coded Character Sets - 7 Bit ASCII

Fri Jul 29 16:42:14 1994

MIL-STD-1840A File Catalog

File Set Directory: /cals/u1210/Set064

Page: 1

File Name	File Type	Record Format/ Length	Block Length/Total	Selected/ Extracted
D001	Document Declaration	D/00260	02048/000001	Extracted
D001C001	CGM	F/00080	00800/000003	Extracted
D001C002	CGM	F/00080	00800/000003	Extracted
D001G003	DTD	D/00260	02048/000013	Extracted
D001G004	DTD	D/00260	02048/000004	Extracted
D001G005	DTD	D/00260	02048/000002	Extracted
D001G006	DTD	D/00260	02048/000002	Extracted
D001Q007	IGES	F/00080	02000/001324	Extracted
<<<<< PART OF LOG FILE REMOVED HERE >>>>>				
D001Q119	IGES	F/00080	02000/000120	Extracted
D001R120	Raster	F/00128	02048/000024	Extracted
<<<<< PART OF LOG FILE REMOVED HERE >>>>>				
D001R134	Raster	F/00128	02048/000021	Extracted
D001T133	Text	D/00260	02048/000456	Extracted Catal

Process terminated normally.

9.2 Tape Evaluation Log

CALS Test Network Tape Evaluation - Version 1.2; Release 10 (C)

Standards referenced:

ANSI X3.27 (1987) - File Structure and labeling of Magnetic Tapes
for Information Interchange

ANSI X3.4 (1986) - Coded Character Sets - 7 Bit ASCII

Mon Aug 8 13:09:19 1994

ANSI Tape Import Log

Allocating tape drive /dev/rmt0...

/dev/rmt0 allocated.

VOL1ONA001

4

Label Identifier: VOL1
Volume Identifier: ONA001
Volume Accessibility:
Owner Identifier:
Label Standard Version: 4

HDR1D001 ONA00100010001000000 94203 00000 000000

Label Identifier: HDR1
File Identifier: D001
File Set Identifier: ONA001
File Section Number: 0001
File Sequence Number: 0001
Generation Number: 0000
Generation Version Number: 00
Creation Date: 94203
Expiration Date: 00000
File Accessibility:
Block Count: 000000
Implementation Identifier:

<<<< PART OF LOG FILE REMOVED HERE >>>>

End of Volume ONA003

End Of Tape File Set

Tape Import Process terminated normally.

9.3 Tape File Set Validation Log

CALS Test Network File Set Evaluation - Version 1.2; Release 10 (C)

Standards referenced:

MIL-STD-1840A (1987) - Automated Interchange of Technical Information

Mon Aug 8 14:48:46 1994

MIL-STD-1840A File Set Evaluation Log

File Set: Set045

Found file: D001

Extracting Document Declaration Header Records...

Evaluating Document Declaration Header Records...

srcsys: O'Neil & Assoc. CAGE 83007

srcdocid: TO_31R2-2T-21

srcrelid: NONE

chglvl: ORIGINAL

dteisu: 19940712

dstsys: RAYTHEON CAGE 49956

dstdocid: TO_31R2-2T-21

dstrelid: NONE

dtetrn: 19940722

dlvacc: NONE

filcnt: C2,G4,Q113,R14,T1

ttlcls: UNCLASSIFIED

doccls: UNCLASSIFIED

doctyp: Technical Publication

docttl: NONE

<<<< PART OF LOG FILE REMOVED HERE >>>>

Evaluating numbering scheme...

No errors were encountered during numbering scheme evaluation.

Numbering scheme evaluation complete.

Checking file count...

No errors were encountered during file count verification.

File Count verification complete.

No errors were encountered in Document D001.

No errors were encountered in this File Set.

MIL-STD-1840A File Set Evaluation Complete.

10. Appendix B - Detailed IGES Analysis

10.1 File D001Q027

10.1.1 Parser/Verifer Log

```
*****  
****  IGES PARSER/VERIFIER  ****  
****      MARCH 1994      ****  
****  IGES Data Analysis  ****  
****      (708) 344-1815  ****  
*****
```

```
Input file is q027.igs  
Checking conformance to CALS Class I (MIL-D-28000A 2/10/92)  
Today is August 1, 1994  1:45 PM
```

```
*****  
****  CHECK FILE SYNTAX  ****  
*****
```

Section	Records
Start	5
Global	3
Directory	6160 (3080 Entities)
Parameter	4749
Terminate	1

No syntax errors detected.

```
*****  
****  SUMMARY AND STATISTICS  ****  
*****
```

*** File and Product Name Information ***

```
File name from sender      = 'MCM.71.dwg'  
File creation Date.Time   = '940506.122123'  
Model change Date.Time    = ''  
Author                     = 'Brian Keefe'  
Department                  = ''  
Product name from sender  = 'Xerox Expert'  
Destination product name  = ''
```

*** Parameter Delimiters ***

Delimiter = ','
Terminator = ';'

*** Originating System Data ***

System ID = 'Xerox Expert version 5.0'
Preprocessor version = '5.0'
Specification version = 6 (IGES 4.0)

*** Precision levels ***

Integer bits = 16
Floating point - Exponent = 38 Mantissa = 7
Double precision - Exponent = 38 Mantissa = 7

*** Global Model Data ***

Model scale = 1.0000E+00
Unit flag = 1
Units = 'INCH'
Line weights = 3
Maximum line thickness = 4.166667E-02
Minimum line thickness = 1.388889E-02
Granularity = 1.000000E-05
Maximum coordinate = 1.100000E+01

Drafting standard applicable to original data is not specified.

*** Status Flag Summary ***

Blank status: Visible	3080
Blanked	0
Independence: Independent	2948
Physically Subordinate	130
Logically Subordinate	2
Totally Subordinate	0
Entity use: Geometry	3015
Annotation	62
Definition	2
Other	1
Logical/Positional	0
2D parametric	0
Construction geometry	0
Not Specified	0

Hierarchy: Structure DE applies 3080
 Subordinate DE applies 0
 Hierarchy property applies 0
 Not Specified 0

*** Entity Occurrence Counts ***

Entity	Form	Level	Count	Type
-----	----	-----	-----	-----
100	0	0	240	Circular arc
102	0	0	26	Composite curve
104	1	0	688	Conic arc - ellipse
110	0	0	1347	Line
124	0	0	688	Transformation matrix
212	0	0	62	General note
230	0	0	26	Sectioned area (Standard Crosshatching)
404	0	0	1	Drawing
406	16	0	1	Property - Drawing size
410	0	0	1	View - Orthographic parallel

*** Entity Count by Level ***

Level	Count
0	3080

*** Labeling Information ***

100% of the entities are labeled.

Unlabeled 0

Label	Count	Label	Count	Label	Count
View	1*	Line	1347*	GNote	62*
Matrix	688*	Ellipse	688*	Circle	69*
Arc	171*	Composit	26	Section	26*
Property	1	Drawing	1*		

NITPICK 2327: One or more of the flagged entity labels are not right-justified.

*** Line Fonts Used in Data ***

100	102	104	106	108	110	112	114	
-	-	-	-	-	-	-	-	Undefined
240	26	688	-	-	1325	-	-	Solid
-	-	-	-	-	8	-	-	Dashed
-	-	-	-	-	-	-	-	Phantom
-	-	-	-	-	14	-	-	Center-line
-	-	-	-	-	-	-	-	Dotted
-	-	-	-	-	-	-	-	User defined
116	118	120	122	124	125	126	128	
-	-	-	-	-	-	-	-	Undefined
-	-	-	-	688	-	-	-	Solid

<<<<< PART OF LOG FILE REMOVED HERE >>>>>

*** Line Widths Used in Data ***

Weight	Count	Width
Defaulted	2138	(0.0139)
1	805	(0.0139)
3	131	(0.0417)
2	6	(0.0278)

*** Colors Used in Data ***

Defaulted	743
Green	2337

 ***** ENTITY ANALYSIS *****

*** Entity type: 100
 *** Entity type: 102

- ERROR 2033: End points of curves D 5789 and D 5791 disjoint by 9.461704E-02 at D 5795.
- NOTE 2391: Start point D 5789 and D 5791 are the same, possible reversal of D 5791.
- ERROR 2033: Messages regarding disjoint composite curves suppressed.
- NOTE 2391: Messages regarding reversed entities suppressed.

*** Entity type: 104

WARNING 2265: Start point off conic by 1.829235E-04 at D 35.
WARNING 2039: End point off conic by 8.419015E-05 at D 35.
WARNING 2265: Messages regarding invalid start point suppressed.
WARNING 2039: Messages regarding conic end points suppressed.

*** Entity type: 110

-- 1347 lines averaging 1.899744E-01 units --

*** Entity type: 124

688 transformation matrices, 688 non-zero translations.
NOTE 2341: 688 matrices contain translation information.

*** Entity type: 212

62 text strings in data file.
Average text aspect ratio in file is 0.9032581.
Minimum text aspect ratio in file is 0.7644440.
Maximum text aspect ratio in file is 0.9553574.

FONTS USED IN FILE
FONT COUNT NAME

1	62	Default ASCII Style
---	----	---------------------

*** Entity type: 230

NITPICK 2076: Entity does not have Annotation flag set at D 5797.
NITPICK 2076: Messages regarding entity use (annotation) suppressed.

*** Entity type: 404

NITPICK 2074: Entity use flag must be 1 for Drawing entity at D 6159.
Drawing at D 6159 contains 1 views.
Drawing at D 6159 contains 0 annotation entities.

*** Entity type: 406

*** Entity type: 410

NITPICK 2073: Entity use flag must be 1 for View entity at D 1.
Scale of view at D 1 is 1.000000E+00.
Orthographic View entity at D 1 has 0 clipping planes specified.
XMIN = Not Set XMAX = Not Set
YMIN = Not Set YMAX = Not Set
ZMIN = Not Set ZMAX = Not Set

*** Message Summary ***

2007: 52 Mathematical discontinuities.
2015: 414 Mathematically incorrect definitions.
2016: 28 Invalid entity use flag.

*** Error Summary ***

0 fatal errors
0 severe errors
52 errors
414 warnings
0 cautions
29 nitpicks
24 notes

*** End of Analysis of q027.igs ***

10.2 D001Q016

10.2.1 Output CADLeaf

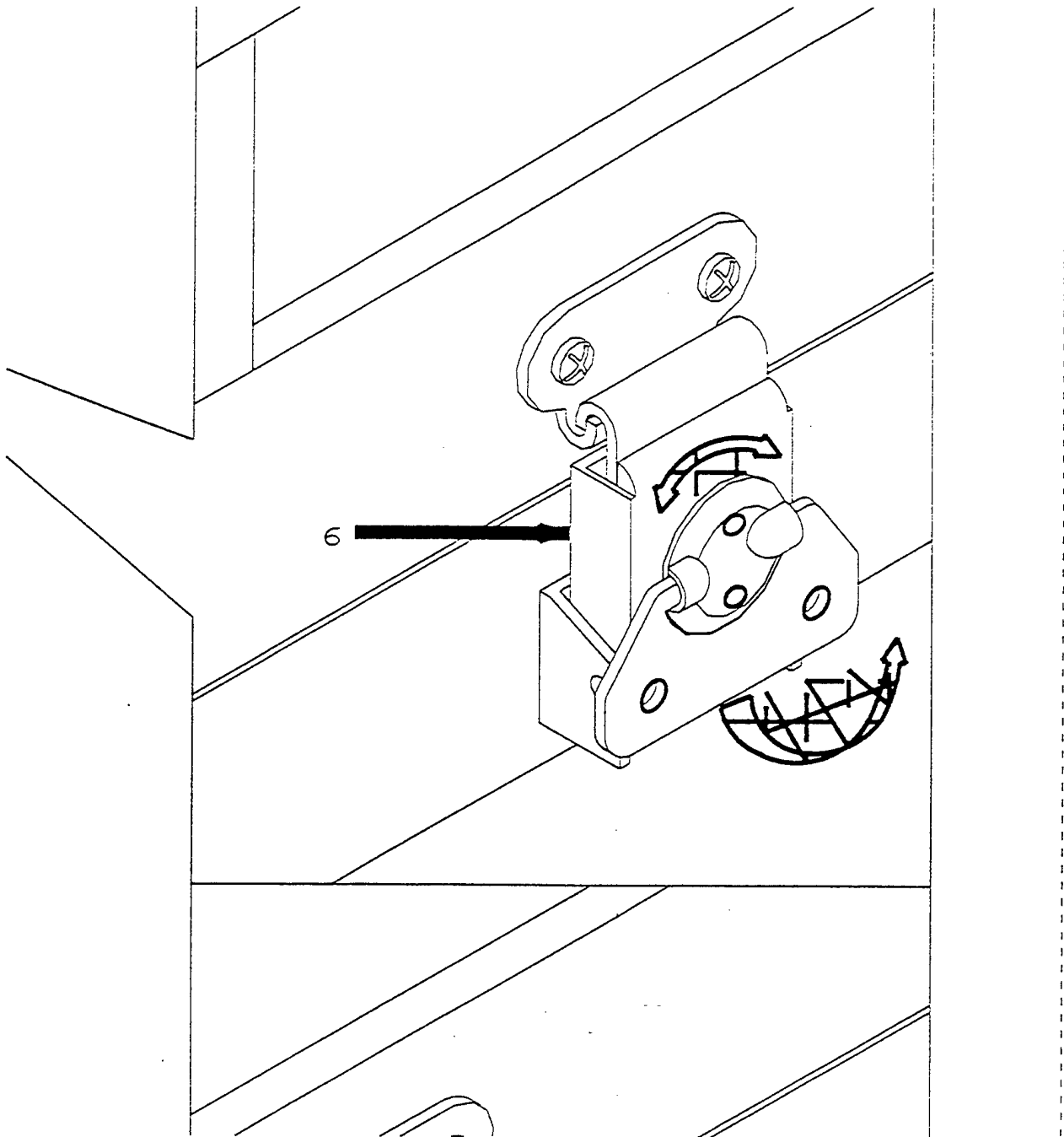

10.2.2 Output IGESView

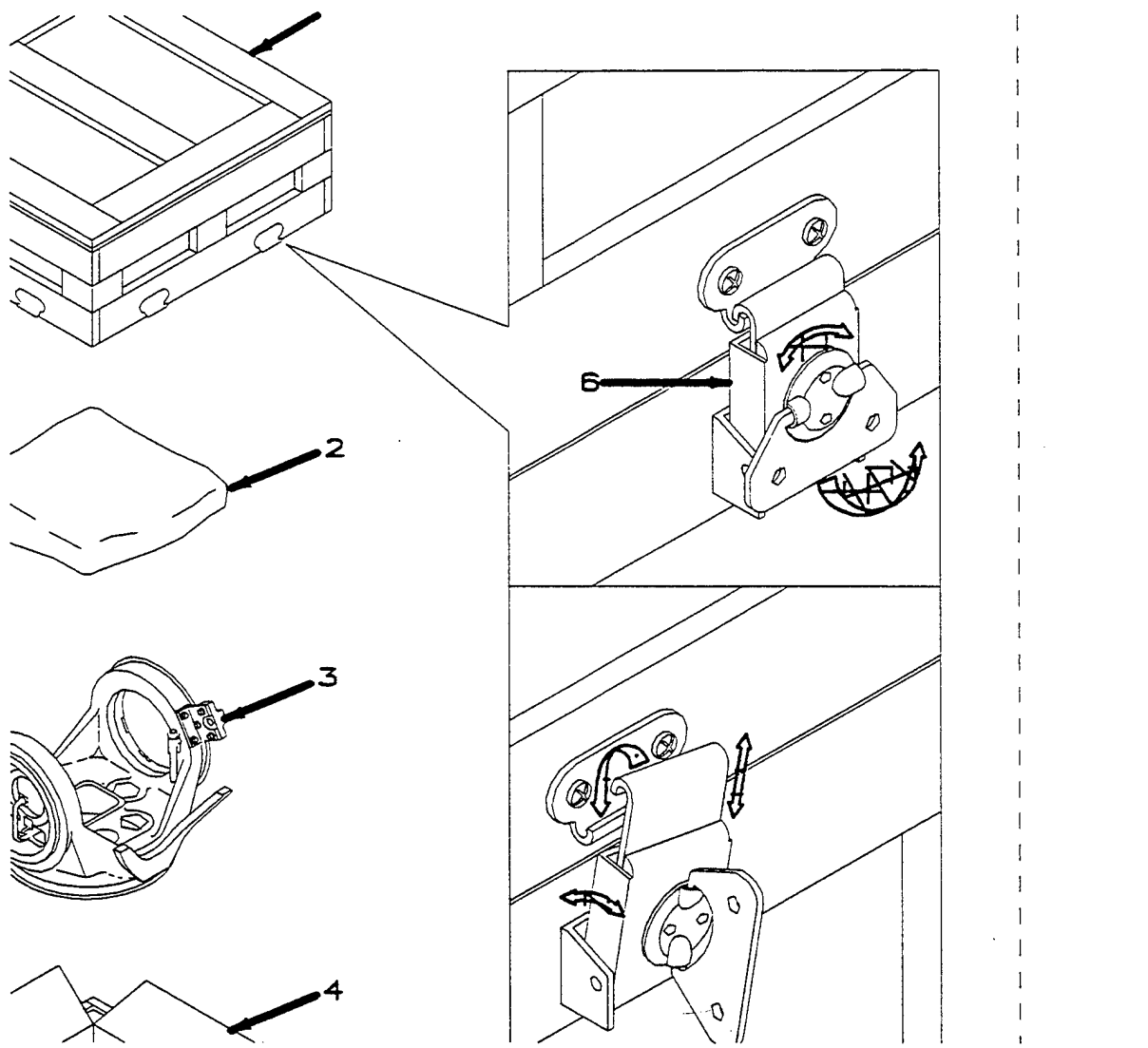

10.2.3 Output iges2draw/IslandDraw

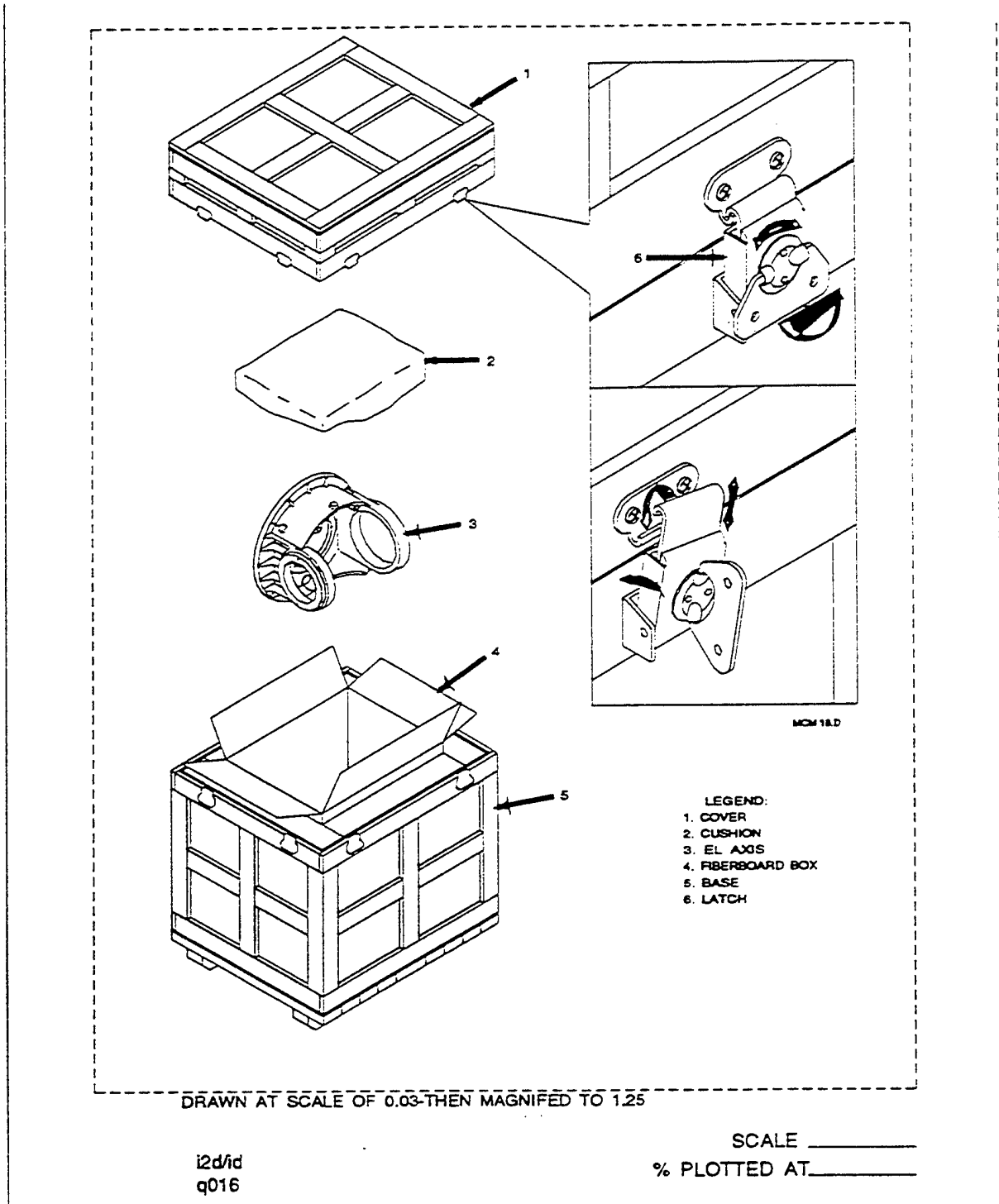

10.2.4 Output IGESWorks

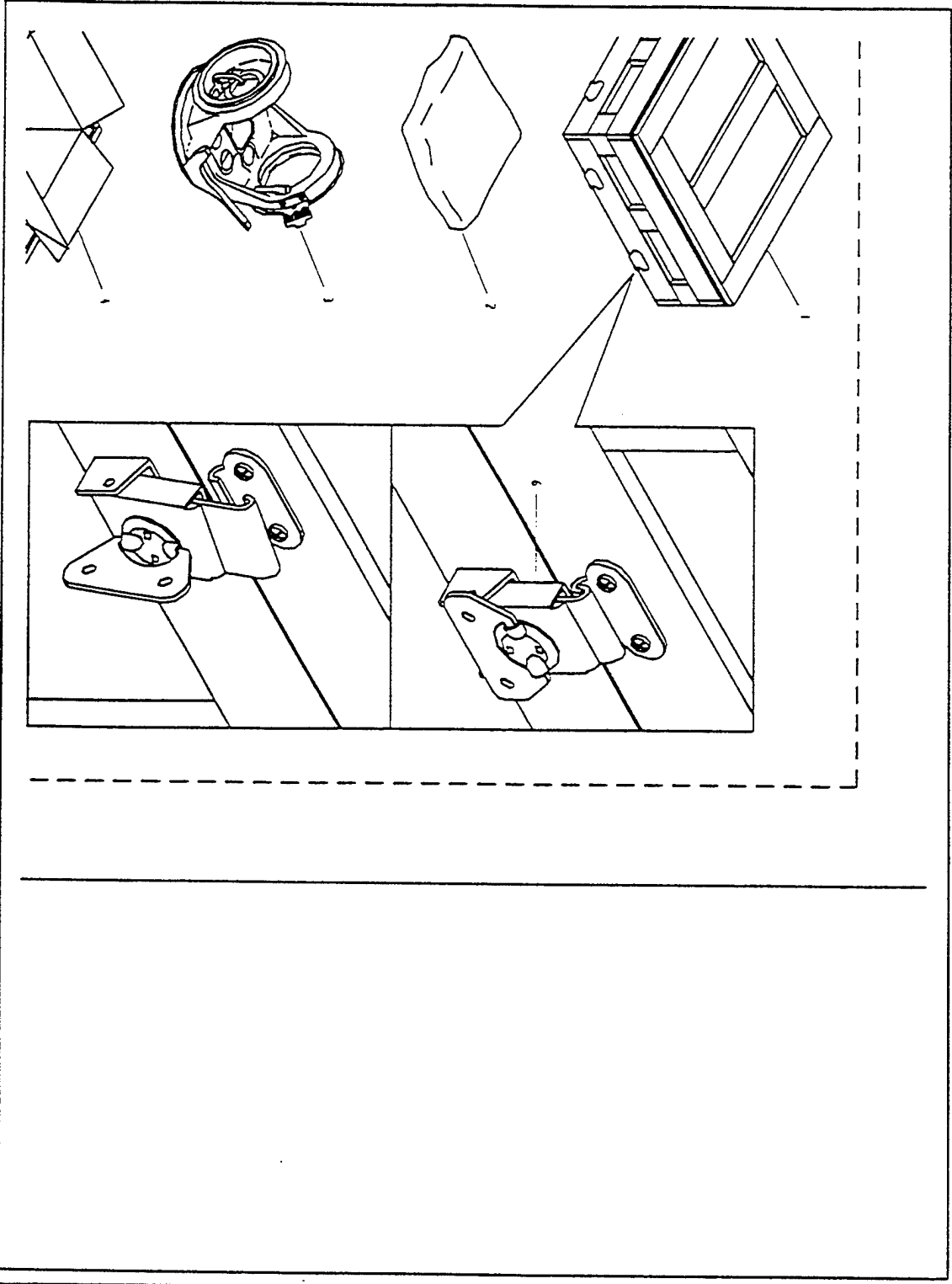

10.2.5 Output X-Change

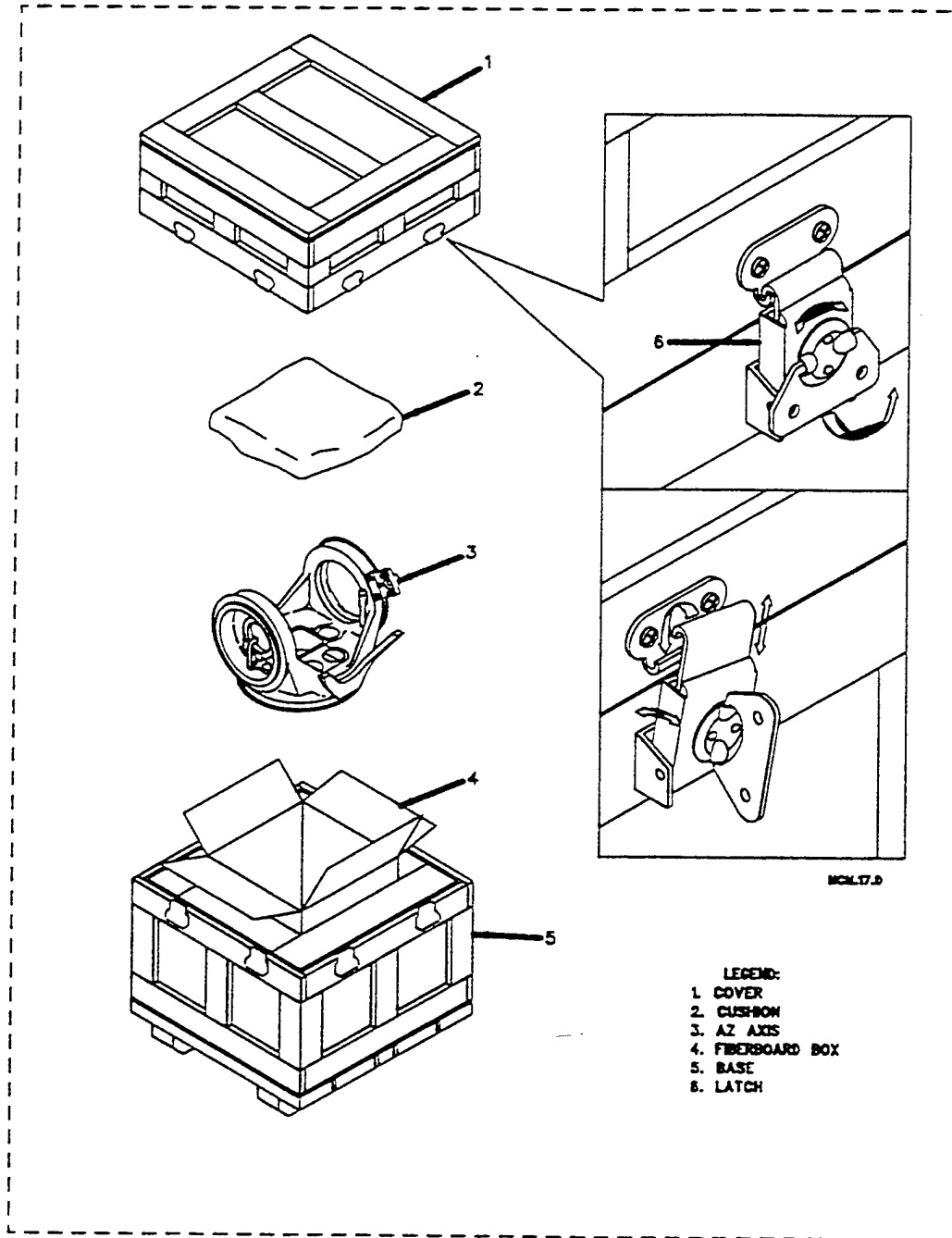

DRAWN AT SCALE OF B.B3-MAGNIFIED TO 1.5

SCALE _____
% PLOTTED AT _____

11. Appendix C - Detailed SGML Analysis

11.1 Exoterica Validator Parser

```
<!-- **Warning** in "i:\94103\BSPEC.DTD" (entity "%BSPEC"), line 600,
      used in "\xgml\94103.dtd", line 266:
      An element with mixed content should permit data characters ("#PCDATA")
      everywhere.
      The element being declared is "WARNING".
      <!ELEMENT warning - - (title?, (%txt; | para | list)+) >
      /\
-->
<!-- Capacity points/limits:
      TOTALCAP =67402/200000
      ENTCAP    =16160/200000
      ENTCHCAP  =3756/70000
      ELEMCAP   =3840/70000
      GRPCAP    =23072/70000
      EXGRPCAP  =896/70000
      EXNMCAP   =3872/70000
      ATTCAP    =5984/200000
      ATTCHCAP  =315/70000
      AVGRPCAP  =9248/70000
      NOTCAP    =96/70000
      NOTCHCAP  =163/70000
      IDCAP     =0/70000
      IDREFCAP  =0/70000
      MAPCAP    =0/70000
      LKSETCAP  =0/70000
      LKNMCAP   =0/70000
-->
<!-- 1 warning reported. -->
```

12. Appendix D - Raster

12.1 Output X-Change - R126

- LEGEND:
· FITTING ASSEMBLY
· LEG
· PIN
· ADJUSTABLE STRUT
· STRUT KNOB
· PAD
· INNER TUBE
· PIN
· STABILIZER LEG
· PIN
· STAKE

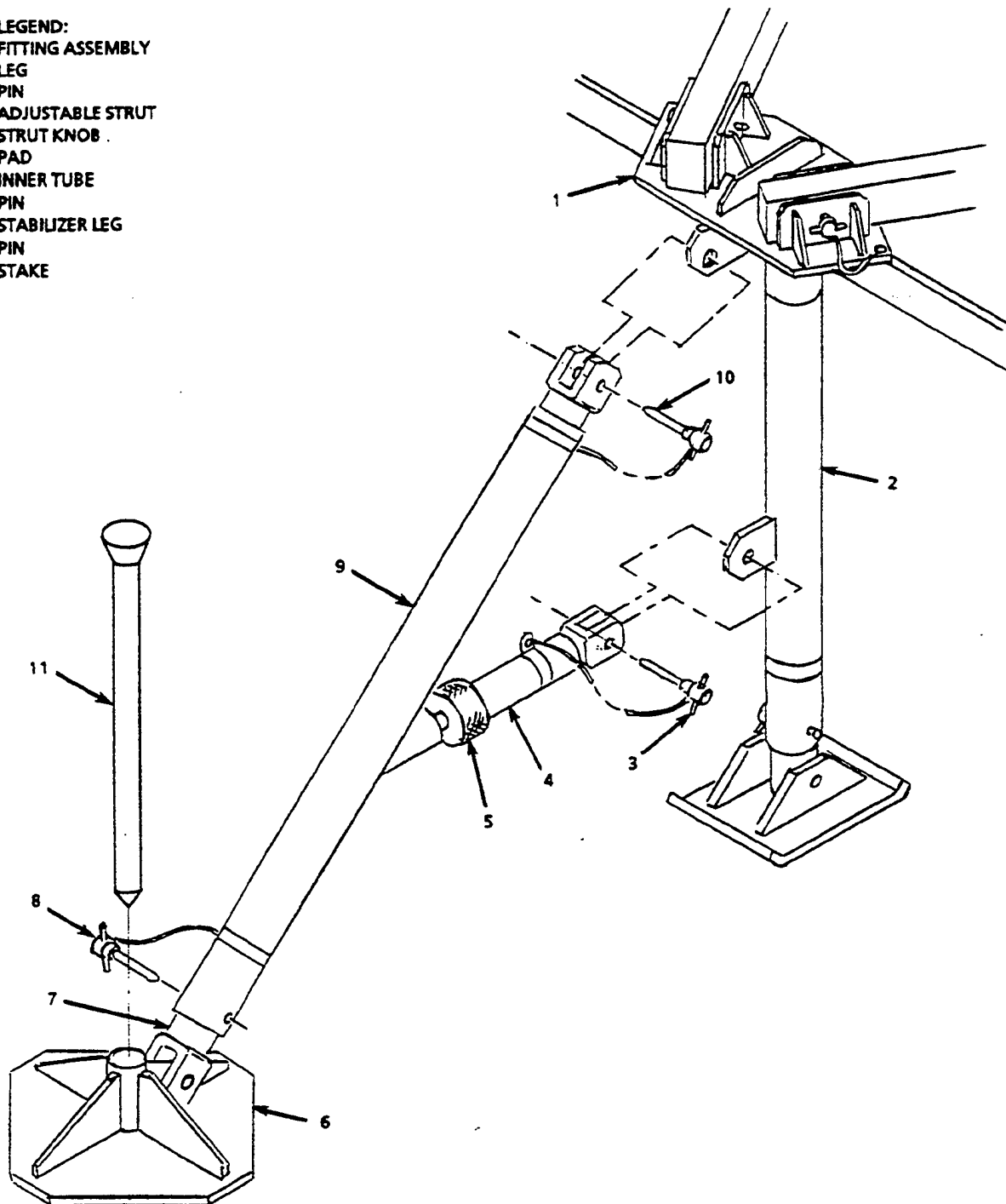

13. Appendix E - Detailed CGM Analysis

13.1 File D001C001

13.1.1 Parser Log MetaCheck

MetaCheck Version 2.10 -- CGM/MIL-D-28003 Conformance Analyzer
Copyright 1988-93 CGM Technology Software
Execution Date: 08/01/94 Time: 13:35:25

Metafile Examined : i:\94103\c001.cgm

Pictures Examined : All
Elements Examined : All
Bytes Examined : All

=====
Trace Report
=====

Tracing not selected.

=====
CGM Conformance Violation Report
=====

No Errors Detected

=====
CAL S CGM Profile (MIL-D-28003) Report
=====

No profile discrepancies detected.

=====
Conformance Summary Report
=====

MetaCheck Version 2.10 -- CGM/MIL-D-28003 Conformance Analyzer
Copyright 1988-93 CGM Technology Software
Execution Date: 08/01/94 Time: 13:35:27

Name of CGM under test: i:\94103\c001.cgm
Encoding : Binary

Pictures Examined : All
Elements Examined : All
Bytes Examined : All

BEGIN METAFILE string : >esdcau<
METAFILE DESCRIPTION : >AUTO-TROL/REL-1.0 MIL-D-28003/BASIC-<
>1<

Picture 1 starts at octet offset 124: >esdcau<

Conformance Summary : This file conforms to the CGM specification.
This file meets the CALS CGM Profile (MIL-D-28003).

Summary of Testing Performed and Errors Found:

1 Pictures Tested
97 Elements Tested
1528 Octets Tested

```
=====
|   No Errors Were Detected   |
=====
```

===== End of Conformance Report =====

13.1.2 validcgm Log

Analysis for file c001.cgm using table table

(0, 1) occurred 1 time
(0, 2) occurred 1 time
(0, 3) occurred 1 time
(0, 4) occurred 1 time
(0, 5) occurred 1 time
(1, 1) occurred 1 time
(1, 2) occurred 1 time
(1, 7) occurred 1 time
(1, 8) occurred 1 time
(1, 9) occurred 1 time
(1, 11) occurred 1 time
(1, 13) occurred 1 time
(2, 1) occurred 1 time
(2, 3) occurred 1 time
(2, 4) occurred 1 time
(2, 5) occurred 1 time
(2, 6) occurred 1 time
(2, 7) occurred 1 time
(4, 1) occurred 40 times
(4, 4) occurred 1 time
(4, 7) occurred 6 times
(5, 3) occurred 2 times
(5, 4) occurred 1 time
(5, 10) occurred 1 time
(5, 14) occurred 1 time
(5, 15) occurred 1 time
(5, 16) occurred 1 time
(5, 18) occurred 1 time
(5, 22) occurred 1 time
(5, 23) occurred 1 time
(5, 28) occurred 1 time
(5, 30) occurred 1 time
(5, 34) occurred 20 times

13.1.3 Output Cadleaf

CAUTION

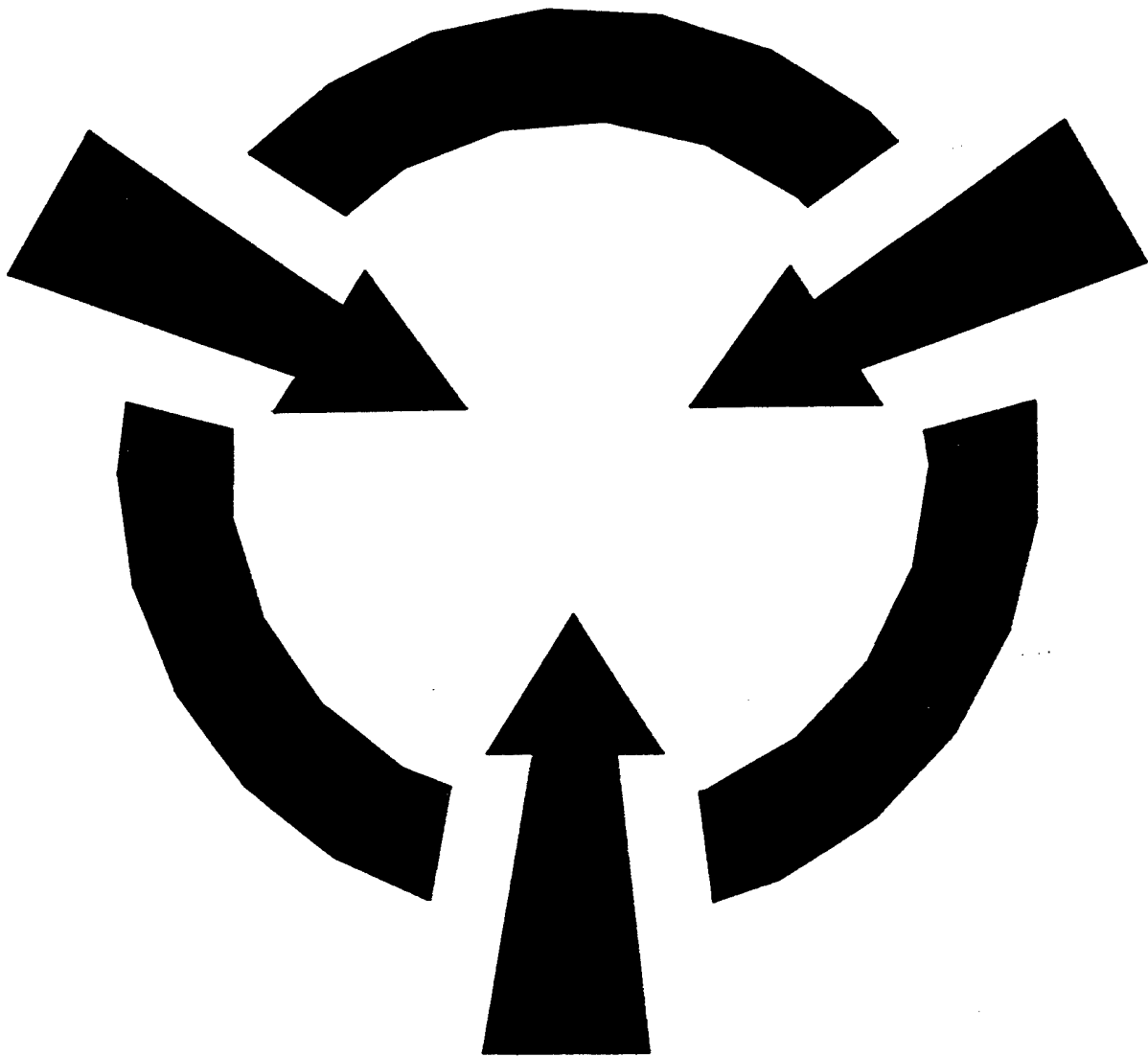

13.1.4 Output CALSView

CAUTION

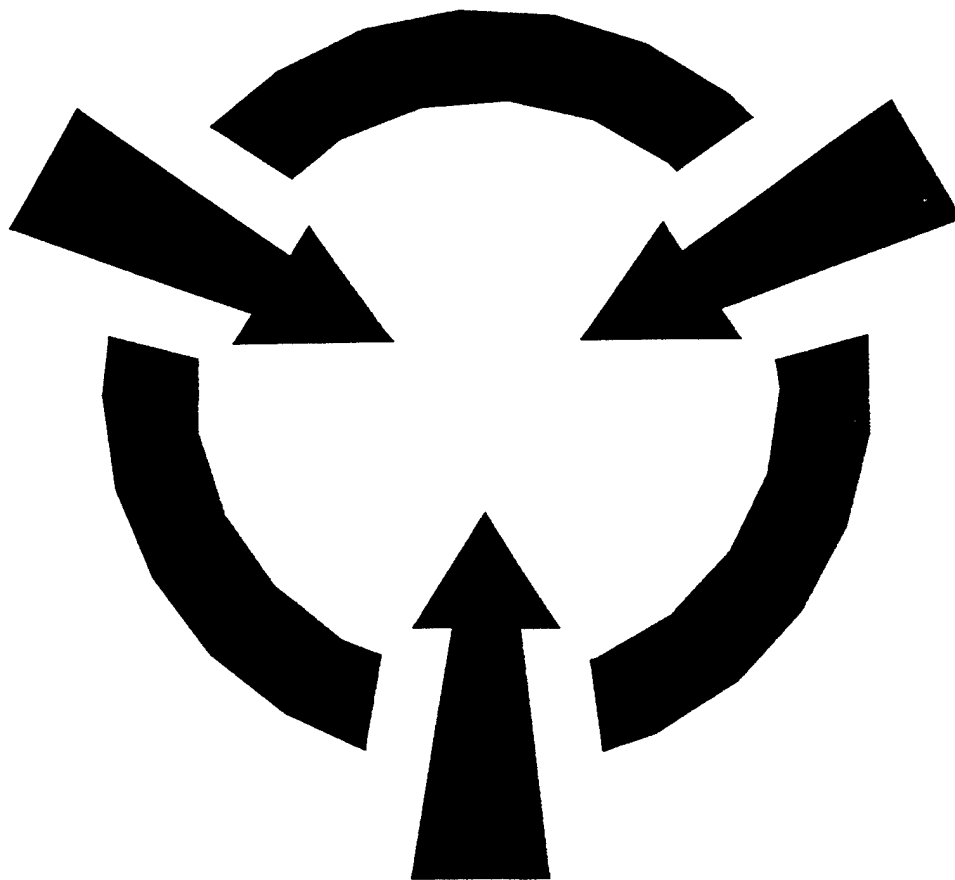

13.1.5 Output cgm2draw/IslandDraw

CAUTION

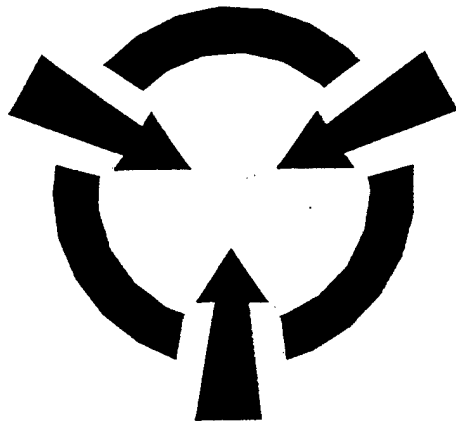

c2d/id

c001i

13.1.6 Output Designer

CAUTION

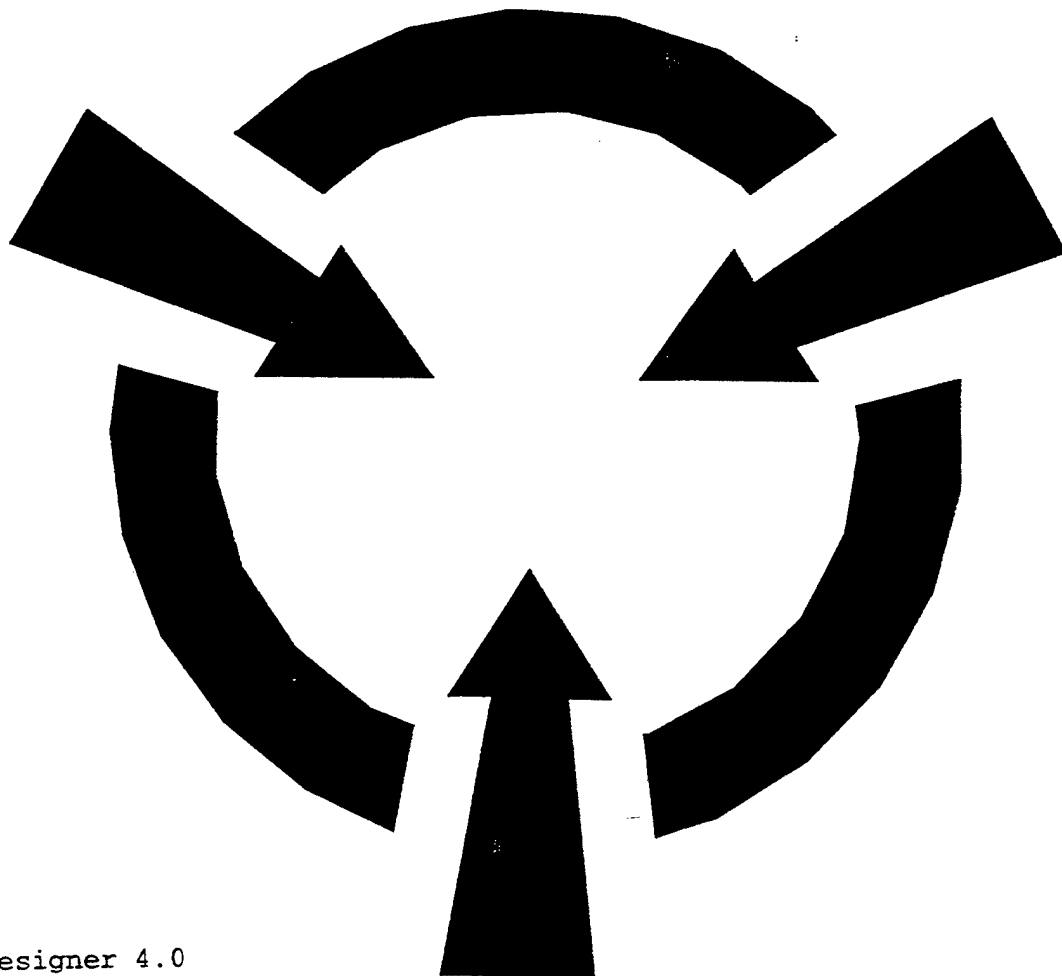

designer 4.0

13.1.7 Output Freelance

CAUTION

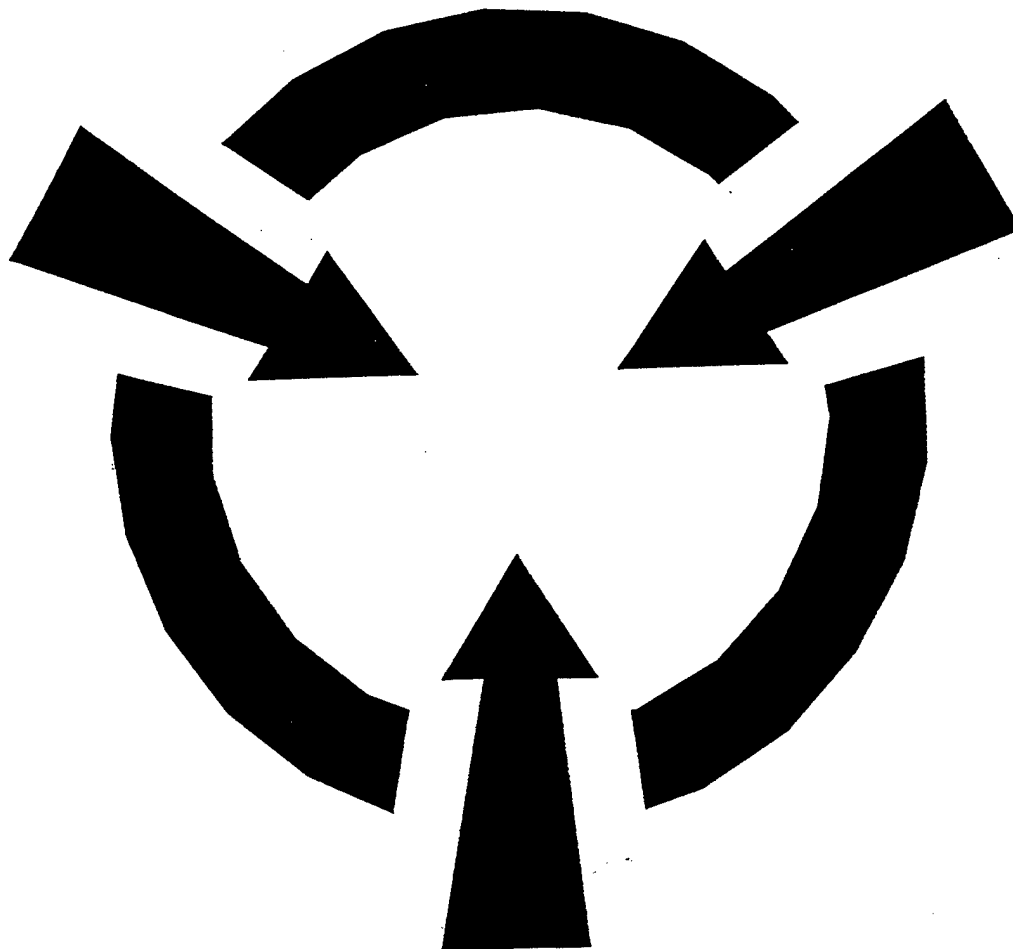

freelance

13.1.8 Output HiJaak Pro

CAUTION

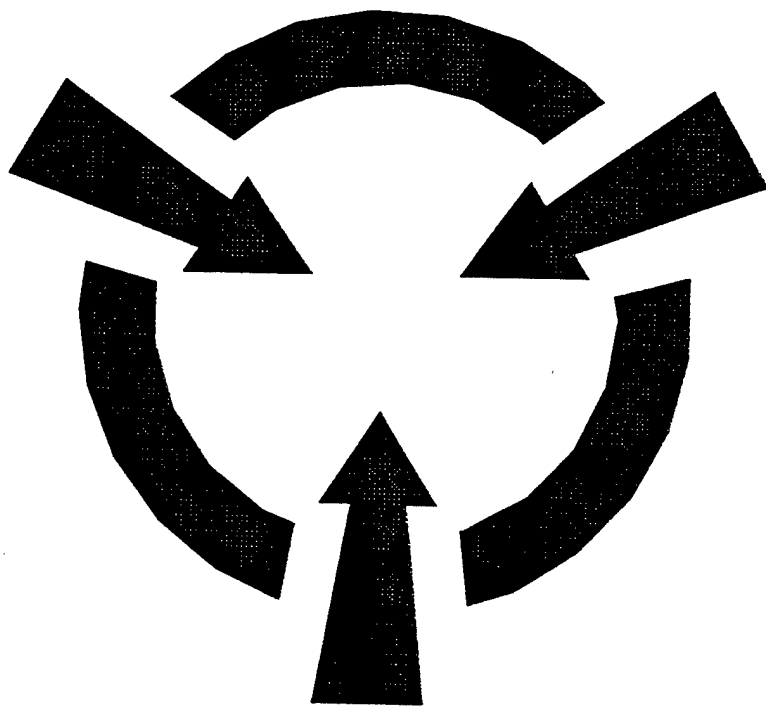

13.1.9 Output IslandDraw 4.0

CAUTION

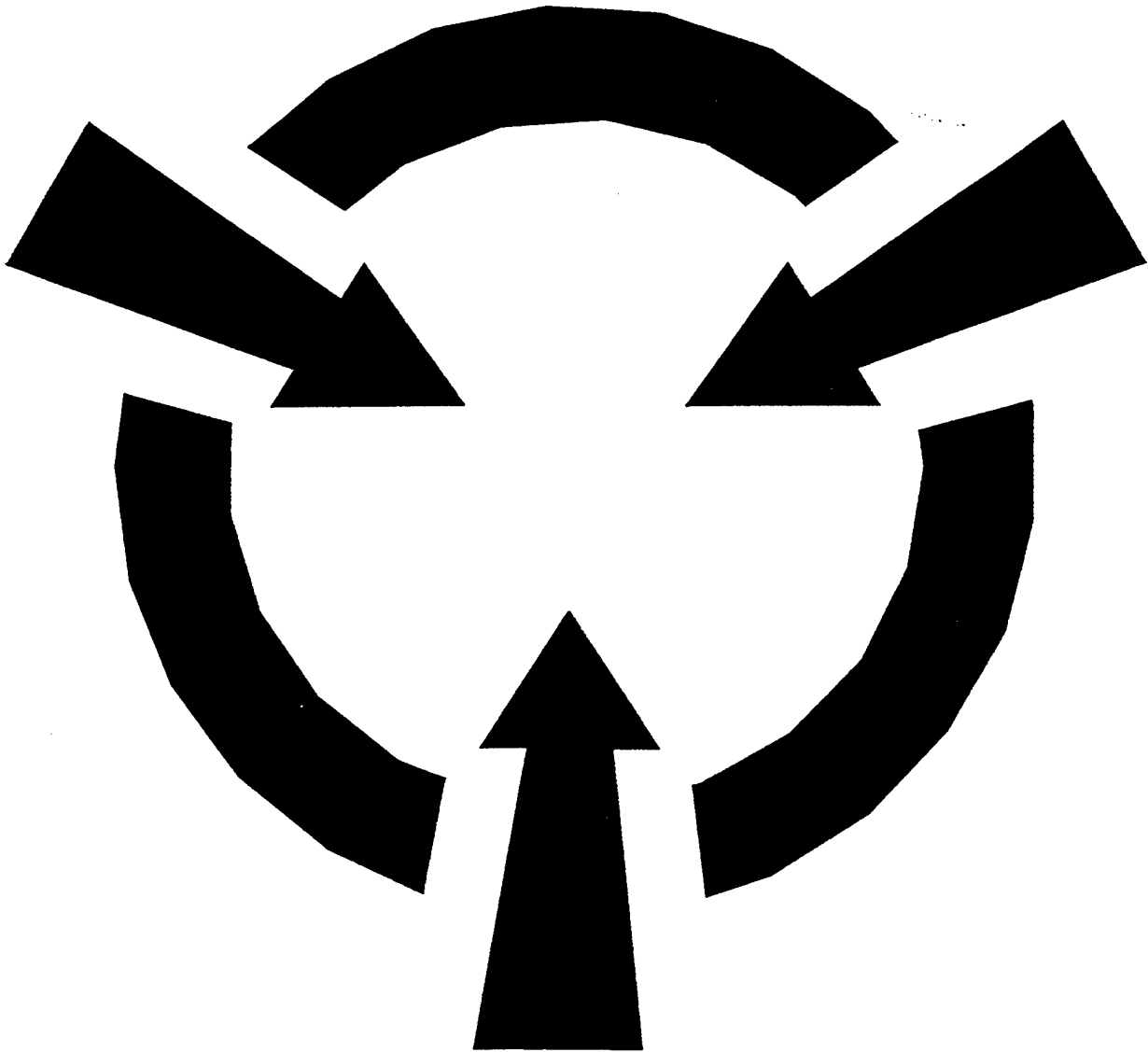

13.1.10 Output X-Change

CAUTION

