



# AFCTN Test Report 94-061

AFCTB-ID  
94-010



## Conscan Drive Assembly TO 31R2-2FRC181-42

Using:



ESC/MSL MILSTAR Program's Data  
(Contract #F19628-89-C-0131)

Submitted By:

O'Neil & Associates, Inc.

MIL-D-28000A (IGES)  
MIL-M-28001A (SGML)  
MIL-D-28003 (CGM)

Quick Short Test Report

09 March 1994

Prepared For:  
Electronic Systems Center  
Det 2 HQ ESC/AV-2  
4027 Colonel Glenn Hwy, Suite 300  
Dayton, Ohio 45431-1672

DMIC QUALITY INSPECTED 3

DISTRIBUTION STATEMENT A

Approved for public release;  
Distribution Unlimited



19960822 081

# DISCLAIMER NOTICE

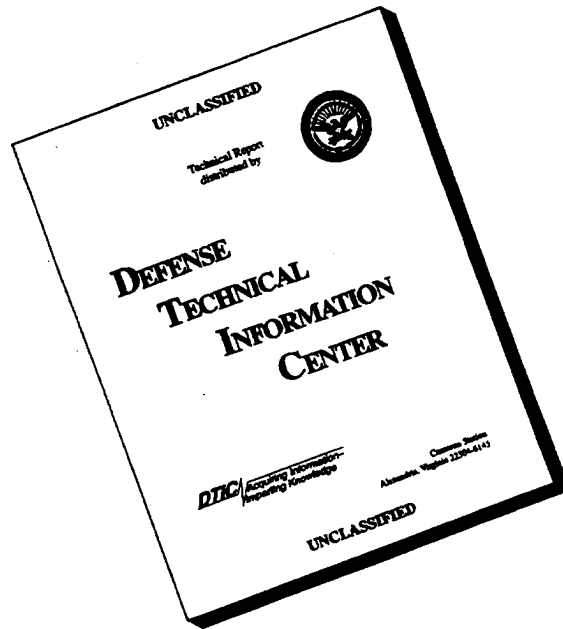

**THIS DOCUMENT IS BEST QUALITY AVAILABLE. THE COPY FURNISHED TO DTIC CONTAINED A SIGNIFICANT NUMBER OF PAGES WHICH DO NOT REPRODUCE LEGIBLY.**

**Conscan Drive Assembly TO 31R2-2FRC181-42**

**Using:**

**ESC/MSL MILSTAR Program's Data**

**(Contract #F19628-89-C-0131)**

**Submitted by:**

**O'Neil & Associates, Inc.**

**MIL-D-28000A (IGES)**

**MIL-M-28001A (SGML)**

**MIL-D-28003 (CGM)**

**Quick Short Test Report**

**09 March 1994**

---

**Prepared By**

Air Force CALS Test Bed  
Wright-Patterson AFB, OH 45433

**AFCTB Contact**

Gary Lammers  
(513) 427-2295

**AFCTN Contact**

Mel Lammers  
(513) 427-2295

**DTIC QUALITY INSPECTED 3**

## DISCLAIMER

This document was prepared as an account of the work sponsored by the Air Force. Neither the United States Government, the Air Force, nor any of their employees makes any warranty, express or implied, or assumes any legal liability or responsibility for the accuracy, completeness, or usefulness of any information, apparatus, product, or process disclosed, nor represents that its use would not infringe on privately owned rights. Reference herein to any specific commercial products, process, or service by trade name, trademark, manufacturer, or otherwise, does not necessarily constitute or imply its endorsement, recommendation, or favoring by the United States Government or the Air Force. The views and opinions of authors expressed herein do not necessarily state or reflect those of the United States Government or the Air Force, and shall not be used for advertising or product endorsement purposes.

Available to the public from the  
National Technical Information Service  
U.S. Department of Commerce  
5285 Port Royal Road  
Springfield, VA 22161

This report and those involved in its preparation do not endorse any product, process, or company stated herein. Use of these means by anyone does not imply certification by the Air Force CALS Test Network (AFCTN).

---

# Air Force CALS Test Bed

## *Notification of Test Results*

09 March 1994

This notice documents the results of an Air Force CALS Test Bed (AFCTB) Quick Short Test Report (QSTR) evaluation of data submitted by:

### **O'Neil & Associates, Inc.**

Identified as follows:

Title:	Conscan Drive Assembly , TO 31R2-2FRC181-42
Program:	MILSTAR
Program Office:	ESC/MSL, Hanscom AFB
Contract No.:	F19628-89-C-0131
QSTR No.:	AFCTB-ID 94-010

Received on the following media:     **9-Track Tape**

The results of the AFCTB Quick Short Test Report evaluation are as follows:

MIL-STD-1840A Media Format:	Pass
MIL-D-28000A IGES:	Pass
MIL-M-28001A SGML:	Pass
MIL-R-28002A Raster:	N/A
MIL-D-28003 CGM:	Pass

Formal results with associated disclaimer are documented and available from the AFCTB.

**Air Force CALS Test Bed  
HQ ESC/AV-2P  
4027 Colonel Glenn Highway, Suite 300  
Dayton, OH 45431-1672  
Phone: 513-257-3085     FAX: 513-257-5881**

---

## Contents

1.	Introduction.....	1
1.1.	Background.....	1
1.2.	Purpose.....	2
2.	Test Parameters.....	3
3.	1840A Analysis.....	6
3.1.	External Packaging.....	6
3.2.	Transmission Envelope.....	6
3.2.1.	Tape Formats.....	6
3.2.2.	Declaration and Header Fields.....	7
4.	IGES Analysis.....	8
5.	SGML Analysis.....	11
6.	Raster Analysis.....	12
7.	CGM Analysis.....	12
8.	Conclusions and Recommendations.....	15
9.	Appendix A - Tapetool Report Logs.....	16
9.1.	Tape Catalog.....	16
9.2.	Tape Evaluation Log.....	17
9.3.	Tape File Set Validation Log.....	19
9.4.	Other Tape Reading Logs.....	22
10.	Appendix B - Detailed IGES Analysis.....	24
10.1.	File D001Q020.....	24
10.1.1.	Parser/Verifier Log.....	24

---

10.1.2.	Parser Log - AutoCAD R12.....	30
10.1.3.	Parser Log - IGESWorks.....	36
10.1.4.	Error Log - Preview.....	39
10.1.5.	Output AutoCAD R12.....	40
10.1.6.	Output Cadkey v6.....	41
10.1.7.	Output CALSView.....	42
10.1.8.	Output Generic.....	43
10.1.9.	Output IGESView.....	44
10.1.10.	Output IGESWorks.....	45
10.1.11.	Output Preview.....	46
10.1.12.	Output X-Change.....	47
10.2.	File D001Q019.....	48
10.2.1.	Output AutoCAD R12.....	48
10.2.2.	Output Cadkey v6.....	49
10.2.3.	Output CALSView.....	50
10.2.4.	Output Generic.....	51
10.2.5.	Output IGESView.....	52
10.2.6.	Output IGESWorks.....	53
10.2.7.	Output Preview.....	54
10.2.8.	Output X-Change.....	55
10.3.	File D001Q023.....	56
10.3.1.	Output AutoCAD R12.....	56
10.3.2.	Output Cadkey v6.....	57
10.3.3.	Output CALSView.....	58

---

---

10.3.4.	Output Generic.....	59
10.3.5.	Output IGESView.....	60
10.3.6.	Output IGESWorks.....	61
10.3.7.	Output Preview.....	62
10.3.8.	Output X-Change.....	63
11.	Appendix C - Detailed SGML Analysis.....	64
11.1.	Parser Log.....	64
11.2.	Exoterica Validator exl Parser.....	64
11.3.	Public Domain sgmls Log.....	65
12.	Appendix D - Detailed CGM Analysis.....	66
12.1.	File D001C004.....	66
12.1.1.	Parser Log MetaCheck.....	66
12.1.2.	validcgm Log.....	68
12.1.3.	Output CADLeaf.....	69
12.1.4.	Output CALSView .....	70
12.1.5.	Output Generic.....	71
12.1.6.	Output Designer.....	72
12.1.7.	Output Freelance .....	73
12.1.8.	Output Harvard Graphics.....	74
12.1.9.	Output HiJaak for Windows.....	75
12.1.10.	Output IslandDraw 4.0.....	76
12.1.11.	Output Ventura Publisher.....	77
12.1.12.	Output X-Change.....	78
12.2.	File D001C005.....	79

---



12.2.1.	Output CADLeaf.....	79
12.2.2.	Output CALSView .....	80
12.2.3.	Output Generic.....	81
12.2.4.	Output Designer.....	82
12.2.5.	Output Freelance .....	83
12.2.6.	Output Harvard Graphics.....	84
12.2.7.	Output HiJaak for Windows.....	85
12.2.8.	Output IslandDraw 4.0.....	86
12.2.9.	Output Ventura Publisher.....	87
12.2.10.	Output X-Change.....	88

## 1. Introduction

### 1.1 Background

The Department of Defense (DoD) Air Force Continuous Acquisition and Life-cycle Support (CALs) Test Network (AFCTN) is conducting tests of the military standard for the Automated Interchange of Technical Information, MIL-STD-1840A, and its companion suite of military specifications. The AFCTN is a DoD sponsored confederation of voluntary participants from industry and government managed by the Electronic Systems Center (ESC).

The primary objective of the AFCTN is to evaluate the effectiveness of the CALs standards for technical data interchange and to demonstrate the technical capabilities and operational suitability of those standards. Two general categories of tests are performed to evaluate the standards; formal and informal.

Formal tests are large and comprehensive, which follow a written test plan, require specific authorization from the DoD, and may take months to prepare, execute, and report.

Informal tests are quick and short, used by the AFCTN technical staff, to broaden the testing base. They include representative samples of the many systems and applications used by AFCTN participants. They also allow the AFCTN staff to gain feedback from many industry and government interpretations of the standards, to increase the base of participation in the CALs initiative, and respond to the many requests for help that come from participants. Participants take part voluntarily, benefit by receiving an evaluation of their latest implementation (interpretation) of the standards, interact with the AFCTN technical staff, gain experience using the standards, and develop increased confidence in them. The results of informal tests are reported in Quick Short Test Reports (QSTRs) that briefly summarize the standard(s) tested, the hardware and software used, the nature of the test, and the results.

---

## 1.2 Purpose

The purpose of the informal test, reported in this QSTR, was to analyze O'Neil & Associates' interpretation and use of the CALS standards in transferring technical publication data. O'Neil used its CALS Technical Data Interchange System to produce data, in accordance with the standards, and delivered it to the AFCTN technical staff on a 9-track magnetic tape.

## 2. Test Parameters

Test Plan: AFCTB 94-010

Date of Evaluation: 09 March 1993

Evaluator: George Elwood  
Air Force CALS Test Bed  
DET 2 HQ ESC/AV-2P  
4027 Colonel Glenn Hwy  
Suite 300  
Dayton OH 45431-1672

Data Originator: Larry McKinley  
O'Neil & Associates, Inc.  
425 North Findlay Street  
Dayton OH 45404-2203  
(513) 461-1602 x3008

Data Description: Technical Manual Test

- 1 Document Declaration file
- 4 Document Type Definitions (DTDs)
- 13 Initial Graphics Exchange Specification (IGES) files
- 1 Text/Standard Generalized Markup Language (SGML) file
- 7 Computer Graphics Metafile (CGM) files

Data Source System:

1840

**HARDWARE**

386 PC

**SOFTWARE**

Tapetool v1.2.10

IGES

**HARDWARE**

Xerox 7650 ProImager  
6085 Workstation

---

**SOFTWARE**

Xerox XTI v.2.2  
Xerox XPI Image Conversion v2.6  
Xerox Expert Drafting v5.0  
O/S-2 Global View  
Conversion Of IGES Files v.5.1

Text/SGML

**HARDWARE**

386 PC

**SOFTWARE**

WordPerfect Intellitag v1.0  
Exoterica Validator v1.1

CGM

**HARDWARE**

HP/Apollo 425T

**SOFTWARE**

Auto-trol 5000/CGM Converter v1.4

**Evaluation Tools Used:**

**MIL-STD-1840A (TAPE)**

SUN 3/280

AFCTN *Tapetool* v1.2.10 UNIX  
XSoft *CAPS/CALS* v40.4

**MIL-D-28000 (IGES)**

HP 735

*InterCAP X-Change* v7.82

SGI Indigo2

AUTODESK *AutoCAD R12*

Cadkey *Cadkey* v6.0

IGES Data Analysis (IDA) *CALSVIEW*

Sun SparcStation 2

AUTODESK *AutoCAD R12*

Carberry *CADLeaf Plus* v3.1

IDA *Parser/Verifier* v92

IDA *IGESVIEW* v3.05

International TechnneGroup Incorporated

(ITI) *IGES/Works* v1.3

Rosetta Technologies *Prepare*

Rosetta Technologies *Preview* v3.2

---

PC 486/50

AUTODESK AutoCAD 386 R12  
Cadkey Cadkey v6.0  
IDA IGESView Windows

MIL-M-28001 (SGML)

SUN SparcStation 2

ArborText ADEPT v4.2.1

PC 486/50

Exoterica XGMLNormalizer v1.2e3.2  
Exoterica Validator v2.0 ex1  
McAfee & McAdam Sema Mark-it v2.3  
Public Domain sgmls

MIL-D-28003 (CGM)

HP 735

InterCAP X-Change v7.82

SGI Indigo 2

IDA CALSView

SUN SparcStation 2

Carberry CADLeaf Plus v3.1  
Island Graphics IslandDraw v3.0  
Island Graphics IslandDraw v4.0

PC 486/50

Advanced Technology Center  
(ATC) MetaCheck R 2.10  
Software Publishing Corporation  
(SPC) Harvard Graphics v3.05  
Inset Systems HiJaak Pro  
Lotus Freelance v2.01  
Micrografx Designer v4.0  
Corel Ventura Publisher

**Standards**

**Tested:**

MIL-STD-1840A  
MIL-D-28000A  
MIL-M-28001A  
MIL-D-28003

### **3. 1840A Analysis**

#### **3.1 External Packaging**

The tape was hand delivered to the Air Force CALS Test Bed (AFCTB) enclosed in an envelop. The exterior of the envelop was not marked with a magnetic tape warning label, as required by MIL-STD-1840A, para. 5.3.1.3.

The tape was not enclosed in a barrier bag or barrier sheet material, as required by MIL-STD-1840A, para. 5.3.1.2. Inspection of the tape reel showed the label indicating the recording density, as required by MIL-STD-1840A, para. 5.3.1. Enclosed in the envelope was a packing list showing all files recorded on the tape.

#### **3.2 Transmission Envelope**

The 9-track tape received by the AFCTB contained MIL-STD-1840A files. The files were named per the standard conventions.

##### **3.2.1 Tape Formats**

The tape was run through the AFCTN *Tapetool v1.2.10* utility. No errors were reported while evaluating the contents of the tape labels.

The tape was read using the XSoft *CAPS read1840A* utility without any reported errors.

The physical tape structure meets the requirements defined in CALS MIL-STD-1840A and ANSI 3.27.

### 3.2.2 Declaration and Header Fields

When the tape was read by the AFCTN *Tapetool*. No errors were reported in the Document Declaration file and data file headers.

When the tape was read by XSoft's *read1840A*, the files were renamed to specific data records in the CALS headers. Upon checking the files, resulting from this operation, only one DTD was found. XSoft's utility renamed the four DTD files using the *dstdocid* value. This value was the same for all four files, and caused each file to over write the previous copy. Note the naming of the files in the *read1840A* log in Appendix A of this report. MIL-STD-1840A permits only three records in the DTD header. The *srcdocid* and *dstdocid* must be the same as the value in the Document Declaration file. The third record is not the same. MIL-STD-1840A does not include the capability to use the automatic naming convention used by XSoft.

A recommended practice using MIL-STD-1840A would be to place the names of the additional DTD files in the notes record. A comment should also be included to the construction of the DTDs.

The same type problem can occur if data files have the same record value for the *srcgph* field. This name becomes critical in large file transfers using DOS based systems. This will also be a larger problem when using MIL-STD-1840B, which permits even higher numbers of files to be transferred.

MIL-STD-1840B has additional records available. The *moduleid* record would be used to provide for the auto-naming conventions.

The CALS headers and Document Declaration file meet the requirements defined in CALS MIL-STD-1840A.



## 4. IGES Analysis

The tape contained thirteen IGES files. The files were inspected for the required conformance statement defined in CALS MIL-D-28000A. Although a statement was included, it did not provide all of the required information. MIL-D-28000A, para 3.2.1.3.1 requires the specification date the file conforms to. Shown below is the start section for file Q020.

Start Section:

Drawing name: M10.13.DWG. This file was converted by Expert.  
Compliant with CALS class 1, per MIL-D-28000 Amendment 1.

DATE: 10-Feb-94 12:30:30

These files were evaluated using IDA's *Parser/Verifier* set for CALS Class I. This utility reported no CALS Class I errors. This utility reported basic IGES errors with most files. These errors relate to incomplete geometry. A visual inspection of the files does not show these errors unless the image is enlarged several times. For illustrations in a technical manual the errors do not cause any impact.

It was also noted that the arrows were made up of several parts; a main line and then smaller lines. These lines were then given a thickness of three, which made them appear as one entity. The line thickness of three was used on many of the images. This resulted in covering over gaps in the geometry.

In file Q020, additional lines were noted around the drawing in some applications. These lines ran between the added arrowheads in several locations. When checked these lines and the included arrowheads were reported as entity type 230, which is a sectioned area entity.

The AFCTB has several tools for viewing IGES files. These tools are not used to generate a pass/fail but to report how commercially available software can handle the files. Many of these products are used in the development of technical publications and are good indicators of usability. The use of these products is not an endorsement nor an indication

---

of CALS capability. All operations were performed using the default settings.

Because of the number of files submitted, a sample was selected for the detailed analysis. All files were viewed by at least four software applications. The log files from file D001Q020 are included in Appendix B, Section 10.1 of this report. Outputs for files D001Q019, Q020 and Q023 were used to illustrate problems.

The files were converted using another utility, available within the AFCTB, with no reported errors. When the resulting files were read into Island Graphics' *IslandDraw*, many of the images were displayed in the lower left corner. This is the result of the origin point being a negative number.

The files were read using AUTODESK's *AutoCAD R12* with translator version 5.1. This translator reported many of the same errors and warnings reported by the *IDA Parser/verifier*. Line styles, specifically the dashed lines, were present but the translator used a very short line which was represented by a dot. This resulted in very faint lines on the output. Extra lines were displayed in file Q020.

The files were read into another software package, available within the AFCTB, without a reported error. The arrow heads were missing on both the displayed and hard copies.

The files were converted using Cadkey's *ig2c* utility. The resulting files were read into Cadkey's *Cadkey*, displayed, and printed. No apparent discrepancies were noted.

The files were read into Carberry's *CADLeaf* software without a reported error. When displayed, some images were incomplete. They displayed either at the top of the screen or the lower left corner. This was traced to the *-x* and *-y* values used to define the start points of the file. Additional lines were noted on file Q020.

The files were read using IDA's *CALSVIEW* with no reported errors. The displayed and printed images showed heavy lines where entities were added. Added lines in file Q020 were noted.

The files were read using IDA's *IGESVIEW* and *IGESVIEW for Windows* without any reported errors. Added lines were noted in file Q020.

---

The files were read using InterCAPS's *X-Change* with no reported errors. No errors were noted in the displayed or printed copies of the files.

The files were read using ITI's *IGESWorks* without a reported error. The files had reported errors and warnings when the parser function was run. See Appendix B, Section 10.1.3 for the log file. On file Q020, the extras lines were not displayed, resulting in no arrowheads on the image.

The IGES files were converted using Rosetta Technologies' *Prepare* with reported errors. See Appendix B, Section 10.1.4 for the error log. The resulting files were read into Rosetta Technologies' *Preview*, displayed and printed. The dotted or dashed lines were displayed as solid lines. The arrowheads displayed without the added lines in file Q020. The sectioned area, which generated these lines, was not supported in *Prepare*.

The submitted IGES files had no reported CALS Class I errors, and meets the CALS MIL-D-28000A specification.

## 5. SGML Analysis

Four DTD and one Text/SGML files were include in this evaluation. The AFCTB has several parsers available for evaluating submitted DTD and text files. These tools are not used to generate a pass/fail but to report how commercially available software can handle the files. These products are used in the development of technical publications and are good indicators of usability. The use of these products is not an endorsement nor an indication of CALS capability. All operations were performed using the default settings unless specified in the report. Changes to DTD or text files required by each system are not documented in the report.

A visual inspection of the provided DTDs was necessary to correctly configure the parsers. The file D001G008 was the main DTD, and contained the graphic references. This DTD pointed to file D001G009, which contains the majority of the tags. Within file G009 were references to files G010 and G011. File G009 was named "BSPEC.DTD" while G010 was named "calsfigs.sgm" and G011 was named "calsfigs.sgm."

The text and DTD files were evaluated using a parser available within the AFCTB. This utility reported an error and did not complete the operation.

The text and DTD files were evaluated using Exoterica's *Validator exl* parser. Only one warning was issued during this operation.

The text and DTD files were tested using Exoterica's *XGML-Normalizer* parser with no reported errors or warnings.

The text and DTD files were evaluated using McAfee & McAdam's *Sema Mark-it* parser with no reported errors or warnings.

The text and DTD files were evaluated using the Public Domain *sgmls* parser. This parser reported errors when it could not find the external graphics files, and the same type errors in the text file where these files were called. These are considered non-errors for this report. There were no other reported errors from this tool.

---

The text file was imported into ArborText's *Adept* software. The text and DTDs parsed without any reported errors or warnings.

The DTD and text/SGML files parsed without any reported errors, and meet the CALS MIL-M-28001A specification.

## 6. Raster Analysis

No Raster files were included in this evaluation.

## 7. CGM Analysis

The tape contained seven CGM files. The files were evaluated using ATC's *MetaCheck* with CALS options. This utility reported the files meet the specifications defined in CALS MIL-D-28003.

The CGM files were evaluated using the beta AFCTN *validcgm* utility with no reported errors.

The AFCTB has several tools for viewing CGM files. These tools are not used to generate a pass/fail but to report how commercially available software can handle the files. Many of these products are used in the development of technical publications and are good indicators of usability. The use of these products is not an endorsement nor an indication of CALS capability. All operations were performed using the default settings.

Because of the number of submitted files only two files will be discussed in detail. All files were viewed using various software applications. All "missing" geometry is due to duplication problems. Some illustrations may have to be reduced slightly to fit on a page, so the copier does not truncate the illustration.

The CGM files were converted using a utility available within the AFCTB without a reported error. The resulting files were read into Island Graphics' *IslandDraw* v3.1, and displayed. Before the images would display the background, which was black, had to be removed. File C005 had text overlap along the bottom of the image.

---

The files were read into Carberry's *CADLeaf* software and displayed. The background color had to be changed to white in order to see the images. File C005 had text overlap in the legend.

The files were read into IDA's *CALSVIEW*. The background color had to be blanked before the image could be seen. Text overlap was noted in file C005.

The files were viewed using another software package available within the AFCTB. The images appeared to be complete when displayed on the screen. Text overlap was noted on file C005, and file C004 did not print completely due to memory limitation in the printer.

The files were imported into the Micrografx *Designer* without a reported error. The black background had to be removed in order to see the image. On file C004, some of the entities were missing. The text overlap problem, noted above in file C005, was not present.

According to Michael Harriosen of Micrografx, "Micrografx is aware of the problems associated with reading these files and is working on a solution to be implemented in a future release of our products."

The files were imported into Lotus' *Freelance* and displayed. The black background had to be removed in order to see the images. File C005 had a text overlap problem.

The files were imported into SPC's *Harvard Graphics 3.05* without a reported error. The background color had to be changed in order to display the images. In file C004, some entities were not displayed and others were noted in error. In file C005, the text overlap problem was displayed along with some entity problems.

The files were read into Inset Systems' *HiJaak Pro* without a reported error. The background color had to be changed to white in order to display the images. File C005 had a text overlap problem.

The files were imported directly into Island Graphics's *IslandDraw v4.0* without a reported error. The images displayed noted errors in the graphics entities; some were missing and others were misplaced.

---

The files were read into InterCAP's *X-Change* without a reported error. The black background had to be removed before the image could be seen. The text overlap problem was noted in file C005.

The files were imported into Corel's *Ventura Publisher* without a reported error. The black background was not noted. Entity errors were noted in most files as missing, misshaped or misaligned. The text overlap problem was not noted in file C005.

The CGM files meet the CALS MIL-D-28003 specification. All applications were able to read the files without a problem. However, most of the applications had problems with black text on a black background. They also had problems with file C005 displaying overlapping text.

## 8. Conclusions and Recommendations

The physical structure and CALS format of the tape from O'Neil & Associates, Inc. was correct. This portion of the tape meets the CALS MIL-STD-1840A requirements. One problem was noted using XSoft's tape reading application, where the naming convention resulted in the loss of three of the four DTDs. This is an error in MIL-STD-1840A, in that it does not provide enough records for the DTD file types.

The IGES files had no reported CALS Class I errors, and meet the CALS MIL-D-28000A specification. Some basic IGES errors and warnings were noted. The most critical error was the added lines, actually sectioned areas, that made up some of the arrowheads.

The SGML files parsed using several different parsers without a reported error, and meet the CALS MIL-M-28001A specification. Because no FOSI was included the documents could not be published.

The CGM files meet the CALS MIL-D-28003 specification. However, most applications had problems with a black background. They also had problems with overlapping text in file C005.

The tape and the data files meet the CALS MIL-STD-1840A requirements. However, problems in with the CGM file could cause problems in most publishing systems.



---

## 9. Appendix A - Tapetool Report Logs

### 9.1 Tape Catalog

CALS Test Network Catalog Evaluation - Version 1.2; Release 10 (C)

Standards referenced:

- MIL-STD-1840A (1987) - Automated Interchange of Technical Information
- ANSI X3.27 (1987) - File Structure and Labelling of Magnetic Tapes  
for Information Interchange
- ANSI X3.4 (1986) - Coded Character Sets - 7 Bit ASCII

Tue Mar 8 16:29:32 1994

MIL-STD-1840A File Catalog

File Set Directory: /cals/u1210/Set049

Page: 1

File Name	File Type	Record Format/ Length	Block Length/Total	Selected/ Extracted
D001	Document Declaration	D/00260	02048/000001	Extracted
D001C001	CGM	F/00080	00800/000003	Extracted
<<<<< PART OF LOG REMOVED HERE >>>>>				
D001G008	DTD	D/00260	02048/000001	Extracted
D001G009	DTD	D/00260	02048/000013	Extracted
D001G010	DTD	D/00260	02048/000002	Extracted
D001G011	DTD	D/00260	02048/000002	Extracted
D001Q012	IGES	F/00080	02000/000106	Extracted
<<<<< PART OF LOG REMOVED HERE >>>>>				
D001Q024	IGES	F/00080	02000/000058	Extracted
D001T025	Text	D/00260	02048/000034	Extracted

Catalog Process terminated normally.

---

## 9.2 Tape Evaluation Log

CALS Test Network Tape Evaluation - Version 1.2; Release 10 (C)

Standards referenced:

ANSI X3.27 (1987) - File Structure and Labelling of Magnetic Tapes  
for Information Interchange

ANSI X3.4 (1986) - Coded Character Sets - 7 Bit ASCII

Tue Mar 8 16:28:38 1994

ANSI Tape Import Log

Allocating tape drive /dev/rmt0...

/dev/rmt0 allocated.

VOL1ONA001

4

Label Identifier: VOL1  
Volume Identifier: ONA001  
Volume Accessibility:  
Owner Identifier:  
Label Standard Version: 4

HDR1D001                    ONA00100010001000000 94067 00000 000000

Label Identifier: HDR1  
File Identifier: D001  
File Set Identifier: ONA001  
File Section Number: 0001  
File Sequence Number: 0001  
Generation Number: 0000  
Generation Version Number: 00  
Creation Date: 94067  
Expiration Date: 00000  
File Accessibility:  
Block Count: 000000  
Implementation Identifier:

HDR2D0204800260

00

Label Identifier: HDR2  
Recording Format: D  
Block Length: 02048  
Record Length: 00260  
Offset Length: 00

\*\*\*\*\* Tape Mark \*\*\*\*\*

<<<< PART OF LOG FILE REMOVED HERE >>>>

\*\*\*\*\* Tape Mark \*\*\*\*\*

##### End of Volume ONA001 #####

##### End Of Tape File Set #####

Deallocating /dev/rmt0...

Tape Import Process terminated normally.

## 9.3 Tape File Set Validation Log

CALS Test Network File Set Evaluation - Version 1.2; Release 10 (C)

Standards referenced:

MIL-STD-1840A (1987) - Automated Interchange of Technical Information

Tue Mar 8 16:29:33 1994

MIL-STD-1840A File Set Evaluation Log

File Set: Set049

Found file: D001

Extracting Document Declaration Header Records...

Evaluating Document Declaration Header Records...

srcsys: O'Neil & Assoc. CAGE 83007

srcdocid: TO 31R2-2FRC181-42

srcrelid: NONE

chglvl: ORIGINAL

dteisu: 19940303

dstsys: Raytheon CAGE 49956

dstdocid: TO 31R2-2FRC181-42

dstrelid: NONE

dtetrm: 19940308

dlvacc: NONE

filcnt: C7,G4,Q13,T1

ttlcls: UNCLASSIFIED

doccls: UNCLASSIFIED

doctyp: Technical Publication

doctl: NONE

Found file: D001C001

Extracting CGM Header Records...

Evaluating CGM Header Records...

srcdocid: TO 31R2-2FRC181-42

dstdocid: TO 31R2-2FRC181-42

txtfilid: W

figid: A

srcgph: ESDCAU

doccls: UNCLASSIFIED

notes: NONE

Saving CGM Header File: D001C001\_HDR

Saving CGM Data File: D001C001\_CGM

---

<<<<< PART OF LOG FILE REMOVED HERE >>>>>

Found file: D001G008  
Extracting DTD Header Records...  
Evaluating DTD Header Records...

srcdocid: TO 31R2-2FRC181-42  
dstdocid: TO 31R2-2FRC181-42  
notes: NONE

Saving DTD Header File: D001G008\_HDR  
Saving DTD Data File: D001G008\_DTD

Found file: D001G009  
Extracting DTD Header Records...  
Evaluating DTD Header Records...

srcdocid: TO 31R2-2FRC181-42  
dstdocid: TO 31R2-2FRC181-42  
notes: BSPEC

Saving DTD Header File: D001G009\_HDR  
Saving DTD Data File: D001G009\_DTD

Found file: D001G010  
Extracting DTD Header Records...  
Evaluating DTD Header Records...

srcdocid: TO 31R2-2FRC181-42  
dstdocid: TO 31R2-2FRC181-42  
notes: calsfigs.sgm

Saving DTD Header File: D001G010\_HDR  
Saving DTD Data File: D001G010\_DTD

Found file: D001G011  
Extracting DTD Header Records...  
Evaluating DTD Header Records...

srcdocid: TO 31R2-2FRC181-42  
dstdocid: TO 31R2-2FRC181-42  
notes: calstabs.sgm

Saving DTD Header File: D001G011\_HDR  
Saving DTD Data File: D001G011\_DTD

Found file: D001Q012  
Extracting IGES Header Records...

---

Evaluating IGES Header Records...

srcdocid: TO 31R2-2FRC181-42  
dstdocid: TO 31R2-2FRC181-42  
txtfilid: W  
figid: 1-1  
srcgph: M1001  
doccls: UNCLASSIFIED  
notes: NONE

Saving IGES Header File: D001Q012\_HDR  
Saving IGES Data File: D001Q012\_IGS

<<<< PART OF LOG FILE REMOVED HERE >>>>

Found file: D001T025  
Extracting Text Header Records...  
Evaluating Text Header Records...

srcdocid: TO 31R2-2FRC181-42  
dstdocid: TO 31R2-2FRC181-42  
txtfilid: W  
doccls: UNCLASSIFIED  
notes: NONE

Saving Text Header File: D001T025\_HDR  
Saving Text Data File: D001T025\_TXT

Evaluating numbering scheme...  
No errors were encountered during numbering scheme evaluation.  
Numbering scheme evaluation complete.

Checking file count...  
No errors were encountered during file count verification.  
File Count verification complete.

No errors were encountered in Document D001.

No errors were encountered in this File Set.

MIL-STD-1840A File Set Evaluation Complete.

---

## 9.4 Other Tape Reading Logs

```
/cals/caps/Bin/read1840A: --- Read declaration file 'D001    ' ---  
/cals/caps/Bin/read1840A: writing data file '9410/TO31R2-2FRC181-4/  
ESDCAU.C.cgm'.  
/cals/caps/Bin/read1840A: writing data file '9410/TO31R2-2FRC181-4/  
TXTRES.D.C.cgm'.  
/cals/caps/Bin/read1840A: writing data file '9410/TO31R2-2FRC181-4/  
M1002.C.cgm'.  
/cals/caps/Bin/read1840A: writing data file '9410/TO31R2-2FRC181-4/  
M1007.C.cgm'.  
/cals/caps/Bin/read1840A: writing data file '9410/TO31R2-2FRC181-4/  
M1008.C.cgm'.  
/cals/caps/Bin/read1840A: writing data file '9410/TO31R2-2FRC181-4/  
M1009.C.cgm'.  
/cals/caps/Bin/read1840A: writing data file '9410/TO31R2-2FRC181-4/  
M1016.C.cgm'.  
/cals/caps/Bin/read1840A: writing data file '9410/TO31R2-2FRC181-4/  
TO31R22FRC18142.G.dtd'.  
/cals/caps/Bin/read1840A: writing data file '9410/TO31R2-2FRC181-4/  
TO31R22FRC18142.G.dtd'.  
/cals/caps/Bin/read1840A: writing data file '9410/TO31R2-2FRC181-4/  
TO31R22FRC18142.G.dtd'.  
/cals/caps/Bin/read1840A: writing data file '9410/TO31R2-2FRC181-4/  
TO31R22FRC18142.G.dtd'.  
/cals/caps/Bin/read1840A: writing data file '9410/TO31R2-2FRC181-4/  
M1001.Q.igs'.  
/cals/caps/Bin/read1840A: writing data file '9410/TO31R2-2FRC181-4/  
M1003A.Q.igs'.  
/cals/caps/Bin/read1840A: writing data file '9410/TO31R2-2FRC181-4/  
M1004A.Q.igs'.  
/cals/caps/Bin/read1840A: writing data file '9410/TO31R2-2FRC181-4/  
M1005A.Q.igs'.  
/cals/caps/Bin/read1840A: writing data file '9410/TO31R2-2FRC181-4/  
M1006A.Q.igs'.  
/cals/caps/Bin/read1840A: writing data file '9410/TO31R2-2FRC181-4/  
M1010A.Q.igs'.  
/cals/caps/Bin/read1840A: writing data file '9410/TO31R2-2FRC181-4/  
M1011A.Q.igs'.  
/cals/caps/Bin/read1840A: writing data file '9410/TO31R2-2FRC181-4/  
M1012A.Q.igs'.  
/cals/caps/Bin/read1840A: writing data file '9410/TO31R2-2FRC181-4/  
M1013A.Q.igs'.  
/cals/caps/Bin/read1840A: writing data file '9410/TO31R2-2FRC181-4/  
M1014A.Q.igs'.  
/cals/caps/Bin/read1840A: writing data file '9410/TO31R2-2FRC181-4/  
M1015A.Q.igs'.
```

/cals/caps/Bin/read1840A: writing data file '9410/TO31R2-2FRC181-4/  
M10B22.Q.igs'.

/cals/caps/Bin/read1840A: writing data file '9410/TO31R2-2FRC181-4/  
T4211.Q.igs'.

/cals/caps/Bin/read1840A: writing data file '9410/TO31R2-2FRC181-4/  
W.T.sgm'.

- declaration file indicates 1 files of type T
- declaration file indicates 4 files of type G
- declaration file indicates 0 files of type H
- declaration file indicates 13 files of type Q
- declaration file indicates 0 files of type R
- declaration file indicates 7 files of type C
- declaration file indicates 0 files of type X
- declaration file indicates 0 files of type P
- declaration file indicates 0 files of type Z



## 10. Appendix B - Detailed IGES Analysis

### 10.1 File D001Q020

#### 10.1.1 Parser/Verifier Log

```
*****  
**** IGES PARSER/VERIFIER ****  
**** MARCH 1993 ****  
**** IGES Data Analysis ****  
**** (708) 344-1815 ****  
*****
```

Input file is q020.igs

Checking conformance to CALS Class I (MIL-D-28000A 2/10/92)  
Today is March 9, 1994 8:17 AM

```
*****  
**** CHECK FILE SYNTAX ****  
*****
```

Section	Records
Start	5
Global	3
Directory	534 ( 267 Entities)
Parameter	320
Terminate	1

No syntax errors detected.

```
*****  
**** SUMMARY AND STATISTICS ****  
*****
```

#### \*\*\* File and Product Name Information \*\*\*

```
File name from sender = 'M10.13.dwg'  
File creation Date.Time = '940210.123030'  
Model change Date.Time = ''  
Author = 'Gary Hahn'  
Department = ''  
Product name from sender = 'Xerox Expert'  
Destination product name = ''
```

---

\*\*\* Parameter Delimiters \*\*\*

Delimiter = ','  
Terminator = ';'

\*\*\* Originating System Data \*\*\*

System ID = 'Xerox Expert version 5.0'  
Preprocessor version = '5.0'  
Specification version = 6 (IGES 4.0)

\*\*\* Precision levels \*\*\*

Integer bits = 16  
Floating point - Exponent = 38 Mantissa = 7  
Double precision - Exponent = 38 Mantissa = 7

\*\*\* Global Model Data \*\*\*

Model scale = 1.0000E+00  
Unit flag = 1  
Units = 'INCH'  
Line weights = 3  
Maximum line thickness = 4.166667E-02  
Minimum line thickness = 1.388889E-02  
Granularity = 1.000000E-05  
Maximum coordinate = 1.491070E+01

Drafting standard applicable to original data is not specified.

\*\*\* Status Flag Summary \*\*\*

Blank status:	Visible	267
	Blanked	0
Independence:	Independent	201
	Physically Subordinate	64
	Logically Subordinate	2
	Totally Subordinate	0
Entity use:	Geometry	218
	Annotation	46
	Definition	2
	Other	1
	Logical/Positional	0
	2D parametric	0
	Construction geometry	0
	Not Specified	0

Hierarchy:    Structure DE applies            267  
               Subordinate DE applies            0  
               Hierarchy property applies        0  
               Not Specified                    0

\*\*\* Entity Occurrence Counts \*\*\*

Entity	Form	Level	Count	Type
-----	----	-----	-----	-----
100	0	0	3	Circular arc
102	0	0	9	Composite curve
104	1	0	3	Conic arc - ellipse
110	0	0	191	Line
124	0	0	3	Transformation matrix
212	0	0	46	General note
230	0	0	9	Sectioned area (Standard Crosshatching)
404	0	0	1	Drawing
406	16	0	1	Property - Drawing size
410	0	0	1	View - Orthographic parallel

\*\*\* Entity Count by Level \*\*\*

Level	Count
0	267

\*\*\* Labeling Information \*\*\*

100% of the entities are labeled.

Unlabeled            0

Label	Count	Label	Count	Label	Count
View	1*	Line	191*	GNote	46*
Arc	2*	Composit	9	Section	9*
Circle	1*	Matrix	3*	Ellipse	3*
Property	1	Drawing	1*		

NITPICK 2327: One or more of the flagged entity labels are not right-justified.

\*\*\* Line Fonts Used in Data \*\*\*

100	102	104	106	108	110	112	114	
-	-	-	-	-	-	-	-	Undefined
3	9	-	-	-	157	-	-	Solid
-	-	-	-	-	-	-	-	Dashed
-	-	-	-	-	-	-	-	Phantom
-	-	-	-	-	-	-	-	Center-line
-	-	3	-	-	34	-	-	Dotted
-	-	-	-	-	-	-	-	User defined
116	118	120	122	124	125	126	128	
-	-	-	-	-	-	-	-	Undefined
-	-	-	-	3	-	-	-	Solid
-	-	-	-	-	-	-	-	Dashed

<<<<< PART OF LOG FILE REMOVED HERE >>>>>

\*\*\* Line Widths Used in Data \*\*\*

Weight	Count	Width
Defaulted	197	(0.0139)
1	70	(0.0139)

\*\*\* Colors Used in Data \*\*\*

Defaulted	24
Green	243

\*\*\*\*\*  
\*\*\*\*\* ENTITY ANALYSIS \*\*\*\*\*  
\*\*\*\*\*

\*\*\* Entity type: 100

\*\*\* Entity type: 102

ERROR 2033: End points of curves D 225 and D 227 disjoint by  
7.470000E-02 at D 231.  
ERROR 2033: End points of curves D 227 and D 229 disjoint by  
7.209840E-02 at D 231.  
ERROR 2033: Messages regarding disjoint composite curves suppressed.

\*\*\* Entity type: 104

WARNING 2265: Start point off conic by 1.594979E-05 at D 407.  
WARNING 2039: End point off conic by 6.735962E-05 at D 407.  
WARNING 2265: Start point off conic by 1.594979E-05 at D 427.  
WARNING 2039: End point off conic by 6.735962E-05 at D 427.  
WARNING 2265: Start point off conic by 1.594979E-05 at D 431.  
WARNING 2039: End point off conic by 6.735962E-05 at D 431.

\*\*\* Entity type: 110

-- 191 lines averaging 6.068996E-01 units --

\*\*\* Entity type: 124

3 transformation matrices, 3 non-zero translations.

NOTE 2341: 3 matrices contain translation information.

\*\*\* Entity type: 212

46 text strings in data file.  
Average text aspect ratio in file is 0.9024965.  
Minimum text aspect ratio in file is 0.9008403.  
Maximum text aspect ratio in file is 0.9071421.

FONTS USED IN FILE

FONT	COUNT	NAME
1	46	Default ASCII Style

\*\*\* Entity type: 230

NITPICK 2076: Entity does not have Annotation flag set at D 233.  
NITPICK 2076: Entity does not have Annotation flag set at D 243.  
NITPICK 2076: Entity does not have Annotation flag set at D 261.  
NITPICK 2076: Entity does not have Annotation flag set at D 289.  
NITPICK 2076: Entity does not have Annotation flag set at D 323.  
NITPICK 2076: Entity does not have Annotation flag set at D 329.  
NITPICK 2076: Entity does not have Annotation flag set at D 339.  
NITPICK 2076: Entity does not have Annotation flag set at D 355.  
NITPICK 2076: Entity does not have Annotation flag set at D 377.

\*\*\* Entity type: 404

NITPICK 2074: Entity use flag must be 1 for Drawing entity at D 533.  
Drawing at D 533 contains 1 views.  
Drawing at D 533 contains 0 annotation entities.

\*\*\* Entity type: 406

---

\*\*\* Entity type: 410

NITPICK 2073: Entity use flag must be 1 for View entity at D 1.  
Scale of view at D 1 is 1.000000E+00.  
Orthographic View entity at D 1 has 0 clipping planes specified.  
XMIN = Not Set XMAX = Not Set  
YMIN = Not Set YMAX = Not Set  
ZMIN = Not Set ZMAX = Not Set

\*\*\* Message Summary \*\*\*

2007: 46 Mathematical discontinuities.  
2015: 6 Mathematically incorrect definitions.  
2016: 11 Invalid entity use flag.

\*\*\* Error Summary \*\*\*

0 fatal errors  
0 severe errors  
46 errors  
6 warnings  
0 cautions  
12 nitpicks  
1 notes

\*\*\* End of Analysis of q020.igs \*\*\*

---

## 10.1.2 Parser Log - AutoCAD R12

Title: IGESIN Journal (v5.1 Nov 05 1992)

=====  
File: C:/TMP/Q020.xli  
Date: Wed, Mar 09, 1994  
Time: 11:05:04  
=====

EVALUATION VERSION -- NOT FOR RESALE

Translator S/N: 117-10075750  
Translating from IGES file: C:/TMP/Q020.IGS  
to AutoCAD Drawing: C:\Q020.dwg  
=====

Options obtained from: default settings  
Curves Approximated to Tolerance of 0.01  
Surfaces Approximated to Tolerance of 0.01

Text Font/Style mapping:

IGES Text font	Style Name	ACAD Font
0	SYMBOL0	iges0
1	STANDARD	txt
2	LEROY	txt
3	FUTURA	txt
6	COMP80	txt
12	GOTHICE	gothice
13	GOTHICI	gothici
14	ROMANS	romans
17	ROMANT	romant
18	ROMAND	romand
19	OCR	txt
1001	SYMBOL1	iges1001
1002	SYMBOL2	iges1002
1003	SYMBOL3	iges1003
2001	KANJI	bigfont

IGES Linefont/AutoCAD Linetype mapping

IGES Line Font	AutoCAD linetype	Shape file
0	BYLAYER	
1	CONTINUOUS	
2	DASHED	acad.lin
3	PHANTOM	acad.lin
4	CENTER	acad.lin
5	DOT	acad.lin

---

=====  
Parse phase

\*\*\* Warning (IAFP\_LARGER\_SGL\_SIG) \*\*\*

C:/TMP/Q020.IGS, line 8: IGES file has greater number of significant digits in single precision numbers than this system.

\*\*\* Warning (IEVM\_LABEL\_NOT\_RJ) \*\*\*

(DE 1, TF 410:0) DE has an invalid label justification.

Action taken: Label has been right justified.

<<<< PART OF LOG FILE REMOVED HERE >>>>

<<<< PART OF LOG FILE REMOVED HERE >>>>

\*\*\* Warning (IEVM\_BAD\_START\_POINT\_104) \*\*\*

(DE 427, TF 104:1) Entity's start point not on the conic. Value found was -1.1200710e-001, 1.1631390e-001.

Action taken: Start point moved 7.7191029e-005 units, from -1.1200710e-001, 1.1631390e-001 to -1.1208429e-001, 1.1631390e-001.

\*\*\* Warning (IEVM\_BAD\_END\_POINT\_104) \*\*\*

(DE 427, TF 104:1) Entity's End Point not on the conic. Value found was 1.4170260e-001, 1.0923000e-001.

Action taken: End point moved 2.4218468e-004 units, from 1.4170260e-001, 1.0923000e-001 to 1.4146042e-001, 1.0923000e-001.

<<<< PART OF LOG FILE REMOVED HERE >>>>

---

Start Section:

Drawing name: M10.13.DWG. This file was converted by Expert.  
Compliant with CALS class 1, per MIL-D-28000 Amendment 1.

DATE: 10-Feb-94 12:30:30

Global Section:

Parameter Delimiter: ,  
Record Delimiter: ;  
Sending Product ID: Xerox Expert  
File Name: M10.13.dwg  
System ID: Xerox Expert version 5.0  
Preprocessor Version: 5.0



Size of Integer: 16  
 Sgl. Precision Mag: 38  
 Sgl. Precision Sig: 7  
 Dbl. Precision Mag: 38  
 Dbl. Precision Sig: 7  
 Receiving Product ID:  
 Model Space Scale: 1.000000  
 Unit Flag: 1  
 Unit String: INCH  
 # of Line Weights: 3  
 Maximum Line Width: 0.041667  
 Creation Date: 02/10/94 12:30:30  
 Minimum Resolution: 0.000010  
 Maximum Coordinate: 14.910700  
 Author: Gary Hahn  
 Organization:  
 IGES Version Number: 6  
 Drafting Standard: 0

Entity Summary:

Type	Form	Description	Count
100	0	Circular Arc	3
102	0	Composite Curve	9
104	1	Ellipse	3
110	0	Line	191
124	0	Transformation Matrix	3
212	0	General Note (Simple)	46
230	0	Section Area (Standard Fill)	9
404	0	Drawing (form 0)	1
406	16	Property (Drawing Size)	1
410	0	View	1
Total			267

=====  
 Translation phase

\*\*\* Warning (IGEO\_DISCONTINUOUS) \*\*\*  
 ( DE: 287 TF: 102:0 NAME: Composite Curve )  
 The IGES entity is discontinuous between segment 1 and 2.  
 A linear segment will be added at the discontinuity for approximation.

<<<<< PART OF LOG FILE REMOVED HERE >>>>>

\*\*\* Error (IGEO\_SECTAREANOTCLOSED) \*\*\*  
 ( DE: 289 TF: 230:0 NAME: Section Area (Standard Fill) )

The section area is not closed.

<<<<< PART OF LOG FILE REMOVED HERE >>>>>

\*\*\* Error (ACAD\_APPROXCURVEERROR) \*\*\*

Internal error 2302 approximating curve at DE: 329, TYPE: 230, FORM: 0

<<<<< PART OF LOG FILE REMOVED HERE >>>>>

Drawing Entity (404 Form 0) at DE 533, with

name = ,  
size = 11.980000, 3.572800,  
units = IN,

was processed in the AutoCAD drawing file: C:\Q020.dwg

\*\*\* Warning (ACAD\_NEW\_VIEW\_VOLUME\_GENERATED) \*\*\*

( DE: 1 TF: 410:0 )

A new view volume has been generated for the view with:

XMIN (1.695464), XMAX (15.999036),  
YMIN (0.095964), YMAX (6.110236),  
ZMIN (-1.235236), ZMAX (1.235236).

#### IGES Entity Summary

Type	Form	Description	Count	Processed	Errors
100	0	Circular Arc	4	4	0
102	0	Composite Curve	14	14	0
104	1	Ellipse	3	3	0
110	0	Line	137	137	0
212	0	General Note (Simple)	46	46	0
230	0	Section Area (Standard Fill)	9	9	0
404	0	Drawing (form 0)	1	1	0
406	16	Property (Drawing Size)	1	1	0
410	0	View	1	1	0
Totals			216	216	0

---

AutoCAD Entity Summary

Entity	Created	Errors
=====	=====	=====
LINE	137	0
CIRCLE	2	0
TEXT	46	0
ARC	2	0
SOLID	4	0
INSERT	6	0
POLYLINE	7	0
BLOCK	7	0
Totals	=====	=====
	211	0

=====  
Error Summary:

The following message was issued 1 time(s)  
IGES file has greater number of significant digits in single precision numbers than this system.

The following message was issued 257 time(s)  
DE has an invalid label justification.

The following message was issued 3 time(s)  
Entity's start point not on the conic. Value found was %.7e, %.7e.

The following message was issued 3 time(s)  
Entity's End Point not on the conic. Value found was %.7e, %.7e.

The following message was issued 4 time(s)  
The section area is not closed.

The following message was issued 38 time(s)  
The IGES entity is discontinuous between segment %d and %d.  
A linear segment will be added at the discontinuity for approximation.

The following message was issued 1 time(s)  
Internal error %d approximating curve at DE: %d, TYPE: %d, FORM: %d

The following message was issued 1 time(s)  
A new view volume has been generated for the view with:  
XMIN (%lf), XMAX (%lf),  
YMIN (%lf), YMAX (%lf),  
ZMIN (%lf), ZMAX (%lf).

AFCTN Test Report  
94-061

AFCTB Test Report  
94-010

---

Status: 0  
Warning: 303  
Error: 5  
Fatal: 0

Elapsed Time:

Processor: 00:00:07  
Clock: 00:00:08

---

### 10.1.3 Parser Log - IGESWorks

IGES/Works v1.4.1  
International TechneGroup Incorporated  
Validation Logfile

Date: March 09, 1994  
Model: q020

\*\*\*\*\* Validation Parameters \*\*\*\*\*

#### TOLERANCE CONFIGURATION VALUES

ZERO\_TOL = 1.000000e-13  
MODEL\_SPACE\_PNT\_COIN\_TOL = 1.000000e-03  
PARM\_SPACE\_PNT\_COIN\_TOL = 1.000000e-08  
ISO\_PARM\_CURVE\_TOL = 1.000000e-08  
NON\_CONV\_TOL = 1.000000e-12  
KNOT\_COIN\_TOL = 1.000000e-10  
SAME\_INTER\_TOL = 1.000000e-12  
PARALLEL\_LINES\_TOL = 1.000000e-07  
ANGLE\_COIN\_TOL = 1.000000e-05  
PNT\_PROJ\_TOL = 1.000000e-07  
COLIN\_TOL = 1.000000e-07  
COPLANAR\_TOL = 1.000000e-08  
ZERO\_NORMAL\_TOL = 1.000000e-06  
SAME\_TANGENT\_TOL = 1.000000e-04  
SAME\_CURVATURE\_TOL = 1.000000e-04  
SAME\_DERIVATIVE\_TOL = 1.000000e-03  
MODEL\_LINEAR\_APPROX\_TOL = 2.220446e-16

\*\*\*\*\* Entity Listing Before Validation \*\*\*\*\*

Count	Type	Form	Description
3	100	0	Circular Arc
9	102	0	Composite Curve
3	104	1	Ellipse
191	110	0	Line
3	124	0	Transformation Matrix
46	212	0	General Note (Simple)
9	230	0	Section Area (Standard Fill)
1	404	0	Drawing (form 0)
1	406	16	Property (Drawing Size)
1	410	0	View

267 - Number of entities in selection list

---

\*\*\*\*\* Entity Validation \*\*\*\*\*

\*\*\* Warning (IEVM\_LABEL\_NOT\_RJ) \*\*\*

(DE 1, TF 410:0) The Label Display field in this entity's DE section was not set for right justification.

Action taken: The Label Display field has been set to be right-justified.

<<<<< PART OF LOG FILE REMOVED HERE >>>>>

\*\*\* Warning (IEVM\_NON\_CONTINUOUS\_102) \*\*\*

(DE 231, TF 102:0) This Composite Curve entity (102) is not continuous within the stated tolerance. The terminate point of the first curve does not equal the start point of the next curve.

Action taken: The curve was made continuous by the following actions. DE 225 was reversed. DE 227 was reversed. DE 229 was reversed.

<<<<< PART OF LOG FILE REMOVED HERE >>>>>

\*\*\* Warning (IEVM\_NON\_CONTINUOUS\_102) \*\*\*

(DE 321, TF 102:0) This Composite Curve entity (102) is not continuous within the stated tolerance. The terminate point of the first curve does not equal the start point of the next curve.

Action taken: The curve was made continuous by the following actions. DE 291 was reversed. DE 293 was reversed. DE 295 was reversed. A line, DE 553, was added between DE's 295 and 297. A line, DE 555, was added between DE's 297 and 299. A line, DE 557, was added between DE's 299 and 301. A line, DE 559, was added between DE's 301 and 303. A line, DE 561, was added between DE's 303 and 305. A line, DE 563, was added between DE's 305 and 307. A line, DE 565, was added between DE's 307 and 309. A line, DE 567, was added between DE's 309 and 311. A line, DE 569, was added between DE's 311 and 313. A line, DE 571, was added between DE's 313 and 315. A line, DE 573, was added between DE's 315 and 317. A line, DE 575, was added between DE's 317 and 319.

\*\*\* Warning (IEVM\_BAD\_START\_POINT\_104) \*\*\*

(DE 407, TF 104:1) The start point for this Conic Arc entity (104) is not on the conic. Start point value found was -1.1200710e-01, 1.1631390e-01.

Action taken: The start point has been moved 7.7191029e-05 units, from -1.1200710e-01, 1.1631390e-01 to -1.1208429e-01, 1.1631390e-01.

\*\*\* Warning (IEVM\_BAD\_END\_POINT\_104) \*\*\*

(DE 407, TF 104:1) The end point for this Conic Arc entity (104) is not on the conic. Start point value found was 1.4170260e-01, 1.0923000e-01.

Action taken: The end point has been moved 2.4218468e-04 units, from 1.4170260e-01, 1.0923000e-01 to 1.4146042e-01, 1.0923000e-01.

<<<<< PART OF LOG FILE REMOVED HERE >>>>>

Entity Validation Summary:

Type	Form	Entity Count	Number Valid	Number of Corrected		Number of Uncorrected	
				Warnings	Errors	Warnings	Errors
Global Section		1	1	0	0	0	0
100	0	3	0	3	0	0	0
102	0	9	1	0	8	0	0
104	1	3	0	3	6	0	0
110	0	221	30	191	0	0	0
124	0	3	0	3	0	0	0
212	0	46	0	46	0	0	0
230	0	9	0	9	0	0	0
404	0	1	0	1	0	0	0
406	16	1	1	0	0	0	0
410	0	1	0	1	0	0	0
Totals:		298	33	257	14	0	0

The following message was issued and suppressed 252 times:

The Label Display field in this entity's DE section was not set for right justification.

The following message was issued and suppressed 3 times:

This Composite Curve entity (102) is not continuous within the stated tolerance. The terminate point of the first curve does not equal the start point of the next curve.

A message is suppressed when it has been issued more than 5 times. This value is controlled by the 'MAX\_MESSAGE' configuration parameter.

\*\*\*\*\*

### 10.1.4 Error Log - Preview

ERROR REPORT FOR FILE /novell/94010/q020.igs

>> File record length is 80

Terminate section report :

File Section	#lines
START	5
GLOBAL	3
DIRECTORY ENTRY	534
PARAMETER DATA	320
TERMINATE	1
TOTAL	863

(Expect 80 X 863 = 69040 bytes)

----- preliminary format scan complete -----

>> WARNING: Sectioned Area type 19 not supported  
: Reading entity #117, DE entry #233 type SECTIONED AREA.  
: Field 2, line 163 of PARAMETER DATA section.  
230,231,19,0.0,0.0,0.0,0.0,0.125,0.0,0,0,0; 00000233P0000163110  
^^

>> WARNING: Sectioned Area type 19 not supported  
: Reading entity #122, DE entry #243 type SECTIONED AREA.  
: Field 2, line 168 of PARAMETER DATA section.  
230,241,19,0.0,0.0,0.0,0.0,0.125,0.0,0,0,0; 000243P0000168110  
^^

<<<< PART OF LOG FILE REMOVED HERE >>>>

>> WARNING: Invalid line font from IGES file.  
: Font #5 is replaced by #1.

>> WARNING: Unsupported sectioned area type 19 modified to 16  
: in entity 117 for graphic output.

Found 0 errors and 19 warnings



### 10.1.5 Output AutoCAD R12

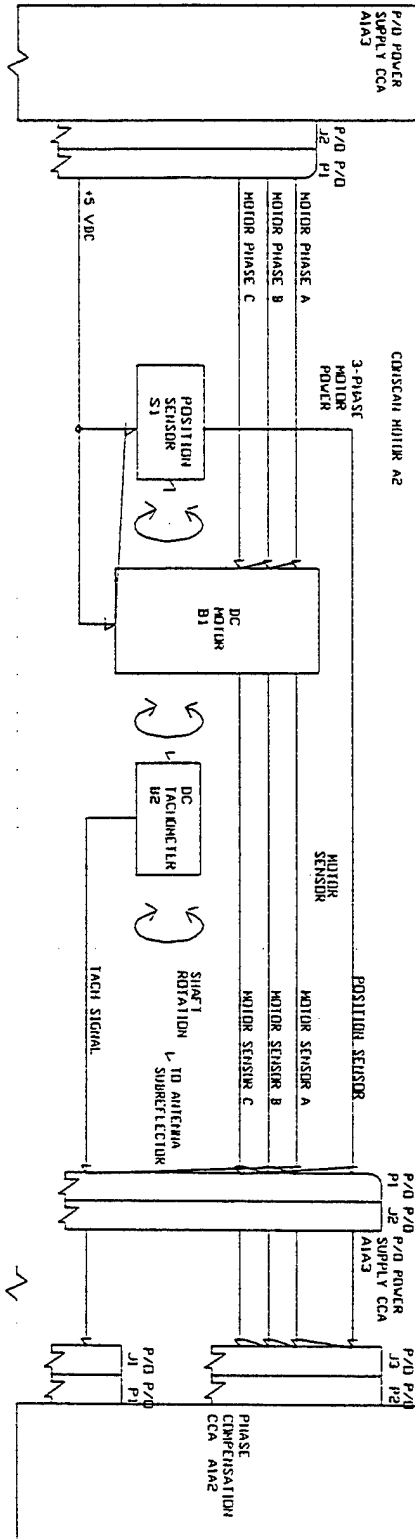

1011-1-2V

### 10.1.6 Output Cadkey v6

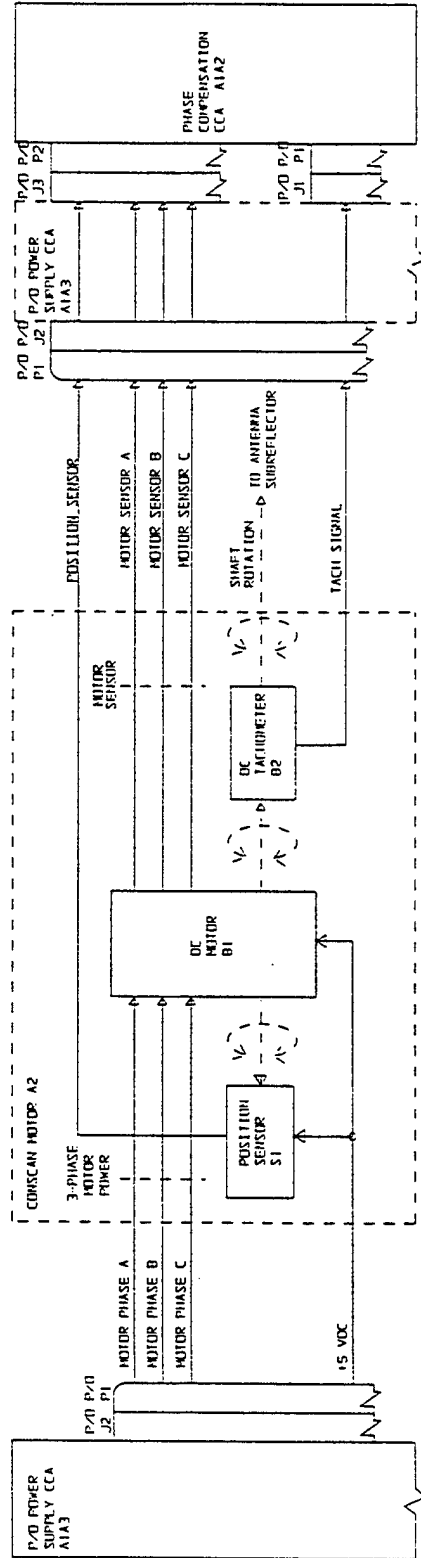
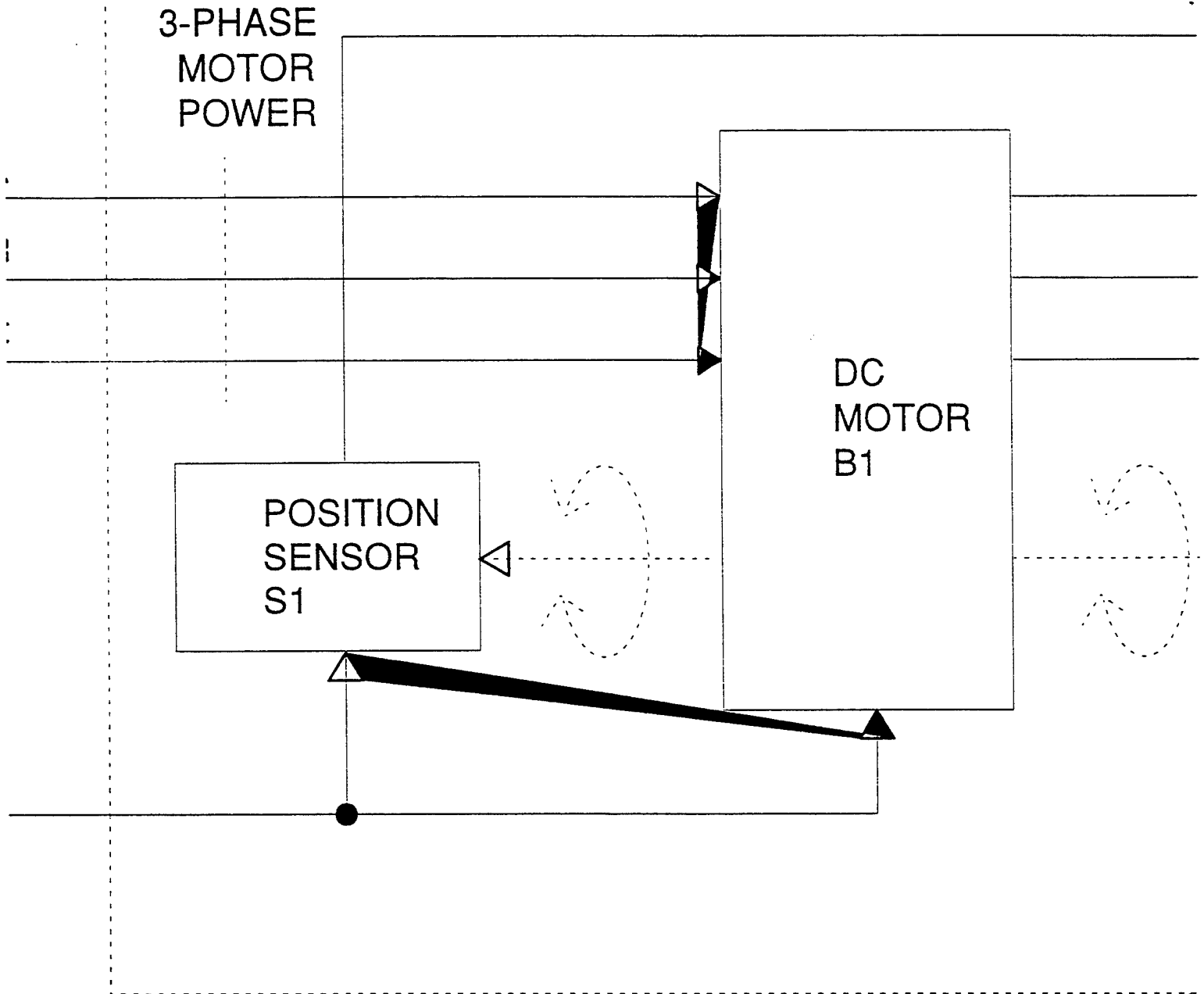
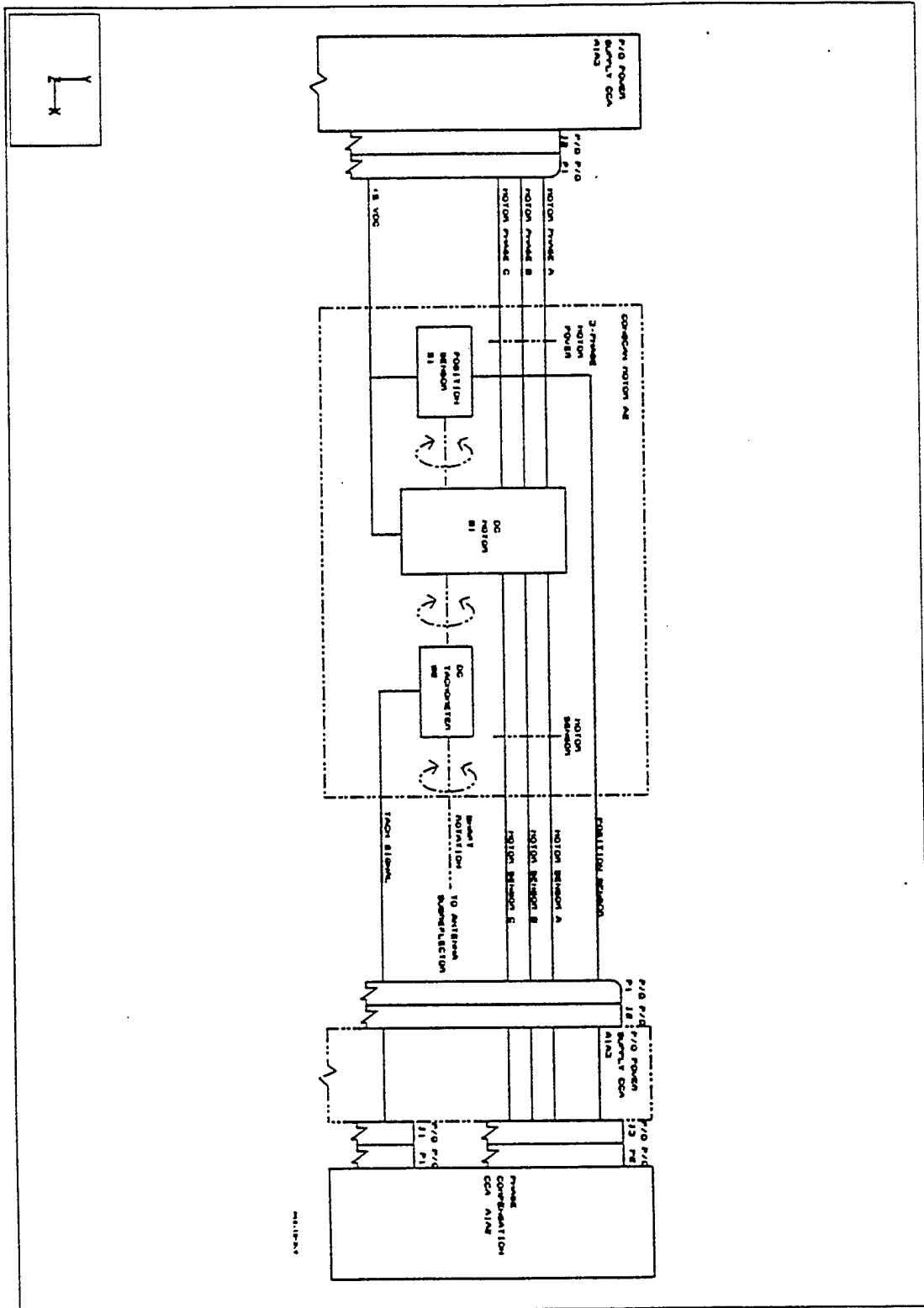

FIG. 13-17

### 10.1.7 Output CALSView



### 10.1.8 Output Generic



### 10.1.9 Output IGESView

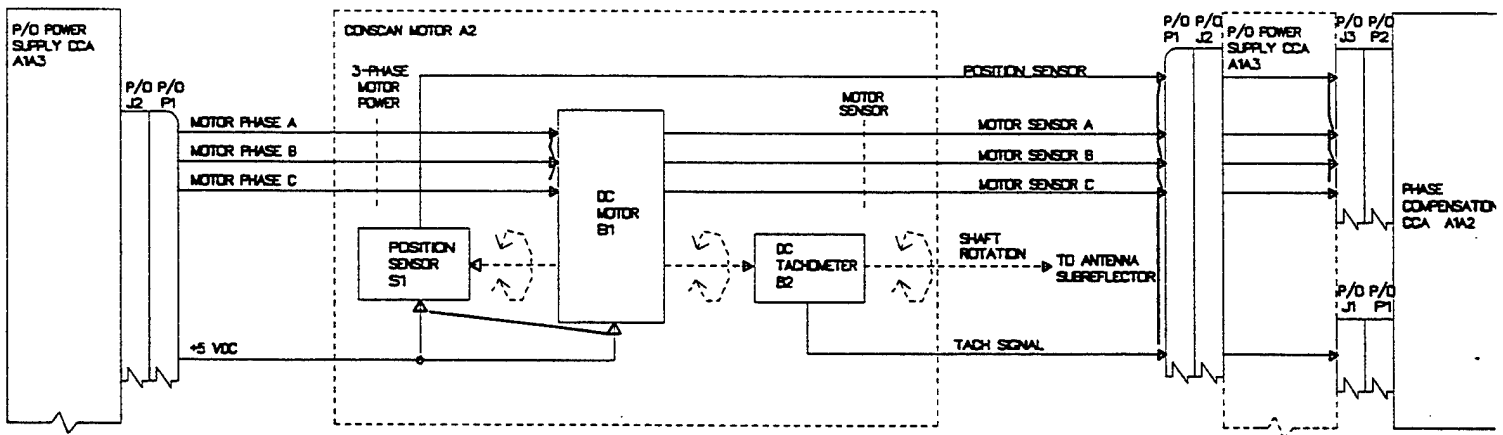

MO 19-31

### 10.1.10 Output IGESWorks

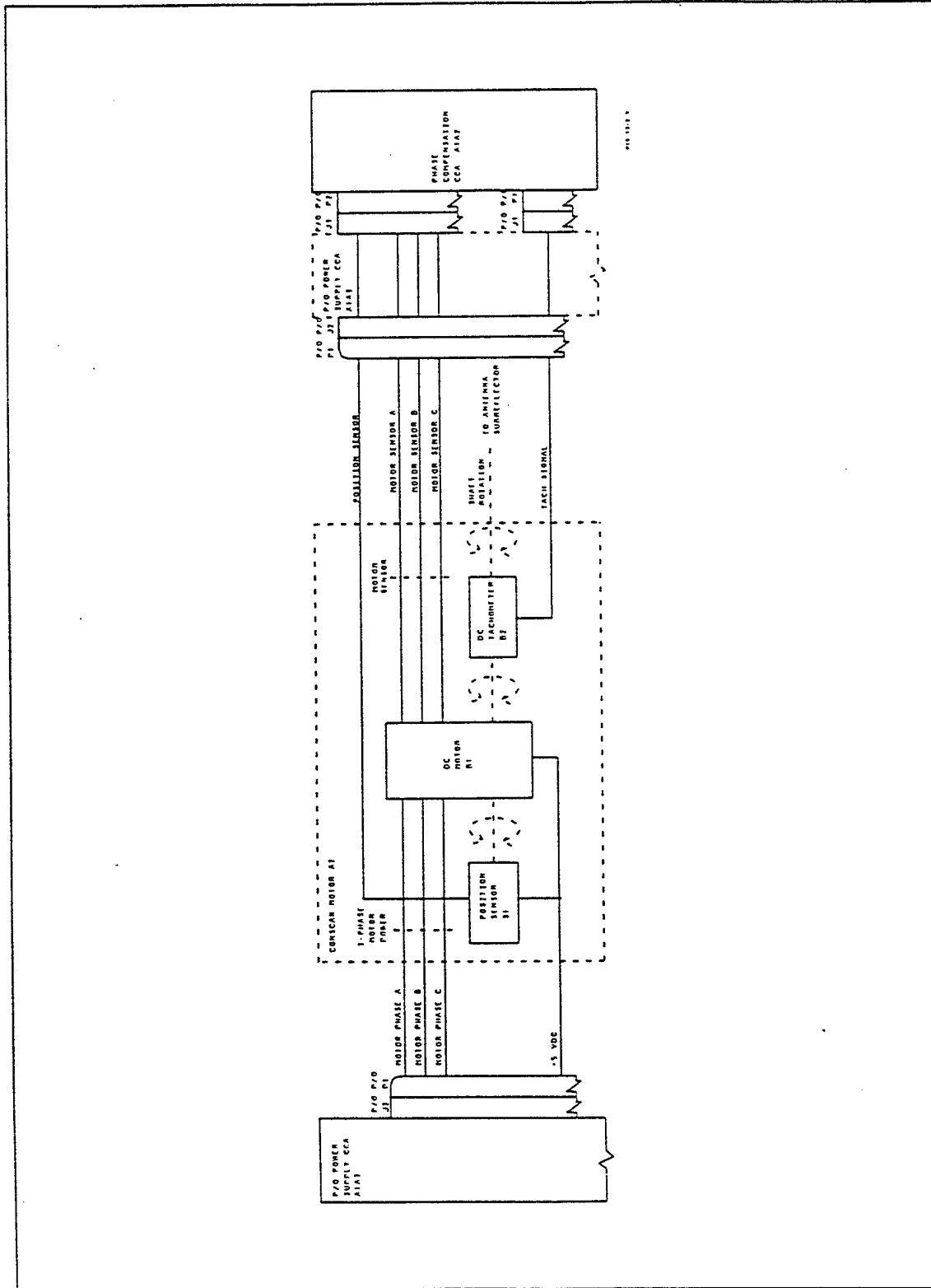

### 10.1.11 Output Preview

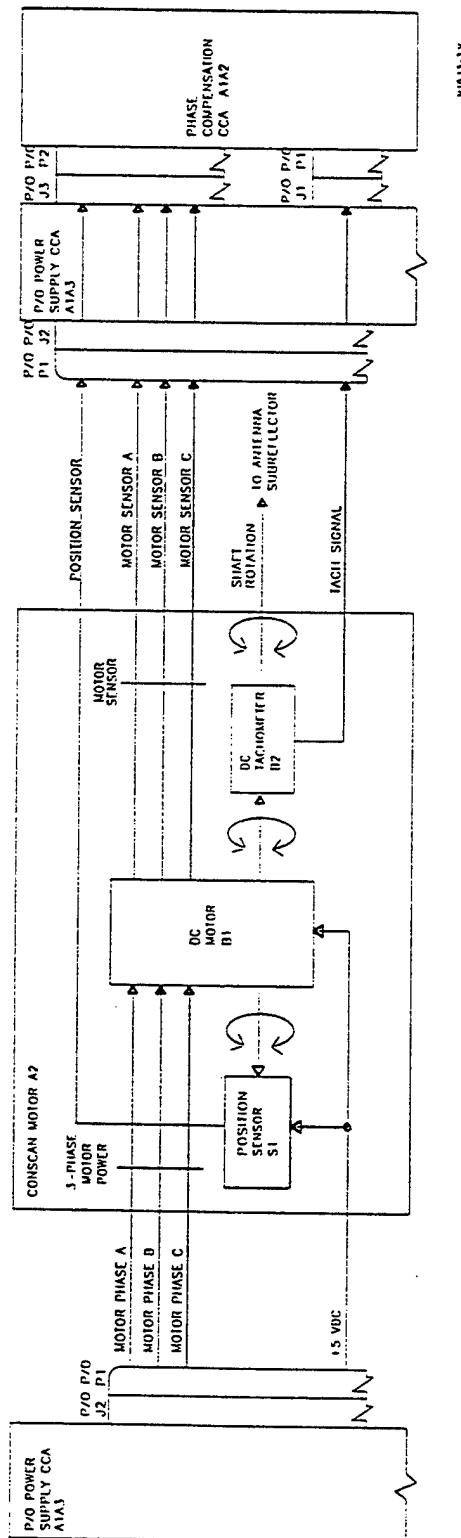

### 10.1.12 Output X-Change

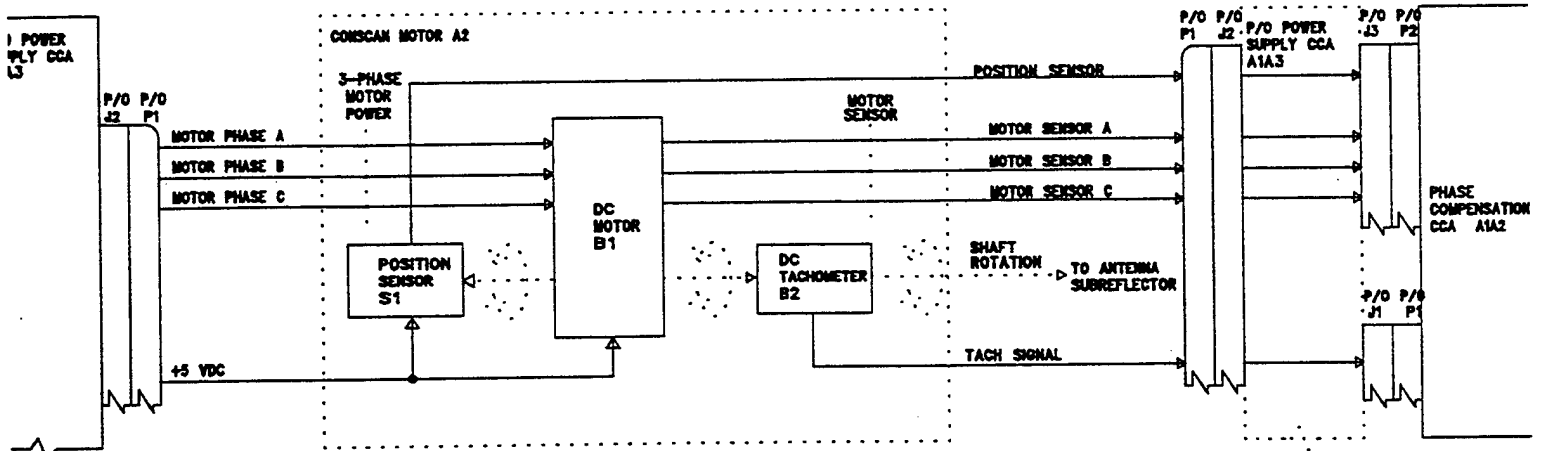

MSB-37



## 10.2 File D001Q019

### 10.2.1 Output AutoCAD R12

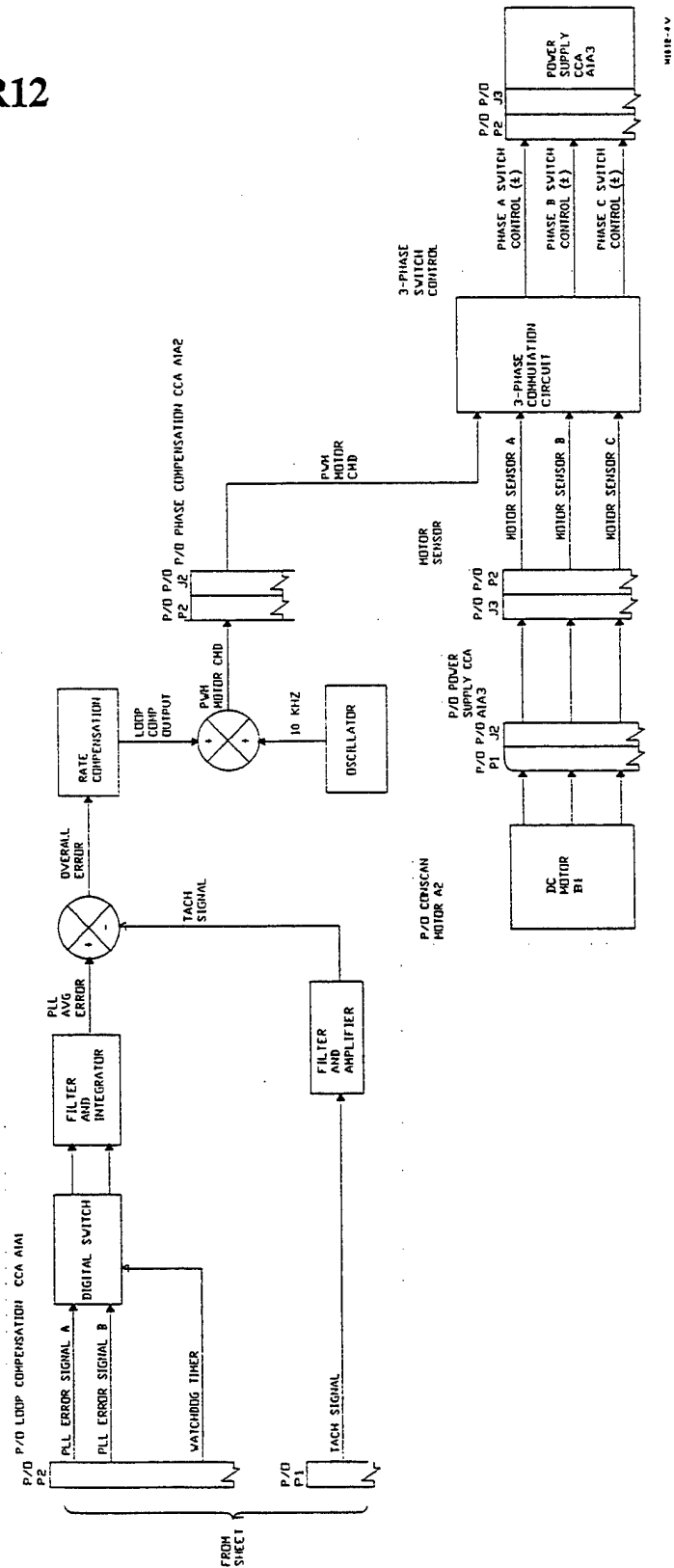

### 10.2.2 Output Cadkey v6

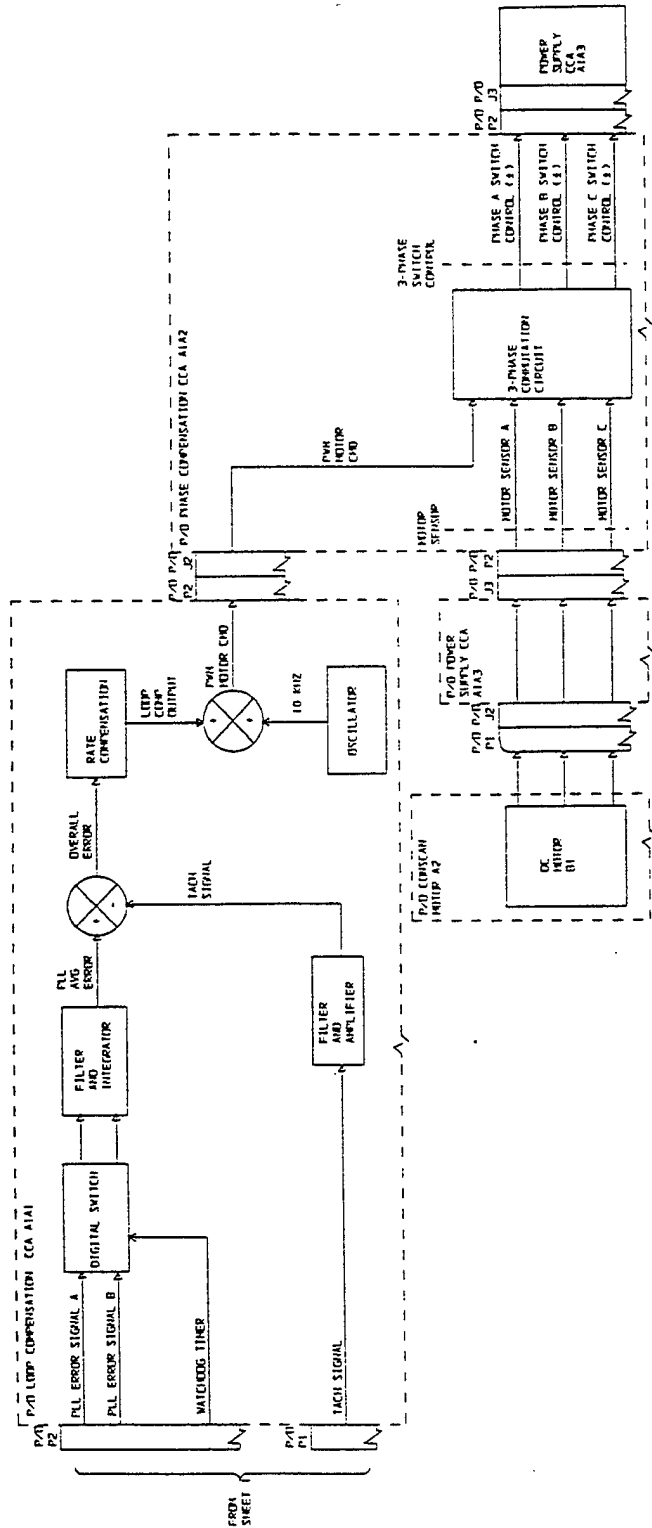

### 10.2.3 Output CALSView

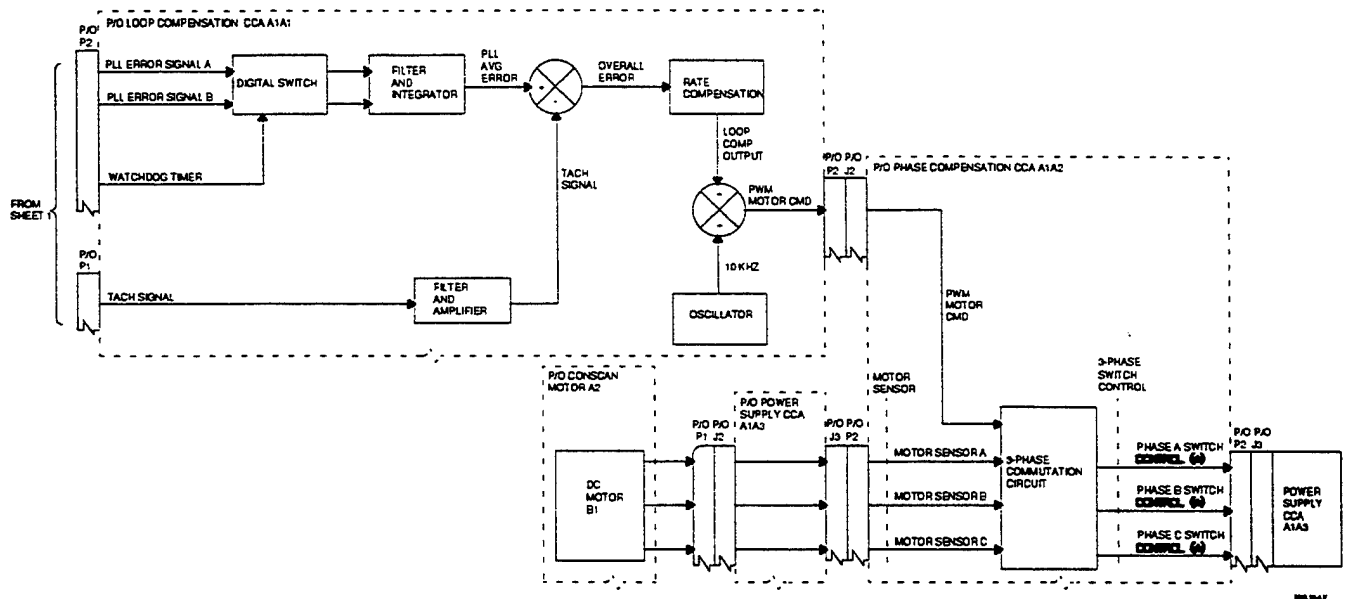

### 10.2.4 Output Generic

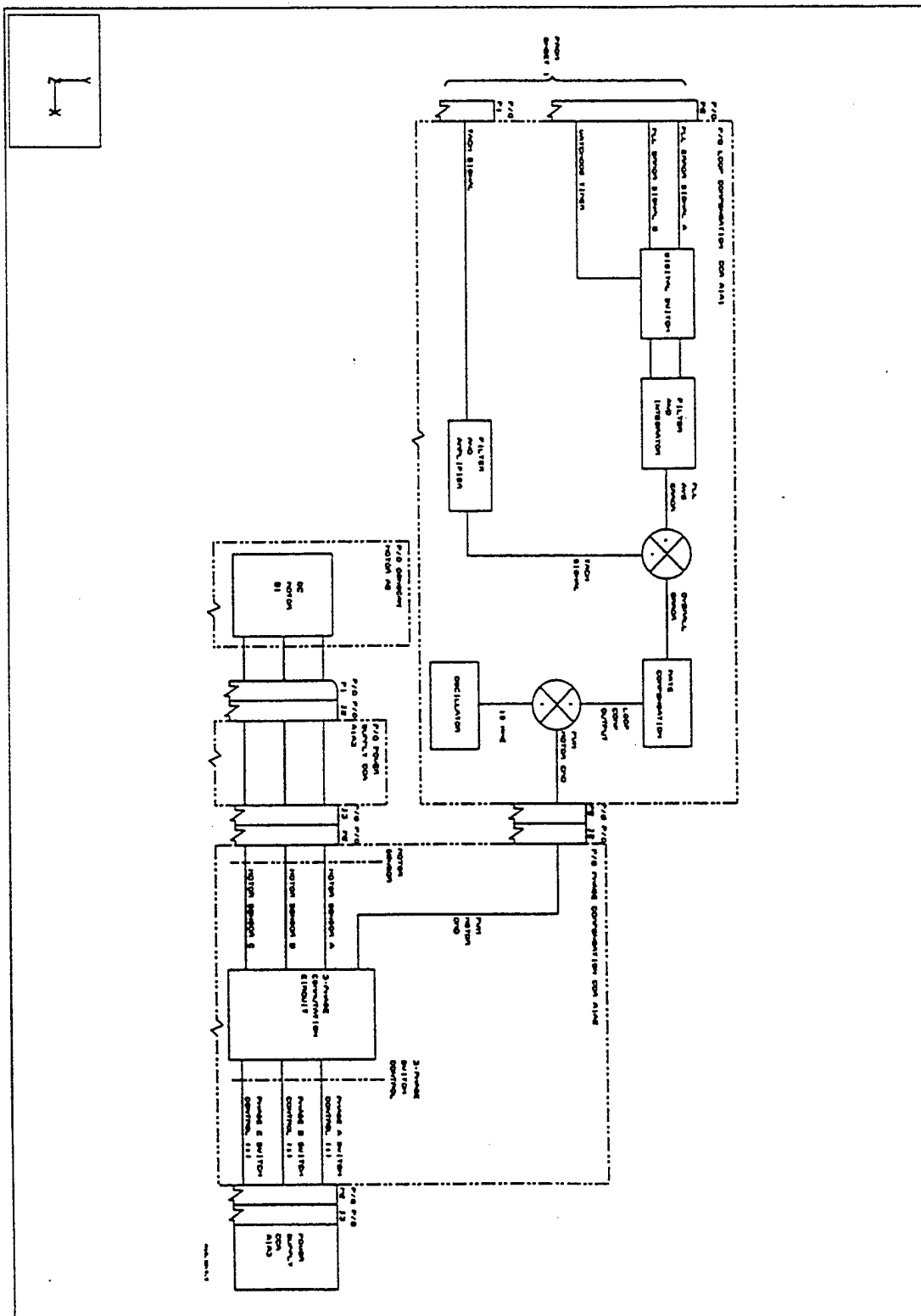

## 10.2.5 Output IGESView

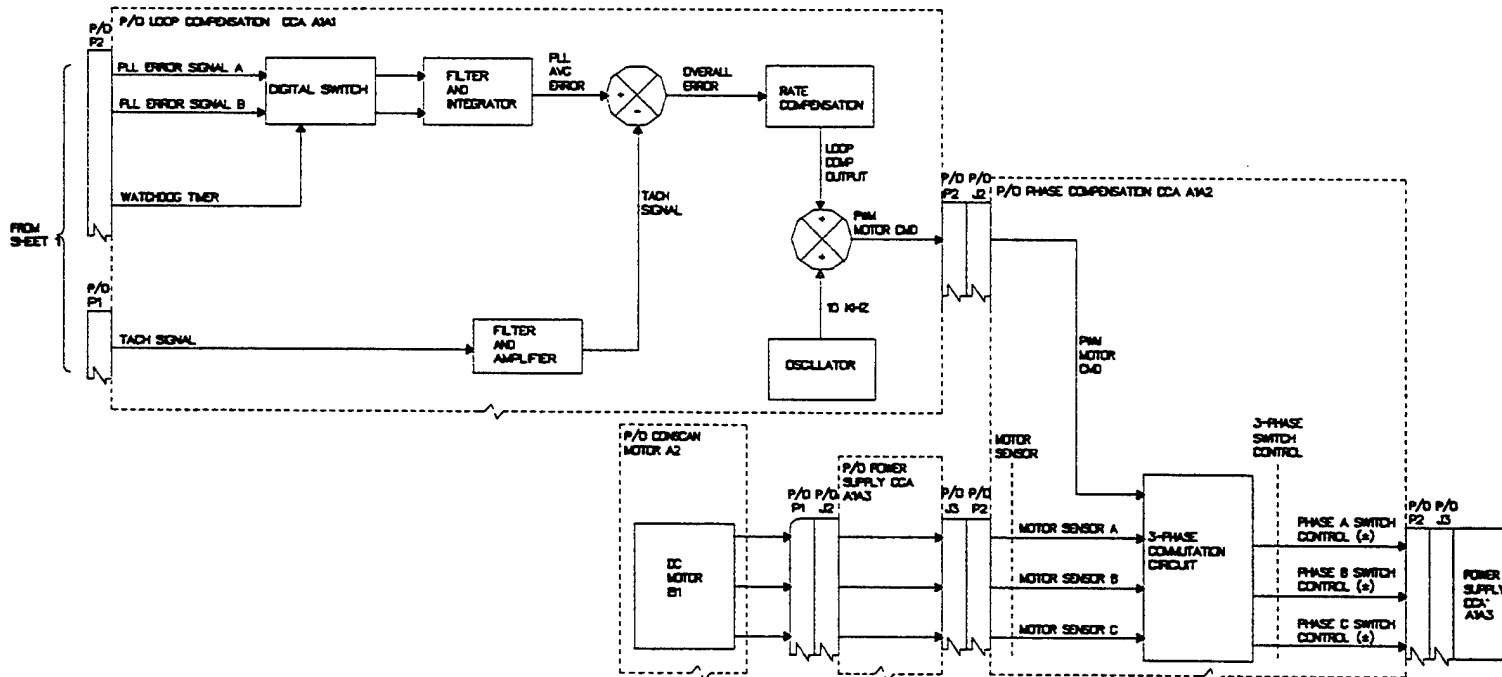

### 10.2.6 Output IGESWorks

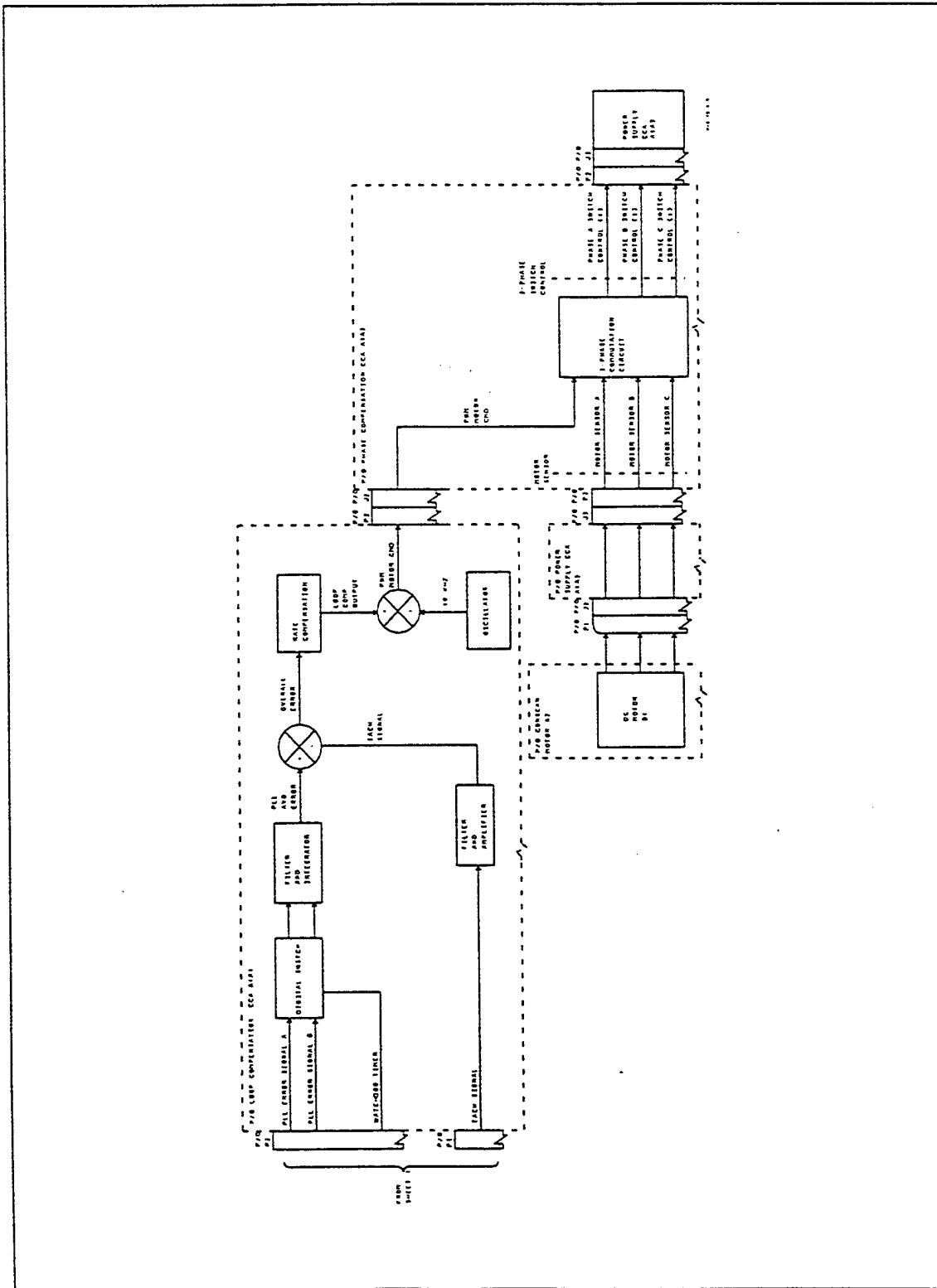

### 10.2.7 Output Preview

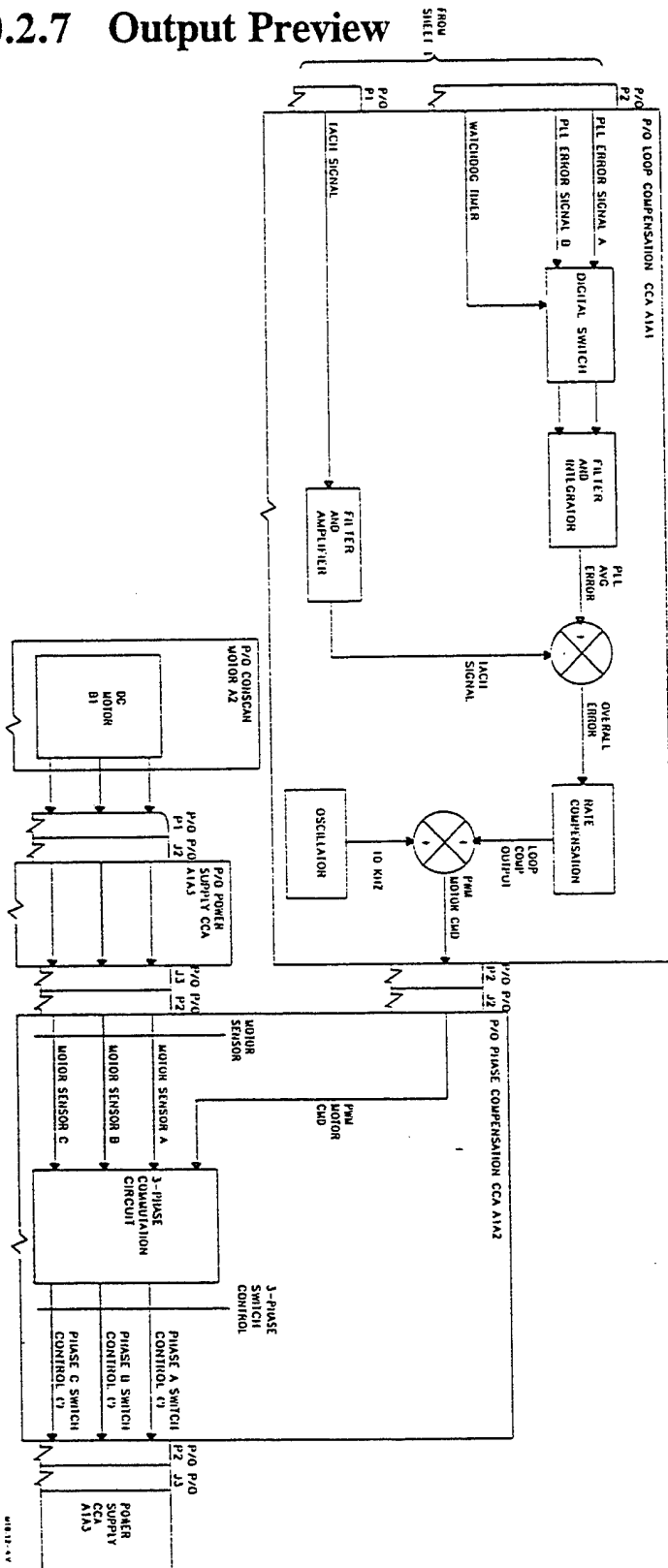

## 10.2.8 Output X-Change

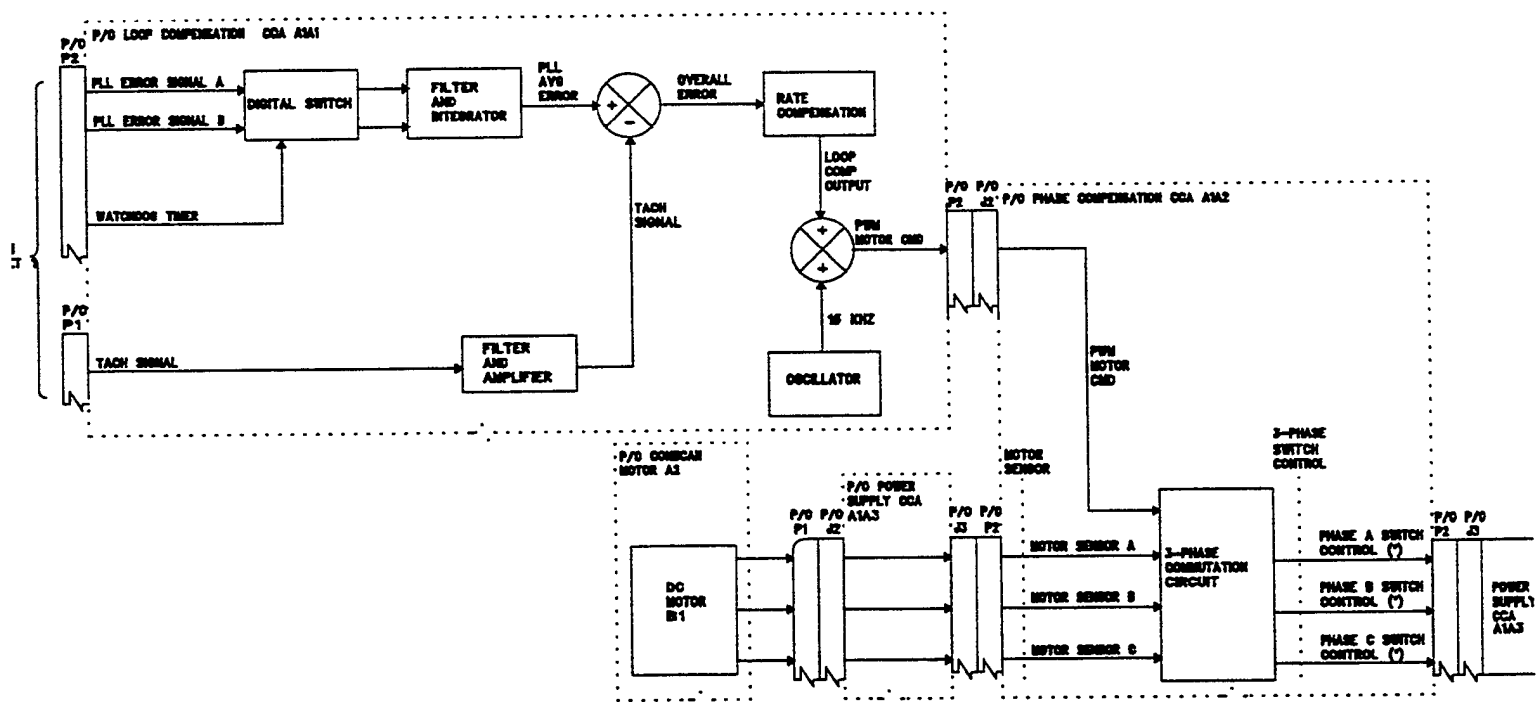



### 10.3 File D001Q023

#### 10.3.1 Output AutoCAD R12

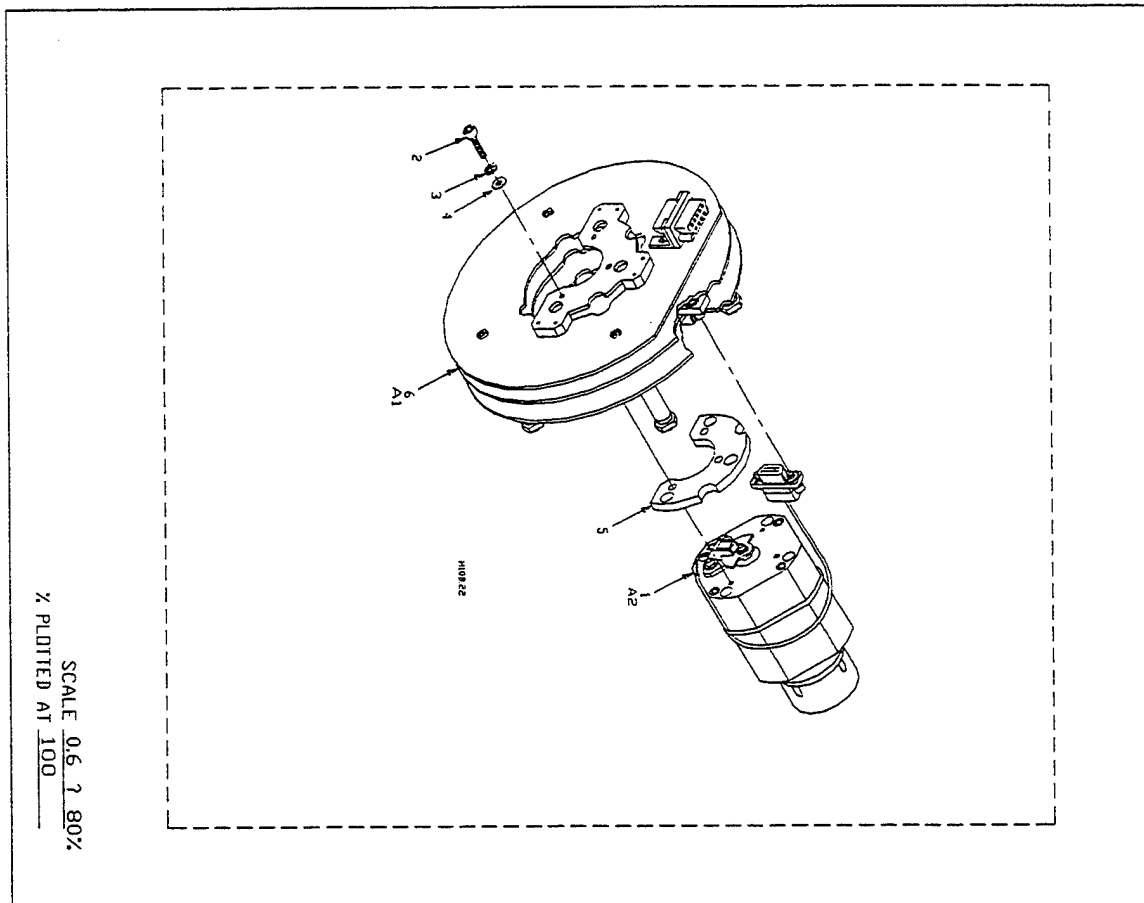

### 10.3.2 Output Cadkey v6

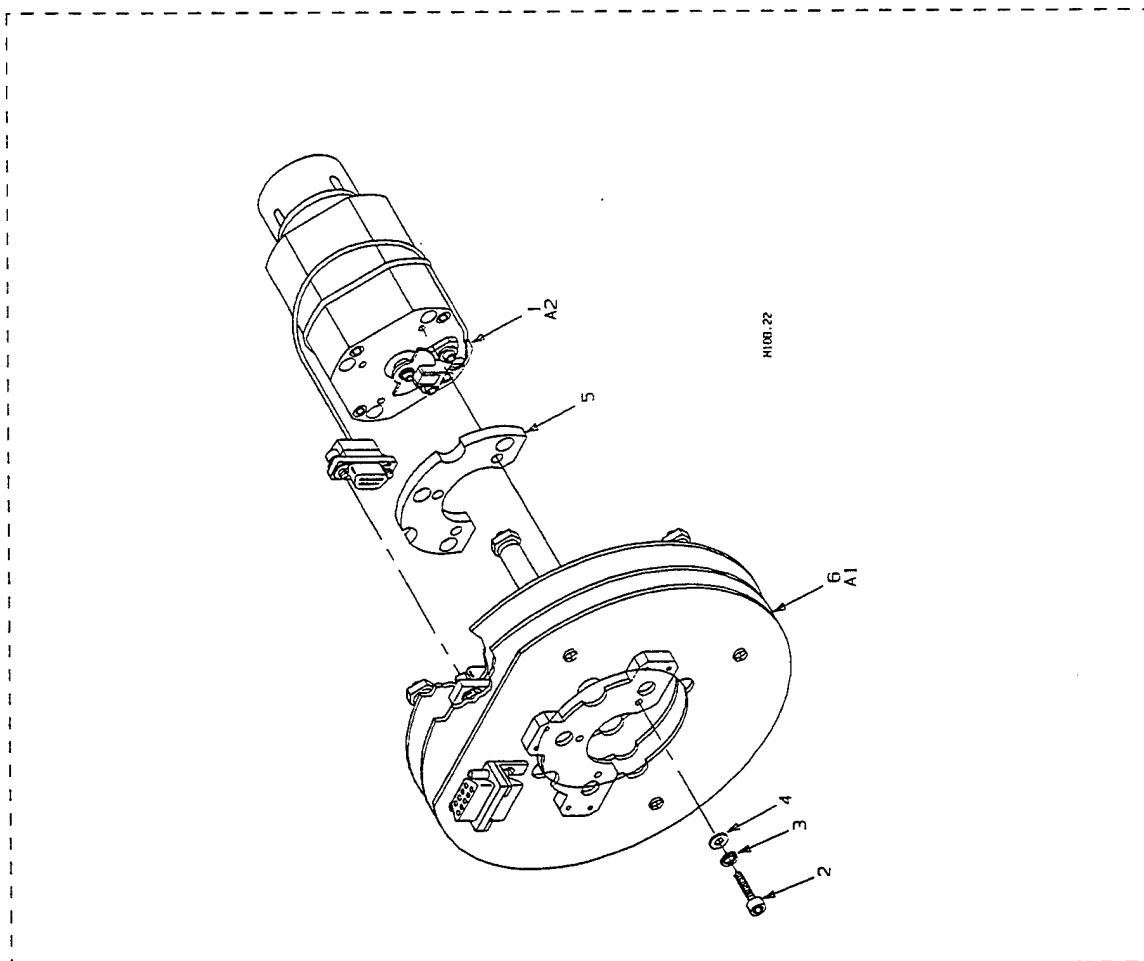

SCALE 0.6 80%  
% PLOTTED AT 100

### 10.3.3 Output CALSView

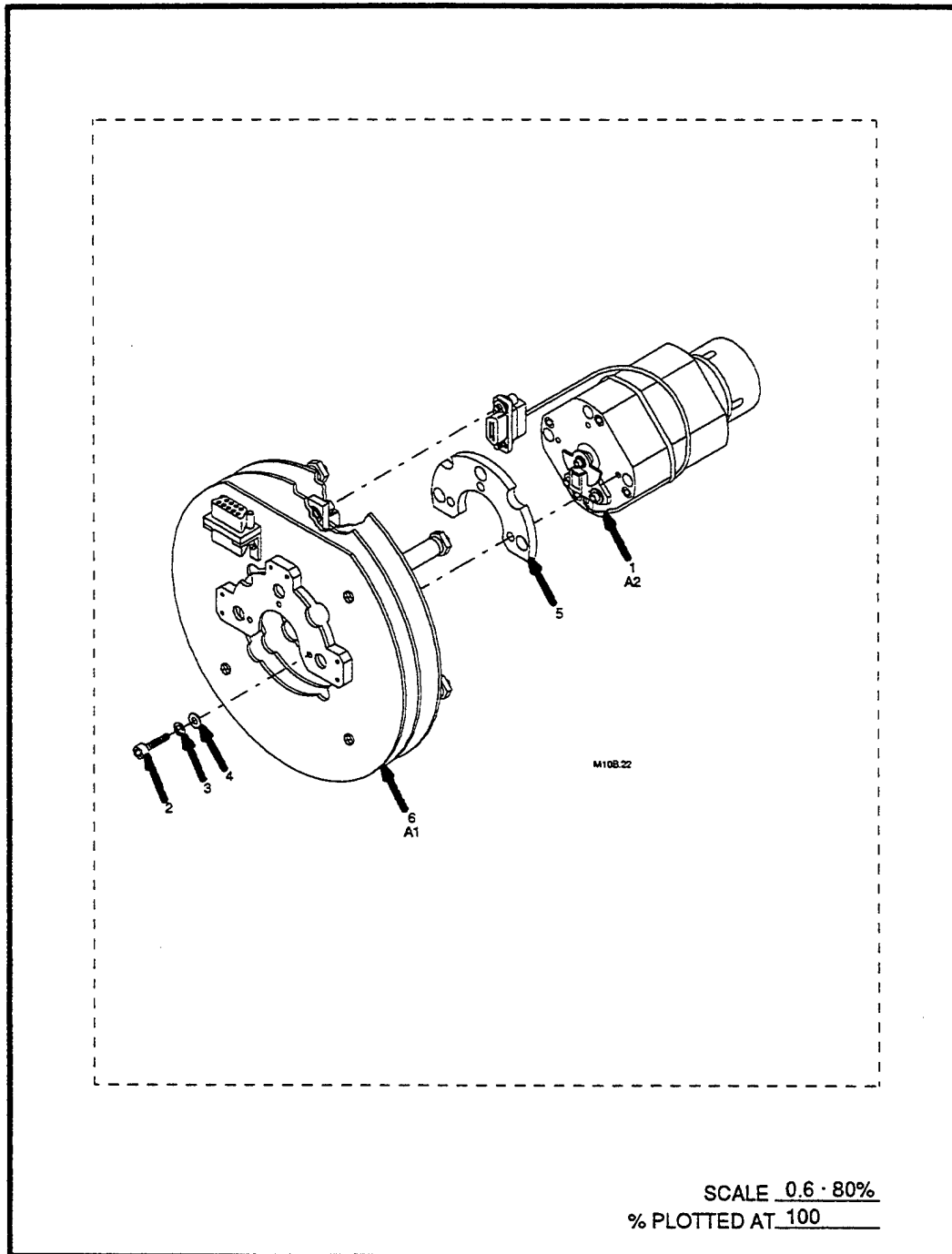

### 10.3.4 Output Generic

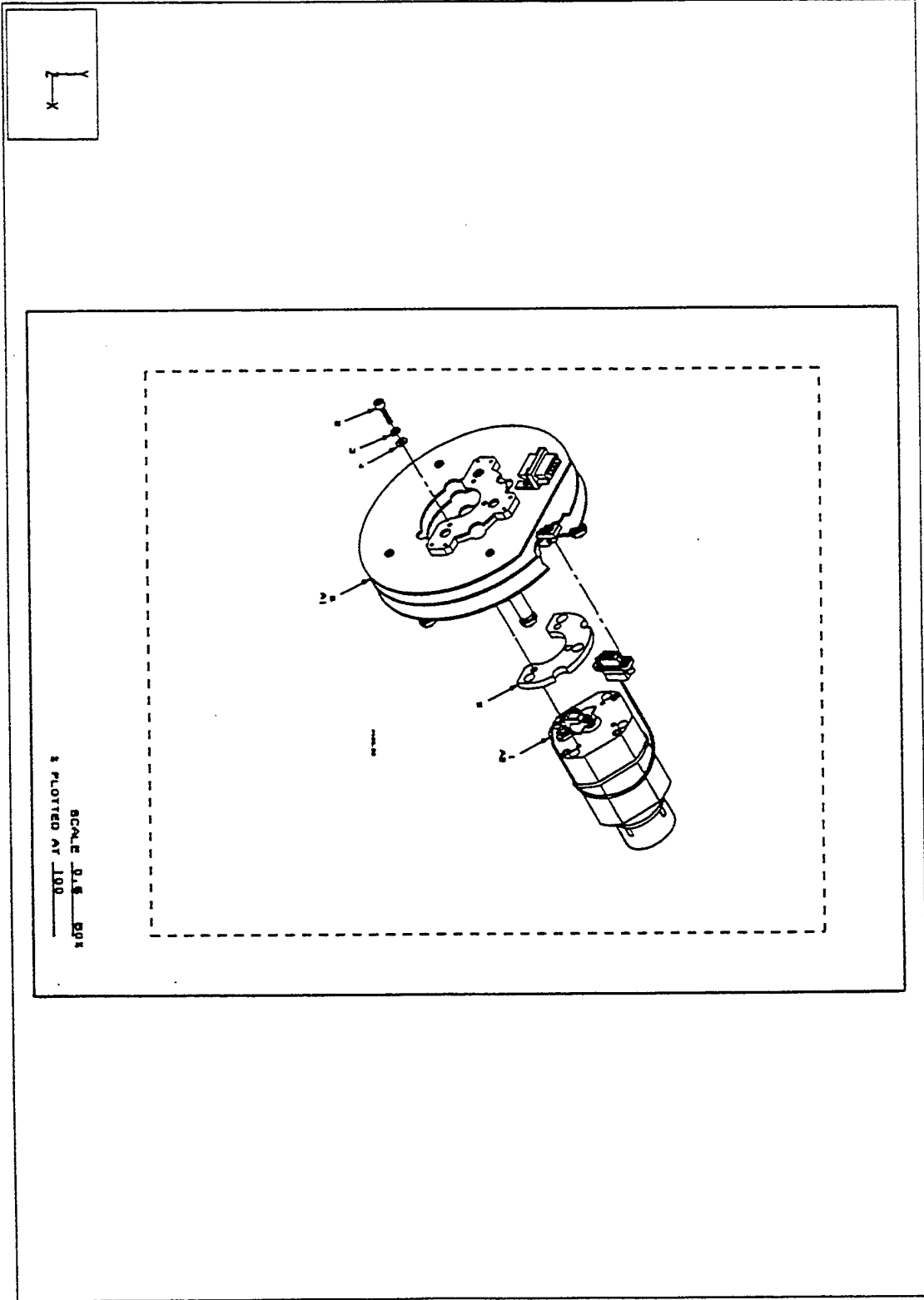

### 10.3.5 Output IGESView

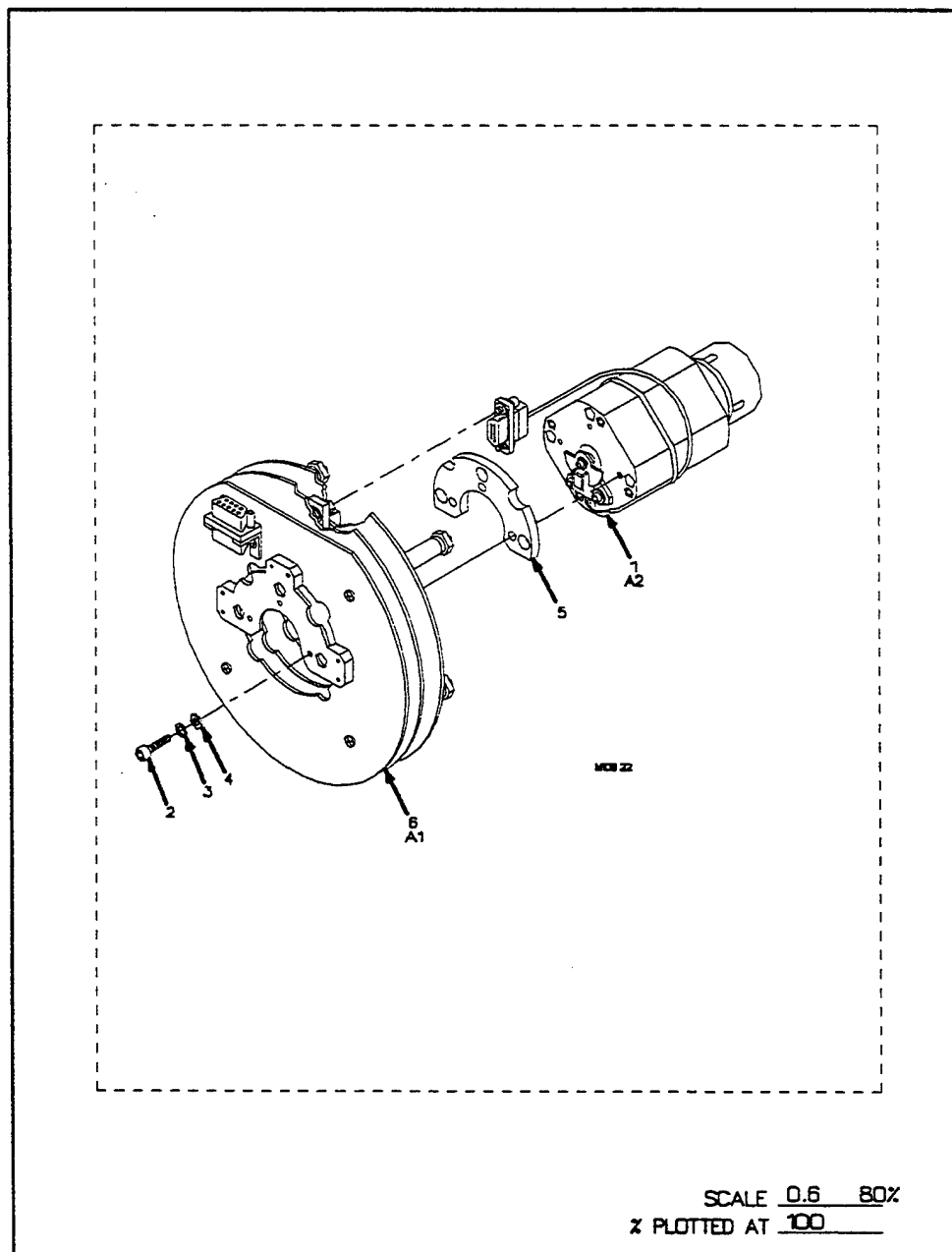

### 10.3.6 Output IGESWorks

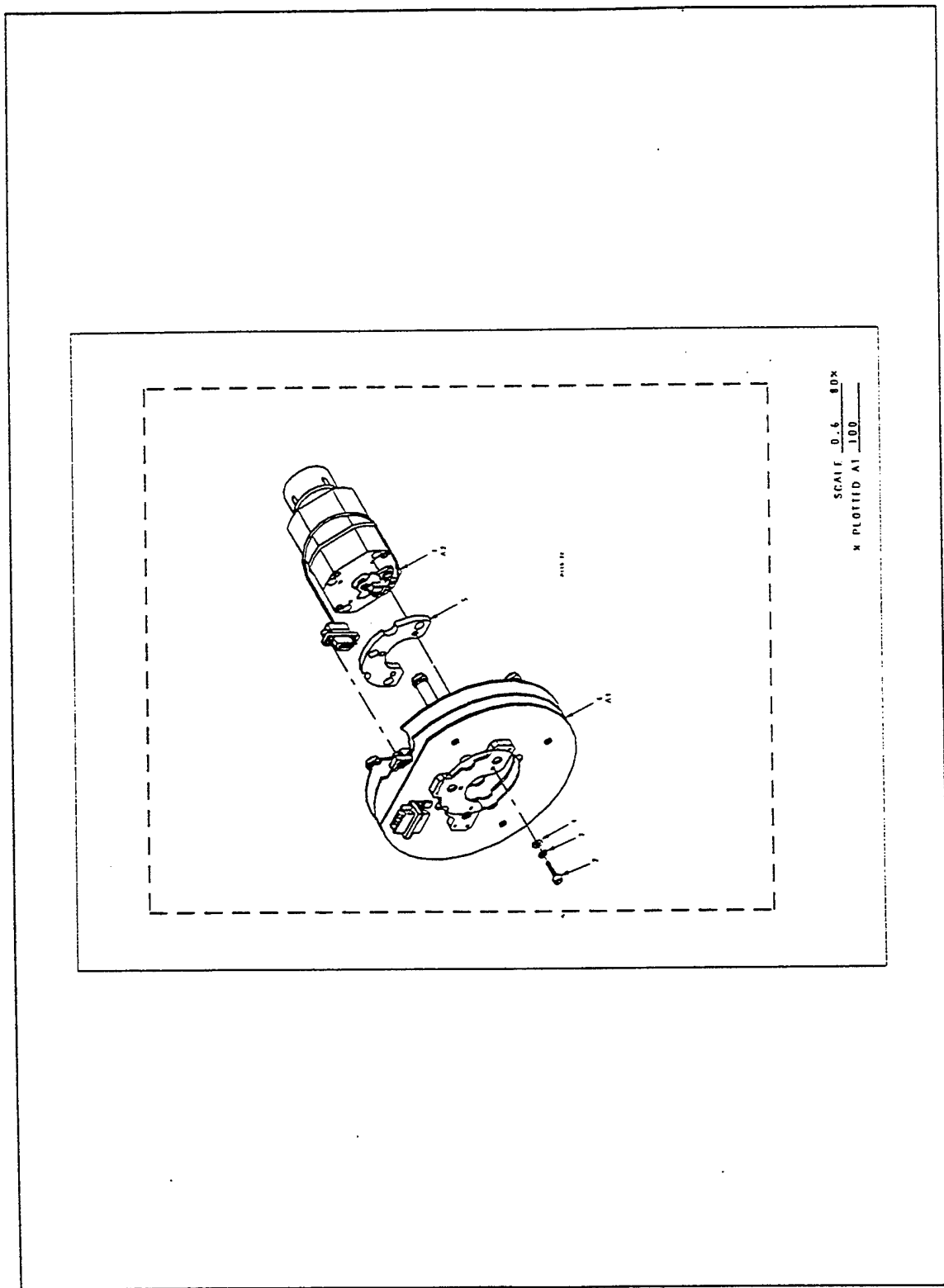

### 10.3.7 Output Preview

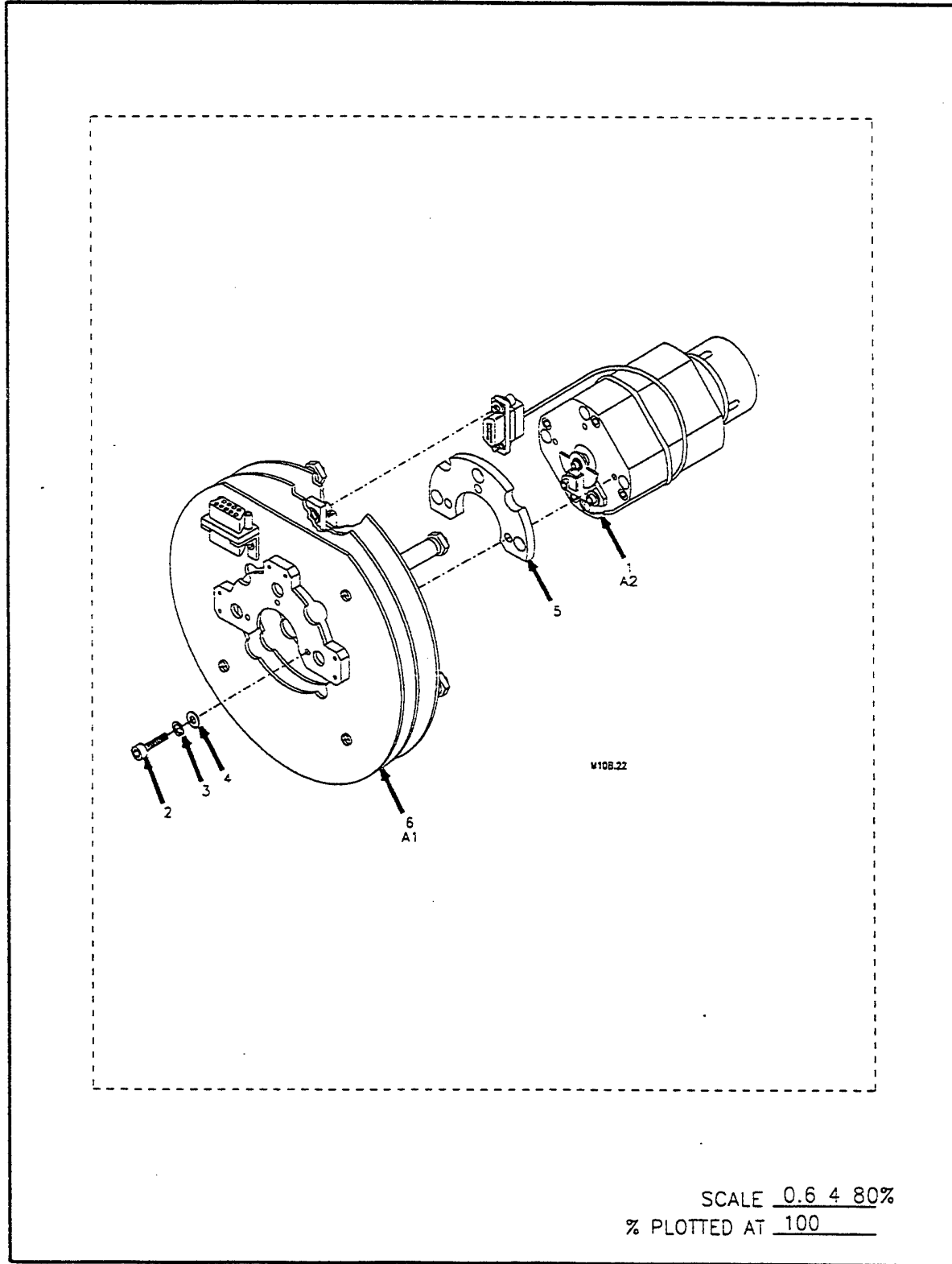

### 10.3.8 Output X-Change

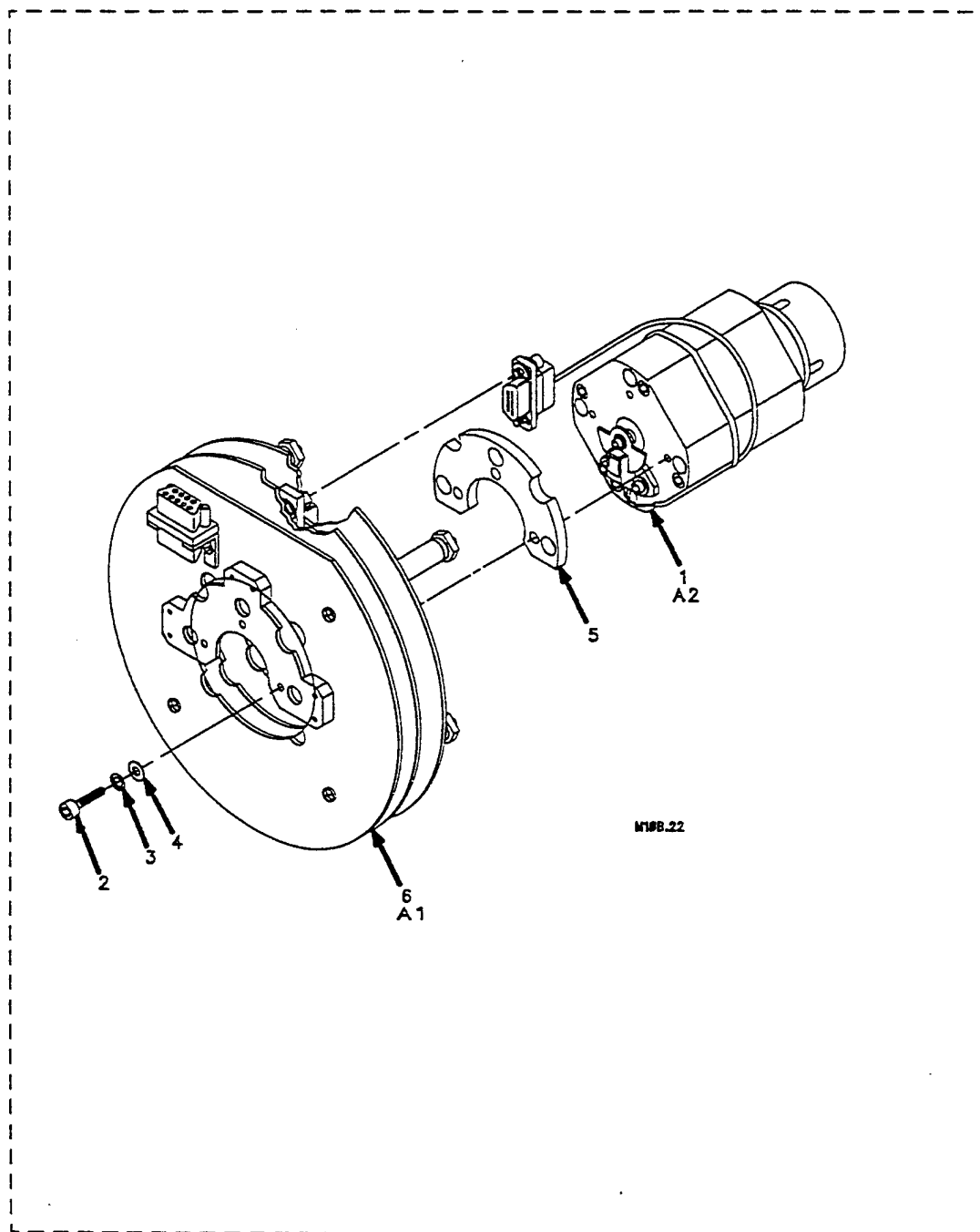

SCALE 0.6 N 80%  
% PLOTTED AT 100



## 11. Appendix C - Detailed SGML Analysis

### 11.1 Parser Log

SGML Document Type Definition Parser  
An SGML System Conforming to  
International Standard ISO 8879  
Standard Generalized Markup Language

Log file: '9410.LOG'  
SDO File: 'ctndecl.sdo'  
Namecase General is yes.  
Namecase Entity is no.  
Parsing DTD file: '9410.dtd'  
Parsing DOCTYPE TM

DTD0137: Incorrect token ']]>'. Parser Ignoring Input Up To Next MDO.  
In declaration: '<![['.  
In declaration: '<!DOCTYPE'.  
in entity 'atos'  
in line 47 in file 'c:\xgml\BSPEC.DTD'  
in line 68 in file '9410.dtd'  
DTD0019: DOCTYPE or LINKTYPE end found in external entity file.  
.DTO file not created due to parsing errors.

Program status code: 19.

### 11.2 Exoterica Validator exl Parser

```
<!-- **Warning** in "9410.sgm", line 1:  
An element with mixed content should permit data characters ("#PCDATA") in  
all parts of its content model.  
The element being declared is "WARNING".  
<!ELEMENT warning - - (title?, (%txt; | para | list)+) >  
<!ATTLIST (warni  
                                                    /\n  
-->  
<!-- 1 warning reported. -->
```

### 11.3 Public Domain sgmls Log

sgmls: Error at \ws\9410.dtd, line 20 in declaration parameter 5:  
Could not find external general entity "ESDCAU"

<<<<< PART OF LOG FILE REMOVED HERE >>>>>

sgmls: SGML error at \ws\9410.txt, line 119 at "":  
BOARDNO = "ESDCAU" ENTITY attribute not general entity; may affect  
processing  
Element structure: TM FRONT INTRO P0 P1 FIGURE

<<<<< PART OF LOG FILE REMOVED HERE >>>>>

TOTALCAP	62367/200000
ENTCAP	11392/200000
ENTCHCAP	3489/200000
ELEMCAP	3840/200000
GRPCAP	23072/200000
EXGRPCAP	896/200000
EXNMCAP	3872/200000
ATTCAP	5984/200000
ATTCHCAP	315/200000
AVGRPCAP	9248/200000
NOTCAP	96/200000
NOTCHCAP	163/200000

## 12. Appendix D - Detailed CGM Analysis

### 12.1 File D001C004

#### 12.1.1 Parser Log MetaCheck

MetaCheck Version 2.10 -- CGM/MIL-D-28003 Conformance Analyzer  
Copyright 1988-93 CGM Technology Software  
Execution Date: 03/09/94 Time: 08:02:10

Metafile Examined : i:\94010\c004.cgm

Pictures Examined : All  
Elements Examined : All  
Bytes Examined : All

=====  
===== Trace Report =====

Tracing not selected.

=====  
===== CGM Conformance Violation Report =====

No Errors Detected

=====  
===== CALS CGM Profile (MIL-D-28003) Report =====

No profile discrepancies detected.

=====  
===== Conformance Summary Report =====

MetaCheck Version 2.10 -- CGM/MIL-D-28003 Conformance Analyzer  
Copyright 1988-93 CGM Technology Software  
Execution Date: 03/09/94 Time: 08:02:23

Name of CGM under test: i:\94010\c004.cgm  
Encoding : Binary

Pictures Examined : All  
Elements Examined : All  
Bytes Examined : All

BEGIN METAFILE string : >m1007<  
METAFILE DESCRIPTION : >AUTO-TROL/REL-1.0 MIL-D-28003/BASIC-<  
>1<

Picture 1 starts at octet offset 122: >m1007<

Conformance Summary : This file conforms to the CGM specification.  
This file meets the CALS CGM Profile (MIL-D-28003).

Summary of Testing Performed and Errors Found:

1 Pictures Tested  
1225 Elements Tested  
95774 Octets Tested

```
=====
|   No Errors Were Detected   |
=====
```

===== End of Conformance Report =====

## 12.1.2 validcgm Log

Analysis for file c004.cgm using table table

(0, 1) occurred 1 time  
(0, 2) occurred 1 time  
(0, 3) occurred 1 time  
(0, 4) occurred 1 time  
(0, 5) occurred 1 time  
(1, 1) occurred 1 time  
(1, 2) occurred 1 time  
(1, 7) occurred 1 time  
(1, 8) occurred 1 time  
(1, 9) occurred 1 time  
(1, 11) occurred 1 time  
(1, 13) occurred 1 time  
(2, 1) occurred 1 time  
(2, 3) occurred 1 time  
(2, 4) occurred 1 time  
(2, 5) occurred 1 time  
(2, 6) occurred 1 time  
(2, 7) occurred 1 time  
(4, 1) occurred 1057 times  
(4, 4) occurred 29 times  
(4, 7) occurred 41 times  
(4, 17) occurred 4 times  
(4, 18) occurred 22 times  
(5, 3) occurred 3 times  
(5, 4) occurred 6 times  
(5, 10) occurred 1 time  
(5, 14) occurred 1 time  
(5, 15) occurred 3 times  
(5, 16) occurred 1 time  
(5, 18) occurred 1 time  
(5, 22) occurred 6 times  
(5, 23) occurred 5 times  
(5, 28) occurred 6 times  
(5, 30) occurred 1 time  
(5, 34) occurred 20 times

### 12.1.3 Output CADLeaf

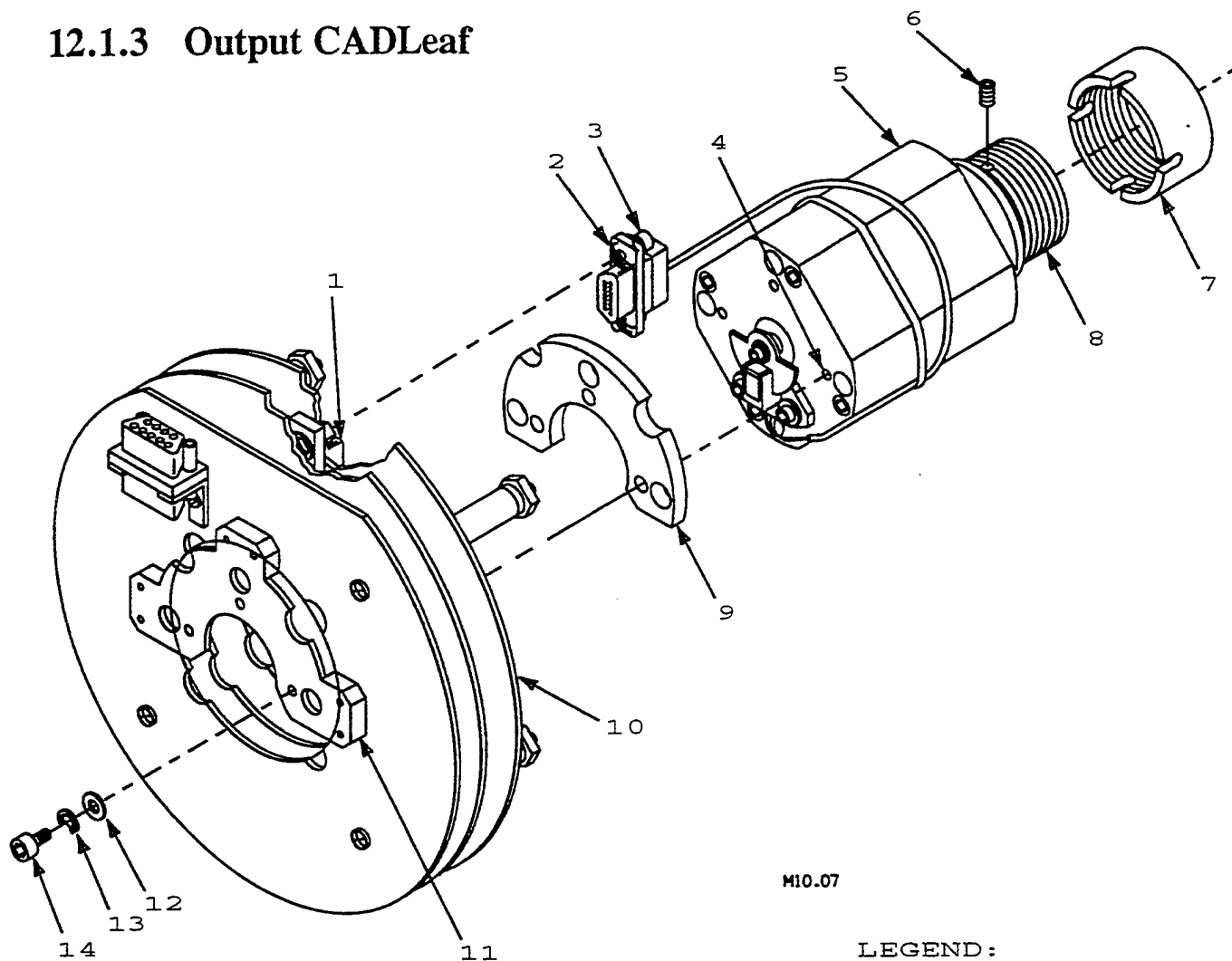

M10.07

#### LEGEND:

- 1 POWER SUPPLY CCA CO
- 2 MOTOR CONNECTOR P1
- 3 JACKSCREW (2 EA)
- 4 MOUNTING HOLE (3 EA)
- 5 MOTOR ASSEMBLY
- 6 SETSCREW
- 7 COLLAR
- 8 SHAFT
- 9 LAMINATED SHIM
- 10 ELECTRONICS ASSEMB
- 11 MOTOR TAB
- 12 #4 FLATWASHER (3 O
- 13 #4 LOCKWASHER (3 E
- 14 #4-40 SCREW (3 EA)

### 12.1.4 Output CALSView

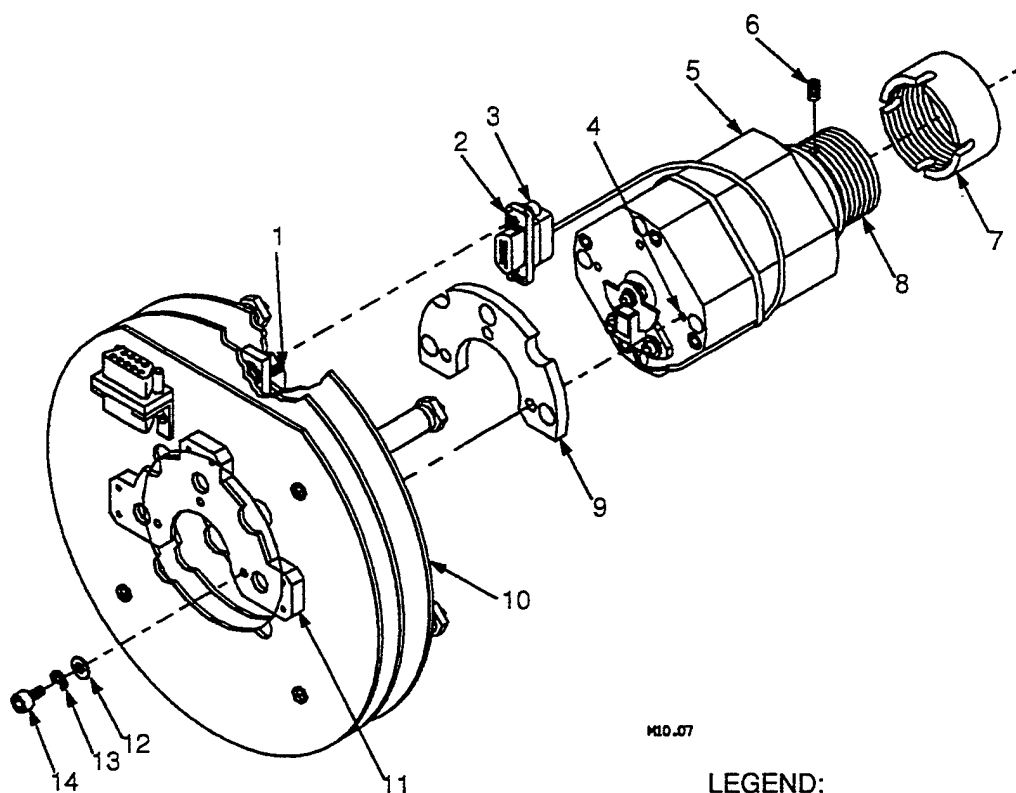

M10.07

**LEGEND:**

- 1 POWER SUPPLY CCA CONNECTOR
- 2 MOTOR CONNECTOR P1
- 3 JACKSCREW (2 EA)
- 4 MOUNTING HOLE (3 EA)
- 5 MOTOR ASSEMBLY
- 6 SETSCREW
- 7 COLLAR
- 8 SHAFT
- 9 LAMINATED SHIM
- 10 ELECTRONICS ASSEMBLY
- 11 MOTOR TAB
- 12 #4 FLATWASHER (3 OR 6 EA)
- 13 #4 LOCKWASHER (3 EA)
- 14 #4-40 SCREW (3 EA)

### 12.1.5 Output Generic

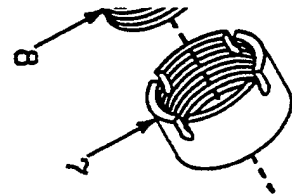

3 PLY CCA CONNECTOR J2  
CONNECTOR P1  
W (2 EA)  
3 HOLE (3 EA)  
ASSEMBLY  
N

10 SHIM  
NICS ASSEMBLY  
AB  
WASHER (3 OR 6 EA)  
WASHER (3 EA)  
CREW (3 EA)



## 12.1.6 Output Designer

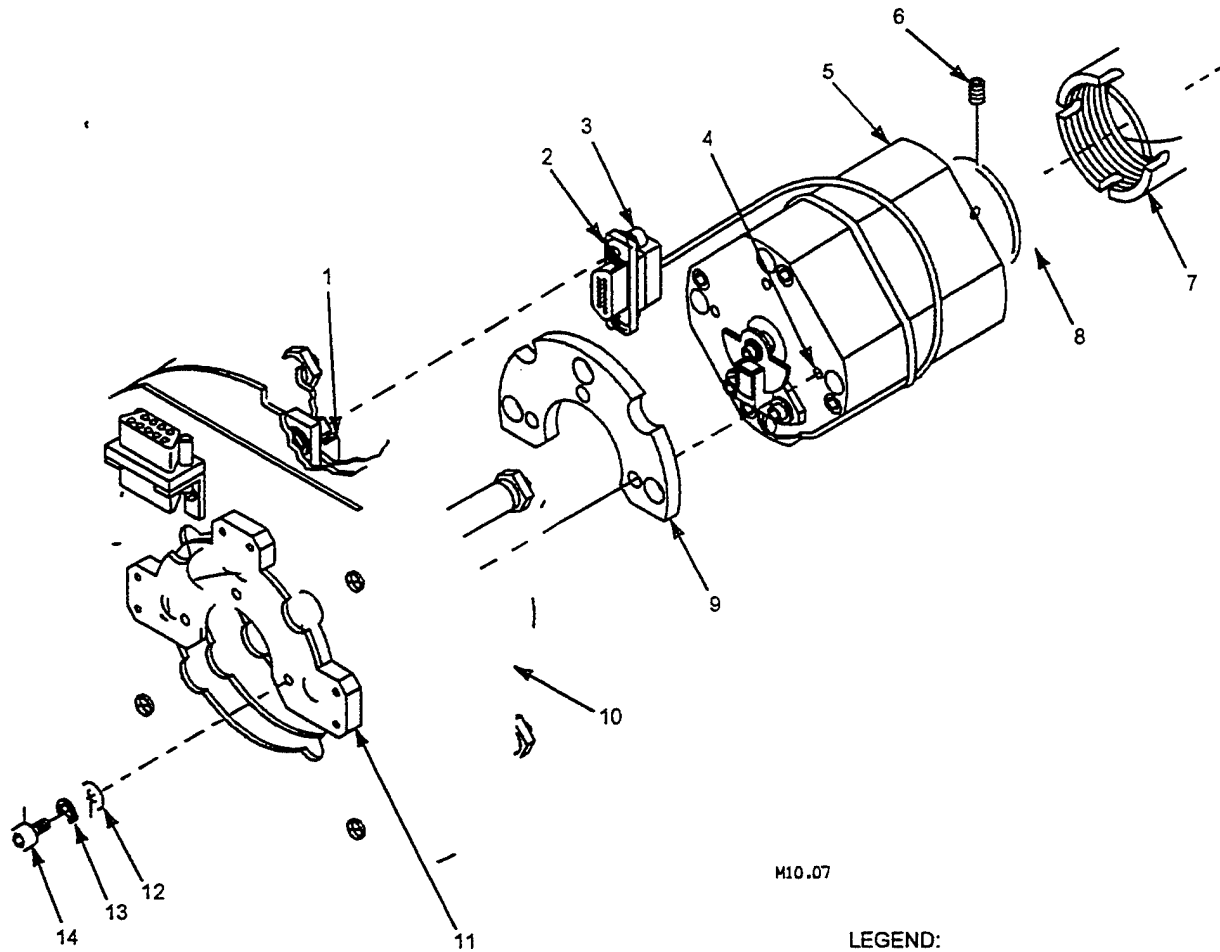

M10.07

LEGEND:

- 1 POWER SUPPLY CCA CONNECTOR J2
- 2 MOTOR CONNECTOR P1
- 3 JACKSCREW (2 EA)
- 4 MOUNTING HOLE (3 EA)
- 5 MOTOR ASSEMBLY
- 6 SETSCREW
- 7 COLLAR
- 8 SHAFT
- 9 LAMINATED SHIM
- 10 ELECTRONICS ASSEMBLY
- 11 MOTOR TAB
- 12 #4 FLATWASHER (3 OR 6 EA)
- 13 #4 LOCKWASHER (3 EA)
- 14 #4-40 SCREW (3 EA)

### 12.1.7 Output Freelance

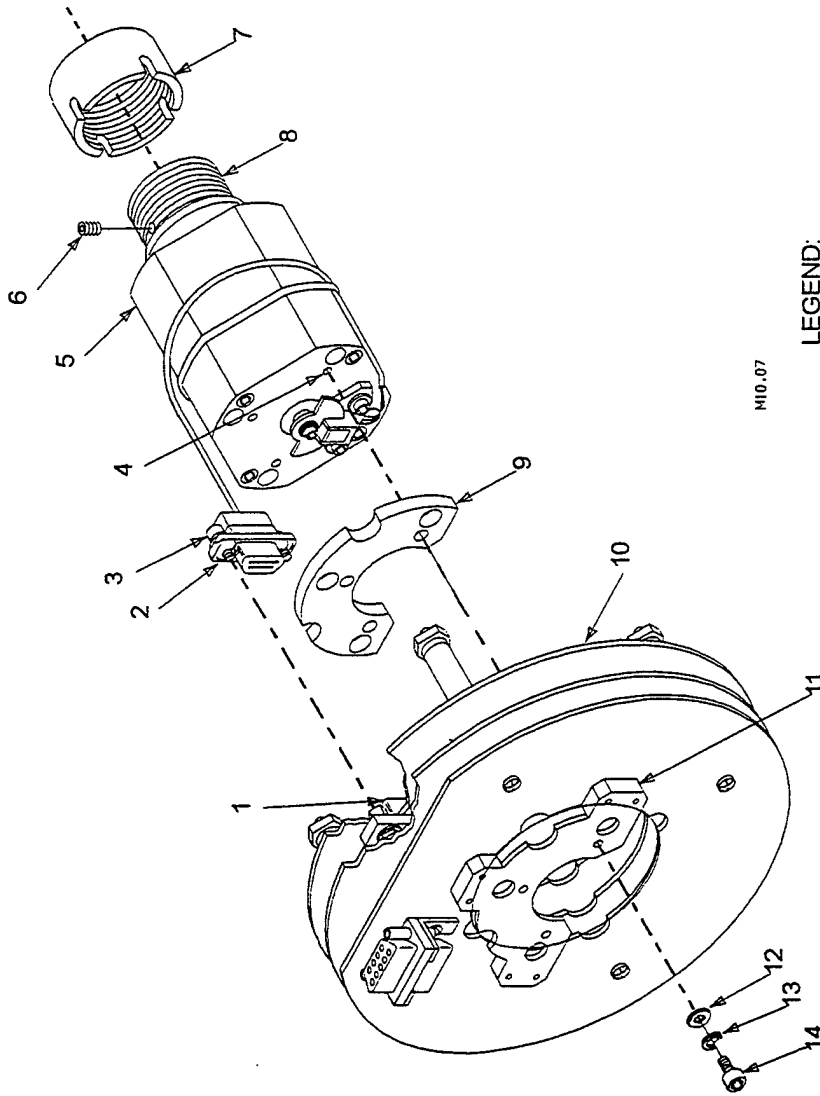

M10.07

- LEGEND:
- 1 POWER SUPPLY CCA CONNECTOR J2
  - 2 MOTOR CONNECTOR P1
  - 3 JACKSCREW (2 EA)
  - 4 MOUNTING HOLE (3 EA)
  - 5 MOTOR ASSEMBLY
  - 6 SETSCREW
  - 7 SHAFT
  - 8 COLLAR
  - 9 LAMINATED SHIM
  - 10 ELECTRONICS ASSEMBLY
  - 11 MOTOR TAB
  - 12 #4 FLATWASHER (3 OR 6 EA)
  - 13 #4 LOCKWASHER (3 EA)
  - 14 #4-40 SCREW (3 EA)

## 12.1.8 Output Harvard Graphics

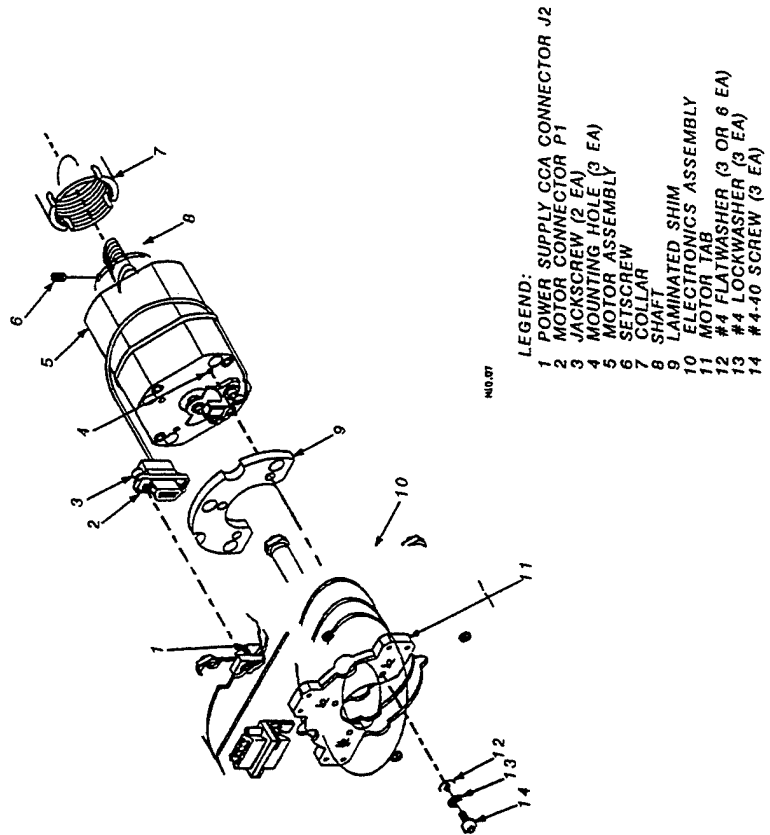

## 12.1.9 Output HiJaak for Windows

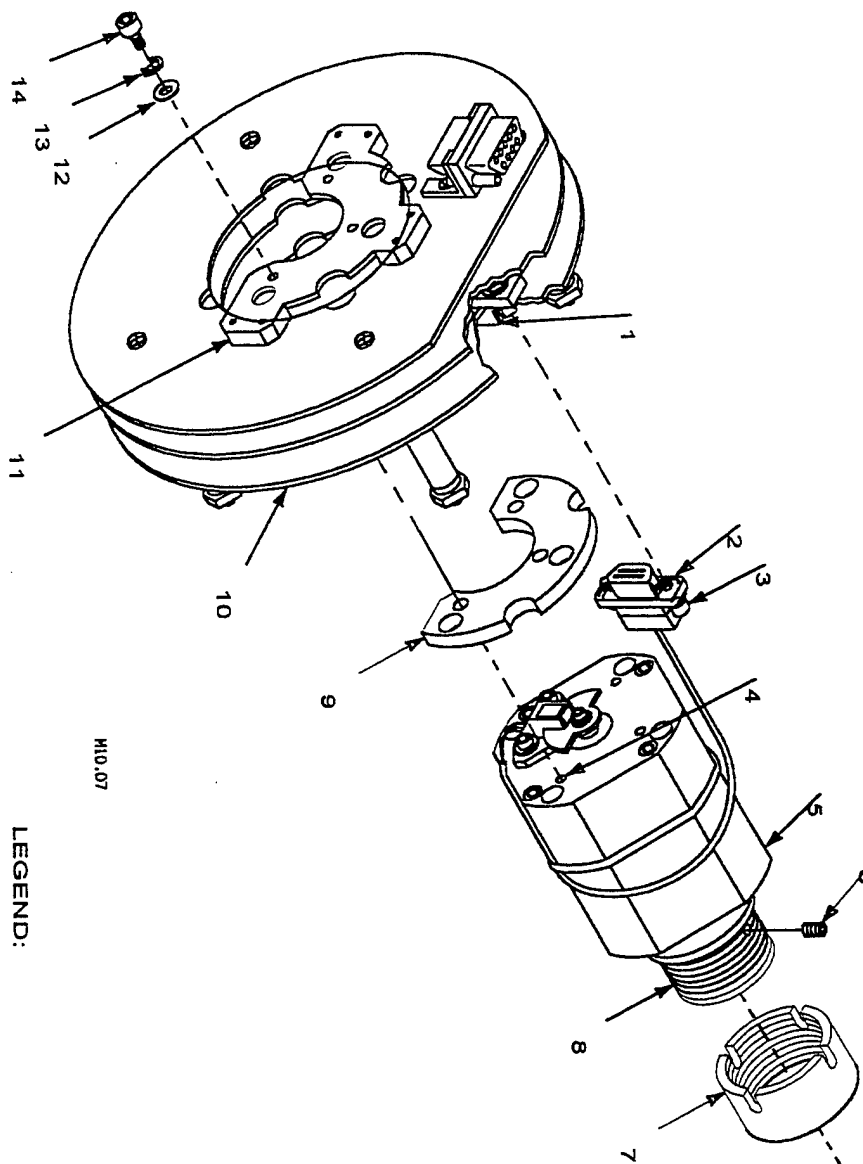

**LEGEND:**

- 1 POWER SUPPLY CCA CON
- 2 MOTOR CONNECTOR P1
- 3 JACKSCREW (2 EA)
- 4 MOUNTING HOLE (3 EA)
- 5 MOTOR ASSEMBLY
- 6 SETSCREW
- 7 COLLAR
- 8 SHAFT
- 9 LAMINATED SHIM
- 10 ELECTRONICS ASSEMBLY
- 11 MOTOR TAB
- 12 #4 FLATWASHER (3 OR 6 E
- 13 #4 LOCKWASHER (3 EA)
- 14 #4-40 SCREW (3 EA)

### 12.1.10 Output Island Draw 4.0

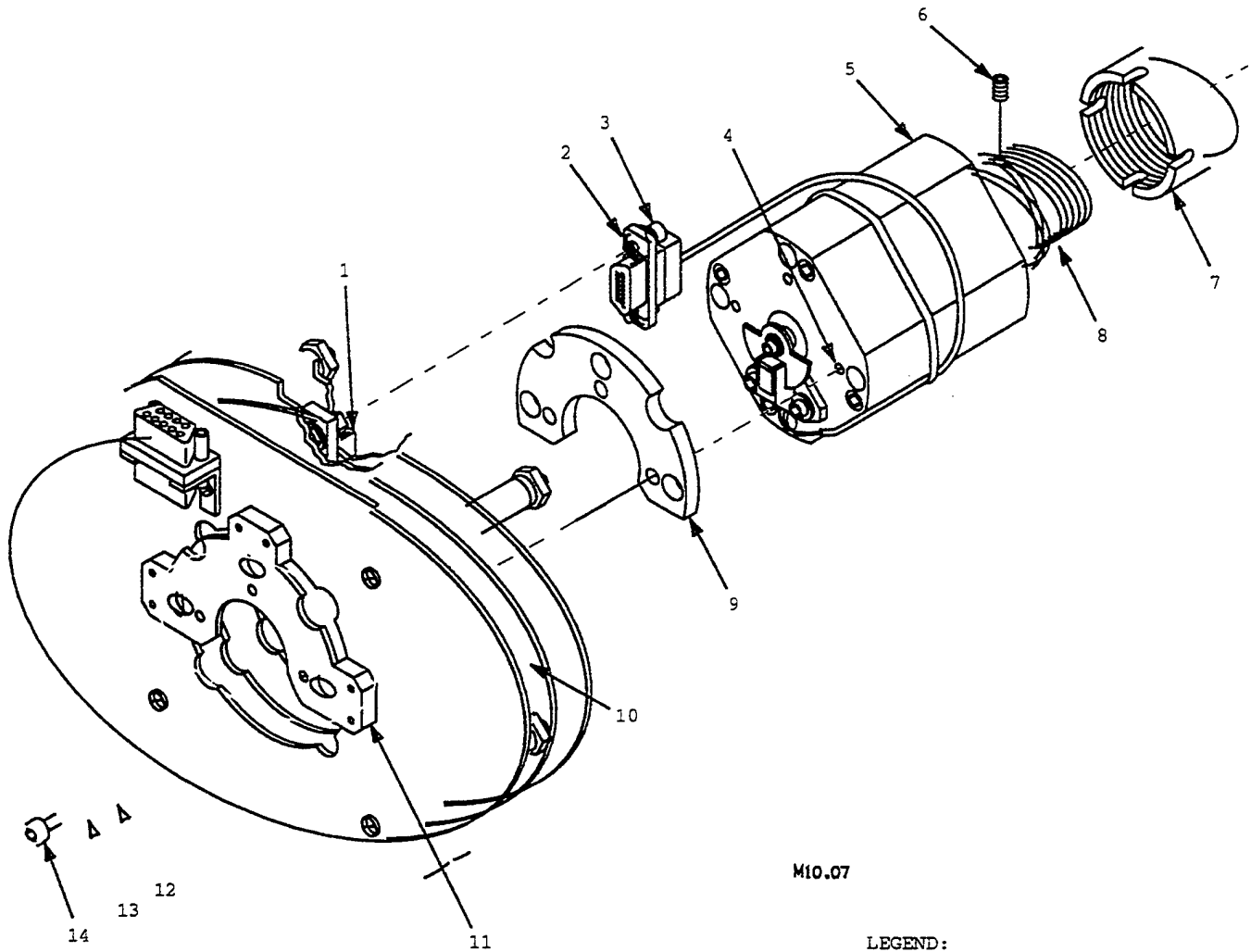

M10.07

LEGEND:

- 1 POWER SUPPLY CCA CONNECTOR J2
- 2 MOTOR CONNECTOR P1
- 3 JACKSCREW (2 EA)
- 4 MOUNTING HOLE (3 EA)
- 5 MOTOR ASSEMBLY
- 6 SETSCREW
- 7 COLLAR
- 8 SHAFT
- 9 LAMINATED SHIM
- 10 ELECTRONICS ASSEMBLY
- 11 MOTOR TAB
- 12 #4 FLATWASHER (3 OR 6 EA)
- 13 #4 LOCKWASHER (3 EA)
- 14 #4-40 SCREW (3 EA)

### 12.1.11 Output Ventura Publisher

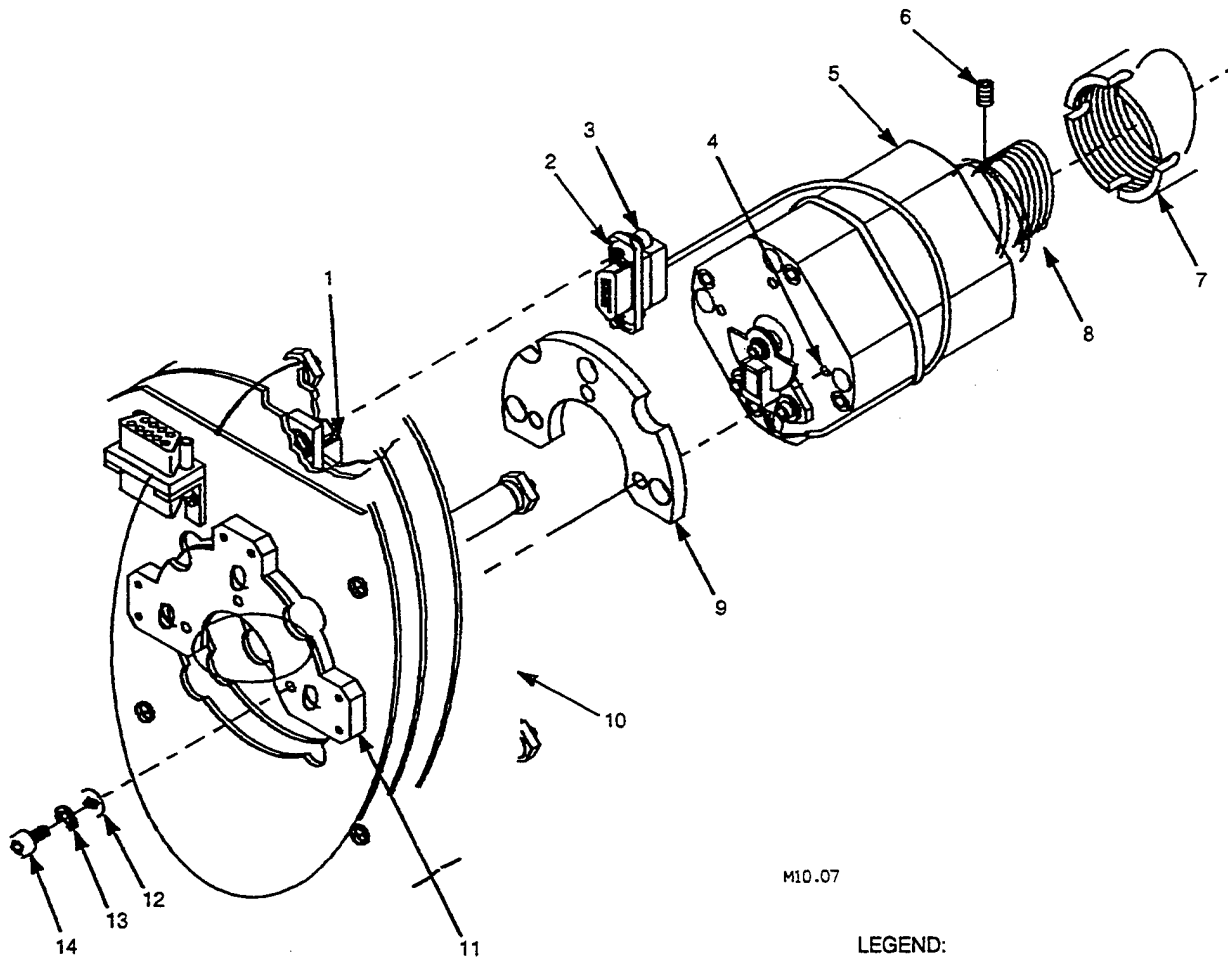

M10.07

LEGEND:

- 1 POWER SUPPLY CCA CONNECTOR J2
- 2 MOTOR CONNECTOR P1
- 3 JACKSCREW (2 EA)
- 4 MOUNTING HOLE (3 EA)
- 5 MOTOR ASSEMBLY
- 6 SETSCREW
- 7 COLLAR
- 8 SHAFT
- 9 LAMINATED SHIM
- 10 ELECTRONICS ASSEMBLY
- 11 MOTOR TAB
- 12 #4 FLATWASHER (3 OR 6 EA)
- 13 #4 LOCKWASHER (3 EA)
- 14 #4-40 SCREW (3 EA)

### 12.1.12 Output X-Change

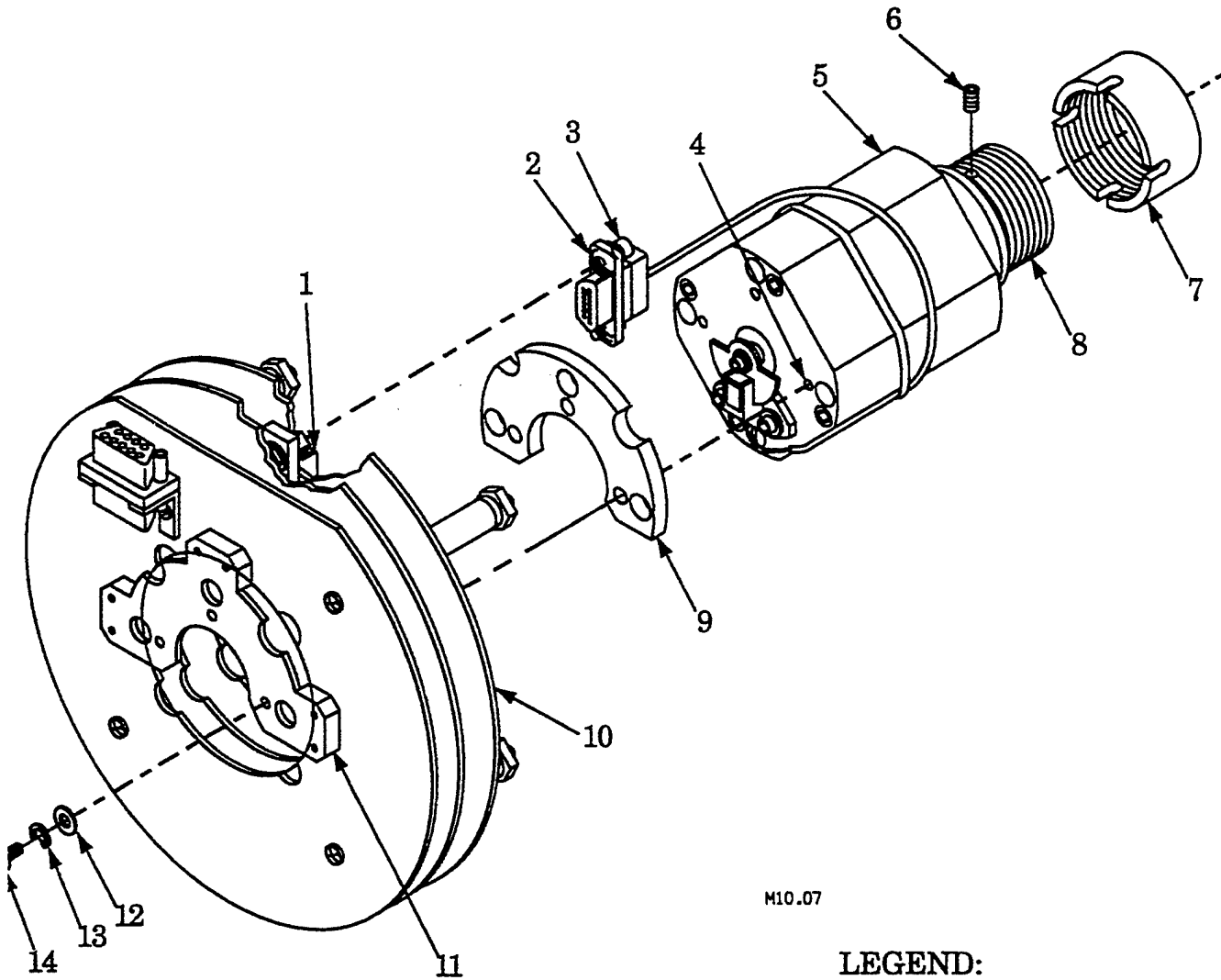

M10.07

#### LEGEND:

- 1 POWER SUPPLY CCA CONNECTOR .
- 2 MOTOR CONNECTOR P1
- 3 JACKSCREW (2 EA)
- 4 MOUNTING HOLE (3 EA)
- 5 MOTOR ASSEMBLY
- 6 SETSCREW
- 7 COLLAR
- 8 SHAFT
- 9 LAMINATED SHIM
- 10 ELECTRONICS ASSEMBLY
- 11 MOTOR TAB
- 12 #4 FLATWASHER (3 OR 6 EA)
- 13 #4 LOCKWASHER (3 EA)
- 14 #4-40 SCREW (3 EA)

## 12.2 File D001C005

### 12.2.1 Output CADLeaf

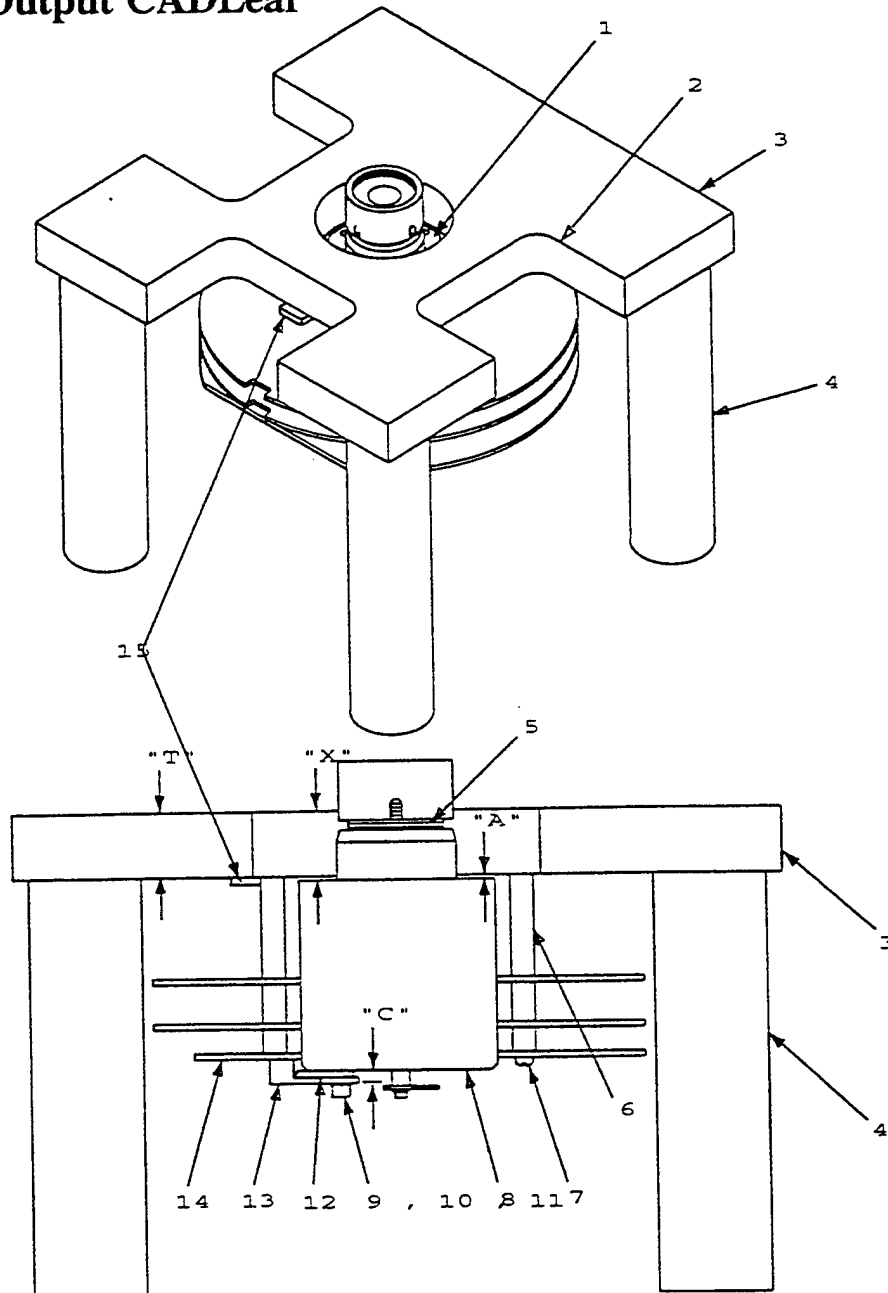

M10.08

LEGEND:

- |   |                                    |    |                   |                   |                      |
|---|------------------------------------|----|-------------------|-------------------|----------------------|
| 1 | MOTOR HOUSING                      | 6  | STANDOFF (4 EA)   | FLATWASHER (6 EA) |                      |
| 2 | MEASUREMENT ACCESS SCREW (4 EA)    | 12 | LAMINATED SHIM    |                   |                      |
| 3 | HOLD / INDICATING FIXTURE ASSEMBLY |    | MOTOR TAB         |                   |                      |
| 4 | POST (4 EA)                        | 9  | SCREW (3 EA)      | 14                | ELECTRONICS ASSEMBLY |
| 5 | DRIVE SHAFT                        | 10 | LOCKWASHER (3 EA) | 15                | FIXTURE TAB          |



### 12.2.2 Output CALSView

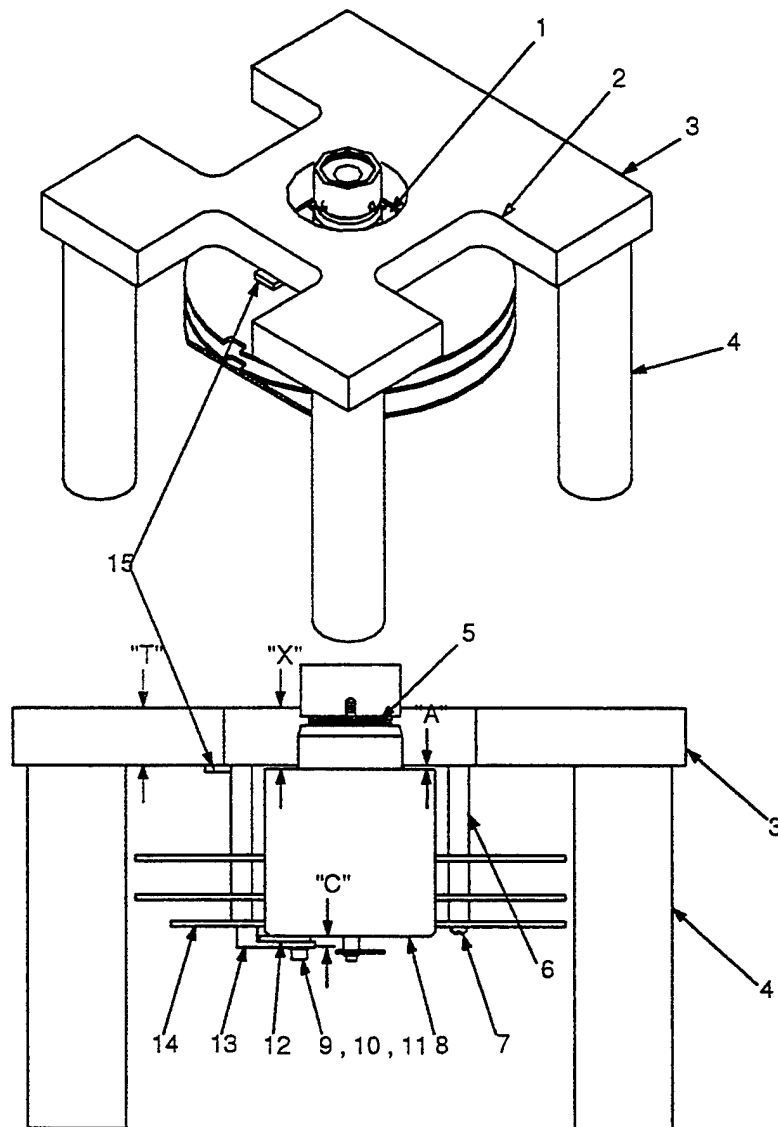

MLO.08

**LEGEND:**

- |                                   |                      |                         |
|-----------------------------------|----------------------|-------------------------|
| 1 MOTOR HOUSING                   | 6 STANDOFF (4 EA)    | 11 FLATWASHER (6 EA)    |
| 2 MEASUREMENT ACCESS SCREW (4 EA) | 7 MOTOR ASSEMBLY     | 12 LAMINATED SHIM       |
| 3 HOLD / INDICATING FIXTURE TAB   | 8 SCREW (3 EA)       | 13 MOTOR TAB            |
| 4 POST (4 EA)                     | 9 SCREW (3 EA)       | 14 ELECTRONICS ASSEMBLY |
| 5 DRIVE SHAFT                     | 10 LOCKWASHER (3 EA) | 15 FIXTURE TAB          |

12.2.3 Output Generic

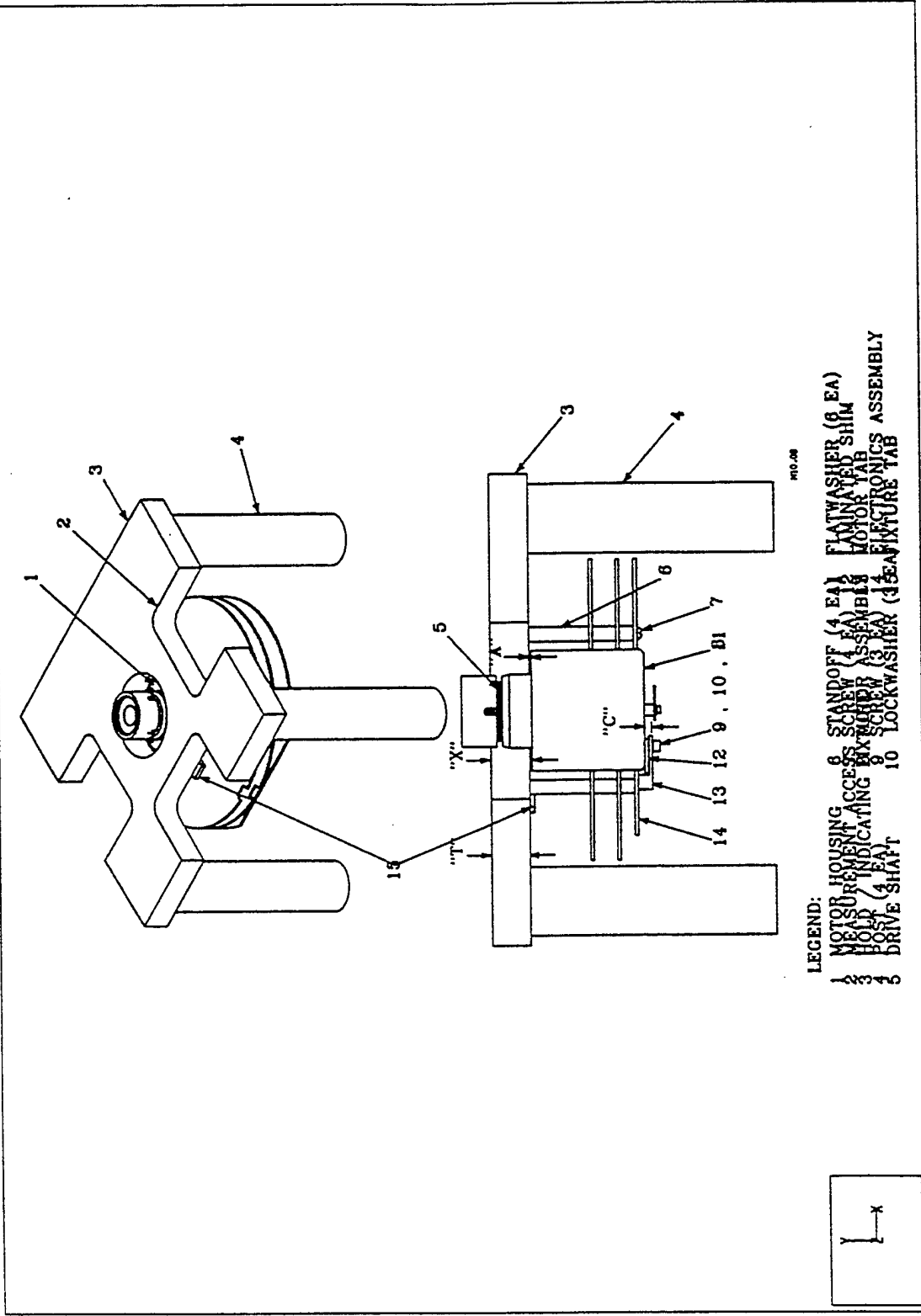

### 12.2.4 Output Designer

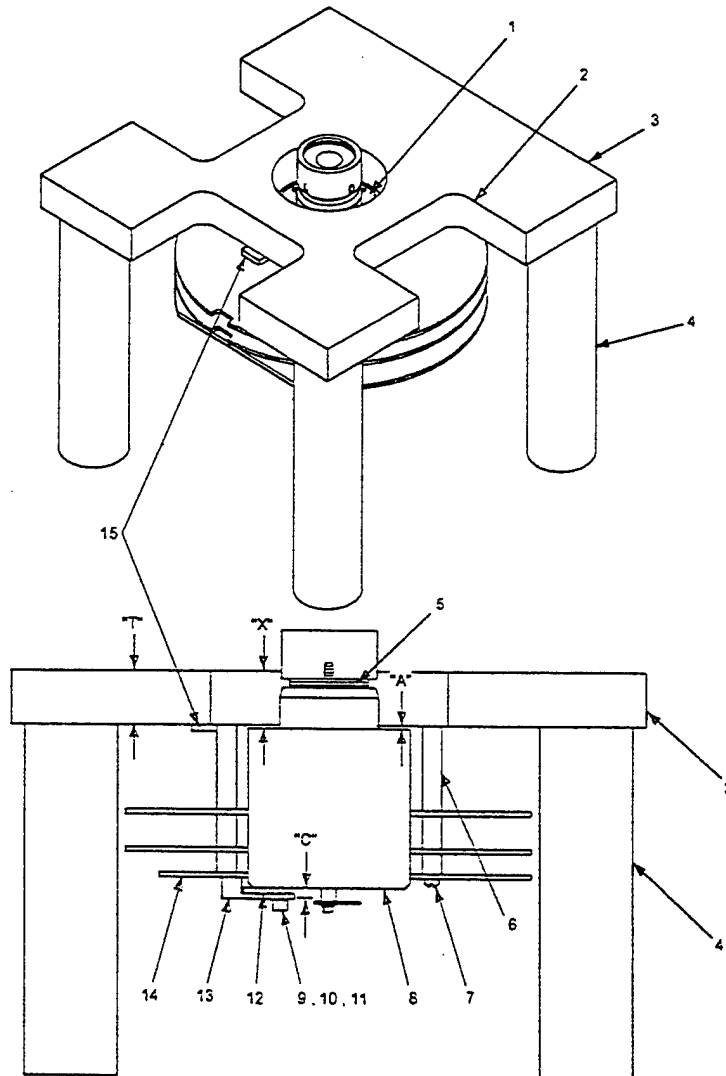

H00.08

LEGEND:

- |                             |                      |                         |
|-----------------------------|----------------------|-------------------------|
| 1 MOTOR HOUSING             | 6 STANDOFF (4 EA)    | 11 FLATWASHER (6 EA)    |
| 2 MEASUREMENT ACCESS        | 7 SCREW (4 EA)       | 12 LAMINATED SHIM       |
| 3 HOLD / INDICATING FIXTURE | 8 MOTOR ASSEMBLY     | 13 MOTOR TAB            |
| 4 POST (4 EA)               | 9 SCREW (3 EA)       | 14 ELECTRONICS ASSEMBLY |
| 5 DRIVE SHAFT               | 10 LOCKWASHER (3 EA) | 15 FIXTURE TAB          |

designer 4

c005

### 12.2.5 Output Freelance

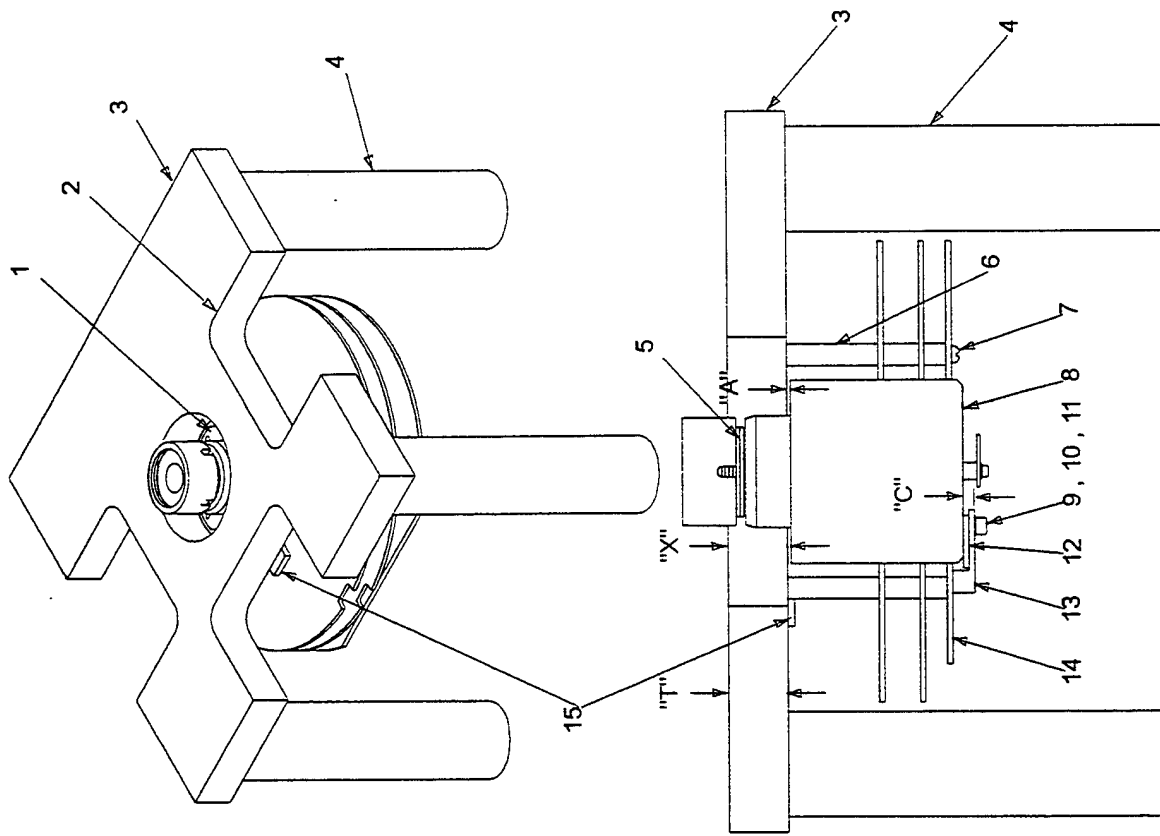

H10.08

**LEGEND:**

- 1 MOTOR HOUSING
- 2 MEASUREMENT ACCESS
- 3 HOLD / INDICATING FIXTURE
- 4 POST (4 EA)
- 5 DRIVE SHAFT
- 6 STANDOFF (4 EA)
- 7 SCREW (4 EA)
- 8 HOLD / INDICATING FIXTURE
- 9 SCREW (3 EA)
- 10 LOCKWASHER (3 EA)
- 11 FLATWASHER (6 EA)
- 12 LAMINATED SHIM
- 13 MOTOR TAB
- 14 ELECTRONICS ASSEMBLY
- 15 FIXTURE TAB

## 12.2.6 Output Harvard Graphics

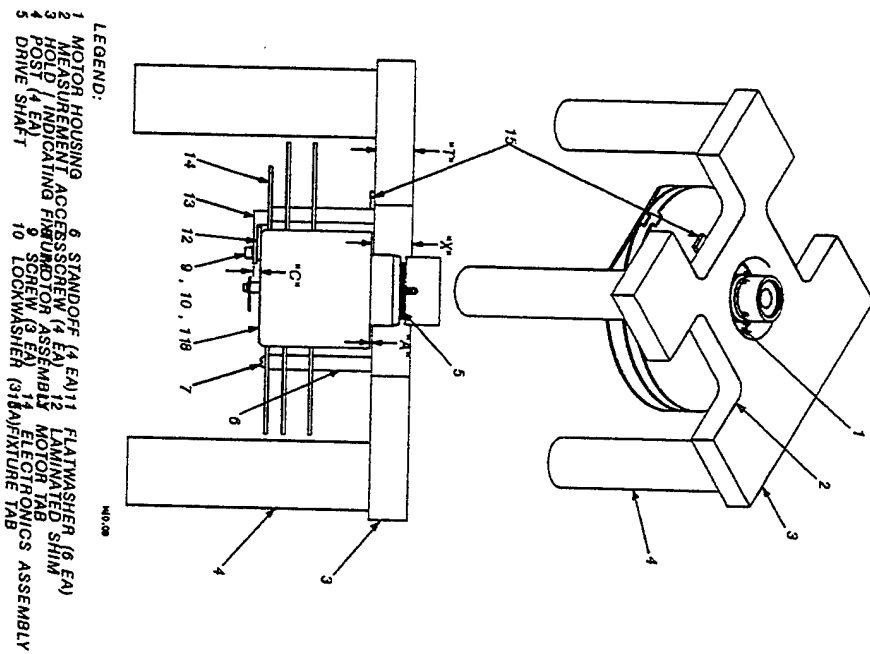

### 12.2.7 Output HiJaak for Windows

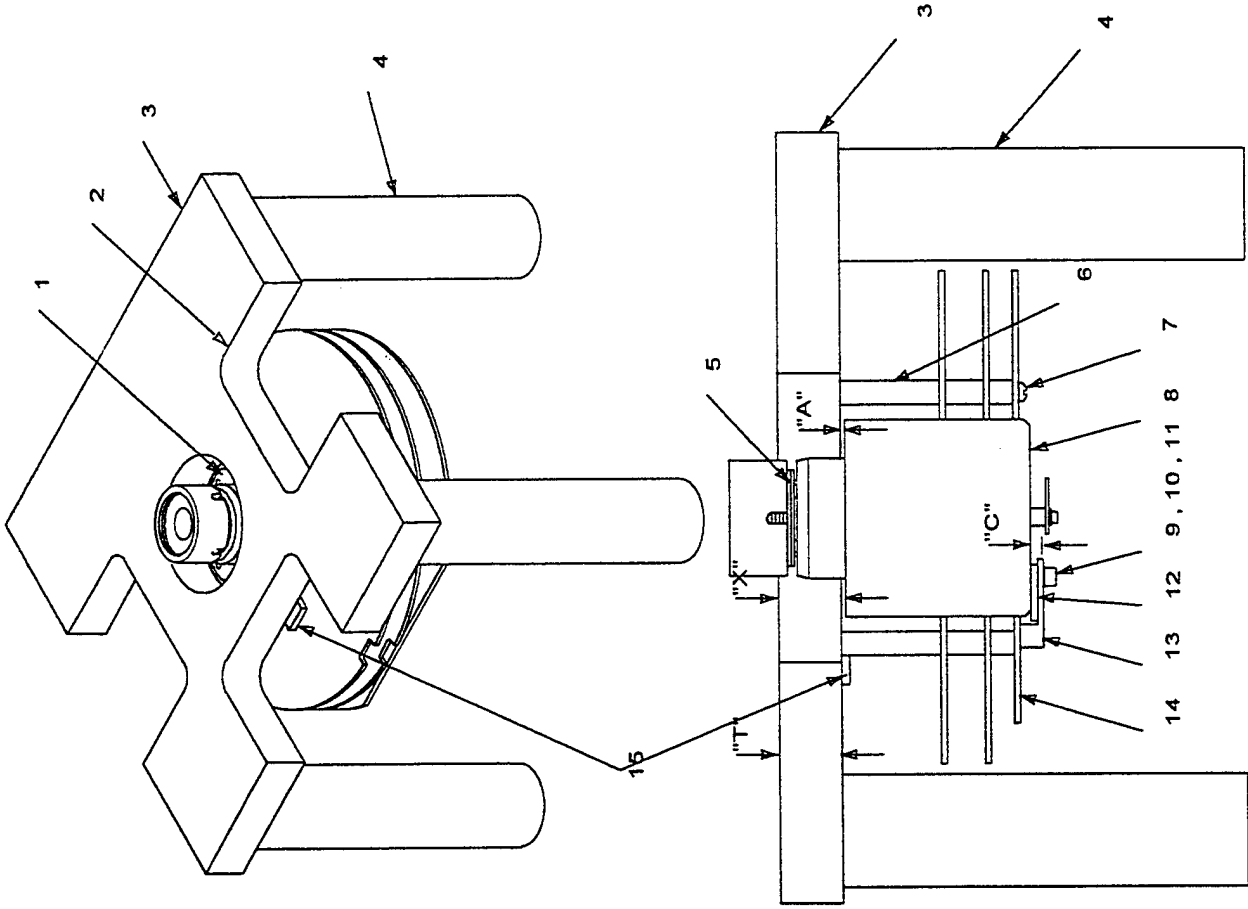

M10.08

**LEGEND:**

- 1 MOTOR HOUSING
- 2 MEASUREMENT ACCESS
- 3 HOLD / INDICATING FIXTURE
- 4 POST (4 EA)
- 5 DRIVE SHAFT
- 6 STANDOFF (4 EA)
- 7 SCREW (4 EA)
- 8 LAMINATED SHIM
- 9 MOTOR ASSEMBLY
- 10 SCREW (3 EA)
- 11 FLATWASHER (6 EA)
- 12 LAMINATED SHIM
- 13 MOTOR TAB
- 14 ELECTRONICS ASSEMBLY
- 15 FIXTURE TAB

### 12.2.8 Output Island Draw 4.0

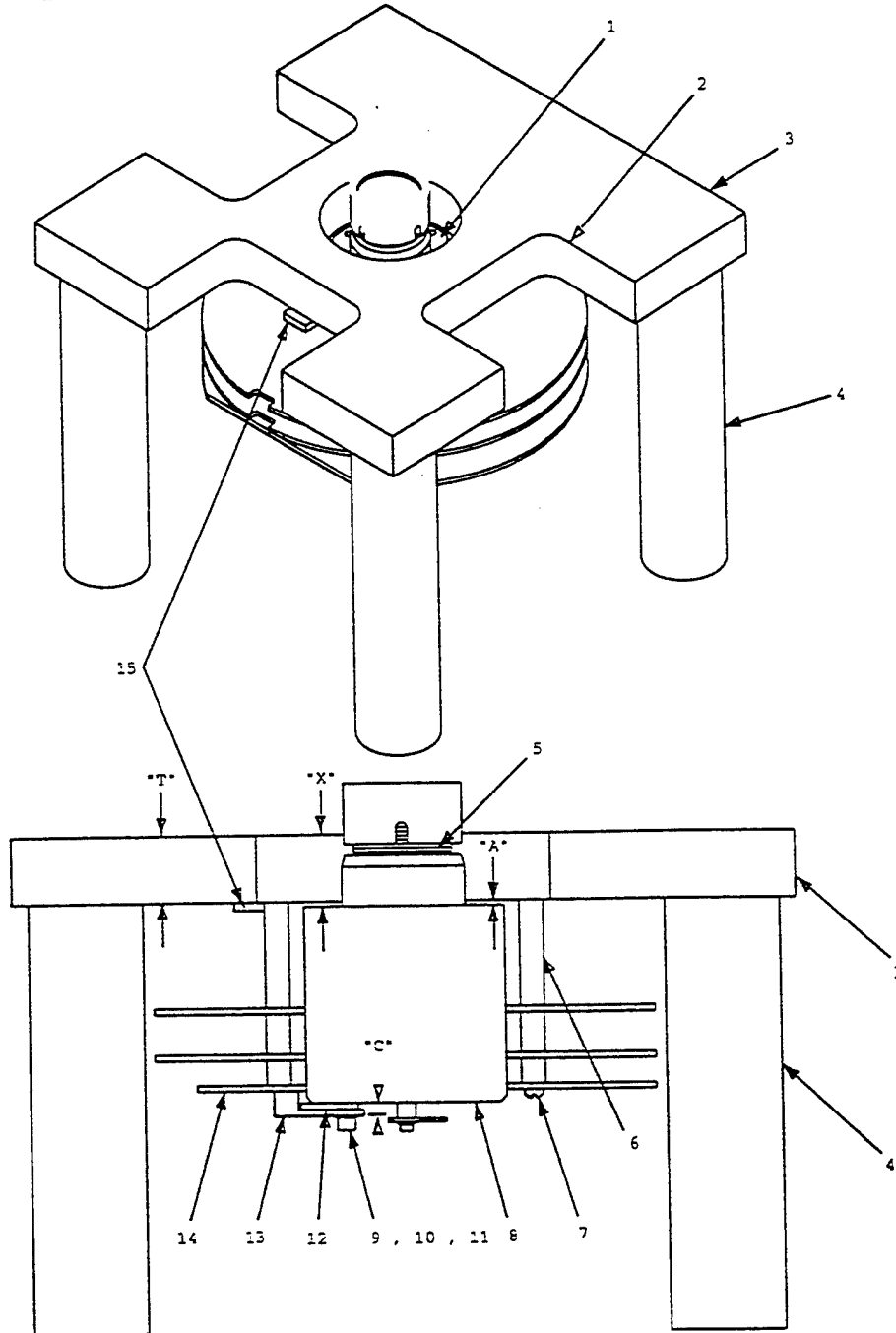

M10.08

LEGEND:

- |                             |                      |                         |
|-----------------------------|----------------------|-------------------------|
| 1 MOTOR HOUSING             | 6 STANDOFF (4 EA)    | 11 FLATWASHER (6 EA)    |
| 2 MEASUREMENT ACCESS        | 7 SCREW (4 EA)       | 12 LAMINATED SHIM       |
| 3 HOLD / INDICATING FIXTURE | 8 MOTOR ASSEMBLY     | 13 MOTOR TAB            |
| 4 POST (4 EA)               | 9 SCREW (3 EA)       | 14 ELECTRONICS ASSEMBLY |
| 5 DRIVE SHAFT               | 10 LOCKWASHER (3 EA) | 15 FIXTURE TAB          |

### 12.2.9 Output Ventura Publisher

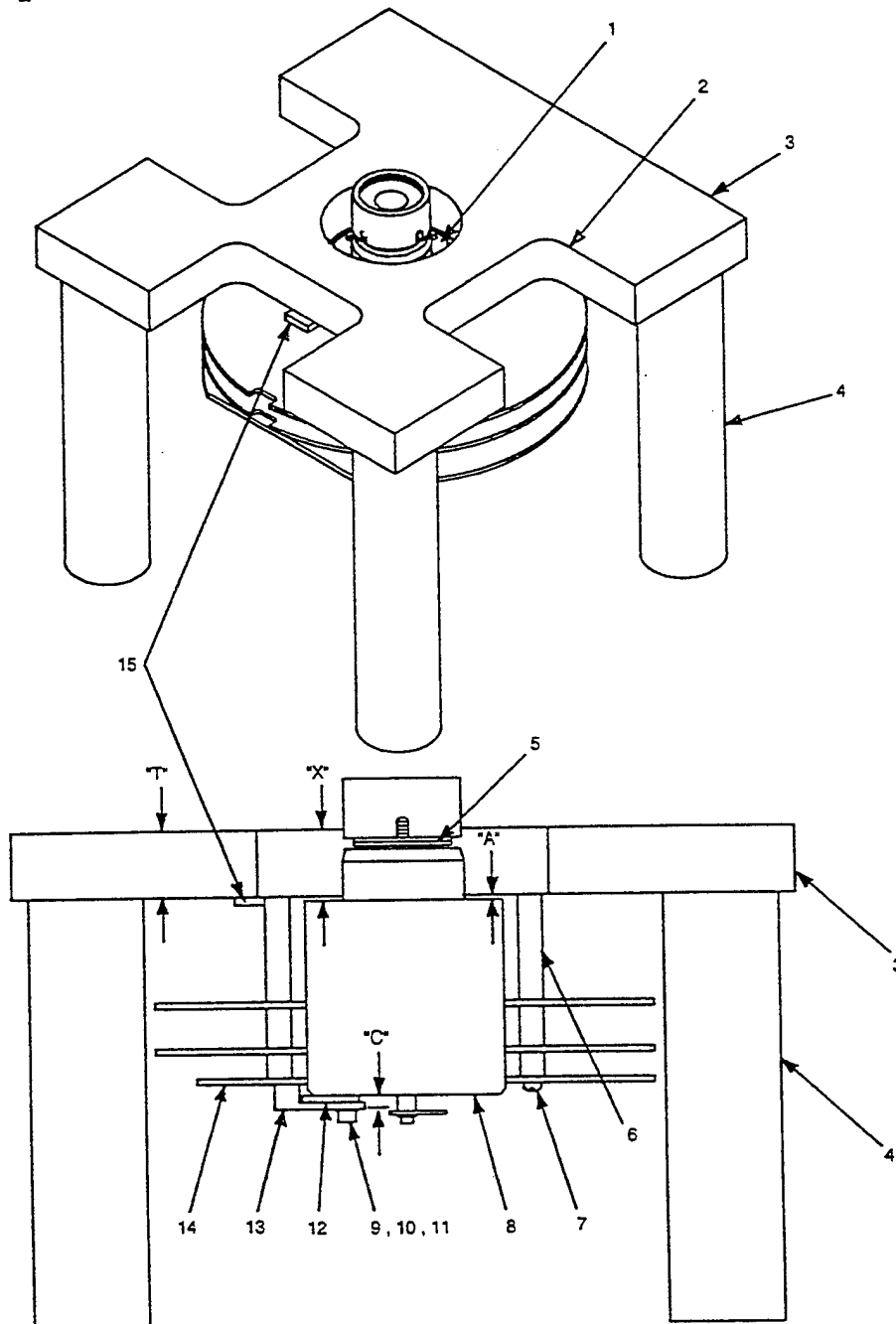

M10.08

**LEGEND:**

- |                             |                      |                         |
|-----------------------------|----------------------|-------------------------|
| 1 MOTOR HOUSING             | 6 STANDOFF (4 EA)    | 11 FLATWASHER (6 EA)    |
| 2 MEASUREMENT ACCESS        | 7 SCREW (4 EA)       | 12 LAMINATED SHIM       |
| 3 HOLD / INDICATING FIXTURE | 8 MOTOR ASSEMBLY     | 13 MOTOR TAB            |
| 4 POST (4 EA)               | 9 SCREW (3 EA)       | 14 ELECTRONICS ASSEMBLY |
| 5 DRIVE SHAFT               | 10 LOCKWASHER (3 EA) | 15 FIXTURE TAB          |



### 12.2.10 Output X-Change

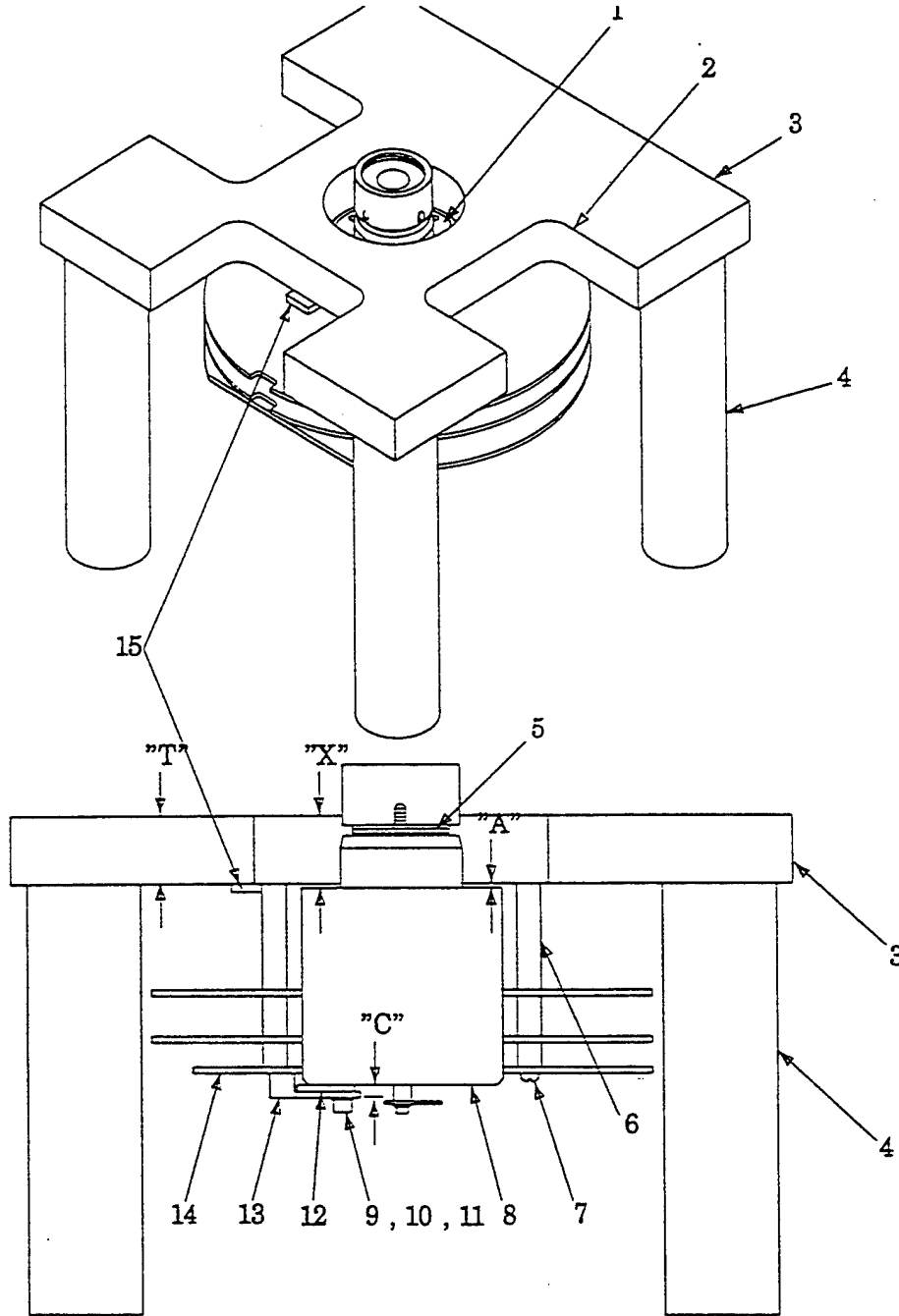

M10.08

**LEGEND:**

- |                                   |                      |                         |
|-----------------------------------|----------------------|-------------------------|
| 1 MOTOR HOUSING                   | 6 STANDOFF (4 EA)    | 11 FLATWASHER (6 EA)    |
| 2 MEASUREMENT ACCESS SCREW (4 EA) | 7 MOTOR ASSEMBLY     | 12 LAMINATED SHIM       |
| 3 HOLD / INDICATING FIXTURE       | 8 MOTOR ASSEMBLY     | 13 MOTOR TAB            |
| 4 POST (4 EA)                     | 9 SCREW (3 EA)       | 14 ELECTRONICS ASSEMBLY |
| 5 DRIVE SHAFT                     | 10 LOCKWASHER (3 EA) | 15 FUTURE TAB           |