

DOT/FAA/AR-96/17

Office of Aviation Research
Washington, D.C. 20591

Reduced Configuration Approach Lighting System: Simulator Evaluation

Eric S. Katz

Federal Aviation Administration
Airport and Aircraft Safety
Research and Development Division
William J. Hughes Technical Center
Atlantic City International Airport, NJ 08405

June 1996

Final Report

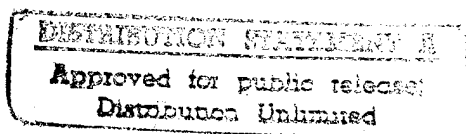

This document is available to the U.S. public through the National Technical Information Service, Springfield, Virginia 22161.



U.S. Department of Transportation
Federal Aviation Administration

19960819 046

NOTICE

This document is disseminated under the sponsorship of the U.S. Department of Transportation in the interest of information exchange. The United States Government assumes no liability for the contents or use thereof. The United States Government does not endorse products or manufacturers. Trade or manufacturer's names appear herein solely because they are considered essential to the objective of this report.

| | | | | | |
|--|--|--|--|--|-----------|
| 1. Report No. DOT/FAA/AR-96/17 | | 2. Government Accession No. | | 3. Recipient's Catalog No. | |
| 4. Title and Subtitle REDUCED CONFIGURATION APPROACH LIGHTING SYSTEM: SIMULATOR EVALUATION | | | | 5. Report Date June 1996 | |
| | | | | 6. Performing Organization Code AAR-410 | |
| 7. Author(s) Eric S. Katz | | | | 8. Performing Organization Report No. | |
| 9. Performing Organization Name and Address Airport and Aircraft Safety Research and Development Division William J. Hughes Technical Center Atlantic City International Airport, NJ 08405 | | | | 10. Work Unit No. (TRAIS) | |
| | | | | 11. Contract or Grant No. | |
| 12. Sponsoring Agency Name and Address U.S. Department of Transportation Federal Aviation Administration Office of Aviation Research Washington, D.C. 20591 | | | | 13. Type of Report and Period Covered Final Report | |
| | | | | 14. Sponsoring Agency Code AFS-1 | |
| 15. Supplementary Notes | | | | | |
| 16. Abstract Recent advances in Global Positioning System (GPS) capabilities have heightened the prospect of providing Category I, II, and III approach and landing capabilities at numerous airports. In addition to the considerable expense of installing approach lighting systems to support these approaches, many airports do not have the necessary real estate that would be required for the installation of standard approach lighting systems. In response to these concerns, an evaluation was needed to help determine if <u>modified</u> approach lighting system configurations could be developed that would be less expensive and occupy less real estate without compromising safety. This report describes an evaluation of a number of proposed approach lighting systems (ALS) modifications involving a reduction in the number of required lights, either through providing a lesser density within the standard configuration or through shortening the pattern length. The evaluation was conducted using the Federal Aviation Administration Boeing 727 flight simulator and employing the services of experienced air carrier and FAA pilots as volunteer subjects. Results of the test effort revealed that the guidance that was provided by the medium-intensity approach lighting system with runway alignment indicator lights (Configuration E) and the high-intensity approach lighting system with sequenced flashers (Configuration H) that contain three lights, in lieu of five, per centerline barrette allowed all of the subject pilots to complete the approaches and landings safely. However, configurational changes to the standard approach lighting systems should not be made until these results are validated by actual weather flight testing. | | | | | |
| 17. Key Words Reduced approach lighting system configurations | | | | 18. Distribution Statement This document is available to the public through the National Technical Information Service (NTIS), Springfield, Virginia 22161. | |
| 19. Security Classif. (of this report) Unclassified | | 20. Security Classif. (of this page) Unclassified | | 21. No. of Pages 73 | 22. Price |

TABLE OF CONTENTS

| | Page |
|--|------|
| EXECUTIVE SUMMARY | vii |
| 1. INTRODUCTION | 1 |
| 1.1 Purpose | 1 |
| 1.2 Background | 1 |
| 1.3 Related Activities/Documents | 1 |
| 2. DISCUSSION | 4 |
| 2.1 Objective | 4 |
| 2.2 Development of Reduced System Configurations | 4 |
| 3. EVALUATION APPROACH | 12 |
| 3.1 Evaluation Method | 12 |
| 3.2 Evaluation Pilots | 12 |
| 4. EVALUATION IMPLEMENTATION | 16 |
| 4.1 General Procedures | 16 |
| 4.2 Evaluation Conditions | 18 |
| 4.2.1 Initial Conditions | 19 |
| 4.2.2 Weather Conditions | 19 |
| 4.2.3 Pilot Operating Procedures | 19 |
| 5. TEST RESULTS | 20 |
| 5.1 Organization of Results | 20 |
| 5.2 Notes on the Results | 20 |
| 5.3 Results Analysis | 62 |
| 5.3.1 Category I Approach Light Systems | 62 |
| 5.3.2 Category II Approach Light Systems | 64 |

| | | |
|-----|---------------------------------|----|
| 6. | CONCLUSIONS AND RECOMMENDATIONS | 65 |
| 6.1 | Conclusions | 65 |
| 6.2 | Recommendations | 65 |

LIST OF FIGURES

| Figure | | Page |
|--------|---|------|
| 1 | Standard MALSR System (Configuration A) | 2 |
| 2 | Standard ALSF-2 System (Configuration B) | 3 |
| 3 | Reduced-Density MALSR System (Configuration E) | 5 |
| 4 | Standard MALSF System (Configuration F) | 6 |
| 5 | Reduced-Density MALSF System (Configuration G) | 7 |
| 6 | Reduced-Density ALSF-2 System (Configuration H) | 9 |
| 7 | Reduced-Density ALSF-2 System (Configuration I) | 10 |
| 8 | Reduced-Density ALSF-2 System (Configuration J) | 11 |
| 9 | Category I Scenario Outline | 13 |
| 10 | Category II Scenario Outline | 14 |
| 11 | Sample Postflight Session Questionnaire | 17 |

LIST OF TABLES

| Table | | Page |
|-------|--|------|
| 1 | Metric Operational Equivalent Values | 15 |
| 2 | Meteorological Visibility Versus RVR | 15 |
| 3 | Reduced ALS Test Results Numerical Ranking | 63 |

EXECUTIVE SUMMARY

Recent advances in Global Positioning System (GPS) capabilities have heightened the prospect of providing precision approach (Category I, II, and III) and landing capabilities at numerous airports. In order for these approaches and landings to be completed in the minimum weather conditions defined by the Category I, II, and III criteria, approach lighting systems will have to be installed. In addition to the considerable expense of these installations, many airports do not have the necessary real estate that would be required for the installation of standard approach lighting systems. In response to these concerns, an evaluation was needed to help determine if modified approach lighting system configurations could be developed that would be less expensive and occupy less real estate without compromising safety.

This report describes an evaluation of a number of proposed approach lighting system (ALS) modifications involving a reduction in the number of required lights, either through providing a lesser density within the standard configuration or through shortening the pattern length. The evaluation was conducted using the Federal Aviation Administration Boeing 727 flight simulator with enhanced visual presentations and employing the services of experienced air carrier and FAA pilots as volunteer subjects.

Results of this simulator test effort revealed that the guidance that was provided by the medium-intensity approach lighting system with runway alignment indicator lights (Configuration E) and the high-intensity approach lighting system with sequenced flashers (Configuration H) that contain three lights, in lieu of five, per centerline barrette allowed all of the subject pilots to complete the approaches and landings safely. However, configurational changes to the standard approach lighting systems should not be made until these results are validated by actual weather flight testing.

1. INTRODUCTION.

1.1 PURPOSE.

This evaluation effort has been undertaken in response to a memorandum request from the Director, Flight Standards Service, AFS-1, dated March 2, 1994. The memorandum specifically requested that the Airport Technology Research and Development Branch, AAR-410, at the William J. Hughes Technical Center perform the analysis, testing, and evaluation necessary to "Establish Lighting Requirements for GPS Approaches."

This report describes the methods by which proposed reductions in configurations for approach lighting systems were evaluated, details the results of the testing effort, and provides conclusions and recommendations where necessary.

1.2 BACKGROUND.

The availability of Global Positioning System (GPS) precision approaches will increase the number of runways capable of handling Instrument Flight Rule (IFR) approach operations. A major factor in upgrading the instrument capability of these runways will be the need for installation of many new approach lighting systems (ALS). Therefore, the present standard systems had to be reevaluated to identify possible means by which installation, operation, and maintenance costs may be reduced.

1.3 RELATED ACTIVITIES/DOCUMENTS.

In January 1995 The Federal Aviation Administration Technical Center (renamed the William J. Hughes Technical Center) published a Technical Note CT-TN94/40 entitled "Visual Guidance Requirements for Global Positioning System Approaches." The technical note concluded that visual aids intended to support GPS approach and landing operations should be identical to those currently provided to support other forms of instrument operations (Nondirectional Beacon (NDB), VHF Omni-Directional Range (VOR), Instrument Landing System (ILS), etc.) and of the configuration dictated only by the category of operations (i.e., Category I, II, or III). In addition, however, the technical note further stated that our existing medium-intensity approach lighting system with runway alignment indicator lights (MALSR) and the high-intensity approach lighting system with sequenced flashers (ALSF-2) (figures 1 and 2 of this report) may not be optimum with regard to efficiency and/or economy. There are still certain areas within which they might be improved and made more cost efficient without negatively impacting pilot acceptance. For example, the number of lights in each ALS barrette might be reduced with virtually no loss of visual effects. A configuration containing fewer lights could result in lower installation, operation, and maintenance costs.

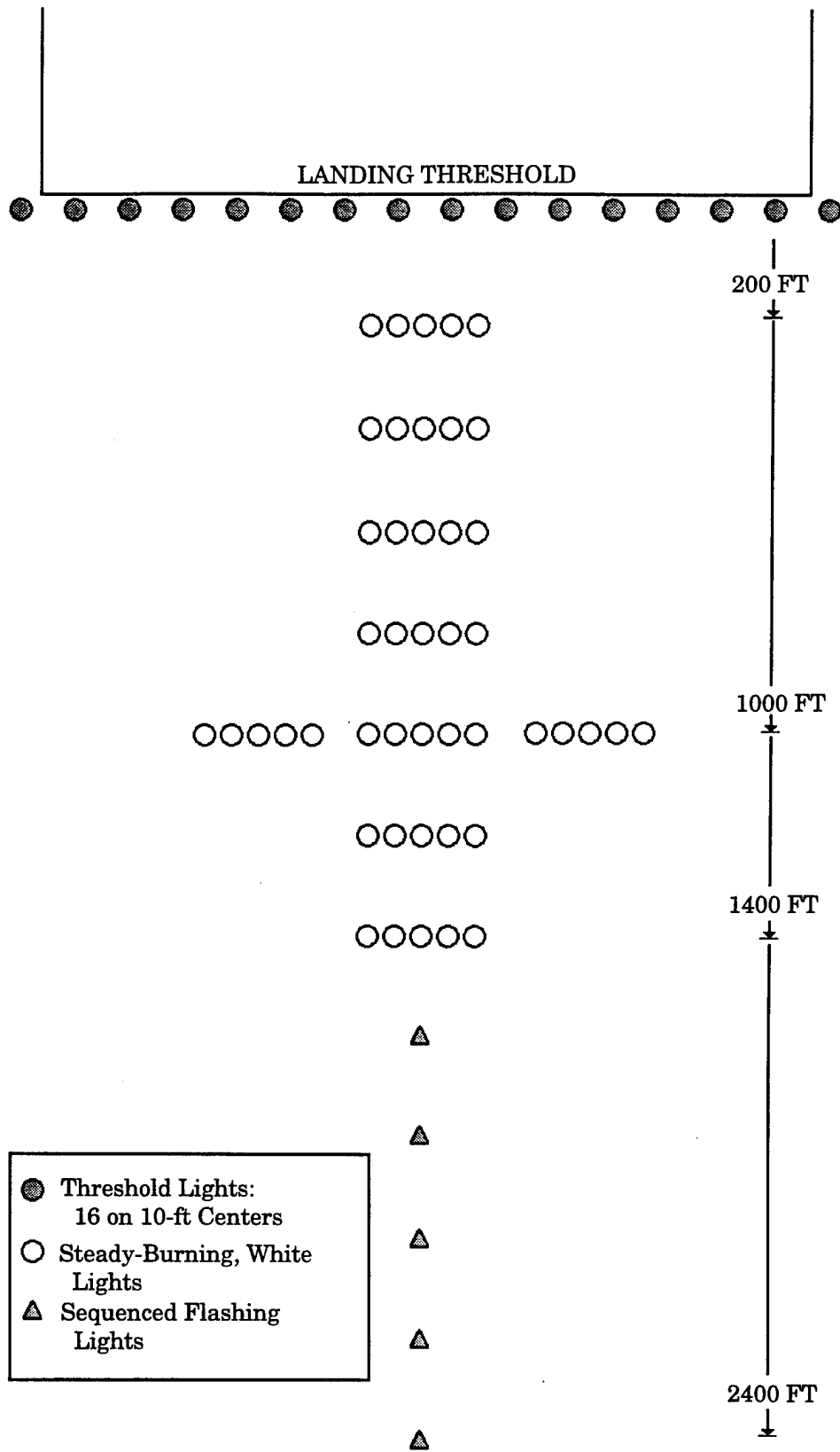

FIGURE 1. STANDARD MALS SYSTEM (CONFIGURATION A)

2. DISCUSSION.

2.1 OBJECTIVE.

This simulator evaluation was specifically directed towards determining if the subject pilots could safely complete approaches and landings if

- the number of lights in the centerline barrettes of the MALSR and ALSF-2 systems were reduced from 5 to 3 or
- the total length of the MALSR was shortened to 1400 feet resulting in a system known as a MALSF or
- the steady-burning lights within the outer 1000 feet of the ALSF-2 system were eliminated along with increasing the strobe light spacing to 200 feet.

2.2 DEVELOPMENT OF REDUCED SYSTEM CONFIGURATIONS.

One method of possibly lowering installation, maintenance, and operational costs of approach lighting systems is to design a system that uses fewer lights and/or requires less real estate. This can be most readily achieved by reducing centerline barrette light density or by reducing the overall system length or a combination of both. It is essential, however, that the basic and distinctive "cross" characteristic be retained. In this segment of the evaluation we elected to take an incremental approach to a solution by first evaluating system configurations having one or the other form of reduced lighting and then, subsequently, evaluating a configuration having the combined reduction of reduced barrette light density and overall length. Since each proposed configuration was a subset of the standard ALS, simulator programming was simplified. Modifications to the FAA standard MALSR and ALSF-2 ALS configurations that were evaluated included the following:

- A reduced-density MALSR with three lights, in lieu of 5, per centerline barrette (Configuration E—figure 3) to support Category I (200' decision height (DH)/2400' runway visual range (RVR)) landing operations.
- A medium-intensity approach lighting system with flashers (MALSF) (Configuration F—figure 4) to support Category I (200'DH/2400'RVR) landing operations.
- A reduced-density MALSF with three lights, in lieu of 5, per centerline barrette (Configuration G—figure 5) to support Category I (200'DH/2400'RVR) landing operations. This change would reduce the number of centerline barrette lights while simultaneously shortening the system length to 1400 feet. It is essentially a combination of the two changes proposed as configurations E and F (figures 3 and 4).

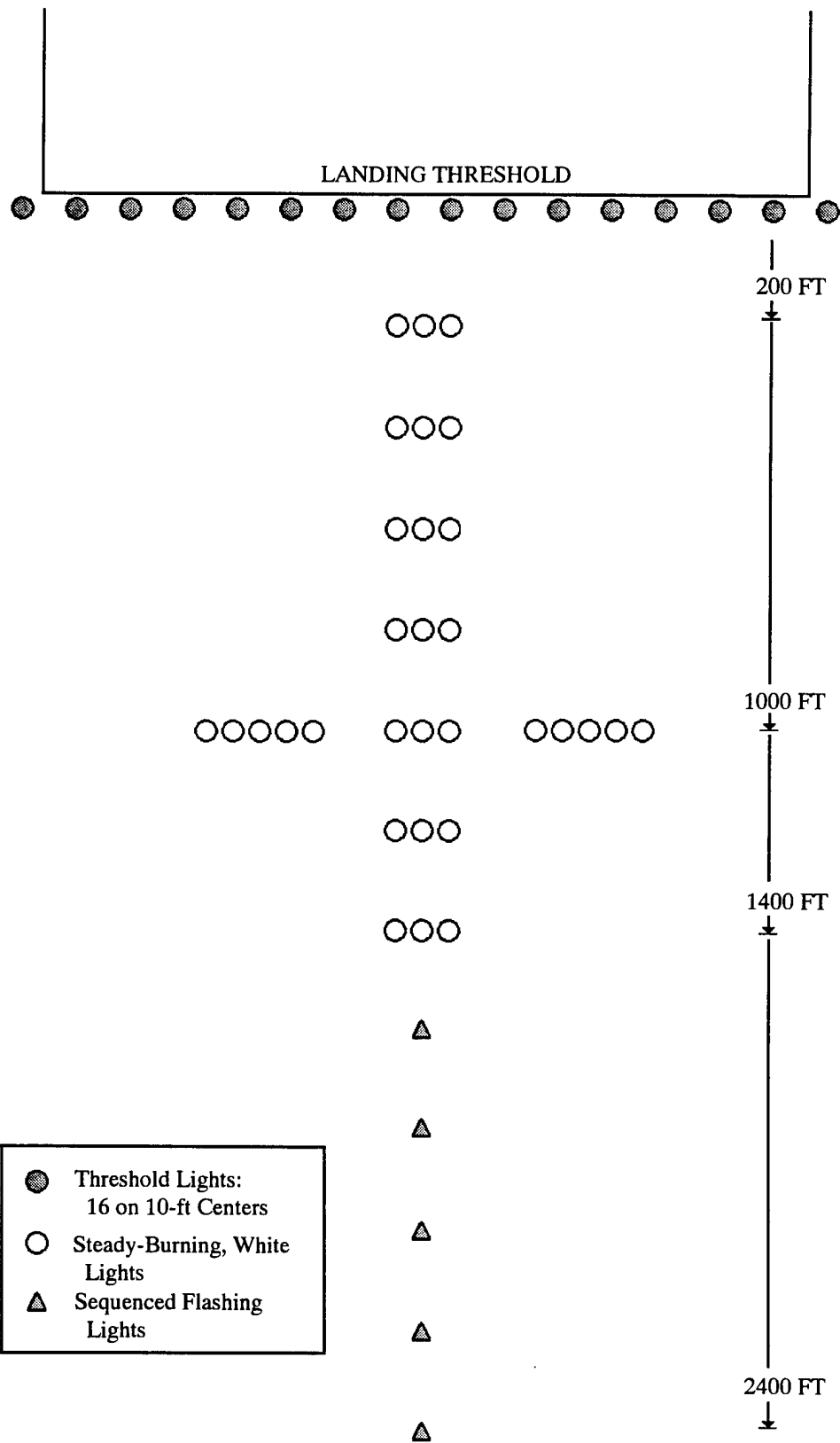
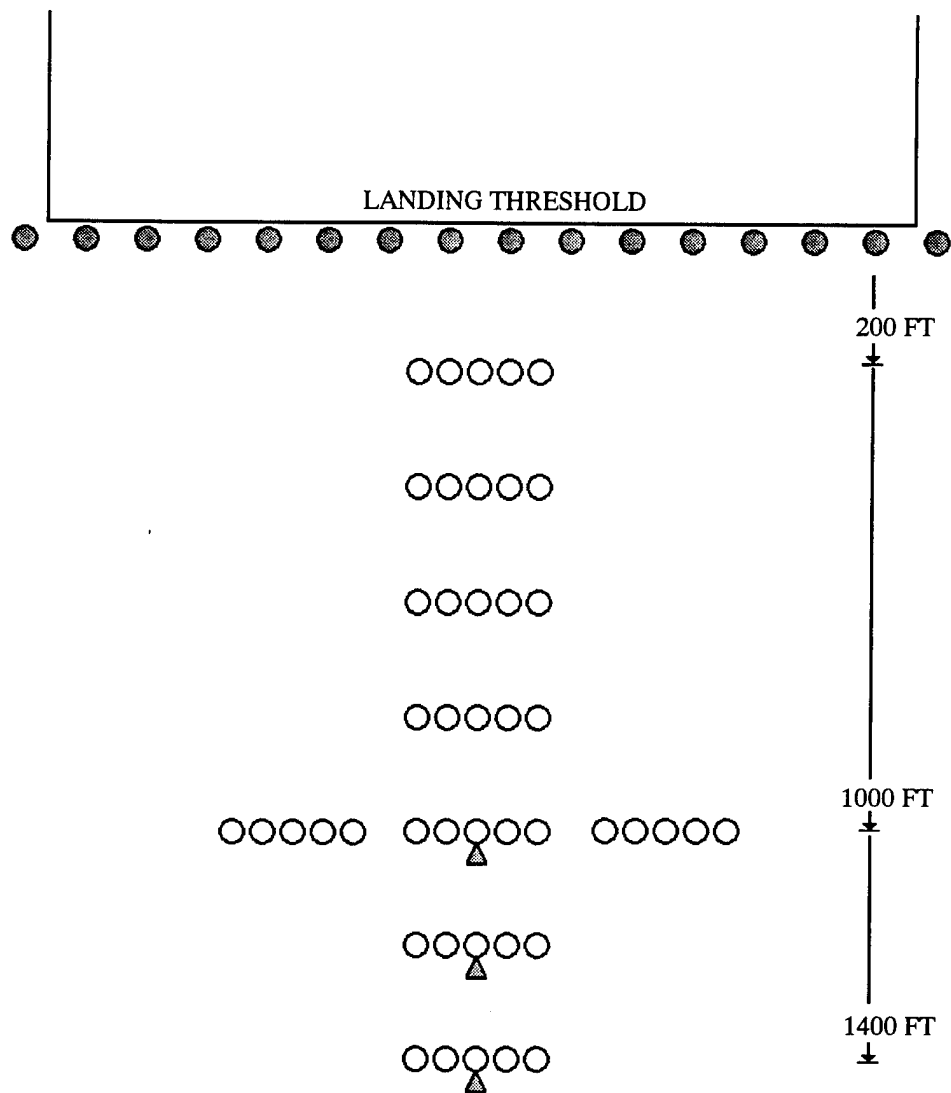
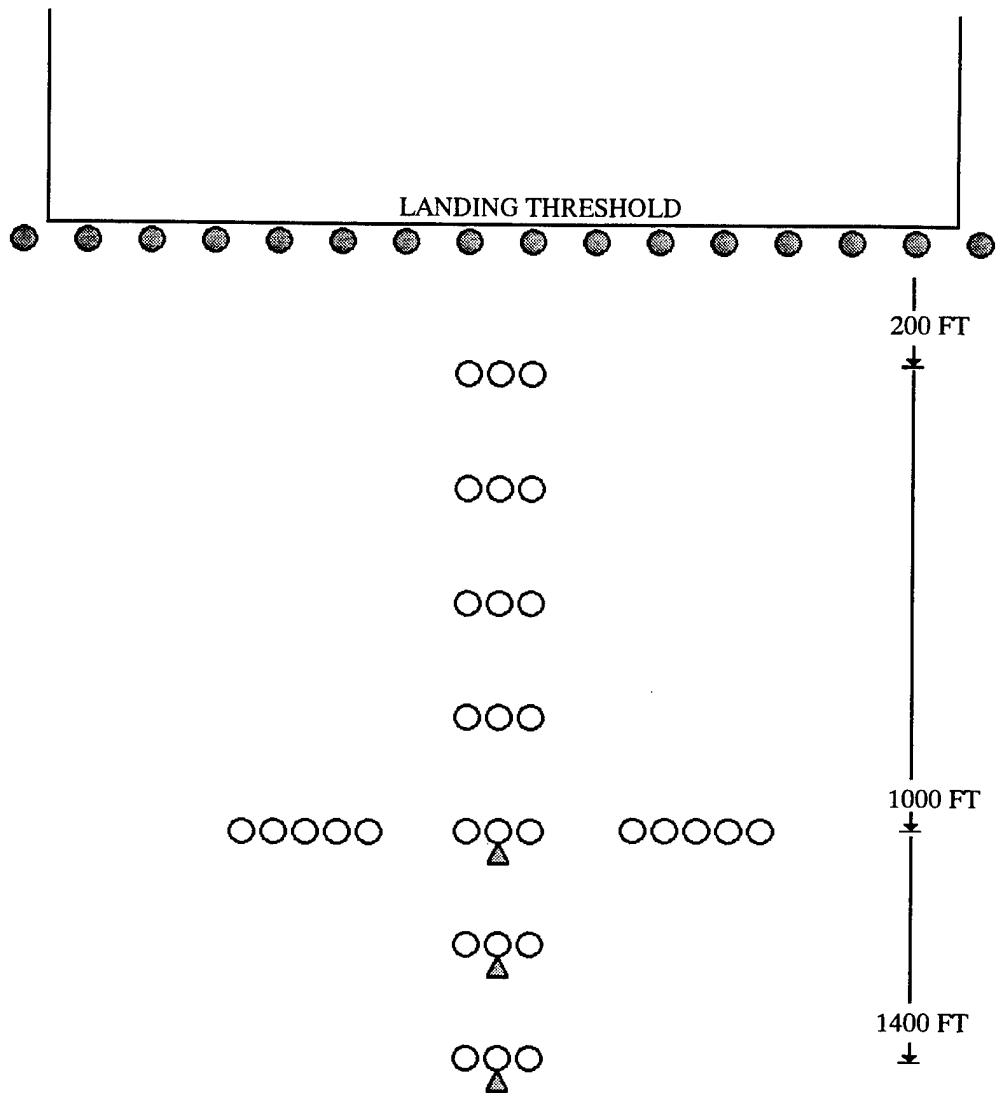

FIGURE 3. REDUCED-DENSITY MALSR SYSTEM (CONFIGURATION E)



- | | |
|---|--|
| ● | Threshold Lights: 16 on 10-ft Centers |
| ○ | Steady-Burning, White Lights |
| ▲ | Sequenced Flashing Lights |

FIGURE 4. STANDARD MALSF SYSTEM (CONFIGURATION F)



- | | |
|---|--|
| ● | Threshold Lights: 16 on 10-ft Centers |
| ○ | Steady-Burning, White Lights |
| △ | Sequenced Flashing Lights |

FIGURE 5. REDUCED-DENSITY MALSF SYSTEM (CONFIGURATION G)

- A reduced-density ALSF-2 system with three lights, in lieu of 5, per centerline barrette (Configuration H—figure 6) to support Category II (100'DH/1200'RVR) landing operations.
- A reduced-density ALSF-2 with condenser discharge lights (200-ft. spacing) in the outer 1400 ft. (Configuration I—figure 7) to support Category II (100'DH/1200'RVR) landing operations. This change would eliminate all steady-burning lights in the outer 1000 ft. of the ALSF-2 system and configure this outer segment so as to be virtually identical to the outer segment of the standard MALSR system.
- A reduced-density ALSF-2 with condenser discharge lights (200-foot spacing) in the outer 1400 ft. and three lights per centerline barrette (Configuration J—figure 8) to support Category II (100'DH/1200'RVR) landing operations. It is essentially a combination of the two changes proposed as configurations H and I (figures 6 and 7).

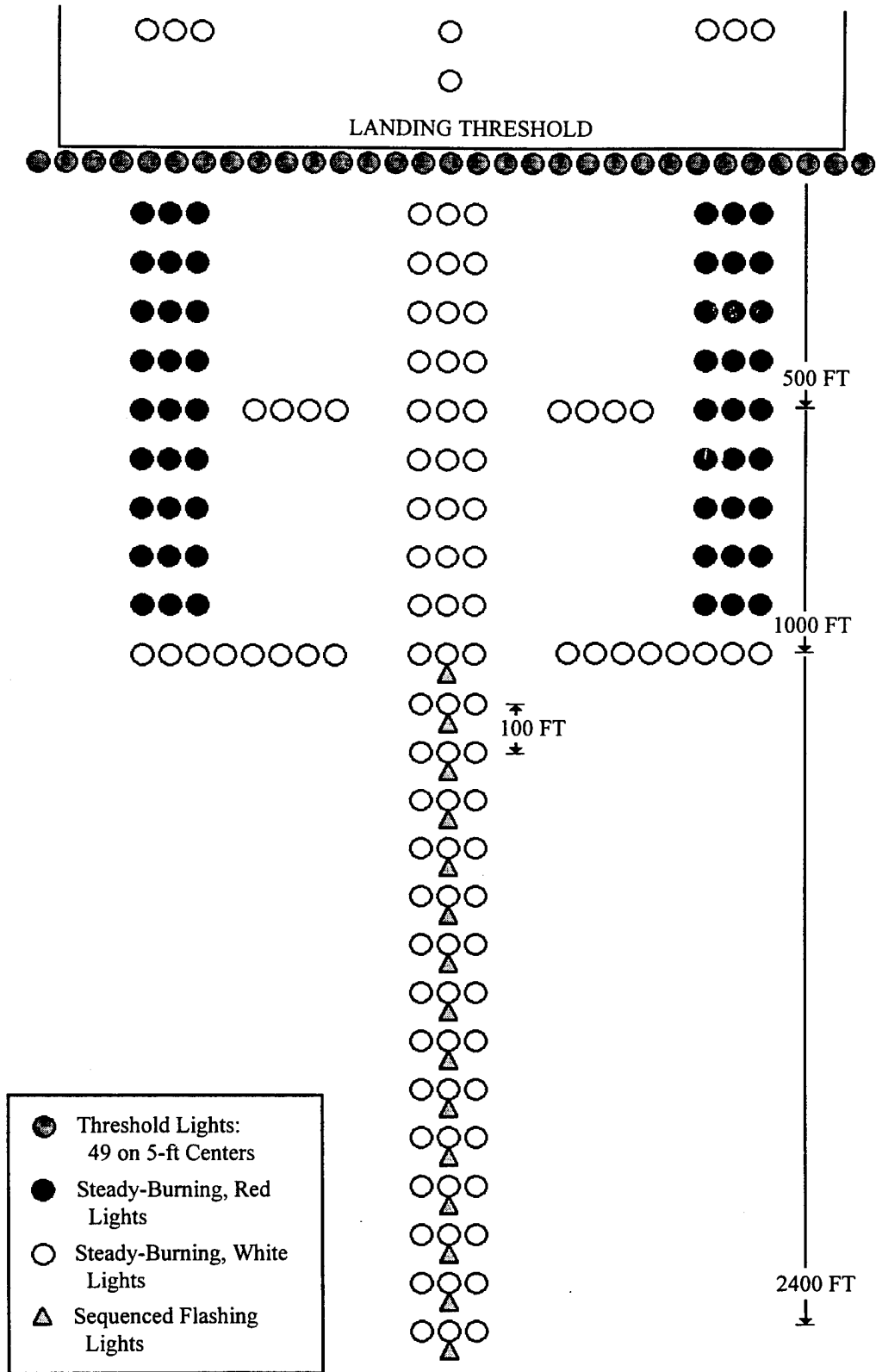

FIGURE 6. REDUCED-DENSITY ALSF-2 SYSTEM (CONFIGURATION H)

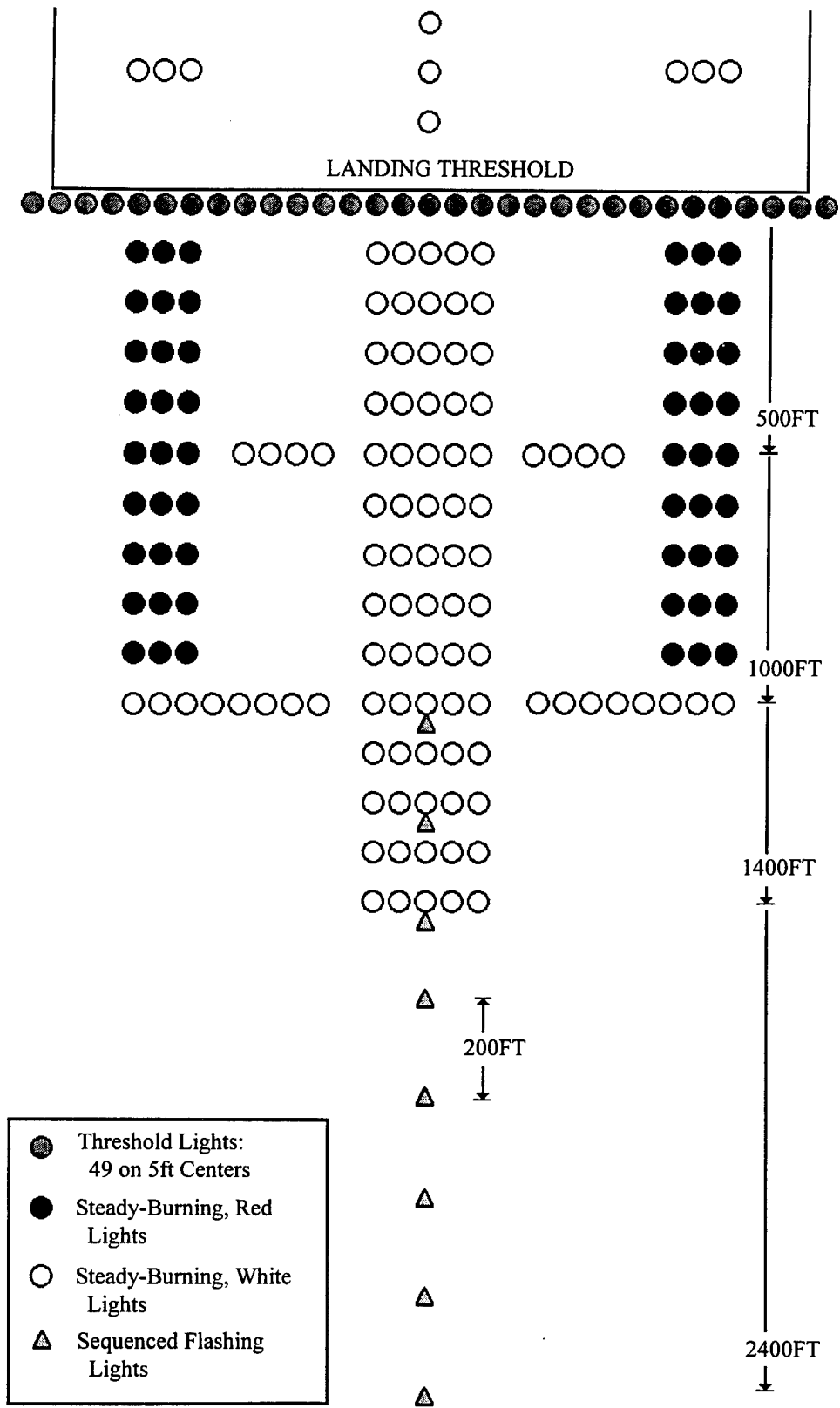

FIGURE 7. REDUCED-DENSITY ALSF-2 SYSTEM (CONFIGURATION I)

3. EVALUATION APPROACH.

3.1 EVALUATION METHOD.

In view of the fact that all of the evaluations involved testing of major lighting systems' configuration effectiveness and adequacy under reduced visibility conditions (Category I and II), it would have been very difficult to conduct actual flight tests under existing weather conditions using modified full-scale approach lighting systems. Therefore, all evaluations were accomplished using the Boeing 727 Flight Simulator located at the FAA Aeronautical Center in Oklahoma City. The visual display component of the flight simulator had recently been upgraded and calibrated in such a manner as to significantly enhance the lighting system presentation and to better suit it to visual aid evaluations.

The simulator is equipped with an SP-1T texturized dusk/night visual display with a full range of visual weather effects available. These include clouds (base and top selectable), scud, homogeneous fog, patchy fog, selectable visibility, and runway visual range (RVR). A modified RVR was also implemented for the test based on data contained in the January 1985 report by C.A. Douglas for Slant Range RVR under stable, homogeneous fog conditions.

3.2 EVALUATION PILOTS.

Twelve industry B727 type-rated pilots from various air carrier organizations (airlines, Airline Pilots Association (ALPA), and Air Transport Association (ATA)) comprised the majority of the evaluation subjects. Three rated FAA pilots also participated as evaluation subjects. The subjects' flight hours ranged from 3,750 to 20,000.

The evaluation involved 15 subject pilots executing a total of 24 approach/landing operations each. Scenario outlines, detailing weather conditions and lighting patterns tested, are provided as figures 9 and 10.

FAA RVR and meteorological conversion tables are provided as table 1 and table 2.

Simulator flight sessions lasted approximately two hours, with the subject pilot participating as Captain (Pilot-in-Command). All of the approaches were flown coupled to the automatic pilot with auto-throttle (AT) engaged to a point at or near the decision height (DH). The captain then decoupled at his discretion and, at decision height, either completed the landing visually or conducted a missed approach maneuver, depending upon the adequacy of the visual system displayed. A qualified FAA pilot occupied the right seat in the simulator and performed such duties as would normally be assigned to the first officer.

REDUCED ALS CONFIGURATIONS

1. Acceptability of standard MALSR (Configuration A) to safely support Category I landing operations to 2400-ft. runway visual range.

| <u>Scenario</u> | <u>App.Type</u> | <u>Ceiling ft.</u> | <u>RVR ft.</u> | <u>Wind kts (dir./gusts)</u> | <u>Offset ft.</u> |
|-----------------|------------------------|--------------------|----------------|----------------------------------|-------------------|
| 23 | Coupled | 250 | 2400 | R10G15 | 0 |
| 24 | with AT | 250 | 2400 | L10G15 | L@60 |
| 25 | to 100 ft. above DH | 250 | 2400 | R10G15 | R@60 |

2. Acceptability of reduced-density MALSR with three lights per centerline barrette (Configuration E) to safely support Category I landing operations to 2400-ft. runway visual range.

| <u>Scenario</u> | <u>App.Type</u> | <u>Ceiling ft.</u> | <u>RVR ft.</u> | <u>Wind kts (dir./gusts)</u> | <u>Offset ft.</u> |
|-----------------|------------------------|--------------------|----------------|----------------------------------|-------------------|
| 26 | Coupled | 250 | 2400 | L10G15 | 0 |
| 27 | with AT | 250 | 2400 | R10G15 | R@60 |
| 28 | to 100 ft. above DH | 250 | 2400 | L10G15 | L@60 |

3. Acceptability of the medium-intensity approach lighting system with sequenced flashers (MALSF) (Configuration F) to safely support Category I landing operations to 2400-ft. runway visual range.

| <u>Scenario</u> | <u>App.Type</u> | <u>Ceiling ft.</u> | <u>RVR ft.</u> | <u>Wind kts (dir./gusts)</u> | <u>Offset ft.</u> |
|-----------------|------------------------|--------------------|----------------|----------------------------------|-------------------|
| 29 | Coupled | 250 | 2400 | R10G15 | 0 |
| 30 | with AT | 250 | 2400 | L10G15 | L@60 |
| 31 | to 100 ft. above DH | 250 | 2400 | R10G15 | R@60 |

4. Acceptability of reduced-density MALSF with three lights per centerline barrette (Configuration G) to safely support Category I landing operations to 2400-ft. runway visual range.

| <u>Scenario</u> | <u>App.Type</u> | <u>Ceiling ft.</u> | <u>RVR ft.</u> | <u>Wind kts (dir./gusts)</u> | <u>Offset ft.</u> |
|-----------------|------------------------|--------------------|----------------|----------------------------------|-------------------|
| 32 | Coupled | 250 | 2400 | L10G15 | 0 |
| 33 | with AT | 250 | 2400 | R10G15 | R@60 |
| 34 | to 100 ft. above DH | 250 | 2400 | L10G15 | L@60 |

FIGURE 9. CATEGORY I SCENARIO OUTLINE

REDUCED ALS CONFIGURATIONS (CONTINUED)

5. Acceptability of standard ALSF-2 (Configuration B) to safely support Category II landing operations.

| <u>Scenario</u> | <u>App.Type</u> | <u>Ceiling ft.</u> | <u>RVR ft.</u> | <u>Wind kts (dir./gusts)</u> | <u>Offset ft.</u> |
|-----------------|------------------------|--------------------|----------------|----------------------------------|-------------------|
| 35 | Coupled | 150 | 1200 | R10 | 0 |
| 36 | with AT | 150 | 1200 | L10 | L@30 |
| 37 | to 100 ft. above DH | 150 | 1200 | R10 | R@30 |

6. Acceptability of reduced-density ALSF-2 with three lights per centerline barrette (Configuration H) to safely support Category II landing operations.

| <u>Scenario</u> | <u>App.Type</u> | <u>Ceiling ft.</u> | <u>RVR ft.</u> | <u>Wind kts (dir./gusts)</u> | <u>Offset ft.</u> |
|-----------------|------------------------|--------------------|----------------|----------------------------------|-------------------|
| 38 | Coupled | 150 | 1200 | L10 | 0 |
| 39 | with AT | 150 | 1200 | R10 | R@30 |
| 40 | to 100 ft. above DH | 150 | 1200 | L10 | L@30 |

7. Acceptability of reduced-density ALSF-2 with condenser discharge lights (200-ft. spacing) in the outer 1400 ft. (Configuration I) to safely support Category II landing operations.

| <u>Scenario</u> | <u>App.Type</u> | <u>Ceiling ft.</u> | <u>RVR ft.</u> | <u>Wind kts (dir./gusts)</u> | <u>Offset ft.</u> |
|-----------------|------------------------|--------------------|----------------|----------------------------------|-------------------|
| 41 | Coupled | 200 | 1200 | R10 | 0 |
| 42 | with AT | 200 | 1200 | L10 | L@30 |
| 43 | to 100 ft. above DH | 200 | 1200 | R10 | R@30 |

8. Acceptability of reduced-density ALSF-2 with condenser discharge lights in the outer 1400 ft. and three lights per centerline barrette (Configuration J) to safely support Category II landing operations.

| <u>Scenario</u> | <u>App.Type</u> | <u>Ceiling ft.</u> | <u>RVR ft.</u> | <u>Wind kts (dir./gusts)</u> | <u>Offset ft.</u> |
|-----------------|------------------------|--------------------|----------------|----------------------------------|-------------------|
| 44 | Coupled | 200 | 1200 | L10 | 0 |
| 45 | with AT | 200 | 1200 | R10 | R@30 |
| 46 | to 100 ft. above DH | 200 | 1200 | L10 | L@30 |

FIGURE 10. CATEGORY II SCENARIO OUTLINE

TABLE 1. METRIC OPERATIONAL EQUIVALENT VALUES

| RUNWAY VISUAL RANGE | |
|---------------------|--------|
| FEET | METERS |
| 300 | 90 |
| 400 | 120 |
| 500 | 150 |
| 600 | 175 |
| 700 | 200 |
| 1000 | 300 |
| 1200 | 350 |
| 1600 | 500 |
| 1800 | 550 |
| 2000 | 600 |
| 2100 | 630 |
| 2400 | 720 |
| 4000 | 1200 |
| 4500 | 1400 |
| 5000 | 1500 |
| 6000 | 1800 |

TABLE 2. METEOROLOGICAL VISIBILITY VERSUS RVR

| METEOROLOGICAL VISIBILITY WHEN RVR IS NOT AVAILABLE | | |
|--|--------|----------------|
| STATUTE MILES | METERS | NAUTICAL MILES |
| 1/4 | 400 | 1/4 |
| 1/2 | 800 | 1/2 |
| 3/4 | 1200 | 7/10 |
| 1 | 1600 | 9/10 |
| 1 1/4 | 2000 | 1 1/10 |
| 1 1/2 | 2400 | 1 3/10 |
| 1 3/4 | 2800 | 1 1/2 |
| 2 | 3200 | 1 3/4 |
| 2 1/4 | 3600 | 2 |
| 2 1/2 | 4000 | 2 2/10 |
| 2 3/4 | 4400 | 2 4/10 |
| 3 | 4800 | 2 6/10 |

4. EVALUATION IMPLEMENTATION.

4.1 GENERAL PROCEDURES.

Subject pilots were briefed prior to each simulated flight session and given an opportunity to familiarize themselves with the nature of the postflight questionnaire that they would be required to complete. During the subject pilot briefing, project personnel detailed such items as first-officer call outs, simulator setup, and the lighting configurations to be evaluated. In addition, the subjects were informed that the project personnel were in no way judging pilot ability. Before a set of approaches was flown to each specific approach lighting configuration, the subject was shown a drawing of that system and an explanation was given that pointed out how that system differed from the standard approach lighting system. Postflight questionnaires were completed in the cockpit immediately after each lighting configuration was evaluated.

Questionnaires used for the evaluation of different systems or system variations were similar but not identical since lighting system components are intended to provide complimentary though unique guidance information. A typical questionnaire form is shown as figure 11.

Qualified observers were present in the simulator cockpit during each evaluation session to record pertinent subject pilot comments. They also noted any unique cockpit occurrences, such as abrupt maneuvering that appeared to be a result of insufficient or inadequate visual guidance provided by the system under evaluation.

No aircraft equipment failures had been incorporated into this evaluation effort, since the intent was to evaluate approach lighting configurations and not the subject pilots' ability to handle emergency situations. In some cases, however, aircraft location at decision height was adjusted (laterally offset) so as to present the lighting system in a slightly different orientation than would occur if the aircraft were perfectly aligned with the runway extended centerline. Any offsets introduced were restricted to values within the limits of a normal approach.

Every effort was made to automate the testing procedure and simulator setup as much as possible to ensure repeatability and high-quality data collection for future analysis and evaluation.

All tests were flown using the Oklahoma City (OKC) runway 35R visual model. The necessary Category I and II features are available on this runway presentation, and the high quality of this particular visual model enhanced test validity.

SAMPLE

SIMULATED FLIGHT SESSION QUESTIONNAIRE

REDUCED LIGHTING DENSITY CONFIGURATIONS

CONFIGURATION PRESENTED: ALSF-2 with no steady-burning lights beyond 1400- and 200-ft. strobe spacing.

REDUCED VISIBILITY COND: 1200-ft. runway visual range

SUBJECT PILOT: _____ DATE: _____

Please place a check in the appropriate square to indicate the relative usefulness of this lighting configuration in providing the following forms of guidance.

1. FINDING THE RUNWAY:

| Excellent | Good | Acceptable | Almost Acceptable | Absolutely Unacceptable |
|--------------------------|--------------------------|--------------------------|--------------------------|--------------------------|
| <input type="checkbox"/> | <input type="checkbox"/> | <input type="checkbox"/> | <input type="checkbox"/> | <input type="checkbox"/> |

2. AWARENESS OF ALTITUDE ABOVE THE GROUND:

| Excellent | Good | Acceptable | Almost Acceptable | Absolutely Unacceptable |
|--------------------------|--------------------------|--------------------------|--------------------------|--------------------------|
| <input type="checkbox"/> | <input type="checkbox"/> | <input type="checkbox"/> | <input type="checkbox"/> | <input type="checkbox"/> |

3. LATERAL ALIGNMENT WITH THE RUNWAY

| Excellent | Good | Acceptable | Almost Acceptable | Absolutely Unacceptable |
|--------------------------|--------------------------|--------------------------|--------------------------|--------------------------|
| <input type="checkbox"/> | <input type="checkbox"/> | <input type="checkbox"/> | <input type="checkbox"/> | <input type="checkbox"/> |

4. ROLL GUIDANCE:

| Excellent | Good | Acceptable | Almost Acceptable | Absolutely Unacceptable |
|--------------------------|--------------------------|--------------------------|--------------------------|--------------------------|
| <input type="checkbox"/> | <input type="checkbox"/> | <input type="checkbox"/> | <input type="checkbox"/> | <input type="checkbox"/> |

FIGURE 11. SAMPLE POSTFLIGHT SESSION QUESTIONNAIRE

SAMPLE

SIMULATED FLIGHT SESSION QUESTIONNAIRE—Page 2

5. Did the guidance that was provided by the displayed Approach Lighting System (ALS) configuration allow you to complete the approach and landing safely?

Yes: _____ No: _____ Could Not Judge: _____

Comments: _____

6. What guidance information (roll, height, direction, etc.), if any, did you feel was lacking or deficient?

None: _____ or See Comments Below: _____

Comments: _____

7. Do you feel that this ALS configuration merits further consideration as a replacement for the standard ALSF-2 (i.e., actual weather flight testing)?

Yes: _____ No: _____

Comments: _____

COCKPIT OBSERVER: _____

Comments: _____

FIGURE 11. SAMPLE POSTFLIGHT SESSION QUESTIONNAIRE (CONTINUED)

4.2 EVALUATION CONDITIONS.

4.2.1 Initial Conditions.

Set initial conditions were as follows:

| | |
|----------------|-------------|
| Gross Weight | 154,000 lb. |
| Fuel Freeze | Set |
| Visual Control | CRT |
| Visibility | As required |
| Ceiling | As required |
| Turbulence | 8% |

4.2.2 Weather Conditions.

Based on the proposed test criteria, there were six different sets of weather conditions required. The correct set of weather conditions, with correlated visual effects, was automatically activated when a test scenario was selected.

4.2.3 Pilot Operating Procedures.

The cockpit operator initiated each test from the pilot instructor's station. When the scenario number was entered and activated, the aircraft was repositioned to a point approximately 5 nm from touchdown. After the simulator was stabilized and "frozen" at the approach position, the pilot was advised of the simulated weather conditions. When the subject indicated that he was ready to begin the scenario, the simulator was then "unfrozen" allowing the approach to commence. All approaches were flown at RVR's between 1200 and 2400 feet.

If the pilot initiated a "go-around" in reaction to what he considered to be unsafe or inadequate visual conditions, he continued his climb-out on the runway heading and the simulator operator ended the scenario. The test runs, from operator initialization to run termination, averaged approximately 4 minutes.

5. TEST RESULTS.

5.1 ORGANIZATION OF RESULTS.

Significant results of this evaluation effort are comprised of the responses to the subject pilot questionnaires, notes and comments recorded by the simulator cockpit observer, and occurrences of incidents (missed approaches, hard landings, crashes, etc.) as recorded by the panel operator.

All subject pilot questionnaire responses have been carefully extracted from the original hand written questionnaires and summarized by "scenario set" in the following section of this report. The term scenario set means the series of three approach/landing operations that each subject was required to accomplish for each specific lighting configuration. The format of these summary sheets follows exactly that of the questionnaire itself. All comments received have been included under the appropriate question heading, making it unnecessary to include copies of the original questionnaire forms with this report.

Following each questionnaire summary, within the scenario set grouping, is an additional section tabulating the "incidents" (missed approaches, hard landings, etc.) that occurred during simulated flight to each lighting configuration.

A compilation of all results data, by scenario sets, is included in table 3 on page 63. Columns 3 through 9 contain the percentage of "acceptable or above" or "positive" responses to questions 1-7, respectively, as expressed by the subject pilots. Column 10 contains the average percentage of the responses to all of the questions except for question 6. This sixth question asked for a response of "None" for no guidance lacking or for a written comment. Since some of the comments received were positive along with some negative, no significance can be attached to the percentage of either answer.

An analysis of the results follows immediately after the summary presentation.

5.2 NOTES ON THE RESULTS.

The following observations were made by evaluation team members (cockpit observer/first officer and panel operator) during the course of the effort:

- Cockpit observers questioned subjects about realism of the offsets and received generally positive responses.
- Some subjects commented on the question of the adequacy of 3-light versus 5-light barrettes while flying 5-light barrette systems. In most cases they had just completed a sequence using a 3-light barrette ALS and compared them in retrospect.
- One subject questioned ALS adequacy for use in RVR conditions lower than that simulated (i.e., flew in 2400-ft. RVR, commented on possible problems in 1800-ft. RVR). These comments should be examined as part of another simulation study.

- One subject persisted in mentioning unrealistic roll guidance in the simulator presentation throughout the session. This resulted in many comments that could be, but should not be, interpreted as a lack of roll guidance in a system or configuration.
- One subject made a general comment that a yes answer to question 7 on any of the questionnaires meant that the subject did not feel actual weather testing would be needed. Category II/III training in the simulator should be sufficient.
- One pilot (out of 15) made numerous comment references to configurations presenting a height (altitude) illusion. No other subject mentioned such an effect.

LANDING SCENARIO 23 - 25 SUMMARY

SIMULATOR POSTFLIGHT SESSION QUESTIONNAIRE

STUDY 2-REDUCED LIGHTING DENSITY CONFIGURATIONS

SCENARIO NOS. 23 TO 25-CONFIGURATION "A"

CONFIGURATION PRESENTED: Standard MALS system

REDUCED VISIBILITY COND: 2400-ft. runway visual range

SUBJECT PILOT NUMBER: _____ DATE: _____

Please place a check in the appropriate square to indicate the relative usefulness of this lighting configuration in providing the following forms of guidance.

1. FINDING THE RUNWAY:

| Excellent | Good | Acceptable | Almost Acceptable | Absolutely Unacceptable |
|-------------------------------------|-------|------------|------------------------------|-------------------------|
| 4 27% | 8 53% | 3 20% | 0 0% | 0 0% |
| Acceptable or Above - 100% | | | Below Acceptable - 0% | |
| (Total of 15 Subject Pilots) | | | | |

2. AWARENESS OF ALTITUDE ABOVE THE GROUND:

| Excellent | Good | Acceptable | Almost Acceptable | Absolutely Unacceptable |
|-----------------------------------|-------|------------|------------------------------|-------------------------|
| 2 13% | 7 47% | 6 40% | 0 0% | 0 0% |
| Acceptable or Above - 100% | | | Below Acceptable - 0% | |

3. LATERAL ALIGNMENT WITH THE RUNWAY:

| Excellent | Good | Acceptable | Almost Acceptable | Absolutely Unacceptable |
|-----------------------------------|--------|------------|------------------------------|-------------------------|
| 2 13% | 10 67% | 3 20% | 0 | 0 |
| Acceptable or Above - 100% | | | Below Acceptable - 0% | |

4. ROLL GUIDANCE:

| Excellent | Good | Acceptable | Almost Acceptable | Absolutely Unacceptable |
|----------------------------------|--------|------------|------------------------------|-------------------------|
| 2 13% | 10 67% | 2 13% | 1 7% | 0 0% |
| Acceptable or Above - 93% | | | Below Acceptable - 7% | |

LANDING SCENARIO 23 - 25 COMMENT SUMMARY

5. Did the guidance that was provided by the displayed Approach Lighting System (ALS) configuration allow you to complete the approach and landing safely?

Yes: $\frac{15}{(100\%)}$ No: $\frac{0}{(0\%)}$ Could Not Judge: $\frac{0}{(0\%)}$

Comments:

- Would like TDZ lights.
- Very comfortable with MALSR.
- More comfort and confidence, partially because of familiarity.
- Would like to see [have] centerline lights.
- Miss R/W centerline lights.
- Strobes to 2400 ft. very helpful.
- ALS adequate. Strobes give first indication of guidance before steady-burning lights become visible.

LANDING SCENARIO 23 - 25 COMMENT SUMMARY (CONTINUED)

6. What guidance information (roll, height, direction, etc.), if any, did you feel was lacking or deficient?

None: 9 or See Comments Below: 6
(60%) (40%)

Comments:

- All OK.
- Threshold too dim.
- Roll guidance [lacking], especially in touchdown area.
- Height [guidance lacking] leading up to and during flare.
- R/W centerline lights [lacking].
- R/W centerline lights and TDZ lights drift, height [guidance lacking]. Red side row bars roll, alignment [guidance lacking].
- Height above ground, depth perception, [lacking] due to ALS (fewer lights than ALSF-2).
- Roll [guidance lacking]- lack of TDZ lights.
- Height after D/H [lacking] due to lack of VASI and audible AGL callouts.

LANDING SCENARIO 23 - 25 COMMENT SUMMARY (CONTINUED)

7. Have you been satisfied with the Category I approach guidance provided by this standard system in the past?

Yes: 15 No: 0
 (100%) (0%)

Comments:

- Subject does not want to disconnect autopilot with only strobes visible (Cockpit observer comment).
- Roll in simulator visual systems is lacking.
- Strobes really help with centerline alignment (early in approach).
- Good ALS.

LANDING SCENARIO 23 - 25 INCIDENT SUMMARY

| SCENARIO | MISSED APPROACH | HARD LANDING | CRASH |
|----------|-----------------|--------------|-------|
| 23 | 2 | 1 | 1* |
| 24 | None | 1 | None |
| 25 | 1 | 1 | None |

*Subject pilot commented that the crash had nothing to do with the visual guidance provided by the ALS.

Definitions:

Missed Approach: Pilot abandoned the approach at Decision Height or later due to lack of visual guidance and/or crosswind.

Hard Landing: The aircraft rate of descent is greater than 500 feet/minute at touchdown.

Crash: At touchdown, if any of the following are exceeded:

1. Bank angle greater than $\pm 6^\circ$
2. Pitch angle greater than 8°
3. Nose gear touches first
4. Rate of descent greater than 13.38 feet/second

LANDING SCENARIO 26 - 28 SUMMARY

SIMULATOR POSTFLIGHT SESSION QUESTIONNAIRE

STUDY 2-REDUCED LIGHTING DENSITY CONFIGURATIONS

SCENARIO NOS. 26 TO 28-CONFIGURATION "E"

CONFIGURATION PRESENTED: Standard MALS System with reduced-density
(three light) centerline barrettes.

REDUCED VISIBILITY COND: 2400-ft. runway visual range

SUBJECT PILOT NUMBER: _____ DATE: _____

Please place a check in the appropriate square to indicate the relative usefulness of this lighting configuration in providing the following forms of guidance.

1. FINDING THE RUNWAY:

| Excellent | Good | Acceptable | Almost Acceptable | Absolutely Unacceptable |
|------------------------------|----------|------------|-----------------------|-------------------------|
| 6 40% | 7 47% | 2 13% | 0 0% | 0 0% |
| Acceptable or Above - 100% | | | Below Acceptable - 0% | |
| (Total of 15 Subject Pilots) | | | | |

2. AWARENESS OF ALTITUDE ABOVE THE GROUND:

| Excellent | Good | Acceptable | Almost Acceptable | Absolutely Unacceptable |
|---------------------------|----------|------------|-----------------------|-------------------------|
| 2 13% | 8 53% | 4 27% | 1 7% | 0 0% |
| Acceptable or Above - 93% | | | Below Acceptable - 7% | |

3. LATERAL ALIGNMENT WITH THE RUNWAY:

| Excellent | Good | Acceptable | Almost Acceptable | Absolutely Unacceptable |
|----------------------------|----------|------------|-----------------------|-------------------------|
| 1 7% | 11 73% | 3 20% | 0 0% | 0 0% |
| Acceptable or Above - 100% | | | Below Acceptable - 0% | |

4. ROLL GUIDANCE:

| Excellent | Good | Acceptable | Almost Acceptable | Absolutely Unacceptable |
|---------------------------|----------|------------|------------------------|-------------------------|
| 1 7% | 10 67% | 2 13% | 2 13% | 0 0% |
| Acceptable or Above - 87% | | | Below Acceptable - 13% | |

LANDING SCENARIO 26 - 28 COMMENT SUMMARY

5. Did the guidance that was provided by the displayed Approach Lighting System (ALS) configuration allow you to complete the approach and landing safely?

Yes: $\frac{15}{(100\%)}$ No: $\frac{0}{(0\%)}$ Could Not Judge: $\frac{0}{(0\%)}$

Comments:

- Want TDZ lights.
- Don't notice 3 [instead of 5] in middle. Would not have known 3 in middle if not told ahead of time.
- Uncomfortable with this system. [checked "yes"]
- As good as MALSR. Three versus 5 not noticeable.
- Want R/W centerline lights.
- Three versus 5 not a problem.
- Much better than 1400-ft. system because of strobes.

LANDING SCENARIO 26 - 28 COMMENT SUMMARY (CONTINUED)

6. What guidance information (roll, height, direction, etc.), if any, did you feel was lacking or deficient?

None: 10 or See Comments Below: 5
(67%) (33%)

Comments:

- All OK—same as standard MALSR.
- Same as standard MALSR. Three versus 5 lights does not matter.
- Simulator roll guidance [lacking].
- Height [guidance lacking].
- With crosswind of 10 gusting 15—centerline runway lights necessary—at night. The R/W centerline stripes do not provide enough guidance.
- More definition of last 1000 ft. Prefer 5 versus 3.
- Runway centerline and TDZ lights [lacking].
- Stobes helpful in early lineup.
- TDZ lights [guidance lacking] for roll.

LANDING SCENARIO 26 - 28 COMMENT SUMMARY (CONTINUED)

7. Do you feel that this ALS configuration merits further consideration as a replacement for the standard MALSR (i.e., actual weather flight testing)?

Yes: $\frac{15}{(100\%)}$ No: $\frac{0}{(0\%)}$

Comments:

- Three versus 5 OK.
- Subject felt that aircraft is too high or fog is too thick for Category I [cockpit observer comment].
- Extension of strobes a real comfort, helped in picking up steady-burning approach lights. Three versus 5—very little difference.
- Length (2400 ft.) makes a big difference in roll and lateral guidance.
- Three versus 5 w/2400-ft. RVR made little difference in roll guidance.
- Fog dissipation should be tested with 3 versus 5. Three versus 5 not a noticeable difference.
- Three is as adequate as 5—no loss in visual cues.
- Three versus 5 OK.

LANDING SCENARIO 26 - 28 INCIDENT SUMMARY

| SCENARIO | MISSED APPROACH | HARD LANDING | CRASH |
|----------|-----------------|--------------|-------|
| 26 | 0 | 2 | None |
| 27 | 2 | 2 | 2* |
| 28 | 1 | 2 | None |

*Subject pilots commented that the crash had nothing to do with the visual guidance provided by the ALS.

Definitions:

Missed Approach: Pilot abandoned the approach at Decision Height or later due to lack of visual guidance or crosswinds and offset.

Hard Landing: The aircraft rate of descent is greater than 500 feet/minute at touchdown.

Crash: At touchdown, if any of the following are exceeded:

1. Bank angle greater than $\pm 6^\circ$
2. Pitch angle greater than 8°
3. Nose gear touches first
4. Rate of descent greater than 13.38 feet/second

LANDING SCENARIO 29 - 31 SUMMARY

SIMULATOR POSTFLIGHT SESSION QUESTIONNAIRE

STUDY 2-REDUCED LIGHTING DENSITY CONFIGURATIONS

SCENARIO NOS. 29 TO 31-CONFIGURATION "F"

CONFIGURATION PRESENTED: Standard MALSF System.

REDUCED VISIBILITY COND: 2400-ft. runway visual range

SUBJECT PILOT NUMBER: _____ DATE: _____

Please place a check in the appropriate square to indicate the relative usefulness of this lighting configuration in providing the following forms of guidance.

1. FINDING THE RUNWAY:

| Excellent | | Good | | Acceptable | | Almost Acceptable | | Absolutely Unacceptable | |
|-------------------------------------|------------|----------|------------|------------|------------|-------------------------------|------------|-------------------------|-----------|
| 2 | 14% | 7 | 46% | 2 | 14% | 4 | 26% | 0 | 0% |
| Acceptable or Above - 74% | | | | | | Below Acceptable - 26% | | | |
| (Total of 15 Subject Pilots) | | | | | | | | | |

2. AWARENESS OF ALTITUDE ABOVE THE GROUND:

| Excellent | | Good | | Acceptable | | Almost Acceptable | | Absolutely Unacceptable | |
|-----------------------------------|-----------|----------|------------|------------|------------|------------------------------|-----------|-------------------------|-----------|
| 1 | 6% | 7 | 47% | 7 | 47% | 0 | 0% | 0 | 0% |
| Acceptable or Above - 100% | | | | | | Below Acceptable - 0% | | | |

3. LATERAL ALIGNMENT WITH THE RUNWAY:

| Excellent | | Good | | Acceptable | | Almost Acceptable | | Absolutely Unacceptable | |
|----------------------------------|-----------|----------|------------|------------|------------|-------------------------------|------------|-------------------------|-----------|
| 1 | 6% | 6 | 40% | 4 | 27% | 4 | 27% | 0 | 0% |
| Acceptable or Above - 73% | | | | | | Below Acceptable - 27% | | | |

4. ROLL GUIDANCE:

| Excellent | | Good | | Acceptable | | Almost Acceptable | | Absolutely Unacceptable | |
|----------------------------------|-----------|----------|------------|------------|------------|-------------------------------|------------|-------------------------|-----------|
| 1 | 6% | 4 | 27% | 7 | 47% | 3 | 20% | 0 | 0% |
| Acceptable or Above - 80% | | | | | | Below Acceptable - 20% | | | |

LANDING SCENARIO 29 - 31 COMMENT SUMMARY

5. Did the guidance that was provided by the displayed Approach Lighting System (ALS) configuration allow you to complete the approach and landing safely?

Yes: 14
(93%)

No: 1
(7%)

Could Not Judge: 0
(0%)

Comments:

- I like seeing rollbar first, better than seeing strobes (only) first.
- Subject does not want to disengage autopilot w/strobes only visible [cockpit observer comment].
- Would prefer a longer system, but acceptable. Shorter system delays decision to land or go missed.
- A lot of light initially-false sense of security. Five lights no better than 3.
- Shorter system delays judgment of alignment and is less safe than a 2400-ft. system.
- ALS is adequate in runway alignment.
- Want R/W centerline lights.
- Strobes were picked up first and are a plus compared to an ALS with no strobes.
- Missed guidance of strobes extended to 2400 ft.

LANDING SCENARIO 29 - 31 COMMENT SUMMARY (CONTINUED)

6. What guidance information (roll, height, direction, etc.), if any, did you feel was lacking or deficient?

None: $\frac{5}{(33\%)}$ or See Comments Below: $\frac{10}{(67\%)}$

Comments:

- Lateral guidance was very deficient (don't take away any strobes from 1600-2400 ft.). MALSF strobes don't help.
- Roll and lateral [guidance lacking] because of approach lights-system is too short.
- Too short.
- Roll guidance [lacking]. Because of absence of TDZ lights.
- Alignment delayed.
- Height-depth perception [lacking].
- Runway centerline lights [guidance lacking].
- Lack of runway centerline and TDZ lights.
- Roll and lateral [guidance lacking] due to lack of strobe extension [to 2400 ft.].
- Lack of strobes to 2400 ft. requires more outside "seeking" and lessens time on instrument scan.
- Missed guidance [from] strobe extension to 2400 ft.

LANDING SCENARIO 29 - 31 COMMENT SUMMARY (CONTINUED)

7. Do you feel that this ALS configuration merits further consideration as a replacement for the standard MALSR (i.e., actual weather flight testing)?

Yes: $\frac{10}{(67\%)}$ No: $\frac{5}{(33\%)}$

Comments:

- Do not like [this] system.
- Yes, with training, experience.
- Five lights versus 3 was heavily depended upon for centerline guidance. ALS OK.
- Three versus 5 not significant—strokes to 2400 ft. is a necessity.
- Three versus 5 no difference.
- Roll possibly better w/5 lights, therefore aircraft in better position when crossing threshold. Little difference in 3 versus 5.
- Strobes easier to pick up than steady-burning lights.
- May not see lights at 1800-ft. RVR.

LANDING SCENARIO 29 - 31 INCIDENT SUMMARY

| SCENARIO | MISSED APPROACH | HARD LANDING | CRASH |
|----------|-----------------|--------------|-------|
| 29 | 1 | 1 | None |
| 30 | 2 | 2 | None |
| 31 | None | 2 | 1* |

*Subject pilot commented that the crash was due to the fact that this shortened ALS did not give him enough time to assimilate the visual cues.

Definitions:

Missed Approach: Pilot abandoned the approach at Decision Height or later due to lack of visual guidance or crosswinds.

Hard Landing: The aircraft rate of descent is greater than 500 feet/minute at touchdown.

Crash: At touchdown, if any of the following exceeded:

1. Bank angle greater than $\pm 6^\circ$
2. Pitch angle greater than 8°
3. Nose gear touches first
4. Rate of descent greater than 13.38 feet/second

LANDING SCENARIO 32 - 34 SUMMARY

SIMULATOR POSTFLIGHT SESSION QUESTIONNAIRE

STUDY 2-REDUCED LIGHTING DENSITY CONFIGURATIONS

SCENARIO NOS. 32 TO 34-CONFIGURATION "G"

CONFIGURATION PRESENTED: MALSF with reduced-density (three light) centerline barrettes.

REDUCED VISIBILITY COND: 2400-ft. runway visual range

SUBJECT PILOT NUMBER: _____ DATE: _____

Please place a check in the appropriate square to indicate the relative usefulness of this lighting configuration in providing the following forms of guidance.

1. FINDING THE RUNWAY:

| Excellent | Good | Acceptable | Almost Acceptable | Absolutely Unacceptable |
|-------------------------------------|----------|------------|-------------------------------|-------------------------|
| 1 6% | 8 53% | 2 14% | 4 27% | 0 0% |
| Acceptable or Above - 73% | | | Below Acceptable - 27% | |
| (Total of 15 Subject Pilots) | | | | |

2. AWARENESS OF ALTITUDE ABOVE THE GROUND:

| Excellent | Good | Acceptable | Almost Acceptable | Absolutely Unacceptable |
|----------------------------------|----------|------------|-------------------------------|-------------------------|
| 1 6% | 3 20% | 9 60% | 2 14% | 0 0% |
| Acceptable or Above - 86% | | | Below Acceptable - 14% | |

3. LATERAL ALIGNMENT WITH THE RUNWAY:

| Excellent | Good | Acceptable | Almost Acceptable | Absolutely Unacceptable |
|----------------------------------|----------|------------|-------------------------------|-------------------------|
| 1 6% | 6 40% | 5 34% | 3 20% | 0 0% |
| Acceptable or Above - 80% | | | Below Acceptable - 20% | |

4. ROLL GUIDANCE:

| Excellent | Good | Acceptable | Almost Acceptable | Absolutely Unacceptable |
|----------------------------------|----------|------------|-------------------------------|-------------------------|
| 1 6% | 4 27% | 6 40% | 4 27% | 0 0% |
| Acceptable or Above - 73% | | | Below Acceptable - 27% | |

LANDING SCENARIO 32 - 34 COMMENT SUMMARY

5. Did the guidance that was provided by the displayed Approach Lighting System (ALS) configuration allow you to complete the approach and landing safely?

Yes: 12
(80%)

No: 3
(20%)

Could Not Judge: 0
(0%)

Comments:

- Seems same as standard MALSF. Like having strobe at 1000-ft. bar and seeing rollbar first. Three versus 5 lights no difference.
- Not as safe as standard MALSF.
- Approach lights insufficient.
- Strobes help, versus ICAO systems [no strobes].
- Three versus 5 [lights] no perceivable difference.
- ALS provided adequate alignment to runway.
- Need 5 lights or runway centerline lights for alignment. From 200 ft., 3 lights did not give enough centerline alignment guidance. Runway edge lights don't adequately help with drift guidance.
- Adequate ALS.
- Strobes were picked up first and are a plus compared to ALS with no strobes. Five versus 3 [difference] negligible.
- Three lights as good as 5 lights.

LANDING SCENARIO 32 - 34 COMMENT SUMMARY (CONTINUED)

6. What guidance information (roll, height, direction, etc.), if any, did you feel was lacking or deficient?

None: 5 or See Comments Below: 10
(33%) (67%)

Comments:

- Lateral guidance appeared too late to see drift across extended runway centerline.
- Roll [and] lateral [guidance lacking]-lights too short.
- Height and roll [guidance lacking].
- Alignment delay.
- Runway edge lights are not adequate for height and roll guidance.
- Alignment [guidance lacking].
- Lack of strobes to 2400 ft. for alignment and early detection.
- Roll guidance [lacking]-due to shorter length.
- Depth [guidance lacking] from lack of runway lights (no centerline and TDZ).
- Roll [guidance lacking] in TDZ.
- Direction-early approach light recognition [lacking] due to lack of strobe extension. Can get used to this system.

LANDING SCENARIO 32 - 34 COMMENT SUMMARY (CONTINUED)

7. Do you feel that this ALS configuration merits further consideration as a replacement for the standard MALSR (i.e., actual weather flight testing)?

Yes: $\frac{9}{(60\%)}$

No: $\frac{6}{(40\%)}$

Comments:

- One versus 3 versus 5 in middle OK. Would prefer longer system.
- OK but prefer MALSR. Shorter system delays decision to land or go missed.
- False sense of security—looks good at first, then later in approach not as good.
- Three versus 5 [lights] OK. ALS adequate.
- Three versus 5 OK. Centerline tracking tougher due to lack of strobe extension. Alignment delayed for same reason.
- Should add centerline and maybe TDZ lights.
- May get more missed approaches [with this ALS]. Delays decision [to land].
- Would not see ALS at D/H in 1800-ft. RVR conditions and would result in missed approaches in 1800-ft. RVR.

LANDING SCENARIO 32 - 34 INCIDENT SUMMARY

| SCENARIO | MISSED APPROACH | HARD LANDING | CRASH |
|----------|-----------------|--------------|-------|
| 32 | 3 | 1 | None |
| 33 | 2 | None | 2* |
| 34 | None | 1 | None |

*Subject pilots commented that the crash had nothing to do with the visual guidance provided by the ALS. One subject stated that the crash was due to the crosswind. The other subject stated that the crash was due to the localizer offset and lack of runway centerline lights.

Definitions:

Missed Approach: Pilot abandoned the approach at Decision Height or later due to lack of visual guidance and lateral offset.

Hard Landing: The aircraft rate of descent is greater than 500 feet/minute at touchdown.

Crash: At touchdown, if any of the following are exceeded:

1. Bank angle greater than $\pm 6^\circ$
2. Pitch angle greater than 8°
3. Nose gear touches first
4. Rate of descent greater than 13.38 feet/second

LANDING SCENARIO 35 - 37 SUMMARY

SIMULATOR POSTFLIGHT SESSION QUESTIONNAIRE

STUDY 2-REDUCED LIGHTING DENSITY CONFIGURATIONS

SCENARIO NOS. 35 TO 37-CONFIGURATION "B"

CONFIGURATION PRESENTED: Standard ALSF-2 system.

REDUCED VISIBILITY COND: 1200-ft. runway visual range

SUBJECT PILOT NUMBER: _____ DATE: _____

Please place a check in the appropriate square to indicate the relative usefulness of this lighting configuration in providing the following forms of guidance.

1. FINDING THE RUNWAY:

| Excellent | Good | Acceptable | Almost Acceptable | Absolutely Unacceptable |
|-------------------------------------|-------|------------|------------------------------|-------------------------|
| 12 80% | 3 20% | 0 0% | 0 0% | 0 0% |
| Acceptable or Above - 100% | | | Below Acceptable - 0% | |
| (Total of 15 Subject Pilots) | | | | |

2. AWARENESS OF ALTITUDE ABOVE THE GROUND:

| Excellent | Good | Acceptable | Almost Acceptable | Absolutely Unacceptable |
|-----------------------------------|-------|------------|------------------------------|-------------------------|
| 6 40% | 7 47% | 2 13% | 0 0% | 0 0% |
| Acceptable or Above - 100% | | | Below Acceptable - 0% | |

3. LATERAL ALIGNMENT WITH THE RUNWAY:

| Excellent | Good | Acceptable | Almost Acceptable | Absolutely Unacceptable |
|-----------------------------------|-------|------------|------------------------------|-------------------------|
| 10 67% | 4 27% | 1 6% | 0 0% | 0 0% |
| Acceptable or Above - 100% | | | Below Acceptable - 0% | |

4. ROLL GUIDANCE:

| Excellent | Good | Acceptable | Almost Acceptable | Absolutely Unacceptable |
|----------------------------------|-------|------------|------------------------------|-------------------------|
| 7 47% | 7 47% | 0 0% | 1 6% | 0 0% |
| Acceptable or Above - 94% | | | Below Acceptable - 6% | |

LANDING SCENARIO 35 - 37 COMMENT SUMMARY

5. Did the guidance that was provided by the displayed Approach Lighting System (ALS) configuration allow you to complete the approach and landing safely?

Yes: 15
(100%)

No: 0
(0%)

Could Not Judge: 0
(0%)

Comments:

- Roll guidance provided by lights in simulator not as good (in general) as reality.
- A greater feeling of confidence, both in disconnecting autopilot and decision to land. Three versus 5 lights doesn't matter—both are safe.
- Good system.
- Good ALS.

LANDING SCENARIO 35 - 37 COMMENT SUMMARY (CONTINUED)

6. What guidance information (roll, height, direction, etc.), if any, did you feel was lacking or deficient?

None: $\frac{12}{(80\%)}$ or See Comments Below: $\frac{3}{(20\%)}$

Comments:

- Roll guidance provided by lights in simulator not as good (in general) as reality.
- Roll information slightly better [than other patterns flown]—could be due to increasing experience with simulator.
- Height, depth perception [lacking], but better than [with systems displayed for] Category I approaches.
- Red side row and TDZ bars give lateral and roll guidance.

LANDING SCENARIO 35 - 37 COMMENT SUMMARY (CONTINUED)

7. Have you been satisfied with the Category II approach guidance provided by this standard system in the past?

Yes: 15 No: 0
 (100%) (0%)

Comments:

- Feel comfortable with this system.
- Centerline and TDZ lights made it easier.
- No complaints reference ALS.
- Good ALS.

LANDING SCENARIO 35 - 37 INCIDENT SUMMARY

| SCENARIO | MISSED APPROACH | HARD LANDING | CRASH |
|----------|-----------------|--------------|-------|
| 35 | None | 2 | None |
| 36 | None | 2 | None |
| 37 | 1* | 3 | None |

* Note: Cockpit observer recorded that missed approach was due to pilot fatigue rather than because of system deficiency. This was based upon subject comment.

Definitions:

Missed Approach: Pilot abandoned the approach at Decision Height or later due to lack of visual guidance.

Hard Landing: The aircraft rate of descent is greater than 500 feet/minute at touchdown.

Crash: At touchdown, if any of the following are exceeded:

1. Bank angle greater than $\pm 6^\circ$
2. Pitch angle greater than 8°
3. Nose gear touches first
4. Rate of descent greater than 13.38 feet/second

LANDING SCENARIO 38 - 40 SUMMARY

SIMULATOR POSTFLIGHT SESSION QUESTIONNAIRE

STUDY 2-REDUCED LIGHTING DENSITY CONFIGURATIONS

SCENARIO NOS. 38 TO 40-CONFIGURATION "H"

CONFIGURATION PRESENTED: ALSF-2 System with reduced-density
(three light) centerline barrettes.

REDUCED VISIBILITY COND: 1200-ft. runway visual range

SUBJECT PILOT NUMBER: _____ DATE: _____

Please place a check in the appropriate square to indicate the relative usefulness of this lighting configuration in providing the following forms of guidance.

1. FINDING THE RUNWAY:

| Excellent | Good | Acceptable | Almost Acceptable | Absolutely Unacceptable |
|-----------------------------------|-------|------------|------------------------------|-------------------------|
| 9 60% | 4 27% | 2 13% | 0 0% | 0 0% |
| Acceptable or Above - 100% | | | Below Acceptable - 0% | |

2. AWARENESS OF ALTITUDE ABOVE THE GROUND:

| Excellent | Good | Acceptable | Almost Acceptable | Absolutely Unacceptable |
|----------------------------------|-------|------------|------------------------------|-------------------------|
| 4 27% | 8 53% | 2 13% | 1 7% | 0 0% |
| Acceptable or Above - 93% | | | Below Acceptable - 7% | |

3. LATERAL ALIGNMENT WITH THE RUNWAY:

| Excellent | Good | Acceptable | Almost Acceptable | Absolutely Unacceptable |
|-----------------------------------|-------|------------|------------------------------|-------------------------|
| 9 60% | 5 33% | 1 7% | 0 0% | 0 0% |
| Acceptable or Above - 100% | | | Below Acceptable - 0% | |

4. ROLL GUIDANCE:

| Excellent | Good | Acceptable | Almost Acceptable | Absolutely Unacceptable |
|----------------------------------|-------|------------|------------------------------|-------------------------|
| 6 40% | 5 33% | 3 20% | 1 7% | 0 0% |
| Acceptable or Above - 93% | | | Below Acceptable - 7% | |

LANDING SCENARIO 38 - 40 COMMENT SUMMARY

5. Did the guidance that was provided by the displayed Approach Lighting System (ALS) configuration allow you to complete the approach and landing safely?

Yes: 15 No: 0 Could Not Judge: 0
(100%) (0%) (0%)

Comments:

- Typical pilot would probably not notice a configuration [difference] with 3 versus 5 in middle.
- Roll guidance in simulator not as good as in reality.
- No difference versus 5 lights in middle. Hardly noticeable.
- Appears slightly higher than normal in beginning, to the point that there could be a question of being above glidepath.
- Noticed 3 versus 5 [condition], but did not affect the outcome of approach. Three lights no negative affect on safety.
- Centerline alignment not affected with reduction to 3 lights.
- Little significance [difference] in 3 versus 5 lights.
- But prefer 5 to 3 lights.
- Three versus 5 [may affect] fog dissipation, otherwise OK.
- Three versus 5 is not a problem.

LANDING SCENARIO 38 - 40 COMMENT SUMMARY (CONTINUED)

6. What guidance information (roll, height, direction, etc.), if any, did you feel was lacking or deficient?

None: 13 or See Comments Below: 2
(87%) (13%)

Comments:

- Roll guidance in simulator not as good as in reality.
- During the period of time when some systems have been changed to a 3-light centerline barrettes, while others have not, a possible illusion of incorrect altitude (glide path) could result. (Three versus 5 is OK once consistent among all systems).
- Three versus 5 no problem. Red side bars help with roll guidance.
- Roll [guidance lacking]-5 lights would be better (more of a horizontal line).

LANDING SCENARIO 38 - 40 COMMENT SUMMARY (CONTINUED)

7. Do you feel that this ALS configuration merits further consideration as a replacement for the standard ALSF-2 (i.e., actual weather flight testing)?

Yes: $\frac{15}{(100\%)}$ No: $\frac{0}{(0\%)}$

Comments:

- Very much so. As good as an ALSF-2!
- Three lights in middle is fine.
- Feel a little more familiar [comfortable ?] with this system.
- Yes, but would prefer ALSF-2 because of familiarity—could get used to 3 lights.
- Three versus 5 doesn't matter.
- Good systems—no problem.
- As good as standard ALSF-2.
- No difference 3 versus 5—did not notice 3 versus 5.

LANDING SCENARIO 38 - 40 INCIDENT SUMMARY

| SCENARIO | MISSED APPROACH | HARD LANDING | CRASH |
|----------|-----------------|--------------|-------|
| 38 | None | 2 | None |
| 39 | None | 3 | None |
| 40 | 1 | 2 | None |

Definitions:

Missed Approach: Pilot abandoned the approach at Decision Height or later due to lack of visual guidance.

Hard Landing: The aircraft rate of descent is greater than 500 feet/minute at touchdown.

Crash: At touchdown, if any of the following are exceeded:

1. Bank angle greater than $\pm 6^\circ$
2. Pitch angle greater than 8°
3. Nose gear touches first
4. Rate of descent greater than 13.38 feet/second

LANDING SCENARIO 41 - 43 SUMMARY

SIMULATOR POSTFLIGHT SESSION QUESTIONNAIRE

STUDY 2--REDUCED LIGHTING DENSITY CONFIGURATIONS

SCENARIO NOS. 41 TO 43--CONFIGURATION "I"

CONFIGURATION PRESENTED: ALSF-2 with no steady-burning lights beyond 1400- and 200-ft. strobe spacing.

REDUCED VISIBILITY COND: 1200-ft. runway visual range

SUBJECT PILOT NUMBER: _____ DATE: _____

Please place a check in the appropriate square to indicate the relative usefulness of this lighting configuration in providing the following forms of guidance.

1. FINDING THE RUNWAY:

| Excellent | Good | Acceptable | Almost Acceptable | Absolutely Unacceptable |
|-------------------------------------|----------|------------|-------------------------------|-------------------------|
| 7 47% | 3 20% | 3 20% | 2 13% | 0 0% |
| Acceptable or Above - 87% | | | Below Acceptable - 13% | |
| (Total of 15 Subject Pilots) | | | | |

2. AWARENESS OF ALTITUDE ABOVE THE GROUND:

| Excellent | Good | Acceptable | Almost Acceptable | Absolutely Unacceptable |
|----------------------------------|----------|------------|------------------------------|-------------------------|
| 3 20% | 9 60% | 2 13% | 1 7% | 0 0% |
| Acceptable or Above - 93% | | | Below Acceptable - 7% | |

3. LATERAL ALIGNMENT WITH THE RUNWAY:

| Excellent | Good | Acceptable | Almost Acceptable | Absolutely Unacceptable |
|----------------------------------|----------|------------|------------------------------|-------------------------|
| 6 40% | 4 26% | 4 27% | 1 7% | 0 0% |
| Acceptable or Above - 93% | | | Below Acceptable - 7% | |

4. ROLL GUIDANCE:

| Excellent | Good | Acceptable | Almost Acceptable | Absolutely Unacceptable |
|----------------------------------|----------|------------|------------------------------|-------------------------|
| 3 20% | 7 46% | 4 27% | 1 7% | 0 0% |
| Acceptable or Above - 93% | | | Below Acceptable - 7% | |

LANDING SCENARIO 41 - 43 COMMENT SUMMARY

5. Did the guidance that was provided by the displayed Approach Lighting System (ALS) configuration allow you to complete the approach and landing safely?

Yes: 15 No: 0 Could Not Judge: 0
(100%) (0%) (0%)

Comments:

- As good as standard ALSF-2.
- Slightly less safe than ALSF-2.
- Yes, but marginally.
- Missed 100-ft. spacing of strobes because it delayed alignment adjustment.
- Two hundred-ft. strobes versus 100 ft. less eye catching when still with instruments. Reduces comfort level significantly.
- Differences are noticeable from standard.
- As good as standard ALSF-2.

LANDING SCENARIO 41 - 43 COMMENT SUMMARY (CONTINUED)

6. What guidance information (roll, height, direction, etc.), if any, did you feel was lacking or deficient?

None: 11 or See Comments Below: 4
(73%) (27%)

Comments:

- Directional guidance was less, but still safe. Transition to approach lighting was later and therefore less comfortable.
- Want steady-burning lights outboard for better lateral and height guidance.
- Depth [guidance lacking]—appeared as if the aircraft was too high—but had nothing to do with ALS.
- Initial centerline direction [guidance lacking].

LANDING SCENARIO 41 - 43 COMMENT SUMMARY (CONTINUED)

7. Do you feel that this ALS configuration merits further consideration as a replacement for the standard ALSF-2 (i.e., actual weather flight testing)?

Yes: 11
(73%)

No: 4
(27%)

Comments:

- Hard to assess the differences in various lighting systems upon breakout—all look fine.
- Very noticeable change in intensity from beginning to end of ALS. Then runway lights appear dimmer than would expect (unless there was patchy fog there).
- Changes to system have small impact on Category II minimums.
- Very little difference between 3 versus 5 lights. Missed extension of steady-burning lights for roll guidance (in the R/W environment, more lights are better).
- Offset easy to pick up due to strobes extending to 2400 ft.—no problem with ALS—good system.
- Prefer this system to "J" [this system, but with 3 lights on ALS centerline barrettes]. Five lights better than 3 because they were seen sooner and helped with depth perception sooner (less reliance on glideslope).
- Big difference versus standard ALSF-2—may want to consider 100-ft. strobe spacing with same steady-burning ALS display.
- Standard should not be reduced for Category II.
- Subject saw strobes at 300 ft. above threshold.

LANDING SCENARIO 41 - 43 INCIDENT SUMMARY

| SCENARIO | MISSED APPROACH | HARD LANDING | CRASH |
|----------|-----------------|--------------|-------|
| 41 | 2 | 1 | None |
| 42 | None | 1 | None |
| 43 | None | None | 1* |

*Subject pilot commented that the crash had nothing to do with the visual guidance provided by the ALS.

Definitions:

Missed Approach: Pilot abandoned the approach at Decision Height or later due to lack of visual guidance.

Hard Landing: The aircraft rate of descent is greater than 500 feet/minute at touchdown.

Crash: At touchdown, if any of the following are exceeded:

1. Bank angle greater than $\pm 6^\circ$
2. Pitch angle greater than 8°
3. Nose gear touches first
4. Rate of descent greater than 13.38 feet/second

LANDING SCENARIO 44 - 46 SUMMARY

SIMULATOR POSTFLIGHT SESSION QUESTIONNAIRE

STUDY 2-REDUCED LIGHTING DENSITY CONFIGURATIONS

SCENARIO NOS. 44 TO 46-CONFIGURATION "J"

CONFIGURATION PRESENTED: ALSF-2 with no steady-burning lights beyond 1400- 200-ft. strobe spacing, and three lights per centerline barrette.

REDUCED VISIBILITY COND: 1200-ft. runway visual range

SUBJECT PILOT NUMBER: _____ DATE: _____

Please place a check in the appropriate square to indicate the relative usefulness of this lighting configuration in providing the following forms of guidance.

1. FINDING THE RUNWAY:

| Excellent | Good | Acceptable | Almost Acceptable | Absolutely Unacceptable |
|-------------------------------------|-------|------------|------------------------------|-------------------------|
| 5 33% | 5 33% | 4 27% | 1 7% | 0 0% |
| Acceptable or Above - 93% | | | Below Acceptable - 7% | |
| (Total of 15 Subject Pilots) | | | | |

2. AWARENESS OF ALTITUDE ABOVE THE GROUND:

| Excellent | Good | Acceptable | Almost Acceptable | Absolutely Unacceptable |
|----------------------------------|-------|------------|-------------------------------|-------------------------|
| 4 27% | 6 40% | 3 20% | 2 13% | 0 0% |
| Acceptable or Above - 87% | | | Below Acceptable - 13% | |

3. LATERAL ALIGNMENT WITH THE RUNWAY:

| Excellent | Good | Acceptable | Almost Acceptable | Absolutely Unacceptable |
|-----------------------------------|-------|------------|------------------------------|-------------------------|
| 6 40% | 3 20% | 6 40% | 0 0% | 0 0% |
| Acceptable or Above - 100% | | | Below Acceptable - 0% | |

4. ROLL GUIDANCE:

| Excellent | Good | Acceptable | Almost Acceptable | Absolutely Unacceptable |
|----------------------------------|-------|------------|-------------------------------|-------------------------|
| 4 27% | 4 27% | 5 33% | 2 13% | 0 0% |
| Acceptable or Above - 87% | | | Below Acceptable - 13% | |

LANDING SCENARIO 44 - 46 COMMENT SUMMARY

5. Did the guidance that was provided by the displayed Approach Lighting System (ALS) configuration allow you to complete the approach and landing safely?

Yes: $\frac{15}{(100\%)}$

No: $\frac{0}{(0\%)}$

Could Not Judge: $\frac{0}{(0\%)}$

Comments:

- Five versus 3 the same.
- Felt the same about lack of steady-burning approach lights [preferred more], but 3 versus 5 is not an additional problem.
- Very late before you realize that it's an approach light system rather than just "some lights."
- Good system.
- Could not tell the difference between this system and the standard ALSF-2. Good guidance provided.
- Yes, but barely.
- Three versus 5 OK. Missed 100-ft. spacing on strobes.
- Three versus 5 [issue] virtually insignificant.
- Strobes help with lateral alignment.
- Three versus 5 lights and 200-ft. strobe [spacing] not as eye catching when still "inside" cockpit.
- Missed outboard [steady-burning] lights.

LANDING SCENARIO 44 - 46 COMMENT SUMMARY (CONTINUED)

6. What guidance information (roll, height, direction, etc.), if any, did you feel was lacking or deficient?

None: $\frac{8}{(53\%)}$ or See Comments Below: $\frac{7}{(47\%)}$

Comments:

- Directional guidance was less, but still safe. Transition to approach lighting was later and therefore less comfortable.
- Lateral guidance lacking.
- Height-depth [guidance lacking]. Felt either too high or too low (an illusion).
- For direction [guidance] would prefer 100-ft. strobe spacing.
- Roll [guidance lacking]. Using 1 light (strobe) is difficult for roll guidance as opposed to a bar (even if only 3 lights).
- Height-depth [guidance lacking]. Was depending on electronic glideslope more than usual—when over strobes lack of steady-burning lights had negative impact on depth perception.
- Roll [guidance lacking] in strobe light only zone. This ALS gives an illusion of worse weather. Strobes only allow you to keep going, but do not produce the visual cues needed to feel comfortable.

LANDING SCENARIO 44 - 46 COMMENT SUMMARY (CONTINUED)

7. Do you feel that this ALS configuration merits further consideration as a replacement for the standard ALSF-2 (i.e., actual weather flight testing)?

Yes: 11 No: 4
 (73%) (27%)

Comments:

- More simulator testing needed.
- Missing lights [steady burning] not noticeable.
- Stobes appear dim.
- Changes to system have small impact on Category II minimums.
- Three versus 5 [lights] no problem-looking for pattern recognition, not specifics.
- Little significance [difference] between 100- and 200-ft. strobe spacing. Lack of steady-burning lights to 2400 ft. makes it more difficult but not impossible. Suggestion: try configuration "H" [2400-ft., 3-light, steady-burning lights] with 200-ft. strobe spacing.
- Two hundred-foot strobe spacing adequate. No problem with ALS. Barely noticeable difference from ALSF-2 because stobes are present to 2400 ft. and inboard lights [red bars] from 1000 ft. help with depth [perception].
- By raising steady-burning light intensity, it might help with depth perception. They are being seen later and if made brighter would appear sooner.
- Consider 100-ft. strobe spacing for this configuration.
- If at 1000 ft. from threshold, [you have] roll guidance, i.e., red side row bars. ALS before this point is OK versus standard system (ALSF-2).

LANDING SCENARIO 44 - 46 INCIDENT SUMMARY

| SCENARIO | MISSED APPROACH | HARD LANDING | CRASH |
|----------|-----------------|--------------|-------|
| 44 | 2 | 1 | None |
| 45 | None | 3 | 1* |
| 46 | None | 3 | None |

*Subject pilot commented that the crash had nothing to do with the visual guidance provided by the ALS.

Definitions:

Missed Approach: Pilot abandoned the approach at Decision Height or later due to lack of visual guidance.

Hard Landing: The aircraft rate of descent is greater than 500 feet/minute at touchdown.

Crash: At touchdown, if any of the following are exceeded:

1. Bank angle greater than $\pm 6^\circ$
2. Pitch angle greater than 8°
3. Nose gear touches first
4. Rate of descent greater than 13.38 feet/second

5.3 RESULTS ANALYSIS.

In developing the reduced Category I and II configurations for evaluation, the assumption was made that economies could be achieved by reducing the number of required lights and associated equipment (transformers, towers, cabling, etc.) through either shortening the configuration or reducing the density (lamps per barrette) of lights. This could only be done to the extent that the resultant configuration still retained a unique and easily recognized pattern, one that pilots could still identify and interpret readily.

Recognizing this, the analysis can best be accomplished by considering the effect of each of these changes or the effect that a combination of both had on the systems' ability to provide visual guidance that would allow for the completion of safe approaches and landings as evaluated by the subject pilots and shown in table 3.

5.3.1 Category I Approach Light Systems.

For the Category I approach light systems, pilots indicated by numerous comments and through their positive ratings for the system addressed in scenarios 26-28 that they considered the reduction in ALS centerline barrette light density (3 lights in place of 5) to be of little or no consequence. The average acceptance percentage (Column 10) changed only by 2.1%, from 98.8% to 96.7%, as a result of removing forty percent of the centerline barrette lights. The missed approach occurrences were identical, 3 out of 45 approaches made, for both the standard MALSR (Configuration A) and for the reduced centerline light density (Configuration E) patterns. Reference to the comments for the reduced-density pattern scenario set (26-28) will reveal comments such as "three versus 5 not a problem" and "As good as the MALSR. Three versus 5 lights not noticeable."

A reduction in MALSR configuration length by eliminating the outer 1000-ft. segment of the system and employing only three strobe lights in the outer 400 feet of the truncated pattern (configuration F), was not nearly as well received as judged by the subject pilots. This shortened system, presented for evaluation in scenarios 29 to 31, received only an 81.2% acceptance rating (Column 10), a change of 17.6% from that of the standard MALSR. It should be noted that this shortened system is already an FAA acknowledged configuration, the MALSF, but not installed to any large extent within the United States. Comments such as "Missed guidance of strobes extended to 2400 ft." and "Shorter system delays judgment of alignment and is less safe than a 2400-ft. system" were recorded during the conduct of these three scenarios. Missed approach occurrences remained at 3 out of 45 approaches made.

During the last three scenarios (32-34) of the Category I ALS evaluation, the subject pilots were presented with a reduced pattern developed by both shortening the length of the MALSR and reducing the density of the centerline barrette lights (Configuration G). This resulted in an even greater reduction in the acceptability percentage to 75.3%, a drop of 23.5%. Missed approach occurrences increased by 66% to 5 out of 45 approaches. Recorded subject pilot comments included "Approach lights insufficient" and "Lateral guidance appeared too late to see drift across runway extended centerline."

TABLE 3. REDUCED ALS TEST RESULTS NUMERICAL RANKING

CATEGORY I APPROACH LIGHT SYSTEMS

| COLUMN 1 | 2 | 3 | 4 | 5 | 6 | 7 | 8 | 9 | 10 | 11 | 12 | 13 | 14 |
|--------------|--|-----|-----|-----|----|-----|----|-----|-------|------------|----------|---------|-------|
| SCENARIO SET | CONFIGURATION | 1% | 2% | 3% | 4% | 5% | 6% | 7% | AVG.% | CAT.I RANK | MISS/APP | HRD LDG | CRASH |
| 23 -25 | STANDARD MALSR SYSTEM | 100 | 100 | 100 | 93 | 100 | 60 | 100 | 98.8 | 1 | 3 | 3 | 1 |
| 26 -28 | STANDARD MALSR WITH 3-LIGHT CENTERLINE | 100 | 93 | 100 | 87 | 100 | 67 | 100 | 96.7 | 2 | 3 | 6 | 2 |
| 29 - 31 | STANDARD MALSF SYSTEM | 74 | 100 | 73 | 80 | 93 | 33 | 67 | 81.2 | 3 | 3 | 5 | 1 |
| 32 -34 | STANDARD MALSF WITH 3-LIGHT CENTERLINE | 73 | 86 | 80 | 73 | 80 | 33 | 60 | 75.3 | 4 | 5 | 2 | 2 |

CATEGORY II/III APPROACH LIGHT SYSTEMS

| COLUMN 1 | 2 | 3 | 4 | 5 | 6 | 7 | 8 | 9 | 10 | 11 | 12 | 13 | 14 |
|--------------|--|-----|-----|-----|----|-----|----|-----|-------|-------------|----------|---------|-------|
| SCENARIO SET | CONFIGURATION | 1% | 2% | 3% | 4% | 5% | 6% | 7% | AVG.% | CAT.II RANK | MISS/APP | HRD LDG | CRASH |
| 35 - 37 | STANDARD ALSF-2 SYSTEM | 100 | 100 | 100 | 94 | 100 | 80 | 100 | 99.0 | 1 | 1 | 7 | 0 |
| 38 - 40 | STANDARD ALSF-2 WITH 3-LIGHT CENTERLINE | 100 | 93 | 100 | 93 | 100 | 87 | 100 | 97.7 | 2 | 1 | 7 | 0 |
| 41 - 43 | ALSF-2 WITH STROBES ONLY AT 200' IN OUTER SECTION | 87 | 93 | 93 | 93 | 100 | 73 | 73 | 89.8 | 4 | 2 | 2 | 1 |
| 44 - 46 | ALSF-2 WITH STROBES ONLY AT 200' IN OUTER SECTION AND 3-LIGHT CENTERLINE | 93 | 87 | 100 | 87 | 100 | 53 | 73 | 90.0 | 3 | 2 | 7 | 1 |

In summary, the subject pilots appeared to feel that reducing the number of lights in the ALS centerline barrettes did not significantly change system effectiveness. Shortening the system significantly, to 1400 feet, did reduce system effectiveness, however, to the extent that more than a few subjects felt that it rendered the configuration unacceptable.

5.3.2 Category II Approach Light Systems.

For the Category II approach light systems, pilots again indicated by numerous comments and through their positive ratings for the systems addressed in scenarios 38-40 that they considered the reduction in ALS centerline barrette light density (3 lights in place of 5) to be of little or no consequence. The average acceptance percentage (column 10) changed only by 1.3%, from 99.0% to 97.7%, as a result of removing forty percent of the centerline barrette lights. The missed approach occurrences were again identical, 1 out of 45 approaches made, for both the standard ALSF-2 (Configuration B) and for the reduced centerline light density (Configuration H) patterns. Comments about the reduced-density system included "Typical pilot would probably not notice a pattern difference with 3 versus 5 in the middle," "Noticed the 3 versus 5 condition but did not affect the outcome of approach. Three lights no negative affect on safety," and "As good as the standard ALSF-2."

Changes to the outer 1000-foot segment of the ALSF-2, such as eliminating the steady-burning lights to leave only the strobes on 200-foot spacing (Configuration I), met with less approval from the subject pilots. This pattern, presented in scenarios 41 to 43, attained an acceptance rating (column 10) of only 89.8%, a drop of 9.2% from the standard ALSF-2 rating of 99.0%. Comments from the pilots were about evenly distributed between favorable and unfavorable, with typical statements being "As good as the standard ALSF-2," "Slightly less safe than the ALSF-2," and "Big difference versus standard ALSF-2."

It appears that the subjects felt more ambivalent toward the change in the outer 1000 ft. of the ALSF-2 than they had toward the change in the outer 1000 ft. of the MALSR. This may have been due to the fact that the ALSF-2 outer segment change involved only the removal of the steady-burning lights, leaving the strobes still in place albeit on a more extended spacing. It should be noted also that the scenarios involving changes to the ALSF-2 outer 1000-ft. segment were flown with simulated 200-ft. ceilings rather than with the more critical 100-ft. Category II ceiling. This permitted the subjects to see and evaluate a portion of the Category II system that they would never view under true Category II minimums (100-ft. ceiling/1200-ft. RVR).

The Configuration J Category II ALS variation involved the removal of the steady-burning lights from the outer 1000-foot segment, changing of the strobe spacing from 100 to 200 feet, and reducing the density of all remaining centerline barrette lights from 5 to 3. The acceptability rating (column 10) for this pattern, flown as scenarios 44 to 46, was actually 2/10 of 1% higher than that accorded the same system with the higher density 5-light centerline barrettes (90% versus 89.8%). It would be improper to interpret such an insignificant difference as a preference for one or the other of the two modified ALS systems. It does, however, give strength to the contention that there is very little difference in effectiveness of a 3-light barrette as opposed to a 5-light barrette on the ALS centerline. Subject pilot's comments were again diversified and

showed no particular trend, either in a positive or negative direction. They included remarks such as "Roll guidance lacking. Using one light (strobe) is difficult for roll guidance as opposed to a bar (even if only 3 lights)," "Little significance between 100- and 200-ft. strobe spacing. Lack of steady-burning lights to 2400 ft. makes it more difficult, but not impossible," and "Very late before you realize that it's an approach light system rather than just some lights."

As a summary relating to the Category II system evaluation, it would seem that changes to the density of lights from 5 to 3 in the centerline barrettes, were viewed by the subject pilots as not being critical to system effectiveness. Opinion on relying on strobes only in the outer ALS segment (Configurations I and J) was more diversified, for both of these configurations. A significant number of the subject pilots (27%) did not feel that these configurations merited further consideration as a replacement for the standard ALSF-2 through actual weather flight testing.

6. CONCLUSIONS AND RECOMMENDATIONS.

6.1 CONCLUSIONS.

From the results of this Reduced Configuration ALS Simulator Evaluation, we can conclude that:

- Subject pilots could safely complete approaches and landings if the number of lights in the centerline barrettes of both the MALSR and the ALSF-2 systems were reduced from 5 to 3.
- Shortening of the standard MALSR lighting system to a total length of 1400 ft., while possibly providing cost benefits, could jeopardize safety and render the resultant system (MALSF) unacceptable for supporting Category I approach/landing operations.
- Eliminating the steady-burning lights within the outer 1000 ft. of the standard ALSF-2 lighting system, along with increasing the strobe light spacing to 200 ft., will achieve installation and operating savings. However the simulator evaluation suggests that this design does not merit further consideration as a replacement for the standard ALSF-2 through actual weather flight testing.

6.2 RECOMMENDATIONS.

From the results of this simulator evaluation, it is recommended that:

- The standard MALSR lighting system with three lights in all centerline barrettes (Configuration E) rather than the five lights presently specified should be subjected to actual weather flight testing.
- Additional evaluation, in the form of actual weather flights or, at least, actual flight/simulated weather testing, be conducted on the ALSF-2 incorporating three lights in all centerline barrettes (Configuration H).

- An additional evaluation, in the form of simulation and actual weather flight testing, should be conducted on Category I ALS configurations that have a total length of less than 2400 ft. but longer than 1400 ft.
- No configurational changes to the standard MALSR or ALSF-2 should be made until these simulator evaluation results are validated by actual weather flight testing.