

FINAL REPORT
APRIL 1996

REPORT NO. 96-28

MULTIPLE LAUNCH ROCKET
SYSTEM (MLRS) PODS ON A
LOAD AND ROLL PALLET (LRP)
RESTRAINED WITH
WOODEN DUNNAGE
TRANSPORTABILITY TESTS

19960807 007

Prepared for:
U.S. Army Defense Ammunition
Center and School
ATTN: SIOAC-DET
Savanna, IL 61074-9639

Distribution Unlimited



VALIDATION ENGINEERING DIVISION
SAVANNA, ILLINOIS 61074-9639

AVAILABILITY NOTICE

A copy of this report will be furnished each attendee on automatic distribution. Additional copies or authority for reprinting may be obtained by written request from Director, U.S. Army Defense Ammunition Center and School, ATTN: SIOAC-DEV, Savanna, IL 61074-9639.

DISTRIBUTION INSTRUCTIONS

Destroy this report when no longer needed. Do not return.

Citation of trade names in this report does not constitute an official endorsement.

The information contained herein will not be used for advertising purposes.

REPORT DOCUMENTATION PAGE				Form Approved OMB No. 0704-0188	
1a. REPORT SECURITY CLASSIFICATION UNCLASSIFIED		1b. RESTRICTIVE MARKINGS			
2a. SECURITY CLASSIFICATION AUTHORITY		3. DISTRIBUTION / AVAILABILITY OF REPORT UNLIMITED			
2b. DECLASSIFICATION / DOWNGRADING SCHEDULE					
4. PERFORMING ORGANIZATION REPORT NUMBER(S) 96-28		5. MONITORING ORGANIZATION REPORT NUMBER(S)			
6a. NAME OF PERFORMING ORGANIZATION U.S. Army Defense Ammunition Center and School		6b. OFFICE SYMBOL (if applicable) SIOAC-DEV	7a. NAME OF MONITORING ORGANIZATION		
6c. ADDRESS (City, State, and ZIP Code) ATTN: SIOAC-DEV Savanna, IL 61074-9639		7b. ADDRESS (City, State, and ZIP Code)			
8a. NAME OF FUNDING / SPONSORING ORGANIZATION U.S. Army Defense Ammunition Center and School		8b. OFFICE SYMBOL (if applicable) SIOAC-DET	9. PROCUREMENT INSTRUMENT IDENTIFICATION NUMBER		
8c. ADDRESS (City, State, and ZIP Code) ATTN: SIOAC-DET Savanna, IL 61074-9639		10. SOURCE OF FUNDING NUMBERS			
		PROGRAM ELEMENT NO.	PROJECT NO.	TASK NO.	WORK UNIT ACCESSION NO.
11. TITLE (Include Security Classification) Multiple Launch Rocket System (MLRS) Pods on a Load and Roll Pallet (LRP) Restrained with Wooden Dunnage Transportability Tests					
12. PERSONAL AUTHOR(S) Alfred C. McIntosh, Jr.					
13a. TYPE OF REPORT Final		13b. TIME COVERED FROM _____ TO _____		14. DATE OF REPORT (Year, Month, Day) 1996 April	15. PAGE COUNT
16. SUPPLEMENTARY NOTATION					
17. COSATI CODES			18. SUBJECT TERMS (Continue on reverse if necessary and identify by block number)		
FIELD	GROUP	SUB-GROUP			
19. ABSTRACT (Continue on reverse if necessary and identify by block number) The U.S. Army Defense Ammunition Center and School (USADACS), Validation Engineering Division (SIOAC-DEV), was tasked by USADACS, Transportation Engineering Division (SIOAC-DET), to test the proposed blocking technique on Multiple Launch Rocket System (MLRS) pods on a Load and Roll Pallet (LRP). Due to the nonavailability of serviceable MILVAN/LRP combinations, a shipping installation submitted a suggestion to ship MLRS pods loaded on an LRP in a standard munitions-type container. In order to secure the loaded LRP in this container type, a section of the closeout angle must be removed. To avoid the required modification, an alternative method of blocking the LRP in a container was suggested. The proposed blocking technique failed to properly restrain the loaded LRP in a container. Damage to the container door and door sill resulted at a rail impact speed of 7.2 mph (to pass, a container must pass a rail impact speed of 8.1 mph). With the container damaged, the container cannot be used to transport ammunition.					
20. DISTRIBUTION / AVAILABILITY OF ABSTRACT <input checked="" type="checkbox"/> UNCLASSIFIED/UNLIMITED <input type="checkbox"/> SAME AS RPT. <input type="checkbox"/> DTIC USERS			21. ABSTRACT SECURITY CLASSIFICATION UNCLASSIFIED		
22a. NAME OF RESPONSIBLE INDIVIDUAL JEROME H. KROHN		22b. TELEPHONE (Include Area Code) 815-273-8929		22c. OFFICE SYMBOL SIOAC-DEV	

U.S. ARMY DEFENSE AMMUNITION CENTER AND SCHOOL
VALIDATION ENGINEERING DIVISION
SAVANNA, IL 61074-9639

REPORT NO. 96-28

MULTIPLE LAUNCH ROCKET SYSTEM (MLRS) PODS ON A LOAD AND ROLL
PALLET (LRP) RESTRAINED WITH WOODEN DUNNAGE TRANSPORTABILITY TESTS

TABLE OF CONTENTS

PART	PAGE NO.
1. INTRODUCTION	1-1
A. BACKGROUND	1-1
B. AUTHORITY	1-1
C. OBJECTIVE	1-1
D. CONCLUSION	1-2
E. RECOMMENDATION	1-2
2. ATTENDEES	2-1
3. TEST PROCEDURES	3-1
4. TEST RESULTS	4-1
5. PHOTOGRAPHS	5-1
6. DRAWING	6-1
7. APPENDIX	7-1

PART 1

INTRODUCTION

A. BACKGROUND. Currently, there is a shortage of serviceable MILVAN/LRP combinations. The MILVANs are unserviceable due to damage. The Load and Roll Pallets (LRPs) are serviceable for shipping Multiple Launch Rocket System (MLRS) pods. Often serviceable containers are available; however, these containers must be physically changed (altered) to permit securing the LRP in them. To avoid modifying the serviceable containers, an alternative method of securing the LRP inside the container was suggested. This suggestion (No. AMVF950060) was sent to the U.S. Army Defense Ammunition Center and School (USADACS), Transportation Engineering Division (SIOAC-DET), for evaluation (see Part 7). As a result of that evaluation, the suggestion was forwarded to USADACS, Validation Engineering Division (SIOAC-DEV), for physical testing. This report documents the results of testing the suggested blocking procedure.

B. AUTHORITY. This test was conducted IAW mission responsibilities delegated by U.S. Army Armament, Munitions and Chemical Command (AMCCOM), Rock Island, IL 61299-6000. Reference is made to Change 4, 4 October 1974, to AR 740-1, 23 April 1971, Storage and Supply Operations; AMCCOMR 10-17, 31 August 1991, Mission and Major Functions of USADACS.

C. OBJECTIVE. The objective of these tests was to determine if the suggested method of securing an LRP loaded with MLRS pods in a container using wooden dunnage instead of the provided chocks would adequately prevent LRP movement in an intermodal transportation environment; specifically, rail and road.

D. CONCLUSION. Three 2- by 8-inch laminated boards were placed between the end of the LRP and the 1-1/4-inch welded angle parallel to the door jamb in the container. Two blocks were placed between each side of the LRP and container wall. A 1- by 8-inch board was placed between the 1-1/4-inch welded angle and the doors. The laminated 2- by 8-inch beam was restrained by the rear side of the 1-1/4-inch angle. After the first impact, the laminated beams were crushed approximately 1/8-inch at the point of contact. After the second impact, the laminated 2- by 8-inch beam cracked at the left side of the container. This failure allowed the LRP to move and strike the closed door of the container, damaging the door locks. As a result of the two tests, three 2- by 8-inch laminated boards with side bracing on the LRP is not strong enough to brace the LRP in a container and prevent damaging the container. The approved chocking method of blocking the loaded LRP in the container prevents this kind of damage.

E. RECOMMENDATION. This suggested procedure is not recommended for blocking and bracing a load of MLRS pods on an LRP in a container. More damage to the container will occur than just removing the lower portion of the closeout angle. It is recommended that the approved procedure be followed for blocking. A copy of this procedure is included in Part 6.

PART 2

28 FEBRUARY 1996

ATTENDEES

Alfred C. McIntosh, Jr.
General Engineer
DSN 585-8989
815-273-8989

Director
U.S. Army Defense Ammunition Center
and School
ATTN: SIOAC-DEV
Savanna, IL 61074-9639

Jerome H. Krohn
Supervisory Engineer
DSN 585-8908
815-273-8908

Director
U.S. Army Defense Ammunition Center
and School
ATTN: SIOAC-DEV
Savanna, IL 61074-9639

David V. Valant
Electronics Technician
DSN 585-8988
815-273-8988

Director
U.S. Army Defense Ammunition Center
and School
ATTN: SIOAC-DEV
Savanna, IL 61074-9639

Gregory Willis
Industrial Engineer
DSN 585-8075
815-273-8075

Director
U.S. Army Defense Ammunition Center
and School
ATTN: SIOAC-DET
Savanna, IL 61074-9639

PART 3

TEST PROCEDURES

TRANSPORTABILITY TEST. The test procedure outlined in this section was extracted from TP-94-01, July 1994, for chassis-mounted container transportation by truck on a railcar. This standard identifies six steps that a load must undergo if it is considered to be acceptable. The tests conducted on the test specimen are synopsized below.

The test load of MLRS pods on an LRP was prepared using the same blocking and bracing methods specified in the tiedown procedures for use with munitions. A copy of these procedures is contained in Part 6. The loaded LRP was placed in a 20-foot munitions container with the recommended forward blocking assembly. The LRP chocks remained stored on the pallet. The LRP was blocked to the 1-1/4-inch angle brackets welded to the container with a laminated 2- by 8-inch wood beam. A 1- by 8-inch filler board was placed between the 1-1/4-inch angle and the doors. A detailed drawing of this suggested closeout method is contained in Part 7.

RAIL IMPACT TEST. The prepared test container was secured to a container transportation chassis. The container and chassis were loaded onto a Trailer-on-flatcar (TOFC) with standard draft gear. Equipment needed to perform the test included the specimen (hammer) car, five empty railroad cars connected together to serve as the anvil, and a railroad locomotive. These anvil cars were positioned on a level section of track with air and hand brakes set and with the draft gears compressed. The locomotive unit pulled the specimen car several hundred yards away from the anvil cars and, then, pushed the specimen car toward the anvil at a predetermined speed, then disconnected from the specimen car approximately 50 yards away from the anvil cars, which allowed the specimen car to roll freely along the track until it struck the anvil (see Figure 1 on page 3-3). This constituted an impact. Impacting is accomplished at speeds of

4, 6, and 8.1 mph in one direction and at a speed of 8.1 mph in the reverse direction. The 4 and 6 mph impact speeds are approximate; the 8.1 mph speed is a minimum. Impact speeds are determined by using an electronic counter to measure the time required for the specimen car to traverse an 11-foot distance immediately prior to contact with the anvil cars.

**ASSOCIATION OF AMERICAN RAILROADS (AAR)
STANDARD TEST PLAN**

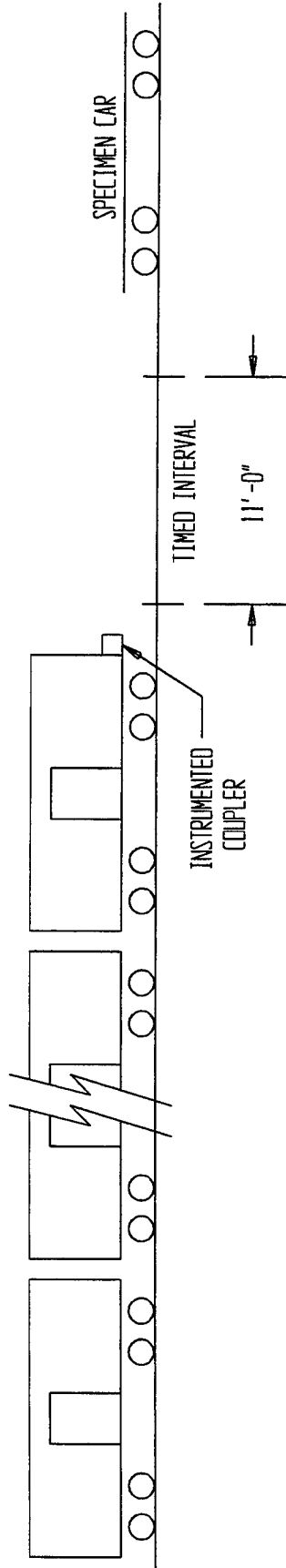

**SPECIMEN CAR
IS RELEASED BY
SWITCHENGINE TO**

**ATTAIN: IMPACT NO. 1 @ 4 MPH
IMPACT NO. 2 @ 6 MPH
IMPACT NO. 3 @ 8.1 MPH**

**THEN THE CAR IS REVERSED AND
RELEASED BY SWITCHENGINE TO**

ATTAIN: IMPACT NO 4. @ 8.1 MPH

**5 BUFFER CARS (ANVIL) WITH DRAFT GEAR
COMPRESSED AND AIR BRAKES IN A SET
POSITION
ANVIL CARS TOTAL WT 250,000 LBS (APPROX)**

FIGURE 1

PART 4

TEST RESULTS

TEST SPECIMEN AND RESULTS RAIL IMPACT DATA

Test No.: 1

Date: 8 April 1996

Specimen Load: Munition container loaded with MLRS pods on a LRP.

TOFC: TTX 600585

Lt. Wt.: 72,000

Chassis No.: 5394

Wt.: 6,500

Container No.: USAA 0168656

Wt.: 5,170

LRP:

Wt.: 1,900

Lading:

Wt.: 21,800

Total Specimen Wt.: 107,370

Buffer Car (five cars) Wt.: 250,000

<u>Impact</u>	<u>End Struck</u>	<u>Velocity (mph)</u>	<u>Remarks</u>
1	Rear	6.50	2- by 8-inch boards in contact with the 1-1/4-inch closeout angle crushed 1/8-inch on both sides of the container.
2	Rear	7.25	Door closing locks and door sill were permanently deformed. Rear beam completely cracked in all three layers on the left side of the container. Does not successfully restrain the LRP.

PART 5

PHOTOGRAPHS

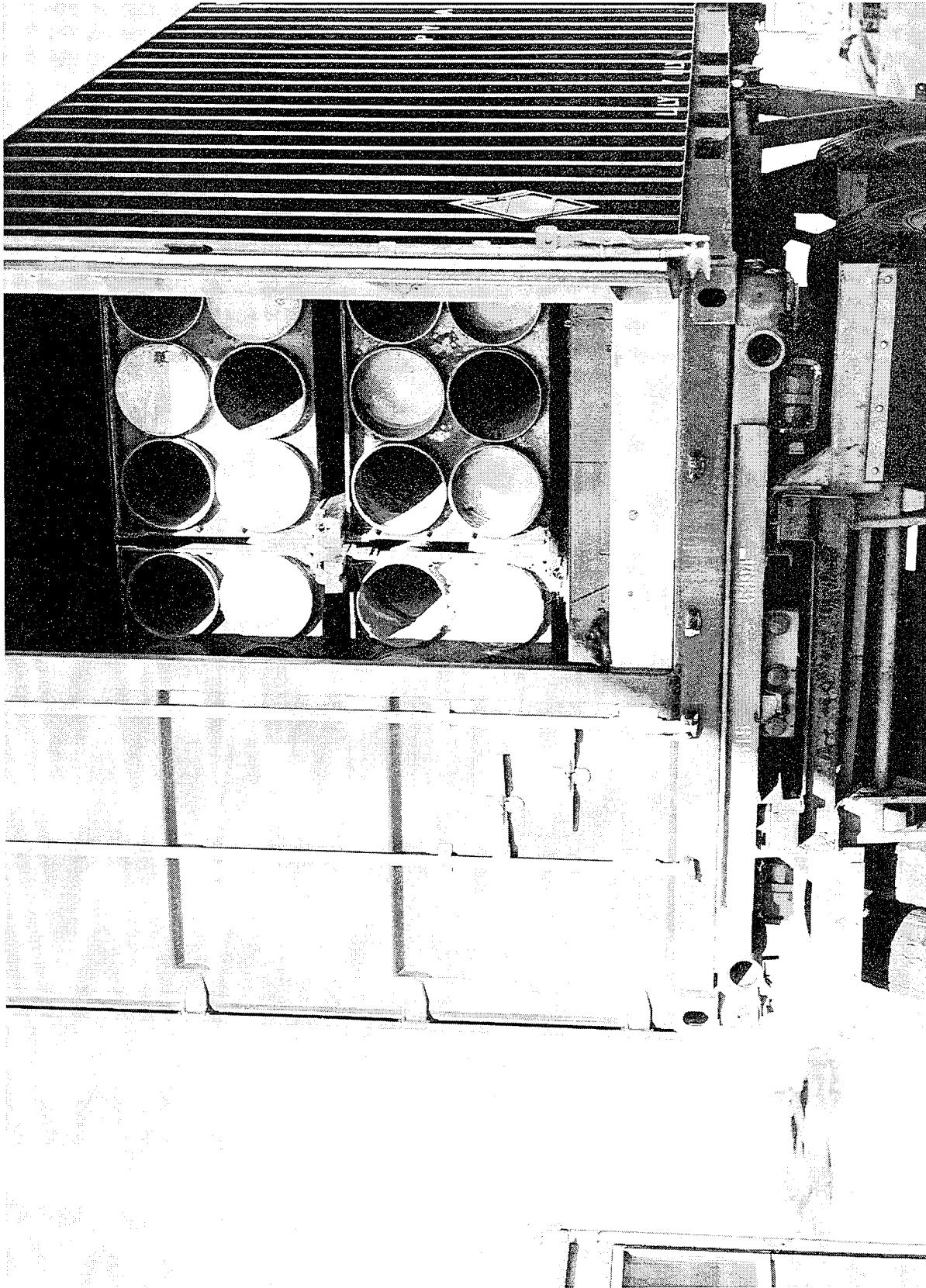

U.S. ARMY DEFENSE AMMUNITION CENTER AND SCHOOL -
SAVANNA, IL

Photo No. SCN-96-115-2403. This photo shows the loaded LRP with four inertly-filled MLRS pods in a container closed out with a single laminated wood beam fabricated with three each 2- by 8-inch boards. The beam was blocked against the internal steel angle just inside the container door. A single 1- by 8-inch board filled between the door and angle.

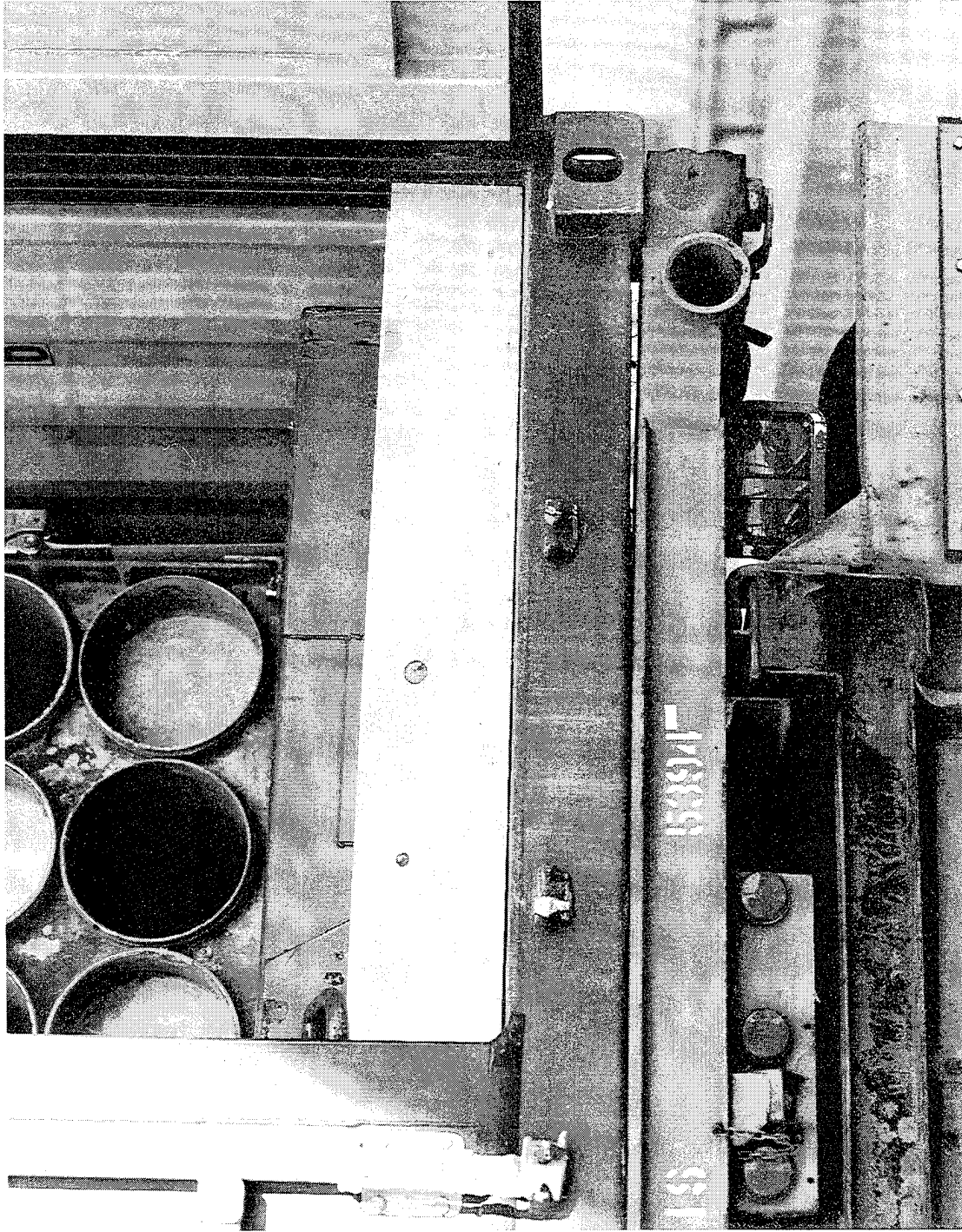

U.S. ARMY DEFENSE AMMUNITION CENTER AND SCHOOL -
SAVANNA, IL

Photo No. SCN-96-115-2402. This photo shows a front view of the 1- by 8-inch filler board between the angle and the door. The LRP with inertly-filled MLRS pods is in the background. A single laminated wood beam fabricated with three each 2- by 8-inch boards blocks the LRP against the closeout angle. The beam was blocked against the internal steel angle just inside the container door.



U.S. ARMY DEFENSE AMMUNITION CENTER AND SCHOOL -
SAVANNA, IL

Photo No. SCN-96-115-2404. This photo shows the suggested method used to block an LRP of MLRS pods inside a munitions container. The gap between the 1 - by 8-inch board is the angle welded to the inside of the container. This is the right side of the container.

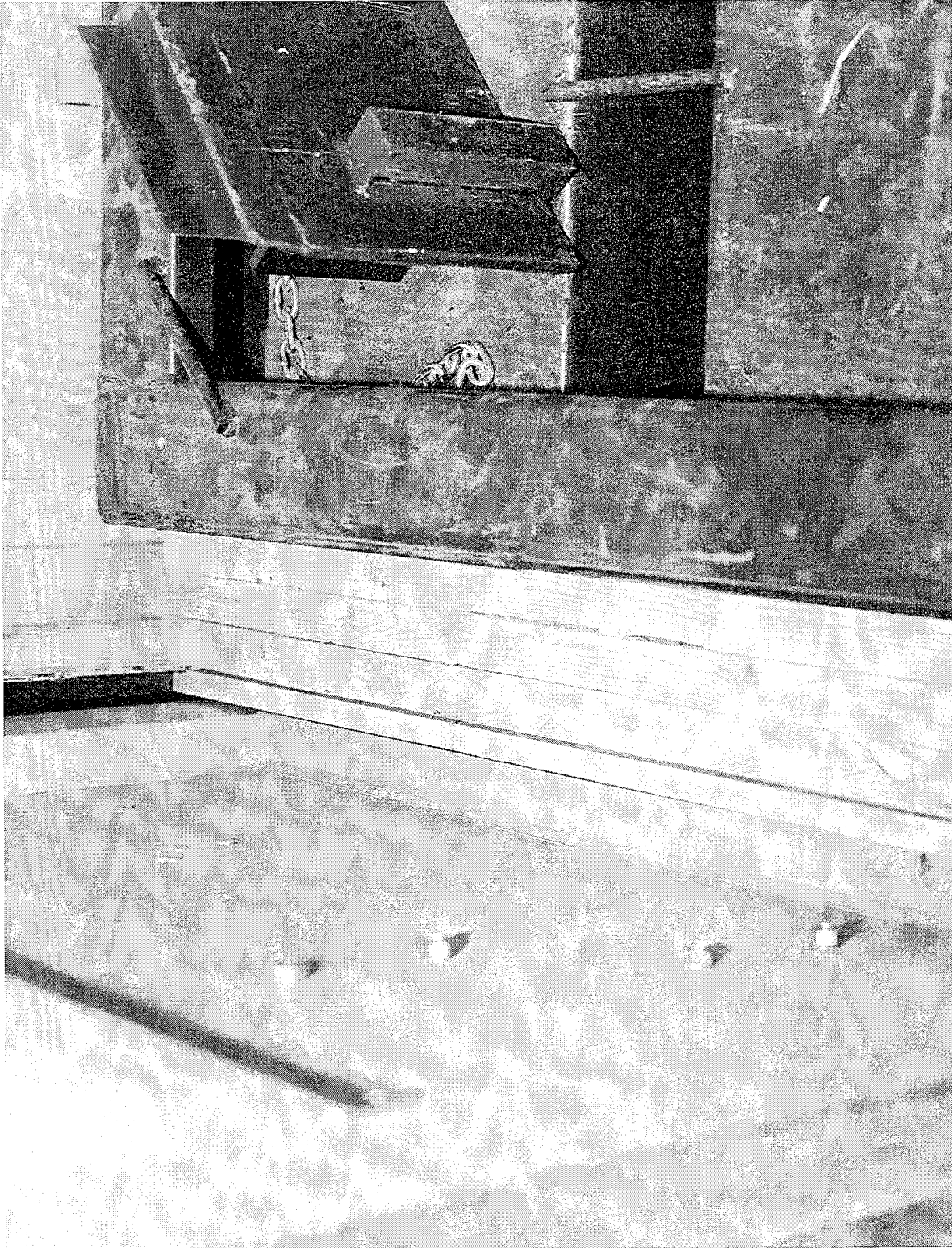

U.S. ARMY DEFENSE AMMUNITION CENTER AND SCHOOL - SAVANNA, IL

Photo No. SCN-96-115-2401. This photo shows the suggested method used to block an LRP of MLRS pods inside a munitions container. The gap between the 1- by 8-inch board is the angle welded to the inside of the container. This is the left side of the container.

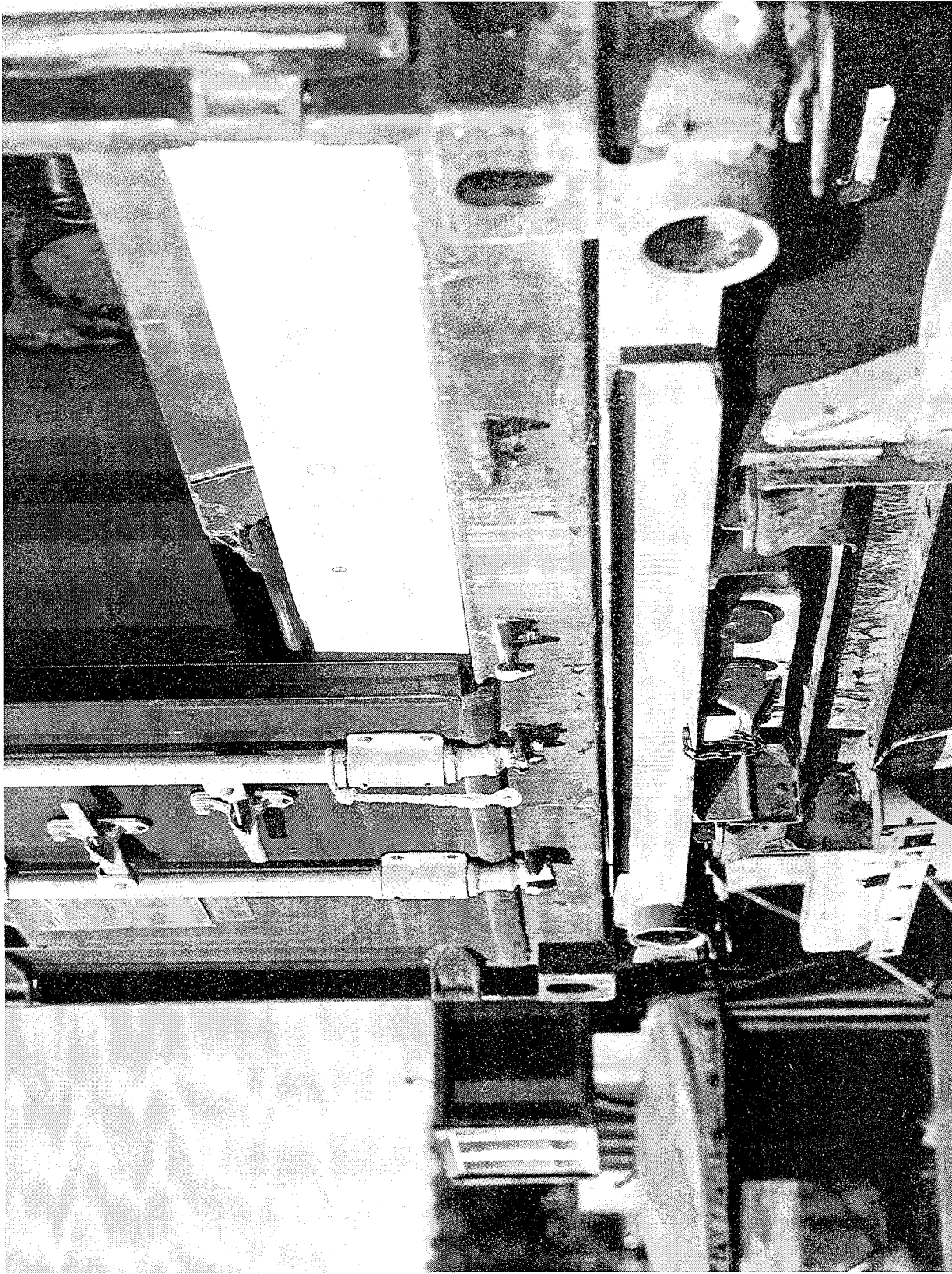

U.S. ARMY DEFENSE AMMUNITION CENTER AND SCHOOL -
SAVANNA, IL

Photo No. SCN-96-115-2399. This photo shows the damage to the container door closure and locks. Note the bend in the lower latching mechanism of the lock assembly. Damage was due to the inadequate strength in blocking with three laminated 2- by 8-inch boards.

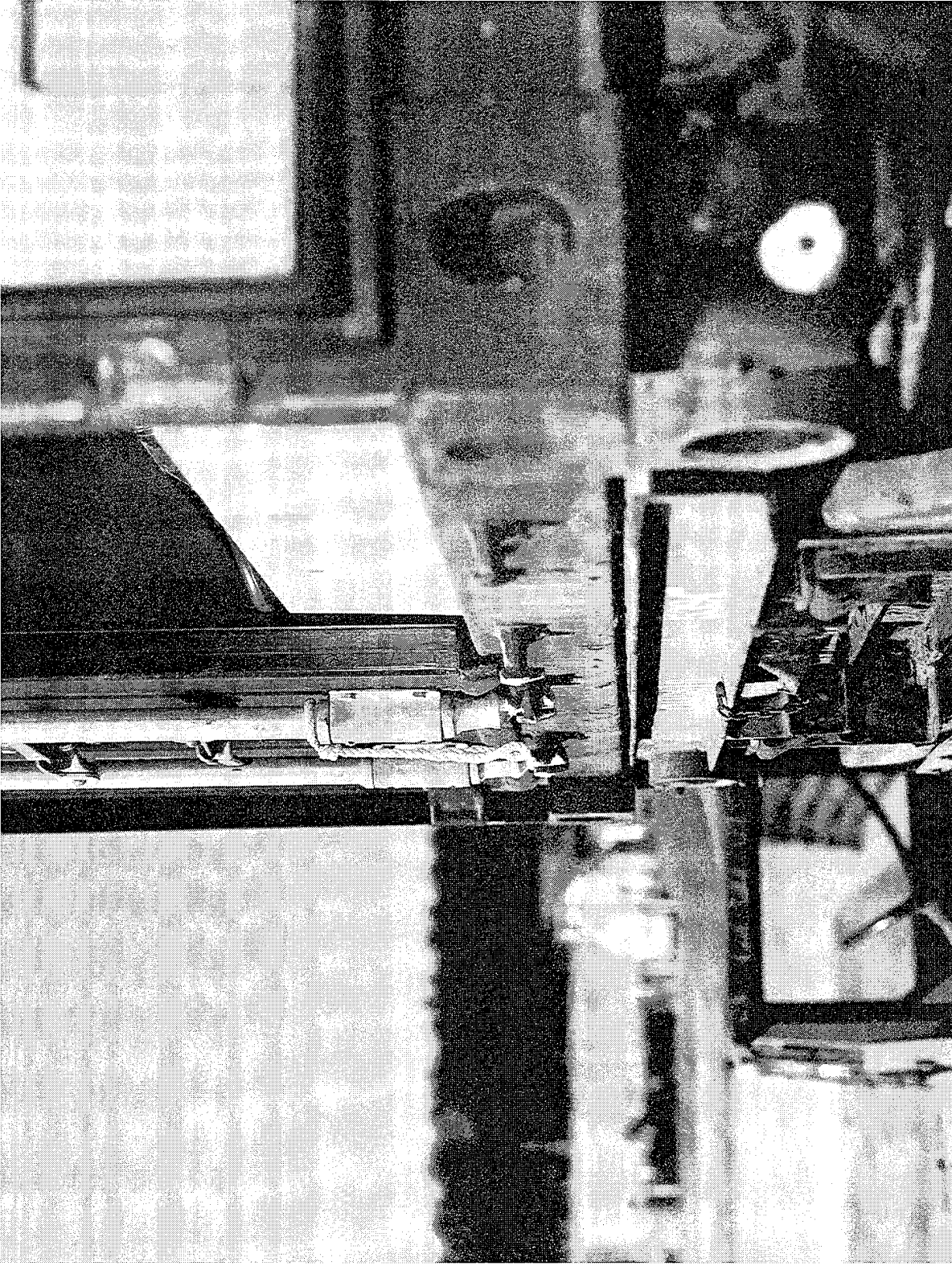

U.S. ARMY DEFENSE AMMUNITION CENTER AND SCHOOL -
SAVANNA, IL

Photo No. SCN-96-115-2398. This photo shows the damage to the container door closure and locks. Note the bend in the lower latching mechanism of the lock assembly. The latch mechanism is normally straight. Damage was due to the inadequate strength in blocking with three laminated 2- by 8-inch boards.

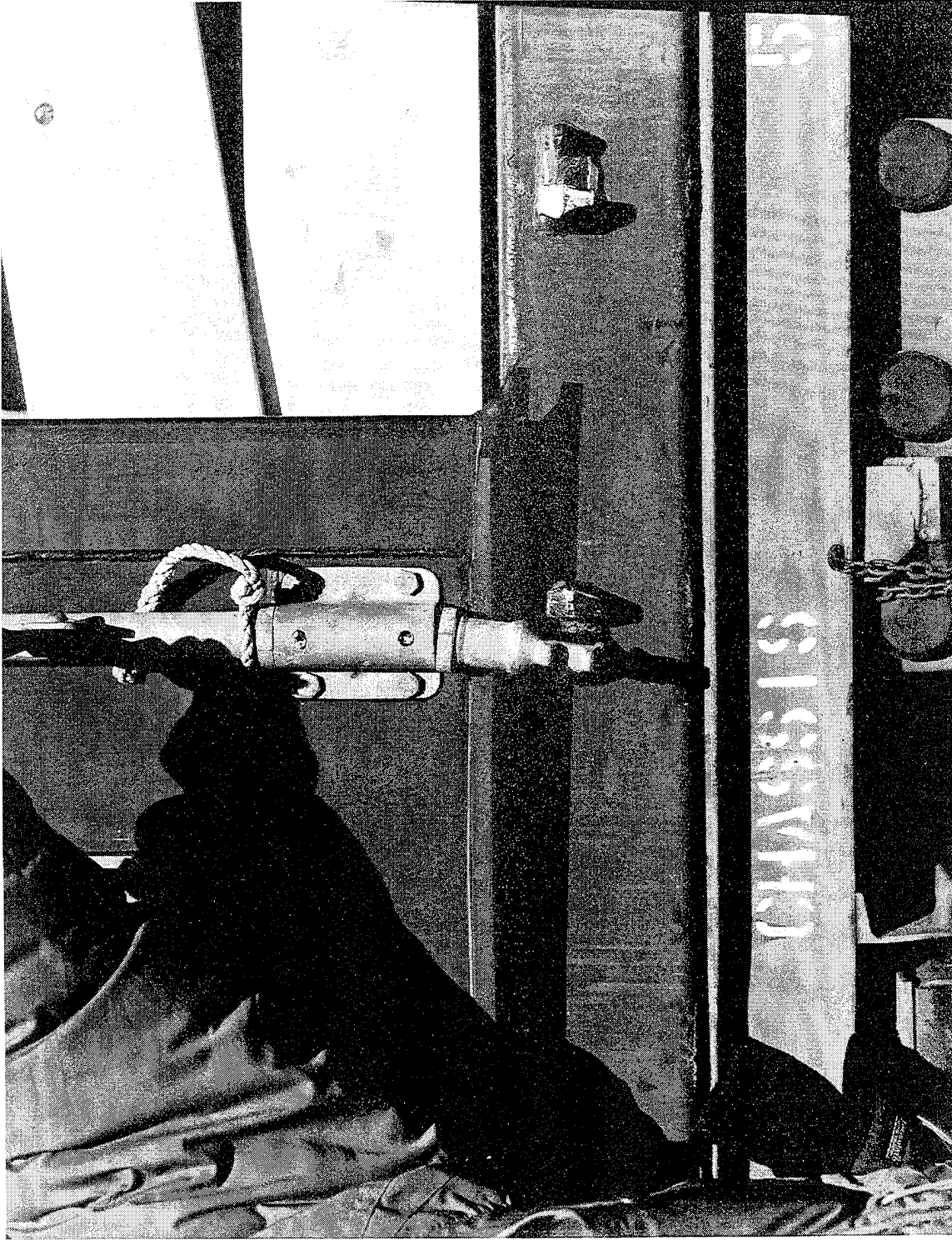

U.S. ARMY DEFENSE AMMUNITION CENTER AND SCHOOL -
SAVANNA, IL

Photo No. SCM-96-115-2396. This photo shows the damage to the container door locks as a result of inadequate dunnage to restrain an LRP load of MLRS pods in a munitions container. Damage was due to a rail impact of 7.2 mph. The bent locking rods and deformed door sill rendered the container structurally unsafe for shipment.

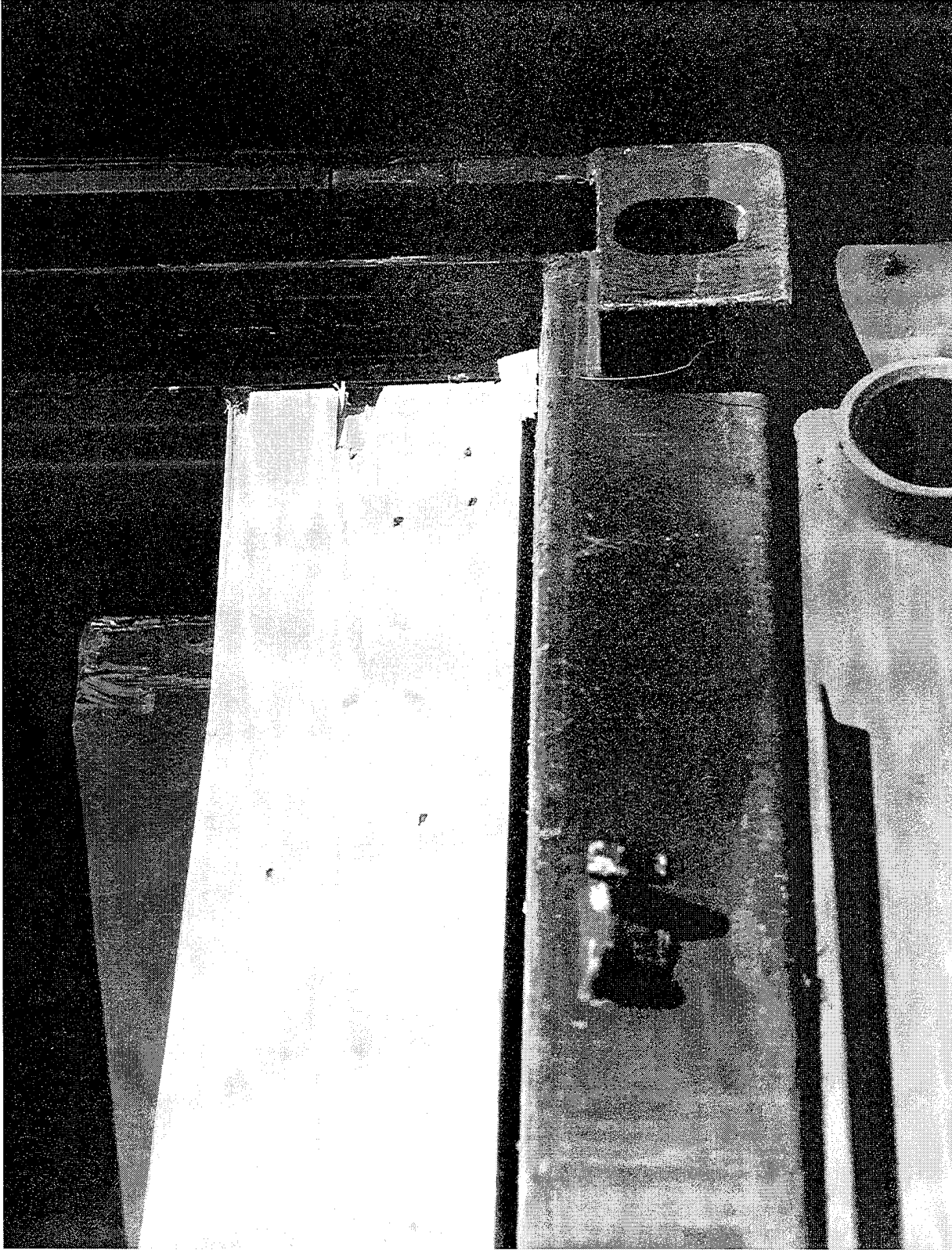

U.S. ARMY DEFENSE AMMUNITION CENTER AND SCHOOL -
SAVANNA, IL

Photo No. SCM-96-115-2400. This photo shows the damage sustained by the right side of the laminated 2- by 8-inch closeout beam. Note that the wood has split in the area of the vertical closeout angle indicating too much unit pressure in the area of contact.



U.S. ARMY DEFENSE AMMUNITION CENTER AND SCHOOL -
SAVANNA, IL

Photo No. SCM-96-115-2397. This photo shows the damage sustained by the right side of the laminated 2- by 8-inch closeout beam. Note that the wood has split in the area of the vertical closeout angle indicating too much unit pressure in the area of contact.



U.S. ARMY DEFENSE AMMUNITION CENTER AND SCHOOL -
SAVANNA, IL

Photo No. SCM-96-115-2406. This photo shows the laminated 2- by 8-inch beam after the 7.2 mph impact. All three laminations are cracked to the point of permanent deformation.

PART 6

DRAWING

APPROVED BY
BUREAU OF EXPLOSIVES

D. Healy

DATE 1-4-95

MLRS

LOADING AND BRACING WITH LOAD AND ROLL PALLET (LRP) IN COMMERCIAL CONTAINERS OF ROCKET POD/CONTAINERS (RP/C) FOR MULTIPLE LAUNCH ROCKET SYSTEM, FOR SHIPMENT BY T/COFC CARRIER

INDEX

<u>ITEM</u>	<u>PAGE(S)</u>
GENERAL NOTES AND MATERIAL SPECIFICATIONS	2
RP/C DETAIL AND SPECIAL HANDLING GUIDANCE	3-5
FULL LOAD PROCEDURES (STEEL STRAPPING METHOD)	6-7
FULL LOAD PROCEDURES (WEB STRAPPING METHOD)	8-9
BLOCKING DETAILS	10

- LOADING AND BRACING SPECIFICATIONS SET FORTH WITHIN THIS DRAWING ARE APPLICABLE TO LOADS THAT ARE TO BE SHIPPED BY TRAILER/CONTAINER-ON-FLATCAR (T/COFC) RAIL CARRIER SERVICE. THESE SPECIFICATIONS MAY ALSO BE USED FOR LOADS THAT ARE TO BE MOVED BY MOTOR OR WATER CARRIERS.

SEE GENERAL NOTE "P" ON PAGE 2.

U.S. ARMY MATERIEL COMMAND DRAWING			
APPROVED, U.S. ARMY MISSILE COMMAND		DRAFTSMAN	TECHNICIAN
<i>Brashen W. Foye</i>			R. HAYNES
APPROVED BY ORDER OF COMMANDING GENERAL, U.S. ARMY MATERIEL COMMAND		VALIDATION ENGINEERING DIVISION	ENGINEER
<i>William Ernest</i>			G. WILLIS
U.S. ARMY DEFENSE AMMUNITION CENTER AND SCHOOL		TRANSPORTATION ENGINEERING DIVISION	LOGISTICS ENGINEERING OFFICE
		<i>JMK</i>	<i>W. French Ernest</i>
DECEMBER 1994			
CLASS	DIVISION	DRAWING	FILE
19	48	8184	GM15RS3

DO NOT SCALE

GENERAL NOTES

- A. THIS DOCUMENT HAS BEEN PREPARED AND ISSUED IN ACCORDANCE WITH AR 740-1 AND AUGMENTS TM 743-200-1 (CHAPTER 5).
- B. THE SPECIFIED OUTLOADING PROCEDURES ARE APPLICABLE TO LOADS OF MULTIPLE LAUNCH ROCKET SYSTEM ROCKET POD/CONTAINERS (RP/C) UTILIZING A LOAD AND ROLL PALLET (LRP). SUBSEQUENT REFERENCE TO POD HEREIN MEANS THE RP/C WITH ROCKET COMPONENTS. NOTE: THE OUTLOADING PROCEDURES ARE ALSO APPLICABLE TO THE ARMY TACTICAL MISSILE SYSTEM (ATACMS) MISSILE LAUNCH POD ASSEMBLY (MLPA) OR OTHER SIMILARLY CONFIGURED ITEMS NOT EXCEEDING 22,000 POUNDS IN TOTAL LADING WEIGHT.
- C. FOR DETAILS OF THE ROCKET POD/CONTAINER, SEE US ARMY MISSILE COMMAND DRAWING NO. 13027900.
- POD DIMENSIONS - - - 13'-10" LONG BY 41-1/2" WIDE BY 33" HIGH
GROSS WEIGHT - - - - 5,078 POUNDS (APPROX)
- D. THE OUTLOADING PROCEDURES SPECIFIED HEREIN CAN ALSO BE UTILIZED FOR THE SHIPMENT OF THE DEPICTED PODS WHEN THEY ARE LOADED WITH AN ITEM WHICH IS IDENTIFIED DIFFERENTLY BY NOMENCLATURE THAN THE ITEM DESIGNATED IN THE DRAWING TITLE.
- E. THE LOAD AS SHOWN IS BASED ON A 4,700 POUND 20' LONG BY 8' WIDE BY 8'-6" HIGH END OPENING ISO CONTAINER WITH INSIDE DIMENSIONS OF 19'-4" LONG BY 92" WIDE BY 95" HIGH (93" CLEAR HEIGHT) AND A MAXIMUM GROSS WEIGHT OF 52,910 POUNDS. THE LOAD IS DESIGNED FOR TRAILER/CONTAINER-ON-FLATCAR (T/COFC) SHIPMENT, HOWEVER, THE LOAD AS DESIGNED CAN ALSO BE MOVED BY OTHER SURFACE MODES OF TRANSPORT. NOTICE: OTHER CONTAINERS OF THE SAME DESIGN CONFIGURATION CAN BE USED.

(CONTINUED AT RIGHT)

MATERIAL SPECIFICATIONS

- LUMBER - - - - - : SEE TM 743-200-1 (DUNNAGE LUMBER) AND FED SPEC MM-L-751.
- NAILS - - - - - : FED SPEC FF-N-105; COMMON.
- STRAPPING, STEEL - - : ASTM D3953; FLAT STRAPPING, TYPE 1, HEAVY DUTY, FINISH A, B (GRADE 2), OR C.
- SEAL, STRAP - - - - : ASTM D3953; CLASS H, FINISH A, B (GRADE 2), OR C, DOUBLE NOTCH TYPE, STYLE I, II, OR IV.
- WEB STRAP - - - - - : ANCRASSEMBLY PART NO.48050-10 (8M-30-24-260P3) OR EQUIVALENT.
- WIRE, CARBON STEEL - : ASTM A853; ANNEALED AT FINISH, BLACK OXIDE FINISH, .0800" DIA, GRADE 1006 OR BETTER.
- STAKE
POCKET PROTECTOR - - : COMMERCIAL GRADE.
- ANTI-CHAFING
MATERIAL - - - - - : FED SPEC PPP-F-320, TYPE SF (SOLID FIBERBOARD), CLASS-DOMESTIC, ALL GRADES.
- LOAD AND ROLL
PALLET - - - - - : LOAD & ROLL INC DRAWING NO. 100-3121 AND PATENT NO. 4,834,000. CAPACITY 22,000 POUNDS.
- LUMBER,
LRP BLOCKING - - - - : FED SPEC MM-L-751; DOUGLAS FIR OR COMPARABLE LUMBER WITH STRAIGHT GRAIN AND FREE FROM MATERIAL DEFECTS.
- PLYWOOD - - - - - : COMMERCIAL ITEM DESCRIPTION A-A-55057, TYPE A, CONSTRUCTION AND INDUSTRIAL PLYWOOD, INTERIOR WITH EXTERIOR GLUE, GRADE C-D. IF SPECIFIED GRADE IS NOT AVAILABLE, A BETTER INTERIOR OR AN EXTERIOR GRADE MAY BE SUBSTITUTED.

(GENERAL NOTES CONTINUED)

- F. WHEN LOADING THE PODS, THEY ARE TO BE POSITIONED SO AS TO ACHIEVE A TIGHT LOAD (TIGHT AGAINST THE FORWARD BLOCKING ASSEMBLY). ADDITIONALLY, LATERAL VOIDS WITHIN THE LOAD ARE TO BE HELD TO A MINIMUM. EXCESSIVE SLACK CAN BE ELIMINATED FROM A LOAD BY LAMINATING ADDITIONAL PIECES OF APPROPRIATE THICKNESS TO THE FILLER BLOCKS ON THE CORNER RETAINER PIECES. NAIL EACH ADDITIONAL PIECE TO THE FILLER BLOCK W/4 APPROPRIATELY SIZED NAILS. ADDITIONALLY, THE THICKNESS OF THE FILLER BLOCKS MAY BE ADJUSTED AS REQUIRED TO FACILITATE VARIANCE IN THE SIZE OF THE LOAD AND ROLL PALLET OR THE CONTAINER INTERIOR LOADING SPACE.
- G. DUNNAGE LUMBER SPECIFIED IS OF NOMINAL SIZE. FOR EXAMPLE, 1" X 4" MATERIAL IS ACTUALLY 3/4" THICK BY 3-1/2" WIDE AND 2" X 6" MATERIAL IS ACTUALLY 1-1/2" THICK BY 5-1/2" WIDE.
- H. WHEN STEEL STRAPPING IS SEALED AT AN END-OVER-END LAP JOINT, A MINIMUM OF ONE SEAL WITH TWO PAIR OF NOTCHES WILL BE USED TO SEAL THE JOINT WHEN A NOTCH-TYPE SEALER IS BEING USED. A MINIMUM OF TWO SEALS, BUTTED TOGETHER WITH TWO PAIR OF CRIMPS PER SEAL WILL BE USED TO SEAL THE JOINT WHEN A CRIMP-TYPE SEALER IS BEING USED. REFER TO THE "STRAP JOINT A" AND "STRAP JOINT B" DETAILS ON PAGE 5 FOR GUIDANCE.
- J. DIMENSIONS GIVEN FOR DUNNAGE PIECES OR ASSEMBLIES WILL BE FIELD CHECKED PRIOR TO THEIR ASSEMBLY AND INSTALLATION INTO THE END OPENING CONTAINER.
- K. MAXIMUM LOAD WEIGHT CRITERIA:
- THE MAXIMUM LOAD WEIGHTS ARE CONTROLLED BY EQUIPMENT CAPABILITY FACTORS. ALTHOUGH THE HEAVIEST MAXIMUM LOADS ARE DELINEATED IN THE LOAD VIEWS, PROVISIONS ARE INCLUDED WITHIN THIS DRAWING SO THAT THE BASIC LOADS CAN BE ADJUSTED TO SATISFY A LESSER QUANTITY OF LADING UNITS, DEPENDING ON TRANSPORTATION ROUTING. IT MAY BE NECESSARY TO REDUCE THE LOAD WEIGHT TO SATISFY "WEIGHT LAWS" OF CERTAIN STATES. ALSO, IT MAY BE NECESSARY TO REDUCE THE LOAD WEIGHT TO SATISFY OTHER WEIGHT RESTRICTIONS IMPOSED ON THE INTERMODAL CONTAINER SYSTEM.
- L. REQUIREMENTS CITED WITHIN THE BUREAU OF EXPLOSIVES PAMPHLET 6C APPLY WHEN THE SHIPMENT MOVES BY TRAILER/CONTAINER-ON-FLATCAR (T/COFC). SPECIAL T/COFC NOTES FOLLOW:
1. A LOADED CONTAINER MUST BE ON A CHASSIS EQUIPPED WITH TWO BOGIE ASSEMBLIES WHEN BEING MOVED IN TOFC SERVICE.
 2. THE LOAD LIMIT OF A T/COFC RAILCAR MUST NOT BE EXCEEDED, NOR WILL A CAR BE LOADED SO THAT THE TRUCK UNDER ONE END OF THE CAR CARRIES MORE THAN ONE-HALF OF THE LOAD LIMIT FOR THAT CAR.
- M. DURING INTRASTATE AND/OR INTERSTATE MOVES BY MOTOR CARRIER, A PROPER CHASSIS OR MODIFIED FLATBED TRAILER MUST BE USED TO PRECLUDE VIOLATION OF ONE OR MORE "WEIGHT LAWS" APPLICABLE TO THE STATE OR STATES INVOLVED.
- N. THREE INCH (3") WIDE WEB CARGO STRAPS MAY BE USED IN LIEU OF THE 2" WIDE STEEL HOLD-DOWN STRAPS USED TO SECURE THE LADING TO THE LOAD AND ROLL PALLET. EACH WEB CARGO STRAP ASSEMBLY MUST HAVE A MINIMUM LOAD RATING OF 9,000 POUNDS AND CONSIST OF A HEAVY CAPACITY RATCHET, 3-INCH WIDE POLYESTER WEBBING, A PAIR OF MOVABLE CORNER PROTECTORS, A FLAT HOOK ON EACH END, AND A KEEPER ON EACH FLAT HOOK. AN ACCEPTABLE WEB STRAP ASSEMBLY IS IDENTIFIED IN THE MATERIAL SPECIFICATIONS BELOW.
- O. CONVERSION TO METRIC EQUIVALENTS: DIMENSIONS WITHIN THIS DOCUMENT ARE EXPRESSED IN INCHES AND WEIGHTS ARE EXPRESSED IN POUNDS. WHEN NECESSARY, THE METRIC EQUIVALENTS MAY BE COMPUTED ON THE BASIS OF ONE INCH EQUALS 25.4 MM AND ONE POUND EQUALS 0.454 KG.
- P. THE LOAD AND ROLL PALLET IS A COMMERCIAL PRODUCT. FOR A SOURCE OF SUPPLY, CONTACT LOAD AND ROLL INC., 10100 KITTY AVENUE, CHICAGO RIDGE, IL 60415. PHONE (708) 499-3370.
- Q. PORTIONS OF THE CONTAINER DEPICTED WITHIN THIS DRAWING, SUCH AS THE SIDEWALL, HAVE NOT BEEN SHOWN IN THE LOAD VIEWS FOR CLARITY PURPOSES.

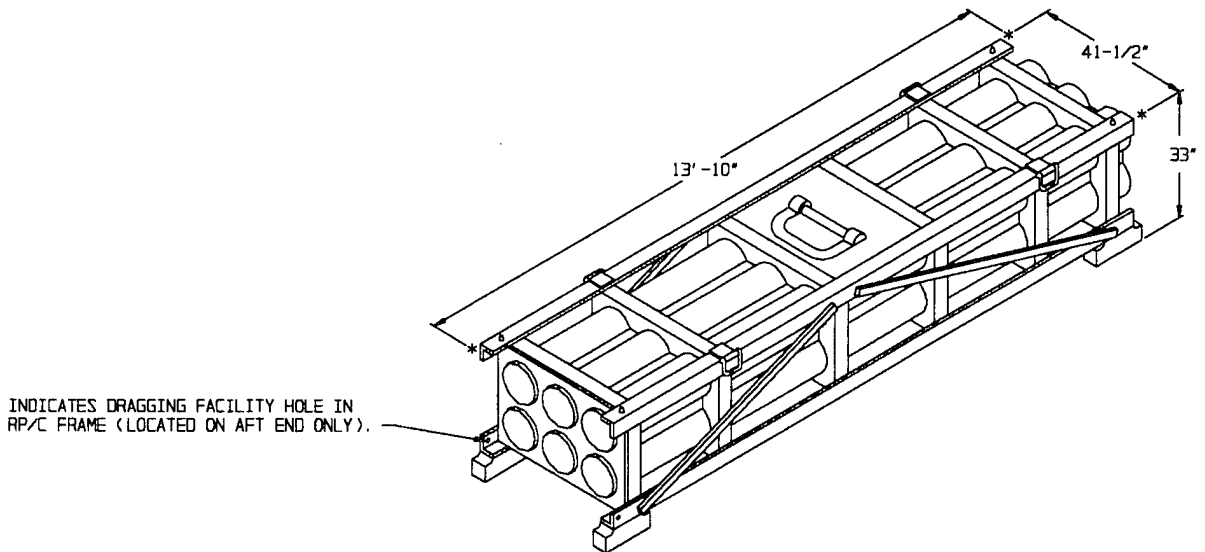

ROCKET POD/CONTAINER

SPECIAL HANDLING GUIDANCE

(SPECIAL HANDLING GUIDANCE CONTINUED)

1. POD STACKING FOR OUTLOADING PURPOSES.

- A. THE UPPER POD SHOULD BE PLACED AS CLOSELY AS POSSIBLE IN VERTICAL ALIGNMENT WITH THE LOWER POD.
- B. WHEN STACKING THESE PODS, CARE MUST BE EXERCISED TO INSURE THAT THE INTERLOCKING HOLES IN THE BOTTOM OF THE POD SKIDS ALIGN CORRECTLY WITH THE INTERLOCKING PINS ON THE TOP OF THE POD FRAME. THIS WILL PRECLUDE DAMAGE TO THE SKIDS AND INSURE PROPER FUNCTIONING OF THE POD INTERLOCKS.

2. POD OR POD STACK HANDLING.

NOTES: (1) MATERIALS HANDLING EQUIPMENT (MHE) IS INTENDED TO MEAN EQUIPMENT, SUCH AS FORKLIFT TRUCKS, CRANES, HAND TRUCKS, DOLLIES, ROLLER ASSEMBLIES, SLINGS, AND SPREADER BARS, THAT CAN BE USED TO HANDLE THE DEPICTED PODS.

(2) PRECAUTIONARY HANDLING TECHNIQUES NORMALLY EMPLOYED OR AS SPECIFIED FOR THE TYPE OF COMMODITY INVOLVED WILL BE OBSERVED.

- A. ONLY APPROVED AND APPROPRIATELY SIZED MHE WILL BE USED FOR HANDLING THE DEPICTED PODS.
- B. IF HANDLING IS ACCOMPLISHED WITH A FORKLIFT TRUCK, THE PODS SHOULD BE HANDLED FROM A SIDE POSITION ONLY. CARE MUST BE EXERCISED WHEN INSERTING THE FORKS UNDER THE POD TO PREVENT DAMAGE TO THE PODS BY THE FORK TINES OR THE FORKLIFT PACKAGE GUARD. ADDITIONALLY, THE FORK TINES SHOULD BE PLACED UNDER THE PODS STRONG AREAS; THAT IS, THE LATERAL FRAME MEMBERS/BULKHEADS LOCATED NEAR THE LONGITUDINAL CENTER OF THE POD.

3. SEQUENTIAL CONTAINER LOADING.

- A. NOTE: FOR EASE IN LOADING THE LOAD AND ROLL PALLET INTO THE END OPENING CONTAINER, SET THE FRONT END PORTION (APPROX 24") OF THE LOAD AND ROLL PALLET IN THE OPEN DOORWAY END OF THE END OPENING CONTAINER AND INSERT CORNER SUPPORTS DIAGONALLY BENEATH THE REAR CORNERS OF THE LOAD AND ROLL PALLET (SEE THE DETAIL ON PAGE 4).

(CONTINUED AT RIGHT)

- B. LOAD THE PODS OR POD STACKS BY FIRST INSERTING THE FAR SKIDS IN THE CENTER SKID RESTRAINT PANS ON THE LOAD AND ROLL PALLET. THEN LOWERING THE NEAR SKIDS INTO THE OUTSIDE SKID RESTRAINT PANS ON THE PALLET. NOTE: THE AFT END OF THE PODS MUST BE POSITIONED AT THE FORWARD END OF THE LOAD AND ROLL PALLET.

- C. APPLY THE STACK UNITIZING STRAP. NOTE: FIBERBOARD ANTI-CHAFING MATERIAL MUST BE INSTALLED UNDER THE STRAPS AT ALL POINTS OF CONTACT WITH THE PODS.

- D. INSTALL THE CENTER FILL PIECES. POSITION THE CENTER FILL PIECES OF THE BOTTOM LAYER SO THAT THEY ARE SUPPORTED BY THE TOP OF THE FORK POCKET (TUNNEL) ON THE LOAD AND ROLL PALLET. POSITION THE CENTER FILL PIECES FOR THE TOP LAYER IN LINE WITH THOSE FOR THE BOTTOM LAYER. WIRE TIE THE CENTER FILL PIECES TO THE POD FRAME.

- E. NEXT, LOAD AND UNITIZE THE REMAINING PODS IN THE MANNER DETAILED IN PARAGRAPHS 3B AND 3C ABOVE.

- F. APPLY THE HOLD-DOWN STRAPS, POSITIONING FIBERBOARD ANTI-CHAFING MATERIAL UNDER THE STRAPS AT ALL POINTS OF CONTACT WITH THE PODS. CAUTION: THE HOLD-DOWN STRAPS MUST BE INSTALLED WITH CARE SO AS NOT TO HAVE EDGE-TO-EDGE CONTACT WITH THE STACK UNITIZING STRAPS.

- G. POSITION THE FORWARD BLOCKING ASSEMBLY IN THE END OPENING CONTAINER. LIFT THE REAR END OF THE LOAD AND ROLL PALLET WITH APPROPRIATELY SIZED MHE UNTIL ONLY THE ROLLER CONTACTS THE END OPENING CONTAINER FLOOR (REF: 6"). ROLL THE PALLET INTO THE CONTAINER UNTIL IT CONTACTS THE FORWARD BLOCKING ASSEMBLY. SET THE REAR OF THE PALLET ON THE END OPENING CONTAINER FLOOR. INSTALL THE CORNER RETAINER PIECES AND FILL MATERIAL AS NECESSARY.

4. UNLOADING THE LOAD AND ROLL PALLET FROM THE END OPENING CONTAINER.

- A. THE LOAD AND ROLL PALLET MAY BE UNLOADED USING THE REVERSE OF THE METHOD DETAILED IN 3G ABOVE.
- B. THE LOAD AND ROLL PALLET MAY ALSO BE UNLOADED USING A VEHICLE WITH AN APPROPRIATELY SIZED WINCH. FIRST, REMOVE THE CORNER RETAINER PIECES. ATTACH THE WINCH TO THE O-RING ON THE REAR OF THE LOAD AND ROLL PALLET, RAISE THE PALLET UNTIL THE ROLLER CONTACTS THE END OPENING CONTAINER FLOOR, AND PULL THE PALLET OUT USING THE WINCHING VEHICLE, TAKING CARE NOT TO PULL THE PALLET TOTALLY OUT OF THE END OPENING CONTAINER. SET CORNER SUPPORTS UNDER THE CORNERS OF THE PALLET, AND UNLOAD THE MLRS PODS, USING APPROPRIATELY SIZED MHE.

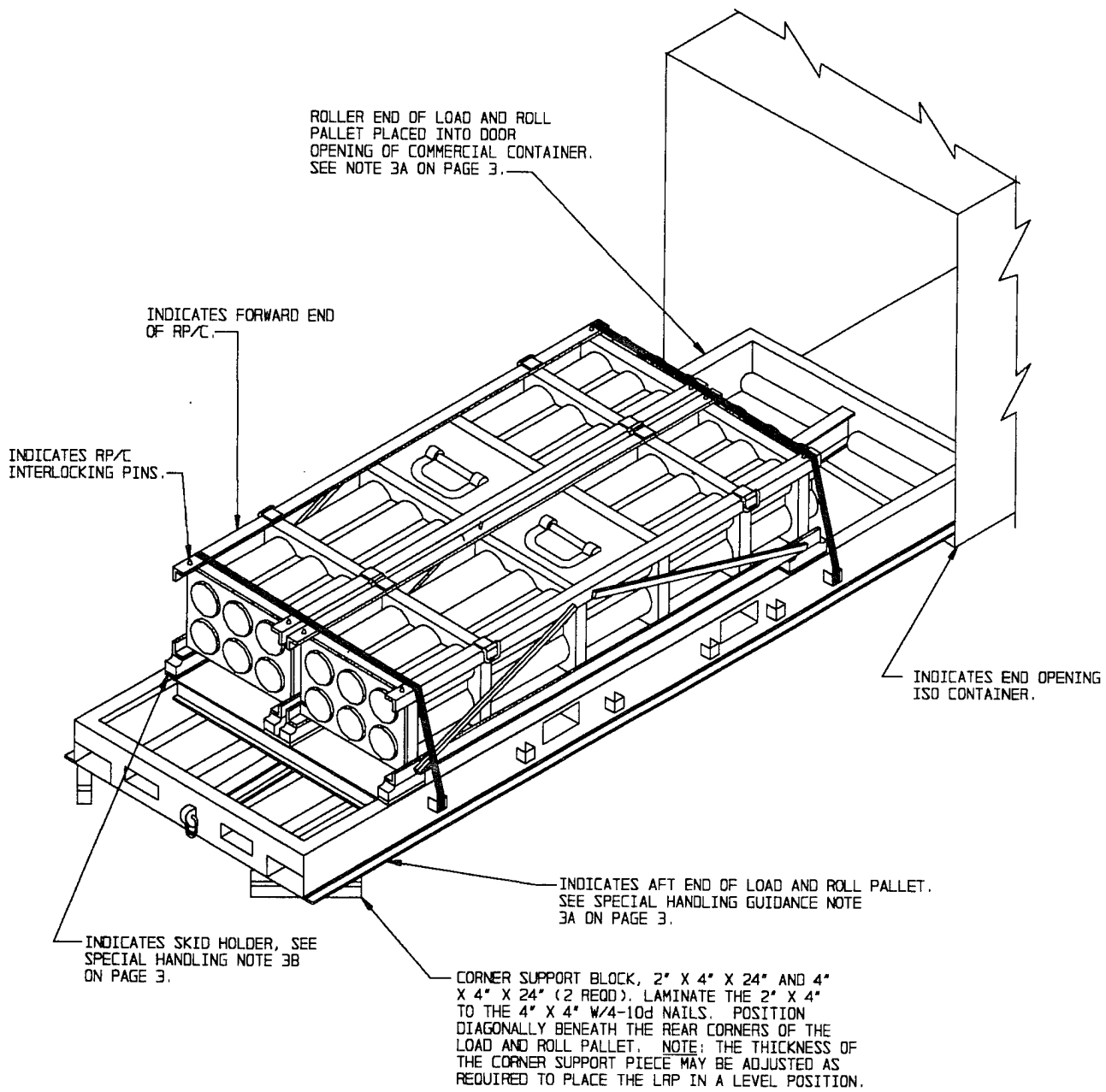

ISOMETRIC VIEW

ALTHOUGH THE ABOVE VIEW DEPICTS ONLY TWO PODS SECURED TO A LOAD AND ROLL PALLET, THE SAME PROCEDURES ARE APPLICABLE FOR A FOUR POD LOAD.

INDICATES END OPENING ISO CONTAINER.

INDICATES ROCKET POD/CONTAINERS SECURED TO LOAD AND ROLL PALLET.

INDICATES FORKLIFT TRUCK (OR PAIR OF FORK-LIFT TRUCKS SIDE BY SIDE).

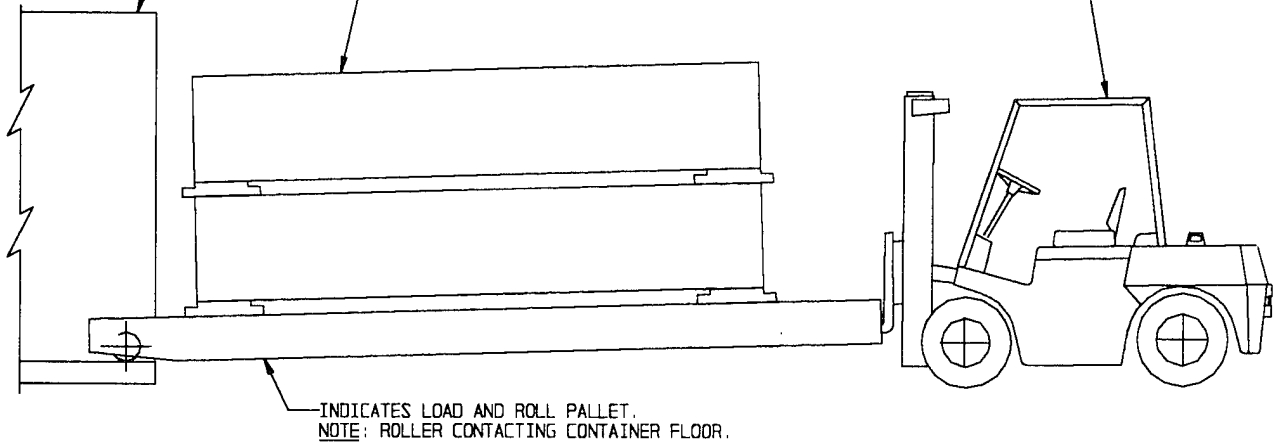

LOADING OF LRP AND MLRS CONTAINERS INTO END OPENING ISO CONTAINER

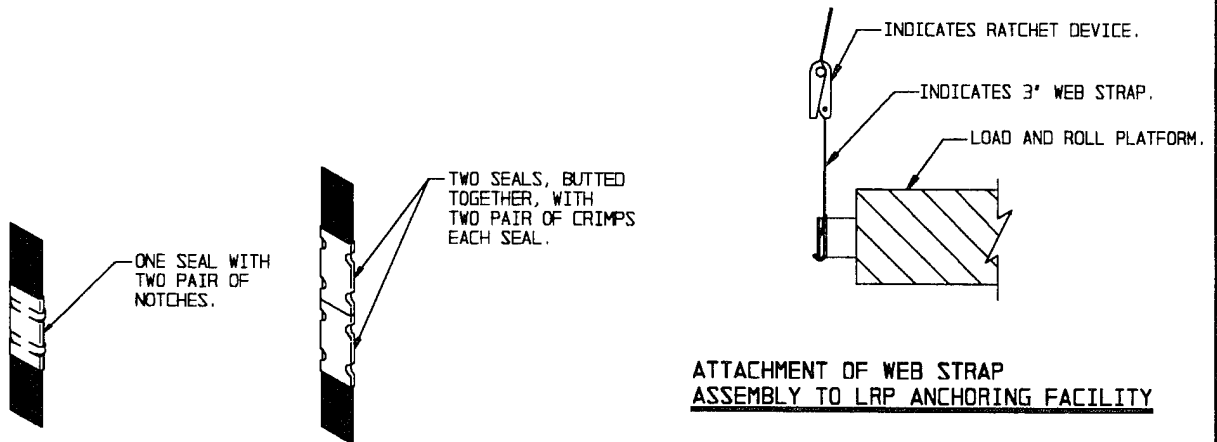

STRAP JOINT A
METHOD OF SECURING A STRAP JOINT WHEN USING A NOTCH-TYPE SEALER.

STRAP JOINT B
METHOD OF SECURING A STRAP JOINT WHEN USING A CRIMP-TYPE SEALER.

END-OVER-END LAP JOINT DETAILS

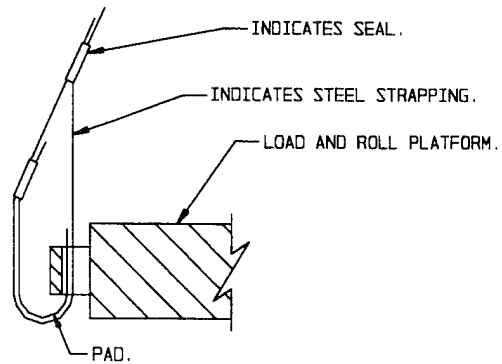

ATTACHMENT OF STEEL STRAPPING TO LRP ANCHORING FACILITY

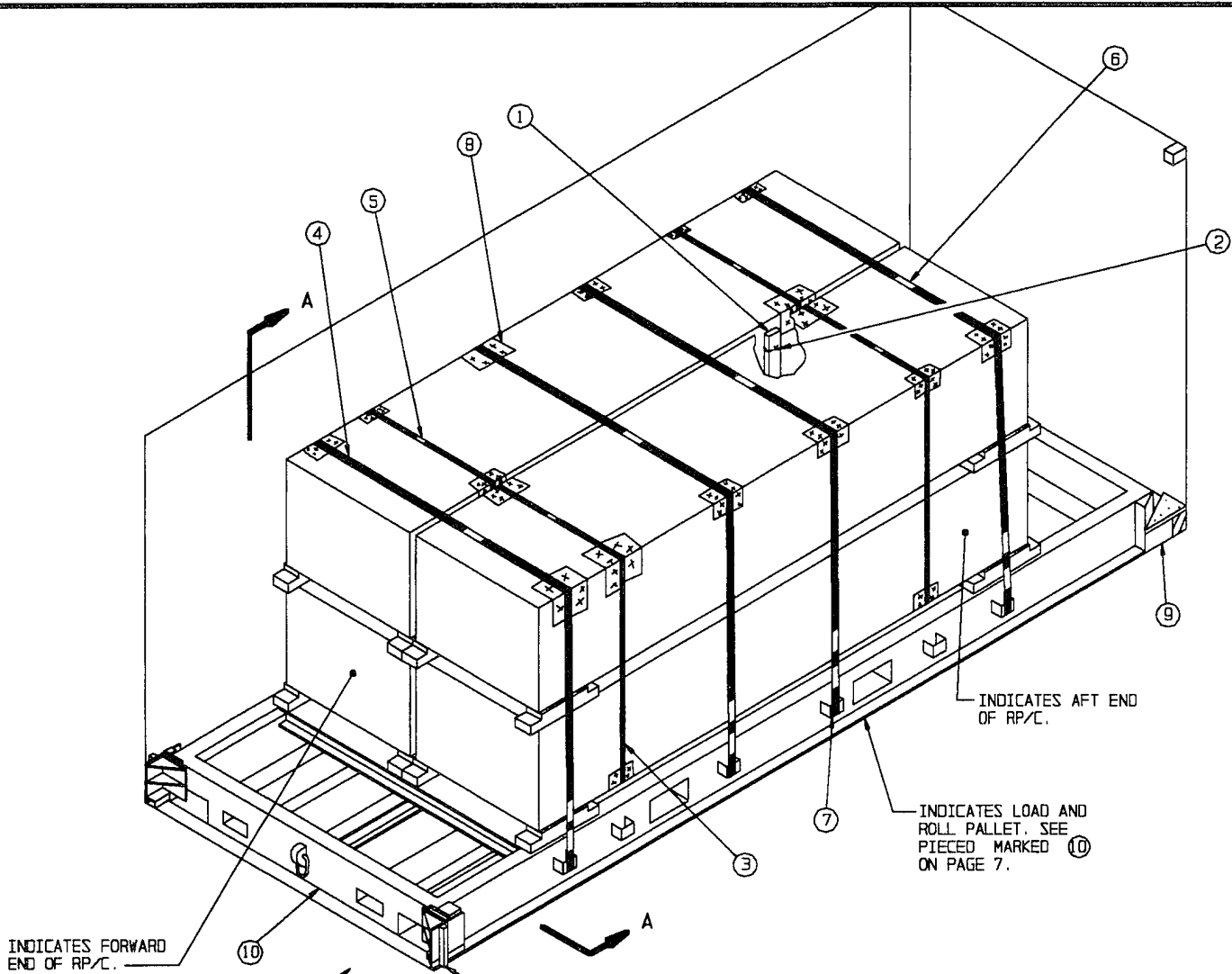

ISOMETRIC VIEW

INDICATES FORWARD END OF RP/C.

REAR OF CONTAINER.

INDICATES AFT END OF RP/C.

INDICATES LOAD AND ROLL PALLET. SEE PIECED MARKED 10 ON PAGE 7.

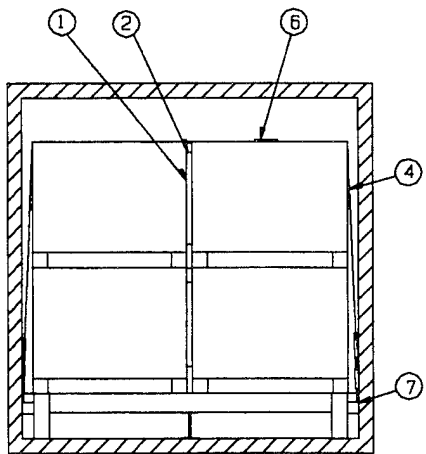

SECTION A-A

KEY NUMBERS

- ① CENTER FILL PIECE, 2" X 4" X 33" (4 REOD). PREPOSITION AS SHOWN AND WIRE TIE TO A VERTICAL FRAME MEMBER OF A ROCKET POD/CONTAINER. SEE NOTE 30 ON PAGE 3.
- ② TIE WIRE, NO. 14 GAGE WIRE, 24" LONG (8 REOD). INSTALL WIRE TO FORM A LOOP AROUND A VERTICAL FRAME MEMBER OF A POD AND THE CENTER FILL PIECE, PIECE MARKED ①. BRING ENDS TOGETHER AND TWIST TAUT.
- ③ STACK UNITIZING STRAP, 1-1/4" X .035" OR .031" BY A LENGTH TO SUIT (REF: 20'-0") (4 REOD). INSTALL SO AS TO ENCIRCLE THE CONTAINERS IN ONE STACK AS SHOWN.
- ④ HOLD-DOWN STRAP, 2" X .050" OR .044" X 28'-0" LONG STEEL STRAPPING (4 REOD). INSTALL EACH STRAP FROM TWO 14'-0" LONG PIECES.
- ⑤ SEAL FOR 1-1/4" STEEL STRAPPING (4 REOD, 1 PER STRAP). CRIMP EACH SEAL WITH TWO PAIR OF NOTCHES. SEE GENERAL NOTE "H" ON PAGE 2.
- ⑥ SEAL FOR 2" STEEL STRAPPING (20 REOD, 5 PER STRAP). CRIMP EACH STRAP WITH TWO PAIR OF NOTCHES, EXCEPT FOR THOSE USED TO SECURE THE PADS, WHICH ONLY REQUIRE ONE PAIR OF NOTCHES. SEE GENERAL NOTE "H" ON PAGE 2.
- ⑦ PAD, STRAPPING, 2" X .050" OR .044" X 24" (8 REOD). PRE-POSITION THE PAD BETWEEN THE STRAPPING, PIECE MARKED ④, AND THE LOAD AND ROLL PALLET TIEDOWN PROVISION AND SECURE WITH ONE SEAL WITH ONE PAIR OF NOTCHES. SEE THE "ATTACHMENT OF STEEL STRAPPING TO LRP ANCHORING FACILITY" DETAIL ON PAGE 5.
- ⑧ FIBERBOARD ANTI-CHAFING MATERIAL (AS REOD). FOLD FIBERBOARD TO FORM A DOUBLE THICKNESS AND PLACE UNDER STRAPPING AT ALL POINTS OF CONTACT WITH THE CONTAINERS.

(CONTINUED ON PAGE 7)

(KEY NUMBERS CONTINUED FROM PAGE 6)

- ⑨ FORWARD BLOCKING ASSEMBLY (1 REQD). SEE THE DETAIL ON PAGE 10. PRE-POSITION PRIOR TO LOADING THE LOAD AND ROLL PALLET IN THE CONTAINER.
- ⑩ LOAD AND ROLL PALLET (1 REQD). SEE THE "SPECIAL HANDLING GUIDANCE" ON PAGES 4 AND 5. SEE GENERAL NOTE "P" ON PAGE 2.
- ⑪ CORNER RETAINER PIECE (2 REQD). SEE THE DETAIL ON PAGE 10. SEE GENERAL NOTE "F" ON PAGE 2.

SPECIAL NOTES:

- 1. A 4-UNIT LOAD OF ROCKET POD/CONTAINERS (RP/C) IS DEPICTED ON A LOAD AND ROLL PALLET IN AN END OPENING ISO CONTAINER.
- 2. PRIOR TO LOADING THE PODS INTO THE END OPENING CONTAINER, SEE THE SPECIAL HANDLING GUIDANCE ON PAGES 3 AND 4.
- 3. ALL STRAPS MUST BE INSTALLED NEAR THE STRONG POINTS OR VERTICALLY REINFORCED AREAS OF THE PODS.

BILL OF MATERIAL

LUMBER	LINEAR FEET	BOARD FEET
2" X 4"	11	8
4" X 4"*	11	15
NAILS	NO. REQD	POUNDS
6d (2")	14	NIL
10d (3")	4	NIL
STEEL STRAPPING, 2" - - - -	128' REQD - - - -	43 LBS
SEAL FOR 2" STRAPPING - - - -	20 REQD - - - -	-5 LBS
STEEL STRAPPING, 1-1/4" - - -	80' REQD - - - -	11 LBS
SEAL FOR 1-1/4" STRAPPING - - -	4 REQD - - - -	-1/4 LB
WIRE, NO. 14 GAGE - - - -	16' REQD - - - -	NIL
PLYWOOD, AS REQD - - - -	2 SQ FT REQD - - - -	NIL
ANTI-CHAFING MATERIAL - - - -	AS REQD - - - -	NIL
LOAD AND ROLL PALLET - - - -	1 REQD - - - -	1,970 LBS

LOAD AS SHOWN

ITEM	QUANTITY	WEIGHT (APPROX)
MLRS (RP/C) - - - - -	4 - - - - -	20,312 LBS
DUNNAGE - - - - -	- - - - -	2,076 LBS
END OPENING CONTAINER - - - - -	- - - - -	4,700 LBS
TOTAL WEIGHT - - - - -		27,088 LBS (APPROX)

* THE 4" X 4" MATERIAL SHOULD MEET THE REQUIREMENTS SET FORTH IN THE MATERIAL SPECIFICATIONS FOR LUMBER, LRP BLOCKING.

FULL LOAD PROCEDURES (STEEL STRAPPING METHOD)

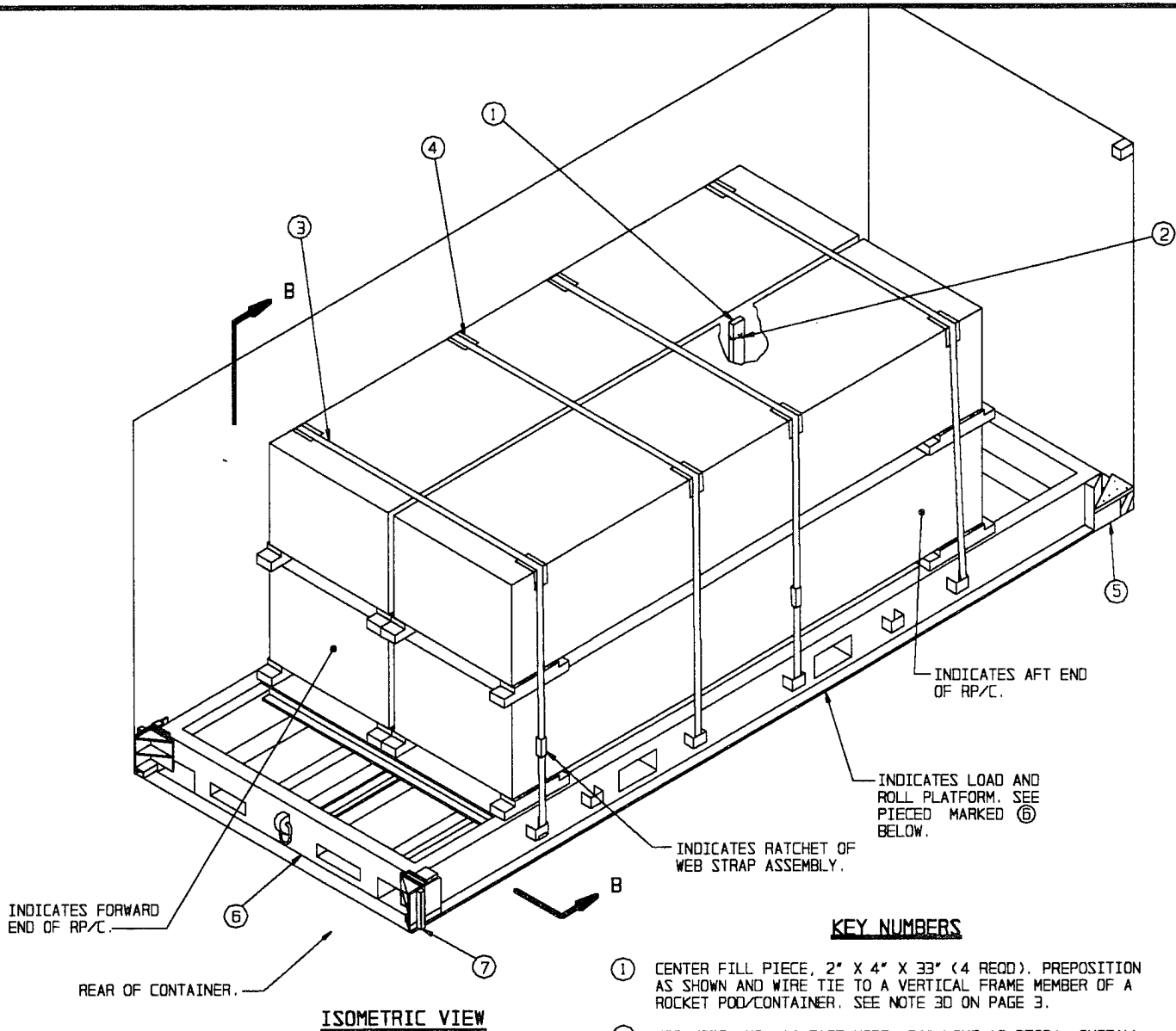

ISOMETRIC VIEW

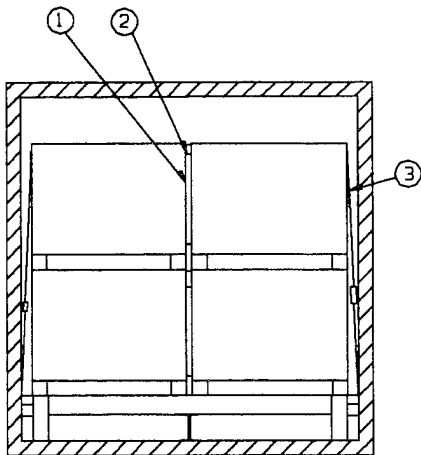

SECTION B-B

KEY NUMBERS

- ① CENTER FILL PIECE, 2" X 4" X 33" (4 REOD). PREPOSITION AS SHOWN AND WIRE TIE TO A VERTICAL FRAME MEMBER OF A ROCKET POD/CONTAINER. SEE NOTE 3D ON PAGE 3.
- ② TIE WIRE, NO. 14 GAGE WIRE, 24" LONG (8 REOD). INSTALL WIRE TO FORM A LOOP AROUND A VERTICAL FRAME MEMBER OF A POD AND THE CENTER FILL PIECE, PIECE MARKED ①. BRING ENDS TOGETHER AND TWIST TAUT.
- ③ WEB STRAP TIEDOWN ASSEMBLY (4 REOD). INSTALL TO EXTEND FROM AN ANCHORING FACILITY ON ONE SIDE OF THE LOAD AND ROLL PALLET, OVER THE POD STACKS, TO AN ANCHORING FACILITY ON THE OPPOSITE SIDE OF THE PALLET. SEE GENERAL NOTE "N" ON PAGE 2. SEE THE "ATTACHMENT OF WEB STRAP ASSEMBLY TO LRP ANCHORING FACILITY" DETAIL ON PAGE 5.
- ④ CORNER PROTECTOR (2 PER STRAP PROVIDED). POSITION ON OUTER EDGE OF THE POD FRAME. NOTE: IF THE CORNER PROTECTOR IS MISSING THEN A FOLDED PIECE OF FIBERBOARD SHALL BE USED TO PROTECT THE WEBBING.
- ⑤ FORWARD BLOCKING ASSEMBLY (1 REOD). SEE THE DETAIL ON PAGE 10. PRE-POSITION PRIOR TO LOADING THE LOAD AND ROLL PALLET IN THE CONTAINER.
- ⑥ LOAD AND ROLL PALLET (1 REOD). SEE THE "SPECIAL HANDLING GUIDANCE" ON PAGES 4 AND 5. SEE GENERAL NOTE "P" ON PAGE 2.
- ⑦ CORNER RETAINER PIECE (2 REOD). SEE THE DETAIL ON PAGE 10. SEE GENERAL NOTE "F" ON PAGE 2.

SPECIAL NOTES:

1. A 4-UNIT LOAD OF ROCKET POD/CONTAINERS (RP/C) IS DEPICTED SECURED WITH WEB STRAPPING TO A LOAD AND ROLL PALLET AND LOADED INTO AN END OPENING ISO CONTAINER.
2. PRIOR TO LOADING THE ROCKET POD/CONTAINERS INTO THE END OPENING CONTAINER, SEE THE SPECIAL HANDLING GUIDANCE ON PAGES 3 AND 4. HOWEVER, WEB CARGO STRAPS AS DESCRIBED IN GENERAL NOTE "N" ON PAGE 2 WILL BE USED IN LIEU OF THE 1-1/4" WIDE STEEL STACK UNITIZING STRAPS AND THE 2" WIDE STEEL HOLD-DOWN STRAPS DEPICTED ON PAGES 3 AND 4.
3. ALL STRAPS MUST BE INSTALLED NEAR THE STRONG POINTS OR VERTICALLY REINFORCED AREAS OF THE PODS.

BILL OF MATERIAL		
LUMBER	LINEAR FEET	BOARD FEET
2" X 4"	11	8
4" X 4" *	11	15
NAILS	NO. REQD	POUNDS
6d (2")	14	NIL
10d (3")	4	NIL
WEB STRAP ASSEMBLY (3") - - - 4 REQD - - - 44 LBS		
WIRE, NO. 14 GAGE - - - - 16' REQD - - - - NIL		
PLYWOOD, AS REQD - - - - 2 SQ FT REQD - - - - NIL		
ANTI-CHAFING MATERIAL - - - - AS REQD - - - - NIL		
LOAD AND ROLL PALLET - - - - 1 REQD - - 1,970 LBS		

* THE 4" X 4" MATERIAL SHOULD MEET THE REQUIREMENTS SET FORTH IN THE MATERIAL SPECIFICATIONS FOR LUMBER, LRP BLOCKING.

LOAD AS SHOWN

<u>ITEM</u>	<u>QUANTITY</u>	<u>WEIGHT (APPROX)</u>
MLRS (RP/C) - - - - -	4 - - - - -	20,312 LBS
DUNNAGE - - - - -	- - - - -	2,060 LBS
END OPENING CONTAINER - - - - -	- - - - -	4,700 LBS
<u>TOTAL WEIGHT - - - - -</u>		<u>27,072 LBS (APPROX)</u>

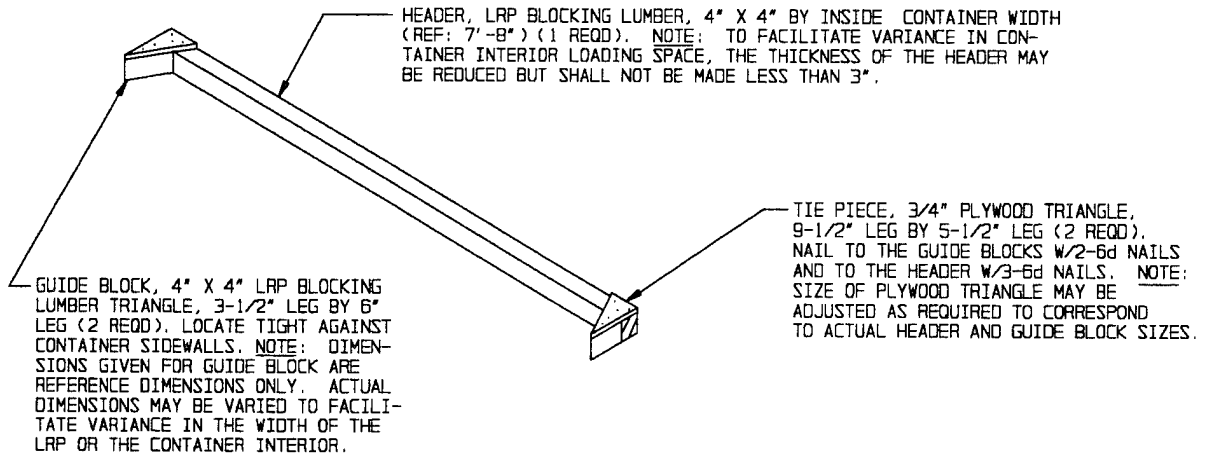

FORWARD BLOCKING ASSEMBLY

SHIM, 6" X 11" PLYWOOD BY THICKNESS TO SUIT (AS REQD). SELECT THICKNESS OF PLYWOOD TO FILL VOID BETWEEN FACE OF RETAINER AND END OF LOADING PLATFORM. NAIL PLYWOOD TO FILLER BLOCK W/2-6d NAILS BEFORE INSERTING INTO RETAINER.

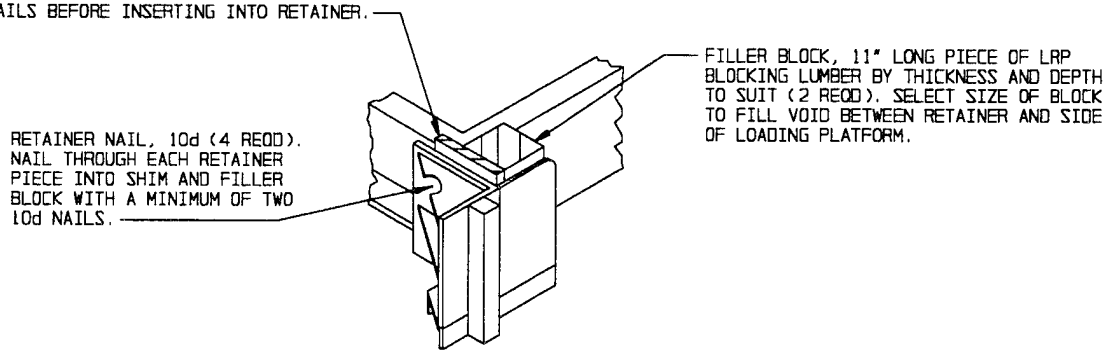

CORNER RETAINER PIECE

NOTE: POSITION SQUARE BAR OF RETAINER PIECE INTO RECESS OF SIDEWALL LOCATED JUST AHEAD OF REAR CORNER POST.

PART 7

APPENDIX

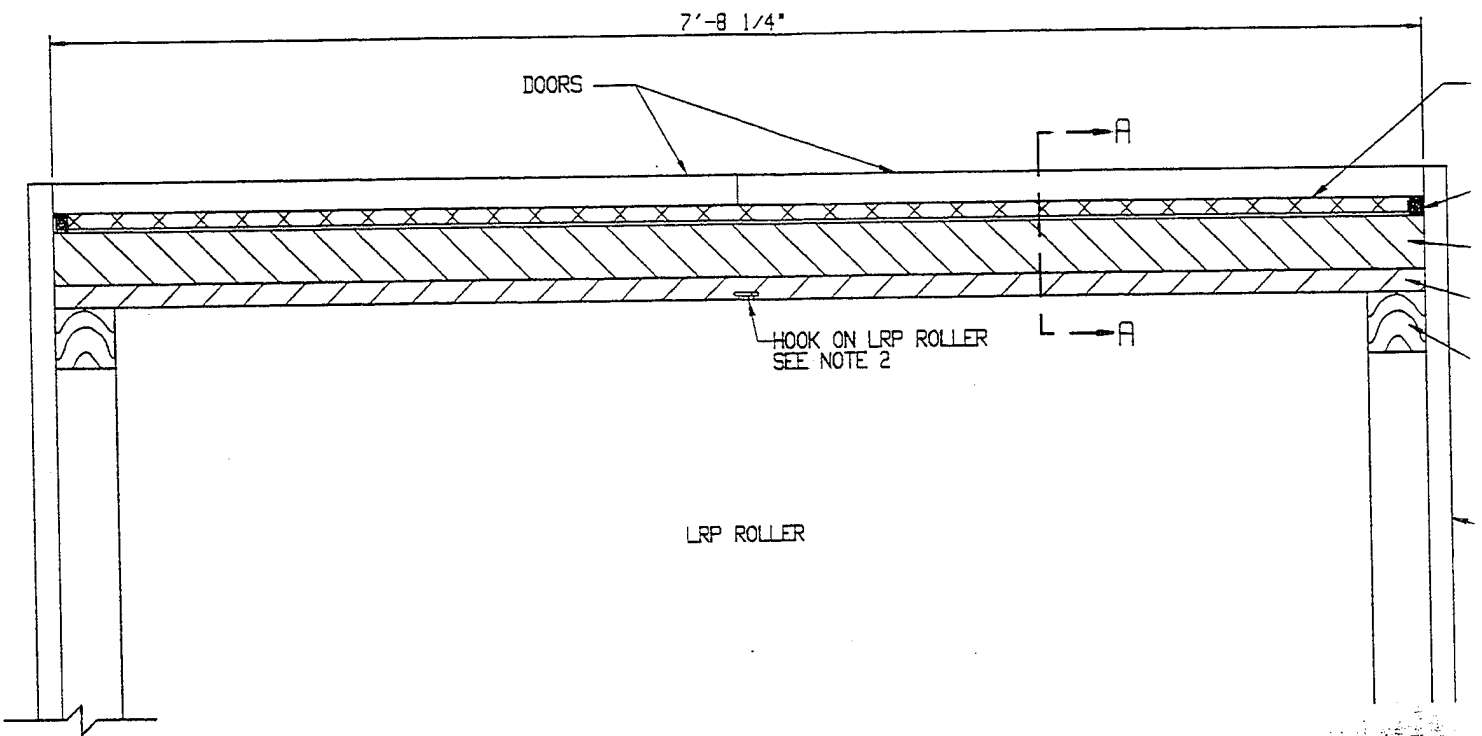

PARTIAL PLAN
 SCALE: 1 1/2" = 1'-0"

NOTES:

1. 4" x 6" AND 2" x 6" SHALL BE NAILED TOGETHER.
2. HOOK ON LRP ROLLER WILL KEEP THE 4" x 6" AND 2" x 6" BLOCKING FROM RISING OFF FLOOR.
3. WOOD WEDGES ON SIDES BETWEEN ROLLER AND WALL SHALL BE TOE NAILED TO 2" x 6" BLOCKING.

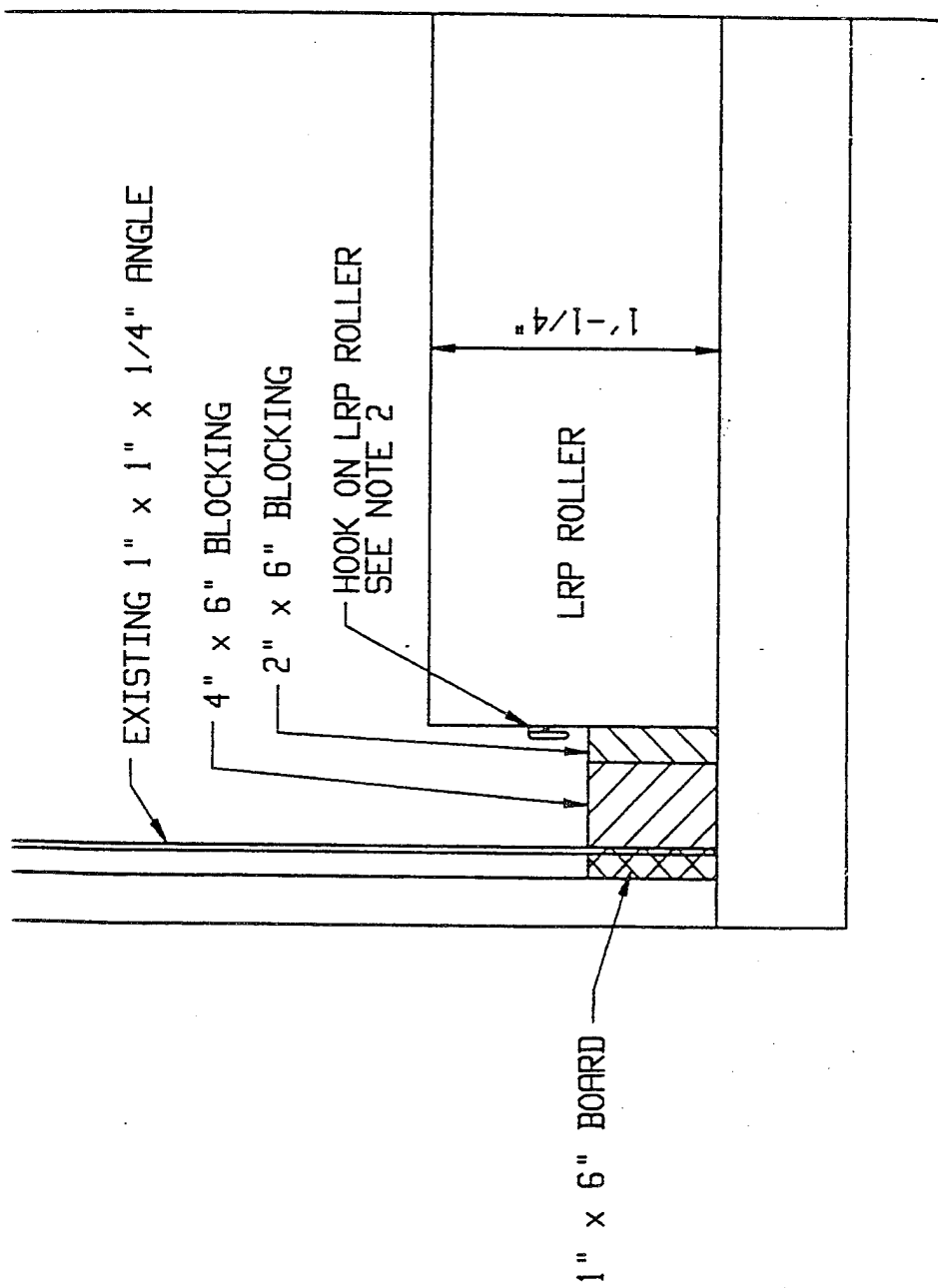

SECTION A-A

SCALE: 1 1/2" = 1'-0"