



Technical Report
CMU/SEI-96-TR-009
ESC-TR-96-009

Carnegie Mellon University
Software Engineering Institute

**Transitioning Domain Analysis:
An Industry Experience**

Karen Schnell
Nathan Zalman
Atul Bhatt

June 1996

DISTRIBUTION STATEMENT A

Approved for public release.
Distribution Unlimited

Carnegie Mellon University does not discriminate and Carnegie Mellon University is required not to discriminate in admission, employment, or administration of its programs or activities on the basis of race, color, national origin, sex or handicap in violation of Title VI of the Civil Rights Act of 1964, Title IX of the Educational Amendments of 1972 and Section 504 of the Rehabilitation Act of 1973 or other federal, state, or local laws or executive orders.

In addition, Carnegie Mellon University does not discriminate in admission, employment or administration of its programs on the basis of religion, creed, ancestry, belief, age, veteran status, sexual orientation or in violation of federal, state, or local laws or executive orders. However, in the judgment of the Carnegie Mellon Human Relations Commission, the Department of Defense policy of, "Don't ask, don't tell, don't pursue," excludes openly gay, lesbian and bisexual students from receiving ROTC scholarships or serving in the military. Nevertheless, all ROTC classes at Carnegie Mellon University are available to all students.

Inquiries concerning application of these statements should be directed to the Provost, Carnegie Mellon University, 5000 Forbes Avenue, Pittsburgh, PA 15213, telephone (412) 268-6684 or the Vice President for Enrollment, Carnegie Mellon University, 5000 Forbes Avenue, Pittsburgh, PA 15213, telephone (412) 268-2056.

Obtain general information about Carnegie Mellon University by calling (412) 268-2000.

Technical Report

CMU/SEI-96-TR-009

ESC-TR-96-009

June 1996

Transitioning Domain Analysis:
An Industry Experience

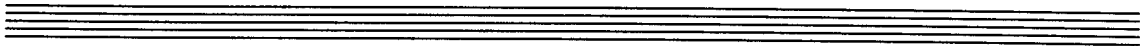

Karen Schnell

Nathan Zalman

Atul Bhatt

Nortel

19960723 024

Unlimited distribution subject to the copyright.

DTIC QUALITY INSPECTED 3

Software Engineering Institute

Carnegie Mellon University
Pittsburgh, Pennsylvania 15213

This report was prepared for the
SEI Joint Program Office
HQ ESC/ENS
5 Eglin Street
Hanscom AFB, MA 01731-2116

The ideas and findings in this report should not be construed as an official DoD position. It is published in the interest of scientific and technical information exchange.

FOR THE COMMANDER

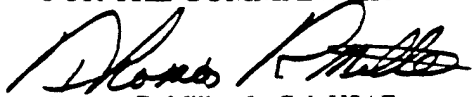

Thomas R. Miller, Lt Col, USAF
SEI Joint Program Office

This work is sponsored by the U.S. Department of Defense.

Copyright © 1996 by Carnegie Mellon University.

Permission to reproduce this document and to prepare derivative works from this document for internal use is granted, provided the copyright and "No Warranty" statements are included with all reproductions and derivative works.

Requests for permission to reproduce this document or to prepare derivative works of this document for external and commercial use should be addressed to the SEI Licensing Agent.

NO WARRANTY

THIS CARNEGIE MELLON UNIVERSITY AND SOFTWARE ENGINEERING INSTITUTE MATERIAL IS FURNISHED ON AN "AS-IS" BASIS. CARNEGIE MELLON UNIVERSITY MAKES NO WARRANTIES OF ANY KIND, EITHER EXPRESSED OR IMPLIED, AS TO ANY MATTER INCLUDING, BUT NOT LIMITED TO, WARRANTY OF FITNESS FOR PURPOSE OR MERCHANTABILITY, EXCLUSIVITY, OR RESULTS OBTAINED FROM USE OF THE MATERIAL. CARNEGIE MELLON UNIVERSITY DOES NOT MAKE ANY WARRANTY OF ANY KIND WITH RESPECT TO FREEDOM FROM PATENT, TRADEMARK, OR COPYRIGHT INFRINGEMENT.

This work was created in the performance of Federal Government Contract Number F19628-95-C-0003 with Carnegie Mellon University for the operation of the Software Engineering Institute, a federally funded research and development center. The Government of the United States has a royalty-free government-purpose license to use, duplicate, or disclose the work, in whole or in part and in any manner, and to have or permit others to do so, for government purposes pursuant to the copyright license under the clause at 52.227-7013.

This document is available through Research Access, Inc., 800 Vinal Street, Pittsburgh, PA 15212.
Phone: 1-800-685-6510. FAX: (412) 321-2994. RAI also maintains a World Wide Web home page. The URL is <http://www.rai.com>

Copies of this document are available through the National Technical Information Service (NTIS). For information on ordering, please contact NTIS directly: National Technical Information Service, U.S. Department of Commerce, Springfield, VA 22161. Phone: (703) 487-4600.

This document is also available through the Defense Technical Information Center (DTIC). DTIC provides access to and transfer of scientific and technical information for DoD personnel, DoD contractors and potential contractors, and other U.S. Government agency personnel and their contractors. To obtain a copy, please contact DTIC directly: Defense Technical Information Center, Attn: FDRA, Cameron Station, Alexandria, VA 22304-6145. Phone: (703) 274-7633.

Use of any trademarks in this report is not intended in any way to infringe on the rights of the trademark holder.

Table of Contents

Acknowledgments	v
1 Introduction	1
1.1 Purpose of the Report	1
1.2 Intended Audience	2
2 Nortel's Motivation for Change	3
2.1 Overview	3
3 Defining the Problem and Investigating Solutions	5
3.1 Developing a Definition of the Current Process	5
3.2 Investigation of a Solution	5
3.3 Lesson Learned	6
4 Obtaining Sponsorship, Participants, and Funding	7
4.1 Proposal Content	7
4.2 Nortel Executive Interest in Domain Analysis	7
4.3 Lessons Learned in Obtaining Sponsorship and Participants	9
5 Project Plan and Contract	11
5.1 Project Plan for the Pilot Study	11
5.1.1 Overview of the Project	11
5.1.2 Goals	11
5.1.3 Study Prerequisites	12
5.1.4 Project's Minimum Success Criteria	13
5.1.5 Conditions for Terminating the Study	14
5.1.6 Deliverables	14
5.1.7 Schedule	15
5.1.8 Checklist of Action Items	15
5.1.9 Overall Lessons Learned from Project Planning Activities	15
5.2 Contracting Resources	16
5.2.1 FODA Research Team	16
5.2.2 Supporting Organizations	18
5.3 Tool & Database Plan	18
5.3.1 Tool Development	19
5.3.2 Tool Study Report	19

6	Implementation	21
6.1	Analysis of Operator Services' Requirements Process	21
6.2	Preliminary Planning for FODA Training by SEI	21
6.3	Domain Selection for Workshop	21
6.4	Three-day Workshop	22
	6.4.1 Lessons Learned	22
	6.4.2 Workshop Report	23
6.5	Selection of Participant Group	23
6.6	Methodology Enhancements and Dry Run	23
6.7	Analysis of IWS Domain Planning	25
6.8	Management Briefing	25
6.9	Briefing of the IWS Domain	25
6.10	Kickoff Meeting for the IWS Domain Analysis	25
6.11	Scoping Report Review	25
6.12	Pilot Study Implementation Plan, Revision I	26
6.13	Context Analysis Meetings for Target Domain	27
6.14	Development of Prototype Domain-Capture Tools	28
6.15	Contract Renegotiation	29
6.16	Domain Modeling Meetings of Target Domain	29
6.17	Review of Reports	30
7	Completion and Closure	31
8	Transition	33
9	Summary	35
10	References	37

List of Figures

Figure 1:	Organizational Structure of the Participating Groups in the Pilot Study	9
Figure 2:	Flow of Communication and Needs Between the SEI, GSP and Operator Services	13
Figure 3:	Nortel FODA Modeling Process	16
Figure 4:	FODA Research Team	17
Figure 5:	Domain Interaction Matrix Example	24
Figure 6:	Structure Chart Comparisons	26
Figure 7:	Model Iteration	29

Acknowledgments

The pilot study documented in this report reflects 18 months of risk taking, dedication, team spirit, partnership, and plain old-fashioned hard work. Through a collaboration between the SEI and Nortel, an academic and industry partnership took feature oriented domain analysis (FODA) from a methodology that is still being defined to a well-documented application and process. To bring this to fruition, the involvement of many individuals was required.

First and foremost, the idea of pilot testing FODA for the capture and management of requirements within Nortel is based on the proposal and vision of Karen Schnell.

To take the challenge and risk to sponsor, fund and support this research, special thanks goes to Roger Bushnell (Director, Global Services Planning); Irving Ebert (Vice President, Nortel Technologies Systems Engineering); Abdul Khawar (Vice President, Nortel Technologies Research Triangle Park); Bob Bloedon (Director, External Research); and Don Richmond (Director of Operator Services).

This program could not have made the progress and the discovery of exciting innovations without the blood, sweat and tears of the FODA Research Team. Special recognition and high praise belongs to Nathan Zalman, Shirley Burdick, Atul Bhatt, John Mainwaring, and Julia Gosztyla. For their many dedicated hours over and above their busy schedule and the sharing of their knowledge, special applause is required for the Intelligent Work Station (IWS) Team which included John Beta, Lorraine Lawson, Ian Dunbar, Carol Marion, Richard Sharpe, and Glen Stewart.

The collaboration with the SEI was pivotal for Nortel to undertake the technology transition of FODA and to support the culture change. Special thanks goes to the Application of Software Models (ASM) Group for providing FODA training and consulting. Recognition goes to Sholom Cohen, Robert Krut, Pat Donohoe, Michael Webb, and Peter Feiler.

As with many research efforts, there are a number of key individuals and groups that made valuable contributions over the course of the endeavor. Maurice Tyler researched and documented the tool study. Steve Fraser introduced FODA to Nortel. The Operator Services Product Group (including developers, marketing, management, documentation, and customers) were involved as key subject matter experts. Carol Lorenz and Nortel's Metrics, Tools, and Analysis (META) Group contributed great insight for process, method, and tool development. Reviewers of the pilot study included David Zubrow, Sholom Cohen, Pat Donohoe, and Robert Krut. Rick Homesley and Suzanne Couturiaux provided superior documentation and editor skills to this publication.

Transitioning Domain Analysis: An Industry Experience

Abstract: This report provides an industry experience in the planning and execution of a research project to pilot the use of the Software Engineering Institute (SEI) domain analysis methodology known as feature-oriented domain analysis (FODA). Supported by examples, experiences, and lessons learned from the industry pilot study conducted by Nortel in collaboration with the SEI, this report addresses seven key areas: (1) Nortel's motivation for change; (2) defining the problem area and the search for a range of solution possibilities and/or approaches; (3) obtaining sponsorship, participants, and funding; (4) development of the project plan and contract; (5) implementation of the project plan for the pilot study; (6) completion and closure of the pilot study; and (7) the transition and deployment of FODA.

1 Introduction

The creation of standards and guidelines such as the Capability Maturity ModelSM (CMMSM)¹ for Software [Paulk 93a, Paulk 93b], ISO 9000, and Baldrige criteria results from the search for a means to achieve effective and efficient product quality by industry and their customers. Adherence to such guidelines and standards can provide industry with an external motivator to evolve quality programs and processes which meet customer requirements. At the same time, cost containment, an internal industry stimulus, is directly tied to the goal of "providing shareholder value." To improve the quality of a set of business practices, new methodologies and technologies need to be investigated to achieve this goal.

1.1 Purpose of the Report

This report shares with the reader the experiences of integrating FODA into Nortel as a new technology. FODA, a domain analysis methodology, has been taught and used in the government sectors, but it has not been used in an industry setting. Based on Nortel's experience, this report provides lessons learned and guidelines for implementing a pilot study to research and refine a methodology for transition into its business environment. The use of a pilot study allows assessment of a new technique to evaluate its merits in a cost- and time-effective manner.

1. Capability Maturity Model and CMM are service marks of Carnegie Mellon University.

The following chapters of this report address the seven key areas listed below:

1. Nortel's motivation for change
2. defining the problem and investigating solutions
3. obtaining sponsorship, participants, and funding
4. project plan and contract
5. implementation
6. completion and closure
7. transition

1.2 Intended Audience

This report is targeted towards individuals or groups that are engaged in exploring new methodologies or techniques for introduction into their business. After discovery of a new practice, one wishes to investigate the applicability of it with minimal investment in time, cost, and resources. One way of doing this is conducting a pilot study.

The information described is useful for internal and external consultants, change agents, graduate students, researchers, project leaders or managers. The background of these users would include expertise in their field with the ability to perform analysis in order to change or evolve the area of interest.

2 Nortel's Motivation for Change

An internal study conducted by Nortel Research Triangle Park (RTP), North Carolina, in 1993 concluded that Nortel RTP's process for managing and capturing product requirements was one of the areas which needed improvement. Trillium, an assessment tool based on the CMM and modified by Bell Canada and Nortel to include key aspects relative to Nortel customers, was used to conduct this study. Nortel RTP's systems engineering group, Global Services Planning (GSP), was given the responsibility to address how to make this process more efficient and effective to meet business needs since the primary focus of GSP is to define product and services specifications.

2.1 Overview

This document shares Nortel's experience and lessons learned while exploring the use of a new methodology to improve the quality of its business processes. Specifically, this document describes the research collaboration between Nortel and the SEI to trial the use of domain analysis to manage and capture software product requirements.

Having been introduced in the government arena, FODA was in the process of being introduced in the industry sector [Peterson 91]. As a telecommunications company, Nortel provided the SEI an opportunity to investigate the use of the FODA methodology within the industry. Since Nortel was willing to implement FODA on a small scale, GSP examined its benefits and merits and could determine how to tailor its use to fit Nortel's corporate environment while minimizing the investment costs of this exploration.

This document also provides the software engineering community with a resource for conducting similar studies and collaborations. The intent is to perpetuate the discovery of new advances in this field of practice which can be utilized by academia, industry, and government.

The steps followed by the researchers provide examples of the best practices discovered and activities to be changed to better understand the problem-on-hand and to implement a similar pilot study.

3 Defining the Problem and Investigating Solutions

With the process for managing and capturing product requirements identified as an area that needed improvement, the next step required GSP to define the current process and investigate a solution to evolve this area into an effective and efficient process.

3.1 Developing a Definition of the Current Process

First, GSP needed to understand the current product requirements process. Since Nortel RTP was undergoing ISO 9000 registration at this time, documentation was being developed which defined Nortel RTP's product requirements process. The documented process and the Trillium results provided a starting point to scope the problem definition of the changes that were required within Nortel. In addition to these, other sources of internal information included reviewing internal publications and white papers, conducting surveys and interviews, and relying upon the authors' personal experiences as users of the product requirements process.

The research to locate key corporate documents and resources was intensive work since the centralized libraries for processes and their supporting documentation was under development. However, the researchers gathered the necessary information through extensive networking into several product groups and across multiple Nortel sites, including Ottawa (Canada), Richardson (Texas) and Maidenhead (United Kingdom).

3.2 Investigation of a Solution

GSP's next step required accessing information external to Nortel which included industry, academic, and government resources. Not only did GSP want to research the experiences of these external resources, but it also wanted to learn from their solutions. Resources used to support the investigation included literature searches, conferences, symposia, and personal conversations. GSP investigated best practices; new techniques or tools; and new research related to requirements elicitation, management, process definition and trends.

The annual SEI symposium and informal introductions within Nortel provided GSP with the information to consider domain analysis as the methodology to be used for improving the product requirements process. One staff member's affiliation as a visiting scientist from Nortel Ottawa to the SEI's Application of Software Models (ASM) Group introduced GSP to FODA. After several meetings with the ASM Group and assessing other domain analysis methodologies, GSP chose FODA to conduct the pilot study on a software development group within Nortel RTP. The ASM Group showed particular interest in a field trial of their methodology within industry since FODA case studies had been performed within the government sector [Cohen 92]. Capturing customer requirements through domain analysis added interest to the investigation since this methodology had previously been used only to gather software architecture requirements.

Finally, GSP originated a proposal for conducting a pilot study to investigate the use of FODA for software requirements management and capture. GSP established a collaboration through the SEI's Resident Affiliate (RA) Program² to work with the ASM Group since this was Nortel's first encounter with the SEI. The RA program provided a basis for conducting the study, a foundation for Nortel to learn more about the SEI, and an opportunity for the SEI to work with the industry sector.

3.3 Lesson Learned

Researching a problem and finding a solution is intensive work. Since a lot of material is produced, it is important to keep careful records of notes, resources, references, and contacts. A spreadsheet is one way of organizing this information. Once all of the pieces of the problem and solution are collected, they must be structured into a succinct description. This description then provides easier communication and learning to educate sponsors, collaborators, and other interested parties. For the pilot study proposal, this addressed the questions: "What needs to be improved, why, and what can be done?"

² The Software Engineering Institute's Resident Affiliate Program at Carnegie Mellon University offers industry and government sponsorship of an individual to work at the SEI to learn software engineering technologies to transition back into the individual's organization.

4 Obtaining Sponsorship, Participants, and Funding

Once the proposal had been written for conducting a pilot study to investigate the use of FODA, GSP needed to secure sponsorship within Nortel for funding and resources to support the necessary research.

4.1 Proposal Content

GSP's proposal required the following four key areas of information to obtain corporate sponsorship and funding:

- *Need* - states the problem that needed to be addressed. For GSP, capturing customer requirements was the problem realized through the Trillium assessment results.
- *Purpose* - describes the purpose of the research that identified the expected impact on the area of investigation. GSP targeted its research to address Nortel's need to improve its methodology for capturing and managing customer requirements. The purpose of the pilot study was to determine if FODA could improve the process and, if so, in what ways. Another purpose was to learn how to introduce Nortel's software development organizations to new technologies without creating massive disruption and incurring unacceptable costs and product turnaround time penalties.
- *Preliminary plan* - includes an outline of the steps of the investigation, i.e., the deliverables, timeframe of the investigation, and resources required to complete the plan. For the pilot study proposal, GSP identified the high-level steps of the 18-month program including employee resources, equipment requirements, and cost estimates.
- *Benefits* - identifies the advantages of pursuing the investigation to use FODA and the perceived value of the results. GSP's pilot study provided concrete steps to improve a key corporate business process and establish a strategic alliance with the SEI for future information.

4.2 Nortel Executive Interest in Domain Analysis

Like many organizations, Nortel constantly explores the improvement of its business processes to create products more effectively and efficiently. Domain analysis provides one means of improving the requirements and software development processes through its capability to formalize the investigation of a product definition [Cohen 92].

Historically, Nortel has utilized domain analysis extensively to define software architecture requirements, e.g., the Generic Services Framework (GSF) project, which is a large-scale object-oriented (O-O) reengineering effort. The adopted development methodology for the GSF project describes the nature of object interactions and focuses on scoping and understanding component interactions, which are key elements of domain analysis. The strength of their methodology is that it details system architecture, but it only captures customer requirements indirectly. However, FODA places emphasis on describing user interactions which

includes customers and end-users, as well as cooperating systems [Peterson 91]. Many of Nortel's product requirements are specifically defined in terms of these interactions.

GSP selected FODA for the domain analysis methodology to be used for requirements capture and analysis because it more closely captures the customer's perceptions of how they interact with the product. Also, the captured description remains independent of the architecture that may be implemented.

Once the vice president of the Systems Engineering Department (SED) accepted the proposal and agreed to sponsor the funding of the project, GSP needed to find a software development group to participate in the pilot study (see Figure 1). The director of GSP established an agreement in principle with the director of the Operator Services product group to become participants in the study. The Nortel Operator Services product line organization retains the responsibility for a group of peripherals and services for its direct customers, i.e., the Regional Bell Operating Companies and the independent long distance carriers.³

GSP provided the Operator Services Group with a project plan which outlined the necessary resource and time commitments before obtaining full commitment from the product group to participate.

3. Operator Services provides toll and assist, directory assistance, and other traditional attendant-based services as well as a wide variety of automated services (such as coin phones, credit card validation, 800-number translation, etc.) within the telecommunications industry.

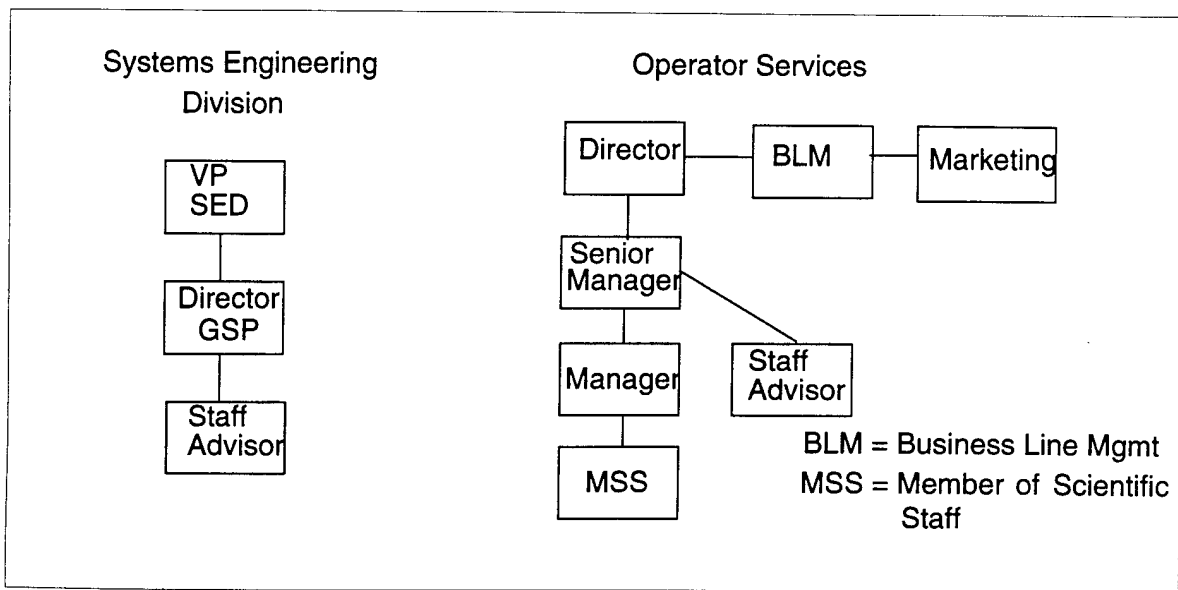

Figure 1: Organizational Structure of the Participating Groups in the Pilot Study

4.3 Lessons Learned in Obtaining Sponsorship and Participants

Obtaining an agreement in principle with a software development group to participate in the pilot study was a challenge for both parties. *GSP's experience revealed that even though a participant group shows interest in the exploration of new ideas, the group must give priority to product commitments and schedules.* This requires the research group to be sensitive to these needs. Also, a careful and thorough definition of the study and its resulting benefits to the participant group needs to be communicated clearly and effectively. The participant group needs to understand the importance of time estimates (or schedules) and resource commitments to the study in order to plan or adjust scheduled project deliverables. Further, the research group needs to provide flexibility in their schedule in case of adjustments to the scheduled product deliverables by the participant group. Clear communication of changes between the participant and research management becomes an important factor throughout the project.

5 Project Plan and Contract

Having obtained an agreement in principle by the Operator Services Group, GSP's next step was to agree on a project plan and establish a contract for resources. Both of these provided the necessary foundation for full commitment to the research project.

5.1 Project Plan for the Pilot Study

The pilot study required a project planning session between the ASM Group from the SEI and the GSP and Operator Services Groups from Nortel. Using several steps from Peter Block's *Flawless Consulting* [Block 81], the plan included the following elements:

- overview of the project
- goals
- study prerequisites
- project's minimum success criteria
- conditions for terminating the study
- deliverables
- schedule
- checklist of action items

The following sections detail these elements of the project plan for the pilot study.

5.1.1 Overview of the Project

The overview provided a high level outline of the pilot study which was divided into the three phases listed below:

- FODA training and workshop - initial training and experience in using FODA for the Operator Services Group
- model and database development - the detail work and design of an object model of the FODA products and a prototype database to store/retrieve information using the object model structure
- FODA technology transition planning - the project plan to transition the FODA methodology from the SEI into Nortel

5.1.2 Goals

During a pilot study planning meeting, the participating groups identified goals for Operator Services, the SEI, and the Nortel-SEI joint effort.

Goals for Operator Services were as follows:

- Capture and validate the current requirements process with an end-to-end team which included customers, management, software designers, and product testers.
- Improve the requirements capture process using the SEI domain modeling techniques.
- Create an environment for the Operator Services Group to evaluate new services options and reuse.

Goals for the SEI were as follows:

- Validate the use of the FODA domain modeling methodology in the area of requirements engineering. It had previously only been applied to software systems.
- Demonstrate SEI responsiveness to industry needs.
- Develop a Nortel case study for presentation.
- Understand the forces at work within Nortel which drive the need for change.

Joint Nortel-SEI goals were as follows:

- Produce an Operator Services requirements model database.
- Establish software modeling competence across Nortel.
- Develop a framework for the models to be used in the software development cycle across other products.

Lesson learned: These goals changed as the research refined FODA and provided a clearer understanding of how it could be used within Nortel. The original goals, stated at a high level, developed more specifically as the pilot study progressed. For example, the goal to “improve the requirements capture process using the SEI domain modeling techniques” became “improve the requirements capture and validation process using domain analysis elicitation and modeling techniques.” During the actual implementation of the pilot study, however, these goals were not updated.

As part of the ongoing planning process, it is recommended that groups revisit, refine, and update the goals.

5.1.3 Study Prerequisites

The needs of the research team required direct communication among the three groups (GSP, Operator Services, and the SEI) in order to perform the investigation most effectively (see Figure 2). To facilitate communication, the FODA Research Team needed to know who retained ownership of the end deliverables and who the key interfaces from Operator Services and the SEI would be. They also needed to schedule time for briefings with Operator Services management.

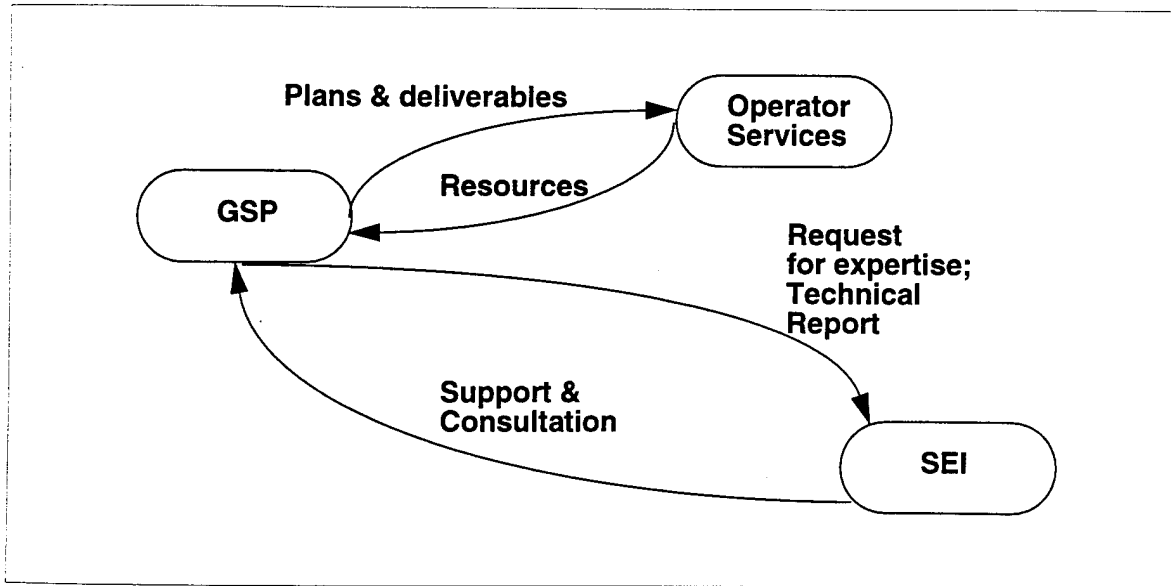

Figure 2: Flow of Communication and Needs Between the SEI, GSP and Operator Services

Lesson learned: The FODA Research Team discovered that it needed to hire contractors, purchase software, and set-up additional meetings as the pilot study was developed and roles were identified (see Section 5.2.1, *FODA Research Team*). It was through discussions with Operator Services and GSP management that the FODA Research Team was able to schedule and secure resources. These factors proved that communication of the research group's prerequisites was of utmost importance throughout the study.

5.1.4 Project's Minimum Success Criteria

The participating groups identified five elements to be the minimal terms for successful completion of the study. These elements included changes to the Operator Services requirements process and plans for the future use of FODA as defined below:

- Develop an understanding of the current Operator Services' requirements process.
- Identify a set of common software product functions to be supported by the Operator Services organization.
- Develop a detailed model of a service or product to be validated with a requirements checklist when planning a service enhancement.
- Gain committed plans for future use and evolution of the product models by business line management (BLM), development groups, and customers.
- Develop tools and methodologies for the requirements process to be applied to other product groups.

Lesson learned: Like the goals, the minimum success criteria changed as the research revealed new discoveries, but the modifications were not documented. Thus, the originally stated criteria were not met. Updating the minimum success criteria during the pilot study implementation proved to be a necessary and beneficial aspect of carefully monitoring procedures for benchmarking and project management.

5.1.5 Conditions for Terminating the Study

A set of checkpoints assessed whether progress was being achieved to satisfy the goals during the pilot implementation. Some of the conditions for termination of the study included the following:

- lack of committed resources
- lack of progress in achieving the minimum success criteria
- insufficient development of models and databases
- insufficient buy-in to use models
- no commitment to plan evolution of the model database

Lesson learned: The research group received the necessary resource commitments at the onset of the pilot study. But only one progress check was conducted to determine if the study was achieving the minimum success criteria. As a result, the FODA Research Team lost resources due to product delivery commitments. To provide more effective planning and project management, regular checkpoint review dates needed to be scheduled at the beginning of the project. These reviews should involve the research and participant group's management.

5.1.6 Deliverables

A list of end products from the research included the following:

- workshop reports - documented information captured from the weekly iteration meetings during the context analysis and domain modeling activities
- domain models - structured models of the Intelligent Work Station (IWS) product domain produced from the information elicited from the iteration meetings
- prototype database - a test database designed using expert systems software to store/retrieve domain model data
- tool study report - a survey of available database packages that could support large-scale collection of domain modeling information
- modified Operator Services requirements process - enhanced process for validating and collecting product requirements based on the use of FODA capabilities

Lesson learned: Each of the deliverables was successfully developed and used. The workshop reports and domain models have been used by the IWS development group in the design of their product to enhance robustness, which decreased errors found in testing. The prototype database and tool reports have provided the foundations for development of a large-

scale database. Operator Services has been repeatedly using their new requirements process for product definition.

5.1.7 Schedule

A timetable of events, activities, and deliverables included details of each activity, i.e., owners, participants, meetings, and reviews. Micro Planner Manager⁴ was used to detail and track the project.

Lesson learned: Since the pilot study had to be extended from 6 to 10 months and because IWS product milestones changed, the schedule and the activities had to undergo several adjustments to accommodate demands on the participants.

5.1.8 Checklist of Action Items

A checklist to track progress and adherence to schedule was developed for each participating group which included scheduled date, description, deliverable, owner, and status for each action item.

Lesson learned: The checklist that was devised was too complicated and cumbersome to keep updated and thus was not used for the full extent of the pilot study. A simpler version and easier-to-update format is recommended.

5.1.9 Overall Lessons Learned from Project Planning Activities

GSP found that the actual exercise of documenting the detailed project plan was the most important activity of this element. Although the research team was embarking on a research assignment that was totally new to GSP and Nortel, the project planning exercise provided the research group with the structure to analyze the task and break it down into steps. Once this occurred, mutually agreeable steps could be identified and scheduled.

The research group noted some key points to consider if the assignment were to be repeated. Even though not every documented item in the project plan was used or tracked, an update of the goals, minimum success criteria, and conditions for terminating the study would have been beneficial.

One of the important benefits of a documented plan was that it provided a basis for contract renegotiation. At the mid-point of the pilot study, the product schedule and deliverables for the Operator Services Group changed. In the perception of management, this placed the pilot study on a critical path of customer deliverables. However, the research group utilized knowledge gained from detailed project planning to modify the schedule to accommodate these

4. Micro Planner Manager is a project management application program copyrighted by Micro Management Inc.

demands in a way which permitted the key objectives of the project to be accomplished. Basically, the process for conducting FODA that was developed used two types of meetings - modeling and review iterations (see Figure 3). Knowing how many meetings were required allowed the research team time to spread the same effort over a longer time period.

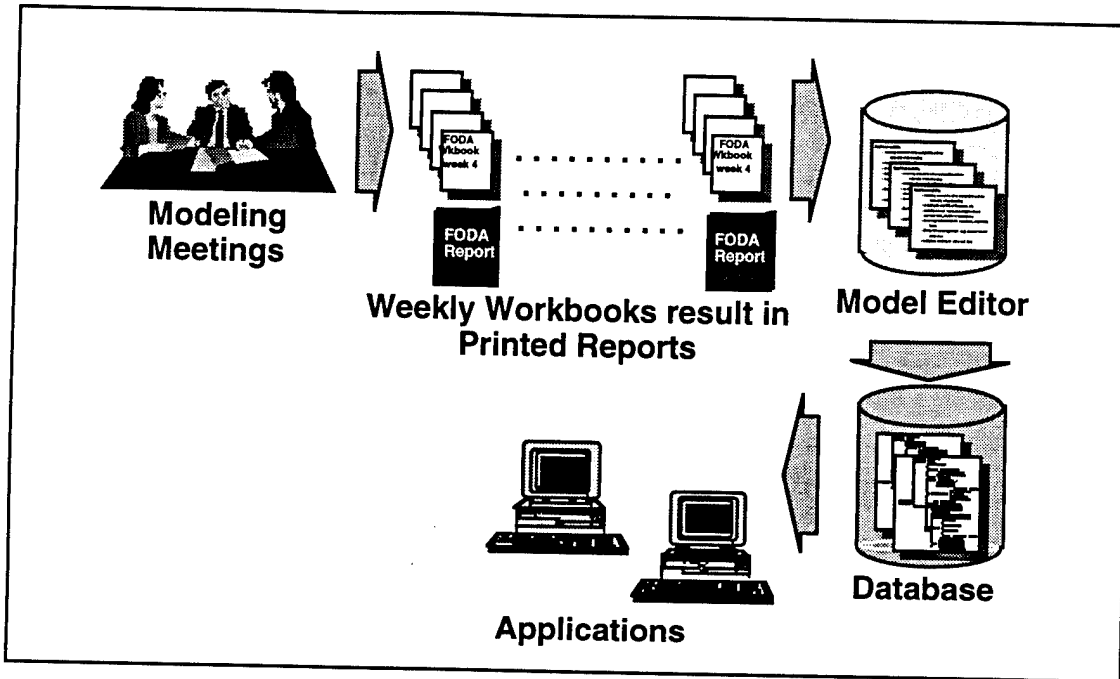

Figure 3: Nortel FODA Modeling Process

5.2 Contracting Resources

With the project plan established, the next step was to define the FODA Research Team roles. To fulfill the roles, resources had to be negotiated and contracted from the GSP and Operator Services Groups and external agencies. Further, special skills such as tool research had to be contracted from internal Nortel support organizations.

5.2.1 FODA Research Team

As the next course of action, GSP established the FODA Research Team once the project plan was reviewed and finalized. The commitment of resources and their time needed to be accomplished through a formal internal contract process.

Nortel requires its business organizations to have interorganizational contracts to provide explicit definitions of the scope and extent of planned collaborations in order for each participating organization to clearly understand the expectations and responsibilities of the

other organization(s) involved. This contracting style proved beneficial during the pilot study when development pressures increased within the Operator Services organization. The contract provided a baseline for renegotiation of Operator Services' deliverables and resource availability.

GSP wanted the FODA Research Team to consist of resources from both the GSP and Operator Services Groups (see Figure 4). In order to maintain management commitment throughout the pilot study, GSP felt that it was necessary to ensure ownership of the project resided not only in GSP, but also in the participating group. Revealing this ownership through resource allocation proved to be effective and strategically important to maintain commitment and understand the cultures that GSP engaged to change. This also strengthened the bond between the groups and fostered an exchange of invaluable knowledge for this study and for future application. The Nortel groups learned from each other, and the SEI and Nortel grew in the breadth of this knowledge through the collaboration.

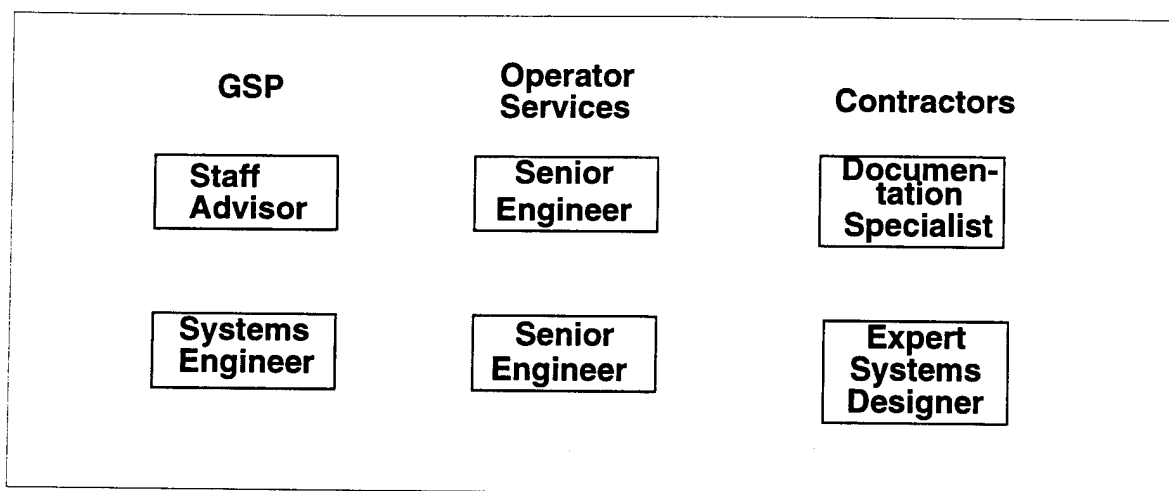

Figure 4: FODA Research Team

Operator Services committed two senior software engineers to the project, one with an in-depth knowledge of the Directory and Operator Services product lines and the other with graphical user interface (GUI) and object-oriented design expertise. GSP assigned two resources, a staff advisor and a systems engineer, to the project. The FODA Research Team hired two external contractors, a documentation specialist and an expert in knowledge-based systems/database design.

This variety of skills and responsibilities provided for a successful group-facilitated domain analysis to emerge. Although individuals took on different roles, as required, the FODA Research Team instituted the following role definitions for the project:

- *domain analyst* to be responsible for model elicitation using the FODA methodology. Utilizing available capture tools, the domain analyst created a domain analysis database.
- *documentation specialist* to be responsible for capturing meeting information and producing the study's documentation
- *project coordinator/manager* to be responsible for project planning, scheduling, etc.
- *trained facilitator* to assist with group facilitation needs
- *an expert in the domain of interest*, teamed with the domain analyst, to help guide the analysis effort and acquire domain analysis skills to become a domain analyst for future projects

In addition to the FODA Research Team members, Operator Services identified a group of four to seven subject matter experts (SMEs) with expertise in the domains of interest to participate in the pilot study.

5.2.2 Supporting Organizations

The FODA Research Team required additional skills to support the efforts of the study and contracted with Nortel's Tools Group for the needed skills. The research team needed expertise for off-the-shelf software recommendations to support development of the prototype database into a full-scale database for deployment beyond the pilot study.

This pilot study was the work of an interdisciplinary team of domain analysts, subject matter experts (aka domain experts), documentation specialists, and project managers, drawn from a wide spectrum of senior designers, project managers, business line management, and support personnel within Nortel, as well as support from the members of the SEI's Application of Software Models Project.

5.3 Tool & Database Plan

In addition to developing the FODA methodology, the research group designed and developed a prototype database for storage and retrieval of domain model information. The FODA database was intended to be a complete and consistent repository of domain information that can be accessed by a user for learning about the domain and for developing further applications.

The database consolidated the information contained in various pilot study reports and workbooks. It was designed by the domain analyst, and developed and maintained by the expert system contractor. The database schema uses an object model to represent domain information in the form of textual descriptions.

The FODA Research Team also prototyped the generation of an HTML-formatted version of the information in the database and in various reports to facilitate hypertext-based access.

5.3.1 Tool Development

As part of the pilot study, a prototype tool, called the "Model Editor," was developed to translate the information captured during the analysis meetings in an object-oriented database. The tool provides the domain analyst with a graphical user interface to populate the database interactively using screens for each aspect of the FODA model: namely, domains, features, entities, and functions. It was implemented with Neuron Data's Smart Elements™, a software tool for developing GUI-based object-oriented and knowledge-based applications.

Lessons learned: The prototype suggests several directions in which domain analysis capture applications can go, beyond static report generation. For instance, an application could be built which allows the domain analyst to explore relationships and interactions within the domain, as well as propose new features and analyze their effect on the operation of the system. The participant domain analysis team from the Operator Services Group expressed an interest in using the domain database for tutorial material. During the pilot study, a set of requirements for further tool development was gathered.

5.3.2 Tool Study Report

Nortel is pursuing options for support of its Model Editor and other tools beyond the pilot study stage. It is frequently noted that effective domain analysis beyond the prototype stage requires tool support [Krut 93], and this effort is no exception. To that end, Nortel's Metrics, Tools, and Analysis (META) Group was requested to conduct a tool study to answer some of the following questions:

- What commercial databases are available that are suitable for representing and maintaining large-scale domain models?
- What commercial tools are available that may assist in building these models?
- Which of the tools identified above are recommended for use within Nortel as the domain analysis toolset?
- What proprietary tool development is needed to fill the gaps?
- What are the long-term support, training, maintenance requirements, and costs for this toolset?

In summary, 6 database tools (ObjectStore, ONTOS, GemStone, POET, Objectivity, and VERSANT) from a pool of 21 were evaluated for their applicability to FODA. Based solely on the requirements given for the tool study, VERSANT emerged as the best candidate in just about every major category evaluated.

Regarding outsourcing the product development of FODA tools, the following four approaches were identified, based essentially on the amount of effort that is outsourced:

- total outsourcing with Nortel ownership
- total outsourcing without Nortel ownership

- partial outsourcing (joint development)
- Nortel spin-off

6 Implementation

With a project plan and resources in place, the actual pilot was ready for execution. The overall implementation had the strategic goals to transfer FODA expertise into Nortel and conduct a full-scale FODA analysis by the research group. The technology transfer of the FODA methodology from the SEI expertise to Nortel proficiency was done in phases. The phases included the following:

- the ASM Group demonstrating the methodology by conducting an analysis of the Operator Services current requirements process
- the ASM Group teaching FODA by giving a three-day workshop
- the Research Group developing FODA enhancements and performing a dry run of the modified methodology
- the ASM Group providing consulting to the FODA Research Group Domain Analyst during the IWS product scoping and target domain selection
- the Research Group domain analyst conducting a full scale analysis on the IWS target domain

The following sections discuss the activities involved in the pilot study implementation at Nortel.

6.1 Analysis of Operator Services' Requirements Process

The SEI conducted a one-day context analysis workshop to document the Operator Services' current requirements process. The workshop's purpose was to demonstrate the methodology to management, to explore its suitability for Nortel's business domains, and to capture the current process. Participants included BLM, marketing, management, design, hardware/software groups, and customers.

6.2 Preliminary Planning for FODA Training by the SEI

This was the first training of FODA by the ASM Group to Nortel. GSP created a preliminary plan for performing this detailed domain analysis and to evaluate the methodology closer as a first step in the pilot study with a cross section of people from the Operator Services Business Unit and observers from other parts of Nortel. This would be Nortel's first experience with trialing FODA on a larger scale.

6.3 Domain Selection for Workshop

Two senior domain experts from Operator Services visited the SEI to exchange information regarding Operator Services business domains and FODA, as well as to review proposed workshop training materials for the ASM Group. As a result of these discussions, the senior

experts and the ASM Group chose a preliminary target domain, Automated Prompt and Response Systems, for a planned three-day workshop.

6.4 Three-day Workshop

The SEI conducted a three-day training workshop at Nortel using the FODA methodology to analyze the Automated Prompt and Response Systems domain selected in the previous step. This workshop was attended by Traffic Operator Position System (TOPS) management, BLM, marketing, senior designers, and Nortel observers.

6.4.1 Lessons Learned

One of the primary goals of the workshop, i.e., to prove the suitability of FODA for analysis of domains pertaining to our lines of business, was clearly established. However, for some of the project managers attending, this workshop did not establish that FODA provided an advantage over existing domain modeling requirements analysis techniques. Using hindsight, it appears that the reason for this was that the unique characteristic of FODA, its classification and analysis of product family capabilities, is difficult to demonstrate in a short time. What is easy to demonstrate is the cost and time commitment necessary to invest before these advantages can be seen clearly in real examples. The Automated Prompt and Response Systems domain analysis produced examples that seemed promising. However, they were not detailed enough to convince those present that investment in further application of FODA to that particular domain was justified.

It is interesting to note that immediately following the workshop there was an opportunity to pursue a detailed analysis with external customers in a domain directly related to the workshop domain. It was not pursued partly because FODA's advantages had not been demonstrated at the workshop.

It became possible to continue the pilot study only by scaling down the scope of the pilot study efforts, choosing a smaller domain, and beginning over. This bypassed the objections of many of the project managers by the choice of a domain where buy-in could be obtained.

Nortel's experience indicates that the tutorial/workshop, as originally presented by the SEI, is not always a very effective means of obtaining sponsorship and support for undertaking domain analysis technology transfer. Shorter, individually tailored presentations have proved more successful. The FODA Research Team does present FODA training materials in detail before achieving initial buy-in, and even then, the training materials are presented only to those participants who are interested in taking on the domain analyst role. In this way, the training furthers the goal of technology transfer directly, decoupled from the need for achieving buy-in.

6.4.2 Workshop Report

Following the three-day workshop, a report, authored jointly by SEI and TOPS, was issued to present the results of the Automated Prompt and Response Systems domain analysis [Krut96].

6.5 Selection of Participant Group

As a follow-up to the three-day workshop, a pilot study planning meeting was held at Nortel. GSP consulted with Operator Services management to select the IWS product domain for conducting a full analysis.

6.6 Methodology Enhancements and Dry Run

As a result of FODA experiences thus far, the research team determined that several process-oriented enhancements to the methodology were needed to ensure a successful technology transfer to Nortel. These enhancements included the development of elicitation questions to ensure a consistent and verifiable FODA application, and a database schema for modeling a product representation to facilitate reuse. The research team conducted a dry run of these enhancements by applying the elicitation questions to a hypothetical non-software domain.

Lessons learned: As a general framework for representing knowledge about domains and systems in a domain, FODA is well documented in the government sector. However, the process steps required to apply it in a verifiable and repeatable manner are not yet clear. Furthermore, formalizing domain model reuse requires modeling representation means as well; i.e., a machine-readable notation is required. To address these needs, the Nortel FODA Research Team developed a set of elicitation questions to guide domain analysts and a database schema for representing the modeling products in a domain independent way. In other words, the modeling products (features, entities, functions, information trees, etc.) are represented instead of the domains directly.

The elicitation questions have been applied in a variety of contexts during the pilot study. By this means, the FODA Research Team has verified that using the elicitation questions produces predictable results. However, the detailed nature of the questions produces a detailed analysis. Further work on the elicitation questions is needed to tailor the questions to the needs of the organization undertaking domain analysis. The FODA Research Team has indicated the general direction that this work should pursue in another paper, *Three Approaches to Domain Analysis Using FODA: Opportunities for Reuse*.⁵ In two recent projects, modifications and subsets of the questions which address the goals of the organization directly were used. In one project, an information model was used as a vehicle to review new feature re-

5. Nathan Zalman and Karen Schnell. Nortel, unpublished paper.

requirements for a product. The information model was developed in conjunction with the product development group, and then presented to a group of developers, business line managers (who served as customer representatives), and project managers responsible for the product. The information model was used as a framework for understanding the changes required, interdependencies, and construction rules implied by each of the proposed features. The organization found this exercise to be very valuable, but strictly speaking, it was not FODA. Yet the experience employed several aspects of FODA to the advantage of the organization. This is an example of a future use for FODA by tailoring its elements to meeting particular business needs. Further, this demonstrates the flexible nature of the methodology.

Since the pilot study, the FODA Consulting Group (formerly the FODA Research Team) has continued to look for ways to improve our understanding of the methodology and our ability to produce meaningful and useful analyses. Recently, the consulting group began using an interaction matrix, such as the one in Figure 5, to track interactions between domains. These interactions are discovered through scenario analysis. We have found that, using this matrix, a variety of context diagrams can be drawn, depending on the point of view required. This is particularly useful when there are several domains of interest.

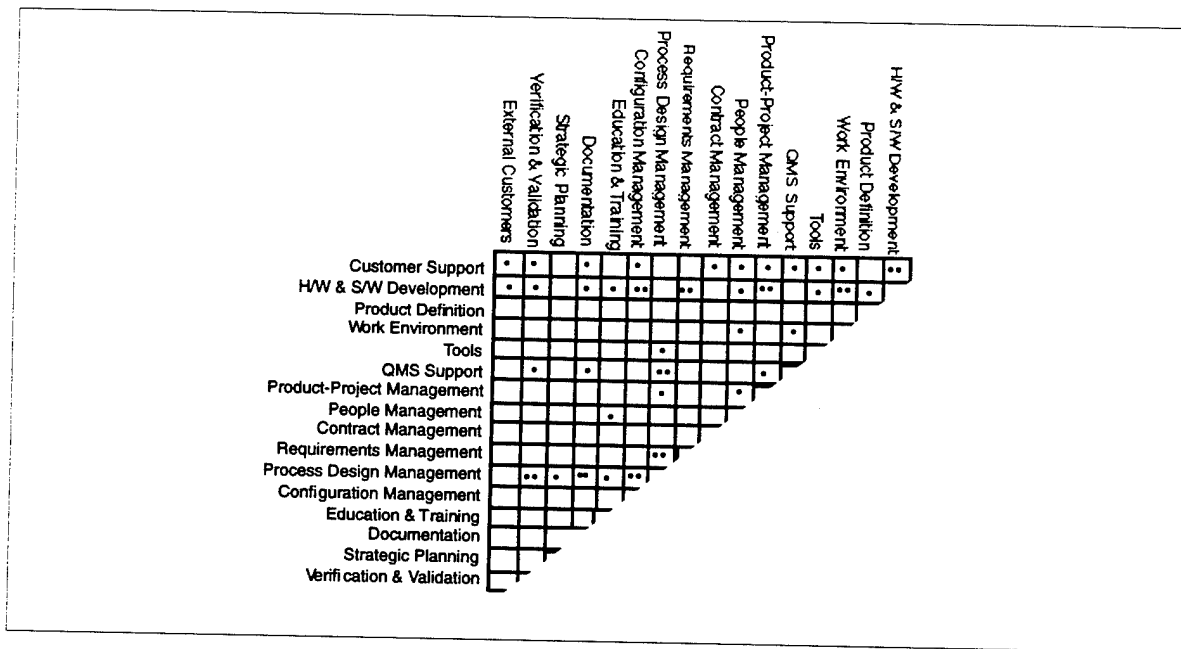

Figure 5: Domain Interaction Matrix Example

In this diagram, the axes are labeled with the domains of interest to Nortel's Quality Management Systems. The dots indicate instances of specific interactions, derived from scenario analysis.

6.7 Analysis of IWS Domain Planning

During this planning step, the FODA Research Team devised a detailed process for performing a modeling meeting iteration using the elicitation questions and developed a schedule for the detailed analysis.

6.8 Management Briefing

The FODA Research Team presented the final pilot study implementation plan to the Operator Services management team. The plan was approved and appropriate resource and scheduling plans were made. It was necessary to adjust the deliverable schedule for the target domain group to accommodate the time commitment required.

6.9 Briefing of the IWS Domain

Prior to beginning the main analysis effort, experts from the IWS product group performed a walkthrough of the domain to facilitate the FODA Research Team in establishing a baseline understanding of it.

6.10 Kickoff Meeting for the IWS Domain Analysis

Following the SEI model, the FODA Research Team held a FODA tutorial and workshop for the IWS group. The FODA Research Team led a basic FODA training session that had been revised to include examples from the three-day workshop analysis and, as an extended activity, a high-level context scoping analysis of the IWS organization's domains. The ASM Group was present to provide consulting during the tutorial.

6.11 Scoping Report Review

The FODA Research Team presented a report of the preliminary context scoping analysis of the IWS domains for review by domain experts. Based on the context scoping analysis of the IWS Group's domains, the group chose a target subdomain, IWS Maintenance.

Lessons learned: The target domain chosen was one in which a reengineering effort had recently been completed. Object-Oriented technology had not yet been adopted, although the relatively independent nature of the products made it a good candidate for domain analysis. However, there was no perceived customer need for the work to be performed. The analysis was seen by the participating development community as an opportunity to begin the transition to O-O tools and technology in their design environment. It soon appeared that it was very difficult for the group to think in terms other than the existing architecture of the systems. That is, in a complex distributed and networking system, it is easy to draw context diagrams and structure charts of the current architectural components identified with different labels. It became a responsibility of the domain analyst to propose alternatives which suggested the

means of discovering the underlying abstractions. This suggests that additional work needs to be completed in the area of understanding the extent of the domain analyst's role in shaping the content of the analysis, as well as other methods for fostering cultural change in organizations.

For comparison purposes, Figure 6 presents two versions of the structure diagrams mentioned above. The arrows indicate the correspondences between the layers derived. The domains named in A are instances of systems in the domains named in B. This transformation allowed an important layer that was not present in A to appear in B, i.e., the layer representing the ultimate customers of applications in these domains.

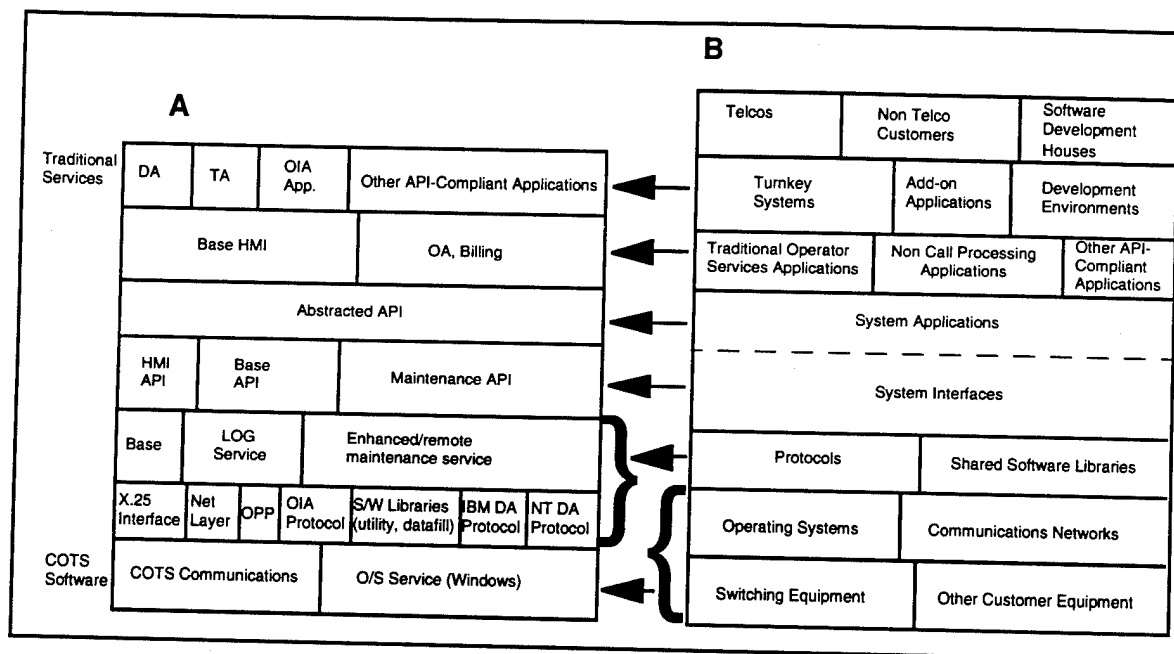

Figure 6: Structure Chart Comparisons

6.12 Pilot Study Implementation Plan, Revision I

The initial schedule was revised based on changes in TOPS understanding of the time required to integrate and document modeling meetings. The first detailed implementation schedule contained two 2-hour analysis sessions per week. Initially, the development group management agreed to this schedule. However, after trying to adjust their product delivery schedules, management felt that two sessions per week could have an impact on their deliverables and thus requested only one session per week. Therefore, the implementation

schedule was basically doubled in length, and the meetings were reduced to one two-hour weekly meeting.

Lessons learned: In hindsight, it appears that the initial schedule would have been too demanding from several angles:

- It would not have allowed enough time to redact the session notes and distribute them to the participants in a timely manner.
- It would not have allowed enough time for reflection between sessions.
- It would have compressed the pilot study in a way that would not have provided enough time for the database tool development and other activities such as documenting the process.
- It would not have effectively used the subject matter experts since it did not take into consideration the demands of their contractually obligated deliverables.

When developing time and scheduling estimates for domain analysis projects, the FODA Research Team learned that it is important to understand the time constraints of the participant organization, as well as the need for time to process the elicited information.

6.13 Context Analysis Meetings for Target Domain

The FODA Research Team and IWS team held eight weekly two-hour modeling sessions using the elicitation questions developed by the FODA Research Team to perform a context analysis of the target domain.

Lessons learned: In the example set by the SEI, a domain analysis using FODA produces two documents: a context analysis report and a domain modeling report. However, this did not address some key needs that existed throughout the Nortel pilot study:

- ability to bring people into the analysis effort during the analysis and have an efficient means of bringing them up to speed
- ability to document the process steps
- ability to preserve alternative interpretations and partial solutions, i.e., a means to remember what had been decided, how the decision was derived, and the alternatives discussed along the way
- establishment of a basis for review and verification

To address these needs, the FODA Research Team developed the concept of the analysis workbook. Each chapter of the workbook contained the results of a modeling session, including diagrams, a list of terms, open issues, and so on. The analysis workbook became our blackboard containing the raw form of all of our modeling products. Most meetings began with a review of the previous meeting's chapter in the workbook.

The workbook concept presented some drawbacks, however. Often, the material required extensive explanation and interpretation to be comprehensible. It became difficult for the documentation specialist to know what background material was required. Further, the FODA Research Team discovered that during the production of the context analysis and domain modeling reports much synthesis and derivation of linking abstractions was not completed. This suggested that some intermediary steps, during which this material would have been proposed and reviewed, had been skipped during the analysis. The result was an incomplete final domain analysis report that was not possible to review completely in the time allocated.

Perhaps periodic analysis reports devoted to some portion of the model representation (e.g., the information model, context features, etc.), rather than one large report, would be easier to produce and review and would address these deficiencies in the methods employed during the pilot study. Furthermore, the FODA Research Team explored, through the database web prototype, strategies for digesting the voluminous information produced. An interface to the database was designed to automatically generate HTML files from it, using templates which formatted and explained the information. These files were then made available for viewing on the corporate WAN via the World Wide Web.

6.14 Development of Prototype Domain-Capture Tools

Several members of the FODA Research Team undertook the development of a prototype tool for capturing domain analysis using Smart Elements™, a commercially available object-oriented GUI and client/server application development system. The tool was named the Model Editor. An HTML-based database browser application was also developed.

Lesson learned: The FODA Research Team attempted to do much more in this area than was possible given the time and resource constraints of the pilot study. The prototype tool for capturing domain analysis was completed too late in the project to be useful for the purpose for which it was designed. Its user interface is quite complex and mouse-movement intensive, making it physically uncomfortable to use for the long periods required. Persistent problems with the underlying object model remain as implemented using Smart Elements™. The research group was hampered by serious bugs in the Smart Elements™ development environment and a lack of vendor support during the capture tool's development.

In spite of these difficulties, the tool effort was valuable in that it provided a clear understanding of the requirements for a good domain analysis capture tool, and the knowledge to provide development plans for contracting this work outside Nortel. In addition, the tool development gave us a framework for evaluating and refining the FODA database schema and elicitation questions.

6.15 Contract Renegotiation

The IWS group's schedule changed and required renegotiation of the end date for the pilot study. Additionally, the FODA Research Team recognized and addressed the need for additional tool development expertise.

6.16 Domain Modeling Meetings of Target Domain

The FODA Research Team and members of the IWS team held 13 weekly 2-hour modeling sessions using the elicitation questions developed by the FODA Research Team to perform the domain modeling phase of the target domain analysis.

Lesson learned: As the modeling meetings progressed, the FODA Research Team discovered that it was easy to become mired in interesting but tangential discussions of a variety of topics of interest to the subject matter experts (SMEs). To assist us in becoming more methodologically rigorous, the research group decided to shift the focus of each meeting among the three kinds of modeling that the methodology describes, i.e., information, feature, and operation. Devoting each meeting to one kind of modeling provided, in effect, a three-session "iteration." Prior to beginning an iteration, a plan of the aspects of the domain to be covered was presented, and the relevant elicitation questions were followed very closely during the meetings. Using this procedure, the most solid and consistent modeling products of the pilot study were produced. Figure 7 illustrates the general view of the process that emerged from these discoveries:

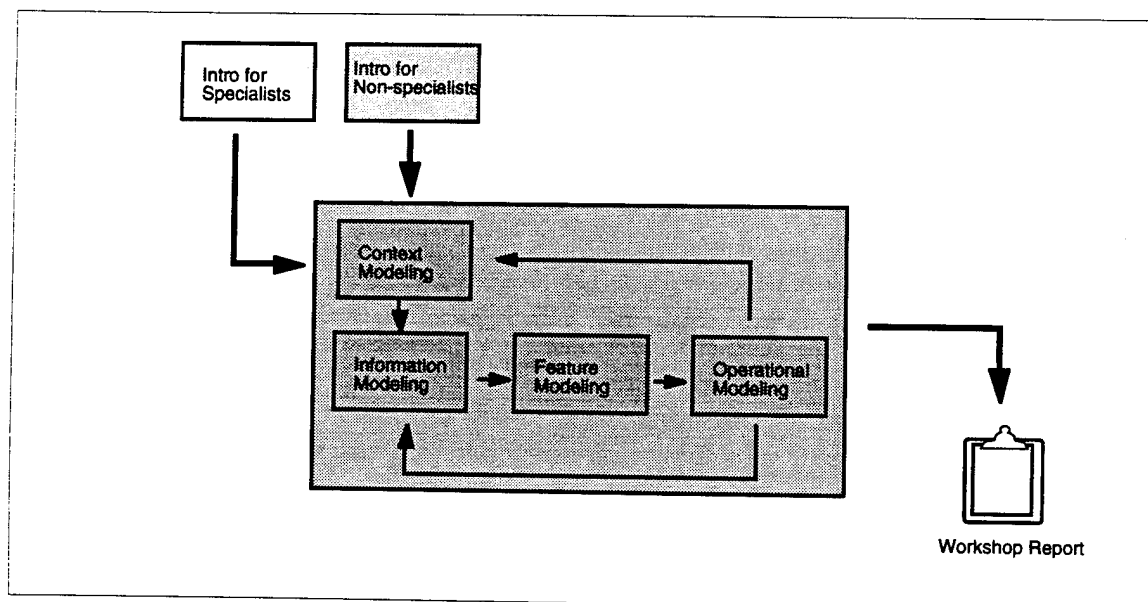

Figure 7: Model Iteration

This was possible because we partitioned the elicitation questions into areas that corresponded to the parts of the FODA methodology named in Figure 7.

It is important to note that this somewhat relentless approach was undertaken late in the pilot study. By this time, a good working relationship had developed between the SMEs and the FODA Research Team, which made it possible to risk changing our approach.

In an analysis project completed by the FODA Consulting Group after the pilot study was completed, this same approach was used from the beginning of the analysis. It worked well there, too. Because "sticking to the questions" during context analysis enabled us to produce more disciplined results, we had more confidence in the results.

6.17 Review of Reports

Context analysis report: The combined FODA and IWS Groups held two two-hour reviews of the context analysis report for the FODA Research Team, SMEs, and the SEI.

Domain modeling report: The combined FODA and IWS Groups held two two-hour reviews of the partially completed Domain Modeling Report for the FODA Research Team, SMEs, and the SEI.

Tool study report: The combined FODA and IWS Groups held a one-hour review of the tool study report.

Final report: The combined FODA and IWS Groups held a one-hour review and wrap-up session which included a demonstration of the prototype domain analysis capture tool and HTML-based database browser application.

7 Completion and Closure

Communicating achievements and completing steps was important during the pilot study. This proved to the FODA Research Team, management, and participants that the pilot was progressing at a steady pace even though unplanned activities developed. Certain milestones were chosen to signify their completion with rewards or formal acknowledgments.

During the pilot study, there were planned and unplanned activities. The project plan identified the key milestones and dates that had to be updated when unplanned work was required. The project planner's task was to keep the plan up-to-date using the software package Micro Planner Manager. But it was the task of the FODA Research Team to notify the project planner of any changes. The notification of changes was formally done during weekly staff meetings and informally as needed.

The planned milestones of the pilot study included the following:

- management briefing
- kickoff meeting
- IWS group training
- domain scoping
- context analysis
- context analysis report review
- domain modeling
- domain modeling report review
- final report
- final report review
- wrap-up and what's next meeting

In addition to the implementation of the domain analysis, the plan included the following parallel activities:

- documentation of innovations and discoveries
- presentations (internal and external)
- article writing
- management and participant updates
- development of a domain dictionary
- development of the database tool

- development of database applications
- documentation of a tool report

The study began with a carefully laid out project plan that spanned six months. However, during the course of the study, several unplanned activities and changes occurred. Unplanned activities included the development of a return-on-investment (ROI) analysis of the study, investigation to map the products of the domain analysis to the products of Nortel's software development process, and design and maintenance of a World Wide Web (WWW) site for the Nortel community. A major change after the management briefing was the determination that two scoping or modeling sessions per week would have an impact on the current product deliverables schedule. So, the number of sessions was reduced to one per week and the pilot was extended to 10 months.

With all of the planned and unplanned activities during the pilot, GSP and Operator Services management learned that it was important to formally acknowledge the completion of a milestone. This was done through a meeting, email notification, and/or the distribution of a report.

Since the implementation of a pilot study was a fairly new concept to Nortel's environment and people were working extra time to participate, GSP and Operator Services management rewarded the accomplishment of activities and milestones to maintain interest and enthusiasm. Rewards included gift certificates, lunches, and a final celebration.

The final celebration was the "wrap-up and what's next" meeting held at the completion of the study. To bring closure to the study, a presentation and discussions were held, covering

- brief history of the pilot
- what the work achieved
- where FODA had been used besides the pilot study and what was its future within Nortel
- wrap-up and summary discussions by the participants of the benefits and the areas requiring work
- awards
- pizza lunch
- demonstrations of the database tool

After 10 months of intensive work, this meeting formally brought the pilot study to closure.

8 Transition

Transition of the FODA methodology occurred during and after the pilot study. During the study, information about Nortel's experience with FODA was shared internally and externally. After the pilot study was closed at the "wrap-up and what's next" meeting and celebration, the FODA Research Team became known as the FODA Consulting Group since the methodology had been proven useful to Nortel's business. Even before the pilot study ended, the services of the group were commissioned. With the FODA Consulting Group, a strategy was developed to transition the FODA methodology internally and externally.

During the pilot study, the FODA Research Team shared information by writing papers and articles. These documents contained information about project planning, TOPS context and domain analysis, Nortel FODA process, tool support research, and innovations discovered by Nortel about implementing the methodology in an industry setting. These documents, in turn, generated presentations. Several of these presentations were given internally to Nortel, and others were given at external conferences such as the SEI Symposium and OOPSLA (Object-Oriented Programming Systems, Languages, and Applications). Further, presentations and articles have been shared with the SEI and external industry. In this manner, technology transfer occurred as discoveries were found and documented.

Once the merits of FODA became valuable to Nortel business, the FODA Research Team was contracted by Operator Services and Nortel Quality organizations to perform analysis activities. The TOPS organization used FODA for validation of product requirements and product negotiations. The Nortel Quality group used FODA to develop a context analysis of its quality management system. In the Operator Services case, they simply wanted to contract the services of the FODA Research Team to conduct the domain analysis. For the Quality Group, they not only wanted to perform a context analysis, but they also wanted the FODA Research Team to transition the FODA methodology to develop a core group of domain analysts. Thus, the FODA Research Team became the FODA Consulting Group.

As a key Nortel resource, the FODA Consulting Group's mission is to perpetuate the transition of domain analysis throughout Nortel as a means to decompose our complex systems into understandable components. The methodology would be used for software, architectural, network, process, and/or business systems. Also, the group will promote and influence industry standards for domain analysis through external consulting and presentations. The goals of the group are to continue refinement and research of the methodology, transition domain analysis and ensure proficiency in the new practitioners, and share best practices and state-of-the-art innovations in the technology with the Nortel domain analyst guild community.

As a consulting group, the FODA Group will provide the following services:

- domain analysis technology transition - provide training and consulting to a group in order to build their own set of skilled, practicing domain analysts.

- contract services - provide domain analysis services on a contractual basis for single sessions when the skill is required in an "as-needed" capacity for customer negotiations, high-level problem definition, requirements validation, and similar scoping activities.
- business planning analysis - assist groups in assessing whether domain analysis is a technology that can aid in scoping the current or perceived business need.
- domain analyst guild - provide leadership for the formation of a network of domain analyst to share innovations and best practices in maintaining the highest quality skill development, and provide opportunities to conduct and research new innovations in the technology and tools.

The planned process for transitioning the FODA methodology to a group of new domain analysts includes five steps:

- Nortel FODA training workshop
- "toy-domain" practice exercise
- domain analysis planning
- plan execution
- consultation

This process uses the concept of "see one, do one, teach one." The training workshop will provide the new domain analysts the opportunity to learn the methodology and observe a domain analysis. This is the "see-one" stage. The "toy-domain" practice exercise session is a small-scale domain analysis led by the new domain analyst under supervision and advisement of an experienced domain analyst, thus the "do-one" stage of learning. The domain analysis planning and execution is the new domain analyst's project plan for implementation of the methodology in his or her area. The experienced domain analyst will be available for consulting during the new domain analyst's application of the methodology in the real environment. This is the stage where the new domain analyst will be able to "teach one."

9 Summary

In today's fast-paced and competitive business environment, industry is constantly looking for ways to improve the development and delivery of its products. Nortel shares this same need with the rest of the business world. To address this need, seven key areas are identified to scope the effort to introduce a change to the corporation. These areas are described below:

1. **Motivation for change:** Based on the findings of Nortel RTP's Trillium assessment, the need was identified and motivation generated to improve the process for managing and capturing product requirements.
2. **Problem definition and solution investigation:** The GSP department was then tasked with developing a definition of the problem area and exploring a set of solutions. After researching possible methodologies, the use of the SEI's FODA was selected to trial.
3. **Obtaining sponsorship, participants, and funding:** With interest from the ASM Group at the SEI to expand their application experience of FODA into the industry sector, a proposal for a collaboration between Nortel and the SEI was developed to research the methodology's use. With the proposal and internal corporate sponsorship, product group participation and funding then had to be located in order to conduct the research pilot study.
4. **Project plan and contract:** Once we had secured corporate sponsorship and the Operator Services commitment in principle to participate, a project plan between GSP, the ASM Group, and Operator Services was required to capture mutually agreed-upon goals, minimum success criteria, deliverables, etc. Next, resources for the FODA Research Team and to participate in the study had to be negotiated and contracted. Further, the skills of one of our support groups to conduct analysis of database tools had to be contracted as well.
5. **Implementation:** With the resources in place, the next step was to implement the project plan for the 10-month pilot study.
6. **Completion and closure:** Upon completion of the study, closure to the activities concluded with a meeting to share the benefits and lessons learned and to reward the participants.
7. **Transition:** Finally, with a successful completion, presentation, and documentation of the results, the need to transition the methodology to other groups was requested. Thus, the FODA Research Team was transformed to a consulting group to support the perpetuation and continued improvement of the use of domain analysis within the corporation.

As part of the collaboration with the SEI, a goal was to share Nortel's experience as an industry to transition a technology into its environment. Thus, this report relates the steps taken and lessons learned in exploring the use of domain analysis, in particular FODA, as an external solution to address the need to improve Nortel's process for managing and capturing product requirements.

10 References

- [Block 81] Block, Peter. *Flawless Consulting*. San Diego, Ca.: University Associates, 1981.
- [Cohen 92] Cohen, Sholom G.; Stanley, J. L., Jr.; Peterson, A. Spencer; & Krut, Robert W., Jr. *Application of Feature-Oriented Domain Analysis to the Army Movement Control Domain* (CMU/SEI-91-TR-28, ADA 245051). Pittsburgh, Pa.: Software Engineering Institute, Carnegie Mellon University, June 1992.
- [Krut 93] Krut, Robert W., Jr. *Integrating OO Tool Support into Feature Oriented Domain Analysis Methodology* (CMU/SEI-93-TR-11). Pittsburgh, Pa.: Software Engineering Institute, Carnegie Mellon University, July 1993.
- [Krut 96] Krut, Robert W. & Zalman, Nathan. *Domain Analysis Workshop Report for the Automated Prompt and Response System Domain* (CMU/SEI-96-SR-001). Pittsburgh, Pa.: Software Engineering Institute, Carnegie Mellon University, 1996.
- [Paulk 93a] Paulk, Mark C.; Curtis, Bill; Chrissis, Mary Beth; & Weber, Charles V. *Capability Maturity Model for Software, Version 1.1* (CMU/SEI-93-TR-24, ADA 263403). Pittsburgh, Pa.: Software Engineering Institute, Carnegie Mellon University, 1993.
- [Paulk 93b] Paulk, Mark C.; Weber, Charles V.; Garcia, Suzanne M.; Chrissis, Mary Beth; & Bush, Marilyn. *Key Practices of the Capability Maturity Model for Software, Version 1.1* (CMU/SEI-93-TR-25, ADA 263432). Pittsburgh, Pa.: Software Engineering Institute, Carnegie Mellon University, 1993.
- [Peterson 91] Peterson, A. Spencer & Cohen, Sholom G. *A Context Analysis of the Movement Control Domain for the Army Tactical Command and Control System (ATCCS)* (CMU/SEI-91-SR-3, ADA 248117). Pittsburgh, Pa.: Software Engineering Institute, Carnegie Mellon University, April 1991.

REPORT DOCUMENTATION PAGE

1a. REPORT SECURITY CLASSIFICATION Unclassified		1b. RESTRICTIVE MARKINGS None	
2a. SECURITY CLASSIFICATION AUTHORITY N/A		3. DISTRIBUTION/AVAILABILITY OF REPORT Approved for Public Release Distribution Unlimited	
2b. DECLASSIFICATION/DOWNGRADING SCHEDULE N/A			
4. PERFORMING ORGANIZATION REPORT NUMBER(S) CMU/SEI-96-TR-009		5. MONITORING ORGANIZATION REPORT NUMBER(S) ESC-TR-96-009	
6a. NAME OF PERFORMING ORGANIZATION Software Engineering Institute	6b. OFFICE SYMBOL (if applicable) SEI	7a. NAME OF MONITORING ORGANIZATION SEI Joint Program Office	
6c. ADDRESS (city, state, and zip code) Carnegie Mellon University Pittsburgh PA 15213		7b. ADDRESS (city, state, and zip code) HQ ESC/ENS 5 Eglin Street Hanscom AFB, MA 01731-2116	
8a. NAME OFFUNDING/SPONSORING ORGANIZATION SEI Joint Program Office	8b. OFFICE SYMBOL (if applicable) ESC/ENS	9. PROCUREMENT INSTRUMENT IDENTIFICATION NUMBER F19628-95-C-0003	
8c. ADDRESS (city, state, and zip code) Carnegie Mellon University Pittsburgh PA 15213		10. SOURCE OF FUNDING NOS.	
		PROGRAM ELEMENT NO 63756E	PROJECT NO. N/A
11. TITLE (Include Security Classification) Transitioning Domain Analysis: An Industry Experience			
12. PERSONAL AUTHOR(S) Karen Schnell, Nathan Zalman, Atul Bhatt			
13a. TYPE OF REPORT Final	13b. TIME COVERED FROM TO	14. DATE OF REPORT (year, month, day) June 1996	15. PAGE COUNT 40
16. SUPPLEMENTARY NOTATION			
17. COSATI CODES		18. SUBJECT TERMS (continue on reverse of necessary and identify by block number) collaboration, feature oriented domain analysis, FODA, pilot study	
FIELD	GROUP SUB. GR.		
19. ABSTRACT (continue on reverse if necessary and identify by block number) This report provides an industry experience in the planning and execution of a research project to pilot the use of the Software Engineering Institute (SEI) domain analysis methodology known as feature-oriented domain analysis (FODA). Supported by examples, experiences, and lessons learned from the industry pilot study conducted by Nortel in collaboration with the SEI, this report addresses seven key areas: (1) Nortel's motivation for change; (2) defining the problem area and the search for a range of solution possibilities and/or approaches; (3) obtaining sponsorship, participants, and funding; (4) development of the project plan and contract; (5) implementation of the project plan for the pilot study; (6) completion and closure of the pilot study; and (7) the transition and deployment of FODA.			
20. DISTRIBUTION/AVAILABILITY OF ABSTRACT UNCLASSIFIED/UNLIMITED <input checked="" type="checkbox"/> SAME AS RPT <input type="checkbox"/> DTIC USERS <input checked="" type="checkbox"/>		21. ABSTRACT SECURITY CLASSIFICATION Unclassified, Unlimited Distribution	
22a. NAME OF RESPONSIBLE INDIVIDUAL Thomas R. Miller, Lt Col, USAF		22b. TELEPHONE NUMBER (include area code) (412) 268-7631	22c. OFFICE SYMBOL ESC/ENS (SEI)

