

C & C TECHNOLOGIES, INC.

A TECHNICAL REPORT

on

PHASE 3: ORCA DOCUMENTATION

for

NRL CONTRACT N00014-94-C-6005

APPROVED FOR PUBLIC RELEASE,
DISTRIBUTION IS UNLIMITED

JANUARY 15, 1996

rev: 02

19960722 036

DTIC QUALITY INSPECTED 1

DISCLAIMER NOTICE

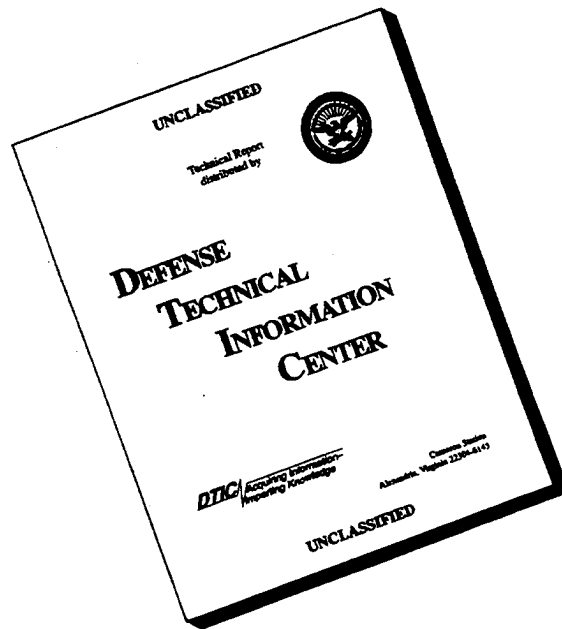

THIS DOCUMENT IS BEST QUALITY AVAILABLE. THE COPY FURNISHED TO DTIC CONTAINED A SIGNIFICANT NUMBER OF PAGES WHICH DO NOT REPRODUCE LEGIBLY.

REPORT DOCUMENTATION PAGE

Form Approved
OBM No. 0704-0188

Public reporting burden for this collection of information is estimated to average 1 hour per response, including the time for reviewing instructions, searching existing data sources, gathering and maintaining the data needed, and completing and reviewing the collection of information. Send comments regarding this burden or any other aspect of this collection of information, including suggestions for reducing this burden, to Washington Headquarters Services, Directorate for Information Operations and Reports, 1215 Jefferson Davis Highway, Suite 1204, Arlington, VA 22202-4302, and to the Office of Management and Budget, Paperwork Reduction Project (0704-0188), Washington, DC 20503.

1. AGENCY USE ONLY (Leave blank)		2. REPORT DATE January 1996	3. REPORT TYPE AND DATES COVERED Contract Report	
4. TITLE AND SUBTITLE Phase 3: ORCA Documentation			5. FUNDING NUMBERS Job Order No. 74-5137-A5 Program Element No. 980101 (OPN) Project No. 0603704N Task No. R1987 Accession No. DN252113	
6. AUTHOR(S) C&C Technologies, Inc.			8. PERFORMING ORGANIZATION REPORT NUMBER NRL/CR/7440--96-0005	
7. PERFORMING ORGANIZATION NAME(S) AND ADDRESS(ES) C&C Technologies, Inc.			10. SPONSORING/MONITORING AGENCY REPORT NUMBER	
9. SPONSORING/MONITORING AGENCY NAME(S) AND ADDRESS(ES) Naval Research Laboratory Marine Geosciences Division Stennis Space Center, MS 39529-5004				
11. SUPPLEMENTARY NOTES				
12a. DISTRIBUTION/AVAILABILITY STATEMENT Approved for public release, distribution is unlimited.			12b. DISTRIBUTION CODE	
13. ABSTRACT (Maximum 200 words) ORCA #1 has been mechanically and electrically modified in order to accommodate sensor systems installation requirements. This report will provide the mechanical and electrical/electronics drawings for inclusion into Navy technical documents.				
14. SUBJECT TERMS Autonomous, Vehicles, Sensors, Multibeam Acoustic Sounding, and Hydrographic Survey Sensor			15. NUMBER OF PAGES 47	
			16. PRICE CODE	
17. SECURITY CLASSIFICATION OF REPORT Unclassified	18. SECURITY CLASSIFICATION OF THIS PAGE Unclassified	19. SECURITY CLASSIFICATION OF ABSTRACT Unclassified	20. LIMITATION OF ABSTRACT SAR	

GENERAL

ORCA #1 has been mechanically and electrically modified in order to accommodate sensor systems installation requirements. This report will provide the mechanical and electrical/electronics drawings for inclusion into Navy technical documents.

MECHANICAL

Two bulkhead penetrations were constructed to accommodate external connections to the Simrad EM 950 transducer, TSS 335B, and Temperature/salinity probe. The Simrad Bulkhead Assembly (see figure 1) provides water tight entry for the eight Simrad transducer cables through a flange assembly (see figure 2). The Auxiliary Sensor Assembly (see figure 3) provides water tight entrance for the TSS 335B and the temperature/salinity probe through a flange assembly also (see figure 4).

Changes were made to the forward ballast tank to accept/mount the EM 950 transducer and the TSS 335B (see figure 5).

The Antenna Assembly (figure 6) provides mounting arrangements for the vehicle control radio, Arlan 620 Ethernet Bridge, a GPS compact Dome antenna and the camera.

The engine exhaust system was modified to eliminate as much of the flex pipe as possible. This was necessary due to corrosion problems which were attributed to the flex pipe design. See figure 7 for details.

The Fuel bladder system had some seepage near the fill spout hardware that we were unable to correct. The hardware and plumbing of the fuel bladders have been modified to correct this problem (see figure 8).

ELECTRICAL/ELECTRONICS

Operators Console

Only minor modifications were made to the Operator's Console. These modifications were:

- The addition of a Remote Control Pack (figure 9)
- The utilization of the previously added 8 control switches

The Remote Control Pack allows the operator limited submarine control from a remote location. This is especially important during deployment and retrieval of the submarine so that the Operator has a clear line of sight of the submarine.

The Remote Control Pack is connected to the Operator's Console by a multi-conductor cable and is given control through a switch on the Console. The functions available on the Remote Control Pack

are as follows.

- Rudder control - port/starboard
- Throttle - up/down
- Transmission - forward/reverse
- Engine - start/stop

A wiring schematic of the Remote Control Pack and connector pin out follows.

Connector - Amphenol MS3102A-20-33S
MS3106A-20-33P

- Pin
- 1 - +5 VDC
 - 2 - Rudder control
 - 3 - Throttle control
 - 4 - Engine - start
 - 5 - Engine - stop
 - 6 - Transmission - forward
 - 7 - Transmission - reverse
 - 8 - Signal/power return

Eight switches were previously added to the Operator's Console to control relay closures in the submarine Control Computer. These relays are located on the MPL 4205 board. The relay closures are being utilized to control electronic equipment operations. The switch/relay assignment is as follows.

- 1 - Communications Box (except the Sun SPARC 20)
- 2 - Sun SPARC 20 Workstation (inside Communication Box)
- 3 - Simrad EM 950 TRU enclosure
- 4 - Simrad EM 950 TRU high voltage power supply
- 5 - Navy Payload - ADCP - ORCA #1 only
 - Wesmar - Orca #2 only
- 6 - Navy Payload - ASCS - ORCA #1 only
- 7 - Navy Payload - future
- 8 - Electronic compartment bilge (manual control)

The MPL 4205 / enclosure connector pin out is as follows.

Switch 1	-	MPL 4205 terminal	3	-	Connector pin	A
2	-		6	-		B
3	-		9	-		C
4	-		12	-		D
5	-		15	-		E
6	-		18	-		J
7	-		21	-		K

Communication Box

The Communication Box is a new addition to the submarine electronics. It serves as the data telemetry center. The following equipment items are located in the Communication Box (see figure 10).

- Arlan 620 radio - wireless ethernet bridge.
- HyperAmp 900 - 900 Mhz remote bilateral power amplifier.
- Sun SPARC 20 workstation.
- Trimble differential GPS survey module.
- One pulse per second (1 PPS) box.
- Equipment power supplies.
- Power control relays.
- Mi Lan (MAU)

The following equipment are external of but wired to the Sun SPARC 20 workstation in the Communication box.

- TSS Model 335B motion sensor.
- YSI Model 600 temperature and conductivity probe.
- Simrad Model OE 1359 CCD camera.
- Submarine gyrocompass.
- ASCS - ORCA # 1 only
- ADCP - ORCA # 1 only
- Wesmar - ORCA # 2 only

Arlan 620 - The Arlan 620 wireless Ethernet bridge provides a transparent, point to point, wireless bridge between two Ethernet cabled LANs. A pair of Arlan 620 radios make all nodes on both Ethernet LANs appear to be physically attached to the same cable.

Connected to the Arlan 620 Ethernet in the submarine are the Simrad BDU computer, the Sun SPARC 20 workstation, and the ASCS (ORCA #1 only).

A radio modulation technique known as spread spectrum is used. Fifteen radio channel settings are offered allowing operation at bit rates from 215 kb/s to 1350 kb/s in the 915 MHz band.

Channel 1	215 kb/s	908 MHz
Channel 2	215 kb/s	910 MHz
Channel 3	215 kb/s	913 MHz
Channel 4	215 kb/s	917 MHz
Channel 5	215 kb/s	920 MHz

Channel 6	215 kb/s	922 MHz
Channel 7	344 kb/s	911 MHz
Channel 8	344 kb/s	915 MHz
Channel 9	344 kb/s	919 MHz
Channel 10	630 kb/s	915 MHz
Channel 11	860 kb/s	915 MHz
Channel 12	946 kb/s	915 MHz
Channel 13	1050 kb/s	915 MHz
Channel 14	1350 kb/s	915 MHz

The following is the Radio Configuration for the ORCA 1 Arlan radio:

Option	Value	Description
Sid	2	System ID
Bit rate	946	Rate kb/s
Frequency	915.0	Central Frequency
Channel	12	Channel Number
Root (Top Side)	On	Root Mode
Root (Wet Side)	Off	Repeater Mode

The following is the Network Identifier Configuration for the ORCA 1 Top Side Arlan radio:

Option	Value	Description
Name	A620_001033	Node Name
Nid	004096001033	Network Address
Inaddr	192.009.200.221	Internet Address
Inmask	255.255.255.000	Internet Subnet Mask

The following is the Network Identifier Configuration for the ORCA 1 Wet Side Arlan radio:

Option	Value	Description
Name	A620_001036	Node Name
Nid	004096001036	Network Address

Inaddr	192.009.200.220	Internet Address
Inmask	255.255.255.000	Internet Subnet Mask

The following is the radio configuration for the ORCA 2 Arlan radio:

Option	Value	Description
Sid	2222	System ID
Bit rate	946	Rate kb/s
Frequency	915.0	Central Frequency
Channel	12	Channel Number
Root (Top Side)	On	Root Mode
Root (Wet Side)	Off	Repeater Mode

The following is the Network Identifier Configuration for the ORCA 2 Top Side Arlan radio:

Option	Value	Description
Name	A620_00144c	Node Name
Nid	00409600144c	Network Address
Inaddr	192.009.204.221	Internet Address
Inmask	255.255.255.000	Internet Subnet Mask

The following is the Network Identifier Configuration for the ORCA 2 Wet Side Arlan radio:

Option	Value	Description
Name	A620_001dd3	Node Name
Nid	004096001dd3	Network Address
Inaddr	192.009.204.220	Internet Address
Inmask	255.255.255.000	Internet Subnet Mask

The Arlan 620 radio requires 24 VDC input power.

- Connections
- TNC - RF Output - RF to HyperAmp 900 bias-T
 - RS-232 Jack - Data/Control - to Aurora Box port 8
 - BNC - Ethernet
 - Power Jack - +24 VDC - from Vicor +24 VDC supply

HyperAmp 900 - The HyperAmp 900 is a 900 MHz remote bilateral power amplifier designed to operate with spread spectrum modulation radios. The amplifier was designed to accept input levels from 1.5 mW to 12.5 mW while developing 5 watts of output. Higher input signals must first be attenuated down to an acceptable level. A bias-T block is used ahead of the amplifier to combine 15 VDC with the input signal to power the amplifier.

- Connections
- Amplifier
 - N connector - RF/+15 VDC from bias-T
 - N connector - RF to antenna
 - Bias-T
 - F connector - RF from Arlan 620
 - F connector - RF to amplifier
 - Power Jack - +15 VDC from Vicor supply

Sun SPARC 20 Workstations - The Sun SPARC 20 workstations serve as an interface between the Simrad EM 950 system, operator controls, and auxiliary equipment. The SPARC 20 on board the ORCA is connected to the Simrad BDU computer over an RS-232 line and to surface vessel systems through the Arlan 620 wireless Ethernet bridge. The auxiliary equipment connected to the SPARC 20 that supplement the Simrad EM 950 data collection and operator controls include the following.

- TSS Model 335B motion sensor
- YSI Model 600 temperature / conductivity probe
- Trimble differential GPS survey module
- Submarine gyrocompass
- Simrad Model OE 1359 CCD camera
- ASCS - ORCA #1 only
- ADCP - ORCA #1 only
- Wesmar- ORCA #2 only

The workstation requires 120 VAC input power.

Sparc 20 - Sub version

The Sun SPARCstation 20 in the vehicle is a model 50 with the following specifications:

RAM:	32 MB
Processor:	Single 50MHz SuperSPARC Processor (1 M-Bus slot free)

Disk Capacity:	2 1.05 GB Fast SCSI-2 Internal Disks (1 GB for the system, 1 GB for data)	
Video:	No Frame Buffer	
Ethernet:	10Base-T (Twisted Wire) with adapter to 10Base-2 (Thinnet)	
Console:	via Console serial port, (/dev/term/a)	
	9600 Baud, 8 Data Bits, No Parity, 1 Stop Bit	
S-Bus Cards:	(4 slots-2 free)	
	Sun-Video:	2 port video capture board
	Aurora Multiport 1600SE:	16 port serial card

Sparc 20 - Operator version

The Sun SPARC 20 Workstation located in the operator's position is a model 50 with the following specifications:

RAM:	64 MB	
Processor:	Single 50MHz SuperSPARC Processor (1 M-Bus slot free)	
Disk Capacity:	1.05 GB Fast SCSI-2 Internal Disk (for the system) 2.1 GB Fast SCSI-2 Desktop Disk Pack (for data)	
Video:	TurboGX Graphics Card with 20" Sun Color Monitor TurboGX Graphics Card with 17" Sun Color Monitor	
Ethernet:	10Base-T (Twisted Wire) with adapter to 10Base-2 (Thinnet) Sun Quad-EtherNet Adapter (10Base-T) 2 10Base-T (twisted Wire) to 10Base-2 (Thinnet) transceivers	
Tape:	Sun 8505 (Exabyte) 10Gb 8mm Tape Drive	
CD-Rom:	SunCD2 Internal CD-Rom Drive	
S-Bus Cards:	(4 slots - 0 free)	
	Aurora Multiport 1600SE:	16 port serial card
	Sun Quad-EtherNet Adapter	4 port 10Base-T card
	Sun TurboGX	graphics card
	Sun TurboGX	graphics card

Trimble Differential GPS Survey Module (DSM) - The DSM features 8 channels of continuous satellite tracking with a 12-channel upgrade available. The DSM accepts DGPS corrections in the RTCM SC-104 standard format from a surface vessel based receiver. The DSM is connected to the onboard Sun SPARC 20 to receive corrections / commands from and send positioning information to surface vessel systems. The DSM requires 24 VDC input power.

Connections - DB9 - RS-232 - Data to 1 PPS Box input
 - DB9 - RS-232 - Control to Aurora Box port 0
 - DB9 - RS-232 - RTCM to Aurora Box port 1

- RF Jack - to compact dome antenna
- Power Jack - +24 VDC from Vicor +24 VDC supply

One Pulse Per Second (1 PPS) Box - The 1 PPS box receives the one microsecond PPS from the DSM, changes the pulse width (variable from 10 to 500 milliseconds), level shifts the pulse to the RS-232 format, and places the pulse on the Carrier Detect line of DSM Data line to the SPARC 20 workstation. This 1 PPS is used in time tagging the Simrad EM 950 data with GPS time. The box requires 24 VDC input power. A circuit schematic follows (figure 11).

- Connections
- DB9 - RS-232 input - Data from DSM
 - DB9 - RS-232 output - Data/1PPS to Aurora Box port 2
 - BNC - 1 PPS - from DSM
 - Power Jack - +24 VDC from Vicor +24 VDC supply

Power Supplies - Three DC-DC converters and one DC-AC converter are utilized in the Communication Box. All converters are 24 VDC input. The converters are as follows.

- Vicor	VI-211-CV	+12 VDC output
- Vicor	VI-2W2-CV	+15 VDC output
- Vicor	VI-213-CV	+24 VDC output
- Newmar	24-300	120 VAC output

Power Control Relays - Two power relays are utilized in the Communication Box. A Stancor 70-903 power relay is used to switch all loads except the Newmar 24-300 DC-AC converter. A P&B KRPA-11DG-24 power relay is used to control power to the Newmar 24-300 DC-AC converter. The Newmar converter is used to power the Sun SPARC 20 workstation. Switches on the operators console are used to control the two power relays and are labeled COM and SUN. Both relays require 24 VDC coil voltage.

TSS Motion Sensor - The TSS Model 335B is a stand-alone sensor system providing accurate measurements of pitch, roll, and heave in real time. The sensors are mounted in an anodized aluminum housing with a depth rating of 100 meters. A single underwater cable connects the sensor housing to the Active Junction Box which is mounted inside the Simrad EM 950 enclosure. The cable carries analog output signals, bi-direction digital communication, and sensor power. The Active Junction Box supplies analog pitch, roll, and heave information to the Simrad EM 950 and RS-232 communication to the SUN SPARC 20 workstation. The Active Junction Box requires 24 VDC input to power itself and the remote sensors.

YSI Model 600 Probe - The YSI Model 600 probe measures water temperature and conductivity at the Simrad EM 950 transducer. This information is transmitted by RS-232 to the Sun SPARC 20 workstation over an underwater power/communication cable. This information is used by the workstation to calculate sound velocity at the transducer. The probe requires 12 VDC input power.

Simrad OE 1359 CCD Camera - The Simrad OE 1359 is a small rugged underwater solid state television camera. The camera requires 24 VDC input power and supplies video output to the Sun SPARC 20 workstation.

Gyrocompass - The submarine gyrocompass is a Robertson Model SKR 82. It is a two-degree-of-freedom, dry, flexure-joint-suspended, free rotor gyro. The gyrocompass supplies a synchro output to both the submarine control computer and the Simrad EM 950 and a RS-232 output to the Sun SPARC 20 workstation. The gyrocompass requires 24 VDC input power.

Connectors

Camera Amphenol MS3102A-14S-6S
 MS3108A-14S-6P

Pin A - Video
 B - 24 VDC Return
 C - +24 VDC
 D - Shield to power return

Sun RS-232 Amphenol MS3102A-14S-6S
 MS3108A-14S-6P

Pin A - TX
 B - RX
 C - Gnd

Bottom Detect Unit (BDU) Amphenol BNC - Ethernet

Temperature Probe Amphenol MS3102A-14S-6S
 MS3108A-14S-6P

Pin A - TX	Probe - Yellow	DB9-2	Flat Cable 7 - Green
B - RX	- Orange	-3	- Black
C - Gnd	- Green	-5	- Yellow
C - Shield	- Bare		
D - 12 VDC	- Red		
E - 12 VDC Rtn	- Black		

Gyrocompass Amphenol MS3102A-14S-6S
 MS3108A-14S-6P

Pin A - RX	DB9-2	Flat Cable 6 - Green	DB25-3
B - TX	-3	- Black	-2
C - DTR	-4	- Orange	-20
D - Gnd	-5	- Yellow	-7

Control

Amphenol MS3102A-14S-9S
MS3108A-14S-9P

Pin - A - Power relay - all loads except Sun SPARC 20 Workstation
B - Power relay - Sun SPARC 20 Workstation

Aurora Serial Box Port Assignment

Port - 0 - DSM Control
1 - DSM RTCM
2 - DSM Data + 1 PPS
3 - TSS Data and Control
4 - Time Synchronization to BDU
5 - Sound Velocity to TRU
6 - Gyrocompass
7 - Temperature Probe Data and Control
8 - Arlan 620 Control
9 - ORCA #1 - ASCS
- ORCA #2 - Wesmar
10 - ORCA #1 - ADCP

Simrad EM 950 Modifications

The Simrad EM 950 Multibeam Echo Sounder was delivered configured for 230 VAC operation. The following areas were modified to configure the unit for 24 VDC operation.

- Simrad Power Supply 290-074478 - received signal amplifier +/- 12 VDC power supply.
- Simrad HV - Power Unit 290-056190 - transmitter high voltage power supply.
- +5 VDC computer board power supply.
- +/- 15 VDC computer board power supply.
- BDU (Bottom Detect Unit) Computer power supply.
- 230 VAC Cooling Fans.

The following were additions made for system wide integration and control.

- TSS Motion Sensor - 333/335 H-R-P sensor active junction box.
- Power Control relays.

Simrad Power Supply 290-074478 - The 230 VAC power supply components and wiring, except the output filter capacitors, were removed from the enclosure chassis. Two Vicor VI-211-CX DC-

DC converters (24 VDC to 12 VDC) and two VI-RAM-C1 ripple attenuators were install and wire configured to supply +/- 12 VDC at 75 watts each. The existing output filter capacitors were re-installed. A 24 VDC LED lamp was install to indicate a blown fuse condition. A wiring schematic follows. Also removed from the enclosure chassis was the wiring for a switched 230 VAC service outlet and a 230 VAC enclosure resistive heater unit. (see figure 12)

Simrad HV - Power Unit 290-056190 - The VAC components (full wave rectifier D20 and surge suppressor R56) (figure 13) and logic chip U9(figure 14) were removed from the units printed circuit (PC) board. A Vicor model VI-213-CW DC-DC converter and an Ultravolt DC-DC converter, model 1/8A24-P20-C (figure 15), was enclosure chassis mounted and PC board wired to supply the unit with 135 VDC at 20 watts. U9 pin sockets 2 and 5 were wire jumpered to complete the logic circuit (figure 16). Wiring schematics follow.

Due to ORCA #2's upgrade to an EM1000, additional storage capacitors were needed to increase the transmitter output power. Two 6,800 mf / 200 WVDC capacitors were externally mounted and wired to the Power Unit.

+5 - +/- 15 VDC Power Supply - The Powec PMP 4.MO2 SIC, 230 VAC input, power supply and associated wiring were removed. A Vicor VI-210-CW DC-DC converter (24 VDC to 5 VDC) and a VI-B10-CW power booster were installed and wire configured to supply +5 VDC at 200 watts (figure 17). Two Vicor VI-2W2-CV DC-DC converts (24 VDC to 15 VDC) were installed and wire configured to supply +/- 15 VDC at 150 watts each (figure 18). A wiring schematic follows.

BDU Computer Power Supply - The Senstro, model SQH4154, 230 VAC input power supply was removed and replaced with a Mesa, model 10448, 24 VDC input power supply.

Cooling Fans - The Simrad EM 950 electronics are cooled by six axial fans. The six EBM, model W2S107-AA01-13, 230 VAC fans were removed and replaced with six Orix, model MD1238A-24, 24 VDC fans.

TSS Motion Sensor - The TSS, model 335B, motion sensor supplies the Simrad EM 950 with analog pitch, roll, and heave information. For convenience of location and cabling, the TSS active junction box was mounted inside the Simrad enclosure.

- Connections
- Multi-conductor to TSS sensor
 - BNC - Pitch to TRU TB2-5,6
 - BNC - Roll to TRU TB2-1,2
 - BNC - Heave to TRU TB2-3,4
 - DB25 - RS-232 - Data/Control to SPARC 20 Workstation
 - Power cable

Power Control Relays - To conserve power while the submarine engine is not running, a power relay, Stancor 70-903 / 24 VDC, was installed in the Simrad enclosure to power down the entire EM

950 system. To shut down the EM 950 transmitter high voltage while the submarine is out of the water, a power relay, P&B KRPA-11DG-24 / 24VDC, was install in the Simrad enclosure to power down the Ultravolt high voltage power supply. The relays are controlled by switches on the operators console through the submarine control computer.

(note* see figure 19 for power distribution layout)

Connectors

Communication Box	Amphenol	MS3102A-14S-6S MS3106A-14S-6P
--------------------------	----------	----------------------------------

Pin - A - Sound Velocity to TRU	TRU - TB3-1
B - Time Sync. to BDU	BDU - DB9-2
C - Control to TSS	TSS - DB25-3
D - Data to SPARC 20	TSS - DB25-2
E - Signal return	TRU - TB3-3
	BDU - DB9-5
	TSS - DB25-7

BDU Ethernet	Amphenol	31-10 (BNC)
---------------------	----------	-------------

Gyrocompass	Amphenol	MS3102A-14S-6S MS3106A-14S-6P
--------------------	----------	----------------------------------

Pin A - S1
B - S2
C - S3
D - Ref +
E - Ref -
F - n/c

TSS	Amphenol	MS3102A-20-11S MS3106A-20-11P
------------	----------	----------------------------------

Pin - A - CL TX +	H - Pitch return
B - Heave	J - + Power
C - CL RX +	K - CL TX -
D - Power return	L - Heave return
E - Roll return	M - Roll
F - CL RX -	N - Shield
G - Pitch	

Power Amphenol MS3102A-32-5P
 MS3206A-32-5S

Pin- A - 24 VDC
 B - 24 VDC return

Control Amphenol MS3102A-14S-9S
 MS3106A-14S-9P

Pin - A - Main Power
 B - HV Power Supply

Submarine Control Computer Modifications

The following are modifications made to the submarine control computer.

- A relay to turn the navigation strobe light on and off.
- A timing relay to time control ballast tank air blows.
- A relay to manually control the electronic compartment bilge pump.
- Wiring to bring out switched relay closures.
- The addition of a Watson Industries x / y displacement sensor.

Navigation Strobe Light Relay - Initially the strobe light was wired to power up when the hull switch is activated. However, the control computer was initially set up with a strobe on/off command wired to the main terminal strip. A power relay was added and wired to the strobe on/off command to control the strobe light from the operators control console keyboard. A circuit schematic is at figure 20.

Air Blow Timing Relay - When an air blow is activated either by a flood alarm or by a manual keyboard entry, the air blow stays on until the blow is manually shut off by a keyboard entry. This type of air blow can rapidly deplete the submarine high pressure air supply. To conserve the on board air supply, a time delay relay was added to time the length of any one blow. The time can be set from 1 to 60 seconds. The blow command must still be shut off from the keyboard to reset the blow circuit for additional blows. A circuit schematic is at figure 21.

Bilge Pump Relay - Due to limited space available in the electronic compartment, the submarine gyrocompass is located in the upper part of the bilge. To check for water accumulation in the bilge below the float switch, the communication box, control computer, and gyrocompass have to be removed. To alleviate this problem a relay was added to manually activate the bilge pump from a switch on the operator's console to pump out the bilge. A circuit schematic is at figure 22.

Switched Relay Wiring - A previous modification to the control computer was the addition of a MPL 4205 relay board. The board contains 16 relays, however the operator's control computer is currently configured to utilize only 8 of the relays. The relays are capable of switching 1.0 amp at

24 VDC. The relays are controlled by switches on the operator's control console (figure 23). The relays have been wired to control the following.

- Switch 1 - all devices in the communication box except the Sun SPARC 20 workstation.
- Switch 2 - the Sun SPARC 20 workstation in the communication box.
- Switch 3 - the Simrad EM 950 main power relay.
- Switch 4 - the Simrad EM 950 high voltage power supply.
- Switch 5 - Navy Payload - ADCP (ORCA #1 only).
 - Wesmar (ORCA #2 only).
- Switch 6 - Navy Payload - ASCS (ORCA #1 only).
- Switch 7 - future Navy Payload.
- Switch 8 - electronic compartment bilge pump.

Watson x / y Displacement Sensor - The Watson Industries x / y displacement sensor replaces the original submarine pitch / roll sensor. The Watson sensor supplies the sensitivity, accuracy, and dependability needed to control the attitude of the submarine. A circuit schematic is at figure 24.

Gyrocompass

Only minor modifications were made to the gyrocompass enclosure. These modifications are as follows.

- Addition of a synchro output to the Simrad EM 950 TRU
- Addition of a RS-232 output to the Sun SPARC 20 Workstation

The synchro output parallels off the existing synchro output for the Control Computer. The compass / connector pin out is as follows.

Compass terminal-	D	-	Connector pin	A	-	S1
	E	-		B	-	S2
	F	-		C	-	S3
	H	-		D	-	Ref +
	G	-		E	-	Ref -

The only digital output available on the Robertson SKR 82 gyrocompass is a 20 mA current loop. A RS-232 Current Loop Interface Converter (101-4Q) by Black Box Corporation was added to obtain the RS-232 output. The pin out is as follows.

Compass - J405-3	Converter - TXB	Current loop +
J405-4	- TXA	Current loop -
Converter - 3	Connector - A	TX
- 2	- B	RX

- 7
- 20

- D
- C

Gnd
DTR

Payload Box

The Payload Box is a new addition to the electronic compartment. It is to house all add on equipment. The box will come with three power relays, P&B KRPA-14DG-24, to independently switch three loads from the Operator's Console. Connectors will be added and wired as needed.

Connectors

Power Amphenol MS3102A-18-3P
MS3108A-18-3S

Pin A - +24 VDC
B - 24 VDC Return

Control Amphenol MS3102A-14S-6S
MS3108A-14S-6P

Pin A - ADCP - ORCA #1 only
- Wesmar - ORCA #2 only
B - ASCS - ORCA #1 only
C - Future
D - n/c
E - n/c
F - n/c

ASCS to Communications Box (ORCA #1 only) Amphenol MS3102A-14S-2S
MS3108A-14S-2P

Pin A - TXD
B - RXD
C - GND
D - n/c

ASCS to Communications Box (ORCA #1 only) Amphenol 31-10

Ethernet BNC

ASCS to Transducer (ORCA # 1 only) Amphenol MS3102A-14S-9S
(see figure 25) MS3108A-14S-9P

Burton 5507-3221-0004
Amphenol Pin A - (+) 5501-3221-0004
B - (-)
Burton Pin 1 - (+)
2 - (-)

ADCP to Communications Box (ORCA #1 only) Amphenol MS3102A-14S-02S
MS3108A-14S-02P

Pin A - RXD B
B - TXD B
C - DATA COM
D - n/c

ADCP to ADCP Bottle (ORCA #1 only) Amphenol MS3102A-14S-6S
(see figure 26) MS3108A-14S-6P
Burton 5507-3221-0004
5501-3221-0004

Amphenol Pin A - RXD B
B - TXD B
C - DATA COM
D - +24 VDC
E - RTN
F - n/c

Burton Pin 1 - TXD B
2 - DATA COM
3 - RXD B
4 - +24 VDC
5 - RTN

Wesmar to Communications Box (ORCA #2) Amphenol MS3102A-14S-6S
MS3108A-14S-6P

Pin A - RXD
B - GND
C - TXD
D - n/c
E - n/c
F - n/c

Wesmar to Transducer (ORCA #2 only) Amphenol MS3102A-20-7S
(see figure 27) MS3108A-20-7P

Pin A - Transducer Gnd
B - Scan Clock
C - Scan Motor 1
D - Scan Motor 2
E - Tilt Motor 1
F - Tilt Motor 2
G - Motor Gnd

H - Transducer Hot

ORCA Electronic Compartment Cabling

From	To	Connector	Lable
Communication Box	Camera	MS3108A-14S-6P	CAMERA : COM
Communications Box	Simrad Box - BDU	BNC	SIMRAD : COM
Communications Box	Temperature Probe	MS3108A-14S-6P	PROBE : COM
Communications Box	Gyrocompass	MS3108A-14S-6P	GYRO : COM
Communications Box	Simrad Box	MS3108A-14S-6P	SIMRAD : COM
Communications Box	Payload - ASCS - Orca #1	MS3108A-14S-2P	ASCS : COM
Communications Box	Payload - ASCS - Orca #1	BNC	ETHERNET
Communications Box	Payload - ADCP - Orca #1	MS3108A-14S-2P	ADCP : COM
Communications Box	Payload - Wesmar - Orca #2	MS3108A-14S-6P	WESMAR : COM
Communications Box	Battery - Power	MS3108A-24-9S	COM POWER
Communications Box	Control Computer - Control	MS3108A-14S-9P	COM CONTROL
Simrad Box	Gyrocompass	MS3108A-14S-6P	GYRO : SIMRAD
Simrad Box	TSS	MS3106S-20-11P	TSS : SIMRAD
Simrad Box	Battery - Power	MS3106A-32-5S	SIMRAD POWER
Simrad Box	Control Computer - Control	MS3106A-14S-9P	SIMRAD CONTROL
Payload Box	Battery - Power	MS3108A-18-3S	AUX.POWER
Payload Box	Control Computer - Control	MS3108A-14S-6P	AUX. CONTROL
Payload Box	ASCS Transducer - Orca #1	MS3108A-14S-9P	ASCS TRANSDUCER
Payload Box	ADCP Bottle - Orca #1	MS3108A-14S-6P	ADCP : AUX BOX
Payload Box	Wesmar Transducer - Orca #2	MS3108A-20-7P	WESMAR
Communications Box	Antenna - MFB-9387	N-Type Coax	ARLAN
Communications Box	GPS Mini-dome Antenna	N-Type Coax	GPS

Figure 1

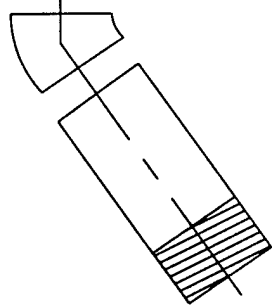
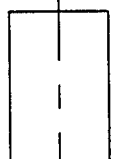
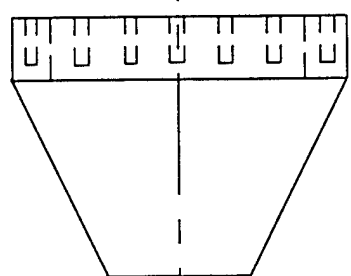
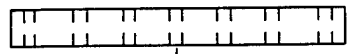
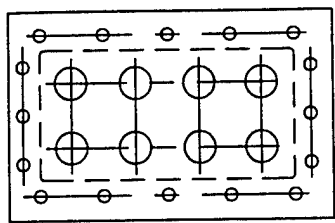

NOTE: For detail of flange fabrication see "DETAIL OF SIMRAD BULKHEAD FLANGES".

3" sch 40 elbow

3" x 2-1/2" sch 40 nipple

3" x 4" sch 40 nipple

3" npt to thread into bulkhead connector

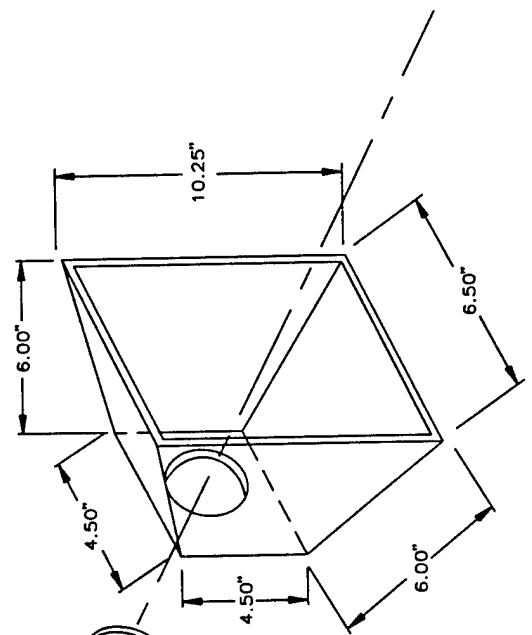

All pieces are welded together for a watertight fit then pressure tested.

U.S. NAVY
ORCA

DETAIL OF
SIMRAD BULKHEAD ASSEMBLY

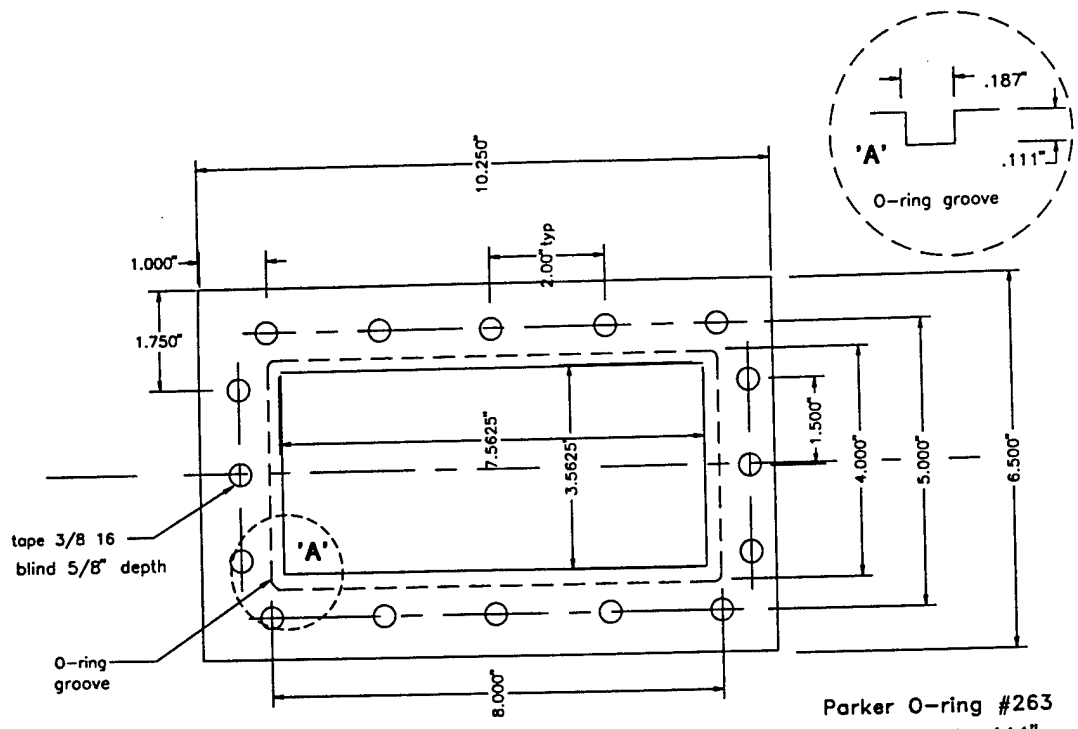

Parker O-ring #263
groove depth .111"
groove width .187"

MATERIALS
3/4" PLATE 6061
quantity needed - 1

8 Wire Back Flange

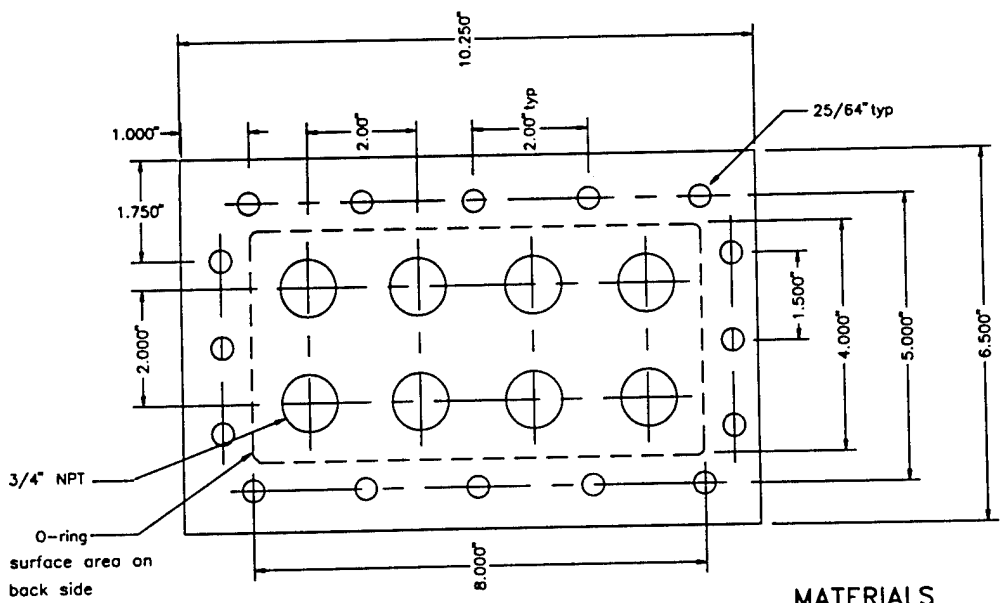

MATERIALS
5/8" PLATE 6061
quantity needed - 1

8 Wire Front Flange

**U.S. NAVY
ORCA**

**DETAIL OF
SIMRAD BULKHEAD FLANGES**

Figure 3

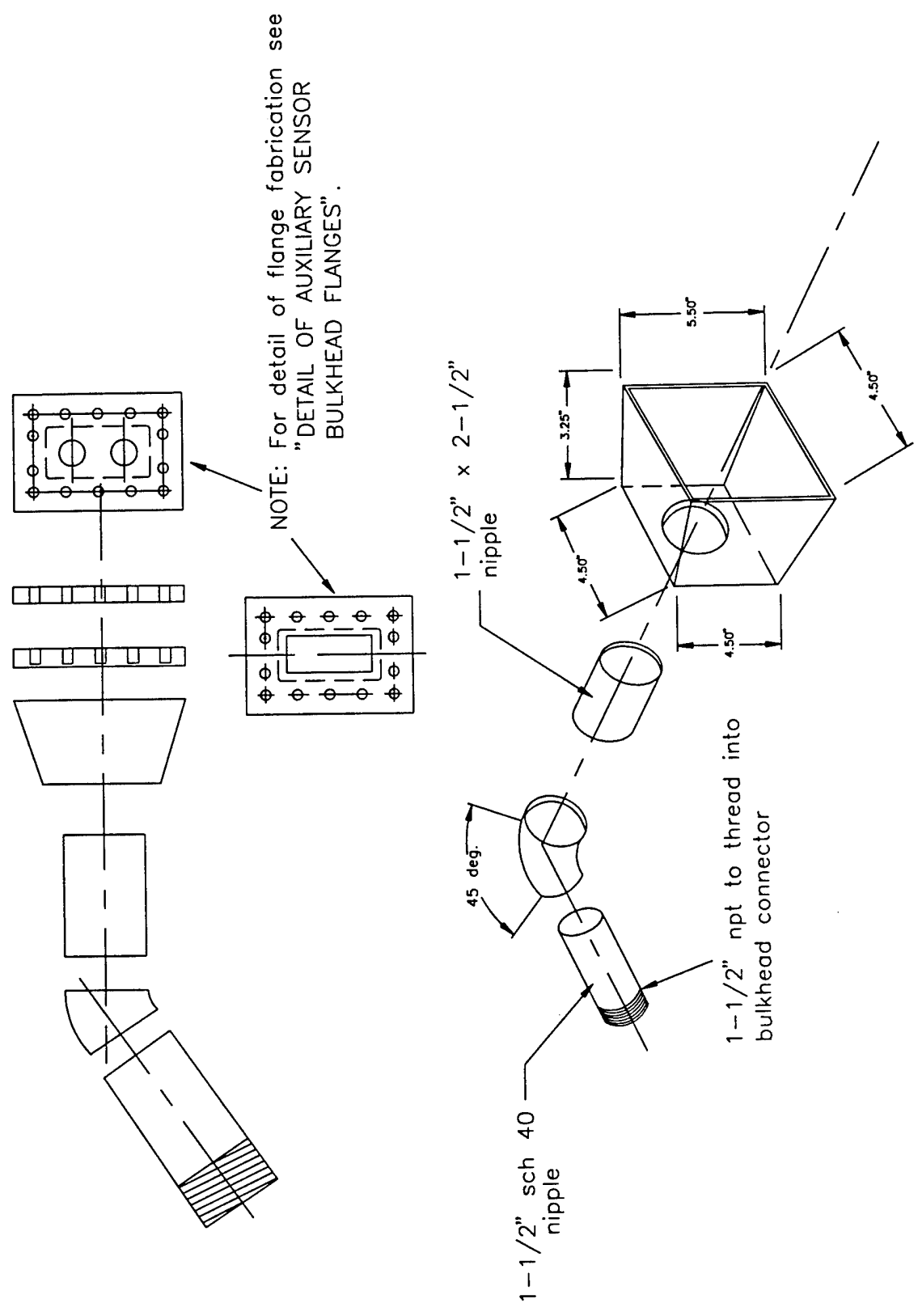

All pieces are welded together for a watertight fit and pressure tested.

U.S. NAVY
ORCA

DETAIL OF
AUXILIARY SENSOR ASSEMBLY

PREPARED BY C & C TECHNOLOGIES, INC.
500 DOVER BLVD. LAFAYETTE, LA
318 / 981-1442

Contract No. N00014-94-C-6005 REVISED
MAP No. SIMRAD-2.DWG

DATE: 04/19/95
SHEET 1 OF 1

Figure 4

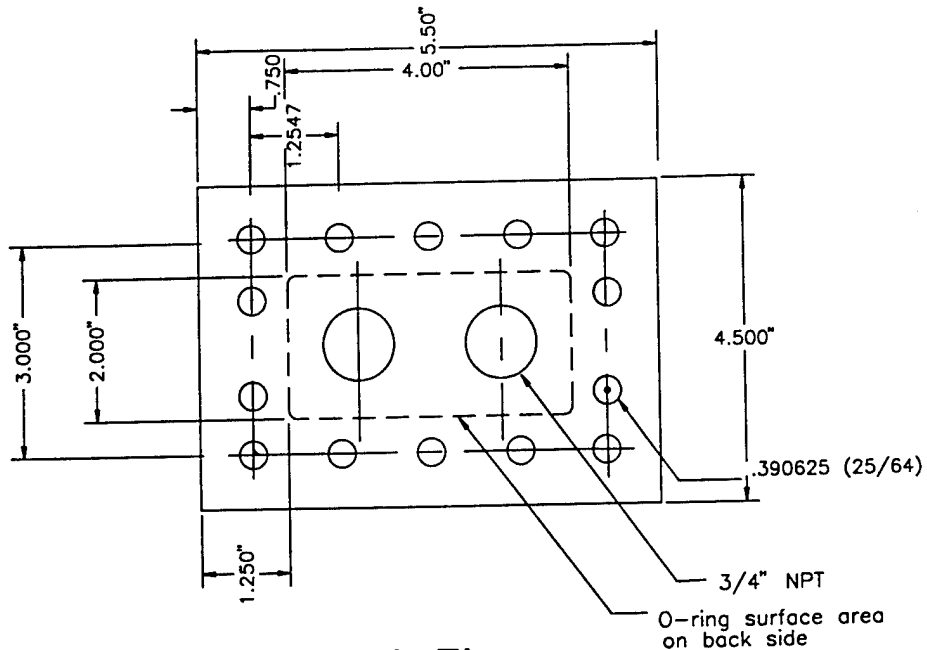

Back Flange

MATERIALS

3/4" plate 6061
 Parker O-ring #236

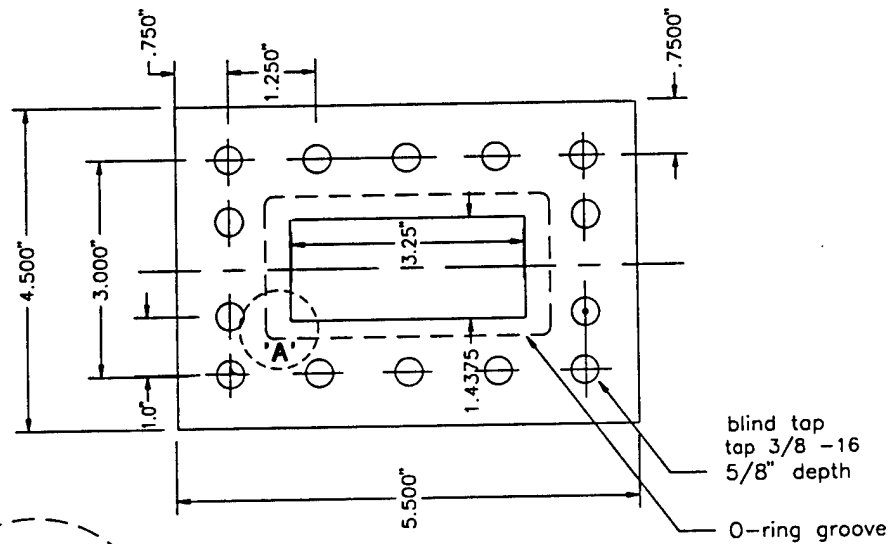

Front Flange

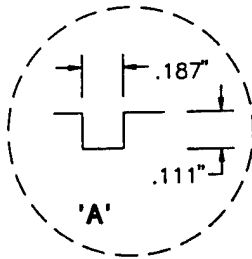

**U.S. NAVY
 ORCA**

**DETAIL OF
 AUXILIARY SENSOR BULKHEAD FLANGES**

PREPARED BY **C & C TECHNOLOGIES, INC.**
 500 DOVER BLVD. LAFAYETTE, LA
 70503 / 981-1442

Contract No. N00014-94-C-6005 REVISED
 MAP No. AUXBULK.DWG

DATE: 04/19/95
 SHEET 1 OF 1

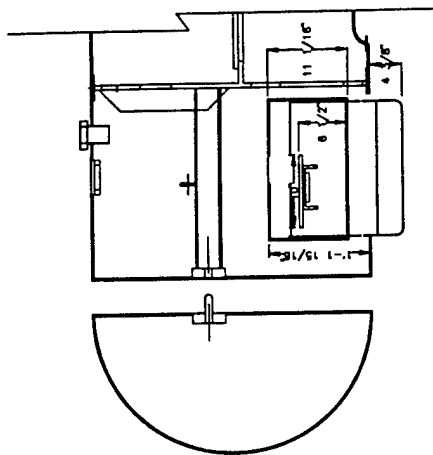

SECTION A-A

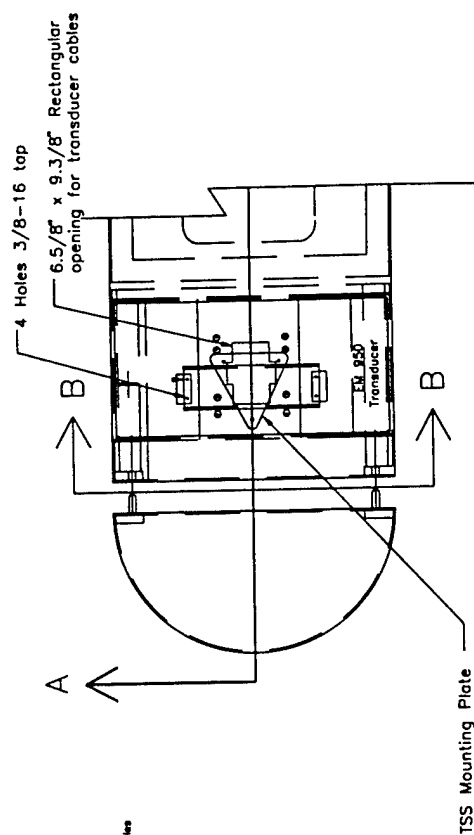

TOP VIEW

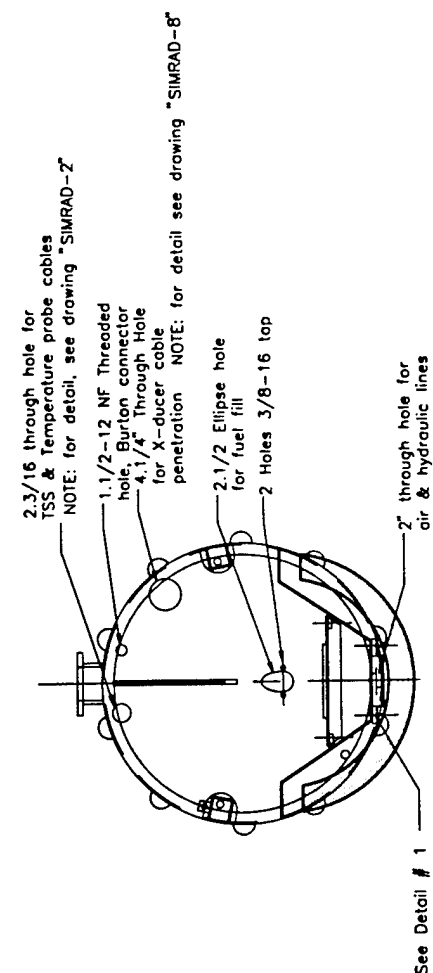

SECTION B-B

2.3/16 through hole for TSS & Temperature probe cables
NOTE: for detail, see drawing "SIMRAD-2"
1.1/2-12 NF Threaded hole, Burton connector
4.1/4" Through Hole for X-ducer cable penetration NOTE: for detail see drawing "SIMRAD-8"
2.1/2 Ellipse hole for fuel fill
2 Holes 3/8-16 top

See Detail # 1

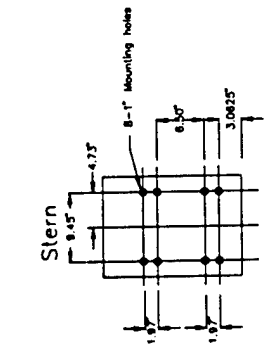

Simrad Transducer Bolt hole Mounting Pattern

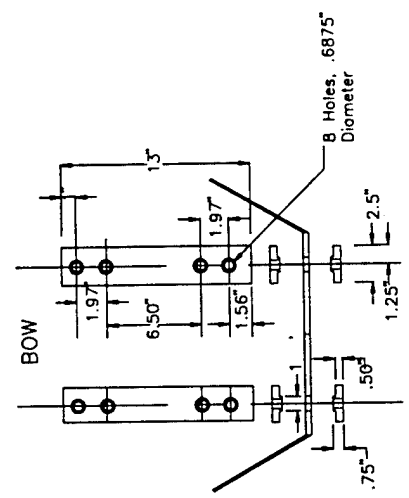

Detail # 1
Exploded View

U.S. NAVY
ORCA

DETAIL OF
FORWARD BALLAST TANK

Figure 6

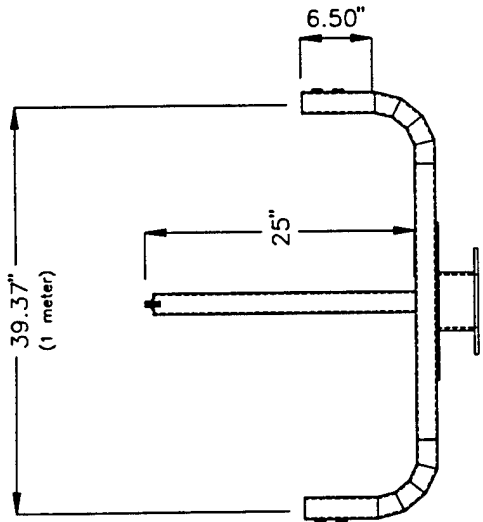

Front View

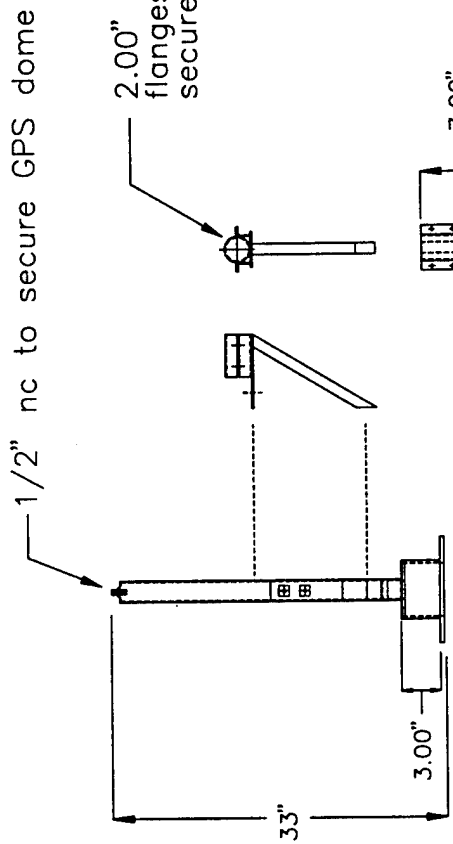

Side View

2.00" tube split with flanges welded on to secure camera

1/2" nc to secure GPS dome

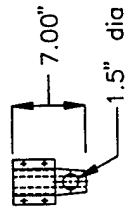

Camera Option

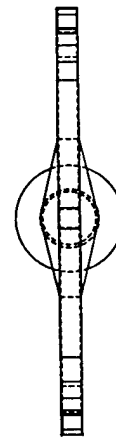

Top View

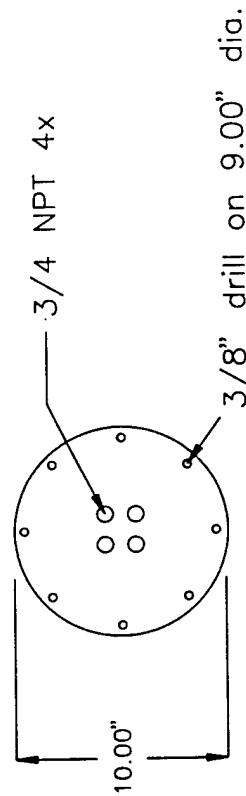

Mounting Flange Detail

U.S. NAVY
ORCA

DETAIL OF
ANTENNA ASSEMBLY

Figure 7

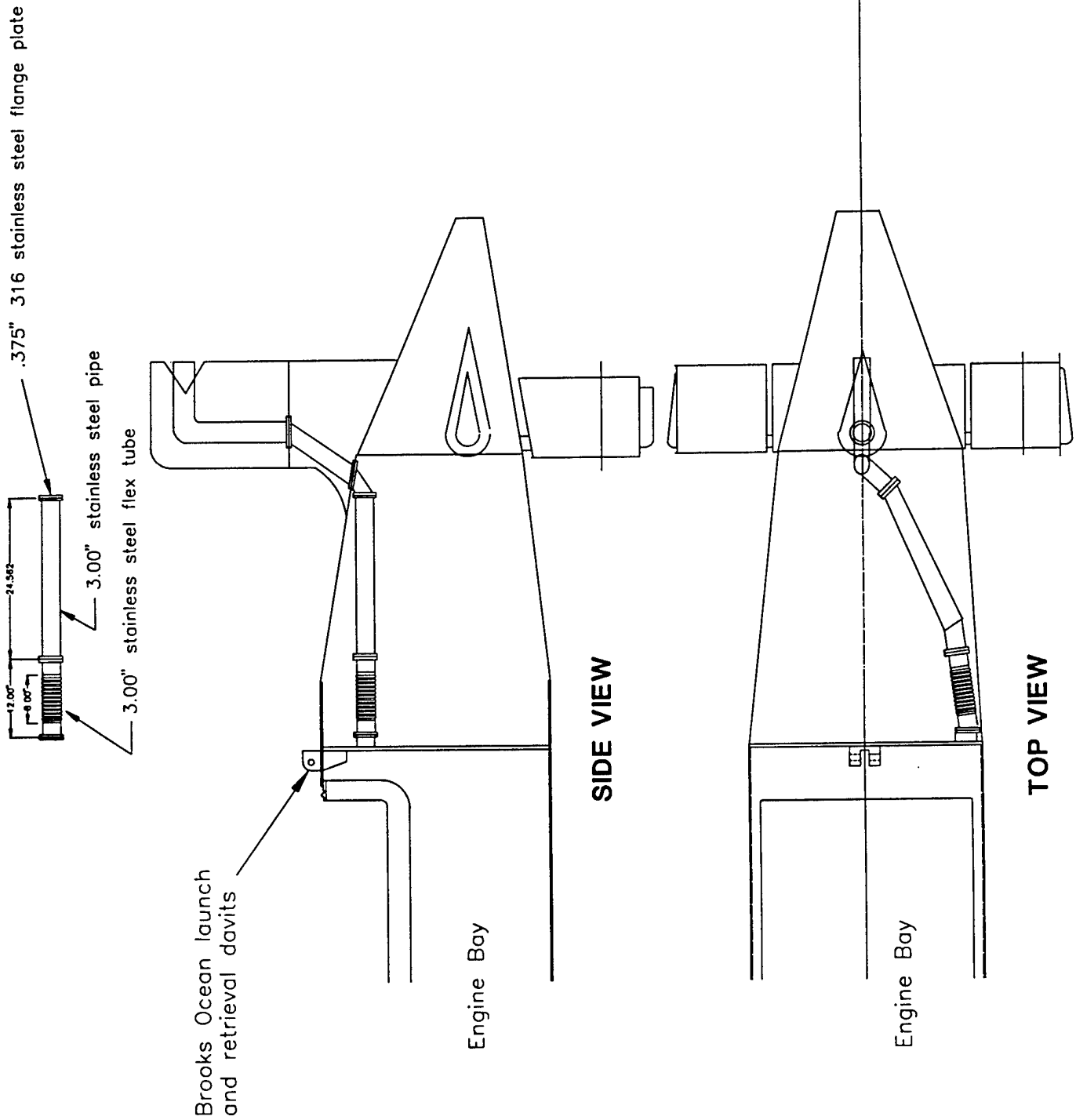

U.S. NAVY
ORCA

DETAIL OF
ENGINE EXHAUST

PREPARED BY **C & C TECHNOLOGIES, INC.**
500 DOVER BLVD. LAFAYETTE, LA
318 / 981-1442

Contract No. N00014-94-C-6005 REVISED
MAP No. REAREXH.DWG

DATE: 04/19/95
SHEET 1 OF 1

Figure 8

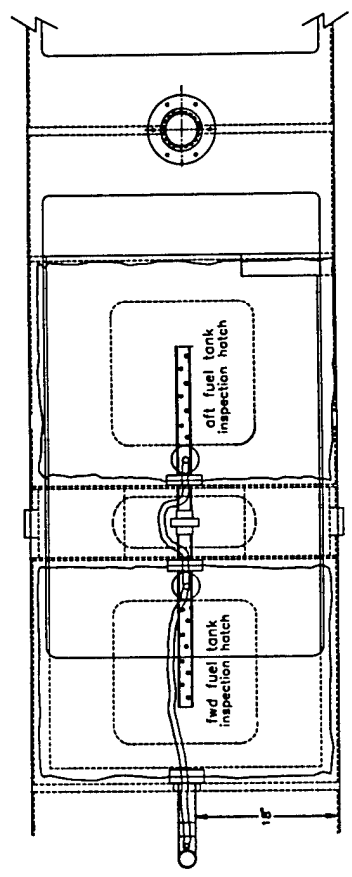
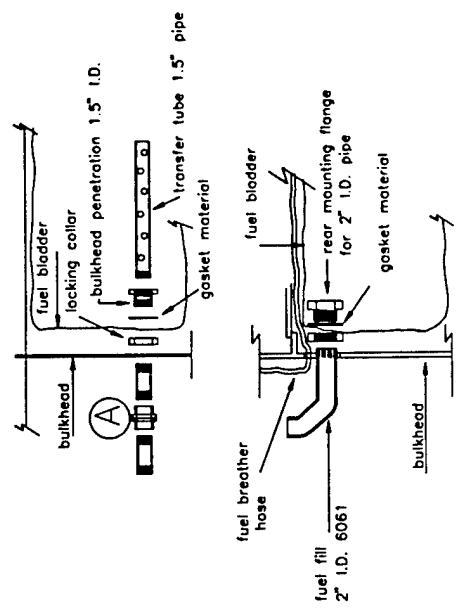
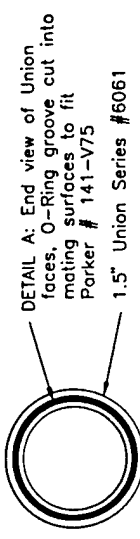

Top View

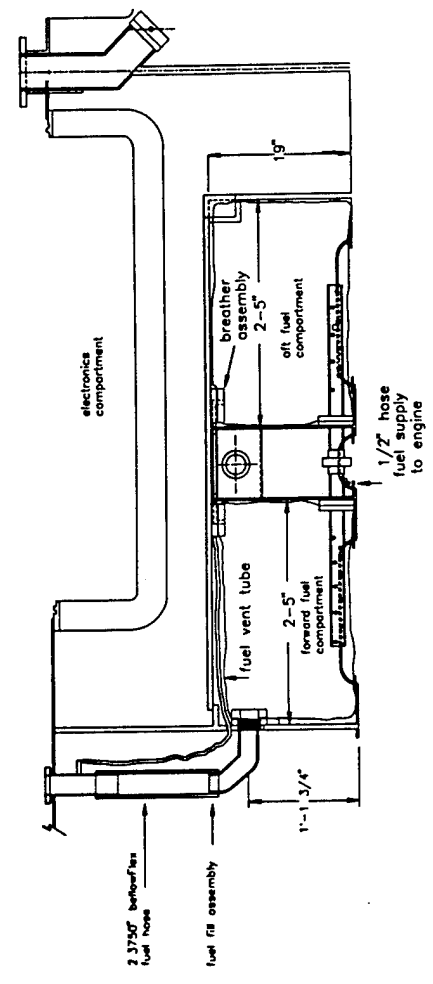

Side View

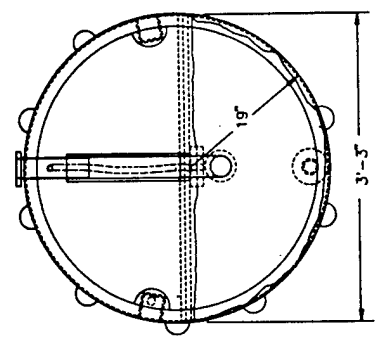

Front View

U.S. NAVY
ORCA

DETAIL OF
FUEL BLADDER

Figure 9

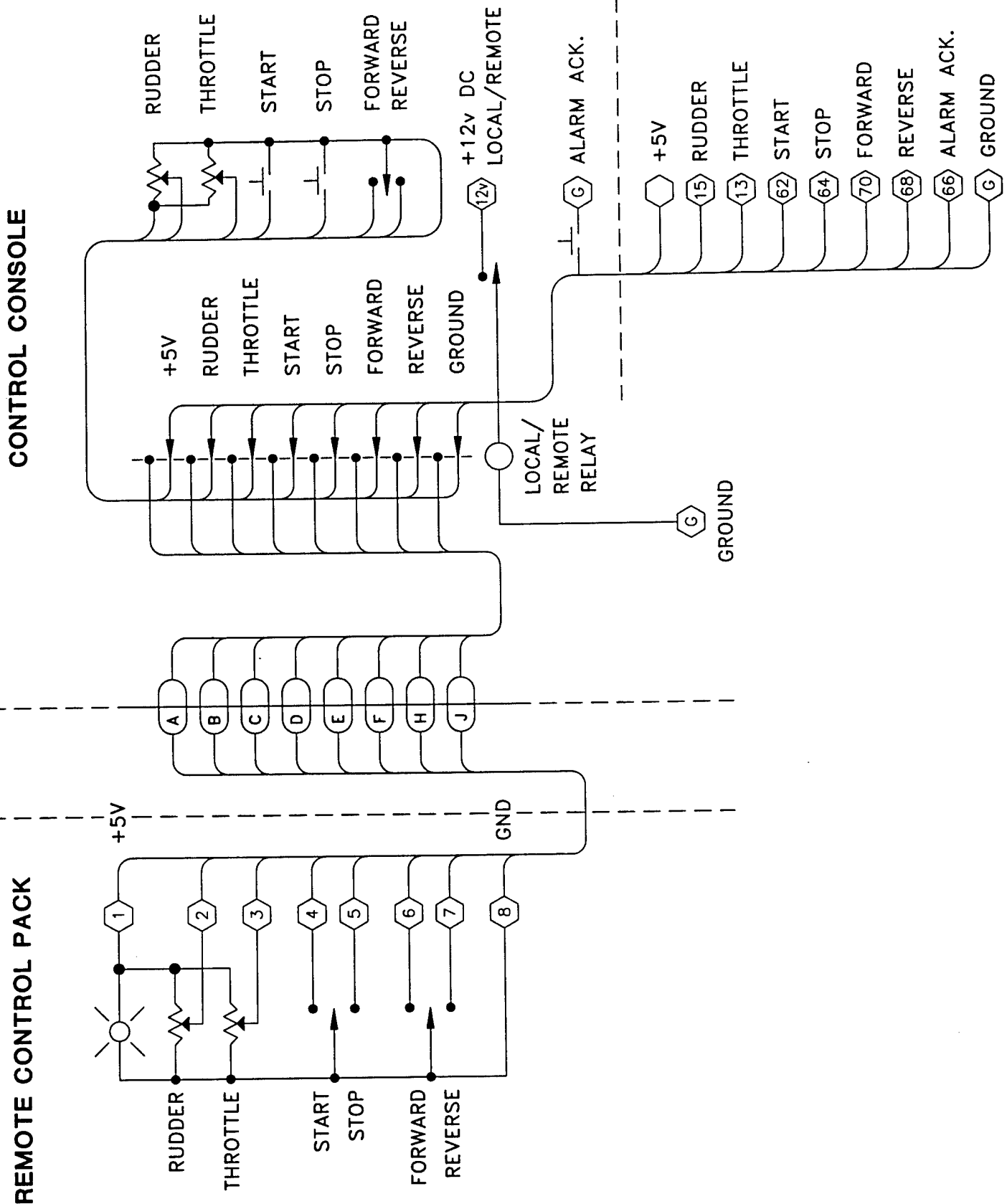

U.S. NAVY
ORCA

SCHEMATIC DIAGRAM
CONTROL CONSOLE & REMOTE PACK

Figure 10

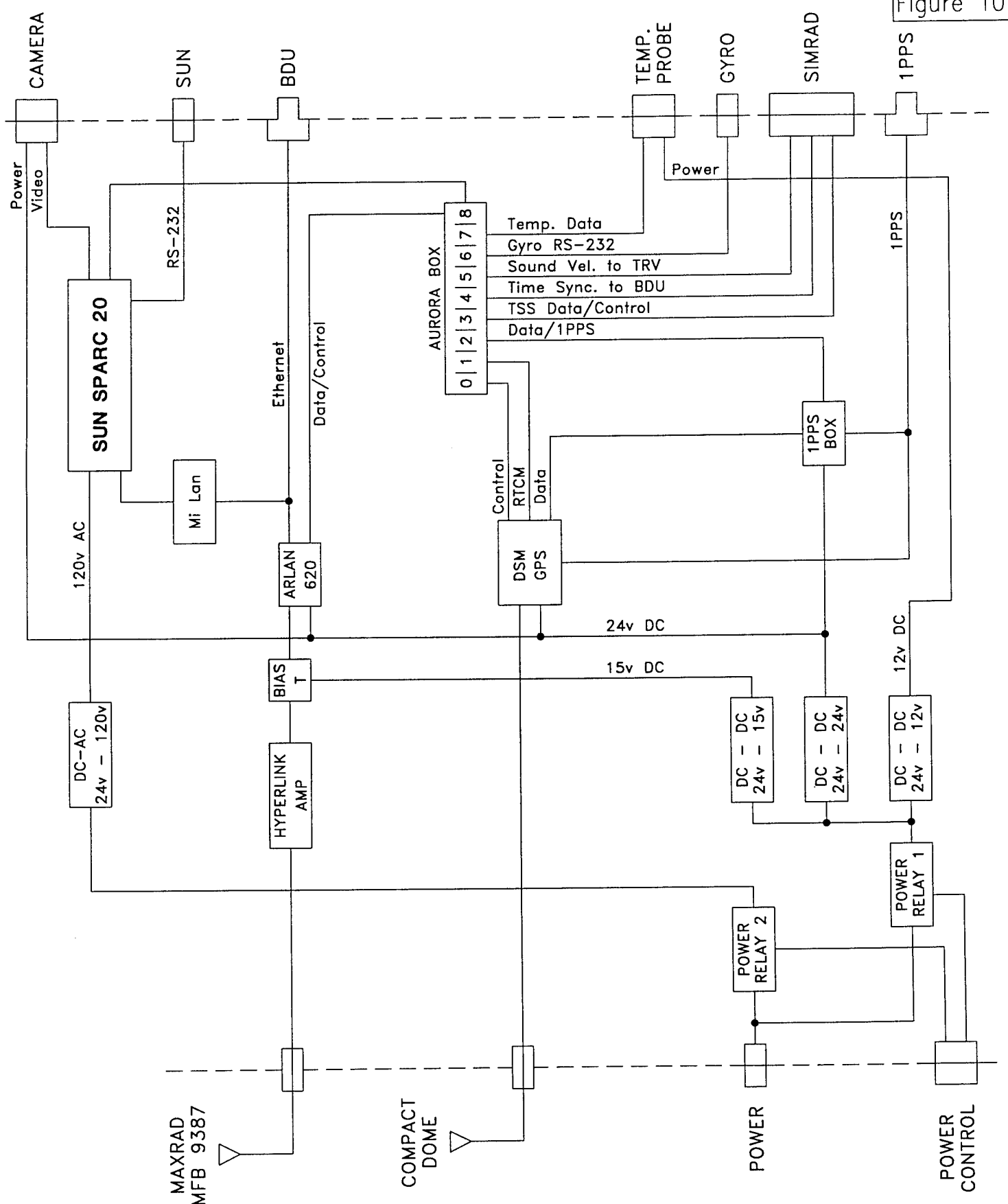

U.S. NAVY
ORCA

SCHEMATIC DIAGRAM
COMMUNICATIONS BOX LAYOUT

PREPARED BY C & C TECHNOLOGIES, INC.
500 DOVER BLVD. LAFAYETTE, LA
318 / 981-1442

Contract No. N00014-94-C-6005
MAP No. COMMBOXL.DWG

REVISED

DATE: 04/19/95
SHEET 1 OF 1

Figure 11

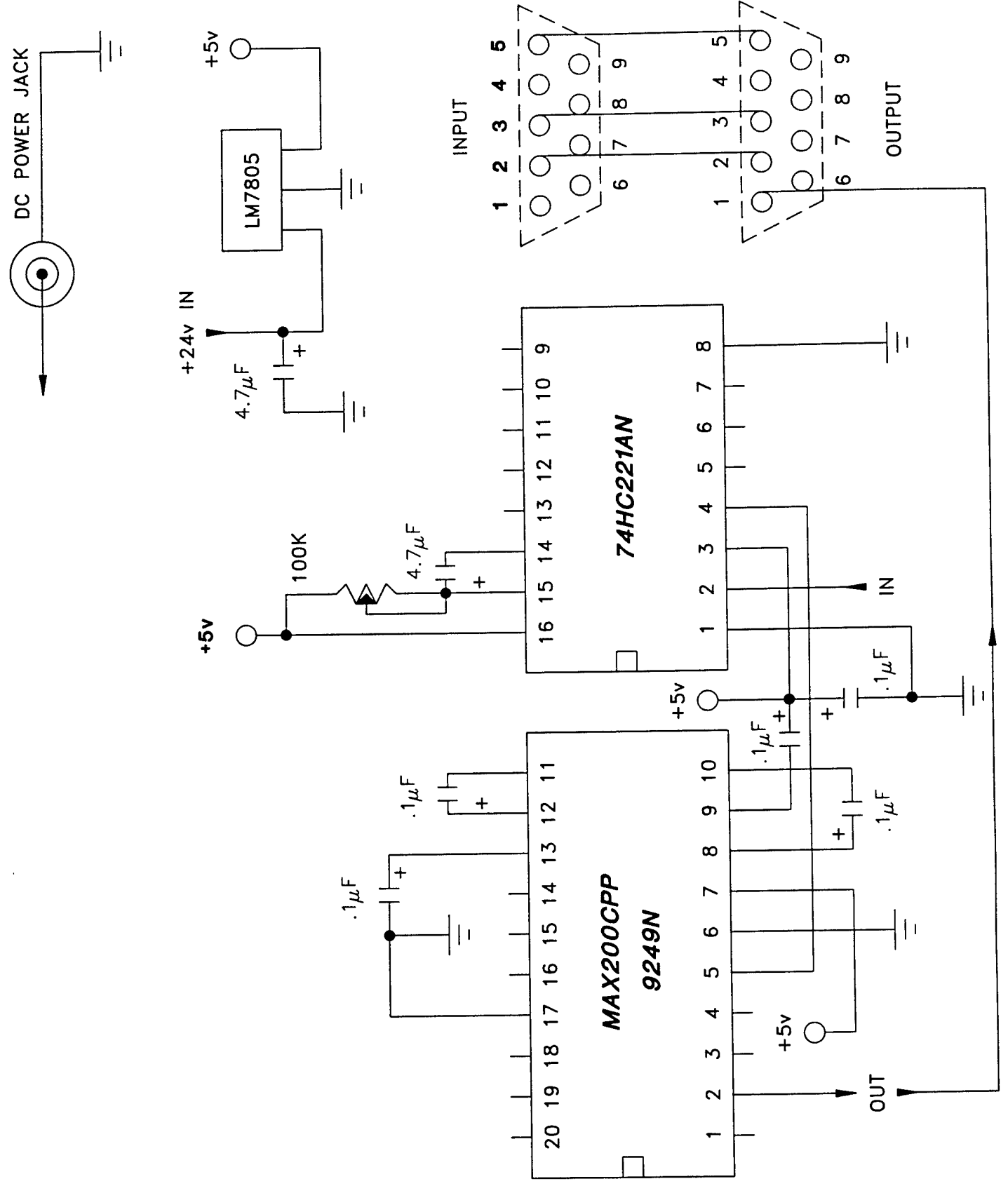

U.S. NAVY
ORCA

SCHEMATIC DIAGRAM
1 PPS BOX

Figure 12

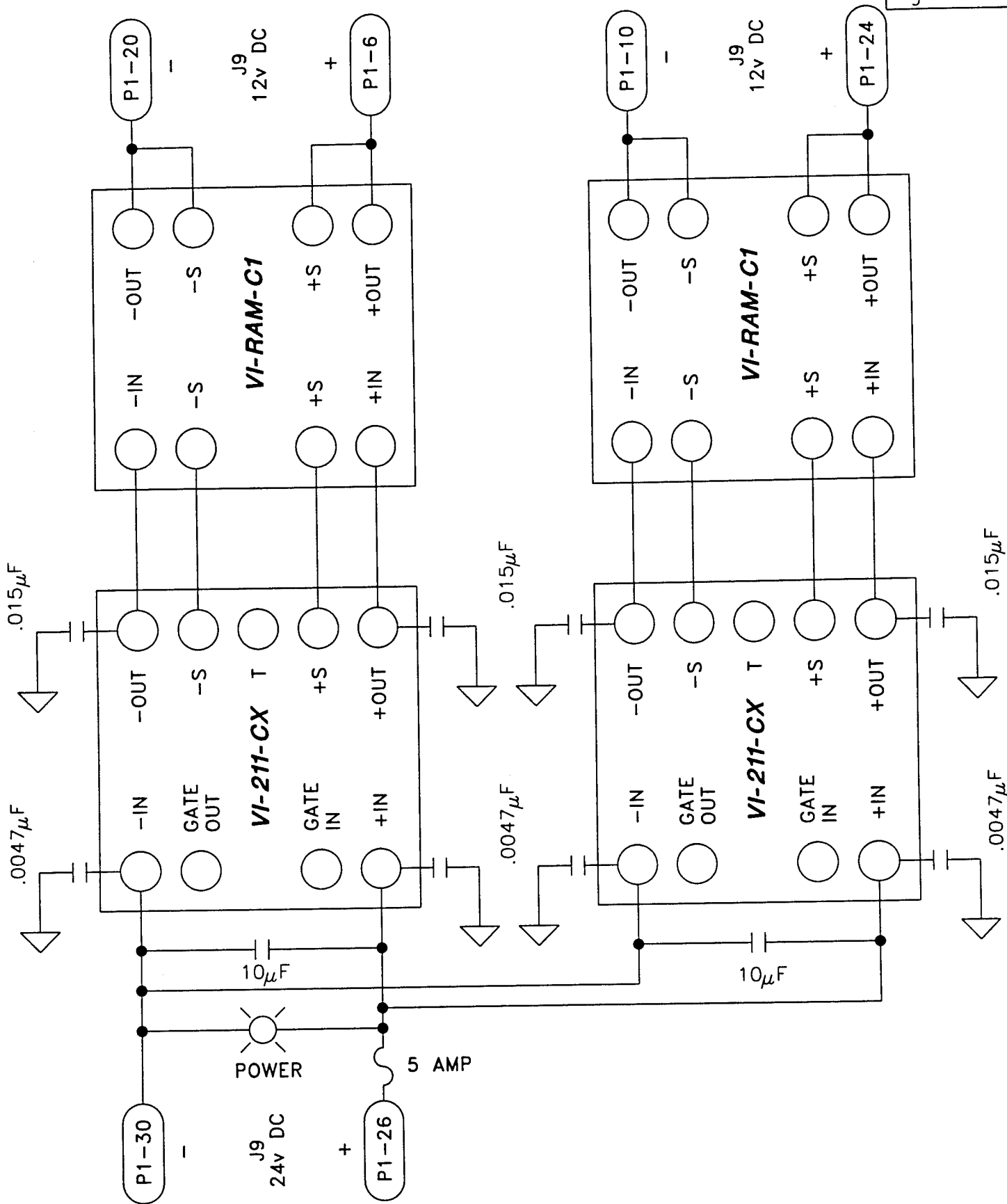

U.S. NAVY
ORCA

SCHEMATIC DIAGRAM
POWER SUPPLY 290-074478

Figure 13

Original HV Power Unit 290-056190

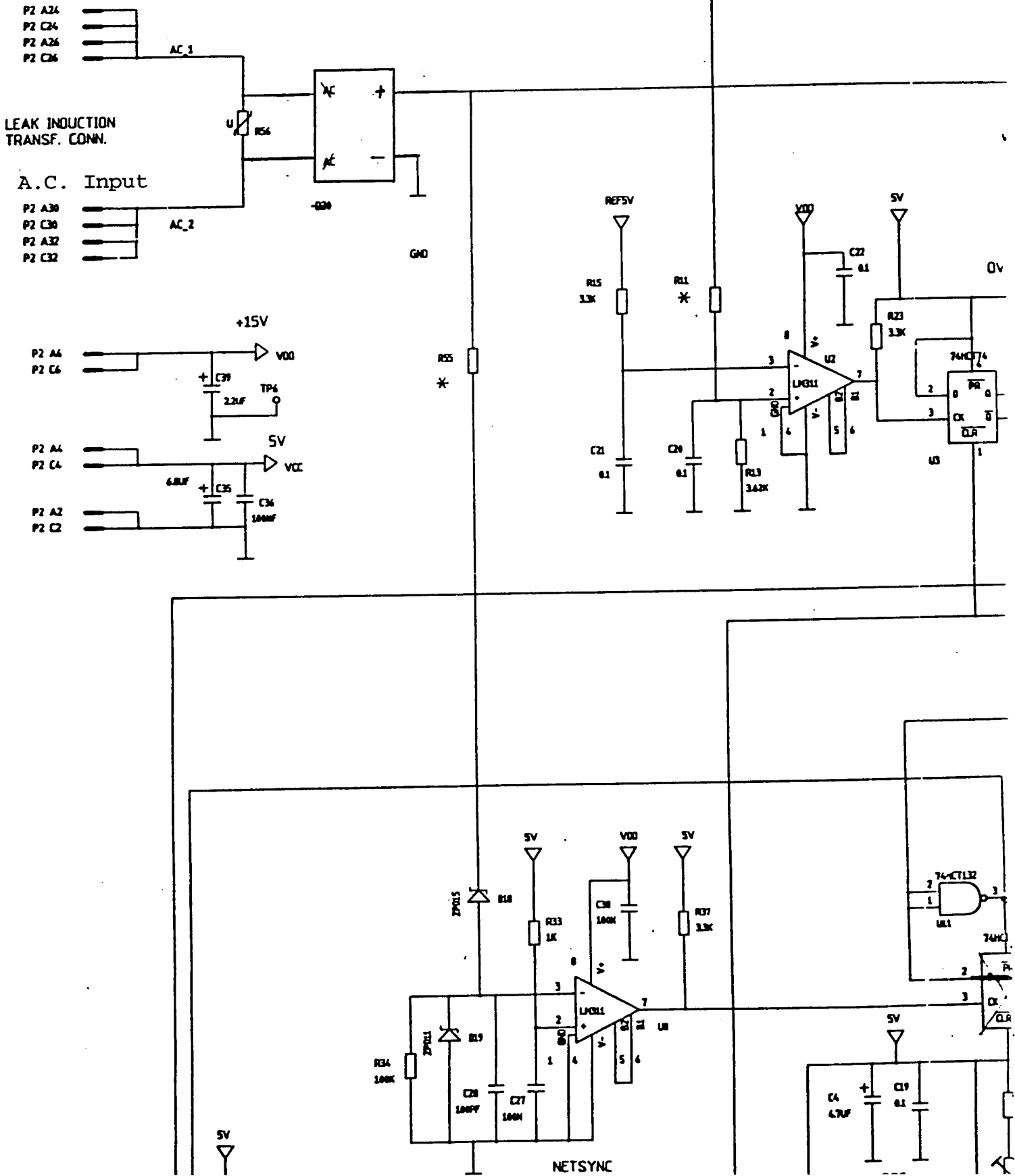

Figure 14

Original HV Power Unit 290-056190

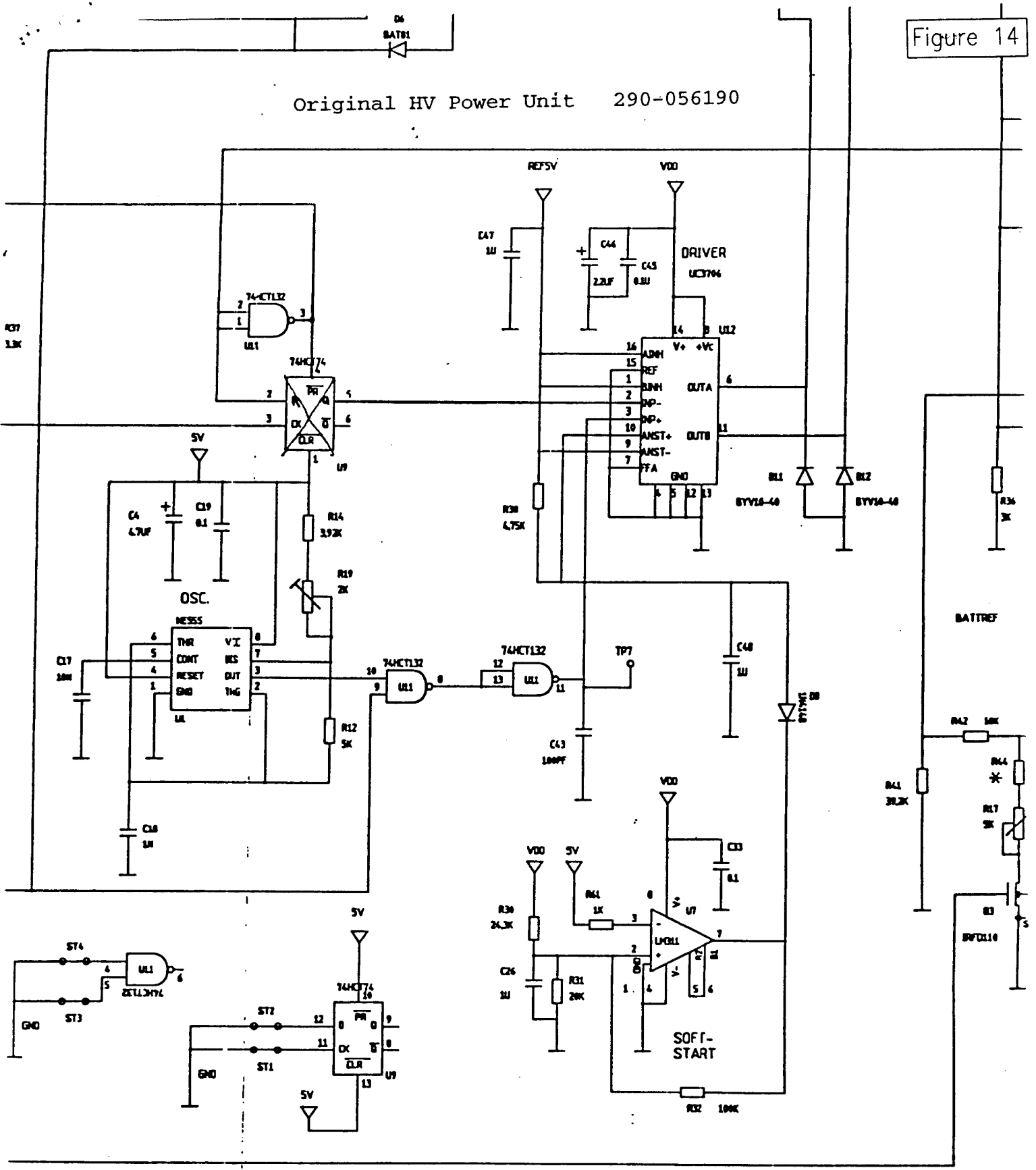

Figure 15

Modified HV Power Unit 290-056190

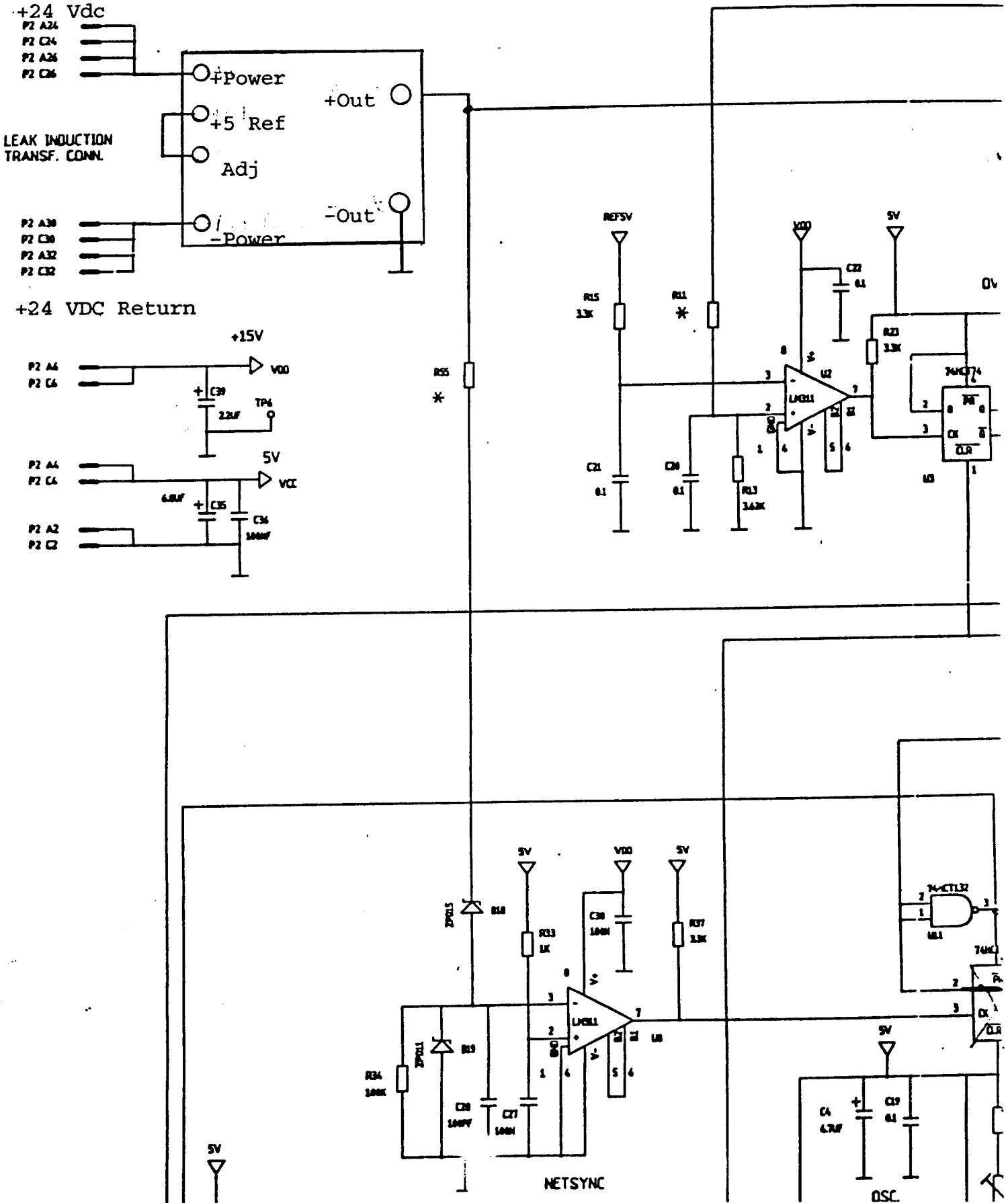

Figure 16

Modified HV Power Unit 290-056190

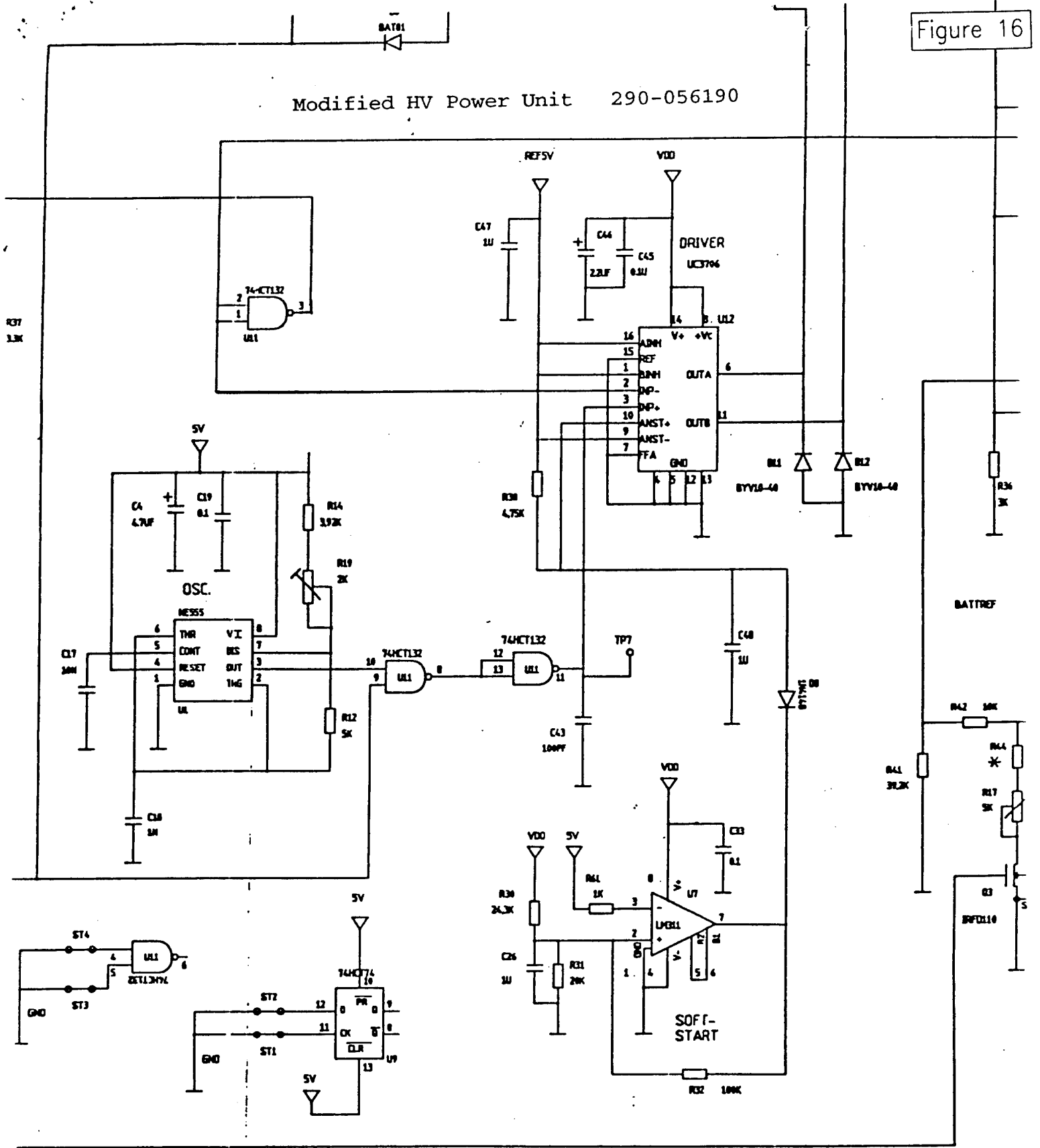
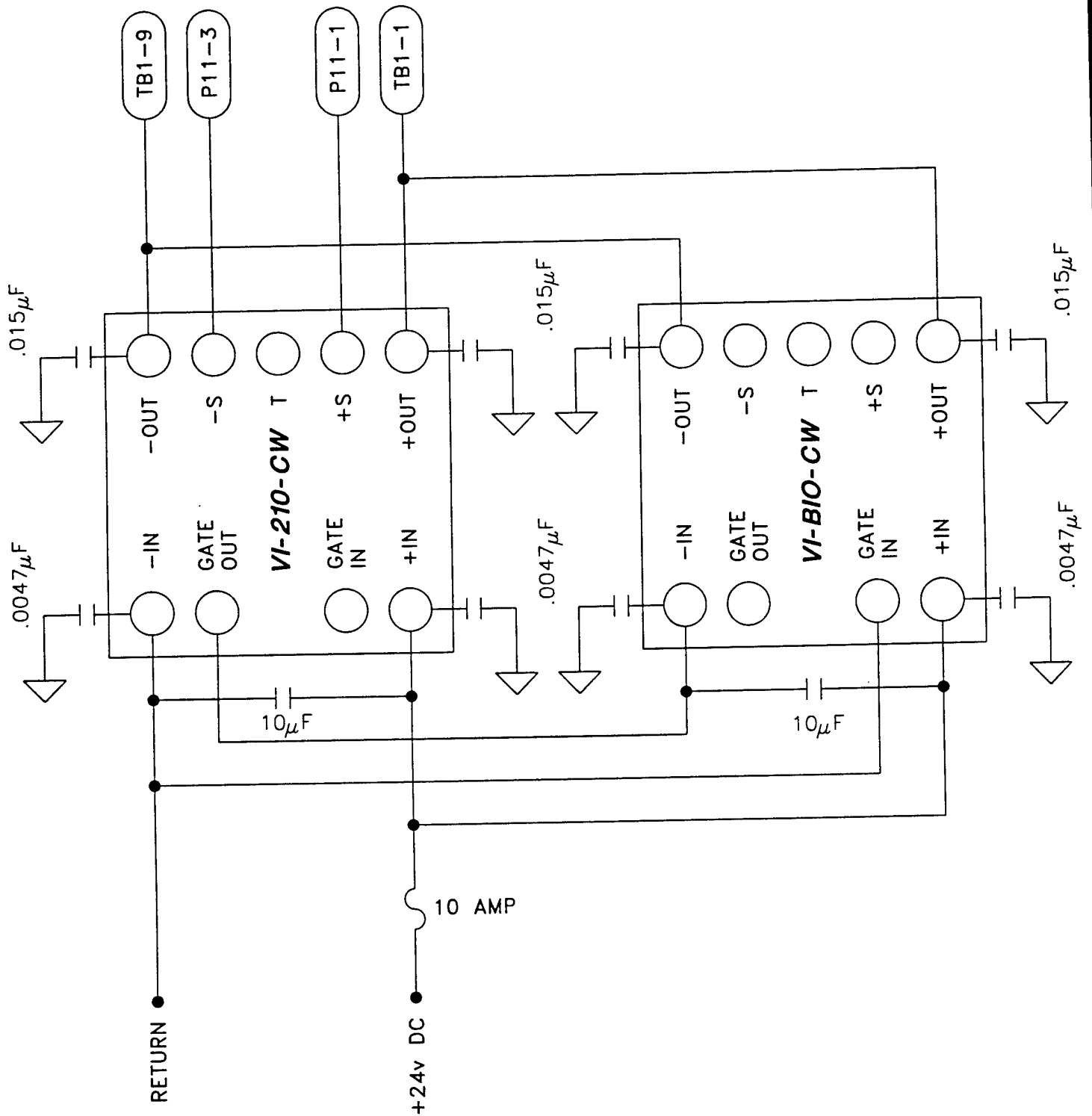

Figure 17



U.S. NAVY
ORCA

SCHEMATIC DIAGRAM
+5v DC POWER SUPPLY

Figure 18

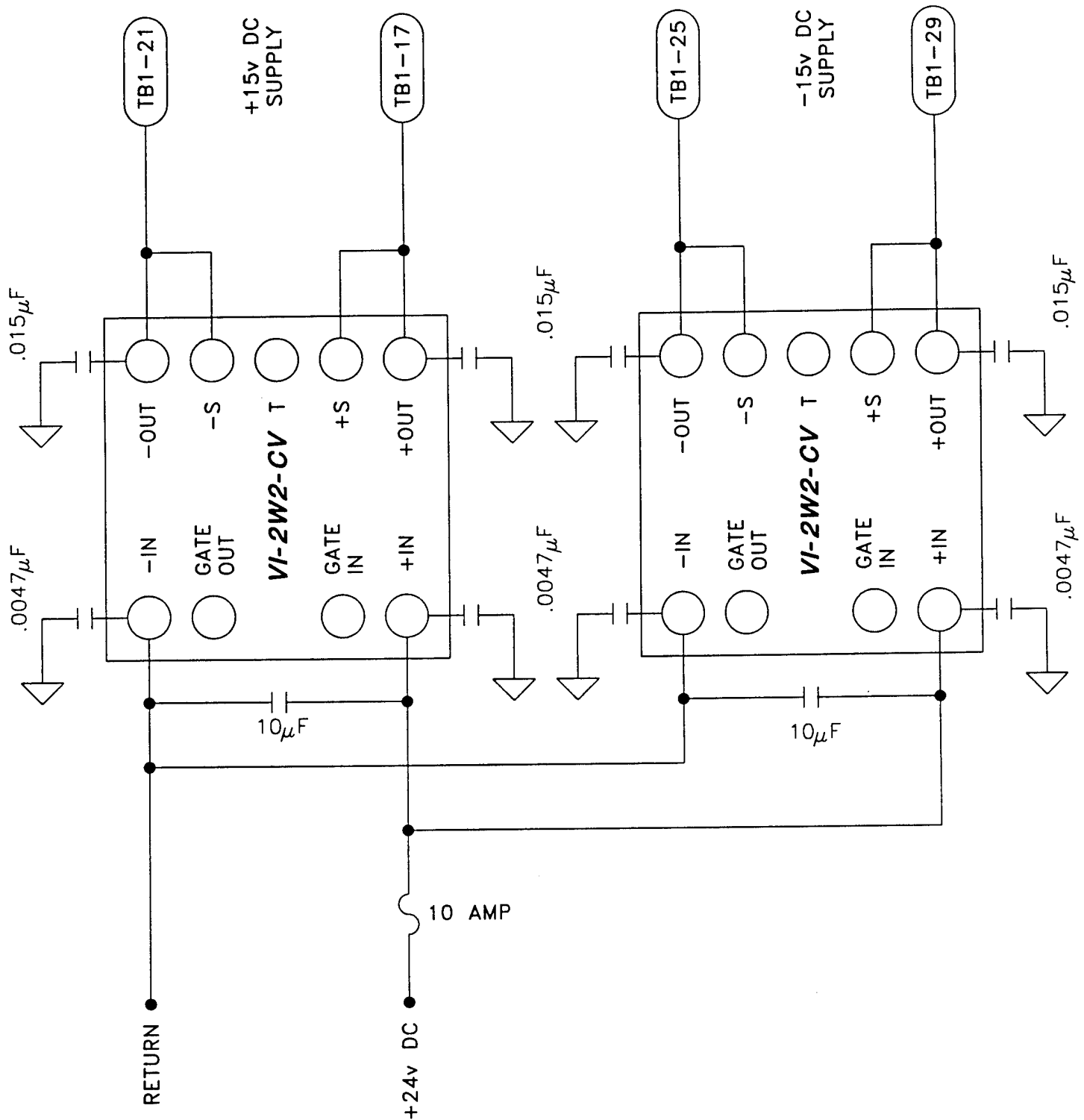

U.S. NAVY
ORCA

SCHEMATIC DIAGRAM
+/- 15v DC POWER SUPPLY

Figure 19

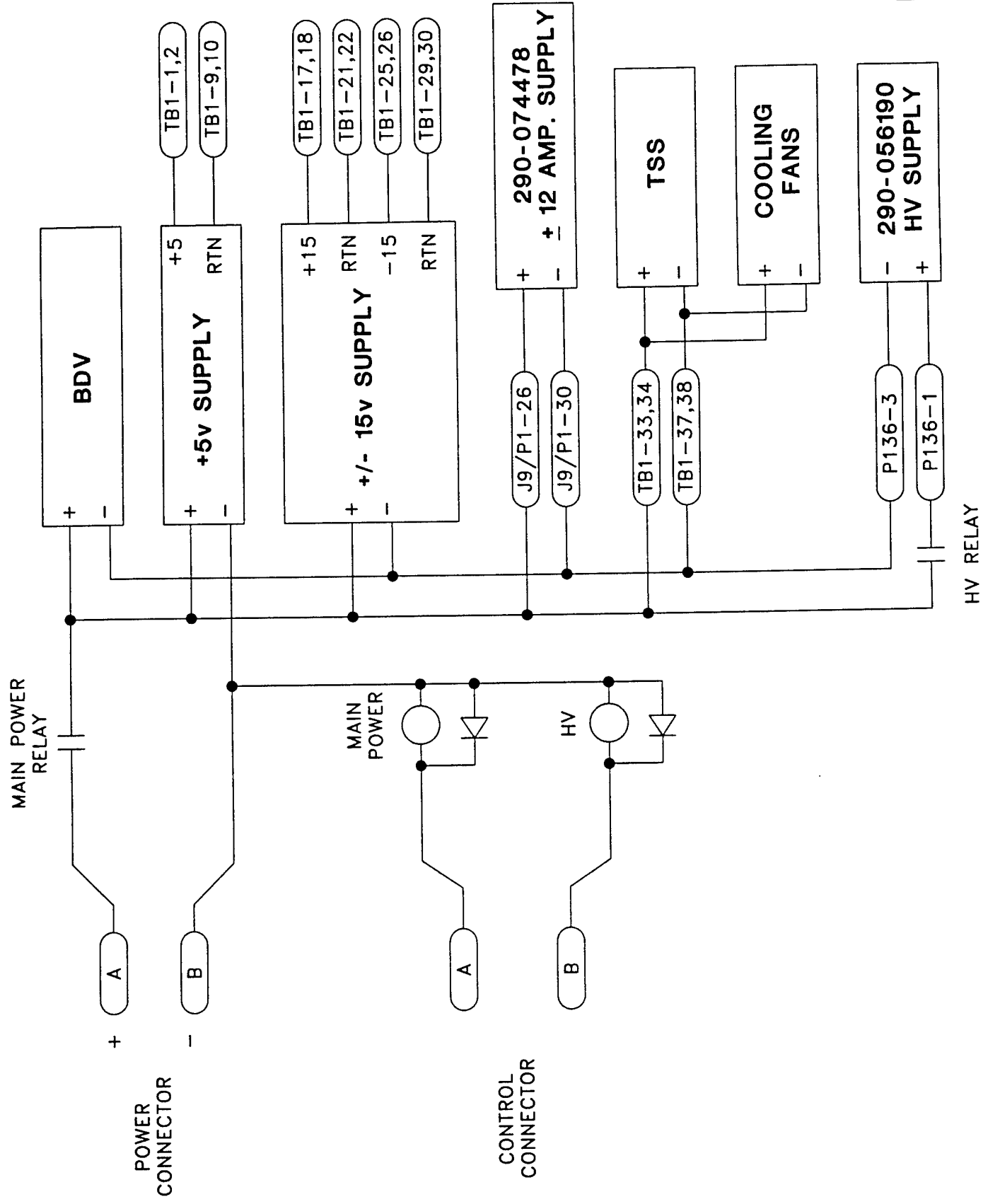

U.S. NAVY
ORCA

SCHEMATIC DIAGRAM
24v DC POWER DISTRIBUTION

Figure 20

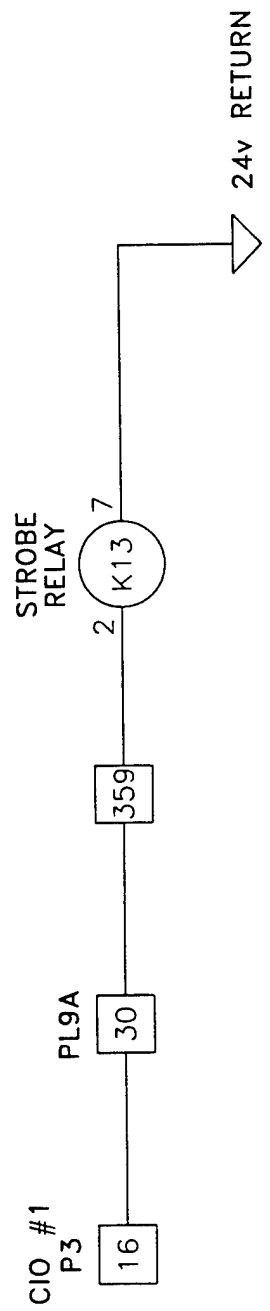

U.S. NAVY
ORCA

SCHEMATIC DIAGRAM
NAVIGATION STROBE LIGHT RELAY

Figure 21

ORIGINAL CIRCUIT

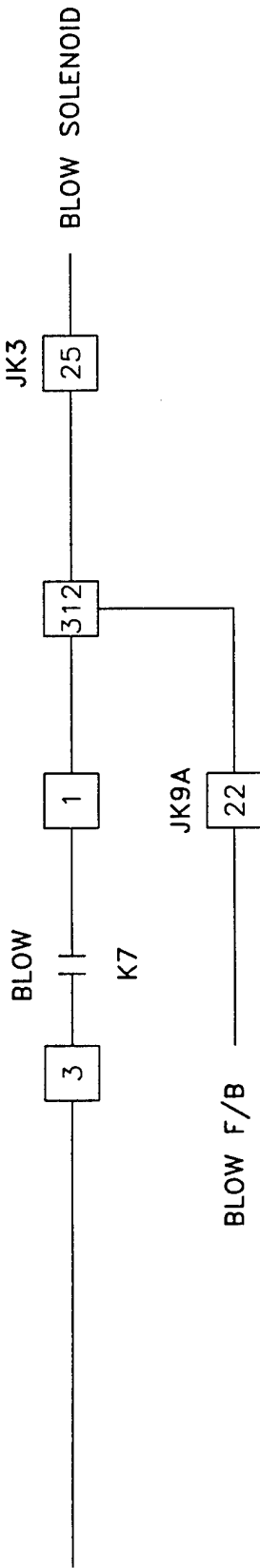

NEW CIRCUIT

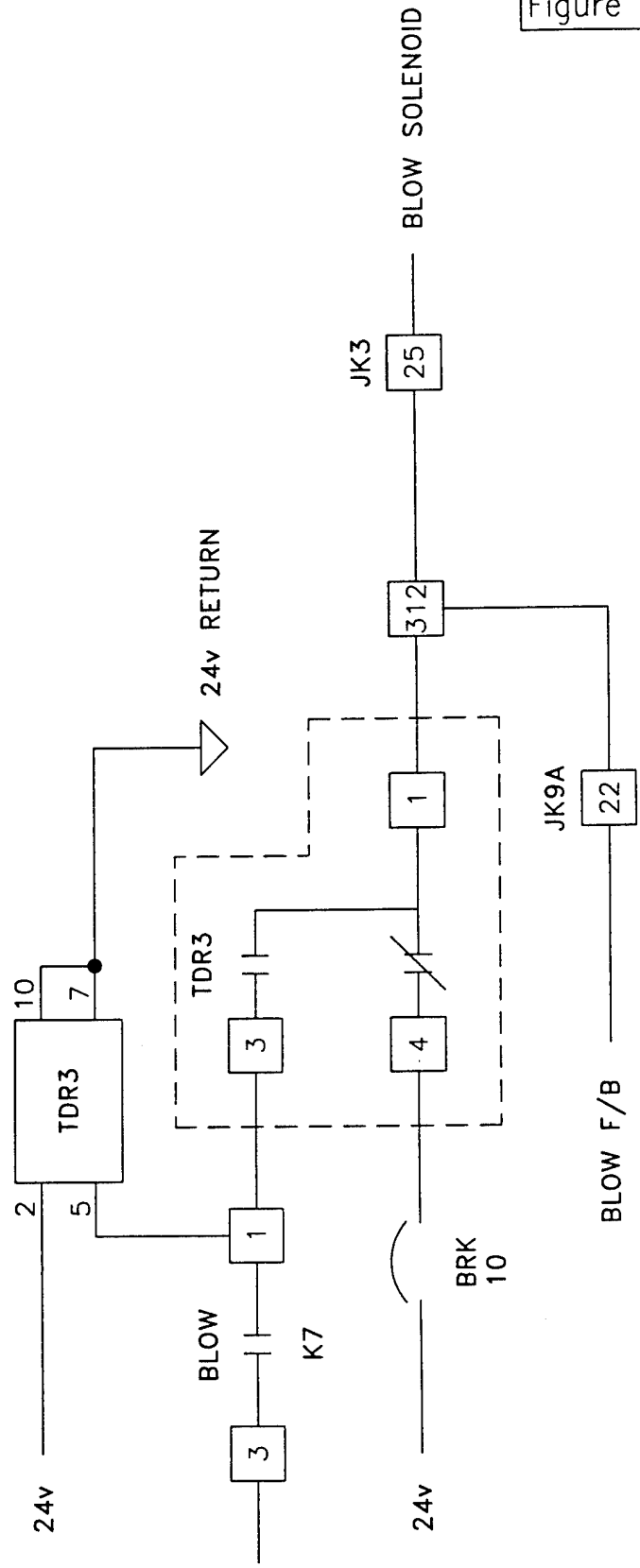

U.S. NAVY
ORCA

SCHEMATIC DIAGRAM
AIR FLOW TIMING RELAY

Figure 22

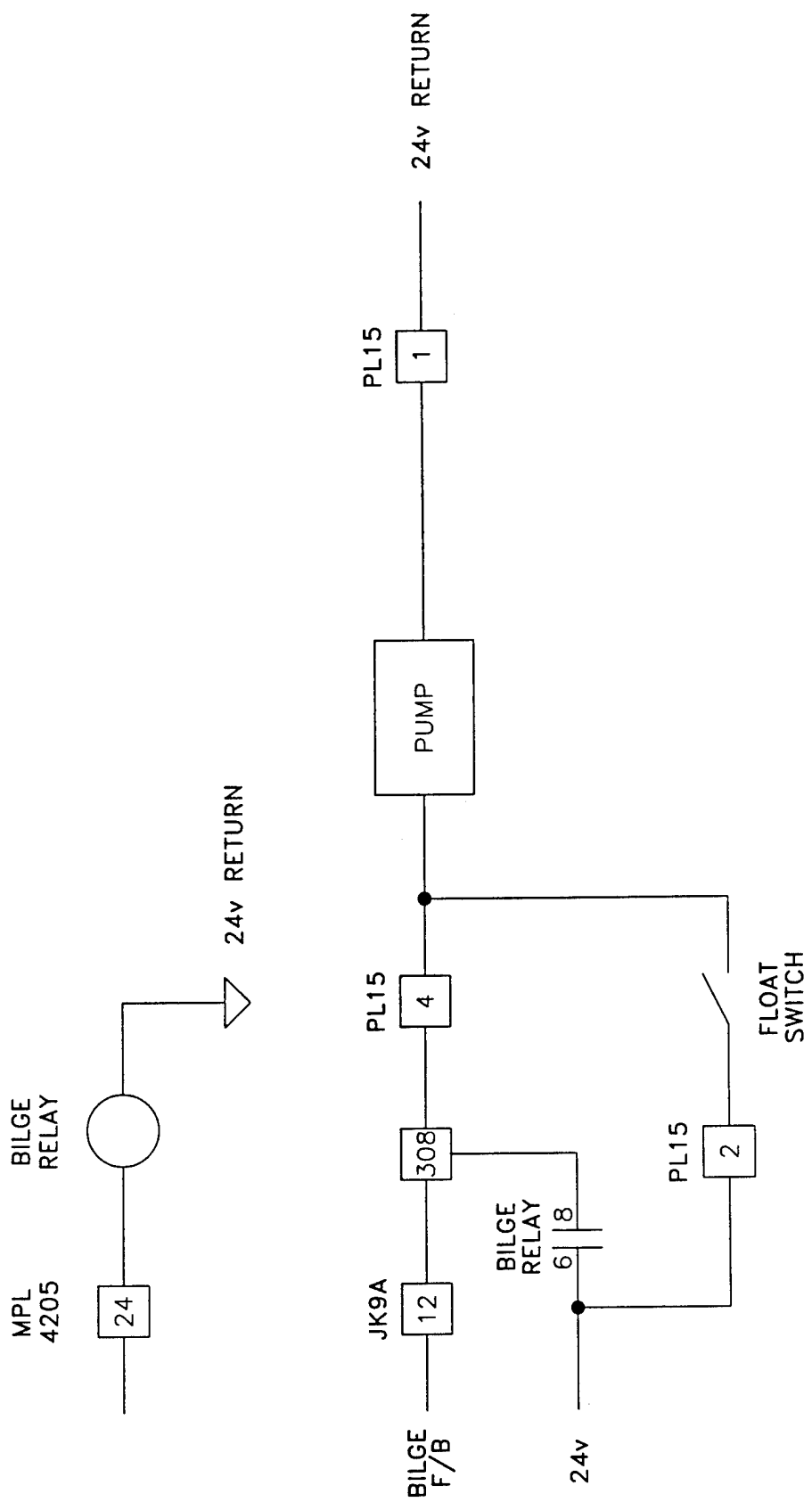

U.S. NAVY
ORCA

SCHEMATIC DIAGRAM
BILGE PUMP RELAY

ALL OUTPUTS 24 VOLTS DC

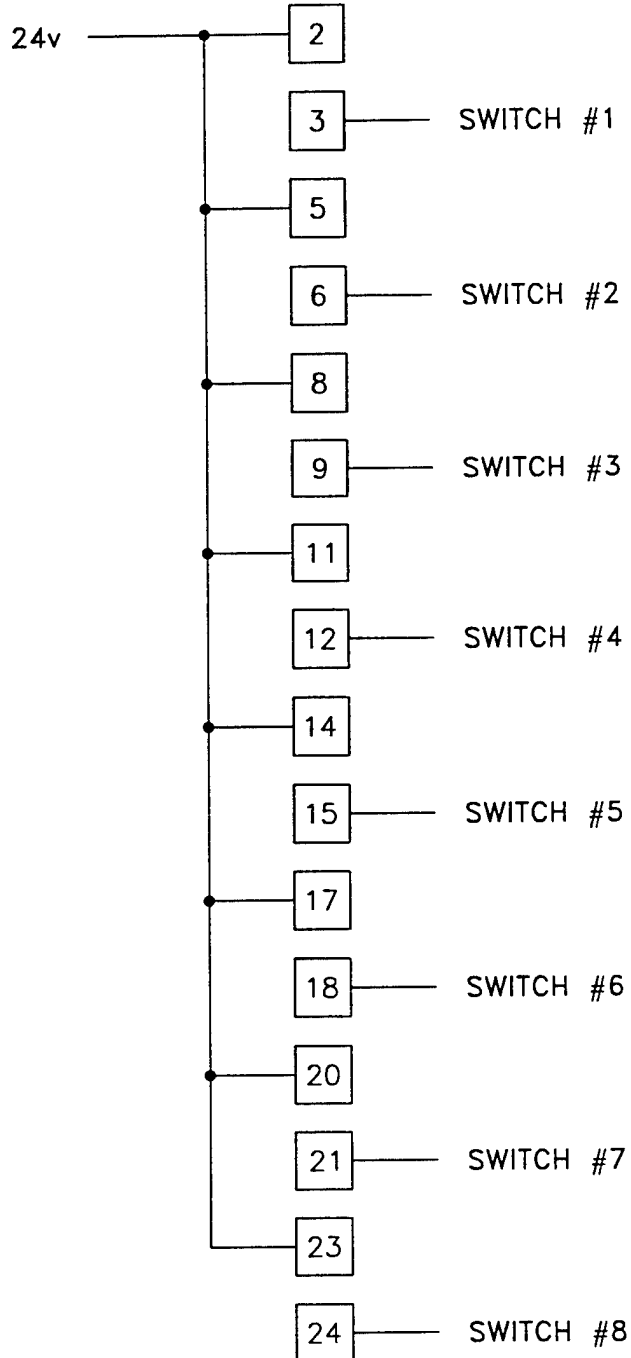

MPL 4205

U.S. NAVY
ORCA

SCHEMATIC DIAGRAM
SWITCHED RELAY WIRING

Figure 24

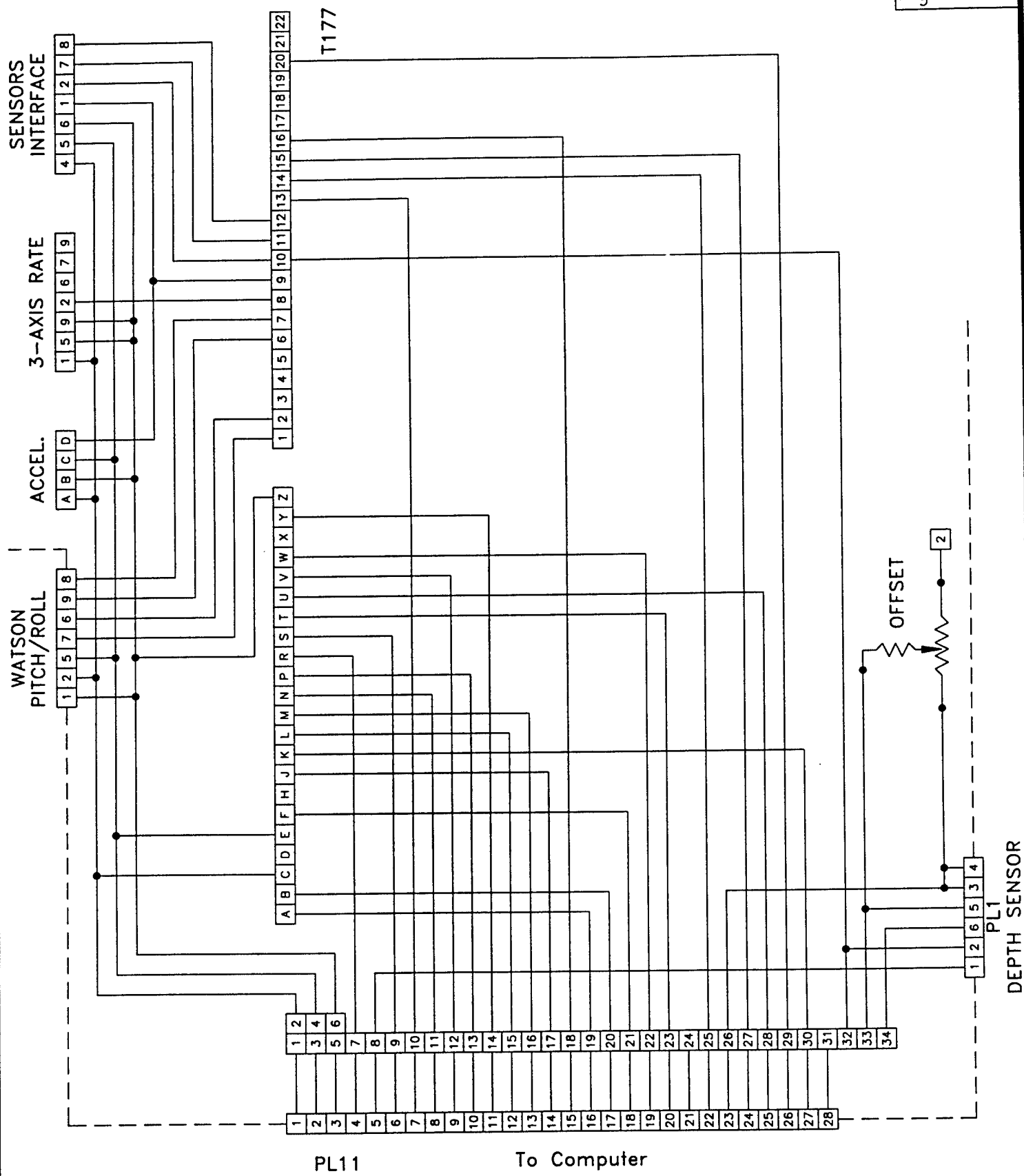

U.S. NAVY
ORCA

SCHEMATIC DIAGRAM
ATTITUDE SENSOR UNIT

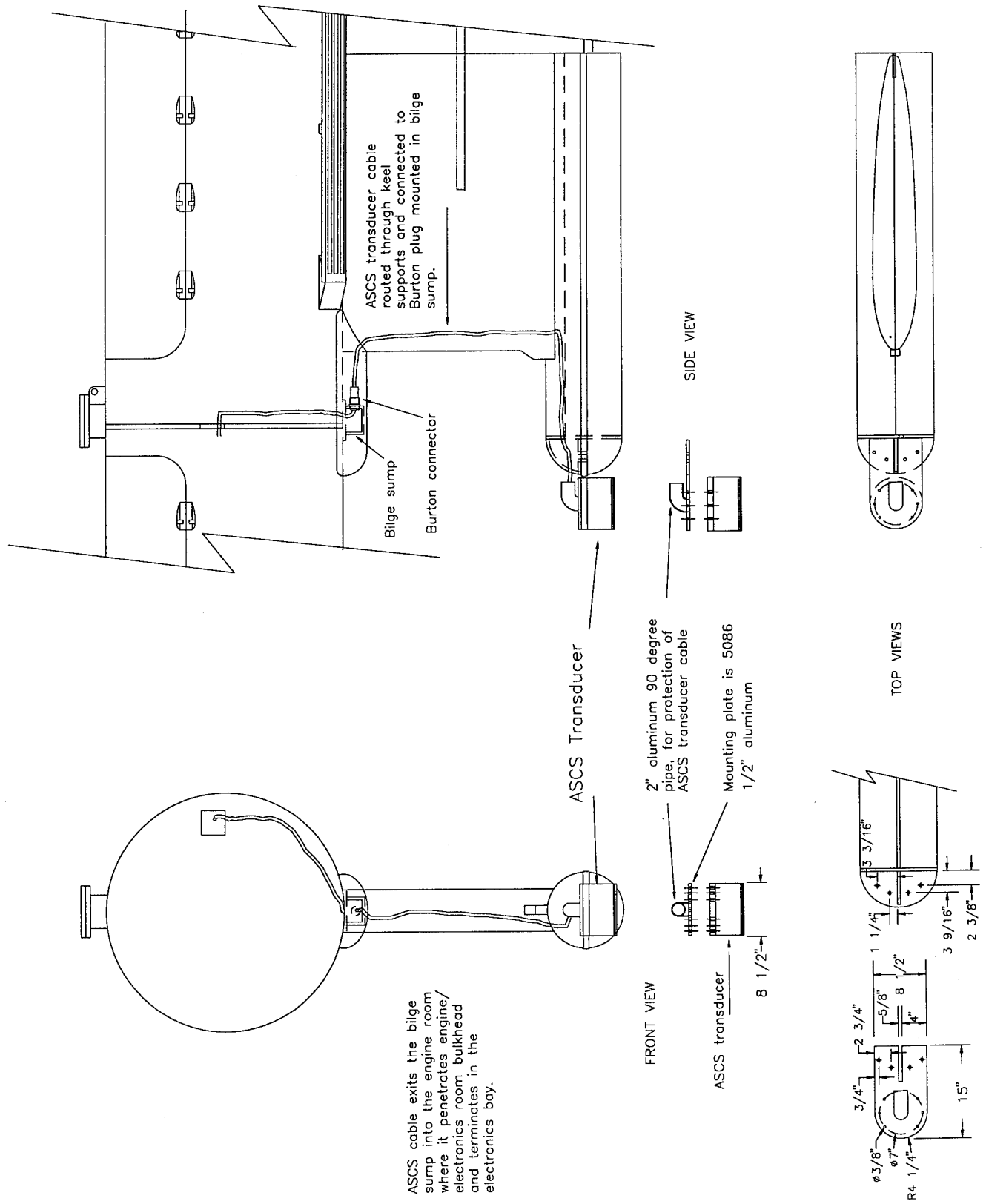

U.S. NAVY
ORCA

DETAIL OF
ACOUSTIC SEDIMENT CLASSIFICATION SYSTEM

PREPARED BY **C & C TECHNOLOGIES, INC.**
500 DOVER BLVD. LAFAYETTE, LA
318 / 981-1442

Contract No. N00014-94-C-6005
MAP No. ASCS.DWG

REVISED

DATE: 03/04/96

SHEET 1 OF 1

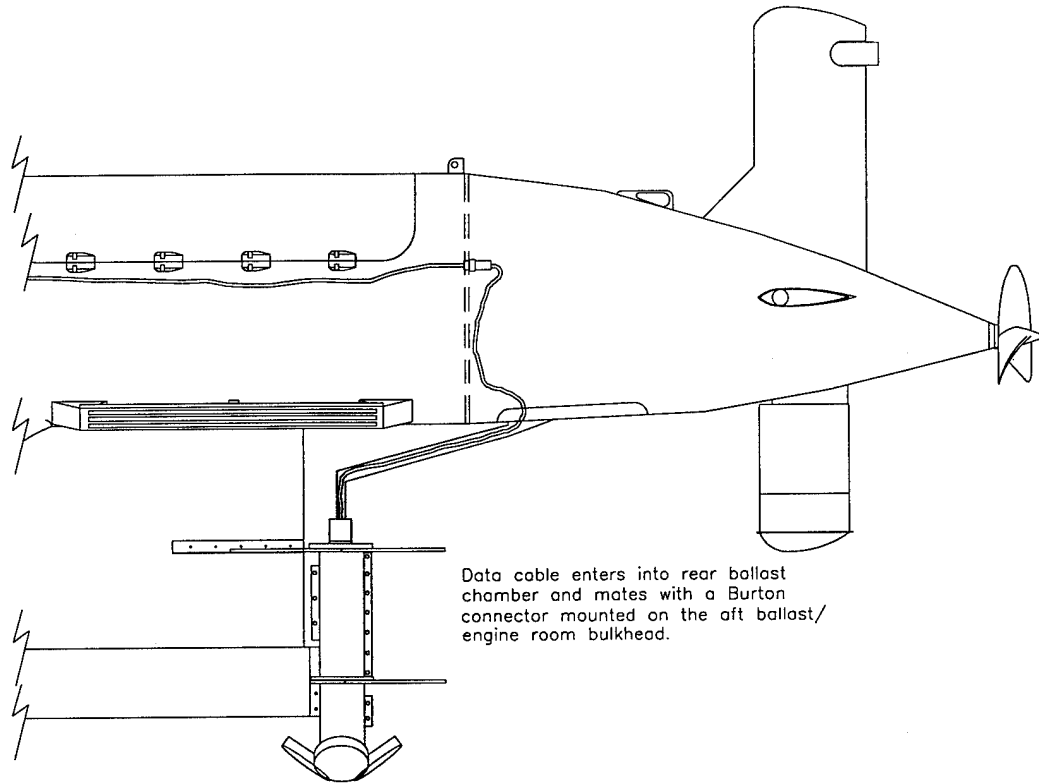

Data cable enters into rear ballast chamber and mates with a Burton connector mounted on the aft ballast/engine room bulkhead.

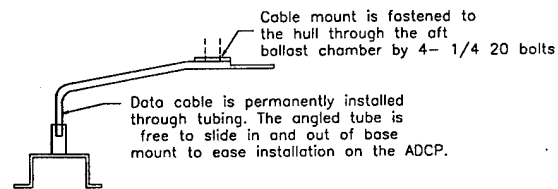

Data cable is permanently installed through tubing. The angled tube is free to slide in and out of base mount to ease installation on the ADCP.

Cable mount is fastened to the hull through the aft ballast chamber by 4- 1/4 20 bolts

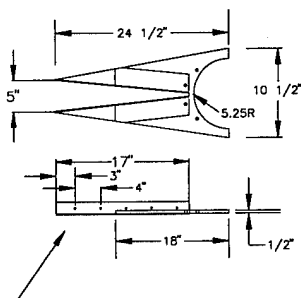

NOTE: Upper supporting bracket fabricated from 5086 1/2" aluminum plate and 5086 3" x 1/8" aluminum angle welded together

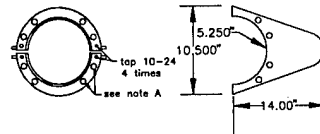

2 plates mounted on the bottom side of flanges aft.

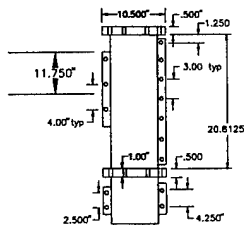

NOTES
A - all holes are drilled thru 25/64 unless noted otherwise.

1 - the mount is constructed of 5086 aluminum

U.S. NAVY
ORCA

DETAIL OF
ACOUSTIC DOPPLER CURRENT PROFILER

PREPARED BY **C & C TECHNOLOGIES, INC.**
500 DOVER BLVD. LAFAYETTE, LA
318 / 981-1442

Contract No. N00014-94-C-6005
MAP No. ADCP1.DWG

REVISED

DATE: 03/04/96

SHEET 1 OF 1

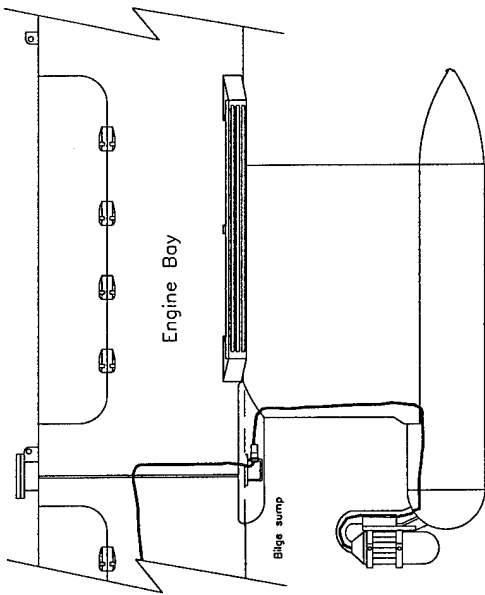

Side view with Wesmar sonar dome and cable routing.

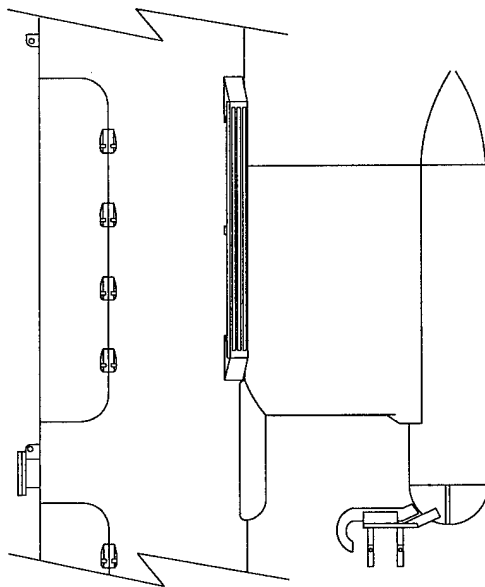

Side View without Sonar Dome

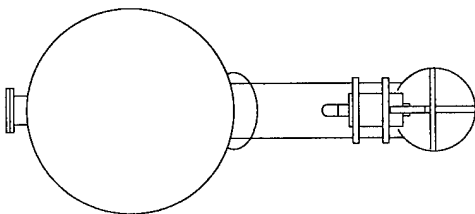

Front

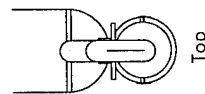

Top

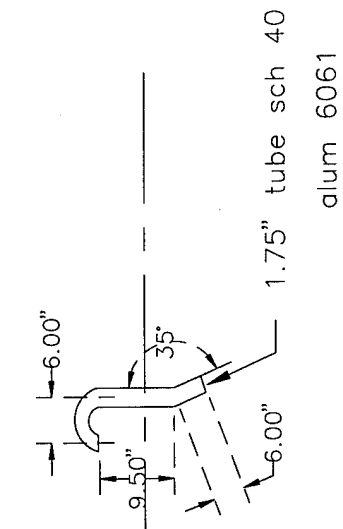
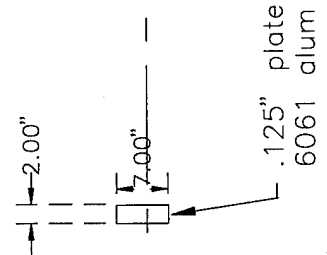
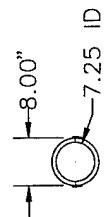
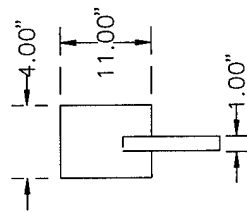

Wesmar data cable is routed through the keel up to the bilge sump where it interconnects with a Burton connector. From the sump, the cable enters the engine room and exits a penetration in the engine/electronics bay bulkhead

U.S. NAVY
ORCA

DETAIL OF
WESMAR CABLE ROUTING

PREPARED BY C & C TECHNOLOGIES, INC.
500 DOVER BLVD. LAFAYETTE, LA
318 / 981-1442

Contract No. N00014-94-C-6005
MAP No. WESMAR.DWG

REVISED

DATE: 03/04/96

SHEET 1 OF 1