



National Defence
Research and
Development Branch

Défense nationale
Bureau de recherche
et développement

TECHNICAL MEMORANDUM 96/217

May 1996

COMPARISONS OF NUMERICALLY PREDICTED
AND EXPERIMENTALLY MEASURED
RADIATED NOISE FROM
A RING-STIFFENED CYLINDER

Layton E. Gilroy

19960715 118

**Defence
Research
Establishment
Atlantic**



**Centre de
Recherches pour la
Défense
Atlantique**

Canada

DISTRIBUTION STATEMENT A
Approved for public release
Distribution Unlimited

DTIC QUALITY INSPECTED 1

DEFENCE RESEARCH ESTABLISHMENT ATLANTIC

9 GROVE STREET

P.O. BOX 1012
DARTMOUTH, N.S.
B2Y 3Z7

TELEPHONE
(902) 426-3100

CENTRE DE RECHERCHES POUR LA DÉFENSE ATLANTIQUE

9 GROVE STREET

C.P. BOX 1012
DARTMOUTH, N.É.
B2Y 3Z7



National Defence
Research and
Development Branch

Défense nationale
Bureau de recherche
et développement

COMPARISONS OF NUMERICALLY PREDICTED
AND EXPERIMENTALLY MEASURED
RADIATED NOISE FROM
A RING-STIFFENED CYLINDER

Layton E. Gilroy

May 1996

Approved by C.W. Bright
Deputy Director General

Distribution Approved by

Deputy Director General

TECHNICAL MEMORANDUM 96/217

Defence
Research
Establishment
Atlantic



Centre de
Recherches pour la
Défense
Atlantique

Canada

Abstract

Defence Research Establishment Atlantic (DREA), with the assistance of Health Canada, conducted an experiment involving the measurement of radiated noise from a ring-stiffened cylinder subjected to a harmonic load in an anechoic chamber. This experiment was performed to provide validation data for structural acoustics computer codes being developed in-house and under contract. These codes are used to predict the vibrations of structures submerged in, or filled with, a dense fluid and to also predict the resulting radiated noise. A subset of these codes, comprising the programs VAST and BEMAP, was used to predict the natural frequencies and radiated noise, on- and off-resonance, from this cylinder. Comparisons are made between the predicted and measured natural frequencies and radiated noise levels and directivity. Overall, the programs were able to accurately predict both the structural resonances and the radiated noise patterns.

Résumé

Le Centre de recherches pour la défense Atlantique (CRDA) avec l'aide de Health Canada, a mené une expérience concernant la mesure du bruit rayonné par un cylindre renforcé d'anneaux soumis à une charge harmonique dans une chambre anéchoïque. L'expérience a été conduite pour fournir des données de validation pour les programmes de calcul d'acoustique de structure développés en interne ou sous contrat. Ces codes sont utilisés pour prédire les vibrations des structures immergées dans, ou remplies avec, un fluide dense et également pour prédire le bruit rayonné. Quelques-uns de ces programmes, par exemple les programmes VAST et BEMAP, ont été utilisées pour prédire les fréquences propres et le bruit rayonné par ce cylindre, dans et hors résonance. Des comparaisons ont été effectuées entre les mesures et les prédictions au niveau des fréquences propres, de la directivité et des niveaux des bruits rayonnés. En général les programmes de calcul ont été capables de prédire précisément à la fois les résonances de structure et les bruits parasites rayonnés.

Comparisons of Numerically Predicted and Experimentally Measured
Radiated Noise from a Ring-Stiffened Cylinder

by

L. E. Gilroy

Executive Summary

Introduction

Suites of computer codes have been developed at Defence Research Establishment Atlantic (DREA) to predict the radiated noise from submerged or floating elastic structures. These codes have been developed in support of the Ship Noise Project whose objective is to provide DND with the expertise and tools necessary to deal successfully with issues related to underwater noise from naval vessels. Such computer programs may be used to either optimize the structural arrangement to minimize radiated noise or to examine existing structures to isolate noise-producing structures. These codes are also capable of predicting the in-air radiated noise of a vibrating structure. DREA recently conducted experiments to measure the radiated noise from a ring-stiffened cylinder subjected to a harmonic load under the controlled conditions at Health Canada's anechoic chamber located at the Radiation Protection Bureau in Ottawa. These experiments were performed to provide validation data for the computer codes.

Principal Results

DREA's ring-stiffened cylinder, used in previous in-water experiments at the DREA Acoustic Calibration Barge, was shipped to Ottawa for testing at the anechoic chamber which is part of the Radiation Protection Bureau of the Health Protection Branch of Health Canada. The DREA cylinder measures 3m long by 0.75m in diameter and weighs in excess of 1 tonne. Health Canada provided the in-air measurement equipment and the laboratory space, as well as the technical expertise for running the chamber. During the test period, the natural frequencies and mode shapes of the cylinder were measured using accelerometers placed throughout the cylinder with excitation provided by an electromagnetic shaker or loudspeakers. A turntable (constructed by DREA for this trial) was then used to rotate the cylinder while the cylinder was excited with the shaker and directivity patterns of the resulting radiated noise were measured using a microphone at a specified position. Directivity patterns were also measured with the cylinder fixed and the microphone moved using the robotic capability of the anechoic chamber.

The DREA finite element computer program, VAST, was used to perform the structural analysis of the cylinder. The VAST code was used to calculate the natural frequencies of the cylinder model and the structural surface velocities under an applied load equal to that of the shaker. These structural velocities were then passed to the boundary element program, BEMAP, which predicted the radiated noise directivity patterns at the specified field points.

The predictions of the natural frequencies were generally accurate to within ten percent. Overall, the predictions at resonance were quite accurate in directivity, quite accurate in sound

level for some modes, and quite poor in sound level for other modes. The off-resonance predictions were quite accurate with excellent predictions of directivity pattern and usually reasonable predictions of sound level.

Significance of Results

The accuracy of the comparisons between the numerical and experimental predictions indicates that the computer codes, VAST and BEMAP, are capable of predicting air-borne radiated noise resulting from excitation of structural resonances. The data also indicate the importance of an accurate assessment of the structural damping, without which accurate prediction of the radiated sound levels is quite difficult.

Future Plans

Based on the results from this experiment, data collected in previous trials (with the cylinder submerged at the DREA Acoustic Calibration Barge) will be analyzed to ascertain the accuracy of the DREA codes in this more difficult scenario. A more representative ship-like structure will also be tested to extend the data set.

Contents

Abstract	ii
Executive Summary	iii
1 Introduction	1
2 Experimental Procedure	2
3 Numerical Codes	5
4 Numerical Model	7
5 Results	8
5.1 Resonant Frequencies	8
5.2 Directivity Patterns	10
6 Conclusions	34
References	35

1 Introduction

Suites of computer codes have been developed at Defence Research Establishment Atlantic (DREA) to predict the radiated noise from submerged or floating elastic structures [1, 2, 3, 4, 5]. These codes have been developed in support of the Ship Noise Project whose objective is to provide DND with the expertise and tools necessary to deal with issues related to underwater noise from naval vessels. Such computer programs may be used to either optimize the structural arrangement to minimize radiated noise or to examine existing structures to isolate noise-producing structures. These codes are also capable of predicting the in-air radiated noise of a vibrating structure. DREA recently conducted experiments to measure the radiated noise from a ring-stiffened cylinder subjected to a harmonic load under the controlled conditions at Health Canada's anechoic chamber located at the Brookfield Road lab in Ottawa. These experiments were performed to provide validation data for the computer codes.

DREA's ring-stiffened cylinder, used in previous experiments at the DREA Acoustic Calibration Barge [6, 7], was tested at the anechoic chamber in Ottawa which is part of the Radiation Protection Bureau (RPB) of the Health Protection Branch of Health Canada. DREA also arranged for the construction of a supporting turntable on which the cylinder could be mounted in the anechoic chamber and which could be driven by a stepper motor in a remote fashion from outside the chamber. Health Canada provided the in-air measurement equipment and the laboratory space, as well as the technical expertise for running the chamber. During the test period, the natural frequencies and mode shapes of the cylinder were measured using accelerometers placed throughout the cylinder with excitation provided by an electromagnetic shaker or loudspeakers. The turntable was then used to rotate the cylinder while the cylinder was excited with the shaker and directivity patterns of the resulting radiated noise were measured using a microphone at a specified position. Directivity patterns were also measured with the cylinder fixed and the microphone moved using the robotic capability of the anechoic chamber.

The cylinder was then modelled using the finite element analysis program, VAST [5]. The natural frequencies of the cylinder were calculated with VAST and compared with those measured in the trials. A point sinusoidal load of fixed amplitude was then applied to the model at each frequency of interest to simulate the load applied by the shaker and the resulting surface velocities of the cylinder were determined. These surface velocities were used as input to the boundary element program, BEMAP [8], which calculated the radiated sound at each frequency for comparison to the measured directivity patterns.

This technical memorandum discusses the dimensions of the cylinder and the experimental procedure and compares the results of the natural frequency testing and the measured directivity patterns with the predicted values. A more detailed description of the experiment and a full listing of all results are given in [9].

2 Experimental Procedure

The anechoic chamber is a part of the Radiation Protection Bureau of the Health Protection Branch of Health Canada and is located at the RPB's laboratory in Ottawa, Canada. The chamber is the largest in Canada and is of double room construction with the inner room floating on coil springs to isolate it from structurally-borne vibrations. The inside dimensions of the chamber are 12m \times 16m \times 11m high. The anechoic lining of the chamber consists of fibreglass wedges roughly 1.5m deep with a low frequency cut-off of 50 Hz. As the floor is covered with these wedges, a working surface is provided by a wire grid floor which may be supplemented by a steel grating floor which is installed on posts fitting into bayonet mounts located between the floor wedges. For this trial, the grating floor was used for the installation and removal of the cylinder, but was not in place for the experiment itself.

The ring-stiffened cylinder's manufacture and detailed dimensions are given in [6]. Briefly, the cylinder consists of a 9.5mm thick tube with a nominal diameter of 762mm, with a weld seam running longitudinally along the entire length. Five circumferential stiffeners were welded into the tube at equal intervals of 0.5m. These stiffeners had a square 38.1mm \times 38.1mm cross-section. Threaded 9.5mm radial holes facing inwards were also provided at 45° intervals on every ring stiffener to allow for the attachment of various pieces of equipment. Removable endcaps 76mm thick were constructed of nominal 3in plate and welded to the tube. The endcaps were of two pieces with a central 'hatch' roughly 600mm in diameter, which was bolted to the remainder of the endcap and sealed with an O-ring. Ring bolts were welded to the endcaps at various positions to allow for handling of the cylinder and the endcaps. A half-section of the cylinder is shown in Figure 1 and a photograph of the cylinder (on its transport cradle) is shown in Figure 2.

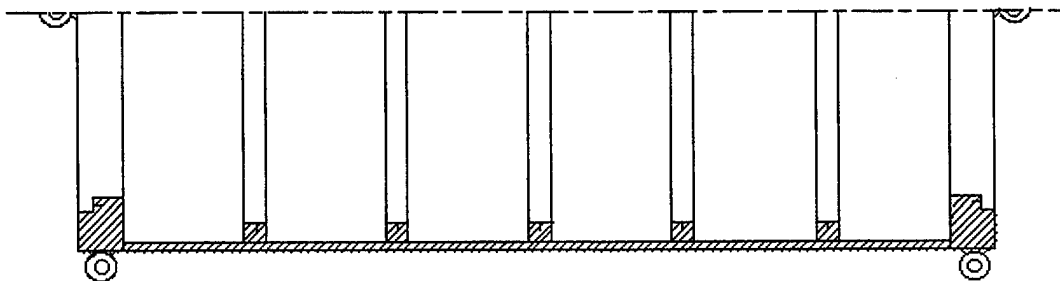

Figure 1: Half-Section Through Test Cylinder

Four connectors penetrated one endcap to permit the use of 48 accelerometers inside the cylinder. Other connectors were installed to provide power and signals for an electromagnetic shaker and to allow access to the signal cables from the shaker's integral accelerometer and force transducer. The accelerometers were mounted on blocks then installed on mounting studs

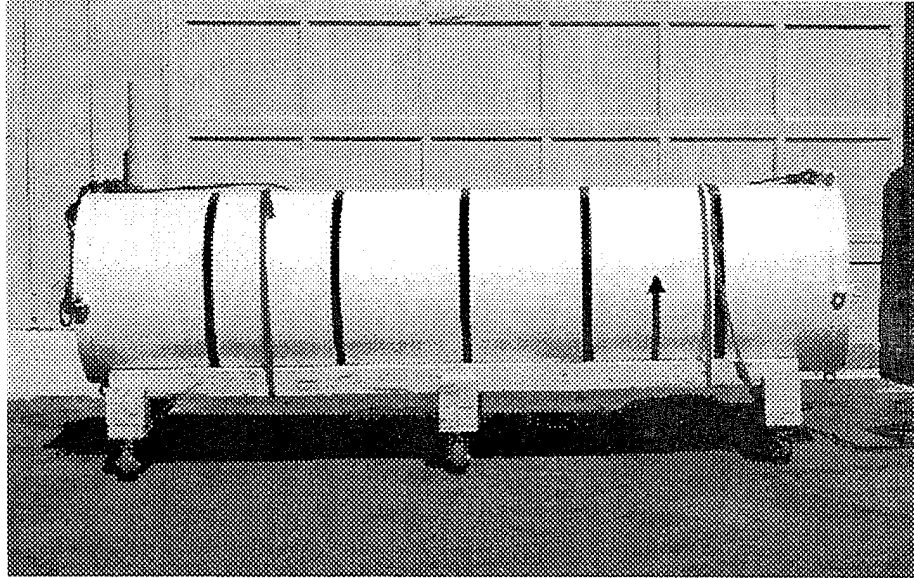

Figure 2: Test Cylinder

previously welded to the stiffeners and skin on the interior of the cylinder. A combination electromagnetic/piezoelectric shaker was installed on the centre stiffener of the cylinder. The shaker uses its piezoelectric portion for high frequency excitation. For this experiment, only the use of the electromagnetic portion of the shaker was required. The shaker was equipped with an impedance head with which were measured the applied force to the cylinder and the resulting acceleration at that point. Acoustic speakers were also used at various times to excite the cylinder, particularly to excite modes which had nulls at the shaker mount point.

The cylinder was placed vertically on a turntable provided by DREA (see photograph in Figure 3). The turntable is driven by a stepper motor which was geared to be capable of rotating the cylinder in increments of 0.45° s and which could be operated in a remote fashion.

The radiated noise measurements were made using a condenser microphone. For the circular directivity pattern testing, the microphone was mounted roughly at the cylinder midheight at a distance of 5.42m from the cylinder centre on a pipe mounted into one of the bayonet mounts in the chamber floor. For the vertical line directivity patterns, the microphone attached to the RPB's remote five degree-of-freedom robotic system was used (see schematic Figure 4).

The first set of tests involved determining the natural frequencies and mode shapes of the cylinder under the test conditions. The cylinder was excited with either the electromagnetic shaker or the acoustic speakers using a random noise signal over a frequency band from 0 Hz to 800 Hz. The response of each accelerometer was examined and the natural frequencies were selected from the peaks of the response. Modal damping factors were determined from the

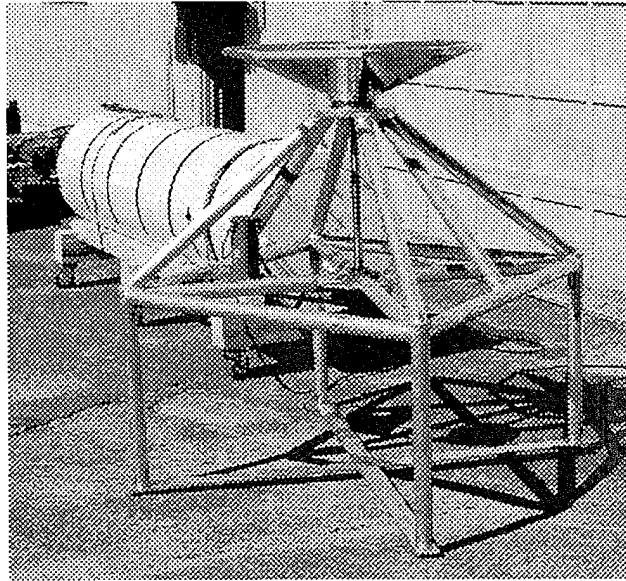

Figure 3: Turntable Support

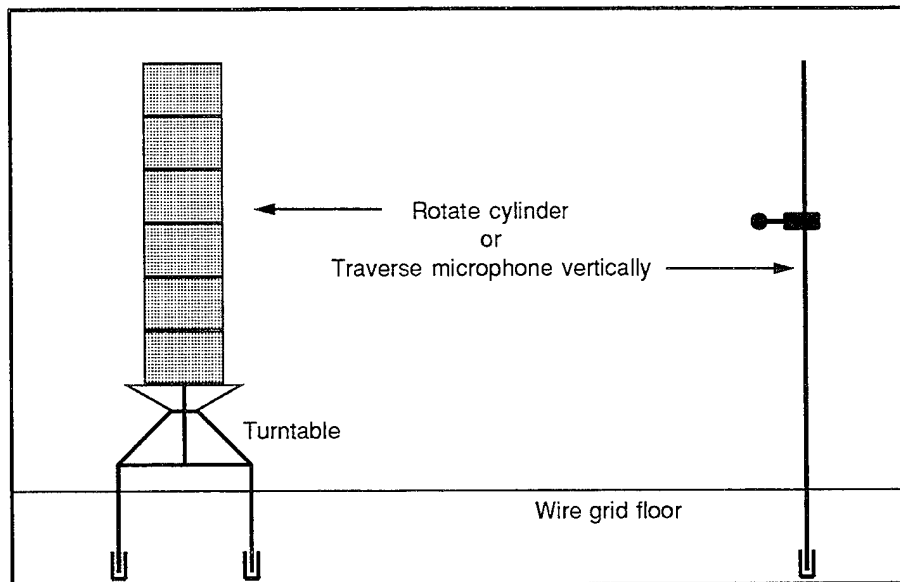

Figure 4: Schematic of Experimental Setup

response spectrums by examining the width of the resonant peak at the half-power point (3dB down).

To determine the mode shapes corresponding to the selected peaks, frequency response trials were done comparing various accelerometers to each other with the cylinder being excited with a pure tone at the particular resonance. Either the shaker or the speaker were used, whichever seemed to give a better excitation to that resonance. The mode shape measurements met with mixed success. Roughly one half the selected modes could be identified (mainly the lower frequency modes) while the measured shapes for the others were not readily identifiable. Further testing was conducted at a later date at DREA using a more refined accelerometer pattern than was possible during the anechoic chamber testing. This will be discussed further in a later section.

Following the natural frequency measurements, directivity patterns were measured for the cylinder with the shaker providing excitation at selected frequencies. For the first set of tests, a fixed microphone was located at a distance of 5.42m from the centre of the cylinder at the same vertical height as the midline of the cylinder (3.15m from the floor of the chamber). A listing of the tests done, the frequencies tested, and the applied force at each frequency is given in Table 1.

For the next set of tests, the microphone attached to the RPB's overhead robotic control system was used. The microphone was initially positioned at a distance of 4.09m (Tests L1 and L2) from the centre of the cylinder with the shaker pointed away from the microphone. For the directivity patterns, the microphone was traversed vertically ranging from 1.3m above to 1.3m below the cylinder midline. For the first test (L1), only the upper half of the cylinder was traversed. Test L2 covered the entire cylinder at the same distance over a broader range of frequencies. Another set of tests (Tests L3 and L4) was performed with the microphone moved to a distance of 2.89m from the cylinder centre. A listing of the tests done, the frequencies tested, and the applied force at each frequency is given in Table 2.

3 Numerical Codes

VAST (Vibration And STrength) is a general purpose, finite element computer code for the analysis of complex structures which has been developed both in-house at DREA and through contracted research since the early 1970's. Over the twenty years of development, many general purpose and special features for naval structural analysis have been implemented in VAST. These include specialized pre- and post-processors, as well as links to commercial model generators, a substantial library of element types, and a wide range of analysis options consisting of the usual linear static, dynamic and eigenvalue solutions. More recent additions to VAST include: large displacement nonlinearity; random response to sea spectra loading; stochastic FEA; elasto-acoustic analysis; complex eigenvalue solutions for vibration isolation; and component mode synthesis.

The VAST code was used for the structural analysis of the cylinder. Both a natural frequency analysis and a frequency response analysis (based on the modal superposition method) were

Frequency (Hz)	Test Number				
	01	03	04	05	06
185.00	99.43				
185.50	12.00				
185.60	7.92				
185.70	7.55				
185.66		7.42			
231.44		17.76		54.14	54.14
273.59		26.58		50.94	
372.65				46.13	
452.28		33.12			
461.94		36.23		55.47	
465.34		4.46			
473.66		12.42		25.44	
475.16		8.75		18.03	
541.47		4.96			
632.81		19.68			
740.13		3.80			
200.00			54.18		
325.00			47.32		
400.00			45.40		
525.00			41.26		
600.00			36.27		
150.00				62.88	

Table 1: Cylinder Directivity Pattern Applied Forces (N_{rms})

Frequency (Hz)	Test Number			
	L1	L2	L3	L4
150.00	63.32	59.85		
185.66	14.13	2.52		2.62
231.44	31.92	4.47		
273.59	51.23	8.68		
372.65	46.13	7.64	7.74	
465.34		1.44		
473.66		5.36	5.41	
541.47		1.63	1.64	1.63
740.13		1.11	2.62	1.09

Table 2: Cylinder Directivity Pattern Applied Forces (N_{rms})

performed. The results of the frequency response analysis were translated to a BEMAP input file for predicting the directivity patterns.

BEMAP (Boundary Element Method for Acoustic Prediction) uses the Boundary Element Method (BEM), also known as the Boundary Integral Equation (BIE) Method, to calculate the acoustic field due to an arbitrary body vibrating at a specified frequency or to calculate the acoustic field inside of an arbitrarily shaped acoustical cavity. Further information on this method may be found in [8] and other well-known references. The frequency response module in VAST is used to predict the surface velocities of the structure which are converted to normal velocities, and passed to BEMAP which then goes on to predict the resulting acoustic radiation.

4 Numerical Model

The structural model was constructed using the 4-noded shell elements and the 2-noded beam elements available in VAST. A total of 962 nodes and 960 elements were used to describe the cylindrical shell and endcaps and an additional 160 elements were used to describe the ring stiffeners. This resulted in the finite element model shown in Figure 5.

Boundary conditions were applied to the finite element model to simulate the placement of the cylinder on the turntable. All nodes on the lower end of the cylinder were assumed to be fixed in all three translational degrees-of-freedom. No other constraints were provided. A lumped mass was added to the model to represent the electromagnetic shaker.

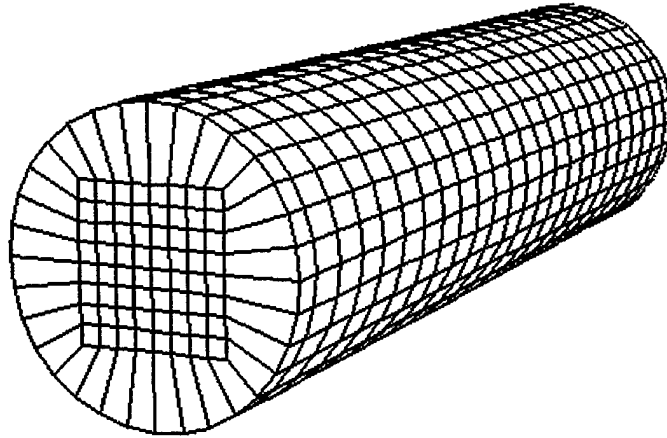

Figure 5: Finite Element Model of Cylinder

5 Results

5.1 Resonant Frequencies

The results of the VAST natural frequency analysis are shown in Table 3 along with the natural frequencies found during the experiment using both the shaker and the speakers, as well as the damping factors and mode associated with each one. The letter N indicates the order of the circumferential mode (number of full sine waves) and M the longitudinal (number of half sine waves).

The initial testing was only partly successful in determining the mode shapes associated with a particular resonance. Difficulties were encountered in producing a clear pattern for many of the higher modes. Analysis of the numerical results revealed that for the higher modes, particularly the 4,1 mode and above, interframe motions began to appear which matched the confusing patterns measured during the experiment. Subsequent testing at DREA, using a more refined pattern for the accelerometers and moving the shaker to another stiffener (to better excite modes asymmetric about the centre), was able to reproduce these more complicated mode patterns, thus allowing more modes to be identified. The numerical analysis also failed to predict four distinct resonances around 350 Hz which were observed during the trials. Further refinement of the FE model also failed to predict these resonances. A request for further testing of the turntable revealed that these four resonances were, in fact, resonances of the triangular support plates of the turntable.

The subsequent testing at DREA also revealed two modes (identified as modes 14 and 16) which were not observed in the anechoic chamber experiments. This additional testing also

No.	Experimental Frequency (Hz)	Mode (N,M)	Damping Factor	Predicted Frequency	Percent Error
1	186	2,1	0.00168	178	-4.3
2	231	1,1	0.00277	251	8.7
3	274	2,2	0.00086	312	13.9
4	291	2,2	0.00297	312	7.2
5	452	2,3	0.00097	495	9.5
6	465	3,1	0.00140	408	-12.3
7	473	3,1	0.00125	412	-12.9
8	475	2,3	0.00156	500	5.3
9	488	3,2	0.00183	444	-9.0
10	541	3,3	0.00114	511	-5.5
11		1,2		568	
12	622	3,4	0.00050	616	-1.0
13	632	3,4	0.00079	616	-2.5
14	647	3,4		616	-4.8
15	669	2,4	0.00120	697	4.2
16	679	2,4		699	2.9
17	688	4,1	0.00134	675	-1.9
18	695	4,1	0.00151	679	-2.3
19	708	4,2	0.00128	682	-3.7
20	721	3,5	0.00097	723	0.3
21	737	3,5	0.00087	731	-0.8
22	765	5,1	0.00095	730	-4.6

Table 3: Natural Frequencies (Hz) of Cylinder

indicated that several frequencies which were observed as small peaks during the anechoic chamber testing were spurious measurements and should not be included.

Examination of Table 3 shows that the resonant frequencies were generally predicted quite accurately by the numerical analysis, with most predicted values within ten percent of the measured values. Given that the material properties were not known exactly, this was quite reasonable accuracy. It is not apparent why the 3,1 mode is so poorly predicted; however, the first 2,2 mode (number 3) may be a measurement error. It produced a strong signal during the chamber testing, but not during the DREA testing. It may have been an artifact of the turntable structure which was sufficiently close to the 2,1 mode to excite the cylinder into that mode shape. It is also not apparent why the 1,2 mode (second bending) was missed completely during the experiment. It should have been excited by the speakers, but was not apparent even during the subsequent testing at DREA.

5.2 Directivity Patterns

Once the validity of the numerical model was established by the accuracy of the natural frequency predictions, a frequency response analysis was performed using the VAST FE code. The modal superposition method was used which utilizes the predicted resonances as a basis set for predicting the response of the structure in the frequency range spanned by the resonances. The method requires both the set of eigenvectors from the natural frequency analysis and modal damping factors for each mode included in the set. The damping factors used were those measured during the trials. Ideally, theoretical damping factors should be used and the results compared with the measured values; however, theoretical values of damping factors could not be found for such a welded steel structure. The use of the measured values, of course, indicates a deficiency in our capability for predicting the radiated noise at resonance.

The response of the cylinder was calculated at the frequencies for which directivity plots were made, including the off-resonant frequencies. The VAST frequency response module produces nodal displacement amplitudes for each frequency of interest. A translator program was run to convert these displacements to nodal velocities, then to normal (to the surface) velocities which are the required input boundary conditions for the BEMAP code. The boundary element model for the BEMAP analysis used the same grid of 4-noded elements as was used in the FE analysis, but without modelling any stiffeners (only a surface model is required). The BEMAP program takes the geometry and the surface velocity boundary conditions and predicts the radiated sound pressure level (SPL) at any requested set of field points. The sound speed and density for the acoustic fluid (air) were assumed to be 330 m/s and 1.2kg/m^3 , respectively.

The following pages contain the predicted and measured directivity plots (Figures 6 to 44). For some of the circular directivity plots, only half patterns were recorded due to time constraints. The first few vertical directivity plots are also only half patterns (from the centreline to the top of the cylinder) for the same reason. The radial scales for the circular plots are sound pressure levels (SPL) in dB re $20\mu\text{Pa}$. Not all measured plots were compared with numerical plots. Tests 03 through 05 are shown, but plots associated with frequencies which were later

determined to not be resonances were omitted. This was also done for Tests L1 through L4.

Overall the predicted directivity patterns were within reasonable accuracy of the experimental plots, but with some exceptions. The 2,1 mode (186 Hz) radiated noise was quite well predicted in most cases, in both shape and noise level (Figures 6, 7, 28, 32). Figure 7 is the predicted orthogonal pair to Figure 6, and as such, does not reflect the actual experiment (where the excitation provided by the shaker establishes the dominant mode). While the shape of the 1,1 (first bending) mode (231 Hz) (Figures 8, 23, 29, 33) was predicted correctly, the levels were not correct. This was true also for the 2,2 mode (274 Hz) (Figures 9, 24, 30, 34), but as this may not have been the true 2,2 mode (as discussed above) this is not unexpected.

Of the higher frequency modes, the 3,1 (465 Hz), 2,3 (475 Hz), and 3,3 (541 Hz) modes were quite well predicted (Figures 11, 13, 14, 26, 35, 37, 40, 43); the 2,3 (452 Hz) and orthogonal 3,1 (473 Hz) modes were quite poorly predicted, in both shape and level (Figures 10, 12, 25, 36); and the 3,4 (632 Hz) and 3,5 (737 Hz) modes were quite accurate in shape and, at times, quite accurate in SPL (Figures 15, 16, 38, 41, 44). In some cases, the patterns may be rotated slightly with respect to each other. This was often due to the selection of which orthogonal pair was selected for analysis and, as such, was not of concern.

The off-resonant frequencies examined (Figures 17, 18, 19, 20, 21, 22, 27, 31) all showed quite good agreement between predicted and measured directivity, and fairly good agreement with predicted levels; however, the response is dominated by the nearest resonance. In each case, the directivity pattern takes the shape of the nearest resonance. The difference in SPL can be attributed to the fact that the predicted values may not be the same distance (in frequency) from the resonance as the experimental values. For example, the 150 Hz test is only 18 Hz away from the predicted resonance, but it is 36 Hz away from the experimental resonance. This leads to an overprediction of SPL. This effect was not observed to this extent in related underwater trials. Similar separations (in frequency) from experimental or predicted resonances resulted in almost complete isolation from the resonance. There was little discernible effect from the resonance on the directivity pattern (most off-resonant frequencies showed as pure dipoles) and the levels were quite well predicted.

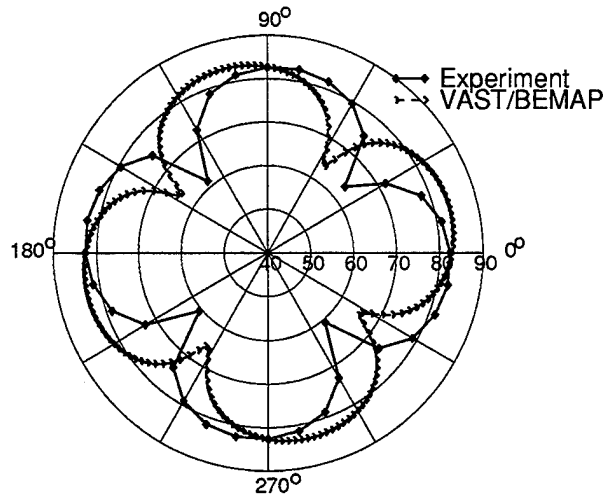

Figure 6: Test 03 Directivity Pattern at 185.66 Hz

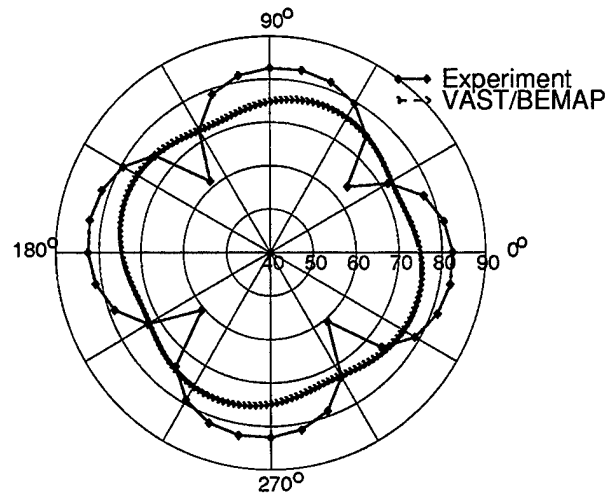

Figure 7: Test 03 Directivity Pattern at 185.66 Hz (orthogonal pair to Figure 5)

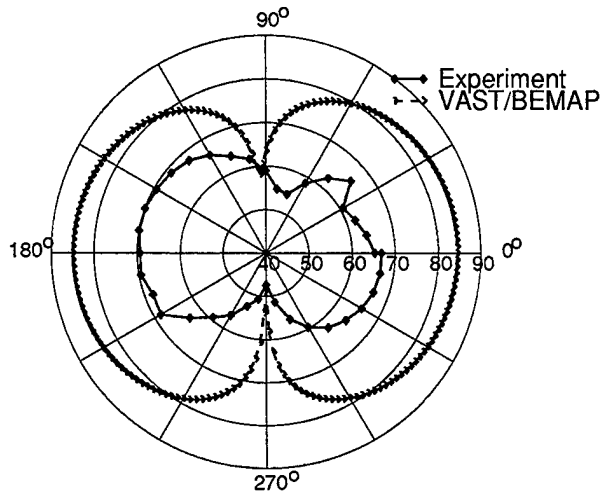

Figure 8: Test 03 Directivity Pattern at 231.44 Hz

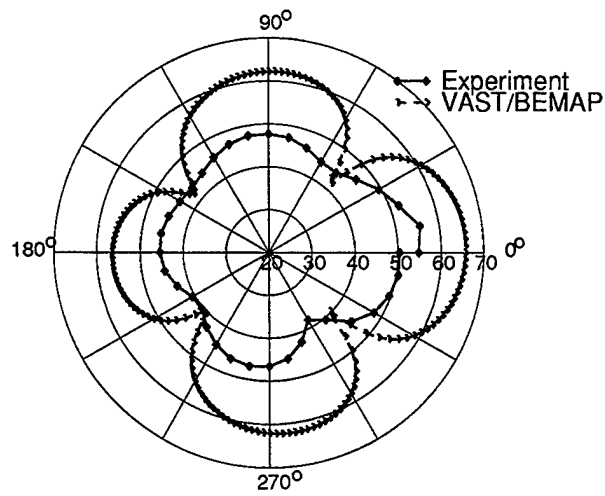

Figure 9: Test 03 Directivity Pattern at 273.59 Hz

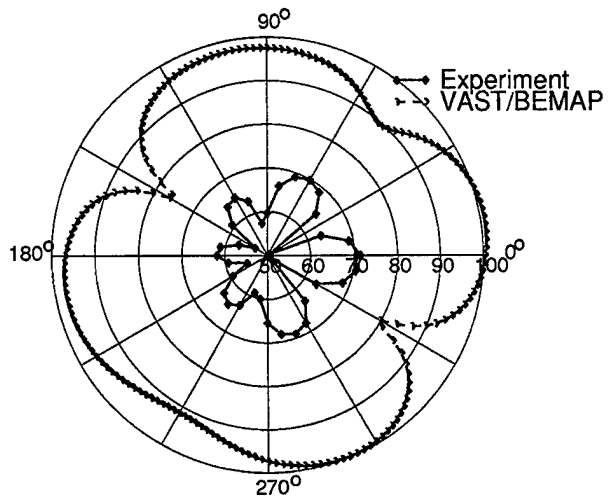

Figure 10: Test 03 Directivity Pattern at 452.28 Hz

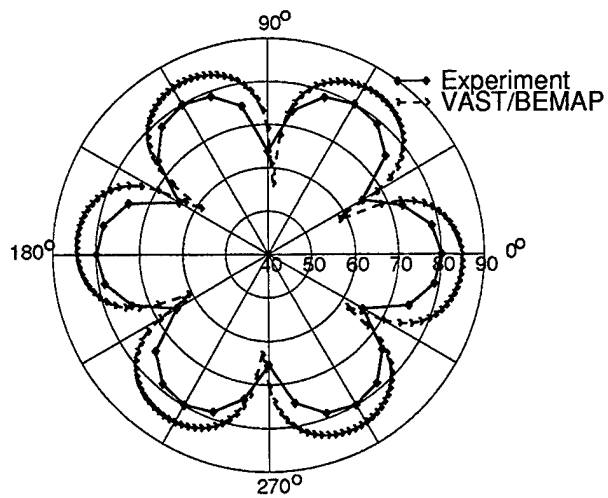

Figure 11: Test 03 Directivity Pattern at 465.34 Hz

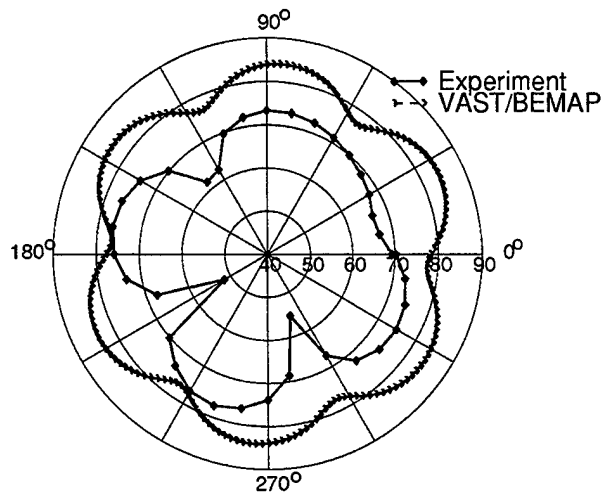

Figure 12: Test 03 Directivity Pattern at 473.65 Hz

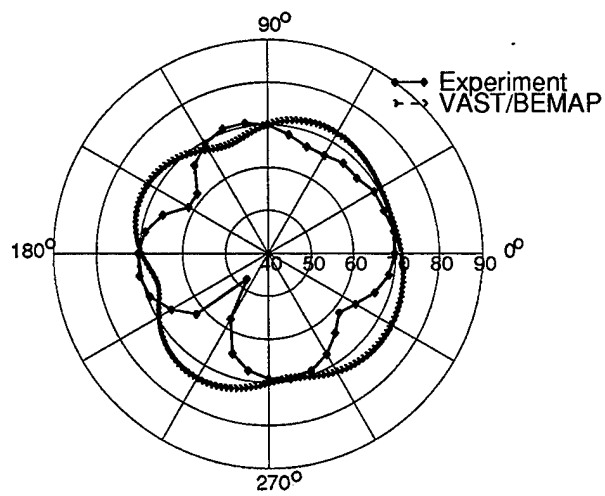

Figure 13: Test 03 Directivity Pattern at 475.16 Hz

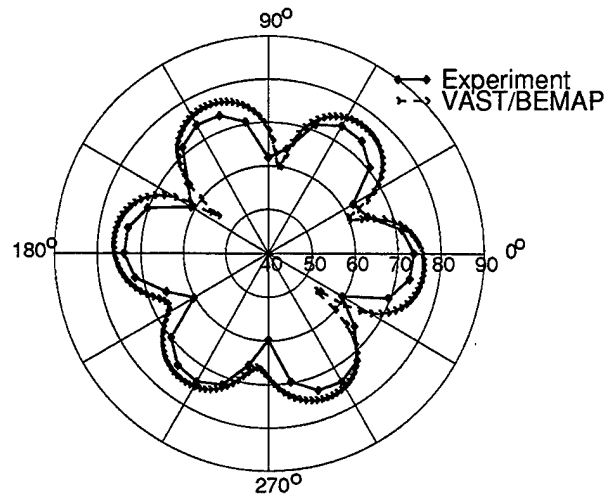

Figure 14: Test 03 Directivity Pattern at 541.47 Hz

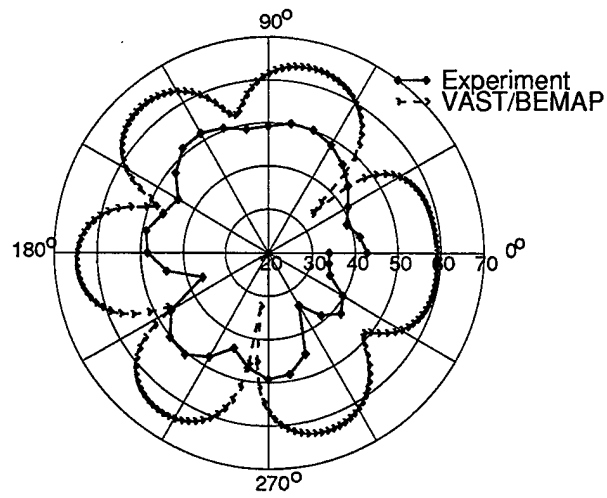

Figure 15: Test 03 Directivity Pattern at 632.81 Hz

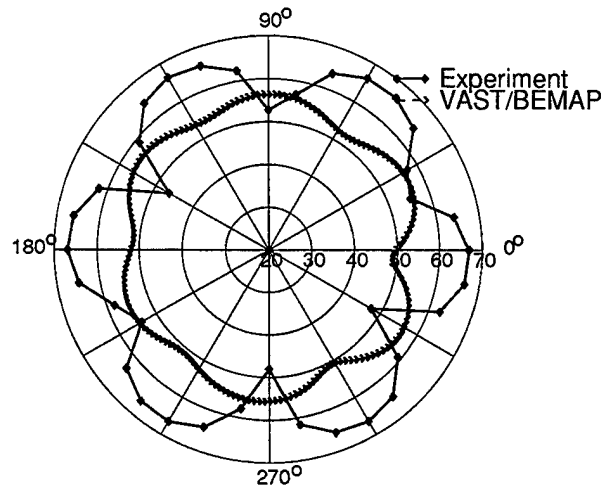

Figure 16: Test 03 Directivity Pattern at 740.13 Hz

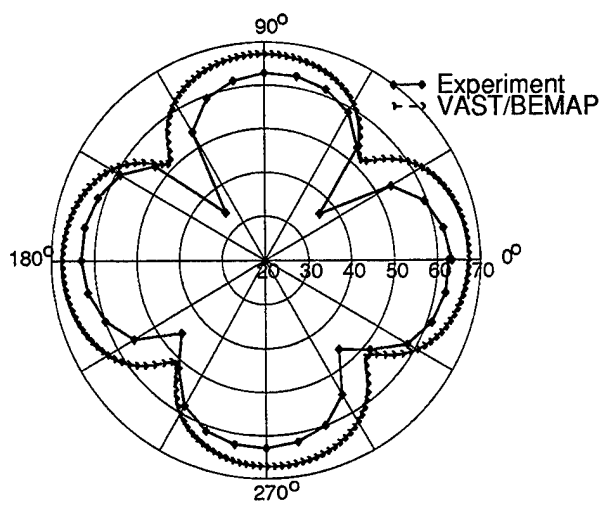

Figure 17: Test 04 Directivity Pattern at 200 Hz

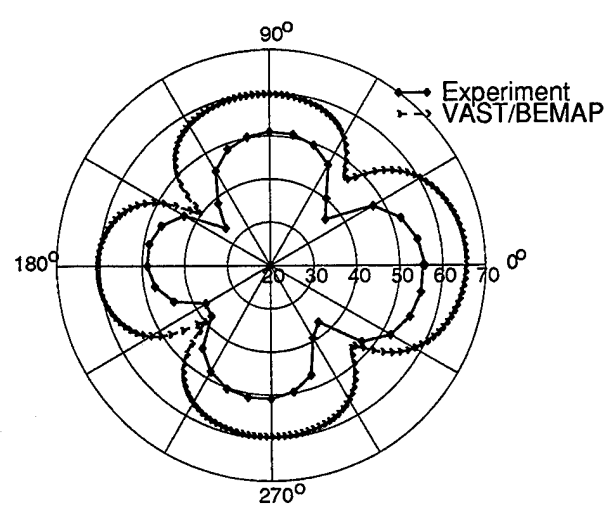

Figure 18: Test 04 Directivity Pattern at 325 Hz

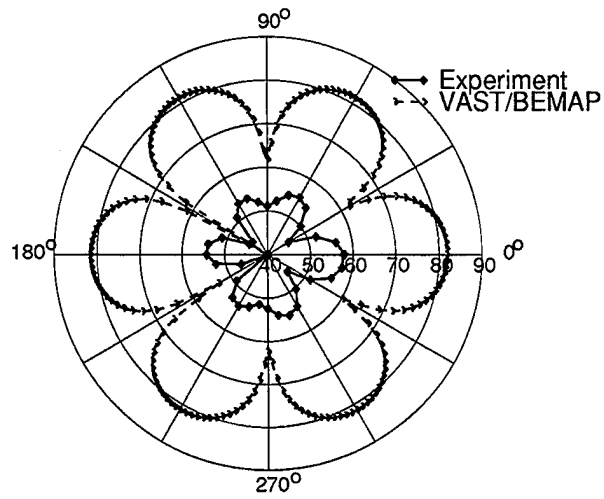

Figure 19: Test 04 Directivity Pattern at 400 Hz

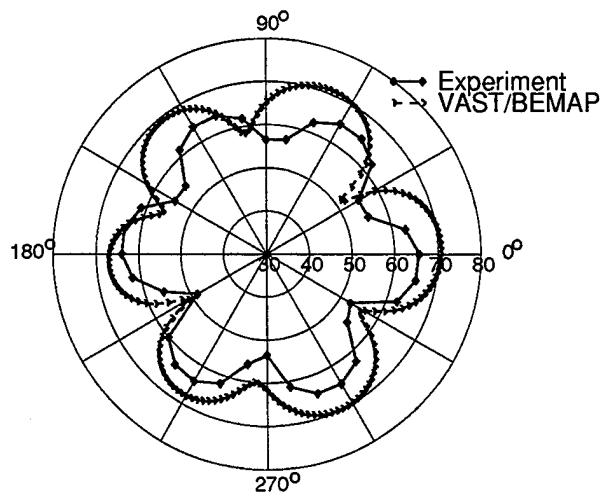

Figure 20: Test 04 Directivity Pattern at 525 Hz

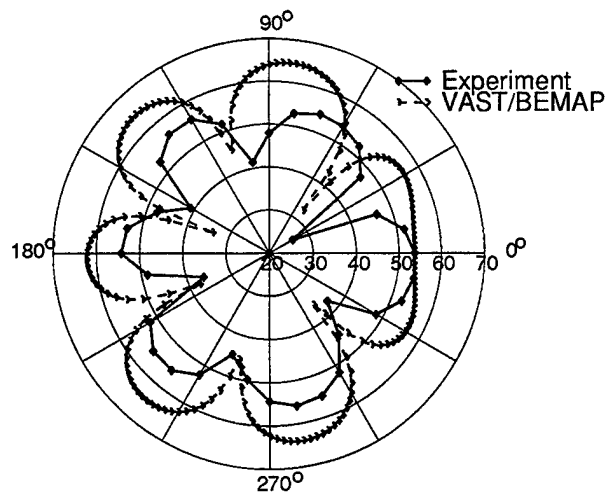

Figure 21: Test 04 Directivity Pattern at 600 Hz

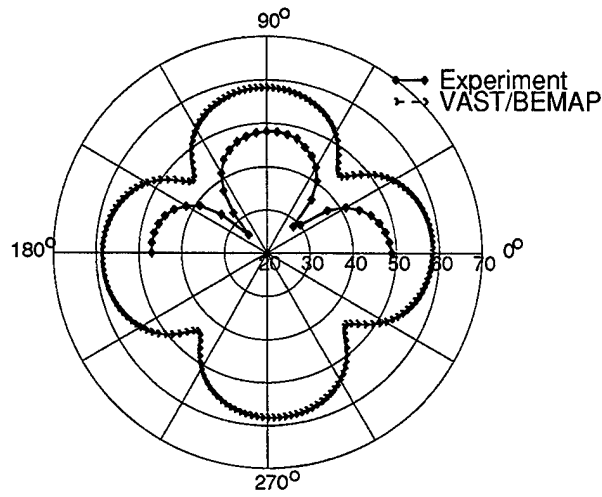

Figure 22: Test 05 Directivity Pattern at 150 Hz

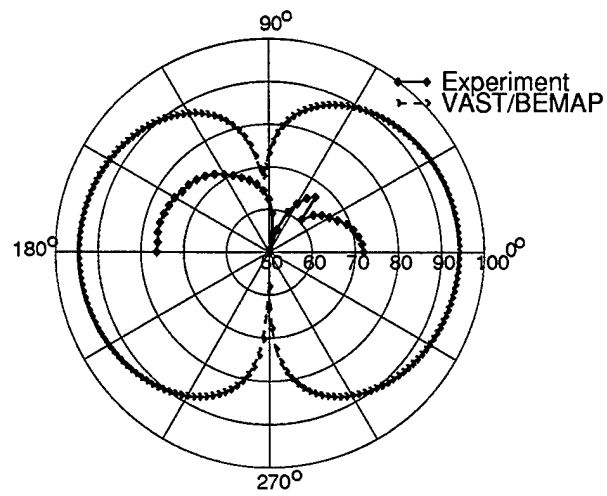

Figure 23: Test 05 Directivity Pattern at 231.44 Hz

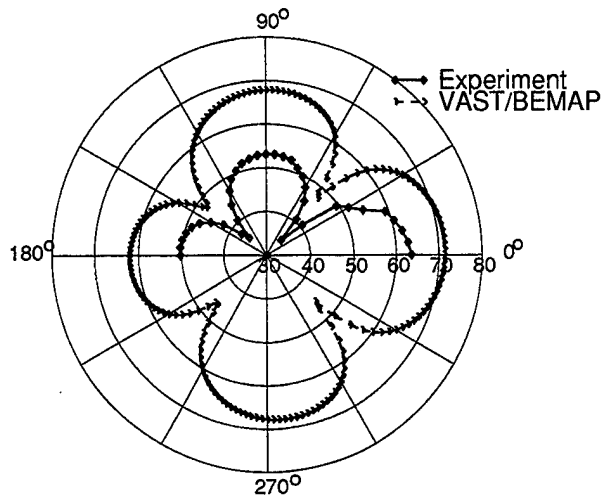

Figure 24: Test 05 Directivity Pattern at 273.59 Hz

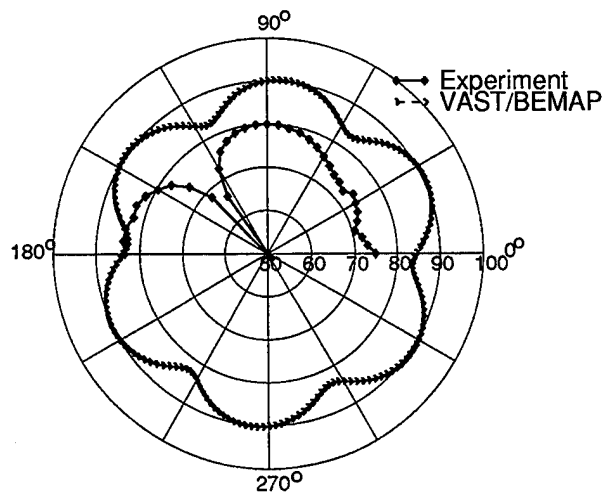

Figure 25: Test 05 Directivity Pattern at 473.66 Hz

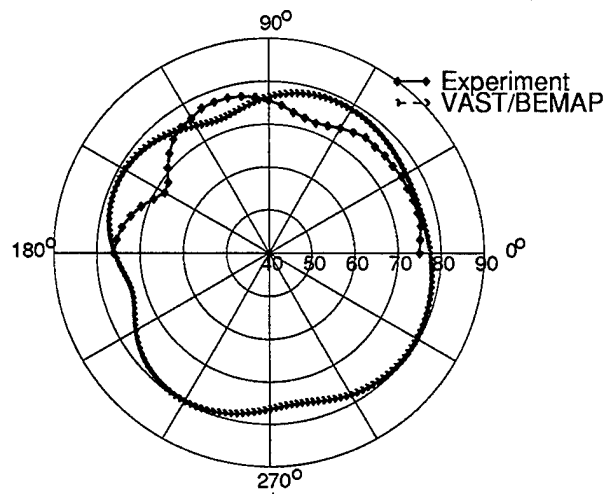

Figure 26: Test 05 Directivity Pattern at 475.16 Hz

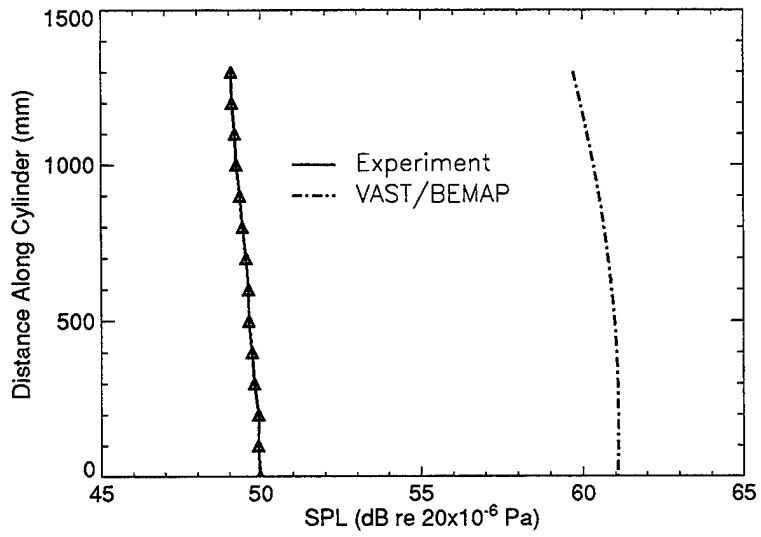

Figure 27: Test L1 Vertical Directivity Pattern at 150 Hz

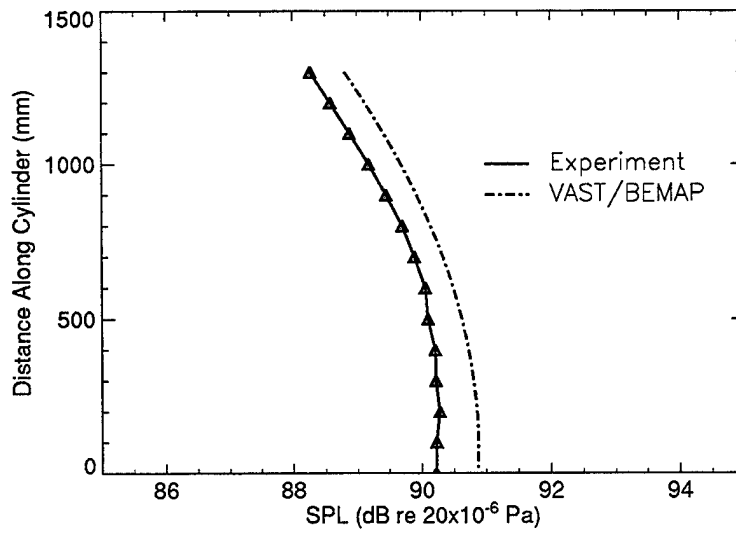

Figure 28: Test L1 Vertical Directivity Pattern at 185.66 Hz

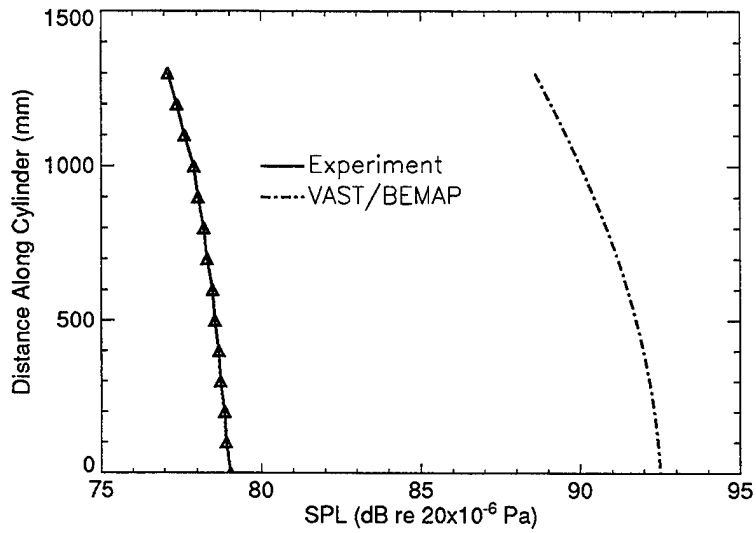

Figure 29: Test L1 Vertical Directivity Pattern at 231.44 Hz

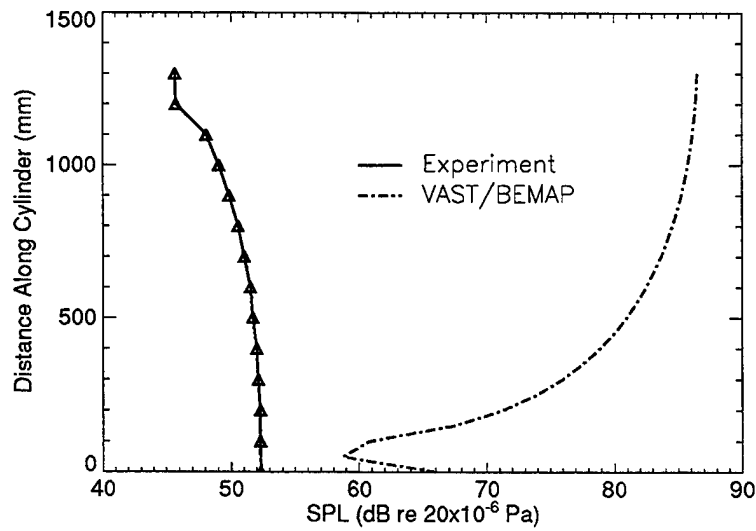

Figure 30: Test L1 Vertical Directivity Pattern at 273.59 Hz

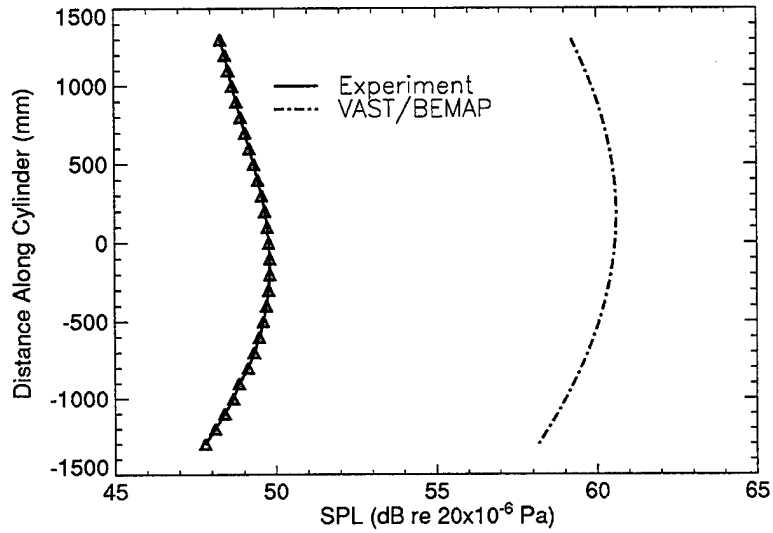

Figure 31: Test L2 Vertical Directivity Pattern at 150 Hz

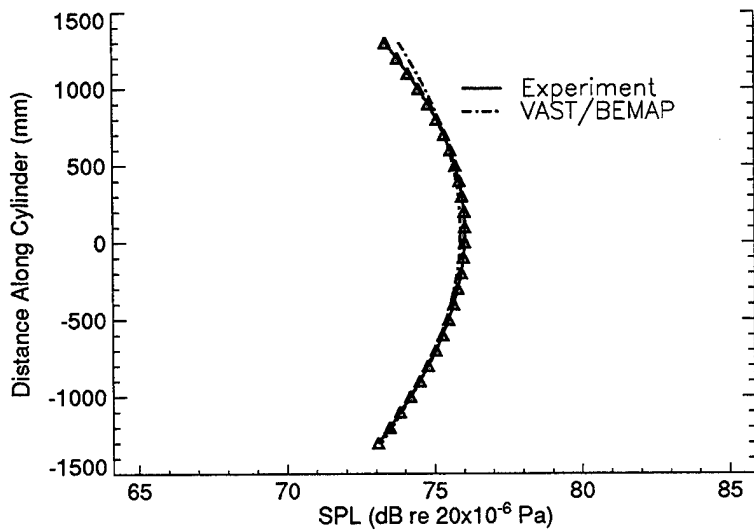

Figure 32: Test L2 Vertical Directivity Pattern at 185.66 Hz

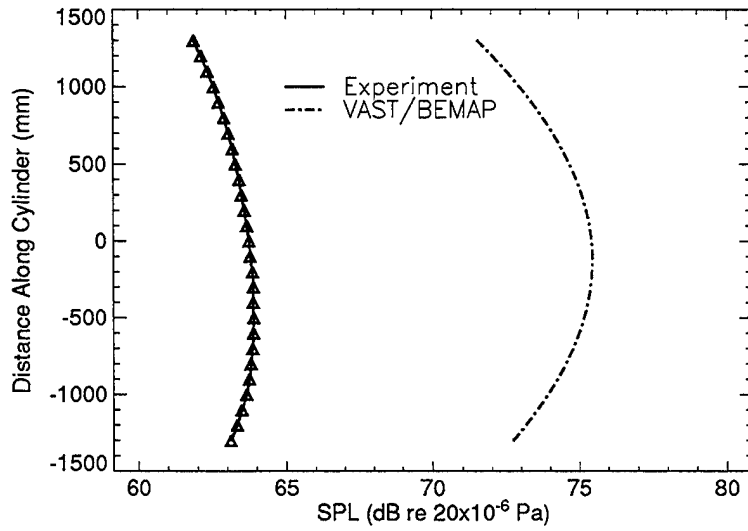

Figure 33: Test L2 Vertical Directivity Pattern at 231.44 Hz

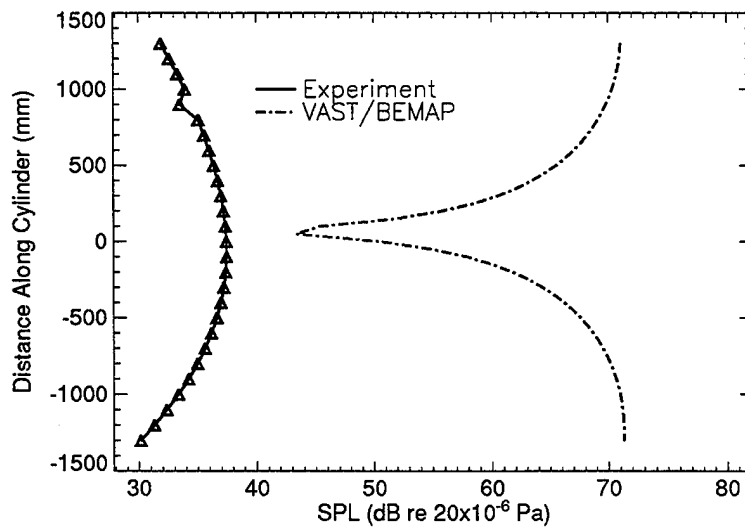

Figure 34: Test L2 Vertical Directivity Pattern at 273.59 Hz

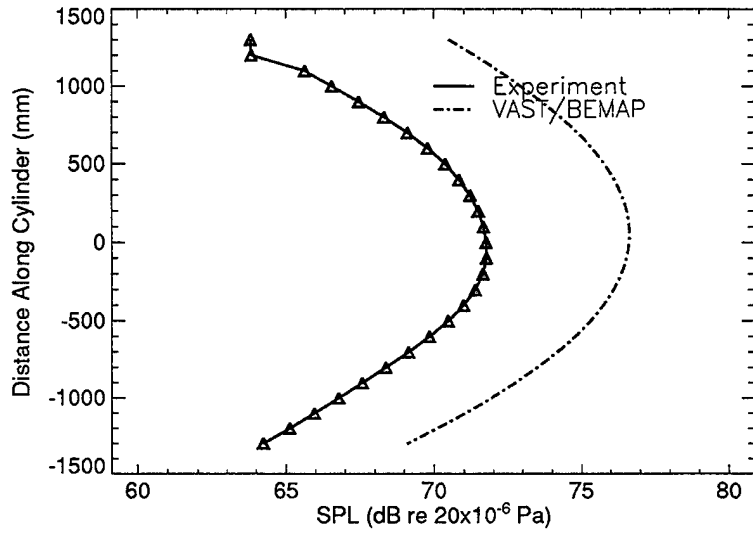

Figure 35: Test L2 Vertical Directivity Pattern at 465.34 Hz

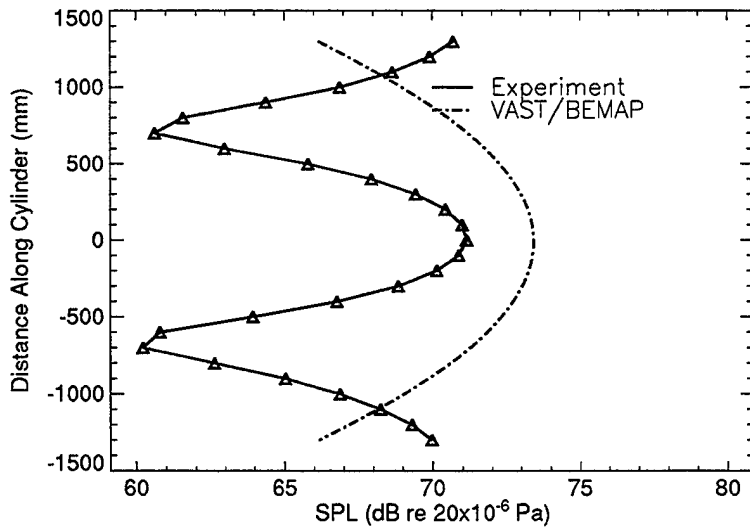

Figure 36: Test L2 Vertical Directivity Pattern at 473.66 Hz

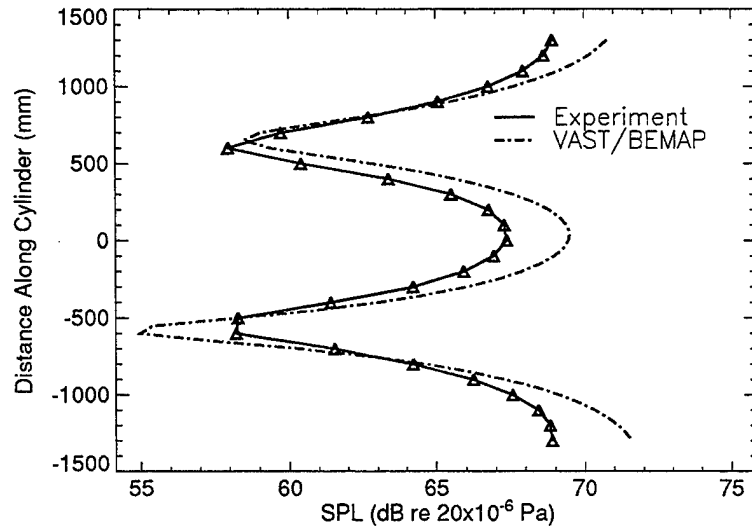

Figure 37: Test L2 Vertical Directivity Pattern at 541.47 Hz

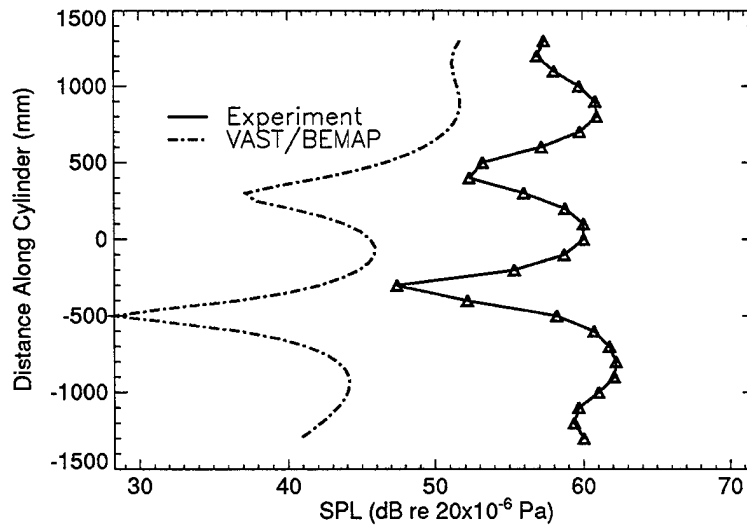

Figure 38: Test L2 Vertical Directivity Pattern at 740.13 Hz

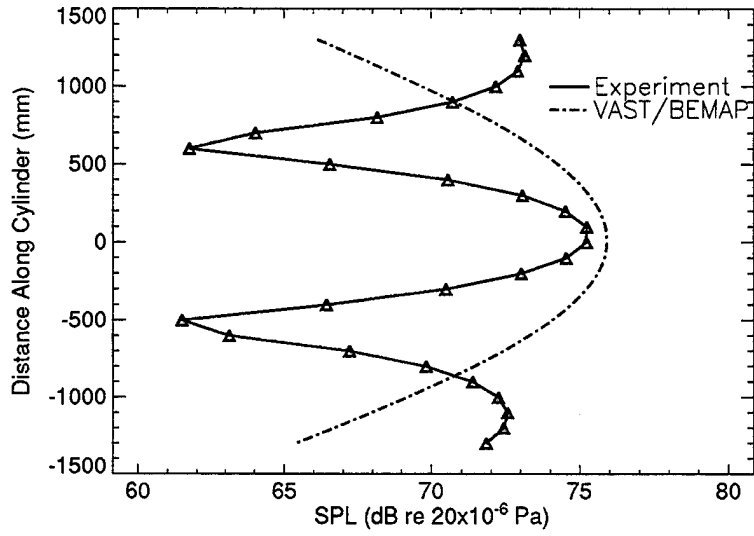

Figure 39: Test L3 Vertical Directivity Pattern at 473.66 Hz

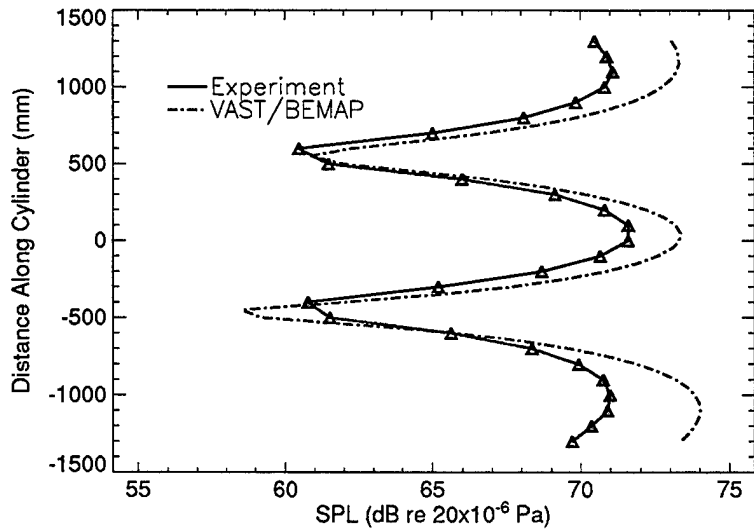

Figure 40: Test L3 Vertical Directivity Pattern at 541.47 Hz

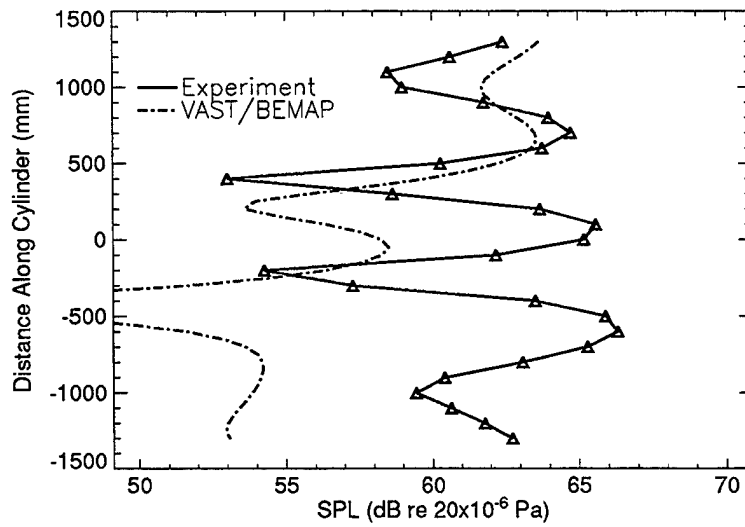

Figure 41: Test L3 Vertical Directivity Pattern at 740.13 Hz

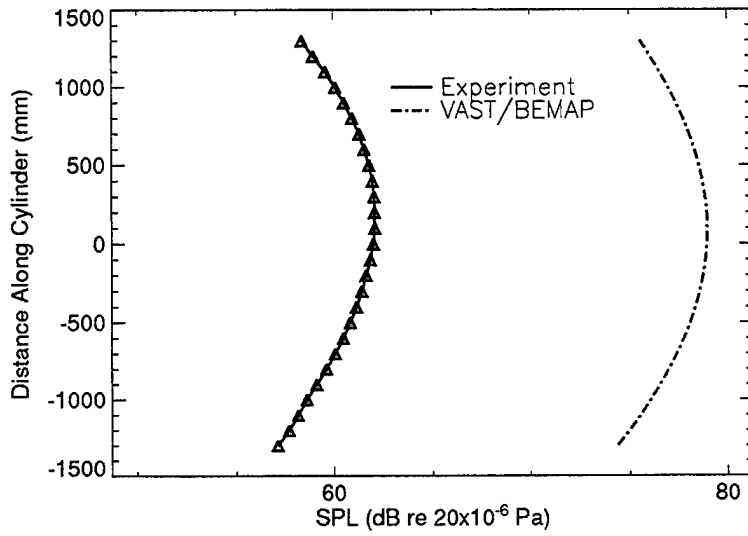

Figure 42: Test L4 Vertical Directivity Pattern at 185.66 Hz

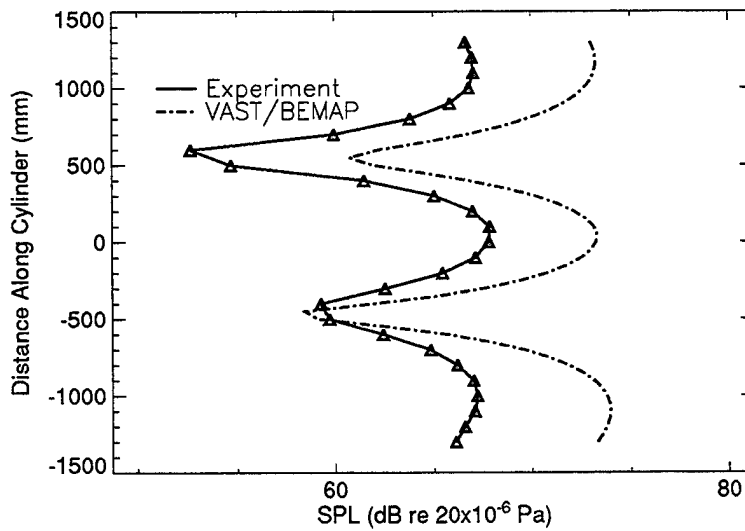

Figure 43: Test L4 Vertical Directivity Pattern at 541.47 Hz

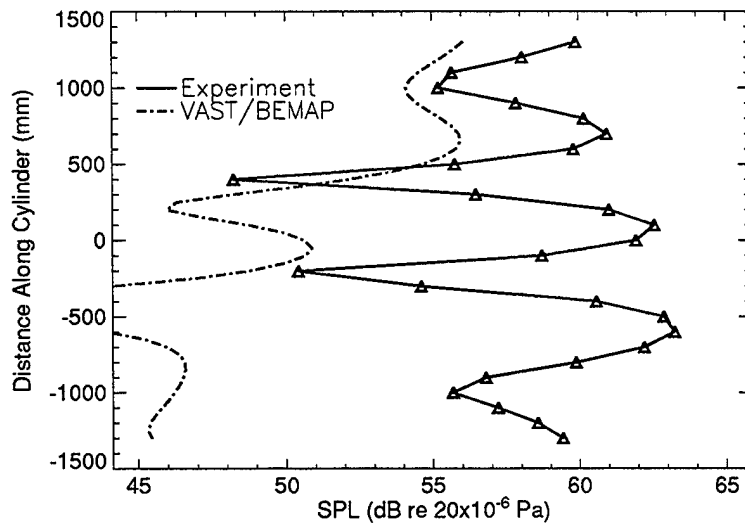

Figure 44: Test L4 Vertical Directivity Pattern at 740.13 Hz

6 Conclusions

Experiments were performed at Health Canada's anechoic chamber at the Radiation Protection Bureau in Ottawa to measure the natural frequencies of a ring-stiffened cylinder and to measure acoustic radiation directivity patterns for the cylinder undergoing point-excitation. These experiments were performed to obtain data with which DREA structural and acoustic computer codes could be evaluated.

The finite element program, VAST, was used for the prediction of the cylinder's natural frequencies. The predicted frequencies were within ten percent of the measured values, with the exception of the 3,1 mode which was within fifteen percent.

The boundary element program, BEMAP, was then used to predict the radiated sound pressure level (SPL) directivity patterns at both resonant and off-resonant frequencies. The off-resonance predictions were quite accurate with excellent predictions of directivity pattern and usually reasonable predictions of SPL. It was noted that the patterns generated at off-resonant frequencies were more closely coupled to the nearest resonance than was the case for previous investigations involving underwater radiated noise. Overall, the predictions at resonance were quite accurate in shape, quite accurate in SPL for some modes, and quite poor in SPL for some modes. Typically the $N=3$ modes and the lowest structural mode (2,1) were well predicted, while the higher $N=2$ modes and the bending modes were poorly predicted.

A major deficiency identified in this analysis, was the lack of theoretical modal damping factors for the cylinder which could be used in the prediction of radiated noise level. In the analysis, measured values were used, but ideally, it should be possible to predict the radiated noise without making any measurements. Unless methods are developed which can predict modal damping for general structures, empirical data will have to be developed from which representative modal factors may be drawn. DREA has measured modal damping factors from trials with this cylinder both submerged and floating and will be measuring damping factors from a floating box-like structure in an upcoming trial. These data will be compared in an attempt to develop modal damping factors representative of ship-like resonances.

In general, the suite of programs comprising VAST and BEMAP have shown a capability for predicting the natural frequencies and radiated noise of a vibrating structure. It has also been shown that the prediction of radiated noise in air is dependent on accurate identification of the mode shape for radiation at a structural resonance and is dependent on the distance from a structural resonance for non-resonant radiation.

The success of this investigation is due in part to the cooperation of the staff of the Radiation Protection Bureau of Health Canada. The use of the anechoic chamber also allowed for a much more controlled investigation than has been possible in the past at the DREA Acoustic Calibration Barge. Further testing at the anechoic chamber may be warranted for future noise investigations.

References

- [1] Vernon, T.A., "Finite Element Formulations for Coupled Fluid/Structure Eigenvalue Analysis," DREA Technical Memorandum 89/223, 1989.
- [2] Vernon, T.A., Tang, S., "Prediction of Acoustic Cavity Modes by Finite Element Methods," DREA Technical Communication 89/302, 1989.
- [3] Gilroy, L.E., Tang, S., "An Improved Finite-Element Based Method for Coupled Fluid/Structure Eigenvalue Analysis," DREA Technical Memorandum 91/209, 1991.
- [4] Gilroy, L.E., "Finite Element Methods for Analyzing Coupled Fluid/Structure Systems," *Proceedings of International Conference on Noise Control Engineering (Noise '93)*, M.J. Crocker and N.I. Ivanov, Ed., St. Petersburg, Russia, 1993.
- [5] "Vibration and Strength Analysis Program (VAST) : User's Manual Version 6.0," Martec Ltd., Halifax, Nova Scotia, 1990.
- [6] Gilroy, L.E., "Natural Frequency and Radiated Noise Measurements on a Ring-Stiffened Cylinder," DREA Technical Memorandum 93/215, October, 1993.
- [7] Gilroy, L.E., "Natural Frequency and Radiated Noise Measurements on a Ring-Stiffened Cylinder - Experimental Data Annex," DREA Technical Communication 93/313, December, 1993.
- [8] Seybert, A.F., Wu, T.W., "BEMAP User's Manual - Version 2.4", Spectronics, Inc., Lexington, Kentucky, 1989.
- [9] Gilroy, L.E., "Anechoic Chamber Measurements of Radiated Noise from a Ring-Stiffened Cylinder," DREA Technical Memorandum 95/231, October, 1995.

UNCLASSIFIED

SECURITY CLASSIFICATION OF FORM
(highest classification of Title, Abstract, Keywords)

DOCUMENT CONTROL DATA (Security classification of title, body of abstract and indexing annotation must be entered when the overall document is classified)		
1. ORIGINATOR (The name and address of the organization preparing the document. Organizations for whom the document was prepared, e.g. Establishment sponsoring a contractor's report, or tasking agency, are entered in section 8.) Defence Research Establishment Atlantic P.O. Box 1012, Dartmouth, N.S. B2Y 3Z7	2. SECURITY CLASSIFICATION (Overall security of the document including special warning terms if applicable.) UNCLASSIFIED	
3. TITLE (The complete document title as indicated on the title page. Its classification should be indicated by the appropriate abbreviation (S,C,R or U) in parentheses after the title.) Comparisons of Numerically Predicted and Experimentally Measured Radiated Noise from a Ring-Stiffened Cylinder		
4. AUTHORS (Last name, first name, middle initial. If military, show rank, e.g. Doe, Maj. John E.) Gilroy, Layton E.		
5. DATE OF PUBLICATION (Month and year of publication of document.) May 1996	6a. NO. OF PAGES (Total containing information. Include Annexes, Appendices, etc.) 36	6b. NO. OF REFS. (Total cited in document.) 9
6. DESCRIPTIVE NOTES (The category of the document, e.g. technical report, technical note or memorandum. If appropriate, enter the type of report, e.g. interim, progress, summary, annual or final. Give the inclusive dates when a specific reporting period is covered.) Technical Memorandum		
8. SPONSORING ACTIVITY (The name of the department project office or laboratory sponsoring the research and development. include the address.) Defence Research Establishment Atlantic P.O. Box 1012, Dartmouth, N.S. B2Y 3Z7		
9a. PROJECT OR GRANT NUMBER (If appropriate, the applicable research and development project or grant number under which the document was written. Please specify whether project or grant.) Project 1.g.1	9b. CONTRACT NUMBER (If appropriate, the applicable number under which the document was written.)	
10a. ORIGINATOR'S DOCUMENT NUMBER (The official document number by which the document is identified by the originating activity. This number must be unique to this document.) DREA Technical Memorandum 96/217	10b. OTHER DOCUMENT NUMBERS (Any other numbers which may be assigned this document either by the originator or by the sponsor.)	
11. DOCUMENT AVAILABILITY (Any limitations on further dissemination of the document, other than those imposed by security classification) <input checked="" type="checkbox"/> Unlimited distribution <input type="checkbox"/> Distribution limited to defence departments and defence contractors; further distribution only as approved <input type="checkbox"/> Distribution limited to defence departments and Canadian defence contractors; further distribution only as approved <input type="checkbox"/> Distribution limited to government departments and agencies; further distribution only as approved <input type="checkbox"/> Distribution limited to defence departments; further distribution only as approved <input type="checkbox"/> Other (please specify):		
12. DOCUMENT ANNOUNCEMENT (Any limitation to the bibliographic announcement of this document. This will normally correspond to the Document Availability (11). However, where further distribution (beyond the audience specified in 11) is possible, a wider announcement audience may be selected.) Full, unlimited		

UNCLASSIFIED

SECURITY CLASSIFICATION OF FORM

DDO03 2/06/87

UNCLASSIFIED
SECURITY CLASSIFICATION OF FORM

13. **ABSTRACT** (a brief and factual summary of the document. It may also appear elsewhere in the body of the document itself. It is highly desirable that the abstract of classified documents be unclassified. Each paragraph of the abstract shall begin with an indication of the security classification of the information in the paragraph (unless the document itself is unclassified) represented as (S), (C), (R), or (U). It is not necessary to include here abstracts in both official languages unless the text is bilingual).

Defence Research Establishment Atlantic (DREA), with the assistance of Health Canada, conducted an experiment involving the measurement of radiated noise from a ring-stiffened cylinder subjected to a harmonic load in an anechoic chamber. This experiment was performed to provide validation data for structural acoustics computer codes being developed in-house and under contract. These codes are used to predict the vibrations of structures submerged in, or filled with, a dense fluid and to also predict the resulting radiated noise. A subset of these codes, comprising the programs VAST and BEMAP, was used to predict the natural frequencies and radiated noise, on- and off-resonance, from this cylinder. Comparisons are made between the predicted and measured natural frequencies and radiated noise levels and directivity. Overall, the programs were able to accurately predict both the structural resonances and the radiated noise patterns.

14. **KEYWORDS, DESCRIPTORS or IDENTIFIERS** (technically meaningful terms or short phrases that characterize a document and could be helpful in cataloguing the document. They should be selected so that no security classification is required. Identifiers, such as equipment model designation, trade name, military project code name, geographic location may also be included. If possible keywords should be selected from a published thesaurus. e.g. Thesaurus of Engineering and Scientific Terms (TEST) and that thesaurus-identified. If it not possible to select indexing terms which are Unclassified, the classification of each should be indicated as with the title).

cylinder
radiated noise
natural frequency
VAST
finite element
boundary element
structures
BEMAP
anechoic

UNCLASSIFIED
SECURITY CLASSIFICATION OF FORM