

---

Logistics Management Institute

Palletized Load System  
An Analysis of Alternative Flatrack  
Acquisition Strategies

AR420MR1

Ronald Bailey  
Raymond Schaible

**DISTRIBUTION STATEMENT A**  
Approved for public release;  
Distribution Unlimited

19960423 048

**LMI**

# DISCLAIMER NOTICE



**THIS DOCUMENT IS BEST QUALITY AVAILABLE. THE COPY FURNISHED TO DTIC CONTAINED A SIGNIFICANT NUMBER OF PAGES WHICH DO NOT REPRODUCE LEGIBLY.**

September 1995

# Palletized Load System

## An Analysis of Alternative Flatrack Acquisition Strategies

AR420MR1

Ronald Bailey  
Raymond Schaible

Prepared pursuant to Department of Defense Contract MDA903-90-C-0006 and Contract DASW01-95-C-0019. The views expressed here are those of the Logistics Management Institute at the time of issue but not necessarily those of the Department of Defense. Permission to quote or reproduce any part except for government purposes must be obtained from the Logistics Management Institute.

Logistics Management Institute  
2000 Corporate Ridge  
McLean, Virginia 22102-7805

## Palletized Load System: An Analysis of Alternative Flatrack Acquisition Strategies

# Executive Summary

A key element of the Army's battlefield distribution system is the Palletized Load System (PLS), comprised of highly mobile trucks, trailers, and flatracks. Demountable flatracks are used for quickly picking up and dropping off loads of ammunition from trucks and trailers using a load-handling system installed on the trucks. This system speeds the delivery of ammunition to artillery units and reduces handling and congestion in forward areas.

The fielded M1077 flatrack (called an "A-frame flatrack" because of the shape of its fixed end wall) meets requirements for ammunition distribution operations in the corps area. However, the A-frame design is *not* intermodal; that is, it cannot be stacked in a containership cell to deliver loads of ammunition from CONUS to a theater of operations.

Intermodal capability is becoming more important in supporting a CONUS-based force that must deploy rapidly to widespread overseas contingency areas. Congress directed the Army to acquire flatracks that provide intermodal capability. In response, the Army designed a new flatrack, with two end walls, that is compatible with containerships. This enhanced flatrack (now called an M1 flatrack) is expected to perform as an acceptable container for intermodal movement and also as a PLS flatrack within the corps area.

In meeting user requirements for intermodal movement and battlefield distribution, the cost, weight, and complexity of the Army's intermodal flatrack grew to be significantly greater than the A-frame flatrack. Acquisition cost for the M1 flatrack is now estimated to be more than double the cost of the A-frame flatrack. The M1 weighs 5,000 pounds more than the A-frame; this added weight reduces the ammunition payload of the PLS. The complexity of the M1 design contributed to a delay in proceeding to full-scale production. In addition, because the Army must be prepared to operate in two nearly simultaneous Major Regional Contingencies, it is estimated that the Army requires more than 50,000 flatracks. Given today's constrained fiscal environment, the combination of high unit flatrack costs and the large quantity required carries an unaffordable price tag.

Accordingly, we examined two alternatives to the M1 and the A-frame flatrack designs: (1) the ammunition container (AMCON) and (2) a commercially available intermodal sideless container. We identified feasible alternatives for providing PLS intermodal capability, considered the operational effectiveness

and relevant costs of each, developed an acquisition strategy utilizing a mix of the available alternatives, and then provided an approach for the Army to equip the force with a less costly intermodal capability that also met battlefield distribution requirements.

We conclude the following:

- ◆ Alternatives built around the M1 design are the most costly options.
- ◆ Providing an intermodal capability by modifying the relatively few PLS trucks to accept a broader range of flatrack alternatives would require a much smaller investment than purchasing significant numbers of M1 flatracks.
- ◆ Modification of the PLS load-handling system to lift any standard container or flatrack that meets the system's weight specifications would add to the flexibility of the PLS as a distribution platform and a mobility asset.
- ◆ Because the need for Army flatracks far exceeds the number under contract, the production of A-frame flatracks should continue until production or acquisition of an intermodal flatrack can begin.
- ◆ Using commercially designed and competitively produced standard sideless containers, with a container handling device or modified load-handling system, offers significant cost savings over the purchase of PLS flatracks (such as the M1), which are specifically designed for intermodal movement and battlefield operations.
- ◆ Commercial standard sideless containers should be thoroughly tested before making a final decision about the production of a PLS-specific intermodal design.
- ◆ A steering group — with representatives from the Army Headquarters and field transportation, distribution, ammunition, artillery, production, and contracting staffs — should be formed to review periodically the PLS program.
- ◆ By investing in a modified PLS load-handling system and a less expensive intermodal flatrack, the Army can meet congressional guidance, reduce unfunded requirements, and enhance PLS operational capabilities for current and future uses.

Our major recommendations are as follows:

- ◆ Continue to produce about 200 to 300 A-frames per month while designing the modified PLS load-handling system.
- ◆ Investigate the compatibility and feasibility of meeting PLS needs by using commercial standard sideless containers and modified load-handling

systems. Perform user acceptance testing of commercial flatracks and the modified PLS load-handling system before moving into acquisition and/or production.

- ▶ If the investigation and testing of commercial flatracks yields positive results, purchase 18,038 commercial standard sideless containers, purchase 8,303 A-frames, and modify 1,283 PLS truck load-handling systems to meet the requirements for one Major Regional Contingency.
- ▶ If the commercial flatracks are found to be unacceptable, the Army should modify 1,283 PLS truck load-handling systems and purchase AMCON or M1 flatracks to fill out user requirements.
- ◆ Do not produce M1 flatracks until their design, performance, and cost have been examined, tested, and accepted by the user community.
- ◆ Establish a PLS steering group.
- ◆ Develop a competitive flatrack procurement plan that will meet intermodal requirements and that is acceptable to Congress.
- ◆ Clarify the policies and doctrine for intermodal ammunition distribution within CONUS, from the CONUS port to the port of debarkation, and from there to the corps area. That clarification also should address the safety and security concerns of moving ready-to-fire ammunition on open flatracks.

# Contents

Chapter 1. Introduction .....	1-1
Background .....	1-1
Objectives .....	1-4
Scope .....	1-5
Study Parameters .....	1-5
Approach .....	1-6
Report Overview .....	1-6
Chapter 2. Analysis of Alternatives .....	2-1
Measures of Effectiveness .....	2-1
Evaluation Criteria .....	2-2
Meets Major Regional Contingency Ammunition Distribution Requirements .....	2-2
Supports Intermodal Ammunition Movement and Force Projection .....	2-2
Satisfies User Equipment Requirements .....	2-3
Has Low Engineering Development or Production Risk .....	2-3
Supports Timely Fielding of PLS and Ensures that the PLS Can Pick Up All 8' x 8' x 20' International Organization for Standardization Containers and Flatracks .....	2-3
Is Cost-Effective .....	2-4
Limits Transportability Concerns .....	2-4
Limits Additional Requirements for PLS Support of MOADS .....	2-7
Satisfies Congressional Objectives .....	2-7
Supports Additional Uses of PLS .....	2-8
Other Factors to be Considered .....	2-8
Payload .....	2-8
Transportability .....	2-8
Containers .....	2-9
Flatrack Ownership .....	2-9

# Contents (Continued)

- The Major Regional Contingency – East Scenario ..... 2-10
- Ammunition Distribution Doctrine ..... 2-10
- Transportation Distribution and Deployment Nodes ..... 2-12
  - Critical Feature at CONUS Depot to Port of Embarkation: Security ..... 2-13
  - Critical Feature at Sea: Containerization ..... 2-14
  - Critical Feature of Movement from Port of Debarkation to Corps Storage Area: Efficient Forward Transport of Required Ammunition ..... 2-16
  - Critical Feature of Battlefield Distribution Forward of the Corps Storage Area: Battlefield Performance ..... 2-17
  - DYNAMO Modeling of Battlefield Performance ..... 2-19
- Flatrack Alternatives ..... 2-20
  - Pure A-Frame Flatrack Alternative ..... 2-21
    - Intermodal Delivery ..... 2-22
    - Force Projection ..... 2-23
    - Battlefield Distribution ..... 2-23
    - Flatrack Fleet Composition ..... 2-24
  - Intermodal Shipping Container (M1) Alternative ..... 2-24
    - Intermodal Delivery ..... 2-26
    - Force Projection ..... 2-26
    - Battlefield Distribution ..... 2-26
    - Flatrack Fleet Composition ..... 2-27
  - International Standards Organization Flatrack Ammunition Container Alternative ..... 2-27
    - Intermodal Delivery ..... 2-27
    - Force Projection ..... 2-28
    - Battlefield Distribution ..... 2-28
    - Flatrack Fleet Composition ..... 2-28
  - Commercial International Organization for Standardization Sideless Container Alternative ..... 2-29
    - Intermodal Delivery ..... 2-31
    - Force Projection ..... 2-32
    - Battlefield Distribution ..... 2-32
    - Flatrack Fleet Composition ..... 2-33



# Contents (Continued)

Mixed (A-Frame/M1) Alternative .....	2-33
Decision Tree .....	2-34
Evaluation of Alternatives .....	2-35
Selection of Preferred Alternatives .....	2-35
Findings .....	2-39
Chapter 3. Conclusions and Recommendations .....	3-1
Conclusions .....	3-1
Recommendations .....	3-2
Chapter 4. Decision Implementation .....	4-1
Decision Implementation Plans .....	4-1
Memorandum of Agreement .....	4-3
Flatrack Acquisition Status (as of the Fourth Quarter of FY95) .....	4-3
Appendix A. U.S. Army Operations Concept for Class V Support Using the Palletized Load System	
Appendix B. Memorandum of Agreement	
Appendix C. Decision Tree Analysis of Alternatives	
Appendix D. DYNAMO Modeling	
Appendix E. Glossary	

# Illustrations

1-1.	Palletized Load System: Truck, Trailer, and A-Frame Flatrack	1-1
1-2.	Enhanced Intermodal PLS Flatrack (M1 or ISC)	1-3
1-3.	Commercial Intermodal Flatrack	1-4
2-1.	MOADS Doctrine	2-11
2-2.	A-Frame Flatrack	2-22
2-3.	Dry Container	2-23
2-4.	M1 Intermodal Flatrack (shown on PLS truck)	2-25
2-5.	ISO (AMCON) Commercial PLS Flatrack	2-28
2-6.	Commercial ISO Sideless Container	2-29
2-7.	Container Handling Device	2-30
2-8.	Container Lift Kit	2-31
2-9.	Container Handling Unit	2-32
2-10.	Full Decision Tree	2-34
2-11.	Equipment Investment Costs for Feasible Alternatives	2-36

# Tables

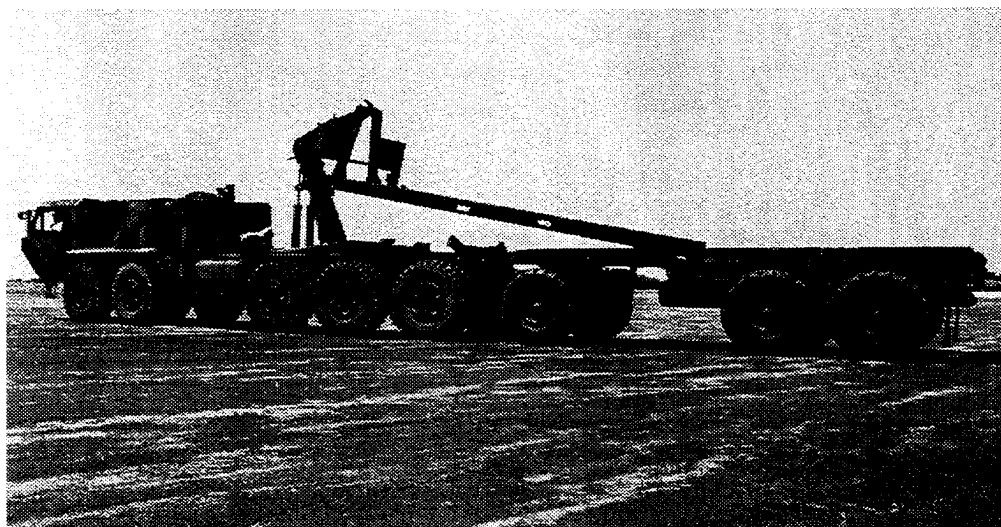
2-1. Equipment Costs .....	2-5
2-2. Transportation, Distribution, and Deployment Stages .....	2-13
2-3. Handling Loading and Unloading Costs and Times .....	2-16
2-4. PLS Flatrack Alternatives .....	2-33
2-5. Evaluation Criteria Matrix for Feasible Alternatives .....	2-37

## CHAPTER 1

# Introduction

## BACKGROUND

The Maneuver Oriented Ammunition Distribution System (MOADS) is the Army's answer to the ammunition distribution needs of the rapidly changing battlefield of modern combat. At the heart of the MOADS doctrine is the Palletized Load System (PLS) (see Figure 1-1), comprised of highly mobile trucks, trailers, and flatracks that distribute ammunition from centralized transfer and distribution points to firing units within the corps area. The use of demountable flatracks allows the truck and trailer to quickly pick up and drop off configured loads of ammunition weighing up to 16.5 tons each using an on-board load-handling system (LHS). This feature allows the operator to avoid the constrictions at ammunition-handling points that characterized earlier doctrine and equipment. Although each truck and trailer assigned to medium truck companies and artillery battalions normally carries one flatrack, the majority of the flatracks are located within the direct support and general support (DS and GS) ammunition companies that operate the ammunition distribution nodes within the corps area. The ammunition companies prepare these flatracks with combat configured loads (CCLs) of ready-to-fire ammunition for pick up and delivery by the truck companies.



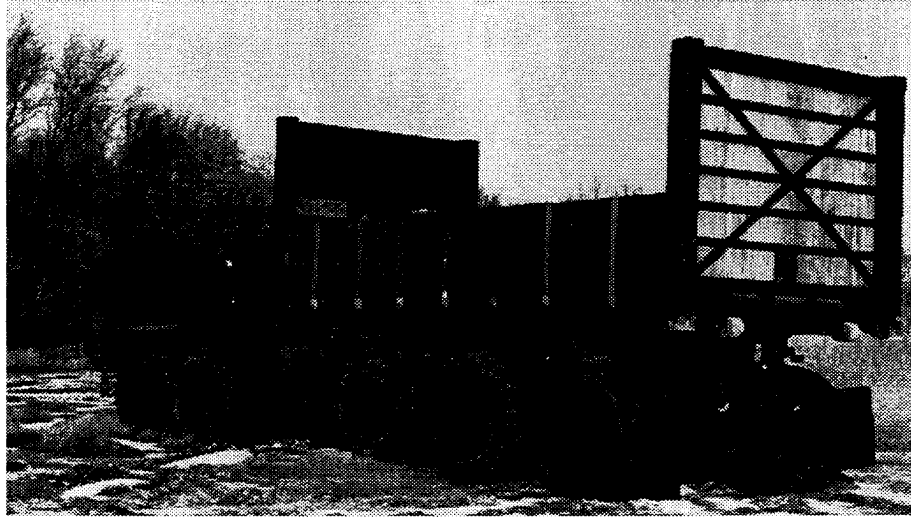
**Figure 1-1.**  
*Palletized Load System: Truck, Trailer, and A-Frame Flatrack*

The fielded flatrack (termed the A-frame flatrack because of the shape of its fixed end wall) meets requirements for ammunition distribution operations forward of the corps storage area (CSA) but does not facilitate intermodal movement and delivery of ammunition from CONUS to a theater of operations. A new flatrack was designed to provide this intermodal capability by adding folding end walls, strengthening the decking and flatbed support, adding more International Organization for Standardization (ISO) pockets, and other features. Although this enhanced flatrack [called an M1, or an intermodal shipping container (ISC)] has not yet completed acceptance testing before moving into full production, it is expected to meet container requirements for intermodal movement and also perform as a PLS flatrack within the corps area.

As design efforts incorporated user battlefield requirements while balancing intermodal specifications, the weight, complexity, and cost of the intermodal flatrack increased. Acquisition costs for the intermodal flatrack escalated from initial estimates to the point at which they are double the costs of the A-frame flatrack. Furthermore, the necessity of being able to operate in two near simultaneous major regional conflict areas led to an Army-wide requirement for 50,848 flatracks. The high unit costs and large flatrack requirements carry a price tag that exceeds the available current and projected funding.

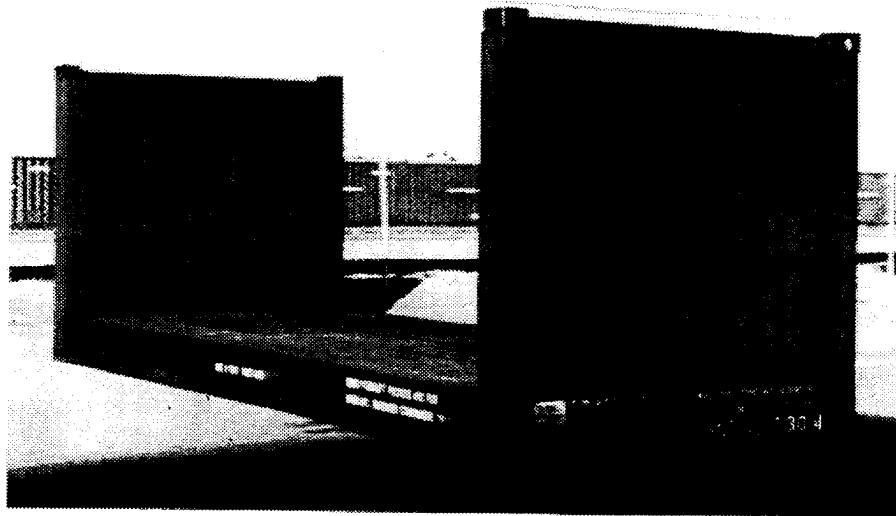
The following factors will impact the flatrack procurement decision:

- ◆ Congress directed more timely acquisition of an intermodal capability for flatracks if found to be PLS compatible. The A-frame flatrack, initially developed as an integral part of the PLS truck (shown lifted by the load handling system in Figure 1-1) and now type-classified as the Army standard, does not meet Container Safety Committee (CSC) requirements for intermodal movement in container cells. Unloaded A-frame flatracks can be nested for shipment or loaded flatracks can be treated as bulk cargo. Intermodal flatracks must have decks and end walls that are load-bearing to CSC standards and that have ISO-compatible fittings.
- ◆ If A-frame flatracks are used, they are transported as cargo on non containerships either nested above deck or stowed below decks. If intermodal flatracks are used, they can be loaded with ammunition in CONUS and handled and transported as containers on containerships. Once in the destination area, the intermodal flatracks can function as PLS flatracks for ammunition distribution.
- ◆ The method of shipping ammunition that has the greatest degree of security and safety is within a fully enclosed container with other ammunition of a compatible type. Shipping ammunition in open containers in mixed types, as on a flatrack, is currently approved for a limited number of ammunition types. The shipment of ready-to-fire ammunition (called combat configured loads, or CCL) from preparation sites in CONUS to the corps battlefield has not been generally approved.



**Figure 1-2.**  
*Enhanced Intermodal PLS Flatrack (M1 or ISC)*

- ◆ Costs of the enhanced PLS flatrack (i.e., ISC) have increased. The intermodal replacement for the original A-frame flatrack provided the features required to move loads in a containership (Figure 1-2). The initial design of the intermodal flatrack was tested in 1991 and had an expected production cost of \$18,800. The user agreed to a simpler redesign, which met intermodal requirements while simultaneously satisfying user battlefield requirements. This design has been designated the M1 flatrack and is expected to cost \$16,300, double the cost of an A-frame flatrack.
- ◆ As the potential uses of the PLS expand, more opportunities open for acceptable alternatives to the A-frame flatrack such as containers or commercial flatracks, deployable medical shelters (DEPMEDS), or petroleum, oil, and lubricants (POL) tankers. The Combat Service Support (CSS) Battle Lab and others have been examining an expansion of the PLS roles to take advantage of the full range of system capabilities. One potential use of the PLS is to assist in port clearing operations in the early phases of power projection. In this role, the PLS truck would be expected to pick up, move, and drop off commercial containers or flatracks. Container movement will necessitate the modification of the LHS of the truck or the addition of a container-handling device (CHD) to provide an interface between the load-handling arm of the truck and the front of a container. When so configured, the PLS can move 8'× 8'× 20' containers or intermodal flatracks. The commercial intermodal flatrack (Figure 1-3) may offer improved performance or cost savings as an alternative to PLS flatracks while also offering an intermodal capability.
- ◆ The costs of feasible alternatives vary substantially. When the A-frame and the ISC flatrack alternatives are compared across the total flatrack requirement, total system costs differ by more than \$100 million. When commercial alternatives replaced PLS ISC flatracks, total system costs differ by \$160 million to \$200 million.



**Figure 1-3.**  
*Commercial Intermodal Flatrack*

Flatracks are an integral part of the PLS but have not been fully evaluated. At the time of the selection of the PLS over other competing transportation systems, only the A-frame flatrack existed as an integral component of the PLS. The cost and operational effectiveness analysis (COEA), which provided analytical decision support, emphasized the ammunition distribution mission of the PLS. The A-frame flatrack was designed to perform this mission.

With increased emphasis on intermodalism, the redesigned flatrack was to accomplish both the battlefield distribution mission and serve as a means for moving the majority of ammunition tonnage into a theater of operations. The 1993 CSS Battle Lab Initiative PLS Distribution Analysis,<sup>1</sup> which examined additional potential uses of the PLS trucks and trailers in support of battle operations, considered the intermodal flatrack as the preferred design for these additional uses. A consensus developed that A-frames alone did not provide the desired intermodality but, on the other hand, that a fleet of 50,000 ISCs would not be affordable. An analytical comparison of these flatracks across all potential missions of the PLS was not done.

## OBJECTIVES

Our objective is to provide an analysis of PLS flatrack alternatives that identifies issues, quantifies performance, benefits, and costs, and makes recommendations about the most cost-effective mix of flatracks, in support of decision-making at Headquarters, Department of the Army (HQDA). This broad objective has these specific subobjectives:

---

<sup>1</sup> *Combat Service Support (CSS) Battle Lab Initiative Palletized Load System (PLS) Distribution Analysis*, 30 December 1993, U.S. Army Training and Doctrine Command's (TRADOC) Analysis Center — Fort Lee (TRAC-LEE), Virginia, 30 December 1993.

- ◆ Identify alternatives for providing PLS intermodal capability.
- ◆ Identify the operational effectiveness of each alternative.
- ◆ Identify the relevant (e.g., research and development, item procurement, and operating and maintenance) costs of each alternative.
- ◆ Determine a production/buy quantity of each flatrack alternative, within available flatrack funding levels and other guidance, which maximizes expected operational effectiveness.
- ◆ Evaluate the costs of intermodal capability vis-a-vis selected measures of effectiveness to determine if the increased costs of the ISC is offset by force structure or operational considerations.
- ◆ Identify unresolved policy or doctrinal issues.
- ◆ Recommend an approach for the Army to provide a PLS intermodal capability.

## SCOPE

This study focuses on the costs, performance, purchase quantities, and fielding of PLS flatrack alternatives. The trucks, trailers, and other components of the PLS were not examined. The PLS fielding quantities reflected in the PLS distribution master plan were used to identify the number and location of system components that would support the MOADS-PLS ammunition distribution plan. This study addresses flatrack quantities and requirements only for the primary MOADS mission of the PLS. The CSS Battle Lab's analysis of follow-on uses of the PLS recommended additional missions and roles for the PLS that may require the development of additional types of flatrack for specific missions. The implementation of these additional uses may require an increase in the number of fielded PLSs or a diversion from the primary ammunition distribution mission: these excursions were not addressed.

## STUDY PARAMETERS

To date, head-to-head field trials have not been conducted to fully assess the battlefield performance of flatrack alternatives. The best available technical test data, discussions with knowledgeable experts, and "best estimates" of costing data were used in this study. Because the results of this analysis are to be published before flatrack alternatives are delivered to the troops, there is some risk that the fielded flatrack alternative may not perform as expected or may cost more than anticipated. Where appropriate, a range of operating and cost parameters was examined to see if the study recommendations were sensitive to these factors. The doctrine and methods of employment of the PLS in the



ammunition distribution role were coordinated with responsible agencies but, in some cases, reflect an extension of MOADS doctrine that may not be an approved Army position.

## APPROACH

We calculated total flatrack requirements using a realistic combat scenario, generated feasible combinations of the numbers of flatracks required (making use of available flatrack technologies), examined the cost and effectiveness of each feasible alternative, and developed study recommendations. The sequential steps we took are as follows:

1. Identify the initial flatrack and PLS deployments for a single Major Regional Contingency (MRC). These initial conditions were based on an expected combat force deployment to MRC-East (MRC-E) and the combat support and CSS forces deployed with the combat forces.
2. Model the ammunition stocks and flows at each ammunition node within the theater using the notional distances and force positioning for MRC-E. Add ammunition supplies (in containers or on flatracks) until MRC firing requirements and stockpile levels are met.
3. Use the ammunition stock and flow modeling results to identify flatrack requirements for each alternative flatrack design.
4. Describe the handling, transit time, load and lift requirements, cost, and other characteristics of each analytic alternative.
5. Develop recommendations on the basis of the cost and performance factors of each alternative.

## REPORT OVERVIEW

The analysis of alternatives is presented in Chapter 2 where we describe the construction of equally effective (in terms of ammunition delivered) flatrack alternatives. We discuss the additional factors (handling, time, space, cost, etc.) for each alternative. Conclusions and recommendations are in Chapter 3 followed by a plan for implementing our recommendations in Chapter 4. Because the Army has already had the time to act on some of the recommendations in this report, discussion of management actions taken and flatrack acquisition status are also included in Chapter 4. Appendices are added to address MOADS-PLS doctrine, the Army's memorandum of agreement on flatrack acquisition strategy, description of the decision tree methodology used in our analysis, DYNAMO modeling, and a glossary.

## CHAPTER 2

# Analysis of Alternatives

This chapter describes the benefits and costs of the flatrack alternatives. We first discuss the measures of effectiveness (MOEs) used to judge each equipment alternative. Then we describe the activities at each of the primary ammunition transportation nodes extending from the manufacturing depots to a hypothetical battlefield. Although all MOEs and nodes are important, we concentrate on the performance demanded of the PLS in its battlefield role as the primary ammunition distribution asset under MOADS. A realistic combat scenario depicting a potential conflict in Southwest Asia was used to establish parameters for a stock and flow model. This process identified flatrack quantities required to meet the ammunition distribution demands of the scenario with the transportation assets available. We then developed flatrack alternatives based on different flatrack designs, which exceed minimum battlefield performance standards. Alternatives consisting of mixes of A-frame or intermodal design flatracks, containers, and container handling devices (CHDs) were generated to provide an equivalent distribution capability. Specific combinations of these equipment options, which included potential modifications to the PLS truck and trailer, were identified as analytic alternatives. We organized these equipment alternatives into a decision tree that shows the sequence of decisions followed to define an equipment mix. To simplify the decision tree, we eliminated alternatives that were infeasible or clearly inferior to another alternative. We then examined the costs and benefits of the remaining alternatives.

## MEASURES OF EFFECTIVENESS

Measures of effectiveness are based on those characteristics (such as weight, load capacity, cost, etc.) that are important in evaluating the performance of each alternative. Ideally, MOEs will be quantitative and the performance of the alternative on the MOE can be measured using physical attributes such as weight and length. Other MOEs are subjective (such as, "meets user operational needs") and have no physical measures. For these MOEs, we made a qualitative assessment of the performance of each flatrack alternative. We combined both quantitative and qualitative measures, emphasizing battlefield performance and cost, in assessing the performance and benefits of each alternative at each critical ammunition distribution transportation node.<sup>1</sup>

---

<sup>1</sup>We used the best engineering and cost information available to develop the costs and benefits of each alternative. After independently offering our recommendations to the study sponsor, the process of building consensus among other decision-makers indicated that the performance of alternatives on some measures (such as force projection or reduced handling) should receive more emphasis than we originally gave. In discussions later in this chapter, we present some of the reasoning behind these other viewpoints.

## Evaluation Criteria

The evaluation criteria for selecting the optimal mix of flatrack alternatives are listed below and described in the following subsections.

- ◆ Meets MRC ammunition distribution requirements
- ◆ Supports intermodal ammunition movement and force projection
- ◆ Satisfies user equipment requirements
- ◆ Has low engineering development or production risk
- ◆ Supports timely fielding of PLS and ensures that the PLS can pick up all 8'x 8'x 20' International Organization for Standardization containers and flatracks
- ◆ Is cost-effective
- ◆ Limits transportability concerns
- ◆ Limits additional requirements for PLS support of the MOADS
- ◆ Satisfies congressional objectives
- ◆ Supports additional uses of PLS.

### MEETS MAJOR REGIONAL CONTINGENCY AMMUNITION DISTRIBUTION REQUIREMENTS

This criterion addresses whether the combination of equipment associated with the flatrack alternative has the operational capability to distribute sufficient amounts of ammunition from the corps storage area (CSA) to the forward firing units employing MOADS-PLS doctrine. To meet this criterion, the alternative must employ a combination of enough flatracks, containers, and CHDs for the available PLS trucks and trailers of the evaluated MRC-E scenario to deliver at least 85 percent of the expected peak ammunition needs within the corps area. In addition, the equipment and usage must provide a high assurance that user acceptance standards for durability, maintainability, and handling can be met.

### SUPPORTS INTERMODAL AMMUNITION MOVEMENT AND FORCE PROJECTION

The reduction in size of the Army has been accompanied by the development of a national strategy that positions most combat forces within CONUS. To respond to overseas conflicts, military forces must be projected from CONUS to the conflict area. A critical part of this force projection strategy is the movement of ammunition from the CONUS depots and ports by ship to a port close to the regional contingency area, and then from the port/theater area to the CSA. This

criterion reflects the ability of the alternative to deliver the total tonnage of ammunition required for a 60-day battle and then to meet MOADS requirements from the CSA forward. Flatracks may be augmented by containers or other types of flatracks to provide an intermodal capability. Other considerations in intermodal movement are efficiency in ammunition configuration (to include break-bulk and containerized cargo as well as the use of CCLs), safety, security, use of critical shipping assets, delays caused by handling and rehandling at transportation nodes, container reuse, manpower requirements, and availability of theater truck and materials handling equipment (MHE) assets.

#### SATISFIES USER EQUIPMENT REQUIREMENTS

This criterion accepts user equipment requirements as stated in the required operational capability (ROC) or statement of work (SOW) for each item. Items that have not been type-classified are assumed to be able to meet ROC and SOW performance standards. User requirements for items still in the development stages (such as the modified LHS or CHD) are not finalized. In these cases, our most likely subjective estimate of future requirements is taken as the performance standard. That is, if the need to move containers is a known requirement, but the performance timelines are not yet finalized, the most likely timeline requirement will be used to assess the alternative's performance.

#### HAS LOW ENGINEERING DEVELOPMENT OR PRODUCTION RISK

This criterion is a qualitative assessment of the degree of risk associated with timely development and production of a component item. Although the PLS truck and trailer have reached first unit equipped (FUE) status, several elements of the total ammunition delivery system have not reached final design development. These include the CHD and bail-bar containers; the M1 flatrack which has not yet passed preproduction acceptance tests; and the modification of the PLS LHS to enable the PLS truck to pick up any ISO-configured container or flatrack. The engineering and production portion of these technological developments have different degrees of risk associated with successful accomplishment which are separate from questions of funding and desirability.

#### SUPPORTS TIMELY FIELDING OF PLS AND ENSURES THAT THE PLS CAN PICK UP ALL 8' X 8' X 20' INTERNATIONAL ORGANIZATION FOR STANDARDIZATION CONTAINERS AND FLATRACKS

This criterion recognizes that it is in the best interest of readiness and increased capability to get the PLS in the hands of the troops as quickly as possible. Decisions that cause a delay in the production of other components of the PLS should be avoided. It is also desirable that the PLS truck and trailer be able to pick up and transport flatracks, intermodal containers, ISO sideless containers, and standard dry containers — in short, anything that has the basic 8' x 8' x 20' dimensions of a container. The redesign of the LHS or the development of an

integrated CHD can potentially meet these needs, but they may require time to develop. Increased time to field and retrofit trucks are negatives that must be outweighed by the positives of more system versatility at lower cost.

#### IS COST-EFFECTIVE

Costs associated with the movement of ammunition through the distribution system are of several types. The primary cost component of each alternative is its acquisition cost: the production cost of the required flatracks, containers, load-handling modifications, or lifting devices. The cost of the truck and trailer components of the basic PLS are not included as a cost in any alternative because these costs common to each alternative have already been "sunk" and do not influence the selection of a particular flatrack type. Other costs examined include operating costs (handling, load and unload, intermodal transportation, and blocking and bracing) and maintenance costs for each flatrack alternative. Non dollar costs include ammunition transload and handling time, demands placed on the theater transportation resources, use of sealift resources, and manpower and equipment resources required at each transportation and distribution node.

Costs for each piece of equipment used to construct fleet alternatives are displayed in Table 2-1.

#### LIMITS TRANSPORTABILITY CONCERNS

This criterion includes the movement of the complete PLS and transported ammunition through the distribution channels from CONUS to the firing units. The primary advantage of flatrack alternatives with an intermodal capability is their ability to move through the distribution nodes already loaded with ammunition rather than moving as cargo, separated from their ammunition loads. Thus, the intermodal flatrack or ISO sideless container can move loaded with ammunition from CONUS to the theater of operations in the cell of a containership. On the other hand, the A-frame flatrack travels unloaded as cargo on a roll-on/roll-off (RO/RO) ship or a breakbulk ship, separate from break-bulk ammunition or containerized ammunition in an ISO container. Once the intermodal flatrack alternative arrives in theater, its load of ammunition can be delivered directly to the forward combat area on the flatrack. The A-frame must be loaded with ammunition after arriving in the contingency area. This loading increases the flatrack and ammunition handling and potentially slows the delivery of ammunition to the firing units.

**Table 2-1.**  
**Equipment Costs**

Item	Investment cost	Operational and maintenance costs (yearly)	Cost to load per short ton <sup>a</sup>	Cost to unload per short ton
A-Frame	\$7,841	\$300	\$15.16	\$6.21
M1 (ISO-compatible PLS flatrack)	\$16,300	\$300	\$27.41	\$3.57
Ammunition containers (AMCON)	\$11,000 ((\$10,000 est. production))	\$300	\$27.41 (LMI est.)	\$3.57 (LMI est.)
Bail-bar ISO containers	\$7,500 – \$11,000	\$300	\$19.73	\$2.97
Modified PLS LHS	\$9,800 – \$18,100 (est.)	TBD	N/A	N/A
Container handling device (CHD) <sup>c</sup>	\$10,700 – \$18,700 (est.)	TBD	N/A	N/A
ISO container (8 feet wide, up to 8½ feet high, and 20 feet long)	\$3,500	\$300	\$17.81	\$3.03
ISO side-opening container	\$6,100	\$300	\$19.69	\$2.42
ISO sideless container	\$6,000 – \$7,000	\$300	\$17.18	\$3.57 (LMI est.)

<sup>a</sup> Costs to load and unload were estimated by the U.S. Army Defense Ammunition Center and School (USADACS). LMI used USADACS costs to generate costs to load and unload that were generated by LMI.

<sup>b</sup> Cost to ship estimated by MTMC-TEA for CONUS – East Coast to Europe.

<sup>c</sup> CHD is a generic term. CLK refers to a proprietary product developed by Cargotec. CHU refers to a product in use with the British DROPS system. CHD (Cargotec)

Cost to load per short ton <sup>a</sup>	Cost to unload per short ton <sup>a</sup>	Cost to ship/STON <sup>b</sup>	Status	Remarks
\$5.16	\$6.21	\$202	In production	Currently 200 per month, type-classified standard.
\$27.41	\$3.57	\$202	In development	Production verification testing.
\$27.41 (LMI est.)	\$3.57 (LMI est.)	\$202	Prototype	HRED developed. Would require some additional modifications and testing.
\$19.73	\$2.97	\$202	Available commercially	Some modification of containers and PLS trucks may be required to make them compatible.
N/A	N/A	N/A	Concept analysis	Makes PLS trucks capable of picking up any ISO 20-foot envelope (flatracks or containers).
N/A	N/A	N/A	Prototype available	Allows PLS M1075 truck to move ISO containers or flatracks.
\$7.81	\$3.03	\$202	Available commercially	9,000 CADS containers on hand, other containers being procured.
\$9.69	\$2.42	\$202	Available commercially	625 in Army inventory, 2,700 in U.S. Air Force inventory.
\$37.18	\$3.57 (LMI est.)	\$202	Available commercially	100 procured by DoD; collapsible end wall.

.MI used USADACS costs to generate a weighted average of 155 mm howitzer, 105mm tank, and 5.56mm small arms ammunition loads. Where indicated estimates

with the British DROPS system. CHD costs are estimates of the range of costs for these different products.

A critical question concerns the efficiency, safety, and security of moving ammunition in a ready-to-fire status with propellant charges, fuses, primers, and explosive warheads in the same container. These combat configured loads, or CCL, are more volatile, less "dense" and more susceptible to sabotage, damage and pilferage than are ammunition loads sent through the distribution system as a grouping of a single ammunition component of one type.<sup>2</sup> If an intermodal alternative is used, the ammunition load could be preconfigured into CCLs in CONUS and not reconfigured before delivery to the firing units. If an A-frame flatrack is used to distribute ammunition, the ammunition arrives at the corps in containers or as break-bulk ammunition and must be configured into CCLs at the CSA or the ammunition supply point (ASP). If CCLs are not prepared in CONUS and loaded on intermodal alternatives, the intermodal alternative is loaded with single DODIC ammunition and a reconfiguration of loads must occur at the CSA or ASP.

The transportability of any flatrack alternative is especially important for force projection missions in which a deploying force must be combat-ready soon after its arrival in theater. The Army Audit Agency emphasized this MOE in its analysis of flatrack procurement in support of force projection.<sup>3</sup>

#### LIMITS ADDITIONAL REQUIREMENTS FOR PLS SUPPORT OF MOADS

This criterion identifies additional items that must be purchased or modifications to the PLS that must be made if the alternative flatrack is selected. The desire is to limit the number of system component pieces that must be developed and fielded to support ammunition delivery and distribution under MOADS. The modification to the LHS of the PLS truck, as an example, would eliminate the need for the development of a separate CHD [such as the container handling unit (CHU) designed by the Cargotec Corporation] and the need for modifying the container through the addition of a bail-bar. Some flatrack alternatives, such as the use of commercial sideless containers or flatracks, may require additional items of equipment for proper operation. The desired limitation of additional system complexity can be traded off to field a cost-effective system.

#### SATISFIES CONGRESSIONAL OBJECTIVES

This criterion reflects the desire of Congress that the Army investigate and implement, if practical, the introduction of an intermodal flatrack to the PLS. Expanded, the congressional direction is taken to mean that any feasible PLS in support of MOADS must address considerations of the need to move ammunition from CONUS to the theater, from the port to the corps area, and from the

---

<sup>2</sup> Ammunition loads containing only one type of ammunition are referred to as "single Department of Defense Identification Code (DODIC)" loads.

<sup>3</sup> In its review of force projection requirements, the Army Audit Agency considered flatrack configurations that allowed intermodal movement of ammunition-loaded flatracks in a container cell to be essential. Details of its analysis have been published for coordination; the final report is expected in late FY95.



CSA to the firing units. Each alternative is addressed against this factory-to-foxhole requirement.

## SUPPORTS ADDITIONAL USES OF PLS

This criterion anticipates that the PLS will continue to expand its usefulness on the future battlefield. Currently, the primary mission of the PLS is to distribute ammunition from the CSA forward. The Combined Arms Support Command (CASCOM) study describes other potentially cost-effective uses for the PLS to include water and fuel distribution from special purpose flatracks.<sup>4</sup> Ammunition distribution may be expanded to encompass the resupply of the Multiple Launched Rocket System's (MLRS's) rocket pods within the corps area. The use of CHDs and modifications to the LHS of the PLS will allow ISO-compatible containers and flatracks to be moved by PLS trucks. Enhancement of driver's information and communication, position locating, and navigation devices will add to the responsiveness of the system. The maturation of these and other technological initiatives could expand future PLS applications beyond ammunition distribution. This criterion allows growth and increases robustness of the PLS.

## Other Factors To Be Considered

### PAYLOAD

The use of any flatrack on the PLS truck reduces the total payload that can be carried. The A-frame flatrack is the lightest flatrack currently identified, at a weight of 3,200 pounds. Other flatracks, especially intermodal flatracks that must support the weight of other containers or flatracks above them in a container cell column, are heavier. The increased weight of these containers or flatracks lowers the cargo tare weight that can be carried by the PLS. PLS is designed to handle a 16.5-ton payload on an A-frame flatrack; with the PLS intermodal flatrack, the payload is 14 tons. This lower tare weight may not be a significant problem because 95 percent of the combat-configured loads are expected to be in the 10- to 14-ton range. On the other hand, single DODIC container loads of ammunition may weigh as much as 20 tons. In these cases, the PLS cannot move the flatrack or container without unloading some of the ammunition. Thus, PLS-designed intermodal flatracks may be able to carry a greater load when moving intermodally than can be moved by the PLS once in the theater of operations.

### TRANSPORTABILITY

The weight of the loaded PLS exceeds the normal peacetime allowances for on-road movement within CONUS and Germany. The total weight is the

<sup>4</sup> *Combat Service Support (CSS) Battle Lab Initiative Palletized Load System (PLS) Distribution Analysis*, prepared by the TRADOC Analysis Center - Fort Lee (TRAC-LEE), Virginia, 30 December 1993.

problem, not the footprint, axle load, or load configuration. In addition, the height of an ISO container when loaded on the flatrack (A-frame) and the height of the container when loaded with a CHD exceeds the 4-meter-height maximum of some road overpasses. This will cause routes to be carefully selected and may restrict PLS operations with containers in some locales. In addition, use of the PLS to move containers or special flatracks may change the center of gravity of the PLS loads. Although the effects of these shifts are expected to be negligible, they should be examined, especially in regions where the PLS may encounter severe side slopes.

## CONTAINERS

Existing emerging doctrine does not contemplate movement of containers forward of the CSA under a normal concept of operations. Ammunition containers arriving in the battle area from the port are expected to be cleaned out in the CSA and stored or returned to the port. However, experiences in Operations Desert Shield and Desert Storm indicate that many containers, some with unit equipment, could be found within the division area. As explained in the description of alternatives below, it is possible that the PLS will be augmented to move sideless containers or any ISO 8'x 8'x 20' envelope. In this case, the probability that the PLS will be called upon to move containers across rugged terrain is high. Such an augmentation of the identified PLS role will increase system versatility but may limit transportability.

## FLATRACK OWNERSHIP

The unit having the PLS truck also owns flatracks at a rate of one flatrack per truck and one per trailer. Because the ownership of PLS trucks and trailers does not imply the ownership of many flatracks, the bulk of the Army's flatrack fleet is owned by ammunition service units that support the combat units in the theater of operations. One thousand flatracks are assigned to the direct support (DS) ammunition companies that operate one to three ammunition transfer points (ATPs) within the division area forward of the CSA. Two thousand five hundred flatracks are assigned to the general support (GS) ammunition companies that operate the CSA. (The CSA may have one to three GS companies depending on the number of units supported by the CSA.) Control and accountability of flatracks is still an issue to be resolved between the Military Traffic Management Command (MTMC), the Transportation Command (TRANSCOM), HQDA, and DoD.

## THE MAJOR REGIONAL CONTINGENCY – EAST SCENARIO

A scenario depicting ammunition movement patterns, times, distances, and consumption mission profiles representative of a Major Regional Contingency – East (MRC-E) was selected as a basis for estimating flatrack requirements.<sup>5</sup> The distances and major units are sketched in Figure 2-1. This scenario provided firing units and consumption rates, which placed a demand on the ammunition distribution system. Medium truck companies and DS and GS ammunition companies accompany the combat units to meet these ammunition demands. The medium truck companies are equipped with 48 PLS trucks and 48 trailers to distribute flatrack loads of ammunition prepared by the ammunition companies. These ammunition companies operate the CSAs, ATPs, and ASPs within the corps area, and they prepare ammunition loads for delivery using organic flatracks and material handling equipment. Ammunition handling and distribution operations follow the MOADS-PLS concepts described below and in Appendix A.<sup>6</sup>

This scenario addressed only ammunition distribution within the corps area. In order to establish flatrack requirements within the corps area, ammunition was consumed at locations, mixes, and rates typical for the friendly forces deployed, the enemy, and mission profiles expected in this scenario. These flatrack requirements were developed to support MOADS-PLS operations in a mature theater in which ammunition supplies, rates, and distribution operations were not constrained by shipping availability, port operations, or transportation from the port to the CSA.

Characteristics of the MRC-E scenario, such as distances between the CSA, ATPs, and ASPs; consumption rates; and ammunition replenishment rates were used to set the simulation parameters of the model we used for our distribution analysis. This model is called DYNAMO and is described later in this chapter and in greater detail in Appendix D.

## AMMUNITION DISTRIBUTION DOCTRINE

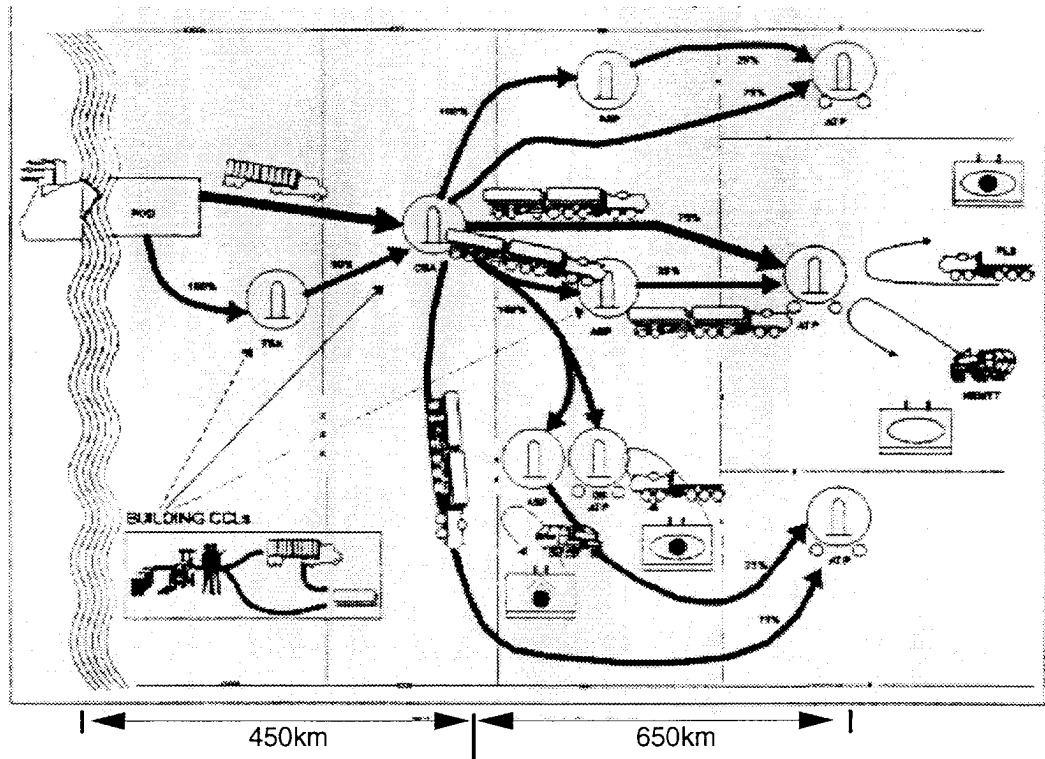
The doctrine associated with the use of PLS in ammunition distribution is described in MOADS-PLS Pamphlet 525-65 found in Appendix A. MOADS-PLS is designed to reduce the ammunition handling that previously occurred at the transportation nodes where corps truck assets were unloaded and artillery unit assets were reloaded.

---

<sup>5</sup>This scenario was set in the Southwest Asia theater, and distances and firing rates are representative of those used by CASCOM in its study of follow-on uses of the PLS.

<sup>6</sup>These concepts are described in detail in TRADOC Pamphlet 525-65, *U.S. Army Operations Concept for Class V Support Using the Palletized Load System (PLS)*, short title: *Maneuver Oriented Ammunition Distribution System (MOADS-PLS)*, 24 August 1992. This pamphlet is reproduced as Appendix A.

The MOADS-PLS pamphlet describes ammunition distribution from the CSA forward to the firing units. Ammunition is transported from the port of arrival to the CSA aboard theater transportation assets. Ammunition arriving at the CSA may be in containers, breakbulk pallets on trucks or trailers, on PLS A-frame flatracks, or on intermodal flatracks. For safety, security, and shipping efficiency reasons, ammunition is usually transported from the CONUS depot or production facility as a single type (e.g., single DODICs such as artillery high-explosive warheads). To meet the firing needs of ammunition users, these single DODIC ammunition loads are combined with other ammunition components (such as fuses or propellant charges) and types to form CCLs. Under MOADS, these CCLs are usually prepared at the CSA, although some may be prepared at the ASPs, and some ammunition may arrive at the CSA already configured as a CCL.<sup>7</sup> The DS and GS ammunition companies that operate the ammunition points prepare the CCL on PLS flatracks. Under the MOADS-PLS concept, these PLS flatrack loads of CCL ammunition are delivered from rear (CSA) to front (ATPs) using the corps medium truck company PLS assets.



**Figure 2-1.**  
*MOADS Doctrine*

<sup>7</sup>The intermodal shipment of CCLs in containerships presents safety and security concerns that have not been fully resolved for ammunition Categories I, II, and III. Other ammunition, such as MLRS pods, can be moved intermodally in a configuration that does not require additional elements to ready the round for firing. This ammunition is already combat-configured in its shipping container.

Once ammunition is uploaded as CCLs on PLS flatracks, it is ready for delivery to firing units without intermediate handling. That is, it is not downloaded from one flatrack and then uploaded at a later time on another flatrack. The use of PLS flatracks under the MOADS-PLS concept favors the direct delivery of ammunition loads to the firing units, eliminating ammunition rehandling and reducing the manpower and MHE previously associated with ammunition supply operations within the corps. The loaded flatracks are readied at the CSA or ASPs for pick up by the corps PLS trucks. The PLS can move rapidly through the ammunition point, stopping only long enough to hook up a prepared flatrack and its ammunition load before moving away. Traffic congestion, the ammunition point combat signature, and the time for uploading ammunition are greatly reduced.

The corps PLS trucks deliver the ammunition, on flatracks, to the ATP or directly to the firing units. Combat support and combat units use their organic transportation to pick up ammunition from the flatracks at the ATP. If these units are equipped with PLS, then the ammunition remains on the flatracks for delivery to the firing units. PLS assigned to the artillery units are equipped with a materials-handling crane to assist in unloading individual pallets of ammunition at each gun site. Units that are not equipped with the PLS, such as MLRS units, use their heavy expanded mobility tactical trucks (HEMTTs) to load MLRS rocket pods or other ammunition from flatracks at the ATPs.

Flatracks are distribution assets that circulate within the battle area, moving forward from the CSA with combat loads of ammunition and moving back from the firing units as "empties" to be reloaded at the CSA. When corps PLS trucks and trailers ground their loaded flatracks at the ATPs or firing units, they normally pick up an empty flatrack for return to the CSA. Similarly, when artillery unit PLSs drop loaded flatracks, they retrieve empty flatracks for reuse. If several empty flatracks are available, most flatrack design alternatives allow stacking or nesting of several flatracks on one truck for retrograde movement. In Figure 2-1, "MOADS Doctrine," we showed PLS and flatrack movement and other features of the MOADS doctrine for a typical MRC.

## TRANSPORTATION, DISTRIBUTION, AND DEPLOYMENT NODES

Table 2-2 identifies four stages that are critical to the throughput of ammunition from CONUS to the firing site in a theater of operation. Certain considerations of ammunition movement, such as safety and security, are common to each stage. Other features become dominant considerations at different stages of the ammunition's movement. We considered the performance of each different flatrack design alternative mix against the critical features at each of the four transportation, distribution, and deployment stages. The engineering design features of the flatrack alternatives will cause the operations at each stage to be different; we discuss these differences below.

**Table 2-2.**  
*Transportation, Distribution, and Deployment Stages*

Node	Activity
CONUS depot to port of embarkation	Rail or road movement
At sea	Movement in container cells or as breakbulk
Port of debarkation to CSA	Road movement on theater assets
CSA to forward firing units	MOADS distribution on PLS

### Critical Feature at CONUS Depot to Port of Embarkation: Security

The MOADS doctrine, which describes battlefield operations from the CSA forward, neither establishes a doctrinal position on the preparation of ammunition loads at the depot nor describes the in-CONUS movement from the depot to the seaport. Depot and transport operations on U.S. roads and railways emphasize the safety and security of the ammunition as it moves through a noncombat zone. Few CCLs of Categories I through III ammunition are approved for movement on open flatracks because of the security concerns such movement might cause. At this stage, the configuration of ammunition is governed in part by the type of ammunition and conveyance; the needs of the ultimate battlefield user; efficiencies in shipping and transport; the ability of the port facilities to load and unload the ammunition (whether over-the-shore operations are required or whether the port can offload containers, etc.); and ultimately, the safety and security of the ammunition en route.

The security of ammunition is a primary concern at all stages of transportation and distribution. In the forward battle area, flatrack ammunition is typically configured in a ready-to-fire status to be able to rapidly respond to hostile activity. Combat configured loads are not normally found at the depot-to-seaport stage. Accident prevention for noncombatants and the physical security of the ammunition are paramount. Opportunities for sabotage or pilferage and the possibility of accidental detonation must be reduced to the minimum. In addition, the ammunition must be blocked, braced, tied down, or otherwise secured to the flatrack, container, or pallet (if in a breakbulk configuration) in a way that is compatible with loading on trailers, ships, rail, and PLS trucks. Flatrack alternatives offering the greatest degree of concealment, all-around protection, and load stability, while enhancing the efficient movement of ammunition, are preferred at this stage. These considerations do not favor ammunition in movement on sideless containers from depot to port.

Most ammunition leaving CONUS depots is configured as a single-DODIC load on one container or flatrack. Ammunition remains in these configurations (all of a single type) throughout the transportation system until it arrives at the CSA where it is matched with other components into CCLs of ready-to-fire ammunition. Stringent safety regulations govern the proximity of different types of ammunition or explosives on transportation assets because the mixing of

warheads, propellants, igniters, and fuses presents a hazardous situation. Except for a limited number of single-DODIC ammunition loads, which are themselves CCLs, such as the MLRS pods, the preparation of CCLs is not performed at the depot or the port.<sup>8</sup>

At this time, the desirability of preparing CCLs in CONUS locations in anticipation of future battlefield use is being studied. CONUS-prepared CCLs are attractive because they can be moved in their shipping container directly to the firing units without reconfiguration in the corps area. Thus, a CCL loaded on a PLS-compatible intermodal container could be loaded and unloaded from strategic transportation assets quickly, be picked up by local line haul trucks and trailers for delivery to the CSA, and be moved on PLS trucks from the CSA to the firing units without stopping for handling, reloading, or reconfiguration at any intermediate node. Waivers to existing regulations are required to move CCLs in this fashion; the safety and security concerns, as well as the difficulty in anticipating future combat needs from depot locations well in advance of delivery, have precluded CCL formation. Flatrack alternatives that provide a platform for the intermodal movement of ammunition are desirable because they provide a future growth potential to load and move CCLs should the problems described above be reconciled.

## Critical Feature at Sea: Containerization

The Army's policy is to maximize containerized ammunition shipments. Ammunition arriving at the CONUS port for seaward movement to the regional conflict will be loaded in an intermodal container for containership transport or as break bulk ammunition for transport on noncontainerships. Ideally, ammunition operations at the depot would load ammunition onto the same platform on which it would enter the corps area. This situation has not yet been realized. We used a planning factor of 75 percent to represent the proportion of regional conflict ammunition requirements that are expected to arrive in containerships using ISO containers. The remainder of the ammunition is assumed to arrive in breakbulk and requires handling and reconfiguration into flatrack loads in the vicinity of the port of debarkation (POD) or at the CSA.

Containerships are by far the preferred mode of intermodal transport of ammunition. Not only are containerships efficient in the tonnage of ammunition moved in a given amount of space but their modular construction allows rapid loading and unloading with currently available equipment at most ports worldwide. The average containership (which is in abundance) contains 3,000 or more container cells and can be loaded or unloaded in one day. Shipping costs by container are significantly less than by breakbulk: \$235 per short ton versus \$403 for a CONUS - East Coast to Europe route. Also, breakbulk ships may take two or three times as long to load and unload as a containership. Of the flatrack alternatives we considered, those that use ISO-compatible, CSC-approved flatracks can be transported with ammunition loads on containerships.

---

<sup>8</sup> A "six pack" of MLRS rocket pods is a single DODIC, which meets safety and security requirements for throughput from CONUS to firing units.

Ammunition arriving in containers (or flatrack equivalents) generally will be configured as single DODIC loads for efficiency in movement and container load preparation at the ammunition depots. When loaded for efficient use of container space (maximum weight of ammunition per unit volume), containers frequently will be loaded to the maximum weight they can safely carry; some loads may exceed 20 short tons.<sup>9</sup> Because the PLS is limited to a 16.5-short-ton payload with the A-frame flatrack, these heavily loaded containers would require the removal, at the POD or the CSA, of a portion of the load before forward movement on the PLS. If ammunition shipments are configured as CCLs, they are not as efficient in terms of ammunition weight per cubic foot of shipping volume; some CCLs reduce the average container load from 14.5 short tons to 11.2 short tons. The reduced payload would then increase the quantity of containers needed to deliver the same tonnage of ammunition.

A-frame flatracks are not well-suited for loaded movement in a container cell. Without a rear end wall and without ISO fittings on the front end wall, an A-frame flatrack cannot support other containers that would normally be stacked above it in the containership. Without this load-bearing capacity, the A-frame flatrack cannot be certified for intermodal movement as a containership-compatible flatrack. Thus, the A-frame is strictly a battlefield distribution asset and is transported as empty cargo, nested to conserve space, or with other components of the PLS. A-frame flatracks will not typically be transported loaded with ammunition. The flatrack alternatives, which we developed for this study, take this ammunition shipment configuration into account. Flatrack alternatives with substantial numbers of A-frame flatracks for battlefield distribution are augmented with additional dry cargo containers to provide an intermodal ammunition shipping capability.

A-frame flatracks could be moved in containerships as cargo on 40-foot Military Sealift Command ISO flatracks, but the more likely configuration for movement of A-frame flatracks is being nested in five-high stacks for movement as general cargo. Currently, 1,147 A-frame flatracks are nested as cargo on afloat prepo ships to provide an initial PLS surge capability. It is expected that replacement of these A-frames with intermodal assets of some type will take place when new equipment becomes available. Use of A-frame flatracks in sufficient quantity to support the modeled MRC-E force is estimated to require an additional 1.8 fast sealift ship equivalents to transport the balance of the 26,341 MRC-E flatrack requirements.

Loading and unloading the sea vessel with break-bulk ammunition is a time-consuming effort; the Army is attempting to minimize the quantity of breakbulk ammunition and to reduce handling operations in the future. Break-bulk configurations require several loading and unloading steps, which could be avoided by the use of an intermodal flatrack alternative. The costs and times to load and unload alternative flatracks are shown in Table 2-3.

---

<sup>9</sup> An average container load of single-DODIC ammunition is 14.5 short tons for this study. This figure was extracted from CASCOT's follow-on uses study (see reference in footnote 1) for representative ammunition loads across DODICs.



**Table 2-3.**  
**Handling Loading and Unloading Costs and Times**  
**[11.2-short-ton (ston) load]**

Item	Load				Unload				Load/unload cycle	
	Cost/ston (\$)	Time/ston (min.)	Cost/load (\$)	Time/load (min.)	Cost/ston (\$)	Time/ston (min.)	Cost/load (\$)	Time/load (min.)	Cost/load (\$)	Time/load (min.)
A-frame	45.16	8.0	506	90	6.21	2.5	70	28	570	118
M1	27.41	4.7	307	53	3.57	1.4	40	16	347	69
AMCON	19.73	3.9	221	44	2.97	1.2	33	13	254	57
Commercial ISC	37.18	8.0	416	90	4.84	2.4	54	27	470	117
Dry container	17.81	2.1	199	24	3.03	1.2	34	13	233	37

**Note:** These costs are extracted from information provided by USADACS to CASCOM for a weighted average load of artillery, tank, and small arms ammunition.

Force projection missions place an emphasis on the rapid deployment of a force into a theater area and the prompt movement out of the port area into the combat zone. These desired activities favor container-compatible movement of ammunition and minimal handling at the port area. These features are significant considerations in the final selection of a flatrack alternative.

### Critical Feature of Movement from Port of Debarkation to Corps Storage Area: Efficient Forward Transport of Required Ammunition

Some 19,100 (14.5-short-ton equivalent) container loads of ammunition are required to meet MRC – E demands for 60 days of combat activity. Scenario demands are estimated at 277,000 short tons for a contingency corps. (MLRS pods are in addition to this requirement.) This ammunition must be moved from shipside at the POD to the CSA. The commander of the deploying force may use all transportation assets available to accomplish this forward movement.

Ammunition moves from the POD to the CSA on theater trucks; no PLS trucks are assigned to the theater for this movement. The PLS truck is versatile enough to carry loads on flatracks, in sideless containers, in containers, or in containers mounted on A-frame flatracks. The present truck configuration would require a CHD or a modified LHS to move containers without using a flatrack. Containers can be moved on PLS trucks, either with a CHD or by attachment to an A-frame flatrack. However, either container-mounting method changes the geometry and center of gravity of the truck and load compared to a PLS truck with a flatrack. The effects of these changes on system performance and the ability of the crane-mounted PLS trucks assigned to artillery units to work with CHDs or modified LHSs have not been fully evaluated.

Early in a force deployment, PLS trucks of the medium truck companies, normally identified as a corps asset, may be available to augment theater assets to clear ammunition from the port area. As the scenario matures, theater line-haul tractor-trailers will move the ammunition from the POD to the CSA on flatracks, as breakbulk on trailers, or in containers. The corps PLS medium truck companies will assume the corps ammunition distribution mission. Ammunition arriving at the CSA may be single-DODIC loads or may be combat-configured. If the ammunition is already in a ready-to-fire CCL configuration on a flatrack, it can be delivered directly to the firing units. For other arriving ammunition configurations, the containers, trailers, or flatracks are unloaded in the CSA using available MHE or on-vehicle cranes. The ammunition is then normally configured as CCLs and secured to available flatracks for forward movement by PLS trucks. If the tactical situation makes it necessary to bypass or augment the CSA, CCLs can be prepared at the forward ammunition points, although MHE is limited at the ATPs and ASPs, especially at those operated by the DS ammunition company.

The emerging Improved Container Handling Organization (ICHO) concept may offer increased flexibility by allowing loaded ammunition containers to move well forward into the corps area before downloading and subsequent forward movement by PLS. However, with present concepts of organization and positioning, the ICHO probably will not be available in the forward area and, even if there, probably will not be large enough to support ammunition handling.

Movement of 8-foot-high dry containers or flatracks into the forward areas may expedite ammunition resupply, but it also creates potential operational problems on the battlefield. The U.S. Army Field Artillery School, as a representative of the primary users of the PLS, does not approve of this forward movement. One reason cited is the compatibility problems of load-handling cranes and the current design of detachable CHDs.<sup>10</sup> Movement of standard 8- or 8.5-foot-high containers on the PLS truck raises the top-of-load above the accepted NATO standard of 4 meters. This height will force careful route reconnaissance and may limit the movement of the PLS ammunition load in commercial containers to selected routes of advance. A final operational problem may arise with the unique signature of the container that is larger, more recognizable, and less easily concealed than an A-frame flatrack.

## Critical Feature of Battlefield Distribution Forward of the Corps Storage Area: Battlefield Performance

The primary measure of battlefield performance is the amount of ammunition tonnage delivered to firing units compared to the amount required under

---

<sup>10</sup>The current design of the CHD used by the British Army is for a demountable unit weighing more than 1,000 pounds. This weight, plus the weight of the crane, reduces the container payload. In addition, the presence of the CHD may interfere with the operation of the auxiliary crane to load and unload ammunition. A revised CHD design for PLS is expected to be tested and approved for production by December 1995.

scenario conditions. The delivered tonnage is dependent on several factors: trafficability; road speed; distances between ammunition distribution points; the availability of PLS trucks, trailers, flatracks, and ammunition; and unit demands for ammunition. TRADOC's Analysis Center – Fort Lee (TRAC-LEE), Virginia, had estimated flatrack requirements for a Southwest Asia MRC at 26,341 based on scenarios used for its PLS distribution analysis.<sup>11</sup> These flatracks and PLS components were required to deliver 4,610 short tons of ammunition (not including Air Force munitions or MLRS rockets) to corps firing units each day. [The Logistics Management Institute's (LMI's) estimate of 25,000 flatracks was slightly smaller than TRAC-LEE's, perhaps because of scenario differences.] The presence of additional flatracks does not improve ammunition distribution because the availability of delivery assets – PLS trucks and trailers – becomes the limiting factor. The total MRC-E corps requirement for 277,000 short tons of ammunition distributed in the division area during a 60-day period cannot be met without more PLS trucks than are currently available or programmed for acquisition.

The battlefield distribution performance within the corps area of the flatrack alternatives are virtually identical. The A-frame and the M1 flatracks can perform all MOADS-PLS-required ammunition distribution missions. The performance of the AMCON, other ISO sideless containers, commercial flatracks, and commercial dry containers has not been tested. Although the design of ISO intermodal sideless containers and flatracks allows them to carry loads in excess of 20 short tons in the intermodal phase, the combination of tare weight and container weight lifted by the LHS of the PLS cannot exceed 16.5 short tons. CCLs of 155mm artillery ammunition (the most prevalent flatrack load in this scenario) are generally less than 14.5 short tons. Thus, in practical terms, the added load-carrying capacity of the commercial containers, ISO sideless containers, and the AMCON cannot be used advantageously in the movement of CCLs from CSA to firing units.

Only quantified ammunition consumption and resupply tonnages were identified to establish flatrack and container requirements. Containers were used in Operations Desert Shield/Desert Storm to move and store unit equipment and ammunition. Although future contingency planning specifically includes the use of containers in a variety of roles (for example, some 1,000 containers were included in planning for the movement of a 16,000-man division into Bosnia), we scaled our container movement requirement for the PLS assets in the MRC-E scenario on only ammunition uses. We included the movement of ammunition within commercial or military specification containers on the PLS truck or trailer into the division area as a desirable feature of all equipment alternatives. We recognize that the ability of the PLS to handle containers, either through modifications to the LHS or stowable CHDs, will represent a significant asset for the warfighter and logistician.

---

<sup>11</sup>This scenario used by TRAC-LEE was an adaptation of a TRADOC Regional Scenario (TRS) and included PLS trucks, trailers, and flatracks in expanded missions. We extracted the number of flatracks used for battlefield ammunition distribution.

## DYNAMO Modeling of Battlefield Performance

Performance on the battlefield was examined through construction of a computer model using the simulation language: DYNAMO. The DYNAMO model is a "stock and flow" model that uses a sequence of snapshots taken in simulation time to show the accumulation of "stocks" of interest at storage points and the movement, or "flow," of stocks from one storage point to another. We identified the stocks as ammunition and transportation assets, the storage points as each ammunition distribution node, and the flows as the movements of ammunition and transportation assets (e.g., PLS flatracks, trucks, and trailers) from node to node. By selecting appropriate time steps (every six hours) in which to take the snapshots, we generated a simulated record of the movements and stock levels of ammunition supplies and transportation assets over the course of an MRC deployment and 60 days of combat action.

The general model was adapted to reflect the specific force structure, ammunition demands, and distances representative of MRC-E. Ammunition flows within the corps area, basically those described by the MOADS-PLS doctrine, were modeled to determine the number of flatracks required to meet corps ammunition distribution, stockage, and firing demands when operating with the expected number of PLS trucks and trailers. The movement of ammunition prior to arrival at the battlefield (from the depots in CONUS, through the ports of embarkation and debarkation, and from the theater to the CSA) was not included in the MOADS-PLS DYNAMO modeling. These movement stages and the primary performance considerations at each were described earlier.

Our methodology was to fix certain DYNAMO model conditions as representative of the MRC-E environment and then to introduce different flatrack fleet alternatives. That is, we determined representative MRC-E road distances from each ammunition node, the force structure, firing rates, and artillery ammunition consumption, the stockpiling of ammunition, and the truck and trailer assets; we built these factors into the DYNAMO model as parameters. We then introduced flatrack fleets to represent the various technical characteristics, arrival times, and mixes of our flatrack alternatives and simulated 60 days of combat ammunition distribution in six-hour increments. DYNAMO modeling is described in more detail in Appendix D.

The DYNAMO model simulation results did not clearly differentiate between alternative flatrack performance in the MOADS-PLS role on the battlefield. Our DYNAMO results showed that the long delivery legs between ammunition nodes of the MRC-E scenario, the limited size of the PLS truck and trailer fleet, and the use of CCLs of less than full flatrack ammunition load capacity dominated the effects of changes in flatrack fleet compositions and masked the different design characteristics of intermodal and A-frame flatracks. That is, even with handling differences, tare weight differences, throughput opportunities of the intermodal flatrack fleet and other flatrack characteristics to be described in the next section of this report, the MOADS-PLS battlefield performance of the flatrack alternatives was essentially equivalent. DYNAMO showed that if 14,800 flatracks of some type arrived in the conflict area and were

available for ammunition distribution, then the delivery of ammunition was more dependent on the availability of PLS trucks and trailers than on the type of flatrack.

In our model, as in an actual battlefield deployment, flatracks at the CSA, ATPs, ASPs, and firing units were dependent on PLS trucks and trailers for delivery to their destinations. The long distances between ammunition nodes meant that PLS trucks were on the road for 20 hours each day and that small time differences in loading or unloading flatracks or containers at each ammunition node were insignificant when compared to the time spent traveling between ammunition nodes or forward in the combat area. MOADS-PLS performance with the truck, trailer, and flatrack fleets met 85 percent of the corps ammunition demands; performance could have been improved more by the addition of trucks and trailers than by the addition of more flatracks or replacement of flatracks by an improved design.

## FLATRACK ALTERNATIVES

The primary issue of our study addresses the flatrack alternative that best supports the PLS. We did not reexamine the relative effectiveness of the PLS truck in competition with other types of trucks nor did we suggest significant changes to the MOADS ammunition distribution doctrine. In order to focus on the flatrack, we fixed the number of PLS trucks and trailers at the levels suggested by the CASCOM CSS Battle Lab PLS report.<sup>12</sup> Then we built flatrack alternatives by adding different design flatracks, container-lifting devices, and other components of the PLS in the numbers required for moving ammunition to support the theater distribution system. Because several thousand A-frame flatracks have already been built, each design alternative includes those A-frame flatracks. Thus, each flatrack alternative (except the pure A-frame alternative) is a mix of at least two types of flatrack designs. Each mix of equipment provides a means for moving ammunition intermodally and for distributing ammunition on the battlefield. The mixes are representative of the flatrack fleet that would likely be deployed to a regional contingency.

The performance of each alternative flatrack fleet is evaluated against the evaluation criteria described earlier in this chapter. Distribution of ammunition to the deployed corps remains the primary criterion, but we weighed the importance of each evaluation criterion to identify the best flatrack alternative for the Army's needs. After battlefield performance as a MOADS distribution platform, the criteria given the greatest importance in our analysis were ammunition handling, intermodal delivery for force projection, and cost.

Because the flatrack or container is a necessary component for effective system performance, PLS costs always include the cost of some flatrack or container. Our flatrack alternatives examine the cost and performance of different flatrack and container designs while holding constant the number of PLS trucks and

---

<sup>12</sup>See footnote 4, this chapter.

trailers. The costs associated with the trucks and trailers are the same for each alternative. This allowed our analysis to isolate the costs of the flatracks, the containers, and the required additions and modifications to the PLS. A complete analysis of the PLS as a distribution system would include the total costs and performance of *all* components of the system; we analyzed only the flatracks.

The flatrack alternatives are built around four designs:

- ◆ A pure A-frame flatrack
- ◆ An intermodal sideless container (previously known as the enhanced flatrack) built by the Oshkosh Truck Company and now designated as the M1 flatracks;
- ◆ The ISO flatrack AMCON design (similar to an early version tested at the Aberdeen Proving Ground, Maryland)
- ◆ The commercial ISO intermodal sideless container.

To provide an initial intermodal resupply of sustainment ammunition for A-frame flatrack alternatives and to fully meet ammunition delivery requirements at the port for other alternatives, we add an appropriate number of ISO 20-foot enclosed dry containers. To allow the PLS to transport ISO containers, we add CHDs or modify the LHS of the truck. Each alternative fleet is described below.

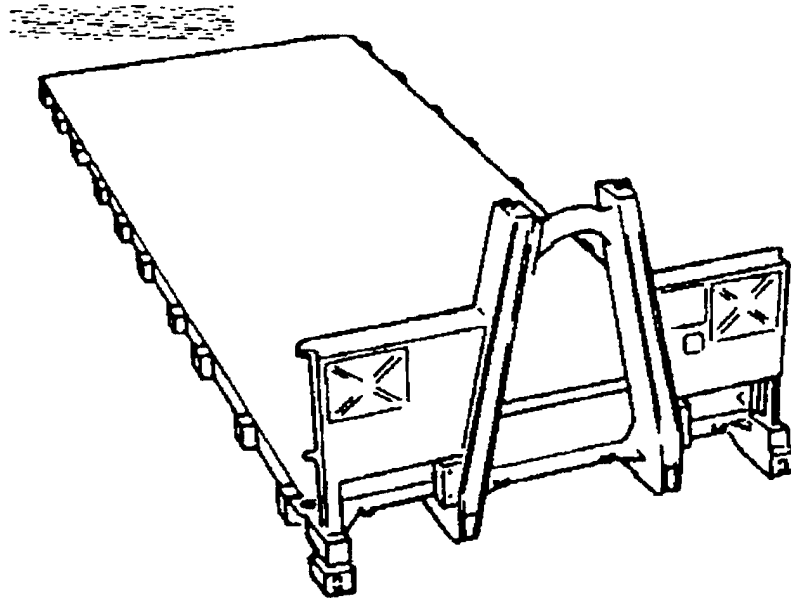
## Pure A-Frame Flatrack Alternative

The A-frame flatrack is shown in Figure 2-2. Note that the A-frame flatrack has only one vertical end wall and cannot support another A-frame or ISO container stacked above it in a vertical container cell. This design does not meet the Committee for Safe Containers (CSC) standards for intermodal movement and A-frame flatracks are not shipped with loads in containerships.<sup>13</sup> The A-frame end wall has a built-in "bail bar" at a height specified by NATO interoperability agreements for lifting by the "hook" of the PLS LHS.

The opposite end of the flatrack from the bail bar has an extension that can be rotated into position to mesh with and lock into the ISO fittings of a second flatrack. This feature allows the flatracks to "nest" for delivery to the corps area or for retrograde. The PLS truck can transport up to five nested A-frame flatracks. The A-frame is type-classified as the U.S. Army standard and can be operated by the PLS of NATO nations.

---

<sup>13</sup>It is possible to position the A-frame flatrack with a load in the topmost position of several containers in a vertical container cell. Additional containers or flatracks cannot be loaded above the A-frame flatrack.



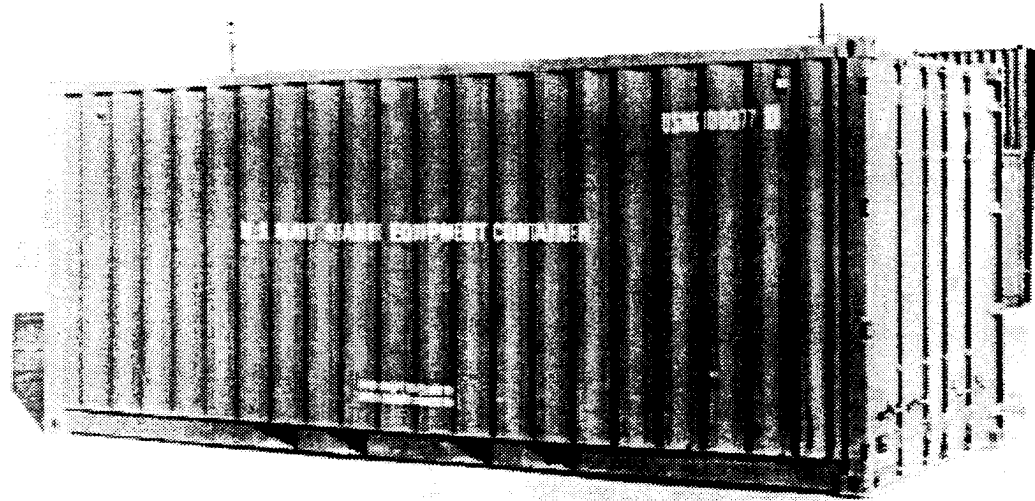
**Figure 2-2.**  
*A-Frame Flatrack*

#### INTERMODAL DELIVERY

Because the A-frame is not ISO-compatible in a container cell, it is shipped as cargo to the contingency area. Containerized ammunition is shipped in dry containers and the pure A-frame alternative includes 19,100 containers for intermodal delivery of the MRC-E scenario ammunition requirements.

A typical dry container measuring 20 feet long, 8 feet wide, and 8 or 8.5 feet high is shown in Figure 2-3. The length and width dimensions are fixed, but the height dimension can be built to suit the expected container cargo. Thus, "half-highs" of 4 feet are available and can be used to minimize broken stow space (space not occupied by cargo) within the container. Some containers are designed with internal tie-downs and braces to hold the transported loads in place. These designs are referred to as "MILVANS" when built to military specifications for the movement of ammunition.

Dry containers are plentiful worldwide and are constructed by several international producers. The container meets CSC certification for intermodal movement with loads in excess of 20 short tons. At this weight, the loaded container would exceed the 16.5-short-ton allowable weight of the LHS of the PLS truck. CCLs have been designed for typical ammunition loads (such as 155mm howitzer ammunition at 14.3 short tons), which do not exceed these PLS limits. When loaded with the CCLs, the entire container load can be transported by the PLS; when the container is loaded to its maximum capacity for intermodal movement, a portion of the load would have to be removed for movement with the PLS.



**Figure 2-3.**  
*Dry Container*

The rear extensions of an A-frame flatrack, which allow flatrack nesting, also allow a 20-foot container to be mounted on an A-frame and secured by means of the bottom ISO corner fittings. Such mounting requires use of container-handling equipment to lift and position the container. The PLS truck and trailer can transport the A-frame/loaded container combination, but the combination is longer than 20 feet (the 20 feet of the container plus the length of the A-frame extension) and cannot fit into a container cell. In constructing the A-frame alternative 1,283 CHDs are added in anticipation of a need for one-half of the PLS trucks (those in the medium truck companies) to move containers.

#### FORCE PROJECTION

A-frame flatracks are loaded on the afloat prepositioned (prepo) ships as an asset for early deploying units with a force projection mission. A basic load of ammunition for the designated prepo units is now stored in containers on the RO/RO ships. The prepo ships also contain resupply ammunition in a break-bulk configuration to be loaded onto the A-frame flatracks ashore. Future prepo ships may use containerized resupply ammunition. If A-frame flatracks continue to be loaded on the prepo ships, this prepo ammunition will be loaded in dry cargo containers and reconfigured onto flatracks at the CSA.

#### BATTLEFIELD DISTRIBUTION

In the pure A-frame alternative, ammunition distribution from the corps forward is exclusively on PLS A-frame flatracks. Ammunition is moved from the port or theater storage area (TSA) to the CSA on 40-foot semi-tractor-trailers, usually in single-DODIC containers. If the contingency area is small or newly



developed, the PLS may be used to assist in port-clearing operations and may move A-frame flatracks from the port to the CSA. Ammunition is configured into CCLs at the TSA or CSA.<sup>14</sup> CCL-configured ammunition on A-frame flatracks is moved from the CSA to the forward ATPs and ASPs on PLS trucks and trailers. The loaded flatracks at the ATPs and ASPs are picked up by artillery units using their organic PLS trucks and positioned for use by firing batteries. When the PLS trucks of the medium truck companies drop their loaded flatracks at the ATPs and ASPs, they pick up empty flatracks and return to the CSA to continue the distribution cycle. Under some conditions, the PLS trucks of the medium truck company may bypass the ASP or ATP and deliver flatrack loads directly to the vicinity of the forward artillery.

## FLATRACK FLEET COMPOSITION

Under this alternative, production of A-frame flatracks will continue until the full current contract amount of 15,047 flatracks is produced. Subsequent competitive contracts will be awarded until the desired total of 26,341 A-frame flatracks is produced. Development and test of the M1 intermodal flatrack as designed by the Oshkosh Truck Company for cut-in on the current contract will cease. Dry cargo containers will be added to the flatrack purchase to provide an intermodal capability; CHDs are added to move and handle containers. Thus, the pure A-frame alternative is composed of 26,341 A-frame flatracks, 19,100 dry containers, and 1,283 CHDs.

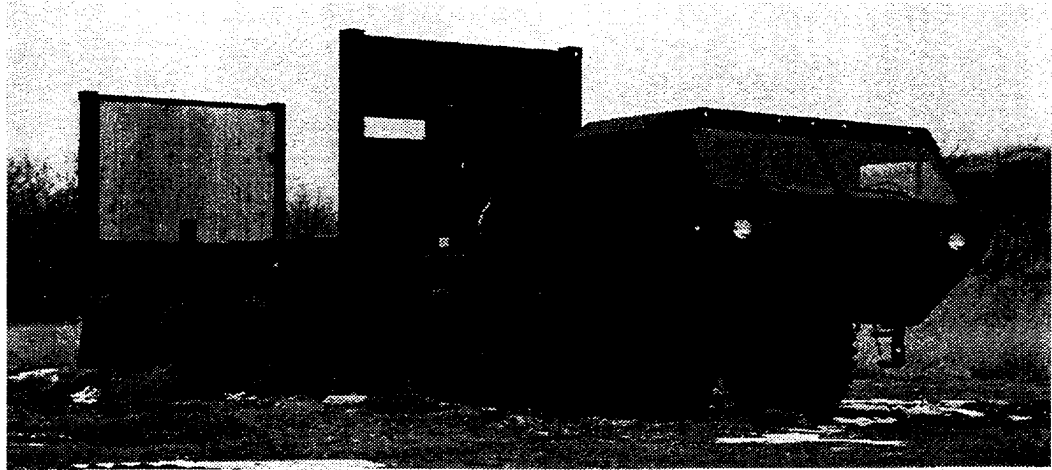
## Intermodal Shipping Container (M1) Alternative

The intermodal shipping container (ISC) is shown in Figure 2-4.<sup>15</sup> The M1 combines the intermodal features of an ISO container with the battlefield distribution capabilities of a PLS flatrack. The primary design feature, which separates the PLS intermodal flatracks from standard container designs, is the location of the main longitudinal support members. The M1 (and the A-frame) flatrack have two support beams close to the center longitudinal line of the flatrack; other ISO containers and flatracks have support beams at the perimeter of the container. The PLS flatracks use the positioning of their support beams to guide the flatrack onto the PLS truck and trailer. The M1 incorporates features that were discussed during a series of design, cost, and performance tradeoff meetings held during the summer of 1994 in response to cost escalation and poor performance on acceptance tests of an earlier intermodal flatrack. The current

---

<sup>14</sup>MOADS-PLS also allows CCLs to be produced at the ASP in the division rear; we considered CCLs to be formed at the CSA.

<sup>15</sup>The intermodal flatrack was redesigned over the summer of 1994 and approved by the U.S. Army Transportation School for tooling by the manufacturer. This redesigned flatrack is now identified as the M1 flatrack or the ISC. Earlier versions of this flatrack were known as enhanced PLS flatracks (EPFs). The M1 and EPF decks and ISO fittings are similar but have distinctly different end wall features.



**Figure 2-4.**  
*M1 Intermodal Flatrack (shown on PLS truck)*

design is expected to meet the CSC standards for intermodal movement with loads in containerships.<sup>16</sup>

The design of the end walls of the M1 has become a critical feature for intermodal delivery of ammunition and performance on the battlefield. The height of the M1 flatrack end walls is 6'10" to maximize inner dimensions and allow the great majority of ammunition loads to be carried while minimizing total PLS height when loaded on a truck. This end wall height also allows the crane mounted on PLS trucks assigned to artillery units to reach over the end wall to individually unload ammunition pallets from the flatrack to the ground without dismounting the flatrack from the truck. Both end walls of the M1 fold inward for shipment or retrograde. In this configuration, a stack of four collapsed M1s can be lifted by the PLS truck using an auxiliary bail bar. The M1 flatracks cannot be used to move dry containers as can the A-frame; the end walls of the M1 do not allow the insertion of a 20-foot container.

M1 flatracks are not yet type-classified, but they will meet interoperability standards as agreed upon by NATO nations. Initial performance testing at Yuma Proving Grounds was not successful in meeting acceptance criteria. Redesign and resumption of performance testing prior to a full production decision is expected to continue into FY96.

---

<sup>16</sup> Fifteen production prototypes were delivered in April 1995 and are undergoing acceptance testing before a full production decision is made. Initial results from the rail impact portion of the tests indicated failure of the end wall pins and surfacing material. These items will be redesigned and retested. Concurrent with the field tests by the Army at Yuma Proving Ground, a copy of the M1 flatrack is undergoing certification testing by the CSC as an intermodal container.

## INTERMODAL DELIVERY

Initial delivery of ammunition will be on intermodal flatracks carrying single-DODIC or CCL ammunition. The M1 flatracks are loaded in CONUS for transport to the contingency area in containerships. A sideless container, such as the M1 flatrack, does not offer the physical security and protection provided by a closed container. Intermodal shipments of ammunition may be subject to increased security procedures, or some types of ammunition may not be shipped in these open flatracks. The bulk of the ammunition arriving in-theater will be in single-DODIC containers to maximize efficiencies of loading and movement. This ammunition will be moved from the port or theater storage area to the CSA on 40-foot semi-tractor-trailers.

## FORCE PROJECTION

Resupply ammunition prepositioned to support the early stages of force deployments is breakbulk; future prepo ships may use containerized ammunition. The M1 flatrack is well-suited for the prepo role because it can deliver ammunition as well as needed PLS flatracks while economizing container space. If future production of the M1 is approved, then a primary claimant for M1 distribution will be the prepo ships in support of force projection missions. In addition to prepo stocks afloat, M1 flatracks based in CONUS or Europe can be loaded with ammunition for rapid deployment aboard containerships to contingency areas.

## BATTLEFIELD DISTRIBUTION

In modeling this alternative, enough enhanced flatracks are assumed to be produced to support the initial intermodal delivery of ammunition for the deployed combat force represented in the MRC-E scenario. If the ammunition has been configured into CCLs in CONUS, the intermodal flatracks do not need to be reconfigured at the CSA and can move directly to the ATPs, ASPs, or firing units. If the ammunition arrives in the CSA as single DODIC loads, it is reconfigured into CCLs at the CSA (at times at the ASP) for subsequent movement forward on either an intermodal flatrack or an A-frame flatrack.<sup>17</sup> Once the ammunition arrives in-theater, whether delivered on an intermodal flatrack, as breakbulk, or as containerized ammunition, its subsequent distribution is on an available flatrack. From the CSA forward, the intermodal and A-frame flatracks exhibit similar performance characteristics while performing the MOADS ammunition distribution mission, except for slight adjustments in load-carrying capability.

This alternative retains the MOADS concepts and the distances, vehicle operation, and load parameters described in CASCOM's CSS Battle Lab PLS report for operations forward of the CSA. In addition, the intermodal capability of the M1 flatrack allows ammunition entering the theater as CCLs to bypass the CSA and ASPs for direct delivery to the ATPs or firing units. Once the intermodal

---

<sup>17</sup>This alternative is based on an intermodal flatrack, but it is not a "pure" alternative because the earlier production of A-frame flatracks provided a fleet of 8,303.

flatrack delivers its initial ammunition load, it becomes a corps asset and remains within the corps area, cycling from the CSA to the ATP in keeping with MOADS-PLS doctrine.

The loaded flatracks at the ATPs and ASPs are picked up by artillery units using organic PLS trucks and positioned for use by firing batteries. PLS trucks of the medium truck companies return from the ATPs and ASPs to the CSA; flatracks return from the artillery units to the CSA for subsequent use. Containers that have delivered the ammunition to the corps area are released to the theater for reuse.

#### FLATRACK FLEET COMPOSITION

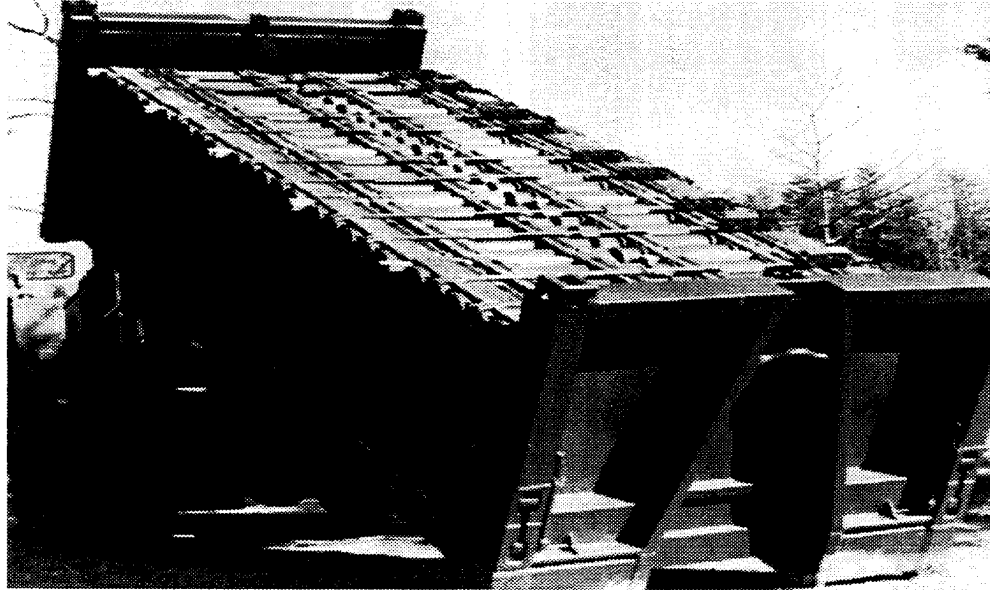
In this alternative, the production of A-frames is halted, no additional A-frame contracts are signed, and intermodal PLS flatracks are produced. Depending upon the timing of the cutover of production from A-frame to intermodal flatracks, this decision creates a fleet of 8,303 A-frames (or more depending on the number of A-frames produced at 200 to 300 per month) and 18,038 M1 intermodal flatracks for the MRC-E scenario. As in the A-frame alternative, subsequent delivery of ammunition will use dry containers as the cheapest means of transport, and 962 additional containers will be purchased. Because the M1 flatrack is also an intermodal container, the PLS will not move dry containers and no CHD are purchased.

#### International Standards Organization Flatrack Ammunition Container Alternative

This alternative uses a commercially produced PLS-compatible flatrack represented by the AMCON (see Figure 2-5) developed for the Program Manager, Ammunition Logistics (PM AMMOLOG). The AMCON can carry ammunition to the full design load of the PLS truck and trailer, is ISO compatible for intermodal movement, and has undergone limited field testing with the PLS truck and trailer. Early versions of the AMCON served as prototypes for many of the features incorporated into the M1 design described above. The AMCON has PLS-type support rails and inward-folding end walls. This equipment alternative has not been tested to meet all user specifications that have been met by the A-frame or designed into the intermodal flatracks.

#### INTERMODAL DELIVERY

This alternative design can be moved in a container cell for intermodal delivery and can also be moved on a PLS truck or trailer for direct delivery to the ATPs or firing units. Once the ISO flatrack delivers its initial ammunition load, it becomes a corps flatrack asset and moves within the Corps area (CSA to ASP or ATP to firing units and return). Subsequent deliveries of ammunition into the theater are in containers or on other flatrack types.



**Figure 2-5.**  
*ISO (AMCON) Commercial PLS Flatrack*

#### FORCE PROJECTION

The AMCON flatrack has the same advantages in the force projection mission as cited for the M1 flatrack above: it can deliver ammunition and the needed PLS flatracks while economizing container space.

#### BATTLEFIELD DISTRIBUTION

Initially, ammunition enters the theater loaded on ISO flatracks and is moved by theater assets to the CSA. If the ammunition has been configured into CCLs in CONUS, the ISO flatracks do not need to be reconfigured at the CSA and can move directly to the ATPs or firing units. If the ammunition arrives in the CSA as single DODIC loads, it is reconfigured into CCL at the CSA (at times at the ASP), for subsequent movement forward on the first available ISO flatrack or A-frame flatrack. From the CSA forward, the ISO, M1, and A-frame flatracks exhibit similar performance characteristics while performing the MOADS ammunition distribution mission, except for slight adjustments in load carrying capability.

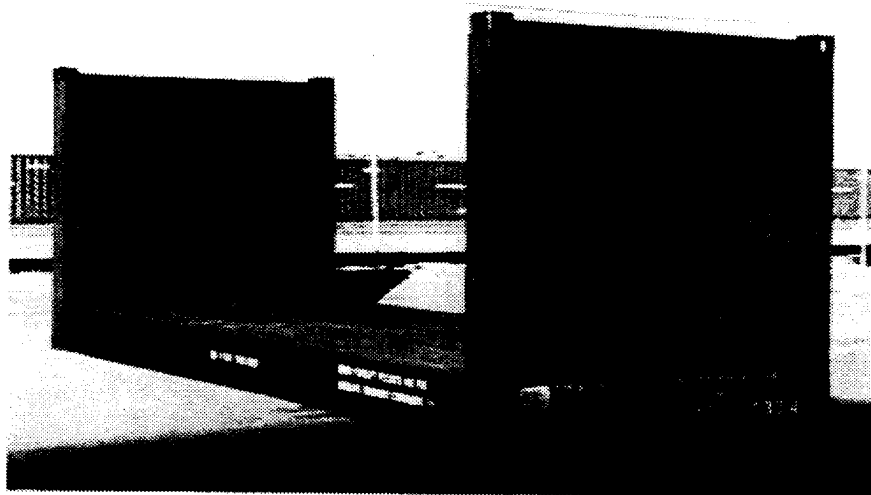
#### FLATRACK FLEET COMPOSITION

Use of the ISO flatrack creates a mixed fleet of the total number of A-frame flatracks currently under contract to Oshkosh (15,047), and 11,294 ISO flatracks to support the initial intermodal delivery of ammunition for the deployed combat force represented in the MRC-E scenario. Because there are several potential

producers of this commercial model, competition should result in a lower price than that charged by the producer of the M1 flatrack. As in the A-frame alternative, subsequent delivery of ammunition will use dry containers as the cheapest means of transport and 7,806 are purchased. No CHD will be purchased to allow the PLS to move ISO containers.

## Commercial International Organization for Standardization Sideless Container Alternative

This alternative uses commercially produced sideless containers certified for intermodal movement but not specifically configured to be PLS-compatible. That is, the ISO sideless container load-bearing supports are on the perimeter (the conventional container design) rather than in the center section (the PLS-type guide rails). (See Figure 2-6.)

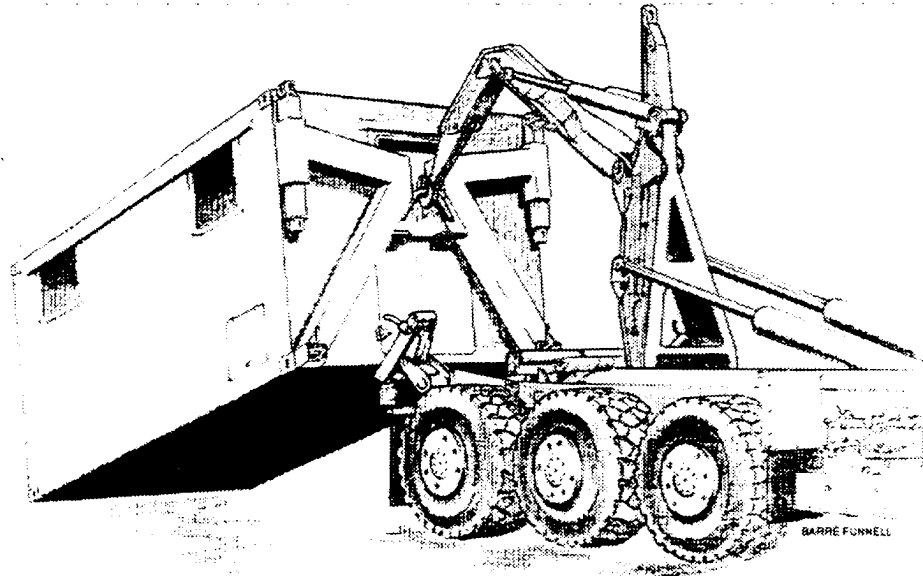


**Figure 2-6.**  
*Commercial ISO Sideless Container*

Matching the design features of a commercial ISO container configuration requires that the lifting and securing method of the PLS be adapted to load and carry the containers. Two methods have been identified to effect this task. The first is a modification of the PLS LHS to allow the PLS hydraulic lift system to attach to the container at the corner ISO fittings and to lift the container to the bed of the truck or trailer. The second is an addition to the PLS called a CHD. (See Figure 2-7.)

With the modified LHS, the lifting device is permanently attached to the LHS of the PLS truck, allowing the truck to lift any 8' x 8' x 20' ISO-compatible envelope (e.g., container, ISO sideless container, or flatrack). In the preferred design, the PLS operator will be able to attach the modified LHS to a container from within the cab and complete the load and secure operation without

dismounting. This remote attachment will require automatic engaging and locking mechanisms not now on the PLS. An interim design may have the operator or his assistant attach the LHS to the container from outside the cab. Neither of the designs for LHS modifications to allow container pick up will interfere with the lift or movement of any of the PLS-compatible flatracks. Those features incorporated into the integral LHS for container movement will retract or swing out of the way when the LHS engages the bail bars of PLS flatracks.



**Figure 2-7.**  
*Container Handling Device*

If the LHS of the PLS is not modified, then the PLS can still transport containers through the addition of a CHD. These CHDs can be of various designs: early versions [e.g., the container lift kit, or CLK, is one (Figure 2-8)] used a cruciform design that attached to the four ISO pockets on one end of a container, an experimental version attaches to two ISO fittings, and the container handling unit (CHU) used by the British PLS (i.e., the DROPS system) is an H-shaped device that can be adapted to a range of container configurations. Operation of the CHU is typical of these CHD designs. The CHU is lifted by the LHS hook of the truck and is then attached to a grounded container. The CHU then locks to the container and the entire assembly is lifted onto the PLS truck. In either case, an additional load-guiding and roller system mounted on the truck is used to assist in positioning and locking the load to the truck bed. With the CLK and the CHU, the device is a stand-alone design that can be mounted when desired to move containers and dismounted when flatracks are to be transported. Future versions may allow stowage aboard the PLS truck. CHDs will be used primarily by the PLS assigned to medium truck companies. If the final design allows operation of the CHD without interfering with the crane mounted on PLS assigned to artillery units, then the CHD design may be added to these systems.

Discussions with the TRADOC user community and the program manager for PLS indicate that a limited number of detachable CHDs will be acquired for testing and use by early deploying forces. Good features of this design will be incorporated into a future modification of the LHS. The LHS modification may eventually be applied to the entire fleet of PLS trucks such that any PLS truck could move any type of flatrack or ISO container it encounters. This approach, modifying the smaller number of PLS trucks rather than modifying a larger number of flatracks or containers, will increase system versatility and flexibility and avoid costs. The British have successfully accomplished container movement in Bosnia using the British Army variant of the PLS truck and trailer (i.e., the DROPS) and a MultiLift CHD called the CHU (see Figure 2-9). Additional testing across the range of combat operations is necessary before the suitability, durability, and long-term reliability of the ISO sideless container and modified LHS or CHD can be judged. For examination of this alternative, 1,283 PLS assigned to medium truck companies are modified.



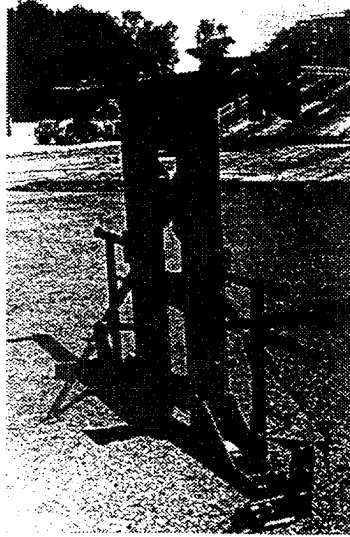
**Figure 2-8.**  
*Container Lift Kit*

## INTERMODAL DELIVERY

Ammunition enters the theater loaded on commercial ISO sideless containers and is moved by theater assets to the CSA. If carrying CCL ammunition, the ISO sideless containers do not need to be reconfigured at the CSA and can move directly to the ATPs or firing units aboard PLS trucks using CHDs. If the ammunition arrives in the CSA as single DODIC loads, it is reconfigured into CCL at the CSA for subsequent movement forward on the first available commercial ISO sideless container or A-frame flatrack. From the CSA forward, the commercial ISO sideless container performs as an A-frame flatrack with the caveat that the



modified LHS or CHD be attached to every PLS truck that is moving the commercial ISO container. Subsequent deliveries of ammunition into the theater are made to maximize efficiencies of loading and movement. The bulk of the ammunition arriving in-theater will be in single-DODIC containers and will be moved from the port or theater storage area to the CSA on 40-foot semi-tractor-trailers.



**Figure 2-9.**  
*Container Handling Unit*

#### FORCE PROJECTION

Basically, the commercial ISO sideless container is an intermodal shipping asset that fits inside a container cell for intermodal movement. Once unloaded from the ship, the ISO sideless container can be moved out of the port area using modified PLS trucks or PLS trucks with a CHD. If a demountable CHD is used with the PLS truck, then this item must be added to the fleet of PLS trucks and trailers for early movement into the theater. The Army is purchasing 68 demountable CHDs to provide the early deploying PLS trucks the equipment to move containers.

#### BATTLEFIELD DISTRIBUTION

In this alternative, commercial ISO sideless containers are substituted for some PLS flatracks to meet the ammunition distribution needs for the deployed combat force represented in the MRC-E scenario. The current contracted for number of 15,047 flatracks is produced as A-frame flatracks. Enough additional ISO sideless containers (11,294) are acquired to support the intermodal delivery of ammunition.

This alternative retains the MOADS concepts, distances, and the vehicle operation and load parameters for operations forward of the CSA. Also, the

intermodal capability of the commercial ISO sideless container allows ammunition entering the theater as CCL on commercial ISO sideless containers to bypass the CSA and ASPs for direct delivery to the ATPs or firing units. Once the commercial ISO sideless container delivers its initial ammunition load, it becomes a corps asset and remains within the corps area, cycling from the CSA to the ATP under MOADS.

Ammunition in CCLs is moved from the CSA to the forward ATPs and ASPs on PLS trucks and trailers as in the PLS alternatives above. The loaded flatracks or sideless containers at the ATPs and ASPs are picked up by artillery units using organic PLS trucks and positioned for use by firing batteries. PLS trucks of the medium truck companies return from the ATPs and ASPs to the CSA; flatracks and sideless containers return from the artillery units to the CSA for subsequent use. Containers, or sideless containers, which have delivered the ammunition to the corps area and are not needed for further ammunition distribution tasks, are released to the theater for reuse.

#### FLATRACK FLEET COMPOSITION

Use of the commercial ISO sideless container creates a mixed fleet of the total number (15,047) of A-frame flatracks currently under contract to Oshkosh Truck Company, 11,294 ISO sideless containers, and 1,283 CHDs to deliver ammunition for the MRC-E scenario combat forces. The ISO sideless container is commonly available from several commercial producers at competitive prices. MultiLift (now Cargotec) owns the patent rights to the CHU but the final design of the CHD or integral LHS is within the production capacity of several manufacturers. Negotiated price for CHU, CHD, and an integral LHS will be obtained by the PM, Heavy Tactical Vehicle (HTV). The cost estimates used are the best available. As in the A-frame alternative, subsequent delivery of ammunition will use dry containers as the cheapest means of transport and an additional 7,806 containers are procured to meet MRC-E requirements.

#### Mixed (A-Frame/M1) Alternative

A meeting of Army principals held in August 1994 led to an agreement for a limited acquisition of M1 flatracks (see Appendix B). At this meeting, it was recognized that an ability to conserve shipping space while providing a ready

**Table 2-4.**  
*PLS Flatrack Alternatives*

Item	A-frame flatracks	Alternate flatracks	Dry containers	CHD/LHS
A-frame	15,047	—	19,100	1,283
M1	8,303	18,038 (M1)	962	—
Mix	10,047	5,000 (M1)	14,100	—
AMCON	15,047	11,294 (AMCON)	7,806	—
Commercial	15,047	11,294 (comm. ISO)	7,806	1,283

capability to use PLS trucks to assist in port-clearing operations in a force projection role were desirable. The number of 5,000 M1 flatracks was determined to provide an intermodal delivery capability for early deployment forces (prepo, Force Package 1, and a small portion of Force Package 2) that could also serve as a PLS distribution flatrack. This mixed fleet of A-frames and M1 flatracks is specifically included in Table 2-4 above and addressed as a flatrack alternative in the decision tree below.

## Decision Tree

We arrayed the various equipment alternatives into a decision tree to show how selecting a particular flatrack affects other equipment decisions. Decision points, or nodes, of the decision tree address three equipment decisions: flatrack type; PLS container-lift mode; and container type. The combination of type of flatrack-type alternative, PLS container transport capability, and type of container generated a decision tree with 60 branches each to be evaluated (Figure 2-10).

NODE 1	NODE 2	NODE 3	Alternatives	Feasible Alternatives
A FRAME	CHD	Containers	1	•
		Bal-Bar/Cont	2	
		ISO Flatracks	3	
		No Cont	4	
	MOD LHS	Containers	5	•
		Bal-Bar/Cont	6	
		ISO Flatracks	7	
		No Cont	8	
	NO CHD	Containers	9	•
		Bal-Bar/Cont	10	
		ISO Flatracks	11	
		No Cont	12	
M1	CHD	Containers	13	•
		Bal-Bar/Cont	14	
		ISO Flatracks	15	
		No Cont	16	
	MOD LHS	Containers	17	•
		Bal-Bar/Cont	18	
		ISO Flatracks	19	
		No Cont	20	
	NO CHD	Containers	21	•
		Bal-Bar/Cont	22	
		ISO Flatracks	23	
		No Cont	24	
Mix M1/A FRAME	CHD	Containers	25	•
		Bal-Bar/Cont	26	
		ISO Flatracks	27	
		No Cont	28	
	MOD LHS	Containers	29	•
		Bal-Bar/Cont	30	
		ISO Flatracks	31	
		No Cont	32	
	NO CHD	Containers	33	•
		Bal-Bar/Cont	34	
		ISO Flatracks	35	
		No Cont	36	
ISO FLATRACK (AMCON)	CHD	Containers	37	•
		Bal-Bar/Cont	38	
		ISO Flatracks	39	
		No Cont	40	
	MOD LHS	Containers	41	•
		Bal-Bar/Cont	42	
		ISO Flatracks	43	
		No Cont	44	
	NO CHD	Containers	45	•
		Bal-Bar/Cont	46	
		ISO Flatracks	47	
		No Cont	48	
COMMERCIAL ISO CONTAINERS	CHD	Containers	49	•
		Bal-Bar/Cont	50	
		ISO Flatracks	51	
		No Cont	52	
	MOD LHS	Containers	53	•
		Bal-Bar/Cont	54	
		ISO Flatracks	55	
		No Cont	56	
	NO CHD	Containers	57	•
		Bal-Bar/Cont	58	
		ISO Flatracks	59	
		No Cont	60	

**Figure 2-10.**  
*Full Decision Tree*

## Evaluation of Alternatives

The detailed evaluation of each node of the decision tree is included in Appendix C. In that appendix we describe the pruning of the 60 branches of the decision tree to 16 feasible alternatives by comparing each alternative against the evaluation criteria.

To be feasible, an option had to meet the following minimum requirements.

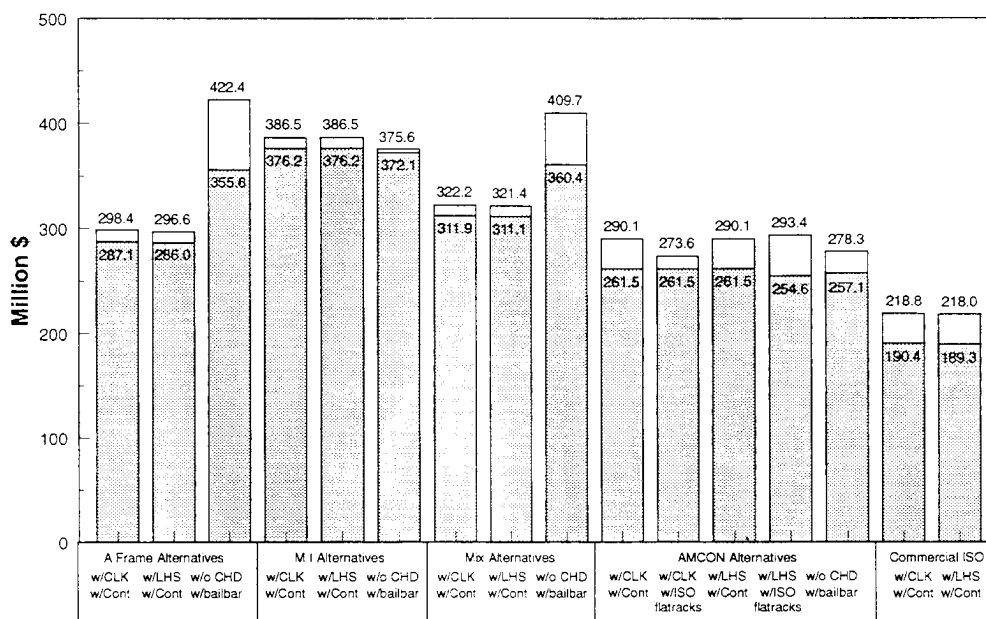
- ◆ The option must meet MRC operational requirement for *battlefield ammunition delivery*.
- ◆ The option must provide for sufficient intermodal movement of ammunition for *force projection*.
- ◆ The option must meet most *user equipment* and operational requirements.
- ◆ The option must be free of significant or high risk *engineering requirements*.
- ◆ The option must support *future PLS development* and fielding.

A summary of our subjective evaluation is shown in Table 2-5, an amplified discussion of the pros and cons of each of the 16 feasible options is in Appendix C.

## Selection of Preferred Alternatives

None of the feasible alternatives is totally acceptable: each has some degree of engineering risk, falls short of the most desired user configuration, or is relatively expensive. On the other hand, all the feasible alternatives identified perform well enough to satisfy MOADS distribution requirements and meet the Army's need to move ammunition intermodally. Because the performance characteristics of the feasible alternatives are at least minimally acceptable, we examined the costs of each alternative in more detail.

We showed the shipping and O&M costs for the flatrack alternatives in Table 2-1. Those costs are similar for the flatrack alternatives and do not clearly favor one alternative over another. The acquisition costs for each of the feasible alternatives are shown in Figure 2-11. In this figure, the costs for alternatives comprising flatracks, containers, CHDs, and LHS modifications are based on a PLS truck fleet of 2,678, which would be augmented by purchasing 1,283 CHDs or modifying 1,283 LHSs. The MRC-E scenario used generated a MOADS flatrack requirement of 26,341 and a delivery requirement of 19,100 TEU containers of ammunition.



**Note:** Figure shown above each cost column is high estimate; figure shown within column is low estimate. Difference is the expected range of costs. Costs are in FY95 dollars.

**Figure 2-11.**  
*Equipment Investment Costs for Feasible Alternatives*

Note that differences in the type of flatrack selected results in significant differences in acquisition cost among the alternatives. For a specific alternative, a range of costs is shown that represents uncertainty in the cost estimate and/or the possibility of tradeoffs of some desired, but not required, design features to realize cost savings. Within each alternative, the range of estimated costs from low to high is relatively small compared to the total cost of the alternative. The narrow band of cost estimate uncertainty means that although further refinements of these initial cost estimates are desirable, it is not expected that these refinements will change the relative cost rankings of the alternatives.

Clearly shown in Figure 2-11 is that flatrack alternatives built around the commercial ISO sideless containers offer dramatic cost avoidance of over \$160 million to \$200 million if they are selected over alternatives built around the M1 flatrack. Also shown is the cost advantage of investing in an ability to move containers by modifying the LHS or purchasing CHDs instead of acquiring specially designed containers with an added bail-bar. In the case of the A-frame alternative (the alternative that purchases the most containers to meet the intermodal requirement), modification of the truck, rather than the container, avoids over \$90 million dollars in cost. The cost avoidance can be attributed to the use of flatracks or containers that are available from the commercial market place for intermodal movement, even if it requires modification of the PLS. The cost figures and the alternative pros and cons (see Appendix C for a complete description) suggest that the most desirable alternatives are those which modify the

**Table 2-5.**  
*Evaluation Criteria Matrix for Feasible Alternatives*

Alternative					
	MRC ammunition requirement	Intermodal ammunition movement	User option requirement	Low-risk engineering development	Supports and enhances PLS
<b>A-Frame</b>					
CHD/container	•	•	•	•	•
Modified LHS/container	•	•	•	•	+
No CHD/container: Bail-bar	•	•	•	+	+
<b>M1</b>					
CHD/container	+	+	•	•	+
Modified LHS/container	+	+	•	•	+
No CHD/container: Bail-bar	+	+	-	•	+
<b>Mix M1/A-Frame</b>					
CHD/container	+	•	•	•	+
Mod LHS/container	•	•	•	•	+
No CHD/container: Bail-bar	•	•	•	•	-
<b>AMCON</b>					
CHD/container	+	+	•	•	+
CHD/container: ISO flatrack	+	+	•	•	•
Mod LHS/container	+	+	•	•	+
Mod LHS/container: ISO flatrack	+	+	•	•	•
No CHD/container: Bail-bar	+	+	•	+	+
<b>ISO</b>					
CHD/container	+	+	•	•	+
Mod LHS/container	+	+	•	•	+

**Note:**

- + = Performs significantly better than other alternatives on this measure.
- = Performs significantly worse.
- = Adequate performance.

MOE

Engineering ent	Supports and enhances PLS	Cost investment	Transportability	Limits additional requirements	Satisfies congressional requirements	Supports additional uses
	•	•	•	-	-	+
	+	•	•	-	•	+
	+	-	•	+	-	-
	+	-	•	-	+	+
	+	-	•	-	+	+
	+	-	•	+	+	•
	+	-	•	-	+	+
	+	-	-	-	+	+
	-	-	•	•	+	•
	+	•	•	-	+	+
	•	•	+	-	+	+
	+	•	+	-	+	+
	•	•	+	-	+	+
	+	•	•	+	+	•
	+	+	•	-	+	+
	+	+	+	-	+	+

PLS vehicle, use commercially available ISO sideless containers or flatracks for intermodal delivery of ammunition from CONUS to the theater, and then use the same containers for throughput of ammunition to the firing units. Our findings below reflect this position.

## FINDINGS

- ◆ On the battlefield, a flatrack's intermodal capability does not enhance ammunition distribution under MOADS; less costly, nonintermodal flatracks such as the A-frame flatrack meet all identified user needs in this role.
- ◆ The A-frame flatrack cannot meet the need for intermodal transport.
- ◆ The combination of A-frame flatrack and containers provides intermodality and offers more flexibility within the theater than the intermodal shipping container (i.e., the M1).
- ◆ Opportunities and requirements to move dry containers forward in the battle area will increase as the Army moves closer to maximizing containerization.
- ◆ A-frame and intermodal flatracks, either of PLS design (i.e., the M1) or commercial design, have not been compared in side-by-side Army evaluations. A final decision to procure any intermodal container design needs to be based on the benefits of field tests by the user.
- ◆ The Army's needs for flatracks will not be satisfied by the funds currently available, regardless of whether A-frames, M1s, or commercial flatracks are purchased.
- ◆ Engineering questions remain unanswered for intermodal flatracks, CLK and other CHD, and for the modified LHS.
- ◆ The use of CCL to ship ready-to-fire ammunition loads present unique efficiency, safety, and security concerns which have not been resolved.
- ◆ Costs for equipment procured in a noncompetitive production environment continue to escalate. Much of this cost escalation could be avoided by the competitive acquisition of commercial products, even if the PLS were modified to accept the commercial design.
- ◆ Because of the extremely long distances from the port to division, which can be expected in an MRC-E conflict, more PLS distribution assets, in addition to flatracks, are needed to deliver the ammunition to artillery units.



## CHAPTER 3

# Conclusions and Recommendations

## CONCLUSIONS

Analysis of the decision tree, MOE, and findings of Chapter 2 lead to the following conclusions:

- ◆ Alternatives built around the M1 flatrack are more costly than alternatives built around all the other flatrack options. This holds true for current cost estimates and is robust enough to continue to hold true if flatrack prices change.
- ◆ Fewer investment funds are needed to modify the PLS trucks to accept a broader range of flatrack alternatives, including containers, while providing an equivalent intermodal capability and a nearly equivalent battlefield capability to the purchase of M1 flatracks.
- ◆ Modification of the PLS LHS capability to lift any ISO container or flatrack within the system weight specifications would add to the flexibility of the PLS as a distribution platform and a strategic mobility asset. The use of detachable CHDs should be considered as an interim measure to assist in the design of a modified LHS and roller assembly for both the truck and trailer. Field trials of the CHD should be conducted to determine its applicability for those PLS trucks assigned to artillery units that mount an auxiliary loading crane.
- ◆ Because the Army requirements for flatracks far exceed the number currently under contract, the production of A-frame flatracks should continue until a final decision is made and production of an intermodal capability flatrack can begin. This includes A-frame production through the design and testing phases of intermodal flatracks, review of user specifications, and the elimination of any engineering shortcomings.
- ◆ The use of commercially designed and competitively produced ISO sideless containers, with a CHD or modified LHS, offers significant cost savings over the purchase of PLS flatracks specifically designed for intermodal movement and battlefield operations. These commercial containers should be thoroughly tested before a final decision on the production of a PLS-specific intermodal design is made.
- ◆ Flatrack requirements should be periodically reviewed in the light of emerging near simultaneous scenarios, changes in the tactical-wheeled vehicle fleet, changes to intermodal ammunition shipment policies and doctrine,

additional uses of the PLS (designation as the distribution platform for MLRS rocket pods, for example), and reduced Army force structure.

- ◆ By investing in a modified LHS and a less expensive intermodal flatrack, congressional objectives can be met, unfunded requirements can be reduced, and PLS system operational capabilities can be enhanced for future uses.
- ◆ As funding, engineering design, and user requirements continue to evolve in the PLS flatrack environment, an oversight group with representatives of the transportation, distribution, ammunition, artillery, production and contracting, and Army Headquarters management would expedite decision-making and enhance communication and understanding.

## RECOMMENDATIONS

Our conclusions lead to the following recommendations:

- ◆ Continue to produce A-frames at a rate of 200 to 300 per month and pursue engineering of the modified LHS.
- ◆ Determine the best configuration of A-frames as cargo on containerhips, fast sealift ships, and RO/RO ships.
- ◆ Investigate the compatibility and feasibility of meeting PLS needs with commercial ISO sideless containers and modified LHS.
  - ▶ If investigation results are positive, purchase 18,038 commercial ISO sideless containers, purchase 8,303 A-frames, and modify 1,283 PLS truck LHS.
  - ▶ If negative, purchase ISO flatracks of a modified AMCON or M1 design (depending on AMCON test results and comparable cost of AMCON and M1) to fill out the user-identified flatrack requirement and modify 1,283 PLS truck LHS.
- ◆ Do not produce M1 flatracks with their intermodal capability until the design, performance, and cost of the M1 flatrack have been fully examined, tested, and accepted by the user community.
- ◆ Perform user acceptance testing of flatracks, the modified PLS LHS, and the CHD before moving into acquisition and/or production.
- ◆ Establish a PLS steering group to integrate system development and issues related to flatracks, ammunition, and programmatic funding to ensure early visibility of concerns and expeditious resolution of issues.
- ◆ Develop a plan to procure commercial flatracks, with a design compatible with container ships, to satisfy the congressional objective of realizing an

intermodal force projection capability. Indicate that subsequent flatrack production will be competitively bid to reduce costs.

- ◆ Develop an integrated doctrine of pre-positioning equipment, containerization, PLS usage, ammunition movement, and MHE availability within the theater. Clarify those policies, especially at the nodes of intersection, that address intermodal shipment of ammunition (to include combat configured loads), distribution from port to corps area, and from the CSA forward. If necessary, separate the need for intermodal delivery of ammunition from the needs for flatrack usage on the battlefield.
- ◆ When intermodal flatracks are available, consider the replacement of A-frame flatracks on prepo ships with PLS intermodal flatracks to enhance the force projection capability.

## CHAPTER 4

# Decision Implementation

## DECISION IMPLEMENTATION PLANS

In April 1994, the recommendations in Chapter 3 were presented in a briefing to the Chief of Transportation; the Assistant Director for Transportation, Engineering, and Troop Support; the Deputy Commander, CASCOM; and the Deputy Acquisition Executive. The following specific elements of an implementation plan, to include responsible offices, were suggested at that time:<sup>1</sup>

- ◆ Continue to procure A-frames at 200 to 300 per month (DCSOPS/PM).
- ◆ Investigate A-frame transportation options on containerships (MTMC-TEA).
- ◆ Communicate to Congress the Army's selected approach to providing an intermodal flatrack to meet congressional objectives for force projection (HQDA).
- ◆ Continue engineering development of modified PLS LHS (PM).
- ◆ Review user requirements for intermodal flatracks with the goal of reducing costs (Transportation School/PM).
- ◆ Identify the number of intermodal flatracks required (TRADOC).
- ◆ Review user requirements for an ISO-lifting capability of a PLS truck in light of the CASCOM study of additional PLS uses (Transportation School).
- ◆ Resolve ammunition transportation safety and security issues (AMCCOM/PM AMMOLOG).
- ◆ Expand MOADS doctrine to include a node from CONUS to CSA (CASCOM).

---

<sup>1</sup>The abbreviations in the text refer to the following offices: DCSOPS is the Deputy Chief of Staff for Operations and Plans, Headquarters, Department of the Army; PM is the Program Manager for Heavy Tactical Vehicles (PLS); MTMC-TEA is the Military Traffic Management Center Transportation Evaluation Agency; HQDA is Headquarters, Department of the Army; Transportation School is the U.S. Army Training and Doctrine Command (TRADOC) Transportation School and Center; AMCCOM is the Army Munitions Command; PM AMMOLOG is the Program Manager for Ammunition Logistics; CASCOM is the U.S. Army Combat Support Center; TARDEC is the Tank-Automotive Research and Development Center; HRED is the Human Research and Engineering Directorate of the Army Research Laboratory; DCSLOG is the Deputy Chief of Staff for Logistics, Headquarters, Department of the Army.

- ◆ Investigate alternative methods for off-loading containers (e.g., slip sheets, container roll-in roll-out platform (CROP), load and roll pallets, and others) (TARDEC/HRED).
- ◆ Evaluate (including, if possible, side-by-side field tests) alternative existing intermodal ISO flatrack and container designs (PM).
- ◆ Identify and resolve engineering shortcomings of intermodal ISO designs (PM).
- ◆ Establish a PLS flatrack working group to coordinate the actions above (DCSLOG).
- ◆ Only after the actions above are resolved, revisit the decision made to produce or procure intermodal flatracks.

After we presented our recommendations and implementation plan, the TRADOC Analysis Center-Fort Lee (TRAC-LEE) was asked to review the cost and operational effectiveness of several flatrack alternatives. TRAC-LEE presented its study results in May 1994 and recommended the continued development of ISCs to deliver 40 percent of the ammunition to the theater and then to perform the MOADS distribution function as a PLS flatrack.<sup>2</sup> Although this was not the least costly alternative, TRAC-LEE rejected others for operational considerations. The recommendations of the TRAC-LEE study were not approved

At the time of the LMI and TRAC-LEE studies, an enhanced PLS flatrack (an early version of the M1 above) was completing acceptance testing prior to a full production decision by the PM and the Transportation School. This design — with inward folding end walls, a half-folding bail-bar end wall, and a rear end wall that folds outward to form a vehicle ramp — did not fully satisfy user requirements. The acceptance testing identified the need for redesign, engineering modifications, and more testing before the Army approves full-rate production. The cost and complexity of the enhanced flatrack as tested led to a directed effort to simplify the design and reduce user requirements.

The continuing debate about operational effectiveness, cost, and flatrack design led to a series of meetings to develop consensus and an action plan for future flatrack development. The features of this action plan are described below in the memorandum of agreement signed by the Chief of Transportation; the Assistant Director for Transportation, Engineering, and Troop Support, ODCSLOG; the Deputy Commander, CASCOM; and the Director, MTMC-TEA.

---

<sup>2</sup>The flatrack of this recommended alternative is most closely compared to the M1 flatracks of the LMI study. Direct comparison of alternatives between the two studies should not be made because the TRAC-LEE study alternatives considered the use of breakbulk ammunition, mixed flatrack alternatives, and a larger flatrack requirement than did the LMI study.

## MEMORANDUM OF AGREEMENT

The MOA<sup>3</sup> addressing an action plan for future flatrack development expressed the following:

- ◆ It recognized a requirement for an intermodal flatrack to support the early entry phase of force projection. The simplified M1 design with inward folding end walls (the ramp and half-folding end walls were deleted in the simplified design) meets this requirement without requiring modification of the PLS truck.
- ◆ The PM will cut in production of the M1 design to procure 5,000 M1s under the current PLS contract, with the balance of 10,047 flatracks filled with the A-frame design flatracks.
- ◆ The user-preferred design is an integral CHD. The immediate needs of the user to support prepo and early-deploying units of the contingency force will be met through the procurement of approximately 50 detachable CHDs for testing and distribution to units.
- ◆ The PM will use available funds to pursue a CHD design integral to the PLS LHS and incorporate this design into PLS trucks assigned to DS/GS ammunition units and truck companies. PLS trucks assigned to field artillery units will not be modified at this time.
- ◆ The PM will test commercial design flatracks and containers.
- ◆ The PM will use funds remaining from the limiting of production of ISCs for the competitive acquisition of additional A-frame, ISC, or commercial intermodal flatrack/containers, as recommended by the user.

## FLATRACK ACQUISITION STATUS (AS OF THE FOURTH QUARTER OF FY95)

Flatrack acquisition status is as follows:

- ◆ The simplified M1 design is currently in production by Steeltech Manufacturing, Inc. as the primary subcontractor for flatracks for Oshkosh Truck Company. Steeltech produced 15 M1 flatracks for acceptance testing and CSC certification before a full production decision was made. The test models did not pass initial acceptance testing and will be modified before acceptance testing is continued. An acceptance decision is expected before the second quarter of FY96.

---

<sup>3</sup>MOA, Subject: "Procurement of Palletized Load System (PLS) Intermodal Flatracks and Container Handling Device (CHD)," signed 22 September 1994, is reproduced as Appendix C.

- ◆ A-frame production continues at a rate of 200 to 300 units per month.
- ◆ The PM has investigated the capability of small businesses to respond to competitive contracts for additional A-frame flatracks.
- ◆ The PM has entered into a contract with Cargotec (previously MultiLift) — a British firm that has produced container handling units for the British Army — for four detachable CHD units that will fit the PLS truck. This contract will require a redesign of the rear portion of the CHD for use on U.S. Army PLS trucks. The four CHDs will be ready to participate in the testing of commercial design flatracks in the second quarter of FY96.
- ◆ Several heavy duty commercial intermodal flatracks from different manufacturers have been identified for concept testing with the CHD and PLS when acceptance testing of the ISC is completed.
- ◆ The PM is negotiating with independent sources for evaluation and design of an integral CHD and modification of the PLS LHS.
- ◆ The Army Audit Agency (AAA), as part of a broader investigation of power projection capability, has examined the use of the PLS as a power projection and battlefield distribution asset. Recommendations on flatrack and container design and AAA assessment of the Army's flatrack decisions and progress are expected in the fourth quarter of FY95.
- ◆ An unsolicited proposal to provide a modified commercial intermodal flatrack has been received by ODCSLOG, HQDA, and the PM, HTV. The basic flatrack has a proven history of use in commercial shipping and is manufactured by an international company with extensive experience in container construction. The modifications described include the addition of a PLS type bail-bar and longitudinal rails. The unsolicited cost is \$8,800 per copy. This proposal is under evaluation.

APPENDIX A

U.S. Army Operations Concept for  
Class V Support Using the Palletized  
Load System



Department of the Army  
 Headquarters, United States Army  
 Training and Doctrine Command  
 Fort Monroe, Virginia 23651-5000

24 August 1992

Military Operations

**U.S. ARMY OPERATIONS CONCEPT FOR CLASS V SUPPORT USING THE PALLETIZED LOAD SYSTEM (PLS) SHORT TITLE: MANEUVER ORIENTED AMMUNITION DISTRIBUTION SYSTEM (MOADS-PLS)**

**Summary.** This pamphlet addresses the ammunition distribution system at corps and below. Use of the PLS allows the transfer of loads to and from the vehicle without the need for materials handling equipment (MHE), thus saving resources and time. Combining MOADS with PLS allows ammunition to be delivered forward of the corps storage area (CSA) more quickly.

**Applicability.** This pamphlet applies to Headquarters TRADOC staff elements, major subordinate commands, TRADOC installations, and TRADOC centers and school.

**Suggested improvements.** The proponent of this pam-

phlet is the Deputy Chief of Staff for Combat Developments (DCSCD). Send comments and suggested improvements on DA Form 2028 through channels to Commander, HQ TRADOC, ATTN: ATCD-P, Fort Monroe, Virginia 23651-5000.

**Distribution restriction.** Distribution authorized to government agencies only because this publication contains technical or operational information for official government use only. This determination was made on 7 March 1990. Other requests for this document will be referred to Commandant, USAOMMCS, ATTN: ATSK-A, Redstone Arsenal, AL 35897-6000.

**Contents**

	Paragraph	Page
<b>Chapter 1</b>		
<b>Introduction</b>		
Purpose .....	1-1	1
References .....	1-2	1
Explanation of Abbreviations and Terms .....	1-3	2
Overview .....	1-4	2
Limitations .....	1-5	2
<b>Chapter 2</b>		
<b>Concept</b>		
Continuous Refill		
System Distribution .....	2-1	2
Shipment and Storage .....	2-2	2
Effects of Palletized Load		
System on Current Ammunition Distribution System .....	2-3	4
<b>Appendix A</b>		
Doctrine .....		5
<b>Appendix B</b>		
Training .....		5
<b>Appendix C</b>		
Leader Development .....		5
<b>Appendix D</b>		
Organization .....		5
<b>Appendix E</b>		
Material .....		6
Glossary .....		6

**Chapter 1  
Introduction**

**1-1. Purpose.** This pamphlet provides the Army with a Class V support concept that is responsive to the combat user's needs. This pamphlet describes the concept of using the Palletized Load System (PLS) to support the Airland Battlefield (ALB). The concept provides a logical transition to the logistical support concepts currently envisioned for the Army of the future. The Maneuver-Oriented Ammunition Distribution System (MOADS) using PLS, will provide faster response times, combat-configured loads (CCLs) for high consumption ammunition, and 100 percent of the user's total ammunition requirement through the ammunition transfer points (ATPs).

**1-2. References.**

Related publications are listed below.

- a. AR 710-1 (Centralized Inventory Management of the Army Supply System)
- b. FM 9-6 (Munitions Support in the Theater of Operations)
- c. FM 9-38 (Conventional Ammunition Unit Operations)
- d. FM 55-10 (Movement Control in a Theater of Operations)
- e. FM 63-3 (Combat Service Support Operations Corps)
- f. FM 100-10 (Combat Service Support)
- g. FM 100-16 (Support Operations: Echelons Above

\*This pamphlet supersedes TRADOC Pamphlet 71-6, 17 September 1990.

Corps)

h. TRADOC Reg 11-16 (Development and Management of Operational Concepts)

i. TRADOC Pam 525-49 (Ammunition Support on the AirLand Battlefield)

### 1-3. Explanation of abbreviations and terms.

The glossary contains abbreviations and explanations of special terms used in this concept.

### 1-4. Overview.

a. MOADS is the foundation for future ammunition support to the ALB; however, the needs of deployed combat forces require rapid movement of ammunition to ensure successful tactical operations on the ALB. The current structure requires a repeated lift capability at CSAs and ammunition supply points (ASPs) and cannot respond quickly to fluctuations on the battlefield. Forward ammunition stocks are not easily relocated or repositioned within the commander's decision window for application of deep attack principles or nonlinear tactical maneuvers.

b. Large quantities of grounded ammunition stocks present lucrative targets for all levels of threat forces. Threat forces will make a concerted effort to locate, target, and destroy ammunition operations storage sites to degrade U.S. combat capabilities and effectiveness. Threat forces include the following:

- (1) Conventional, unconventional and special purpose forces.
- (2) Air mobile, ground, and airborne units.
- (3) Tactical and bomber aircraft.
- (4) Long-range artillery, rockets, and missiles (air and ground launched).
- (5) Nuclear, biological, and chemical (NBC) weapons.
- (6) Directed energy weapons.

c. Threat forces vary in size from one-man saboteurs to an operational maneuver group. The ammunition distribution system must be designed so that a nuclear or nonnuclear attack on one or several storage sites does not produce catastrophic losses to the theater or corps.

d. The PLS enhances the MOADS. The PLS facilitates the relocation of ammunition stocks by combining the use of loaded sideless containers (SCs) and PLS transportation prime movers in ammunition supply point (CSAs, ASPs, and ATPs). Stocks are no longer grounded but are stored on SCs. These SCs, in simplified terms, slide directly on or off the PLS vehicle. The vehicle can drop off or pick up an SC loaded with ammunition in a matter of minutes. The ammunition transfer and movement capability increases, and the need for organic MHE decreases.

e. The PLS is a highly flexible system that is employable worldwide and complements operational requirements of the ALB. PLS eliminates the need to transload ammunition for those user units owning PLS vehicles, freeing MHE and personnel from transload operations.

Those units having PLS capabilities will normally pick up loaded SCs of ammunition at designated ammunition supply points. Currently, the only units designated to receive the PLS vehicle are corps transportation units, direct support (DS) and general support (GS) ammunition companies, and self-propelled (8-inch, 155-mm) artillery units. Units not equipped with PLS will continue to be supported at designated supply/transfer points using onboard MHE or ammunition supply/transfer point MHE to transload ammunition onto organic vehicles. If and when Multiple Launch Rocket System (MLRS) units are equipped with PLS vehicles, they will be supplied in the same manner as other artillery units with PLS vehicles. In the future, SCs may allow throughput of ammunition directly from Continental United States (CONUS) to the using unit, reducing the need for intermediate handling.

### 1-5. Limitations.

a. PLS must be fielded in corps sets. A corps set consists of corps transportation units, DS and GS ammunition companies, self-propelled artillery units, and additional SCs for storage of ammunition at the theater storage area (TSA), CSA, and ASP.

b. The ammunition distribution system uses air transportation. SCs will be transportable by C-141, C-5, C-130, and C-17 aircraft and can be carried externally by CH-47D helicopters.

## Chapter 2 Concept

### 2-1. Continuous refill system distribution.

Ammunition support in a theater of operations is based on a continuous refill system distribution to the ATPs and ASPs in the division area. Stocks issued to users are replenished by stocks moved up from storage areas in the rear. Ammunition is delivered on SCs from CSAs and ASPs by PLS prime movers to the ATPs. The ATPs receive 75 percent of their ammunition from the CSA and 25 percent from the ASPs.

### 2-2. Shipment and storage.

A theater's ammunition is shipped from CONUS to sea-ports, airheads, or logistics over-the-shore operations sites. Once in theater, the ammunition (containerized or breakbulk) is shipped on theater transportation assets to the TSA or the CSA.

a. Theater Storage Area. The TSA stores up to 30 days of supply of the theater's Class V reserves. One or more GS ammunition companies operates the TSA. The TSA receives 100 percent of its ammunition from the port of debarkation (POD). The TSA generally ships ammunition on theater line haul trailers or rail flatcars to the CSA. The TSA may use inland waterways if available. Theater transportation will not include PLS prime movers unless they are available from host nation support units. TSAs also provide support on an area basis to communication zone users who pick up required/allocated ammunition at their supporting TSA.

b. Corps storage area. The CSA maintains 7 to 10 days of supply for the supported corps. One or more GS

ammunition companies, depending on the corps authorized stockage level operate the CSA. The CSA receives up to 50 percent of its ammunition from the POD. The rest, 50 percent or more, comes from the TSA transported on line haul trailers or rail flatcars. Ammunition received by the CSA can be in either CCL or single Department of Defense Identification Code (DODIC) configuration. All ammunition shipped from the CSA to ATPs will be combat-configured loads on PLS SCs transported by corps transportation units using PLS prime movers. Ammunition shipped from the CSA to ASPs may be in breakbulk or single DODIC configuration.

(1) Based on divisional forecasted needs and updated changes, the CSA, using PLS corps transportation, ships ammunition to the ATP in CCL configuration.

(2) The CSAs provide support to units operating in the corps rear on an area basis with local units picking up required/allocated ammunition at the CSA.

c. Ammunition supply prints. ASPs maintain a 1- to 3- day supply of ammunition to meet surge and emergency requirements for divisional and nondivisional units. ASP stockage levels are dependent on tactical plans, availability of ammunition, and vulnerability of lines of communication (LOC) to interdictions (air or ground). Their primary role is to allow continuous resupply to ATPs even if the CSA-ATP LOC is interrupted.

(1) The DS ammunition company is capable of operating up to three ASPs and provides personnel and equipment for operation of an ATP. One hundred percent of the tonnage arriving at the ASPs is shipped from the CSA in either break bulk or single DODIC configuration on PLS vehicles.

(2) The ASP can provide up to 25 percent of the division requirement in the form of CCL, break bulk, and single DODIC shipments on PLS SCs. ASPs primarily support the ATPs but will provide support on an area basis when required.

d. Ammunition transfer point. Corps PLS vehicles supply the three forward ATPs organic to the forward support battalion of the division and the ATP operated by the DS ammunition company. These ATPs provide support, on an area basis, to divisional units and corps units (in support of division) based upon established corps/division priorities. Forward ATP supplies, equipment, and personnel move with the brigade trains.

(1) The ATP receives 75 percent of its ammunition from the CSA and 25 percent from the ASP. The ammunition shipped to ATPs is carried on corps PLS vehicles. Seventy-five percent of the ammunition from the CSA and 25 percent from the ASP is shipped to ATPs on corps PLS vehicles. Ammunition is transferred from corps PLS vehicles to the user's tactical vehicles, using either resupply vehicles with onboard MHE, such as Heavy Expanded Mobility Tactical Truck (HEMTT) or PLS, or the ATP's organic MHE. The division ammunition office (DAO) coordinates ATP operations/resupply with corps and divisional units. All division and corps users will pick up their ammunition at the DAO- designated ASP or ATP. The ATPs are replenished as required.

(2) (An ATP staffed with personnel and equipment from the DS ammunition company of the corps support group.) This ATP augments the three brigade ATPs so that divisional and corps units can receive 100 percent of their ammunition through ATPs. This ATP provides support on an area basis to divisional and corps units as directed by the DAO.

(3) Under emergency/surge conditions and, when METT -T factors permit, ammunition may be delivered to the battalion trains area of those units equipped with PLS vehicles.

(4) Multiple Launch Rocket System ammunition for divisional and corps units will be delivered to designated ATPs. Using units will transload rocket pods from corps PLS vehicles onto user vehicles, using their onboard MHE.

(5) Corps transportation assets will recover empty SCs at the ATP and return them to the ammunition distribution system. Empty PLS SCs are designed to allow stacking one upon another, allowing movement of more than one SC per lift. Using units equipped with PLS vehicles are responsible for managing and recovering SCs used for internal distribution. At the ATP, exchange of empty SCs from the using unit should be on a one-for-one basis with loaded SCs. If corps transportation units are directed to deliver loaded SCs to the using unit field trains area, the using unit should provide empty SCs to the using battalion trains area for recovery by corps transportation trucks. If such provisions are not possible, the using unit will consolidate empty SCs and deliver them to the supporting ATP as soon as possible for subsequent reintegration into the distribution system. Accountability and control of war-reserve SCs are covered by AR 710-1, Chapter 6.

(a) During transition to war, SCs will be loaded at storage sites and released for movement to upload forward locations. Once ammunition starts flowing to using combat units, loaded SCs will be exchanged for unloaded ones on a one-for-one basis. Retrograded SCs will be delivered to designated ammunition activities for their subsequent MOADS use.

(b) The Department of the Army Movement Management System (DAMMS) will provide transportation management information that allows in transit visibility. The theater/corps/division movement control organization will control the flow in accordance with procedures in FM 55-10.

(6) Ammunition support for rear operations is by supply point distribution. Units draw from the nearest ammunition supply activity—ASP, CSA, or TSA.

(7) FM 9-6, chapter 2, describes the communications requirements and capabilities of ammunition units from ATP to Theater Army Area Command (TAACOM) Materiel Management Center (MMC). The use of PLS within the MOADS system does not create additional ammunition communications requirements or impact on the existing communications capabilities of ammunition units.

(8) The introduction of PLS within the MOADS does not generate additional information management requirements within the Standard Army Ammunition System (SAAS) beyond that outlined in FM 9-6.

2-3. Effects of palletized load system on current ammunition distribution system. The PLS, in simplified terms, allows an SC of ammunition to slide on or off the PLS prime mover and trailer, which provides more flexibility in ammunition distribution by reducing the need for MHE. Because the transfer is quicker, users spend less time in the area, thus reducing the signature of the ammunition supply points and ammunition transfer points. (See figure 2-1). The introduction of the PLS in the current concept causes some changes in ammunition distribution throughout the theater.

a. The port of debarkation receives 100 percent of its ammunition stocks from the wholesale Class V system, either from CONUS depots or Outside the Continental United States (OCONUS) pre-positioned war reserve sites. This ammunition will arrive at the port in either break bulk or containerized shipments. Ammunition will

be shipped forward to the TSAs and CSAs via theater transportation assets.

b. The TSAs receive 100 percent of their ammunition from PODs. Containerized ammunition arriving from the POD will be removed from the container and loaded onto SCs in a single DODIC configuration for storage at the TSA or forward movement to the CSA via theater transportation assets.

c. The CSA receives 50 percent of its Class V stock requirement from the POD, either break bulk or containerized. The remaining 50 percent of the CSA requirement will arrive on SCs from the TSA. The CSA builds CCLs of ammunition on SCs and ships them to ATPs on corps transportation PLS vehicles. Additionally, CSAs ship single DODIC break bulk stocks on SCs to ASPs on corps transportation PLS vehicles.

d. The CSA ships 100 percent of the ASP requirements on break bulk or single, DODIC-loaded SCs and 75 percent of the ATP requirements on CCL-loaded SCs transported by PLS vehicles. The ASP ships the remain-

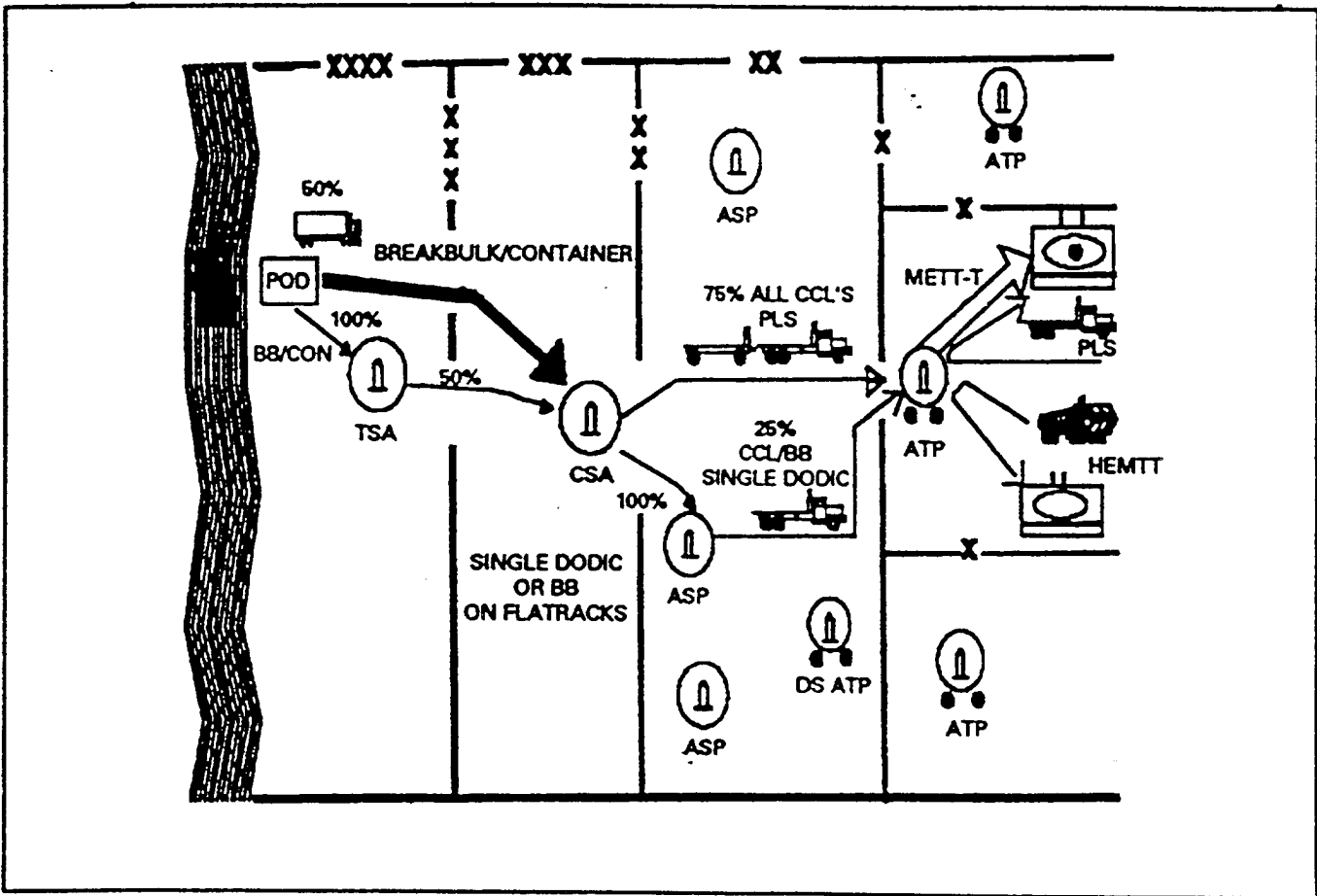


Figure 2-1.  
MANEUVER ORIENTED AMMUNITION DISTRIBUTION SYSTEM  
USING PALLETIZED LOAD SYSTEM (PLS)

ing 25 percent of the ATP requirements in the form of CCLs and single DODIC shipments.

e. The addition of PLS to MOADS will eliminate the need to transload ammunition at ATPs for those user units owning PLS vehicles, thus reducing the requirement for personnel and MHE involved in transloading operations.

f. While the ultimate goal of using PLS is to reduce transload functions at the ATP, units not possessing PLS vehicles will still require some transload support. Unit vehicles with on-board MHE will be used to self-transload ammunition whenever possible. Ammunition units and ATPs will retain adequate personnel and MHE to provide transload support to non-PLS units.

g. When an SC is delivered to the battalion trains area, ATP, or ASP, corps transportation picks up an empty SC for recycling within the distribution system.

h. The ammunition distribution system uses air transportation. PLS SCs will be air transportable.

i. The PLS offers the potential to connect the wholesale and retail ammunition distribution system by loading SCs at the manufacturer and shipping them to any destination within the system. Interface between the wholesale/retail systems would reduce redundant handling and decrease shipping time.

j. Impact assessments for doctrine, training, leader development, organization, and materiel are provided in appendices A, B, C, D, and E respectively.

## Appendix A Doctrine

Where appropriate, MOADS, including PLS doctrine, will fit the standard Army supply system. Specific comments and guidelines regarding MOADS are found in several manuals. When PLS is fielded, the following publications may require revision.

- a. AR 385-64  
(Ammunition and Explosives Safety Standards)
- b. FM 9-6  
(Munitions Support in the Theater of Operations)
- c. FM 9-13  
(Ammunition Handbook)
- d. FM 9-38  
(Conventional Ammunition Unit Operations)
- e. FM 63-3  
(Combat Service Support Operations - Corps)
- f. FM 100-10  
(Combat Service Support)
- g. FM 100-16  
(Support Operations)
- h. ST 9-38-1  
(Division Ammunition Operations)
- i. TM 9-1300-206  
(Ammunition Explosive Standards)

## Appendix B Training

a. Existing training programs impacted at the U.S. Army Ordnance Missile and Munitions Center and School include the following:

(1) Some instruction in the Maneuver Oriented Ammunition Distribution System utilizing Palletized Load System (include in the program of instruction (POI) for Ordnance Officer advances and Basic courses.)

(2) Some instruction for MOADS/PLS in the 55B, 55X, Advanced and Basic Warrant Officer, Basic Noncommissioned Officer Course (BNCOC) and Advanced Noncommissioned Officer course (ANCO) courses.

b. Implementation of MOADS/PLS initial operational capability (IOC) should not generate any new instructor contact hours for courses in para B-1.

c. MOADS/PLS training will be included in corps storage area, ammunition supply point, and ammunition transfer point exercises conducted during 55B, BNCOC, and ANCO courses.

d. The system training plan (STRAP) for the PLS developed by the U.S. Army Transportation School on 1 November 1990. The plan identifies training impacts for transportation, field artillery, ordnance munitions, and ordnance maintenance proponents, including active and reserve components. Paragraph 8 of the STRAP, "Significant Training Issues at Risk," identifies no problem areas with system or proponent training.

## Appendix C Leader Development

There are no specific leader development impacts identified at this time.

## Appendix D Organizations

a. Successful tactical operations on the AirLand Battlefield (ALB) will require rapid movement of ammunition. The current structure requires a repeated lift capability at corps storage areas and ammunition storage points. It cannot respond quickly to fluctuations on the battlefield. While the Maneuver Oriented Ammunition Distribution System serves as the foundation for future ammunition support to the ALB, it does not allow forward ammunition stocks to be easily relocated or repositioned.

b. The Palletized Load System (PLS) will enhance MOADS. The PLS will be incorporated into unit operations as a means of providing an efficient method of storage and distribution of ammunition as follows:

(1) The general support (GS) ammunition company from the theater storage area (TSA) to the CSA and from the CSA to the combat user.

(2) The direct support (DS) ammunition company from the ASPs through ammunition transfer points to the combat user or, in some instances, directly to combat

users.

c. The mission and support requirements of such organizations indicate they should be 50 percent mobile with organic equipment/vehicles.

(1) The DS ammunition company (at ASP, ATP) must be able to establish and operate three ATPs and one ATP engaged in the receipt, storage, combat configuration, and issue of conventional ammunition to the combat user using the PLS.

(2) The GS ammunition company (at TSA, CSA) must be able to establish and operate an ammunition supply facility engaged in the receipt, storage, rewarehousing, and container unstuffing of conventional ammunition. Additionally, the GS ammunition company at the CSA builds combat-configured loads and issues conventional ammunition using the PLS.

## Appendix E Materiel

Material requirements. Incorporation of the Palletized Load System (PLS) into ammunition units provides for increased efficiency in ammunition distribution by reducing the transload requirement and need for MHE.

## Glossary Section I

### Abbreviations

ADA	air defense artillery
ALB	AirLand Battle/Battlefield
ASP	ammunition supply point
ATP	ammunition transfer point
BB	break bulk
BSA	brigade support area
BTOE	base table of organization and equipment
CCL	combat-configured load
CON	containerized
CONUS	Continental United states
CSA	corps storage area
CSR	controlled supply rate
DAMMS	Department of the Army Movement Management System
DAO	division ammunition office
DIVARTY	division artillery
DODIC	Department of Defense Identification Code
DS	direct support
FAASV	field artillery ammunition support vehicles
GS	general support
HEMTT	heavy expanded mobility tactical truck
HNS	host nation support
LOC	lines of communication
LOTS	logistics over the shore
MECH	mechanized
MHE	materials handling equipment
MLRS	Multiple Launch Rocket System
MOADS	Maneuver Oriented Ammunition Distribution System

MMC	Material Management Center
MOPP	mission oriented protective posture
NBC	nuclear, biological, and chemical
OCONUS	Outside Continental United states
OTOE	objective table of taganization adn equipment
PLS	Palletized Load System
POD	port of debarkation
SC	sideless container
S&P	stake and platform trailer
TAACOM	Theater Army Area Command
TSA	theater storage area

## Section II Terms

### Ammunition transfer point

The point where corps transportation Palletized Load System vehicles, loaded with ammunition, rendezvous with user representatives and ground their ammunition loaded SC, pick up empty SC and return to designated distribution points.

### Combat configured loads

A preplanned package of ammunition transported as a single unit. CCLs are designed to support a type unit or weapon system and to maximize the transportation assets available either a PLS SC or a stake & platform (S&P) trailer. The design of CCLs should take into consideration both U.S. and host nation transportation assets. (See also FM 9-6, 1 Sep 89).

### DODIC

Department of defense Identification Code used to identify a type round of ammunition (i.e., A080 for 5.56-mm blank).

### Port of debarkation

The point of initial off-load of ammunition received in theater from CONUS.

### Push/pull system

Ammunition is delivered delivered regularly on a push type basis. Forecasted changes to the type and quantity of ammunition delivered are submitted by the unit when the standard delivery requires deviation.

### Self-loading

A vehicle with the capability to load itself using on-board materials handling equipment.

### Throughport

Term used to describe shipments that bypass intermediate activities in the supply system, thereby avoiding multiple handling.

FOR THE COMMANDER:

OFFICIAL:

JOHN P. HERRLING  
Major General, GS  
Chief of Staff



DAVID G. FITZ-ENZ  
Colonel, GS  
Deputy Chief of Staff for  
Information Management

DISTRIBUTION:

H1; H3; S1

Copies furnished:  
H2

APPENDIX B

# Memorandum of Agreement



MEMORANDUM OF AGREEMENT  
BETWEEN  
THE CHIEF OF TRANSPORTATION,  
ASSISTANT DIRECTOR OF TRANSPORTATION, ODCSLOG,  
DEPUTY TO THE COMMANDER, CASCOM,  
AND  
DIRECTOR, MILITARY TRAFFIC MANAGEMENT COMMAND TRANSPORTATION  
ENGINEERING AGENCY

SUBJECT: Procurement of Palletized Load System (PLS) Intermodal Flatracks and Container Handling Device (CHD)

1. Reference:

a. Memorandum, USATSCH, ATSP-CDM, 10 Jan 92, subject: Palletized Load System (PLS) Flatrack Program.

b. Memorandum, USATSCH, ATZF-CG, 26 May 94, subject: Palletized Load System (PLS) Intermodal Shipping Container (ISC).

c. Briefing by PEO Representative, Fort Eustis, VA, 19 Jul 94, SAB.

d. Video Teleconference, Fort Eustis, VA, 27 Jul 94, SAB.

e. Teleconference, Fort Eustis/Fort Lee/Pentagon, 28 Jul 94 SAB.

2. Reference 1a identified ISC characteristics required to meet the user need. Reference 1b modified the characteristics to reduce ISC cost and weight and requested MG Whaley be briefed on status of ISC prior to execution of Engineering Change Proposal (ECP). Reference 1c was an ISC and CHD status briefing to MG Whaley by the Program Manager for Heavy Tactical Vehicles (PM-TVH). Reference 1d was a decision briefing on the need and required capabilities of both an intermodal flatrack and a container handling device. Reference 1e was a teleconference among principal participants in reference 1d.

3. The purpose of reference 1d was to obtain decisions on the Army need for an intermodal flatrack, capabilities an intermodal flatrack should have, ~~whether~~ or not a commercial flatrack could meet Army requirements, CHD requirements, and the use of funds available for PLS flatracks.

4. Principal participants were MG Whaley, Chief of Transportation; Mr. O'Konski, Assistant Director of Transportation, HQDA ODCSLOG; Mr. Edwards, Deputy to the

SUBJECT: Procurement of Palletized Load System (PLS) Intermodal Flatracks and Container Handling Device (CHD)

Commander, CASCOM; and Mr. Collinsworth, Director, MTMC Transportation Engineering Agency. Other attendees are at enclosure 1.

5. During decision meetings on 27 and 28 July 1994 (reference id and 1e), the principal participants agreed to the following:

a. A requirement exists for an intermodal flatrack to support the early entry phase of force projection. The current ISC design will satisfy this requirement without requiring modification to the PLS truck.

b. The required feature for storage/retrograde capability of an intermodal flatrack is two inward folding end walls for empty stacking. A previous decision to delete the requirements for a ramp and a half-fold hook-bar end wall (reference 1b) is confirmed.

c. The user will request PM-Heavy proceed with the cut-in of the ISC design, to procure 5,000 ISCs at best value price under the current PLS flatrack contract. The 5,000 ISC buy will be used for the following:

- (1) PREPO.
- (2) Carry unit basic load for contingency corps lead units.
- (3) Staged to be loaded into an ammunition containership for surge resupply.
- (4) Support Corps MOADS distribution.

d. The balance of the current flatrack contract requirement of 15,047 will be filled with A-Frame version flatracks.

e. The user preferred design is an integral CHD which will provide the flexibility needed for PLS trucks in ammunition support and transportation units to move any 20 foot ISO envelope items and PLS flatracks.

f. An immediate requirement exists for CHDs to support PREPO, and early deploying units of the contingency force. The user will

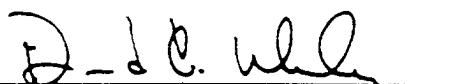
SUBJECT: Procurement of Palletized Load System (PLS) Intermodal Flatracks and Container Handling Device (CHD)

request PM-Heavy to procure approximately 50 detachable CHDs for testing and distribution to units as directed by ODCSOPS.

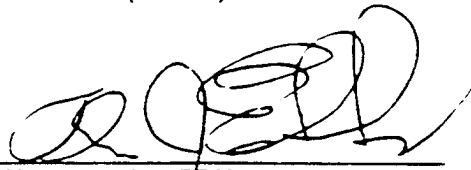
g. The CHD procurement will be supported by \$15M of current flatrack program funding previously identified for CHD, plus an additional \$5M designated by ODCSOPS from other flatrack funds. The user will request PM-Heavy use these funds (and required R&D dollars) to pursue a CHD design integral to the PLS truck load handling system. PM-Heavy will identify R&D funding requirements and request assistance with R&D funding shortfall from SARD and ODCSOPS. This integral design will be incorporated into PLS trucks (currently estimated to number 1286) assigned to DS/GS ammunition units and truck companies under the existing BOIP. The PLS trucks assigned to Field Artillery units will not be modified at this time.

h. The user will request PM-Heavy to test commercial design flatracks and containers to coincide with PM testing of early production ISCs planned for 1QFY95. ODCSOPS and ODCSLOG will assist in identifying and recommending commercial sources for testing.


i. The User will request PM-Heavy use the remaining flatrack funds conserved by the decision to limit ISC production to 5,000 under the current contract, for the competitive acquisition of additional A-Frame, ISCs, or commercial specification intermodal flatrack/containers, as recommended by the user.


  
DAVID A. WHALEY  
Major General, USA  
Chief of Transportation

9 September 1994  
(date)

  
THOMAS J. EDWARDS  
Deputy to the Commander,  
CASCOM

20 September 1994  
(date)

  
MARK J. O'KONSKI  
Assistant Director of  
Transportation, ODCSLOG  
22 Sep 94  
(date)

  
T. D. COLLINSWORTH  
Director, MTMCTEA

12 September 1994  
(date)

APPENDIX C

# Decision Tree Analysis of Alternatives

# DECISION TREE ANALYSIS OF ALTERNATIVES

We arrayed the various equipment alternatives described in Chapter 2 into a decision tree to show how selecting a particular flatrack affects other equipment decisions. Decision points, or nodes, of the decision tree correspond to three equipment decisions: flatrack type (Node 1); PLS container-lift mode (Node 2); and container type (Node 3). The combinations of these three factors (flatrack-type, PLS container transport capability, and type of container) generated a full decision tree with 60 branches (i.e., five flatrack alternatives times three container lift alternatives times four container-type alternatives). The end of each branch represents the composition of options to be evaluated, which results from an equipment decision at each decision point. The evaluation criteria described in Chapter 2 were used to narrow the number of options to be analyzed to those considered most feasible.

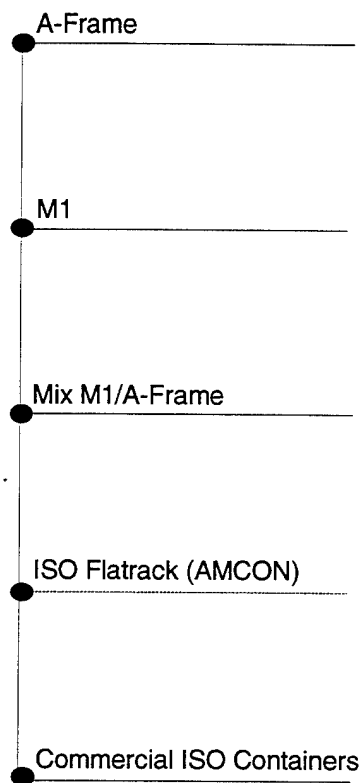
	<u>NODE 1</u>	<u>NODE 2</u>	<u>NODE 3</u>	<u>Alternatives</u>	<u>Feasible Alternatives</u>		
● A FRAME		CHD	Containers	1	•		
		MOD LHS	Bar-Bar Cont	2			
			ISO Flatracks	3			
			No Cont	4			
			Containers	5	•		
		NO CHD	Bar-Bar Cont	6			
			ISO Flatracks	7			
			No Cont	8			
			Containers	9			
		● M1		CHD	Bar-Bar Cont	10	•
				MOD LHS	ISO Flatracks	11	
					No Cont	12	
Containers	13				•		
Bar-Bar Cont	14						
NO CHD	ISO Flatracks			15			
	No Cont			16			
	Containers			17	•		
	Bar-Bar Cont			18			
● Mix M1/A FRAME				CHD	ISO Flatracks	19	
				MOD LHS	No Cont	20	
					Containers	21	•
		Bar-Bar Cont	22				
		ISO Flatracks	23				
		NO CHD	No Cont	24			
			Containers	25	•		
			Bar-Bar Cont	26			
			ISO Flatracks	27			
		● ISO FLATRACK (AMCON)		CHD	No Cont	28	
				MOD LHS	Containers	29	•
					Bar-Bar Cont	30	
ISO Flatracks	31						
No Cont	32						
NO CHD	Containers			33	•		
	Bar-Bar Cont			34			
	ISO Flatracks			35			
	No Cont			36			
● COMMERCIAL ISO CONTAINERS				CHD	Containers	37	•
				MOD LHS	Bar-Bar Cont	38	
					ISO Flatracks	39	•
		No Cont	40				
		Containers	41		•		
		NO CHD	Bar-Bar Cont	42			
			ISO Flatracks	43	•		
			No Cont	44			
			Containers	45			
		●		CHD	Bar-Bar Cont	46	•
				MOD LHS	ISO Flatracks	47	
					No Cont	48	
Containers	49				•		
Bar-Bar Cont	50						
NO CHD	ISO Flatracks			51			
	No Cont			52			
	Containers			53	•		
	Bar-Bar Cont			54			
NO CHD	ISO Flatracks			55			
	No Cont			56			
	Containers			57			
	Bar-Bar Cont	58					
NO CHD	ISO Flatracks	59					
	No Cont	60					

**Figure C-1.**  
*Full Decision Tree*

The major decision nodes of the decision tree, identified as "Node 1: Flatracks," "Node 2: Container Lift," and "Node 3: Containers," are shown in Figure C-1. The process is to move from left to right through the decision tree nodes, addressing each in sequence: First a flatrack alternative is selected, then the means of lifting a container, and finally the type of container.

## Node 1: Flatracks

This node (Figure C-2) identifies the type of flatrack selected from the five alternatives identified above: the A-frame, the M1, the AMCON, the commercial model, and the mix of A-frame/M1.



**Figure C-2.**  
*Node 1: Flatrack Alternatives*

### A-FRAME

Selection of the A-frame causes production of the M1077 A-frame flatracks to continue at 200 units per month until the total number of 15,407 flatracks under contract is produced. Subsequent contracts will be used to purchase additional A-frame flatracks until a total of 26,341 flatracks is produced.<sup>1</sup> These

---

<sup>1</sup>The Army's requirement for flatracks has been identified as over 50,000. Available funding in the foreseeable future will not support acquisition of the full requirement.

flatracks will be issued to units under the current basis of issue plans (BOIPs), one per truck and one per trailer, to all units assigned PLS trucks. GS and DS ammunition companies receive the bulk of flatracks for ammunition storage and distribution, with 1,000 flatracks per DS company and 2,500 per GS company.

The A-frame meets basic user needs and supports MOADS doctrine for ammunition distribution forward of the CSA; however, it cannot be loaded to move ammunition intermodally in a containership. The A-frame flatrack must be stacked as cargo for delivery to a theater of operations aboard RO/RO ships or fast sealift ships. A decision to select A-frame flatracks at this point in the decision tree will force later decisions to select other equipment solutions to accomplish the intermodal delivery of ammunition to the CSA.

## M1 FLATRACK

Selection of the M1 flatrack at the first node of the decision tree means that production of M1 ISO compatible flatracks begins when the production design is finalized. The current production rate of 200 A-frame flatracks per month will continue until the cut-in point of the M1 is reached (in June 1995, 8,303 A-frame flatracks had been produced), after which only M1 flatracks will be produced. A total of 18,038 M1 and 8,303 A-frame flatracks will be produced to provide an ammunition distribution capability equivalent to the A-frame flatracks alternative. M1 flatracks will be issued in accordance with the BOIP for PLS medium truck and DS and GS ammunition companies described above. The intermodal compatible flatrack will be loaded with ammunition and moved in a containership to the POD. M1 flatracks are transported from the POD to the forward division area using theater assets or PLS trucks.

The M1 meets basic user needs and supports MOADS doctrine for ammunition distribution forward of the CSA. Selection of the intermodal flatrack allows the potential configuration in CONUS of ammunition such that an M1 load is ready to fire upon delivery to the firing units without intermediate handling. Subsequent decisions will consider these features of the M1.

## MIXED A-FRAME AND M1

Selection of a mix of M1 flatracks and A-frame flatracks at the first node of the decision tree means that production of M1 ISO-compatible flatracks begins when the production design is finalized. Current production of A-frame flatracks will continue until the cut-in point of M1 is reached, after which a mix of 5,000 M1 and 10,047 A-frame flatracks will be produced under the current contract. Upon completion of the contracted M1 production quantity of 5,000, a contract for additional A-frame flatracks will be executed until the 26,341 flatracks are produced. This will provide a fleet of 5,000 M1 and 21,341 A-frame flatracks with a MOADS ammunition distribution capability equivalent to the other alternatives.

Flatracks will be issued in accordance with the BOIP for PLS medium truck and DS and GS ammunition companies described above. The M1 flatracks will be issued to support the regional deployment of one heavy division (one DS, one GS ammunition company, and supporting PLS medium truck companies).

The A-frame and M1 mix meets basic user needs and supports MOADS doctrine for ammunition distribution forward of the CSA. Selection of the flatrack mix, with the numbers of each type as shown in the decision tree, provides an intermodal ammunition distribution capability sufficient to support one deploying division. Other mixes are feasible for increasing the support of early deploying forces in a force projection role. These other mixes will alter the number of CHDs and containers at subsequent decision nodes.

#### INTERNATIONAL ORGANIZATION FOR STANDARDIZATION FLATRACK AMMUNITION CONTAINER

Selection of the AMCON at the first node of the decision tree means that production of the AMCON design flatrack begins in lieu of the M1 ISO-compatible flatracks. A-frame flatrack production continues at 200 units per month until the contract amount of 15,047 is reached, after which only AMCON flatracks will be produced. A total of 11,294 AMCONs and the 15,047 A-frame flatracks will provide a MOADS distribution capability equivalent to the 26,341 A-frame flatracks. AMCON flatracks will be issued in accordance with the BOIP for PLS medium truck and DS and GS ammunition companies described above. The AMCON is PLS compatible with intermodal features. AMCONs can be loaded with ammunition in CONUS, moved in a containership to the POD, and distributed on the PLS truck and trailer.

The AMCON supports MOADS doctrine for ammunition distribution but does not meet the full array of user needs identified for the M1 flatrack. It is anticipated that the design of PLS intermodal flatracks would start with the AMCON and evolve to a final design with appropriate tradeoffs of desired features for simplicity of design and cost. As opposed to the ISO sideless container described below, the AMCON would not require the addition of a CHD for operation.

#### COMMERCIAL INTERNATIONAL ORGANIZATION FOR STANDARDIZATION SIDELESS CONTAINER

Selection of the commercial ISO sideless containers at the first node of the decision tree would replace the M1 with a commercial design of an ISO sideless container. The intent would be to satisfy the current contract by the production of 15,407 A-frame flatracks. Additional commercial ISO sideless containers (11,294) would be competitively purchased to bring the total to 26,341. Investigation of the use of commercial products is warranted because the commercial flatracks or sideless containers are a proven commodity that can be produced by several manufacturers at a fraction of the cost of the M1 PLS flatrack. It is recognized that this sideless container may not have the suite of features desired in a military flatrack designed for ammunition distribution and will not have the



characteristic PLS load-bearing rails that allow seamless interface with the PLS truck and trailer. On the other hand, these containers have a history of successful intermodal movement of loads heavier than those anticipated for PLS movement and have competitively proven designs of hinges, tie-downs, and support rails. Acceptance testing will be necessary before a decision is made leading to production of these commercial sideless containers.

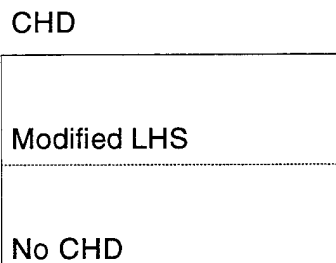
Flatracks will be issued in accordance with the BOIP for PLS medium truck and DS and GS ammunition companies described above. The sideless containers will be issued as an intermodal movement and distribution asset, first to early deploying units and afloat prepositioned stocks and then to follow-on combat and support units.

The proven design of the commercial ISO sideless container meets CSC specifications and certification requirements for intermodal movement in a container cell but has not been adapted or tested for use with PLS in a MOADS distribution role. One of the CHD variants described below will be necessary to move the sideless container with the PLS truck.

The A-frame and sideless container mix meets basic user needs, supports MOADS doctrine for ammunition distribution forward of the CSA, and provides an intermodal ammunition distribution capability.

## Container Lift

This alternative identifies the means by which ISO containers are lifted, secured, and transported on the PLS truck and trailer. Container movement is a natural mission for the PLS truck operating under the current MOADS doctrine as 75 percent of the corps sustaining ammunition moves into the CSA in containers where it is configured into CCL and loaded onto flatracks for forward distribution. Three options must be considered at this node: purchase a separate CHD, modify the LHS of the PLS truck, or do nothing (no CHD) and not transport containers (Figure C-3).<sup>2</sup>



**Figure C-3.**  
*Node 2: Container Movement Alternatives*

---

<sup>2</sup>No current design for the CHD allows a trailer as well as the PLS truck to be uploaded with a container.

## CONTAINER-HANDLING DEVICE

The CHDs are of two basic design types: a separate interface piece of equipment that connects to the container and then is engaged by the PLS LHS, and a device that becomes an integral part of the PLS LHS. An example of a separate item of equipment which serves as the prototype for detachable CHD, is the CLK, a cruciform design currently manufactured by Cargotec for use with the British Army's DROPS version of the PLS. The CHD has evolved to an H-shaped device (the CHU) whose pneumatic arms are adjustable to match with the four ISO fittings at one end of a container. The CHD is picked up by the PLS LHS and maneuvered into position on the container where the four corner ISO fittings are engaged. The container is then lifted and dragged onto the bed of the truck where it can be secured for transport.<sup>3</sup> With both the detachable and integral CHD designs, the rear of the PLS truck is modified by the addition of roller mechanisms on each side to guide and position the container as it is lifted onto the truck bed. With the detachable CHD, the CHD must be removed from the LHS hook and placed on the ground, left attached to a container, or stored on the PLS truck when the truck switches from moving containers to moving flatracks.

The basis of issue for the CHD has not yet been determined and may await the final design of the CHD. If the detachable CHD is selected, PLS trucks in artillery units may not receive the CHD because the presence of the auxiliary crane on the truck models may preclude CHD operation or storage. In this case, the CHD issue will be issued to PLS truck companies that must move containers in support of the MOADS ammunition distribution mission. If the integral CHD is selected, all PLS trucks may be modified to allow them to move ISO-configured containers or flatracks.

## MODIFIED PLS LOAD-HANDLING SYSTEM

The integral LHS design allows any PLS truck with this modification to transport any flatrack or ISO container fitting within the 8'x 8'x 20' envelope of the container without the addition of a separate piece of equipment that must be stored or carried. Conceptual designs of the modified LHS include retention of the LHS hook for flatrack transport, the addition of a lifting mechanism to the hook arm that engages two or more of the ISO fittings on one end of a container, and additional rollers on the rear of the PLS truck to support the perimeter load-bearing rails of the container.

As with the CHD above, the basis of issue for the modified LHS has not yet been determined; PLS trucks in artillery units may be modified, but their typical mission profile does not include the forward movement of containers. PLS truck companies, which interchangeably move containers and flatracks in support of the MOADS ammunition distribution mission, would be the first to receive the modified LHS.

---

<sup>3</sup>The desired operation for the U.S. Army provides for remote hookup of the CHD from within the PLS truck cab. The British Army dismounts the driver to engage the corner fitting and then operate an external set of hydraulic controls to load the container.

## NO CONTAINER-HANDLING DEVICE

Selection of this option would limit the ability of the PLS to move standard containers to those cases in which a container is first secured to an A-frame flatrack. This option is frequently chosen by the British Army and the flatrack and container become a permanent, special-purpose unit. Only A-frame flatracks can be used to move containers in this fashion because the interior dimensions of ISO intermodal flatracks are less than the outside dimensions of the container footprint. As another design possibility, standard containers could be modified by attaching a lifting point on one end (a PLS bail-bar) for pickup by the LHS on PLS trucks that had been modified by the addition of a system of rear rollers. These modified containers could be transported by the PLS without further modification of the load-handling arm or without the addition of a CHD.

### Node 3: Containers

At the third-level node, the decision centers on the choice of commercial containers for the movement of sustainment ammunition supplies to support an MRC through 60 days of combat (see Figure C-4). In this context, a container is any type of ISO-compatible shipping device that is CSC certified for intermodal movement and fits within an 8' x 8' x 20' envelope. These containers include dry-box, end-opening, side-opening, compartmented (i.e., TRICON and QUADCON), and sideless containers, along with flatracks. The number of additional containers needed for sustainment varies with the number of intermodal flatracks purchased at the flatrack decision point, because these flatracks are assumed to be deployed into the theater fully loaded.

Containers
Bail-Bar Container
ISO Flatracks
No Container

**Figure C-4.**  
*Node 3: Container Alternative*

Containers are off-loaded from containerhips at the POD and are moved forward to the CSA on theater assets. Depending on their configuration and the availability of CHD, commercial ISO containers may be transported on semi-trailers, on flatracks, or on PLS trucks. At the CSA, containers are unstuffed and their ammunition loads formed into CCL. CCL may be formed on PLS flatracks or commercial sideless containers for distribution within the corps battle area using PLS trucks.

Four alternatives were considered for this decision node: closed dry containers, modified containers with bail-bars, ISO flatracks (sideless containers), and no containers.

### *Closed Dry Containers*

This alternative uses the most commonly available type of commercial container to deliver ammunition to the CSA. Dry containers provide protection for their contents from the elements and offer a measure of security. Movement of certain types of ammunition, such as STINGER missiles or shoulder-launched rockets, warrants taking extra precautions to avoid sabotage or misappropriation. The closed container conceals its contents and at least delays and identifies unauthorized entry. In addition to protection, the closed container provides several points for internal blocking and bracing of ammunition loads. Containers can be stacked vertically in a container cell, can be offloaded by the containership with onboard cranes, and can be handled with standard container-handling equipment.

The most common method of loading ammunition containers in CONUS is in single-DODIC loads, not CCL. Single-DODIC loads usually provide the most efficient use of space within the container and avoid the safety hazards of mixed DODIC or CCL loads. To capture shipping efficiencies, the containers may be loaded to 20 short tons or more. This weight is within the design strength of the container but above the load limit of the PLS LHS. This presents no problems if the containers are moved with container-handling equipment onto semi-tractor-trailer and delivered to the CSA for reconfiguration but they would require a reduction of the load weight to a maximum of 16.5 short tons for movement by the PLS.

Most commonly, dry containers would be unloaded at the CSA and the ammunition load would be reconfigured into CCL flatrack loads for forward PLS movement. The container then would be returned to the POD for reuse. As described above, dry containers may be mounted on A-frame flatracks or may be moved on PLS trucks through the use of a CHD.

### *Modified Containers with Bail-Bar*

This alternative uses containers that have been modified by the addition of a bail-bar at one end. The bail-bar allows the PLS LHS to lift and transport the container without the addition of a CHD or modification of the LHS. The addition of a roller mechanism at the PLS truck rear is required to guide and lock down the bail-bar containers. The number of modified containers varies with the number of intermodal flatracks purchased because these flatracks are assumed to be deployed fully loaded into the theater.

### ISO Flatracks (Sideless Containers)

This alternative uses commercial flatracks to deliver ammunition to the CSA. Commercial flatracks do not offer the intermodal security and protection of dry containers but have similar handling characteristics. Flatracks offer a reduced silhouette for operations forward into combat zones and allow greater flexibility in the load-unload process through access from the top and sides. Easier access has the negative effect of increasing the attention to cargo tiedowns, blocking and bracing, or other load restraints. Flatracks, like containers, can be stacked vertically in a container cell, can be offloaded by the containership with onboard cranes, and can be handled with standard container-handling equipment. Sideless containers, with a CHD, may be unloaded at the CSA or may be throughput directly to the firing unit on a PLS truck.

### No Containers

This alternative relies on the purchase of additional PLS intermodal flatracks to replace additional container purchases. Without these additional purchases this alternative would not meet ammunition distribution needs for an MRC.

## EVALUATION OF ALTERNATIVES

The 60 branches of the complete decision tree are too many to consider in depth and include some branches that do not meet the objectives of force projection or lower cost or are clearly dominated by other decision options.<sup>4</sup> We screened these branches by means of a qualitative assessment matrix which evaluates each branch against each of the criteria. The results of this qualitative assessment are shown in the tables below. Although all criteria were considered to discriminate among alternatives, some criteria are of greater importance. The minimum requirements that must be satisfied by an acceptable alternative are as follows:

- ◆ The option must meet MRC operational requirements for *battlefield ammunition delivery*.
- ◆ The option must provide for sufficient intermodal movement of ammunition for *force projection*.
- ◆ The option must meet most *user equipment* and operational requirements.
- ◆ The option must be free of significant or high risk *engineering requirements*.
- ◆ The option must support *future PLS development* and fielding.

---

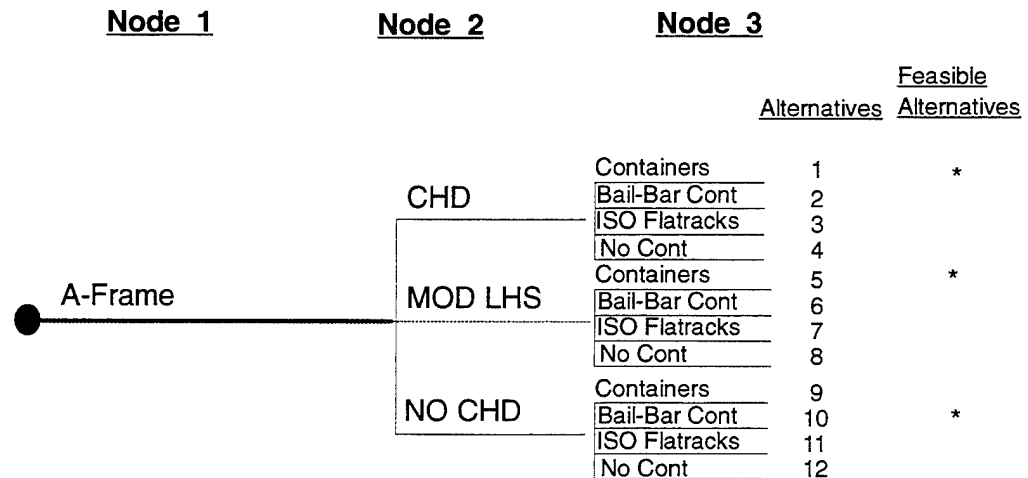
<sup>4</sup>An alternative "dominates" another alternative if it rates equal or better on all evaluation criteria and better than the second alternative on at least one criterion.

Application of these minimum requirements to the 60 decision-tree branches reduced our decision-tree outcomes to 16 feasible options. The pros and cons of each of these feasible alternatives are identified in the following subsections.

Twelve possible combinations of flatrack, CHD, and container emanate from each major flatrack alternative (Node 1) of the decision tree. We examined each of these major branches of the decision tree below. For each case, we show the portion of the decision tree we are focusing on, the matching portion of the qualitative assessment with an identification of the feasible alternatives that remain after the screening, and a table indicating pros and cons for the alternative combination.

## A-Frame

A-frame flatracks can meet the MRC ammunition distribution mission but must be augmented with containers to ensure sufficient intermodal ammunition delivery. ISO containers can be moved using either the CHD or the modified LHS. If these CHDs are present then dry containers or ISO flatracks can be selected. The lower cost and weight and increased security of closed containers would lead to preferences for the dry container. If CHD were not present, only the bail-bar container could provide an intermodal delivery and force projection capability. The result of our qualitative assessment of A-frame flatrack branches (see Figure C-5) is shown in Table C-1. The A-frame branch provides three acceptable alternatives that are identified in Table C-1. Their pros and cons are summarized in Tables C-2 through C-4.



**Figure C-5.**  
*Decision Tree: A-Frame Node*

**Table C-1.**  
*Evaluation Criteria Matrix for A-Frame*

Alternative	M				
	MRC ammunition requirement	Intermodal ammunition movement	User option requirement	Low-risk engineering development	Supports and enhances PLS
* CHD/container	•	•	•	•	•
Bail-bar	•	•	+	•	•
ISO flatrack	•	•	•	•	•
No container	•	-	•	•	•
* Modified LHS/cont.	•	•	•	•	+
Bail-bar	•	•	+	•	+
ISO flatrack	•	•	+	•	+
No container	•	-	•	•	+
No CHD/container	•	•	-	+	-
* Bail-bar	•	•	•	+	+
ISO flatrack	•	•	-	•	-
No container	•	-	-	+	-

**Note:**

- + = Performs significantly better than other alternatives on this measure.
- = Performs significantly worse.
- = Adequate performance.
- \* = Feasible.

MOE

ing	Supports and enhances PLS	Cost investment	Transportability	Limits additional requirements	Satisfies congressional requirements	Supports additional uses
	•	•	•	-	-	+
	•	-	•	-	•	+
	•	-	•	-	•	+
	•	•	•	-	-	+
	+	•	•	-	•	+
	+	-	•	-	•	+
	+	-	•	-	•	+
	+	•	•	-	•	+
	-	•	-	+	-	-
	+	-	•	+	-	-
	-	-	-	+	-	-
	-	•	-	+	-	-



**Table C-2.**  
*A-Frame with CHD with Container*

Pros	Cons
<ul style="list-style-type: none"> <li>• A-frame flatracks and containers are tested and produced.</li> <li>• The lower weight of the A-frame flatrack allows a greater ammunition payload on the PLS.</li> <li>• Containers can be moved on A-frame flatracks or with the CHD.</li> <li>• A-frame flatracks can be unloaded by a PLS crane or by a 6,000-pound forklift.</li> <li>• An operational test of the flatrack indicates that the simple design is accepted by soldiers.</li> <li>• The CHD provides the capability to pick up any ISO 20-foot envelope.</li> <li>• This is a moderate-cost alternative.</li> <li>• Satisfies MOADS distribution without modification of doctrine, training, or procedures.</li> </ul>	<ul style="list-style-type: none"> <li>• The CHD design is not tested; CLK introduces another PLS component.</li> <li>• The fixed end wall A-frame flatracks cannot be stacked in containership cell guides but instead must be loaded on 40-foot MSC flatracks or on RO/RO ships.</li> <li>• A-frames arrive as non-container cargo.</li> <li>• Ammunition containers must be handled in the CSA with or without the use of CCLs.</li> <li>• One would need to convince Congress that this movement of ammunition in containers satisfies its objectives for intermodal movement.</li> </ul>

**Table C-3.**  
*A-Frame with Modified LHS with Containers*

Pros	Cons
<ul style="list-style-type: none"> <li>• An integral modified LHS would be designed to offer great flexibility and versatility without introducing a separate component to the PLS system.</li> <li>• Containers can be mounted on A-frames for movement or can be moved with the LHS.</li> <li>• A-frame flatracks and containers are tested and produced.</li> <li>• The lower weight of A-frame flatrack allows a greater ammunition payload on the PLS.</li> <li>• A-frame flatracks can be unloaded by a PLS crane or by a 6,000-pound forklift.</li> <li>• An operational test of the flatrack indicated that the simple design is acceptable to soldiers</li> <li>• This moderate-cost alternative.</li> <li>• This satisfies MOADS distribution without modification of doctrine, training, or procedures</li> </ul>	<ul style="list-style-type: none"> <li>• The LHS design is not completed or tested; PLS truck modifications have not been accomplished.</li> <li>• LHS has an engineering risk.</li> <li>• LHS would need to meet all PLS component interoperability requirements.</li> <li>• The fixed end wall A-frame flatracks cannot be stacked in containership cell guides but instead must be loaded on 40-foot MSC flatracks or on RO/RO ships.</li> <li>• Ammunition containers must be handled in the CSA with or without the use of CCLs.</li> <li>• One would need to convince Congress that this satisfies its objectives.</li> </ul>

**Table C-4.**  
*A-Frame with No CHD with Bail-Bar Containers*

Pros	Cons
<ul style="list-style-type: none"> <li>• Current design of PLS and containers has proven producibility.</li> <li>• Bail-bar containers provide some intermodal capability.</li> <li>• A-frame flatracks and containers are tested and produced.</li> <li>• Lower weight of A-frame flatrack allows a greater ammunition payload on the PLS.</li> <li>• A-frame flatracks can be unloaded by PLS crane or by 6,000-pound forklift.</li> <li>• Operational test of the flatrack indicate that the simple design is accepted by soldiers.</li> <li>• Satisfies MOADS distribution without modification of doctrine, training, or procedures.</li> </ul>	<ul style="list-style-type: none"> <li>• Requires the addition of roller/slider system and locking system if the bail-bar container does not have PLS rails.</li> <li>• Would need to convince Congress that this satisfies its objectives.</li> <li>• Does not support all follow-on uses of PLS [such as deployable medical shelters (DEP-MEDS), etc.].</li> <li>• Fixed end wall A-frame flatrack cannot be stacked in containership cell guides but must be loaded on 40-foot MSC flatracks or on RO/RO ships.</li> <li>• A-frames arrive as noncontainer cargo.</li> <li>• Ammunition containers must be handled in the CSA with or without the use of CCLs.</li> <li>• This is a high cost alternative.</li> <li>• No capability to move other ISO containers except when mounted on A-frame.</li> </ul>

## M1 Flatracks

The M1 flatracks are CSC certified for intermodal movement in container cells and can meet the MRC ammunition distribution mission as a PLS asset, at a weight penalty when compared to the A-frame. If the existing flatrack contract with Oshkosh Truck Company/Steeltech Manufacturing, Inc. were immediately switched to the sole purchase of M1 flatracks, 6,744 M1s and 8,303 A-frame flatracks would be produced (see Figure C-6). Filling out the required 26,341 flatracks by purchasing M1 flatracks also requires that an additional 1,062 ISO intermodal containers of some type be purchased. Either dry containers or ISO flatracks can be moved with the CLK or modified LHS. Closed containers would be preferred for the safety and security provided the ammunition. If CHD were not present, the M1 could continue to function but only the bail-bar container could be moved on the PLS truck. The truck would need rear-end slider/roller modifications to move the ISO containers. The three feasible alternatives are identified in Table C-5 and their pros and cons summarized in Tables C-6 through C-8.

**Table C-5.**  
*Evaluation Criteria Matrix for M1*

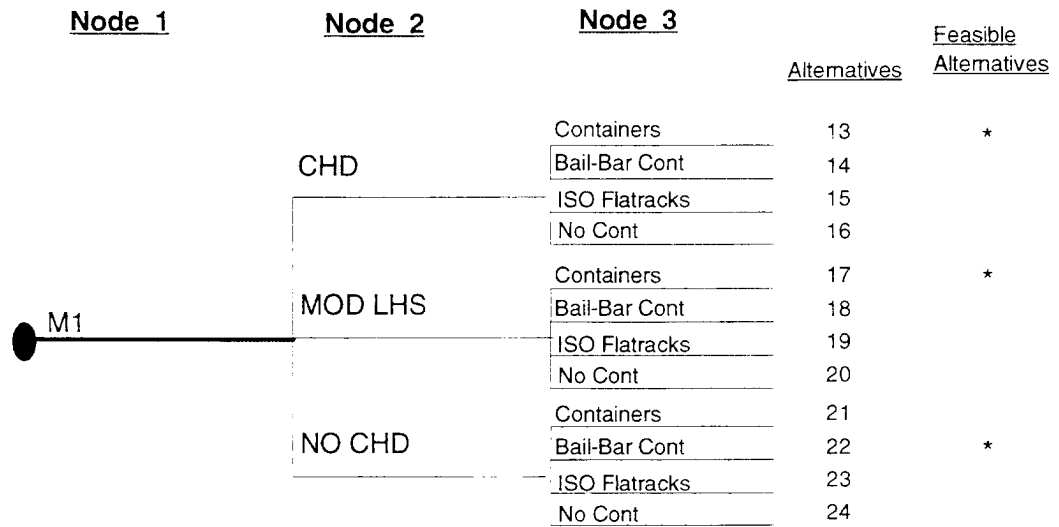
Alternative					
	MRC ammunition requirement	Intermodal ammunition movement	User option requirement	Low-risk engineering development	Support enhance
* CHD/container	+	+	•	•	+
Bail-bar	+	+	•	•	-
ISO flatrack	+	+	•	•	+
No container	•	+	•	•	-
* Modified LHS/container	+	+	•	•	+
Bail-bar	+	•	•	•	+
ISO flatrack	+	+	•	•	+
No container	•	+	•	•	+
NoCHD/container	+	-	-	-	-
* Bail-bar	+	+	-	•	+
ISO flatrack	+	+	-	•	-
No container	•	-	-	•	-

**Note:**

- + = Performs significantly better than other alternatives on this measure.
- = Performs significantly worse.
- = Adequate performance.
- \* = Feasible.

MOE

Engineering ment	Supports and enhances PLS	Cost investment	Transport ability	Limits additional requirements	Satisfies congressional requirements	Supports additional uses
	+	-	•	-	+	+
	-	-	+	-	+	+
	+	-	•	-	+	+
	-	-	•	-	+	+
	+	-	•	-	+	+
	+	-	+	-	+	+
	+	-	•	-	+	+
	+	-	•	-	+	+
	-	-	-	+	+	-
	+	-	•	+	+	•
	-	-	-	+	+	•
	-	-	-	-	-	•



**Figure C-6.**  
*Decision Tree: M1 Node*

**Table C-6.**  
*Intermodal Shipping Container (M1) with CHD with Containers*

Pros	Cons
<ul style="list-style-type: none"> <li>• M1 offers the potential capability to move from depot to forward of the CSA without intermediate handling or reconfiguring (if CCLs are used).</li> <li>• M1 flatracks can be stacked fully loaded in a container cell; supports force projection.</li> <li>• Reduces the quantity of containers to be bought; full production of M1 may lower per item costs.</li> <li>• CHD provides capability to pick up any ISO 20-foot envelope.</li> <li>• Satisfies congressional objectives.</li> <li>• Satisfies MOADS distribution doctrine.</li> </ul>	<ul style="list-style-type: none"> <li>• High-cost alternative.</li> <li>• Flatrack can not move containers.</li> <li>• M1 flatrack weight reduces PLS truck payload by 4,500 pounds and could be potentially more difficult to handle in field (6,000-pound forklift cannot lift empty M1).</li> <li>• CHD design is not tested; CHD introduces another PLS component.</li> <li>• CCLs formed in CONUS may not meet present safety and security standards for intermodal movement. In addition, configuration of ammunition into CCL generally does not use container space as efficiently as single-DODIC loads (less weight per container load).</li> <li>• Combination of M1 and CHD adds greatest weight of all alternatives to the PLS.</li> <li>• Detachable CHD may not be available when needed; CHD must be removed to transport containers.</li> </ul>

**Table C-7.**  
*Intermodal Shipping Container (M1) with Modified LHS with Containers*

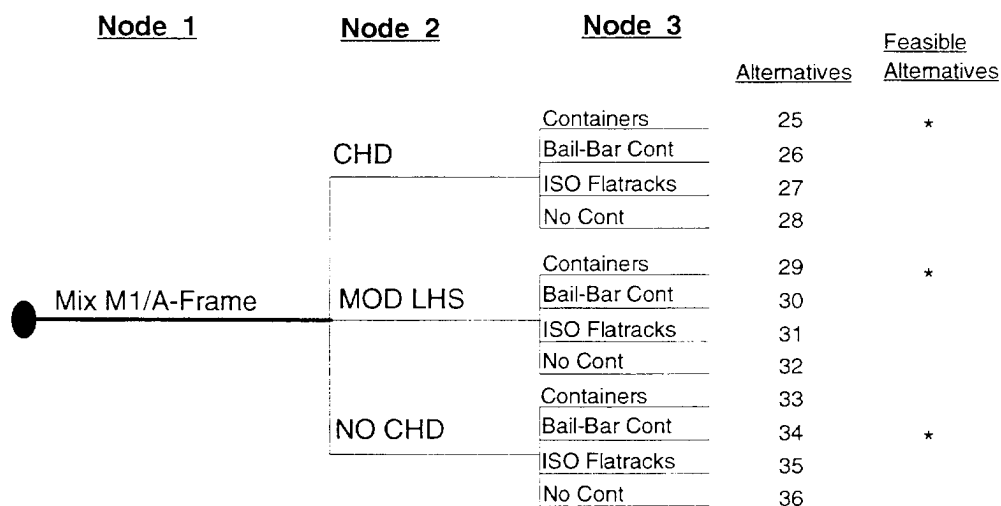
Pros	Cons
<ul style="list-style-type: none"> <li>• An integral modified LHS would always be available to move M1 or any ISO 20-foot containers.</li> <li>• Reduces the number of containers to be bought.</li> <li>• Satisfies congressional objectives</li> <li>• M1 offers the potential capability to move from depot to forward of the CSA without intermediate handling or reconfiguration (if CCL's are used).</li> <li>• M1 flatracks can be stacked fully loaded in a container cell; supports force projection</li> <li>• Reduces the quantity of containers to be bought; full production of M1 may lower per item costs.</li> <li>• CLK provides capability to pick up any ISO 20-foot envelope.</li> <li>• Satisfies MOADS distribution doctrine.</li> </ul>	<ul style="list-style-type: none"> <li>• LHS design has engineering risk.</li> <li>• High-cost alternative.</li> <li>• Flatrack cannot move containers.</li> <li>• M1 flatrack weight reduces PLS truck payload by 4,500 pounds and could be potentially more difficult to handle in field (6,000-pound forklift cannot lift empty M1).</li> <li>• CCLs formed in CONUS may not meet present safety and security standards for intermodal movement. In addition, configuration of ammunition into CCL generally does not use container space as efficiently as single-DODIC loads (less weight per container load).</li> </ul>

**Table C-8.**  
*M1 with No CHD with Bail-Bar Containers*

Pros	Cons
<ul style="list-style-type: none"> <li>• Requires no redesign or addition of PLS components.</li> <li>• Bail-bar containers are PLS compatible with addition of real roller/sider.</li> <li>• Satisfies congressional objectives.</li> <li>• M1 offers the potential capability to move from depot to forward of the CSA without intermediate handling or reconfiguration (if CCL's are used).</li> <li>• M1 flatracks can be stacked fully loaded in a container cell; supports force projection.</li> <li>• Reduces the quantity of containers to be bought; full production of M1 may lower per item costs.</li> <li>• Satisfies MOADS distribution doctrine.</li> </ul>	<ul style="list-style-type: none"> <li>• Does not support all follow-on uses of PLS (such as DEPMEDS, etc.).</li> <li>• Highest-cost M1 alternative.</li> <li>• Flatrack cannot move containers.</li> <li>• M1 flatrack weight reduces PLS truck payload by 4,500 pounds and could be potentially more difficult to handle in field (6,000-pound forklift cannot lift empty M1).</li> <li>• CCLs formed in CONUS may not meet present safety and security standards for intermodal movement. In addition, configuration of ammunition into CCL generally does not use container space as efficiently as single-DODIC loads (less weight per container load).</li> <li>• PLS can move only bail-bar containers.</li> </ul>

## Mix M1/A-Frame

This mixed-fleet alternative has some of the features of a pure A-frame fleet and some features of a pure M1 fleet (see Figure C-7). The M1s are certified for intermodal movement, but the 5,000 M1s in this alternative will supply an intermodal capability for only the prepo and early deploying units. The remainder of the intermodal requirement would be filled by purchasing 14,100 containers of some type. As with the other M1 mixes, the containers require a CHD or integrated LHS for their movement unless configured with a bail-bar. This M1/A-frame mix branch has three acceptable alternatives. The three feasible alternatives are identified in Table C-9, and their pros and cons are summarized in Tables C-10 through C-12.



**Figure C-7.**  
*Decision Tree: Mix M1/A-Frame Node*





**Table C-9.**  
*Evaluation Criteria Matrix for Mix M1/A-Frame*

Alternative					
	MRC ammunition requirement	Intermodal ammunition movement	User operational requirement	Low-risk engineer development	Supports and enhances PLS
* CHD/container	+	•	•	•	+
Bail-bar	+	•	•	•	-
ISO flatrack	+	+	+	•	+
No container	•	-	•	•	+
* Mod LHS/container	•	•	•	•	+
Bail-bar	+	•	•	•	+
ISO flatrack	+	+	+	•	+
No container	•	-	-	•	+
NoCHD/container	•	•	-	•	-
* Bail-bar	•	•	•	•	-
ISO flatrack	+	+	-	-	-
No container	•	-	-	•	-

**Note:**

- + = Performs significantly better than other alternatives on this measure.
- = Performs significantly worse.
- = Adequate performance.
- \* = Feasible

MOE						
per t	Supports and enhances PLS	Cost investment	Transportability	Limits additional requirements	Satisfies congressional requirement	Supports additional uses
	+	-	•	-	+	+
	-	-	+	-	+	+
	+	-	•	-	+	+
	+	-	•	-	+	+
	+	-	-	-	+	+
	+	-	-	-	+	+
	+	•	•	-	+	+
	+	•	+	-	•	+
	-	+	-	+	+	•
	-	-	•	•	+	•
	-	-	-	+	+	-
	-	+	+	+	-	•

**Table C-10.**  
*Mix M1/A-Frame with CHD with Containers*

Pros	Cons
<ul style="list-style-type: none"> <li>• M1 offers the potential capability to move from depot to forward of the CSA without intermediate handling or reconfiguration (if CCL's are used).</li> <li>• M1 flatracks can be stacked fully loaded in a container cell; supports prepo and early deploying force.</li> <li>• CHD provides capability to pick up any ISO 20-foot envelope.</li> <li>• Limited satisfaction of congressional objectives.</li> <li>• Satisfies MOADS distribution doctrine.</li> </ul>	<ul style="list-style-type: none"> <li>• Moderate/high-cost alternative.</li> <li>• Flatrack can not move containers.</li> <li>• M1 flatrack weight reduces PLS truck payload by 4,500 pounds and could be potentially more difficult to handle in field (6,000-pound forklift cannot lift empty M1).</li> <li>• CHD design is not tested; CLK introduces another PLS component.</li> <li>• CCLs formed in CONUS may not meet present safety and security standards for intermodal movement. In addition, configuration of ammunition into CCL generally does not use container space as efficiently as single-DODIC loads (less weight per container load).</li> <li>• Combination of M1 and CHD adds greatest weight of all alternatives to the PLS.</li> <li>• Detachable CHD may not be available when needed; CHD must be removed to transport containers.</li> </ul>

**Table C-11.**  
*Mix M1/A-Frame with Modified LHS with Containers*

Pros	Cons
<ul style="list-style-type: none"> <li>• An integral modified LHS would always be available to move M1 or any ISO 20-foot containers.</li> <li>• Limited satisfaction of congressional objectives.</li> <li>• M1 offers the potential capability to move from depot to forward of the CSA without intermediate handling or reconfiguration (if CCLs are used).</li> <li>• M1 flatracks can be stacked fully loaded in a container cell; supports PREPO and early deploying force.</li> <li>• Reduces the quantity of containers to be bought; full production of M1 may lower per item costs.</li> <li>• Satisfies MOADS distribution doctrine.</li> </ul>	<ul style="list-style-type: none"> <li>• LHS design has engineering risk.</li> <li>• Moderate/high-cost alternative.</li> <li>• Flatrack can not move containers.</li> <li>• M1 flatrack weight reduces PLS truck payload by 4,500 pounds and could be potentially more difficult to handle in field (6,000-pound forklift cannot lift empty M1).</li> <li>• CCLs formed in CONUS may not meet present safety and security standards for intermodal movement. In addition, configuration of ammunition into CCL generally does not use container space as efficiently as single-DODIC loads (less weight per container load).</li> </ul>

**Table C-12.**  
*Mix M1/A-Frame with No CHD with Bail-Bar Containers*

Pros	Cons
<ul style="list-style-type: none"> <li>• Requires no redesign or addition of PLS components.</li> <li>• Bail-bar containers are PLS-compatible with the addition of rear roller/slider.</li> <li>• Satisfies congressional objectives.</li> <li>• M1 offers the potential capability to move from depot to forward of the CSA without intermediate handling or reconfiguration (if CCL's are used).</li> <li>• M1 flatracks can be stacked fully loaded in a container cell; supports force projection.</li> <li>• Reduces the quantity of containers to be bought; full production of M1 may lower per item costs.</li> </ul>	<ul style="list-style-type: none"> <li>• Does not support all follow-on uses of PLS (such as DEPMEDS, etc.).</li> <li>• High cost M1 alternative.</li> <li>• M1 flatrack weight reduces PLS truck payload by 4,500 lbs. and could be potentially more difficult to handle in field (6,000 lb. forklift cannot lift empty M1).</li> <li>• CCLs formed in CONUS may not meet present safety and security standards for intermodal movement. In addition, configuration of ammunition into CCL generally does not use container space as efficiently as single DODIC loads (less weight per container load).</li> <li>• PLS can move only bail-bar containers.</li> </ul>

### ISO Flatrack (AMCON)

The AMCON is similar to the M1 in major design features: end walls, PLS rails, CSC certification for container cell movement (see Figure C-8). The AMCON can satisfy MOADS distribution requirements but does not meet such user requirements as load tie-downs, sides, or end wall handling. The AMCON is an open sided flatrack and is subject to breaches of security, safety, or damage when transporting ammunition. AMCON does not require a CHD or rear slider/rollers for movement on a PLS. Unless the Oshkosh/Steeltech contract were changed, use of the AMCON would lead to A-frame, M1, AMCON, and possibly ISO sideless containers on the battlefield. The AMCON branch has five acceptable alternatives (see Table C-13). The pros and cons of these alternatives are shown in Tables C-14 through C-18.

**Table C-13.**  
*Evaluation Criteria Matrix for AMCON*

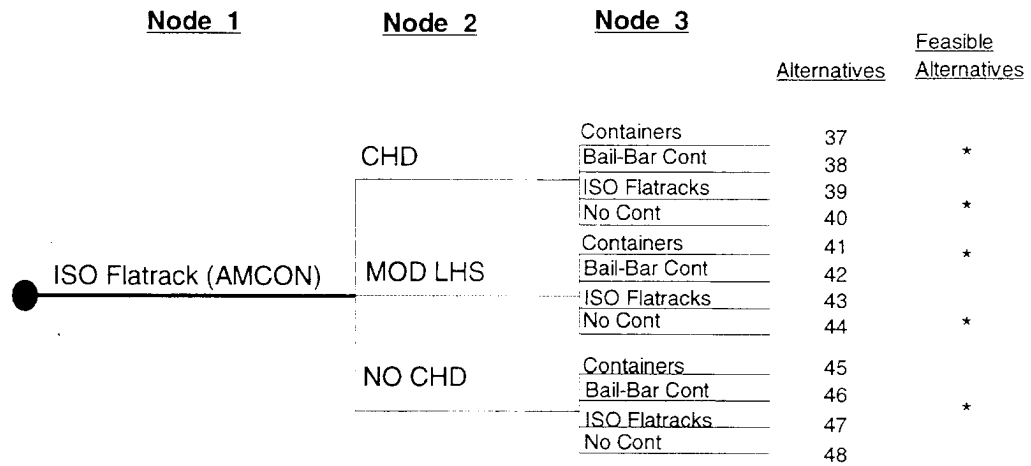
Alternative					
	MRC ammunition requirement	Intermodal ammunition movement	User option requirement	Low-risk engineering development	Si en
* CHD/container	+	+	•	•	
Bai-lbar	+	+	-	•	
* ISO flatrack	+	+	•	•	
No container	•	+	-	•	
* Mod LHS/container	+	+	•	•	
Bail-bar	+	+	-	•	
* ISO flatrack	+	+	•	•	
No container	•	+	-	•	
NoCHD/container	+	-	-	+	
* Bail-bar	+	+	•	+	
ISO flatrack	+	•	-	+	
No container	•	•	-	+	

**Note:**

- + = Performs significantly better than other alternatives on this measure.
- = Performs significantly worse.
- = Adequate performance.
- \* = Feasible

MOE

Engineering component	Supports and enhances PLS	Cost investment	Transportability	Limits additional requirements	Satisfies congressional requirements	Supports additional uses
•	+	•	•	-	+	+
•	-	-	+	-	+	+
•	•	•	+	-	+	+
•	•	-	-	-	+	+
•	+	•	+	-	+	+
•	+	-	+	-	+	+
•	•	•	+	-	+	+
•	-	•	•	+	+	•
+	-	•	-	+	+	•
+	+	•	•	+	+	•
+	-	•	•	•	+	•
+	-	•	-	+	+	•



**Figure C-8.**  
*Decision Tree: AMCON Node*

**Table C-14.**  
*ISO Flatrack (AMCON) with CHD and Containers*

Pros	Cons
<ul style="list-style-type: none"> <li>• Provides intermodal advantages; CSC approved.</li> <li>• AMCON can be stacked fully loaded in a container cell; supports force projection.</li> <li>• Reduces the quantity of containers to be brought.</li> <li>• Other containers can be moved with PLS.</li> <li>• CHD provides the capability to pick up any ISO 20-foot envelope.</li> <li>• Satisfies congressional objectives.</li> <li>• Moderate-cost alternative.</li> <li>• Lighter than M1.</li> <li>• Satisfies MOADS distribution.</li> </ul>	<ul style="list-style-type: none"> <li>• Testing of AMCON required; may not meet current CSC standards and does not meet all user operational requirements.</li> <li>• MLRS PODS cannot be double-stacked for intermodal movement (low AMCON end walls).</li> <li>• CHD design not tested, CHD introduces another PLS component.</li> <li>• CHD may not be available when needed.</li> <li>• Cannot transport containers on AMCON.</li> <li>• Heavier than A-frame.</li> </ul>

**Table C-15.**  
*ISO Flatrack (AMCON) with CHD and ISO Flatracks*

Pros	Cons
<ul style="list-style-type: none"> <li>• Provides intermodal advantages; CSC approved.</li> <li>• AMCON can be stacked fully loaded in a container cell.</li> <li>• Reduces the quantity of containers to be bought.</li> <li>• Other containers can be moved with PLS.</li> <li>• CHD provides the capability to pick up any ISO 20-foot envelope.</li> <li>• Satisfies congressional objectives.</li> <li>• Moderate-cost alternative.</li> <li>• Lighter than M1.</li> <li>• Satisfies MOADS distribution.</li> </ul>	<ul style="list-style-type: none"> <li>• Testing of AMCON required; may not meet current CSC standards and does not meet all user operational requirements.</li> <li>• MLRS PODS cannot be double-stacked for intermodal movement (low AMCON end walls).</li> <li>• CHD design not tested, CHD introduces another PLS component.</li> <li>• Open sided flatracks do not offer the security of closed containers.</li> <li>• Cannot transport containers on AMCON.</li> <li>• Heavier than A-frame.</li> </ul>

**Table C-16.**  
*ISO Flatrack (AMCON) with Modified LHS and Containers*

Pros	Cons
<ul style="list-style-type: none"> <li>• AMCON can be loaded in container cells.</li> <li>• Provides intermodal advantages; CSC approved.</li> <li>• PLS truck can move all ISO containers and flatracks.</li> <li>• Satisfies congressional objectives.</li> <li>• Reduces the number of containers to be bought.</li> <li>• Moderate-cost alternative.</li> <li>• Satisfies MOADS distribution.</li> </ul>	<ul style="list-style-type: none"> <li>• Testing of AMCON required; may not meet current CSC standards and does not meet all user operational requirements.</li> <li>• Some engineering risk associated with modifications to LHS.</li> <li>• LHS not yet designed or tested.</li> <li>• Cannot transport containers on AMCON.</li> <li>• Open sided flatracks do not offer the security of closed containers.</li> </ul>



**Table C-17.**  
*ISO Flatrack (AMCON) with LHS and ISO Flatracks*

Pros	Cons
<ul style="list-style-type: none"> <li>• Provides intermodal advantages; CSC approved.</li> <li>• AMCON can be stacked fully loaded in a container cell.</li> <li>• Reduces the quantity of containers to be bought.</li> <li>• Other containers can be moved with PLS.</li> <li>• LHS provides the capability to pick up any ISO 20-foot envelope.</li> <li>• Satisfies congressional objectives.</li> <li>• Moderate-cost alternative.</li> <li>• Lighter than M1.</li> <li>• Satisfies MOADS distribution.</li> </ul>	<ul style="list-style-type: none"> <li>• Testing of AMCON required; may not meet current CSC standards and does not meet all user operational requirements.</li> <li>• MLRS PODS cannot be double-stacked for intermodal movement (low AMCON end walls).</li> <li>• LHS design not tested.</li> <li>• Open sided flatracks do not offer the security of closed containers.</li> <li>• Cannot transport containers on AMCON .</li> <li>• Heavier than A-frame.</li> </ul>

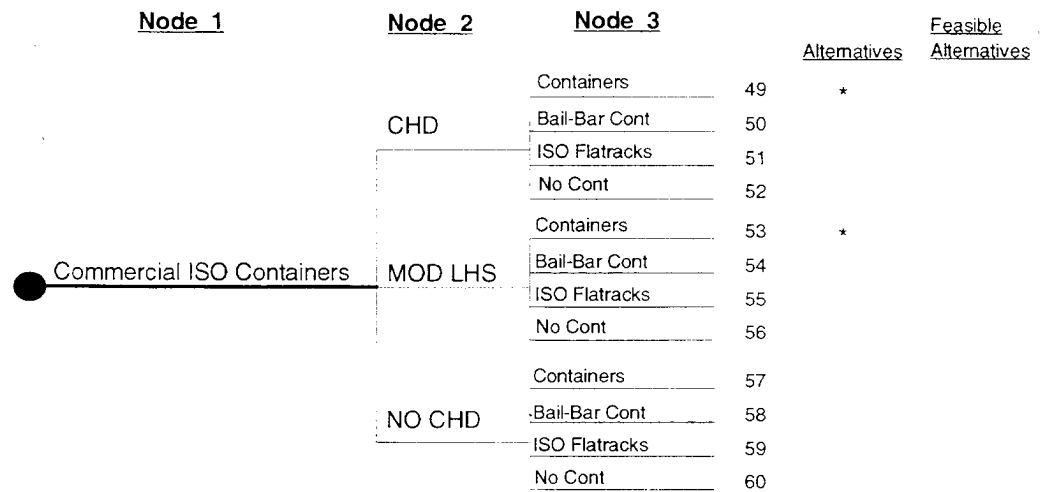
**Table C-18.**  
*ISO Flatrack (AMCON) with No CHD with Bail-Bar Containers*

Pros	Cons
<ul style="list-style-type: none"> <li>• Provides intermodal advantages; CSC approved.</li> <li>• Bail-bar containers are PLS-compatible.</li> <li>• Satisfies congressional objectives.</li> <li>• AMCON can be stacked fully loaded in a container cell.</li> <li>• Moderate-cost alternative.</li> <li>• Satisfies MOADS distribution.</li> </ul>	<ul style="list-style-type: none"> <li>• Testing of AMCON required; may not meet current CSC standards and does not meet all user operational requirements.</li> <li>• PLS trucks cannot move other containers.</li> <li>• Does not support all follow-on uses of PLS (such as DEPMEDS, etc.).</li> </ul>

### Commercial ISO Sideless Containers

The commercial ISO sideless container is similar in outward appearance to the M1 with two primary differences: the location of the longitudinal support rails and the absence of a bail-bar (see Figure C-9). The commercial sideless container is not PLS compatible without a CHD and adaptation of the PLS truck rear end. The commercial sideless container is CSC certified for intermodal movement and is typically a rugged container of proven value in the hauling of heavy loads for commercial purposes. The commercial sideless container could be

manufactured to meet most military requirements, including end wall height and cargo tiedowns. As an open container, the commercial ISO sideless container provides less load safety and security than a closed container. The commercial ISO sideless container branch provides two potentially acceptable alternatives. They are identified in Table C-19, and their pros and cons are discussed in Table C-20 and Table C-21.



**Figure C-9.**  
*Decision Tree: Commercial ISO Container Node*

**Table C-19.**  
*Evaluation Criteria Matrix for Commercial ISO*

Alternative					
	MRC ammunition requirement	Intermodal ammunition movement	User option requirement	Low-risk engineering development	Supports and enhances PLS
* CHD/container	+	+	•	•	+
Bail-bar	+	+	•	•	•
ISO flatrack	+	+	•	•	+
No container	•	+	•	•	-
* Mod LHS/container	+	+	•	•	+
Bail-bar	+	+	•	•	•
ISO flatrack	+	+	•	•	+
No container	•	+	•	•	-
NoCHD/container	+	+	•	+	-
Bail-bar	+	+	•	+	-
ISO flatrack	+	+	•	+	-
No container	•	+	-	+	-

**Note:**

- + = Performs significantly better than other alternatives on this measure.
- = Performs significantly worse.
- = Adequate performance.
- \* = Feasible

MOE

Supports and enhances PLS	Cost investment	Transportability	Limits additional requirements	Satisfies congressional requirements	Supports additional uses
+	+	•	-	+	+
•	-	•	-	+	+
+	+	•	-	+	+
-	+	•	-	+	+
+	+	+	-	+	+
•	-	+	-	+	+
+	+	+	-	+	+
-	+	+	-	+	+
-	•	-	+	+	•
-	-	-	+	+	•
-	•	-	+	+	•
-	+	-	+	+	•

**Table C-20.***Commercial ISO Sideless Containers with CHD and Containers*

Pros	Cons
<ul style="list-style-type: none"> <li>• Provides intermodal advantages; CSC approved and proven in use.</li> <li>• PLS trucks can move any ISO container or flatrack.</li> <li>• Version with folding endwalls provides stacking capability.</li> <li>• Provides capability to pick up any ISO 20-foot envelope.</li> <li>• Satisfies congressional objectives.</li> <li>• Low-cost alternative.</li> <li>• Satisfies MOADS distribution.</li> </ul>	<ul style="list-style-type: none"> <li>• Testing of ISO sideless container for PLS application is required.</li> <li>• Height of sideless containers on PLS truck could restrict routing.</li> <li>• PLS crane may not be able to fully unload a sideless container with an 8-foot high end wall when on the truck.</li> <li>• Requires CHDs on all PLS trucks, which would limit payload on M1074 truck.</li> <li>• CHD may not be available when needed.</li> <li>• CHD introduces another PLS component; CHD not tested.</li> </ul>

**Table C-21.***Commercial ISO Sideless Containers with Modified LHS and Containers*

Pros	Cons
<ul style="list-style-type: none"> <li>• Provides intermodal advantages; CSC approved and proven in use.</li> <li>• LHS advantages give the PLS truck the capability of moving any ISO container or flatrack.</li> <li>• ISO container with folding end walls provides stacking capability.</li> <li>• Satisfies congressional objectives.</li> <li>• Low-cost alternative.</li> <li>• Satisfies MOADS distribution.</li> </ul>	<ul style="list-style-type: none"> <li>• Testing of ISO sideless container for PLS application is required.</li> <li>• Height of sideless container on PLS truck may restrict routing.</li> <li>• PLS crane may not be able to fully unload a sideless container with an 8-foot high end wall when on the truck.</li> <li>• Requires modification of LHS on all PLS trucks, which would limit payload on M1074 truck.</li> <li>• LHS modification not designed or tested.</li> </ul>

To summarize the results of the decision tree analysis, there are 16 feasible alternatives whose subjective analysis against the evaluation criterion are shown in Table C-22. This subjective matrix is matched to cost data in Chapter 2 to select a preferred alternative.



**Table C-22.**  
*Evaluation Criteria Matrix for Feasible Alternatives*

Alternative					
	MRC ammunition requirement	Intermodal ammunition movement	User option requirement	Low-risk engineering development	Support enhancement
<b>A-Frame</b>					
CHD/container	•	•	•	•	•
Modified LHS/container	•	•	•	•	+
No CHD/container: Bail-bar	•	•	•	+	+
<b>M1</b>					
CHD/container	+	+	•	•	+
Modified LHS/container	+	+	•	•	+
No CHD/container: Bail-bar	+	+	-	•	+
<b>Mix M1/A-Frame</b>					
CHD/container	+	•	•	•	+
Mod LHS/container	•	•	•	•	+
No CHD/container: Bail-bar	•	•	•	•	-
<b>AMCON</b>					
CHD/container	+	+	•	•	+
CHD/container: ISO flatrack	+	+	•	•	•
Mod LHS/container	+	+	•	•	+
Mod LHS/container: ISO flatrack	+	+	•	•	•
No CHD/container: Bail-bar	+	+	•	+	+
<b>ISO</b>					
CHD/container	+	+	•	•	+
Mod LHS/container	+	+	•	•	+

**Note:**

- + = Performs significantly better than other alternatives on this measure.
- = Performs significantly worse.
- = Adequate performance.

MOE

Engineering element	Supports and enhances PLS	Cost investment	Transportability	Limits additional requirements	Satisfies congressional requirements	Supports additional uses
	•	•	•	-	-	+
	+	•	•	-	•	+
	+	-	•	+	-	-
	+	-	•	-	+	+
	+	-	•	-	+	+
	+	-	•	+	+	•
	+	-	•	-	+	+
	+	-	-	-	+	+
	-	-	•	•	+	•
	+	•	•	-	+	+
	•	•	+	-	+	+
	+	•	+	-	+	+
	•	•	+	-	+	+
	+	•	•	+	+	•
	+	+	•	-	+	+
	+	+	+	-	+	+



APPENDIX D

# DYNAMO Modeling

# DYNAMO MODELING

## OVERVIEW

Professional DYNAMO Plus is a commercially developed product by Pugh-Roberts Associates, Inc., designed for the computer simulation of dynamic systems that are characterized by stocks and flows. Much of the DYNAMO modeling of Palletized Load System (PLS) flatracks and trucks was accomplished using a student version of DYNAMO available at the George Washington University simulation lab. The purpose of the DYNAMO simulation was to examine the effects on ammunition distribution of different PLS flatrack fleets. Separate DYNAMO runs were made for each major flatrack alternative and the flows and stocks at the distribution nodes compared.

## MODEL DESCRIPTION

DYNAMO consists of a grouping of equations that determine the flows and accumulation of discrete entities at specified system locations over time. For this analysis, artillery ammunition, PLS trucks, trailers, and flatracks were the entities and the Maneuver Oriented Ammunition Distribution System (MOADS) supplied the system locations. Ammunition and distribution assets accumulated at model nodes, selected to represent the ammunition transfer points (ATPs), ammunition supply points (ASPs), corps storage area (CSA), and firing units on a Corps battlefield. Ammunition was distributed from node to node on PLS trucks, trailers, and flatracks in order to meet battlefield requirements. The flow of ammunition was constrained by the supply of ammunition, the availability of distribution assets, the demands, and simulated battlefield characteristics such as the distances between nodes and the expected road speeds of the vehicles.

A Major Regional Conflict (MRC) set in Southwest Asia was used to set model parameters. Distances between supply nodes, artillery demands for ammunition, the force structures of combat and supporting units, and the availability of distribution platforms were taken from the MRC descriptions to be as realistic as possible. Ammunition usage rates duplicated those required to meet expected combat activities during 60 days of the regional conflict. For this MRC, ammunition arriving at the port or stockpiled close to the port was moved into the Corps area and then loaded on PLS assets for distribution to the firing units. This forward flow and distribution within the Corps area followed the MOADS doctrine described in Chapter 2. Distribution assets at each ammunition node were specified by the basis of issue plan (BOIP) of general support and direct support ammunition companies (the greatest concentrations of PLS flatracks in the contingency area), transportation units, and by theater force deployment schedules.

Specific mixes of ammunition were not addressed in the DYNAMO modeling; the aggregate tonnage of ammunition moved over time was the primary measure of system effectiveness. In combat, the flatrack ammunition loads would be combat configured or tailored for the particular targets to be engaged by the firing unit. This configuring would present a great variety of possible ammunition mixes for distribution. To simplify the flatrack loads and to focus on the distribution of ammunition using PLS assets, we selected an artillery combat configured load of 155mm howitzer ammunition weighing 11.2 short tons as representative of the most typical combat configured loads. This weight and composition is within the load limits and configuration parameters of any of the flatrack / container alternatives examined, regardless of the flatrack design or mix.

The period from Day C+30 to C+90 was modeled in six hour increments. The DYNAMO model activity in each increment began with a requirement to deliver ammunition to the artillery firing units forward in the combat area. If the necessary ammunition, PLS trucks, and trailers were available at the closest ASP or ATP to the firing unit, then ammunition "flowed" out of the ATP or ASP on PLS assets to the unit. The flow was on discrete PLS trucks and trailers from one ammunition node to another. Depending on the time required to travel between the ammunition nodes, the start of the next time increment could find that the ammunition had been delivered or was still enroute. The ammunition supply levels at each ammunition node were augmented or decremented to reflect the dispatch and delivery of ammunition.

To satisfy a request for ammunition at a node, ammunition, flatracks, and trucks must be available. If all distribution assets are present, a truck (with trailer, if also available) and a loaded flatrack are dispatched to the requesting node or unit. The supply of ammunition, trucks, and flatracks at the issuing node are decremented. The quantity of trucks and trailers to be deployed in the MRC-E scenario is determined by the BOIP of the artillery, ammunition, and transportation units identified as deployed to the contingency area. The quantity of A-frame flatracks within the MRC MOADS area was allowed to increase to the point at which the flow of ammunition was no longer constrained by the availability of flatracks. For the combat forces and support force mix portrayed, this number was 14,800 flatracks in the corps area and an additional 9,200 flatracks to meet Army requirements elsewhere. This A-frame flatrack level provided a baseline for the minimum number of flatracks required to support a representative MRC-E combat force. We constructed each of the flatrack alternatives to deliver an amount of ammunition equivalent to that delivered by the A-frame flatracks. For intermodal flatracks, we allowed the flow of ammunition to originate at the port area on loaded flatracks.

## MODEL RESULTS

The use of different types of flatracks and different starting locations for the flatracks created DYNAMO model initial conditions that were unique for each flatrack type. These initial conditions continued to influence ammunition

delivery until the last increment of intermodal flatracks arrived at the port and became a MOADS distribution asset. After the effects of these different starting conditions were overcome (about 10 days), each flatrack alternative reached a steady state condition in which the supply of flatracks, trailers, and trucks at all ammunition nodes remained within a band of minimum and maximum values. At these values 85 percent of the firing unit daily demands could be met, but not 100 percent. Each flatrack alternative modeled was able to meet this level of demand satisfaction, and no alternative performed significantly better than another on the primary measure of ammunition delivered over time.

These model results are not surprising, but do require explanation. Our DYNAMO modeling shows that the battlefield ammunition delivery performances of the flatrack alternatives are equivalent in the MRC scenario. DYNAMO modeled operations under MOADS concepts using combat configured loads (CCL) and with limited PLS truck assets to meet the distribution demands of a corps with very long road distances between ammunition nodes. The DYNAMO model was not sufficiently detailed to allow inclusion of performance measures such as time to load and unload flatracks and containers, the ability to move heavier combat configured loads, movement of ammunition within the division area in containers, force projection ashore, or transportability of PLS trucks and trailers with intermodal versus A-frame flatracks. These factors may produce real differences between flatracks in other situations or combat scenarios but in the MRC-E scenario, these performance differences between flatrack alternatives are masked by the long delivery times and the average CCL loads used.

## MODEL CODE LISTING

Refer to the following page for model code listings.

```

* A FRAME PURE
* AMMUNITION LEVELS AT EACH AMMO HOLDING AREA AND IN TRANSIT
L AMMOPRT.K=AMMOPRT.J+DT*(DELAMMO.JK-PRTAMMO.JK-PRTE.JK)
* AMMO AT PORT EQUALS AMMO DELIVERED LESS AMMO SHIPPED ON FLATS AND EPF
L AMMOCSA.K=AMMOCSA.J+DT*(PRTAMMO.JK-CSAMMOS.JK-CSAMATS.JK)
* AMMO AT CSA EQUALS AMMO DEL FROM PORT LESS AMMO SHIP TO ASP LESS AMMO TO AT
L AMMONR1.K=AMMONR1.J+DT*(CSAMMOS.JK-CSAMMOD.JK)
* AMMO ENROUTE CODED WITH N
* NR1 ENROUTE FROM CSA TO ASP
L AMMOASP.K=AMMOASP.J+DT*(CSAMMOD.JK-ASPAMOS.JK)
L AMMONR2.K=AMMONR2.J+DT*(ASPAMOS.JK-ASPAMOD.JK)
* NR2 ENROUTE FROM ASP TO ATP
L AMMOATP.K=AMMOATP.J+DT*(ASPAMOD.JK-ATPAMOS.JK+NR4E.JK+epfatp.jk*11.2)
* ATP RECEIVES AMMO FROM ASP AND ON EPF FROM PORT
R EPFATP.KL=CLIP(240,0,MIXEPF,LEVEPF,K)
L LEVEPF.K=LEVEPF.J+DT*EPFATP.JK
N LEVEPF=0
C MIXEPF=0
L AMMONR3.K=AMMONR3.J+DT*(ATPAMOS.JK-ATPAMOD.JK)
* NR3 ENROUTE FROM ATP TO ARTY
L AMMOART.K=AMMOART.J+DT*(ATPAMOD.JK+CSAMMOE.JK-FIRERT.JK)
* FIRERT IS DEMAND FUNCTION OF ARTY BNS
L MOEAMMO.K=MOEAMMO.J+DT*(ATPAMOD.JK+CSAMMOE.JK)
* MOEAMMO IS TOTAL AMNT OF AMMO DELIVERED TO ARTY BNS
L OVERART.K=OVERART.J+DT*(CLIP(1,0,AMMOART.J-ARTYPOL.J,ARTYPOL.J*.2))
L UNDRART.K=UNDRART.J+DT*(CLIP(1,0,ARTYPOL.J-AMMOART.J,ARTYPOL.J*.2))
* OVERART AND UNDRART INDICATE SUPPLY AT ARTY NOT WITHIN LIMITS
L AMMONR4.K=AMMONR4.J+DT*(PRTE.JK-NR4E.JK)
* NR4 ENROUTE FROM PORT TO ATP ON FLATRACKS
L AMMODEL.K=AMMODEL.J+DT*(100000-DELAMMO.JK)
L AMMONR5.K=AMMONR5.J+DT*(CSAMATS.JK-CSAMATD.JK)
* NR5 ENROUTE FROM CSA TO ATP ON EPF
R CSAMMOE.KL=0
* E REFERS TO EPF
R DELAMMO.KL=AMMODEL.K/10
R PRTAMMO.KL=MIN(AMMOPRT.K,ORDCSA.K)
* AMMO SHIPPED FROM PORT IS MIN OF AVAILABLE AMMO, CSA ORDERS
A EFLTRAC.K=0
R PRTE.KL=MIN(EFLTRAC.K*14.3,AMMOPRT.K)
* AMMO SHIPPED FROM PORT ON EPF TO ATP
R NR4E.KL=CLIP(AMMONR4.K,(SPDHR/DISTPAR)*AMMONR4.K,SPDHR/DISTPAR,1)
* NR4E ENROUTE FROM PORT TO ATP ON EPF
* SPDHR/DISTPAR IS SPEED AND DISTANCE FACTOR
R CSAMATS.KL=MIN(VAR12.K,VAR12A.K)
* CSA SHIPS ONE TENTH OF AMMO DIRECTLY TO ARTY
* AMMO SHIP RATE FROM CSA TO ARTY IS BOUND BY AVAIL AMMO, PLS, FLATS
R CSAMATD.KL=CLIP(AMMONR5.K,(SPDHR/DISTCAR)*AMMONR5.K,SPDHR/DISTCAR,1)
R CSAMMOS.KL=MIN(VAR15.K,VAR15A.K)
A VAR15.K=MIN(AMMOCSA.K-CSAMATS.KL,ORDASP.K)
A VAR15A.K=MIN(FLATCSA.K*11.2*.9,PLSCSA.K*22.4*.9)
A VAR12.K=MIN(AMMOCSA.K,(ORDATP.K+ORDARTY.K)*.75)
A VAR12A.K=MIN(FLATCSA.K*11.2*.1,PLSCSA.K*22.4*.1)
* AMMO SHIP RATE BOUND BY AVAIL AMMO, FLATS, PLS, ORDERS FROM ASP
R CSAMMOD.KL=CLIP(AMMONR1.K,(SPDHR/DISTCAS)*AMMONR1.K,SPDHR/DISTCAS,1)
R ASPAMOS.KL=MIN(VAR13.K,VAR13A.K)
A VAR13.K=MIN(AMMOASP.K,ORDATP.K)
A VAR13A.K=MIN(PLSASP.K*22.4,FLATASP.K*11.2)
* AMMO SHIP RATE BOUND BY AVAIL AMMO, FLATS, PLS, ORDERS FROM ATP
R ASPAMOD.KL=CLIP(AMMONR2.K,(SPDHR/DISASAT)*AMMONR2.K,SPDHR/DISASAT,1)
R FIRERT.KL=MIN(AMMOART.K,FRATE)

```

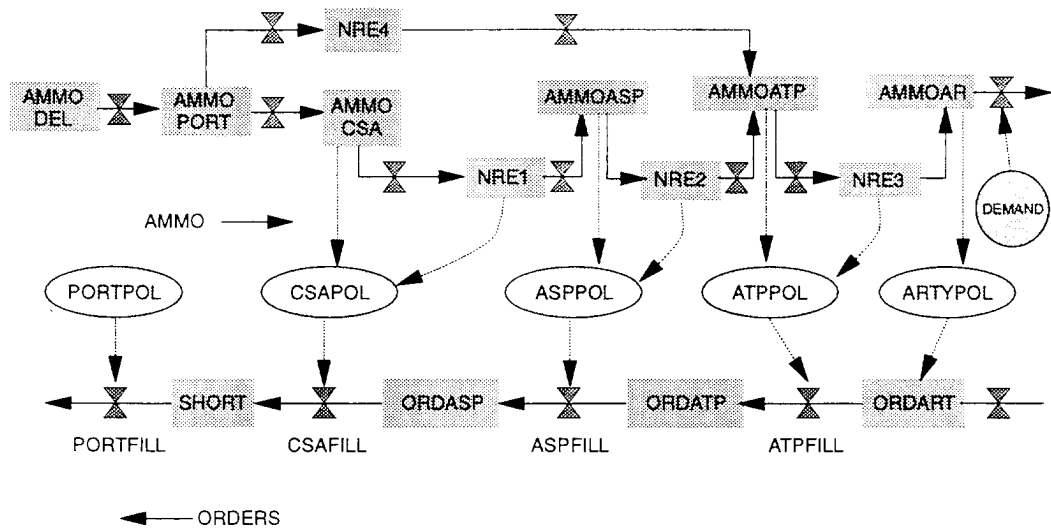
```

R ATPAMOS.KL=MIN(VAR14A.K, PLSATP.K*2*11.2)
A VAR14.K=MIN(AMMOATP.K, ORDARTY.K)
A VAR14A.K=MIN(VAR14.K, FLATATP.K*11.2)
R ATPAMOD.KL=CLIP(AMMONR3.K, (SPDHR/DISATAR)*AMMONR3.K, SPDHR/DISATAR, 1)
N SPDHR=24*20
N DISTPAR=454
N DISTCAR=660
N DISTCAS=658
N DISASAT=12
N DISATAR=10
N FRATE=4610
L ORDARTY.K=ORDARTY.J+DT*(ARTYORD.JK-ATPAMOS.JK)
L ORDATP.K=ORDATP.J+DT*(ATPORDR.JK-ASPAMOS.JK)
L ORDASP.K=ORDASP.J+DT*(ASPORDR.JK-CSAMMOS.JK)
L ORDCSA.K=ORDCSA.J+DT*(CSAORDR.JK-PRTAMMO.JK)
N ORDCSA=0
R PRTFILL.KL=clip(AMMOPRT.K+DELAMMO.KL, varx1.k, AMMOPRT.K+DELAMMO.KL, CSAORDR.KL)
A VARX1.K=CSAORDR.KL-AMMOPRT.K-DELAMMO.KL
A ARTYPOL.K=2*DOS
A ATPPOL.K=2*DOS
A ASPPOL.K=2*DOS
A CSAPOL.K=10*DOS
R ARTYORD.KL=CLIP(0, ARTYPOL.K+FIRERT.KL-AMMOART.K, AMMOART.K-FIRERT.KL, ARTYPOL.K)
R ATPORDR.KL=CLIP(VCLIPART.K, ATPPOL.K+ARTYORD.KL-AMMOATP.K, AMMOATP.K-ARTYORD.KL)
A VCLIPART.K=CLIP(ORDARTY.K, 0, ORDARTY.K, 0)
R ASPORDR.KL=CLIP(VCLIPATP.K, ASPPOL.K+ORDATP.K-AMMOASP.K, AMMOASP.K-ORDATP.K, ASP)
A VCLIPATP.K=CLIP(ORDATP.K, 0, ORDATP.K, 0)
R CSAORDR.KL=CLIP(VCLIPASP.K, CSAPOL.K+ORDASP.K-AMMOCSA.K, AMMOCSA.K-ORDASP.K, CSA)
A VCLIPASP.K=CLIP(ORDASP.K, 0, ORDASP.K, 0)
L FLATCSA.K=FLATCSA.J+DT*(PRTFLAT.JK-CSAFLAT.JK-CSFLATA.JK+ARTYRET.JK)
L FLATASP.K=FLATASP.J+DT*(CSAFLAT.JK-ASPFLAT.JK-ASPFLTA.JK)
L FLATATP.K=FLATATP.J+DT*(ASPFLAT.JK-ATPFLAT.JK+epfatp.jk)
L FLATART.K=FLATART.J+DT*(ATPFLAT.JK+CSFLATA.JK+ASPFLTA.JK-ARTYRET.JK)
A FLATNR1.K=PLSNR1.K*2
A FLATNR2.K=PLSNR2.K*2
A FLATNR3.K=PLSNR3.K*2
A FLATNR4.K=PLSNR4.K*2
A FLATNR5.K=PLSNR5.K*2
R CSAFLAT.KL=CSAMMOS.KL/11.2
R CSFLATA.KL=CSAMATS.KL/11.2
R ASPFLAT.KL=ASPAMOS.KL/11.2
R ASPFLTA.KL=0
R PRTFLAT.KL=VAR2.K
A VAR2.K=CLIP(200, 0, 14764, A2.K+A2NR.K)
R ATPFLAT.KL=ATPAMOS.KL/11.2
A A2.K=FLATCSA.K+FLATATP.K+FLATASP.K+FLATART.K
A A2NR.K=FLATNR1.K+FLATNR2.K+FLATNR3.K+FLATNR4.K+FLATNR5.K
R ARTYRET.KL=MAX(FLATART.K/2, PLSARTY.K/4)
C DOS=6474
L PLSPORT.K=PLSPORT.J+DT*(-PORTPLS.JK)
L PLSCSA.K=PLSCSA.J+DT*(PORTPLS.JK-CSAPLSA.JK-CSAPLS.JK+ARTYPLS.JK)
L PLSASP.K=PLSASP.J+DT*(CSAPLS.JK-ASPPLS.JK)
L PLSATP.K=PLSATP.J+DT*(ASPPLS.JK-ATPPLS.JK)
L PLSARTY.K=PLSARTY.J+DT*(CSAPLSA.JK+ATPPLS.JK-ARTYPLS.JK)
A PLSNR1.K=AMMONR1.K/22.4
A PLSNR2.K=AMMONR2.K/22.4
A PLSNR3.K=AMMONR3.K/22.4
A PLSNR4.K=AMMONR4.K/22.4
A PLSNR5.K=AMMONR5.K/22.4
R PORTPLS.KL=CLIP(48, 0, 1632, A1.K+A1NR.K)

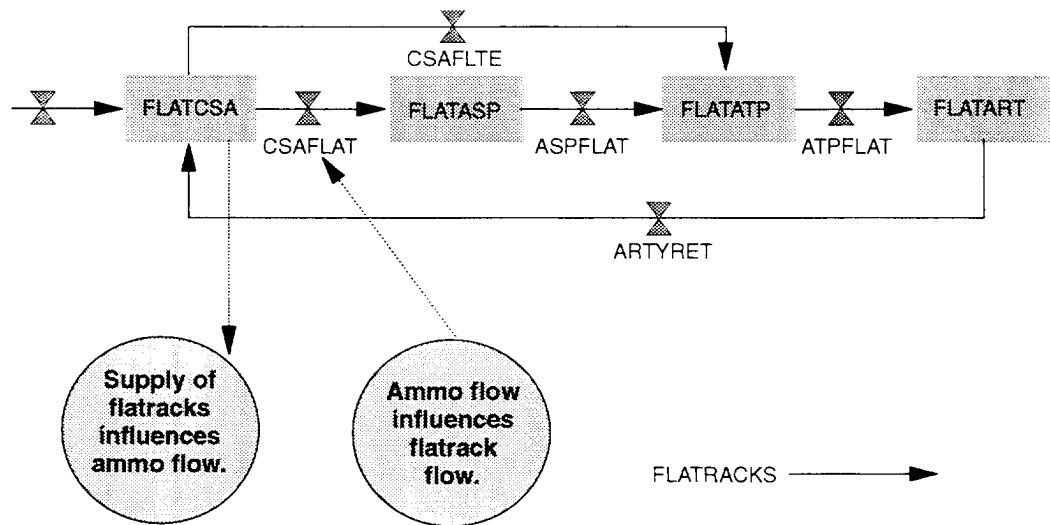
```

A A1.K=PLSCSA.K+PLSASP.K+PLSATP.K+PLSARTY.K  
 A A1NR.K=PLSNR1.K+PLSNR2.K+PLSNR3.K+PLSNR4.K+PLSNR5.K  
 N A1=576  
 N A1NR=0  
 R CSAPLSA.KL=CSAMATS.KL/22.4  
 R ASPPLS.KL=ASPAMOS.KL/22.4  
 R ATPPLS.KL=ATPAMOS.KL/22.4  
 R ARTYPLS.KL=PLSARTY.K  
 R CSAPLS.KL=CSAMMOS.KL/22.4  
 N AMMOPRT=DOS\*30  
 N AMMOCSA=DOS\*15  
 N AMMONR1=0  
 N AMMONR2=0  
 N AMMONR3=0  
 N AMMONR4=0  
 N AMMONR5=0  
 N AMMOASP=DOS\*2  
 N AMMOATP=DOS\*1  
 N AMMOARTY=DOS\*1  
 N AMMODEL=0  
 N ORDARTY=0  
 N ORDATP=0  
 N ORDASP=0  
 N SHORT=0  
 N FLATCSA=2500  
 N FLATASP=400  
 N FLATATP=400  
 N FLATART=200  
 N PLSPORT=2000  
 N PLSCSA=336  
 N PLSASP=96  
 N PLSATP=96  
 N PLSARTY=0  
 N MOEAMMO=0  
 N OVERART=0  
 N UNDRART=0

SPEC DT=1/LENGTH=60/SAVPER=1  
 SAVE AMMOPRT/AMMOCSA/AMMONR1/AMMOASP/AMMONR2/AMMOATP/AMMONR3/AMMOART/AMMODEL  
 SAVE AMMONR4/AMMONR5/ORDARTY/ORDATP/ORDASP/SHORT/FLATCSA/FLATASP/FLATATP  
 SAVE FLATART/PLSPORT/PLSCSA/PLSASP/PLSATP/PLSARTY  
 SAVE DELAMMO/PRTAMMO/PRTE/CSAMATS/CSAMATD/CSAMMOS/CSAMMOD  
 SAVE ATPAMOS/ATPAMOD/FIRERT/ASPPOL/ATPPOL/CSAPOL/ARTYORD/PRTFILL/ARTYPOL  
 SAVE ASPAMOS/ASPAMOD/ATPORDR/ASPORDR/CSAORDR/FLATCSA/FLATASP/FLATART  
 SAVE CSAFLAT/CSAFLATA/ASPFLAT/PRTFLAT/ATPFLAT/ARTYRET  
 SAVE ASPPLS/ATPPLS/PORTPLS/CSAPLS/CSAPLSA/MOEAMMO/UNDRART/OVERART

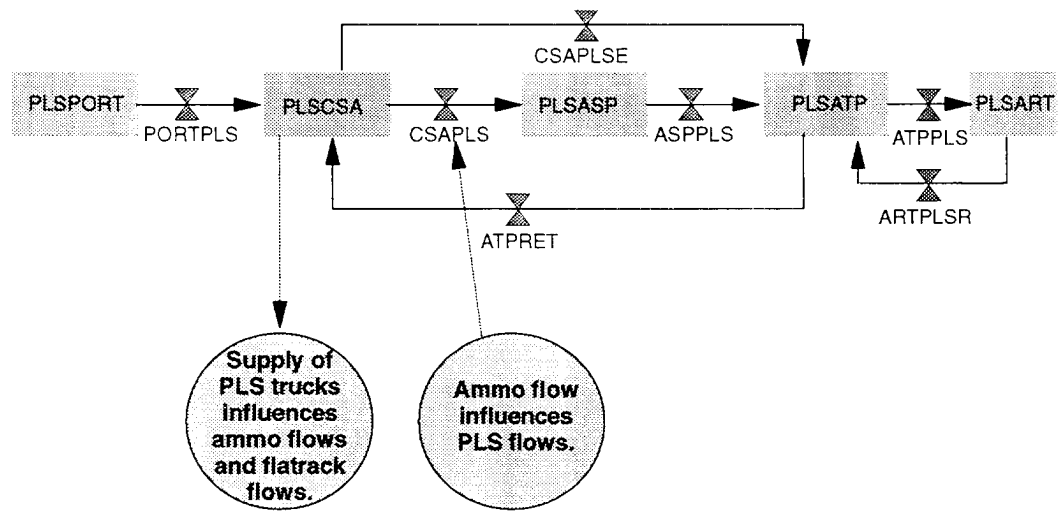


**Figure D-1.**  
*DYNAMO Flow Diagram: Ammunition and Order Flows Within Theater*



**Figure D-2.**  
*DYNAMO Flow Diagram: Flatrack Flows Within Theater*





**Figure D-3.**  
*DYNAMO Flow Diagram: PLS Truck Flows Within Theater*

APPENDIX E

# Glossary

# Glossary

AAA	= Army Audit Agency
AMCON	= ammunition container
ASP	= ammunition supply point
ATP	= ammunition transfer point
c.g.	= center of gravity
CADS	= Containerized Ammunition Distribution System
CASCOM	= Combined Arms Support Command
CCL	= combat configured load
CHD	= container handling device
CHU	= container handling unit
CLK	= container lift kit
COEA	= cost and operational effectiveness analysis
CONUS	= Continental United States
CSA	= corps storage area
CSC	= committee for safe containers
CSS	= combat service support
DEPMEDS	= deployable medical shelters
DoD	= Department of Defense
DODIC	= Department of Defense Identification Code
DROPS	= Demountable Rack Offloading and Pickup System
DS	= direct support
DYNAMO	= Dynamic Modeling, a proprietary simulation language

EPF	=	enhanced PLS flatrack
FSS	=	fast sealift ship
FUE	=	First Unit Equipped
FY	=	fiscal year
GS	=	general support
HEMTT	=	heavy expanded mobility tactical truck
HQDA	=	Headquarters, Department of the Army
HRED	=	Human Research and Engineering Directorate
HTV	=	heavy tactical vehicle
ICHO	=	Improved Container Handling Organization
IPF	=	ISO-compatible PLS flatrack
ISC	=	intermodal shipping container
ISO	=	international organization for standardization
LHS	=	load handling system
LMI	=	Logistics Management Institute
MHE	=	materials handling equipment
MILVANS	=	military vans
MLRS	=	Multiple Launched Rocket System
mm	=	millimeter
MOADS	=	maneuver oriented ammunition distribution system
MOADS-PLS	=	maneuver orientation ammunition distribution system – palletized load system
MOE	=	measures of effectiveness
MRC	=	Major Regional Contingency
MRC-E	=	Major Regional Contingency – East

MSC	=	Military Sealift Command
MTMC	=	Military Traffic Management Command
MTMC-TEA	=	Military Traffic Management Command – Transportation Engineering Agency
N/A	=	not applicable
NATO	=	North Atlantic Treaty Organization
O&M	=	operations and maintenance
PLS	=	Palletized Load System
PM AMMOLOG	=	Program Manager, Ammunition Logistics
POD	=	port of debarkation
POL	=	petroleum, oil, and lubricants
prepo	=	pre-positioned
QUADCON	=	an 8'× 8'× 20' container with four compartments
RO/RO	=	roll-on/roll-off
ROC	=	required operational capability
SOW	=	statement of work
STINGER	=	a shoulder fired surface-to-air missile
ston	=	short ton
TBD	=	to be determined
TRAC-LEE	=	TRADOC Analysis Center – Fort Lee
TRADOC	=	U.S. Army Training and Doctrine Command
TRANSCOM	=	U.S. Army Transportation Command
TRICON	=	an 8'× 8'× 20' container with three compartments
TRS	=	TRADOC Regional Scenario
TSA	=	theater storage area

U.S. = United States  
USADACS = U.S. Army Defense Ammunition Center and School  
USAF = U.S. Air Force

# Epilogue (15 March 1996)

## FLATRACK DEVELOPMENT AND PRODUCTION STATUS A-FRAME PRODUCTION

The initial purchase of 10,047 A-frame flatracks was accomplished through the original Palletized Load System (PLS) truck contract with Oshkosh Truck Corporation. Oshkosh subcontracted with Steeltech Manufacturing Corporation for flatrack production. A contract for 3,000 additional A-frame flatracks, of a strengthened design with galvanized rust protection (the M2 version), was awarded on 12 January 1996 to Steeltech as low bidder among the small disadvantaged businesses allowed to compete. On 7 March 1996, the U.S. Army Tank-Automotive Command (TACOM) terminated the contract when Steeltech's qualifications were challenged and Steeltech was found to be not qualified for the contract. It is expected that the next best qualified bidder will be awarded the contract by the end of March 1996 and that production of the reinforced flatracks will begin before the end of FY96.

### M1 Intermodal Flatrack Production

In early FY95, a contract for 5,000 M1 intermodal flatracks was awarded to Steeltech as a subcontractor to Oshkosh. The original M1 design has been modified to use chains to provide extra support to the endwalls in order to successfully pass the rail impact portion of acceptance testing. Retest of this design is anticipated to occur after the delivery of the initial 15 production models expected on 15 March 1996 and to continue for six weeks. If tests indicate that the design is acceptable, full production is expected to begin on 1 May 1996. An additional 4,000 M1s required by the U. S. Combined Arms Support Command (CASCOM) to support forces deploying early are scheduled to be competitively procured in FY97 at an estimated cost of \$12,000 each.

### Commercial Flatrack Testing and Production

Commercially designed prototypes are being evaluated as alternatives to future M1 procurement. Two prototypes built by VSE Corporation and Barnes, Reinecke, Incorporated (BRI) are ISO container-compatible and also have PLS bailbars and rail guides. These prototypes and the accompanying engineering drawings will be used to establish contract specifications to meet the Army's needs. This contract will be open to competition from all interested parties, not as a small business set-aside. The Program Manager for Heavy Tactical Vehicles (PM HTV) is concerned that money identified in the 1997 and 2001 programs will be diverted from flatrack procurement unless committed. This would lead to an unacceptable delay in fielding intermodal flatracks for forces deploying early.

## Container Roll-in Roll-out Pallet (CROP) Development

Investigation of the CROP, a shipping platform that fits inside a standard ISO container for shipment as a unit, is proceeding in two phases with the goal of developing an alternative to a PLS intermodal sideless container that offers greater security and safety at lower cost. The CROP resembles an A-frame flatrack and can function as a PLS-compatible flatrack when removed from the container.

CROP Phase I has been completed. Phase I was a concept validation effort led by the Human Research and Engineering Directorate (HRED), Army Research Laboratory. HRED fabricated a CROP prototype by modifying an existing A-frame flatrack with additional rollers, repositioned tie-down points, and removed ISO corner casings to fit inside a container. The CROP prototype was shown to be PLS truck-compatible and could be loaded and unloaded from a container using the PLS LHS. Using experience gained in the first prototype development to establish initial design specifications, the PM, HTV acquired two CROP prototypes from a commercial flatrack producer and delivered them to the U.S. Army Ordnance Missile and Munitions Center and School (OMMCS) and the U.S. Army Defense Ammunition Center and School (USADACS) for evaluation.

Phase II of CROP development includes the evaluation of the CROP prototypes, user trials, and the development of specifications for another generation of commercially produced CROP. The Phase II effort is described in an "Action Plan Memorandum" distributed by the Office of the Deputy Chief of Staff for Logistics (ODCSLOG). This plan identifies responsible headquarters and actions necessary to ready the CROP for procurement as a strategic distribution asset. Analyses and development of the final user CROP features and mix of flatracks is included as part of Phase II. Phase II objectives include the generation of detailed engineering drawings and specifications that will allow the PM, HTV to solicit production of the CROP as a nondevelopment item. Phase II is expected to end in September 1996 and will be funded using ODCSLOG-controlled Army Strategic Mobility Program funds.

## CONTAINER-HANDLING DEVICE (CHD) STATUS

Two similar versions of CHD have been produced in prototype form for testing. The first is the container handling unit (CHU) modeled after the device used by the British version of the PLS (DROPS) and made by CargoTech. This is an H-shape configuration that first attaches to the LHS of the PLS and then uses the four ISO pockets on one end of the container for lifting and securing to the PLS bed. Rollers and slider guides are permanently mounted on the rear of the PLS truck to position and secure the container. The second CHD is the container lift kit (CLK) made by Oshkosh Truck Company. This is an X-shaped device that uses the same attachment points and a similar roller system as the CHU to lift and secure containers. Both the CHU and the CLK are heavy, removable devices



that are set aside when flatracks are lifted. The CHD are to be installed on PLS trucks that are not equipped with the auxiliary crane for unloading individual pallets. Neither device allows containers to be carried on a PLS trailer. The goal is to use the information developed by observing the performance of the CHD to develop a lighter, permanently mounted device that allows the PLS to quickly switch from carrying containers to carrying flatracks. This modification of the LHS of the PLS is a future development effort.

## DOCTRINE, REQUIREMENTS, AND ORGANIZATIONAL REVIEW

In a September 1995 memorandum, the DCSLOG requested that CASCOM conduct a review of flatrack requirements in light of CROP and other commercial variant developments and emerging force deployment requirements. CASCOM has chartered a working group to evaluate flatrack requirements and PLS developments. Until the working group's work is completed, CASCOM's position is that the Army's requirement is for 9,000 intermodal flatracks and 42,000 A-frame flatracks. The Office of the Deputy Chief of Staff for Operations and Plans (ODCSOPS)' position is that buys of flatracks will be supported until the total inventory reaches some number in the vicinity of 39,000, at which point analyses will be required to justify additional flatracks. The CROP Phase II action memorandum requests that the cost and benefits of the CROP be reviewed in comparison to other flatrack alternatives.

## PLS PROGRAM INITIATIVES

With the success of PLS operations and more exposure of the flatrack-type system to artillery, engineer, medical, and other potential users, CASCOM and the PM, HTV expect that the use of flatrack-type operations will be expanded. This expansion may take the form of special purpose flatracks mounted with fuel pods, flatracks that carry air defense missiles (THAADs), other uses of PLS, or addition of the LHS to modified Heavy Expanded Mobility Tactical Trucks (HEMTT's). CASCOM is also investigating the addition of PLS enhancements to include position location, improved communications, and driver performance devices. Investigation of these initiatives has not proceeded beyond the concept evaluation stage; procurement is not fully funded.

## BOSNIAN EMPLOYMENT

PLS in CONUS units and those deployed to Bosnia is being used to transport a variety of loads beyond ammunition. CASCOM was asked to identify these loads to allow the PM, HTV and/or the Transportation Engineering Agency (TEA) to investigate proper loading and transport. The centers of gravity (CG) of some loads (e.g., containers) are higher than ammo. When these

loads are carried on the PLS truck or trailer, the CG height increases the potential for instability and may lead to unsafe operations.

## FLATRACK TESTING, EVALUATION, AND MANAGEMENT

The commercial variants and CROP described in the LMI study as offering potential cost savings as alternatives to the \$16,300 M1 intermodal flatrack have been engineered as prototype equipment and currently exist for user evaluation. The doctrinal use, mix studies, performance testing, and cost analyses necessary to support final decisions on acquisition of these alternatives have not been started. To provide guidance to the PM, HTV to focus acquisition actions, the following actions must be taken:

- ◆ Review total distribution flatrack requirements to support likely scenarios using the most recent Major Regional Scenario Bottom-up Review Update (MRS BURU) data and ammunition usage rates. Use this review to identify the most appropriate flatrack mix that may include A-frame, reinforced A-frame, M1 intermodal, commercial specification intermodal, CROP, and dry containers. This mix addresses the ammunition mission only.
- ◆ Investigate and analyze additional applications of PLS LHS/flatrack technology. Use the results of these studies to weed out the promising, desirable, and cost-effective configurations. Develop programs that will put these initiatives in the hands of the troops.
- ◆ Develop a flatrack procurement plan that includes the purchase of additional PLS or HEMTTs with load handling systems that can articulate the Army's needs and a cost-effective program for meeting those needs.

# REPORT DOCUMENTATION PAGE

Form Approved  
OPM No.0704-0188

Public reporting burden for this collection of information is estimated to average 1 hour per response, including the time for reviewing instructions, searching existing data sources gathering, and maintaining the data needed, and reviewing the collection of information. Send comments regarding this burden estimate or any other aspect of this collection of information, including suggestions for reducing this burden, to Washington Headquarters Services, Directorate for Information Operations and Reports, 1215 Jefferson Davis Highway, Suite 1204, Arlington, VA 22202-4302, and to the Office of Information and Regulatory Affairs, Office of Management and Budget, Washington, DC 20503.

1. AGENCY USE ONLY (Leave Blank)		2. REPORT DATE Sep 95	3. REPORT TYPE AND DATES COVERED Final	
4. TITLE AND SUBTITLE Palletized Load System: An Analysis of Alternative Flatrack Acquisition Strategies			5. FUNDING NUMBERS DASW01-95-C-0019 PE 0902198D	
6. AUTHOR(S) Ronald B. Bailey Raymond A. Schaible				
7. PERFORMING ORGANIZATION NAME(S) AND ADDRESS(ES) Logistics Management Institute 2000 Corporate Ridge McLean, VA 22102-7805			8. PERFORMING ORGANIZATION REPORT NUMBER LMI- AR420MR1	
9. SPONSORING/MONITORING AGENCY NAME(S) AND ADDRESS(ES) Director, Transportation, Energy and Troop Support Office of the Deputy Chief of Staff for Logistics Headquarters, Department of the Army The Pentagon Washington, D.C. 20310			10. SPONSORING/MONITORING AGENCY REPORT NUMBER	
11. SUPPLEMENTARY NOTES				
12a. DISTRIBUTION/AVAILABILITY STATEMENT A: Approved for public release; distribution unlimited			12b. DISTRIBUTION CODE	
13. ABSTRACT (Maximum 200 words) A key element of the Army's future battlefield distribution system is the Palletized Load System (PLS), comprised of highly mobile trucks, trailers, and flatracks. The system features demountable flatracks to quickly pick up and drop off loads of ammunition using an on-board load handling system. This system speeds ammunition delivery and reduces handling and congestion in forward areas. The Army has identified some 3,000 trucks and trailers and 50,000 flatracks to meet its ammunition distribution needs. Improvements to the flatrack to allow preparation of combat loads to occur in the stateside depots and be transported to the using units have been suggested. These modifications add to the weight and cost of the flatracks and a cost-benefit analysis was performed to examine the tradeoffs between cost and design features. The report simulated distribution activities on a major regional contingency battlefield and analyzed the fleet costs for various flatrack alternatives. The comparison of benefits to costs resulted in recommendations to examine commercial variants of the flatrack before proceeding with a costly unique design of the flatrack and to modify the PLS truck for these commercial flatrack variants. Potential cost savings of over \$160 million are associated with the LMI recommendation.				
14. SUBJECT TERMS Palletized Load System, cost benefit, decision tree, flatrack, battlefield distribution, DYNAMO			15. NUMBER OF PAGES 142	
			16. PRICE CODE	
17. SECURITY CLASSIFICATION OF REPORT Unclassified	18. SECURITY CLASSIFICATION OF THIS PAGE Unclassified	19. SECURITY CLASSIFICATION OF ABSTRACT Unclassified	20. LIMITATION OF ABSTRACT UL	

Logistics Management Institute  
2000 Corporate Ridge  
McLean, Virginia 22102-7805