

Potential of Composite Materials in Surface Transportation Applications

Satish V. Kulkarni

DISTRIBUTION STATEMENT R
Approved for public release
Distribution Unlimited

DEPARTMENT OF DEFENSE
ARMY TECHNICAL EVALUATION CENTER
ATTENTION: DTD: 5.6. 070

December 16, 1982

 Lawrence
Livermore
National
Laboratory

STEER

19960321 070

DNIC QUALITY INSPECTED 1

450576

DISCLAIMER

This document was prepared as an account of work sponsored by an agency of the United States Government. Neither the United States Government nor the University of California nor any of their employees, makes any warranty, express or implied, or assumes any legal liability or responsibility for the accuracy, completeness, or usefulness of any information, apparatus, product, or process disclosed, or represents that its use would not infringe privately owned rights. Reference herein to any specific commercial products, process, or service by trade name, trademark, manufacturer, or otherwise, does not necessarily constitute or imply its endorsement, recommendation, or favoring by the United States Government or the University of California. The views and opinions of authors expressed herein do not necessarily state or reflect those of the United States Government thereof, and shall not be used for advertising or product endorsement purposes.

DISCLAIMER NOTICE



THIS DOCUMENT IS BEST QUALITY AVAILABLE. THE COPY FURNISHED TO DTIC CONTAINED A SIGNIFICANT NUMBER OF PAGES WHICH DO NOT REPRODUCE LEGIBLY.

Potential of Composite Materials in Surface Transportation Applications

Satish V. Kulkarni

Manuscript date: December 16, 1982

LAWRENCE LIVERMORE LABORATORY 
University of California • Livermore, California • 94550

FOREWORD

This study was performed for the Oak Ridge National Laboratory (ORNL)/
Department of Energy, Energy Conservation Utilization Technology (ECUT)
Program.

CONTENTS

Foreword	ii
Abstract	1
Introduction	1
Objectives and Approach	3
Unique Aspects Associated with Downsizing and Materials Substitution in Vehicles	4
Product Design with New Materials	6
Motivation for the Use of Fiber-Reinforced Composite Materials	7
Various Composite Materials and Processes	9
Matrices	10
Reinforcements	11
Composite Forms	12
Matched Metal Die Compression Molding	14
Filament Winding	15
Pultrusion	18
Elastic Reservoir Molding (ERM)	18
Stamping of Thermoplastics	18
Reinforced Reaction Injection Molding (RRIM)	20
Status of Composite Material Applications in Surface Transportation Vehicles	21
Composite Vehicle Prototypes	21
Drive Train	26
Chassis and Suspension	27
Body	29
Engine	30
Energy Storage Flywheels	34
Factors Inhibiting the Use of Composites in Vehicular Applications	39
Future R&D Areas for Composite Materials for Vehicular Applications	41
General Research and Development Areas	42
Materials	42
Design Data Base	42
Manufacturing Technology	43
Bonding and Joining	43
Nondestructive Inspection and Evaluation	43
Crashworthiness	43

Recyclability	44
Research and Development Areas Recommended for ECUT Consideration . . .	44
Acknowledgments	45

POTENTIAL OF COMPOSITE MATERIALS IN
SURFACE TRANSPORTATION APPLICATIONS

ABSTRACT

This study addresses the different issues associated with materials substitution with fiber-reinforced composites in surface transportation vehicles, and identifies pertinent "high risk" R & D areas having payoff in the far term. Initially, a brief summary of the various materials and processes, and prototype development programs is presented. Subsequently, factors inhibiting the use of composites are listed and finally, future R & D areas are delineated. No attempt has been made to perform an exhaustive study and cover every aspect and activity in this technology area. This is due primarily to the limited scope of this effort and to the vastness of the field. (A57170R)

INTRODUCTION

The motivation for obtaining improved fuel economy in the U.S. automobile industry has been provided by the following factors:

- The petroleum supply crisis of 1973 suddenly focused attention on the ability (1) to drive over given distances (e.g., a typical urban driving cycle) with lesser gasoline/diesel requirements, and (2) to change established driving patterns. This need was again underscored by the shortage in 1979. The impact of petroleum shortage is felt most in the surface transportation area because automobiles, buses, and trucks typically consume about 40% of the petroleum marketed in the U.S.A.
- In response to the 1973 oil embargo, the Environmental Protection Agency (EPA) has mandated a Corporate Average Fuel Economy (CAFE) rating of 27.5 mpg by 1985 (up from 18 mpg in 1978.)
- From the consumer's viewpoint, the cost of fuel to operate a vehicle has played a significant role in making a decision to buy a particular make of vehicle. The shift in the last few years towards buying imports that have better fuel-economy ratings is undoubtedly a matter of grave concern to the U.S. automobile industry.

There are four basic approaches either to meet or exceed the EPA-mandated goal:

- Downsizing of the vehicle fleet. This can be achieved by producing a larger number of smaller cars.
- More efficient utilization of current materials such as steel.
- Weight reduction in existing vehicles by lightweight materials substitution.
- Improvements in engine performance, power train efficiency, and aerodynamics.

The current effort in Detroit consists of an appropriate mix of the preceding four approaches. This study, however, deals primarily with the third approach. Its scope is further restricted to the use of semistructural and structural fiber-reinforced composite materials. The utilization of both aluminum and high-strength low-alloy (HSLA) steels as replacement materials has not been considered.

In general, fiber-reinforced composite materials offer the following major advantages:

- High specific strength and stiffness.
- Material tailorability and design flexibility.
- Fatigue resistance.
- Damage tolerance.
- Corrosion resistance.
- Economics associated with production costs, life cycle costs, and energy conservation during manufacture.

Successful development of fiber-reinforced composite material aerospace components has demonstrated the potential of these materials for aerospace applications, and has provided the necessary confidence to utilize them in other application areas such as transportation vehicles. A major effort was launched, with much publicity, in the late seventies to build and test composite material prototype components for cars and trucks. The optimism associated with successful completion of the prototype development programs, which involved the use of "millions of pounds of graphite at \$5/lb," has faded somewhat because of technological barriers and current economic difficulties in Detroit. There is no doubt, however, that lightweight material substitutions will play a major role in improving the fuel economy rating of transportation vehicles, both in the near and far term.

This study addresses the different issues associated with materials substitution with fiber-reinforced composites, and identifies pertinent "high risk" R & D areas having payoff in the far term. No attempt has been made to perform an exhaustive study and cover every aspect and activity in this technology area. This is due primarily to the limited scope of this effort and to the vastness of the field. Rather, effort has been directed towards presenting a brief summary of the various materials and processes, and prototype development programs. Subsequently, factors inhibiting the use of composites are listed and finally, future R & D areas are delineated.

OBJECTIVES AND APPROACH

This effort has been sponsored by the U.S. Department of Energy/Oak Ridge National Laboratory Energy Conservation Utilization Technology (ECUT) Program. The objective of the ECUT program is to pursue high-risk, far-term payoff R & D areas in materials technologies that have a significant impact on energy conservation.

On the average, each pound of weight saved corresponds to an increase of approximately 0.00725 mpg. In light of the total fuel consumption for surface transportation vehicles, it is evident that the impact of the improvement in fuel economy with weight reduction on energy conservation can be enormous.

The specific objectives of the LLNL effort are:

- Conduct a survey of the current status of the application of fiber-reinforced composite materials in the automotive industry.
- Identify high-risk research and development areas having payoff in the far term. The payoff can be measured in terms of the impact on fuel conservation and the relevance of the research and development areas to the needs of the automobile industry.

It is worthwhile to note here that in spite of the losses incurred by the automotive companies in the past two years, there is a growing realization in Detroit that in order to remain competitive and to maintain a technological edge, it is imperative to plan, invest, and wait for future benefits, and avoid concentrating just on near-term profits. In view of this, a directed effort in composite materials R & D and prototype design/fabrication/testing/evaluation are underway in Detroit at this time.

An extensive literature search was conducted, and the following organizations were visited:

- General Motors.
 - Manufacturing Development, Warren, MI.
 - Research Laboratories, Warren, MI.
- Ford Motor Company.
 - Scientific Research Laboratories, Dearborn, MI.
 - Plastics Development Center, Detroit, MI.
 - Car Product Development Group, Dearborn, MI.
- Budd Company.
 - Plastics R & D Center, Troy, MI.
- Ewald Associates, Detroit, MI.
(U.S. Army TACOM 5-T Truck Program).
- Kelsey Hays, Brighton, MI.
- International Harvester, Hinsdale, IL.
- Polimotor Research Inc., Fairlawn, NJ.

Discussions held with various individuals in these organizations provided the basic framework for this report.

UNIQUE ASPECTS ASSOCIATED WITH DOWNSIZING AND MATERIALS SUBSTITUTION IN VEHICLES

In deciding whether to emphasize vehicle downsizing or materials substitution in order to achieve the CAFE requirements, one is confronted with the following question:

If the current trend in the marketplace is to buy subcompacts (Chevette, Escort, etc.) which have higher mpg by virtue of size, is there a real need for investing billions of dollars in developing larger, lightweight cars?

The general consensus in Detroit is YES! This is because the consumer really prefers to buy a compact (Fairmont, X-Car, K-Car, etc.) that has the following characteristics:

- An mpg rating that either equals or exceeds that of the present subcompacts.
- Comfort, practicality, and flexibility (subcompacts cannot combine all these features, and there is also a limit to downsizing).

The weight of an average car in Detroit has been reduced from 4000 lb in 1970 to about 3200 lb in 1980, and the projected weight of a six-passenger car that uses lightweight composite materials is about 1800 lb. Hence, there is a considerable optimism about the ability of U.S. auto manufacturers to deliver the "ideal" car to the consumer.

There are some additional factors that play a role in the lightweight material substitution approach for improving mpg:

- The classification of car categories by weight is rigidly controlled by the EPA when determining whether the CAFE requirements are met by a manufacturer or not. For example, subcompacts weigh from 2000 to 3000 lb in increments of 250 lb. Each increment puts the car in a different class (see Fig. 1). The effort by the vehicle manufacturer is always directed more towards downgrading a vehicle class so that the CAFE requirements can be met rather than just reducing weight. Thus, in Fig. 1, if the present car weight is more towards the upper bound of a particular Class (Class B here), there is little motivation for weight reductions because the weight-cost trade-off weighs heavily towards increased costs. On the contrary, if the

- **Car classification rigidly controlled by EPA**

For example:

Subcompacts	2000 lbs - 3000 lbs	} In increments of 125 and 250 lbs
Compacts	3000 lbs - 4000 lbs	

- **Efforts by car manufacturers is directed towards downgrading vehicle class so that the CAFE requirements can be met**

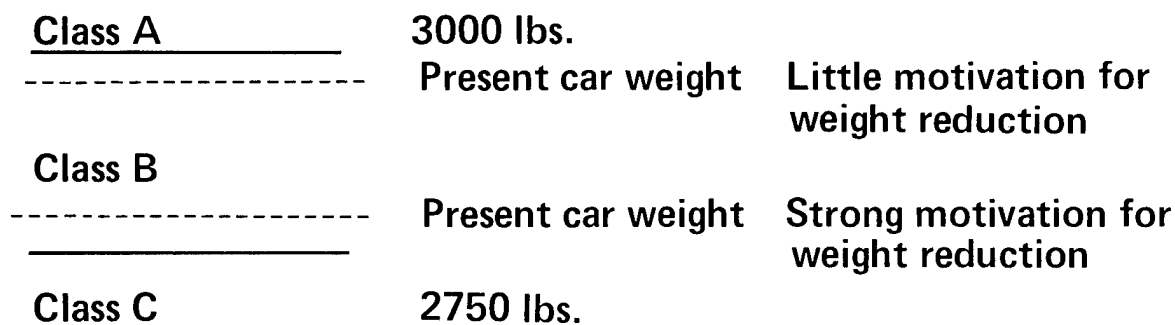

Figure 1. Effect of car classification on the motivation for weight reduction.

weight is closer to the lower bound of that vehicle class, a slight reduction in weight downgrades the vehicle class and improves the CAFE mpg.

- Lighter components require less structural support from other vehicle subsystems, such as chassis, suspension, tires, etc. So these components can also be reduced in size. Utilization of lighter components may also allow a smaller, less powerful engine to be used. Thus, a secondary weight reduction results.
- Material substitution with composite materials requires a complete changeover to "nonfamiliar" manufacturing/repair processes. These processes, while being different, must still satisfy the criteria for mass producing automobiles. Thus, all manufacturing steps for composite parts (including bonding, NDI, etc.) must be of the order of a few minutes.
- The National Highway Transportation Safety Administration (NHTSA) safety standards and SAE specifications applicable for metallic materials cannot be translated to composites in a straightforward manner. Thus, the regulatory agencies have to devote considerable effort in rewriting these standards and specifications (parallel exists for the Federal Aviation Administration FAR .25 Standards for damage tolerance requirements of composite aircraft structures.)
- Finally, because of antitrust laws, the U.S. automobile companies cannot establish joint cooperative development programs like those in Europe and Japan and save valuable resources. This has a direct effect upon the cost of the automobiles manufactured in this country.

PRODUCT DESIGN WITH NEW MATERIALS

Some observations regarding product design with new materials should be made at this juncture:

- In new materials, original trend is always toward performance optimization.
- Subsequently, there is an evolution toward better design balance between performance and economics.
- There is a reluctance on the part of designers to use a new material without a large data base.

- Willingness to compromise between economics and performance dramatically affects manufacturing costs.
- Cooperation and coordination among preliminary design, tool design, manufacturing, and capital expenditure groups are necessary and useful.

It is evident that a transition from "performance only" to a balance of "performance and cost" for composite materials technology is occurring in the aerospace field, and is occurring in the surface transportation industry as well. Such a transition occurs in the following sequence:

From yesterday's

- High material costs.
- Direct substitution in design.
- Labor-intensive operations.
- Limited material forms.
- Limited structural applications.

With

- Weight savings.

And seldom

- Any cost savings.

To today's

- Lower material costs.
- Innovative design configurations.
- Semiautomated and automated manufacturing processes.
- Wide range of secondary and primary structure applications.

With proven

- Weight and cost savings.

MOTIVATION FOR THE USE OF FIBER-REINFORCED COMPOSITE MATERIALS

It has been said that "Available materials set a limit to the techniques of any age." Hence, we have had the stone age, copper/bronze age, iron age, steel age, and aluminum-titanium age. A plateau has now been reached in the mechanical properties of structural metals, and the materials of the future are clearly the high specific strength/stiffness fiber-reinforced composite materials.

In the last decade, certain developments in aerospace technology have profoundly influenced the design of automobiles. Prominent among these developments are finite-element analysis, computer-aided design, composite materials, and electronics. The successful application of composite materials in many aerospace structural components for civil and military aircraft, helicopters, satellites, rocket motor cases and fuel tanks has played a significant role in overcoming the traditional "resistance to change" in Detroit.

Some of the advantages that accrue from the use of composite materials for aerospace applications are equally applicable for surface transportation vehicles. Among them are:

- High specific strength/stiffness resulting in weight reduction of up to 50% over existing steel components and consequent improvement in mpg. Table 1 gives the weight reductions obtained by using graphite composites in the Ford lightweight vehicle program. Weight savings assume greater significance for heavy- and light-duty trucks because they can be translated into greater cargo-carrying capacity.

Table 1. Ford Lightweight Vehicle Program. Graphite component weight summary.

Component	Component weight (lb)		Reduction (lb)	Weight ratio ^a
	Steel	Graphite composite		
Hood	40	15	25	0.38
Door, right hand, rear	30.25	12.65	17.60	0.42
Hinge, upper left hand, front	2.25	0.47	1.78	0.21
Hinge, lower left hand, front	2.67	0.77	1.90	0.29
Door guard beam	3.85	2.40	1.45	0.62
Suspension arm, front upper	3.85	1.68	2.17	0.44
Suspension arm, front lower	2.90	1.27	1.63	0.44
Transmission support	2.35	0.55	1.80	0.23
Drive shaft	17.40	12	5.40	0.69
Air conditioning, lateral brace	9.50	3.25	6.25	0.34
Air conditioning, compressor bracket	5.63	1.35	4.28	0.24

^a Weight ratio = $\frac{\text{weight of graphite composite component}}{\text{weight of steel component}}$.

- Tailorability of material properties and greater design flexibility. Design flexibility through the use of composites allows the designer to form any shape he may desire, simple or complex, large or small. It is this flexibility that also allows modular modifications at minimum expense. Another aspect of design flexibility is the anisotropy of the materials and the consequent capability of putting the fibers in the direction of the applied loads. This allows design and fabrication of weight-efficient structures. The ability to tailor a composite includes another advantage -- hybridization, or the combining of two or more fibers in the same laminate. This enables the use of lower-cost fibers to enhance specific properties such as impact resistance.
- Improved fatigue resistance. (This is particularly true for continuous fiber-reinforced composites.) Longer fatigue life results in fewer parts being worn out.
- Part consolidation resulting in manufacturing cost savings. The front end of many automobiles, for example, which used to be constructed with numerous metal parts, can now be formed out of a single piece of fiberglass-reinforced polyester.
- Superior corrosion resistance to salt water and other hostile environments (certain countries like Canada now have a no-perforation requirement for five years.) This reduces the need for preventive maintenance and painting.
- The vibrational dampening characteristics of composites are beneficial for applications like drive shafts.
- Low coefficients of thermal expansion of graphite composites are also a unique property that can be useful for some applications.
- Lower energy consumption during manufacture. A comparison between the energy consumption in the manufacture of car hoods from steel, aluminum, and fiber-reinforced plastics (FRP) is given in Table 2.

VARIOUS COMPOSITE MATERIALS AND PROCESSES

The range of composite materials and forms that can be employed in automobiles is rather wide. The utilization of a particular material and form is influenced by the manufacturing process, and performance and cost

Table 2. Energy comparisons for manufacturing a car hood.

	Part weight (lb)	Material energy need (Btu/lb)	Part energy need (10 ⁶ Btu/hood)
Steel	75	28,000	2.0
Aluminum	36.7	108,300	3.98
FRP (2 piece) ^a	47	40,000	1.89
FRP (1 piece) ^a	34	40,000	1.36

^a Fiber-reinforced plastic composite consisting of 30% resin and 70% fiberglass and mineral filler.

requirements. We summarize here the various materials and forms and their unique attributes.

MATRICES

Two basic matrix systems are utilized in fabricating composite materials components for automobiles.

- Thermosets. This is the primary matrix system. Thermosets undergo a cross-linking chemical reaction during molding/curing and cannot be reformed once hardened.
 - Polyesters. They are rapid-curing, low-cost thermosets, and constitute the bulk of the matrix material utilized today. They cannot be used for higher temperature (more than 200°F) applications and do not have good matrix-dominated composite properties. For automotive components, low-shrinkage (low-profile) polyester resins containing a thermoplastic or elastomeric component are used to enhance the surface finish.
 - Vinyl esters. Vinyl ester resins have a greater resistance to hydrolysis and have lower peak exotherm temperatures and less shrinkage upon cure. At present, the largest commercial use of vinyl ester resins is in chemical-resistant FRP equipment. Vinyl ester resin-based bulk molding compounds (BMC) and sheet molding compounds (SMC) are used in some automotive components.

- Epoxies. They are used primarily for high performance aerospace applications and in automobiles where high temperature capability and interlaminar shear strength are important (e.g., leaf springs). They exhibit good adhesive properties and good resistance to chemicals, and shrinkage after cure is lower than polyesters. They are moderate in cost.
- Thermoplastics. They are used primarily in injection molded and stamped parts, and are moderate in cost. They can be repeatedly softened by heating and hardened by cooling. Consequently, they can be reformed if required.
- Other matrices that have the potential for high temperature applications, such as engine parts, are polyimides (thermoset) and aluminum/magnesium alloys. Their costs are rather high and the need for their use must be strongly justified by performance requirements.

REINFORCEMENTS

Fiber reinforcements can be either continuous or chopped (1/8 in. to 2 in.). A comparison of material properties of different materials is given in Table 3.

- E-Glass. This is the primary reinforcement material for automotive applications. It has moderate strength and low cost.
- S2-Glass. It has higher strength and cost than E-glass, and is used either when higher strength is desired or in a hybrid form with graphite to reduce cost and improve impact resistance.
- Aramids. Kevlar-49, -29 are high-cost, high-tensile/low-compressive- strength reinforcements, and can be used in a hybrid form with graphite to improve impact resistance. Kevlar chord is used extensively as a tire reinforcement.
- Graphite. These are high strength, high modulus, high-cost fibers having superior fatigue resistance. Much has been said about the projected reduction of the cost of graphite fibers (\$5/lb) with a significant increase in the volume of production (millions of pounds). However, it still costs about \$20/lb as compared with E-glass fiber at less than \$1/lb. From the standpoint of automotive economics, this price is too high and it is unlikely that they will see much use in the near term.

Table 3. Comparison of material properties.

Material	Density (lb/in. ³)	Tensile Modulus (msi)	Tensile Strength (ksi)	Cost per pound (\$)
High strength				
graphite fiber	0.065	34	450	18-30
Kevlar-29 fiber	0.052	9	400	10
Kevlar-49 fiber	0.052	18	400	12
E-Glass fiber	0.094	10.5	500	0.6
S2-Glass fiber	0.090	12.5	665	2.5
FP ^a fiber	0.143	55	200 (400) ^b	--
Aluminum	0.096	10	40	1.5 ^c
Steel				
Ordinary	2.83	30	50-65	0.25 ^c
HSLA	2.83	30	65-90	0.30 ^c

^a DuPont polycrystalline alumina fiber.

^b Composite compressive strength with 50 to 55% fiber volume fraction.

^c Cost for large volumes.

- Other reinforcements such as the DuPont polycrystalline alumina fiber, FP, (low tensile/high compressive strength) and the Exxon SiC whiskers have applications primarily in metal matrix composites.

COMPOSITE FORMS

There are many composite forms (combinations of the reinforcement and matrix) which can be employed for fabricating automotive components. Quite often, the use of a particular form is dictated by the manufacturing process.

- Sheet molding compounds (SMC). These compounds consist of a polyester or vinyl ester resin mixture (resin, catalyst, initiator, and thickener) reinforced with glass strands and formed into a sheet (Fig. 2) that can be handled easily, cut to shape, and placed in a compression mold. This is the primary form used for molding both semistructural and structural automotive components such as hoods,

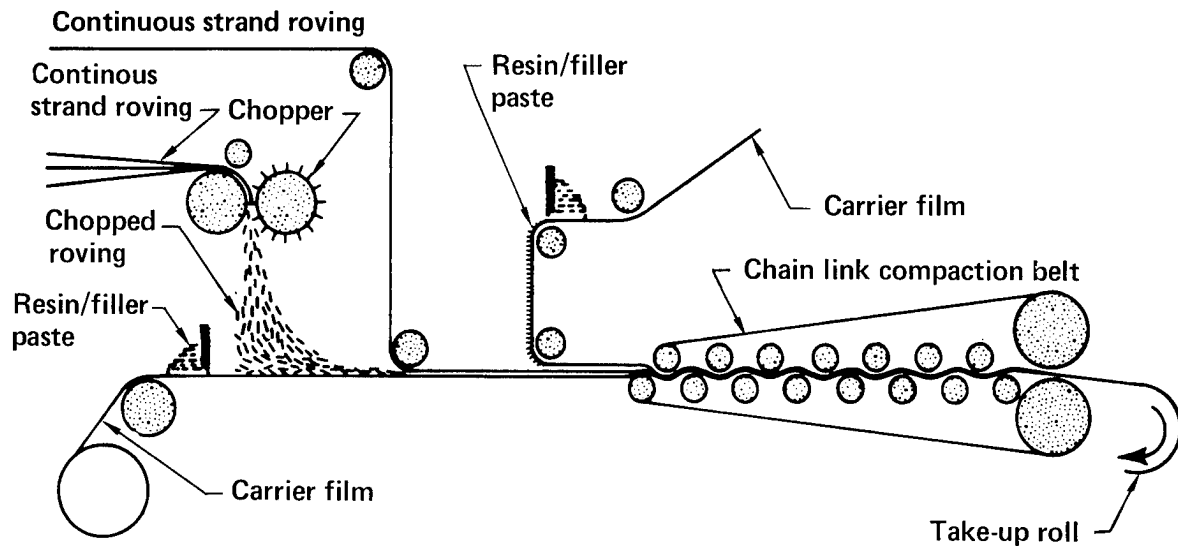

Figure 2. Schematic of SMC machine capable of producing random chopped and continuous fiber SMC.

deck lids, and wheel rims. It is a low-to-moderate-cost material (as compared to other reinforced plastics) and the reinforcement can be either chopped-random (1/2 to 2 in.), chopped-aligned, continuous, or oriented in a $\pm(X)$ direction (Fig. 3).

- Prepreg. It is primarily an aerospace material, similar to the continuous fiber SMC, but with an epoxy or polyimide matrix that is partially cured. Prepreg cost is higher than SMC and it has limited applications in the automotive industry.
- Sandwich construction. This form consists of a thin, continuous fiber-laminate bonded to the top and bottom surfaces of a core that is either a foam or aluminum honeycomb. Sandwich construction has not been used except for some special applications, like body shells of racing cars. In the elastic reservoir molding (ERM) technique (discussed later), composite parts are fabricated in a sandwich form with foam as a core.
- Reinforced cast metals. These consist of aluminum/magnesium alloys reinforced with FP fiber and SiC whiskers. They have potential for use in high temperature engine applications.
- In manufacturing techniques like filament winding and "pultrusion," an intermediate step of fabricating a composite form is not required because the final part is made directly from the reinforcement and matrix.

- Composite forms

- SMC, HMC (semi-structural, and structural applications: low to moderate cost)

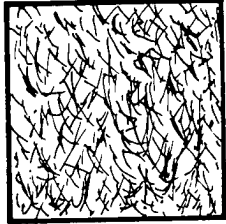

Chopped-random
(primary material)

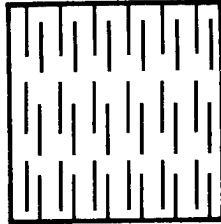

Chopped-aligned

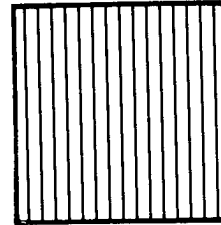

Continuous

- XMC (structural applications: low to moderate cost)

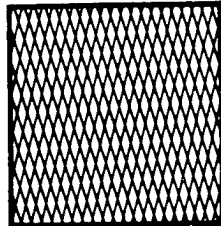

Figure 3. Various SMC forms.

A brief description of the manufacturing processes employed in fabricating composite material parts is also given here. Whether or not composite material automotive parts can be mass-produced in the same way as steel parts will be ultimately determined by how efficient and economical a particular process is.

MATCHED METAL DIE COMPRESSION MOLDING

This is the most commonly used fabrication technique to mold SMC parts. The favorable characteristics of compression molding are:

- High volume production.
- Excellent part reproducibility.
- Low labor requirement per unit produced.
- Minimum material scrap.

- Excellent design flexibility (simple to complex shapes).
- Fully mechanized production capabilities.

As shown in Fig. 4, the die consists of a male and female mold with cores heated either by steam or oil. The SMC charge is placed in the cavity (which corresponds to the shape of the component), the molds are closed, and pressure is applied via the press rams. Depending upon part size and thickness, molding times vary from 3 to 20 min, pressures from 200 to 2000 psi, and mold temperatures from 200 to 300°F.

FILAMENT WINDING

Filament winding is a comparatively simple operation in which continuous reinforcements, in the form of rovings or yarn, are impregnated with matrix and wound over a rotating mandrel. The basic process is subject to numerous variations offering a broad spectrum of structural types (various geodesic shapes, pipes, etc.), design features, material combinations, and equipment. The size of these parts may vary from a few inches to several feet in diameter. Currently, this process is used for winding drive shafts for automobiles. One of the drawbacks of this process is that it is too slow for

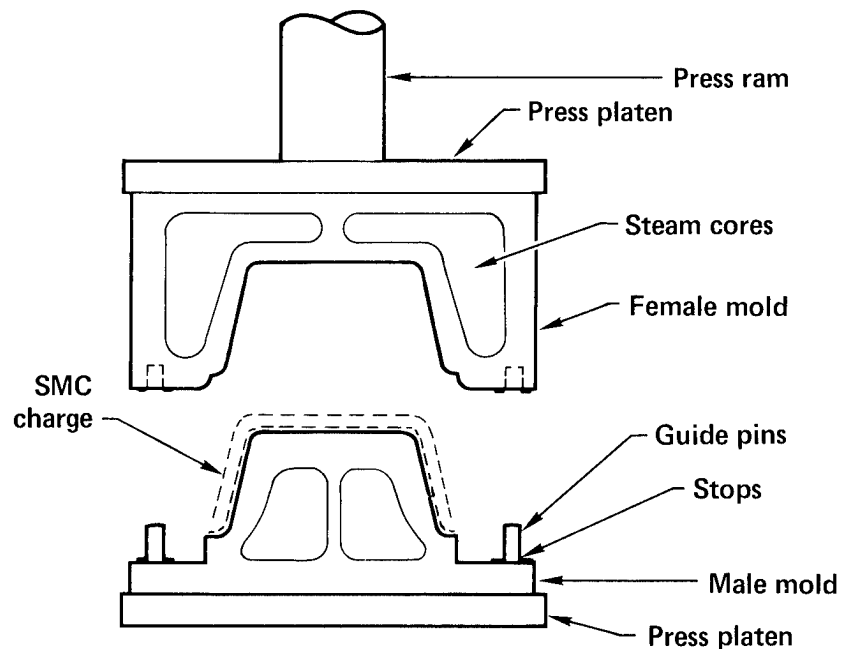

Figure 4. Matched metal die compression molding.

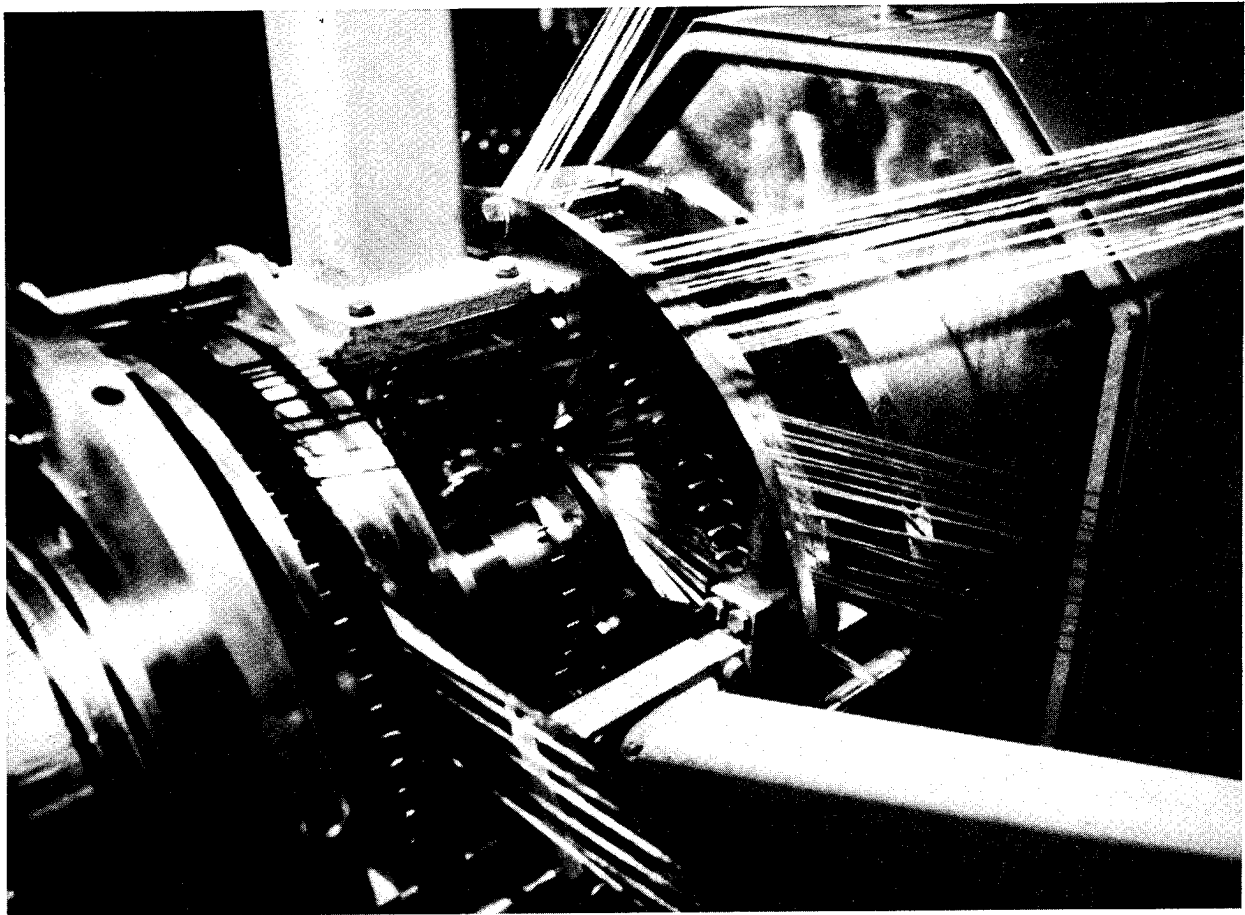
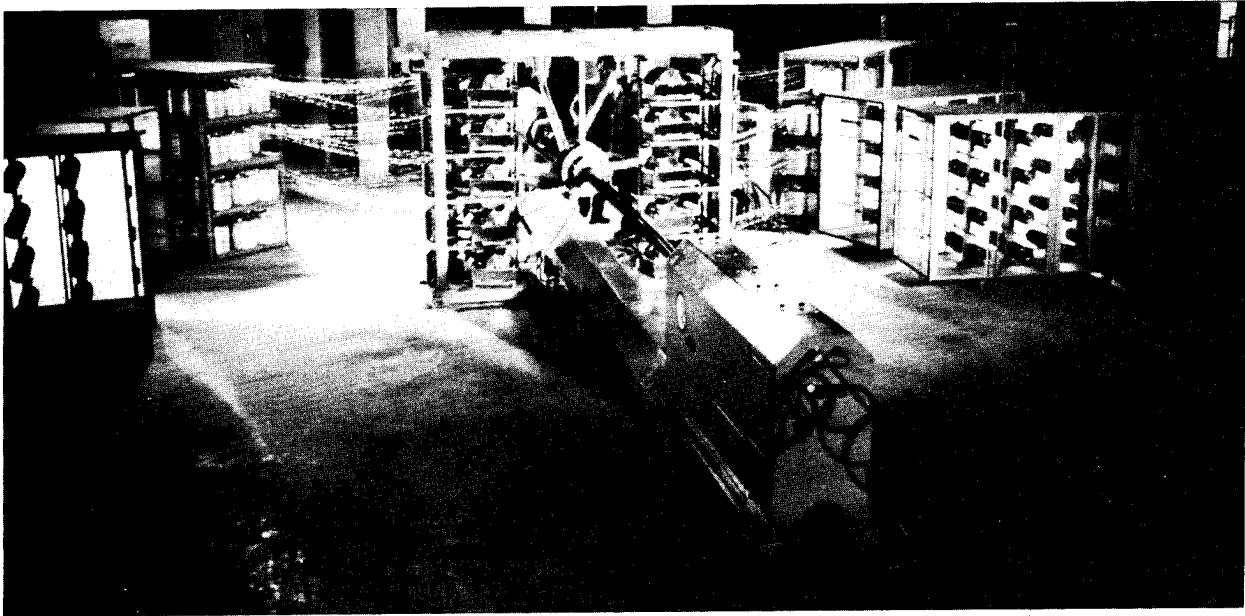

Figure 5. The Celanese/McClearn Anderson Mark IV Filament Winder.
(a) Fully automated filament winder turns out hybrid-reinforced parts at mass-production rates. Called Mark IV, it has dual-fiber continuous-strand delivery system (see close-up detail below) and accommodates mandrels up to 27 ft. (b) Stationary delivery system has capacity for 220 ends of each fiber type. [(a) and (b) courtesy of Celanese Corp.]

mass production. However, Celanese and McClean-Anderson have recently designed a high speed winder (Fig. 5) that has the following features:

- Microprocessor control with preprogramming of winding sequences.
- Fast changeover to different patterns and from one fiber type to another.
- 360-deg fiber placement capability.

Celanese has wound Gr/GI hybrid auto drive shafts in 3 min on this machine.

Another novel production technique involves the combinations of filament winding and compression molding (Fig. 6). This process is used for winding/molding leaf springs and steering wheel inserts.

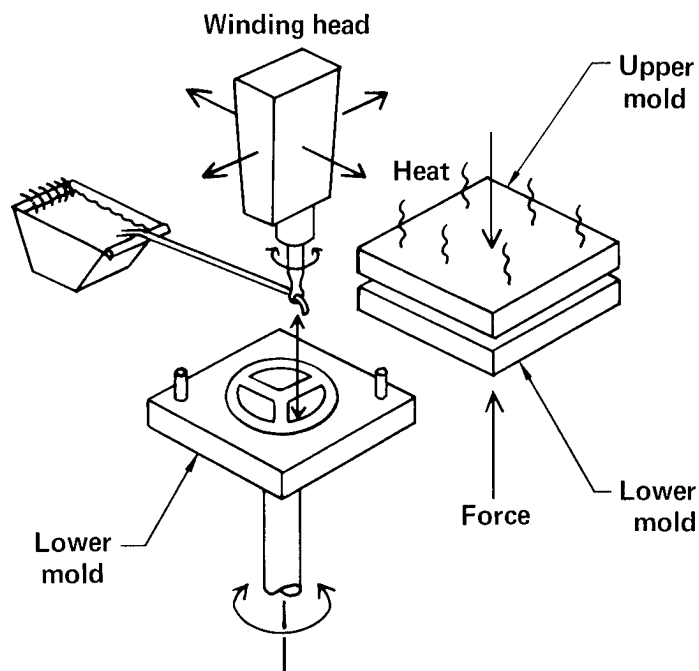

Figure 6. Hybrid approach to structural steering-wheel insert production involves two processes synchronized to operate in sequence. First, part is filament wound. Second, it is compression molded. (Courtesy of McClean Anderson.)

PULTRUSION

This technique, which is used to manufacture structural profiles from composites on a continuous basis, consists of resin-impregnated fiber-reinforcements that are pulled through a heated die. The composite is cured in the die. Pultrusion was originally viewed as a method of making simple solid sections reinforced with unidirectional fiber. It has evolved into a process capable of producing an almost infinite variety of solid and hollow profiles, with the capability to tailor the properties of these profiles to fit a wide range of structural requirements. Presently, pultrusion is being employed to fabricate glass/polyester bumpers. Producing curved parts by the pultrusion method (ideally suited for monoleaf "bow-tie" spring fabrication) is being investigated by Goldsworth Engineering (Fig. 7).

ELASTIC RESERVOIR MOLDING (ERM)

This process, developed by Composite Technology Corp., consists of making a sandwich of resin-impregnated open-celled flexible polyurethane foam between face layers of fibrous reinforcement. When the product is placed in a mold and squeezed, the foam is compressed forcing the resin out and into the face layers. The elastic foam exerts sufficient pressure to force the face layers into contact with the mold surfaces. When the components are properly proportioned, it is possible to end up with a molding having the advantages of sandwich construction; that is, a low density core with strong faces providing a favorable stiffness-to-weight ratio. Figure 8 shows the process schematically. The molding pressures are low, and less than 100 psi may be used. Applications include relatively large, flat shapes, such as decks, hoods, and roofs of vehicles.

STAMPING OF THERMOPLASTICS

Stamping of plastics is not new to the automotive industry. It is currently used for deck lids, hoods, etc. and the materials employed are glass-reinforced nylon and polypropylene (Azdel). The ability to warm-form and stamp oriented fiber, high strength and stiffness composites in standard metal presses without the complication of curing, bleeding, and storage

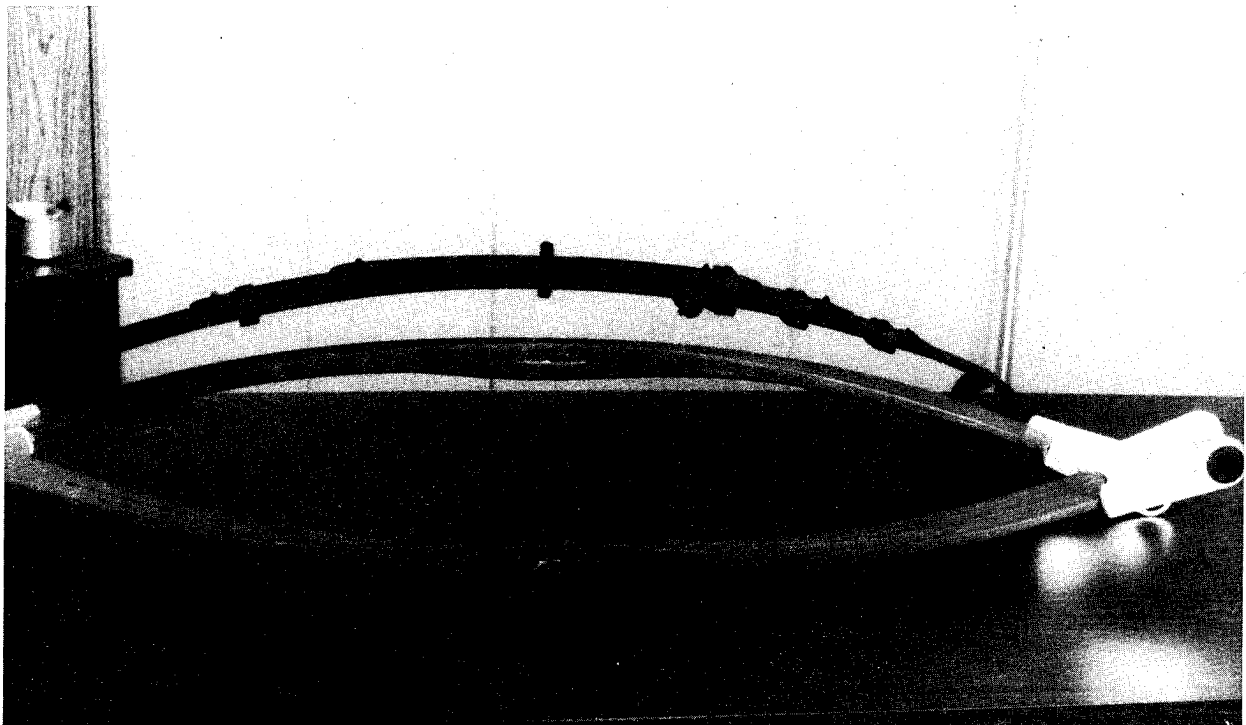
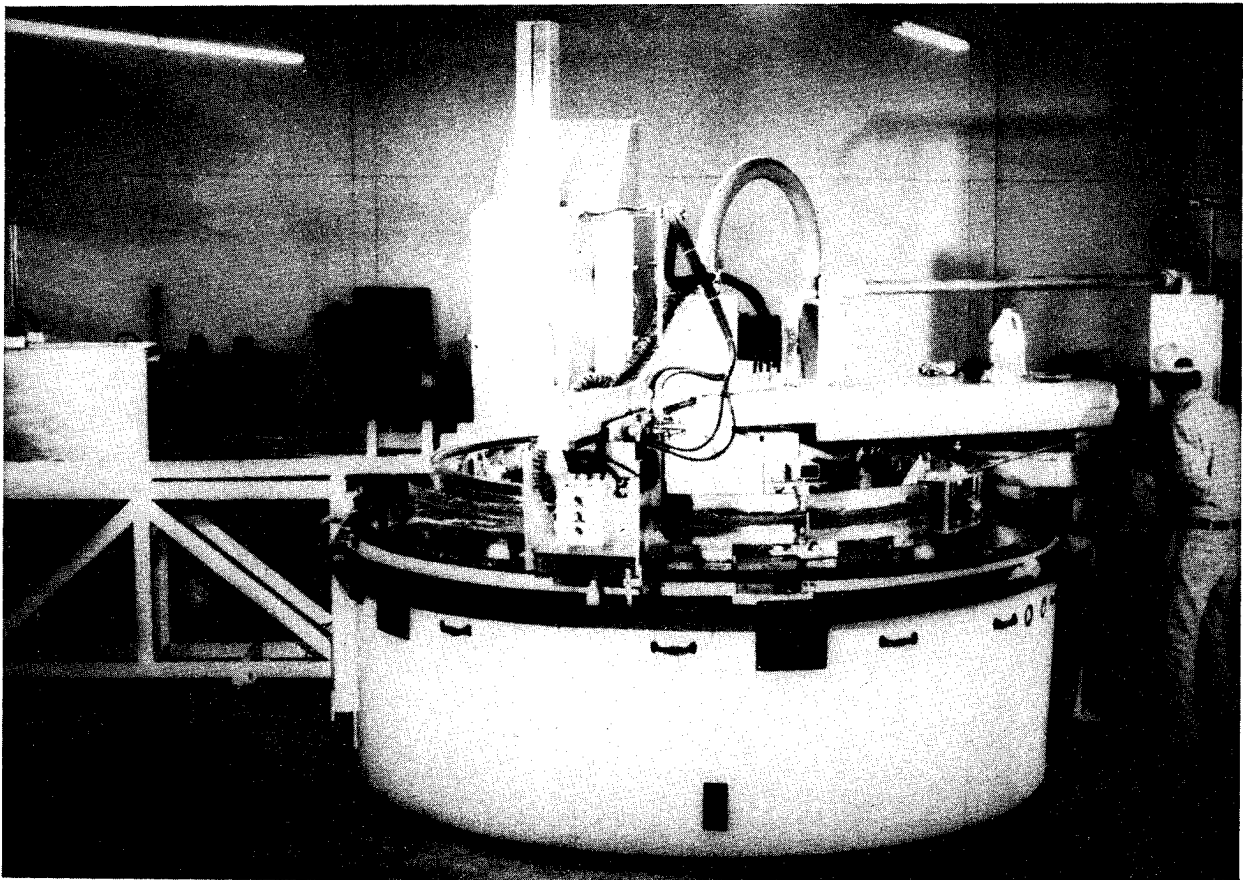

Figure 7. Fabrication of curved composite "bow-tie" leaf spring by the pultrusion method. (Courtesy of Goldsworthy Engineering.)

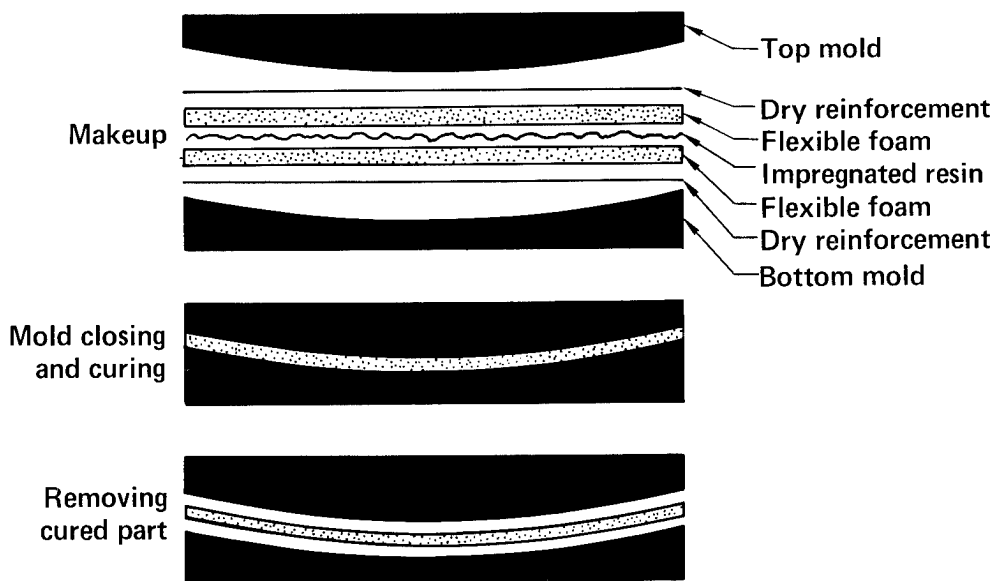

Figure 8. Schematic of elastic reservoir molding.

associated with thermosets would be a big boost to the utilization of these materials in automotive applications.

REINFORCED REACTION INJECTION MOLDING (RRIM)

Automotive external parts such as fascia, bumper covers, air-spoilers, etc., have been made from urethane elastomers by the RIM process. In this process, two or more reactive urethane components are pumped into a mixing head under high pressure. The mixed components are then injected into a mold wherein they begin reacting immediately. Reinforcing the urethane elastomer by the addition of fillers such as milled glass not only increases the strength and stiffness but also reduces the coefficient of thermal expansion. The former makes these materials competitive with some low-glass content SMC, while the latter enables them to be matched with automotive body sheet metal. It should be noted that RRIM urethane is not a substitute material where the rigidity of the part is a prime requirement. However, in some parts such as fenders and door panels that are subject to low speed impacts, the ability of RRIM urethane to yield and recover offers an advantage over other materials.

STATUS OF COMPOSITE MATERIAL APPLICATIONS IN SURFACE TRANSPORTATION VEHICLES

Having discussed the motivation for the use of composite materials, the various materials, their forms, and the manufacturing processes, it remains to consider some specific applications. Almost every automotive manufacturer and materials and parts supplier have ongoing programs at the present time to demonstrate the feasibility of various composite materials and processes for different components.

Before describing the salient features of some specific components, two major composite vehicle prototype demonstration programs will be reviewed here briefly.

COMPOSITE VEHICLE PROTOTYPES

- The Ford Motor Company exhibited at the 1979 SAE Exposition in Detroit an experimental automobile that uses mainly graphite composites while retaining the appearance, but exceeds performance characteristics of the Ford Granada, an intermediate-size automobile (Figs. 9, 10, and 11). The relative weights of some comparable graphite and steel components that have been released by Ford are given in Table 1. Depending on the specifics of a particular component, a composite part may weigh from about 20 to 60% as much as the steel part it replaces. Use of these composite components in a vehicle will result in a significant reduction in vehicle weight, and a corresponding improvement in fuel economy. For example, the Ford lightweight vehicle has a curb weight of 2517 lb, or 1230 lb less than that of the standard Granada. Because of the lower structural weight, a smaller V-6 engine instead of a larger V-8 can be used without changing performance (0 to 60 mph in 12 s). Fuel economy (city/highway) increased from 17 mpg for the standard Granada to 23 mpg for the composite replacement. In summary, substituting graphite composites for steel in this automobile results in a 30% reduction in inertia weight and a 35% increase in fuel economy.¹ The cost of this demonstration vehicle was about

¹ R. Kaiser, "Automotive Applications of Composite Materials," DOT HS-804 745 (1978), Argus Associates Inc., Winchester, MA.

4 DR. A/T, P.S. P.B. A/C

Weight = 2517 Curb, 2750 Inertia

Fuel Economy Objective = 23.0 MPG Metro Highway

Performance Objective 0-60 = 12.0 Seconds

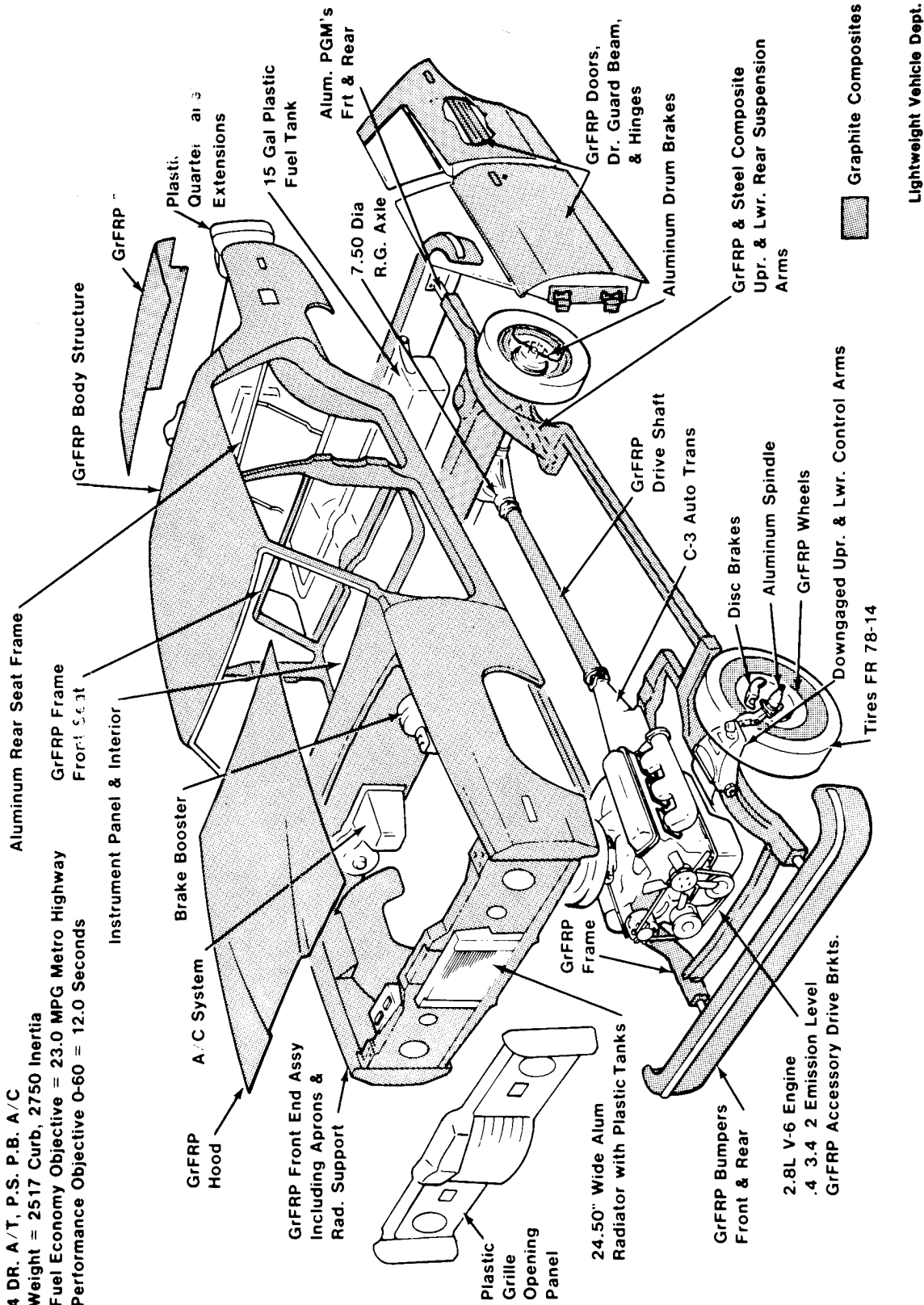

Figure 9. Ford Lightweight Vehicle Program. (Courtesy of Ford Motor Co.)



Figure 10. The Ford graphite composite car before painting. (Courtesy of Ford Motor Co.)

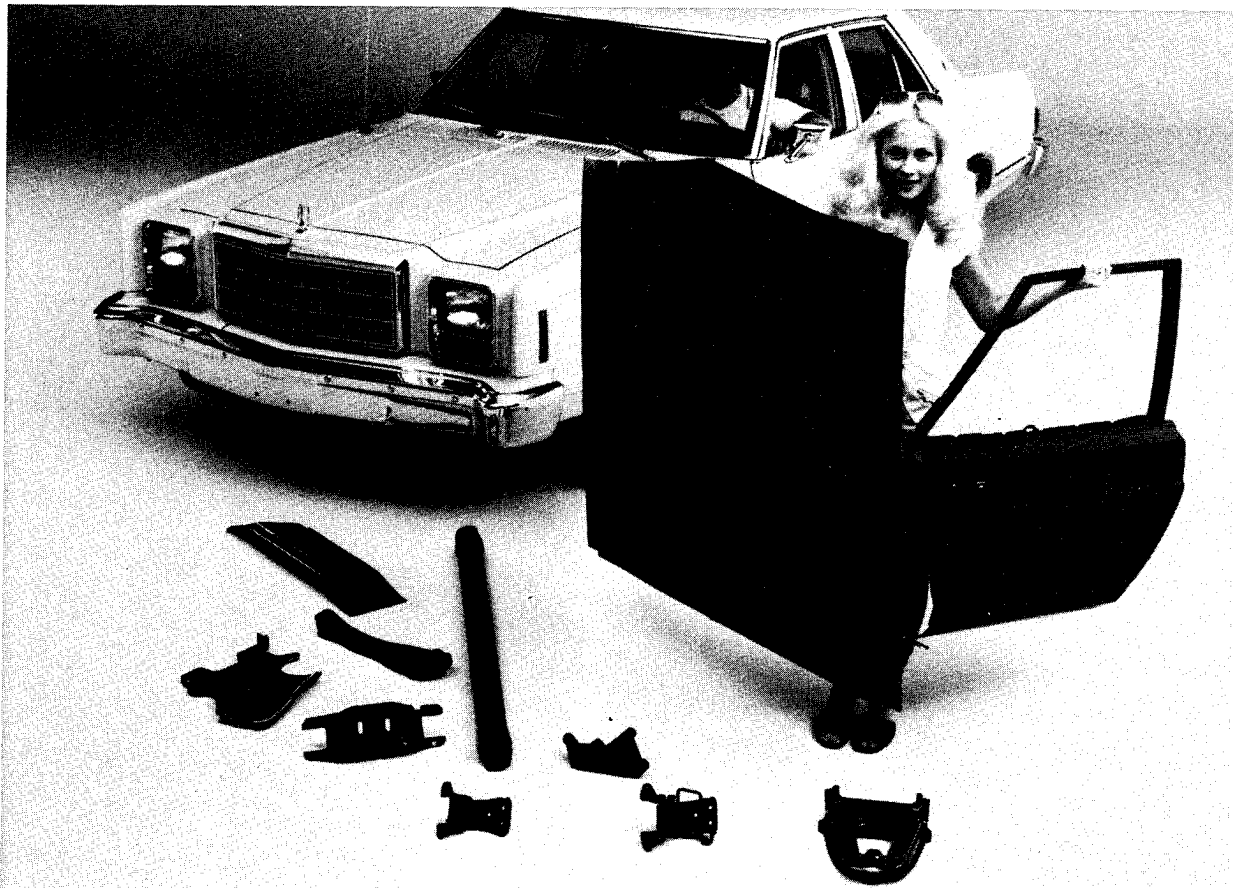

Figure 11. The finished Ford graphite composite car. (Note the lightness of the engine hood and the door frame). (Courtesy of Ford Motor Co.)

\$3.5 M and it should be emphasized that mass production techniques were not investigated.

- In another program funded by the U.S. Army TACOM in Warren, MI, Ewald Associates of Detroit have fabricated a prototype composite 5-T Army truck (Figs. 12, 13, and 14). Weight savings of up to 50% over steel components were realized by using continuous fiberglass and graphite/ glass hybrid composites.

The Army is also exploring the feasibility of using composites for the following components of the M-60 combat tank (Fig. 15):

- Torsion bar.
- Drive wheel.
- Track support roller.
- Track idler wheel.
- Track road wheel.
- Track end connector link.

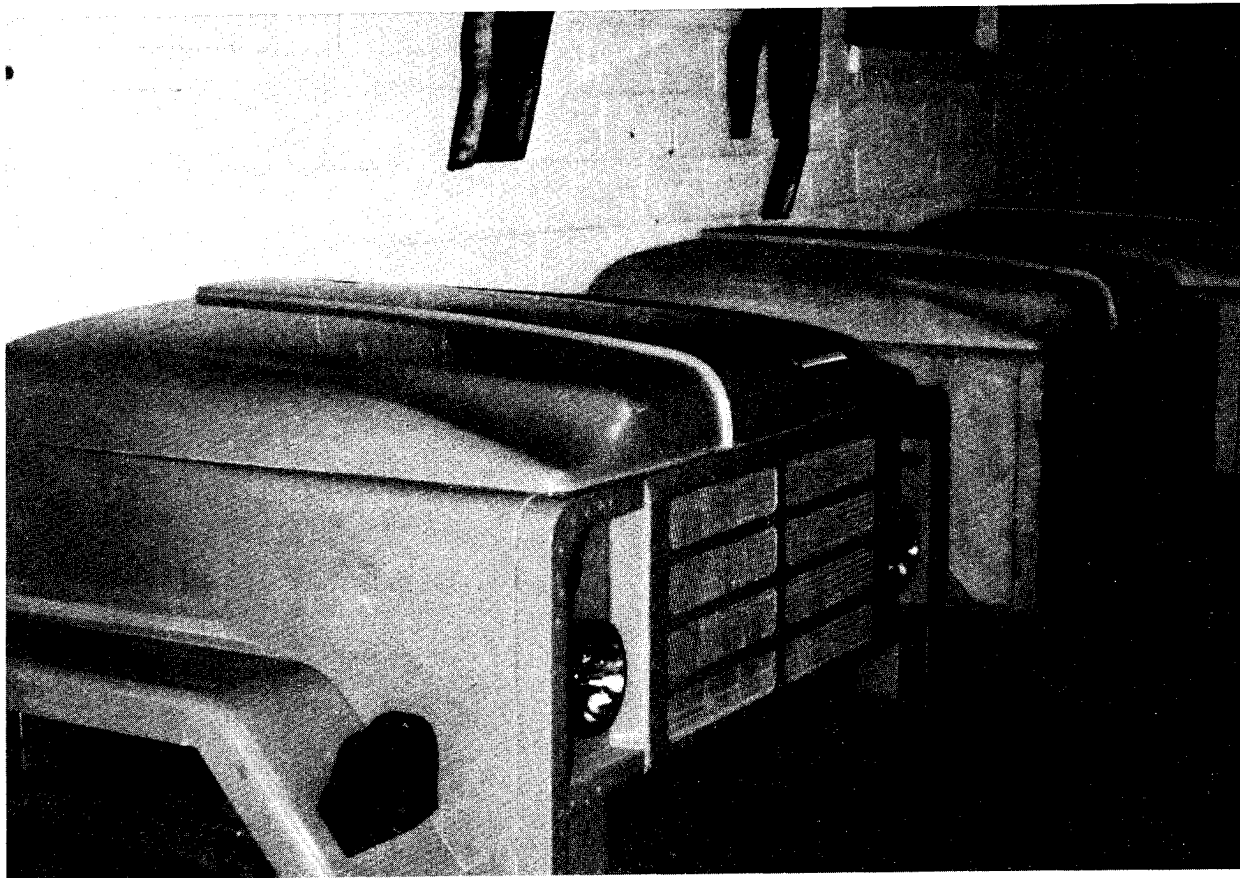

Figure 12. Continuous-fiberglass/polyester composite front hood of the U.S. Army 5-T truck. (Courtesy of Ewald Associates.)



Figure 13. Continuous fiber Gr/GI/polyester composite chassis (frame-rails, cross-members) of the U.S. Army 5-T truck. (Courtesy of Ewald Associates.)

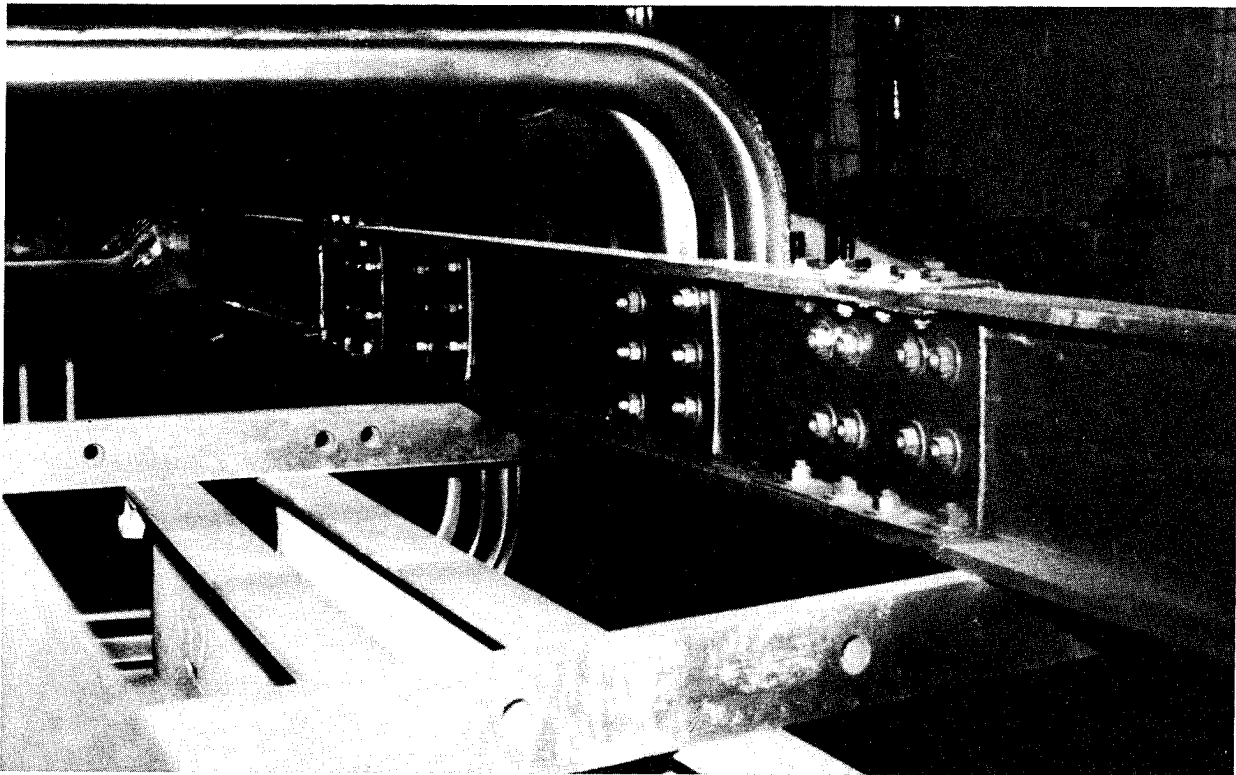

Figure 14. Close-up view of the chassis of the U.S. Army 5-T truck showing the bonded/bolted joints. (Courtesy of Ewald Associates.)

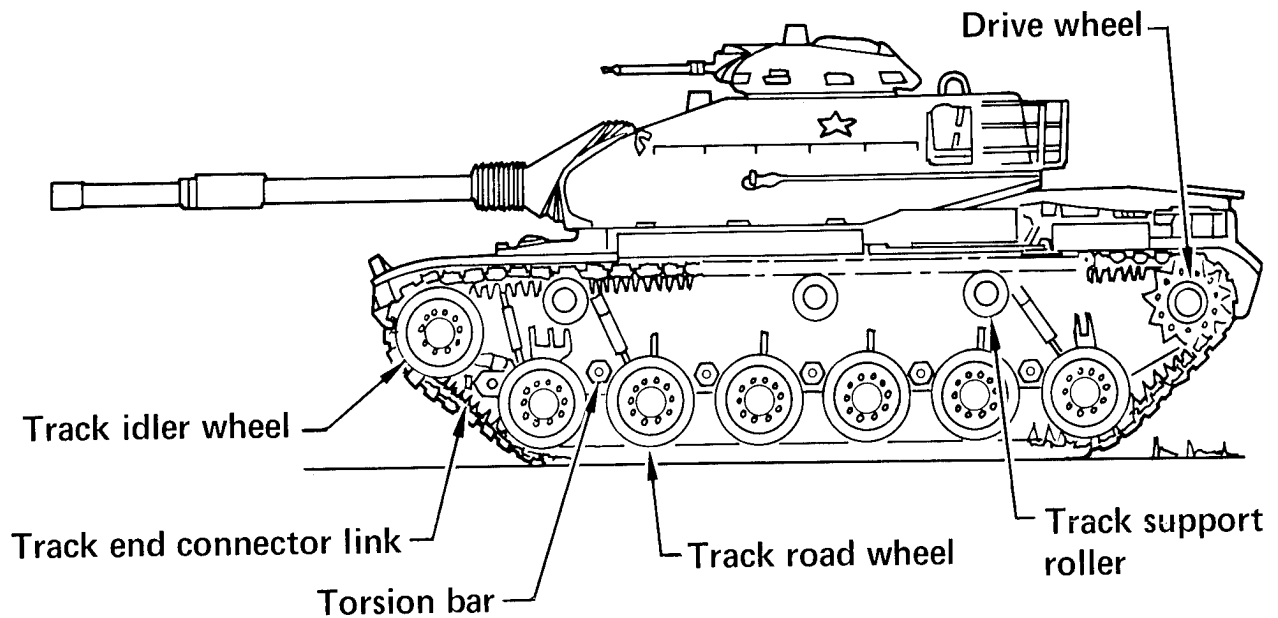

Figure 15. Composite parts for the M-60 combat tank.

There are five main categories of automotive applications:

- Drive train.
- Chassis and suspension.
- Body.
- Engine.
- Energy storage flywheels

DRIVE TRAIN

The drive shaft is the most interesting example of the use of graphite composite material. (With the advent of front wheel drive cars, the necessity of the drive shaft has been eliminated.) The high dampening characteristics of the composite reduce vibrations induced in the engine, transmission, differential, or wheels. The low transmissibility factors tend to separate wheel and differential noise from transmission and engine noise. The low mass of the graphite fiber composite coupled with the high lateral stiffness allows for high rotational speeds to be achieved successfully. Typically, weight savings up to 200% can be obtained by using a graphite fiber-composite drive shaft with bonded metal end fittings in lieu of a two-piece steel shaft (Fig. 16). Impact resistance of the shaft to road debris can be improved by using a graphite/glass hybrid.

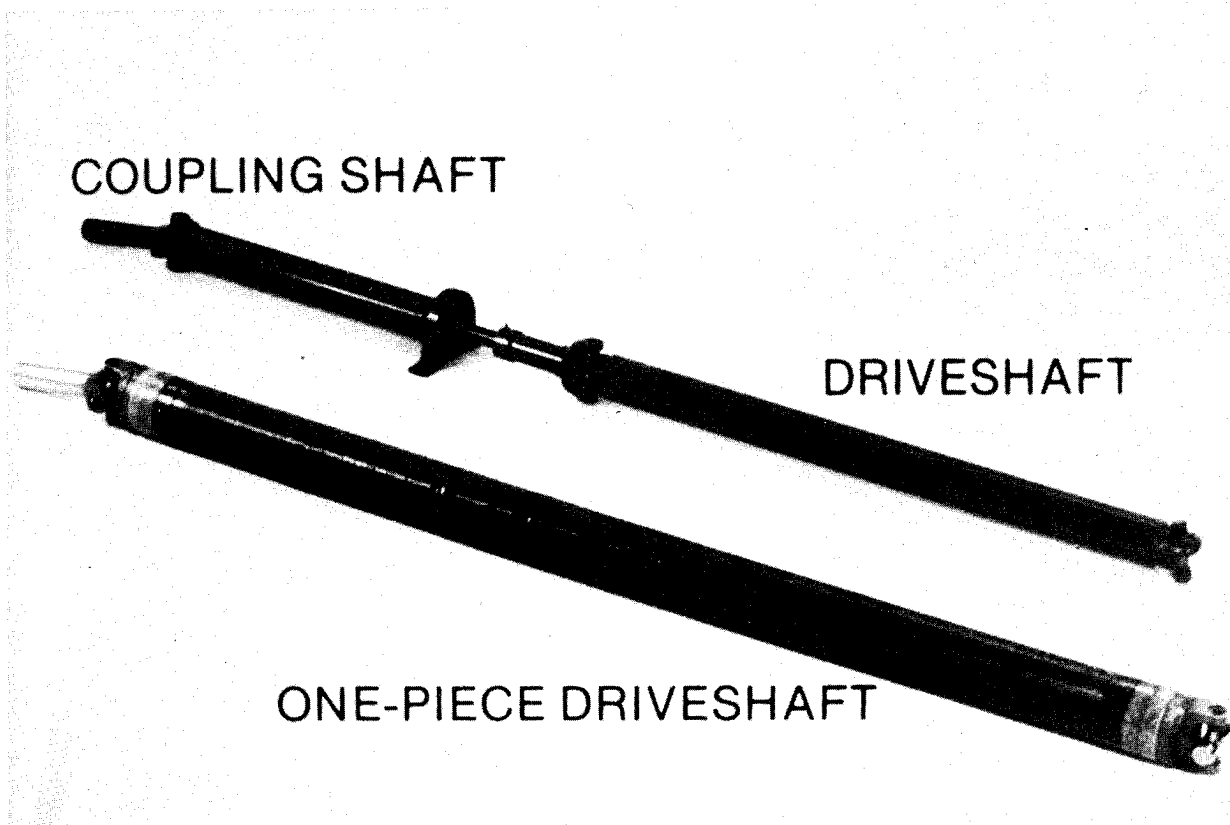

Figure 16. Automotive drive shafts (Courtesy of Hercules Inc.)

CHASSIS AND SUSPENSION

Applications in this area include frame-rails and cross-members, leaf springs, and wheel rims. Advantages of composite materials for leaf spring design are:

- Leaves can be tailored to give varying stiffness by thickness variation for a given cross-sectional area ("bow-tie" configuration).
- High strength - low modulus gives a softer spring constant with same load capability of steel.
- Good fatigue characteristics.
- Low transmissibility of noise.

The 1982 Corvette model has a one-piece E-Glass/epoxy "Liteflex" leaf rear spring (Fig. 17) which replaces a ten-leaf steel spring with 80% weight saving. A prototype E-Glass/epoxy filament-wound/compression-molded spring for a light duty truck is also shown in Fig. 18.

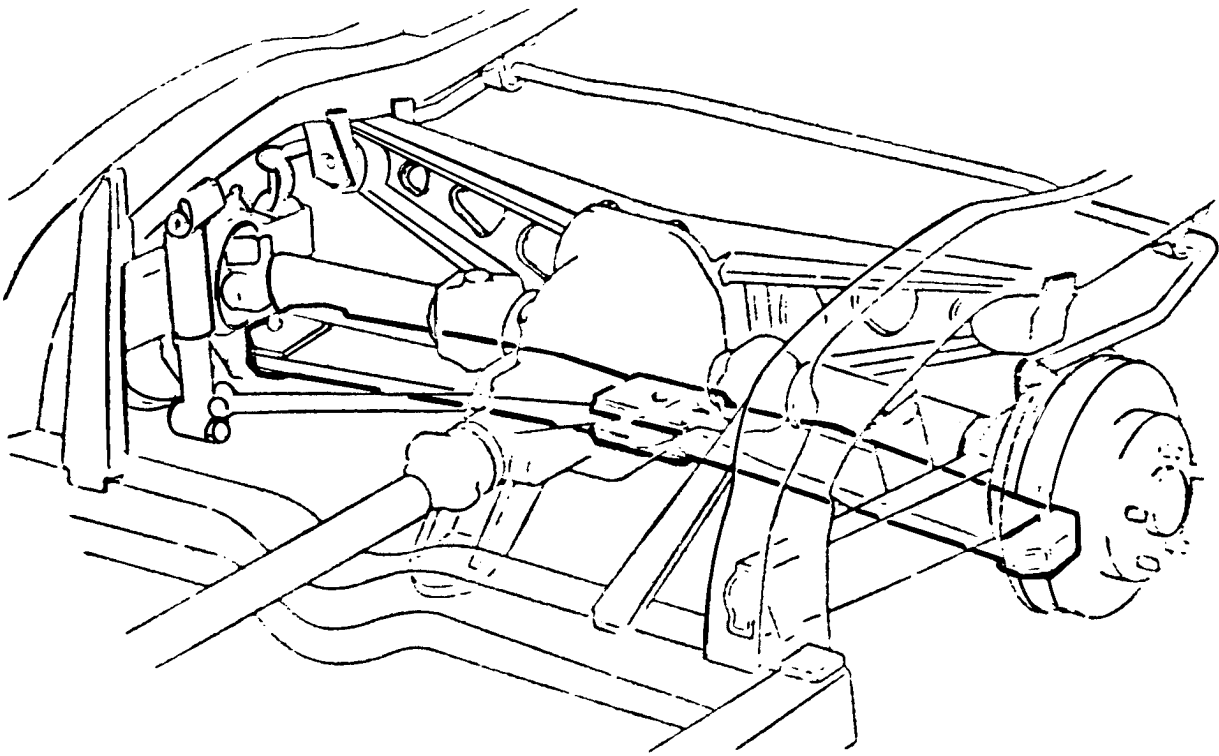

Figure 17. 1982 Corvette composite rear spring. (Courtesy of General Motors)

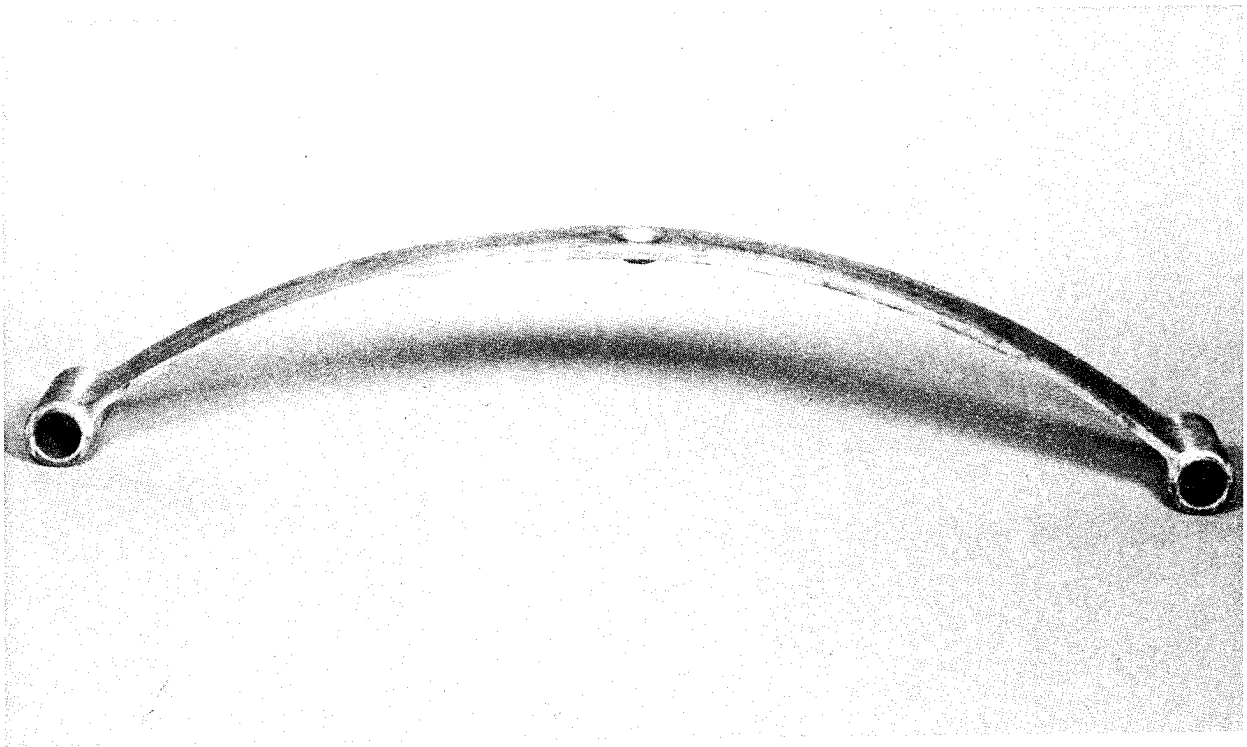

Figure 18. E-Glass/epoxy filament-wound/compression-molded single-leaf spring for a light-duty truck. (Courtesy of Ewald Associates.)

A component in the unsprung weight area is the wheel rim (tires are also composite material components since they are made from Kevlar or steel-reinforced rubber). Prototype composite wheel rims (Fig. 19) have been fabricated and tested. The primary material has been continuous fiber E-Glass/polyester (such as XMC). Some of the concerns with the design and fabrication of composite wheel rims are:

- Complex structural configuration.
- The ability to mold continuous fiber composites into complex shapes.
- Resistance to fatigue, creep, and lateral loads.
- The lack of adequate quality assurance (NDI) procedures.

However, composite wheels have been demonstrated to have advantages over steel wheels in the areas of energy conservation during manufacture, weight, corrosion resistance, and styling flexibility. Over aluminum wheels, composite wheels have advantages of energy conservation during manufacture, cost, and corrosion resistance.

BODY

Composite material applications in the body of a vehicle (hoods, body panels, seats, etc.) are mostly semistructural and are not safety critical.

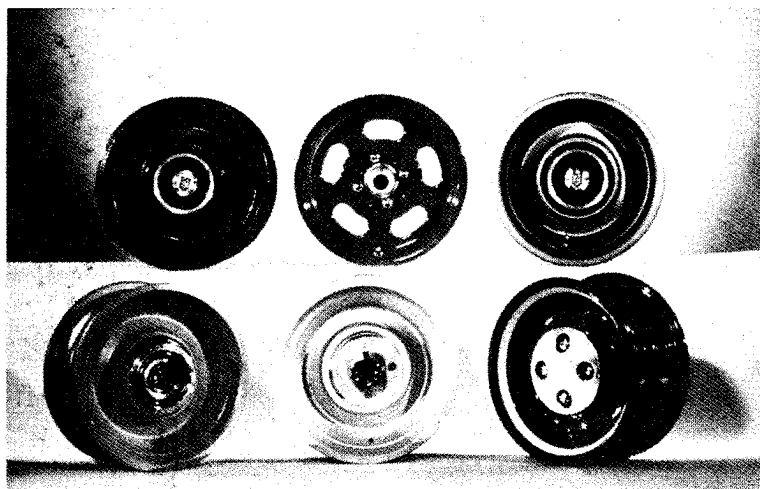

Figure 19. FRP wheel styling variations. (Courtesy of Firestone Tire Co.)

ENGINE

Applications of composites in engine components range from fiberglass-reinforced nylon fans to various engine parts such as engine block, cylinder head, valve cover, connecting rods, push rods, pistons, etc. Polimotor Research, Inc., has pioneered the use of composites with polymeric matrices for these engine parts (Figs. 20 and 21). All parts in the engine are reinforced with either chopped or continuous glass or graphite fibers. Matrices used include epoxies and polyimides. To survive continuous temperatures in the 500 to 600°F range, piston crowns are treated with a ceramic coating. The utilization of composites for engine parts is motivated by the reduction of weight of the stationary components and the inertia of moving components.

The greater use of diesel/turbo-charged diesel engines for improved fuel economy has the effect of (1) increased weight (20 to 25% as compared to an equivalent gasoline engine), and (2) increased engine temperatures. The temperatures go further up for adiabatic diesel engines. The additional weight penalty partially offsets the improved mileage. Thus, there is definitely a payoff associated with weight reduction of diesel engine components. Organic matrix composites may not be able to withstand the high temperatures in the diesel engines. Hence, metal matrix composites such as SiC whisker aluminum (Fig. 22) and FP/aluminum, magnesium (Fig. 23) are prime candidate materials. The FP metal matrix composite material is characterized by high specific strength and stiffness, high temperature stability, less heat loss, and chemical inertness. Table 4 shows design requirements for a connecting rod and the merits associated with using FP/aluminum. Chopped FP and SiC whisker/metal matrix composites can be cast into complex shapes and have the potential for lower material and manufacturing costs.

Toyota Motor Corp. has recently announced that it will use alumina/silica fiber-reinforced aluminum inserts in the pistons of the turbo-diesel engine. They will replace the nickel cast iron inserts now used in the aluminum pistons. The inserts constitute a small portion of the cast aluminum piston from the bottom of the uppermost piston ring groove to the crown (Fig. 24). This is the area of the piston that is subjected to the most heat and pressure.

Toyota claims that utilization of metal-matrix composites results in weight as well as cost savings. In addition, the superior temperature and

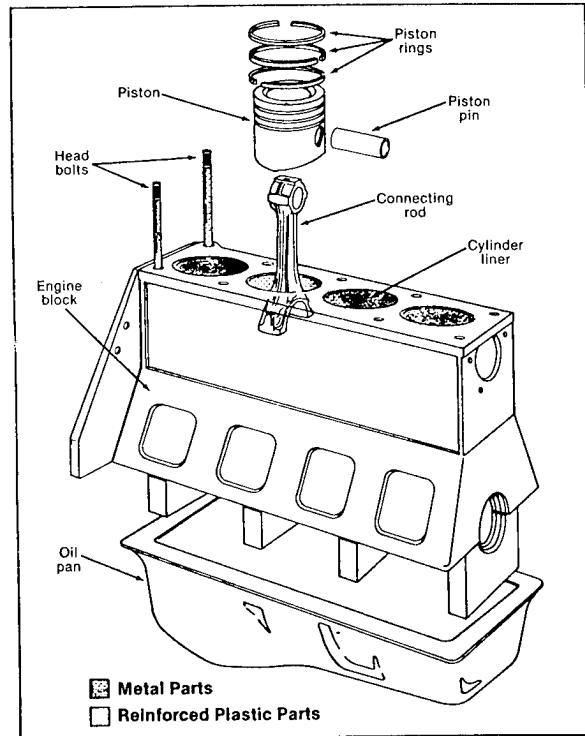
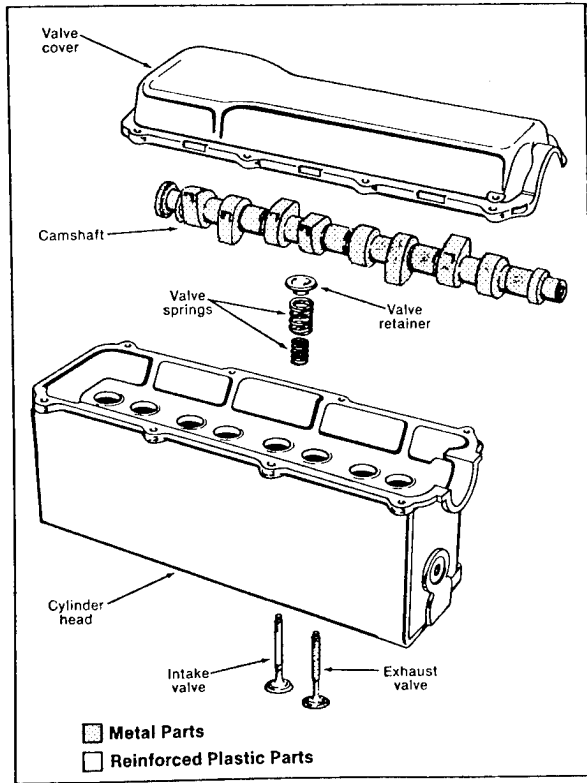

Figure 20. Metal and reinforced plastic parts in a composite engine. (Courtesy of Polimotor Research Inc.)

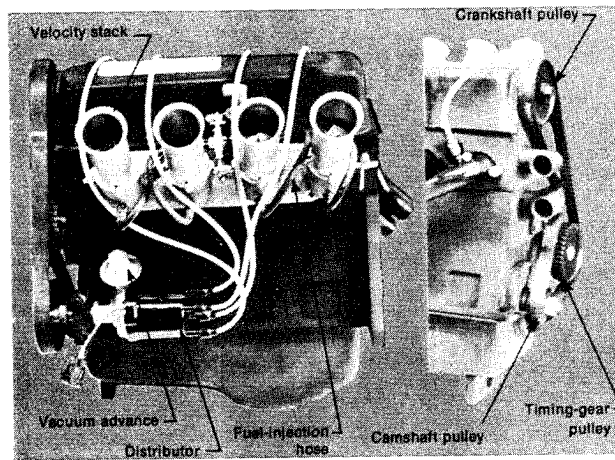
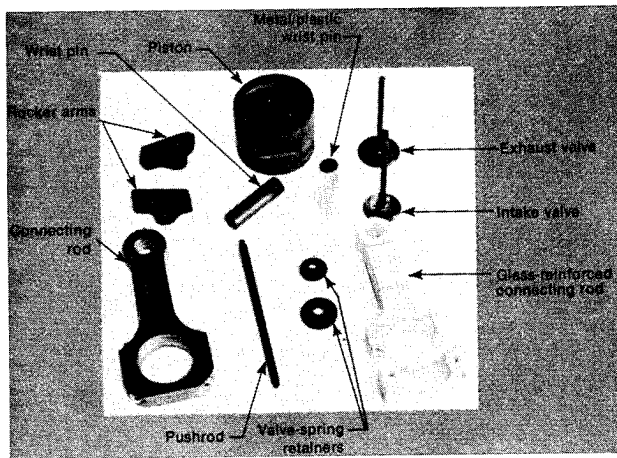

Figure 21. Plastic Engine developed by Polimotor Research. (Courtesy of Polimotor Research Inc.)

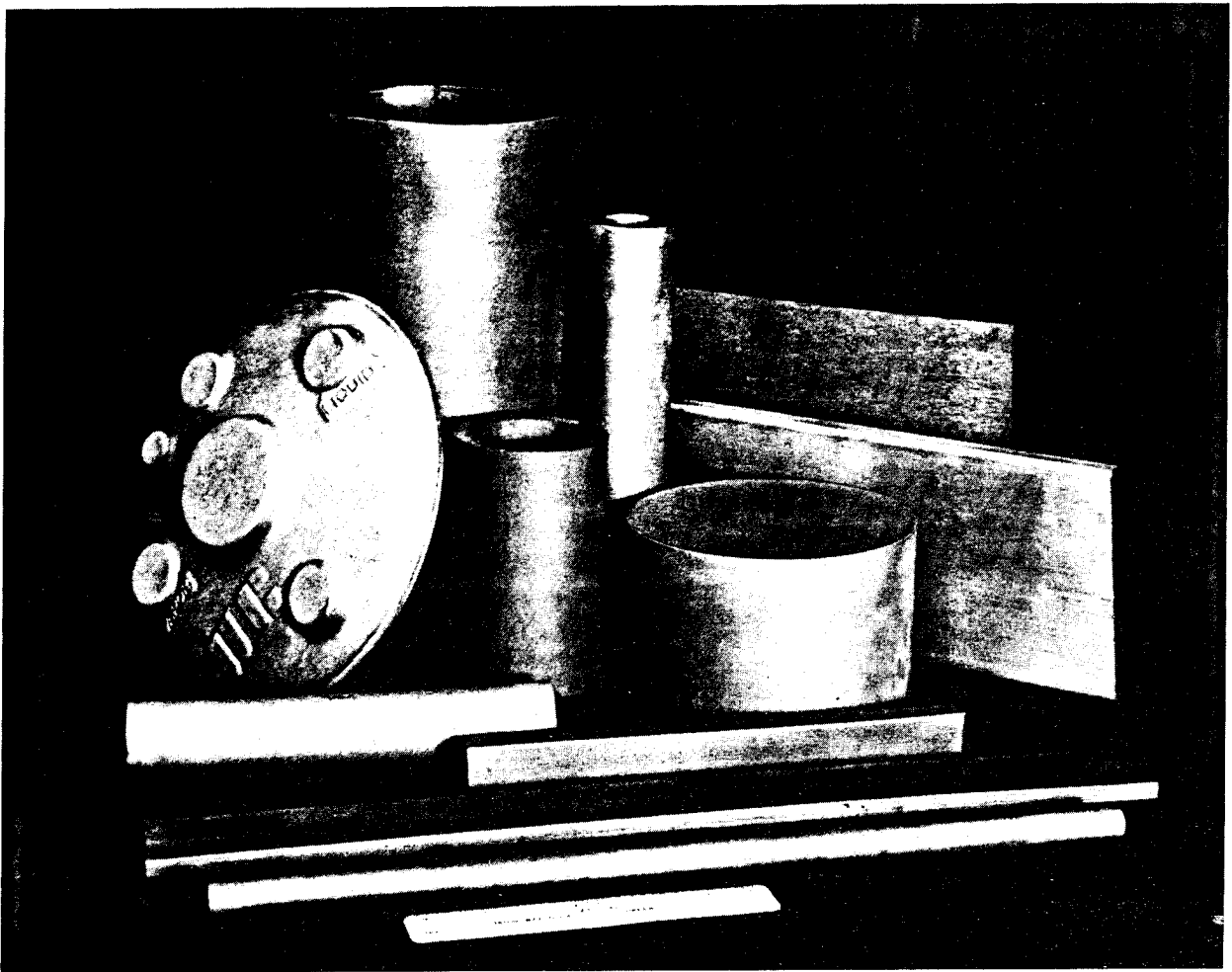

Figure 22. Partial product mix of SiC Whisker/aluminum composite.
 (Courtesy of Arco Metals Company, Silag Operations)

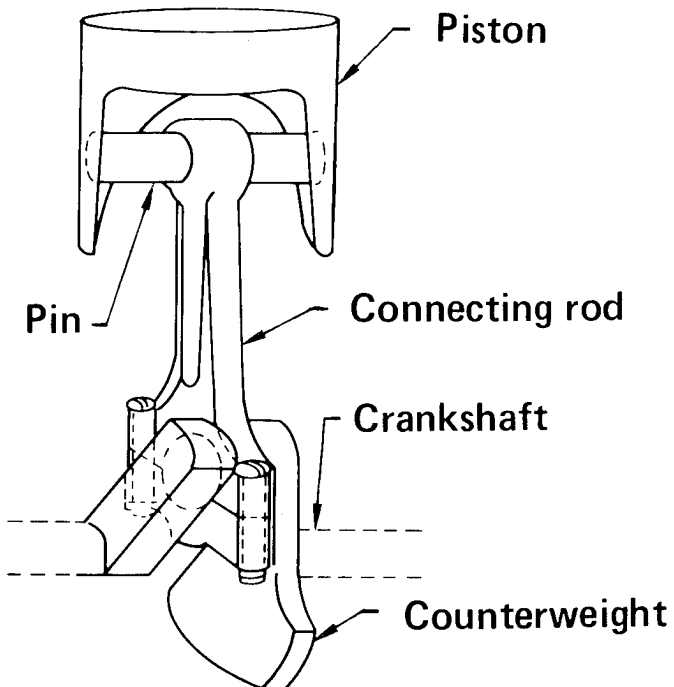

Figure 23. Prototype FP/aluminum composite connecting rods are being fabricated by DuPont to replace steel connecting rods.

Table 4. FP/aluminum connecting rod property merits and potential payoff.²

Connecting rod specifications/environment

Current material: steel forging; heat-treated/quenched

Connecting rod assembly wt: ~800 g.

Maximum engine speed: 5500 rpm

Temperature range: -30°C to 175°C

FP/aluminum property merits

- | | |
|-----------------------------------|---|
| ● High stiffness: | Equal to steel at 1/3 the weight
3× aluminum |
| ● Excellent compressive strength: | 5× aluminum or steel |
| ● High temperature capability: | 2× aluminum |
| ● Long fatigue life: | 2 to 4× aluminum |

Potential payoff assessments

- 50% weight savings over steel
 - Improved engine performance
 - Reduced fuel consumption
-

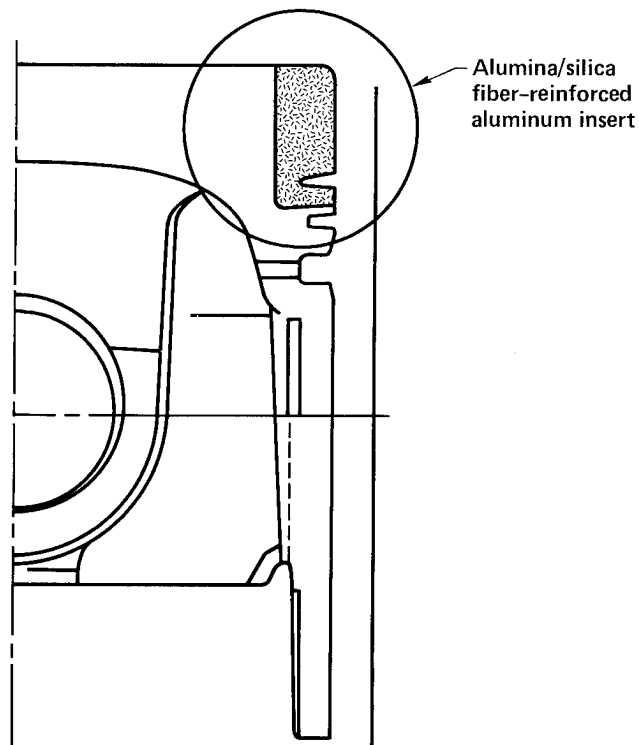

Figure 24. Alumina/silica fiber reinforced aluminum inserts in the piston of the Toyota turbo-diesel engine.

² From W. H. Kruger and A. K. Dhingra, "Alumina Fiber Reinforced Metal Composites for Potential Automotive Engine Applications," presented at 1982 AIChE meeting, Detroit.)

Table 5. Comparison of metal-matrix composites with aluminum alloys and ceramics.

Properties/ materials	Aluminum alloys	Ceramics	Metal-matrix composites
Toughness	E	P	E
Rigidity	F	E	G
Heat resistance	F	E	G
Heat radiation	G	P	G
Wear resistance	F	E	E
Machinability	G	P	G

NOTE: E - Excellent, G - Good, F - Fair, P - Poor.

abrasion resistance of metal-matrix composites, combined with their high thermal conductivity, will allow pistons to be cast to closer tolerances with the cylinder walls. This will increase combustion efficiency and reduce piston slap.

A comparison of some of the pertinent properties of metal-matrix composites with aluminum alloys and ceramics is given in Table 5.

ENERGY STORAGE FLYWHEELS

A sizable effort is presently being directed by the Lawrence Livermore National Laboratory for the Department of Energy to develop composite material flywheels for transportation and stationary applications. Composite material flywheels have the following advantages over steel flywheels:

- They store more energy per unit weight. Flywheels having energy densities of 36 W•h/lb have been tested to date.
- They have a benign failure mode. Breakup occurs in many crushable fragments rather than the customary three or four pieces for steel flywheels. The result is greater safety and lower containment weights.

Figures 25-27 illustrate the three most successful designs. These designs use Kevlar-49, -29, S2-glass (chopped and continuous fiber), and graphite/epoxy composites. Processes employed include cloth weaving, filament

Fig. 25. Garrett
AiResearch Multimaterial
(S2 glass/Kevlar-29/
Kevlar-49, multiring
rim flywheel with
Gr/Ep-Al hub.

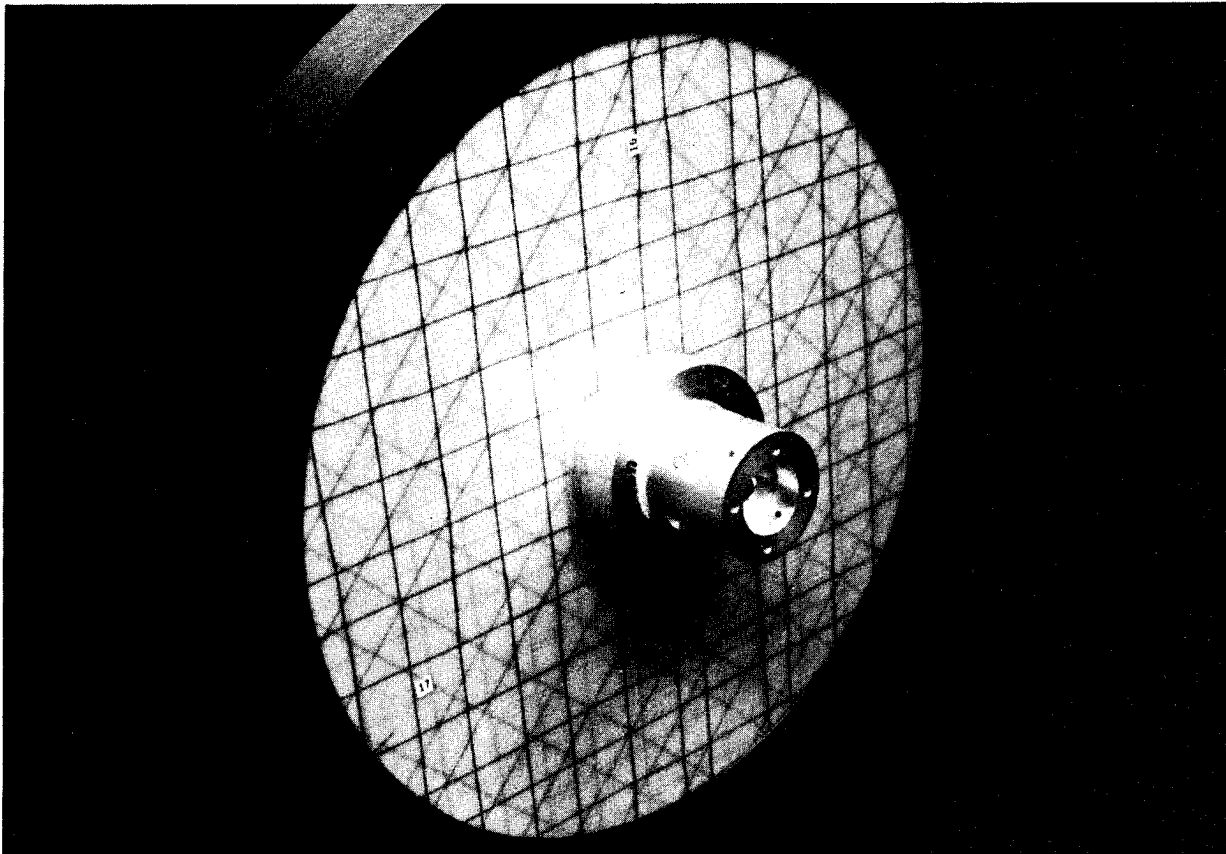
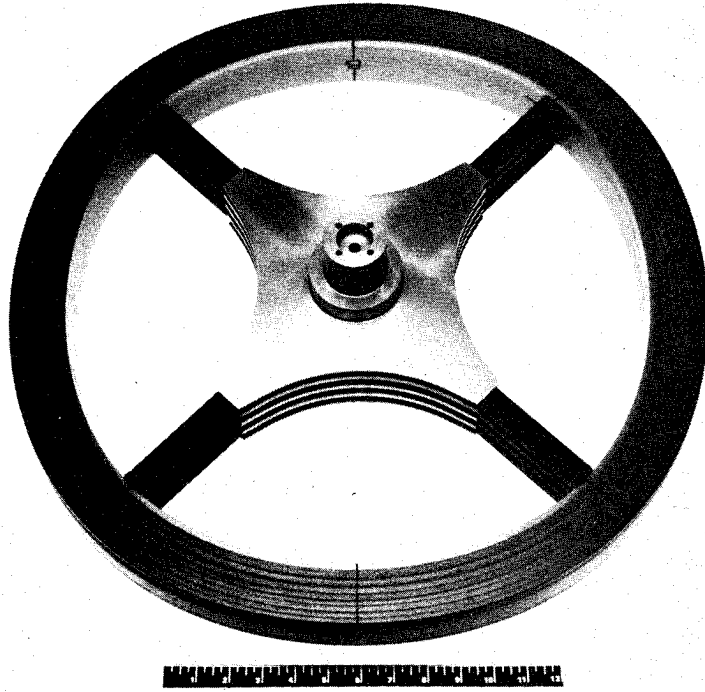

Figure 26. General Electric S2-glass/epoxy quasi-isotropic laminated disk -
Gr/Ep ring hybrid flywheel.

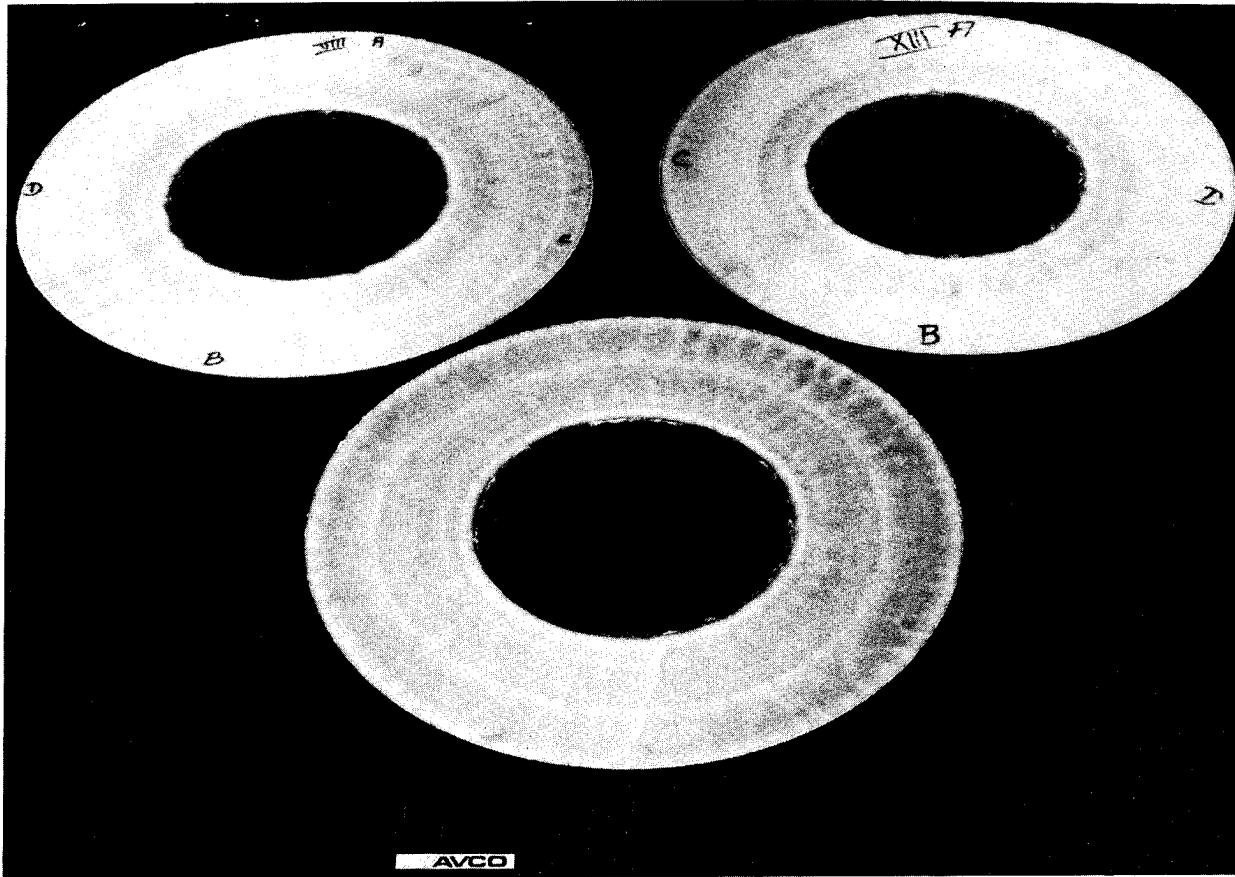

Figure 27. Avco S2-glass bidirectional weave disk flywheel.

winding, and matched metal die compression molding. For the flywheel in Fig. 28, a filament wound graphite/epoxy ring is shrink-fitted over a random chopped S2-glass fiber molded SMC disk. Since the disk was 1-in. thick, a special molding technique had to be developed to inhibit residual stress cracking. The approach, which was developed by Owens-Corning, is illustrated in Fig. 29. Three SMC materials with different cure rates are stacked in the mold, with the SMC with slowest cure rate placed at the top and bottom. In this manner, curing is initiated almost simultaneously through the entire thickness.

Figure 30 shows the Electric Trolley Bus with a 15 kW·h composite flywheel being developed by Garrett AiResearch for the Department of Transportation.

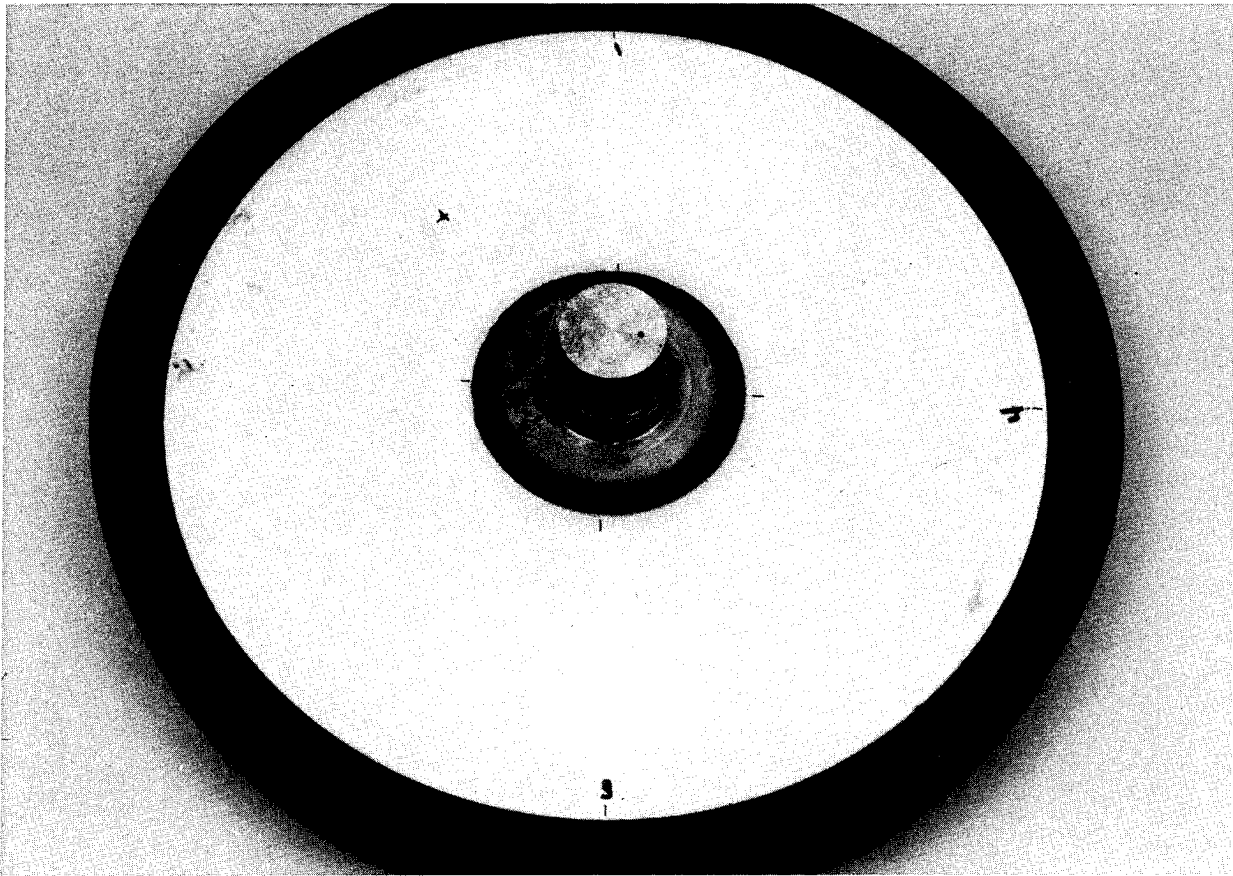
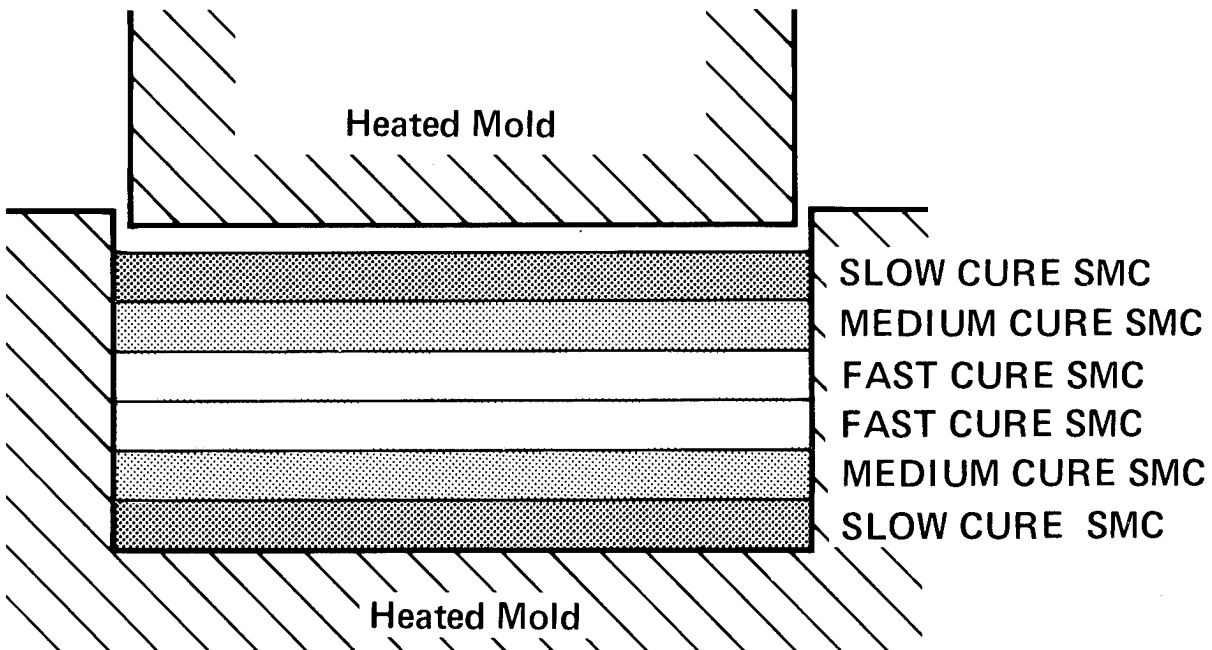

Figure 28. LLNL/Owens-Corning/Lord Corp. random, chopped, S2-glass molded SMC disk-Gr/Ep ring hybrid flywheel.



Vertical scale of composite part is exaggerated

Figure 29. Use of SMC materials with different reactivities to mold thick parts.

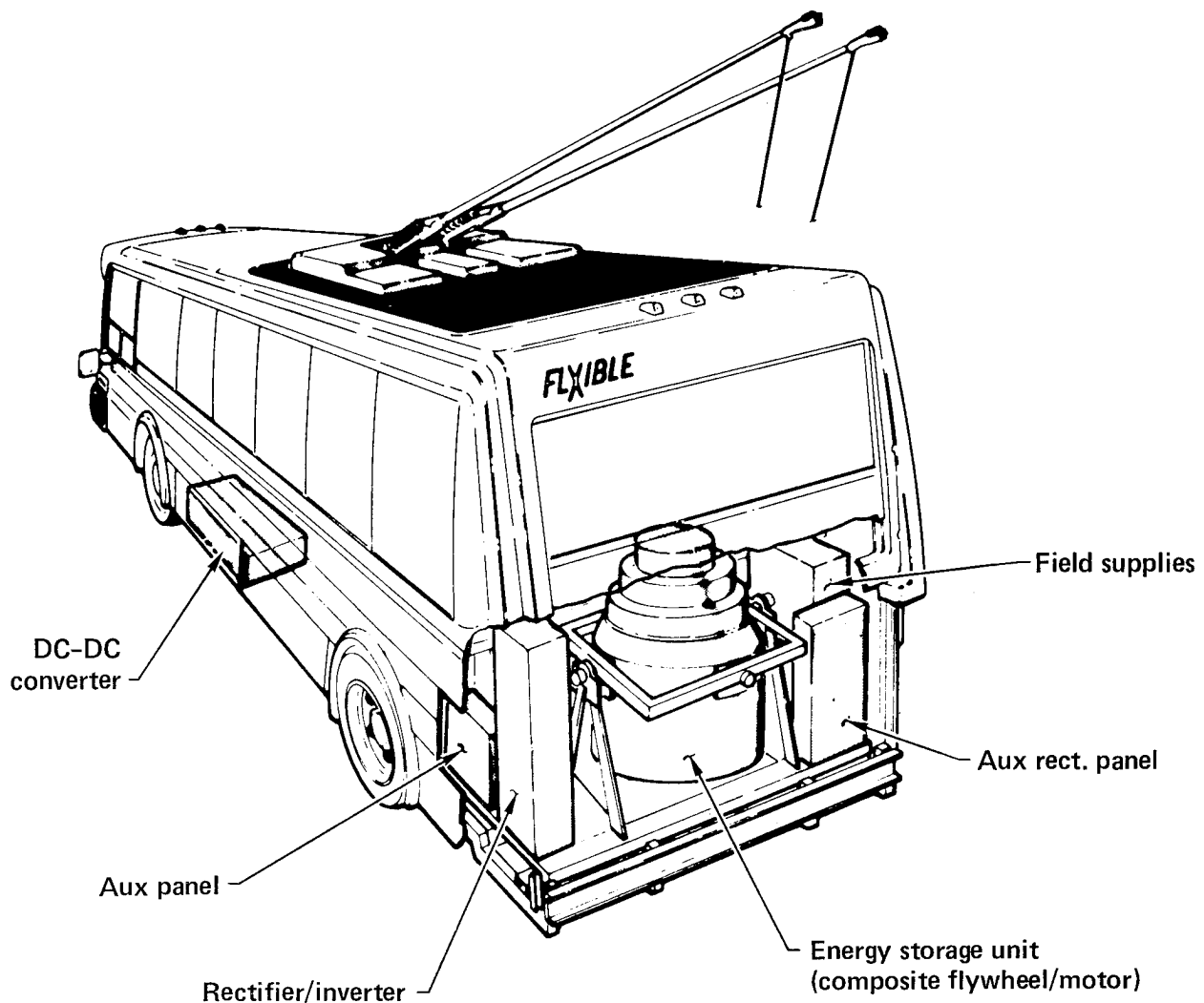

Figure 30. An electric trolley bus being developed by Garrett AiResearch for the U.S. Department of Transportation. The energy-storage unit (a composite-material flywheel) powers the bus between stops, and may also recapture energy that would otherwise be lost in braking. The flywheel is recharged from the overhead power lines only when stopped to load or discharge passengers.

The current status of automotive uses of composite materials can be summarized as follows:

- Parts that are the equivalent of steel parts in performance but significantly lower in weight have been built on an experimental basis.
- These parts have passed successfully a variety of laboratory tests, and have performed well in actual service.
- It is possible to integrate composite structures into a standard automotive system, as demonstrated by the Ford lightweight vehicle and the U.S. Army 5-T Truck Program.

- There are no critical structural components in full production at the present time except for the Corvette E-glass/epoxy spring. Use of composite material structural components can be economically justified only for speciality cars with limited production volume (less than 100,000).
- With an appropriate choice of materials and processes, there appear to be few components in a car where composites cannot be used.

FACTORS INHIBITING THE USE OF COMPOSITES IN VEHICULAR APPLICATIONS

There was considerable euphoria associated with the "plastics revolution" in the automobile industry during the late seventies. Overly optimistic projections regarding the volume of use and costs of fiber-reinforced composite materials are now being reassessed in light of the technological barriers encountered, and the current state-of-affairs in Detroit. Some of these barriers are listed:

- Manufacturing processes are still not suitable for mass production of structural components.
 - Part consolidation is not possible for all components.
 - For part requirements in excess of 100,000 units, capital investment costs are high as compared to those for metallic parts.
 - Additional plant fire protection and OSHA requirements because of the use of plastics will further increase capital costs.
 - High speed manufacturing techniques with rapid cure systems are not fully developed.
- Cost and availability of raw materials is a matter of concern.
 - Basic polymer availability and costs are subject to OPEC supply patterns and price increases. Furthermore, alternative sources for plastic raw materials such as coal and oil shale are not being pursued actively.
 - At current prices, graphite, Kevlar and even S2-glass are prohibitively expensive for nearly all automotive uses.
- Plastics are difficult to recycle.
 - As shown in Table 6, the percentage of plastics used in a car will double from 1978 to 1985.

Table 6. Expected changes in the composition of the U.S. automobile, 1978 to 1985.³

	1978 ^a	1985 ^b
Cast iron	14.3 wt%	8 to 9 wt%
High strength steel	3.7	17 to 19
Other ferrous metals	58.6	41 to 44
Total ferrous fraction	76.6	68 to 72
Aluminum	3.2	7 to 8
Copper	0.8	0.8 to 1.0
Diecast zinc	0.9	0.1 to 0.3
Plastics	5.0	9 to 11
Nontire rubber	3.2	3 to 4
Total dry weight	1620 kg	1220 to 1240 kg

NOTE: Not considered: glass, cardboard, cloth, brake linings, fluids, lubricants, tire rubber, lead.

^a Wards Automotive Yearbook 1978, p. 65.

^b Estimate by Ford.

- Although there are methods for recovering and recycling thermoplastic resins from automobile scrap, it is frequently not cost-effective. Thermosets cannot be recycled but can be burned as fuel or used as a filler material. (Existing filler materials like calcium carbonate are, however, cheaper; also energy content of the fuel is low because of fillers and fibers.)
- Insufficient understanding of the durability of composites.
 - As expected, there has been no demonstration that composite material structural components can withstand 100,000 miles of actual use over a number of years.
- Composites are brittle materials, thus imposing limitations in a crash environment. (Damage tolerance of composites should not be equated with ductility.) The failure mode of fibrous composites, which are brittle materials, is very different from the failure of

³ This table is from "Effect of Changing Automobile Materials on the Junk Car of the Future," by L. R. Mahoney, J. Braslaw, and J. J. Harwood, SAE Paper No. 790299.

metals, which can yield. Composites could shatter and form sharp edges upon severe impact in some cases, or simply delaminate in other instances. There is still much to be learned in terms of the energy absorption characteristics under impact loads.

- The ability to repair major structural components made of any reinforced plastic is an open issue. It would be desirable to be able to repair rather than replace large components. Also, strength degradation due to nonvisible damage is also a concern.
- Noise, Vibrations, and Handling.
 - The road-handling characteristics of a large, low-weight automobile wherein the payload could be a significant fraction of the gross vehicle weight are not known at the present time.
- It has been difficult to obtain a class A type surface finish for composite panels.
 - Surface finishing requires immersion in acrylic lacquer (200 to 270°F for 30 min) and electrode priming (390°F for 20 min) and some composites may not be able to withstand this environment.
- The utilization of HSLA steels and aluminum as substitution materials are achieving similar weight reductions as composite materials, but at lower costs with existing manufacturing techniques.
- Significant improvements in engine performance have resulted in a lesser emphasis on weight reduction.

FUTURE R&D AREAS FOR COMPOSITE MATERIALS FOR VEHICULAR APPLICATIONS

Future research and development areas for composite materials for vehicular applications have been identified from the the information obtained from:

- Current prototype development programs.
- Factors inhibiting the widespread use of composites.
- Discussions held with various individuals in the automotive industry.

Initially, a complete range of future research and development areas are listed; subsequently, specific research and development areas that

satisfy the "high-risk" far-term payoff criteria are recommended for consideration by the ECUT Program.

GENERAL RESEARCH AND DEVELOPMENT AREAS

Materials

- Synthesis of fast-cure, low-cost resins with higher temperature capability and thermal stability. (Cost of resin has less impact on overall part cost than cure time.)
 - Structure-property-morphology relationships for resins.
- Further development of RIM polymers.
- Fiber surface treatment and control of fiber-resin interface properties. (This work should be done in collaboration with fiber manufacturers).
- Effects of catalysts, co-catalysts, inhibitors, and fillers (this work should be performed in collaboration with resin manufacturers such as Union Carbide, Mobay, Dow, ICI, Shell, Ciba-Geigy, . . .)
- Development of hybrid, polyimide, and SiC, FP/aluminum, magnesium composites.

Design Data Base

- Design data base particularly with regard to long-term performance under various service conditions, e.g., temperature, moisture (including salt), solvents, ultraviolet, and aging. (Advantage should be taken here of similar efforts in progress under the auspices of the DOE Flywheel Program, DOD, and NASA.)
- Strain-rate effects on material properties.
- Understanding of the effects of processing parameters on material properties.
- Design data base for hybrids and metal-matrix composites. (For engine applications, effects of oxidation and erosion must be also considered.)
- Development of life prediction methodology, and assurance of product reliability.

Manufacturing Technology

Innovative processing techniques will be the key to the success of composite materials. (Research and development in processing is difficult per se unless a specific application is in sight.)

- Kinetics of cure reactions and faster cure thermoset systems.
 - On-line processing control, e.g., degree of cure.
 - Rheology of flow in molds.
 - Mechanism of defect formation during molding, e.g., "knit line" formation.
 - Modeling of molding and forming processes.
 - Heat transfer relationships in molding.
- High speed process technology, e.g., curved pultrusion, alternative heating methods during curing.
- High speed compression molding of continuous-fiber composites.
- Thermoplastic stamping as a low-investment, high-productivity process.
- RRIM with longer fibers.
- Fabrication of metal-matrix composite engine parts.

Bonding and Joining

- Bonding of plastics to plastics and metals with sealing capability.
- Automated high speed adhesives application technology.
- NDE for bond quality and strength assessment.

Nondestructive Inspection and Evaluation

- Development of NDI methods that can be performed reliably at high rates and low costs consistent with manufacturing speeds.
- Correlation of defects with part performance.

Crashworthiness

- Understanding fundamental failure mechanisms of automotive composites (e.g., SMC) under impact loading.

- Impact "energy management."
- Rewriting NHTSA rules on crashworthiness for composites.

Recyclability

- Efficient methods for recovery of energy and materials from plastics.

RESEARCH AND DEVELOPMENT AREAS RECOMMENDED FOR ECUT CONSIDERATION

Since it is not feasible (and appropriate, in some cases) for the ECUT program to support all the areas listed above, specific R & D programs are recommended here.

- Synthesis of fast-cure, low-cost resins with higher temperature capability and thermal stability.
- Assessing the potential of metal-matrix composites for engine parts.
- Development of life-prediction methodologies for automotive composite materials and structures.
- Establishing crashworthiness criteria for composites.
- Exploring options for recycling reinforced plastics from automobiles.

Besides satisfying the basic ECUT criteria, these activities are generic in nature and are of considerable interest to the auto manufacturers. It is also recommended that these tasks should be performed in collaboration with industry in order to have the greatest impact and utility to the end user.

ACKNOWLEDGMENTS

The author would like to acknowledge the contributions of the following individuals, without whose cooperation it would not have been possible to present in a concise form, the various issues and aspects of this all-encompassing technology.

- General Motors
 - Ms. Barbara Sanders
 - Mr. Irv Poston
 - Dr. M. Kamal
- Ford Motor Company
 - Dr. Seymour Newman
 - Mr. Charles Bazzy
 - Dr. K. Kinsman
- Budd Company
 - Dr. Joseph Epel
- Ewald Associates
 - Dr. Frank Soliman
- Kelsey Hayes
 - Dr. Irving Adler
- International Harvester
 - Dr. M. Amateau
- Polimotor Research
 - Mr. M. Holtzberg

Special thanks are due to Dr. Seymour Newman of Ford Motor Company for sharing some of his thoughts on the future R & D areas of composite materials.

Technical Information Department · Lawrence Livermore National Laboratory
University of California · Livermore, California 94550

First Class Mail

First Class Mail
U.S. Postage
PAID
Livermore, Ca.
Permit No. 154