



NATIONAL TRANSONIC FACILITY FAN BLADE
PREPREG MATERIAL CHARACTERIZATION TESTS

P. J. Klich, W. H. Richards and E. L. Ahl, Jr.

JULY 1981

DESTRUCTION STATEMENT
Approved for public release
Distribution Unlimited

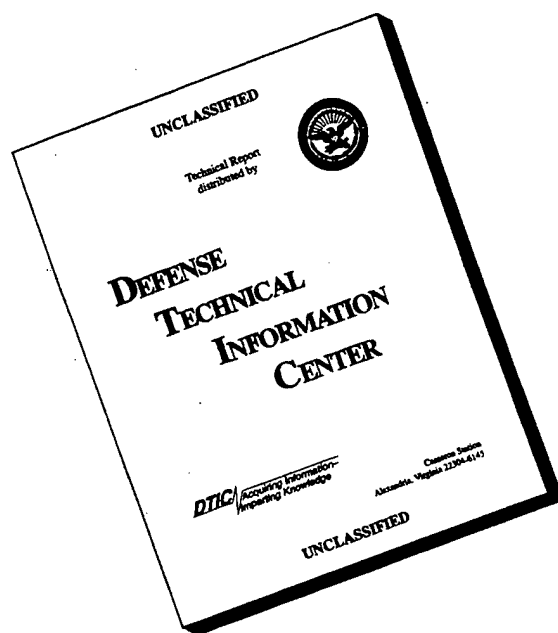
DEPARTMENT OF DEFENSE
DEFENSE TECHNICAL EVALUATION CENTER
Cameron Station Alexandria, VA 22304

19960321 055

NASA
National Aeronautics and
Space Administration
Langley Research Center
Hampton, Virginia 23665

MASTED
45067

DISCLAIMER NOTICE



THIS DOCUMENT IS BEST QUALITY AVAILABLE. THE COPY FURNISHED TO DTIC CONTAINED A SIGNIFICANT NUMBER OF PAGES WHICH DO NOT REPRODUCE LEGIBLY.

TABLE OF CONTENTS

	<u>Page</u>
SUMMARY	1
INTRODUCTION	1
SYMBOLS LIST	2
MATERIAL DESCRIPTION	3
Preimpregnated Fiberglass	3
Resin Description	3
Resin Content	4
Preparation and Cure Process	4
TEST PROGRAM	5
Tensile Tests	6
Compression Tests	7
Fatigue Tests	9
Shear Tests	10
Inplane shear tests	10
Punch type shear tests	11
Interlaminar shear tests	12
Thermal Expansion Tests	14
Thermal Cycle Tests	16
Creep Tests	18
CONCLUDING REMARKS	19
REFERENCES	21
TABLES	22
FIGURES	41

LIST OF TABLES

<u>Table</u>	<u>Page</u>
1.- BASIC MATERIAL PREPREG CHARACTERIZATION TESTS	22
2.- DESIGN LAMINATE TESTING	23
3.- PROPERTIES OF 7576 EF-2 E GLASS	24
4.- PROPERTIES OF 7781 EF-2 E GLASS	25
5.- PROPERTIES OF DESIGN LAMINATE	26
6.- TENSILE TEST RESULTS.	27
7.- TENSILE (YIELD) TEST RESULTS.	28
8.- COMPRESSIVE TEST RESULTS.	29
9.- FATIGUE TENSION-TENSION TEST RESULTS.	30
10.- FATIGUE COMPRESSION-COMPRESSION TEST RESULTS.	31
11.- INPLANE SHEAR TEST RESULTS.	32
12.- PUNCH SHEAR TEST RESULTS.	33
13.- INTERLAMINAR SHEAR TEST RESULTS	34
14.- LINEAR THERMAL EXPANSION TEST RESULTS	36
15.- THERMAL CYCLED TENSILE TEST RESULTS	37
16.- THERMAL CYCLED INTERLAMINAR SHEAR TEST RESULTS	38
17.- CREEP TEST RESULTS (ELONGATION VS. TIME).	39
18.- CREEP TEST RESULTS (ELONGATION VS. TIME).	40

LIST OF FIGURES

<u>Figure</u>	<u>Page</u>
1.- Material and laminate identification	41
2.- Test specimen ply orientation.	42
3.- NTF fan blade material test program.	43
4.- NTF fan blade materials tensile test setup	44
5.- Typical tensile test specimen.	45
6.- Typical test specimen mounting	46
7.- Tensile stress vs temperature (0 radians).	47
8.- Tensile modulus vs temperature (0 radians)	48
9.- Yield tensile stress vs temperature ($\pi/2$ radians).	49
10.- Tensile modulus vs temperature ($\pi/2$ radians)	50
11.- Compression test specimens and test fixture.	51
12.- Compressive test setup at low temperatures	52
13.- Compression test setup	53
14.- Ultimate compressive strength vs temperature	54
15.- Compressive modulus vs temperature	55
16.- Fatigue test setup for room temperature tests.	56
17.- Fatigue test setup for the cryogenic tests	57
18.- Typical fatigue test beam.	58
19.- Typical inplane shear test beam.	59
20.- Inplane shear stress vs temperature.	60
21.- Inplane yield shear moduli vs temperature.	61
22.- Punch shear test fixture	62
23.- Punch type shear test fixture.	63
24.- Punch shear unassembled test fixture	64

LIST OF FIGURES - Concluded

<u>Figure</u>	<u>Page</u>
25.- Interlaminar shear test fixtures	65
26.- Interlaminar shear test specimens.	66
27.- Interlaminar shear L/T curve	67
28.- Interlaminar ultimate shear stress vs temperature.	68
29.- Typical linear thermal expansion test specimen	69
30.- Thermal expansion test apparatus	70
31.- Thermal cycling test setup	71
32.- Typical creep test specimen.	72
33.- Creep test setup	73
34.- Creep test specimen installation	74
35.- Elongation vs time for design laminate	75
36.- Elongation vs time for design laminate.	76

SUMMARY

The test program developed for the basic prepreg materials used in process development work and fabrication of the National Transonic Facility fan blade is presented. The basic prepreg materials and the design laminate are characterized at 89 K (-300° F), RT (room temperature), and 366 K (200° F). A discussion of the characterization tests, test equipment, and test data is presented. Material test results in the warp direction are given for tensile, compressive, fatigue (tension-tension), interlaminar shear and thermal expansion.

INTRODUCTION

The National Transonic Facility (NTF) is a closed loop, cryogenic wind tunnel being constructed at the NASA Langley Research Center in Hampton, Virginia. This wind tunnel will operate at test section Mach numbers from 0.1 to 1.2; pressures from 8.3 to 130 psia; flow stream temperatures from 352.6 K to 88.7 K and Reynolds numbers up to 120 million. The gaseous medium in the tunnel will be dry air or nitrogen. The fan blades to be constructed are a part of the single stage compressor which provides the aerodynamic power for the NTF. Twenty-five blades are attached to the fan disk near its outer rim. The fan blades rotate at speeds up to 600 rpm and are exposed to the temperature environment of the tunnel stream.

Physical properties of available composite materials were screened for their suitability for this application. A preimpregnated (prepreg) epoxy resin, E glass, was selected as the most promising material for the fan blades

because of its damage tolerances, repairability and high damping. Also fiber-glass is known to have high strength and fatigue resistance at cryogenic temperatures. However, the physical and mechanical properties at elevated and cryogenic temperatures had to be determined before this material could be used. This report gives in detail the material specifications, the processing parameters used to prepare the test specimens and the tests that were used to characterize the basic materials and the design laminate. The temperature range for the tests were 88.7 K (-300° F), room temperature (RT) and 366.5 K (200° F).

SYMBOLS LIST

T	subscription for tension
C	subscription for compression
RT	room temperature
σ_1	tensile strength for the 0 radians ply orientation, MPa (psi)
σ_2	tensile strength for the $\pi/2$ radians ply orientation, MPa (psi)
σ_{12}	inplane shear strength for the $\pm \pi/4$ radians ply orientation, MPa (psi)
σ'_{12}	interlaminar shear strengths, 0 radians ply orientation MPa (psi)
ν_{12}	Poisson's ratio for the 0 radians ply orientation
ν_{21}	Poisson's ratio for the $\pi/2$ radians ply orientation
E_1	Young's moduli for the 0 radians ply orientation, GPa (psi)
E_2	Young's moduli for the $\pi/2$ radians ply orientation, GPa (psi)
G_{12}	shear modulus, GPa (psi)
α_1	coefficient of linear thermal expansion for the 0 radians ply orientation, $m/m/^\circ K \times 10^{-3}$, (in./in. $^\circ F$)

- α_2 coefficient of linear thermal expansion for the $\pi/2$ radians ply orientation, $m/m/^\circ K \times 10^{-3}$, (in./in. $^\circ F$)
- SL 11 fatigue tensile limit load for the 0 radians ply orientation, MPa (psi)
- SL 22 fatigue tensile limit load for the $\pi/2$ radians ply orientation, MPa (psi)

MATERIAL DESCRIPTION

The 7781 E glass has a volan finish with 60 fibers in the warp direction and 54 in the fill direction (figs. 1 and 2). The fibers are 0.23 mm (0.009 in.) thick. The 7576 E glass has a UM 665 finish with 120 fibers in the warp direction and 24 in the fill direction. The fibers are 0.28 mm (0.011 in.) thick. A combination of both materials were made in laminates and tested as design laminate test specimens representing the ply orientation and stacking sequence of the material layup used in the fan blade design.

Preimpregnated Fiberglass

A preimpregnated (prepreg) epoxy resin, E glass, was selected as the material for the fan blades. Fiberglass was the most promising material for the fan blades because of its damage tolerances, repairability, high damping, high strength and fatigue resistance at cryogenic temperatures.

Resin Description

The epoxy resin system selected has exhibited excellent physical properties in missile body construction. The epoxy resin system combines good fabricating qualities with moderate cure temperatures. The EF-2 resin is 50 parts by weight (PBW) diglycidyl ether of bisphenol A, 50 PBW

tetraglycidoxy tetraphenylethane, 90 PBW nadic methyl anhydride and 0.5 PBW benzyl dimethyl amine.

Resin Content

A sample of each roll of material was tested for resin content and volatiles. The resin content on material used for the test specimens ranged from 29 percent to 36 percent with volatiles ranging from 1.5 to 6 percent.

Preparation and Cure Process

In preparation for the cure process, the laminate was installed in a vacuum bag and placed in the autoclave at ambient temperatures with a 0 absolute pressure.

A pressure of 0.586 MPa (85 psi) was applied and the temperature increased at a rate of 5° per minute until 347 K (165° F) was reached and held for 30 minutes. The temperature was raised at a rate of 5° per minute until 394 K (250° F) was reached and held for 3 hours. The temperature was raised at 5° per minute and held for 2 hours at 436 K (325° F). The laminate was allowed to cool under 0.586 MPa (85 psi) pressure until the temperature reached 338 K (150° F). The pressure was reduced to atmospheric and the laminate temperature returned to ambient. At room temperature an ultrasonic test (C-scan) displaying any discontinuity in a plan view of the laminate was performed to detect any voids. A sample of each laminate was used to conduct a burnout test to determine the percent of resin content. The resin content on laminates used for test specimens ranged from 29 to 34 percent with volatiles ranging from 1.5 to 6.00 percent. The cure process (temperatures and pressure profiles) may vary for the fabrication of various fan blade parts requiring thick cross sections.

TEST PROGRAM

The interaction between testing the basic material, the analysis and the design laminate is shown in figure 3. The basic materials data were used for the design (analysis) to assist in establishing a design laminate that represents the material and ply orientation of the fan blade. The various tests of the prepreg materials are listed in tables 1 and 2. Laminates were made for the 7781 and the 7576 E-glass (basic materials) and the design ply laminate. Test specimens were machined from the various laminates with a minimum of five test specimens, used for most tests. In the warp direction, the individual material tests included tensile, compressive, fatigue (tension, tension), interlaminar shear (regular and co-cured) and thermal expansion. The interlaminar shear regular specimens were cured in one curing cycle. However, the co-cured specimens are made by partially curing the first part and then co-curing the two parts together. This allows the resin matrix to be tested in different manners. In the fill direction, tensile and thermal expansion tests were conducted. The in-plane shear tests were conducted with a fiber orientation of $\pm \pi/4$ radians. Several tensile and shear specimens were thermal cycled before they were tested for their residual strength.

In the warp direction, the design laminate tests included tensile, compressive, fatigue (tension, tension) interlaminar shear (co-cured), thermal expansion and creep. The design laminate tests in the fill direction were limited to tensile tests.

A summary of properties obtained from tests on the basic material and the design laminate are shown in tables 3, 4 and 5.

Tensile Tests

The American Society for Testing and Materials (ASTM) D3039-76 (ref. 1) test method for the determination of the tensile properties of resin-matrix reinforced continuous or discontinuous fibers was used to test the fan blade material.

The equipment used for the tensile test (fig. 4) was a 89.0 kn (20,000 lb) tensile test machine. The tensile specimens (fig. 5) are 0.0254 m (1 in.) wide by 0.279 m (11 in.) long with a varying thickness range depending on the laminate construction (basic material or the design laminate). The tensile specimens were mounted in the test equipment grips as shown in figure 6. The lower grips were fixed to the base of the test frame with a load cell mounted at the top frame of the testing machine above the upper grips. The test specimen and grips, etc., are enclosed by an environmental chamber used to obtain the elevated and cryogenic temperature. LN₂ was piped in the back of the chamber controlled by a solenoid valve to cool the chamber to 88.7 K (-300° F). The temperature of the chamber was monitored and each specimen was allowed to "soak" prior to testing.

A tensile load is applied through the test machine drive. This load was measured by the load cell, then recorded on recorder number 1 along with the head speed of the test machine.

Strain gages were used to measure the material strain at 366.5 K (200° F), RT and -300° F and also strain in the lateral and parallel fiber directions within the proportional limit to obtain Poisson's ratio. The yield strength was determined by the 0.2 percent offset method. Recorder number 2 was used to record the strain as measured by the gages. The tensile load from recorder number 2 was transferred to recorder number 1 every 1000 lbs to

calibrate the recorders together. Five test specimens were tested at each temperature 366.5 K (200° F), RT and 88.7 K (-300° F). The tensile tests 0 radians (0°), and $\pi/2$ radians (90°) results are shown in tables 6 and 7. The tensile strength curves (stress/modulus vs. temperature) for the 0 and $\pi/2$ radian fiber directions are shown in figures 7, 8, 9 and 10. For the $\pi/2$ radian ply orientation the yield strength data were used due to the elasticity of the laminate matrix after yield. The design laminate test data stress curve indicates the material becomes increasingly stronger at colder temperature. The tensile strength of the design laminate as shown on the stress curve falls between the 7781 EF-2 material and the 7576 EF-2 material. The tensile tests at 88.7 K (-300° F) were hampered with a "grip" slippage problem; however, the test data reported for the design laminate is considered conservative. The ultimate tensile strength of the material was used to establish material fatigue limits. The lower stress levels at the 366.5 K (200° F) temperature are well above the design limits of the fan blades. The average tensile ultimate material stress at 366.5 K in 0 radian direction is 394.0 MPa (57,086 psi) and the yield strength in the $\pi/2$ radian direction is 235.0 MPa (34,128 psi). All tensile test data indicate the selected design laminate meets the tensile strength requirements for the fan blade design.

Compression Tests

The American Society for Testing and Materials (ASTM) D3410-75 (ref. 2) test method for the determination of the compressive properties of resin-matrix composites reinforced by oriented continuous or discontinuous high modulus fibers was used as a guideline for compressive testing of the fan blade

material. However, because of the complexity of the compressive fixture, a face supported compression fixture was used.

In order to accomplish the compression testing of specimens after environmental conditioning, a fixture (figs. 11 and 12) was utilized which provided constraint for the specimen and also allowed for heating and cooling using cartridge heaters or liquid nitrogen manifolding. Axial strain was monitored using mechanical extensometers. The inner platens were split to allow for axial extension while the outer platen provided primary constraint. The outer platens were also channeled to allow for insertion of cartridge heaters or attachment of liquid nitrogen manifolding for heating and cooling. Cutouts were made through both platens on each side to allow for attachment of mechanical extensometers on both sides of the specimen. Hydraulic grips were utilized to transfer the load to the specimen by frictional forces between grips and tabs and between the tabs and the specimen. In figure 13, the test fixture is shown equipped with manifolding for liquid nitrogen circulation through the platen in place.

Five test specimens were tested at each of the following temperatures, 366.5 K (200° F), RT and 88.7 K (-300° F). Compression loads are transmitted to the specimen through the specimen tabs. Great care was taken installing the fixture and specimen in the testing machine to insure alignment of the specimen and testing machine axes. Load-strain data were obtained for each specimen throughout the test by monitoring the output of a load-cell mounted in the load train of the testing machine. Extensometers were used to measure the strain.

Ultimate compressive stress-strain, strength and modulus data were obtained from these tests. The stress curves (0 radian fiber direction)

indicates the compressive strength was higher at colder temperatures (figs. 14 and 15 and table 8).

Fatigue Tests

The American Society for Testing and Materials (ASTM) D3479-76 (ref. 3) test method was used for the determination of the constant-amplitude tension-tension fatigue properties of resin-matrix composites reinforced by oriented continuous or discontinuous high modulus fibers.

The servo hydraulic fatigue machine (figs. 16 and 17) was equipped with a load cell mounted at the top of the main structure of the test equipment. The fatigue specimens were mounted between two grips, the top grip being fixed and the bottom grip of the test equipment being driven with a hydraulic driver to the specified Hz. The specimen was cycled between two tensile loads at 15 Hz testing in axial fatigue. The fatigue test specimen was 38.1 mm (1.5 in.) wide and 279.4 mm (11 in.) long with a varying thickness depending on the laminate ply orientation (fig. 18).

A special fixture was used to allow temperature control during the fatigue tests. Electric heaters were mounted in the fixture to heat the fixture and test specimen to 366.5 K (200° F). LN₂ was piped through the test fixture cooling the fixture and test specimen to 88.7 K (-300° F). Thermocouples were mounted on the test fixture and a probe was used to monitor the temperature of the test specimen with a digital readout. The fatigue limits for 1×10^6 cycles were established for the basic materials and the design laminate.

The material (0 radians ply orientation) fatigue limits were found by testing specimens for 1×10^6 cycles at various loads. The fatigue limits

were established by testing to be 20 percent of the ultimate tensile load for the 7576 EF-2 prepreg and 25 and 30 percent of the ultimate tensile load for the 7781 EF-2 prepreg (table 9). However, when both materials were used in the design laminate the fatigue limit was 30 percent of the ultimate tensile load. The design laminate residual strength after 1×10^6 fatigue cycles was approximately 75 percent of the ultimate strength of the material. Several laminate design specimens were tested to 5×10^6 cycles without failure. Five specimens were tested at each of the following temperatures 366.5 K and 88.7 K. When testing at 88.7 K some difficulty was experienced with specimen failure outside the cooling fixture. Therefore, RT ultimate tensile loads were applied to all tests at 88.7 K to eliminate fracture of the test specimen outside the cooled fixture.

The fatigue tension-tension tests results are shown in table 9. All of the design laminate specimens tested with 30 percent of the ultimate tension-tension load reached 1×10^6 cycles with no failures. One specimen was tested at RT to 5×10^6 cycles. The average residual strength after 1×10^6 fatigue cycles, showed a slight reduction in strength.

The 7781 EF-2 prepreg with a $\pi/2$ radians ply orientation was tested in fatigue compression-compression at 366.5 K and 88.7 K. All test specimens were cycled 1×10^6 without failure with a 30 percent ultimate compression load (table 10).

Shear Tests

Inplane shear tests.- The American Society for Testing and Materials (ASTM) D3518-76 test method was used for the determination of the inplane shear stress-strain response of unidirectional resin-matrix composites reinforced by continuous or discontinuous high-modulus fibers (ref. 4). The method is based on the

uniaxial tensile stress-strain response of a $\pm \pi/4$ radians laminate which is symmetrically laminated about the midplane. The inplane shear test is essentially a tension test of a $\pm \pi/4$ radians symmetric laminate in accordance with the tensile test procedure described in ASTM test method D3039.

The test setup for these inplane shear tests is the same as shown in figure 4 of the tensile test section. The inplane shear test beam specimen shown in figure 19 is mounted in the testing machine grips as shown in figure 6 of the tensile test section. Five specimens were tested at each of the following temperatures; 366.5 K (200° F) RT and 88.7 K (-300° F). The chamber is used to control the temperature at 366.5 K and at 88.7 K. The yield strength of the inplane shear test is designed to produce shear property data for the design analysis of the fan blade. The yield strength was determined by the 0.2 percent offset from the proportional limit.

Inplane shear tests were completed for both the 7781 EF-2 and 7576 EF-2 materials. The inplane shear tests were not considered a viable test for the design laminate because the design laminate does not make up a $\pm \pi/4$ radians symmetric laminate. The data from these tests are shown in figures 20 and 21, and table 11 in the form of temperature (°K) versus stress (MPa) for each material at ultimate and yield strength. These data show that for the balanced weave (7781 EF-2), the ultimate strength is greater than twice the yield strength. For the unbalanced weave (7576 EF-2), the ultimate strength at RT and 352.6 K is approximately three times the yield strength and at 88.7 K about 1.6 times the yield strength.

Punch type shear tests. - The American Society for Testing and Materials (ASTM) D732-78 was used to determine the across ply shear strength of test

specimens in the form of sheets or laminates (ref. 5). Five design laminate shear specimens were tested at room temperature.

The tensile testing machine is equipped with the necessary drive mechanism for imparting to the crosshead a uniform, controlled velocity with respect to the base (fig. 22). The load was applied to the special punch type shear fixture shown in figure 23 causing a shear failure across the fibers. A load cell mounted at the base structure of the test equipment measured the shear load. The load and head speed of the test equipment were recorded. The test specimens are 50.8 mm (2 in.) square by 4.4 mm (0.175 in.) thick (fig. 24).

The results from these tests are shown in table 12. These results show an average shear strength of 184 MPa (26,713 psi) for the specimens tested.

Interlaminar shear tests.- The American Society for Testing and Materials (ASTM) D2733-70 is one of the methods used to determine the interlaminar shear strength of structural reinforced plastic (ref. 6). The other interlaminar shear test procedure was recommended by Dr. M. B. Kasen (National Bureau of Standards) after a telecon discussion about the "low" shear values obtained from the ASTM test procedures. Using the "guillotine" method as shown in figure 25 with a special adapter, the shear values substantially increased as shown in table 13.

The interlaminar shear test primarily is a strength test on the resin matrix. Two methods of fabricating test specimens were used for the interlaminar shear tests, the regular and co-cured test specimens. The "regular" test specimens were cured and machined with a saw cut through the center ply on opposite sides of the test specimen 12.7 mm (0.5 in.) apart. The "co-cured" test specimen begins with a partially cured part, co-cured to a second part

allowing a gap on opposite sides of the test specimen approximately 12.7 mm (0.5 in.) apart (fig. 26).

The testing machine and test procedures for the interlaminar (guillotine) shear tests are the same as those used for the tensile tests (figs. 4 and 6). The use of side supporting steel plates, tightened evenly and firmly to the extent necessary to prevent peeling of the specimen during the test. With the steel plates in place, the specimen is inserted in the grips of the testing machine and stressed until rupture occurs.

"Co-cured" and "regular" shear tests (ASTM method) were completed on the 7781 EF-2 and the 7576 EF-2 prepreg with only the co-cured shear tests on the design laminate. All tests were completed at temperatures: 366.5 K, RT and 88.7 K (200° F, RT and -300° F). The test data shown in table 13 indicate the matrix of the regular shear specimens are stronger than the co-cured specimens.

The average shear strength values of the co-cured design specimens at 366.- K (200° F) are 17 MPa (2517 psi) and 23 MPa (3406 psi) at 88.7 K (-300° F) as table 13 shows.

Regular shear specimens were tested using the guillotine test method with a special fixture torqued 8 in./lbs to the test beam. The test data (table 13) indicates the interlaminar shear data from these tests to be more realistic than results from tests shown in table 13. The strength at RT are 43 MPa (6,415 psi), 36 MPa (5,386 psi) at 366.5 K (200° F) and 49 MPa (7,206 psi) at 88.7 K (-300° F). Data were also taken on specimens where the length between the grooves and the thickness of the test beam (L/T ratio) was varied. Plotting these data and projecting the curve to $L/T = 0$ indicates a shear strength of 61 MPa (9,000 psi) (fig. 27). The test data indicates the

projected interlaminar shear strength at 366.5 K (200° F) are 53 MPa (7,900 psi) and 66 MPa (9,800 psi) at 88.7 K (-300° F) as shown in table 13. In figure 28 the stress curve indicates the matrix strength increases as the temperature decreases to 88.7 K (-300 K).

Thermal Expansion Tests

Coefficient of thermal expansion tests were performed for the 7781 EF-2, 7576 EF-2 materials and the design laminate. Each of the materials and the design laminate were tested with the ply orientated at 0 and $\pi/2$ radians. A total of 30 specimens were tested, 5 for each ply orientation of each material and the design laminate. A sketch of the typical test specimen is shown in figure 29.

The test setup consisted of a test stand, specimen holder, two quartz rods with copper caps on their top ends, two metric micrometers, two thermal canisters, a portable electrode type thermostatic controlled water heater, and test specimen (ASTM standard D696-70, ref. 7).

To insure the micrometer's contact sensitivity, a flashlight bulb and battery were used. This produced a closed circuit when the pointer made contact with the copper cap, thus lighting the bulb. This enabled one to obtain very fine micrometer reading.

The tests were performed by first installing the specimen in the specimen holder as shown in figure 30. Room temperature zero reference readings from each micrometer were tabulated and the specimen and holder were placed in a thermal canister. The canister was then filled with liquid nitrogen, and the specimen was allowed to soak. During this soaking time, periodic micrometer readings were taken until there was no change in the readings. At

this time the readings were tabulated and the specimen and holder removed from the liquid nitrogen. The specimen was allowed to set in room temperature for approximately 15 minutes, then the specimen in the specimen holder was placed in a canister of room temperature water to soak. The water temperature was monitored by a thermometer. Micrometer readings were taken from each micrometer to check the expansion of the specimen until the readings coincided with the first ones taken. At this point, the water temperature and micrometer readings were tabulated. Then the specimen and holder were removed from this canister and placed in a thermal canister of water at a temperature of 373 K (212° F) to soak. The temperature of this water was controlled by the water heater and monitored by a thermocouple and digital readout. During this soaking time, periodic micrometer readings were taken until no change occurred in the readings. These readings were then tabulated and the specimen and holder were removed from the canister and dried. This test procedure was repeated three times per specimen.

The results of these tests are shown in table 14, in the form of material and ply orientation versus coefficient of linear thermal expansion for 77.6 K (-320° F) to 293 K (68° F) and 293 K (68° F) to 373 K (212° F).

The accuracy of the test setup and procedure was verified by performing a test using a copper specimen whose coefficient of linear thermal expansion was known. The coefficient of linear thermal expansion obtained from these test data was 1 percent less than the known value for copper. Therefore, based on the data from this test, we feel confident in the data obtained from the NTF fan blade material specimens.

Thermal Cycle Tests

The 7781 EF-2 and 7576 EF-2 fan blade materials were thermally cycled from 88.7 K (-300° F) to 352.6 K (175° F) to determine what effects thermal cycling would have on these materials. The specimens used for these tests included 14 tensile test beams described in figure 5 of the tensile test section, 5 interlaminar shear test beams described in figure 24 of the interlaminar shear test section and 4 thermal expansion specimens described in figure 29 of the thermal expansion test section. The tensile test beams consisted of eight specimens of the 7781 EF-2 material and six of the 7576 EF-2 material. These specimens were at 0 radians ply orientation. The interlaminar shear specimens were all 7781 EF-2 co-cured material of 0 radians ply orientation. The thermal expansion specimens consisted of two each of the 7781 EF-2 and 7576 EF-2 materials. For each material there was one specimen of 0 and $\pi/2$ radians ply orientation.

The thermal cycling setup consisted of an insulated cryo container, an insulated oven, a reversible drive motor, control box with a timer, a 63.5 mm (2.5 in.) blower, two electronic recorders, two thermocouple reference junction boxes, three thermocouples, a digital counter, a liquid nitrogen supply, a perforated tray and the test specimens. Figure 31 is a photograph of the test setup.

The specimens to be thermally cycled were placed in the tray while liquid nitrogen was allowed to flow into the cryo container to a depth of 152 mm (6 in.). The depth of the nitrogen was controlled by two thermocouples and an automatic shut-off valve in the nitrogen supply line. One thermocouple was installed 146 mm (5.75 in.) from the bottom of the cryo container with the other one approximately 6.4 mm (0.25 in.) above the first one. The signals from the

thermocouples were each fed through the reference junction boxes to the automatic shut-off valve. The lower thermocouple sensing temperatures greater than 77.6 K (-320° F) would open the automatic valve to replace the nitrogen that boiled off. The upper thermocouple sensing a temperature of 77.6 K (-320° F) would close the automatic valve. The signals from the reference junction boxes were monitored on a model 194 electronic recorder. The reversible motor was then engaged allowing the tray with the specimens to be lowered to 6.4 mm (0.25 in.) above the liquid nitrogen level in the cryo container. The tray was then elevated to ambient temperature and to the oven where the temperature was maintained at 352.6 K (200° F). Four 305 mm (12 in.) long thermostatic controlled quartz lamps were used to maintain this temperature. The specimens were in each environment approximately 20 minutes. To complete the thermal cycle, the specimens were returned to the ambient environment before returning to the cryo environment. These temperatures were monitored by a thermocouple taped to one of the specimens in the tray and the temperature recorded on a model 153 electronic recorder. The digital counter recorded the number of cycles, with the recorded temperature peaks as a cross reference. The control box and the timer were used to operate the drive motor automatically.

The tensile specimens were thermal cycled 256 cycles. Tensile tests after thermal cycling showed an approximate decrease in strength of 12.5 percent for the 7781 EF-2 material and 7 percent for the 7576 EF-2 material at 352.6 K. The test data are shown in table 15. These specimens were periodically checked visually with a magnifying glass for any thermal damage to the specimens during the cycling tests. The specimens showed no visible signs of thermal damage from these tests.

The interlaminar shear specimens were thermal cycled 251 cycles without any visual thermal damage. Tensile tests after thermal cycling showed an approximate decrease in strength of about 18 percent at room temperature (table 16).

Creep Tests

The American Society for Testing and Materials (ASTM) D2990-77 test method for the determination of tensile creep under specified environmental conditions was used to test the fan blade material (ref. 8). The creep specimen shown in figure 32 is mounted in the grips of the testing machine (figs. 33 and 34). The lower grip is attached to a load cell and then to the frame of the test equipment. The upper grip is attached to a steel rod that is off loaded by a chain and a platform of weights that apply the designated load to the test specimen. The three thermocouples on the test specimen are monitored by a digital temperature recorder. The strain and time are monitored on a recorder for the duration of the test.

Three design laminate specimens were tested each for 100 hours at 366.5 K (200° F). The ASTM D3639-76 was used to determine the ultimate tensile strength of the creep specimen. The creep specimen was loaded to 89.6 MPa (12,938 psi), 35 percent of the ultimate tensile strength and tested for 100 hours at 366.5 K (200° F). The maximum average elongation for these specimens under load was $3.59 \text{ m/m} \times 10^{-3}$ (0.0359 in./in.).

The temperature was reduced to room temperature and the load reduced to zero. The specimens returned to their original length showing no signs of a permanent set. To simulate the fan blade operation in the NTF, several short duration (1/2 hour) tests were completed with the specimen under load

accumulating the elongation measurement from the beginning until the end of the tests. These tests were completed by heating the chamber to 366.5 K, applying a 39.6 MPa load for one-half hour, releasing the load and allowing the specimen to return to RT. The maximum elongation under load was approximately $3.61 \text{ m/m} \times 10^{-3}$ returning to zero elongation when the load was released. Again, the test data showed no sign of a permanent set in the material. The 89.6 MPa load at 366.5 K was then applied and monitored for 500 hours at which time the load was released and the specimen temperature returned to ambient. Upon releasing the load, the specimen was allowed to relax at ambient temperature for 7 hours to check for any permanent set. The maximum elongation after 500 hours of testing was $3.70 \text{ m/m} \times 10^{-3}$. A minimal permanent set in the material of $0.21 \text{ m/m} \times 10^{-3}$ at 0 load was recorded.

The data from the 100 and 500 hours tests are shown in figure 35 and table 17. These data show the elongation immediately reaching approximately 96 percent of its total upon applying the load.

The data from the one-half hour tests are shown in table 18. Figure 36 is a plot of elongation versus time of the one-half hour data and the data from the first hour of the 100 and the 500 hour tests. Figure 36 shows the slope of the elongation curves decreasing rapidly at approximately 0.05 hour or 3 minutes after applying the load. This indicates the material is reaching its maximum elongation.

CONCLUDING REMARKS

The results of the NTF fan blade characterization tests have been presented. The test data results given in this paper provides new mechanical and physical properties information on the subject "prepreg material at cryogenic

and elevated temperatures." The characterization test results indicate that the material follows the general trends of metals and glass reinforced plastics at cryogenic temperatures. That is, the material strength and fatigue properties increase with a decrease in temperature with some degradation at elevated temperatures. The test data were used as the basis for ascertaining that the material physical mechanical and thermal properties over the extreme temperature range would satisfy design requirements for the NTF fan blades.

REFERENCES

1. ANON: Standard Test Method for Tensile Properties of Orientation Fiber Composites, ANSI/ASTM Standard No. D3039-76, October 1976.
2. ANON: Standard Test Method for Compressive Properties of Oriented Fiber Composites ANSI/ASTM Standard No. D3410-75, June 1975.
3. ANON: Standard Test Methods for Tension-Tension Fatigue of Oriented Fiber Resin Matrix Composites, ANSI/ASTM, Standard No. 3479-76, March 1976.
4. ANON: Standard Test Method for Inplane Shear Stress-Strain Response of Unidirectional Reinforced Plastics, ANSI/ASTM Standard D3518-76, August 1976.
5. ANON: Standard Test Method for Shear Strength of Plastics, ANSI/ASTM D732-78.
6. ANON: Standard Test Methods for Interlaminar Shear Strength of Structural Reinforced Plastics at Elevated Temperatures ANSI/ASTM Standard No. D2733-70, December 1970.
7. ANON: Standard Test Method for Coefficient of Linear Thermal Expansion of Plastic, ANSI/ASTM Standard No. D696-70, February 1970.
8. ANON: Standard Test Methods for Tensile, Compressive, and Flexural Creep and Creep Rupture of Plastic, ANSI/ASTM Standard No. 2990-77, November 1977.

TABLE 1.- NTF FAN BLADES
PREPREG CHARACTERIZATION TESTS (BASIC MATERIAL)
(REQUIRED FOR EACH MATERIAL)

TEST	5 TESTS @ EACH TEMPERATURE		
	77.6 K, RT, 353 K (-320° F, RT, 175° F)**		
	0 RADIANS	$\pi/2$ RADIANS	$\pm \pi/2$ RADIANS
TENSILE	20 (15 + 5)*	15	N/A
COMPRESSIVE	15	-	-
FATIGUE _{T-T}	15	-	-
INTERLAMINAR SHEAR (REGULAR)	15		
INTERLAMINAR SHEAR (CO-CURED)	20 (15 + 5)*	-	-
THER. EXPANSION 77.6 K TO 366.5 K (-320° F TO 200° F)	5	5	N/A
INPLANE SHEAR	N/A	N/A	15
TOTAL TESTS FOR EACH MATERIAL	90	20	15

*THERMAL CYCLE SPECIMEN BEFORE TESTING AT RT

**TEMPERATURE INCREASED TO 366.5 K (200° F DURING TEST PROGRAM)

TABLE 2.- DESIGN LAMINATE TESTING

TESTS	5 TESTS @ EACH TEMPERATURE	
	ROOT AREA	BLADE AREA
	77.6 K, RT, 366.5 K (-320° F, RT & 200° F)	
TENSILE (0 & $\pi/2$ RADIANS)	30	30
COMPRESSIVE	15	-
FATIGUE _{T-T}	15	-
INTERLAMINAR SHEAR (CO-CURED)	15	-
THERMAL EXPANSION	5	-
CREEP @ 366.5 K (200° ONLY)	5	-
TOTAL TESTS	85	30

TABLE 3.- PROPERTIES OF 7576 EF-2 E-GLASS CLOTH

Property	T = 366.5 K (200° F)	RT	88.7 K (-300° F)
$(\sigma_1)_T$ ULT	728 (105524)	730 (105900)	1122 (162735)
$(\sigma_2)_T$ ULT	68.7 (9966)	69.3 (10053)	129 (18729)
$(\sigma_2)_T$ yield	52.8 (7662)	55.8 (8087)	69.5 (10087)
$(\sigma_1)_C$ ULT	528 (76651)	692 (100337)	875 (126959)
(σ_{12}) ULT	73.3 (10637)	76.3 (11062)	102 (14775)
(σ_{12}) yield	24.3 (3530)	23.7 (3442)	63.4 (9202)
$(E_1)_T$	41.7 (6.05×10^6)	41.5 (6.02×10^6)	45.1 (6.54×10^6)
$(E_2)_T$	17.2 (2.49×10^6)	18.2 (2.64×10^6)	26.3 (3.82×10^6)
$(E_1)_C$	40.7 (5.91×10^6)	39.6 (5.75×10^6)	42.5 (6.17×10^6)
G_{12}	5.52 (0.80×10^6)	6.83 (0.99×10^6)	10.35 (1.50×10^6)
ν_{12}	0.245	0.257	0.290
ν_{21}	0.085	0.098	0.182
(SL 11) _T 20% σ_1	146 (21105)	164 (21180)	224 (32547)
(SL 22) 20% σ_2	13.7 (1993)	13.9 (2010)	25.8 (3746)
	RT to 373 K		RT to 78 K
α_1	8.07 (4.48×10^{-6})		6.59 (3.66×10^{-6})
α_2	16.32 (9.07×10^{-6})		15.51 (8.62×10^{-6})

TABLE 4.- PROPERTIES OF 7781 EF-2 GLASS CLOTH

Property	T = 366.5 K (200° F)	RT	T = 88.7 K (-300° F)
$(\sigma_1)_T$ ULT	355 (48523)	393 (57023)	720 (104390)
$(\sigma_2)_T$ ULT	295 (42652)	301 (43582)	617 (89450)
$(\sigma_1)_C$ ULT	327 (47473)	379 (54992)	619 (89758)
(σ_{12}) ULT	68.9 (9988)	82.1 (11911)	144 (20889)
(σ_{12}) yield	26.2 (3803)	32.5 (4712)	71.9 (10421)
$(E_1)_T$	27.4 (3.97×10^6)	30.1 (4.37×10^6)	31.7 (4.60×10^6)
$(E_2)_T$	24.2 (3.51×10^6)	26.5 (3.84×10^6)	28.6 (4.15×10^6)
$(E_1)_C$	24.8 (3.60×10^6)	26.2 (3.80×10^6)	31.9 (4.62×10^6)
G_{12}	4.28 (0.62×10^6)	5.18 (0.75×10^6)	9.87 (1.43×10^6)
ν_{12}	0.108	0.144	0.281
ν_{21}	0.119	0.129	0.231
(SL 11) 25% σ_1	83.6 (12131)	98.3 (14256)	180 (26098)
(SL 22) 30% σ_2	89.0 (12907)	101 (14600)	162 (23504)*
	RT to 373 K		RT to 78 K
α_1	12.70 (7.06×10^{-6})		10.82 (6.01×10^{-6})
α_2	14.37 (7.98×10^{-6})		10.87 (6.04×10^{-6})

*25% σ_2

TABLE 5.- PROPERTIES OF DESIGN LAMINATE (7781 EF-2 + 7576 EF-2)

Property	T = 366.5 K (200° F)	RT	88.7 K (-300° F)
$(\sigma_1)_T$ ULT	394 (57086)	450 (65282)	518 (75086)
$(\sigma_2)_T$ ULT	235 (34128)	263 (38138)	407 (59055)
$(\sigma_1)_C$ ULT	387 (56112)	401 (58222)	593 (86016)
$(\sigma_2)_C$ ULT	329 (47700)	370 (53700)	-
(σ_{12}) ULT	37.1 (5386)	37.1 (5386)	50 (7206)
$(E_1)_T$	28.6 (4.15×10^6)	30.2 (4.37×10^6)	36.7 (5.32×10^6)
$(E_2)_T$	20.1 (2.97×10^6)	22.3 (3.24×10^6)	31.7 (4.60×10^6)
$(E_1)_C$	24.1 (3.50×10^6)	24.8 (3.60×10^6)	29.0 (4.20×10^6)
$(E_2)_C$	26.1 (3.79×10^6)	26.6 (3.86×10^6)	-
ν_{12}	0.299	0.299	0.359
ν_{21}	0.199	0.208	0.224
(SL 11) _T 30% σ_1	118 (17126)	135 (19585)	155 (22526)
(SL 22) _T 30% σ_2	70.6 (10238)	78.9 (11441)	122 (17717)
	RT to 373 K		RT to 78 K
α_1	10.66 (5.92×10^{-6})		8.58 (4.77×10^{-6})
α_2	16.02 (8.90×10^{-6})		12.78 (7.10×10^{-6})

TABLE 6.- NTF FAN BLADE MATERIALS TENSILE TEST RESULTS FOR THE
 7781 EF-2 AND 7576 EF-2 MATERIALS AND THE DESIGN LAMINATE
 (7781 EF-2 + 7576 EF-2) WITH 0 RADIAN PLY ORIENTATION

Material	Ultimate stress MPa (psi) (Average of 5 tests)		
	RT	353 K (175° F)	88.7 K (-300° F)
7781 EF-2	393 (57023)	335 (48523)	720 (104390)
7576 EF-2	730 (105900)	728 (105524)	1122 (162735)
(7781 EF-2 + 7576 EF-2)	450 (65282)	**394 (57086)	*518 (75086)

*Tab bond failure

**Tested at 366.5 K (200° F)

TABLE 7.- NTF FAN BLADE MATERIALS YIELD TENSILE TEST RESULTS FOR THE
 7781 EF-2 AND 7576 EF-2 MATERIALS AND THE DESIGN LAMINATE
 (7781 EF-2 + 7576 EF-2) WITH $\pi/2$ RADIAN PLY ORIENTATION

MATERIAL	YIELD STRESS MPA (PSI) (AVERAGE OF 5 TESTS)		
	RT	366.5 K (2000 F)	88.7 K (-300° F)
7781 EF-2	105.7 (15327)	110.8 (16077)	*177.6 (25754)
7576 EF-2	55.8 (8087)	52.8 (7662)	69.5 (10087)
(7781 EF-2 + 7576 EF-2)	81.6 (11842)	73.9 (10716)	108.1 (15672)

*SPECIMEN SLIPPED IN GRIPS

TABLE 8.- COMPRESSIVE STRENGTH TEST RESULTS FOR THE NTF FAN
 BLADE MATERIALS WITH 0 RADIAN PLY ORIENTATION

MATERIAL	ULTIMATE COMPRESSIVE STRENGTH, MPA (PSI) (AVERAGE OF 5 TESTS)				
	77 K	116 K	294 K	336 K	366.5 K
7576 EF-2	875 (126959)	-	692 (100337)	609 (88388)	528 (76651)
7781 EF-2	619 (89758)	-	379 (54992)	332 (48347)	327 (47473)
DESIGN LAMINATE	593 (86016)	576 (83602)	401 (58222)	-	387 (56112)

TABLE 9.- FATIGUE TENSION-TENSION TEST RESULTS FOR THE NTF FAN BLADE
MATERIALS WITH 0 RADIAN PLY ORIENTATION

MATERIAL	TEMP, °K	ULT TENSILE STRENGTH MPA (PSI)	APPLIED FATIGUE LOAD % OF ULTIMATE	NUMBER OF SPECIMENS @ CYCLES × 10 ⁶	AVERAGE RESIDUAL STRENGTH AFTER FATIGUE, MPA (PSI)
7576 EF-2	83	*730 (105900)	20	3 @ 1	503 (72919)
7576 EF-2	RT	730 (105900)	20	5 @ 1	--
7576 EF-2	366.5	728 (105524)	20	2 @ 1	542 (78648)
7781 EF-2	83	*393 (57024)	25	7 @ 1	349 (50651)
7781 EF-2	RT	393 (57024)	25	6 @ 1	306 (44382)
7781 EF-2	366.5	335 (48523)	25	**5 @ 1	335 (48645)
DESIGN LAMINATE	83	*448 (65000)	30	4 @ 1	347 (50371)
	RT	448 (65000)	30	4 @ 1	333 (48328)
	RT	448 (65000)	30	1 @ 5	--
	366.5	394 (57086)	30	4 @ 1	--
	366.5	394 (57086)		***1 @ 5	--

*RT ULTIMATE TENSILE STRENGTH USED

**1 TEST BEAM TESTED AT 79 K (1750 F)

***TESTED AT 25% ULTIMATE TENSILE STRENGTH

TABLE 10.- FATIGUE COMPRESSION-COMPRESSION TEST RESULTS FOR THE 7781
PREPREG MATERIAL WITH $\pi/2$ RADIAN PLY ORIENTATION

TEMP, °K	ULT COMPRESSION STRENGTH MPA (PSI)	FATIGUE LIMITS %	NUMBER OF SPECIMENS @ CYCLES × 10 ⁶	AVERAGE RESIDUAL STRENGTH AFTER FATIGUE MPA (PSI)
83	370 (53700)*	30	5 @ 1	544 (79,000)
366.5	329 (47700)	30	5 @ 1	314 (45,580)

*RT ULTIMATE COMPRESSION STRENGTH USED

TABLE 11.- INPLANE SHEAR TEST RESULTS FOR THE NTF
FAN BLADE MATERIALS

MATERIAL	TEMP °K	STRESS MPa (PSI)(AVERAGE OF 5 TESTS)	
		ULTIMATE	YIELD
7576EF-2	88.7	102 (14775)	63 (9202)
	RT	76 (11062)	24 (3442)
	352.6	73 (10637)	24 (3530)
7781EF-2	88.7	144 (20889)	72 (10421)
	RT	82 (11911)	32 (4712)
	352.6	69 (9988)	26 (3803)

TABLE 12.- NTF FAN BLADE MATERIAL PUNCH SHEAR TESTS
 FOR THE DESIGN LAMINATE (7781 EF-2 + 7576 EF-2)
 (TEST AT ROOM TEMPERATURE)

SPECIMEN NUMBER	STRESS	
	MP _A	PSI
1	181	(26206)
2	183	(26604)
3	183	(26604)
4	185	(26800)
5	189	(27415)

TABLE 13.- INTERLAMINAR SHEAR TEST RESULTS FOR THE
NTF FAN BLADE MATERIALS

MATERIAL	TEMP °K	ULTIMATE SHEAR STRESS,	
		MPa	(PSI)
7576EF-2 CO-CURED	88.7	23	(3401)
	RT	23	(3404)
	352.6	24	(3432)
REGULAR	88.7	30	(4409)
	RT	17	(2529)
	366.5	15	(2240)
7781EF-2 CO-CURED	88.7	11	(1573)
	RT	11	(1573)
	352.6	12	(1798)
REGULAR	88.7	27	(3875)
	RT	15	(2208)
	366.5	17	(2477)
DESIGN LAMINATE CO-CURED	88.7	23	(3406)
	RT	19	(2809)
	366.5	17	(2517)
DESIGN* LAMINATE REGULAR	88.7	49	(7206)
	RT	43	(6415)
	366.5	36	(5386)

*SPECIAL TEST FIXTURE USED WITH BOLTS TORQUED 8 IN-LB.

TABLE 13.- CONCLUDED

MATERIAL	TEMP °K	ULTIMATE SHEAR STRESS			
		ACTUAL		PROJECTED	
		MPA	PSI	MPA	PSI
DESIGN LAMINATE (REGULAR)	88.7	49	7,206	66	9,800
	RT	43	6,415	61	9,000
	366.5	36	5,386	53	7,900

TABLE 14.- NTF FAN BLADE MATERIALS LINEAR THERMAL EXPANSION TEST RESULTS

MATERIAL	PLY ORIENTATION	COEFFICIENT OF LINEAR THERMAL EXPANSION, $m/m \times 10^{-6}/^{\circ}K$ (IN./IN. $^{\circ}F \times 10^{-6}$)	
		293 K TO 77.6 K	293 K TO 373 K
7576 EF-2	0	6.59 (3.66)	8.07 (4.48)
	$\pi/2$	15.51 (8.62)	16.32 (9.07)
7781 EF-2	0	10.82 (6.01)	12.70 (7.06)
	$\pi/2$	10.87 (6.04)	14.37 (7.98)
DESIGN LAMINATE	0	8.58 (4.77)	10.66 (5.92)
	$\pi/2$	12.78 (7.10)	16.02 (8.90)

TABLE 15.- NTF FAN BLADE MATERIALS THERMAL CYCLED TENSILE TEST BEAM
STRENGTH TESTS

MATERIAL	TENSILE STRESS @ 352.6 K, MPA (PSI)		% DECREASE IN STRENGTH
	BEFORE THERMAL CYCLING	AFTER THERMAL CYCLING	
7576EF-2	728 (105524)	674 (97889)	7.4
7781EF-2	335 (48523)	293 (42518)	12.5

TABLE 16.- NTF FAN BLADE MATERIALS THERMAL CYCLED INTERLAMINAR SHEAR
TEST BEAM STRENGTH TESTS

MATERIAL	INTERLAMINAR SHEAR STRESS @ RT, MPA (PSI)		% DECREASE IN STRENGTH
	BEFORE THERMAL CYCLING	AFTER THERMAL CYCLING	
7781EF-2 CO-CURED	11 (1573)	9 (1263)	18.2

TABLE 17.- AVERAGE ELONGATION VERSES TIME
 100 HOUR AND THE 500 HOUR CREEP TESTS

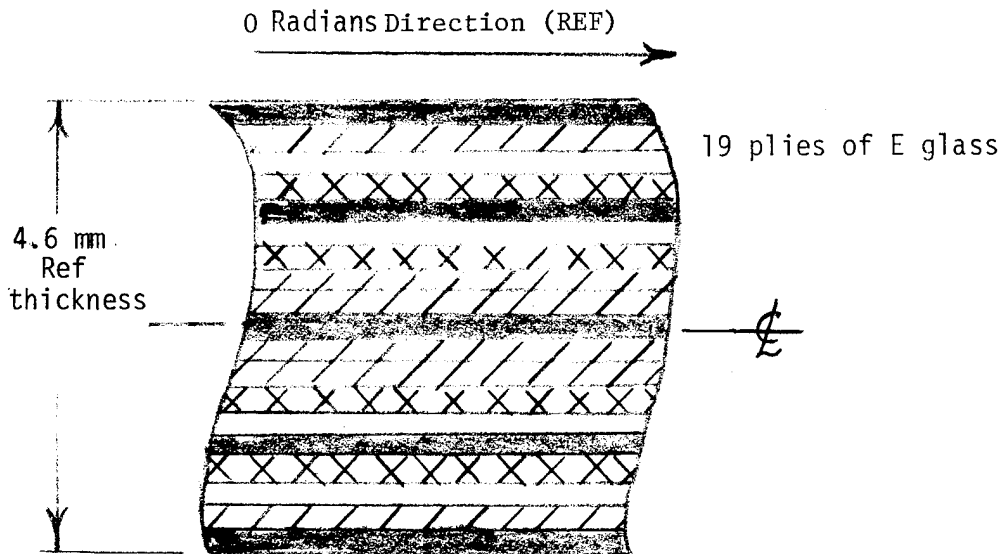
DESIGN LAMINATE				
Time Hours	Average Elongation			
	m/m $\times 10^3$		in./in.	
0	0	0	0	0
0	3.50	3.52	.0350	.0352
0.05	3.50	3.54	.0350	.0354
0.10	3.50	3.55	.0350	.0355
0.15	3.50	3.56	.0350	.0356
0.50	3.50	3.57	.0350	.0357
1.0	3.54	3.57	.0354	.0357
10.0	3.57	3.59	.0357	.0359
20.0	3.58	3.61	.0358	.0361
30.0	3.58	3.63	.0358	.0363
40.0	3.58	3.63	.0358	.0363
50.0	3.59	3.63	.0359	.0363
60.0	3.59	3.63	.0359	.0363
70.0	3.59	3.63	.0359	.0363
80.0	3.59	3.64	.0359	.0364
90.0	3.59	3.64	.0359	.0364
100.0	3.59	3.64	.0359	.0364
120.0	-	3.65	-	.0365
140.0	-	3.66	-	.0366
160.0	-	3.67	-	.0367
180.0	-	3.67	-	.0367
200.0	-	3.67	-	.0367
300.0	-	3.69	-	.0369
500.0	-	3.70	-	.0370
500.0	-	0.33	-	.0033
502.0	-	0.24	-	.0024
503.0	-	0.23	-	.0023
503.0	-	0.22	-	.0022
505.0	-	0.21	-	.0021
507.0	-	0.21	-	.0021


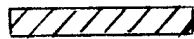
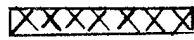

TABLE 18.- AVERAGE ELONGATION VERSUS TIME
(0.5 HOUR CYCLING CREEP TEST)

DESIGN LAMINATE		
TIME, HRS.	AVERAGE ELONGATION	
	M/M × 10 ³	IN./IN.
0.00	0.00	0.00
0.00	3.53	0.0353
0.05	3.56	0.0356
0.10	3.57	0.0357
0.15	3.58	0.0358
0.50	3.61	0.0361

Material	Fibers Warp Direction	Fibers Fill Direction	Material Plies per Laminate
Basic 7781	60	54	14
Basic 7576	120	24	11
Design	Combination of 7781E and 7576E glass (Refer to design laminate.)		19

MATERIAL AND LAMINATE DESCRIPTION



-  7576E Glass w/0 Radians Ply Orientation
-  7781E Glass w/0 Radians Ply Orientation
-  7781E Glass w/+ $\pi/6$ Radians Ply Orientation
-  7781E Glass w/- $\pi/6$ Radians Ply Orientation

DESIGN LAMINATE

Figure 1.- Material and laminate identification.

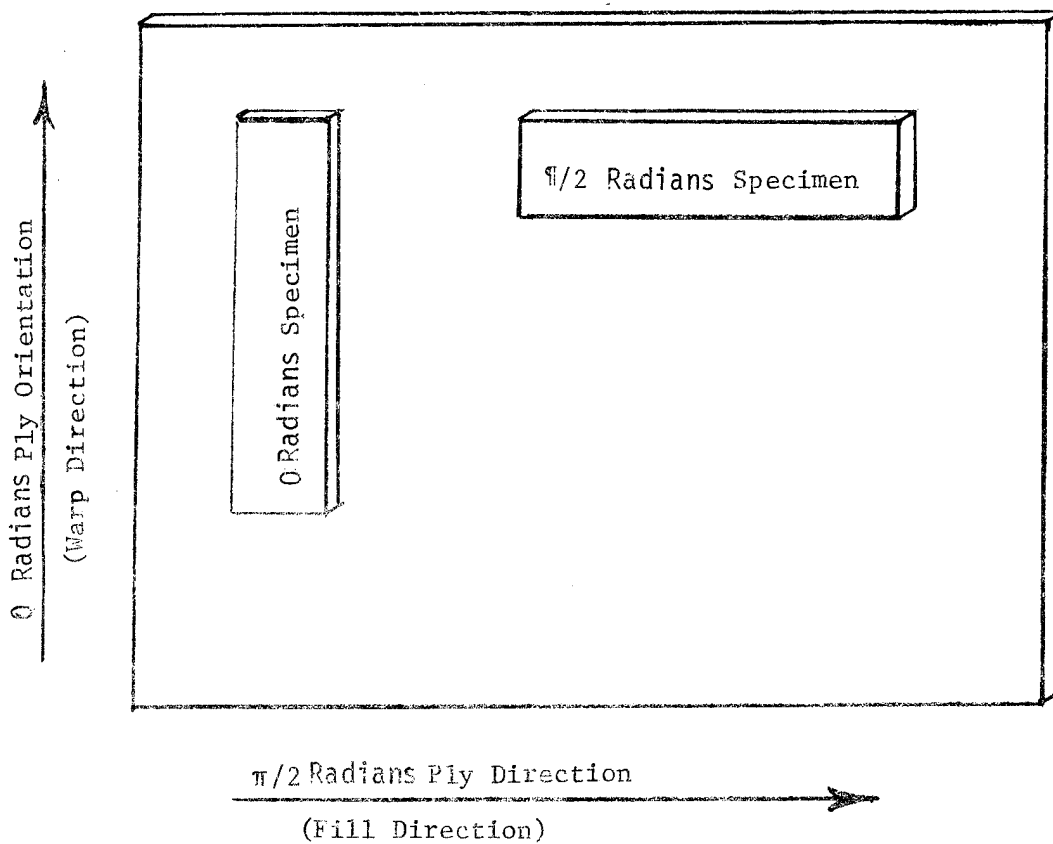


Figure 2.- Test specimen ply orientation.

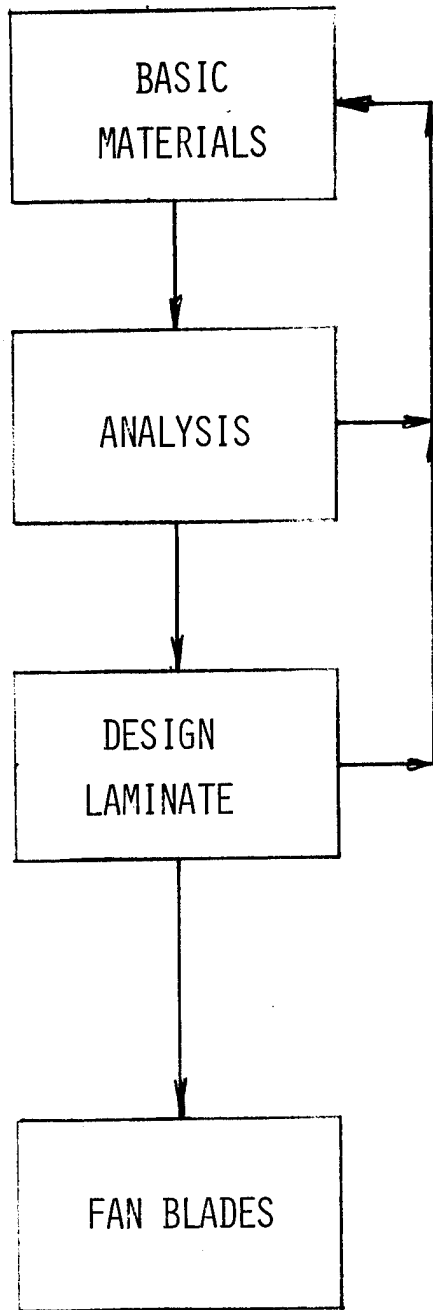


Figure 3.- NTF fan blades material test program.

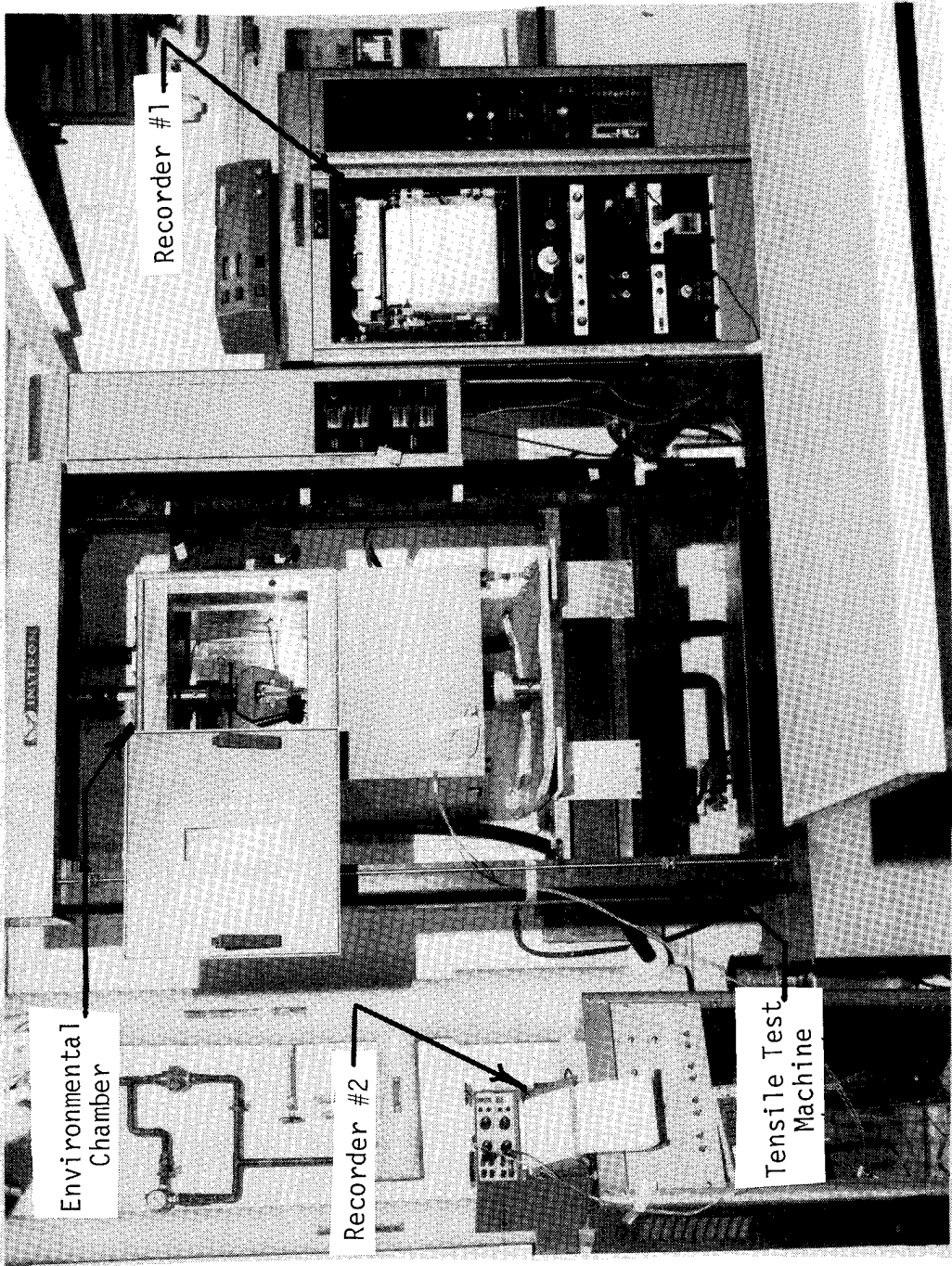


Figure 4.- NTF fan blade materials tensile test setup.

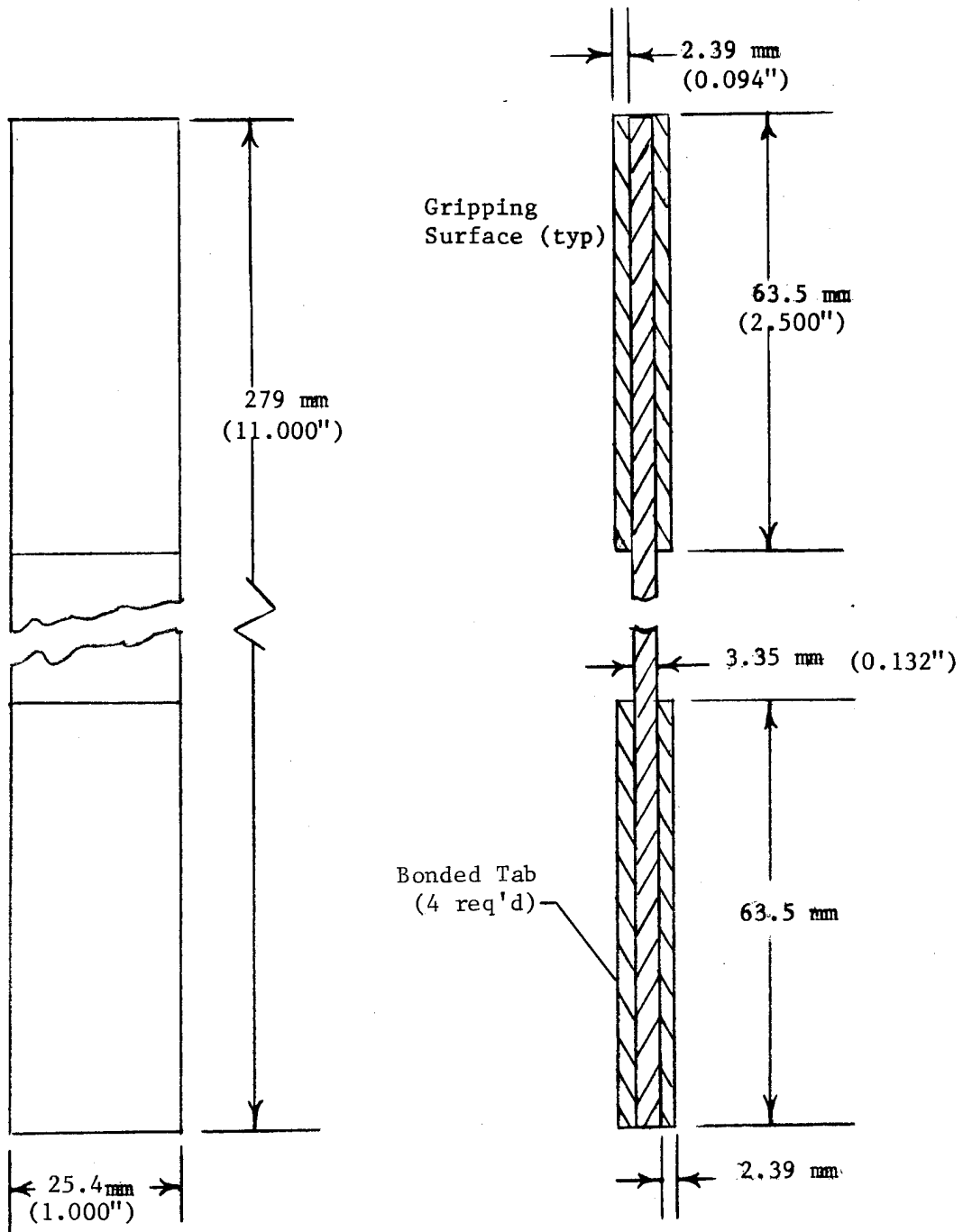


Figure 5.- Typical tensile test specimen.

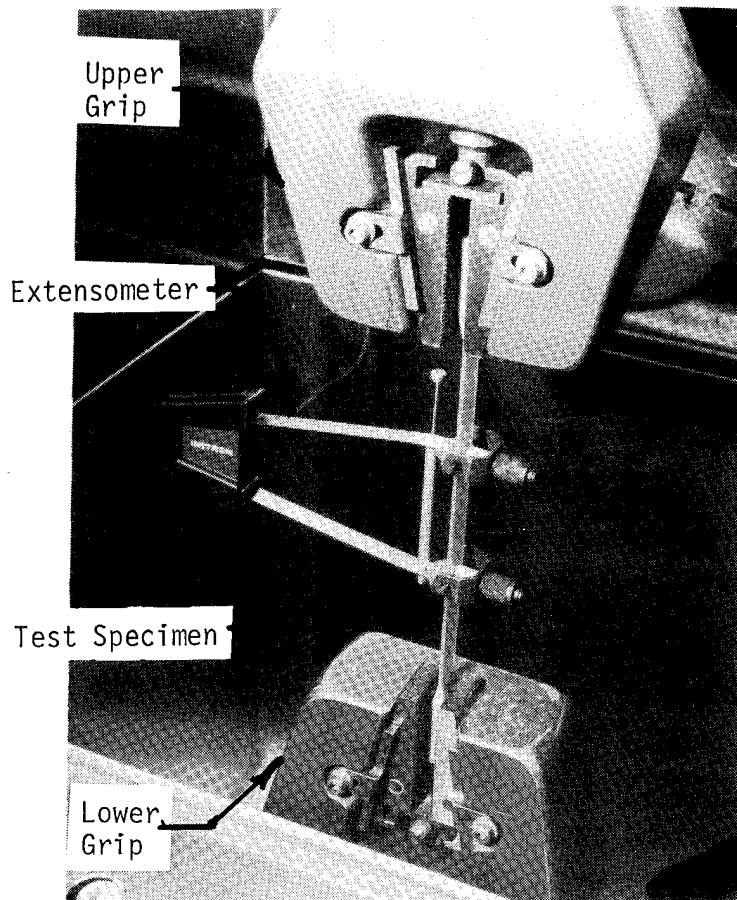


Figure 6.- Typical test specimen mounting.

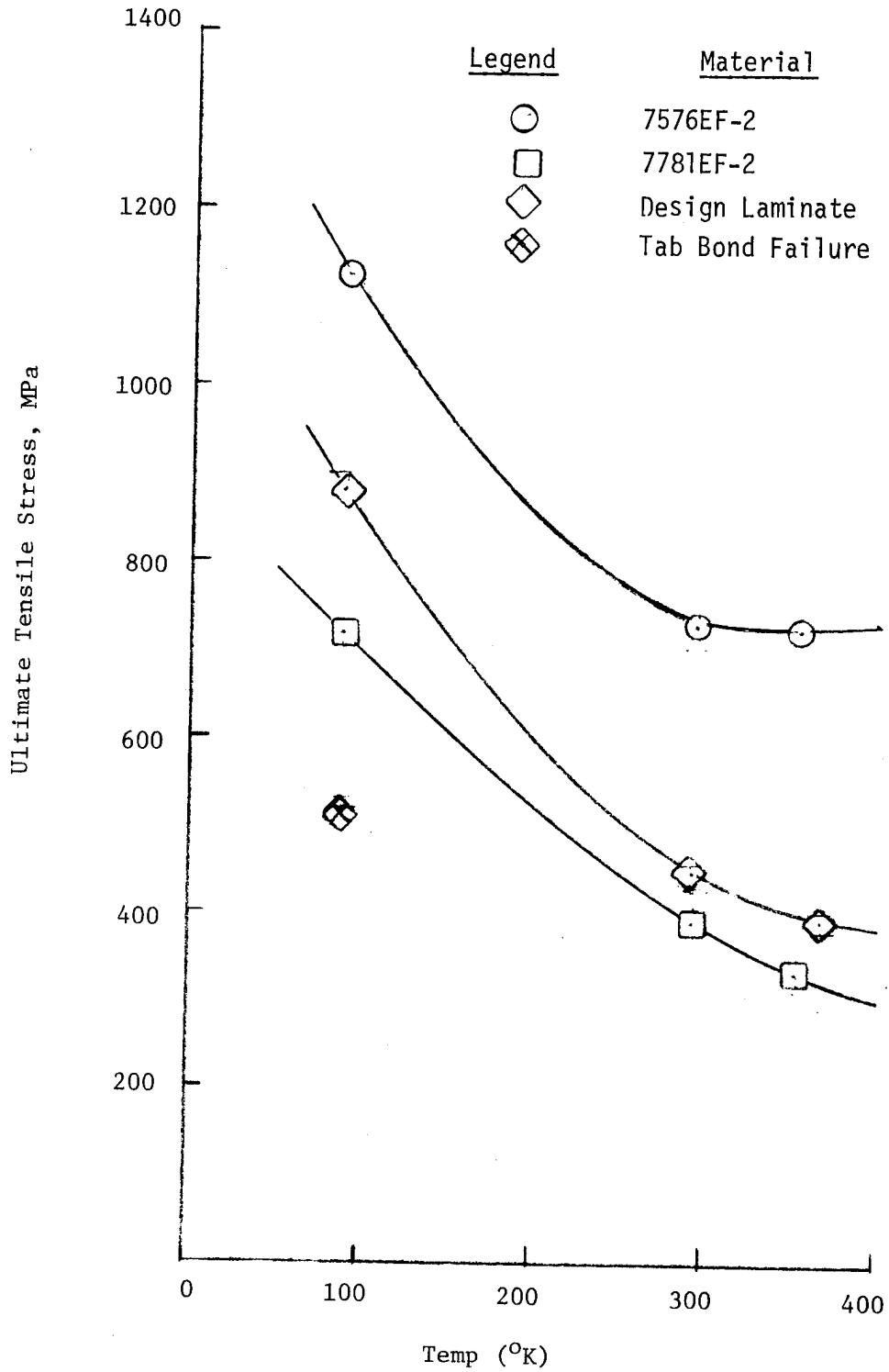


Figure 7.- Ultimate tensile stress versus temperature for the NTF fan blade materials with 0 radians ply orientation.

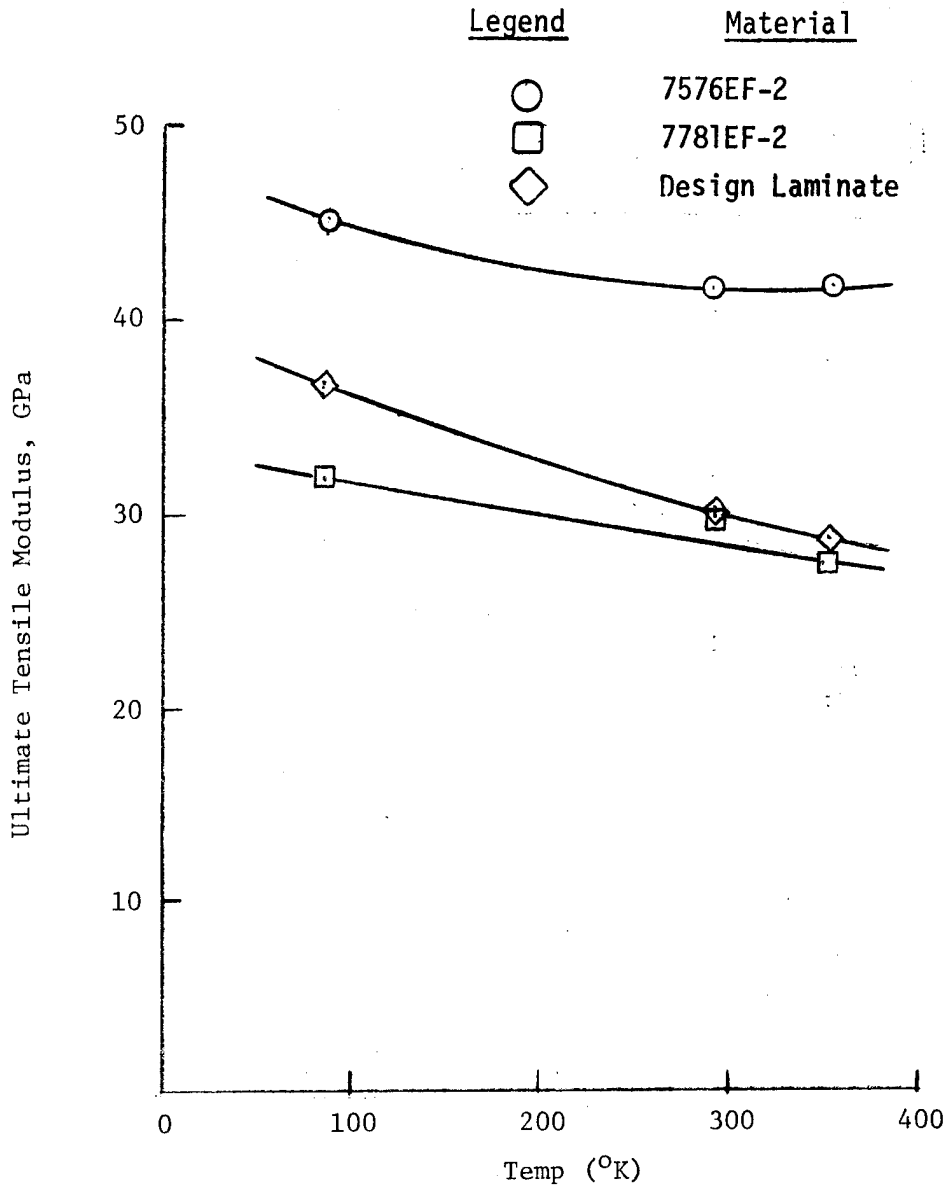


Figure 8.- Tensile modulus of elasticity versus temperature for the NTF fan blade materials with 0 radians ply orientation.

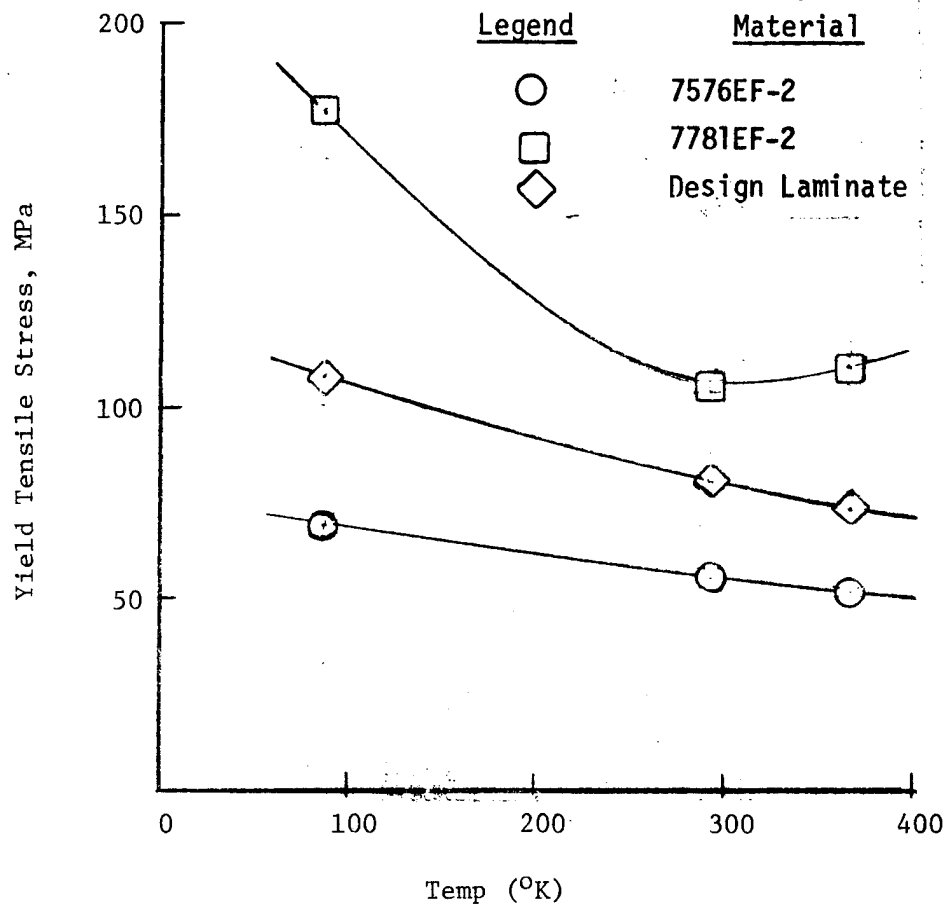


Figure 9.- Yield tensile stress versus temperature for the NTF fan blade materials with $\pi/2$ radians ply orientation.

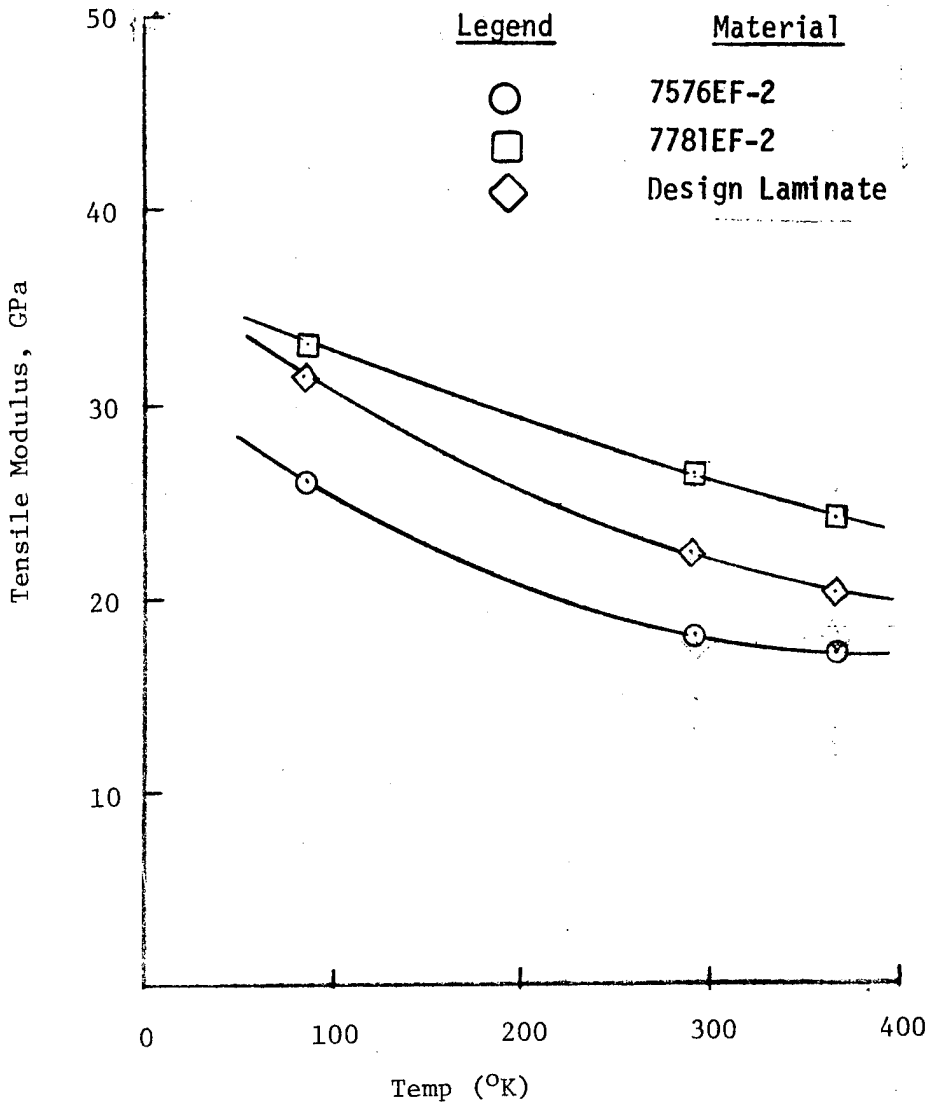


Figure 10.- Tensile modulus of elasticity versus temperature for the NTF fan blade materials with $\pi/2$ radians ply orientation.

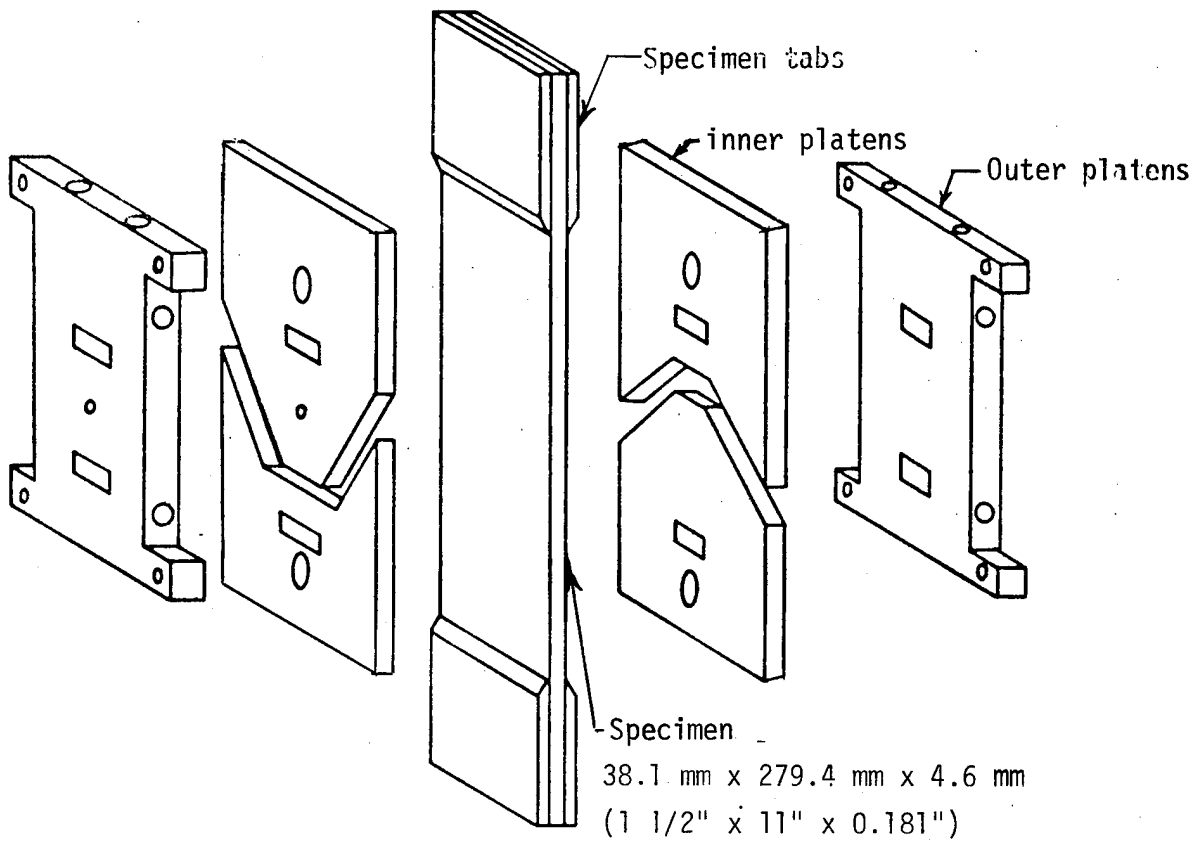


Figure 11.- Compression test specimen and test fixture.

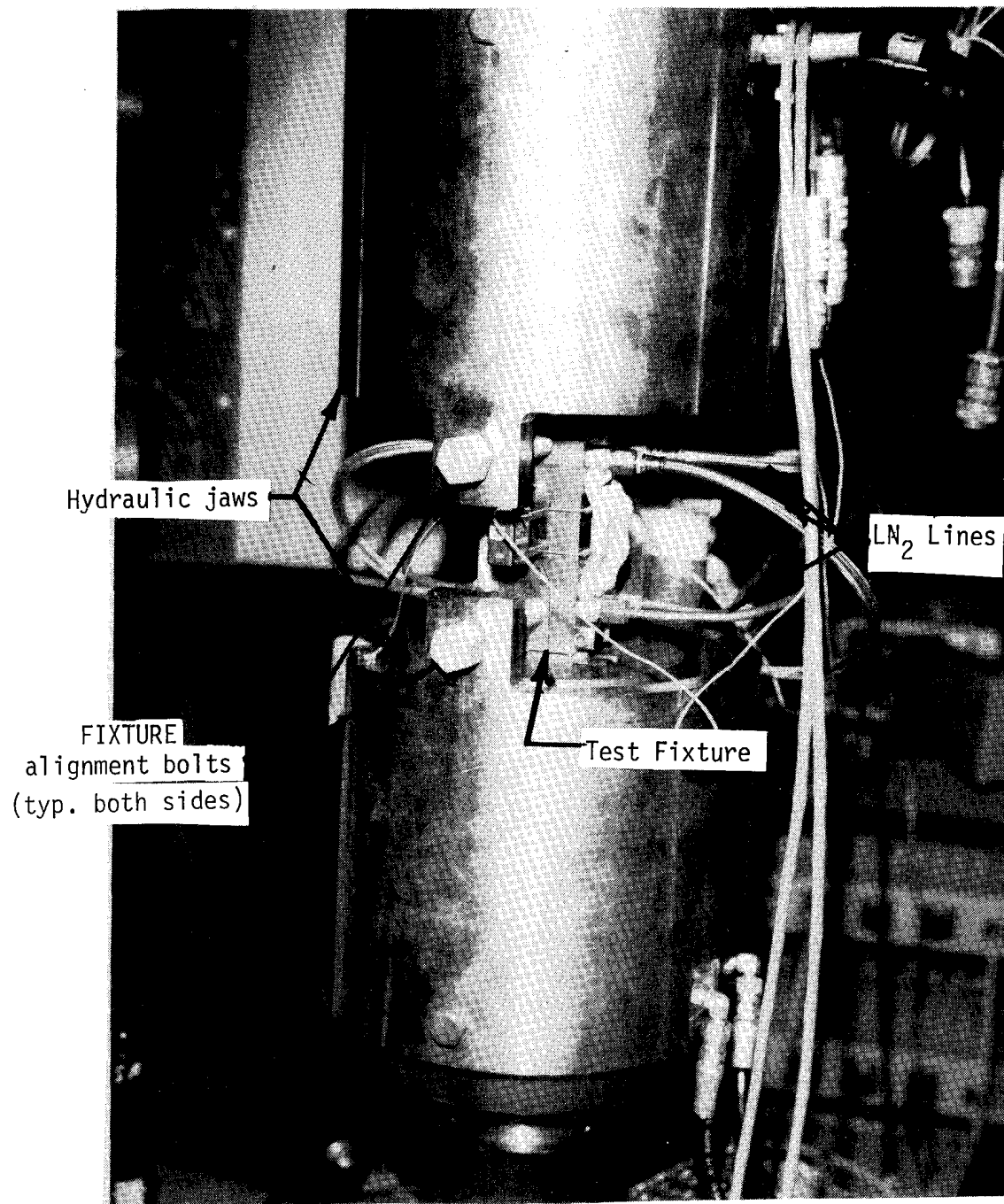
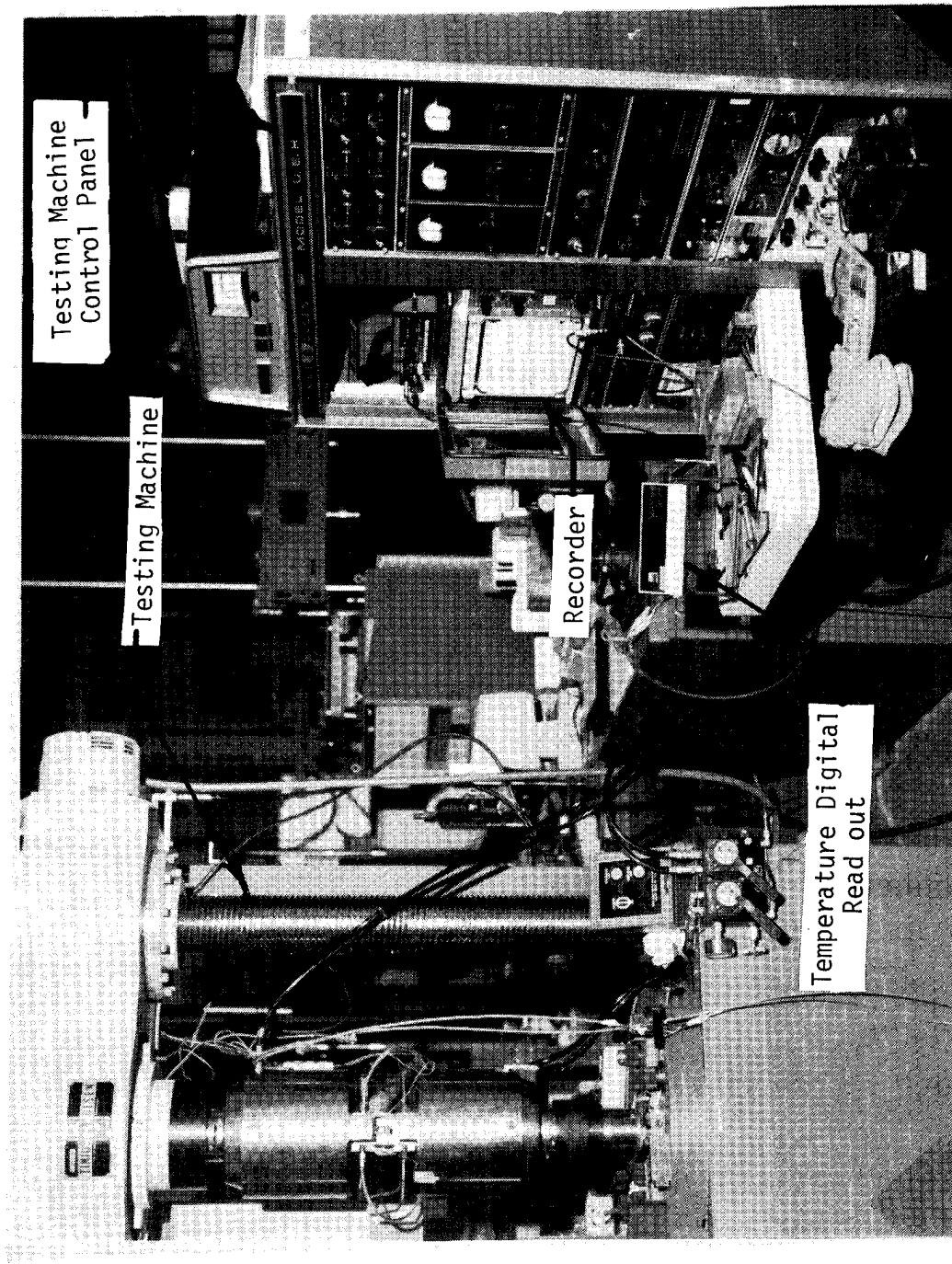


Figure 12.- Compressive test fixture setup for low temperature.



Testing Machine
Control Panel

Testing Machine

Recorder

Temperature Digital
Read out

Figure 13.- Compression test setup.

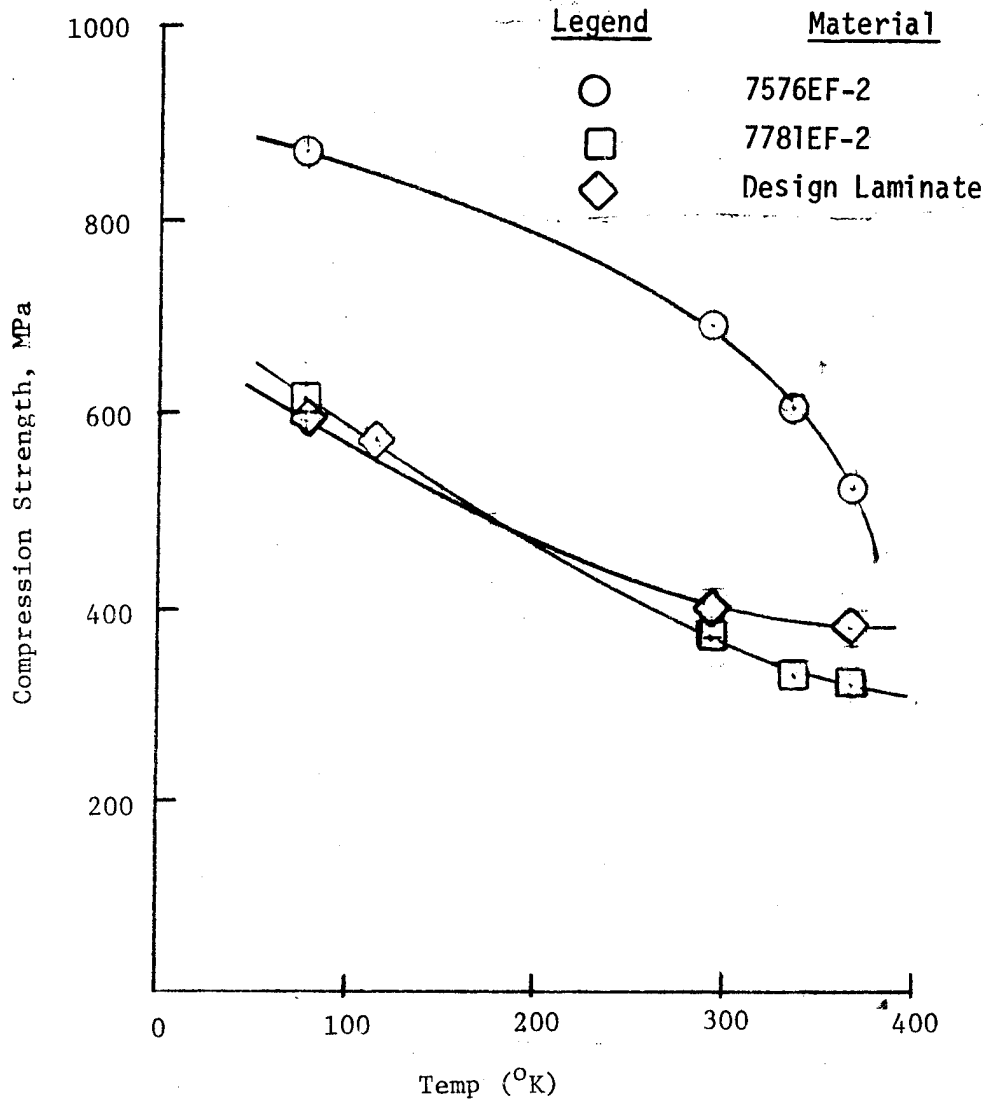


Figure 14.- Ultimate compressive strength versus temperature for the NTF fan blade materials with 0 radians ply orientation.

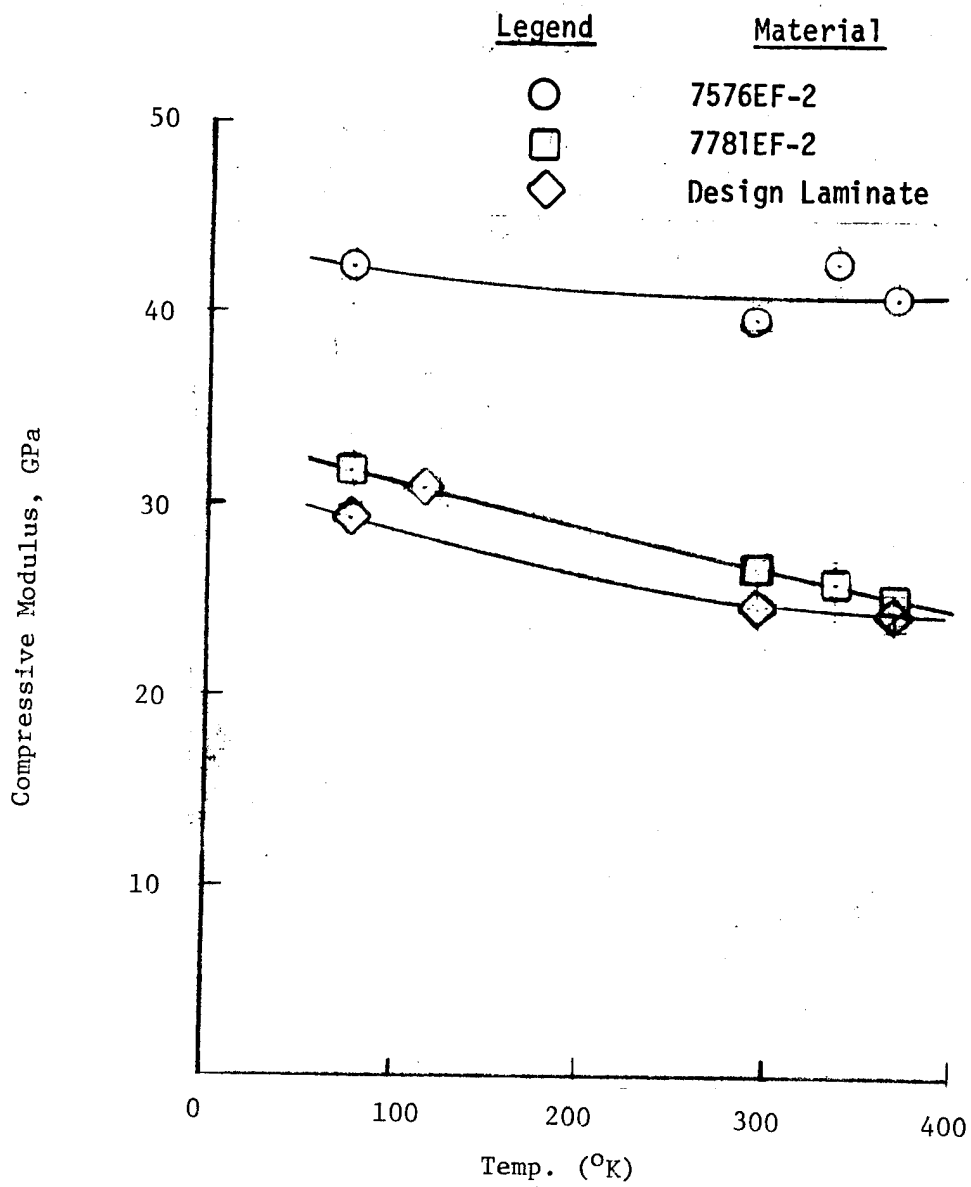


Figure 15.- Compressive modulus of elasticity versus temperature for the NTF fan blade materials with 0 radians ply orientation (root section).

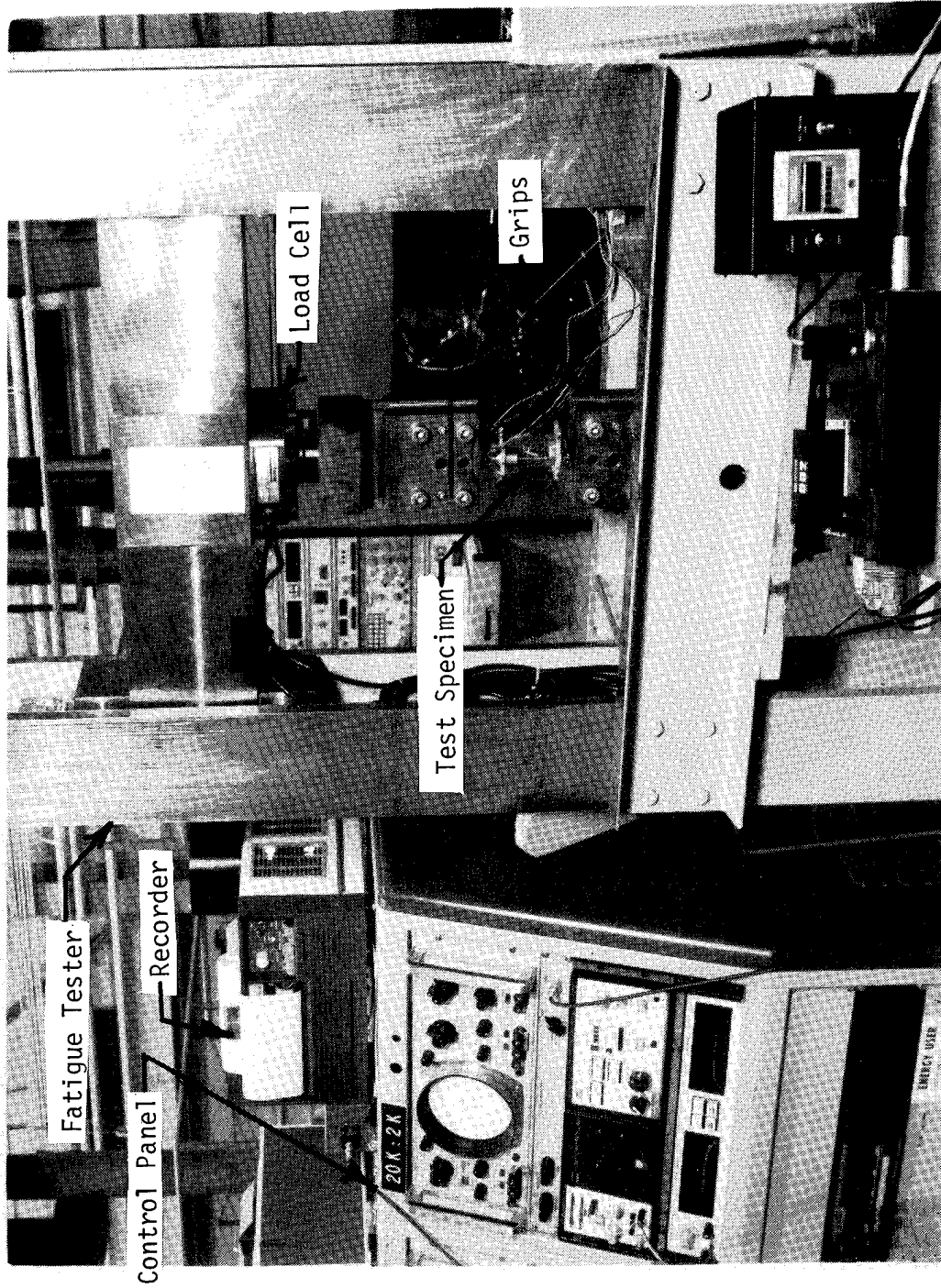


Figure 16.- Fatigue test setup for the room temperature tests.

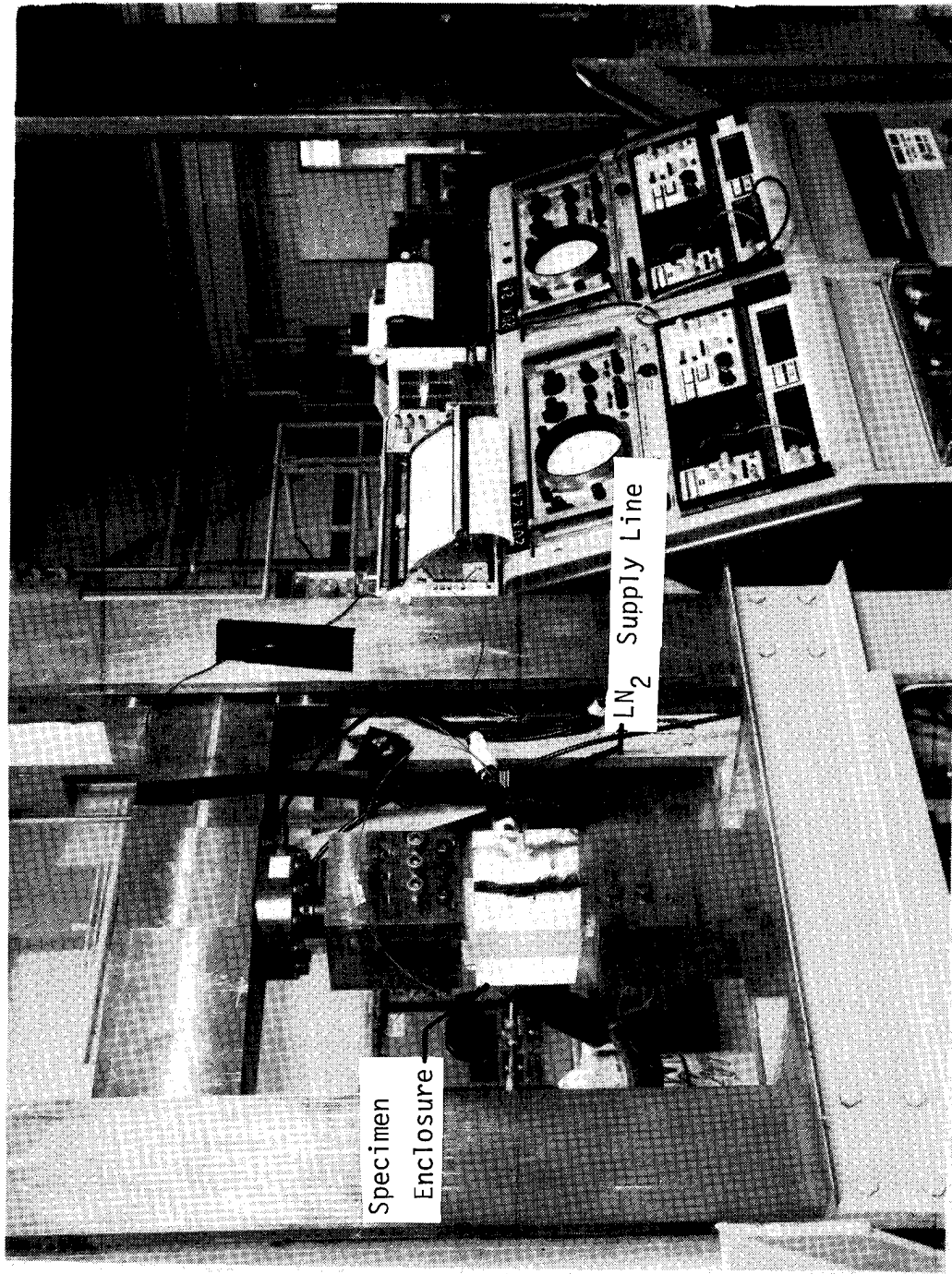


Figure 17.- Fatigue test setup for the cold temperature tests.

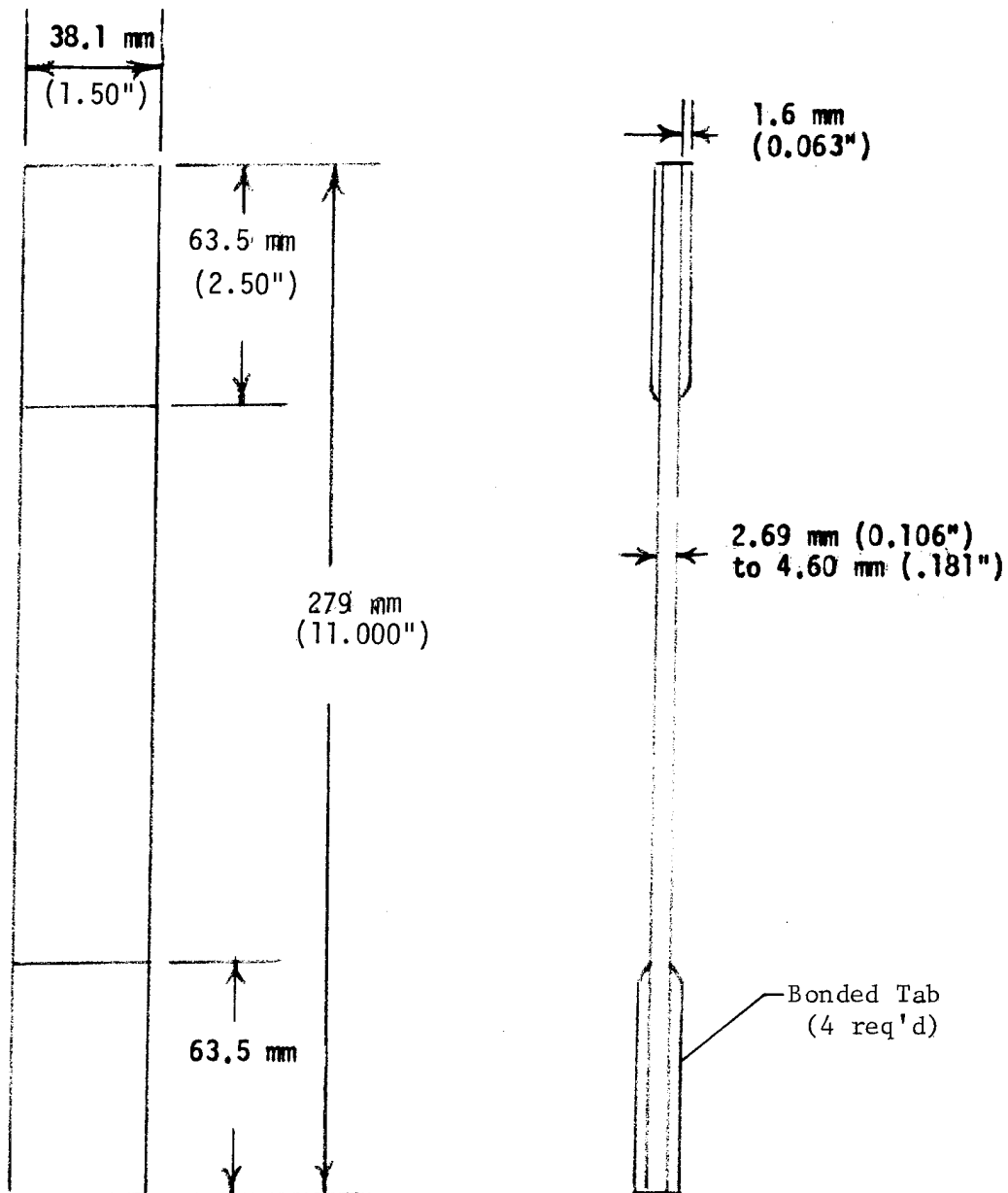


Figure 18.- Typical fatigue test beam.

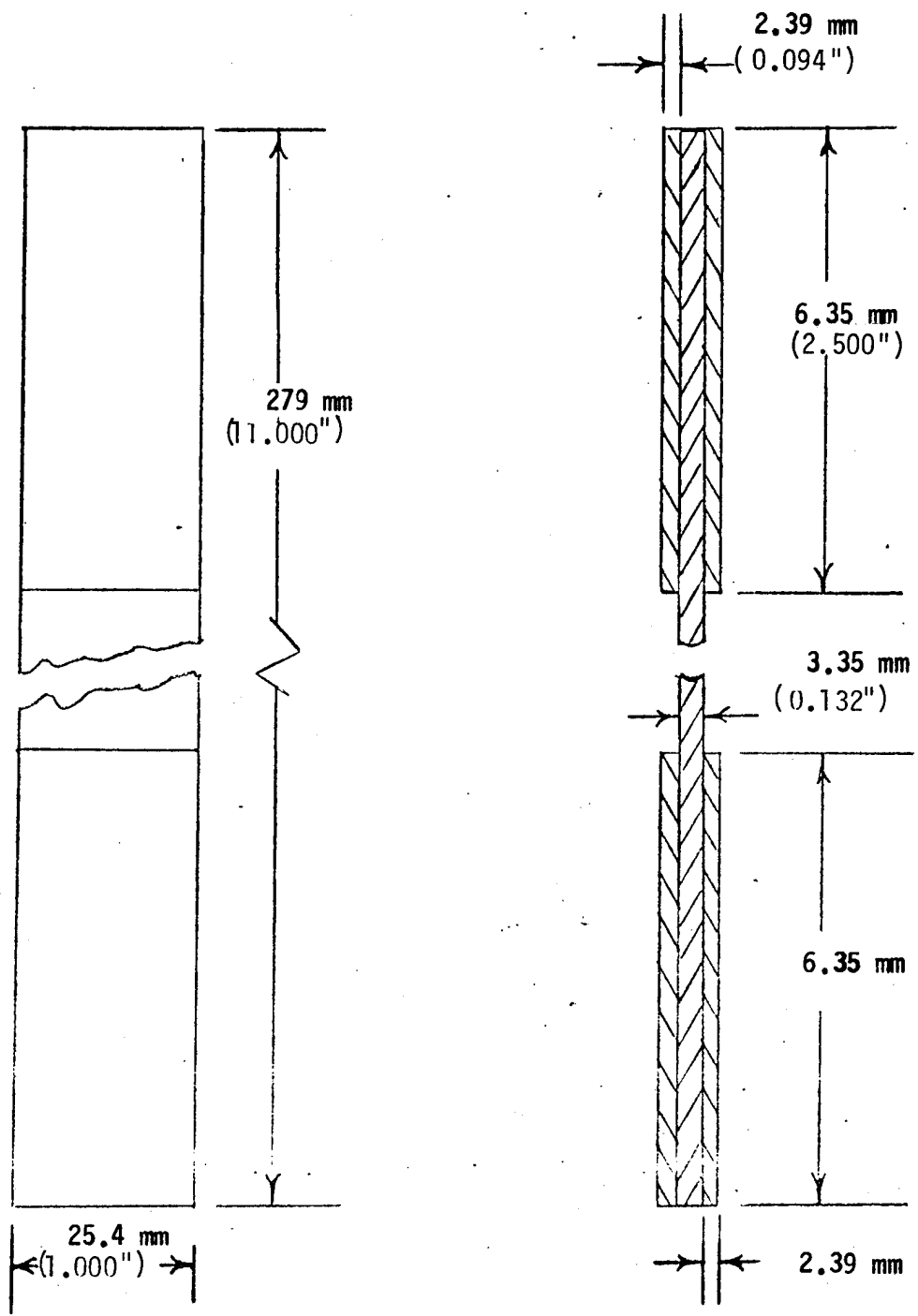


Figure 19.- Typical inplane shear test beam.

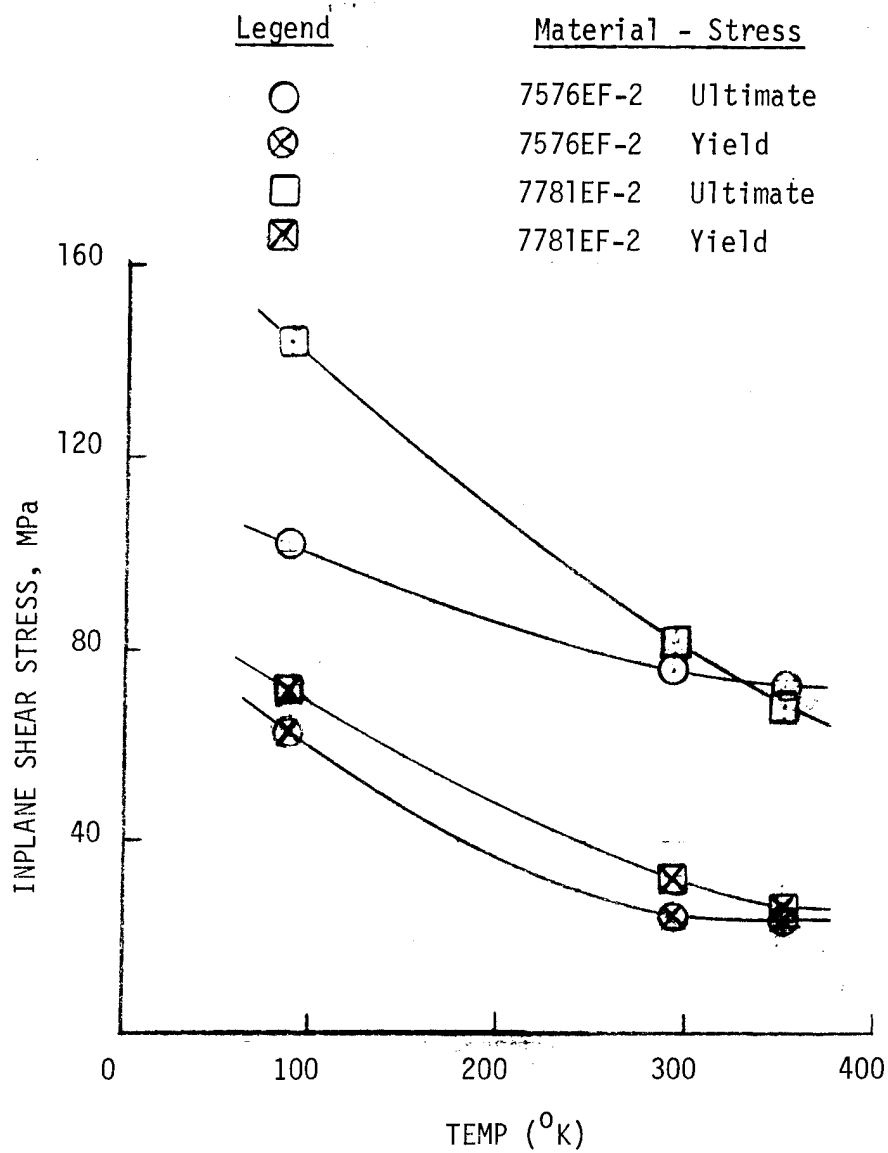


Figure 20.- Inplane shear stress versus temperature for the 7576 EF-2 and 7781 EF-2 NTF fan blade materials.

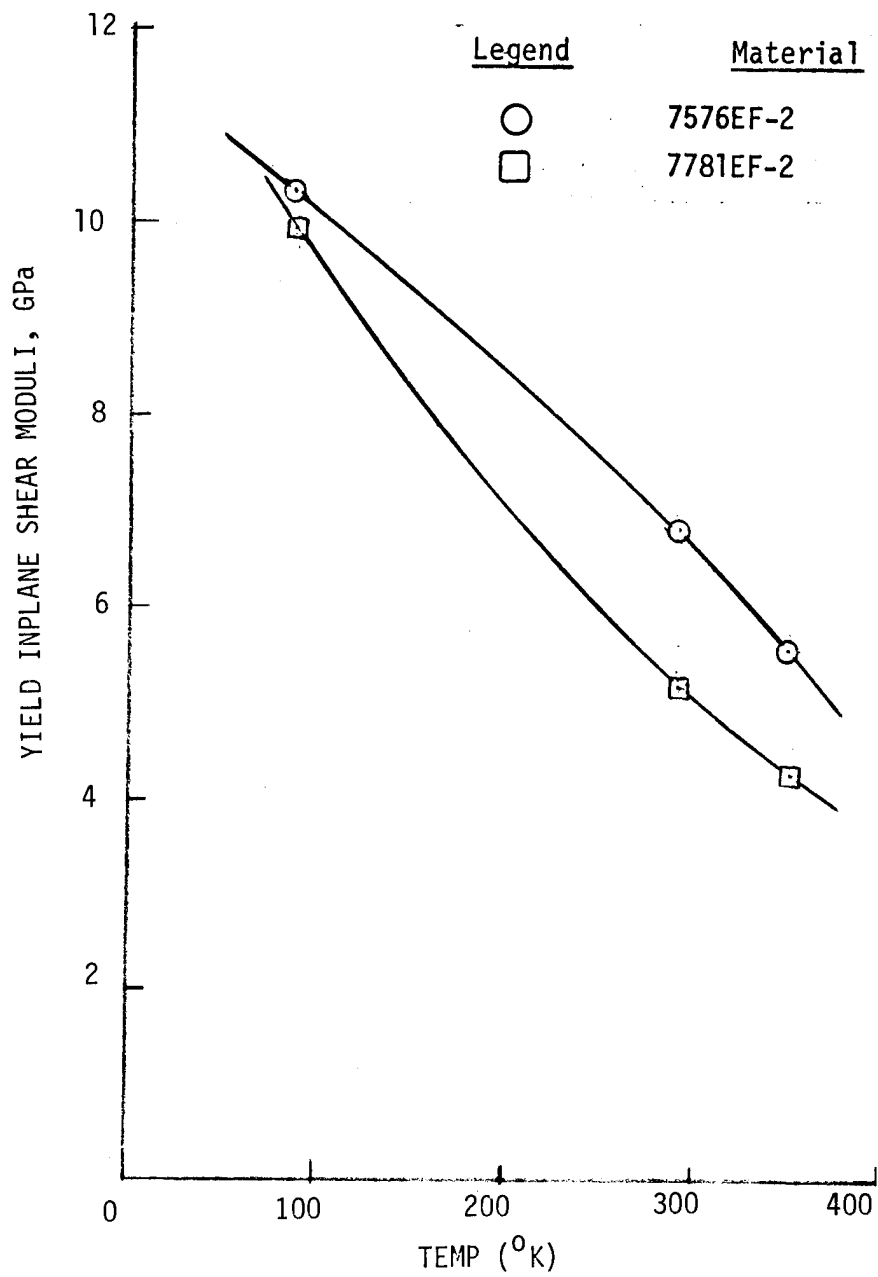


Figure 21.- Inplane yield shear moduli versus temperature for the 7576 EF-2 and 7781 EF-2 NTF fan blade materials.

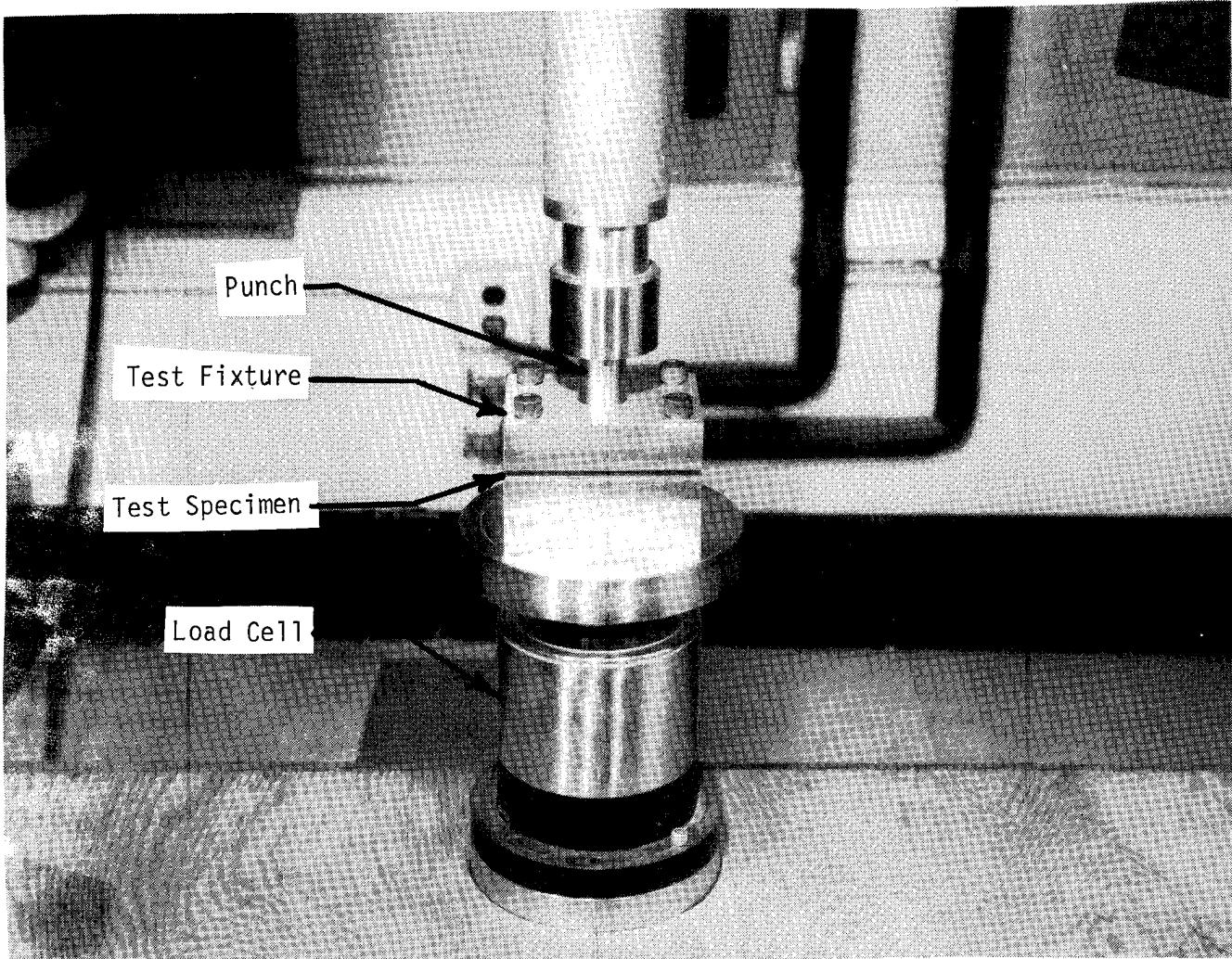


Figure 22.- Punch shear test fixture.

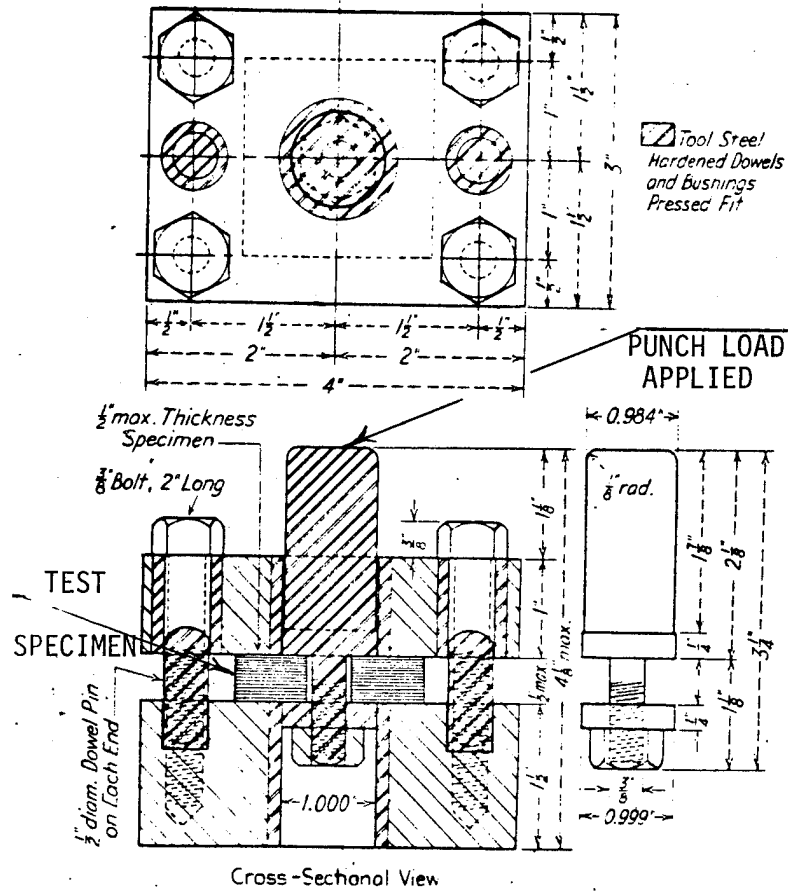


Figure 23.- Punch type shear test fixture.

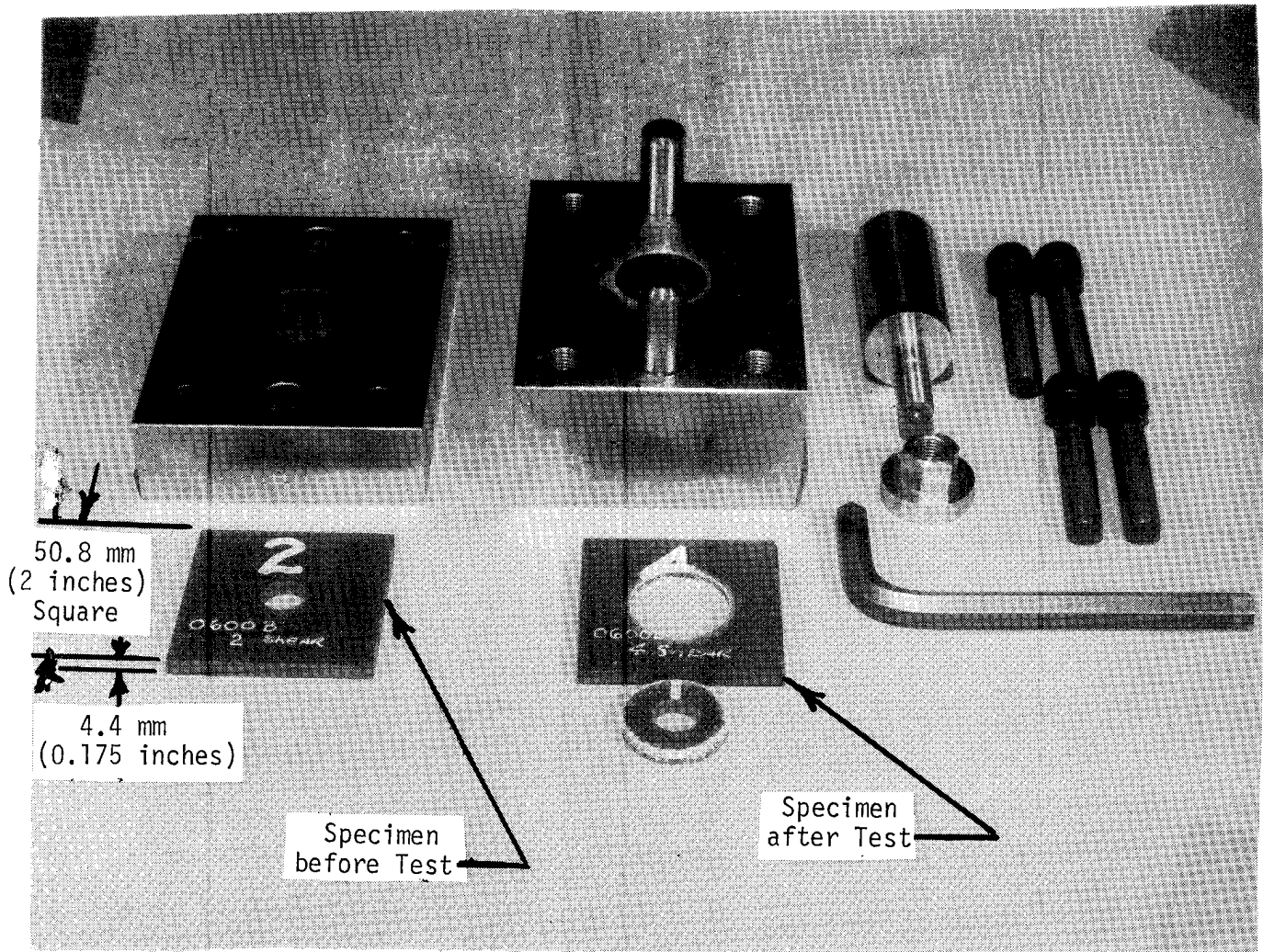


Figure 24.- Punch shear unassembled test fixture and specimens.

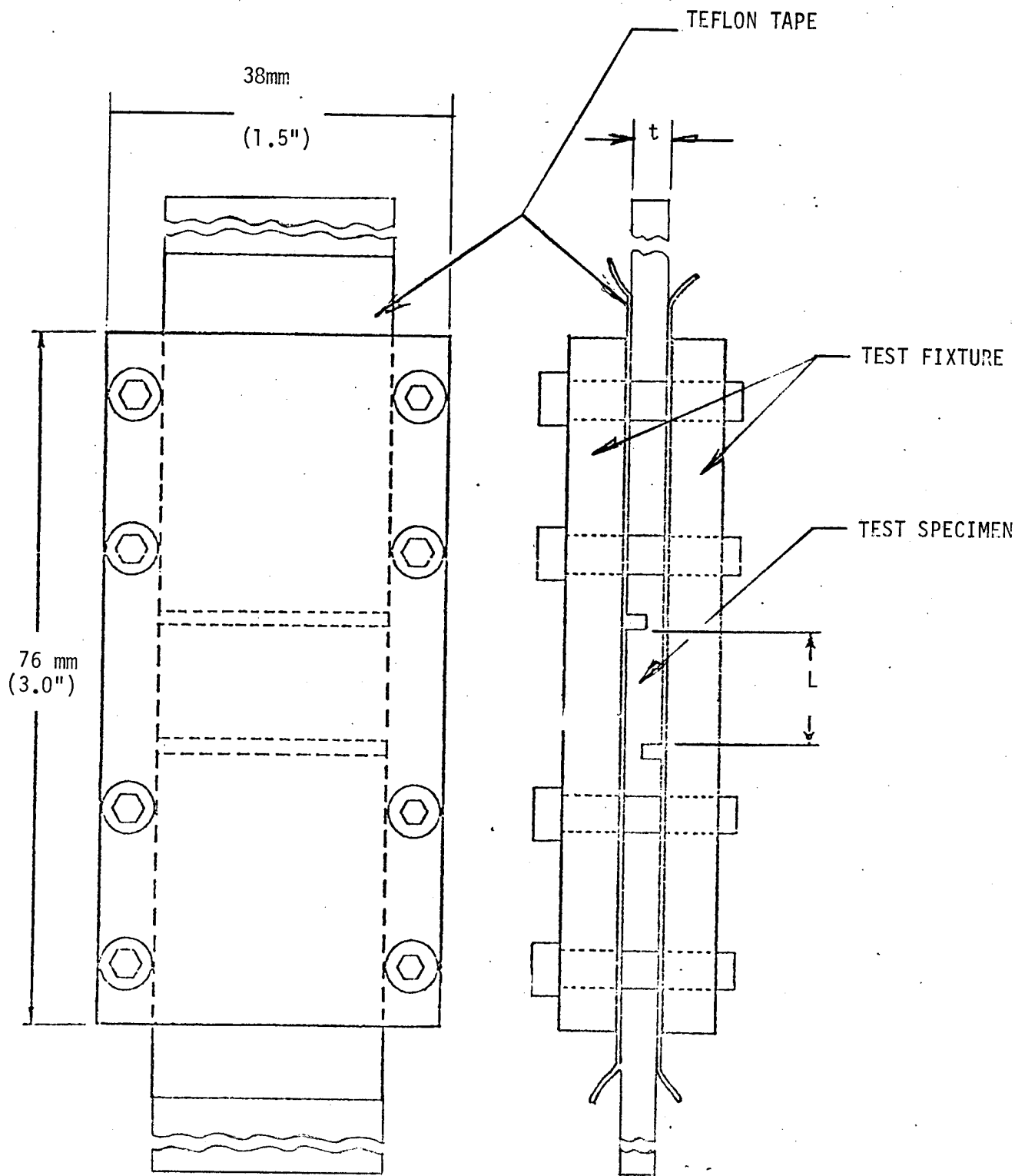


Figure 25.- Interlaminar shear test fixture.

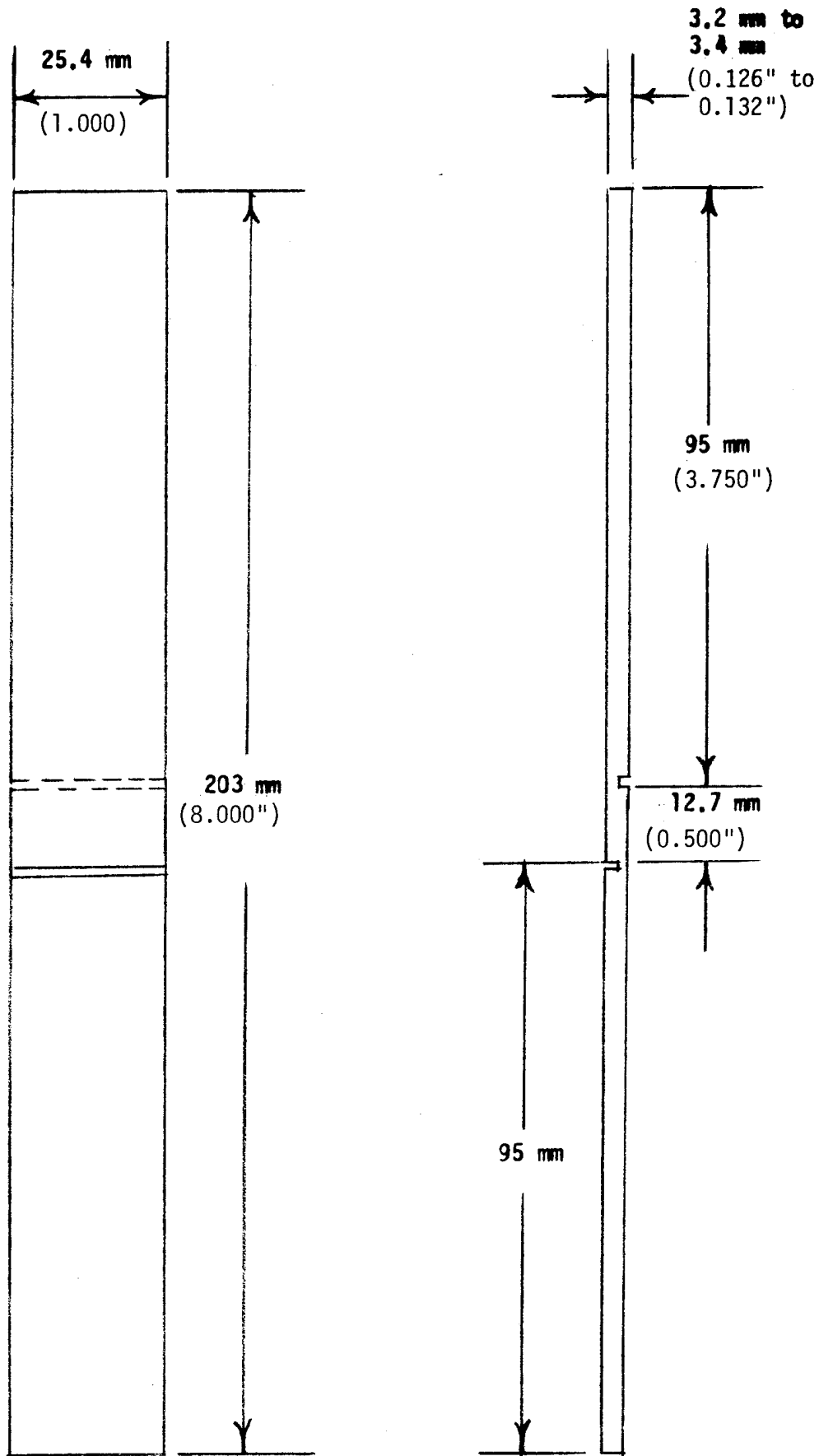


Figure 26.- Typical interlaminar shear test specimen.

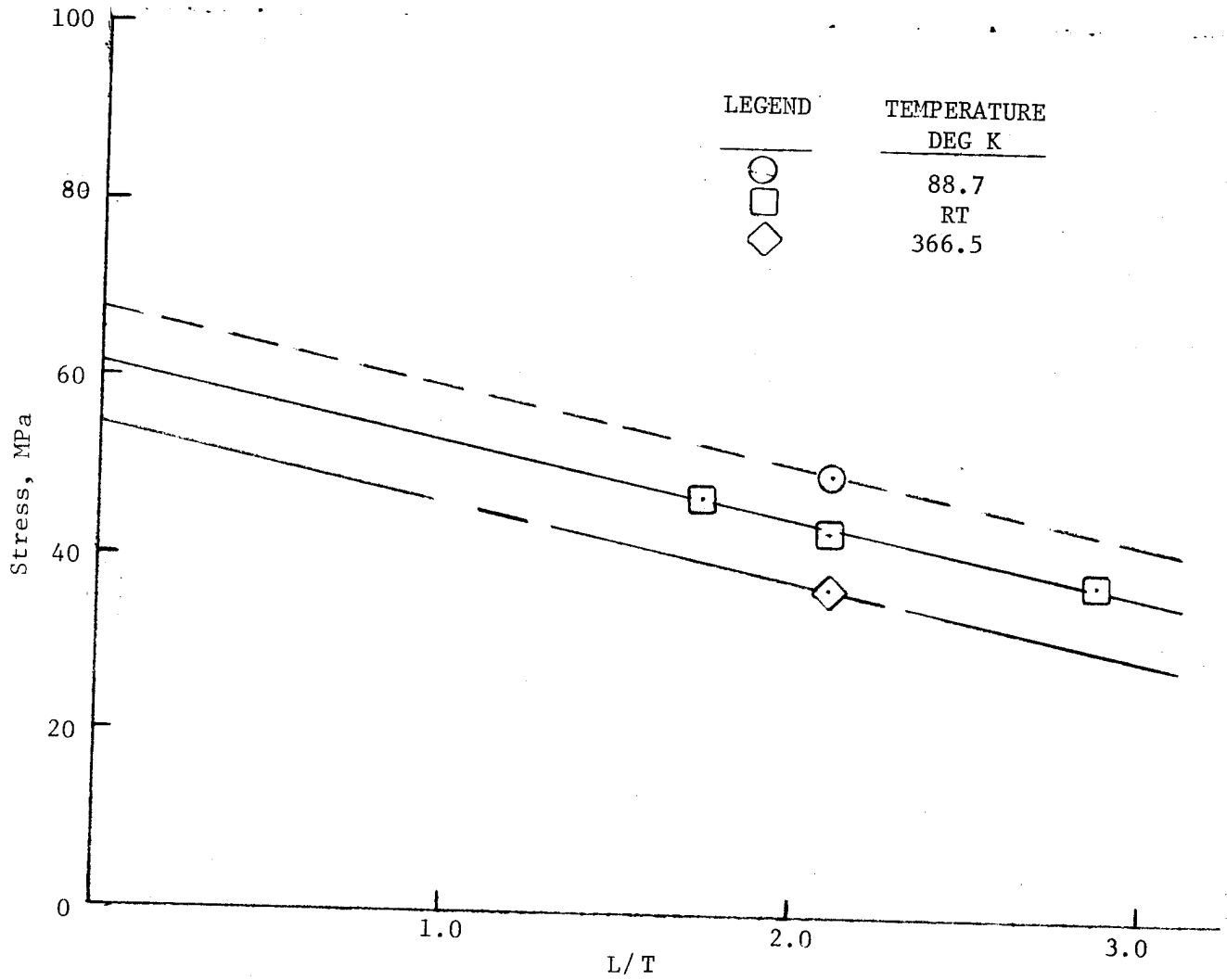
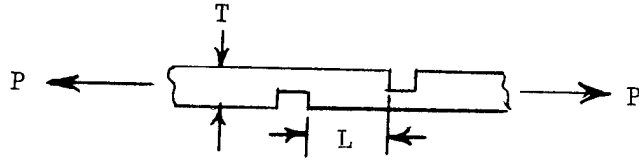


Figure 27.- Interlaminar shear stress versus L/T for the design laminate of 0 radians ply orientation.

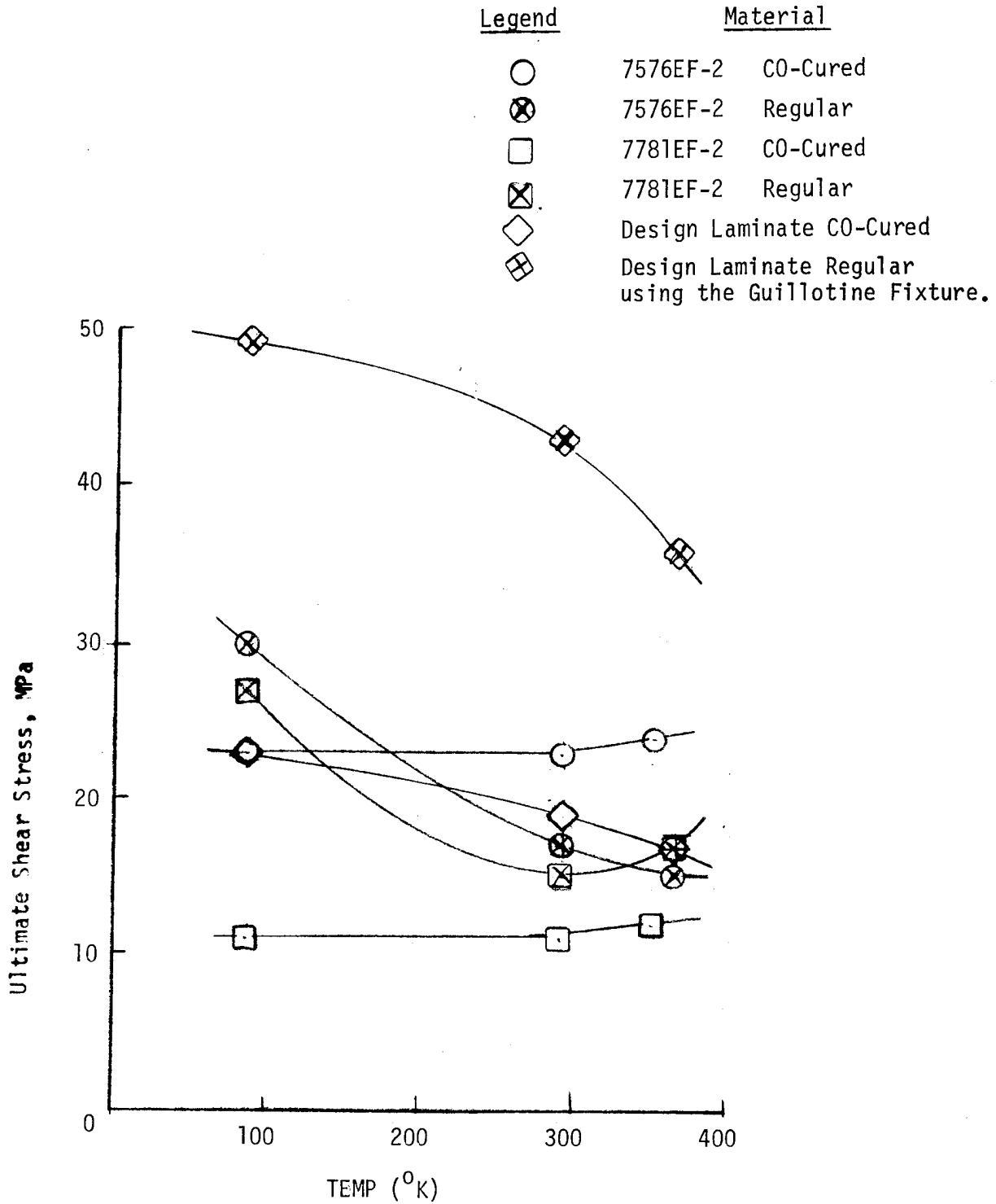


Figure 28.- Interlaminar ultimate shear stress versus temperature for the NTF fan blade materials (regular and co-cured).

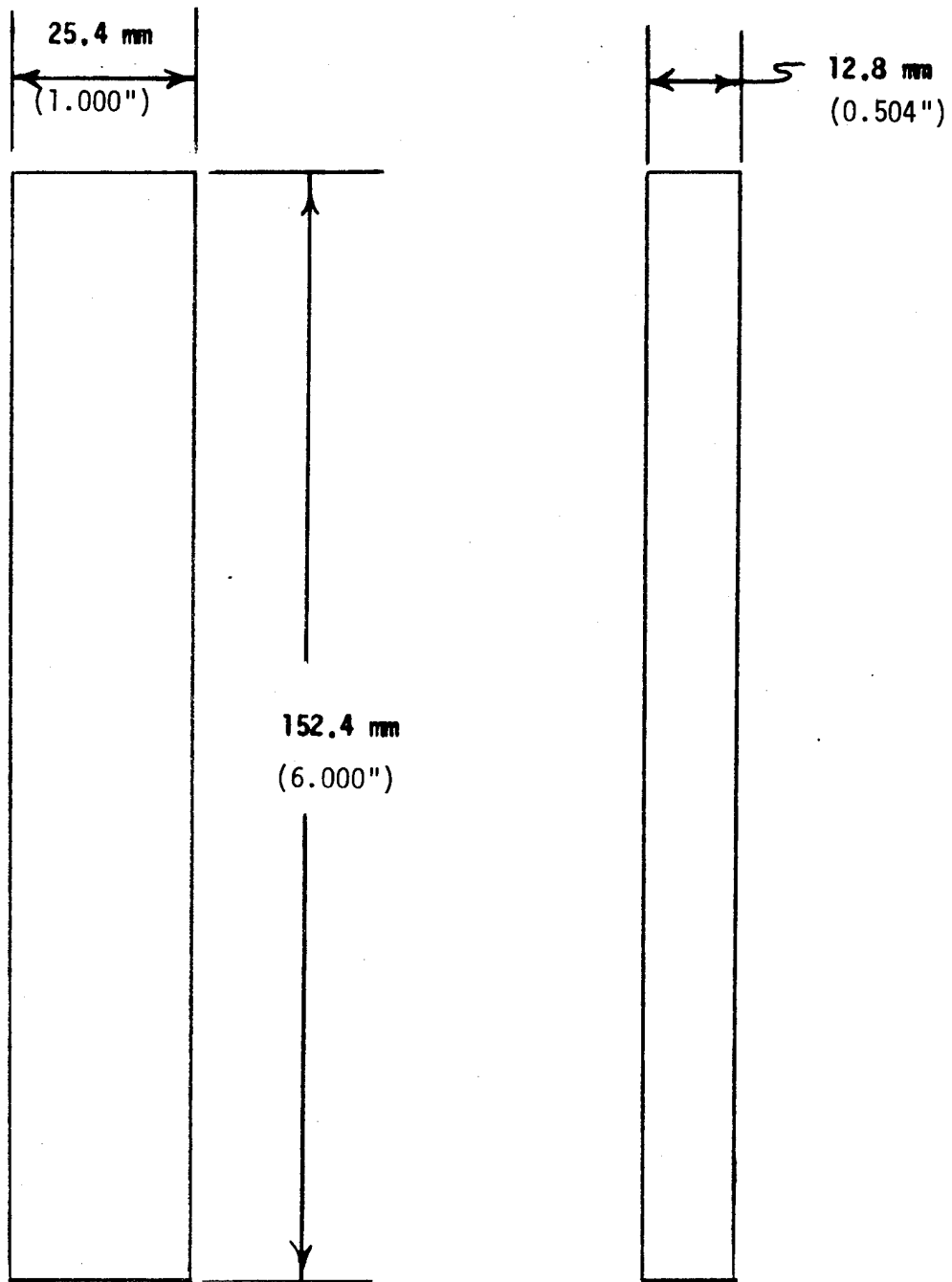


Figure 29.- Typical linear thermal expansion test specimen.

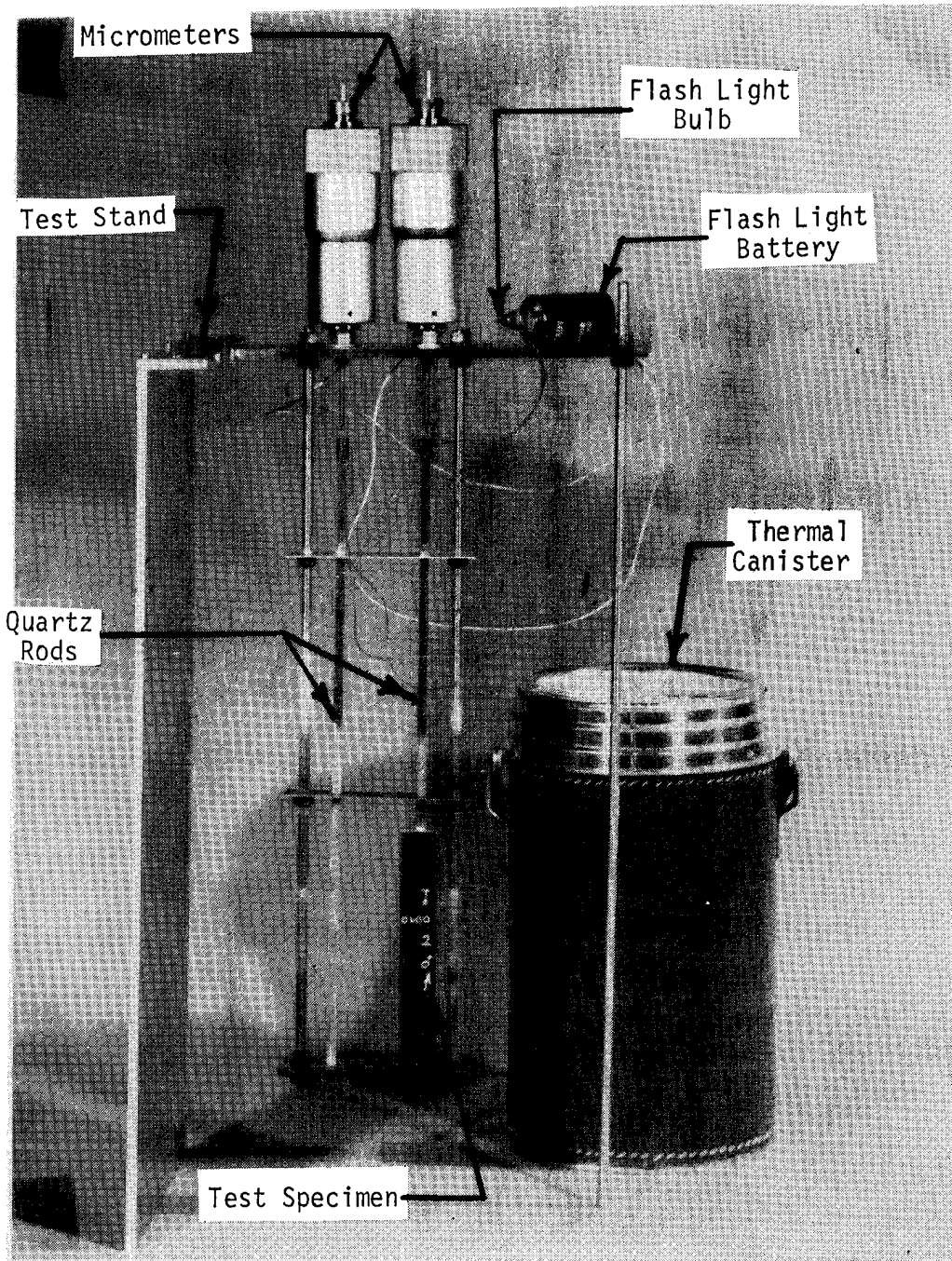


Figure 30.- Thermal expansion test apparatus.

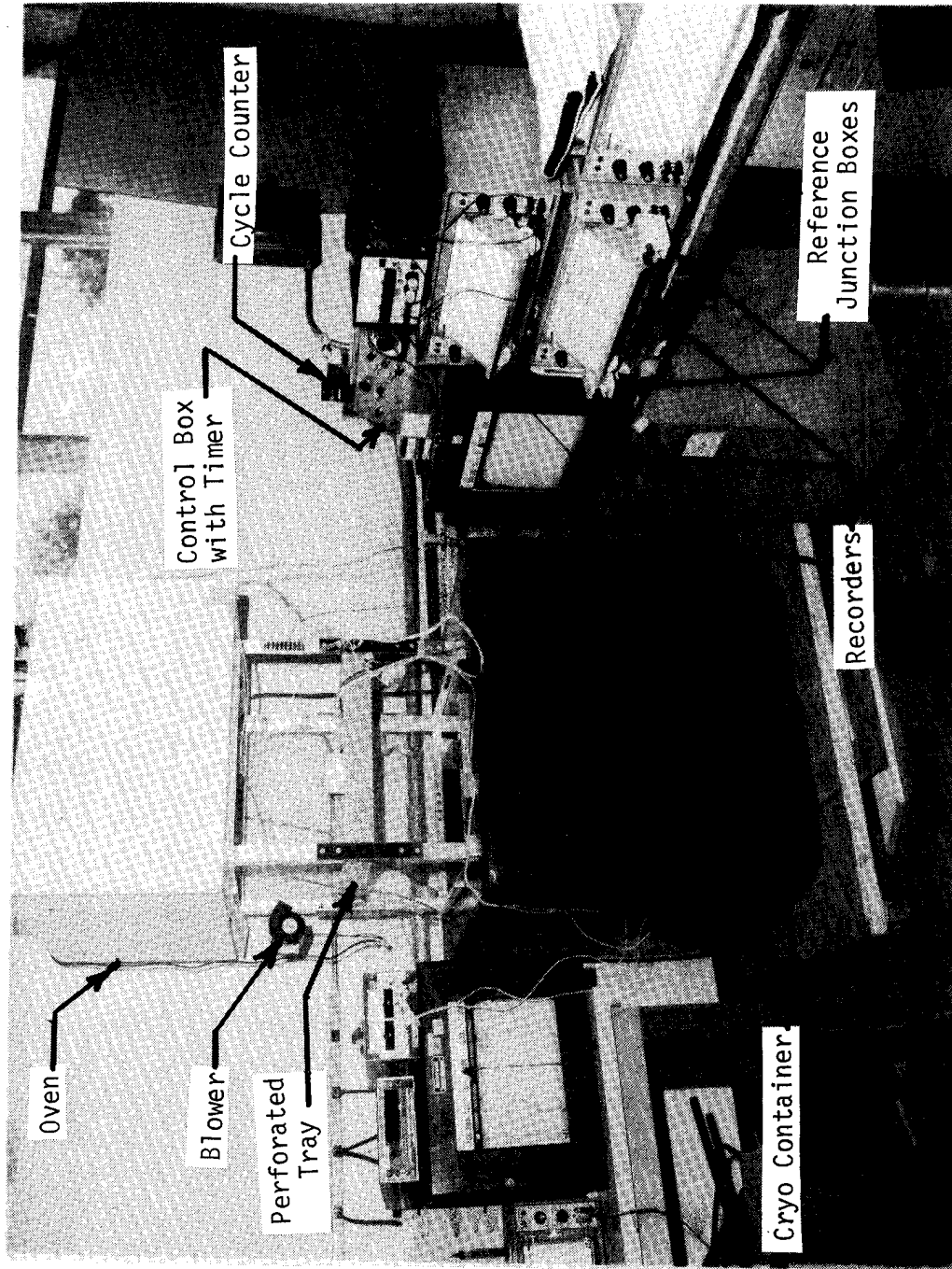


Figure 31.- Thermal cycling test setup.

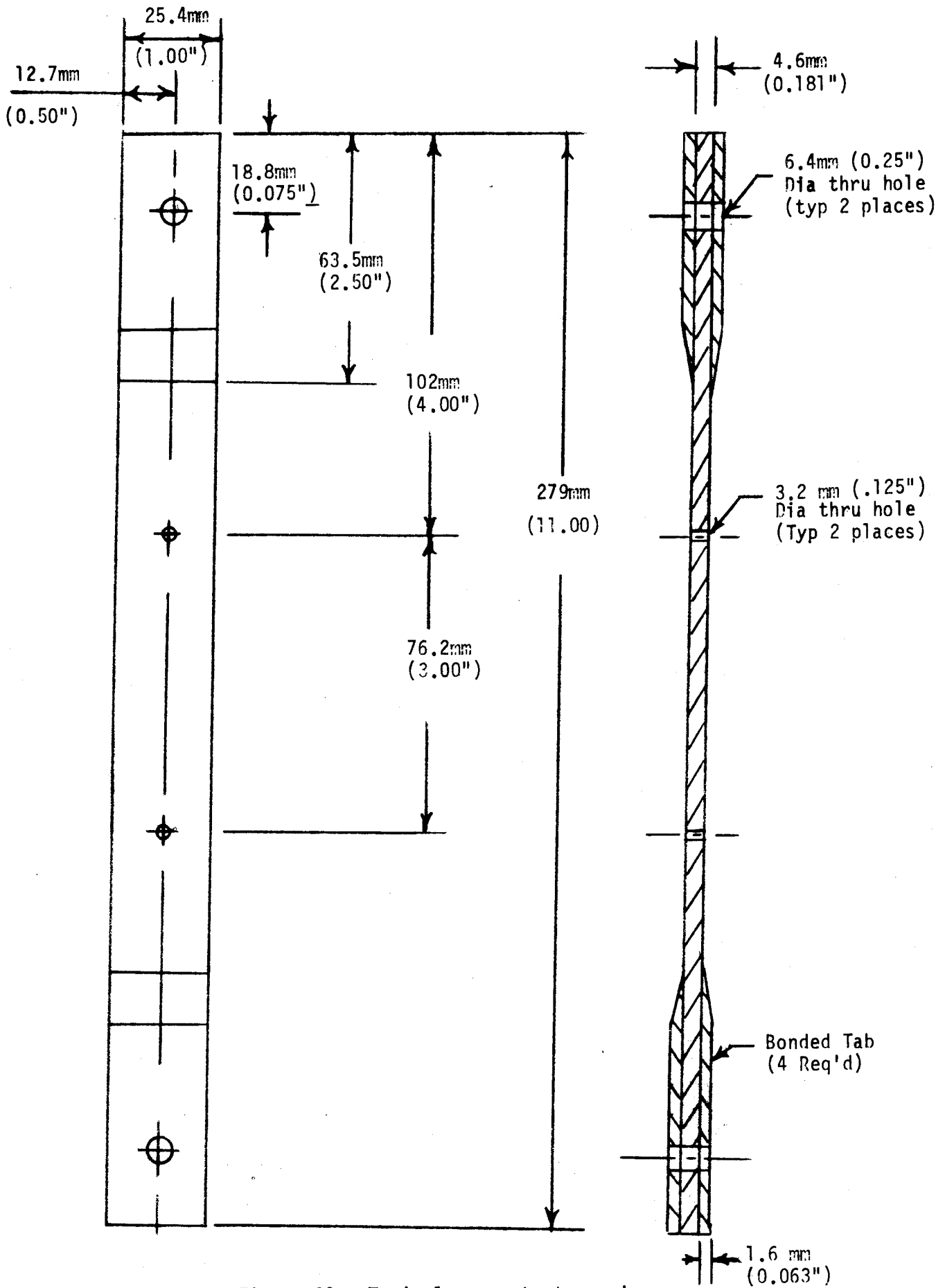


Figure 32.- Typical creep test specimen.

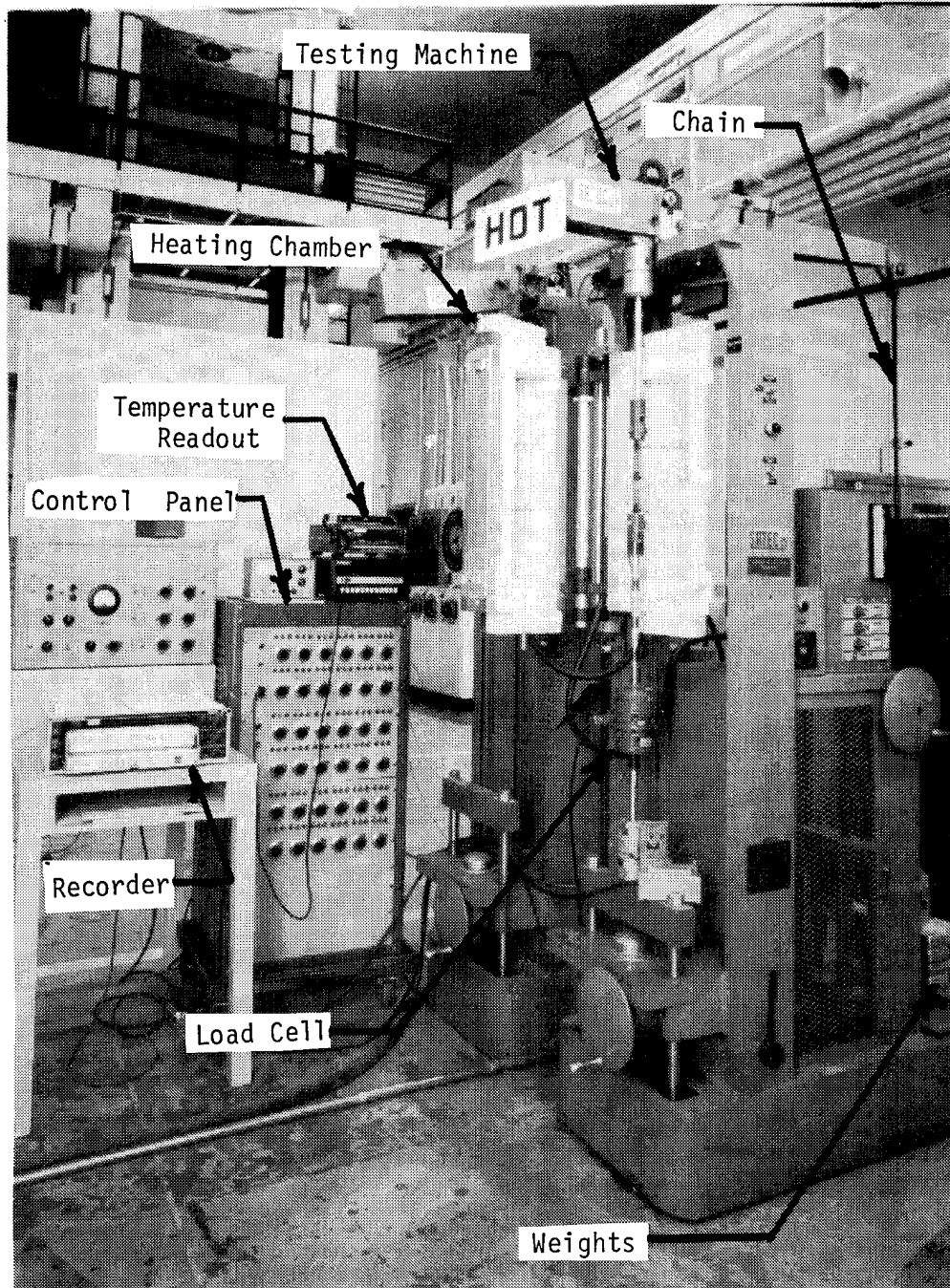


Figure 33.- Creep test setup.

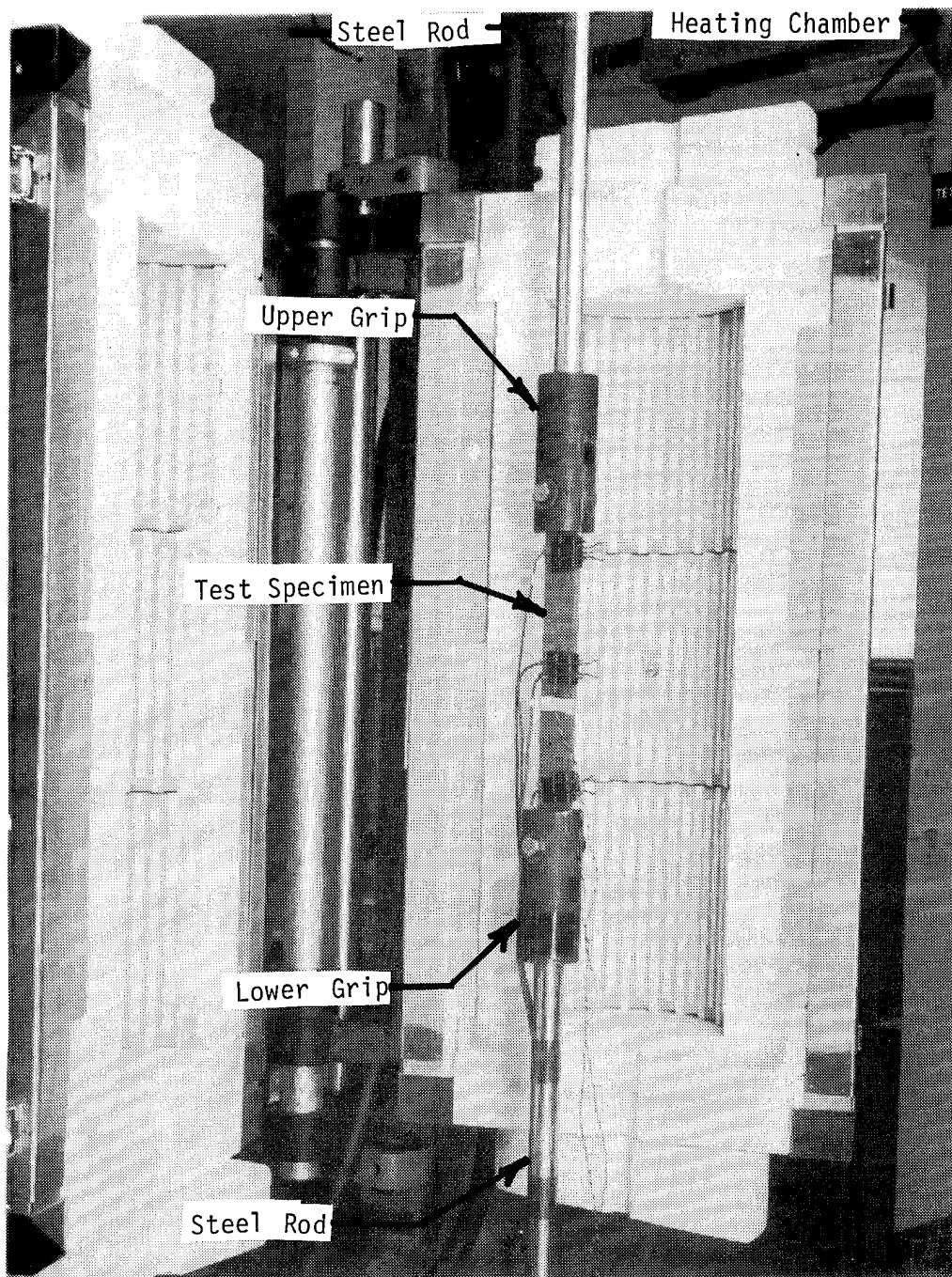


Figure 34.- Creep test specimen installation.

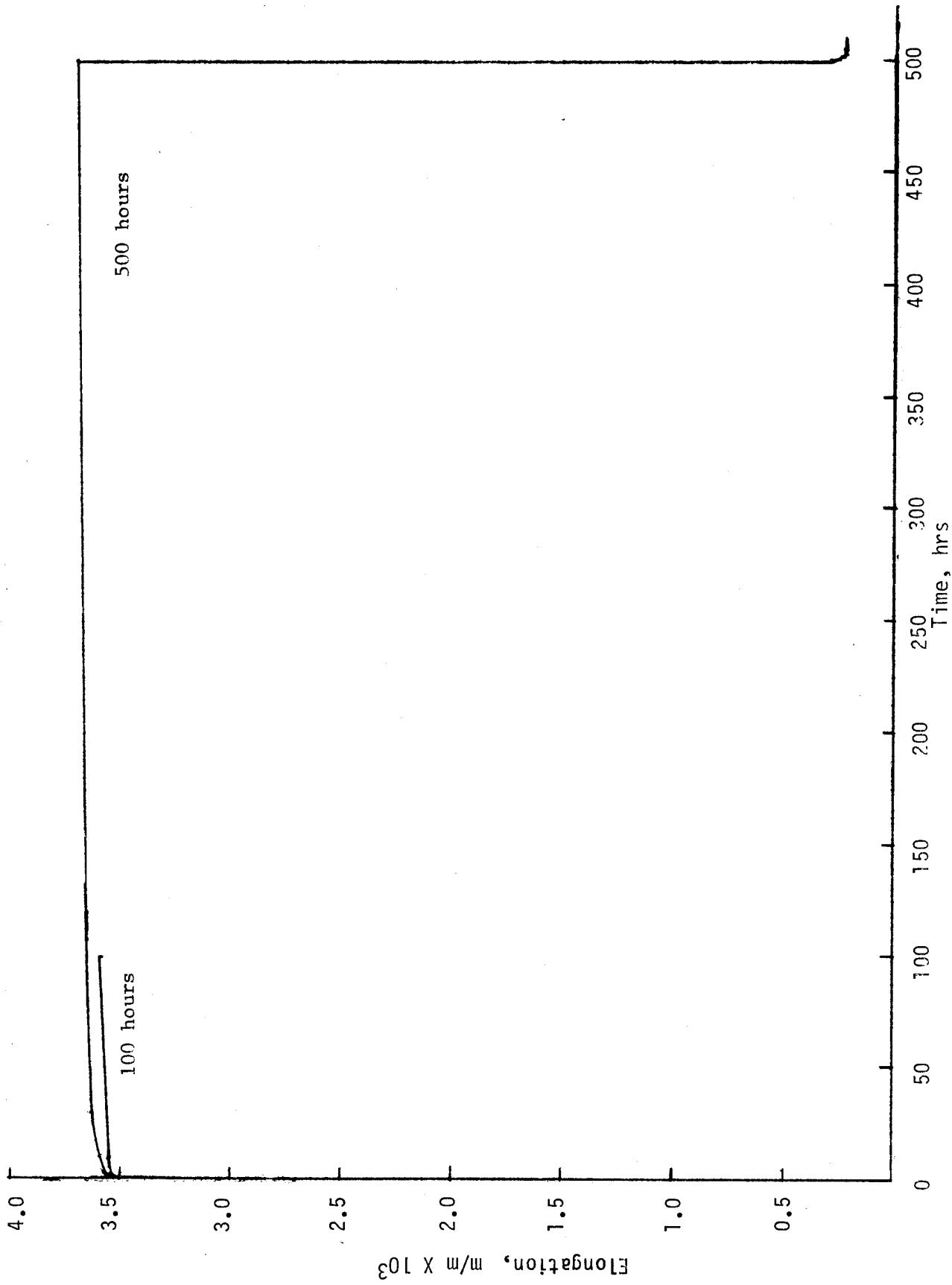


Figure 35.- Elongation versus time for the NTF fan blade design laminate.

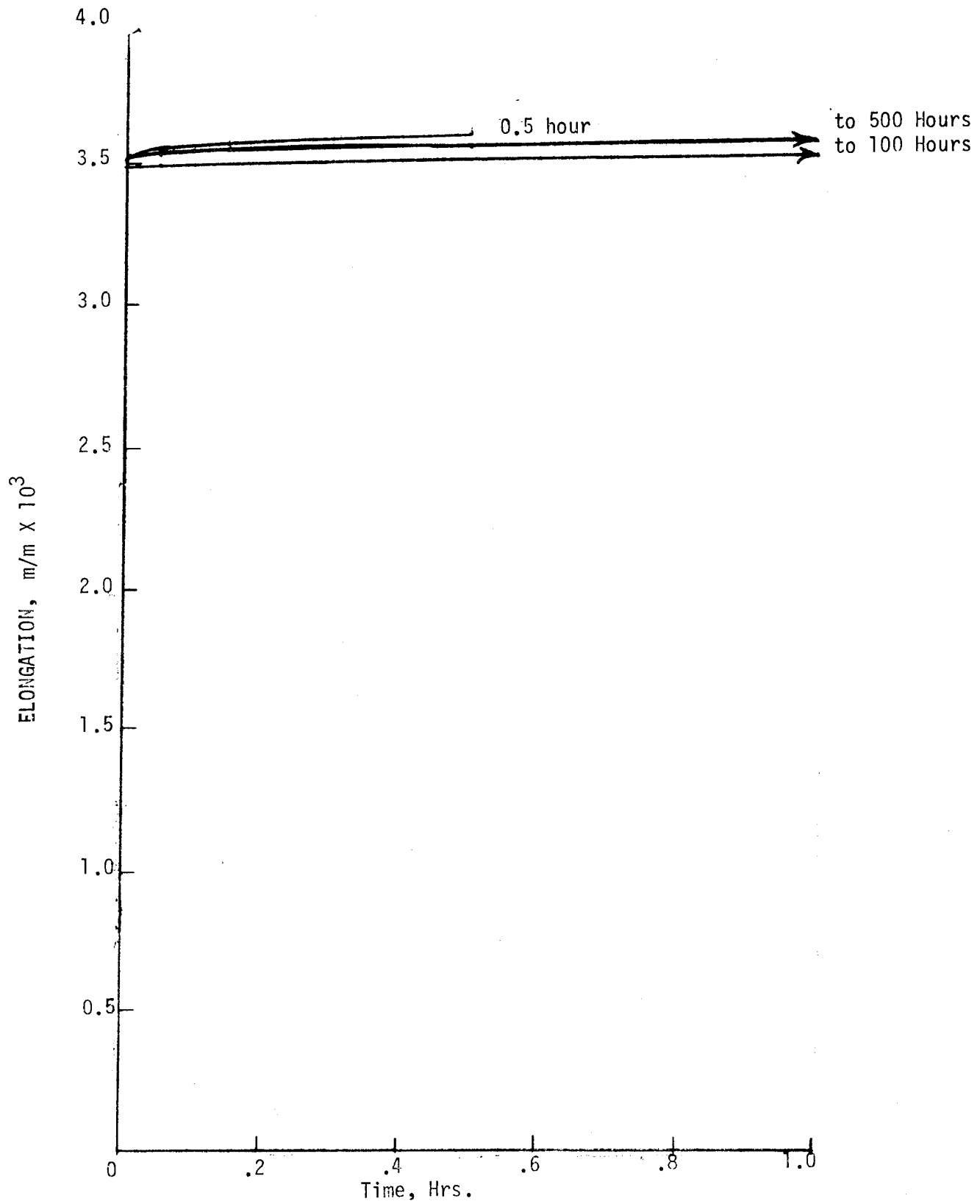


Figure 36.- Elongation versus time for the NTF fan blade design laminate.

1. Report No. NASA TM-81800		2. Government Accession No.		3. Recipient's Catalog No.	
4. Title and Subtitle NATIONAL TRANSONIC FACILITY FAN BLADE PREPREG MATERIAL CHARACTERIZATION TESTS				5. Report Date July 1981	
				6. Performing Organization Code 505-31-63-06	
7. Author(s) P. J. Klich, W. H. Richards, and E. L. Ahl, Jr.				8. Performing Organization Report No.	
				10. Work Unit No.	
9. Performing Organization Name and Address NASA Langley Research Center Hampton, VA 23665				11. Contract or Grant No.	
				13. Type of Report and Period Covered Technical Memorandum	
12. Sponsoring Agency Name and Address National Aeronautics and Space Administration Washington, DC 20546				14. Sponsoring Agency Code	
15. Supplementary Notes					
16. Abstract The test program developed for the basic prepreg materials used in process development work and planned fabrication of the National Transonic Facility Fan Blade is presented. The basic prepreg materials and the design laminate are characterized at 89°K, room temperature and 366°K. A discussion of the characterization tests, test equipment, and test data is presented. Material tests results in the warp direction are given for tensile, compressive, fatigue (tension-tension), interlaminar shear and thermal expansion.					
17. Key Words (Suggested by Author(s)) National Transonic Facility (NTF) Fan Blade Prepreg Characterization Tests Fiberglass GRP			18. Distribution Statement Unclassified - Unlimited Subject Category 09		
19. Security Classif. (of this report) Unclassified		20. Security Classif. (of this page) Unclassified		21. No. of Pages 83	22. Price A05