

ADD 421554

rec'd 9/13/76 MR.

U.S. DEPARTMENT OF COMMERCE  
National Technical Information Service

PB-239 241

DEVELOPMENT DOCUMENT FOR EFFLUENT LIMITATIONS  
GUIDELINES AND NEW SOURCE PERFORMANCE STANDARDS  
FOR THE SYNTHETIC RESINS SEGMENT OF THE PLASTICS  
AND SYNTHETIC MATERIALS MANUFACTURING POINT SOURCE  
CATEGORY

DAVID L. BECKER

ENVIRONMENTAL PROTECTION AGENCY  
WASHINGTON, D.C.

MARCH 1974

DTIC QUALITY INSPECTED 2

CONVERSION STATEMENT A  
Approved for public release,  
Distribution Unlimited

19960314 127

PLASTIC 24520

# DISCLAIMER NOTICE

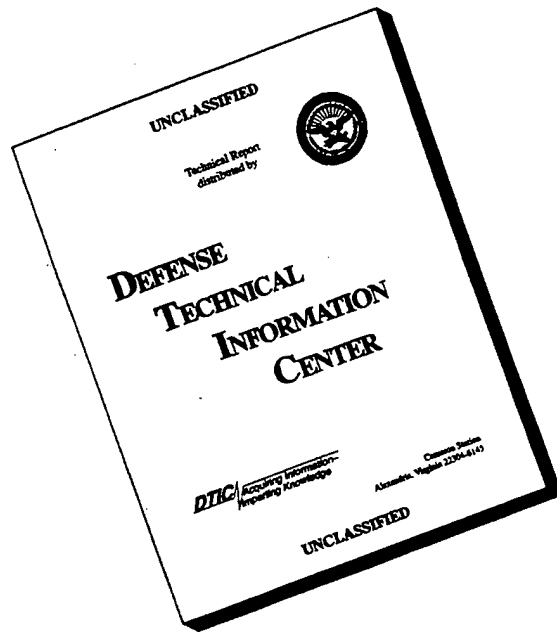

**THIS DOCUMENT IS BEST  
QUALITY AVAILABLE. THE  
COPY FURNISHED TO DTIC  
CONTAINED A SIGNIFICANT  
NUMBER OF PAGES WHICH DO  
NOT REPRODUCE LEGIBLY.**

## KEEP UP TO DATE

Between the time you ordered this report—which is only one of the hundreds of thousands in the NTIS information collection available to you—and the time you are reading this message, several *new* reports relevant to your interests probably have entered the collection.

Subscribe to the **Weekly Government Abstracts** series that will bring you summaries of new reports as *soon as they are received by NTIS* from the originators of the research. The WGA's are an NTIS weekly newsletter service covering the most recent research findings in 25 areas of industrial, technological, and sociological interest—invaluable information for executives and professionals who must keep up to date.

The executive and professional information service provided by NTIS in the **Weekly Government Abstracts** newsletters will give you thorough and comprehensive coverage of government-conducted or sponsored re-

search activities. And you'll get this important information within two weeks of the time it's released by originating agencies.

WGA newsletters are computer produced and electronically photocomposed to slash the time gap between the release of a report and its availability. You can learn about technical innovations immediately—and use them in the most meaningful and productive ways possible for your organization. Please request NTIS-PR-205/PCW for more information.

The weekly newsletter series will keep you current. But *learn what you have missed in the past* by ordering a computer **NTISearch** of all the research reports in your area of interest, dating as far back as 1964, if you wish. Please request NTIS-PR-186/PCN for more information.

WRITE: Managing Editor  
5285 Port Royal Road  
Springfield, VA 22161

## Keep Up To Date With SRIM

SRIM (Selected Research in Microfiche) provides you with regular, automatic distribution of the complete texts of NTIS research reports *only* in the subject areas you select. SRIM covers almost all Government research reports by subject area and/or the originating Federal or local government agency. You may subscribe by any category or subcategory of our WGA (**Weekly Government Abstracts**) or **Government Reports Announcements and Index** categories, or to the reports issued by a particular agency such as the Department of Defense, Federal Energy Administration, or Environmental Protection Agency. Other options that will give you greater selectivity are available on request.

The cost of SRIM service is only 45¢ domestic (60¢ foreign) for each complete

microfiched report. Your SRIM service begins as soon as your order is received and processed and you will receive biweekly shipments thereafter. If you wish, your service will be backdated to furnish you microfiche of reports issued earlier.

Because of contractual arrangements with several Special Technology Groups, not all NTIS reports are distributed in the SRIM program. You will receive a notice in your microfiche shipments identifying the exceptionally priced reports not available through SRIM.

A deposit account with NTIS is required before this service can be initiated. If you have specific questions concerning this service, please call (703) 451-1558, or write NTIS, attention SRIM Product Manager.

This information product distributed by

**NTIS**

U.S. DEPARTMENT OF COMMERCE  
National Technical Information Service  
5285 Port Royal Road  
Springfield, Virginia 22161

**BIBLIOGRAPHIC DATA SHEET**

1. Report No.  
EPA-440/1-74-010-a

2.

**PB 239 241**

4. Title and Subtitle  
Development Document for Effluent Limitations Guidelines and New Source Performance Standards for the Synthetic Resins Segment of the Plastics and Synthetic Materials Manufacturing Point Source Category

5. Report Date  
March 1974

6.

7. Author(s)  
David L. Becker

8. Performing Organization Rept. No.  
EPA-440/-74-010-a

9. Performing Organization Name and Address  
Environmental Protection Agency  
Effluent Guidelines Division  
WSM-E, Rm. 913  
Washington, DC 20460

10. Project/Task/Work Unit No.  
NA

11. Contract/Grant No.  
68-01-1500

12. Sponsoring Organization Name and Address  
Same as Item 9.

13. Type of Report & Period Covered  
Final

14.

15. Supplementary Notes

16. Abstracts This development document presents the findings of an extensive study of the synthetic resin segment of the Plastics and Synthetics Industry for the purposes of developing effluent limitation guidelines, and standards of performance for the industry to implement Sections 304, 306 and 307 of the Federal Water Pollution Control Act of 1972 (PL 92-500). Guidelines and standards were developed for the following major products: ABS/SAN; Acrylics; Cellophane; Cellulose Acetate; High-Density Polyethylene; Low-Density Polyethylene; Nylon 6, Nylon 66; Polyester; Polypropylene; Polystyrene; Polyvinyl Acetate; Polyvinyl Chloride; Rayon.

Effluent limitation guidelines contained herein set forth the degree of reduction of pollutants in effluent that is attainable through the application of best practicable control technology currently available (BPCTCA), and the degree of reduction attainable through the application of best available technology economically achievable (BATEA) by existing point sources for July 1, 1977, and July 1, 1983, respectively. Standards of performance for new sources are based on the application of best available demonstrated

17. Key Words and Document Analysis. 17a. Descriptors technology (BADT).

17b. Identifiers/Open-Ended Terms

**PRICES SUBJECT TO CHANGE**

17c. COSATI Field/Group

18. Availability Statement  
GPO  
Washington, DC

Reproduced by  
**NATIONAL TECHNICAL INFORMATION SERVICE**  
US Department of Commerce  
Springfield, VA. 22151

19. Security Class (This Report)  
UNCLASSIFIED  
20. Security Class (This Page)  
UNCLASSIFIED

21. No. of Pages



DEVELOPMENT DOCUMENT  
for  
EFFLUENT LIMITATIONS GUIDELINES  
and  
NEW SOURCE PERFORMANCE STANDARDS  
for the  
SYNTHETIC RESINS SEGMENT OF THE  
PLASTICS AND SYNTHETIC MATERIALS MANUFACTURING  
POINT SOURCE CATEGORY

Russell E. Train  
Administrator

Roger Strelow  
Acting Assistant Administrator for Air & Water Programs



Allen Cywin  
Director, Effluent Guidelines Division

David L. Becker  
Project Officer

March, 1974

Effluent Guidelines Division  
Office of Air and Water Programs  
U.S. Environmental Protection Agency  
Washington, D.C. 20460

## ABSTRACT

This development document presents the findings of an extensive study of the synthetic resin segment of the Plastics and Synthetics Industry for the purposes of developing effluent limitation guidelines, and standards of performance for the industry to implement Sections 304, 306 and 307 of the Federal Water Pollution Control Act of 1972, (PL 92-500). Guidelines and standards were developed for the following major products:

ABS/SAN	Nylon 66
Acrylics	Polyester
Cellophane	Polypropylene
Cellulose Acetate	Polystyrene
High-Density Polyethylene	Polyvinyl Acetate
Low-Density Polyethylene	Polyvinyl Chloride
Nylon 6	Rayon

Effluent limitation guidelines contained herein set forth the degree of reduction of pollutants in effluents that is attainable through the application of best practicable control technology currently available (BPCTCA), and the degree of reduction attainable through the application of best available technology economically achievable (BATEA) by existing point sources for July 1, 1977, and July 1, 1983, respectively. Standards of performance for new sources are based on the application of best available demonstrated technology (BADT).

Annual costs for this segment of the plastics and synthetics industry for achieving BPCTCA control by 1977 are estimated at \$66,000,000, and costs for attaining BATEA control by 1983 are estimated at \$192,000,000. The cost for BADT for new sources is estimated at \$35,000,000.

Supporting data and rationale for the development of proposed effluent limitation guidelines and standards of performance are contained in this development document.

**Blank Pages**

## CONTENTS

<u>Section</u>		<u>Page</u>
I	Conclusions	1
II	Recommendations	3
III	Introduction	11
	Purpose and Authority	11
	Methodology	12
	General Description of the Industry	13
	Plastics	13
	Synthetic Fibers	16
	Cellophane	18
	Product and Process Technology	18
	Typical Polymerization Products	18
	Emulsion and Suspension Polymerization	18
	Atmospheric or Low-Pressure Mass	22
	Polymerization	
	High-Pressure Mass Polymerization-Low	25
	Density Polyethylene	
	Polyolefins - Solution Polymerization	27
	Polyolefins - Ziegler Process	29
	Polyolefins - Particle Form Process	29
	Polyacetal Resins	31
	Cellophane	33
	Rayon	34
	Polyester Resin and Fiber	39
	Nylon 66 Resin and Fibers	44
	Cellulose Acetate Resin	46
	Cellulose Acetate Fibers	48
	Cellulose Triacetate Fibers	50
	Epoxy Resins	50
	Phenolic Resins	54
	Amino Resins - Urea and Melamine	63
	Acrylic Fibers	70
	Nylon 6 Resins and Fibers	72
IV	Industry Categorization	79
V	Waste Characterization	83
	Raw Waste Loads	83
VI	Selection of Pollutant Parameters	87
	Selection Criteria	87
	Selected Parameters	87
	BOD5	87
	COD	88
	Total Suspended Solids	88

	pH Acidity, and Alkalinity	89
	Zinc	90
	Phenols	91
	Chromium	92
	Nitrogenous Compounds	92
	Dissolved Solids	93
	Toxi and Hazardous Chemicals	94
	Iron, Alluminum, Nickel, Vanadium, Titanium, and Molybdenum	95
	Oil and Grease, Color, Turbidity, Phosphates, Sulfides, Copper, Cadmium, Manganese, Magnesium, Antimony	95
VII	Control and Treatment Technology	97
	Presently Used Wastewater Treatment	97
	Treatment Potentially Usable Wastewater Technology	110
	Adsorption	112
	Suspended Solids Removal	118
	Chemical Precipitation	118
	Anaerobic Process	119
	Air Stripping	119
	Chemical Oxidation	120
	Foam Separation	120
	Algae Systems	120
	Incineration	121
	Liquid-Liquid Extraction	121
	Ion Exchange	122
	Reverse Osmosis	122
	Freeze Thaw	122
	Evaporation	123
	Electrodialysis	123
	In-Plant Control of Waterborne Pollutants	123
	Operational Philosophy	127
	Organization	127
	Specific Measures	127
	Procedures and Operating Methods for Elimination or Reduction of Pollutants	129
VIII	Cost, Energy and Non-Water Quality Aspects	133
	Alternative Treatment Technologies	132
	Costs of Treatment Technology Now in Practice	13 <sup>f</sup>
	Cost of advanced Treatment Technologies	139
	Non-Water Quality Aspects of Alternate Treatment Technologies	143
	Disposal of Solids and Slurries	143
	Generation of Commerically-Valuable By-Products	147
	Disposal of Off-Specification and Scrap Products	152
	Other Non-Water Quality Pollution Problems	152
	Industry Cost Perspectives	152
	Water Effluent Treatment Costs	154

	Industrial Waste Treatment Model Data	157
IX	Best Practicable Control Technology Currently Available Guidelines and Limitations	199
	Definition of Best Practicable Control Technology Currently Available (BPCTCA)	199
	The Guidelines	200
	Attainable Effluent Concentrations	200
	Demonstrated Wastewater Flows	202
	Statistical Variability of a Properly Designed and Operated Waste Treatment Plant	203
X	Best Available Technology Economically Achievable	209
	Definition of Best Available Technology Economically Achievable (BATEA)	209
	The Guidelines	210
	Achievable Effluent Concentrations	210
	Suspended Solids	210
	Oxygen Demanding Substances	210
	Waste Load Reduction Basis	212
	Variability	212
XI	New Source Performance Standards - Best Available Demonstrated Technology	215
	Definition of New Source Performance Standards - Best Available Demonstrated Technology (NSPS-BADT)	215
	The Standards	215
	Achievable Effluent Concentrations	215
	Waste Load Reduction Basis	215
	Variability	215
XII	Acknowledgments	225
XIII	References	227
XIV	Glossary	233

## FIGURES

<u>Number</u>	<u>Title</u>	<u>Page</u>
1	Typical Polymerization Reactions for Polyethylene, Polypropylene, Polyvinyl acetate, Polyvinyl chloride, Polystyrene	19
2	Typical Polymerization Reactions for Polyacrylonitrile and Polybutadiene	20
3	Typical Polymerization Reaction for Polyacetol Resins	21
4	Emulsion Polymerization	23
5	Mass Polymerization	24
6	Low-Density Polyethylene Production - High Pressure Process	26
7	Polyolefin Production - Solution Process	28
8	Polyolefin Production - Ziegler Process	30
9	Polyolefin Production - Particle Form Process	32
10	Cellophane Production	35
11	Viscose Rayon Production	37
12	Typical Polymerization Reaction for Polyester Resins and Fiber	41
13	Polyester Fiber and Resin Production	43
14	Typical Polymerization Reaction for Nylon 66 Resins and Fiber	45
15	Nylon 66 Production	47
16	Cellulose Acetate Resin Production	49
17	Cellulose Acetate Fiber Production	51
18	Reactions Between Epichlorohydrin and Bisphenol A	53
19	Liquid Epoxy Resin Production	55
20	Solid Epoxy Resin Production	56

<u>Number</u>	<u>Title</u>	<u>Page</u>
21	Typical Reaction to Form One-Step Resins or Resols	58
22	Typical Reaction to Form Novolak Resin	60
23	Phenolic Resin Production	61
24	Typical Polymerization Reaction for Urea and Formaldehyde	64
25	Typical Polymerization Reactions for Melamine and Formaldehyde	67
26	Amino Formaldehyde Resin Production	69
27	Acrylic Fiber Production - Wet Spinning	72
28	Acrylic Fiber Production - Dry Spinning	75
29	Typical Polymerization Reactions to Form Nylon 6 Resin and Fiber	76
30	Nylon 6 Production	77
31	BOD Removal as Function of Total System Residence Time	101
32	COD Removal as Function of Total System Residence Time	103
33	Biological Treatment in Plastics and Synthetics Industry - Capital Costs	137
34	Biological Treatment in the Plastics and Synthetics Industry - Operating Costs	138
35	Biological Treatment in the Plastics and Synthetics Industry - Energy Requirements - Initial Treatment	140
36	Biological Treatment in the Plastics and Synthetics Industry - Energy Requirements - Aeration and Sludge Handling Equipment	141
37	Granular Media Filtration for the Plastics and Synthetics Industry - Capital Investment	142
38	Activated Carbon Adsorption for the Plastics and Synthetics Industry - Capital Investment	144
39	Activated Carbon Adsorption for the Plastics and Synthetics Industry - Operating Costs	145
40	Net Cost of Recovering Dilute Wash Solutions	148



TABLES

<u>Number</u>	<u>Title</u>	<u>Page</u>
1	Best Practicable Control Technology Currently Available Effluent Limitation Guidelines	5
2	Best Practicable Control Technology Currently Available Effluent Guidelines for Other Elements	6
3	Best Available Technology Economically Achievable Effluent Limitation Guidelines	7
4	Best Available Technology Economically Achievable Effluent Guidelines for Other Elements or Compounds	8
5	Best Available Demonstrated Technology for New Sources Performance Standards	9
6	Best Available Demonstrated Technology for New Source Performance Standards for Other Elements or Compounds	10
7	1972 Consumption of Plastics and Synthetics	15
8	Major Resin Producers	16
9	Synthetic Fiber Producers	17
10	Capacity	17
11	Markets for Amino Resins	66
12	Performance of Observed Waste Water Treatment Plants	81
13	Industry Subcategorization	82
14	Wastewater Loading for the Plastics and Synthetics Industry	84
15	Plastics and Synthetics Industry Raw Waste Loads	85
16	Other Elements, Compounds and Parameters	86
17	Other Elements and Compounds Specific to Plastics and Synthetics Products	96
18	Performance of Observed Waste Water Treatment Plants	99
19	Operational Parameters of Wastewater Treatment Plants (Metric Units)	105

<u>Number</u>	<u>Title</u>	<u>Page</u>
20	Operational Parameters of Wastewater Treatment Plants (English Units)	106
21	Observed Treatment and Average Effluent Loading From Plant Inspections	111
22	Summary of Industrial Sources Using Granular Activated Carbon Systems	113
22a	Summary of EPA Research Development and Demonstration projects utilizing Activated Carbon Technology	114-117
23	Matrix for Evaluating Liquid Handling Facilities	125
24	Perspectives on the Plastics and Synthetics Industry - Water Usage	134
25	Typical Stream Compositions	150
26	By-Product Credit Value for Break-Even Stream	150
27	Operating Cost Per 1000 lbs (4536 kg) H2O Recycled	151
28	Perspectives on the Plastics and Synthetics Industry - Treatment Costs	155
29	Perspectives on the Plastics and Synthetics Industry - Cost Impact	156
30	Summary of Water Effluent Treatment Costs for Representative Plants in the Plastics and Synthetics Industry	158-159
30-1	Water Effluent Treatment Cost - Plastics and Synthetics Industry - Epoxies (small)	160
30-2	Water Effluent Treatment Costs - Plastics and Synthetics Industry - Epoxies (large)	161
30-3	Water Effluent Treatment Costs - Plastics and Synthetics Industry - Melamine (Small)	162
30-4	Water Effluent Treatment Costs - Plastics and Synthetics Industry - Melamine (large)	163
30-5	Water Effluent Treatment Costs - Plastics and Synthetics Industry - Urea (small)	164
30-6	Water Effluent Treatment Costs Plastics and Synthetics Industry - Urea (large)	165
30-7	Water Effluent Treatment costs - Plastics and Synthetics Industry - Phenolics (small)	166

<u>Number</u>	<u>Title</u>	<u>Page</u>
30-8	Water Effluent Treatment Costs - Plastics and Synthetics Industry - Phenolics (large)	167
30-9	Water Effluent Treatment Costs - Plastics and Synthetics Industry - Polyvinyl Chloride (small)	163
30-10	Water Effluent Treatment Costs - Plastics and Synthetics Industry - Polyvinyl Chloride (large)	169
30-11	Water Effluent Treatment Costs - Plastics and Synthetics Industry - ABS/SAN (small)	170
30-12	Water Effluent Treatment Costs - Plastics and Synthetics Industry - ABS/SAN (large)	171
30-13	Water Effluent Treatment Costs - Plastics and Synthetics Industry - Polystyrene (small)	172
30-14	Water Effluent Treatment Costs - Plastics and Synthetics Industry - Polystyrene (large)	173
30-15	Water Effluent Treatment Costs - Plastics and Synthetics Industry - Polyvinyl Acetate (large)	174
30-16	Water Effluent Treatment Costs - Plastics and Synthetics Industry - Polyvinyl Acetate (large)	175
30-17	Water Effluent Treatment Costs - Plastics and Synthetics Industry - Low Density Polyethylene (small)	176
30-18	Water Effluent Treatment Costs - Plastics and Synthetics Industry - Low Density Polyethylene (large)	177
30-19	Water Effluent Treatment Costs - Plastics and Synthetics Industry - High Density Polyethylene (small)	178
30-20	Water Effluent Treatment Costs - Plastics and Synthetics Industry - High Density Polyethylene (large)	179
30-21	Water Effluent Treatment Costs - Plastics and Synthetics Industry - Polypropylene (small)	180
30-22	Water Effluent Treatment Costs - Plastics and Synthetics Industry - Polypropylene (large)	181

<u>Number</u>	<u>Title</u>	<u>Page</u>
30-23	Water Effluent Treatment Costs - Plastics and Synthetics Industry - Acrylics (small)	182
30-24	Water Effluent Treatment Costs - Plastics and Synthetics Industry - Acrylics (medium)	183
30-25	Water Effluent Treatment Costs - Plastics and Synthetics Industry - Acrylics (large)	184
30-26	Water Effluent Treatment Costs - Plastics and Synthetics Industry - Polyester (small)	185
30-27	Water Effluent Treatment Costs - Plastics and Synthetics Industry - Polyester (large)	186
30-28	Water Effluent Treatment Costs - Plastics and Synthetics Industry - Nylon 6 (small)	187
30-29	Water Effluent Treatment Costs - Plastics and Synthetics Industry - Nylon 6 (large)	188
30-30	Water Effluent Treatment Costs - Plastics and Synthetics Industry - Nylon 66 (small)	189
30-31	Water Effluent Treatment Costs - Plastics and Synthetics Industry - Nylon 66 (large)	190
30-32	Water Effluent Treatment Costs - Plastics and Synthetics Industry - Cellophane	191
30-33	Water Effluent Treatment Costs - Plastics and Synthetics Industry - Cellulose Acetate	192
30-34	Water Effluent Treatment Costs - Plastics and Synthetics Industry - Rayon	193
31	Industrial Waste Treatment Model Data - Plastics and Synthetics Industry (Product Group #1)	194
32	Industrial Waste Treatment Model Data - Plastics and Synthetics Industry (Product Group #2)	195
33	Industrial Waste Treatment Model Data - Plastics and Synthetics Industry (Product Group #3)	196
34	Industrial Waste Treatment Model Data - Plastics and Synthetics Industry (Product Group #4)	197

<u>Number</u>	<u>Title</u>	<u>Page</u>
35	Industrial Waste Treatment Model Data - Plastics and Synthetics Industry (Product Group #5)	198
36	COD/BOD Ratios in Effluent Streams	201
37	COD/BOD Guidelines Basis	202
38	Demonstrated Wastewater Flows	204
39	Demonstrated Variability	205
40	Variability Factor	206
40A	Suspended Solids Removal	207
40B	Variability Factors BATEA	212
40C	Lowest Demonstrated Wastewater Flows	216
41	Best Practicable Control Technology Currently Available Effluent Limitation Guidelines	218
42	Best Practicable Control Technology Currently Available Effluent Guidelines for other Elements	219
43	Best Available Technology Economically Achievable Effluent Limitation Guidelines	220
44	Best Available Technology Economically Achievable Effluent Guidelines for Other Elements or Compounds	221
45	Best Available Demonstrated Technology for New Source Performance Standards	222
46	Best Available Demonstrated Technology for New Source Performance Standards for Other Elements or Compounds	223
47	Metric Units Conversion Table	238

## SECTION I

### CONCLUSIONS

In this survey of the plastics and synthetics industry, approximately 280 company operations are involved in the seventeen larger-volume product subcategories. The 1972 production for these products was estimated at 12 million kkg (26 billion pounds) per year. The 1972 water usage was estimated to be 1035 thousand cubic meters per day (275 MGD). Water usage (at current hydraulic loads) was projected to increase at 6.7 percent per year through 1977, while production was projected to increase at 10 percent per year in the same period.

For the purpose of setting effluent limitations guidelines and standards of performance, the industry parameters giving the most effective categorization were found to be waste water characteristics, specifically:

Raw waste load, with a BOD<sub>5</sub> value of more than or less than 10 kg/kkg of product separating high and low waste load subcategories; and attainable BOD<sub>5</sub> concentrations as demonstrated by plastics and synthetics plants using technologies which are defined herein as the basis for BPCTCA. Three groupings were defined with average effluent concentrations under 20 mg/l (low attainable BOD<sub>5</sub> concentration), from 30 to 75 mg/l (medium attainable BOD<sub>5</sub> concentration), and over 75 mg/l (high attainable BOD<sub>5</sub> concentration).

Based on these two dimensions of categorization, four major subcategories were defined:

Major Subcategory I - low waste load, low attainable BOD<sub>5</sub> concentration (5 products: polyvinyl chloride, polyvinyl acetate, polystyrene, polyethylene, and polypropylene).

Major Subcategory II - high waste load, low attainable BOD<sub>5</sub> concentration (3 products: ABS/SAN, cellophane, and rayon).

Major Subcategory III - high waste load, medium attainable BOD<sub>5</sub> concentration treatability (4 products: polyesters, Nylon 66, Nylon 6 and cellulose acetates).

Major Subcategory IV - high waste load, low treatability (1 product: acrylics).

Additional subcategorization within the above four major subcategories was necessary to account for the waste water generation which is specific to the individual products and their various processing methods. The separation of each individual product into separate subcategories simplifies the application of the effluent limitation guidelines and standards of performance

by providing clear and unambiguous direction as to the proper standard applicable to that product. The substantial advantage of clarity appears to outweigh any technical advantages of product grouping. Hence, for these reasons the individual product subcategories are used for the application of effluent limitation guidelines and standards of performance in this category.

Annual costs of treatment for this segment of the plastics and synthetics industry in 1972 were roughly estimated at \$25 million. By 1977, under BPCTCA guidelines, these same plants in seventeen product subcategories were estimated to expect annual costs for pollution control of \$66 million - an increase of 21 percent per year. By 1983, under BATEA guidelines, existing plants would be expected to have annual costs for pollution control of \$192 million - an increase of 19 percent per year between 1977 and 1983. By 1977, under BADT-NSPS and estimated product growth, the annual costs for new plants is estimated at \$35 million. The estimated average costs of treatment over the industry for BPCTCA, BATEA, and BADT-NSPS technologies respectively were: \$0.19 (\$0.73), \$0.56 (\$2.11), and \$0.27 (\$1.02) per cubic meter (per thousand gallons).

On average for BPCTCA the costs for the smaller plants with higher water usage were 3.5 times higher than the larger plant in each subcategory. The average range for the smaller plants was 0.7 percent to 2.8 percent of sales price. On average for BATEA the costs for the smaller plants with higher water usage were 3.9 times higher than the larger plants in the industry. The average range of costs for applying BATEA to existing plants was 2.1 to 8.1 percent of sales price. The cost of NSPS was estimated at 0.9 percent of sales price over the broad industry.

## SECTION II

### RECOMMENDATIONS

BOD<sub>5</sub>, COD and suspended solids are the critical constituents requiring guidelines and standards. Other constituents are even more specific to the product subcategory, and are summarized below.

Subcategory	Other Element or Compound
ABS/SAN	Iron Aluminum Nickel Total Chromium Organic Nitrogen
POLYSTYRENE	Iron Aluminum Nickel Total Chromium
POLYPROPYLENE	Vanadium Titanium Aluminum
HI-DENSITY POLYETHYLENE	Titanium Aluminum Vanadium Molybdenum Total Chromium
CELLOPHANE	Dissolved Solids
RAYON	Zinc Dissolved Solids
NYLON 6 and 66	Organic Nitrogen
ACRYLICS	Phenolic Compounds

Effluent limitations guidelines and standards of performance are proposed for total chromium, phenolic compounds, and zinc for the specified product. The additional pollutant parameters of dissolved solids, organic nitrogen, iron, nickel, aluminum, vanadium, titanium and molybdenum were selected because they are known to be used in the processes or to occur in the waste waters of specific product subcategories. However, insufficient data was available on raw waste loads or treated waste waters to permit proposing guidelines and standards at this time. In most cases where metals are used, biological treatment systems reduce or remove them to low concentration levels. Receiving water quality standards should determine if limitations are necessary.

Best practicable control technology currently available (BPCTCA) for existing point sources is based on the application of end-of-pipe technology such as biological treatment for BOD reduction as typified by activated sludge, aerated lagoons, trickling filters, aerobic-anaerobic lagoons, etc., with appropriate preliminary treatment typified by equalization, to dampen shock loadings, settling, clarification, and chemical treatment, for removal of suspended solids, oils, other elements, and pH control, and sub-



sequent treatment typified by clarification and polishing processes for additional BOD and suspended solids removal and dephenolizing units for phenolic compound removal when needed. Application of in-plant technology and changes which may be helpful in meeting BPCTCA include segregation of contact process waste from noncontact waste waters, elimination of once through barometric condensers, control of leaks, and good housekeeping practices.

Best available technology economically achievable (BATEA) for existing point sources is based on the best in-plant practices of the industry which minimize the volume of waste generating water as typified by segregation of contact process waters from noncontact waste water, maximum waste water recycle and reuse, elimination of once through barometric condensers, control of leaks, good housekeeping practices, and end-of-pipe technology, for the further removal of suspended solids and other elements typified by media filtration, chemical treatment, etc., and further COD removal as typified by the application of adsorption processes such as activated carbon and adsorptive flocs, and incineration for the treatment of highly concentrated small volume wastes and additional biological treatment for further BOD<sub>5</sub> removal when needed.

Best available demonstrated technology (BADT) for new source performance standards (NSPS) are based on BPCTCA and the maximum possible reduction of process waste water generation and the application of media filtration and chemical treatment for additional suspended solids and other element removal and additional biological treatment for further BOD<sub>5</sub> removal as needed.

The levels of technology defined above as BPCTCA, BATEA, and BADT-NSPS are correlated to effluent limitation guidelines and standards of performance in the following tables. The tables are based on attainable effluent concentration by the application of BPCTCA, BATEA and BADT as defined above, demonstrated process waste water flowrates, and consideration for the normal variations which occur in properly designed and operated treatment facilities.

TABLE NO. 1

BEST PRACTICABLE CONTROL TECHNOLOGY CURRENTLY AVAILABLE  
EFFLUENT LIMITATIONS GUIDELINES

kg/kg (lb/1000 lb of production)

Subcategory	BOD5		COD		SS	
	Maximum Average of daily values for any period of thirty consecutive days	Maximum for any one day	Maximum Average of daily values for any period of thirty consecutive days	Maximum for any one day	Maximum Average of daily values for any period of thirty consecutive days	Maximum for any one day
Polyvinyl chloride						
Suspension	0.36	.70	3.6	7.0	0.99	1.8
Emulsion	0.13	.26	1.3	2.6	0.36	.65
Bulk	0.06	.12	0.60	1.2	0.16	.29
Polyvinyl Acetate	0.20	.39	2.0	3.9	0.55	1.00
Polystyrene						
Suspension	0.22	.43	2.2	4.30	0.61	1.1
Bulk	0.04	.08	0.40	.80	0.11	.20
Polypropylene	0.42	.81	2.1	4.10	1.16	2.11
Polyethylene						
Low Density	0.20	.39	2.0	3.9	0.55	1.00
High Density Solvent	0.30	.58	3.0	5.8	0.83	1.51
High Density Polyform.	0.052	.10	0.52	1.0	0.14	.25
Cellophane	8.7	17.8	87	178	16	29.10
Rayon	4.8	10	72	150	8.8	16.0
ABS/SAN	0.63	1.30	6.3	13.0	1.16	2.1
Polyester						
Resin	0.78	1.4	11.7	21.5	0.52	.95
Fiber	0.78	1.4	11.7	21.5	0.52	.95
Resin and Fiber Continuous	0.78	1.4	11.7	21.5	0.52	.95
Resin and Fiber Batch	1.56	2.8	23.4	43.00	1.04	1.90
Nylon 66						
Resin	0.66	1.20	3.3	6.0	0.44	.80
Fiber	0.58	1.1	3.0	5.3	0.39	.70
Resin and Fiber	1.24	2.3	6.2	11.3	0.83	1.52
Nylon 6						
Resin	3.71	6.8	37.1	68.1	2.48	4.51
Fiber	1.90	3.5	19	35.1	1.27	2.31
Resin and Fiber	5.61	10.3	56.1	103.1	3.75	6.81
Cellulose Acetate						
Resin	4.13	7.5	41.3	75.1	2.75	5.0
Fiber	4.13	7.5	41.3	75.1	2.75	5.0
Resin and Fiber	8.26	15.0	82.6	150.1	5.5	10.0
Acrylics	2.75	5.00	13.8	25.0	1.1	2.0

TABLE NO. 2

BEST PRACTICABLE CONTROL TECHNOLOGY CURRENTLY AVAILABLE  
EFFLUENT LIMITATIONS GUIDELINES

Product	Parameter	kg/kg (lb/1000 lb of production)	Maximum Average of daily values for any period of thirty consecutive days	Maximum for any one day
Polystyrene suspension High Density Polyethylene Solvent ABS/SAN Rayon Acrylics	Total Chromium	0.0023		0.0046
	Total Chromium	0.0031		0.0062
	Total Chromium	0.0044		0.0088
	Zinc	0.534		0.91
	Phenolic Cmpds.	0.0083		0.017

TABLE NO. 3

BEST AVAILABLE TECHNOLOGY ECONOMICALLY ACHIEVABLE  
EFFLUENT LIMITATION GUIDELINES

Subcategory	BOD <sub>5</sub>		COD		SS	
	Maximum Average of daily values for any period of thirty consecutive days	Maximum for any one day	Maximum Average of daily values for any period of thirty consecutive days	Maximum for any one day	Maximum Average of daily values for any period of thirty consecutive days	Maximum for any one day
kg/kg (lb/1000 lb of production)						
Polyvinyl chloride						
Suspension	0.28	0.41	1.28	1.92	0.19	0.23
Emulsion	0.13	0.20	0.61	0.92	0.092	0.11
Bulk	0.06	0.09	0.28	0.42	0.042	0.05
Polyvinyl Acetate	0.19	0.29	0.89	1.33	0.14	0.16
Polystyrene						
Suspension	0.22	0.33	1.03	1.55	0.16	0.18
Bulk	0.040	0.06	0.19	0.29	0.028	0.033
Polypropylene	0.32	0.48	2.14	3.21	0.23	0.27
Polyethylene						
Low Density	0.19	0.29	1.65	2.48	0.14	0.16
High Density Solvent	0.30	0.45	1.60	2.40	0.21	0.25
High Density Polyform	0.052	0.078	0.28	0.42	0.037	0.043
Cellophane	5.1	7.9	43.9	68.3	3.19	3.75
Rayon	2.8	4.4	24.4	37.9	1.77	2.08
ABS/SAN	.45	.70	3.3	5.1	0.28	0.33
Polyester						
Resin	.44	.59	2.3	3.1	0.13	0.16
Fiber	.44	.59	2.3	3.1	0.13	0.16
Resin and Fiber Continuous	.34	.47	1.8	2.4	0.11	0.13
Resin and Fiber Batch	.87	1.20	4.5	6.2	0.27	0.32
Nylon 66						
Resin	.37	.5	1.9	2.6	0.11	0.13
Fiber	.32	.44	1.7	2.3	0.10	0.12
Resin and Fiber	.69	.94	3.6	4.9	0.21	0.25
Nylon 6						
Resin	1.8	2.45	9.3	12.7	0.55	0.65
Fiber	.92	1.25	4.8	6.5	0.28	0.33
Resin and Fiber	2.7	3.7	14.1	19.2	0.84	0.98
Cellulose Acetate						
Resin	1.7	2.35	8.9	12.2	0.53	0.63
Fiber	1.7	2.35	8.9	12.2	0.53	0.63
Resin and Fiber	3.4	4.7	17.8	24.4	1.06	1.26
Acrylics	.89	1.2	4.7	6.3	0.27	0.33

TABLE NO. 4

BEST AVAILABLE TECHNOLOGY ECONOMICALLY ACHIEVABLE  
EFFLUENT LIMITATIONS GUIDELINES

kg/kg (lb/1000 lb of production)

Product	Parameter	Maximum Average of daily values for any period of thirty consecutive days	Maximum for any one day
Polystyrene suspension High Density Polyethylene ABS/SAN Rayon Acrylics	Total Chromium	0.0023	0.0046
	Solvent	0.0031	0.0062
	Total Chromium	0.0042	0.0084
	Zinc	0.105	0.210
	Phenolic Compds	0.0016	0.0032

TABLE NO. 5

BEST AVAILABLE DEMONSTRATED TECHNOLOGY FOR  
NEW SOURCE PERFORMANCE STANDARDS

kg/kg (lb/1000 lb of production)

Subcategory	BOD5		COD		SS	
	Maximum Average of daily values for any period of thirty consecutive days	Maximum for any one day	Maximum Average of daily values for any period of thirty consecutive days	Maximum for any one day	Maximum Average of daily values for any period of thirty consecutive days	Maximum for any one day
Polyvinyl chloride						
Suspension	0.19	0.37	0.89	1.70	0.13	.19
Emulsion	0.13	0.26	0.61	1.20	0.092	.14
Bulk	0.06	0.12	0.28	.54	0.042	.06
Polyvinyl Acetate	0.18	0.35	0.84	1.60	0.13	.19
Polystyrene						
Suspension	0.22	0.43	1.03	2.00	0.16	.24
Bulk	0.04	0.08	0.19	0.37	0.028	.04
Polypropylene	0.22	0.43	1.47	2.9	0.16	.24
Polyethylene						
Low Density	0.18	0.35	1.80	3.47	0.13	.19
High Density Solvent	0.30	0.58	1.60	3.10	0.21	.31
High Density Polyform	0.054	0.10	0.28	.54	0.036	.05
Cellophane	3.6	7.41	48	98	2.27	3.3
Rayon	2.02	4.17	47	97	1.28	1.92
ABS/SAN	.43	.88	3.1	6.5	0.27	.40
Polyester						
Resin	.44	.79	4.0	7.3	0.13	.19
Fiber	.44	.79	4.0	7.3	0.13	.19
Resin and Fiber Continuous	.25	.46	2.32	4.2	0.078	.12
Resin and Fiber Batch	.87	1.58	8.0	14.6	0.27	0.40
Nylon 66						
Resin	.37	.67	2.6	4.8	0.11	.16
Fiber	.32	.58	2.3	4.2	0.10	.15
Resin and Fiber	.69	1.25	4.95	9.0	0.21	.31
Nylon 6						
Resin	1.51	2.75	15.7	28.6	0.47	.69
Fiber	.78	1.42	8.1	14.7	0.24	.35
Resin and Fiber	2.29	4.17	23.9	43.4	0.71	1.1
Cellulose Acetate						
Resin	1.15	2.08	11	20	0.35	.51
Fiber	1.15	2.08	11	20	0.35	.51
Resin and Fiber	2.29	4.17	22	40	0.71	1.1
Acrylics	.87	1.58	16.7	30.4	0.27	0.40

TABLE NO. 6

BEST AVAILABLE DEMONSTRATED TECHNOLOGY FOR  
NEW SOURCE PERFORMANCE STANDARDS

kg/kg (1b/1000 lb of production)

Product	Parameter	Maximum Average of daily values for any period of thirty consecutive days	Maximum for any one day
Polystyrene suspension	Total Chromium	0.0023	0.0046
High Density Polyethylene Solvent	Total Chromium	0.0031	0.0062
ABS/SAN	Total Chromium	0.0040	0.0080
Rayon	Zinc	0.075	0.150
Acrylics	Phenolic Cmpds	0.0016	0.0032

## SECTION III

### INTRODUCTION

#### Purpose and Authority

Section 301(b) of the Act requires the achievement by not later than July 1, 1977, of effluent limitations for point sources, other than publicly owned treatment works, which are based on the application of the best practicable control technology currently available as defined by the Administrator pursuant to Section 304(b) of the Act. Section 301(b) also requires the achievement by not later than July 1, 1983, of effluent limitations for point sources, other than publicly owned treatment works, which are based on the application of the best available technology economically achievable which will result in reasonable further progress toward the national goal of eliminating the discharge of all pollutants, as determined in accordance with regulations issued by the Administrator pursuant to Section 305(b) to the Act. Section 306 of the Act requires achievement by new sources of a Federal standard of performance providing for the control of the discharge of pollutants which reflects the greatest degree of effluent reduction which the Administrator determines to be achievable through the application of the best available demonstrated control technology, processes, operating methods, or other alternatives, including, where practicable, a standard permitting no discharge of pollutants.

Section 304(b) of the Act requires the Administrator to publish within one year of enactment of the Act, regulations providing guidelines for effluent limitations setting forth the degree of effluent reduction attainable through the application of the best practicable control technology currently available and the degree of effluent reduction attainable through the application of the best control measures and procedure innovations, operation methods and other alternatives. The regulations proposed herein set forth effluent limitations guidelines pursuant to Section 304(b) of the Act for the largest volume products of the plastic and synthetic materials manufacturing source category.

Section 306 of the Act requires the Administrator, within one year after a category of sources is included in a list published pursuant to Section 306(b) (1) (A) of the Act, to propose regulations establishing Federal standards of performances for new sources within such categories. The Administrator published in the Federal Register of January 16, 1973 (38 F.R. 1624), a list of 27 source categories. Publication of the list constituted announcement of the Administrator's intention of establishing, under Section 306, standards of performance applicable to new sources within the plastic and synthetic materials manufacturing source category, which was included within the list published January 16, 1973.



## Methodology

The effluent limitations guidelines and standards of performance proposed herein were developed in the following manner. The plastics and synthetics industry was first categorized for the purpose of determining whether separate limitations and standards are appropriate for its different segments. Considerations in the industry subcategorization process included raw materials, products, manufacturing processes, raw waste characteristics and raw waste treatability and attainable effluent concentrations.

The raw waste characteristics for each subcategory were identified through analyses of (1) the sources and volumes of water and waste waters and (2) the constituents (including thermal) of all waste waters including toxic or hazardous constituents and other constituents which result in taste, odor, color, or are toxic to aquatic organisms. The constituents of waste waters which should be subject to effluent limitations guidelines and standards of performance were identified.

The full range of control and treatment technologies existing within the industry was identified. This included an identification of each distinct control and treatment technology, including both in-plant and end-of-process technologies, which are existent or capable of being designed for each subcategory. It also included an identification, in terms of the amount of constituents (including thermal) and the chemical, physical, and biological characteristics of pollutants, of the effluent level resulting from the application of each of the treatment and control technologies. The problems, limitations, and reliability of each treatment and control technology and the required implementation time were also identified. In addition, the non-water quality environmental impact, such as the effects of the application of such technologies upon other pollution problems, including air, solid waste, noise, and radiation were identified. The energy requirements of each of the control and treatment technologies were identified as well as the cost of the application of such technologies.

The information, as outlined above, was then evaluated in order to determine what levels of technology constituted the "best practicable control technology currently available," "best available technology economically achievable," and the "best available demonstrated control technology, processes, operating methods, or other alternatives." In identifying such technologies, various factors were considered. These included the total cost of application of technology in relation to the effluent reduction benefits to be achieved from such application, the age of equipment and facilities involved, the process employed, the engineering aspects of the application of various types of control techniques process changes, non-water quality environmental impact (including energy requirements), the treatability of the wastes, water use practices, and other factors.

The data for identification and analyses was derived from a number of sources. These sources included EPA research information, EPA permit applications, records of selected state agencies, published literature, previous EPA technical guidance for plastics and synthetics manufacture, a survey of waste water treatment practice by the Manufacturing Chemists Association, qualified technical consultation, and on-site visits and interviews at plastics and synthetics manufacturing facilities practicing exemplary waste water treatment in plants within the United States. Samples for analyses were obtained from selected plants in order to establish the reliability of the data obtained. All references used in developing the guidelines for effluent limitations and standards of performance or new sources reported herein are listed in Section XIII of this document.

### General Description of the Industry

The plastics and synthetics industry is composed of three separate segments: the manufacture of the raw material or monomer; the conversion of this monomer into a resin or plastic material; and the conversion of the plastic resin into a plastic item such as a toy, synthetic fiber, packaging film, adhesive, paint, etc. This analysis is concerned primarily with the manufacture of the basic plastic or synthetic resin (SIC 2821). We are also including within this study the production of synthetic fibers such as nylon (SIC 2824), man-made fibers such as rayon (SIC 2823), and cellulose film, namely, cellophane (SIC 3079).

The present report segment deals with 16 of the major resins, all of the major synthetic fibers, all of the cellulosic fibers, and cellophane film, and covers over 90 percent of the total consumption of the plastics and synthetics industry.

### Plastics

The synthetic plastics industry for this segment, accounts for approximately 12 million kkg (26 billion lbs) of material having a dollar value of about \$5 billion. This is an increase over the 1962 consumption of 3.18 million kkg (7 billion lbs) for an average growth rate over the last decade of just over 13 percent. The industry supplies a secondary converting industry with annual sales of \$21 billion and supports a raw material industry by purchasing \$3 billion of materials. This larger industry is composed of some 300 producers operating over 400 plants. Of these 300 producers, there are about 35 major corporations having individual sales of over \$500 million. These are primarily the major oil companies, which have integrated from oil and monomer raw material production to the manufacture of the resins and chemical companies, some of whom have integrated back to raw materials and forward to end-products. Perhaps one-third of all the final plastic items are fabricated by the basic resin producers. A large number of the basic resin producers are integrated to raw material production. In many cases, a given installation will produce both monomer, polymer, and the end-use

items, and it is difficult to isolate the source of pollution between the three separate segments. At the small end of the scale, the plastics industry includes many companies having sales of less than \$1 million per year, often producing one resin in small quantities for a specific customer. Such companies might average no more than twenty employees.

The major plastic materials considered in this report with their annual consumption are shown in Table 7, along with the number of producers.

The industry considered is expected to grow at a rate of approximately 10 percent per year over the next five years. Its major outlets are:

1. The building and construction industries, i.e., paint, flooring, wall covering and siding.
2. The packaging industry, notably polyethylene films, rigid plastic containers and bottles.
3. The automotive industry, including trim, steering wheels, outside grill, etc.

These three industries account for somewhat over 50 percent of the total production of plastic materials.

The type of plant constructed depends primarily on the specific resins being produced. The large volume commodity resins, polyvinyl chloride, polystyrene and the polyolefins are generally produced in plants ranging in size from 45,500 kkg (100 million lbs) to 226,700 kkg (500 million lbs) per year. They are usually part of a petrochemical complex, which includes the production of monomer, such as ethylene, and the production of end products, such as film.

TABLE 7

## 1972 CONSUMPTION OF PLASTICS AND SYNTHETICS

<u>Products</u>	<u>Consumption 1000 kkg</u>	<u>Number of Producing Units</u>
Urea and Melamine**	411	11
Polyvinyl Acetate	198	26
Low Density Polyethylene	2,372	12
High Density Polyethylene	1,026	13
Polypropylene	767	9
Polystyrene	1,196	19
ABS/SAN	431	8
Polyvinyl Chloride	1,975	23
Phenolic**	652	81
Acrylic Resins	208	5
Polyester Resins	30	4
Nylon Resins	110	6
Acrylic Fibers	286	6
Polyester Fibers	1,040	15
Nylon Fibers	896	14
Cellulose Acetates*	257	7
Cellophane	145	4
Rayon	430	7
Total	12,508	278

\*Includes fibers and resins.

\*\*These products will be covered in greater detail in the Development Document for the Synthetic Polymers Segment of the Plastics and Synthetics Industry.

Because of their dependence on petroleum and gas feedstocks, these plants are usually located on the Gulf Coast. Operations are generally continuous in nature, and the product is shipped in hopper cars to distribution points throughout the United States where fabrication is carried out. Fabricating operations are often located near population centers. There are four main centers of converting operations: New England, Middle Atlantic States, Mid-West and Far West. A second segment of the industry consists of the manufacture of resins by batch processes for particular end uses. These plants are generally smaller, i.e., under 45,500 kkg (100 MM lbs), and are likely to be oriented toward markets rather than raw materials since the raw materials can be readily shipped from producing points. Thus a manu-

facturer of phenol formaldehyde resin for grinding wheels may locate a plant in upper New York State and buy his raw materials from petrochemical plants located elsewhere in the country. Such products are produced in relatively small quantities and often discharge their waste water to municipal systems. A list of major producers of resins is shown in Table 8.

TABLE 8

MAJOR RESIN PRODUCERS

Allied Chemical	Hercules
American Cyanamid	Koppers
Ashland Oil	Mobay (Bayer)
Borden	Monsanto
Borg-Warner (Marbon)	National Distillers
Celanese Occidental	Petroleum (Hooker)
Dart Industries	Phillips Petroleum
Diamond Shamrock	Reichhold
Dow	Rohm & Haas
DuPont	Shell
Eastman	Standard Oil (Indiana)
Ethyl	Standard Oil (New Jersey)
Foster Grant	Standard Oil (ohio)
General Electric	Stauffer Chemical
B.F. Goodrich	Tenneco
W.R. Grace	Union Carbide
Gulf	Uniroyal

Synthetic Fibers

The synthetic fiber industry is composed of both synthetic materials based on nylon, polyester and acrylic resins, and man-made fibers based on cellulose acetate, cellulose triacetate and rayon. The synthetic fibers which generally produce relatively minor quantities of pollutants when compared with celluloses account for 2,280,000 kkg (5 billion lbs), whereas the cellulose fibers account for about 685,000 kkg (1.5 billion lbs). There are 6 producers of acrylic fibers, 15 producers of polyester fibers, and 11 producers of nylon fibers. There are 5 producers of cellulose acetate fibers and 7 producers of rayon. In many cases there is overlap since a given producer of fibers may produce as many as four types.

The table showing the producers of synthetic fibers is found below:

Table 9

SYNTHETIC FIBER PRODUCERS

<u>Company</u>	<u>Nylon</u>	<u>Polyester</u>	<u>Acrylic</u>
Allied Chemical	x		
American Cyanamid			x
American Enka	x	x	
Celanese	x	x	
Courtaulds	x		
Dow Badische	x	x	x
DuPont	x	x	x
Eastman		x	x
Beaunit	x	x	
Midland		x	
Firestone	x		
Goodyear		x	
Hystron		x	
Monsanto	x	x	x
Phillips Fibers	x	x	
Rohm & Haas	x		
Union Carbide			x

As can be seen, this industry is dominated by major corporations. In general synthetic fibers have been growing in importance whereas the cellulose acetate and rayon fibers have been declining in importance over the years.

Capacity by producer for the cellulosic based fibers is shown below:

Table 10

CAPACITY  
1000 kkg/Year (MM lbs/Year)

<u>Company</u>	<u>Rayon Filament</u>	<u>Rayon Staple</u>	<u>Acetate Filament</u>
American Cyanamid	33 (73)		
Akzona (American Enka)	45 (100)	45 (100)	
Celanese		88.5 (195)	120 (265)
Courtaulds		88.5 (195)	
DuPont			22.8 (50)
Eastman			41 (90)
El Paso (Beaunit)	11 (24)		
FMC	41 (90)	210 (460)	

Growth for these materials is limited, and major new capacity additions are not expected. The profitability of the cellulose and rayon fiber industry depends on its pricing policy in relation to cotton and synthetic fibers. Many of the plants are quite old and may not have modern waste water treating facilities.

### Cellophane

Cellophane, which was originally produced in 1912, reached its peak of consumption in 1960 with sales of 200,000 kkg (440 million lbs). Due to competition from polyethylene in the baked goods business, polyvinyl chloride in the meat and produce wrap business, and the introduction of new competing clear films, such as polypropylene, polyester and polybutylene, consumption of cellophane has dropped uninterruptedly since 1964, reaching a level of 145,000 kkg (320 million lbs) in 1971. Continued decline is expected with consumption reaching as low as 123,000 kkg (270 million lbs) by 1975. Further inroads from other synthetic films as well as a shift to the use of thinner gauges of cellophane, possible in combination with other packaging films, can be expected to further reduce demand. Cellophane production is carried out by three companies (Olin, FMC Corporation, and Du Pont) in relatively old plants.

### Product and Process Technology

#### Typical Polymerization Products

Polymers are characterized by vinyl polymerizations. The common reaction is the "opening" of a carbon-to-carbon double bond to permit growth of a polymer chain by attachment to the carbons. Substitute groups on the carbons may be all hydrogen (ethylene) or one or more other radicals (e.g. methyl for propylene, and phenyl for styrene). Polymerization proceeds until propagation is stopped by the attachment of a saturated group. In the formulae shown in Fig. 1 hydrogen is written as this "chain-stopper." ABS (acrylonitrile, butadiene, styrene) plastics are co-polymers of two or three of the monomers named. Polystyrene has been diagrammed in Fig. 1. Polyacrylonitrile and polybutadiene are shown in Fig. 2. Polybutadiene forms the rubbery backbone of ABS polymers, and is modified by the substitution of styrene and/or acrylonitrile elements. The presence of the double-bond in the polybutadiene introduces both stereospecificity and the opportunity for cross-linking. Polyacetal resins are condensation polymers of formaldehyde and may be synthesized in a one or two step process. This is shown in Fig. 3.

#### Emulsion and Suspension Polymerization

A large number of polymers are manufactured by processes in which the monomer is dispersed in an aqueous, continuous phase during the course of the reaction. There are technical differences between emulsion and suspension systems which pertain to the

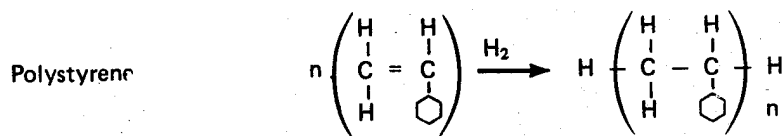
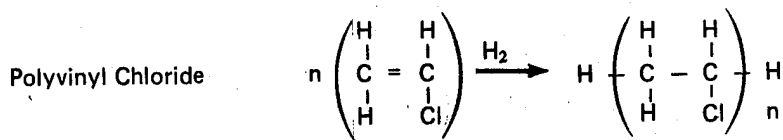
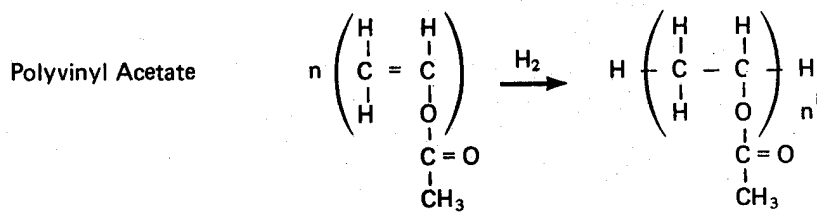
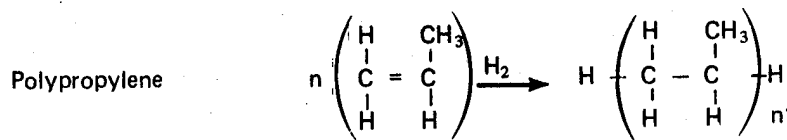
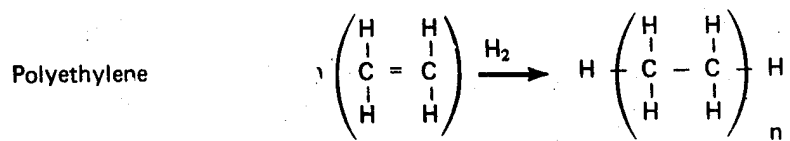
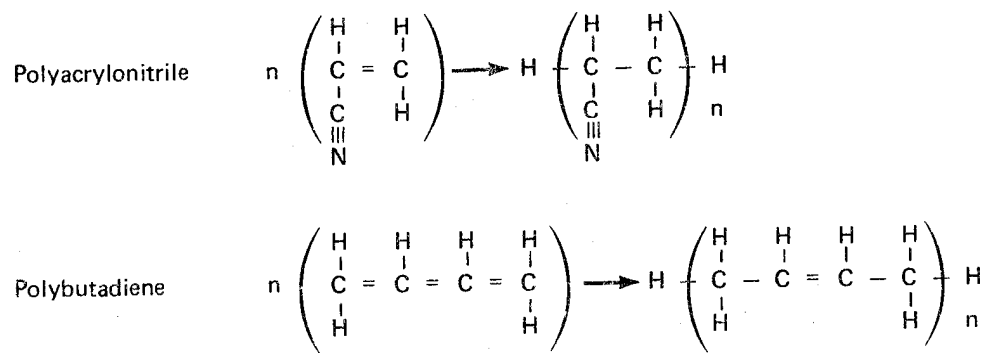

FIGURE 1 TYPICAL POLYMERIZATION REACTIONS FOR POLYETHYLENE, POLYPROPYLENE, POLYVINYL ACETATE, POLYVINYL CHLORIDE, POLYSTYRENE





**FIGURE 2** TYPICAL POLYMERIZATION REACTIONS  
FOR POLYACRYLONITRILE AND POLYBUTADIENE

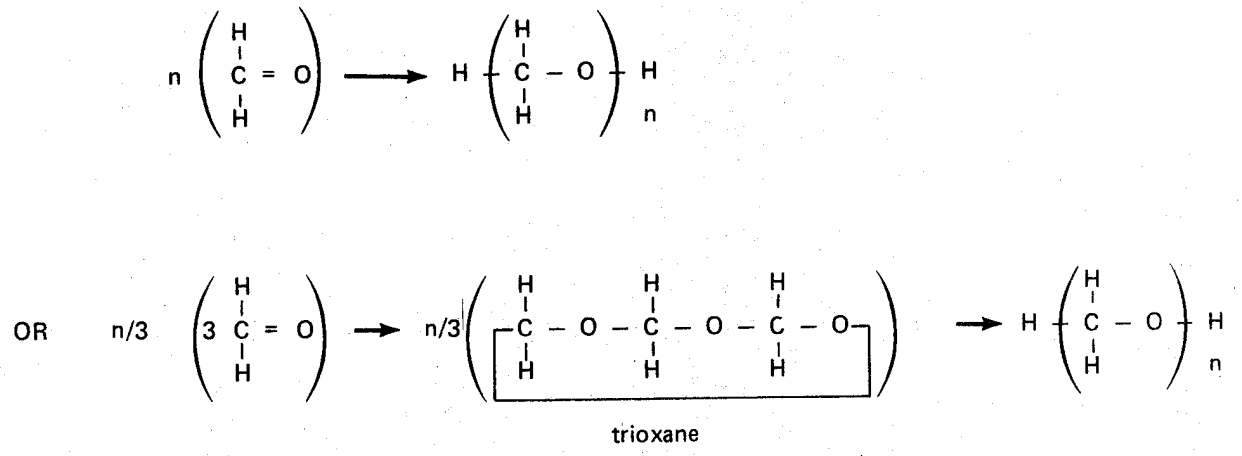

FIGURE 3 TYPICAL POLYMERIZATION REACTION FOR POLYACETAL RESINS

polymerization reaction itself, but these do not have a bearing on the potential aqueous pollution problem. Therefore both methods will be covered by this discussion.

Products of this process include:

- Polystyrene (PS)
- Acrylonitrile, butadiene, styrene (ABS)
- Styrene, acrylonitrile (SAN)
- Polyvinyl chloride (PVC)
- Polyvinyl acetate (PVA)

A batch process, as shown in Fig. 4, is commonly used. Typical reactor size is 5,000 to 30,000 gal (18.9 to 113.5 cu m). The batch cycle consists of the continuous introduction of a water-monomer emulsion to the stirred reactor. Polymerization occurs at about the rate of monomer addition; the heat of reaction is removed to coolingtower water circulated through the jacket. The reactor is vented through a condenser for monomer recovery; and the condensate, including any water, is returned directly to the vessel. On completion of the batch, a short "soaking" time is allowed for completion of the reaction, and water is then added to dilute to the desired end composition. The batch is drawn off through a screen to product storage. Oversize screenings (a very small amount) are disposed of to landfill.

Monomers, the principal raw materials, are often protected during shipping and storage by an inhibitor, such as catechol, which may be removed prior to polymerization by washing. This contributes to the waste water load.

A number of products, polyvinyl acetate for example, are marketed in this latex form with no further processing required. Thus, although water is a process material, there is no aqueous waste inherent. When the product is isolated and sold in solid form, the screened latex is pumped to another reactor. A small quantity of a flocculating agent is added which destroys the emulsion and permits subsequent separation of the polymer.

#### Atmospheric or Low-Pressure Mass Polymerization

A number of important plastics are manufactured by mass polymerization, a system in which the purified monomer is allowed to polymerize under controlled conditions of temperature and reaction rate. This process is shown in Fig. 5. Catalysts and modifiers are used to initiate the reaction, control its rate, and influence the final molecular weight. These materials are used in very small amounts, and their residue remains in the product. Removal of the heat of reaction is a difficult problem in this process and limits the type of equipment which can be used.

Products of this process include:

- Polystyrene (PS)

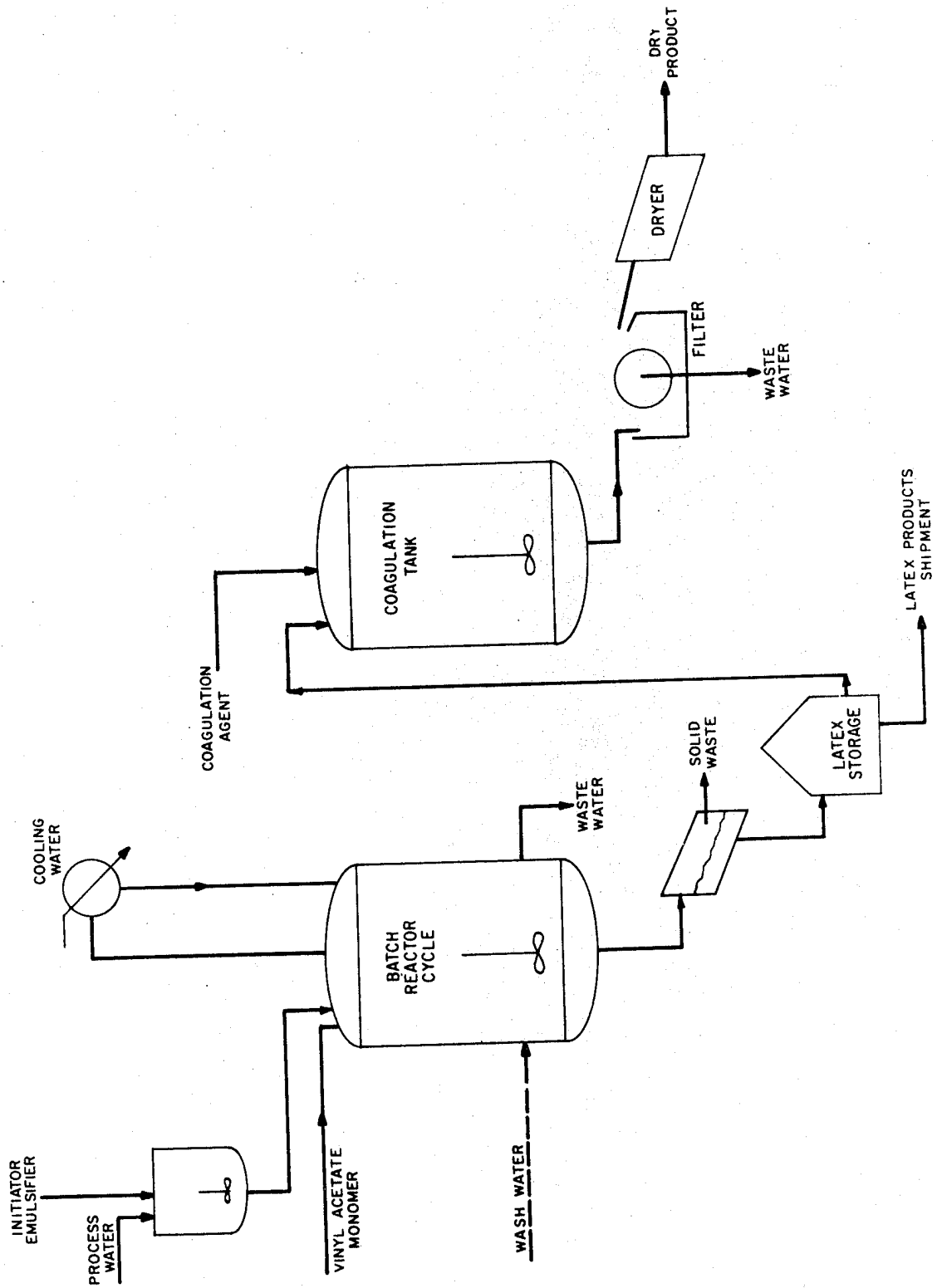

FIGURE 4

EMULSION POLYMERIZATION

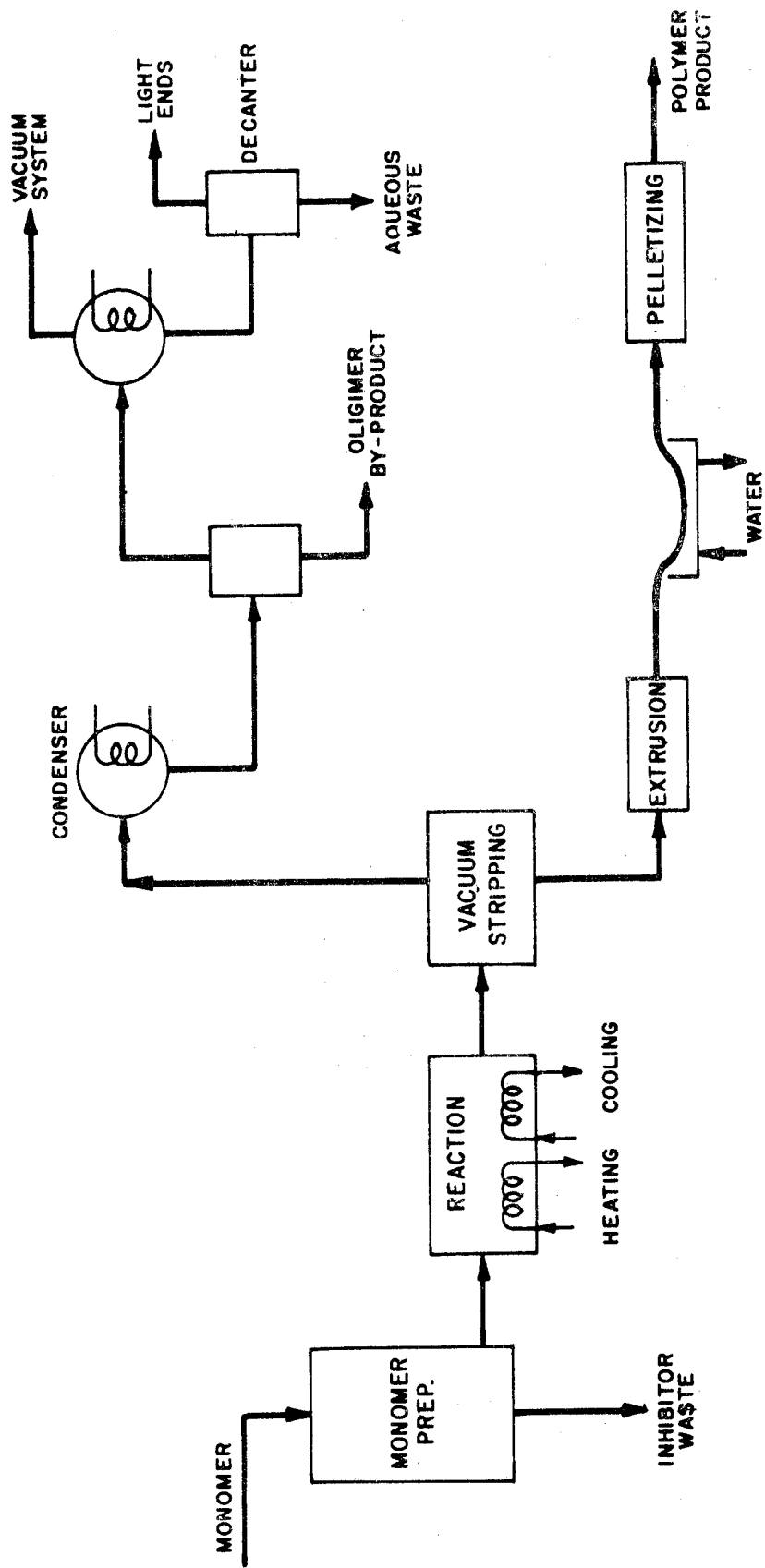

FIGURE 5  
MASS POLYMERIZATION

Acrylonitrile, butadiene, styrene (ABS)  
Styrene, acrylonitrile (SAN)  
Polyvinyl chloride (PVC).

It is usually necessary to protect the purified monomers from autopolymerization in storage. The inhibitor used for this purpose is removed by distillation or washing. This frequently results in an aqueous waste. The reaction system is usually continuous, or multi-stage, and the first step is to bring the monomer to reaction temperature by indirect heating. A heat-transfer oil or fluid such as Dowtherm, circulated from a fired heater, is used. Once reaction begins the heat is removed by transfer to a cooling oil circulated through coils or in a jacket. The circulated oil is cooled by water in conventional heat-exchange equipment.

On leaving the reactor, the polymer contains unreacted monomer and small amounts of contaminants and by-products. These materials are removed by vacuum stripping.

Vapors from this unit pass through an oil-cooled tar condenser. The vent from this condenser is connected to a steam jet ejector, and steam and volatile hydrocarbons condense in a water-cooled surface condenser. Insoluble oils are decanted and recovered, and contaminated condensate goes to the process sewer.

Pure polymer from the bottom of the stripper is forced through multiple orifice extruders to make strands of polymer, which are cooled in a water bath before pelletizing for storage and shipment.

#### High Pressure Mass Polymerization - Low Density Polyethylene

The high pressure process for low density polyethylene is a very simple one, as illustrated in Fig. 6. Ethylene gas is mixed with a very small quantity of air or oxygenated organic compounds as a catalyst, and with recycled ethylene, and raised to high pressure in reciprocating compressors. The operating pressure is considered to be confidential information, but the trend in the industry has been to the highest practical pressures, and literature references to design ratings of 40,000 psi (2722 atm) and up are common. At the operating pressure and at an appropriate temperature, polymerization is carried out in jacketed tubular reactors. The heat of reaction is removed to hot water in the jacket, which circulates through a waste heat boiler for the generation of steam. On completion of the reaction, the pressure is reduced and specification polymer separated in flash drums. This molten material is pumped through a multiple orifice extruder to an underwater chiller and chopper to produce polyethylene pellets. The water is separated on a screen and pumped through a cooler for recycling. A purge stream of this water is removed and replaced with high-quality, clean water. The purge is at a rate sufficient to remove polymer fines generated in chipping. The quantity of fines depends on the

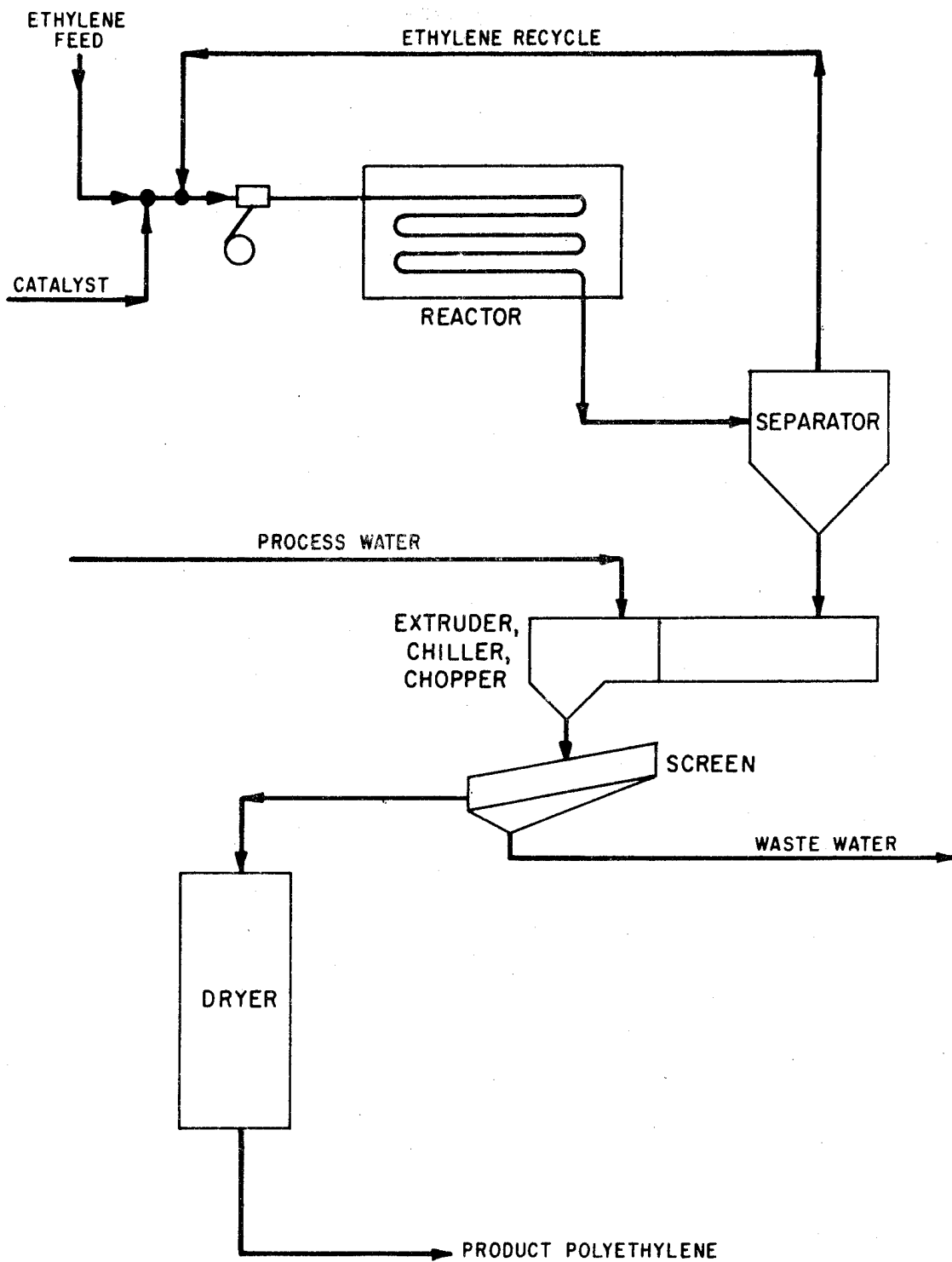

FIGURE 6

LOW-DENSITY POLYETHYLENE PRODUCTION - HIGH PRESSURE PROCESS

grade of polymer produced and with some grades is negligible. Wet polymer from the screen is dried and stored in silos.

### Polyolefins - Solution Polymerization

In the solution process for polyolefins shown in Fig. 7, the polymer is dissolved in the reaction solvent as it is formed, and the catalyst is present as a separate solid phase. The catalyst system is activated chromium oxide deposited on a carrier such as alumina. This process is one of two for polyolefins which first came into prominence in the late 1950's; the other is the Ziegler process, in which the polymer precipitates as it is formed. Products of the solution system include high density polyethylene and a limited number of co-polymers.

As the concentration of polymer, or the molecular weight of the polymer in solution, increases, the viscosity of the solution also increases markedly. This phenomenon places severe limitations on the processability of the reaction mass. Temperature control is accomplished by indirect cooling with refrigerated water, and the viscosity must not be allowed to exceed a reasonable limit for efficient heat transfer.

Viscosity is also an important limitation in the next step, which is the removal of the catalyst by filtration or centrifugation. From the filter, the catalyst, wet with solvent, is mixed with hot water and the solvent removed by steam stripping. Solvent-free catalyst slurry is processed in a skimmer and solid catalyst removed to land fill.

The aqueous phase is recycled to the steam stripper. Vapor from the steam stripper is combined with other recovered solvent for purification.

The catalyst-free polymer solution is processed in a system which concentrates and precipitates the polymer, and then removes the last traces of solvent by steam stripping, leaving the polymer as a slurry in water. The slurry is filtered or centrifuged, and the filtrate recycled to the stripper.

Solvent recovered in the concentrator and vapors from the steam strippers are processed by distillation in the solvent recovery section. All process water used in the catalyst and polymer separation area appears as an aqueous waste stream from this distillation unit. It contains small quantities of dissolved hydrocarbons, but in at least one plant it is used as boiler feed water.

Dry polymer crumb or flake is blended, melted, extruded and pelletized. This pelletizing operation is carried out under water, with cooling and transport accomplished with recirculated, clean, softened water. A purge stream amounting to a few percent of the circulation rate is withdrawn to waste. This system is the same as already described for the low-density polyethylene process.



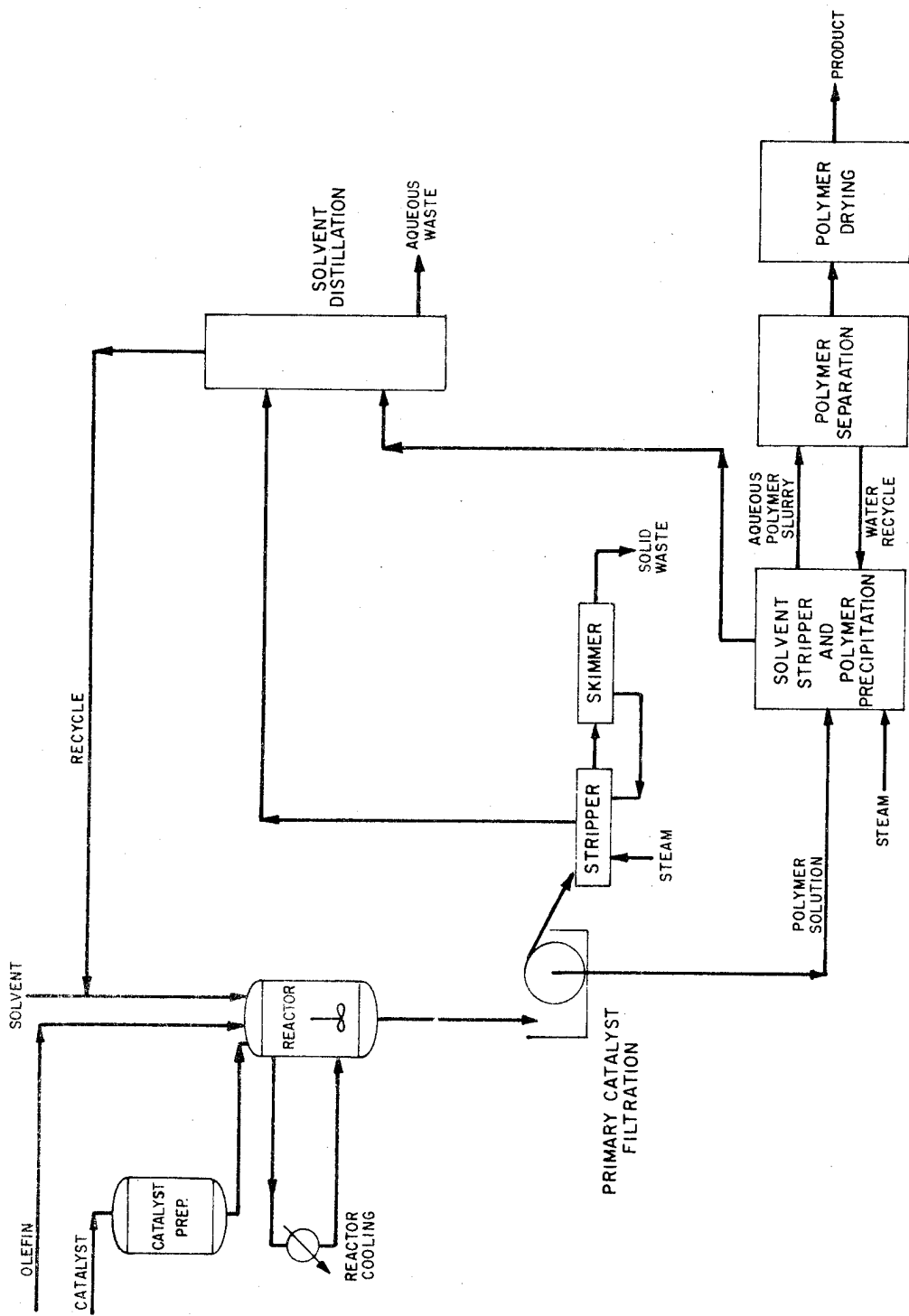

FIGURE 7

POLYOLEFIN PRODUCTION - SOLUTION PROCESS

## Polyolefins - Ziegler Process

This process depends on a catalyst system discovered and patented by Dr. Karl Ziegler. There have been a number of improvements by companies using the basic principle, and the name in fact applies to the catalyst system. Each user has had to design his own plant. It is convenient, however, to group under this name all polyolefin processes which employ a reaction solvent in which the polymer precipitates as it is formed. Fig. 8 details this type of polyolefin production. The catalyst is a relatively complex alkyl, or alkyl halide, of metals such as titanium and aluminum.

Products of this process include:

- High Density Polyethylene
- Polypropylene
- Polybutene
- Copolymers.

Catalyst preparation, monomer addition, and reaction proceed as already described for the solution process. Temperatures and pressures are lower; and, because the polymer does not dissolve, problems caused by excessive viscosity do not arise.

The next step is the removal of the catalyst, which historically has been the most troublesome part of the system. The residual catalyst content of the final polymer must be very low, and for this reason a system is employed which allows transfer of catalyst to a separate liquid phase. Aqueous alcohol is used for this purpose and the catalyst is removed in solution, leaving the polymer slurried in the hydrocarbon solvent.

The aqueous alcohol phase is treated to precipitate the catalyst as the oxides (e.g., titanium, aluminum), and these materials eventually appear as finely-divided suspended solids in the aqueous waste. They will settle sufficiently to permit discharge of a clarified effluent, but consolidation of the sludge left behind has been a problem. Alcohol is recovered for reuse by distillation. The aqueous phase remaining is the principal waste product of the plant. This water contains a finite amount of dissolved alcohol, and this chemical constitutes the largest raw waste load on the treatment facilities.

The polymer slurry is processed by steam stripping, filtration, drying, extruding and pelletizing as is done for the solution process, and the hydrocarbon solvent is purified by distillation. A small quantity of aqueous waste is recycled to the alcohol unit.

## Polyolefin - Particle Form Process

The problems of the solution process for polyolefins described above have to a large degree been overcome in a newer version called the particle form process, and the method has a growing

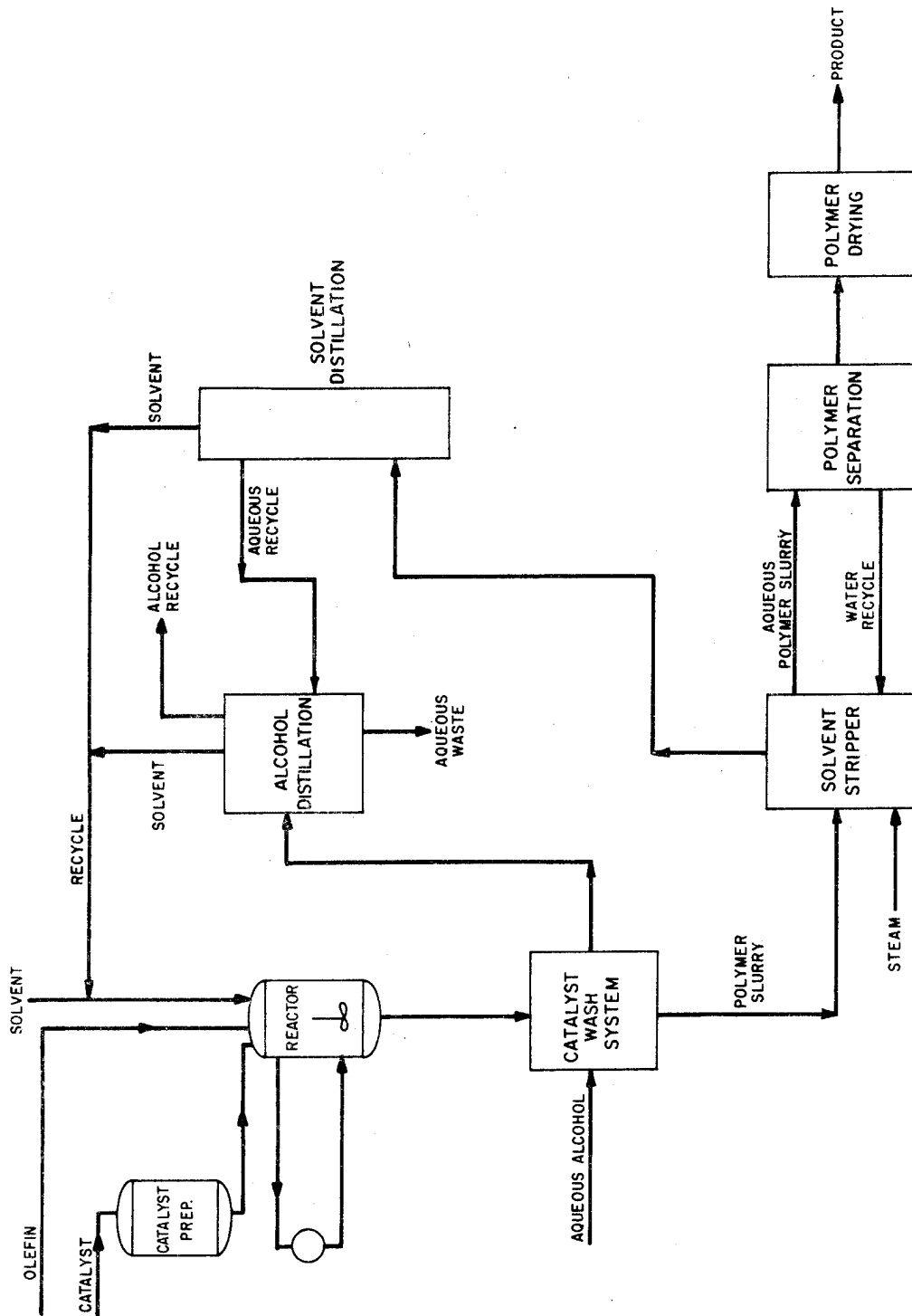

FIGURE 8

POLYOLEFIN PRODUCTION - ZIEGLER PROCESS

commercial acceptance. Fig. 9 details this method of production. There have been three major changes:

1. The catalyst system has been modified and its activity increased to the point that special measures for catalyst removal are unnecessary for many grades of polymer.
2. The solvent system has been modified so that the polymer is obtained as a slurry rather than a solution in the diluent.
3. Special design loop-reactors have been developed which allow the polymerization system to operate under good control of reaction conditions and at satisfactory rate.

In practicing this method, catalyst and olefin feed are added to the reaction mass which is circulated continuously through the loop reactors. A stream is also withdrawn continuously from the reactor to a flash drum. Polymer is removed from the bottom of the flash drum, dried, and processed through an extruder - pelletizer as with the other methods.

The vapor stream from the flash drum is scrubbed to remove polymer fines. This step produces a small quantity of waste water. Both unreacted olefin, and recovered diluent are then separated from the overhead stream and recycled to the reaction step.

#### Polyacetal Resins

These resins are polymerization products of formaldehyde. At present they are manufactured at two U.S. plants, operated by different companies and by quite different processes. Polyacetal resins might have been eliminated from the scope of this report on the basis of unique process considerations. This was not done because of the growing commercial importance of the material, and because of the large dependence on aqueous processing which its manufacture involves.

The specific discussion of process details, and the presentation of a process flow sheet is, however, inappropriate and this has not been included.

As stated above, formaldehyde is the raw material, other process materials required include caustic soda, benzene, methanol, formic acid, and intermediate condensation products such as trioxane, dioxalene, dioxane, and tetroxane.

Process operations include the polymerization reaction steps, solvent extraction using aqueous wash solutions, and distillation.

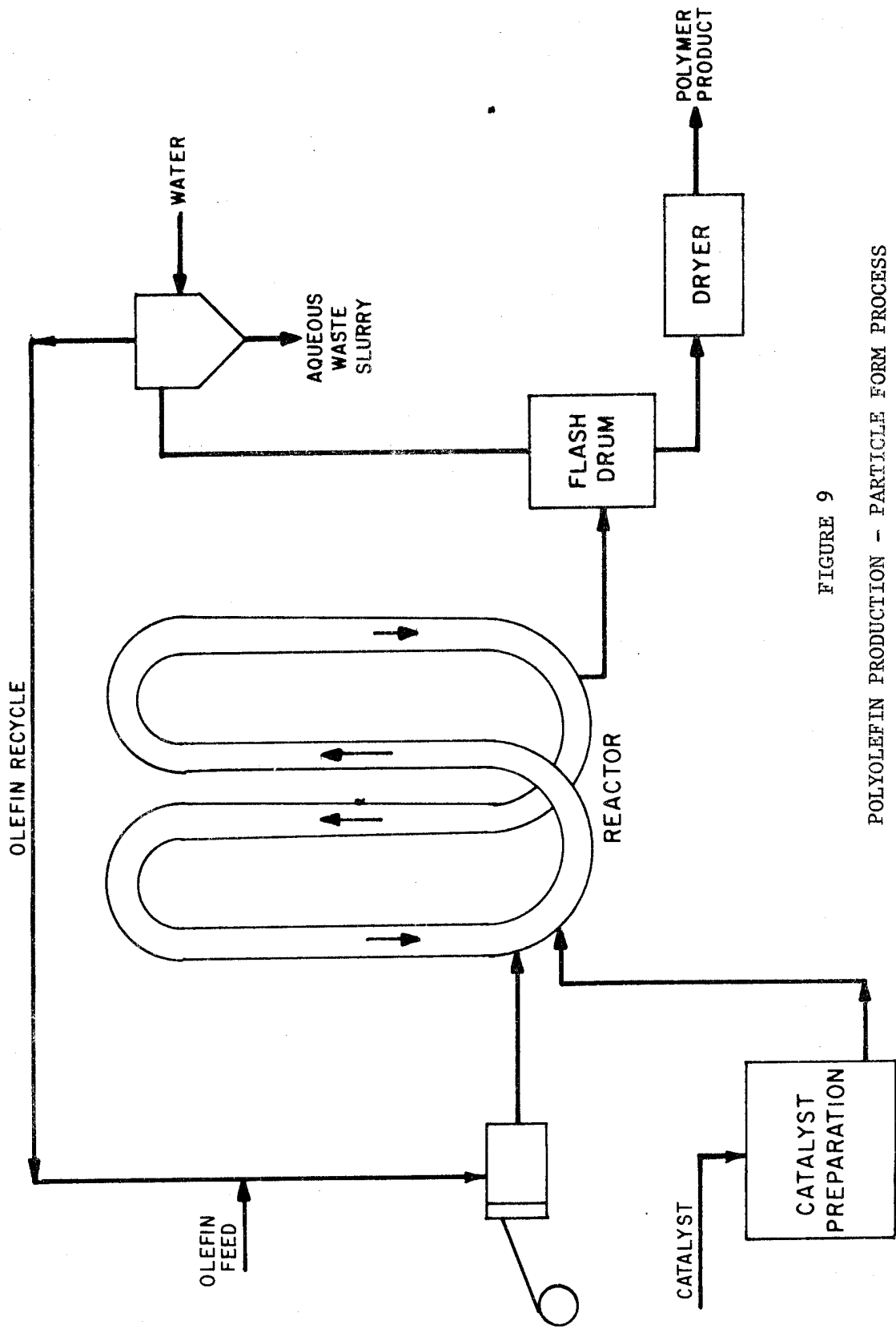

FIGURE 9  
POLYOLEFIN PRODUCTION - PARTICLE FORM PROCESS

## Cellophane

Cellophane is produced in a wide variety of grades. However, these variations primarily represent differences in film thickness, plasticizer content, and coatings applied. Waste loads are essentially independent of product mix.

Process Description - Cellophane manufacture is divided into three major process operations: viscose preparation, film casting, and coating. A schematic diagram of the manufacturing operations is shown in Fig. 10. The basic reactions involved are represented by the following:

### Steeping

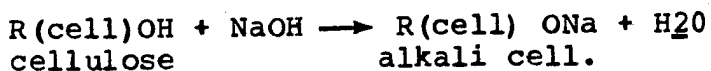

### Xanthation

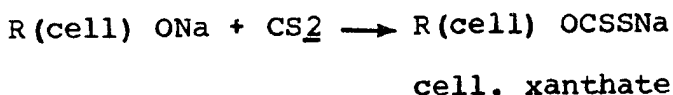

### Coagulation and Regeneration



Viscose Preparation - Viscose, a solution of sodium cellulose xanthate in dilute aqueous caustic, is prepared by a series of multiple-batch type operations.

Dissolving grade wood pulp, received in baled sheet form, is slurried in caustic solution to form alkali cellulose. Most of the caustic is then squeezed from the fiber on perforated roll presses. Part of the caustic solution is reused for steeping, the remainder is used in subsequent xanthate dissolving or other steps. There is no caustic purification (dialysis) system as in rayon manufacture since the requirements for cellophane are less stringent. Impurities (mainly hemicelluloses) extracted from the pulp by the caustic solution are maintained at a controlled level in the system by the purging effect of using a portion of the caustic steeping liquor in subsequent process steps such as to dissolve the xanthate.

The alkali crumbs from the roll presses are aged in the presence of air in cans in a controlled temperature environment to a specified degree of depolymerization of the cellulose. They are then reacted in churns with carbon disulfide to form xanthate. The xanthate is dissolved by the addition of dilute aqueous caustic to form viscose. The viscose is aged in tanks, filtered in plate and frame filter presses, deaerated, and pumped to the casting machines.

Film Casting - Film casting and processing is a continuous operation. Viscose is metered by pump through a slit die into a primary spin bath containing an aqueous solution of sulfuric acid and sodium sulfate. Cellophane is formed in this bath. The film subsequently passes through a series of processing baths as indicated in Fig. 10. These include dilute acid wash, warm water wash, cool water bath to cool film prior to bleach, bleach bath, water rinse, and plasticizer bath. An "anchoring" resin which serves as a tie-coat for subsequent coatings is usually applied in this bath. For colored film (a minor portion of total) a dye bath is included in the wet processing sequence. After the plasticizer bath, the film is dried, wound into rolls, and sent to coating.

Film Coating - Most of the cellophane production is coated. Coatings are generally applied from organic solvent solutions. The solvents are recovered by an activated carbon recovery system. Water usage related to solvent recovery is cooling water and steam for stripping solvent from the carbon beds. Water/solvent mixtures condensed from the carbon beds are separated by decanting and/or distillation.

Spin Bath Reclaim - Water and sodium sulfate are generated in the primary spin bath by the reaction between viscose and sulfuric acid. To maintain proper bath composition and recover chemicals, the spin bath liquor is recycled through a reclaim operation. The effluents from the dilute acid backwash and countercurrent water wash processes are also sent to the reclaim plant. In the reclaim plant, one portion of the spent baths is passed through double-effect evaporators to remove water. The other portion is passed through crystallizers where sodium sulfate is separated out, subsequently converted to the anhydrous form, and sold as a by-product. The liquors from the evaporators and crystallizers are adjusted in concentration as required, and recycled to film processing. The yield from the sodium sulfate recovery operation is estimated at about 80 percent of the total generated in the process.

#### Rayon

Rayon is a generic term covering regenerated cellulose fibers in which not more than 15 percent of the hydrogens of the hydroxyl groups have been substituted. Rayon fibers are produced in a wide variety of cross-sectional shapes, sizes, and performance characteristics by modification in the viscose process and spinning condition. The major product types may be classified as:

High tenacity continuous filament (tire and industrial type yarn)

Regular tenacity continuous filament (textile yarn)

Regular tenacity staple

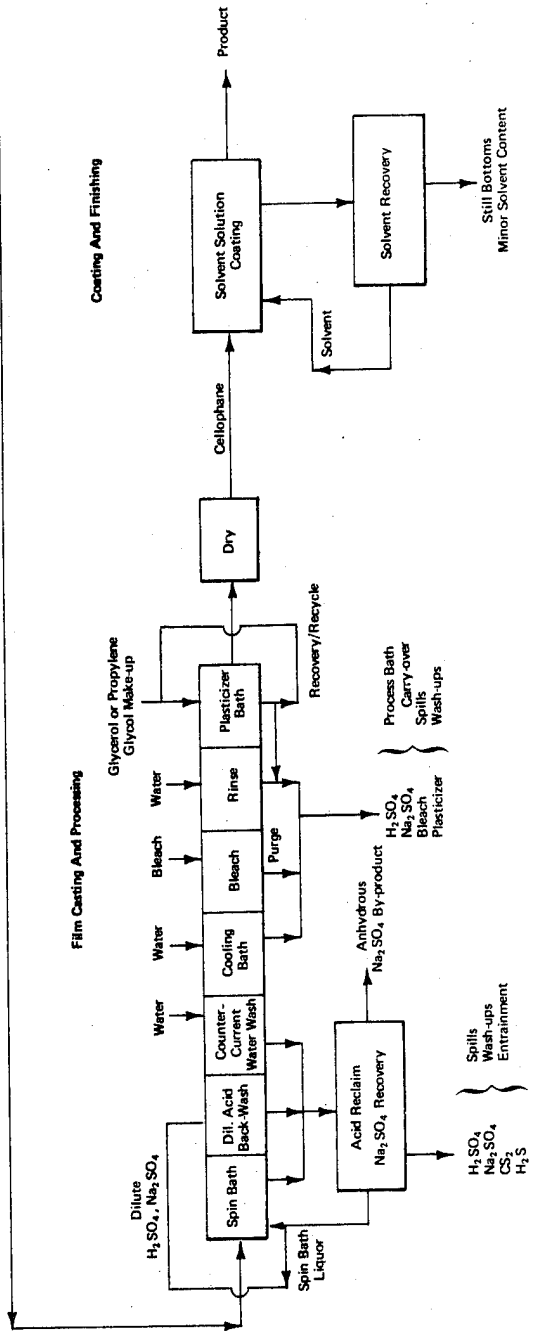
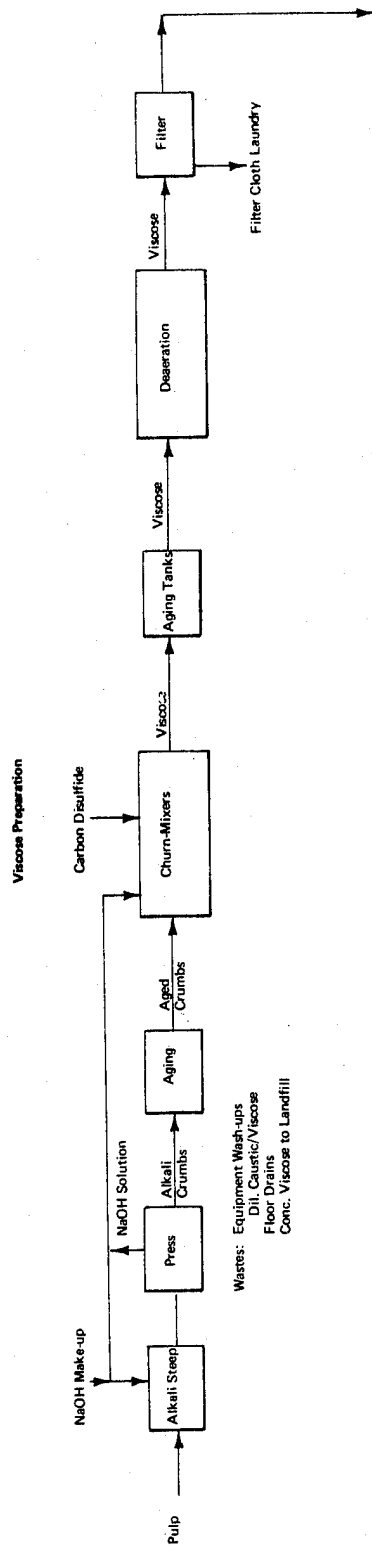

Notes: For dyed film, spent dye bath to dye bath pit.  
Cooling Water Boiler Discharges not shown.

FIGURE 10  
CELLOPHANE PRODUCTION



High performance (e.g., high wet modulus) staple.

The types of fiber produced at any one rayon plant vary from plant to plant.

Process Description - Rayon manufacture is divided into two major process operations: viscose preparation and fiber spinning. Viscose, a solution of sodium cellulose xanthate in dilute aqueous caustic, is prepared by a series of multiple-batch-type operations. In the spinning operation, fibers are produced by continuously metering the viscose through spinnerettes into coagulation and regeneration baths. The fibers are then processed through a series of water-based purification steps prior to drying. These operations are described further below. The basic reactions involved are represented by the following:

#### Steeping



cellulose                      alkali cell.

#### Xanthation



cell. xanthate

#### Coagulation and Regeneration

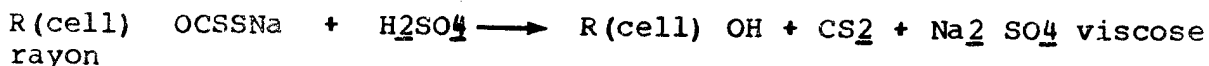

Viscose Preparation - A schematic flow diagram of the viscose process is shown in Fig. 11. Dissolving grade wood pulp is received in baled sheet form. The sheets are steeped in about 111 percent NaOH solution in steeping presses. After the specified time, the presses close to squeeze out caustic solution to a controlled alkali/cellulose ratio. The initial, relatively free draining caustic solution is recycled. The final, and much smaller, portion pressed from the sheets contains hemicelluloses and other impurities which cannot be tolerated in the process. This press liquor is sent to dialysis units to recover purified caustic solution and purge the hemicelluloses.

The alkali cellulose sheets are shredded to crumb form and aged in containers in the presence of air at controlled temperature to a specified degree of polymerization. The aged crumbs are charged to churns and reacted with carbon disulfide to form cellulose xanthate. The xanthate is then dissolved in relatively dilute aqueous caustic to form viscose. Special additives or modifiers may be added to the viscose at this stage.

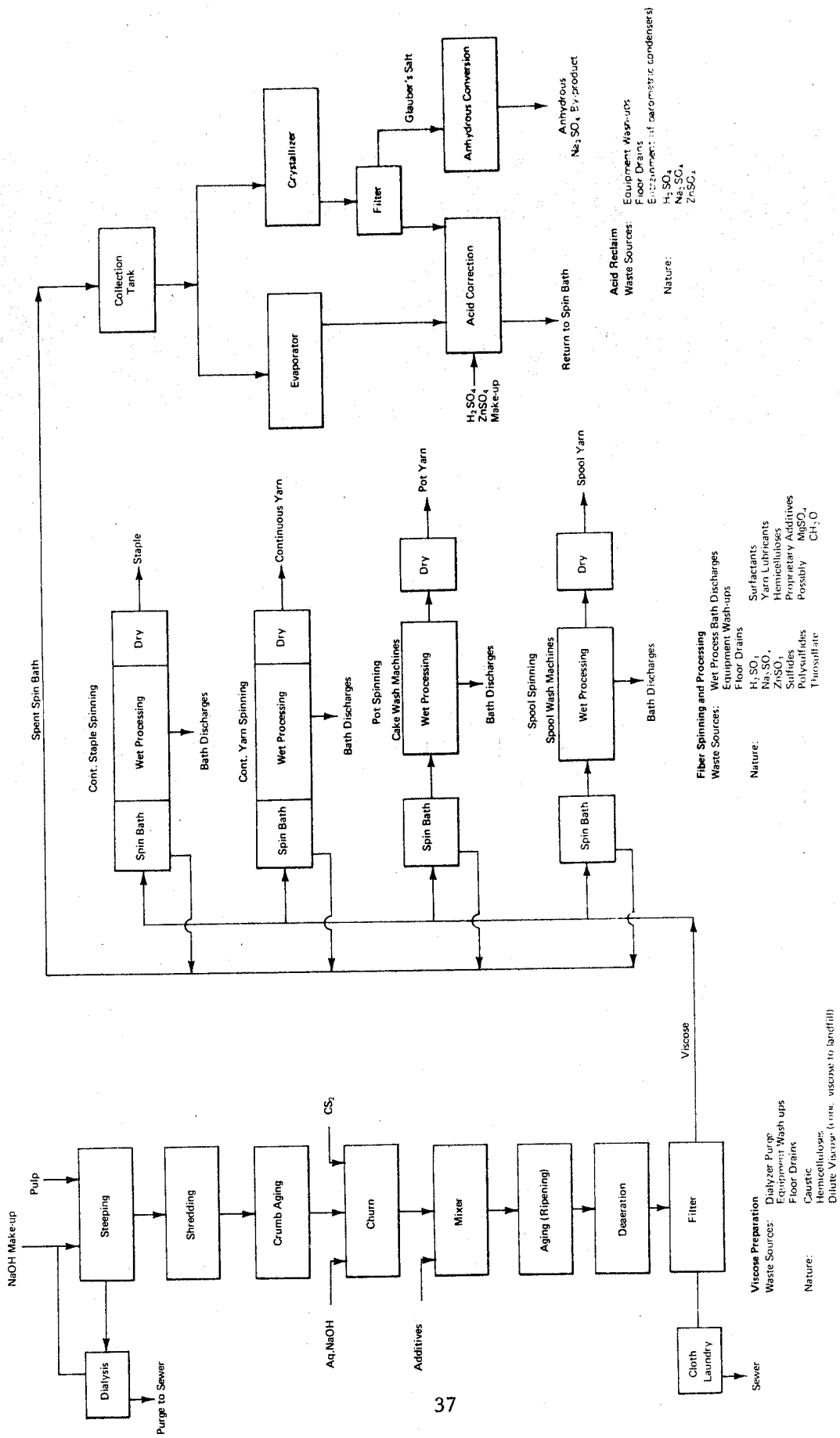

FIGURE 1.1

VISCOSE RAYON PRODUCTION

From the dissolver the viscose is usually pumped to a blending or receiving tank where a number of batches are blended to minimize possible batch-to-batch variations. From the blend tank the viscose is pumped through plate and frame filter presses to remove contaminants and undissolved cellulosic material. The filtered viscose is aged in ripening tanks at controlled temperature until it reaches the proper condition for spinning. The ripened viscose is deaerated under vacuum, usually filtered a second time, and pumped to the spinning machines. Details of viscose preparation are tailored to the performance characteristics required in the fiber to be spun.

Spinning Operations - Rayon fibers are produced in spinning operations by pumping the viscose through spinnerettes into a primary spin bath containing sulfuric acid, sodium sulfate, and, in most cases, zinc sulfate. The specific composition of the bath depends primarily on the type of rayon being spun, but will vary with the process from plant to plant. Modifiers or spinning aids (proprietary) may also be present in minor quantities. Coagulation and regeneration of the cellulose occurs in this bath. In some instances, regeneration may be completed in a secondary, dilute acid bath. The bundle of fibers produced is stretched during the regeneration process to produce the desired degree of orientation within the fibers.

The fibers from the spin bath are in an acid condition, contain salts and occluded sulfur, and must be purified to prevent degradation. This is accomplished by a series of wet process washes which include extensive water washes, and, depending on application requirements, some combination of treatment in aqueous desulfurizing, bleaching, and pH adjustment baths, and application of fiber lubricating oil. The manner in which the treatments are carried out varies with the spinning method. After these purification treatments, the fibers are dried and converted by dry mechanical processes to final product forms.

A number of different spinning methods are employed in the production of rayon fibers. Briefly, these are as follows:

1. Continuous Staple Machines

On continuous staple production machines, fibers are spun in the form of a relatively large bundle of untwisted, continuous filaments called tow. After the regeneration step, the tow is wet-cut in rotary cutters to the desired staple length. The staple is sluiced with water onto some form of porous conveyor belt to form a "blanket." Subsequent wet purification steps are carried out by shower application of treating liquors as the staple is carried along the washing line.

2. Pot or Box Spinning

In pot spinning, the bundle of continuous fila-

ments from the spin bath, after stretching, is fed through a tube down into a pot rotating at high speed which imparts a controlled twist to form yarn. The yarn builds up on the walls of the pot to form a cylindrical package or "cake." Water is sprayed into the pot to wash out some of the salt to prevent crystal formation and consequent fiber damage. This "pot spray" spins out through holes in the side of the pot.

The cakes are transferred from the pots to cake washing machines where the wet process purification treatments are completed.

### 3. Spool Spinning

Spool spinning is similar to pot spinning except that the bundle of filaments is wound on a revolving spool. The spools are mounted in spool washing machines for the final purification washings.

### 4. Continuous Yarn Spinning

In continuous yarn spinning, the bundle of regenerated filaments travels over thread advancing rolls where the washes are applied to individual yarns on a continuous basis to complete the purification treatments before the yarn is wound into a package.

**Spin Bath Reclaim** - In the spin bath, water and sodium sulfate are generated by the reaction between the alkaline viscose and sulfuric acid. To maintain proper spin bath compositions and conserve chemicals, the spin bath liquors are continuously circulated through a reclaim operation. One portion of the spent liquors is sent to evaporators to strip off water; another portion is sent to crystallizers to remove excess sodium sulfate. The mother liquors are recombined, corrected in composition as required, and returned to the spin baths. Spin bath liquors of different composition are kept segregated through the reclaim operation.

Sodium sulfate recovered from the crystallizers is purified by washing, converted to the anhydrous form, and sold as a by-product. Implications of this reclaim operation with respect to further reducing dissolved solids discharge from rayon manufacturing are discussed in Section VIII.

### Polyester Resin and Fiber

A polyester fiber is defined by the FTC as a manufactured fiber in which the fiber forming substance is any long-chain synthetic polymer composed of at least 85 percent by weight ester of a dihydric alcohol (usually ethylene glycol) and terephthalic acid.

The most common polyester is derived from the linear polymer poly(ethylene terephthalate). The only other homopolymer to achieve commercial significance is manufactured by Eastman Kodak. In this polymer, the dihydric alcohol is 1,4-cyclohexanedimethanol rather than ethylene glycol.

Molecular weights in the region of 15,000 are required for useful textile fiber properties. Most products contain a delusterant, typically titanium dioxide, added in quantities up to 2 percent.

The term polyester resin as used in this report refers to the saturated polyester polymers based on poly (ethylene terephthalate) or poly (1,4 cyclohexanedimethylene terephthalate). These polymers are quite different in method of manufacture, chemistry, and areas of application from the unsaturated polyester resins in which a site of unsaturation is incorporated into the polymer chain for subsequent reaction to form a crosslinked structure. The reactions involved in polymerizing saturated polyesters are shown in figure 12.

The saturated polyester resins referred to in this report represent about 10 percent of total polyester fiber manufacture, and are used primarily in film form (i.e., Mylar, Celenar). These resins are produced by the same polymerization process used to polymerize resin for fiber production. Resin chips are often taken as a side stream from integrated polyester fiber plants. There are, however, some U.S. polyester resin facilities which produce resin alone and are not integrated to fiber production. In addition, there are polyester film facilities which are integrated back to resin production. Since the polymerization process, raw materials and waste loads are, with some exceptions, identical, polyester resin and fiber are treated as a single subcategory.

The dihydric alcohol most frequently used in the polyester condensation reaction is ethylene glycol. Specific requirements for the dihydric alcohol are that it be quite pure and particularly free from color-forming impurities and traces of strong acids and bases.

The other component can be either dimethyl terephthalate (DMT) or terephthalic acid (TPA). The use of DMT as a polyester raw material is more common. There is a difference in waste products generated during polymerization depending on whether DMT or TPA is used. The use of DMT results in the generation of methyl alcohol as a waste stream in addition to ethylene glycol, whereas the TPA based polymerization process generates only ethylene glycol.

Titanium dioxide is used in polyester fibers as a delusterant. Optical brighteners are often used. These are applied either topically (by the textile finisher) or via addition of fluorescent dyes to the molten polymer prior to melt spinning.

- (1) Via dimethyl terephthalate (DMT) route:  
 a - Alcoholysis with ethylene glycol

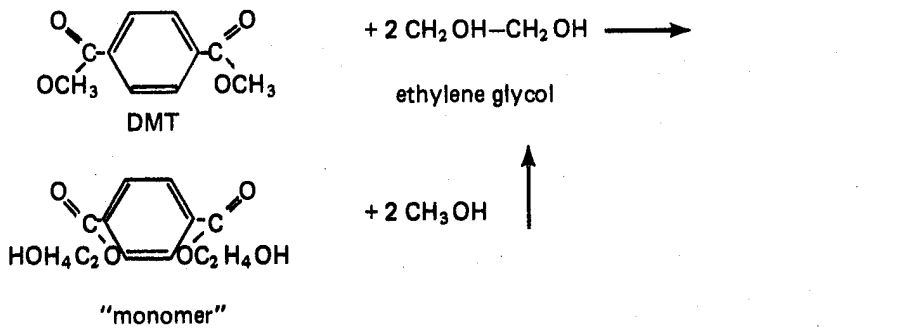

- b - Polymerization of "monomer"

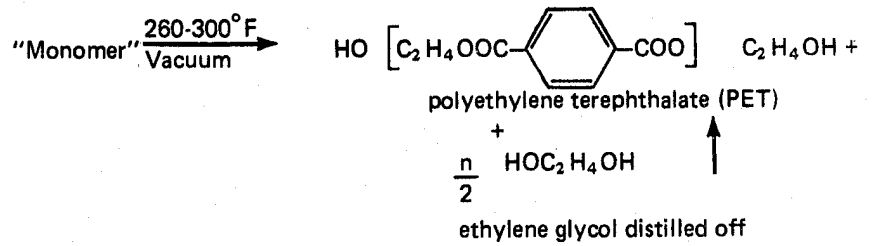

- (2) Via terephthalic acid (TPA) route:

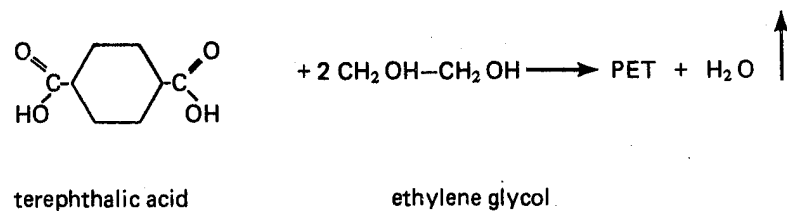

FIGURE 12 TYPICAL POLYMERIZATION REACTION FOR POLYESTER RESINS AND FIBER

The exact nature of the catalysts used in the polymerization process varies somewhat and is regarded as proprietary information. They are, however, known to include acetates of cobalt, manganese, and cadmium.

Many different finish formulations are used and their exact compositions are regarded as proprietary, but they are known to contain long chain fatty acids, emulsifiers, bacteriostats, and humectants.

The end product from a polyester fiber plant is in the form of staple (usually shipped in bale form), continuous industrial yarn or textile filaments. Shipment is in the form of either spools or bales. Polyester resin is shipped in the form of solid chips.

Process Description - Although many plants still use the batch polymerization process, continuous polymerization and direct spinning combinations are more common for new facilities.

A typical continuous polymerization process based on DMT consists of a DMT melter, ester exchange column, two polymerization reactors (low- and high-molecular weights), and a molten polymer manifold system feeding several banks of spinning heads. The alternative system based on TPA involves a direct esterification rather than ester interchange.

In the case of plants producing both resin and fiber, the molten polymer stream from the final reactor is divided. Polymer destined to become resin is chilled by once-through cooling water during a band casting operations and broken up into chip form for shipping. Fig. 13 shows polyester resin and fiber production.

The spinning operation involves forcing the molten polymer (at about 290°C) through a sand bed filter to a steel spinnerette containing cylindrical holes. The extruded filaments cool by air convection in a carefully controlled environment free from turbulence. Solidification of the filaments occurs within two feet below the spinnerette. The spinning threadline is conveyed below this point and passed over a spin finish application. In the case of staple production, several threadlines, each containing 250 to 1000 filaments, can be brought together, passed over capstans and through an air ejector, and coiled in a large can for subsequent drawing. For continuous filament yarns, the spun threadline comprising 15 to 50 filaments is either wound on bobbins for subsequent draw twisting or drawn directly at high speed and wound on the final package.

In order to produce the oriented crystalline structure that gives the fiber its characteristic strength, stiffness and abrasion resistance, the spun filaments are drawn to about four times their original length.

For staple manufacture, large tows made by plying several ends of spun yarn are drawn on a draw frame at temperatures above 80°C. Heat is supplied by steam, hot water, heated rolls or infrared

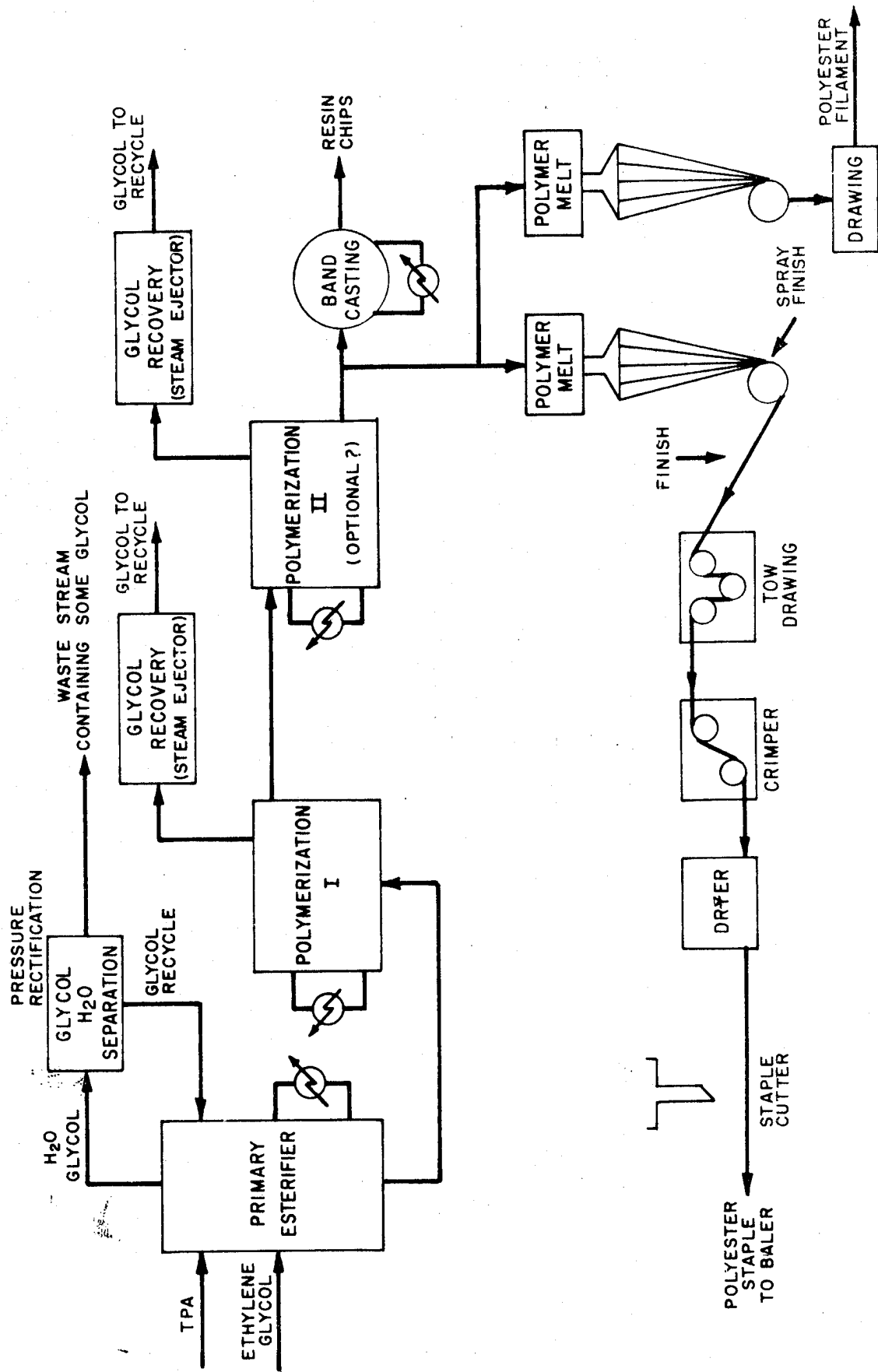

FIGURE 13

POLYESTER FIBER AND RESIN PRODUCTION



heat. The drawn tow is then crimped using a stuffer box crimper, dried and heat set. It is either packaged as tow or cut into staple (lengths range from 1.5 to 6 in. or 3.8 to 15.2 cm) and baled.

Continuous filament yarn is made by stretching between two rolls running at a speed ratio of 3.5/1. The drawn yarn is wound at speeds up to 4000 fpm (1200 meters per min) in a cylindrical tube.

After the initial finish application, just after the spinnerette, subsequent applications are made prior to filament drawing or tow drawing. The filament drawing finish is more concentrated and is usually applied as a light coating to individual filaments by means of a spin-finish wheel. In drawing tow, however, the entire tow bundle is passed through a bath. The quantities of waste spin finish from tow operations are significantly higher than from textile yarns and contribute significantly higher BOD loads to the waste stream. Air conditioning plays a significant role in the production process, thereby necessitating cooling towers. In the large cooling towers often associated with the air conditioning system, chromium salts and various algacides are used; consequently the blowdown from the cooling towers is usually treated separately from other waste water streams.

#### Nylon 66 Resin and Fibers

Nylon 66 is a condensation polymer produced by reacting hexamethylene diamine with adipic acid to form nylon salt (hexamethylene diammonium adipate). Polymerization involves a condensation reaction of this nylon salt.

In addition to hexamethylene diamine and adipic acid, other raw materials involved in nylon production are acetic acid (used as a chain terminating agent), titanium dioxide ( $TiO_2$ ), and spin finishes. The latter two are used only in fiber production. The reactions involved in polymerizing nylon 66 resins are shown in figure 14.

The major difference between nylon resins used for plastics and those used for fibers is that the plastics resins have a higher molecular weight and viscosity. As a result, both resin and fibers are often produced in a common polymerization facility from the same raw materials but with slightly different process conditions. For the purposes of this study, we have included nylon 66 resins and fibers in the same subcategory.

The end products from nylon plants are similar to those described above for polyester. Fiber is in the form of staple bales, continuous yarn, or textile filaments. Resin is in the form of chip or pellets.

Process Description - The hexamethylene diammonium adipate is made by neutralizing the adipic acid with the diamine. This is followed by an activated carbon decolorization step which results

(a) Formation of nylon "salt"

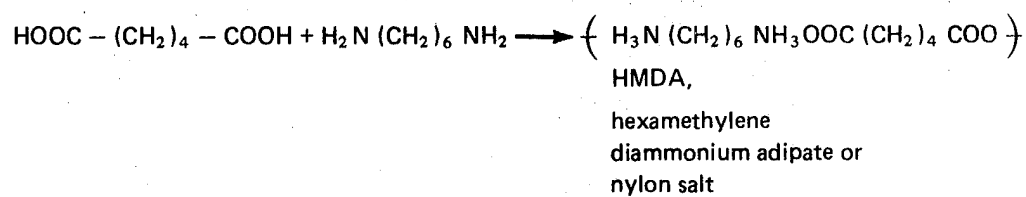

(b) Polymerization of salt

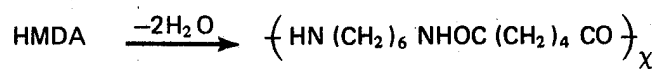

**FIGURE 14** TYPICAL POLYMERIZATION REACTIONS  
FOR NYLON 66 RESINS AND FIBER

in a liquid waste stream containing spent carbon, diatomaceous earth, and some nylon salt (the backwash from the carbon filtration), and a subsequent solids disposal problem. Some plants start with a concentrated nylon salt solution as the raw material rather than diamine and diacid. Such facilities also carry out a decolorization step as described above.

The nylon 66 polymerization process consists of mixing nylon salt with water and small quantities of acetic acid. This solution is then passed to a steam-heated evaporator. The vapor from the evaporator is composed of water mixed with a small percentage of hexamethylene diamine (HMDA). This stream is passed through a condenser and the condensate is then passed to the waste treatment plant. (Condensate contains up to 1 percent HMDA and is one of the primary sources of BOD in the waste stream.)

The concentrated salt from the evaporator is then passed to a Dowtherm heated autoclave. Titanium dioxide (delusterant) is added at this point. The polymerization proceeds in the autoclave under the appropriate temperature, pressure and time conditions to produce the desired molecular weight product. Water is evolved in the polycondensation reaction and is discharged overhead as a vapor (containing some HMDA) during venting from the autoclave. This stream is passed to a water scrubber system. The exit stream from the scrubber then joins the exit stream from the condenser previously described, and the combined stream is routed to the waste treatment plant. Some waste heat is recovered. This process is shown in Fig. 15.

#### Cellulose Acetate Resin

Process Description - Cellulose acetate resin (flake) is produced by a batch type operation shown schematically in Fig. 16. Purchased, dissolving grade wood pulp is defiberized in attrition mills, pretreated with acetic acid to activate the cellulose, and charged to acetylation reactors where it is reacted with acetic anhydride in the presence of glacial acetic acid. Sulfuric acid is added as a catalyst. The acetic acid/anhydride mixture is pre-chilled by refrigeration to aid in removing heat of reaction. The reaction is carried to nearly complete acetylation of the cellulose.

The clear, viscous solution is then transferred to a hydrolysis reactor where dilute aqueous acetic acid is added, and the acetate hydrolyzed back to the specified acetyl content. Some magnesium acetate may be added to adjust the concentration of sulfuric acid which also serves as a catalyst for the hydrolysis. The hydrolysis step is necessary to remove sulfate ester groups and to provide close control of the final acetyl content. At the desired point, the reaction is stopped by adding magnesium acetate to neutralize remaining sulfuric acid.

The overall reactions involved in the production of cellulose acetate and triacetate may be represented as follows:

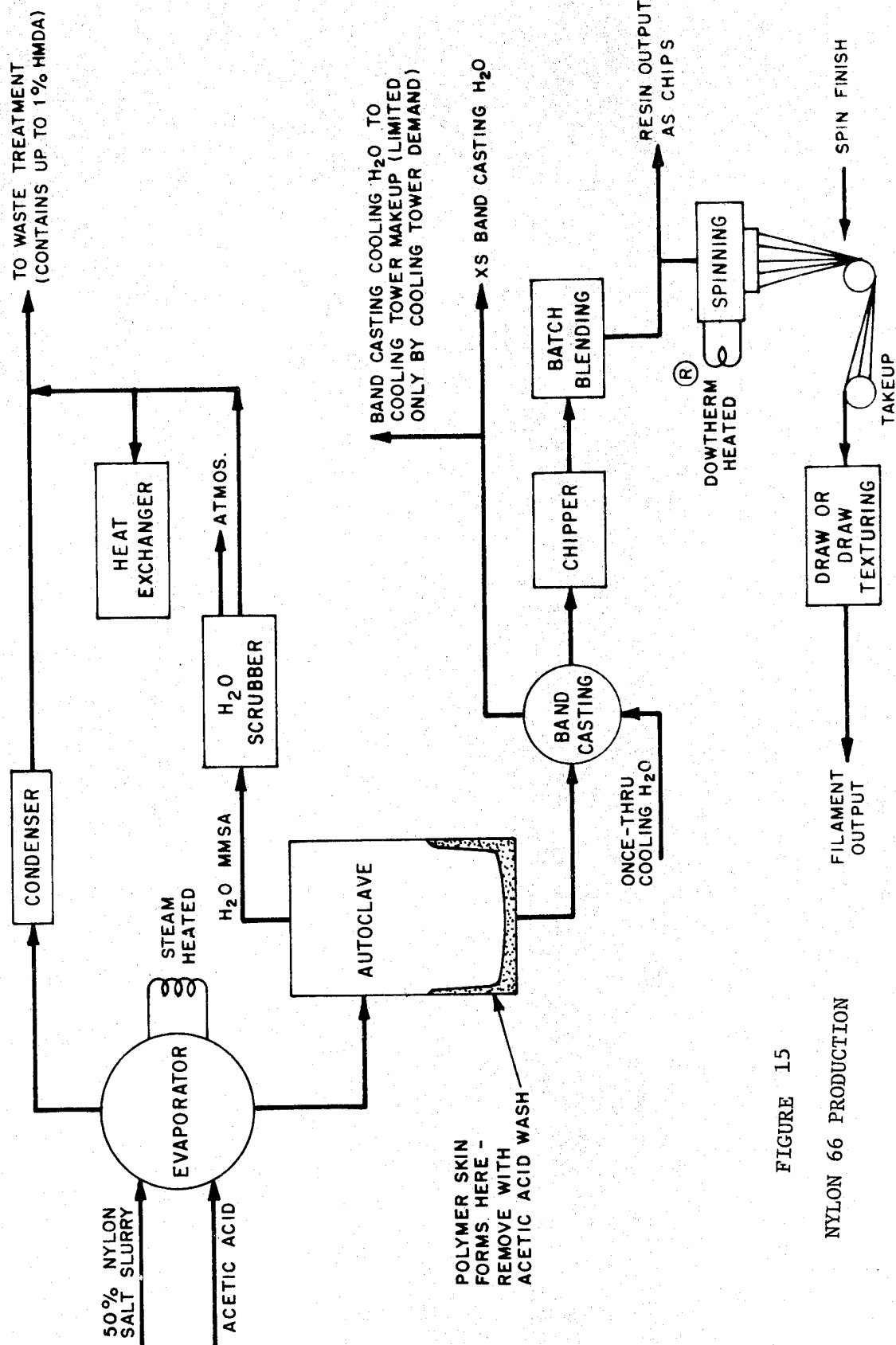
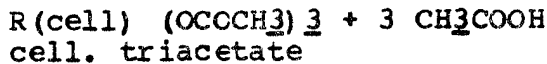
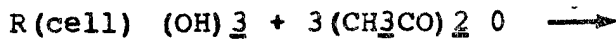
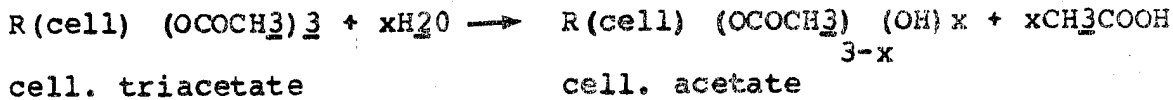

FIGURE 15  
 NYLON 66 PRODUCTION

### Acetylation



### Hydrolysis



Cellulose acetate flake is recovered from the reaction solution on a continuous precipitator by precipitation with weak acetic acid solution from the counter current wash step that follows.

In the flake washing process, fresh water enters the second stage washer, and flows counter-current to the flake through the second and first-stage washers. As noted above, the water from the first stage washer is used for the flake precipitation step. This water, which is separated from the flake on the vibrating screens, is sent to acid recovery. Entrained fines are collected in filters and recycled to the process.

Process waste waters from acetate resin production are treated in an acid recovery plant to recover acetic acid. A recovery plant flowsheet is shown in Fig. 16. The process waste streams are filtered and held in a filtered acid tank. Miscellaneous streams with sufficient acid value may also be collected in this tank.

Acetic acid is separated from the process water by solvent extraction and distillation. Glacial acetic acid is recovered from the bottom of the still. Reportedly about 99.8 percent of the acetic acid in the collected process water is recovered in this operation for reuse. A portion of the acid is converted by a catalytic pyrolysis process to anhydride for the acetylation reaction.

The solvent and water mixture from the top of the acid recovery stills is sent to effluent stills where the solvent is recovered and recycled to the extraction column. The water removed from the bottom of the effluent stills flows to waste treatment. This stream represents the major source of dissolved solids (magnesium sulfate) in the plant discharge.

### Cellulose Acetate Fibers

Process Description - Cellulose acetate fiber is produced by a dry spinning process as indicated by the flowsheet in Fig. 17. Cellulose acetate flake is dissolved in acetone, filtered, and deaerated. Fibers are produced by pumping the solution through spinnerettes down through a hot air atmosphere in enclosed cabinets where fibers are formed by evaporation of solvent. The bundle of filaments from each spinnerette is drawn over a series

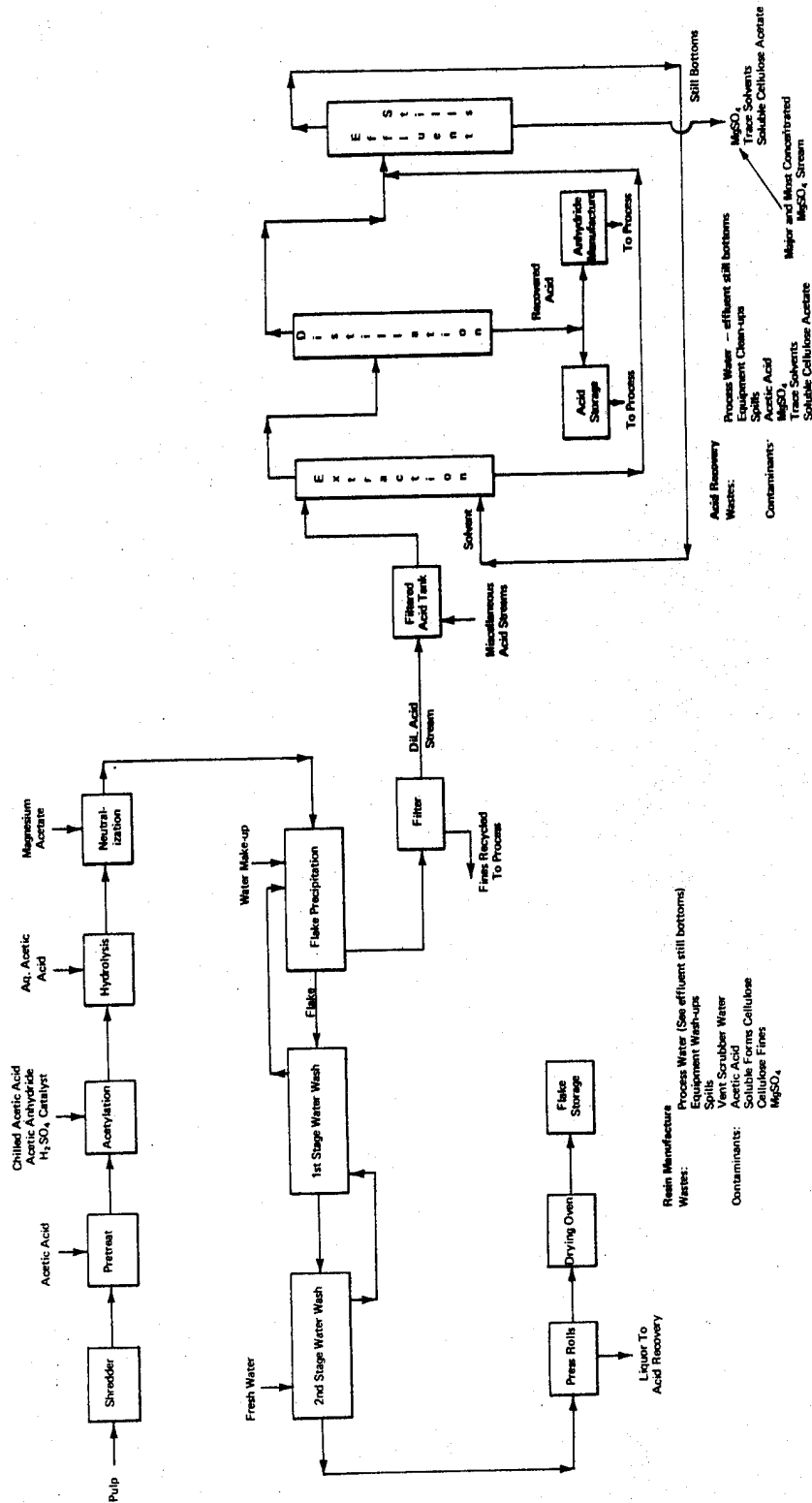

FIGURE 16  
 CELLULOSE ACETATE RESIN PRODUCTION

of wheels to orient the fibers before being wound on a bobbin. The filaments pass over a small roll applicator in this process where a fiber lubricant is applied. There is no significant waste discharge from this lubricating bath. The yarn is subsequently converted by various dry mechanical processes to final product form.

The acetone-laden air from the spinning cabinets is continuously transported through ducts to an activated carbon solvent recovery system. The acetone/air mixture is cooled and passed through carbon beds, where the acetone is absorbed. When the beds become saturated, the acetone is stripped out with steam and the vapors condensed. The solvent is recovered by distillation. Direct stream injection is employed in these stills. The water stream which comes off the bottom of the stills is discharged to waste treatment.

### Cellulose Triacetate Fibers

Process Description - Cellulose triacetate fiber spinning and associated solvent recovery operations are the same as those described for cellulose acetate fibers except that the solvent employed for triacetate is a mixture of methanol and methylene chloride.

### Epoxy Resins\*

Epoxy resins are characterized by the presence of the epoxy group within their structure. Rather than an end resin in itself, the epoxy family should be regarded as intermediates. They all require further reaction with a second component, or curing agent as the second material is often termed, in order to yield the final thermoset material.

Almost all of the commercially-produced epoxy resins are made by the reaction between epichlorohydrin and bisphenol A. Small volumes, however, are produced from polyols other than bisphenol A, such as aliphatic glycols and novolak resins formed from phenol and formaldehyde. It is also possible to produce epoxy resins by introducing the epoxy group after polymer has been formed. An example of this is the epoxidation of a polybutadiene material. The double bond present in these materials forms the site for the epoxy linkage. The following discussion, however, is limited to the materials produced from epichlorohydrin and bisphenol A.

Epichlorohydrin is a liquid with a boiling point of 117°C. Bisphenol A is a solid which melts at 152°C. Bisphenol A is insoluble in water, dissolving to the extent of 0.3 percent at 85°C, whereas epichlorohydrin is somewhat more soluble (in the order of 5 percent).

The reaction between the two raw materials takes place under alkaline conditions as shown by the equations in Fig. 18.

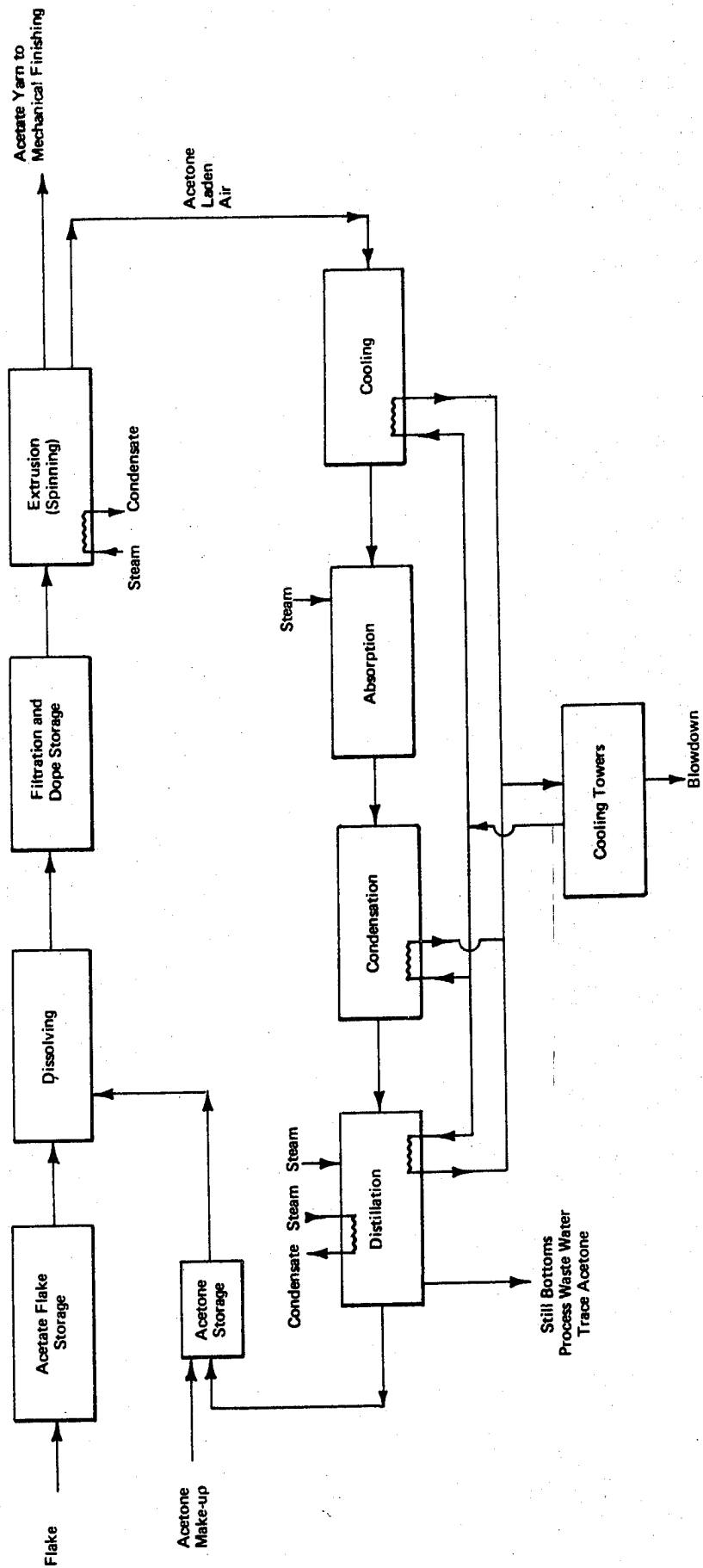

FIGURE 17

CELLULOSE ACETATE FIBER PRODUCTION



The first step, shown by reaction 1, is the condensation of the epichlorohydrin with the bisphenol A to form the chlorohydrin compound. This compound is dehydrohalogenated with caustic soda to form epoxy linkages yielding diglycidyl ether of bisphenol A, as shown by Eq. 2. Sodium chloride and water of reaction are also formed as by-products with the ether. Further reaction between the ether and additional bisphenol A results in growth in the chain length, as shown by Eq. 3.

Operating conditions and type of catalyst are selected to minimize the formation of side chains and to prevent phenolic termination of the chain. The final resin properties are enhanced when the chain is terminated with epoxy groups, as shown in Eq. 3, and when the chain is linear with a minimum of branching. The possibility of branching exists since epichlorohydrin could react with the hydroxyl group to start a side chain.

The product epoxy resins fall into two broad categories, the low molecular weight liquids and the high molecular weight solids. In the liquids,  $n$ , the number of repeating units in the final chain as designated in Eq. 3, is low, ranging in commercial materials from 0.1 to 0.6 as the average value. For solid materials,  $n$  ranges from 1.8 to 16. Control over chain length is exercised primarily by the ratio of the two reactants charged to the system. To produce the low molecular weight liquids, a large excess of epichlorohydrin is used so that  $n$  is close to 0 in the final product. In order to produce the high molecular weight solid resins, the ratio of epichlorohydrin per mole of bisphenol A is usually less than 2.

There are two general approaches to carrying out the synthesis of epoxy resins. In the one-step process all of the reactions shown earlier proceed at the same time. These are usually carried out in the presence of sodium or potassium hydroxide. In the two-step process, reaction 1 is carried out by itself in the presence of a catalyst. Sodium or potassium hydroxide is then added to carry out the dehydrohalogenation and further condensation or polymerization as a second stage. Regardless of which of these two approaches is used, the overall chemistry remains the same.

The product resins are utilized by the customer in conjunction with a curing agent to provide the cross-linking necessary to form a thermo-set material. The curing agents used cover a broad variety of materials such as amines, polyamides, acids, acid anhydrides, resins such as phenolic, urea or melamine formaldehyde combinations; any of which are capable of reacting with either the epoxy groups or the hydroxyl groups present in the resin. The specific material picked depends upon the properties desired in the end resin.

There is substantial production of the so-called modified epoxies. Most of these are manufactured by reacting some material such as a fatty acid, tall oil or the like to form an ester with some of the epoxy groups present in the resin. The

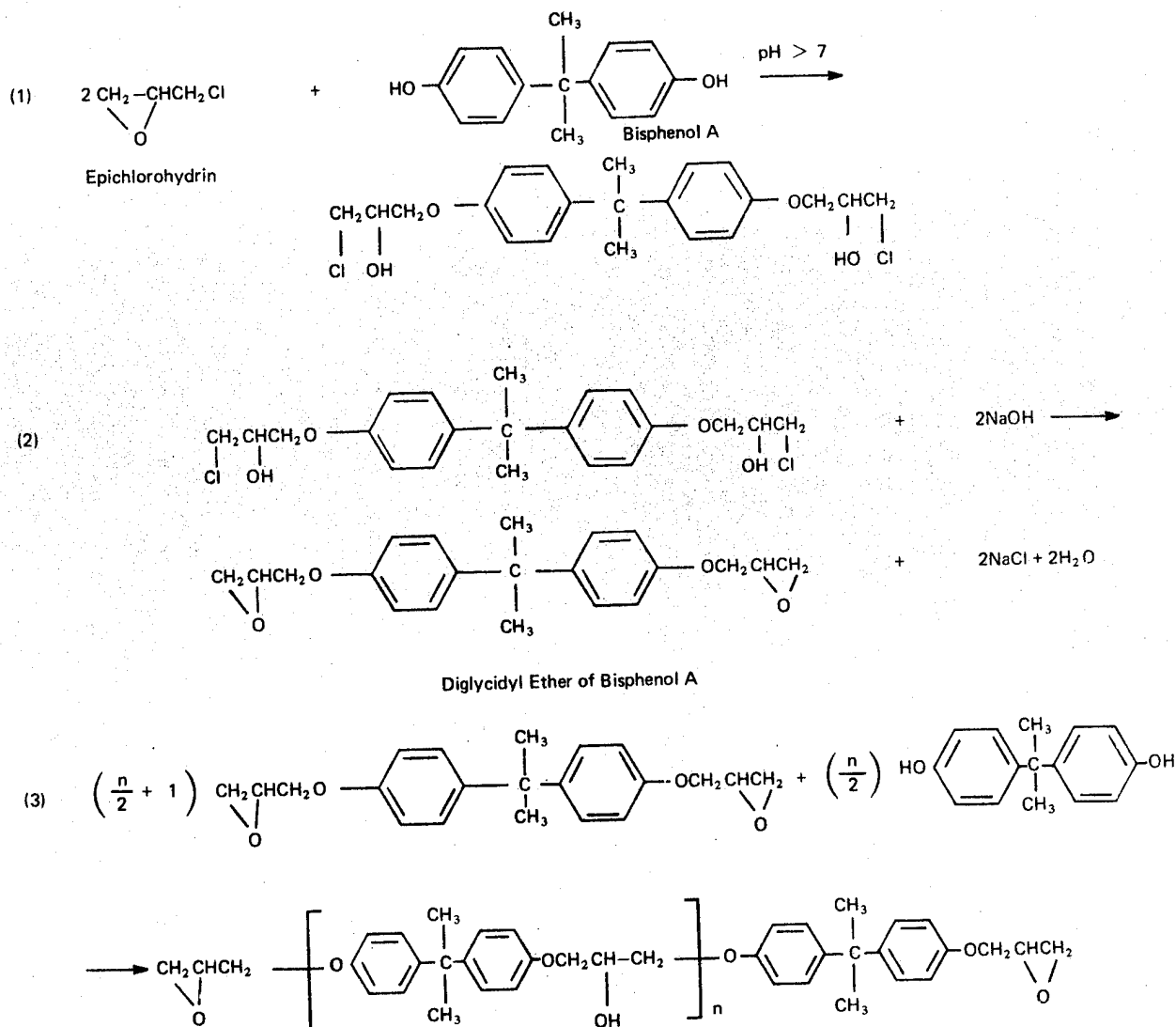

FIGURE 18 REACTIONS BETWEEN EPICHLOROHYDRIN AND BISPHENOL A

degree of esterification carried out depends upon the properties desired in the final material. Most of these modified epoxies find their way into coatings markets.

Process Description - The low molecular weight liquid resins can be manufactured by either batch or continuous processes. Most of the larger producers utilize a continuous process for this material. Fig. 19, a schematic flowsheet of a typical continuous process, is based upon using the two-step technique in order to minimize the molecular weight of the epoxy resin produced. Bisphenol A, with a large mole excess of epichlorohydrin, is introduced into the polymerizer where, under the influence of the catalyst and caustic conditions, the first step of the reaction takes place. The excess epichlorohydrin is then vaporized from the material and recycled.

A solvent, usually a ketone such as methylisobutyl ketone, is then added together with additional caustic and water. The epoxidation of the resin takes place with the formation of salt.

A solution of resin in the ketone solvent is water-washed to remove the final traces of salt, the water decanted is sent to waste, and the solvent is removed by vaporization. The liquid epoxy resin product is then sent to storage.

The solid resins, which have a high molecular weight, are usually produced by batch techniques in resin kettles. In producing these materials where the repeating part of the epoxy chain is a high number ranging from 1.8 to 16, the mole ratio of epichlorohydrin to bisphenol A charged to the kettle is less than 2. No excess epichlorohydrin is used in this case. The process is shown schematically in Fig. 20. Aqueous sodium or potassium hydroxide is added to serve both as a catalytic agent and as one of the reactants to form the epoxy links during the polymerization reaction. Upon completion of the polymerization reaction, the water-containing salt and a very small amount of excess caustic is decanted to the process waste line.

A solvent such as methylisobutyl ketone is then added to dissolve the resin, and the solution is washed with water to remove the remaining amounts of sodium chloride and other salts which may be present. This water is decanted to the process waste lines, and then the methylisobutyl ketone is vaporized from the resin. The solid resins have melting points ranging from about 70°C to 150°C, and the final temperature is such that the resin is molten. It is then drained and cooled to form a solid mass which is crushed to provide the final granular solid product.

#### Phenolic Resins\*

The family of phenolic resins includes our oldest synthetic polymers. The term is used to describe a broad variety of materials, all of which are based upon the reaction between phenol, or a substituted phenol such as creosol or resorcinol, and an aldehyde such as formaldehyde or acetaldehyde. Nearly all

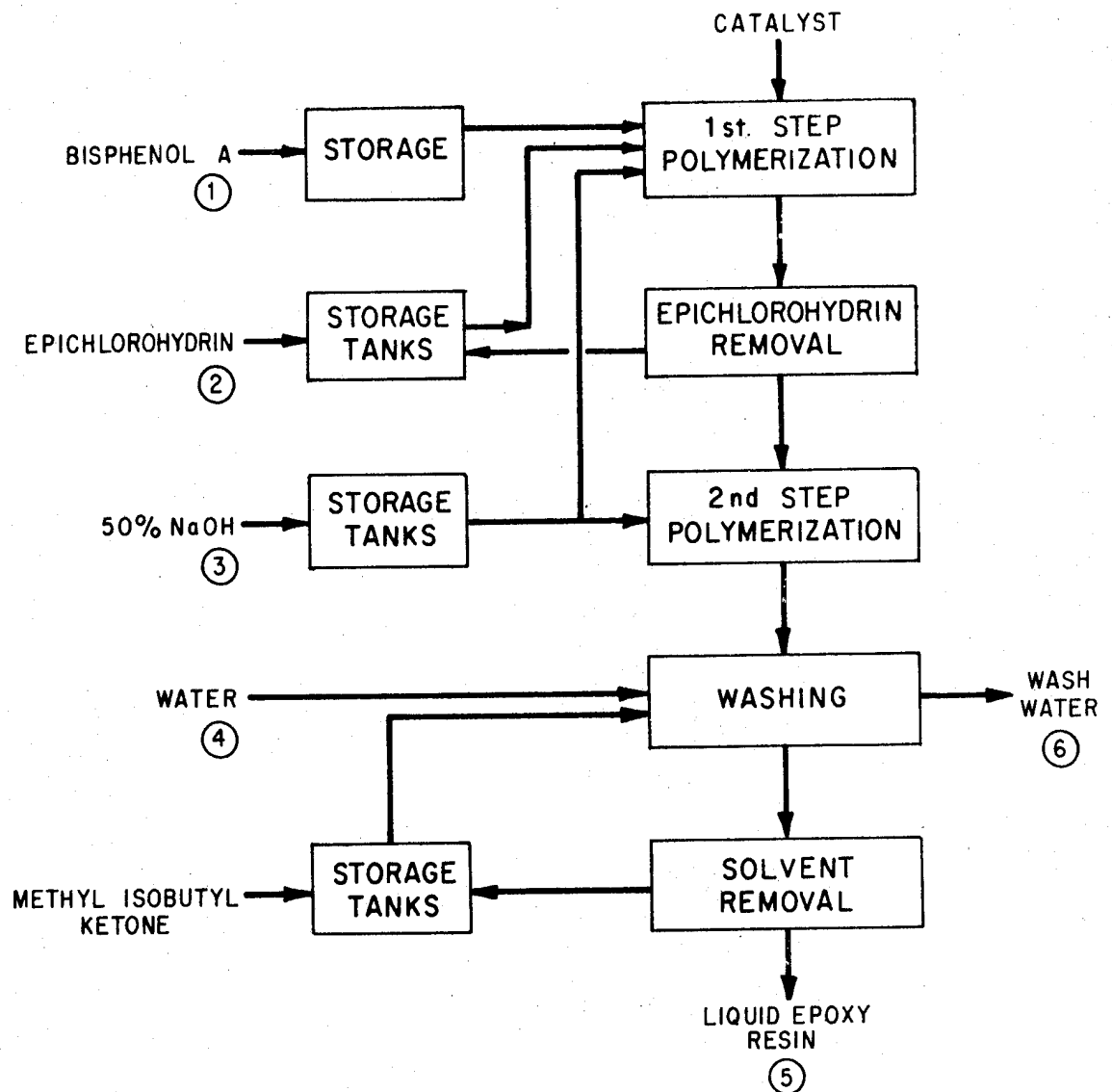

	lbs/1000 lbs PRODUCT
① BISPHENOL A	690.4
② EPICHLOROHYDRIN	512.7
③ 50% CAUSTIC	443.4
NaOH	221.7
H <sub>2</sub> O	221.7
④ WASH WATER	2218.0
⑤ LIQUID RESIN	1000.0
⑥ WASTE WATER	2859.0
H <sub>2</sub> O	2535.0
NaCl	324.0

n = 0.2

FIGURE 19

LIQUID EPOXY RESIN PRODUCTION

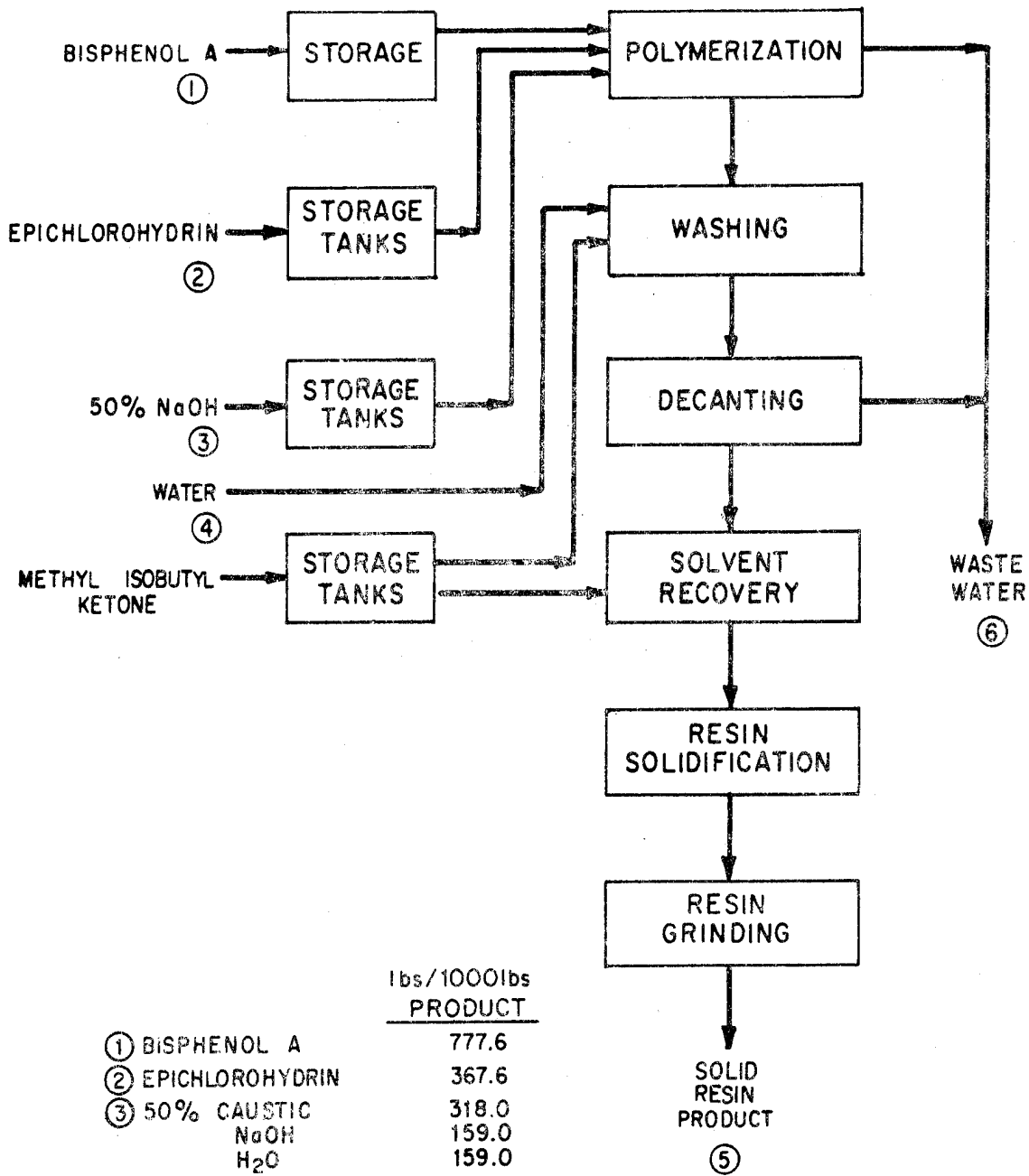

	lbs/1000lbs PRODUCT
① BISPHENOL A	777.6
② EPICHLOROHYDRIN	367.6
③ 50% CAUSTIC	318.0
NaOH	159.0
H <sub>2</sub> O	159.0
④ WASH WATER	2218.0
⑤ SOLID RESIN	1000.0
⑥ WASTE WATER	2681.0
H <sub>2</sub> O	2449.0
NaCl	232.0

n = 5

FIGURE 20

SOLID EPOXY RESIN PRODUCTION

industrially-significant resins, however, are based upon the reaction of phenol with formaldehyde.

Phenol, commonly known as carbolic acid, is a solid at room temperature but melts at between 42 and 43°C. It is usually shipped and handled as a liquid by keeping it above its melting point. Formaldehyde is normally a gas. It is handled commercially in the form of formalin, which is a 37 percent by weight solution of formaldehyde and water.

There are two broad types of resins produced by this industry for subsequent utilization by their customers. In the first category are the one-step resins, sometimes termed resols. These are characterized by being formed from a mixture of phenol and formaldehyde which contains more than one mole of formaldehyde per mole of phenol. Often the mole ratio is about 1.5 to 1. An alkali such as sodium hydroxide is used to catalyze the polymerization which takes place at a pH of between 8 and 11. The reaction is shown in Fig. 21.

The reacting mixture contains sufficient formaldehyde so that, if allowed to proceed to completion, a cross-linked thermo-set resin would be formed. The reaction, however, is stopped short of completion at an average molecular weight of the polymer appropriate for the end use of the material. The product may be in the form of an aqueous syrup, or the water may be removed so that a solid product is obtained. For other uses, such as many coating applications, the material may be dissolved in alcohol before it is shipped to the customer.

The material already contains sufficient formaldehyde to completely cross-link the ultimate product so that it can be thermally set into an infusible material by the application of heat at the customer's facilities. Since cooling the mixture in its partially polymerized form does not completely stop further polymerization but merely retards it, these materials have a somewhat limited shelf life (in the order of 60 days for many types).

The second category of resins is the novolaks. These are formed from a reacting mixture which contains less than one mole of formaldehyde per mole of phenol. The normal commercial range for this mole ratio is between 0.75 and 0.90. To produce this material, polymerization is carried out in an acid medium, using a catalyst such as sulfuric acid. The pH of the reaction usually ranges from 0.5 to 1.5. For special uses where a high ortho linkage is desired, the polymerization may be carried out at a pH of from 4 to 7, but this is not typical. The reaction is shown in Fig. 22. Since the reacting mixture contains a deficiency of formaldehyde, essentially all of the formaldehyde is consumed during polymerization. Thus, no further polymerization can take place, and the product is a low molecular weight, stable material. The water which enters with the formaldehyde plus the water reaction is removed at the end of the reaction, and a solid meltable material results.

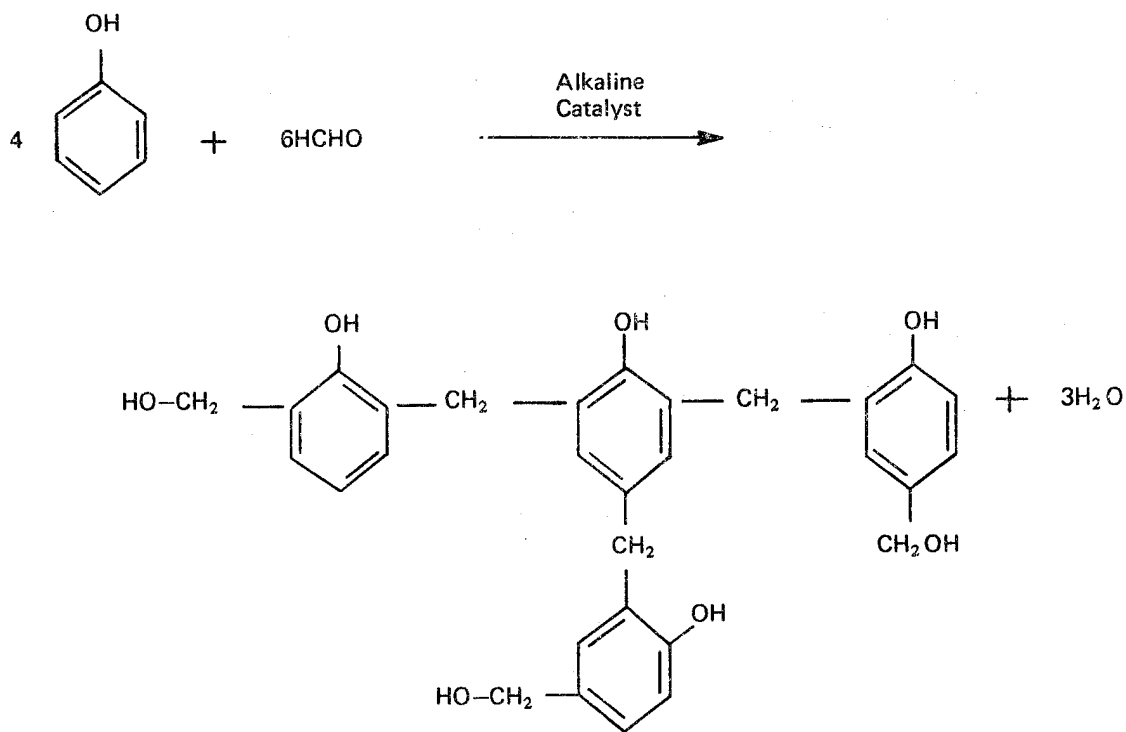

FIGURE 21 TYPICAL REACTION TO FORM ONE-STEP RESINS OR RESOLS

In order to complete the polymerization, the user must add additional formaldehyde. Sometimes this is done by using paraformaldehyde, a solid polymer of formaldehyde, but the extremely irritating nature of this material has limited its use. Most users complete the reaction by using hexamethylenetetramine. With this material ammonia is evolved from the reacting mass, leaving the same types of methylene linkages as can be obtained by using additional formaldehyde.

The basic resins described above are sometimes modified by the use of materials such as drying oils or epoxy compounds in the final stages of polymerization. These modified phenolics find many specialty uses but do not affect the basic manufacturing processes to any significant degree.

Manufacturing Processes for Typical Resins - Although continuous processes for the production of phenolic resins have been developed, they are seldom used. The production of these continuous units must be high, and the industry calls for such a wide variety of materials that it is seldom possible to have a large enough run on a single grade of polymer to justify their use.

The standard producing unit of the industry is typically a batch resin kettle arrangement, such as is shown in Fig. 23. The heart of the process, the resin kettle, varies in size from 2,000 to 10,000 gal. (7.6 to 38 cu m) These are jacketed, and in the larger sizes internal cooling coils are used in order to provide sufficient surface-to-volume ratio to remove the considerable amount of heat generated during polymerization. The kettles are agitated and can operate under either pressure or vacuum conditions.

The feed system generally consists of two weigh tanks which weigh in the required amounts of phenol and 37 percent formaldehyde solution. The kettle is equipped with a water-cooled condenser, which is also joined to a vacuum system.

In a typical cycle for a one-step resin, the phenol is charged in a molten form to the kettle followed by formaldehyde, which washes any residual phenol out of the lines leading to the kettle. A sodium hydroxide catalyst solution is then added, and the kettle is heated to bring the mixture to a temperature of about 60°C. During this period the condensation reaction starts, and the reaction becomes highly exothermic so that a change is made from supplying steam to the coils to cooling water. The mixture is held at a temperature ranging from 60°C to about 80°C for a period of three to five hours. During this period temperature is controlled by circulating cooling water through the coils as well as by using total reflux returning from the water-cooled condenser mounted above the kettle. When the polymerization has reached the desired state, as shown by laboratory tests, the mixture is cooled to about 35°C to essentially stop further reaction. At this point the caustic is



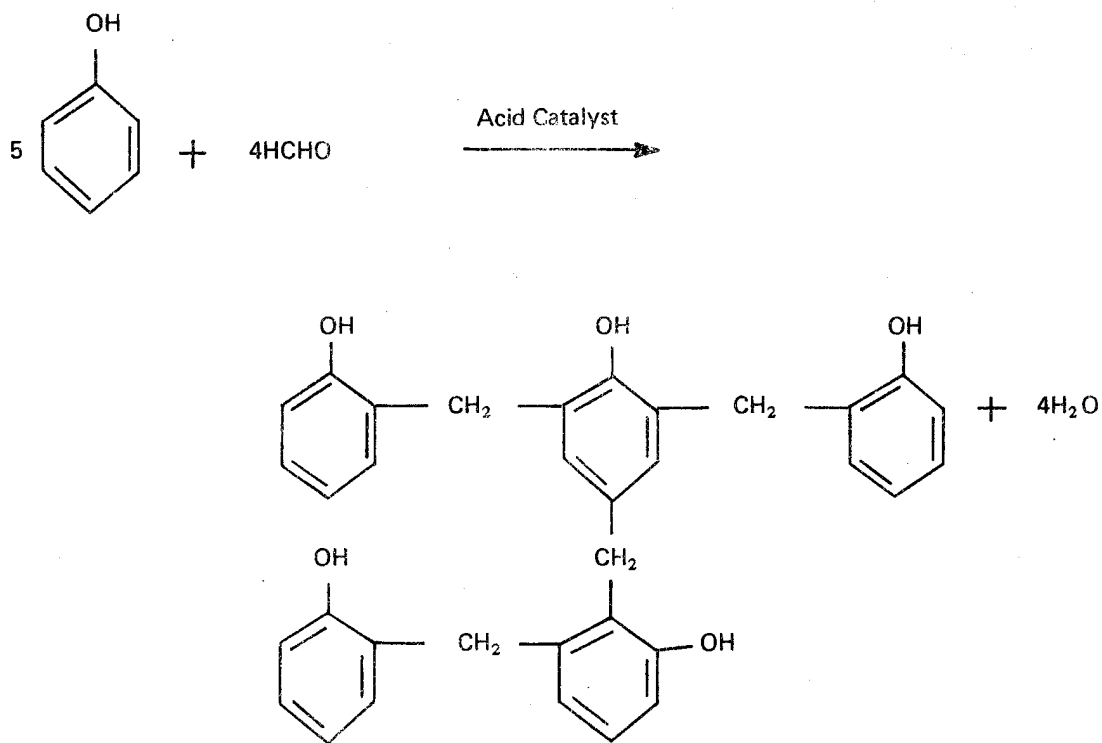

FIGURE 22 TYPICAL REACTION TO FORM NOVOLAK RESIN

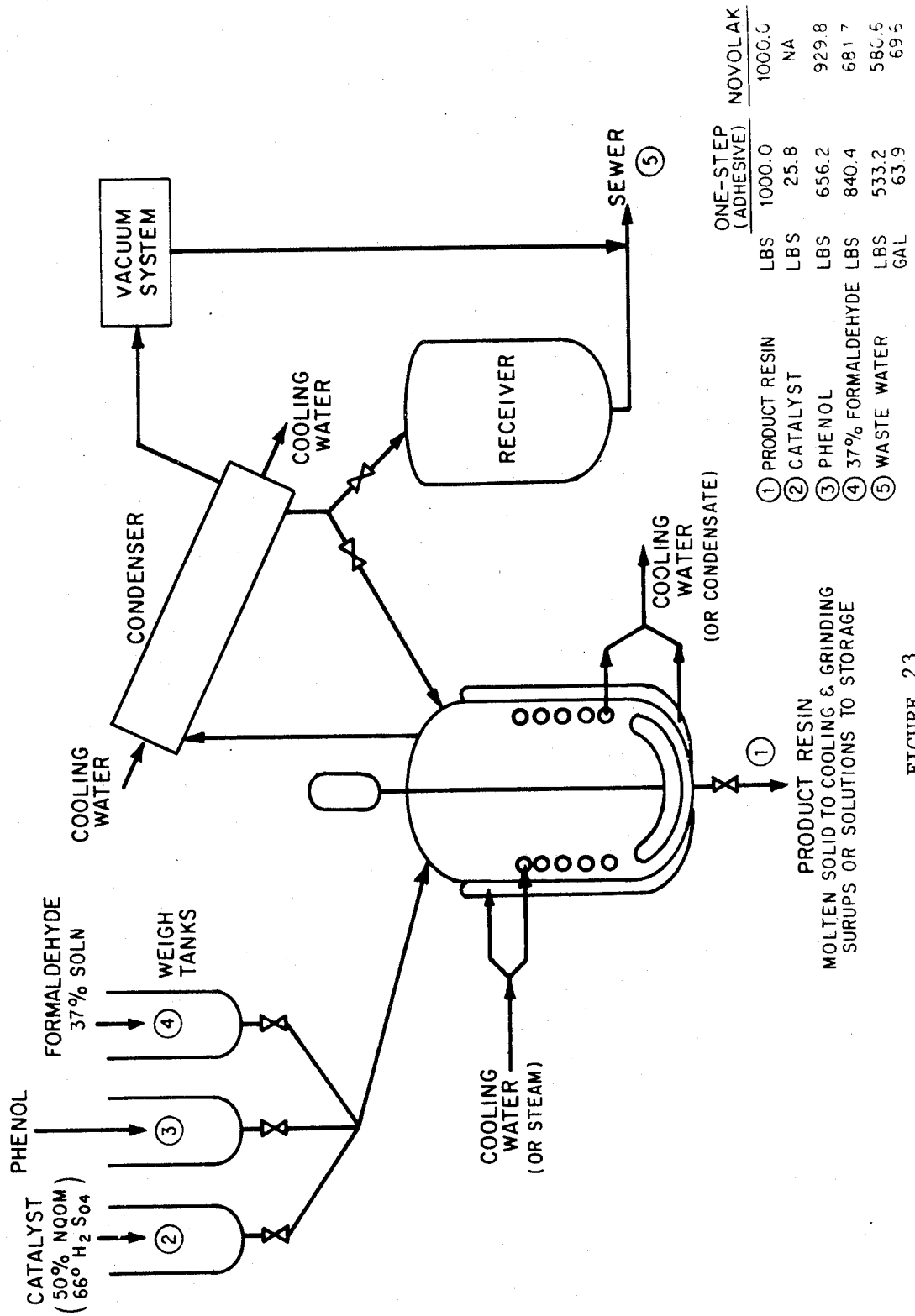

FIGURE 23

PHENOLIC RESIN PRODUCTION

neutralized by the addition of sulfuric acid, which brings the mixture to a pH of about 7.

The mixture is then heated by admitting steam to the coil, and the resin is dehydrated to the desired water content at its boiling point, about 98°C. The water which has been removed contains some unreacted monomer and is collected in the receiver. This water is waste water from the process. When the desired amount of water has been removed, the mixture is cooled and discharged for packaging and shipment. The total cycle takes about 12 hours.

If a resin is desired which contains a very small amount of water such that it cannot be dehydrated at a temperature low enough to prevent further polymerization, a vacuum is applied during the latter part of the dehydration cycle. This technique can be used to produce an essentially anhydrous melt of a single-step resin.

The resin must be quickly discharged from the bottom of the kettle through cooling plates for a quick quench in order to prevent the mass from setting up into an insoluble, infusible material. The cast material, when solidified, can be broken up and crushed for shipment as a powder.

The manufacture of novolak resins is entirely analogous except that an acid catalyst, such as sulfuric acid, is added at the start of the batch. With strongly acid catalysts it is necessary to utilize a vacuum reflux in order to maintain temperatures at 85 to 90°C, a slightly higher temperature range than that used for the one-step reaction. Under milder reaction conditions, atmospheric reflux is adequate to control the temperature.

At the end of the reflux period, three to six hours after initiating the reaction, the condensate is switched to the receiver and water is removed from the batch. When the temperature reaches the order of 120 to 150°C, the vacuum is applied to aid in removing the final traces of water and part of any unreacted phenol. Final temperatures may rise to about 160°C under a vacuum of 25 to 27 in. (63.5 to 68.5 cm) of mercury. These higher temperatures are possible since the reaction proceeds to completion and, therefore, no further polymerization can be carried out until additional formaldehyde is added. The completed batch is dumped in the molten form onto cooling pans where it solidifies, or onto a flaker. If the product is needed in solution form, solvent is added at the end of the batch as it cools in the kettle and the solution discharged from the kettle to storage tanks for drumming.

The finished products may be shipped to customers as such or may be compounded with additives at the resin-producing point. The solid resins may be ground, and wood fillers, pigmenting materials and hexamethylenetetramine added to form a finished molding compound. These processes all involve solids-handling and do not give rise to waste water generation.

## Amino Resins - Urea and Melamine\*

The term "amino resins" is used to describe a broad group of polymers formed from formaldehyde and various nitrogen-containing organic chemicals. The nitrogen group is in the form of the  $\text{NH}_2$ . Although called amino resins, in the case of most of the compounds used they are more in the nature of amides than true amines. The resins are characterized as being thermo-setting, amorphous materials which are insoluble in most solvents. Although many amino compounds are used in the formation of amino resins, the two of primary commercial significance are urea and melamine. Specialty materials are formed from other amino compounds such as thiourea, acrylamide or aniline. These, however, are produced only in small volumes and have little significance in the total amino resin market.

Formaldehyde, the common raw material in all types of amino resins, is normally a gas but is handled industrially as an aqueous solution. It is infinitely miscible with water. Urea, a solid under normal conditions, is highly soluble in water. Melamine could be described as sparingly soluble and is also a solid under the usual conditions, melting at the high temperature of  $355^\circ\text{C}$ .

Another characteristic of the group of amino resins is that the polymerization reaction proceeds in two distinct stages. In the first of these, as indicated, for urea and formaldehyde in Eqs. 1 and 2 of Fig. 24, formaldehyde reacts with urea (depending upon the mole ratio of the reactants) to form materials such as monomethylol urea and dimethylol urea which are the reactive monomers involved in the final polymer. As indicated in Eq. 2, these materials may react among themselves to form dimers. Although the structure of just one dimer is shown, a consideration of the active hydrogen groups involved shows that many other dimers containing both methylene and ether linkages are possible. The initial reaction is an addition reaction with no water formed as a result of the combination. The condensation reaction, as indicated by Eq. 3, involves the formation of one mole of water for each linkage formed.

As shown in Fig. 25, the reactions in the case of melamine and formaldehyde are entirely analogous to those shown for urea and formaldehyde. It should be noted, however, that since melamine contains three  $\text{NH}_2$  groups, as contrasted with the two present in urea, the combinations and permutations are much greater than in the case for urea. Again, the first two reactions indicate the initial step of the polymerization. This consists of the formation of reactive monomers between melamine and formaldehyde. The further reactions, as indicated schematically by Eq. 3, can involve the reaction of an additional mole of melamine with one of the monomers, shown in this case as trimethylol melamine, to form condensation compounds which involve the elimination of water of reaction. Although not shown, it can be readily visualized that a mole of trimethylolamine could react with an additional mole of trimethylolamine to eliminate water and form

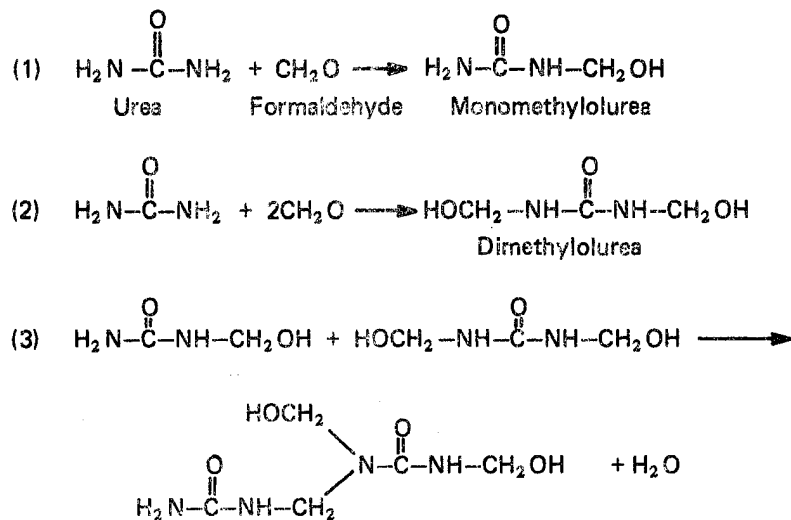

FIGURE 24 TYPICAL POLYMERIZATION FOR UREA AND FORMALDEHYDE

an ether linkage as contrasted to the methylene linkage formed between the trimethylolamine and another molecule of melamine.

These reactions are catalyzed by hydrogen ions and, in general, are moderated or slowed down by hydroxyl ions. Thus, the proper pH selection is an important consideration in determining the structure of the ultimate polymer formed.

The basic amino resin manufacturing process is generally stopped with the formation of a predetermined amount of monomers, dimers and trimers depending upon the specifications desired for the ultimate resin. This mixture of materials is then utilized by the customer to form the final thermal-set resin which is an insoluble, heat resistant material. This is contrasted with the mixture of very low molecular weight materials produced by the basic manufacturer which are usually a water soluble, very heat sensitive material.

Consideration of the equations presented above will show there are numerous possibilities for cross-linking the various monomers, dimers and trimers which would be involved in the initial stages of the reaction. The ultimate customer forms these cross-links between the molecules by the application of heat and pressure, sometimes with the aid of a catalyst depending upon the nature of his application.

The ultimate markets for the amino resins are approximately as shown in the table below.

Table 11

Markets for Amino Resins

<u>Applications</u>	<u>Percentage of Amino Resins</u>
Adhesives	36%
Textile and Paper Treating and Coating	22%
Laminating and Protective Coatings	18%
Moulding Compounds and All	
Other Applications	<u>24%</u>
	100%

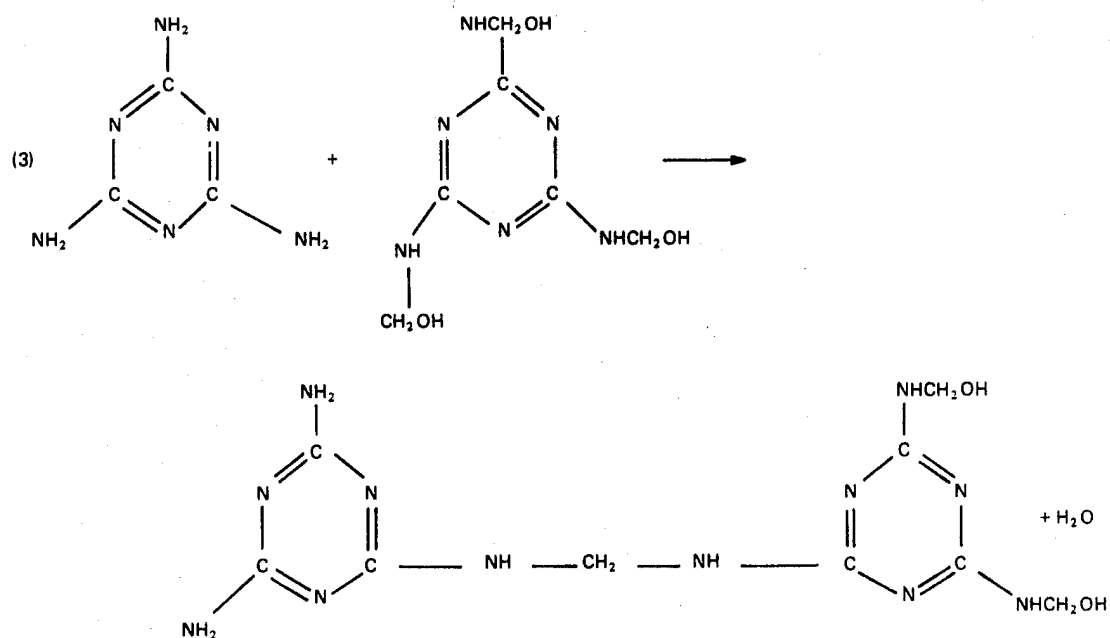
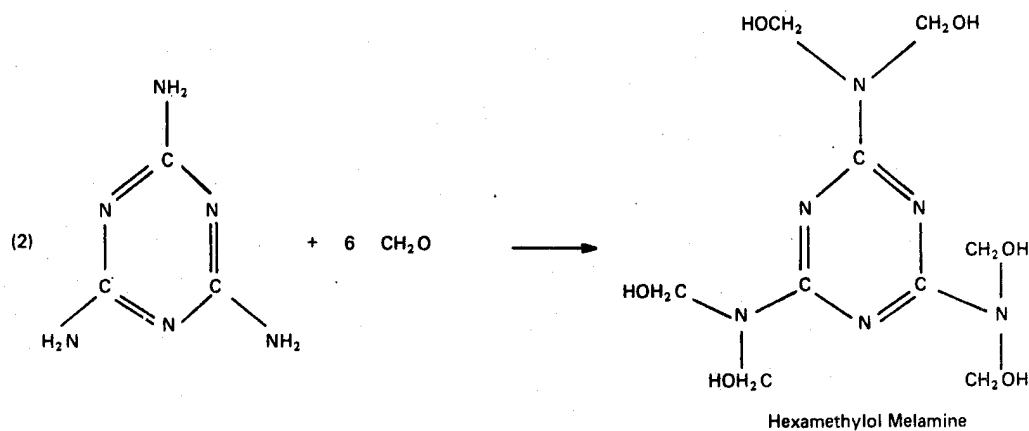
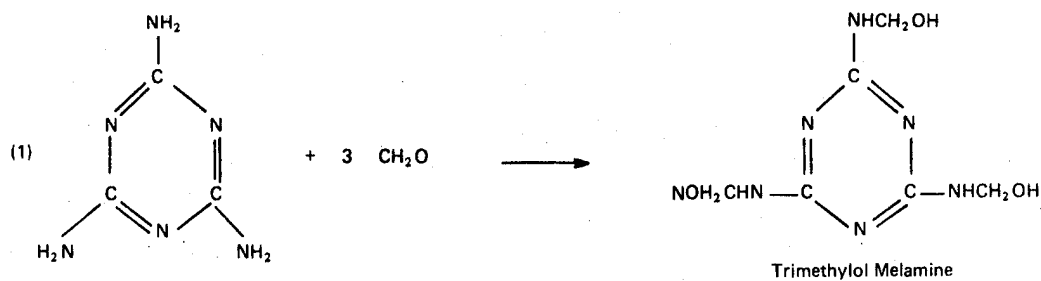

FIGURE 25 TYPICAL POLYMERIZATION REACTIONS FOR MELAMINE AND FORMALDEHYDE



For most of these applications the resin is used in the form of either an aqueous solution or a mixture of an aqueous and alcohol solution, ethanol being the usual alcohol. For moulding compounds and some of the others, a solid material is utilized. In nearly all of these applications, the melamine part of the amino resin family has superior properties. Because of its higher cost, however, it is utilized principally where these superior properties are necessary. In other instances the urea formaldehyde resins, which are lower cost, are equally applicable.

Since, as mentioned above, the reactive monomers, polymers, trimers and low molecular weight material formed by the basic resin manufacturer contain all of the reactive groups necessary to further crosslink, the solution materials have a limited shelf life, in the order of 60 days. Thus, the users who have a large volume requirement for solution forms, such as paper mills, textile mills and the like, may purchase material made in solution form by the manufacturer since they will utilize it quickly and not have a residual inventory. Other users, where the shelf life of the product is of considerable importance, will purchase the material in an anhydrous solid form which has a relatively indefinite shelf life. Often, before the final use, the solid may be re-dissolved in either water or alcohol or mixtures thereof if a solution form is utilized in the application.

Process Description - Since amino resins are produced in many specialty grades with each run being a relatively modest volume, continuous processes are not in general use in the industry. The typical process is a standard batch polymer kettle arrangement. As shown in Fig. 26, the normal arrangement consists of a jacketed polymer kettle ranging in size from about 2,000 up to 10,000 gallons. The larger sizes contain internal coils for additional heating and cooling surface in order to provide a reasonable surface-to-volume ratio. The kettles are agitated and can operate under either pressure or vacuum condition.

The kettle is equipped with a water-cooled condenser and tied into a vacuum system so that the operating temperature can be controlled through the use of both reflux and cooling or heating in the jacket and coils of the kettle. The feed system consists generally of weigh tanks for the batch operation of the kettle.

The techniques used are very similar for both melamine or urea types of formaldehyde amino resins. As a typical example, the production of a plywood adhesive grade urea formaldehyde resin is as follows. Formaldehyde as a 30 percent solution is added to the kettle and the pH adjusted to about 7 to 7.8. Boric acid, the catalyst, is then added, and then urea in the form of a solid is fed into the reaction vessel. The pH of the mixture is again brought back to approximately neutral and the mixture heated to 100°C under atmospheric reflux conditions. During this initial heating period the pH drops to about 4 as the reaction between

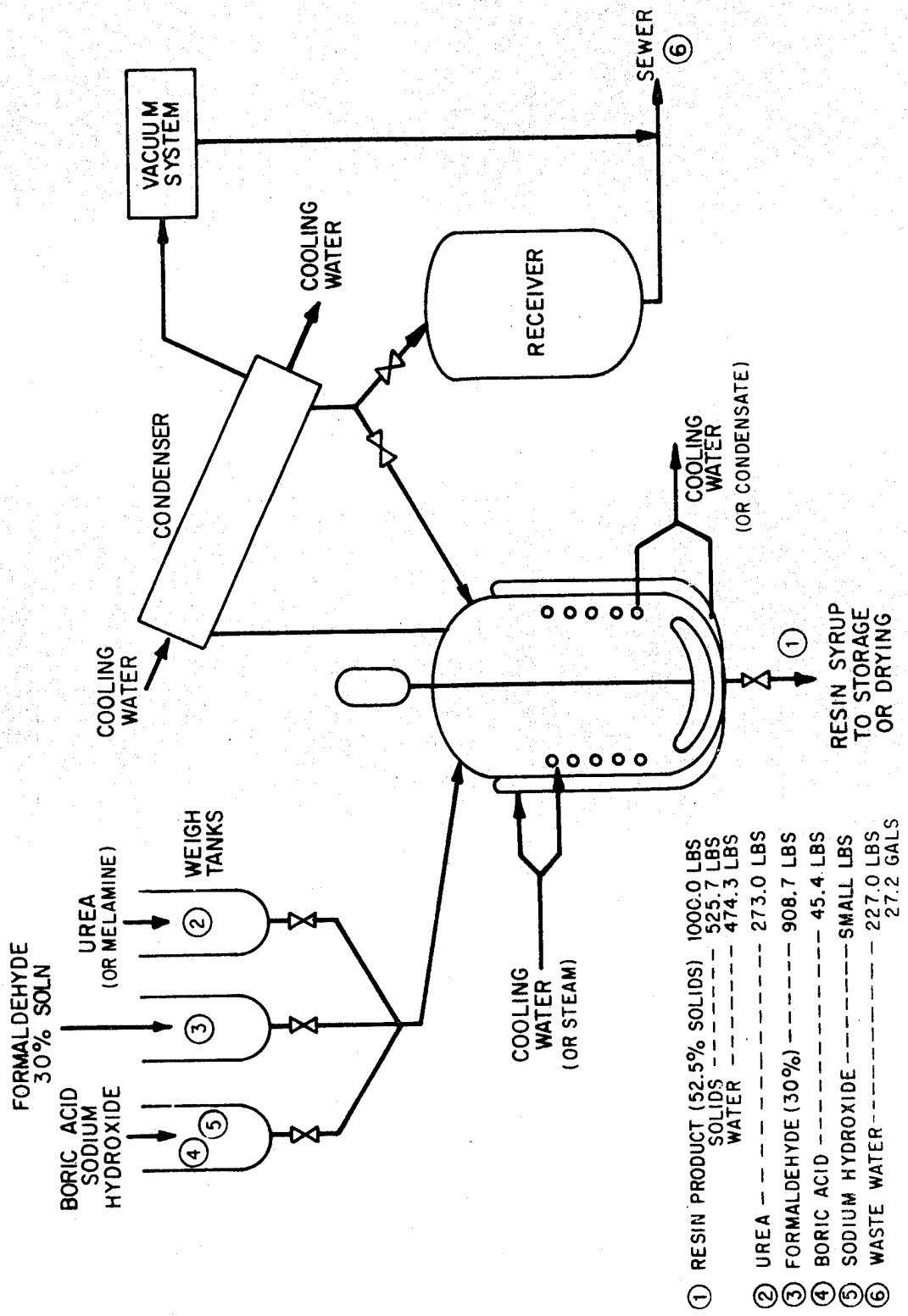

FIGURE 26

urea and formaldehyde takes place to form di- and trimethylol urea. Atmospheric reflux is maintained for a period of about two hours. Then the vacuum is applied, and the system temperature drops to approximately 40°C. It is maintained at this level for approximately five hours. During this period of time there is a limited amount of condensation reaction taking place between the various monomers formed earlier. Simultaneous with this further reaction water is removed from the system so that the final water content, in the case of this particular adhesive formulation, is about 50 percent. The water in the system derives from two sources: that introduced with the 30 percent formaldehyde solution used as a raw material, and that produced by the reaction between the monomers, which eliminates a mole of water for each pair of monomers or trimers reacting.

At the end of the vacuum reflux period, the system is put on total reflux and the pH adjusted to slightly alkaline conditions. The reactor is then returned to atmospheric pressure, and the product is ready to be removed. The total cycle time is about 10 hours.

The mixture, at this point in the form of a thick syrup, is drained to storage where quality checks are made to determine the exact condition of the polymers. The material may be shipped in this form for further polymerization by the customer or it may be dried to be shipped as a solid which, as mentioned earlier, has a much longer shelf life. If the material is to be dried, it is fed to either a belt drier or a spray drier where the remaining water is removed at low temperature in order to prevent further polymerization. As mentioned earlier, the final adjustment of the pH also helps prevent further condensation reaction and polymerization of the monomers. The water removed during these final drying operations is vented to the atmosphere.

Depending upon the end-use requirements, the final solid product may be milled with pigments, dyes and fillers to provide a moulding compound suitable for the particular end use desired.

The equipment used for the production of the first-step amino resins is often used for other materials, such as phenolics. Between these different uses, and indeed between production batches of melamine and urea resins or between batches of significantly different resins, it is customary to clean the equipment by utilizing a hot dilute caustic solution. This material is drained as process waste.

### Acrylic Fibers

The term acrylic fibers refers to the general category of fibers based on polyacrylonitrile. The modacrylic variation of the basic fiber, which accounts for a minor proportion of total acrylic fiber production, is based on the use of comonomers such as vinylidene chloride or vinyl chloride. (The Federal Trade Commission defines a modacrylic as a man-made fiber in which the fiber forming substance is any long chain synthetic polymer

composed of less than 85 percent but at least 35 percent by weight acrylonitrile units.) Other monomers such as the vinyl halogens or acrylates may be included in the polymerization mixture when fire retardance or specific property modification is desired.

Solvent is used to dissolve the polymer. This can be dimethyl formamide, dimethyl acetamide, tetramethylene cyclic sulfone, or acetone. In-organic salts such as lithium bromide or sodium sulfocyanide are also known to be solvents, although these are not used in conventional U.S. practice. The wet spinning solvent is not a raw material in the conventional sense since its recovery is necessary for economical operation. Small solvent losses, however, are a significant factor in wet spinning waste loads. Other raw materials involved in the production process include polymerization catalysts and finishing oils. The end product of the production process is a white, unpigmented synthetic fiber in staple, tow, or continuous filament form.

Process Description - Both wet and dry spinning are used in acrylic fiber production. The wet spinning process is predominant. This process consists of mixing acrylonitrile monomer, water, catalyst and activator in a continuous polymerization reactor where polymerization is carried to approximately 65 percent conversion. The polymer slurry, after passing through a holding tank, is then passed through a centrifugal filter and drying bed. The product at this point is a fine white powder. The polymerization reaction can be represented as

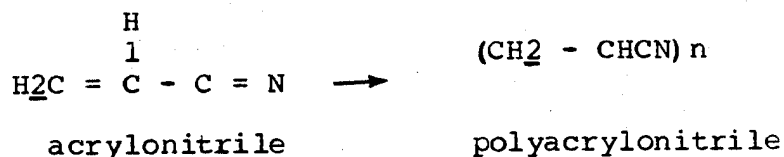

Polymer and solvent are then mixed to form a spinning dope which is forced through spinnerettes into a coagulating bath (solvent + H<sub>2</sub>O) to form the fiber. This is followed by washing baths, steam stretching operations and a finish bath in which a spin finish (fatty acids, ethylene glycol) is applied. After leaving the spin finish bath, the product is then crimped, set (by passing through a heated oven) and either cut or baled as staple.

In the dry spinning process the spinning dope is forced through the spinnerette into a heated air chamber rather than a coagulation bath.

Fig. 27 shows a typical large-scale acrylic fiber production facility which includes both polymerization and fiber spinning. Fig. 28 shows acrylonitrile polymerization and dry spinning of acrylic fibers.

Nylon 6 Resins and Fibers

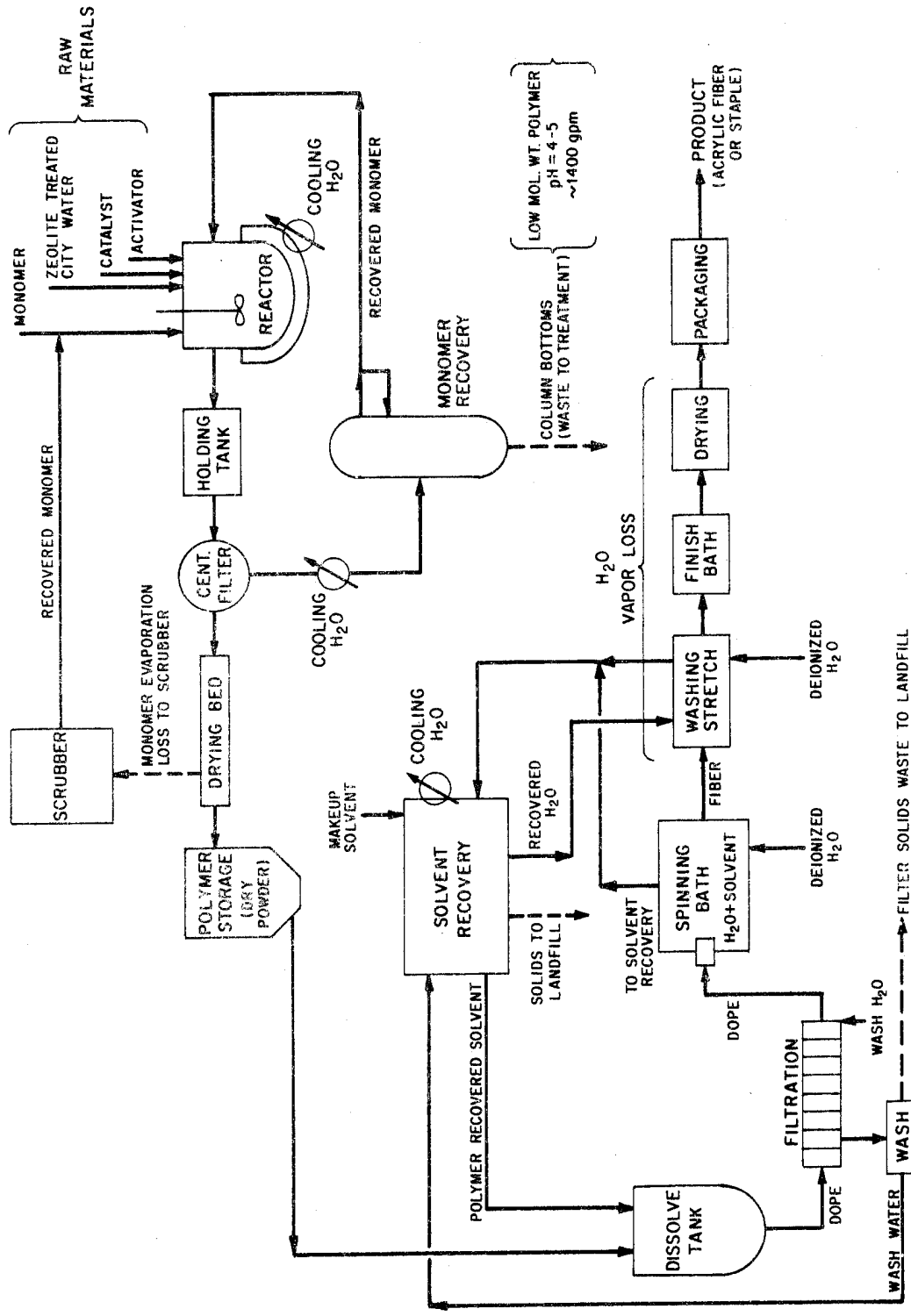

ACRYLIC FIBER PRODUCTION - WET SPINNING PROCESS  
 FIGURE 27

Of the many commercially available polyamides, nylon 6 ranks second in importance to nylon 66. Nylon 6 resin and fibers are made from caprolactam. Other raw materials include a catalyst and acetic acid (chain terminator). As with other fibers,  $TiO_2$  is added in the polymerization step as a delusterant, spin finishes are used in processing and thermal stabilizers are added. End products from the nylon 6 polymerization process are either resin chips or fiber in the form of staple or continuous filament.

Process Description - The polycaproamide polymerization process involves three steps. In the first step (initiation and addition) caprolactam adds a molecule of  $H_2O$  to form aminocaproic acid. Caprolactam successively adds to this growing chain. The second step involves condensation polymerization of the short chains formed in the first stage. In the third step the chain stopping agent (usually a monofunctional acid, such as acetic acid, or occasionally a monofunctional amine) terminates the growing chains. The reactions for nylon 6 polymerization are shown in figure 29.

Numerous processes for both batch and continuous polymerization are in use. The current economic situation favors the continuous process, particularly for facilities integrated to fiber production.

The Lurgi process for continuous polymerization is shown in Fig. 30.

After melting, the molten caprolactam is mixed with catalyst, acetic acid (chain stopper) and  $TiO_2$  delusterant and then passed to a continuous polymerization tube. Molten polymer from the polymerization tube is then passed to an extruder which forms the resin into continuous strands which are solidified by cooling in a water bath. The strands are continuously cut into chips which must be subsequently washed by continuous, counter-current exposure to water in order to extract residual caprolactam. After extraction, the polymer chips are dried with hot nitrogen and spun into filament.

The monomer recovery process consists of concentrating the 5 percent caprolactam solution, from the extractor, by a two-stage distillation to 70 percent caprolactam. This stream is then exposed to  $KMnO_4$  to oxidize impurities and purified by batch distillation to pure caprolactam which is recycled to the process.

The Vickers-Zimmer process, which is also frequently used for continuous nylon 6 polymerization, is similar to the Lurgi process with the important exception that following polymerization the residual monomer is extracted under vacuum from nylon 6 polymer in the molten state rather than from solid chips. It is then possible to avoid chip production, water extraction, vacuum drying, chip conveying and renewed melting.

The Vickers-Zimmer process is thus based on two main units: the polymerization reactor column and a thin-film evaporator.

\*Revisions and updating of the process descriptions for the epoxy resins, phenolic resins, urea and melamine resins will be incorporated into the Development Document for the Synthetic Polymers Segment of the Plastics and Synthetics Industry.

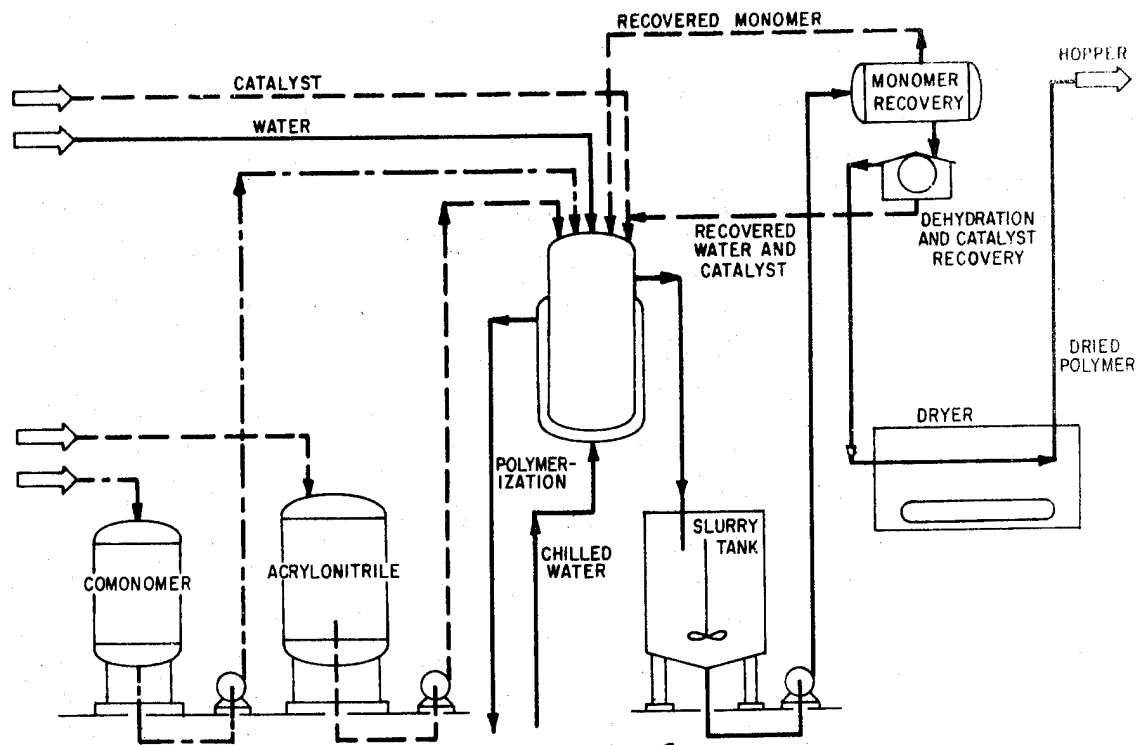

AQUEOUS - SUSPENSION ACRYLONITRILE POLYMERIZATION

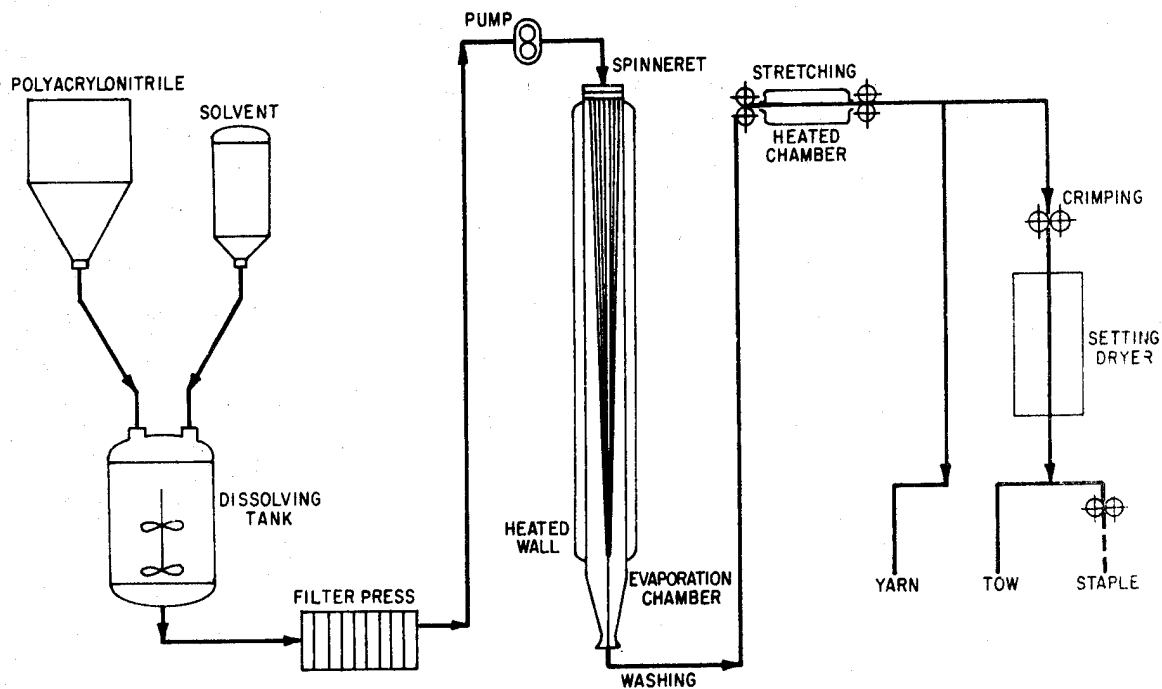
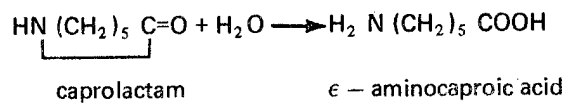

FIGURE 28

ACRYLIC FIBER PRODUCTION - DRY SPINNING PROCESS



(a) Initiation and addition to form aminocaproic acid



(b) Polycondensation

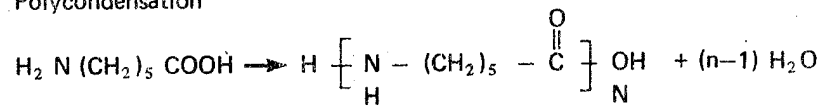

Nylon 6

**FIGURE 29 TYPICAL POLYMERIZATION REACTIONS TO FORM NYLON 6 RESIN AND FIBER**

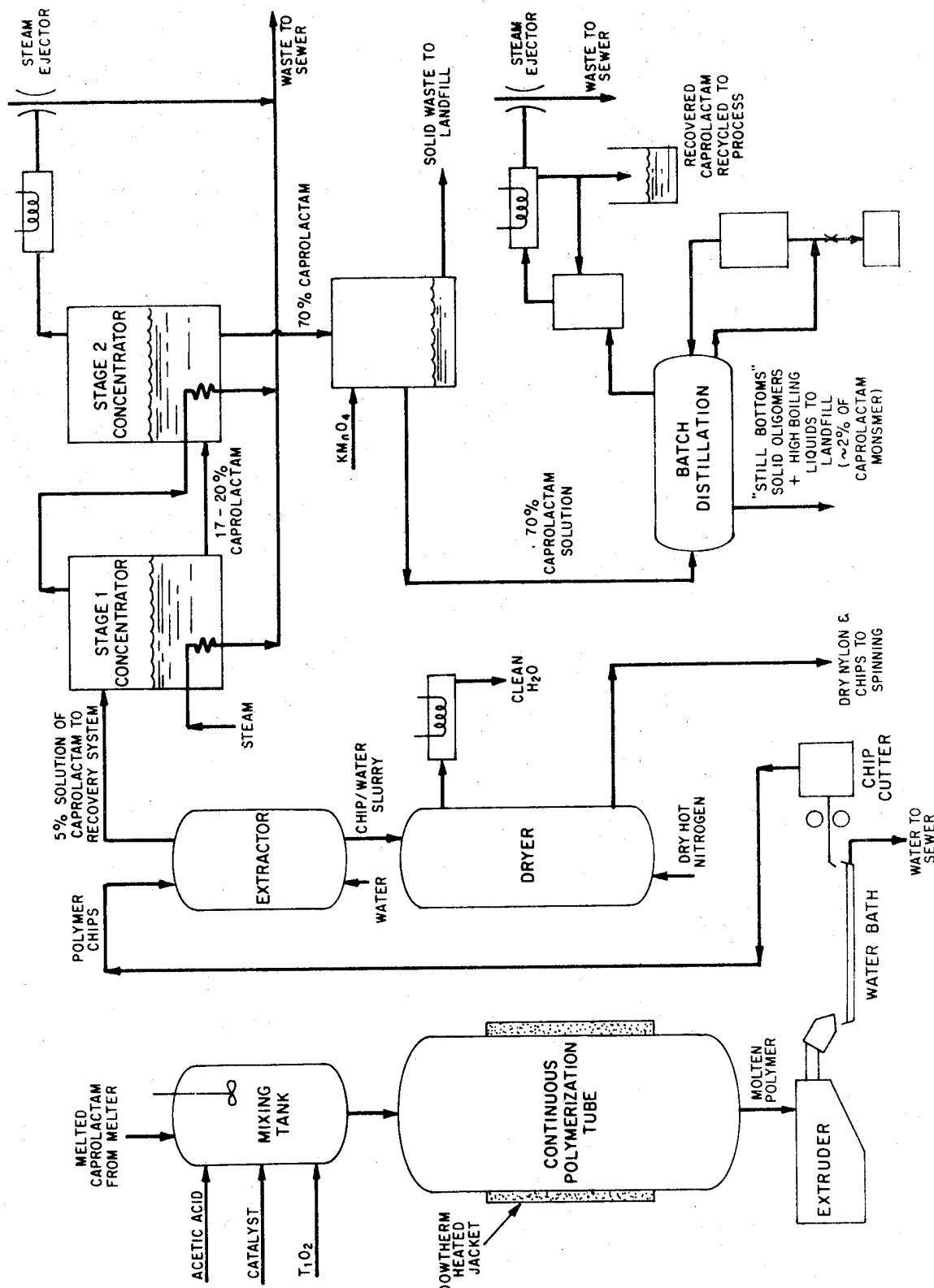

FIGURE 30

NYLON 6 PRODUCTION

## SECTION IV

### INDUSTRY CATEGORIZATION

The most effective means of categorizing the plastics industry for setting effluent guidelines is based on the characteristics of the waste water. In particular, the two most relevant characteristics are (a) raw waste load, expressed in kg of pollutant/kg of product, and (b) attainable BOD<sub>5</sub> concentrations as demonstrated by plastics and synthetics plants using technologies which are defined as the basis for BPCTCA. The data on treated wastewater characteristics obtained from the exemplary plants visited in this program are summarized in Table 12. They are grouped in four major subcategories representing combinations of the waste characteristics discussed above.

Major Subcategory I - A low raw waste load; raw waste load less than 10 units/1000 units of product; attainable low BOD<sub>5</sub> concentrations - less than 20 mg/liter.

Major Subcategory II - High raw waste load; raw waste load greater than 10 kg/tonne product; attainable low BOD<sub>5</sub> concentrations.

Major Subcategory III - High raw waste load; attainable medium BOD<sub>5</sub> concentrations - in the 30-75 mg/liter range.

Major Subcategory IV - High raw waste load; attainable high BOD<sub>5</sub> concentrations over 75 mg/liter.

The attainable BOD<sub>5</sub> concentration in the effluent is influenced by the treatability and, for a specific plant, by the variations in the influent concentrations. In major subcategory I where raw waste loads are less than 10 units/1000 units of product and where hydraulic flows ranged from 8.3 to 29.2 cu m/kg (1000 to 3500 gal/1000 lb), the influent concentrations ranged from 33 to 530 mg/liter. Disregarding the low influent concentration of the high density polyethylene plant, the influent concentrations varied over nearly a five-fold range while the effluents varied over a two-fold range. This indicates that practicable waste water treatment plants should be capable of attaining effluent BOD<sub>5</sub> average concentrations in the vicinity of 15 mg/liter when using properly designed and well operated biological systems. The plants in major subcategory II are characterized by high raw waste loads but with waste waters that can be treated to low attainable BOD<sub>5</sub> concentrations. Raw and effluent loads are a factor of 10 higher than for the major subcategory I plants, largely because of the high water usage for Rayon and Cellophane and the high BOD<sub>5</sub> influent concentration for ABS/SAN resins. Major subcategory III plants are characterized by high raw waste loads and moderate observed flows, which lead to high influent concentrations. The waste treatment plants achieve BOD<sub>5</sub> removals ranging from 96.5 to 99.3 percent, which are high efficiencies by

general standards of industrial waste treatment. Even with these high removal efficiencies, effluent concentrations are moderate due to the high concentration of the raw wastes. Major subcategory IV plants have relatively high raw waste loads and the observed attainable BOD<sub>5</sub> concentrations were found to be high. The design bases and operational modes of these plants are such as to indicate that practicable waste water treatment technology (e.g., two-stage biological treatment) might reduce the effluent concentrations by a factor of nearly two which would make them comparable to the plants appearing in major subcategory III. However, attainable BOD<sub>5</sub> concentrations below these levels has not been documented.

Additional subcategorization within the above four major subcategories was necessary to account for the wastewater generation which is specific to the individual products and their various processing methods. The separation of each individual product into separate subcategories simplifies the application of the effluent limitation guidelines and standards of performance by providing clear and unambiguous direction as to the proper standard applicable to that product. The substantial advantage of clarity appears to outweigh any technical advantage of product grouping. The resulting major subcategories and product and process subcategories are summarized in table 13.

Several other methods of subcategorization of the industry were considered. These included plant size, plant age, raw materials and products, and air pollution and solid waste generation. The rate of higher unit treatment costs on smaller plants or their potential for utilizing municipal systems was examined in the economic analysis but was not sufficient to warrant categorization. The age of the plants in this industry are determined by obsolescence due to size or process changes and not physical age. Similar raw materials are often used to make dissimilar products. The impact of air pollution control and solid waste disposal are not sufficient to warrant segmentation. For those reasons, none of the above-mentioned factors had sufficient impact on categorization of the industry to be considered further.

TABLE 12

## PERFORMANCE OF OBSERVED WASTE WATER TREATMENT PLANTS

	BOD		COD		TSS	
	Inlet (mg/liter)	Outlet (mg/liter)	Inlet (mg/liter)	Outlet (mg/liter)	Inlet (mg/liter)	Outlet (mg/liter)
Category A						
Polyvinyl Chloride	380	9	1590	70	1312	35
Polyvinyl Acetate	167	10	--	72	--	11
Polystyrene	110	10	--	72	--	20
Polypropylene	517	19	--	--	40	32
Low Density Polyethylene	530	16	1499	149	50	32
High Density Polyethylene	33	6	--	80	--	25
Category B						
Cellophane	91	20	288	197	960	70
Rayon	160	24	550	350	--	--
ABS/SAN	1605	11	2077	109	400	16
Category C						
Polyester	4412	29	5790	231	382	45
Nylon 66	1267	44	2076	183	20	58
Nylon 6	545	65	--	265	--	32
Cellulose Acetate	1200	41	--	240	--	48
Epoxy	--	--	--	--	--	--
Phenolics	--	--	--	--	--	--
Urea	--	--	--	--	--	--
Melamine	--	--	--	--	--	--
Category D						
Acrylics	990	140	1735	647	--	75

TABLE 13  
INDUSTRY SUBCATEGORIZATION

Major Subcategory I	Major Subcategory II	Major Subcategory III	Major Subcategory IV
Polyvinyl chloride Suspension Emulsion Bulk	Cellophane Rayon ABS/SAN	Polyester Resin Fiber Resin & Fiber Continuous Resin & Fiber Batch	Acrylics
Polyvinyl Acetate		Nylon 66 Resin Fiber Resin & Fiber	
Polystyrene Suspension Bulk		Nylon 6 Resin & Fiber Resin Fiber	
Polypropylene		Cellulose Acetate Resin Fiber Resin & Fiber	
Polyethylene High Density Solvent Polyform Low Density			

## SECTION V

### WASTE CHARACTERIZATION

The general process flow diagrams in Section III have indicated some of the waste water generation points for individual processes where information was readily available; however, flow rates and analyses for process waste water streams at points of origin were not obtainable since the companies surveyed have been concerned principally with the combined waste water streams. Analyses of these streams have been performed only because of the necessity to establish basis for design of waste water treatment plants or to provide effluent data under present permits from state regulatory bodies. As previously discussed, waste water may emanate from within the process where it was required for the process operating conditions; it may be formed during the course of chemical reactions; or it may be used in washdown of process vessels, area housekeeping, utility blowdowns and other sources such as laboratories, etc.

#### Raw Waste Loads

The Industrial Waste Study of the Plastics and Synthetics Industry by Celanese Research Company (EPA Contract No. 68-01-0030) (8) the Manufacturing Chemists Association survey of the industry and plant visits by EPA and their representatives provided ranges of pollutants occurring in the different product subcategories of the industry. The reported ranges of raw waste loads vary all the way from 0 to 135 units per 1000 units of product for BOD<sub>5</sub>, from 0 to 334 for COD, and from 0 to 70 for suspended solids.

Data from the above sources are recorded in Tables 14 and 15 for waste water flows, BOD<sub>5</sub>, COD and T.S.S. for each of the product subcategories. Other elements, compounds, and parameters which are reported in the wastes from the industry are summarized in Table 16. Information on raw waste loads for these parameters was not available from the industry with the exception of zinc from rayon manufacture. This range is reported in Table 15.

TABLE NO. 14

## WASTEWATER LOADING FOR THE PLASTICS AND SYNTHETICS INDUSTRY

Product	Wastewater Loading (gal/1000#)		Wastewater Loading (cu m/kg)	
	Observed Flow	Reported Range	Observed Flow	Reported Range
Polyvinyl Chloride--Suspension Polyvinyl Chloride--Emulsion Polyvinyl Chloride--Bulk	1800	(300-5000)	15.0	2.5-41.72
ABS/SAN	2060	(200-3500)		1.67-24.03
Polyvinyl Acetate	1000	(0-3000)	8.3	0-25.03
Polystyrene--Suspension Polystyrene--Bulk	1100	(0-17,000)	9.2	0.141.8
Polypropylene	1000	(300-8000)	8.3	2.50-66.75
Lo Density Polyethylene	2130	(0-5,000)	17.8	0-41.72
Hi Density Polyethylene--Solvent Hi Density Polyethylene--Polyform	3500	(0-3700)	29.2	0.30.87
Cellophance	29400	(12,000-67,000)	245	100-559
Rayon	16500	((4000-23,000)	138	33.38-191.9
Polyester Resin Polyester Resin and Fiber	540	(0-20,000)	4.5	0-167
Nylon 66 Resin Nylon 66 Resin and Fiber	11250	(0-18,250)	10.4	0-152.3
Cellulose Acetate Resin Cellulose Acetate Fiber	5000	(2000-50,000)	41.7	16.69-417
Epoxy	430	(300-610)	3.62	2.5-5.1
Phenolics	1480	(60-2400)	12.34	0.5-20
Urea Resins	220		1.8	
Melamine	160		1.3	
Acrylics	3400	(300-6160)	28.4	2.50-50.87
Nylon 6 Resin and Fiber Nylon 6 Resin	6500		54.2	



TABLE 15  
 PLASTICS AND SYNTHETICS INDUSTRY  
 RAW WASTE LOADS

All Units Expressed as Kg/kkg (lb/1000 lb of Production)

PRODUCT	BOD <sub>5</sub>		COD		SS	
	Reported Range	Observed Value	Reported Range	Observed Value	Reported Range	Observed Value
Polyvinyl Chloride	0.1 - 48	5.7	0.2-100	25	1 - 30	30
ABS/SAN	2 - 20.7	20.7	5 - 33.5	33.5	0 - 30	8
PVAcetate	0 - 2	1.4	0 - 3	--	0 - 2	--
Polystyrene	0 - 2.2	1.0	0 - 6.0	--	0 - 8.4	--
Polypropylene	0 - 10		0 - 20			
LDPE	0.2 - 4.4	4.4	0.2- 54	12	0 - 4.1	0.4
HDPE	0 - 1	1.0	0		0 - 3.4	
Cellophane	20 - 133	22	40 - 334	--	6 - 70	48
Rayon (Zinc: 12-50)	20 - 45	22	33 - 100	55	--	--
Polyester	3 - 20	20	6 - 45	26	0 - 12	0.7
Nylon 6 & 66 Resins	1 - 135	66	1 - 300	66	0 - 8	
Nylon 6 & 66 Fibers	0.1 - 60	6	0.2- 90	8	0.1- 6	(66)0.2
Cellulose Acetate	6 - 70	55	11 - 100	--	2 - 20	--
Epoxy	57 - 82	--	30 - 127	--	5 - 24	--
Phenolic Resin	15 - 51	--	90 - 64	--	0.5- 7	--
Urea Resin	--	--	--	--	--	--
Melamine	--	--	--	--	--	--
Acrylics	10 - 40	26	10 - 70	45	0.1- 1.7	1.7

Table 16  
Other Elements Compounds and Parameters

Phenolic Compounds  
Nitrogen Compounds (organic, ammonia, and nitrate nitrogen)  
Phosphates  
Oil and Grease  
Dissolved Solids  
pH  
Color  
Turbidity  
Alkalinity  
Temperature  
Sulfides  
Cyanides  
Mercury  
Chromium  
Copper  
Zinc  
Iron  
Titanium  
Cobalt  
Cadmium  
Manganese  
Aluminum  
Magnesium  
Molybdenum  
Nickel  
Vanadium  
Antimony  
Toxic Organic Chemicals

The other elements and compounds listed in Table 16 were based on surveys of the Corps of Engineers permit applications for discharge of wastewaters from a number of plants in the plastics and synthetics industry, reviews with personnel in regional EPA offices, the Industrial Waste Study of the Plastics Materials and Synthetics Industry by the Celanese Research Company (8), the EPA Interim Guideline Document (51), discussions with industry representatives, literature data on process operations, and internal industrial technical consultants.

## SECTION VI

### SELECTION OF POLLUTANT PARAMETERS

#### Selection Criteria

Parameters selected for the purpose of effluent limitation guidelines and standards of performance were based on the following criteria:

- a. Sufficient data on a parameter known to have deleterious effects in the environment were available for all of the product subcategories with regard to the raw waste load and the observed degree of removal with demonstrated technology.
- b. The parameter is present in the raw waste load for an individual product subcategory in sufficient quantity to cause known deleterious effects in the environment and there is demonstrated technology available to remove the parameter.

#### Selected Parameters

The following parameters have been selected for the purpose of effluent limitation guidelines and standards of performance based on the criteria discussed above:

BOD<sub>5</sub>  
COD  
TSS  
Zinc  
Phenolic Compounds  
Total Chromium  
pH

#### Biochemical Oxygen Demand (BOD)

Biochemical oxygen demand (BOD) is a measure of the oxygen consuming capabilities of organic matter. The BOD does not in itself cause direct harm to a water system, but it does exert an indirect effect by depressing the oxygen content of the water. Sewage and other organic effluents during their processes of decomposition exert a BOD, which can have a catastrophic effect on the ecosystem by depleting the oxygen supply. Conditions are reached frequently where all of the oxygen is used and the continuing decay process causes the production of noxious gases such as hydrogen sulfide and methane. Water with a high BOD indicates the presence of decomposing organic matter and subsequent high bacterial counts that degrade its quality and potential uses.

Dissolved oxygen (DO) is a water quality constituent that, in appropriate concentrations, is essential not only to keep organisms living but also to sustain species reproduction, vigor,

and the development of populations. Organisms undergo stress at reduced D.O. concentrations that make them less competitive and able to sustain their species within the aquatic environment. For example, reduced DO concentrations have been shown to interfere with fish population through delayed hatching of eggs, reduced size and vigor of embryos, production of deformities in young, interference with food digestion, acceleration of blood clotting, decreased tolerance to certain toxicants, reduced food efficiency and growth rate, and reduced maximum sustained swimming speed. Fish food organisms are likewise affected adversely in conditions with suppressed DO. Since all aerobic aquatic organisms need a certain amount of oxygen, the consequences of total lack of dissolved oxygen due to a high BOD can kill all inhabitants of the affected area.

If a high BOD is present, the quality of the water is usually visually degraded by the presence of decomposing materials and algae blooms due to the uptake of degraded materials that form the foodstuffs of the algal populations.

### COD

Chemical oxygen demand (COD) provides a measure of the equivalent oxygen required to oxidize the materials present in a waste water sample, under acid conditions with the aid of a strong chemical oxidant, such as potassium dichromate, and a catalyst (silver sulfate). One major advantage of the COD test is that the results are available normally in less than three hours. Thus, the COD test is a faster test by which to estimate the maximum oxygen exertion demand a waste can make on a stream. However, one major disadvantage is that the COD test does not differentiate between biodegradable and non-biodegradable organic material. In addition, the presence of inorganic reducing chemicals (sulfides, reducible metallic ions, etc.) and chlorides may interfere with the COD test.

The slow accumulation of refractory (resistant to biological decomposition) compounds in watercourses has caused concern among various environmentalists and regulatory agencies. However, until these compounds are identified, analytical procedures developed to quantify them, and their effects on aquatic plants and animals are documented, it may be premature (as well as economically questionable) to require their removal from waste water sources.

### Total Suspended Solids

Suspended solids include both organic and inorganic materials. The inorganic components include sand, silt, and clay. The organic fraction includes such materials as grease, oil, tar, animal and vegetable fats, various fibers, sawdust, hair, and various materials from sewers. These solids may settle out rapidly and bottom deposits are often a mixture of both organic and inorganic solids. They adversely affect fisheries by covering the bottom of the stream or lake with a blanket of

material that destroys the fish-food bottom fauna or the spawning ground of fish. Deposits containing organic materials may deplete bottom oxygen supplies and produce hydrogen sulfide, carbon dioxide, methane, and other noxious gases.

In raw water sources for domestic use, state and regional agencies generally specify that suspended solids in streams shall not be present in sufficient concentration to be objectionable or to interfere with normal treatment processes. Suspended solids in water may interfere with many industrial processes, and cause foaming in boilers, or encrustations on equipment exposed to water, especially as the temperature rises. Suspended solids are undesirable in water for textile industries, paper and pulp, beverages, dairy products, laundries, dyeing, photography, cooling systems, and power plants. Suspended particles also serve as a transport mechanism for pesticides and other substances which are readily sorbed into or onto clay particles.

Solids may be suspended in water for a time, and then settle to the bed of the stream or lake. These settleable solids discharged with man's wastes may be inert, slowly biodegradable materials, or rapidly decomposable substances. While in suspension, they increase the turbidity of the water, reduce light penetration and impair the photosynthetic activity of aquatic plants.

Solids in suspension are aesthetically displeasing. When they settle to form sludge deposits on the stream or lake bed, they are often much more damaging to the life in water, and they retain the capacity to displease the senses. Solids, when transformed to sludge deposits, may do a variety of damaging things, including blanketing the stream or lake bed and thereby destroying the living spaces for those benthic organisms that would otherwise occupy the habitat. When of an organic and therefore decomposable nature, solids use a portion or all of the dissolved oxygen available in the area. Organic materials also serve as a seemingly inexhaustible food source for sludgeworms and associated organisms.

Turbidity is principally a measure of the light absorbing properties of suspended solids. It is frequently used as a substitute method of quickly estimating the total suspended solids when the concentration is relatively low.

#### pH, Acidity and Alkalinity

Acidity and alkalinity are reciprocal terms. Acidity is produced by substances that yield hydrogen ions upon hydrolysis and alkalinity is produced by substances that yield hydroxyl ions. The terms "total acidity" and "total alkalinity" are often used to express the buffering capacity of a solution. Acidity in natural waters is caused by carbon dioxide, mineral acids, weakly dissociated acids, and the salts of strong acids and weak bases. Alkalinity is caused by strong bases and the salts of strong alkalies and weak acids.

The term pH is a logarithmic expression of the concentration of hydrogen ions. At a pH of 7, the hydrogen and hydroxyl ion concentrations are essentially equal and the water is neutral. Lower pH values indicate acidity while higher values indicate alkalinity. The relationship between pH and acidity or alkalinity is not necessarily linear or direct.

Waters with a pH below 6.0 are corrosive to water works structures, distribution lines, and household plumbing fixtures and can thus add such constituents to drinking water as iron, copper, zinc, cadmium and lead. The hydrogen ion concentration can affect the "taste" of the water. At a low pH water tastes "sour." The bactericidal effect of chlorine is weakened as the pH increases, and it is advantageous to keep the pH close to 7. This is very significant for providing safe drinking water.

Extremes of pH or rapid pH changes can exert stress conditions or kill aquatic life outright. Dead fish, associated algal blooms, and foul stench are aesthetic liabilities of any waterway. Even moderate changes from "acceptable" criteria limits of pH are deleterious to some species. The relative toxicity to aquatic life of many materials is increased by changes in the water pH. Metalocyanide complexes can increase a thousand-fold in toxicity with a drop of 1.5 pH units. The availability of many nutrient substances varies with the alkalinity and acidity. Ammonia is more lethal with a higher pH.

The lacrimal fluid of the human eye has a pH of approximately 7.0 and a deviation of 0.1 pH unit from the norm may result in eye irritation for the swimmer. Appreciable irritation will cause severe pain.

### Zinc

Occurring abundantly in rocks and ores, zinc is readily refined into a stable pure metal and is used extensively for galvanizing, in alloys, for electrical purposes, in printing plates, for dye-manufacture and for dyeing processes, and for many other industrial purposes. Zinc salts are used in paint pigments, cosmetics, pharmaceuticals, dyes, insecticides, and other products too numerous to list herein. Many of these salts (e.g., zinc chloride and zinc sulfate) are highly soluble in water; hence it is to be expected that zinc might occur in many industrial wastes. On the other hand, some zinc salts (zinc carbonate, zinc oxide, zinc sulfide) are insoluble in water and consequently it is to be expected that some zinc will precipitate and be removed readily in most natural waters.

In zinc-mining areas, zinc has been found in waters in concentrations as high as 50 mg/1 and in effluents from metal-plating works and small-arms ammunition plants it may occur in significant concentrations. In most surface and ground waters, it is present only in trace amounts. There is some evidence that zinc ions are adsorbed strongly and permanently on silt, resulting in inactivation of the zinc.

Concentrations of zinc in excess of 5 mg/l in raw water used for drinking water supplies cause an undesirable taste which persists through conventional treatment. Zinc can have an adverse effect on man and animals at high concentrations.

In soft water, concentrations of zinc ranging from 0.1 to 1.0 mg/l have been reported to be lethal to fish. Zinc is thought to exert its toxic action by forming insoluble compounds with the mucous that covers the gills, by damage to the gill epithelium, or possibly by acting as an internal poison. The sensitivity of fish to zinc varies with species, age and condition, as well as with the physical and chemical characteristics of the water. Some acclimatization to the presence of zinc is possible. It has also been observed that the effects of zinc poisoning may not become apparent immediately, so that fish removed from zinc-contaminated to zinc-free water (after 4-6 hours of exposure to zinc) may die 48 hours later. The presence of copper in water may increase the toxicity of zinc to aquatic organisms, but the presence of calcium or hardness may decrease the relative toxicity.

Observed values for the distribution of zinc in ocean waters vary widely. The major concern with zinc compounds in marine waters is not one of acute toxicity, but rather of the long-term sub-lethal effects of the metallic compounds and complexes. From an acute toxicity point of view, invertebrate marine animals seem to be the most sensitive organisms tested. The growth of the sea urchin, for example, has been retarded by as little as 30 ug/l of zinc.

Zinc sulfate has also been found to be lethal to many plants, and it could impair agricultural uses.

### Phenols

Phenols and phenolic wastes are derived from petroleum, coke, and chemical industries, wood distillation, and domestic and animal wastes. Many phenolic compounds are more toxic than pure phenol; their toxicity varies with the combinations and general nature of total wastes. The effect of combinations of different phenolic compounds is cumulative.

Phenols and phenolic compounds are both acutely and chronically toxic to fish and other aquatic animals. Also, chlorophenols produce an unpleasant taste in fish flesh that destroys their recreational and commercial value.

It is necessary to limit phenolic compounds in raw water used for drinking water supplies, as conventional treatment methods used by water supply facilities do not remove phenols. The ingestion of concentrated solutions of phenols will result in severe pain, renal irritation, shock and possibly death.

Phenols also reduce the utility of water for certain industrial uses, notably food and beverage processing, where it creates unpleasant tastes and odors in the product.

### Chromium

Chromium, in its various valence states, is hazardous to man. It can produce lung tumors when inhaled and induces skin sensitizations. Large doses of chromates have corrosive effects on the intestinal tract and can cause inflammation of the kidneys. Levels of chromate ions that have no effect on man appear to be so low as to prohibit determination to date.

The toxicity of chromium salts toward aquatic life varies widely with the species, temperature, pH, valence of the chromium, and synergistic or antagonistic effects, especially that of hardness. Fish are relatively tolerant of chromium salts, but fish food organisms and other lower forms of aquatic life are extremely sensitive. Chromium also inhibits the growth of algae.

In some agricultural crops, chromium can cause reduced growth or death of the crop. Adverse effects of low concentrations of chromium on corn, tobacco and sugar beets have been documented.

### Nitrogenous Compounds

Nitrogenous compounds can occur as a result of biological activity in the waste water treatment and can also come from manufacturing processes such as urea, melamine, nylon, ABS/SAN and acrylics. Ammonia is a common product of the decomposition of organic matter. Dead and decaying animals and plants along with human and animal body wastes account for much of the ammonia entering the aquatic ecosystem. Ammonia exists in its non-ionized form only at higher pH levels and is the most toxic in this state. The lower the pH, the more ionized ammonia is formed and its toxicity decreases. Ammonia, in the presence of dissolved oxygen, is converted to nitrate ( $\text{NO}_3$ ) by nitrifying bacteria: Nitrite ( $\text{NO}_2$ ), which is an intermediate product between ammonia and nitrate, sometimes occurs in quantity when depressed oxygen conditions permit. Ammonia can exist in several other chemical combinations including ammonium chloride and other salts.

Nitrates are considered to be among the poisonous ingredients of mineralized waters, with potassium nitrate being more poisonous than sodium nitrate. Excess nitrates cause irritation of the mucous linings of the gastrointestinal tract and the bladder; the symptoms are diarrhea and diuresis, and drinking one liter of water containing 500 mg/l of nitrate can cause such symptoms.

Infant methemoglobinemia, a disease characterized by certain specific blood changes and cyanosis, may be caused by high nitrate concentrations in the water used for preparing feeding formulae. While it is still impossible to state precise concentration limits, it has been widely recommended that water



containing more than 10 mg/l of nitrate nitrogen ( $\text{NO}_3\text{-N}$ ) should not be used for infants. Nitrates are also harmful in fermentation processes and can cause disagreeable tastes in beer. In most natural water the pH range is such that ammonium ions ( $\text{NH}_4^+$ ) predominate. In alkaline waters, however, high concentrations of un-ionized ammonia in undissociated ammonium hydroxide increase the toxicity of ammonia solutions. In streams polluted with sewage, up to one half of the nitrogen in the sewage may be in the form of free ammonia, and sewage may carry up to 35 mg/l of total nitrogen. It has been shown that at a level of 1.0 mg/l un-ionized ammonia, the ability of hemoglobin to combine with oxygen is impaired and fish may suffocate. Evidence indicates that ammonia exerts a considerable toxic effect on all aquatic life within a range of less than 1.0 mg/l to 25 mg/l, depending on the pH and dissolved oxygen level present.

Ammonia can add to the problem of eutrophication by supplying nitrogen through its breakdown products. Some lakes in warmer climates, and others that are aging quickly are sometimes limited by the nitrogen available. Any increase will speed up the plant growth and decay process.

#### Dissolved Solids

Essentially inorganic salts, dissolved solids are an integral part of many industry processes. The following manufacturing processes are known to have the greatest unit loads of dissolved solids.

- Cellulose acetate resins
- Cellophane
- Polystyrene
- ABS/SAN
- Epoxy resins
- Nylon
- Rayon
- Polyester resins

The major loads occur in the rayon and cellophane industries where removal is sometimes carried out on selected, concentrated streams.

In natural waters the dissolved solids consist mainly of carbonates, chlorides, sulfates, phosphates, and possibly nitrates of calcium, magnesium, sodium, and potassium, with traces of iron, manganese and other substances.

Many communities in the United States and in other countries use water supplies containing 2000 to 4000 mg/l of dissolved salts, when no better water is available. Such waters are not palatable, may not quench thirst, and may have a laxative action on new users. Waters containing more than 4000 mg/l of total salts are generally considered unfit for human use, although in hot climates such higher salt concentrations can be tolerated

whereas they could not be in temperate climates. Waters containing 5000 mg/l or more are reported to be bitter and act as bladder and intestinal irritants. It is generally agreed that the salt concentration of good, palatable water should not exceed 500 mg/l.

Limiting concentrations of dissolved solids for fresh-water fish may range from 5,000 to 10,000 mg/l, according to species and prior acclimatization. Some fish are adapted to living in more saline waters, and a few species of fresh-water forms have been found in natural waters with a salt concentration of 15,000 to 20,000 mg/l. Fish can slowly become acclimatized to higher salinities, but fish in waters of low salinity cannot survive sudden exposure to high salinities, such as those resulting from discharges of oil-well brines. Dissolved solids may influence the toxicity of heavy metals and organic compounds to fish and other aquatic life, primarily because of the antagonistic effect of hardness on metals.

Waters with total dissolved solids over 500 mg/l have decreasing utility as irrigation water. At 5,000 mg/l water has little or no value for irrigation.

Dissolved solids in industrial waters can cause foaming in boilers and cause interference with cleanliness, color, or taste of many finished products. High contents of dissolved solids also tend to accelerate corrosion.

Specific conductance is a measure of the capacity of water to convey an electric current. This property is related to the total concentration of ionized substances in water and water temperature. This property is frequently used as a substitute method of quickly estimating the dissolved solids concentration.

#### Toxic and Hazardous Chemicals

The industry uses a large number of accelerators and inhibitors which are considered proprietary and, consequently, no information was obtainable. Some of these components may be on EPA's recently established list of toxic substances shown below and the guidelines must adhere to regulations established for their usage.

- Polychlorinated biphenyls
- Eldrin
- Dieldrin
- Benzidine and its salts
- Cyanide and all cyanide compounds
- Mercury and all mercury compounds
- Endrin
- Toxaphene
- DDT
- DDD
- DDE

Iron, Aluminum, Nickel, Vanadium, Titanium and Molybdenum

The above metals were selected because they are known to be used in the processes or to occur in the waste waters of specific product subcategories. However, insufficient data were available on raw waste loads or treated waste waters to permit establishing guidelines at this time. In most cases where these metals are used, biological treatment systems reduce or remove them to low concentration levels; however, they should be considered to be present in specific product subcategories as summarized in Table 17. Receiving water quality standards should determine if limitations are necessary.

Oil and grease -Color -Turbidity-Phosphates -Sulfides -Copper -  
Cadmium -Manganese -Magnesium-Antimony

These pollutants are known to be present in waste waters from certain processes in varying amounts; however, no data was available which would permit establishing raw or treated waste loads. Consequently, they are listed so that appropriate cognizance can be taken in determining if they may be present in amounts requiring limitation by water quality standards.

OTHER ELEMENTS AND COMPOUNDS SPECIFIC TO  
 PLASTICS AND SYNTHETICS PRODUCTS  
 TABLE 17

<u>Subcategory</u>	<u>Other Element or Compound</u>
ABS/SAN	Iron Aluminum Nickel Total Chromium
POLYSTYRENE	Organic N Iron Aluminum Nickel Total Chromium
POLYPROPYLENE	Vanadium Titanium Aluminum
HI DENSITY POLYETHYLENE	Titanium Aluminum Vanadium Molybdenum Total Chromium
CELLOPHANE	Dissolved Solids
RAYON	Zinc Dissolved Solids
NYLON 6 & 66	Organic N
ACRYLICS	Organic N Phenolic Compounds

## SECTION VII

### CONTROL AND TREATMENT TECHNOLOGY

The control and treatment technology for the plastics and synthetics industry can encompass the entire spectrum of water treatment technologies since selection of specific waste water treatment technologies must be on the basis of performance capability. The control and treatment technology for the plastics and synthetics industry can be divided into three major categories. These are:

1. Presently used waste water treatment technology.
2. Potentially usable waste water treatment technology.
3. In-plant control of waterborne pollutants.

Categories 1 and 2 are often designated as end-of-pipe treatment; however, selective applications to segregated streams prior to a centralized wastewater treatment plant should be considered as an integral part of waste water control. In-process control technology is dependent upon two major considerations. (1) process requirements for water usage and the pollutants resulting from these operations, such as unreacted raw materials, partially reacted by-products which must be removed to meet major product specifications, catalysts or accelerators required for controlling the reactions, and additives necessary to provide the appropriate chemical characteristics; and (2) emission of pollutants into water streams due to poor housekeeping practices, excessive use of water for control of hazardous conditions such as fires, leaks and spills due to inadequate equipment maintenance, and accidental occurrences due to equipment failure or personnel errors.

This survey found no waste water treatment technology unique to the plastics and synthetics industry. The application of end-of-pipeline waste water treatment technology throughout the industry subcategories has a marked similarity in operational steps, but, of course, a considerable variation in the results obtained. Therefore, the waste water treatment technology presently used in the industry is generally applicable across all industry subcategories.

#### Presently Used Wastewater Treatment Technology

Wastewater treatment technology in the plastics and synthetics industry relies heavily upon the use of biological treatment methods. These are supplemented by appropriate initial treatment to insure that proper conditions, especially by pH controls and equilization are present in the feed to the biological system.

Initial treatment for the removal of solids is not routinely required in the industry and is installed on a selective basis where the quantity of solids would interfere with subsequent treatment. The initial step in wastewater is often equalization basins for control of pH. Consequently, the disposal of sludges or solids from the initial treatment step is not the same type of problem as encountered in municipal sewage systems especially since many of the solids that are removed are polymeric materials which are not significantly affected by biological systems. Biochemical-oxygen-demanding pollutants in the waste waters from the industry are amenable to varying degrees of removal depending upon the usual parameters associated with the specific biochemical oxidation rates of the waste waters. Table 18 records pertinent operational parameters and average BOD<sub>5</sub> COD and TSS wastewater concentrations found among the waste water treatment plants selected as exemplary of practical technology.

During the course of this survey, 19 plants were visited. These plants were selected on the following bases: (1) being exemplary of practical waste water treatment plant, and (2) being representative of typical manufacturing processes. Operating data from 12 of these plants was reasonably complete so that Tables 19 and 20 could be constructed. Data from the other plants were inadequate for reasons such as: they discharge into municipal sewage systems or treat for specific parameters such as phenolic compound metals or phenolic compound removal; the plants have only the equivalent of initial waste water treatment; or plant waste water flows combine with waste waters from other process units in a manner or quantity which prohibited determining any meaningful information.

Examination of the waste water treatment plant flowsheet indicated that the conditions prevailing did not fit into a single operational category. Although all of the waste water treatment plants employed biological systems, the treatability of the different waste waters undoubtedly influence both the design and established operational modes of practical waste water treatment systems. In selection of the plants, efforts were made, whenever possible, to choose plants from which relatively long-term operational data, e.g. one-year, could be obtained. While the dominant mode of operation of the biological system is single-stage aeration, a significant number of the plants have a two-stage system since long residence time polishing lagoons follow the aeration step. However, in no instances were a two-stage activated sludge system found or activated sludge in combination with trickling filters although these modes of operation are certainly practicable. One large multi-product chemical plant achieves excellent pollutant removal through a series of anaerobic and facultative lagoons in which the total residence time of the waste water is 150 days. However, this type of installation often is not practical because of land availability or soil conditions. Another multi-product plant, known for the consistently low BOD<sub>5</sub> concentrations in its effluents, is based on an elaborate system of monitoring, holding ponds, waste equalization and/or segregation in conjunction with

TABLE 18

PERFORMANCE OF OBSERVED WASTE WATER TREATMENT PLANTS

	BOD		COD		SS	
	Inlet (mg/liter)	Outlet (mg/liter)	Inlet (mg/liter)	Outlet (mg/liter)	Inlet (mg/liter)	Outlet (mg/liter)
<b>Category A</b>						
Polyvinyl Chloride	380	9	1590	70	1312	35
Polyvinyl Acetate	167	10	--	72	--	11
Polystyrene	110	10	--	72	--	20
Polypropylene	517	19	--	--	40	32
Low Density Polyethylene	530	16	1499	149	50	32
High Density Polyethylene	33	6	--	80	--	25
<b>Category B</b>						
Cellophane	91	20	288	197	960	70
Rayon	160	24	550	350		
ABS/SAN	1605	11	2077	109	400	16
<b>Category C</b>						
Polyester	4412	29	5790	231	382	45
Nylon 66	1267	44	2076	183	20	58
Nylon 6	545	65	--	265	--	32
Cellulose Acetate	1200	41	--	240	--	48
Epoxy	--	--	--	--	--	--
Phenolics	--	--	--	--	--	--
Urea	--	--	--	--	--	--
Melamine	--	--	--	--	--	--
<b>Category D</b>						
Acrylics	990	140	1735	647	--	75

biological treatment. The success of this waste water treatment plant for removing chemically-active substances is based on its achieving a high degree of composition uniformity in the feed to the biological portion. In short, no shortcut method for removal of chemically-active substances was found when a biological system was used. Operational success depends upon good design coupled with competent operation.

Examination of the effluent BOD<sub>5</sub> concentrations achieved by the plants indicates that many are achieving BOD<sub>5</sub> concentrations comparable to those for municipal sewage secondary treatment plants as proposed by the Environmental Protection Agency in the Federal Register of April 30, 1973 <sup>26</sup>. However, because the influent concentrations of biochemically active substances are often much greater than in municipal sewage, especially the soluble portions, the operational modes are different - most immediately obvious is the much longer residence times. The effects of influent concentration, residence time, biomass concentration, aeration capacity and treatability of wastewaters upon the effluent concentration of pollutants in treated wastewaters from the synthetics and plastics industry cannot be categorized as well as for municipal sewage treatment; nevertheless, biochemically active portions of these waste waters can be removed by practicable biological treatment systems to concentration levels typical of those achieved in other situations by the application of available technology. The practical application of that technology will depend upon such things as the occurrence of substances reducing or inhibiting the action of the biological system, the operational nature of the waste water generating processes, the operational flexibility of the waste water treatment system, availability of land and the attention given to operation and maintenance of the waste water treatment system.

Although the operational conditions of the waste water treatment plant surveyed were quite different, the general effect of long residence time in the treatment facilities is increased efficiency of BOD<sub>5</sub> removal. To provide a rough indication of the magnitude of the effect of residence time on BOD<sub>5</sub> removal efficiency, data from the plants surveyed are shown in Figure 31. In this Figure the total load of BOD<sub>5</sub> removed has been computed on the basis of the aeration basin volume and recorded as pounds of BOD<sub>5</sub>/1000 cu ft as a number besides the plotted point. The effect of this procedure is, of course, to indicate higher values for the long residence time system. It is recognized that this procedure is meaningless from the basis of waste water treatment plant theory; however, for aeration basins loaded in the range of 40 to 70 lbs/BOD<sub>5</sub>/1000 cu ft (0.6 to 1.1 kg BOD<sub>5</sub>/cu meter) figure 31 reflects practices in operational waste water treatment plants. Regardless of the biological methods employed, these data as well as design considerations reflect the necessity for extensive facilities to effect high removal efficiencies of biochemically oxygen demanding substances or to achieve low concentrations in the treated waste waters. If large land areas are available, the most practicable method of treating these



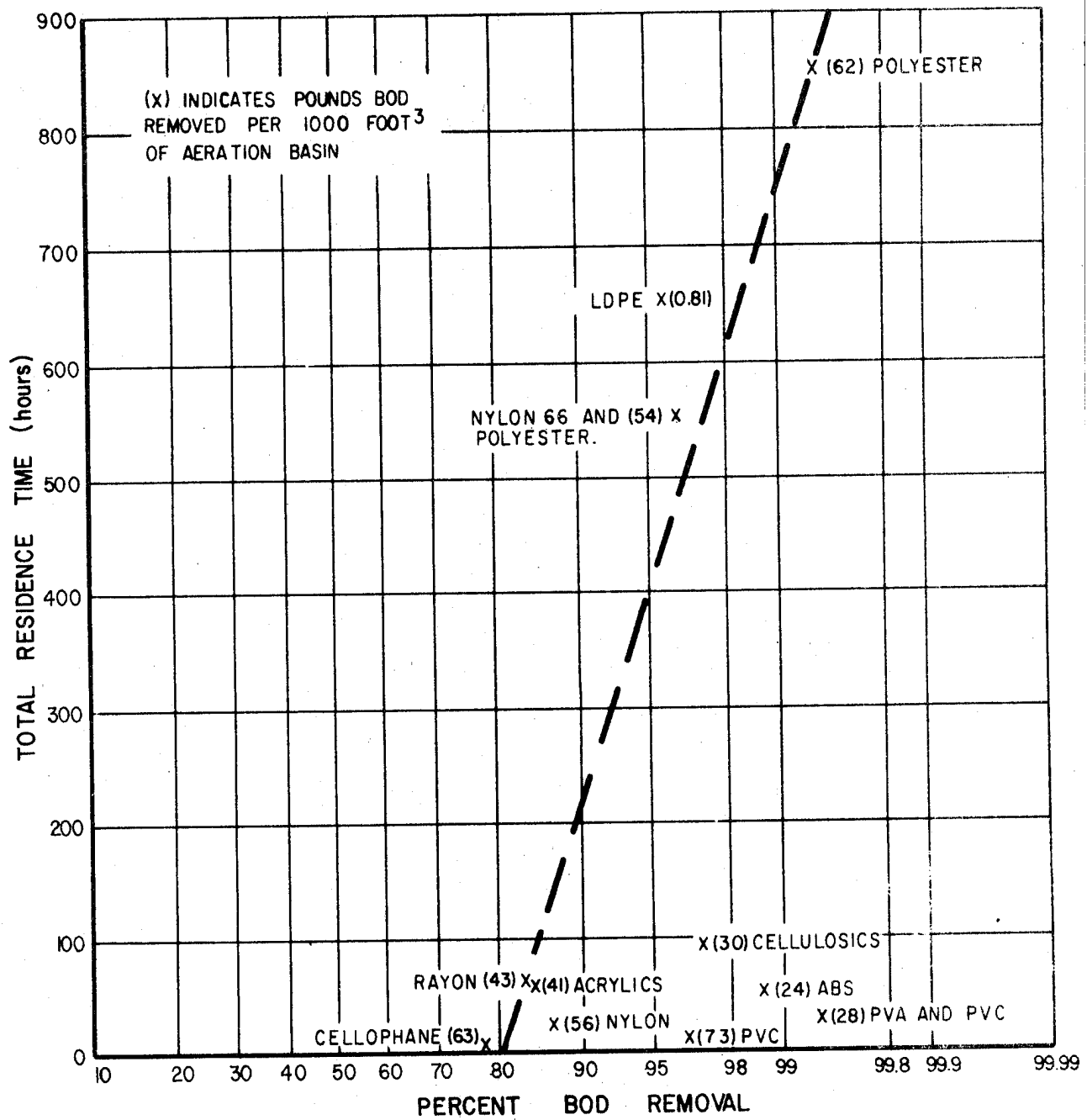

FIGURE 31

BOD REMOVAL AS FUNCTION OF TOTAL SYSTEM RESIDENCE TIME

waste waters may be in long residence time systems; on the other hand in space limited locations waste water treatment based on biological systems may require staged operations or be supplemented by other treatment methods.

Although the waste water treatment data from different process plants indicate that biological systems are capable of removing BOD<sub>5</sub> substances to roughly similar concentration levels despite wide variations in influent concentrations, the removal of carbonaceous substances, characterized by chemical oxygen demand (COD) or total organic carbon (TOC), is specific to a particular industry.

In contrast to municipal sewage where the COD/BOD ratios are generally less than 5 (32, 30, 37, 23) in the treated effluent, the plastics and synthetics industry is more apt to have a ratio in the range of 4 to 12, as shown in Tables 19 and 20. This reflects the fact that the waste waters contain carbonaceous substances which are not readily biodegradable, as typified by the relatively large increase in the COD/BOD<sub>5</sub> ratios from the influent to the effluent of the waste water treatment plant. These variations have been well established and are reported in the literature for sewage as well as industrial waste. The waste waters in the plastics and synthetics industry which were surveyed during this study indicated the same types of variability as other industrial waste water.

Considerably greater difficulty is encountered in the high-efficiency removal of substances measured by the COD test. This is reflected by the data shown in Figure 32. The wide variations in removal efficiencies indicate that the limits of biological systems for removal of components measured as COD depend strongly upon the magnitude of the biologically refractive portion of the incoming COD. Consequently, these data confirm that COD is highly specific with respect to the composition of the waste waters from the various industry subcategories.

Variations in the capabilities of biological systems for removing biochemically-active substances is especially apparent among the nylon, polyester and acrylic plants. In effect, two of the wastewater treatment plants have two-stage biological treatment due to the long total residence time (554 and 852 hours) in polishing ponds. The other two plants have single-stage biological systems. Although insufficient data were available to determine what portion of the BOD<sub>5</sub> was removed in the polishing ponds of the plants surveyed, it is apparent that the difficulties of removing pollutants from acrylic plants are more severe than from Nylon 66 and polyester plants.

The refractory nature of waste waters from acrylic plants was further supported by data from a second acrylic plant where a lightly-loaded biological waste water treatment system was obtaining high removal efficiencies for BOD<sub>5</sub> at low inlet concentrations, but achieving only a 33 percent removal of COD - whereas the plant reviewed in Tables 19 and 20 was achieving 62

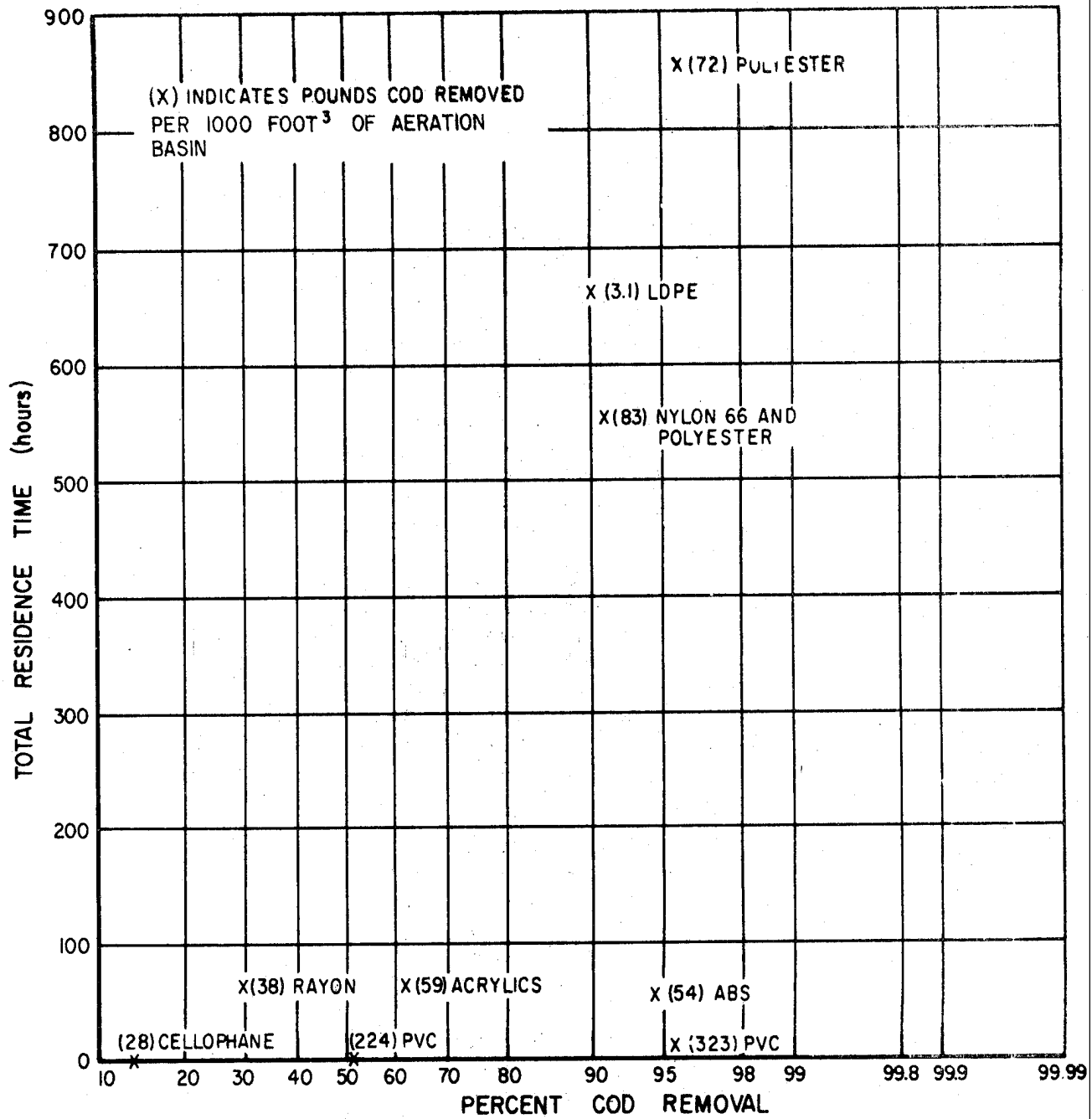

FIGURE 32

COD REMOVAL AS FUNCTION OF TOTAL SYSTEM RESIDENCE TIME

percent removal. Although the estimated raw waste BOD<sub>5</sub> loads for the second acrylic plant are approximately one-tenth of those for the plant surveyed, consideration of the processes indicate that the lower BOD<sub>5</sub> loads should be expected; however, its effluent has a high concentration of zinc which must be removed prior to discharge. This plant has an average BOD<sub>5</sub> effluent concentration of less than 10 mg/l.

In addition to the Nylon plants reported in Tables 19 and 20, a small (0.01 MGD or 37 cubic meters/day), three-stage biological treatment plant treating highly concentrated wastes from a Nylon 66 plant was surveyed. Although only a meager amount of data were available, a small number of analyses indicated that the waste water BOD<sub>5</sub> concentrations were approximately three times those of the plant reported in Tables 19 and 20. The total residence time in the three sequential aerated basins (with 1.1 to 1.39 HP/1000 cu ft) was 679 hours, and the BOD<sub>5</sub> concentration was estimated (via differential balances on the total process plant waste waters) to be approximately 160 mg/liter in the effluent. Although the BOD<sub>5</sub> removal efficiency was estimated to be in the vicinity of 95 percent, the differences in inlet concentration and, presumably, composition indicated outlet concentrations nearly four times those of the Nylon 66 plant chosen as exemplary for this study.

Based on the limited data available on operating waste water treatment plants, a consensus of industry experiences on treatability, and a knowledge of the processes generating the waste waters, it seems that the treatment of waste water from acrylic plants represents one of the most difficult treatment problems in the industry.

Wastewater streams from cooling towers, steam generating facilities and water treating systems are generally combined with the process waste waters and sent to the treatment plant. Although the proportion of the total waste water flow contributed by these streams varies from plant to plant, once-through cooling sometimes keeps the proportion low; however, where thermal discharge regulations require the installation of cooling towers, this portion can be expected to increase. Separate treatment of cooling tower and boiler blow-downs for removal of corrosion inhibiting chemicals was found infrequently in this survey. The procedure for handling these blow-downs most frequently installed or contemplated was the replacement of the more toxic corrosion-inhibiting chemicals, such as chromates, with less toxic substances. Generally, the plants rely upon obtaining precompounded treatment chemicals and, consequently, depend upon the supplier to provide information about the toxic aspects of treatment plants and receiving waters. The choice of anti-corrosion chemicals and other treating chemicals will depend upon the operating conditions and construction materials in the process plant. Since chromate-based anti-corrosion systems are usually more effective in controlling rate of corrosion, the choice of using a less toxic anticorrosion system, where the blowdown can be discharged to waste water or streams without

TABLE No. 19  
OPERATIONAL PARAMETERS OF WASTEWATER TREATMENT PLANTS  
(Metric Units)

Type of Plant	ACRYLICS	POLYESTER	NYLON-66 POLYESTER	NYLON-6	RAYON	CELLULOSE	AHS	FVC	FVA & FVC	FVC	LDPE	CELLULOSE
1. Type of Treatment	Mud/Settle/Pool Act. Al. Clarif. Aerobic Sludge Digest. (plant in step)	Settle/Equal Act. Sl. Clarif. Polish Pond	Equal/Ext. Aer. Act. Sl. Clarif. Aer. Lagoon, sand Filtr./Pol. Pond	Skimming, Mix. Act. Sl. Clarif.	Mud Prin. Treatment Filtr. in L. From Filtr. Second. Treat.	Act. Sl. Clarif.	Act. Sl. Plus Aerobic Sl. Digestion	Equal/Chem. Settle Act. Sludge Clarif. Polish Pond	Chem. Settle Act. Sludge Polish Pond	Chem. Settle Mud Act. Sl. Clarif.	API Sep/Equal & Cool/Aer. Lagoons/Clarif. Aer. Lagoons/Clarif./Polish	Equal, Act. Sludge
2. Byd Load cu m/day	10370	3030	1550	3860	31560	26000	5450	2270	1020	1400	3000	12870
3. hrs. Time (hrs.)	(86% of design) (1)15 (63)	(67% of design) (1)47 (832)	(1)24 (556)	9 (21)	[67]	1.5	56	8.2	24	2.7	(27.6 hrs)	64 (98)
4. BOD (kg removed/day) (cu. meter)	0.66	0.99	0.86	0.89	[0.69]	1.00	0.38	1.17	0.45	Need RML	0.13	0.48
5. COD ( " ) (4)	0.94	1.15	1.33	M.G.	[0.61]	0.45	0.86	5.17	M.G.	3.59	.05	M.G.
6. FPR ( " ) (4)	0.032	.039	.109	.062	[0.25]	0.117	.028	0.113	0.152	0.194	.006	.025
7. Kg BOD Removed HP - Hr.	0.81	1.04	0.32	0.54	[1.13]	0.36	-	0.45	0.12	Need RML	.09	0.86
8. Suspended Solids (mg/liter)	53	45	58	53	[30]	71	17	38	9	M.G.	30	68
9. Clarif Overflow (meters/day)	M.G.	16.7	M.G.	21.2	37.7	30.56	24.7	30.8 (act) 17.4 (2nd)	M.G.	34.4	12.2 (act) 12.2 (2nd)	24.4
10. Biomass (MG/Liter)	2000	3000	500	2540	M.G.	M.G.	M.G.	0.21	7000 (3)	4000	M.G.	3300
11. Kg MLSS removed/day	0.38	0.37	1.72	0.36	M.G.	M.G.	M.G.	M.G.	.07 (3)	Need RML	M.G.	0.15
12. Typical Values												
13. Typical Values												
14. BOD (in)	906	4412	1267	387	[200]	90	61	350	1500	-	376	1324
15. BOD (out)	145	28	44	48	[60]	20	1206	10	7	65	17	37
16. COD/BOD (in)	1.91	1.31	1.63	-	[2.5]	2.5	1.76	4.54	-	-	3.98	-
17. COD (in)	1735	5790	2076	-	[500]	228	2077	1590	-	816	1499	-
18. COD (out)	647	231	183	-	[350]	197	109	70	-	416	149	196
19. COD/BOD (out)	4.46	8.25	4.15	-	[1.6]	9.8	10	7.0	-	Need RML	8.76	5.3
20. Efficiency BOD (%)	84	99.4	96.5	87.6	[85]	78	99.1	97.5	99.4	Need RML	95.5	97.2
21. Efficiency COD (%)	62	96	91.4	87.6	[30]	14	94.7	95.6	M.G.	51	90.0	M.G.

NOTE: (1) First value is residence time in activated sludge plant. Value in ( ) is residence time in total system.

(2) Air Injection: H.P. required calculated by ABL.

(3) About 70% of MLSS are inorganic.

(4) Total BOD<sub>5</sub> removed divided by volume of aeration basin.

TABLE NO. 20  
OPERATIONAL PARAMETERS OF WASTEWATER TREATMENT PLANTS  
(English Units)

TYPE OF PLANT	ACRYLICS	POLYESTER	NYLON-66 AND POLYESTER	NYLON-6	RAYON	CELLOPHANE	ABS	PVC	PVA & PVC	PVC	PVC	LDPE	CELLULOSIC
1. Type of Treatment	Heat/ser:1/ cool act.al. clarif, Aerobic Sludge Digest. (plant in start-up)	Settle/Equal Act. Sl/clarif Polish Pond	Equal/Ext. Aer Act. Sl/ Clarif Aer Lagoon, sand Filters/Pol Pond	Skimming, Blking, Act. Sludge, Clarif	Heat Pre Treatment Filtration from Primary Secondary Treatment	Act. Sl. Clarif.	Act. Sl. Plus Aerobic Sl. Digestion	Equal/Chem Settle Act. Sludge Clarif.	Chem Settle Act Sludge Polish Pond	Chem Settle Act Sl. Clarifier	API Sep/Equal & Cool/Aer Lagoon/Clar Aer Lagoon/ Clarif/Polish		Equal, Act. Sludge
2. Hyd. Load (MGD)	2.74 (86% of design)	0.8 (67% of design)	0.41 (1) 24 (534)	1.02 (21)	8.34 [67]	6.87	1.44	0.6	0.27	0.37	0.8	0.8	3.4
3. Res. Time (Hrs.)	(1) 15 (63)	(1) 47 (852)	(1) 24 (534)	9 (21)	[67]	1.5	56	8.2	24	2.7	66	66	64 (98)
4. BOD Removed (1000 ft <sup>3</sup> )	41	62	5	56	[73]	63	24	73	28	Need RML	0.81	0.81	30
5. COD ( " ) (4)	59	72	83	N.G.	[38]	28	54	323	N.G.	224	3.1	3.1	N.G.
6. PWR (HP/1000 Ft <sup>3</sup> )	0.9	1.1	3.1	1.75	[0.7]	3.3	0.8	3.2	4.3 (2)	5.5	0.17	0.17	0.7
7. #BOD Removed H.P.-hour	1.8	2.3	0.7	1.2	[2.5]	0.8		1.3	0.27 (2)	Need RML	0.2	0.2	1.9
8. Suspended Solids (mg/liter)	53	45	58	53	[50]	71	17	38	9	N.G.	30	30	68
9. Clarif Overflow (GPD/ft <sup>2</sup> )	N.G.	410	N.G.	520	975 (o'load)	750	606	756 (1st) 427 (2nd)	N.G.	918	300 (1st) 300 (2nd)	300 (1st) 300 (2nd)	600
10. Biomass (MG/Liter)	2000	3000	500	2540	N.G.	N.G.	N.G.	5550	7000 (3)	4000	N.G.	N.G.	3300
11. #BOD Removed/Dry #MSS	0.38	0.37	1.72	0.36	N.G.	N.G.	57	0.21	.07 (3)	Need RML	N.G.	N.G.	0.15
12. Typical Values NH <sub>3</sub> N (out)													
13. Typical Values TN, N (out)													
14. BOD (in)	906	4412	1267	387	[200]	90	1206	350	1500	-	376	376	1324
15. BOD (out)	145	28	44	48	[30]	20	11	10	7	65	17	17	37
16. COD/BOD (in)	1.91	1.31	1.63	-	[2.5]	2.5	1.76	4.54	-	-	3.98	3.98	-
17. COD (in)	1735	5790	2076	-	[500]	228	2077	1590	-	816	1499	1499	-
18. COD (out)	647	231	183	-	[300]	197	109	70	-	416	149	149	196
19. COD/BOD (out)	4.46	8.25	4.15	-	[11.6]	9.8	7.2	7.0	-	Need RML	8.76	8.76	5.3
20. Efficiency, BOD (%)	84	99.4	96.5	87.6	[83]	78	99.1	97.5	99.4	Need RML	95.5	95.5	97.2
21. Efficiency, COD (%)	62	96	91.4		[90]	14	94.7	95.6	N.G.	51	90.7	90.7	N.G.

NOTE: (1) First value is residence time in activated sludge plant. Value in ( ) is residence time in total system.

(2) Air injection: H.P. required calculated by ADL.

(3) About 70% of MSS are inorganic.

(4) Total BOD<sub>5</sub> removed divided by volume of aeration basin.

prior treatment, or using a chromate system which requires the treatment of blowdown before discharging it to wastewater treatment plants or streams is predominantly an economic one. Although only one instance was found in which a system treats blowdown from a cooling tower, the technology and availability of equipment for removal of chromium is well established and widely available. The treatment and/or removal of other constituents is less well established, although biological treatment systems will have the capability of removing some of these substances because they tend to degrade at point of usage, such as in cooling towers. Obviously, these blowdowns will be high in total dissolved solids because of the concentrating effects that occur in the operations.

End-of-pipe treatment technology is based on well-established chemical methods, such as neutralization and biological treatment, which can be carried out in various types of equipment and under a wide variety of operating conditions. The operability of the end-of-pipe treatment systems for the synthetics and plastics industry is probably most affected by intermittent highly-concentrated waste loads, due to the periodic nature of certain pollutant-generating operations or to inadvertent spills and leaks. Since one result of these "slugs" of pollutants is the creation of momentary overloads or conditions toxic to the micro-organisms, due principally to concentration effects, the only effective control methods are preventing their occurrence or providing sufficient volumetric capacity in equalization basins to ameliorate their effect.

A combination of methods may be used depending upon the nature of the process operations, safety requirements (such as the dumping of reactors to prevent runaway reactions and possible explosions), and the availability of land area for the construction of equalization basins. For presently-operating plants, the most practical solution is the installation of an equalization basin of sufficient volume and residence time to insure that any "slugs" of pollutants can be mixed into larger volumes. This will usually guarantee that concentration levels are lowered to the point where the operability of the ensuing treatment step, usually the biological system, will not be overly affected unless the pollutants are highly toxic to the microorganisms.

The importance of equalization prior to biological treatment cannot be overstressed when the potential exists for large variations in either flow or concentrations of waste waters. Design and operability of an equalization basin involves the application of sound hydrodynamic considerations to insure that mixing of the "slugs" with large volumes of waste waters with lower concentrations. Consequently, equalization basin designs may vary from simple basins, which prevent short circuiting of inlet waste waters to the basin outlet going into the waste water treatment plant, to basins which are equipped with mixers to insure rapid and even mixing of influent waste water flows with the basin volume. In either case, the operability and reliability of an equalization basin should be high with minimal

expenditure of operating labor and power. The results are well-designed and well-operated equalizations basins that insure that the subsequent treatment steps, especially those steps sensitive to fluctuating conditions (i.e., biological treatment), are not confronted with widely-varying conditions which may drastically affect overall performance.

The operability, reliability and consistency of biological waste water treatment systems are subject to a host of variables. Some of the most important are the nature and variability of both the flow and the waste water composition. The best overall performance of biological treatment systems is realized when the highest consistency of flow and waste water composition occurs. While it must be recognized that no waste water stream can be expected to have constant flow at constant composition, it is possible to insure that these effects are ameliorated with the institution of the previously described equalization basins, in which sufficient capacity has been incorporated in order to minimize surge flows. In this manner hydraulic flows, at least, can be varied in an orderly way so that the biological system is not "shocked" by either high flow rates or high concentrations. In other words this insures that the most consistent conditions prevail at all times for the micro-organisms. Because there are so many variables that can affect the operation of wastewater systems based on biological activities, and because biological activity is often affected by climatic conditions, especially temperature, the effects of these variables must be recognized and action taken to minimize them. Since acclimatization of biological systems is important in achieving and maintaining maximum performance, it follows that equalization, coupled with attention to such items as the possible occurrence of chemical species toxic to micro-organisms, is the basis for achieving the maximum potential in operability, reliability, and consistency of biological systems. Although in-line instrumentation such as pH, dissolved oxygen, total organic carbon analyzers, etc., are available, their usage, except for pH and, infrequently, dissolved oxygen, for in-line control is minimal. In other words, the reliability of some in-line instrumentation for control has not been developed to a degree where it is frequently used. Therefore, control of the biological waste water treatment process relies principally on adequate designs and judicious attention to the physical aspects of the plant. Consequently, well-trained, conscientious operators are most important in achieving the maximum potential reliability and consistency in biological treatment plants.

Achieving a high degree of operability and consistency in a wastewater treatment plant is contingent upon the application of good process design considerations and an effective maintenance program. The most important factor is the incorporation of dual pieces of equipment where historical experience indicates that high maintenance or equipment modification is apt to occur. (For example, sludge pumps, and provisions for either parallel treatment facilities or surge capacities large enough to permit effective repair.) Of course, shutdown of the production plant



is a possibility in the case of a malfunctioning waste water treatment plant; however, it is usually more economical to provide the required spare equipment to handle conditions that might reduce the operability of the waste water treatment plant. Although the highest degree of performance reliability would probably be achieved by installing two independent waste water treatment facilities, each capable of handling the entire waste water load, practical installations and operating costs as well as the well-demonstrated operability of municipal sewage treatment plants, indicate that a judicious blend of parallelism, surge capacity, and spare equipment are the major factors to be considered. Some of the most critical parameters that should be incorporated in the design of waste water treatment for the synthetics and plastics industry are as follows:

1. Provision for surge capacities in equalization basins or special receiving basins to permit repair and maintenance of equipment.
2. Installation of excess treatment capacity or provisions for rapidly overcoming effects which may destroy or drastically reduce the performance of biologically based treatment systems.
3. Installation of spare equipment, such as pumps and compressors, or multiple units, such as surface aerators, so that operations can be continued at either full or reduced capacity.
4. Layout of equipment and selection of equipment for ease of maintenance.

Water recycle has not been used with any consistency or frequency as a method for minimizing water usage and possibly assisting in reducing the size, if not the total pollution load, of the waste water treatment system. Two of the major reasons for this are (1) the industry, except for the cellulose, is a relatively low user of water per unit of product; and (2) high-quality process water is often required in order to maintain product quality. Consequently, the recycling of water into the process has not been encountered. In one instance, however, intermittent usage of treated waste waters for washdown of process areas was found. The major potential for reduced water usage lies in the judicious control of process steps using water for washing, scrubbing, and so on, by employing countercurrent flow operations and by strict attention to housekeeping operations. The effects of recycling treated waste waters in which buildup of refractory substances is permitted has never been determined. Consequently, recycle of treated waste water as it might influence control and treatment technology is limited to utilization of a lower-quality water commensurate with lowered requirements, such as might be encountered in the washing of floors or in hydraulic transport systems where product quality is unaffected.

The waste waters in the synthetics and plastics industry are generally deficient in the nitrogen and phosphorus needed to maintain a viable mass of micro-organisms. Consequently, it is often necessary to add nitrogen and phosphorus, usually in the form of liquid ammonia and liquid phosphoric acid. In some instances, such as waste water from ABS/SAN, urea and melamine manufacturing, the nitrogen content in the chemicals results in an overabundance of nitrogen. In general, the addition of nitrogen and phosphorus is difficult to control because of the waste water composition and variations in the biological treatability coupled with the lack of satisfactory in-line instrumentation. Consequently nutrient additions are often at either a constant rate or in proportion to the volumetric flow rate with the result that these nutrients often appear in appreciable quantities in the treated effluent due to either excessive feed or because the variability in waste composition caused these excesses to occur. When nutrients are required, it can be expected that their concentration levels will be within the ranges found in municipal sewage treatment plant effluent, except that the ammonia nitrogen content will probably be greater. Effluent loadings of BOD<sub>5</sub>, COD, and TSS from observed exemplary operating biological treatment plants for each product subcategory are summarized in Table 21. For the product subcategories of epoxy resins, phenolic resins, urea resins, and melamine resins the waste loadings are estimated based on levels of attainable concentrations associated with other products that have similar waste constituents.

It is apparent that presently used waste water treatment technology for the plastics and synthetics industry has been demonstrated sufficiently so that effective treatment of the biologically degradable portions can be achieved. The design and operational bases for effective biological waste water treatment systems are well understood; however, because each plant of the industry may generate waste water pollutants that have unique biological refractoriness, the removal of COD substances to the same degree as BOD<sub>5</sub> is not achievable in biological systems.

#### Potentially Usable Wastewater Treatment Technology

Technologies for removal of pollutants from water or, conversely, water from pollutants have been widely investigated in recent years. As a result, a voluminous literature exists on waste water treatment; however, the categorization of these technologies is readily effected on the basis of the physical, chemical and biological operations involved. The technologies described in the ensuing paragraphs are not now being utilized in any significant number for the treatment of waste waters in the industry. Three of the technologies with most promise for near future application of waste water treatment are believed to be adsorption, suspended solids removal and chemical precipitation.

TABLE 21  
Observed Treatment and Average Effluent Loadings  
From Plant Inspections

PRODUCT	PVC	ABS/SAN	PVAcetate	Poly- styrene	Polypropylene	LDPE	HDPE			
Control and Treatment Technology Currently In Use	Equalization Chemical Treatment Settling Activated Sludge Clarification	Equalization Activated Sludge Aerobic Sludge Clarification	Equalization Chemical Treatment Activated Sludge Clarification Polishing Pond	Discharge Into Multi-Plant Effluent	Screen Equalization Chem. Treatment Activated Sludge Polishing Pond	API Separator Equalization Aerobic Lagoon	Screen Chemical Treatment Aeration Pond			
Observed Average Effluent Loadings (Kg/Tonne (lb/1000 lb Production))										
BOD <sub>5</sub>	0.14	0.184	0.08	0.09	0.33	0.13	0.18			
COD	1.0	1.83	0.60*	0.66*	0.66	0.87	1.0			
SS	0.80	0.52	0.09	0.18*	0.57	0.26	.31			
PRODUCT	Cellophane	Rayon	Polyester	Nylon 66	Nylon 6	Epoxide Resin	Phenolic Resin	Urea Resin	Cellulose Acetate	Acrylic
Control and Treatment Technology Currently In Use	Equalization Activated Sludge Clarification	Chem. Treatment Equalization Activated Sludge Clarification	Settle Chemical Treatment Equalization Activated Sludge Clarification	Equalization Chem. Treat. Activated Sl. Clarification Aerated Lagoon Polishing Pond	Skimming Equalization Chem. Treatment Activated Sludge Clarification	No separate treatment facilities encountered. Most plants discharge to municipal systems or are part of a major complex.	Equalization Chem. Treatment Settling Activated Sludge Clarification	Equalization Chem. Treatment Settling Activated Sludge Clarification	Equalization Chem. Treatment Settling Activated Sludge Clarification	
Observed Average Effluent Loadings (Kg/Tonne (lb/1000 lb Production))										
BOD <sub>5</sub>	4.9	3.3**	.13	0.55	3.7	0.16*	0.55*	0.08*	1.7	4.0
COD	41	38**	1.5	2.0	13*	0.80*	2.8*	0.40*	14	17
SS	3.5	4.1	0.20	0.66	1.8	0.32*	1.1*	.16*	2.8	1.5

\* Estimated value  
\*\* Estimated value for proposed system

## Adsorption

Removal of soluble substances, such as characterized by the COD or TOC measurements, is relying increasingly on the use of adsorptive techniques either by the use of a solid adsorbent usually contained in a fixed bed or the use of adsorbent flocs such as the hydroxides of aluminum and iron. For soluble substances the fixed bed adsorption system such as typified by granular activated carbon has been most widely used in the waste water treatment industry although the use of powdered activated carbon is technically feasible. Adsorptive flocs are more frequently used for the less soluble substances although flocs are known to be effective for removal of color bodies under certain conditions. However, granular activated carbon is believed to be the leading technology for removal of soluble organic species since it has been demonstrated for the removal of phenolic compounds, although its efficiency varies widely. (18, 19, 31, 41, 56) Consequently, it is necessary to establish removal capabilities through either pilot plant tests or laboratory determinations of adsorption isotherms before design and operating conditions can be determined. Process designs for carbon adsorption systems are readily available from consultants and equipment manufactures. Also, process design procedures (67, 68) are available in the literature. Table 22 illustrates a number of applications of granular activated carbon systems currently in use by industry. Table 22A gives a summary of EPA research, development and demonstration projects utilizing activated carbon adsorption technology.

Although granular activated carbon adsorption for the removal of refractory organic species from waste waters is proving to be effective, there is an economic necessity that the spent granular activated carbon be regenerated without undue loss of carbon or adsorptive capacity. Consequently, the activated carbon systems usually include a method for carbon regeneration (thermal regeneration is used most frequently) or arrangements are made for custom regeneration. The operation of activated carbon systems for removal of pollutants in this industry is not presently practiced although activated carbon is being used for the selective removal of phenols (56) which are a constituent of some of the industry wasterwaters. Like all technologies, activated carbons adsorption is not without problems, e.g., the occurrence of biological growths in the activated carbon bed is well known. Since these may often occur under anaerobic conditions the generation of hydrogen sulfide and other odoriferous substances is encountered. Furthermore, since thermal regeneration is most frequently used, care must be taken

TABLE 22  
SUMMARY OF  
INDUSTRIAL SOURCES USING GRANULAR ACTIVATED CARBON SYSTEMS

<u>Industry</u>	<u>Location</u>	<u>Principal Product</u>	<u>Contaminant(s) Removed</u>
1. Velvet Textiles	Blackstone, VA	Velvet	Dyes, Detergents, Organics
2. BASF Wyandotte Chemical Corp.	Washington, NJ	Polyethers	Polyethers (MW 1000-3000)
3. ARCO-Watson Refinery	Wilmington, CA	Refinery Products	COD
4. Stephen Leedom	Southampton, PA	Carpet Mill	Dyes
5. Reichhold Chemicals, Inc.	Tuscaloosa, AL	Phenol, Formaldehyde, Pentaerythritol, Orthophenylphenol, synthetic resins, and plastics	COD, Phenols
6. Schnectady Chemicals, Inc.	Rotterdam, NY	Phenolic Resins	Phenols
7.. Chipman Div. of Rhodia, Inc.	Portland, OR	Herbicides-2,4-D acid, MCPA acid, 2, 4-DB acid and esters of these products	COD, Phenols
8. Sherwin-Williams Co.	Chicago, IL	p-Cresol	p-Cresol
9. Mobay Chemical Co.	Houston, TX	----	Color
10. Burlington Army Ammunition Plant	Burlington, IA	Explosives	TNT
11. Stepan Chemical Co.	Bordentown, NJ	Intermediate Detergents	Color and organics
12. Georgia Pacific	Conway, NC	Phenolic Resins	Phenols
13. Stauffer Chemical	Skaneateles Falls, NY	Strong Alkaline Detergents	COD
14. General Electric Co.	Selkirk, NY	Plastics	Phenols and COD
15. C.H. Masland & Sons	Wakefield, RI	Carpet Yarn	Color and COD
16. St. Regist Paper Co.	Pensacola, FL	Kraft products	Color
17. Monsanto Industrial Chemicals	Anniston, AL	Intermediate Organic Chemicals (polynitrophenol)	Polynitrophenol
18. Hercules, Inc.	Hattiesburg, MS	Acid Resins, turpines & solvents	Organics
19. Dow Chemical	Midland, MI	Phenol	Phenols and Acetic Acid
20. Hardwicke Chemical Co.	Elgin, SC	Intermediate and Specialty Organic chemicals	COD, Color
21. Crompton and Knowles Corp.	Gibraltar, PA	Dyes	Dye, COD

TABLE 22a

Summary of EPA Research Development and  
Demonstration Projects Utilizing Activated  
Carbon Adsorption Technology

- (1) EPA Advanced Wastewater Treatment Demonstration Grant No. 17080 EDV, "Tertiary Treatment by Lime Addition at Santee, California, "Santee County Water District, Santee, California, January 12, 1966.
- (2) EPA Advanced Wastewater Treatment Demonstration Grant No. 802719, "Interim Wastewater Treatment Plant Demonstration, Covington Kentucky, "Campbell and Kenton Counties Sanitation District, July 23, 1973.
- (3) EPA Advanced Wastewater Treatment Demonstration Grant No. 80266, "Physical Chemical Treatment Evaluation," Metropolitan Sewer Board Minneapolis, St. Paul Minn., January 1, 1974.
- (4) EPA Storm and Combined Sewer Research Grant No. 802433 Rice University, Houston, Texas, "Maximum Utilization of Water Resources in a Planned Community, July 16, 1973.
- (5) EPA Industrial Research Grant No. 17020 EPF, "Adsorption from Aqueous Solution," University of Michigan, Ann Arbor Michigan, October 1, 1969.
- (6) EPA Industrial Demonstration Grant No. 12050GXE, "Treatment of Oil Refinery Wastewaters for Reuse Using a Sand Filter Activated Carbon System, B.P. Oil Company, Marcus Hook, Pennsylvania January 1, 1971.
- (7) EPA Industrial Demonstration Grant No. 12020EAS "Recondition and Reuse of Organically Contaminated Waste Sodium Chloride Brines, Dow Chemical Company, Midland, Michigan, January 6, 1969.
- (8) EPA Advanced Wastewater Treatment Demonstration Grant No. 11060 EGP, "Advanced Waste Treatment at Painesville, Ohio, City of Painesville, Ohio, December 15, 1969.
- (9) EPA Research Grant No. 12040 HPK, "Organic Compounds in Pulp Mill Lagoon Discharge," University of Washington.
- (10) EPA Research Study No. 21ACU07, "Development of Analog Chemical Treatment," EPA NERC Cincinnati, Ohio, January 7, 1972.

- (11) EPA Research Study No. 21 ABD 06, "Process Modification to Enhance Removal of Heavy Metals, NERC Cincinnati, Ohio, January 4, 1973.
- (12) EPA Advanced Wastewater Treatment Demonstration Grant No. 11010 EHI, "Territory Treatment of Combined Storm Water Sanitary Relief Discharge and Sewage Treatment Plant Effluent," Sanitary District of East Chicago, January 12, 1966.
- (13) EPA Advanced Waste Treatment Demo Grant No. 11010 DAB, "Chemical Clarification and Carbon Filtration and Adsorption as Secondary Treatment for Rocky River Wastewater Treatment Plant, Cuyahoga County, Ohio Sewer District, August 16, 1968.
- (14) EPA Industrial Demonstration Grant No. 801431, "An Activated Carbon Secondary Treatment System for Purification of a Chemical Plant Wastewater for maximum Reuse, "Hercules, Inc., January 3, 1973.
- (15) EPA Demonstration Grant No. 800554, "Carbon Adsorption and Regeneration for Petrochemical Waste Treatment," University of Missouri, Columbia, Missouri, January 6, 1972.
- (16) EPA Research Contract No. 68-01-0183 "Physical Chemical Treatment of Municipal Waste," Envirotech Corporation Salt Lake City, Utah, July 4, 1972.
- (17) EPA Research Contract No. 68-01-0137, "Development and Demonstration of Device for on Board Treatment of Wastes from Vessels," AWT Systems Inc, Wilmington Delaware, March 6, 1971.
- (18) EPA Research Contract No. 68-01-0130, "Device for On Board Treatment of Wastes from Vessels," Fairs banks Morse, Inc., Beloit, Wisconsin, March 6, 1971.
- (19) EPA Research Contract No. 68-01-0104, "Recreational Water Craft Waste Treatment System," Ametek/Calmech Inc., Los Angeles California, March 6, 1971.
- (20) EPA Research Contract No. 68-01-0099, "Development of Modular Transportable Prototype System for Treating Spilled Hazardous Materials," Hernord, Inc., Milwaukee, Wisconsin, June 29, 1971.

- (21) EPA Research Contract No. 68-01-0077, "Process for Housing and Community Development Industries," Levitt and Son, Nassau County, New York, June 15, 1971.
- (22) EPA Research Contract No. 68-01-0013, "Waste Heat Utilization in Waste Water Treatment," URS Research Company, San Mateo, California, December 31, 1970.
- (23) EPA Research Contract No. 58-01-0901, "Study of Improvements in Granular Carbon Adsorption Process," FMC Corporation, Princeton, New Jersey, June 26, 1970.
- (24) EPA Advanced Waste Treatment Contract No. 58-01-0444, "Carbon Adsorption and Electro dialyses for Demineralization at Santee California," Santee County Water District, Santee California, June 29, 1968.
- (25) EPA Research Contract No. 58-01-0400, "Activated Carbon Powder Treatment in Slurry Clarifiers," Infilco, Fullers Company, Tucson, Arizona, June 9, 1968.
- (26) EPA Research Contract No. 58-01-0075, "Study of Powdered Carbons for Waste Water Treatment," West Virginia Pulp and Paper Company, Covington, Virginia, June 29, 1967.
- (27) EPA Research Study No. 21ABK-31, "Treatability of Organic Compounds," EPA NERC Cincinnati, Ohio, January 7, 1973.
- (28) EPA Research Study No. 21 ABK 16, "Treatability of Organic
- (29) EPA Research Study No. 21 ACP 09, "Removal of Toxic Metals in Physical Chemical Pilot Plant," EPA NERC Cincinnati, Ohio January 1, 1972.
- (30) EPA Research Study No. 16 ACG-05, "Identify Pollutants in Physical Chemical Treated Wastes," EPA NERC Corvallis, Oregon, January 8, 1971.
- (31) EPA Advanced Waste Treatment Demonstration Grant No. 800685, "A Demonstration of Enhancement of Effluent from Trickling Filter Plant," City of Richardson, Texas, December 24, 1971.
- (32) EPA Advanced Waste Treatment Demonstration Grant No. 801026, "Removal of Heavy Metals by Waste Water Treatment Processes," City of Dallas, Texas, January 2, 1972.
- (33) EPA Advanced Waste Treatment Demonstration Grant No. 801401,



"Piscataway Model advanced Waste Treatment Plant," Washington Suburban Sanitary Commission, Hyattsville, Maryland, January 1, 1967.

- (34) EPA Research Grant No. 800661, "Oxidation Mechanisms on Supported Chromia Catalysts," Purdue Research Foundation, Lafayette, Indiana, January 6, 1970.
- (35) EPA Research Grant No. 12130 DRO, "Deep Water Pilot Plant Treatability Study," Delaware River Basin Commission, Trenton, New Jersey, July, 1971.

to insure that the gaseous products from regeneration do not cause air pollution.

### Suspended Solids Removal

Suspended solids removal from the effluent of biological waste water treatment plants has not been widely practiced in the plastics and synthetics industry. Although a wide variety of methods can be used for removing suspended solids from liquids, the application of these methods to wastewaters inevitably containing biochemically active substances requires special consideration because biological growths and slimes can result in poorly operating systems. Process designs for suspended solids removal systems applicable to municipal waste waters have been reviewed (69) and the same equipment will be applicable for suspended solids removal in this industry's waste waters. In-depth media filtration is most frequently utilized for the removal of suspended solids from waste waters because the media can be cleaned by suitable hydraulic methods. Other methods for suspended solids removal that might be applicable are precoated filters, wherein a material such as diatomaceous earth is used and subsequently discarded, and membrane filtration. However, neither of these are expected to take precedence over the more conventional in-depth media filters that have been widely used in water treatment. The selection of suspended solids removal equipment is dependent, obviously, upon the physical and chemical nature of the solids and the degree of removal to be achieved.

### Chemical Precipitation

By changing the chemical characteristics of waste waters it is often possible to effect removal of soluble substances by rendering them insoluble at which point the problem becomes one of removing suspended solids. The most common technique is alkaline precipitation used for the removal of metallic species. The removal of zinc in the rayon and acrylic industries by alkaline precipitation is the only instance of its practice in this industry. Zinc removal has been the subject of a demonstration project (65) although the technology for removal of other metals is well known and has been reviewed by Patterson & Minear (47) in some detail. Since many of the precipitated substances are in the form of hydrous oxides, removal of the precipitated solids are often difficult with the frequent result that concentrations in the treated effluents are greater than would be indicated by the solubility products of the chemical species. An excellent example is the aforementioned project (47) where the effluent concentration of zinc varied widely over an extended period for reasons as yet not completely understood.

Prior chemical reactions may be required to effect removal of certain species such as the conversion of Cr<sup>+6</sup> to Cr<sup>+3</sup> by sulfur dioxide followed by precipitation with an alkali such as lime. Obviously, where chemical precipitation changes the pH of the treated waste waters to a value outside the specified limits for discharge, subsequent readjustment of pH will be required. Another area where chemical precipitation is finding increasing usage is for the removal of phosphates from the effluents of biological waste water treatment plants. Phosphate precipitation relies primarily on the use of calcium, iron, or aluminum compounds and has been the subject of widespread investigations which are well reviewed in a design manual (70) and mathematical model (71). Since the results of chemical precipitation are dependent upon the complex interrelationships of chemical species, equilibrium constants and kinetics, the degree of applicability of chemical precipitation for the removal of pollutants from waste waters cannot be generalized and its effectiveness must be determined for each application.

Among waste water treatment technologies, the following have reached various stages of development or can be readily transferred from other fields when their unique capabilities are required.

#### Anaerobic Process

Although anaerobic processes has been most widely used for the digestion of biological sludges, the removal of nitrates from waste waters is receiving increasing attention (72, 73, 74). To effect removal of nitrogen values, it is necessary that a biological treatment plant be operated in a manner which results in a nitrified waste water such as from extended aeration treatment plants. Denitrification usually requires the addition of a supplementary carbon source and methanol or molasses has been found especially useful. The largescale demonstration of biological denitrification is being pursued at a number of municipal installations. Because excess supplementary carbonaceous substances are usually required to provide adequate food supply for the denitrification bacteria, the effluent from biological denitrification often has a greater concentration of BOD<sub>5</sub> or COD than the influent. However, because of the difficulties of removing nitrogen substances due to high solubilities and the complex interactions in secondary biological treatment systems, denitrification is expected to be utilized more frequently where low concentrations of nitrogenous substances in treated waste waters is necessary.

#### Air Stripping

The removal of ammonia from alkaline solution is the major potential application for air stripping (22, 34) in this industry. Although the process has been demonstrated in moderately large operations, its selection will depend upon the nature of the waste waters and receiving stream requirements for the removal of nitrogenous substances. Scale formation in equipment, typically of a cooling tower configuration, can cause severe operational problems or demand close control of the chemistry of the system. In addition, air stripping of ammonia is very temperature sensitive - i.e., proceeding at very slow rates at low temperatures. The stripped substances are usually in such low concentrations that they are not considered to be air pollutants.

#### Chemical Oxidation

Chlorine, permanganate, hypochlorite, ozone and so on may be used to chemically oxidize some pollutants. Breakpoint chlorination for destruction of ammonia in treated waters from municipal sewage plants has long been recognized and ozone has been used for the treatment of potable water. The application of oxidative chemicals requires that specific determination be made of their effectiveness in removing the pollutants and, in particular, to determine if the reaction products are innocuous. As a particular example, the chloramines produced by chlorine and ammonia are more toxic to aquatic life than the ammonia. Similarly, the toxic aspects of manganese, ozone, etc., must be carefully evaluated to insure that the removal of one type of pollution does not result in creating a different or, perhaps, even more severe pollution problem. Consequently, it is expected that chemical oxidation will be employed on a highly selective basis such as in the destruction of cyanide where its overall effectiveness is assured.

#### Foam Separation

Surfactants added to a waste water followed by air blowing to produce a foam can effect a concentration of various substances often found in waste waters. However, successful development above the pilot plant scale has not been demonstrated and its usefulness as a treatment technology will probably be extremely limited.

#### Algal Systems

Nutrient removal by the growing of algae is well known; however, it has not achieved any significant acceptance due primarily to (1) the necessity of having a relatively warm climate with high incidence of sunshine

and (2) the difficulties of removing the algae from the waste water before discharge.

### Incineration

Destruction of pollutants by combustion or incineration is technically feasible regardless of the concentration insofar as the products of combustion do not create an air pollution problem. At the present time, incineration of concentrated liquid wastes containing phenolic compounds is being practiced. Equipment is available for achieving incineration of virtually any type of waste; however, the use of supplementary fuel is usually required. Incineration is not frequently used because of the high cost of energy. In some instances where the removal of pollutants cannot be achieved in a less costly manner or because disposal of the removed pollutants still presents a severe problem, incineration may be the best method of water pollution control.

### Wet Air Oxidation

The oxidation of organic pollutants by introducing air or oxygen into water under pressures of from 300 to 1800 psig that has been primarily used for the destruction of sludges. For the oxidation to proceed autogenously, it is necessary that a sufficient concentration of oxidizable substances be present to provide the exothermic energy necessary to maintain the required temperatures. Partial oxidation of concentrated biological streams such as the sludges from initial and biological treatment results in a stabilized solid which can be used as a soil conditioner. Wet air oxidation will probably continue to be considered primarily for the destruction of concentrated pollutants such as slurries or sludges.

### Liquid-Liquid Extraction

The transfer of mass between two immiscible phases, known as liquid-liquid extraction, is often capable of achieving high degrees of removal and recovery of selected components. The technology has been well developed in the chemical and nuclear fuel industries but has been infrequently applied to the treatment of waste water streams. Liquid-liquid extraction would usually be employed to remove a relatively valuable component or a particular noxious substance from a waste water stream prior to additional treatment. A typical example is the recovery of phenolic compounds.<sup>75</sup> Loss of the extracting liquid to the water stream must be considered since it may then be a pollutant which requires further removal before discharge of the treated waste water.

## Ion-Exchange

The removal of ions from water by the use of ion-exchange resins has been well established in the field of water treatment. Man-made resins or naturally occurring minerals such as zeolites or clinoptilolite have been used. The removal of zinc from viscose rayon wastes by ion-exchange has been demonstrated; however, successful long-time operation has not been achieved. Ion exchange has been used for the removal of nitrates and clinoptilolite has been shown to be effective in the removal of ammonium ion from waste waters. Although ion exchange can be an effective method for the removal of ionic species from waters, the economic necessity for regeneration of the ion-exchange media results in a concentrated liquid stream for which further disposal must be considered. It is expected that the use of ion exchange in waste water treatment would be limited to the selective removal or concentration of pollutants for which more economically effective methods are not available. Since ion-exchange regenerates add mass to the waste stream from the regeneration, ultimate disposal of concentrated streams from ion-exchange systems will contain more total dissolved solids than removed from the waste waters.

## Reverse Osmosis

Desalination research and development efforts have been responsible for the development of reverse osmosis as a method for removal of ionic species from waste waters. Also, non-ionic species can be removed; however, control of membrane fouling must be given special consideration. The major process advantage of reverse osmosis is its low energy demand when compared with evaporation and electro dialysis; however, the costs of replacement membranes may be an offsetting factor to the total cost picture. The applicability of reverse osmosis to the treatment of waste water streams can only be determined by laboratory and pilot plant tests on the waste water of concern. As in the case of ion exchange reverse osmosis produces a concentrated stream containing the removed pollutants and further consideration must be given to its disposal.

## Freeze-Thaw

Controlled freezing followed by separation and thawing of the ice crystals has undergone extensive development as a desalination method. As in the case of reverse osmosis, it must be evaluated for specific situations. Again, the ultimate disposal of a liquid stream highly concentrated in pollutants must be taken into consideration when evaluating the overall waste water disposal problems.

## Evaporation

Evaporation has been well developed and widely used for the desalination of seawater. Furthermore, it is a well developed operation in the chemical process industries. Unfortunately, direct evaporation is the most energy consuming of the water removal processes; therefore, elaborate multi-stage systems are required to effect energy economy. Its application to the concentration of selected waste water streams is established; however, evaporation is usually used in conjunction with other process operations where the energy demands and resulting concentrated solutions can be justified on the basis of most economic overall performance.

This approach can be expected to continue in the face of rising energy costs and increasingly stringent limitations on waste water discharges. The technical feasibility of evaporation will have to be determined for specific situations since a highly concentrated waste water may cause fouling of heat transfer substances. Also, volatile species which can be removed by the steam stripping action and, consequently, appear in the condensate would mean further treatment before reuse or discharge. Again, the disposal of highly concentrated streams of pollutants (primarily inorganic species) must be considered.

## Electrodialysis

Developed for the desalination of water, electrodialysis is a separation technique that would be expected to compete with ion exchange, reverse osmosis, freezing and evaporation for the removal of pollutants from waste water streams. As in the case of all of these, electrodialyses for waste water treatment must be chosen on the basis of achieving the necessary performance under required operating conditions.

## In-Plant Control of Waterborne Pollutants

Pollutants removed from process streams in the course of removing water generated by reactions, or water required for effecting reactions or purifying products, are specific to particular processes. However, an ubiquitous source of waterborne pollutants is attributable to spills, leaks and accidents, within process plants handling liquids. The synthetic and plastic industry is, of necessity, required to handle and process liquids under a wide variety of conditions, although the major products are usually solids. Consequently, all segments of the industry will be found to contribute waterborne pollutants due especially to spills and leaks in process operations as well as support operations. The importance of this subject has been reviewed in

several articles based on work funded by the Environmental Protection Agency. (60, 61)

The major way to control the emission of pollutants from spills and leaks is to recognize the potential that exists in various areas of the plant. The following matrix was developed in the previously referenced work as a method for controlling and ranking the main functions of areas in liquid handling facilities.



TABLE 23

MATRIX FOR EVALUATING LIQUID  
HANDLING FACILITIES

Probability of Spillage

	Storage	Transfer	Loading and Unloading	Processing
Inventory of Contained Liquid	Very High	Low	Very Low	Low
Frequency of Operating Cycles	Low	Moderate	Very High	Moderate
Ratio: Temporary Connections Permanent Connection	Very Low	Very Low	Very High	Moderate
Volumetric Transfer Rate	Low	High	High	Variable
Dependence Upon Human Factor	High	Low	Very High	High

The following list of spill prevention and control techniques are commonly found throughout the liquid handling industries (15, 21, 44) and apply equally well to the synthetic and plastics industry:

1. Diked areas around storage tanks. For flammable substances these are required; however, as a passive barrier to tank rupture, and tank and pipe connection leaks, a diked tank storage area is considered the first-line barrier to containing and reducing the spread of large-volume spills.

2. Tank level indicators and alarms. The sounding of alarms at prescribed levels during tank filling could be expected to minimize the common occurrence of overflow when reliance is on manual gauging for control.

3. Above-ground transfer lines. Above-ground installation permits rapid detection of pipeline failures and minimizes hazardous polluting substances from polluting ground waters. Although increasing the possible mobility into surface waters, long-term considerations are believed to favor above-ground transfer lines.

4. Curbed process areas. Spills from processing equipment must often be removed rapidly from the area but prevented from spreading widely in the immediate area; consequently, curbed areas connected to collecting sewers are indicated.

5. Area catchment basins or slop tanks. For containment of small spills and leaks in the immediate area thereby effecting removal at the highest concentrations, local catchment basins can provide significant flexibility in preventing spills from entering water courses.

6. Holding lagoons for general plant area. Lagoons which can be used to segregate spills and prevent them from passing as slugs into waste water treatment plant or water courses, give the surge capabilities necessary for handling large volume or highly toxic spills.

7. Initial waste water treatment. For removal of floating substances or for the chemical neutralization or destruction of spilled materials, the initial waste water treatment plants serve to ameliorate the more drastic effects of spills in receiving waters.

8. Biological waste water treatment. The removal of soluble substances usually through biological action, where possible, can insure that the plant waste water discharges have a high degree of uniformity at acceptable quality regardless of in-plant variations such as would occur from spills.

9. Availability of spill cleanup equipment. Vacuum trucks, booms, neutralizing chemicals and so on, represent obvious contingency planning to cope with spills.

10. Routine preventative maintenance schedules. Because literature sources indicated that the cause of many fires in the chemical industry could be traced to failures that might have been avoided by a thorough preventative maintenance program, it was recognized that this program would be an indicator of the possible reduction in spill potential.

11. Spill control plan. The formalization of a plan for coping with spills and the training of personnel in courses of action similar to plant safety programs, was reasoned to be a prime indicator of the operational possibility of coping with spills in a manner which would avoid entry into water courses.

The application of ancillary control techniques requires judicious planning of operational philosophy, organization, and specific measures such as discussed below.

#### Operational Philosophy

Each plant management needs to formulate a "Spill Exposure Index" which will reveal potentially-serious problems in connection with its operation. Once the problems are defined, remedies and the costs of implementing them are not difficult to determine. The next step is establishing priorities, a budget, and a commitment to capital and operating expenditures. As new production projects are proposed for a plant site, each should incorporate adequate measures for spill prevention as an integral part of its design. Capital investment in this category should be considered to be fully as necessary as investment in process equipment or, alternatively, in more elaborate waste water handling procedures.

One approach is the development of a classification index (taking into consideration the minimum aquatic biological toxicity, etc.) which establishes ratings of hazardous polluting substances and recommends the minimum acceptable containment measures.

#### Organization

Since most of the prevention and control measures represent added inconvenience and costs in the eyes of the plant operating staff, even when wholeheartedly accepted, establishment of an independent group with a direct assignment to minimize spills and authorized to take action is especially desirable.

#### Specific Measures

In a facility with a "high spill exposure index" there should be a review of the designs and conditions to determine the potential consequences of spills and leaks in a truly objective manner. The review should consider the design of the process and

equipment and should involve a piece-by-piece physical inspection. In common with most successful projects, there is no substitute for careful attention to details. All possible accidents and departures from routine should be considered and then analyzed in terms of the hazard, and the corrective action or control measures which could be applied.

All plant facilities need to be included, both process and service units. One frequently neglected item is the condition of underground lines of sewers. A number of potential sources of leaks and spills can frequently be eliminated without real inconvenience to the process.

In the process area, a number of spill exposure conditions are often found. One of the most serious is limited storage between coupled process units which may not be in balanced operation. Intermediate storage of this type is most often designed on the basis of surge volume provided. But often operating rates are difficult to adjust, and overflow of the surge tank results. When spill prevention per se, becomes an important criterion, a major revision in standard operating procedure, and perhaps a revised standard for the size of storage may be called for. Small leaks at shafts of pumps, agitators, and valve stems is frequently tolerated; and in the case of rotating equipment, is desirable for shaft lubrication and cooling. In the aggregate such losses may be significant spills and should be prevented or contained. Sampling stations and procedures should also be reviewed to curtail unnecessary discard of small quantities of process fluids. Vent systems are potential points of accidental spill and, on hot service, may allow a continuous spill due to vaporization and condensation.

The major hazard in storage areas is catastrophic failure of the tank, an accident which on economic grounds alone justifies careful attention to tank design, maintenance, and inspection. Containment of a large spill is desirably provided by diking or curbing, but these systems need analysis as to proper operation both in standby status and in the event of a spill; safety principles and operating convenience can both be in conflict with spill prevention and the differences must be reconciled. Venting and tank overflow problems can be severe because of the cyclic nature of storage operations; accessories such as heating or cooling systems, agitators, instrumentation, and fire prevention control systems all can represent potential for spill.

Loading, unloading, and transfer operations are particularly accident prone. Where materials with obviously high hazard are involved - a high degree of reliability of the transfer system is achievable at a cost which is really quite reasonable. This success is due to provision of adequate equipment but also in large measure to strict adherence to well-thought-out procedures. Carelessness and shortcuts in operation do not often occur. The same philosophy applied to less dangerous materials can be fruitful, and we have seen a number of good installations of this kind.

Permanent piping, swing joint systems, and flexible hoses are all used successfully for transfer and each has its place. There is a need to recognize that each has inspection and maintenance problems as well. The design of transfer lines must consider such questions as leaving them full or empty when idle, purging before and after use, protection with check valves, and manifolding. Multiple use of a transfer line should be avoided but when necessary on economic or other grounds the design should provide a clear indication to the operator that valves are properly set. Remote setting of valves, and panel indication of valve position are practical systems that could be more widely employed.

In addition to active spill-prevention measures, curbing, diking and collection systems are desirable and are common at land-based transfer points. Where marine transfer is involved, passive safeguards are difficult to apply and their adoption is new even in the petroleum industry where the apparent need has been highest. The plastics and synthetics industry can and should follow suit. Watersoluble and heavier-than-water fluids both obscure and complicate the problem. In any event all such passive systems which contain rather than prevent spills should be looked upon as back-up measures and not as a crutch to permit neglect of active spill prevention.

The emphasis on ancillary process control technology must be based equally on adequate, well-maintained equipment and on operational vigilance and supervision. Attention to these details will often result in reducing significantly not only the total loads on wastewater treatment plants but, most importantly, reducing the variability of pollutant flows with a concomitant improvement in the quality of treated waste waters emitted to receiving bodies.

#### Procedures and Operating Methods for Elimination or Reduction of Pollutants

Consideration of the process operations employed throughout the plastics and synthetics industry indicates a high degree of commonality in that the usual process flowsheet is developed around a judicious combination of batch and continuous operations. Only in the case of high volume materials, such as the polyolefins, do truly continuous process operations seem to predominate. Skillful process designs and operations in the other industry segments provide essentially continuous flow of product from the process; however, this is frequently due to the effects of multiple-batch operations in conjunction with appropriate storage and surge of process streams. Where the process operations have been put on a continuous operational basis, it is found that the basic process utilized is less demanding of process water usages or is based on technology that does not require water or does not generate water from reactions. The principal example of this, of course, is the particle form process for the production of polyethylene. But, generally, the similarity of basic process operations throughout the plastics

and synthetics industry indicates that similar philosophical approaches to the elimination or reduction of pollutants can be employed and that their application must be approached on a plant-by-plant basis.

The reduction or elimination of waterborne pollutants in the plastics and synthetics industry will depend upon the following factors.

1. The replacement of present technology with technology which generates less waterborne pollutants. Examples of this are the particle form process of polyethylene and the mass polymerization process for polystyrene, ABS/SAN and polyvinyl chloride. The possibilities for applying this approach will require assessment of the availability of new technology and the capital investment required for retiring present plants and erecting new plants. It will also require determining if the quality range of products produced can meet the requirements of the market. In those product categories, such as the ones listed above, where less water use and lower pollutant-generating processes exist, the replacement approach is dependent upon a socioeconomic decision, i.e., is the early retirement of more polluting processes and their replacement with less polluting processes going to result in effectively reducing the emission of environmental pollutants in a manner in which the greatest benefits/cost ratios result for the environment and society. At the present time, significant reductions in pollutant loads can be achieved, in the above-listed products by replacing one production method with another. In general, however, the plastics and synthetics industry considered in this survey is a mature industry, and there appears little potential for dramatic breakthroughs in the production technology. The most probable results will be replacement of some products with newer products.

2. The age of the plant and equipment. In some segments of the plastics and synthetics industry, notably rayon and cellophane, the age of the plants and equipment is one of the most important aspects of reducing loads of waterborne pollutants. These plants were designed and built in an era when there was little concern about the emission of water pollutants and, consequently, the process, equipment and plant layout designs did not provide for incorporating techniques for reducing water flows, and segregating and preventing pollutants from entering the water streams. The process conditions and engineering applicability of techniques such as countercurrent washing, segregation of non-process water streams from process waste water streams, water usage in housekeeping, and so on, are well known; however, incorporation of these procedures into old plants becomes, again, more a question of economics and less a question of applying methods of water conservation and reduction in pollutant loads.

3. Process Operational Changes. Certain obvious process operational changes can be made such as replacement of direct water condensers with surface condensers, better control of reactions, and, possibly, less generation of wastes either because of less offspecification product or more efficient reactions, replacement of water scrubbing systems by non-aqueous methods, and so on. Engineering design procedures and equipment necessary to accomplish these improvements are usually available; however, it is the hour-by-hour operating details, such as the functioning of controllers or operator attention and skill, that determines the overall success of these changes.

4. Maintenance and Housekeeping. It is well-established that in the chemical processing industries the polluttional load imposed on the waste water treatment plant can frequently be reduced significantly by improved maintenance and equipment, i.e., repair of leaking pump seals, valves, piping drips, instrumentation and so on. Housekeeping practices which utilize procedures other than water for the flushing of samples, the disposal of offspecification product, the disposal of samples, etc., can reduce polluttional loads. It must be made clear to operating personnel that the difficulties inherent in applying the best and most economical methods for removal of pollutants from water streams to be emitted from the plant are never as useful as preventing the pollutants from entering the water stream in the first place.

## SECTION VIII

### COST, ENERGY, AND NON-WATER QUALITY ASPECTS

Approximately 280 company operations participate in the manufacture of the eighteen products for which guidelines and standards are recommended (see Table 24). The actual number of plants involved is not known, but there are believed to be more than 300 of them. Some of the 280 company operations include multi-plant divisions; some represent multi-product plants. By comparison, 240 permit applications have been received by EPA from plants in this industry which discharge into streams. Again, counting those that discharge into municipal sewers, the total number of plants is probably over 300.

Total production in 1972 for these products is estimated at 12 million kkg or 26 billion pounds per year. Overall, production of these products is expected to grow at 10 percent per year. Current water usage (1972) is estimated at 1035 thousand cubic meters per day (275 MGD). Assuming that hydraulic loads (unit of flow/unit of production) remain constant, water usage is expected to grow to 1440 thousand cubic meters per day (380 MGD) or at 6.7 percent per year through 1977.

The first part of this section summarizes the costs (necessarily generalized) and effectiveness of end-of-pipe treatment systems either currently in use or recommended for future use in the plastics and synthetics industry. In order to reflect the very different treatment economics of existing versus new plants or small versus large ones, costs have been developed for, typically, two plant sizes in each product subcategory. These appear later in this section. The purpose of this discussion is to describe the basic cost analyses upon which the product-specific estimates are based.

The final part of this section reports updated inputs for EPA's Industrial Waste Treatment Model. The estimated total volume of waste waters discharged for product subcategories have been provided for 1972 and 1977. Also, general estimates of the current level of treatment in different industry segments have been made.

#### Alternative Treatment Technologies

The range of components used or needed to effect best practicable control technology currently available (BPCTCA), best available technology economically achievable (BATEA), and best available demonstrated technology for new source performance standards (BADT-NSPS) in this portion of the plastics and synthetics industry have been combined into eight alternative end-of-pipe treatment steps. These are as follows:

- A. Initial Treatment: For removal of suspended solids and heavy metals. Includes equalization, neutralization, chemical coagulation



TABLE 24

**PERSPECTIVES ON THE PLASTICS AND SYNTHETICS INDUSTRY  
- WATER USAGE -**

Guideline Sub category Product	Number of Company Operations (1)	Percent of Total 18 Product Production (2)	Percent of Water Used by 18 Products	Percent of Growth in Water Usage of 18 Products (3)
		1972	1972	1972-1977
<b>A</b>				
PVC	23	14.7	7.4	14.6
ABS/SAN	8	3.1	1.6	4.1
P Styrene	19	12.4	4.2	5.9
PV Acetate	26	1.7	0.7	0.4
LDP Ethylene	12	19.4	7.2	14.3
HDP Ethylene	13	8.4	4.6	12.2
Polypropylene	9	5.5	4.0	10.4
<b>B</b>				
Cellophane	4	1.2	13.9	(5.1)
Rayon	7	3.5	19.1	7.8
<b>Subtotal - A &amp; B</b>	<b>121</b>	<b>69.9</b>	<b>62.7</b>	<b>64.6</b>
<b>C</b>				
Cellulose Acetates	7	3.3	16.8	4.5
* Epoxy	8	0.7	0.1	0.1
* Melamine	11	3.5	0.2	0.4
* Urea Resins				
* Phenolics	81	4.7	0.4	0.4
Polyester	19	8.9	8.5	22.4
Nylon 66	20	6.9	9.5	6.8
Nylon 6				
<b>D</b>				
Acrylics	11	2.1	1.8	0.8
<b>Subtotal - C &amp; D</b>	<b>157</b>	<b>30.1</b>	<b>37.3</b>	<b>35.4</b>
<b>TOTAL - 18 PRODUCTS</b>	<b>278</b>	<b>100.0</b>	<b>100.0</b>	<b>100.0</b>

(1) Number of companies producing each of the products; the number of plants is greater because of multiple sites for any one company.

(2) Estimated 18-product production in 1972: 12 million kkg (26 billion lbs).

(3) Result of projected product growth at current hydraulic loads.

\* See footnote, p. 136.

or precipitation, API separators, and primary clarification.

- B. Biological Treatment: Primarily for removal of BOD. Includes activated sludge (or aerated stabilization basins), sludge disposal, and final clarification.
- C. Multi-Stage Biological: For further removal of BOD loadings. Either another biological treatment system in series or a long-residence-time polishing lagoon.
- D. Granular Media Filtration: For further removal of suspended solids (and heavy metals) from biological treatment effluents. Includes some chemical coagulation as well as granular media filtration.
- E. Physical-Chemical Treatment: For further removal of COD, primarily that attributable to refractory organics, e.g., with activated carbon adsorption.
- F. Liquid Waste Incineration: For complete treatment of small volume wastes.
- G. Zinc Removal and Recovery: For two-stage precipitation and recycle of zinc used in production of rayon.
- H. Phenol Extraction: For removal of phenol compounds, e.g. from epoxy, acrylics, and phenolics wastes.

#### Costs of Treatment Technology Now in Practice

Information on actual treatment cost experience in the plastics and synthetics industry was not plentiful from the exemplary plants visited. Data of varying degrees of completeness were available from twelve of those plants. To both verify the reasonableness of the data received and to provide a broader basis for estimation, a costing model was developed based on standard waste water treatment practice. This model covers both capital and operating costs for the equivalent of what appears to be the best technology currently practiced by the industry: essentially initial and biological treatment from either activated sludge or aerated stabilization pond systems. Over a plant size range of 2 to 12 thousand cubic meters per day (0.5 to 3.0 MGD), the cost experience data from the plants visited came within  $\pm$  20 percent of that predicted by the cost model. The costs calculated from the model, therefore, are believed to be a realistic basis for estimating the replacement value of existing facilities and the economic impact of further secondary-type treatment requirements.

For the purposes of these cost analyses, the products were initially grouped according to their chemical, rather than waste water, nature.

Group I:\* epoxies, melamine, urea resins, and phenolics.

Group II: PVC, ABS/SAN, polystyrene, PV acetate.

Group III: low-density polyethylene, high-density polyethylene, polypropylene.

Group IV: acrylics, polyesters, nylon 6, nylon 66.

Group V: cellophane, rayon, cellulose acetates.

Cost curves developed from the cost model are presented in Figs. 33 and 34. Fig. 33 presents the capital costs of activated sludge and aerated stabilization pond systems as a function of hydraulic load. Fig. 34 presents the operating and maintenance costs over the ranges of production found in the five product groups studied. The initial capital cost of biological treatment systems is mainly dependent upon (and here related to) the hydraulic load, the other factors making only minor variations in the total cost. Operating costs, on the other hand, have been viewed as dependent on pollutant as well as hydraulic loads.

Costs for representative plants in the product subcategories were developed using these curves together with as many product-specific differences as were known. "Representative" plants defined here for the purpose of determining overall industry costs are not to be confused with "exemplary" plants which were sought as a basis for setting guidelines. Cost data from exemplary plants were used to validate our cost model, which could then be used to estimate the costs for representative-sized plants, i.e., the costs required in order for the rest of the industry to catch up.

The two principal biological waste treatment processes considered to best represent the options available are the aerated stabilization basin and the activated sludge system. Of the two, the aerated stabilization basin is much preferred on an initial cost basis when land is readily available. The following items were determined for the individual treatment steps.

\*Revisions and updating of the cost analysis for the epoxy resins, phenolic resins, urea and melamine resins will be incorporated into the Development Document for the Synthetic Polymers Segment of the Plastics and Synthetics Industry.

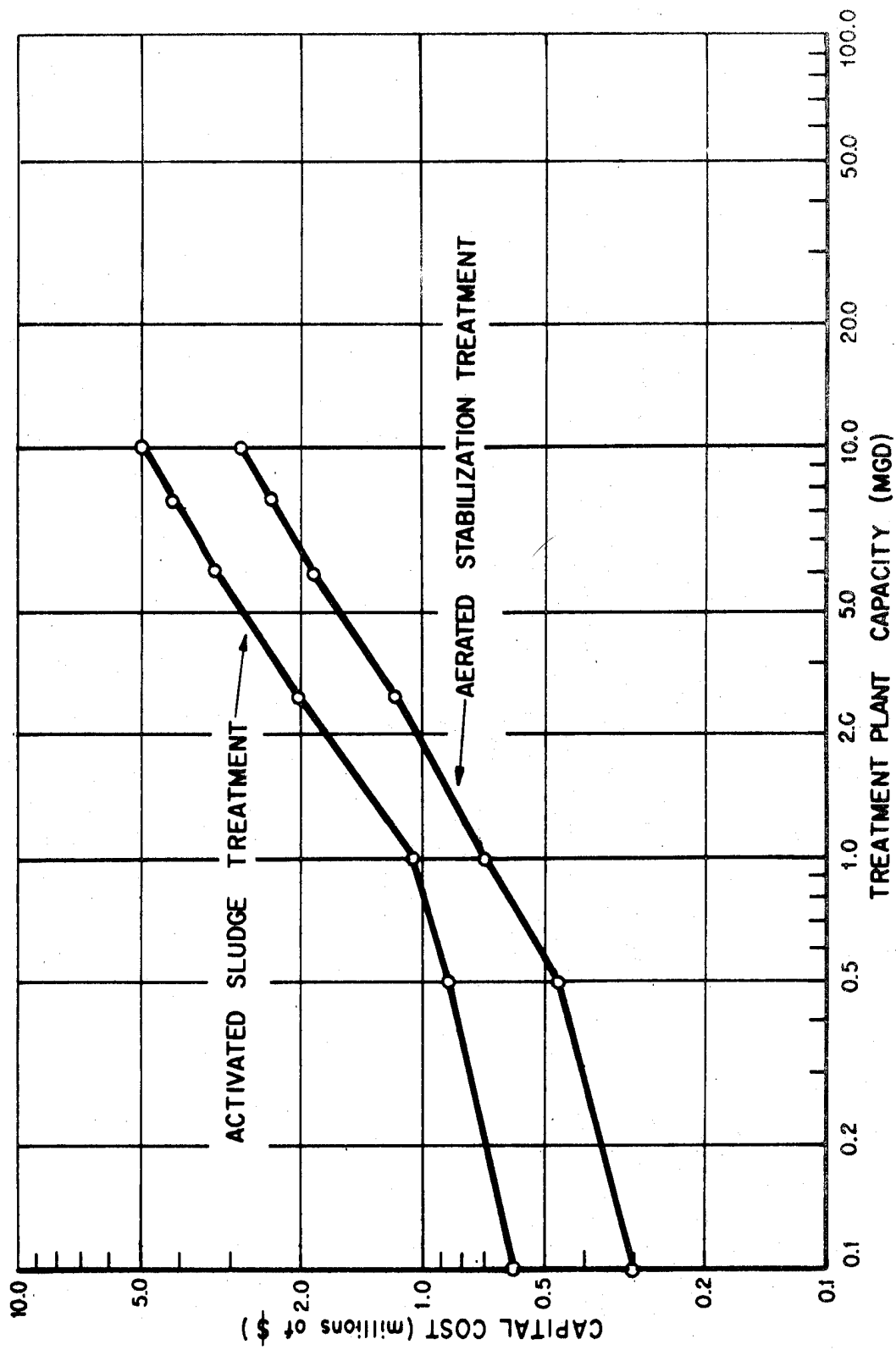

FIGURE 33

BIOLOGICAL TREATMENT IN THE PLASTICS AND SYNTHETICS INDUSTRY -  
CAPITAL COSTS

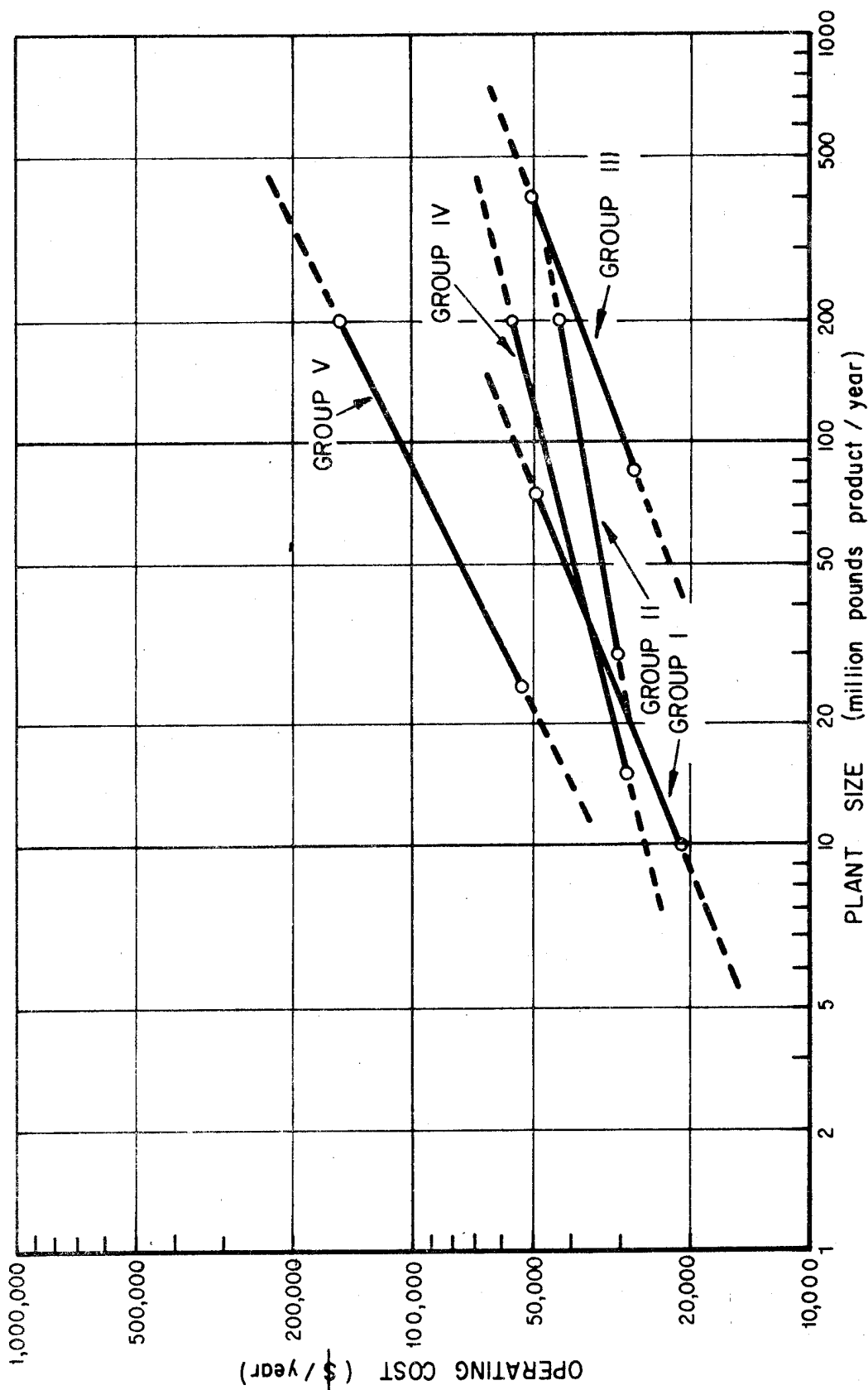

FIGURE 34

BIOLOGICAL TREATMENT IN THE PLASTICS AND SYNTHETICS INDUSTRY -  
OPERATING COSTS

(1) construction cost as a function of hydraulic load at a given pollutant level; (2) operating and maintenance labor as a function of hydraulic load; (3) chemical requirements as a function of hydraulic and pollutant load; (4) power requirements as a function of hydraulic and pollutant load; (5) additional material and supply cost as a function of hydraulic load. An estimate of land requirements is provided for each total treatment system. The cost data used were derived from varied industrial and municipal applications. They are adjusted where possible to reflect specific changes necessary for the plastic industry. Costs have been adjusted to a national average cost level of January 1973 using the ENR Construction Cost Index (16). The estimated cost curves have been adjusted to exclude unusual construction or site-specific requirements. The curves include all elements of construction cost which a contract bidder would normally encounter in completing the waste water treatment. Included are building materials, labor, equipment, electrical, heating and ventilation, normal excavation and other similar items. Also included are engineering costs. The annual operating costs include operation and maintenance labor, chemicals, power, material and supplies.

Biological treatment systems as practiced in the plastics and synthetics industry are not large users of energy. The amounts needed in the initial and biological steps are indicated in Figs. 35 and 36.

#### Cost of Advanced Treatment Technologies

Although not presently practiced by the most exemplary waste water treatment plants in the plastics and synthetics industry, the technology exists to achieve very low concentrations of suspended solids. The technology chosen for capital and operating cost estimates is granular media filtration although other types of filtration systems and, in certain instances, long residence time lagoons might be effective, however, the uniformity of effluent is not as controllable in the latter. Granular media filtration used with chemical precipitation and coagulation should be further effective in reducing the concentration of metals and insoluble BOD<sub>5</sub>. The capital costs (operating costs and energy requirements are minimal) for granular media filtration used in our estimates are shown in Fig. 37 for the five product groups studied. Costs have been calculated on the basis of hydraulic loads and annual production rates.

The question of capital and operating costs required to achieve, by 1983, best available treatment of the organics which escape biological treatment is difficult to address on the basis of present technical knowledge. Review of the waste water treatment technology field seems to indicate that activated carbon adsorption applied following the secondary (biological) treatment is the most probable technology.

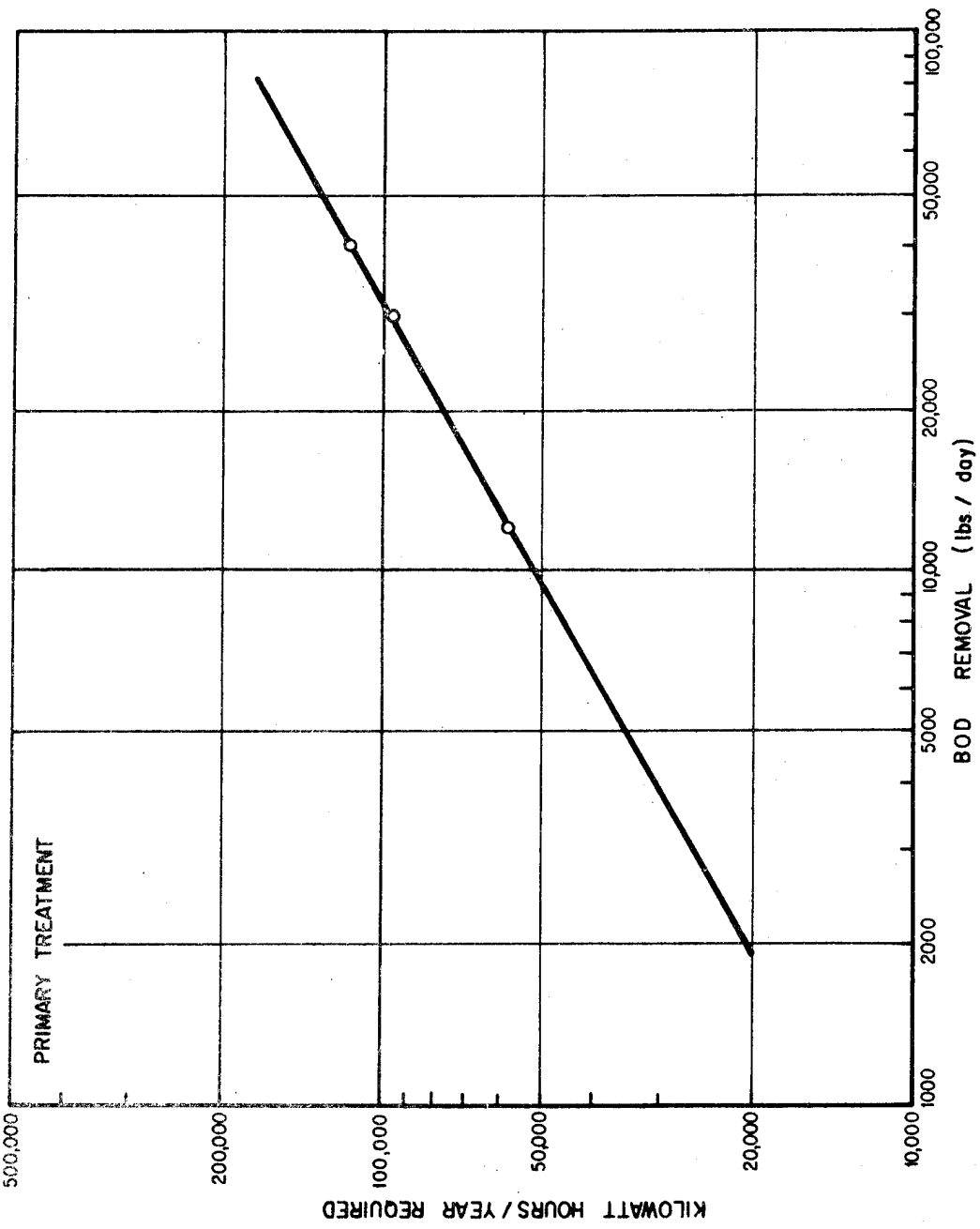

FIGURE 35

BIOLOGICAL TREATMENT IN THE PLASTICS AND SYNTHETICS INDUSTRY -  
 ENERGY REQUIREMENTS - PRIMARY TREATMENT

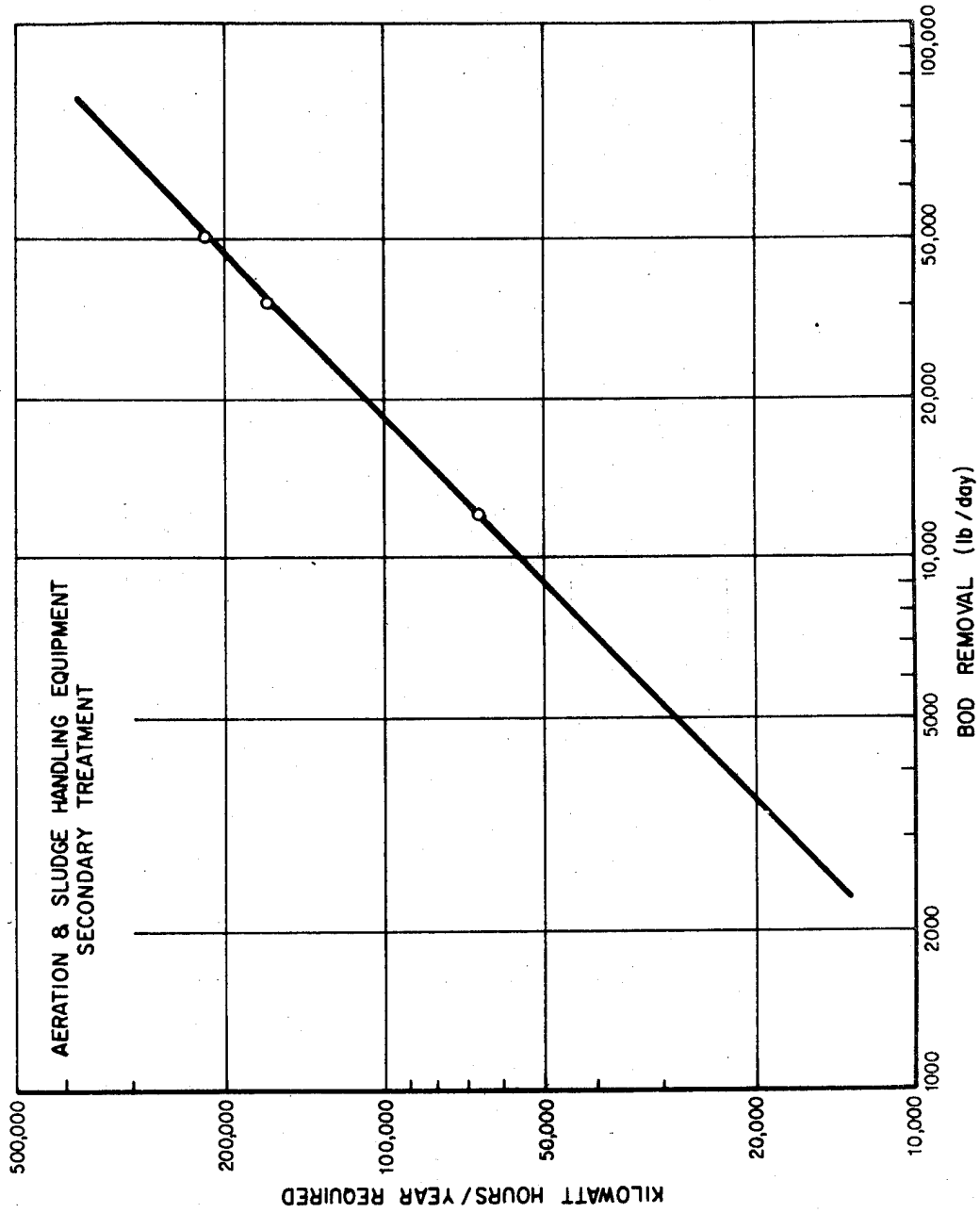

FIGURE 36

BIOLOGICAL TREATMENT IN THE PLASTICS AND SYNTHETICS INDUSTRY -  
ENERGY REQUIREMENTS - AERATION AND SLUDGE-HANDLING EQUIPMENT



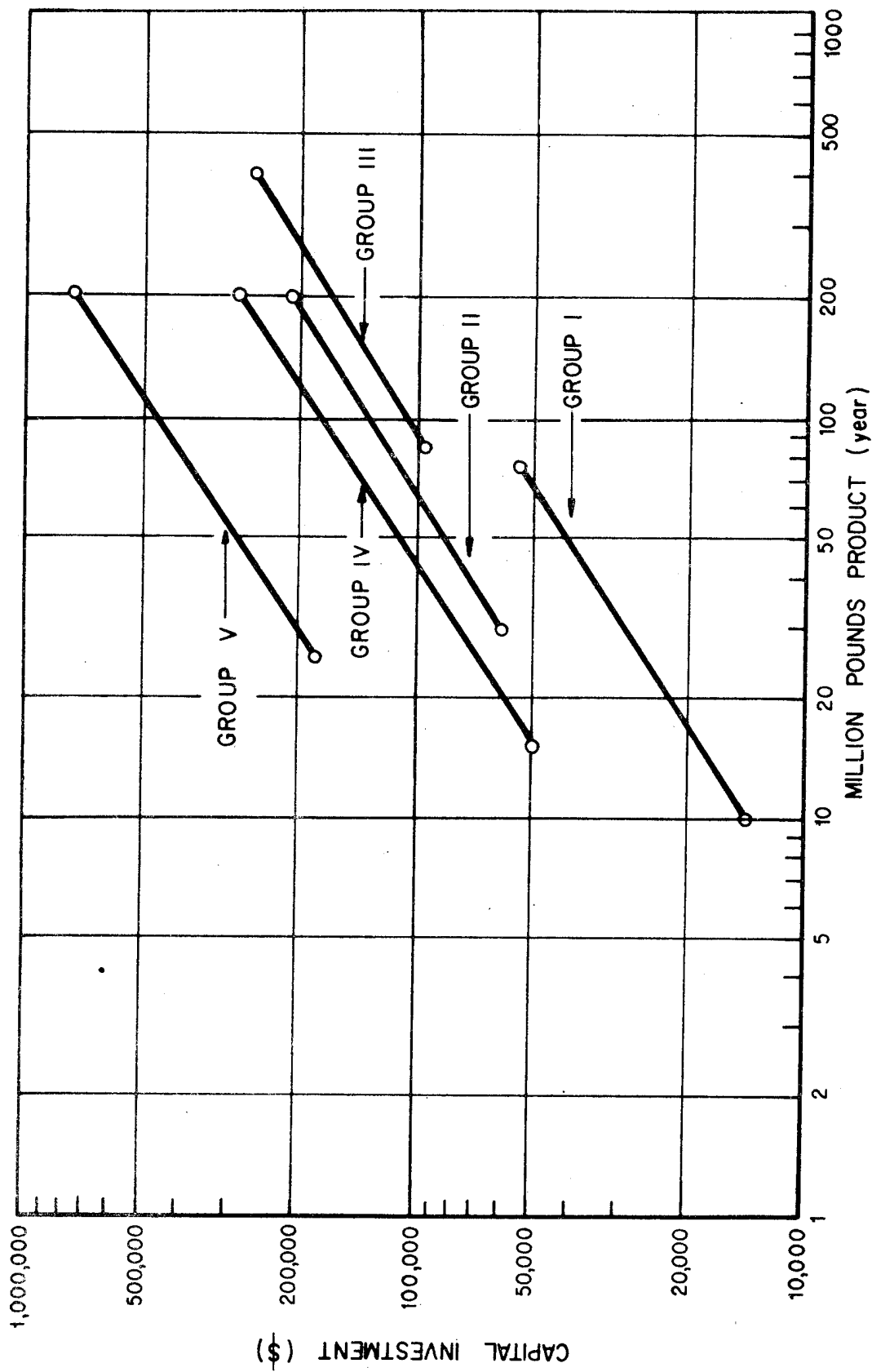

FIGURE 37

GRANULAR MEDIA FILTRATION FOR THE PLASTICS AND SYNTHETICS INDUSTRY -  
CAPITAL INVESTMENT

This assumes that the nature of the wastes is such that the refractory organic substances (measured as COD or TOC) would not be susceptible to treatment by other adsorptive methods, such as flocs, or that high dosages of lime would be ineffective. Because the removal of COD can be expected to be highly specific to the type of pollutant in the waste waters (31, 41), the applicability of carbon adsorption across the industry is technically still in doubt. Nevertheless, in order to provide an indication of the probable magnitude of advanced waste water treatment, activated carbon adsorption has been chosen as a process which would be considered as an add-on to biological treatment. The assumption is made, based on meager data in the literature, that only 60 percent removal of the COD would be achieved and that the carbon loading would be 0.07 lb COD/lb of carbon (kg COD/kg of carbon) at a bed volume per hour flow rate of 0.5, i.e., 120 minutes contact time in the adsorbers. Capital and operating costs have been prepared using the input parameters of hydraulic load and COD per day applied to the activated carbon system (1, 22, 20).

Fuel consumption was taken as 6,000 Btu/lb of dry carbon regenerated and carbon makeup as 5 percent of carbon regeneration rate. These costs (capital and operating) are indicated in Figs. 38 and 39.

#### Non-Water Quality Aspects of Alternate Treatment Technologies

The non-water quality aspects of the treatment and control technology found in the synthetics and plastics industry are related to (1) the disposal of solids or slurries resulting from waste water treatment and in-process plant control methods, (2) the generation of a byproduct of commercial value, (3) disposal of off-specification and scrap products, and (4) the creation of problems of air pollution and land utilization.

#### Disposal of Solids and Slurries

Biological sludges are the principal disposal problem resulting from end-of-pipe treatment of waste waters. Occasionally chemical sludge (such as from neutralization and precipitation of an inorganic chemical) is of concern. Biological sludges are most frequently subjected to some type of continued biological degradation. Aerobic digestion is the most frequently used method. When lagoons are operated in the extended-aeration mode, the solids accumulate in these lagoons or in polishing lagoons. The long-term consequence of these operations is a gradual filling of the lagoons. They then must be dredged or abandoned. Presently, sludges from end-of-pipe wastewater treatment plants are stabilized by biological means and disposed of to landfills. Prior treatment to dewater the biological sludges by chemical or mechanical means will probably be increasingly employed. However, the problem of landfill disposal remains. Consequently, one of the long-term aspects of waste water treatment is ascertaining that appropriate landfill sites have been obtained. The cost of sludge disposal from plastics and synthetics plants

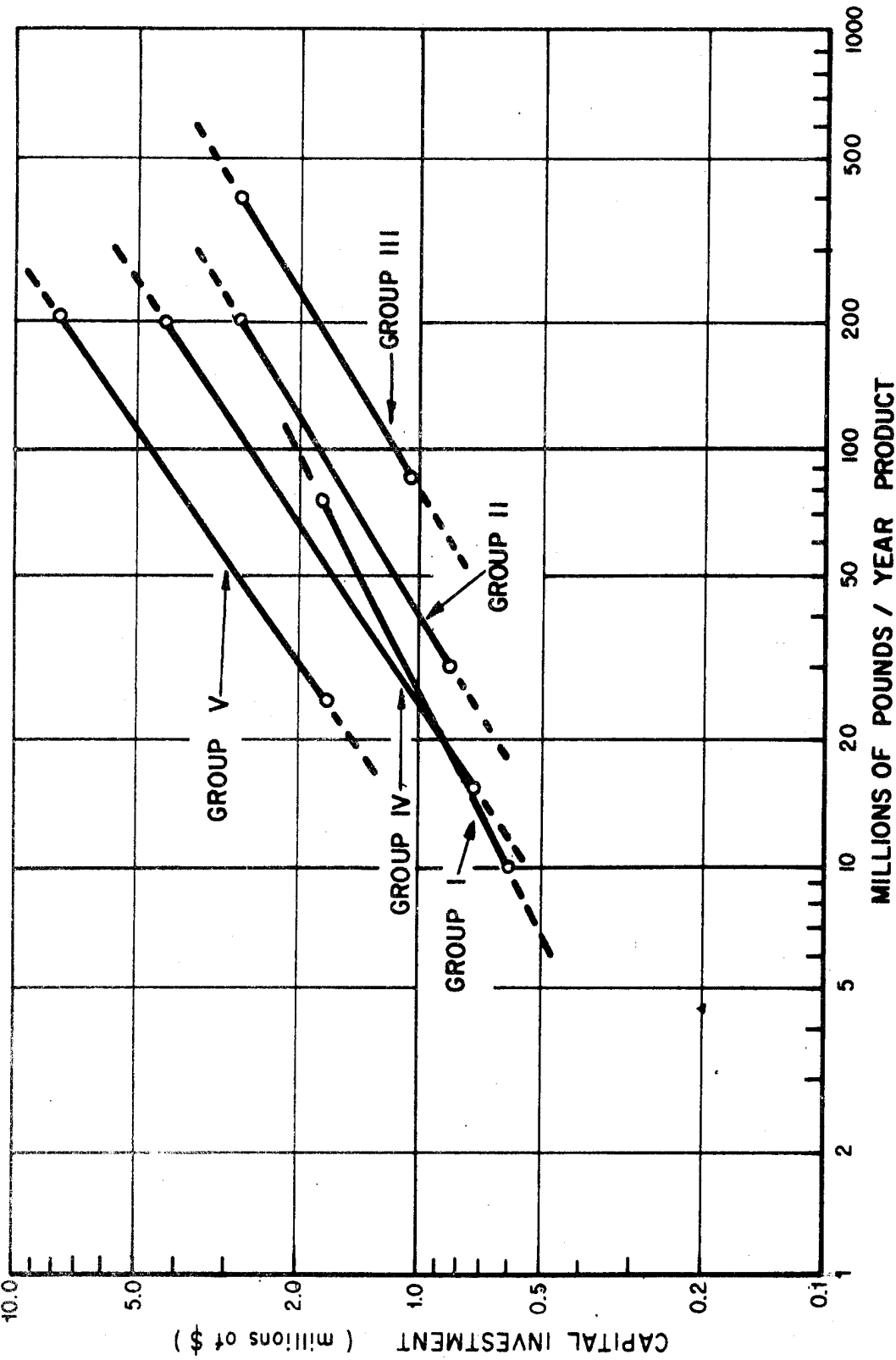

FIGURE 38

ACTIVATED CARBON ADSORPTION FOR THE PLASTICS AND SYNTHETICS INDUSTRY -  
CAPITAL INVESTMENT

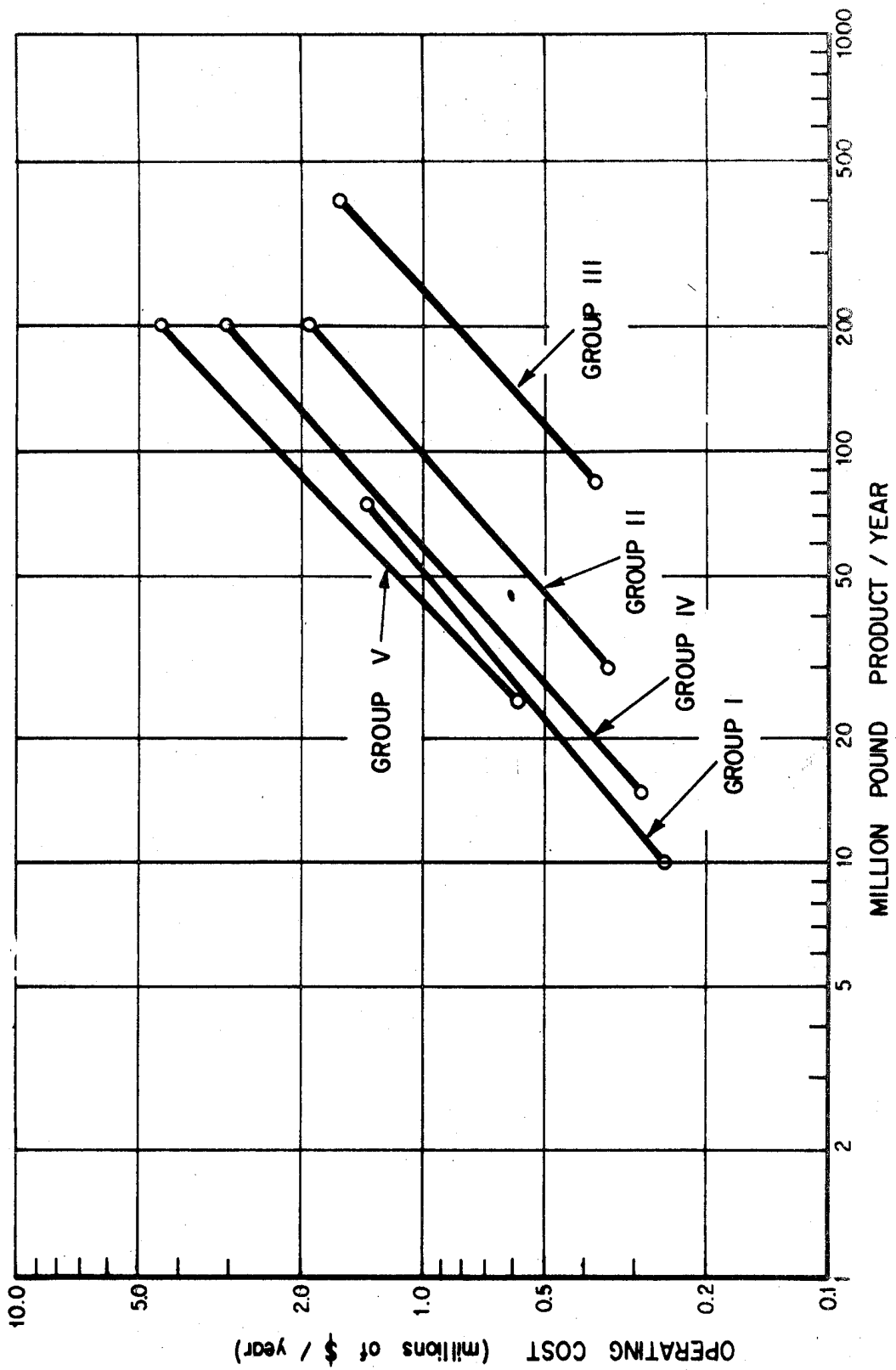

FIGURE 39

ACTIVATED CARBON ADSORPTION FOR THE PLASTICS AND SYNTHETICS INDUSTRY -  
OPERATING COSTS

will be essentially equivalent to the cost of sludge disposal from municipal sewage treatment plants. The same type of disposal methods are applicable, but there will be significant variations in the amounts of sludge generated. Estimates based on raw waste loads reported in the Celanese report (8) indicate the range of dry solids to be disposed of would be as follows:

	<u>Type of Plant</u>	<u>Units/1000/Units of Product</u>
(1)	Cellulosic-based	25-50
(2)	Phenolics, epoxy, nylon acrylics, polyesters	10-25
(3)	Polystyrene, PVC, ABS/SAN, polyethylene, polypropylene	1-10

Burd (11) reports that lagooning or landfilling cost (capital and operating) lie in the range of \$1 to \$5 per ton of dry solids.

Utilizing the higher value, the range of disposal costs per pound of product becomes:

	<u>Type of Plant</u>	<u>¢/Pound of Product</u>	<u>¢/kg of Product</u>
(1)	Cellulosic-based	0.00625-0.0125	0.0138-0.0276
(2)	Phenolics, epoxy, nylon, acrylics, polyesters	0.00250-0.00625	0.00551-0.0138
(3)	Polystyrene, PVC, APS/SAN, polyethylene, polypropylene	0.00025-0.0025	0.00055-0.00551

Burd also reports capital and operating costs for incineration to be \$10 to \$50 per ton (\$11-\$55/kg). Due to the rapid increase in fuel costs and the relatively small volume of sludge at individual plants, \$50.00 per ton is probably more nearly the cost that will prevail in this industry. Consequently, sludge incineration costs might be expected to be in the following ranges:

	<u>Type of Plant</u>	<u>¢/Pound of Product</u>	<u>¢/kg of Product</u>
(1)	Cellulosic-based	0.0625-0.125	0.1378-0.2756
(2)	Phenolics, epoxy, nylon acrylics, polyesters	0.250-0.0625	0.00551-0.0138
(3)	Polystyrene, PVC, ABS/SAN, polyethylene polypropylene	0.00250-0.0250	0.00551-0.0551

The yearly volume of biological sludges (acre feet) generated for each 10,000,000 lbs of product is estimated to be the following:

	<u>Type of Plant</u>	<u>Biological Sludges Only</u> <u>Acre Feet/Year</u>	<u>Cu Meters/Year</u>
(1)	Cellulosic-based	0.4-0.80	493-986
(2)	Phenolics, epoxy, nylon acrylics, polyesters	0.10-0.40	123-493
(3)	Polystyrene, PVC, APS/SAN, polyethylene, polypropylene	0.04-0.10	49-123

The most significant sludge disposal problem is the volume of sludge generated during the removal of zinc from rayon plant waste waters. These sludges, mixed with calcium sulfate, are presently being lagooned. An EPA demonstration project for zinc removal and recovery has been completed. Undoubtedly, the future disposal of zinc sludge will depend upon economics as well as the need to meet effluent limits. Although large diked land areas are required for lagooning and, consequently, large-scale flooding might be considered a hazard, zinc sludge tends to attain a jelly-like consistency, which would prevent this. This means that, if a dike wall breaks, large amounts of the contained sludge will not flow from the filled lagoon.

#### Generation of Commercially-Valuable By-Products

Within the plastics and synthetics industry, only cellophane and rayon plants recover a by-product from their waste water which has appreciable commercial value. This is sodium sulfate or Glaubers salt, which is sold largely to the pulp and paper industry. Although this might be viewed as transferring part of the problem of disposing of inorganic dissolved salts to another industry, within the framework of this industry the sale of Glauber salt can be considered a valuable by-product.

Costs of Sulfate Recovery - The opportunity for reclamation of byproduct values as opposed to disposal or treatment appears in the rayon and cellophane subcategories. One such instance of recovery - that of sodium sulfate - is in spin bath reclamation. Rayon is made by spinning viscose into a bath of sulfuric acid, sodium sulfate, and, in most cases, zinc sulfate. The sulfuric acid reacts with the alkaline viscose to produce sodium sulfate and water. This neutralization is a continuous operation. Because of the speed at which the rayon filaments are spun (several hundred meters per minute) and the need to achieve a quick reaction to set the fibers, a large amount of acid must be used, and the acid must not change appreciably in composition from one end of the bath to the other. For example, a typical inlet composition might contain 13 percent acid, 22 percent

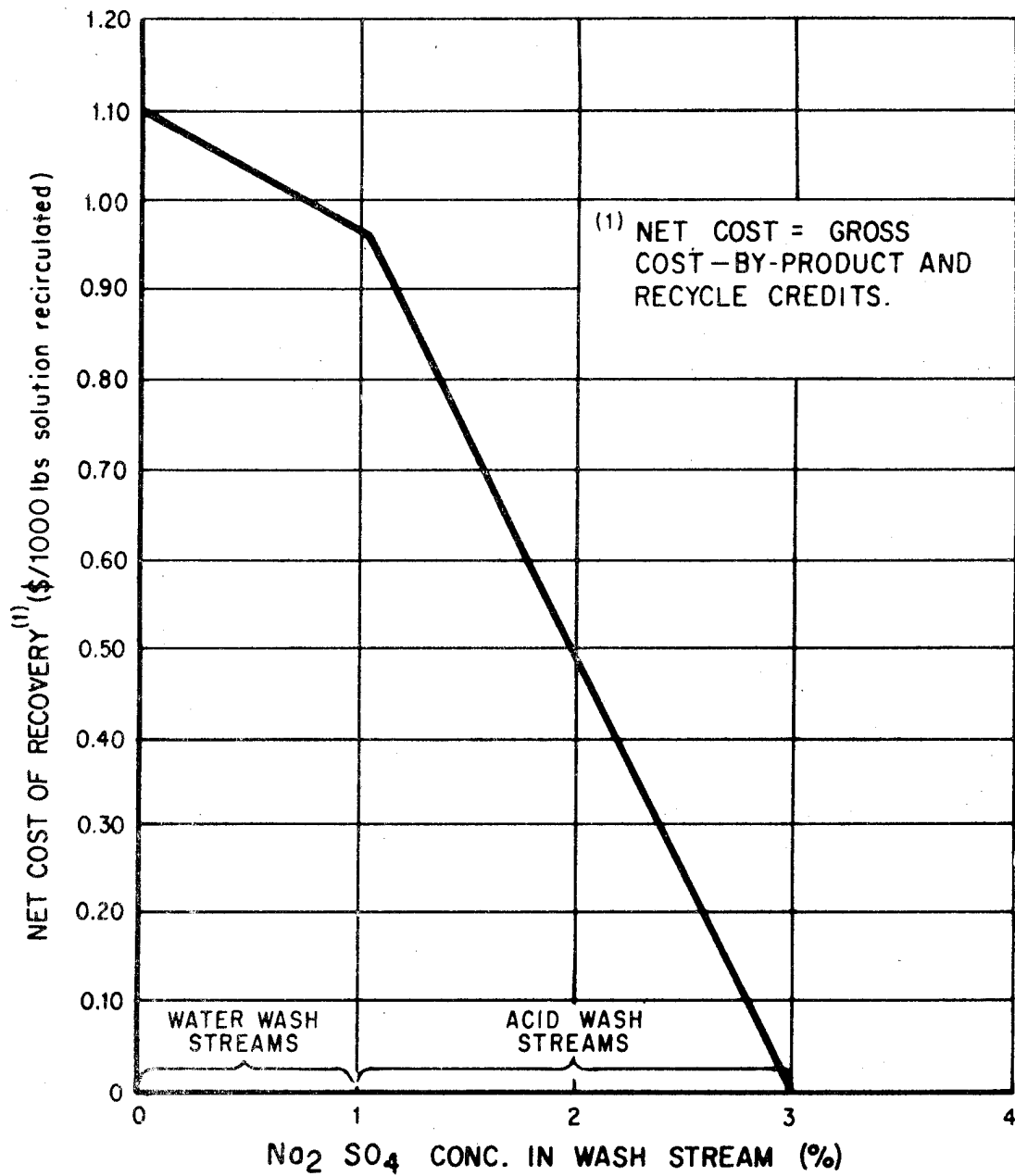

FIGURE 40

NET COST OF RECOVERING DILUTE WASH SOLUTIONS

sodium sulfate, and 6 percent  $ZnSO_4$ , and the exit composition 12-1/2 percent acid, 23 percent sodium sulfate, and 5.8 percent  $ZnSO_4$ . This acid is returned to acid recovery where some of the sodium sulfate is removed by evaporation and crystallization, and the remaining sodium sulfate, zinc sulfate, and acid (with new acid and zinc sulfate added) is recirculated back to the spin bath. To the extent that rayon carries acid (and zinc) from the spin bath into subsequent acid and water washes, acid and zinc are lost from the system. These chemicals are washed out of the rayon in such dilute solutions (the most concentrated is approximately one-tenth the strength of the original spin bath) that at current prices for zinc and sodium sulfate, reclamation is not economic.

Different rayons require different bath compositions. A typical bath for tire cord contains 6.5 percent sulfuric acid, 15 percent sodium sulfate, and 7 percent zinc sulfate. For regular staple a typical bath contains 13 percent sulfuric acid, 22 percent sodium sulfate, and 1 percent zinc sulfate. Table 25 shows the comparative concentrations from typical streams associated with the spin bath.



TABLE 25

TYPICAL STREAM COMPOSITIONS  
(Basis (kg/kkg))

Exit from Spin Bath	First Acid Wash		Water Wash	
	Most Conc.	Most Dil.	(Avg)	
Na <sub>2</sub> SO <sub>4</sub>	230	30	10	0.05
ZnSO <sub>4</sub>	58	5	0	0.4

Recycle to acid recovery (To sewer)  
(To sewer) (To sewer)

A rule-of-thumb cut-off point used by one rayon company in determining which streams are economic to recover, is 2 percent sulfuric, 3 percent sodium sulfate, 0.5 percent zinc. We have calculated the economics of recovery in Table 26.

TABLE 26

## BY-PRODUCT CREDIT VALUE FOR BREAK-EVEN STREAM

(Basis: 1000 lbs (453.6 kg) H<sub>2</sub>O Solution, or 700 lbs (317.5 kg) evaporation capacity)

	lbs.	Net Values, recycle or feed to reclaim operation (¢/lb)	Total (¢/lb)
H <sub>2</sub> SO <sub>4</sub>	20 (9.07 kg)	0.9 (2.0 ¢/kg)	18 (40 ¢/kg)
Na <sub>2</sub> SO <sub>4</sub>	30 (13.61 kg)	0.5* (1.1 ¢/kg)	15 (33 ¢/kg)
ZnSO <sub>4</sub>	5 (2.27 kg)	9.75 (21.5 ¢/kg)	48.7 (106.5 ¢/kg)
	55 (24.95 kg)	11.15 (24.6 ¢/kg)	81.7 (179.5 ¢/kg)

\*Value as raw material feed to anhydrous sodium sulfate by-product operation.

The cost for concentrating this stream sufficiently to recirculate it is shown in Table 27. It appears, according to our calculations, that this is, indeed, a breakeven stream.

TABLE 27

OPERATING COST PER 1000 LBS (453.6 kg) H<sub>2</sub>O RECYCLED

(Basis: Evaporation of 700 lbs (317.5 kg) H<sub>2</sub>O to 3-1/3 fold concentration, i.e., same as Table 26 above\*)

<u>¢/1000 lbs recycled</u>		
Utilities (steam @ \$1.00/1000 lbs)	70.0	(154 ¢/kg)
Labor (@ \$5.50/hr including fringe)	2.4	( 5.3)
Overhead (@ 100% of labor)	2.4	( 5.3)
Depreciation (\$950,000** @ 10 yrs)	3.6	( 7.9)
Insurance and Taxes (@ 2% of CI)	0.7	( 0.2)
Maintenance (@ 6% of CI)	2.2	( 4.9)
TOTAL COST	81.3	(179.6)

\*This assumes concentrating the acid wash stream of Table 18 to the most dilute of typical spin bath compositions, namely 7% H<sub>2</sub>SO<sub>4</sub>, 10% Na<sub>2</sub>SO<sub>4</sub>, 1.5% ZnSO<sub>4</sub>.

\*\*Based on single-effect evaporators designed to handle 32,000 gal/hr (121 cu.m./hr) acid wash stream (approximately one-fourth to one-third of total acid washwater from a typical large rayon plant).

The component of chief environmental concern is the dissolved salts, primarily sodium sulfate, which is the neutralized product of sulfuric acid plus caustic. The major side-stream component which is of any economic value to recycle and reclaim is zinc sulfate; but to the extent that a company disposes of zinc, the various state laws and proposed federal guidelines require that zinc be precipitated and not discharged into receiving waters.

There is no inexpensive way of minimizing the sulfate in the final effluent other than by further evaporation and reclamation of some of the dilute streams. We have, therefore, taken the data on acid and water wash streams in Table 25 above and calculated approximate compositions of various intermediate streams (relative to Na<sub>2</sub>SO<sub>4</sub>, H<sub>2</sub>SO<sub>4</sub>, and ZnSO<sub>4</sub>) in order to examine various wash stream combinations from different grades of rayon being processed. The by-product value and cost of recovery for these streams was calculated, and the net cost versus composition expressed in terms of Na<sub>2</sub>SO<sub>4</sub>, is plotted in Fig. 40.

The acid wash stream represents approximately one-quarter of all the water in the plant effluent and three-quarters of all the dissolved solids in the effluent. If an average integrated acid wash stream has 1.5 percent Na<sub>2</sub>SO<sub>4</sub>, then, from Fig. 40, the net cost of recycling this stream would be \$0.72/1000 lbs (\$1.59/kg) of solution recycled. At a total water usage of 16.5 gal/lb of rayon, the cost is 2.4¢ per lb (5.3¢/kg) of rayon.

These cost estimates are based on use of single-effect evaporators, which represent current U.S. practice. We

understand double-effect evaporators are used in some European rayon operations. The use of double-effect evaporators would reduce steam consumption, but would be partially off-set by the higher capital investment required; so that even then total cost of treating this full acid wash stream would be on the order of 1.4 to 1.9¢/lb (3.1 to 4.2¢/kg) of rayon. Clearly what is needed to make significant inroads on the dissolved solids problem is a study of the judicious application of multiple effect evaporation technology to the more concentrated of these acid wash streams.

#### Disposal of Off-Specification and Scrap Products

The disposal of solid wastes resulting from off-specification products and solids removed by in-plant separation processes prior to the waste water treatment plant present problems to the industry. These wastes are, we believe, generally disposed of to landfills which are often on company property. Since most of the waste solids can be expected to be resistant to biological degradation, their disposal will probably not have significant potential for ground water pollution.

#### Other Non-Water Quality Pollution Problems

Other non-water quality aspects of treatment and pollution control are minimal in this industry and largely depend upon the type of waste water treatment technology employed. In general, noise levels from typical waste water treatment plants are not excessive. If incineration of waste sludges is employed, there is potential for air pollution, principally particulates and possibly nitrogen oxides, although the latter should be minimal because incineration of sludges does not normally take place at temperature levels where the greatest amounts of nitrogen oxide are generated. There are no radioactive nuclides used within the industry, other than in instrumentation, so that no radiation problems will be encountered. Odors from the wastewater treatment plants may cause occasional problems since waste waters are sometimes such that heavy, stable, foams occur on aerated basins and septicity is present. But, in general, odors are not expected to be a significant problem when compared with odor emissions possible from other plant sources.

#### Industry Cost Perspectives

As the primary purpose of this program was to study exemplary treatment systems and not to audit the range of treatment in the industry, this overview is based on information from available sources on the degree of treatment generally practiced in the plastics and synthetics industry. Rough estimates were made of the current degree of BOD removal across each of five product groups. These ranged from 30 percent average removal in Group V to 60 percent in Group IV. (Other current BOD removal estimates are 30 percent in Group I, 50 percent in Group II, and 40 percent in Group III.) Using these estimates, a weighted average removal of 42 percent was calculated for the entire industry in 1972. By 1977, the similar weighted average implicit in the BPCTCA (best

practicable control technology currently available) guidelines to be achieved is 95 percent removal. That would imply a significant annual increase in removal efficiency, i.e., 18 percent per year. The technology exists and is in practice to achieve this broad requirement.

The expected annual costs for existing plants in the plastics and synthetics industry in 1977 consistent with the BPCTCA guidelines are \$66 million. This is a sum of estimates by product subcategory (Table 28) calculated from: estimates of the mix of existing plants between large and small sizes; the average costs (per cubic meter or thousand gallons) considering plant size effects; and the flow (in 1972) associated with these existing plants. Similarly, by 1983, the estimated costs for existing plants to comply with BATEA (best available technology economically achievable) guidelines are \$192 million. It should be noted that these costs are associated with end-of-pipe treatment only. Costs for in-plant additions or modifications are not included.

For the purpose of gauging the implicit level of additional needs, a working estimate of current annual costs was developed. A rough estimate of \$110 million (replacement value) of installed investment was developed assuming that existing secondary treatment facilities remove 80 to 85 percent of BOD as opposed to the 95 percent generally required by BPCTCA. This level of removal was associated with initial investment costs equal to two-thirds the per-unit costs of BPCTCA technology.

Similar consideration was given to the proportion of the industry having either no treatment or primary treatment only. Primary treatment facilities were costed at one-fourth the per-unit costs of BPCTCA technology. Finally, with an assumption that annual costs run about 22 percent of the investment costs, the annual costs for existing plants in 1972 was estimated at \$25 million.

The above annual cost estimates for 1972, 1977, and 1983 indicate average increases of 21 percent per year between 1972 and 1977, and 19 percent per year between 1977 and 1983 for existing plants.

To those costs for existing plants in the plastics and synthetics industry must be added the costs associated with new plants - governed by BADT (best available demonstrated technology) new source performance standards. Assuming the production volume of new plants to be equal to the expected growth in production, the potential annual cost associated with new plants in 1977 was estimated at \$35 million. Altogether, that means that the industry's annual costs are expected to increase 32 percent per year (from \$25 million in 1972 to \$101 (66 + 35) in 1977) - supported by a sales growth of 10 percent per year. This assumes a balancing out of factors like expansion of existing facilities, the replacement of existing facilities by new plants, and industry utilization rates over time. A similar estimate for

1983 was precluded by the lack of a meaningful forecast of product growth.

The average costs of treatment over the industry consistent with the figures in Table 28 for BPCTCA, BATEA, and BADT technologies respectively are: \$0.19 (\$0.73), \$0.56 (\$2.11), and \$0.27 (\$1.02) per cubic meter (thousand gallons).

One measure by which to gauge the importance of the costs in Table 28 is to relate them to the sales price of the products as is done in Table 29. A range of costs as a percentage of sales was calculated (1) from a lower level associated with a large representative plant with basis (i.e., associated with the suggested guidelines) water usage to (2) a higher level associated with a small representative plant with high water usage.

On average, BPCTCA costs for the smaller plants with higher water usage were 4.0 times higher than the larger plant in each subcategory. The average range was 0.7 percent to 2.8 percent of sales price. On average, BATEA costs for the smaller plants with higher water usage were 3.9 times higher than the larger plants in the industry. The average range of BATEA costs was 2.1 to 8.1 percent of sales price. BADT costs (for a large plant at basis water usage) were 0.9 percent.

#### Water Effluent Treatment Costs

Table 30 and its 34 associated tables (arranged by product groups) portray the costs of major treatment steps required to achieve the recommended technologies. In fourteen of the eighteen product subcategories, costs are indicated for two different plant sizes which are representative of the mix of production facilities. In the cases of cellophane, cellulose acetates, and rayon, only one representative plant size was needed to adequately describe industry costs. In the acrylics subcategory, on the other hand, three plant sizes were appropriate.

The use of different economics for two plant sizes is, at best, only a step better than using a single treatment plant economics. Current and future treatment costs for an overall industry subcategory should ideally reflect an average cost consistent with the plant-size mix. The costs for new plants were tied to the economics of the larger representative plant.

In each of the 34 installments to Table 30, the representative plant is identified in terms of production capacity, hydraulic load, and treatment plant size. Capital costs have been assumed to be a constant percentage (8 percent) of fixed investment. Depreciation costs have been calculated consistent with the faster write-off (financial life) allowed for these facilities (10 percent per year) over 10 years even though the physical life is closer to 20 or 25 years.

TABLE 28

PERSPECTIVES ON THE PLASTICS AND SYNTHETICS INDUSTRY  
 - TREATMENT COSTS -

<u>Guideline Sub category</u>	<u>Total Annual Costs, \$ Million</u>			
	<u>Existing Plants</u>		<u>New Plants</u>	
	<u>Product</u>	<u>1977</u>	<u>1983</u>	<u>1973-1977</u>
<b><u>A</u></b>				
PVC	6.6	19.9	4.2	
ABS/SAN	1.4	5.0	1.3	
PV Acetate	1.1	3.8	0.2	
Polystyrene	5.3	17.1	2.4	
LDP Ethylene	4.5	14.6	3.3	
HDP Ethylene	3.3	9.4	2.9	
Polypropylene	2.9	6.8	2.7	
<b><u>B</u></b>				
Cellophane	3.7	10.6	0.0	
Rayon	6.8	18.8	1.1	
Subtotal	35.6	106.0	19.0	
<b><u>C</u></b>				
Cell. Acetates	5.2	15.0	0.9	
* Epoxies	0.3	1.0	0.1	
* Melamine	1.2	4.4	0.7	
* Urea Resins	4.4	16.6	1.2	
* Phenolics	7.6	17.2	9.6	
Polyester				
Nylon 66	10.2	28.0	3.0	
Nylon 6				
<b><u>D</u></b>				
Acrylic	1.9	4.5	0.3	
Subtotal	30.8	86.1	15.8	
Industry Total	66.4	192.1	34.8	

\*See footnote, p. 136.

TABLE 29

PERSPECTIVES ON THE PLASTICS AND SYNTHETICS INDUSTRY  
—COST IMPACT—

Guideline Subcategory	Price Level ¢/lb	Control Cost Range as % of Sales Price		
		BPTCA %	BATEA %	BADT %
<b>A</b>				
PVC	12	1.1-4.8	3.5-13.6	1.3
ABS/SAN	25	0.7-1.2	1.9-4.5	0.8
P Styrene	14	0.8-2.1	2.1-7.9	0.9
PV Acetate	20	0.6-3.0	1.5-12.8	0.7
LDP Ethylene	12	0.5-3.4	1.6-10.3	0.6
HDP Ethylene	13.5	0.7-3.0	2.2-7.9	0.9
Polypropylene	17	0.9-4.7	2.1-10.8	1.0
<b>B</b>				
Cellophane	60	1.5-3.5	4.1-9.4	1.7
Rayon	32	2.2-3.1	5.6-8.1	2.5
<b>C</b>				
Cell. Acetates	60	0.3-3.0	0.8-8.0	0.5
* Epoxies	60	0.2-0.4	6.7-1.2	0.2
* Melamine/Urea	20	0.4-0.5	1.5-2.3	0.4
* Phenolics	22	1.3-3.3	4.3-12.3	1.3
Polyester	60	0.1-5.0	0.3-11.9	0.3
Nylon 66	70	0.2-2.9	0.5-7.7	0.4
Nylon 6	70	0.6-1.6	1.8-4.8	1.4
<b>D</b>				
Acrylics	35	0.5-1.7	1.2-4.1	0.7
UNWEIGHTED AVERAGE		0.7-2.8	2.1-8.1	0.9

\*See footnote, p. 136.

Cost-effectiveness relationships are implicit in the use of these costs together with the effluent levels achieved by each treatment step in each major relevant pollutant dimension. These effluent levels are indicated at the bottom of each representative plant sheet.

#### Industrial Waste Treatment Model Data

The general practice in these larger volume plastics and synthetics products is to treat the entire waste stream (mostly process water). Without significant separation of streams, therefore, data are provided for EPA's Industrial Waste Treatment Model in terms of total flows. Each product subcategory is covered on a table with other members of its product group (Tables 31-35).

Total discharges for each product subcategory are estimated for 1972 and 1977. The quality of effluents remaining untreated in 1977 is indicated as that consistent with the application of BACTCA technology. Finally, the current status of treatment in each product group is estimated in terms of the proportion utilizing primary treatment and that utilizing a form of biological treatment.



TABLE 30

SUMMARY OF WATER EFFLUENT TREATMENT COSTS FOR REPRESENTATIVE PLANTS IN THE PLASTICS AND SYNTHETICS INDUSTRY

Group No. Product	Representative Plant Size		BPCTCA Costs		BATEA Costs		BADT Costs	
	Millions kg/yr	Millions #/yr	\$/stere <sup>1</sup>	\$/1000 gal	\$/stere	\$/1000 gal	\$/stere <sup>1</sup>	\$/1000 gal
*Group I <sup>2</sup>								
Epoxies	11	25	1.47	5.56	4.88	18.46	1.47	5.56
	45	100	.78	2.93	2.84	10.72	.78	2.93
Melamine	7	15	2.01	7.58	7.55	28.57	2.01	7.58
	27	60	1.52	5.75	5.05	19.12	1.52	5.75
Urea	7	15	1.50	5.65	6.49	24.55	1.50	5.65
	27	60	1.20	4.55	4.74	17.95	1.20	4.55
Phenolics	11	25	.79	2.98	2.99	11.31	.79	2.98
	45	100	.51	1.91	1.68	6.35	.51	1.91
Group II								
PVC	45	100	.31	1.16	.86	3.26	.34	1.30
	90	200	.20	.74	.61	2.32	.22	.84
ABS/SAN	23	50	.32	1.20	1.23	4.65	.37	1.38
	90	200	.22	.82	.59	2.23	.24	.92
Polystyrene	23	50	.45	1.69	1.72	6.51	.50	1.89
	90	200	.27	1.03	.69	2.63	.30	1.15
PV Acetate	11	25	.52	1.98	2.25	8.51	.59	2.23
	45	100	.32	1.22	.81	3.06	.36	1.36

\*See footnote, P. 136.

TABLE 30 (cont)

Group No. Product	Representative Plant Size		BPCTCA Costs		BATEA Costs		BADT Costs	
	Millions kg/yr	Millions #/yr	\$/stere <sup>1</sup>	\$/1000 gal	\$/stere	\$/1000 gal	\$/stere <sup>1</sup>	\$/1000 gal
Group III								
LDP Ethylene	90	200	.21	.81	.66	2.48	.24	.92
	180	400	.16	.60	.50	1.88	.18	.68
HDP Ethylene	57	125	.29	1.09	.76	2.88	.32	1.23
	115	250	.18	.69	.53	1.99	.21	.79
Polypropylene	45	100	.26	.99	.61	2.29	.29	1.10
	90	200	.19	.73	.45	1.71	.22	.83
Group IV								
Acrylics	23	50	.46	1.76	1.12	4.24	.67	2.53
	45	100	.30	1.15	.76	2.87	.44	1.67
	90	200	.22	.84	.56	2.12	.32	1.21
Polyester	23	50	.40	1.49	.94	3.57	.57	2.15
	90	200	.23	.86	.50	1.89	.33	1.24
Nylon 6	11	25	.30	1.15	.88	3.33	.47	1.79
	45	100	.18	.66	.51	1.94	.27	1.03
Nylon 66	23	50	.53	2.02	1.42	5.39	.82	3.09
	90	200	.25	.97	.66	2.48	.40	1.52
Group V								
Cellophane	45	100	.08	.31	.22	.84	.09	.35
Cell. Acetate	90	200	.09	.33	.26	.98	.16	.61
Rayon	68	150	.11	.43	.30	1.12	.13	.49

1. Stere = cubic meter.

2. Costs for Group I are estimated industry charges for discharging into larger municipal systems.

TABLE 30-1

**WATER EFFLUENT TREATMENT COSTS  
PLASTICS AND SYNTHETICS INDUSTRY**

Product Subcategory : Epoxies (small plant) \*\*

Representative Plant Capacity			
million kilograms (pounds) per year	:	11	(25)
Hydraulic Load			
cubic meters/metric ton of product (gal/lb)	:	3.6	(0.43)
Treatment Plant Size:			
thousand cubic meters per day (MGD)	:	0.12	(0.033)

**Costs - \$1000****Alternative Treatment Steps \***

	<u>A</u>	<u>B</u>	<u>H</u>	<u>F</u>
Initial Investment	240	560	205	227
Annual Costs:				
Capital Costs (8%)	19	45	16	18
Depreciation (10%)	24	56	20	23
Operation and Maintenance	6	25	4	21
Energy and Power	1	9	2	139
Total Annual Costs	50	135	42	201

**Effluent Quality** (Expressed in terms of yearly averages)

	Raw Waste <u>Load</u>	<u>Resulting Effluent Levels</u> (Units per 1000 Units of Product)			
		<u>A</u>	<u>B</u>	<u>H</u>	<u>F</u>
B.O.D.	70	-	0.2	-	0.06
C.O.D.	110	-	1	-	0.4
Suspended Solids	15	-	0.7	-	0.04
Phenolic Compounds	N/A	-	-	0.002	0.0004

\* Steps A and B only are based upon a dilution factor of 10; 1.2 thousand cubic meters per day (0.33 MGD). Step F is incineration of total undiluted waste stream. Calculation of costs per thousand gallons assumes pay-your-way user charges equal to 0.5 of steps A and B, corresponding to waste load share on municipal system.

\*\*See footnote, p. 136.

TABLE 30-2

**WATER EFFLUENT TREATMENT COSTS  
PLASTICS AND SYNTHETICS INDUSTRY**

Product Subcategory : Epoxies (large plant) \*\*

Representative Plant Capacity			
million kilograms (pounds) per year	:	45	(100)
Hydraulic Load			
cubic meters/metric ton of product (gal/lb)	:	3.6	(0.43)
Treatment Plant Size:			
thousand cubic meters per day (MGD)	:	0.49	(0.13)

**Costs - \$1000****Alternative Treatment Steps\***

	<u>A</u>	<u>B</u>	<u>H</u>	<u>E</u>
Initial Investment	375	875	465	1165
Annual Costs:				
Capital Costs (8%)	30	70	37	93
Depreciation (10%)	38	88	46	117
Operation and Maintenance	11	67	6	115
Energy and Power	3	33	3	9
Total Annual Costs	102	238	92	334

**Effluent Quality** (Expressed in terms of yearly averages)

	<u>Raw Waste Load</u>	<u>Resulting Effluent Levels</u> (Units per 1000 Units of Product)			
		<u>A</u>	<u>B</u>	<u>H</u>	<u>E</u>
B.O.D.	70	-	0.2	-	0.06
C.O.D.	110	-	1	-	0.4
Suspended Solids	15	-	0.1	-	0.04
Phenolic Compounds	N/A	-	-	0.002	0.0004

\* Steps A, B and E are based upon a dilution factor of 10; 4.9 thousand cubic meters per day (1.3 MGD). Calculations of costs per thousand gallons assumes pay-your-way user charges equal to 0.5 of steps A and B corresponding to waste load share on municipal system.

\*\*See footnote, p. 136.

TABLE 30-3

**WATER EFFLUENT TREATMENT COSTS  
PLASTICS AND SYNTHETICS INDUSTRY**

Product Subcategory : Melamine (small plant) \*\*\*

Representative Plant Capacity			
million kilograms (pounds) per year	:	7	(15)
Hydraulic Load			
cubic meters/metric ton of product (gal/lb)	:	1.3	(0.16)
Treatment Plant Size:			
thousand cubic meters per day (MGD)	:	0.03	(0.007)

**Costs - \$1000**

**Alternative Treatment Steps \***

	<u>A</u>	<u>B**</u>	<u>F</u>
Initial Investment	240	560	100
Annual Costs:			
Capital Costs (8%)	19	45	9
Depreciation (10%)	24	56	11
Operation and Maintenance	2	24	16
Energy and Power	1	4	30
Total Annual Costs	46	129	66

**Effluent Quality** (Expressed in terms of yearly averages)

	<u>Raw Waste Load</u>	<u>Resulting Effluent Levels</u> (Units per 1000 Units of Product)		
		<u>A</u>	<u>B</u>	<u>F</u>
B.O.D.	N/A	—	0.06	0.02
C.O.D.	N/A	—	0.3	0.1
Suspended Solids	N/A	—	0.04	0.01

\* Steps A and B only are based upon a dilution factor of 50; 1.5 thousand cubic meters per day (0.35 MGD). Step F is incineration of total undiluted waste stream. Costs per thousand gallons assumes pay-your-way user charges equal to 0.1 of steps A and B, corresponding to waste load share on municipal system.

\*\* No raw waste load data available; costs based upon BOD load of 2200 lb/day.

\*\*\*See footnote, p. 136.

TABLE 30-4

**WATER EFFLUENT TREATMENT COSTS  
PLASTICS AND SYNTHETICS INDUSTRY**

Product Subcategory : Melamine (large plant)\*\*\*

Representative Plant Capacity			
million kilograms (pounds) per year	:	27	(60)
Hydraulic Load			
cubic meters/metric ton of product (gal/lb)	:	1.3	(0.16)
Treatment Plant Size:			
thousand cubic meters per day (MGD)	:	0.11	(0.029)

**Costs - \$1000**

**Alternative Treatment Steps \***

	<u>A</u>	<u>B</u> **	<u>F</u>
Initial Investment	270	630	220
Annual Costs:			
Capital Costs (8%)	22	50	18
Depreciation (10%)	27	63	22
Operation and Maintenance	4	38	21
Energy and Power	2	14	122
Total Annual Costs	55	165	183

**Effluent Quality (Expressed in terms of yearly averages)**

	<u>Raw Waste Load</u>	<u>Resulting Effluent Levels</u> (Units per 1000 Units of Product)		
		<u>A</u>	<u>B</u>	<u>F</u>
B.O.D.	N/A	-	0.06	0.02
C.O.D.	N/A	-	0.3	0.1
Suspended Solids	N/A	-	0.04	0.01

\* Steps A and B only are based upon a dilution factor of 20; 2.2 thousand cubic meters per day (0.58 MGD). Step F is incineration of total undiluted waste stream. Costs per thousand gallons assumes pay-your-way user charges equal to 0.25 of steps A and B, corresponding to waste load share on municipal system.

\*\* Raw waste load unavailable; costs based upon BOD loading of 9100 lb/day.

\*\*\*See footnote, p. 136.

TABLE 30-5

**WATER EFFLUENT TREATMENT COSTS  
PLASTICS AND SYNTHETICS INDUSTRY**

Product Subcategory : Urea (small plant) \*\*\*

Representative Plant Capacity million kilograms (pounds) per year	:	7 (15)
Hydraulic Load cubic meters/metric ton of product (gal/lb)	:	1.8 (0.22)
Treatment Plant Size: thousand cubic meters per day (MGD)	:	0.04 (0.01)

**Costs -- \$1000****Alternative Treatment Steps \***

	<u>A</u>	<u>B</u> **	<u>F</u>
Initial Investment	260	600	126
Annual Costs:			
Capital Costs (8%)	21	48	10
Depreciation (10%)	26	60	13
Operation and Maintenance	3	24	16
Energy and Power	1	4	42
Total Annual Costs	51	136	81

**Effluent Quality** (Expressed in terms of yearly averages)

	Raw Waste Load	Resulting Effluent Levels (Units per 1000 Units of Product)		
		<u>A</u>	<u>B</u>	<u>F</u>
B.O.D.	N/A	—	0.08	0.03
C.O.D.	N/A	—	0.4	0.2
Suspended Solids	N/A	—	0.02	0.02

\* Steps A and B only are based upon a dilution factor of 50; 2.0 thousand cubic meters per day (0.5 MGD). Step F is incineration of total undiluted waste stream. Costs per thousand gallons assumes pay-your-way user charges equal to 0.1 of steps A and B, corresponding to waste load share on municipal system.

\*\* No raw waste load data available; costs based upon BOD load of 2,200 lb./day.

\*\*\*See footnote, p. 136.

TABLE 30-6

**WATER EFFLUENT TREATMENT COSTS  
PLASTICS AND SYNTHETICS INDUSTRY**

Product Subcategory :	Urea (large plant)***		
Representative Plant Capacity			
million kilograms (pounds) per year :	27	(60)	
Hydraulic Load			
cubic meters/metric ton of product (gal/lb) :	1.8	(0.22)	
Treatment Plant Size:			
thousand cubic meters per day (MGD) :	0.15	(0.04)	
<b>Costs — \$1000</b>	<b>Alternative Treatment Steps *</b>		
	<b>A</b>	<b>B**</b>	<b>F</b>
Initial Investment	294	686	250
Annual Costs:			
Capital Costs (8%)	24	55	20
Depreciation (10%)	29	69	25
Operation and Maintenance	8	36	24
Energy and Power	3	15	168
Total Annual Costs	64	175	237

**Effluent Quality** (Expressed in terms of yearly averages)

	<b>Raw Waste Load</b>	<b>Resulting Effluent Levels (Units per 1000 Units of Product)</b>		
		<b>A</b>	<b>B</b>	<b>F</b>
B.O.D.	N/A	—	0.08	0.03
C.O.D.	N/A	—	0.4	0.2
Suspended Solids	N/A	—	0.02	0.02

\*Steps A and B only are based upon a dilution factor of 20; 3.0 thousand cubic meters per day (0.8 MGD). Step F is incineration of total undiluted waste streams. Costs per thousand gallons assumes pay-your-way user charges equal to 0.25 of steps A and B, corresponding to waste load share on municipal system.

\*\*No raw waste load data available; costs based upon BOD loading of 9100 lb/day.

\*\*\*See footnote, p. 136.



TABLE 30-7

**WATER EFFLUENT TREATMENT COSTS  
PLASTICS AND SYNTHETICS INDUSTRY**

Product Subcategory :	Phenolics (small plant) **			
Representative Plant Capacity million kilograms (pounds) per year :	11	(25)		
Hydraulic Load cubic meters/metric ton of product (gal/lb) :	12.3	(1.48)		
Treatment Plant Size: thousand cubic meters per day (MGD) :	0.42	(0.11)		
<b>Costs – \$1000</b>	<b>Alternative Treatment Steps *</b>			
	<u>A</u>	<u>B</u>	<u>H</u>	<u>E</u>
Initial Investment	330	770	420	1065
Annual Costs:				
Capital Costs (8%)	26	62	34	85
Depreciation (10%)	33	77	42	107
Operation and Maintenance	3	34	5	95
Energy and Power	2	6	3	2
Total Annual Costs	64	179	84	289

**Effluent Quality** (Expressed in terms of yearly averages)

	<b>Raw Waste Load</b>	<b>Resulting Effluent Levels (Units per 1000 Units of Product)</b>			
		<u>A</u>	<u>B</u>	<u>H</u>	<u>E</u>
B.O.D.	35	—	0.6	—	0.09
C.O.D.	50	—	3	—	0.6
Suspended Solids	4	—	0.4	—	0.06
Phenolic Compounds	N/A	—	—	0.006	0.0006

\* Steps A, B and E are based upon a dilution factor of 10; 4.2 thousand cubic meters per day (1.1 MGD). Costs per thousand gallons assumes pay-your-way user charges equal to 0.1 of steps A and B, corresponding to flow share on municipal system.

\*\*See footnote, p. 136.

TABLE 30-8

**WATER EFFLUENT TREATMENT COSTS  
PLASTICS AND SYNTHETICS INDUSTRY**

Product Subcategory :	Phenolics (large plant) **			
Representative Plant Capacity million kilograms (pounds) per year :	45	(100)		
Hydraulic Load cubic meters/metric ton of product (gal/lb) :	12.3	(1.48)		
Treatment Plant Size: thousand cubic meters per day (MGD) :	1.70	(0.45)		
<b>Costs -- \$1000</b>	<b>Alternative Treatment Steps*</b>			
	<u>A</u>	<u>B</u>	<u>E</u>	<u>H</u>
Initial Investment	900	2100	2425	975
Annual Costs:				
Capital Costs (8%)	72	168	194	78
Depreciation (10%)	90	210	243	98
Operation and Maintenance	11	88	115	21
Energy and Power	4	20	9	10
Total Annual Costs	177	588	561	207

**Effluent Quality** (Expressed in terms of yearly averages)

	<u>Raw Waste Load</u>	<u>Resulting Effluent Levels</u> (Units per 1000 Units of Product)			
		<u>A</u>	<u>B</u>	<u>H</u>	<u>E</u>
B.O.D.	35	—	0.6	—	0.09
C.O.D.	50	—	3	—	0.6
Suspended Solids	4	—	0.4	—	0.06
Phenolic Compounds	N/A	—	—	0.006	0.0006

\* Steps A, B and E are based upon a dilution factor of 10; 17.0 thousand cubic meters per day (4.5 MGD). Costs per thousand gallons assumes pay-your-way user charges equal to 0.1 of steps A and B, corresponding to flow share on municipal system.

\*\*See footnote, p. 136.

TABLE 30-9

**WATER EFFLUENT TREATMENT COSTS  
PLASTICS AND SYNTHETICS INDUSTRY**

Product Subcategory : Polyvinyl Chloride (small plant)

Representative Plant Capacity			
million kilograms (pounds) per year	:	45	(100)
Hydraulic Load			
cubic meters/metric ton of product (gal/lb)	:	13.3	(1.60)
Treatment Plant Size:			
thousand cubic meters per day (MGD)	:	1.82	(0.48)

Costs - \$1000Alternative Treatment Steps

	<u>A</u>	<u>B</u>	<u>D</u>	<u>E</u>
Initial Investment	255	595	107	790
Annual Costs:				
Capital Costs (8%)	20	48	9	63
Depreciation (10%)	26	60	11	79
Operation and Maintenance	3	24	2	146
Energy and Power	0.5	3	-	22
Total Annual Costs	49.5	135	22	310

Effluent Quality (Expressed in terms of yearly averages)

	Raw Waste <u>Load</u>	<u>Resulting Effluent Levels</u> (Units per 1000 Units of Product)			
		<u>A</u>	<u>B</u>	<u>D</u>	<u>E</u>
B.O.D.	6	-	0.3	-	0.09
C.O.D.	25	-	3	-	0.4
Suspended Solids	30	-	-	0.5	0.04

TABLE 30-10

**WATER EFFLUENT TREATMENT COSTS  
PLASTICS AND SYNTHETICS INDUSTRY**

Product Subcategory : Polyvinyl Chloride (large plant)

Representative Plant Capacity			
million kilograms (pounds) per year	:	90	(200)
Hydraulic Load			
cubic meters/metric ton of product (gal/lb)	:	13.3	(1.60)
Treatment Plant Size:			
thousand cubic meters per day (MGD)	:	3.67	(0.97)

**Costs - \$1000****Alternative Treatment Steps**

	<u>A</u>	<u>B</u>	<u>D</u>	<u>E</u>
Initial Investment	315	735	170	1260
Annual Costs:				
Capital Costs (8%)	25	60	14	101
Depreciation (10%)	32	74	17	126
Operation and Maintenance	4	36	2	203
Energy and Power	1	5	-	44
Total Annual Costs	62	175	33	474

**Effluent Quality** (Expressed in terms of yearly averages)

	Raw Waste Load	<u>Resulting Effluent Levels</u> (Units per 1000 Units of Product)			
		<u>A</u>	<u>B</u>	<u>D</u>	<u>E</u>
B.O.D.	6	-	0.3	-	0.09
C.O.D.	25	-	3	-	0.4
Suspended Solids	30	-	-	0.5	0.04

TABLE 30-11

**WATER EFFLUENT TREATMENT COSTS  
PLASTICS AND SYNTHETICS INDUSTRY**

Product Subcategory : ABS/SAN (small plant)

Representative Plant Capacity			
million kilograms (pounds) per year	:	23	(50)
Hydraulic Load			
cubic meters/metric ton of product (gal/lb)	:	15.6	(1.87)
Treatment Plant Size:			
thousand cubic meters per day (MGD)	:	1.06	(0.28)

Costs -- \$1000

Alternative Treatment Steps

	<u>A</u>	<u>B</u>	<u>D</u>	<u>E</u>
Initial Investment	113	284	75	560
Annual Costs:				
Capital Costs (8%)	9	23	6	45
Depreciation (10%)	11	28	8	56
Operation and Maintenance	2	35	2	118
Energy and Power	0.5	3	—	11
Total Annual Costs	22.5	89	16	230

Effluent Quality (Expressed in terms of yearly averages)

	<u>Raw Waste Load</u>	<u>Resulting Effluent Levels</u> (Units per 1000 Units of Product)			
		<u>A</u>	<u>B</u>	<u>D</u>	<u>E</u>
B.O.D.	20	—	0.4	—	0.1
C.O.D.	30	—	4	—	0.9
Suspended Solids	10	—	—	0.5	0.09

TABLE 30-12

**WATER EFFLUENT TREATMENT COSTS  
PLASTICS AND SYNTHETICS INDUSTRY**

Product Subcategory : ABS/SAN (large plant)

Representative Plant Capacity			
million kilograms (pounds) per year	:	90	(200)
Hydraulic Load			
cubic meters/metric ton of product (gal/lb)	:	15.6	(1.87)
Treatment Plant Size:			
thousand cubic meters per day (MGD)	:	4.28	(1.13)

**Costs - \$1000**

**Alternative Treatment Steps**

	<u>A</u>	<u>B</u>	<u>D</u>	<u>E</u>
Initial Investment	345	885	185	1350
Annual Costs:				
Capital Costs (8%)	28	71	15	108
Depreciation (10%)	35	89	19	135
Operation and Maintenance	4	72	2	203
Energy and Power	1	6	-	44
Total Annual Costs	68	238	36	490

**Effluent Quality** (Expressed in terms of yearly averages)

	<u>Raw Waste Load</u>	<u>Resulting Effluent Levels</u> (Units per 1000 Units of Product)			
		<u>A</u>	<u>B</u>	<u>D</u>	<u>E</u>
B.O.D.	20	-	0.4	-	0.1
C.O.D.	30	-	4	-	0.9
Suspended Solids	10	-	-	0.5	0.09

TABLE 30-13

**WATER EFFLUENT TREATMENT COSTS  
PLASTICS AND SYNTHETICS INDUSTRY**

Product Subcategory : Polystyrene (small plant)

Representative Plant Capacity			
million kilograms (pounds) per year	:	23	(50)
Hydraulic Load			
cubic meters/metric ton of product (gal/lb)	:	9.67	(1.16)
Treatment Plant Size:			
thousand cubic meters per day (MGD)	:	0.68	(0.18)

**Costs - \$1000**

**Alternative Treatment Steps**

	<u>A</u>	<u>B</u>	<u>D</u>	<u>E</u>
Initial Investment	102	258	56	475
Annual Costs:				
Capital Costs (8%)	8	21	4	38
Depreciation (10%)	10	26	6	48
Operation and Maintenance	2	31	2	113
Energy and Power	0.5	2	-	11
Total Annual Costs	20.5	80	12	210

**Effluent Quality (Expressed in terms of yearly averages)**

	<u>Raw Waste Load</u>	<u>Resulting Effluent Levels</u> (Units per 1000 Units of Product)			
		<u>A</u>	<u>B</u>	<u>D</u>	<u>E</u>
B.O.D.	1	-	0.1	-	0.05
C.O.D.	3	-	1	-	0.3
Suspended Solids	4	-	-	0.2	0.03

TABLE 30-14

**WATER EFFLUENT TREATMENT COSTS  
PLASTICS AND SYNTHETICS INDUSTRY**

Product Subcategory : Polystyrene (large plant)

Representative Plant Capacity			
million kilograms (pounds) per year	:	90	(200)
Hydraulic Load			
cubic meters/metric ton of product (gal/lb)	:	9.67	(1.16)
Treatment Plant Size:			
thousand cubic meters per day (MGD)	:	2.7	(0.7)

Costs - \$1000Alternative Treatment Steps

	<u>A</u>	<u>B</u>	<u>D</u>	<u>E</u>
Initial Investment	285	725	135	960
Annual Costs:				
Capital Costs (8%)	23	58	11	77
Depreciation (10%)	29	73	14	96
Operation and Maintenance	3	50	2	146
Energy and Power	0.5	2	-	22
Total Annual Costs	55.5	183	27	341

Effluent Quality (Expressed in terms of yearly averages)

	<u>Raw Waste Load</u>	<u>Resulting Effluent Levels</u> (Units per 1000 Units of Product)			
		<u>A</u>	<u>B</u>	<u>D</u>	<u>E</u>
B.O.D.	1	-	0.1	-	0.05
C.O.D.	3	-	1	-	0.3
Suspended Solids	4	-	-	0.2	0.03



TABLE 30-15

**WATER EFFLUENT TREATMENT COSTS  
PLASTICS AND SYNTHETICS INDUSTRY**

Product Subcategory : Polyvinyl Acetate (small plant)

Representative Plant Capacity			
million kilograms (pounds) per year	:	11	(25)
Hydraulic Load			
cubic meters/metric ton of product (gal/lb)	:	12.5	(1.50)
Treatment Plant Size:			
thousand cubic meters per day (MGD)	:	0.42	(0.11)

**Costs - \$1000**

Alternative Treatment Steps

	<u>A</u>	<u>B</u>	<u>D</u>	<u>E</u>
Initial Investment	90	210	40	405
Annual Costs:				
Capital Costs (8%)	7	17	3	32
Depreciation (10%)	9	21	4	41
Operation and Maintenance	2	15	2	98
Energy and Power	0.5	0.5	-	3
Total Annual Costs	18.5	53.5	9	174

Effluent Quality (Expressed in terms of yearly averages)

	<u>Raw Waste Load</u>	<u>Resulting Effluent Levels</u> (Units per 1000 Units of Product)			
		<u>A</u>	<u>B</u>	<u>D</u>	<u>E</u>
B.O.D. (Units/1000 of Product)	1	-	0.1	-	0.06
C.O.D.	2	-	1	-	0.4
Suspended Solids	1	-	-	0.3	0.04

TABLE 30-16

**WATER EFFLUENT TREATMENT COSTS  
PLASTICS AND SYNTHETICS INDUSTRY**

Product Subcategory : Polyvinyl Acetate (large plant)

Representative Plant Capacity			
million kilograms (pounds) per year	:	45	(100)
Hydraulic Load			
cubic meters/metric ton of product (gal/lb)	:	12.5	(1.50)
Treatment Plant Size:			
thousand cubic meters per day (MGD)	:	1.70	(0.45)

**Costs - \$1000**

**Alternative Treatment Steps**

	<u>A</u>	<u>B</u>	<u>D</u>	<u>E</u>
Initial Investment	255	595	102	685
Annual Costs:				
Capital Costs (8%)	20	48	8	55
Depreciation (10%)	26	60	10	69
Operation and Maintenance	2	24	2	118
Energy and Power	0.5	1	-	11
Total Annual Costs	48.5	133	20	253

**Effluent Quality (Expressed in terms of yearly averages)**

	Raw Waste <u>Load</u>	<u>Resulting Effluent Levels</u> (Units per 1000 Units of Product)			
		<u>A</u>	<u>B</u>	<u>D</u>	<u>E</u>
B.O.D.	1	-	0.1	-	0.06
C.O.D.	2	-	1	-	0.4
Suspended Solids	1	-	-	0.3	0.04

**TABLE 30-17**  
**WATER EFFLUENT TREATMENT COSTS**  
**PLASTICS AND SYNTHETICS INDUSTRY**

Product Subcategory :	Low Density Polyethylene (small plant)		
Representative Plant Capacity			
million kilograms (pounds) per year	:	90	(200)
Hydraulic Load			
cubic meters/metric ton of product (gal/lb)	:	10.7	(1.29)
Treatment Plant Size:			
thousand cubic meters per day (MGD)	:	2.95	(0.78)

**Costs – \$1000**

**Alternative Treatment Steps**

	<u>A</u>	<u>B</u>	<u>D</u>	<u>E</u>
Initial Investment	290	680	145	1070
Annual Costs:				
Capital Costs (8%)	23	54	12	85
Depreciation (10%)	29	68	15	107
Operation and Maintenance	11	21	2	176
Energy and Power	0.5	2	–	33
Total Annual Costs	63.5	145	29	401

**Effluent Quality** (Expressed in terms of yearly averages)

	<u>Raw Waste Load</u>	<u>Resulting Effluent Levels</u> (Units per 1000 Units of Product)			
		<u>A</u>	<u>B</u>	<u>D</u>	<u>E</u>
B.O.D.	2	–	0.1	–	0.06
C.O.D.	30	–	1	–	0.4
Suspended Solids	2	–	–	0.3	0.04

**TABLE 30-18**  
**WATER EFFLUENT TREATMENT COSTS**  
**PLASTICS AND SYNTHETICS INDUSTRY**

Product Subcategory :      Low Density Polyethylene (large plant)

<b>Representative Plant Capacity</b>			
million kilograms (pounds) per year	:	180	(400)
<b>Hydraulic Load</b>			
cubic meters/metric ton of product (gal/lb)	:	10.7	(1.29)
<b>Treatment Plant Size:</b>			
thousand cubic meters per day (MGD)	:	6.1	(1.6)

**Costs - \$1000**

**Alternative Treatment Steps**

		<u>A</u>	<u>B</u>	<u>D</u>	<u>E</u>
Initial Investment		435	1015	235	1670
<b>Annual Costs:</b>					
Capital Costs (8%)		35	81	19	134
Depreciation (10%)		44	102	24	167
Operation and Maintenance		4	44	3	263
Energy and Power		1	4	-	65
<b>Total Annual Costs</b>		<b>84</b>	<b>231</b>	<b>46</b>	<b>629</b>

**Effluent Quality (Expressed in terms of yearly averages)**

	<u>Raw Waste Load</u>	<u>Resulting Effluent Levels</u> (Units per 1000 Units of Product)			
		<u>A</u>	<u>B</u>	<u>D</u>	<u>E</u>
B.O.D.	2	-	0.1	-	0.06
C.O.D.	30	-	1	-	0.4
Suspended Solids	2	-	-	0.3	0.04

TABLE 30-19

**WATER EFFLUENT TREATMENT COSTS  
PLASTICS AND SYNTHETICS INDUSTRY**

Product Subcategory : High Density Polyethylene (small plant)

Representative Plant Capacity			
million kilograms (pounds) per year	:	57	(125)
Hydraulic Load			
cubic meters/metric ton of product (gal/lb)	:	10.9	(1.30)
Treatment Plant Size:			
thousand cubic meters per day (MGD)	:	1.9	(0.5)

**Costs — \$1000****Alternative Treatment Steps**

	<u>A</u>	<u>B</u>	<u>D</u>	<u>E</u>
Initial Investment	255	595	110	725
Annual Costs:				
Capital Costs (8%)	20	48	9	58
Depreciation (10%)	26	60	11	73
Operation and Maintenance	2	23	2	128
Energy and Power	0.5	1	-	14
Total Annual Costs	48.5	132	22	273

**Effluent Quality** (Expressed in terms of yearly averages)

	<u>Raw Waste Load</u>	<u>Resulting Effluent Levels</u> (Units per 1000 Units of Product)			
		<u>A</u>	<u>B</u>	<u>D</u>	<u>E</u>
B.O.D.	1	-	0.1	-	0.06
C.O.D.	2	-	1	-	0.4
Suspended Solids	2	-	-	0.2	0.04

TABLE 30-20

**WATER EFFLUENT TREATMENT COSTS  
PLASTICS AND SYNTHETICS INDUSTRY**

Product Subcategory :	High Density Polyethylene			
<b>Representative Plant Capacity</b>				
million kilograms (pounds) per year :	115		(25)	
<b>Hydraulic Load</b>				
cubic meters/metric ton of product (gal/lb) :	10.9		(1.30)	
<b>Treatment Plant Size:</b>				
thousand cubic meters per day (MGD) :	3.8		(1.0)	
 <b>Costs -- \$1000</b>				
	<u>Alternative Treatment Steps</u>			
	<u>A</u>	<u>B</u>	<u>D</u>	<u>E</u>
Initial Investment	315	735	175	1160
Annual Costs:				
Capital Costs (8%)	25	59	14	93
Depreciation (10%)	32	74	18	116
Operation and Maintenance	3	32	2	160
Energy and Power	0.5	1	—	27
Total Annual Costs	60.5	166	34	396

**Effluent Quality (Expressed in terms of yearly averages)**

	<b>Raw Waste Load</b>	<b><u>Resulting Effluent Levels</u> (Units per 1000 Units of Product)</b>			
		<u>A</u>	<u>B</u>	<u>D</u>	<u>E</u>
B.O.D.		—	0.1	—	0.06
C.O.D.		—	1	—	0.4
Suspended Solids		—	—	0.2	0.04

TABLE 30-21

**WATER EFFLUENT TREATMENT COSTS  
PLASTICS AND SYNTHETICS INDUSTRY**

Product Subcategory :	Polypropylene (small plant)	
Representative Plant Capacity million kilograms (pounds) per year :	45	(100)
Hydraulic Load cubic meters/metric ton of product (gal/lb) :	21.0	(2.52)
Treatment Plant Size: thousand cubic meters per day (MGD) :	2.88	(0.76)

**Costs – \$1000****Alternative Treatment Steps**

	<u>A</u>	<u>B</u>	<u>D</u>	<u>E</u>
Initial Investment	294	747	145	880
Annual Costs:				
Capital Costs (8%)	24	60	12	70
Depreciation (10%)	29	75	15	88
Operation and Maintenance	3	53	2	126
Energy and Power	0.5	3	—	13
Total Annual Costs	56.5	191	29	297

**Effluent Quality** (Expressed in terms of yearly averages)

	<u>Raw Waste Load</u>	<u>Resulting Effluent Levels</u> (Units per 1000 Units of Product)			
		<u>A</u>	<u>B</u>	<u>D</u>	<u>E</u>
B.O.D.	4	—	0.3	—	0.1
C.O.D.	10	—	1	—	0.9
Suspended Solids	N/A	—	—	0.5	0.09

TABLE 30-22

**WATER EFFLUENT TREATMENT COSTS  
PLASTICS AND SYNTHETICS INDUSTRY**

Product Subcategory :	Polypropylene (large plant)			
Representative Plant Capacity million kilograms (pounds) per year :	90	(200)		
Hydraulic Load cubic meters/metric ton of product (gal/lb) :	21.0	(2.52)		
Treatment Plant Size: thousand cubic meters per day (MGD) :	5.7	(1.5)		
<b><u>Costs</u> - \$1000</b>	<b><u>Alternative Treatment Steps</u></b>			
	<b><u>A</u></b>	<b><u>B</u></b>	<b><u>D</u></b>	<b><u>E</u></b>
Initial Investment	420	1076	250	1400
Annual Costs:				
Capital Costs (8%)	34	86	20	112
Depreciation (10%)	42	108	25	140
Operation and Maintenance	4	82	2	160
Energy and Power	1	5	-	27
Total Annual Costs	81	281	47	439

**Effluent Quality** (Expressed in terms of yearly averages)

	<b><u>Raw Waste Load</u></b>	<b><u>Resulting Effluent Levels</u></b> (Units per 1000 Units of Product)			
		<b><u>A</u></b>	<b><u>B</u></b>	<b><u>D</u></b>	<b><u>E</u></b>
B.O.D.	4	-	0.3	-	0.1
C.O.D.	10	-	1	-	0.9
Suspended Solids	N/A	-	-	0.5	0.09



TABLE 30-23

**WATER EFFLUENT TREATMENT COSTS  
PLASTICS AND SYNTHETICS INDUSTRY**

Product Subcategory :	Acrylics (small plant)				
Representative Plant Capacity					
million kilograms (pounds) per year :	23	(50)			
Hydraulic Load					
cubic meters/metric ton of product (gal/lb) :	25	(3.0)			
Treatment Plant Size:					
thousand cubic meters per day (MGD) :	1.70	(0.45)			
<b>Costs — \$1000</b>	<b>Alternative Treatment Steps</b>				
	<u>A</u>	<u>B</u>	<u>C</u>	<u>D</u>	<u>E</u>
Initial Investment	255	643	595	102	685
Annual Costs:					
Capital Costs (8%)	20	51	48	8	55
Depreciation (10%)	26	64	60	10	69
Operation and Maintenance	3	43	27	2	118
Energy and Power	1	7	6	—	11
Total Annual Costs	50	165	141	20	253

**Effluent Quality** (Expressed in terms of yearly averages)

	<u>Raw Waste Load</u>	<u>Resulting Effluent Levels</u> (Units per 1000 Units of Product)				
		<u>A</u>	<u>B</u>	<u>C</u>	<u>D</u>	<u>E</u>
B.O.D.	25	—	—	1	—	0.1
C.O.D.	50	—	—	6	—	0.8
Suspended Solids	2	—	—	—	0.5	0.08

TABLE 30-24

**WATER EFFLUENT TREATMENT COSTS  
PLASTICS AND SYNTHETICS INDUSTRY**

Product Subcategory :	Acrylics (medium plant)				
Representative Plant Capacity million kilograms (pounds) per year :	45	(100)			
Hydraulic Load cubic meters/metric ton of product (gal/lb) :	25	(3.0)			
Treatment Plant Size: thousand cubic meters per day (MGD) :	3.4	(0.9)			
<b>Costs - \$1000</b>	<b>Alternative Treatment Steps</b>				
	<u>A</u>	<u>B</u>	<u>C</u>	<u>D</u>	<u>E</u>
Initial Investment	306	783	714	160	1050
Annual Costs:					
Capital Costs (8%)	24	63	57	13	84
Depreciation (10%)	31	78	71	16	105
Operation and Maintenance	5	69	42	2	146
Energy and Power	1	12	11	-	22
Total Annual Costs	61	222	181	31	357

**Effluent Quality (Expressed in terms of yearly averages)**

	Raw Waste Load	Resulting Effluent Levels (Units per 1000 Units of Product)				
		<u>A</u>	<u>B</u>	<u>C</u>	<u>D</u>	<u>E</u>
B.O.D.	25	-	-	1	-	0.1
C.O.D.	50	-	-	6	-	0.8
Suspended Solids	2	-	-	-	0.5	0.08

Table 30-25

**WATER EFFLUENT TREATMENT COSTS  
PLASTICS AND SYNTHETICS INDUSTRY**

Product Subcategory :	Acrylics (large plant)				
Representative Plant Capacity					
million kilograms (pounds) per year :	90	(200)			
Hydraulic Load					
cubic meters/metric ton of product (gal/lb) :	25	(3.0)			
Treatment Plant Size:					
thousand cubic meters per day (MGD) :	6.8	(1.8)			
<b>Costs – \$1000</b>	<b>Alternative Treatment Steps</b>				
	<u>A</u>	<u>B</u>	<u>C</u>	<u>D</u>	<u>E</u>
Initial Investment	480	1230	1120	255	1640
Annual Costs:					
Capital Costs (8%)	38	98	90	20	131
Depreciation (10%)	48	123	112	26	164
Operation and Maintenance	5	94	49	3	203
Energy and Power	1	7	6	—	44
Total Annual Costs	92	322	257	49	542

**Effluent Quality** (Expressed in terms of yearly averages)

	<u>Raw Waste Load</u>	<u>Resulting Effluent Levels</u> (Units per 1000 Units of Product)				
		<u>A</u>	<u>B</u>	<u>C</u>	<u>D</u>	<u>E</u>
B.O.D.	25	—	—	1	—	0.1
C.O.D.	50	—	—	6	—	0.8
Suspended Solids	2	—	—	—	0.5	0.08

TABLE 30-26

**WATER EFFLUENT TREATMENT COSTS  
PLASTICS AND SYNTHETICS INDUSTRY**

Product Subcategory :		Polyester (small plant)					
Representative Plant Capacity							
million kilograms (pounds) per year	:	23	(50)				
Hydraulic Load							
cubic meters/metric ton of product (gal/lb)	:	31	(3.7)				
Treatment Plant Size:							
thousand cubic meters per day (MGD)	:	2.12	(0.56)				
<b>Costs -- \$1000</b>				<b>Alternative Treatment Steps</b>			
		<b>A</b>	<b>B</b>	<b>C</b>	<b>D</b>	<b>E</b>	
Initial Investment		270	682	630	117	765	
Annual Costs:							
Capital Costs (8%)		22	55	50	9	61	
Depreciation (10%)		27	68	63	12	77	
Operation and Maintenance		3	47	27	2	113	
Energy and Power		1	6	5	-	11	
Total Annual Costs		53	176	145	23	262	
<b>Effluent Quality</b> (Expressed in terms of yearly averages)							
			<b>Resulting Effluent Levels</b>				
			<b>(Units per 1000 Units of Product)</b>				
	<b>Raw Waste Load</b>	<b>A</b>	<b>B</b>	<b>C</b>	<b>D</b>	<b>E</b>	
B.O.D.	20	-	-	0.3	-	0.06	
C.O.D.	25	-	-	5	-	0.4	
Suspended Solids	1	-	-	-	0.2	0.04	

TABLE 30-27

**WATER EFFLUENT TREATMENT COSTS  
PLASTICS AND SYNTHETICS INDUSTRY**

Product Subcategory :	Polyester (large Plant)				
Representative Plant Capacity million kilograms (pounds) per year :	90	(200)			
Hydraulic Load cubic meters/metric ton of product (gal/lb) :	31	(3.7)			
Treatment Plant Size: thousand cubic meters per day (MGD) :	8.5	(2.2)			
<b>Costs — \$1000</b>	<b>Alternative Treatment Steps</b>				
	<u>A</u>	<u>B</u>	<u>C</u>	<u>D</u>	<u>E</u>
Initial Investment	570	1465	1330	290	1670
Annual Costs:					
Capital Costs (8%)	46	117	106	23	134
Depreciation (10%)	57	147	133	29	167
Operation and Maintenance	8	126	70	3	145
Energy and Power	2	18	17	—	22
Total Annual Costs	113	408	326	55	468

**Effluent Quality** (Expressed in terms of yearly averages)

	<u>Raw Waste Load</u>	<u>Resulting Effluent Levels</u> (Units per 1000 Units of Product)				
		<u>A</u>	<u>B</u>	<u>C</u>	<u>D</u>	<u>E</u>
B.O.D.	20	—	—	0.3	—	0.06
C.O.D.	25	—	—	5	—	0.4
Suspended Solids	1	—	—	—	0.2	0.04

TABLE 30-28

**WATER EFFLUENT TREATMENT COSTS  
PLASTICS AND SYNTHETICS INDUSTRY**

Product Subcategory :		Nylon 6 (small plant)				
Representative Plant Capacity						
million kilograms (pounds) per year	:	11	(25)			
Hydraulic Load						
cubic meters/metric ton of product (gal/lb)	:	67	(8)			
Treatment Plant Size:						
thousand cubic meters per day (MGD)	:	2.3	(0.6)			
<b>Costs – \$1000</b>				<b>Alternative Treatment Steps</b>		
		<u>A</u>	<u>B</u>	<u>C</u>	<u>D</u>	<u>E</u>
Initial Investment		270	630	630	120	840
Annual Costs:						
Capital Costs (8%)		22	50	50	10	67
Depreciation (10%)		27	63	63	12	84
Operation and Maintenance		2	23	23	2	136
Energy and Power		0.5	3	3	–	18
Total Annual Costs		51.5	139	139	24	305
<b>Effluent Quality</b> (Expressed in terms of yearly averages)						
				<b>Resulting Effluent Levels</b>		
				<b>(Units per 1000 Units of Product)</b>		
	<u>Raw Waste Load</u>	<u>A</u>	<u>B</u>	<u>C</u>	<u>D</u>	<u>E</u>
B.O.D.	20	–	–	2	–	0.3
C.O.D.	N/A	–	–	20	–	2
Suspended Solids	N/A	–	–	–	2	0.2

TABLE 30-29

**WATER EFFLUENT TREATMENT COSTS  
PLASTICS AND SYNTHETICS INDUSTRY**

Product Subcategory :	Nylon 6 (large plant)				
Representative Plant Capacity					
million kilograms (pounds) per year :	45	(100)			
Hydraulic Load					
cubic meters/metric ton of product (gal/lb) :	67	(8)			
Treatment Plant Size:					
thousand cubic meters per day (MGD) :	9.1	(2.4)			
<b>Costs – \$1000</b>	<u>Alternative Treatment Steps</u>				
	<u>A</u>	<u>B</u>	<u>C</u>	<u>D</u>	<u>E</u>
Initial Investment	600	1400	1400	300	2050
Annual Costs:					
Capital Costs (8%)	48	112	112	24	164
Depreciation (10%)	60	140	140	30	205
Operation and Maintenance	7	62	62	3	278
Energy and Power	1	9	9	–	72
Total Annual Costs	116	323	323	57	719

**Effluent Quality** (Expressed in terms of yearly averages)

	<u>Raw Waste Load</u>	<u>Resulting Effluent Levels</u> (Units per 1000 Units of Product)				
		<u>A</u>	<u>B</u>	<u>C</u>	<u>D</u>	<u>E</u>
B.O.D.	20	–	–	2	–	0.3
C.O.D.	N/A	–	–	20	–	2
Suspended Solids	N/A	–	–	–	0.2	0.2

TABLE 30-30

**WATER EFFLUENT TREATMENT COSTS  
PLASTICS AND SYNTHETICS INDUSTRY**

Product Subcategory :	Nylon 66 (small plant)				
Representative Plant Capacity million kilograms (pounds) per year :	23	(50)			
Hydraulic Load cubic meters/metric ton of product (gal/lb) :	16.7	(2.0)			
Treatment Plant Size: thousand cubic meters per day (MGD) :	1.1	(0.3)			
<b>Costs - \$1000</b>	<b>Alternative Treatment Steps</b>				
	<u>A</u>	<u>B</u>	<u>C</u>	<u>D</u>	<u>E</u>
Initial Investment	231	539	539	78	575
Annual Costs:					
Capital Costs (8%)	18	42	43	6	46
Depreciation (10%)	23	54	54	8	58
Operation and Maintenance	2	23	23	2	113
Energy and Power	0.5	3	3	-	11
Total Annual Costs	43.5	123	123	16	228

**Effluent Quality (Expressed in terms of yearly averages)**

	<b>Raw Waste Load</b>	<b>Resulting Effluent Levels (Units per 1000 Units of Product)</b>				
		<u>A</u>	<u>B</u>	<u>C</u>	<u>D</u>	<u>E</u>
B.O.D.	10	-	-	0.4	-	0.07
C.O.D.	15	-	-	2	-	0.5
Suspended Solids	N/A	-	-	-	0.2	0.05



TABLE 30--31

**WATER EFFLUENT TREATMENT COSTS  
PLASTICS AND SYNTHETICS INDUSTRY**

Product Subcategory :	Nylon 66 (large plant)				
Representative Plant Capacity					
million kilograms (pounds) per year :	90	(200)			
Hydraulic Load					
cubic meters/metric ton of product (gal/lb) :	16.7	(2.0)			
Treatment Plant Size:					
thousand cubic meters per day (MGD) :	4.5	(1.2)			
<b>Costs -- \$1000</b>	<b>Alternative Treatment Steps</b>				
	<u>A</u>	<u>B</u>	<u>C</u>	<u>D</u>	<u>E</u>
Initial Investment	360	840	840	190	1200
Annual Costs:					
Capital Costs (8%)	29	67	67	15	96
Depreciation (10%)	36	84	84	19	120
Operation and Maintenance	8	67	67	2	145
Energy and Power	2	27	27	—	22
Total Annual Costs	75	245	245	36	383

**Effluent Quality** (Expressed in terms of yearly averages)

	<b>Raw Waste Load</b>	<b>Resulting Effluent Levels (Units per 1000 Units of Product)</b>				
		<u>A</u>	<u>B</u>	<u>C</u>	<u>D</u>	<u>E</u>
B.O.D.	10	—	—	0.4	—	0.07
C.O.D.	15	—	—	2	—	0.5
Suspended Solids	N/A	—	—	—	0.2	0.05

TABLE 30-32

**WATER EFFLUENT TREATMENT COSTS  
PLASTICS AND SYNTHETICS INDUSTRY**

Product Subcategory : Cellophane (all plants)

Representative Plant Capacity			
million kilograms (pounds) per year	:	45	(100)
Hydraulic Load			
cubic meters/metric ton of product (gal/lb)	:	325	(39)
Treatment Plant Size:			
thousand cubic meters per day (MGD)	:	44.7	(11.8)

Costs - \$1000

Alternative Treatment Steps

	<u>A</u>	<u>B</u>	<u>D</u>	<u>E</u>
Initial Investment	1620	3780	880	5550
Annual Costs:				
Capital Costs (8%)	130	302	70	444
Depreciation (10%)	162	378	88	555
Operation and Maintenance	20	181	7	692
Energy and Power	2	20	-	209
Total Annual Costs	314	881	165	1900

Effluent Quality (Expressed in terms of yearly averages)

	<u>Raw Waste Load</u>	<u>Resulting Effluent Levels</u> (Units per 1000 Units of Product)			
		<u>A</u>	<u>B</u>	<u>D</u>	<u>E</u>
B.O.D.	50	-	5	-	2
C.O.D.	150	-	50	-	10
Suspended Solids	50	-	-	10	1

TABLE 30-33

**WATER EFFLUENT TREATMENT COSTS  
PLASTICS AND SYNTHETICS INDUSTRY**

Product Subcategory :	Cellulose Acetate				
<b>Representative Plant Capacity</b>					
million kilograms (pounds) per year :	90	(200)			
<b>Hydraulic Load</b>					
cubic meters/metric ton of product (gal/lb) :	157	(18.8)			
<b>Treatment Plant Size:</b>					
thousand cubic meters per day (MGD) :	43.2	(11.4)			
<b>Costs - \$1000</b>					
	<u>Alternative Treatment Steps</u>				
	<u>A</u>	<u>B</u>	<u>C</u>	<u>D</u>	<u>E</u>
Initial Investment	1590	3710	3710	850	4840
<b>Annual Costs:</b>					
Capital Costs (8%)	126	297	297	68	387
Depreciation (10%)	159	371	371	85	484
Operation and Maintenance	28	204	204	7	395
Energy and Power	3	40	40	-	109
Total Annual Costs	317	912	912	160	1375

Effluent Quality (Expressed in terms of yearly averages)

	<b>Raw Waste Load</b>	<b>Resulting Effluent Levels (Units per 1000 Units of Product)</b>				
	<u>Load</u>	<u>A</u>	<u>B</u>	<u>C</u>	<u>D</u>	<u>E</u>
B.O.D.	50	-	-	3	-	0.5
C.O.D.	75	-	-	30	-	3
Suspended Solids	15	-	-	-	1	0.3

TABLE 30-34

**WATER EFFLUENT TREATMENT COSTS  
PLASTICS AND SYNTHETICS INDUSTRY**

<b>Product Subcategory :</b>		<b>Rayon (all plants)</b>				
<b>Representative Plant Capacity</b>						
million kilograms (pounds) per year	:	68	(150)			
<b>Hydraulic Load</b>						
cubic meters/metric ton of product (gal/lb)	:	151	(18.1)			
<b>Treatment Plant Size:</b>						
thousand cubic meters per day (MGD)	:	31.0	(8.2)			
<b>Costs - \$1000</b>		<b>Alternative Treatment Steps</b>				
		<b><u>A</u></b>	<b><u>B</u></b>	<b><u>G</u></b>	<b><u>D</u></b>	<b><u>E</u></b>
<b>Initial Investment</b>		1320	3380	1210	700	4650
<b>Annual Costs:</b>						
Capital Costs (8%)		106	270	97	56	372
Depreciation (10%)		132	338	121	70	465
Operation and Maintenance		15	273	485	6	692
Energy and Power		2	16	28	-	209
Zinc Recovery Credit				(681)*		
<b>Total Annual Costs</b>		<b>255</b>	<b>897</b>	<b>50</b>	<b>132</b>	<b>1738</b>
<b>Effluent Quality (Expressed in terms of yearly averages)</b>						
	<b>Raw Waste Load</b>	<b>Resulting Effluent Levels (Units per 1000 Units of Product)</b>				
		<b><u>A</u></b>	<b><u>B</u></b>	<b><u>G</u></b>	<b><u>D</u></b>	<b><u>E</u></b>
B.O.D.	25	-	3	-	-	1
C.O.D.	50	-	40	-	-	7
Suspended Solids	N/A	-	-	-	6	0.7
Zinc	30	-	-	0.3	-	0.07

\* Assumes 75% recovery of zinc values at \$.20/lb.

TABLE 31

INDUSTRIAL WASTE TREATMENT MODEL DATA  
 PLASTICS AND SYNTHETICS INDUSTRY  
 (Product Group #1) \*

	Product Subcategory		
	Epoxies	Melamine/Urea	Phenolics
<b>Total Industry Discharge</b>			
1000 cubic meters/day or (million gallons/day)			
1972	0.8(0.2)	2.3(0.6)	21.0(5.5)
1977	1.1(0.3)	3.8(1.0)	28.0(7.4)

**Flow Through Components Employed**

One hundred percent of total flow in each industry subcategory is assumed to pass through each treatment step or component.

**Quality of Untreated Wastewater in 1977**

(Expressed in terms of yearly averages.)

**Parameters:**

(in units/1000 units of product)

B.O.D.	0.2	0.07	0.6
C.O.D.	1	0.3	3
S.S.	0.1	0.03	0.4
Phenolic Compounds	0.002	—	0.006

**Number of Companies in**

Subcategory	8	11	81

**Percent of Treatment in 1972**

**Treatment Steps:**

(in percent now treated)	Estimate
A. Initial Treatment	55
B. Biological Treatment	30

\*See footnote, p. 136.

TABLE 32

INDUSTRIAL WASTE TREATMENT MODEL DATA  
 PLASTICS AND SYNTHETICS INDUSTRY  
 (Product Group #2)

	<u>Product Subcategory</u>			
	<u>PVC</u>	<u>ABS/SAN</u>	<u>PStyrene</u>	<u>PV Acetate</u>
<b><u>Total Industry Discharge</u></b>				
1000 cubic meters/day or (million gallons/day)				
1972	76.1(20.1)	16.3(4.3)	43.4(11.5)	7.6(2.0)
1977	134.0(35.4)	32.7(42.4)	66.9(17.7)	9.1(2.4)

**Flow Through Components Employed**

One hundred percent of total flow in each industry subcategory is assumed to pass through each treatment step or component.

**Quality of Untreated Wastewater in 1977**

(Expressed in terms of yearly averages.)

**Parameters:**

(in units/1000 units of product)

B.O.D.	0.3	0.4	0.1	0.1
C.O.D.	3	4	1	1
S.S.	0.5	0.5	0.2	0.3

**Number of Companies in**

<b><u>Subcategory</u></b>	23	8	19	26
---------------------------	----	---	----	----

**Percent of Treatment in 1972**

**Treatment Steps:**

(in percent now treated)	Estimate
A. Initial Treatment	90
B. Biological Treatment	45

TABLE 33

INDUSTRIAL WASTE TREATMENT MODEL DATA  
 PLASTICS AND SYNTHETICS INDUSTRY  
 (Product Group #3)

	Product Subcategory		
	<u>LDP Ethylene</u>	<u>HDP Ethylene</u>	<u>Polypropylene</u>
<b><u>Total Industry Discharge</u></b>			
1000 cubic meters/day or [million gallons/day]			
1972	74.2[19.6]	47.7(12.6)	40.9(10.8)
1977	130.6(34.5)	95.8(25.3)	82.1(21.7)

**Flow Through Components Employed**

One hundred percent of total flow in each industry subcategory is assumed to pass through each treatment step or component.

**Quality of Untreated Wastewater in 1977**

(Expressed in terms of yearly averages.)

**Parameters:**

(in units/1000 units of product)

B.O.D.	0.1	0.1	0.3
C.O.D.	1	1	1
S.S.	0.3	0.2	0.5

**Number of Companies in**

<b><u>Subcategory</u></b>	12	13	9
---------------------------	----	----	---

**Percent of Treatment in 1972**

**Treatment Steps:**

(in percent now treated)	Estimate
A. Initial Treatment	55
B. Biological Treatment	35

TABLE 34

**INDUSTRIAL WASTE TREATMENT MODEL DATA  
PLASTICS AND SYNTHETICS INDUSTRY  
(Product Group #4)**

	<u>Product Subcategory</u>		
	<u>Acrylic</u>	<u>Polyester</u>	<u>Nylons</u>
<b><u>Total Industry Discharge</u></b>			
1000 cubic meters/day or (million gallons/day)			
1972	18.9(5.0)	87.2(23.1)	97.2(25.7)
1977	22.0(5.8)	175.6(46.5)	124.0(32.8)
<b><u>Flow Through Components Employed</u></b>			
One hundred percent of total flow in each industry subcategory is assumed to pass through each treatment step or component.			
<b><u>Quality of Untreated Wastewater in 1977</u></b>			
(Expressed in terms of yearly averages.)			
<b><u>Parameters:</u></b>			
(in units/1000 units of product)			
B.O.D.	1	0.3	[6] / [66]
C.O.D.	6	5	2/0.4
S.S.	0.5	0.2	20/2 2/0.2
<b><u>Number of Companies in Subcategory</u></b>	11	19	20

**Percent of Treatment in 1972****Treatment Steps:**

(in percent now treated)	Estimate
A. Initial Treatment	99
B. Biological Treatment	60



TABLE 35

INDUSTRIAL WASTE TREATMENT MODEL DATA  
 PLASTICS AND SYNTHETICS INDUSTRY  
 (Product Group #5)

	Product Subcategory		
	Cellophane	Cellulose Acetate	Rayon
<u>Total Industry Discharge</u>			
1000 cubic meters/day or (millions gallons/day)			
1972	143.1(37.8)	171.8(45.4)	195.4(51.7)
1977	123.0(32.5)	189.6(50.1)	226.6(59.9)

Flow Through Components Employed

One hundred percent of total flow in each industry subcategory is assumed to pass through each treatment step or component.

Quality of Untreated Wastewater in 1977

(Expressed in terms of yearly averages.)

Parameters:

(in units/1000 units of product)

B.O.D.	5	3	3
C.O.D.	50	30	40
S.S.	10	1	6
Zinc	--	--	.3

Number of Companies in

<u>Subcategory</u>	4	7	7
--------------------	---	---	---

Percent of Treatment in 1972

Treatment Steps:

(in percent now treated)	Estimate
A. Initial Treatment	60
B. Biological Treatment	30

## SECTION IX

### BEST PRACTICABLE CONTROL TECHNOLOGY CURRENTLY AVAILABLE

#### GUIDELINES AND LIMITATIONS

##### Definition of Best Practicable Control Technology Currently Available (BPCTCA)

Based on the analysis of the information presented in Sections IV-VIII the basis for BPCTCA is defined herein.

Best practicable control technology currently available (BPCTCA) for existing point sources is based on the application of end-of-pipe technology such as biological treatment for BOD<sub>5</sub> reduction as typified by activated sludge, aerated lagoons, trickling filters, aerobic-anaerobic lagoons, etc., with appropriate preliminary treatment typified by equilization, to dampen shock loadings, settling, clarification, and chemical treatment, for removal of suspended solids, oils, other elements, and pH control, and subsequent treatment typified by clarification and polishing processes for additional BOD<sub>5</sub> and suspended solids removal and dephenolizing units for the removal of phenolic compounds. Application of in-plant technology and changes which may be helpful in meeting BPCTCA include segregation of contact process waste from noncontact waste waters, elimination of once through barometric condensers, control of leaks, and good house-keeping practices.

The best practicable control technology currently available has been found to be capable of achieving effluent concentrations of BOD<sub>5</sub> comparable to the secondary treatment of municipal sewage. The design and operational conditions of these biological systems are, of course, significantly different than for municipal sewage. The capabilities of biological treatment for industrial wastes are specific to a particular plant's waste waters. However, as discussed in Section VII, end-of-pipe treatment for the removal of biologically active substances from waste waters has been demonstrated successfully in different sections of the plastics and synthetics industry. This technology has proven applicable regardless of the age or size of the manufacturing plant. Depending upon the treatability of the wastewaters, it has been demonstrated to be practical in maintaining concentrations of biologically active substances in the effluent stream within reasonable limits. However, variations due to the vagaries of micro-organisms as well as process and climatic conditions are normal for any biological waste water treatment plant. The Guidelines for best practicable control technology take these factors into consideration and recognize that certain unique properties such as measured by COD exists in the waste waters from the industry. Besides BOD<sub>5</sub>, COD, and SS, certain metals, phenolic compounds, and nitrogen compounds are among the parameters of major concern to the industry.

Table 21, Section VII of this report describes effluent loadings which are currently being attained by the product subcategories of the industry for BOD<sub>5</sub>, COD, and suspended solids. The results of this work show that exemplary, practical waste water treatment plants are presently in operation and that their operational procedures are comparable with those of biological systems in other industries. Consequently, the most significant factors in establishing effluent limitation guidelines on a basis of units of pollutants per unit of production are (1) the waste water generation rates per unit of production capacity and (2) the practicable treatment levels of the waste waters from the particular manufacturing process.

### The Guidelines

The guidelines in terms of kg of pollutant per kkg of production (lb/1000 lb) are based on attainable effluent concentrations and demonstrated waste water flows for each product and process subcategory.

### Attainable Effluent Concentrations

Based on the definition of BPCTCA the following long term average BOD<sub>5</sub> and T.S.S. concentrations were used as a basis for the guidelines.

	BOD <sub>5</sub>	T.S.S.
Major Subcategory I	15	30
Major Subcategory II	20	30
Major Subcategory III	45	30
Major Subcategory IV	75	30

The BOD<sub>5</sub> and T.S.S. concentrations are based on the exemplary plant data presented in Table 18, Section VII, and in some cases technology transfer such as multi-stage biological systems as presented in Section VII.

The COD characteristics of process wastes in the plastics industry vary significantly from product to product, and within a plant over time. The ratio of COD to BOD<sub>5</sub> in plant effluents is shown in Table 36 to range from a low of 2 in polypropylene to a high of 11.8 in polyester. The COD limits for BPCTCA are based on levels achieved in the exemplary plants for which data were available. They are expressed as ratio to the BOD<sub>5</sub> limits in Table 37. Considering the variability of the COD/BOD<sub>5</sub> ratio between plants the upper limits of COD/BOD<sub>5</sub> of 5, 10, and 15 were used for determining limitations. Upon applying the variability factors discussed below to determine the BOD<sub>5</sub> limitations, the COD/BOD<sub>5</sub> factors as applied to the BOD<sub>5</sub> limitations result in a COD limitation that is liberal. The resulting COD limitations do not determine the technology required but in effect require that COD wastes be treated along with the BOD<sub>5</sub> wastes.

TABLE 36

## COD/BOD RATIOS IN EFFLUENT STREAMS

<u>Product</u>	<u>COD/BOD</u>
Polyvinyl chloride	7.5
ABS/SAN	9.5
LD Polyethylene	6.7
Polypropylene	2.0
HD Polyethylene	5.7
Cellophane	8.5
Rayon	11.7
Polyester	11.8
Nylon 66	4.2
Cellulose acetate	8.5
Acrylics	4.3

TABLE 37  
COD/BOD Guideline Bases

<u>Product</u>	<u>COD/BOD</u>
Polypropylene, Nylon 66, and Acrylics	
Polyvinyl chloride, ABS, polyvinyl acetate, polystyrene, low density and high density polyethylene, cellophane, cellulose acetate and Nylon 6	10
Polyester, Rayon	15

The removal of phenolic compounds is based on an attainable concentration level of 0.5 mg/liter monthly limit as demonstrated by dephenolizing units (75) (76), activated carbon (18) (19) (56) (47) or biological degradation (47) (76).

The removal of total chromium is based on an attainable concentration level of 0.25 mg/liter monthly limit as demonstrated by various chemical precipitation techniques followed by biological degradation (47) (76).

The removal of zinc is based on an attainable concentration of 1.4 mg/liter as demonstrated by an alkaline chemical precipitation process (65) (76).

Demonstrated Wastewater Flows

The waste water flow basis for BPCTCA is based on demonstrated wastewater flows found within the industry for each product and process subcategory. Wastewater flows observed at exemplary plants were used as the basis when they fell at the approximate middle of the wastewater flow ranges reported by previous industry and EPA surveys. When the observed flows fell outside of the middle range, a waste water flow within this range was used as the basis.

The waste water flow basis includes process water, utility blowdowns and auxiliary facilities such as laboratories, etc. The waste water flow basis is summarized in Table 38. It is essential to note that the waste water flow is often an integral part of the basic design and operation of the plant or the process and may therefore be subject to significant reduction only at large expense. In general, the hydraulic load is larger for older plants. However, the availability of water also influences design as does the philosophy of the company constructing the plant. No simple formula for relating hydraulic load to plant age, size or location can be established. Demonstrated wastewater flows which fall in the middle of the reported range of wastewater flow is the best available basis for use in determining guidelines.

## Statistical Variability of a Properly Designed and Operated Waste Treatment Plant

The effluent from a properly designed and operated treatment plant changes continually due to a variety of factors. Changes in production mix, production rate, climatic conditions and reaction chemistry influence the composition of raw wasteload and, therefore, its treatability. Changes in biological factors influence the efficiency of the treatment process. A common indicator of the pollution characteristics of the discharge from a plant is the long-term average of the effluent load. The long-term (e.g., design or yearly) average is not a suitable parameter on which to base an enforcement standard. However, using data which show the variability in the effluent load, statistical analyses can be used to compute short-term limits (monthly or daily) which should not be exceeded, provided that the plant is designed and run in the proper way to achieve the desired long-term average load. It is these short-term limits on which the effluent guidelines are based.

In order to reflect the variabilities associated with properly designed and operated treatment plants for each of the major subcategories as discussed above, a statistical analysis was made of plants where sufficient data was available to determine these variances for day-to-day and month-to-month operations. The standard deviations for day-to-day and month-to-month operations were calculated. For the purpose of determining effluent limitation a variability factor was defined as follows:

$$\begin{aligned} \text{Standard deviation} &= Q \text{ monthly, } Q \text{ daily} \\ \text{Long-term average (yearly or design)} &= x \\ \text{Variability factor} &= y \text{ monthly, } y \text{ daily} \\ y \text{ monthly} &= \frac{x + 2Q \text{ monthly}}{x} \\ y \text{ daily} &= \frac{x + 3Q \text{ daily}}{x} \end{aligned}$$

The variability factor is multiplied by the long-term yearly average to determine the effluent limitation guideline for each product subcategory. The monthly effluent limitation guideline is calculated by use of a variability factor based on two standard deviations and is only exceeded 2-3 percent of the time for a plant that is attaining the long-term average. The daily effluent limitation guideline is calculated by the use of a variability factor based on three standard deviations and is exceeded only 0.0-0.5 percent of the time for a plant that is attaining the long term average. Any plant designed to meet the monthly limits should never exceed the daily limits. The data used for the variability analysis came from plants under voluntary operation. By the application of mandatory requirements, the effluent limitation guidelines as discussed in this paragraph should never be exceeded by a properly designed and operated waste treatment facility.

TABLE 38

## Demonstrated Wastewater Flows

	Wastewater Flow Basis	
	<u>ccm/kg</u>	<u>gal/1000#</u>
Polyvinyl chloride		
Suspension	15.02	1800
Emulsion	5.42	650
Bulk	2.50	300
Polyvinyl Acetate	8.34	1000
Polystyrene		
Suspension	9.18	1100
Bulk	1.67	200
Polypropylene	17.52	2100
Lo Density Polyethylene	8.34	1000
Hi Density Polyethylene		
Solvent	12.52	1500
Polyform	2.17	260
Cellophane	242	29,000
Rayon	133	16,000
ABS/SAN	17.52	2,100
Polyester		
Resin	7.93	950
Fiber	7.93	950
Resin and Fiber Continuous	7.93	950
Resin and Fiber Batch	15.86	1900
Nylon 66		
Resin	6.67	800
Fiber	5.84	700
Resin and Fiber	12.52	1500
Nylon 6		
Resin and Fiber	56.94	6800
Resin	37.55	4500
Fiber	19.39	2300
Cellulose Acetate		
Resin	41.72	5000
Fiber	41.72	5000
Resin and Fiber	83.44	10,000
Epoxy	3.59	430
Phenolics	12.3	1480
Urea Resins	1.84	220
Melamine	1.34	160
Acrylics	16.69	2000

The following table summarizes the basis for the BOD<sub>5</sub> variability factors.

TABLE 39  
Demonstrated Variability

Major Subcategory	Influent Concentration mg/l	Long-Term Effluent Concentration mg/l	Variability Factor	
			Monthly	Daily
I	33	6	1.80	3.0
	380	9	1.33	2.1
	380	17	1.80	3.3
II	1206	11	1.76	3.3
	91	20	1.77	3.8
III	1267	44	2.2	4.0*
IV	--	--	2.2*	4.0*

\*estimated values



Based on the table of demonstrated variability the following variability factors were applied to determine the effluent limitation guidelines.

TABLE 40  
Variability Factor

Major Subcategory	Monthly	Daily
I	1.6	3.1
II	1.8	3.7
III	2.2	4.0
IV	2.2	4.0

The variability factors for suspended solids removal is based on the variabilities presented in table 40A for suspended solids removal. The monthly variability was calculated at 2.2 and daily estimated at 4.0.

TABLE 40A

## Suspended Solids Removal

<u>Product</u>	<u>Demonstrated monthly Variability</u>
Cellulose Acetate	2.2
Nylon 6	1.7
Polyester	2.2
Nylon 66	2.2
Acrylics	2.6
Polyvinyl Chloride	1.9

The variability for total chromium and phenolic compounds are based on the monthly limits and a variability factor of 2.0 for the daily maximum.

The variability of zinc concentrations is based on the variability encountered by the EPA demonstration project(65). The analysis of variability set the zinc limits at 4.0 mg/l monthly and 6.8 mg/l daily.

Based on the factors discussed in this Section the effluent limitation guidelines for BPCTCA are presented in Tables 41 and 42.

## SECTION X

### BEST AVAILABLE TECHNOLOGY ECONOMICALLY ACHIEVABLE

#### Definition of Best Available Technology Economically Achievable (BATEA)

Based on the analysis of the information presented in Sections IV-VIII, the basis for BATEA is defined below.

Best available technology economically achievable (BATEA) for existing point sources is based on the best in-plant practices of the industry which minimize the volume of waste generating water as typified by segregation of contact process waters from noncontact waste water, maximum waste water recycle and reuse, elimination of once-through barometric condensers, control of leaks, good housekeeping practices, etc., and end-of-pipe technology, for the further removal of suspended solids and other elements typified by media filtration, chemical treatment, etc., and further COD removal as typified by the application of adsorption processes such as activated carbon and adsorptive flocs, and incineration for the treatment of highly concentrated small volume wastes and additional biological treatment for further BOD<sub>5</sub> removal when needed.

Best available technology economically achievable can be expected to rely upon the usage of those technologies which provide the greatest degree of pollutant control per unit expenditure. Historically, this has been the approach to the solution of any pollution problem - as typified by the mechanical and biological treatment used for removal of solids and biochemically-active dissolved substances, respectively. At the present state of technological development it is possible to achieve complete removal of pollutants from waste water streams. The economic impact of doing this must be assessed by computing cost benefits to specific plants, entire industries, and the overall economy. The application of best available technology will demand that the economic achievability be determined, increasingly, on the basis of considering water for its true economic impact. Unlike best practicable technology, which is readily applicable across the industry, the selection of best available technology economically achievable becomes uniquely specific in each process and each plant. Furthermore, the human factors associated with conscientious operation and meticulous attention to detail become increasingly important if best available technology is to achieve its potential for reducing the emission of pollutants from industrial plants.

## The Guidelines

### Achievable Effluent Concentrations

#### Suspended Solids

The removal of suspended solids from waste water effluent is based on well-understood technology developed in the chemical process industries and in water treatment practices. Application of filtration to the effluents from waste water treatment plants has not been applied often, although its feasibility has been demonstrated in projects sponsored by the Environmental Protection Agency. The operation of filtration systems, such as the in-depth media filter for waste waters, is not usually as straightforward as it is in water treatment. This is due, especially, to the biological activity still present in waste waters. Long residence time lagoons with their low flow through rates are often effective means for the removal of suspended solids although the vagaries of climatic conditions, which can cause resuspension of settled solids, and the occurrence of algal growth can cause wide fluctuations in the concentration of suspended solids in the effluent. Although technology is available for reducing suspended solids in effluents to very low levels (approaching a few mg/liter); the capital and operating cost for this technology adds significantly to waste water treatment costs. The concentration basis for BATEA is 10 mg/l for all product and process subcategories. (1) (22) (47)

#### Oxygen-Demanding Substances

Removal of biochemical-oxygen-demanding substances to concentration levels less than the range proposed for municipal sewage treatment plants will require the utilization of physical-chemical processes. It is expected, however, that the chemical-oxygen-demanding substances will present a far greater removal problem than BOD, because the biochemically-treated waste water will have proportionally much higher ratios of COD to BOD than entered the waste water treatment plant. To reduce the COD in a treated effluent, it will be necessary either to alter processes so that nonbiodegradable fractions are minimized or attempt to remove these substances by some method of waste water treatment. Both of these approaches may be difficult. Alteration of processes so that they produce less refractory wastes may not be possible within the constraints of the required chemical reactions. However, reduction in the quantities of wastes generated by spills, leaks, and poor housekeeping practices can contribute significantly to reducing the total COD discharges, especially where a large fraction of the pollutants are refractory to biological degradation. Consequently, one of the first steps in a program to reduce emissions should be a thorough evaluation of the process operation alternatives and techniques for preventing pollutants from entering the waste water streams.

In other methods for removal of oxygen demanding substance, adsorption by surface-active materials, especially activated

carbon, has gained preeminence. Although the effectiveness of activated carbon adsorption has been well demonstrated for removing BOD and COD from the effluents of conventional municipal sewage treatment plants, its effectiveness for the removal of the complex chemical species found in the waste water of this industry can be expected to be highly specific. Evidence of the low adsorption efficiency of activated carbon for a number of different chemical species is beginning to appear in the technical literature. However, the only way to determine if activated carbon adsorption is an effective method for removing COD is to make direct determinations in the laboratory and in pilot plants. In some instances, activated carbon adsorption may be used to remove substances selectively (for example, phenols) prior to treatment by other methods. Although activated carbon adsorption is proving to be a powerful tool for the removal of many chemical oxygen-demanding and carbonaceous substances from waste water streams, it is not a panacea. Its use must be evaluated in terms of the high capital and operating costs, especially for charcoal replacement and energy, and the benefits accrued.

Removal of carbonaceous and oxygen-demanding substances can sometimes be achieved through oxidation by chlorine, ozone, permanganates, hypochlorites, etc. However, not only must the cost benefits of these be assessed but certain ancillary effects, such as (1) the production of chlorinated by-products which may be more toxic than the substance being treated, (2) the addition of inorganic salts and (3) the toxic effects of the oxidants themselves must be taken into account. Consequently, when chemical oxidation is employed for removal of COD, it may be necessary to follow the treatment with another step to remove the residuals of these chemicals prior to discharge to receiving waters.

Degradation of oxygen-demanding substances may take place slowly in lagoons if sufficiently long residence time can be provided. If space is available, this may be an economic choice. Also, the use of land irrigation, or the "living filter" approach to water purification, is receiving selected attention. Ultra-filtration and reverse osmosis, both of which are membrane techniques, have been shown to be technically capable of removing high molecular species, but they have not been shown to be operationally and economically achievable. With these techniques the molecular distribution of the chemical species determines the efficiency of the separation. They probably have limited potential in the plastics and synthetics industry, due to the particular spectrum of molecular weights occurring in the waste waters.

The concentration basis for BATEA for COD is 130 mg/l as demonstrated in an activated carbon-pilot plant (77) or the concentrations which are attainable by biological treatment in the exemplary plants as expressed in Table 18, Section VII, and for BOD<sub>5</sub> is 15 mg/l for major subcategory I and II product subcategories and 25 mg/l for major subcategory III and IV product subcategories.

The removal of phenolic compounds is based on the application of dephenolizing units, or activated carbon followed by biochemical degradation. The concentration basis for phenolic compounds is 0.1 mg/l for the Acrylic product subcategory.

The removal of total chromium is based on an attainable concentration level of 0.25 mg/liter as demonstrated by various chemical precipitation techniques followed by biological degradation (47).

The removal of zinc from the rayon subcategory wastes is based on an achievable concentration of 1.0 mg/l as demonstrated by the EPA demonstration project (65).

Waste Load Reduction Basis

The waste load basis for BATEA is based on overall loading reduction through the use of the best achievable concentrations and the reduction of waste water flows from BPCTCA to a level between the BPCTCA waste water flows and the identified BADT waste water flows as described in Section XI. Increased efficiency in the utilization of water combined with closer operational control on preventing pollutants from entering waste water streams have the greatest promise for reducing the amounts of pollutants discharged from waste water treatment plants. While the reduction of water usage may directly reduce the total emission of certain pollutants, it may mean that advanced waste water treatment systems become more economically feasible.

Variability

The variability factors for BATEA guidelines are based on the variability determined by data from BPCTCA. Both the monthly and daily variabilities are based on two standard deviations. As technology and plant operations improve, it is expected that these variabilities will become more stringent. The BOD<sub>5</sub>, COD and TSS variabilities are presented in Table 40B. The TSS factors are based on data obtained from multi-media filters used in the petroleum refining industry. The other parameters are based on the achievable concentration for monthly maximum and a variability factor of 2 to determine the daily maximum.

TABLE 40B

Variability Factors BATEA

	BOD <sub>5</sub> and COD		TSS	
	Monthly	Daily	Monthly	Daily
Major Subcategory I	1.6	2.4	1.7	2.0
Major Subcategory II	1.8	2.8	1.7	2.0
Major Subcategory III	2.2	3.0	1.7	2.0
Major Subcategory IV	2.2	3.0	1.7	2.0

Based on the factors discussed in this section, the Effluent Limitation Guidelines for Best Available Technology Economically Achievable, BATEA, are presented in tables 43 and 44.

## SECTION XI

### NEW SOURCE PERFORMANCE STANDARDS BEST AVAILABLE DEMONSTRATED TECHNOLOGY

#### Definition of New Source Performance Standards Best Available Demonstrated Technology (NSPS-BADT)

Based on the analysis of the information presented in sections IV-VIII, the basis for NSPS-BADT is defined below.

Best available demonstrated technology (BADT) for new source performance standards (NSPS) are based on BPCTCA and the maximum possible reduction of process waste water generation and the application of media filtration and chemical treatment for additional suspended solids and other element removal and additional biological treatment for further BOD<sub>5</sub> removal as needed.

#### The Standards

##### Achievable Effluent Concentrations

The concentration basis for NSPS-BADT is the same as for BATEA for all parameters except COD. They are discussed in section X. The COD concentration basis for NSPS - BADT is based on the concentrations which were attainable in exemplary plants as expressed in Table 18, Section VII. The acrylics COD concentration for a plant designed for 25 ppm average BOD<sub>5</sub> was estimated from plant data at 480 mg/l. To determine limitations, the variability factors determined from BPCTCA (Table 40, Section IX) are applied to the COD concentration basis. By the application of these factors the COD limitations are liberal, do not determine the technology required, but in effect require that COD wastes be treated along with the BOD<sub>5</sub> wastes.

##### Waste Load Reduction Basis

The waste water flow basis for NSPS - BADT is based on the lowest identified as to primary source flows associated with each product. The waste water basis ranges from 0 to 50 percent of the BPCTCA basis and is product specific. These waste water flows are summarized in Table 40C.

It is apparent that effluent limitation standards requiring significant reductions over that attainable by best practicable control technology currently available (BPCTCA) requires considerable attention to both the process generation of waterborne pollutants as well as the water use practices of the plant.

##### Variability

The variability factors for BADT standards are based on the variability factors determined for BPCTCA for BOD<sub>5</sub> and COD. The



TABLE NO. 40 C

Product Subcategory	Lowest Demonstrated Waste Water Flows	
	<u>gal/1000 lb production</u>	<u>ccm/kgg</u>
Polyvinyl chloride suspension	950	7.92
emulsion	650	5.42
bulk	300	2.50
Polyvinyl Acetate	900	7.51
Polystyrene suspension	1100	9.17
bulk	200	1.67
Polypropylene	1100	9.17
Polyethylene Low Density	900	7.51
High Density Solvent	1500	12.51
High Density Polyform	260	2.17
Cellophene	16,000	133.44
Rayon	9000	75.06
ABS/SAN	1900	15.85
Polyester resin	950	7.92
Fiber	950	7.92
resin and fiber continuous	550	4.59
resin and fiber batch	1900	15.85
Nylon 66 resin	800	6.67
Fiber	700	5.84
Resin and Fiber	1500	12.51
Nylon 6 resin	3300	27.52
Fiber	1700	14.18
Resin and Fiber	5000	41.70
Cellulose Acetate resin	2500	20.85
Fiber	2500	20.85
Resin and Fiber	5000	41.70
Acrylics	1900	15.85

TSS variability factors are 1.7 monthly and 2.5 daily as demonstrated by multi-media filtration data obtained from the petroleum industry. The other parameters are based on the achievable concentration for monthly maximum and a variability factor of 2 to determine the daily maximum.

Based on the factors discussed in this section, the New Source Performance Standards for Best Available Demonstrated Technology NSPS-BADT are presented in tables 45 and 46.

TABLE NO. 41

BEST PRACTICABLE CONTROL TECHNOLOGY CURRENTLY AVAILABLE  
EFFLUENT LIMITATIONS GUIDELINES

Subcategory	kg/kg (1b/1000 lb of production)				
	BOD <sub>5</sub>		COD		SS
	Maximum Average of daily values for any period of thirty consecutive days	Maximum for any one day	Maximum Average of daily values for any period of thirty consecutive days	Maximum for any one day	Maximum Average of daily values for any period of thirty consecutive days
Polyvinyl chloride					
Suspension	0.36	.70	3.6	7.0	0.99
Emulsion	0.13	.26	1.3	2.6	0.36
Bulk	0.06	.12	0.60	1.2	0.16
Polyvinyl Acetate	0.20	.39	2.0	3.9	0.55
Polystyrene					
Suspension	0.22	.43	2.2	4.30	0.61
Bulk	0.04	.08	0.40	.80	0.11
Polypropylene	0.42	.81	2.1	4.10	1.16
Polyethylene					
Low Density	0.20	.39	2.0	3.9	0.55
High Density Solvent	0.30	.58	3.0	5.8	0.83
High Density Polyform	0.052	.10	0.52	1.0	0.14
Cellophane	8.7	17.8	87	178	16
Rayon	4.8	10	72	150	8.8
ABS/SAN	0.63	1.30	6.3	13.0	1.16
Polyester					
Resin	0.78	1.4	11.7	21.5	0.52
Fiber	0.78	1.4	11.7	21.5	0.52
Resin and Fiber Continuous	0.78	1.4	11.7	21.5	0.52
Resin and Fiber Batch	1.56	2.8	23.4	43.00	1.04
Nylon 66					
Resin	0.66	1.20	3.3	6.0	0.44
Fiber	0.58	1.1	3.0	5.3	0.39
Resin and Fiber	1.24	2.3	6.2	11.3	0.83
Nylon 6					
Resin	3.71	6.8	37.1	68.1	2.48
Fiber	1.90	3.5	19	35.1	1.27
Resin and Fiber	5.61	10.3	56.1	103.1	3.75
Cellulose Acetate					
Resin	4.13	7.5	41.3	75.1	2.75
Fiber	4.13	7.5	41.3	75.1	2.75
Resin and Fiber	8.26	15.0	82.6	150.1	5.5
Acrylics	2.75	5.00	13.8	25.0	1.1

TABLE NO. 42

BEST PRACTICABLE CONTROL TECHNOLOGY CURRENTLY AVAILABLE  
EFFLUENT LIMITATIONS GUIDELINES

Product	Parameter	kg/kg (lb/1000 lb of production)	Maximum Average of daily values for any period of thirty consecutive days	Maximum for any one day
Polystyrene suspension High Density Polyethylene Solvent ABS/SAN Rayon Acrylics	Total Chromium	0.0023	0.0046	0.0062
	Total Chromium	0.0031	0.0062	0.0088
	Total Chromium	0.0044	0.0088	0.91
	Zinc	0.534	0.91	0.017
	Phenolic Compds	0.0083	0.017	

TABLE NO. 43

BEST AVAILABLE TECHNOLOGY ECONOMICALLY ACHIEVABLE  
EFFLUENT LIMITATION GUIDELINES

kg/kg (1b/1000 lb of production)

Subcategory	BOD <sub>5</sub>		COD		SS
	Maximum Average of daily values for any period of thirty consecutive days	Maximum for any one day	Maximum Average of daily values for any period of thirty consecutive days	Maximum for any one day	
Polyvinyl chloride					
Suspension	0.28	0.41	1.28	1.92	0.23
Emulsion	0.13	0.20	0.61	0.92	0.11
Bulk	0.06	0.09	0.28	0.42	0.05
Polyvinyl Acetate	0.19	0.29	0.89	1.33	0.16
Polystyrene					
Suspension	0.22	0.33	1.03	1.55	0.18
Bulk	0.040	0.06	0.19	0.29	0.033
Polypropylene	0.32	0.48	2.14	3.21	0.27
Polyethylene					
Low Density	0.19	0.29	1.65	2.48	0.16
High Density Solvent	0.30	0.45	1.60	2.40	0.25
High Density Polyform	0.052	0.078	0.28	0.42	0.043
Cellophane	5.1	7.9	43.9	68.3	3.75
Rayon	2.8	4.4	24.4	37.9	2.08
ABS/SAN	.45	.70	3.3	5.1	0.33
Polyester					
Resin	.44	.59	2.3	3.1	0.16
Fiber	.44	.59	2.3	3.1	0.16
Resin and Fiber Continuous	.34	.47	1.8	2.4	0.13
Resin and Fiber Batch	.87	1.20	4.5	6.2	0.27
Nylon 66					
Resin	.37	.5	1.9	2.6	0.13
Fiber	.32	.44	1.7	2.3	0.12
Resin and Fiber	.69	.94	3.6	4.9	0.25
Nylon 6					
Resin	1.8	2.45	9.3	12.7	0.65
Fiber	.92	1.25	4.8	6.5	0.33
Resin and Fiber	2.7	3.7	14.1	19.2	0.98
Cellulose Acetate					
Resin	1.7	2.35	8.9	12.2	0.63
Fiber	1.7	2.35	8.9	12.2	0.63
Resin and Fiber	3.4	4.7	17.8	24.4	1.26
Acrylics	.89	1.2	4.7	6.3	0.33

TABLE NO. 14

BEST AVAILABLE TECHNOLOGY ECONOMICALLY ACHIEVABLE  
EFFLUENT LIMITATIONS GUIDELINES

kg/kgg (lb/1000 lb of production)

Product	Parameter	Maximum Average of daily values for any period of thirty consecutive days	Maximum for any one day
Polystyrene suspension High Density Polyethylene Solvent ABS/SAN Rayon Acrylics	Total Chromium	0.0023	0.0046
	Total Chromium	0.0031	0.0062
	Total Chromium	0.0042	0.0084
	Zinc	0.105	0.210
	Phenolic Compds	0.0016	0.0032

TABLE NO. 45

BEST AVAILABLE DEMONSTRATED TECHNOLOGY FOR  
NEW SOURCE PERFORMANCE STANDARDS

kg/kkg (lb/1000 lb of production)

Subcategory	BOD <sub>5</sub>		COD		SS	
	Maximum Average of daily values for any period of thirty consecutive days	Maximum for any one day	Maximum Average of daily values for any period of thirty consecutive days	Maximum for any one day	Maximum Average of daily values for any period of thirty consecutive days	Maximum for any one day
Polyvinyl chloride						
Suspension	0.19	0.37	0.89	1.70	0.13	.19
Emulsion	0.13	0.26	0.61	1.20	0.092	.14
Bulk	0.06	0.12	0.28	.54	0.042	.06
Polyvinyl Acetate	0.18	0.35	0.84	1.60	0.13	.19
Polyethylene						
Suspension	0.22	0.43	1.03	2.00	0.16	.24
Bulk	0.04	0.08	0.19	0.37	0.028	.04
Polypropylene	0.22	0.43	1.47	2.9	0.16	.24
Polyethylene						
Low Density	0.18	0.35	1.80	3.47	0.13	.19
High Density Solvent	0.30	0.58	1.60	3.10	0.21	.31
High Density Polyform	0.054	0.10	0.28	.54	0.036	.05
Cellophane	3.6	7.41	48	98	2.27	3.3
Rayon	2.02	4.17	47	97	1.28	1.92
ABS/SAN	.43	.88	3.1	6.5	0.27	.40
Polyester						
Resin	.44	.79	4.0	7.3	0.13	.19
Fiber	.44	.79	4.0	7.3	0.13	.19
Resin and Fiber Continuous	.25	.46	2.32	4.2	0.078	.12
Resin and Fiber Batch	.87	1.58	8.0	14.6	0.27	0.40
Nylon 66						
Resin	.37	.67	2.6	4.8	0.11	.16
Fiber	.32	.58	2.3	4.2	0.10	.15
Resin and Fiber	.69	1.25	4.95	9.0	0.21	.31
Nylon 6						
Resin	1.51	2.75	15.7	28.6	0.47	.69
Fiber	.78	1.42	8.1	14.7	0.24	.35
Resin and Fiber	2.29	4.17	23.9	43.4	0.71	1.1
Cellulose Acetate						
Resin	1.15	2.08	11	20	0.35	.51
Fiber	1.15	2.08	11	20	0.35	.51
Resin and Fiber	2.29	4.17	22	40	0.71	1.1
Acrylics	.87	1.58	16.7	30.4	0.27	0.40

TABLE NO. 46

BEST AVAILABLE DEMONSTRATED TECHNOLOGY FOR  
NEW SOURCE PERFORMANCE STANDARDS

Product	Parameter	kg/kg (1b/1000 lb of production)	Maximum Average of daily values for any period of thirty consecutive days	Maximum for any one day
Polystyrene suspension High Density Polyethylene Solvent ABS/SAN Rayon Acrylics	Total Chromium		0.0023	0.0046
	Total Chromium		0.0031	0.0062
	Total Chromium		0.0040	0.0080
	Zinc		0.075	0.150
	Phenolic Compds		0.0016	0.0032



## SECTION XII

### ACKNOWLEDGEMENTS

The preparation of the initial draft report was accomplished through a contract with Arthur D. Little, Inc. and the efforts of their staff under the direction of Henry Haley with James I. Stevens, Terry Rothermel and C. M. Mohr as the Principal Investigators. Industry subcategory leaders were Harry Lambe, W. V. Keary, Stanley Dale, Robert Eller, and Richard Tschirch. J. E. Oberholtzer was the sampling and analytical leader,

David L. Becker, Project Officer, Effluent Guidelines Division, through his assistance, leadership, advice, and reviews has made an invaluable contribution to the preparation of this report. Mr. Becker provided a careful review of the draft report and the original Development Document and suggested organizational, technical and editorial changes.

Allen Cywin, Director, Effluent Guidelines Division, Ernst Hall, Assistant Director, Effluent Guidelines Division and Walter J. Hunt, Chief Effluent Guidelines Development Branch, offered many helpful suggestions during the program.

The members of the working group/steering committee who coordinated the internal EPA review are:

Walter J. Hunt - Effluent Guidelines Division (Chairman)  
Allen Cywin - Effluent Guidelines Division  
David Becker - Effluent Guidelines Division (Project Officer)  
Taylor Miller - Office of General Counsel  
John Savage - Office of Planning and Evaluation  
Robert Wooten - Region IV  
Walter Lee - Region II  
Frank Mayhue - Office of Research and Monitoring (Ada)  
Wayne Smith - National Field Investigation Center (Denver)  
Lawrence Roslinski - Office of Categorical Programs  
Paul Des Rosiers - Office of Research and Monitoring

Acknowledgment and appreciation is also given to the secretarial staffs of both the Effluent Guidelines Division and Arthur D. Little, Inc. for the administrative coordination, typing of drafts, necessary revisions, and final preparation of the effluent guidelines document. The following individuals are acknowledged for their contributions. Kit Krickenberger, Sharon Ashe, Kay Starr, and Nancy Zrubek - Effluent Guidelines Division. Anne Witkos, Mary Jane Demarco, Martha Hanaman and Violet Gaumont - Arthur D. Little, Inc.

Appreciation is extended to staff members from EPA's Regions I, II, III, IV, V, and VI offices for their assistance and cooperation.

Appreciation is extended to the following State organizations for assistance and cooperation given to this program.

Alabama-Water Improvement Commission  
Illinois Division of Water Pollution Control  
Illinois Environmental Protection Agency  
Louisiana-Stream Control Commission  
New Jersey-Water Resources Division  
State Department Environmental Protection  
North Carolina-Office of Water and Air Resources  
Ohio Environmental Protection Agency  
South Carolina Pollution Control Authority

Appreciation is extended to the following trade associations and corporations for assistance and cooperation given to this program.

American Enka  
Borden Company  
Celanese Fibers Company  
Dart Industries  
Dow Chemical Company  
E.I. du Pont de Nemours and Company  
Exxon Chemicals  
Fiber Industries  
FMC Corporation  
B. F. Goodrich Chemical Company  
The Goodyear Tire & Rubber Company  
Hercules Incorporated  
Manufacturing Chemists Association  
Marbon Division Borg-Warner Chemicals and Plastics Group  
Monsanto  
Northern Petrochemical Company  
Reichhold Chemicals, Inc.  
Rohm & Haas  
Sinclair-Koppers  
Tenneco Chemicals  
Tennessee Eastman Company  
Union Carbide Corporation

## SECTION XIII

### REFERENCES

1. "Advanced Wastewater Treatment as Practiced at South Tahoe," EPA Water Pollution Control Research Series Report No. 17010 ELP, Washington, D.C. (August 1971).
2. "Aerobic Digestion of Organic Waste Sludge," EPA Water Pollution Control Research Series Report No. 17070 (December 1972).
3. Albright, Lyle F., "Vinyl Chloride Polymerization by Emulsion, Bulk and Solution Processes," Chemical Engineering, Modern Chemical Technology, Part 16 (July 3, 1967).cc
4. "An Act to Amend the Federal Water Pollution Control Act," Public Law 92-500, Ninety-Second Congress, S. 2770 (October 18, 1972).
5. Arthur D. Little, Inc., "Technical Proposal: Effluent Limitation Guidelines for the Plastics and Synthetics Industry to the Environmental Protection Agency," Cambridge, Massachusetts (November 16, 1972).
6. Aston, R.S., "Recovery of Zinc from Viscose Rayon Effluent," Presented at Purdue Industrial Waste Conference (May 1968).
7. Baloga, J.M., F.B. Hutto, Jr., and E.I. Merrill, "A Solution to the Phenolic Pollution Problem in Fiberglass Plants: A Progress Report," Chemical Engineering Progress Symposium Series, No. 97, Water - 1969 65, 124 (1969).
8. Barson, Norman and James W. Gilpin, "Industrial Waste Study of the Plastic Materials and Synthetics Industry," Draft report prepared by Celanese Research Company for the Water Quality Office, Environmental Protection Agency, Contract No. 68-01-0030 (undated).
9. Bibliography of Water Quality Research Reports, Environmental Protection Agency, Office of Research and Monitoring, Washington, D.C. (June 1972).
10. Black, H.H., "Planning Industrial Waste Treatment," J. Water Pollution Control Federation 41, 1277-1284 (1969).
11. Burd, R.S., "A Study of Sludge Handling and Disposal," Federal Water Pollution Control Administration Publication WP 20-4, Washington, D.C. (1968).
12. "Can Plants Meet EPA's New Effluent Guidelines?", Chemical Week, pp. 59-60 (November 22, 1972).

13. Chemical Engineering Flowsheets, Prepared by the editors of Chemical and Metallurgical Engineering, McGraw-Hill, New York (1940).
14. "Chemical Bugs Tame Process Wastes," Env. Sci. Technol. 4 637-638 (1970).
15. Clarke, James S., "New Rules Prevent Tank Failures," Hydrocarbon Processing 50(5), 92-94 (1971).
16. "Construction Scoreboard," Engineering News-Record 190(3), 32 (1973).
17. Contract for Development of Data and Recommendations for Industrial Effluent Limitation Guidelines and Standards of Performance for the Plastics and Synthetics Industry," No. 68-01-1500, Issued to Arthur D. Little, Inc., Cambridge, Massachusetts (December 1972).
18. Conway, R.A., et al., "Conclusions from Analyzing Report 'Treatability of Wastewater from Organic Chemical and Plastics Manufacturing - Experience and Concepts'," Unpublished document (January 1973).
19. Conway, R.A., J.C. Hovious, D.C. Macauley, R.E. Riemer, A.H. Cheely, K.S. Price, C.T. Lawson, "Treatability of Wastewater from Organic Chemical and Plastics Manufacturing - Experience and Concepts," Prepared by Union Carbide Corporation, South Charleston, W. Virginia (February 1973).
20. Cost and Performance Estimates for Tertiary Wastewater Treatment Purposes, Report No. TWRC-9, PB 189953, Robert A. Taft Water Research Center, Environmental Protection Agency, Cincinnati, Ohio (June 1969).
21. Crocker, Burton B., "Preventing Hazardous Pollution During Plant Catastrophes," (4, 1970). 22. Culp, Gordon L. and Robert W. Culp, Advanced Wastewater Treatment, Van Nostrand Reinhold Company, New York, N.Y. (1971).
23. Davis, Ernest M., "BOD vs. COD vs. TOC vs. TOD," Water and Wastes Engineering, pp. 32-38 (February 1971).
24. Devey, D.G. and N. Harkness, "Some Effluents from the Manufacture and Use of Synthetic Resins and Other Polymers," Effl. Water Treat. J. 11, 320-321 and 323-334 (1971).
25. Eisenhauer, H.R., "The Organization of Phenolic Wastes," J. Water Pollution Control Federation 40, 1887-1899 (1968).
26. "Environmental Protection Agency 40 CFR Part 1331 Secondary Treatment Information, Notice of Proposed Rulemaking," Federal Register 38(82), 10642-10643 (April 30, 1973).

27. Environmental Protection Agency, Toxic and Hazardous Chemicals Designations, Report in progress.
28. Faith, W.L., Donald B. Keys, and Ronald L. Clark, Industrial Chemicals, Third Ed., John Wiley and Sons, Inc., New York, N.Y. (1965).
29. Federal Water Pollution Control Act Amendments of 1972, House of Representatives, Report No. 92-1465, U.S. Government Printing Office, Washington, D.C. (September 28, 1972).
30. Ford, D.L., "Application of Total Carbon Analyzer for Industrial Wastewater Evaluation," Proc. of Twenty-Third Industrial Waste Conf., Part Two, Purdue University, Lafayette, Indiana, pp. 989-99 (May 1968).
31. Ford, D.L., "The Applicability of Carbon Adsorption in the Treatment of Petrochemical Wastewaters," Presented at Conference on Application of New Concepts of Physical-Chemical Wastewater Treatment (September 1972).
32. Ford, Davis L., "Total Organic Carbon as a Wastewater Parameter," Public Works, pp. 89-92 (April 1968).
33. Golding, Brage, Polymers and Resins: Their Chemistry Chemical Engineering, Van Nostrand Reinhold Company, New York,
34. Gonzales, John G. and Russell L. Culp, "New Developments in Ammonia Stripping," Public Works, pp. 78-84 (May 1973).
35. Hackert, R.L., "Spray Irrigation Disposal of Industrial Wastes," Presented at Fourteenth Annual A.S.M.E. Plant Engineering and Maintenance Conf., Milwaukee, Wisconsin (October 1971).
36. Industrial and Engineering Chemistry, Modern Chemical Processes, Reinhold Publishing Corp., New York, N.Y. (1950).
37. Jones, Robert H., "TOC: How Valid Is It?", Water and Wastes Engineering, pp. 32-33 (April 1972).
38. Kwie, William W., "Ozone Treats Wastestreams from Polymer Plant," Water and Sewage Works 116, 74 (1969).
39. Lamb, A. and E.L. Tollefson, "Toxic Effects of Cupric, Chromate and Chromic Ions on Biological Oxidation," Water Research 7, 599-613 (1973).
40. Lash, L.D. and G.L. Shell, "Treating Polymer Wastes," Chemical Engineering Progress 65(6), 63-69 (1969).
41. Lawson, Cyron T. and John A. Fisher, "Limitations of Activated Carbon Adsorption for Upgrading Petrochemical

Effluents." Presented at the Sixty-Fifth Annual Meeting of the A.I.Ch.E., New York, N.Y. (November 1972).

42. Lundgren, Hans., "Air Flotation Purifies Wastewater from Latex, Polymer Manufacture," Chemical Engineering Progress Symposium Series, No. 97, Water - 1969 65, 191 (1969).
43. Matthews, George, et. al., Vinyl and Allied Polymers, Chemical Rubber Co. Press, Cleveland, Ohio, pp. 13-40 (1972).
44. McDermott, G.N., "Industrial Spill Control and Pollution Incident Prevention," J. Water Pollution Control Federation 43(8), 1629 (1971).
45. "National Pollutant Discharge Elimination System, Proposed Forms and Guidelines for Acquisition of Information from Owners and Operators of Point Sources," Federal Register 37(234), 25898
46. Naughton, P., "Bug Husbandry is the Secret of Waste Disposal Plant Success," Process Engineering, pp. 67068 (March 1971).
47. Patterson, J. W. and R. A. Minear, Wastewater Treatment Technology, Second Edition, pp. 216-162, State of Illinois Institute of Environmental Quality (January 1973).
48. "Dipper-Type Sampler for Collecting Samples of Sewage, Industrial Waste or other Liquids," Prepared by Phipps and Bird, Inc., Providence, Rhode Island.
49. Poon, C. P. C., "Biodegradability and Treatability of Combined Nylon and Municipal Wastes," J. Water Pollution Control Federation 42, 100-105 (1970).
50. "Pretreatment Guidelines for the Discharge of Industrial Wastes to Municipal Treatment Works," Draft report prepared by Roy F. Weston, Inc., for the Environmental Protection Agency, Contract No. 68-01-0346 (November 17, 1972).
51. "Procedures, Actions, and Rationale for Establishing Effluent Levels and Compiling Effluent Limitation Guidance for the Plastic Materials and Synthetics Industries," Unpublished report of the Environmental Protection Agency and the Manufacturing Chemists Association, Washington, D.C. (November 1972).
52. Process Industries Pictured Flowsheets, Prepared by the editors of Chemical and Metallurgical Engineering, McGraw-Hill, New York, N.Y. (1945).
53. Robinson, Donald M. and Dennis R. Bolten, "From Problem to Solution with ABS Polymer Wastewater," Presented at 17th Ontario Industrial Waste Conference, Niagara Falls, Ontario (June 7-10, 1970).

54. Santoleri, J. J. "Chlorinated Hydrocarbon Waste Disposal and Recovery Systems," Chemical Engineering Progress 69, 68 (1973).
55. Shreve, R. Norris, Chemical Process Industries, Third Ed., McGraw-Hill, New York, N.Y. (1967).
56. Shumaker, T. P., "Granular Carbon Process Removes 99.0-99.2% Phenols," Chemical Processing (May 1973).
57. Sittig, Marshall, Organic Chemical Process Encyclopedia, Second Ed., Noyes Development Corporation, Park Ridge, N.J. (1969).
58. Smith, W. Mayo, Ed., Manufacture of Plastics, Vol. 1, Reinhold Publishing Corp., Park Ridge, N.J. (1964).
59. Steinmetz, C. E. and William J. Day, "Treatment of Waste from Polyester Manufacturing Operations," Chemical Engineering Progress Symposium Series, No. 97, Water - 1969 65, 188 (1969).
60. Stevens, J. I., "The Roles of Spillage, Leakage and Venting in Industrial Pollution Control," Presented at Second Annual Environmental Engineering and Science Conference, University of Louisville (April 21, 1972).
61. Stevens, J. I. and W. V., Keary, "Industrial Utilization of Techniques for Prevention and Control of Spills," Presented at American Institute of Chemical Engineers Workshop, Charleston, West Virginia (October 1971).
62. "Waste-Water Treatment Costs for Organics 1969-1973," Envir. Sci. Technol. 3, 311-313 (1969).
63. "Water Pollution Abatement Costs, Plastic Materials and Synthetic Rubber Industries (SIC 282)," Unpublished report provided by the Environmental Protection Agency.
64. Woodruff, P. H., W. J. Moore, W. D. Sitman, G. A. Omohundro, "Viscose Waste-Profile of a Successful Pollution Control Program." Water Sewage Works 115, 44-450 (1968).
65. "Zinc Precipitation and Recovery from Viscose Rayon Wastewaters," EPA Water Pollution Control Research Series, Report 12090 ESG (January 1971).
66. Bess, F.C., J.C. Hovious, R.A. Conway and B.H. Cheely, "Proposed Method for Establishing Effluent Guidelines for the Organic and Plastics Manufacturing Industry," Letter and Attachment to Dr. Martha Sager, Chairman, Effluent Standards and Water Quality Information Advisory Committee, June 12, 1973.

67. Swindell-Dressler Company, "Process Design Manual for Carbon Adsorption," Environmental Protection Agency, Contract 14-12-928, October 1971.
68. Weber, W. J., "Physicochemical Processes for Water Quality Control," Wiley Interscience, New York 1972.
69. Burns & Roe, Inc., "Process Design Manual for Suspended Solid Removal," Environmental Protection Agency, Contract 14-12-930, October 1971.
70. Black & Veatch, "Process Design Manual for Phosphorous Removal," Environmental Protection Agency, Contract 14-12-936, October 1971.
71. Seiden, L. and K. Patel, "Mathematical Model of Tertiary Treatment by Lime Addition," Robert A. Taft Water Research Center, Report No. TWRC-14, September 1969.
72. Barker, J. E., and R. J. Thompson, "Biological Removal of Carbon and Nitrogen Compounds from Coke Plant Wastes," EPA-R2-73-167, April 1973.
73. Eliasson, R. and G. Tchobanglous, "Removal of Nitrogen and Phosphorous Compounds from Wastewaters," Environmental Science and Technology, 3, No. 6, p. 536-541, June 1969.
74. Gould, R. F., Editor, "Anaerobic Biological Treatment Processes," American Chemical Society, Advances in Chemistry Series No. 105, February 1970.
75. Supplement B - Detailed Record of Data Base for the "Development Document for proposed Effluent Limitations Guidelines and New Source Performance Standards for the Steelmaking Segment of the Iron and Steel Manufacturing Point Source Category," EPA 440/1-73/024, February 1974.
76. Supplement B - Detailed Record of Data Base for the "Development Document for Effluent Limitations Guidelines and New Source Performance Standards for the Synthetic Resins Segment of the Plastics and Synthetics Manufacturing Point Source Category," March 1974.
77. "Reuse of Chemical Fiber Plant Wastewater and Cooling Water Blowdown," EPA Water Pollution Control Research Series Report 12090EUX (October 1970).
78. Hager, D.G., "A Survey of Industrial Wastewater Treatment by Granular Activated Carbon," Presented at the 4th Joint Chemical Engineering Conference, American Institute of Chemical Engineers, Canadian Society for Chemical Engineering, Vancouver, British Columbia, September 10, 1973.



## SECTION XIV

### GLOSSARY

#### Acetyl

Refers to that portion of a molecular structure which is derived from acetic acid.

#### Aerobic

A living or active biological system in the presence of free, dissolved oxygen.

#### Alkyl

A general term for monovalent aliphatic hydrocarbons.

#### Alumina

The oxide of aluminum.

#### Anaerobic

Living or active in the absence of free oxygen.

#### Aryl

A general term denoting the presence of unsaturated ring structures in the molecular structure of hydrocarbons.

#### Autoclave

An enclosed vessel where various conditions of temperature and pressure can be controlled.

#### Bacteriostate

An agent which inhibits the growth of bacteria.

#### Blowdown

Removal of a portion of a circulating stream to prevent buildup of dissolved solids, e.g., boiler and cooling tower blowdown.

#### BOD5

Biochemical Oxygen Demand - 5 days as determined by procedures in Standard Methods, 19th Edition, Water Pollution Control Federation, or EPA's Manual 16020-07/71, Methods for Chemical Analysis of Water and Wastes.

#### Catalyst

A substance which initiates primary polymerization or increases the rate of cure or crosslinking when added in quantities which are minor as compared with the amount of primary reactants.

#### Caustic Soda

A name for sodium hydroxide.

#### Cellulose Xanthate

An intermediate in the production of rayon by the viscose process, formed by reaction of carbon disulfide with alkali cellulose. The solution of this material in dilute aqueous caustic is termed "viscose."

#### Chain Terminator

An agent which, when added to the components of a polymerization reaction, will stop the growth of a polymer chain, thereby preventing the addition of MER units.

#### COD

Chemical Oxygen Demand - Determined by methods explained in the references given under BOD5.

#### Copolymer

The polymer obtained when two or more monomers are involved in the polymerization reaction.

#### Delusterant

A compound (usually an inorganic mineral) added to reduce gloss or surface reflectivity of plastic resins or fibers.

#### Dialysis

The separation of substances in solution by means of their unequal diffusion through semipermeable membranes.

#### Diatomaceous Earth

A naturally-occurring material containing the skeletal structures of diatoms - often used as an aid to filtration.

#### Double-Effect Evaporators

Two evaporators in series where the vapors from one are used to boil liquid in the other.

#### Effluent

The flow of wastewaters from a plant or wastewater treatment plant.

Emulsifier

An agent which promotes formation and stabilization of an emulsion, usually a surface-active agent.

Emulsion

A suspension of fine droplets of one liquid in another.

Facultative Lagoon or Pond

A combination of aerobic surface and anaerobic bottom existing in a basin holding biologically-active wastewaters.

Fatty Acids

An organic acid obtained by the hydrolysis (saponification) of natural fats and oils, e.g., stearic and palmitic acids. These acids are monobasic and may or may not contain some double bonds. They usually contain sixteen or more carbon atoms.

Filtration

The removal of particulates from liquids by membranes on in-depth media.

Formalin

A solution of formaldehyde in water.

GPD

Gallons per day.

GPM

Gallons per minute.

Halogen

The chemical group containing chlorine, fluorine, bromine, iodine.

Humectant

An agent which absorbs water. It is often added to resin formulations in order to increase water absorption and thereby minimize problems associated with electrostatic charge.

Influent

The flow of wastewaters into a treatment plant.

M

Thousands (e.g., thousands metric tons).

#### MM

Millions (e.g., million pounds).

#### Monomer

A relatively simple compound which can react to form a polymer.

#### pH

A measure of the relative acidity or alkalinity of water on a scale of 0-14. A pH of 7 indicates a neutral condition, less than 7 an acid condition, greater than 7 an alkaline condition.

#### Phenol

Class of cyclic organic derivatives with the basic chemical formula  $C_6H_5OH$ .

#### Polymer

A high molecular weight organic compound, natural or synthetic, whose structure can be represented by a repeated small unit (MER)  $n$ .

#### Polymerization

A chemical reaction in which the molecules of a monomer are linked together to form large molecules whose molecular weight is a multiple of that of the original substance. When two or more monomers are involved, the process is called copolymerization.

#### Pretreatment

Treatment of wastewaters prior to discharge to a publicly-owned wastewater treatment plant.

#### Primary Treatment

First stage in sequential treatment of wastewaters - essentially limited to removal of readily-settlable solids.

#### Reflux

Condensation of a vapor and return of the liquid to the zone from which it was removed.

#### Resin

Any of a class of solid or semi-solid organic products of natural or synthetic origin, generally of high molecular weight with no definite melting point. Most resins are polymers.

Scrubber

Equipment for removing condensable vapors and particulates from gas streams by contacting with water or other liquid.

Secondary Treatment

Removal of biologically-active soluble substances by the growth of micro-organisms.

Slurry

Solid particles dispersed in a liquid medium.

Spinnerette

A type of extrusion die consisting of a metal plate with many small holes through which a molten plastic resin is forced to make fibers and filaments.

Staple

Textile fibers of short length, usually one-half to three inches.

TDS

Total dissolved solids - soluble substances as determined by procedures given in reference under BOD5.

TOC

Total Organic Carbon - a method for determining the organic carbon content of wastewaters.

Tow

A large number of continuous filaments of long length. Tow is the usual form of fibers after spinning and stretching and prior to being chopped into short lengths of staple.

Vacuum

A condition where the pressure is less than atmospheric.

TABLE 47  
METRIC UNITS  
CONVERSION TABLE

MULTIPLY (ENGLISH UNITS)		by	TO OBTAIN (METRIC UNITS)	
ENGLISH UNIT	ABBREVIATION	CONVERSION	ABBREVIATION	METRIC UNIT
acre	ac	0.405	ha	hectares
acre - feet	ac ft	1233.5	cu m	cubic meters
British Thermal Unit	BTU	0.252	kg cal	kilogram-calories
British Thermal Unit/pound	BTU/lb	0.555	kg cal/kg	kilogram calories/ kilogram
cubic feet/minute	cfm	0.028	cu m/min	cubic meters/minute
cubic feet/second	cfs	1.7	cu m/min	cubic meters/minute
cubic feet	cu ft	0.028	cu m	cubic meters
cubic feet	cu ft	28.32	l	liters
cubic inches	cu in	16.39	cu cm	cubic centimeters
degree Fahrenheit	°F	0.555(°F-32)*	°C	degree Centigrade
feet	ft	0.3048	m	meters
gallon	gal	3.785	l	liters
gallon/minute	gpm	0.0631	l/sec	liters/second
horsepower	hp	0.7457	kw	kilowatts
inches	in	2.54	cm	centimeters
inches of mercury	in Hg	0.03342	atm	atmospheres
pounds	lb	0.454	kg	kilograms
million gallons/day	mgd	3,785	cu m/day	cubic meters/day
mile	mi	1.609	km	kilometer
pound/square inch (gauge)	psig	(0.06805 psig +1)	*atm	atmospheres (absolute)
square feet	sq ft	0.0929	sq m	square meters
square inches	sq in	6.452	sq cm	square centimeters
tons (short)	ton	0.907	kkg	metric tons (1000 kilograms)
yard	yd	0.9144	m	meters

Actual conversion, not a multiplier