

**NASA Contractor Report 158969**

**ASSESSMENT OF STATE-OF-THE-ART  
OF IN-SERVICE INSPECTION METHODS  
FOR GRAPHITE EPOXY COMPOSITE  
STRUCTURES ON COMMERCIAL  
TRANSPORT AIRCRAFT**

**M. L. Phelps**

**Boeing Commercial Airplane Company  
Seattle, Washington**

**Contract NAS 1-15304  
January 1979**

**NASA**  
National Aeronautics and  
Space Administration

**DTIC QUALITY INSPECTED 1**

**19960229 115**

**POSTED  
33119**

# CONTENTS

	<u>Page</u>
1.0 SUMMARY . . . . .	1
2.0 INTRODUCTION . . . . .	2
3.0 SPECIFIC OBJECTIVES . . . . .	3
4.0 ASSESSMENT OF IN-SERVICE INSPECTION METHODS AND CAPABILITIES . .	4
4.1 Procedures . . . . .	4
4.1.1 Literature Survey . . . . .	4
4.1.2 Questionnaire Survey . . . . .	5
4.1.3 On-Site Survey . . . . .	5
4.1.4 Telephone Contacts . . . . .	5
4.2 Results . . . . .	6
4.2.1 Airlines . . . . .	6
4.2.1.1 Aircraft Structures and Service Defects . .	6
4.2.1.2 Inspection Methods and Usage Rating . . . .	7
4.2.1.3 Inspection Method Preference and Desirable Characteristics . . . . .	7
4.2.1.4 Advanced Composites Inspection . . . . .	8
4.2.1.5 Future Needs and General Comments . . . . .	9
4.2.2 Manufacturers . . . . .	10
4.2.2.1 Structures and Service-Generated Defects . .	10
4.2.2.2 Inspection Methods . . . . .	11
4.2.2.3 Manufacturers' Comments on In-Service Inspection of Advanced Composites . . . . .	11
4.2.3 Military . . . . .	12
4.2.3.1 Structures and Inspection Methods-- General . . . . .	12
4.2.3.2 Advanced Composite Structures and Service Defects . . . . .	12
4.2.3.3 Inspection Methods--Advanced Composites . .	15
4.2.4 Advanced Composites Inspection Technology Development . . . . .	16

CONTENTS - (Continued)

	<u>Page</u>
5.0 DISCUSSION AND CONCLUSIONS . . . . .	18

APPENDICES

## 1.0 SUMMARY

A survey was conducted to determine current in-service inspection practices for all types of aircraft structure and specifically for advanced composite structures. The survey consisted of written questionnaires to commercial airlines, visits to airlines, aircraft manufacturers, and government agencies, and a literature search.

Existing inspection methods and equipment for in-service inspection of aircraft structures are documented in this report. A reference in-service inspection baseline and preliminary in-service inspection program for advanced composite structures on commercial transport aircraft have been documented and are appendices to this report.

With the data obtained in Phase I, a Phase II plan has been prepared for development and improvement of in-service inspection methods for graphite-epoxy composite aircraft structures and presented to NASA-LRC for approval.

## 2.0 INTRODUCTION

The DOD and NASA are expending considerable effort in research and development for the application of advanced composite structures in aircraft. Numerous advanced composite structures are in flight service on both military and commercial aircraft, and others are in various stages of development. However, in order for this advanced composites technology to be applied to production of commercial aircraft, the airlines must be ready to accept the new technology in their operations. Important considerations in this acceptance are the economics and safety in maintaining the new technology aircraft. To a large extent, this will depend on the background information available on fabrication, maintenance, and inspection methods and costs for advanced composite structures.

NASA is involved in an extensive advanced composite systems program to develop the technology necessary for production application in commercial transport aircraft. The purpose of this program is to assure that adequate in-service inspection methods are available for commercial transport aircraft. Phase I establishes current methods and practices on today's aircraft and determines needs and guidelines for development of additional in-service inspection technology. Phase II develops and documents the needed technology within the program level of effort. The program focuses on in-service inspection methods for graphite-epoxy composite structures for commercial transport aircraft.

### 3.0 SPECIFIC OBJECTIVES

#### PHASE I

- o Conduct a survey to determine existing capability and requirements for in-service inspection of commercial airplanes. This includes a literature survey, a questionnaire to commercial airlines, and personal interviews with key airlines, manufacturers, and government representatives.
- o Document the current in-service inspection baseline and an in-service inspection program for graphite/epoxy composites.
- o Prepare a Phase I report and a Phase II plan.

#### PHASE II

- o Fabricate test specimens and acquire additional specimens as needed from other graphite/epoxy composite structures development programs.
- o Conduct NDT development to adapt existing methodology and define new methods for in-service inspection of graphite/epoxy structures.
- o Demonstrate applicability, improvements, and cost effectiveness of developed in-service inspection methods.
- o Present an oral review and prepare a final report for the program.

## 4.0 ASSESSMENT OF IN-SERVICE INSPECTION METHODS AND CAPABILITIES

### 4.1 PROCEDURES

Assessment procedures were literature survey, on-site visits with airline, manufacturer, and military personnel, and written responses, from the airlines, to our questionnaires. The purpose was to determine the following:

- o Current inspection methods and practices used on in-service airplanes
- o Established in-service inspection methods for advanced composites, specifically graphite/epoxy composites, validated by actual use on in-service airplanes
- o User (airlines) inspection method requirements and preferences to use as a guideline in Phase II work and developmental efforts beyond the scope of this program
- o Emerging technology that potentially could be adapted to the current inspection baseline and that would define future developmental programs

#### 4.1.1 LITERATURE SURVEY

Literature sources were defined through two searches ordered from the Boeing library specifically in support of this program--one conducted by the Library Service and one ordered from the Defense Documentation Center. Key words in these searches were nondestructive testing, advanced composites, composite materials, carbon fibers, reinforced plastics, thermoplastics, Kevlar, and in-service inspection. Also, an earlier library search on nondestructive test methods for graphite-epoxy composites was reviewed. These searches were supplemented by a review of the Boeing Quality Control Research Organization files and references identified or furnished by individuals at Boeing, contacts during the on-site visits, and by telephone contacts.

More than 200 references were surveyed, of which 106 were obtained, reviewed, and entered into an advanced composites and in-service inspection technology file in support of this program for the duration of Phase II. These are listed in the bibliography.

#### 4.1.2 QUESTIONNAIRE SURVEY

Questionnaires were delivered to the airlines by Boeing Customer Support Engineering on-site representatives and by mail. The intent of the questionnaire was to cover those airlines not visited during the on-site survey; however, some of the airlines visited also returned questionnaires. The questionnaire and on-site surveys were limited to domestic airlines operating jet transports purchased new from the manufacturer (as opposed to used airplanes purchased from the initial buyer). Several charter or cargo carriers were included. The questionnaire covered inspection methods in use, frequency of use, flaw types/conditions, structures, advanced composites experience, concerns with graphite-epoxy structures inspection, desirable and undesirable attributes of inspection methods, and future needs for inspection methods.

#### 4.1.3 ON-SITE SURVEY

Two trips were made--one in the western states and one in the east and midwest. The purpose was to obtain data, opinions, and references pertinent to the objectives listed in section 3.0 and to acquaint those contacted, especially airline personnel, with the program. Personal contact provided an exchange and discussion opportunity not available with questionnaires. The on-site survey consisted of visits to 14 airlines selected to achieve a mix of large and small operators, and some cargo and/or charter operators, while maintaining a geographic distribution consistent with travel limitations. Manufacturers visited included Douglas Aircraft Company, Long Beach, California; Lockheed-California Company, Burbank California; and Grumman Aerospace Company, Bethpage L.I., New York. Inspection and NDT personnel were visited at the following military sites: Kelly AFB; Air Force Materials Lab, Wright-Patterson AFB; and Naval Air Development Center, Warminster, Pennsylvania. Also, FAA Airframe Branch personnel in the Washington, D.C. office were visited and a brief discussion was held with the Chief-Airframe Section in the FAA Northwest Regional office.

#### 4.1.4 TELEPHONE CONTACTS

A considerable amount of additional information was obtained through numerous telephone conversations with individuals. This was particularly useful in obtaining details and latest status on military programs.



## 4.2 RESULTS

Data are reported relative to the source of the data--airlines, manufacturers, or military. The data are restricted to in-service inspection of aircraft structures and do not include manufacturers' fabrication inspection methods or nonstructural inspection methods. Appendices A and B to this report were compiled from the acquired data and they provide more detailed information on current in-service inspection practices.

### 4.2.1 AIRLINES

#### 4.2.1.1 Aircraft Structures and Service Defects

Outer surfaces and exposed structure of aircraft receive the most frequent and usually the most cursory inspections termed "walk-around visual." Any suspect areas are subjected to a closer inspection, including visual/optical, tapping, pushing, and others. Substructures hidden from view also may be inspected visually and visually/optically by removal of access doors, plates, or other easily removed items. Where access is possible only by extensive teardown, one of the nondestructive test methods is required. Primary structures are metal, predominantly aluminum, with a few high-strength steel components in high load applications. Structural members include skin, stringers, ribs, spars, frames, plates, beams, posts, attach fittings, and landing gear components. The most serious defects in primary structures are cracks. The intent of most in-service inspections, and the primary capability of most in-service NDT methods, is crack detection. Other defects in primary structures include corrosion, wear, fastener and hole deterioration, and externally caused damage such as fire, lightning strike, and impact damage.

Secondary structures may be of aluminum alloy skin/stringer construction, adhesive bonded aluminum laminates or honeycomb sandwich, and fiberglass skin/metal or nonmetal honeycomb core. Structural applications include leading and trailing edges; control members such as ailerons, elevators, spoilers, and flaps; and various doors. A few nonstructural items similar in construction to secondary structures that may require NDT include fiberglass radomes and engine inlet cowlings.

Defects include the usual visual defects plus disbonds, delaminations, core damage, entrapped water in honeycomb, fastener pull-through, and externally caused damage.

#### 4.2.1.2 Inspection Methods and Usage Rating

Inspection methods used by the airlines are as follows in order of greatest frequency of use: visual and visual/optical, eddy current, ultrasonic, radiographic, fluorescent penetrant, magnetic particle, dye check, tap test, bond testers. These ratings are based on usage indicated by questionnaire and interview. In the case of questionnaires, the interpretation of questions apparently differed somewhat from individual to individual. Some re-ordering of the data would result if it were based on interview (visits) information only. For example, radiographic testing would be placed ahead of ultrasonic testing. Also, these ratings are based on inspection of parts after removal from the airplane as well as those inspected on the airplane. At some facilities, a considerable amount of fluorescent penetrant inspection is done on removed and new parts prior to installation. Another consideration is that crack detection methods are used much more frequently than adhesive bond test methods due to the amount of structure on airplanes requiring periodic inspection for cracks.

#### 4.2.1.3 Inspection Method Preference and Desirable Characteristics

Airline inspection personnel were asked to rate inspection methods as to preference and identify the most desirable and least desirable features of an inspection method. The most desirable method, of those in general use, was visual/optical and least desirable was bond test methods. As expected, the visual/optical method was their first preference, being simple, straightforward, having no equipment problems and no interpretation difficulties usually associated with instrument methods. In descending order of preference, methods were visual/optical, eddy current, dye check, fluorescent penetrant, ultrasonic, tap test, radiographic, magnetic particle, and bond tester. The comments regarding the bond tester method indicated too much variability in sensitivity on various structures, inconclusive defect indications, and general lack of use in lieu of visual and

tap test. The eddy current method was the first choice of the instrument and NDT methods due to portability, ease of use, quick results, no surface preparation, and no couplant required.

The desirable features in an inspection method were as follows:

<u>Feature</u>	<u>Number of Times Listed</u>
Repeatable; conclusive, nonarbitrary results	11
Fast, easy to use	6
Portable, operated by one person	5
Positive readout	2
Applicable in the field	1
Minimum special training	1
Low equipment cost	1
Battery-operated equipment	1
Waterproofed equipment	1
Not temperature-sensitive	1
No couplant medium required	1
Nonradioactive or nontoxic	1
Accessibility to part being inspected	1

The opposite to the above question was also asked, i.e., what feature would render an inspection method unusable? The responses were: limited application, high-cost equipment, not reliable or repeatable, not safe, no reference standards or well-defined procedures available, marginally effective method requiring too much inspection time, operating procedure too complex.

Several responses emphasized the need for conclusive results to avoid the questionable practice of verifying the presence of a defect with a second method that usually is less reliable than the initial inspection.

#### 4.2.1.4 Advanced Composites Inspection

None of the airlines had sufficient experience on graphite-epoxy composites to provide comments. In fact, a large number of airline inspection personnel have not seen fiber/resin composites other than fiberglass, and their experience is limited to fiberglass structures such as control

surfaces, trailing edge panels, spoilers, fairings, and radomes. Generally, the procedure followed is to conduct a visual inspection with tap test to detect damaged areas. If there is suspicion of entrapped water, the part is radiographed. A moisture meter instrument was reported in use by two airlines for water-in-honeycomb detection. Bond test instruments are used very little and, due to the nature of these structures, visual detection of defects or damage is usually adequate.

Having no experience with graphite-epoxy, the airlines had few comments regarding anticipated inspection problems. Their concerns included inspection time required, access to structure for inspection purposes, attenuation of ultrasound, inspections requiring use of nonportable, complex inspection instruments, moisture and delamination defects, and lack of appropriate reference standards.

#### 4.2.1.5 Future Needs and General Comments

The airlines' opinions were requested regarding future needs for in-service inspection. All responses to this question are quoted as follows:

- o Need reasonable, positive method for corrosion detection.
- o Reference standards should be supplied by manufacturers.
- o Need detailed drawings, exploded views, illustrations, etc. to clearly define inspection areas and procedure.
- o Define type of defects of concern in graphite-epoxy and other advanced composites.
- o Identify paint strippers that can be used in preparation for certain inspections.
- o Need method to determine accurate defect size and depth for repair purposes.
- o Need further development of neutron radiography and portable, easy-to-operate holography equipment.
- o Need more portable and reliable instruments.
- o Design for better access to structure for inspection and repair.
- o Need to eliminate downtime for X-ray.
- o Expand low-frequency eddy current applications.
- o Improve bond test instruments.
- o Would prefer throw-away batteries for battery-operated instruments.

- o Need audible and light defect indications on instruments.
- o Provide samples of graphite-epoxy for NDT familiarization.
- o Develop improved water detection method.
- o Develop fast, remote scan capability.
- o Develop improved thermal NDT method.
- o When visual inspection is impaired due to complex access, the manufacturer should provide alternate NDT procedures.
- o Evaluate acoustic emission for various applications.
- o Design aircraft with easy access to all critical areas or include sufficient openings for good visual/optical inspection.
- o Design and develop in-service NDT during aircraft manufacture so that it is available when needed.

#### 4.2.2 MANUFACTURERS

The discussions with manufacturers concerned their advanced composite structures programs and in-service inspection methods. Their comments were solicited as to inspection needs or concerns relative to in-service advanced composite hardware.

##### 4.2.2.1 Structures and Service-Generated Defects

The manufacturers of commercial jet transports have installed a limited number of advanced composite structures on commercial jet transports. These include Boeing 707 boron-epoxy foreflaps, Lockheed L-1011 Kevlar-epoxy fillet and fairing panels, Boeing 737 graphite-epoxy spoilers and graphite-polysulfone spoilers, Lockheed L-1011 graphite-epoxy floor posts, Douglas DC-10 boron-aluminum aft pylon skin panels, Douglas DC-9 graphite-epoxy engine nose cowl outer barrel, and Douglas DC-10 graphite-epoxy upper aft rudders.

Service experience on all components has been very good except for a problem with the 737 polysulfone spoiler apparently due to Skydro1 contamination. Defects, most of which were of minor consequence, include delaminations attributed to corrosion of an aluminum spar, fastener hole fraying and elongation, fastener pull-through, impact damage and resultant cracks, and other visible defects such as scratches and blisters.

#### 4.2.2.2 Inspection Methods

Except for the airlines' routine walk-around visual and close-up examination of suspicious areas, the manufacturers' personnel have performed nearly all the inspections of the advanced composite structures installed on in-service airplanes. Inspections have been predominantly visual with the usual tapping, pushing, prying, etc. associated with close visual inspections. Other methods that have been used are Fokker bond tester, ultrasonic pulse-echo, and ultrasonic digital thickness gage. The Douglas Aircraft Company has a written procedure for their DC-10 aft rudder inspection that specifies these methods and describes required reference standards for delamination and disbond detection.

As these evaluation programs often involve periodic removal of selected parts for in-depth evaluation, inspection methods typically used on newly fabricated parts are also used on these in-service parts. Methods include ultrasonic through-transmission "C" scan, ultrasonic pulse-echo scanning, bond tester inspections, and radiography. Weight determinations on removed parts have been used to determine moisture pickup, but have been found unreliable due to repainting, resealing, and other rework-caused weight variations.

#### 4.2.2.3 Manufacturer's Comments on In-Service Inspection of Advanced Composites

Manufacturer personnel made several observations or voiced some concern regarding the following items:

Fire Damage. As there has been little study of minor fire damage such as slight scorching of painted surfaces and other damage short of charred surfaces, there is no definite acceptance level or no proven inspection method for fire damage.

Nonvisible Impact Damage. It is impractical to perform 100% surface NDT on the suspicion of impact damage not visually evident. Consequently, a point was made that manufacturers would have to demonstrate damage tolerance in primary structure until such time that the damage could be detected visually. Also, one manufacturer indicated some interest in investigating paints that would show a visible indication of moderate impact occurrence.

Access to Critical Areas. Improved inspection and lower costs can be achieved by identifying the most critical areas in a structure and designing to facilitate the latest optically-aided visual inspection.

Fabrication Defects. Since some parts containing acceptable fabrication defects will be installed on aircraft, some consideration must be given as to how to avoid identifying these as-fabricated defects during in-service inspections.

General Surface Deterioration/Water Absorption. These conditions are currently undergoing evaluation within environmental exposure and laboratory investigative programs. Should the data indicate a need to detect severity of deterioration or water absorption, an NDT method will be required.

#### 4.2.3 MILITARY

##### 4.2.3.1 Structures and Inspection Methods--General

In-service inspection methods and the type of structures inspected on military airplanes do not differ noticeably from commercial airplanes. The structures are basically identical, with the military somewhat more advanced in use of new materials/structures such as advanced composites on production airplanes. Inspection methods include visual, visual/optical, tap testing, and the five major NDT methods: radiography, ultrasonics, eddy current, magnetic particle, and fluorescent penetrant. Some specialized methods are in limited use, such as the acoustic emission/thermal method of detecting corrosion in aluminum honeycomb. This method detects noise generated in corroded areas when heated locally with a hot-air blower. Other bonded and composite structures are inspected with bond testers, ultrasonics, and radiography.

##### 4.2.3.2 Advanced Composite Structures and Service Defects

The most experience to date with advanced composite structures on in-service airplanes has been acquired by the Air Force and Navy. Table 1 is a summary of these structures, materials and construction, inspection methods used, and the defects that the inspection methods would detect. The defects listed do not necessarily indicate that the structures shown were found to have these defects.

TABLE 1. IN-SERVICE INSPECTION OF ADVANCED COMPOSITE STRUCTURES ON MILITARY AIRPLANES

Airplane	Structure	Test (T) or Production (P) Part	Materials	Inspections Performed with Part Installed	Inspections Performed with Part Removed	Defects to be Detected
F-4	Access doors (with other test structure attached)	T	-Gr/Ep (graphite/epoxy) laminate door -Gr/Ep and Al honeycomb (test structure) -Gr/Ep laminate bonded and fastened to Al plate (test structure)	-Visual	-Visual examination -Tests for moisture pickup -NDT evaluation	-Visible damage -Corrosion -Moisture degradation
F-4	Rudder	T	-Boron/Ep bonded to Al honeycomb	-Visual	-Detailed evaluation of failed part at Air Force Materials Laboratory (see text paragraph 3.3.3)	(See text paragraph 3.3.3)
A-7	Outer wing panel	T	-Boron/Ep and Gr/Ep hybrid skins bonded to Al honeycomb -Hybrid skin/honeycomb panels bonded to Gr/Ep ribs and stringers	-Visual with borescope inspection through access holes in spar -Ultrasonic pulse-echo of skin-to-spar closeout bonds		-Impact damage -Disbonds -Corrosion
T-37 A-37	Landing gear side brace	T	-Laminated Gr/Ep	-Visual -Radiography		-Damage or suspicious areas
F-14	Horizontal stabilizer	P	-Gr/Ep and Boron/Ep hybrid skins bonded to Al honeycomb	-Visual and tap test		-Impact damage -Ground equipment damage
F-14	Overwing fairing	T	-Gr/Ep and Glass/Ep skins bonded to Al honeycomb -Gr/Ep and Glass/Ep laminate outboard beam	-Probable (not determined) (1) Visual and tap test (2) NDT will be designated for defect areas (3) Suspicious visual or tap indications may warrant ultrasonic inspection	-Periodic return to lab for evaluation including visual and NDT	-Delaminations -Disbonds -Entrapped water in honeycomb
F-14	Main landing gear door	T	-Gr/Ep and Glass/Ep skins bonded to Al honeycomb	(Being determined)		



TABLE 1. (CONCLUDED)

Airplane	Structure	Test (T) or Production (P) Part	Materials	Inspections Performed with Part Installed	Inspections Performed with Part Removed	Defects to be Detected
F-15	Stabilator torque box	P	-Boron/Ep skins bonded to Al honeycomb core and stepped T1 fittings (torque box closeout bonds)	-Visual -Ultrasonic pulse-echo -Ultrasonic through-transmission -Radiography -Harmonic bond tester		-Visible damage -Skin-to-honeycomb disbonds -Delaminations -Entrapped water -Foam-to-core separation
F-15	Speed brake	P	-Gr/Ep laminate bonded to Al honeycomb	-Visual		-Visible damage
F-16	Vertical stabilizer	P	-Gr/Ep skins bonded to Al ribs	-Visual		-Impact damage
	Horizontal stabilizer	P	-Gr/Ep skins bonded to Al honeycomb	-Ultrasonic high-resolution pulse-echo of suspect areas -Radiography and other NDT as necessary		-Delaminations -Disbonds -Entrapped water
	Rudder	P				
F-111	Doublor on wing pivot fitting plate	P	-Boron/Ep skin bonded to steel plate	-Visual -Ultrasonic pulse-echo		-Skin delaminations and disbond between doublor and plate
BQM-34E (Unmanned airplane)	Wing	P	-Gr/Ep skins bonded to Al honeycomb core	-Visual	-Visual -NDT methods	-Any detectable damage
S-3A	Spoiler	T	-Gr/Ep skins bonded to fiberglass core	-Visual -Ultrasonic through-transmission	-Two damaged parts inspected with ultrasonic through-transmission and neutron radiography	-Delaminations -Disbonds -Impact damage
C-130	Center wing box reinforcement	T	-Boron/Ep bonded to Al wing surface panel and stringer	-Visual -Ultrasonic pulse-echo		-Delaminations -Disbonds

Since table 1 lists only those components that have been in service, several upcoming significant applications of advanced composite structures on military airplanes have been omitted. The most prominent of these are the AV8-B with an all graphite-epoxy wing and the F-18 with extensive use of graphite-epoxy composites in the wing, empennage, and other structure. There will be considerable interest in the in-service inspection methods later designated for these structures, particularly the all-composite wing.

#### 4.2.3.3 Inspection Methods--Advanced Composites

The most frequently used inspection is visual and visual with tap testing. Optical aids are also employed as, for example, on the A-7 wing panel that has access holes in the spar for visual/borescope inspection. Several ultrasonic techniques are used for disbond and delamination detection. These techniques, as described in appendix B to this report, include straight and angle beam pulse-echo, through-transmission with both hand-held and yoke-held transducers, and bond testers. Radiography has been used on several components to detect water entrapped in honeycomb and, in one instance, specified for detecting honeycomb core separation from foam adhesive and metal substructure.

Several NDT methods were evaluated on a damaged F-4 rudder by G. Hardy at AFML. Although not all of these methods are current "in-service methods," the results are of interest. The areas of the rudder evaluated consisted of thin boron-epoxy skins bonded to aluminum honeycomb and to a titanium doubler and a fiber glass spar to hinge fitting bond. The results were:

- o Radiography--Detected entrapped water, corrosion, core node , disbond, and crushed core.
- o Ultrasonic--Sondicator detected skin-to-doubler disbonds.
- o Eddy Current--Good method for confirming aluminum core corrosion.
- o Thermal--Photochromic paints and liquid crystals detected core corrosion. Liquid crystals superior to photochromic paints in both ease of use and performance.

#### 4.2.4 ADVANCED COMPOSITES INSPECTION TECHNOLOGY DEVELOPMENT

This section briefly describes pertinent technology development and trends as identified from the survey. Applicability for in-service inspection is not judged nor indicated by inclusion in this summary.

Radiography. Low-kv (10-50 kv) radiography has proven valuable on light aluminum adhesive bonded structure. This method has also shown good results on graphite/epoxy structures. Radio-opaque penetrants such as tetrobromoethane and diiodobutane have been successfully used on graphite/epoxy composites to aid in seeing cracks, damaged holes, and impact damage by radiography.

Ultrasonic Methods. Various means of measuring ultrasound velocity or attenuation have been developed and these measurements related to void content or mechanical properties. An ultrasonic pulse-echo method using "focused shock-wave and RF display" has been defined and shows promise for more precise flaw depth location of disbonds and delaminations in multi-laminate structure.

Eddy Current. Although application on graphite/epoxy composites (which are slightly conductive) has not been adequately determined, indications are that the eddy current method may be feasible for cracks and surface damage detection. One researcher determined that high frequencies (50-100 MHz) are necessary for better defect resolution.

Thermal Methods. Three sources reported good results with encapsulated liquid crystals. Capability to detect corroded aluminum honeycomb core beneath a fiber/composite skin and nonvisually evident impact damage in a graphite/epoxy laminated panel has been demonstrated. No tests were conducted on skins or panels exceeding 0.041 inch in thickness.

Localized heating in areas of early fatigue damage has been observed. A temperature-sensitive paint or strips of material in key locations on in-service structure were suggested as a possible monitoring method.

Acoustic Emission. It has been established that stressing of fiber composites results in noise generation that indicates the degree of internal damage to fibers and matrix material. Suggested applications include analysis of failure mechanisms in laboratory studies of advanced composites and possible use with proof testing to determine residual strength. A more promising application, described in paragraph 4.2.3.1, uses thermal stressing of localized areas on aluminum honeycomb structures with increased acoustic emission activity indicating corroded honeycomb.

Hardness Test. Hardness test results have been shown to have a definite relationship to moisture content in moisture absorption tests on graphite composite specimens. A portable method may have potential for inspecting other conditions such as impact damage.

Scanning Systems. As part of an effort to improve inspection reliability, there is a trend to develop electromechanical field scanners for in-service inspection of structures primarily by ultrasonic methods. The objective is to develop small, portable, easily used systems with "C" scan recording capability. One small prototype scanner is vacuum attached to skin surfaces and the search unit is moved by hand through a mechanically controlled scan motion. A 1:1 scale plan view recording is made simultaneously. Another approach is a remote position-sensing monitor to read and record search unit position while it is moved manually over the inspection "window." Rotating fastener hole scanners are also in use or under development. Microprocessing and minicomputer technology is being incorporated for scanner control, data storage, and presentation.

## 5.0 DISCUSSION AND CONCLUSIONS

Indications are that commercial jet transports manufactured in the near future will have secondary, and eventually primary, structure made of one or more of the new advanced composites. The leading candidate material is graphite/epoxy with a huge structures development and validation effort under way in industry funded by NASA, plus additional company-funded efforts such as the work at Boeing on graphite/epoxy structures for new airplanes. Other materials such as Kevlar and glass/epoxy are candidates for use in combination with graphite/epoxy for some applications. Although this is a major development activity, there is essentially no experience with these new materials in the airlines. Consequently, inspection personnel have no knowledge of in-service inspection requirements, methods applicability, or application data.

From the survey data, the airlines criteria for in-service inspection methods include: low cost, ease of use, rapid, and direct, nonarbitrary readout. Methods requiring complex equipment, involved procedures, and high inspection costs are not desirable and will not be used unless absolutely necessary. Radiography probably defines the limit in inspection cost and time required for current airline inspection practices. To consider technology such as acoustic emission, holography, or ultrasonic attenuation and velocity measurements, there must be a concept that assures that the method would be practical and within reason regarding cost.

Another conclusion that can be drawn from the survey findings is that current inspection technology is adaptable to graphite/epoxy composites inspection. Inspections used on service evaluation hardware and military production components are doing a satisfactory job--at least, no urgent, serious deficiencies were identified. While the airlines listed numerous apparent exceptions in paragraph 4.2.1.5, current in-service inspection technology is doing an acceptable job. Most comments in paragraph 4.2.1.5 identified desired improvements in existing technology, rather than development of new technology.

Based on the foregoing discussion and conclusions, the Phase II effort should be devoted to the detailed work required to define specific inspection method applications, develop application guideline data, and document the data in a reference handbook for airline use. Generally, it should include all applicable inspection and NDT methods and define structural defects, and details of inspection techniques required. Because it is one of the most efficient and easy-to-use methods, the eddy current method should be investigated thoroughly to determine applicability on graphite/epoxy structures. Other items such as radio-opaque penetrants, low-kv radiography, and hardness testing should be investigated.

It is recommended that the following items be considered for future investigation:

- o Heat damage and detection methods and criteria
- o Encapsulated liquid crystals
- o Acoustic emission techniques
- o Impact-sensitive paints
- o Water absorption measurement

Improved scanning methods are desirable, but there is sufficient activity in this area that an additional funded effort is not recommended at this time.

Finally, as identified by the airlines, there is a need for improved access for inspection of critical areas. While this problem can only be addressed in the design function, it should be a coordinated effort between design and quality control/NDT engineers.

## BIBLIOGRAPHY

- Stoecklin, Robert L. The 737 Graphite Composite Flight Spoiler Flight Service Evaluation. Annual Report. Apr. 1976 - Apr. 1977, August 1977 33 p refs (NASA-CR-145207:AR-3).
- Stoecklin, Robert L. The 737 Graphite Composite Flight Spoiler Flight Service Evaluation. Annual Report, Apr. 1975 - Mar. 1976, May 1976 33 p refs (NASA-CR-144984:AR-2).
- Matley, W., Howser, P. and Brock, D. Acoustic-Emission Detection System. Non-Destructive Testing, October 1974, pp. 257-258.
- Aircraft "Health" Checkups via NDT. Materials Evaluation, March 1974, pp. 20A-22A.
- Martin, B. G. An Analysis of Radiographic Techniques for Measuring Resin Content in Graphite Fiber Reinforced Epoxy Resin Composites. Materials Evaluation, vol. 35, Sept. 1977, pp. 65-68, 75.
- Anderjaska, A. E. and Soderquist, J. R. Application of Composites on Civil Aircraft. Proceedings of the Ninth National Technical Conference, Atlanta, Ga., October 4-6, 1977. (A78-25176 09-23) Azusa, Calif., Society for the Advancement of Material and Process Engineering, 1977, pp. 297-304.
- Stoecklin, Robert L. Commercial Service Experience of a Graphite-Epoxy Flight Control Component. In: Materials and Processes - In service Performance; Proceedings of the Ninth National Technical Conference, Atlanta, Ga., October 4-6, 1977. (A78-25176 09-23) Azusa, Calif., Society for the Advancement of Material and Process Engineering, 1977, pp. 289-296.
- Composite Materials: Testing and Design; Proceedings of the Fourth Conference, Valley Forge, Pa. May 3, 4, 1976. Conference sponsored by the American Society for Testing and Materials, Philadelphia, Pa., American Society for Testing and Materials (ASTM Special Technical Publication, No. 617).
- Shelton, W. L. and Atkins, G. R. The Correlation of Nondestructive Test Techniques with the Fracture Behavior of ATJ-S Graphite. Technical Report, 30 Nov. 1968 - Dec. 1970, Aug. 1972, pp. 177, AFML-TR-72-38.
- Bar-Cohen, Y., Arnon, U. and Meron, M. Defect Detection and Characterization in Composite Sandwich Structure by Ultrasonics. (Israel Aircraft Industries, Ltd., Lod, Israel). SAMPE Journal, vol. 14, Jan.-Feb. 1978, pp. 4-8.

- Bailey, C.D., Freeman, S.M., and Hamilton, J.M. Detection and Evaluation of Impact Damage in Graphite/Epoxy Composites. In: Materials and Processes - In Service Performance; Proceedings of the Ninth National Technical Conference, Atlanta, Ga., October 4-6, 1977. (A78-25176 09-23) Azusa, Calif., Society for the Advancement of Material and Process Engineering, 1977, pp. 491-503.
- Stone, R.H. Flight Service Evaluation of Kevlar-49/Epoxy Composite Panels in Wide-Bodied Commercial Transport Aircraft. Mar. 1977, pp. 42, Report No. NASA-CR-145141, AR-3.
- Wooley, J.H., Paschal, D.R. and Crilly, E.R. Flight Service Evaluation of PRD-49/Epoxy Composite Panels in Wide-Bodied Commercial Transport Aircraft-Final Report. NASA CR-112250, Mar. 1973.
- Wooley, J.H. Flight Service Evaluation of PRD-49/Epoxy Composite Panels in Wide-Bodied Commercial Transport Aircraft - First Annual Flight Service Report. NASA CR-132647, July 1974.
- Shelton, W.L. NDI of Composite Materials. NATO-AGARD AG-201, Non-Destructive Inspection Practices, Oct. 1975, pp. 579-592, vol. II.
- Hagemaiier, D. J. NDT of DC-10 Graphite-Epoxy Rudder. Materials Evaluation, May 1978, pp. 57-61.
- Dingwall, P.F. and Mead, D.L. Nondestructive Inspection and Volume Fraction Determination of CFRP Using an Eddy Current Method. June, 1976, pp. 44, (RAE-TR-76078; BR53685) Avail: NTIS HC A03/MF A01.
- Smith, A.G. Nondestructive Testing in Industry Aviation. Nondestructive Testing, June, 1972, pp. 170-174.
- Hagemaiier, D.J., McFaul, H.J., and Moon, D. Nondestructive Testing of Graphite Fiber Composite Structures. Materials Evaluation 29, no. 6 (1971): 133.
- Dougherty, T.A., Epstein, G., and Allinikov, S. Nondestructive Testing of Lightweight Graphite-Epoxy Sandwich Panels. In: Technology in transition; Proceedings of the Twentieth National Symposium and Exhibition, San Diego, Calif., April 29 - May 1, 1975. (A75-40955 20-23) Azusa, Calif., Society for the Advancement of Material and Process Engineering, 1975, pp. 117-128.
- Hagemaiier, D.J., McFaul, H.J., and Parks, J.T. Nondestructive Testing Techniques for Fiberglass, Graphite Fiber, and Boron Fiber Composite Aircraft Structure. American Society for Nondestructive Testing, Spring Conference, Los Angeles, Calif., Mar. 9-12, 1970, Paper.



- Harvill, W.E. and Kizer, J.A. Program for Establishing Long-Time Flight Service Performance of Composite Materials in the Center Wing Structure of C-130 Aircraft: Phase IV - Ground/Flight Acceptance Tests. NASA CR 145043, Lockheed-Georgia Company, September 1976.
- Knight, R.C. and McGovern, S.A. S-3A Composite Spoiler In-service Evaluation. In: Materials and Processes - In service performance; Proceedings of the Ninth National Technical Conference, Atlanta, Ga., October 4-6, 1977. (A78-25176 09-23) Azusa, Calif., Society for the Advancement of Material and Process Engineering, 1977, pp. 470-477.
- Stone, R.H. and Harvill, W.E. Service Experience of Composite Parts on the L-1011 and C-130. SAMPE Quarterly, vol. 9, Jan. 1978, pp. 34-40.
- Stone, D.E.W. Some Problems in the Nondestructive Testing of Carbon-Fibre-Reinforced Plastics. Plastics Institute, International Conference on Carbon Fibres, their Place in Modern Technology, London, England, Feb. 18-20, 1974, Paper.
- Kuperman, M.H. and Wilson, R.G. Today's Non-Metallic Composite Airframe Structure - An Airline Assessment. (United Air Lines, Inc., San Francisco, Calif.) In: Materials and Processes - In service performance; Proceedings of the Ninth National Technical Conference, Atlanta, Ga., October 4-6, 1977. (A78-25176 09-23) Azusa, Calif., Society for the Advancement of Material and Process Engineering, 1977, pp. 255-275.
- Jones, B.R. and Stone, D.E.W. Towards an Ultrasonic-Attenuation Technique to Measure Void Content in Carbon-Fibre Composites. Non-Destructive Testing, April 1976, pp. 71-79.
- Stone, D.E.W. and Clarke, B. Ultrasonic Attenuation as a Measure of Void Content in Carbon-Fibre Reinforced Plastics. Non-Destructive Testing, June 1975, pp. 137-145.
- Reynolds, W.N. Ultrasonic Wave Velocities in Carbon-Fibre Reinforced Plastics. Non-Destructive Testing, April 1974, pp. 74-75.
- Sachse, Wolfgang and Pao, Yih-Hsing. Ultrasonic Nondestructive Testing of Composite Materials. Final Report, 1 Apr. 1976 - 31 Mar. 1977, AFOSR-77-1288TR.
- Vary, Alex and Bowles, K.J. Use of an Ultrasonic-Acoustic Technique for Nondestructive Evaluation of Fiber Composite Strength. 1978, pp. 12, Presented at the 33rd Ann. Conf. of the Soc. of the Plastics Ind., Washington, D.C., 7-10 Feb. 1978.

- Nevadunsky, J.J., Lucas, J.J., and Salkind, M.J. Early Fatigue Damage Detection in Composite Materials. Journal of Composite Materials, vol. 9, Oct. 1975, pp. 394-408.
- Thies, D.J., Sanders, L.R., and Neff, R.M. Effects of Fabrication Defects on Boron/Epoxy Composites. AIAA, ASME, and SAE, Structures, Structural Dynamics and Materials Conference, 15th, Las Vegas, Nev. Apr. 17-19, 1974.
- Pless, W.M. and Lewis, W.H. The Fabrication, Testing, and Delivery of Boron/Epoxy and Graphite/Epoxy Nondestructive Test Standards. Final Report, Dec. 1971, pp. 70, (Contract NAS8-27565).
- Jaffe, E.H. Nondestructive Inspection Practices Used in Production of Composite Airframe Structures. In AGARD, Nondestructive Testing and Inspection Applied to Composite Matls. and Structures, Feb. 1972, pp. 23-31.
- Schultz, Arnold W. Nondestructive Testing of Advanced Fiber-Reinforced Composites. SAMPE Quarterly, Jan. 1971, pp. 31-37.
- Roderick, G.L. and Whitcomb, J.D. X-Ray Method Shows Fibers Fail During Fatigue of Boron-Epoxy Laminates. Journal of Composite Materials, vol. 9, Oct. 1975, pp. 391-393.
- Lowney, J.R. and Goff, J.F. Fracture in Carbon-Epoxy Composites. Rept. No. 1 (Annual) 1 Oct. 1976-30 Sept. 1977, Rept. No. NSWC/WOL/TR-77-179.
- Dexter, P.F. and Shumaker, G.C. Development Tests and Flight Test of Graphite Composite Landing Gear Side Brace Assembly for A-37B Aircraft. Air Force Flight Dynamics Lab Wright-Patterson AFB, Ohio, Final Technical Rept. 15 May 1973-15 Mar. 1977, Rept. No. AFFDL-TR-77-56.
- Stalnaker, D.O. and Stinchcomb, W.W. An Investigation of Edge Damage Development in Quasi-Isotropic Graphite Epoxy Laminates. Interim Rept. No. VPI-E-77-24, Sept. 1977, Contract: F33615-75-C-5119.
- Scott, W.R. Ultrasonic Reflection Spectrum Analysis for NDT of Periodic Layered Media. Final Rept., Rept. No. NADC-77093-30, June 1977 38p.
- Adsit, N.R. and Waszczak, J. Investigation of Damage Tolerance of Graphite/Epoxy Structures and Related Design Implications. Final Rept., July 1975-Nov. 1976, Contract: N62269-75-C-0385.
- Ferris, R.L. Low Energy Impact Loading of Graphite-Epoxy Plates. Master's Thesis, Naval Postgraduate School, Monterey, CA, Dec. 1976.

- Schaum, R.T. Development of a Nondestructive Inspection Technique for Advanced Composite Materials Using Cholesteric Liquid Crystals. Master's Thesis, Nav Grad School, Monterey, CA. Sept. 76
- Francis, P.H., Walrath, D.E., and Weed, D.N. Strength Behavior of Graphite/Epoxy Composite Laminates Under Biaxial Load. Annual Rept. 15 Feb. 1975-15 Feb. 1976, Contract: F33615-75-C-5115.
- Reifsnider, K.L., Henneke, E.G., and Stinchcomb, W.W. Defect Property Relationships in Composite Materials. Annual Rept. 3 Feb. 1975-3 Jan. 1976, Apr. 1976, 52 p., Contract F33615-75-C-5119.
- Springer, G.S. and Shen, Chi-Hung. Moisture Absorption and Desorption of Composite Materials. Annual technical Rept. Mar. 1975-Mar. 1976, June 1976, 72p. AFML TR-76-102.
- Blosser, E.G., McGovern, S.A., and Dhonau, O.E. S-3A Graphite/Epoxy Spoiler Development Program, Volume II. Final Technical Report. July 1975, Rept. No. 2-53443/4R-3172-Vol-2.
- Nevadunsky, J.J., Matusovich, C.J., and Lucas, J.J. Static and Fatigue Damage Characterization in Composite Materials. Final Report. June 1974-July 1975, AFOSR TR-75-1535.
- Carlyle, J.M. Acoustic Emission in Fiber Reinforced Composites. Master's Thesis, May 1975, 107p, Report No. NADC-75082-30.
- Advanced Composites Design Guide. Volume III. Manufacturing. Report for March 1971-Jan. 1973, Contract: F33615-71-C-1362.
- Armour, W.H., Bird, J.O., and King, K.R. Holographic Inspection and Evaluation of Propulsion Materials. Final Report. 15 March 1971-15 June 1972, Contract F04611-71-C-0029.
- Fisher, F.A. and Fassell, W.M. Lightning Effects Relating to Aircraft. Part I. Lightning Effects on and Electromagnetic Shielding Properties of Boron and Graphite Reinforced Composite Materials. Final Report. 15 Nov. 1969-15 Oct. 71, Contract: F33615-70-C-1144.
- Stone, D.E.W. The Use of Radiography in the Nondestructive Testing of Composite Materials. Technical Report. Dec. 1971, 42p, Report No. RAE-TR-71235.
- Evangelides, J.S. and Meyer, R.A. Investigation of the Properties of Carbon-Carbon Composites and their Relationship to Nondestructive Test Measurements. Annual Report. 1 June 1969-1 June 1970, Report No. MDC-G1004, Contract: F33615-69-C-1640.

- Schultz, A.W. The Development of Nondestructive Methods for the Quantitative Evaluation of Advanced Reinforced Plastic Composites. Contract Report. 1 Aug. 1968-31 Oct. 1969, Report No. AVATD-0195-69-RR, Contract: F33615-67-C-1285.
- Lenoe, E.M. The Effect of Voids on the Mechanical Properties of High Modulus Graphite Fiber/Epoxy - Reinforced Composites. Contract Report March 1970, Report No. AVSD-0170-70-RR, Contract N00019-69-C-0208.
- Schultz, A.W. The Effect of Voids on the Mechanical Properties of High Modulus Graphite Fiber/Epoxy-Reinforced Composites. Contract Report 27 May 1968-26 Aug. 1969, Report No. AVATD-0153-69-RR, Contract: N00019-68-C-0461.
- Stinebring, R.C., Schultz, A.W., and Orner, J.W. Investigation of Nondestructive Methods for the Evaluation of Graphite Materials, Part 2. Technical Report, 15 Apr. 1967-15 May 1968, Report No. AVSSD-0236-68-RR, Contract: AF 33(615)-3942.
- Marchant, Monica J. Holographic Interferometry of CFRP Honeycomb Panels. Technical Report, Mar. 1974, 34p. Report No. RAE-TR-73192.
- Lehman, G.M. Development of a Graphite Horizontal Stabilizer. Interim Technical Report, No. 8, 28 Feb. 1974, Apr. 1974, 46p. Report No. MDC-J6507, Contract: N00156-70-C-1321.
- Fehrle, A.C., Gilbert, G.J., and Young, E.C. Development of an Understanding of the Fatigue Phenomena of Bonded and Bolted Joints in Advanced Filamentary Composite Materials. Volume II. Fabrication, Inspection and Testing. Final Technical Report, Aug. 1970-Apr. 1972, Report No. LGR-ER-11319-Vol-2, Contract: F33615-70-C-1302.
- Olster, Elliot F. Effect of Voids on Graphite Fiber Reinforced Composites. Final Report, 1 Apr. 1971-1 Jul. 1972, Contract: N00019-71-C-0305.
- Owston, C.N. and Jaffe, E.H. Non-Destructive Testing and Inspection Applied to Composite Materials and Structures. Feb. 72, 35p. Report No. AGARD-R-590.
- Lenoe, E.M. Effects of Voids on Mechanical Properties of Graphite Fiber Composites. Contract Report. Dec. 1970, Report No. AVSD-0166-71-RR, Contract: N0019-70-C-0242.
- Hamstad, M.A. Nondestructive Testing. Lawrence Livermore Laboratory, University of California, 1978, SME Tech. Bulletin EM 78-400.
- Martin, B.G. Some Techniques for the Nondestructive Evaluation of Graphite-Fiber-Reinforced Composites. Douglas Aircraft Co., 1978, SME Technical Bulletin EM 78-402.

- Schneider, Hendricks, and Olson. Vulnerability/Survivability of Composite Structures - Lightning Strike (Program Results). Boeing Commercial Airplane Company, AFFDL-TR-77-127.
- Freund, N.P. Advanced Composite Missile and Space Design Detail. Perkin-Elmer Corp., Mar. 1974, AD-919-165L.
- Van Averbeke, M. Eddy Current NDI in Airplane Maintenance. NATO-AGARD-AG-201, Nondestructive Inspection Practices, Oct. 1975, Chapter 3.2, p 181, Vol. I.
- Van Averbeke, M. Gammagraphy in Airplane Maintenance. NATO-AGARD-AF-201, Nondestructive Inspection Practices, Oct. 1975, Chapter 3.5, p 295, Vol. I.
- Walter, K.G. Ultrasonic and Acoustic Methods. NATO-AGARD-AG-201, Nondestructive Inspection Practices, Oct. 1975, Chapter 3.6, p 333, Vol. I.
- Treca, M. NDI of Bonded Structures. NATO-AGARD-AG-201, Nondestructive Inspection Practices, Oct. 1975, Chapter 4.3, p 531, Vol. II.
- Shelton, W.L. NDI of Composite Materials. NATO-AGARD-AG-201, Nondestructive Inspection Practices, Oct. 1975, Chapter 4.4, p 581, Vol. II.
- Vary, Alex. Ultrasonic Strength Evaluation of Fiber-Reinforced Composites. NASA Tech Brief LEW-12769, November 1977.
- Raatz, C. Development of NDT Methods for Detection and Growth of Fatigue Damage in GR/EP Composite Structure. Boeing Commercial Airplane Company, Renton, WA. Quality Control Research and Development Report No. 121-726-1.
- Platt, R.J. and Thurston, L.B. Holographic and Ultrasonic Detection of Bond Flaws in Aluminum Panels Reinforced with Boron Epoxy. NASA Technical Note, TND-7632, Jul. 1974.
- Bowen, R. Quality Control Evaluation of Composite Wing Feasibility Hardware. Boeing Commercial Airplane Company, Quality Control Research and Development Report No. 562-904.
- Woodmansee, W. NDT of Titanium/Graphite Test Panel. Boeing Commercial Airplane Company Coordination Sheet B-6620-5620, Sept. 20, 1976.

- Hagemaiyer, D.J. Nondestructive Testing of Adhesive Bonded Structure. Douglas Paper 6652, 1977 Nondestructive Testing Forum, Air Transport Association, Hartford, Conn.
- Brecht, J., Schwalbe, H., and Eisenblaetter, J. Acoustic Emission as an Aid for Investigating the Deformation and Fracture of Composite Materials. Composites, 1976, pp 245-248.
- Manno, A. Navy In-Service Evaluation Program. AIAA Paper 77-467, 1977.
- Waggoner, G., Erbacher, H. Damage Tolerance Program for the B-1 Composite Stabilizer. AIAA Paper 77-464, 1977.
- Weinberger, R. and Somaroff, A., NASC, and Riley, B. U.S. Navy Certification of Composite Wings for the F-18 and Advanced Harrier Aircraft, AIAA Paper 77-466, 1977.
- Clark, H.T. Definition and Non-Destructive Detection of Critical Adhesive Bond-Line Flaws. McDonnell Aircraft Co. Report MDC A4127, Apr. 1976, Third Interim Report, USAF Contract F33615-75-C-5209.
- Moore, J.A. Status of Acoustic Emission NDT at Vought. Vought Corporation, Report No. 2-42211/7NDT-04, July 1977.
- Horak, C. and Hencken, A. Demonstration of Acoustic Emission System for Damage Monitoring of Full Scale Metallic Aircraft Structures During Fatigue Testing. Grumann Aerospace, Sept. 77. USAF Report AFFDL-TR-77-87.
- Desper, O.E. Advanced Composite Stabilizer for Boeing 737 Aircraft. Boeing Commercial Airplane Co., Second Quarterly Tech. Progress Report, Jan. 1978, NASA Contract NAS 1-15025.
- Scott, W.R., Gordon, P.F., Ultrasonic Spectrum Analysis for Nondestructive Testing of Layered Composites. J. Acoust, Soc. Am., Vol. 62, No. 1, July 1977.
- Carlyle, J.M. and Scott, W.R. Acoustic-Emission Fatigue Analyzer. Naval Air Development Center, Experimental Mechanics, Oct. 1976, pp. 369-372.
- Hayes, J. and others. Nondestructive Thickness Measurement of Fiber Reinforced Plastic (FRP) Using Ultrasonic Techniques. Paper presented at The Society of Plastics Industry, Reinforced Plastics/Composites Institute 33rd Annual Conference, Feb. 7-10, 1978.

Altman, J., and others. Advanced Composites Serviceability Quarterly Progress Report. Rockwell Int. Report No. NA-76-783-6, Jan-Mar, 1978, USAF Contract F33615-76-C-5344.

Labor, I.D. Service/Maintainability of Advanced Composite Structures. Northrop Corp., 5th Qtrly. Prog. Report, Feb. 1978, USAF Contract F-33615-76-C-3142.

Bunsell, A.R. Acoustic Emission for Proof Testing of Carbon Fibre-Reinforced Plastics. NDT International, Feb. 1977, pp. 21-25.

Weyhreter, A. and Horak, C. Acoustic Emission System for Estimation of Ultimate Failure Strength and Detection of Fatigue Cracks in Composite Materials. 33rd Annual Tech. Conf., 1978, Reinforced Plastics/Composites Institute, Society of the Plastics Industry.

Stewart, K. Development of NDT Methods for Detection of Fatigue Damage in Graphite Composite Structure. Boeing Commercial Airplane Company, Renton, WA., Quality Control Research and Development Report No. 121-726.

Kettering D., and Mastik E. Development of a Radio-Opaque Penetrant for Use in Composite Material Radiography. Grumman Aerospace Corp. Interoffice Memo, Sept. 28, 1977.

Golam, G. Environmental Sensitivity of Advanced Composites. F-33615-76-C-5324, 6th Quarterly Report, Grumman Aerospace Corp., Mar. 1978.

Kibler, K.G., and others. Residual Strength of Laser-Damaged Graphite Composites. General Dynamics, Ft. Worth, J. Comp. Mtls., Jan 1975.

Pettit, D.E. Residual Strength Degradation for Advanced Composites. Contract F-336-5-77-C-3084, Lockheed-California Co., Feb. 1978.

Altman, J. and Olsen, W. Qualification of Low-Cost Composite Secondary Structures. Final Report, Dec. 1977. Tech. Report AFFDL-TR-77-129.

Fenton, J.D. Evaluation of the Nortec NDT-12 Eddy Current Unit for Measuring RCC Coating Thickness. Vought Systems Division, LTV Aerospace, Report #2-42000/5 QCR-07.

McGovern, S.A. Nondestructive Inspection of the High Technology Graphite/Epoxy A-7 Speedbrake Final Assembly. Vought Systems Division, LTV Aerospace, Report No. 2-42211/5 NDT-08.

Nondestructive Test Manual for Boeing Jet Transports. Boeing Document D6-7170.

Nondestructive Testing for Aircraft. FAA Advisory Circular AC 20-61, Department of Transportation, Federal Aviation Administration.

Nondestructive Inspection Methods. Military Technical Manual, T.O. 33B-1-1.

CURRENT STRUCTURES INSPECTION  
BASELINE FOR IN-SERVICE AIRCRAFT

APPENDIX A  
TO  
PHASE I REPORT

"ASSESSMENT OF STATE-OF-THE-ART OF  
IN-SERVICE INSPECTION METHODS FOR  
GRAPHITE EPOXY COMPOSITE STRUCTURES  
ON COMMERCIAL TRANSPORT AIRCRAFT."

CONTRACT NAS1-15304

Prepared for

NATIONAL AERONAUTICS AND SPACE ADMINISTRATION  
LANGLEY RESEARCH CENTER  
Hampton, Virginia



CONTENTS

	Page
1.0 INTRODUCTION . . . . .	1
2.0 SCOPE . . . . .	1
3.0 INSPECTION METHODS . . . . .	1

## 1.0 INTRODUCTION

This document fulfills task (d) of the Phase I documentation requirements under NASA Contract NAS1-15304. The data contained herein were derived from a 106 article literature review, written responses to a questionnaire by eleven commercial airlines, and two separate trips for on-site visits with three government agencies, three manufacturers, and fourteen airlines. The purpose was to identify current in-service inspection methods. Consequently details, as in a user's guide, are omitted.

## 2.0 SCOPE

All methods that are being used to inspect structures on in-service aircraft are described. Inspection methods that have not been used in service or are used only to inspect nonstructural items such as hydraulic or electrical components are excluded. In-service structures for this document include parts or assemblies that are on the aircraft, as well as items that have been removed for maintenance or inspection purposes but will be reinstalled and returned to service.

## 3.0 INSPECTION METHODS

### 3.1 VISUAL AND VISUAL-OPTICAL

Description. Visual inspection is the major inspection method. It is relied on as an initial detector of suspicious conditions and, with aids, to perform more detailed investigation to verify presence of a defect. It is often used with aids and with tapping and tactile techniques of pushing, prying, scraping, and insertion of bladed devices in laminated edges to confirm disbond, corrosion, etc. Optical aids include magnifiers, mirrors, and hard and flexible borescopes.

Equipment. Drop lights, flashlights, mirrors, low-power magnifiers, rigid and fiberoptic borescopes.

### 3.2 TAP TEST (COIN TAP)

Description. This method is normally used during visual inspection to locate or verify disbonds, delaminations, and damaged conditions in adhesive bonded and fiberglass structures.

Equipment. A small, blunt, hard object such as a coin. Small, ball-peen type tappers have also been used.

### 3.3 RADIOGRAPHY

Description. Both X-rays from an X-ray tube and gamma rays from a radioactive isotope are used on in-service aircraft. Gamma radiography is used primarily to take advantage of the small size of the source that can be placed in small areas. X-ray machines may range from small portable field units to large accelerators.

Using either source, radiation passes through the part and is differentially absorbed by the materials through which it passes. With industrial radiographic film placed on the opposite side of the part, an image is recorded on the film. Less dense defects such as voids and cracks allow more radiation to pass. Denser defects such as inclusions, debris, and water-in-honeycomb attenuate the radiation. The film is developed on which an image of the structure and defective conditions are recorded.

Equipment.

Gamma ray sources: cesium 137, cobalt 60, iridium 192, thalium 70, radium.

X-ray machines: small portable machines from 0-150 kv up to betatron machines capable of energy levels in the million electron volt range.

Other equipment: automatic film processors, dark room equipment, film viewers, penetrameters, densitometers, fluoroscopic viewers, and filters and screens.

### 3.4 ULTRASONIC METHODS

Description. Ultrasonic methods use high-frequency sound waves generated by a piezoelectric transducer which, either in contact with the part surface or through a water-filled or plastic shoe standoff device, transmits sound waves into a part. Defects cause some of the sound energy to reflect back to the transducer or, by scattering, reduce the amount of sound traveling through the part to the opposite surface. The pulse-echo method, using a single transducer, detects the reflected sound from a defect and the through-transmission method, with a second transducer on the other side of the part, detects the reduced sound energy level caused by the defect. The response pattern on a cathode ray tube "A"-scan presentation is interpreted by the operator for presence of defects. Variations of the pulse-echo method including straight-beam, angle-beam, and surface wave transmission are selectively used to optimize defect detection in various structures and defect locations within these structures. Ultrasonic pulse-echo thickness gaging is also used extensively with the most common presentation being a digital readout of thickness.

Equipment. There are a variety of ultrasonic instruments that can be used for pulse-echo or through-transmission operation. They range from small, portable, battery-generated instruments to large laboratory models. Accessories used include transducers of various frequencies from 1 through 25 MHz, plastic shoes, transducer holders for special jobs such as yoke-type holders for through-transmission inspection, and simulated defect reference standards.

### 3.5 EDDY CURRENT METHODS

Description. To initiate eddy currents in a test object, an alternating current of selected frequency is applied to a test coil. When placed next to a metal part, the coil, in turn, induces a magnetic field of the same frequency in the part. This causes eddy currents to flow in the part. This flow of eddy currents generates its own magnetic fields, which affects the initial field from the coil. The resultant magnetic field then becomes the source of information that is analyzed electronically to yield the required data. The condition of the part is determined from these data.

The method is limited in application to conductive materials, primarily aluminum, in which it can detect cracks and other discontinuity defects, measure thickness and corrosion thinning, and detect heat treatment and alloy variations. Its application to steels is limited due to permeability effects.

High frequencies (above 50 KHz) are used for surface defect detection, bolt-hole inspection with fastener removed, conductivity measurements for heat treatment or fire damage detection, and thickness measurement.

Low frequencies (below 50 KHz) are used for subsurface crack detection, crack detection in second layer substructure, and some thinning measurement for corrosion loss on the inner surface of aluminum skins.

Equipment. There are numerous eddy current instruments for general use and for specific applications. Included are conductivity measurement instruments, plating and coating thickness measurement instruments, and portable crack and thinning detection instruments--both high-frequency and low-frequency models. Various probes are required for different applications and access to specific areas. Also, simulated defect, conductivity, or thickness reference standards are required.

### 3.6 FLUORESCENT AND DYE PENETRANT METHODS

Description. Penetrant methods are used to detect surface cracks predominantly in aluminum structure. After cleaning, a part is coated with a fluorescent penetrating liquid that seeps into the cracks. Excess penetrant is removed, and a developer film is applied into which defect indications bleed. The surfaces are inspected in a darkened area with an ultraviolet light and the fluorescent dye causes visual indications of defects. Visible dye penetrant or dye check inspections follow the same general procedure, but use a colored (usually red) dye rather than a fluorescent dye, and parts are inspected in natural light or with a flashlight.

Equipment. Fluorescent penetrant with remover and developer, dye penetrant with remover and developer, cleaning solvents, applicator and cleaning cloths, ultraviolet light, flashlight, mirror, and low-power magnifier.

### 3.7 MAGNETIC PARTICLE METHOD

Description. This method is usable only on ferromagnetic materials to detect surface or near-surface defects. A part is magnetized by inducing a magnetic field from a coil, probes, or magnetizing yoke. During magnetization, wet or dry iron particles are caused to flow over the part. Magnetic leakage fields at a defect cause particles to accumulate along the defect, resulting in a visible defect indication.

Equipment. Large, stationary or mobile magnetic particle inspection units; smaller portable units; hand-held probes or yokes with permanent magnets; dry particles, wet particles in a petroleum distillate; cleaners for field use; wiping cloths, demagnetizing units.

### 3.8 BOND TESTER METHODS

Description. These methods are identified by the name of the instrument used. Sonic vibrations are either introduced by piezoelectric transducers, vibrating contact probes, or by induced eddy currents caused by placing an alternating current-driven coil near the surface. Conditions of resonance, responding vibration, amplitude, or phase are detected and presented on a meter or cathode ray tube readout. Defects such as disbonds or delaminations in adhesive bonded structures cause resonance frequency shift, increased vibration, or signal amplitude or phase change.

Equipment. There are several different instruments in use including the Fokker Bondtester, Sondicator, Harmonic Bond Tester, and 210 Bondtester. Transducers are required, liquid or paste couplant is required for use with the Fokker Bondtester and the 210 Bondtester, and cleaning aids are needed if part surface is dirty. Reference standards representative of the structure containing simulated defects are required.

### 3.9 MAGNETIC RUBBER

Description. This method has had limited use but has proven valuable for specific applications on ferromagnetic parts. It is a magnetic particle test method that uses finely divided magnetic particles suspended in a room-temperature curing, liquid RTV rubber. It is applied to holes and

small areas by using clay, putty, aluminum foil, tape, etc. to form a reservoir and pouring the prepared liquid rubber into the reservoir. Permanent magnets or direct current yokes are used to provide the magnetizing field and must remain in place for a considerable time to allow the magnetic particles to migrate through the rubber to possible defects. About 1 hour cure time is normal. The result is a rubber mold containing a very high resolution image of defects that can easily be viewed with magnification and retained as a record.

Equipment. Liquid RTV rubber, fine magnetic particles, materials for reservoir construction surface cleaning aids, and viewing optics.

### 3.10 NITAL ETCH INSPECTION

Description. This method is in limited use to inspect reworked steel alloy parts. Detectable defective conditions include overtempering, re-hardening, decarburized areas, improper carburization, and arc burns. The method requires surface cleaning, application by swagging with a 10% nitric in alcohol solution, rinsing with acetone, reswabbing with a 6-10% hydrochloric acid solution, neutralizing the surface, and visual inspection. Defective conditions are indicated by surface appearance and colors (MIL-STD-867).

Equipment. Swabs, nital solution, 6-10% hydrochloric acid, acetone, water, wiping cloths, neutralizing solution.

### 3.11 MOISTURE REGISTER METER

Description. This method is used to detect water in nonmetallic honeycomb structures. It consists of a 10-MHz tuned circuit with electrodes mounted in a probe. With the probe in contact with the part surface, the dielectric constant of the underlying structure, as modified by water content, is measured.

Equipment. A Moisture Register Meter instrument, surface cleaning materials as needed, and a reference standard of structure similar to the part to be inspected containing water in a localized area.

PRELIMINARY  
INSPECTION PROGRAM FOR  
ADVANCED COMPOSITE STRUCTURES ON  
IN-SERVICE AIRCRAFT

APPENDIX B  
TO  
PHASE I REPORT

"ASSESSMENT OF STATE-OF-THE-ART OF  
IN-SERVICE INSPECTION METHODS FOR  
GRAPHITE EPOXY COMPOSITE STRUCTURES  
ON COMMERCIAL TRANSPORT AIRCRAFT."

CONTRACT NAS1-15304

Prepared for  
NATIONAL AERONAUTICS AND SPACE ADMINISTRATION  
LANGLEY RESEARCH CENTER  
Hampton, Virginia



CONTENTS

	Page
1.0 INTRODUCTION . . . . .	1
2.0 SCOPE . . . . .	1
3.0 INSPECTION METHOD SELECTION . . . . .	2
4.0 DEFECTS . . . . .	3
5.0 METHODS . . . . .	4
6.0 REFERENCE STANDARDS . . . . .	19

## 1.0 INTRODUCTION

This document was prepared under NASA Contract NAS1-15034 and fulfills task (e) the contract Phase I documentation requirements. It establishes the inspection methods, particularly nondestructive testing (NDT), that have been or currently are being used to inspect advanced composite structures on in-service aircraft. The data for this document were obtained from a literature review of articles, written questionnaires to commercial airlines, and visits to 14 airlines, three manufacturers, and three government agencies.

## 2.0 SCOPE

Each inspection method that has been used or is in current use on advanced composite structures on in-service airplanes is included in this document. Inspection methods that have not been used in service are excluded. For example, a particular method may have been evaluated and determined to be acceptable in a laboratory evaluation of a part removed from an in-service airplane. However, this method would be excluded, as confidence in it has not been demonstrated by using it for flight-status aircraft.

### 3.0 INSPECTION METHOD SELECTION

#### 3.1 PRE-INSPECTION DATA

Determine:

1. Structural areas or items to be inspected, their location, geometry, and material identification.
2. Details of the underlying structure, including modifications.
3. Type and probable location of potential defects. Acceptable defects detected in fabricated parts prior to installation on the airplane should be identified for type and location.
4. Removals required for access to inspection area.
5. Safety precautions or special requirements.

#### 3.2 METHOD SELECTION

1. Refer to table 1 for selection of appropriate inspection method. Section 4.0, Defects, and section 5.0, Inspection Methods should be consulted for details.
2. A "Primary Method" normally would be used for initial inspection and the "Secondary Method" would be used if special circumstances prevent use of the Primary Method.
3. Use either category method for backup verification of defect and evaluation to determine size, type, and location.
4. The category "Potential Application" indicates that the method may detect the type of defect in question, but not enough evidence of capability or details of the specific technique are available.
5. "Not Applicable" is indicated when this is obvious by the nature of the method or if recent experience on advanced composite structures have demonstrated lack of capability.

#### 4.0 DEFECTS

In-service defects as listed in table 1 are defined as follows:

1. Blisters--localized raised areas--may result from a delamination or disbond.
2. Scratches--visual surface scratches--readily detected on painted surfaces.
3. Dents--localized depressions--may indicate damage beneath the surface.
4. Delaminations--separation between plies in a laminated epoxy/fiber composite part or at the bondline of two separately identified parts.
5. Disbonds--separation at the bondline of parts joined by an adhesive bond.
6. Cracks--material separation in the resin matrix or across plies rather than between plies.
7. Impact Damage--shattering of matrix, small cracks, broken fibers, etc. resulting from impact of an object on part surface.
8. Fastener Hole Damage--cracks, small delaminations, matrix shattering, hole elongation, etc. caused by shear loads at the fastener-to-hole surface interface.
9. Fastener Pull-Through--fastener head has pulled into or beneath the surface of the part.
10. Lightning Damage--burns, matrix shattering, fiber damage, etc. resulting from lightning strike.
11. Honeycomb Core Damage--separation of honeycomb walls, crushed core, corrosion, etc. resulting from impact, entrapped water, and other causes.
12. Water-in-Honeycomb--entrapped water that may cause damage through freezing, thawing, corrosion of aluminum honeycomb, etc.

13. Moisture Absorption/Degradation--absorption of water by graphite-epoxy parts in high humidity environments has resulted in degraded mechanical properties.
14. Heat Damage--overheating due to localized fire or overheated hardware may cause discolored or scorched paint and charred surfaces.
15. General Surface Deterioration--any gradual deterioration that may result from severe environmental or service conditions.

## 5.0 METHODS

### 5.1 VISUAL AND VISUAL/OPTICAL

#### 5.1.1 EQUIPMENT

Lights, low-power magnifying glasses, rigid and fiber-optic borescopes, mirrors.

#### 5.1.2 REFERENCE STANDARD

Not required.

#### 5.1.3 INSPECTION TECHNIQUE

With appropriate lighting and optical aids, inspect for abnormal surface conditions: bulges, dents, scratches, cracks, edge delaminations, corrosion products, wear, etc.

Abnormal conditions should be evaluated to determine if a defective condition exists. Other inspection methods detailed herein should be used as needed. Record and report probable defects in accordance with established procedures.

TABLE 1. GRAPHITE-EPOXY COMPOSITES IN-SERVICE DEFECTS AND RECOMMENDED DETECTION METHODS

DEFECT	METHOD					
	VISUAL-OPTICAL TAP TEST	ULTRASONIC PULSE ECHO	ULTRASONIC THRU TRANSMISSION	ULTRASONIC THICKNESS GAGE	BOND TESTER	RADIOGRAPHY
VISUALLY EVIDENT:	◇◇◇◇◇◇◇◇◇◇	◇◇◇◇◇◇◇◇◇◇	◇◇◇◇◇◇◇◇◇◇	◇◇◇◇◇◇◇◇◇◇	◇◇◇◇◇◇◇◇◇◇	◇◇◇◇◇◇◇◇◇◇
BLISTERS	□	□	□	□	□	□
SCRATCHES	□	□	□	□	□	□
DENTS	□	□	□	□	□	□
CRACKS	□	□	□	□	□	□
IMPACT DAMAGE	□	□	□	□	□	□
LIGHTNING DAMAGE	□	□	□	□	□	□
HEAT DAMAGE	□	□	□	□	□	□
FASTENER PULL-THROUGH	□	□	□	□	□	□
FASTENER HOLE DAMAGE (WITH FASTENER REMOVED)	□	□	□	□	□	□
GENERAL SURFACE DETERIORATION	□	□	□	□	□	□
NOT VISUALLY EVIDENT:	◇	◇	◇	◇	◇	◇
DELAMINATIONS	◇	◇	◇	◇	◇	◇
DISBONDS	◇	◇	◇	◇	◇	◇
CRACKS	◇	◇	◇	◇	◇	◇
IMPACT DAMAGE	◇	◇	◇	◇	◇	◇
WATER-IN-HONEYCOMB	◇	◇	◇	◇	◇	◇
HONEYCOMB CORE DAMAGE	◇	◇	◇	◇	◇	◇
FASTENER HOLE DAMAGE (WITHOUT FASTENER REMOVAL)	◇	◇	◇	◇	◇	◇
MOISTURE ABSORPTION/DEGRADATION	◇	◇	◇	◇	◇	◇

◇ PRIMARY DETECTION METHOD      □ SECONDARY METHOD  
? POTENTIAL APPLICATION      - NOT APPLICABLE

## 5.2 TAP TEST (COIN TAP)

### 5.2.1 PRINCIPLE

Surface of part is tapped by hand using a blunt, hard object (often a coin) and tone difference or deadening as compared to surrounding area indicates a delaminated, disbonded, or damaged area.

### 5.2.2 EQUIPMENT

Any lightweight, hard-surface object that will not mar the part surface. Electrical/electronic tapping instruments are excluded (see para. 5.7.1).

### 5.2.3 REFERENCE STANDARD

Recommended (currently, this method is usually used without a reference standard).

### 5.2.4 INSPECTION TECHNIQUE

Tap, with appropriate object, over inspection area and note any tone changes or sound deadening as compared to surrounding area of identical underlying structure and material gages. Tone change will indicate possible delamination, disbond, or impact damage. It also may indicate micro-cracking and softening in the epoxy matrix.

Tap testing is not reliable and becomes insensitive to delamination and disbonds under certain structural conditions, particularly increasing skin thickness. Optimum sensitivity is associated with very thin skin structure. For this reason, a reference standard containing a defect in a reproduction of the actual part or section of the part should be used for

validation of the tap test. Failure to positively detect the reference defect disqualifies the tap test method, and other NDT methods detailed herein must be used.

Defect indications should be evaluated and probable defects recorded and reported per established procedures.

### 5.3 ULTRASONIC PULSE-ECHO

#### 5.3.1 PRINCIPLE

Ultrasonic pulses are generated by a single transducer in contact, through a couplant, with the part surface. The pulses travel internally in the part and reflect or echo from each material change, for example, the interface of skin bonded to substructure. The reflected pulses are detected by the transducer and resultant signals on a Cathode Ray Tube (CRT) are monitored for changes caused by defects within the part.

#### 5.3.2 EQUIPMENT

- o Standard ultrasonic test instrument equipped with a high-resolution pulser-receiver unit for 5, 10, and 15 MHz transducers.
- o One each 5, 10, and 15 MHz high-resolution contact search units.
- o One each 5, 10, and 15 MHz transducers adaptable to angle beam shoes.
- o Angle beam shoes.
- o Couplant: oil, grease, commercial couplant. Also, water bubblers, squirters, and encapsulated water standoffs have been used. The latter is illustrated in figure 1.



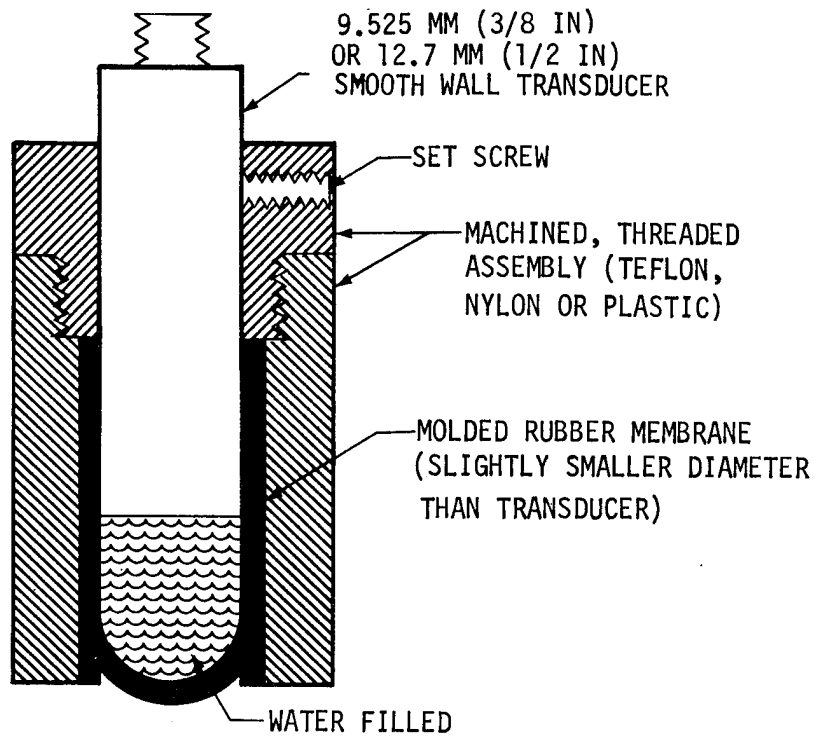

FIGURE 1. STAND-OFF SEARCH UNIT

### 5.3.3 REFERENCE STANDARD

Required (see sec. 6.0).

### 5.3.4 INSPECTION TECHNIQUE

Two methods are described--the straight beam method and the angle beam method. Both are effective in detecting delaminations in the laminated composite skin and delaminations or disbonds at the skin-to-underlying structure interface. The angle beam method is applicable only to metal honeycomb. (It is unlikely that nonmetallic honeycomb will support sufficient sound transmission levels.) The straight beam method is applicable both to skin-to-honeycomb and skin-to-underlying laminate bonds. The two methods are illustrated in figures 2 and 3.

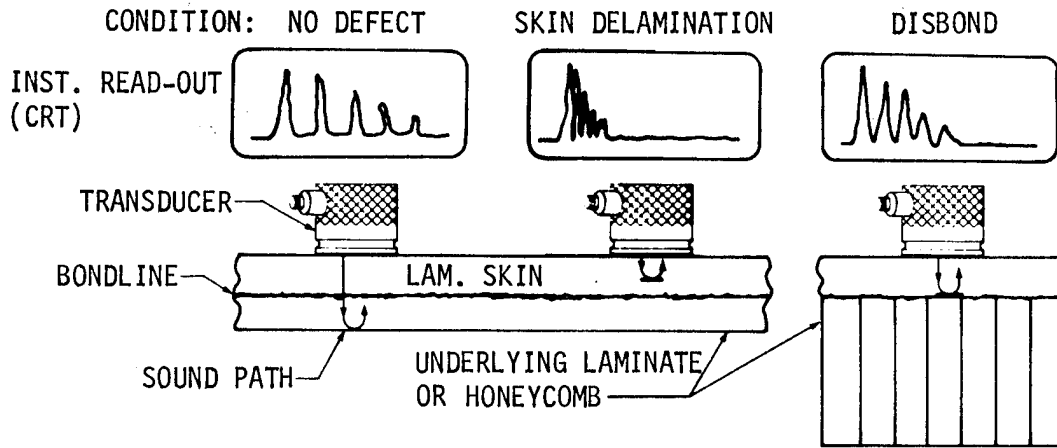

FIGURE 2. STRAIGHT BEAM TECHNIQUE

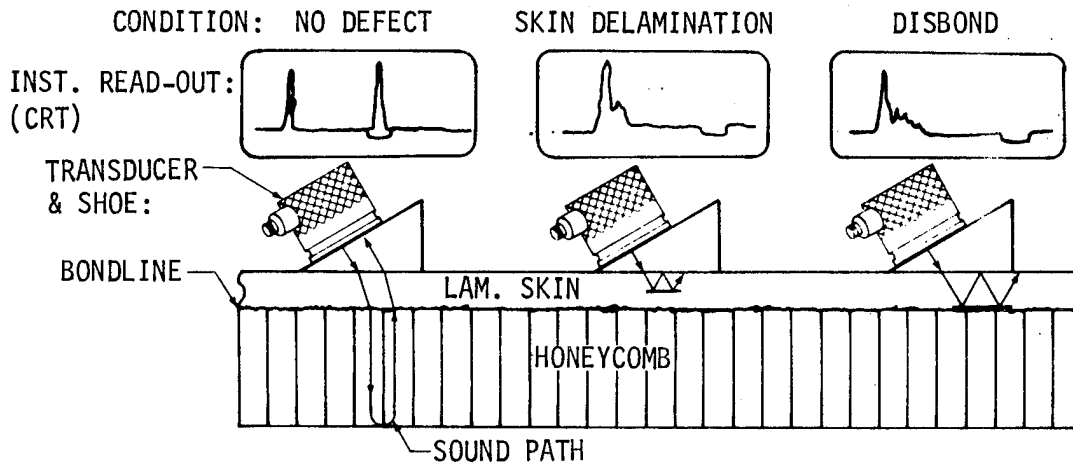

FIGURE 3. ANGLE BEAM TECHNIQUE

Using applicable instrument setup instructions and reference standards, verify instrument sensitivity with reference standard defects. It may be necessary to vary search unit assemblies using plastic shoes or encapsulated water standoff devices and various shoe angles for the angle beam method. Only certain frequencies or specific transducers may be usable on the structure and defect combination under investigation.

Clean part if oily or dirty, apply couplant, and inspect by moving or positioning search unit over areas requiring inspection. Evaluate defect indications and record and report probable defects in accordance with established procedures.

#### 5.4 ULTRASONIC THROUGH-TRANSMISSION

##### 5.4.1 PRINCIPLE

Ultrasonic pulses are generated by a "transmit" transducer coupled by water bath, water column to the part surface, or by direct contact with the part surface. The ultrasonic pulses enter the part and travel internally through the part and are detected by a "receive" transducer on the opposite side of the part also coupled to the part in the same manner as the "transmit" transducer. Detectable defects are those that block or reduce sound transmission seen as a loss or reduction in signal amplitude on the instrument readout (see fig. 4).

The through-transmission technique is predominantly used to inspect parts prior to installation on an airplane or after removal from an in-service airplane. With the part removed, it can be submerged in water or placed in a holding device for inspection by water column search units. With this setup, transducers do not contact the part surface and mechanical scanning with "C" scan recording is usually performed over the entire part. Defects are detected as anomalies on the "C" scan recording. However, this technique can also be used on installed parts using one of two methods.

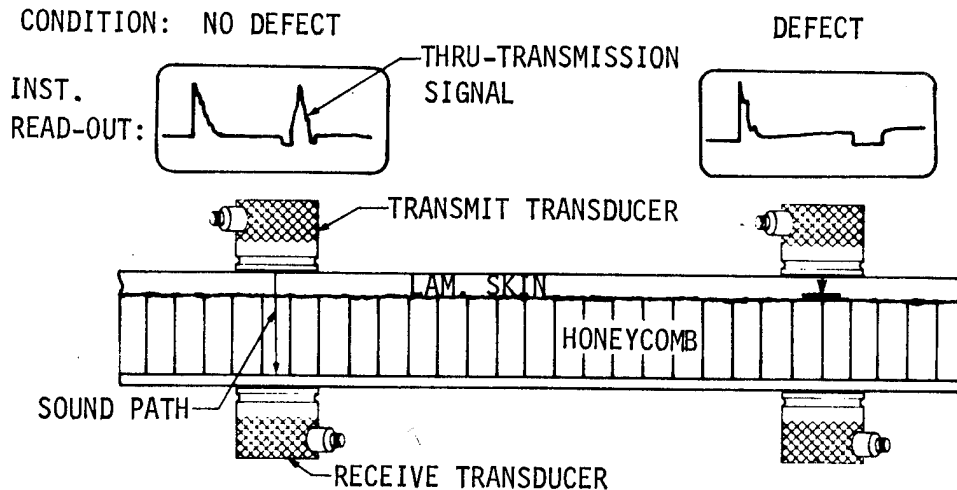

FIGURE 4. THRU-TRANSMISSION TECHNIQUE

One of these is to manually place one of the transducers in direct contact with the part (using a couplant) and position the other transducer over the opposite surface to obtain a maximum through-transmission signal. This is repeated until the area of interest has been covered. The other method uses a yoke assembly to hold both transducers in constant alignment while scanning the transducers over the area of interest. These methods have been used to inspect limited areas of a given part.

#### 5.4.2 EQUIPMENT

- o Standard ultrasonic test instrument equipped with transmit-receive connections for through-transmission operation with 1.0, 2.25, and 5.0 MHz transducers.

- o Two each 1.0, 2.25, and 5.0 MHz transducers for contact inspection or search unit assemblies for noncontact mechanical scan inspection.
- o If noncontact mechanical scan inspection is used, additional equipment needed includes tank or squirter assemblies, part holding devices, mechanical scan apparatus, and "C" scan recorder coupled to the mechanical scanner and connected to the "recorder" output of the ultrasonic instrument.
- o Oil, grease, or commercial couplant.
- o Yoke (optional): Yokes are built for specific application depending on part thickness and required "throat" length, i.e., distance from part edge to inspection area. A yoke design is shown in figure 5.

#### 5.4.3 REFERENCE STANDARD

Required (see sec. 6.0).

#### 5.4.4 INSPECTION TECHNIQUE--CONTACT METHOD

Set up instrument per applicable instructions, place transducers on reference standard, and identify through-transmission signal. Verify signal and sensitivity by positioning over defect location and observing signal loss. Select best frequency and transducers for sound transmission through the part and optimum defect sensitivity. The lowest frequency is usually best for high-attenuation materials. Defect resolution is best at the higher frequencies.

Clean part if greasy or dirty and inspect by the contact method described in section 5.4.1. Evaluate defect indications and record and report probable defects in accordance with established procedures.

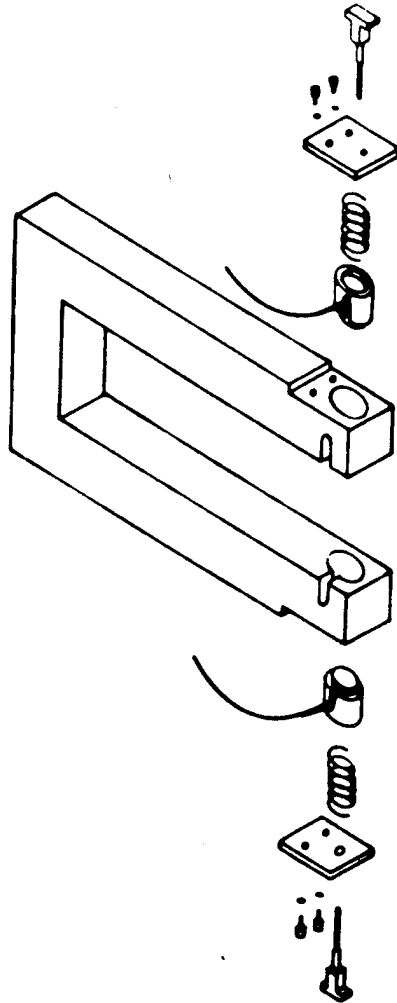

FIGURE 5. YOKE FOR THRU-TRANSMISSION INSPECTION \* \*(FROM "S-3A GRAPHITE/EPOXY SPOILER DEVELOPMENT PROGRAM, VOL II" JULY 1975, E.G.BLOSSER, ET AL.)

#### 5.4.4 INSPECTION TECHNIQUE--WATER IMMERSION OR WATER COLUMN

Follow equipment manufacturer instructions and internally developed procedures for mechanical scan/"C" scan recording inspections in a water bath or when using water column search units.

## 5.5 ULTRASONIC DIGITAL THICKNESS GAGE

### 5.5.1 PRINCIPLE

This method uses the pulse-echo principle wherein a transducer in contact, through a couplant, with the part surface generates a pulse that travels to the opposite surface of the laminated skin, echoes from this surface, and returns to the transducer. The time interval from pulse initiation to its return to the transducer is measured electronically and presented as the part thickness on a digital readout. This method detects delaminations in a laminate and may detect disbonds if the skin-to-underlying structure bond permits the pulse to pass into the underlying structure. It is illustrated in figure 6.

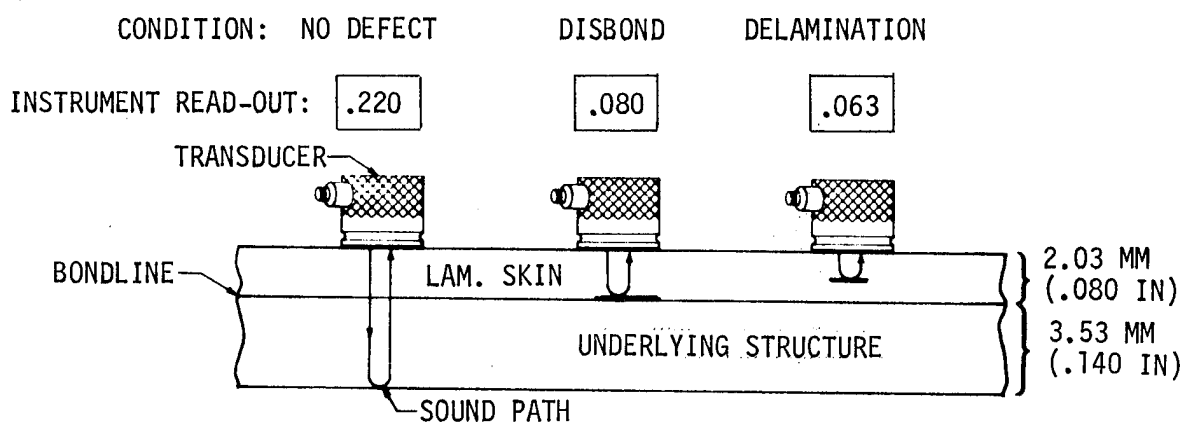

FIGURE 6. DIGITAL THICKNESS GAGE METHOD

#### 5.5.2 EQUIPMENT

Digital readout ultrasonic thickness test instrument and recommended transducers. Oil or commercial couplant.

#### 5.3.3 REFERENCE STANDARD

Required (see sec. 6.0).

#### 5.5.4 INSPECTION TECHNIQUE

Using the applicable instrument setup instructions and reference standard, calibrate instrument on a thickness reference standard to verify proper instrument adjustment and sensitivity throughout the thickness range of materials to be inspected. Clean part as necessary. Inspect by applying couplant and placing the transducer on the surface for each reading. Reliable readings cannot be obtained when sliding the transducer along the surface for a scan type of inspection.

Defect indications will appear as thinner than normal readings characterized by an abrupt change in thickness reading. Some variation in thickness reading of total thickness may result from local variations in resin content. However, these should not be abrupt and would appear as a variable total thickness reading.

Evaluate all defect indications and record and report probable defects in accordance with established procedures.



## 5.6 RADIOGRAPHY

### 5.6.1 PRINCIPLE

A beam of penetrating radiation in the form of X or gamma rays is directed through a part or structure with such energy as to be partially absorbed. Sensitized film is placed on the opposite side of the test object. After exposure and processing the film, the transmitted portion of the beam will have formed a density image of the test object on the film. The image density is proportional to the variation of absorption by the test object.

Because X-rays are electrically generated, the radiation energy (penetrating power) can be selected to any appropriate absorption-transmission ratio for a wide range of test objects. Isotope-generated gamma rays are emitted at fixed energies and thus are limited to the radiography of specific material thicknesses.

### 5.6.2 EQUIPMENT

Iridium 192 (300 to 600 kv) and cobalt 60 (1200-1300 kv) are two isotopes in wide use for metal radiography. With steel penetration of 2 inches and 8 inches respectively, they are obviously unsuitable (too powerful) for the general metal airframe components requiring 50 to 250 kv. X-ray machines rather than isotopes are used in the 50-250 kv range and are in common use as standard aircraft inspection equipment.

With the introduction of nonmetals into aircraft structures, lower kv equipment is becoming necessary. Energy levels as low as 10 kv are suitable for graphite-epoxy thicknesses. X-ray machines with beryllium windows and 10-50 kv are recommended for low-kv inspection of advanced composites.

### 5.6.3 REFERENCE STANDARD

Not required. Sensitivity is assured by using the optimum radiographic technique developed for the structure and defect type being inspected.

### 5.6.4 LOW-KV RADIOGRAPHIC TECHNIQUE

Normal radiographic practices are followed except that, for aluminum or graphite thicknesses that are less than 0.10 inch, the X-ray tube distance from the film may be minimized without loss of image sharpness. This plus the use of a medium-speed film permits the lowest possible exposure kilovoltage for a reasonable exposure time.

## 5.7 BOND TEST INSTRUMENTS

### 5.7.1 PRINCIPLE

Several instruments of different types and principles of operation are grouped under this section. They are used primarily as adhesive bond test instruments. However, they are also applicable to composites for detection of ply delamination, disbonds, impact damage, and possibly others. Specific capability depends on the instrument used, the specific structure, and the defect type. Operating principles are summarized as follows, although the manufacturers' instrument manuals should be consulted for detailed information.

Sound generation is accomplished by piezoelectric transducers, electromechanical tapping, or induced eddy currents causing vibration of metal (conductive) members in the structure. Some instruments use fixed frequencies, some a variable frequency as selected by the operator, and some a repetitive sweep of frequencies through a given range. Frequencies used

may range from a few kHz to as high as 80-100 kHz. All instruments require transducer contact with the surface, but some do not require a couplant. Detection of the sonic energy, as modified by the structure and possible defects, is accomplished by piezoelectric transducers or microphone devices. Readout methods include cathode ray tube, meter, and audible or visible alarms.

#### 5.7.2 EQUIPMENT

- o Any of several bond test instruments currently being marketed that will clearly detect the simulated defects in the required reference standards.
- o Search units and other accessories required.
- o Some instruments will require the use of a couplant--oil, grease, or commercial couplant.

#### 5.7.3 REFERENCE STANDARD

Required (see sec. 6.0).

#### 5.7.4 INSPECTION TECHNIQUE

Because the sensitivity of these instruments varies considerably with the type and geometry of the structure, it is important that the exact structure with appropriate defects (reference standard) be used in initial instrument setup and sensitivity verification. Set up the instrument and verify sensitivity in accordance with established procedures. Clean part as needed, apply couplant if required, and inspect by placing the search unit at specific locations throughout the area to be inspected. Sliding the transducer over the surface in a scanning motion may be permissible, but should be verified as a reliable procedure on the reference standard.

Evaluate all defect indications and record and report probable defects in accordance with established procedures.

## 6.0 REFERENCE STANDARDS

Reference standards are required for in-service inspection of advanced composite structures with ultrasonic and bond tester methods and recommended for tap test. The best reference standard would be a duplicate part or section of structure to be inspected, including the actual defects of concern. However, obtaining parts with defects of the desired sizes and locations is not always possible, and the alternative is to fabricate reference standards that duplicate the parts to be inspected with built-in simulated defects of the required sizes and locations.

An alternative to the built-in defect standards is the step wedge thickness standard, which contains several thicknesses each representing a delamination or disbond depth below the surface. This type of reference standard simulates large defects only. It is suitable for ultrasonic pulse echo, ultrasonic thickness gage, and bond tester standardization. It is not suitable for tap test validation.

The following reference standards are recommended to be consistent with the most common nonvisual defects occurring in graphite-epoxy composite structures and as dictated by nondestructive test methods standardization requirements.

### 6.1 DELAMINATION/DISBOND STANDARDS

These are suitable for standardization of ultrasonic pulse-echo and through-transmission, bond test, and validation of tap test methods. They are fabricated by placing Teflon tape, mylar-covered porous filter material, Tedlar, precured adhesive, or prepreg tape in the bondline and between plies of a laminated part. The size is determined by the defect allowables criteria and shape may be either round or square. Figure 7 is typical. Step wedge thickness standards are illustrated in figure 8.

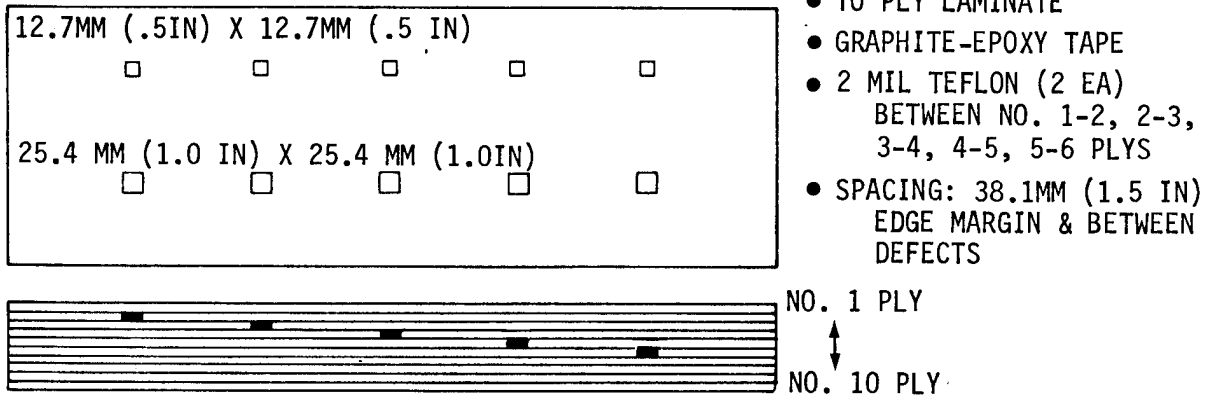

FIGURE 7. TYPICAL GRAPHITE-EPOXY DELAMINATION AND DISBOND REFERENCE STANDARD

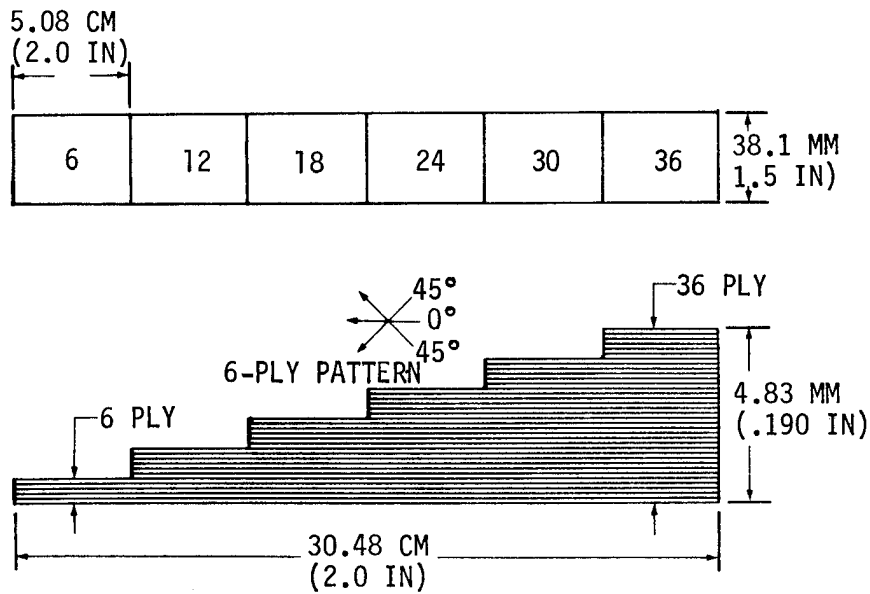

FIGURE 8. STEP-WEDGE THICKNESS REFERENCE STANDARD

## 6.2 IMPACT DAMAGE AND ENTRAPPED WATER

While reference or "verification" standards are not commonly used for these defects, sensitivity assurance and confidence levels would be enhanced with their use.

**Impact Damage:** This is created in the laminated skin member by impact of a blunt object with the test standard surface. A typical method is illustrated in figure 9. Impact defects in the reference specimen should range in severity up to visible damage. The nonvisible defects are used to verify sensitivity of ultrasonic, bond tester, and tap test methods.

**Entrapped Water:** This reference standard can be used to verify the capability of radiography and other methods to detect water-in-honeycomb structure. A tiny drilled hole through the skin in the center of one or more cells allows introduction of water with a hypodermic needle or similar device. Water amounts can be varied to determine detectable levels for various methods.

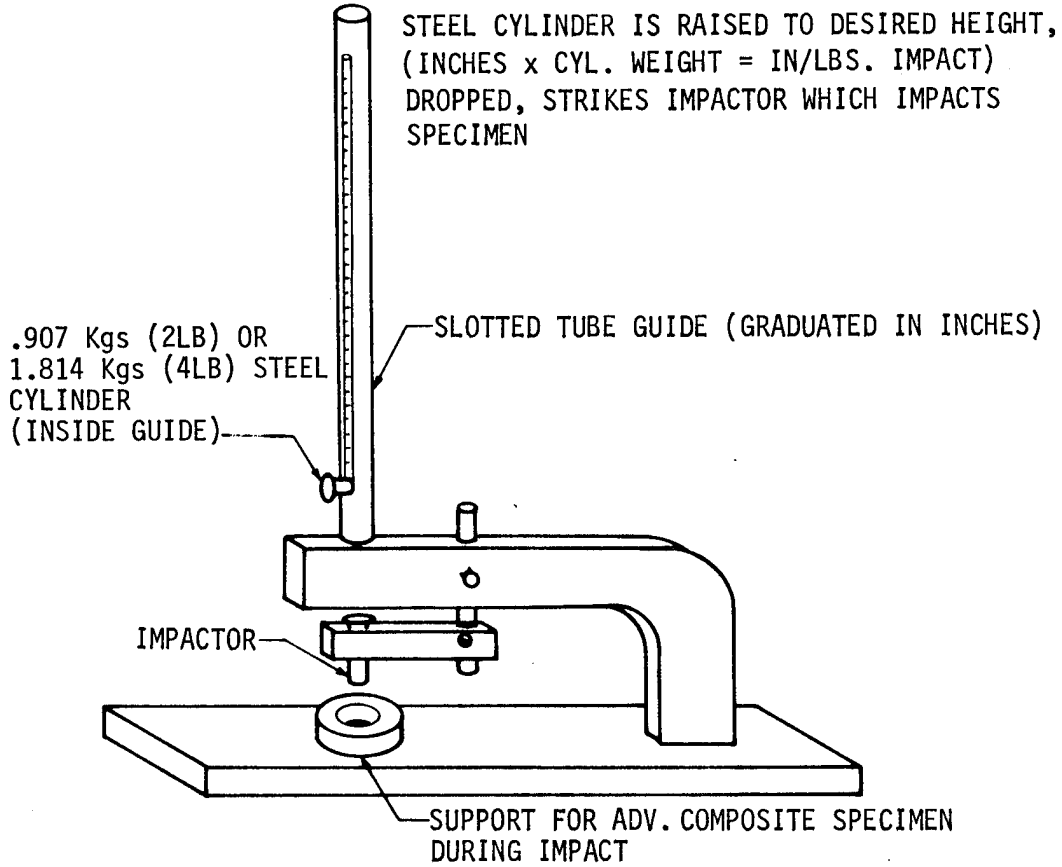

FIGURE 9. METHOD TO ACCOMPLISH CONTROLLED IMPACT DAMAGE

1. Report No. NASA CR-158969	2. Government Accession No.	3. Recipient's Catalog No.	
4. Title and Subtitle Assessment of State of the Art of In-Service Inspection Methods for Graphite Epoxy Composite Structures on Commercial Transport Aircraft		5. Report Date January, 1979	
		6. Performing Organization Code	
7. Author(s) M. L. Phelps		8. Performing Organization Report No.	
9. Performing Organization Name and Address Boeing Commercial Airplane Company P.O. Box 3707 Seattle, Washington 98124		10. Work Unit No.	
		11. Contract or Grant No. NAS 1-15304	
12. Sponsoring Agency Name and Address National Aeronautics and Space Administration Langley Research Center Hampton, Virginia		13. Type of Report and Period Covered Contractor Report	
		14. Sponsoring Agency Code	
15. Supplementary Notes Interim Report for the Period March 3, 1978 Through September 3, 1978			
16. Abstract  A survey was conducted to determine current in-service inspection practices for all types of aircraft structure and particularly for advanced composite structures. The survey consisted of written questionnaires to commercial airlines, visits to airlines, aircraft manufacturers, and government agencies, and a literature search.  Details of the survey including visits, questions asked, a bibliography of reviewed literature and details of the results have been reported. From the results, a current in-service inspection baseline and a preliminary inspection program for advanced composite structures was documented as appendices to the report.			
17. Key Words (Suggested by Author(s)) Nondestructive Testing In-Service Inspection Advanced Composite Structures Graphite Epoxy Service Defects		18. Distribution Statement Unclassified - Unlimited	
19. Security Classif. (of this report) Unclassified	20. Security Classif. (of this page) Unclassified	21. No. of Pages 56	22. Price*



ARRADCOM

Plastics Technical Evaluation Center  
ATTN: A. M. Anzalone, Bldg. 3401  
Dover, New Jersey 07801  
IN REPLY REFER TO:

No 2327

NASA  
Langley Research Center  
Hampton, VA 23665

DATE 13 Sept 1979  
SUBJECT:  REQUEST FOR REPORTS  
 RETURN  FORWARDING OF REPORTS

Contract NAS1=15304

REFERENCE:

FOR OFFICIAL USE:

- 1.  THE DOCUMENTS LISTED BELOW  ARE REQUESTED  ARE FORWARDED  ARE RETURNED
  - ON LOAN
  - FOR RETENTION.
  - COPIES ADDITIONAL TO THOSE RECEIVED ON DISTRIBUTION.
  - FOR TRANSMITTAL TO
  - FOR USE ON CONTRACT.
- 2. X IN REFERENCE TO THE ITEMS BELOW WE WOULD APPRECIATE:
  - RECEIVING A COPY, IF AVAILABLE FOR FREE DISTRIBUTION.
  - INFORMATION ON COST AND AVAILABILITY.
  - BEING PLACED ON DISTRIBUTION LIST.
  - IT IS TO BE UNDERSTOOD THAT THIS IS AN INQUIRY FOR INFORMATION ONLY AND THAT IT IS NOT INTENDED TO CONSTITUTE AN ORDER OR COMMITMENT BY OR FOR THE ORDNANCE CORPS OR GOVERNMENT.

RETURN DUE

3. X NUMBER OF COPIES REQUIRED. ONE

4.  ITEM(S) A Plastec specialist has noticed in MCIC Current Awareness Bulletin dated June 9, 1978, that work is being done by Boeing under your sponsorship entitled "GRAPH/EPOXY COMP. STR. FOR COM. TRANSPORT AIRCRAFT, EVAL. & DEVEL. OF IN-SERVICE INSP. METHODS" on contract NAS1-15304. Please add plastec to your distribution list for reports issued under this contract. Thank you.

INCL. A/S

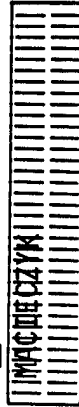

NOT AVAILABLE FROM DDC

SARPA FORM 1420 JUN 76 REPLACES SMUPA FORM 1420 APR 69, WHICH IS OBSOLETE.

Return copy of form with Item. If unable to supply use reverse side for reply.

SIGNED A. M. Anzalone  
A. M. Anzalone, Librarian