

ARMY RESEARCH LABORATORY

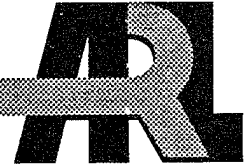

Application of an Inertial Reticle System to an Objective Personal Weapon

Raymond Von Wahlde
Mark Kregel
Tom Haug
Tim Brosseau

ARL-MR-289

February 1996

APPROVED FOR PUBLIC RELEASE; DISTRIBUTION IS UNLIMITED.

EXCLUDED FROM AUTOMATIC DOWNGRADING AND DECLASSIFICATION

19960221 059

NOTICES

Destroy this report when it is no longer needed. DO NOT return it to the originator.

Additional copies of this report may be obtained from the National Technical Information Service, U.S. Department of Commerce, 5285 Port Royal Road, Springfield, VA 22161.

The findings of this report are not to be construed as an official Department of the Army position, unless so designated by other authorized documents.

The use of trade names or manufacturers' names in this report does not constitute indorsement of any commercial product.

REPORT DOCUMENTATION PAGE

Form Approved
OMB No. 0704-0188

Public reporting burden for this collection of information is estimated to average 1 hour per response, including the time for reviewing instructions, searching existing data sources, gathering and maintaining the data needed, and completing and reviewing the collection of information. Send comments regarding this burden estimate or any other aspect of this collection of information, including suggestions for reducing this burden, to Washington Headquarters Services, Directorate for Information Operations and Reports, 1215 Jefferson Davis Highway, Suite 1204, Arlington, VA 22202-4302, and to the Office of Management and Budget, Paperwork Reduction Project(0704-0188), Washington, DC 20503.

1. AGENCY USE ONLY (Leave blank)		2. REPORT DATE February 1996	3. REPORT TYPE AND DATES COVERED Final, May 1995 - August 1995	
4. TITLE AND SUBTITLE Application of an Inertial Reticle System to an Objective Personal Weapon			5. FUNDING NUMBERS	
6. AUTHOR(S) Raymond Von Wahlde, Mark Kregel, Tom Haug, and Tim Brosseau				
7. PERFORMING ORGANIZATION NAME(S) AND ADDRESS(ES) U.S. Army Research Laboratory ATTN: AMSRL-WI-WC Aberdeen Proving Ground, MD 21005-5066			8. PERFORMING ORGANIZATION REPORT NUMBER ARL-MR-289	
9. SPONSORING/MONITORING AGENCY NAME(S) AND ADDRESS(ES)			10. SPONSORING/MONITORING AGENCY REPORT NUMBER	
11. SUPPLEMENTARY NOTES				
12a. DISTRIBUTION/AVAILABILITY STATEMENT Approved for public release; distribution is unlimited.			12b. DISTRIBUTION CODE	
13. ABSTRACT (Maximum 200 words) The Inertial Reticle System (IRS) is a novel fire control system that improves the accuracy of direct-fire weapons by stabilizing the aim point rather than the weapon. Miniature inertial sensors measure weapon motion and drive an electronically generated reticle in opposition so that it appears to remain fixed relative to the target. The system senses when the actual aim point will cross the inertial reticle and then fires the weapon. The U.S. Army Research Laboratory (ARL) has equipped small-caliber weapons such as an M16 and a sniper rifle with the IRS. An IRS on a pistol-sized Objective Personal Weapon (OPW) would help achieve the OPW accuracy goals by reducing weapon pointing error. In addition, by enabling a shooter to preselect an aim point and maintain it despite weapon motion, the IRS would reduce collateral damage and aid in immediate incapacitation. An OPW, equipped with inertial sensors and a video sight, might function much like the current IRS. The target could be viewed on a weapon or helmet-mounted display. Miniaturization of components is the greatest technical barrier to fitting the IRS on an OPW. However, progress in electronics and work in micromachines make application of the IRS to an OPW feasible.				
14. SUBJECT TERMS inertial sensors, personal weapon concepts, fire control			15. NUMBER OF PAGES 22	
			16. PRICE CODE	
17. SECURITY CLASSIFICATION OF REPORT UNCLASSIFIED	18. SECURITY CLASSIFICATION OF THIS PAGE UNCLASSIFIED	19. SECURITY CLASSIFICATION OF ABSTRACT UNCLASSIFIED	20. LIMITATION OF ABSTRACT UL	

INTENTIONALLY LEFT BLANK

TABLE OF CONTENTS

	<u>Page</u>
LIST OF FIGURES	v
LIST OF TABLES	v
1. INTRODUCTION	1
2. INERTIAL RETICLE SYSTEM ON A SNIPER RIFLE	2
3. INERTIAL SENSORS.....	5
3.1 Quartz Rate Sensors	6
3.2 Ring Laser Gyros	7
3.3 Fiber Optic Gyros.....	7
3.4 Silicon Micromachined Gyros	7
4. IRS ON AN OBJECTIVE PERSONAL WEAPON.....	8
4.1 IRS/OPW with Video Sight and Display	9
4.2 IRS/OPW with Fiber Optic Sight.....	10
4.3 IRS/OPW with Video Scope.....	11
4.4 IRS/OPW with Heads-Up Display.....	12
4.5 IRS/OPW with Laser Pointer	12
4.6 IRS/OPW with Lased Target Detector.....	14
4.7 IRS/OPW as a Training Device	15
5. TECHNICAL BARRIERS	15
6. CONCLUSIONS.....	16
7. REFERENCES.....	17
DISTRIBUTION LIST	19

INTENTIONALLY LEFT BLANK

LIST OF FIGURES

<u>Figure</u>	<u>Page</u>
1. Inertial Reticle System on a Sniper Rifle	2
2. Inertial Measurement Unit.	3
3. Weapon Motion.....	3
4. IRS Video Sight Image.	4
5. IRS Firing Sequence.	5
6. IRS/OPW with Video Sight.	9
7. IRS/OPW with Fiber Optic Sight.....	10
8. IRS/OPW with Video Scope.....	11
9. IRS/OPW with Heads-Up Display.....	12
10. IRS/OPW with Laser Pointer.....	13
11. IRS/OPW with Lased Target Detector.....	14

LIST OF TABLES

<u>Table</u>	<u>Page</u>
1. Objective Personal Weapon Goals.....	1
2. Inertial Rate Sensors.	6

INTENTIONALLY LEFT BLANK

1. INTRODUCTION

The Joint Service Small Arms Program (JSSAP) has developed a master plan that seeks to create a future Objective Family of Small Arms to meet the needs of the six participating service entities (Army, Navy, Air Force, Marine Corps, Coast Guard, and Special Operations Command). This family includes a rifle-sized Objective Individual Combat Weapon (OICW), a platform-mounted Objective Crew-Served Weapon (OCSW), and a pistol-sized Objective Personal Weapon (OPW). Small arms are used against protected and unprotected personnel and lightly armored or unarmored vehicles. At a conference sponsored by the JSSAP Office, participants devised the desired capabilities and characteristics of the OPW (Tullington 1995). Table 1 lists these specification and performance goals. "Threshold" goals are considered absolutely necessary. "Objective" goals are desirable characteristics.

Table 1. Objective Personal Weapon Goals

Operational Environment: All Weather, 24 Hr, Air, Land, Sea (3 Atmospheres), Surf			
Time Frame : 2010			Targets :
	Threshold	Objective	Personnel: with Body Armor in Light Vehicles in Structures
Range (m)	150	200	
Accuracy (Minutes of Angle)	6	3	
Effects:		Mode of Operation	
Immediate Incapacitation (No Longer a Threat) Lethal & Less Than Lethal Capability Reduced Collateral Damage Selected Penetration		Selected Fire (Semi/Automatic) Multiple Engagement Capability Simplicity of Operation (Get on Target, Stay on Target)	
Ergonomic Considerations		Reliability, Maintainability, and Safety	
Easily Concealable on a Person Holsterable Operate Easily with Either Hand Felt Recoil (< 9-mm Pistol) Weight < 1.4 kg (3 lb) Fully Loaded		Primary & Secondary Safety Realism and Safety in Training Equal to 9-mm Pistol Uniform Firing Mechanism (Trigger Pull on a Hand Gun)	

The OPW objectives call for substantial improvements in probability of hit (PH), target effects, and effective range over the current M1911A1 and/or M9 pistols (baseline systems). The launch and kill mechanisms of the weapon will determine the ability to engage a target at 200 m with increased lethality. Increased PH will require minimizing weapon pointing error during firing. A novel, fire control system, the Inertial Reticle System (IRS), has been developed that can accomplish this task.

The IRS improves the accuracy of direct-fire weapons by stabilizing the aim point rather than the weapon itself. The U. S. Army Research Laboratory (ARL) has equipped small-caliber weapons such as an M16 and a sniper rifle with suitable versions of the IRS. Depending on the application, performance improvements have ranged from nominal to significant. On the basis of this experience, it may be feasible to apply an IRS to an OPW. An IRS could significantly improve the accuracy of a hand-held weapon. This report describes the IRS as it has been implemented on a sniper weapon and presents several conceptual versions of how the IRS might be applied to an OPW.

2. INERTIAL RETICLE SYSTEM ON A SNIPER RIFLE

The IRS, as demonstrated on a Remington 700 Sniper Rifle (Figure 1), employs angular rate sensors, a video sight and display, a user control interface, and a computer to provide the operator with an easy-to-use, complete fire control system. The system enables a shooter to acquire a target and stay on target despite unwanted weapon motion.

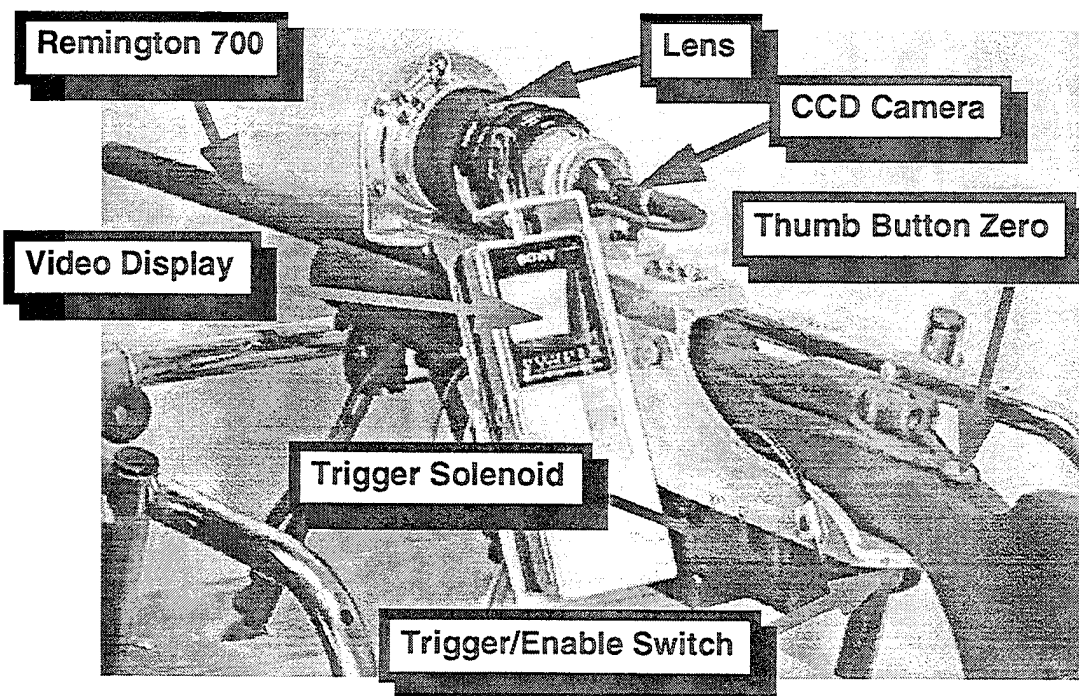

Figure 1. Inertial Reticle System on a Sniper Rifle.

An inertial measurement unit (IMU), mounted beneath the rifle, contains two miniature, quartz rate sensors mounted in two planes (Figure 2). The sensors provide real-time measurements of the angular motion of the weapon. The yaw and pitch velocities are integrated to provide the instantaneous weapon rotations in azimuth and elevation (Figure 3). Cant (roll) measurements are not made because the rifle does not tilt about its centerline when fired from a prone position with a bipod support. These inertial measurements are used to stabilize a reticle (in the form of a crosshair) in inertial space.

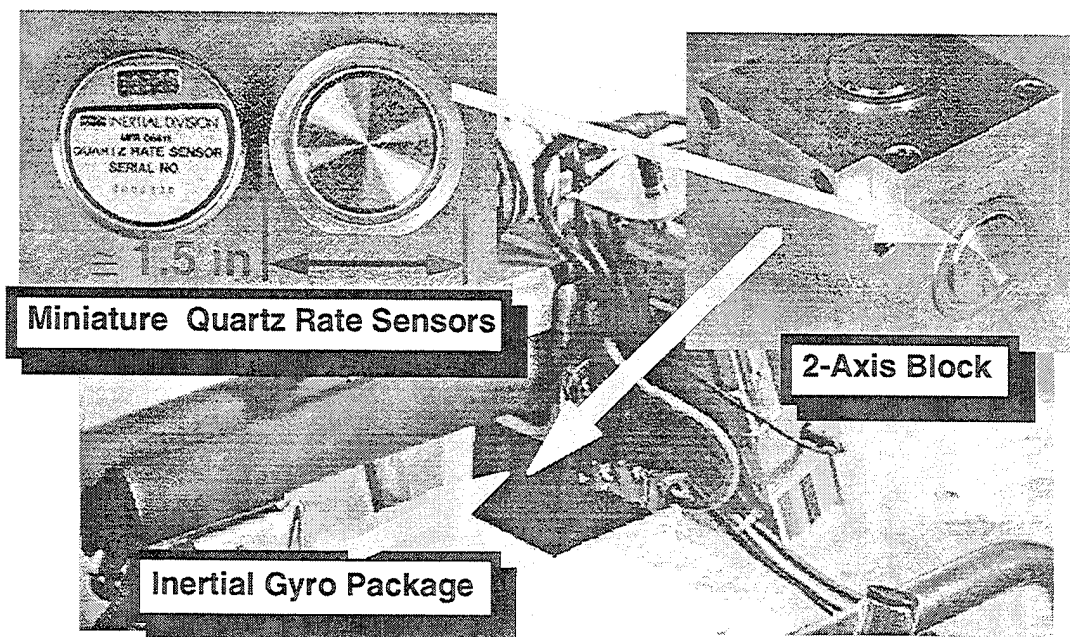

Figure 2. Inertial Measurement Unit.

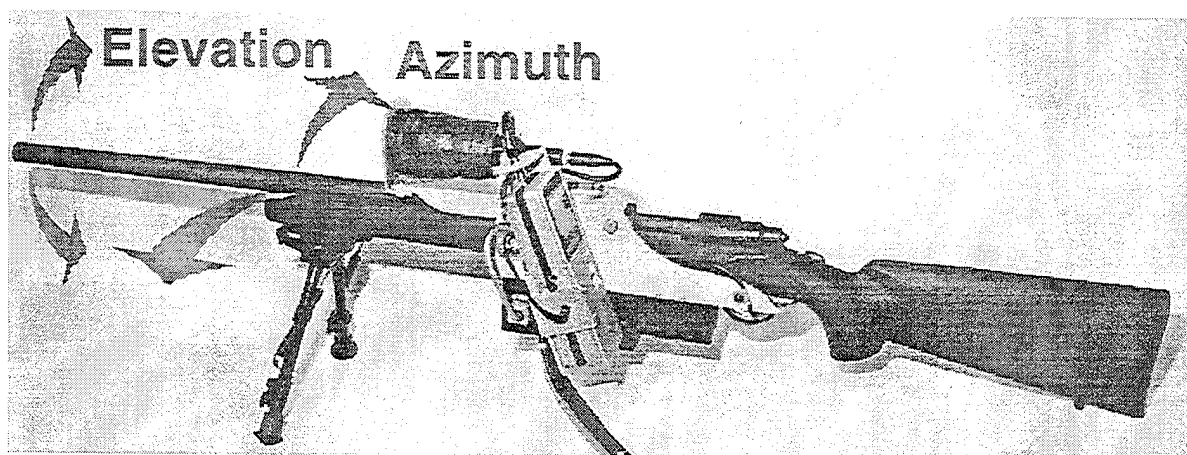

Figure 3. Weapon Motion.

The shooter views a video sight image on a rifle-mounted display. The weapon's standard 10x scope has been replaced with a series of lenses and a Charged Coupled Device (CCD) camera. The actual weapon aim point and the inertial reticle are overlaid on the video image (Figure 4). The inertial reticle is driven in opposition to the weapon motion so that it appears to remain fixed relative to the target. With input from sensors, the weapon aim point can be ballistically corrected for range, crosswind, etc.

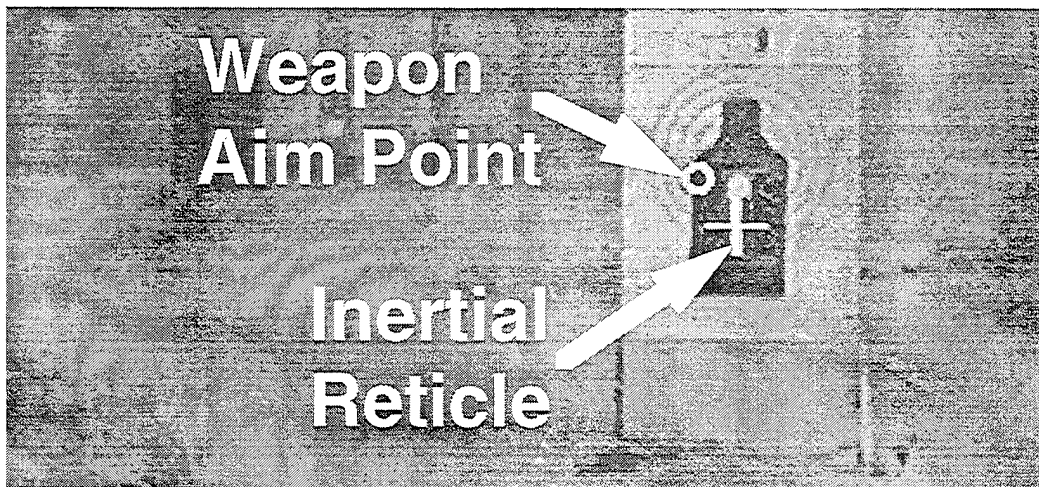

Figure 4. IRS Video Sight Image.

Figure 5 shows a typical IRS firing sequence. In Step 1, an operator depresses a Thumb Button Zero that aligns the inertial reticle with the weapon aim point. Then, the shooter moves the weapon to position the reticle over the desired position on the target. The user then releases the thumb button which "drops" the inertial reticle over the target (Step 2), where it remains unaffected by any subsequent weapon motion. If satisfied with the aim, the shooter arms the system by pulling the trigger/enable switch. The system tracks the weapon aim point and the inertial reticle, and inhibits firing except when the two are aligned to the desired accuracy (Steps 3-4). The system anticipates when the two aim points will cross (Step 5) and fires the weapon automatically (Step 6). If desired, the IRS can be overridden and fired manually.

The IRS on an OPW would require the same subsystems: an Inertial Sensor Package, an Inertial Reticle Positioning System (for Aiming/Acquiring), an Inertial Reticle and Target Display, and a computer. The challenge lies in finding and designing miniature components that are compact, lightweight, and rugged.

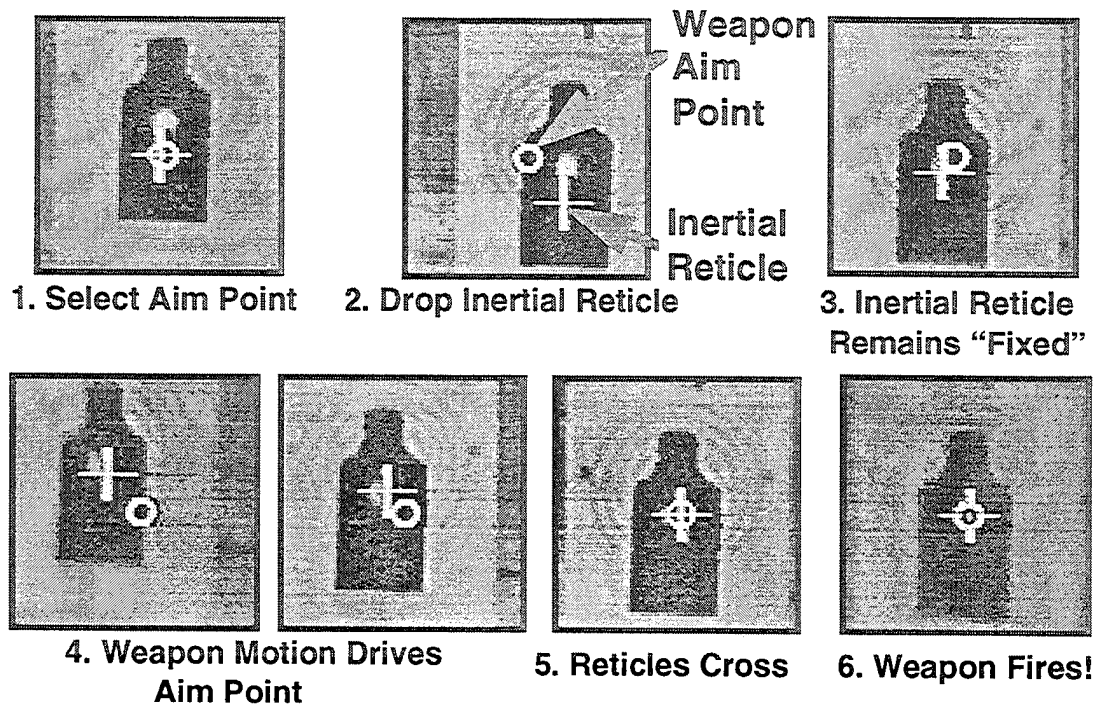

Figure 5. IRS Firing Sequence.

3. INERTIAL SENSORS

The IMU must be located on the weapon. A hand-held weapon will require three orthogonally mounted sensors to measure cant, azimuth, and elevation. Table 2 lists several types of rate sensors that may serve this task. In comparing and choosing a sensor, some of the characteristics that should be examined are sensor input range, bias stability, power consumption, and size.

Input range is the range of angular velocity over which the sensor is capable of performing measurements. Generally, when there is no input to a sensor, the signal is not zero. This offset is called bias (Lawrence 1993) and can be accounted for by calibration. However, the value of the bias varies over time. This drift rate consists of both random and systematic components and is expressed as an equivalent input angular displacement per unit time with respect to inertial space (IEEE STD 528-1994). If the sensor is allowed to run on a stable base, its output will wander some small amount. Such a disturbance is called a random drift and can be characterized by the standard deviation of the output measured periodically for a specified time (Lawrence 1993).

Table 2. Inertial Rate Sensors

Sensor Type	Input Range (\pm °/s)	Bias Stability (°/hr)	Random Walk Angle (°/√hr)	Power (W)	Size	Cost
Quartz Rate Sensors	50-1000	7	0.05 - 1	0.8	2.8 cm ϕ x 1.5 cm deep, 60 gms	\$2000/axis
Ring Laser Gyros	1000	1	low	10	5 - 10 cm, heavy	prohibitive
Fiber Optic Gyros	1000	1	0.1	10	2.5 - 5 cm ϕ	\$1000/axis goal
Silicon Micro-machine Gyros	100	50	high	very low	very small	low

Bias stability (more properly called bias instability) is one measure of this variability in drift rate and is typically given in °/hr for specified operating conditions (e.g., 100 seconds at constant temperature and rate). The random component causes the inertial reticle to "dance" around the desired aim point.

Some gyros have an approximately white noise rate output that causes a long-term growth in angle error called random walk. This drift causes the inertial reticle to move off the desired aim point. For the IRS on the sniper rifle, this is the dominant factor resulting in the inertial reticle moving off the target.

3.1 Quartz Rate Sensors. Systron Donner makes the microminiature, solid-state Quartz Rate Sensors (QRS) used on the sniper rifle (Systron Donner 1994). The QRS sensing element is a micromachined, oscillating, quartz tuning fork. By using the Coriolis effect, a rotational motion about the sensor's input axis produces a DC voltage proportional to the rate of rotation. The sniper weapon uses $\pm 100^\circ/\text{s}$ sensors. The short-term bias stability (100 seconds at constant temperature) is $7^\circ/\text{hr}$. The random walk angle is approximately $0.6^\circ/\sqrt{\text{hr}}$. The device's power requirement is low (<0.8 W). It is self-contained in a compact, lightweight, rugged cylindrical package approximately 3.8 cm (1.5 in) in diameter and 1.5 cm (0.6 in) deep, with a nominal weight of 60 g. For the sniper weapon, two sensors are mounted in an aluminum block approximately 8 cm (3 in) square. For the OPW application, both the size and weight of this packaging must be reduced. The drift and walk of the sensors must also be lessened.

3.2 Ring Laser Gyros. The Ring Laser Gyro (RLG) is currently the most common type of sensor used for navigation systems. Precise, but relatively expensive, they offer bias stabilities on the order of $1^\circ/\text{hr}$ or better and have low noise characteristics. RLGs rely upon the Sagnac effect to measure rotation of the sensor. This effect is the phase difference that arises from counterrotating light in a closed cavity (e.g., a triangular cavity) when the cavity is rotated about an axis perpendicular to the plane of the cavity (Lawrence 1993, Chapter 13). Individual sensors are normally machined from blocks of thermally stable materials and have dimensions on the order of inches resulting in relatively substantial weights. Currently, cost is also a prohibitive constraint for the application of RLGs to the OPW.

3.3 Fiber Optic Gyros. Fiber Optic Gyros (FOG) are a lower cost, lower accuracy application of the Sagnac effect, in which (from a simplified view) a long spool of fiber optic cable replaces the laser cavity as the active element in the sensor (Lawrence 1993, Chapter 12). Efforts are now underway, in an Air Force-sponsored program, to reduce the sensor costs for a $1^\circ/\text{hr}$ device to the level of \$1000/axis or less. Sensor sensitivities are a function of the fiber optic cable spool diameter. Sensors of the described accuracy are expected to have a diameter between 2.5 cm and 5 cm (1 to 2 in).

3.4 Silicon Micromachined Gyros. Fabrication of silicon micro-machined gyros is based upon the technology used in the semiconductor industry to manufacture integrated circuits. In one example, a miniature drive mechanism is employed to move a proof mass in an oscillatory motion (Weinberg 1993). As in the case of the QRS, the motion of the proof mass together with the rotation of the sensor produces an out-of-plane force (or acceleration) that is sensed, usually by a capacitive pick-off. This force is proportional to the angular velocity. Significant effort has also been directed towards the development of these sensors for commercial applications such as active suspensions for automotive applications. Although this represents a significant driving force towards improvement of sensor capabilities, at present, these devices probably do not have the accuracy required for an IRS application.

4. IRS ON AN OBJECTIVE PERSONAL WEAPON

Whether the OPW will be a ballistic or directed-energy type weapon, the aiming technique that the IRS provides would apply. Without a fire control system like the IRS, it would be impossible, with a hand-held weapon, to hold the aim point steady on a target at 200 m long enough to acquire it and fire a shot. With the IRS, a shooter is able to position the inertial reticle onto the desired location of the target and have it remain there. He has time to confirm his aim point. The IRS anticipates when the two aim points will cross and fires the weapon within a very short time interval.

For a relatively stable platform like a prone sniper, the inertial reticle is placed on the target by moving the weapon. The IRS has also been implemented in more dynamic environments such as on board a helicopter and a fast attack vehicle. In these applications, the inertial reticle is positioned over the target by means of a joystick. A servo-motor controlled weapon platform causes the weapon aim point to chase after the inertial reticle.

The IRS on an OPW would operate much like the IRS on the sniper weapon. However, with a hand-held weapon, positioning the reticle over the target by means of gun motion alone would be difficult. For this reason, the IRS on an OPW would have two methods of positioning the inertial reticle: a coarse adjustment and a fine one. The coarse adjustment would be accomplished by slewing the weapon. This would allow a shooter to position the inertial reticle near the desired aim point. The inertial reticle would then be moved in finer steps by a thumb-controlled joystick or disk. Another possibility would be to "nudge" the reticle by means of short jerky motions of the weapon. The amount and direction of the nudge would be proportional to the speed and direction of the weapon jerk.

4.1 IRS/OPW with Video Sight and Display. This target and aim point information must be presented to the shooter in some manner. It could be displayed in a number of ways. The IRS/OPW could have a video sight and display similar to that on the IRS/sniper rifle (Figure 6). A small camera would be mounted parallel with the weapon barrel. The target image would be viewed on a compact, flat panel, video display mounted on the weapon. The image could be magnified, which might help with aiming. The weapon aim point and inertial reticle would be overlaid on the video image.

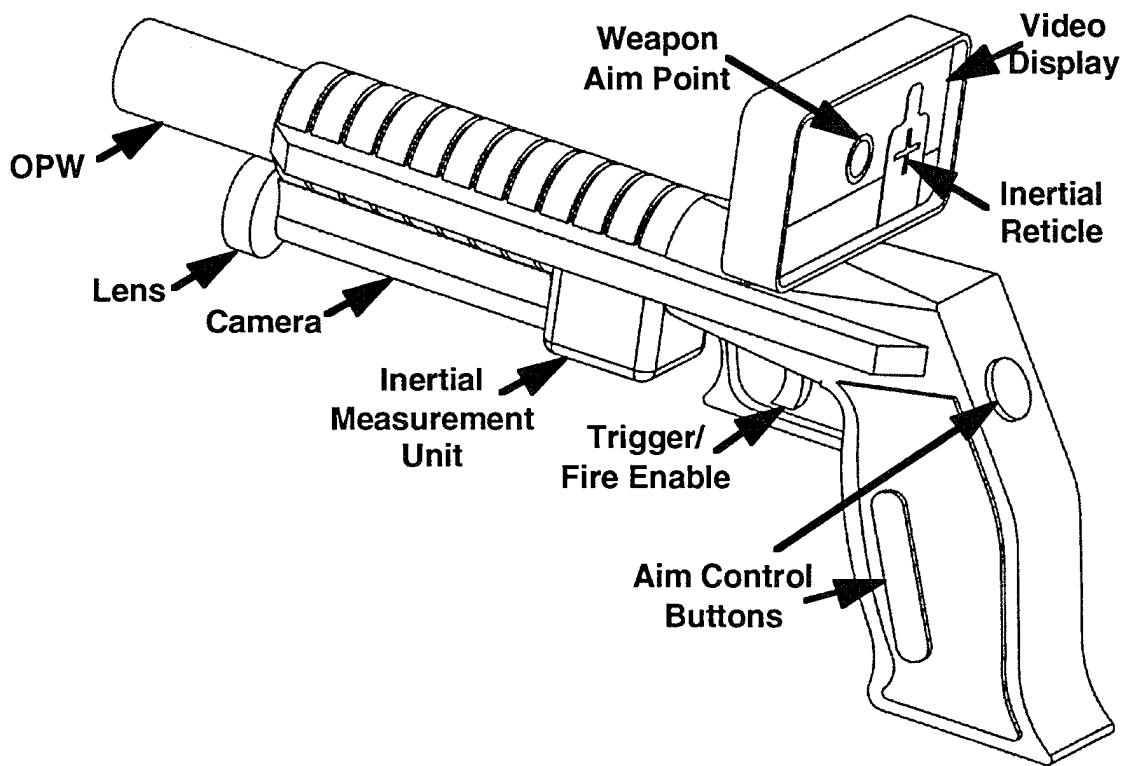

Figure 6. IRS/OPW with Video Sight.

4.2 IRS/OPW with Fiber Optic Sight. Because of the small size of the proposed OPW, it may not be practical to place a video sight and display system on the weapon itself. A fiber optic sight could greatly simplify the design by removing those functions from the weapon (Figure 7). A simple lens and fiber optic cable with a connection would be all that remains on the weapon. A CCD camera would be at the other end of the fiber optic cable rather than along the weapon line of sight. The image would be processed by off-weapon equipment and displayed on a helmet-mounted or goggle display or perhaps a display strapped to the operator's wrist.

This arrangement would have the advantage of enabling a shooter to "shoot from the hip," or fire from under cover or around corners. A disadvantage would be the need for a physical connection to the weapon. The cable leading to the CCD could be a stretchy, phone-cord type that would self-retract when the weapon is reholstered.

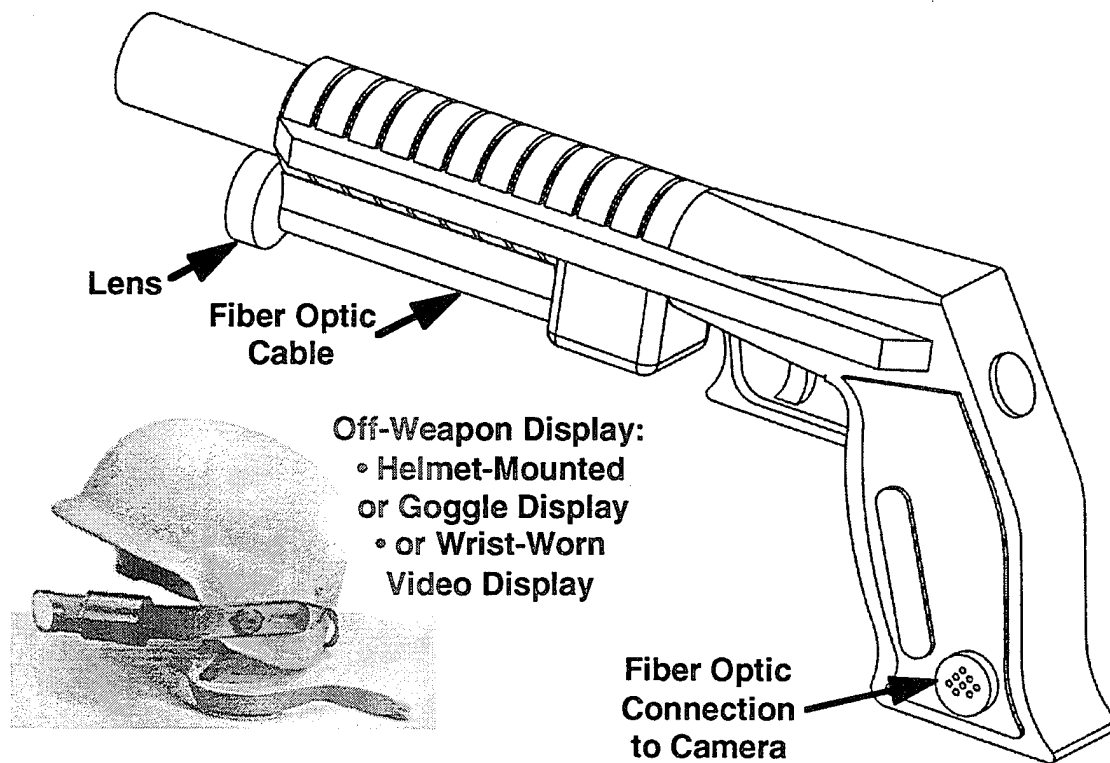

Figure 7. IRS/OPW with Fiber Optic Sight.

4.3 IRS/OPW with Video Scope. A video scope (Figure 8) integrates a video image into the optical path of a conventional scope that can be viewed through the eyepiece. A prototype video scope has been made for the sniper rifle. A notch filter is mounted at the front of the scope. When the filter is up, a conventional target image is viewed through the eyepiece. When the filter is down, the light from the target is reflected off an internal beam splitter into a CCD detector. This video image, along with the overlaid aim points, is then projected onto the opposite side of the beam splitter and out through the eyepiece. The shooter then sees a video image through the eyepiece instead of the direct target image.

A pistol is not typically equipped with a scope. Aiming is achieved by sighting down the length of the weapon barrel using iron sights. Even off-loaded, a video sighting system may add unacceptable complexity to the OPW. For these reasons, other methods for presenting the targeting information were sought.

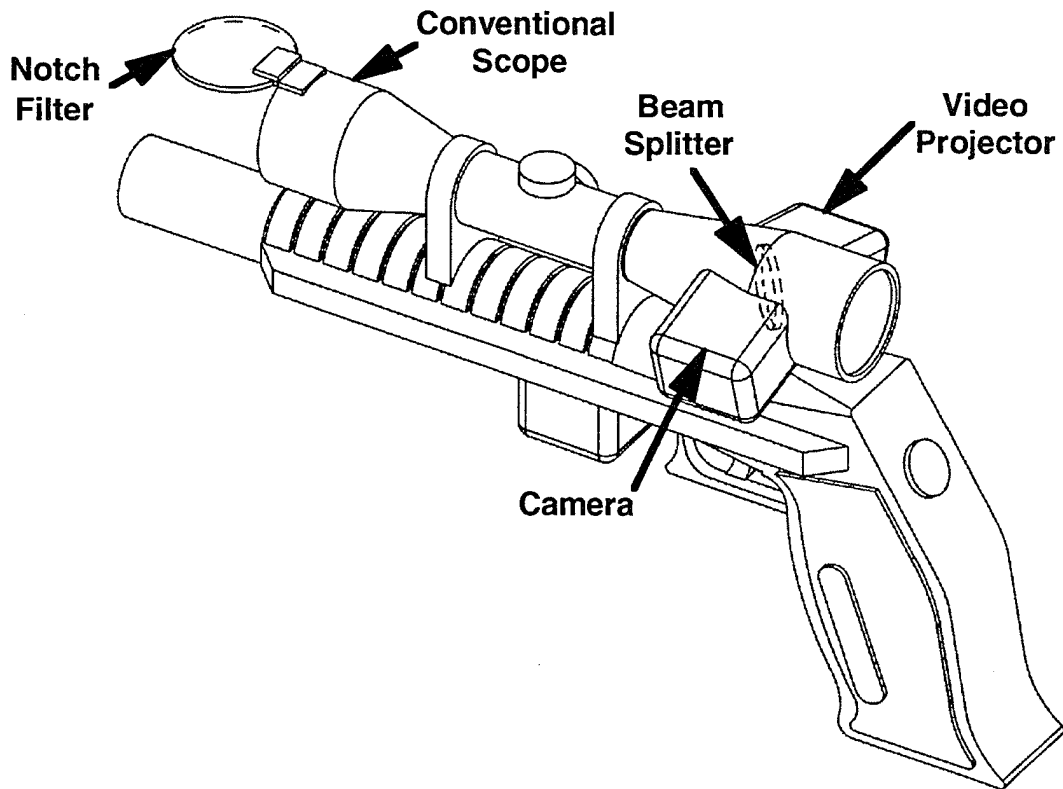

Figure 8. IRS/OPW with Video Scope.

4.4 IRS/OPW with Heads-Up Display. A possible alternative to a video system might be to have a type of heads-up display on the weapon (Figure 9). In this concept, the shooter views the target through a flip-up display panel onto which the aim points are projected.

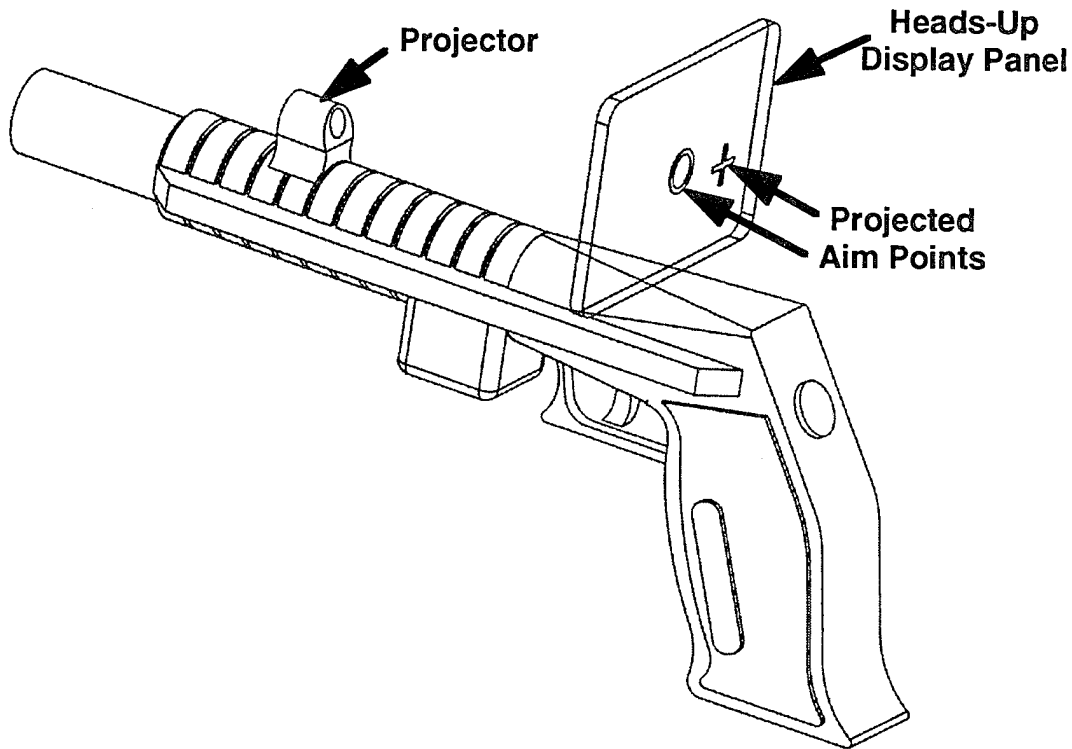

Figure 9. IRS/OPW with Heads-Up Display.

4.5 IRS/OPW with Laser Pointer. An intriguing method of allowing the shooter to select the desired aim point, without needing a gun's-eye-view at all, would be to have him designate the target with a laser pointer (Figure 10). In this proposal, a weapon-mounted laser would simply serve as a visual cue to the shooter as to where the weapon is pointing at any moment, much like current laser sights. However, an operator would not need to hold the laser spot on the target until the round was fired. Instead he would release a button on the weapon when the laser is on the desired aim point. The weapon would then "remember" its inertial position in space at that moment, and the next time it passes through that point the weapon would fire, provided the shooter had also enabled it to do so. If he had not fire-enabled the system, the laser would pulse (or

perhaps change color) each time the weapon passed through the previously selected aim point. This approach has the advantage of giving the shooter a chance to verify his aim point.

Laser pointers are already used on weapons. However, it may be difficult to project a laser beam out to 200 m from a weapon-mounted laser. In addition, it might not be possible to see a laser spot at 200 m without aided optics.

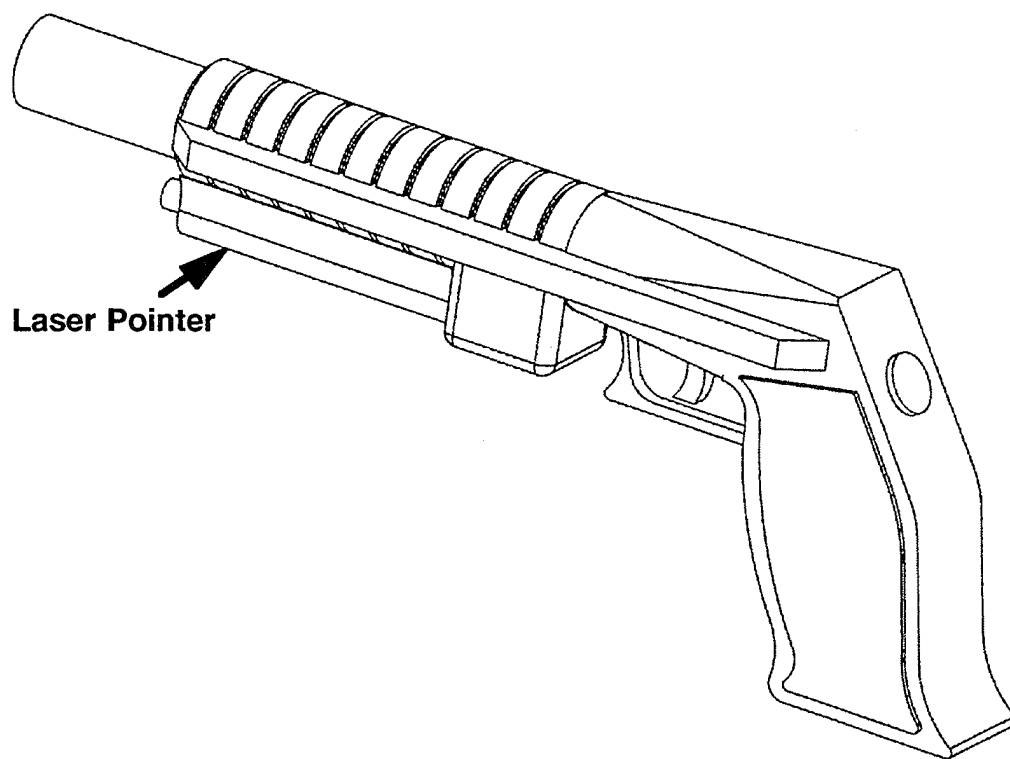

Figure 10. IRS/OPW with Laser Pointer.

4.6 IRS/OPW with Lased Target Detector. Another possible use of laser designation would be to have a helmet-mounted laser that points wherever the shooter looks. A sensor on the weapon would detect the laser spot on the target (Figure 11). The IRS would determine when the laser spot would cross through the center of the detector's field of view and fire the weapon automatically, provided the shooter has enabled the OPW to do so. However, it would be difficult to hold one's head steady in order to aim the laser designator at a target.

With this application, the target could be designated remotely by another party. A remote designator would be more stable. A shooter could more readily fire without having to stop running or walking and go into a fixed stance. The designator could identify one or more targets to be fired upon by more than one shooter. He could utilize a more powerful laser than could be carried by the shooter. The laser beam could even carry information through a modulated signal that could, for example, synchronize firings among several shooters.

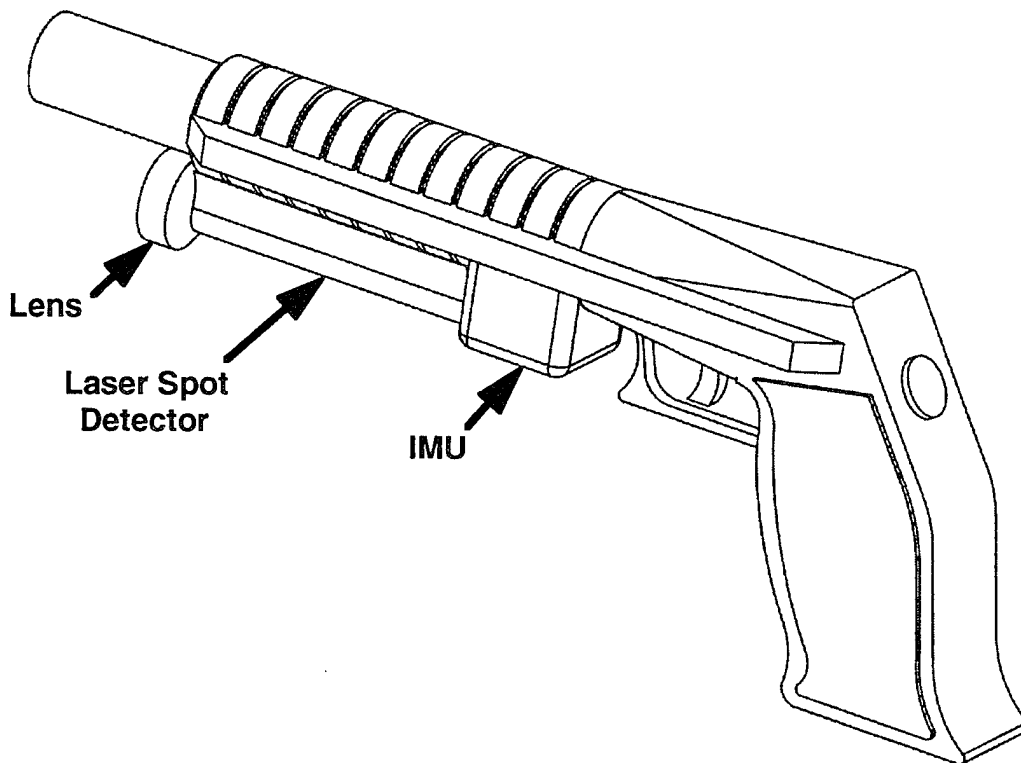

Figure 11. IRS/OPW with Lased Target Detector.

4.7 IRS/OPW as a Training Device. To achieve and maintain handgun proficiency requires extensive training and firing practice. Shooters are taught firing techniques and stances. Many rounds are expended at firing ranges. Ammunition and range time is expensive. Simulators have been developed whereby live ammunition is not fired. Proficiency is measured by the ability to hit a paper, pop-up, or video-projected target. Sheer repetition is often required to improve hit accuracy.

The IRS/OPW would measure weapon orientation and time of trigger pull. This information could be stored and played back after a firing session. Such data could reveal an improper aiming technique. A shooter could more readily learn the skill of target acquisition. An IRS-equipped handgun could be used in a firing range simulator without needing to fire live ammunition. The training device would thus save time and money by reducing training time and rounds fired.

5. TECHNICAL BARRIERS

Perhaps the greatest technical barrier to fitting the IRS on a pistol-size weapon is the need for miniaturization of components. The weight and bulk of an IRS on an OPW must be minimized. Therefore, small, lightweight, inertial sensors must be employed. Progress in inertial measurement units and work in micromachines make this possible. A pistol-mounted video sight system must also be made compact. A number of possible approaches have been mentioned.

The calculations and computations controlling the IRS could theoretically reside on the weapon, provided sufficient resources were expended to produce a custom microchip. An interim solution would be to use conventional electronics off the weapon. This would require a data link to the weapon.

Power requirements must be minimized so that available and realistically obtainable man-portable power packs will suffice. In addition, these components must be rugged enough to withstand the shock loading they would experience with the recoil of the weapon. One concern that must be addressed is the reliability of inertial sensors in this environment.

6. CONCLUSIONS

The IRS on an OPW would help achieve the OPW accuracy goal by reducing weapon pointing error. As a result, it will provide higher first hit probability. In addition, by enabling a shooter to preselect an aim point and maintain it despite weapon motion, the IRS would reduce collateral damage and aid in immediate incapacitation. The IRS has already been successfully demonstrated on small-caliber weapons. Several concepts for applying the IRS to an OPW have been presented. For the immediate future, quartz rate sensors, of the type used on the sniper rifle, would most likely be used on any prototype OPW. The IRS/OPW concept with the off-weapon display might offer the best means for the operator to select the desired aim point with the possible exception of the laser pointer. Technical barriers to fitting the IRS on a pistol-size weapon have been identified. Advances in electronics, IMUs, micromachines, and power sources make application of the IRS to an OPW feasible.

7. REFERENCES

Tullington, B.J., et al. The Objective Personal Weapon Shooters' Conference, 22-23 February 1995. Final Report, June 1995.

Lawrence, A. Modern Inertial Technology. New York: Springer-Verlag, 1993.

IEEE STD 528-1994. Standard for Inertial Sensor Terminology.

Systron Donner Inertial Division. Model QRS-11-00100-101 Quartz Rate Sensor Summary Specifications, 30 November 1994.

Weinberg, M., et al. "A Micromachined Comb-Drive Tuning Fork Rate Gyroscope." Proceedings of the 49th Annual Meeting "Future Global Navigation and Guidance." Cambridge, MA, 21-23 June 1993.

INTENTIONALLY LEFT BLANK

NO. OF
COPIES ORGANIZATION

2 DEFENSE TECHNICAL INFO CTR
ATTN DTIC DDA
8725 JOHN J KINGMAN RD
STE 0944
FT BEL VOIR VA 22060-6218

1 DIRECTOR
US ARMY RESEARCH LAB
ATTN AMSRL OP SD TA
2800 POWDER MILL RD
ADELPHI MD 20783-1145

3 DIRECTOR
US ARMY RESEARCH LAB
ATTN AMSRL OP SD TL
2800 POWDER MILL RD
ADELPHI MD 20783-1145

1 DIRECTOR
US ARMY RESEARCH LAB
ATTN AMSRL OP SD TP
2800 POWDER MILL RD
ADELPHI MD 20783-1145

ABERDEEN PROVING GROUND

5 DIRECTOR US ARL
ATTN AMSRL OP AP L (305)

5 COMMANDER
US ARMY ARMAMENT RD&E CTR
ATTN AMSTA AR FSF T
R LIESKE
J MATTS
F MIRABELLE
R PUHALLA
J WHITESIDE

34 DIR USARL
ATTN AMSRL WT
I MAY
J ROCCHIO
ATTN AMSRL TT TA
R DIMMICK
ATTN AMSRL WT W
C MURPHY
AMSRL WT WC
C SHOEMAKER
R PHELPS
J BORNSTEIN
B HAUG
T VONG
C HENRY
R VON WAHLDE (5)

T BROSSAU
M KREGEL
G HAAS
M TRAN
J SPANGLER
J McLAUGHLIN
N WOLFE
AMSRL WT WB
F BRANDON
G BROWN
B DAVIS
W D'AMICO
M HOLLIS
AMSRL WT WD
A NILER
AMSRL WT PB
E SCHMIDT
J GARNER
B GUIDOS
P PLOSTINS
H EDGE
K FANSLER

<u>NO. OF COPIES</u>	<u>ORGANIZATION</u>		
2	COMMANDER US ARMYARMAMENT RD&E CTR ATTN AMSTA AR CCJ S SMALL J GOLDMAN PICATINNY ARSENAL NJ 07806-5000	1	COMMANDER USA SOCOM ATTN AOFI RI SI MSG G HOPPLE FORT BRAGG NC 28307 5200
1	COMMANDER US ARMYARMAMENT RD&E CTR ATTN AMSTA AR CCL D H MOORE PICATINNY ARSENAL NJ 07806-5000	1	NICHOLS RESEARCH CORP ATTN G KAMERMAN URBAN CENTER TWO, SUITE 475 4890 WEST KENNEDY BLVD TAMPA FL 33609
1	DIRECTOR LOS ALAMOS NATIONAL LAB ATTN CST DO MS J563 O PETERSON LOS ALAMOS NM 87545	1	AAI CORP ATTN S BROWN PO BOX 126 HUNT VALLEY MD 21030-0126
1	DIRECTOR LOS ALAMOS NATIONAL LAB ATTN CST 2 MS J564 B NEWNAM LOS ALAMOS NM 87545	1	LORAL ATTN C PEARSON SUITE 900 1725 JEFFERSON DAVIS HWY ARLINGTON VA 22202-4159
1	DIRECTOR LOS ALAMOS NATIONAL LAB ATTN CST 1 MS J565 D MOORE LOS ALAMOS NM 87545	1	OPTICAL AIR DATA SYSTEMS ATTN P ROGERS PO BOX 34601 WEST BETHESDA MD 20827
1	DIRECTOR LOS ALAMOS NATIONAL LAB ATTN MS J567 R KARL LOS ALAMOS NM 87545	1	VISTA CONTROLS ATTN M NEMECHEK 27825 FREMONT COURT SANTA CLARITA CA 91355
3	DIRECTOR OAK RIDGE NATIONAL LAB PO BOX 2008 ATTN R DAVIS E WACHTER W FISHER LOS ALAMOS NM 87545	1	UNIVERSITY OF CONNECTICUT ATTN D MILLER 1376 STORRS RD, U-87 STORRS CT 06269-4087
1	ATTN AFWAL/AARI 2 R RICHMOND WRIGHT PATTERSON AFB OH 45433-6543	1	EO TECH ATTN M TAI PO BOX 134010 ANN ARBOR MI 48113-4010
1	OFFICE OF SPECIAL TECHNOLOGY ATTN J LAWRENCE 10530 RIVERVIEW RD, BLDG 3 FT WASHINGTON MD 20744-5841	1	FLEXIMATION INC ATTN W DITTRICH 4 TONNELIER WAY DENVER NJ 07834
		1	COR-BON CUSTOM BULLET CO ATTN L EICHLER 1311 INDUSTRY RD STURGIS SD 57785
		1	CONTRAVES FIRE CONTROL SYSTEMS ATTN L HARKLESS 615 EPSILON DR PITTSBURG PA 15238-2880

USER EVALUATION SHEET/CHANGE OF ADDRESS

This Laboratory undertakes a continuing effort to improve the quality of the reports it publishes. Your comments/answers to the items/questions below will aid us in our efforts.

- 1. ARL Report Number ARL-MR-289 Date of Report February 1996
- 2. Date Report Received _____
- 3. Does this report satisfy a need? (Comment on purpose, related project, or other area of interest for which the report will be used.) _____

- 4. Specifically, how is the report being used? (Information source, design data, procedure, source of ideas, etc.) _____

- 5. Has the information in this report led to any quantitative savings as far as man-hours or dollars saved, operating costs avoided, or efficiencies achieved, etc? If so, please elaborate. _____

- 6. General Comments. What do you think should be changed to improve future reports? (Indicate changes to organization, technical content, format, etc.) _____

CURRENT
ADDRESS

Organization

Name

Street or P.O. Box No.

City, State, Zip Code

7. If indicating a Change of Address or Address Correction, please provide the Current or Correct address above and the Old or Incorrect address below.

OLD
ADDRESS

Organization

Name

Street or P.O. Box No.

City, State, Zip Code

(Remove this sheet, fold as indicated, tape closed, and mail.)
(DO NOT STAPLE)

DEPARTMENT OF THE ARMY

OFFICIAL BUSINESS

BUSINESS REPLY MAIL
FIRST CLASS PERMIT NO 0001,APG,MD

POSTAGE WILL BE PAID BY ADDRESSEE

DIRECTOR
U.S. ARMY RESEARCH LABORATORY
ATTN: AMSRL-WT-WC
ABERDEEN PROVING GROUND, MD 21005-5066



NO POSTAGE
NECESSARY
IF MAILED
IN THE
UNITED STATES

