

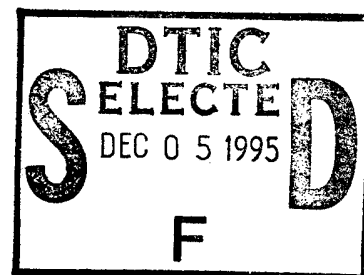

U.S. ARMY CORPS OF ENGINEERS  
BALTIMORE DISTRICT  
BALTIMORE, MARYLAND

CONTRACT NO. DACW31-90-D-0038



FINAL REPORT

ARCHAEOLOGICAL INVESTIGATIONS AT THE  
MEMORIAL PARK SITE (36CN164)  
CLINTON COUNTY, PENNSYLVANIA

by  
GAI CONSULTANTS, INC.  
570 BEATTY ROAD  
MONROEVILLE, PENNSYLVANIA

\*Original contains color  
plates: All DTIC reproductions  
will be in black and  
white\*

PROJECT 89-412

19951130 088

JANUARY 1995

DTIC QUALITY INSPECTED 5

DISTRIBUTION STATEMENT A: APPROVED FOR PUBLIC RELEASE

# DISCLAIMER NOTICE



**THIS DOCUMENT IS BEST QUALITY AVAILABLE. THE COPY FURNISHED TO DTIC CONTAINED A SIGNIFICANT NUMBER OF PAGES WHICH DO NOT REPRODUCE LEGIBLY.**



U.S. ARMY CORPS OF ENGINEERS  
BALTIMORE DISTRICT  
BALTIMORE, MARYLAND

CONTRACT NO. DACW31-90-D-0038

FINAL REPORT

ARCHAEOLOGICAL INVESTIGATIONS AT THE  
MEMORIAL PARK SITE (36CN164)  
CLINTON COUNTY, PENNSYLVANIA

by  
GAI CONSULTANTS, INC.  
570 BEATTY ROAD  
MONROEVILLE, PENNSYLVANIA

PROJECT 89-412

JANUARY 1995

Accession For	
NTIS CRA&I	<input checked="" type="checkbox"/>
DTIC TAB	<input type="checkbox"/>
Unannounced	<input type="checkbox"/>
Justification .....	
By .....	
Distribution / .....	
Availability Codes	
Dist	Avail and/or Special
A-1	

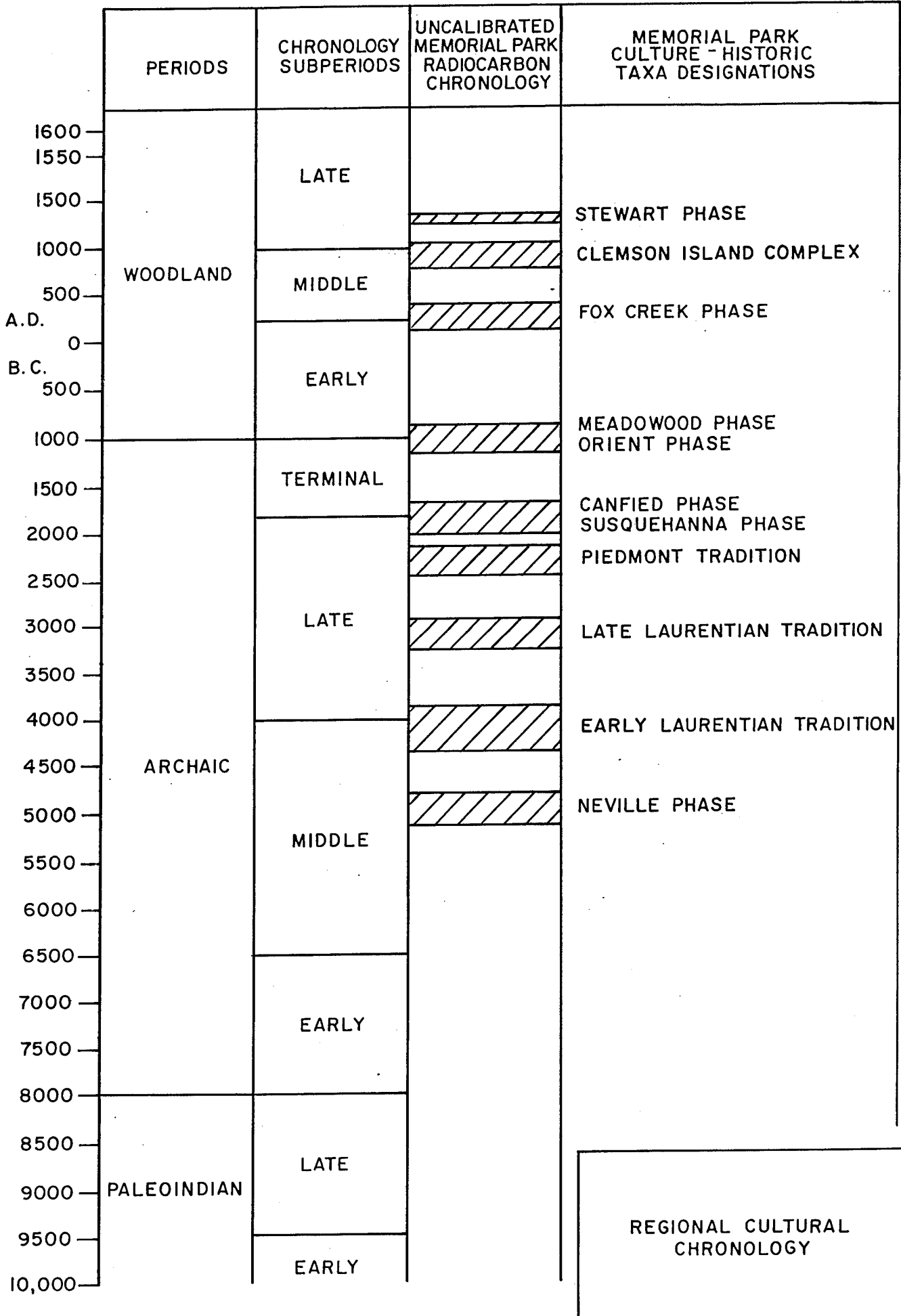

1600  
1550  
1500  
1000  
500  
A.D.  
0  
B.C.  
500  
1000  
1500  
2000  
2500  
3000  
3500  
4000  
4500  
5000  
5500  
6000  
6500  
7000  
7500  
8000  
8500  
9000  
9500  
10,000

## ABSTRACT

The Memorial Park site (36Cn164) is a multicomponent, prehistoric, open-air site, located in the valley of the West Branch of the Susquehanna River. The archaeological investigations at the Memorial Park site, reported in this volume, were designed to mitigate adverse impacts to Late Woodland deposits that will result from floodwall-levee construction, and to test deep deposits within the three-meter zone of compaction.

These investigations resulted in the definition of 13 components: four Late Woodland, one Middle Woodland, one Early Woodland, three Terminal Archaic, three Late Archaic, and one Middle Archaic. Geomorphological investigations indicate that the landscape has undergone substantial change from the Middle Archaic through Late Woodland periods. Factors in this change included the migration of the south channel of the West Branch, the formation of a terrace, a channel remnant, and a natural levee, and subsequent upbuilding of these landforms.

Changes in site function occurred throughout the site's history. During the Archaic period, the site served as a procurement camp during the Middle Archaic Neville and Late Archaic Piedmont occupations, and as a base camp during the Late Archaic early and late Laurentian occupations, the Terminal Archaic Canfield phase and Orient phase occupations. During the Late Woodland period, the site functioned as a farming hamlet or small habitation site.

Botanical data recovered from the site indicate that pepo gourd was in use during the late Laurentian occupation. This is the earliest report of cultigen use in central Pennsylvania, but is contemporaneous with use of this crop in the Midwest and Northeast. Squash was in use beginning in the Early Woodland period. Maize was recovered from a Middle Woodland feature dated to A.D. 150, suggesting an early adoption of this domesticate in central Pennsylvania. The recovery of two varieties of domesticated *Chenopodium*, little barley and tobacco seeds, in addition to maize, indicate a complex agricultural system during the Late Woodland. Late Woodland faunal remains indicate the exploitation of riverine, wetland, and terrestrial resources.

Pottery first appears at the Memorial Park site during the Orient phase occupation. During the Late Woodland period, pottery technology changes to facilitate an apparent increase in the utilization of agricultural produce. Lithic technology changes from an emphasis on a reliable, curated technology during the Archaic period, to an expedient technology during the Late Woodland period.



## TABLE OF CONTENTS

ABSTRACT .....	i
TABLE OF CONTENTS.....	iii
LIST OF APPENDICES .....	v
LIST OF FIGURES .....	vi
LIST OF TABLES .....	xi
I. INTRODUCTION <i>by John P. Hart, Ph.D.</i> .....	1
PURPOSE .....	1
PROJECT ADMINISTRATION AND ORGANIZATION .....	1
PREVIOUS RESEARCH AT THE MEMORIAL PARK SITE.....	4
CURRENT PROJECT SUMMARY .....	10
REPORT STRUCTURE.....	14
II. PROJECT LOCATION AND PHYSICAL SETTING <i>by David L. Cremeens, Ph.D.</i> ....	15
SITE LOCATION.....	15
PHYSIOGRAPHY.....	15
REGIONAL BEDROCK GEOLOGY.....	18
LOCAL BEDROCK GEOLOGY .....	18
GEOMORPHOLOGY AND HYDROLOGY .....	23
SOILS .....	25
PALEOCLIMATE .....	27
PALEOBOTONY.....	27
SUMMARY .....	30
III. CULTURAL BACKGROUND <i>by Jeffrey R. Graybill, Ph.D.</i> .....	33
PALEOINDIAN PERIOD (? - 8000 B.C.) .....	33
ARCHAIC PERIOD (8000-1000 B.C.).....	35
WOODLAND PERIOD (1000 B.C.-A.D. 1600) .....	44
CONTACT PERIOD AND HISTORICAL BACKGROUND <i>by Erica S. Gibson</i> .....	53
IV. RESEARCH DESIGN <i>by John P. Hart, Ph.D.</i> .....	57
GEOMORPHOLOGICAL INVESTIGATIONS AND SITE FORMATION STUDIES.....	57
OCCUPATIONAL SEQUENCES AND CHRONOLOGY.....	59
SUBSISTENCE STRATEGIES.....	60
TECHNOLOGY .....	63
SETTLEMENT PATTERNS .....	68
V. FIELD METHODS <i>by Jeffrey R. Graybill, Ph.D.</i> .....	73
TASK 1 .....	73
TASK 2 .....	81
TASK 3 .....	83
PUBLIC SAFETY PRECAUTIONS .....	86
SEDIMENT CONTROL .....	86
WATER SCREENING .....	86
FLOTATION PROCESSING.....	86
TASK 4 <i>by John P. Hart, Ph.D.</i> .....	87

VI.	GEOMORPHOLOGY AND SITE FORMATION <i>by David L. Cremeens, Ph.D.</i> .....	93
	INTRODUCTION AND OBJECTIVES.....	93
	METHODOLOGY .....	93
	RESULTS.....	95
	DISCUSSION.....	111
	SEDIMENTATION AND PEDOGENESIS.....	119
	SUMMARY .....	131
VII.	FIELD RESULTS.....	135
	INTRODUCTION <i>by John P. Hart, Ph.D.</i> .....	135
	LATE WOODLAND FEATURES <i>by Jeffrey R. Graybill, Ph.D.</i> .....	135
	OSTEOLOGICAL ANALYSIS OF HUMAN BONE FROM CLEMSON ISLAND FEATURES <i>by Susan R. Frankenberg, Ph.D.</i> .....	152
	PRE-LATE WOODLAND FEATURES <i>by Barbara A. Munford</i> .....	157
	RADIOCARBON ASSAYS <i>by Michael G. Spitzer and John P. Hart, Ph.D.</i> .....	192
	SUMMARY AND CONCLUSIONS .....	200
VIII.	POTTERY ANALYSIS <i>by John P. Hart, Ph.D.</i> .....	203
	METHODOLOGY .....	203
	LATE WOODLAND POTTERY ASSEMBLAGE DESCRIPTION.....	204
	LATE WOODLAND POTTERY FROM BLOCK 7 EXCAVATIONS.....	231
	LATE WOODLAND SMOKING-PIPE FRAGMENTS.....	235
	PRE-LATE WOODLAND POTTERY ASSEMBLAGE DESCRIPTION .....	235
	CROSS-FEATURE REFITTING.....	237
	TECHNICAL/FUNCTIONAL ANALYSIS.....	238
	SUMMARY .....	245
IX.	CHIPPED STONE ANALYSIS <i>by Michael G. Spitzer</i> .....	249
	INTRODUCTION AND RESEARCH OBJECTIVES .....	249
	METHODOLOGY .....	249
	ASSEMBLAGE DESCRIPTION.....	253
	TOOL DESCRIPTIONS .....	278
	TECHNOLOGICAL ANALYSIS.....	317
	SUMMARY AND CONCLUSIONS .....	406
X.	USE-WEAR ANALYSIS OF CHIPPED STONE ARTIFACTS	
	<i>by John P. Nass, Jr.</i> .....	411
	INTRODUCTION.....	411
	METHODS OF FUNCTIONAL ANALYSIS.....	411
	SAMPLES .....	416
XI.	COBBLE TOOLS, GROUND AND PECKED STONE TOOLS, AND STEATITE	
	<i>by John P. Hart, Ph.D.</i> .....	427
	LATE WOODLAND .....	427
	ORIENT.....	431
	TERMINAL ARCHAIC.....	433
	PIEDMONT.....	436
	LATE LAURENTIAN .....	437
	EARLY LAURENTIAN.....	439
	NEVILLE.....	443
	SUMMARY .....	443

XII.	ARCHAEOBOTANY <i>by Nancy Asch Sidell</i> .....	445
	NATURAL ENVIRONMENT .....	445
	METHODS OF RECOVERY AND ANALYSIS .....	446
	SAMPLE COMPOSITION.....	447
	WOOD.....	450
	BARK.....	452
	NUTS.....	452
	CUCURBITA RIND.....	453
	MAIZE .....	454
	SEEDS .....	455
	SUMMARY AND CONCLUSIONS .....	458
XIV.	FAUNAL ANALYSIS <i>by Cheryl A. Holt</i> .....	441
	METHODOLOGY.....	441
	COMPUTER ENTRY OF FAUNAL DATA.....	442
	RESULTS.....	442
	ANALYSIS OF ARCHAIC FAUNAL SPECIMENS.....	462
	SUMMARY .....	483
XIV.	POLLEN ANALYSIS <i>by Grace Brush, Ph.D.</i> .....	485
XV.	SPATIAL ANALYSIS OF FOUR MEMORIAL PARK COMPONENTS	
	<i>by Michael G. Spitzer</i> .....	493
	INTRODUCTION.....	493
	DYNAMIC PROCESSES AND FRACTAL GEOMETRY .....	494
	METHODOLOGY .....	495
	RESULTS.....	496
	SUMMARY AND CONCLUSIONS .....	504
XVI.	SUMMARY AND CONCLUSIONS <i>by John P. Hart, Ph.D.</i> .....	507
	GENERAL PROJECT SUMMARY.....	507
	GEOMORPHOLOGY AND SITE FORMATION.....	508
	OCCUPATIONAL SEQUENCES AND CHRONOLOGY.....	510
	SUBSISTENCE STRATEGIES.....	527
	TECHNOLOGY .....	530
	SETTLEMENT PATTERNS .....	539
	CONCLUSION .....	547
XVII.	REFERENCES CITED .....	549

Note: Document file was created for front-to-back pagination to reduce volume. To provide quality photo prints, single-side copy was required on photo figures. Some pages are renumbered with (a) in order to maintain integrity of pagination along with table-of-contents-referenced figures and tables.

## LIST OF APPENDICES

- Appendix A. Block Profiles and Descriptions: Soil Analysis Data
- Appendix B. Stripped Surface Non-cultural Soil Anomalies
- Appendix C. Late Woodland Human Skeletal Remains Coding Forms
- Appendix D. Artifact Analysis Instructions and Coding Forms
- Appendix E. Basics of Lithic Reduction Theory
- Appendix F. Microwear Photographs and Data Analysis Sheets
- Appendix G. Archaeobotanical Analysis Data
- Appendix H. Catalog of Faunal Specimens
- Appendix I. Artifact Catalog
- Appendix J. Qualifications of Key Personnel
- Appendix K. Schematic Profiles of 1x2m Test Units Showing Top of B Horizon
- Appendix L. Map of Estimated Overstripping



## LIST OF FIGURES

Figure 1.	Site Location.....	2
Figure 2.	Location of Site Relative to Northeastern and Mid-Atlantic Sites.....	3
Figure 3.	Estimated Site Boundaries based on National Register Nomination, Hay and Stevenson, 1982. ....	5
Figure 4.	Location of Phase II Test Pits.....	7
Figure 5.	Relationship of Memorial Park Site to Physiographic Provinces of the Northeastern United States. ....	16
Figure 6.	Location of Memorial Park Site in Relation to Pennsylvania Study Units.....	17
Figure 7.	Regional Bedrock Geology.....	21
Figure 8.	Local Bedrock Geology.....	22
Figure 9.	Project Area Soils .....	29
Figure 10.	Location of Study Area.....	75
Figure 11.	Location of 1 x 2 m Test Units.....	78
Figure 12.	Location of Shovel-Scraped Area Within Project Area and Distribution of Exposed Features.....	79
Figure 13.	Location of Task 2, 3, and 4 Block Excavations.....	84
Figure 14.	Sampling Scheme .....	99
Figure 15a.	Particle -Size Distributions for Blocks 1.....	101
Figure 15b.	Particle -Size Distributions for Blocks 2.....	102
Figure 15c.	Particle -Size Distributions for Blocks 3.....	103
Figure 15d.	Particle -Size Distributions for Blocks 4.....	104
Figure 15e.	Particle -Size Distributions for Blocks 5.....	105
Figure 15f.	Particle -Size Distributions for Blocks 6.....	106
Figure 15g.	Particle -Size Distributions for Blocks 7.....	107
Figure 16.	USDA Textural Classification of Soil Samples.....	108
Figure 17.	Lithostratigraphic Model.....	113
Figure 18.	Pedostratigraphic Model.....	120
Figure 19.	Site Formation Model.....	123
Figure 20.	Stratigraphic Model.....	127
Figure 21	Regional Correlation of Buried Soils.....	129
Figure 22a-d.	Geomorphic History Model of the Memorial Park Site.....	132
Figure 22e-g.	Geomorphic History Model of the Memorial Park Site.....	133
Figure 23.	Distribution of Features Exposed During Task 1 Investigations.....	137
Figure 24.	Location of Clemson Island Sites Mentioned in Text.....	139
Figure 25.	Storage Pits, Representative Plan Views and Profiles.....	144
Figure 26.	Fire-related Pits, Representative Plan Views and Profiles.....	150
Figure 27.	Distribution of Middle Woodland Features.....	165
Figure 28.	Distribution of Early Woodland Features.....	166
Figure 29.	Distribution of Orient phase Features.....	167
Figure 30.	Representative Plan Views and Profiles of Orient Phase Features.....	168
Figure 31.	Representative Notched Disks from Feature 182 Cache.....	171
Figure 32.	Representative Plan Views and Profiles of Terminal Archaic Pits.....	173
Figure 33.	Distribution of Terminal Archaic Features.....	174

Figure 34.	Cache from Terminal Archaic Feature 338.....	178
Figure 35.	Distribution of Piedmont Features.....	180
Figure 36.	Representative Plan Views and Profiles of Piedmont Features.....	181
Figure 37.	Representative Plan Views and Profiles of Late Laurentian Features.....	183
Figure 38.	Distribution of Late Laurentian Features.....	184
Figure 39.	Distribution of Early Laurentian Features.....	186
Figure 40.	Representative Plan Views and Profiles of Early Laurentian Features.....	187
Figure 41.	Distribution of Neville Features.....	193
Figure 42.	Plan Views and Profiles of Neville Features.....	194
Figure 43.	Pre-Late Woodland Radiocarbon Assays.....	197
Figure 44.	Late Woodland Radiocarbon Assays.....	198
Figure 45.	Group 1 Rim Sherd.....	207
Figure 46.	Group 2 Rim Sherd.....	208
Figure 47.	Group 3 Rim Sherds.....	210
Figure 48.	Group 4 Rim Sherds.....	211
Figure 49.	Group 5 Rim Sherds.....	212
Figure 50.	Group 6 Rim Sherds.....	213
Figure 51.	Group 7 Rim Sherds.....	217
Figure 52.	Group 8 Rim Sherds.....	218
Figure 53.	Group 9 Rim Sherds.....	219
Figure 54.	Group 10 Rim Sherds.....	220
Figure 55.	Group 11 Rim Sherds.....	222
Figure 56.	Group 12 Rim Sherds.....	223
Figure 57.	Group 13 Rim Sherd.....	225
Figure 58.	Early Clemson Island Incised Pipe Bowl.....	236
Figure 59.	Plots of Wall Thickness by Diameter for Clemson Island Vessels.....	242
Figure 60.	Plots of Wall Thickness and Diameter for Clemson Island Body Sherds.....	243
Figure 61.	Plot of Late Clemson Island Functional/Technological Groups Defined Through Cluster Analysis.....	246
Figure 62.	Representative Late Clemson Island Diagnostic Bifaces.....	281
Figure 63.	Representative Early Clemson Island Diagnostic Bifaces.....	286
Figure 64.	Representative Orient Phase Diagnostic Bifaces.....	291
Figure 65.	Representative Terminal Archaic Diagnostic Bifaces.....	296
Figure 66.	Representative Piedmont Diagnostic Bifaces.....	301
Figure 67.	Representative Late Laurentian Diagnostic Bifaces.....	304
Figure 68.	Representative Early Laurentian Diagnostic Bifaces.....	310
Figure 69.	Representative Neville Diagnostic Bifaces.....	315
Figure 70.	Cross Section of Workpiece and Flake Removed. Changes in Width (AW) and Thickness (AT) Illustrated.....	322
Figure 71.	Feedback Loop Illustrating the Relationship of Stimulus-Response to Sensory and Monitoring Process.....	323
Figure 72.	Polygonized Plot Representing Radioactive Decay.....	327
Figure 73.	Cumulative Decay by Weight (count) of Radioactive Material. a) Data Points, b. Step Plot.....	328
Figure 74.	Straight Line Fit and Nonlinear Fit to Same Data Set.....	329

Figure 75.	An example of Cumulative Flake Weight for Thinning versus Thickening.....	333
Figure 76.	Phase Plain Portrait of the Thinning Index vs. the Mean Reduction Effort.....	335
Figure 77.	Basic Reduction Subspaces on the Phase Plot.....	338
Figure 78.	Plot of Data Points and Linearized Best Fit Function Relating Workpiece width Decreases to Number of Flake Removals.....	343
Figure 79.	Plot of Data Points and Linearized Best Fit Function Relating Workpiece Thickness to Number of Flake Removals. ....	344
Figure 80.	Plot of Data Points and Linearized Best Fit Function Relating Workpiece Size Decreases to No. of Flake Removals. ....	345
Figure 81.	Polygon Plot of Individual Flake Weights versus Flake Number for Newcomer's Experimental Handaxe b. ....	346
Figure 82.	Plot of Workpiece (handaxe) Weight versus Number for Newcomer's Experimental Handaxe b. Least Squares Fit Indicated by Solid Line. ....	347
Figure 83.	Log-Log Plot of Width versus Thickness for Spitzer's and Cowan's Experimental Biface 1.....	348
Figure 84.	Plot of Data and Linearized Fit of Weight and Number of Flakes for a Cobble Testing Experiment. ....	350
Figure 85.	Weibull Fit of Weight versus Grade Size for a Knife River Flint Blade Core.....	351
Figure 86.	Weibull Fit of Count versus Grade Size for a Knife River Flint Blade Core.....	352
Figure 87.	Plot of Transformed Data for Experiment 1, 6 Large Cores, from Van Dyke and Behm (1981). ....	353
Figure 88.	Least Squares Fit and Data Plot for Knife River Flint Aggregate Data of Bipolar Cores. ....	354
Figure 89.	Least Squares Fit and Data Plot for Knife River Flint Aggregate Data of Bipolar Cores. ....	355
Figure 90.	Plot of Values for Raw Material Types in Phase Space for Stewart Phase. ....	361
Figure 91.	Plot of Values for Raw Material Types in Phase Space for Late Clemson Island.....	362
Figure 92.	Plot of Values for Raw Material Types in Phase Space for Early/Middle Clemson Island. ....	363
Figure 93.	Plot of Values for Raw Material Types in Phase Space for Late Woodland. ....	364
Figure 94.	Histogram of Proportions of Features with Values for Gray Chalcedony. ....	366
Figure 95.	Histogram of Proportions of Features with Values for Rhyolite. ....	367
Figure 96.	Histogram of Proportions of Features with Values for Yellow Jasper .....	368
Figure 97.	Plot of Values for Raw Material Types in Phase Space for the Orient Phase.....	372
Figure 98.	Plot of Values for Raw Material Types in Phase Space for the Terminal Archaic.....	373
Figure 99.	Plot of Values for Raw Material Types in Phase Space for the Piedmont Component.....	374
Figure 100.	Plot of Values for Raw Material Types in Phase Space for the Late Laurentian Component.....	375
Figure 101.	Plot of Values for Raw Material Types in Phase Space for the Early Laurentian Component. ....	377
Figure 102.	Plot of Values for Raw Material Types in Phase Space for the Neville Component.....	378
Figure 103.	Location in Phase Space of Dated Features for Argillite.....	382
Figure 104.	Location in Phase Space of Dated Features for Black Agate. ....	383
Figure 105.	Location in Phase Space of Dated Features for Dark Gray Chert. ....	384
Figure 106.	Location in Phase Space of Dated Features for Gray Chalcedony.....	385
Figure 107.	Location in Phase Space of Dated Features for Gray Chert.....	386
Figure 108.	Location in Phase Space of Dated Features for Rhyolite.....	387
Figure 109.	Location in Phase Space for Feature Group 2.....	388
Figure 110.	Location in Phase Space for Feature Group 3.....	389
Figure 111.	Location in Phase Space for Feature Group 5.....	390
Figure 112.	Plot Illustrating Direction of Dynamical Reduction Process.....	393
Figure 113.	An Example of Biface Thinning Reduction.....	397

Figure 114.	Space Occupied by Tools in Thinning Trajectory.....	398
Figure 115.	Thickening Trajectory. ....	399
Figure 116.	Space Occupied by Tools in Thickening Trajectory.....	400
Figure 117.	Cumulative Percentage of Width/Thickness Ratios for All Tools.....	401
Figure 118.	Plots of Width Thickness Ratios for Stewart Phase through Early Woodland Components .....	403
Figure 119.	Plots of Width Thickness Ratios for Orient through Neville Components.....	404
Figure 120.	Tool Actions Resulting in Microwear. ....	412
Figure 121.	Selected Artifacts Showing Areas with Use-wear. ....	417
Figure 122.	Distribution of Features Containing Artifacts with Use-wear. ....	422
Figure 123.	Photograph of Late Woodland Hafted Implements.....	428
Figure 124.	Photograph of Clemson Island Pendent.....	430
Figure 125.	Photograph of Terminal Archaic Notched Disks and Grooved Stones.....	435
Figure 126.	Photograph of Terminal Archaic Groundstone Implements. ....	437
Figure 127.	Photograph of Late Laurentian Groundstone Implements.....	438
Figure 128.	Photograph of Early Laurentian Adzes. ....	441
Figure 129.	Photograph of Early Laurentian Pestles. ....	442
Figure 130.	Temporal Assignments of Features on Stripped Surface.....	523
Figure 131.	Percent Weight of Non-local Raw Material Debris for Memorial Park Component.....	536
Figure 132.	Shannon-Weaver Information Statistic for Lithic Raw Material Debris Counts.....	538

## LIST OF TABLES

Table 1.	Feature Sampling Design.....	77
Table 2.	Vertical Distribution of Artifacts in Block 1. ....	88
Table 3.	Vertical Distribution of Artifacts in Block 2. ....	88
Table 4.	Vertical Distribution of Artifacts in Block 3. ....	89
Table 5.	Vertical Distribution of Artifacts in Block 4. ....	89
Table 6.	Vertical Distribution of Artifacts in Block 5. ....	90
Table 7.	Vertical Distribution of Artifacts in Block 6. ....	90
Table 8.	Vertical Distribution of Artifacts in Block 7. ....	91
Table 9.	Temporal Distribution of Features Exposed During Tasks 2 and 3.....	91
Table 10.	Distribution of Task 4 Excavations. ....	92
Table 11.	Geomorphic History of the Memorial Park Site.....	134
Table 12.	Form and Metric Summary of Postmold Sample. ....	136
Table 13.	Metric Attribute Summary for Postmold Pits.....	140
Table 14.	Summary of Structure Patterns.....	140
Table 15.	Metric Summary of Storage Pits .....	143
Table 16.	Metric Data for Individual Storage Pits.....	147
Table 17.	Comparison of Storage Pits from Three Clemson Island Sites.....	148
Table 18.	Metric Summary of Fire-related Pits.....	148
Table 19.	Metric Data for Individual Fire-related Pits.....	149
Table 20.	Comparison of Fire-Related Pits from Three Clemson Island Sites.....	151
Table 21.	Itemized Description of Human Skeletal Remains from Feature 92. ....	155
Table 22.	Itemized Description of Human Skeletal Remains from Feature 96. ....	156
Table 23.	Metric Data for Pre-Late Woodland Features.....	159
Table 24.	Metric Summary of Orient Fire-Related Pits.....	169
Table 25.	Metric Summary of Orient Oxidized and Charcoal Stains.....	169
Table 26.	Metric Summary of Orient Oxidized Stains.....	169
Table 27.	Metric Summary of Terminal Archaic Fire-Related Pits.....	170
Table 28.	Metric Summary of Terminal Archaic Cobble Hearths.....	172
Table 29.	Metric Summary of Terminal Archaic Oxidized Charcoal Stains.....	175
Table 30.	Metric Summary of Terminal Archaic Oxidized Stains.....	175
Table 31.	Metric Summary of Terminal Archaic Charcoal Stains.....	176

Table 32.	Bone Identification of Tentative Feature 257 Cremation .....	176
Table 33.	Bone Identification of Cache Feature 338.....	177
Table 34.	Metric Summary of Piedmont Fire-Related Pits.....	177
Table 35.	Metric Summary of Piedmont Oxidized and Charcoal Stains.....	179
Table 36.	Metric Summary of Late Laurentian Fire-Related Pits.....	182
Table 37.	Metric Summary of Late Laurentian Burned-wood Features.....	182
Table 38.	Metric Summary of Late Laurentian Oxidized Charcoal Stains.....	185
Table 39.	Metric Summary of Late Laurentian Rock Clusters.....	185
Table 40.	Metric Summary of Early Laurentian Fire-Related Pits.....	185
Table 41.	Metric Summary of Early Laurentian Smudge Pits. ....	188
Table 42.	Metric Summary of Early Laurentian Burned Wood Features.....	188
Table 43.	Metric Summary of Early Laurentian Oxidized and Charcoal Stains.....	189
Table 44.	Metric Summary of Early Laurentian Charcoal Stains.....	189
Table 45.	Metric Summary of Early Laurentian Rock Clusters.....	190
Table 46.	Metric Summary of Neville Fire-Related Pits. ....	190
Table 47.	Radiocarbon Assay Summary.....	195
Table 48.	Two by Two Comparisons of Radiocarbon Assays from Late Woodland Features.....	199
Table 49.	Summary of Radiocarbon Dating Information for Late Woodland Feature Groups.....	200
Table 50.	Technological and Form Attributes for Descriptive Group 1.....	205
Table 51.	Technological and Form Attributes for Descriptive Group 2.....	206
Table 52.	Technological and Form Attributes for Descriptive Group 3.....	216
Table 53.	Technological and Form Attributes for Descriptive Group 4.....	209
Table 54.	Technological and Form Attributes for Descriptive Group 5.....	209
Table 55.	Technological and Form Attributes for Descriptive Group 6.....	214
Table 56.	Technological and Form Attributes for Descriptive Group 7.....	214
Table 57.	Technological and Form Attributes for Descriptive Group 8.....	215
Table 58.	Technological and Form Attributes for Descriptive Group 9.....	216
Table 59.	Technological and Form Attributes for Descriptive Group 10.....	216
Table 60.	Technological and Form Attributes for Descriptive Group 12.....	222
Table 61.	Technological and Form Attributes for Descriptive Group 12.....	221
Table 62.	Technological and Form Attributes for Descriptive Group 13.....	224
Table 63.	Technological and Form Attributes for Descriptive Group 14.....	224
Table 64.	Technological and Form Attributes for Descriptive Group 15.....	226
Table 65.	Technological and Form Attributes for Stewart Incised Rim Sherds.....	226

Table 66.	Distribution of Late Woodland Descriptive Pottery Groups. ....	227
Table 67.	Distribution of Temper Groups for Late Woodland Components.....	228
Table 68.	Exterior Surface Treatment of Late Woodland Component Body Sherds.....	229
Table 69.	Interior Surface Treatment of Late Woodland Component Body Sherds. ....	230
Table 70.	Early Clemson Island Interior and Exterior Surface Finish Combinations.....	230
Table 71.	Middle Clemson Island Interior and Exterior Surface Finish Combinations.....	230
Table 72.	Late Clemson Island Interior and Exterior Surface Finish Combinations.....	231
Table 73.	Stewart Phase Interior and Exterior Surface Finish Combinations.....	231
Table 74.	Late Woodland Component Body Sherd Decorative Technique. ....	232
Table 75.	Vertical Distribution of Rimsherds in Block 7.....	232
Table 76.	Distribution of Tempering Groups for Block 7 Late Woodland Pottery.....	233
Table 77.	Exterior Surface Treatment of Block 7 Late Woodland Body Sherds. ....	233
Table 78.	Interior Surface Treatment of Block 7 Late Woodland Body Sherds.....	234
Table 79.	Exterior Decorative Treatment of Block 7 Late Woodland Body Sherds.....	234
Table 80.	Regression of Diameter on Wall Thickness for All Clemson Island Vessels. ....	239
Table 81.	Regression of Diameter on Wall Thickness for Early/Middle Clemson Island Vessels.....	240
Table 82.	Regression of Diameter on Wall Thickness for Late Clemson Island Vessels.....	240
Table 83.	Regression of Diameter on Wall Thickness for All Clemson Island Body Sherds.....	240
Table 84.	Regression of Diameter on Wall Thickness for Early/Middle Clemson Island Body Sherds.....	240
Table 85.	Regression of Diameter on Wall Thickness for Late Clemson Island Body Sherds. ....	240
Table 86.	Pearson Correlation Matrix for Combined Early/Middle Clemson Island Pottery.....	241
Table 87.	Pearson Correlation Matrix for Combined Early/Middle Clemson Island Pottery.....	244
Table 88.	Cluster Analysis of Late Clemson Island Pottery Technological Attributes.....	244
Table 89.	Summary Statistics for Late Clemson Island Sherd Cluster Analysis Groups. ....	244
Table 90.	Standard Sieve Size and Opening Data for Mass Analysis.....	252
Table 91.	Stewart Phase Debris Frequencies by Raw Material Class. ....	256
Table 92.	Stewart Phase Debris Weights by Raw Material Class. ....	256
Table 93.	Stewart Phase Debris with Cortex by Raw Material Class.....	256
Table 94.	Stewart Phase Heat-altered Debris by Raw Material Class. ....	257
Table 95.	Late Clemson Island Debris Counts by Raw Material Class.....	257
Table 96.	Late Clemson Island Debris Weights by Raw Material Class. ....	258
Table 97.	Late Clemson Island Debris with Cortex by Raw Material Class. ....	258
Table 98.	Late Clemson Island Heat-alteration Debris by Raw Material Class.....	258

Table 99.	Early Clemson Island Debris Counts by Raw Material Class. ....	259
Table 100.	Early Clemson Island Debris Weights by Raw Material Class. ....	259
Table 101.	Early Clemson Island Debris with Cortex.....	260
Table 102.	Early Clemson Island Heat-altered Debris. ....	260
Table 103.	Middle Woodland Debris Counts by Raw Material Class.....	261
Table 104.	Middle Woodland Debris Weights by Raw Material Class. ....	261
Table 105.	Middle Woodland Debris with Cortex.....	261
Table 106.	Middle Woodland Heat-altered Debris.....	262
Table 107.	Early Woodland Debris Counts by Raw Material Class.....	262
Table 108.	Early Woodland Debris Weights by Raw Material Class. ....	263
Table 109.	Early Woodland Debris with Cortex.....	263
Table 110.	Early Woodland Heat Altered Debris.....	263
Table 111.	Orient Phase Debris Counts by Raw Material Class. ....	264
Table 112.	Orient Phase Debris Weights by Raw Material Class.....	264
Table 113.	Orient Phase Debris with Cortex.....	265
Table 114.	Orient Phase Heat-altered Debris.....	265
Table 115.	Terminal Archaic Debris Counts by Raw Material Class.....	266
Table 116.	Terminal Archaic Debris Weights by Raw Material Class.....	266
Table 117.	Terminal Archaic Debris with Cortex.....	267
Table 118.	Terminal Archaic Heat-altered Debris. ....	267
Table 119.	Piedmont Debris Counts by Raw Material Class. ....	268
Table 120.	Piedmont Debris Weight by Raw Material Class.....	268
Table 121.	Piedmont Debris with Cortex.....	269
Table 122.	Piedmont Heat-altered Chipped Stone Debris. ....	269
Table 123.	Late Laurentian Debris Counts by Raw Material Class. ....	270
Table 124.	Late Laurentian Debris Weights by Raw Material Class. ....	270
Table 125.	Late Laurentian Debris with Cortex.....	271
Table 126.	Late Laurentian Heat-altered Debris.....	271
Table 127.	Early Laurentian Debris Counts by Raw Material Class. ....	272
Table 128.	Early Laurentian Debris Weight by Raw Material Category.....	272
Table 129.	Early Laurentian Debris with Cortex.....	273
Table 130.	Early Laurentian Heat-altered Debris. ....	273
Table 131.	Neville Debris Counts by Material Class.....	274
Table 132.	Neville Debris Weights by Raw Material Class. ....	274



Table 133.	Neville Debris with Cortex. ....	275
Table 134.	Neville Heat-altered Debris. ....	275
Table 135.	Summary of Sampling Results for Macrowear. ....	276
Table 136.	Frequency of Activities/Worked Material by Feature. ....	277
Table 137.	Raw Material Counts of Utilized Debris. ....	278
Table 138.	Metric Attributes for Stewart Phase Non-diagnostic Bifaces. ....	279
Table 139.	Stewart Phase Non-diagnostic Biface Counts by Raw Material. ....	279
Table 140.	Metric Attributes for Stewart Phase Edge-only Tools. ....	280
Table 141.	Edge-only Tool Counts by Raw Material Class. ....	280
Table 142.	Raw Material and Metric Data for Late Clemson Island Diagnostic Bifaces. ....	280
Table 143.	Metric Attributes for Late Clemson Island Non-diagnostic Bifaces. ....	282
Table 144.	Late Clemson Island Non-diagnostic Biface Counts by Raw Material Class. ....	282
Table 145.	Metric Attributes for Late Clemson Island Unifaces. ....	282
Table 146.	Late Clemson Island Uniface Counts by Raw Material Class. ....	282
Table 147.	Metric Attributes Late Clemson Island Edge-only Tools. ....	283
Table 148.	Late Clemson Island Edge-only Tool Counts by Raw Material Class. ....	283
Table 149.	Metric Attributes for Late Clemson Island Core Types. ....	284
Table 150.	Late Clemson Island Core Counts by Raw Material Class. ....	284
Table 151.	Raw Material and Metric Data for Early/Middle Clemson Island Diagnostic Bifaces. ....	285
Table 152.	Metric Attributes for Early/Middle Clemson Island Non-diagnostic Bifaces. ....	285
Table 153.	Early/Middle Clemson Island Non-diagnostic Bifaces by Raw Material Class. ....	287
Table 154.	Metric Attributes for Early and Middle Clemson Island Unifaces. ....	287
Table 155.	Early/Middle Clemson Island Uniface Counts by Raw Material Class. ....	287
Table 156.	Metric Attributes for Early/Middle Clemson Island Edge-only Tools. ....	288
Table 157.	Early/Middle Clemson Island Edge-only Tool Counts by Raw Material Class. ....	288
Table 158.	Metric Attributes for Early/Middle Clemson Island Core Types. ....	289
Table 159.	Early/Middle Clemson Island Core Counts by Raw Material Class. ....	289
Table 160.	Raw Material and Metric Data for Early Woodland Diagnostic Bifaces. ....	290
Table 161.	Raw Material and Metric Data for Orient Phase Diagnostic Bifaces. ....	290
Table 162.	Metric Attributes for Orient Phase Non-diagnostic Bifaces. ....	292
Table 163.	Orient Phase Non-diagnostic Biface Counts by Raw Material Class. ....	292
Table 164.	Metric Attributes of Orient Phase Unifaces. ....	293
Table 165.	Orient Phase Uniface Counts by Raw Material Class. ....	293
Table 166.	Metric Attributes for Orient Phase Edge-only Tools. ....	293

Table 167.	Orient Phase Edge-only Tool Counts by Raw Material Class.....	294
Table 168.	Metric Attributes for Orient Phase Core Types.....	294
Table 169.	Orient Phase Core Counts by Raw Material Class.....	294
Table 170.	Raw Material and Metric Data for Terminal Archaic Diagnostic Bifaces.....	295
Table 171.	Metric Attributes for Non-diagnostic Terminal Archaic Bifaces.....	297
Table 172.	Non-diagnostic Terminal Archaic Biface Counts by Raw Material Class.....	297
Table 173.	Metric Attributes for Terminal Archaic Unifaces.....	298
Table 174.	Terminal Archaic Uniface Counts by Raw Material Class.....	298
Table 175.	Metric Attributes for Terminal Archaic Edge-only Tools.....	299
Table 176.	Terminal Archaic Edge-only Tool Counts by Raw Material Class.....	299
Table 177.	Metric Attributes for Terminal Archaic Core Types.....	299
Table 178.	Terminal Archaic Core Counts by Raw Material Class.....	300
Table 179.	Raw Material and Metric Data for Diagnostic Piedmont Bifaces.....	300
Table 180.	Metric Attributes for Non-diagnostic Piedmont Bifaces.....	300
Table 181.	Non-diagnostic Piedmont Biface Raw Material Frequencies.....	302
Table 182.	Metric Attributes for Piedmont Edge-only Tools.....	302
Table 183.	Piedmont Edge-only Tool Counts by Raw Material Class.....	302
Table 184.	Raw Material and Metric Data for Late Laurentian Diagnostic Bifaces.....	305
Table 185.	Late Laurentian Non-diagnostic Biface Metric Attributes.....	306
Table 186.	Late Laurentian Non-diagnostic Biface Counts by Raw Material Class.....	306
Table 187.	Metric Attributes for Late Laurentian Unifaces.....	306
Table 188.	Late Laurentian Uniface Counts by Raw Material Class.....	306
Table 189.	Metric Attributes for Late Laurentian Edge-only Tools.....	307
Table 190.	Late Laurentian Edge-only Tool Counts by Raw Material Class.....	307
Table 191.	Metric Attributes for Late Laurentian Core Types.....	308
Table 192.	Late Laurentian Core Counts by Raw Material Class.....	308
Table 193.	Raw Material and Metric Data for Early Laurentian Diagnostic Bifaces.....	309
Table 194.	Early Laurentian Non-diagnostic Biface Metric Attributes.....	311
Table 195.	Early Laurentian Non-diagnostic Biface Counts by Raw Material.....	311
Table 196.	Early Laurentian Uniface Metric Attributes.....	311
Table 197.	Early Laurentian Uniface Counts by Raw Material Class.....	312
Table 198.	Early Laurentian Edge-only Tool Metric Attributes.....	312
Table 199.	Early Laurentian Edge-only Tool Raw Material Frequencies.....	313
Table 200.	Metric Attributes for Early Laurentian Core Types.....	313

Table 201.	Early Laurentian Core Counts by Raw Material Class. ....	314
Table 202.	Raw Material and Metric Data for Neville Diagnostic. ....	314
Table 203.	Non-diagnostic Neville Biface Metric Attributes.....	314
Table 204.	Non-diagnostic Neville Biface Counts by Raw Material Class.....	314
Table 205.	Metric Attributes for Neville Edge-only Tools. ....	316
Table 206.	Neville Edge-only Tool Counts by Raw Material Class.....	316
Table 207.	Metric Attributes for Neville Core Types. ....	316
Table 208.	Neville Core Counts by Raw Material Class.....	316
Table 209.	Summary of Testing Results for Experimental Data. ....	317
Table 210.	Stewart Phase Scale Values for Raw Material by Locality.....	340
Table 211.	Late Clemson Island Scale Values for Raw Material by Locality. ....	358
Table 212.	Early/Middle Clemson Island Scale Values for Raw Material by Locality. ....	359
Table 213.	Combined Late Woodland Scale Values for Raw Material by Locality.....	360
Table 214.	Middle Woodland Scale Values for Raw Material by Locality.....	365
Table 215.	Early Woodland Scale Values for Raw Material by Locality.....	365
Table 216.	Orient Phase Scale Values for Raw Material by Locality.....	369
Table 217.	Terminal Archaic Scale Values for Raw Material by Locality. ....	370
Table 218.	Piedmont Component Scale Values for Raw Material by Locality ....	370
Table 219.	Late Laurentian Scale Values for Raw Material by Locality. ....	371
Table 220.	Early Laurentian Scale Values for Raw Material by Locality. ....	371
Table 221.	Neville Component Scale Values for Raw Material by Locality.....	376
Table 222.	Late Woodland Dated Feature Groups and Scale Values for Argillite. ....	376
Table 223.	Late Woodland Dated Feature Groups and Scale Values for Black Agate.....	379
Table 224.	Late Woodland Dated Feature Groups and Scale Values for Dark Gray Chert.....	379
Table 225.	Dated Feature Groups and Scale Values for Gray Chalcedony.....	379
Table 226.	Late Woodland Dated Feature Groups and Scale Values for Gray Chert. ....	380
Table 227.	Late Woodland Dated Feature Groups and Scale Values for Rhyolite.....	380
Table 228.	Contingency Table Analysis of Feature Group 2 ....	381
Table 229.	Theoretical Contingency Tables of Observed (a) and Postulated (b) Relations Among Feature Groups from Earlier versus Later Time Periods in Phase Subspace. ....	391
Table 230.	Results of Feature Group Comparisons for Phase Space Subspaces.....	392
Table 231.	Results for the Kolmogorov-Smirnov Test Between Components for Width-Thickness Ratio (see text for explanation). ....	402
Table 232.	Frequencies of Edge-only Tools and Bifaces for Six Memorial Park Components.....	405

Table 233.	Frequencies of Edge-only Tools and Bifaces for Woodland and Archaic Periods.....	405
Table 234.	Summary of Chi-square Test Results for Two by Two Comparisons. ....	405
Table 235.	Chipped-Stone Tools from Late Woodland Features.....	418
Table 236.	Percentage of Used Lithic Items from Late Woodland Features. ....	418
Table 237.	Summary of Tool Actions for Late Woodland Features.....	418
Table 238.	Tool Actions Associated with Clemson Island Components .....	419
Table 239.	Microwear Summary of Actions for Clemson Island Artifacts.....	420
Table 240.	Microwear Summary for Stewart Phase and Unassigned Late Woodland Features. ....	425
Table 241.	Lithics Artifacts from all Archaic Period Components. ....	425
Table 242.	Frequency of Artifact Types with Use-wear.....	426
Table 243.	Component Distribution of Examined Tools.....	426
Table 244.	Microwear Summary of Actions for Archaic Components.....	426
Table 245.	Archaic Period Microwear According to Tool Class.....	426
Table 246.	Summary of Metric data for Pitted Stones .....	429
Table 247.	Summary Statistics for Orient Phase Notched Disks.....	432
Table 248.	Summary Statistics for Orient Phase Pitted Stones .....	432
Table 249.	Summary Statistics for Orient Phase Hammerstones .....	432
Table 250.	Summary Statistics for Terminal Archaic Pitted Cobbles/Anvils.....	434
Table 251.	Summary Statistics for Late Laurentian Hammerstones.....	439
Table 252.	Summary of Carbonized Plant Remains. ....	447
Table 253.	Percentage Composition of Carbonized Plant Remains.....	449
Table 254.	Wood Summary.....	451
Table 255.	Nutshell Summary.....	453
Table 256.	Seed Summary.....	456
Table 257.	Economic Categories of Seeds .....	456
Table 258.	<i>Chenopodium berlandieri</i> Measurements .....	457
Table 259.	Late Woodland Faunal Distribution.....	463
Table 260.	Distribution of Late Woodland Faunal Specimens by Feature.....	464
Table 261.	Late Woodland Deer Element Distribution .....	469
Table 262.	Distribution of Fish Elements. ....	476
Table 263.	Minimum Number of Individuals by Late Woodland Feature.....	479
Table 264.	Minimum Number of Fish Individuals by Late Woodland Feature Level.....	480
Table 265.	Terminal Archaic and Late Archaic Faunal Specimens.....	483
Table 266.	Pollen and Spore Percentages for Late Woodland Features. ....	485

Table 267.	Pollen and Spore Percentages for the Orient Phase.....	487
Table 268.	Pollen and Spore Percentages for the Terminal Archaic Period.....	488
Table 269.	Pollen and Spore Percentages for the Piedmont Tradition.....	489
Table 270.	Pollen and Spore Percentages for Late Laurentian.....	490
Table 271.	Pollen and Spore Percentages for Early Laurentian.....	491
Table 272.	Pollen and Spore Percentages for Neville.....	491
Table 273.	Pollen Assemblages and Environmental Interpretations of Dated Horizons.....	486
Table 274.	Pollen Assemblages and Tentative Environmental Interpretation of Cultures.....	492
Table 275.	Global Rank Correlation Coefficients for the Orient Component.....	497
Table 276.	Local Rank Correlation Coefficients for the Orient Component.....	497
Table 277.	Global Rank Correlation Coefficients for the Terminal Archaic Component.....	497
Table 278.	Local Rank Correlation Coefficients for the Terminal Archaic Component.....	497
Table 279.	Global Rank Correlation Coefficients for the Late Laurentian Component.....	497
Table 280.	Local Rank Correlation Coefficients for the Late Laurentian Component.....	498
Table 281.	Global Rank Correlation Coefficients for the Early Laurentian Component.....	498
Table 282.	Local Rank Correlation Coefficients for the Early Laurentian Component.....	498
Table 283.	Orient Component Shannon's Entropy Values for Three Partition Sizes.....	498
Table 284.	Terminal Archaic Shannon's Entropy Values for Three Partition Sizes.....	499
Table 285.	Late Laurentian Shannon's Entropy Values for Three Partition Sizes.....	499
Table 286.	Early Laurentian Shannon's Entropy Values for Three Partition Sizes.....	499
Table 287.	Orient Component Information Dimension Values for Three Partition Sizes.....	499
Table 288.	Terminal Archaic Information Dimension Values for Three Partition Sizes.....	499
Table 289.	Late Laurentian Information Dimension Values for Three Partition Sizes.....	500
Table 290.	Early Laurentian Information Dimension Values for Three Partition Sizes.....	500
Table 291.	Estimates of the Information Dimension.....	500
Table 292.	Estimates of the Hausdorff Dimension.....	500
Table 293.	T-Tests Between Information Dimension and the Hausdorff Dimension Estimates.....	501
Table 294.	Student's t Values for Comparison of Means for Debris Across Components.....	501
Table 295.	Student's t Values for Comparison of the Information Dimension for FCR Across Components	502
Table 296.	Student's t Values for Comparison of the Information Dimension for Tools Across Components	502
Table 297.	Student's t Values for Comparison of the Information Dimension for Features Across Components	503
Table 298.	Student's t Values for Comparison of the Information Dimension for Material Classes for the Orient Component.....	503

Table 299.	Student's t Values for Comparison of the Information Dimension for Material Classes for the Terminal Archaic Component.....	503
Table 300.	Student's t Values for Comparison of the Information Dimension for Material Classes for the Late Laurentian Component.....	504
Table 301.	Student's t Values for Comparison of the Information Dimension for Material Classes for the Early Laurentian Component.....	504

## I. INTRODUCTION

by

John P. Hart, Ph.D.

### PURPOSE

This report presents the results of archaeological investigations performed at the National Register of Historic Places, Memorial Park site (36Cn164), in Clinton County, Pennsylvania. GAI Consultants, Inc. (GAI) conducted these investigations under contract to the U.S. Army Corps of Engineers, Baltimore District. The site is situated on a floodplain terrace of the West Branch of the Susquehanna River at the east end of the city of Lock Haven, where the West Branch channel splits to form Great Island (figures 1 and 2). The Memorial Park site encompasses an area of approximately 3.5 ha (Neumann 1989). Work performed under this contract was designed to (1) mitigate adverse impacts to deposits containing Late Woodland components as a result of dike-levee and associated construction activities, and (2) more fully test deeper deposits containing earlier prehistoric deposits within the project zone of impact. Levee construction will encompass a portion of the site approximately 30 m wide and 275 m long. Potential impacts to the site as a result of construction activities include heavy equipment movement and earth disturbance, parking lot construction, the relocation of East Water Street, and excavation of inspection trenches. The potential zone of impact is approximately three meters deep: two meters of actual disturbance and one meter of potential compaction. Field work was performed under four tasks: Task 1, extensive exposure of Late Woodland features; Task 2, excavation of seven 5 x 5 m blocks to a depth of 1.5 m below original ground surface; Task 3, excavation of seven 2 x 2 m blocks at the base of the 5 x 5 m blocks to a depth of 3.0 m below original ground surface; and Task 4, expanded excavations to investigate the most promising deposits defined during tasks 2 and 3.

### PROJECT ADMINISTRATION AND ORGANIZATION

Fieldwork was performed at the Memorial Park site by GAI between April 1991 and August 1992. During the course of this lengthy project, the personal commitments of some GAI staff members resulted in personnel changes that affected project administration. During Task 1, Jack B. Irion, Ph.D., served as Project Manager; Jeffrey R. Graybill, Ph.D., served as Principal Investigator in charge of fieldwork; and John P. Hart, Ph.D., served as Principal Investigator in charge of labwork. As Principal Investigator in charge of field investigations, Dr. Graybill was responsible for all decisions regarding field procedures, including depth of stripping, feature identification, and feature excavation within the confines of the mitigation plan. As Principal Investigator in charge of laboratory work, Dr. Hart was responsible for ensuring that laboratory procedures were consistent with those delineated in the mitigation plan. During tasks 2 and 3, Dr. Graybill continued to serve as Principal Investigator in charge of fieldwork, while Dr. Hart assumed responsibilities for project management after Dr. Irion departed to accept another professional position. Dr. Hart also continued to serve as Principal Investigator in charge of labwork. Finally, during Task 4, Diane D. Landers, Ph.D., assumed responsibility for project management. Dr. Graybill continued as Principal Investigator for fieldwork during the initial two-thirds of the task. Dr. Hart continued to serve as Principal Investigator for labwork throughout the task and served as field Principal Investigator during the last third of the task after Dr. Graybill's departure from GAI due to prior personal commitments. Throughout the course of the project, Barbara Munford, M.A., served as Field Director. Crew Chiefs for tasks 1 through 3 were

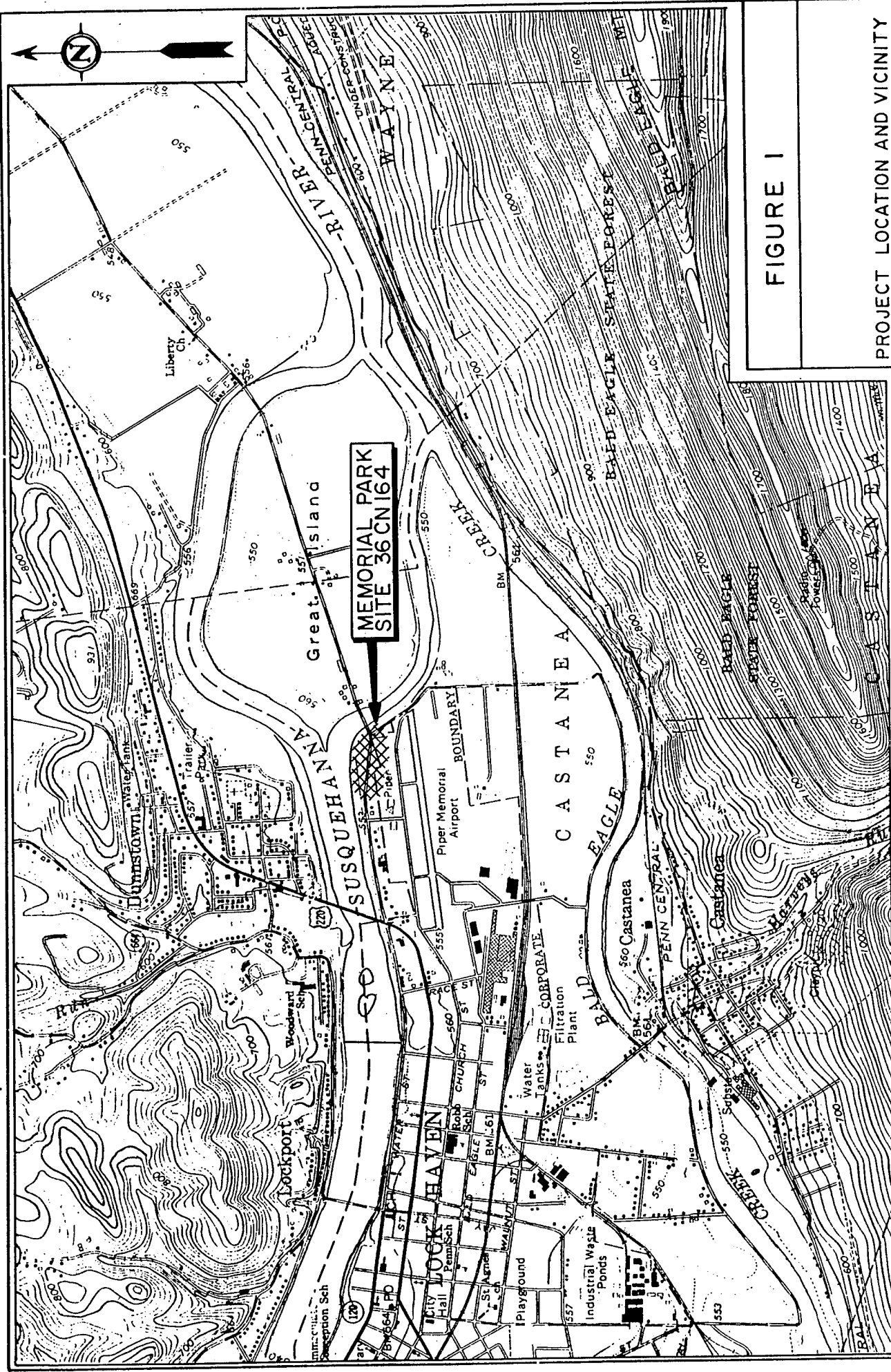

**MEMORIAL PARK  
SITE 36CN164**

**FIGURE 1**

PROJECT LOCATION AND VICINITY

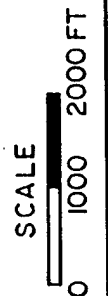

PA. QUAD. LOC.

REFERENCE:  
U.S.G.S. 7.5 MIN. SERIES TOPO, LOCK HAVEN AND  
MILL HALL, PA., QUADRANGLES, PHOTOREVISED 1973.



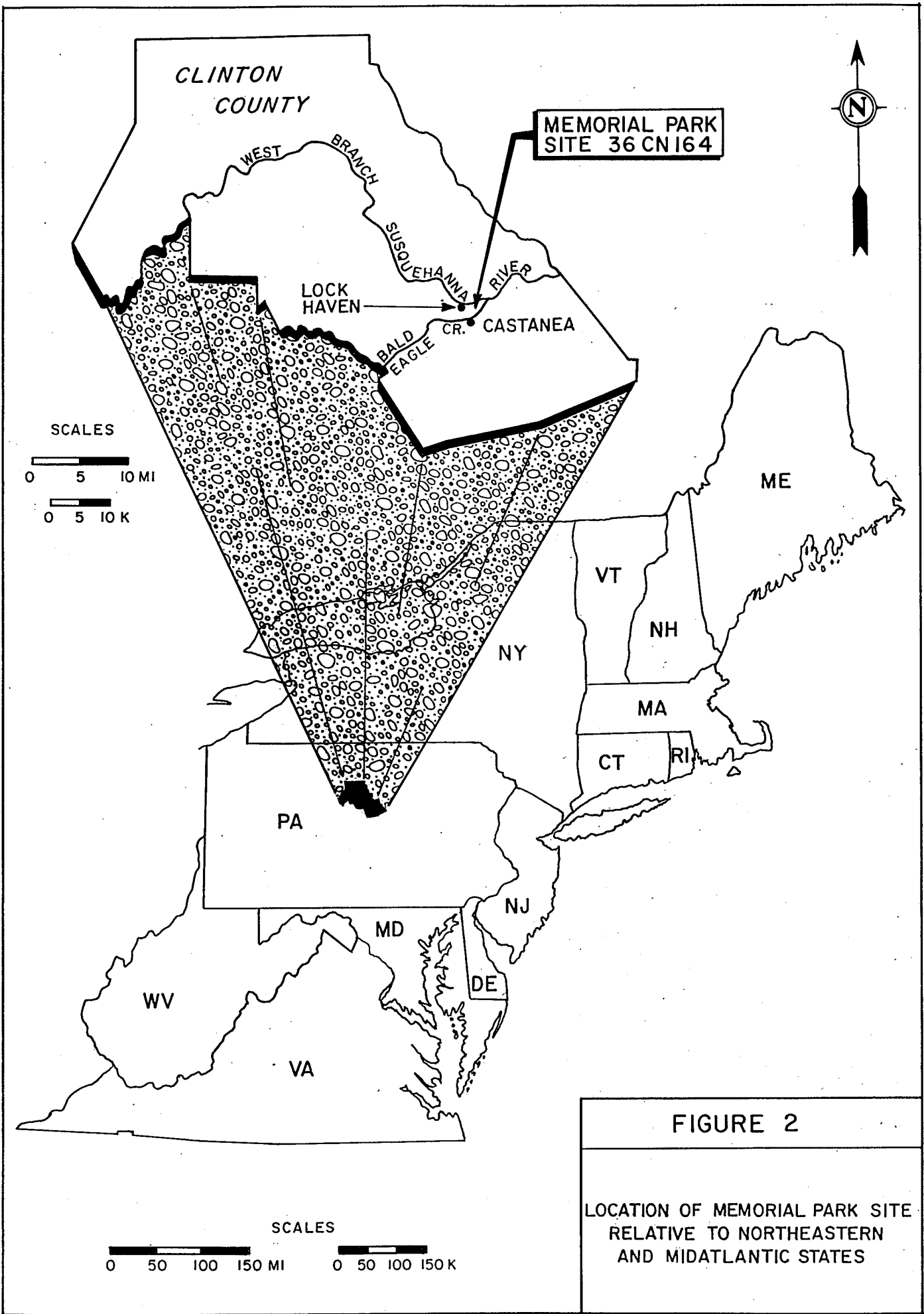

**FIGURE 2**

LOCATION OF MEMORIAL PARK SITE  
RELATIVE TO NORTHEASTERN  
AND MIDATLANTIC STATES

Gemma Mehalchik, Karl Kleinbach, and Rick Duncan. During Task 4, Crew Chiefs consisted of Rick Duncan, Dave Funk, Bryan Henderson, and Rodney DeMott. David L. Cremeens, Ph.D., served as project pedologist/geomorphologist for the entirety of the project.

#### PREVIOUS RESEARCH AT THE MEMORIAL PARK SITE

The Memorial Park site was first recorded by Hay et al. (1979) during a cultural resources survey of the proposed Lock Haven floodwall and levee alignments. The site was documented as occupying approximately 4.6 ha (Figure 3), and the primary occupation was believed to be a relatively undisturbed Clemson Island village. Posthole sondages and two small test excavations were used by Hay and associates in an attempt to define site boundaries. These excavations suggested that the Clemson Island component was buried beneath 50 to 70 cm of recent alluvium. A postmold was documented in one of the test excavations, suggesting that Clemson Island features were present at the site. Artifacts were recovered across the entire area of Memorial Park as well as from portions of the Piper Airport.

Additional investigations were initiated in July 1980 under the auspices of the Office of State Archaeology and Office of Historic Preservation, Pennsylvania Historical and Museum Commission, to determine site boundaries (Stevenson and Hay 1980). These investigations involved the excavation of deep, posthole sondage probes at 30-meter intervals in two transects, resulting in an estimation of site boundaries (Figure 3), the filing of a National Register of Historic Places Inventory Nomination Form and, ultimately, placement of the site on the NRHP.

Phase II testing of the Memorial Park site was performed during 1987-1988 by R. Christopher Goodwin & Associates, Inc. (Neumann 1989). Testing consisted of the excavation of fifteen 1 x 2 m units to a depth of 2 m below ground surface, 178 auger probes, and three 1.0-1.9-m-deep backhoe trenches in the base of three of the 1 x 2 m test units (Figure 4). These investigations resulted in the identification of what were believed to be five buried soils, and the recovery of artifacts and features relating to the Late Archaic, Transitional (Terminal Archaic), Middle Woodland, and Late Woodland periods (Neumann 1989).

Neumann (1989) suggested that the proposed buried soils were associated with the following date range estimates and components:

1. Soil 1 (A.D. 1937 - present), recent alluvium
2. Soil 2 (c A.D. 150 - 1937), Clemson Island (early Late Woodland) and Middle Woodland
3. Soil 3 (c 1250 B.C. - A.D. 150), Middle Woodland and Late Woodland
4. Soil 4. (c 1850 - 1250 B.C.), Late Archaic
5. Soil 5 (c 2400 - 1850 B.C.), Late Archaic (?)
6. Soil 6 (undetermined - 2400 B.C.), Late Archaic (?)

These soils were thought to be relatively undisturbed, although Soil 2 had been impacted by plowing that began around A.D. 1850 and continued until the early twentieth century.

①



CONSTRUCTION LIMITS OF

FLOW

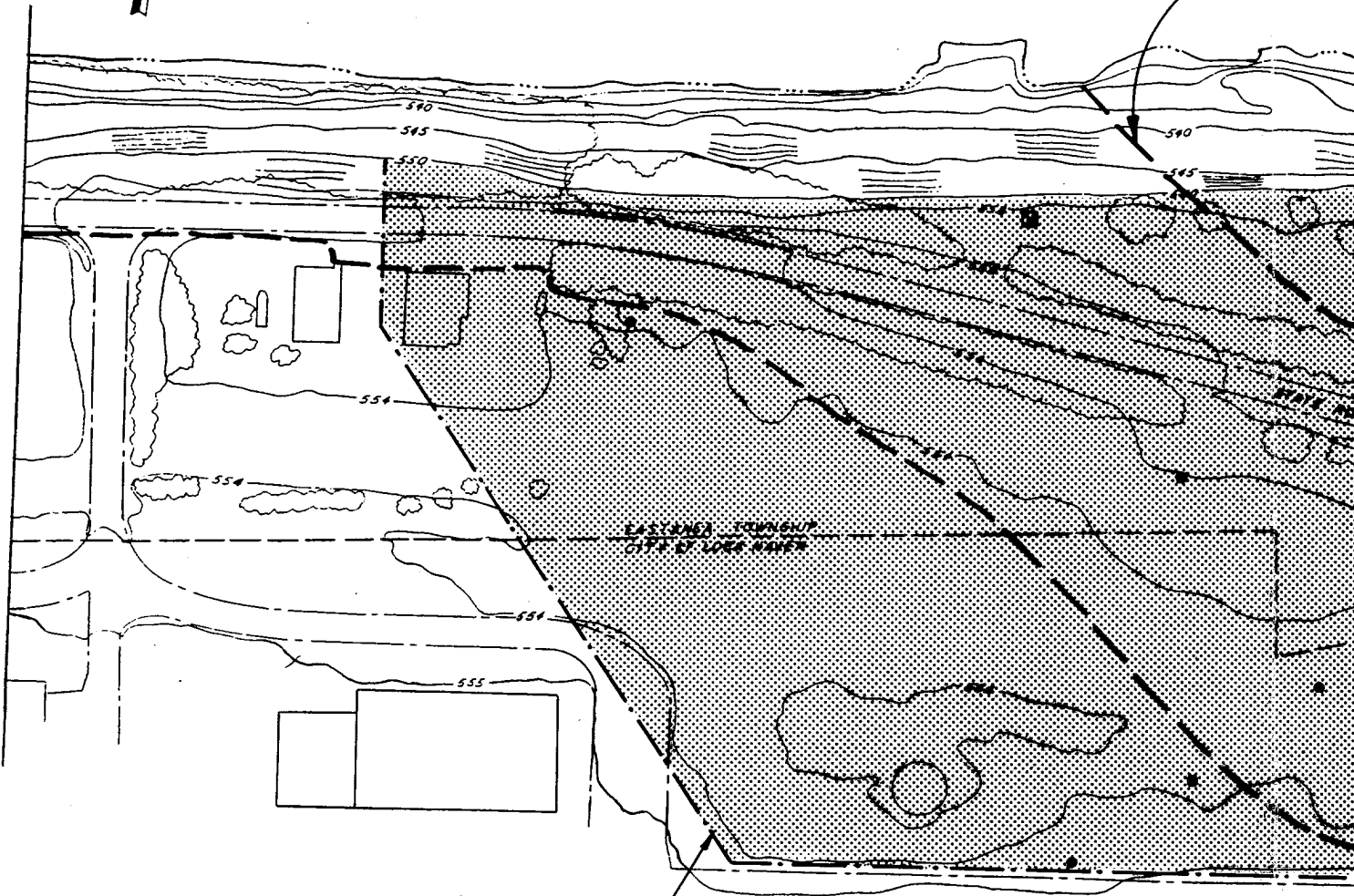

EASTMAN TOWNSHIP  
CITY OF LORE REVER

ESTIMATED SITE BOUNDARY

PIPER AIRPORT

⑤  
⑥

SCALES

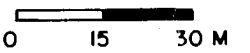
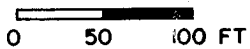

SOURCE:  
ADAPTED FROM BUCHART-HORN, INC., DRAWING  
FOR BALTIMORE DISTRICT CORPS OF ENGINEERS.

0  
1  
2  
3  
4  
5  
6  
7  
8  
9  
10  
11  
12  
13  
14  
15  
16  
17  
18  
19  
20  
21  
22  
23  
24  
25  
26  
27  
28  
29  
30  
31  
32  
33  
34  
35  
36  
37  
38  
39  
40  
41  
42  
43  
44  
45  
46  
47  
48  
49  
50  
51  
52  
53  
54  
55  
56  
57  
58  
59  
60  
61  
62  
63  
64  
65  
66  
67  
68  
69  
70  
71  
72  
73  
74  
75  
76  
77  
78  
79  
80  
81  
82  
83  
84  
85  
86  
87  
88  
89  
90  
91  
92  
93  
94  
95  
96  
97  
98  
99  
100

CONSTRUCTION WORK  
LIMITS OF LEVEE

WEST BRANCH SUSQUEHANNA RIVER

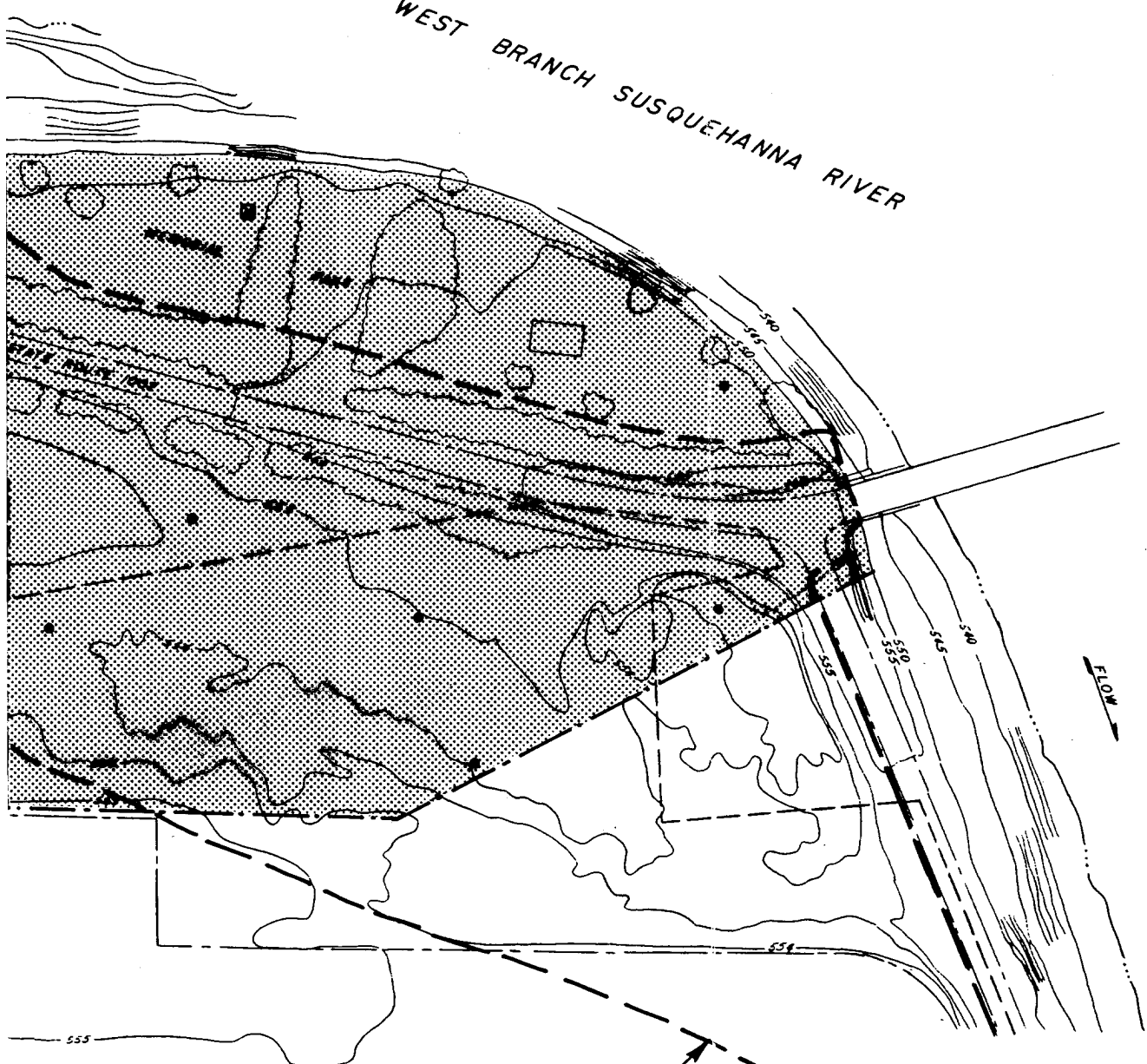

CONSTRUCTION WORK  
LIMITS OF LEVEE

KEY

- ☒ - APPROX. LOCATION OF TEST PIT
- - APPROX. LOCATION OF AUGER TEST

100 FT

30 M

FIGURE 3

ESTIMATED SITE BOUNDARIES BASED  
ON NATIONAL REGISTER NOMINATION,  
HAY AND STEVENSON, 1982

①



FLOW →

DWS. NO. \_\_\_\_\_  
JFN \_\_\_\_\_  
APPROVED \_\_\_\_\_  
RE. VI \_\_\_\_\_  
DWN. \_\_\_\_\_  
GAI CONSULTANTS, INC.

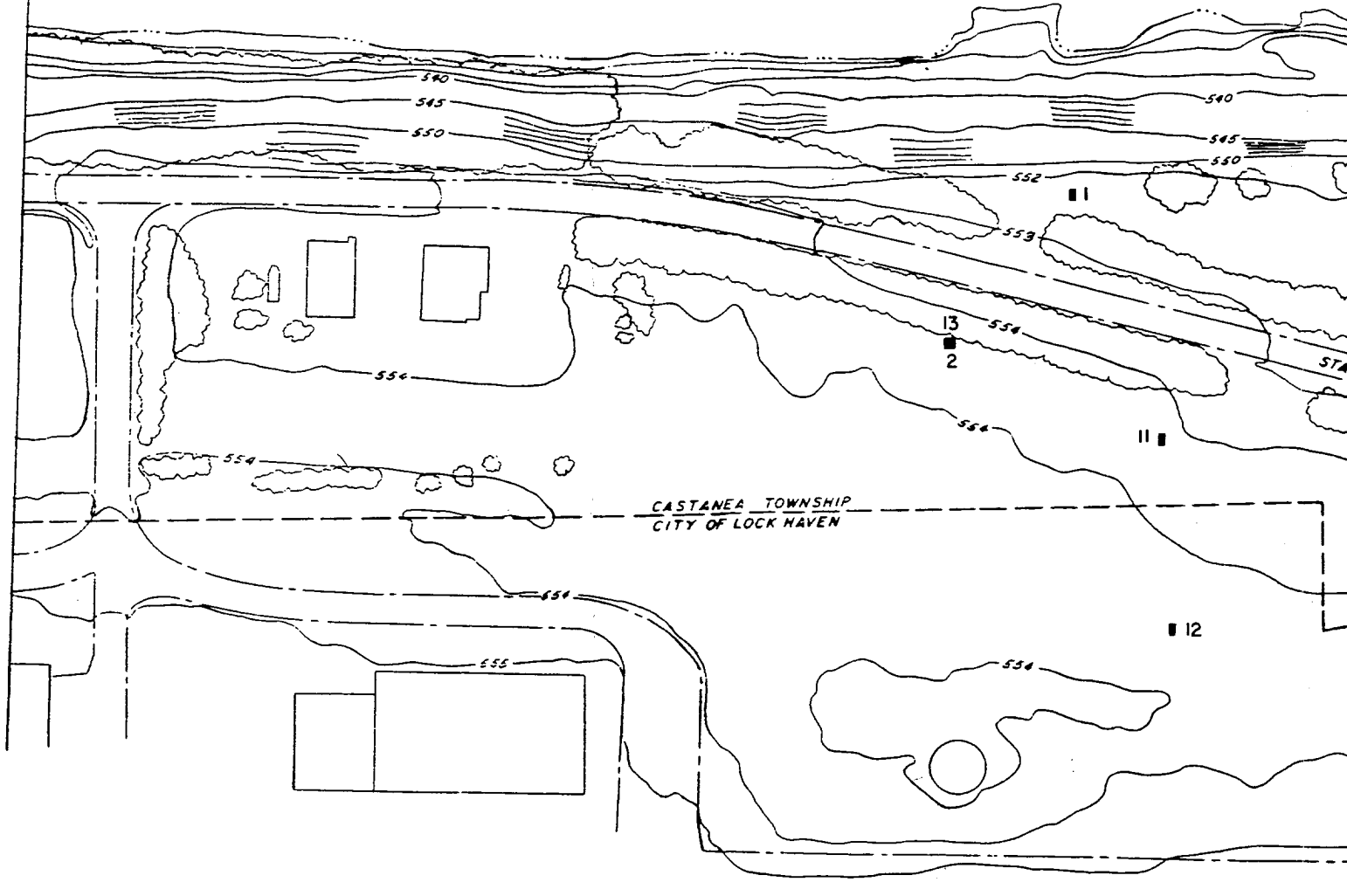

CASTANEA TOWNSHIP  
CITY OF LOCK HAVEN

PIPER AIRPORT

②  
③

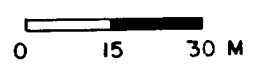
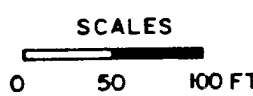

SOURCE :  
ADAPTED FROM BUCHART-HORN, INC., DRAWING  
FOR BALTIMORE DISTRICT CORPS OF ENGINEERS.

2

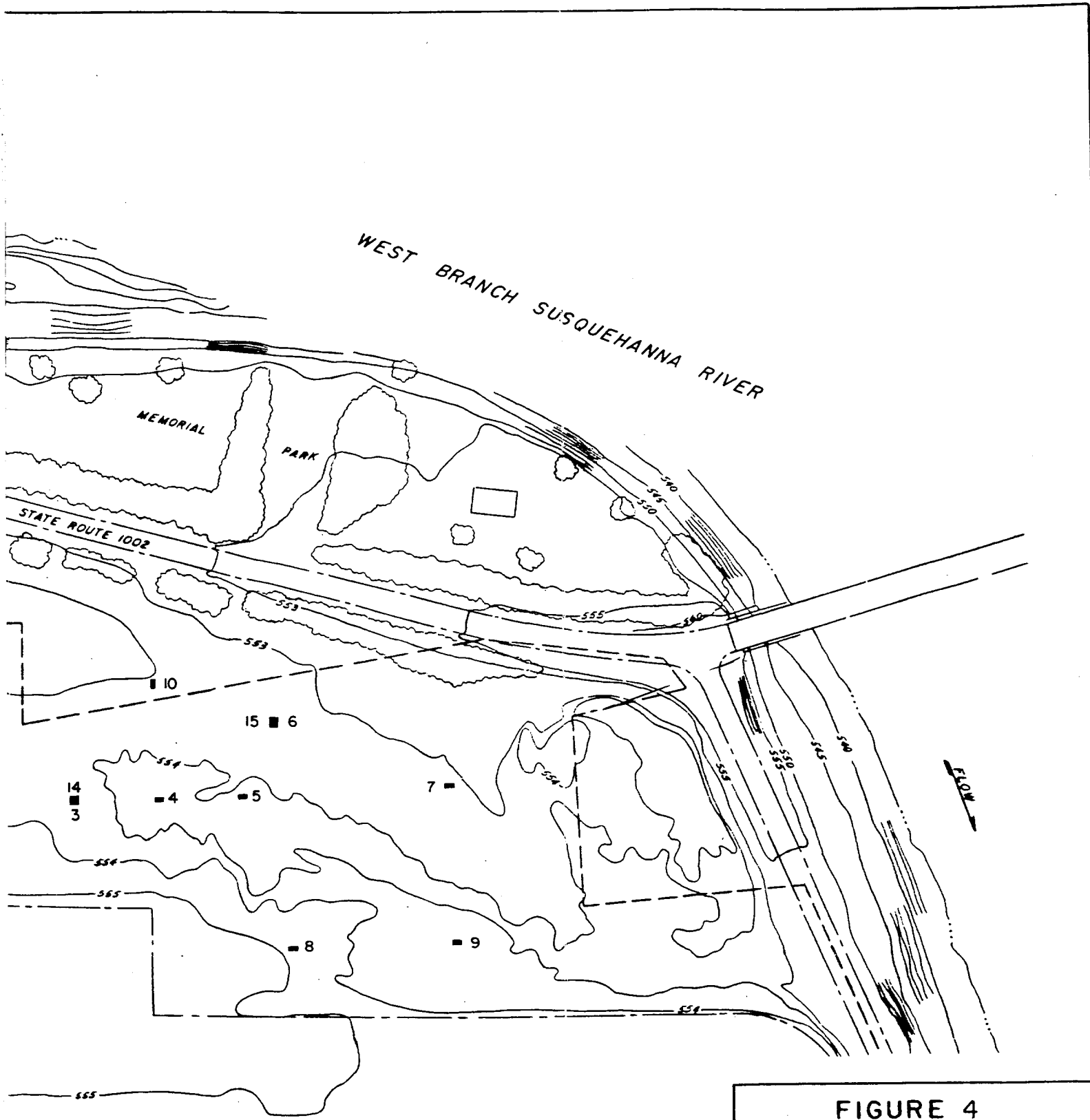

KEY

■ - EXCAVATION UNIT (1M x 2M)

FIGURE 4

LOCATION OF PHASE II TEST PITS,  
AFTER NEUMANN, 1988

0 FT

0 M

Based upon the proposed soils model and the recovery of diagnostic artifacts apparently associated with distinct soil horizons, Neumann (1989) proposed the following occupational sequence and site chronology model, collapsed into seven analytical units:

1. Analytical Unit 1 (Undifferentiated Late Woodland). This analytical unit combined what were believed to be two Clemson Island components. Neumann (1989) suggested a date range of A.D. 960 to 1300 for the Clemson Island occupations on the basis of pottery types. Ten postmolds, two pit features, and one area of burned soil were assigned to this analytical unit, which was contained within Soil 2.
2. Analytical Unit 2 (Middle Woodland). This analytical unit was associated with the lower portions of the B horizon of Soil 2. Neumann (1989) inferred a date range of A.D. 140 to 600 for this analytical unit, based upon diagnostic artifacts. Two postmolds and one pit feature were assigned to this analytical unit. Diagnostic artifacts listed for this unit included one Bare Island and one Poplar Island biface, and variously tempered pottery, including steatite.
3. Analytical Unit 3 (Middle Woodland to Transitional?). This analytical unit consisted of Middle Woodland materials associated with the upper portions of Soil 3 and temporally unidentified materials potentially associated with the Transitional period. No date range was assigned to this analytical unit by Neumann, although he suggests a pre-A.D. 150 date, based upon dates assigned to soil horizons in the West Branch valley by Vento et al. (1988). No features were assigned to this analytical unit. Diagnostic artifacts listed for this unit include Sylvan Side Notched, Bare Island, and Lamoka-like bifaces, and pottery tempered with grit, grog, quartz, chert, or steatite.
4. Analytical Unit 4 (Late Archaic). This analytical unit is composed of the Late Archaic materials recovered from below 10 cm in Soil 3. Four features were assigned to this unit. Diagnostic artifacts included a Canfield Lobate biface and a small, triangular, Brewerton-like biface.
5. Analytical Unit 5 (Late Archaic). This analytical unit was defined on the basis of Late Archaic materials recovered in Soil 4. Three features were assigned to this unit. Neumann suggested a date range of 2235 to 1595 B.C., based upon a roasting platform-like feature similar to features found in sites in New York. Diagnostic artifacts consisted of a Brewerton Side Notched-like biface and a Sylvan or Lamoka-like biface.
6. Analytical Unit 6 (Late Archaic). This analytical unit is also associated with Soil 4. Two features were assigned to this unit. No diagnostic artifacts were recovered, and Neumann did not suggest a date range other than the limits for the proposed Soil 4.
7. Analytical Unit 7 (Late Archaic?). This analytical unit is represented by one pecked stone artifact recovered from the proposed Soil 5.

On the basis of the results of Phase II testing and the listing of the Memorial Park site on the National Register of Historic Places, and after a competitive-proposal process, the U.S. Army Corps of Engineers, Baltimore District, contracted with GAI Consultants, Inc. to perform Phase III data recovery investigations at the site. A research design and mitigation plan were developed for the project, based upon what was known about the site as a result of these earlier

investigations, and according to general excavation plans developed previously by the Baltimore District. A revised, updated statement of the research design is presented later in this volume.

#### CURRENT PROJECT SUMMARY

During the course of the current project, GAI was able to more fully document the extent and nature of the Late Woodland occupations of the site. Four Late Woodland components were identified: early Clemson Island, middle Clemson Island, late Clemson Island, and Stewart phase. A total of 80 pit features was identified as pertaining to these occupations. In addition to these, both Early and Middle Woodland occupations were identified. During block excavations, GAI identified seven additional components: Orient phase, Susquehanna phase, Canfield Island phase, Piedmont tradition, late Laurentian tradition, early Laurentian tradition, and Neville phase. Dates associated with these components range from 880 B.C. for the Orient phase to 5140 B.C. for the Neville, extending our knowledge of site occupation to the Middle Archaic period. The results of these investigations significantly expand our knowledge of prehistoric occupations of the West Branch valley.

Also during the course of the current project, GAI was able to more fully investigate the geomorphology and stratigraphy of the site. These investigations resulted in lithological, pedological, geomorphological, and site formation models for the site (Cremeens, this volume). These various models present a picture of a changing landscape through time involving at least three landforms in the study area. Pedological data combined with palynological and botanical data provide a model of climatic change through time as well, supporting a widely-cited model of mid-Holocene climatic change for the Mid-Atlantic region (Custer 1988).

The following paragraphs provide a short summary of the components identified during the current investigations. More complete material culture descriptions, subsistence data, pedology and geomorphology, and climatic change are provided later in this report.

#### *Middle Archaic*

A single Middle Archaic component was identified during the current investigations. This identification was based upon the recovery of Neville bifaces in the western block excavations. Evidence for this component is described briefly below.

Five radiocarbon assays that pertain to this occupation were obtained from the site; they range from 5140 to 4770 B.C., representing the later portions of the Middle Archaic period. Diagnostic artifacts associated with this component include Neville bifaces and basal-notched bifaces that resemble Eva-I or Eva-II points. Both Neville and Eva bifaces are consistent with the fifth to sixth millennium B.C. dates. Eva I bifaces date from 6000 to 4000 B.C., Eva II from 4000 to 2000 B.C., and Neville from 6000 to 5000 B.C. (Justice 1987). The Neville and Eva-like bifaces do not appear to be stratigraphically separated at this site.

The only ground/pecked stone tool associated with this component is a possible anvil. Two features were associated with this component, both of them fire-related pits. The Neville component is contained within buried soils 6 and 7, as defined in this report.

#### *Late Archaic*

Three Late Archaic components are represented at Memorial Park: early Laurentian dating between 4405 B.C. and 3840 B.C.; late Laurentian, dating between 3250 and 2950 B.C.; and



Piedmont, dating from 2460 B.C. to 2100 B.C. The evidence for each of these occupations is reviewed briefly below.

*Early Laurentian.* Four radiocarbon assays associated with this component were obtained, ranging between 4405 and 3840 B.C.; these place the component at the beginning of the Late Archaic period as defined by Graybill (Section III, this volume). These dates are consistent with the Vergennes-like complex in the Hudson, Schoharie, and Susquehanna basins of New York, where radiocarbon assays ranging between 4300 and 3700 B.C. have been reported (Funk 1988). They are also contemporaneous with site 36AS188 in the Upper Ohio River valley where George and Davis (1986) report a date of 4140 B.C. for a feature containing two Brewerton Side Notched bifaces.

The Vergennes phase is generally considered the earliest Laurentian phase in the Northeast (Funk 1988). The trait list for this phase, as defined by Ritchie (1965), includes primarily Otter Creek bifaces, adzes, gouges, winged atlatl weights, plummets, choppers, copper gorges, ground slate points, and semilunar ground or flaked knives, or ulus. Turnbaugh (1977) suggests "a very weak infiltration" of the Vergennes phase in the West Branch, based upon the recovery of Otter Creek-like bifaces and ground slate knives as surface finds on several sites.

Material culture associated with the early Laurentian component at Memorial Park includes many of these diagnostic artifacts. Bifaces include Otter Creek with straight, ground bases; Brewerton Eared Triangular; Brewerton Side Notched; Brewerton Eared-Notched; Chillesquaque Triangle; Stark/Morrow Mountain; and Vosburg. Ground/pecked stone and cobble tools associated with this component include a contracting-wing, ground-slate bannerstone with a ridged shaft, a quartz-crystal plummet, ground slate semilunar knife fragments, pestles, adzes, chopping tools, hammerstones, and grinding slab fragments. While it is not suggested here that this component is representative of the Vergennes phase, especially given the range of diagnostic bifaces, the similarities are interesting.

Thirty-three features are associated with this occupation, all of which are fire-related. The Early Laurentian occupations are associated with Buried Soil 5 as defined in this report.

*Late Laurentian.* Six radiocarbon assays are associated with a later Laurentian component ranging from 3250 to 2950 B.C., contemporaneous with the Brewerton Phase in central and northern New York, the Upper Saint Lawrence Valley, and the Upper Susquehanna Valley (Funk 1988). They are also contemporaneous with Bressler's (1989) date of 3150 B.C. for the Laurentian occupation at Canfield Island. Turnbaugh (1977) identified all of the Brewerton phase biface types in his West Branch survey, as well as some of the ground/pecked-stone tools identified with the Brewerton phase.

Diagnostic artifacts for the Brewerton phase include the various notched Brewerton bifaces, short broad gouges, netsinkers, bannerstones, plummets, and ground slate points and ulus (Ritchie 1965; Turnbaugh 1977). Diagnostic bifaces associated with the late Laurentian component at Memorial Park include: Beekman Triangles, Brewerton Corner Notched, Brewerton Side Notched, Brewerton Eared Notched, Otter Creek-like (concave, unground bases), and Vosburg. The ground/pecked-stone assemblage associated with this assemblage consists of two celts, pitted cobbles, anvils, hammerstones, and grinding slabs. While it is not suggested here that this assemblage can be equated with the Brewerton phase, there are obvious similarities. Twenty-one fire-related features have been assigned to this component. The late Laurentian occupations of the site are associated with Buried Soil 4, as defined in this report.

*Piedmont.* This represents the lowest-density Late Archaic occupation at Memorial Park. Two radiocarbon assays were obtained pertaining to this occupation of the site: 2460 B.C. and 2100 B.C. These dates are consistent with dates associated with the Piedmont tradition in other

areas of Pennsylvania, New Jersey, and New York (Graybill, this volume). Diagnostic bifaces for this occupation include the Bare Island and Lamoka types. The groundstone assemblage consists of only a few cobble tools and a large anvil. Thirteen fire-related features were assigned to this component. The Piedmont occupation is associated with Buried Soil 3 as defined in this report.

### *Terminal Archaic*

Three Terminal Archaic components are represented at the Memorial Park site: a Canfield Island component dated between 2100 and 1640 B.C.; an undated low-density Susquehanna phase component; and an Orient component dated between 1145 B.C. and 880 B.C. Evidence for each of these components is reviewed briefly below.

*Canfield.* Three radiocarbon assays are associated with the Canfield occupations of the site and range from 2100 to 1640 B.C. These are somewhat earlier than the 1570 B.C. and 1540 B.C. dates obtained by Bressler (1989:72) for the Canfield component at Canfield Island, and appear to be too early to be associated with the Susquehanna phase occupation at Memorial Park.

Diagnostic bifaces relating to this occupation consisted primarily of the Canfield Lobate type as defined by Bressler (1989). These were most frequently manufactured from rhyolite. Other bifaces included several Bare Island points recovered from a cache consisting primarily of Canfield Lobate points and Lehigh/Koens-Crispin bifaces. Groundstone implements recovered from Canfield contexts include several notched disks, a pestle, a small celts, several celt fragments, and grooved stones. In all, 79 features were assigned to this component, most of them classified as fire-related. This component is associated with Buried Soil 2 as defined in this report.

*Susquehanna.* The Susquehanna phase component is the lowest-density Terminal Archaic component at Memorial Park. No radiocarbon assays were obtained for this component, but the phase is generally dated to 1465-1270 B.C in central Pennsylvania (Bressler 1989; Michels and Smith 1967). Diagnostic artifacts for this component include two Susquehanna Broadpoints and several steatite sherds. This phase is associated with Buried Soil 2: diagnostics are discontinuous across the site, being limited to blocks 1, 8, and 14. Because of the apparently discontinuous nature of this occupation across the site, and an inability to clearly separate it from the Canfield occupations, these are combined in much of the subsequent analysis under the Terminal Archaic label.

*Orient.* Two radiocarbon assays were obtained for this component: 1145 B.C. and 880 B.C. These dates are consistent with those reported elsewhere in the Mid-Atlantic and Northeast of the Orient phase. However, the 880 B.C. date is also acceptable for the Early Woodland Meadowood phase and may be related to a light Meadowood phase occupation of the site evinced by several Meadowood bifaces (see below).

Diagnostic bifaces for this occupation consist of Orient Fishtail points. Steatite-tempered Marcey Creek pottery was also recovered in these contexts, as were steatite sherds. Ground, pecked stone artifacts consisted primarily of notched disks. Nineteen features, most classified as fire-related were associated with this component. A large, fire-cracked rock midden (Feature 124) located in blocks 5, 8, and 9, was also associated with this occupation. The Orient component is associated with buried soils 1 and 2, as defined in this report.

### *Early Woodland*

The Meadowood phase is the only Early Woodland phase represented at the site. This phase is represented by the recovery of four Meadowood bifaces: two from one feature exposed

during Task 1 investigations (Feature 110), and two recovered during block excavations. The 880 B.C. date obtained from the upper levels of Block 3 in Buried Soil 1 may also pertain to this component. Other material probably associated with this component includes thin, grit-tempered pottery recovered from the upper levels of several blocks. A Rossville-like biface recovered from Feature 129 also suggests an Early Woodland origin.

### *Middle Woodland*

One Middle Woodland component was identified during the current investigations. This component has been identified on the basis of three features exposed during Task 1 investigations, features 32, 143, and 175. A radiocarbon assay of A.D. 150±115 was obtained from Feature 143. A body sherd from Feature 175 refit a body sherd from Feature 143, indicating that these two features are probably contemporaneous. Feature 143 also contained a large, heavily fabric-impressed, chert-tempered, interior cordmarked rim sherd. The A.D. 150 date places these features early in the Middle Woodland period as defined by Graybill (this volume) suggesting a Fox Creek phase origin. Feature 32 contained a rhyolite Fox Creek stemmed-like biface. Kent (1970) suggests the type name Conewago for Fox Creek-like bifaces manufactured from rhyolite for south central Pennsylvania into Maryland.

### *Late Woodland*

At least four Late Woodland components are present at Memorial Park: an early Clemson Island component pre-dating A.D. 900, a middle Clemson Island component dating to the tenth century A.D., a late Clemson Island component dating to the eleventh century A.D., and a Stewart phase occupation dating between c. A.D. 1250 and 1400. The evidence for each of these components is discussed briefly below.

*Early Clemson Island.* Four radiocarbon assays obtained from Clemson Island features predate A.D. 900, and range from A.D. 760 to A.D. 830. A total of 15 features has been assigned to this occupation, based upon pottery stylistic attributes. Pottery traits associated with this component include heavy, oblique cord impressions or cord-wrapped paddle impressions on flat-to-bevelled lips, cord-marked interior rim surfaces, cord-marked or fabric impressed exterior surfaces, and interior punctations/exterior nodes on the upper rim. These attributes share similarities with both the Point Peninsula and Clemson Island pottery series (Hay et al. 1987; Ritchie and MacNiesh 1949). Diagnostic bifaces associated with the Early Clemson Island component consist of Jack's Reef Side Notched and Jack's Reef Pentagonal, as well as Levanna bifaces. Both the Jack's Reef bifaces and the pottery attributes suggest a continuity between the late Middle Woodland and early Late Woodland occupations of the West Branch valley.

*Middle Clemson Island.* Two radiocarbon assays obtained from Clemson Island features provided dates of A.D. 920 and 930. Five pit features have been assigned to this component, based upon pottery attributes. These include heavily cord-marked exteriors or fabric-impressed rims with broadly expanding rim profiles, and cord-marked lips with interior cordmarking. Diagnostic biface types include Jack's Reef Pentagonal and Levanna.

*Late Clemson Island.* Four radiocarbon assays, ranging between A.D. 1050 and A.D. 1090, were obtained from Clemson Island features and have been assigned to this component. Eight pit features were assigned to this component, based upon pottery stylistic attributes. Pottery traits include smooth interiors with or without cord-wrapped dowel impressions, undecorated lips or lips with lateral cord impressions and/or hollow-reed-like impressions, cord-marked or very-fine fabric impressed exteriors, and interior punctate/exterior nodes on the rims. In general, the

execution of these pottery attributes is finer than on the earlier sequence. Diagnostic bifaces associated with this occupation consist primarily of large Levanna and Madison points.

*Stewart Phase.* Three radiocarbon assays, ranging between A.D. 1290 and A.D. 1385, are associated with this component. These are consistent with dates obtained from Stewart phase occupations at other sites in the West Branch drainage basin. The 1385 date, although somewhat late for the Stewart phase as defined by Graybill (this volume), does not relate to a McFate-Quiggle occupation of the site, given the lack of shell-tempered pottery from features recorded during the current project.

Thirteen pit features were assigned to this component, based upon the presence of Stewart Incised pottery and the radiocarbon assays. Diagnostic bifaces consist of Levanna and Madison bifaces. Pottery attributes include incised rim sherds, collared rims with smooth, flat lips, smooth rim interiors, fine cord-marked exterior surfaces, and fine-grit or quartz temper. At least one postmold pattern, presumably representing a longhouse, is also associated with this component. Other linear postmold patterns on the eastern end of the site may represent additional longhouses.

#### REPORT STRUCTURE

This report is comprised of three constituent components: background information, analysis, and synthesis. The background component consists of four major sections: (1) Project Location and Physical Setting, which provides a general environmental setting for the project; (2) Cultural Background, which provides a cultural setting for subsequent sections of the report; (3) Research Design, which provides a series of research questions addressed during the investigations; and (4) Field Methodology, which provides a review of the data recovery methods employed during field investigations.

The Analysis component consists of nine sections, each providing an analysis of a particular data set in relation to the research design. This includes Pedological Investigations and Site Formation; Pottery Analysis; Chipped-Stone Analysis; Microwear Analysis; Ground, Pecked, and Cobble Tools and Steatite; Archaeobotany; Faunal Analysis; Palynology; and Spatial Analysis. Finally, the Synthesis component consists of the Summary and Conclusions section in which all of the various analyses are combined to present an interpretation of the site through time in terms of the questions raised in the Research Design section.

## II. PROJECT LOCATION AND PHYSICAL SETTING

by

David L. Cremeens, Ph.D.

### SITE LOCATION

The Memorial Park site (36Cn164) is located on the south bank of the West Branch of the Susquehanna River on the eastern edge of the city of Lock Haven, Clinton County, Pennsylvania (Figure 1). The site is situated on a floodplain terrace between the Piper Memorial Airport on the south and west, and the West Branch on the north and east, at the point where the West Branch splits into two channels, forming Great Island. The confluence of Bald Eagle Creek with the West Branch is approximately 1.3 km southeast of the site (Figure 1). The combined floodplains of the West Branch and Bald Eagle Creek are 1.6 km wide at this location. Bald Eagle Mountain is located to the south of Bald Eagle Creek and the West Branch, while to the north are Simcox Mountain and associated uplands.

### PHYSIOGRAPHY

The Memorial Park site is located at the junction of three major physiographic provinces: the Unglaciated Appalachian Plateau, the Glaciated Appalachian Plateau, and the Ridge and Valley, near the border between Pennsylvania Archaeological Study Units II and III (Raber 1984) (figures 5 and 6). The Allegheny Front is the division between the gently-folded Appalachian Plateaus to the north and west and the more complexly-folded Ridge and Valley to the south.

The Appalachian Plateau Province is a maturely dissected plateau characterized by altitudes being higher, in most places, than those in adjacent provinces, and by rocks largely younger than those of the other provinces (Thornbury 1965). The rocks are dominantly clastic in nature with some coals; limestones are of minor extent. Rocks in the Appalachian Plateaus have not been subjected to intense deformation. A few mild folds exist, particularly adjacent to the Ridge and Valley, but they are broad open folds and not strongly compressed or faulted. The plateaus are bounded on all sides by outfacing escarpments which reflect the regional synclinal structure of the plateaus. Most of the plateaus have undergone considerable dissection. Valley systems in the plateaus commonly display a dendritic drainage pattern. The Glaciated Appalachian Plateau was modified by Pleistocene glaciation, particularly early to late Wisconsinan glaciation. This modification included deposits of materials associated with the glaciations, periglacial phenomena, and an enhancement of the degree of dissection from both the glacial meltwaters and the subsequent uplift following deglaciation.

The Allegheny Mountains Section (or Allegheny Front) is a subdivision of, and a northeastern margin to, the Appalachian Plateaus (Thornbury 1965). The dissection of the Allegheny Mountains is so advanced that the topography has lost its plateau characteristics. Several open folds are expressed as linear ridges, and the topography was largely unmodified by glaciation. Drainage patterns become trellis-like near the Allegheny Front.

The Ridge and Valley province is an assemblage of valleys or valley lowlands surmounted by narrow, linear, often even-topped ridges (Thornbury 1965). The many striking geomorphic features of the Ridge and Valley include: a marked parallelism of ridges and valleys commonly in a

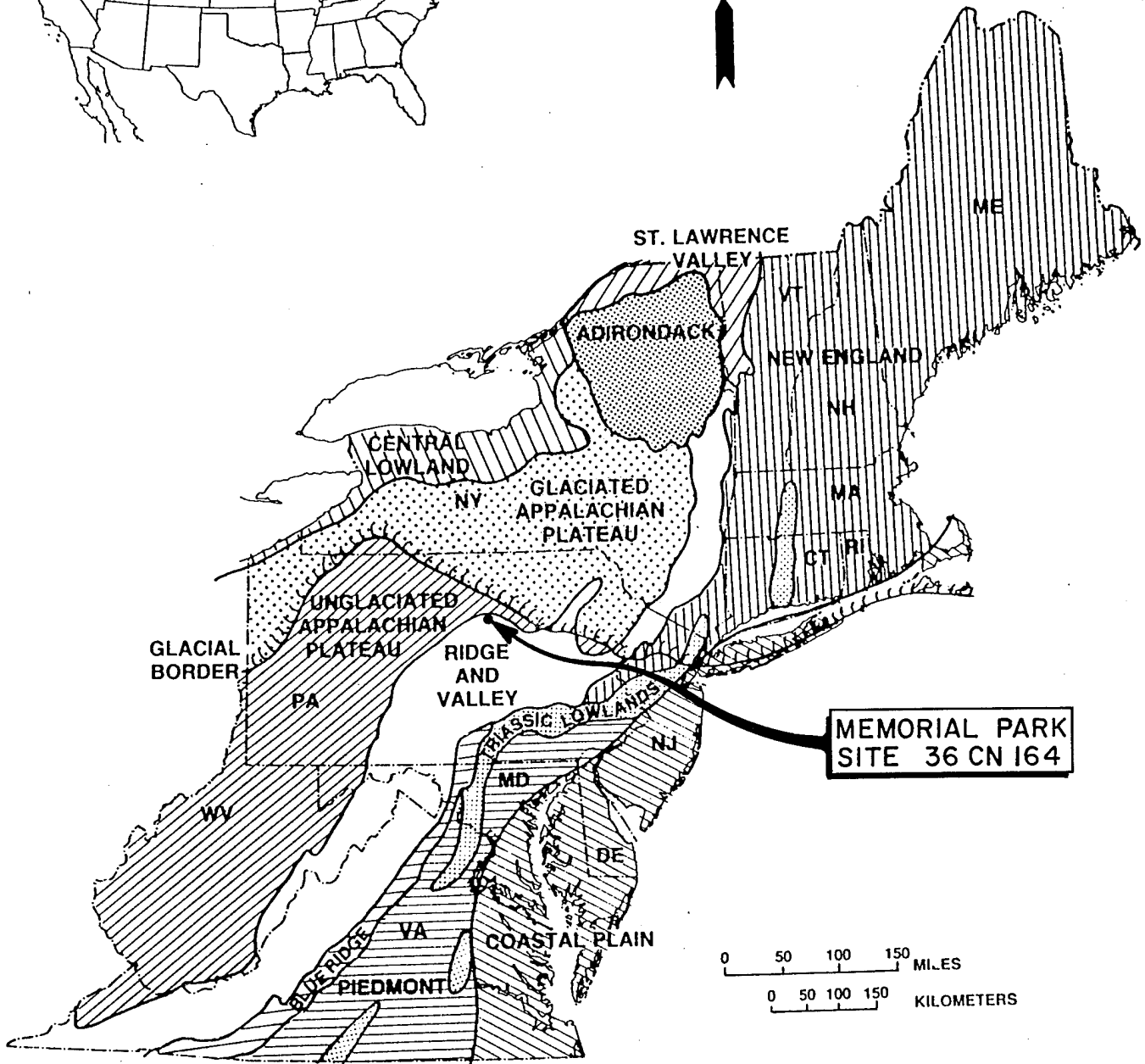

FIGURE 5

RELATIONSHIP OF MEMORIAL PARK SITE TO PHYSIOGRAPHIC PROVINCES OF THE NORTHEASTERN UNITED STATES

SOURCE : MODIFIED FROM E. J. CIOLKOSZ, ET AL, 1989.

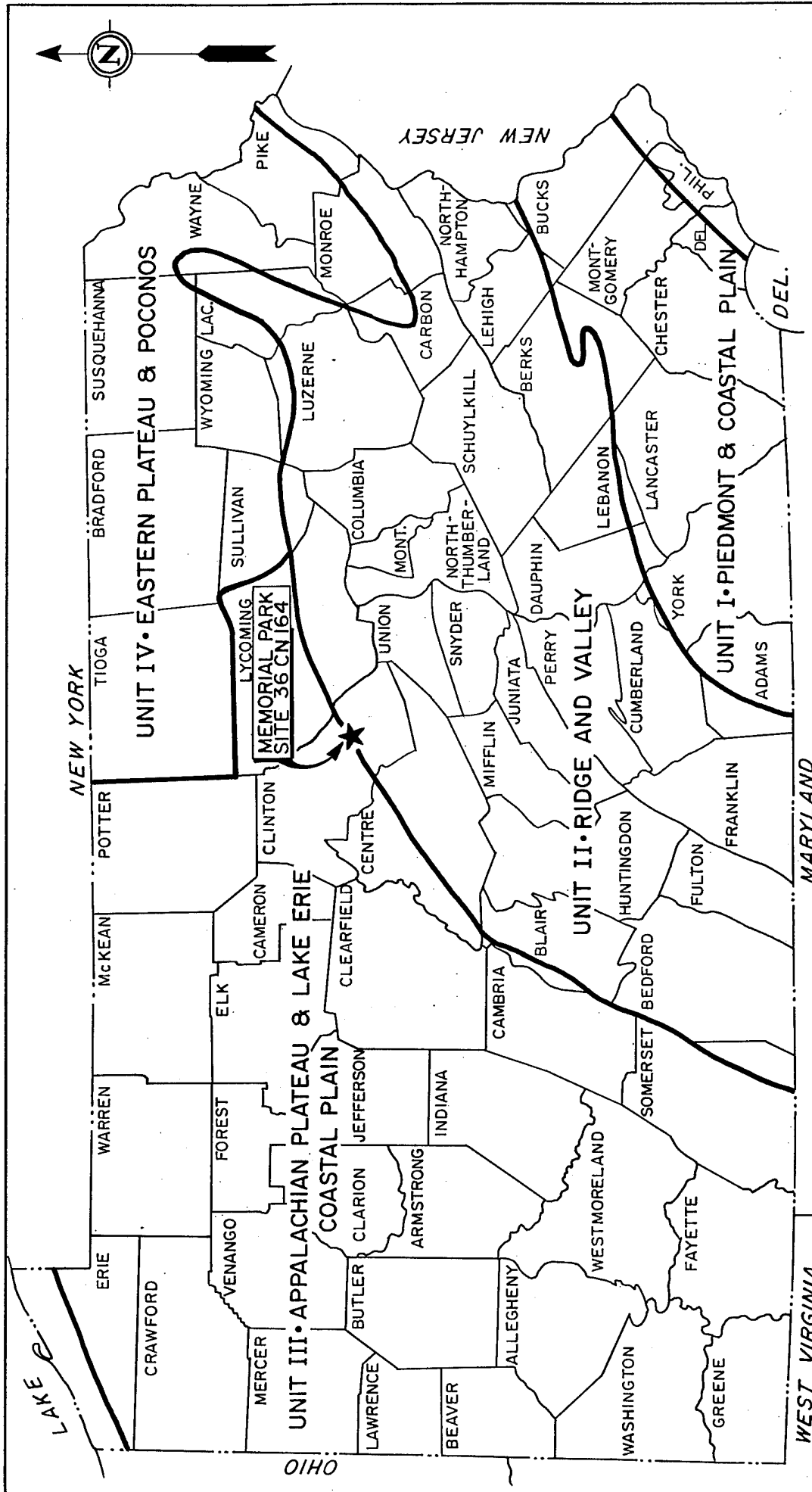
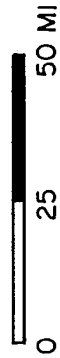

FIGURE 6

LOCATION OF MEMORIAL PARK SITE 36 CN 164 IN RELATION TO PENNSYLVANIA STUDY UNITS, AFTER RABER, 1985

SCALE



NE-SW direction, an influence of alternating strong and weak strata upon topographic forms, a few major transverse streams with notable development of subsequent streams giving rise to a trellis drainage pattern, many ridges which display enough accordance of summit level to suggest a former erosion surface, and hundreds of water gaps through hard rock ridges.

Present Ridge and Valley topography is a result of truncation of folds during several erosion cycles (Thornbury 1965). Differential erosion of weak and strong beds has brought out the structure. The topographic expression of the structure includes: anticlinal ridges, anticlinal valleys, synclinal ridges, synclinal valleys, homoclinal ridges, and homoclinal valleys. Bald Eagle Mountain, south of the Memorial Park site, is a homoclinal ridge on the northwest edge of the Ridge and Valley Province. It extends from near Altoona to Williamsport, a distance of 225 km. Between Bald Eagle Mountain and the Allegheny Front is a narrow valley on Devonian limestone. This valley is followed by the northeastward-flowing Bald Eagle Creek. The West Branch of the Susquehanna River enters the valley at Lock Haven.

#### REGIONAL BEDROCK GEOLOGY

Bedrock geology of the Appalachian Plateaus is represented by Devonian, Mississippian, and Pennsylvanian rocks consisting primarily of sandstone, shale, conglomerate, and minor amounts of limestone (Braker 1981). The Lower Devonian, consisting of limestone, chert, sandstone, and shale, is succeeded by the Middle and Upper Devonian gray marine shale, siltstone, and a minor limestone (Kohler 1986). The Mississippian and Pennsylvanian systems are dominated by sandstone that is mostly quartzitic and, in some places, conglomeratic.

Formation of the Appalachian Plateaus began after Paleozoic marine and non-marine deposition (Braker 1981). During the late Paleozoic Era, regional uplift from the southeast caused this area to rise uniformly without much disturbance. The present rolling hills topography is the result of the dissection of the plateaus by streams.

The bedrock geology of the Ridge and Valley province is represented by the Cambrian, Ordovician, Silurian, and Devonian rocks consisting primarily of dolomite, limestone, sandstone, quartzite, conglomerate, and shale (Braker 1981). Lower and Middle Ordovician rocks are predominantly limestone with some dolomite (Kohler 1986). Upper Ordovician rocks are shale, siltstone, and sandstone, including some that are conglomeratic. Ordovician rocks are overlain by Lower Silurian quartzite. The rest of the Silurian rocks consist of shale, calcareous shale, and limestone.

The Paleozoic beds of the Ridge and Valley Province underwent lateral compression from the southeast that resulted in many deeply folded anticlinal and synclinal landforms (Braker 1981). The final stage in the formation of this province was characterized by many erosional episodes, followed by the last period of compressional uplift. Differing bedrock lithology and exposure in the complex network of folds has resulted in the development of broad and narrow valleys and ridges. The ridges formed because the sandstone and quartzite formations capping the ridges resisted erosion, while the valleys formed in less resistant limestone and dolomite.

#### LOCAL BEDROCK GEOLOGY

South of the West Branch of the Susquehanna River, in the Lock Haven vicinity, is a series of high, even-crested ridges and narrow valleys typical of the Ridge and Valley province (figures 7 and 8). Between the Allegheny Front and the West Branch is an irregular series of low rolling hills. North of the Allegheny Front is the deeply dissected Appalachian Plateau.



South of the Memorial Park site, on the south side of Bald Eagle Creek, is an undivided unit comprised of the Upper Silurian Tonoloway, Wills Creek, and Bloomsburg formations (Taylor, 1977), and consisting of limestone and shale. The only portion exposed near the study area is the red shale of the Bloomsburg Formation, which exists as a reddish soil along the road at the base of Bald Eagle Mountain. It is mostly covered with colluvium and alluvium. Further south, up Bald Eagle Mountain, is an undivided unit comprised of the Middle Silurian Mifflintown and Rose Hill formations. This undivided unit consists of gray to greenish gray shale with interbedded argillaceous, fossiliferous gray limestone beds and lenses. This unit on Bald Eagle Mountain is covered by transported regolith (colluvium) from the Tuscarora Formation. Further east, near the crest of Bald Eagle Mountain, is the Lower Silurian Tuscarora Formation. This formation consists of light gray to yellowish gray, fine- to medium-grained quartzose sandstone. The Tuscarora weathers to very large talus blocks covering the northern flank of the mountain. Large boulder fields occurring on mountains in this region are believed to be periglacial in origin (Ciolkosz et al. 1986; Denny 1951). South of the Tuscarora, at the crest of Bald Eagle Mountain, is the reddish, very fine-grained sandstone of the Upper Ordovician age Juniata Formation.

To the north of the site, directly across the West Branch of the Susquehanna River, is a sequence of increasingly younger shales and limestones, followed by sandstones. The West Branch makes a 90° turn to the east at Lock Haven. Older shales, limestones, and sandstones that exist on the west side of the river, immediately west of Lock Haven, appear to have been eroded and/or buried by alluvium. The increasingly younger shales and limestones occur as a series of stepped bedrock benches or terraces.

To the north, the first unit is the Tully Limestone Member of the Middle Devonian Mahantango Formation. This limestone is gray, micrograined, and interbedded with thin shale beds. Some of the thin shale beds merge into the Shale Member of the Mahantango. Above the Tully Member, further to the north, is the Burket Black Shale Member of the Harrel Formation. The Harrel Formation is the basal unit in the Susquehanna Group of the Upper Devonian. The Burket is a black to grayish black, very fissile shale with limestone nodules. Above the Burket is the Upper Shale Member of the Harrel Formation. This shale is grayish and contains thin to thick beds of black shale, siltstone, and sandstone.

From the vicinity of Dunnstown north to the Allegheny Front, the units become wider and form the low rolling hills described by Kohler (1986). Located stratigraphically above the Harrel Formation and further to the north is the Brallier Formation of the Susquehanna Group. The Brallier Formation is a quartzose, gray, fine-grained sandstone with thin beds of shales and siltstones in the lower portion. Above the Brallier Formation and further north is the Lock Haven Formation of the Susquehanna Group. This formation consists of interbedded shale, sandstone, siltstone, mudstone, and minor conglomerate. The shales, siltstones, and mudstones are grayish and micaceous. The sandstones are quartzose, grayish, thin-to thick-bedded, and are very fine-to-coarse grained.

The Sherman Creek and Irish Valley Members, undivided, of the Upper Devonian Catskill Formation lie stratigraphically above and north of the Lock Haven Formation. These basal members of the Catskill consist of grayish red and grayish brown interbedded shale, siltstone, and sandstone. The upper portion of the Catskill Formation is the Duncannon Member, which also consists of interbedded shale, sandstone, and siltstone. The Pocono Formation straddles the Devonian-Mississippian boundary and marks the beginning of the Appalachian Plateaus (Allegheny Front). The Lower Sandstone Member of the Pocono consists of sandstone, shale, and conglomerate. The sandstone is quartzose, micaceous, grayish, and is very fine to coarse grained; the shale is reddish. The conglomerate occurs in the lower portion of the member. The Burgoon Sandstone Member of the Pocono consists of quartzose, yellowish-gray to yellowish-brown, very fine to medium-grained sandstone, and coarse to very coarse-grained conglomerate.

Figure 7. Regional Bedrock Geology

*Mississippian*

Mb –  
Mmc

Burgoon Sandstone Formation  
–Mauch Chunk Formation

*Mississippian/Devonian*

MDhm –

Huntly Mountain Formation

*Devonian*

Dlh –  
Dh –  
Dck –  
Dbh –  
Doo –

Lock Haven Formation  
Hamilton Formation  
Catskill Formation  
Brallier/Harrell Formation  
Onondaga/Old Port Formation

*Devonian/Sillurian*

DSkt –  
DSkm –

Keyser/Tonoloway Formation  
Keyser/Mifflerton Formation

*Silurian*

Sc –  
Sbm –  
Swc –  
St –

Clinton Group  
Bloomsburg/Mifflertown Formation  
Wills Creek Formation  
Tuscarora Formation

*Ordovician*

Obl –  
Oj –  
Or –  
Obf –  
Ocn –  
Obe –  
Obv –  
On –  
Oa –  
Osl –

Benner-Loysburg Formation  
Junita Formation  
Reedsville Formation  
Bellefonte Formation  
Coburn - Nealmont Formation  
Bald Eagle Formation  
– Benner Formation – Valentine Formation  
Nittany Formation  
Axemann Formation  
Stonehenge/Larke Formation

*Cambrian*

Cg –  
Cgl –  
Cgm

Gateburg Formation  
Ore Hill/Stacy Member  
– Mines Member

*Pennsylvanian*

IPp –

Pottsville Group

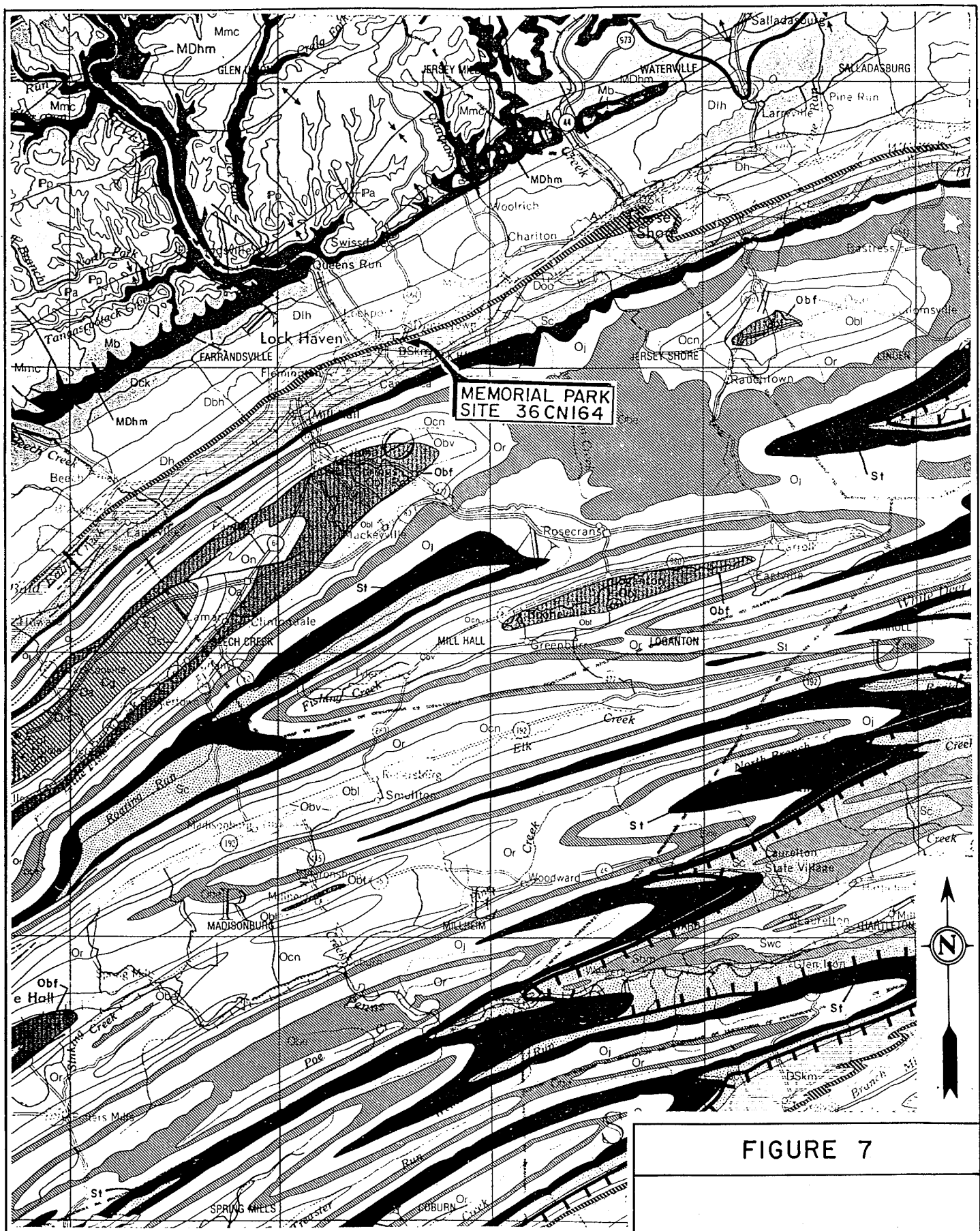

MEMORIAL PARK SITE 36 CNI64

FIGURE 7

REGIONAL BEDROCK GEOLOGY

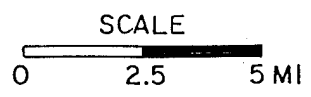

SOURCE: ARTHUR A. SOCOLOW, ET AL., 1980

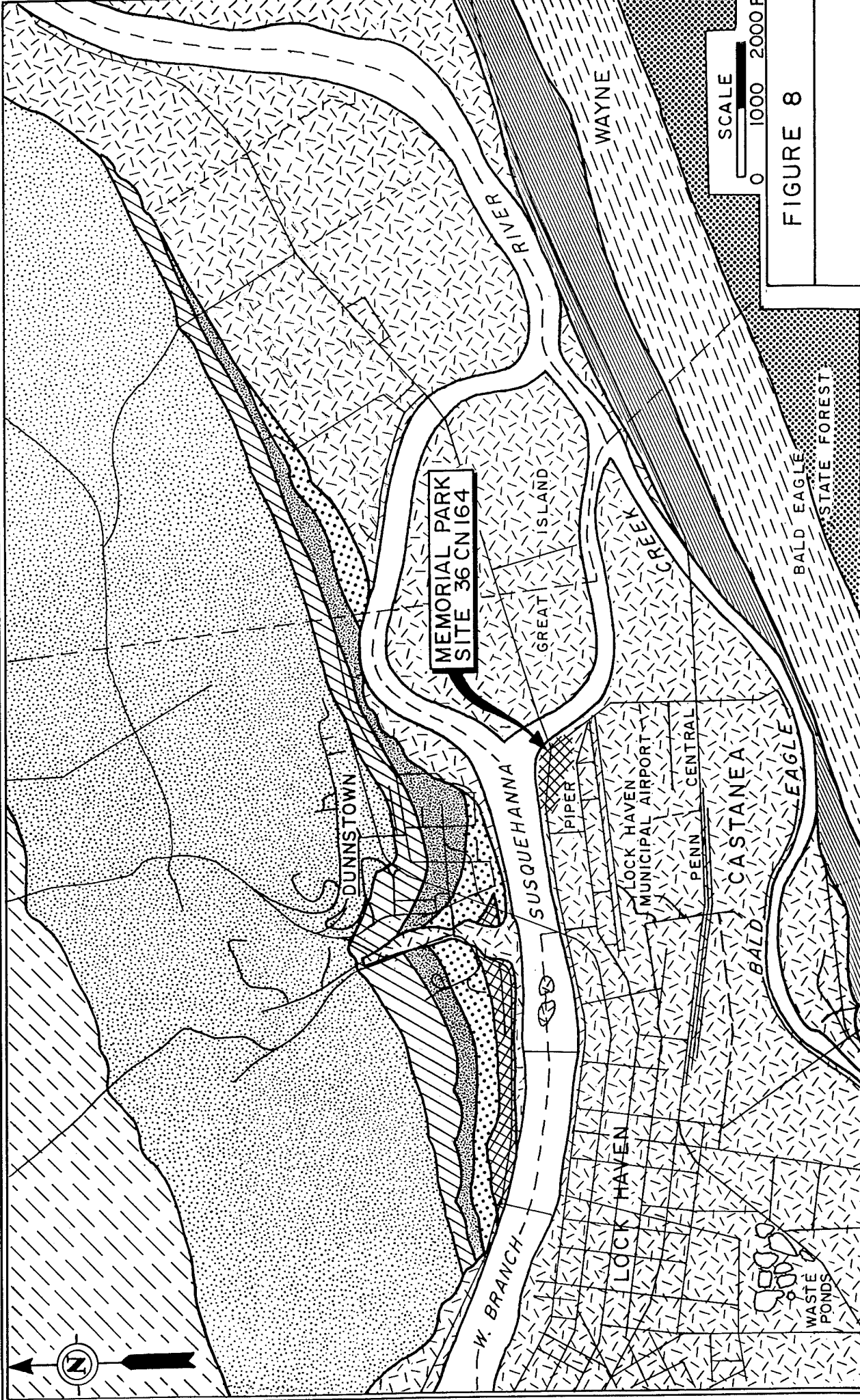

FIGURE 8

**FORMATION LEGEND**

	LOCK HAVEN		BURKET SHALE
	BRALLIER		TULLY LIMESTONE
	UPPER SHALE		SHALE

**LOCAL BEDROCK GEOLOGY**

	ALLUVIUM		TONLOWAY, WILLS CREEK & BLOOMSBURG
	MIFFLINTOWN AND ROSE HILL		TUSCARORA

**REFERENCE:**  
 GEOLOGY AND MINERAL RESOURCES,  
 LOCK HAVEN QUADRANGLE, CLINTON  
 AND LYCOMING COUNTIES, PA.,  
 ALFRED R. TAYLOR, 1977.

The Upper Mississippian is represented by the Mauch Chunk Formation. The Mauch Chunk forms the highlands (Allegheny Mountains) of the Appalachian Plateau in the vicinity of Lock Haven. The Mauch Chunk consists of quartzose, micaceous, yellowish-gray to light-red sandstone.

#### GEOMORPHOLOGY AND HYDROLOGY

The Memorial Park site occurs near the confluence of Bald Eagle Creek and the West Branch of the Susquehanna River (Figure 1). The floodplain near the site is approximately 1.6 km wide. The West Branch of the Susquehanna River emerges from the Appalachian Plateau as a transverse stream meandering through a floodplain approximately 0.9 km wide. Bald Eagle Creek occurs in a subsequent valley along the base of Bald Eagle Mountain. The floodplain in this valley varies from 0.5 to 1.8 km wide, becoming widest near Lock Haven. At the confluence, the West Branch makes a 90° turn to the east and follows the subsequent valley eastward to Montoursville, where it turns to the south again as a transverse stream.

The West Branch system on the Appalachian Plateau is a trellis drainage pattern. In this type of pattern the principle streams (which here include the West Branch), in general, flow across rock structure (transversely), but have long segments parallel to rock structure (Thornbury 1969). Most of the first-order tributary valleys are subsequent strike valleys (Denny 1956). Most second-order tributaries flow transversely across rock structure.

Bald Eagle Creek is an underfit stream; it appears to be too small for the size of the valley it occupies (Thornbury 1969). Underfit streams commonly result from drainage changes effected by stream diversion (stream piracy) or derangement. The West Branch is a larger stream that emanates from the Allegheny Front of the Appalachian Plateau, and then turns and occupies the subsequent valley along Bald Eagle Mountain. At one time, a larger stream may have occupied the subsequent valley all the way to Altoona or beyond. A smaller stream, occurring in the valley now occupied by the West Branch north of Lock Haven, then became the master stream through stream piracy due to headward erosion. The smaller stream was able to accomplish this because of its much steeper gradient to the north, despite the fact that it was eroding much more resistant rocks. The smaller stream subsequently became the master stream of the area as it enlarged its drainage basin and its erosive ability.

The confluence of the West Branch and Bald Eagle Creek may give some insight as to their past relations. Near Lock Haven, the two streams run parallel to each other for approximately three kilometers. Where they meet, the West Branch splits into two channels: one to the north, and one to the south. The land between the channels is known as Great Island. Either of the channels may be a remnant of the former smaller stream, and the diversion occurred when the original channel was choked with glacio-fluvial sediments. Bucek (1975) described how short tributaries to the West Branch deliver abundant sediments into the main valley and have caused deflection of the West Branch southward to the toe of Bald Eagle Mountain.

The Quaternary System is represented by a variety of deposits in the vicinity of the study area (Bucek 1975). The floodplain areas are mapped as Quaternary Alluvium (Figure 8) on the map by Taylor (1977). As mentioned earlier, the Glaciated Appalachian Plateau border is near the site. The distinction between the Glaciated Appalachian Plateau and the Unglaciated Plateau is often drawn at the Wisconsin glacial drift boundary. The effects of the more extensive pre-Wisconsin glaciations are poorly expressed in the topography (Thornbury 1965). Leverett (1934) shows the area around Lock Haven as an area of questionable location of glacial deposits. Lock Haven is south of the Wisconsin drift border. The nearest advance is approximately 20 km north of Williamsport (Bucek 1975; Crowl and Sevon 1980; Denny 1956). However, proglacial deposits, pre-Wisconsin deposits, and periglacial phenomenon extend throughout Clinton

County and south into the Ridge and Valley Province (Bucek 1975; Ciolkosz et al. 1986; Denny 1951; Marsh 1987; Steputis et al. 1966).

Throughout the area north and east of the West Branch, and at all elevations, are small pockets of soil that contain gravel and stones, including rounded quartzite (Steputis et al. 1966). The material in the pockets has many characteristics of till. The closest glacial till soils mapped near the site are the Allenwood soils mapped near Woolrich. The soils mapped immediately north of the site, on the shale benches, are largely Berks soils formed in shale bedrock. Colluviated residual soils are difficult to distinguish from colluviated old tills (Crowl and Sevon 1980). In neighboring Lycoming County, the glacial drift consists of unsorted till, outwash, and stratified drift (Kohler 1986). There are also large areas of stony and bouldery colluvium, and some boulder fields.

According to Denny (1956), pre-Wisconsinan deposits are mapped up-valley of all major streams in the northern Appalachian Plateau of Pennsylvania. These deposits include kame terraces, valley train terraces, and strongly-weathered drift, colluvium, alluvium, or residuum. The latter is collectively referred to as the pre-Wisconsinan paleosol (Denny 1956; Denny and Lyford 1963) and is assumed to be Sangamon in age (Snyder and Bryant 1992; Waltman et al. 1990). Waltman et al. (1990) have named this the Pine Creek Paleosol. Pre-Wisconsinan terraces and Wisconsinan terraces are difficult to differentiate, as are colluvial deposits of similar age (Denny 1956; Leverett 1934). The strongly weathered Sangamon age paleosol is used in stratigraphic work to distinguish pre-Wisconsinan from Wisconsinan aged materials (Denny 1956; Snyder and Bryant 1992; Waltman et al. 1990). One terrace, approximately 30 meters above the West Branch near Shintown had a reddish paleosol (Sangamon) covered with 50 cm of yellowish-brown loam (Denny 1956). Kettle Creek and Pine Creek both have alluvial fans and colluvial benches that do not contain the paleosol and, thus, are assumed to be late Wisconsinan in age. Pre-Wisconsinan colluvial and fluvial deposits were identified near Lock Haven, based on the existence of a well-developed paleosol (Bucek 1975).

The Pre-Wisconsinan (Illinoian) glacial lakes Lesley I and Lesley II, are described by Bucek (1975). These lakes formed when the Illinoian Muncy ice sheet dammed the West Branch valley at Muncy. The resultant lakes fluctuated between 201 and 213 m (Lesley I) and 182 and 189 m (Lesley II) elevation. During the highest lake level, the lake was at least 64 km long and backed up Bald Eagle Creek valley to Milesburg. Two phases of Lake Lesley I and possibly three lake fill sequences, separated by Muncy and Warrensville Tills (Bucek 1975). Leverett (1934) expressed reservation about the existence of Lake Lesley as it was described by Williams (1917). However, the work of Bucek (1975) and workers cited within, present convincing evidence of a proglacial lacustrine environment of Illinoian age. All of the lake deposits (terraces described by Bucek [1975]) occur at elevations greater than 182 m. The lake-fill sequence consists of true lake-bottom varved clays and silts grading to fluviolacustrine cross-laminated silts and sands and, further, to cross-bedded fluvial sands and gravels. Coarse-grained sands and gravels with distinct foreset beds were deposited in the deltas of large tributary streams.

As with older deposits, it is often difficult to distinguish between late Wisconsinan and Holocene gravelly and cobbly alluvial fans (Denny 1956). One distinction is based on topographic form associated with periglacial phenomena. The gravelly and cobbly fans at McElhattan, Raughtown, and Woolrich were probably deposited during Wisconsinan time by the large volumes of water that emanated from mountain streams (Steputis et al. 1966). The possibility of a Wisconsinan loessal input has been suggested to explain the silty nature of the upper horizons (Denny 1956; Denny and Lyford 1963; Marchand 1978; Snyder and Bryant 1992; Waltman et al. 1990). Bucek (1975) described a loessal unit from 10 cm to nearly 100 cm thick in the vicinity of Muncy and the West Branch valley, between Montoursville and Pennsdale. The loess overlies a variety of older Pleistocene deposits.



South of the glacial border the Wisconsin is largely represented by periglacial deposits and features ( Ciolkosz et al. 1986; Denny 1951; Denny 1956). One of the more striking examples is the large block field on Bald Eagle Mountain, visible from the site. The periglacial environment is characterized by intense freeze-thaw and mass wasting processes, with or without permafrost, and with or without tundra vegetation (Braun 1989). Periglacial features that have been identified throughout the Appalachians include patterned ground (sorted and non-sorted), rock and soil wedges, grezes littees (shale chip rubble), assorted colluvial deposits, blockfields and streams, cryoplanation surfaces, and nivatation hollows (Clark and Ciolkosz 1988). In the vicinity of the study area, the majority of periglacial features are believed to be early Wisconsin in age (Denny 1951, 1956), although Waltman et al. (1990) describe the Slate Run Colluvium, possibly a periglacial solifluction deposit, as a Woodfordian (late Wisconsin) deposit. The periglacial zone is described as Woodfordian (late Wisconsin) near Lock Haven by Bucek (1975).

The late Wisconsin is also represented by fluvial deposits in the form of both fans and terraces. Crowl and Sevon (1980) describe an outwash terrace bordering the Susquehanna River near Nescopeck, to which they ascribe an Olean age (Woodfordian). Alluvial terraces in Lycoming County consist of sheet-like deposits and lengthy gravel bars (Kohler 1986). The recent alluvial deposits occur in most of the small tributaries and main streams.

Vento and Rollins (1989) describe four distinct late Wisconsin age terraces within the Susquehanna drainage basin. Marchand et al. (1978) state that as many as six or seven Woodfordian outwash terraces can be recognized, but for mapping purposes they have been grouped into three: low terrace/floodplain, intermediate terrace, and high terrace. In the Vento and Rollins (1989) scheme the oldest and highest of the four terraces is the Olean terrace, described above. In decreasing age and elevation the remaining terraces are the Binghamton, the Valley Heads, and the Port Huron. The Rose Valley Till, described by Bucek (1975), correlates in age with the Olean and Binghamton units. The Rose Valley terrace is formed by a continuous body of outwash along the West Branch at its tributaries, Loyalsock and Muncy Creeks, and can be traced to the Rose Valley end moraine. Its surface is at elevations between 158 and 164 m.

The Memorial Park site occurs on the Port Huron terrace (Vento and Rollins 1989). Artifact-bearing buried soils occur in the Port Huron terrace, four meters above the current channel, and on the Valley Heads terrace, seven meters above the current channel. The lack of multiple paleosols on the stable, higher, older terraces (Binghamton, Olean) indicates that late Pleistocene to early Holocene overbank deposition rarely reached the 10 m (Binghamton) to 14 m (Olean) heights above the current channel. Buried soils on lower terraces near bank-edge and levees within the Susquehanna drainage basin are attributed to intervals of floodplain stability punctuated by episodes of overbank discharge and channel avulsion.

Surfaces of the Port Huron terrace are the highest that are typically breached by Holocene inundations of the West Branch (Schuldenrein and Vento, 1993). Periodic floods differentially sealed and eroded prehistoric deposits. Buried soils on bank edge low terrace contexts within the Susquehanna Basin have been attributed to intervals of floodplain stability, punctuated by intervals of overbanking and channel avulsion.

## SOILS

Two associations of alluvial soils occur in Clinton County (Steputis et al. 1966). The Ashton-Huntington Association consists of deep and mainly well-drained soils on floodplains and terraces in materials washed from soils underlain by limestone. The Ashton soils occur along the West Branch from Lock Haven eastward, including the Memorial Park site (Figure 9). These soils are occasionally flooded by Bald Eagle Creek. Huntington soils are on floodplains of streams that drain highly calcareous areas. This association includes minor areas of the moderately well-

drained Lindside soils, the somewhat poorly drained Newark soils, and the poorly-drained Melvin soils. These soils are similar to the Huntington soils and flood more frequently than the Ashton soils.

The Pope-Barbour-Sequatchie Association occurs on nearly-level to gently-sloping and gently-undulating terraces and floodplains, along streams that drain uplands underlain by acid sandstone and shale. Pope soils occur on alluvial fans at the mouth of small streams and are deep, well drained, and gravelly and cobbly. Barbour soils are deep, well-drained, reddish soils that are sandy or loamy. The Sequatchie soils are mostly on the moderately high, nearly level floodplains of the West Branch north of Lock Haven. These soils are deep, well drained, and have silt loam to fine sandy loam textures.

No associations of alluvial soils are included in the general soils map of Centre County (Braker 1981). However, several alluvial soils are mapped along Bald Eagle Creek and the West Branch of the Susquehanna River, and several of their tributaries. The Allegheny soils consist of deep, well-drained soils formed in old alluvium washed from uplands underlain by sandstone, siltstone, and shale. These soils occur on nearly level to gently sloping terraces above the floodplains of major streams. The Atkins soils consist of deep, poorly drained soils on level floodplains formed from alluvium washed from uplands underlain by sandstone, siltstone, and shale. The Basher soils are deep, moderately well drained, and occur on level floodplains of alluvium from uplands underlain by red shale, siltstone, and sandstone. The Chagrin soils consist of deep, well-drained soils on level floodplains formed from alluvium washed from uplands underlain by limestone, sandstone, and shale. The Dunning soils consist of deep, very poorly drained soils on level floodplains of alluvium from uplands underlain by limestone and shale. Lindside soils are deep, moderately well-drained, and occur on level floodplains of alluvium from uplands underlain by limestone and shale. Philo soils are deep, moderately well drained, and occur on level floodplains of alluvium from uplands underlain by shale, siltstone, and sandstone. Pope soils are deep, well drained, and occur on level floodplains of alluvium from uplands underlain by sandstone, siltstone, and shale. Purdy soils are deep, poorly drained, and occur on terraces above floodplains along major streams. These soils formed in slackwater sediment of clay and silt washed from uplands underlain mainly by shale and siltstone.

In Lycoming County, two associations are mapped in alluvial landscapes (Kohler 1986). The Linden-Holly-Wheeling Association consists of deep soils, formed in stream deposits, and occurring on floodplains and river terraces. The Linden soils are deep, well-drained, and occur on level floodplains of recent alluvium adjacent to streams. The Holly soils are deep, poorly to very poorly drained, and occur on level, frequently flooded floodplains of recent alluvium. Wheeling soils are deep, well drained, and occur on nearly-level to gently-sloping terraces of old alluvium. Bucek (1975) correlates the Wheeling soil with the Post-Rose Valley paleosol.

The Barbour-Tunkhannock-Basher Association consists of deep soils formed on floodplains and glacial outwash terraces (Kohler 1986). The most extensive areas are adjacent to the tributaries of the West Branch. Barbour soils are deep, well drained, and occur on level, frequently flooded floodplains of recent alluvium adjacent to streams. Tunkhannock soils are deep, well drained and occur on level to moderately steep terraces of glacial outwash and have been correlated to Post-Rose Valley paleosols Bucek (1975). Basher soils are deep, moderately well to somewhat poorly drained, and occur on level floodplains of recent alluvium adjacent to streams. Minor areas of the Chenango soils, the Linden soils, the Rexford soils, and the Wyoming soils are mapped along streams. The Chenango soils are deep, somewhat excessively drained to well drained, and occur on stream terraces and kames of gravelly, glacial outwash material. The Linden soils are deep, well drained, and occur on nearly level floodplains of alluvium from red and brown shale and sandstone. The Rexford soils are deep, somewhat poorly to poorly drained, and occur on nearly level glacial outwash terraces. Wyoming soils are deep, somewhat excessively drained,



and occur on nearly level, low-lying outwash terraces of water-laid sand and gravel derived from red and gray sandstone, siltstone, and shale.

#### PALEOCLIMATE

The final advance of Pleistocene ice sheets, into the central and eastern Great Lakes region, occurred about 13,000 B.P., and was followed by a more or less continuous glacial retreat, with minor interruptions just before the Holocene transition (Barry 1983). By the Holocene transition, the Laurentide ice sheet was gone from most of the Great Lakes region. A tundra zone was present until about 12,500 to 12,000 B.P., in southern Connecticut, western Massachusetts, and northeastern Pennsylvania. There was less seasonal variation in circulation intensity in the late-glacial climate than there was in Holocene climates as a whole. In temperate latitudes, the Wisconsinan/Holocene boundary is placed at 10,000 B.P.

The Holocene has been subdivided into three divisions throughout most of the United States (Wright 1983). The Early Holocene may still have reflected the waning ice sheets. The Middle Holocene seems to have represented the maximum expression of the interglacial climate. The Late Holocene has displayed the climatic reversal leading to the Little Ice Age.

The most eventful portion of the Holocene was the very beginning, when the glacial climatic mode was rapidly changing to the interglacial (Wright 1983). The regional climate during the Early Holocene apparently involved the response of the general circulation of the atmosphere to rapidly-changing patterns of solar radiation (insolation), and the periglacial influence of the waning ice sheet. Kutzbach's (1983) model of orbital variation indicated that solar radiation, occurring 9000 B.P., was greater in June through August, resulting in a warming of the land surface and an increase in the land-ocean temperature contrast, as compared to present conditions. In December through February, decreased solar radiation cooled the land surface, relative to present conditions.

The classical Holocene climatic discontinuities, or intervals, are based on European peat stratigraphy developed before radiocarbon dating-techniques were developed (Bradley 1985). The peat stratigraphy is based on climatically-sensitive changes in peat growth rates. Objective analysis of peat stratigraphy indicated that the classical intervals may not be of regional significance. Nevertheless, the descriptors (Atlantic, Sub-Atlantic, etc.) are still commonly used to refer to a particular time period. Wendland and Bryson (1974) analyzed radiocarbon dates and botanical records, and indicated that the classical interval boundaries were not precise, but varied over the ranges indicated.

The first classical interval of the Holocene—the Boreal—extended from 10,000 to 8,000 B.P. (Bradley 1985). Some workers delineate the interval from 10,200 to 9,500 B.P. as the Pre-Boreal. The Boreal interval was characterized by a climate warmer and drier than today's conditions. The hypsithermal interval was a post-glacial warm interval, extending from about 9000 B.P. to 2500 B.P. During the Boreal interval, zonal flow (west to east) was dominant throughout most of the year because of the continuing effects of the abating Laurentian ice sheet (Knox 1983). Warm and dry air masses from the Pacific were predominant during the Boreal, particularly in the west and midwest (Vento and Rollins 1989).

Figure 9. Project Area Soils

AoC	–	Andover Very Stoney Loam
As	–	Ashton Silt Loam
At	–	Atkins Silt Loam
Ba	–	Barbour Fine Sandy Loam
BeB2	–	Berks Channery Silt Loam 3 – 8% Slope
BeC2	–	Berks Channery Silt Loam 8 – 15% Slope
BeD	–	Berks Channery Silt Loam 15 – 25% Slope
BeD2	–	Berks Channery Silt Loam 15 – 25% Slope
BmC3	–	Berks–Montevallo Channery Silt Loam 8 – 15% Slope
BmD3	–	Berks–Montevallo Channery Silt Loam 15 – 25% Slope
BmF2	–	Berks–Montevallo Channery Silt Loam 35 – 100% Slope
BrA2	–	Brinkerton Silt Loam
BuC2	–	Buchanan Gravelly Loam
BvC	–	Buchanan Very Stoney Loam
CmC2	–	Comly Silt Loam 3 – 8% Slope
CnC3	–	Comly Silt Loam 8 – 15% Slope
DkC	–	Dekalb Very Stoney Soils 8 – 25% Slope
DkE	–	Dekalb Very Stoney Soils 25 – 100% Slope
HhB2	–	Hartleton Channery Silt Loam 3 – 8% Slope
HhC2	–	Hartleton Channery Silt Loam 8 – 15% Slope
LaC2	–	Laidig Gravelly Loam
Lz	–	Lindside Silt Loam
Ma	–	Made Land
Mn	–	Melvin and Newark Silt Loams
PoB	–	Pope Loam
Rb		Rubble Land
Sa	–	Sequantchie Loam
Sf	–	Sequeche Fine Sandy Loam
So	–	Stoney Land
WaA	–	Watson Silt Loam



Dissipation of the ice sheet, from the Quebec/Labrador highlands, coincided with the cool and wet Atlantic interval, approximately 7800 to 5000 B.P. (Knox 1983; Wendland and Bryson 1974). This interval was characterized by a weakened westerly circulation and a greater penetration of both polar and tropical air masses in a meridional circulation. In the classic peat stratigraphy scheme, the Atlantic interval was considered cool and wet, while in the United States it was interpreted as a warm-moist interval, coinciding with the altithermal (post-glacial thermal optimum) (Wendland and Bryson 1974). In Pennsylvania, the position and intensity of the subtropical Bermuda High determined the penetration of the tropical air masses (Vento and Rollins 1989). A high-pressure cell that was further west, and stronger, would result in a drier air mass in the general circulation.

The Sub-Boreal climatic interval, characterized as warm and dry, occurred from 4500 to 2800 B.P. (Bradley 1985). During the Sub-Boreal, there was less influence of meridional circulation and the associated cyclonic storms, and a return to more of a zonal west-to-east flow of drier air (Vento and Rollins 1989). The end of the Sub-Boreal coincided with the end of the hypsithermal, approximately 2800 B.P. This was followed by the cooler, wet conditions of the Sub-Atlantic interval. The classical divisions of the Holocene place the Sub-Atlantic interval at 2,800 B.P. to the present. Regional schemes divide the Sub-Atlantic into the warm, moist Sub-Atlantic (2800 to 1700 B.P.), the cool, moist Scandic (1700 to 1000 B.P.), the warm, moist, Neo-Atlantic (1000 to 800 B.P.), the cold, wet Pacific (800 to 450 B.P.), and the Neo-Boreal (450 to 100 B.P.). These divisions are based on pollen stratigraphy and intervals of temperature maximums and minimums, based on Icelandic ice cores (Vento and Rollins 1989; Neuman 1988).

Knox (1983) proposed a generalized scheme of regional alluvial chronologies based on inferred climatic variation during the Holocene. In the Eastern Woodlands, the period from the beginning of the Holocene to 8000 B.P., the Boreal interval, was characterized by active alluviation in response to the rapid warming and drying. From 8,000 to 6,000 B.P., the Atlantic interval, alluviation slowed or ceased, and fluvial landscapes became stable. The period from 6000 to 4500 B.P., the late Atlantic to early Sub-Boreal interval, was one of significant erosion of early Holocene fills in response to increased meridional patterns of atmospheric circulation. A period of relative stability occurred from 4000 to 3000 B.P., the warm and dry Sub-Boreal interval, followed by renewed cutting and filling, and active lateral channel migration, during the Sub-Atlantic interval (3000 to 1000 B.P.). Since about 800 B.P., modest alluviation seems to have dominated most regions until the nineteenth century.

#### PALEOBOTANY

The invasion of the deglaciated Northeast by forest vegetation was a relatively slow process (Watts 1983). From 15,000 B.P. to 11,500 B.P., the Northeast was dominated by *Picea* (spruce) with *Betula* (birch) early on, and *Abies* (fir) and *Alnus* (alder) coming in between 13,300 and 11,500 B.P. After 11,500 B.P., the *Picea* died out, and *Quercus* (oak), *Carya* (hickory), and *Castanea* (chestnut) predominated.

In eastern Pennsylvania, a date of 12,500 B.P. is considered minimal for the end of the tundra phase (Watts, 1983). The rise of *Quercus* and *Tsuga* (hemlock) in Pennsylvania can be used to mark the beginning of the Holocene.

According to diagrams prepared by David (1983), the arrival of boreal vegetation in north-central Pennsylvania included *Picea*, *Pinus* (pine), *Larix* (larch) and *Abies*, by 12,000 B.P. By 11,000 B.P., *Pinus strobus* (white pine), *Tsuga*, and *Ulmus* (elm) had begun to arrive in the area. *Quercus* arrived about 10,000 B.P. Later arrivals included *Acer* (maple) about 9000-10,000 B.P., *Fagus* (beech) about 7000 B.P., and *Carya* and *Castanea* about 4000-5000 B.P. These

generalizations are based on pollen stratigraphy at a number of locations throughout the eastern United States.

In response to Holocene climatic trends, *Picea* dropped off sharply from the pollen record after 10,000 B.P., and then had a resurgence after about 2000 B.P. (Davis 1983). The resurgence actually started about 5000 B.P. at higher elevations, possibly an indication of the end of the Holocene hypsithermal interval. In the northeastern United States, indicators of warm and dry conditions declined in abundance, or contracted in range, about 5000 B.P. This suggested that the warmest and driest portion of the Holocene had ended. The Middle Holocene decline and subsequent recovery of *Tsuga* was evidently the result of biotic factors rather than climatic ones (Davis 1983).

#### SUMMARY

The Memorial Park site is located near the junction of three major physiographic provinces and the confluence of two major drainages, in a broad, dynamic floodplain. All of these factors would have had major influences on prehistoric human settlement of the locale. The location near three major physiographic zones and the confluence of two major drainages would have provided prehistoric populations with access to a wide array of resources. The stream valleys would have served as corridors for movement of mobile hunter-gatherer populations during their annual subsistence cycle. The broad floodplain would have provided rich floodplain soils for agricultural fields for later, less mobile, agricultural populations. Climatic changes throughout the Holocene would have had impacts on the availability of resources within foraging range of the Memorial Park, influencing local subsistence-settlement patterns. The Memorial Park site is one small area of a very dynamic floodplain that underwent significant change during the Holocene. These changes, as described in the Geomorphology and Site Formation section of this report, influenced the manner in which the location was used, as well as site formation. However, throughout the Holocene, the Memorial Park site would have been a well-positioned location for populations, exploiting the West Branch valley and its environs.



### III. CULTURAL BACKGROUND

by

Jeffrey R. Graybill, Ph.D.

As part of the larger northeast North American culture area, prehistoric central Pennsylvania is divided chronologically into three general periods: Paleoindian, ?-8000 B.C.; Archaic 8000-1000 B.C.; and Woodland, 1000 B.C. - A.D. 1600 (Kent et al. 1971; Witthoft 1954; see Custer 1984, 1989 for an alternative periodization scheme). The chief rationale for these periods was originally technological change, but subsistence, settlement, mortuary, and other correlates have since been added. Useful as this northeast chronology is in summarizing change, it does not accurately reflect how change develops: cultural change rarely occurs in convenient time blocks dictated by periodization schemes; rather, it is a continuous, systemic process (Dunnell 1971; Graybill 1981). Thus, the following synopsis attempts to deal with this problem, to varying degrees, by addressing change both within and between periods.

The geographic focus of this overview is central Pennsylvania in general and, when sufficient data exists, the West Branch of the Susquehanna Valley (hereafter, West Branch Valley) specifically. All radiocarbon dates referenced herein are calibrated using a half-life of 5568 years, and represent uncorrected figures (see Herbstritt 1988).

#### PALEOINDIAN PERIOD (? - 8000 B.C.)

Although there is basic agreement that the first peoples to inhabit the Americas came from Asia, there is considerable disagreement as to precisely when this happened. Some investigators believe that American Indian populations were present here by 40,000 B.C., or earlier (Bryan 1965); others place their arrival as late as 9500 B.C. (Haynes 1967).

#### *Early Paleoindian (?-9500 B.C.)*

The evidence for an Early Paleoindian subperiod in the northeast, as well as the Americas as a whole, is both controversial and largely conjectural (see Custer and Stewart 1990). As of this writing, the best candidate for an Early Paleoindian occupation in or near the project area occurs at Meadowcroft Rockshelter, southwestern Pennsylvania (Adovasio et al. 1978, 1990). At Meadowcroft, with specific reference to uppermost stratum IIa radiocarbon dated at 10,850-9350 B.C., a single, unfluted "Miller Lanceolate" projectile point and small, somewhat distinctive, lithic assemblage were found. Although they lack diagnostic lithics, still earlier, more deeply buried cultural remains occur at Meadowcroft with seven radiocarbon dates averaging 14,000 B.C.

If valid, the radiocarbon dates from Meadowcroft Rockshelter suggest that central Pennsylvania may have been inhabited 16,000 years ago or more. No Miller Lanceolate points, or similarly early artifacts, have been reported for the study area; this is also the case for other parts of the northeast.

### *Late Paleoindian Subperiod (9500-8000 B.C.)*

It is not until Late Paleoindian times that there is conclusive evidence for human habitation in central Pennsylvania. These early inhabitants were few in number, lived in what was basically a colder environment than exists in the area today, hunted large game animals supplemented to varying degrees by other wild foodstuffs, exhibited a high degree of residential mobility, and operated in what must have been extremely large sustaining areas.

As recently as 16,000 B.C., the southern margins of the great Laurentide ice sheet which buried much of the northeast, stood within 25 miles of the project area, but by 9500 B.C. this ice front had retreated northward into Canada (Turnbaugh 1977). Largely because of its proximity to this ice mass, the climate of central Pennsylvania at that time was considerably cooler and more moist than it is today. In keeping with this climatic picture, the area supported what has been termed an open boreal forest or spruce parkland, perhaps with tundra conditions at higher elevations (Carr 1989; Turnbaugh 1977). Still later, with the continued retreat of the Laurentide ice mass, the climate became somewhat warmer, and by the end of Late Paleoindian times a closed boreal forest appeared across the area.

A curated lithic technology prevailed during Late Paleoindian times (Parry 1989). This technology emphasized the production of bifaces and standardized, retouched tools through a formal core reduction strategy that used only the highest grade cryptocrystalline raw materials (Gardner 1974, 1981; Goodyear 1979). As Parry (1989) suggests, the Late Paleoindian tool kit was characterized by multifunctional, multiuse implements noted for their portability and thus ideally suited for populations exhibiting a high degree of residential mobility. Specific tool types included projectile points and a variety of other bifacial implements such as end scrapers, side scrapers, graters, drills, and wedges, at least some of which presumably served cutting functions.

Two basic subsistence-settlement models have been proposed for Late Paleoindian times in the northeast. The first emphasized the hunting of caribou, a migratory herd animal now extirpated from the area (Funk 1972; Turnbaugh 1977). The pursuit of caribou typified more northerly parts of the northeast, resulting in large, recurrent campsites optimally sited to facilitate intercept of caribou herds (Carr 1989). Numerous examples of this site type have been reported in the literature, including Holcombe Beach, Michigan (Fitting 1964); Bull Brook, Massachusetts (Byers 1954); Vail, Maine (Gramly 1982); and Debert, Nova Scotia (MacDonald 1968). The Shoop site in southcentral Pennsylvania is the site closest to the project area that conforms to this pattern, although it remains somewhat of an anomaly at the latitude where it occurs (Carr 1989; Witthoft 1952).

A second, more southerly adaptation, emphasized the hunting of solitary, nonmigratory game such as deer, elk, and perhaps moose (Gardner 1981). It is likely that this adaptation also placed a greater emphasis on plants, small game, fish, and other non-large-game foodstuffs than did its more northerly counterpart. This subsistence pattern resulted almost exclusively in small, one-time occupations of limited duration; specifically, hunting stations, processing camps, and other transient site types. The only exceptions are large, recurrent sites associated with source areas for preferred lithic raw materials, as typified by Thunderbird, Virginia (Gardner 1974) and West Athens, New York, (Funk 1972; Ritchie and Funk 1973).

Based largely upon stylistic changes in fluted projectile points at the Thunderbird site, Gardner (1974; Gardner and Verrey 1978) has subdivided the Late Paleoindian subperiod into three successive phases. The earliest, Clovis, is dominated by large, classic Clovis spearpoints differing little in shape from their western counterparts. The intermediate phase, unnamed, is characterized by smaller, thinner, fluted-point forms with pronounced flutes. The last phase is identified by Gardner (1974) as a Dalton phase, with trianguloid, bifacially-thinned Dalton points.



In his archaeological survey of the West Branch Valley from Muncy, Lycoming County, upstream to near the current project area, Turnbaugh (1973, 1977) identified 27 fluted projectile points in collections, six of which had been previously reported upon by Kinsey (1958). In general, the stylistic variability reported for these points parallels Gardner's (1974) chronology, with 9 Clovis-phase points, 11 intermediate-phase fluted points, and 3 Dalton phase points represented. According to this chronology, the Dalton phase witnessed a sharp decline in numbers of points, and this decline Turnbaugh (1977) attributes to the onset of a closed boreal forest, which had a much lower carrying capacity than did the forest conditions which preceded it (cf. Fitting 1968).

The vast majority of fluted points tabulated by Turnbaugh (1977) represent isolated finds or small, ephemeral occupations, with only a few sites producing more than a single point. Given this thin, spotty distribution, it is not possible to assign these finds to either of the two subsistence-settlement systems referenced above, as small occupations characterize both.

The excavated Late Paleoindian site nearest to the project area is Shawnee-Minisink along the Delaware River, northeast Pennsylvania (McNett et al. 1985). Here, Clovis fluted points and retouched tool forms were recovered from stratified, alluvial contexts radiocarbon dated at 9100-8640 B.C.

#### ARCHAIC PERIOD (8000-1000 B.C.)

The Archaic period is a direct development from Paleoindian times. This lengthy period is characterized by slow, steady cultural change. It coincides with the advent of an essentially modern climate, and in keeping with the concurrent formation of distinct biotic provinces across eastern North America, it is with this period that the first indications of regional cultural diversity appear.

The salient characteristics of the Archaic period include steady population growth; band fissioning, producing a general increase in the number of communities present; territorial fragmentation, resulting in the creation of numerous, smaller sustaining territories; broad-spectrum hunting and gathering, accompanied by increasing economic diversification; a seasonally rotating settlement system characterized by movement according to the location and availability of wild foodstuffs; and technological innovation, specifically grooved axes, atlatl weights, milling stones, and related tools.

#### *Early Archaic Subperiod (8000-6000 B.C.)*

As recently as 1965, writing in *The Archaeology of New York State*, Ritchie placed the beginning of the northeast Archaic at 3500 B.C., and thus a 4500-year hiatus separated this period from the preceding Paleoindian period. Shortly thereafter, Fitting (1968) proposed the onset of a closed boreal forest across the northeast to account for this hiatus and, more recently, this same hypothesis has been advocated by others (Funk 1977; Turnbaugh 1977). The theory maintains that this coniferous forest had a significantly lower carrying capacity than that prevailing under conditions before and after it, and thus supported low human population densities.

More recent research, however, suggests that Early Archaic occupations in the northeast are not quite as rare as Ritchie (1965) first thought. In 1967, a scant two years after Ritchie's overview was published, Michels and Smith (1967) reported on the presence of Early Archaic occupations at the deep, stratified Sheep Rock Shelter in southcentral Pennsylvania. Still later, Ritchie himself (Ritchie and Funk 1971) reported on the first Early Archaic occupations to be identified for New York State and environs.

In the northeast, as elsewhere throughout eastern North America, the Early Archaic subperiod displays clear cultural continuity with Paleoindian times. Indeed, parallels between Late Paleoindian and Early Archaic are so pronounced that, in contrast to a more conventional approach, the two culture history intervals are sometimes combined (e.g., Custer 1984, 1988; Gardner 1974). Much like the Late Paleoindian subperiod, the Early Archaic exhibits a curated lithic technology emphasizing the production of bifaces and standardized retouched tools, a preference for, but not total reliance upon, the use of high-grade cryptocrystalline raw materials, a high degree of residential mobility, and the hunting of large game animals as its primary economic focus. Indeed, as Gardner (1981) suggests, the only significant change that occurs at this time is a shift from lanceolate to notched points.

A warm, dry, trend began by approximately 8500 B.C., and this climate continued late into the Early Archaic subperiod. As a consequence, the northeast supported a closed boreal forest characterized by pine, fir, spruce, and other coniferous species, but with oak and other hardwoods increasingly evident (Fitting 1968; Turnbaugh 1977). This boreal forest, in turn, supported few game animals of economic importance. It has thus been conjectured that Early Archaic groups were primarily reliant upon aquatic/riverine food resources (Funk 1977), but tool kits from this time period fail to support this interpretation (Gardner 1981).

The primary basis for Early Archaic chronology is various projectile point styles documented from stratified, radiocarbon dated contexts in North Carolina (Coe 1964), West Virginia (Broyles 1971), Tennessee (Chapman 1976), and Virginia (Gardner 1974). In order of decreasing antiquity, styles present at the St. Albans site, West Virginia (Broyles 1971), include Kessel Side Notched, a regional variant of the Big Sandy I type as defined for the Southeast (Cambron and Hulse 1964); Charleston Corner Notched, a regional variant of the Thebes/St. Charles point as defined for the Midwest (Justice 1987); Kirk Corner Notched; MacCorkle Stemmed; St. Albans Side Notched; LeCroy Stemmed; and, Kanawha Stemmed. This outline of the Early Archaic sequence specifically excludes the Kirk Stemmed type referenced by Broyles (1971), as more recent research has shown it to be Middle Archaic in age.

Turnbaugh (1973, 1977), with reference to his West Branch Valley survey, identified 57 Early Archaic projectile points (excluding Kirk Stemmed, see above) in collections. Specific point styles included Charleston Corner Notched, four specimens; Kirk Corner Notched (a.k.a. McCool-like), five specimens; MacCorkle Stemmed, eight specimens; St. Albans Side Notched, 11 specimens; LeCroy Stemmed, 15 specimens; and Kanawha Stemmed, 15 specimens. According to Turnbaugh (1977), a general increase in numbers of Early Archaic points through time suggests the reversal of a local population decline that began late in the Paleoindian period. Population increase, in turn, is ascribed to improving forest conditions, with an increasing number of oaks and other hardwoods supplanting coniferous species.

As of this writing, no Early Archaic sites have been excavated in the West Branch Valley; indeed, other than Sheep Rock Shelter (Michels and Smith 1967), Huntingdon County, referenced above, no sites dating to this time have been excavated in central Pennsylvania. At Sheep Rock, with specific reference to Level 7, radiocarbon dated at 5100 B.C., two Kirk Corner Notched points, one LeCroy Stemmed point, and one chipped-stone celt were found (a sixth millennium B.C. date is too late for this Early Archaic assemblage, but since the assay was on raw, undecomposed wood, it may date later than Level 7 itself). Still deeper, a chipped-stone celt with polished bit was recovered from Level 8, radiocarbon dated to 6920 B.C.

Beyond central Pennsylvania, but still in the Susquehanna drainage system, Funk (1977, 1979) has reported on the excavation of several sites along the North Branch of the Susquehanna River yielding scant, buried Early Archaic remains. At the Gardepe site (Locus 1) near Wells Bridge, New York, Funk (1979) reports a LeCroy Stemmed(?) point from Zone 6, the deepest culture-bearing stratum at this locale. Unfortunately, a Jack's Reef Corner Notched point (A.D.

700) was also recovered from this zone, as was a radiocarbon date of 7430 B.C., a figure generally considered to be too early for the LeCroy type (cf. Broyles 1971; Chapman 1976).

Also near Wells Bridge at the Russ site, Funk (1979) and associates recovered a myriad of Early Archaic point styles from buried, alluvial contexts, although clear physical stratigraphy was lacking here. Specific Early Archaic point styles present included Kessel Side Notched; Kirk Corner Notched(?), or perhaps some regional variant thereof; and, Kanawha Stemmed. Three radiocarbon dates: 6270 B.C., 6010 B.C., and 5930 B.C., were obtained for the Kanawha Stemmed type at Russ, a date range that compares well with figures available for St. Albans (Broyles 1971).

#### *Middle Archaic Subperiod (6000-4000 B.C.)*

The Middle Archaic interval witnessed numerous cultural changes, but only a small increase in human numbers. It is during this subperiod that we get our first indications of regional cultural variability across the northeast (Fitzhugh 1972). It is also at this time that a broad repertoire of ground stone tools is introduced into the archaeological record; specifically, grooved axes, atlatl weights, and milling stones, among others (Coe 1964; Dincauze 1976).

The single most important Middle Archaic change is the inception of a broad-spectrum hunting and gathering economy, as opposed to the preceding economy with its focus on hunting (Gardner 1981; Stewart 1980; Wall 1981). This subsistence change, in turn, had important ramifications for other aspects of the Middle Archaic cultural system. The rudiments of a seasonally-rotating settlement pattern are first established at this time, with Middle Archaic populations tethered to riverine base camps for most the year (Gardner 1981; Stewart 1980). In keeping with decreasing residential mobility, an expedient lithic technology prevailed, and rhyolite, local cherts, and other low-grade lithic materials were first used to any appreciable extent (Parry 1989; Turnbaugh 1977). It was also during the Middle Archaic that milling stones, pitted stones, and related processing tools first appeared on sites, presumably due to the increasing importance of plant resources in the diet (Gardner 1981; Wall 1981).

It is generally believed that a warm, moist climate prevailed throughout the area during the Middle Archaic. Pine, which formerly dominated forests, was increasingly supplanted by oak, butternut, and other hardwoods, with large numbers of hemlock occurring as well. In consequence of these vegetational changes, Turnbaugh (1973, 1977) sees improvement in the area's overall carrying capacity, and a resulting increase in deer and small mammals.

A tight internal chronology for the Middle Archaic has yet to be formulated for the West Branch Valley. Between 6000-5000 B.C., Neville Stemmed, Stanley Stemmed, and Kirk Stemmed points are characteristic, and for that portion of the West Branch Valley surveyed by Turnbaugh (1973, 1977), he reports 33 Neville/St Stanley Stemmed points and three Kirk Stemmed points in collections. The Stanley Stemmed type has been radiocarbon dated to 5745 B.C. at the Hansford site, West Virginia (Hemmings 1985; Wilkins 1985); the Neville Stemmed to 5790-5065 B.C. at the Neville site, New Hampshire (Dincauze 1976); and the Kirk Stemmed to 5430-5370 B.C. at the Harry's Farm site, New Jersey (Kraft 1975).

During the fifth millennium B.C., the precise attributes of Middle Archaic point types are less clear, but two proto-Laurentian types presumably characterize this interval (Funk 1977). These include large, Side Notched Otter-Creek-like points and untyped Corner Notched specimens, the latter not unlike Brewerton Corner Notched points as defined by Ritchie (1961). The earliest date for Otter-Creek-like points in the northeast comes from Sylvan lake Rockshelter, New York, where a radiocarbon assay of 4610 applies (Funk 1977). Insofar as is known, the untyped Corner Notched points of presumed Middle Archaic antiquity remain undated in the

northeast, but obvious similarities exist to the Amos Corner Notched-type in the Ohio Valley, radiocarbon dated at 4365-4790 B.C. (Hemmings 1985; Youse 1985).

The Otter-Creek-like and untyped Corner Notched points have obvious cultural antecedents in what Fitzhugh (1972) terms the Central Valley Notched Point tradition, a Lower Midwest cultural expression dating to 6000 B.C. or earlier (Justice 1987). These notched points, in turn, stand in sharp contrast to taper-stemmed Stark/Morrow Mountain points, Middle Archaic forms that characterize the Atlantic Slope and more easterly parts of the northeast (Dincauze 1976).

The extant literature reveals a single site in the West Branch Valley that has yielded Middle Archaic materials from buried, alluvial contexts: the Hall 1 site along Lycoming Creek, Lycoming County. Here, in the course of Phase II archaeological investigations, Graybill (1984) recovered two Neville Stemmed points, both of untyped chert, from a depth of approximately 60-80 cm below surface.

Approximately 15 km downstream from the project area, the deep, stratified Canfield Island site in Lycoming County has produced two radiocarbon assays from the fifth millennium B.C., but unfortunately associated time-marker artifacts were lacking. From Level 11 at Canfield, the deepest culture-bearing stratum at the site, Bressler (1989) reports a radiocarbon date of 4835 B.C. in association with a pestle fragment, pitted stones, at least one hearth, and large amounts of carbonized butternut. At a slightly higher depth, Level 10 yielded a radiocarbon date of 4585 B.C., also associated with large amounts of carbonized butternut. In addition, Level 10 yielded a chopper, pitted stones, and indications of several hearths.

At Sheep Rock Shelter, Michels and Smith (1967) report the recovery of six Neville Stemmed (a.k.a. Raystown Stemmed) points from Level 7A, immediately superior to Early Archaic cultural deposits. At slightly higher levels (specifically, Levels 7B-6), various notched, proto-Laurentian point forms make their initial appearance.

Farther away, but still in the Susquehanna watershed, the Gardepe site (Zone 5) in New York has produced three broad, thin, Corner Notched points, potentially Middle Archaic in age (Funk 1979). At the nearby Russ site, similar Corner Notched styles, Neville Stemmed, and Kirk Stemmed points were found stratified beneath Late Archaic to Woodland materials, but intermixed with Early Archaic forms (Funk 1979; see also above).

#### *Late Archaic Subperiod (4000-1800 B.C.)*

The single most important change during Late Archaic times was a pronounced population increase that coincided with the spread of basically modern forest conditions across the northeast (Funk and RippetEAU 1977; Michels 1968). According to Turnbaugh (1977), the onset of oak-chestnut forest conditions (Carolinian biotic province) in and near the project area signaled a marked increase in the area's biomass, and a concomitant increase in human numbers.

Accompanying human population growth, there is an expansion and refinement of the broad-spectrum hunting and gathering subsistence pattern begun in Middle Archaic times, and culminating in what Caldwell (1958) has termed "primary forest efficiency." A mature, fully-developed, seasonally rotating, settlement system was now firmly in place, with warm-weather base camps located along major waterways, accompanied by population dispersal into hinterland areas during cooler parts of the year (Gardner 1981; Ritchie and Funk 1973). Consequently, it is during the Late Archaic that rugged, more interior parts of the Appalachian physiographic area are first utilized to any appreciable extent (Turnbaugh 1977).

Two cultural traditions define the Late Archaic subperiod in the northeast: Laurentian (Ritchie 1965) and Piedmont (Kinsey 1971). The Laurentian tradition's (4000-2500 B.C.) cultural antecedents rest with proto-Laurentian groups that inhabited the area during the last half of the Middle Archaic. Specific point types ascribed to this tradition include Otter Creek, Vosburg, Brewerton Side Notched, Brewerton Corner Notched, Brewerton Eared Notched, and Brewerton Eared Triangle, all types described and illustrated by Ritchie (1961; also see Justice 1987). Other Laurentian diagnostics include items such as gouges, plummets, semilunar knives, ground slate points, and copper implements (Fitzhugh 1972; Ritchie 1965).

The Laurentian tradition is radiocarbon dated to the period from 3780 to 2350 B.C. in the Susquehanna Valley, Pennsylvania and New York (Funk 1977; Michels and Smith 1967); from 3620 to 3030 B.C., in the Delaware Valley, Pennsylvania and New Jersey (Kinsey 1972, 1975; Kraft 1975); from 3120 to 2524 B.C., in the Hudson Valley, New York (Funk 1965; Ritchie 1965); and from 3680 to 3360 B.C. in the Ohio Valley, Pennsylvania, New York, and West Virginia (Calkin and Miller 1977; Dragoo 1959). Thus, the age of this tradition is somewhat earlier than first suggested by radiocarbon assays from the O'Neil 1 site, New York, dated between 2050 and 2010 B.C. (Ritchie 1965).

The Laurentian tradition in the West Branch Valley, unlike its more northerly expressions, is primarily defined by its constituent projectile point styles. Although Fitzhugh (1972), Ritchie (1965), and others would limit the use of the Laurentian concept to sites exhibiting a full range of Laurentian traits, following Dragoo (1959), Michels and Smith (1967), and others, Pennsylvania sites are generally assigned to the Laurentian tradition solely on the basis of point typology.

Turnbaugh (1977), following Ritchie (1965), subdivides the Laurentian tradition into three chronological phases. In the absence of radiocarbon dates or stratified deposits from the West Branch Valley, however, it would appear that the extension of Ritchie's (1965) chronology to this area may be somewhat premature. In short, various Laurentian point styles often occur intermixed on the same sites in the West Branch Valley; outside of this area, these phases often appear to be more a product of spatial than of temporal variability.

While notched Laurentian points are among the most common artifact finds at central Pennsylvania sites, few excavations have been performed at these sites. At Canfield Island, Bressler (1989) reports a Laurentian component that he believes to have functioned as a processing station. From Level 8, radiocarbon dated to 3150 B.C., Bressler reports the recovery of 13 Brewerton Side Notched(?) points of black, fine-grained chert and 13 cultural features, primarily hearths. In association with these finds, there were 27 preforms/knives, 3 scrapers, 16 hammerstones, 2 milling stones, 12 netsinkers, and 6 nutting stones. Botanical remains were limited to large amounts of carbonized butternut, hickory nut, and some black walnut.

Turnbaugh (1977) describes excavations somewhat closer to the project site at a small Laurentian site believed to represent a hunting station. This site, 36LY76, Lycoming County, is located along an unnamed branch of Antes Creek, itself a tributary to the West Branch of the Susquehanna River. The site consisted of lithic artifacts recovered from the plowzone, plus various features that had penetrated into the underlying subsoil. From an excavation plot of 370 square meters, lithic artifacts included four projectile points, all Brewerton Side Notched(?) forms of chert, utilized flakes, two fragmentary atlatl weights, abraded hematite, and one hammerstone. Seven features included four hearths and three rock clusters. Additionally, there were 14 postmolds arranged in a weak arc.

To the south of the project area, Sheep Rock Shelter produced a large amount of Laurentian cultural materials (Michels and Smith 1967). Various Laurentian point styles were found in Level 6, with Brewerton Corner Notched forms predominating, albeit intermixed with other Late and Terminal Archaic point types. From Level 6, Michels and Smith (1967) report a radiocarbon date

of 2350 B.C., associated with a living floor yielding Brewerton Side Notched and Brewerton Corner Notched points.

In the Susquehanna watershed, New York, Funk (Funk and Rippeteau 1977) reports a single Laurentian component from buried, alluvial contexts. From Zone G at the Camelot 2 site, the deepest culture-bearing stratum at the site, three Brewerton Eared Triangle points were found, but unfortunately no charcoal suitable for radiocarbon dating was retrieved.

Dating to the last part of the Late Archaic subperiod, the Piedmont tradition (2500-1800 B.C.) follows the Laurentian. In contrast to notched points, which characterize Laurentian sites, a variety of narrow-bladed, stemmed points define Piedmont cultural manifestations. The cultural tradition embracing these stemmed points has been variously termed Taconic (Brennan 1963), Small Stemmed Point (Ritchie 1965), and Narrow Stemmed Point (Turnbaugh 1977), but following Kinsey's (1971) lead, the term Piedmont tradition is used in this overview to identify this Late Archaic cultural entity.

Constituent point styles include Bare Island (Kinsey 1959; Ritchie 1961); Lackawaxen Stemmed (Kinsey 1972); Lamoka (Ritchie 1961); Merrimack Stemmed (Dincauze 1976); Normanskill (Ritchie 1961); Squibnocket Stemmed (Ritchie 1965); Sylvan Stemmed and Side Notched (Funk 1965); Taconic (Brennan 1963); Wading River (Ritchie 1965); and a myriad of other stemmed forms, primarily differentiated by geography and lithic raw materials. In addition to projectile points, various axes, adzes, atlatl weights, and processing tools characterize the Piedmont tradition.

The Piedmont tradition dates to 2570-1800 B.C. in the Upper Susquehanna Valley, Pennsylvania and New York (Funk and Rippeteau 1977); to 2610-1880 B.C., in the Delaware Valley, Pennsylvania and New Jersey (Kinsey 1975; Kraft 1975); and to 2210-1760 B.C., in the Hudson Valley, New York (Funk 1965; Ritchie 1965). For the Lower Susquehanna Valley in Pennsylvania, Kent (1970; Herbstritt 1988) reports radiocarbon dates of 4440-1770 B.C. for various point styles comprising the Piedmont tradition. According to Kinsey (1971), this last area is the Piedmont tradition's heartland.

At Canfield Island, the Piedmont tradition is well represented by Levels 6 and 7. From Level 7, radiocarbon dated to 1910 B.C., Bressler (1989) reports a series of stemmed points which he ascribes to the Savannah River Stemmed type, a type designation which is clearly erroneous. Rather, inspection of Plate 10 in Bressler (1989) reveals that the majority of points illustrated are expanded stemmed forms analogous to the Lackawaxen Stemmed, Expanded Stem Subtype of Kinsey (1971, 1975) and Type E of Kent's (1970) Lower Susquehanna Valley chronology. Specific functional classes included 34 projectile points of chert and indurated shale, 24 preforms/knives, one scraper, three choppers, 22 hammerstones, 10 milling stones, and 29 netsinkers. A total of 17 cultural features was found, including 2 artifact caches, 10 hearths, and 5 rock clusters.

Immediately above Level 7 at Canfield, Level 6 yielded 61 straight stemmed points (lithic preference unspecified) intermixed with large numbers of Canfield Stemmed points, a Terminal Archaic point style. Bressler (1989) variously ascribes the straight stemmed points to Bare Island and Lamoka types (Kinsey 1959; Ritchie 1961, 1965).

From 36LY160, a rockshelter along Lycoming Creek, Lycoming County, Turnbaugh (1977) reports the excavation of a hunting/fishing station pertaining to the Piedmont tradition. Artifact recoveries included 15 projectile points, all ascribable to the Lamoka type and made of chert and indurated shale; four scrapers; three adzes, at least one of which is beveled in typical Lamoka fashion; 1 hammerstone; 13 netsinkers; and 3 nutting stones.

At Sheep Rock Shelter, only a few points of Piedmont cultural derivation were found (Michels and Smith 1967). Two Wading River points were recovered from Level 6, dating to Late/Terminal Archaic times. Five Bare Island points were found in Levels 6, 5, and 2, ranging from Late/Terminal Archaic to Late Woodland in age. In addition, two Bare Island points were recovered from indeterminate contexts.

For the Susquehanna Valley in New York, Funk (Funk and Rippeteau 1977) reports the excavation of 14 Lamoka occupations at nine sites. Typical of these sites is the Fortin site (Locus 1) near Oneonta, where three buried, stratigraphically superimposed Lamoka occupations (Zones 4, 5, and 7) were exposed at the base of excavations. In the case of Zone 7, the deepest culture-bearing stratum, the excavator postulates that Fortin 1 functioned as a spring-summer fishing station. In the case of zones 5 and 4, he infers the presence of fall-winter encampments, emphasizing hunting and butternut collecting.

#### *Terminal Archaic Subperiod (1800-1000 B.C.)*

This subperiod is synonymous with the Susquehanna tradition as defined by Dincauze (1968) and, to a lesser extent, the Transitional period of Witthoft (1953). Unlike the narrow-bladed, stemmed points of the preceding Piedmont tradition, the onset of the Susquehanna tradition is defined by broad-bladed, stemmed points (hence, "Broad" points) analogous to and presumably inspired by Savannah River Stemmed points of the Southeast (Claflin 1931; Coe 1964).

The Terminal Archaic marks a sharp break with previous cultural patterns, specifically as regards settlement behavior (Witthoft 1953). Whereas upland, interior areas witness increasing habitation and use, up through Late Archaic times; these same areas are all but abandoned during the Terminal Archaic (Witthoft 1953). Indeed, Gardner (1981), Kinsey (1971, 1975), Turnbaugh (1975, 1977), and Witthoft (1953) argue for a pervasive riverine settlement focus during this interval.

While change in Terminal Archaic settlements is clear, the nature, meaning, and larger significance of this change is less obvious. Witthoft, writing as early as 1953, concluded that "a migrant river life with emphasis upon canoes" best accounted for Terminal Archaic settlement patterns as well as other peculiarities of this subperiod. Similarly, Parry (1969) sees increasing residential mobility during the Terminal Archaic as suggested by what he perceives to be the revival of a curated lithic technology (this is perhaps true of the Perkiomen phase, but less true of other Terminal Archaic phases). Other studies, in contrast, suggest that the basic Terminal Archaic settlement pattern was a semi-sedentary one, and thus this interval constitutes a logical step in the progression from Archaic seasonal habitations to later sedentary settlements (Custer 1984; Gardner 1981).

It is often conjectured that a riverine settlement orientation in the northeast coincided with some form of economic specialization, specifically the intensive, focused exploitation of aquatic food resources like fish, particularly anadromous forms such as shad and alewife, and shellfish; (Gardner 1981; Kinsey 1971, 1975; Turnbaugh 1975, 1977). Unfortunately, however, there is little tangible evidence in the form of faunal remains from sites to support this hypothesis.

If the nature and meaning of Terminal Archaic settlement change is obscure, the larger significance of this change is even more perplexing. Several investigators, Gardner (1981) and Turnbaugh (1975) among them, have advanced the hypothesis that settlement change was largely due to environmental changes at this time, resulting in improved conditions for aquatic food resources (Gardner 1981; Turnbaugh 1975). Specific changes included a decrease in stream flows and sea level stabilization for estuarine areas (see Custer 1986). Still other changes possibly included degradation of upland, interior mass-producing areas, with consequences for both people

and the animals they hunted, and growing economic reliance upon incipient horticulture or food production. The effects of horticulture on the northeast Archaic in particular remain largely unevaluated, but in the Midwest cultivated plants like gourd (*Legenaria siceraria*), squash, *Cucurbita pepo*, and sunflower (*Helianthus annuus*) occur as early as 4000 B.C., and constitute an increasingly important part of the diet thereafter (Asch et al. 1972; Watson 1988).

Another important aspect of the Terminal Archaic is that it provides the first evidence for mortuary ceremonialism in the northeast. Both in New England (Dincauze 1968) and neighboring parts of New York, Pennsylvania, and New Jersey (Hawkes and Linton 1916; Regensburg 1970; Ritchie 1959), there are cemeteries dating to this time, that have yielded cremated human interments often accompanied by artifacts such as finely-made projectile points, preforms/knives, and atlatl weights. These artifact inclusions were often ritually "killed," and then covered with powdered red ochre.

Chronologically, the Terminal Archaic subsumes three phases in the West Branch Valley; namely, Canfield (Bressler 1989), Susquehanna (Witthoft 1953), and Orient (Ritchie 1959, 1965). Canfield, the earliest of these phases, is characterized by Canfield Stemmed points, radiocarbon dated to 1830-1540 B.C. in central Pennsylvania (Bressler 1989; Weed et al. 1987). Cognate forms include the Koens-Crispin point, radiocarbon dated to 1880-1830 B.C. in New Jersey (Kinsey 1975; Mounier 1978); the Lehigh Broad point, dated to 1720 B.C. in eastern Pennsylvania (Kinsey 1972, 1975); the Snook Kill point, dated to 1670-1470 B.C. in upstate New York (Funk and Rippeteau 1977; Ritchie 1965); and the Atlantic point, radiocarbon dated to 1620 B.C. in New England (Dincauze 1968).

The Canfield phase has only recently been defined, and thus the geographic extent and other aspects of this phase remain to be fully appreciated (Bressler 1989). As recently as 1977, Turnbaugh (1977) assigned the Canfield component at the Canfield Island site to Middle Woodland times, erroneously ascribing Canfield Stemmed points to the morphologically similar, but later, Rossville point type (Ritchie 1961). This same error is repeated in the Sheep Rock Shelter report, with Canfield Stemmed points again being mistyped as Rossville (Michels and Dutt 1968; Michels and Smith 1967).

At Canfield Island, the Canfield phase represents the largest, densest component at this site. From Level 6, radiocarbon dated at 1570-1540 B.C., Bressler (1989) reports the recovery of 144 Canfield Stemmed points fashioned from Upper Helderberg chert (62%), rhyolite (27%), indurated shale (8%), and other materials (3%), intermixed, however, with narrow-bladed, stemmed point forms like Bare Island and Lamoka (thus, technically speaking, Level 6 is somewhat a multicomponent level). From the Canfield component, other artifact finds included 3 drills; 86 preforms/knives; 7 scrapers; 11 celts; 4 choppers; 153 hammerstones; 29 milling stones; 314 netsinkers; 10 nutting stones; and 71 pottery sherds, the last presumably intrusive from higher levels at the site. Sixty-two features included 5 artifact concentrations, 42 hearths, 14 rock clusters, and 1 burial. The burial, consisting of cremated human bone accompanied by six whole and broken projectile points, is of special interest as it constitutes the earliest human interment reported for the area.

Next, chronologically, is the Susquehanna phase of Witthoft (1953), not to be confused with the Susquehanna tradition (Dincauze 1968). This phase is characterized by Susquehanna Broad points, radiocarbon dated to 1465-1270 B.C. in central Pennsylvania (Bressler 1989; Michels and Smith 1967); to 1650 B.C. in eastern Pennsylvania (Kinsey 1971); and to 1595-1250 B.C. in upstate New York (Funk and Rippeteau 1977; Ritchie 1965). Cognates include the Ashtabula type, as defined for northern Ohio (Converse 1965); the Forest Notched type, northwest Pennsylvania (Mayer-Oakes 1955); and the Wayland Notched type, New England (Dincauze 1968). Other Susquehanna phase traits include thick, exterior chiseled, flat-bottomed, lug-handled steatite bowls or containers—a technological first for the area; a variety of implements such as drills



and scrapers reworked from points; end-notched netsinkers; and large, notched cobbles or so-called "canoe anchors" (Witthoft 1953).

Witthoft (1953), in particular, has contrasted the Susquehanna phase and preceding Archaic cultural developments, but the magnitude of these contrasts is perhaps overstated. While Witthoft (1953) is correct in observing that upland, interior sites of the Susquehanna phase are virtually unknown, this does not mean that they never occur. For example, Hay and Graetzer (1985) tabulate 11 Susquehanna Broad points for the upland, interior Jacks Mill site to the south of the project area. Also, while it is true that the majority of Susquehanna Broad points are fashioned from Pennsylvania-derived South Mountain rhyolite, this lithic preference is less true as one approaches New York State. For example, of 20 Susquehanna Broad points illustrated for the Fortin site, New York (Funk and Rippeteau 1977), fully 85 percent are made of Onondaga chert.

Susquehanna-phase sites are numerous throughout the Susquehanna Valley, the West Branch area being no exception (Turnbaugh 1977). At the Canfield Island site, the Susquehanna phase is represented by Level 4, radiocarbon dated to 1465 B.C. From this level, Bressler (1989) reports 63 projectile points, the majority of which are Susquehanna Broad points of rhyolite, chert, and indurated shale; 3 drills; 26 preforms/knives; 3 scrapers; 2 celts; 16 steatite bowl fragments; 1 chopper; 44 hammerstones; 2 milling stones; 38 netsinkers; 1 nutting stone, and 286 pottery sherds (in contrast to the excavator, this writer views pottery as intrusive into this level). Twenty-eight features were as follows: 1 artifact concentration, 24 hearths, 2 pits, and 1 rock cluster.

At Sheep Rock Shelter, nine Susquehanna Broad points were recovered from Level 5, radiocarbon dated at 1270 B.C. Four other Susquehanna Broad points were recovered from Level 4 (Michels and Dutt 1968; Michels and Smith 1967).

The final Terminal Archaic phase to be considered is Orient (Ritchie 1959, 1965). Since pottery occurs at Orient-phase sites, it is often argued that this phase more properly belongs to the Woodland period (cf. Kinsey 1972, 1975; Kraft 1975). Following Ritchie (1965), Turnbaugh (1977), and others; however, the Orient phase is assigned to the Terminal Archaic in this overview because it is an obvious participant in the Susquehanna tradition generally and represents basic continuity with Witthoft's (1953) Susquehanna phase.

The Orient phase takes its name from a coastal site on Long Island, New York. While coastal and interior manifestations of this phase share the same basic Orient Fishtail point type, it is obvious that they constitute very different adaptations, and thus the wisdom in subsuming them within a single cultural unit is suspect (cf. Kinsey 1972, 1975; Ritchie 1959, 1965). In any case, this overview adheres to convention, and thus the Orient phase is found in the West Branch Valley.

There is a single acceptable radiocarbon date of 1220 B.C. for the Orient phase in the Susquehanna Valley (Bressler 1980), another date of 400 B.C. being unacceptably late (Weed et al. 1988). Elsewhere in the northeast and environs, the Orient Fishtail point and related items have been radiocarbon dated as follows: 1220-810 B.C. in the Delaware Valley, New Jersey, and Pennsylvania (Kinsey 1972, 1975); 1090-870 B.C. in the Hudson Valley, New York (Funk and Lord 1972); 1043-763 B.C. on Long Island, New York (Ritchie 1959, 1965); 950 B.C. in the Potomac Valley, Maryland and Virginia (Gardner and McNett 1971); and 1170-1080 B.C. in the Kanawha Valley, West Virginia (Hemmings 1985; Youse, personal communication, 1991). In the Delaware Valley, there is a radiocarbon date of 1290 B.C. for the Dry Brook "phase," culturally intermediate between the Susquehanna and Orient phases, but perhaps best viewed as part of the Orient phase (Kinsey 1972, 1975).

An important technological change at this time is the shift from thin, exterior smoothed steatite vessels (supplanting thick, chiseled forms of the Susquehanna phase) to fired-clay pottery vessels. This earliest pottery in the area has been termed Marcey Creek Plain, a pottery type

exhibiting steatite temper, a plain exterior surface, and a vessel shape analogous to earlier steatite forms (Manson 1948; Smith 1971). The advent of Marcey Creek Plain pottery, in turn, has implications for residential mobility. In short, various authors relate the first appearance of pottery in the area to increasingly sedentary populations (cf. Gardner 1981; Ritchie 1965).

The Orient and Susquehanna phases share similar settlement patterns, but two notable exceptions occur. First, Orient phase settlements tend to be somewhat larger on average than their Susquehanna counterparts (cf. Kinsey 1972, 1975). Second, large, burned-rock platforms are a conspicuous feature at Orient sites, but they are rare or perhaps non-existent at Susquehanna sites. The meaning and significance of these platforms remains uncertain and, indeed, their precise function has been the subject of much conjecture. Kinsey (1975:45) suggests that platform features served as communal food-processing areas, perhaps for drying and curing fish. Similarly, Turnbaugh (1977:142) argues for their use as fish-drying facilities, or perhaps as roasting areas for processing acorns and other nuts. An alternative explanation for platforms would be that they served as spoil heaps or throw piles, where burned rock from nearby, smaller cooking pits was discarded (cf. Handsman 1973:38; Turnbaugh 1977:161).

During the Orient phase, the Canfield Island site witnessed a type of a cultural hiatus, and human habitation shifted to the nearby Bull Run site. Here, in the course of extensive horizontal exposure of a Late Woodland village area, an Orient component and radiocarbon date of 1220 B.C. were recovered from a small area delimited by a short, linear rise (Bressler 1980). Artifact associations included 12 Orient points, primarily of Upper Helderberg chert; steatite-tempered, Marcey Creek Plain pottery; netsinkers; nutting stones; and related items. Eight features included 1 hearth, 2 pits, and 5 "probable" burials. Four of the presumed burials produced osseous material ranging from tooth enamel to bone residue, but no intentionally placed artifacts were found.

The deep, stratified Highbanks site in Lycoming County, occurs just upstream from the Bull Run site. Here, limited excavations (18 m square) by Turnbaugh (1977:156-164) exposed a buried Orient component confined to Level 4a, a 10-15 cm band of cultural debris at about 90 cm below surface (see also Vento and Rollins 1989). Artifact recoveries included 11 rhyolite projectile points, the majority typologically intermediate between Orient Fishtail and Susquehanna Broad forms; one drill; two preforms/knives; three celts, all chipped stone; 11 steatite bowl fragments of the thin, smooth variety; six hematite pieces, all abraded; one hammerstone; 13 netsinkers; and two nutting stones. Four features included two pits, one burned rock platform, and one red ochre stained area, the last feature perhaps denoting a human burial. A few carbonized hickory nuts and a very small amount of wood charcoal were recovered from the platform.

At Sheep Rock Shelter, a single point of the Orient Fishtail type is reported for Level 5 (Michels and Smith 1967). Other artifacts included steatite-tempered, Marcey Creek Plain pottery; netsinkers; nutting stones; and related items. Eight features included one hearth, two pits, and five "probable" burials. Four of the presumed burials produced osseous material ranging from tooth enamel to bone residue, but no intentionally placed artifacts were found.

#### WOODLAND PERIOD (1000 B.C.-A.D. 1600)

The Woodland period in the northeast embraces much cultural variability, and thus the wisdom of subsuming Early, Middle, and Late Woodland subperiods within a single cultural unit is suspect. Before an approximate date of A.D. 750, the Woodland period exhibits clear continuity with Archaic subsistence, settlement, and other cultural patterns. Later, however, pronounced changes occur; specifically, there is the shift from a basically hunting and gathering to an intensive, maize-based agricultural subsistence economy. Indeed, the onset of the Late Woodland subperiod probably constitutes the single most radical change in the northeast prehistory.

### *Early Woodland Subperiod (1000 B.C.-A.D. 1)*

It is during the Early Woodland subperiod that the majority of earthen burial mounds found throughout Eastern North America were built. Most mounds dating to this time provide evidence for mortuary ceremonialism, and finely crafted artifacts placed within mounds were typically made of exotic raw materials procured through extra-regional trade (Dragoo 1963). It is also during this subperiod that there is the first evidence for the cultivation of Eastern Agricultural Complex seed plants, including goosefoot, sumpweed, and maygrass (Asch et al. 1972; Watson 1988).

No Early Woodland burial mounds have been reported for the West Branch Valley, nor in the absence of excavated Early Woodland sites have Eastern Agricultural complex cultivated plants been reported. However, quite a few finely crafted artifacts do occur, some fabricated from exotic lithic raw materials (Smith 1972, 1979; Turnbaugh 1977:178-186).

The Early Woodland subperiod subsumes two phases in the West Branch Valley: Meadowood (Ritchie 1965) and Bushkill (Kinsey 1971, 1975). The Meadowood phase has been radiocarbon dated to 750 B.C. in eastern Pennsylvania (Kinsey 1972, 1975:Table 32); 841 B.C. in northern New York (Ritchie 1965:Figure 1); and 998-553 B.C. in central New York (Ritchie 1965:Figure 1). Diagnostic artifacts of this phase include thin, Side Notched Meadowood points, typically made of Onondaga chert; and interior-exterior cordmarked, Vinette I pottery (Ritchie 1965; Turnbaugh 1977). The recovery of Vinette I-like pottery from Late Woodland contexts in central Pennsylvania (Hay 1991), however, renders suspect the historical utility of this type for this area.

The evidence for a Meadowood cultural presence in and near the project area is clear, but limited (Turnbaugh 1977:171-178). At the Canfield Island site, the Meadowood phase is represented by Level 3 (Bressler 1989:31-33). From this level, 60 projectile points, primarily Meadowood forms fashioned from rhyolite and Upper Helderberg Chert, with an unacceptably late radiocarbon date of A.D. 270 were recovered. Other Meadowood phase artifacts included 4 drills, 30 preforms/knives, 9 retouched flake tools, 2 celts, 3 choppers, 33 hammerstones, 3 pestles, 6 pitted stones, and 2 mortars, and 157 pottery sherds, mostly of the Vinette I type, tempered with sand. Thirteen features were as follows: 2 artifact concentrations, 9 hearths, and 2 probable burials, both cremations.

At Sheep Rock Shelter, two Meadowood points were recovered from Level 4; one specimen from Level 3 (Michels and Dutt 1968:335). Juniata Thick pottery, including an interior-exterior cordmarked variant of the same, were also recovered from these levels (Michels and Smith 1967:468-469).

The Bushkill phase dates late in the Early Woodland subperiod (Kinsey 1972, 1975; Turnbaugh 1977:186-193). This phase has been radiocarbon dated to 400-100 B.C. in eastern Pennsylvania (Kinsey 1975:Table 32); 480 B.C. in New Jersey (Kinsey 1975:Table 32); 570 B.C. in eastern New York (Funk and Rippeteau 1977:32); and 380 B.C. in central New York (Funk and Rippeteau 1977:32). Diagnostic artifacts of this phase include Lagoon points (Kinsey 1972:436-437; Ritchie 1969:245), analogous in form to the Adena-related Cresap Stemmed type (Dragoo 1963); and Rossville points (Kinsey 1972:435-436; Ritchie 1961:46, 1969:224), reminiscent of the Adena Stemmed type (Dragoo 1963). The major pottery type is Brodhead Netmarked (Kinsey 1972:455-456), although pottery with cordmarked and other surface treatments also occur.

The Bushkill phase displays cultural similarities (point styles, in particular) to the Adena complex of the Ohio Valley, and it was presumably through this phase (or the Meadowood phase before it, see above) that the majority of exotic artifacts such as tubular pipes and boatstones, among others, were introduced into the local archaeological record (Smith 1972, 1979; Turnbaugh 1977:178-186). If not locally made, then these exotic artifacts were most likely procured from the

Adena complex and related peoples through extra-regional trade, not by an actual influx of Adena peoples into the area, contra Ritchie and Dragoo (1959, 1960). Radiocarbon dates for the Adena complex in general range from 500 B.C.-A.D. 1 (cf. Dragoo 1963; Hemmings 1985:Table 2).

The evidence for Bushkill phase sites in the West Branch Valley is not compelling. Turnbaugh (1977:186-193) describes two sites, Canfield Island (or 36LY37) and Maple Hill, relating to this phase, but there are identity problems with both. In the case of Canfield Island, it is now known that the Rossville points described for this site were, in fact, Terminal Archaic, Canfield Stemmed forms (Bressler 1989:43-53). As for Maple Hill, this site was reported based upon Lagoon and Rossville point types in an artifact collection, purportedly from an upland, interior site in southern Lycoming County. Based upon the lithic raw materials illustrated for this site and its atypical physiographic setting, however, the presence of a Bushkill phase component at this location is suspect. Rather, verification of this component must await the rediscovery of the Maple Hill site, and further investigations there to ascertain whether or not Bushkill phase artifacts actually occur.

At Sheep Rock Shelter, as at Canfield Island, bifaces ascribed to the Rossville point type were actually Terminal Archaic, Canfield Stemmed points (Michels and Dutt 1968:331). In fact, no obvious Bushkill phase traits are illustrated for this site, suggesting that it may fall outside the geographic range of this phase.

#### *Middle Woodland Subperiod (A.D. 1-1000)*

The Middle Woodland subperiod in the West Branch Valley includes two phases, Fox Creek (Funk 1968; Ritchie and Funk 1973) and Kipp Island (Ritchie 1965). The Fox Creek phase has been radiocarbon dated to A.D. 410-450 in eastern New York (Funk 1968; Ritchie and Funk 1973) and A.D. 360 in central New York (Hesse 1968), with a possible date of A.D. 630 available for eastern Pennsylvania (Kinsey 1975:Table 32). Diagnostic artifacts include Fox Creek Stemmed and Lanceolate points, typically fashioned from soft, weathered, purple argillite in the West Branch area (Turnbaugh 1970, 1977). In eastern New York, these points are found with plain, netmarked, and rockerstamped pottery (Ritchie and Funk 1973).

In the West Branch Valley, the Fox Creek phase is represented by a thin scatter of Fox Creek Stemmed and Lanceolate points at various sites, none of which have been excavated or explored in-depth (Turnbaugh 1970, 1977:193-198). Pottery associations, if any, are unknown.

At Sheep Rock Shelter, two Fox Creek Stemmed points were recovered from Level 2, but they were presumably found out of context, as this level dates to the Late Woodland subperiod (Michels and Dutt 1968:343-344).

The Kipp Island phase (or late Point Peninsula tradition) dates late in the Middle Woodland subperiod. This phase has been radiocarbon dated to A.D. 700 in eastern New York (Ritchie 1965:Figure 1) and A.D. 560-830 in central New York (Funk and RippetEAU 1977:33; Ritchie 1965:Figure 1). Diagnostic artifacts include Jack's Reef Corner Notched and Jack's Reef Pentagonal points, both types described by Ritchie (1961:26-28) and fashioned from nonlocal lithic raw materials such as Onondaga chert and black oolitic chert (Turnbaugh 1977:208). A variety of rockerstamped, cordmarked, and cord-on-cord pottery types occur (Ritchie 1965:Plate 78), the latter anticipating Clemson Island complex pottery.

The Kipp Island phase is the cultural equivalent of the Intrusive Mound complex in the Ohio Valley (Graybill 1986; Ritchie 1965:228). Here, too, Jack's Reef Corner Notched and Jack's Reef Pentagonal points predominate, the majority of which are made of nonlocal lithic raw

materials (Upper Mercer chert, "Carter Cave" flint) like their northeast counterparts. Radiocarbon dates for the Intrusive Mound complex in general range from A.D. 600-800.

For the West Branch Valley, few Kipp Island sites have been reported (Turnbaugh 1977:204-208). Given the considerable overlap between Kipp Island and later Clemson Island complex artifact classes, however, it is probable that many Kipp Island components have been masked by larger, more intensive Clemson Island occupations. For example, the Kress site, which occurs at the head of Great Island in the Susquehanna River just opposite the Memorial Park site, is often labeled a Clemson Island component in the literature (Hay et al. 1987; R.M. Stewart 1988, 1990). However, an examination of the artifacts recovered from it suggests that a Kipp Island component probably occurs as well.

At Canfield Island, a small, ephemeral Kipp Island component was exposed, for which little information is available. Bressler (1989:82) reports that Jack's Reef Corner Notched, Jack's Reef Pentagonal, and "Kipp Island" pottery were found, evidently at the same depth as Level 1 (McFate-Quiggle horizon) artifacts.

Turnbaugh (1977:205,208) reports a Kipp Island site (36CN51) along Bald Eagle Creek near Mill Hall, Clinton County, just upstream from the current project area. Surface artifact finds included a Jack's Reef Corner Notched point of Onondaga chert; a few chert-tempered, Point Peninsula Corded pottery; and a single chert-tempered, punctated sherd.

#### *Late Woodland Subperiod (A.D. 750-1550)*

This subperiod marks the onset of an intensive, maize-based agriculture subsistence economy in the area. It is subdivided chronologically into three periods: the Clemson Island complex, dating A.D. 750-1250; the Stewart phase, dating A.D. 1250-1350; and the McFate-Quiggle horizon, dating A.D. 1350-1550 (cf. Graybill 1987:Table 1).

It has been suggested (Graybill 1989a) that four temporal trends characterize the Late Woodland settlement record (specifically, habitation sites) throughout much of the northeast and adjacent midwest as follows:

1. A shift from riverine to upland, interior settlement locations
2. A decrease in the size of inhabited territories, not sustaining territories
3. An increase in the size of settlements
4. A decrease in the number of settlements

The shift from riverine to upland, interior settlements is believed to result from agricultural intensification; in particular, the rise of corn as the single most important subsistence resources. Other settlement trends argue for the consolidation of populations through time, including settlement fusion and geographic constriction (the last often accompanied by the initial appearance of palisades). These trends, in turn, are best accounted for by increasing stress, competition, and resultant hostilities such as raids and warfare. The extant database is not sufficient to evaluate the extent, if any, to which these settlement trends apply to Late Woodland peoples who inhabited the West Branch Valley and its environs.

#### *Clemson Island Complex (A.D. 750-1250)*

A major focus of data recovery at Memorial Park was the Clemson Island complex. In recent years, the Clemson Island complex has been subjected to intensive archaeological study at a

number of sites, and thus the complex has been the subject of two recent summary papers. The first of these, *A Management Plan of Clemson Island Archaeological Resources in the Commonwealth of Pennsylvania*, was prepared by Hay et al. (1987) for the Bureau for Historic Preservation, Pennsylvania Historical and Museum Commission. The second, *Clemson's Island Studies: A New Perspective*, was prepared by R.M. Stewart (1990) within the context of Phase II/III archaeological investigations at the St. Anthony site, Union County, sponsored by Pennsylvania Department of Transportation (Stewart 1989).

Like most other culture-historical units in use today, the Clemson Island complex is the product of modern historical accident and accretion. Following Jones's (1931) work at the Clemson Island Mound, Dauphin County, and the Book Mound, Juniata County, both mortuary sites that produced early Late Woodland pottery, the list of Clemson Island complex sites was expanded to include other similar, pottery-producing sites located along the Susquehanna River proper upstream from Harrisburg, the Juniata River, and the West Branch of the Susquehanna River (e.g., Kent et al. 1971:331-332; Schmitt 1952:61, Jones focus; Turnbaugh 1977). More recently, the geographic extent of the Clemson Island complex has been expanded to include sites located along the North Branch of the Susquehanna River as well as in parts of the upper Allegheny watershed (Hay et al. 1987:Figure 5.1).

In keeping with its culture-historical origins, it is not surprising that the Clemson Island concept today lacks adequate definition and purpose. Nevertheless, there is an obvious tendency in much of the literature to view all Clemson Island complex sites as if they once belonged to some real cultural entity, the archaeological equivalent of an ethnographic group or society. This almost certainly was not the case. Within this context, Dunnell (1971) observes that, properly formulated, time-space units such as phases and traditions are purposeful creations, and thus they are designed by the investigator to serve a particular end. They are not real entities, inherent in the archaeological record itself.

The Clemson Island concept, as used here, is synonymous with sites producing a preponderance of punctated, early Late Woodland or "Clemson Island" pottery. This effectively limits the geographic extent of the Clemson Island complex to an 11-county area in central Pennsylvania and excludes peripheral areas like the North Branch Valley from consideration (contra Hay et al. 1987:Figure 5.1), as well as sites like Airport II, Luzerne County (Garrahan 1990); Catawissa Bridge, Columbia County (East et al. 1988); and Wells, Bradford County (Lucy and McCann 1983). The specific counties comprising this Clemson Island culture area are Centre, Clinton, Dauphin, Huntingdon, Juniata, Lycoming, Mifflin, Northumberland, Perry, Snyder, and Union. Pottery alone, of course, constitutes an insufficient basis for recognizing a formal cultural entity, and it is for this reason that the term Clemson Island complex is used (cf. Kinsey 1972:xxv).

The Clemson Island complex, then, is a pottery-based unit. This complex, in turn, is an obvious participant in a larger Point Peninsula-Owasco pottery tradition or interaction sphere (cf. Graybill 1989:53; R.M. Stewart 1988, 1990:89-91). Viewed within this context, it is doubtful that distinct Clemson Island cultural boundaries will ever emerge; rather, these limits will be arbitrary. In fact, during early Late Woodland times in the northeast, much spatial variability in pottery was clinal in nature. To the south, in what is today central Pennsylvania, what was basically a punctated variant of Point Peninsula-Owasco pottery predominated; to the north, in upstate New York, this pottery variant was rare to non-existent; and for intervening areas like the North Branch of the Susquehanna River, its frequency was intermediate. Rather than combine North Branch-early Late Woodland sites with Clemson Island or Point Peninsula-Owasco sites, it seems best to accord them a separate cultural status. It has been suggested recently (Graybill 1989:53) that the Clemson Island complex, together with later Late Woodland groups in central Pennsylvania, be ascribed to a larger "West Branch" cultural tradition. While the formal creation of such a tradition at this time is clearly premature, particularly given problems inherent in the

Clemson Island concept itself, the general notion of a West Branch tradition does serve to emphasize basic Late Woodland cultural continuity in this area through time. Thus, the recognition of this tradition stands in sharp contrast to previous culture-historical reconstructions for the area. Specifically, these reconstructions viewed Late Woodland cultural change as a result of population replacement (cf. Heisey 1971; Witthoft 1959).

As summarized by R.M. Stewart (1990:Tables 1 and 2), the age range for Clemson Island radiocarbon assays is A.D. 705-1470. If we eliminate a few aberrantly early and late dates from this series, then a reasonable age estimate for the Clemson Island complex is A.D. 750-1250 (cf. Hay et al. 1987:18; R.M. Stewart 1988, 1990:82). Based upon typological comparisons to Point Peninsula-Owasco artifact assemblages from upstate New York, the Clemson Island complex is the temporal equivalent of the Hunter's Home, Carpenter Brook, and Canandaigua phases (Ritchie 1965:Figure 1). The age range for these New York phases is A.D. 800-1200, corroborating radiocarbon dates available for Clemson Island contexts.

A tight internal chronology for the Clemson Island complex does not exist. In large part, this failure to produce a Clemson Island chronology has resulted from an inability of researchers to locate and investigate Clemson Island sites of limited occupational duration. Because of the large amount of cultural mixing that typically occurs at Clemson Island sites, it has proven difficult to ascertain precisely what features or artifacts at sites are early, late, or intermediate in age. Radiocarbon dating, given the level of imprecision inherent in the method for a 500-year time frame, has been of limited use in clarifying matters. Stratified cultural deposits like those found at Fisher Farm (Hatch 1980) and Clarks Ferry (Hay 1991) have been of more help, but they too presumably suffer the effects of cultural mixing, although less so.

To date, the primary approach to Clemson Island chronology-building has been through pottery typology, and it is this approach that will most likely succeed in the future. Hatch (1980, 1983), modelling his efforts after Ritchie and MacNeish (1953), formulated a series of pottery types, the historical validity of which he then tested against stratified cultural remains found at Fisher Farm. Hay (1991), based upon his work at the stratified Clarks Ferry site, reevaluated Hatch's typology with the addition of a few new types.

Clemson Island pottery types are treated at length elsewhere (Hatch 1980, 1983; Hay 1991; Hay et al. 1987:19- 57; Stewart 1988, 1990:Table 3), and no attempt is made to repeat this information here. Theoretically, as with Ritchie and MacNeish's (1953) types, it is not their presence or absence through time that is of temporal significance, but rather their frequency of occurrence relative to one another. To date, 23 Clemson Island pottery types (or variants thereof) have been proposed in the literature (Hay et al. 1987). Of this number, four types, Levanna Cord-on-Cord, Clemson Island Cord-on-Cord, Clemson Island Corded Horizontal, and Clemson Island Gashed, are most prominent at sites, accounting for 60 percent of all pottery tabulated by Hay et al. (1987:Table 5.3). At the St. Anthony site, Stewart (1988:Table 6.10) reports that three of these pottery types (Clemson Island Gashed was absent) accounted for 55 percent of all early Late Woodland pottery found.

The pottery typology proposed by Hatch (1980, 1983) was an important first step in Clemson Island chronology-building, but it is clearly a typology that is in need of refinement and revision. This study views extant Clemson Island pottery types as basically descriptive classes, only some of which exhibit low-level temporal correlations. In some instances, the historical significance of proposed types is unclear because sample sizes are too small to clarify this point; in other cases, historical significance is apparent to a limited extent.

As noted by R.M. Stewart (1990:88), there is a need to better define Clemson Island pottery types, as ambiguities among types exist. Several of R.M. Stewart's (1990:85-89) other criticisms of Clemson Island pottery types, however, lack relevance. The intended purpose of

Hatch's (1980) pottery types is temporal control. Under such circumstances, it matters little that one type can be collapsed into another type: what matters is whether or not the distinction drawn is historically significant. Also, R.M. Stewart (1990:85-87) overstates the utility of radiocarbon dates in evaluating the historical significance of Clemson Island pottery types, particularly given the mixed cultural contexts from which pottery often derives.

At this juncture, it would appear that attribute analysis, when combined with inter-site comparisons, provides the logical starting point for revising Clemson Island pottery typologies. As part of the current project, the writer examined pottery recovered from three Clemson Island sites located near the Memorial Park site: Kress, Nash, and Ramm (Hay et al. 1987:8; Smith 1976, 1977), all of which had been investigated by the Archaeology Section, Pennsylvania Historical and Museum Commission in the mid-1970s. This cursory inspection suggested that Kress was the product of recurrent habitations, but that this was less true of Nash and Ramm. Of these two, Nash appeared to be the earlier site, based upon typological comparisons to upstate New York assemblages.

If this temporal relationship between Nash and Ramm is reasonably accurate, then the following temporal trends are suggested by their respective pottery assemblages:

1. An increase in plain (smoothed), decorated rim exteriors at the expense of cordmarked, decorated (i.e., cord-on-cord) rim exteriors
2. An increase in plain rim interiors at the expense of cordmarked rim interiors
3. An increase in neat, fine cordmarked impressions at the expense of sloppy, coarse impressions;
4. An increase in the use of punctations as a rim decorative technique at the expense of unpunctated rims
5. An increase in decorated lips at the expense of undecorated lips
6. An increase in fine, low-density temper at the expense of coarse, high-density temper

In the absence of statistics these trends remain little more than unsubstantiated impressions. In general, those attributes which appear to be most sensitive to temporal change involve surface treatment, decorative technique, and temper. Presumably lip form and rim form are also significant, but no temporal trends were suggested for these by the Nash and Ramm samples. Decorative motifs, in particular, appear to be of limited use and, thus, distinctions like Clemson Horizontal, Clemson Platted Horizontal, and Clemson Island Platted Oblique, may be of limited use.

Finally, Clemson Island pottery has long been characterized as chert- or quartz-tempered, with minor amounts of other crushed rock temper sometimes present (Jones 1936:95; Kent et al. 1971:331; Lucy 1959:31; McCann 1971:419). Recently, however, R.M. Stewart (1990:84) argued for the presence of shell temper as an integral, though limited, part of Clemson Island pottery assemblages. While R.M. Stewart (1990) is perhaps correct on this point, particularly in the case of fired-clay smoking pipes, he errs in ascribing incised, high-collared, shell-tempered pottery to the Clemson Island complex (Stewart 1988:Plate 6.20). This pottery, either McFate Incised (Mayer-Oakes 1955:204) or Shultz Incised (Witthoft 1959:42-51), clearly dates no earlier than A.D. 1400. If this pottery was found in the Clemson Island component at St. Anthony, then it was intrusive.

The literature is replete with descriptions and illustrations of Clemson Island tool types. Most, if not all Clemson Island tool types, however, are intuitive classes, and thus their functional



significance, if any, remains to be demonstrated. Specifically, the significance of tool types has not undergone rigorous testing via methods such as use-wear studies and analysis of spatial behavior.

In any case, the prevailing Clemson Island chipped-stone technology was an expedient one, emphasizing the production of a limited array of bifaces and informal flake tools (Parry 1989:32). The manufacture of chipped-stone tools, generally, was accomplished by the bipolar reduction of small, often nodular chert pieces (pebble cherts, in the main) into usable flakes, suitable for the production of bifaces or immediate use as informal tools (Parry 1989:32). Major biface categories included projectile points, primarily broad, triangular forms or Levanna points, but occasional Jack's Reef Corner Notched and Madison points also occur (Ritchie 1961) as well as preforms, roughouts, or rejects, often recycled as cutting and scraping implements. Because of the small size of flake tools at the Memorial Park site, Neumann (1989) suggests that these were perhaps hafted.

In addition to chipped-stone implements, ground stone tools (formed by pecking and grinding) included anvilstones and hammerstones, used in the production of chipped-stone tools; celts or ungrooved axes, used in woodworking; mortars, mullers, pestles, and pitted stones, used in processing plant foods; and netsinkers, used in fishing (Hay and Hamilton 1984: Appendix C; R.M. Stewart 1988:VI41-49; Turnbaugh 1977: Table 11).

Because acid soil conditions often prevail at Clemson Island sites, the preservation of bone and antler tools is rare. At the Brock site, a Clemson Island site near Muncy, Lycoming County, however, numerous bone and antler tools were recovered, including awls, used in leatherworking; fishhooks and barbed harpoons, used in fishing; flakers, used in the production of chipped-stone tools; and needles, used in working textiles (Carpenter 1949; Turnbaugh 1977:Table 11).

Pottery vessels presumably served cooking and storage functions. For the St. Anthony site, Stewart (1988:Table 6.12) tabulated vessel size by Clemson Island pottery type, assuming a correlation between vessel size and vessel function results. Otherwise, most Clemson Island pottery analyses emphasize stylistic criteria; thus, data relevant to vessel function is rarely presented (e.g., Hatch 1980, 1983; Hay and Hamilton 1984:41; Hay et al. 1987:19-57).

#### *Stewart Phase (A.D. 1250-1350)*

The Stewart phase is often collapsed into the downriver Blue Rock phase of the Shenks Ferry tradition (Heisey 1971:47-50; Turnbaugh 1977:230-236), but this cultural placement is clearly no longer tenable (Graybill 1989a:53). Like the Clemson Island complex before it, together with downriver Shenks Ferry cultural developments, the Stewart phase participated in a larger Point Peninsula-Owasco-Iroquois pottery tradition or interaction sphere (Graybill 1989a:53). It is this shared participation that results in pottery similarities, but not identity between the two phases. However, there are important differences between the two, specifically settlement patterns, mortuary patterns, and presumably other cultural behaviors.

The Stewart phase has been radiocarbon dated to A.D. 910 at the Bald Eagle site, Clinton County (Hay and Hamilton 1984:66, Table 3); A.D. 1230 at the Ramm site, Clinton County (Herbstritt 1988:9; R.M. Stewart 1990:93); A.D. 1230-1480 at the Bull Run site, Lycoming County (Bressler 1980:52); and A.D. 1350 at the Fisher Farm site, Centre County (Hatch 1980). Based upon typological comparisons to Owasco-Iroquois artifact assemblages, the Stewart phase is the cultural and temporal equivalent of the Transitional Iroquois phase of upstate New York (Niemczycki 1984:Table 6), dating to approximately A.D. 1250-1350. In the West Branch Valley, as well as elsewhere throughout its geographic range, the Stewart phase is believed to be a local development from the antecedent Clemson Island complex (Graybill 1989a:53; Stewart 1990).

Diagnostic pottery types for the Stewart phase include Shenks Ferry Incised and Shenks Ferry Cordmarked (Heisey 1971:47-50; Witthoft and Farver 1952:16-21), both low-collared forms with crushed rock temper, and shared with the downriver Blue Rock phase (Graybill 1989a). Subtle differences between upriver and downriver variants of these two pottery types exist primarily in terms of temper, however, and these are enumerated by Witthoft (1954). In addition to pottery, Stewart phase artifacts include triangular projectile points, primarily Levanna forms, but also Madison varieties (Bressler 1980:Figure 5); and items such as obtuse-angled, fired-clay smoking pipes; celts; mortars; mullers; pitted stones; and netsinkers (cf. Bressler 1980:45-52).

As of this writing, the only Stewart phase site sufficiently exposed to reveal its total community plan is the Bull Run site, located near Williamsport, Lycoming County. At this site, Bressler's (1980) excavations revealed a small, elliptical village, surrounded by multiple palisade lines and a ditch. A limited range of feature types was found including 3 graves, containing flexed interments, and 8 shallow, mostly fire-related pits. Significantly, from one of these pits, flotation processing yielded maize as well as a variety of seeds and nuts. Another Stewart phase component that is perhaps similar to Bull Run is the Wolf Run site near Muncy, Lycoming County, briefly reported by Kahler (1938) and perhaps visited by Weiser (1852) in 1737. This site was also enclosed by multiple palisade lines, a ditch and, apparently unique to this Stewart phase site, an earth embankment.

The Stewart site, located near McElhattan, Clinton County, and type site for the Stewart phase, was explored by T.B. Stewart (1934; Anonymous 1934). Pottery from this site was described and illustrated by Witthoft (1954). Of special note at the Stewart site was the discovery of two longhouse structures defined by postmolds, as well as several hearth features. Large numbers of netsinkers and fish scales were also found, suggesting the importance of fishing activities at this site. The only other Stewart phase component known thus far to have produced a structure pattern is the Canfield Island site, where a longhouse measuring about 20 m long x 6 m wide was recently exposed (Herbstritt, personal communication, 1991).

Other Stewart phase components reported in the literature have been the by-product of work at sites that were perceived as basically Clemson Island sites. These include Bald Eagle (Hay and Hamilton 1984), Brock (Carpenter 1949; Turnbaugh 1977:217-228), Fisher Farm (Hatch 1980), Ramm Smith 1976, 1977), Milton Bridge (Mair 1988), and 36LY34 (Turnbaugh 1977:215-217), among others. Of special note at several of these sites was the discovery of semisubterranean, so-called "keyhole" structures, believed to have functioned as sweat lodges by Smith (1976:11) and food-drying facilities by Hatch (1980:187).

#### *McFate-Quiggle Horizon (A.D. 1350-1550)*

Incised, high-collared, shell-tempered pottery characterizes the archaeological record after A.D. 1350 in the West Branch Valley. In the past, this shell-tempered pottery was often erroneously ascribed to the Susquehannock Indians (e.g., Hatch 1980; Michels and Smith 1967; Turnbaugh 1977; Witthoft 1959), but it is now known to pertain to a separate, unrelated cultural entity, sometimes referred to as the *McFate-Quiggle horizon* (Bressler 1989:80-81; Graybill 1989a:Table 1; Kent 1984:309; Smith 1984). This horizon is believed to be, in part, a local development from the antecedent Stewart phase (Graybill 1989a:53).

The *McFate-Quiggle horizon* has been radiocarbon dated to A.D. 1520-1780 at the Bell Hegarty site, Clearfield County (Herbstritt 1988:9); A.D. 1210-1670 at the Kalgren site, Clearfield County (Herbstritt 1988:8); A.D. 1505-1600 at the Fisher Farm site (Hatch 1980); A.D. 1595-1715 at the Nash site (Smith 1976); and A.D. 1460-1690 at Sheep Rock Shelter (Michels and Dutt 1968). Based upon typological comparisons to other Late Woodland artifact assemblages in the northeast, the *McFate-Quiggle horizon* is the cultural and temporal equivalent of the Late Iroquois

and Late Prehistoric Iroquois phases of upstate New York (Niemczycki 1984:Table 6); the Lancaster and Funk phases of the Shenks Ferry tradition, southeast Pennsylvania (Graybill 1989a:Table 1; Kinsey and Graybill 1971); and the Wyoming complex, northeast Pennsylvania (Smith 1973). All of these related cultural units are estimated to date to between A.D. 1350 and A.D. 1550.

The prevailing McFate-Quiggle settlement pattern involved habitation in large, planned, fortified villages which occur in the West Branch Valley proper; rather, they achieve their highest density in the Allegheny Plateau area to the west, portions of this area being drained by the upper reaches of the Susquehanna River. To date, the single most thoroughly explored McFate-Quiggle site in the Allegheny Plateau area is the Kalgren site, where Herbstritt (personal communication, 1986) exposed a large, circular village, surrounded by a palisade line and ditch, graves containing flexed interments, a longhouse, and numerous keyhole structures.

In the West Branch Valley, only two McFate-Quiggle village sites, Quiggle and Young (Smith 1984; Turnbaugh 1977), have been recorded, and only one of these has been the focus of horizontally extensive excavations. At Quiggle near Pine, Clinton County, first explored by the Lock Haven Expedition in 1929 (Davidson 1929; Ritchie 1929), Smith (1984), excavated portions of a large, circular village, enclosed by multiple palisade lines and two interconnecting ditches, suggested at least one episode of village expansion. A limited range of feature types occurred at Quiggle, including 4 graves containing flexed interments, 18 keyhole structures, and a very few small, mostly shallow, pits. Numerous postmolds were also found, although no discrete structure patterns could be discerned.

It is believed that the Quiggle and Young sites represent a rather late, village-unit intrusion into the West Branch Valley, following the general abandonment of this area toward the close of the Stewart phase.

Most other McFate-Quiggle components in the West Branch Valley relate to small, ephemeral occupations, the majority of which were previously thought to be Susquehannock sites (cf. Witthoft 1959). At the Canfield Island site, Bressler (1989:26-27) exposed a small McFate-Quiggle component characterized by incised, high-collared, shell-tempered pottery, Madison points, and a limited range of other tool types. Only a single feature, a hearth, was associated with the component. What is perhaps another minor McFate-Quiggle component occurs at 36LY34, where Turnbaugh (1977:215) reports the recovery of shell-tempered pottery, intermingled with other Late Woodland varieties.

The McFate-Quiggle horizon, although dating no later than A.D. 1550, terminates Native American prehistory of the West Branch Valley. In common with the downriver Shenks Ferry tradition, which also disappears at about this time, the demise of the McFate-Quiggle horizon most likely resulted from depopulation and cultural systems collapse resulting from the introduction of European epidemic disease (Graybill 1989a, 1989b, 1992), presumably affecting Native American populations living throughout the Susquehanna Valley.

#### CONTACT PERIOD AND HISTORICAL BACKGROUND — *by Erica S. Gibson*

The aboriginal inhabitants of Clinton County, when the first Europeans arrived in the region, were the Delaware or Lenni Lenape Indians who, from the time of William Penn's arrival in 1682, were subjects of the Iroquois or Six Nations (Linn 1883). The Lock Haven area was inhabited by the Munsee division of the Delaware, who lived on Great Island and were prominent in Clinton County (Miller 1966). Great Island, located at the confluence of Bald Eagle Creek and the West Branch of the Susquehanna, was a convergence point of several Indian trails crisscrossing the state.

According to historical legend, Great Island was acquired by William Dunn sometime around 1769. Mr. Dunn was an Irishman who accompanied a team of land surveyors to the area. A Munsee chief, Ne-wak-lee-ka, liked Dunn's rifle and traded the island to him for a keg of whiskey, the rifle, and a hatchet (Miller 1966). Regardless of the authenticity of the legend, the land did not officially belong to Mr. Dunn until it was opened for purchase from the Commonwealth on May 1, 1785 (Linn 1883).

The first settler in Clinton County was Cleary Campbell, who arrived from Juniata in 1769 (Linn 1883). The same year, during a land survey for the officers of the 1st and 2nd Battalions of the Pennsylvania Regiment, he was discovered living on the land where the northern portion of Lock Haven, the current site of Lock Haven University, is now located (Miller 1966). Shortly afterward, he moved to another location. Over the course of the next few years, other settlers came to the area, many choosing to live in the area of Great Island.

The year of 1777 saw a decline in Indian and settler relations. This was the beginning of the Revolutionary War and all the local men were off fighting. The British seized the opportunity and allied themselves with the local Indian populations. Raids became more frequent when the British set a price on every settler's scalp (Miller 1966). By the end of 1778, the county had been vacated by almost every settler. It was not until 1783, after the end of the war, that they began to return.

Clinton County, south of the West Branch of the Susquehanna, was purchased from the Iroquois by the Commonwealth on November 5, 1768 and was opened for purchase on April 3, 1769. The area south of the river and west of Pine Creek was purchased on October 23, 1784 and was opened for purchase on May 1, 1785 (Linn 1883). The land at the confluence of Bald Eagle Creek and the West Branch of the Susquehanna, the Allison Tract, was purchased by the Reverend Dr. Francis Allison, who sold the 1650 acres to John Fleming in 1773. In 1777, Fleming died and the estate was divided between his heirs. Dr. John Henderson married Fleming's granddaughter in 1800, thereby acquiring the two hundred acres where Lock Haven was later established (Miller 1966). Over the succeeding years, this area became increasingly populated.

Canal construction became popular in Pennsylvania during the early 1800s. By 1817, a channel had been constructed in the Susquehanna, reaching the present site of Lock Haven (Miller 1966). Construction of the West Branch Division was initiated in 1828 and was completed to the area in 1834 (Hannigan and May 1989). From the canal basin, the canal stretched from Northumberland to Farrandsville, a distance of 73 miles. During 1833 and 1834, a dam across the Susquehanna and a cross-cut connecting the West Branch Division with the Bellefonte Canal was constructed (Linn 1883). Further activity included the extension of the Bald Eagle branch of the canal to Bellefonte in 1848, the completion of the Sunbury and Erie Railroad to Lock Haven in 1859, and the construction of the Bald Eagle Railroad in 1864 (Linn 1883). With the building of the canals, large, heavily laden boats could easily traverse the state, and the area of Lock Haven, with its confluence of railroads and canals, became an important industrial and shipping location.

On April 1, 1834, Jeremiah Church purchased from Dr. John Henderson the 200 acres of land where the city of Lock Haven is now located (Linn 1883). Shortly after his purchase, he proceeded to lay out the city. Church can be credited with providing the impetus for the creation of Clinton County in 1839. For three years, he beleaguered the state legislature with petitions and personal appearances, until 1839 when the Honorable Judge Burnside created Clinton County. Prior to this, on March 21, 1772, Northumberland County, which encompassed Clinton County, was formed. In 1795, Lycoming County was created from portions of Northumberland County. With the formation of Centre County in 1800, Clinton County was cut in two. When Clinton County was finally established in 1839, its combined townships included: Bald Eagle, Lamar, and Logan from Centre County; and Allison, Chapman, Colebrook, Dunstable, Grove, Lumber, Limestone, Pine Creek, and Wayne from Lycoming County (Linn 1883). At the time of the

formation of the county, the state governor of New York was Governor Clinton, a strong proponent of the canal system; it was his name that was given to the new county.

Once the county was established, the need for a county seat became evident and the area where Lock Haven is now located, with its established population and businesses, was an appropriate choice. On May 25, 1840, Lock Haven was incorporated as a borough and on March 28, 1870 became a city (Linn 1883). The name Lock Haven came from the use of the canal as a lock, and the river as a 'haven' for rafts loaded with timber from upstate. In 1849, with the construction of the West Branch Boom, a structure built to store the passage of cut timber as it floated down the river, this "haven" became even more important (Linn 1883).

Probably the single most important industry in this section of the state during the 1800s was the timber industry. White pine grew throughout the state, and stands of hemlock, oak, ash, maple, poplar, cherry, beech and magnolia were common. Lock Haven's excellent location along the river, and the proliferation of quality white pine in the valley, combined to produce a thriving industry. With the high demand for wood, the lumber trade thrived and by 1830 had become a prominent business. With the expansion of the canal in 1834, Lock Haven became an important commercial and timber center. By 1860, Pennsylvania was the leading producer of timber (Miller 1966).

In the beginning, the logs were floated along the river by raftsmen who created rafts of the timber and sold them downriver. Later, after the building of the West Branch Boom, log drivers guided free-floating logs downriver where they were caught in the boom. Saw mills sprouted up and down the river valleys, and the population increased rapidly. The first county census in 1840 showed 8,323 persons, up from 4,429 twenty years earlier. By 1850 there were 11,207 residents and by 1860, 17,723. In 1880, the population had ballooned to 26,278 (Linn 1883). Many of these residents were raftmen or lumbermen and their families, some of whom remained in the county after the industry began to slump. This decline was a direct result of overcutting and wasteful timbering. Only the best timber was kept; branches and brush were left on the forest floor where they became a fire hazard. With the decreased forestation, flooding became common. Eventually, there was no timber left to cut and as early as 1898, the forests were being replanted (Miller 1966).

With Clinton County's large drainage system, water power was readily available and mills were located up and down the river valleys. In addition to the aforementioned saw mills, there was a clover mill to separate clover seed from the flower, two fanning mills to clean grain, and several feed mills to grind grain for livestock. Two feed mills are in operation today (Hannigan and May 1989).

Flax was planted and sheep raised to provide linen and wool. As a direct result, fulling and carding mills were established. In Mill Hall, two woolen factories were built. In 1833, S. McCormick constructed a factory which continued operation through the early 1880s. John Rich built another woolen factory in the early 1820s. After a move to Dunnstable Township in the late 1820s, Rich settled in Pine Creek Township approximately thirteen years later. Here, with the strong flowing water available, he established the Chatham Run Mill. The current town of Woolrich, previously called Factoryville and later Richville, grew up around the factory. The family business continues in operation today (Hannigan and May 1989).

Additional enterprises included papermaking, which was started in Clinton County in 1880. Today, the Lock Haven plant of International Paper, Hammermill Papers, continues to manufacture paper. More recently, William T. Piper invested in Taylor Brothers Aircraft Corporation in Bradford. By 1937, he became president of the organization, and the company was highly successful. During the same year, a fire destroyed the plant and the business was moved to

Lock Haven, where it was renamed Piper Aircraft Corporation and continued to produce aircraft until 1984. Piper Memorial Airport remains in existence today.

#### IV. RESEARCH DESIGN

by

John P. Hart, Ph.D.

Archaeological investigations at the Memorial Park site represented a unique opportunity for Pennsylvania prehistory. The site's significance stems from the fact that it is a large, relatively undisturbed, stratified, open-air prehistoric site with a long sequence of occupations. Archaeology occupies a singular position within the social sciences in that its primary strength is the ability to address long-term evolutionary processes and change (Plog 1974). The Memorial Park site presented an excellent opportunity to exploit this strength because, as indicated by the results of the current project, it has occupations dating from at least the Middle Archaic through Late Woodland periods. This time represents a period of considerable change in subsistence, settlement, technological and social systems throughout the Eastern Woodlands: from mobile hunter-gatherers during the Middle Archaic, to less mobile hunter-gatherers with incipient horticulture and social differentiation during the Late Archaic, to fairly settled villagers with the first substantial reliance upon maize agriculture and greater development of social differentiation during the Late Woodland. Because of the vertical extent of the site, the data recovered opportunities to test and revise models dealing with a broad range of concerns, including the development of agriculture, social differentiation and complexity, the development of sedentism, and technological change for the West Branch basin.

At the same time, the project presented an opportunity to address questions regarding social and economic systems within the the various time periods represented. Contrary to the results of earlier investigations at the site, for example, the Late Woodland occupations appear to represent small habitation sites rather than villages. How did such occupations relate to the Late Woodland settlement systems of the West Branch drainage basin? What role did the various Archaic occupations at the site play within the subsistence-settlement systems, and was there change in site function through time? The location of the Memorial Park site at the confluence of the West Branch and Bald Eagle Creek suggests that the site would have been used for Late Archaic base camps similar to those found in the Middle and Lower portions of the Susquehanna River valley and other areas of eastern North America (e.g., Custer and Wallace 1982; Custer 1988; Hatch et al. 1985; Ritchie and Funk 1973); an interpretation that is supported through data recovered during the current project.

The horizontal extent of the site for the Late Woodland occupations and the delineation of site geomorphology has led to a definition of site type and an interpretation of how the Memorial Park site functioned within local Late Woodland settlement systems. This portion of data recovery operations also allowed for an interpretation of site structure: that is, what activities took place on the site and how these activities were spatially defined. This was true not only for the extensive exposure of the Late Woodland occupation, but also for the small exposures of the earlier occupations. The research design questions that guided investigations at the Memorial Park site are detailed below, by subject.

## GEOMORPHOLOGY AND SITE FORMATION

Critical to any modern archaeological study is a determination of site formation processes (e.g., Schiffer 1983, 1987). This is particularly true on stratified sites, where a variety of processes during, before, and following various occupations can affect interpretations of both archaeological and natural deposits. While Neumann (1989) had formulated a stratigraphic model for the site, a more-detailed assessment of site stratigraphy and formation processes was performed during the current project. This, in conjunction with the additional cultural materials recovered, has resulted in more detailed models of site formation and stratigraphy.

Soil stratigraphy is that aspect of geomorphology that concerns the delineation and evaluation of former land surfaces. The delineation of buried soils is a major step in the evaluation of hiatuses in the sedimentological record and short- and long-range correlation (Birkeland 1974). Each soil represents a period of landscape stability occurring near the surface, as differentiated from the period and processes that deposited the material (North American Commission on Stratigraphic Nomenclature 1983). This temporal separation of soils from their parent materials was critical to paleoenvironmental reconstruction at the Memorial Park site.

Alluvial sediments are continuous aggradation layers; soils in alluvial sequences are breaks in the lithologic record. After delineation of buried soils, paleoenvironmental reconstruction requires that the soil stratigraphic record be distinguished from the lithostratigraphic record; those processes that relate to the dynamics of sedimentation must be distinguished from post-depositional processes (Birkeland 1974; Gladfelter 1985). For example, if the period of landscape stability is long enough, or if soil-forming environment intense enough, soil formation can cross lithologic boundaries.

Vertical breaks in cultural deposits coinciding with breaks in sediment or soil stratigraphic units are difficult to prove beyond association because of the effects of pedoturbation (e.g., Johnson and Watson-Stegner 1990). Since soil surfaces are biologically and physically active, materials can be mixed and/or translocated. Coarse fragments in a finer matrix are particularly susceptible to frost heaving and burial by burrowing organisms. The extent of pedoturbation must be assessed both in specific locations of interest and throughout major soil stratigraphic units, and related to specific soil stratigraphic units. The extent of pedoturbation can be evaluated best in the field using soil morphology.

Radiocarbon dating can be used to date specific soil horizons in the context of the alluvial environment (Gladfelter 1985). These dates permit a determination of the time span between periods of stability; these intervals were compared to soil development as an aid to paleoenvironmental reconstruction. Well-developed soils formed over short periods of time indicate particularly intense environments (Holiday 1985). The spatial analysis of radiocarbon dates for specific horizons aided in the short range correlation of soil horizons between the various block excavations.

The evaluation of soil development and weathering provided an estimation of the intensity of environment (climatic and biological) associated with each land surface, an important concept in the reconstruction of the past landscape (Birkeland 1974). The distinction between soil stratigraphic units and lithological units was based both on field morphology and on detailed particle-size analysis. These analyses provided the framework for determining the degree of soil development at the Memorial Park site.

After the soils in the local succession were ranked on the basis of their relative degree of profile development, the stage was set for longer-range correlation (Morrison 1967). In the other areas to which correlations were made, the soils were similarly ranked, again with respect to the



local succession (Birkeland 1974). The youngest strongly-developed soils were matched in the correlation. Together with radiocarbon dating, these techniques aided in the long-range correlation and evaluation of similar deposits in the Susquehanna Valley, helping to refine current predictive models of prehistoric site location (Vento and Rollins 1989).

The following methods were used to elucidate soil formation processes and rates:

1. *Particle-size Analysis.* Particle-size analysis was performed with the pipette method. Five sand fractions (sieved), three silt fractions, and two clay fractions were measured. These analyses allowed for a precise evaluation of clay and silt translocation—two key indicators of soil formation, and sand distribution—a key factor in the analysis of the mode of sedimentation.
2. *Radiocarbon Dating.* Radiocarbon dating was performed on bulk A horizon samples of various buried soils. These data were important in determining a limiting date for overlying deposits. Radiocarbon dates from features originating in particular soil horizons also aided in temporal reconstructions of soil development and deposition rates.

#### OCCUPATIONAL SEQUENCES AND CHRONOLOGY

The second necessary step in the analysis of data recovered from the Memorial Park site, a task closely related to the site formation study, was the placement of all data in their correct temporal and cultural context. The refinement of the chronological sequence at the Memorial Park site was thus a major focus of research. Components from all periods from Late Archaic through Late Woodland were documented at the site during Phase II investigations; they were reported to have been vertically distinct (Neumann 1989). No radiocarbon assays were reported; dates for the components in Neumann (1989) were estimated upon diagnostic artifacts and estimated dates for the five buried soils, based upon the work of Vento et al. (1988). During the current investigations, this occupation span was expanded to at least the Middle Archaic period. In order to model temporal change and synchronous relationships (of the various components) to regional subsistence-settlement systems, it was necessary to more fully document occupations through radiocarbon assays and temporally- and spatially-sensitive artifact stylistic attributes. This portion of data analysis included the identification of stylistic elements of pottery and lithic attributes, the association of these to specific strata across the site, and the use of radiocarbon dating to address temporal variation in stylistic elements, including those on Clemson Island pottery (cf. Stewart 1990). This process was performed in conjunction with the site-formation analysis.

#### *Research Questions*

Major research questions addressed with data recovered from the Memorial Park site during the current investigations included the following:

1. What was the occupational sequence at the site?
2. What were the absolute dates for each component at the site?
3. Was it possible to aid the development of an absolute chronology for Clemson Island pottery style change?
4. Was it possible to differentiate multiple components for the various time periods represented at the site, and did these correspond to previously defined phases?

## Research Methods

Several lines of evidence were used to refine occupational sequences and chronology at the Memorial Park site during the present project. These included the recovery of greater amounts of diagnostic artifacts, greater control over vertical provenience of artifacts, and radiocarbon assays from features with associated diagnostic artifacts.

1. *Diagnostic Artifacts.* The excavation of broader areas of the site than were exposed during Phase II operations resulted in the recovery of additional diagnostic artifacts for the various occupations at the site. This led in part to a refinement of the sequence of site occupations, including more specific identification of previously defined phases, complexes, and traditions represented at the site. One major goal was obtaining dates for various classes of Clemson Island pottery to aid in the development of an absolute chronology for the Clemson Island pottery types.
2. *Radiocarbon Assays.* Charcoal samples recovered from flotation samples taken from features, as well as separate samples obtained during the excavation of features, were submitted for radiocarbon assays. Samples were chosen (a) from features with associated diagnostic artifacts, including various Clemson Island pottery classes, and (b) from features that represent components in discrete stratigraphic positions that lack diagnostic artifacts. These dates were combined with bulk soil dates to refine the temporal sequence of occupations at the site.
3. *Refinement of Stratigraphy.* Through the excavation of larger areas, it was possible to refine the basic stratigraphic model presented in Neumann (1989). This incorporated the two methods listed above, as well as geomorphological/pedological investigations described earlier.

## SUBSISTENCE STRATEGIES

Although the investigation of prehistoric subsistence has grown in importance throughout eastern North America over the past several decades (e.g. Ford 1985; Fritz 1990; Keegan 1987; Neusius 1986; Smith 1989, 1992), there remains much to be learned regarding subsistence change in the prehistoric record of the West Branch. A major trend in subsistence, addressed with data from the Memorial Park site, was the development of horticulture and maize agriculture. Especially important was the representation of periods from Late Archaic through early Late Woodland. This time span represents a transition throughout much of eastern North America, from primarily hunting-gathering subsistence economies with very limited reliance on horticulture to the development of maize-based agricultural systems (Ford 1985).

By the Late Archaic period, the Eastern Agricultural complex (Ford 1985), or Eastern Horticultural Complex (Riley 1987), was in place throughout much of eastern North America (e.g., Crites 1987; Ford 1985; Smith 1987, 1989; Watson 1985). This complex, which became an important component of Early and Middle Woodland subsistence, consisted of indigenously domesticated starchy and oily seed-bearing annuals, including sumpweed (*Iva annua*), sunflower (*Helianthus annuus*), and goosefoot (*Chenopodium berlandieri* spp.). Domesticated Cucurbita squash, which was also probably an indigenous domesticate (Crites 1987; Smith 1987), was grown throughout eastern North America at this time. These plants had a long history of cultivation and domestication, dating in some instances to as early as the Middle Archaic (Smith 1989). In addition to this complex, numerous other seed-bearing annuals, such as knotweed (*Polygonum erectum*), little barley (*Hordeum pusillum*), and maygrass (*Phalaris caroliniana*), were cultivated but not necessarily domesticated (Asch and Asch 1985; Smith 1987, 1989; Watson 1985).

Neumann (1988:43) reported recovering very little charred plant material from features documented during Phase II investigations at the Memorial Park site, and offered no data on the material that was recovered. Therefore, floral material recovered during the current investigations of the site represented the first significant data on subsistence activities associated with its various occupations. A review of the literature on central Pennsylvania, and the northeast in general, suggest the following trends in prehistoric subsistence.

Indigenous domesticates have been recovered from Middle and Late Archaic sites in other areas of the eastern United States (Ford 1985; Riley et al. 1989). Sumpweed, sunflower, goosefoot, and Cucurbita show signs of morphological modification denoting domestication by at least 4000 and 3000 B.P. These resources generally have not been documented in central Pennsylvania. While the earliest examples of these domesticates all occur well west of the West Branch, Smith (1987, 1989) asserts that they were present throughout the middle latitudes of the eastern United States west of the Allegheny Front. The position of the Memorial Park site at the Allegheny Front, with direct access to the west through the West Branch valley, suggested a high probability for the presence of these domesticates during the Late Archaic period in the West Branch.

### *Research Questions*

Major questions addressed through data recovery at the Memorial Park Site included the following:

1. Was the Eastern Horticultural Complex utilized in the West Branch of the Susquehanna River Valley during the Late or Terminal Archaic periods, and if so, to what extent?
2. Was the complex in use during the Early and/or Middle Woodland periods?
3. Were any local seed-bearing annuals cultivated?

The Late Woodland period also represents a transitional period for agricultural development in many areas of eastern North America (Smith 1989). During this period in the northeast and Mid-Atlantic, and the corresponding Late Woodland and Mississippian periods in the Midwest and Southeast, there was probably, for the first time, a substantial reliance upon maize (*Zea mays*). Although numerous reports of maize in Middle Woodland contexts have been made over the years (e.g., Struever and Vickery 1973), early direct dating of maize from contexts earlier than the Late Woodland tended to discount an important role for this domesticate before this period (Conard et al. 1984). However, Cutler and Blake (1981) report that maize was present in western Pennsylvania by at least A.D. 660 (cf. Adovasio and Johnson 1981), and other recent reports of maize in earlier Woodland contexts (e.g., Chapman and Crites 1987; Riley et al. 1994) suggest that maize was in use prior to the Late Woodland period, but the level of use prior to the Late Woodland appears to have been low (Riley et al. 1994).

Current opinion on Clemson Island suggests a mixed subsistence strategy of maize agriculture, with hunting, gathering, and fishing playing major roles. Hay et al. (1987) suggest that the routine recovery of maize, beans, and squash, and a greater association of Clemson Island sites with highly productive agricultural soils as opposed to earlier periods, support this interpretation. Maize, squash (Custer, Watson, and Bailey 1994; Hatch 1980; Hay and Hamilton 1984; Stewart 1988), and bean (Custer, Watson, and Bailey 1994; Hatch 1980) have been recovered from Clemson Island sites in small quantities. Nuts and non-domesticated seeds have also been consistently recovered from Clemson Island sites. One possible sunflower seed was recovered from the Fisher Farm site (Hatch 1980). Other indigenous domesticates have been

identified only tentatively (King 1988). The extent to which these various resources contributed to the Clemson Island diet, however, remains obscure.

Major research questions addressed with data recovered from the Memorial Park site included the following:

1. Is maize present in the West Branch of the Susquehanna prior to the early Late Woodland?
2. To what extent is maize represented in the Clemson Island complex? Nearby work in the Bald Eagle Creek drainage at the Fisher Farm Site (Hatch 1980) and to the east at the St. Anthony Street Bridge (Stewart 1988) suggest that maize formed only part of a mixed horticultural-hunting-gathering economy. Could this be substantiated at the Memorial Park site? Could any differences be explained by the various roles these sites played within local Clemson Island settlement systems?
3. To what, if any, extent are the Eastern Horticultural Complex or other indigenously domesticated annuals utilized during the Late Woodland period?

In conjunction with the study of changes in the degree of reliance on cultivated and domesticated crops, questions concerning changes in the use of wild resources are addressed. For example, with the introduction of starchy and oily seeds within the subsistence economy, is there a corresponding decrease in the use of nuts? Also, as more time and energy is devoted to the production of domesticates and cultigens, is there a corresponding change in the exploitation of various animal resources as a result of scheduling conflicts and changes in marginal cost levels (cf. Earle 1980) within the local subsistence economy? And, to what extent does the reliance on fishing change as the result of the adoption of agriculture? Changes in climatic and vegetational patterns, such as the proposed xerothermal during the Late Archaic period and the warm-moist climatic episode during the early portions of the Late Woodland period, may have had a substantial influence on subsistence and settlement patterns. How are these changes reflected in the archaeological record at the Memorial Park site?

### *Research Methods*

The following analyses were used to address subsistence-related research questions.

1. *Macrobotanical Analysis.* Analysis included the identification of seeds, domesticates, nuts, and wood charcoal, to the species or genera level when possible. These data were used to generate ubiquity indexes, nut/wood ratios, seeds/liter ratios, maize kernels/liter ratios, and other indexes and ratios typically used to quantify the extent to which various classes of floral resources are present for particular components. Changes in these indexes and ratios were used to infer changes in subsistence patterns. Included in this analysis was an identification of wood charcoal to the species or genera level that was helpful in the determination of local vegetation patterns.
2. *Faunal Analysis.* Analysis was performed to detail how animal products contributed to the economy of the various components of the Memorial Park site. Data were organized in the following manner for all analyses: (a) total number of recovered fragments per identified species, (b) adjusted totals which reflect cross-mends and articulating bones, (c) total gram weight for all identified species, (d) percentages, (e) minimum number of individuals, (f) minimum number of meat units, (g) spatial differentiation, (h) butchering patterns and techniques, (i)

functional patterning of the sites as reflected in refuse deposition, and (j) statistical manipulation to demonstrate relationships between data sets, including temporal, spatial and economic trends.

3. *Palynology.* In order to track changes in environment and local vegetation patterns, palynological analysis was performed on soil samples taken from specific strata at the Memorial Park site. The data obtained from this analysis were compared to current models of vegetational change for the northeast, to determine local variation and to determine anthropogenic changes around the site resulting, for example, from agricultural practices during the early Late Woodland. When combined with the reconstruction of geomorphological and sedimentological development of the site, palynology allowed for a fairly detailed model of environmental patterns.

## TECHNOLOGY

There have been major advances in theoretical and methodological approaches to prehistoric pottery and lithic function and technology during the past decade (e.g., Braun 1983, 1987; Schiffer and Skibo 1987; Torrence 1989a). Torrence (1989a:58) has stated that "technology is developed in order to solve problems. Tools are not ends in themselves but are used by people as part of a larger strategy for coping with their social and physical environment. We need to envisage technology as part of the larger set of behaviors in which it plays a part." This statement is applicable to all forms of prehistoric technology, including lithic tools (e.g., Kelly 1988; Myers 1989) and pottery (e.g., Braun 1983, 1987; Schiffer and Skibo 1987).

The problems for which technology is developed are defined by the functional field; that is, the complex of techno-functions, socio-functions, and ideo-functions (cf. Binford 1962) that tools perform within particular subsistence-settlement systems (Schiffer and Skibo 1987). Changes in technology are brought about through changes in the functional field. Through the observation of technological change through time, it is possible to infer changes in the functional field in conjunction with other lines of evidence. For example, as subsistence systems change, there should be a corresponding change in food-getting and processing technology because "tools used in food-getting will be designed in such a way as to ensure that an adequate supply of appropriate resources is obtained" (Torrence 1989a:58).

While the refinement of chronology was one of the major goals of the current investigations of the Memorial Park site, the investigation of technological change and artifact function was of equal importance. The theoretical justification for this focus is presented below for pottery and lithics. Attribute recording schemes and analytical frameworks are described in the Pottery Analysis and Chipped Stone Analysis sections of this report.

### *Pottery*

In the past, prehistoric pottery analysis has tended to mix both stylistic and functional attributes in the definition of wares and types. These types and wares have been used as temporally- and spatially-sensitive cultural historical markers. Functional attributes, such as temper type and size, often have been mistaken as being stylistically determined. However, as Braun (1983a) has demonstrated, pottery vessels are tools, and their success as tools is determined by their physical properties and how these properties react to physical stress. A pot that fractures when used for cooking not only represents a waste of time and energy in the production of the pot, but it also causes a loss of the food being cooked. Therefore, although pottery contains significant amounts of stylistic information, it is important not to mistake functional for stylistic attributes (e.g., Bronitsky and Hamer 1986; Rice 1987; Steponaitis 1983).

In the eastern United States, there is a general change through time from thicker-walled vessels with large angular grit temper to thinner-walled vessels with smaller grit tempering, a greater preference for mafic grit temper or limestone and, in later pottery traditions, shell temper (e.g., Braun 1983a, 1987; Skibo and Schiffer 1989). These changes indicate a greater emphasis on thermal shock resistance as starchy seeds and eventually maize were increasingly incorporated into the diet: it is necessary to cook starchy seeds in water to the point of gelatinization if they are to be readily digested. For this to occur, pots must be placed directly on a source of heat for extended periods, which subjects them to thermal stress. Thinner walls conduct heat more readily and are, therefore, less subject to thermal stress-induced fracturing than thicker walls (Braun 1983a; Rice 1987). Smaller, more regular grit temper also aids in the resistance to cracking by increasing flexural strength (Braun 1983a; Rice 1987; Rye 1976). The change to mafic mineral and shell tempering also corresponds to changes in vessel function. These tempering materials have expansion rates similar to those of clay minerals, and are less likely to result in fracturing when pots are subjected to direct heat as the minerals expand at similar rate to the clay (Braun 1983a; Rye 1976).

To date, the earliest evidence of pottery in the West Branch of the Susquehanna is during the Terminal Archaic period with the Orient phase (Graybill, this volume). This is steatite-tempered pottery, which has coarse paste and relatively thick walls; it is generally referred to as Marcey Creek. During the Early Woodland and perhaps the early portions of the Middle Woodland, pottery is thick and coarse-grit or sand tempered with cordmarked interiors and exteriors (Turnbaugh 1977), similar to that found throughout much of eastern North America during this time (see, for example, papers in Farnsworth and Emmerson 1986). During the later Middle Woodland, pottery becomes somewhat less thick and temper is perhaps less coarse, although this time period is poorly represented in the extant literature (Graybill, this volume). Late Woodland Clemson Island pottery is first noted in the West Branch starting around A.D. 700. Clemson Island pottery continues the trend towards thinner walls and temper size. Temper is typically grit, chert or quartz, and exterior surfaces are cordmarked or fabric impressed. Changes in pottery type frequencies have been noted for Clemson Island at the stratified Fisher Farm Site in the Bald Eagle drainage (Hatch 1980; Hay et al. 1987) near the Memorial Park Site, but it is unclear how technological aspects of the pottery assemblage change through time. Much of the Clemson Island pottery recovered from Memorial Park is thick-walled and coarse-tempered. Although shell-tempered pottery is often found in small quantities on Clemson Island sites, it is generally considered intrusive from the later McFate-Quiggle phase (but see Stewart 1988). Stewart phase pottery continues the trend of thinner walls and finer temper. This pottery is primarily tempered with crushed quartz or shale (Witthoft 1954). Finally, McFate-Quiggle pottery is shell-tempered, as is common for the Late Prehistoric throughout the Eastern Woodlands. Thus, the basic trends in pottery technology noted in other areas of eastern North America appear to be present in the West Branch of the Susquehanna, although quantification of these trends is lacking. One of the major focuses of GAI's investigations at the Memorial Park site was the examination of changes in pottery technology, and how they reflect changes in subsistence trends (c.f. Braun 1983a, 1987).

*Research Questions.* Research questions addressed with data recovered from the Memorial Park Site include the following:

1. Are distinct functional classes present in Clemson Island pottery, and are there changes in Clemson Island pottery technology through time?
2. Are there changes in technological attributes through time that correspond to changes in subsistence? That is, how does pottery technology change from the early Clemson Island to the Stewart phase as maize presumably became an increasingly important part of the subsistence regime?

*Research Methods.* One of the management goals listed in Hay et al. (1987) is the use of new approaches to the study of Clemson Island pottery. In order to address the technological/functional questions listed above, it was necessary to employ an attribute-recording scheme that went beyond those used in the past to recognize and refine pottery types. The main thrust of Clemson Island pottery studies to date has been the refinement of typology and a separation of Clemson Island from Owasco pottery. Although these are important goals, technological and functional studies have been neglected. An attribute-recording scheme that took into account variations in vessel wall thickness; temper type, size, and density (and other technological and functional attributes) was used to address the research questions in conjunction with thin-section analysis, following Stoltman (1989, 1991).

1. *Attribute Analysis.* To document technological and functional differences between synchronous pottery types and their differences through time, an attribute recording scheme was used to record vessel wall thickness (after Braun 1983a, 1983b, 1987), vessel diameter, temper type/size/density, and paste characteristics, among other variables. A detailed attribute recording scheme that took into account technical, stylistic, and functional attributes was used on rim sherds. A less detailed recording scheme was used for body sherds, focusing primarily upon technological attributes. Details of this scheme are presented in the pottery analysis section of this report.
2. *Thin Section Analysis.* The geological analysis of pottery temper through petrographic thin sectioning has proven extremely helpful in supplementing an objective classification of pottery assemblages, and in helping to understand the cultural implications of their manufacture (e.g., Beynon et al. 1986; Stoltman 1989). A selected sample of potsherds from the Memorial Park site, representing previously defined technological, functional, and stylistic groupings, was subjected to petrographic analysis. Standard, covered-rock thin sections, finished to 40 microns, were prepared for each sherd. Thin sections were examined in both plain and cross-polarized light with a petrographic microscope at the GAI archaeological laboratory. Grain composition, grain size, grain shape, and temper density were determined. These results were used as an aid to interpreting functional /technological aspects of the Late Woodland pottery collection.

### *Lithics*

Great strides have been made over the last decade in theory and methods of lithic analysis in terms of function and technology (e.g., Bleed 1986; papers in Henry and Odell 1989; Kelly 1988; papers in Torrence 1989b). Lurie (1989:46) has suggested that "in recent years archaeologists have become aware of the limitations of traditional stone tool typologies. These typologies which are based on a mixture of technological, functional, and stylistic variables can mask rather than elucidate human behavior." Analysis of lithic material recovered from the Memorial Park site went beyond simple typological description and limited lithic reduction trajectory descriptions. Like pottery vessels, lithic tools are designed to solve certain problems, and have technological constraints (Torrence 1983, 1989a, 1989b). Lithic technology responds to changes in the functional field such as subsistence change. By addressing these issues, it was possible to integrate lithic material into the database used to test models of cultural evolution.

Once lithic tools are recognized as solutions to particular problems, it is possible to perform analyses that integrate lithic technology into the broad patterns of cultural evolution and to study synchronous variation. A number of theoretical and methodological trends in lithic studies were addressed with data recovered from the Memorial Park site. For example, Bleed (1986) has proposed that lithic tools are designed either for maintainability or for reliability, and Torrence

(1989a) has expanded upon this typology by suggesting that these tool designs represent end points on a continuum of lithic tool design. Maintainable tools are designed to enable easy repair through the replacement of modular parts. These tools thus take the form of compound tools, such as those produced with microblades. Maintainable tools are designed to respond to situations where resources are available on a continuous or unpredictable basis. Reliable tools, on the other hand, are designed to operate above the level of stress inherent in resource extraction activities. Therefore, these are made up of very strong components, and have redundant parallel parts that operate as fail-safe mechanisms. These tools are designed to avoid breakage during use, and to exploit resources with discontinuous but predictable availability. Such tools would consist of well-made bifacial tools that can easily be repaired through retouch. Through the identification of these design variables, it was possible to infer the type of resource extraction for which the tools were designed. This, in turn, was used to aid in the modeling of subsistence change. Torrence (1989a:63), for example, suggests that reliability "is a response to the severity of risk, whereas the timing of risk determines the need for maintainability."

Similarly, through the identification of expedient versus curated tool technology, it was possible to infer site type and activities. First proposed by Binford (1977, 1979), this basic division has become a major theoretical tool in the investigation of lithic tool technology and function. Curated tools, such as hafted bifaces, are tools with a high degree of energy and time investment in their production, are maintainable, and can be used for a wide variety of tasks (Kelly 1988). These tools are generally transported from site to site or are cached at a site in anticipation of future use. Expedient tools are situational, with little energy or tool design required for their manufacture, and are generally discarded after use rather than curated. The identification of relative frequencies of these tool types can be used as an aid in the identification of mobility and settlement patterns, and site function (e.g., Camilli 1989). Curated technology is most often associated with logistically organized settlement patterns and base camp sites. Expedient tools are most often associated with residential mobility and temporary resource extraction camps. Camilli (1989) has suggested that the frequency of expedient tools can be used as an indication of the intensity of site usage. Alternatively, increased sedentism and reliance on agricultural production generally results in a decrease in energy expenditure on lithic tools, and greater reliance on expedient tools (Jeske 1989; Parry and Kelly 1987; Torrence 1989).

The use of raw material can also be an indication of mobility patterns. For example, because the extraction of lithic raw material is often encompassed within other subsistence activities (Binford 1977), more mobile societies will generally have access to greater amounts and varied kinds of lithic materials. Mobile societies can afford, therefore, to be less conservative in the use of high-quality lithic materials than more sedentary societies that have less access to high-quality materials. A higher frequency of expedient tools will be manufactured with high-quality lithic materials in highly mobile societies. In sedentary societies, the cost of obtaining high-quality materials will necessitate conservation and maintainability of tools made from the high-quality material (Jeske 1987, 1989; Lurie 1982, 1989). As it becomes less available through diminished mobility options and/or depletion of resources, high-quality material will be used for artifacts with standardized forms, smaller tools, and maintainable tools. Similarly, the pattern noted by Schindler et al. (1982) for the Bald Eagle Drainage, where more variation for lithic raw materials was noted on Archaic sites than on Late Woodland sites, can also be explained under this model. Presumably, less mobility resulted in fewer opportunities to exploit a wide variety of lithic raw materials.

The combination of these concepts can lead to expectations regarding lithic tool design and use through time and space. For example, Torrence (1989a) has suggested that as subsistence patterns change from hunting-gathering to agriculture, lithic technology will become less complex. Tools will become less well designed because it is no longer necessary to expend energy either to obtain high-quality raw material, or to design and produce tools to minimize short-term risk (cf. Jeske 1987).



*Research Questions.* Major questions addressed with data recovered from the Memorial Park site included the following:

1. To what extent did lithic technology vary through time as risk factors changed with modifications in subsistence activities? For example, was there a change toward more expediently manufactured tools as maize was adopted? Were there recognizable changes in maintainable and reliable tool design that reflect changes in subsistence risk? Did the incidence of expedient and curated tools change with changing mobility patterns?
2. What changes occurred in lithic procurement during the time span from Middle Archaic through Late Woodland periods? Was there a trend towards lithic material conservation as mobility decreased, or were locally available raw materials of high enough quality to preclude such conservation?
3. What changes occurred in lithic reduction systems at the site through time, and is this reflected in changes in subsistence, trade, etc? Was there less evidence of expedient tool manufacture during the Late Archaic as settlement systems become more logistically organized? Did amorphous core and bipolar reduction become more common on locally available resources later in the cultural sequence, or is bifacial reduction more common (Parry and Kelly 1987)? Was there greater evidence for high-quality lithic resource conservation through time through the production of blades or bladelets, or was there a greater incidence of biface maintenance of tools manufactured from high-quality lithic material (Jeske 1987)?

*Research Methods.* To address the various questions posed for lithic technology, several analytical procedures were used. These included a detailed morphological analysis of shaped lithic tools and retouched pieces. A method of aggregate analysis was performed on lithic debris to ascertain the manner of lithic reduction performed at the site during the various periods of occupation. And finally, to ascertain tool use, high-powered microwear analysis was performed on a subset of shaped lithic tools and retouched pieces.

1. *Morphological Analysis.* Detailed morphological analysis of shaped lithic tools and retouched pieces was used to elucidate changes in lithic technology that may have accompanied changes in subsistence patterns. An attribute-recording scheme was used that took into account functional, technological, and stylistic attributes. This scheme was developed to provide a means for consistency and speed of data recording, with a major goal of recovering data concerning the economic management of lithic resources and technology (Jeske 1987; Lurie 1982). It has been used successfully on numerous projects throughout the eastern United States (e.g., Hart 1990, 1991, 1992; Jeske 1989; Jeske and Hart 1988; Lurie 1982, 1989). This attribute-recording scheme maintains compatibility with traditional lithic typologies in order to facilitate communication with other archaeologists concerned with spatial and temporal variability in lithic tool design. It included the macroscopic identification of lithic resources at a gross level, primarily the identification of local versus nonlocal material, and the relative quality of various raw materials. Details of this recording scheme are presented in the Lithic Analysis section of this report.
2. *Aggregate Analysis of Lithic Debris.* A modified version of mass analysis as defined by Ahler (1986, 1989a, 1989b; Ahler and Christenson 1983) was performed on lithic debris recovered from the Memorial Park Site, as stipulated in the mitigation plan for the project (COE 1990). This procedure was based upon the assumptions of progressive size reduction during lithic reduction. Lithic debris

were sorted into size categories with standard geological sieves of 1-inch, 0.5-inch, 0.25-inch, 0.125-inch, and 0.0625-inch for each provenience unit. These size classes were initially sorted into raw material classes. Within each raw material class, counts and weights were made for each size class, numbers of pieces with cortex, and number of heat-altered pieces were recorded. When data recording was complete, multivariate techniques, developed for this project, were used to compare data from the Memorial Park site with experimental reduction data to determine the reduction techniques employed at the site. This procedure had the advantage of providing a relatively fast and objective means of lithic debris analysis, and allowed for examination of the entire assemblages of lithic debris rather than only a subset. A related procedure was used successfully on at least one other site in Pennsylvania (Hart and Cremeens 1991). Details of aggregate analysis procedures are presented in the Chipped-Stone Technological Analysis section of this report.

3. *Use-wear Analysis.* In addition to detailed morphological analysis, research questions were addressed through data obtained by high-powered microwear analysis and breakage pattern analysis. A sample of shaped tools and retouched pieces representing morphological types was examined under high-powered magnification (at least 200X) for edge wear, characteristic of certain usage: polish, striations, microchipping, etc. This was accomplished through comparisons with published use-wear patterns and experimental use of reproduced tools and debris, using the same lithic materials as those used by the prehistoric occupants of the site. A sample of non-retouched debris was examined under low-power (less than 200x) magnification to determine use-wear not visible to the naked eye.

#### SETTLEMENT PATTERNS

Settlement pattern analysis was performed at two levels of integration: site structure and regional settlement patterns. To date, settlement pattern analysis in the West Branch has focused primarily upon regional settlement patterns (but see Custer, Watson, and Bailey 1994).

Hatch et al. (1985) suggest that a multiple base-camp radial-settlement pattern became established during the Archaic period and continued through the Woodland period, with the addition of several site types. During the Archaic period, base camps occupied by groups of maximal size were situated in major river valley floodplains, with access to a variety of resources. Specialized resource extraction camps were located away from the valley floors and were used as temporary camps for the extraction of resources. This radial system would have been moved several times during the year to track changes in resource availability. This proposed system follows Binford's (1980) and Kelly's (1983) descriptions of the logistic settlement pattern that has been recognized throughout the eastern United States for the Archaic period (e.g., papers in Phillips and Brown 1983).

In a number of widely-cited publications, Custer has developed a model of Late Archaic subsistence-settlement systems for the Mid-Atlantic region that may have general applicability to the Memorial Park site (e.g., Custer 1984, 1988, 1989; Custer and Wallace 1982). This model is integrated with models of regional climatic change that produced temporally and spatially varied resource distributions. Changed climatic patterns, including a series of warm-dry climatic episodes between approximately 3050 B.C. and 1050 B.C., resulted in a major differentiation between resource productivity in major river valleys and upland settings. Custer (1988:50) argues that upland settings were productive, but "the nature of productivity changed such that the most effective strategy was to exploit these areas via periodic transient forays from semi-permanent base camps in riverine areas." This pattern resulted in large riverine macro-base camps and many smaller, upland procurement camps.

During the Woodland period, Hatch et al. (1985) suggest that this basic pattern continued with the addition of farming hamlets and villages. Semi-permanent villages are more common during the Middle Woodland period, with permanent villages being established during the Late Woodland period. In their more detailed model of Clemson Island settlement pattern, Hay et al. (1987:57) recognize three site types: (1) villages with associated burial mounds, (2) villages and hamlets without associated burial mounds, and (3) special activity, resource-extraction camps. Site type 1, villages with associated burial mounds, tend to be located on major waterways near large expanses of arable soils. These sites are the least documented because many have been destroyed through urban expansion, and through the activities of looters and early, non-scientific excavations. Early reports describe a burial mound in Lock Haven (Meguinnes 1889) that was destroyed during excavation of the Pennsylvania Canal (Hay et al. 1987).

More data exists for site type 2, villages and hamlets without associated mounds. These sites are smaller than those of site type 1, and have been the focus of recent archaeological research (e.g., Hatch 1980; Hay and Hamilton 1984; Graybill 1984; Mitchum 1983; Smith 1976; Stewart 1988). These sites tend to be located on floodplains of major rivers, such as the North, West, and Main branches of the Susquehanna and their major tributaries (Hay et al. 1987), and are located near arable land. The number of households represented at the sites varies, but houses are generally associated with food processing and storage features. Hay et al. (1987) suggest that these sites represent a second tier within the Clemson Island settlement system, which is analogous to the Pacific "Big Man" system.

Site type 3, special purpose sites, is a hypothetical site type; no special activity sites with diagnostic Clemson Island artifacts have been reported. These sites would have been used to extract subsistence items and other goods, such as lithic raw materials. Possible special activity sites have been reported in the Bald Eagle Drainage by Hatch (1980), although the lack of diagnostics prevents definite assignment to Clemson Island.

Stewart (1988:IV-22), noting that there have been no villages recorded in association with mounds, revised Hay et al.'s (1987) model to include four site types: (1) planned villages, (2) hamlets with associated burial mounds, (3) hamlets with no burial mound association, and (4) special purpose camps.

More recently, Custer, Watson, and Bailey (1994: 19-22) provide an evolutionary model of Late Woodland community patterns for Pennsylvania that extends beyond Clemson Island to the latter portions of the Late Woodland period. This model includes six developmental stages, the first three of which, they believe, are applicable to Clemson Island, while the last three are more likely associated with later Late Woodland culture-historical taxa. The first type, Individual Farmsteads/Household Cluster, consists of an isolated household structure and nearby features, associated with a nuclear family. The St. Anthony Bridge site (Stewart 1988) is cited as an example of this type of settlement. The second stage, Hamlets, consists of multiple household clusters, each representing a full suite of household activities; communal activities are limited. The Fisher Farm site (Hatch 1980) is cited as an example of this type of settlement. The third type, Fortified Hamlet, Agglunated Village consists of a hamlet or village surrounded by a stockade with the first evidence of communal activities, although individualized household activities are represented by feature distributions. Communal work areas and middens indicate some integration of community activities. The Airport II (Garraghan 1990) and Ramm (Smith 1976) sites are cited as examples of this type of site.

Custer and associates' (1994) fourth site type, Communal Village, was occupied by hundreds of individuals, housed in up to 60 structures (compared to the first three types, which are limited to no more than 10 houses). Communal activities are common, and specialized central facilities/structures reflect suprahousehold socio-religious activities. Two Shenks Ferry sites, Slackwater (Custer et al. 1993) and Kauffman (Nass and Graybill 1991) are cited as examples of

this site type. The fifth site type, Planned Village I, is represented by regular, planned structure placement within the community. Special-purpose structures suggests a continuation of suprahousehold activities initiated in site type 4. The Murry (Kinsey and Graybill 1971) and Mohr (Gruber 1971) sites are cited as examples of this type of site. The final site type, Planned Village II, is the larger site represented in Pennsylvanian prehistory and was occupied by thousands of individuals. The presence of outlying cemeteries and lack of household burials, suggest to Custer and associates the presence of community or lineage-based socio-religious integration. They cite the Strickler (Kent 1984) and Washington Boro Village (Kent 1984) sites as examples of this site type.

Investigation of the Memorial Park site offered several opportunities to address both levels of settlement pattern integration, and provided an opportunity to build upon and modify current models through data gathered on each level of integration. This analysis was the integrating focus of research at the site.

### *Site Structure Analysis*

Site structure consists of "the spatial interrelationships of materials and facilities. In this way an archaeological site represents, in the form of material residues, the behaviors and activities of individuals and groups conducted over some period of time at a given location on the landscape" (Doershuk 1989). In other words, the manner in which artifacts and features are patterned across a site reveals how that site was utilized by various groups of people. The analysis of site structure was thus integral to the interpretation of the Memorial Park site. This analysis served to integrate all other types of analyses that were conducted; that is, those commonly performed on data recovered from a site.

*Research Questions.* Research questions addressed through site structure analysis included:

1. What function(s) did the site play during the Late Woodland period?
2. Was there economic or social differentiation represented at the site in the form of distinct artifact and feature patternings?
3. Was the site a base camp during the Late Archaic period, and were there changes in site function through time?

*Research Methods.* These questions could only be answered through the spatial integration of all other data sets, including feature locations and pottery and lithic spatial distributions, as well as subsistence data. This level of analysis involved the combination of all data sets obtained from the site as well as the specific procedures outlined below.

1. *Cross-Mending.* One method of isolating socially distinct areas of a site is through the cross-mending of artifacts between features. This procedure was used in an attempt to identify contemporaneous features (Nass 1989).
2. *Variation in Technological and Functional Attributes.* Another manner of determining site structure was through variation in technological and functional attributes of lithic tools and pottery. The spatial distribution of attribute clusters aided in the identification of activity areas. This procedure was carried out on materials recovered from all components.
3. *Artifact Densities and Feature Patterning.* A third procedure used to evaluate site structure was the association of artifact densities with features in the deep testing

portion of the investigations. The excavation of small units (50 x 50 cm) enabled a fine level of control to be established over the spatial distribution of artifacts.

### *Regional Settlement Patterns/Social and Trade Networks*

The study of regional settlement patterns flowed from the investigation of site structure and activity area structure. Also included in this analysis were social and trade networks. Through comparison with published accounts from other sites in the region, and through the result of site structure analysis, it was possible to determine how the Memorial Park site functioned within regional settlement systems through time.

*Research Questions.* Important questions addressed with data from the Memorial Park site included:

1. How did the Clemson Island occupation(s) relate to Clemson Island sites within the West Branch drainage basin?
2. How did this site fit into the subsistence-settlement systems during the Archaic period? Did the site represent a seasonal or multiseasonal base camp as would be expected from its geomorphological setting, or was it a specialized extraction camp? Was the site used for different purposes during different times within the Archaic period, and would this indicate changes in site usage and regional settlement patterns to, for example, a more logistically-oriented settlement system (Binford 1980)?
3. Was there evidence during the span of the Late Archaic for sedentism, as has been noted in other areas of eastern North America (e.g., Brown 1985)? At what date is there evidence for multiple season and/or year round occupation?

*Research Methods.* As with site structure analysis, regional settlement pattern analysis involved the integration of all data sets generated during the current investigations at the Memorial Park site. This analysis built upon the findings of the site structure analysis. These data sets were compared to published data sets from other local and regional sites to model the function of the various Memorial Park components in the local and regional subsistence-settlement systems. Included in this analysis were interpretations of site function, pottery-style analysis, lithic raw material analysis, and identification of exotic materials recovered from the site.



## V. FIELD METHODS

by

Jeffrey R. Graybill, Ph.D.

The specifications for the current archaeological investigations at the Memorial Park site were prescribed by the Data Recovery Plan (USCOE 1990), which in turn followed an earlier Statement of Work (USCOE 1989). This Data Recovery Plan subsumed four tasks: Task 1, Extensive Excavations of the Clemson Island Component; Task 2, Hand Excavation of Seven 5 x 5 m Blocks; Task 3, Initial Deep Testing in Seven 2 x 2 m Blocks; and Task 4, Expanded Excavations.

Field methods employed at Memorial Park are summarized below, within the context of the Data Recovery Plan.

### TASK 1: EXTENSIVE EXCAVATIONS OF THE LATE WOODLAND COMPONENTS

The purpose of this task was to mitigate adverse effects to the Clemson Island component at Memorial Park. To facilitate this, the Data Recovery Plan specified the investigation of an extensive, horizontal area covering approximately 1 ha, limited to those parts of the site to be impacted by dike-levee and related construction. The removal of overburden across the site was to be performed by heavy machinery to the plane of recognition of Clemson Island features.

#### *Sampling Design*

To facilitate Task 1 investigations, a horizontal area measuring 50 x 200 m (1 ha) was designated for study. Because overburden was to be removed from this area by large, heavy machinery, the dimensions of this study area were dictated in part by the space requirements of this machinery.

Prior to locating this study area within the site, the limits of dike-levee construction were established by GAI, Inc., professional surveyors using electronic survey equipment. This was accomplished with the aid of a design map prepared by Buckhart-Horn, Inc., using a Corps of Engineers benchmark located at the northwest corner of the Memorial Park site as the primary reference point (Figure 10).

With the construction limits defined, the Task 1 study area was placed within the zone of adverse effect. This study area, located just to the south of and parallel to East Water Street, was positioned so as to encompass the eastern two-thirds of the site's construction corridor (Figure 10). The western one-third of this corridor was reserved for stockpiling spoil resulting from mechanical stripping south of East Water Street, and for water screening north of East Water Street.

#### *Excavation Strategy*

*Hand Excavation of Units.* Prior to mechanical removal of overburden, 27 1 x 2 m units were dug, without screening, across the area where Task 1 investigations were to be performed (Figure 11). These units were spaced at regular intervals across this area, with all units dug to a depth of 60 cm or more below ground surface. The purpose of these units was to obtain soil

profiles for areas where mechanical removal of overburden would occur. Additionally, all observed Clemson Island cultural materials were collected.

The excavation of these units suggested that the depth of overburden was highly variable across the site. Although few artifacts were recovered by this activity, those that were found generally supported Neumann's (1989:Figures 22, 23) contention that soil horizons Apb, Ab, and the upper part of Bwb (in short, all but the very lower part of Soil 2), provided the stratigraphic context for Clemson Island cultural remains. Thus, it was anticipated that the plane of recognition of Clemson Island features would be at varying depths within the Bwb horizon, depending on the thickness of this horizon across the site and changes in soil color and texture.

Previously, Neumann (1989:45) had shown that the vertical thickness of Bwb horizon at Memorial Park was highly variable across the site, ranging from 12 to 38 cm. Moreover, based upon wall profiles illustrated for Phase II investigations, there was much horizontal variability in soil color and texture, with this variability often overlapping within higher and lower soils. Under such conditions, it was believed that the plane of recognition of Clemson Island features would often be ill-defined and that, for some areas, feature recognition would be problematical.

*Machine Stripping of Overburden.* Once this stratigraphic information had been obtained, mechanical removal of overburden was begun. This was performed by a small pan scraper, assisted by a bulldozer. Horizontal stripping began at the east end of the 50 x 200 m study area, first proceeding laterally across this area, and then westward in long, narrow strips. In conformity with the Data Recovery Plan, the primary frame of reference used to establish the depth of machine stripping was feature recognition itself. Thus, once the pan scraper had removed approximately 50 cm of sediments from an area, two or more individuals accompanied the pan scraper on successive passes across this area until soil anomalies were discerned. Once features were recognized, machine stripping was terminated in that area, and the pan scraper was redeployed to a nearby, usually adjacent area.<sup>1</sup> The spoil produced by the mechanical removal of overburden from the site was stockpiled in a triangular area just to the west of Task 1 excavations.

---

<sup>1</sup>Based upon an extensive examination of field notes and profiles, it is apparent that stripping was performed too deeply in several areas. Profiles of block excavations, presented in Appendix A (figures A-1 through A-16), depict the estimated overstripping in each block, and Appendix L presents a plan view of the site with isopacs (graded in 0.1 m increments) indicating the estimated amount of overstripping across the site. In both appendices, the elevation of the B horizon is estimated from schematic profiles of the 1 x 2-meter test units (see Appendix K), and the elevation of the stripped surface was measured with an alidade and an automatic leveling device in the field. Overstripping was the result of several factors: 1) the difficulty in recognition of some Clemson Island features due to a low degree of contrast between the feature fill and the surrounding matrix; 2) the low density of Clemson Island features at the site (1 pit per 144 m square, or more than three times as low as the lowest density reported for other Late Woodland sites in the Upper Delaware Valley) (Kinsey 1975:Table 4); 3) the low degree of visual contrast between adjacent soil horizons, making soil changes of limited use in anticipating the depth at which Clemson Island features would be found; 4) the plasticity of the soils across the site, which resulted in moderate-to-severe compaction (rutting) during stripping; and 5) a mistaken field interpretation of the buried landforms at the site. Rather than a single southeast-to-northwest trending ridge, with swales on either side, the landforms were later interpreted as two, roughly parallel, north/south-trending ridges, separated by a partially filled-in channel remnant. Because the swale on the south was thought to encompass the entire southern portion of the stripped area west of E222 (Figure 10), the western ridge was stripped 10 to 40 cm too deeply between E150 and E100 and N0 to approximately N25 (Appendix L). Across the length of the area originally interpreted as a linear landform, stripping and subsequent shovel scraping extended approximately 1 to 40 cm below the Ap-B horizon boundary. Within the block excavations, overstripping ranged from 0-5 cm in Blocks 1 and 2, at the eastern end of the site, to 37-49 cm in Block 6, at the western end of the site.



①

DWG. NO. 89-112-B2

APPROVED JPH

DWN. REIM

GAI CONSULTANTS, INC.



COE BENCHMARK  
(MONUMENT 3)

FLOW

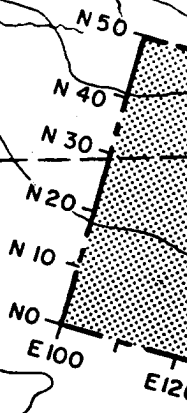
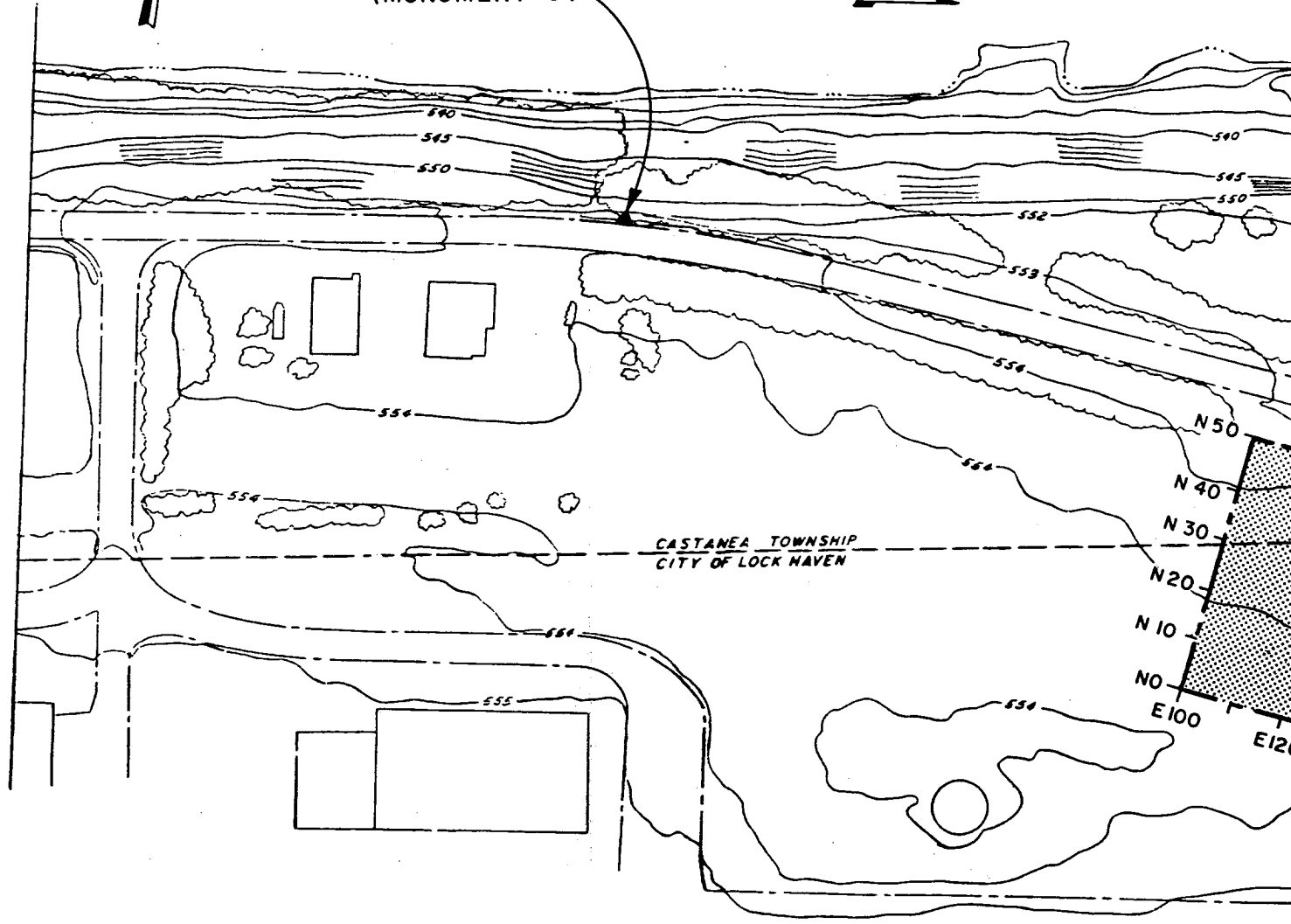

75  
76

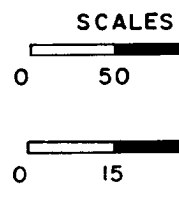

SOURCE :  
ADAPTED FROM BUCHART-HORN, INC., DRAWING  
FOR BALTIMORE DISTRICT CORPS OF ENGINEERS.

②

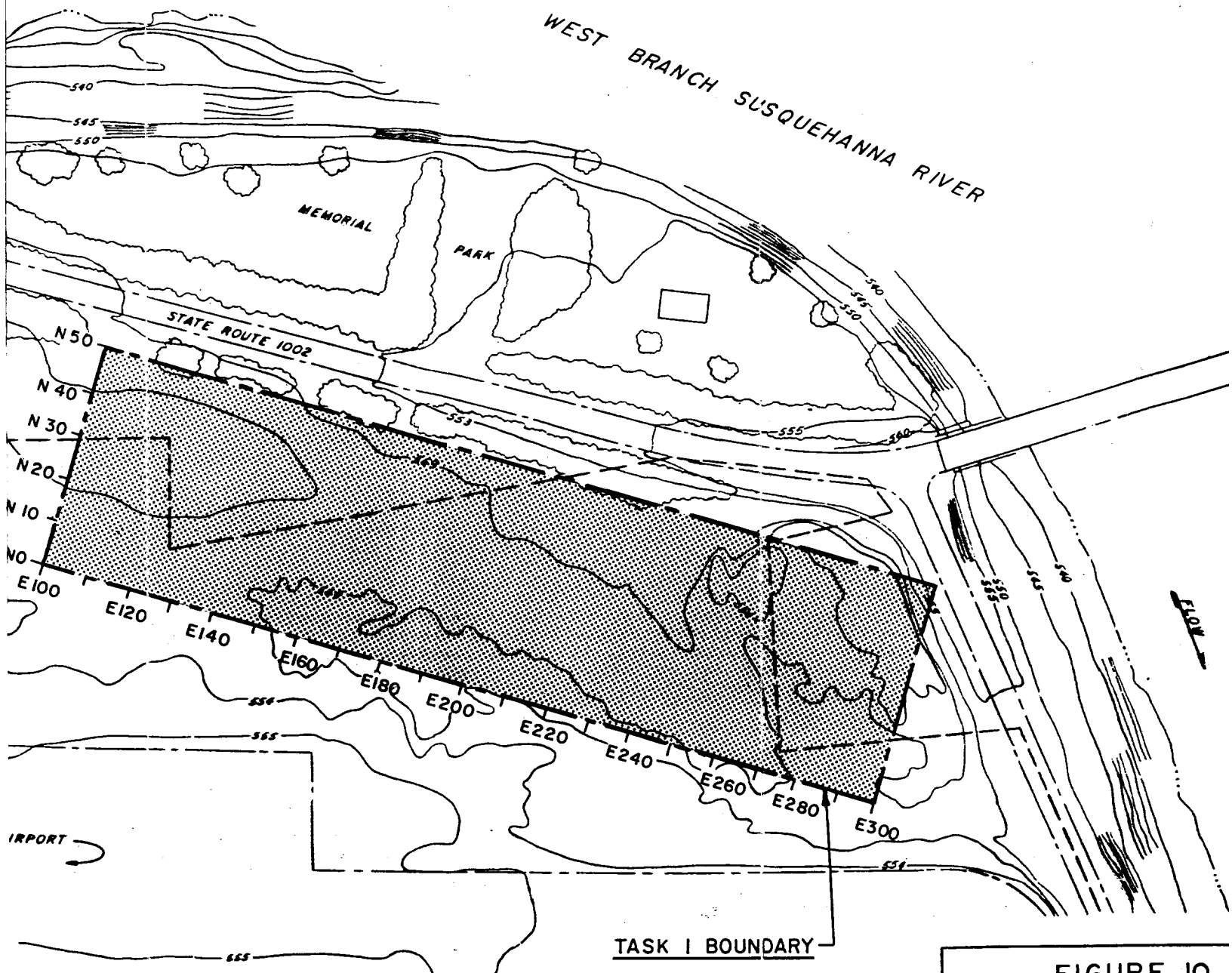
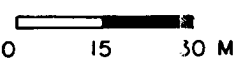
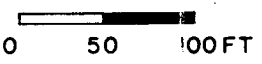

FIGURE 10

LOCATION OF STUDY A

SCALES



2

3

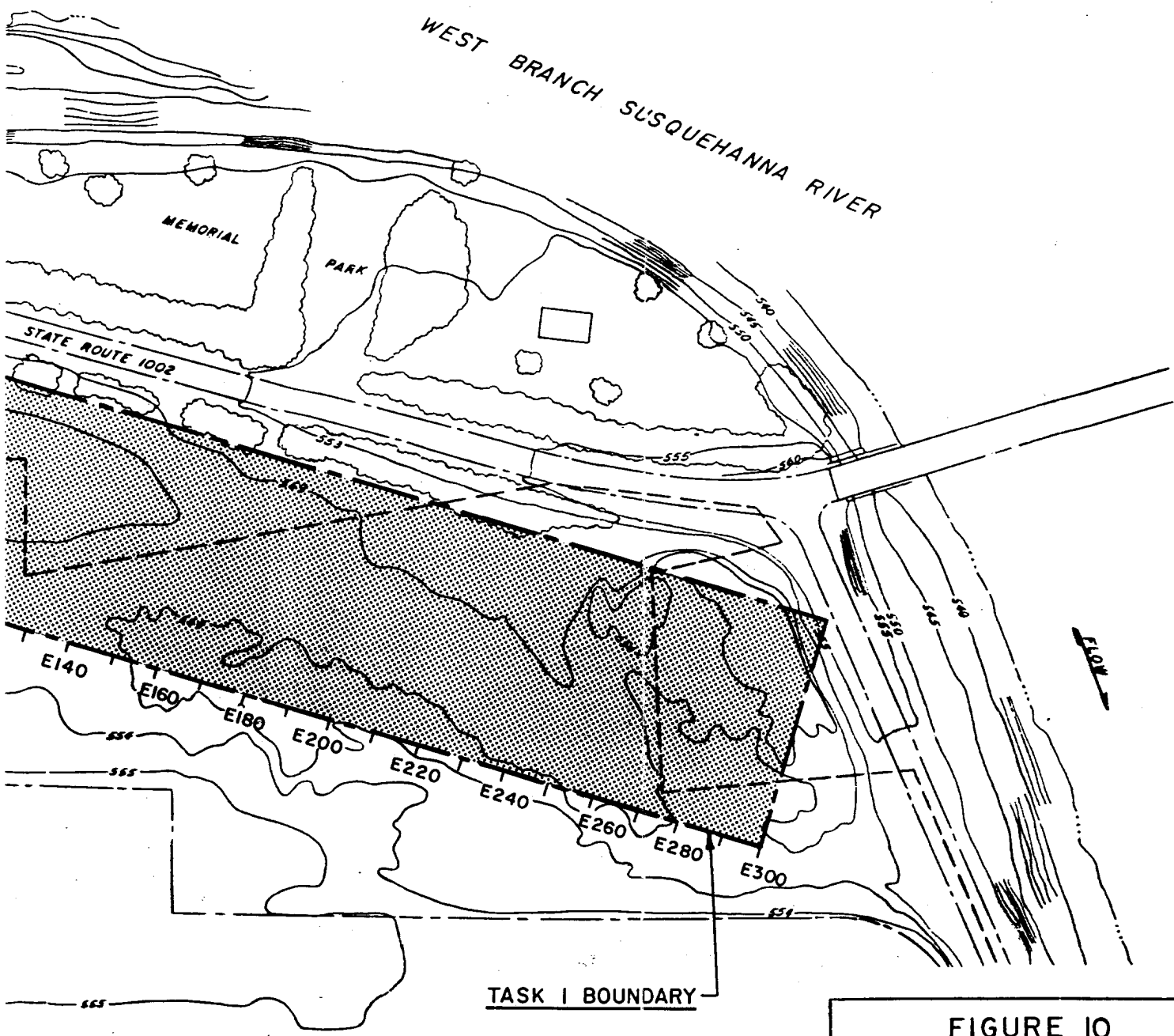

FIGURE 10

LOCATION OF STUDY AREA

100 FT  
10 M

*Shovel Scraping.* Following the removal of overburden, shovel scraping allowed the definition of soil anomalies. This shovel scraping was limited to the linear rise traversing Task 1 excavations at a diagonal (Figure 12). In most areas, sufficient overburden had been removed so that minimal hand excavation was necessary, but in areas where dark, mottled subsoil prevailed, it was often necessary to lower stripped surfaces by 10 cm or more before features could be discerned. Once exposed, features were marked with blue flagging and their boundaries were inscribed with a trowel. Postmolds were marked by green flagging, and similarly inscribed.

To facilitate the mapping of soil anomalies, the 50 x 200 m excavation plot was gridded off into 2 x 2 m units. These units, the corners of which were marked by orange flagging, were laid out by transit and tape. Beginning with N0 E100 at the southwest corner of the site, 2 x 2 m units were identified according to their distance from N0 E0. The southwest coordinates of a unit served to designate the unit.

Once the installation of 2 x 2 m units was completed, three portable mapping devices were used to facilitate rapid, accurate mapping of features. These mapping devices consisted of a 2 x 2 m frame built of PVC pipe, laced with string to form 20 x 20 cm cells.

In the course of mapping soil anomalies, features were numbered consecutively across the site, in a general east-to-west pattern. Postmolds, in contrast, were numbered consecutively within 2 x 2 m units.

*Excavation of Features.* Once mapped, soil anomalies were excavated. In the case of features or anomalies greater than 20 cm across, all soil matrix was removed by hand excavation, and water screened. Postmolds or anomalies less than 20 cm across were sectioned only.

The Data Recovery Plan specified that the number of features to be dug per 10 x 10 m area was to be determined by the following sampling scheme:

Table 1. Feature Sampling Design.

Features per 100 square m	Percentage to be dug
1-5	100
5-10	67
11-15	45
16-20	34
21-25	27
26-30	22

In the end, only two of 100 10 x 10 m areas produced five or more features.

The first step in excavating a feature was to photograph it using color slide and black-and-white film, and draw it in plan view. Next, the feature was bisected along an imaginary north-south axis, with actual digging beginning in the east half, proceeding downward in arbitrary 10 cm levels. When the east half of the feature had been removed, the resultant profile was studied and photographed, and the feature boundaries and any physical strata present were drawn. Clemson Island features were often ill-defined, due primarily to a lack of sufficient soil contrast between the feature fill and the surrounding soil matrix. In part, this lack of soil contrast was due to dark,

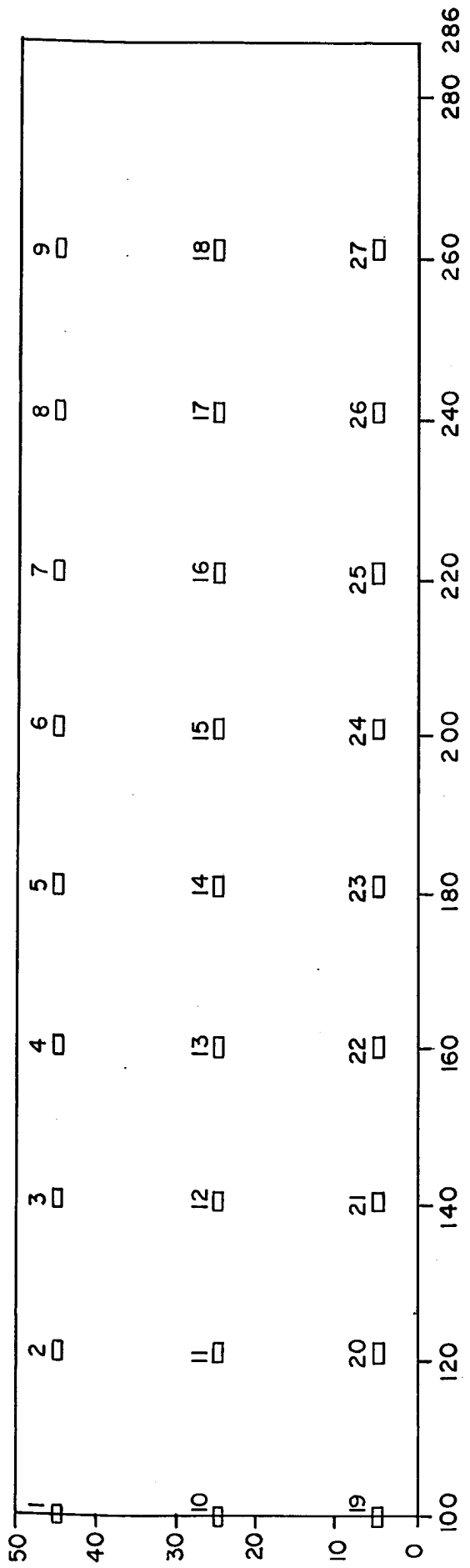
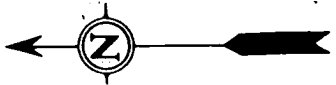

FIGURE II

LOCATION OF  
1 X 2 METER TEST UNITS

①

DWG. NO. 89-412-B6

APPROVED JPH

DWN. REM

GAI CONSULTANTS, INC.



FLOW →

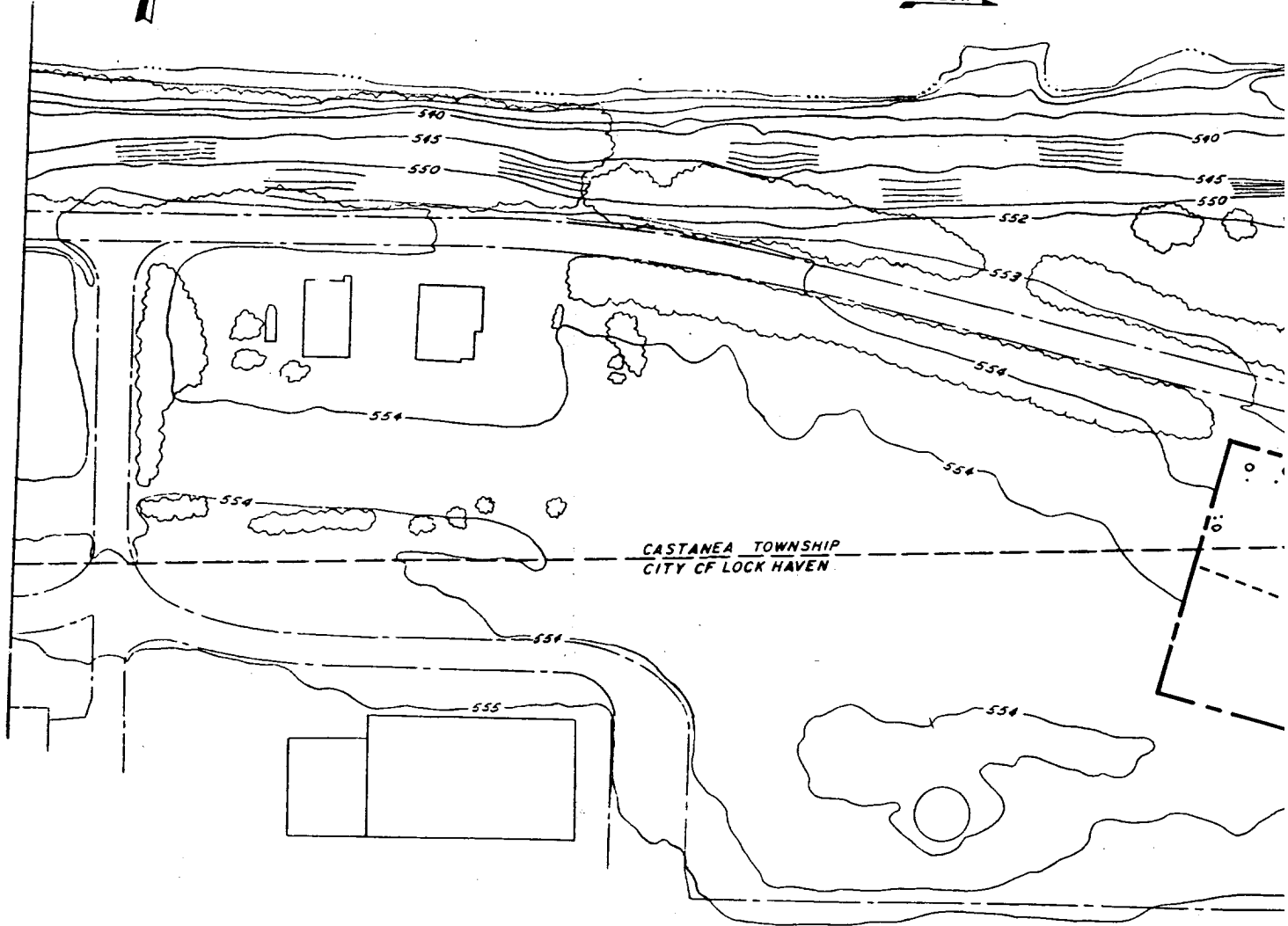

CASTANEA TOWNSHIP  
CITY OF LOCK HAVEN

PIPER AIRPORT

79  
80

SCALES

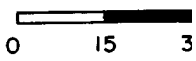
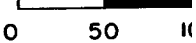

SOURCE :

ADAPTED FROM BUCHART-HORN, INC., DRAWING  
FOR BALTIMORE DISTRICT CORPS OF ENGINEERS.

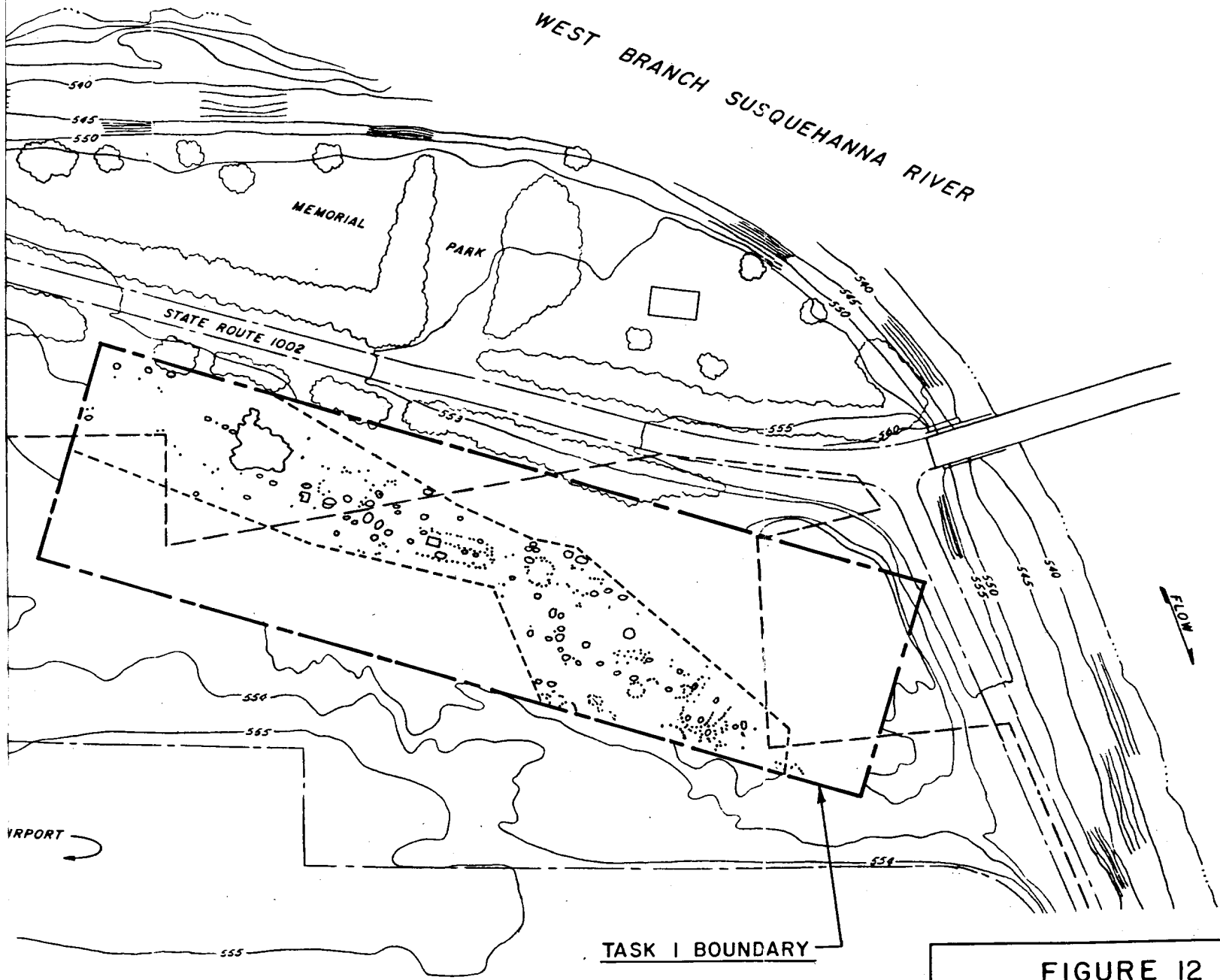

FIGURE 12

LOCATION OF SHOVEL-SCR  
AREA WITHIN PROJECT AR  
DISTRIBUTION OF EXPOSED

SCALES

0 50 100 FT

0 15 30 M

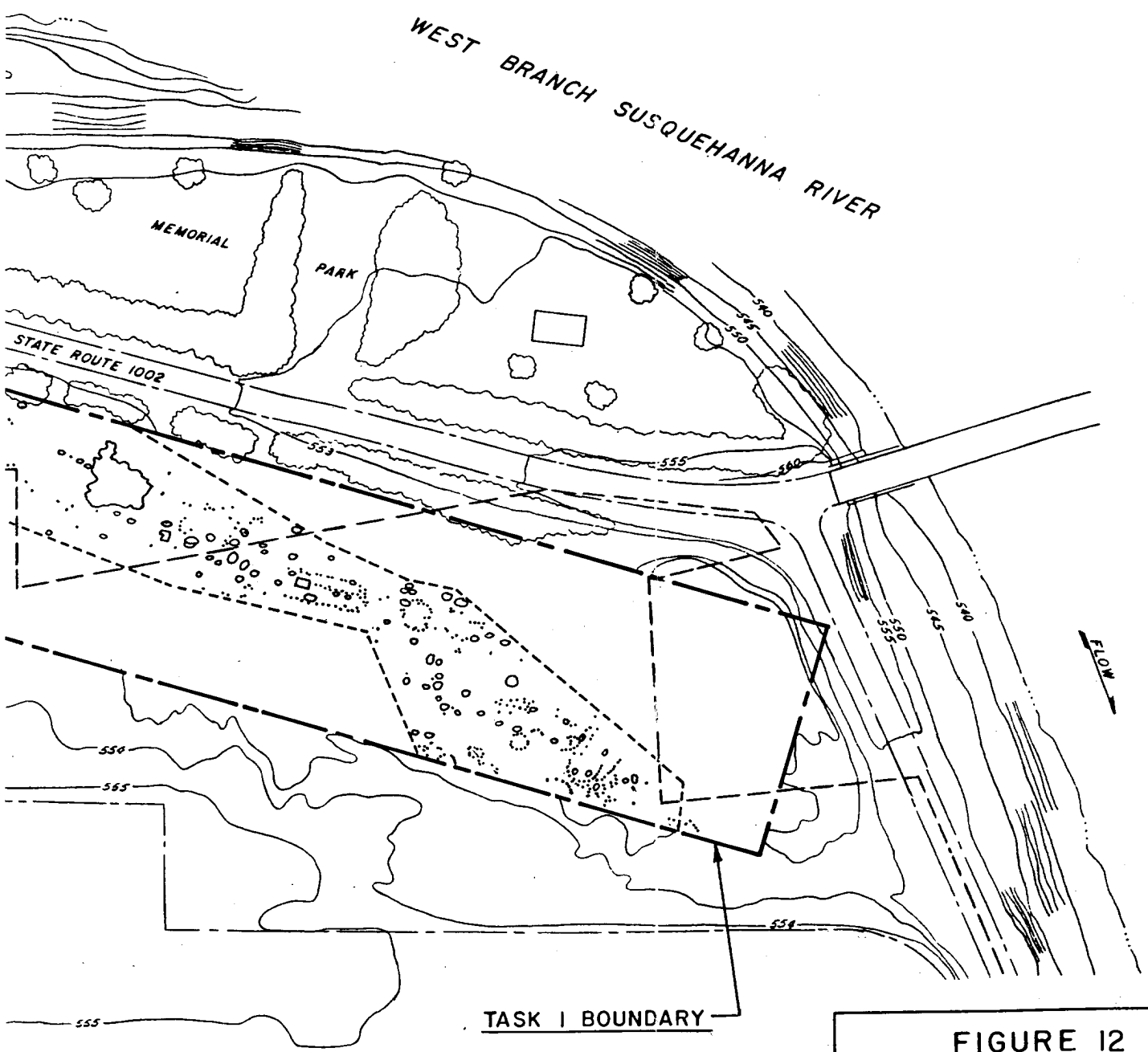

**FIGURE 12**

LOCATION OF SHOVEL-SCRAPED AREA WITHIN PROJECT AREA AND DISTRIBUTION OF EXPOSED FEATURES

0 FT

1 M



mottled, Bwb soils which characterized some parts of the site and, in part, it was due to the light color of the features themselves, resulting from low organic content, leaching of the upper portions of the feature fill and, possibly, depositional factors. In many cases it was necessary to excavate feature profiles larger than necessary before approximate limits could be discerned. This was particularly true of the west half of the study area, where soil contrasts were weakest.

Feature profiles were drawn, and flotation samples were also procured for each stratum present, via column sampling. The Data Recovery Plan specified a sample size of two liters for each flotation sample taken, but initial flotation results suggested that few botanical remains were being recovered from these samples. Thus, after completing work in the east half of the study area, this sample size was adjusted upwards to four liters, as it was for all subsequent, deep features found across the site. In the case of approximately 10 features, additional samples were collected for pollen analysis.

Once profiling and related activities were complete, excavations began in the west half of the feature, with this work proceeding downward by physical strata, if present. In the absence of internal stratigraphy, the soil matrix removed from the west half of the feature was ascribed to a single bulk provenience.

In the course of excavations, all soil matrix removed from a feature was transported to river's edge to be water screened through 1/8 inch hardware cloth. This transport was done in plastic tubs, to which plastic tags with the soil's provenience were attached. Fire-cracked rock was weighed in the field and then discarded.

After drying, collections produced by water screening were placed in zip-lock plastic bags for shipment to GAI's archaeological laboratory. The provenience for collections was entered into an FS log, with this same information marked on the front of each bag in black, waterproof pen.

For each feature that was excavated, a standard form was used to record information on location; dimensions; collections, including flotation, carbon-14, and pollen samples; observations, specifically the presence of burnt soil and charcoal, either as lenses or scattered particles; and fire-cracked rock, quantified by weight. In addition, the rear of the form was used to draw each feature in plan view and profile.

## TASK 2: HAND EXCAVATION OF SEVEN 5 X 5 M BLOCKS

The purpose of this task was to mitigate adverse effects to Archaic components buried beneath the Late Woodland components. To facilitate this, the Data Recovery Plan specified the excavation of seven 5 x 5 m units within the area to be impacted by proposed dike-levee construction. Excavations were to proceed downward to a depth of 150 cm below the original ground surface as interpolated from topographic data presented on USCOE design maps prepared by Buckhart-Horn, Inc. (see Figure 10). Fifty percent of the sediments removed from blocks was to be water-screened.

### *Sampling Design*

Six of seven 5 x 5 m blocks were placed along the linear rise which bisects the Task 1 study area (labeled Blocks 1 - 6 in Figure 13). Because of the subsurface topography of the site as revealed by Task 1, it was felt that this area offered the best potential for the recovery of substantial Archaic cultural deposits. It was also in this area that Phase II investigations (specifically, Units 6, 10, and 15, shown in Figure 4) had produced the highest concentration of Archaic features.

Beginning at E260, the six 5 x 5 m blocks were spaced at 30-m intervals on or near the crest of the rise. In the case of Block 4, however, it ultimately proved necessary to move this area 5 m to the west to avoid conflict with work that was still in progress on two burials. Coordinates for the six blocks along the rise were: Block 1, N1 E260; Block 2, N10 E230; Block 3, N30 E200; Block 4, N25 E165; Block 5, N35 E140; and Block 6, N40 E110.

At the request of the Baltimore District, the seventh block was placed along the proposed dike-levee centerline, just outside the limits of the 50 x 200 m study area. Based upon Task 1 investigations, the dominant landform in this area was believed to be a linear depression. Coordinates for Block 7 were S13 E200.

### *Excavation Strategy*

Prior to the start of block excavations, each 5 x 5 m block was subdivided into 50 x 50 cm units to facilitate horizontal control.<sup>2</sup> Beginning at the southwest corner of each block, 50 x 50 cm units were numbered consecutively from south to north and then west to east. To provide vertical control, a datum stake was placed next to each corner of each block, and a theodolite was used to establish level lines at the stakes. Within each block, the four level lines at the corner datum stakes were established at a single plane. During excavations, elevations of all 50 x 50 cm units were measured from the closest datum stake.

In the course of excavating 5 x 5 m blocks, work proceeded downward by shovel, mattock, and small hand tools in increments of arbitrary 10 cm levels. In conformity with the 50 percent sample prescribed by the Data Recovery Plan, only every other 50 x 50 cm unit was water screened, resulting in a sampling scheme that was checkerboard-like in appearance. To insure consistency in later artifact distribution analysis, this sampling scheme was employed throughout all 10 cm levels. For units excavated without water screening, artifact recovery was by visual inspection alone. To insure the recovery of small-scale lithic debris from water-screened units, all soil matrix was processed through 1/8 inch hardware cloth.

Upon completion of each level within a block, the floor of each was troweled, examined for features, and mapped. In the event that features were found, these were recorded and excavated using the same procedures as those outlined for features in Task 1 excavations. The sole exception to this statement was Feature 124, a massive, fire-cracked rock pavement. Because of the large size of this feature, it was excavated using the same format as that used for levels, to preserve the horizontal distribution of artifacts within it. In general, because of the age of features found within 5 x 5 m blocks, these lacked organic staining and, thus, they were largely defined by fire-cracked rock, burnt soil, charcoal, and related items not subject to leaching. Pit outlines, presumably once present in some cases, were no longer apparent.

For each level that was excavated, a standard form was used to record the locations of features and the distribution of fire-cracked rock, which was weighed and discarded in the field.

All 5 x 5 m blocks were excavated to a depth of 150 cm below ground surface. The upper part of each block had been removed by machine grading; hence, the original elevation of ground surface for each was established by interpolation from the design map prepared by Buckhart-Horn, Inc. The interpolated elevations were used to determine when excavators had reached a depth of 150 cm below the original ground surface. In the case of Block 7, located just south of the Task 1

---

<sup>2</sup>Precedence for the use of this approach in an alluvial setting can be found in Klinger, Imhoff, and Kandare (1992:87-88).

study area, the upper 60 cm of fill was removed by hand shoveling, and excavations proceeded downward in 10 cm arbitrary levels from this point. The extent of the levels excavated from each block was as follows: Block 1, 8 levels; Block 2, 9 levels; Block 3, 10 levels; Block 4, 6 levels; Block 5, 9 levels; Block 6, 6 levels; and Block 7, 9 levels.

After the completion of each block, the north and west wall profiles of each were drawn with the aid of David Cremeens, Ph.D., GAI's Staff Soil Scientist. In each case, all visible strata were shown, and these were described in a key. As noted above (see Hand Excavation of Units), the differences Neumann (1989) illustrated between strata were often overlapping across space (in a few cases, there were no differences between adjacent strata defined in the same wall profile); otherwise, most differences were of a minute and subtle nature. The ability to perceive soil changes is a function of lighting, vertical or horizontal perspective, the amount of ground moisture present, and other factors. In general, it was easiest to see strata once wall profiles had dried for a period of time, were wetted with a plant sprayer, and then allowed to partially dry again. The effect of this procedure was to emphasize changes in soil particle size produced by variable moisture content.

Once drawn, wall profiles were photographed using color slide and black-and-white film. After completion of this step, soil samples were collected from all strata. From one wall profile only, pollen samples were taken at 10 cm increments.

As with Task 1, there were problems in implementing Task 2 excavations. First, were the firm soils that characterized deeper parts of the Memorial Park site and which, in its most extreme form, represented a nearly impenetrable fragipan (Cremeens, this volume). These soils were extremely difficult to work with hand tools, and thus the pace of excavations was much slower than had been anticipated. In addition to slowing hand excavations, fragipan slowed the pace of water screening.

During Task 2 excavations (July 1991), the re-measuring of exposed Phase II test units identified a calibration problem with the theodolite which had been used for measuring elevations at the site. By re-measuring between COE benchmarks and grid stakes which had been established by GAI surveyors outside of the stripped area prior to the start of excavations, it was determined that the internal vertical calibration of the theodolite had an error of 0° 7'. The net effect of this error was that rather than placing a given level across the site in the same plane, this level was at varying elevations with respect to that plane. Following this discovery, the theodolite was replaced by an alidade, and all previous elevations recorded at the site were re-measured with the alidade. The elevations assigned to the level lines at each block corner were changed to reflect the corrected elevation and corrected elevations were noted on all completed excavation forms. In addition to these corrections, in September 1991, GAI surveyors used an automatic leveling device to re-measure all grid points on the scraped surface, all features, and all 5 x 5 m blocks. The agreement between their measurements and those taken with the alidade confirmed that all measurements taken after the discovery of the theodolite's calibration problem were accurate.

### TASK 3: INITIAL DEEP TESTING IN 2 X 2 M BLOCKS

The purpose of this task was to sample Archaic cultural materials between 150-300 cm below surface. To facilitate this, 2 x 2 m blocks were to be placed within 5 x 5 m blocks. Excavation procedures were to duplicate those used in Task 2, except that shoring was to be used when necessary.



DWG. NO. 89-412-B7

APPROVED JPH

DWN. REM

GAI CONSULTANTS, INC.

①



FLOW →

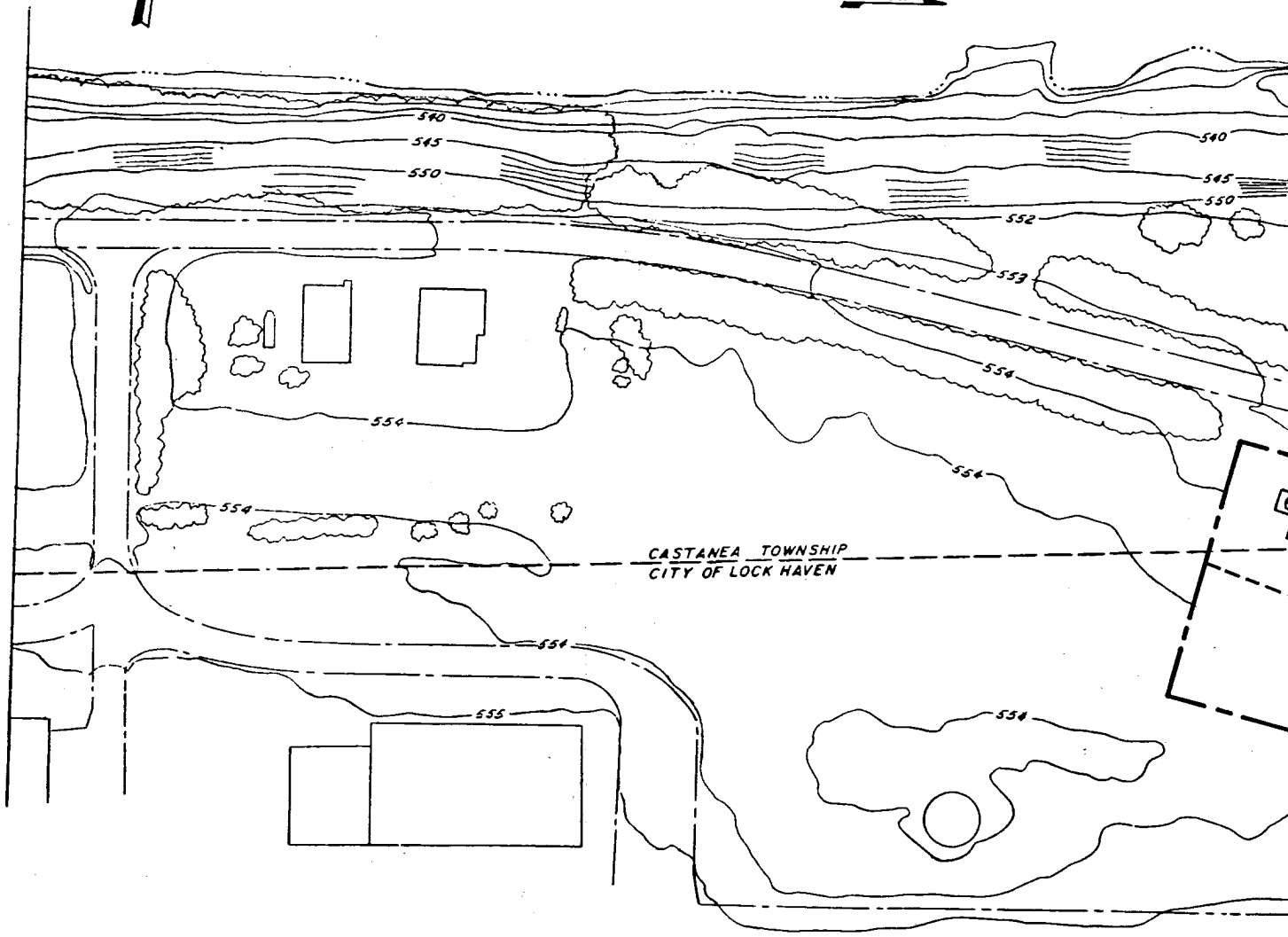

CASTANEA TOWNSHIP  
CITY OF LOCK HAVEN

PIPER AIRPORT

55

SCALES

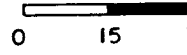
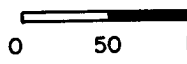

SOURCE :  
ADAPTED FROM BUCHART-HORN, INC., DRAWING  
FOR BALTIMORE DISTRICT CORPS OF ENGINEERS.

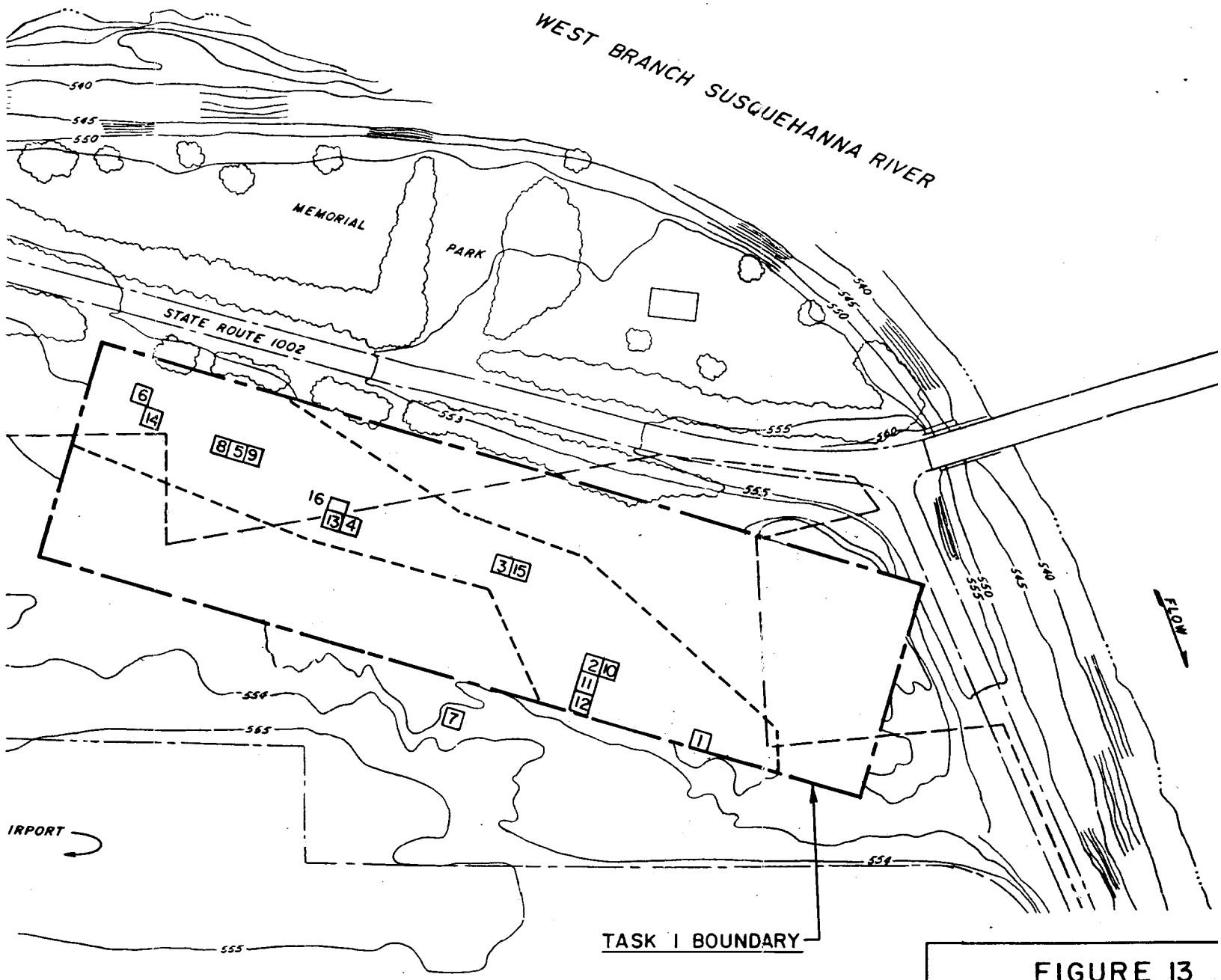
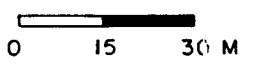
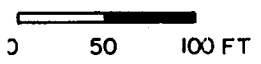

FIGURE 13

LOCATION OF TASK 2, 3  
BLOCK EXCAVATION

SCALES



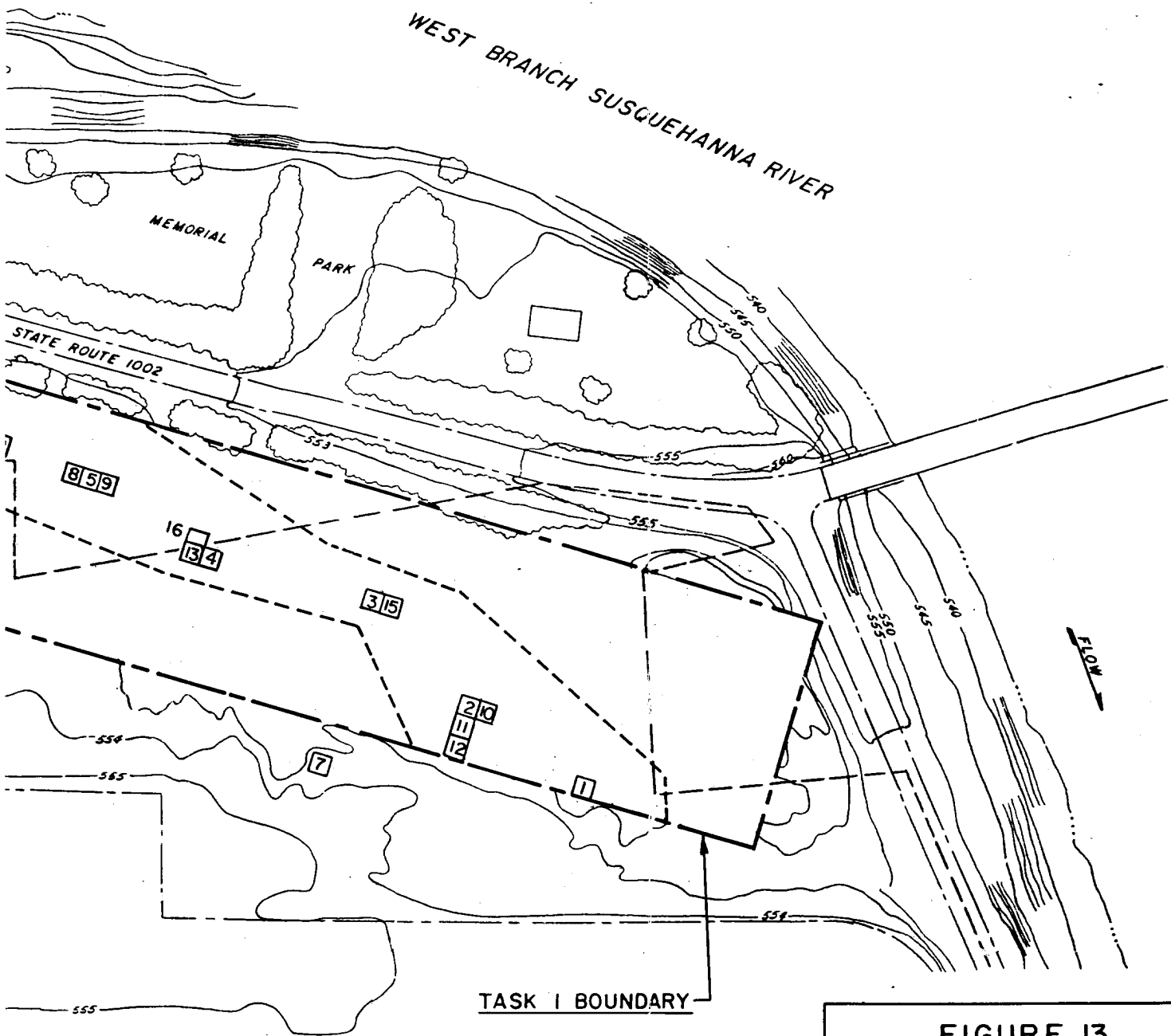

FIGURE 13

LOCATION OF TASK 2, 3, & 4  
BLOCK EXCAVATIONS

1 FT

M

### *Sampling Design*

As indicated, the locations of 2 x 2 m blocks followed from the distribution of 5 x 5 m blocks across the site (Figure 5.2). In all cases, 2 x 2 m blocks were centered within larger, previous blocks.

### *Excavation Strategy*

As indicated, the excavation procedures used for Task 3 were the same as those used in Task 2. Because of the stepped effect that resulted from the central placement of 2 x 2 m blocks within 5 x 5 m blocks, producing a satisfactory height-to-width ratio for excavations, it was not necessary to shore Task 3 excavations.

### PUBLIC SAFETY PRECAUTIONS

Procedures for public safety were followed per U.S. Army Corps of Engineers guidelines. At the start of fieldwork at Memorial Park, the area where excavations were to be performed was enclosed by a fence. At the entrance to this area (see Sediment Control, below) and other points along East Water Street, amber flashing lights, mounted on orange plastic barrels, were placed. Once water screening operations were installed next to the river, this area was also enclosed by a fence.

### SEDIMENT CONTROL

Procedures for sediment control were formulated in consultation with the local office of the Soil Conservation Service. Prior to the arrival of heavy machinery on the site, a short, gravel entrance connecting East Water Street to the excavations proper was built to curb erosion in this area. Nearby, a similar entrance was built to provide access to water screening operations. The triangular area where spoil from machine stripping was stockpiled was enclosed by a silt fence to prevent sediment runoff. It was also seeded with grass to reduce erosion.

### WATER SCREENING

In accordance with the Data Recovery Plan, water screening was performed throughout all facets of the Memorial Park excavations. To facilitate this operation, water was pumped from the nearby Susquehanna River, and then used to wash soil matrix through screens built from 1/8 inch hardware cloth. Initially, a bank of five screens served this purpose; this number was later increased to 10 screens and eventually 15 screens to accommodate a greater volume.

To control sediment runoff, two large settling ponds were built to either side of the screens. These ponds were above-ground, earth dike constructions, with a gravel filter on the river side to permit the outflow of water. Immediately downslope from the settling ponds, three U-shaped silt fences were installed to trap any sediment that might escape from them. As settling ponds became filled, their contents were removed with a backhoe and transported by dump truck to the northeast corner of excavations for disposal. Sediment trapped behind silt fences was removed by hand.

### FLOTATION PROCESSING

The Data Recovery Plan prescribed the processing of two-liter flotation samples, but halfway through Task 1 excavations (specifically, for all features west of E200) this sample size



was adjusted upwards to four-liter samples, as it was for all subsequent deep features found across the site. This was done because preliminary results from 21 samples suggested that only a very few botanical remains were being recovered. Flotation was performed with a SMAP flotation machine as described by Watson (1976). This machine was located immediately adjacent to water-screening operations. As was the case for the water screening, the water used in flotation was pumped from the nearby Susquehanna River. The same devices used to trap sediment from water screening served flotation processing as well.

#### TASK 4: EXPANDED EXCAVATIONS —by John P. Hart, Ph.D.

Task 4 constituted an expansion of excavations begun during tasks 2 and 3, with the goal of further sampling Archaic period deposits. Excavation procedures during this task were the same as those used during the previous two tasks. As stipulated in the mitigation plan, these excavations were to constitute an additional 262 cubic meters. Of these, a minimum of 37.5 cubic meters were to be excavated between 1.5 and 3 meters below the original ground surface. The remaining 224.5 cubic meters were to be distributed across the site so as to investigate the most promising Archaic deposits as identified during tasks 2 and 3.

The placement and distribution of Task 4 excavations were based upon artifact densities and feature distributions obtained during Tasks 2 and 3. Artifact distributions used in the placement of Task 4 excavations are presented in tables 2 through 8. An examination of these tables indicates that artifact densities increased dramatically from east to west across the site, with the highest densities occurring in blocks 5 and 6. In blocks 1, 2, and 3 on the eastern end of the study area the highest artifact densities occurred in deposits associated with the Orient and Terminal Archaic (Canfield and Susquehanna) components. Only very low densities were associated with earlier occupations, which is consistent with the landscape evolution model presented in Section VI of this report. In the western blocks 4 and 6, the highest artifact densities were associated with Laurentian occupations of the site, followed by Terminal Archaic (Canfield and Susquehanna) and Orient occupations, while in Block 6, Neville deposits also contained high artifact densities. These results are also consistent with the landscape evolution model presented in Section VI. It was also evident that artifact densities dropped drastically toward the base of all of the blocks, reaching 0.0 artifacts larger than 0.25 inch for consecutive levels in blocks 1, 2, 4, 5, and 6, and very low densities of artifacts between 0.25 and 0.125 inch in all of the blocks. Because small artifacts are highly susceptible to vertical movement as a result of pedoturbation, the low densities of small artifacts were not considered significant. In Block 7, the highest artifact densities were associated with the Late Woodland deposits and remained consistently low below these deposits, which is consistent with the landscape-evolution model presented later in this report.

The distribution of features followed the same pattern as that noted for artifacts (Table 9). The largest number of features associated with the Terminal Archaic occupations occurred in blocks 1, 2, and 3. The largest number of Laurentian features, on the other hand, occurred in blocks 4 and 5, while the single Neville feature occurred in Block 6. No features were documented in Block 7.

These data were then used to guide the placement and allocation of excavations during Task 4 (see Figure 13 for location of Task 4 block excavations). Because of the low artifact densities in Block 1, no additional excavations were placed in this area. Because of the generally low artifact densities and lack of features in Block 7, no additional excavations were placed in this area. Excavations in blocks 10, 11, and 12, placed adjacent to Block 2, were allocated so as to more intensively sample the Terminal Archaic deposits with 5 x 5 m blocks, and to further test Laurentian deposits with 2 x 2 m blocks. A single 5 x 5 m block, Block 15, was placed adjacent to Block 3 to more fully sample the Orient and Terminal Archaic (Susquehanna and Canfield) deposits on this portion of the site. Block 13 was placed adjacent to Block 4 to more fully sample

Table 2. Vertical Distribution of Artifacts in Block 1

Level	Debris ≥0.25 in	Debris ≥0.125 in	Tools	Diagnostics	Ground- stone	Pot- sherds	Total ≥0.25 in	Total ≥0.125 in	Artifacts/m <sup>3</sup> ≥0.25 in	Artifacts/m <sup>3</sup> ≥0.125 in
1	28	138	0	none	0	1	29	139	24.2	115.8
2	34	147	1	none	0	1	36	149	28.8	119.2
3	12	65	0	none	0	6	18	71	14.4	56.8
4	35	108	2	none	0	0	37	110	29.6	88.0
5	6	28	2	none	0	0	8	30	6.4	24.0
6	6	26	1	none	0	0	7	27	5.6	21.6
7	2	12	0	none	0	0	2	12	1.6	9.6
8	1	3	0	none	0	0	1	4	0.8	2.3
9	0	0	0	none	0	0	0	0	0.0	0.0
10	0	3	0	none	0	0	0	3	0.0	15.0
11	0	1	0	none	0	0	0	1	0.0	5.0
12	0	0	0	none	0	0	0	0	0.0	0.0
13	0	0	0	none	0	0	0	0	0.0	0.0
14	0	0	0	none	0	0	0	0	0.0	0.0
15	0	0	0	none	0	0	0	0	0.0	0.0
16	1	1	0	none	0	0	1	1	0.0	5.0
17	0	2	0	none	0	0	0	2	0.0	10.0
18	0	4	0	none	0	0	0	4	0.0	20.0
19	0	1	0	none	0	0	0	1	0.0	5.0
20	0	0	0	none	0	0	0	0	0.0	0.0
21	0	1	0	none	0	0	0	1	0.0	5.0
22	0	1	0	none	0	0	0	1	0.0	5.0
23	0	1	0	none	0	0	0	1	0.0	5.0
Total	125	548	6		0	8	139	557	10.7	43.2

Table 3. Vertical Distribution of Artifacts in Block 2.

Level	Debris ≥0.25 in	Debris ≥0.125 in	Tools	Diagnostics	Ground- stone	Pot- sherds	Total ≥0.25 in	Total ≥0.125 in	Artifacts/m <sup>3</sup> ≥0.25 in	Artifacts/m <sup>3</sup> ≥0.125 in
1	2	6	0	none	0	0	2	6	6.7	20.0
2	6	24	2	none	0	1	9	26	10.8	31.5
3	3	24	1	none	1	0	5	26	4.4	23.1
4	19	61	0	none	0	0	19	61	15.2	48.8
5	11	59	2	T. Archaic	0	0	13	61	10.4	48.8
6	87	401	2	T. Archaic	1	0	90	404	72.0	323.2
7	28	133	0	T. Archaic	1	0	29	134	23.2	107.2
8	11	59	1	T. Archaic	0	0	12	60	9.6	48.0
9	3	18	0	none	0	0	3	18	2.4	14.4
10	3	72	0	none	0	0	3	72	15.0	360.0
11	0	11	0	none	0	0	0	11	0.0	55.0
12	0	2	0	none	0	0	0	2	0.0	10.0
13	0	0	0	none	0	0	0	0	0.0	0.0
14	1	2	0	none	0	0	1	2	5.0	10.0
15	1	9	0	none	0	0	1	9	5.0	45.0
16	1	2	0	none	0	0	1	2	5.0	10.0
17	0	1	2	Laurentian	0	0	2	3	10.0	15.0
18	6	8	1	Laurentian	0	0	7	9	35.0	45.0
19	1	5	0	none	0	0	1	5	5.0	25.0
20	3	5	0	none	0	0	3	5	15.0	25.0
21	0	7	0	none	0	0	0	7	0.0	35.0
22	0	5	1	none	0	0	1	6	5.0	30.0
23	0	2	0	none	0	0	0	2	0.0	10.0
24	0	4	0	none	0	0	0	4	0.0	20.0
Total	186	920	12		3	1	202	935	14.2	65.6

Table 4. Vertical Distribution of Artifacts in Block 3.

Level	Debris ≥0.25 in	Debris ≥0.125 in	Tools	Diagnostics	Ground- stone	Pot- sherds	Total ≥0.25 in	Total ≥0.125 in	Artifacts/m <sup>3</sup> ≥0.25 in	Artifacts/m <sup>3</sup> ≥0.125 in
1	1	5	0	Meadowood	0	0	1	5	3.6	18.1
2	7	22	1	none	1	1	10	25	11.6	29.1
3	7	39	2	none	0	0	9	41	7.7	34.9
4	10	36	0	none	2	12	24	50	19.2	40.0
5	16	47	2	T. Archaic	0	0	18	49	14.4	39.2
6	22	66	1	none	0	0	23	67	18.4	53.6
7	45	213	0	none	0	0	45	213	36.0	170.4
8	78	354	1	none	0	0	79	355	63.2	284.0
9	12	35	2	T. Archaic	0	0	14	37	11.2	29.6
10	0	5	0	none	0	0	0	5	0.0	4.0
11	1	2	0	none	0	0	1	2	5.0	10.0
12	0	2	0	none	0	0	0	2	0.0	10.0
13	0	0	0	none	0	0	0	0	0.0	0.0
14	1	1	0	none	0	0	1	1	5.0	5.0
15	0	5	0	none	0	0	0	5	0.0	25.0
16	0	9	0	none	0	0	0	9	0.0	45.0
17	0	7	0	none	0	0	0	7	0.0	35.0
18	2	11	0	none	0	0	2	11	10.0	55.0
19	1	5	0	none	0	0	1	5	5.0	25.0
20	0	4	0	none	0	0	0	4	0.0	20.0
21	0	2	0	none	0	0	0	2	0.0	10.0
22	3	9	0	none	0	0	3	9	15.0	45.0
23	2	11	0	none	0	0	2	11	10.0	55.5
24	0	2	0	none	0	0	0	2	0.0	10.0
25	1	1	0	none	0	0	1	1	5.0	5.0
Total	209	893	9		3	13	234	918	15.1	59.2

Table 5. Vertical Distribution of Artifacts in Block 4.

Level	Debris ≥0.25 in	Debris ≥0.125 in	Tools	Diagnostics	Ground- stone	Pot- sherds	Total ≥0.25 in	Total ≥0.125 in	Artifacts/m <sup>3</sup> ≥0.25 in	Artifacts/m <sup>3</sup> ≥0.125 in
1	44	165	3	none	0	1	48	168	64	224.0
2	73	289	4	Orient	1	1	79	294	62.4	235.2
3	41	205	6	none	20	11	78	242	62.4	193.5
4	41	95	1	none	0	0	42	96	33.6	76.8
5	42	173	3	none	0	0	45	176	36.0	140.8
6	23	113	2	none	0	0	25	115	20.6	92.0
7	14	73	0	none	0	0	14	73	11.2	58.4
8	57	315	2	Laurentian	0	0	59	317	47.2	253.6
9	111	396	4	none	0	0	115	400	92.0	320.0
10	30	186	0	none	0	0	30	186	150.0	930.0
11	41	200	0	none	0	0	41	200	205.0	1000.0
12	46	338	1	Laurentian	0	0	47	339	235.0	1695.0
13	4	42	0	none	0	0	47	42	20.0	210.0
14	5	60	0	none	0	0	4	60	25.0	300.0
15	20	94	1	none	0	0	5	95	105.0	475.0
16	30	157	2	none	0	0	21	159	64.0	795.0
17	30	182	1	Laurentian	0	0	31	183	155.0	915.0
18	55	268	2	Laurentian	0	0	57	270	285.0	1350.0
19	40	251	0	none	0	0	40	251	200.0	1255.0
20	5	54	0	none	0	0	5	54	25.0	270.0
21	0	6	0	none	0	0	0	6	0.0	30.0
22	0	4	0	none	0	0	0	4	0.0	20.0
23	0	4	0	none	0	0	0	4	0.0	20.0
24	0	1	0	none	0	0	0	1	0.0	5.0
Total	752	3671	32		21	13	833	3735	58.5	262.1

Table 6. Vertical Distribution of Artifacts in Block 5.

Level	Debris ≥0.25 in	Debris ≥0.125 in	Tools	Diagnostics	Ground- stone	Pot- sherds	Total ≥0.25 in	Total ≥0.125 in	Artifacts/m <sup>3</sup> ≥0.25 in	Artifacts/m <sup>3</sup> ≥0.125 in
1	31	238	2	none	0	1	34	240	28.3	200.0
2	50	239	2	Meadowood	1	0	53	242	42.4	193.6
3	26	169	5	T. Archaic	0	0	31	174	24.8	139.2
4	79	262	1	T. Archaic	0	0	80	263	64.0	210.4
5	49	213	4	Piedmont	0	0	53	217	42.4	173.6
6	22	92	0	none	0	0	22	92	17.6	73.6
7	19	109	0	none	1	0	20	110	16.0	8.0
8	116	589	3	Laurentian	0	0	119	595	95.2	476.0
9	562	2496	7	Laurentian	2	0	571	2505	456.8	2004.0
10	17	92	0	Laurentian	0	0	17	92	85.0	460.0
11	5	44	1	Laurentian	0	0	6	45	30.0	225.0
12	42	250	3	Laurentian	0	0	45	253	225.0	1265.0
13	25	208	5	Laurentian	0	0	30	213	150.0	1065.0
14	3	27	0	none	0	0	3	27	15.0	135.0
15	2	14	0	none	0	0	2	14	10.0	70.0
16	1	7	0	none	0	0	1	7	5.0	35.0
17	0	11	0	none	0	0	0	11	0.0	55.5
18	5	36	2	Neville	0	0	7	38	25.0	190.0
19	5	30	1	none	0	0	6	31	30.0	155.0
20	0	10	0	none	0	0	0	10	0.0	50.0
21	0	6	0	none	0	0	0	6	0.0	30.0
22	0	1	0	none	0	0	0	1	0.0	5.0
23	0	3	0	none	0	0	0	3	0.0	15.0
Total	1059	5146	37		7	1	1104	5187	78.6	369.2

Table 7. Vertical Distribution of Artifacts in Block 6.

Level	Debris ≥0.25 in	Debris ≥0.125 in	Tools	Diagnostics	Ground- stone	Pot- sherds	Total ≥0.25 in	Total ≥0.125 in	Artifacts/m <sup>3</sup> ≥0.25 in	Artifacts/m <sup>3</sup> ≥0.125 in
1	74	332	4	none	0	1	75	336	79.0	336.0
2	78	281	8	Orient	0	2	88	291	70.4	232.8
3	118	557	5	Orient	1	1	120	563	100.0	450.4
4	147	638	10	Orient	0	0	157	648	125.6	518.4
5	88	400	10	Orient	0	0	98	410	78.4	328.0
6	92	672	15	Laurentian	0	0	107	687	85.6	549.6
7	17	155	0	none	0	0	17	155	85.0	775.0
8	35	221	0	none	0	0	35	221	175.0	1105.0
9	29	302	2	Laurentian	0	0	31	304	155.0	1520.0
10	18	98	3	Laurentian	0	0	21	101	105.0	505.0
11	27	57	0	none	0	0	27	57	135.0	285.0
12	0	11	0	Laurentian	0	0	0	11	0.0	55.0
13	0	28	1	none	0	0	1	29	5.0	145.0
14	55	321	2	Neville	0	0	57	323	285.0	1615.0
15	49	301	1	none	0	0	50	302	250.0	1510.0
16	16	130	0	none	0	0	16	130	80.0	650.0
17	2	18	0	none	0	0	2	18	10.0	90.0
18	2	16	0	none	0	0	2	16	10.0	80.0
19	0	3	0	none	0	0	0	3	0.0	15.0
20	0	9	0	none	0	0	0	9	0.0	45.0
Total	847	4550	63		1	4	904	4616	100.0	510.1

Table 8. Vertical Distribution of Artifacts in Block 7.

Level	Debris ≥0.25 in	Debris ≥0.125 in	Tools	Diagnostics	Ground- stone	Pot- sherds	Total ≥0.25 in	Total ≥0.125 in	Artifacts/m <sup>3</sup> ≥0.25 in	Artifacts/m <sup>3</sup> ≥0.125 in
1	120	594	2	L. Woodland	0	17	139	613	111.2	490.4
2	117	704	3	L. Woodland	0	49	169	756	135.2	604.8
3	226	1374	7	L. Woodland	0	122	335	1503	268.0	1202.4
4	186	1090	10	L. Woodland	1	82	279	1183	223.2	946.4
5	89	639	2	L. Woodland	0	21	112	662	89.6	529.6
6	17	93	0	Orient	0	0	17	93	13.6	74.4
7	8	57	1	Orient	0	0	9	59	7.2	47.2
8	9	51	1	none	0	0	10	52	8.0	41.6
9	8	46	0	none	0	0	8	46	6.4	36.8
10	1	7	0	none	0	0	1	7	5.0	35.0
11	0	3	0	none	0	0	0	3	0.0	15.0
12	0	0	0	none	0	0	0	0	0.0	0.0
13	0	1	0	none	0	0	0	1	0.0	5.0
14	1	9	0	none	0	0	1	9	5.0	45.0
15	1	8	0	none	0	0	1	8	5.0	40.0
16	6	21	1	none	0	0	7	22	35.0	110.0
17	3	31	0	none	0	0	3	31	15.0	155.0
18	4	31	0	none	0	0	4	31	20.0	155.0
19	3	26	1	none	0	0	3	27	15.0	135.0
20	12	22	0	none	0	0	12	22	60.0	110.0
21	2	16	0	none	0	0	2	16	10.0	80.0
22	6	14	0	none	0	0	6	14	30.0	70.0
23	4	10	0	none	0	0	4	10	20.0	50.0
24	1	6	0	none	0	0	1	6	5.0	30.0
Total	824	4854	28		1	287	1123	5174	78.8	363.1

Table 9. Temporal Distribution of Features Exposed During Tasks 2 and 3.

Block	Orient	Terminal Archaic	Piedmont	Laurentian	Neville
1	0	4	1	3	0
2	0	1	0	1	0
3	0	6	0	1	0
4	0	0	0	5	0
5	0	0	0	8	0
6	0	0	0	1	0
7	0	0	0	0	0

the Orient, Terminal Archaic, and high-density Laurentian deposits with a 5 x 5 m exposure, while a 2 x 2 m exposure was used to more fully sample the lower deposits in this area. The 3.5 x 5 m Block 16, placed adjacent to Block 13, was used to more fully sample the high-density Orient, Terminal Archaic (Canfield and Susquehanna), and Laurentian deposits on this portion of the site. Blocks 8 and 9 were placed adjacent to Block 5 to more fully sample the high-density Orient, Terminal Archaic, and Laurentian deposits through 5 x 5 m exposures, and the lower-density Neville deposits with 2 x 2 m exposures. Finally, Block 14 placed adjacent to Block 6, was used to more fully sample the Orient and upper portions of the Laurentian deposits with a 5 x 5 m exposure and the deeper Laurentian and Neville deposits with a 2 x 2 m exposure. Additional excavations were also performed in blocks 4, 5, and 6 where particularly high artifact densities warranted expansion of the 2 x 2 m excavations during the earliest portions of Task 4 excavations. In the case of Block 4, three extra levels were excavated in the 5 x 5 m during Task 2 as a result of a miscalculation. However, these excavations were useful in the sampling of the Piedmont and Laurentian deposits. The cubic meter volume for each block excavated above and below 1.5 m below the original ground surface during Task 4 is presented in Table 10.

Table 10. Distribution of Task 4 Excavations.

Block	m <sup>3</sup> above 1.5 m	m <sup>3</sup> below 1.5 m	Total m <sup>3</sup>
4	0.0	7.5	7.5
5	0.0	9.0	9.0
6	0.0	2.1	2.1
8	20.4	14.4	34.8
9	18.4	16.4	35.0
10	19.4	8.6	28.0
11	18.0	9.0	27.0
12	15.5	11.5	27.0
13	9.5	22.3	31.8
14	11.7	9.0	20.7
15	19.5	0.0	19.5
16	8.8	12.5	21.0
Total	141.2	122.3	263.4

## VI. GEOMORPHOLOGY AND SITE FORMATION

by

David L. Cremeens, Ph.D.

### INTRODUCTION AND OBJECTIVES

Geomorphological analysis of Holocene alluvial settings is an integral part of the evaluation of archaeological context, and is essential for reconstructing past human environments (Hassan 1979). The geomorphic context consists of a site's landscape setting, including the deposits and landforms that make up the landscape, its soils, slopes, streams, and vegetation (Kolb et al. 1990). Elucidation of landscape events in an alluvial archaeological site, particularly fluvial events, erosion, and pedogenesis, is paramount to correlation of occupational episodes. The application of pedology (the study of the genesis and classification of soil) to archaeological research has been ongoing for several decades. Pedology is founded on geomorphic principles and data, and includes physical, chemical, and biological parameters. Holliday (1990) outlined three traditional ways in which pedology has been applied to archaeological studies: (1) using soils as stratigraphic markers, (2) using soils as an inference to landscape and climate reconstruction, and (3) using soils to indicate the presence, and the degree, of human occupation.

The major objectives of the geomorphological/pedological investigations at the Memorial Park site were to evaluate and interpret the Holocene alluvial stratigraphy and geomorphology in light of contemporary models, and to delineate site formation processes. Specific objectives included: (1) developing a detailed stratigraphic/geomorphic framework, (2) identifying natural and disturbed soil horizons, (3) evaluating buried soil horizons for relative age and degree of development, and (4) evaluating the association of archaeological zones with buried soil horizons. These objectives were addressed with a soil-geomorphology reconnaissance study and a unit column sampling scheme.

This study was site-specific in that samples were collected within the immediate boundary of the study area. The regional geology and geomorphology of the valley were studied (Section II, this volume) and a reconnaissance of the area between Bald Eagle Creek and the West Branch was performed to identify fluvial landforms. A definitive interpretation of the study area's geomorphic history is neither to be suggested nor inferred by the present study, and any interpretation outside of the study area is strictly an extrapolation.

### METHODOLOGY

The soil-geomorphology reconnaissance study was performed in order to obtain a general evaluation of soil property variation across the site, and to identify natural and disturbed components of site landforms. The study was performed (1) by investigating 27 1 x 2 m units, each hand excavated to approximate depths of 0.5 to 1.5 m, prior to overburden removal, (2) by shallow (<1m) hand auguring over various portions of the study area following overburden removal, and (3) by observing the south wall of the study area following overburden removal. Additionally, three deep hand auger observations, to depths of 3.0 to 3.8 m, were made at the southeast corner, the center, and the northwest corner of the study area. Detailed observations were also made of each unit excavated, as described below.

Unit column sampling was performed to more precisely evaluate physical and chemical properties of soils and sediments occurring at the site. Profiles in excavation blocks 1 through 7 were described in detail and then sampled by collecting 5 to 10 kg of material from natural and cultural horizons. Thick horizons (>20 cm) were subdivided into 10-15 cm increments. Hand auger sampling was used to collect deeper materials from blocks 2 and 3. Sample columns were generally located in the northwest corner of both the 5 x 5 m and the 2 x 2 m portion of each block. In addition, detailed profile descriptions were made of blocks 8-16 to provide more information on soil variation across the site. Profile descriptions are located in Appendix A.

Particle-size analysis (PSA) was used to evaluate a range of physical characteristics of the study area. PSA is used to determine lithology and stratigraphy, which, in turn, are used to interpret the sedimentology and geomorphology of a site. PSA is also used to evaluate pedogenesis and disturbance, both of which are used to interpret site formation and post-occupation alteration.

Particle-size analysis of the < 2mm (fine earth) fraction was performed using the pipet method (Gee and Bauder 1986). This is a precise method for the fine earth fraction, and can be modified to accommodate any of the size-grade scales in common use. The USDA particle-size classification was used for this study. Samples were pretreated with 3 percent hydrogen peroxide to destroy organic matter, and dispersed with sodium hexametaphosphate (Calgon) prior to analysis. Dispersed samples were washed through a No. 300 (50  $\mu$ m) sieve. The fraction retained on the sieve, the total sand (2-0.05 mm), was dried, weighed, and then fractionated by dry sieving. The following USDA sand fractions were determined:

very coarse sand	2.0 - 1.0 mm	(0 $\phi$ )
coarse sand	1.0 - 0.5 mm	(1 $\phi$ )
medium sand	0.5 - 0.25 mm	(2 $\phi$ )
fine sand	0.25 - 0.1 mm	
very fine sand 1	0.1 - 0.075 mm	
very fine sand 2	0.075 - 0.050 mm	

Except for the fine and very fine sand fractions, these class breaks are the same as the Udden-Wentworth scale (Blatt et al. 1980).

The fraction washed through the No. 300 sieve was suspended in a one-liter, graduated cylinder. The suspension was sampled at periodic intervals, with a calibrated pipet, to determine the following classes:

coarse silt	50 - 20 $\mu$ m
medium silt	20 - 5 $\mu$ m
fine silt	5 - 2 $\mu$ m
clay	< 2 $\mu$ m

Organic carbon is an important component of soils and sediments that has been used to evaluate stratigraphic relations, degree of soil development, and prehistoric activity (Stein 1987; Holliday 1990). Organic carbon was determined by the loss on ignition method (induction at 950° C) (Thurmann et al 1992). Soil pH has been used to evaluate sources of sediments, the degree of weathering and, potentially, the occupation of a site (Stein 1987). However, soil pH can be altered



upon burial and give no information of the preexisting soil values (Birkeland 1984). The 1:1 soil:water pH was measured using a commercial pH meter (McLean 1982).

Radiocarbon dates are obtained in an attempt to date a soil, or some of its features, in a stratigraphic analysis (Birkeland 1984). Because of the dynamic nature of organic carbon in the A horizon of a surface soil, the radiocarbon dates of buried soils are used to obtain a limiting date for overlying deposits, and thus become a correlation tool. Radiocarbon determinations were made on bulk samples from selected horizons. The samples were prepared by suspending bulk materials with a commercial blender, and then evaporating them in large pans. The finer mineral fractions cracked, and then curled and peeled. The peels were collected for the sample (Follmer, personal communication). Radiocarbon assays were made using a scintillation counter on gasified samples, at the University of Pittsburgh Radiocarbon Laboratory.

Micromorphology, or the study of soils in thin section, traditionally has focused on soil genesis and classification (Kooistra 1990). It has also been used to obtain essential extra information on aspects of the soils being studied for the interpretation of past events. Thin-section samples were collected from Block 14 (samples DLC 14-1, DLC 14-2) in order to evaluate the fragipan horizon, and from Block 12 (sample DLC 12) in order to observe the B horizon lamellae described below. Thin-section samples were collected in the field using "Kubiena boxes." The 5.5 cm x 9 cm x 4 cm blocks were then impregnated with epoxy resin and, when cured, were cut and polished with standard lapidary thin-section equipment to make two 5 x 8 cm thin sections. Thin sections were made at the University of Wisconsin Soil Department. These thin sections were observed with plain and cross-polarized light, using techniques and nomenclature of Cady et al. (1986) and Brewer (1976).

Bulk clod samples for bulk density determinations (Blake and Hartge 1986) were collected in the field and analyzed in the laboratory according to methods specified by the Agronomy Department, Pennsylvania State University (Thurman et al. 1992). Bulk density is used in soil genesis studies to evaluate horizon development, porosity, and structure development (Blake and Hartge 1986). Bulk density was measured on six samples from blocks 13 and 14 in order to evaluate the degree of fragipan development. Samples were collected from horizons above the fragipan (samples DLC 13-2, DLC 14-2), within the fragipan (samples DLC 13-5, DLC 14-5, DLC 14-6), and below the fragipan (DLC 13-9).

## RESULTS

The results of this study are presented in two sections: (1) Field Observations, and (2) Laboratory Results. Field Observations include all observations made throughout the the project and the detailed profile descriptions (Appendix A). Laboratory Results includes all data obtained from samples collected in the blocks (Appendix A). Field observations were used to guide the collection of samples and to interpret the data.

### *Field Observations*

*Geomorphology.* Prior to the mechanical stripping of the study area, 27 1 x 2 m test units were hand excavated to delineate disturbance and extent of fill materials (Figure 11). The investigation indicated that the entire area was covered by fill material, ranging between 45 cm and > 130 cm deep. The shallowest fill occurred in the middle of the study area, and the deepest fill occurred on the northeastern and southern portions.

When the study area was stripped in May 1991, lateral variations in soil properties became evident. A linear NW-SE trend of lighter-colored (higher-value, higher-chroma) soils with

prehistoric features throughout its length was observed through the middle of the stripped off area. This trend was interpreted as a ridge landform, such as a natural levee or point bar. To the northeast and south of the "ridge" were dark colored, more poorly drained (mottled and gray) soils, and deeper fill, interpreted as a swale or channel landscape. The swale to the north and northeast was mostly fill material, probably associated with bridge construction activities. This material was sandier than surrounding soils and contained a highly variable coarse fragment content. The swale to the south contained a siltier, dark-colored soil with a grayer (lower-chroma) more mottled subsoil. This indicated a more poorly drained portion of the landscape. The swale to the south did not run the entire length of the area; rather, it entered from the southeast corner, parallel to the ridge, and graded at the southwest corner into lighter-colored, better-drained soils similar to the ridge.

Excavation of the 5 x 5 m blocks was limited to the ridge portion of the study area with the exception of Block 7, which was located to the south of and outside of the stripped area. A difference was noted in textures from the west end of the ridge area to the east end. The east end of the ridge was sandier than the west end, the change being rather gradual. On the east end (Blocks 1, 2, 3, 10, 11, and 12), alternating sandy and clayey bands were found in the base of the 5 x 5 blocks and in the 2 x 2 blocks. These short, alternating bands, dipping slightly to the north, have previously been interpreted as illuvial B horizon lamellae (Kinsey 1972), but also resemble ripple and trough cross-bedded bed forms (Blatt et al. 1980), or deformed lacustrine bed forms (Bucek 1975). Both the bands and soil horizons typically dipped to the north in almost all units, indicating a sloping landscape.

*Stratigraphy.* The deep-augering study revealed subtle variations in soil texture and soil color with depth. Buried A horizons were difficult to distinguish and were often delineated based on faint color differences, charcoal content, fabric, and granular soil structure (Scully and Arnold 1981). Often, gray mottles or reddened soil were observed in association with concentrations of charcoal. Vento and Rollins (1989) described both cumulic and incipient A horizons near bank-edges and levees in the Susquehanna drainage basin, and attributed them to intervals of floodplain stability punctuated by episodes of overbank discharge and channel avulsion. At the southeast corner of the study area (Test Unit 27), three buried A horizons were tentatively delineated based on the above properties. In the middle of the study area (Test Unit 14), three buried A horizons, were delineated. Test Unit 1 at the western edge of the study area also revealed three buried A horizons based on the above criteria. The depths of the buried A horizons were rather consistent between the three test units: 1 meter, 1.2-1.7 meters, and 2.5 meters below ground surface. Observations of all 27 of the 1 x 2 units revealed a varying surficial stratigraphy of 45 cm to >130 cm of fill. In most of the units the fill was underlain by a thin, coarse-to-medium sand lens, and then by an Ap horizon of varying thickness.

The observations of the excavated 5 x 5 m and 2 x 2 m units permitted more precise delineations of site stratigraphy and buried soils than the augering study. The distinctiveness of buried soils was variable, both laterally and vertically, throughout the entire site due to differences in the degree of soil development. In general, buried soils were more distinguishable in the western portions of the site and at shallower depths. In the eastern end of the site, buried soils were more subtle, and delineations were largely based on charcoal content and textural differences.

In the eastern end of the site, the buried soil profiles consisted of thin, diffuse, or weakly developed A horizons overlying weak Bw horizons and/or C horizons. C horizons were defined as those horizons containing primary stratification and/or lacking pedologic structure.

In the western portion of the site, buried soil profiles consisted of a complex of buried soils. The most noticeable soil horizon encountered was a buried fragipan (Bx or Btx), a diagnostic subsurface horizon characterized by a brittle moist consistence, an extremely firm to indurated dry consistence, and a polygonal cracked structure (Soil Survey Staff 1975).

Stratigraphically, the fragipan represents a strongly-developed paleosol B horizon that is superimposed over one or more weakly developed A horizons. This leads to complex stratigraphy and the interpretation of a rather stable surface environment. Figure 14 shows the sampling scheme of the study area based on profile descriptions (Appendix A) and field observations. Some of the columns were extended below the base of the excavation unit by hand-augering. Due to differences in surface elevations, the top of arbitrary level 1 in each block may not coincide with the corner of the block in which the column was observed. Because detailed observations were not made of Block 10, this block is not included in Figure 14.

### *Laboratory Results*

*Particle-size Analysis.* The distribution of particle size with depth, for blocks 1-7, is shown in Figures 15a-15g. Data for the particle-size analyses are located in Appendix A. Overall, soil samples from the blocks fell into the loam and silt loam fields of the USDA textural triangle (Figure 16). With very few exceptions, the largest sand fraction occurring regularly in the samples was fine sand (0.1-0.25 mm). Medium sand occurred in proportions of one to four percent, by weight, in a few of the samples. Coarse and very coarse sands occurred only in trace proportions.

The vertical distribution of the various particle-size fractions shows an overall uniform proportion of each fraction, with occasional small inflections indicative of a change in the percentages (Figure 16). The changes are subtle and can be interpreted in terms of source, mechanism of transport, mode of deposition, or post-depositional alteration (Stein 1987). Post-depositional alteration, particularly soil formation, involves translocation of the smaller size fractions. Thus, the delineation of the vertical profile into lithologic units usually is based on the coarser size fractions. Particle-size analysis was used to develop a lithostratigraphic model that is included in the discussion section of this chapter.

No strong overall fining-upward or coarsening-upward sequences dominated in any of the blocks. Slight coarsening-upwards or fining-upwards sequences did occur in portions of every block. These sequences were used to define specific lithologic units and breaks between the units. Overall, the vertically uniform distribution of the size fractions is indicative of deposition by vertical accretion (vertically uniform sequence) punctuated by brief episodes of lateral accretion (fining-upward sequence) or accretion from a crevasse splay or increased channel flow (coarsening-upward sequence) (Blatt et al. 1980; Scully and Arnold 1981; Vento and Rollins 1989).

The overall, vertically-uniform distribution of the proportions of sand, silt, and clay indicate deposition by overbank floodwaters with slight variations in the competence of the depositing currents (Gray 1984; Vento and Rollins 1989). The interpretation of each of the sequences, and of the lithostratigraphic model, is based on a discussion of facies models by Blatt et al. (1980). Vertically uniform sequences result from overbank flooding and the associated vertical accretion. During overbank flooding the more coarse fraction accumulates to form natural levees bordering large, relatively stable channels, and the finer fractions (silt and clay) accumulate in low points such as shallow lakes or backswamps. In aggrading floodplains, vertical accretion is generally important in meandering systems. Spike deposits result from a crevasse splay type of mechanism. Fining-upward sequences in a fluvial plain, or broad aggradational floodplains are indicative of lateral accretion by the slow migration of river channels. Coarsening-upward sequences indicate an increase in current velocity. A crevasse splay is a coarsening-upward subdelta that forms when local natural levees are washed away or otherwise breached during periods of high flow. Channel fill deposits and channel lag deposits tend to be the most coarse deposits in a typical alluvial sequence. A coarsening-upward sequence might be interpreted as the result of an increase in current velocity, possibly by the development of a channel.

In Block 1 the top 50 cm of the profile (168.00-167.50 m AMSL) was characterized by a fining-upward sequence underlain by a 40-cm-thick zone of relatively uniform distribution of the fractions (Figure 15a). Below approximately 167.10 m AMSL, two thin bands of increased sand content (mostly fine sand) occurred, probably the result of a crevasse splay-type of mechanism. Rounded cobbles, and gravels with sand were observed at an elevation of 166.40 m AMSL in Block 1 and at 166.50 m AMSL in Block 13. Below approximately 166.40 m AMSL another gently fining-upward to nearly vertically uniform sequence occurred. Below 166.00 m AMSL was a coarsening-upward sequence.

Sediments in Block 2 were fairly uniform with depth, with approximately 40 percent sand in the upper third of the profile, and 30 percent sand in the lower two thirds (Figure 15b). The top 40 cm of the profile, to 167.65 m AMSL, consisted of a slight fining-upward sequence underlain by a relatively uniform sequence to an elevation of 167.30 m AMSL, where decreases in fine sand and fine silt occurred. At approximately 166.90 m AMSL, a coarsening-upwards sequence was encountered. At an elevation of approximately 166.56 m AMSL, the sediments became uniform with depth except for a slight decrease in clay content at approximately 165.95 m AMSL.

Block 3 was characterized by several thin deviations from an otherwise vertically uniform distribution of the particle-size fractions (Figure 15c). The top of the profile had a thin (10 cm) fining-upward sequence. The next sequence was uniform with depth to 167.36 m AMSL except for a 5 cm band of material containing less sand and more clay. Below 167.31 to 166.46 m AMSL was a sequence of nearly-uniform distribution, except for small variations in the proportions of coarse and medium silt. This was underlain by a thin band of increased sand and decreased clay, presumably from a crevasse splay. Another uniform to slightly coarsening-upward sequence occurred to 165.81 m AMSL. Below this, was a zone with a sharp increase in the coarse silt content and a decrease in clay. The last stratigraphic break occurred at 165.46 m AMSL and is the top of a thick, uniform sequence.

Several thin, slightly contrasting layers occurred in the top 50 cm of Block 4 to an elevation of 167.40 m AMSL (Figure 15d). These thin layers were differentiated by their contrasting sand and coarse silt contents. Below this, to an elevation of approximately 167.10 m AMSL, was a zone with uniform sand, silt, and clay contents. This, in turn, was underlain by a zone with a slight coarsening-upward sequence to an elevation of approximately 166.80 m AMSL. A thicker sequence of uniform sand, silt, and clay contents occurred to 166.30 m AMSL. Below this were two relatively thin zones; one with a sharp increase in sand to approximately 166.1 m AMSL, the other with a rather uniform distribution of particle-size classes to 165.90 m AMSL. Below 165.90 m AMSL, was a fining-upward sequence.

Block 5 consisted of a sequence vertically differentiated by three zones of increased sand content and other minor inflections (Figure 15e). The top zone, down to 167.78 m AMSL, was a coarsening-upward sequence. Underneath this was a zone of increased sand and coarse silt underlain by a coarsening-upward sequence down to 167.17 m AMSL. At this point the distribution became vertically uniform to an elevation of 166.85 m AMSL. From 166.85 to 166.17 m AMSL, was a fining-upward sequence, punctuated by a zone of increased sand between 166.77 and 166.57 m AMSL. The latter probably resulted from a crevasse splay. From 166.17 m AMSL down to 165.97 m AMSL, the distribution was coarsening upward.

In Block 6 the upper two-thirds of the column had a relatively uniform clay content of approximately 20 percent, and a sand content that ranged from 20 percent to 30 percent (Figure 15f). The upper 75 cm to an elevation of 167.01 m AMSL was slightly coarsening upwards.

EXCAVATION BLOCKS

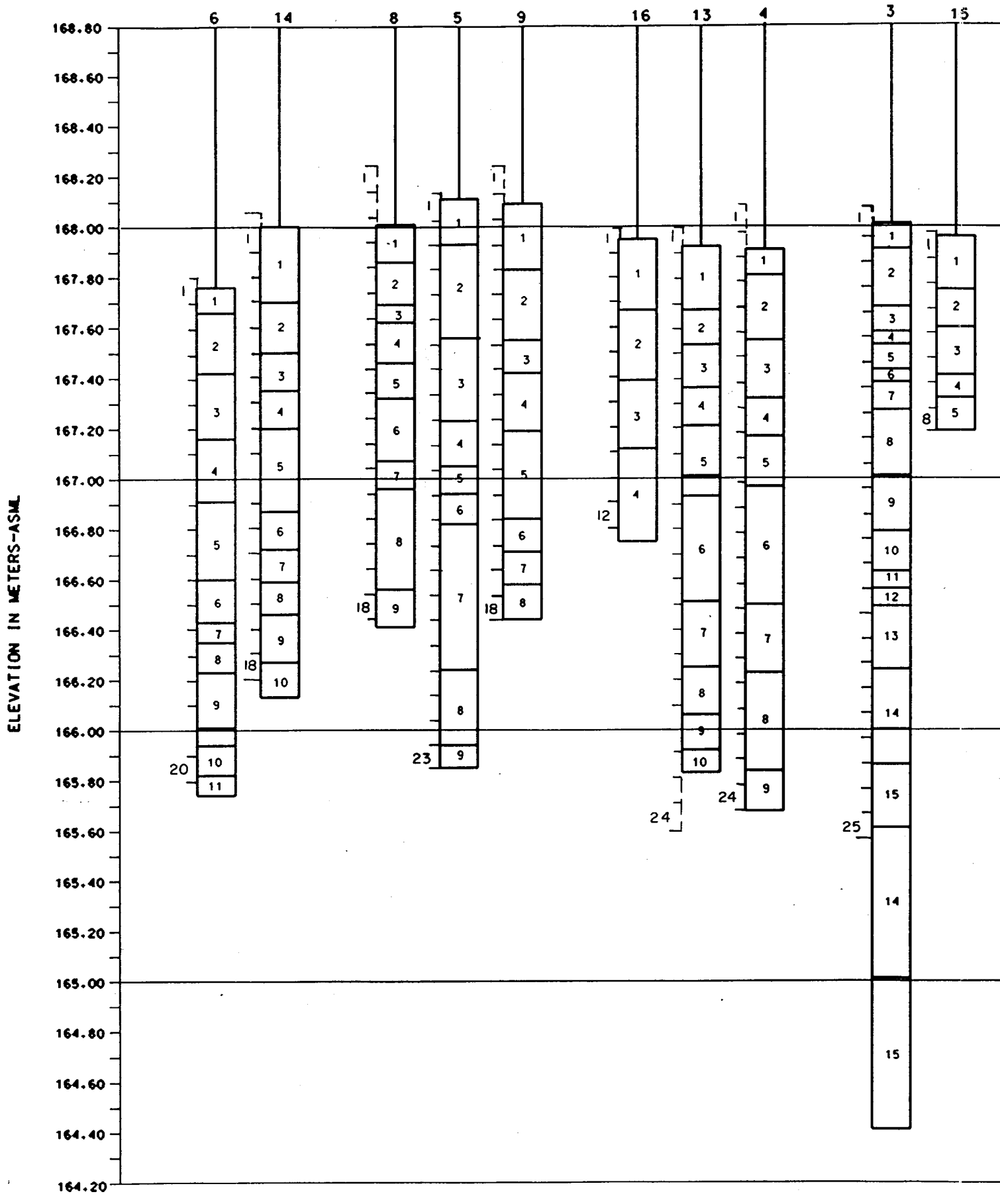

2

KS

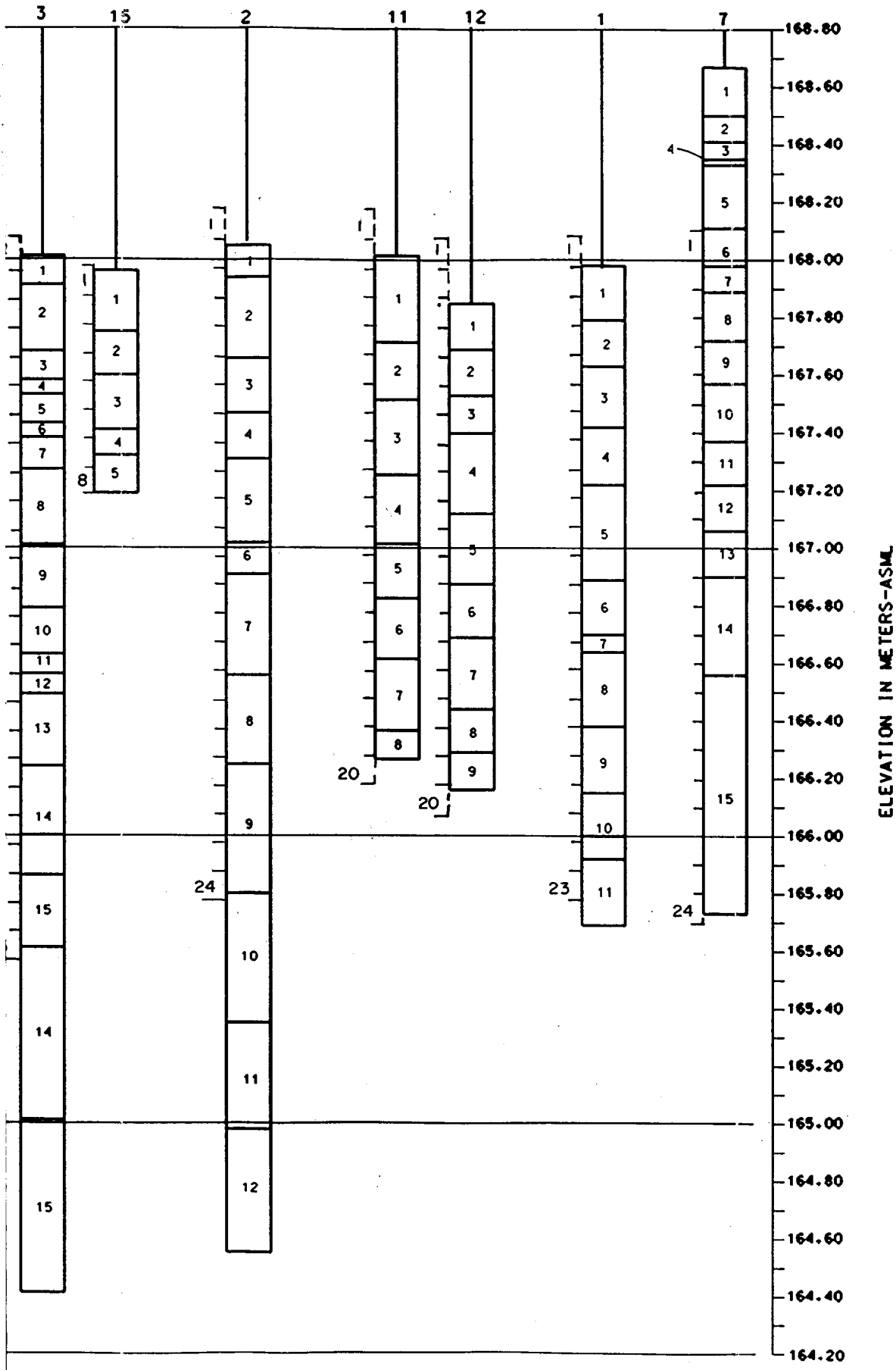

ELEVATION IN METERS-ASML

99

KEY

-  10 CM ARBITRARY LEVEL
- \* COLUMNS REPRESENT S AND CORINGS TAKEN FR ONE CORNER OF EACH

FIGURE 14

COLUMN SAMPLING AND OBSERVATION SCHEME

2

3

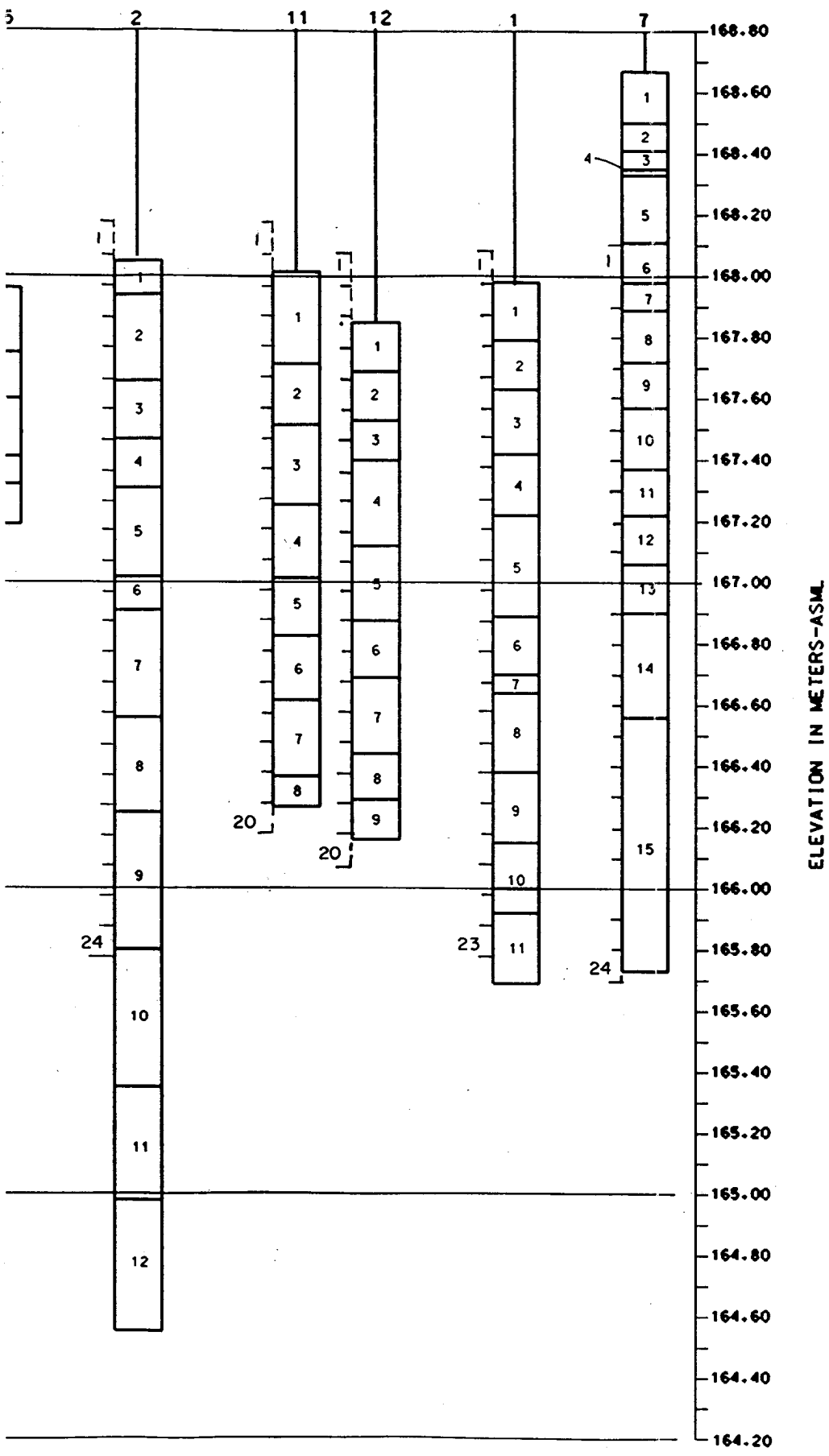

Handwritten signature or initials.

**FIGURE 14**

**COLUMN SAMPLING AND OBSERVATION SCHEME**

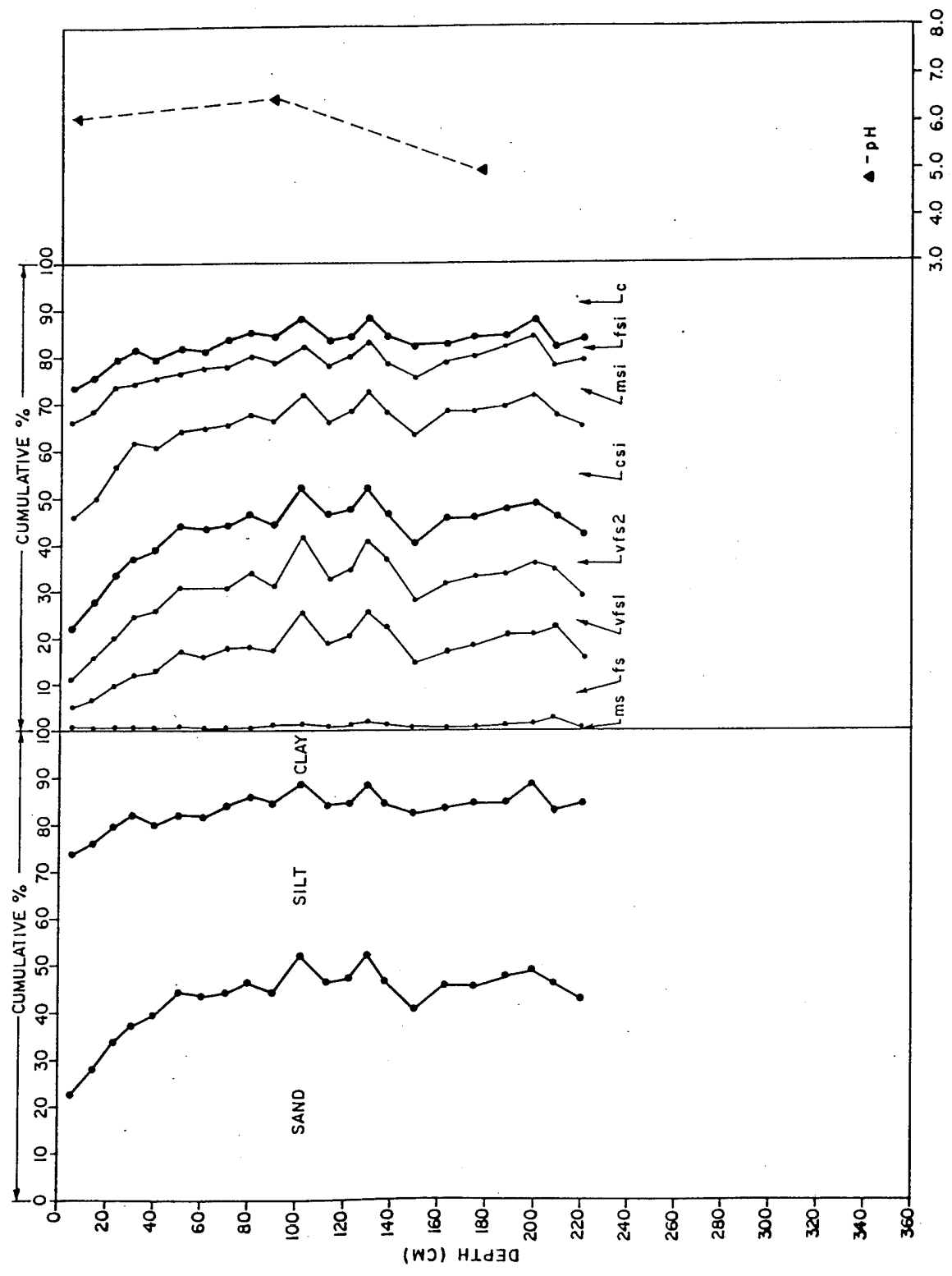

FIGURE 15a

DISTRIBUTION OF PARTICLE SIZE, ORGANIC CARBON, AND pH WITH DEPTH FOR BLOCK 1



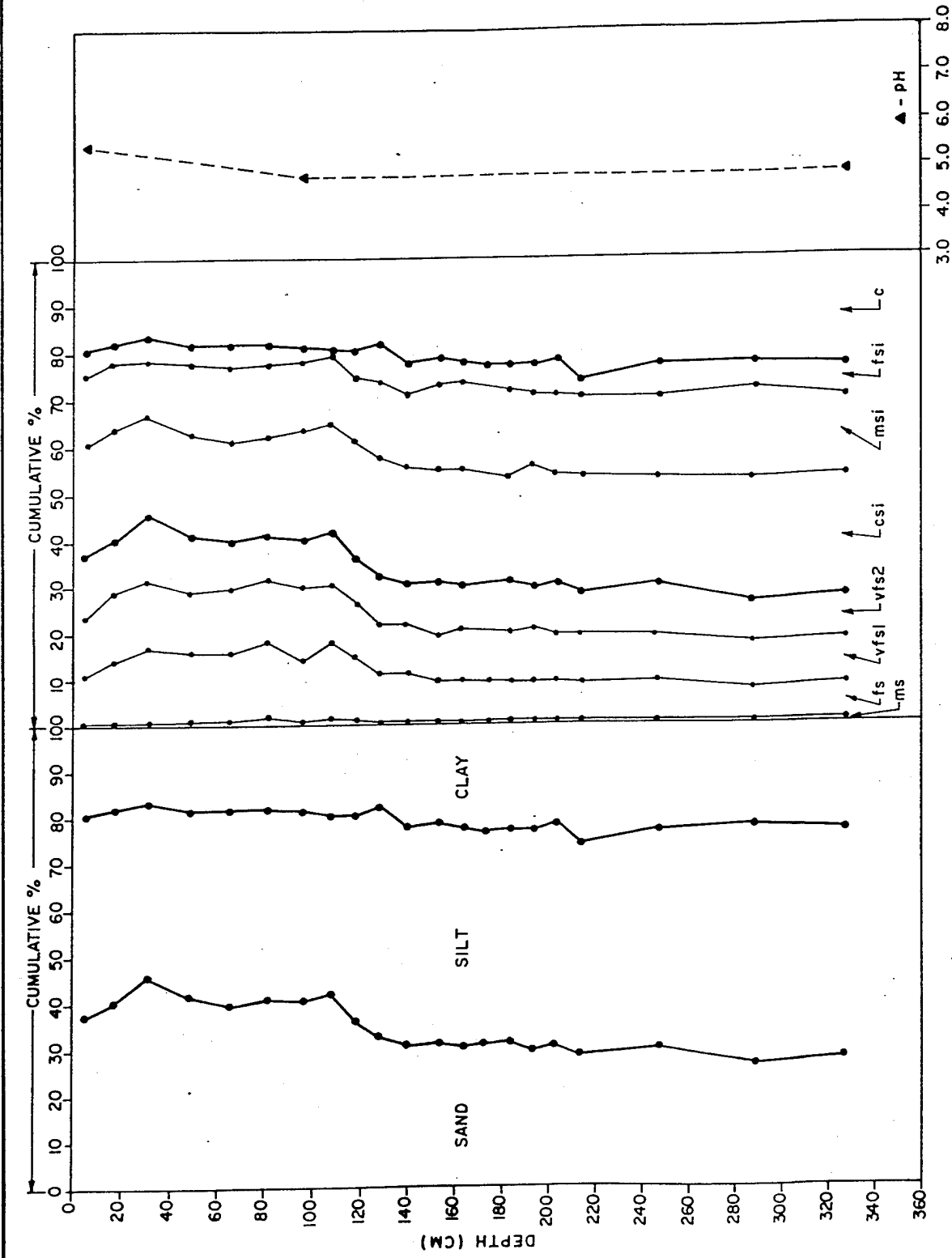

FIGURE 15b

DISTRIBUTION OF PARTICLE SIZE, ORGANIC CARBON, AND pH WITH DEPTH FOR BLOCK 2

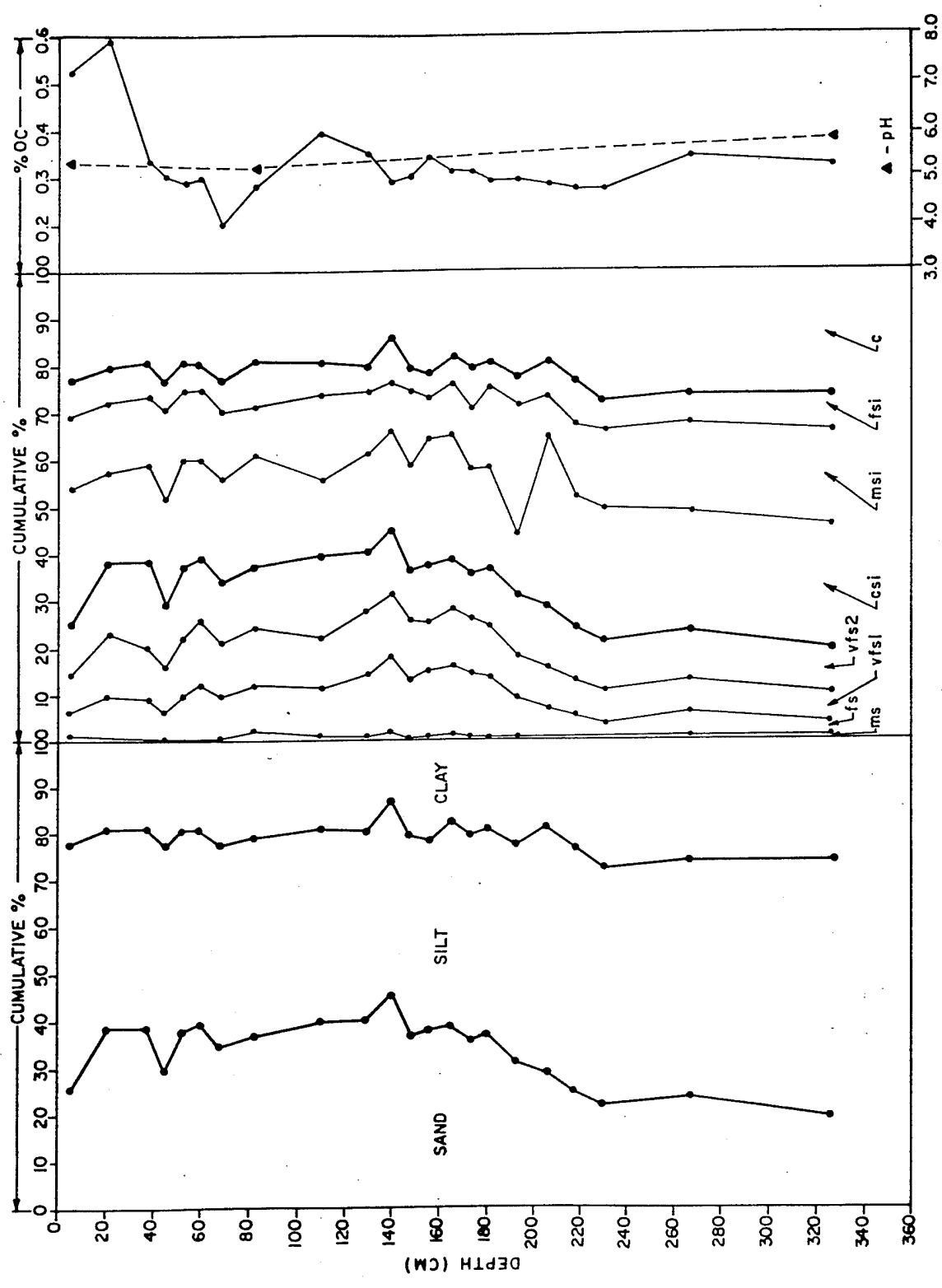

FIGURE 15c

DISTRIBUTION OF PARTICLE SIZE,  
ORGANIC CARBON, AND pH WITH  
DEPTH FOR BLOCK 3

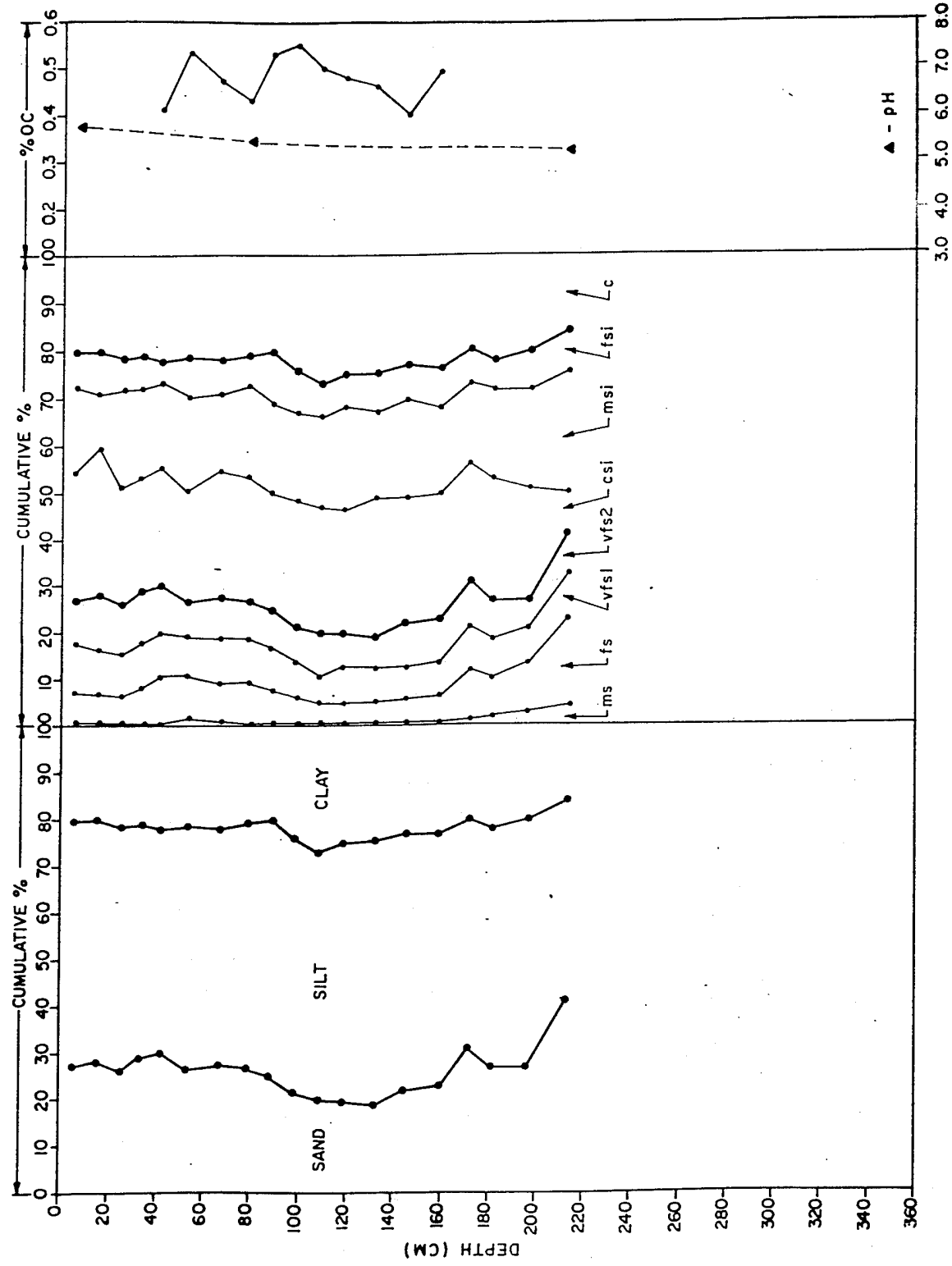

FIGURE 15d

DISTRIBUTION OF PARTICLE SIZE,  
ORGANIC CARBON, AND pH WITH  
DEPTH FOR BLOCK 4

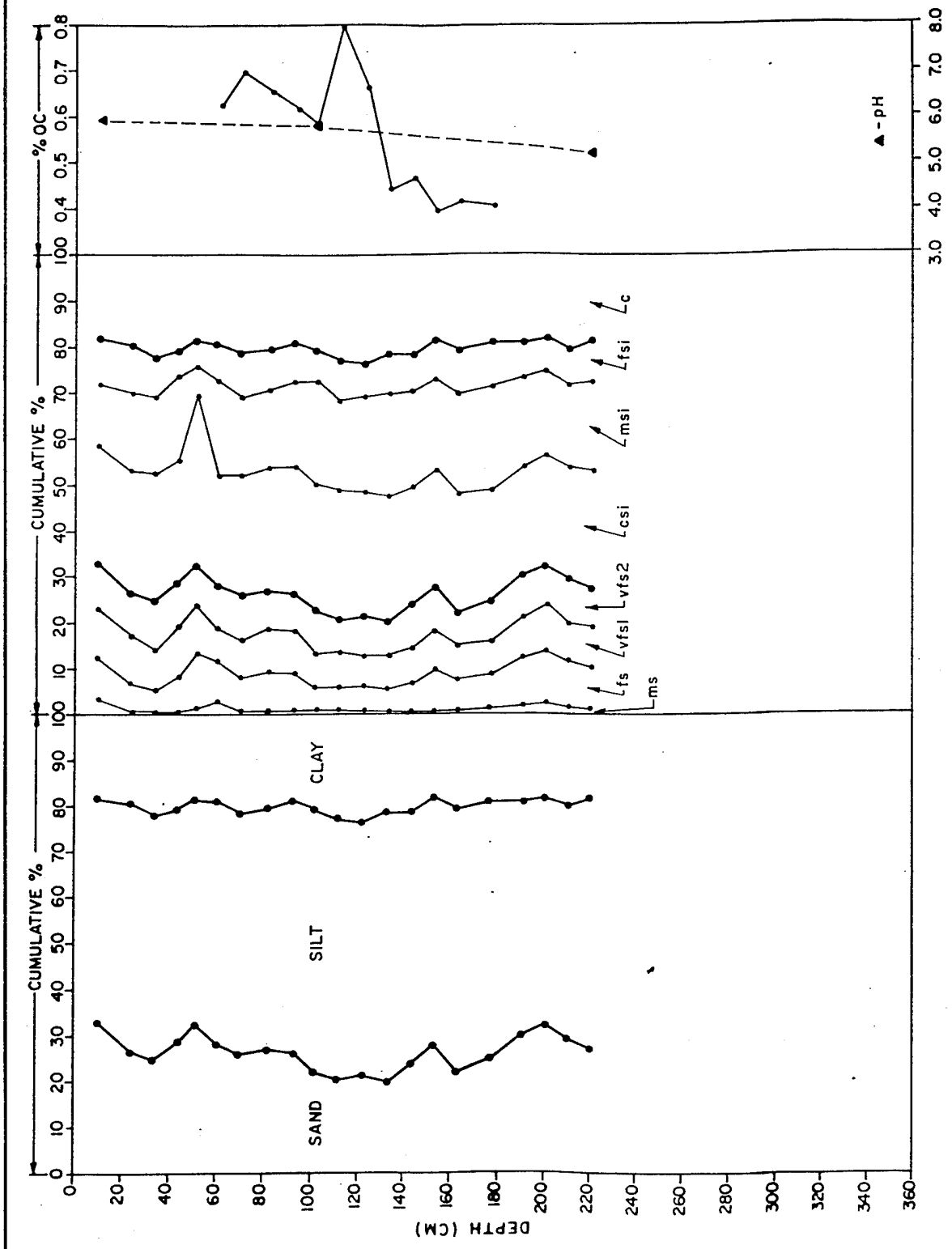

FIGURE 15e  
 DISTRIBUTION OF PARTICLE SIZE,  
 ORGANIC CARBON, AND PH WITH  
 DEPTH FOR BLOCK 5

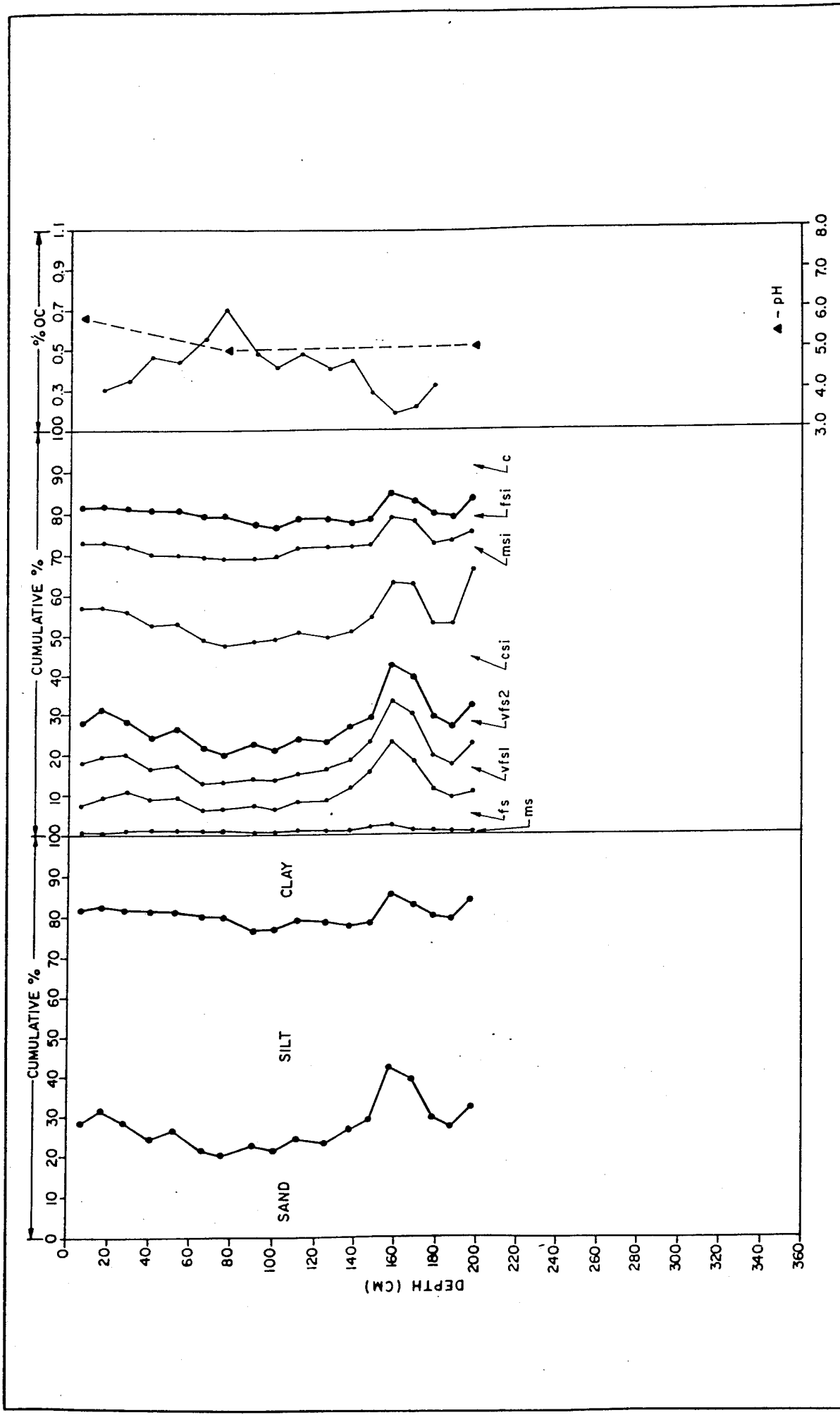

FIGURE 15f  
DISTRIBUTION OF PARTICLE SIZE, ORGANIC CARBON, AND pH WITH DEPTH FOR BLOCK 6

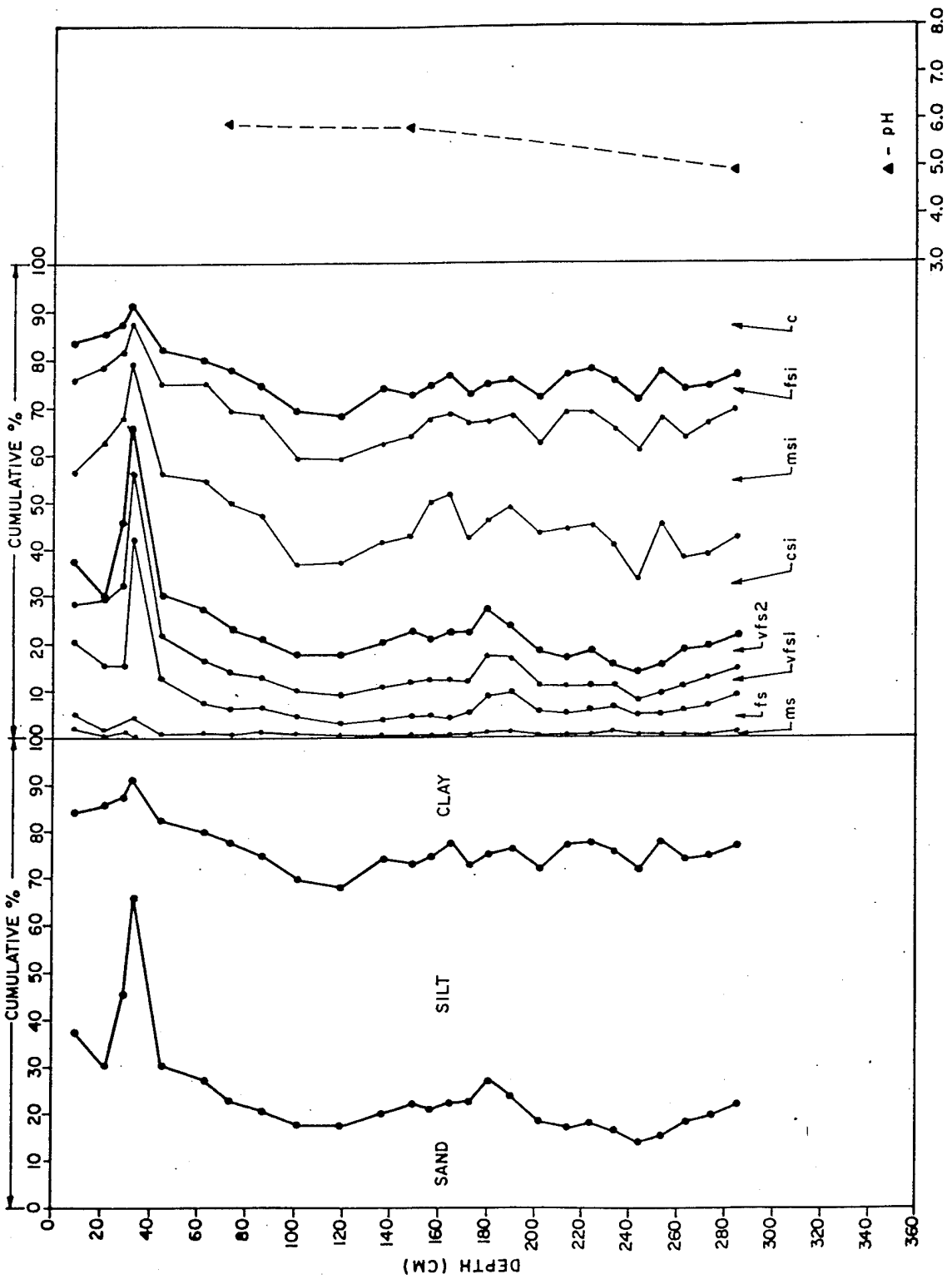

FIGURE 159

DISTRIBUTION OF PARTICLE SIZE,  
ORGANIC CARBON, AND pH WITH  
DEPTH FOR BLOCK 7

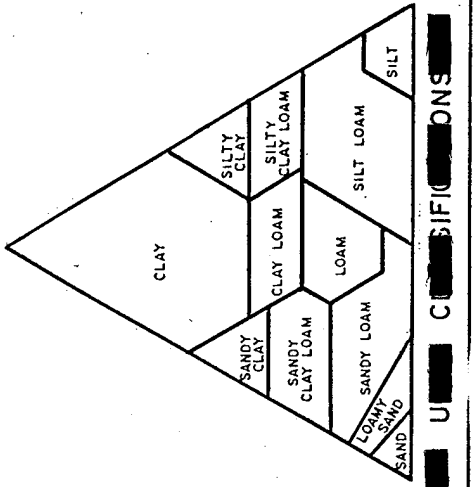
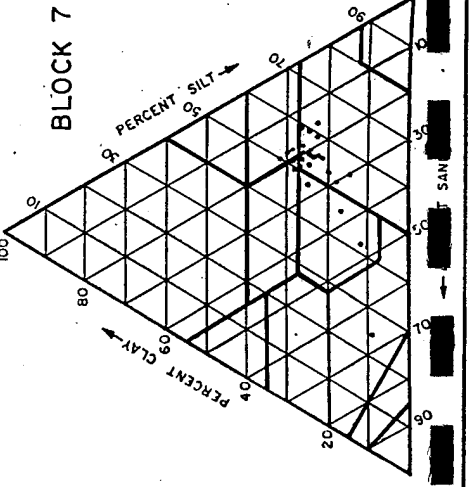
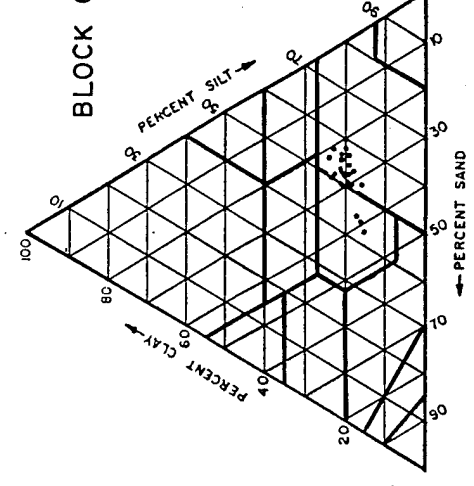
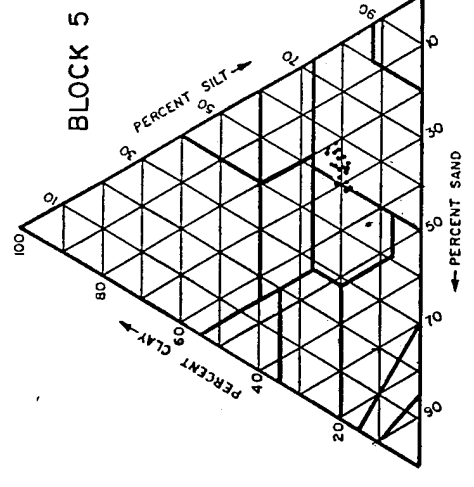
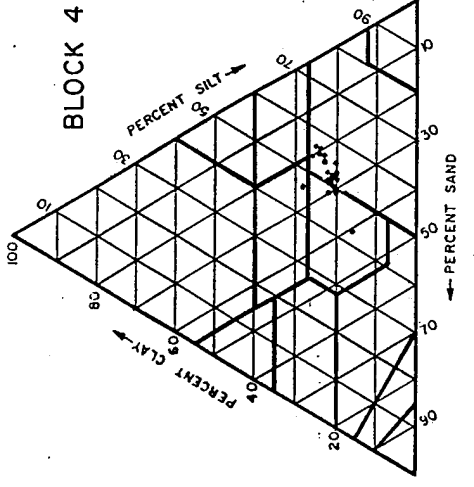
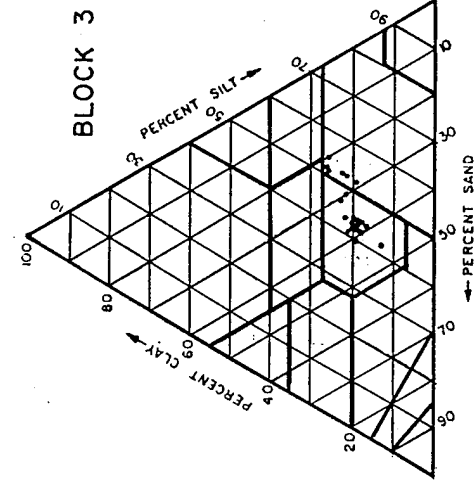
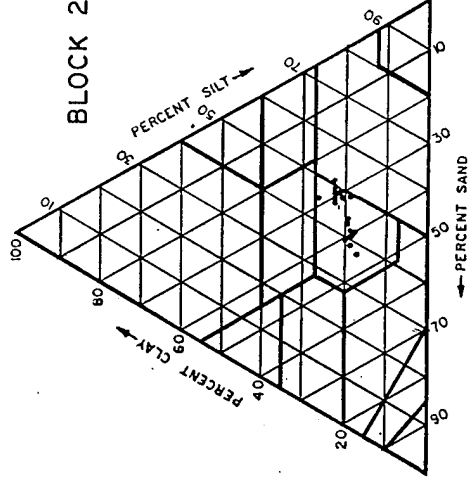
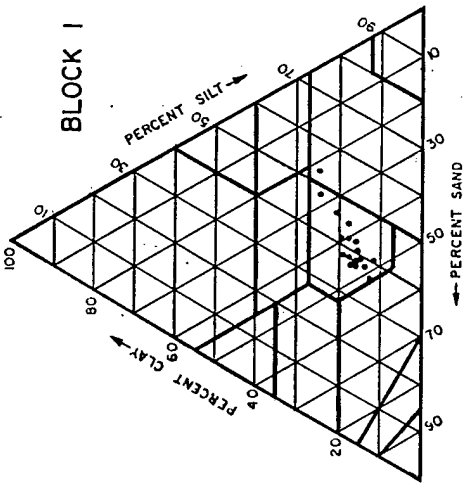

FIGURE 16

TEXTURAL CLASSIFICATION OF SOIL SAMPLES FROM MEMORIAL PARK

UNCLASSIFIED

From 167.01 to 166.51 m AMSL was a zone of nearly vertical distribution of the fractions. The sequence from 166.51 to 166.16 m AMSL was fining upward, from a sharp increase in fine sand at 166.16 m. The sequence became coarsening upward, from 166.16 to 165.86 m AMSL. Below 165.86 m AMSL the sequence again became fining upward.

Block 7 had approximately 0.7 m of fill materials, over natural materials, in the column (Figure 15g). The top portion of the natural column, to an elevation of 167.67 m AMSL, was coarsening upwards. From 167.67 m to 167.47 m AMSL was a vertically uniform distribution underlain by a fining-upwards sequence to an elevation of 166.87 m AMSL. Between 166.87 and 166.67 m AMSL, was a coarsening-upward sequence underlain by a vertically uniform sequence to an elevation of 166.27 m AMSL. Down to an elevation of 165.77 m AMSL, the sequence became fining upward.

*Organic Carbon Analysis.* Organic carbon (OC) contents were measured on select horizons in Blocks 4, 5, 6, and on the complete column in Block 3. Horizons were selected to encompass zones in which buried A horizons were delineated in the field. The analyses show several inflections in the vertical distribution that are interpreted as buried A horizons (Figure 15c-15f). However, it should be noted that most alluvial sediments came from eroding soils or streambanks, and contain an appreciable amount of organic carbon that is mainly in the clay fraction (Soil Survey Staff 1975). Strata of clayey or loamy materials commonly have more organic carbon than overlying, more sandy, strata. Thus, the interpretation of the distribution of organic carbon must take into account the textural distribution (Birkeland 1984; Soil Survey Staff 1975).

The greatest content of organic carbon in Block 3 occurred in the upper 40 cm of the column, where OC contents reached 0.6 percent by weight (Figure 15c). Another OC peak was reached at 166.66 m AMSL, and then again at 166.16 m AMSL. Below this, the content of organic carbon became uniform with depth. Two peaks in OC content were evident in the samples from Block 4: at 167.50 m AMSL and, again, at approximately 166.90 m AMSL (Figure 15d). Both of these peaks were about 0.55 percent OC. A third increase was evident in the deepest sample analyzed in Block 4 at an elevation of 166.30 m AMSL. In Block 5 two peaks were also evident (Figure 15e). The first maximum occurs at an elevation of 167.47 m AMSL with 0.7 percent OC. The second peak occurs at approximately 167.07 m AMSL and contains 0.8 percent OC, the highest level of OC measured in the study. Below 166.97 m AMSL the OC content drops to 0.4 percent. In Block 6 five peaks in OC content were found (Figure 15f). One peak was found at 167.40 m AMSL with an OC content of 0.47 percent. The greatest content of organic carbon in Block 6, 0.7 percent, occurred at 167.05 m AMSL on top of the fragipan. The OC content decreased below this elevation, with small peaks occurring at 166.70 m, 166.40 m, and 166.00 m AMSL. The OC content dropped with the increase in sand content in the lower portions of the profile. The increase in OC at 166.00 m AMSL did not coincide with an increase in clay and was therefore interpreted as the remnants of an A horizon.

*Analysis of pH.* The water pH of selected horizons in Blocks 1-7 was analyzed to evaluate the source of sediments. Horizons were selected from approximately consistent elevations in each block, near the surface, approximately one meter below the surface, and from the deepest portions in each unit. West Branch sediments, coming from the plateau, are acid. Bald Eagle Creek sediments, coming from a limestone valley, are neutral to mildly alkaline (Steptutis et al. 1966). All of the pH values measured were below 7.0, indicating the overall influence of West Branch sediments. Overall, the distribution of pH values was similar in the blocks, with the exception of Block 1 where pH values in the upper meter indicated a possible input from Bald Eagle Creek sediments.

In Block 1, pH values measured were 6.1 at an elevation of 167.88 m AMSL, and 6.5 at approximately 167.08 m AMSL (Figure 15a). These were the greatest pH values measured in the



study. At approximately 166.28 m AMSL, a pH of 5.0 was measured. In Block 2, pH values were notably lower with 5.5 in the upper 11 cm, 4.8 at an elevation of 167.10 m AMSL, and 4.9 at an elevation of 164.77 m AMSL (Figure 15b). Block 3 pH measurements were 5.4 in the upper 10 cm (167.66 m AMSL), 5.3 at an elevation of approximately 166.96 m AMSL, and 5.9 in the interval from 164.76 to 164.16 m AMSL (Figure 15c). In Block 4, the pH values ranged from 5.8 at an elevation of 167.80 m AMSL to 5.5 at 167.10 m AMSL and 5.3 at 165.75 m AMSL (Figure 15d). The distribution of pH values in Block 5 was similar to that in Block 4, decreasing from 5.9 at 168.07 m AMSL, to 5.8 at 167.17 m, and to 5.2 at 165.97 m AMSL (Figure 15e). Block 6 also had lower pH values than did Blocks 4 and 5. In Block 6, materials at the elevation of 167.66 m AMSL had a pH of 5.8 (Figure 15f), decreasing to 5.0 at 166.96 m, and 5.1 at 165.76 m AMSL. In Block 7, pH values were 6.0 at the top of the natural materials (approximately 167.92 m AMSL), 5.9 at 167.17 m AMSL, and 5.0 at 165.77 m AMSL (Figure 15g).

*Radiocarbon Analysis.* The results of the analyses of selected soil samples and features for radiocarbon content are discussed in Section VI of this report. Soil samples were selected from those horizons considered to be A horizons during the field observations. Corrected dates (dendrochronology) ranged from modern to pre-Holocene. Obviously, some of the dates have a large degree of error. Enough viable dates were available to delineate a chronology of soils and sediments across the study area. These data were used mainly as a correlation tool for pedostratigraphic delineation of the study area, and in conjunction with the correlation of artifact typologies across the study area. Because of the small areal extent of the study area, the assumption was made that post-depositional and burial diagenesis processes and their influence on radiocarbon dates were similar across the study area.

*Micromorphology.* The micromorphological description of selected samples is presented in Appendix A. These descriptions are based on the terminology of Brewer (1976) and are divided into four categories: the related distribution patterns, the elementary fabric, the plasmic fabric, and a listing of pedological features. The related distribution pattern is the arrangement of individuals with regard to one another. Elementary fabric is the integration of a characteristic size, shape, and arrangement of specific pedological features (recognizable units within a soil material which are distinguishable from the associated material), along with the structure of the s-matrix (materials within the simplest peds that do not occur as pedological features). The property of fine particles (clays, iron oxides, organic particles, etc.) to disperse and flocculate in colloidal suspension causes them to be susceptible to movement in energy fields. Thus "plasma" is one of the most mobile constituents observable with a light microscope. The organization of the plasma of the s-matrix is referred to as plasmic fabric. Plasmic fabrics probably reflect more of the energetics of soil processes than any other micromorphological property. Plasmic fabrics that are dominantly anisotropic with no plasma separations are called asepic (Brewer 1976). Sepic plasmic fabrics are delineated where plasma has become separated and concentrated—an indication of pedogenesis. Varieties of sepic plasmic fabrics are recognized, based on characteristics of the plasma separations.

Sample DLC-12, taken from the B horizon lamellae in Block 12, had a vughy porphyroskelic-related distribution pattern in both the "yellow band" and the "red band." This pattern indicates that the plasma occurs as a dense ground mass in which the skeleton grains are set (Brewer 1976). Vughy refers to the dominant, irregularly-shaped pores. In the yellow band, the pattern approached agglomeroplasmic in places where the plasma was scarce. In agglomeroplasmic patterns, the plasma occurs as loose or incomplete fillings in the intergranular spaces between skeleton grains—a possible indication of its removal. The elementary fabric in the yellow band was subcutanic to weakly cutanic with associated insepic, and skel-insepic plasmic fabrics, respectively. Insepic plasmic fabrics are those in which plasma separations occur as isolated patches within the dominantly flecked plasma. The skel modifier indicates plasma coatings associated with skeleton grain surfaces (embedded grain argians). The elementary fabric of the red band is cutanic with a skel-vosepic plasmic fabric. This indicates that the clay (plasma) occurs

mainly as argillans (cutans) along vugh and channel walls, and associated with grain surfaces (Brewer 1976). This clay is illuvial in origin and the red bands formed by illuvial clay accumulation. The yellow bands have accumulated little clay beyond that in the original sediments, and may actually serve as a source of clay for the red bands.

Sample DLC 14-1 And DLC 14-2 were taken from the fragipan on the west side of the study area. The related distribution pattern for both the bleached streaks and the matrix was porphyroskelic in both samples. In both samples, the elementary fabric of the bleached streaks was mainly subcutanic with skel-lattiseptic plasmic fabrics. This suggests that the dominant energetic process in the bleached streaks is stress, probably hydrostatic stress (Brewer 1976). This may be an indication of one mechanism of fragipan formation at this site. The fragipan matrix, on the other hand, has a more complicated s-matrix with a cutanic elementary fabric and a vo-masepic plasmic fabric. Plasma exists as vugh and channel argillans, neostrians, and neoferrans which indicate a multitude of processes including translocation of clay and iron, and diffusion of iron. The lattaer is an indication of fluctuating redox conditions (Brewer 1976). Wetting and drying is a continuous process in the initial phase of fragipan formation (Ciolkosz et al. 1992). Similar properties were noted by Linbo and Veneman (1989), and Smith and Callahan (1987), when they examined thin sections from fragipan Bx horizons. These observations identify some processes associated with formation of the fragipan. Considerable translocation of clay and iron has taken place, with some of the iron moving by diffusion. The reprecipitated iron may be partially responsible for the fragipan brittleness (Smith and Callahan 1987). The translocation of clay is thought to occur in intermediate phases of fragipan formation (Ciolkosz et al. 1992).

*Bulk-Density Analysis.* Results of the bulk-density anbalysis, given in Appendix A, showed values with a range of 1.42 to 1.59 g/cm<sup>3</sup> when analyzed at at 1/3 bar moisture content, and 1.47 to 1.60 g/cm<sup>3</sup> at oven dry. No significant difference in bulk density, as measured in this study, was found between the fragipan horizons and overlying and underlying horizons.

Most fragipans in the northeast exhibit bulk densities, ranging from 1.65 to 2.15 g/cm<sup>3</sup> (Linbo and Veneman 1989). The exception is from fragipans formed in silty materials, such as that at Memorial Park, which tend to have lower bulk densities.

Recent data from Linbo et al. (1994) suggested inconsistent relationships between fragipans and bulk density for loess soils (silty) of the lower Mississippi River valley. They found that bulk density of fragipan horizons was not statistically unique, and did not always represent the maximum for a given soil. They concluded that bulk density should not be used as a principle test for differentiating between fragipan and non-fragipan horizons. Bulk density appears to be a partial function of parent material properties.

## DISCUSSION

This section is divided into the sub-sections Stratigraphy, and the Site Formation Model. In the Stratigraphy sub-section, data from the particle-size analysis are used to develop a lithostratigraphic model. From this model, the geomorphic and sedimentary history of the study area are delineated. The pedostratigraphic model is developed using profile descriptions (Appendix A), radiocarbon data, organic carbon data, and the distribution of artifacts across the study area. The pedostratigraphic model is used to provide insight into the landsurface conditions at various points in the history of the study area. The lithostratigraphic model forms the base upon which the pedostratigraphic model is superimposed. The two models are then combined to develop the site formation model.

## *Stratigraphy*

*Lithostratigraphy.* Following guidelines established in the North American Stratigraphic Code (NASC, North American Commission on Stratigraphic Nomenclature-NACSN 1983), the particle-size distribution data were used to establish a lithostratigraphic classification model for the site. The concept of rock-stratigraphic or lithostratigraphic units has changed little through the years. In the 1961 Code of Stratigraphic Nomenclature (American Commission on Stratigraphic Nomenclature, ACSN 1961) lithostratigraphic units are defined simply as a subdivision of the rocks in the earth's crust, distinguished and delimited on the basis of lithologic characteristics. In the 1983 North American Stratigraphic Code (NACSN 1983), lithostratigraphic units fall under Material Categories Based on Content or Physical Limits. In these categories, emphasis is placed on the relative objectivity and reproductivity of data used in defining units within each category. Lithostratigraphic units in the NACSN (1983) system are defined as "a stratum or body of strata distinguished and delimited on the basis of lithic characteristics and stratigraphic position, generally but not invariably layered, generally but not invariably tabular, and which conforms to the Law of Superposition." Lithic characteristics include composition, texture, fabric, structure, and color. By definition, lithostratigraphic units are independent of inferred geologic history and of time concepts.

Boundaries of lithostratigraphic units may be placed at clearly distinguished contacts, or drawn arbitrarily within a zone of gradation. Both vertical and lateral boundaries are based on the lithic criteria that provide the greatest unity and utility. Unconformities, where based on recognizable objective lithic criteria, are ideal boundaries for lithostratigraphic units (NACSN 1983).

Stein (1990) discusses the use of standard stratigraphic nomenclature in archaeological studies, along with stratigraphic systems developed specifically by archaeologists, and concludes that in archaeology, strata are differentiated in the same manner as in geology (lithic characteristics) but on a vastly different scale (centimeters as opposed to meters). Gasche and Tunca (1983) proposed a new category of lithologic unit in archaeological stratigraphy: three dimensional bodies characterized by a dominant lithologic type, or combination of types. Lithologic units are divided into "Layers" (the basic unit used in stratigraphic correlation), "Sublayers," and "Inclusions." Stein (1990) discussed the classification system of Gasche and Tunca (1983), and concluded that a new type of lithostratigraphic unit was unwarranted. Instead, she proposed a new rank of lithostratigraphic unit, the Layer, that is smaller than the existing unit of lowest rank (the Bed).

As noted by Stein (1990), the main difference between the proposed Layer and formal lithostratigraphic units is one of scale, and the subsequent requirement that Formations, Members, and Beds be mappable on a geologic scale. The "mapping" of Layers on an archaeological site scale was not discussed by Stein (1990).

In this study, we have incorporated the ideas presented by Stein (1990), and define the Layer as an informal lithostratigraphic unit, unique to a specific study area, and not necessarily correlatable across the entire site. Because of the great variance in thickness and contained facies in alluvial sequences, lithofacies correlation is virtually impossible (Vento and Rollins 1989). Any lithostratigraphic unit of a larger scale that can be correlated beyond a specific site should fall into the category of the Bed.

The lithostratigraphic model for the Memorial Park site is presented in Figure 17. This west (Block 6) to east (Block 1) transect can be divided roughly into two sections. The west section (Blocks 4-6) consist of thinner, more numerous layers, while the east section (Blocks 1-3) consist of fewer, thicker layers. The layers over the entire site can be grouped into four types: 1) fining upward, 2) coarsening upward, 3) spike, and 4) vertically uniform. Fining-upward and coarsening-upward layers are self explanatory and are correlated from column sequences in which

①

# EXCAVATION BLOCKS

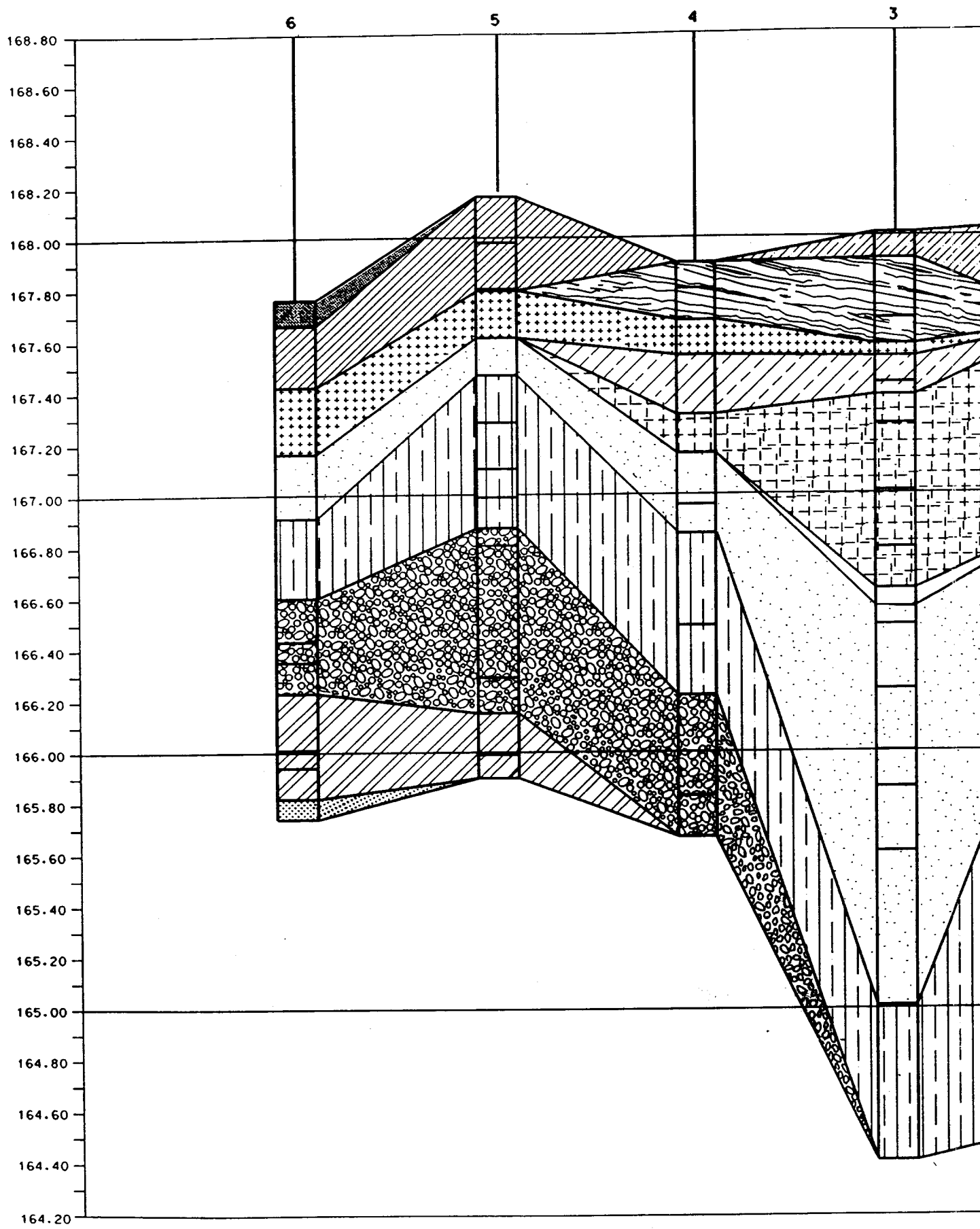

89-412-82

DWG. NO.

DATE

APPROVED

CHECKED







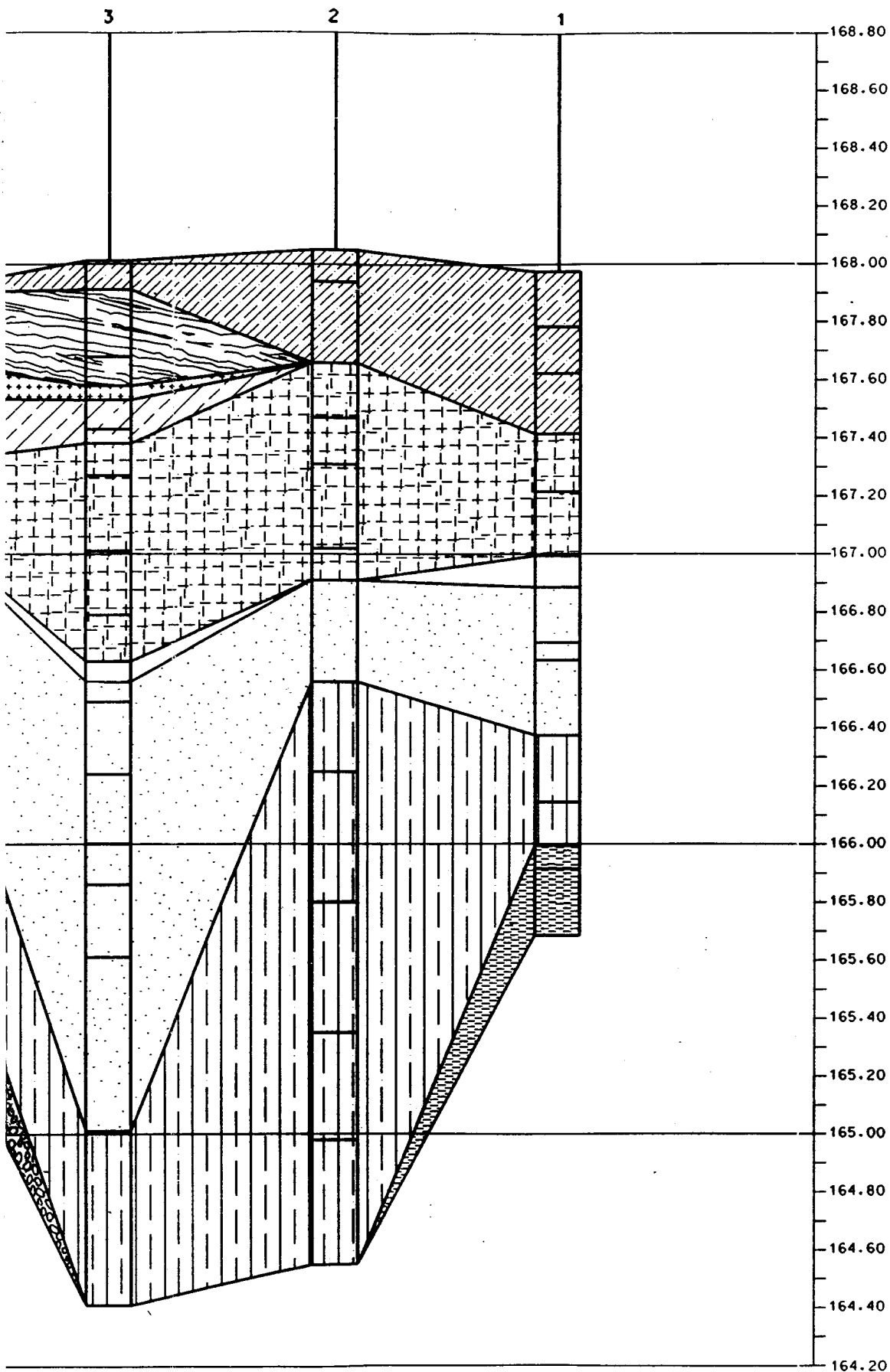







DRAWN



3 BLOCKS



KEY

-  - LAYER 1  
FINING UPWARD
-  - LAYER 2  
VERTICALLY UNIFORM
-  - LAYER 3  
COARSENING UPWARD
-  - LAYER 4  
FINING UPWARD
-  - LAYER 5  
FINING UPWARD
-  - LAYER 6  
SPIKE (COARSE)
-  - LAYER 7  
VERTICALLY UNIFORM
-  - LAYER 8  
SPIKE (COARSE)
-  - LAYER 9  
COARSENING UPWARD
-  - LAYER 10  
VERTICALLY UNIFORM
-  - LAYER 11  
COARSENING UPWARD
-  - LAYER 12  
FINING UPWARD
-  - LAYER 13  
COARSENING UPWARD
-  - LAYER 14  
FINING UPWARD







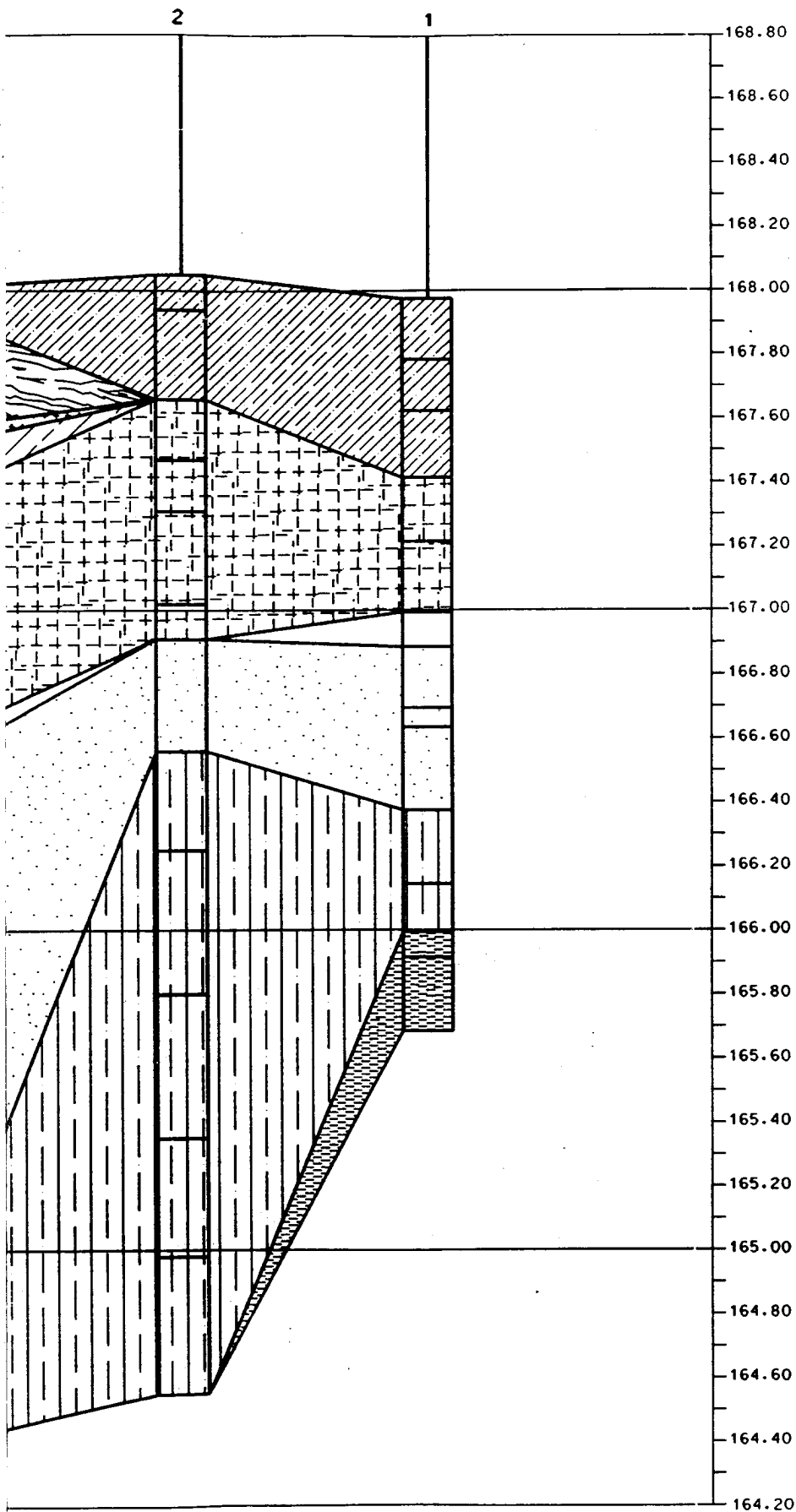







ELEVATION IN METERS-ASML

113  
114

FIGURE  
LITHOSTRATIGRAPHIC  
MODEL



**KEY**

-  - LAYER 1  
FINING UPWARD
-  - LAYER 2  
VERTICALLY UNIFORM
-  - LAYER 3  
COARSENING UPWARD
-  - LAYER 4  
FINING UPWARD
-  - LAYER 5  
FINING UPWARD
-  - LAYER 6  
SPIKE (COARSE)
-  - LAYER 7  
VERTICALLY UNIFORM
-  - LAYER 8  
SPIKE (COARSE)
-  - LAYER 9  
COARSENING UPWARD
-  - LAYER 10  
VERTICALLY UNIFORM
-  - LAYER 11  
COARSENING UPWARD
-  - LAYER 12  
FINING UPWARD
-  - LAYER 13  
COARSENING UPWARD
-  - LAYER 14  
FINING UPWARD

ELEVATION IN METERS-ASML

113  
114

**FIGURE 17**

**LITHOSTRATIGRAPHIC  
MODEL**

the texture becomes increasingly finer, or increasingly more coarse, toward the surface. The spikes are defined as thin interruptions in an otherwise gradual sequence, generally consisting of one or two samples, and are usually coarse. Vertically uniform layers are derived from correlated sequences in columns in which the proportion of sand, silt, and clay remain uniform over some vertical distance.

The layers depicted in Figure 17 are the Layers in the lithostratigraphic classification of the site. Starting from the top of the model, Layer 1 is fining upward and occurs over the eastern one-half of the site. It is thickest in Block 1, and thins to the west where it onlaps Layer 2. Layer 2 is vertically uniform and occurs in the middle of the site (Blocks 3 and 4). Layer 3, coarsening upward, overlaps Layer 2 and occurs in the westernmost portion of the site (Blocks 5 and 6). Layer 4, a fining-upward sequence, is only identified in Block 6 where it overlies Layer 3. Layer 4 may be correlated with Layer 1 and separated by an erosion surface. Layer 5 occurs as a relatively thin, fining-upward unit over the western 2/3 of the site (Blocks 3-6). Layer 5 is underlain by the coarse spike Layer 6 in Blocks 3 and 4. Layer 7 is a relatively thick, vertically uniform unit that occurs in the eastern two-thirds of the site (Blocks 1-4) and pinches out before Block 5. Layer 7 is separated from Layer 9 by the coarse spike, Layer 8, in the eastern half of the site, but onlaps Layer 9 near Block 4. Layer 9, a coarsening-upward unit, occurs across the site. It is thickest in Block 3, thins slightly to the east, and becomes very thin in Blocks 4, 5, and 6. Layer 9 is underlain by the vertically uniform Layer 10 across the entire site. Layer 10 reaches its greatest thickness in Block 2 where it is 2 meters or more thick. It thins to the west where the thickness is relatively uniform across Blocks 3-6. To the east, in Block 1, Layer 10 is underlain by the coarsening upward Layer 11. Layer 11 may be a coarse spike in an otherwise thick Layer 10. Layer 10 is the deepest unit sampled in Blocks 2 and 3. The units below Layer 10, except for Layer 11 discussed above, are found in Blocks 4-6. Layer 12 is fining upward and is the deepest unit sampled in Block 4. It reaches its greatest thickness in Block 5 where it is underlain by the coarsening upward Layer 13. Layer 13 becomes thickest in Block 6, and there is underlain by the fining upward Layer 14. Layer 14 is only found in Block 6.

The interpretation of each of the types of layers and of the lithostratigraphic model is based on a discussion of facies models by Blatt et al. (1980). As discussed earlier, the overall vertically uniform distribution of the proportions of sand, silt, and clay indicate deposition by overbank floodwaters with slight variations in the competence of the depositing currents (Gray 1984; Vento and Rollins 1989). Fining-upward sequences in a fluvial plain, or broad aggradational floodplain, are indicative of lateral accretion by the slow migration of river channels. Coarsening-upward sequences indicate an increase in current velocity. A crevasse splay is a coarsening-upward subdelta that forms when local natural levees are washed away or otherwise breached during periods of high flow. Channel fill deposits and channel lag deposits tend to be the most coarse deposits in a typical alluvial sequence. A coarsening-upward sequence might be interpreted as the result of the nearby development of a channel, and the subsequent increase in current velocity.

Vertically uniform sequences result from overbank flooding and the associated vertical accretion. During overbank flooding the more coarse fraction accumulates to form natural levees bordering large, relatively stable channels, and the finer fractions (silt and clay) accumulate in low points, such as shallow lakes or backswamps. In aggrading floodplains, vertical accretion is generally important in meandering systems. Spike deposits result from a crevasse splay-type of mechanism.

The geomorphic scenario that emerges from the lithostratigraphic model is that of a hybrid-point bar, natural levee on the western half of the site, and a channel fill or abandoned meander on the eastern half of the site. The hybrid-point bar, natural levee landform resulted from lateral accretion as a stream channel migrated to the east (Layers 14, 12, 5, 4), punctuated by periodic overbank flooding (Layers 10, 7, 2), and splay development (Layers 13, 9, 6, 3). The channel fill consisted largely of vertical accretion overbank deposits that filled the abandoned meander from

backwater deposition at one time (Layer 10) that was later downcut by channel erosion and partially filled with coarsening-upward channel deposits (Layer 9). Subsequently, the channel was filled in by periodic overbank deposition (Layers 7, 2), splay deposition (Layers 8, 6) and, eventually, lateral accretion (Layers 5, 1), as the channel migrated further eastward. The alluvial geomorphic history of a specific site, or even several sites is, by nature, fragmentary (Gladfelter 1983). Not all erosional or depositional events are preserved. Soil formation and the resultant soils account for a significant portion of the time interval contained in an alluvial geomorphic history. Thus, the pedostratigraphic model was developed to interpret those periods of time marked by relative landscape stability and little or no deposition. The geomorphology of the site will be discussed in greater detail in the site formation model section.

*Pedostratigraphy.* Soils are three-dimensional natural bodies, on the earth's surface, intimately related to the landscape, containing living matter, and capable of supporting vegetation out-of-doors (Soil Survey Staff 1975; Holliday 1990). Soils consist of one or more horizons which are generally parallel to the earth's surface, and that differ from the underlying material as a result of the interactions, through time, of climate, living organisms, parent materials, and relief. Pedologic horizons are products of soil formation (pedogenesis), that develop in situ, subsequent to the formation of the lithostratigraphic unit on which the soil occurs (NACSN 1983).

Pedostratigraphic units, like lithostratigraphic units, are in the category of Material Categories Based on Content or Physical Limits (NACSN 1983). In the NACSN (1983) system pedostratigraphic units are defined as buried, traceable, three dimensional bodies of rock that consist of one or more differentiated pedologic horizons. Pedologic horizons are developed on one or more lithostratigraphic units and are overlain by one or more formally defined lithostratigraphic units. This concept differs somewhat from that outlined for soil-stratigraphic units in the 1961 Code (ACSN 1961) by being more specific with regard to content, boundaries, and the basis for determining stratigraphic position. In the 1961 Code (ACSN 1961), a soil-stratigraphic unit is defined as a soil with physical features and stratigraphic relations that permit its consistent recognition and mapping as a stratigraphic unit.

In the NACSN (1983) system, the upper boundary of a pedostratigraphic unit is the top of the uppermost pedologic horizon in a buried soil profile. The lower boundary of a pedostratigraphic unit is the lowest definite physical boundary of a pedologic horizon within a buried soil profile. The boundaries and stratigraphic position requirements of the formal pedostratigraphic units help define the only formal rank, that of the geosol. Thus, a geosol consists of the identifiable portions of the A and B horizons of a buried soil and excludes O and C horizons.

An important distinction between geosols and other stratigraphic units is that a single geosol may be formed in situ in lithostratigraphic units of diverse compositions and ages. In other words, a single geosol may transgress several lithostratigraphic units. The boundaries of geosols are independent of time concepts and, potentially, are time-transgressive. Concepts of time spans, however measured, play no part in defining the boundaries of a pedostratigraphic unit (NACSN 1983).

The International Association for Quaternary Research (INQUA) defines the formal pedostratigraphic unit, the pedoderm, as similar to the geosol (Birkeland 1984). The exception is that the pedoderm does not have to be buried and can include exhumed or relict paleosols.

The formal definition of pedostratigraphic units, geosols, or pedoderms, appears to be too rigid for use in this and similar projects. The requirement of being overlain by formally defined lithostratigraphic units cannot be met at this site, and probably cannot be met at most archaeological sites occurring in Holocene alluvial landscapes, because these landscapes contain too many facies variants to permit lithocorrelation (Vento and Rollins 1989). A more informal unit is needed to



address the scale of archaeological excavations. The term paleosol, as currently used in North America for any soil that formed on a landscape of the past, may be a more appropriate unit. Paleosols may be a buried soil, a relict (surface) soil, or an exhumed (surface) soil (NACSN 1983).

In Soil Taxonomy (Soil Survey Staff 1975), a buried soil is a soil with a surface mantle of new material that is 50-cm-or-more thick, or if there is a surface mantle between 30 and 50 cm thick and the thickness of the mantle is at least half that of the named diagnostic horizons that are preserved in the buried soil. By surface mantle, the definition indicates relatively unaltered materials or C-horizon type materials. This definition, less rigid than the geosol concept, allows for the inclusion of entire profiles, more critical on the scale of archaeology. The definition of buried soils also does not require being overlaid by formally defined lithostratigraphic units.

The informally defined buried soil should be used for stratigraphic delineation in archaeological studies. The requirements of the overlying mantle (Soil Survey Staff 1975) can be modified to include thinner mantles and a wider variety of materials. Thus, a buried soil will be defined in this study as an identifiable soil profile (A horizon and underlying B and/or C horizons) buried beneath a mantle of pedologically-differing materials. The mantle can be as thin as a few centimeters if the contrast between it and the underlying buried soil is distinct. Pedologically differing materials include C horizon materials (relatively unaltered), or B horizon materials overlying a buried A horizon. A buried soil could be delineated where a soil profile is immediately overlain by the B horizon of the next overlying buried soil. The B-horizon-over-A-horizon sequence is the reverse of a normal profile sequence and indicates the boundary between a buried soil and the overlying materials. In complex buried soils there is an overlap of one soil profile upon another. If the A horizon is gone due to erosion, then it must be demonstrated that adjacent B horizons, or C horizons over B horizons, come from different profiles and reflect differing soil forming periods, before a buried soil can be delineated.

The concept of a soil profile being a vertical sequence of soil horizons, with the horizons falling into a specific sequence, is a pedologic paradigm that must be carefully incorporated into stratigraphic considerations. The normal A-B-C-horizon sequence is a function of the earth-surface pedological environment and does not necessarily obey the Law of Superposition. This law states that in a sequence of undisturbed strata, the youngest strata is at the top of the sequence and the oldest strata is at the base (AGI 1976). The lithostratigraphic units on which the buried soils are formed obey the law. Because soil horizons do not obey the law, they cannot be considered as separate stratigraphic units. The entire soil profile can be considered as a single stratigraphic unit. In the NACSN Code (1983), a statement is made that the physical boundaries of buried pedologic horizons are objective traceable boundaries with stratigraphic significance. This is true for the top of the profile and the bottom of the profile, but not necessarily true for the individual horizon boundaries.

With the above discussion in mind, the pedostratigraphic model of the Memorial Park site is presented in Figure 18. Seven buried soils are identified across the study area, differentiated on the basis of pedologic properties and correlated on the basis of radiocarbon dates and diagnostic artifacts. Buried soils were delineated from the top of a buried A horizon and down to and including all associated subsoil horizons (B and/or C horizons). In some cases, the buried soils at Memorial Park are simply stacked one on top of the other, the bottom of one profile being defined by the top (A horizon) of the next underlying profile. No overlap of the profiles is discernible. In other cases, the profiles overlap to produce a complex pedostratigraphic unit. This is especially notable on the west side of the study area where the buried soil with the fragipan (Buried Soil 4) overlaps two underlying and less developed soils as evidenced by the existence of Ab (buried) horizons within the fragipan Bx horizons. The interpretation is that the fragipan containing soil, Buried Soil 4, formed later than the underlying Buried Soils 5 and 6. The pedologic environment for 4 was more intense, resulting in a thicker, more mature (more strongly developed) profile that overlapped 5 and 6. This is the concept of the composite geosol as discussed by Morrison (1978).

Buried soils were correlated across the site using radiocarbon dates and diagnostic artifacts. Birkeland (1984) indicated that such dates should not be accepted at face value because soil systems are complex, with both new and old carbon being introduced or exchanged in the soil. Radiocarbon dates from A horizons of surface soils include the influence of organic matter varying from that fraction being added daily, to that synthesized and resynthesized over several thousand years. The dates that reflect this dynamic system are mean residence times (MRT). The MRT are important in dating buried A horizons to obtain a limiting date on overlying deposits. In archaeological sites, carbon deposited as a result of cultural activities might have a major effect on the resulting assay. This can be demonstrated by a correlation of bulk soil dates, diagnostic artifacts, and assays, obtained from cultural features.

Buried Soil 1 occurs in the southeastern portion of the study area. It is correlated through blocks 7, 15, 11 and 12. In Block 7, the uppermost unplowed A horizon had a radiocarbon date of 1470 B.P. Buried Soil 1 is an immature soil with a thin, faint A horizon and a weakly-formed cambic B horizon.

Buried Soil 2 is correlated across the entire study area. It underlies Buried Soil 1 in the eastern half of the site, and is the uppermost buried soil in the western half. Buried Soil 2 is thin and not well defined in the northwest corner of the site (Block 6). Over the rest of the site, it is a moderately-thick soil, with an A horizon more developed than that in Buried Soil 1 and a moderately well-developed cambic Bw horizon. The cambic horizon in blocks 10, 11, and 12 of the eastern portion of the study area consisted of alternating bands (lamellae) of yellowish (10YR hue) more silty sediments, and redder (7.5YR hue) more clayey sediments. As discussed earlier, these lamellae are believed to be illuvial in origin. Radiocarbon dates associated with the correlation of Buried Soil 2 ranged from 2830 to 3590 B.P. Within Buried Soil 2 are two or more incipient A horizons underlain by Bw or C horizons, most notably in blocks 3 and 7. These faint, weakly developed A horizons represent the least developed, youngest soils occurring on a landscape that is susceptible to relatively rapid burial.

Buried Soil 3 is correlated across the study area. Where it occurs, Buried Soil 3 is a thin, relatively immature soil with a thin, faint A horizon and a weakly formed cambic Bw horizon, or as in blocks 1, 2 and 3, an underlying C horizon. In the western portion of the site, Buried Soil 3 was difficult to differentiate from the strongly developed Buried Soil 4. In this portion of the site Buried Soil 3 is little more than an A horizon, which may be a vertical extension of the A horizon from Buried Soil 4 caused by developmental upbuilding (Johnson and Watson-Stegner 1990).

Buried Soil 4 was correlated across the entire study area and represents the most strongly developed buried soil at the study area. In the eastern one-half of the site it occurs as a moderately well-developed A horizon underlain by a well-formed cambic Bw horizon. In the western one-half of the site, the B horizon was a fragipan Bx or Btx horizon. Fragipans are strongly expressed subsoil horizons that are the result of a significant period of landscape stability (Foss and Collins 1987). Bilzi and Ciolkosz (1977) indicated that it probably requires >2000 years for a fragipan to form in alluvial sediments in Pennsylvania. The profile of Buried Soil 4 was over 1 m thick in places and overlapped, or was superimposed, over buried soils 5 and 6 (Blocks 4, 5, 8, 9, 13, and 16). Radiocarbon dates associated with the correlation of Buried Soil 4 ranged from 4035 to 5025 B.P.

Buried Soil 5 was correlated across most of the site. In the eastern half of the site, it consisted of a thin, faint A horizon underlain by a weakly developed cambic Bw horizon, or by a C horizon. This soil is the deepest buried soil encountered in the eastern portion of the site. In the western one-half of the site, Buried Soil 5 was difficult to delineate because it was overprinted by Bx or Btx fabric. Any B horizon development associated with Buried Soil 5 was indistinguishable from the fragipan. Buried Soil 5 was not delineated in Block 6. Radiocarbon dates associated with the correlation of Buried Soil 5 ranged from 5790 to 6355 B.P.

Buried Soil 6 was delineated across the western half of the site. This steeply sloping soil was overprinted by the fragipan in blocks 5, 8 and 9. In blocks 4 and 13, Buried Soil 6 was the deepest buried soil encountered and was defined by a thin A horizon at the base of Block 13. In blocks 6 and 14, Buried Soil 6 was faint and difficult to delineate. Radiocarbon dates associated with correlation of Buried Soil 6 ranged from 6720 to 6830 B.P.

Buried Soil 7 was the oldest and least extensive buried soil delineated during this study. This buried soil was correlated across blocks 5 and 6. In both cases it consisted of a thin, faint A horizon underlain by a cambic Bw horizon. Two radiocarbon dates were associated with this soil;  $7090 \pm 80$  B.P. from the 7Ab horizon of Block 6, and  $7045 \pm 210$  B.P. from the 6BCb horizon of Block 5.

The pedologic record above the stripped surface was delineated from the Block 7 profile, the south wall profile of the stripped area, and profiles exposed in test units 1, 14, and 27. From these observations, the sequence of materials consists of fill materials, a thin ash/cinder layer, two plowzones, and the remnants of an unplowed A horizon. The thickness of the fill materials varied from 30 to 60 cm. The fill was subdivided in Block 7, based on color, texture, and structure. These subdivisions may represent different filling episodes and/or different fill materials. An incipient A horizon existed at the surface. The ash/cinder layer was a dark, loose sandy material at irregular depths and irregular thickness across the site. The two Ap horizons were differentiated by color. The upper Ap horizon was brown (10YR 4/3), and the lower Ap horizon was dark-brown (10YR 3/3). Both of these horizons had weak granular structure which was the main criteria used to separate them from the underlying Ab horizon. In some places on the south wall, the two Ap horizons could not be differentiated. The underlying buried A horizon (3Ab horizon of Block 7) was dark-brown (10YR 3/3) and had a moderate grade of granular structure, indicating the lack of intensive cultivation. The underlying B horizon was faint and relatively thin (3BAb horizon of Block 7). In the south wall, the Bw horizon, underlying the buried A and Ap horizons, was brighter colored (higher value and chroma) and thicker than in Block 7.

#### SEDIMENTATION AND PEDOGENESIS

The sedimentation and pedogenesis model for the Memorial Park site is presented in Figure 19. This model was derived by combining elements of the lithostratigraphic model (Figure 17) and the pedostratigraphic model (Figure 18). The lithostratigraphic model forms a base upon which the pedostratigraphic model is superimposed. Superimposition is critical to the interpretation of boundary conditions. Soil horizons can be influenced by, but are not necessarily coincident with, lithologic boundaries. Soil horizons are time-transgressive and litho-transgressive and, thus, younger than lithologic boundaries.

In the same sense, the ethnostratigraphic model (Stein 1990) is superimposed over the pedostratigraphic model. Cultural features and artifacts associated with a certain geomorphic surface transgress soil boundaries and, thus, are younger than soil boundaries. Feature fill materials are commonly the youngest materials occurring at a particular elevation. However, subsequent burial and/or pedogenesis would then supersede underlying materials.

At any given time in a fluvial setting, a variety of depositional environments represented by a variety of deposits, some with soils formed on them, occur at the surface. A soil forming at this time (pedogenesis) leaves a pedological record on all of these deposits. This "landsurface" is the geomorphic surface described by Ruhe (1956). It includes all soil types or facies existing on a landsurface during a particular period of time. These soil types or facies vary both in the materials in which they are formed, and in their degree of development.

### EXCAVATION BLOCKS

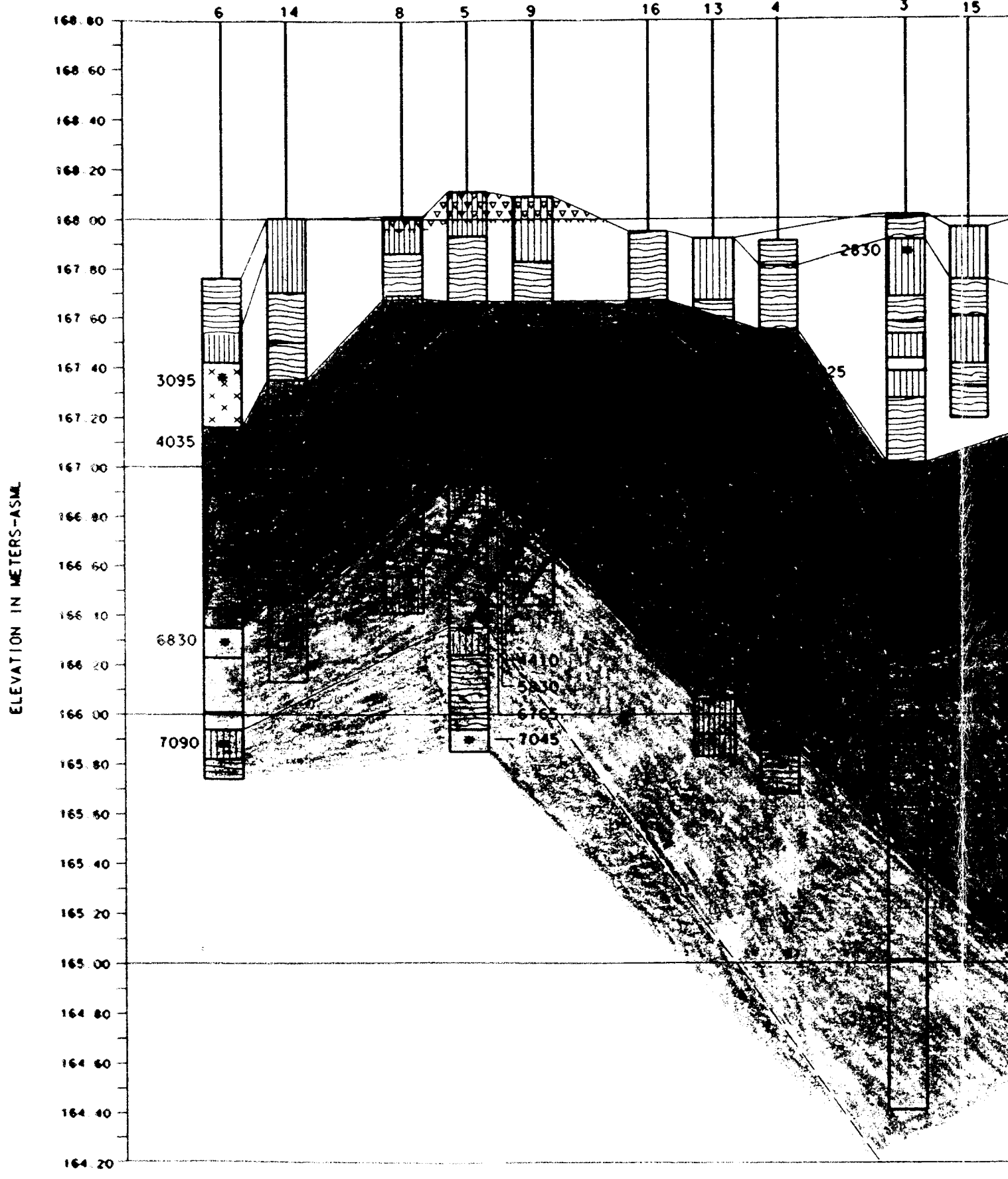

DCKS

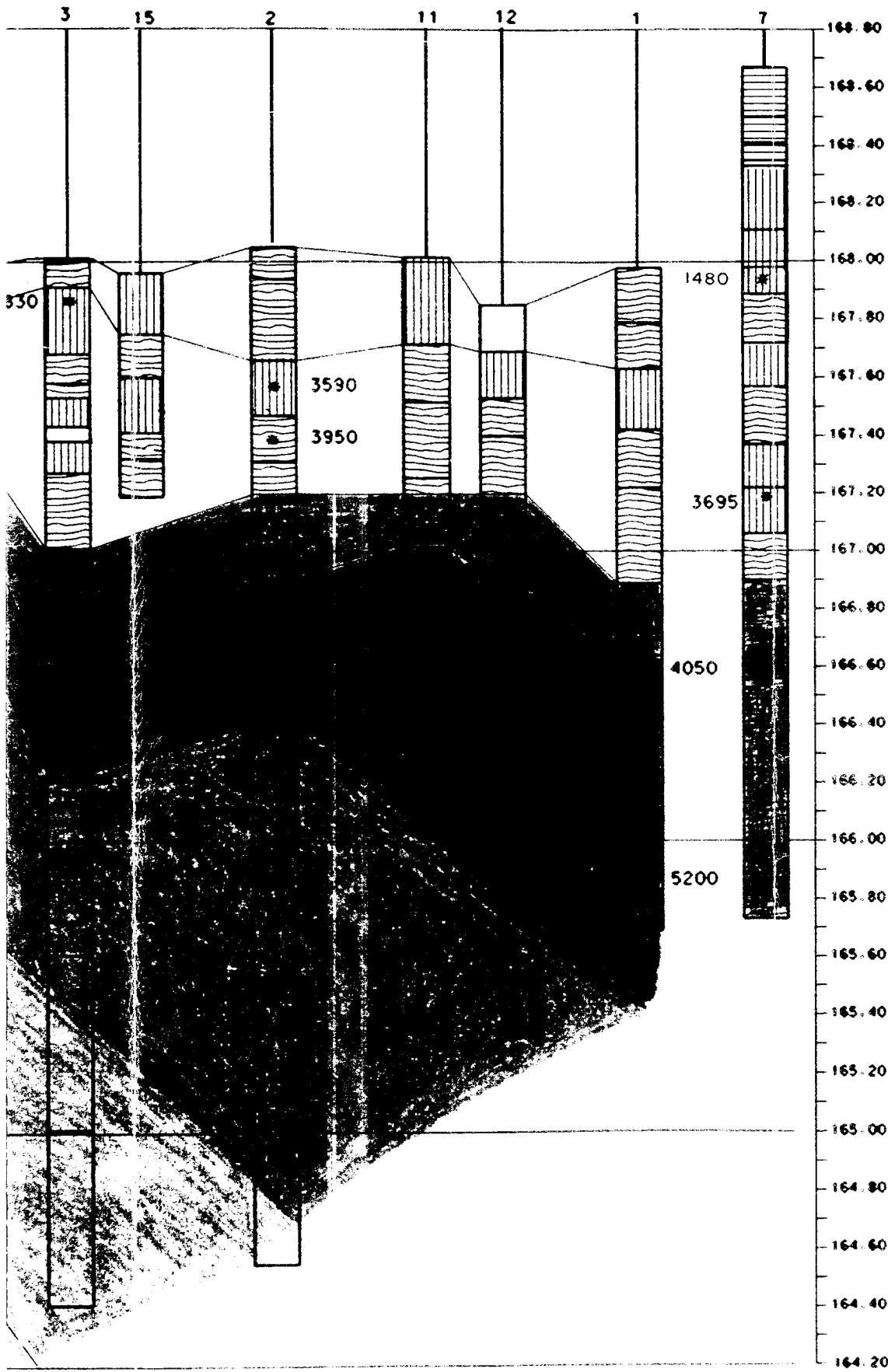

KEY:

HORIZONS

- Ab HORIZONS
- Bwb HORIZONS
- Bxb or B+xb HORIZONS
- C or BC HORIZONS
- FILL MATERIAL

BURIED SOILS

- BURIED SOIL 1, [TERMINAL ARCHAIC (ORIENT) ARTIFACTS]
- BURIED SOIL 2, [TERMINAL ARCHAIC ARTIFACTS]
- BURIED SOIL 3, [PIEDMONT (LATE ARCHAIC) ARTIFACTS]
- BURIED SOIL 4, [LATE LIAISON (LATE ARCHAIC) ARTIFACTS]
- BURIED SOIL 5, [EARLY LIAISON (LATE ARCHAIC) ARTIFACTS]
- BURIED SOIL 6, [NEVILL (MIDDLE ARCHAIC) ARTIFACTS]
- BURIED SOIL 7, [NEVILL (MIDDLE ARCHAIC) ARTIFACTS]

OTHER CHARACTERISTICS

- RADIO CARBON DATES IN
- INFERRED BOUNDARY
- MIDDEN

ELEVATION IN METERS-ASML

FIGURE 18

PEDOSTRATIGRAPHIC MODEL

3

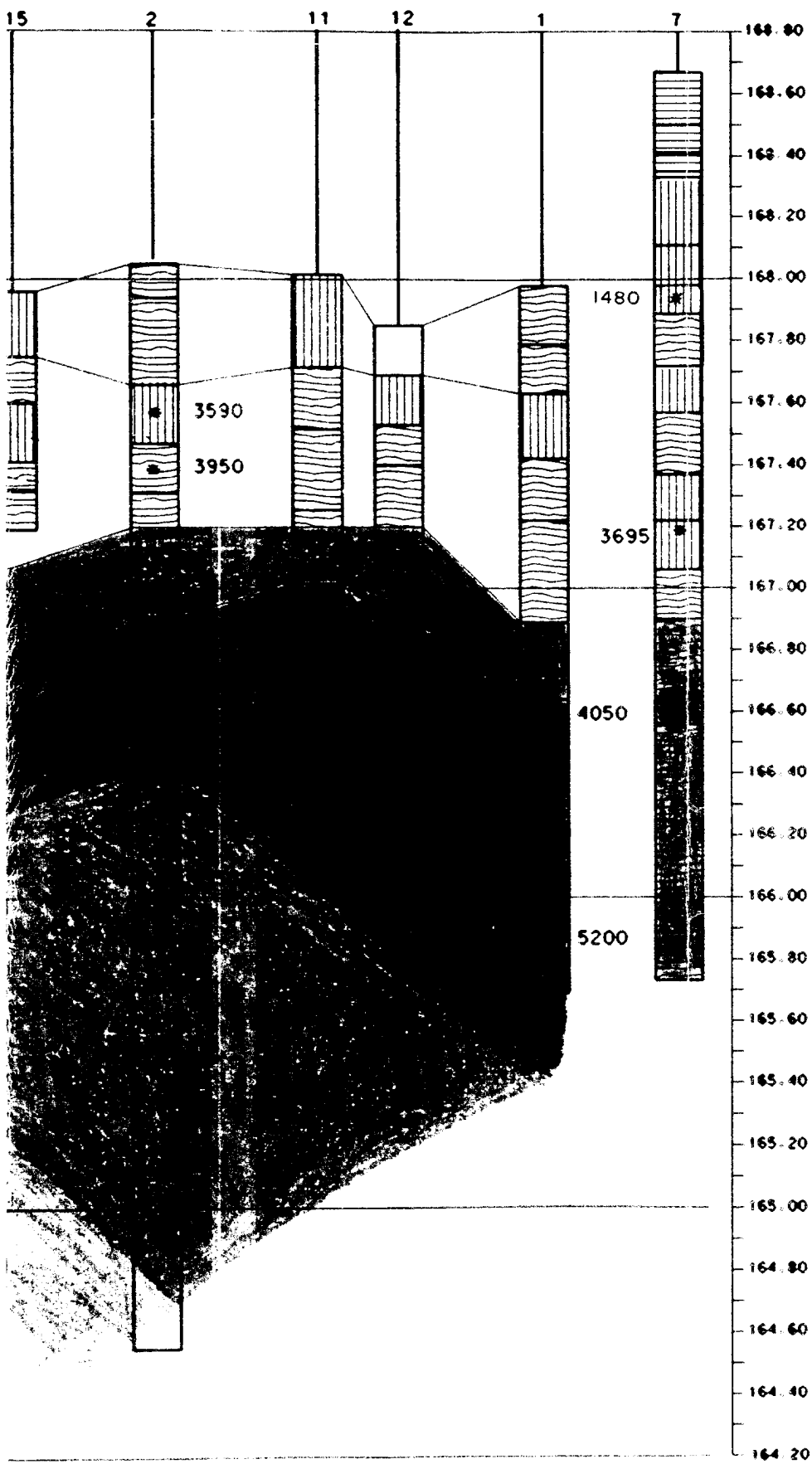

KEY:

HORIZONS

- Ab HORIZONS
- Bwb HORIZONS
- Bxb or Bt**x**b HORIZONS
- C or BC HORIZONS
- FILL MATERIAL

BURIED SOILS

- BURIED SOIL 1, [TERMINAL ARCHAIC (OFIENT) ARTIFACTS]
- BURIED SOIL 2, [TERMINAL ARCHAIC ARTIFACTS]
- BURIED SOIL 3, [PIEDMONT (LATE ARCHAIC) ARTIFACTS]
- BURIED SOIL 4, [LATE LAURENTIAN (LATE ARCHAIC) ARTIFACTS]
- BURIED SOIL 5, [EARLY LAURENTIAN (LATE ARCHAIC) ARTIFACTS]
- BURIED SOIL 6, [NEVILLE (MIDDLE ARCHAIC) ARTIFACTS]
- BURIED SOIL 7, [NEVILLE (MIDDLE ARCHAIC) ARTIFACTS]

OTHER CHARACTERISTICS

- RADIO CARBON DATES IN YEARS B.P.
- INFERRED BOUNDARY
- MIDDEN

FIGURE 18

---

PEDOSTRATIGRAPHIC  
MODEL

Associated with any particular geomorphic surface are the cultural record(s), or features and artifacts, of the people that lived on that geomorphic surface. The association is not necessarily spatially precise because artifacts can move vertically and horizontally after site occupation (Schiffer 1983; Hofman 1986; Johnson and Watson-Stegner 1990). However, some features can be spatially precise.

During the early Holocene (8000-10000 B.P.), the West Branch of the Susquehanna River was carrying and depositing a large volume of sediments. The cause of this phase of alluviation/aggradation was the expansion of tributary streams supplying an increase in sediment yields to the river and its main tributaries (Vento and Rollins 1989). Knox (1983) also describes the early Holocene as a time of active alluviation in the Eastern Woodlands of the United States. Although no coarse alluvial sediments were found during the current study, Vento and Rollins (1989) describe sands and gravels at Kettle Creek, the Sinnemahoning River, and at the confluence of Black Moshannon Creek and the West Branch. The latter were found at a depth of approximately four meters.

By the Middle Holocene (4500-8000 B.P.), the stream was transporting and depositing finer materials, an indication that stream velocities were lower, and depositional modes were more of the overbank type. Deposits for the study area may have been influenced by both the main channel of the West Branch, north of the site, and by the channel that travels south of Great Island (the "south channel") to the east of the site. The south channel appears to have migrated eastward during the Late Pleistocene-Early Holocene to its present position. A filled-channel remnant of an earlier position, in the area of Block 3, adjacent to an older, topographically higher ridge is indicated by the lithostratigraphic and pedostratigraphic models (figures 17 and 18). The topographically lower channel contains a wider variety and subsequently younger deposits than portions of the site at similar elevations. This possible buried-channel remnant was suggested by Neumann (1989) in the area of the Phase II test unit 4.

The earliest deposit excavated during the current study was Layer 14 on the western side of the site (Block 6). The fining-upward sequence in particle size is indicative of lateral accretion from a migrating channel. This was followed by an increase in channel velocity and a coarsening-upward deposit (Layer 13). Buried Soil 7 formed on these two deposits during a period of landscape stability. The radiocarbon date of approximately 7050 B.P. is used to define the burial of the soil and is earlier than any soil dates reported by Neumann (1989). Vento and Rollins (1989) define a buried soil dated at 6040 B.P. at a depth of 2.5 meters in an idealized profile of Gould Island, North Branch of the Susquehanna River, underlain by sand and pea-size gravel. Buried Soil 7 at Memorial Park is a weakly-formed alluvial soil that was probably no more than 300-500 years old when it was buried.

Layer 12 represents a fining-upward sequence of sediments, resulting from lateral accretion associated with a migrating channel. Layers 12, 13, and 14 appear to have been eroded somewhat on the west side, and particularly on the east side, of the site. Layer 12, along with Layers 13 and 14, defines a north-south-trending ridge on the west side of the site. The axis of the ridge appears to be centered around Block 5.

Layer 11, a coarsening-upward, channel-splay deposit, formed on the east side of the study area due to actions of the south channel at approximately the same time Buried Soil 6 was forming on Layers 12 and 13. This weakly-developed soil is radiocarbon dated to approximately 6800 B.P., an indication of its youthfulness upon burial.

Layer 10 represents a vertically uniform deposit indicative of vertical accretion from a ponding or still water event, such as overbank flooding. Layer 10 is correlated across the site; thus, we assume that the depositional event may have been of a large magnitude. Vento and Rollins (1989) suggest that the stratigraphic record of the Susquehanna basin after 6000 B.P.,

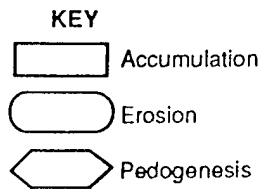
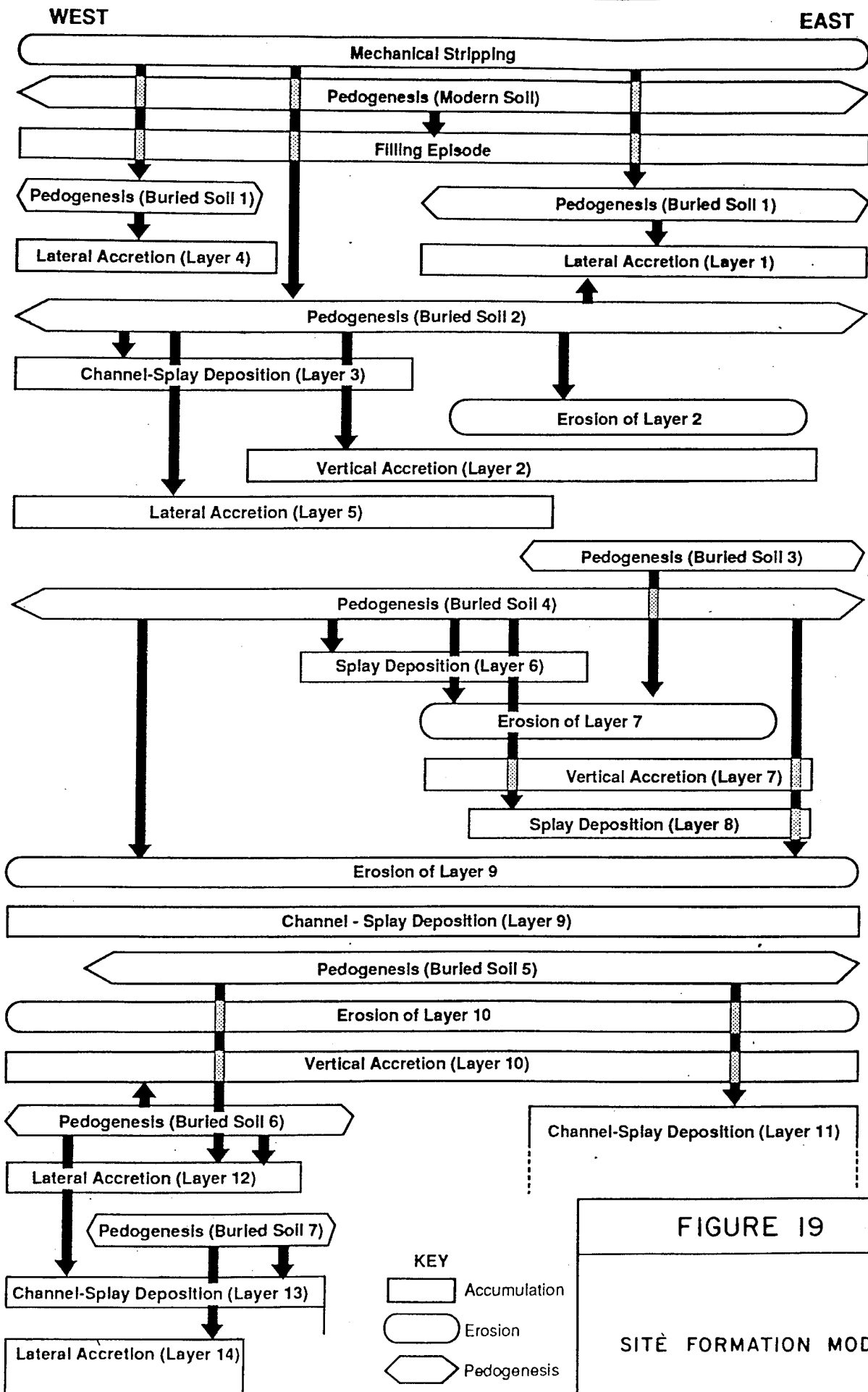

FIGURE 19  
SITE FORMATION MODEL



coarse-grained vertical and lateral accretionary deposits, indicates the increased occurrence of large floods resulting from slow-moving cyclonic storms. In places, the deposition of Layer 10 must have been slow enough that formation of the A horizon of Buried Soil 6 kept pace. The result was developmental upbuilding as the surface-added materials were pedogenically assimilated into the profile (Follmer 1982; Johnson and Watson-Stegner 1990). Subsequent erosion of Layer 10 is especially evident in the former channel and on the east side of the site. Layer 10 was preserved at the highest elevation near Block 5.

Buried Soil 5 formed mostly in Layer 10, but on the west side of the study area it is also superimposed on Layer 12. This soil represents a geomorphic surface associated with the incision of Layer 10; it is radiocarbon dated to approximately 6000 B.P. The soil's thinness on the west side of the study area may be due to erosion or subsequent pedogenesis associated with Buried Soil 4.

Layer 9, another site-wide deposit, is a coarsening-upward, channel-splay deposit. This material occurs in varying thickness across the site—over 1.5 meters near Block 3, to less than 15 cm near Block 5. The latter may be due to erosion as Layer 9 was incised following deposition. Following the erosion of Layer 9, a number of thin and/or spatially limited deposits were formed.

Layer 8 is a thin, relatively-coarse spike that probably represents a single event splay deposition. Layer 7 is a vertically uniform deposit resulting from vertical accretion. It is correlated from Block 4 eastward, and probably represents an overbank depositional mode coming from the east and backing up against the ridge. Layer 7 was eroded slightly in the area of blocks 4 and 5. Layer 6, a relatively coarse-textured splay deposit, was deposited on top of Layer 7, apparently coming from the west. Layer 6 may be a splay of the ridge.

Following deposition and erosion of Layer 9, and coincident with the deposition of Layers 8, 7, and 6, Buried Soil 4 began forming. Buried Soil 4 is the most strongly developed and thickest soil found during this study. Buried Soil 4 exhibited two facies: the fragipan subsoil to the west, and the cambic subsoil to the east. The fragipan subsoil horizon overlapped Buried Soil 5 in blocks 4, 5, 8, 9, 13, and 16, and Buried Soil 6 in blocks 5, 8, and 9. In the eastern portion of the site, Buried Soil 4 is formed in Layer 9, except in Block 1 where it was formed in Layers 9, 10, and 11. This soil is relatively thin in the middle portion of the site, indicating that a portion of it may have been eroded when layers 9, 8 and 7 were eroded. The radiocarbon dates associated with Buried Soil 4, approximately 4000-5000 B.P., are consistent with the 4200-4500 B.P. dates in which Vento and Rollins (1989) describe typically thick, often mottled, cambic B-horizons attributed to warm and dry conditions (meridional stabilization of the sub-tropic high zone over Pennsylvania). Desiccation has been suggested as the principle cause of fragipan development (Lindbo and Veneman 1987).

Layer 5, a fining-upward deposit formed by lateral accretion, was probably deposited across the entire site and then later eroded on the east side. It was not correlated east of Block 3. It is not apparent whether the sediments came from the main channel or from the south channel.

Buried Soil 3 formed in Layers 9, 8, 7, 6, and in Layer 5 at Block 5. This indicates the time-transgressive and litho-transgressive nature of pedogenesis as Layer 5 and Layer 9 are adjacent layers in Block 5 but are widely separated in Blocks 4 and 3. The radiocarbon dates associated with these layers and soils, in the middle portion of the site, indicate that this was a time period and landscape of rapid accumulation of sediments and development of immature incipient soils. Buried Soil 3 is a thin, faint soil consisting of a thin A horizon and a weakly formed cambic Bw horizon. It may represent an extension of Buried Soil 4 caused by developmental upbuilding. Buried Soil 3 is generally 20 to 30 cm thick except in Block 3, where it is approximately 45 cm thick.

Layer 2, a vertical accretion deposit, occurs in the middle of the site. The geometry of this deposit indicates that it has also undergone extensive erosion, particularly the thinning-out, approaching the ridge near Block 5, and its absence in the eastern portion of the site. The former may be the result of the sediment source being to the east (south channel) and the materials not being deposited above a certain elevation. Its absence in the east appears to be the result of removal by erosion. The deposition of the coarsening-upward Layer 3 occurred either simultaneously or immediately after the deposition of Layer 2. It appears that Layer 3 was also eroded on the eastern side of the site, as it is not correlated past Block 5. Layer 3 is interpreted as being the result of increased channel velocity associated with large flood events, possibly a meandering of the channel(s) closer to the site, or a splay mechanism.

Buried Soil 2, correlated across the site, formed in Layers 2, 3, 5, and at Block 3 in Layer 9. Block 3 contains several faint, incipient A horizons indicative of rapid sedimentation. These cryptic soils (Vento and Rollins 1989) are similar to the subdivided geosol described by Morrison (1978) and might be correlated with Buried Soil 3 or Buried Soil 2. Buried Soil 2 is a moderately thick soil with an easily distinguished A horizon and a cambic Bw horizon. On the east side of the site the Bw horizon consists of lamellae or bands of redder materials (7.5YR hue) and yellower materials (10YR hue). On the west side of the site, in the area of Block 5, the A horizon was associated with a large midden. In Block 6, Buried Soil 2 rests directly on Buried Soil 4. Evidently the conditions conducive to the formation of the fragipan in Buried Soil 4 also occurred in Buried Soil 2 in the area of Block 6. This may be the result of developmental upbuilding where sediment accumulation occurs at a rate conducive to the overthickening of the B horizon (Follmer 1982). Block 6 stratigraphy was difficult to delineate because it appeared to have been subjected to a great deal of disturbance, such as tree fall. The radiocarbon dates associated with Buried Soil 2 range from 2830 to 3950 B.P.

Layers 1 and 4 both formed by lateral accretion, possibly simultaneously. They may be the same deposit that was subsequently eroded from the ridge portion of the site. Buried Soil 1 was formed in these layers. Buried Soil 1 is a thin, faint soil that may have been the surficial soil at the time of European settlement. This soil and the soils above it were probably removed during mechanical stripping over a large portion of the site. A radiocarbon date from Block 7 indicates that the unplowed A horizon remnant, occurring at an elevation of 167.90- 167.98 m AMSL, was approximately 1500 years old. The unplowed A horizon was overlain by two plowzones up to an elevation of 168.30 m AMSL. These probably correlate with Neumann's Soil 2 (1989), and were probably, in historic age, floodplain materials. Above these plow zones was an obvious fill material, Neumann's Soil 1(1989), probably associated with the construction of the airport in the mid-1930s.

### *Stratigraphic Classification Model*

The stratigraphic classification model, shown in Figure 20, was developed to facilitate communication about the Memorial Park site. According to the North American Stratigraphic Code (NACSN 1983), the objective of a system of classification is essential to promoting unambiguous communication in a manner that is not restrictive to scientific progress. More specifically, the understanding of the geometry and sequence of rocks is promoted through stratigraphic classification. Stratigraphic classification, conceptually, is not an interpretative process; it is an objective description of the way strata are found in the field (Stein 1990).

Buried Soil 1, in this report, correlated with Soil 3 in Neumann's (1989), and with similar aged soils described in Vento and Rollins (1989), and by Schuldenrein and Vento (1993) (Figure 21). Buried Soil 1, which occurs on the eastern and extreme western portions of the study area (Fig. 18), contains Terminal Archaic artifacts and features, and is intruded by Early, Middle, and

Late Woodland features. The pollen record at Memorial Park suggested that the environment of this soil was warm and open, possibly riparian.

Buried Soil 2 correlated with Soil 4 of Neumann (1989), and with a buried soil reported in the upper Susquehanna basin (Scully and Arnold 1981) (Figure 21). The latter was reported as a buried A horizon on the lower terrace of the Unadilla River in southern New York. Neumann (1989) described Soil 4 as the most developed, and thickest, soil in the study. Buried Soil 2, in this study, was relatively thick and moderately developed, and contained Terminal Archaic (including Orient) artifacts and features. It was also intruded by Orient and Late Woodland features. The Orient phase was largely represented by a large midden on the western portion of the site in the vicinity of Blocks 5, 8, and 9 (Fig. 18).

Buried Soil 3 and Buried Soil 4 correlated with Soil 6 of Neumann (1989), and with a Late Archaic (4500 B.P.) soil presented on an idealized stratigraphic profile of the Port Huron terrace in the Wyoming Valley (Vento and Rollins 1989) (Figure 21). Neumann's (1989) Soil 5 dated to about 4000 B.P., did not correlate with any buried soils in the current study, or with any buried soil suggested by Vento and Rollins (1989). Neumann (1989) did not provide much information about Soil 6 except that it was only encountered in one backhoe unit, it was less acidic than overlying soils, and that the A horizon contained utilized flakes. Buried Soil 3 of this study contained Late Archaic artifacts and features, predominantly a Piedmont site-specific assemblage, and was intruded by Late Woodland features.

Buried Soil 4 was distributed across the entire study area (Fig. 18). In the western one-half of the study area, Buried Soil 4 was the most strongly developed soil encountered during the current study, and indicated a relatively lengthy period of pedogenesis and/or a more intense environmental setting. The Sub-Boreal climatic phase (4500 to 4200 B.P.) was characterized by warm and dry conditions, probably in association with Meridional stabilization of the sub-tropic high zone over Pennsylvania, or with increased importance of warm/dry zonal flow (Vento and Rollins 1989). The pollen record at Memorial Park (Section XIII) indicated a warm environment that was followed by a generally dry period. These warm, dry conditions were conducive to the formation of the fragipan subsoil of Buried Soil 4. Many authors consider dessication under dry conditions to be a principle process in fragipan development (Linbo and Veneman 1989; Ciolkosz et al. 1992). Buried Soil 4 contained Late Archaic artifacts and features, represented by a late Laurentian site-specific assemblage, and was intruded by Late Woodland features.

Buried Soil 5 was not correlated with any soils described by Neumann (1989), presumably due to the deeper excavations in this study. The radiocarbon dates associated with Buried Soil 5 do correlate with the 6040 B.P. date of a Late Archaic Ab3 horizon from the idealized stratigraphic profile of Gould Island, North Branch of the Susquehanna River (Vento and Rollins 1989) (Figure 21). Features and artifacts associated with Buried Soil 5 are from the early Laurentian. Late Laurentian features intrude Buried Soil 5. A sharp increase in oak and hemlock pollen, during the Atlantic climatic episode, indicates that the prevailing conditions were warm and moist (Vento and Rollins 1989).

Buried Soils 6 and 7 were radiocarbon dated to the Middle Archaic (approximately 7000 B.P.), and were correlated with Middle Archaic soils identified by Schuldenrein and Vento (1993) (Figure 21). Buried Soil 6 contained Middle Archaic artifacts of the Neville type, features from the Middle Archaic, and Late Archaic (early Laurentian) intrusions.

Buried Soil 7 was only found on the far western portions of the study area (Blocks 5 and 6). It also contained Neville artifacts, but did not contain any features. The Boreal climatic phase of this time period was characterized by warm and dry conditions inferred by pine and hemlock pollen (Neumann 1989; Vento and Rollins 1989). Within the Susquehanna River drainage basin, the Pre-Boreal and Boreal climatic phases were time of active alluviation/aggradation (Vento and

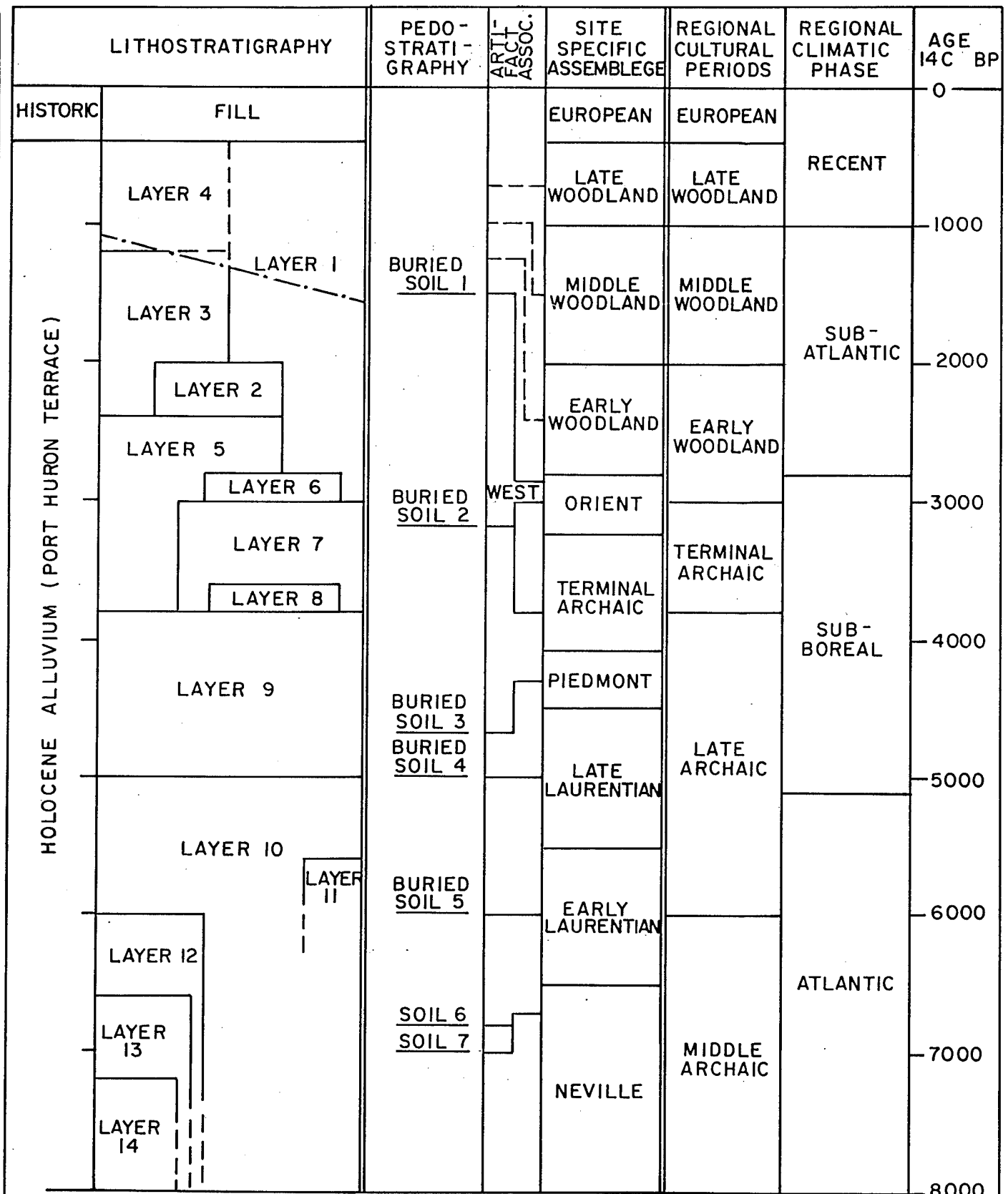

LEGEND

- INFERRED BOUNDARY
- .-.-.- MECHANICALLY STRIPPED SURFACE

FIGURE 20

STRATIGRAPHIC CLASSIFICATION MODEL

Rollins 1989; Knox 1983). Buried Soil 7 was the oldest soil observed and evaluated in this study. Schuldenrein and Vento (1993) describe "Early Holocene surfaces (Middle Archaic)" in composite profiles across their study area. These surfaces consist of thin sola, widely expressed across the differentiated floodplain, specifically preserved in the older western portion of their study area. Older, deeper soil characteristics were recognized by Schuldenrein and Vento (1993) as essentially isolated, truncated B horizon remnants.

Correlation of buried soils within a basin is not without problems. Scully and Arnold (1981) warn that there may be a finite limit to the detail with which alluvial events can be correlated, particularly for events 200-600 years long in the last 1000 years. If specific lithic facies in an alluvial setting are non-correlatable, locally developed autogenic, genetic units, then the soils that develop on such surfaces may be also non-correlatable. Cryptic, immature paleosols, which are essentially weak A-C profiles, may occur on rapidly accreting surfaces (Vento and Rollins 1989). Such a situation probably is responsible for some of the Ab horizons in Block 3. The subdivided geosol concept presented by Morrison (1978) describes a scenario where several buried soils may be correlatable with a single buried soil on a more stable landscape. However, the individual soils of the subdivided geosol would be difficult, if not impossible to correlate for any distance. The rate of burial becomes crucial in accreting landscapes. If burial is slow enough, then soil formation can keep pace in the process of developmental upbuilding (Johnson and Watson-Stegner 1990). Follmer (1982) describes three situations in which the Sangamon soil was slowly buried by thin increments of sediment. In the first situation the rate of burial was slow enough that the A and B horizons grew upward and produced an over-thickened B horizon. If the rate of burial was somewhat faster and/or the pedogenic processes were slowed for some reason, the added material developed A horizon characteristics (accumulation of organic matter, porosity, granularity, etc.). Thus, the A horizon thickens upwards, leaving the B horizon more or less unchanged. This is the mechanism in which cumulic A horizons form. If the rate of burial was fast enough, then the incorporation ability or developmental upbuilding ability is surpassed and a distinct boundary can be found between the soil and the new deposits.

The rate of burial thus has implications for the identification, delineation, and interpretation of boundary conditions. Surfaces that bound allogenic genetic units, genetic surfaces, are represented in stratigraphic sections by sharp contacts (Vento and Rollins 1989). Developmental upbuilding where it occurs, prevents the formation of these sharp contacts and thereby obscures the genetic surface of allogenic units. Buried Soil 4 is a highly significant soil because of the fragipan subsoil and the implied dessication conditions of the mid-Holocene. Defining the top of the fragipan profile is difficult. Buried Soil 3 may represent the top of a soil that started out as the fragipan soil and then developed upward upon slow burial.

The alloformation was introduced in the North American Stratigraphic Code (NACSN 1983) to distinguish between (1) superposed discontinuity-bounded deposits of similar lithology, (2) contiguous discontinuity-bounded deposits of similar lithology, (3) geographically separated discontinuity-bounded units of similar lithology, or (4) to distinguish as single units, discontinuity-bounded deposits characterized by lithic heterogeneity. Allostratigraphic units are defined and identified on the basis of bounding discontinuities. This concept may hold promise for more precise correlation within an alluvial basin. However, the key rests in being able to recognize the bounding discontinuities, a situation made difficult because of developmental upbuilding. The use of allostratigraphy in Holocene floodplain studies has not been prevalent in geological literature. The applicability of alloformation mapping on a regional scale basis was tested in a meander belt segment of a small valley in southeastern Louisiana (Autin 1992). Allostratigraphy provided a relative chronology for the units identified, allowed the relation of the evolution of each alloformation to a common set of fluvial processes, and conformed with formally defined stratigraphic procedures. Boundary criteria proved difficult to replicate and spatially constrain. Overbank sedimentation and subsequent pedogenesis on abandoned meander belts, however, produced an indistinct alloformation boundary within a cumulic soil profile developed in the

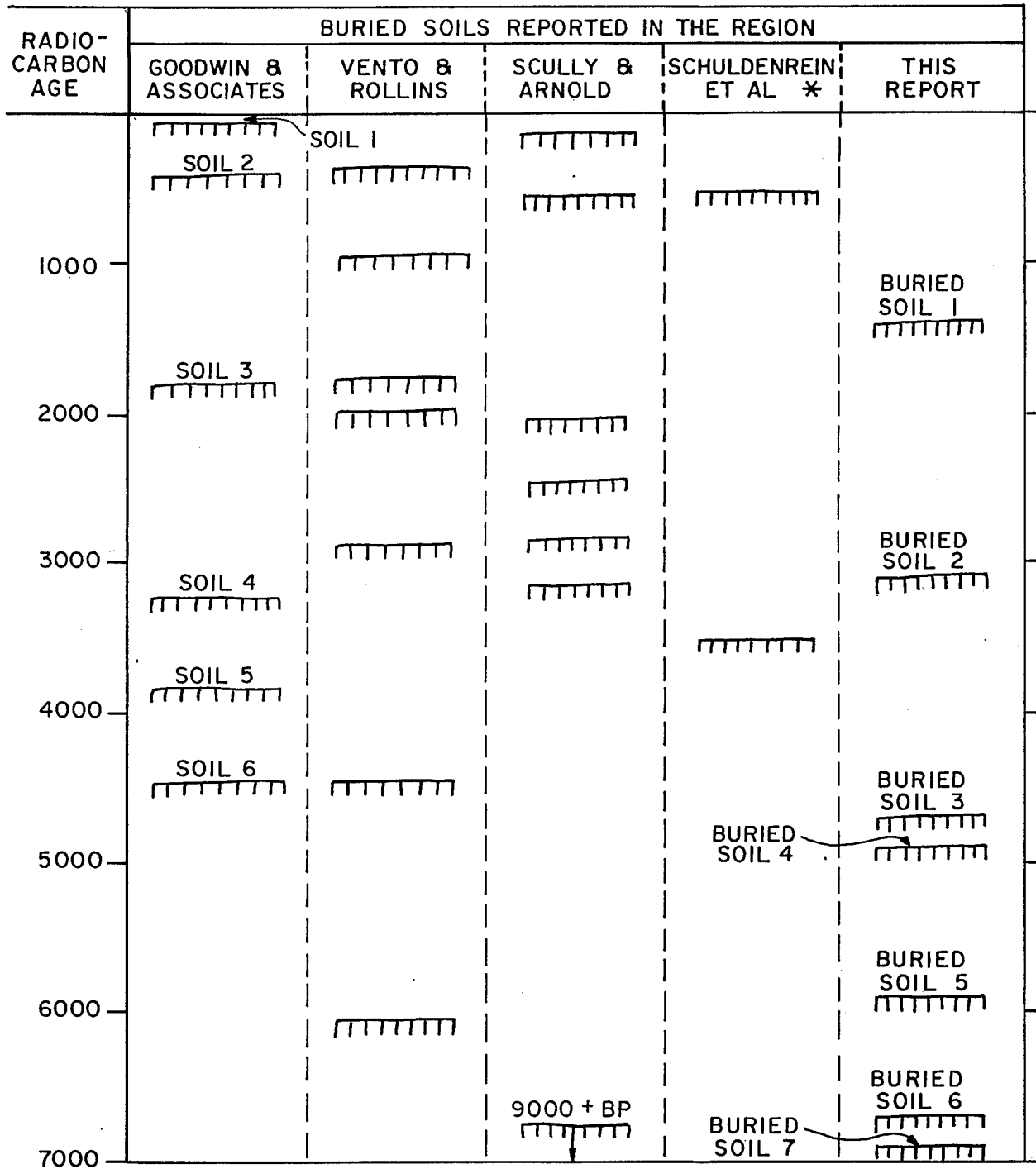

\* - SCHULDENREIN ET AL IS FROM THE DELAWARE VALLEY

FIGURE 21

REGIONAL CORRELATION OF BURIED SOILS

bioturbated brown silt. The usefulness of the alloformation concept in pedological-archaeological studies remains to be proven.

### *Model of Site Formation*

The Holocene floodplain sediments at the Memorial Park site were delineated into fourteen lithostratigraphic units (Layers) and seven pedostratigraphic units (Buried Soils). Textures of the sediments, for the most part, occurred in a narrow range of silt loams, and loams indicating that the dominant mode of deposition was by overbank flooding. Lithostratigraphic layers were delineated on the basis of sequences in the vertical distribution of textures; e.g., fining-upward, coarsening-upward, vertically-uniform, and coarse spike. Pedostratigraphic buried soils were delineated on the basis of soil morphology, radiocarbon dating, and correlation of diagnostic artifacts. These results were used in the analysis of the cultured data sets, and are integrated into the Summary and Conclusions (Chapter XVII).

Six of the seven buried soils were weakly developed, youthful soils, typical of sporadically accreting terraces and floodplains. Buried Soil 4, in the western portion of the study area, was characterized by a fragipan Bx horizon subsoil. The development of the fragipan is believed to be caused by desiccation and may be associated with a mid-Holocene period of climatic dryness.

A history of the site formation processes at the Memorial Park site was developed from the lithostratigraphic and pedostratigraphic models (Figures 22a-22g). During the Early Holocene (>8000 B.P.) the study area was undergoing active alluviation by lateral and vertical aggradation, possibly in a braided stream environment (Table 11). Between 7000 and 9000 B.P., these sediments were eroded to form a ridge like landform, or terrace escarpment on the western side of the study area, the oldest landform documented in the current study. Brief periods of floodplain stability followed in which immature soils developed on the western side of the study area. Buried Soil 7, radiocarbon dated at approximately 7050 B.P., and Buried Soil 6, radiocarbon dated at 6800 B.P. both contained Middle Archaic (Neville) artifacts. Pollen analytical studies suggest a drier climate at this time. These soils, and the entire study area, were buried by overbank vertical accretion sediments (Layer 10), which were later eroded and then weathered.

Buried Soil 5, radiocarbon dated at approximately 6000 B.P., formed largely on the eroded surface associated with Layer 10, across the entire study area. This soil contained Late Archaic (early Laurentian) artifacts, dominantly in the western portion of the study area. The pollen record indicated a cooling of the climate. Aggradation continued after the period of stability in which Buried Soil 5 formed. Sediments accumulated across the site in a coarsening-upward mode (Layer 9) punctuated by a period of erosion, and then partially capped by a coarse splay deposit (Layer 8). This was followed by vertical accretion, presumably from overbank flooding (Layer 7), and another coarse spike (Layer 6). Layers 6 and 7 only occur in the eastern two thirds of the site indicating that they were being deposited east of the ridge landform, and/or were subsequently eroded.

Buried Soil 4, radiocarbon dated to approximately 4500-5000 B.P., began forming during deposition of Layers 9, 8, 7, and 6, and continued to form thereafter. This soil is the most developed soil documented during this study. Schuldenrein and Vento (1993) described their Soil 4 (ca. 4500 B.P.) as the most extensive soil represented at the site. Buried Soil 4 of this study had a fragipan Bx horizon that developed deeply enough to overlap or weld buried soils 5 and 6. This Buried 4 soil contained Late Archaic (late Laurentian) artifacts. The pollen record indicated a cooler climate. Buried Soil 3 may be an extension of Buried Soil 4, formed by developmental upbuilding. However, Buried Soil 3 contained Piedmont (Late Archaic) artifacts, as compared to the predominant content of late Laurentian artifacts in Buried Soil 4. This necessitated a formal

separation of the two soils. Buried Soil 3 is also associated with a pollen record that indicated a shift to a warmer, more reparation environment.

Several brief periods of aggradation, separated by erosional events and at least two periods of soil formation, occurred during the last 4000 years. Buried Soil 2 was extensive across the entire study area, although it was not particularly well developed. It had an approximate radiocarbon age of 3200 B.P., and contained Terminal Archaic features and artifacts throughout the study area, and Orient artifacts and a midden on the west side. The pollen record associated with Buried Soil 2 was indicative of a generally drier climate.

Buried Soil 1, radiocarbon dated to approximately 1500 B.P., was only found on the eastern portion of the study area, and in Block 6. This distribution may be due to post-depositional erosion, as indicated in the lithostratigraphic model, or to mechanical stripping. This soil contained Orient (Terminal Archaic) artifacts and intruding Woodland features. Schuldenrein and Vento (1993) indicated that the Middle Woodland (2000-1000 B.P.) was a time of geomorphic transition, from a migrating stream environment to an overbanking environment, at the Memorial Park site.

Subsequent aggradation, erosion, cultivation, and filling occurred at this site. The filling was associated with airport construction in the 1930s. This record was largely removed by mechanical stripping at the beginning of this project. Block 7, excavated outside of the stripped area, contained a complete profile from the contemporary surface to Buried Soil 3.

The 3Ab horizon of Block 7, radiocarbon dated at 1480 B.P., was correlated to Buried Soil 1 (Figure 18) and, thus, Neumann's (1989) Soil 3. Younger soils identified by Neumann (Soil 1 and Soil 2), and by Schuldenrein and Vento (1993), were removed during mechanical stripping. Neumann's (1989) Soil 2, correlated with the 3Ap1 and 3Ap2 horizons of Block 7, contained the uppermost intact Late Woodland (i.e., Clemson Island) components (Schuldenrein and Vento 1993). Neumann's (1989) Soil 1 correlates with the historic fill and the incipient soil developed on it.

#### SUMMARY

The geomorphic history and variability of the Memorial Park site certainly had a significant influence on the activities of prehistoric people. Changes in the surficial environment and soils were associated with the late Pleistocene to mid-Holocene channel dynamics of the West Branch and the evolving Port Huron Terrace. The eastward migration of a meander channel resulted in older, more stable, geomorphic surfaces on the western portion of the site, and younger, less stable, geomorphic surfaces on the eastern portions of the site. Periods of floodplain stability, during which pedogenesis occurred, resulted in seven distinct buried soils distributed across the site. The association of these buried soils with cultural artifacts and features was used in the development of the pedostratigraphic model and the model of site formation. Both of these models, in turn, were used in the analysis of the cultural data sets and are integrated into the summary and conclusions.



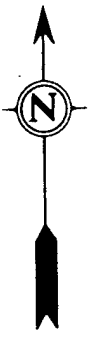

STUDY AREA

STUDY AREA

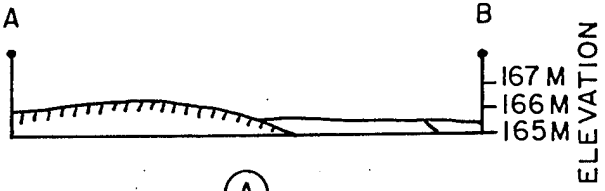
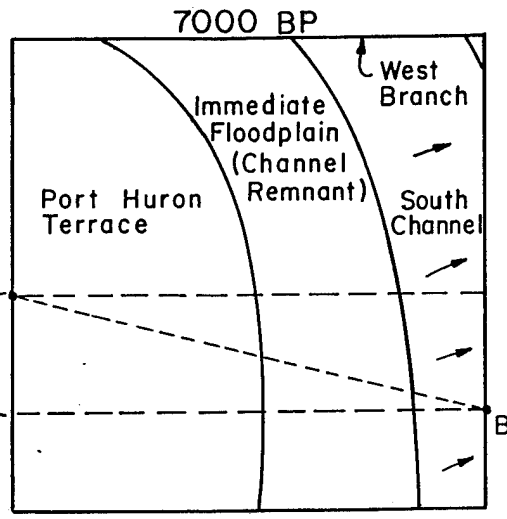

STUDY AREA

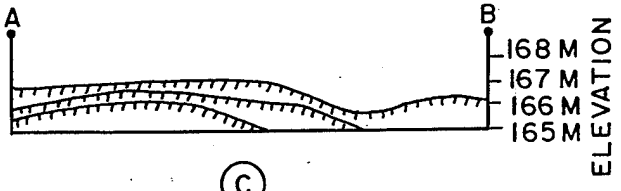
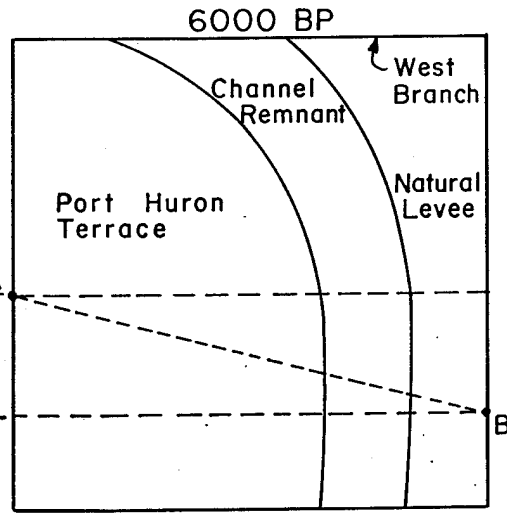
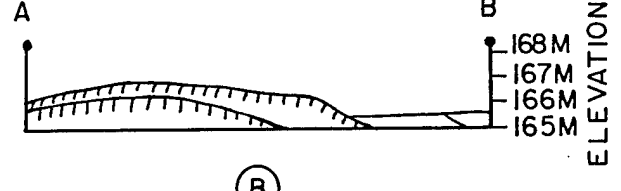
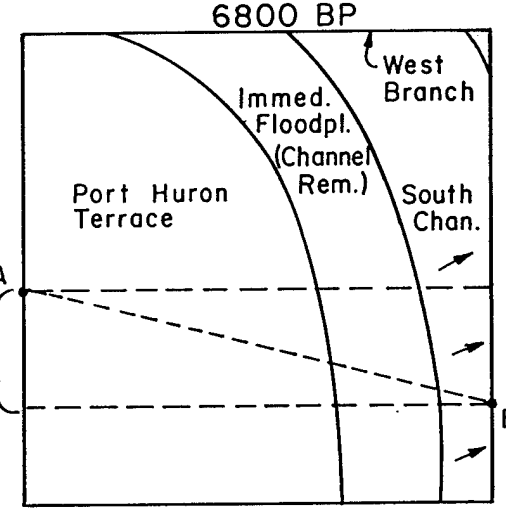

STUDY AREA

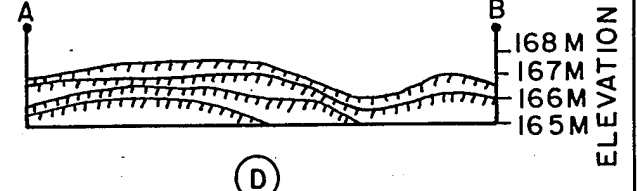
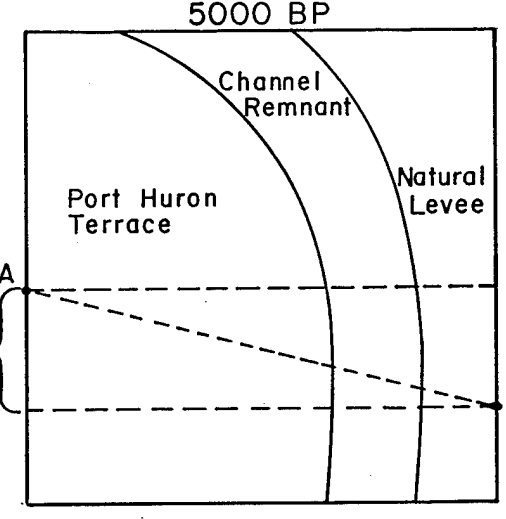

FIGURES 22 a-d

GEOMORPHIC HISTORY MODEL OF MEMORIAL PARK, 7000 BP - 5000 BP

NOTE: NOT TO SCALE. VERTICAL EXAGGERATION ≈ 10 X

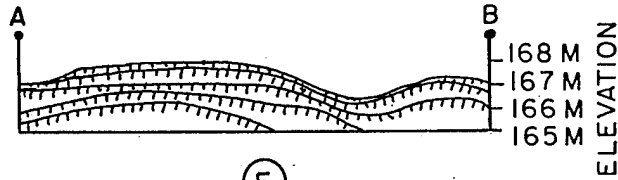
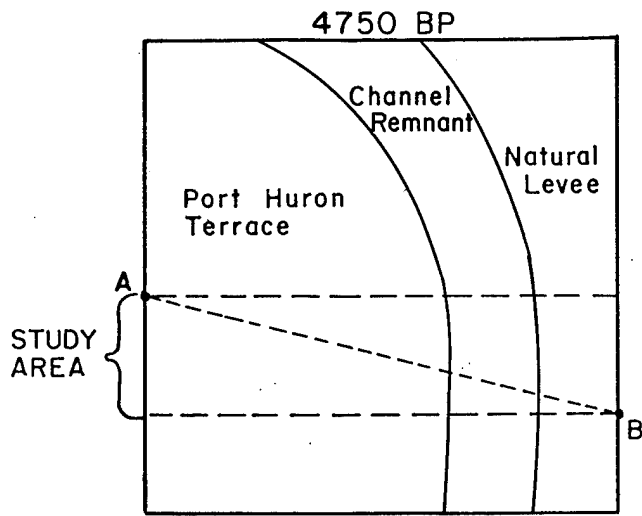

(E)

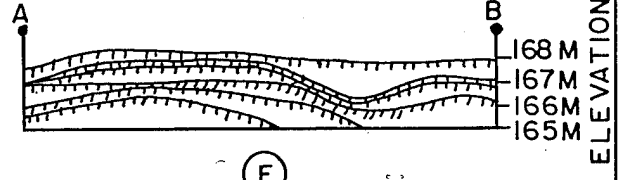
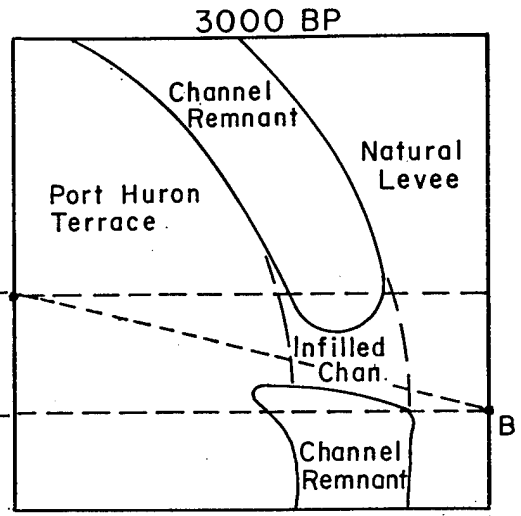

(F)

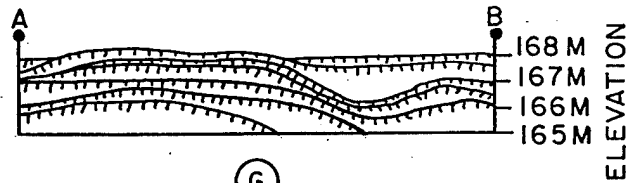
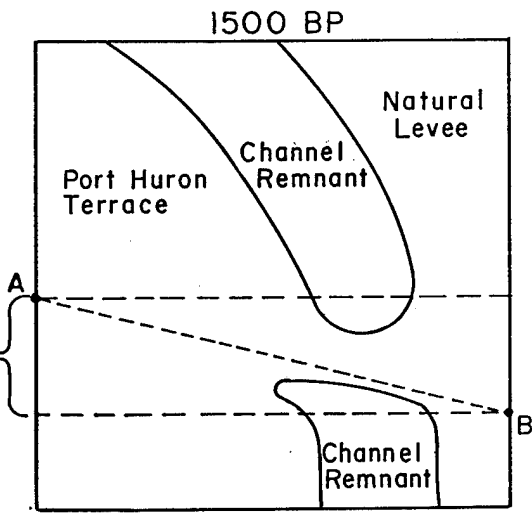

(G)

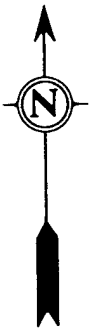

FIGURES 22 e-g

GEOMORPHIC HISTORY MODEL OF MEMORIAL PARK, 4750 BP - 1500 BP

NOTE: NOT TO SCALE. VERTICAL EXAGGERATION ≈ 10 X

Table 11. Geomorphic History of the Memorial Park Site.

Interval (B.P.)	Geomorphic History		Vegetation/Climate	Occupation
	West	East		
10,000-8000	Alluviation of natural levee/ point bar by meandering channel	Incision-channel migration		
8000-7000	Stability, formation of Buried Soil 7	Incision	oak/warm and dry	Neville
7,000-6,800	Rapid alluviation by lateral accretion followed by stability and formation of Buried Soil 6	Incision followed by alluviation	oak/warm and dry	Neville
6,800-6,000	Site-wide alluviation by overbank deposition of silts, followed by extensive incision along older topographic ridges and channels, and finally stability and formation of Buried Soil 5 across site		becoming cooler	Early Laurentian
6,000-5000	Site-wide alluviation followed by an increased velocity flow, followed by extensive incision along older topographic landforms, and then a period of stability and possibly dryness during which Buried Soil 4 formed		Birch and pine/ cooler climate	Late Laurentian
5,000-4,500	Slow alluviation, in which incremental additional of sediment to Buried Soil 4 caused in places developmental upbuilding and the subsequent formation of Buried Soil 3. On east side deposition was more rapid and Buried Soil 3 is more distinct.		Walnut, elm with grass and wood fern/warm riparian	Piedmont
4500-3000	Periodic alluviation by overbank deposition, splay deposition, and lateral accretion mainly on the east side of the study area, site specific episodes of erosion, followed by a period of stability and the formation of Buried Soil 2.		Pine, oak, ragweed, pigweed, woodfern, and club moss/generally drier	Terminal Archaic
3000-1500	Probable erosional interval, particularly on the east site of the study area, followed by deposition through lateral accretion and formation of Buried Soil 1.		Alder, birch, hornbeam, chestnut, beech, walnut, pine and oak/moderately warm, open, possibly riparian	Orient
1500-present	Periodic alluviation and erosion intervals, historic cultivation, filling for airport construction, mechanical stripping.		Pine, oak, pigweed, ferns, composites, sunflower, club moss/ warm to mildly cold, open, moist to wet	Late Woodland

## VII. FIELD RESULTS

### INTRODUCTION *by John P. Hart, Ph.D.*

In all, 340 soil anomalies representing possible cultural features were recorded during the course of current investigations at Memorial Park. Of these, 249 were eventually interpreted as cultural features, including 80 Late Woodland, three Middle Woodland, two Early Woodland, 19 Orient, 79 Terminal Archaic, 13 Piedmont, 20 late Laurentian, 35 early Laurentian, and two Neville. In addition to these, 511 postmolds were also recorded, 465 (91%) of which were associated with the Late Woodland occupations, and 46 (9%) with the pre-Late Woodland occupations. The following summary of these features is divided into two main sections, Late Woodland and pre-Late Woodland. Analysis of human skeletal remains from two Late Woodland features is presented, following the Late Woodland feature descriptions. Finally, the results of radiocarbon assays are reviewed.

### LATE WOODLAND FEATURES *by Jeffrey R. Graybill, Ph.D.*

Following Dunnell et al. (1971:7), Late Woodland cultural features have been classified as structural remains and non-structural remains (hereafter, features). The distribution of features exposed during Task 1 investigations is presented in Figure 23.

#### *Structural Remains*

Structural remains are limited to postmolds and related phenomena evidenced by wooden posts inserted into the ground. Often, postmolds define linear patterns that can be inferred to represent structures such as houses, palisades, fences, or screens (Dunnell et al. 1971:7-14).

*Postmolds.* Potential postmolds, totaling 511, associated with the site's Late Woodland occupations, were recognized and mapped in the course of Task 1 excavations. After cross-sectioning, 465 (91%) were determined to represent actual postmolds. The remainder were either rootmolds, or exhibited no profile. The majority of the postmolds relate to the Clemson Island occupations and were distributed across the length of the excavations. Other postmolds relate to a later Stewart phase component, based upon their association with a single, longhouse structure pattern.

Table 12 summarizes metric and other attributes for a random sample of 50 postmolds. These postmolds ranged in diameter from 3 to 12 cm with a mean of 5.1 cm, while their depths ranged from 1 to 38 cm with a mean of 11.0 cm. In profile, they ranged in shape from rounded (68%) to subconical (32%). The size and shape of these postmolds compare favorably with examples illustrated for Fisher Farm (Hatch and Daugirda 1980:Figure 12.3), St. Anthony (R.M. Stewart 1988:Figure 6.40), and other Clemson Island sites (Figure 24). Except for a single keyhole structure reported for Fisher Farm (Hatch 1980:Table 12.1), a structure type not found at Memorial Park, detailed comparative data for postmolds at these other sites is not available.

Table 12. Form and Metric Summary of Postmold Sample.

Postmold	5 m mapping square	Shape	Diameter (cm)	Depth (cm)
1	N4 E260	round	6	16
2	N4 E260	subconical	4	12
3	N4 E260	subconical	4	17
4	N4 E260	round	6	11
5	N4 E260	subconical	4	7
6	N4 E260	round	9	31
7	N8 E252	subconical	5	14
8	N8 E252	round	5	4
9	N8 E252	round	7	14
10	N10 E250	round	3	3
11	N10 E250	round	5	8
12	N10 E250	round	4	19
13	N10 E250	subconical	4	6
14	N10 E250	round	4	4
15	N18 E254	subconical	4	7
16	N24 E176	subconical	4	19
17	N28 E196	round	7	18
18	N28 E196	round	5	15
19	N28 E196	round	7	20
20	N28 E196	round	4	5
21	N28 E196	round	6	11
22	N28 E196	round	6	7
23	N28 E198	round	4	14
24	N28 E198	round	5	4
25	N28 E198	round	4	4
26	N28 E198	round	4	4
27	N28 E210	subconical	8	38
28	N28 E210	subconical	5	13
29	N28 E210	round	3	2
30	N28 E210	round	7	30
31	N28 E226	subconical	3	8
32	N28 E226	subconical	5	7
33	N28 E226	round	5	6
34	N30 E140	round	8	10
35	N30 E206	subconical	5	27
36	N30 E220	round	3	1
37	N30 E220	round	4	8
38	N30 E220	round	5	7
39	N30 E220	round	5	7
40	N32 E132	round	5	6
41	N34 E170	round	12	14
42	N38 E152	round	6	12
43	N38 E174	subconical	5	5
44	N38 E174	subconical	3	22
45	N38 E174	round	5	3
46	N38 E174	round	3	1
47	N38 E174	round	5	6
48	N42 E116	round	8	2
49	N42 E110	subconical	3	12
50	N46 E110	subconical	6	9
mean			5.10	11.0

DWG. NO. 89-412-M/

JPH

APPROVED

REM

GAI CONSULTANTS, INC. DWN.

137  
138

1

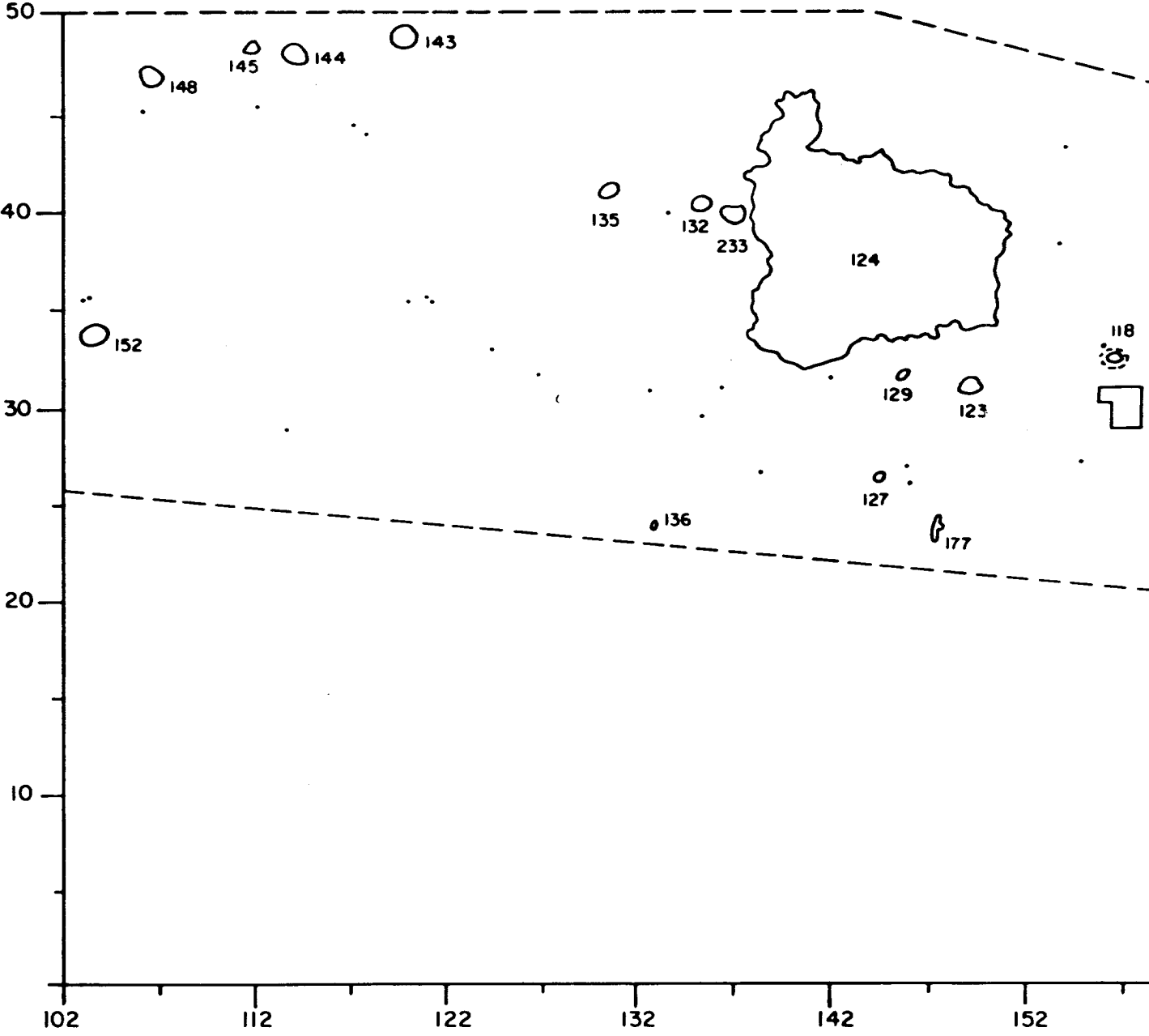

KEY

- POSTMOLD
- S2 - STRUCTURE (2)
- 13 - FEATURE (13)
- - PHASE 2 TEST PIT

2

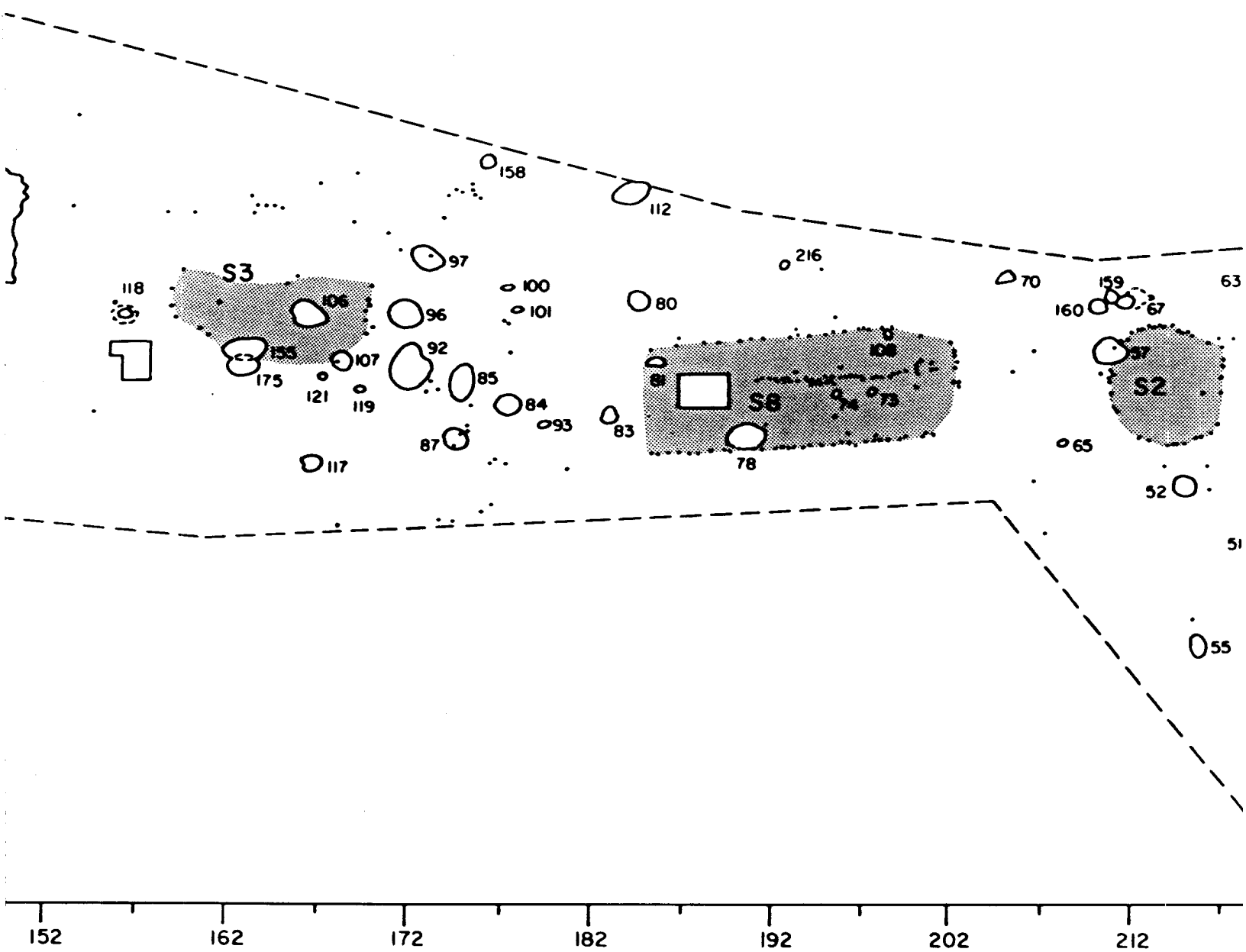

SCALE

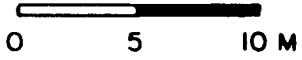

3

4

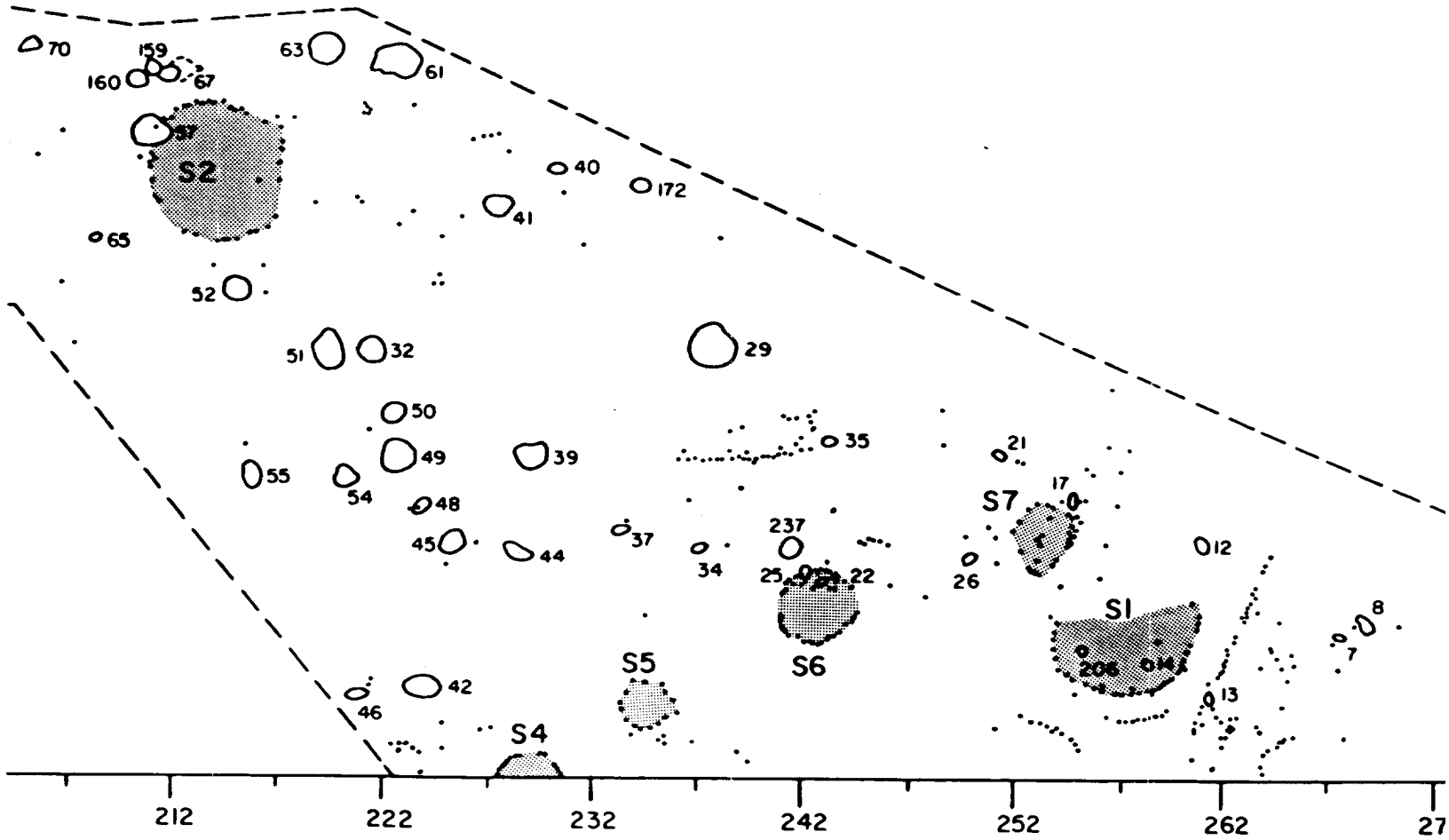

F
DIS LATE W



4

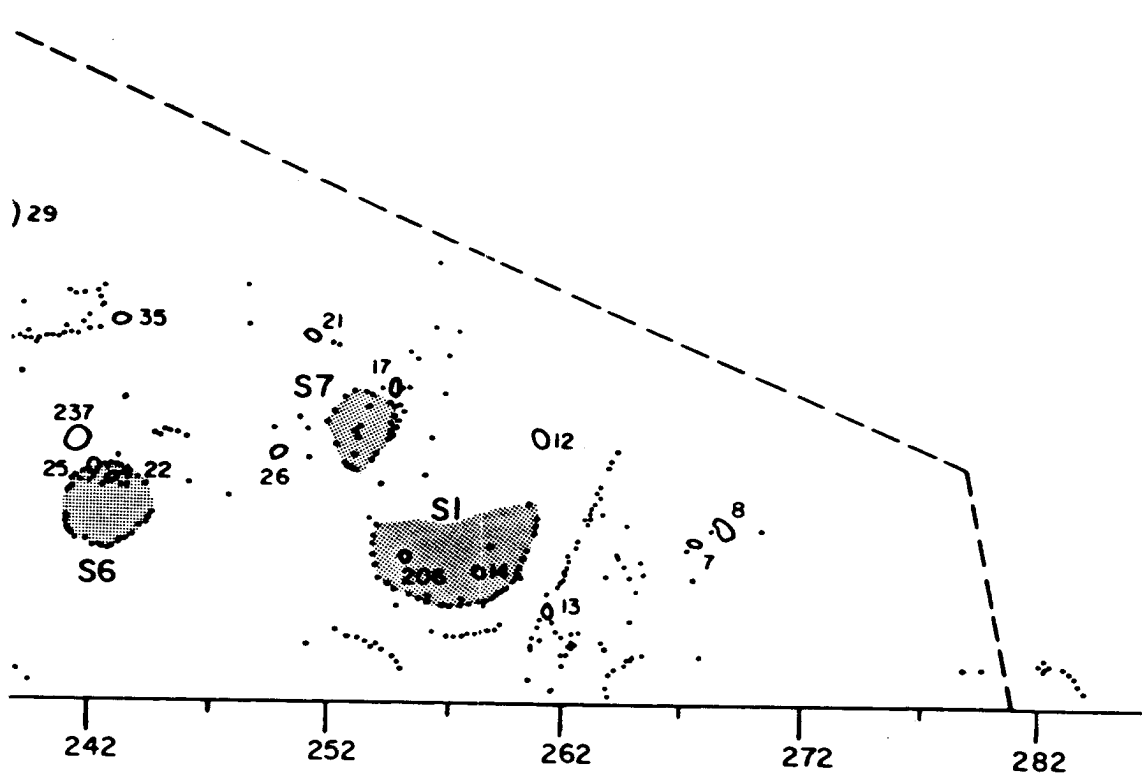
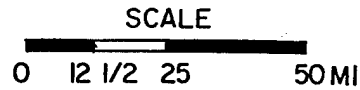
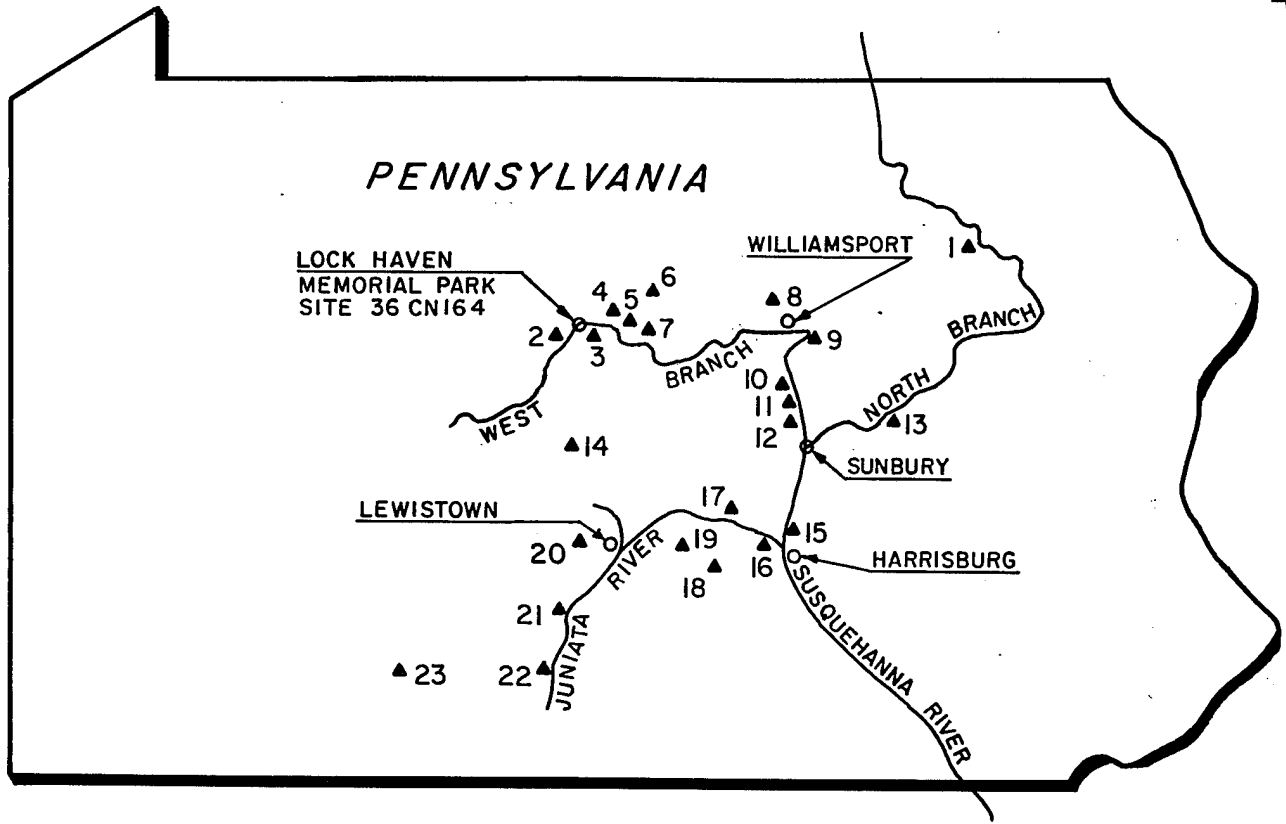
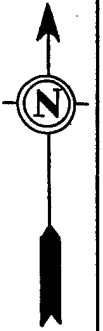

FIGURE 23

DISTRIBUTION OF  
LATE WOODLAND FEATURES



KEY

- |                      |                      |
|----------------------|----------------------|
| 1 WELLS              | 13 CATAWISSA         |
| 2 BALD EAGLE         | 14 FISHER FARM       |
| 3 LOCK HAVEN         | 15 CLEMSON'S ISLAND  |
| 4 KRESS              | 16 CLARKS FERRY      |
| 5 RAMM               | 17 MEXICO            |
| 6 MILLER             | 18 SHERMANS CREEK    |
| 7 NASH               | 19 BOOK              |
| 8 BULL RUN           | 20 PETERSBURG BRIDGE |
| 9 BROCK              | 21 SHEEP ROCK        |
| 10 ALLENWOOD         | 22 WORKMAN           |
| 11 MONTGOMERY ISLAND | 23 GNAGEY            |
| 12 ST. ANTHONY       |                      |

FIGURE 24

LOCATION OF CLEMSON ISLAND SITES REFERENCED IN TEXT

SOURCE :  
ADAPTED FROM SWARTZ, 1985, AND STEWART, 1988.

*Post Pits.* Six anomalies were classified as post pits; i.e., shallow pits penetrated by a distinct postmold. This association suggests that in some cases a sizable, well-defined pit was excavated prior to insertion of a post into the ground (cf. Dunnell et al. 1971:16-18). Presumably, this practice was limited to more-substantial posts, particularly those with large diameters. Metric attributes for post pits are presented in Table 13.

Table 13. Metric Attribute Summary for Postmold Pits.

Feature No.	Provenience	Age/Cult	Length	Width	Depth
13	N2 E260	Clemson Island	36	29	21
14	N4 E256	Clemson Island	30	28	18
21	N14 E250	Clemson island	36	30	11
22	N18 E242	Clemson Island	26	24	9
73	N28 E196	Stewart Phase	29	27	12
74	N28 E194	Stewart Phase	30	30	8
mean			31.2	28.0	13.2

Two of the post pits, features 73 and 74, were spatially associated with a longhouse-type structure pertaining to the Stewart phase. Shenks Ferry Incised pottery from Feature 74 provides the primary basis for assigning this structure to the Stewart phase.

*Structural Patterns.* Eight whole or partial structural patterns were defined on the basis of postmold patterns. Metric and other attributes for these patterns are presented in Table 14.

Table 14. Summary of Structure Patterns.

Structure	Age/Cult	Shape	Length	Width	Area (m <sup>2</sup> )	Associated Features
1	Clemson Island	circular	6.8	6.8	35	none
2	Clemson Island	circular	6.3	6.3	30	57
3	Clemson Island	elliptical	8.0	10.5	64	106, 107
4	Clemson Island	circular	3.0	3.0	7	none
5	Clemson Island	circular	2.3	2.3	4	none
6	Clemson Island	circular	3.5	3.5	9	22, 25
7	Clemson Island	circular	2.8	2.8	6	17
8	Stewart Phase	rectangular	18.0?	6.0	108	73, 74, 78, 8

*Structures 1 and 2.* Two large, circular structures were defined in the east half of the excavations (Figure 23). Structure 1 had a diameter of 6.8 m representing a surface area of 35 square meters, and Structure 2 had a diameter of 6.3 m representing a surface area of 30 square meters. The size and shape of these structures suggest that they were used as domestic dwellings. Based upon figures supplied by MacCord (1971), household size was probably 8 to 10 persons, suggesting use by extended family groups. Only one feature was spatially associated with these structures, a storage pit (Feature 57) into which a postmold from Structure 2 intruded, indicating non-contemporaneity.

Few circular structures with diameters greater than four meters have been reported for Clemson Island sites; most Clemson Island structure shapes range from elliptical to subrectangular. At St. Anthony, a somewhat smaller, less convincing, circular pattern was found, measuring approximately 4.9 m in diameter (R.M. Stewart 1988:figures 6.42-6.44). At the Fisher Farm and Bald Eagle sites, similar structures may have occurred, but postmold alignments in the areas exposed were too confused to permit definition of specific structures with certainty (Hatch 1980:Figure 11.6; Hay and Hamilton 1984:Figure 2).

The large, circular patterns at Memorial Park are most similar to structures reported for the middle Owasco, Canandaigua phase (A.D. 1100-1200) Sackett site in central New York (Ritchie 1965:Figure 11), the Early Monongahela (A.D. 1000-1250), Somerset phase Gnagey site (George 1983:Figure 2), and related sites in southwestern Pennsylvania.

*Structure 3.* A third, less convincing postmold pattern was present in the western half of the excavations (Figure 23). This pattern, Structure 3, was elliptically shaped, measuring 10.5 m long by 8.0 m wide, representing a surface area of 64 square meters. Two storage pits (features 106 and 107) occurred in or near this pattern, but there is no evidence to suggest contemporaneity. In fact, one of the postmolds comprising Structure 3 intruded into Feature 106. As with Structures 1 and 2, Structure 3 most likely served as a domestic residence. Following MacCord (1971), a household size of 17 individuals is suggested.

Structure 3 resembles elliptical to subrectangular forms reported for other Clemson Island sites, although it is somewhat larger in size. At the Ramm site in Clinton County (Smith 1976:Figure 7), a subrectangular structure measured 7.6 m long by 6.1 m wide, while at the Shermans Creek site in Perry County (Adovasio et al. 1988), an elliptical pattern was 6.4 m long by 3.7 m wide. At 36LY34, a very large, though less convincing, subrectangular pattern was 29.0 m long by 10.6 m wide (Turnbaugh 1977:215-217). While the dominant component at 36LY34 is Clemson Island, a Stewart phase component was also present; as a result, the precise age of this structure remains unclear (Turnbaugh 1977:217). At the middle Owasco, Canandaigua phase Bates site in central New York, Ritchie (1965:Figure 10) illustrates an elliptical structure that underwent four expansion stages, resulting in structures ranging from 12.2 m long by 7.0 m wide to 23.2 m long by 7.6 m wide.

*Structures 4, 5, 6, and 7.* At least four small, circular postmold patterns (structures 4, 5, 6, and 7) were present on the eastern half of the excavations near Structure 1 (Figure 23). The diameters of these patterns ranged from 2.3 to 3.5 m with a mean of 2.9 m representing floor areas ranging from 4 to 9 square meters with a mean of 6.5 square meters. The small size of these patterns suggests that they represent temporary winter residences, perhaps inhabited by small groups of two to three people, at least one of whom was presumably a male hunter (cf. MacCord 1971). The fact that these structures appear to be arranged in an arc suggests that they may be contemporaneous; winter hunts may have been communal activities, as described by Fitting (1969:371), for the Potawatomi pattern.

These four structures most closely resemble patterns reported for the Petersburg Bridge and Milton Bridge sites, both of which were interpreted as temporary encampments by R.M. Stewart (1990:95), based upon the presence of few features and small pottery samples. At Petersburg Bridge, two small-structure patterns were found, both measuring approximately 1.8 m in diameter (Mitchum 1968:28-29). At Milton Bridge, a single small structure measured 1.8 m in diameter (Mair 1988).

*Structure 8.* The final structural pattern, Structure 8, was a large, rectangular-shaped Stewart phase longhouse (Figure 23). This construction was found very near the center of the Task 1 excavations. This structure measured approximately 18.0 m long by 6.0 m wide, with a

surface area of approximately 108 square meters. A postmold alignment ran along the structure's longitudinal centerline.

Several features occurred in and near Structure 8 but, with the exception of two post pits their presence is probably unrelated to the structure itself. The post pit Feature 74 yielded Shenks Ferry Incised pottery, as did a soil stain (Feature 79) located within the structure. Other than Feature 61 and Block 7, which occurs beyond the limits of Task 1 excavations, this was the only Shenks Ferry pottery found at Memorial Park during these investigations, and constitutes the primary basis for assigning Structure 8 to the Stewart phase.

Other features spatially associated with Structure 8 included Feature 78, a storage pit; and Features 81 and 108, both fire-related pits. Feature 78, which produced an A.D. 997 calibrated radiocarbon assay, was intruded by two postmolds from Structure 8, indicating that it predates the structure. The two fire-related pits may be contemporary with Structure 8; however, they appear to be too close to the structure's walls to have been used during the its occupation.

At least one, and possibly three longhouses have been recorded in Stewart phase contexts. At the Stewart site excavated by T. B. Stewart in 1934, traces of two "probable" longhouse configurations were recorded (T.B. Stewart 1934). More recently, excavations at the Canfield Island site produced a Stewart-phase longhouse very similar to the pattern at Memorial Park. This structure was approximately 18 m long by 6 m wide, and had posts extending down the structure's longitudinal centerline (Bressler 1993).

In central New York, the earliest longhouses date to the late Owasco or transitional Iroquois Castle Creek phase (A.D. 1250-1350), which is coeval with the Stewart phase (cf. Ritchie and Funk 1973; Tuck 1971). In this same area, however, morphologically similar structures (i.e., large, elliptical forms), like that reported at the Maxon-Derby site occur at least two centuries earlier (cf. Ritchie 1965:Figure 9).

At the Castle Creek phase Chamberlin site in central New York, Tuck (1971:Figure 2) exposed a longhouse measuring 24.7 m long by 6.7 m wide, dimensions that closely approximate the Memorial Park longhouse. The largest longhouse on record is from the Chance phase or early Iroquois (A.D. 1350-1450) Schoff site, central New York (Tuck 1971:Figure 5), where a longhouse measured 122 m long by 6.7 m wide.

*Other Postmold Patterns.* In addition to structure patterns, a number of short arcs, lines, and other configurations were recorded (Figure 23). Three to four arcs and two straight lines of postmolds were recorded on the eastern end of the stripped area. Another possible arc was present on the west half of the stripped area. If these do not represent incomplete structure patterns, they may represent fences or screens (Dunnell et al. 1971:13). Similar configurations occur at most other Clemson Island sites where large, horizontal areas have been exposed, including Fisher Farm (Hatch 1980:figures 11.6- 11.10), Bald Eagle (Hay and Hamilton 1984:Figure 2), 36LY34 (Turnbaugh 1977:Figure 18), and St. Anthony (R.M. Stewart Figure 6.41).

#### *Features or Non-Structural Remains*

A total of 166 potential Late Woodland features were identified and mapped during the course of Task 1 excavations and subsequent block excavations. Upon closer examination, 74 of these were classified as cultural features, seven were assigned to earlier occupations, 10 were classified as structural remains (see above), one as a historic fence-post hole, six were disturbances produced by machine grading, and 72 were non-cultural. The seven assigned to earlier occupations are described in the pre-Late Woodland feature section of this chapter.

The non-cultural anomalies included 18 soil stains, two animal disturbances, and five plant disturbances that represent natural occurrences, while 32 burned stains and 15 charcoal stains may be of natural or cultural origin. Non-cultural phenomena are listed in Appendix B; they are not plotted on Figure 23 because they might obscure cultural patterns, and they are not discussed further in this section.

Ritchie and Funk (1973:181) have suggested that Late Woodland features were primarily storage or cooking (fire-related) facilities:

The features at the Roundtop site [coeval with the Clemson Island complex] pertain functionally to two major categories, viz., food storage and food preparation or cooking. In some cases a single feature served both purposes at different times. In addition, the features of both major kinds often became at some stage of their existence, trash bins or perhaps latrines. In the main, the food caches or granaries were of larger size than the cooking pits. The latter can probably be further subdivided into earth ovens for hot-rock cooking and smaller hearths or fireplaces for pot-boiling, and probably for providing heat and light. All varieties have many times been described by the writer in his reports on the Owasco culture and elsewhere.

Following Ritchie and Funk (1973), Late Woodland features recorded at Memorial Park were assigned to two broad functional/descriptive classes: storage pits, of which there are 38 examples (55%); and fire-related pits, of which there are 31 examples (45%).

*Storage Pits.* Following Kinsey (1972:164; 1975:18) and Ritchie and Funk (1973:166-167), storage pits were defined as large, deep features with basin-, cylindrical-, or bell-shaped profiles and elliptical to circular plans. Thirty-eight storage pits, including 30 completely excavated examples, two partially excavated examples, and three unexcavated examples are included in the Memorial Park sample. Metric data for these facilities are summarized in Table 15 and are presented for individual facilities in Table 16. Representative profiles and plan views are presented in Figure 25.

Table 15. Metric Summary of Storage Pits

Dimensions	N	Range (cm)	Mean (cm)
Length	35	74-225	132.7
Width	35	65-220	116.2
Depth	32	16-84	39.8

The storage pits produced varying physical strata, largely defined by degree of organic staining. Of 32 storage pits for which stratigraphy could be discerned, 19 (59%) contained one stratum, 10 (31%) contained two strata, two (6%) contained three strata, and one (3%) contained nine strata. Those storage pits with a single stratum are believed to have been rapidly in-filled, with artifacts being deposited in one or a few closely spaced episodes. Storage pits with multiple strata, in contrast, were apparently filled over extended periods of time, and may contain stratified cultural remains of earlier and later dates.

PLAN VIEWS

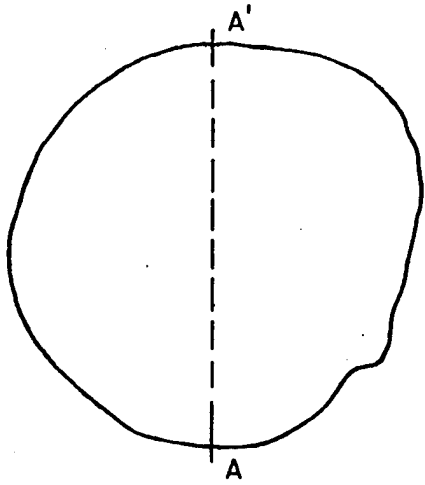

# 57

PROFILES

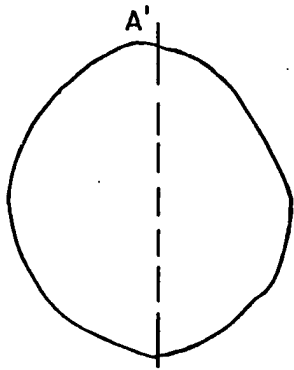
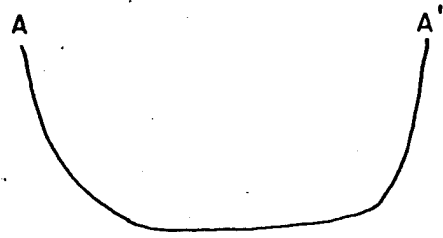

F52

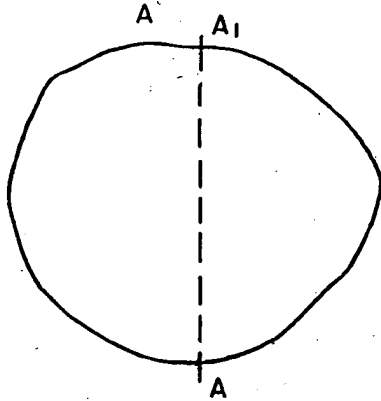
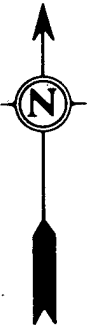

F160

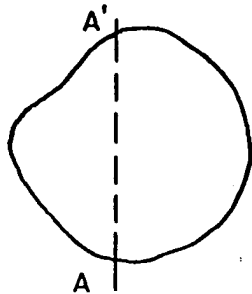
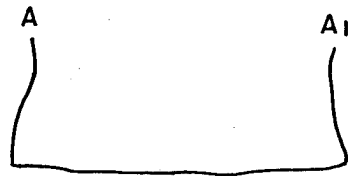

F117



SCALE  
  
 0 40 CM

**FIGURE 25**

LATE WOODLAND  
 STORAGE PITS, REPRESENTATIVE  
 PLAN VIEWS AND PROFILES

In addition to their general matrix, storage pits produced varying amounts of charcoal, burned soil, and ash, either as lenses or as isolated, scattered particles. In most instances the lenses provided evidence of in situ burning, sometimes with evidence of multiple burning episodes. The scattered particles are interpreted as redeposited fire residue.

In two instances, a layer of charred, fibrous plant material (tentatively identified as a grass) was present at the bottom of storage pits. Burned soil, in turn, was found stratified above the charred material. This stratigraphic relationship is the opposite of what might be expected for hearths. Rather, it suggests that grass was used to line the pit's walls, which subsequently caught fire, and fell to the bottom. During the course of burning, the grass fired the pit walls, and this fired material later eroded and slumped downward, covering the plant material.

All of the storage pits contained lithic debris and pottery sherds, while 19 (54 %) contained faunal remains. The relatively low percentage of storage pits with faunal remains probably resulted from the site's highly acidic soils, which caused poor bone preservation. Generally, large, well-preserved faunal samples were limited to pits with significant ash deposits, which served to neutralize soil acidity and enhance bone preservation. Faunal remains in pits lacking large ash deposits consisted of small, burned, pieces of bone. Two storage pits contained flexed human interments, both individuals of indeterminate sex. These interments are described in detail later in this section.

By weight, the amount of fire-cracked rock in storage pits ranged from 0.0 to 67.0 kg, with a mean of 6.26 kg. One pit (3%) contained no fire-cracked rock, 22 (69%) contained 0.1 to 5 kg, four (13%) contained 5.1 to 10.0 kg, three (9%) contained 10.1 to 15.0 kg, one (3%) contained 15.1 to 20.0 kg, and one (3%) contained more than 20 kg.

The artifactual content of these features is believed to constitute secondary refuse deposits; the distribution of artifacts relates to refuse disposal patterns rather than primary function. Presumably, the nature and amount of refuse contained within a storage pit was the product of the length of time it was open before being filled and its proximity to various domestic activities.

These pits probably functioned as subterranean storage facilities where food stores were cached. In addition to their size and form, this interpretation is supported by the recovery of charred grass at the bottom of two features, presumably having been used to line the pits' interiors (Kinsey 1975:18; Ritchie and Funk 1973:166-167). The primary basis for inferring a storage function for large, deep pits is ethnographic analogy; the use of storage pits by Native American groups persisted well into the historic period (DeBoer 1988). Quoting Champlain (in M.C. Stewart 1977:160) on the Iroquois:

In the sand of the slope of the hills they dig holes some five to six feet deep more or less, and place their corn and other grains in large grass sacks, which they throw into said holes, and cover them with sand to a depth of three or four feet above ground. They take away the grain according to their needs, and it is preserved as well as it would be in our granaries.

Similarly, Wood (in Hooton and Willoughby 1920:37) said of New England Indians: "Their corne being ripe, they gathered it, and drying it hard in the Sunner, conveyed it to their barnes, which be great holes digged in the ground in the form of a brass pot, seeled with rinds of trees, wherin they put their corne."



Once their primary function became obsolete, storage pits were often recycled as trash receptacles, burial pits, and hearths. Quoting Fletcher (in Hooton and Willoughby 1920:39) on the Omaha Indians:

The old caches [storage pits] were used for ash-pits. The accumulations of ashes in the center fireplace would be cleared, and the ashes thrown in the pit. So also the bones and refuse of eating, and of feasts, and the broken implements and weapons, worn-out moccasins, and other articles.

There is some evidence to suggest that storage pits were primarily the product of a semi-sedentary settlement pattern, in which habitation sites were abandoned by all or part of the community for a brief period each year. Under such circumstances, the function of storage pits was as much food concealment as food storage and preservation (DeBoer 1988).

Storage pits like those found at Memorial Park have a broad temporal and geographical distribution throughout eastern North American prehistory. Through time, however, there were important changes in the size and morphology of storage pits (Ritchie and Funk 1973:365). In general, the more obvious of these changes included a trend from larger to smaller orifices, lesser to greater depths, and basin- to cylindrical- to bell-shaped profiles.

Storage pits are prolific at Clemson Island sites in the West Branch Valley drainage basin. Somewhat smaller, but morphologically similar pits occur on earlier Woodland and Archaic sites in the area (cf. Bressler 1989:Table 2; Hay and Graetzer 1985:48; Turnbaugh 1977:161). After A.D. 1250, however, storage pits have not been reported in the local archaeological record, and there has been no evidence that they persist into subsequent Stewart phase or McFate-Quiggle horizon times. For example, both the Bull Run site (Bressler 1980), dating to ca. A.D. 1300, and the Quiggle site (Smith 1984), dating to ca. A.D. 1500, lacked storage pits. These sites are Late Woodland villages located just downstream from the project area, and they post-date the Memorial Park site.<sup>1</sup>

The size and form of storage pits at Memorial Park and at other Clemson Island sites are most similar to examples reported for Archaic and earlier Woodland contexts in the Northeast, not later Woodland sites where pits sometimes attain depths of 180 cm or more (cf. Kinsey 1975:18) and are more typically cylindrical- to bell-shaped in profile. For the Clemson Island complex, Hay et al. (1987:65) suggest that there is intersite variability in these pits. They observe that both the Ramm and St. Anthony sites produced many large, well-prepared storage pits, while the Fisher Farm and Bald Eagle sites produced fewer and relatively smaller pits. The Memorial Park storage facilities vary somewhat from those at the St. Anthony and Bald Eagle sites.

Metric data for storage pits recorded at Memorial Park, Bald Eagle (Hamilton 1984:Table 10), and St. Anthony (R. M. Stewart 1989:Table 6.15) are summarized in Table 17. The Memorial Park storage pits were broader and deeper than those recorded at Bald Eagle, and they were broader and shallower than those at St. Anthony. It is of interest to note that the shortest length for the Memorial Park sample exceeds the mean for the Bald Eagle sample. The functional or temporal significance of these size differences, if any, remain to be demonstrated. It is possible that the size of storage pits was a function of the ease with which they could be excavated given the soil characteristics of a particular site.

---

<sup>1</sup>The fourteenth-century dates obtained from features 144 and 233 suggest that these features did persist into the Stewart phase.

Table 16. Metric Data for Individual Storage Pits.

Feature Number	Provenience	Length	Width	Depth
29	N20 E236	204	196	40
39	N14 E228	74	65	N/A
40	N28 E228	83	75	25
42	N4 E224	160	100	19
45	N10 E224	122	112	33
49	N14 E222	160	160	36
50	N16 E220	96	88	N/A
51	N18 E218	188	140	48
52	N22 E244	123	118	48
54	N14 E218	97	77	24
55	N14 E214	85	83	16
57	N30 E210	170	160	83
63	N34 E218	130	117	66
78	N24 E190	153	130	46
80	N32 E184	115	100	35
83	N26 E182	118	102	50
84	N26 E176	120	101	43
85	N28 E174	200	142	N/A
87	N24 E174	140	120	43
92	N28 E170	225	220	54
96	N32 E170	130	130	43
97	N34 E172	170	155	38
106	N32 E166	202	150	43
107	N28 E168	110	100	22
112	N38 E184	168	142	45
117	N24 E166	106	92	20
123	N30 E148	130	119	26
132	N40 E134	89	86	18
144	N46 E112	120	100	43
148	N46 E106	100	90	24
152	N32 E102	75	75	16
160	N32 E208	160	136	70
172	N26 E232	82	77	37
233	N40 E136	138	120	84
237	N13 E235	100	90	35

Table 17. Comparison of Storage Pits from Three Clemson Island Sites.

	Memorial Park	Bald Eagle	St. Anthony
N	35	19	22
Length (cm):			
Range	74 - 225	18 - 110	30 - 210
Mean	132.7	53.9	106.7
Width (cm):			
Range	65 - 220	16 - 90	30 - 210
Mean	116.2	46.5	97.5
Depth (cm):			
Range	16 - 84	4 - 48	18 - 106
Mean	39.8	21.6	48.8

*Fire-Related Pits.* Following Hay and Hamilton (1984:65), fire-related pits were defined as small, shallow features that are saucer- to irregularly-shaped in profile, and elliptical-, circular-, or irregularly-shaped in plan view.

Thirty-six fire-related pits were recorded at Memorial Park, including 34 that were completely excavated and two that were unexcavated. Metric data for these features are summarized in Table 18 and are presented for individual features in Table 19. Representative plan views and profiles are presented in Figure 26.

Table 18. Metric Summary of Fire-related Pits.

Dimensions	N	Range (cm)	Mean (cm)
Length	35	25-210	67.3
Width	35	18-150	47.3
Depth	34	3-36	9.0

Fire-related pits exhibited a single physical stratum or fill episode and produced varying amounts of charcoal and burned soil, either as lenses or scattered, isolated particles. Charcoal and burned soil lenses were found in 13 (38%) of the excavated fire-related pits, and these provide evidence for in situ burning. Scattered, isolated, particles may represent the residue from previous fires. No ash deposits were found in any of the features classified as fire-related pits.

For the 34 excavated fire-related pits, in terms of the distribution of artifacts by raw material class, 20 (59%) contained lithic debris, 23 (68%) contained pottery sherds, and three (9%) contained faunal remains. Feature 135 produced an in situ broken, though nearly complete, pottery jar. Sixteen (47%) of these features contained no fire-cracked rock, while the remaining 18 (53%) contained between 0.1 and 65.1 kg. As with storage pits, the majority of artifacts in fire-related pits are believed to constitute secondary refuse deposits, but fire-cracked rock may relate to the features' primary function.

The fact that only 38 percent of features classified as fire-related pits produced evidence of in situ burning suggests that this classification may be inappropriate. Additionally, the lack of ash from these features is contrary to expectations for hearths, although Dunnell (1983:128) notes that fire-related pits are often swept clean of debris. In all probability, the majority of small, shallow

pits like those reported here were used to contain fires, but may have also served a variety of other functions.

Table 19. Metric Data for Individual Fire-related Pits.

Feature	Provenience	Length (cm)	Width (cm)	Depth (cm)
7	N6 E266	40	26	5
8	N6 E268	94	55	9
12	N10 E260	44	38	7
17	N50 E255	50	25	6
26	N10 E248	70	48	8
34	N10 E236	35	35	7
35	N14 E242	26	23	6
37	N10 E237	60	42	10
41	N26 E226	124	100	8
44	N10 E228	100	65	12
46	N4 E220	66	37	9
48	N12 E222	75	62	7
61	N32 E222	210	150	10
65	N24 E206	25	18	7
67	N32 E210	100	80	12
68	N32 E208	116	68	4
70	N32 E204	55	52	3
81	N28 E124	76	31	3
89	N36 E170	102	10	12
93	N26 E178	40	38	9
100	N32 E176	40	25	N/A
101	N32 E178	34	30	3
108	N32 E198	28	21	7
118	N32 E156	80	70	13
119	N28 E168	32	20	4
121	N28 E166	32	31	6
127	N26 E144	32	30	14
135	N40 E130	66	60	10
145	N48 E110	66	61	8
155	N28 E162	200	10	15
158	N40 E176	80	80	12
159	N32 E210	67	56	4
171	N4 E100	50	38	8
177	N22 E146	10	90	36
216	N34 E195	32	32	11

PLAN VIEWS

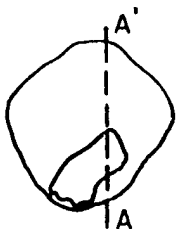
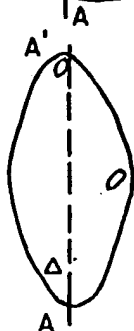
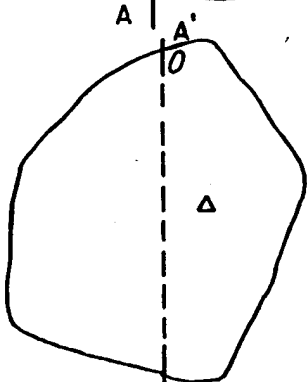
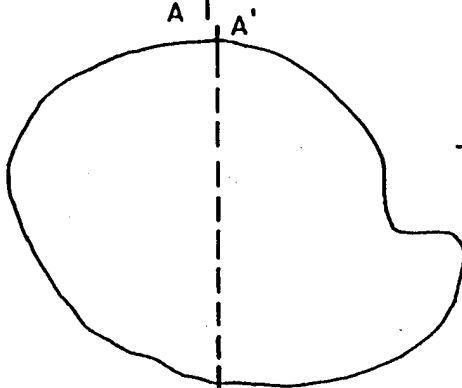
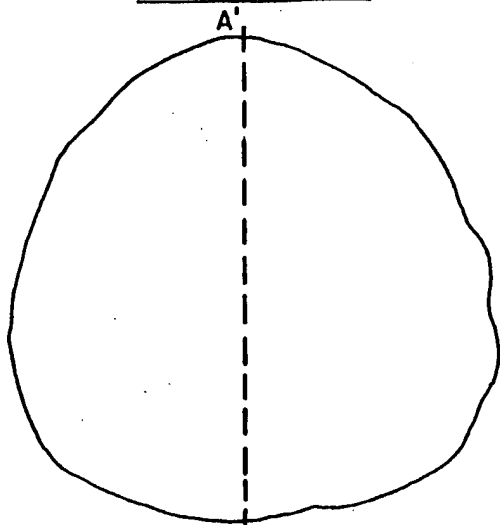

PROFILES

F89



F118



F48



F17



F34



KEY

- FCR
- △ CERAMICS

SCALE

0 20 CM

**FIGURE 26**

LATE WOODLAND  
FIRE-RELATED PITS,  
REPRESENTATIVE PLAN  
VIEWS AND PROFILES



Skinner (in M.C. Stewart 1977:160), discussing fire-related pits used by the Menomini Indians, observed that:

In order to prevent flying sparks from setting fire to the house, an ever-present danger when the roofing of bark or mats is dry, a round basin-like pit is often dug in the floor to contain the fire. These holes, as observed by the writer, are about two and one-half to three feet in diameter, and six inches to a foot in depth. Sometimes stones are placed in them to act as a support for kettles.

In the extant literature, small pits of the type described here are generally referred to as fire pits, cooking pits, and hearths (cf. Ritchie and Funk 1973). This broad category, in turn, is sometimes subdivided into more specialized functional classes such as earth ovens, boiling pits, smudge pits, and parching trenches (Hay and Hamilton 1984; M.C. Stewart 1977). The criteria for these more specialized functions, however, are often ambiguous, and no attempt is made here to subdivide this feature class.

Fire-related pits occur at prehistoric sites of all ages in the Northeast. They are ubiquitous at most, if not all Clemson Island sites where large, horizontal areas have been exposed (cf. Hatch 1980; Hay and Hamilton 1984; R.M. Stewart 1988). Metric comparisons of fire-related pits recorded at Memorial Park with those recorded at the Bald Eagle (employing features in Hay and Hamilton [1984:Table 7] listed as hearths) and St. Anthony sites (employing features in R.M. Stewart [1988:Table 6.15, Appendix D], listed as basins) are presented in Table 20.

The Memorial Park fire-related pits are intermediate in size as compared to those from the other two sites. The Memorial Park features have smaller average lengths and widths than those recorded at Bald Eagle, but average approximately the same depth. In comparison to the St. Anthony sample, however, the pits recorded at Memorial Park were approximately the same length and width but were somewhat less deep.

Table 20. Comparison of Fire-Related Pits from Three Clemson Island Sites.

	Memorial Park	Bald Eagle	St. Anthony
N	35	11	21
Length (cm):			
Range	25 - 210	32 - 142	24 - 182
Mean	67.3	94.3	61.0
Width (cm):			
Range	18 - 150	25 - 86	24 - 182
Mean	47.3	68.1	51.8
Depth (cm):			
Range	3 - 36	4 - 16	3 - 24
Mean	9.0	8.7	12.2

### Summary

Task 1 excavations at the Memorial Park site exposed abundant Clemson Island structural remains and features. Seven structures included two large, circular configurations, ranging from

6.3 to 6.8 m in diameter; one large, elliptical pattern, measuring 10.5 m long by 8.5 m wide; and four small, circular patterns, ranging from 2.3 to 3.5 m in diameter. These structures resemble those recorded at other Clemson Island sites. The two large, circular structures, both dwellings, are similar to a circular, somewhat smaller, configuration reported for the St. Anthony site (R.M. Stewart 1988). The single elliptical pattern, also a domicile, displays similarities to structures reported for the Ramm (Smith 1976) and Shermans Creek (Adovasio et al. 1988) sites, although the Memorial Park example is larger. Based upon analogies to Owasco-Iroquois discoveries in central New York, it is believed that the circular structures are earlier than elliptical forms (Hatch 1980; Ritchie and Funk 1973). If so, the presence of these two structure types at Memorial Park suggests the presence of at least two Clemson Island occupations. A third Clemson Island occupation may be represented by the four small, circular structures. These structures are most similar to small, circular patterns reported for the Petersburg Bridge (Mitchum 1968) and Milton Bridge (Mair 1988) sites, both interpreted as temporary encampments. Finally, Task 1 excavations produced a single large, rectangular-shaped structure or longhouse, measuring 18.0 m long by 6.7 m wide. Based upon associated Shenks Ferry Incised ceramics, this longhouse dates to the Stewart phase, and closely resembles another Stewart phase longhouse recently exposed at the Canfield Island site (Bressler 1993).

In addition to structures, 69 Late Woodland features were found at the Memorial Park site that have been classified as storage and fire-related pits. Thirty-eight were large, deep, storage pits, with basin-shaped or cylindrical profiles. The primary function of these pits was probably food storage, concealment, and preservation. Secondary functions probably included use as trash receptacles, burial pits, and hearths. Dimensions for Memorial Park storage pits compare favorably with examples reported for the Bald Eagle (Hay and Hamilton 1984), St. Anthony (R.M. Stewart 1988), and other Clemson Island sites.

Thirty-one small, shallow, fire-related pits were also recorded. Nearly half of these features produced evidence of in situ burning, while the remainder were presumably swept clean of fire-related debris. Dimensions for Memorial Park fire-related pits are similar to examples reported for the Bald Eagle (Hay and Hamilton 1984), St. Anthony (R.M. Stewart 1988), and other Clemson Island sites.

#### OSTEOLOGICAL ANALYSIS OF HUMAN BONE FROM CLEMSON ISLAND FEATURES *by Susan R. Frankenberg, Ph.D.*

The following paragraphs present the results of macroscopic osteological analysis of human remains recovered from features 92 and 96 related to the Clemson Island occupations of the Memorial Park site, and list recommendations for additional skeletal analyses. Methods used to clean and stabilize the remains, and procedures followed in assessing age, sex and health history of the remains are described. Detailed inventories of the bone are provided in tables 21 and 22.

#### *Processing Methods*

Six soil blocks thought to contain human bone, and four bags of excavated tooth fragments were received for analysis. Prior to transport, the soil blocks were wrapped in poly bubble-wrap, and the blocks and individual bags were then packed into cardboard boxes with newsprint as additional padding. Immediately upon receipt at the laboratory, the blocks were unwrapped in order to avoid molding, and both blocks and individual bags were examined to assess damage due to transport and appropriate methods for processing the remains.

Teeth that were bagged loose, and skeletal remains in block appeared to be free of damage due to transport. These materials continued to be at risk of degradation, however, as long as they

remained in contact with soil. The appearance of exposed bone in the blocks and the condition of the excavated teeth suggested that the soil matrix was highly acidic, and that these materials were recovered from an area in which high levels of leaching had occurred. To halt degradation due to soil acids and compaction, loose bone and teeth were freed of adhering soil using either dry cleaning techniques or gentle, brief, water-washing. Materials in block were removed from the surrounding soil matrix by a combination of in-laboratory excavation, flotation and water-screening procedures.

Loose bone and teeth were cleaned using dry techniques, when bone was powdery or lacked intact cortices and when tooth enamel fragments showed fracture lines. Dry cleaning consisted of brushing soil from the bone and enamel fragments using fine-grade, small-sized, camel-hair brushes. Soil removed during dry-brushing was collected on newsprint and passed through a screen of approximately 1 mm-square metal mesh (window-screen) before being discarded. The bone and enamel fragments cleaned in this way were then placed in new poly zip-lock bags; labels from the original bags were clipped and attached to the new bags to protect against errors in provenience information.

Wet cleaning techniques were used for loose bone or enamel that appeared capable of withstanding the process. Materials were washed over an approximately 1 mm-square metal mesh screen using tap-water gently applied through a fine-spray garden-hose attachment. Soil still adhering to bone and enamel was gently rubbed off by hand under the water-spray; no brushes or other implements were applied to the materials, and no materials were allowed to sit in standing water. Fragments were removed from the screen as they became clean, and were placed on newsprint in cardboard trays. The trays of cleaned materials were loosely covered by additional newsprint, and were placed indoors on ventilated shelves to dry slowly. Once dry, the materials were sorted and bagged following the same procedure as that for dry cleaned remains.

The recovery of materials from the bone-blocks involved several steps before reaching the wet or dry cleaning procedures. As much soil matrix as possible was excavated away from encased materials using small trowels, metal spatulas of the kind used in biological and chemical laboratories, and bamboo picks of assorted shapes. Metal implements were used only on those parts of the block that were devoid of bone, teeth or charcoal. Materials recovered during table-top excavation were then dry-brushed or water-washed following procedures described above. The remaining soil matrix consisted of fine sediment particles, larger soil peds, and small blocks of bone, antler or charcoal fragments still encased in compact, unyielding soil.

The block remnants resulting from table-top excavation were processed according to particle size and friability. The fine sediments were water-screened over a 1 mm-square metal mesh, and the few recovered materials were dried, sorted and bagged following the procedures for water-washed bone. The larger soil peds and small blocks were processed through basin flotation using softened water, the light fraction was skimmed from the basin using very fine veil-type nylon mesh, and the heavy fraction was then water-screened over 1 mm-square metal mesh. The materials recovered by combined flotation and water-screening were dried, sorted and bagged in the same way as water-screened materials.

Once clean and dry, all materials larger than 6.35 mm in size were sorted and inventoried by material class. In addition, all identifiable bone and tooth fragments smaller than 6.35 mm were separated from water-screen or flotation fractions and inventoried. Inventory of materials other than human skeletal remains consisted of only general identifications such as wood charcoal, charred seeds or nutshell, non-human animal bone, lithic debris, and coarse fragments. Human skeletal remains were inventoried by element and by region on that element, where possible. Identifiably human bone and tooth fragments that could not be assigned to an element were inventoried according to more general regions of the body. A detailed inventory of the human skeletal remains is provided in tables 21 and 22.



### *Bone Stabilization Methods*

No attempts were made to stabilize the human skeletal remains while they were in block because little bone was actually observable on the blocks, and because most known preservatives would have simply glued the sediments to the bone and/or created a wet environment promoting the action of soil acids. The most promising course to follow in terms of halting bone degradation was to remove the remains from block, free them of sediments as quickly as possible, and then place them in a relatively acid-free, humidity- and temperature-controlled environment. This course was accomplished shortly after receipt of the remains.

Further stabilization of the clean, dry remains by application of a readily-soluble preservative, was considered but was decided against, for the present. The preservatives considered were polyvinyl acetate (PVA) and Alvar, both of which coat the exterior surfaces and permeate any internal spaces with plastic, protecting against moisture and fragmentation, can be partly removed from the bone at a later time, and remain transparent. The teeth were not treated with either preservative because the plastic often obscures features of interest (e.g., wear facets, mild hypoplasias); plastic in interior spaces creates problems for thin-section analysis; and evaporation of the solvent, together with constriction of the plastic, may cause further fracturing of the enamel. The bone was not treated with PVA or Alvar because of concern over removing the preservative, should microscopic or chemical analyses be desired at a later date. Coating some of the remains with PVA or Alvar at a later time is recommended if the remains will be exposed to large amounts of handling or great variations in temperature or humidity.

### *Methods of Osteological Analysis*

Osteological analysis of the human remains was conducted during and after the inventory process. The results of this analysis are presented in subsequent sections of this report. The human skeletal remains, once inventoried, were examined macroscopically for minimum number of individuals/repetition of elements, age and sex indicators, general bone condition and pathology. Observations were recorded as comments and listings, rather than in a coding format, because of the small number and incomplete and fragmentary nature of the remains. No metric or standard discrete trait observations were possible. No microscopic observations (e.g., osteon aging, cementum annulation) or chemical analyses (e.g., trace elements and stable carbon isotopes) were performed. The possibilities for, and net return from, microscopic and chemical analyses will be considered below.

The human bone and teeth recovered from the Clemson Island features are poorly preserved, fragmentary, and incomplete. No bony landmarks commonly used to assess sex (i.e., features of the innominate and cranium) are present on the remains, and none of the bones and teeth are sufficiently intact for a metric estimation of sex. Consequently, sex assignment of the remains was not attempted. Bony age indicators (e.g., epiphyseal union, dental eruption, endocranial suture closure, and remodeling of the pubis or ilium) also are absent. Age estimates of the remains, therefore, are restricted to broad categories based on bone size and shape and tooth wear. The relative age standard used in assessing age from tooth wear is based on observations by the author on Woodland populations from the Midwest.

### *Results of the Osteological Analysis*

Clemson Island human skeletal remains were recovered from two features (Feature 92 and Feature 96) in association with habitation debris. Although both of these features contain charcoal and burned animal bone, none of the human remains are burned. Each feature appears to contain the incomplete remains of a single individual. Whether or not an entire skeleton was deposited in

each feature is discussed below. The observations made on the human skeletal remains are summarized in tables 21 and 22; detailed observations are presented in Appendix C.

All of the human remains recovered from Feature 92 (N 28 E170) appear to belong to one early middle-aged adult individual of indeterminate sex. Only portions of the anterior cranium, fragments from all of the upper dentition, and fragments from the anterior lower dentition are present. No pathology is apparent on the cranium; pathology of the dentition consists of small caries and calculus on the posterior teeth. The human remains recovered from Feature 96 (N 32 E170, N 32 E172) represent the incomplete remains of a single young adult individual of indeterminate sex. Only portions of the mid-left to posterior cranium, fragments of all of the dentition (upper and lower), and part of a femur are present. No pathology is evident on the cranium or femur; pathology of the dentition consists of very mild calculus on the posterior teeth and faint hypoplasias on the mid-arch teeth.

Table 21. Itemized Description of Human Skeletal Remains from Feature 92.

FS #	Items	Description
1296 <sup>a</sup>	several cranial and enamel fragments	Not reconstructable. Represents parts of the anterior upper splanchno- and neuro-cranium, and several teeth. Bones represented are the midline frontal, right petrous temporal, unisided sphenoid, and right maxilla. Teeth represented are all upper permanent, and lower permanent anterior to the molars. The teeth show mild to moderate wear, with spot dentin exposure on the canines and premolars, and planar wear on the molars. No observable pathology on the cranial fragments. Moderate calculus on molars; caries on all right and third left upper molars, and on lower right second premolar. Probably belonged to an early middle-aged adult, sex unknown.

<sup>a</sup>Copies of the original skeletal inventory and observation sheets for materials catalogued as field specimen number 1296 are attached as Appendix C.

The human remains from features 92 and 96 include thick, dense parts of the cranium and femur, and tooth crown enamel. In general, these remains are slightly weathered around the edges of fragments, but have intact cortices or external surfaces. Tooth roots and dentin are only present as a powdery residue within some of the enamel crowns. However, parts of the sphenoidal wing and maxilla, which consist of very little diploe and thin cortices, are present. Also, dense areas of the basicranium and of the postcranial skeleton (e.g., shoulder, hip and knee joint areas), are absent. If a relatively complete skeleton was deposited in either feature, and if preservation conditions were relatively constant across the area of deposition, we would expect to have recovered at least some portions of the postcranium other than the one femur diaphysis. The absence of postcranium suggests, tentatively, that only the cranium was deposited in Feature 92, and that the cranium and possibly some of the large long bones were deposited in Feature 96.

### *Summary and Conclusions*

The human skeletal remains recovered from features 92 and 96 represent parts of two adult individuals, one in early middle-age and one in young adulthood, and both of indeterminate sex. These remains may represent winter burial of the two individuals in a habitation context with unusual selective preservation, or deposition/redeposition of "curated" parts of the individuals after an unknown period of time. Whether or not these remains were buried fleshed or dry cannot be determined from the bone because of its incomplete, fragmented, and weathered condition.

Table 22. Itemized Description of Human Skeletal Remains from Feature 96.<sup>a</sup>

FS #	Items	Description
534	14 enamel fragments	Not reconstructable. Represent four or five permanent premolar and molar crowns. Eleven fragments show clear but light wear facets. No observable pathology. Probably belonged to a young adult, sex unknown.
562	several small enamel fragments	Not reconstructable. Represent an unsided upper second premolar, possibly another premolar, and right (?) upper first and second molars of the permanent dentition. Molars show buccal pits; molars and second premolar show faint interstitial facets and mild occlusal polish. No observable pathology. Probably belonged to a young adult, sex unknown.
1076	1 enamel fragment	Represents a permanent premolar (part of occlusal surface), showing little wear. Probably belongs to the same individual represented above.
1297	several cranial, enamel and femur fragments	Not reconstructable. Represents parts of the mid-left to posterior neurocranium, unsided upper leg, and the lower dentition. Bones represented are midline and unsided occipital, left petrous temporal, left sphenoid, and unsided upper to mid-shaft diaphysis of femur. Teeth represented are all lower permanent anterior to the third molars, and one upper right canine. The teeth show light wear and no dentin exposure. No observable pathology on the cranial or femur fragments. Mild calculus on molars; very faint linear hypoplasias and discoloration on the canines and possibly premolars; no caries. Probably belonged to a young adult, sex unknown.

<sup>a</sup>Copies of the original skeletal inventory and observation sheets for materials catalogued as field specimen number 1297 are presented in Appendix C.

No microscopic observations or chemical analyses were performed. Cementum annulation and other thin-section studies of the teeth are not possible because of the absence of dentin and roots, and because of the brittle nature of the enamel. Thin-section or coring of the femur shaft for osteon studies and of cranial fragments for bone histomorphology is physically possible, but of questionable utility. Quantitative information derived from microscopic examination of the cranial and femur fragments would be suspect because of the amount of weathering apparent at the gross level, and because of the lack of a prehistoric population or sample against which to compare the results. Chemical analyses for trace elements or stable carbon isotopes also are physically possible, but the results of such analyses are suspect for similar reasons.

Chemical analyses would be difficult, if not impossible, to interpret in terms of diet because reference information is lacking and because of "noise" produced by circumstances of preservation. In addition to difficulty in defining a reference population of prehistoric individuals, the bone lacks the common anatomical locations from which samples are drawn. Since trace element and carbon isotope levels vary across and within skeletal elements, inability to sample from standard locations or to pinpoint a sample location anatomically would create comparability problems. The gross appearance of the remains indicates that they have been subject to high levels of leaching. The presence of other organic materials with differing types and levels of trace elements and carbon isotopes in the same features as the human remains, together with leaching, suggests that diagenetic factors and contaminants would obscure any dietary meaning trace element or carbon isotope analyses may provide.

In summary, microscopic and chemical analyses of the two adult individuals recovered from the Memorial Park site would yield little information about lifeways, given current

technologies. (Discussion of the current state of trace element and stable carbon isotope studies can be found in Price [1989]). Curation of the human remains, or retention of bone and enamel samples for future chemical analysis if the remains are to be repatriated, however, is strongly recommended. In addition, if a comparative or reference population of prehistoric individuals is identified in the future, the Memorial Park site human remains should be subject to metric estimates of sex.

None of the cultural materials recovered from the features containing human remains appear to be grave goods. Rather, they appear to represent general village debris consistent with that found in features with no associated human remains.

#### PRE-LATE WOODLAND FEATURES by Barbara A. Munford

Excavations conducted during tasks 2, 3 and 4 at the Memorial Park site resulted in the identification of 182 soil anomalies. Included within this number are 13 that proved to be of non-cultural origin (root disturbances, bioturbation or non-features), and two that were associated with the Late Woodland occupations of the site. The remaining 167 were classified as pre-Late Woodland features. These features have been assigned to the Orient, Terminal Archaic, Piedmont, late Laurentian, early Laurentian, and Neville occupations based upon stratigraphic position, radiocarbon assays, and diagnostic artifacts. Seven pre-Late Woodland features and one pre-Late Woodland fire-cracked rock midden were identified during Task 1 excavations. Two of the features were assigned to the Early Woodland, three to the Middle Woodland, one to the Orient, and one to the Terminal Archaic occupations of the site based upon diagnostic artifacts or elevation and feature form. The midden uncovered during Task 1 investigations, Feature 124 (Figure 23), was assigned to the Orient occupation of the site. The pre-Late Woodland periods, in total, are represented by 174 features and one midden. Forty-six postmolds were recorded that predate the Late Woodland period, based upon their stratigraphic position.

#### *Feature Classification*

Features recorded during block excavations were divided into three types following Graybill's classification of Late Woodland features: postmolds, fire-related features, and nonfire-related features. Given the wider range of variation in these types than was present in the Late Woodland features, the latter two were subdivided into various subtypes to facilitate description. Fire-related features, which account for 92 percent of the pre-Late Woodland features excluding postmolds, were divided into seven subtypes: fire-related pits (54%), cobble hearths (3%), smudge pits (3%), burned wood (5%), oxidized charcoal stains (24%), oxidized stains (8%), and charcoal stains (3%). Non-fire-related features, which account for only 8 percent of the pre-Late Woodland features excluding postmolds, were divided into four descriptive subclasses: rock clusters (54%), storage pits (23%), caches (15%), cremations (8%). Postmolds were defined according to the criteria established by Graybill for the Late Woodland features. Definitions for fire-related features and nonfire-related features and their respective subtypes are provided below. Metric data for these various classes are presented in Table 23 by culture/period.

*Fire-related Features.* Fire-related features were divided into seven subtypes, each of which is characterized by burned soil and charcoal staining or inclusions. They range in form from amorphous scatters to prepared pits.

1. *Fire-related pit.* These features were generally circular to oval in plan, and basin-shaped in profile, with charcoal-stained, charcoal-flecked and/or oxidized fill.

2. *Cobble Hearth.* These features consisted of circular concentration of river cobbles, with soil containing charcoal flecking and oxidation. The cobbles were sometimes underlain by dense layers of charcoal.
3. *Smudge Pit.* These features were circular to slightly oval in plan, with straight to belled sides, containing at least one stratum of very loose, moist, heavily charcoal-laden soil.
4. *Burned Wood.* These features were oval to circular concentrations of burned wood. The bases of these features were flat to basin-shaped.
5. *Oxidized Stain.* These features were amorphous, reddened stains with no clear shape in plan or profile. These usually were not excavated as features; the soil was removed during excavation of 50 x 50 cm units.
6. *Oxidized Charcoal Stain.* These were amorphous reddened stains with charcoal flecking. They had no clear shape in plan or profile, but were excavated as features.
7. *Charcoal Stain.* These features consisted of scatters of charcoal flecking or charcoal-stained soil. They had no clear shape in plan or profile, but were excavated as features.

*Non-Fire-Related Features.* Non-fire-related features were divided into four subclasses as follows:

1. *Storage Pits.* These features were defined according to the same criteria as those used by Graybill for the Late Woodland features.
2. *Rock Cluster.* These features consisted of river cobble concentrations lacking associated staining or pit.
3. *Caches.* Two features of this subtype were recorded: one, a cache of flat, side-notched disks in a faint circular stain, and the other, a slightly oval pit (76 x 62 cm) with depth of 9 cm, containing bone fragments and a cache of artifacts, including 10 bifaces, quartz crystals and grooved grinding stones.
4. *Cremation.* One feature of this subtype, consisting of an oxidized stain containing a concentration of burned bone fragments and tools, was tentatively identified during excavations. An assessment of the bone recovered from this feature is presented later in this section, and indicates that the feature may not have been a human cremation.

### *Historic*

One possible historic feature was recorded: a slightly-oval stain (55 x 40 cm) with depth of 36 cm, containing a nail.

### *Non-cultural*

These generally consisted of rootmolds and krotovenia, identified on the basis of irregularity in plan, view, and profile. Also defined as noncultural were several anomalies that probably represented differential moisture content in the soil at the time of feature identification and mapping, but could not be spatially defined in plan or profile during excavation.

Table 23. Metric Data for Pre-Late Woodland Features.

Feature	Culture/Period	Subtype <sup>a</sup>	Length (cm)	Width (cm)	Depth (cm)	Block	Level <sup>b</sup>	Elevation	Strata <sup>c</sup>
110	Early Woodland	FRP	172	166	50	--	SS	167.59	BS 2
129	Early Woodland	FRP	38	38	N/A	--	SS	167.92	BS 2
32	Middle Woodland	SP	131	117	27	--	SS	167.84	BS 1
143	Middle Woodland	SP	118	118	44	--	SS	167.87	BS 1
175	Middle Woodland	SP	200	90	36	--	SS	167.89	BS 2
182	Orient	C	58	55	8	4	3	167.84	BS 1
149	Orient	FRP	112	80	10	--	SS	167.89	BS 1
178	Orient	FRP	77	62	9	6	3	167.60	BS 1
186	Orient	FRP	33	18	3	6	6	167.26	BS 2
191	Orient	FRP	36	30	12	2	6	167.68	BS 1
243	Orient	FRP	59	59	11	10	4	167.88	BS 1
265	Orient	FRP	49	37	10	9	9	167.94	BS 2
322	Orient	FRP	90	63	11	15	1	167.93	BS 1
323	Orient	FRP	65	34	6	15	2	167.76	BS 2
337	Orient	FRP	110	56	13	16	1	167.95	BS 2
201	Orient	OCS	16	11	6	3	4	167.77	BS 3
235	Orient	OCS	92	47	13	8	2	168.06	BS 2
246	Orient	OCS	65	36	6	10	5	167.78	BS 1
252	Orient	OCS	68	60	6	10	6	167.64	BS 2
342	Orient	OCS	42	43	2	16	2	167.84	BS 2
179	Orient	OS	75	64	--	4	3	167.89	BS 1
180	Orient	OS	100	50	6	4	3	167.89	BS 1
192	Orient	OS	>50	>45	10	3	2	167.98	BS 1
313	Orient	OS	81	40	--	13	1	167.92	BS 2
181	Orient	RC	74	70	10	6	3	167.58	BS 1
290	Terminal Archaic	BW	28	20	4	11	6	167.64	BS 2
338	Terminal Archaic	C	76	62	9	12	8	167.36	BS 2
273	Terminal Archaic	CbH?	66	49	21	9	6	167.76	BS 2
274	Terminal Archaic	CbH	98	85	16	9	6	167.74	BS 2
275	Terminal Archaic	CbH	93	75	22	9	6	167.71	BS 2
279	Terminal Archaic	CbH	87	50	12	9	6	167.74	BS 2
283	Terminal Archaic	CbH	79	>43	22	11	5	167.69	BS 2
257	Terminal Archaic	CR?	147	136	13	8	6	167.74	BS 2
282	Terminal Archaic	CS	>240	>150	2	11	5	167.73	BS 1
317	Terminal Archaic	CS	129	80	2	14	5	167.56	BS 2
161 <sup>d</sup>	Terminal Archaic	FRP	110	94	21	--	SS	167.61	BS 2

Table 23 (cont.)

Feature	Culture/Period	Subtype	Length (cm)	Width (cm)	Depth (cm)	Block	Level	Elevation	Strata
187	Terminal Archaic	FRP	>70	>50	6	4	5	167.67	BS 2
190	Terminal Archaic	FRP	40	22	5	5	6	167.64	BS 3
193	Terminal Archaic	FRP	82	80	8	2	7	167.58	BS 2
195	Terminal Archaic	FRP	46	40	6	2	7	167.58	BS 2
199	Terminal Archaic	FRP	90	90	15	2	7	167.58	BS 2
203	Terminal Archaic	FRP	20	14	14	2	9	167.38	BS 2
212	Terminal Archaic	FRP	86	66	1-5	1	5	167.69	BS 1
214	Terminal Archaic	FRP	25	17	11	1	6	167.59	BS 2
215	Terminal Archaic	FRP	46	42	15	1	6	167.59	BS 2
241	Terminal Archaic	FRP	52	43	18	8	5	167.84	BS 2
242	Terminal Archaic	FRP	73	>42	9	8	5	167.84	BS 2
244	Terminal Archaic	FRP	63	57	20	8	5	167.84	BS 2
245	Terminal Archaic	FRP	72	67	31	8	5	167.84	BS 2
254	Terminal Archaic	FRP	90	88	8	10	7	167.58	BS 2
256	Terminal Archaic	FRP	80	71	16	10	7	167.52	BS 2
258	Terminal Archaic	FRP	62	50	9	8	6	167.74	BS 2
260	Terminal Archaic	FRP	37	32	9	10	8	167.47	BS 2
261	Terminal Archaic	FRP	105	46	8	10	8	167.45	BS 2
270	Terminal Archaic	FRP	63	38	4	9	6	167.72	BS 2
271	Terminal Archaic	FRP	59	56	5	9	6	167.72	BS 2
272	Terminal Archaic	FRP	36	>30	3	9	6	167.74	BS 2
291	Terminal Archaic	FRP	97	62	6	11	6	167.60	BS 2
301	Terminal Archaic	FRP	50	48	10	11	8	167.47	BS 2
307	Terminal Archaic	FRP	100	42	4	14	3	167.70	BS 2
308	Terminal Archaic	FRP	58	59	6	14	4	167.67	BS 2
309	Terminal Archaic	FRP	52	51	14	14	4	167.69	BS 2
316	Terminal Archaic	FRP	94	56	7	14	5	167.59	BS 2
320	Terminal Archaic	FRP	70	40	6	14	5	167.53	BS 2
321	Terminal Archaic	FRP	63	58	14	14	5	167.54	BS 2
328	Terminal Archaic	FRP	33	26	13	12	6	167.56	BS 2
330	Terminal Archaic	FRP	42	32	4	12	6	167.50	BS 2
334	Terminal Archaic	FRP	46	46	7	12	7	167.47	BS 2
335	Terminal Archaic	FRP	160	116	18	12	7	167.46	BS 2
339	Terminal Archaic	FRP	67	26	6	12	7	167.47	BS 2
340	Terminal Archaic	FRP	31	18	2	12	9	167.28	BS 2
347	Terminal Archaic	FRP	64	63	7	16	4	167.70	BS 2

Table 23 (cont.)

Feature	Culture/Period	Subtype	Length (cm)	Width (cm)	Depth (cm)	Block	Level	Elevation	Strata
352	Terminal Archaic	FRP	86	66	19	16	4	167.70	BS 2
361	Terminal Archaic	FRP	103	67	8	15	7	167.36	BS 2
183	Terminal Archaic	OCS	44	28	4	5	4	167.84	BS 2
184	Terminal Archaic	OCS	76	36	5	5	4	167.84	BS 2
185	Terminal Archaic	OCS	112	103	3	5	5	167.72	BS 2
199A	Terminal Archaic	OCS	44	20	5	2	8	167.48	BS 2
207	Terminal Archaic	OCS	55	53	3	3	8	167.38	BS 2
210	Terminal Archaic	OCS	101	79	3	3	9	167.28	BS 2
213	Terminal Archaic	OCS	35	>10	3	3	8	167.30	BS 2
255	Terminal Archaic	OCS	90	84	4	8	6	167.74	BS 2
259	Terminal Archaic	OCS	70	32	3	8	6	167.79	BS 2
269	Terminal Archaic	OCS	80	46	4	9	5	167.76	BS 2
277	Terminal Archaic	OCS	84	59	4	9	6	167.69	BS 2
281	Terminal Archaic	OCS	62	38	4	9	7	167.64	BS 3
299	Terminal Archaic	OCS	112	55	1-3	9	7	167.51	BS 2
319	Terminal Archaic	OCS	68	36	6	11	7	167.60	BS 2
324	Terminal Archaic	OCS	95	59	2	14	5	167.60	BS 2
329	Terminal Archaic	OCS	130	90	8	13	5	167.60	BS 2
332	Terminal Archaic	OCS	58	26	7	12	6	167.58	BS 2
343	Terminal Archaic	OCS	51	25	7	12	7	167.46	BS 2
348	Terminal Archaic	OCS	95	40	5	12	10	167.18	BS 3
350	Terminal Archaic	OCS	80	63	--	16	4	167.70	BS 2
194	Terminal Archaic	OS	50	45	8	16	4	167.65	BS 3
196	Terminal Archaic	OS	60	55	--	2	6	167.68	BS 1
197	Terminal Archaic	OS	60	50	--	2	7	167.58	BS 2
198	Terminal Archaic	OS	60	50	--	2	7	167.58	BS 2
200	Terminal Archaic	OS	59	51	5-14	2	7	167.58	BS 2
211	Terminal Archaic	OS	30	25	--	2	7	167.58	BS 2
239	Terminal Archaic	OS	40	>30	--	1	5	167.69	BS 1
251	Terminal Archaic	OS	69	50	--	8	4	167.94	BS 2
318	Terminal Archaic	OS	78	63	--	10	6	167.63	BS 2
345	Terminal Archaic	OS	53	34	--	13	3	167.80	BS 2
189	Terminal Archaic	RC	100	70	--	16	3	167.77	BS 2
262	Piedmont	FRP	42	30	9	5	6	167.55	BS 3
331	Piedmont	FRP	103	60	15	8	7	167.62	BS 3
356	Piedmont	FRP	29	22	17	14	8	167.27	BS 3
	Piedmont	FRP	74	66	18	16	5	167.59	BS 3



Table 23 (cont.)

Feature	Culture/Period	Subtype <sup>a</sup>	Length (cm)	Width (cm)	Depth (cm)	Block	Level	Elevation	Strata
351	Piedmont	FRP	26	23	6	16	5	167.60	BS 3
353	Piedmont	FRP	30	30	7	16	5	167.60	BS 3
354	Piedmont	FRP	28	28	6	16	5	167.60	BS 3
355	Piedmont	FRP	37	33	3	16	5	167.59	BS 3
359	Piedmont	FRP	34	30	11	16	5	167.56	BS 3
228	Piedmont	OCS	20	16	3	1	14	166.76	BS 3
325	Piedmont	OCS	35	26	8	13	6	167.55	BS 3
326	Piedmont	OCS	67	51	3	13	6	167.50	BS 3
327	Piedmont	OCS	83	68	10	13	6	167.50	BS 3
217	Late Laurentian	BW	38	28	7	5	12	167.02	BS 5
238	Late Laurentian	BW	28	25	7	5	12	166.96	BS 5
266	Late Laurentian	BW	48	28	3	10.	17	166.52	BS 4
278	Late Laurentian	BW	31	29	6	8	12	167.09	BS 4
341	Late Laurentian	BW	41	28	8	13	9	167.13	BS 4
226	Late Laurentian	FRP	34	26	10	2	20	166.29	BS 5
263	Late Laurentian	FRP	42	36	8	8	10	167.30	BS 4
264	Late Laurentian	FRP	62	40	6	8	10	167.34	BS 4
300	Late Laurentian	FRP	49	32	5	9	11	167.24	BS 4
312	Late Laurentian	FRP	41	38	8	11	21	166.18	BS 4
333	Late Laurentian	FRP	32	26	9	14	9	167.16	BS 4
225	Late Laurentian	OCS	100	70	9	3	22	165.98	BS 5
231	Late Laurentian	OCS	22	12	2	1	23	165.81	BS 4
236	Late Laurentian	OCS	98	77	14	5	10	167.20	BS 4
267	Late Laurentian	OCS	45	20	4	10	19	166.38	BS 5
363	Late Laurentian	OCS	66	54	5	16	12	166.90	BS 5
268	Late Laurentian	RC	160	80	--	8	11	167.27	BS 4
276	Late Laurentian	RC	80	50	--	8	12	167.14	BS 4
280	Late Laurentian	Smp	15	11	11	8	12	167.08	BS 4
344	Late Laurentian	Smp	36	35	20	13	11	167.00	BS 4
224	Early Laurentian	BW	27	25	2	5	14	166.79	BS 6
289	Early Laurentian	BW	32	20	6	8	14	166.90	BS 5
247	Early Laurentian	CS	>80	?	10	4	15	166.65	BS 5
292	Early Laurentian	CS	36	18	3	8	14	166.89	BS 5
302A	Early Laurentian	CS	20	15	2	8	16	166.73	BS 6
218	Early Laurentian	FRP	96	>56	10	5	13	166.94	BS 5
219	Early Laurentian	FRP	65	54	14	4	12	166.92	BS 5

Table 23 (cont.)

Feature	Culture/Period	Subtype <sup>a</sup>	Length (cm)	Width (cm)	Depth (cm)	Block	Level	Elevation	Strata
221	Early Laurentian	FRP	23	22	4	5	13	166.87	BS 6
222	Early Laurentian	FRP	22	18	4	5	13	166.86	BS 6
227	Early Laurentian	FRP	90	52	8	4	15	166.61	BS 5
286	Early Laurentian	FRP	28	24	11	8	14	166.94	BS 5
287	Early Laurentian	FRP	60	20	11	8	13	167.02	BS 5
293	Early Laurentian	FRP	28	26	5	8	14	166.96	BS 5
294	Early Laurentian	FRP	52	30	5	8	14	166.96	BS 5
295	Early Laurentian	FRP	84	40	10	8	14	166.93	BS 5
296	Early Laurentian	FRP	108	64	17	8	14	166.93	BS 5
297	Early Laurentian	FRP	96	93	15	8	14	166.98	BS 5
298	Early Laurentian	FRP	50	40	9	8	14	166.98	BS 5
302	Early Laurentian	FRP	200	80	20	8	15	166.82	BS 5
305	Early Laurentian	FRP	48	>17	8	9	15	166.83	BS 5
306	Early Laurentian	FRP	35	30	8	9	15	166.84	BS 5
310	Early Laurentian	FRP	38	33	3	9	15	166.79	BS 5
311	Early Laurentian	FRP	32	29	3	9	15	166.80	BS 5
349	Early Laurentian	FRP	67	35	3	13	12	166.90	BS 5
358	Early Laurentian	FRP	36	34	4	13	12	166.85	BS 5
288	Early Laurentian	OCS	35	32	3	8	14	166.91	BS 5
303	Early Laurentian	OCS	86	40	5	9	14	166.94	BS 5
304	Early Laurentian	OCS	32	31	5	9	14	166.87	BS 5
346	Early Laurentian	OCS	>49	>30	7	13	11	166.88	BS 5
220	Early Laurentian	RC	55	43	8	4	13	166.89	BS 5
223	Early Laurentian	RC	23	>12	8	4	13	166.84	BS 5
285	Early Laurentian	RC	34	23	10	8	13	166.95	BS 5
357	Early Laurentian	Smp	18	13	10	13	13	166.80	BS 5
362	Early Laurentian	Smp	24	21	14	12	18	166.33	BS 4
232	Neville	FRP	>103	>100	>22	6	16	166.30	BS 6
360	Neville	FRP	32	32	3	14	18	166.26	BS 6

<sup>a</sup>BW: burned wood; C: cache; CbH: cobble hearth; CS: charcoal stain; FRP: fire-related pit; CR: cremation; OS: oxidized stain; OCS: oxidized charcoal stain; RC: rock cluster; SMP: smudge pit; Sp: storage pit.

<sup>b</sup>SS: Task 1 scraped surface.

<sup>c</sup>BS: Buried Soil (see Figure 18).

<sup>d</sup>Tentative assignment based upon feature's elevation on Task 1 scraped surface.

The following pages present a summary of these various features by culture/period assignments.

### *Middle Woodland Features*

Three pits exposed during Task 1 investigations of the site were assigned to the Middle Woodland (Figure 27) period, based upon artifact content and one radiocarbon assay. A radiocarbon date of A.D. 150 was obtained from Feature 143, placing it at the beginning of the Middle Woodland period as defined by Graybill (Section III, this volume). The date suggests a Fox-Creek-phase occupation of the site. This feature contained a large, fabric-impressed rimsherd. A body sherd recovered from Feature 175, refit a body sherd from Feature 143, suggesting that these features were contemporaneous. Finally, the recovery of a rhyolite Fox-Creek-like, or Conewago, biface from Feature 32 suggests a Fox-Creek-phase origin for this feature. All three of these pits meet the criteria established above for Late Woodland storage pits. Feature 143 contained charred grass at its base, like two of the Clemson Island storage pits as described by Graybill (this volume). The three Middle Woodland pits averaged 150 cm in length, 118 cm in width, and 36 cm in depth. Features 143 and 175 each had two distinct strata, while Feature 32 had a single stratum.

### *Early Woodland Features*

Two features exposed during Task 1 investigations (Figure 28) were assigned to the Early Woodland period, based upon diagnostic artifacts. Feature 110 was assigned to the Early Woodland period based upon the recovery of two Meadowood bifaces in its fill. This was a fire-related pit measuring 166 x 172 cm in plan and 50 cm in depth. In addition to the bifaces, 123.8 kg of fire-cracked rock and a pitted cobble were recovered from this feature. Feature 129, a fire-related pit, was assigned to the Early Woodland period, based upon the recovery of a Rossville-like rhyolite biface from its fill. No other features were clearly identified with the Early Woodland occupation of the site.

### *Orient Features*

Nineteen features identified during block excavations, and one feature uncovered during surface scraping, were associated with the Orient occupation(s). These constituted 11 percent of the pre-Late Woodland features, excluding postmolds. The features included nine fire-related pits, five oxidized charcoal stains, four oxidized stains, one cache, and one rock cluster. Representative planviews and profiles are presented in Figure 30. Orient features were found in all block clusters except Block 1 (Figure 29). One large, fire-cracked, rock midden on the scraped surface was also of Orient origin. In addition, 32 postmolds were identified within Orient contexts, representing 69.6% of all pre-Late Woodland postmolds.

*Fire-related Pits.* Fire-related pits accounted for 45% of the Orient features. These nine features were roughly circular to oval in plan, and of a smooth-to-irregular basin shape in profile. Their mean dimensions were 70.1 by 48.7 cm in plan and 9.4 cm in depth (Table 24). Fill included charcoal-stained soil, charcoal flecking, and oxidized soil flecking as well as in situ oxidized soil. Six of the pits (66.6%) had a single stratum, and three (33.3%) exhibited two or three strata. Two of the pits contained bands of charcoal flecking and/or oxidized soil marking their bases. Lithic debris was recovered from five of the pits, with a mean count of 2.8, and fire-cracked rock was recovered from five of the pits, with a mean weight of 4.8 kg.

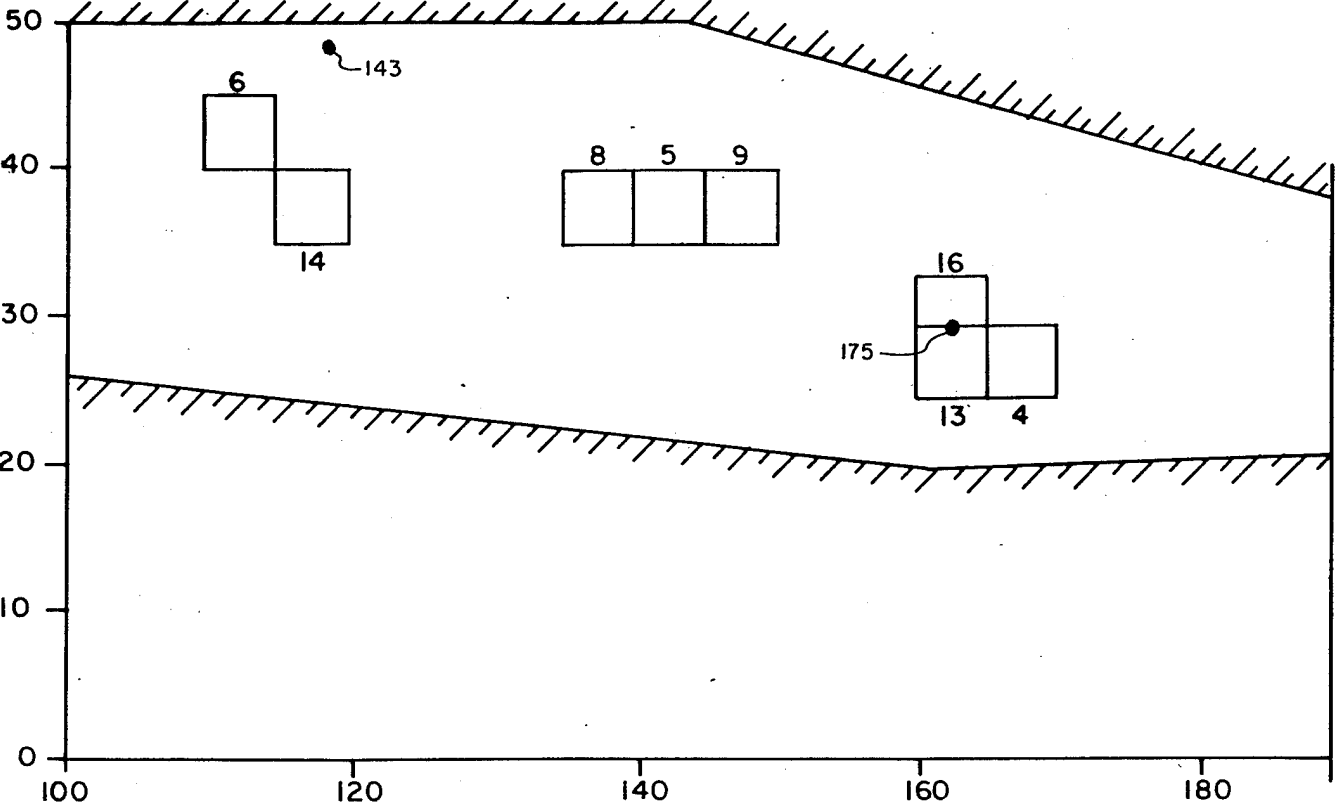

MATCH LINE - THIS SHEET

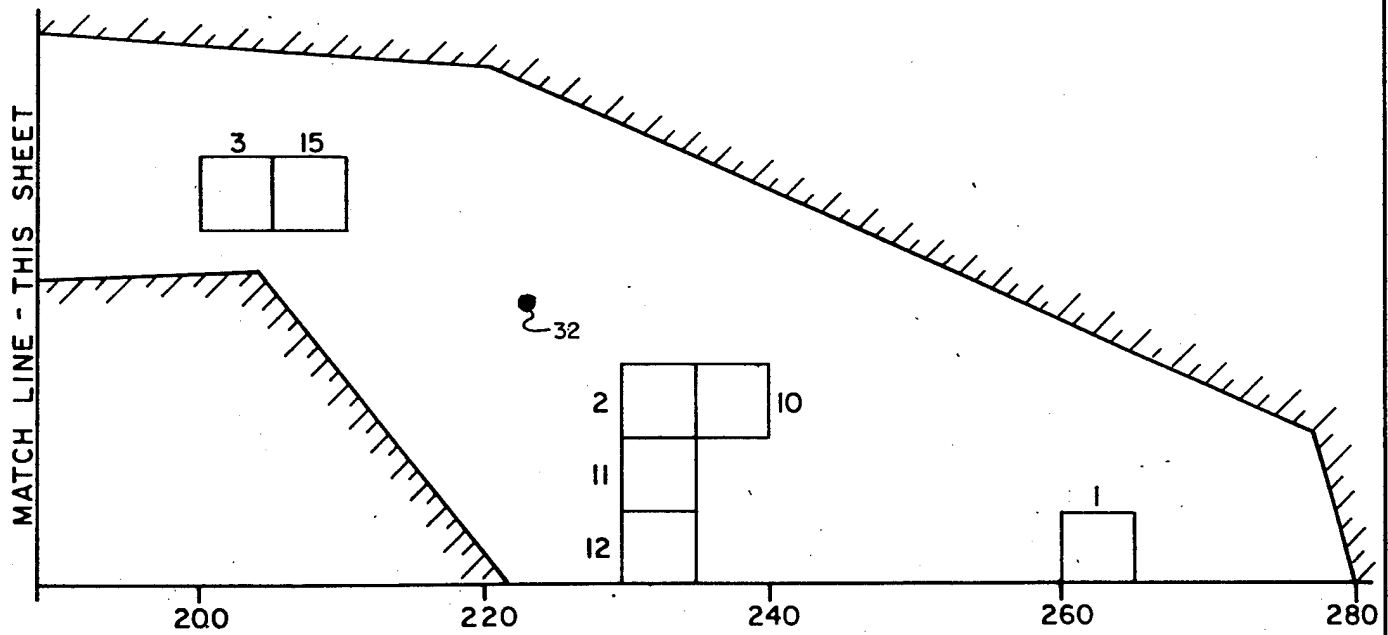

MATCH LINE - THIS SHEET

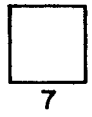

KEY

- - FEATURE
- ⋯ - POSTMOLDS

FIGURE 27

DISTRIBUTION OF MIDDLE WOODLAND FEATURES

DWG. NO. 89-412-A26

JPH

APPROVED

REM

GAI CONSULTANTS, INC. DWN.

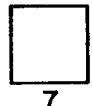
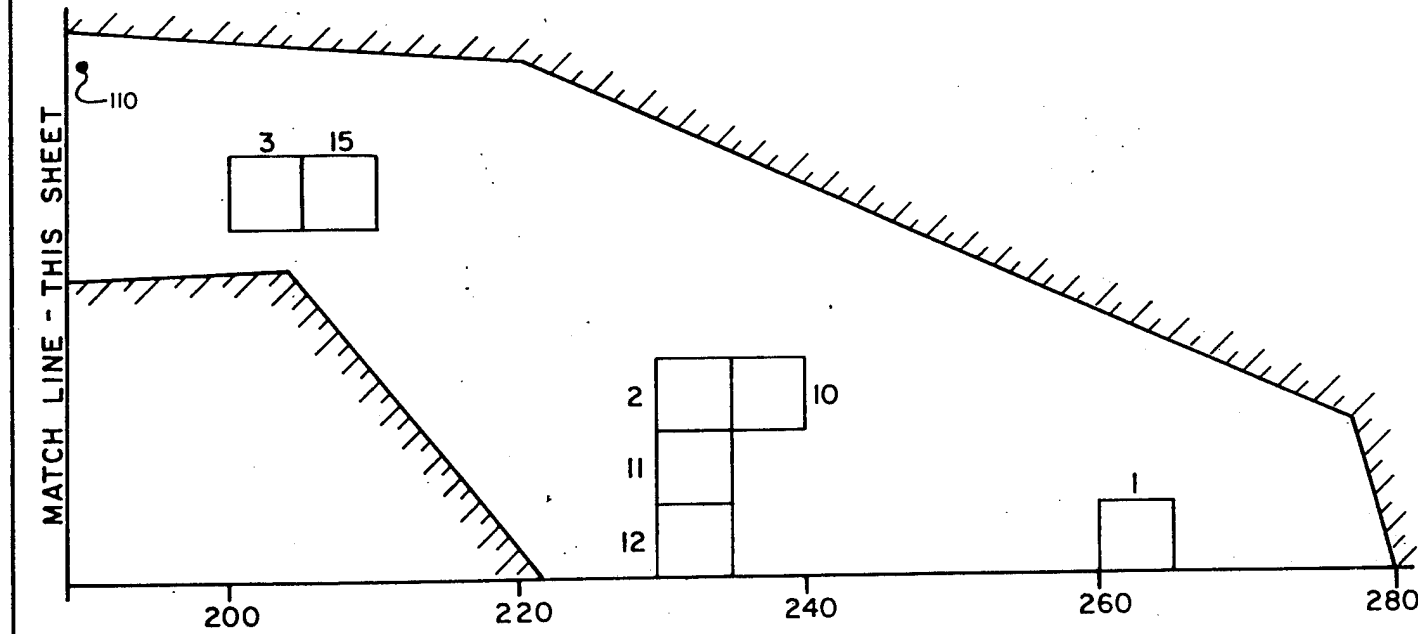
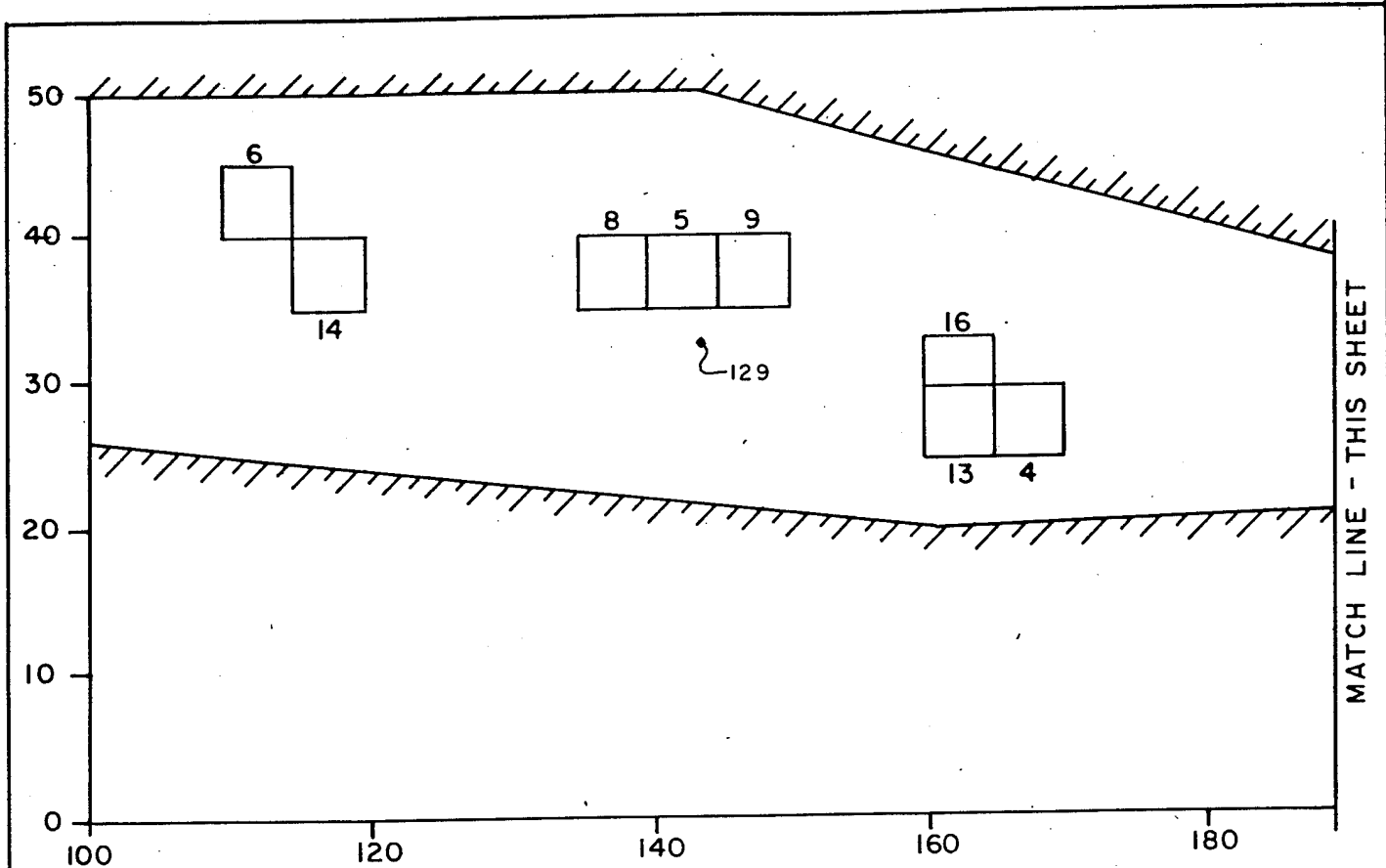

KEY  
 - - FEATURE  
 ... - POSTMOLDS

**FIGURE 28**  
 DISTRIBUTION OF  
 EARLY WOODLAND FEATURES

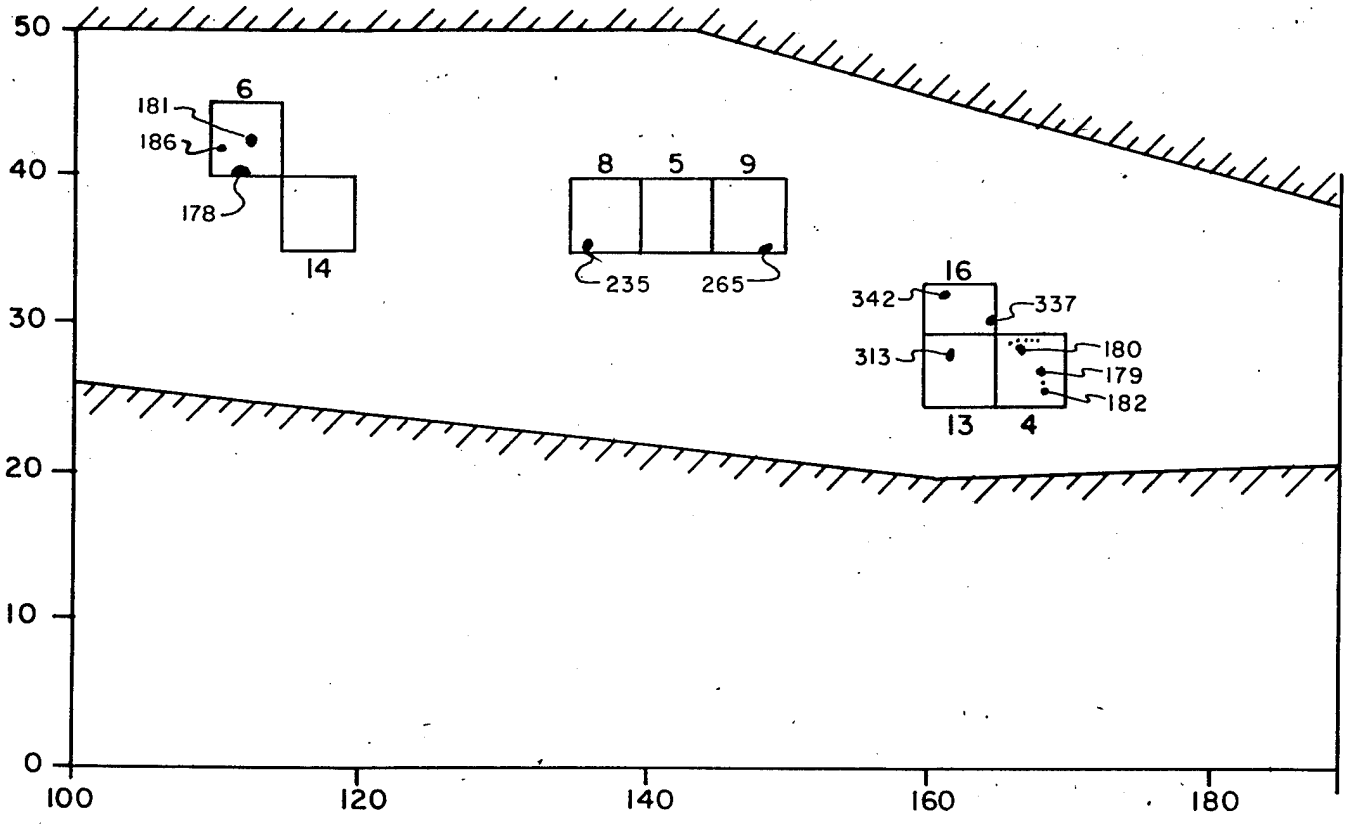

MATCH LINE - THIS SHEET

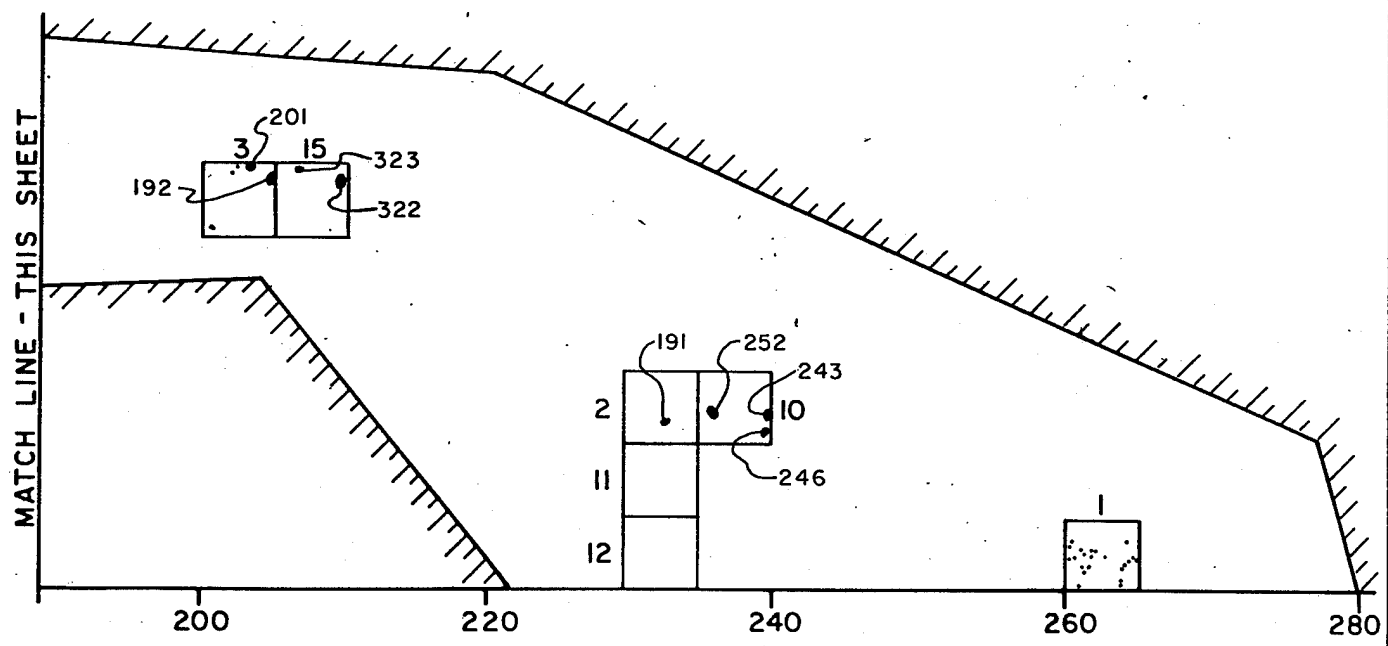

MATCH LINE - THIS SHEET

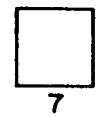

KEY

- - FEATURE
- ⋯ - POSTMOLDS

FIGURE 29

DISTRIBUTION OF ORIENT FEATURES

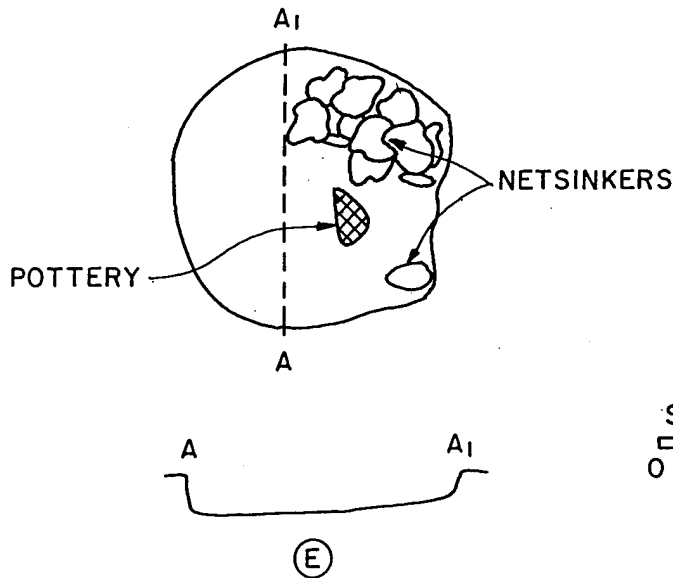
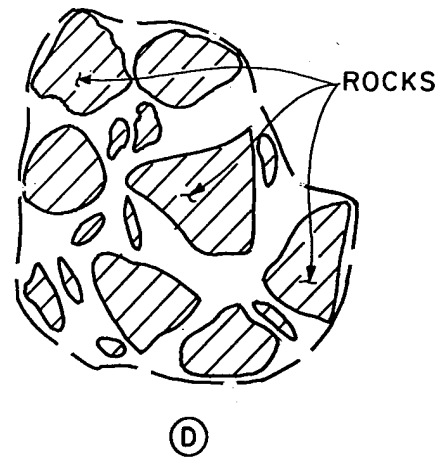
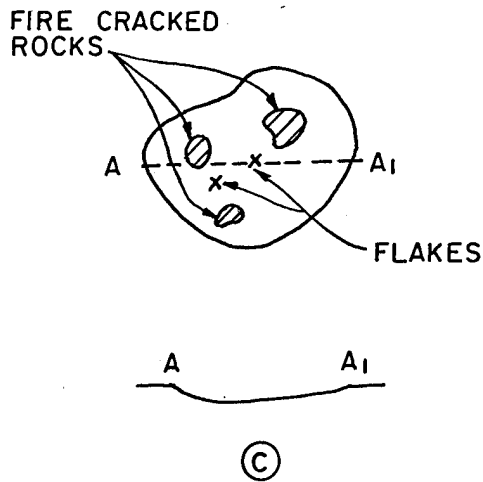
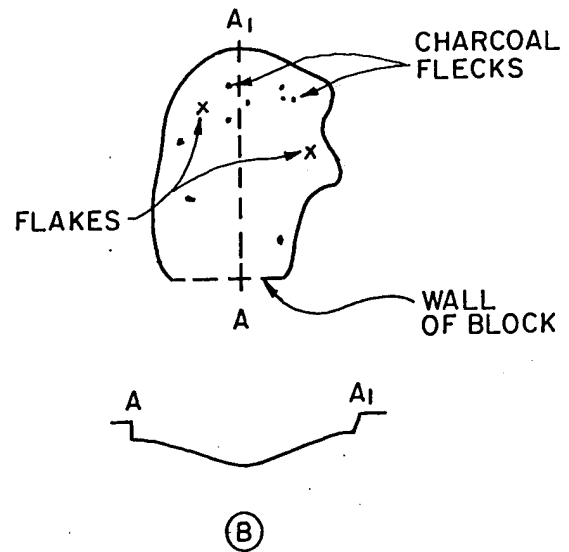
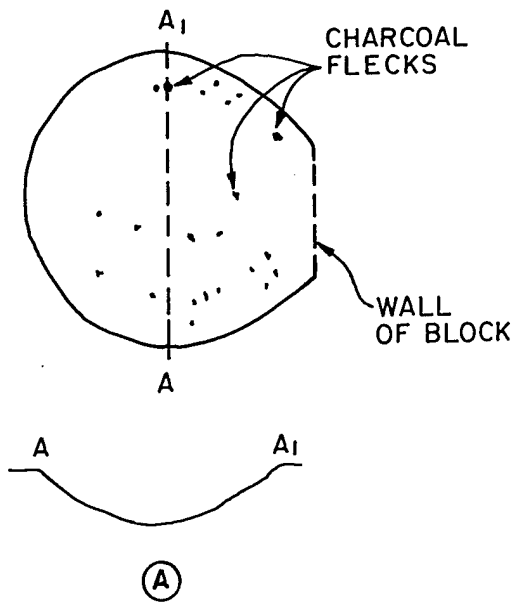

LEGEND

- A = FEATURE 243, FIRE-RELATED PIT
- B = FEATURE 265, FIRE-RELATED PIT
- C = FEATURE 323, FIRE-RELATED PIT
- D = FEATURE 181, ROCK CLUSTER
- E = FEATURE 182, NETSINKER CACHE

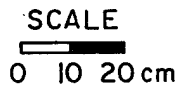

FIGURE 30

ORIENT FEATURES,  
REPRESENTATIVE PLAN VIEWS AND  
PROFILES

The pit identified on the scraped surface at the western end of the site (Feature 149) was composed of a concentration of fire-cracked rock and an associated stain. Several pieces of steatite-tempered pottery and a flaked stone tool were recovered from this feature.

Table 24. Metric Summary of Orient Fire-Related Pits.

Dimensions	N	Range (cm)	Mean (cm)
Length	9	33-112	70.1
Width	9	18-80	48.7
Depth	9	3-13	9.4

*Oxidized Charcoal Stains.* Five oxidized charcoal stains were located within Orient strata. Like the fire-related pits, these stains were circular-to-oval in shape. Their mean dimensions were 56 x 39 cm, and their irregular profiles had a mean depth of 6.6 cm (Table 25). Two yielded lithic debris (5-13 artifacts).

Table 25. Metric Summary of Orient Oxidized and Charcoal Stains.

Dimensions	N	Range (cm)	Mean (cm)
Length	5	16-92	56.6
Width	5	11-60	39.4
Depth	5	2-13	6.6

*Oxidized Stains.* The four oxidized stains identified in Orient strata were not excavated as features; their fill was removed by 50 x 50 cm units during the block excavations. These anomalies were oval in shape with slightly larger mean dimensions (76.5 x 49.7 cm) than the oxidized charcoal stains described above (Table 26). The depth of two of these features was noted during excavation of the blocks, yielding a mean depth of 8 cm. Three pieces of lithic debris were recovered from one of these stains.

Table 26. Metric Summary of Orient Oxidized Stains.

Dimensions	N	Range (cm)	Mean (cm)
Length	4	50-100	76.5
Width	4	40-64	49.7
Depth	2	6-10	8.0

*Cache.* Feature 182, a pit located in Block 4 contained a cache of 18 flat, side-notched sandstone disks and one steatite-tempered pottery sherd (Figure 31). The pit was defined by a faint, circular stain measuring 58 x 55 cm in plan and 8 cm in depth.

*Rock Clusters.* One rock cluster consisting of a circular concentration of large angular rocks was associated with the Orient occupation(s) of the site. It had dimensions of 74 x 70 cm in plan and consisted of 51 kg of rocks that exhibited fire-reddened surfaces, but were not cracked. No obvious pit was defined.



*Midden.* Feature 124 (Figure 23) was a large midden, encompassing an area approximately 10 x 15 m, was exposed during stripping operations during Task 1. While originally thought to be associated with the Late Woodland occupations of the site, the recovery of Marcey Creek pottery and its general stratigraphic position relative to the rest of the site suggests that it is associated with the Orient phase occupations of the site. The recovery of a Meadowood biface in Block 5 suggests the possibility of an Early Woodland association. In Block 5, at its approximate center, the midden was 10 to 20 cm-thick. In Block 8, it was 10 to 15 cm thick, while in Block 9 it ranged from approximately 20 to 40 cm-thick.

*Postmolds.* Thirty-two postmolds were clearly assignable to the Orient occupation(s). Twenty-three of these were recorded in Level 2 of Block 1. They originated at an average elevation of 167.97 m, and ranged in depth from 3 to 14 cm, with a mean depth of 7.5 cm. Diameters ranged from 3 to 15 cm, with a mean of 5 cm. No obvious pattern was evident in their distribution across the block.

Three postmolds were recorded in Block 3 at an average elevation of 167.66. One of these consisted of a post hole and mold, measuring 16 x 14 cm in plan and 10 cm in depth. The second postmold was conical in shape, while its post hole was rectangular. The second postmold measured 4 cm in diameter and 4 cm in depth. This postmold was rectangular in cross section. The final postmold in this block was conical in profile, and measured 12 x 8 cm in plan and 10 cm in depth.

Four postmolds in Block 4 originated at an elevation of 167.89 m. A fifth postmold originated at the base of Feature 107 at an elevation of 167.89, while the sixth originated at the top of this feature at an elevation of 167.82. All of these postmolds occurred along the northern edge of the block in a weak arc, perhaps representing portions of a structure.

### *Terminal Archaic Features*

Seventy-nine features were identified in Terminal Archaic contexts, comprising nearly half (46%) of all pre-Late Woodland features excluding postmolds. Included in the fire-related features were 38 fire-related pits, six cobble hearths, one burned wood feature, 20 oxidized charcoal stains, nine oxidized stains, and two charcoal stains (Figure 32). Other features included one rock cluster, one possible cremation, and one cache. Terminal Archaic features were identified in all block clusters but were concentrated in Block Group 2 (blocks 2, 10, 11, and 12) (39%), and Block Group 5 (blocks 5, 8, and 9) (29%) (Figure 33).

*Fire-related Pits.* The 38 fire-related pits account for approximately half (48%) of the features assigned to this period. These pits were circular-to-oval in plan, and smooth-to-irregular basin-shaped in profile. Their mean dimensions were 66 x 50 cm in plan, and 9.8 cm in depth (Table 27). Eight of the pits (21%) exhibited two strata, and the remainder (79%) contain one stratum. Bands of heavy charcoal flecking lined the bases of two features, and one feature included a dense charcoal layer at its top. The other features, containing two strata, had pockets or lenses of heavily oxidized or charcoal flecked soil distinct from their general matrix.

Table 27. Metric Summary of Terminal Archaic Fire-Related Pits

Dimensions	N	Range (cm)	Mean (cm)
Length	38	25-160	66.13
Width	38	14-116	50.44
Depth	38	3-31	9.8

DWG. NO. 89-412-A29

APPROVED JPH

DWN. REM

GAI CONSULTANTS, INC.

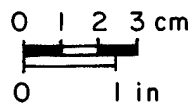
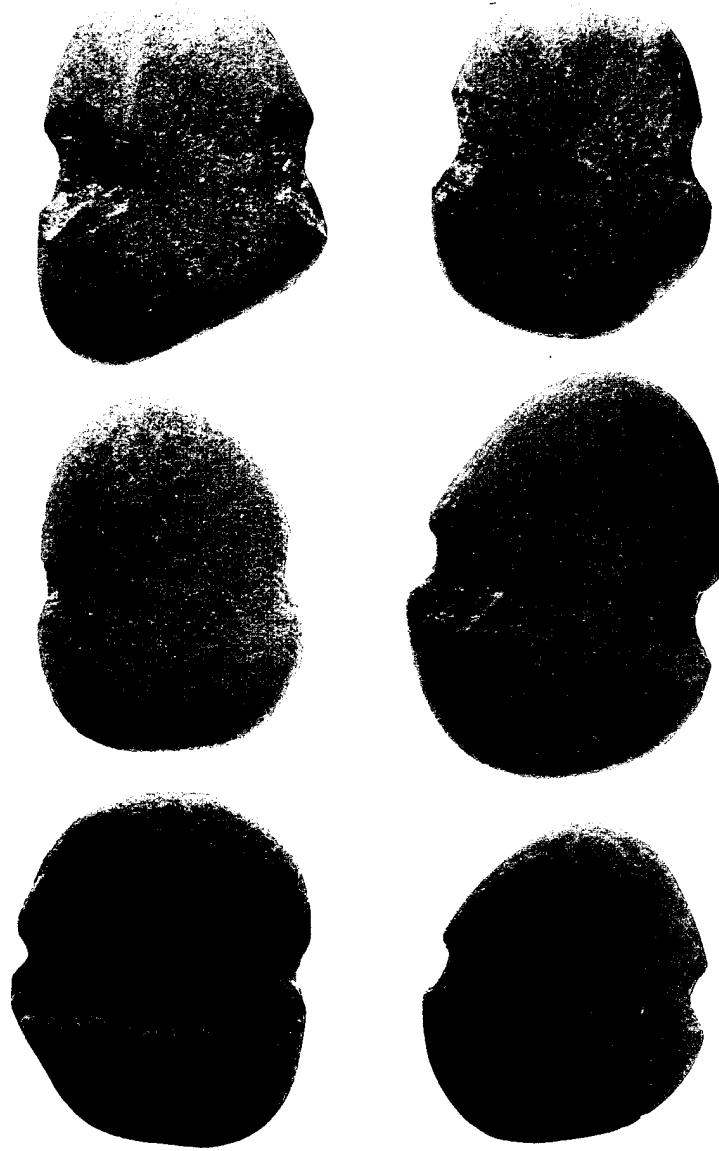

FIGURE 31

REPRESENTATIVE NOTCHED DISCS  
FROM ORIENT FEATURE 182

Cultural materials, including lithic debris, lithic tools, and groundstone, were recovered from 27 (71%) of these features. Lithic debris counts ranged from one to 87; only six features yielded more than 20 pieces. Seventeen features (44%) contained fire-cracked rock that ranged in weight from .05 to 5.0 kg (mean weight of 1.10 kg). Small fragments of bone were recovered from the fill of two features. Burned acorn meat, similar to that found in nearby pits of the Piedmont phase, was found in one feature (Feature 347).

One fire-related pit, Feature 161, uncovered during Task 1 investigations at N8E136, tentatively has been assigned to the Terminal Archaic, based upon its elevation. No diagnostic cultural materials were recovered from this feature. This feature measured 110 x 94 cm in plan, and was 21 cm deep. It contained 117 kg of fire-cracked rock. No additional features were recorded in its general vicinity.

*Cobble Hearths.* Five cobble hearths were identified within Terminal Archaic strata during block excavations. Another possible cobble hearth was identified below a Clemson Island feature during Task 1. Because the elevation of this feature is within the range of Terminal Archaic cobble hearths in nearby block excavations, it has been assigned to this component. Since its dimensions are not known, it is not included in the following descriptions.

In three instances, these features extended into the block walls; their full dimensions and shape are not known. Based on the more completely-exposed features, they are characterized by circular-to-slightly-oval concentrations of large, densely-packed cobbles in basin-shaped pits. The mean dimensions of these features were 84.6 x 60.4 cm in plan, and 18.6 cm in depth (Table 28). Cobbles of one feature (Feature 279) were more dispersed, possibly representing disturbance. These were the only examples of this feature type identified at the Memorial Park site. When the measurements of this dispersed feature and the two features truncated most severely by block walls are eliminated, the remaining two features provide what may be more reliable mean plan dimensions of 95.5 x 80 cm.

Table 28. Metric Summary of Terminal Archaic Cobble Hearths.

Dimensions	N	Range (cm)	Mean (cm)
Length	5	66-98	84.6
Width	5	49-85	60.4
Depth	5	12-22	18.6

The cobbles often rested on a layer of dense charcoal. In some instances, this layer was limited to the base of the feature and in other instances it was located between layers of cobbles. Near the center of one feature (Feature 274) a concentration of shattered rock was underlain by a dense charcoal layer. The fill of these features generally consisted of charcoal-stained soil with charcoal flecks and patches of oxidized soil. In two instances, a layer of oxidized soil marked the base of the feature.

All of these cobble hearths occurred within a very limited range of elevations, including the one identified beneath the Clemson Island feature. Their elevations varied by only 7 cm (167.76-167.69), even though one of the features was located over 120 m from the remaining group of features. Four of the five cobble hearths were located within a radius of 3 m in one level of Block 9 (Figure 33). The cobble hearth identified below the Clemson Island feature was also located in this same area, approximately 4 m south of Block 9.



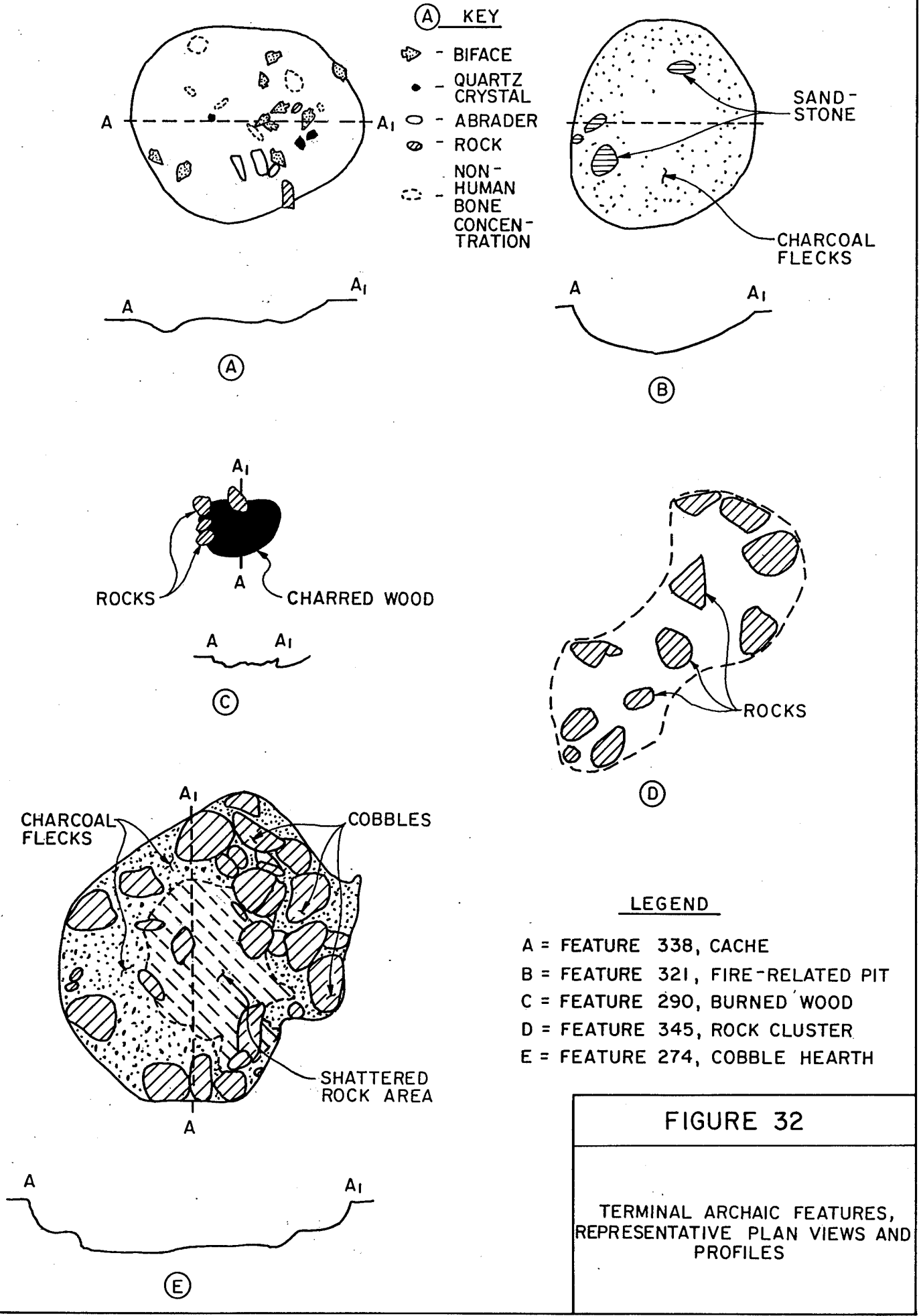
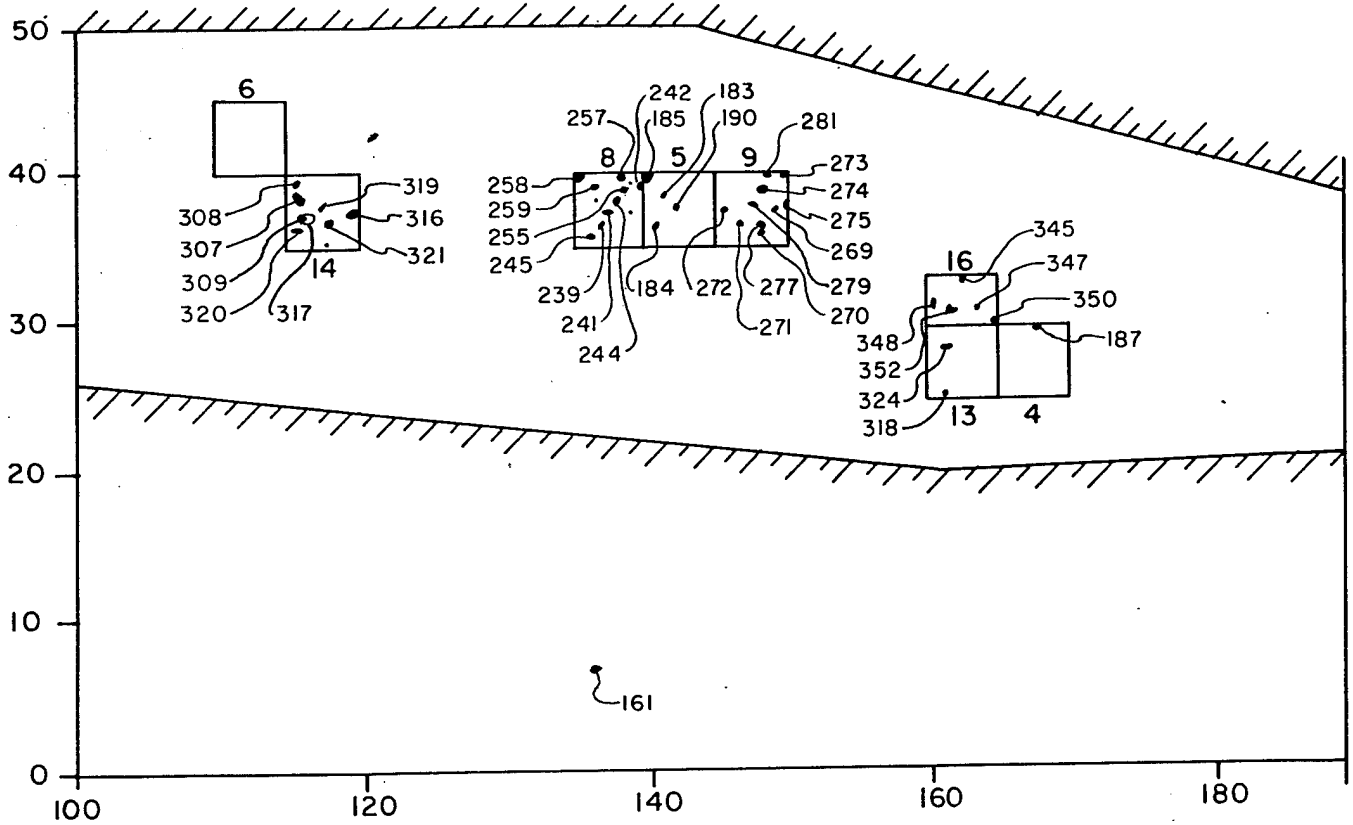
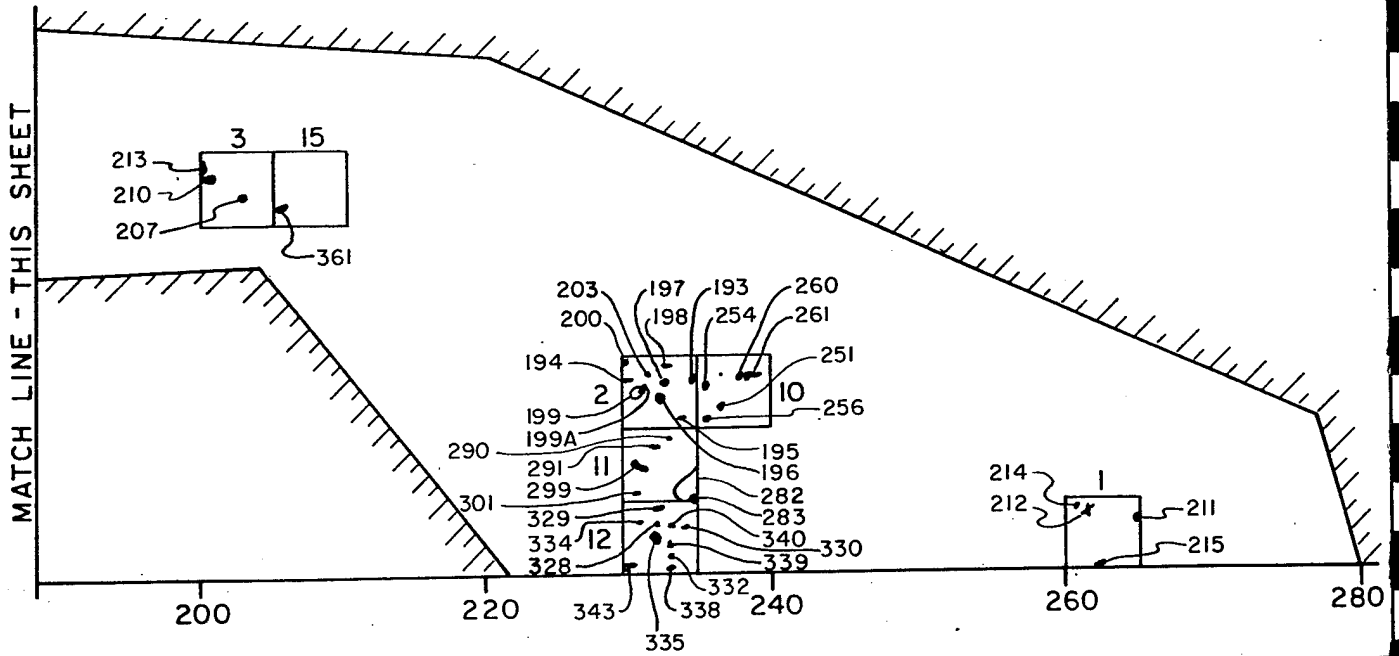

FIGURE 32

TERMINAL ARCHAIC FEATURES, REPRESENTATIVE PLAN VIEWS AND PROFILES



MATCH LINE - THIS SHEET



MATCH LINE - THIS SHEET

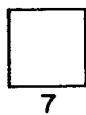

KEY

- o/- - FEATURE
- ... - POSTMOLDS

FIGURE 33

DISTRIBUTION OF  
TERMINAL ARCHAIC FEATURES

Lithic debris were recovered from all of these features. One feature yielded 66 pieces of debris and a biface, while the remainder contained between two and seven pieces of debris. The total weight of cobbles ranged from 13-113 kg (mean weight of 46.3 kg). The weight of cobbles in Feature 275 (113 kg) was twice that of any of the other features. Since three of the features were not fully excavated because they extended into block walls, the mean weight of rock for the total features is low. A mean weight of 85.5 kg, based on the weight of cobbles in the two most fully exposed features, is probably more representative for the class of feature as a whole.

*Oxidized Charcoal Stains.* Twenty oxidized charcoal stains were identified in the Terminal Archaic strata. These were oval in plan with mean dimensions of 77.1 by 49.1 cm, and they were irregular in profile with a mean depths of 4.6 cm (Table 31). Three were not excavated as features; their fill was removed within 50 x 50 cm units during block excavations. The excavation of two of the features was terminated after removal of their first half, due to their very faint fill and irregular boundaries.

Table 29. Metric Summary of Terminal Archaic Oxidized Charcoal Stains.

Dimensions	N	Range (cm)	Mean (cm)
Length	20	35-112	77.1
Width	20	20-103	49.1
Depth	20	3-9	4.6

Thirteen (65%) oxidized charcoal stains yielded lithic artifacts, including one Canfield biface. Lithic debris counts ranged from 1 to 51, with a mean of 11.2. Three of the features yielded more than 10 pieces of debris. Small bone fragments were observed in one feature. Four (20%) contain fire-cracked rock, which ranged in weight from 1 to 7.5 kg, with a mean of 2.4 kg.

*Oxidized Stains.* The nine oxidized stains recorded within the Terminal Archaic strata were circular-to-oval in shape, with mean plan dimensions of 55.4 x 44.2 cm (Table 30). The two stains excavated as features had a mean depth of 8.5 cm, although the stains removed as units within the block excavations were usually of less depth. A grooved stone was recovered from one of these stains (Feature 251).

Table 30. Metric Summary of Terminal Archaic Oxidized Stains.

Dimensions	N	Range (cm)	Mean (cm)
Length	9	30-78	55.4
Width	9	25-63	44.2
Depth	2	8-9	8.5

*Charcoal Stains.* Two large charcoal scatters/stains were identified in the Terminal Archaic strata. They were oval-to-irregular in plan and had flat-to-irregular bases in profile. Their mean dimensions were 184.5 x 115 cm in plan with 2 cm in depth (Table 31). One charcoal scatter (Feature 282) was determined to be part of an occupation horizon extending beyond the original feature dimensions, and was associated with a series of fire-related features (including fire-related pits and a cobble hearth). Both features yielded lithic debris (ranging from 10-15 pieces) and one also contained a small amount of fire-cracked rock (0.05 kg).

Table 31. Metric Summary of Terminal Archaic Charcoal Stains.

Dimensions	N	Range (cm)	Mean (cm)
Length	2	129-240	184.5
Width	2	80-150	115.0
Depth	2	2	2.0

*Burned Wood Features.* The single Terminal Archaic burned wood feature consisted of an oval concentration of dense, woody charcoal. It had dimensions of 28 x 20 cm in plan, and 4 cm in depth at the center of its basin-shaped profile. Four small pieces of fire-cracked rock (0.05 kg) were noted along the west edge of its surface. No artifacts were recovered from this feature.

*Rock Clusters.* One dispersed cluster of rock was recorded in the Terminal Archaic strata. It was composed of unmodified cobbles (17 kg) in an oval scatter measuring 100 x 70 cm in plan; there was no stain or pit associated with this cluster.

*Cremation.* One possible cremation, Feature 257, was identified in the Terminal Archaic strata. It consisted of a heavily oxidized and charcoal flecked stain, with a concentration of burned bone along its west edge. The oxidized stain covered an area of 147 x 136 cm while the bone concentration had dimensions of 66 x 45 cm. In profile the feature had an irregular basin shape with a depth of 6-8 cm. A pocket along the west edge of the feature, in the area of burned bone, extended to a depth of 13 cm. The feature fill included 58 pieces of lithic debris and a ground and flaked celt, a ground celt fragment, two grooved stones, a muller, and an unclassified groundstone fragment exhibiting a potmark suggesting exposure to intense heat. The bone recovered from the feature was analyzed by Dr. Susan R. Frankenburg, an expert on human cremations. It was identified primarily as non-human mammal or unidentified fragments (Table 32). The apparent lack of human bone from this feature suggests that it was not a human cremation.

Table 32. Bone Identification of Tentative Feature 257 Cremation.

Size (inch)	Fragments	Identification	Element	Wt (g)	Comments
0.25	1	non-human mammal	post-cranial	0.1	burned
0.125	1	unidentified	undetermined	0.1	burned
0.125	1	md/lg. non-human mammal	undetermined	0.1	burned
>0.125	several	unidentified	undetermined	0.7	

*Cache.* One cache was exposed in Feature 338 in the Terminal Archaic strata. This feature consisted of an oval stain with charcoal flecking and a very few flecks of oxidized soil. Its dimensions in plan were 76 x 62 cm and its basin-shaped profile had a maximum depth of 9 cm. The feature contained an upper artifact layer with 10 rhyolite bifaces (four Canfield, three Bare Island, and three Coens-Krispen), three quartz crystal fragments, three grooved stones, and two unmodified pieces of fine-grained conglomerate (Figure 34). These artifacts were located in the northern and eastern portions of the feature. Nineteen pieces of lithic debris were also present in the feature's fill. Interspersed between these tools, and below the artifact layer, was a central concentration of burned bone fragments. Analysis of this bone by Dr. Susan R. Frankenburg did not result in the positive identification of human bone (Table 33). This fact, together with the lack of burned artifacts, suggests that, like Feature 257, this feature probably did not contain a human cremation.



Table 33. Bone Identification of Cache Feature 338.

Size (inch)	Fragments	Identification	Element	Wt (g)	Comments
0.50	1	lg. non-human mammal	post cranium	1.3	burned
0.25	10	lg. non-human mammal	cranium	1.5	burned
0.25	27	md./lg. non-human mammal	post cranium	3.6	burned
0.25	2	lg. non-human mammal	vertebra	0.5	burned
0.25	5	sm. non-human mammal	whole vertebra	0.8	burned
0.25	4	unidentified	undetermined	0.1	burned
0.25	8	sm./md. non-human mammal	cranium	2.7	burned
0.25	2	md./lg. mammal	long bone	1.7	burned
0.125	3	md. non-human mammal	tooth	0.1	burned
0.125	7	sm. non-human mammal	vertebra	0.3	burned
0.125	2	fish	vertebra	0.1	burned
0.125	sev.	unidentified	undetermined	12.3	burned
>0.125	sev.	unidentified	undetermined	12.6	

*Postmolds.* Five postmolds were recorded in Terminal Archaic contexts, one each in blocks 10 and 14, and three in Block 8, originating at an average elevation of 167.72 m. These varied considerably in size, with those in Block 8 ranging from 6 to 20 cm in diameter and 14-23 cm in depth, the one in Block measuring 10 cm in diameter and 6 cm in depth, and the one in Block 14 measuring 14 x 17 cm in plan and 20 cm in depth.

#### *Piedmont Features*

The 13 features recorded within Piedmont contexts represent 7 percent of the pre-Late Woodland features, excluding postmolds. They were distributed unevenly across the site, being clustered in the west half of the tested area, with only one feature recorded on the east end of the site (Figure 35). Nine features (69%) were located in Block Group 4 (blocks 4, 13, and 16), two were identified in Block Group 5 (blocks 5, 8, and 9), and one each was found in Block Group 6 (block 6 and 14) and in Block 1. The Piedmont feature assemblage was composed of 9 fire-related pits and 4 oxidized charcoal stains. Representative plan views and profiles of these features are presented in Figure 26.

*Fire-Related Pits.* The nine fire-related pits were circular-to-oval in plan and generally had basin-shaped cross sections. Their mean dimensions were 44.8 x 35.8 cm in plan, and 11.2 cm in depth (Table 34). Their fill was limited to one strata in all but one pit, characterized by scatters and concentrations of charcoal and by oxidized soil stains or flecking, and in five cases, charred acorn meat.

Table 34. Metric Summary of Piedmont Fire-Related Pits.

Dimensions	N	Range (cm)	Mean (cm)
Length	9	26-103	44.8
Width	9	22-66	35.8
Depth	9	3-18	10.2

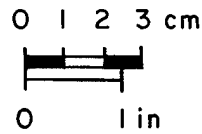
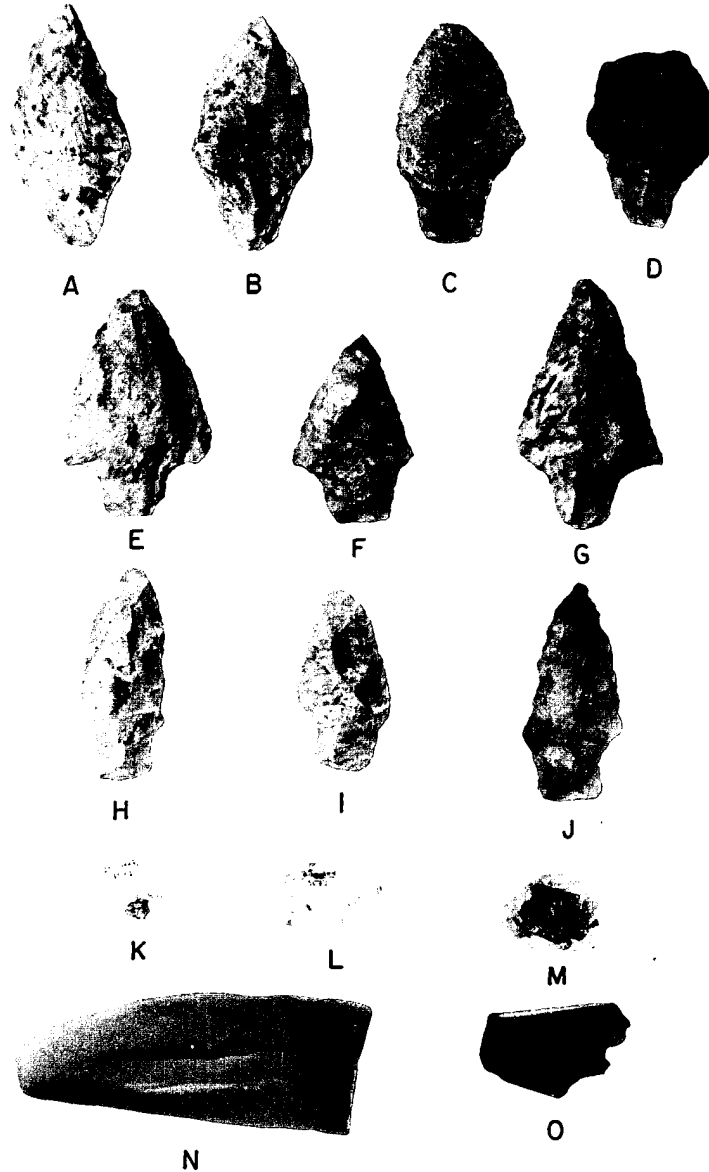

KEY

- A, B, C & D - CANFIELD LOBATE
- E, F & G - LEHIGH COENS-KRISPEN
- H, I & J - BARE ISLAND
- K, L & M - QUARTZ CRYSTALS
- N & O - ABRADING STONES

FIGURE 34

CACHE FROM TERMINAL  
ARCHAIC FEATURE 338

Seven of the pits yielded lithic debris ranging in number from 1 to 26. One, Feature 262, contained two Bare Island bifaces. Three included fire-cracked rock weighing between 0.25 kg and 37.0 kg.

A number of these pits were unusual and require a more detailed description. The first of these, Feature 331 recorded in Block 14, was unusual in both depth and number of strata. This was a small (29 x 22 cm), 17 cm deep, circular, basin-shaped pit that exhibited three distinct strata. The lowest stratum was dark grayish-brown and loosely compacted, with a heavy charcoal content. Its upper boundary was flat. It was overlain by a dark yellowish-brown stratum with heavy mottles of charcoal that sloped sharply to the southwest. The upper strata was dark-brown with light oxidation and charcoal flecking. Six pieces of lithic debris were recovered from this feature.

A second pit, Feature 356 recorded in Block 16, consisted of a circular concentration of large fire-cracked rock and associated charcoal and oxidized staining. It had plan dimensions of 74 x 66 cm. In the center of the concentration was a large anvil stone with a pecked depression on one surface. The base of this anvil extended 16 cm below the surface of the feature and rested on a layer of charcoal approximately two cm thick. A layer of charcoal was also noted at the edges of the stone at the pit's surface, suggesting that the stone had migrated downward from its original position, carrying the underlying charcoal layer with it. The presence of the anvil stone suggests an association between this feature and the series of pits containing charred acorn meat identified at the same level in an arc to its north.

Five fire-related pits contained concentrations of charred acorn meat (351, 353, 354, 355, and 359). These were somewhat smaller than the other fire-related pits, with mean dimensions of 31 x 28.8 cm in plan, and basin-shaped profiles with a mean depth of 6.6 cm. These pits were all uncovered along the east edge of Block 16 in an arc, extending from the southwest to the northeast. They were separated horizontally by 10 to 40 cm and vertically, by a maximum of 4 cm. An association may exist between these pits and other nearby features. The similarity in elevation and location, and the presence of an anvil stone in Feature 356 (described above) suggest the possible inclusion of this feature within any such feature complex.

*Oxidized Charcoal Stains.* Four oxidized charcoal stains were recorded within the Piedmont strata. These were circular-to-oval in shape, exhibiting mean dimensions of 51.3 x 40.3 cm in plan and 6 cm in depth (Table 35). Their profiles ranged from flat to basin-shaped, to irregular. No cultural materials were recovered from any of these features.

Table 35. Metric Summary of Piedmont Oxidized and Charcoal Stains.

Dimensions	N	Range (cm)	Mean (cm)
Length	4	20-83	51.25
Width	4	16-68	40.25
Depth	4	3-10	6

### *Late Laurentian Features*

Twenty features were recorded within late Laurentian contexts, accounting for 12% of the pre-Late Woodland features, excluding postmolds. These included six fire-related pits, two smudge pits, two burned-wood features, three oxidized charcoal stains, one oxidized stain, three charcoal stains, and three rock clusters. Representative plan views and profiles are presented in Figure 37. These features occurred in all block groups except blocks 3/15 and Block 7 (Figure 38). Fifty percent were recorded in Block Group 5 (block 5, 8, and 9).

DWG. NO. 89-412-A33

JPH

APPROVED

REM

GAI CONSULTANTS, INC. DWN.

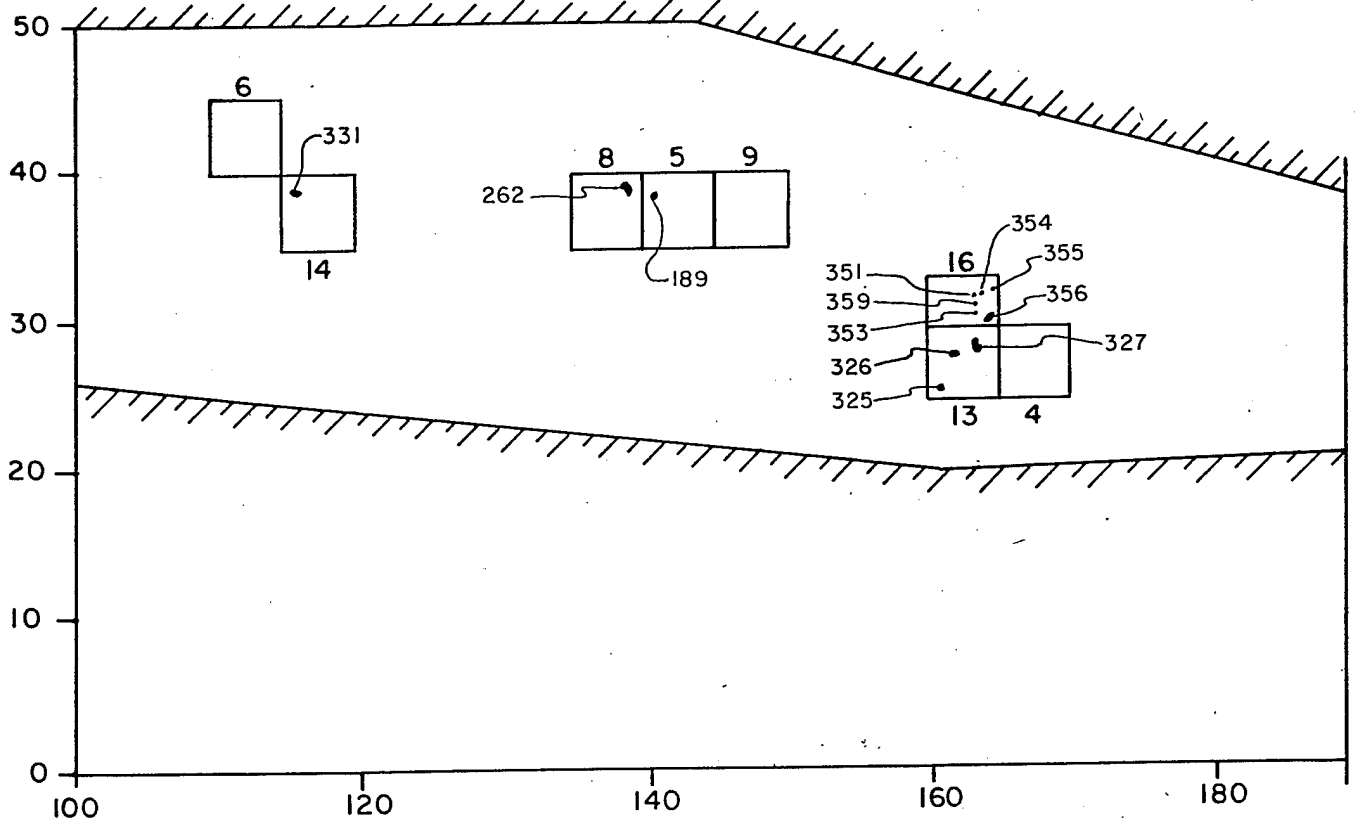

MATCH LINE - THIS SHEET

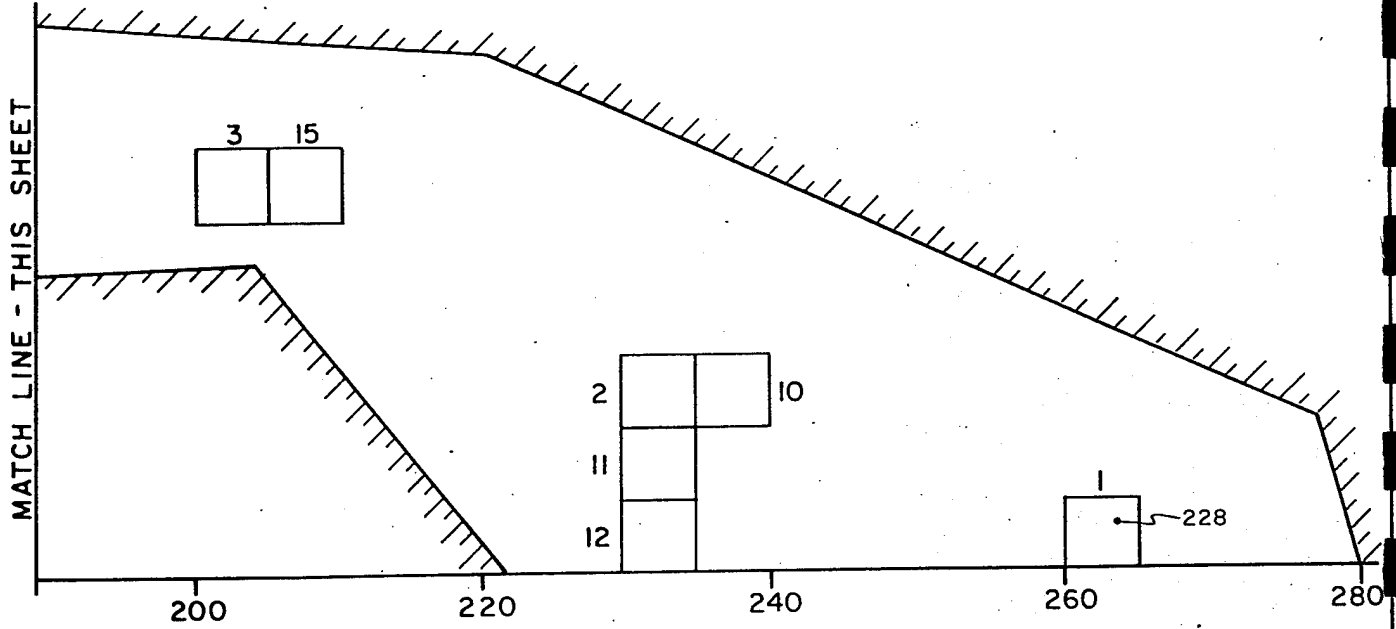

MATCH LINE - THIS SHEET

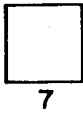

7

KEY

- - FEATURE
- ⋯ - POSTMOLDS

**FIGURE 35**

DISTRIBUTION OF  
PIEDMONT FEATURES

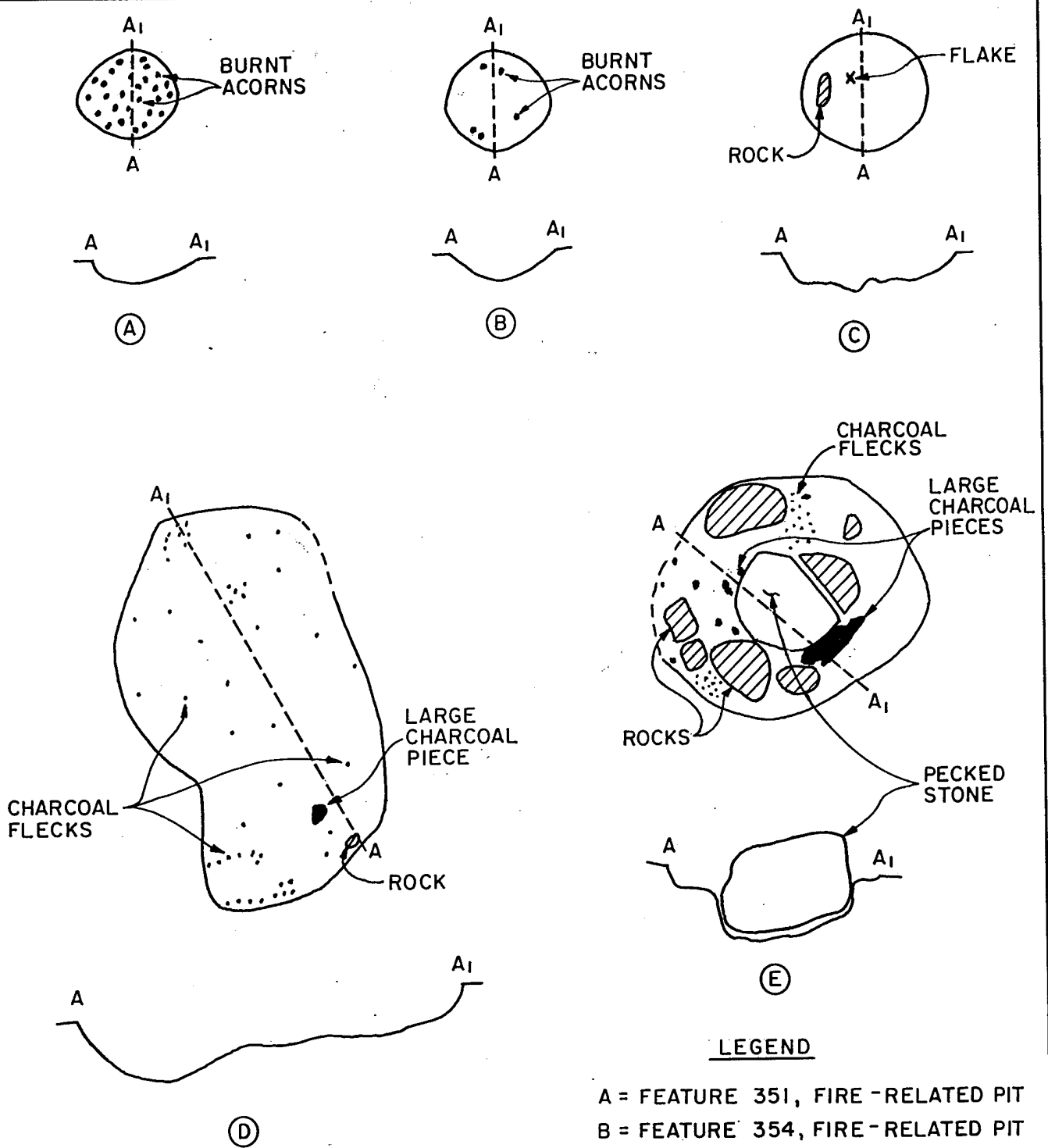

LEGEND

- A = FEATURE 351, FIRE-RELATED PIT
- B = FEATURE 354, FIRE-RELATED PIT
- C = FEATURE 359, FIRE-RELATED PIT
- D = FEATURE 262, FIRE-RELATED PIT
- E = FEATURE 356, FIRE-RELATED PIT

SCALE  
  
 0 10 20 cm

**FIGURE 36**  
 PIEDMONT FEATURES,  
 REPRESENTATIVE PLAN VIEWS AND  
 PROFILES

*Fire-Related Pits.* The six fire-related pits were circular-to-oval in plan and basin-shaped in cross section. Their mean dimensions were 43.3 x 33 cm in plan 7.6 cm in depth (Table 36). Four had a single charcoal-stained and flecked fill stratum. In addition to this typical fill, one of the remaining pits had an oxidized lens at its surface and one had a charcoal lens at its base. Lithic debris, ranging in number from 3-16 with a mean of 8 were recovered from four of these pits; one pit yielded a biface. All six features contained fire-cracked rock, with a mean weight of 1.2 kg.

Table 36. Metric Summary of late Laurentian Fire-Related Pits.

Dimensions	N	Range (cm)	Mean (cm)
Length	6	32-62	43.3
Width	6	26-40	33.0
Depth	6	5-10	7.6

*Smudge Pits.* Two circular smudge pits with slightly-belled sides were recorded in late Laurentian strata. One extended into the corner of Block 8, limiting excavation to approximately one-quarter of the feature. The dimensions of the fully exposed pit were 36 x 35 cm in plan, and 20 cm in depth.

The fill of these features was characterized by loose, moist, heavily charcoal laden soil. Four strata were observed in the completely exposed feature, consisting of a lower, discontinuous lens of oxidized soil overlain by a black stratum containing charcoal throughout, followed by a layer of loose, moist, black, soil and, finally, an upper layer of dark-brown soil containing charcoal flecking and an irregularly shaped lens of dense charcoal. Nine pieces of lithic debris were recovered from this feature. No cultural material was recovered from the partially exposed feature.

*Burned-wood Features.* The five burned-wood features were characterized by dense, circular-to-oval concentrations of woody charcoal with visible wood grain. They had irregular basin-shaped profiles with abrupt lower boundaries. Their mean dimensions were 37 x 27.6 cm in plan, and 6.2 cm in depth (Table 37). Lithic debris were recovered from three, with a mean count of 6.6. One feature contained 0.8 kg of fire-cracked rock.

Table 37. Metric Summary of late Laurentian Burned-wood Features.

Dimensions	N	Range (cm)	Mean (cm)
Length	5	28-48	37.2
Width	5	25-29	27.6
Depth	5	3-8	6.2

*Oxidized Charcoal Stains.* The five oxidized charcoal stains recorded in late Laurentian contexts were oval in plan, and had flat-to-irregular bases. They had mean dimensions of 66.2 x 46.6 cm in plan, and 6.8 cm in depth (Table 38). One of these was not excavated as a feature, and its fill was removed within units during block excavation. Three of the five stains contained lithic debris, with total counts ranging from 7 to 151. Feature 236 yielded the highest debris count as well as a biface, a pitted cobble, and a grinding slab.

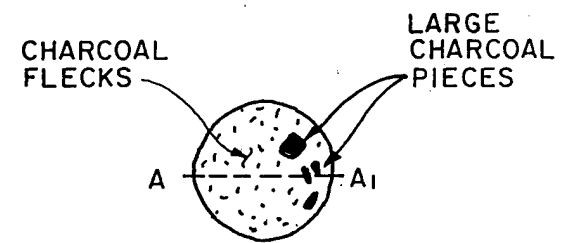

(A)

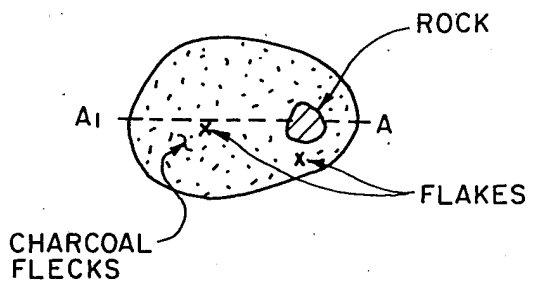

(B)

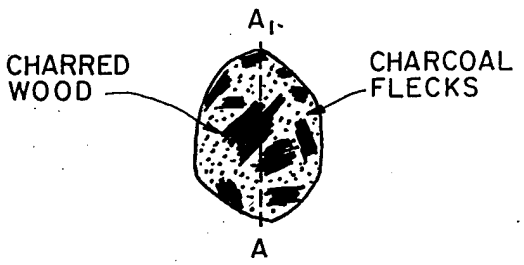

(C)

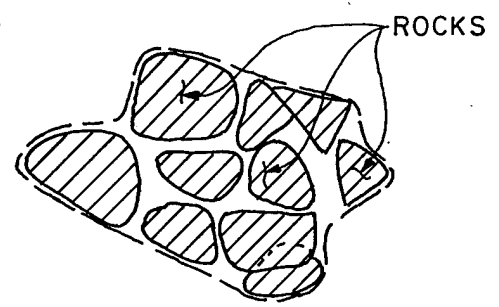

(D)

LEGEND

- A = FEATURE 344, SMUDGE PIT
- B = FEATURE 300, FIRE-RELATED PIT
- C = FEATURE 217, BURNED WOOD
- D = FEATURE 276, ROCK CLUSTER

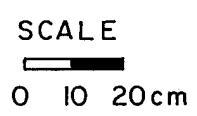
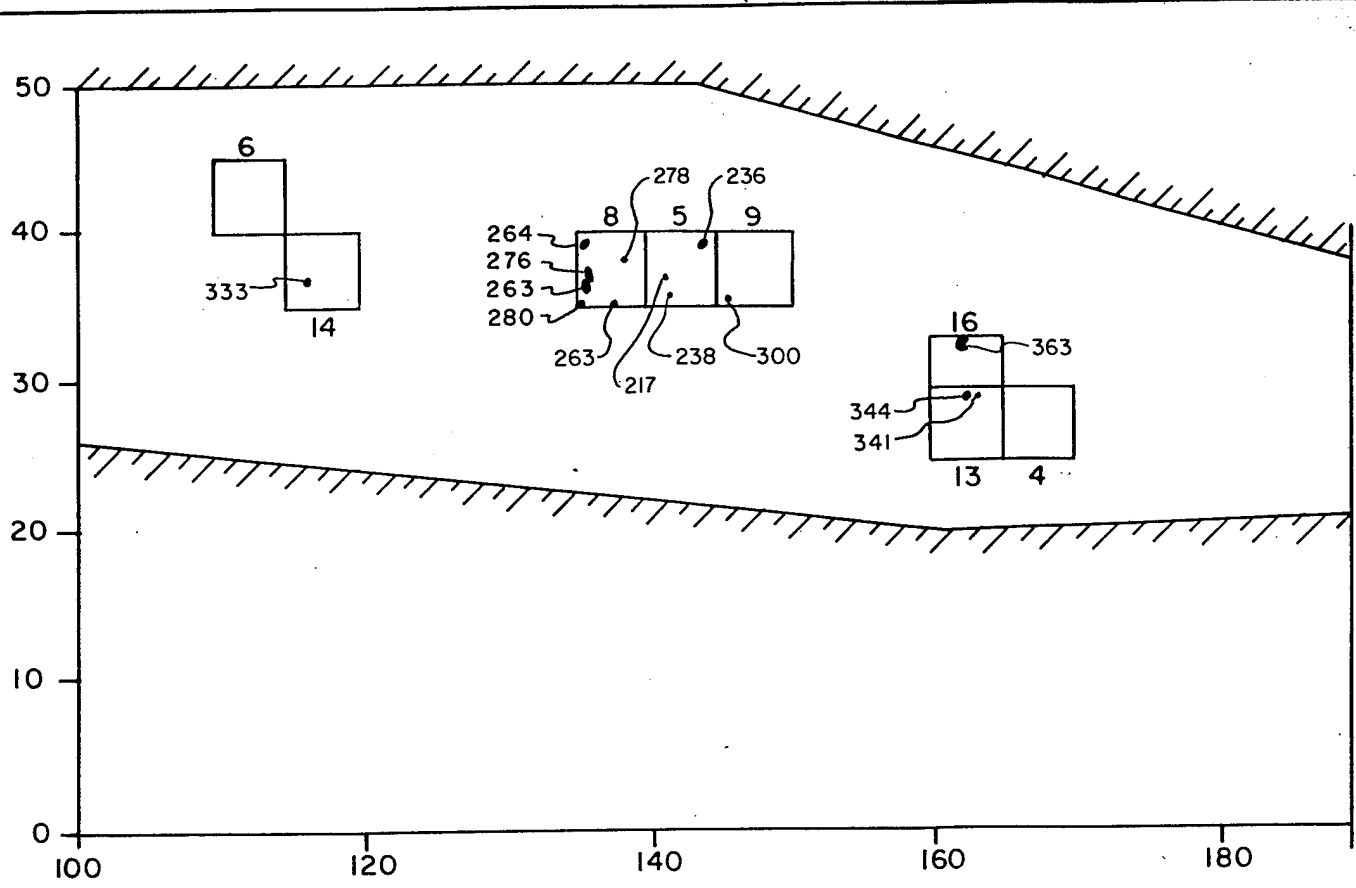
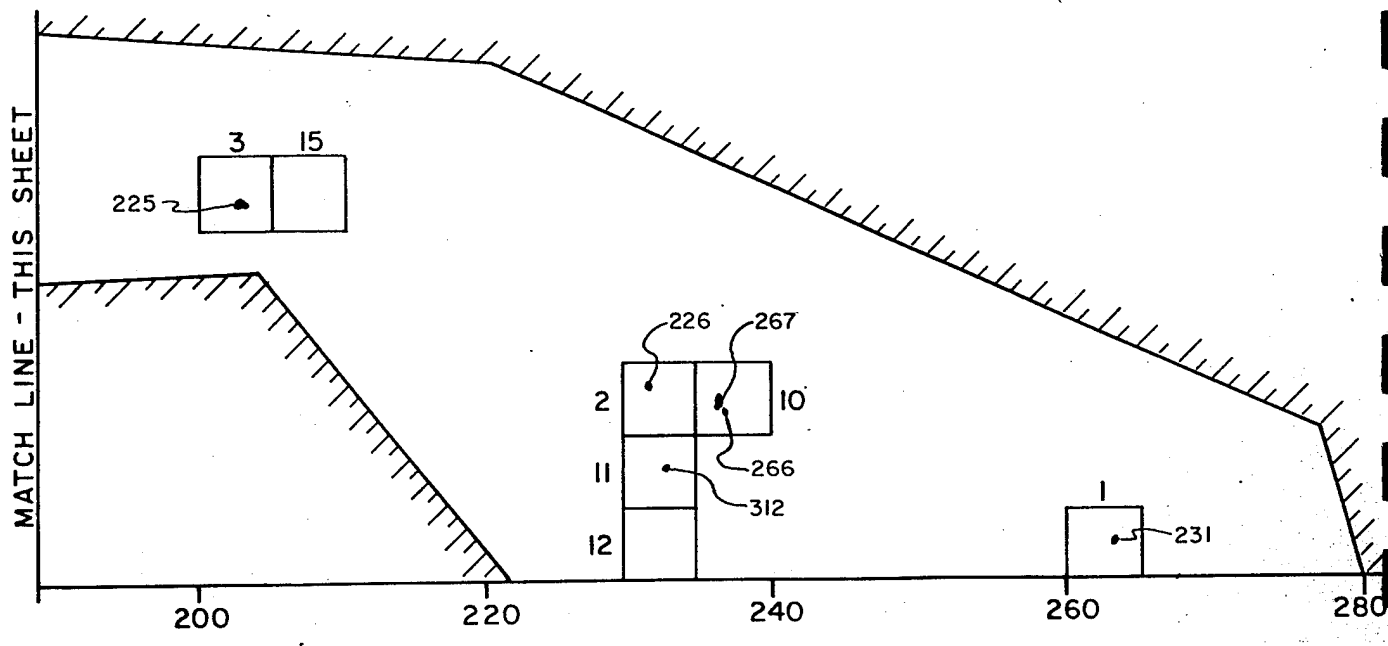

FIGURE 37

LATE LAURENTIAN FEATURES,  
REPRESENTATIVE PLAN VIEWS AND  
PROFILES



MATCH LINE - THIS SHEET



MATCH LINE - THIS SHEET

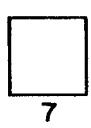

KEY

- - FEATURE
- - POSTMOLDS

**FIGURE 38**

DISTRIBUTION OF  
LATE LAURENTIAN FEATURES



Table 38. Metric Summary of late Laurentian Oxidized Charcoal Stains.

Dimensions	N	Range (cm)	Mean (cm)
Length	5	28-48	37.2
Width	5	25-29	27.6
Depth	5	3-8	6.2

*Rock Clusters.* Two rock clusters consisting of oval concentrations of cobbles with no associated staining were recorded within late Laurentian contexts, located in adjoining levels in Block 8. They had mean dimensions of 120 x 65 cm in plan (Table 39). Included among the cobbles of one feature was a grinding slab. No other cultural materials were observed.

Table 39. Metric Summary of late Laurentian Rock Clusters.

Dimensions	N	Range (cm)	Mean (cm)
Length	2	80-160	120
Width	2	50-80	65

#### *Early Laurentian Features*

Thirty-four features representing 20 percent of the pre-Late Woodland features, excluding postmolds, were recorded in early Laurentian contexts. These were clustered in the western half of the site; only one feature was identified in Block Group 2 (blocks 2, 10, 11, and 12) at the east end of the site, while 24 features (71%) were observed in Block Group 5 (blocks 5, 8, and 9) and nine were found in Block 4 Group (blocks 4, 13, and 16) (Figure 39). early Laurentian features included 20 fire-related pits, two smudge pits, two burned-wood features, four oxidized charcoal stains, three charcoal stains, and three rock clusters. Representative plan views and profiles are presented in Figure 40. One postmold was identified in Block 14.

*Fire-related Pits.* Fire-related pits were the most numerous category of features in early Laurentian contexts. Sixteen (80%) of the 20 pits were located in Block Group 5. These were circular-to-oval in plan, and had basin-shaped cross-sections and smooth-to-irregular lower boundaries.

Included in this category was Feature 302, which consisted of an oval cobble concentration measuring 200 x 80 cm in plan, lying beneath charcoal-stained, charcoal-flecked, oxidized soil. Feature 302 was nearly twice the length of any other feature in this category. The mean dimensions of these features were 62.9 x 39.8 cm in plan, and 8.6 cm in depth (Figure 40). When Feature 302 is eliminated from the calculations, the mean plan dimensions decrease to 55.6 x 37.7 cm.

Table 40. Metric Summary of early Laurentian Fire-Related Pits.

Dimensions	N	Range (cm)	Mean (cm)
Length	20	22-200	62.9
Width	20	18-93	39.8
Depth	20	4-20	8.6

DWG. NO. 89-412-A37

JPH

APPROVED

REM

DWN.

GAI CONSULTANTS, INC.

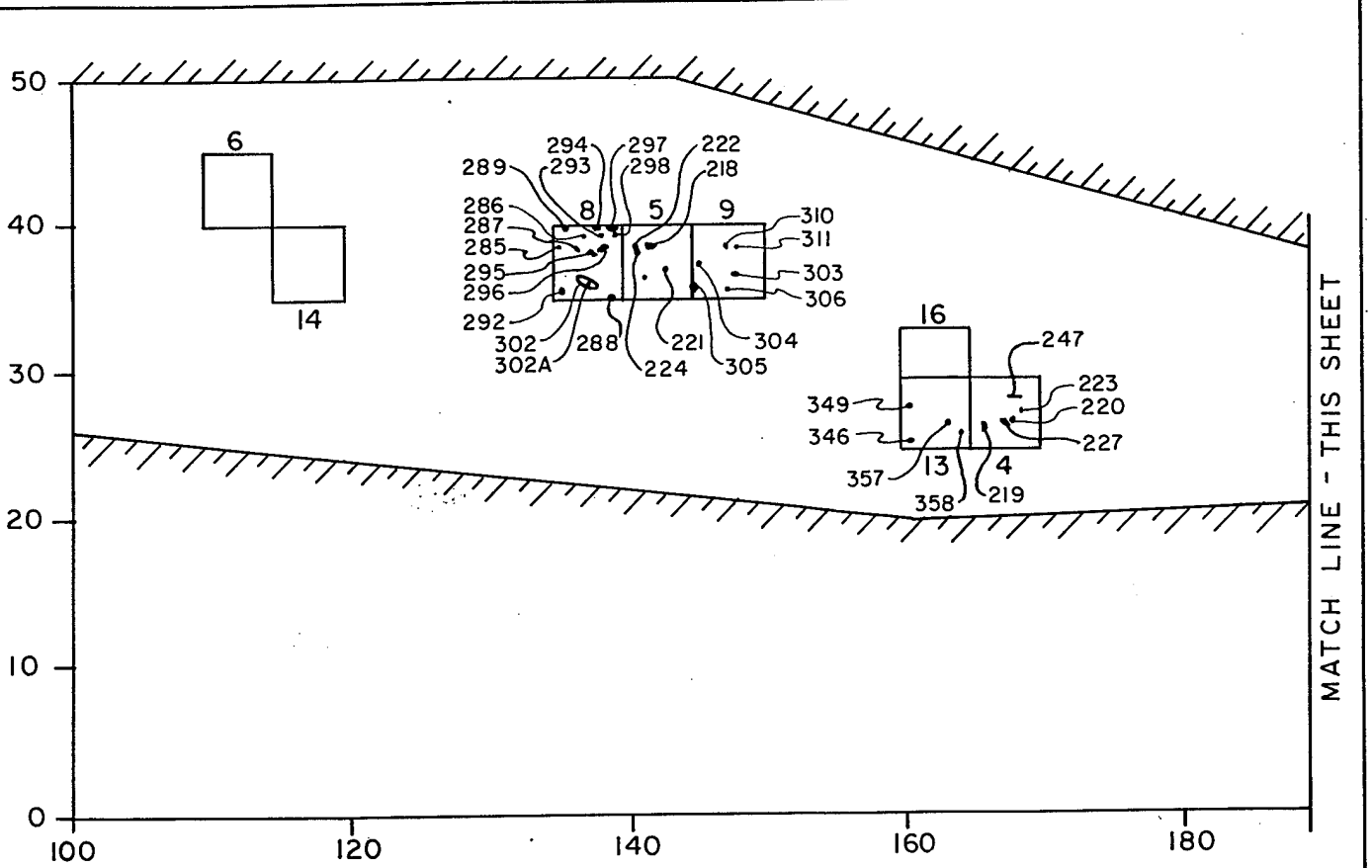

MATCH LINE - THIS SHEET

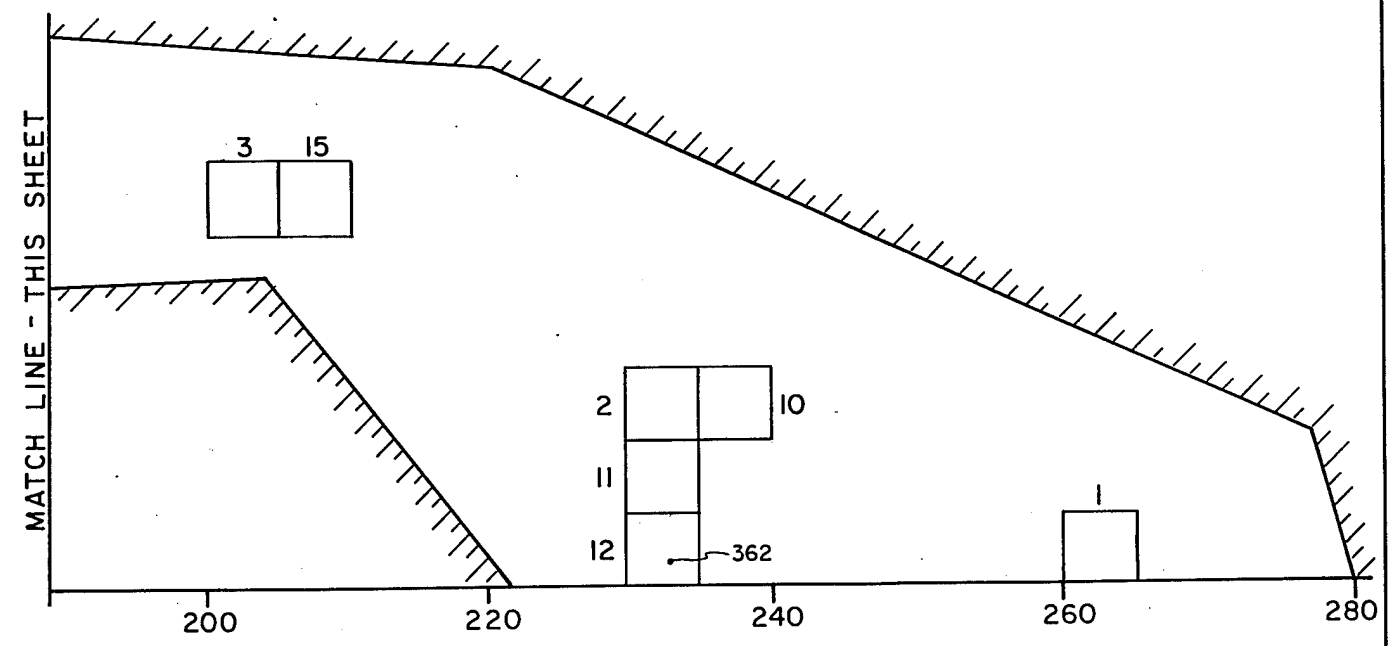

MATCH LINE - THIS SHEET

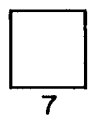

KEY

- - FEATURE
- ... - POSTMOLDS

**FIGURE 39**

DISTRIBUTION OF  
EARLY LAURENTIAN FEATURES



(A)

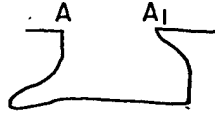
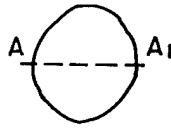

(B)

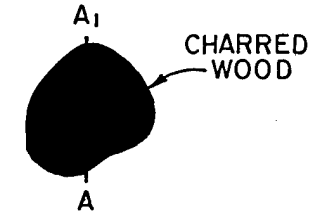

(C)

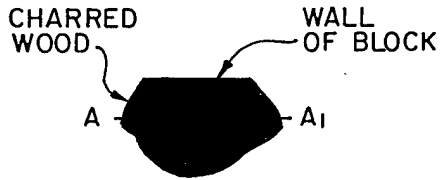

(D)

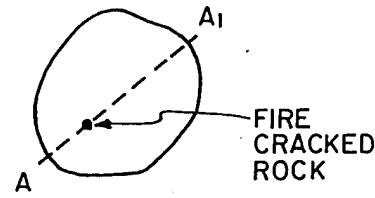

(E)

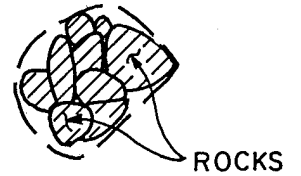

(F)

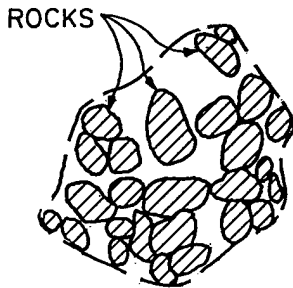

(G)

LEGEND

- A = FEATURE 357, SMUDGE PIT
- B = FEATURE 362, SMUDGE PIT
- C = FEATURE 224, BURNED WOOD
- D = FEATURE 289, BURNED WOOD
- E = FEATURE 310, FIRE-RELATED PIT
- F = FEATURE 285, ROCK CLUSTER
- G = FEATURE 200, ROCK CLUSTER

SCALE  
  
 0 10 20 cm

FIGURE 40

EARLY LAURENTIAN FEATURES,  
 REPRESENTATIVE PLAN VIEWS AND  
 PROFILES

Seventeen of these features contained a single stratum, two contained pockets or lenses of oxidized soil at their upper boundary, and one contained an oxidized layer in its center and a charcoal lens at its base.

Lithic debris were recovered from 18 of these features. These ranged in number from 1 to 86 with a mean of 18.5. Only four of these features yielded more than 20 pieces of debris. Feature 302 contained 86 pieces of debris. Also found in the fill of these features were two flaked-stone tools and one adze. Fire-cracked rock was recovered from 16 of the pits.

Features 305 and 306 were located within an occupation horizon in Block 9, identified by a dense scatter of charcoal flecking and oxidized soil. Although these features had basin-shaped profiles, it is possible that they represent low spots within the occupation horizon.

*Smudge Pits.* Two circular smudge pits were identified in the early Laurentian contexts. One of these exhibited straight sides and a basin-shaped base, while the sides of the other pit were belled sharply near its relatively-flat base. These features had mean dimensions of 21 x 17 cm in plan and 12 cm in depth (Table 41).

Table 41. Metric Summary of early Laurentian Smudge Pits.

Dimensions	N	Range (cm)	Mean (cm)
Length	2	18-24	21
Width	2	13-21	17
Depth	2	10-14	12

The fill of these pits was characterized by loose, moist, black, heavily charcoal-laden soil. The smaller of the two pits had a single fill strata. The larger, bell-sided pit was composed of two strata; the upper was mottled with burned organic material and the lower consisted of the loose, moist, black, charcoal-rich soil. No cultural materials were recovered from either pit.

*Burned-wood Features.* Two burned-wood features were identified in early Laurentian contexts: one in Block 5 (Feature 224), and one in Block 8 (Feature 289). These features were circular-to-oval concentrations of solid woody charcoal with flat or basin-shaped profiles. Feature 289 extended into the wall of Block 8 and, as a result, its total width is unknown. The exposed portion of this feature suggested an oval shape. The dimensions of the fully exposed feature were 32 x 20 in plan and 6 cm in depth (Table 42). No cultural materials were recovered from either feature. A radiocarbon assay of 2965 B.C. obtained from Feature 224 suggests that it may represent the base of a feature that originated within the higher late Laurentian strata.

Table 42. Metric Summary of early Laurentian Burned Wood Features.

Dimensions	N	Range (cm)	Mean (cm)
Length	2	27-32	29.5
Width	2	20-25	22.5
Depth	2	2-6	4

*Oxidized Charcoal Stains.* Four circular-to-oval oxidized charcoal stains were recorded within early Laurentian contexts. They had mean dimensions of 50.6 x 33.25 cm in plan, and had basin-shaped to irregular profiles with a mean depth of 5 cm (Table 43). Two of these stains,

features 303 and 304, occur in the same level, within Block 9, which contained a dense scatter of oxidized soil and charcoal flecking identified as an occupation horizon. It is possible that they represent undulations in the base of the occupation zone rather than discrete cultural features. One of the features contained a small, shallow concentration of bone fragments, lying within an oxidized stain and surrounded by a band of scattered charcoal flecking.

Table 43. Metric Summary of early Laurentian Oxidized and Charcoal Stains.

Dimensions	N	Range (cm)	Mean (cm)
Length	3	32-86	50.6
Width	3	30-40	33.25
Depth	3	5-7	5

Lithic debris were recovered from two these features ranging from 2 to 4 in count, and a third feature yielded a Brewerton Side-Notched biface and a biface tip at its surface. No fire-cracked rock was found in association with any of these features.

*Charcoal Stains.* Three circular-to-oval charcoal stains/scatters were found in early Laurentian contexts. Feature 247 was only visible as a lens in the wall profile of Block 15. Its length was twice that of the other two features and its width was unknown. These features had mean plan dimensions of 45.3 cm x 16.5 cm, and flat-to-irregular bases in profile with a mean depth of 5 cm (Table 44).

Table 44. Metric Summary of early Laurentian Charcoal Stains.

Dimensions	N	Range (cm)	Mean (cm)
Length	3	20-80	45.3
Width	2	15-18	16.5
Depth	3	2-10	5

The smallest of these stains, Feature 302A, originated below Feature 302, was a fire-related pit consisting of a large oval concentration of cobbles with an associated stain. Feature 302A was found beneath the cobbles of this feature and contained fragments of shell. One feature yielded two pieces of lithic debitage. No fire-cracked rock was observed in the feature fill.

*Rock Clusters.* Three slightly-oval cobble concentrations were recorded in early Laurentian contexts. These lacked associated stains and appear not to have been contained within pits. One feature extended into the wall of the block excavation, resulting in an incomplete measurement of its size. The mean dimensions of these features were 37.3 x 26 cm (Table 45). A mean recorded thickness of 8.6 cm indicates the depth excavated to expose the deepest rock. Three pieces of lithic debris were found in association with one of the rock clusters. The mean weight of rock in the features was 6.7 kg, with a range of 1.5 kg to 12.7 kg.

*Postmolds.* A single possible postmold was recorded in early Laurentian contexts, at an elevation of 166.84 in Block 5. It measured 4 by 8 cm in plan, and 11 cm in depth.

Table 45. Metric Summary of early Laurentian Rock Clusters.

Dimensions	N	Range (cm)	Mean (cm)
Length	3	23-55	37.3
Width	3	12-43	26
Depth	3	8-10	8.6

### *Neville Phase Features*

*Fire-Related Pits.* Two features were recorded within the Neville strata, accounting for one percent of the pre-Late Woodland features excluding postmolds. Both features were circular, basin-shaped, fire-related pits located at the extreme western end of the site in Block Group 6. One had dimensions of 103 x 100 cm in plan, and 22 cm in depth with fill consisting of charcoal-flecked and heavily oxidized soil (Table 46). The other had dimensions of 32 x 32 cm in plan and 3 cm in depth, the fill consisting of very faint flecks of charcoal, and oxidized soil. Only one fill strata was present in each pit. Six pieces of lithic debris were recovered from the larger of the two pits. No fire-cracked rock was observed. Feature 232 produced a radiocarbon assay of 6830 B.P.

Table 46. Metric Summary of Neville Fire-Related Pits.

Dimensions	N	Range (cm)	Mean (cm)
Length	2	32-103	67.5
Width	2	32-100	66
Depth	2	3-22	12.5

*Postmolds.* Eight postmolds were recorded in Neville contexts, four in Block 5 and three in Block 8. The four recorded in Block 5 occurred along the southern edge at an average elevation of 166.67m. They averaged 7 cm in depth and 5.9 cm in diameter. One of these had a flat base, one had a rounded base, and two has conical bases. The four postmolds recorded in Block 8 were recorded along the northern edge of the excavation at an average elevation of 166.73 m. They averaged 6 cm in diameter and 6.7 cm in depth. All of these were subconical in profile.

### *Summary*

The current investigations at the Memorial Park site resulted in the documentation of 174 pre-Late Woodland cultural features and one pre-Late Woodland midden. These range in age from the Middle Archaic period to the Middle Woodland period, and help to document some 5600 years of occupation at the site. Both the placement and frequency of features changed through time, reflecting varied spatial use of the site and occupational intensity.

The earliest features at the site date to the Middle Archaic period and represent the Neville phase component at the site (5140 to 4770 B.C.). Two features were documented, both probably representing hearths, on the west end of the excavations. The location of these features corresponds to the early development of the Port Huron terrace as described by Cremeens (this volume). The eastern end of the site was probably not habitable at this time because it formed the immediate floodplain of the eastward-migrating West Branch. The small number of features exposed in deposits relating to this time period suggest limited, perhaps short-term, occupation of the site.

By the earliest portions of the Late Archaic period, corresponding to the early Laurentian component (4405 to 3840 B.C.), occupations at Memorial Park appear to have been more intense as represented by 34 features. Like the Middle Archaic features, these are concentrated on the Port Huron Terrace which had continued to upbuild, providing a high and at least seasonally-dry locus above the West Branch. Thirty-three of the features were concentrated on this landform, primarily in excavation blocks 5, 8, and 9, with smaller numbers in blocks 13 and 14. One feature occurred in Block 12, representing the first recorded use of a natural levee forming on the east end of the project area between the West Branch to the east and its abandoned channel to the west. All of the features appear to represent hearths or other fire-related facilities. Feature morphology suggests use of surface hearths, pit hearths, and smudge pits, the latter perhaps representing the processing of animal skins (Binford 1965). Taken together with the relatively large number of ground-stone implements (Chapter 11) and the results of the chipped-stone analysis (Chapter 9), the features suggest the use of the site as a base camp during this time.

The subsequent late Laurentian (3250 to 2950 B.C.) component continues the trend established by the early Laurentian, with the majority of the 20 features located on the Port Huron terrace. The largest number of features occurred in blocks 5, 8, and 9, with lesser numbers documented in the other block clusters. Four of the features were documented on the natural levee, and one was documented in the abandoned channel, which had been infilling with sediment. While the natural levee to the east had continued to upbuild, the terrace continued to represent the highest and perhaps the driest landform, at least on a seasonal basis. The feature on the channel remnant indicates that a larger portion of the area was available for use than during earlier periods. The features represent fire-related facilities, and probably include surface, pit hearths, and smudge pits. The relatively large number of features, combined with the ground stone assemblage (Chapter 11) and the results of the chipped-stone analysis (Chapter 9) suggest that the site probably functioned as base camps during this period of time.

Only 13 features are associated with the Piedmont component (2460 to 2100 B.C.). The distribution of these features is more similar to the Neville and early Laurentian components than the late Laurentian component, with all but one located on the Port Huron terrace. This distribution may reflect a less stable landscape on the eastern portion of the site where more rapid sedimentation and, thus, flooding was occurring compared to the western portion of the site (Cremeens, this volume). The features associated with the Piedmont component appear to be less diverse than those associated with the earlier Late Archaic occupations. Four of the features may represent surface hearths. The cluster of six features whose contents included large quantities of charred acorn meat and an anvil stone suggest a single resource processing event. Combined with the results of the chipped-stone analysis (Chapter 9), the features suggest a less intensive use of the study area at this time.

Almost half of all pre-Late Woodland features are associated with the Terminal Archaic (2100 to c. 1270 B.C.) occupations of the site. The 79 Terminal Archaic features are widely distributed across the study area, occurring in all of the excavation blocks except Block 6. This distribution reflects the continued upbuilding of the entire study area, including the continued filling of the abandoned channel remnant, and a period of landscape stability with the formation of Buried soil 2 (Cremeens, this volume). These conditions made a larger portion of the study area available for use compared to earlier periods. As with earlier Archaic component features, all of the Terminal Archaic features were probably fire-related facilities, reflecting resource processing. The distinctive cobble hearths probably reflect a distinct resource processing activity. Other features probably represent surface and pit hearths. The cache of bifaces in Feature 338 probably reflects planned periodic use of the site, perhaps on a seasonal basis. Combined with the chipped-stone assemblage analysis (Chapter 9) and ground, pecked, and cobble tool assemblage, which includes steatite bowl sherds (Chapter 11), the large number of Terminal Archaic features indicates that the site was intensively used at this time, and that it probably represents a series of base camps positioned to take advantage of riverine resources.

Nineteen features and a midden were associated with the Orient phase component (1145 to 880 B.C.). As with the Terminal Archaic features, they are distributed across the study area. The features are primarily fire-related facilities including surface hearths and pit hearths. One feature contained a cache of 18 side-notched disks and Marcey Creek sherds. This is the first occurrence of large numbers of postmolds at the site, and their concentration in blocks 1 and 4 may indicate structures. The features, postmolds, and midden combined with the results of the chipped-stone analysis (Chapter 9) and the presence of pottery (Chapter 8), suggests that the site represents a series of base camps, perhaps situated to take advantage of riverine resources.

Two Early Woodland and three Middle Woodland features were exposed during Task 1 investigations of the site. The two Early Woodland features are fire-related pits, probably representing hearths. The three Middle Woodland features can be defined as storage facilities based upon the definition used by Graybill for the Late Woodland features. The small number of features makes interpretation difficult, but the presence of pottery (Chapter 8) and maize (Chapter 12) in the Middle Woodland features, and their presumed use as storage facilities, suggests possible use of the site for seasonal agricultural activities.

#### RADIOCARBON ASSAYS *by Michael G. Spitzer and John P. Hart*

In order to permit a better assessment of the temporal contexts of the site's stratigraphy and its associated cultural materials, 47 charcoal samples were submitted for radiocarbon assays (Table 47, figures 43 and 44). Of these samples, 25 (53.2%) were obtained from cultural features, while the remainder were obtained from isolated charcoal samples or from bulk soil samples associated with distinct soil horizons. The resulting radiocarbon dates have aided in the temporal definition of various components and in the modeling of site stratigraphy and formation.

Of the 47 radiocarbon assays, 36 (76.6%) were accepted as valid, given their association with particular material culture assemblages. The remaining 11 (23.4%) returned dates either much too early or much too late for the associated material culture assemblages. Two of these dates (PITT-1074 and PITT-1076) were obtained on charcoal samples from Clemson Island features. The modern assays suggest either contamination of the samples through bioturbation at the site or lab error. A third modern assay (PITT-1167) was returned on a bulk soil sample from the upper soil horizon of Block 2. Given that this portion of the site had been subjected to plowing and other historic disturbances, it is likely that the soil contained charcoal of recent origin. The cultural material assemblage of this stratum is related to the Orient phase occupation of the site, and is clearly not of modern origin. The anomalously early date of 12,180 B.C. obtained from the first soil stratum of Block 1 (PITT-1164), suggests contamination with coal, as does the 1100 B.C. date obtained from the Clemson Island Feature 37 (BETA-46539). The date of 1240 B.C. returned for a bulk soil sample of Stratum 17 in Block 3 (PITT-1170) is clearly much too late for this stratum's early Late Archaic context. Similarly, the date of 2640 B.C. returned for Stratum 5 of Block 3 is too early for the Terminal Archaic material culture assemblage recovered from this context. The A.D. 1700 date obtained from Stratum 4 of Block 6 (PITT-1178) is much too late for the Orient phase material culture assemblage recovered from this context. The 2130 B.C. date returned from a charcoal sample from Feature 178 in Block 6 (PITT-1079) is too early for the Orient-phase material culture in this context. These latter two dates probably reflect the disturbed nature of these deposits as discussed in Section VI of this report.

The acceptable dates were distributed as follows: Late Woodland (13), Middle Woodland (1), Orient (2), Terminal Archaic (Canfield/Susquehanna) (3), Piedmont (4), late Laurentian (5), early Laurentian (4), and Neville (5). This distribution does not necessarily reflect the intensity of these various occupations, but an attempt to clarify various stratigraphic contexts. These dates are discussed in later chapters in more detail in association with analyses of various artifact classes and overall site interpretation.



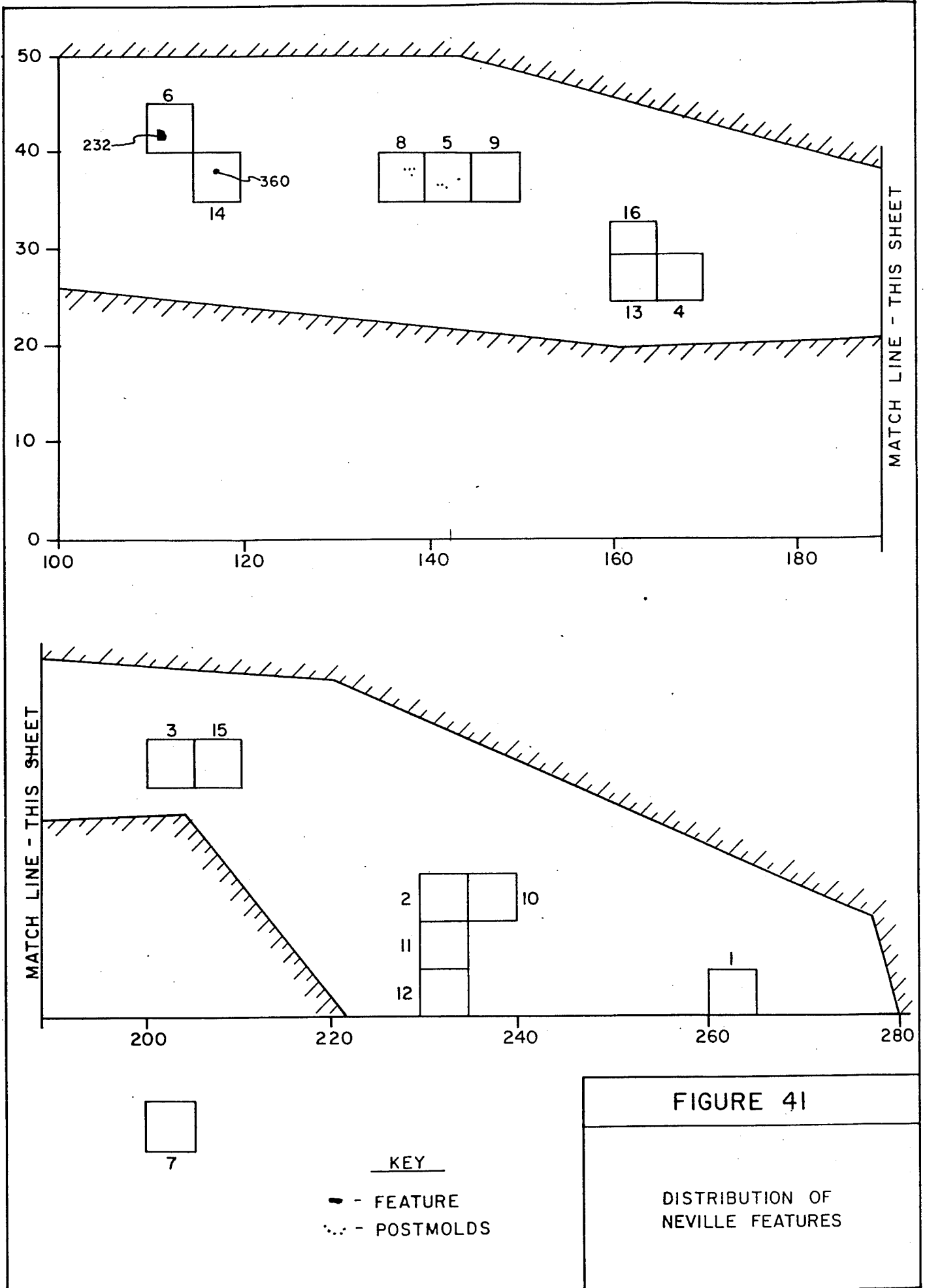
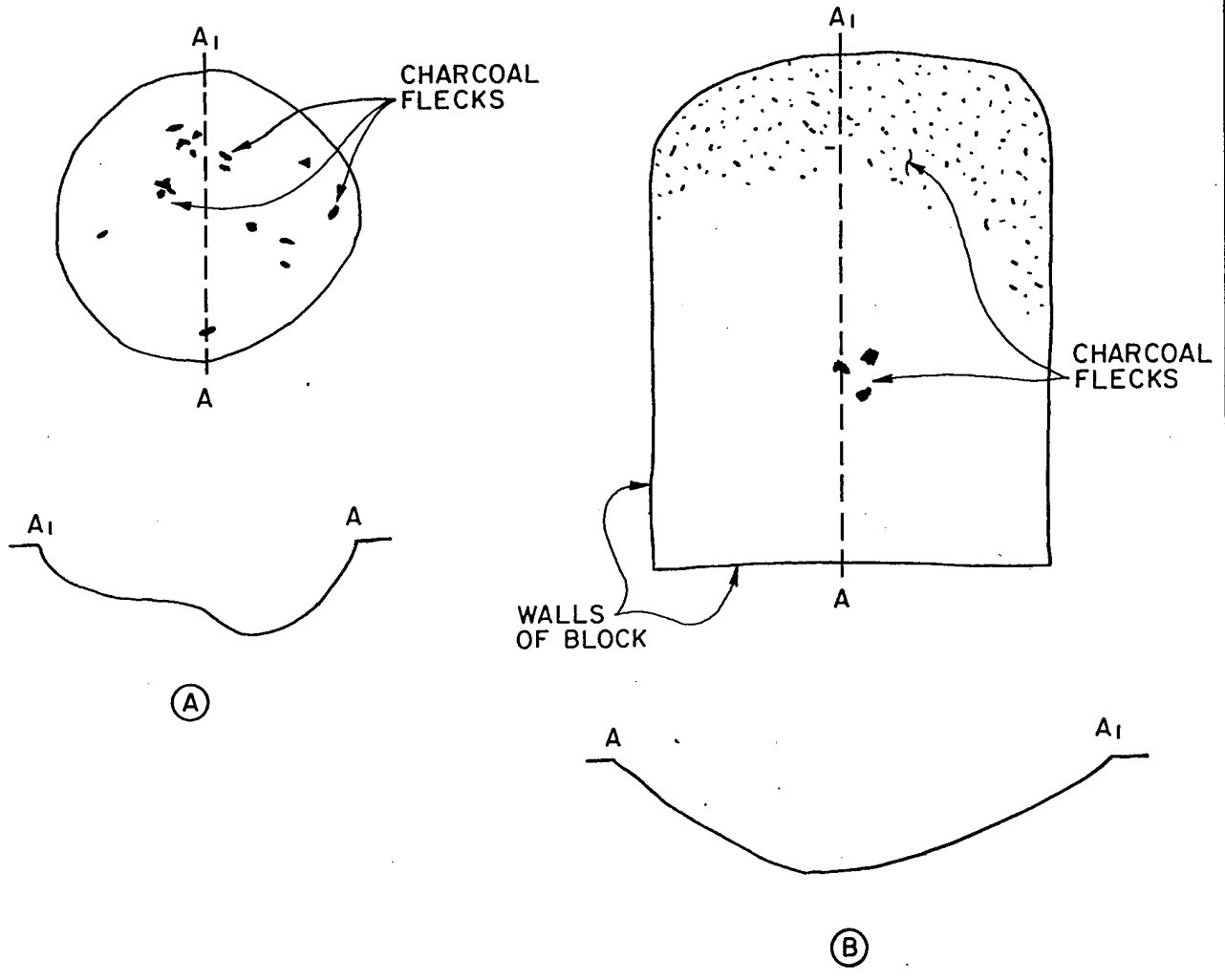

FIGURE 41

DISTRIBUTION OF NEVILLE FEATURES



LEGEND

- A = FEATURE 360, FIRE-RELATED PIT
- B = FEATURE 232, FIRE-RELATED PIT

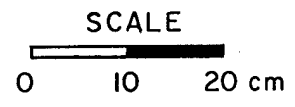

**FIGURE 42**

NEVILLE FEATURES,  
REPRESENTATIVE PLAN VIEWS AND  
PROFILES

Table 47. Radiocarbon Assay Summary.

Lab No.	Provenience <sup>a</sup>	Sample Type <sup>b</sup>	Elev. <sup>c</sup>	Radiocarbon Age (Years BP)	Radiocarbon Date	Calibrated Date(s) <sup>d</sup>	Culture/Period
BETA-46539	Feature 37	CW	168.03	3050±80	1100 B.C.		Too early for context
BETA-46540	Feature 41	CW	167.99	660±60	A.D. 1290	A.D. 1284	Late Woodland
BETA-46541	Feature 29	CW	166.80	900±60	A.D. 1050	A.D.1133, 1136, 1156	Late Woodland
BETA-46542	Feature 172	CW	N/A	1140±60	A.D.810	A.D.892, 925, 936	Late Woodland
BETA-46543	Feature 78	CW	167.89	1030±60	A.D.920	A.D.997	Late Woodland
BETA-46544	Feature 80	CW	167.64	870±50	A.D.1080	A.D.1163, 1174, 1188	Late Woodland
BETA-46545	Feature 63	CW	167.195	1120±60	A.D. 830	A.D.898, 920, 942	Late Woodland
BETA-46546	Feature 107	CW	167.98	900±50	A.D.1050	A.D.1133, 1136, 1156	Late Woodland
BETA-46547	Feature 152	CW	167.86	860±60	A.D. 1090	A.D. 1191	Late Woodland
BETA-46548	Feature 92	CW	167.58	1020±50	A.D. 930	A.D. 999	Late Woodland
PITT-1073	Feature 22	CW	168.15	1190±40	A.D. 760	A.D.830, 859	Late Woodland
PITT-1074	Feature 57	CW	167.23	modern			Too late for context
PITT-1075	Feature 83	CW	167.73	1160±60	A.D.790	A.D.886	Late Woodland
PITT-1076	Feature 106	CW	167.57	modern			Too late for context
PITT-1077	Feature 143	CW	167.47	1800±115	A.D.150	A.D.227	Middle Woodland
PITT-1078	Feature 144	CW	167.795	600±45	A.D. 1350	A.D.1326, 1353, 1363, 1365, 1389	Late Woodland
PITT-1079	Fea 178/Bik6/Lv3	CW	167.60	4080±50	2130 B.C.	2850, 2845, 2652, 2647, 2612 B.C.	Too early for context
PITT-1080	Fea 186/Bik6/Lv6	CW	167.26	3095±45	1145 B.C.	1403 B.C.	Orient
PITT-1081	Fea 189/Bik5/Lv6	CW	167.55	4410±40	2460 B.C.	3037 B.C.	Piedmont
PITT-1082	Fea 194/Bik2/Lv6	CW	167.685	3590±60	1640 B.C.	1947 B.C.	Canfield
PITT-1083	Fea 224/Bik5/Lv14	CW	166.79	4915±45	2965 B.C.	3771, 3768, 3700 BC	late Laurentian
PITT-1084	Fea 225/Bik3/Lv22	CW	165.98	6115±265	4165 B.C.	5191, 5188, 5060 BC	early Laurentian
PITT-1085	Fea 226/Bik2/Lv20	CW	166.29	4900±130	2950 B.C.	3697 B.C.	late Laurentian
PITT-1086	Fea 232/Bik6/Lv20	CW	166.20	6830±130	4880 B.C.	5697, 5689, 5657 B.C.	Neville
PITT-1087	Bik3/Lv5	CW	167.68	4590±110	2640 B.C.	3356 B.C.	Too early for context
PITT-1088	Bik3/Lv2	CW	167.98	2830±50	880 B.C.	998 B.C.	Orient
PITT-1089	Fea 203/Bik2/Lv9	CW	167.38	3950±65	2000 B.C.	2468 B.C.	Canfield
PITT-1124	Fea 233/Bik8/Lv10	CW	167.26	565±40	A.D. 1385	A.D. 1399	Late Woodland
PITT-1164	Bik1/Lv1/SS# 1-1	BSS	168.05	14130±870	12180 B.C.		Too early for context
PITT-1165	Bik1/Lv14/SS# 8-1	BSS	166.71	4050±230	2100 B.C.	2584 B.C.	Piedmont
PITT-1166	Bik1/Lv22/SS# 12-1	BSS	165.99	5200±350	3250 B.C.	3998 B.C.	late Laurentian
PITT-1167	Bik2/Lv2/SS# 1	BSS	168.04	modern			Too late for context
PITT-1168	Bik2/Lv22/SS# 9-3	BSS	166.04	6355±155	4405 B.C.	5319, 5257, 5248 B.C.	early Laurentian
PITT-1169	Bik3/Lv18/SS# 13-2	BSS	166.37	5045±420	3095 B.C.	3931, 3876, 3815 B.C.	late Laurentian
PITT-1170	Bik3/Lv25/SS# 17	BSS	165.59	3190±450	1240 B.C.	1491, 1489, 1451 B.C.	Too late for context

Table 47 (continued)

Lab No.	Provenience <sup>a</sup>	Sample Type <sup>b</sup>	Elev	Radiocarbon Age (Years BP)	Radiocarbon Date	Calibrated Date(s) <sup>c</sup>	Culture/Period
PITT-1171	Blk4/Lv7/SS# 3-2	BSS	167.48	5025±60	3075 B.C.	3898, 3885, 3811, 3801, 3789 B.C.	late Laurentian
PITT-1172	Blk 4/Lv12/SS# 6-2	BSS	166.90	5790±240	3840 B.C.	4713,4696,4687 BC	early Laurentian
PITT-1173	Blk4/Lv23/SS# 9-1	BSS	165.87	6720±225	4770 B.C.	5626 B.C.	Neville
PITT-1174	Blk5/Lv10/SS# 4-2	BSS	167.16	5830±130	3880 B.C.	4725 B.C.	early Laurentian
PITT-1175	Blk5/Lv12/SS# 6-1	BSS	166.97	6765±55	4815 B.C.	5638 B.C.	Neville
PITT-1176	Blk5/Lv22/SS# 9-1	BSS	165.97	7045±210	5095 B.C.	5960 B.C.	Neville
PITT-1177	Blk6/Lv1/SS# 3	BSS	167.74	4455±70	2505 B.C.	3098,3051,3050 B.C.	Too early for context
PITT-1178	Blk6/Lv3/SS# 4-1	BSS	167.52	250±130	A.D. 1700		Too late for context
PITT-1179	Blk6/Lv6/SS# 9-1	BSS	167.26	4035±110	2085 B.C.	2578 B.C.	Piedmont
PITT-1180	Blk6/Lv18/SS# 16-1	BSS	166.04	7090±80	5140B.C.	5972 B.C.	Neville
PITT-1181	Blk7/Lv2/SS# 7	BSS	167.98	1480±35	A.D. 470	A.D. 596	Too early for context
PITT-1182	Blk7/Lv9/SS# 12-1	BSS	167.22	3695±75	1745 B.C.	2132, 2082, 2046 B.C.	Canfield

<sup>a</sup>Fea: Feature; Blk: Block; Lv: Block Level; SS#: soil sample number -- The first number in this designation represents the block-specific soil horizon, which is keyed to the block profiles in Appendix A. The second number represents the appropriate 10-cm level within the soil horizon, if multiple levels were used.

<sup>b</sup>CW: charred wood fragment; BSS: bulk soil sample

<sup>c</sup>Elevation represents the elevation of the sample taken within the feature fill or the block and level.

<sup>d</sup>Calibrated with the University of Washington Quaternary Isotope Laboratory's Radiocarbon Calibration Program 1987 REV. 21 (Stuiver and Person 1986).

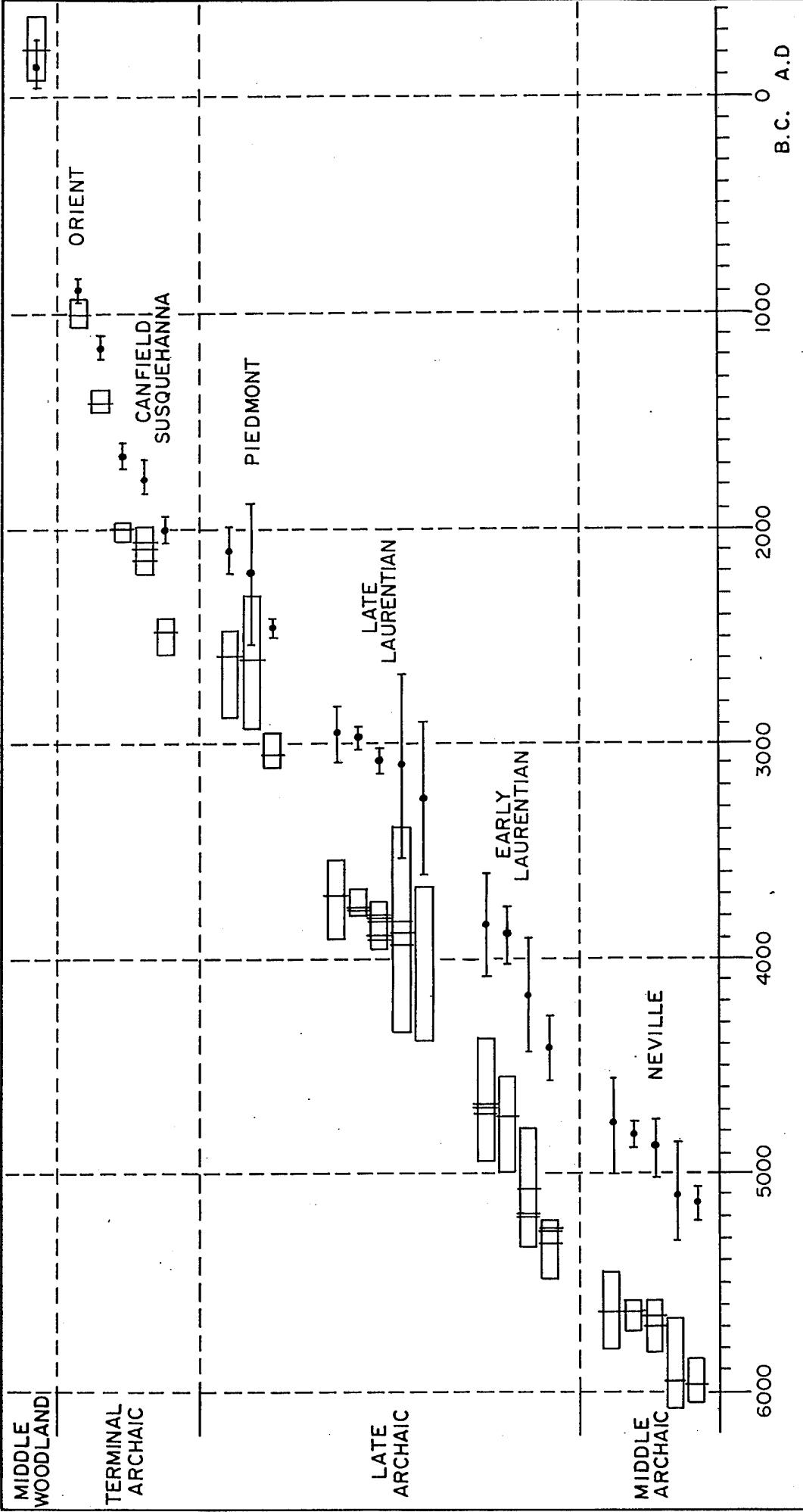
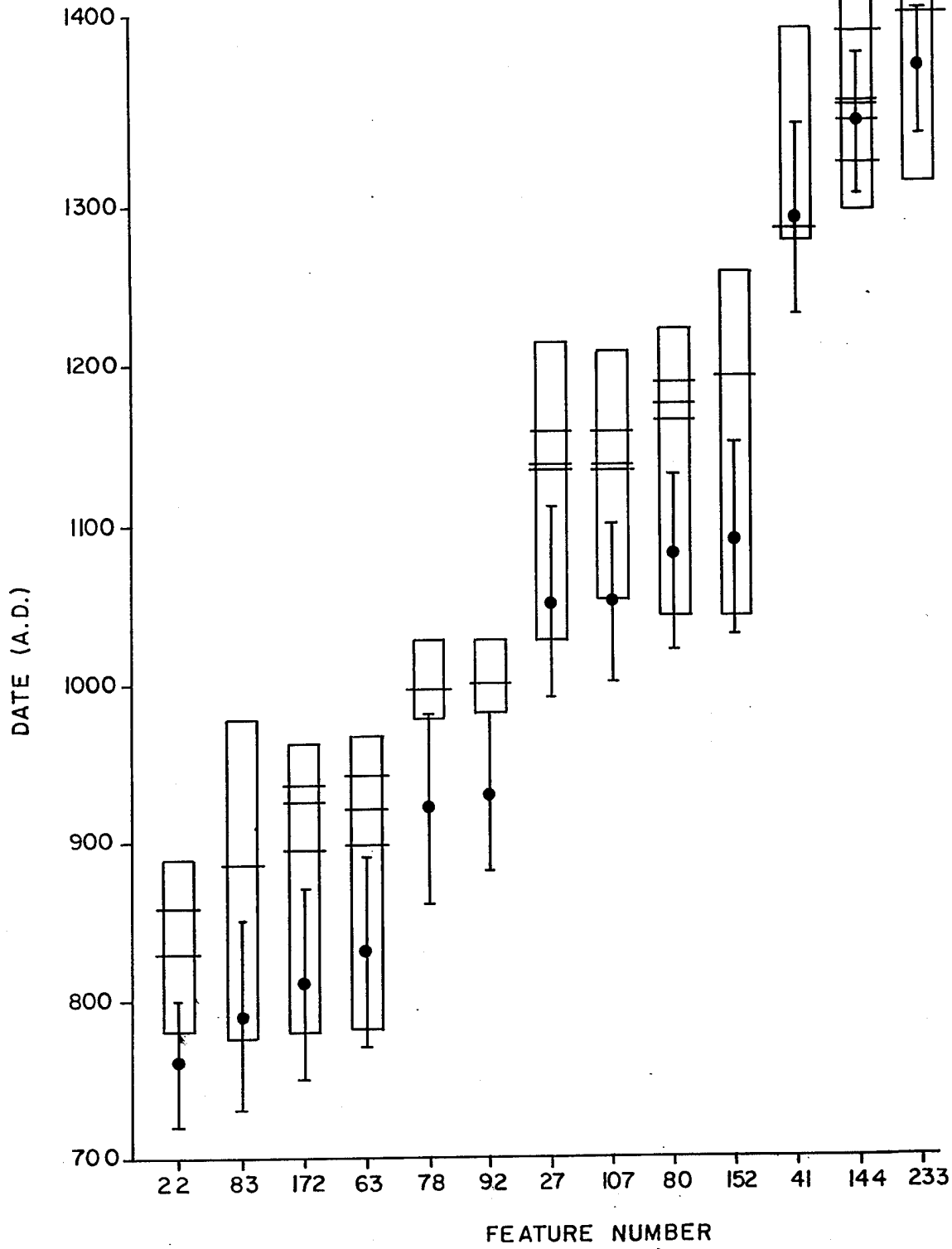

FIGURE 43

KEY

- RADIOCARBON AGE WITH ONE SIGMA RANGE
- ONE SIGMA CALIBRATED AGE RANGE WITH INTERCEPT (S)

PRE-LATE WOODLAND RADIOCARBON ASSAYS



KEY



-  - RADIOCARBON AGE WITH ONE SIGMA RANGE
-  - ONE SIGMA CALIBRATED AGE RANGE WITH INTERCEPT (S)

FIGURE 44

LATE WOODLAND  
RADIOCARBON ASSAYS

Late Woodland Assays

Radiocarbon dated features were subdivided into groups based on the significant or non-significant relationship of dates, based on 2x2 comparisons and intra- and inter-group comparison testing for significant differences in the dates (Ward and Wilson 1978). Table 48 is a summary of the results of the 2x2 comparisons made. A 0 (zero) in a cell indicates a test statistic with a probability >0.1, while an asterisk (\*) indicates a test statistic with a probability <0.1.

Table 48. Two-by-Two Comparisons of Radiocarbon Assays from Late Woodland Features.

Feature	22	83	172	63	78	92	29	107	80	152	41	144	233
83	0	-											
172	0	0	-										
63	0	0	0	-									
78	*	0	0	0	-								
92	*	*	0	0	0	-							
29	*	*	*	*	0	0	-						
107	*	*	*	*	*	0	0	-					
80	*	*	*	*	*	*	0	0	-				
152	*	*	*	*	*	*	0	0	0	-			
41	*	*	*	*	*	*	*	*	*	*	-		
144	*	*	*	*	*	*	*	*	*	*	0	-	
233	*	*	*	*	*	*	*	*	*	*	0	0	-

Under ideal conditions, when the feature dates are arranged in ascending order, as in Table 49, the groups of features with dates that are not significantly different can be blocked off. This is done in Table 49. The interior of the blocks in the table will have a symbol indicating insignificant differences, while all symbols outside of the blocks will indicate significant differences. However, the situation is rarely as clear-cut as this, and Table 48 illustrates some variation from the ideal. Hence, some "optimal" way of subdividing feature groups must be employed, as was done for Table 49.

The criterion employed here was to *include* feature pairs that are not significantly different, and *exclude* feature pairs which are significantly different. Using this approach, some members of a group may not be different from some of the members of another group. However, once the groups are constructed this way and tested for differences between groups, they are significantly different. This assures that the appropriate internal and external relationships are maintained.

Four groups were identified using this procedure. These four groups are blocked out in Table 49. Group 1 consists of features 22, 63, 83, and 172, and has a pooled radiocarbon age of 1161±26 B.P. (A.D. 789). Group 2 consists of features 78 and 92 and has a pooled radiocarbon date of 1024±38 B.P. (A.D. 926). Group 3 includes Features 29, 80, 107, and 152, and has a pooled radiocarbon date of 883±27 B.P. (A.D. 1067). Group 4 is composed of Features 41, 144, and 233, and has a pooled radiocarbon age of 616±27 B.P. (A.D. 1334)

Table 49. Summary of Radiocarbon Dating Information for Late Woodland Feature Groups.

Feature Group	Feature	Radiocarbon Age (BP)	Pooled Radiocarbon Age
1	22	1190±40	1161±26
	83	1160±60	
	172	1140±60	
	63	1120±60	
2	78	1030±60	1024±38
	92	1020±50	
3	29	900±60	883±27
	107	900±50	
	80	870±50	
4	152	860±60	616±27
	41	660±60	
	144	600±45	
	233	565±40	

### Summary

A total of 47 charcoal samples were submitted for radiocarbon assay. Of these, 36 returned assays that were acceptable given the provenience of the sample and the associated artifacts. As a result, the Memorial Park site has provided more radiocarbon assays than any other West Branch valley site. Of these 36 assays, five are associated with the Neville component, ranging from 5140 B.C. to 4815 B.C. (uncalibrated); four are associated with the early Laurentian component ranging from 4405 B.C. to 3840 B.C. (uncalibrated); five with the late Laurentian component, ranging from 3250 B.C. to 2950 B.C. (uncalibrated); four with the Piedmont component ranging from 2460 B.C. to 2100 B.C. (uncalibrated); three with the Terminal Archaic (Canfield/Susquehanna) components, ranging from 2000 B.C. to 1640 (uncalibrated); two with the Orient component, 1145 B.C. and 880 B.C. (uncalibrated); one with the Middle Woodland component, A.D. 150 (uncalibrated); four with the Early Clemson Island component, ranging from A.D. 760 to A.D. 830 (uncalibrated); two with the Middle Clemson Island component, A.D. 920 and A.D. 930 (uncalibrated); four with the Late Clemson Island component, ranging from A.D. 1050 to A.D. 1090 (uncalibrated); and four with the Stewart phase, ranging from A.D. 1290 to A.D. 1385 (uncalibrated).

### SUMMARY AND CONCLUSIONS

Excavations at the Memorial Park site resulted in the documentation of 249 features, excluding postmolds. Of these, 80 are associated with the Late Woodland components, three with the Middle Woodland component, two with the Early Woodland component, 19 with the Orient phase component, 79 with the Terminal Archaic components, 13 with the Piedmont component, 20 with the late Laurentian component, 35 with the early Laurentian component, and two with the Neville component. In addition to these, 511 postmolds were documented, of which 465 were associated with the Late Woodland components, and 46 with the pre-Late Woodland components.

The placement of features across the study area was associated with changes in landscape development as described by Cremeens in this volume. Features associated with the earliest components (Neville, early Laurentian) were restricted to the Port Huron terrace, which was the



highest and most stable portion of the landscape above the abandoned channel/immediate floodplain. As the West Branch valley migrated eastward and a natural levee began to form between the active and abandoned channels, use of the study area expanded to the east, as represented by late Laurentian features, although the most intensive use continued on the Port Huron terrace. An apparent contraction of occupied space to the Port Huron terrace occurred during the Piedmont occupations, perhaps reflecting a less stable landscape to the east during this time. Finally, as the West Branch channel remnant filled and the entire landscape continued to upbuild, the entire study area was intensively utilized, as reflected by the distribution of Terminal Archaic, Orient, and Late Woodland features. Features associated with the Early and Middle Woodland periods probably reflect a diminished use of the study area for undetermined reasons.

The features also reflect changes in regional settlement systems. Archaic period features represented fire-related facilities, presumably associated with the resource processing. Woodland period features include both fire-related facilities and large pits, presumably representing processing and storage activities, respectively. Three storage facilities were associated with the Middle Woodland period, while 38 were associated with the Late Woodland components. Numerous postmolds, perhaps representing structures, were first documented with the Orient component. At least eight structures are associated with the Late Woodland occupations of the site. These developments probably reflect changes in the manner in which the study area was utilized through time.

During the Archaic period, the lack of obvious structures and the apparent lack of storage facilities probably reflect relatively short-term use of the study area as compared to the Late Woodland occupations. The presence of several caches associated with the Terminal Archaic and Orient occupations of the site probably reflect planned reoccupations of the site. However, the lack of storage facilities indicates that the site was used seasonally in a logistical settlement system where food was processed and consumed immediately, or over brief periods of time. The possible presence of structures during the Orient reflects longer-term use, or at least planned longer-term use than during previous periods. The presence of storage facilities during the Woodland period, particularly during the Late Woodland period, reflects seasonal abandonment of the site with planned, scheduled reoccupations. That agricultural production was performed by the occupants of the site, as documented by the recovery of a variety of domesticated plant remains including maize cob fragments (Sidell, this volume), suggests storage of agricultural produce. Subterranean storage pits generally reflect settlement abandonment and the wish to conceal stored goods during periods when the settlement was unoccupied for planned reoccupation of the site during the subsequent year (DeBoer 1988). The presence of structures at the site during this time also indicates at least planned, long-term use of the site (Kent 1993). As a result, the features reflect regional settlement system trends toward sedentism, which corresponds to the results of the chipped-stone analysis presented by Spitzer later in this volume.

Human bone recovered from two Late Woodland storage facilities represents incomplete skeletons of two individuals, which Frankenburg (this volume) suggests were winter burials. If correct, this indicates that the site may have been inhabited year-round during at least some of the Late Woodland occupations. Alternatively, if Graybill (this volume) is correct in his suggestion that the small circular structures arranged in an arc on the eastern end of the study area represents a winter hunting camp, they could account for the proposed winter burials.

Charcoal samples recovered from features and distinct soil horizons, as well as from bulk soil samples, provide absolute dates for the full range of occupations documented during the present investigations. Uncalibrated radiocarbon assays ranging from 5140 B.C. to 4815 B.C. (associated with the Neville phase) document the apparently earliest occupation of the study area. Uncalibrated radiocarbon assays, ranging between A.D. 1290 and A.D. 1385 (associated with the Stewart phase), represent the latest occupation of the study area. Uncalibrated date ranges for other components include 4405 B.C. to 3840 B.C. for the early Laurentian, 3250 B.C. to 2950

B.C. for late Laurentian, 2460 B.C. to 2100 B.C. for the Piedmont, 2000 B.C. to 1640 for Terminal Archaic (Canfield Island), 1145 B.C. to 880 B.C. for the Orient, and A.D. 150 for the Middle Woodland. Analysis of radiocarbon assays associated with the Late Woodland suggests three Clemson Island components, in addition to the Stewart phase, with mean pooled uncalibrated dates of A.D. 789, A.D. 926, and A.D. 1067.

The features documented during the present investigations, then, reflect varied use of the study area through time as a result of both landscape evolution and changes in regional settlement systems. Radiocarbon assays of charcoal recovered from the features, and other contexts, help to establish approximately 6500 years of prehistoric use of the study area. In addition, the features were the primary source of subsistence remains, which are discussed by Sidell (botanical) and Holt (faunal) later in this volume. Finally, the Late Woodland features represented the primary source of artifacts for the Woodland occupations of the site, as discussed in several of the subsequent chapters.

## VIII. POTTERY ANALYSIS

by

John P. Hart, Ph.D.

A total of 27,873.34 g of pottery was recovered from Late Woodland features at the Memorial Park site. In addition, 535.9 g of Late Woodland pottery were recovered from soil anomalies that were later determined to be of non-cultural origin (Appendix B), and 2,204.3 g of Late Woodland pottery were recovered from block excavations. A total of 544.04 g of pre-Late Woodland pottery was recovered during block excavations, and 306.8 g of pre-Late Woodland pottery were recovered from features exposed during Task 1 investigations.

The pottery sherd analysis, as presented in this section, had several major goals: 1) to provide a detailed description of the sherd collection from all contexts to determine if the collection matched form and style attributes generally associated with prehistoric pottery traditions in the Susquehanna River basin (e.g., Hay et al. 1987; Stewart 1989; Turnbaugh 1977); 2) to isolate temporally discrete Late Woodland occupations exposed during Task 1 excavations; 3) to provide a description of the pre-Late Woodland pottery recovered during block excavations; and 4) to provide a technical/functional characterization of the pottery collection and to delineate changes in pottery technology through time.

### METHODOLOGY

The initial step in pottery analysis was the identification of sherds that belonged to individual vessels. This was accomplished by first examining all rim sherds from individual features or other recovery units to determine if (1) any sherds refit, thereby indicating origination from the same vessel or (2) any sherds that did not refit were similar enough that it reasonably could be inferred that they probably originated from the same vessel. After the isolation of vessels based upon rim sherds, the second step consisted of an attempt to refit neck, shoulder, and body sherds to the rim sherds to further isolate individual vessels. Finally, the third step involved refitting sherds between features and other recovery units to determine if sherds from individual vessels were contained in multiple features or recovery units. This process was performed by matching sherds from each feature or other recovery unit with sherds from all other features or recovery units.

The second step of analysis involved placing body sherds into sherd clusters based upon refits and the presence of similar surface treatment, decoration, temper, and color attributes. This was done under the assumption that these sherds originated from vessels for which no rim sherds were recovered. Alternatively, the sherds clusters may represent vessels for which rim sherds are present, but no refits were evident between the body and rim sherds, and the body surface treatment differed from that of the rims to an extent that assignment of the body sherds to a particular vessel was not possible. The procedure for determining sherd clusters was the same as that described for vessel identification.

All pottery sherds that could not be assigned to a particular vessel or sherd cluster, and that had one axis of at least 2 cm, were counted, weighed, and subjected to attribute analysis. Any sherds that refit were treated as a single sherd. Representative rim, neck, body, and basal sherds

from identified vessels and sherd clusters were also coded. The attributes coded during this procedure can be subdivided into three major subcategories: technical/functional, form, and style. A copy of the coding instructions used in this process, which should be consulted for detailed attribute definitions and descriptions, is provided in Appendix D. All small sherds, those with no axis of at least 2 cm, were weighed within recovery units and were not subjected to further analysis.

Sherds were initially coded for state of preservation (good, leached, eroded, severely eroded) and weighed. Technical/functional attributes were then recorded. Sherd wall thickness was determined with dial calipers to the nearest 0.1 mm by averaging four measurements, one taken on each of four edges. Horizontal wall diameter was determined for rim and body sherds by taking an impression of the interior surface with a contour profile gauge, and then matching this impression with a vessel-wall diameter chart (cf. Braun 1983b). Sherd edges were microscopically inspected (10 to 20X) for primary, secondary, and tertiary temper types. Stylistic attributes, including exterior and interior surface finishes and decorative techniques, cordage twist for sherds with cordmarked surfaces, lip decorative technique, the presence or absence of punctations, and the surface from which the punctation originates, were then recorded. Finally, form attributes were coded for rim sherds, including rim stance, rim form, rim cross section, and lip form.

The next step of analysis was the placement of individual vessels into groups based upon shared stylistic and form attributes. As reviewed by Graybill in the Culture History portion of this report, the temporal and spatial sensitivity of the current Clemson Island pottery typology developed by Hay et al. (1988) is highly questionable. Rather than attempting to modify this typology, or combine it with some other regional typology as has been done recently on almost a site-by-site basis (e.g., Johnson 1988; Stewart 1988), the groups defined for this project were simply assigned numbers. Many of the resulting groups approach the descriptions of types found in Hay et al. (1988) or other regional typologies (e.g., Ritchie and MacNiesh 1947). In such cases the type is identified, and attributes that differ from the definition of the type are discussed.

The final step in the pottery analysis was an analysis and interpretation of functional/technical attributes of the pottery assemblage. One particularly important goal was to determine whether there were any changes in technical/functional attributes through time, under the assumption of increased reliance on maize production. Expected changes included a decrease in vessel wall thickness and in temper size. This analysis was facilitated through the examination of petrographic analysis of thin sections, prepared from selected sherds, reflecting the range of pottery variation present at the site. This was performed following the procedures discussed by Stoltman in two recent articles (1989, 1991). Details of the methods used in this analysis are presented later in this chapter.

## LATE WOODLAND POTTERY ASSEMBLAGE DESCRIPTION

### *Rim Sherds*

A total of 154 Late Woodland rim sherds was recovered from Late Woodland features exposed during Task 1 excavations. These sherds were assigned to 55 vessels. Vessels were assigned to descriptive groups on the basis of shared stylistic and form attributes. Descriptions of the various groups are presented in the following paragraphs, accompanied by tables listing metric and form attributes, and photographs of representative rim sherds.

*Group 1.* This group consists of chert- or grit-tempered vessels that have slightly everted rims. Very-fine, oblique cord impressions occur on squared lips, continuing onto the exterior surface of the rim above a single row of interior punctations-exterior bosses (Table 50, Figure 45). The lip and exterior-rim cord impressions are oriented in opposite directions. The cord impressions continue on the interior rim surface on one vessel. The exterior surface of the rim below the node, neck, and shoulder have very fine horizontal cordmarking or fabric impressions over a smooth surface. The interior surface below the punctations is smooth. Three vessels, 44, 45 and 49, recovered from features 29 and 152 were assigned to this group. This group approaches the description for the type Clemson Island Fine Impressed (Hay et al. 1987). Radiocarbon dates of A.D. 1050 and 1090 indicate that this group is associated with the late Clemson Island occupation.

Table 50. Technological and Form Attributes for Descriptive Group 1.

Temper	Chert or Grit
Thickness:	
Mean	6.7
Range	5.1 - 7.6
Diameter:	
Mean	13
Range	8 - 18
Orifice Diameter:	
Mean	14
Range	10 - 18
Cross Section	parallel to tapered
Rim Stance	Vertical
Lip Form	Square
Vessel Form	Jar

*Group 2.* This group consists of chert-tempered vessels that have vertical rims with heavy, oblique cord impressions on outwardly bevelled lips that continue onto the interior and exterior rim surfaces to a single row of interior punctations-exterior bosses (Table 51, Figure 46). The cord impressions on the lip and exterior rim surface are oriented in the same direction. Moderately-heavy, cord-wrapped, paddle-edge impressions run horizontally across the exterior of the vessels on the rim and neck below the row of nodes. These impressions are superimposed over partially smoothed-over vertical cordmarking. The shoulder of one of the vessels assigned to this group has a row of inverted V-shaped, cord-wrapped dowel, or paddle-edge impressions, overprinted on the horizontal cord impressions. The interior surface is smooth on all of these vessels. Three vessels, 5, 10, and 21, all originating from Feature 63, were assigned to this group which approaches the description of Clemson Island Corded Horizontal (Hay et al. 1987). A radiocarbon date of A.D. 830 was obtained from Feature 63, indicating that this group is associated with the early Clemson Island occupations of the site.

*Group 3.* This group consists of chert-tempered vessels, with rims that have heavy, oblique cord impressions on outwardly-beveled or squared lips continuing onto the outer rim surface above a single row of interior punctations-exterior nodes (Table 52). The exterior rim and neck surface below the nodes has heavy horizontal cord or cord-wrapped, paddle-edge impressions imprinted over partially smoothed-over, vertical cordmarking (Figure 47). The interior surfaces have partially smoothed-over, oblique cordmarking from the lip, across and below the punctations. Seven vessels, 12, 13, 16, 20, 22, 25, and 46, were assigned to this group, which approaches the type Clemson Island Corded Horizontal as defined by Hay et al. (1987).

An A.D. 830 radiocarbon date from Feature 63 indicates that this group is associated with the early Clemson Island occupations.

Table 51. Technological and Form Attributes for Descriptive Group 2.

Temper	Chert
Thickness:	
Mean	5.7
Range	5.4 - 6.0
Diameter:	
Mean	31.5
Range	27 - 36
Orifice:	
Mean	32
Range	28 - 36
Cross Section	Parallel
Rim Stance	Vertical
Lip Form	Bevelled out
Vessel Form	Jar

Table 52. Technological and Form Attributes for Descriptive Group 3.

Temper	Chert
Thickness:	
Mean	8.2
Range	5.4 - 10.4
Diameter:	
Mean	28.5
Range	28 - 30
Orifice:	
Mean	-
Range	-
Cross Section	Parallel
Rim Stance	Vertical
Lip Form	Squared to Bevelled out
Vessel Form	Jar

*Group 4.* This group consists of small vertical-to-slightly everted, chert-tempered rim sherds that are thinner and have decorative elements that are more finely executed than those assigned to groups 2 and 3 (Table 53, Figure 48). Oblique cord impressions on the lip and exterior rim are oriented in the same direction. Interior punctations-exterior bosses are generally smaller and more regularly spaced than in groups 2 and 3, and temper tends to be much smaller. Seven vessels, 14, 15, 17, 19, 23, and 24, each represented by a single, small rim sherd, were assigned to this group. All of these sherds were recovered from Feature 63, radiocarbon dated at A.D. 830, and thus associated with the early Clemson Island occupation of the site. This group approaches the description of the type Clemson Island Cordmarked Horizontal (Hay et al. 1987).



DWG. NO. 89-412-A 43

APPROVED JPH

DWN. REM

GAI CONSULTANTS, INC.

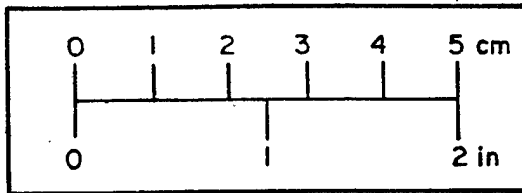
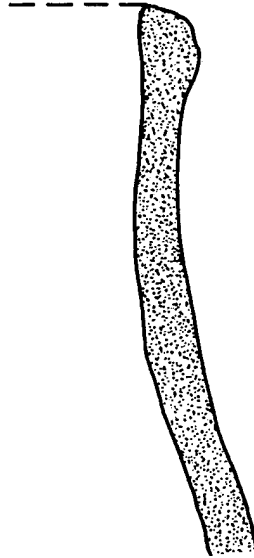
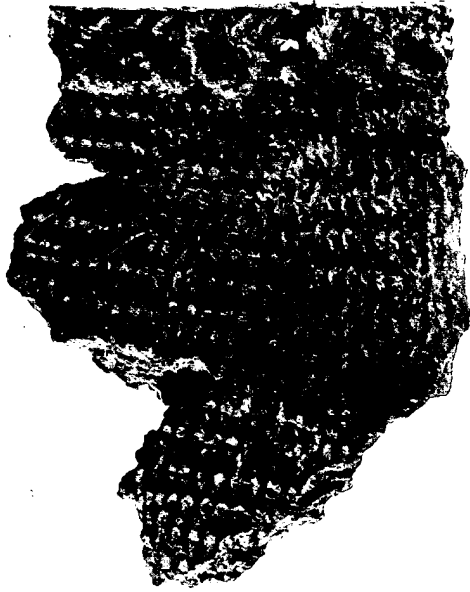

FIGURE 45

GROUP I RIMSHERD



GAI CONSULTANTS, INC.

DWN.

REM

APPROVED

JPH

DWG. NO.

8-2-11C-444

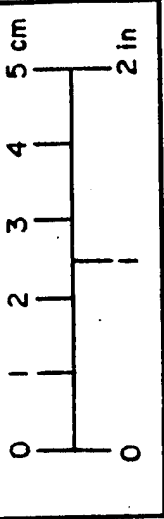

FIGURE 46

GROUP 2 RIMSHERD

Table 53. Technological and Form Attributes for Descriptive Group 4.

Temper	Chert
Thickness:	
Mean	4.8
Range	4.1 - 5.4
Diameter:	
Mean	24
Range	-
Orifice:	
Mean	-
Range	-
Cross Section	Parallel
Rim Stance	Vertical
Lip Form	Squared to Bevelled out
Vessel Form	Jar

*Group 5.* This group consists of the chert-tempered vessel 41 from Feature 135. It has a vertical rim, and a squared lip with oblique cord impressions. Oblique cord impressions cover the exterior and interior rim surfaces above a row of interior punctates-exterior bosses (Table 54, Figure 49); those on the interior are partially smoothed. The interior surface below the punctations is smooth. Fine cordmarking or fabric impressions occur in a chevron pattern on the exterior below the nodes, and the body is heavily fabric-impressed in a vertical orientation. Although the upper portion of the rim shares characteristics with Clemson Island Corded Horizontal, the treatment of the lower rim and shoulder depart from this type. No other type in Hay et al. (1987) or other regional typology have these attributes. Based upon the heavy lip treatment and heavy exterior fabric impressions, the group is probably associated with the early Clemson Island occupations.

Table 54. Technological and Form Attributes for Descriptive Group 5.

Temper	Chert
Thickness:	
Mean	7.9
Range	-
Diameter:	
Mean	40
Range	-
Orifice:	
Mean	40
Range	-
Cross Section	Parallel
Rim Stance	Vertical
Lip Form	Squared
Vessel Form	Jar

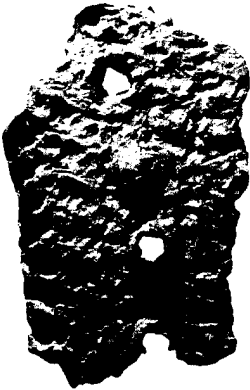
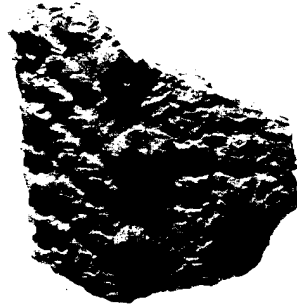
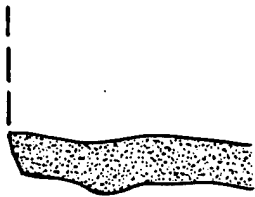

A

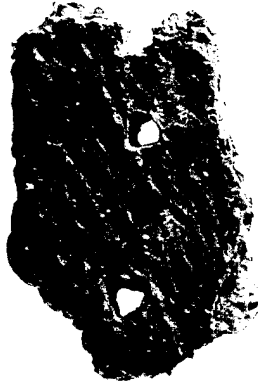

B

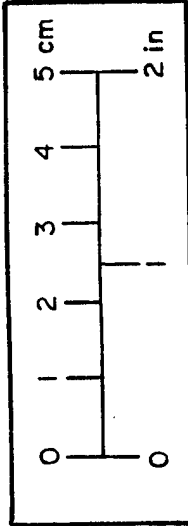

FIGURE 47

GROUP 3 RIMSHERDDS:  
(A) EXTERIOR, (B) INTERIOR

DWG. NO. 89-412-A46

APPROVED JPH

DWN. REM

GAI CONSULTANTS, INC.

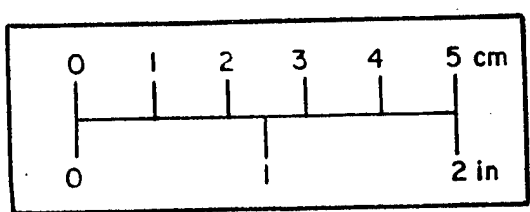
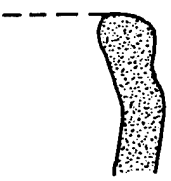
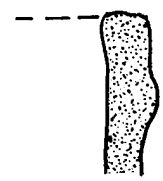
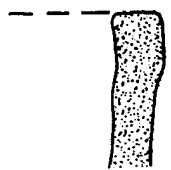
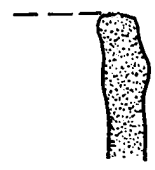
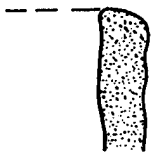

FIGURE 48

GROUP 4 RIMSHERDS

GAI CONSULTANTS, INC.

DWN.

REM

APPROVED

JPH

DWG. NO.

03 412 871

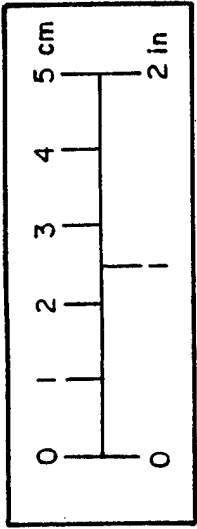

FIGURE 49

GROUP 5 RIMSHERD

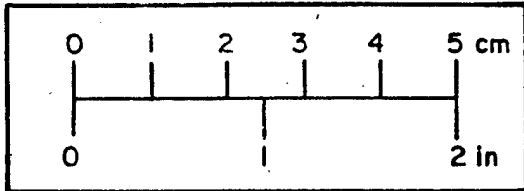
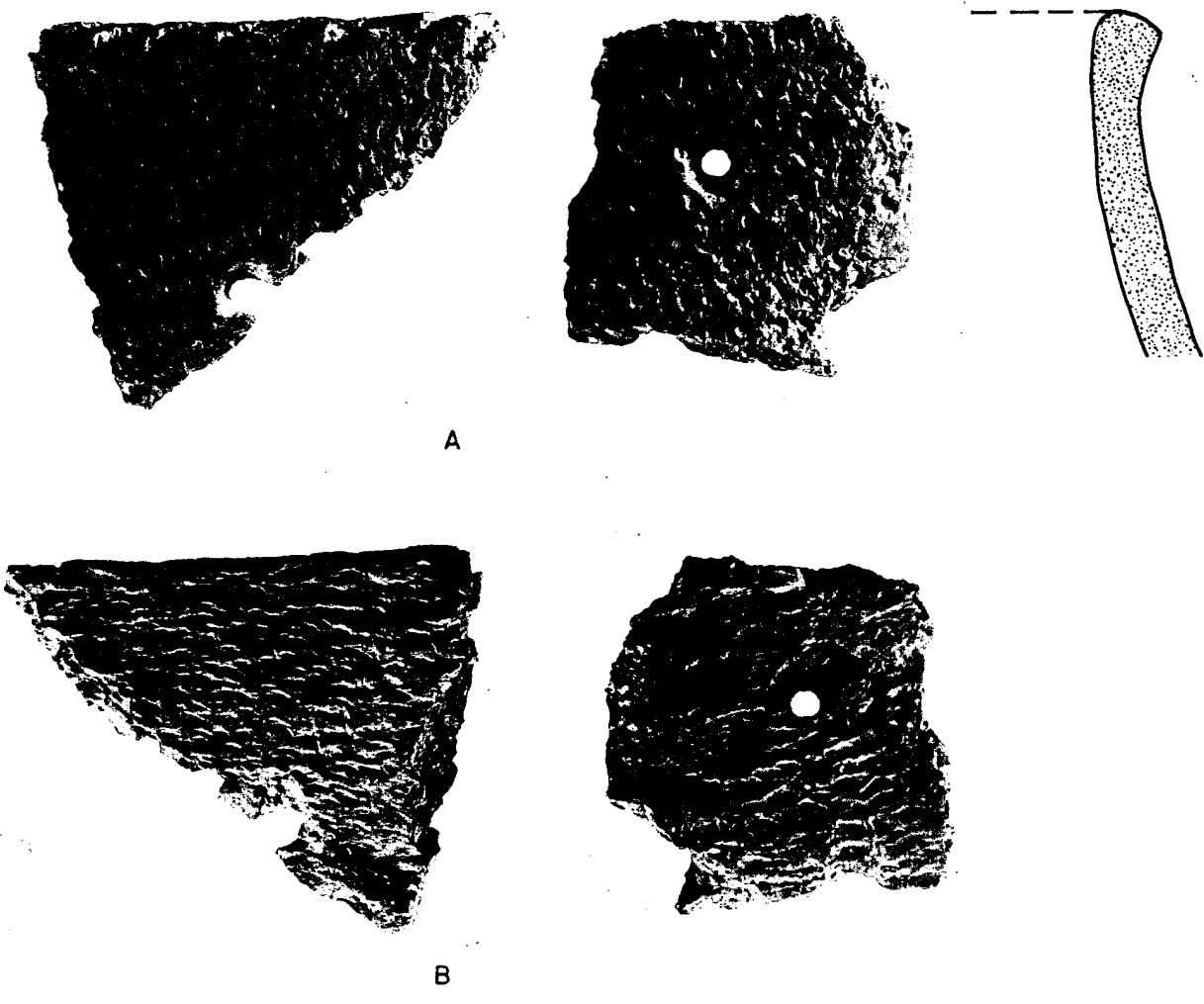

FIGURE 50

GROUP 6 RIMSHERDS:  
(A) EXTERIOR, (B) INTERIOR

*Group 6.* This group consists of chert-tempered vessels that have slightly-everted-to-everted rims with heavy, oblique cord impressions on squared lips (Table 55, Figure 50). Heavy-to-moderate oblique cord impressions occur on the rims' exteriors and continue beyond a single row of exterior punctations which extend through the vessel wall, or terminate in interior bosses. The rims' interiors exhibit oblique cordmarking. The vessels' bodies, below the shoulder, are vertically cordmarked. Three vessels from features 63 and 96 (11, 18, and 34) were assigned to this group. With the exception of the interior cordmarking, they match the description for Clemson Island Cord-on-Cord (Hay et al. 1987). A radiocarbon date of A.D. 830 from Feature 63 indicates that the group is associated with the early Clemson Island occupations.

Table 55. Technological and Form Attributes for Descriptive Group 6.

Temper	Chert
Thickness:	
Mean	8.0
Range	7.6 - 8.3
Diameter:	
Mean	34
Range	28 - 40
Orifice:	
Mean	34
Range	28 - 40
Cross Section	Parallel
Rim Stance	Outcurved
Lip Form	Squared
Vessel Form	Jar

*Group 7.* This group consists of the chert-tempered vessel 56 from Feature 237 with a slightly everted rim (Table 56, Figure 51). The squared lip of this vessel has heavy, oblique cord impressions. The entire exterior surface is fabric-impressed from the lip to the base. The interior surface is smooth. A horizontal row of interior punctations-exterior nodes occurs immediately below the lip. This vessel approaches the description of Clemson Island Cord-on-Cord (Hay et al. 1987), and is probably associated with the early Clemson Island occupations.

Table 56. Technological and Form Attributes for Descriptive Group 7.

Temper	Chert
Thickness:	
Mean	6.9
Range	-
Diameter:	
Mean	18
Range	-
Orifice:	
Mean	18
Range	-
Cross Section	Expanded
Rim Stance	Outcurved
Lip Form	Squared
Vessel Form	Jar





*Group 8.* This group consists of chert-tempered vertical rim sherds with squared lips exhibiting oblique cord impressions (Table 57, Figure 52). The exterior surfaces have vertical, moderately-heavy cordmarking, overprinted by irregularly spaced, horizontal cord-wrapped dowel or paddle-edge impressions. This pattern extends onto the shoulder; the vertical cordmarking continues across the body. The interior rim and neck surfaces are smooth with closely spaced, relatively heavy, cord-wrapped dowel impressions extending from the lip to the shoulder. The interior surface is smooth below the neck. Horizontal cordmarking occurs on the uppermost portion of the interior rim surface. Four vessels, 1, 2, 29, and 30, from features 29 and 80 were assigned to this group. Radiocarbon dates of A.D. 1050 and 1080 from these features indicate that this group is associated with the late Clemson Island occupation. With the exception of the interior surface dowel impressions and the lack of heavy lip treatment, this group is similar to the description of Levanna Cord-on-Cord in Ritchie and MacNiesh (1949).

Table 57. Technological and Form Attributes for Descriptive Group 8.

Temper	Chert
Thickness:	
Mean	8.4
Range	7.3 - 10.3
Diameter:	
Mean	28.8
Range	17 - 42
Orifice:	
Mean	29.8
Range	17 - 42
Cross Section	Parallel to tapered
Rim Stance	Vertical
Lip Form	Squared
Vessel Form	Jar

*Group 9.* This group consists of chert- or grit-tempered vessels with slightly everted rims that have cordmarked, squared lips (Table 58, Figure 53). The lip may have heavy, oblique cord impressions overprinted on the cordmarking. The exterior surface is most typically fabric impressed, although vertical cordmarking also occurs. The interior surface typically exhibits horizontal-to-oblique cordmarking. This group is similar to Levanna Cord-on-Cord (Ritchie and MacNiesh 1949), with the exception of the interior cordmarking. Nine vessels assigned to this group were recovered from features 57, 83, 92, 112, 117, 155, and 160. Radiocarbon dates of A.D. 790 and 930 were obtained from feature 83 and 92, respectively, indicating that this group is associated with the early Clemson Island occupations.

*Group 10.* This group consists of chert-tempered vessels with slightly everted rims that have broadly expanded cross sections (Table 59, Figure 54). The rims have squared lips with vertical cordmarking or fabric impressions. The exterior surface of the rims has heavy-fabric impressions in oblique or chevron patterns that continue across the shoulders and bodies. The interior surfaces are smooth, although the uppermost portion of the interior rim of one vessel has horizontal cordmarking. Two vessels, 27 and 28, recovered from Feature 78 which has a radiocarbon date of A.D. 920, have been assigned to this group. The radiocarbon assays indicate that this group is associated with the early Clemson Island occupations of the site. No equivalent type is defined in Hay et al. (1987) or any other regional typology.

Table 58. Technological and Form Attributes for Descriptive Group 9.

Temper	Chert or Grit
Thickness:	
Mean	7.5
Range	5.7 - 9.0
Diameter:	
Mean	26.0
Range	14 - 34
Orifice:	
Mean	27.5
Range	14 - 36
Cross Section	Parallel
Rim Stance	Outcurved
Lip Form	Squared
Vessel Form	Jar

Table 59. Technological and Form Attributes for Descriptive Group 10.

Temper	Chert
Thickness	
Mean	7.2
Range	6.8 - 7.6
Diameter	
Mean	29.3
Range	26 - 34
Orifice	
Mean	36
Range	26 - 46
Cross Section	Expanded
Rim Stance	Vertical
Lip Form	Squared
Vessel Form	Jar

*Group 11.* This group consists of chert-tempered vessels with slightly everted rims that have oblique cord impressions and hollow reed impressions on rounded lips (Table 60, Figure 55). The interior surface of these vessels is for the most part smooth, although some smoothed-over cordmarking is evident. The exterior surface has vertical cordmarking overprinted by single horizontal cord impressions. This group consists of two vessels, 54 and 55, recovered from Feature 78. The radiocarbon date of A.D. 920 from Feature 78, indicates that this group is associated with the middle Clemson Island occupation. No equivalent type is defined in Hay et al. (1987) or other regional typology.

*Group 12.* This group consists of slightly everted, chert-tempered rim sherds with smooth, squared lips (Table 61, Figure 56). The exterior surface is smooth and is overprinted with horizontal cord-wrapped dowel impressions. The interior surface is smooth. One vessel, 37, recovered from Feature 107, was assigned to this group. A radiocarbon date of A.D. 1050 was obtained for Feature 107, indicating that this group is associated with the late Clemson Island occupation. No equivalent type is defined in Hay et al. (1987) or any other regional typology.

DWG. NO. 89-412-A49

APPROVED JPH

DWN. REM

GAI CONSULTANTS, INC.

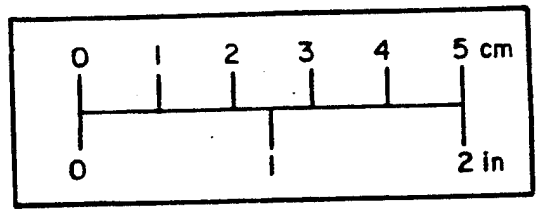
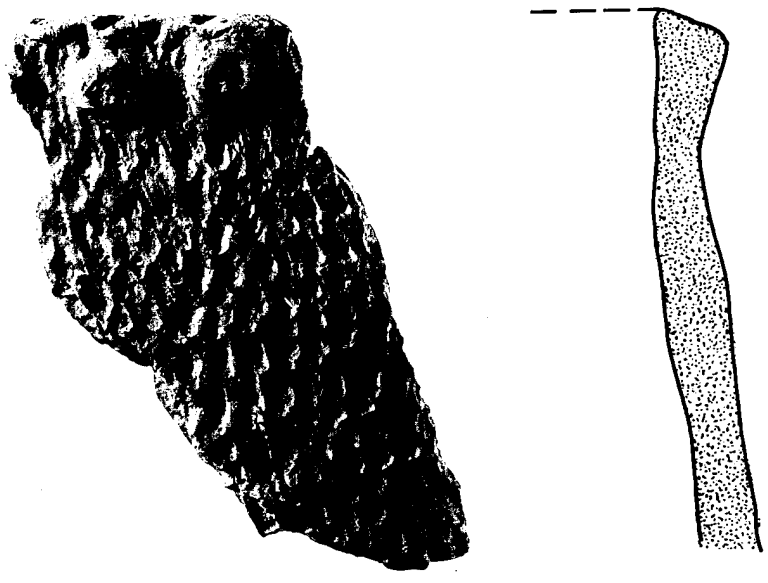
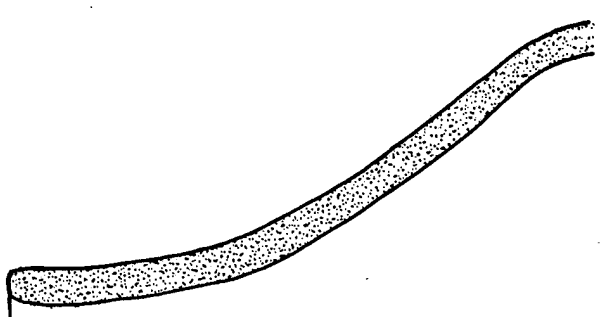

FIGURE 51

GROUP 7 RIMSHERD



A



B

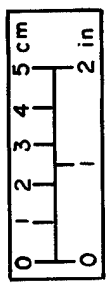

FIGURE 52

GROUP 8 RIMSHERD:  
(A) EXTERIOR, (B) INTERIOR

DWG. NO. 89-412-A37

JPH

APPROVED

REM

DWN.

GAI CONSULTANTS, INC.

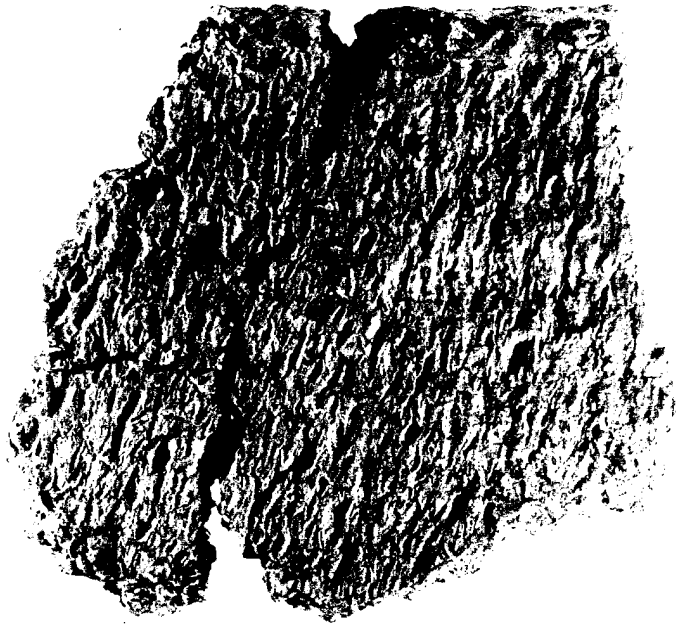

A

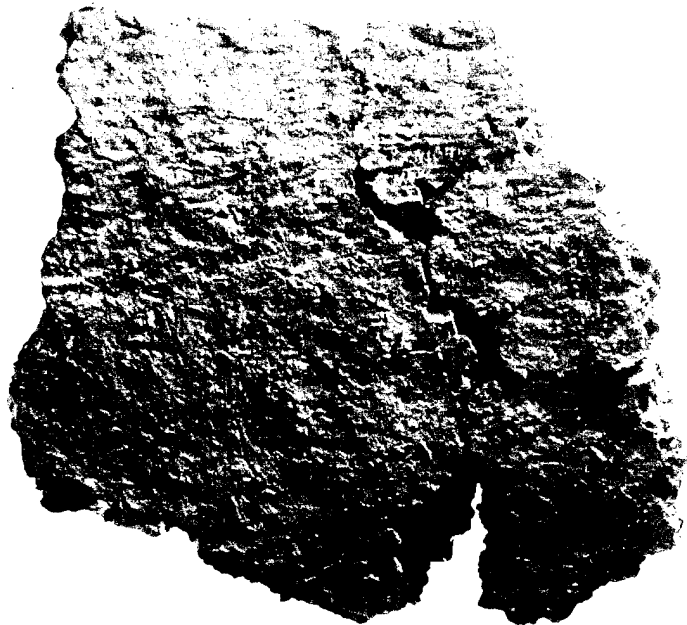

B

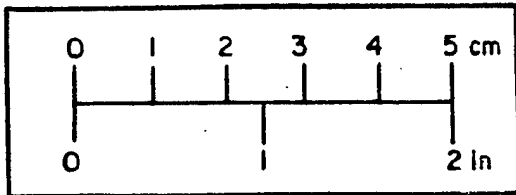
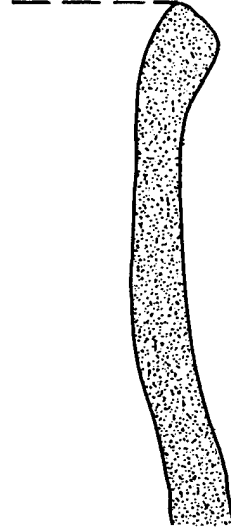
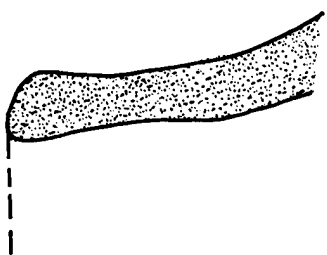

FIGURE 53

GROUP 9 RIMSHERD:  
(A) EXTERIOR, (B) INTERIOR



A



B

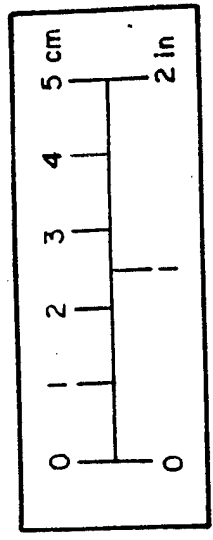

FIGURE 54

GROUP 10 RIMSHERD:  
(A) EXTERIOR, (B) INTERIOR

Table 60. Technological and Form Attributes for Descriptive Group 12.

Temper	Chert
Thickness	
Mean	6.5
Range	6.4 - 6.6
Diameter	
Mean	33
Range	30 - 36
Orifice	
Mean	-
Range	-
Cross Section	Parallel
Rim Stance	Vertical
Lip Form	Squared
Vessel Form	Jar

Table 61. Technological and Form Attributes for Descriptive Group 12.

Temper	Chert
Thickness	
Mean	5.4
Range	-
Diameter	
Mean	-
Range	-
Orifice	
Mean	-
Range	-
Cross Section	Tapered
Rim Stance	Outcurved
Lip Form	Squared
Vessel Form	Jar

*Group 13.* This group consists of a single, chert-tempered, vertical, slightly expanding rim sherd from Feature 51 that has a squared lip with very heavy, oblique cord impressions (Table 62, Figure 57). The exterior surface has partially smoothed-over vertical cordmarking, overprinted by oblique cordmarking. The interior surface exhibits partially smoothed-over oblique cordmarking. This sherd does not match the description an established type in Hay et al. (1987) or any other regional typology. The heavy cord impressions on the lip of this vessel indicate that it is associated with the early Clemson Island occupations.

*Group 14.* This group consists of small rim sherds from two vessels, 4 and 31 (Table 63). These sherds have an expanded cross section with squared lips. The top of the lip has oblique cord impressions. The exterior of the rims has vertical cordmarking beginning at the lip. The interior surface of two of the rims is smooth, while that of the third has oblique cord impressions. This group is similar to Group 14, but is much thinner. No equivalent type is described in Hay et al. (1987) or other regional reference.

GAI CONSULTANTS, INC. DWN. REM APPROVED JPH DWG. NO. 89-412-A53

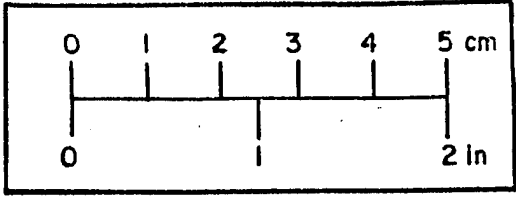
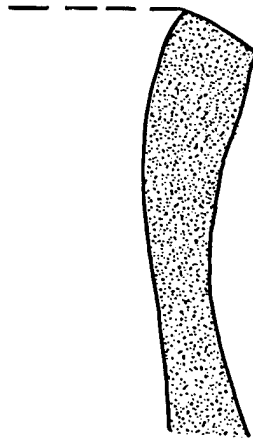
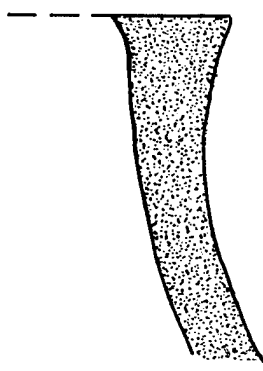
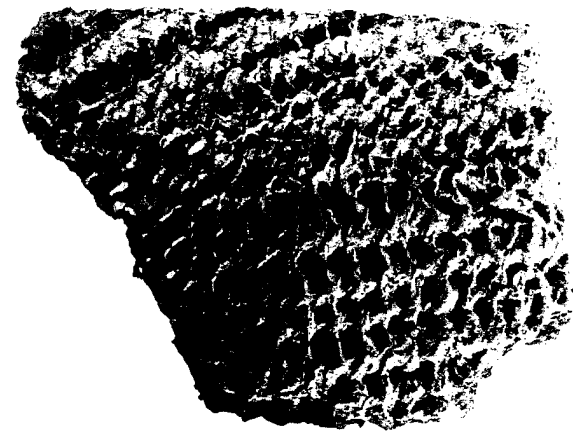

FIGURE 55

GROUP II RIMSHERDS



DWG. NO. 89-412-A54

JPH

APPROVED

REM

DWN.

GAI CONSULTANTS, INC.

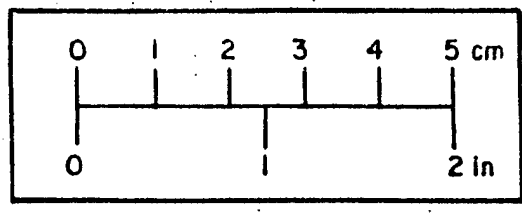
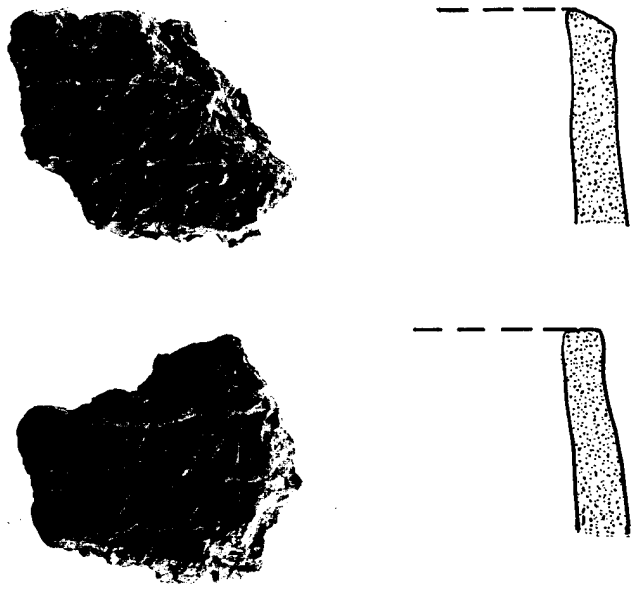

FIGURE 56

GROUP 12 RIMSHERDS

Table 62. Technological and Form Attributes for Descriptive Group 13.

Temper	Chert
Thickness	
Mean	6.0
Range	-
Diameter	
Mean	30
Range	-
Orifice	
Mean	30
Range	-
Cross Section	Expanded
Rim Stance	Outcurved
Lip Form	Squared
Vessel Form	Jar

Table 63. Technological and Form Attributes for Descriptive Group 14.

Temper	Chert
Thickness	
Mean	7.0
Range	7.9 - 8.3
Diameter	
Mean	-
Range	-
Orifice	
Mean	-
Range	-
Cross Section	Parallel
Rim Stance	Incurved, Outcurved
Lip Form	Squared
Vessel Form	Jar

*Group 15.* This group consists of a single small pinch pot, vessel 7, from Feature 57, an early Clemson Island storage pit (Table 64). This vessel has a flared rim with a rounded lip. The lip is smooth, while the exterior surface has fine vertical cordmarking from the lip across the body. Partially smoothed-over vertical cordmarking is present on the interior of the neck. Hay et al. (1987) report the recovery of miniature pots from Clemson Island contexts at the Clarks Ferry site.

*Group 16.* This group consists of a single, small, fine chert- and quartz-tempered, collared rimsherd recovered from Feature 61. This sherd has a flat, undecorated lip. The collar is decorated with three horizontal lines of fine punctations. At least one horizontal row of punctations is also present on the rim, immediately below the collar. The interior surface is smooth. Small, incised body sherds that apparently originated from the same vessel were also recovered from Feature 61. Based upon the collar and its decoration, and the incised body sherds, the sherds apparently originated from either a Castle Creek Punctate or Brainbridge Incised vessel, both of which Ritchie and MacNiesh (1949) assign to the Late Owasco period, coterminous with the earlier portions of the Stewart phase.



DWG. NO. 89-412-A33

APPROVED JPH

DWN. REM

GAI CONSULTANTS, INC.

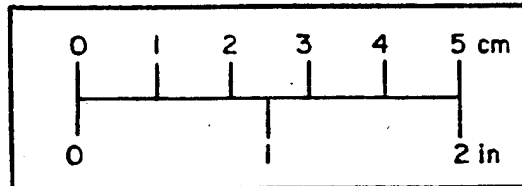
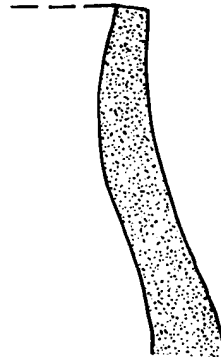
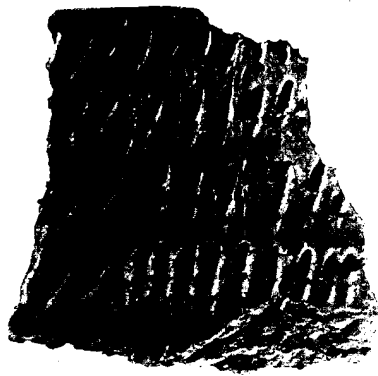

FIGURE 57

GROUP 13 RIMSHERD

Table 64. Technological and Form Attributes for Descriptive Group 15.

Temper	Grit, Quartz, and Chert
Thickness	
Mean	3.6
Range	-
Diameter	
Mean	19
Range	-
Orifice	
Mean	19
Range	-
Cross Section	Parallel
Rim Stance	Flared
Lip Form	Round
Vessel Form	Jar

*Group 17.* Stewart Incised pottery rim sherds were recovered from features 73 and 74 (Table 65). These sherds are collared, with horizontal incising on the collar.

Table 65. Technological and Form Attributes for Stewart Incised Rim Sherds.

Temper	Chert or Chert and Quartz
Thickness	
Mean	5.4
Range	3.8 - 7.0
Diameter	
Mean	18
Range	-
Orifice	
Mean	24
Range	-
Cross Section	Tapered
Rim Stance	Vertical
Lip Form	Squared
Vessel Form	Jar

### *Temporal Assignments*

The distribution of the various descriptive groups across features is presented in Table 66, along with established historical types that the descriptive groups resemble, and associated radiocarbon dates.



Table 66. Distribution of Late Woodland Descriptive Pottery Groups.

Group	Similar Historical Type	Features	Radiocarbon Dates (A.D.)
1	Clemson Island Fine Impressed	29, 152	1050, 1090
2	Clemson Island Corded Horizontal	63	830
3	Clemson Island Corded Horizontal	63, 84	830
4	Clemson Island Cord Horizontal	63	830
5	Clemson Island Cord Horizontal	135	None
6	Clemson Island Cord-on-Cord	63, 96	830
7	Clemson Island Cord-on-Cord	237	None
8	None	29, 80	1050, 1080
9	Levanna Cord-on-Cord	57, 83, 92, 112, 117, 155, 160	790, 930
10	None	78, 109	920
11	None	78	820
12	None	107	1050
13	None	51	None
14	None	52, 63, 80	830, 1080
15	None	57	None
16	Castle Creek Punctate or Brainbridge Incised	61	None
17	Stewart Incised	74	1290, 1326, 1385 <sup>a</sup>

<sup>a</sup>Dates not from features containing Stewart Incised pottery.

Based upon various decorative attributes associated with radiocarbon dates, it is possible to assign various features to specific components. Additional assignments to particular occupations within particular components is also possible, although somewhat more tentative. The attributes used in these assignments, and a listing of specific features assigned to the various components are listed below.

*Early and Middle Clemson Island.* Early Clemson Island pottery at Memorial Park is characterized by several stylistic attributes: (1) heavy treatment of lips, including cord impressions and cord-wrapped paddle impressions, (2) cord-marked interior rim surfaces, (3) heavy fabric impressed exterior surfaces, and (4) generally coarser treatment of stylistic attributes. Features assigned to this component include 22, 26, 51, 55, 57, 63, 83, 96, 112, 117, 123, 135, 160, and 172. Descriptive groups associated with this occupation include 2, 3, 4, 6, 8, 9, 11, 12, 13, 14, 15, and 16. Established types that these groups approach include Clemson Island Corded Horizontal, Clemson Island Cord-on-Cord, and Levanna Cord-on-Cord. Based upon radiocarbon assays, at least two occupations of the site are associated with this component: A.D. 760 - 830 (early Clemson Island), and A.D. 920-930 (middle Clemson Island). All of the features except 78, 84, 92, 97, and 155 were assigned to the earlier of the two occupations. The middle Clemson Island occupation is most clearly typified by descriptive group 11.

*Late Clemson Island.* This component is typified by stylistic elements including, (1) undecorated lips, or lips with light treatments, (2) smooth interior surfaces that may be overprinted by cord-wrapped dowel impressions, (3) cordmarked as opposed to heavy fabric-impressed, exterior surfaces, and (4) finer execution of decorative elements. Features assigned to this group include 29, 80, 87, 106, 107, 132, and 152. Decorative groups associated with this occupation include 1, 10, and 13. These groups approach the established types of Clemson Island Fine Impressed and Levanna Cord-on-Cord.

*Stewart Phase.* Stewart phase pottery is characterized by: (1) collared rims, (2) incising, (3) smooth to cord-marked exterior surfaces, and (4) smooth interior surfaces. Features assigned to this component include: 41, 42, 54, 61, 67, 73, 74, 79, 144, 148, 204, 233, and 261. Descriptive groups associated with this occupation include 17 and 18, which consist of Stewart

Incised and Castle Creek Punctate or Brainbridge Incised pottery. Based upon radiocarbon assays, two occupations may be associated with this component: A.D. 1290 and A.D. 1350-1385. It was not possible to separate these occupations with the pottery because of the small sample present in Feature 41 with the A.D. 1290 radiocarbon assays.

### Body Sherds

A total of 1,275 body sherds, with at least one axis  $\geq 2.0$  cm, was recovered from Late Woodland features. The total weight for these sherds was 18,390.2 g. Of this total, 5,543.4 g were assigned to 23 sherd lots which are thought to represent neck, body, and basal sherds of individual vessels, and 965.3 g of body sherds were assigned to vessels defined on the basis of rim sherds. A total of 5,526.9 g of these two groups of sherds, and an additional 4627.6 g of sherds assigned to sherd lots or vessels, were subjected to attribute analysis. An additional 7,344.9 g of small sherds, those with no axis  $\geq 2$  cm, were recovered. Because of their small size, none of these sherds were subjected to further analysis. Summaries of the various stylistic, technical/functional, and form attributes are presented in the following sections by Late Woodland component. The few sherds from unassigned features are not included in this descriptive section.

*Temper.* Frequencies and percentages of tempers, and temper combinations by count and weight, are presented by Late Woodland components in Tables 67. Chert is the most prevalent temper for the Clemson Island components, occurring in over 90 percent of the sherds by count and weight for the early, middle, and late components. Quartz occurs in much lower percentages.

Table 67. Distribution of Temper Groups for Late Woodland Components.

Early CI	Weight (g)	5798.10	28.4	339.5	79.3	0.0	6245.3
	Weight (%)	92.84	0.46	5.44	1.26	0.0	100.0
	Count	357	2	31	12	0	402
	Count (%)	88.81	0.49	7.71	2.99	0.0	100.0
Middle CI	Weight (g)	962.50	0.0	61.3	0.0	0.0	1023.8
	Weight (%)	94.01	0.0	5.99	0.0	0.0	100.0
	Count	52	0	5	0	0	57
	Count (%)	91.23	0.0	8.77	0.0	0.0	100.0
Late CI	Weight (g)	2481.90	81.1	106.4	94.4	2.9	2766.7
	Weight (%)	89.71	2.93	3.85	3.41	0.10	100.00
	Count	163	2	10	23	1	199
	Count (%)	81.91	1.01	5.03	11.55	0.50	100.00
Stewart	Weight (g)	32.3	0.0	25.2	16.6	0.0	74.1
	Weight (%)	43.59	0.0	34.01	22.40	0.0	100.00
	Count	6	0	5	5	0	16
	Count (%)	37.5	0.0	31.25	31.25	0.0	100.00

This contrasts markedly with the Stewart Phase, where quartz occurs in 56.41 percent of the sherds by weight and 62.5 percent by count, while chert occurs in 77.6 percent by weight and 68.75 percent by count.

*Surface Treatment.* Exterior surface treatment for the various Late Woodland components are presented by count and weight in Table 68. As is evident in these tables, there are several changes in exterior body treatment through time. Fabric-impressed exteriors are most common for the middle Clemson Island, representing 72.66 percent by weight and 66.67 percent by count. Fewer of the late Clemson island sherds are fabric impressed (8.5 percent by weight and 24.75 percent by count), while fabric impressed sherds account for only 13.44 percent by weight and



6.67 percent by count for the Stewart phase. While not quantified, fabric impressions on the early and middle Clemson island sherds were, in general, more coarse than on the late Clemson Island sherds. Smooth exteriors are most common in the early Clemson Island collection representing 17 percent by weight and 18.3 percent by count. Smooth exterior surface sherds are not present in the middle Clemson Island and Stewart phase collections, and account for only 0.3 percent by weight and 1.01 percent by count for the late Clemson Island collection.

Table 68. Exterior Surface Treatment of Late Woodland Component Body Sherds.

Occupation		Exterior Surface treatment					Total
		Fabric	Smooth	S-twist Cord	Z-twist Cord	Smoothed Cord	
Early CI	Weight (g)	859.4	1022.7	1801.3	769.9	1562.7	6016.0
	Weight (%)	14.28	17.00	29.94	12.80	25.98	100.0
	Count	59	71	140	18	100	388
	Count (%)	15.21	18.30	36.08	4.64	25.77	100.0
Middle CI	Weight (g)	743.9	0.0	279.9	0.0	0.0	1023.8
	Weight (%)	72.66	0.0	27.34	0.0	0.0	100.0
	Count	38	0	19	0	0	198
	Count (%)	66.67	0.0	33.34	0.0	0.0	100.0
Late CI	Weight (g)	911.1	8.5	1521.2	41.2	268.0	2750.0
	Weight (%)	8.5	0.30	55.32	1.50	9.75	100.00
	Count	49	2	112	9	26	198
	Count (%)	24.75	1.01	56.56	4.55	13.13	100.00
Stewart	Weight (g)	8.8	0.0	34.8	5.3	16.6	65.5
	Weight (%)	13.44	0.0	53.13	6	40.00	100.00
	Count	1	0	6	2	6	15
	Count (%)	6.67	0.00	40.00	13.33	40.00	100.00

Interior surface treatments for body sherds of the various Late Woodland components are presented in Table 69. The majority of the sherds for each time component have smooth interior surfaces, generally reflecting the origin of these sherds from portions of the vessels below the neck and shoulder. Those sherds with cordmarked interior surfaces constitute, for the most part, rim and neck sherds.

Combined exterior and interior surface treatments for the various Late Woodland components are presented in tables 70 through 73. By weight, the most common combination for the early Clemson Island component is s-twist cordmarked exteriors with smooth interiors (27.65%) and partially smoothed-over cordmarked exteriors with smooth interiors (19.41%). This compares with middle Clemson Island, where the most common combinations by weight are fabric impressed exteriors with smooth interiors (38.90%) and fabric-impressed exteriors with s-twist cordmarked interiors (32.99%). For the late Clemson Island component, by far the most common combination by weight is s-twist cordmarked exteriors with smooth interiors (53.68%) followed by fabric-impressed exteriors and smooth interiors (24.85%). Finally, for the Stewart phase, the most common combinations by weight are s-twist cordmarked exteriors with smooth interiors (53.13%) and partially smoothed-over cordmarking with smooth interiors (25.34%).

Table 69. Interior Surface Treatment of Late Woodland Component Body Sherds.

Occupation		Interior Surface Treatment					Total
		Smooth	S-twist Cord	Z-twist Cord	Smoothed Cord	Indeterminate	
Early CI	Weight (g)	5211.7	205.5	79.6	744.7	0.0	6241.5
	Weight (%)	83.50	3.29	1.28	11.93	0.00	100.0
	Count	364	16	1	19	0	400
	Count (%)	91.00	4.00	0.25	4.75	0.00	100.00
Middle CI	Weight (g)	548.7	355.5	0.00	93.7	0.00	997.9
	Weight (%)	54.98	35.63	0.00	9.39	0.00	9.09
	Count	39	11	0	5	0	55
	Count (%)	70.91	20.00	0.00	9.09	0.0	100.0
Late CI	Weight (g)	2471.7	81.4	0.0	191.7	5.2	2750.0
	Weight (%)	89.88	2.96	0.00	6.97	0.19	100.00
	Count	180	7	0	10	1	198
	Count (%)	91.91	3.54	0.00	5.05	0.51	100.00
Stewart	Weight (g)	74.1	0.0	0.0	0.0	0.0	74.1
	Weight (%)	100.0	0.0	0.0	0.0	0.0	100.0
	Count	16	0	0	0	0	16
	Count (%)	100.0	0.0	0.0	0.0	0.0	100.0

Table 70. Early Clemson Island Interior and Exterior Surface Finish Combinations

Exterior Surface Finish	Interior Surface									
	Smooth		S-twist cord		Z-twist Cord		Smooth Cord		Total	
	%Wt	%Ct	%Wt	%Ct	%Wt	%Ct	%Wt	%Ct	%Wt	%Ct
Smooth	15.92	16.92	0.64	0.76	0.00	0.00	0.19	0.25	16.75	17.93
S-twist cordmarking	27.65	32.83	1.16	1.52	0.00	0.00	0.69	1.01	29.50	35.36
Z-twist cordmarking	6.25	3.54	0.00	0.00	1.30	0.25	5.05	0.76	12.60	4.55
Partially smoothed cordmark	19.41	22.47	0.09	0.25	0.00	0.00	6.10	2.53	25.60	25.25
Indeterminate	0.98	1.52	0.34	0.25	0.00	0.00	0.16	0.25	1.48	2.02
Fabric Impressed	12.94	13.64	1.13	1.25	0.00	0.00	0.00	0.00	14.07	14.89
Total	83.15	90.92	3.36	4.03	1.30	0.25	12.19	4.80	100.0	100.0

Table 71. Middle Clemson Island Interior and Exterior Surface Finish Combinations.

Exterior Surface Finish	Interior Surface									
	Smooth		S-twist cord		Z-twist Cord		Smooth Cord		Total	
	%Wt	%Ct	%Wt	%Ct	%Wt	%Ct	%Wt	%Ct	%Wt	%Ct
S-twist cordmarking	16.08	20.00	2.64	5.45	0.00	0.00	6.73	5.45	25.45	30.90
Fabric Impressed	38.90	50.91	32.99	14.55	0.00	0.00	2.66	3.64	74.55	69.10
Total	54.98	70.91	35.63	20.00	0.00	0.00	9.39	9.09	100.0	100.0

Table 72. Late Clemson Island Interior and Exterior Surface Finish Combinations

Exterior Surface Finish	Interior Surface									
	Smooth		S-twist cord		Z-twist Cord		Smooth Cord		Total	
	%Wt	%Ct	%Wt	%Ct	%Wt	%Ct	%Wt	%Ct	%Wt	%Ct
Smooth	0.30	1.01	0.00	0.00	0.00	0.00	0.00	0.00	0.30	1.01
S-twist cordmarking	53.68	53.03	0.38	1.01	0.00	0.00	1.26	2.52	54.06	54.04
Z-twist cordmarking	1.50	4.55	0.00	0.00	0.00	0.00	0.00	0.00	1.50	4.55
Partially smoothed cordmark	9.55	12.62	0.00	0.00	0.00	0.00	0.20	0.50	9.75	13.12
Fabric Impressed	24.85	19.70	2.58	2.53	0.00	0.00	5.70	2.53	33.13	24.76
Total	89.88	90.91	2.96	3.54	0.00	0.00	7.16	5.55	100.0	100.0

Table 73. Stewart Phase Interior and Exterior Surface Finish Combinations

Exterior Surface Finish	Interior Surface									
	Smooth		S-twist cord		Z-twist Cord		Smooth Cord		Total	
	%Wt	%Ct	%Wt	%Ct	%Wt	%Ct	%Wt	%Ct	%Wt	%Ct
S-twist cordmarking	53.13	40.00	0.00	0.00	0.00	0.00	0.00	0.00	53.13	40.00
Z-twist cordmarking	8.09	13.33	0.00	0.00	0.00	0.00	0.00	0.00	8.09	13.33
Partially smoothed cordmark	25.34	40.00	0.00	0.00	0.00	0.00	0.00	0.00	25.34	40.00
Fabric Impressed	13.44	6.67	0.00	0.00	0.00	0.00	0.00	0.00	13.44	6.67
Total	100.0	100.0	0.00	0.00	0.00	0.00	0.00	0.00	100.0	100.0

*Decoration.* Several decorative techniques are present on the body sherd assemblage. These generally consist of cord impressions overprinted upon exterior surface finishes. For the purposes of this descriptive analysis, the cord impressions have been broken down into two categories: light and moderate. The latter may actually represent fabric impressions, particularly when the heavier cord impressions appear to be overprinted upon cordmarked surfaces. In this instance, the thinner, vertical cordmarking may represent warps. As a result, rather than representing decoration, this category may in fact represent a surface finish. The only other decorative technique in this assemblage was incising. The distribution of exterior decorative techniques for the various late Woodland components is presented in Table 74. The highest occurrence of medium cord impressions is in the early Clemson Island collection, accounting for 41.91 percent by weight. The early Clemson Island collection also has the only sherds with light cord impressions, accounting for 1.43 percent by weight.

#### LATE WOODLAND POTTERY FROM BLOCK 7 EXCAVATIONS

During the course of Task 2 excavations in Block 7, several plowzones were sampled that contained both Clemson Island and Stewart Phase pottery. While it is possible that some of this pottery relates to earlier occupations of the site, given the mixed nature of the deposits from which it was recovered it is not possible to identify potentially earlier pottery from the obviously Late Woodland pottery. This pottery collection is characterized in the following pages. Comparisons are made with the Late Woodland pottery retrieved from the Late Woodland features exposed during Task 1 excavations, when appropriate.

Table 74. Late Woodland Component Body Sherd Decorative Technique.

Component		Decorative Technique				Total
		Medium Cord	Fine Cord	Incised	None	
Early CI	Weight (g)	2615.7	89.1	0.0	3536.7	6241.5
	Weight (%)	41.91	1.43	0.0	56.66	100.0
	Count	179	10	0	211	400
	Count (%)	44.75	2.50	0	52.75	100.0
Middle CI	Weight (g)	127.0	0.0	0.0	896.8	1023.8
	Weight (%)	12.40	0.0	0.0	87.60	100.0
	Count	7	0	0	50	57
Late CI	Count (%)	12.28	0.0	0.0	87.72	100.0
	Weight (g)	794.5	0.0	6.1	1949.4	2750.0
	Weight (%)	28.89	0.0	0.22	70.89	100.0
	Count	61	0	2	135	198
Stewart	Count (%)	30.81	0.0	1.01	68.18	100.0
	Weight (g)	15.1	0.0	6.8	52.2	74.1
	Weight (%)	20.38	0.0	9.18	70.44	100.0
	Count	2	0	3	11	16
	Count (%)	12.50	0.0	18.75	68.75	100.0

### Rim Sherds

Fifteen Late Woodland rim sherds were recovered from Block 7. As would be expected from plowzone deposits, these sherds are considerably smaller and in poorer condition than most rimsherds recovered from feature contexts. Given the small size of the sherds, it was not possible to assign most of them to the descriptive groups defined with the feature rim sherds, nor was it possible in most cases to confidently ascribe these sherds to individual vessels. One of the primary aims of the analysis of these rim sherds, then, was simply to classify the sherds as either Clemson Island or Stewart Phase, and to determine whether there was vertical separation of the sherds from these two temporally distinct pottery assemblages.

All but one of the rim sherds, which was recovered from level 2, were recovered from levels 3 and 4. There is no vertical separation between the Clemson Island and Stewart Phase rim sherds, as is indicated in Table 75. The three levels represented comprised two plowzones and a possible A horizon remnant. Given the vertical displacement associated with plowing, and the bioturbation associated with agricultural activities in the apparent A horizon remnant, these results were not unanticipated.

Table 75. Vertical Distribution of Rimsherds in Block 7.

	Levels		
	2	3	4
Clemson Island	1	5	3
Stewart Phase	0	2 <sup>a</sup>	1
Unidentified	0	0	3
Total	1	7	7

<sup>a</sup>Count includes one Stewart Phase neck sherd.

## Body Sherds

A total of 2203.8 g of body sherds was recovered from levels 1 through 5 in Block 7, comprising the Late Woodland body sherd collection for this block. Of this total, 980 g (44.47%), or 264 sherds by count, were large enough for attribute coding.

*Temper.* As with the pottery recovered from the features, those recovered from Block 7 were predominantly chert tempered. Chert occurred alone or in combination with other tempers in 93.18 percent of the sherds by count, and 93.35 percent by weight. Quartz was the second most frequent temper, occurring in 12.12 percent of the sherds by count, and 10.91 percent by weight, while grit and sand each occurred in 0.38 percent of the sherds by count, and 0.52 percent and 0.27 percent, respectively, by weight. Temper data are presented in Table 76 by level and for the block as a whole. Very little difference is evident in the vertical distribution of the various tempers. Chert alone is the predominant temper in all of the levels, ranging from 100 percent in level one (for which there were only 11 sherds) to 80.76 percent by weight and 79.76 percent by count in level four. Quartz alone ranges from a low of 0.0 percent in level one to a high of 8.68 percent by weight in level 5 and 10.72 percent by count in level 4. Grit temper occurs only in level 2, and sand temper is present only in level 3.

Table 76. Distribution of Tempering Groups for Block 7 Late Woodland Pottery.

Temper	Level										Total	
	1		2		3		4		5			
	Wt%	Ct%	Wt%	Ct%	Wt%	Ct%	Wt%	Ct%	Wt%	Ct%	Wt%	Ct%
Chert	100.0	100.0	89.79	87.18	91.48	90.74	80.76	79.76	91.32	90.91	88.30	87.12
Grit	0.00	0.00	3.67	2.56	0.00	0.00	0.00	0.00	0.00	0.00	0.52	0.38
Chert& Quartz	0.00	0.00	0.93	2.56	3.03	3.70	8.53	10.72	8.68	9.09	5.05	6.06
Quartz	0.00	0.00	5.61	7.70	4.76	4.63	10.71	9.52	0.00	0.00	5.86	6.06
Sand	0.00	0.00	0.00	0.00	0.73	0.93	0.00	0.00	0.00	0.00	0.27	0.38
Total	100.0	100.0	100.0	100.0	100.0	100.0	100.0	100.0	100.0	100.0	100.0	100.0

*Surface Treatment.* The exterior surface of the majority of the sherds was cordmarked, with partially smoothed over cordmarking accounting for 7.3 percent, indeterminate cordmarking 19.5 percent, s-twist cordmarking 8.0 percent, and z-twist cordmarking 8.0 percent by count, while smooth exteriors accounted for 18.7 percent by count (Table 77). Interior surface finishes were primarily smooth, accounting for 79.4 percent of the collection by count (Table 78).

Table 77. Exterior Surface Treatment of Block 7 Late Woodland Body Sherds.

Surface Treatment	Weight	Percentage	Count	Percentage
Fabric Impressed	229.7	26.00	53	23.35
Indeterminate	205.2	23.23	62	27.31
Partially Smoothed Cord	64.3	7.28	19	8.37
S-twist cordmarking	70.7	8.00	23	10.13
Smooth	208.0	23.55	49	21.59
Z-twist cordmarking	105.5	11.94	21	9.25
Total	883.4	100.00	227	100.00

Table 78. Interior Surface Treatment of Block 7 Late Woodland Body Sherds.

Surface Treatment	Weight	Percentage	Count	Percentage
Indeterminate	3.3	0.4	1	0.5
Fabric Impressed	3.9	0.5	1	0.5
Smooth	827.6	99.1	210	99.0
Total	834.8	100.0	212	100.0

### Decoration

The same range of decorative techniques is evident on the Late Woodland sherds recovered from Block 7, as on those recovered from features exposed during Task 1 investigations (Table 79). The majority of sherds exhibited no decoration beyond surface treatment (55.96 percent by weight and 63.44 percent by count). Incising is much more common on the Block 7 sherds, accounting for 19.33 percent of the collection by weight and 11.01 percent by count. The majority of these sherds probably originated from Stewart Incised vessels.

Table 79. Exterior Decorative Treatment of Block 7 Late Woodland Body Sherds.

Surface Treatment	Weight	Percentage	Count	Percentage
Cord-wrapped dowel impressed	49.7	5.63	16	7.04
Cord impressed	132.4	14.99	30	13.22
Fine cord impressed	33.4	3.78	11	4.85
Incised	170.8	19.33	25	11.01
Knotted-cord impressed	2.7	0.31	1	0.44
None	494.4	55.96	144	63.44
Total	883.4	100.00	226	100.00

### Assemblage Description Summary

The Late Woodland pottery assemblage from the Memorial Park site is dominated by pottery sherds with attributes generally characteristic of the Clemson Island complex. These sherds represent primarily chert-tempered jars, generally with slightly everted rims. Decorative and surface treatment attributes of many of the vessels tend toward types established by Hay et al. (1987) for Clemson Island, although certain attributes such as cordmarked interior surfaces are not consistent with these types. Because of the apparent problems with the typology developed by Hay et al. (1987), and the development and/or modification of typologies almost on a site-by-site basis (Johnson 1988; Stewart 1988), and to avoid contributing to the current confusion, this pottery was not specifically assigned to specific types. Surface treatment and certain form attributes on other vessels do not approach previously described Clemson Island types or types established in nearby areas.

Several changes in rim and body surface treatments are evident through time at the Memorial Park site. Pottery associated with the early and middle Clemson Island components is characterized by (1) heavy treatment of lips including cord impressions and cord-wrapped, paddle-edge impressions, (2) cordmarked interior rim surfaces, (3) heavy fabric-impressed exterior surfaces, (4) generally coarser surface treatments, and (5) higher percentages of smooth exterior surfaces than occur in the pottery assemblage of the late Clemson Island component. Pottery associated with the late Clemson island component, on the other hand, is characterized by (1) undecorated lips or lips with light treatments, (2) smooth interior surfaces that may be overprinted

by cord-wrapped, dowel impressions, (3) cordmarked exterior surfaces, (4) finer execution of surface treatments, and a low percentage of Incised sherds.

#### LATE WOODLAND SMOKING-PIPE FRAGMENTS

Nine smoking-pipe fragments weighing 71.8 g, were recovered from the Clemson Island features. All of these fragments are tempered with finely ground shell, which is consistent with smoking pipe fragments reported from other Clemson Island sites (e.g., Stewart 1988). Six are bowl fragments representing four pipes. One shell-tempered pipe bowl was recovered from Feature 63. It is sub-rectangular in cross section, its dimensions are 5.3 x 3.05 x 2.63 cm, and it weighs 49.4 g. The outer surface has been engraved with four designs, one on each face (Figure 58). One small fragment from Feature 63, from another pipe, is engraved with what appears to be approximately half of a circle. Two small bowl fragments from Feature 152 have a collared-like lip, below which are fine cord impressions. A large bowl fragment from Feature 84 is undecorated. Pipestem fragments were recovered from features 52, 63, and 152. Assuming that the stem fragments from features 63 and 152 originated from the same pipes as the bowl fragments from these same features, then this collection represents a minimum of six pipes.

#### PRE-LATE WOODLAND POTTERY ASSEMBLAGE DESCRIPTION

Pottery recovered from three features exposed during Task 1 investigations has been assigned to the Middle Woodland period Fox Creek phase, based on independent data. Additionally, pottery recovered during block excavations on the stripped portion of the site relates to pre-Late Woodland occupations, most of it pertaining to the Orient phase occupation of the site. This pottery is described in the following pages.

##### *Middle Woodland Pottery*

Pottery recovered from three features exposed during Task 1 investigations has been assigned to the Middle Woodland period Fox Creek phase, based upon a radiocarbon date of A.D. 150 and diagnostic artifacts. This pottery included 14 body sherds weighing 153.7 g, and one rim sherd weighing 34.5 g. The rim sherd, recovered from Feature 143, is chert-tempered and has a mean thickness of 7.3 mm. This sherd is heavily fabric impressed on the exterior surface and lip. The interior surface has horizontal-to-slightly-oblique cordmarking. The rim has an expanded cross section and flat lip.

The 14 body sherds are also chert-tempered. One of the sherds also has grit temper, and another sherd has chert, grit, and quartz temper. These sherds range in thickness from 6.3 mm to 9.2 mm, with a mean of 7.7 mm and standard deviation of 0.826. Eleven of the sherds (78.6%), weighing 130.5 g (84.9%), have s-twist cordmarked exterior surfaces, 1 sherd (7.1%) weighing 11.1 g (7.2%) has a z-twist cordmarked exterior surface, and two (14.3%), weighing 12.1 g (7.9%), have a partially smoothed-over, cordmarked exterior surface. The interior surface of one sherd (7.1%), weighing 11.1 g (7.2%), is partially smoothed over cordmarking, while the remainder have smooth interiors.

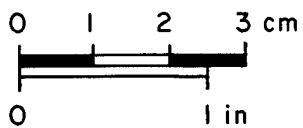
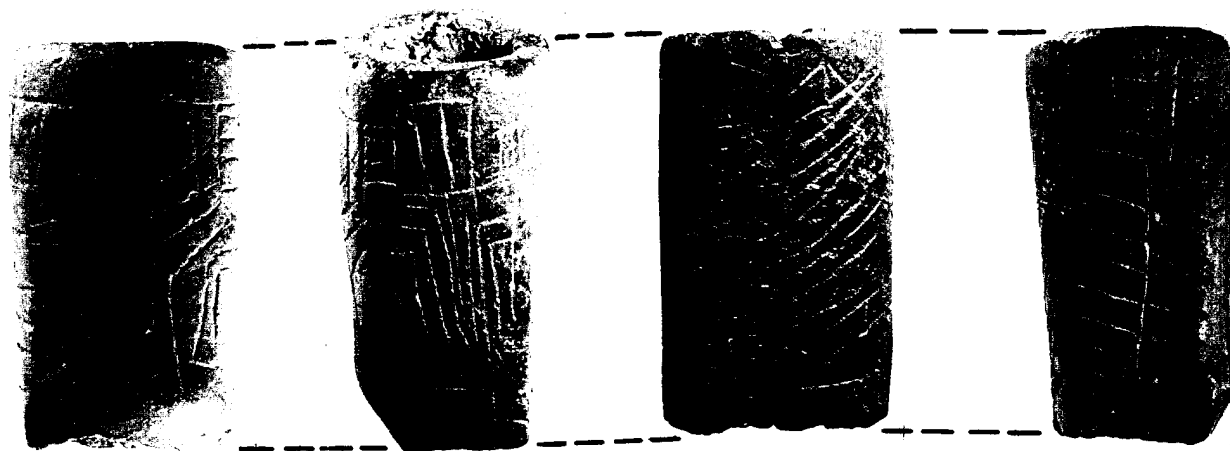

FIGURE 58

EARLY CLEMSON ISLAND  
INCISED PIPE BOWL



## *Orient*

Twenty-five steatite-tempered, Marcey Creek body sherds, weighing 112.1 g with at least one axis  $\geq 2$  cm, recovered during the present investigations, can be assigned to the Orient phase. Four of these were recovered from Feature 182, and one from Feature 149. Those recovered from Feature 182 were associated with a cache of notched disks or netsinkers. Those sherds recovered from block excavations had a very limited distribution: 8 sherds weighing 52.1 g were recovered from Block 4, one sherd weighing 1.6 g was recovered from Block 5, eight sherds weighing 36.2 g were recovered from Block 6, and two sherds weighing 3.1 g were recovered from Block 7.

Three of the sherds had quartz as a secondary temper, while a fourth sherd had an unidentified secondary temper. The exterior surface of 17 sherds (68.0%) weighing 73.7 g (65.7%) was too eroded to determine treatment, while the exterior surface on the remaining sherds was smooth. The interior surface of 12 (48.0%) sherds weighing 60.9 g (54.3%) was smooth, while the interior surface of the remaining sherds was too eroded to determine treatment. None of the sherds showed any evidence of design.

## *Unassigned Pre-Late Woodland Pottery*

During the course of block excavations, a small amount of pottery that was recovered from blocks other than Block 7 cannot be assigned to a particular component, other than that it is probably of pre-Late Woodland age. The general provenience of these sherds suggests an Early or Middle Woodland origin, although it is possible that at least some relate to the Late Woodland occupations of the site. Eighteen body sherds weighing 152.2 g were recovered from the upper levels of blocks 1, 3, 4, 6, and 10.

Seven of these sherds (38.9%), weighing 23.9 g, are quartz tempered; eight (44.4%), weighing 34.7 g (22.8%), are fiber tempered; one sherd (5.5%), weighing 88.8 g (58.2%), has no obvious temper; and, two sherds (11.1%), weighing 5.1 g (3.3%), are chert-tempered. The exterior surfaces of 11 of these sherds are too eroded to determine surface finish. Three sherds, weighing 20.0 g, have exterior surfaces with z-twist cordmarking, and four sherds, weighing 12.5 g, have exterior surfaces with indeterminate cordmarking. The interior surfaces of 11 sherds are too eroded to determine treatment, while the remaining seven sherds, weighing 37.2 g, have smooth interior surfaces. One 8.2 g chert- and quartz-tempered rim sherd with a squared lip was recovered from Block 1; both surfaces of this sherd are too eroded to determine treatment.

## CROSS-FEATURE REFITTING

In order to identify contemporaneous features, refitting was performed with pottery sherds recovered from features exposed during Task 1 investigations. This procedure consisted of matching sherds recovered from each feature with sherds from all other features with similar stylistic and technical attributes. This analysis was performed independently by three individuals.

This activity resulted in only two refits between features. One of the refits was between two small rim sherds from features 57 and 160, and the other between two large body sherds from features 143 and 175. The refit between features 57 and 160 pertain to the early Clemson Island occupation of the site, while the refit between features 143 and 175 pertain to the Middle Woodland occupation of the site.

## TECHNICAL/FUNCTIONAL ANALYSIS

Up to this point, the analysis of pottery from the Memorial Park site has been geared toward stylistic attributes as a means of testing certain assumptions regarding changes in such attributes through time for the Clemson Island complex. While important from a cultural-historical perspective, this type of analysis provides little or no means for ascertaining changes in pottery technology and function through time. As reviewed in the Research Design section of this report, pots are generally designed to perform as tools. If pottery is to serve a particular task, it must be designed and constructed in such a way that it can perform that task adequately for a reasonable amount of time without breaking. A cooking pot that breaks when exposed to heat not only represents a wasted expenditure of time and energy on its manufacture, but may also result in the loss of the food it contains. Similarly, a storage pot that breaks under the stress of the weight of its contents represents a wasted expenditure of time and energy on its manufacture and may also result in the loss of its contents. Since pots are tools manufactured to meet certain needs, it is reasonable to assert that changes in pottery technology will reflect changes in the functional field (Schiffer and Skibo 1987). For example, Braun (e.g., 1983a, 1987) has demonstrated a change from thick- to thin-walled pottery during the Woodland period in the American Midwest, corresponding to changes in subsistence regimes (also see O'Brien 1988).

This basic argument has been recognized in the archaeological literature for many years; however, relatively few functional or technological studies have been performed on archaeologically-derived pottery collections in the Mid-Atlantic region (cf. Hart 1990). One of the only attempts at a functional analysis of Clemson Island pottery, to date, has been a correlation of vessel size with cultural-historical types by Stewart (1989) for the St. Anthony Bridge site. The following section represents a first attempt at functional analysis for Clemson Island pottery. The results suggest that there were changes in pottery construction techniques through time at the Memorial Park site, perhaps corresponding to an increased reliance on maize-based agriculture.

### *Methodology*

One means of recording technological and functional attributes of pottery paste is through thin-section analysis (e.g., Stoltman 1989, 1991). For this analysis, 72 sherds representing the range of macroscopic variation for all components yielding pottery were selected for thin sectioning. Sixty-eight of these were selected from Late Woodland features. At least one sherd was chosen for thin section from each feature yielding pottery, unless only a single sherd was recovered from a feature or the sherds from a feature were extremely small. For features yielding abundant pottery, enough sherds were selected to cover the range of macroscopic variation present in the feature. The other four sherds selected for thin sectioning included three Marcey Creek sherds from Orient phase contexts, and one apparently fiber-tempered sherd recovered during block excavations.

Sherds were submitted to Quality Thin Sections of Tucson, Arizona for thin-section preparation. Standard thin sections were prepared for each sherd, according to procedures established for prehistoric pottery. The resulting slides were point-counted, according to the procedures suggested by Stoltman (1989, 1991), by a GAI technician trained in the use of petrographic microscopy, but not familiar with the ultimate goals of the analysis. This procedure ensured a high degree of objectivity in the coding. Slides were positioned on a mechanical stage and examined under 40x magnification with polarized light. Each slide was examined at 1 mm increments. At each point, the type of grain (clay, silt, sand, temper) or the presence of a void was recorded. Grain measurement, for distinguishing between silt- and sand-size particles, was accomplished using a calibrated grid contained within one objective; clay-sized grains were not identified if no individual grains were visible at a particular point (cf. Stoltman 1991). If a grain was determined to be temper, the type of temper (e.g., chert, quartz, sandstone) was recorded.

Sand-size particles were determined to be either natural inclusions or temper, based upon shape and configuration. In general, smooth sand-sized particles were coded as natural sand inclusions, while irregularly shaped, angular, sand-sized inclusions were coded as temper. The point counting procedure continued until the entire slide was covered. A second stage in the coding consisted of a scan along transects parallel to the long axis of each slide to record the size of temper particles. The long axis and type of the first 10 temper particles encountered were recorded. This provided a means of estimating the general size of temper inclusions within each sherd. Because of the irregular shape and general platiness of the chert inclusions, the third-largest particle size is used as a means of comparing temper size in the following discussions (cf. Steponaitis 1983).

### *Vessel Wall Thickness*

The thickness of vessel walls is one means that a potter can use to control the ability of a pot to withstand various stresses encountered during manufacture and use (Braun 1983a, 1987). Wall thickness has several implications for vessel manufacture and function (Braun 1983a; Rice 1987); vessel wall thickness reflects both technological and functional considerations. During the forming of a pottery vessel, the walls must be strong enough to support the weight of the clay. One means for ensuring vessel wall strength during construction is by thickening walls (Rice 1987:227). On the other hand, wall thickness also affects three aspects of mechanical performance: (1) thinner walls have greater thermal conductivity; they are better able to conduct heat from the exterior surface to interior surface than are thicker walls; (2) other things being equal, thicker walls have greater flexural strength; they resist breakage as a result of mechanical stress; they are better able to withstand load-bearing stress and are more impact resistant than are thinner walled vessels; and (3) thinner walls have greater resistance to thermal stress; they are more likely to withstand the stress of sudden increases and decreases in temperature (Braun 1983a:118).

Within the Memorial Park Late Woodland pottery assemblage, if wall thickness were a simple function of vessel size, we would expect to find a linear relationship between wall thickness and vessel diameter, one measure of vessel size. Tables 80 through 82 and Figure 59 present the results of the regression of sherd diameters on sherd thicknesses for various groupings of sherds. A regression of diameter on thickness for all Clemson Island rim sherds indicates a significant ( $p=0.01$ ), but weak ( $R^2=0.178$ , standard error of estimate = 1.316) positive relationship between diameter and thickness. This is also true for the combined early and middle Clemson Island rim sherds in that there is a significant ( $p=0.055$ ) positive but weak ( $R^2=0.130$ , standard error of estimate=1.317) relationship between thickness and diameter. However, for late Clemson Island rims, there is a significant ( $p=0.001$ ) and strong ( $R^2=0.922$ , standard error of estimate= 0.472) relationship between wall thickness and diameter. This latter relationship is possibly the result of the small sample size, although other possible implications for this will be discussed later.

Table 80. Regression of Diameter on Wall Thickness for All Clemson Island Vessels.

Variable	Coefficient	Std. Error	Std Coefficient	Tolerance	t	p
Constant	5.075	0.762	0.000		6.657	0.000
Diameter	0.072	0.026	0.422	1.00	2.717	0.010
n=36    R=0.422 $R^2=0.178$ Adj $R^2=0.154$ Standard error of estimate=1.316						

Table 81. Regression of Diameter on Wall Thickness for Early/Middle Clemson Island Vessels.

Variable	Coefficient	Std. Error	Std Coef	Tolerance	t	p
Constant	5.012	0.973	0.000		5.153	0.000
Diameter	0.066	0.033	0.361	1.00	2.009	0.055
n=29 R=0.361 R <sup>2</sup> =0.130 Adj R <sup>2</sup> =0.098 Standard error of estimate=1.317						

Table 82. Regression of Diameter on Wall Thickness for Late Clemson Island Vessels.

Variable	Coefficient	Std. Error	Std Coef.	Tolerance	t	p
Constant	4.533	0.450	0.000		10.07	0.000
Diameter	0.136	0.018	0.960	1.00	7.668	0.001
n=7 R=0.96 R <sup>2</sup> =0.922 Adj R <sup>2</sup> =0.906 Standard error of estimate=0.472						

The trend for positive but weak relationships between wall thickness and diameter also holds true for Clemson Island body sherds (tables 83 through 85, Figure 60). For all Clemson Island body sherds, there is a significant (p=0.000) but weak (R<sup>2</sup>=0.256, standard error of estimate=1.842) relationship between wall thickness and diameter. For both the combined early and middle Clemson Island body sherds (p=0.000, R<sup>2</sup>=0.242, standard error of estimate=1.898), and late Clemson Island body sherds (p=0.005, R<sup>2</sup>=0.262, standard error of estimate=1.813) there are significant but weak relationships between diameter and wall thickness.

Table 83. Regression of Diameter on Wall Thickness for All Clemson Island Body Sherds.

Variable	Coefficient	Std. Error	Std Coef	Tolerance	t	p
Constant	2.771	1.004	0.000		2.760	0.007
Diameter	0.147	0.029	0.506	1.00	5.042	0.000
n=76 R=0.506 R <sup>2</sup> =0.256 Adj R <sup>2</sup> =0.246 Standard error of estimate=1.842						

Table 84. Regression of Diameter on Wall Thickness for Early/Middle Clemson Island Body Sherds.

Variable	Coefficient	Std. Error	Std Coef	Tolerance	t	p
Constant	2.673	1.399	0.000		1.910	0.063
Diameter	0.150	0.040	0.492	1.000	3.791	0.000
n=47 R=0.492 R <sup>2</sup> =0.242 Adj R <sup>2</sup> =0.225 Standard error of estimate=1.898						

Table 85. Regression of Diameter on Wall Thickness for Late Clemson Island Body Sherds.

Variable	Coefficient	Std. Error	Std Coef	Tolerance	t	p
Constant	2.920	1.506	0.000		1.939	0.063
Diameter	0.142	0.046	0.512	1.000	3.098	0.005
n=29 R=0.512 R <sup>2</sup> =0.262 Adj R <sup>2</sup> =0.235 Standard error of estimate=1.813						

In general, then, larger Clemson Island pottery vessels at Memorial Park have thicker walls. This may reflect a technological constraint on the manufacture of pottery; thicker walls were used to support the weight of vessels while under construction. Because in craft-level production systems, pottery manufacture results in numerous compromises (Bronitsky 1986), the weakness of the relationship suggests that other technological and/or functional considerations may have also influenced pottery manufacture.

### *Temper*

Temper also plays an important role in the mechanical performance of pottery vessels. Among other things, temper affects pottery's ability to resist cracking as a result of physical stress in two ways: (1) resistance to crack initiation, and (2) resistance to crack propagation (e.g., Braun 1983a; Bronitsky and Hamer 1986; Steponaitis 1983). Resistance to crack initiation prevents cracks from forming. In general, the smaller the size of the temper, the greater the ability to withstand crack initiation. Resistance to crack propagation, on the other hand, prevents cracks that have formed from enlarging. Larger pieces of temper, on the other hand, serve to increase resistance to crack propagation. Temper particles act as points of focus for internal stress, dissipating the stress and preventing formation of larger cracks up to a point (Braun 1983a:123). Voids in paste can also serve as points of focus for cracks, preventing their spread once formed (Rye 1976).

In addition to temper size, temper density can also affect resistance to cracking. If a temper is used that expands at a rate significantly different than that of clay minerals when subjected to heat, temper density should be low and temper size should be small (Rye 1976:114). On the other hand, large amounts of temper may be required during the construction of pottery in order to ensure workability (Rice 1987; Rye 1976). Because the primary temper used in Clemson Island pottery at Memorial Park was chert, an acidic rock with an expansion rate very different from that of clay minerals, we might expect that cooking vessels would have lower densities of smaller chert inclusions, as compared to storage vessels which should have higher densities of larger chert inclusions.

Variation is present between the bodies (see Stoltman 1991 for definitions of paste and body) of the combined early and middle Clemson Island and late Clemson Island. For the combined early and middle Clemson Island chert-tempered pottery, there is a moderately strong positive correlation (0.459,  $p=0.019$ ) between the wall thickness and temper size, as represented by the third largest temper particle (Table 86). A different pattern is present for the late Clemson Island chert-tempered pottery (Table 87). While the correlation between wall thickness and temper size is still present (0.412), it is not significant ( $p=0.339$ ); however, there is a relatively strong negative correlation (-0.617,  $p=0.003$ ) between wall thickness and temper density. In general, thinner walled vessels have high densities of relatively smaller pieces of chert temper.

Table 86. Pearson Correlation Matrix for Combined Early/Middle Clemson Island Pottery.

	Temper Size	Wall Thickness	Temper Density
Temper Size	1.000		
Wall Thickness	0.459 $p=0.019$	1.000	
Temper Density	-0.041 $p=1.000$	0.023 $p=1.000$	1.000

Bartlett Chi-square statistic: 7.504, d.f. = 3,  $p=0.057$

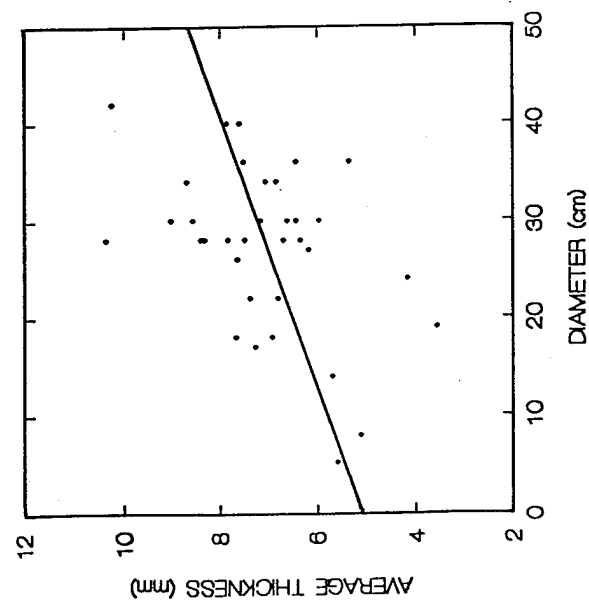

COMBINED CLEMSON ISLAND

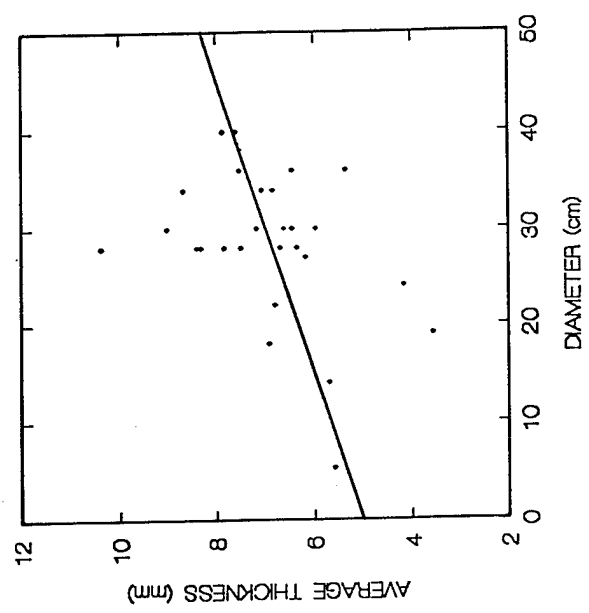

EARLY/MIDDLE CLEMSON ISLAND

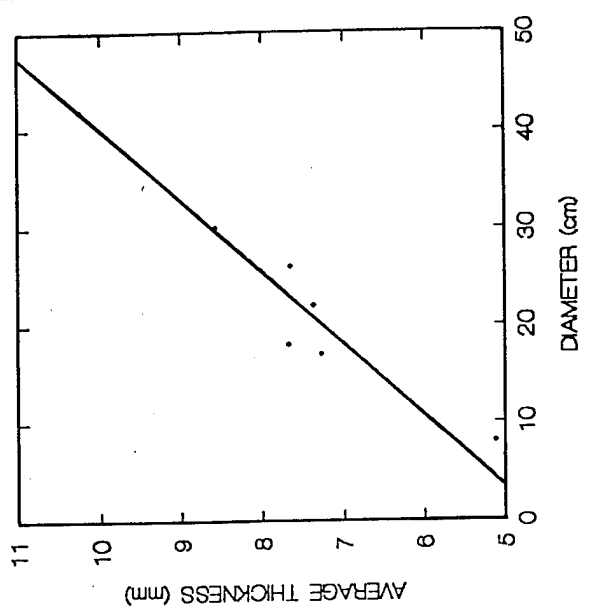

LATE CLEMSON ISLAND

FIGURE 59

PLOTS OF WALL THICKNESS  
AND DIAMETER FOR  
CLEMSON ISLAND RIM SHERDS

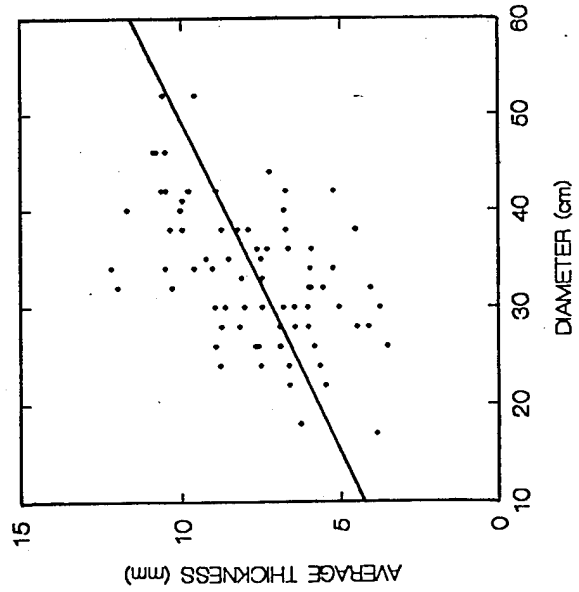

COMBINED CLEMSON ISLAND

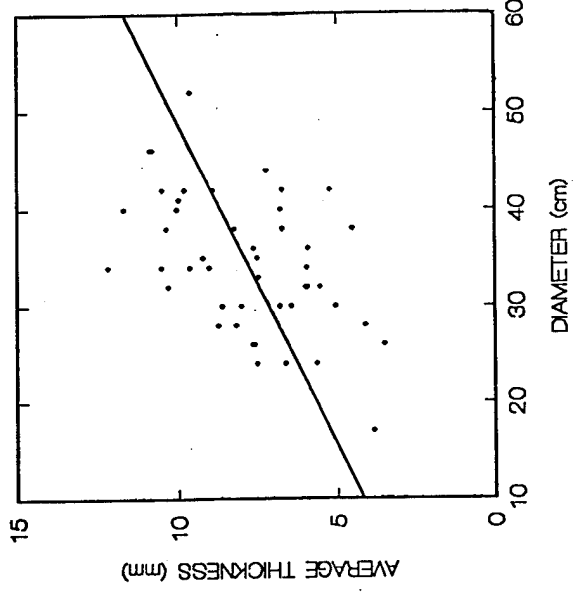

EARLY/MIDDLE CLEMSON ISLAND

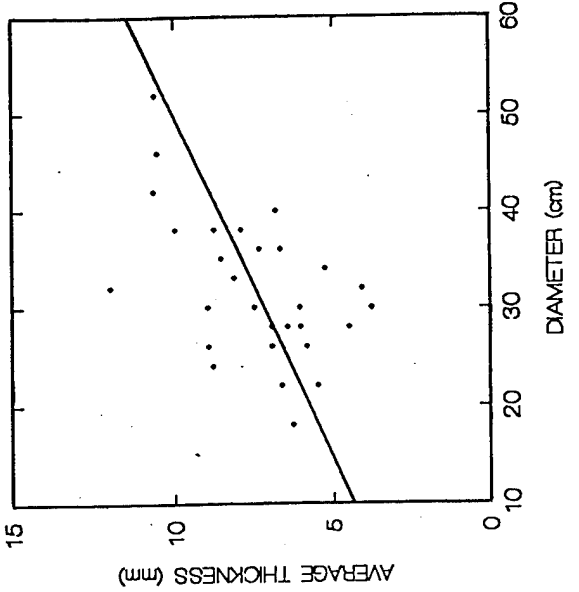

LATE CLEMSON ISLAND

**FIGURE 60**

PLOTS OF WALL THICKNESS  
AND DIAMETER FOR  
CLEMSON ISLAND BODY SHERDS

Table 87. Pearson Correlation Matrix for Combined Early/Middle Clemson Island Pottery.

	Temper Size	Wall Thickness	Temper Density
Temper Size	1.000		
Wall Thickness	0.412	1.000	
	p=0.339		
Temper Density	-0.249	-0.617	1.000
	p=1.000	p=0.033	

Bartlett Chi-square statistic: 8.752, d.f. = 3, p=0.033

A K-means cluster analysis (Wilkinson 1989), using standardized values for temper size, wall thickness, and temper density for the late Clemson Island chert-tempered pottery, specifying two groups, yields significant results for each variable (tables 88 and 89, Figure 61). Group 1, consisting of nine samples, has a mean wall thickness of 7.36 mm, a mean temper density of 22.4 percent, and a mean temper size (as represented by the third-largest particle) of 1.398 mm. The second group, consisting of seven samples, has a mean wall thickness of 9.014 mm, a mean temper density of 15.3 percent, and a mean temper size of 2.319 mm. A similar analysis of the combined early and middle Clemson Island sherds failed to produce significant results.

Table 88. Cluster Analysis of Late Clemson Island Pottery Technological Attributes.

Variable	Between SS	df	Within SS	df	F-Ratio	p
Temper Density	5.183	1	7.818	14	9.281	0.009
Temper Size	11.604	1	7.833	14	20.741	0.000
Wall Thickness	2.245	1	3.559	14	8.833	0.010

Table 89. Summary Statistics for Late Clemson Island Sherd Cluster Analysis Groups.

	Temper Size		Wall Thickness		Temper Density	
	Group 1	Group 2	Group 1	Group 2	Group 1	Group 2
n	9	7	9	7	9	7
Minimum	0.86	1.70	5.8	7.00	16.3	7.8
Maximum	2.00	2.99	8.9	10.20	27.5	26.1
Mean	1.398	2.319	7.356	9.014	22.4	15.3
Variance	0.116	0.220	1.098	1.398	0.1	0.3
Standard Deviation	0.341	0.47	1.048	1.12	3.6	5.7

While the majority of Late Woodland sherds subjected to thin-section analysis were tempered exclusively with chert, seven sherds also contained quartz and/or sandstone temper. These are associated primarily with late Clemson Island and Stewart phase features: one sandstone and quartz-tempered sherd originated from Feature 57, an early Clemson Island feature, and one quartz and sandstone-tempered sherd originated from Feature 17, an unassigned Late Woodland feature. Based on these results, it is probable that Feature 17 originated during the Late Clemson Island or Stewart phase occupations. The sherd from Feature 52 is somewhat puzzling, although it is possible that it is intrusive.

For those five sherds definitely of late Clemson Island or Stewart phase origin, with quartz and sandstone temper, there are strong positive correlations between temper size and sherd thickness (0.59), and temper density and thickness (0.752). However, on the whole, the size of the temper is relatively small compared to the chert-tempered pottery of the same components. The



mean of the third-largest particle for the quartz and sandstone-tempered sherds is 0.48 mm, while for the chert-tempered sherds, it is 1.8 mm. Similarly, the average thickness of these sherds, 4.8 mm is considerably thinner than the average thickness of the chert-tempered sherds, 8.1 mm. Finally, mean temper density for the quartz and sandstone-tempered sherds is 10.2 percent versus 19.3 percent for the chert-tempered sherds. In general, then, the quartz and sandstone-tempered pottery is thinner and contains lower densities of smaller temper than does the chert-tempered pottery.

Thin-section analysis confirmed that the inferred fiber-tempered pottery from Orient phase contexts was fiber tempered. No temper was present in the thin-sectioned sherd—only voids. This is consistent with the use of fiber or other plant-derived temper, which burns and leaves voids during firing (Rye 1976). Analysis of the three Marcey Creek sherds did not identify any temper other than steatite, which accounted for between 27.8 percent and 50.4 percent of the body. Voids accounted for 6.2 percent to 16.8 percent of the body, while paste accounted for between 32.7 percent and 72.2 percent of the body.

#### SUMMARY

Functional/technological analysis of Late Woodland pottery from the Memorial Park site suggests that pottery technology did change through time. This is evident in the general class of chert-tempered pottery, and in the introduction of quartz and sandstone-tempered pottery. In general, for all Late Woodland components, there is a positive, although weak, correlation between vessel size and wall thickness; larger pots tend to have thicker walls. This can be interpreted as a technological constraint on the construction of larger vessels. Thicker walls were needed to support the weight of the vessels while under construction. This trend was modified during the late Clemson Island occupation.

Examination of the distributions of temper and temper size through thin-section analysis indicates that the bodies (Stoltman 1991) of the vessels underwent change from the early Clemson Island through late Clemson Island occupations. During the early and middle Clemson Island occupations, there is a significant, weak, positive correlation between vessel wall thickness and temper size. In general, thicker-walled vessels contained larger particles of temper. This can be interpreted in several ways. First, larger pieces of temper may have been added to the paste in order to strengthen the walls during construction. Alternatively, if the emphasis was on resistance to crack propagation, larger pieces of temper would have served as a focus for cracks to prevent their growth. This, in conjunction with thicker walls, would have produced pots more resistant to crack propagation.

During the late Clemson Island occupation, there is also a positive correlation between wall thickness and temper size, although the relationship is not significant. There is a negative correlation between temper density and wall thickness. Two groups of sherds were identified through cluster analysis—one with relatively thick walls, relatively larger temper, and relatively lower temper density as compared to the other group. This suggests at least two technological groups within the chert-tempered vessels, perhaps relating to different functions. The first group pertains to larger vessels engineered to withstand crack propagation (larger pieces of temper and lower temper density). The second group consisted of smaller vessels engineered to retard crack initiation (higher temper density with smaller pieces of temper). It is uncertain whether these two groups represent discrete functional classes. However, large vessels engineered to withstand crack propagation may represent storage vessels designed to withstand impact fractures and load-bearing stresses. The second class, engineered to withstand crack initiation, may have been used for cooking purposes, although the higher densities of chert temper are counter-intuitive, given that the expansion rate of this acidic rock is greater than that of clay minerals (Rye 1976).

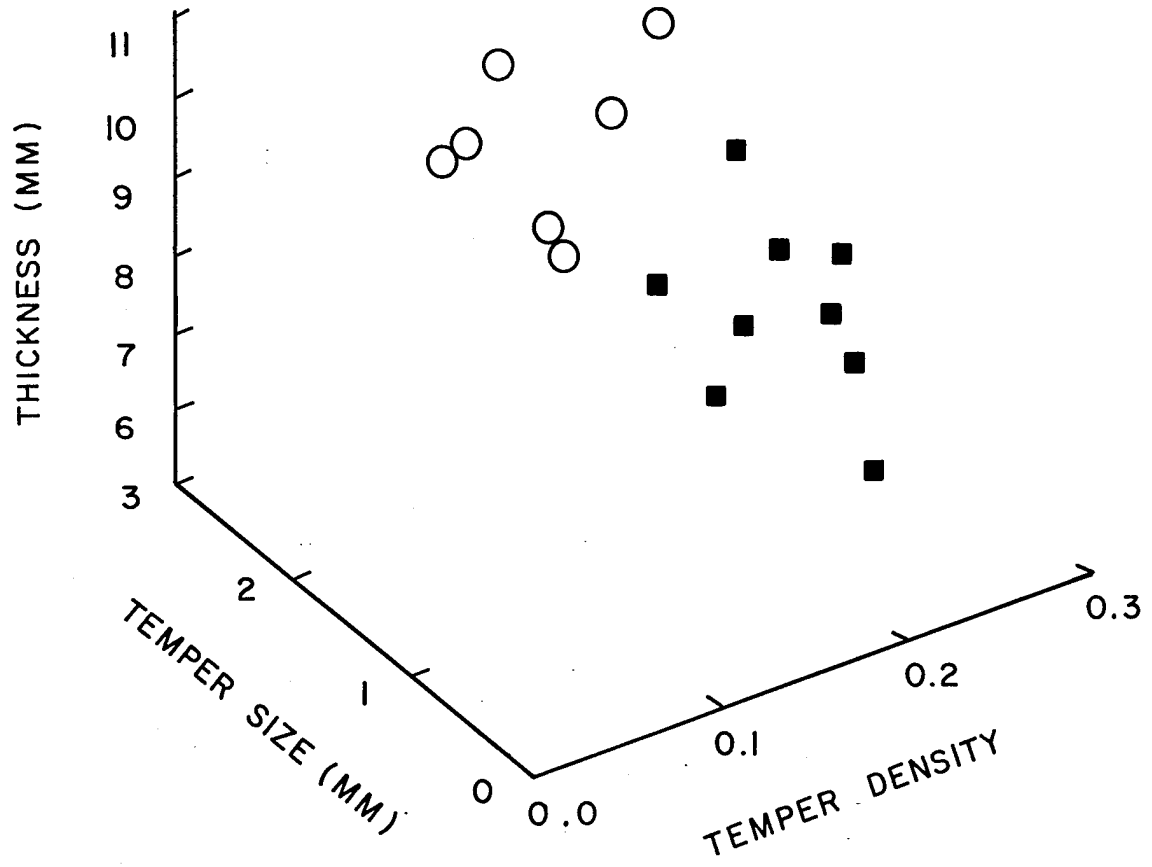

FIGURE 61

PLOT OF LATE CLEMSON ISLAND  
TECHNICAL/FUNCTIONAL GROUPS  
DEFINED THROUGH CLUSTER ANALYSIS

During the late Clemson Island occupation and continuing into the Stewart phase occupation, there may be the first occurrence of a third technological group: quartz and sandstone-tempered pottery. While the sample size is small, these pots generally had thinner walls, smaller pieces of temper, and lower temper densities. This suggests a concern with thermal stress resistance, perhaps coterminous with an onset of greater dependency on maize in the diet.



## IX. CHIPPED STONE

by

Michael G. Spitzer

### INTRODUCTION

Analysis of the chipped-stone assemblage from the Memorial Park site was designed to address specific questions regarding raw material management, tool manufacture, and tool maintenance, as detailed in the Research Design section of this report. The following sections provide a brief summary of methodology, a descriptive summary of the assemblages associated with the various components identified at the site, and a detailed analysis of these assemblages.

The methodology section provides a brief summary of the procedures used in the analysis of the assemblage. More detailed descriptions of the procedures can be found in appendices referred to in the text and, where appropriate, in the individual analysis sections.

The assemblage description section provides information for general comparative purposes and for use in the analytical section. This section also contains some discussion of methodology where considered necessary. A discussion and accompanying tables are presented for diagnostic and non-diagnostic bifaces, unifaces, edge-only tools, cores, debris, multifaces, blades, and macrowear of a sample of the debris, from grade sizes 1 and 2, for the Late Woodland materials.

The technological analysis section presents test results for various hypotheses derived from the Research Design section of this report, and from further ideas developed in the course of solving the analytical difficulties encountered in the original hypotheses. These hypotheses concern raw material management, tool manufacture, and tool maintenance. The first subsection addresses technological and raw material management questions, using the debris database. This provides the basic thrust of the analytical positions subsequently taken in the next subsection for tools. This is followed by an overall interpretation of the chipped-stone assemblage in the context of the various components discovered during excavations at the Memorial Park site.

### METHODOLOGY

#### *Raw Material Identification*

The chipped-stone assemblage from the various components at the Memorial Park site is composed of a variety of raw materials. The majority of these materials consist of various colored cherts and chalcedonies. In addition, there are smaller quantities of agate, argillite, jasper, quartz, quartzite, rhyolite, sandstone, and siltstone.

Raw material classification is based upon descriptive categories, as opposed to geographically identified sources (e.g. Onondaga chert). The variation in raw material attributes within and between source locations makes the assignment of specific source location, on the basis of color and textural variation a very unreliable method. Raw material categories were determined on the basis of macroscopic and microscopic examination, and palpation of the material for texture, density, mineral inclusions, and degree of translucence. Descriptive subcategories refer to visual

characteristics such as color and composition of grains in the material. The number of subclasses chosen was designed to address physical variation without specifying geographical source.

In order to be consistent with the Phase II investigations at the site, the raw material categories established by Neumann (1989) were used as a point of departure for the current classification. The chipped-stone assemblage from the Phase II investigations was examined prior to the initiation of lab work for the current project, and examples of the various raw materials from this assemblage were used for comparative purposes during the current analyses. Additional raw material classes were defined, as necessary, during the course of the analysis. When significant variation occurred in materials encountered during the current project, as compared to those recovered during Phase II investigations, new categories were established. For the most part, these new categories consisted of variously colored cherts.

Although the identification of raw material classes for this analysis was primarily descriptive, especially for the cherts and chalcedonies, an attempt was made to identify potential sources for the various classes. This was particularly important for later analysis of raw material management, for comparisons between the treatment of local versus nonlocal materials. To this end, both local (e.g., Beckerman 1980; Butts and Moore 1936; Taylor 1977) and regional (e.g., Custer and Gallasso 1980; Didier 1975; Hatch and Miller 1985; Prothero and Lavin 1990; Schindler et al. 1982; Socolow 1980; Stewart 1987) references on raw material source locations were reviewed to determine potential sources for the various raw materials.

### *Tools*

All chipped-stone tools were subjected to attribute analysis. A copy of the attribute coding scheme is provided in Appendix D. This scheme was developed at Northwestern University with the specific goal of elucidating the economic management of lithic raw materials (Jeske 1987; Lurie 1982). Major tool forms are defined briefly below. The appendix should be consulted for explanations of other variables.

Edge-only tools are flakes, or other pieces of debris, that have one or more edges modified through retouch or use, but where no attempt has been made to modify the body of the tool. Unifaces are tools of which the body has been modified on one side; at least one flake scar that does not originate from an edge must be present on the piece. Bifaces are tools that have two faces formed by flaking; at least one flake scar that does not originate from an edge must be present on both faces of the piece. A prismatic blade, or bladelet, is a flake that has one or more ridges running the length of the piece on its dorsal side, and is usually much longer than it is wide.

### *Debris*

A modified form of the mass analysis procedure developed by Ahler (1986, 1989a, 1989b), was performed on chipping debris. Mass analysis is a form of aggregate analysis under which aggregates of chipping debris from specific contexts are compared to an experimental replication database to determine reduction strategies. This type of analysis is a departure from the individual flake identification analysis (IFI) generally used in the Mid-Atlantic region. A review of the various weaknesses and strengths of IFI and aggregate analyses is presented in the following paragraphs, followed by a brief discussion of the data recording techniques used for aggregate analysis during the current project. A more detailed discussion of the analytical and statistical procedures used for the current analysis is presented in the Technological Analysis section.

IFI is a more traditional approach to chipped-stone debris than aggregate analysis. IFI has been performed on many of the recent mitigation projects in eastern and central Pennsylvania (e.g., East et al. 1987; Rue et al. 1988; Stewart 1988; but see Hart and Cremeens 1991). During IFI analysis, individual pieces of chipped-stone debris are examined for attributes that are thought to be characteristic of particular stages of one or more reduction sequences (e.g., primary core reduction, bifacial core reduction, bipolar core reduction). Theoretically, the benefit of this type of debris analysis is that it is possible to directly elucidate the type or types of knapping activities performed at a particular site or portion of a site. If multiple reduction strategies were used on a site, it should be possible to identify them through this process.

A number of IFI analysis schemes are currently employed in Pennsylvania, often on the basis of raw material type (e.g., East et al. 1987; Hay and Hamilton 1986; Rue et al. 1988). Often these schemes, which tend to focus on bifacial reduction, are applied uncritically to a lithic assemblage without taking into account the possibility of alternative reduction strategies.

Ahler (1989a:86-87) has identified five potential problems with traditional IFI analysis that question its efficiency for large collections, its analytical effectiveness and objectivity, and the ability to replicate results:

1. Generally, only whole flakes are analyzed, which introduces unknown sources of bias.
2. Depending on the number of attributes examined, individual flake analysis can be highly time-consuming. As a result, subsets must often be used rather than the entire assemblage.
3. Because detailed attribute coding is difficult at best on small flakes, bias is often introduced into the analysis by excluding small debris.
4. It is often not possible to replicate data because of individual recorder biases and the polythetic nature of flakes.
5. Different reduction techniques can produce the same flake types. Ahler (1989), for example, has recorded the production of bipolar and bifacial flakes during a number of other reduction processes.

A sixth criticism identified by Sullivan and Rozen (1985:755) is that lithic reduction processes represent a continuum rather than particular stages: "technological origins of debitage cannot, in most cases, be reliably observed on individual specimens...the manufacture of chipped-stone artifacts is most realistically viewed as a continuum rather than as a set of distinct technological events."

An alternative approach to chipped-stone debris analysis is aggregate analysis, which focuses on entire assemblages of chipped-stone debris or some sample thereof rather than on individual flakes. A number of aggregate analytical schemes have been devised (e.g., Ahler 1989a; Amick 1985; Patterson 1990; Stahle and Dunn 1984). These schemes are based upon the collection of a few classes of quantitative data (e.g., size class counts and weights) and low level attribute coding, which is often subsequently compared to data from replication experiments.

Ahler (1989a:87-88) has identified four potential advantages to this type of analysis:

1. All debris are used from a particular context, eliminating potential biases from the selective exclusion of particular debris categories such as broken flakes.

2. It is a time-efficient procedure readily suited to large debris collections.
3. Size biases are removed because small pieces of debris are incorporated into the analysis.
4. There is a high level of objectivity and replicability. "Because analytic procedures involve such steps as size-grading, counting, weighing, and perhaps recording only very low level attribute data, virtually anyone trained in elementary lab procedures can record data in a replicable manner" (Ahler 1989a:88).

Potential problems with aggregate analysis include (Ahler 1989a:89):

1. The inability to link data generated through aggregate analysis to prehistoric activities without concurrent controlled replications or a database of previously generated, replication experiments.
2. Mixed samples might obscure multiple reduction strategies. This problem can be mitigated, however, through the careful assessment of the spatial distribution of raw material types within an assemblage and through certain statistical procedures, as discussed later in this report.

Ahler (1986, 1989a, 1989b) has developed an aggregate analysis scheme called mass analysis. This scheme involves size-sorting unmodified lithic debris through a series of standardized screens, the recording of counts and weights of all debris from a particular raw material class within each size grade, and the recording of the number of debris for each raw material class in the size grade with cortex.

Mass-analysis coding procedures for the current application involved the recording of counts and weights of debris within various size grades, and the frequency of debris with cortex in each size grade. All material from each recovery unit was sorted through five embedded screens with nominal openings of 1.0, 0.5, 0.25, 0.125, and 0.0625 inch, corresponding to size grades 1, 2, 3, 4, and 5, respectively. Size data for these screens is presented in Table 90. Within size grades 1 through 4, all materials were sorted into raw material classes, and any non-cultural material was removed. Within each raw material class for each size grade, total count and total weight were determined, as well as the number of debris pieces with cortex and evidence of heat treatment. Since the size of the mesh used for screening in the field corresponds to Grade 4, coding was not performed on Grade 5 material because it represented fortuitous recovery rather than part of the controlled sample.

Table 90. Standard Sieve Size and Opening Data for Mass Analysis.

Size Grade	Square Opening		Diagonal Opening	
	inches	mm	inches	mm
Grade 1	1.00	25.40	1.41	35.81
Grade 2	0.50	12.70	0.71	18.03
Grade 3	0.25	6.35	0.35	8.89
Grade 4	0.125	3.18	0.18	4.57
Grade 5	0.0625	1.59	0.09	2.28



In order for mass-analysis data to be linked with reduction sequences, a program of experimental replication must be performed, or existing databases of replication experiments that are compatible with the raw material and tool classes recovered from a particular site must be available. For the current project, a number of experimental databases were investigated, including a large database developed by Ahler (1989) in various experiments with cherts, Stahle and Dunn's (1984) chert biface replications, and Kahlin's (1980; Hart and Cremeens 1991) core and biface replications with quartz, quartzite, and chalcedony. Ahler's database was obtained from Ahler in electronic form, and Kahlin's experiments for Hart and Cremeens (1991) were available in electronic form at GAI's Archaeological Laboratory, while Kahlin's (1980) and Stahle and Dunn's data were extracted from their respective texts. Arguments concerning the applicability of these experiments for comparison with the Memorial Park assemblage are presented below, in the Technological Analysis section.

### *Cores and Core Fragments*

Cores and core fragments were examined under a scheme designed to yield information on core morphology so that reasonable inferences might be made regarding the kind, or kinds of core reduction strategies used at the site. A sample coding form is presented in Appendix D. Attributes recorded for cores included raw material class, presence and amount of cortex, heat alteration (present, possible, absent), direction of flake removal (unidirectional, bidirectional opposed, bidirectional non-opposed, and multidirectional), method of modification (flaking, battering, flaking and battering), and morphology (nodular, multifaceted, tabular, pavidal, and indeterminate). With the exception of direction of flaking, morphology, and modification, the definitions for the variables are identical to those of the tool coding form (see Appendix D).

## ASSEMBLAGE DESCRIPTIONS

### *Raw Materials*

For the purpose of addressing questions of raw material management, the raw materials from the site can be combined in ways reflecting geological origin/source location and relative accessibility; that is, local or nonlocal. The result of this collapsing yields seven varieties of raw material: argillite, cherts (2 groups), quartz, quartzite, rhyolite, sandstone, and siltstone.

*Argillite and Siltstone.* Argillite is an aphanitic mudstone, derived from siltstone, claystone or shale (Didier 1975). It is a sedimentary deposit subjected to low-grade metamorphism. Argillite is harder and more compacted than siltstone, making it superior to siltstone for knapping.

Although specific source locations are unknown in the immediate vicinity of Memorial Park, deposits of argillite were potentially available from a number of formations within 20 km of the site. Ordovician formations containing siltstone include the Juniata formation and the Reedsville formation. Devonian formations include Old Port, Mahantang, Brallier, Harrell, Lockhaven, Catskill, Keyser, Tonolowan, Miles Creek, and Mifflintown. The Mauck Chunk formation of the Mississippian also contains siltstone.

*Cherts.* Cherts are sedimentary rocks of microcrystalline or cryptocrystalline silica occurring as cryptocrystalline quartz, chalcedony, or opal (Prothero and Lavin 1990:561). This raw material class includes what we have identified as agates, cherts, chalcedonies, and jaspers. With the exception of the jaspers, these materials are readily available within 20 km of the site,

potentially originating from a number of formations in both nodular and bedded forms, as well as in secondary stream deposits as cobbles.

Three major systems in the vicinity of the site contain chert-bearing formations: Upper Cambrian, Ordovician, and Devonian. An oölitic chert is found in the Gatesburg formation of Upper Cambrian age. The chert-bearing Ordovician formations include the Axemann, Nittany, Bald Eagle, and Bellefonte. Axemann limestones (Butts and Moore 1936: 27) contain both chert and chalcedonies (flint). This formation is the most likely source of the gray and black chalcedony, and occurs approximately 15 km southwest of Memorial Park. Cherts of the Nittany dolomite occur in masses and spherical nodules. This formation is present adjacent to the Axemann limestones, as are those of the Bellefonte formation.

Formations of the Devonian system contain cherts, including the Onondaga, Old Port, Helderberg, and Keyser. The black, gray, and grayish brown chert subcategories recovered from the site most likely derive from the Onondaga formation, which underlies the site and is dissected by both the river and by tributaries within 5 km of the site (Socolow 1980; Taylor 1977). Similarly, the Keyser formation is adjacent to the site, dissected by river tributaries (Taylor 1977), and contains brown, mottled gray, brown/gray and other grayish cherts.

Both yellow and caramel jasper, and their likely heat-altered counterparts, red and burgundy, are potentially derived from the Bald Eagle formation (Hatch and Miller 1985; Schindler et al. 1982). Although the formation occurs within 5 km of the site, exposures apparently do not occur locally, but at a distance of more than 21 km to the southwest in the Huntsville area.

*Sandstone.* A small percentage (1.3) of the material recovered consists of sandstone. Sandstone is locally abundant and is available from a number of Silurian, Ordovician, and Devonian formations (Socolow 1980; Taylor 1978).

*Rhyolite.* Rhyolite is a fine-grained, sialic, aphanitic, igneous rock with light-colored minerals (Stewart 1987). It occurs in outcrops, boulder fields, river cobbles, and terrace deposits. This raw material is not locally available, and may derive from an isolated outcrop along the Susquehanna River, near Wrightsville, in southeastern Pennsylvania (Stewart 1987). Other potential sources are located within the Blue Ridge physiographic province in Maryland (Stewart 1987).

*Quartz and Quartzite.* Both quartz and quartzite are available locally. Some quartz cobbles, up to 1-1/2 inches in diameter, do occur (Butts and Moore 1936). These are rather small, and would presumably be difficult to reduce successfully. The source location for this quartz is unknown. Quartzite is available locally, in unknown quantities associated with the Tuscarora formation (Tuscarora quartzite) of the Silurian. Historically, quartzite has been quarried in the Milesburg Gap where irregular veins of quartzite occur.

### *Debris*

The summary material tabulated in the following descriptive section is not exhaustive. Frequently used local materials and exotic, or nonlocal materials, were included. For instance, the common local cherts and chalcedonies, as well as black agate and argillite, are included. Minor color variants, present in small quantities, are not included (e.g., brown chert) as separate categories. The varieties of nonlocal materials, such as jaspers, rhyolite, and quartzite, are included. Those raw materials that were both infrequent and of sedimentary materials, and are not at least moderately fracturable, are not necessarily listed in the tables. Small quantities of these

materials may reflect the chance occurrence of noncultural material on the site. The recognition of the cultural nature of such materials is much less reliable than that of the cryptocrystalline materials. Examples of these materials are sandstone, mudstone, and siltstone. The percentages (reported in the tables in this descriptive section) refer to those percentages relative to the numbers reported in the tables. They are not adjusted for the total collection. The total quantity and weight of debris is summarized in the first paragraph under each component description. For a complete listing of these materials, refer to Appendix D.

Counts and weights were recorded for each raw material type within each size grade, and the frequency of pieces with cortex and heat alteration for selected raw material types in each size grade was recorded. Results are summarized in the accompanying tables. Analysis of these data is presented in the Technological Analysis section later in this section.

### *Late Woodland*

A total of 26,845 pieces of lithic debris was recovered from the Late Woodland features. The Late Woodland materials are discussed separately, under the Stewart Phase, Late Clemson Island, and Early Clemson Island (combining early and middle Clemson Island as defined elsewhere in this volume). Results are summarized in Tables 91 through 102, by raw material class.

*Stewart Phase.* Table 91 is a summary of raw material frequencies and percentages for the four size grades and total debris. Table 92 presents debris weights for each size grade by raw material class. The largest percentage of debris, by count, falls within size grade 4 (78.0%), and the highest percentage by weight occurs in size grade 4 as well (54.1%). The collection is dominated by rhyolite, which accounts for 52.7 percent of the debris by count (30.2 percent by weight). Jasper also constitutes a sizeable percentage, 13.6 percent by count (5.9 percent by weight). Among the local materials, cherts account for 24.7 percent by count, and 11.6 percent by weight; chalcedony accounts for 20.6 percent by count, and 17.8 percent by weight; and argillite accounts for 2.3 percent by count, and 1.0 percent by weight.

This pattern of raw material frequencies is much different than that for the rest of the Memorial Park components. No other Late Woodland component is dominated by nonlocal materials. By comparison to the other samples from the components, the sample size for the Stewart Phase is relatively small, and it is likely that the sample has captured special raw material management practices for this phase, which are addressed in the analysis.

Table 93 lists counts and frequencies of cortex, by raw material class, for the higher-frequency raw materials from the Stewart Phase. Local raw materials overwhelmingly possess higher raw material frequencies with cortex than do the nonlocal materials, as might be expected if nonlocal materials are partially reduced prior to transport to the site. The agates, chalcedonies, and cherts have 31.0 percent, 27.2 percent, and 27.1 percent debris by count with cortex, respectively, while rhyolite has the highest percentage of cortex for a nonlocal material, 5.4 percent.

Table 91. Stewart Phase Debris Frequencies by Raw Material Class.

Raw Material	Grade 1		Grade 2		Grade 3		Grade 4		Total	
	n	col. %	n	col. %	n	col. %	n	col. %	n	col. %
Agates <sup>a</sup>	0	0.0	3	42.9	8	4.7	18	2.8	29	3.5
Argillite	0	0.0	0	0.0	5	2.9	14	2.1	19	2.3
Chalcedonies <sup>b</sup>	0	0.0	2	28.6	30	17.5	141	21.6	173	20.6
Cherts <sup>c</sup>	0	0.0	0	0.0	33	19.3	174	26.6	207	24.7
Jaspers <sup>d</sup>	0	0.0	0	0.0	30	17.5	84	12.8	114	13.6
Quartz	0	0.0	0	0.0	0	0.0	0	0.0	0	0.0
Quartzite	0	0.0	0	0.0	0	0.0	0	0.0	0	0.0
Rhyolite	0	0.0	0	0.0	58	33.9	178	27.2	442	52.7
Silicified Sandstone	0	0.0	0	0.0	3	1.8	39	6.0	42	5.0
Siltstone	0	0.0	2	28.6	4	2.3	6	0.9	12	1.4
Total	0	100.0	7	100.0	171	100.0	654	100.0	838	100.0

<sup>a</sup> Agates refer to both black and white agates combined, although very few of the debris are white.

<sup>b</sup> Chalcedonies refers to all forms of chalcedony present, although the overwhelming majority is gray.

<sup>c</sup> Cherts refers to dark gray and gray cherts.

<sup>d</sup> Jaspers refers to all forms of jasper combined.

Table 92. Stewart Phase Debris Weights by Raw Material Class.

Raw Material	Grade 1		Grade 2		Grade 3		Grade 4		Total	
	g	col. %	g	col. %	g	col. %	g	col. %	g	col. %
Agates <sup>a</sup>	0.0	0.0	16.1	36.4	22.4	17.2	39.7	19.3	68.2	18.0
Argillite	0.0	0.0	0.0	0.0	1.6	1.2	2.3	1.1	3.9	1.0
Chalcedonies <sup>b</sup>	0.0	0.0	6.2	14.0	23.4	18.0	37.9	18.5	67.5	17.8
Cherts <sup>c</sup>	0.0	0.0	0.0	0.0	17.4	13.4	26.5	12.9	43.9	11.6
Jaspers <sup>d</sup>	0.0	0.0	0.0	0.0	9.8	7.5	12.7	6.2	22.5	5.9
Quartz	0.0	0.0	0.0	0.0	0.0	0.0	0.0	0.0	0.0	0.0
Quartzite	0.0	0.0	0.0	0.0	0.0	0.0	0.0	0.0	0.0	0.0
Rhyolite	0.0	0.0	12.2	27.6	40.8	31.4	61.7	30.1	114.7	30.2
Silicified Sandstone	0.0	0.0	0.0	0.0	1.9	1.5	2.0	1.0	3.9	1.0
Siltstone	0.0	0.0	9.7	21.9	12.8	9.8	22.5	11.0	45.0	11.9
Total	0.0	100.0	44.2	100.0	130.1	100.0	205.3	100.0	379.6	100.0

<sup>a</sup> Agates refers to both black and white agates combined, although very few of the debris are white.

<sup>b</sup> Chalcedonies refers to all forms of chalcedony present, although the overwhelming majority is gray.

<sup>c</sup> Cherts refers to dark gray and gray cherts.

<sup>d</sup> Jaspers refers to all forms of jasper combined

Table 93. Stewart Phase Debris with Cortex by Raw Material Class.

Raw Material Class	Count	Percent of Raw Material
Agates	9	31.0
Chalcedony	47	27.2
Chert	56	27.1
Jasper	0	0.0
Quartzite	0	0.0
Rhyolite	24	5.4
Silicified Sandstone	1	2.4
Total	128	12.5

Table 94 lists counts and percentages of heat-altered material by raw material classes. Heat alteration is uncommon, accounting for only 5.5 percent of the entire collection. By far, heat alteration was most common in the jasper category (37.7%), as would be expected, given the nature of this raw material (Hatch and Miller 1985).

Table 94. Stewart Phase Heat-altered Debris by Raw Material Class.

Raw Material Class	Count	Percent of Raw Material
Chalcedony	3	1.7
Chert	11	5.3
Jasper	43	37.7
Total	57	5.5

*Late Clemson Island.* Table 95 is a summary of the raw material frequencies and percentages for the four size grades and total debris among the raw material categories tabulated. Debris weights are presented in Table 96 for each size grade by material class, as is done for the counts. The largest percentage of debris by count (80.0%) and weight (55.1%) falls within size grade 4. The collection is dominated by local raw materials. Chalcedonies account for 47.4 percent by count, and 39.9 percent by weight. Cherts account for 39.1 percent of the material by count, and 44.1 percent by weight. Argillite accounts for 4.0 percent of the material by count, and 4.4 percent by weight, and agate represents 6.5 percent by count, and 8.7 percent by weight. By contrast, rhyolite, the most frequently represented nonlocal material, makes up only 1.9 percent of the material tabulated by count, and 2.6 percent by weight.

Table 95. Late Clemson Island Debris Counts by Raw Material Class.

Raw Material	Grade 1		Grade 2		Grade 3		Grade 4		Total	
	n	col. %	n	col. %	n	col. %	n	col. %	n	col. %
Agates <sup>a</sup>	0	0.0	8	6.7	130	9.4	349	5.8	487	6.5
Argillite	0	0.0	7	5.9	47	3.4	250	4.2	304	4.0
Chalcedonies <sup>b</sup>	0	0.0	48	40.3	725	52.3	2792	46.3	3565	47.4
Cherts <sup>c</sup>	0	0.0	51	42.9	446	32.2	2446	40.6	2943	39.1
Jaspers <sup>d</sup>	0	0.0	0	0.0	2	0.1	8	0.1	10	0.1
Quartz	0	0.0	0	0.0	0	0.0	0	0.0	0	0.0
Quartzite	0	0.0	0	0.0	1	0.1	5	0.1	6	0.1
Rhyolite	0	0.0	3	2.5	25	1.8	114	1.9	142	1.9
Silicified Sandstone	0	0.0	2	1.7	7	0.5	22	0.4	31	0.4
Siltstone	0	0.0	0	0.0	2	0.1	38	0.6	40	0.5
Total	0	100.0	119	100.0	1385	100.0	6024	100.0	7528	100.0

<sup>a</sup>Agates refers to both black and white agates combined, although very few of the debris are white.

<sup>b</sup>Chalcedonies refers to all forms of chalcedony present, although the overwhelming majority is gray.

<sup>c</sup>Cherts refers to dark gray and gray cherts.

<sup>d</sup>Jaspers refers to all forms of jasper combined.

Table 97 lists counts and percentages of debris with cortex, for the most common materials in the Late Clemson Island collection. The range for local raw materials is 6.5 percent to 83.3 percent. The range of percentages for the nonlocal materials is 20.0 percent to 24.6 percent. The percentages for jasper and rhyolite are relatively high and may represent the transport of partially reduced, nonlocal material to the site; however, the total number of pieces is small (only 37).

Table 96. Late Clemson Island Debris Weights by Raw Material Class.

Raw Material	Grade 1		Grade 2		Grade 3		Grade 4		Total	
	g	col. %	g	col. %	g	col. %	g	col. %	g	col. %
Agates <sup>a</sup>	0.0	0.0	28.9	6.3	116.4	10.0	168.7	8.5	314.0	8.7
Argillite	0.0	0.0	23.8	5.2	46.9	4.0	89.0	4.5	159.7	4.4
Chalcedonies <sup>b</sup>	0.0	0.0	160.9	34.8	488.8	42.2	791.2	39.8	1440.9	39.9
Cherts <sup>c</sup>	0.0	0.0	233.0	50.5	474.1	40.9	885.0	44.5	1592.1	44.1
Jaspers <sup>d</sup>	0.0	0.0	0.0	0.0	2.5	0.2	2.9	0.1	5.4	0.1
Quartz	0.0	0.0	0.0	0.0	0.0	0.0	0.0	0.0	0.0	0.0
Quartzite	0.0	0.0	0.0	0.0	0.3	<0.1	0.6	<0.1	0.9	<0.1
Rhyolite	0.0	0.0	15.1	3.3	27.7	2.4	49.7	2.5	92.5	2.6
Silicified Sandstone	0.0	0.0	0.0	0.0	0.0	0.0	0.0	0.0	0.0	0.0
Siltstone	0.0	0.0	0.0	0.0	2.9	0.3	3.1	0.2	6.0	0.2
Total	0.0	100.0	461.7	100.0	1159.6	100.0	1990.2	100.0	3611.5	100.0

<sup>a</sup>Agates refers to both black and white agates combined, although very few of the debris are white.

<sup>b</sup>Chalcedonies refers to all forms of chalcedony present, although the overwhelming majority is gray.

<sup>c</sup>Cherts refers to dark gray and gray cherts.

<sup>d</sup>Jaspers refers to all forms of jasper combined.

Table 97. Late Clemson Island Debris with Cortex by Raw Material Class.

Raw Material Class	Count	Percent of Raw Material
Agates	113	23.2
Argillite	28	9.2
Chalcedony	747	21.0
Chert	818	27.8
Jasper	2	20.0
Quartzite	5	83.3
Rhyolite	35	24.6
Silicified Sandstone	2	6.5
Total	1750	23.2

Table 98 lists counts and percentages of heat altered material by raw material classes. Heat alteration is very uncommon, accounting for only 0.9 percent of the entire collection. Heat alteration was most common in the jasper category (30.0%).

Table 98. Late Clemson Island Heat-alteration Debris by Raw Material Class.

Raw Material Class	Count	Percent of Raw Material
Chalcedony	1	<0.1
Chert	62	2.1
Jasper	3	30.0
Total	66	0.9

*Early Clemson Island.* Table 99 is a summary of the raw material frequencies and percentages for the four size grades and total debris among the raw material categories tabulated. Debris weights are presented in Table 100 for each size grade by material class as is done for the counts. The largest percentage of debris by count (86.4%) and weight (54.0%) falls within size grade 4. The collection is dominated by local raw materials. Cherts account for a very high 71.4 percent of the material by count, and 55.6 percent by weight. Chalcedonies account for only 15.6 percent by count, and 16.5 percent by weight. Argillite accounts for only 6.3 percent of the material by count, and 9.4 percent by weight. By contrast, rhyolite, the most frequently represented nonlocal material, makes up only 1.3 percent of the material tabulated by count, and 0.5 percent by weight.

Table 99. Early Clemson Island Debris Counts by Raw Material Class.

Raw Material	Grade 1		Grade 2		Grade 3		Grade 4		Total	
	n	col. %	n	col. %	n	col. %	n	col. %	n	col. %
Agates <sup>a</sup>	0	0.0	14	7.8	52	3.0	283	2.3	349	2.4
Argillite	2	22.2	16	8.9	130	7.4	752	6.1	900	6.3
Chalcedonies <sup>b</sup>	0	0.0	24	13.4	425	24.3	1782	14.4	2231	15.6
Cherts <sup>c</sup>	3	33.3	115	64.2	1041	59.5	9051	73.3	10210	71.4
Jaspers <sup>d</sup>	0	0.0	0	0	8	0.5	57	0.5	65	0.5
Quartz	0	0.0	0	0	0	0.0	0	0.0	0	0.0
Quartzite	0	0.0	0	0	5	0.3	34	0.3	39	0.3
Rhyolite	0	0.0	0	0	23	1.3	168	1.4	191	1.3
Silicified Sandstone	0	0.0	2	1.1	50	2.9	175	1.4	227	1.6
Siltstone	4	44.4	8	4.5	17	1.0	49	0.4	78	0.5
Total	9	100.0	179	100.0	1751	100.0	12351	100.0	14290	100.0

<sup>a</sup>Agates refers to both black and white agates combined, although very few of the debris are white.

<sup>b</sup>Chalcedonies refers to all forms of chalcedony present, although the overwhelming majority is gray.

<sup>c</sup>Cherts refers to dark gray and gray cherts.

<sup>d</sup>Jaspers refers to all forms of jasper combined.

Table 100. Early Clemson Island Debris Weights by Raw Material Class.

Raw Material	Grade 1		Grade 2		Grade 3		Grade 4		Total	
	g	col. %	g	col. %	g	col. %	g	col. %	g	col. %
Agates <sup>a</sup>	0.0	0.0	80.4	10.2	114.6	5.8	222.3	6.5	417.3	6.6
Argillite	34.2	21.4	69.1	8.8	170.9	8.7	320.9	9.4	595.1	9.4
Chalcedonies <sup>b</sup>	0.0	0.0	94.8	12.1	382.0	19.4	568.5	16.6	1045.3	16.5
Cherts <sup>c</sup>	51.2	32.0	456.8	58.1	1093.2	55.7	1918.2	56.2	3519.4	55.6
Jaspers <sup>d</sup>	0.0	0.0	0.0	0.0	3.6	0.2	4.5	0.1	8.1	0.1
Quartz	0.0	0.0	0.0	0.0	0.0	0.0	0.0	0.0	0.0	0.0
Quartzite	0.0	0.0	0.0	0.0	1.5	0.1	3.6	0.1	5.1	0.1
Rhyolite	0.0	0.0	0.0	0.0	10.0	0.5	18.8	0.6	28.8	0.5
Silicified Sandstone	0.0	0.	4.2	0.5	27.1	1.4	42.0	1.2	73.3	1.2
Siltstone	74.6	46.6	81.2	10.3	161.3	8.2	317.4	9.3	634.5	10.0
Total	160.0	100.0	786.5	100.0	1964.2	100.0	3416.2	100.0	6326.9	100.0

<sup>a</sup>Agates refers to both black and white agates combined, although very few of the debris are white.

<sup>b</sup>Chalcedonies refers to all forms of chalcedony present, although the overwhelming majority is gray.

<sup>c</sup>Cherts refers to dark gray and gray cherts.

<sup>d</sup>Jaspers refers to all forms of jasper combined.

Table 101 contains frequencies and percentages of debris with cortex, for the various raw material classes. The raw material class with the highest percentage of debris with cortex, of those that are locally available, is agate (21.2%). The highest percentage of debris with cortex in a nonlocal raw material is rhyolite (9.4%).

Table 101. Early Clemson Island Debris with Cortex.

Raw Material Class	Count	Percent of Raw Material
Agates	74	21.2
Argillite	54	6.0
Chalcedony	77	3.5
Chert	818	8.0
Quartzite	13	33.3
Rhyolite	18	9.4
Silicified Sandstone	21	9.3
Total	1075	7.6

Table 102 lists counts and percentages of heat altered material, by raw material classes. Heat alteration is very uncommon, accounting for only 0.5 percent of the entire collection, and is most common in the jasper category (1.5%).

Table 102. Early Clemson Island Heat-altered Debris.

Raw Material Class	Count	Percent of Raw Material
Agate	1	0.3
Chalcedony	1	<0.1
Chert	71	0.7
Jasper	1	1.5
Total	74	0.5

*Middle Woodland.* Table 103 is a summary of the raw material frequencies and percents for the four size grades and total debris, among the raw material categories tabulated. Debris weights are presented in Table 104 for each size grade by material class, as is done for the counts. The largest percentage of debris by count fall within size grade 4 (79.2%). The highest percentage by weight occurs in grade 2 (53.5%). The collection is dominated by local raw materials. Cherts account for a 59.9 percent of the material by count and 54.8 percent by weight. Chalcedonies account for 23.5 percent by count, and 17.8 percent by weight. Argillite accounts for only 8.6 percent of the material by count, and 4.4 percent by weight. By contrast, rhyolite, as the most frequently represented nonlocal material, makes up only 4.0 percent of the material tabulated by count, and 13.5 percent by weight.

Table 105 contains frequencies and percentages of debris with cortex for the various raw material classes. The raw material class with the highest percentage of debris with cortex, of those that are local, is agate (33.3%), although the sample size is only one. Chalcedony is 31.2 percent. The highest percentage of debris with cortex in a nonlocal raw material is rhyolite (15.4%).



Table 103. Middle Woodland Debris Counts by Raw Material Class.

Raw Material	Grade 1		Grade 2		Grade 3		Grade 4		Total	
	n	col. %	n	col. %	n	col. %	n	col. %	n	col. %
Agates <sup>a</sup>	0	0.0	1	12.5	0	0.0	2	0.8	3	0.9
Argillite	0	0.0	0	0.0	0	8.3	23	8.9	28	8.6
Chalcedonies <sup>b</sup>	0	0.0	2	25.0	20	33.3	55	21.2	77	23.5
Cherts <sup>c</sup>	0	0.0	4	50.0	30	50.0	162	62.5	196	59.9
Jaspers <sup>d</sup>	0	0.0	0	0.0	0	0.0	6	2.3	6	1.8
Quartz	0	0.0	0	0.0	0	0.0	1	0.4	1	0.3
Rhyolite	0	0.0	1	12.5	3	5.0	9	3.5	13	4.0
Silicified Sandstone	0	0.0	0	0.0	2	3.3	1	0.4	3	0.9
<b>Total</b>	<b>0</b>	<b>0.0</b>	<b>8</b>	<b>100.0</b>	<b>60</b>	<b>100.0</b>	<b>259</b>	<b>100.0</b>	<b>327</b>	<b>100.0</b>

<sup>a</sup>Agates refers to both black and white agates combined, although very few of the debris are white.

<sup>b</sup>Chalcedonies refers to all forms of chalcedony present, although the overwhelming majority is gray.

<sup>c</sup>Cherts refers to dark gray and gray cherts.

<sup>d</sup>Jaspers refers to all forms of jasper combined.

Table 104. Middle Woodland Debris Weights by Raw Material Class.

Raw Material	Grade 1		Grade 2		Grade 3		Grade 4		Total	
	g	col. %	g	col. %	g	col. %	g	col. %	g	col. %
Agates <sup>a</sup>	0.0	0.0	10.8	15.7	0.0	0.0	0.2	0.9	11.0	8.5
Argillite	0.0	0.0	0.0	0.0	3.8	9.8	1.9	8.9	5.7	4.4
Chalcedonies <sup>b</sup>	0.0	0.0	7.2	10.4	12.0	31.0	3.8	17.8	23.0	17.8
Cherts <sup>c</sup>	0.0	0.0	37.6	54.5	19.5	50.4	13.6	63.8	70.7	54.8
Jaspers <sup>d</sup>	0.0	0.0	0.0	0.0	0.0	0.0	0.6	2.8	0.6	0.5
Quartz	0.0	0.0	0.0	0.0	0.0	0.0	0.1	0.5	0.1	0.1
Rhyolite	0.0	0.0	13.4	19.4	3.2	8.3	1.0	4.7	17.4	13.5
Silicified Sandstone	0.0	0.0	0.0	0.0	0.2	0.5	0.1	0.5	0.3	0.2
<b>Total</b>	<b>0.0</b>	<b>0.0</b>	<b>69.0</b>	<b>100.0</b>	<b>38.7</b>	<b>100.0</b>	<b>21.3</b>	<b>100.0</b>	<b>129.0</b>	<b>100.0</b>

<sup>a</sup>Agates refers to both black and white agates combined, although very few of the debris are white.

<sup>b</sup>Chalcedonies refers to all forms of chalcedony present, although the overwhelming majority is gray.

<sup>c</sup>Cherts refers to dark gray and gray cherts.

<sup>d</sup>Jaspers refers to all forms of jasper combined.

Table 105. Middle Woodland Debris with Cortex.

Raw Material Class	Count	Percent of Raw Material
Agates	1	33.3
Argillite	2	7.1
Chalcedony	24	31.2
Chert	42	21.4
Rhyolite	2	15.4
Silicified Sandstone	1	33.3
<b>Total</b>	<b>72</b>	<b>22.5</b>

Table 106 lists counts and percentages of heat-altered material by raw material classes. Heat alteration is very uncommon, accounting for only 5.5 percent of the entire collection. Heat alteration is most common in the jasper category (83.3%).

Table 106. Middle Woodland Heat-altered Debris.

Raw Material Class	Count	Percent of Raw Material
Chert	13	6.6
Jasper	5	83.3
Total	18	8.9

*Early Woodland.* Table 107 is a summary of the raw material frequencies and percentages for the four size grades and total debris, among the raw material categories tabulated. Debris weights are presented in Table 108 for each size grade by material class, as is done for the counts. The largest percentage of debris by count falls within size grade 4 (78.9%). The highest percentage by weight also occurs in grade 3 (72.0%). The collection is dominated by local raw materials. Chalcedonies account for 42.1 percent of the material by count, but only 12.0 percent by weight. Cherts account for 39.5 percent by count, and 38.7 percent by weight. Argillite accounts for only 10.5 percent of the material by count, and 1.3 percent by weight. By contrast, jasper, as the only nonlocal material, makes up only 2.6 percent of the material tabulated by count, and 1.3 percent by weight.

Table 109 contains frequencies and percentages of debris with cortex, for the various raw material classes. These sample sizes are very small and are not suitable for extrapolation.

Table 110 lists counts and percentages of heat-altered debris by raw material classes. Heat alteration is very uncommon, accounting for only 5.3 percent of the entire Early Woodland collection.

Table 107. Early Woodland Debris Counts by Raw Material Class.

Raw Material	Grade 1		Grade 2		Grade 3		Grade 4		Total	
	n	col. %	n	col. %	n	col. %	n	col. %	n	col. %
Agates <sup>a</sup>	0	0.0	0	0.0	1	12.5	0	0.0	1	2.6
Argillite	0	0.0	0	0.0	0	0.0	4	13.3	4	10.5
Chalcedonies <sup>b</sup>	0	0.0	0	0.0	1	12.5	15	50.0	16	42.1
Cherts <sup>c</sup>	0	0.0	0	0.0	5	62.5	10	33.3	15	39.5
Jaspers <sup>d</sup>	0	0.0	0	0.0	0	0.0	1	3.3	1	2.6
Silicified Sandstone	0	0.0	0	0.0	1	12.5	0	0.0	1	2.6
Total	0	0.0	0	0.0	8	100.0	30	100.0	38	100.0

<sup>a</sup>Agates refers to both black and white agates combined, although very few of the debris are white.

<sup>b</sup>Chalcedonies refers to all forms of chalcedony present, although the overwhelming majority is gray.

<sup>c</sup>Cherts refers to dark gray and gray cherts.

<sup>d</sup>Jaspers refers to all forms of jasper combined.

Table 108. Early Woodland Debris Weights by Raw Material Class.

Raw Material	Grade 1		Grade 2		Grade 3		Grade 4		Total	
	g	col. %	g	col. %	g	col. %	g	col. %	g	col. %
Agates <sup>a</sup>	0.0	0.0	0.0	0.0	2.1	38.9	0.0	0.0	2.1	28.0
Argillite	0.0	0.0	0.0	0.0	0.1	1.9	0.0	0.0	0.1	1.3
Chalcedonies <sup>b</sup>	0.0	0.0	0.0	0.0	0.2	3.7	0.7	33.3	0.9	12.0
Cherts <sup>c</sup>	0.0	0.0	0.0	0.0	1.6	29.6	1.3	61.9	2.9	38.7
Jaspers <sup>d</sup>	0.0	0.0	0.0	0.0	0.0	0.0	0.1	4.8	0.1	1.3
Silicified Sandstone	0.0	0.0	0.0	0.0	1.4	25.9	0.0	0.0	1.4	18.7
Total	0.0	0.0	0.0	0.0	5.4	100.0	2.1	100.0	7.5	100.0

<sup>a</sup>Agates refers to both black and white agates combined, although very few of the debris are white.

<sup>b</sup>Chalcedonies refers to all forms of chalcedony present, although the overwhelming majority is gray.

<sup>c</sup>Cherts refers to dark gray and gray cherts.

<sup>d</sup>Jaspers refers to all forms of jasper combined.

Table 109. Early Woodland Debris with Cortex.

Raw Material Class	Count	Percent of Raw Material
Agates	1	100.0
Chalcedony	1	6.3
Chert	4	26.7
Silicified Sandstone	1	100.0
Total	7	21.2

Table 110. Early Woodland Heat Altered Debris.

Raw Material Class	Count	Percent of Raw Material
Chert	1	6.7
Jasper	1	100.0
Total	2	12.5

*Orient Phase.* A total of 10,759 pieces of lithic debris, weighing 2821.51 grams, was recovered from the Orient component. Table 111 is a summary of raw material frequencies and percentages for the four size grades and total debris. Table 112 presents debris weights for each size grade by raw material class. The highest percentage of debris by count is within size grade 4 (80.6%), while the highest percentage by weight occurs in size grades 2 and 3 (29.5 percent and 36.2 percent, respectively). The collection is dominated by local raw materials. Cherts account for 44.0 percent by count, and 41.4 percent by weight; chalcedony accounts for 21.6 percent by count, and 12.0 percent by weight; and argillite accounts for 11.7 percent by count, and 17.0 percent by weight. Among the nonlocal raw materials, rhyolite accounts for a significant 11.2 percent by count, and 11.4 percent by weight, while jasper, the second most frequently represented nonlocal raw material, accounts for only 3.0 percent by count, and 3.3 percent by weight.

Table 111. Orient Phase Debris Counts by Raw Material Class.

Raw Material	Grade 1		Grade 2		Grade 3		Grade 4		Total	
	n	col. %	n	col. %	n	col. %	n	col. %	n	col. %
Agates <sup>a</sup>	0	0.0	1	0.5	9	0.5	84	1.0	94	0.9
Argillite	3	18.8	22	11.8	251	13.8	937	11.2	1213	11.7
Chalcedonies <sup>b</sup>	1	6.3	11	5.9	338	18.6	1893	22.6	2243	21.6
Cherts <sup>c</sup>	2	12.5	75	40.1	765	42.1	3730	44.6	4572	44.0
Gray Sandstone	1	6.3	7	3.7	38	2.1	140	1.7	186	1.8
Jaspers <sup>d</sup>	0	0.0	8	4.3	49	2.7	259	3.1	316	3.0
Quartz	0	0.0	0	0.0	6	0.3	32	0.4	38	0.4
Quartzite	0	0.0	2	1.1	14	0.8	78	0.9	94	0.9
Rhyolite	6	37.5	42	22.5	208	11.5	905	10.8	1161	11.2
Silicified Sandstone	2	12.5	4	2.1	42	2.3	125	1.5	173	1.7
Siltstone	0	0.0	10	5.3	76	4.2	148	1.8	234	2.3
Slate	1	6.3	3	1.6	19	1.0	41	0.5	64	0.6
Total	16	100.0	187	100.0	1815	100.0	8372	100.0	10388	100.0

<sup>a</sup>Agates refers only to the black agates.

<sup>b</sup>Chalcedonies refers only to the black/gray chalcedonies.

<sup>c</sup>Cherts refers to gray cherts.

<sup>d</sup>Jaspers refers to all forms of jasper.

Table 112. Orient Phase Debris Weights by Raw Material Class.

Raw Material	Grade 1		Grade 2		Grade 3		Grade 4		Total	
	g	col. %	g	col. %	g	col. %	g	col. %	g	col. %
Agates <sup>a</sup>	0.00	0.0	5.72	0.7	6.61	0.7	7.89	1.3	20.22	0.7
Argillite	192.39	59.5	70.62	8.8	132.23	13.4	69.03	10.9	464.27	17.0
Chalcedonies <sup>b</sup>	2.30	0.7	55.90	6.9	145.56	14.7	125.14	19.8	328.90	12.0
Cherts <sup>c</sup>	38.57	11.9	384.16	47.6	430.47	43.5	278.48	44.2	1131.68	41.4
Gray Sandstone	18.60	5.8	61.30	7.6	31.00	3.1	13.15	2.1	124.05	4.5
Jaspers <sup>d</sup>	0.00	0.0	33.30	4.1	33.22	3.4	22.84	3.6	89.56	3.3
Quartz	0.00	0.0	0.00	0.0	5.60	0.6	3.07	0.5	8.67	0.3
Quartzite	0.00	0.0	13.10	1.6	9.92	1.0	8.37	1.3	31.39	1.1
Rhyolite	12.10	3.7	128.34	15.9	100.29	10.1	69.34	11.0	310.07	11.4
Silicified Sandstone	36.32	11.2	13.72	1.7	29.35	3.0	11.52	1.8	90.91	3.3
Siltstone	0.00	0.0	32.06	4.0	52.36	5.3	16.00	2.5	100.42	3.7
Slate	4.51	1.4	8.52	1.1	11.96	1.2	5.76	0.9	30.75	1.1
Total	323.39	100.0	806.74	100.0	988.57	100.0	630.59	100.0	2730.69	100.0

<sup>a</sup>Agates refers only to the black agates.

<sup>b</sup>Chalcedonies refers only to the black/gray chalcedonies.

<sup>c</sup>Cherts refers to gray cherts.

<sup>d</sup>Jaspers refers to all forms of jasper.

Table 113 contains frequencies and percentages of debris with cortex for the various raw material classes. In general, raw material classes with the highest percentage of debris with cortex

are those that are local, agates (20.2%), chalcedonies (20.7%), cherts (38.2%), other (34.1%), quartz (26.3%), and siltstone (20.9%). Much of the debris designated as Other contains material which is entirely cortical material. The highest percentage of material with cortex in a nonlocal material is jasper (13.9%).

Table 113. Orient Phase Debris with Cortex.

Raw Material Class	Count	Percent of Raw Material
Agates	19	20.2
Argillite	155	12.8
Chalcedony	464	20.7
Chert	1745	38.2
Jasper	44	13.9
Other	15	34.1
Quartz	10	26.3
Quartzite	32	34.0
Rhyolite	98	8.4
Gray Sandstone	15	8.1
Silicified Sandstone	27	15.6
Siltstone	49	20.9
Slate	1	1.6
Total	2674	25.6

Counts and percentages of heat-altered material are listed in Table 114 by raw material classes. Heat alteration is relatively uncommon, accounting for only 5.4 percent of the collection tabulated below. Heat alteration is most common in the jasper category (56.6%), a result that might be expected in terms of practice, and certainly in terms of our ability to recognize its presence given the color change that occurs.

Table 114. Orient Phase Heat-altered Debris

Raw Material Class	Count	Percent of Raw Material
Agates	1	1.1
Chalcedony	77	3.4
Chert	297	6.5
Jasper	179	56.6
Total	564	5.4

*Terminal Archaic.* A total of 7,115 pieces of lithic debris weighing 2,088.74 g was recovered from the Terminal Archaic component. Table 115 is a summary of raw material frequencies and percentages for the four size grades and total debris. Table 116 presents debris weights for each size grade by raw material class. The highest percentage of debris by count is within size grade 4 (79.6%), while the highest percentage by weight occurs in size grades 2 and 3 (36.4 percent and 32.4 percent, respectively). The collection is dominated by rhyolite, a nonlocal raw material (46.4 percent by count, and 34.1 percent by weight). Among the local materials, cherts account for 26.3 percent by count, and 18.1 percent by weight; chalcedony accounts for 8.9 percent by count, and 3.4 percent by weight; and argillite accounts for 5.1 percent by count and 5.8 percent by weight.

Table 115. Terminal Archaic Debris Counts by Raw Material Class.

Raw Material	Grade 1		Grade 2		Grade 3		Grade 4		Total	
	n	col. %	n	col. %	n	col. %	n	col. %	n	col. %
Agates <sup>a</sup>	0	0.0	1	0.5	8	0.6	45	0.8	54	0.8
Argillite	1	14.3	9	4.8	59	4.8	289	5.2	358	5.1
Chalcedonies <sup>b</sup>	0	0.0	4	2.1	45	3.6	574	10.3	623	8.9
Cherts <sup>c</sup>	1	14.3	23	12.2	285	23.0	1536	27.5	1845	26.3
Gray Sandstone	2	28.6	27	14.3	99	8.0	244	4.4	372	5.3
Jaspers <sup>d</sup>	0	0.0	4	2.1	15	1.2	78	1.4	97	1.4
Quartz	0	0.0	0	0.0	1	0.1	29	0.5	30	0.4
Quartzite	0	0.0	0	0.0	2	0.2	11	0.2	13	0.2
Rhyolite	0	0.0	87	46.0	616	49.8	2554	45.7	3257	46.4
Silicified Sandstone	3	42.9	26	13.8	68	5.5	170	3.0	267	3.8
Siltstone	0	0.0	2	1.1	28	2.3	34	0.6	64	0.9
Slate	0	0.0	6	3.2	12	1.0	23	0.4	41	0.6
Total	7	100.0	189	100.0	1238	100.0	5587	100.0	7021	100.0

<sup>a</sup>Agates refers only to the black agates.

<sup>b</sup>Chalcedonies refers only to the black/gray chalcedonies.

<sup>c</sup>Cherts refers to gray cherts.

<sup>d</sup>Jaspers refers to all forms of jasper.

Table 116. Terminal Archaic Debris Weights by Raw Material Class.

Raw Material	Grade 1		Grade 2		Grade 3		Grade 4		Total	
	g	col. %	g	col. %	g	col. %	g	col. %	g	col. %
Agates <sup>a</sup>	0.00	0.0	6.18	0.8	5.33	0.8	4.34	1.1	15.85	0.8
Argillite	30.57	12.6	36.85	4.9	30.31	4.5	22.35	5.5	120.08	5.8
Chalcedonies <sup>b</sup>	0.00	0.0	16.73	2.2	17.30	2.6	36.69	9.1	70.72	3.4
Cherts <sup>c</sup>	10.40	4.3	96.03	12.8	168.04	25.1	99.19	24.6	373.66	18.1
Gray Sandstone	69.33	28.6	120.88	16.1	76.44	11.4	29.82	7.4	296.47	14.3
Jaspers <sup>d</sup>	0.00	0.0	23.10	3.1	6.59	1.0	5.92	1.5	35.61	1.7
Quartz	0.00	0.0	0.00	0.0	0.50	0.1	2.15	0.5	2.65	0.1
Quartzite	0.00	0.0	0.00	0.0	1.91	0.3	0.79	0.2	2.70	0.1
Rhyolite	0.00	0.0	247.18	32.8	286.03	42.7	172.10	42.6	705.31	34.1
Silicified Sandstone	141.19	58.3	139.67	18.6	50.98	7.6	16.37	4.1	348.21	16.8
Siltstone	0.00	0.0	8.04	1.1	14.84	2.2	2.97	0.7	25.85	1.2
Slate	0.00	0.0	57.94	7.7	11.73	1.8	10.91	2.7	80.58	3.9
Total	242.13	100.0	752.60	100.0	670.00	100.0	403.60	100.0	2068.33	100.0

<sup>a</sup>Agates refers only to the black agates.

<sup>b</sup>Chalcedonies refers only to the black/gray chalcedonies.

<sup>c</sup>Cherts refers to gray cherts.

<sup>d</sup>Jaspers refers to all forms of jasper.

Table 117 contains frequencies and percentages of debris with cortex for the various raw material classes. In general, raw material classes having the highest percentage of debris with cortex are those that are local: agates (29.6%), chalcedonies (11.6%), and other (25.7%). Much

of the debris designated as Other contains material which is entirely cortical. The highest percentage of material with cortex, in a nonlocal material, is jasper (12.4%).

Table 117. Terminal Archaic Debris with Cortex.

Raw Material Class	Count	Percent of Raw Material
Agates	16	29.6
Argillite	22	6.1
Chalcedony	72	11.6
Chert	157	8.5
Jasper	12	12.4
Other	9	25.7
Quartzite	6	46.2
Rhyolite	65	1.1
Gray Sandstone	16	4.3
Silicified Sandstone	19	7.1
Siltstone	2	3.1
Slate	5	12.2
Total	401	5.7

Table 118 lists counts and percentages of heat-altered debris by raw material classes. Heat alteration is very uncommon, accounting for only 1.2 percent of the collection tabulated. Heat alteration is most common in the jasper category (58.8%).

Table 118. Terminal Archaic Heat-altered Debris.

Raw Material	Count	Percent of Raw Material
Agates	0	0.0
Chalcedony	6	0.9
Chert	23	1.2
Jasper	57	58.8
Other	0	0.0
Total	86	1.2

*Piedmont.* A total of 2,434 pieces of lithic debris, weighing 458.17 g, was recovered from the Piedmont component. Table 119 is a summary of raw material frequencies and percentages for the four size grades and total debris. Table 120 presents debris weights for each size grade by raw material class. The highest percentage of debris by count is within size grade 4 (81.7%), while the highest percentage by weight occurs in size grades 2 and 3 (24.0 percent and 37.6 percent, respectively). The collection is dominated by local raw materials. Cherts account for 45.2 percent by count, and 47.2 percent by weight; chalcedony accounts for 14.5 percent by count, and 14.7 percent by weight; and argillite accounts for 17.4 percent by count, and 14.7 percent by weight. Among the nonlocal raw materials, rhyolite accounts for a significant 10.1 percent by count, and 7.8 percent by weight, while jasper, the second most frequently-represented nonlocal raw material, accounts for only 3.6 percent by count, and 2.9 percent by weight.

Table 121 contains frequencies and percentages of debris with cortex for the various raw material classes. In general, raw material classes with the highest percentage of debris with cortex are those that are local: agates (58.8%), chalcedonies (12.8%), cherts (7.1%), other (29.8%), and

siltstone (14.3%). Much of the debris designated as Other contains material which is entirely cortical material. The highest percentage of material with cortex in a nonlocal material is jasper (9.4%), though it must be emphasized that this is from a sample of size eight.

Table 119. Piedmont Debris Counts by Raw Material Class.

Raw Material	Grade 1		Grade 2		Grade 3		Grade 4		Total	
	n	col. %	n	col. %	n	col. %	n	col. %	n	col. %
Agates <sup>a</sup>	0	0.0	0	0.0	3	0.9	14	0.7	17	0.7
Argillite	0	0.0	3	13.0	69	20.5	339	17.5	411	17.4
Chalcedonies <sup>b</sup>	0	0.0	4	17.4	29	8.6	310	16.0	343	14.5
Cherts <sup>c</sup>	3	100.0	11	47.8	149	44.3	906	46.8	1069	45.2
Gray Sandstone	0	0.0	0	0.0	11	3.3	54	2.8	65	2.7
Jaspers <sup>d</sup>	0	0.0	1	4.3	12	3.6	72	3.7	85	3.6
Quartz	0	0.0	0	0.0	1	0.3	8	0.4	9	0.4
Quartzite	0	0.0	0	0.0	1	0.3	2	0.1	3	0.1
Rhyolite	0	0.0	1	4.3	45	13.4	194	10.0	240	10.1
Silicified Sandstone	0	0.0	3	13.0	11	3.3	29	1.5	43	1.8
Siltstone	0	0.0	0	0.0	3	0.9	4	0.2	7	0.3
Slate	0	0.0	0	0.0	2	0.6	3	0.2	5	0.2
Total	3	100.0	23	100.0	336	100.0	1935	100.0	2367	100.0

<sup>a</sup>Agates refers only to the black agates.

<sup>b</sup>Chalcedonies refers only to the black/gray chalcedonies.

<sup>c</sup>Cherts refers to gray cherts.

<sup>d</sup>Jaspers refers to all forms of jasper.

Table 120. Piedmont Debris Weight by Raw Material Class.

Raw Material	Grade 1		Grade 2		Grade 3		Grade 4		Total	
	wt	col. %	wt	col. %	wt	col. %	wt	col. %	wt	col. %
Agates <sup>a</sup>	0.0	0.0	0.0	0.0	3.76	2.3	1.41	1.1	5.17	1.2
Argillite	0.0	0.0	9.4	8.9	34.85	21.0	20.55	16.2	64.80	14.7
Chalcedonies <sup>b</sup>	0.00	0.0	29.37	27.7	14.76	8.9	20.87	16.4	65.00	14.7
Cherts <sup>c</sup>	42.24	100.0	52.45	49.5	58.06	35.0	55.60	43.7	208.35	47.2
Gray Sandstone	0.00	0.0	0.00	0.0	12.25	7.4	5.60	4.4	17.85	4.0
Jaspers <sup>d</sup>	0.00	0.0	2.70	2.5	4.50	2.7	5.51	4.3	12.71	2.9
Quartz	0.00	0.0	0.0	0.0	0.27	0.2	0.92	0.7	1.19	0.3
Quartzite	0.00	0.0	0.00	0.0	1.20	0.7	0.20	0.2	1.40	0.3
Rhyolite	0.00	0.0	2.98	2.8	18.38	11.1	13.00	10.2	34.36	7.8
Silicified Sandstone	0.00	0.0	9.12	8.6	6.85	4.1	2.56	2.0	18.53	4.2
Siltstone	0.00	0.0	0.00	0.0	10.70	6.4	0.66	0.5	11.36	2.6
Slate	0.00	0.0	0.00	0.0	0.51	0.3	0.25	0.2	0.76	0.2
Total	42.24	100.0	106.02	100.0	166.09	100.0	127.13	100.0	441.48	100.0

<sup>a</sup>Agates refers only to the black agates.

<sup>b</sup>Chalcedonies refers only to the black/gray chalcedonies.

<sup>c</sup>Cherts refers to gray cherts.

<sup>d</sup>Jaspers refers to all forms of jasper.



Table 121. Piedmont Debris with Cortex.

Raw Material	Count	Percent of Raw Material
Agates	10	58.8
Argillite	21	5.1
Chalcedony	44	12.8
Chert	76	7.1
Jasper	8	9.4
Other	14	29.8
Quartzite	2	66.7
Rhyolite	3	1.3
Gray Sandstone	1	1.5
Silicified Sandstone	4	9.3
Siltstone	1	14.3
Total	184	7.8

Table 122 lists counts and percentages of heat-altered debris by raw material classes. Heat alteration is very uncommon, accounting for only 2.9 percent of the collection tabulated. Heat alteration is most common in the jasper category (1.5%).

Table 122. Piedmont Heat-altered Chipped-stone Debris.

Raw Material	Count	Percent of Raw Material
Chalcedony	5	1.5
Chert	14	1.3
Jasper	50	1.5
Total	69	2.9

*Late Laurentian.* A total of 19,366 pieces of lithic debris weighing, 3,652.66 g, was recovered from the late Laurentian contexts. Table 123 is a summary of raw material frequencies and percents for the four size grades and total debris. Table 124 presents debris weights for each size grade, by raw material class. The highest percentage of debris by count is within size grade 4 (84.1%), while the highest percentage by weight occurs in size grades 2, 3, and 4 (25.6 percent, 38.4 percent, and 28.5 percent, respectively). The collection is dominated by local raw materials. Cherts account for 47.3 percent by count, and 43.1 percent by weight; chalcedony accounts for 15.7 percent by count, and 10.6 percent by weight; and argillite accounts for 19.4 percent by count, and 14.8 percent by weight. Among the nonlocal raw materials, jasper dominates with 5.3 percent by count, and 5.3 percent by weight, while rhyolite, the second most frequently represented nonlocal raw material, accounts for 3.5 percent by count, and 1.8 percent by weight.

Table 125 contains frequencies and percentages of debris with cortex for the various raw material classes. In general, raw material classes with the highest percentage of debris with cortex are those that are local: agates (12.3%), chalcedonies (10.5%), cherts (8.0%), and other (46.3%). Much of the debris designated as Other contains material which is entirely cortical. The highest percentage of material with cortex in a nonlocal material is jasper (7.9%).

Table 126 lists counts and percentages of heat-altered debris by raw material classes. Heat alteration is very uncommon, accounting for only 3.6 percent of the collection tabulated below. Heat alteration is most common in the jasper category (50.0%).

Table 123. Late Laurentian Debris Counts by Raw Material Class.

Raw Material	Grade 1		Grade 2		Grade 3		Grade 4		Total	
	n	col. %	n	col. %	n	col. %	n	col. %	n	col. %
Agates <sup>a</sup>	1	10.0	8	3.6	170	6.2	529	3.3	708	3.8
Argillite	1	10.0	38	17.0	483	17.5	3137	19.8	3659	19.4
Chalcedonies <sup>b</sup>	0	0.0	14	6.3	309	11.2	2632	16.6	2955	15.7
Cherts <sup>c</sup>	2	20.0	108	48.4	1381	50.0	7419	46.9	8910	47.3
Gray Sandstone	4	40.0	25	11.2	140	5.1	302	1.9	471	2.5
Jaspers <sup>d</sup>	1	10.0	8	3.6	131	4.7	858	5.4	998	5.3
Quartz	0	0.0	0	0.0	10	0.4	41	0.3	51	0.3
Quartzite	0	0.0	1	0.4	9	0.3	26	0.2	36	0.2
Rhyolite	0	0.0	4	1.8	57	2.1	294	3.8	655	3.5
Silicified Sandstone	0	0.0	9	4.0	46	1.7	257	1.6	312	1.7
Siltstone	0	0.0	4	1.8	12	0.4	8	0.1	24	0.1
Slate	1	10.04	4	1.8	15	0.5	25	0.2	45	0.2
Total	10	100.0	223	100.0	2763	100.0	15828	100.0	18824	100.0

<sup>a</sup> Agates refers only to the black agates.

<sup>b</sup> Chalcedonies refers only to the black/gray chalcedonies.

<sup>c</sup> Cherts refers to gray cherts.

<sup>d</sup> Jaspers refers to all forms of jasper.

Table 124. Late Laurentian Debris Weights by Raw Material Class.

Raw Material	Grade 1		Grade 2		Grade 3		Grade 4		Total	
	g	col. %	g	col. %	g	col. %	g	col. %	g	col. %
Agates <sup>a</sup>	19.34	7.4	31.07	3.5	125.32	9.4	48.91	4.9	224.64	6.4
Argillite	10.89	4.2	136.75	15.3	186.94	14.0	181.86	18.3	516.44	14.8
Chalcedonies <sup>b</sup>	0.00	0.0	44.34	5.0	160.95	12.0	163.24	16.4	368.53	10.6
Cherts <sup>c</sup>	30.20	11.5	401.53	44.9	623.20	46.5	448.19	45.1	1503.12	43.1
Gray Sandstone	161.90	61.7	131.24	14.7	89.92	6.7	29.22	2.9	412.28	11.8
Jaspers <sup>d</sup>	23.79	9.1	21.07	2.4	81.54	6.1	59.41	6.0	185.81	5.3
Quartz	0.00	0.0	0.00	0.0	6.76	0.5	3.58	0.4	10.34	0.3
Quartzite	0.00	0.0	3.41	0.4	5.29	0.4	3.38	0.3	12.08	0.3
Rhyolite	0.00	0.0	7.67	0.9	19.33	1.4	36.11	3.6	63.11	1.8
Silicified Sandstone	0.00	0.0	87.89	9.8	24.58	1.8	17.91	1.8	130.38	3.7
Siltstone	0.00	0.0	12.94	1.4	5.18	0.4	0.55	0.1	18.67	0.5
Slate	16.20	6.2	16.80	1.9	10.59	0.8	2.46	0.2	46.05	1.3
Total	262.32	100.0	894.80	100.0	1339.60	100.0	994.82	100.0	3491.54	100.0

<sup>a</sup>Agates refers only to the black agates.

<sup>b</sup>Chalcedonies refers only to the black/gray chalcedonies.

<sup>c</sup>Cherts refers to gray cherts.

<sup>d</sup>Jaspers refers to all forms of jasper.

Table 125. Late Laurentian Debris with Cortex.

Raw Material	Count	Percent of Raw Material
Agates	87	12.3
Argillite	102	2.8
Chalcedony	310	10.5
Chert	716	8.0
Jasper	79	7.9
Other	50	46.3
Quartz	4	7.8
Quartzite	7	19.4
Rhyolite	16	2.4
Gray Sandstone	23	4.9
Silicified Sandstone	17	5.4
Slate	4	8.9
Total	1415	7.5

Table 126. Late Laurentian Heat-altered Debris.

Raw Material	Count	Percent of Raw Material
Agates	0	0.0
Chalcedony	22	<0.1
Chert	137	1.5
Jasper	527	50.0
Other	0	0.0
Total	686	3.6

*Early Laurentian.* A total of 16,492 pieces of lithic debris, weighing 4,285.62 g, was recovered from the early Laurentian contexts. Table 127 is a summary of raw material frequencies and percentages for the four size grades and total debris. Table 128 presents debris weights for each size grade by raw material class. The highest percentage of debris by count is within size grade 4 (86.8%), while the highest percentage by weight occurs in size grades 2, 3, and 4 (31.7%, 26.0%, and 21.7%, respectively). The collection is dominated by local raw materials. Cherts account for 54.0 percent by count, and 45.5 percent by weight; chalcedony accounts for 17.4 percent by count, and 8.2 percent by weight; and argillite accounts for 9.0 percent by count, and 7.4 percent by weight. Among the nonlocal raw materials, jasper accounts for 4.8 percent by count and 3.7 percent by weight, while rhyolite, the second most frequently represented nonlocal raw material, accounts for only 3.0 percent by count, and 1.7 percent by weight.

Table 129 contains frequencies and percentages of debris with cortex for the various raw material classes. In general, raw material classes with the highest percentage of debris with cortex are those that are local: agates (33.5%), cherts (10.3%), and other (48.8%). Much of the debris designated as Other contains material which is entirely cortical. The highest percentage of material with cortex in a nonlocal material is jasper (8.1%).

Table 130 lists counts and percentages of heat-altered material by raw material classes. Heat alteration is very uncommon, accounting for only 2.3 percent of the entire collection. Heat alteration is most common in the jasper category (52.2%).

Table 127. Early Laurentian Debris Counts by Raw Material Class.

Raw Material	Grade 1		Grade 2		Grade 3		Grade 4		Total	
	n	col. %	n	col. %	n	col. %	n	col. %	n	col. %
Agates <sup>a</sup>	0	0.0	6	2.5	66	3.6	540	4.0	612	3.9
Argillite	3	17.6	15	6.3	137	7.5	1254	9.2	1409	9.0
Chalcedonies <sup>b</sup>	0	0.0	16	6.7	193	10.6	2525	18.5	2734	17.4
Cherts <sup>c</sup>	4	23.5	125	52.3	932	51.0	7436	54.5	8497	54.0
Gray Sandstone	5	29.4	30	12.6	231	12.6	476	3.5	742	4.7
Jaspers <sup>d</sup>	0	0.0	12	5.0	93	5.1	644	4.7	749	4.8
Quartz	0	0.0	3	1.3	19	1.0	129	0.9	151	1.0
Quartzite	0	0.0	2	0.8	16	0.9	50	0.4	68	0.4
Rhyolite	0	0.0	7	2.9	40	2.2	432	3.2	479	3.0
Silicified Sandstone	4	23.5	19	7.9	79	4.3	148	1.1	250	1.6
Siltstone	0	0.0	0	0.0	5	0.3	9	0.1	14	0.1
Slate	1	5.9	4	1.7	17	0.9	13	0.1	35	0.2
Total	17	100.0	239	100.0	1828	100.0	13656	100.0	15740	100.0

<sup>a</sup>Agates refers only to the black agates.

<sup>b</sup>Chalcedonies refers only to the black/gray chalcedonies.

<sup>c</sup>Cherts refers to gray cherts.

<sup>d</sup>Jaspers refers to all forms of jasper.

Table 128. Early Laurentian Debris Weight by Raw Material Category.

Raw Material	Grade 1		Grade 2		Grade 3		Grade 4		Total	
	g	col. %	g	col. %	g	col. %	g	col. %	g	col. %
Agates <sup>a</sup>	0.00	0.0	38.45	2.9	41.09	3.8	34.03	3.8	113.57	2.74
Argillite	110.55	13.0	70.45	5.4	49.93	4.6	76.63	8.2	304.56	7.36
Chalcedonies <sup>b</sup>	0.00	0.0	76.60	5.8	101.34	9.4	160.31	17.8	338.25	8.18
Cherts <sup>c</sup>	221.79	26.1	662.30	50.5	530.56	49.3	467.41	52.0	1882.06	45.49
Gray Sandstone	282.37	33.2	223.72	17.1	181.77	16.9	68.06	7.6	755.92	18.27
Jaspers <sup>d</sup>	0.00	0.0	53.27	4.1	53.22	4.9	46.35	5.2	152.84	3.69
Quartz	0.00	0.0	18.78	1.4	12.58	1.2	12.57	1.4	43.93	1.06
Quartzite	0.00	0.0	9.17	0.7	13.28	1.2	5.04	0.6	27.49	0.01
Rhyolite	0.00	0.0	25.81	2.0	18.73	1.7	26.72	3.0	71.26	1.72
Silicified Sandstone	225.74	26.5	107.81	8.2	58.90	5.5	12.35	1.4	404.80	9.78
Siltstone	0.00	0.0	0.00	0.0	2.32	0.2	0.60	0.1	3.22	0.01
Slate	10.71	1.3	25.50	1.9	11.81	1.1	1.22	0.1	49.24	1.19
Total	851.16	100.0	1311.86	100.0	1075.53	100.0	911.29	100.0	4147.14	100.0

<sup>a</sup>Agates refers only to the black agates.

<sup>b</sup>Chalcedonies refers only to the black/gray chalcedonies.

<sup>c</sup>Cherts refers to gray cherts.

<sup>d</sup>Jaspers refers to all forms of jasper.

Table 129. Early Laurentian Debris with Cortex.

Raw Material Class	Count	Percent of Raw Material
Agates	205	33.5
Argillite	42	3.0
Chalcedony	380	1.4
Chert	874	10.3
Jasper	61	8.1
Other	63	48.8
Quartz	9	6.0
Quartzite	15	22.1
Rhyolite	17	3.5
Gray Sandstone	34	4.6
Silicified Sandstone	60	24.0
Siltstone	12	85.7
Slate	5	14.3
Total	1777	11.2

Table 130. Early Laurentian Heat-altered Debris.

Raw Material	Count	Percent of Raw Material
Chalcedony	71	2.6
Chert	271	3.2
Jasper	24	52.2
Total	366	2.3

*Neville.* A total of 1,630 pieces of lithic debris, weighing 1583.00 g, was recovered from Neville contexts. Table 131 is a summary of raw material frequencies and percentages for the four size grades and total debris. Table 132 presents debris weights for each size grade, by raw material class. The highest percentage of debris by count is within size grade 4 (84.4%), while the highest percentage by weight occurs in size grades 1, 2, and 3 (21.7 percent, 35.5 percent, and 23.7 percent, respectively). The collection is dominated by local raw materials. Cherts account for 60.5 percent by count, and 38.6 percent by weight; chalcedony accounts for 14.0 percent by count, and 15.4 percent by weight; and argillite accounts for 3.2 percent by count and 2.5 percent by weight. Among the nonlocal raw materials, jasper accounts for 12.3 percent by count and 11.6 percent by weight, while rhyolite, the second most frequently represented nonlocal raw material, accounts for only 3.0 percent by count and 1.2 percent by weight.

Table 133 contains frequencies and percentages of debris with cortex for the various raw material classes. In general, raw material classes with the highest percentage of debris with cortex are those that are local: chalcedonies (14.5%), and cherts (4.3%). If we assume that all chert in this collection is local, then there is no nonlocal material with cortex in the Neville component.

Table 134 lists counts and percentages of heat-altered debris by raw material classes. Heat alteration is very uncommon, accounting for only 5.4 percent of the collection tabulated below. Heat alteration is most common in the jasper category (66.7%).

Table 131. Neville Debris Counts by Material Class.

Raw Material	Grade 1		Grade 2		Grade 3		Grade 4		Total	
	n	col. %	n	col. %	n	col. %	n	col. %	n	col. %
Agates <sup>a</sup>	0	0.0	0	0.0	3	1.6	12	0.9	15	0.9
Argillite	0	0.0	1	3.4	9	4.9	41	3.1	51	3.2
Chalcedonies <sup>b</sup>	1	25.0	3	10.3	28	15.2	189	14.1	221	14.0
Cherts <sup>c</sup>	0	0.0	11	37.9	86	46.7	860	64.4	957	60.5
Gray Sandstone	2	50.0	4	13.8	7	3.8	16	1.2	29	1.8
Jaspers <sup>d</sup>	0	0.0	7	24.1	34	18.5	154	11.5	195	12.3
Quartz	0	0.0	0	0.0	1	0.5	5	0.4	6	0.4
Quartzite	0	0.0	0	0.0	0	0.0	1	0.1	1	0.1
Rhyolite	0	0.0	1	3.4	8	4.3	38	2.8	47	3.0
Silicified Sandstone	0	0.0	2	6.9	5	2.7	36	2.7	43	2.7
Siltstone	1	25.0	0	0.0	3	1.6	2	0.1	6	0.4
Total	4	100.0	29	100.0	184	100.0	1336	100.0	1583	100.0

<sup>a</sup>Agates refers only to the black agates.

<sup>b</sup>Chalcedonies refers only to the black/gray chalcedonies.

<sup>c</sup>Cherts refers to gray cherts.

<sup>d</sup>Jaspers refers to all forms of jasper.

Table 132. Neville Debris Weights by Raw Material Class.

Raw Material	Grade 1		Grade 2		Grade 3		Grade 4		Total	
	g	col. %	g	col. %	g	col. %	g	col. %	g	col. %
Agates <sup>a</sup>	0.00	0.0	0.00	0.0	1.28	1.1	1.19	1.3	2.47	0.5
Argillite	0.00	0.0	5.28	3.1	3.88	3.4	3.04	3.3	12.20	2.5
Chalcedonies <sup>b</sup>	21.40	20.4	11.11	6.5	27.92	24.4	13.94	15.1	74.37	15.4
Cherts <sup>c</sup>	0.00	0.0	86.61	50.5	45.40	39.6	54.61	59.2	186.62	38.6
Gray Sandstone	58.38	55.8	21.86	12.8	7.64	6.7	1.94	2.1	89.82	18.6
Jaspers <sup>d</sup>	0.00	0.0	23.35	13.6	21.25	18.5	11.53	12.5	56.13	11.6
Quartz	0.00	0.0	0.00	0.0	0.70	0.6	0.36	0.4	1.06	0.2
Quartzite	0.00	0.0	0.00	0.0	0.00	0.0	0.10	0.1	0.10	0.02
Rhyolite	0.00	0.0	1.63	1.0	2.04	1.8	2.01	2.2	5.68	1.2
Silicified Sandstone	0.00	0.0	21.55	12.6	4.18	3.6	3.54	3.8	29.27	6.1
Siltstone	24.91	23.8	0.00	0.0	0.30	0.3	0.00	0.0	25.21	5.2
Total	4	100.0	29	100.0	184	100.0	1336	100.0	1583	100.0

<sup>a</sup>Agates refers only to the black agates.

<sup>b</sup>Chalcedonies refers only to the black/gray chalcedonies.

<sup>c</sup>Cherts refers to gray cherts.

<sup>d</sup>Jaspers refers to all forms of jasper.

Table 133. Neville Debris with Cortex.

Raw Material Class	Count	Percent of Raw Material
Agates	8	53.3
Argillite	2	3.9
Chalcedony	55	24.9
Chert	119	12.4
Jasper	33	16.9
Other	3	30.3
Gray Sandstone	7	24.1
Silicified Sandstone	13	30.2
Siltstone	1	16.7
<b>Total</b>	<b>241</b>	<b>15.2</b>

Table 134. Neville Heat-altered Debris.

Raw Material	Count	Percent of Raw Material
Chalcedony	32	14.5
Chert	41	4.3
Jasper	130	66.7
<b>Total</b>	<b>203</b>	<b>5.4</b>

#### *Late Woodland Debris Macrowear Analysis*

In order to better assess the use frequency of non-retouched lithic debris, a stratified random sample of debris from the Woodland features was microscopically examined for use-wear. This was done under the assumption that use of some debris would not have resulted in wear evident to the naked eye. The sample was chosen to incorporate approximately 30 percent of the debris in grades 1 and 2 for each feature. Table 135 is a summary of the number of debris, the frequency sampled, and number and percent of sampled debris with wear from each feature. Debris identified as having use-wear were reclassified as edge-only tools, and removed from the debris database.

The examination was performed with a Spencer binocular microscope at 10X to 20X for all edges of each piece. Because more than one edge on any given piece may evidence use-wear and this wear may be of a different type, some of the data summaries refer to numbers of edges rather than numbers of pieces. Use-wear assessment was based on the presence and nature of edge scarring, crushing, and polish. The criteria employed with regard to use versus non-use, type of activity, and nature of the worked material, are summarized in the three basic references on the low-power approach (Odell 1980; Odell and Odell-Vereecken 1980; Tringham et al 1974).

The activities represented by the used debris include longitudinal (both cutting and sawing), transverse (scraping), and graving. Graving includes both longitudinal and transverse motion on a point, tip, or corner. The relative frequencies of these various activities are graving, 18.5 percent; cutting, 11.1 percent; scraping, 69.1 percent; and sawing, 1.2 percent. The nature of the worked material was designated as soft, medium, or hard. Soft corresponds to use on materials such as meat, fat, skin, and soft vegetable substances. Medium corresponds to use on both soft and hard woods. Hard refers to use on bone, antler, and some dry hardwoods. The relative percentages of worked materials are soft, 9.9 percent; medium, 58.0 percent; and hard, 32.1 percent. Two tables

provide summary results of the analysis. Table 136 presents the frequencies of activity/worked material for each feature. Table 137 presents frequencies and percentages of raw material for the used debris.

In total, 34.9 percent of the debris sampled had some evidence of use-wear. If this percentage is projected across the entire assemblage and added to the edge-only tools identified earlier, an estimated 43.2 percent of the debris within grades 1 and 2 were subjected to use. This percentage might actually be higher given that the identification of use-wear on some raw materials is very hard to discern, and may have been missed during the current analysis.

Table 135. Summary of Sampling Results for Macrowear.

Feature	# Debris in Grades 1 & 2	# Sampled	% Sampled	#Pieces with wear	% Pieces with wear
8	3	1	33.3	0	0.0
26	1	1	100.0	0	0.0
29	36	12	33.3	2	16.7
40	1	1	100.0	0	0.0
49	5	2	40.0	1	50.0
51	31	9	29.0	3	33.3
52	5	2	40.0	0	0.0
55	11	3	27.3	2	27.3
57	19	7	36.8	3	50.0
61	5	2	40.0	1	50.0
63	55	20	36.4	8	40.0
67	2	1	50.0	1	100.0
78	21	7	33.3	3	42.9
80	69	23	33.3	10	43.5
83	16	6	37.5	2	33.3
84	10	3	30.0	0	0.0
87	4	2	50.0	1	50.0
92	21	7	33.3	2	28.6
96	2	1	50.0	1	100.0
97	13	5	38.5	1	20.0
106	17	5	29.4	2	40.0
107	7	3	42.9	1	33.3
112	29	10	34.5	3	30.0
117	2	1	50.0	0	0.0
121	2	1	50.0	1	100.0
123	29	10	34.5	3	30.0
132	2	1	50.0	0	0.0
135	2	2	100.0	0	0.0
143	7	3	42.9	1	33.3
144	2	1	50.0	0	0.0
152	10	3	30.0	1	33.3
155	11	3	27.3	2	66.7
160	8	3	37.5	0	0.0
175	1	1	100.0	1	100.0
233	12	4	33.3	2	50.0
<b>Total</b>	<b>166</b>	<b>71</b>	<b>35.2</b>	<b>58</b>	<b>34.9</b>



Table 136. Frequency of Activities/Worked Material by Feature.<sup>a</sup>

Feature	Activity/Worked Material for Size Grades 1 and 2											
	ScS	ScM	ScH	GS	GM	GH	CS	CM	CH	SS	SM	SH
8	-	-	-	-	-	-	-	-	-	-	-	-
26	-	-	-	-	-	-	-	-	-	-	-	-
29	-	2	-	-	1	1	-	-	-	-	-	-
40	-	-	-	-	-	-	-	-	-	-	-	-
49	-	-	1	-	-	-	-	-	-	-	-	-
51	-	2	1	-	-	-	-	-	-	-	-	-
52	-	-	-	-	-	-	-	-	-	-	-	-
55	-	2	-	-	-	-	-	-	-	-	-	-
57	-	-	4	-	1	-	-	-	-	-	-	-
61	-	1	-	-	-	-	-	-	-	-	-	-
63	-	3	2	-	4	1	-	-	-	-	-	-
67	-	-	-	-	1	-	-	-	-	-	-	-
78	-	5	-	-	-	-	-	-	-	-	-	-
80	-	3	4	-	-	2	1	2	-	-	-	-
83	-	-	1	-	-	-	-	-	-	-	-	-
84	-	-	-	-	-	-	-	-	-	-	-	-
87	-	1	-	-	-	-	-	-	-	-	-	-
92	-	1	3	-	-	-	1	-	1	-	-	-
96	-	-	-	-	-	1	-	-	-	-	-	-
97	-	-	2	-	-	-	-	-	-	-	-	-
106	-	1	-	-	1	-	-	-	-	-	-	-
107	-	2	-	-	-	-	-	-	-	-	-	-
112	1	2	-	-	-	1	-	-	-	-	-	-
117	-	-	-	-	-	-	-	-	-	-	-	-
121	-	-	-	-	1	-	-	-	-	-	-	-
123	1	4	-	-	-	-	2	2	-	-	-	-
132	-	-	-	-	-	-	-	-	-	-	-	-
135	-	-	-	-	-	-	-	-	-	-	-	-
143	2	-	-	-	-	-	-	-	-	-	-	-
144	-	-	-	-	-	-	-	-	-	-	-	-
152	-	-	-	-	-	-	-	-	-	-	1	-
155	-	2	1	-	-	-	-	-	-	-	-	-
160	-	-	-	-	-	-	-	-	-	-	-	-
175	-	1	-	-	-	-	-	-	-	-	-	-
233	-	1	-	-	-	-	-	-	-	-	-	-
Activity Total	4	33	19	0	9	6	4	4	1	0	1	0
% of Total	4.9	40.7	23.5	0.0	11.1	7.4	4.9	4.9	1.2	0.0	1.2	0.0
Total												81

<sup>a</sup> Activity: Sc=scraping; G=graving; C=cut; S=saw  
 Worked Material: S=soft; M=medium; H=hard

Of the debris with documented use-wear, cherts are most frequently represented (44.0%), followed by chalcedonies (42.4%). Since use-wear is so difficult to identify on rhyolite, argillite, gray sandstone, and siltstone, the percentages of use for these materials may be attenuated.

Whereas 53 of 129 pieces (41.1%) of the cherts, agates, chalcedonies and jaspers collectively evidenced use-wear, only 6 of 37 pieces (16.2%) of the last four materials evidenced use-wear. Any interpretations of relative frequencies must take into consideration the possible reason for this difference.

Table 137. Raw Material Counts of Utilized Debris.

Raw Material	Count	Percent
Dark Gray Chert	11	18.6
Gray Chert	15	25.4
Black/Gray Chalcedony	24	40.7
Other Chalcedony	1	1.7
Yellow Jasper	1	1.7
Black Agate	1	1.7
Rhyolite	2	3.4
Argillite	1	1.7
Gray Sandstone	1	1.7
Siltstone	2	3.4
Total	59	100.0

#### TOOL DESCRIPTIONS

This descriptive section is organized by component, from the most recent components to the oldest. Within each component section, the tools are subdivided into groupings: diagnostic bifaces, non-diagnostic bifaces, unifaces, edge-only tools, cores, and indeterminate. Multifaces are present in only one of the component assemblages; thus, they will be listed and discussed in only this one case. Blades are present only in the Late Clemson Island component assemblage. Each of these categories is summarized and described if present in the particular component. The analyses of technology and raw material management are presented in the Technological Analysis section of this chapter.

#### *Late Woodland - Stewart Phase*

*Bifaces.* Six bifacial tools and tool fragments were recovered from Stewart Phase features. These tools can be divided into two general descriptive categories: diagnostic and non-diagnostic. Descriptive summaries of the two groups are presented in the following paragraphs.

One diagnostic biface, a Madison Triangle, was recovered from Feature 233. This biface is an incomplete specimen made of gray chalcedony. As a result, only a thickness measurement was meaningful, equalling 5.3 millimeters.

The five non-diagnostic bifaces consist of biface fragments lacking diagnostic hafting elements, and whole bifaces that do not fit into any established type. These bifaces have a wide range of metric variation (Table 138).

Three of these tools have evidence of heat alteration. All of the tools lack cortex. As might be anticipated, edge modification on all pieces was bifacial. Edges of all of the tools were modified through flaking. Well over half of these tools (80.0%) had two modified edges, followed by one modified edge (20.0%).

Locally available raw materials are most frequently represented in the non-diagnostic biface category (Table 139). These include gray chert (40.0%), gray chalcedony (20.0%), and white chert (20.0%). The only nonlocal raw material present in this category was yellow jasper (20.0%).

Table 138. Metric Attributes for Stewart Phase Non-diagnostic Bifaces.

	Length(mm)	Width(mm)	Thickness (mm)	Weight(g)
Number of Cases	0	1	2	0
Minimum	-	1.83	0.36	-
Maximum	-	1.83	0.38	-
Range	-	0.0	0.02	-
Mean	-	1.83	0.37	-
Standard Deviation	-	-	0.01	-

Table 139. Stewart Phase Non-diagnostic Biface Counts by Raw Material.

Raw Material	Count	Percentage
Gray Chalcedony	1	20.0
Gray Chert	2	40.0
White Chert	1	20.0
Yellow Jasper	1	20.0
Total	5	100.0

*Unifaces.* One uniface is present in the chipped-stone assemblage for the Stewart Phase. This tool is incomplete, and no measurements were taken. The raw material is gray chert.

*Edge-only Tools.* Six edge-only tools are present in the Stewart Phase, chipped-stone assemblage. Table 140 is a summary of metric attributes for the edge-only tools, and Table 141 is a summary of the raw material types.

The majority of the tools had only a single retouched or utilized edge (57.7%), although 30.9 percent had two edges, 10.1 percent had three edges, and 1.3 percent had four edges. Of the total of 15 edges, over half (93.3%) had edge angles between 46° and 75°, and 6.7 percent had angles of less than 46°. Only two of the edge-only tools had been obviously subjected to heat alteration. The edges of most of the tools had been altered uniaxially (77.2%), followed by bifacially (15.4%), and uniaxially and bifacial (7.4%). The highest percentage of edge modification was through use-wear (75.8%), followed by flaking and use-wear (12.8%), flaking (10.7%), and battering (0.7%).

Five raw material types are represented in the edge-only tool collection, and these are dominated by locally available raw materials (Table 141). The most frequently represented raw material is black agate (33.3%), followed by gray chalcedony (16.7%), siltstone (16.7%), and slate (16.7%). The only nonlocally available raw material represented in this tool category is rhyolite (16.7%).

*Cores.* Two cores are present in the Stewart Phase chipped-stone assemblage. One of these cores is composed of dark gray chert, and the other is a black agate core. The black agate core is a nodular core 20.0 mm long, 18.0 mm wide, 18.0 mm thick, and 7.1 g. This core was recovered from Feature 233. The chert core was recovered from Feature 144. The chert core is an indeterminate type. This core is 36.0 mm in length, 22.0 mm in width, 20.0 mm in thickness, and 27.1 g in weight.

Table 140. Metric Attributes for Stewart Phase Edge-only Tools.

	Length (mm)	Width (mm)	Thickness (mm)	Weight (mm)
Number of Cases	4	4	5	2
Minimum	1.2	0.8	0.2	0.3
Maximum	29.0	19.0	6.0	1.3
Range	27.8	18.2	5.8	1.0
Mean	8.4	5.6	2.0	0.8
Standard Deviation	13.7	8.9	2.5	0.7

Table 141. Edge-only Tool Counts by Raw Material Class.

Raw Material	Count	Percentage of Cases
Black Agate	2	33.3
Gray Chalcedony	1	16.7
Rhyolite	1	16.7
Siltstone	1	16.7
Slate	1	16.7
Total	6	100.0

### Late Clemson Island

*Diagnostic Bifaces.* The diagnostic bifaces for the late Clemson Island consist of one Levanna, one Madison Triangle, and one other possible Madison Triangle (Figure 62). Table 142 lists the projectile point types with raw material and metric characteristics.

Table 142. Raw Material and Metric Data for Late Clemson Island Diagnostic Bifaces.

Type	Raw Material	Length (mm)	Width (mm)	Thick (mm)	Weight (g)
Levanna	Black Agate	37.4	22.9	6.6	3.7
Madison	Gray Chalcedony	32.4	28.8	5.5	3.8
Madison?	Gray Chalcedony	-	33.2	13.5	17.0

*Non-diagnostic Bifaces.* The 14 non-diagnostic bifaces consist of biface fragments lacking diagnostic hafting elements, and whole bifaces that do not fit into any established type. Metric attributes for non-diagnostic bifaces are presented in Table 143. Locally-available raw materials are the only material types represented in the non-diagnostic biface category (Table 144). These include cherts (35.7%), gray chalcedony (42.9%), black agate (14.3%), and argillite (7.1%).

The following characteristics apply to the Late Clemson Island non-diagnostic bifaces. The percentage with cortex is 50 percent. Edge modification is predominantly bifacial (85.7%), with the remainder unifacial (14.3%). All of these tools are flaked. The breakdown for the number of edges per tool is 21.4 percent with one edge, 64.3 percent with two edges, 7.1 percent with three edges, and 7.2 percent with four edges.



A

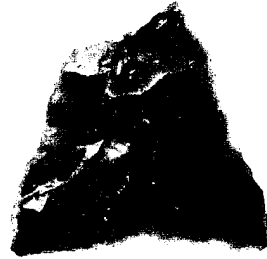

B

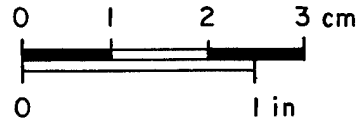

KEY

- A - LEVANNA
- B - MADISON

FIGURE 62

REPRESENTATIVE LATE CLEMSON  
ISLAND DIAGNOSTIC BIFACES

Table 143. Metric Attributes for Late Clemson Island Non-diagnostic Bifaces.

	Length (mm)	Width (mm)	Thickness (mm)	Weight (g)
Number of Cases	8	10	17	1
Minimum	7.3	2.6	3.2	7.3
Maximum	38.4	33.2	19.5	7.3
Range	31.1	30.6	16.3	0.0
Mean	27.4	15.7	7.3	7.3
Standard Deviation	12.2	10.5	4.1	-

Table 144. Late Clemson Island Non-diagnostic Biface Counts by Raw Material Class.

Raw Material	Count	Percentage
Dark Gray Chert	1	7.1
Gray Chert	4	28.6
Gray Chalcedony	6	42.9
Black Agate	2	14.3
Argillite	1	7.1
Total	14	100.0

*Unifaces.* Six unifaces are present in the chipped-stone assemblage. These exhibit a wide range of metric variation (Table 145). None of these tools have evidence of heat alteration. Edge modification on the majority of the tools was unifacial (66.7%), followed by bifacial (16.7%) and combined unifacial and bifacial (16.7%). Edges on the majority of these tools were modified by flaking (50.0%), followed by use-wear (33.3%), and then use-wear and flaking (16.7%). Most pieces have only a single modified edge (43.3%), followed by two edges (36.7%), and three edges (16.7%). Of the 27 total edges, most have edge angles between 46° and 75° (81.5%) and the remainder were less than 46° (18.5%). All of the unifaces are manufactured from locally available raw materials. The most frequently represented raw material class is gray chalcedony (66.7%), followed by gray chert (16.7%) and dark gray chert (16.7%) (Table 146).

Table 145. Metric Attributes for Late Clemson Island Unifaces.

	Length (mm)	Width (mm)	Thickness (mm)	Weight (mm)
Number of Cases	6	6	6	6
Minimum	7.3	4.6	2.9	1.1
Maximum	34.8	24.9	7.5	6.8
Range	27.5	20.3	4.6	5.7
Mean	24.9	14.6	5.4	2.6
Standard Deviation	9.6	7.1	1.7	2.2

Table 146. Late Clemson Island Uniface Counts by Raw Material Class.

Raw Material	Count	Percentage
Dark Gray Chert	1	16.7
Gray Chert	1	16.7
Gray Chalcedony	4	66.7
Total	6	100.0



*Edge-only Tools.* Thirty six edge-only tools are present in the chipped-stone assemblage. The edge-only tools exhibit a wide range of metric variation (Table 147). On the whole, they represent relatively large pieces of debris. The mean width for the collection, 14.6 mm, falls within size grade 2 for lithic debris. When combined with the high percentage of tools with cortex on their dorsal surfaces (83.3%), this indicates that they represent flakes removed early during reduction.

The majority of the tools had only a single retouched or utilized edge (57.7%), although 30.9 percent had two edges, 10.1 percent had three edges, and 1.3 percent had four edges. Of the 82 edges, 36.6 percent had edge angles less than 46°, 30.5 percent had angles between 46° and 75°, and 32.9 percent had angles greater than 75°. None of the edge-only tools had been obviously subjected to heat alteration. The edges of most of the tools had been altered unifacially (72.2%), followed by bifacially (25.0%), and unifacially and bifacially (2.8%). The highest percentage of edge modification was through use-wear only (80.6%), followed by flaking (11.1%), and finally use-wear and flaking (8.3%). Seven raw material types are represented in the edge-only tool collection, and these are dominated by locally-available raw materials (Table 148). The most frequently-represented raw material is gray chalcedony (58.3%), followed by gray chert and dark gray chert (13.9 percent each), black agate (5.6%), gray sandstone (2.8%), and siltstone (2.8%). Nonlocally-available raw materials represented in this tool category consist only of yellow jasper (2.8%).

Table 147. Metric Attributes Late Clemson Island Edge-only Tools.

	Length (mm)	Width (mm)	Thickness (mm)	Weight (mm)
Number of Cases	35	35	35	35
Minimum	10.6	4.3	1.6	0.1
Maximum	46.0	37.0	16.0	30.5
Range	35.4	32.7	14.4	30.4
Mean	26.1	19.0	5.7	3.6
Standard Deviation	7.2	6.0	3.3	5.5

Table 148. Late Clemson Island Edge-only Tool Counts by Raw Material Class.

Raw Material	Count	Percentage of Cases
Dark Gray Chert	5	13.9
Gray Chert	5	13.9
Gray Chalcedony	21	58.3
Yellow Jasper	1	2.8
Black Agate	2	5.6
Gray Sandstone	1	2.8
Siltstone	1	2.8
Total	36	100.0

*Cores.* Nine cores are present in the chipped-stone assemblage. Table 149 presents metric data for the three core types found in the collection, and Table 150 presents raw material categories for the four core types. The most frequently represented core type was indeterminate (44.4%), followed by nodular (33.3 percent), and tabular (22.2%). Of the cores, most were of locally available raw materials, with the most frequently represented being gray chalcedony (44.4%), followed by gray chert (33.3%), and dark gray chert (11.1%). The other chert category, which accounts for 11.1 percent of the material, is unknown as to derivation.



Table 149. Metric Attributes for Late Clemson Island Core Types.

Core Type		Length (mm)	Width (mm)	Thick (mm)	Weight (mm)
Nodular	No. of Cases	3	3	3	3
	Minimum	36.0	20.0	17.0	10.3
	Maximum	44.0	39.0	31.0	62.9
	Range	8.0	19.0	14.0	52.6
	Mean	39.3	26.3	22.7	29.9
	Std. Dev.	4.2	11.0	7.4	28.7
Tabular	No of Cases	2	2	2	2
	Minimum	29.0	24.0	18.0	16.5
	Maximum	47.0	39.0	23.0	28.6
	Range	18.0	15.0	5.0	12.1
	Mean	38.0	31.5	20.5	22.6
	Std. Dev.	12.7	10.6	3.5	8.6
Indeterminate	No of Cases	4	4	4	4
	Minimum	30.0	21.0	10.0	8.4
	Maximum	40.0	30.0	22.0	19.1
	Range	10.0	9.0	12.0	10.7
	Mean	34.8	24.8	16.0	13.7
	Std. Dev.	5.0	3.8	5.0	5.4

Table 150. Late Clemson Island Core Counts by Raw Material Class.

Raw Material	Number of Cases	Percentage of Cases
Dark Gray Chert	1	11.1
Gray Chert	3	33.3
Other Chert	1	11.1
Gray Chalcedony	4	44.4
Total	9	100.0

*Bladelets.* Two bladelets are present in the collection. They measure 13.0 and 14.7 cm long, and weigh 2.1 and 2.3 g, respectively. Both pieces have length measurements approximately three times their width.

#### *Early and Middle Clemson Island*

This section provides brief descriptive summaries for various tool classes recovered from Early and Middle Clemson Island features.

*Diagnostic Bifaces.* The diagnostic bifaces from the Early Clemson Island component include four Jack's Reef Pentagonals, one Jack's Reef Side Notched, four Levanna, and two Madison Triangles. Table 151 lists these types as well as their raw material and metric characteristics. Representative specimens are illustrated in Figure 63.

Table 151. Raw Material and Metric Data for Early/Middle Clemson Island Diagnostic Bifaces.

Type	Raw Material	Length (mm)	Width (mm)	Thick (mm)	Weight (g)
Fishtail-like	Other	46.7	23.3	7.4	6.4
Jack's Reef Pentagonal	Gray Chert	36.7	23.2	17.4	6.0
Jack's Reef Pentagonal	Black Agate	29.1	23.7	9.0	5.4
Jack's Reef Pentagonal	Dark Gray Chert	43.2	24.1	5.7	6.3
Jack's Reef Pentagonal	Gray Chalcedony	32.5	25.8	5.4	4.7
Jack's Reef Side Notched	Gray Chalcedony	34.8	20.5	5.4	2.9
Levanna	Gray Chert	-	2.3	0.4	-
Levanna	Gray Chert	44.0	41.3	6.9	11.0
Levanna	Dark Gray Chert	18.5	-	4.5	-
Levanna	Dark Gray Chert	-	29.9	4.4	2.3
Madison	Gray Chert	-	-	6.8	-
Madison	Gray Chert	21.0	-	4.1	1.3

*Non-diagnostic Bifaces.* The 15 non-diagnostic bifaces consist of biface fragments lacking diagnostic hafting elements, and whole bifaces that do not fit into any established type. These bifaces have a wide range of metric variation (Table 152).

None of these tools show evidence of heat alteration. The majority (58.3%) of the tools lack cortex. Edge modification on all pieces was bifacial. All edges of the tools were modified through flaking. The highest percentage of these tools (64.3%) had two modified edges, followed by three modified edges (21.4%), one modified edge (7.1%), and four modified edges (7.1%).

Locally available raw materials are most frequently represented in the non-diagnostic biface category (Table 153). These include gray chert (53.3%), dark gray chert (26.7%), gray chalcedony (6.7%), and argillite (6.7%). The only nonlocal raw material present in this category is caramel jasper (6.7%).

Table 152. Metric Attributes for Early/Middle Clemson Island Non-diagnostic Bifaces.

	Length(mm)	Width(mm)	Thickness (mm)	Weight(g)
Number of Cases	2	7	13	0
Minimum	18.7	8.7	3.2	-
Maximum	33.1	52.3	22.5	-
Range	14.4	43.6	19.3	-
Mean	25.9	21.4	7.1	-
Standard Deviation	10.2	14.3	5.7	-

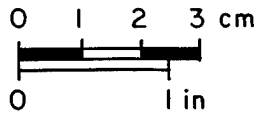
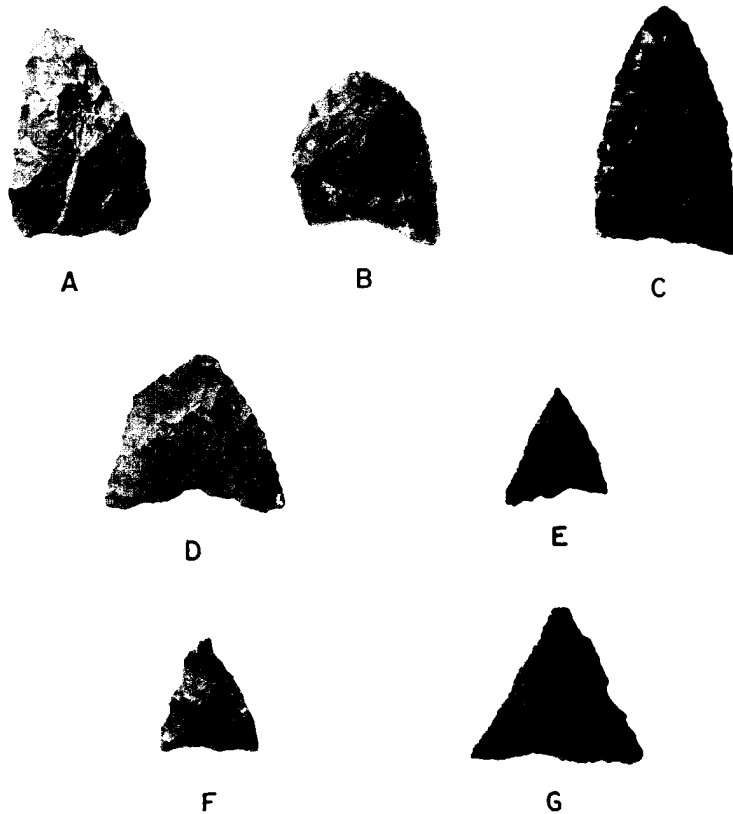

KEY

A, B & C - JACK'S REEF  
 D, E, F & G - LEVANNA

FIGURE 63

REPRESENTATIVE EARLY CLEMSON  
 ISLAND DIAGNOSTIC BIFACES

Table 153. Early/Middle Clemson Island Non-diagnostic Bifaces by Raw Material Class.

Raw Material	Count	Percentage
Dark Gray Chert	4	26.7
Gray Chert	8	53.3
Gray Chalcedony	1	6.7
Caramel Jasper	1	6.7
Argillite	1	6.7
Total	15	100.0

*Unifaces.* Five unifaces are present in the chipped-stone assemblage. These exhibit a wide range of metric variation (Table 154). None of these tools showed evidence of heat alteration. Edge modification on the tools was unifacial (40.0%), bifacial (40.0%), and combined unifacial and bifacial (20.0%). Edges on the majority of these tools were modified through use-wear and flaking (60.0%), and the remainder by use-wear only (40.0%). Most pieces had only a single modified edge (43.3%), followed by two edges (36.7%), and three edges (16.7%). Of the 14 edges, most had edge angles between 46° and 75° (71.4%), followed by those less than 46° (28.6%). All of the unifaces were manufactured from locally-available raw materials. The most frequently represented raw material classes are gray chalcedony and black agate (40.0 percent each), followed by dark gray chert (20.0%) (Table 155).

Table 154. Metric Attributes for Early and Middle Clemson Island Unifaces.

	Length (mm)	Width (mm)	Thickness (mm)	Weight (mm)
Number of Cases	5	5	5	5
Minimum	24.8	18.8	2.4	1.4
Maximum	31.6	25.0	5.5	3.1
Range	6.8	6.2	3.1	1.7
Mean	28.4	21.7	4.3	2.3
Standard Deviation	2.4	2.3	1.4	0.7

Table 155. Early/Middle Clemson Island Uniface Counts by Raw Material Class.

Raw Material	Count	Percentage
Dark Gray Chert	1	20.0
Gray Chalcedony	2	40.0
Black Agate	2	40.0
Total	5	100.0

*Edge-only Tools.* Forty-one edge-only tools are present in the chipped-stone assemblage. The edge-only tools exhibit a wide range of metric variation (Table 156). On the whole, they represent relatively large pieces of debris. The mean width for the collection, 18.3 mm, falls within size grade 2 for lithic debris. When combined with the high percentage of tools with cortex on their dorsal surfaces (68.3%), this indicates that they represent flakes removed early during reduction trajectories.

The majority of the tools had only a single, retouched or utilized edge (57.7%), although 30.9 percent had two edges, 10.1 percent had three edges, and 1.3 percent had four edges. Of the

102 edges, 35.3 percent have edge angles less than 46°, 29.4 percent have edge angles between 46 and 75°, and 35.3 percent have angles greater than 75°. Only one of the edge-only tools has been subjected to heat alteration. The edges of most of the tools had been altered unifacially (80.5%), followed by bifacial (9.8%) and bifacial and unifacial (9.8%). The highest percentage of edge modification was through use-wear (80.5%), followed by flaking and use-wear (14.6%), and flaking (4.9%).

Four raw material types are represented in the edge-only tool collection, and these are all locally-available materials (Table 157). The most frequently represented raw material is gray chalcedony (46.3%), followed by gray chert (26.8%), dark gray chert (22.0%), and black agate (4.9%).

Table 156. Metric Attributes for Early/Middle Clemson Island Edge-only Tools.

	Length (mm)	Width (mm)	Thickness (mm)	Weight (mm)
Number of Cases	40	40	40	40
Minimum	15.8	9.5	1.9	0.4
Maximum	46.0	37.0	18.0	25.2
Range	30.2	27.5	16.1	24.8
Mean	25.5	18.3	6.0	3.1
Standard Deviation	5.9	6.2	4.3	4.5

Table 157. Early/Middle Clemson Island Edge-only Tool Counts by Raw Material Class.

Raw Material	Count	Percentage of Cases
Dark Gray Chert	9	22.0
Gray Chert	11	26.8
Gray Chalcedony	19	46.3
Black Agate	2	4.9
Total	41	100.0

*Cores.* Seven cores are present in the chipped-stone assemblage. Table 158 presents metric data for the three core types found in the collection, and Table 159 presents raw material categories for the three core types. The most frequently represented core type is indeterminate (57.1%), followed by tabular (28.6 percent each), and nodular (14.3%). All of the cores are of locally-available raw materials, with the most frequently represented being gray chalcedony (57.1%), followed by dark gray chert (28.6%), and gray banded chert (14.3%).

### *Middle Woodland*

*Diagnostic Bifaces.* Only two diagnostic bifaces are present in the Middle Woodland collection. One is a Fox Creek-like biface. This piece is a rhyolite biface, 58.3 mm in long, 30.5 mm wide, 10.5 mm thick, weighing 16.5 g. The other biface is a Meadowood-like biface 41.3 mm long, 21.5 mm wide, 4.7 mm thick, weighing 4.4 g. The raw material type of this piece is dark gray chert.

*Non-diagnostic Bifaces.* Two non-diagnostic bifaces are present in the Middle Woodland assemblage. One is a drill and is composed of dark gray chert, and the other is an untyped,

stemmed biface made of rhyolite. The drill is 32.1 mm long and 7.6 mm thick. Neither width nor weight were recorded on this incomplete specimen. The untyped stemmed specimen is 41.4 mm wide and 9.1 mm thick. Neither length nor weight were recorded for this incomplete specimen.

Table 158. Metric Attributes for Early/Middle Clemson Island Core Types.

Core Type		Length (mm)	Width (mm)	Thick (mm)	Weight (mm)
Nodular	No of Cases	1	1	1	1
	Minimum	33.0	23.0	13.0	8.0
	Maximum	33.0	23.0	13.0	8.0
	Range	0.0	0.0	0.0	0.0
	Mean	33.0	-	13.0	8.0
	Std. Dev.	-	-	-	-
Tabular	No of Cases	2	2	2	2
	Minimum	27.0	26.0	12.0	7.5
	Maximum	52.0	44.0	21.0	35.4
	Range	25.0	18.0	9.0	27.9
	Mean	39.5	35.0	16.5	21.5
	Std. Dev.	17.7	12.7	6.4	19.7
Indeterminate	No of Cases	4	4	4	4
	Minimum	19.0	14.0	13.0	4.3
	Maximum	30.0	26.0	19.0	9.9
	Range	11.0	12.0	6.0	5.6
	Mean	24.0	19.3	15.0	7.3
	Std. Dev.	4.7	5.1	2.7	2.6

Table 159. Early/Middle Clemson Island Core Counts by Raw Material Class.

Raw Material	Number of Cases	Percentage of Cases
Dark Gray Chert	2	28.6
Gray Chalcedony	4	57.1
Gray Banded Chert	1	14.3
Total	7	100.0

*Edge-only Tools.* Two edge-only tools are present in the Middle Woodland assemblage. Both are composed of dark gray chert. The first has one edge with an edge angle greater than 75 degrees. The second has two edges both of which have an edge angle between 46 and 75 degrees. Metric measurements for this piece are 37.0 mm long, 24.0 mm wide, 9.0 mm thick, weighing 4.9 g. The second tools is 26.0 mm long, 18.0 mm wide, 6.0 mm thick, weighing 2.1 g. Neither tool is heat treated. Both tools are unifacially modified by use-wear.

#### *Early Woodland*

*Diagnostic Bifaces.* The Early Woodland component consists of only four diagnostic bifaces. All of these are Meadowood points. Table 160 lists these diagnostics, as well as their metric characteristics.

Table 160. Raw Material and Metric Data for Early Woodland Diagnostic Bifaces.

Type	Raw Material	Length (mm)	Width (mm)	Thick (mm)	Weight (g)
Meadowood	Gray Chert	-	28.1	4.0	-
Meadowood	Gray Chert	-	35.6	4.1	-
Meadowood	Gray Chert	-	23.1	4.1	-
Meadowood	Gray Chert w/ Light Bands	-	2.8	0.4	-

### Orient Phase

*Diagnostic Bifaces.* The diagnostic bifaces associated with the Orient Phase component are listed in Table 161. There are thirteen Orient Fishtails, and one possible Orient Fishtail. The Orient Fishtail is considered by Justice (1987) to be part of the Susquehanna Cluster. Figure 64 illustrates representative bifaces of this type.

Table 161. Raw Material and Metric Data for Orient Phase Diagnostic Bifaces.

Type	Raw Material	Length (mm)	Width (mm)	Thick (mm)	Weight (g)
Orient Fishtail	Dark Gray Chert	27.7	14.9	7.0	2.5
Orient Fishtail	Gray Chert	31.7	14.9	6.0	2.8
Orient Fishtail	Red Jasper	37.5	15.0	7.3	3.8
Orient Fishtail	Gray Chert	40.4	15.1	6.2	3.5
Orient Fishtail	Gray Chert	30.7	11.8	7.2	2.5
Orient Fishtail	Gray Chert	-	14.3	6.8	-
Orient Fishtail	Argillite	42.1	19.4	8.1	4.9
Orient Fishtail	Gray Chert	27.3	16.2	5.3	2.1
Orient Fishtail	Dark Gray Chert	47.7	18.6	7.6	5.8
Orient Fishtail	Dark Gray Chert	4.5	1.6	0.8	4.9
Orient Fishtail	Gray Chert	-	1.6	0.4	1.7
Orient Fishtail	Black Chalcedony	-	1.8	0.9	4.6
Orient Fishtail	Red Jasper	-	-	-	-
Orient Fishtail?	Dark Gray Chert	-	-	4.3	-

*Non-diagnostic Bifaces.* The 57 non-diagnostic bifaces consist of biface fragments lacking diagnostic hafting elements, and whole bifaces that do not fit into any established type. These bifaces have a wide range of metric variation (Table 162). Only five of these tools show definite evidence of heat alteration. The majority (73.7%) of the tools lack cortex. As would be anticipated, edge modification on most pieces was bifacial (96.5%), while modification was unifacial on 3.5 percent of the pieces. The edges of most of the tools were modified through flaking (93.0%), followed by flaking and battering and use-wear and flaking (3.5%). Over half of these tools (57.9%) had two modified edges, followed by one modified edge (28.1%), three modified edges (10.5%), four modified edges (1.8%), and five modified edges (1.8%).

Locally-available raw materials are most frequently represented in the non-diagnostic biface category. These include cherts (47.4%), gray chalcedony (5.3%), and argillite (14.0%). The nonlocal raw materials present in this category are rhyolite (10.5%) and jasper (5.3%).



A



B



C



D



E



F



G



H

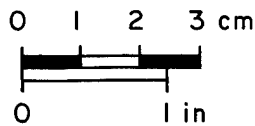

KEY

A TO H - ORIENT FISHTAIL

FIGURE 64

REPRESENTATIVE ORIENT  
DIAGNOSTIC BIFACES



Table 162. Metric Attributes for Orient Phase Non-diagnostic Bifaces.

	Length(mm)	Width(mm)	Thickness (mm)	Weight(g)
Number of Cases	18	29	43	12
Minimum	1.4	1.4	0.4	1.4
Maximum	80.1	54.1	31.3	89.4
Range	78.7	52.7	30.9	88.0
Mean	36.3	18.8	7.4	12.7
Standard Deviation	18.1	12.7	6.0	24.7

Table 163. Orient Phase Non-diagnostic Biface Counts by Raw Material Class.

Raw Material	Count	Percentage
Dark Gray Chert	14	24.6
Gray Chert	13	22.8
Other Chert	4	7.0
Gray Chalcedony	3	5.3
Yellow Jasper	2	3.5
Red Jasper	1	1.8
Black Agate	2	3.5
Rhyolite	6	10.5
Argillite	8	14.0
Other	2	3.5
Gray Sandstone	1	1.8
Brown Chert	1	1.8
Total	57	100.0

*Unifaces.* Eight unifaces are present in the Orient chipped-stone assemblage. These exhibit a wide range of metric variation (Table 164). One of these tools shows evidence of heat alteration. Edge modification on the majority of the tools was unifacial and bifacial (50.0%), followed by unifacial (37.5%), and bifacial (12.5%). Edges on the majority of these tools were modified through flaking (50.0%), followed by flaking and battering, and use-wear and flaking, each 25.0 percent. Most pieces had only a single, modified edge (43.3%), followed by two edges (36.7%), and three edges (16.7%). Of the 28 edges, most have edge angles between 46° and 75° (50.0%), followed by greater than 75° (32.1%), and between 46° and 75° (17.9%).

Half of the unifaces are manufactured from locally-available raw materials. The most frequently represented local raw material class is gray chalcedony (46.7%), followed by gray chert (23.3%) and black agate (16.7%) (Table 165). Rhyolite represents 37.5 percent of the unifaces, while red jasper represents 12.5 percent (Table 165).

Table 164. Metric Attributes of Orient Phase Unifaces.

	Length (mm)	Width (mm)	Thickness (mm)	Weight (mm)
Number of Cases	5	6	7	3
Minimum	20.4	17.0	5.1	0.8
Maximum	62.6	59.0	22.0	67.3
Range	42.2	42.0	16.9	66.5
Mean	40.3	27.4	11.9	24.5
Standard Deviation	16.2	15.7	6.1	37.1



Table 165. Orient Phase Uniface Counts by Raw Material Class.

Raw Material	Count	Percentage
Dark Gray Chert	1	12.5
Gray Chert	1	12.5
Gray Chalcedony	1	12.5
Red Jasper	1	12.5
Rhyolite	3	37.5
Argillite	1	12.5
Total	8	100.0

*Edge-only Tools.* Twenty five edge-only tools are present in the chipped-stone assemblage. The edge-only tools exhibit a wide range of metric variation (Table 166). On the whole, they represent relatively large pieces of debris. The mean width for the collection, 11.9 mm, falls within size grade 3 for lithic debris. When combined with the high percentage of tools with cortex on their dorsal surfaces (48.0%), this indicates that many represent flakes removed early during reduction trajectories.

The majority of the tools had only a single, retouched or utilized edge (72.0%), although 16.0 percent had two edges, 8.0 percent had three edges, and 4.0 percent had four edges. Of the 68 edges, 37.7 percent had edge angles less than 46°, 56.6 percent between 46° and 75°, and 5.7 percent greater than 75°. Only three of the edge-only tools had been obviously subjected to heat alteration. The edges of most of the tools had been altered unilaterally (76.0%), followed by bifacially (12.0%) and unilaterally and bifacially (12.0%). The highest percentage of edge modification was through use-wear (48.0%), followed by flaking (40.0%), flaking and use-wear (8.0%), and battering (4.0%).

Eleven raw material types are represented in the edge-only tool collection, and these are dominated by locally-available raw materials (Table 167). The most frequently-represented raw materials are chalcedony (40.0%), followed by chert (28.0%). The only nonlocally-available raw material represented in this tool category is jasper (16.0%).

*Cores.* Six cores are present in the chipped-stone assemblage. Table 168 presents metric data for the three core types found in the collection, and Table 169 presents raw material categories for the three core types. The most frequently represented core type was indeterminate (53.6%), followed by nodular (17.9%), and tabular (10.6%). All of the cores were of locally-available raw materials, with the most frequently represented being gray chert (50.0%), followed by gray chalcedony, black agate, and brown-banded chert (16.7 percent each).

Table 166. Metric Attributes for Orient Phase Edge-only Tools.

	Length (mm)	Width (mm)	Thickness (mm)	Weight (mm)
Number of Cases	22	23	24	24
Minimum	0.9	0.9	0.3	0.1
Maximum	55.6	37.0	26.2	78.4
Range	54.7	36.1	26.0	78.3
Mean	17.2	11.9	3.9	4.7
Standard Deviation	13.6	8.6	5.2	15.7

Table 167. Orient Phase Edge-only Tool Counts by Raw Material Class.

Raw Material	Count	Percentage of Cases
Dark Gray Chert	4	16.0
Gray Chert	2	8.0
White Chert	1	4.0
Gray Chalcedony	9	36.0
Other Chalcedony	1	4.0
Yellow Jasper	3	12.0
Burgundy Jasper	1	4.0
Black Agate	1	4.0
Argillite	1	4.0
Brown Chert	1	4.0
Chert w/ Cryptocrystalline	1	4.0
Total	25	100.0

Table 168. Metric Attributes for Orient Phase Core Types.

Core Type		Length (mm)	Width (mm)	Thick (mm)	Weight (mm)
Nodular	No of Cases	1	1	1	1
	Minimum	31.0	25.0	24.0	20.0
	Maximum	31.0	25.0	24.0	20.0
	Range	0.0	0.0	0.0	0.0
	Mean	31.0	25.0	24.0	20.0
	Std. Dev.	-	-	-	-
Tabular	No of Cases	1	1	1	1
	Minimum	64.0	52.0	19.0	58.1
	Maximum	64.0	52.0	19.0	58.1
	Range	0.0	0.0	0.0	0.0
	Mean	64.0	52.0	19.0	58.1
	Std. Dev.	-	-	-	-
Indeterminate	No of Cases	4	4	4	4
	Minimum	34.0	21.0	11.0	14.5
	Maximum	45.0	39.0	22.0	20.2
	Range	11.0	18.0	11.0	5.7
	Mean	40.0	31.5	17.8	17.2
	Std. Dev.	5.4	8.2	5.3	2.7

Table 169. Orient Phase Core Counts by Raw Material Class.

Raw Material	Number of Cases	Percentage of Cases
Gray Chert	3	50.0
Gray Chalcedony	1	16.7
Black Agate	1	16.7
Brown Banded	1	16.7
Total	6	100.0

*Multifaces.* There are two multifaces in the collection. Both are relatively small, weighing 7.1 and 8.0 grams, and are thick pieces, with width-thickness ratios less than 1.5.

Table 170. Raw Material and Metric Data for Terminal Archaic Diagnostic Bifaces.

Type	Raw Material	Length (mm)	Width (mm)	Thick (mm)	Weight (g)
Bare Island	Rhyolite	57.7	23.6	10.4	13.0
Bare Island	Rhyolite	49.0	25.6	9.3	10.2
Bare Island	Rhyolite	58.6	27.1	9.7	12.8
Canfield Island Lobate	Rhyolite	47.6	28.4	9.8	12.2
Canfield Island Lobate	Rhyolite	-	29.1	9.8	-
Canfield Island Lobate	Rhyolite	-	31.3	9.7	-
Canfield Island Lobate	Rhyolite	-	2.4	0.8	-
Canfield Island Lobate	Rhyolite	66.6	33.6	10.6	19.6
Canfield Island Lobate	Rhyolite	-	-	-	-
Canfield Island Lobate	Rhyolite	54.2	46.3	7.9	18.9
Canfield Island Lobate	Rhyolite	64.1	32.6	11.7	21.0
Canfield Island Lobate	Rhyolite	56.2	27.5	8.9	12.6
Canfield Island Lobate	Rhyolite	45.4	28.0	8.4	9.7
Canfield Island Lobate	Rhyolite	48.1	33.8	8.0	12.5
Canfield Island Lobate	Rhyolite	37.9	24.8	9.9	7.9
Canfield Island Lobate	Argillite	49.0	25.9	7.6	5.3
Canfield Island Lobate	Gray Chert	71.6	32.8	10.2	19.2
Canfield Island Lobate	Rhyolite	56.0	29.3	10.9	18.1
Canfield Island Lobate	Rhyolite	42.0	28.8	9.1	8.6
Canfield Island Lobate	Argillite	45.8	27.9	10.7	12.0
Canfield Island Lobate	Rhyolite	-	-	7.8	-
Canfield Island Lobate	Rhyolite	-	27.4	9.6	-
Canfield Preform	Rhyolite	50.5	-	7.8	-
Canfield Island Lobate	Gray Chalcedony	-	-	-	-
Canfield Island Lobate	Rhyolite	-	-	-	-
Canfield Island Lobate	Rhyolite	-	-	-	-
Canfield Island Lobate	Rhyolite	57.2	35.5	9.4	16.0
Canfield Island Lobate	Rhyolite	-	34.6	10.6	-
Canfield Island Lobate	Other Chert	37.5	31.1	10.1	11.6
Lehigh	Rhyolite	42.2	25.0	8.3	7.2
Lehigh	Rhyolite	38.1	32.1	9.5	9.5
Lehigh	Rhyolite	50.6	33.2	9.9	12.9
Lehigh	Rhyolite	66.1	39.7	12.1	21.9
Lehigh	Rhyolite	62.6	38.8	10.5	17.4
Lehigh	Rhyolite	-	-	-	-
Lehigh	Rhyolite	61.4	40.0	10.4	21.8
Susquehanna	Other Chert	43.4	23.1	7.6	7.6
Susquehanna	Rhyolite	-	26.0	6.8	-
Susquehanna	Rhyolite	-	29.8	7.8	-
Susquehanna	Rhyolite	-	-	0.6	-

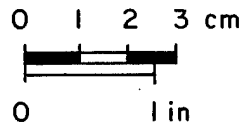
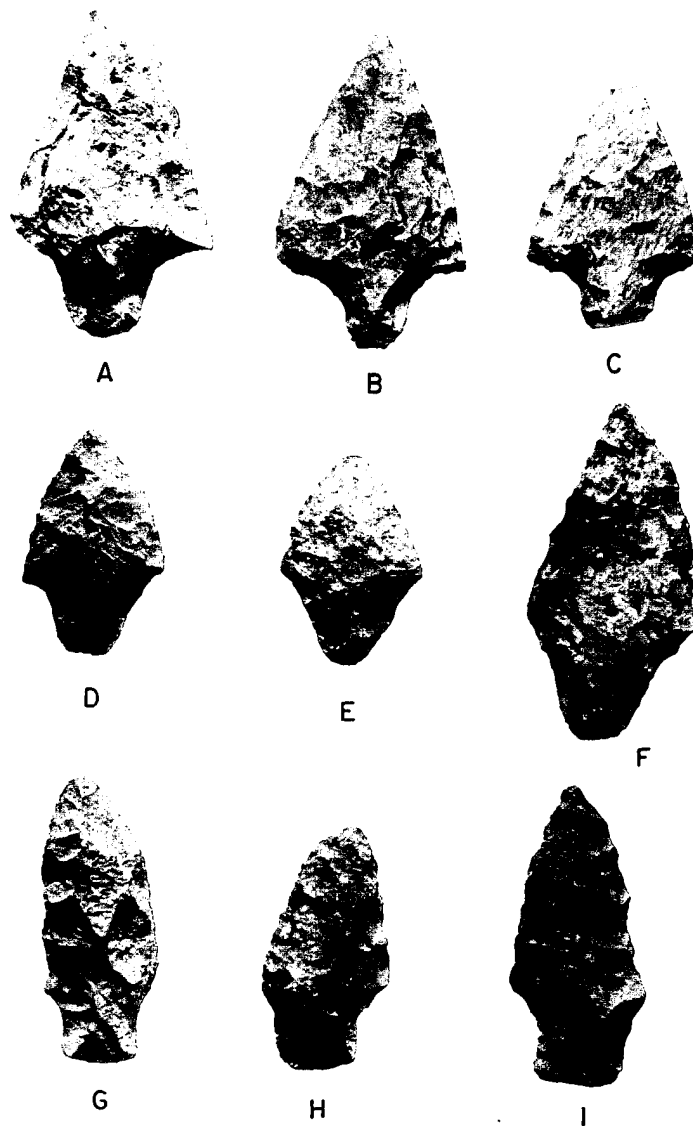

KEY

- A, B & C LEHIGH COENS - KRISPEN
- D, E & F - CANFIELD LOBATE
- G, H & I - BARE ISLAND

FIGURE 65

REPRESENTATIVE TERMINAL  
ARCHAIC DIAGNOSTIC BIFACES

*Terminal Archaic - Canfield/Susquehanna*

*Diagnostic Bifaces.* Four diagnostic biface types are part of the Terminal Archaic assemblage. These include Bare Island, Canfield Island Lobate, Lehigh, and Susquehanna. The specimens of these types are listed in Table 170, where raw material type and some metric characteristics are listed as well. The assemblage includes three Bare Island, twenty five Canfield Island Lobates, one Canfield preform, seven Lehigh, and four Susquehanna. All but four of the bifaces are manufactured from rhyolite. Some representative specimens of these types are illustrated in Figure 65. The Bare Island bifaces were recovered from Feature 338, a cache that also contained four Canfield, and three Lehigh, bifaces.

*Non-diagnostic Bifaces.* The 47 non-diagnostic bifaces consist of biface fragments lacking diagnostic hafting elements, and whole bifaces that do not fit into any established type. These bifaces have a wide range of metric variation (Table 171). Only two of these tools show evidence of heat alteration. The majority (89.4%) of the tools lack cortex. As would be anticipated, edge modification on most pieces was bifacial (95.7%), while modification was unifacial and bifacial on 2.1 percent of the pieces, use-wear and flaking on 4.3 percent, and not applicable on 2.1 percent of the tools. The edges of most of the tools were modified through flaking (93.6%), followed by flaking and battering (2.1%). Well over half of these tools (61.6%) had two modified edges, followed by one modified edge (19.2%), three modified edges (15.1%), and four modified edges (4.1%).

Locally-available raw materials, as a whole, are most frequently represented in the non-diagnostic biface category. These include gray chert (21.3%), dark gray chert (17.0%), gray chalcedony (8.5%), and argillite (8.5%). However, a nonlocal material, rhyolite, is the single largest raw material type in this collection (34.0%).

Table 171. Metric Attributes for Non-diagnostic Terminal Archaic Bifaces.

	Length(mm)	Width(mm)	Thickness (mm)	Weight(g)
Number of Cases	4	24	32	3
Minimum	15.2	1.6	0.6	1.7
Maximum	70.9	66.5	17.1	20.3
Range	55.7	64.9	16.5	18.6
Mean	49.5	24.3	7.4	9.5
Standard Deviation	24.0	16.6	3.9	9.6

Table 172. Non-diagnostic Terminal Archaic Biface Counts by Raw Material Class.

Raw Material	Count	Percentage
Dark Gray Chert	8	17.0
Gray Chert	10	21.3
Other Chert	1	2.1
Gray Chalcedony	4	8.5
Rhyolite	16	34.0
Argillite	4	8.5
Brown Chert	1	2.1
Light Brown Chert	1	2.1
Gray Banded Chert	2	4.3
Total	47	100.0

*Unifaces.* Five unifaces are present in the chipped-stone assemblage. These exhibit a wide range of metric variation (Table 173). None of these tools evidenced heat alteration. Edge modification on the majority of the tools was unifacial (60.0%) followed by bifacial (40.0%). Of the five unifaces, two (40.0%) are flaked, and one each is flaked and battered, use-wear only, and use-wear and flaked. Most pieces have two modified edges (62.5%), followed by one edge (25.0%), and three edges (12.5%). Of the sixteen edges, most had edge angles of less than 46° (66.7%), followed by 46° to 75° (33.3%).

Two of the unifaces are manufactured from locally-available raw materials: dark gray chert, and argillite, representing 20 percent each. Rhyolite comprises 60.0 percent of the unifaces (3 tools) (Table 174).

Table 173. Metric Attributes for Terminal Archaic Unifaces.

	Length (mm)	Width (mm)	Thickness (mm)	Weight (mm)
Number of Cases	2	2	3	2
Minimum	32.2	18.4	4.0	0.8
Maximum	40.6	33.6	10.1	2.9
Range	8.4	15.2	6.1	2.1
Mean	36.4	26.0	6.5	1.9
Standard Deviation	5.9	10.7	3.2	1.5

Table 174. Terminal Archaic Uniface Counts by Raw Material Class.

Raw Material	Count	Percentage
Dark Gray Chert	1	20.0
Rhyolite	3	60.0
Argillite	1	20.0
Total	5	100.0

*Edge-only Tools.* Seventeen edge-only tools are present in the chipped-stone assemblage. The edge-only tools exhibit a wide range of metric variation (Table 176). On the whole, they represent relatively large pieces of debris. The mean width for the collection, 19.6 mm, falls within size grade 2 for lithic debris.

The majority of the tools had only a single retouched or utilized edge (76.5%), although 17.7 percent had two edges, and 5.9 percent had four edges. Of the 32 edges, half (50.0%) have edge angles less than 46°, 31.3 percent have angles between 46 and 75°, and 18.8 percent have angles greater than 75°. Only one of the edge-only tools had been obviously subjected to heat alteration. The edges of most of the tools had been altered unifacially (88.2%), followed by bifacially (11.8%). The highest percentage of edge modification was through use-wear (64.7%), followed by flaking (23.5%), flaking and use-wear (5.9%), and battering (5.9%).

Eight raw material types are represented in the edge-only tool collection, and these are dominated by locally-available raw materials (Table 176). The most frequently represented raw materials are the cherts (52.8%). Nonlocally-available raw materials represented in this tool category consist of rhyolite (11.8%), and yellow jasper (5.9%).



Table 175. Metric Attributes for Terminal Archaic Edge-only Tools.

	Length (mm)	Width (mm)	Thickness (mm)	Weight (mm)
Number of Cases	15	17	17	12
Minimum	1.7	2.1	0.4	0.3
Maximum	85.0	61.2	21.9	165.5
Range	83.3	59.1	21.5	165.2
Mean	25.8	19.6	4.8	16.5
Standard Deviation	18.5	12.9	4.9	47.1

Table 176. Terminal Archaic Edge-only Tool Counts by Raw Material Class.

Raw Material	Count	Percentage of Cases
Dark Gray Chert	3	17.7
Gray Chert	4	23.5
Gray Chalcedony	1	5.9
Yellow Jasper	1	5.9
Rhyolite	2	11.8
Argillite	4	23.5
Brown Banded Chert	1	5.9
Gray Banded Chert	1	5.9
Total	17	100.0

*Cores.* Two cores are present in the chipped-stone assemblage. Table 177 presents metric data for the two core types found in the collection, and Table 178 presents raw material categories for the two core types. One core is a tabular type composed of oolitic chert. The other core is a gray chalcedony of indeterminate type.

Table 177. Metric Attributes for Terminal Archaic Core Types.

Core Type		Length (mm)	Width (mm)	Thick (mm)	Weight (mm)
Tabular	No of Cases	1	1	1	1
	Minimum	65.9	25.0	24.0	58.2
	Maximum	65.9	25.0	24.0	58.2
	Range	0.0	0.0	0.0	0.0
	Mean	65.9	25.0	24.0	58.2
	Std. Dev.	-	-	-	-
Indeterminate	No of Cases	1	1	1	1
	Minimum	30.8	23.7	20.0	15.8
	Maximum	30.8	23.7	20.0	15.8
	Range	0.0	0.0	0.0	0.0
	Mean	30.8	23.7	20.0	15.8
	Std. Dev.	-	-	-	-

Table 178. Terminal Archaic Core Counts by Raw Material Class.

Raw Material	Number of Cases	Percentage of Cases
Gray Chert	1	50.0
Oolitic	1	50.0
Total	2	100.0

### Piedmont

*Diagnostic Bifaces.* Nine diagnostic bifaces are present in the Piedmont materials. These include five Bare Islands and four Lamokas (Figure 66). A list of these specimens and accompanying raw material type and metric data are presented in Table 179.

Table 179. Raw Material and Metric Data for Diagnostic Piedmont Bifaces.

Type	Raw Material	Length (mm)	Width (mm)	Thick (mm)	Weight (g)
Bare Island	Argillite	46.8	-	10.3	-
Bare Island	Dark Gray Chert	-	-	-	-
Bare Island	Argillite	-	28.3	9.3	-
Bare Island	Rhyolite	62.7	21.1	11.1	13.7
Bare Island	Rhyolite	59.0	27.1	10.9	16.4
Lamoka	Other Chert	-	-	8.0	-
Lamoka	Rhyolite	40.0	31.0	8.0	7.9
Lamoka	Gray Chert	38.2	18.0	7.1	4.6
Lamoka	Dark Gray Chert	-	16.8	6.4	4.4

*Non-diagnostic Bifaces.* The six non-diagnostic bifaces consist of biface fragments lacking diagnostic hafting elements, and whole bifaces that do not fit into any established type. These bifaces have a wide range of metric variation (Table 180).

None of these tools shows evidence of heat alteration. The majority (83.3%) of the tools lack cortex. All pieces are bifacial. The edges of all of the tools were modified through flaking. Well over half of these tools (83.3%) had two modified edges, followed by one modified edge (16.7%).

Locally-available raw materials are most frequently represented in the non-diagnostic biface category (Table 181). These include gray chert (50.0%), dark gray chert (33.3%), and argillite (16.7%). The only nonlocal raw material present in this category is one rhyolite tool.

Table 180. Metric Attributes for Non-diagnostic Piedmont Bifaces.

	Length (mm)	Width (mm)	Thickness (mm)	Weight (g)
Number of Cases	1	2	2	0
Minimum	59.4	1.4	0.4	-
Maximum	59.4	12.9	6.0	-
Range	0.0	11.5	5.6	-
Mean	59.4	7.2	3.2	-
Standard Deviation	-	8.1	4.0	-



A



B



C

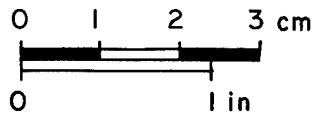

KEY

A & B - BARE ISLAND

C - LAMOKA

FIGURE 66

REPRESENTATIVE PIEDMONT  
DIAGNOSTIC BIFACES

Table 181. Non-diagnostic Piedmont Biface Raw Material Frequencies.

Raw Material	Count	Percentage
Dark Gray Chert	2	33.3
Gray Chert	3	50.0
Rhyolite	1	16.7
Total	6	100.0

*Edge-only Tools.* Five edge-only tools are present in the chipped-stone assemblage. The edge-only tools exhibit a wide range of metric variation (Table 182). On the whole, they represent relatively large pieces of debris. The mean width for the collection, 24.0 mm, falls within size grade 2 for lithic debris. When combined with the high percentage of tools with cortex on their dorsal surfaces (75.0%), this suggests that they represent flakes removed early during reduction trajectories.

The majority of the tools had only a single retouched or utilized edge (76.5%), although 17.7 percent had two edges, and 5.9 percent had four edges. Of the 9 total edges, only 20.0 percent have edge angles less than 46°, while 80.0 percent have angles between 46 and 75°. Only two of the edge-only tools had been obviously subjected to heat alteration. The edges of two of the tools had been altered uniaxially (50.0%), followed by bifacially (25.0%), and unifacially and bifacially (25.0%). The highest percentage of edge modification was flaking (75.0%), followed by use-wear (25.0%).

Four raw material types are represented in the edge-only tool collection, and these are dominated by locally-available raw materials (Table 183). The most frequently represented raw materials are cherts (60.0%), followed by argillite (20.0%). There is one, yellow jasper, edge-only tool in this collection.

Table 182. Metric Attributes for Piedmont Edge-only Tools.

	Length (mm)	Width (mm)	Thickness (mm)	Weight (mm)
Number of Cases	5	5	5	5
Minimum	2.6	1.5	0.5	1.0
Maximum	67.5	52.4	20.5	64.2
Range	64.9	50.9	20.0	63.2
Mean	36.0	24.0	9.1	21.6
Standard Deviation	27.8	21.3	8.3	28.9

Table 183. Piedmont Edge-only Tool Counts by Raw Material Class.

Raw Material	Count	Percentage of Cases
Gray Chert	2	40.0
Other Chert	1	20.0
Yellow Jasper	1	20.0
Argillite	1	20.0
Total	5	100.0

*Cores.* The Piedmont assemblage contained only one core. This core is composed of dark-gray chert, and is 46.0 mm long, 40.0 mm wide, 21.0 thick, weighing 34.4 g.

## *Late Laurentian*

*Diagnostic Bifaces.* Fifty-one diagnostic bifaces are present in the late Laurentian assemblage representing six types: thirteen Brewerton Corner Notched, two Brewerton Eared, thirty one Brewerton Side Notched, one Beekman, two Otter Creek, and two Vosburg. Table 184 lists the specimens of these types, with accompanying information regarding raw material type and metric attributes. Representative specimens of these types are presented in Figure 67.

*Non-diagnostic Bifaces.* The 95 non-diagnostic bifaces consist of biface fragments lacking diagnostic hafting elements, and whole bifaces that do not fit into any established type. These bifaces have a wide range of metric variation (Table 185).

Only six of these tools show evidence of heat alteration. The majority (83.2%) of the tools lack cortex. As would be anticipated, edge modification on most pieces was bifacial (96.8%), while modification was unifacial on 1.1 percent of the pieces, both bifacial and unifacial on 2.1 percent, and use-wear and flaking on (1.1%) of the tools. The edges of most of the tools were modified through flaking (96.8%), followed by flaking and battering (2.1%). Well over half of these tools (57.9%) have two modified edges, followed by one modified edge (22.1%), three modified edges (16.8%), and four modified edges (4.1%).

Locally-available raw materials are most frequently represented in the non-diagnostic biface category (Table 186). These include gray chert (32.9%), gray chalcedony (23.3%), dark gray chert (15.1%), and argillite (13.7%). The only nonlocal raw material present in this category was yellow jasper (3.2%).

*Unifaces.* Nine unifaces are present in the chipped-stone assemblage. These exhibit a wide range of metric variation (Table 187). None of these tools showed evidence of heat alteration. Edge modification on the majority of the tools was unifacial (55.6%), followed by bifacial (22.2%), and combined unifacial and bifacial (22.2%). Edges on the majority of these tools were modified through flaking (77.8%), followed by use-wear only (11.1%), and use and battering (11.1%). Most pieces had only a single, modified edge (63.0%), followed by two edges (29.6%), and three edges (7.4%). Of 30 edges, most had edge angles between 46° and 75° (73.3%), followed by those less than 46° (16.7%), and greater than 75° (10.0%). All of the unifaces were manufactured from locally-available raw materials (Table 188). These materials include cherts and black agate.

*Edge-only Tools.* Twenty-seven edge-only tools are present in the chipped-stone assemblage. The edge-only tools exhibit a wide range of metric variation (Table 189). On the whole, they represent relatively large pieces of debris. The mean width for the collection, 18.4 mm, falls within size grade 2 for lithic debris. When combined with the high percentage of tools with cortex on their dorsal surfaces (44.4%), this indicates that they tend to represent flakes removed early during reduction trajectories.

The majority of the tools had only a single retouched or utilized edge (63.0%), although 29.6 percent had two edges, and 7.4 percent had three edges. Of 65 edges, 27.7 percent have edge angles less than 46°, 58.5 percent have angles between 46 and 75°, and 13.8 percent have angles greater than 75°. Twenty-three of the edge-only tools had been obviously subjected to heat alteration. The edges of most of the tools had been altered unifacially (77.8%), followed by unifacially and bifacially (14.8%), and bifacially (7.4%). The highest percentage of edge modification was through flaking (44.4%), followed by use-wear (29.6%), use-wear and flaking (18.5%), and flaking and battering (7.4%).



A



B



C



D



E



F



G



H



I



J

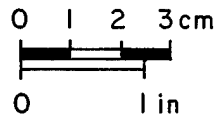

- A, B, D, F & G - BREWERTON SIDE NOTCHED
- C & E - BREWERTON EARED
- H & I - BREWERTON CORNER NOTCHED
- J - BEEKMAN TRIANGLE

FIGURE 67

REPRESENTATIVE LATE  
LAURENTIAN DIAGNOSTIC BIFACES

Table 184. Raw Material and Metric Data for Late Laurentian Diagnostic Bifaces.

Type	Raw Material	Length (mm)	Width (mm)	Thick (mm)	Weight (g)
Brewerton Corner Notched	Dark Gray Chert	21.5	22.8	6.4	3.2
Brewerton Corner Notched	Gray Chert	-	22.0	6.0	1.6
Brewerton Corner Notched	Dark Gray Chert	26.1	-	-	-
Brewerton Corner Notched	Gray Chalcedony	22.2	17.5	7.0	2.4
Brewerton Corner Notched	Brown Chert	42.8	-	-	-
Brewerton Corner Notched	Gray Chert	-	26.6	7.3	6.2
Brewerton Corner Notched	Rhyolite	-	29.2	10.0	-
Brewerton Corner Notched	Gray Chert	30.6	21.4	6.8	4.2
Brewerton Corner Notched	Argillite	38.9	26.6	7.8	6.3
Brewerton Corner Notched	Gray Chert	-	19.1	-	-
Brewerton Corner Notched	Argillite	-	33.3	6.8	12.8
Brewerton Corner Notched	Gray Chert	-	-	3.9	-
Brewerton Corner Notched	Dark Gray Chert	-	26.7	6.2	5.6
Brewerton Eared	Gray Chert	28.3	18.4	6.4	2.4
Brewerton Eared	Dark Gray Chert	19.0	18.6	7.5	2.2
Brewerton Side Notched	Rhyolite	-	17.9	5.3	-
Brewerton Side Notched	Other Chalcedony	-	-	-	-
Brewerton Side Notched	Slate	46.3	23.6	6.9	8.3
Brewerton Side Notched	Argillite	-	21.4	8.8	-
Brewerton Side Notched	Gray Chert	21.1	15.1	6.1	2.0
Brewerton Side Notched	Gray Chert	26.9	16.5	5.6	2.4
Brewerton Side Notched	Gray Chalcedony	25.5	18.5	6.3	3.7
Brewerton Side Notched	Gray Chalcedony	20.6	18.8	6.0	2.4
Brewerton Side Notched	Dark Gray Chert	-	22.0	9.1	-
Brewerton Side Notched	Quartzite	-	-	0.5	-
Brewerton Side Notched	Brown Chert	39.1	22.6	7.9	6.5
Brewerton Side Notched	Brown Chert	50.2	29.0	10.2	14.5
Brewerton Side Notched	Brown Chert	-	23.0	6.5	-
Brewerton Side Notched	Brown Chert	-	1.8	0.7	-
Brewerton Side Notched	Gray Chalcedony	3.1	2.0	0.5	4.1
Brewerton Side Notched	Gray Chalcedony	2.5	1.6	0.5	2.2
Brewerton Side Notched	Dark Gray Chert	31.2	16.2	6.9	3.8
Brewerton Side Notched	Pinkish-grayish chert	-	-	-	-
Brewerton Side Notched	Dark Gray Chert	31.0	20.0	6.2	3.4
Brewerton Side Notched	Argillite	-	-	-	-
Brewerton Side Notched	Dark Gray Chert	47.6	22.3	7.5	8.4
Brewerton Side Notched	Brown Banded Chert	-	-	3.74	-
Brewerton Side Notched	Other Chalcedony	21.8	17.8	7.1	2.4
Brewerton Side Notched	Brown Chert	-	19.1	8.0	4.5
Brewerton Side Notched	Rhyolite	28.3	18.1	7.5	4.7
Brewerton Side Notched	Gray Chalcedony	-	16.8	5.1	1.2
Brewerton Side Notched	Argillite	67.5	52.4	14.8	64.2
Brewerton Side Notched	Dark Gray Chert	34.5	26.4	5.6	4.7
Brewerton Side Notched	Argillite	47.7	22.3	7.9	8.3
Brewerton Side Notched	Dark Gray Chert	50.7	23.7	9.4	10.8
Brewerton Side Notched	Dark Gary Chert	38.7	19.1	9.0	6.0
Beekman Triangle	Dark Gray Chert	25.7	23.2	5.0	2.6
Otter Creek	Gray Chert	-	2.5	0.7	-
Otter Creek	Gray Chert	51.2	27.9	7.7	9.1
Vosburg	Red Jasper	2.8	2.5	0.6	3.3
Vosburg	Argillite	-	2.3	0.6	3.9

Table 185. Late Laurentian Non-diagnostic Biface Metric Attributes.

	Length(mm)	Width(mm)	Thickness (mm)	Weight(g)
Number of Cases	17	38	54	12
Minimum	24.0	1.8	0.3	2.1
Maximum	61.1	41.1	13.8	22.9
Range	37.1	39.4	13.6	20.8
Mean	40.1	22.5	7.5	7.7
Standard Deviation	11.5	8.3	3.0	6.9

Table 186. Late Laurentian Non-diagnostic Biface Counts by Raw Material Class.

Raw Material	Count	Percentage
Dark Gray Chert	32	33.7
Gray Chert	14	14.7
Other Chert	2	2.1
Gray Chalcedony	15	15.8
Yellow Jasper	2	2.1
Red Jasper	1	1.0
Black Agate	4	4.2
Rhyolite	4	4.2
Argillite	9	9.5
Siltstone	2	2.1
Brown Chert	5	5.3
Light Brown Chert	2	2.1
Gray Banded Chert	2	2.1
Black Chalcedony	1	1.1
Total	95	100.0

Table 187. Metric Attributes for Late Laurentian Unifaces.

	Length (mm)	Width (mm)	Thickness (mm)	Weight (mm)
Number of Cases	4	7	8	3
Minimum	4.0	2.5	0.5	2.4
Maximum	28.3	33.5	13.2	10.8
Range	24.3	31.0	12.7	8.4
Mean	18.7	17.4	5.4	5.4
Standard Deviation	10.7	10.9	4.2	4.7

Table 188. Late Laurentian Uniface Counts by Raw Material Class.

Raw Material	Count	Percentage
Dark Gary Chert	3	33.3
Gray Chert	3	33.3
Black Agate	1	11.1
Brown Chert	2	22.2
Total	9	100.0



Nine raw material types are represented in the edge-only tool collection, and these are dominated by locally-available raw materials (Table 190). The most frequently-represented raw material is chert (55.5%). Jasper is the sole nonlocal material, comprising 14.8 percent of the edge-only tools.

Table 189. Metric Attributes for Late Laurentian Edge-only Tools.

	Length (mm)	Width (mm)	Thickness (mm)	Weight (g)
Number of Cases	23	24	27	15
Minimum	1.7	1.1	0.3	0.1
Maximum	67.5	52.4	23.2	14.5
Range	65.9	51.3	22.9	14.4
Mean	24.1	18.4	6.4	3.6
Standard Deviation	16.4	12.8	5.2	4.2

Table 190. Late Laurentian Edge-only Tool Counts by Raw Material Class.

Raw Material	Count	Percentage of Cases
Dark Gray Chert	7	25.9
Gray Chert	5	18.5
Gray Chalcedony	5	18.5
Yellow Jasper	2	7.4
Red Jasper	1	3.7
Burgundy Jasper	1	3.7
Argillite	3	11.1
Brown Chert	2	7.4
Black Chert w/ brown mottling	1	3.7
Total	27	100.0

*Cores.* Seventeen cores are present in the chipped-stone assemblage. Table 191 presents metric data for the two core types found in the collection, and Table 192 presents raw material categories for the two core types. The most frequently represented core type is indeterminate (82.4%), followed by tabular (17.6%), and bidirectional opposing (10.6%). All of the cores are of locally-available raw materials, with the most frequently represented being dark gray chert (55.6%), followed by gray chert (27.8%), gray chalcedony (11.1%), and black agate (5.6%).

### *Early Laurentian*

*Diagnostic Bifaces.* There are 54 diagnostic bifaces present in the early Laurentian material. Eight types are in the collection, represented by six Brewerton Corner notched, eight Brewerton Eared, eighteen Brewerton Side Notched, two Chillesquaque triangles, three Morrow Mountain/Stark, one Neville-like, ten Otter Creek, and five Vosburg. Table 193 lists these types and includes information regarding raw material type and metric data. Figure 68 illustrates representative specimens from these groups.

*Non-diagnostic Bifaces.* The 73 non-diagnostic bifaces consist of biface fragments lacking diagnostic hafting elements, and whole bifaces that do not fit into any established type. These bifaces have a wide range of metric variation (Table 194).

Table 191. Metric Attributes for Late Laurentian Core Types.

Core Type		Length (mm)	Width (mm)	Thick (mm)	Weight (g)
Tabular	No of Cases	3	3	3	3
	Minimum	31.7	24.1	12.1	11.3
	Maximum	47.6	39.5	18.1	23.6
	Range	15.9	15.4	6.0	12.3
	Mean	39.5	31.4	14.7	19.1
	Std. Dev.	8.0	7.7	3.1	6.8
Indeterminate	No of Cases	14	14	14	14
	Minimum	21.0	18.0	10.0	4.4
	Maximum	104.0	80.0	46.0	366.7
	Range	83.0	62.0	36.0	362.3
	Mean	37.7	29.6	17.5	36.8
	Std. Dev.	20.2	15.0	8.7	91.4

Table 192. Late Laurentian Core Counts by Raw Material Class.

Raw Material	Number of Cases	Percentage of Cases
Dark Gray Chert	10	55.6
Gray Chert	5	27.8
Gray Chalcedony	2	11.1
Black Agate	1	5.6
Total	18	100.0

Only four of these tools show evidence of heat alteration. The majority (86.3%) of the tools lack cortex. Edge modification on all pieces is bifacial. The edges of most of the tools were modified through flaking (95.9%), followed by use-wear and flaking (2.7%), and flaking and battering (1.4%). Well over half of these tools (64.4%) have two modified edges, followed by one modified edge (17.8%), and three modified edges (17.8%).

Locally-available raw materials are most frequently represented in the non-diagnostic biface category (Table 195). These include gray chert (32.9%), gray chalcedony (23.3%), dark gray chert (15.1%), and argillite (13.7%). The only nonlocal raw material present in this category was yellow jasper (1.4%).

*Unifaces.* Eight unifaces are present in the chipped-stone assemblage. These exhibit a wide range of metric variation (Table 196). One of these tools shows evidence of heat alteration. Edge modification on the majority of the tools was unifacial (50.0%), followed by bifacial (25.0%), and combined unifacial and bifacial (25.0%). Edges on the majority of these tools were modified through flaking (75.0%), followed by use-wear only (12.5%), and flaking and use-wear (12.5%). Some pieces have two edges (37.5%), followed by three edges (37.5%), and only a single modified edge (37.5%). Of 33 edges, those with edge angles between 46° and 75° represented 36.4 percent of the edges, with those less than 46°, 18.2 percent, and greater than 75° representing 45.5 percent of the edges.

Table 193. Raw Material and Metric Data for Early Laurentian Diagnostic Bifaces.

Type	Raw Material	Length (mm)	Width (mm)	Thick (mm)	Weight (g)
Brewerton Corner Notched	Gray Chert	32.6	20.1	5.7	3.3
Brewerton Corner Notched	Gray Chalcedony	-	4.4	1.2	-
Brewerton Corner Notched	Argillite	32.1	19.5	4.8	2.6
Brewerton Corner Notched	Gray Chert	-	22.8	6.1	-
Brewerton Corner Notched	Gray Chert	-	1.8	0.5	3.1
Brewerton Corner Notched	Gray Chert	35.6	19.6	6.1	3.2
Brewerton Eared	Gray Chert	33.1	-	6.1	1.2
Brewerton Eared	Dark Gray Chert	-	15.6	4.5	-
Brewerton Eared	Argillite	35.1	18.3	6.3	3.6
Brewerton Eared	Gray Chalcedony	27.9	18.1	4.9	2.2
Brewerton Eared	Rhyolite	-	22.9	6.5	4.3
Brewerton Eared	Other Chert	32.5	17.5	7.2	2.3
Brewerton Eared	Yellow Jasper	-	22.7	6.3	-
Brewerton Eared	Gray Chalcedony	-	-	-	-
Brewerton Side Notched	Red Jasper	15.4	18.0	5.2	1.6
Brewerton Side Notched	Dark Gray Chert	46.1	24.9	8.9	9.1
Brewerton Side Notched	Rhyolite	21.8	22.1	5.7	3.1
Brewerton Side Notched	Light Brown Chert	-	-	5.3	-
Brewerton Side Notched	Gray Chert	26.3	18.3	5.5	2.1
Brewerton Side Notched	Dark Gray Chert	29.1	22.9	5.4	3.7
Brewerton Side Notched	Dark Gray Chert	41.9	28.4	8.4	8.1
Brewerton Side Notched	Brown Chert	-	-	5.3	-
Brewerton Side Notched	Dark Gray Chert	17.8	18.8	5.1	1.8
Brewerton Side Notched	Gray Chert	-	-	-	-
Brewerton Side Notched	Dark Gray Chert	37.9	19.1	7.3	5.0
Brewerton Side Notched	Argillite	-	-	7.1	-
Brewerton Side Notched	Argillite	-	20.3	7.4	-
Brewerton Side Notched	Gray Chert	-	18.6	7.2	-
Brewerton Side Notched	Gray Chert	30.7	17.9	6.3	3.2
Brewerton Side Notched	Argillite	40.98	21.4	5.0	3.6
Brewerton Side Notched	Argillite	-	-	-	-
Brewerton Side Notched	Dark Gray Chert	-	1.9	0.6	-
Chillesquaque Triangle	Dark Gray Chert	-	20.5	-	-
Morrow Mountain/Stark	Gray Chalcedony	24.7	14.8	5.0	1.5
Morrow Mountain/Stark	Light Brown Chert	31.3	17.0	6.5	3.2
Morrow Mountain/Stark	Brown Chert	41.3	18.6	5.6	3.2
Morrow Mountain/Stark	Brown Chert	71.2	43.0	13.6	34.0
Neville-like	Brown Chert	-	1.8	0.9	5.9
Otter Creek	Dark Gray Chert	-	20.0	5.0	3.9
Otter Creek	Gray Chert	42.9	23.9	6.8	6.4
Otter Creek	Argillite	-	20.4	7.5	-
Otter Creek	Dark Gray Chert	40.0	20.8	6.1	5.0
Otter Creek	Brown Chert	45.7	20.8	7.3	7.6
Otter Creek	Brown Chert	41.5	20.2	6.6	5.3
Otter Creek	Red Jasper	36.0	21.9	5.8	4.3
Otter Creek	Gray Chert	40.7	20.7	6.2	4.9
Otter Creek	Gray Chert	-	18.8	6.5	3.3
Otter Creek	Dark Gray Chert	39.5	19.1	7.1	5.0
Vosburg	Brown Chert	24.3	20.9	5.2	2.4
Vosburg	Gray Chert	38.2	19.6	6.5	4.2
Vosburg	Dark Gray Chert	2.9	2.0	0.7	4.2
Vosburg	Other Chert	34.0	20.8	6.4	3.9
Vosburg	Gray Chert	-	2.2	0.6	-



A



B



C



D



E



F



G



H



I



J



K

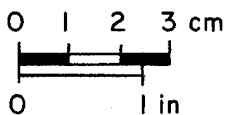

KEY

- A & B - OTTER CREEK
- C, D, G, H & I - BREWERTON SIDE NOTCHED
- E & F - VOSBURG
- J - BREWERTON CORNER NOTCHED
- K - CHILLESQUAQUE

FIGURE 68

REPRESENTATIVE EARLY LAURENTIAN DIAGNOSTIC BIFACES

Table 194. Early Laurentian Non-diagnostic Biface Metric Attributes.

	Length (mm)	Width (mm)	Thickness (mm)	Weight (g)
Number of Cases	10	28	40	4
Minimum	4.8	1.2	0.5	4.7
Maximum	89.4	39.2	14.0	55.0
Range	84.6	38.0	13.5	50.4
Mean	40.5	16.9	6.0	26.4
Standard Deviation	22.1	11.6	3.8	25.9

Table 195. Early Laurentian Non-diagnostic Biface Counts by Raw Material.

Raw Material	Count	Percentage
Dark Gray Chert	21	28.8
Gray Chert	15	20.6
White Chert	1	1.4
Other Chert	7	9.6
Gray Chalcedony	5	6.9
Other Chalcedony	1	1.4
Yellow Jasper	2	2.7
Burgundy Jasper	1	1.4
Black Agate	1	1.4
Argillite	5	6.9
Other	1	1.4
Gray Sandstone	1	1.4
Brown Chert	5	6.9
Light Brown Chert	2	2.7
Pinkish-grayish Chert	1	1.4
Gray Banded Chert	1	1.4
Chert w/ Cryptocrystalline	1	1.4
Rhyolite	2	2.7
Total	73	100.0

Table 196. Early Laurentian Uniface Metric Attributes.

	Length (mm)	Width (mm)	Thickness (mm)	Weight (g)
Number of Cases	6	7	8	6
Minimum	1.2	1.5	0.2	0.4
Maximum	46.6	25.5	12.8	13.0
Range	45.4	24.0	12.6	12.6
Mean	23.2	19.0	7.4	4.5
Standard Deviation	15.1	8.2	3.9	4.5

Most of the unifaces are manufactured from locally-available raw materials. The most frequently represented raw material class is chert (75.0%). One red jasper uniface is present in the collection.

Table 197. Early Laurentian Uniface Counts by Raw Material Class.

Raw Material	Count	Percentage
Dark Gray Chert	3	37.5
Gray Chert	2	25.0
Gray Chalcedony	1	12.5
Red Jasper	1	12.5
Brown Chert	1	12.5
Total	8	100.0

*Edge-only Tools.* Thirty-five edge-only tools are present in the chipped-stone assemblage. Edge-only tools exhibit a wide range of metric variation (Table 198). On the whole, they represent relatively large pieces of debris. The mean width for the collection, 22.0 mm, falls within size grade 2 for lithic debris. The percentage of tools with cortex on the dorsal surface is 35.3 percent.

The majority of the tools had only a single retouched or utilized edge (67.7%), although 23.5 percent had two edges, 5.9 percent had three edges, and 2.9 percent had four edges. Of 84 edges, less than half (20.2%) have edge angles less than 46°, 69.0 percent have angles between 46 and 75°, and 10.7 percent have angles greater than 75°. Thirty (88.2%) of the edge-only tools have been subjected to heat alteration. The edges of most of the tools had been altered unilaterally (64.7%), followed by bifacially (26.5%) and unilaterally and bifacially (8.8%). The highest percentage of edge modification was through flaking (50.0%), followed by use-wear (32.4%), use-wear and flaking (14.7%), and flaking and battering (2.9%).

Table 198. Early Laurentian Edge-only Tool Metric Attributes.

	Length (mm)	Width (mm)	Thickness (mm)	Weight (g)
Number of Cases	27	32	33	25
Minimum	1.6	1.5	0.3	0.1
Maximum	114.4	76.5	44.7	34.7
Range	112.9	75.0	44.4	34.6
Mean	32.0	22.0	7.3	7.2
Standard Deviation	20.8	13.9	7.9	8.7

Thirteen raw material types are represented in the edge-only tool collection, and these are dominated by locally-available raw materials (Table 199). The most frequently represented raw material is chert (68.7%). The only nonlocal edge-only tools are comprised of jasper (5.8%).

*Cores.* Twenty-four cores are present in the assemblage. Table 200 presents metric data for the three core types, and Table 201 presents raw material categories for the three core types. The most frequently represented core type is indeterminate (63.0%), followed by tabular (25.2%), and nodular (11.0%). Twenty cores are of locally-available raw materials; two are jasper.

### Neville

*Diagnostic Bifaces.* Materials from the Neville component include six diagnostic bifaces. The two types present include two Eva-like bifaces and four Neville bifaces. A listing of these specimens, their raw material type, and metric data, are presented in Table 202. An illustration of typical representatives is presented in Figure 69.

*Non-diagnostic Bifaces.* The seven non-diagnostic bifaces consist of biface fragments lacking diagnostic hafting elements, and whole bifaces that do not fit into any established type. These bifaces have a wide range of metric variation (Table 203).

Only one of these tools has evidence of heat alteration. All of the tools lack cortex. As would be anticipated, edge modification on all pieces is bifacial. The edges of all of the tools were modified through flaking. Most of these tools (85.7%) have two modified edges, followed by three modified edges (14.3%).

Locally-available raw materials are most frequently represented in the non-diagnostic biface category. These include gray chert (28.6%), gray chalcedony (42.9%), and argillite (14.3%). The category, Other, refers to unidentified material types, which are usually all cortex.

Table 199. Early Laurentian Edge-only Tool Raw Material Frequencies.

Raw Material	Count	Percentage of Cases
Dark Gray Chert	4	11.4
Gray Chert	12	34.3
Other Chert	1	2.9
Gray Chalcedony	4	11.4
Other Chalcedony	2	5.7
Caramel Jasper	1	2.9
Red Jasper	1	2.9
Argillite	2	5.7
Gray Sandstone	1	2.9
Brown Banded Chert	1	2.9
Brown Chert	3	8.6
Light Brown Chert	2	5.7
Pinkish-grayish Chert	1	2.9
Total	35	100.0

Table 200. Metric Attributes for Early Laurentian Core Types.

Core Type		Length (mm)	Width (mm)	Thick (mm)	Weight (g)
Nodular	No of Cases	3	3	3	3
	Minimum	36.9	27.3	18.0	18.6
	Maximum	49.6	48.9	21.5	62.6
	Range	12.7	21.6	3.5	44.0
	Mean	42.6	35.4	19.7	36.9
	Std. Dev.	6.5	11.8	1.8	22.9
Tabular	No of Cases	6	6	6	6
	Minimum	27.9	22.7	16.5	11.6
	Maximum	83.9	73.7	26.8	172.8
	Range	56.0	51.0	10.3	161.2
	Mean	45.4	35.6	22.1	50.1
	Std. Dev.	21.6	19.1	3.7	61.5
Indeterminate	No of Cases	15	15	15	15
	Minimum	22.5	17.8	9.9	3.0
	Maximum	64.0	118.0	33.0	79.7
	Range	41.5	100.2	23.1	76.7
	Mean	38.6	34.7	19.3	25.3
	Std. Dev.	14.9	24.6	6.5	22.8

Table 201. Early Laurentian Core Counts by Raw Material Class.

Raw Material	Number of Cases	Percentage of Cases
Dark Gray Chert	7	29.2
Gray Chert	6	25.0
Other Chert	5	20.8
Gray Chalcedony	1	4.2
Yellow Jasper	1	4.2
Red Jasper	1	4.2
Gray Sandstone	2	8.3
Pinkish-grayish Chert	1	4.2
Total	24	100.0

Table 202. Raw Material and Metric Data for Neville Diagnostic.

Type	Raw Material	Length (mm)	Width (mm)	Thick (mm)	Weight (g)
Eva like	Dark Gray Chert	-	2.5	0.7	-
Eva like	Gray Chert	-	29.7	-	-
Neville	Gray Chert	4.3	2.1	0.8	5.6
Neville	Argillite	41.2	20.4	6.9	4.6
Neville	Brown Chert	30.3	23.1	5.8	4.0
Neville	Dark Gray Chert	3.8	1.5	0.7	3.8

Table 203. Non-diagnostic Neville Biface Metric Attributes.

	Length(mm)	Width(mm)	Thickness (mm)	Weight(g)
Number of Cases	0	1	3	0
Minimum	-	14.4	0.9	-
Maximum	-	14.4	5.2	-
Range	-	0.0	4.3	-
Mean	-	14.4	3.5	-
Standard Deviation	-	-	2.3	-

Table 204. Non-diagnostic Neville Biface Counts by Raw Material Class.

Raw Material	Count	Percentage
Gray Chert	2	28.6
Gray Chalcedony	3	42.9
Argillite	1	14.3
Other	1	14.3
Total	7	100.0

*Edge-only Tools.* Six edge-only tools are present in the chipped-stone assemblage. The edge-only tools exhibit a wide range of metric variation (Table 205). On the whole, they represent relatively large pieces of debris. The mean width for the collection, 16.6 mm, falls within size grade 2 for lithic debris. Only one of these edge-only tools has cortex.





A



B



C



D

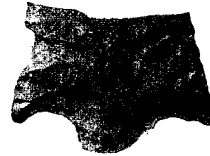

E

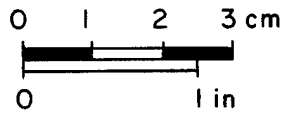

KEY

- A & B - NEVILLE
- C - UNTYPED TRIANGLE
- D & E - EVA-LIKE

FIGURE 69

REPRESENTATIVE NEVILLE  
DIAGNOSTIC BIFACES

Most of the tools exhibit only a single retouched or utilized edge (66.7%), although 16.7 percent have two edges, and 16.7 percent have three edges. Of the total of 15 edges, less than half (26.7%) have edge angles less than 46°, 53.3 percent have angles between 46° and 75°, and 20.0 percent have angles greater than 75°. Five of the edge-only tools had been obviously subjected to heat alteration. The edges of all of the tools had been altered unilaterally. The highest percentage of edge modification was through use-wear (66.7%), followed by flaking and use-wear (16.7%), and flaking (16.7%).

Five raw material types are represented in the edge-only tool collection, and these are dominated by locally-available raw materials (Table 206). The local material represents 66.7 percent of the raw material types, and 16.7 percent each of jasper and quartzite are present.

Table 205. Metric Attributes for Neville Edge-only Tools.

	Length (mm)	Width (mm)	Thickness (mm)	Weight (mm)
Number of Cases	5	5	5	5
Minimum	1.3	0.9	0.3	0.2
Maximum	43.2	35.7	8.1	10.4
Range	41.9	34.8	7.8	10.3
Mean	19.4	16.6	3.8	3.0
Standard Deviation	16.3	13.3	3.0	4.3

Table 206. Neville Edge-only Tool Counts by Raw Material Class.

Raw Material	Count	Percentage of Cases
Dark Gray Chert	1	16.7
Gray Chert	2	33.3
Gray Chalcedony	1	16.7
Burgundy Jasper	1	16.7
Quartzite	1	16.7
Total	6	100.0

Table 207. Metric Attributes for Neville Core Types.

Core Type		Length (mm)	Width (mm)	Thick (mm)	Weight (g)
Tabular	No of Cases	1	1	1	1
	Minimum	54.0	27.0	14.0	19.0
	Maximum	54.0	27.0	14.0	19.0
	Range	0.0	0.0	0.0	0.0
	Mean	54.0	27.0	14.0	19.0
	Std. Dev.	-	-	-	-
Indeterminate	No of Cases	6	6	6	6
	Minimum	28.0	22.0	10.0	6.4
	Maximum	52.4	28.7	29.1	32.5
	Range	24.4	6.7	19.1	26.1
	Mean	36.8	25.0	19.8	20.1
	Std. Dev.	9.9	2.2	7.1	10.7



*Cores*. Seven cores are present in the chipped-stone assemblage. Table 207 presents metric data for the two core types found in the collection, and Table 208 presents raw material categories for the two core types. The most frequently represented core type is indeterminate (85.7%), followed by tabular (14.3%). Locally-available materials account for 85.7 percent of the collection, while one caramel jasper core is also present.

Table 208. Neville Core Counts by Raw Material Class.

Raw Material	Number of Cases	Percentage of Cases
Dark Gray Chert	1	14.3
Gray Chert	2	28.6
Gray Chalcedony	1	14.3
Caramel Jasper	1	14.3
Black Agate	1	14.3
Brown Banded	1	14.3
Total	7	100.0

#### TECHNOLOGICAL ANALYSIS

The basic objectives of the chipped-stone technological analysis are to characterize technological dimensions of thinning, and reduction effort using debris, and to integrate these conclusions, insofar as possible, with the information available on the tools. The goal is to address questions regarding the observed variability in the debris, within and between components across space and time, using scales constructed for measuring these dimensions. Questions of technology and raw material management are addressed in the context of dynamically organized systems and their static archaeological consequences. Attempts are made to suggest the nature of systemic change, testability within and among sites, and over time.

Because they are fundamental concerns of prehistoric archaeology, lithic technology and reduction processes have received concerted attention by many researchers, both through experimentation and applications (e.g., Ahler 1989; Bonnicksen 1977; Bradley 1974, 1975; Burton 1980; Callahan 1974; Crabtree 1966, 1973; Dibble and Whittaker 1981; Henry, Haynes, Bradley 1976; Magne and Pokotylo 1981; Muto 1971; Newmann and Johnson 1979; Newcomer 1971; Patterson 1977, 1979, 1982, 1990; Raab, Cande, Stahle 1979; Speth 1972, 1974, 1975, 1981; Stahle and Dunn 1982). Although there have been general advances in the development of principles related to lithic reduction, theory in the more technical sense has been lacking. As a result, archaeologists do not know what to measure, how to measure it, what the measurements convey, and how to extend the resulting information to higher-level problems. Vague connections are postulated between measurements and general paradigms regarding lithic reduction, but the resulting inferences, in an applied context, lack the generality or explanatory import to extend beyond the case in question. This fact accounts for the insistence of many researchers upon replications of the assemblage being studied, as a basis for subsequent analysis.

The problem of measurement seems deceptively simple in a culture possessing the degree of scientific and technical sophistication characteristic of modern western society. Archaeologists apply well-accepted and deeply-understood measurement systems to archaeological material without recognizing a number of important factors involved. One, is that all measurement systems are based on theory (Kemeny 1959; Kuhn 1977). For example, consider the theory of the uniform expansion of mercury in a closed tube in conjunction with the concept that this expansion directly

measures the thermodynamic property of degree of heat. The function of a thermometer as a laboratory instrument, rather than an object of study depends on the acceptance of these ideas (Kuhn 1977). Second, employing an instrument in place of human sensation as a basis for measurement necessitates the recognition that human sensation is a highly equivocal phenomenon and that the thermometer is preferred, even when the two give divergent results. Third, the route to theory is almost never made from measurement, but instead, measurement almost always derives from theory (Kuhn 1977). As Kuhn has argued, (1977:197)

Because most scientific laws have so few quantitative points of contact with nature, because investigations of these contact points usually demand such laborious instrumentation and approximation, and because nature itself needs to be forced to yield the appropriate results, *the route from theory or law to measurement can almost never be travelled backward* (italics added).

To discover quantitative regularity one must normally know what regularity one is seeking and *one's instruments must be designed accordingly* (Kuhn 1977:219, italics added).

Finally, even at the point that the fundamental basics of borrowed measurement scales are accepted and used with archaeological material, archaeologists rarely have well-explicated, logically sound arguments of how these measurements articulate with generalizations regarding human behavior, systemic structure, or cultural evolution.

The approach of this author has been to derive scales of measurement from a theory of human production behavior based on neurosensory principles. The theory refers to human production behavior mediated by neurosensory processing as the fundamental measuring apparatus, and is developed for lithic reduction.

Theory constitutes a systematically-related set of statements, including some lawlike generalizations, that are empirically testable (Rudner 1966:10). The current system does have deductive relatedness. However, this set of statements does not necessarily correspond to a community-wide acceptance by fellow researchers, although much of the neurosensory and psychophysical background is widely accepted in psychobiology.

It must also be made clear that this corpus of statements is not a model. It is not an empirical model that admits easy visualization of a particular subject matter by a kind of analogy, although a feedback model is used to aid in its development. Further, it is not a mathematical model. This system includes mathematical modeling as an efficacious logical device that is claimed to be isomorphic with empirical theory. This mathematical (logical) structure allows a large array of already proven theorems to be translated into empirical theory. Theories are useless unless we can deduce interesting consequences from them, and the deductive process is essentially a mathematical process (Kemeny 1959).

Neurosensory production theory, as applied to lithic reduction, is a deductive system including testable consequences concerning workpiece and debris attributes, singly and in aggregate. This theory is presented in some detail in Appendix E. From these generalizations, I have deductively developed three scales of measurement that provide important information

concerning aggregate thinning estimates, total reduction effort, and mean reduction effort, all defined below and in the appendix. With respect to thinning and mean reduction effort, basic subsystems of reduction are postulated. These dynamical subsystems are identified in the Clemson Island debris data. Based on the organization of these scales and dynamical subsystems, postulates of dynamic processes involved in technology and raw material management, and their linkage to site organization are discussed. Various conclusions are proposed regarding what has occurred at the Memorial Park site with respect to lithic technology, raw material management, and economic organization through time.

### *Debris*

*Explanatory Principles.* Detailed elaboration of the theory from which the thinning and effort scales are derived is presented in Appendix E. The mathematical development may be formidable, but the mathematics provide the power of a logical structure that can handle asylogistic arguments, unlike Aristotelean logic. In the absence of this theory, the scales could not have been developed. However, the key premises of the theory can be stated in understandable, verbal terms that are consistent with archaeological conceptions of lithic reduction.

The first assumption is that the patterned reduction of lithic artifacts depends upon the human organism as the measuring instrument against which the progress of reduction is monitored in anticipation of some goal, or goals. This assumption has always been made, but the additional premise that this measuring process is a simple linear relationship and can be neglected as part of the analytical process, is incorrect (e.g., Adams 1971; Baird 1970a, 1970b; Baird and Stein 1970; Candland 1968; Baird and Nona 1978; Cope 1976; Eisler 1963; Ekman 1959, 1964; Falmagne 1971, 1974; Graham and Ratoosh 1962; Krantz 1971; Marks 1974; Newell and Simon 1972; Ono 1967; Stevens 1946, 1951, 1957, 1959, 1966, 1971, 1975; Stevens and Galanter 1957; Stevens and Savin 1962; Stevens and Stevens 1960; Teghtsoonian 1971; Treisman 1964; Valter 1970). Specifically, measurement is a function of neurosensory processes and brain-monitoring processes which are not linear. Understanding the form of the processes, as described by mathematical functions, allows us, in principle, to deduce the form that reduction trajectories take, given further postulates of what morphological variables are relevant in the monitoring process, and the contingencies of fracture mechanics.

Considering a given reduction trajectory of a single workpiece, it is postulated that two basic variables are relevant to lithic reduction: width and thickness, as defined in Appendix E. From these variables, all other variables that change during reduction can be derived. The questions to ask are: why so few variables, and why pick workpiece width and thickness?

A small number of relevant variables are required because, although neurosensory processing can certainly be multivariate it is not capable of simultaneously monitoring more than three dimensions--a well-known evolutionary consequence of living in a universe of finite dimensionality (Kemeny 1959). Given this restriction, lithic reduction depends on three or fewer dimensions that can be monitored neurophysiologically, while at the same time being relevant in the sense of goals and end products expressed as final width, thickness, and other variables.

A flintknapper has causal control (in the efficient or narrow sense) over the size and angular orientation of the striking platform of the flake which is removed with each blow. This flake possesses a morphology that changes the workpiece to a given degree in the width and thickness dimensions (see Figure 70). The flintknapper does not pick up the flake to determine the nature of the next removal but instead examines the workpiece. Thus the feedback loop, which includes the

monitoring of the current state of the workpiece relative to the goal state, depends on morphological measures of the workpiece.

This feedback loop is diagrammatically represented in Figure 71, with the equations describing bivariate processes located next to the relevant arrows. The direction of the arrows indicates the order of this cyclical process. One of the keys to the development of the explanatory scheme, presented in Appendix E, is the postulation of a particular set of interrelationships among stimuli, responses, and sensation, as well as the perceptual-cognitive dynamics controlling the outcomes of these processes. In conjunction with certain developments in explaining extant psychophysical laws (Stevens' law and the Weber-Fechner law), as stated in MacKay (1963), the conceptual framework of psychophysics has been reorganized, redefining the two previously mentioned laws within the production framework, and formulating the existence of a third relation--the stimulus-response relation or interactive relation. It is from these principles that relationships among workpiece and debris variables were deduced, given the postulation of an isomorphism between the deductive system and characteristics of dynamic reduction processes.

In terms of efficiency, monitoring and neurosensory processes are best accomplished using the fewest number of dimensions. It would be appropriate to argue that the set of relevant variables be sufficient to permit the derivation of other variables known, or conjectured to change, and be important in lithic reduction. Further, these variables must be directly tied to flake characteristics under causal control of the flintknapper. If these conditions are met, then the proposed set of variables is sufficient and necessary to characterize reduction.

Lithic reduction theory incorporates just this postulate for width and thickness as the basic changing variables. As is demonstrated in Appendix E, variables such as width-thickness ratio, weight, surface area, edge angle, length, lateral edge offset, and symmetry of the length and width axes, can be derived from width and thickness of the workpiece. These concepts are connected to the idea of thinning-thickening trajectories, the concept of reduction effort, and the potential for further reduction, as well as technological factors, such as choice of indenter types and angle of blow, among others.

Development of the basic relations for the workpiece is the first step, and deriving a set of relations for debris, is the second. Debris changes are developed and related to workpiece modifications. For example, changes in the decrease in weight of the workpiece are simply the inverse of changes in the cumulative weight of the resulting debris. Testable relationships, as well as practical applications, are provided in terms of specific measurement scales. It is demonstrated that the debris generated in addition to the "intended" flake removals possess a particular probability distribution, and this affects the monitoring of width and thickness changes in predictable ways. These additional debris are not contaminating, and do not prohibit construction and use of scales in meaningful and reliable ways. Further, the fact that flakes are broken, regardless of cause, can be addressed and shown to be a solvable difficulty as well.

What can be learned from debris that cannot be learned from tools, at a given site? There are several difficulties encountered in using tools for addressing many technological concerns. One is that they do not provide monitors of reduction trajectories. Tool morphology represents a state of reduction, which can arise through multiple paths. Debris in aggregate, whether from a single reduction episode or multiple episodes, represents the steps or increments of one or more particular trajectories as evidenced at the site. Knowing the state of an object does not indicate how it got that way. Measuring the steps taken during the change process does, as long as those steps can be ordered in a meaningful way. Another problem is that tools found at the site are not necessarily made there, nor are tools made at the site necessarily represented in the tool assemblage (Binford 1977, 1978a, 1978b, 1979).

Those variables of debris which relate to the width and thickness changes of workpieces are length, thickness, and platform size. Relations among these variables have been investigated experimentally by Dibble and Whittaker (1981), Henry, Haynes, and Bradley (1976), Patterson and Sollberger (1978), Speth (1972, 1974, 1975, 1981), and Tsirk (1974). Thus as illustrated in the appendix, the results indicate that as smaller platforms are used (proportional to the width change), longer and wider flakes are produced, thereby removing thickness over a wider surface area of the workpiece. The result is an increase in the width-thickness ratio over a distance across the width axis, which is proportional to the flake length. Hence, information can be obtained for flake size (surface area) versus weight at various numbers of flake removals in the reduction sequence; in principle, the means is provided to measure degrees of thinning-thickening that occurred at the site.

A convenient, reliable, and reasonably valid means of data collection has been proposed by Ahler (1989a, 1989b), the analysis of which he refers to as mass analysis. Although the current analysis does not employ the analytical techniques proposed by Ahler, the data collection techniques lend themselves well to the goals of this analysis. That they would do so is established in the appendix.

In the introduction to this chapter, some important reasons were given for using the data collection techniques associated with mass analysis, in contrast to IFI analysis. However, the foundations of mass analysis were left until this section so that they could be systematically examined in relation to the alternative analytical procedures employed here. A number of analytical difficulties arise in using Ahler's mass analysis. Two general areas of concern are conceptual, and statistical-analytical. These are addressed in the following discussion.

*Foundations of Mass Analysis and the Analytical Alternative.* The foundation for mass analysis rests on three empirical generalizations drawn from knapping experiments: progressive size reduction, progressive cortex removal, and load application. Ahler (1989a:90-93) has recently provided an in-depth review of these generalizations. A brief summary and critique of Ahler's arguments is provided in the following paragraphs.

Progressive size reduction refers to the reductive aspect of knapping. The size of the first flake removed from a nucleus cannot be larger than the nucleus itself, and all subsequent debris removed must in turn be smaller than the core or tool. As reduction of the core or the manufacture, use, and subsequent rejuvenation or reworking of a tool continues, the smaller all subsequent flakes must be. The early portions of core reduction and tool manufacture will generally result in the production of larger quantities of large flakes, than will the later portions. This change in flake size production can be documented by the frequency of flakes across size classes. Because all reduction strategies produce more small flakes than large flakes, and because large flakes weigh much more than small flakes, the weight of flakes within various size classes should also demonstrate variation between reduction sequences.

What Ahler fails to provide for us, in the context of this generalization, is a clear definition of what form progressive size reduction takes. Is it highly stochastic? If the size of flakes removed was plotted sequentially, would the resulting plot appear linear, or would it suggest another shape? These concerns make a significant difference in determining whether or not the resulting data collection can provide the necessary information to yield whatever distinctions are forecasted. In the absence of this kind of understanding, these data can only be analyzed in a "shotgun" approach that is not likely to yield generally applicable information, and is likely to degenerate into site-specific storytelling that cannot serve as comparable information for higher-level analyses.



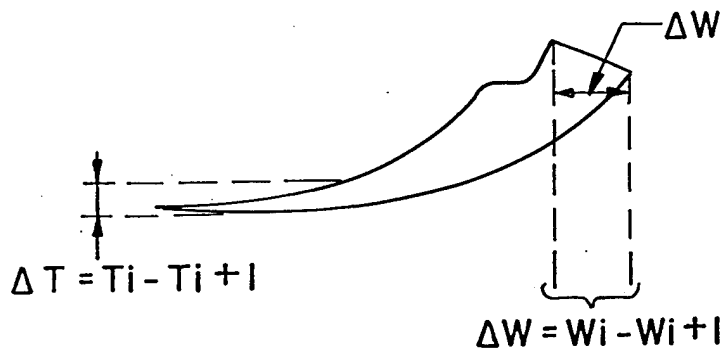
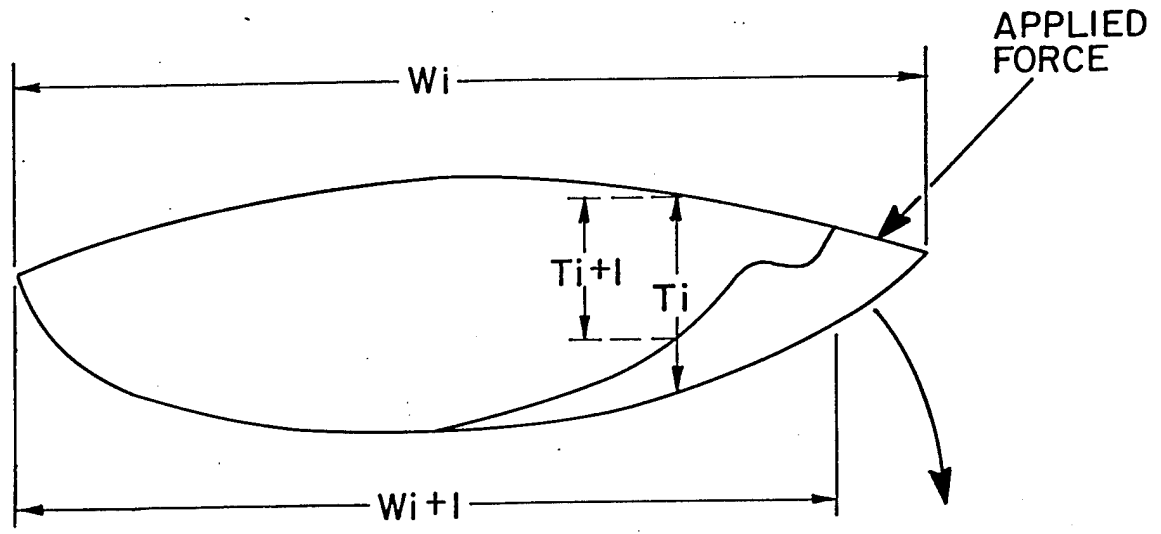

FIGURE 70  
CROSSSECTION OF WORKPIECE  
AND FLAKE REMOVED.  
CHANGES IN WIDTH ( $\Delta W$ )  
AND THICKNESS ( $\Delta T$ ) ILLUSTRATED

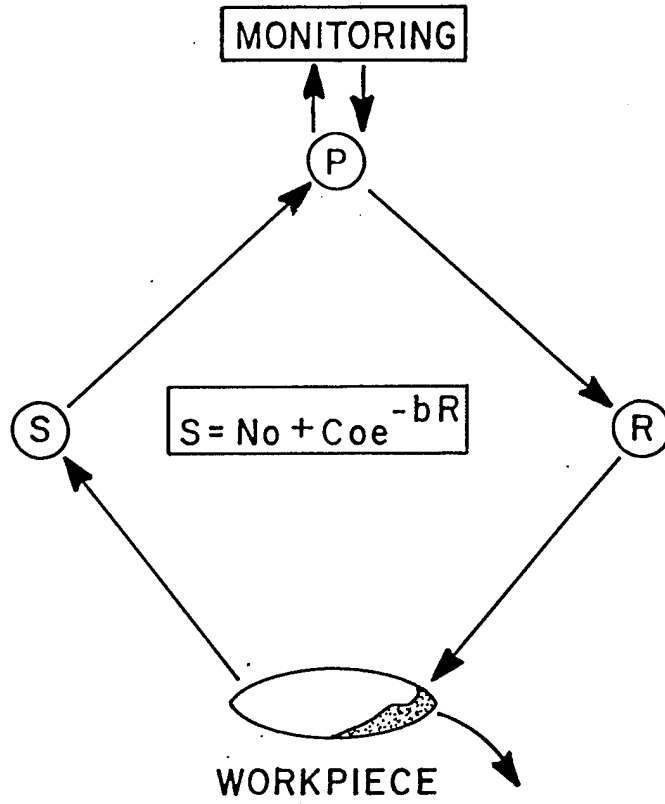

FIGURE 71

FEEDBACK LOOP ILLUSTRATING THE RELATIONSHIP OF STIMULUS-RESPONSE TO SENSORY AND MONITORING PROCESS

The common, unstated assumption underlying most analyses in archaeology is one of linearity. Change processes are typically characterized as before/after processes for which anything in-between can be located on a straight line connecting the beginning and end points. In verbal expositions of change phenomena, the locution designating change from X to Y without any qualifications is the signal of assumed linearity. In statistical/mathematical analyses, the application of linear models such as correlation, regression, factor analysis, and discriminant analysis, signal this assumption. Some statistical difficulties of assuming linearity, when linearity does not obtain, are discussed below.

Some of the difficulties might be avoided by the simple act of graphing and examining bivariate plots of the variables. Often, significant departures from linearity are obvious in the resulting plots. If nonlinearity is noted, then another assumption is warranted, and various alternatives can be tried. Further problems arise, however, when a multivariate analysis is proposed, and, yet, there is no way to simultaneously linearize a set of relationships among the variables.

Another difficulty arises in the process of graphing the data. The manner in which the data are graphed strongly influences the ability of an investigator to recognize patterning when it is present, and to further recognize the nature of that patterning. The familiar example below illustrates these points regarding linearity and pattern recognition, using the same data set as a starting point.

Suppose that an investigation is conducted of the decay of 1 gram of carbon 14 over time. Two measurements are taken: weight of the carbon 14 that has disappeared within a given time interval, and the total elapsed time. Although counts are taken in the radiocarbon lab, each count represents a decrement of mass, and the usual formulation of the problem of characterizing radioactive decay is in terms of weight (Burghes and Barrie 1982; White 1968).

If the weight lost is plotted on the vertical axis, against the elapsed time on the horizontal axis, the plot would appear like Figure 72, where the individual points have been sequentially connected by straight lines. This is called a polygonized plot. The process of producing such a plot emphasizes and enhances the disorder inherent in the data, and one is forced to explain this disorder.

A typical attempt at such an explanation would involve an a priori subdivision of the total elapsed time into "stages." In stage 1, the amount of C-14 remaining is large. In stage 2, the amount remaining is medium. In stage 3 the amount of C-14 remaining is small. This may result from different sets of processes at each stage. Then, when these stages are correlated with time, a scale of old, older, oldest is constructed, against which future C-14 bearing materials are "dated."

If the data are replotted using the amount of C-14 remaining in the sample, then a figure like Figure 73a results. If the data points are connected by steps, then the plot resembles Figure 73b.

Minimally, Figure 73b maintains the representation of decay as a constantly decrementing process, unlike Figure 72. The figure also illustrates the reality of C-14 decay. It is not a continuous process. C-14 decay occurs in a number of discrete steps. It certainly does not occur in three stages.

If C-14 decay is to be viewed as a stage-wise process, then it will be considered, realistically, a process of a large number of finite steps, each, on the average, smaller than the last. Those steps at the beginning appear larger than those at the other end, but there are no clear divisions along the way larger than each individual step. Further, many different sets of arbitrarily

chosen dividing lines, sequentially ordered, would produce significant mean differences between the weights in one group and the weights in another group. Any group of functionally dependent, ordered measurements, whether continuous or of a large finite number, can be subdivided to produce these statistically significant differences. What is lost in this procedure, however, is an understanding of both the robustness of the ordering and the processes responsible for the ordering.

The question is, can this ordered set of values be described (approximately) by a particular mathematical function, and can this function, an empirical generalization, be explained by some set of law-like generalizations?

With respect to radioactive decay, the answer is yes. In conjunction with well-established explanatory principles, a function of the form  $A=AI*\exp(-b*t)$  can be deduced (explained), where A is the weight of radioactive material present at time t, AI is the starting weight, and b is the rate at which the process occurs. This function, and the theory behind it, is the basis for C-14 dating. A fit of this function to observed values is illustrated in Figure 74. A straight line fit, Figure 74a, is a poor approximation to the actual data set. Alternatively, a fit of the theoretically-derived function, Figure 74b, is a superior fit to the data.

Just as the decay of C-14 is described by a decreasing weight, the growth in the amount of the resulting product of the decay is described by an increasing function, which is the inverse of the former function. It is this perspective that forms the basis of the following analysis. As is illustrated and developed below, and further explicated in Appendix E, lithic reduction can be described in an analogous way; approximated by a continuous process. The workpiece is a decreasing function, and the debris produced is an increasing function.

Ahler's second empirical generalization, progressive cortex removal, refers to the process whereby the cortex of a nucleus is progressively removed during the reduction sequence. The amount of cortex present on a nucleus at any point in the reduction process will vary, depending upon the type of process used. As a result, the recording of the presence/absence of cortex on flakes within a size class should be indicative of various reduction processes. Additionally, because of variation in the initial presence of cortex according to the type of raw material used, and the manner in which it is procured, different cortex removal patterns will obtain between raw material classes.

Although the presence/absence of cortex was recorded for the debris recovered from the Memorial Park site, this information was not used in the subsequent in-depth technological analysis presented below. There are two reasons for this. First, the analytical system constructed is general enough to apply to all raw material types, regardless of size and shape, hence, cortex provides redundant information; second, the reliability of recording the presence/absence of cortex is considerably lower than the other measurements (grade sizes, weights, counts). The contribution of this information is negligible, if not confusing.

Ahler's third empirical generalization, load application, refers to the amount and kind of force applied to the nucleus (e.g., hardhammer freehand versus freehand pressure). Different types of load application result in different sized flakes and different average weights within a size class. As a result, the determination of total counts and weights within particular size classes should demonstrate variation in the amount and kind of force produced. Because it is the length, width, and thickness of resulting flakes that are the characteristics indicative of various load applications, the average weight of flakes within a size class provides a measure of flake shape.

The writer entirely agrees with Ahler that variation in load application results in flakes of different sizes and shapes, but here, again, there are no specific suggestions or generalizations as to how the sizes and shapes differ from one load application to the next. Further, the types of percussion and pressure techniques employed by flintknappers have strongly overlapping ranges of measurable properties which may provide little information on reduction in terms of the products that we can observe and measure. It may be more helpful to understand the extent to which a workpiece is actually thinned, than to identify the precise technique used to produce that result. Only if there is a one-to-one correspondence between percussor and technique and the precise, measurable, morphological characteristics of the product can we argue for the necessity of understanding this connection as a basis for technological analysis of an aggregate of debris.

A further underlying assumption made in mass analysis is that morpho-technological classifications of tools (e.g., cores, bifaces) capture fundamental differences in reduction trajectories. Variables sensitive to reduction will differ among morpho-technological types. If the morpho-technological types are fundamentally different in terms of reduction, then one would expect emergent or alternative qualitative properties to be associated with each type. Then, each given type, with respect to the debris generated, would be measurable on a different scale and debris could be sorted accordingly.

An alternative assumption is that the differences are quantitative in nature and exist in bounded units on a continuum (likely multivariate). Archaeologists have never been able to demonstrate that such differences exist, after taking only measurement error into consideration. Instead, all such units are found to overlap, usually extensively, even if measurement error is considered negligible, or is adjusted for or taken into account.

Perhaps the error is in equating the rationalizations for what people do; i.e., their classification systems constructed in specific neural subsystems, with the processes occurring in other neural subsystems (Corballis and Beale 1976; Galin 1974; Gazzinga 1970; Ornstein 1978; Pribram 1971; Sperry 1968). Outside of science, people do not explicate the how of a given process without referring to formal goals, to the product, or to a list of the elements of the response repertoire associated with the process. Naturally, people have ideas regarding the product they intend to produce and a response repertoire consisting of actions (e.g., angle of blow) and accessories (e.g., indenter types) to facilitate this end. What more is necessary for a complete causal analysis of the reduction process?

The approach taken in this analysis is metascientifically materialistic. Causality in the narrow sense is not emphasized by analyzing the response repertoire for a reduction process, such as the use of different indentors for pressure versus percussion flaking. The emphasis is not the search for explanations of departures from order or patterning, but on regularity, order, and robust patterning, as the result of nonmechanical physical entities and processes of the human organism. It is subsequent to this analytical posture that it is proposed to apply this work to materialistic, systemic (cultural) questions.

Another area of concern is statistical. A number of statistical problems are encountered when submitting these data to analysis using a multivariate linear model such as discriminant analysis, as is done by Ahler (1986, 1989a). The primary point to understand is that failing to meet the assumptions of the analytical technique invalidates the interpretations made subsequent to that analysis.

The first assumption made for linear models is, of course, linearity. Some of the problems associated with this assumption were addressed above, but there is a statistical side to this problem as well. Even if one were to argue that a given relationship can be "adequately" characterized as

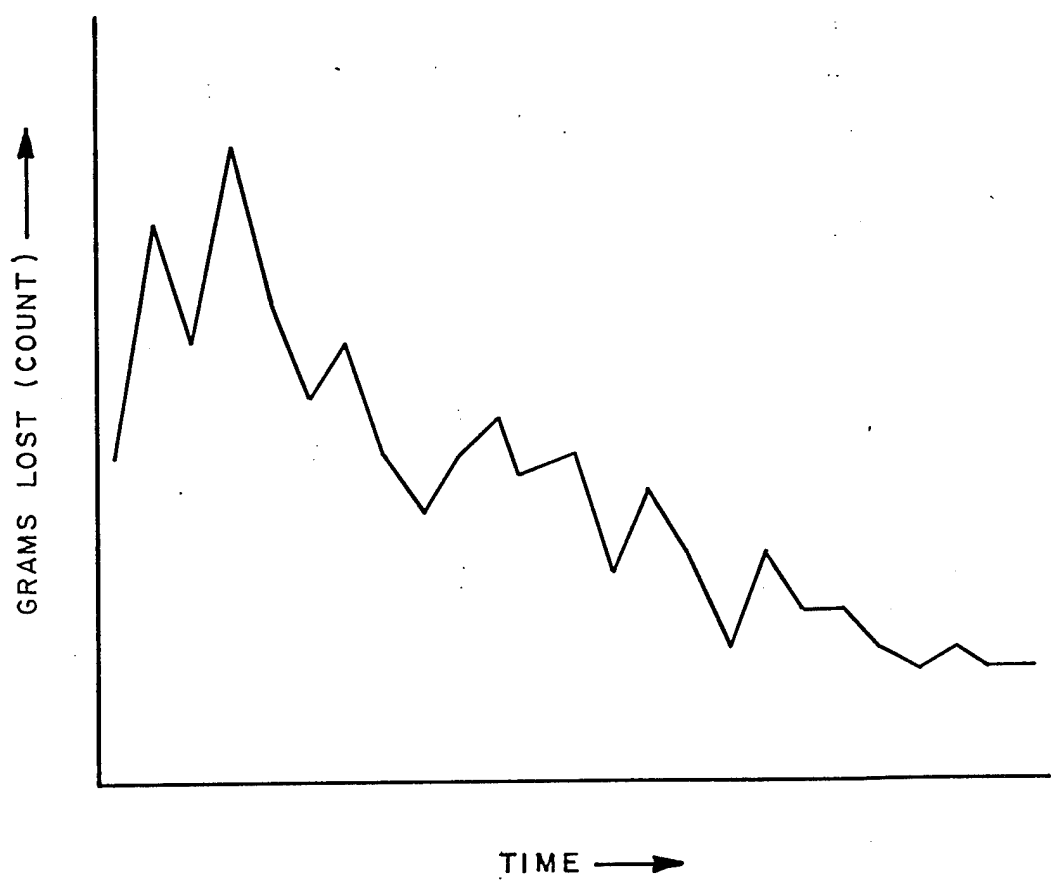
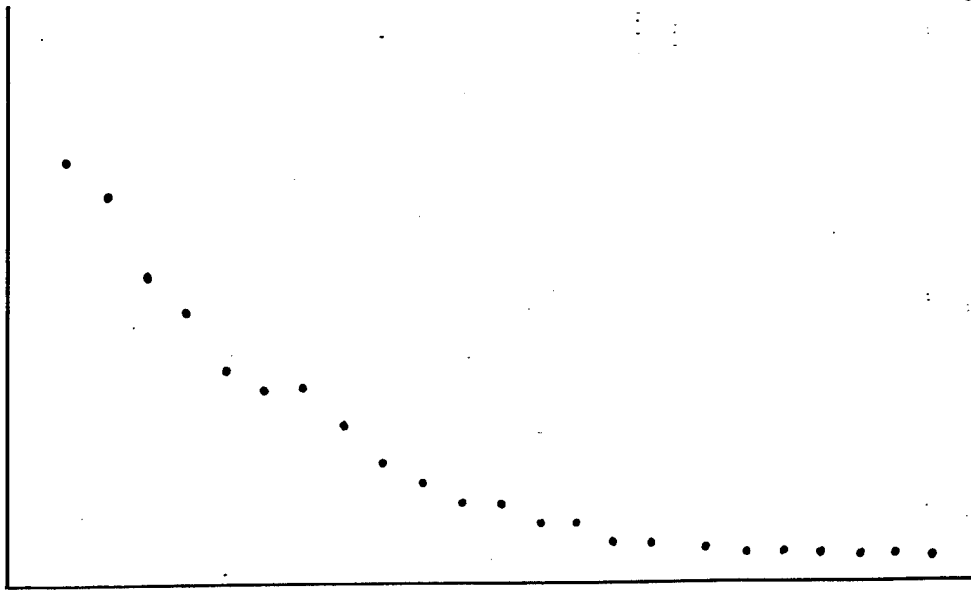

FIGURE 72

POLYGONIZED PLOT  
REPRESENTING RADIOACTIVE DECAY

GRAMS →



TIME →  
a.

GRAMS →

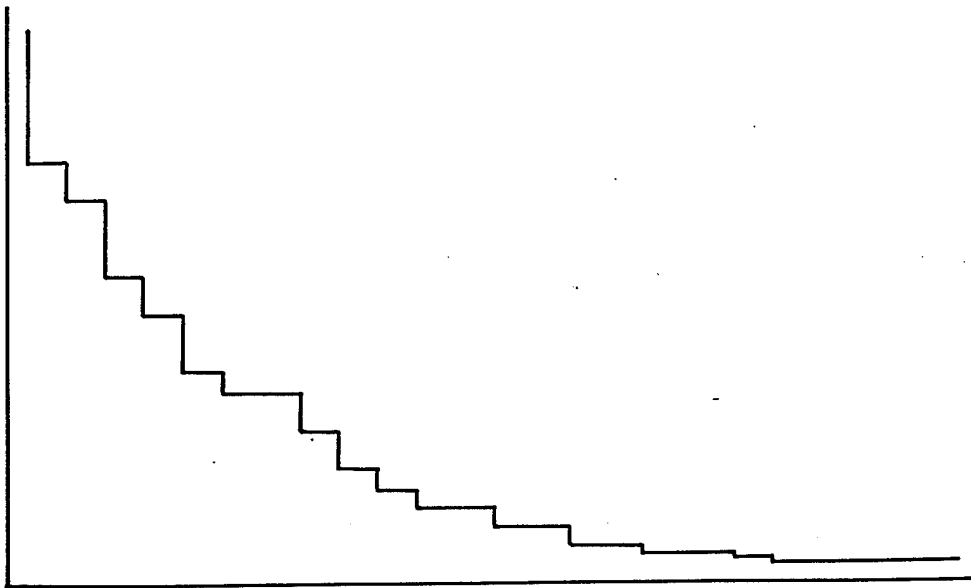

TIME →  
b.

FIGURE 73

CUMULATIVE DECAY BY WEIGHT  
(COUNT) OF RADIOACTIVE MATERIAL  
a. DATA POINTS, b. STEP PLOT

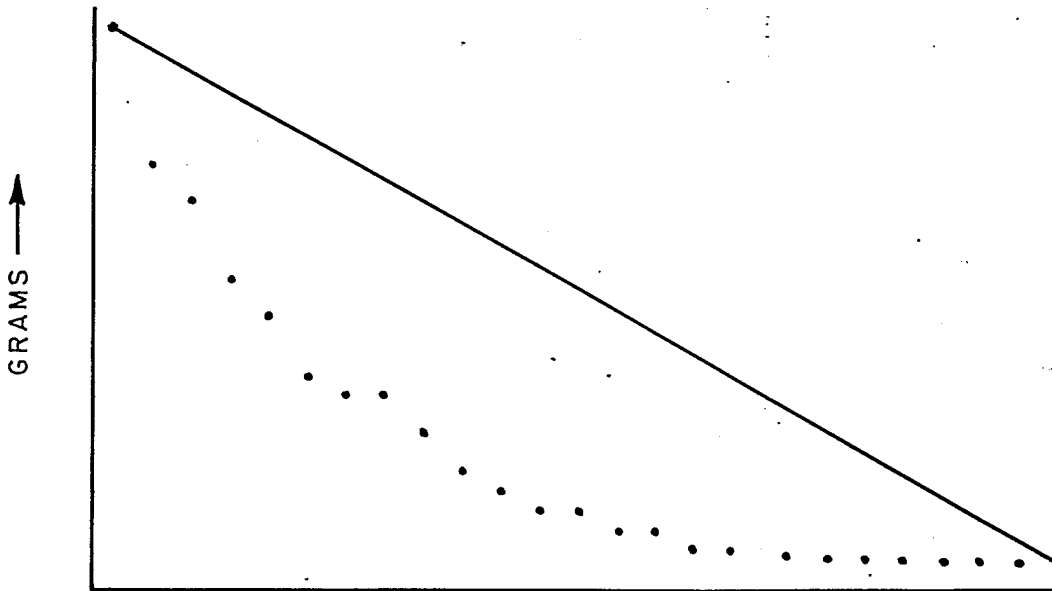

a.

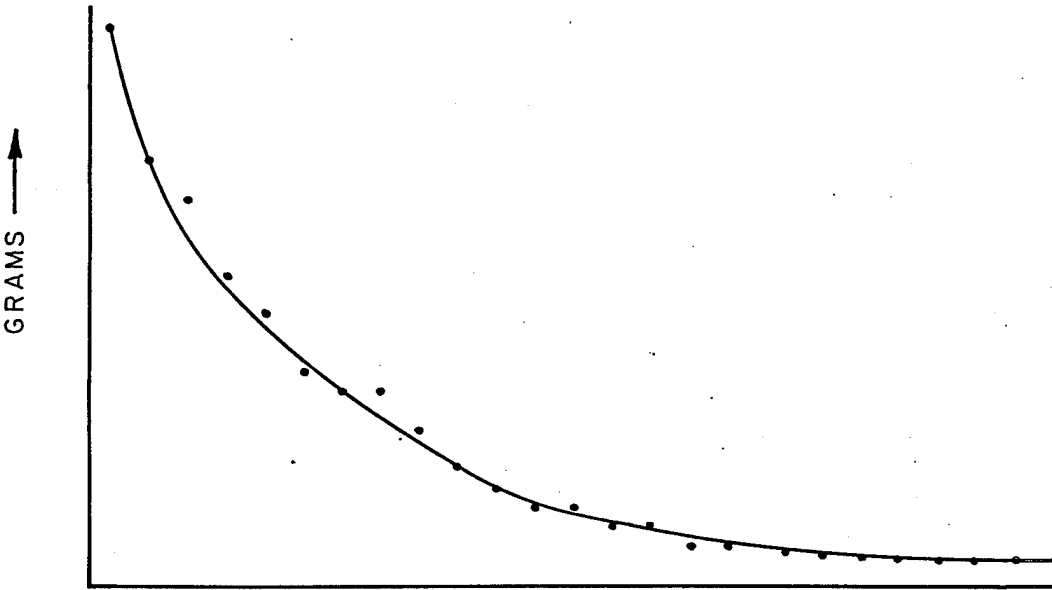

b.

FIGURE 74

STRAIGHT LINE FIT AND  
NONLINEAR FIT TO SAME DATA SET



linear, what would it mean to generate two correlation coefficients of equal magnitude for two sets of data, one of which is linear and the other nonlinear? How are these two correlation coefficients comparable? They are not, and subsequent treatment, as if they were, is inappropriate. The multivariate linear techniques mentioned would yield results which are not logically interpretable.

A second difficulty is encountered with the assumption of statistical independence. Whenever the measurements from a single piece are taken in order of occurrence, the assumption of independence is violated. This is particularly bothersome in analyzing experimental data generated at intervals for the same experimental object. As an example, consider the experimental data generated in knapping experiments. Suppose flake weight is measured for flakes as they are removed from a workpiece. If there is any kind of functional interdependence between the weight of a flake as a function of the order of removal, then these measures are not statistically independent. Consequently, the usual statistical procedures do not apply. For bivariate analyses, alternative procedures are available, but in the multivariate case, the situation is much more complicated and the alternatives have rarely been employed by archaeologists. As an example, for bivariate regression, alternative computational techniques apply to the minimum variance, unbiased estimation of the slope (Mandel 1957).

A third problem arises in the analysis of data that possess non-negligible measurement error. The basic assumption of *all* statistical procedures is that the data used are subject to negligible measurement error. If interobserver or intraobserver measurement errors are large, then the techniques are incapable of yielding valid results. The problem of data reliability has been addressed in archaeology, but it has never been properly appreciated. This problem has been studied in great detail, through the analysis and coding of lithic data in relation to tools and debris using nominal, ordinal, and interval data. This study demonstrated that the questions asked are usually too sensitive to be answered given the low degree of reliability involved (Spitzer 1981). An example includes the spatial distribution of artifact types on a site. Applying various spatial-statistical techniques does not yield appropriate results when the interobserver reliability, with respect to artifact classification is low (50%-75%). This applies to the simplest statistical techniques, such as chi-square analysis of a 2x2 table.

The last difficulty encountered in multivariate analyses is multicollinearity. Whenever the battery of variables is highly intercorrelated, their joint contribution inflates the associated statistics and endangers computational accuracy of the procedures. In discriminant analysis, for instance, the resulting classification probabilities can be grossly inflated, so that when the classification functions are applied to a new data set, the results are far less accurate than the initial analysis would lead one to believe. Even with the multicollinear problem properly addressed, applications to new data sets of known classification yield misclassification rates as much as 12 percent higher (Afifi and Azen 1972). With functionally interrelated variables of grade size and weights, the problem becomes severe.

Although Ahler's method of mass analysis is suspect as an analytical process, the data collection techniques are highly reliable, as well as time- and cost-efficient. More importantly, as a data collection procedure, size-sorting yields information that becomes a powerful tool in further technological studies. It is not argued here that more reliable and valid measurement techniques have been considered, only that grade sorting is a satisfactory beginning.

The measuring process is accomplished when the debris is passed through a series of screens of progressively smaller size grade (see methods section). The resulting information provides us with a set of points on the reduction continuum, specified in terms of count, weight, and grade size accumulated from smallest to largest. As thinning increases, the surface area of the flakes increases, while the weight is not substantially different compared to a shorter flake removed

by the same applied force. Hence, for a given size grade, which is proportional to the surface area of the debris, fewer flakes per gram can be expected than with non-thinning (edging, platform preparation, etc.). This information is provided in an approximate manner by weight/count ratios (Ahler's mean flake weight), although in this study the concept is addressed in a more sensitive way.

*Transition to Applications.* A distinction must be made between a flake removal as a single action of relative thinning, and a sequence of flake removals which constitute a thinning (or thickening) trajectory. A thinning trajectory is one in which the width-thickness ratio is increased early in the reduction continuum. It does not mean that the width-thickness ratio is increased and then stops. Bifaces produced from nodules, for instance, go through initial edging, thinning, and subsequent thickening, during shaping, reworking, and resharpening.

Alternatively, a thickening trajectory (such as a flake reduced to a biface form) does not refer to a uniform increase in width-thickness ratio. Here, the width-thickness ratio decreases early in the continuum, and may increase again in later parts of the continuum. This sequence of removals produces a very different distribution of flake sizes-weights-counts than a thinning trajectory. Graphical representations of the consequences of these contrasting trajectories are presented in Figure 75.

The two factors to consider in the analysis of these graphs are the location of the increased flake weight, and the number of flakes generating that weight. If relatively more weight is generated at the larger size grades by fewer flakes, then a thinning trajectory is indicated by a higher rate parameter. If relatively more weight is generated at the smaller size grades, then a thickening trajectory is indicated by a lower-rate parameter.

To substantially reduce a workpiece, thinning is a necessary component. Otherwise, the edges and the width-thickness ratio would prohibit further flake removals. The piece would "thicken up" and the problem of removal would become intractable. Further, every flake removal decreases the width dimension. Consequently, the size and weight of debris grow progressively smaller. The manner in which the debris grows smaller is not a simple proportional relationship of the manner in which they thin. Therefore, a second dimension of variability is important to consider, and that dimension can be labeled size (here, weight and size grade are jointly employed).

A third concept of importance is the degree of reduction effort represented by debris. A meaningful concept of reduction effort would jointly include the degree of thinning occurring, which increases the potential for further reduction, number of debris, and size of debris. Two different measures of reduction effort are useful here. One, the total effort, is related to the concept of total effort expended. The second, the mean effort, gives us a relative measure of reduction effort by adjusting for the total material weight.

Finally, the concept of trajectory subspaces that represent the relation of thinning-thickening changes to mean effort changes, is introduced. A mathematical analysis of dynamic systems can reveal different regions, or subspaces, in the total space within which processes occur. By total space, I refer to the rectangular space bounded by the maximum and minimum values of each variable. In terms of thinning and mean-reduction effort, the space can be subdivided, as presented in Figure 76. This figure illustrates the global patterning or structure of the space. The plotting of specific values on the scale, and assignment of specific meanings are results presented in the applied section. At this juncture, the important point to understand is that dynamic systems, in general, tend to possess subspaces into which dynamical processes are attracted, and each subspace has a different meaning in terms of one or more parameter values with

which these systems begin. The boundaries of the subspaces are defined by the direction in which a process tends to go, as symbolized by the arrows.

The subspaces, of practical interest to lithic reduction theory, are represented in Figure 77. These three subspaces are labeled thinning space, thickening space, and late reduction; resharpening; and, low representation space.

Reduction occurring in thinning space corresponds to what archaeologists commonly refer to as biface thinning, but can represent any trajectory that emphasizes curative technologies in which tools are produced, and designed for long term use, through repair and resharpening. It is essential to understand, however, that thinning space is only occupied by those assemblages of debris which essentially represent the whole reduction trajectory. If the site is a short-term occupation during which only some repair and resharpening occur, then regardless of the general technology employed by the artisans involved, only a very constricted subset of the reduction trajectory will be present, and can be expected to fall within the space labeled late reduction - resharpening.

The derived values in thinning space, the x-axis, are over 7.5 and under 12.5, not as high as for the thickening trajectory described below. However, the mean reduction effort is higher, usually much higher than in the other two subspaces. Continued repair and resharpening brings the overall thinning value down, but the amount of effort per unit of material is much higher, as it is ultimately reduced more.

The thickening space represents the relatively full range of what is referred to as an expedient technology. An expedient technology may produce relatively large numbers of useable flakes for immediate use and discard, but less effort is put into surficially modifying the tool.

The range of values for the thickening space is much different than for the thinning space. Here, the thinning x-axis value is higher, ranging from 10 to 15. However, the mean reduction effort, y-axis, is relatively low. This is sensible for a technology that emphasizes the production of many useable flakes, a process which must be characterized by continued thinning to produce more flakes. However, since the flakes produced are not modified to a large extent subsequent to detachment, the mean effort is smaller.

The third reduction space, termed late reduction-resharpening, is a space characteristic of short term occupations for which repair and or resharpening are the dominant activities carried out at the site during specific procurement activities unrelated to lithic reduction. This space is characterized by both low thinning values and low mean reduction effort.

Understanding the nature of these subspaces implies recognizing a number of factors. These factors include the relative abundance of useable raw material close to the site, the fracturability of the raw material, the type of reduction trajectories used at the site (thinning versus thickening), the span of the trajectories represented at the site, the size of the raw material involved, the locality or origin of the raw material, and the general nature of the lithic technology (expedient versus curated).

A site such as Memorial Park may have a number of readily accessible raw materials nearby. If there is a supply of several raw material types of equivalent reducibility, such as high quality chert and chalcedony, then the frequency of use may be more a function of frequency of encounter in the environment than any other factor. Hence, the total effort represented at the site, the degree of thinning, and the mean reduction effort, could be expected to be larger for a given raw material which is encountered and picked up more frequently than for a less abundant material.

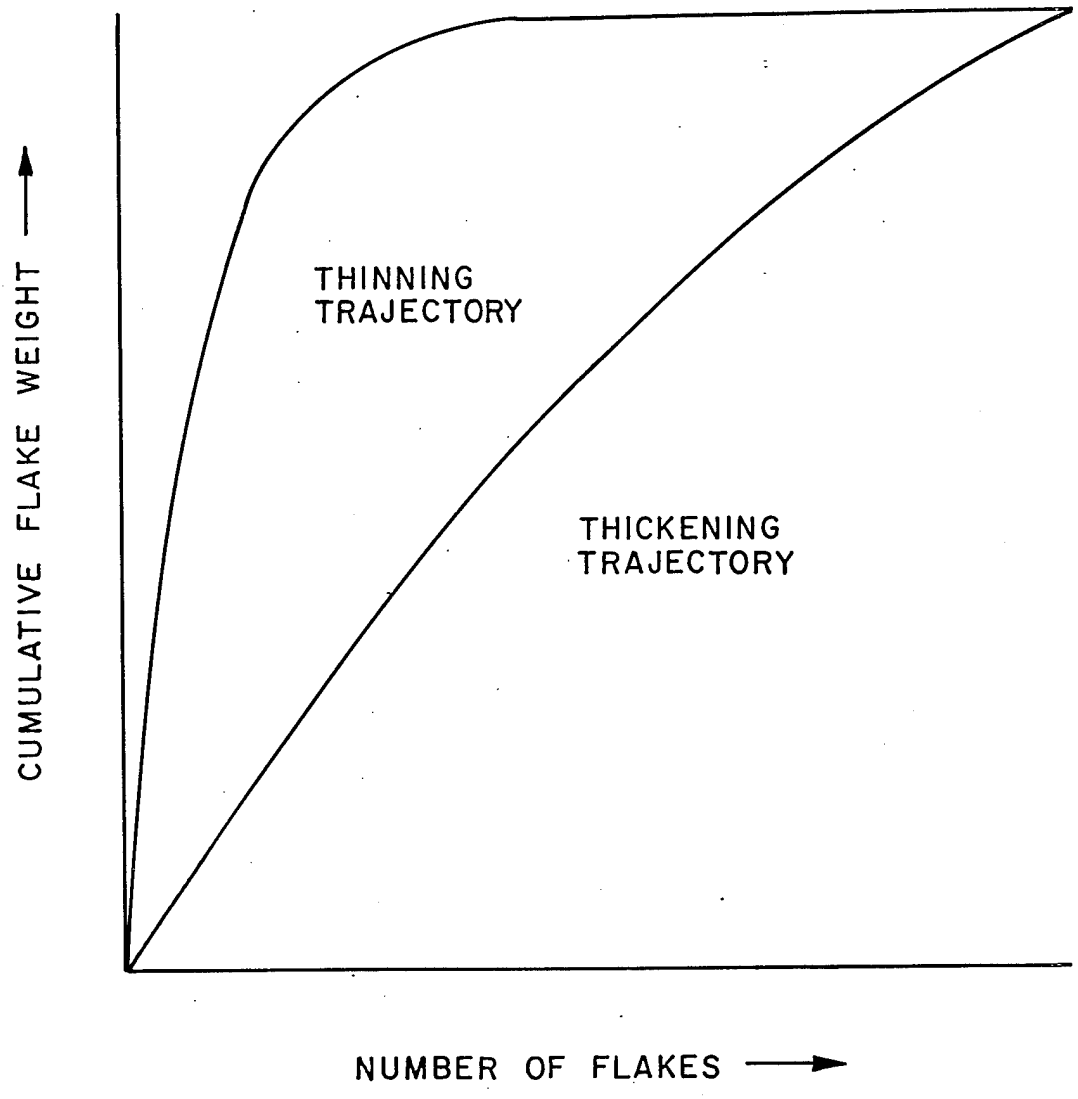

**FIGURE 75**

AN EXAMPLE OF  
CUMULATIVE FLAKE WEIGHT  
FOR THINNING VERSUS THICKENING

Alternatively, a less workable raw material may be overlooked even if its relative abundance is higher. Argillite, for example, may not be used as frequently and for the same range of production activities as cherts or chalcedonies, even if it is more abundant. Therefore, the degree of thinning and reduction effort would be expected to be less than for more workable materials at a given site.

The type of reduction trajectory characteristically employed by the site inhabitants also affects the resulting reduction space occupied by the scale values of the debris. The size distribution of flakes from a thickening trajectory, beginning with small, thin flakes and dominated by edge modification to shape the piece, is smaller than that of a thinning trajectory. In the latter case, more overall material is removed and longer, thinner flakes are produced during the reduction episode.

Even if a thinning trajectory is employed, not all of that trajectory is necessarily represented at a single location. Initial reduction may occur at distant locations if the raw material is obtained there. Resharpening may be the only activity occurring at a site such as a temporary procurement camp. These differing portions of the entire reduction trajectory for a given piece produce different signatures in reduction space.

The initial size of the available raw material also conditions the potential for subsequent reduction. Not only do smaller nodules yield a smaller range of flake sizes, they have a lesser potential for what we might recognize as thinning flakes, since the difficulties of producing a workable platform for such a piece (one that is large enough to successfully use) are much greater. The origin of the raw material is another factor conditioning the degree of reduction represented at a site. A long-term camp near suitable raw material may serve as the principal reduction locus for a given piece of material. The material, after acquisition and testing for quality, may be transported back to the site in large nodular form and reduced there. Further, subsequent repair and resharpening after procurement activities may occur largely at the site. Hence, the range of reduction represented at the site may be relatively complete. Alternatively, more exotic raw materials procured at distant locations may be reduced to workable form at or near those locations, and transported to a long term camp. In this case, the latter parts of the reduction trajectory may be present at the site. Consequently, the thinning parameter and the total reduction effort can be expected to be smaller.

Finally, approaches to material use differ in curated versus expedient technologies. In curated technologies, a long reduction trajectory is employed and results in a moderate thinning parameter and larger total reduction effort, *ceteris paribus*. In expedient technologies, less reduction is performed per piece, hence the thinning value may be larger, but the total reduction effort may be smaller due to the use of larger quantities of material that are subsequently discarded.

*Description of the Scales.* The thinning scale, based on debris data, is constructed on the basis of relative rates of change of width, to thickness, respectively. A particular functional form describes both the change of width and the change of thickness during reduction. This form is symbolized mathematically by:

$$A=N_a+C_a*\exp(-b_a*F). \quad (1)$$

This function describes the decrease in a dimension as a function of the number of flake removals. "A" represents the width or thickness at flake removal number "F". "N<sub>a</sub>" is the ending width or thickness. "C<sub>a</sub>" is the difference between the initial width or thickness and the ending width or thickness. The parameter, "b<sub>a</sub>", is the rate at which the process takes place.

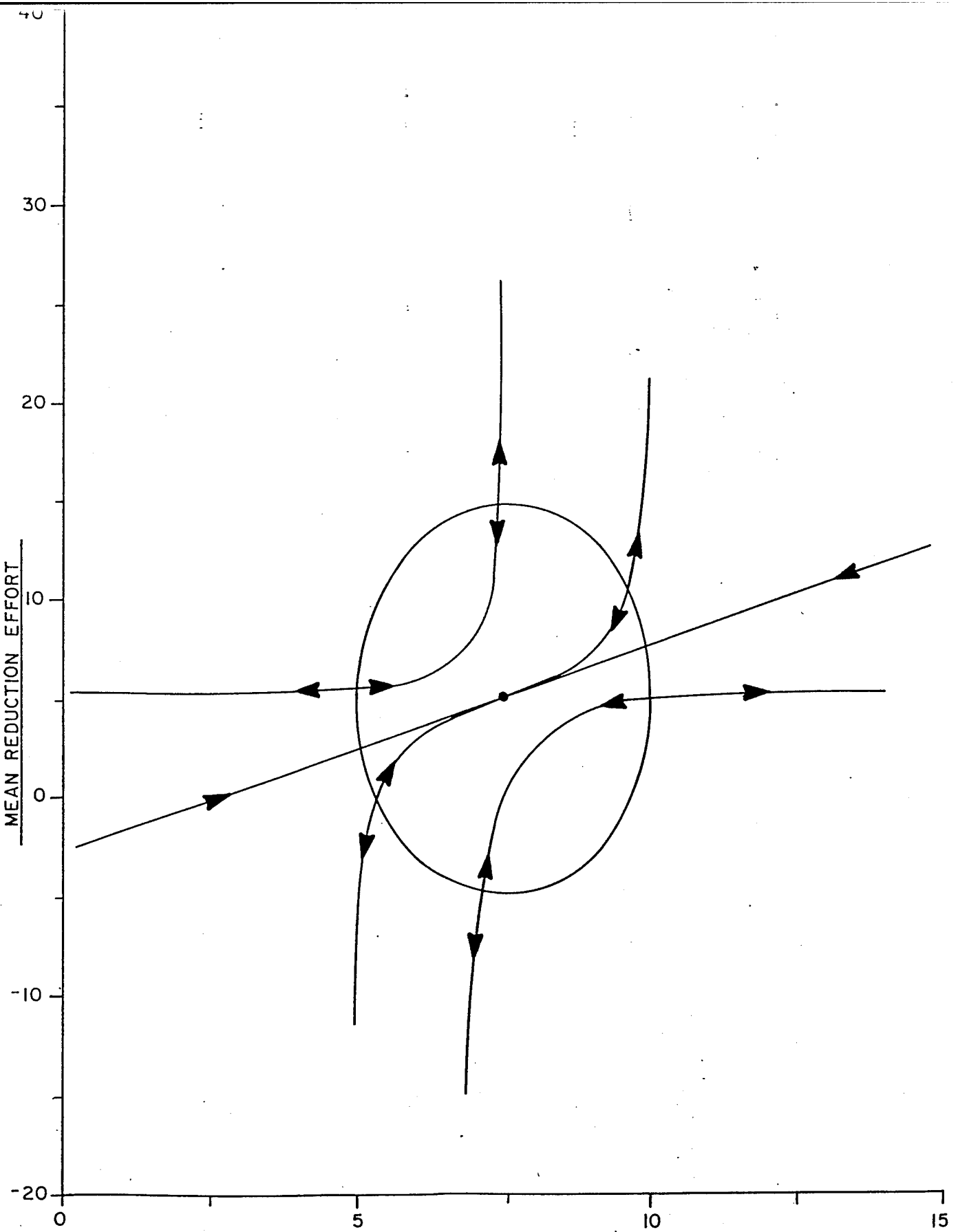

FIGURE 76

PHASE PLANE PORTRAIT OF  
THE THINNING INDEX VERSUS  
THE MEAN REDUCTION EFFORT

Since both width and thickness changes are expressed in terms of the number of flake removals, one can be solved in terms of the other. To directly address the changing width-thickness ratio, the width equation was solved in terms of thickness, yielding a rate parameter describing the width change, divided by the thickness change. Where the width equation is represented by  $W=N_W+C_W*\exp(-b_W*F)$  and the thickness equation is represented by  $T=N_T+C_t*\exp(-b_t*F)$ , in terms of thickness, width changes are described by the function :

$$W=N_W+((C_W/C_t)*(T-N_T))^{b_W/b_t} \quad (2)$$

Reformulated in terms of  $b_t/b_W$ , the rate parameter describing the degree of thinning is:

$$(b_t/b_W) = \log((C_W/C_t)*(T-N_T)) / \log(W-N_W). \quad (3)$$

When the rate of thickness-change,  $b_t$ , is greater than the rate of width change,  $b_W$ , the trajectory is a thinning trajectory. A  $b_t > b_W$  increases the size of the numerator on the right side of the equation. Conversely, when the width rate is larger than the thickness rate, a thickening trajectory is obtained.

As demonstrated in the appendix, the rate parameter of width-thickness change is directly proportional to the rate of change in debris weight per number of flakes. The equation describing the cumulative increase in weight of debris is :

$$W=W_t*(1-\exp(-b*F)), \quad (4)$$

where  $W$  is the weight of the debris at the removal of flake number  $F$ .  $W_t$  is the total ending weight of the debris, and  $b$  is the rate parameter describing the rate of the process of accumulating debris weight. The equation derived in Appendix E, which relates the thinning rate to the rate of debris weight accumulation, is:

$$b=B/C \quad (5)$$

where  $b$  is the rate of weight removal;  $B$  is the rate parameter  $b_t/b_W$ ; and  $C$  is a constant. As  $B$  (the thinning rate) increases,  $b$  (the cumulative debris weight), increases.

For a single trajectory, this scale can be based upon the rate parameter alone. However, as is shown in the appendix, the aggregate of debris from more than one reduction episode yields a parameter which becomes smaller with increasing number of debris. Therefore, a comparative scale is constructed by multiplying the calculated mean rate by the number of flakes. The numbers associated with the thinning scale might be termed trajectory thinning units. The total reduction effort scale is a composite scale of two nonlinearly related variables: weight, and number of flakes. An increase in any one variable results in an increase in mean reduction effort. The equation describing the total reduction effort is:

$$TE=(\log(W_t)-1)*(F_t+((\exp(-b*F_t)-1)/b)), \quad (6)$$

where "TE" is the total reduction effort; "Wt" is the total weight of the debris; "Ft" is the total number of debris; and "b" is the rate parameter for the increase in debris weight. The relative contributions of each variable are different, but consistent with the established relationships between the two variables. The sign of the value is not physically meaningful; what is meaningful is the relative position of the value on this scale.

The mean-reduction effort scale is a scale adjusted for the total weight of the debris present. It is the total reduction effort divided by the total weight. Again, the sign of the value is not physically meaningful; the relative position of this value on the scale is important.

*Testing the Theory.* Lithic reduction theory does not exist in a void. It has rigorously testable and tested consequences, at several levels and over a wide range of implications. The purpose of this section is to illustrate the support for lithic reduction theory, both experimentally and archaeologically.

The first point to make is the nature of the testing process. Some propositions can be tested directly. The relationships postulated for width and thickness changes of the workpiece are subject to direct testing, the results of which have been relatively robust. Similarly, the relationship for debris weight can be tested directly. However, the construction of the thinning scale, presented here, relies on indirect methods. If flake weight increases are functionally (logically) related to workpiece width and thickness changes in the ways deduced from the theory, it can be argued that the thinning scale, as a consequence of these aforementioned functions, is appropriate if the thinning concept developed for the workpiece is acceptable. Similarly, if the number of flakes, weight of these flakes, and the rate parameter describing these changes are increased, it is plausible that effort, defined to require the removal of these flakes, would increase as well.

The primary bases of the testing are briefly reviewed here. The neurosensory background is referred to simply by way of summary assertions and referral to relevant references detailing the results of the testing programs in neurosensory metrics. The workpiece, as a point of departure for reduction processes, is then addressed in terms of four sets of tests of postulated relationships between changes in width, thickness, length, and weight, and the number of flake removals. Finally, postulated debris changes are supported with a discussion of the experimental background relating length-thickness-platform size of flakes, as well as weight, flake count, and grade size changes for both single and multiple reduction episodes.

The relationships tested, discussed, and developed for this analysis are derived from higher order generalizations which were developed in the context of neurosensory metrics. This fact is mentioned here to indicate that the following analysis is part of a more complete deductive system, the mathematical part of which is presented in Appendix E. Only a brief justification is presented here for the validity of this higher order set of generalizations.

Four basic relationships in neurosensory metrics have been tested: the Elovich equation, the Lowenstein equation, Stevens' law and the Weber-Fechner law. The latter is the oldest relation, proposed in different forms by Weber and Fechner in the 19th century to describe the postulated relation between a stimulus magnitude and the resulting sensation magnitude which, of course, had to be measured indirectly. The range of empirical support for the Weber-Fechner relation is impressive (Stevens 1962). Stevens introduced another formulation, now known as Stevens' law, which was demonstrated to apply to a multitude of sense modalities, and which Stevens claimed measured the relationship between the stimulus magnitude and the response magnitude (Stevens 1946, 1951, 1957, 1959, 1966, 1971, 1975; Stevens and Galanter 1957; Stevens and Savin 1962; Stevens and Stevens 1960). It was later discovered that the Weber-Fechner law could be derived from the Elovich equation, which successfully describes sensory



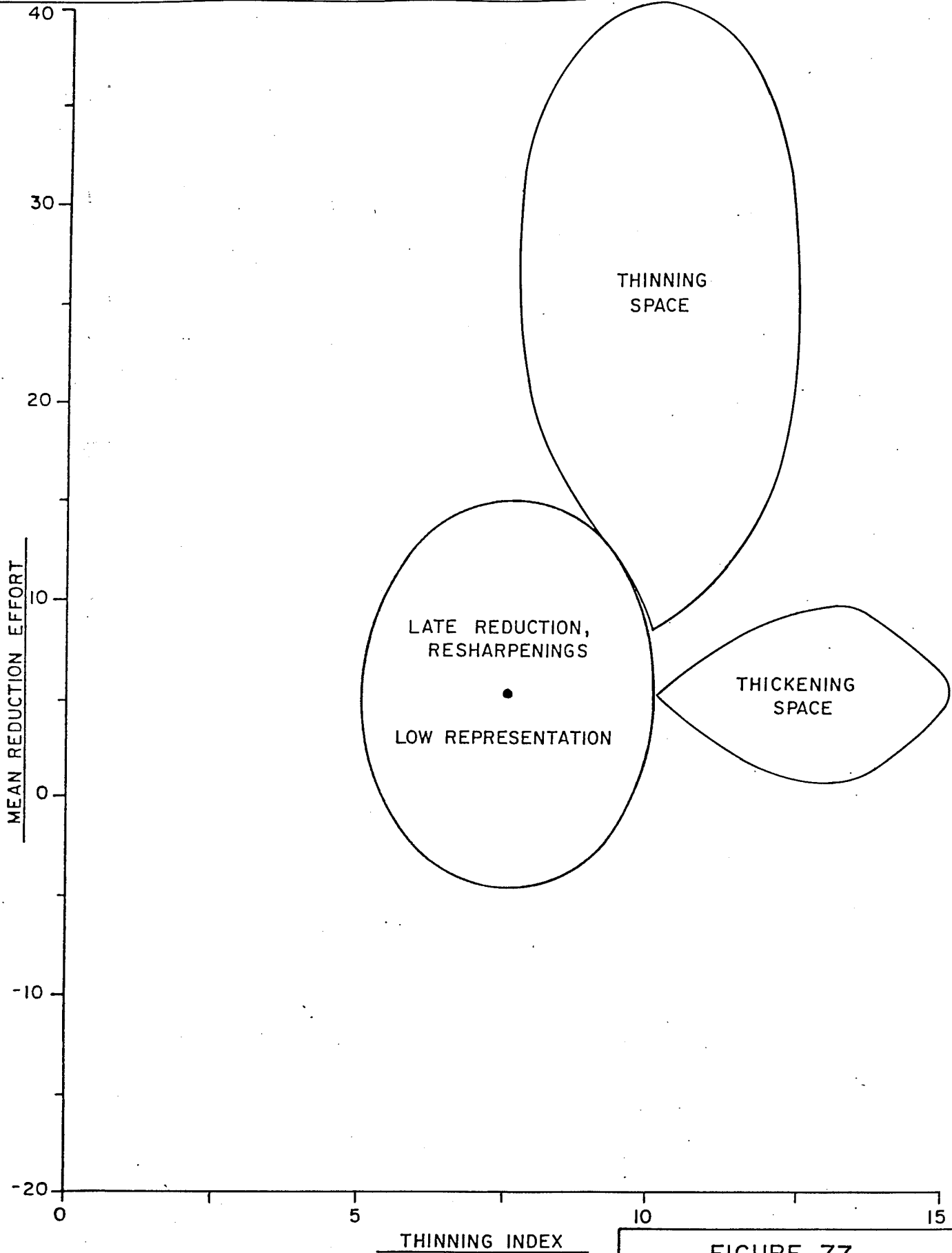

FIGURE 77

BASIC REDUCTION SUBSPACES ON THE PHASE PLOT

processes in neurochemical terms as a solid state biological system, and which is an approximation of the Lowenstein equation shown to be applicable to wider ranges of stimulus magnitudes for many sensory modalities (Adams 1971; Cope 1976).

The writer has reformulated Stevens law and the Weber-Fechner law, arguing that they measure slightly different phenomena (conceptually) than their respective authors have claimed. The result of this reformulation was the deduction of the stimulus-response relation or interactive relation. That this relation is supported, from above, in the explanatory scheme, is a consequence of the wide range of empirical support cited above, for both Stevens' law and the Weber-Fechner law.

The testing of the relationships for workpieces and debris was based on experimental data obtained from seven sources. The combined data permitted the testing of 27 relationships for workpieces, and 956 relationships for debris.

For workpiece variables, two sources provided valuable experimental information regarding the change relations for width, thickness, length, weight, and the width-thickness ratio. The first is an important and often quoted source (Newcomer 1971). Newcomer summarized data on flake weight, in order of removal, for three experimentally manufactured flint hand axes. These have been used to plot the relationship of weight change over the number of flake removals, resulting in very tightly-patterned data, unlike the plots presented by Newcomer.

The second set of data resulted from a series of 6 knapping experiments in the production of bifaces from chert. This author recorded flake removals, elapsed time, and workpiece lengths, widths, and thicknesses at preselected intervals during the reduction process (knapping done by Frank Cowan). These variables permitted the testing of relationships between workpiece widths, thicknesses, lengths, and weights, and the width-thickness ratio.

Experimental data for the testing of the debris relationships was obtained from five sources. The data file referred to by Ahler (1986) provided the summary data for grade size, counts, weights, and presence of cortex for 277 experiments, including cobble testing, biface manufacture, hard-hammer core production, bipolar core production, blade core production, and small tool production with Knife River Flint and Peoria chert. A similar set of data, for 35 cases of debris, which included core and biface (point) production using slate, quartz, quartzite, and chert, was obtained from Kalin (1981). Hart and Cremeens (1991) provide this same set of variables for 59 cases of stemmed and triangular points and bipolar cores, manufactured by Kalin from quartz and chalcedony. Stahle and Dunn (1984) give weight and count data for 12 bifaces, manufactured from chert, over 4 stages. Finally, Van Dyke and Behm (1981) provide grade size, weight, and count data for 6 aggregated groups of experiments representing 99 cases, also manufactured from cherts.

A summary of the tests performed is presented in Table 209. The relative degrees of robustness of the results are indicated by the squared multiple correlation coefficients ( $R^2$ , or percent of variance accounted for) in the last column of the table. The  $R^2$  values are based on regression results for non-independent data of the linearized functions for the tests. The overall range of the  $R^2$  for the fits to 956 experimental units is 0.92-0.99. The median value is about 0.98. The experimental data, thus, strongly confirm the hypothesized relationships.

Some of the debris data could not be used in the testing, which accounts for the number of tested cases being smaller than the number of cases in the original data sets. This occurred whenever the number of grades into which the debris was sorted was less than three. Estimates of the parameters, based on linearized form of the postulated functions cannot be made with less than

two points, and tests of the statistical significance of the results cannot be made with fewer than three points, where a datum point corresponds to cumulative weight and count for a given grade size.

A brief set of examples is now given for each of the tests performed. One test case each is illustrated for changes of width, thickness, length, and weight of the workpiece. Then, a brief overview of the relationship of flake morphology to thinning-reduction processes is provided. Finally, one test case each is illustrated for weight, flake number, and size grade for single reduction episodes, and multiple or aggregate episodes, respectively.

The width changes of the workpiece during reduction are described by a function of the form, discussed above:

$$W=Nw+Cw*\exp(-b*F),$$

where the parameters were previously defined. The linearized form of the function, used for obtaining regression estimates of the slope and the intercept, is:

$$-\log((W-Nw)/Cw)=b*F.$$

However, with experimental data, the minimum variance, unbiased estimate of the slope is simply the slope of the line connecting the initial point and the end point (Mandel 1957). This form still requires the estimation of  $Nw$ , which is accomplished via a nonlinear iterative technique which converges rapidly to a solution. It is important to note that  $Nw$  does not measure the state of the piece at the end of the reduction episode but, instead, measures the final state it can assume with further reduction at the same rate.

Table 209. Summary of Testing Results for Experimental Data.

Object(s) Studied	Relation Tested	# Single Episodes	# Single Episodes Tested	# Aggregate Episodes	# Aggregate Episodes Tested	Reduction Categories <sup>a</sup>	Range R <sup>2</sup> Values for Least Squares Fits
Workpiece	Width-# Flakes $W=N+C*\exp(-b*F)$	6	6			B	.98-.99
	Thick-# Flakes $T=N+C*\exp(-b*F)$	6	6			B	.92-.99
	Length-# Flakes $L=N+C*\exp(-b*F)$	6	6			B	.97-.99
	Weight-# Flakes $W=N+C*\exp(-b*F)$	3	3			B	.98-.99
	Width/Thick-# Flakes	6	6	1	1	B	.97-.99
	Debris	Weight-# Flakes $W=Wt(1-\exp(-b*f))$	354	311	6	6	B,BC,HHC, BIC,CT
Weight-Grade $Pw=1-\exp(-\lambda x^\beta)$		386	311	6	6	B,BC,HHC, BIC,CT	.97-.99
# Flakes-Grade $Pn=1-\exp(-\lambda x^\beta)$		386	311	11	11	B,BC,HHC, BIC,CT	.97-.99

<sup>a</sup>B=biface; BC=Bipolar core; HHC=Hard hammer core; BIC=Blade core; CT=Cobble testing

Figure 78 is an illustration of the width changes of a biface, reduced in an experiment supervised by the author. A strong fit is indicated by the proximity of the data points to the estimated regression line. It is important to be aware that experimental data typically displays runs in which the points, on one side of the line or the other, are not randomly distributed. This is not a function of the existence of relation which better fits the data.

Similarly, figures 79 and 80 are illustrations of the thickness, and overall changes, respectively, of bifaces reduced in one of the same set of experiments. These, too, are a close fit and strongly support the hypotheses.

Using data obtained from Newcomer (1971), the slope and fit of the functional form for weight changes of the workpiece was estimated. Newcomer did not publish the initial and final weights of the workpieces themselves, so an initial weight as a starting value was arbitrarily chosen large enough to leave material remaining at the end of the sequence. This procedure does not allow a realistic estimate of the final state, but the slope and  $R^2$  values and associated tests are unaffected by this procedure. The point was to test the form of the relationship, not the values of the parameters. The weight decrease of the workpiece possesses the same functional form as conjectured for width, thickness, and length. Figure 81 illustrates a reproduction of Newcomer's plot for handaxe b. Figure 82 illustrates the data, replotted cumulatively, which reveal the same robust fit as is found in the other cases.

The available literature on the relationships of flake length-thickness-platform size reveals the following generalizations: 1) the exterior platform angle is directly proportional to the flake length; 2) the exterior platform angle is directly proportional to the flake length-width ratio; 3) the exterior platform angle is directly proportional to the flake length-platform thickness ratio; 4) the exterior platform angle is directly proportional to the flake width-platform thickness ratio; and 5) the flake length is directly proportional to the platform thickness (Dibble and Whittaker 1981; Henry, Haynes, and Bradley 1976; Patterson and Sollberger 1978; Speth 1972, 1974, 1975, 1981; Tsirk 1974).

Based on these generalizations, and the accompanying definitions of these variables provided by the above-cited authors, it was possible to demonstrate that the concept of width-thickness changes on the workpiece could be functionally related to these variables (see Appendix E). Further, it was possible to relate general flake morphology, in terms of surface area and weight, to the concept of thinning. All of this experimental data is, thus, either consistent with, or not contradictory to, the principles proposed in this report. That width and thickness would be functionally related as specified above is illustrated by an example in Figure 83.

Another deduction from lithic reduction theory is the form of the relationships between weight and size grade, and count and size grade, respectively. Stahle and Dunn (1984) provided experimental data and the results of fitting particular functional forms to the distributions of weights and counts. They found that the Weibull distribution fit the experimental data very well for all cases. They presented it as an empirical generalization. Based upon the principles involved in originally proposing the Weibull distribution in fracture studies in conjunction with the principles proposed here, it was possible to demonstrate that the Weibull fit is expected to occur as the result of production behavior and fracture mechanics. This formed the basis for additional tests discussed below.

With regard to single reduction episodes, three examples are illustrated for the relationship of debris weight to count, debris weight to size grade, and debris count to size grade. Figures 84 through 86 are plots of the linearized functions, and the data points for these three relationships,

respectively. All cases provide excellent fits to the data, strongly confirming lithic reduction theory.

The same three tests were conducted for aggregate debris data. It was argued in the theoretical introduction that aggregated data possess the same functional form as data from a single episode, and that the rate parameter is a mean measure of the thinning rate represented by the aggregate of reduction episodes. This was established in Appendix E. Figures 87 through 89 are plots of the linearized functions and the data points for these three relationships, respectively. As with single episodes, these fits provide strong evidence in support of lithic reduction theory.

### *Applications and Site Analysis - Debris*

*Introduction.* The principles of lithic reduction discussed in this section, and their support, form the foundations for the application of three scales of measurement: thinning, total reduction effort, and mean reduction effort. Their use is directed to the analysis of technology, raw material management, and systemic organization and change. The arguments in this section address the following questions.

- 1) How does the size and shape of acquired raw material condition subsequent technological variability?
- 2) How does the origin of raw material (locally derived versus nonlocal) affect technological variability?
- 3) Specifically, with respect to the heat treatment of jasper, a nonlocal material, what might we expect to see at Memorial Park as opposed to the location of acquisition?
- 4) How are these variable patterns distributed over space and what do these patterns imply regarding organization?
- 5) How can the use of these scales be applied to the identification of the type of site, or duration of occupation, for a given component?
- 6) How are these patterns altered through time, and what changing systemic patterns account for these changes?

These questions are first addressed in a general way. Data from all components is employed in the general discussions of size, origin, and heat treatment. These considerations help to form a background for the discussion of patterns in the component data. Each component is discussed separately, regarding the inferred occupation type. A general discussion of site occupation for the site as a whole, through time, is left until the conclusion. A discussion of spatial distribution within a component, which is only applicable to the Late Woodland component, is addressed in that subsection.

Using procedures previously discussed, measurements were made for each raw material from each recovery unit, if the raw material was present in at least two grades. Estimates of the weight parameters require a minimum of two points (grades), if we assume that they are functionally related in the manner discussed above. If we were not to assume this relationship, then a minimum of four grades would be necessary to statistically confirm the form of the relationship, and subsequently estimate the parameters.

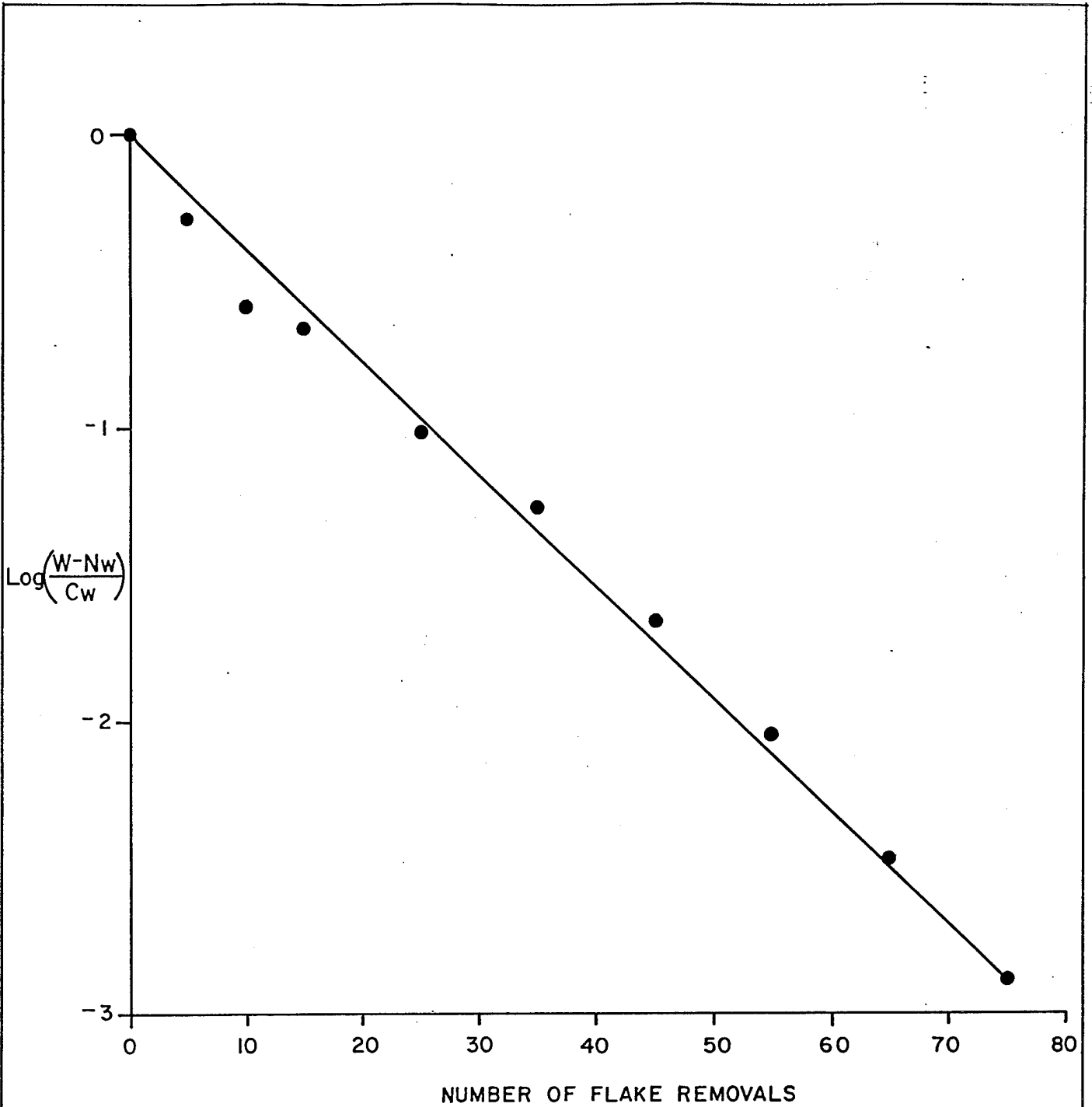
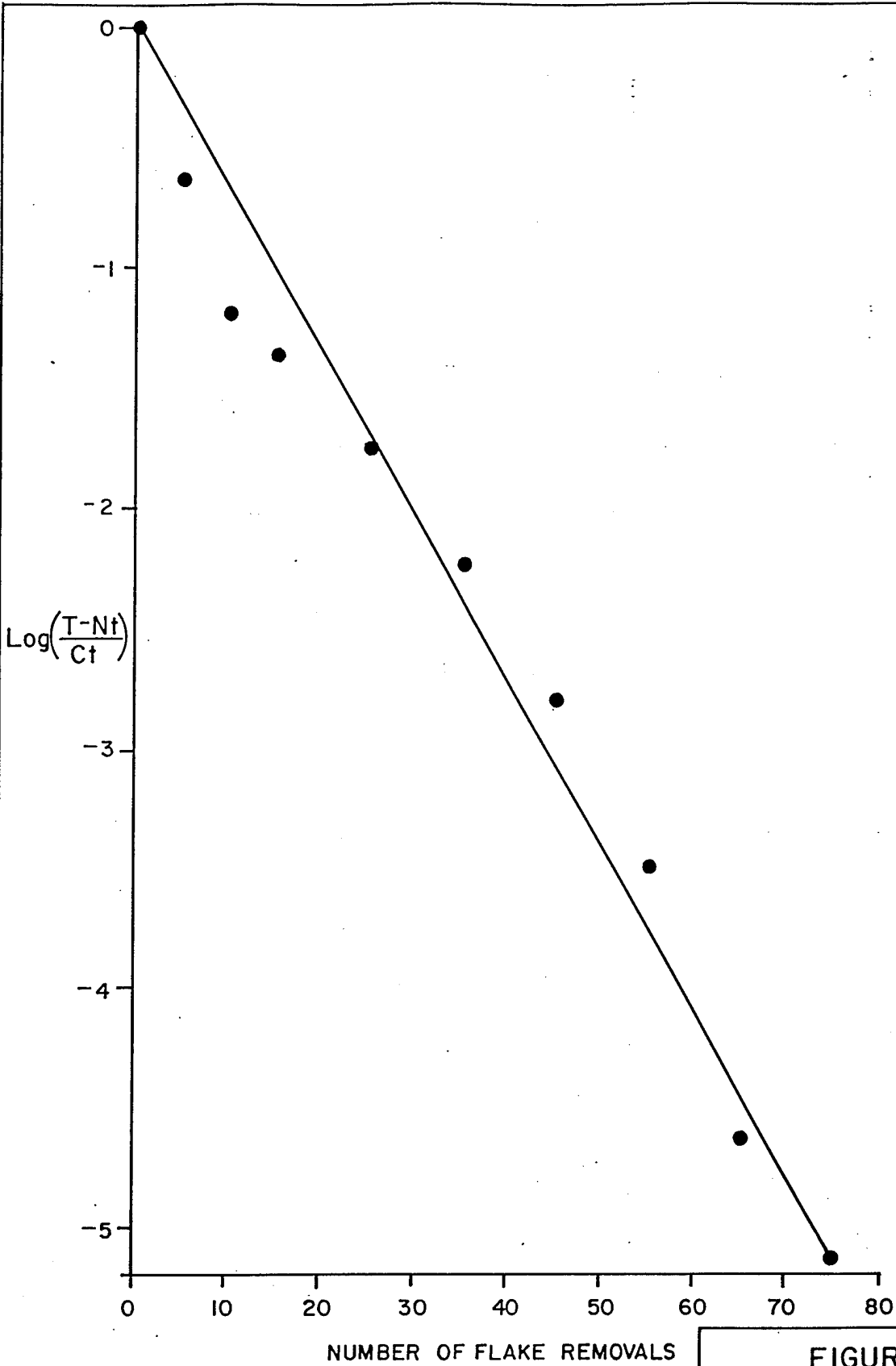

FIGURE 78

PLOT OF DATA POINTS AND LINEARIZED BEST FIT FUNCTION RELATING WORKPIECE WIDTH DECREASES TO NUMBER OF FLAKE REMOVALS



**FIGURE 79**

PLOT OF DATA POINTS AND LINEARIZED BEST FIT FUNCTION RELATING WORKPIECE THICKNESS TO NUMBER OF FLAKE REMOVALS

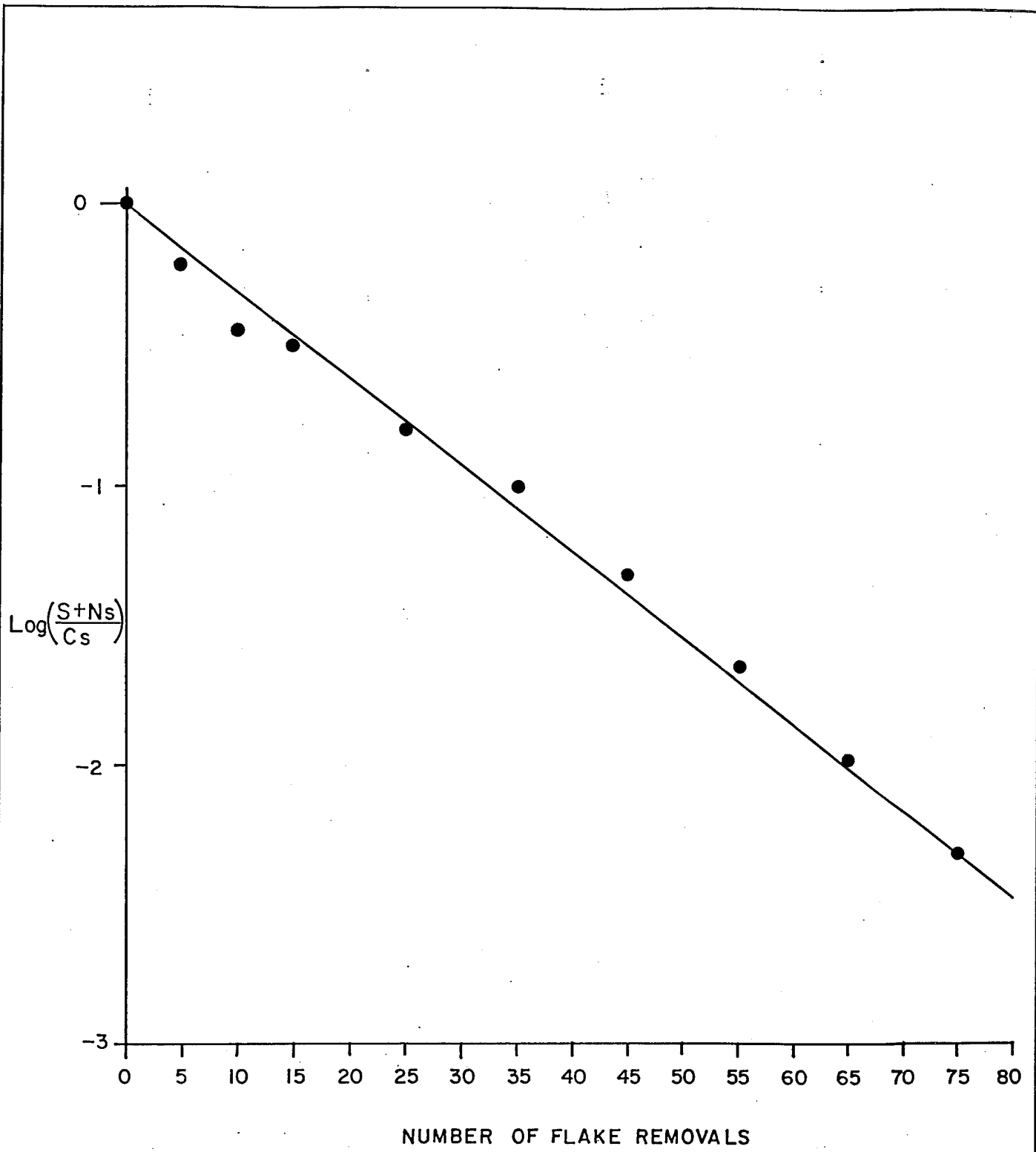
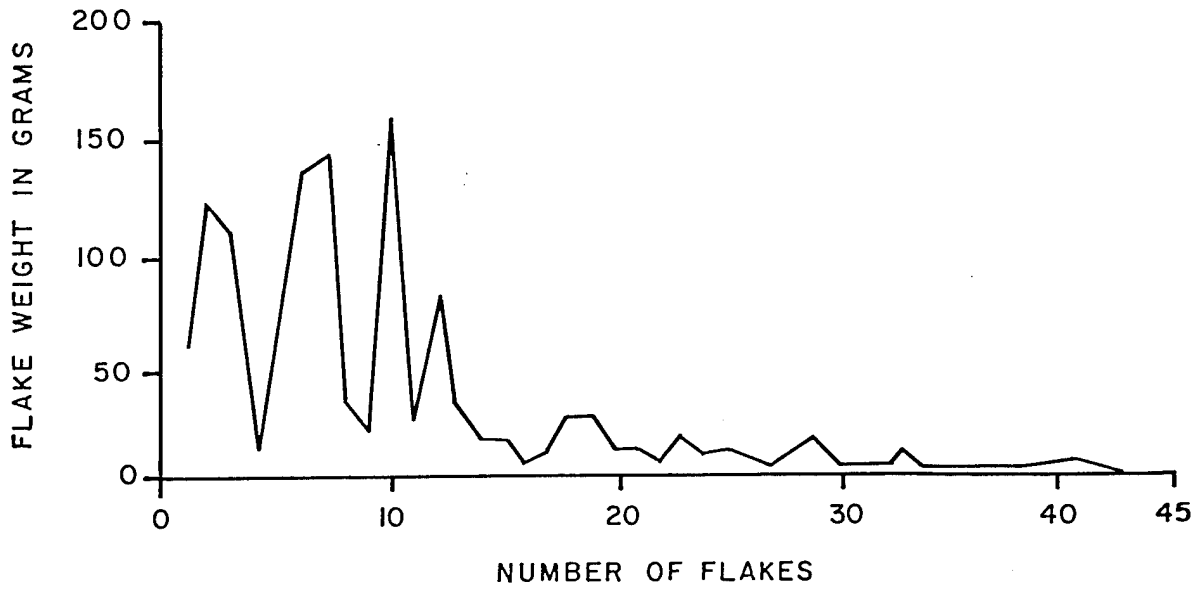

FIGURE 80

PLOT OF DATA POINTS AND  
LINEARIZED BEST FIT FUNCTION  
RELATING WORKPIECE SIZE DE-  
CREASES TO NO. OF FLAKE REMOVALS





**FIGURE 81**

POLYGON PLOT OF INDIVIDUAL FLAKE WEIGHTS VERSUS FLAKE NUMBER FOR NEWCOMER'S EXPERIMENTAL HANDAXE b.

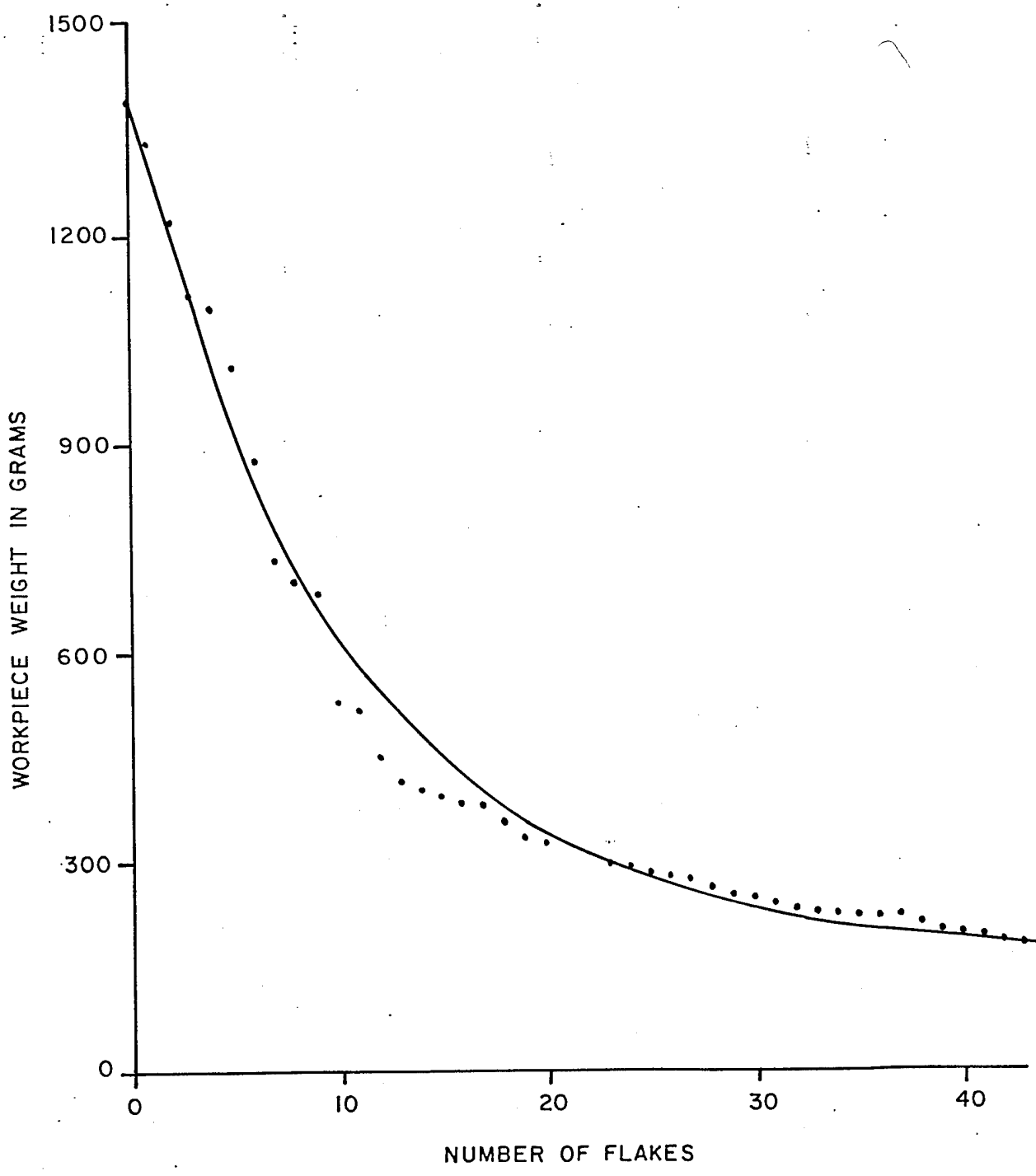

**FIGURE 82**  
PLOT OF WORKPIECE (HANDAXE) WEIGHT VERSUS NUMBER OF FLAKES FOR NEWCOMER'S EXPERIMENTAL HANDAXE b. LEAST SQUARES FIT INDICATED BY SOLID LINE.

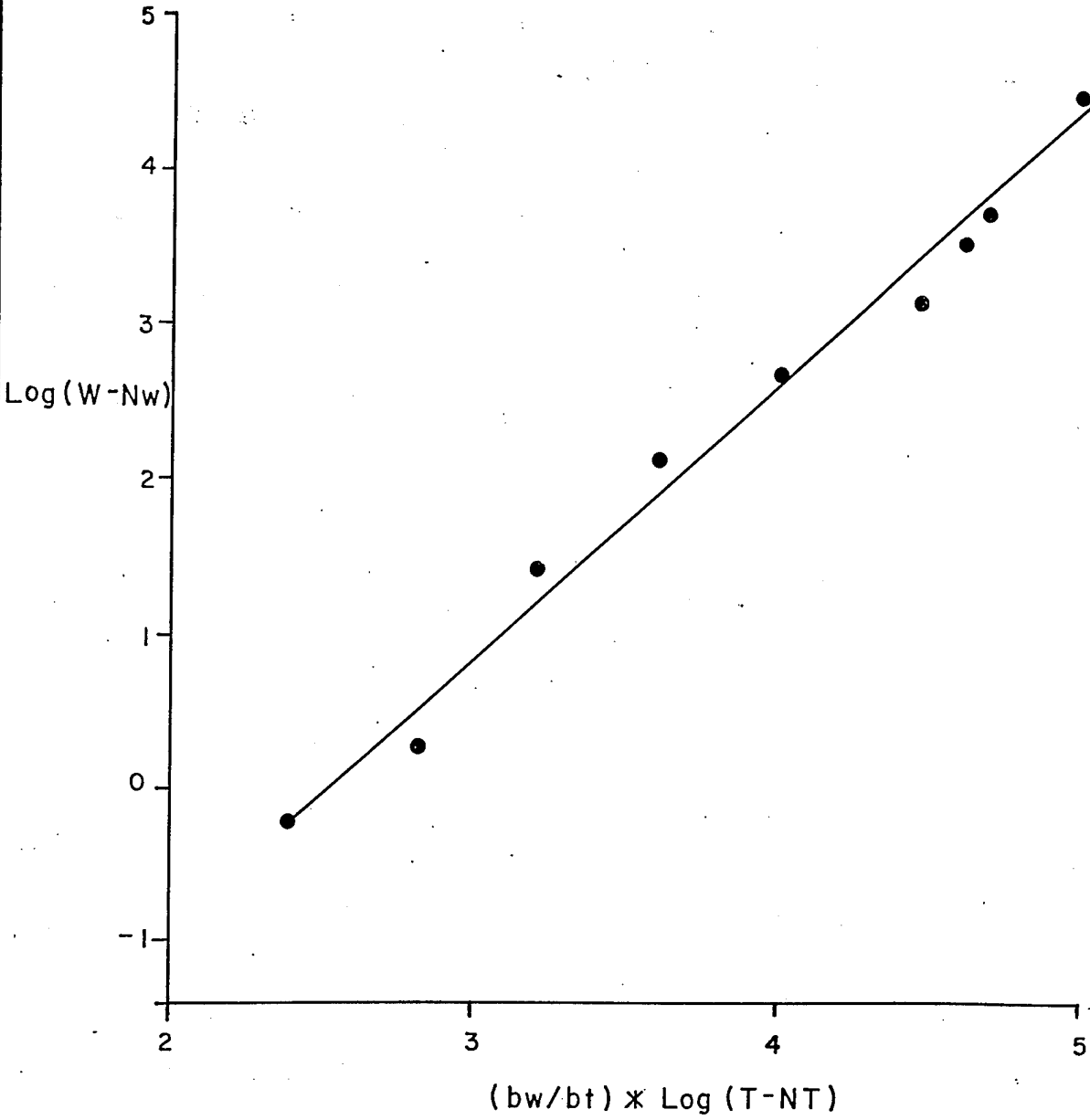

FIGURE 83

LOG-LOG PLOT OF WIDTH VERSUS THICKNESS FOR SPITZER'S AND COWAN'S EXPERIMENTAL BIFACE 1.

The upper and lower limits of these scales, as represented by the data from the Memorial Park site, are relatively wide. These scales are not standardized against a particular physical constant the way that a thermometer is for degrees in centigrade, where 0° corresponds to the freezing point of water. Further, negative values do not, of course, mean a lack of material. The scales are, however, comparable between data sets: For the thinning scale, the lowest value is 4.301 and the highest value is 14.185. The lowest possible value is 1.0. The highest possible value is 15.0.

For the total reduction effort, the the lowest value is -11.353 and the highest value is 69526. No lower limit has been determined, but the higher limit is bounded only by the total amount of raw material (count and weight) in the sample. For the mean reduction effort, the lowest value represented is -20.117 and the highest value is 35.594. Neither a lower nor an upper limit have been established for mean reduction effort.

*Size Effects.* Understanding the effect of size and shape of the raw material on a site is a necessary condition for subsequent contrasts. It is intuitively apparent that both smaller and thinner initial materials can be thinned less and reduced less than larger, thicker material. The scales developed incorporate this understanding, since they are sensitive to the amount of material and relative thinning that takes place. Among the locally-available raw materials, agate, overwhelmingly dominated by black agate, is of a significantly smaller starting size and shape than the cherts, chalcedonies, and argillite. Black agate occurs in small nodular form. Evidence of this effect is not only available by reference to the size of nodules discovered near the site, but by the proportion of debris which has a high degree of curvature (rounded) and cortex on the dorsal surface. A further example of the small size of these nodules among the tools is a Levanna point from Late Woodland Feature 80. The widest part of the point, measured from barb to barb, is 28.1 mm, and each barb has cortex remaining on the outer edge.

Referring to tables 210 to 213, the following observations concerning the scale values for agate versus those for chalcedonies, cherts, and argillite can be made. Regarding the Late Woodland components, the thinning values are moderately high, but tend to be lower than those of cherts and chalcedonies, except for the Stewart Phase material. However, the comparative values for argillite tend to be lower with correspondingly low mean reduction values. For the Archaic components, agate is uniformly lower for both the thinning and mean reduction effort scales. Other things being equal, smaller nodular material appears to be used as expected, given that it is smaller nodular material as compared to argillite, cherts, and chalcedonies.

Size of nonlocal material arriving at the site from distant locations can be expected to be a conditioning factor in a similar way. Among the nonlocal materials, rhyolite tends to come in larger blocks and, as will be discussed in the tool section, the resulting tools tend to be larger. For the Late Woodland material, either the thinning value or the mean reduction effort, or both, are larger for rhyolite than those of the other nonlocal materials. For the Archaic material, both the thinning value and the mean reduction effort value are larger than the other nonlocal materials, excepting some cases of burgundy/red jasper taken as a separate raw material type. The Neville component is the exception to this trend. Here, the rhyolite has lower thinning and mean reduction scale values than jasper. It also has a total reduction effort value that is only one-eighteenth that of jasper. Little reduction of any kind is represented for rhyolite for the Neville component. Hence, the generalization regarding size seems to hold for nonlocal materials as well.

*Origin of Raw Material - Local vs. Nonlocal.* The origin of the raw material is important in contrasting the measures of the three scales for local versus nonlocal raw material. Locality, raw material types, thinning, total reduction effort, and mean reduction effort ranges are presented in tables 210 to 213. One would expect the range of values for these materials to differ significantly,

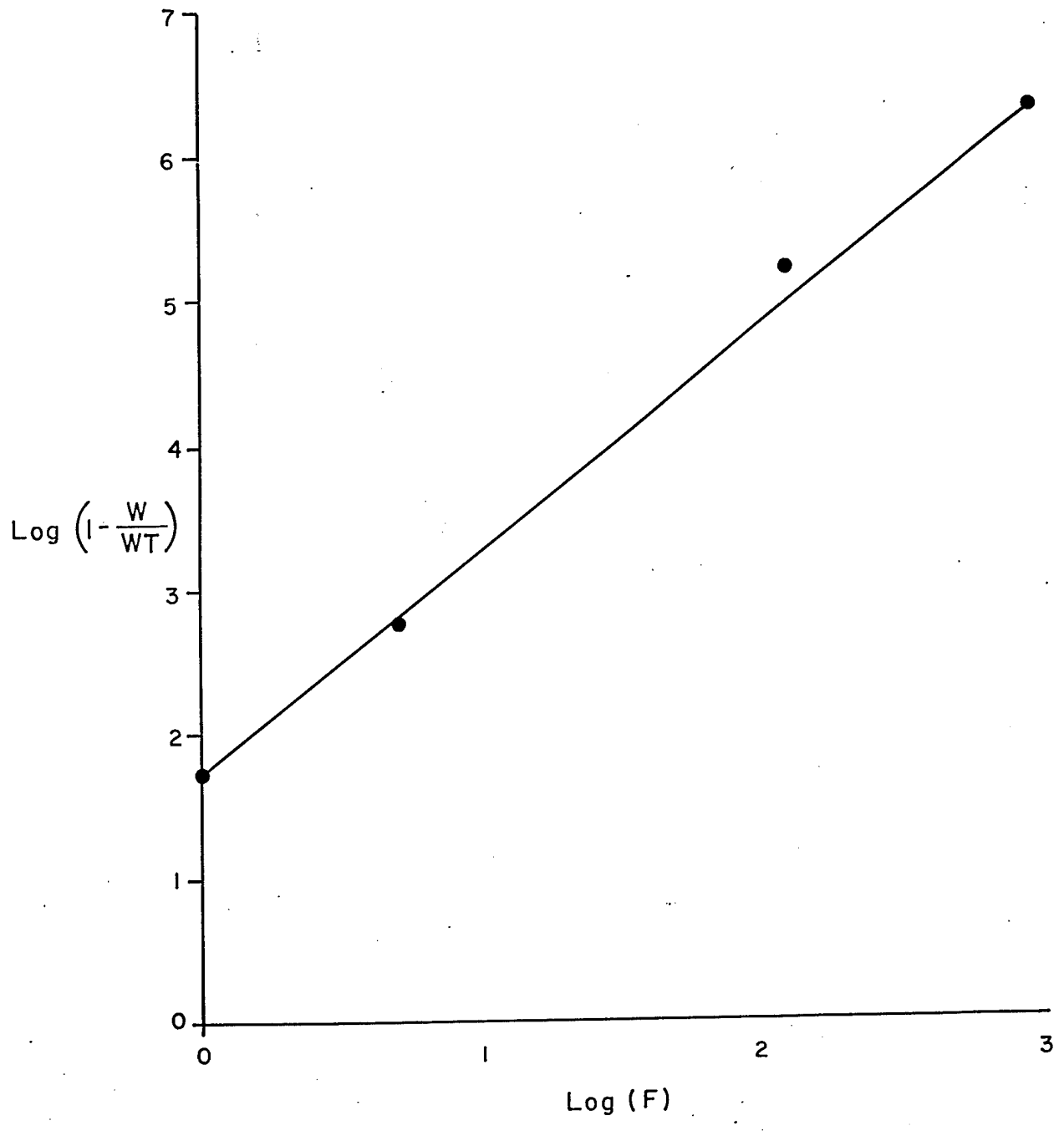

FIGURE 84

PLOT OF DATA AND LINEARIZED FIT OF WEIGHT AND NUMBER OF FLAKES FOR A COBBLE TESTING EXPERIMENT

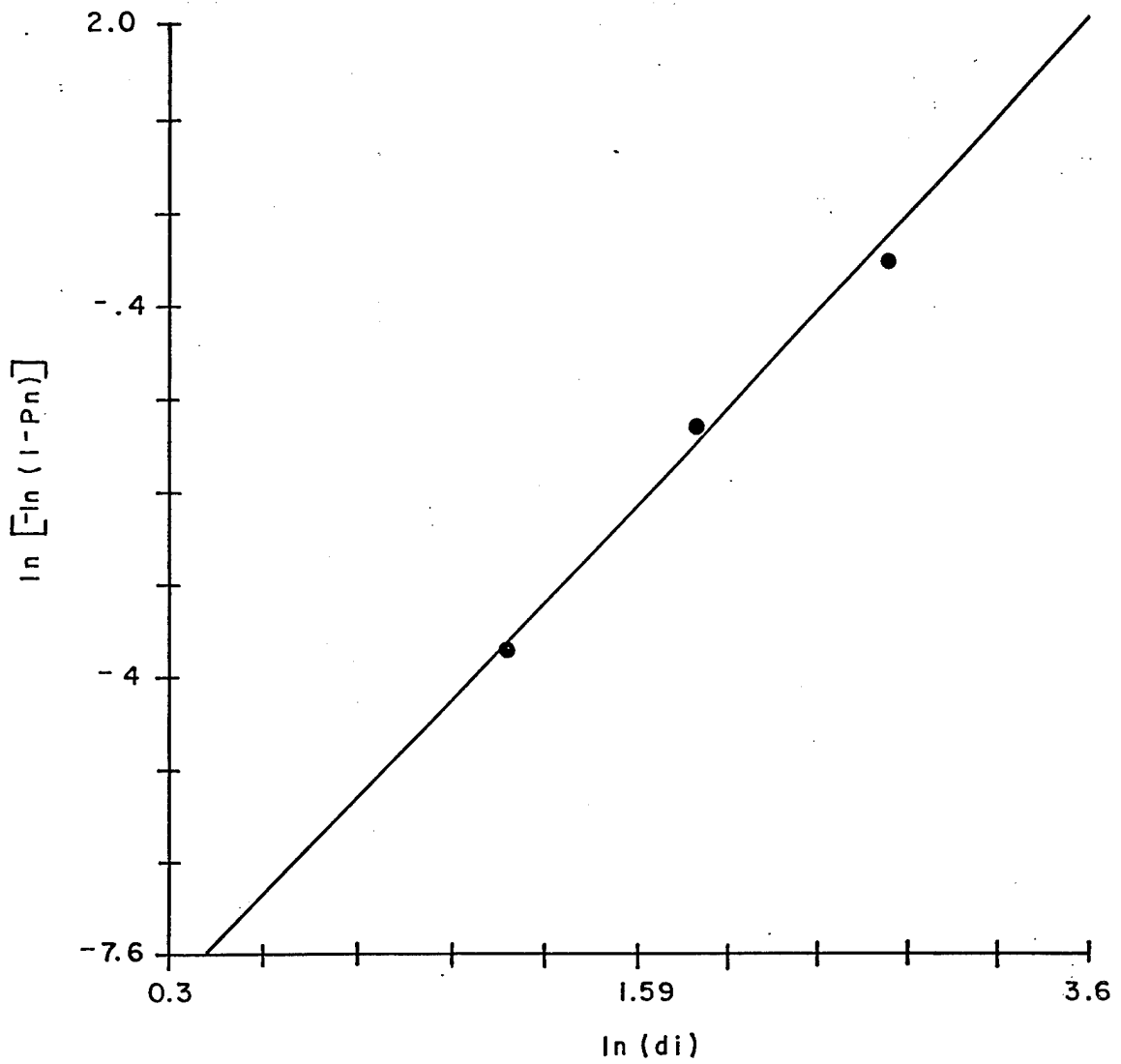

FIGURE 85

WEIBULL FIT OF WEIGHT VERSUS GRADE SIZE FOR A KNIFE RIVER FLINT BLADE CORE

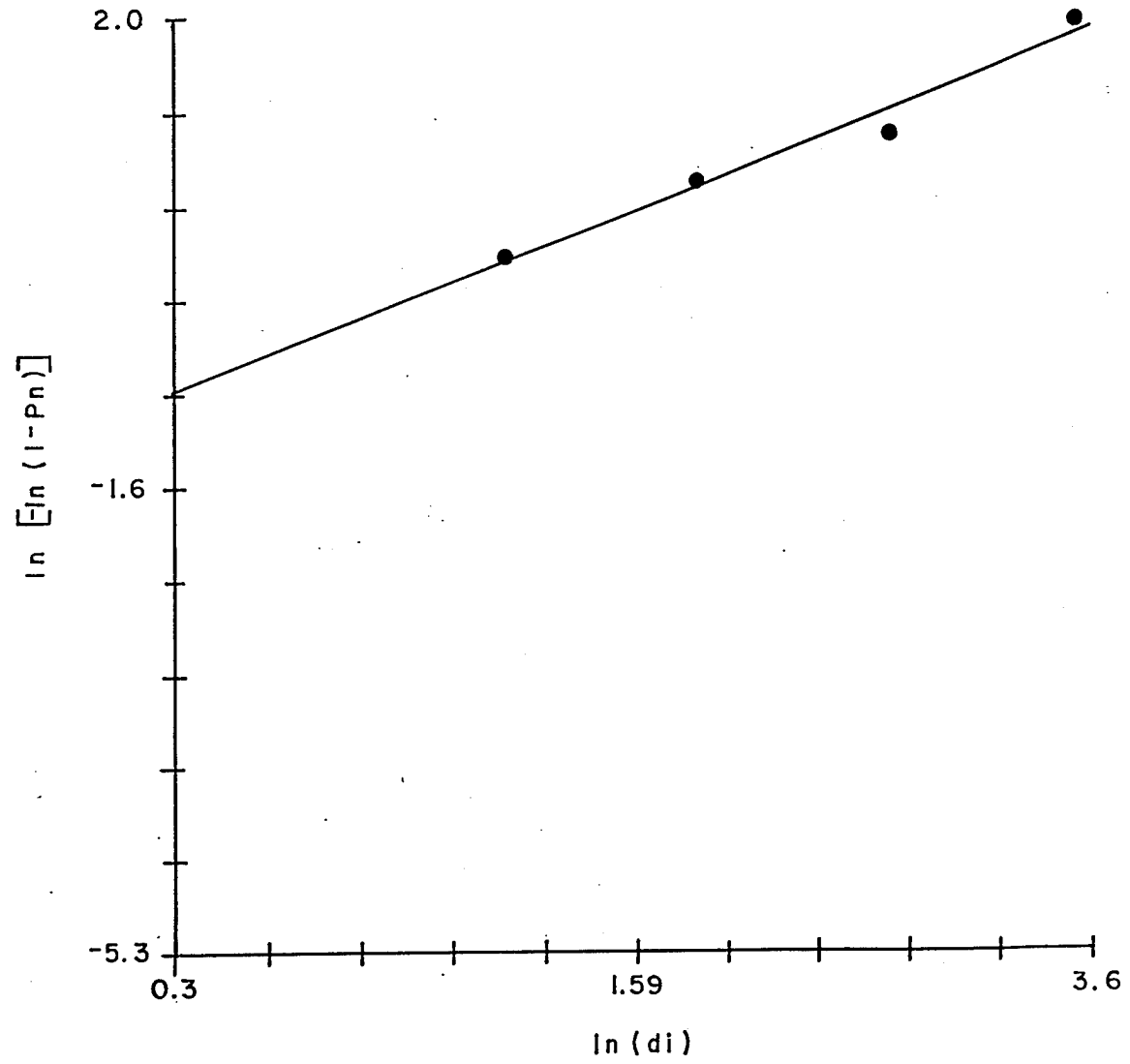
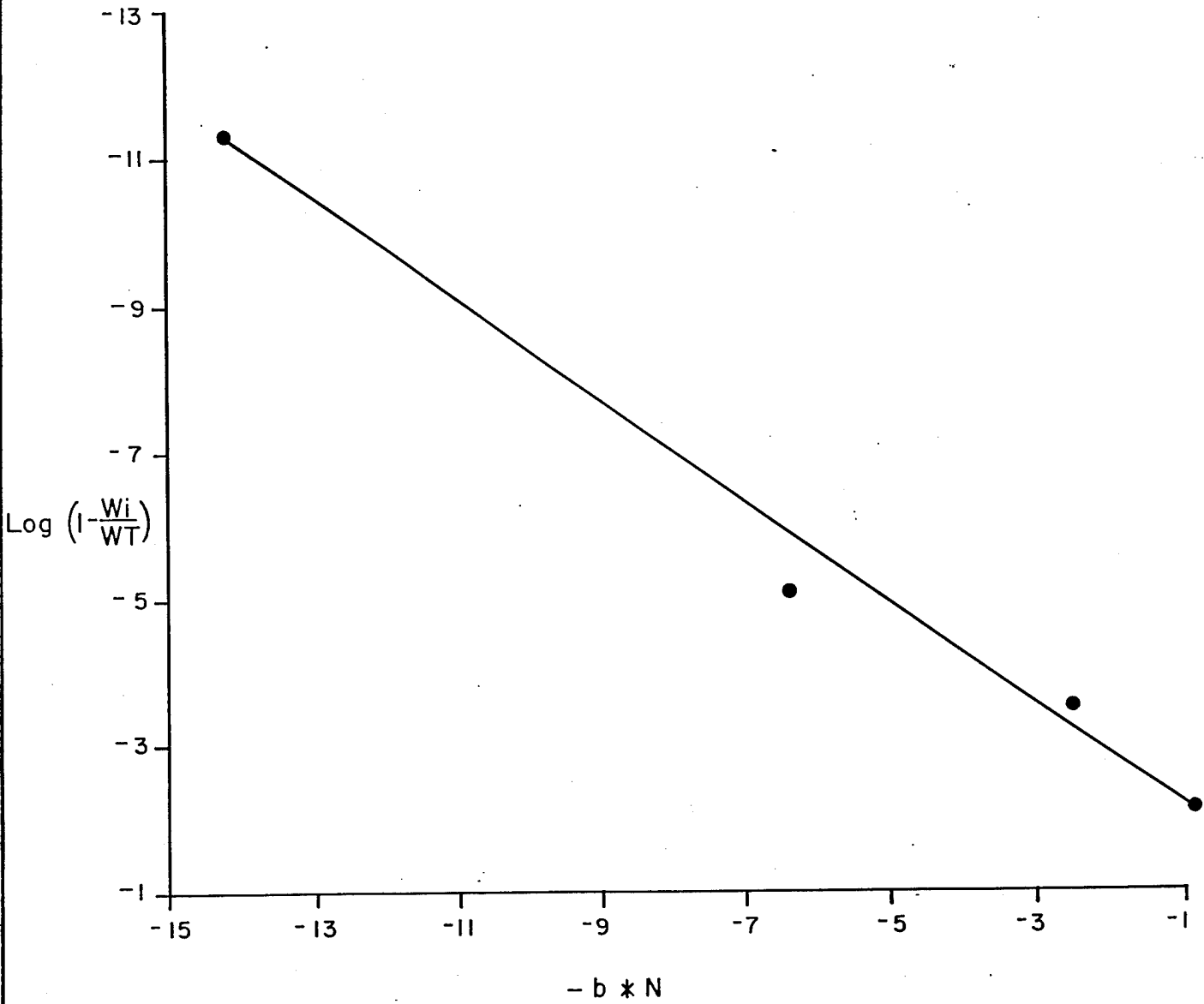
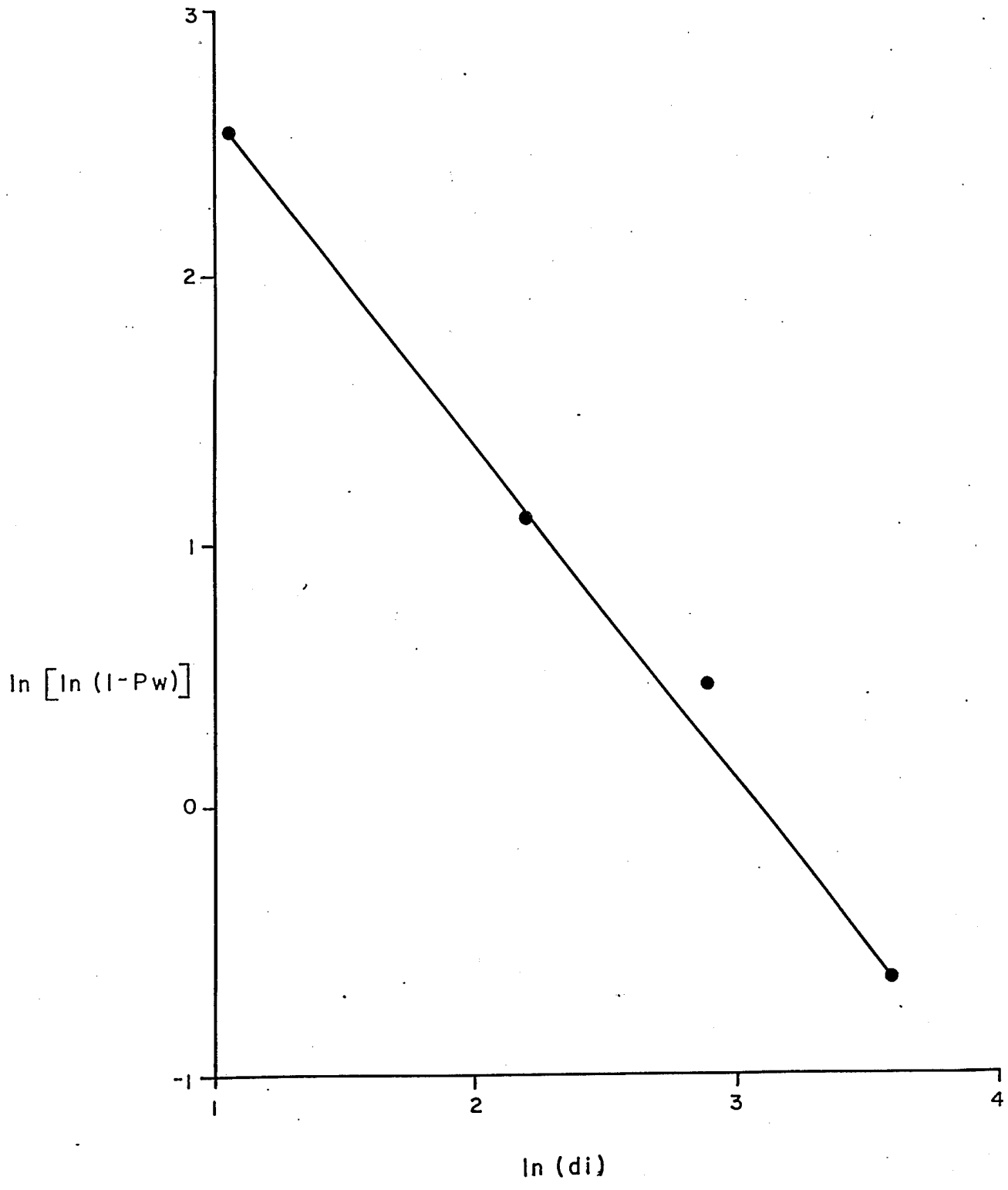

FIGURE 86  
WEIBULL FIT OF COUNT VERSUS  
GRADE SIZE FOR A KNIFE RIVER  
FLINT BLADE CORE



**FIGURE 87**  
PLOT OF TRANSFORMED DATA FOR  
EXPERIMENT 1, 6 LARGE CORES,  
FROM VAN DYKE AND BEHM (1981)





**FIGURE 88**  
LEAST SQUARES FIT AND DATA PLOT FOR KNIFE RIVER FLINT AGGREGATE DATA OF BIPOLAR CORES. THE PLOT IS A WEIBULL FIT OF WEIGHT PERCENT AND SIZE GRADE.

DWG. NO. 89-412-A87

APPROVED MGS

DWN. REM

GAI CONSULTANTS, INC.

$\ln [-\ln (-P_n)]$

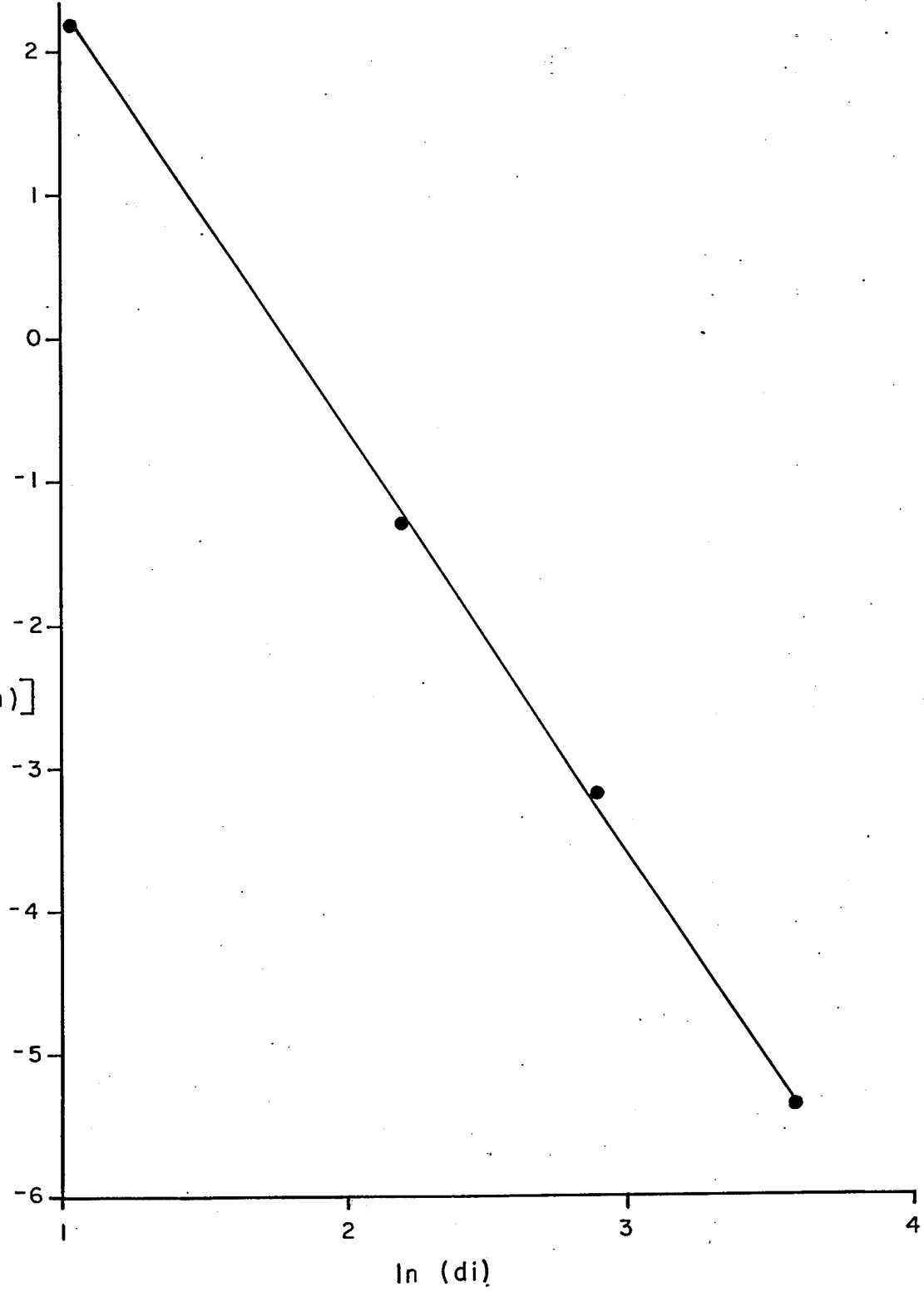

FIGURE 89

LEAST SQUARES FIT AND DATA PLOT FOR KNIFE RIVER FLINT AGGREGATE DATA OF BIPOLAR CORES. THE PLOT IS A WEIBULL FIT OF COUNT PERCENT AND SIZE GRADE.

controlling for initial size of the on-site material. Nonlocal materials which are more fully reduced prior to transport to the site can be expected to have smaller values than those of the local materials, taking size into consideration. An examination of the tables confirms this expectation.

For example, the Late Woodland material, with the exception of the Stewart Phase material, illustrates lower thinning, total reduction effort, and mean reduction effort than in every case in contrast to the local material. Being such a small sample, the Stewart Phase material may result from sampling deficiencies or it may actually represent a different occupation or reduction situation.

When cherts, chalcedonies, and argillite are compared to jasper (to account for size differentials), the values on all three scales are larger for the local material than for the nonlocal material, with one exception. For the Neville component, the values for argillite tend to be smaller.

*Heat Treatment of Bald Eagle Jasper.* Another observation is valuable in examining the above-cited tables. When Bald Eagle jasper is heat treated, color changes occur from yellow to red as the result of the decomposition of goethite to hematite (Schindler et al. 1982). Schindler et al. found that this reaction occurs whether the material is heated in an oxidizing environment or a reducing environment. More importantly, Schindler and associates claim, in effect, that the desired goal of heat treatment, improved fracturability, exhibits a one-to-one correspondence with the color change. Thus they argue that the reduction sequence for this jasper entails multiple heat treatments, as necessary, to alter a surface for further reduction, at least as it applies to the early reduction episodes represented at the Houserville site. Each heat treatment episode presumably alters the exterior portion of the piece but not the interior, both with respect to color change and fracturability.

There are flaws in this argument that must be addressed, and a re-analysis suggests that the proposed sequence of multiple heat treatments and reduction episodes is not the appropriate explanation. The main difficulty with the argument is the identification of a change in red coloration as one-to-one with improved fracturability. Schindler and associates specifically state that the improved fracture of the jasper occurs as the result of a loss of mass in the form of water, and the subsequent development of microcracks in the alpha-quartz regions where the goethite once bound together the alpha-quartz. If the color change failed to occur but mass was lost and microcracks occurred, then the fracturability would be improved anyway.

Schindler et al. further state that the the specific mechanism of the color change is not well understood in terms of the resulting replacement of ionic structures in the coordination polyhedra of the ferrous cations. It is suggested that the replacement is different near the exterior of the heated piece than on the interior. That a piece would be heated only enough to improve the exterior flaking characteristics is not plausible. Although the interior is not subjected to a color change, it may be that chemical alteration does occur such that microcracks develop and fracturability is improved. I simply propose the alternative--that a one-to-one correspondence between color change and fracturability is not the case, and that a single heat-treating episode prepares the workpiece for all following reduction.

Under this proposal, initial reduction subsequent to heat treating at the source location removes the great bulk of reddened or burgundy material, leaving a largely yellow or caramel workpiece which is transported to the habitation site. If heat treatment was performed at the importing site, then the removal of reddened heat-treated flakes would be done there as well, and the grade sizes of the red jasper would be larger than those of the yellow jasper and would increase the value on the reduction effort scale. The resulting value for red jasper would make the size of the value relatively large compared to that of the yellow jasper. This being the case, not only would

most of the jasper at a habitation site be yellow, but the degree of reduction represented by the yellow jasper would be greater.

An examination of the tables cited above reveals that the total reduction effort and the mean reduction effort are larger for the burgundy/red jasper in the Archaic components, suggesting more and larger flakes being removed for the burgundy/red jasper. Further, the thinning values for burgundy/red jasper, and caramel/yellow jasper, respectively, are approximately equal for the Orient, Terminal Archaic, late Laurentian, and early Laurentian. However, the magnitude of the values for the burgundy/red jasper is larger than for caramel/yellow jasper for the Piedmont and Neville components. This implies that heat treatment is either accomplished at the site, or that earlier reduction is postponed until the material arrives at the site. Further, with respect to the Neville and Piedmont components, if they are short term camps, as I will argue below, then one would expect that a significant amount of the caramel/yellow jasper removal would be removed off the site where repair and resharpening occurs.

With respect to the Late Woodland components, the situation is different. Because the amounts present in each component are small, this discussion applies to the combined Late Woodland materials. In this case, the thinning value for caramel/yellow jasper is larger than that of the burgundy/red jasper, even though the total reduction effort is approximately equal. It is reasonable to suggest that the material is heat treated at the source location and that partial reduction with removal of some of the red material is accomplished there as well. Touching up, with the removal of the reddened material, is done at the site prior to commencing thinning of what is then largely yellow material.

*Summary and Further Implications.* The theory presented above is based upon a point of view that necessitates the recognition of real material systems, as opposed to thought processes originating from a disembodied mind. This is the reason that neurochemical and neurophysiological processes are referred to and relied upon as the basis for the work presented here. The processes in question are not conscious processes, in the sense that the flintknapper cannot specify the values of the parameters of the equations that describe the changes which take place on the workpiece or the byproducts. There are linguistic conventions which flintknappers employ to describe what they do, but these conventions are rationalizations for the behavior in which they engage and are not objective descriptions of reduction process.

The theory presented above was tested in several ways under a number of different conditions. Implications relating to both workpieces and debris were tested. A variety of raw materials were present in the test data, including flints, cherts, slate, quartz, quartzite, and chalcedony. The production activities included biface production, cobble testing, hard-hammer core production, bipolar core production, blade core production, and small tool production. The results of the tests were uniformly robust and strongly confirm the theory.

A critical connection that was made is the relationship between the width and thickness changes that occur on the workpiece, and the size and weight of the resulting debris. The consequence of establishing this connection is that we are now able to use debris as a monitor of the changes that took place on tools as they were reduced. Further, it was established that aggregate measures of debris from multiple reduction episodes provide a reasonable estimate of the median reduction processes that occurred at a site.

The next step was the development of scales, based on data collected from debris, to serve as monitors of the type of reduction processes that occurred. These scales have the potential to be meaningful in energetic and entropic terms. This effort led to the development of the thinning scale, the total reduction effort scale, and the mean reduction effort scale. I chose thinning and

mean reduction effort as the best comparative measures for specifying the lithic reduction subsystem in terms of debris characteristics. This yielded a two-dimensional representation of the space within which reduction occurs, and led to the implications regarding the existence of two basic reduction practices which are termed thinning and thickening trajectories. Archaeologists are aware that these two fundamental reduction methods exist, but they have never been objectified or explained.

The thinning scale and mean reduction effort scale together serve as a new level of theory building in that implications about the subspaces, within which we may expect to find the values, are derived directly from them. Further, the set of functions specifying these scales constitutes the formal cause of the two basic reduction systems, now clearly tied to basic brain processes which are not dependent on linguistic conventions employed by either the original knappers or the archaeologist.

As a subsystem, lithic reduction is a structure with two alternative forms: thinning and thickening. These are the two forms which account for the structural variation we observe in the archaeological record. Why a given form arises requires yet another level of explanation, since it must refer to one or more other subsystems operating within the cultural system. Presumably, such references would be addressed in energetic and entropic terms. It would be consistent with current archaeological thought to suggest that thinning trajectories are associated with mobile societies employing curative practices, and that thickening trajectories are associated with sedentary societies using expedient tools. This is a reasonable and satisfactory beginning, but the specifications of other relevant systems, in the kind of terms used here, are needed to test these ideas.

#### *Analysis of Component Debris Assemblages*

*Late Woodland - Stewart Phase.* Table 210 is a summary of the values of the reduction scales for the Stewart Phase, and Figure 90 is a plot of the thinning values versus the mean reduction effort. The Stewart Phase is unique in the degree of restriction of the range of values on these scales. Referring to Figure 90, note that all of the values fall within the ellipse, the space representing late reduction, resharpening, or low representation. This implies one of two situations: short term occupation with tool use, and the need for resharpening, or a relative underrepresentation of the component in the excavated portion of the Memorial Park site. The amount of material from these three features is very small. Which of the alternatives apply to this case is unknown.

Table 210. Stewart Phase Scale Values for Raw Material by Locality.

Locality	Raw Material	Thinning	Reduction Effort	
			Total	Mean
Local	Agates	9.7	6	0.3
	Chalcedonies	8.8	493	2.8
	Combined Cherts	9.4	514	2.5
	Argillite	7.4	6	0.3
Nonlocal	Caramel/Yellow Jasper	9.4	108	1.5
	Burgundy/Red Jasper	7.9	38	0.9
	All Jasper	9.7	216	1.9
	Rhyolite	9.5	810	3.3

*Late Woodland - Late Clemson Island.* The late Clemson Island component is typical of a long-term occupation site from the Late Woodland period. Scale values are presented in Table 211, and Figure 91 is a plot of the thinning values versus the mean reduction effort. The local raw materials are fully used here, and with the exception of argillite and quartzite, occupy the thickening space. The quartzite constitutes such a small amount of material that the calculated scale values may be suspect. As expected, values for the nonlocal materials, both jasper and rhyolite, occupy the ellipse.

*Late Woodland - Early/Middle Clemson Island.* The scale values for the combined early and middle Clemson Island components are presented in Table 212, and a plot of the thinning index versus mean reduction effort is presented in Figure 92. Local materials are all within the thickening trajectory. This is the case for chert, chalcedony, argillite, and agate. This fact suggests that we are seeing a sedentary group at a long-term camp. Rhyolite and jasper are in the ellipse, as would be expected for nonlocal materials at a long term camp. Quartzite is present in very small quantities, and occupies the ellipse as well.

Table 211. Late Clemson Island Scale Values for Raw Material by Locality.

Locality	Raw Material	Thinning	Reduction Effort	
			Total	Mean
Local	Agates	10.4	1920	4.3
	Chalcedonies	11.9	20487	5.7
	Combined Cherts	12.0	17194	5.8
	Argillite	9.7	1567	3.7
Nonlocal	Caramel/Yellow Jasper	6.2	-0	-0.0
	Burgundy/Red Jasper	-	-	-
	All Jasper	6.2	-0	-0.0
	Rhyolite	9.1	531	3.1

Table 212. Early/Middle Clemson Island Scale Values for Raw Material by Locality.

Locality	Raw Material	Thinning	Reduction Effort	
			Total	Mean
Local	Agates	10.9	1737	4.6
	Chalcedonies	11.6	12280	5.4
	Combined Cherts	12.8	45054	6.7
	Argillite	11.0	4407	4.9
Nonlocal	Caramel/Yellow Jasper	7.6	1	0.1
	Burgundy/Red Jasper	6.0	51	0.5
	All Jasper	7.0	118	1.1
	Rhyolite	8.9	460	2.4

*Combined Late Woodland.* As a summary of the Late Woodland, the scale values for the combined materials are presented in Table 213, and the plot of the thinning values versus the mean reduction effort is presented in Figure 93. This plot and range of values indicate the pattern described for the separate Late Woodland components. Local materials, including chert, chalcedony, agate, and argillite, occupy the thickening trajectory. Rhyolite occupies space at the border of the ellipse and at the thickening trajectory. Jasper is in the ellipse. Again, quartzite is a very small proportion of the material and is found in the ellipse.

Table 213. Combined Late Woodland Scale Values for Raw Material by Locality.

Locality	Raw Material	Thinning	Reduction Effort	
			Total	Mean
Local	Agates	11.5	4453	5.2
	Chalcedonies	12.5	37760	6.3
	Combined Cherts	13.2	69520	7.0
	Argillite	11.2	6914	5.1
Nonlocal	Caramel/Yellow Jasper	9.8	155	1.8
	Burgundy/Red Jasper	7.4	186	1.3
	All Jasper	9.3	513	2.3
	Rhyolite	10.1	2448	4.1

*Late Woodland Spatial Patterning.* There is one aspect of spatial patterning of the thinning and reduction effort scale values that is informative regarding variation in raw material management. The relationships of thinning and total reduction effort indicate how the material arrived at the site, and how it was subsequently distributed to the inhabitants. Assessment of this spatial variation, however, is complicated by the temporal range evidenced at the site since, as argued below, there is a change in technological patterns over time.

Two basic areas of raw material management practices have already been identified. One was the local acquisition of relatively plentiful materials, which were transported to the site, in an unmodified or partially reduced form and reduced at the site. The second was the acquisition from distant sources of raw material, which was subjected to preliminary reduction at the source location and then transported to the site. This second scenario presents two possibilities. One is the acquisition of nonlocal material by an individual, or individuals on group forays, to be used by the individuals acquiring the material. The second is the acquisition by a unit (one individual or group) either through actively obtaining the material at the source or through trade with other individuals or groups. In this case, the unit obtaining the material prepares and distributes it at the site.

The implications for these two basic forms of acquisition and distribution are different. If access to raw material is controlled by individuals, however acquired, then the distribution of values for total reduction effort and mean reduction effort should be represented by a wide, but continuous, distribution across the features as a whole. Some features will evidence more or less total reduction effort and more or less mean reduction. The distribution of features with high values on these scales, in contrast to features with low values on these scales, will primarily be a function of size, and we would expect a scattered distribution across the site as a whole.

The second form of acquisition and distribution involved raw material controlled by a particular unit, either a single individual or group, who reduced and distributed the material to others on the site. If this occurred, one (or a very few) feature would contain the byproducts for which high thinning and total reduction effort values would be calculated. These features with particularly high values would appear like "outliers" on a histogram, and they would have these high values on both the thinning scale and total reduction effort scale. The remaining features would have a clustered set of low values and would be distributed across the site.

As an example of the probable control of resources by individual consumers, Figures 94a and 94b are histograms containing summary information of the proportion of features having total and mean reduction values, respectively, for gray chalcedony. Feature 80 exhibits a demonstrably higher total reduction effort, as is made clear in Figure 94b where it is a distant outlier on the

GA NS AN NC DW NED BEM  
APPROVED  
DWG. NO. 89-412-A88

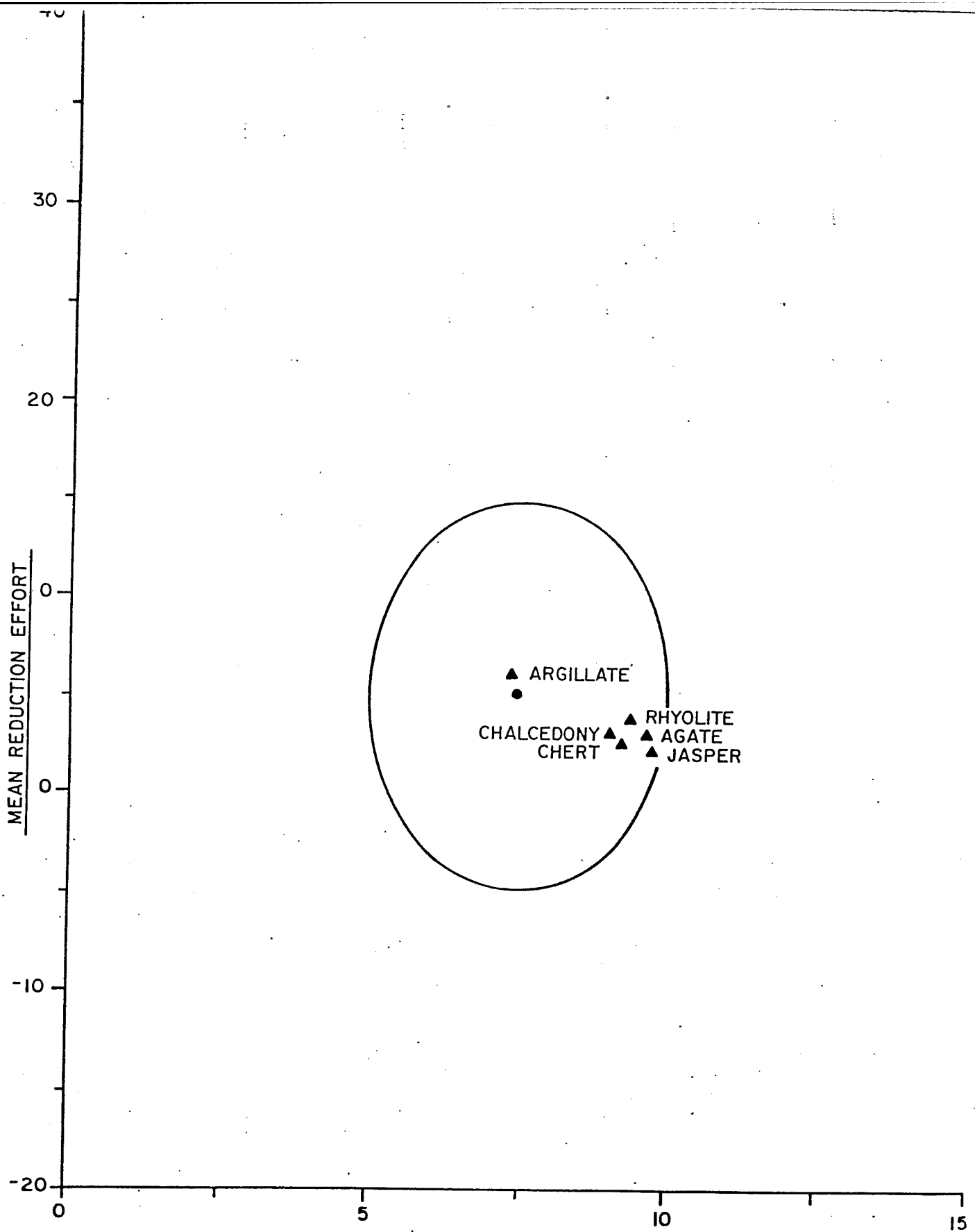
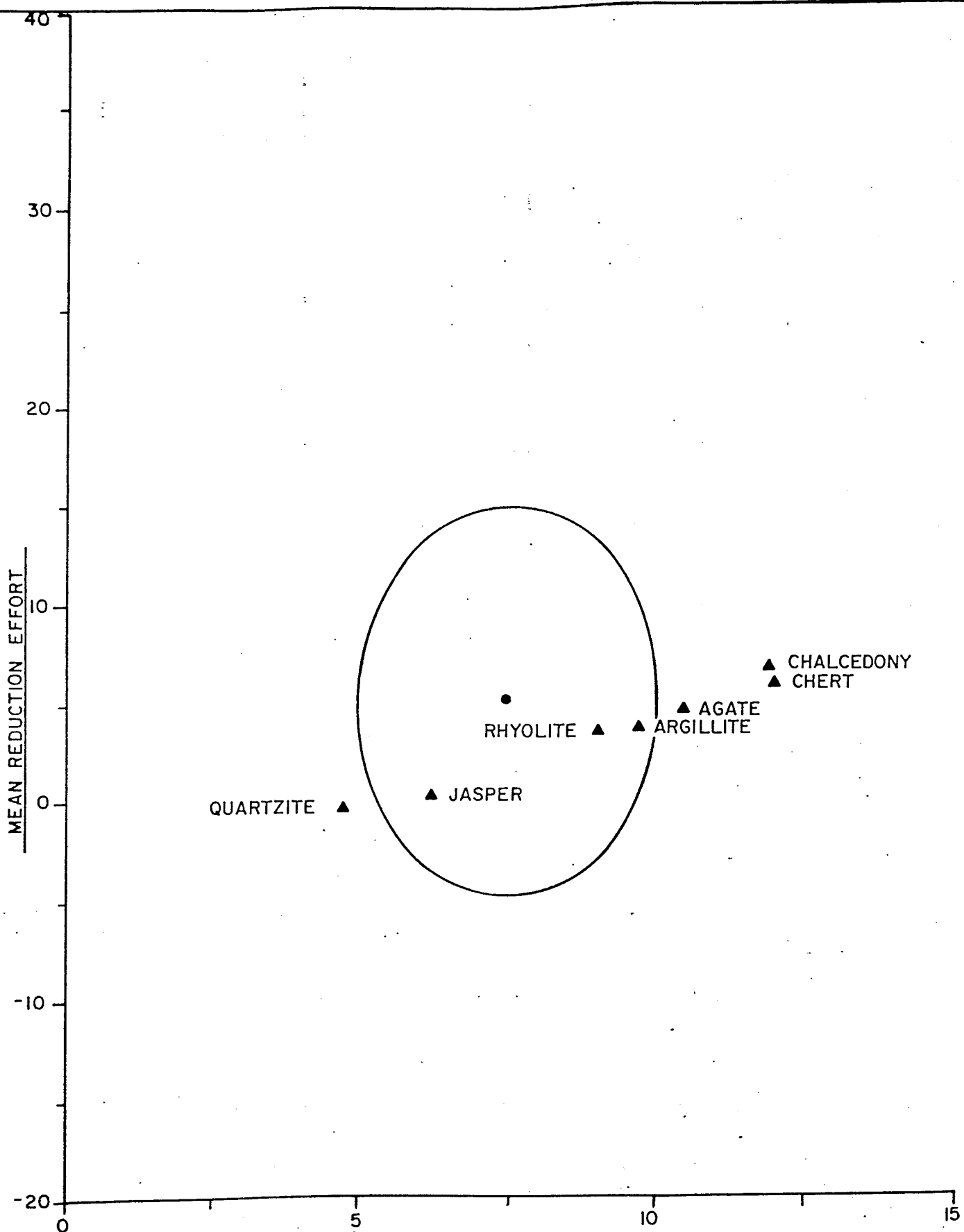

FIGURE 90  
PLOT OF VALUES FOR RAW MAT'L  
TYPES IN PHASE SPACE FOR THE  
STEWART PHASE





**FIGURE 91**  
PLOT OF VALUES FOR RAW MAT'L TYPES IN PHASE SPACE FOR THE LATE CLEMSON ISLAND

SAI CONSULTANTS, INC. EM APPROVED MGS DWG. NO. 89-112-A30

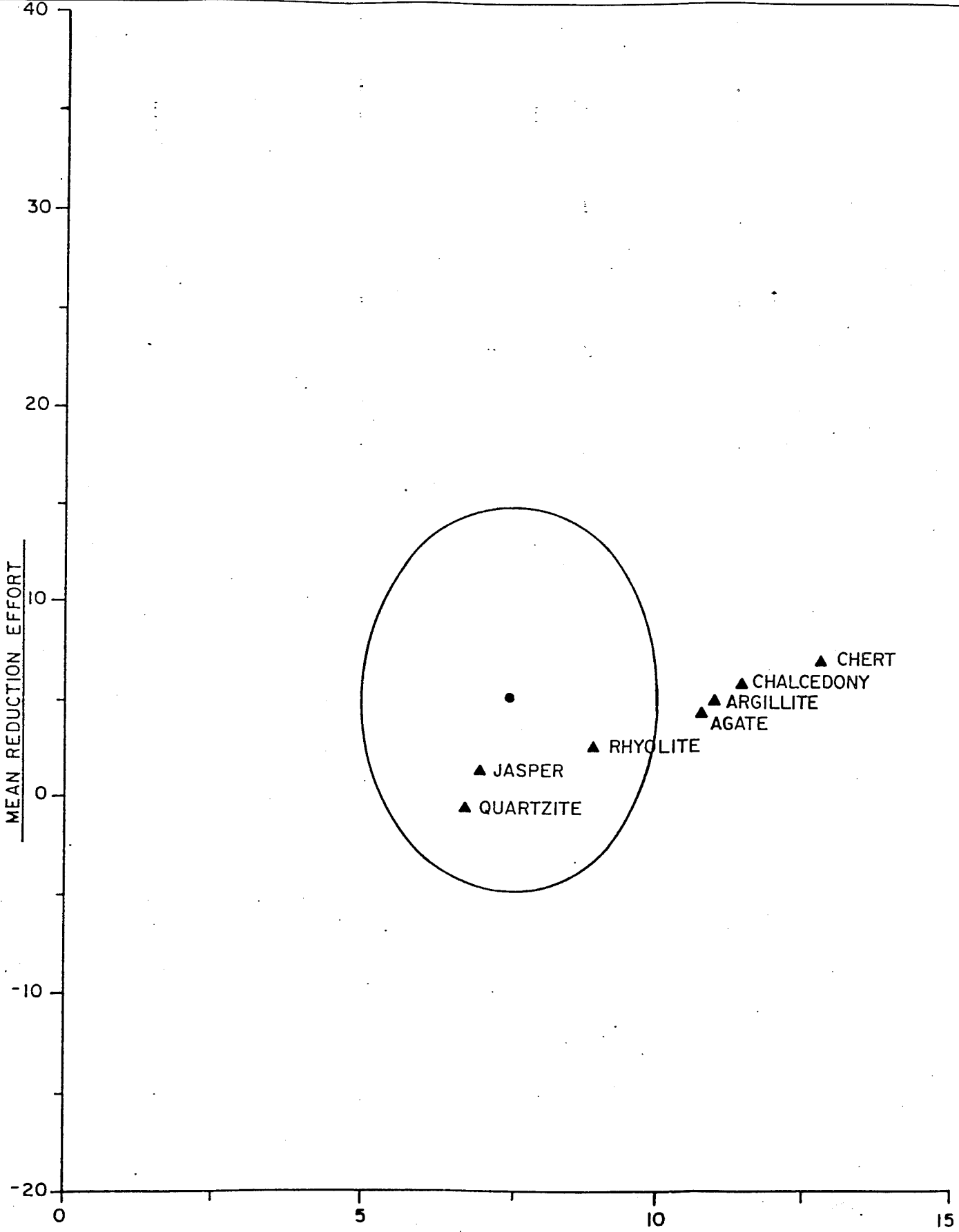

FIGURE 92  
PLOT OF VALUES FOR RAW MAT'L TYPES IN PHASE SPACE FOR THE EARLY/MIDDLE CLEMSON ISLAND

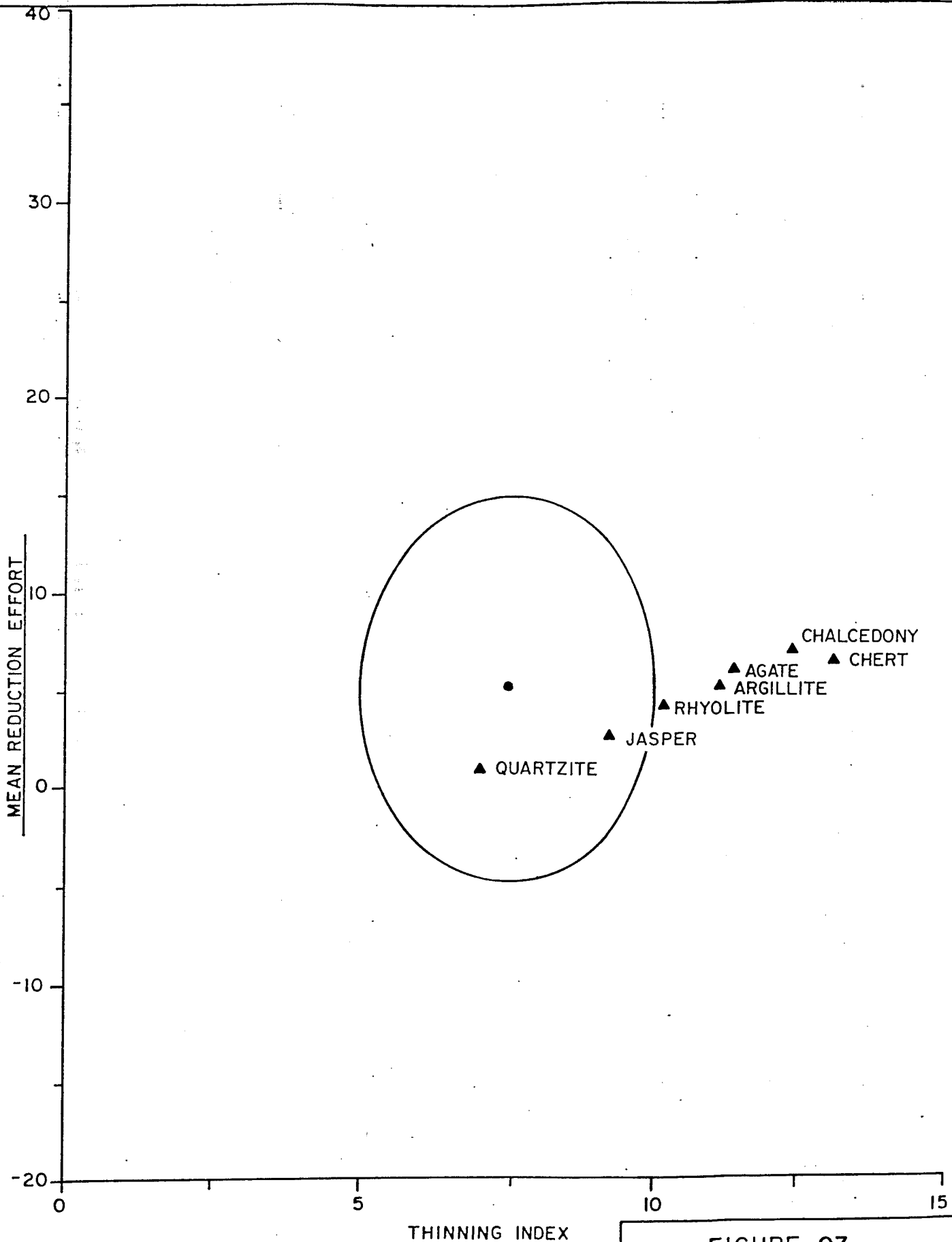

FIGURE 93  
PLOT OF VALUES FOR RAW MAT'L  
TYPES IN PHASE SPACE FOR THE  
LATE WOODLAND

histogram. This higher value, however, is principally the result of the quantity of material present and not the consequence of an outlying mean value generated by both a large thinning value and total reduction effort.

The situation for both rhyolite and yellow jasper is different (see Figures 95 and 96). In these cases both the total reduction effort and mean reduction effort are outliers for a single feature: Feature 144 for jasper, and Feature 233 for rhyolite. The disproportionately large mean values are generated by the fact that for the amount of material represented, the thinning rate is high. This suggests that more material is being thinned to a larger extent in a discrete space. The remaining values are clustered and spread across a number of features on the site. These two features are dated in a later time period than the remaining Late Woodland features on the site. Suggestions for why this apparent specialization occurs are presented below.

*Middle Woodland.* The scale values for the Middle Woodland component are presented in Table 214. The total amount of material for this component is rather small, which may affect the scale values. However, the chalcedonies do occupy thickening space, suggesting a pattern similar to the Late Woodland. The remainder of the local materials are within the ellipse, as is the single nonlocal material, rhyolite.

Table 214. Middle Woodland Scale Values for Raw Material by Locality.

Locality	Raw Material	Thinning	Reduction Effort	
			Total	Mean
Local	Agates	4.5	-0.9	-0.1
	Argillite	6.4	17.5	3.1
	Chalcedonies	10.6	69.7	3.0
	Cherts	7.5	723.9	10.2
Nonlocal	Rhyolite	6.5	20.4	1.2

*Early Woodland.* Only two raw material types are represented in the Early Woodland lithic assemblage: chalcedonies and cherts. The quantities are very small, and an adequate interpretation is not warranted. Scale values for this component are presented in Table 215.

Table 215. Early Woodland Scale Values for Raw Material by Locality.

Locality	Raw Material	Thinning	Reduction Effort	
			Total	Mean
Local	Chalcedonies	4.5	-13.8	-15.3
	Combined Cherts	7.3	12.9	4.5

*Orient Phase.* Thinning scale values, total reduction values, and mean reduction effort values have been calculated for the Orient component as a whole, by locality and raw material class. A summary of these values is presented in Table 216. Figure 97 is a plot of thinning versus mean reduction effort. The resulting pattern is different than that seen for the Late Woodland components. As an Archaic component, a thinning trajectory is to be expected if the site is also a long-term occupation or base camp. This would seem to be the case for the Orient component. The local raw materials are well within the thinning space, with the exception of agate, which may reasonably be expected. The nonlocal materials fall within the resharpening space, except for rhyolite which, as was argued above, may be transported to a site in relatively large pieces for subsequent reduction.

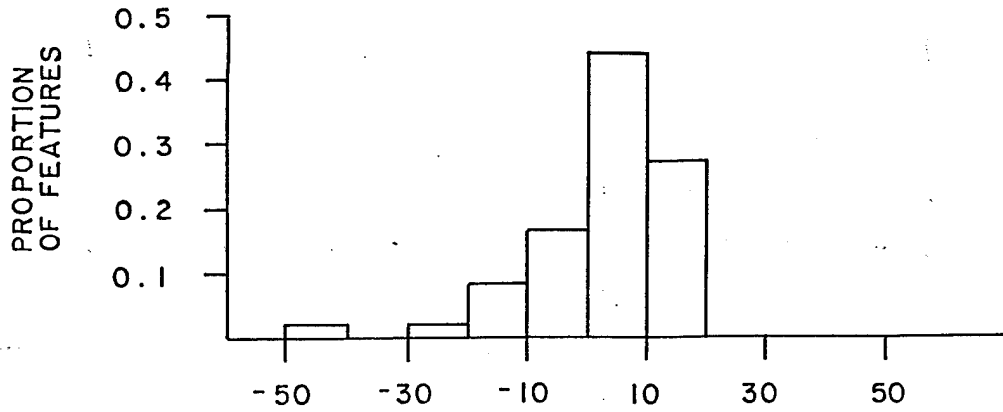

a. MEAN REDUCTION EFFORT

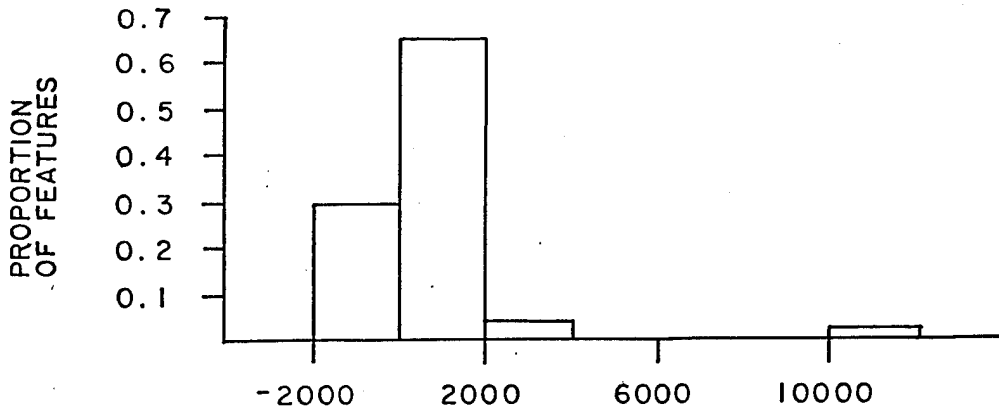

b. TOTAL REDUCTION EFFORT

FIGURE 94

HISTOGRAM OF PROPORTIONS OF  
FEATURES WITH VALUES  
FOR GRAY CHALCEDONY

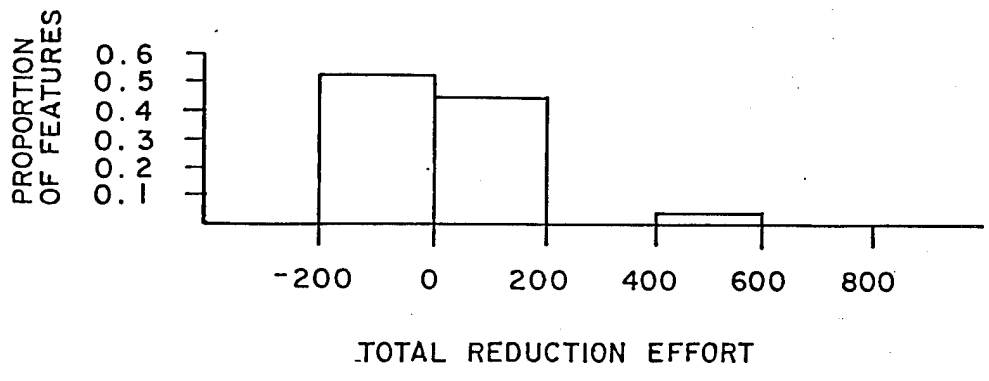
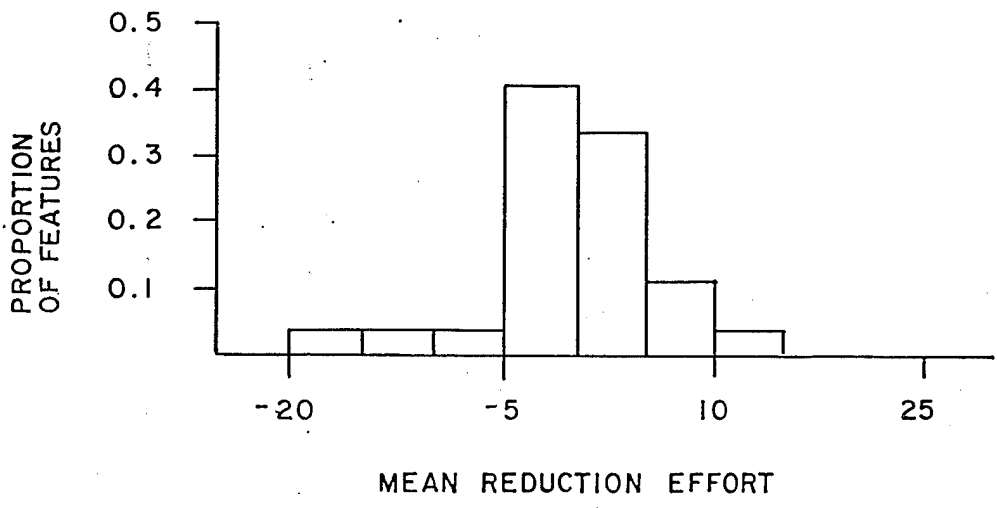

FIGURE 95

HISTOGRAM OF PROPORTIONS OF FEATURES WITH VALUES FOR RHYOLITE

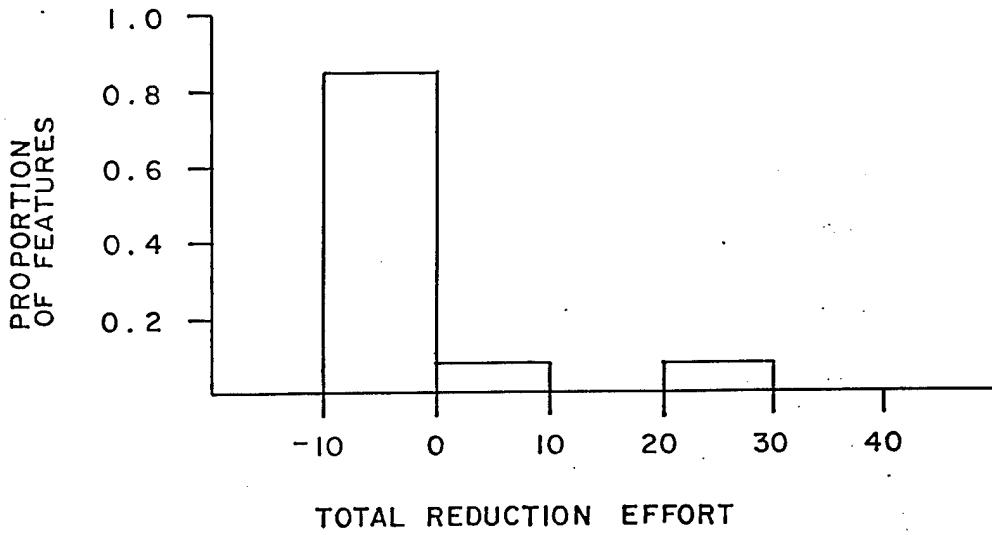
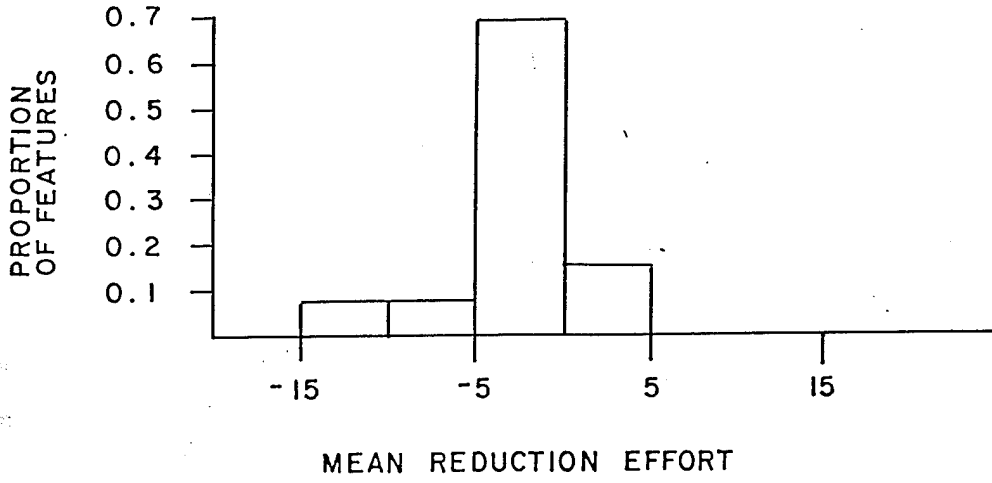

FIGURE 96

HISTOGRAM OF PROPORTIONS OF  
FEATURES OF VALUES  
FOR YELLOW JASPER

Table 216. Orient Phase Scale Values for Raw Material by Locality.

Locality	Raw Material	Thinning	Reduction Effort	
			Total	Mean
Local	Agates	7.4	163	8.1
	Chalcedonies	10.4	9710	29.7
	Combined Cherts	11.6	25200	22.3
	Argillite	10.2	5626	12.1
Nonlocal	Caramel/Yellow Jasper	8.2	470	9.2
	Burgundy/Red Jasper	8.2	569	14.8
	All Jasper	8.9	979	11.0
	Rhyolite	10.4	4968	16.0

Figure 97 is a plot of the thinning value versus the mean reduction effort. Compared to the theoretical plots presented in the analytical introduction, the pattern in the Figure 97 clearly corresponds to expectations regarding a base camp or long-term camp. Local raw materials are more thinned, with more effort expended than would be expected for transient or temporary occupations. All locally-obtained materials have thinning values greater than 10.0, and a mean reduction effort greater than 10.0. More thinning is performed for the chalcedonies than for cherts, which is probably the result of the changing use of raw material for production of a larger number of smaller, thinner tools.

The use of black agate is rather limited compared to its use in other long-term camps, as represented by the early and late Laurentian components, for instance. However, the relative relationships for the key, widely-used materials, hold, as expected. Hence, this limited usage may well be the result of selective pressures for efficiency.

*Other Terminal Archaic Components.* Thinning scale values, total reduction values, and mean reduction effort values have been calculated for the remainder of the Terminal Archaic components as a whole. A summary of these values is presented in Table 217. These values are plotted in Figure 98

Note that this pattern exhibits that expected for a long-term camp. The cherts and chalcedonies are well within the middle portion of the thinning space. Both argillite and agate occupy the ellipse, a situation which may be expected to arise if these latter two materials were not exploited by these people.

Rhyolite has a unique pattern in the Terminal Archaic as opposed to the other components. As is well known and documented in the tool section, the Terminal Archaic includes diagnostic point types which belong to one of several broadpoint categories, as well as other generally large rhyolite points. Given the size of these points and the reduction necessary to produce and resharpen the piece, it can be expected that the plot of rhyolite values would fall within the thinning space if the material is transported to the site and largely reduced there subsequent to arrival.

*Piedmont Component.* Thinning scale values, total reduction values, and mean reduction effort values have been calculated for the Piedmont component as a whole. A summary of these values is presented in Table 218. Figure 99 is a plot of thinning versus mean reduction effort.



Table 217. Terminal Archaic Scale Values for Raw Material by Locality.

Locality	Raw Material	Thinning	Reduction Effort	
			Total	Mean
Local	Agates	7.0	82	5.2
	Chalcedonies	8.7	1796	25.4
	Combined Cherts	10.5	8177	22.4
	Argillite	9.1	1208	10.1
Nonlocal	Caramel/Yellow Jasper	6.8	86	6.4
	Burgundy/Red Jasper	6.8	150	6.8
	All Jasper	7.4	216	7.4
	Rhyolite	11.0	16463	23.3

The distribution of plotted scores is more constricted than that of the Orient and Terminal Archaic, but the relative relationships are similar. First, the nonlocal materials are located in thinning space. Second, the nonlocal materials are located as expected, except for rhyolite. Again, rhyolite is used by these thinning technologists, and the size of the material arriving on site, is relatively larger, producing a somewhat greater mean reduction effort. Whether the restriction is the effect of shorter-term occupation of the site or the result of low density and sampling, is unclear.

Table 218. Piedmont Component Scale Values for Raw Material by Locality .

Locality	Raw Material	Thinning	Reduction Effort	
			Total	Mean
Local	Agates	6.0	9	1.8
	Chalcedonies	8.3	957	14.7
	Combined Cherts	9.7	4163	20.0
	Argillite	8.7	1153	17.8
Nonlocal	Caramel/Yellow Jasper	6.1	49	7.7
	Burgundy/Red Jasper	6.5	71	11.2
	All Jasper	7.0	112	8.8
	Rhyolite	8.1	534	15.5

*Late Laurentian Component.* Thinning scale values, total reduction values, and mean reduction effort values have been calculated for the late Laurentian component as a whole. A summary of these values is presented in Table 219, and Figure 100 has the plotted values for thinning versus mean reduction effort.

The plot in reduction space illustrates a dramatic example of a thinning technology at a long-term occupation. Chalcedony, chert, and argillite have high mean reduction values. Agate, which comes in small nodular form, is also within the thinning space.

Both nonlocal materials illustrate a pattern of high reduction effort. Rhyolite, transported in relatively large pieces, has a very high mean reduction effort (28.9). Since the thinning value and the mean reduction effort value for burgundy/red jasper is higher than for the caramel/yellow jasper, it is suggested that the jasper was transported to the site for later heat treatment and

reduction. With mean reduction values greater than 20, significant thinning of jasper also occurred at the site.

Table 219. Late Laurentian Scale Values for Raw Material by Locality.

Locality	Raw Material	Thinning	Reduction Effort	
			Total	Mean
Local	Agates	9.9	2811	12.5
	Chalcedonies	10.4	13118	35.6
	Combined Cherts	11.9	51542	34.3
	Argillite	10.8	17427	33.7
Nonlocal	Caramel/Yellow Jasper	8.8	1876	20.8
	Burgundy/Red Jasper	9.0	2077	24.3
	All Jasper	9.7	3782	20.4
	Rhyolite	8.7	1822	28.9

*Early Laurentian Component.* Table 220 is a summary of thinning, total reduction effort values, and mean reduction effort values, by locality and raw material. Figure 101 is a plot of the values in reduction space. With the exception of chalcedony, the size of the mean reduction effort for local materials is smaller than that for the late Laurentian material. However, the early Laurentian is also a clear example of a long-term occupation by inhabitants practicing a thinning technology. Similar to the pattern for the late Laurentian, the nonlocal materials, jasper and rhyolite, also have high mean reduction effort values. The pattern of transport of jasper for heat treating at the camp is also apparent here, where the thinning value and the mean reduction effort value for burgundy/red jasper are higher than for the caramel/yellow jasper.

Table 220. Early Laurentian Scale Values for Raw Material by Locality.

Locality	Raw Material	Thinning	Reduction Effort	
			Total	Mean
Local	Agates	9.0	2031	17.9
	Chalcedonies	10.2	11899	35.2
	Combined Cherts	12.0	50950	27.1
	Argillite	9.9	5977	19.6
Nonlocal	Caramel/Yellow Jasper	8.6	1412	16.1
	Burgundy/Red Jasper	8.7	1439	22.1
	All Jasper	9.4	2695	17.6
	Rhyolite	8.5	1382	19.4

*Neville Component.* Thinning scale values, total reduction values, and mean reduction effort values have been calculated for the Neville component as a whole. A summary of these values is presented in Table 221 and a plot of the thinning values versus the mean reduction values is presented in Figure 102. In this case, a different pattern is evident, resembling one characteristic of a short-term camp, where the dominant reduction practices are repair and resharpening. However, chert is well within the thinning space. It is postulated that this is representative of a short-term camp, but that the abundant chert resources were procured for later use.

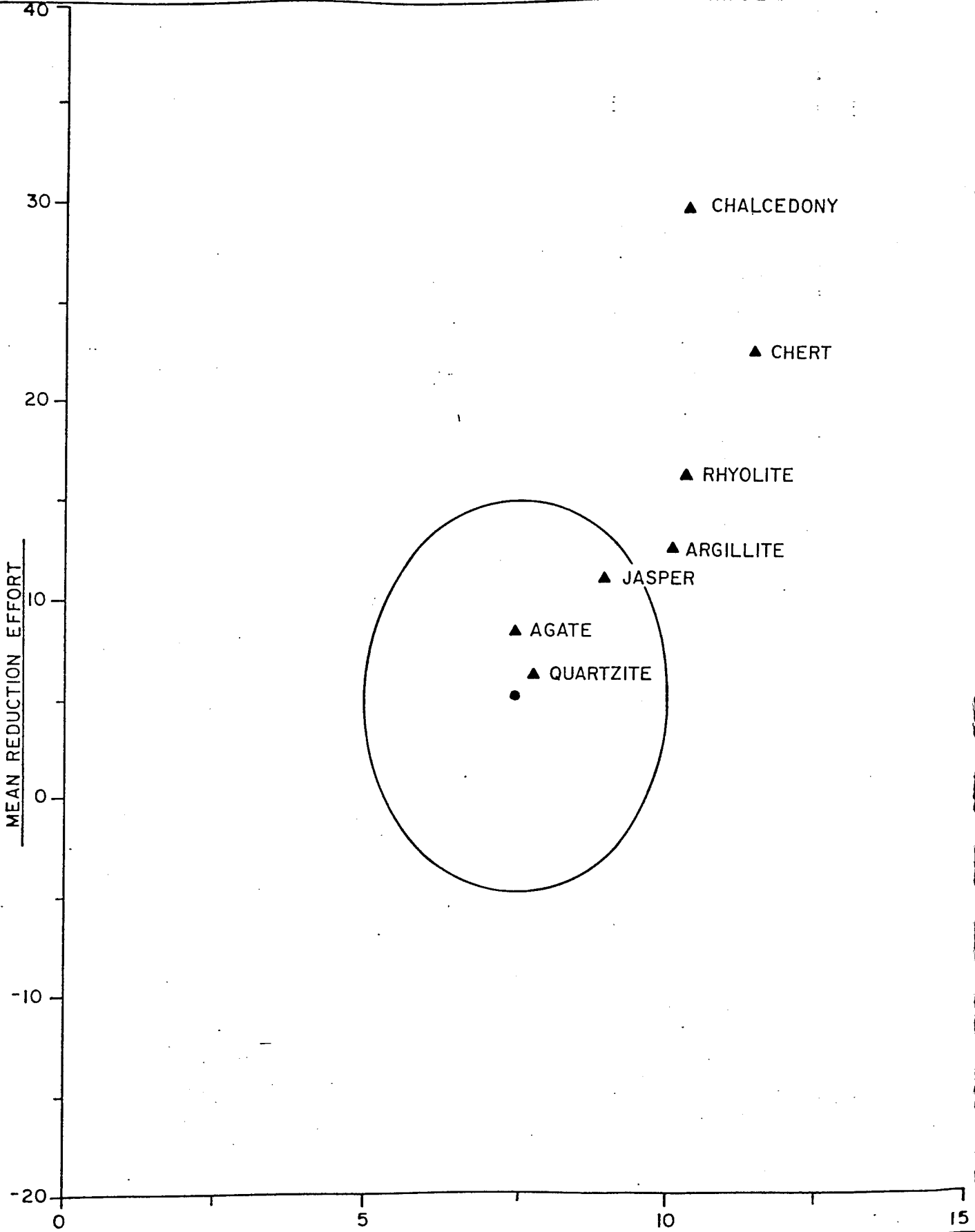

FIGURE 97  
PLOT OF VALUES FOR RAW MAT'L TYPES IN PHASE SPACE FOR THE ORIENT COMPONENT

GAI CONSULTANTS, INC. DWN. REM APPROVED MGS DWG. NO. 89-412-A96

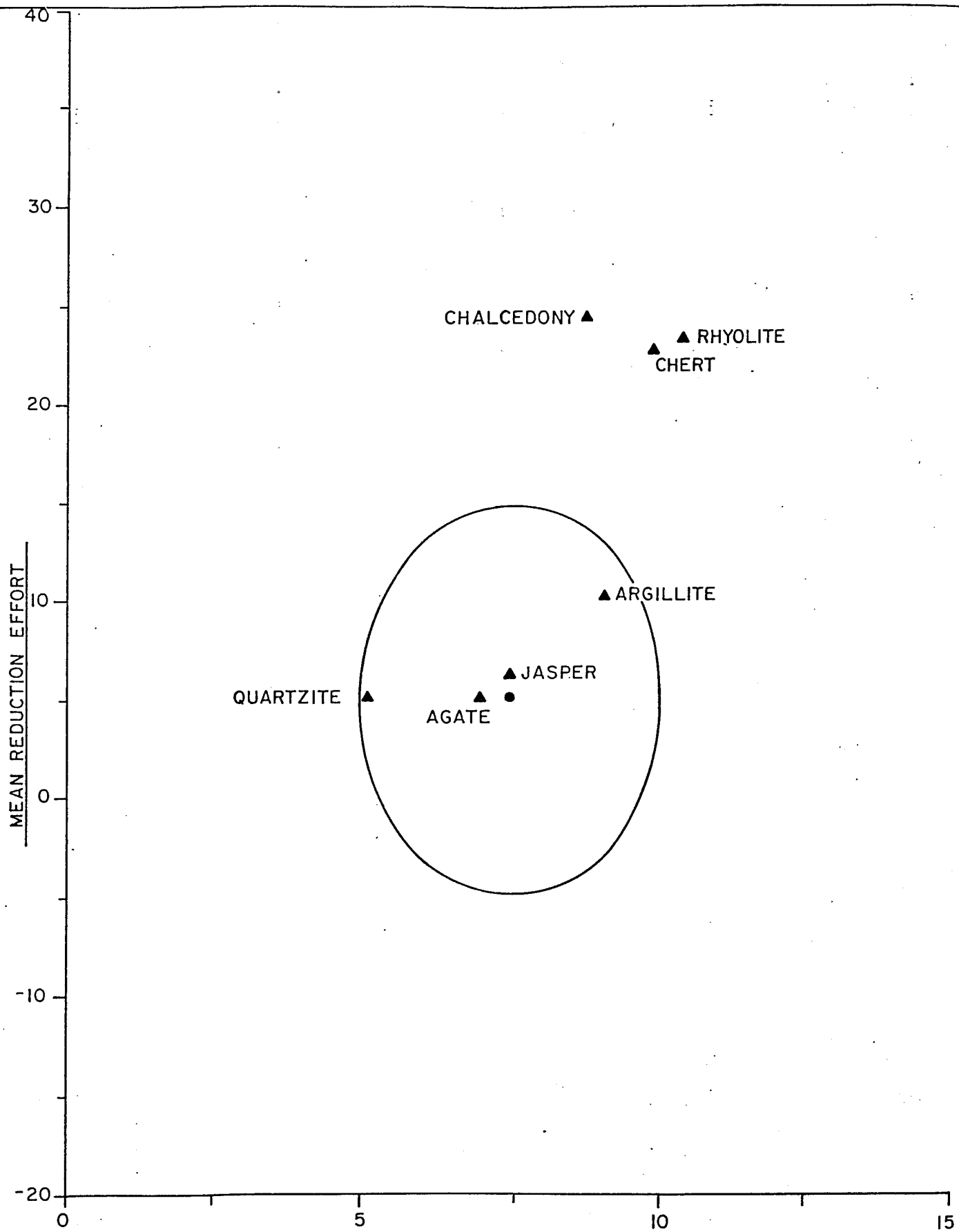

FIGURE 98  
PLOT OF VALUES FOR RAW MAT'L  
TYPES IN PHASE SPACE FOR THE  
TERMINAL ARCHAIC COMPONENT

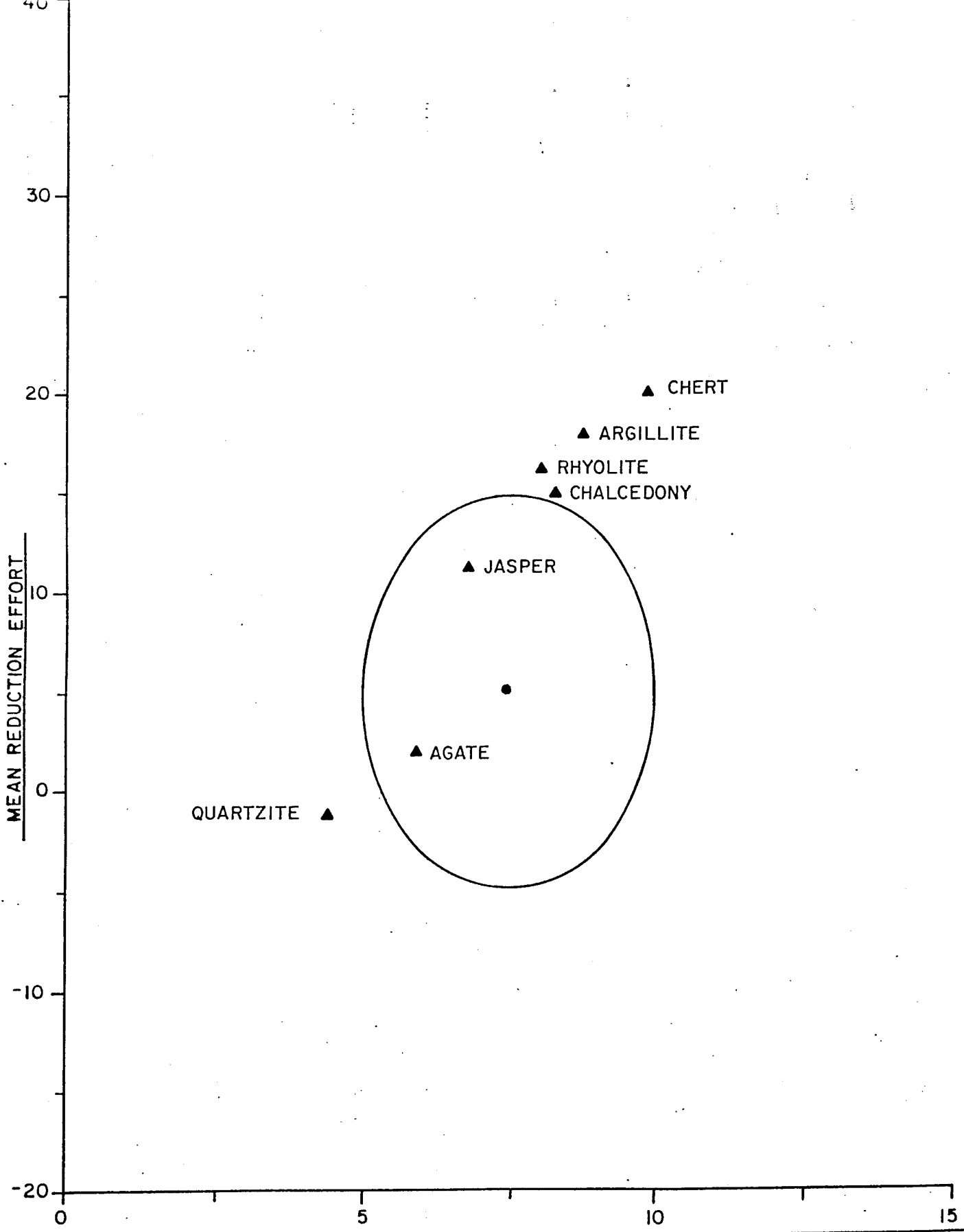

FIGURE 99  
PLOT OF VALUES FOR RAW MAT'L  
TYPES IN PHASE SPACE FOR THE  
PIEDMONT COMPONENT

89-112-A98  
DWG. NO.  
MCS  
APPROVED  
RE  
S.M.N.  
SAL CONSULTANTS, INC.

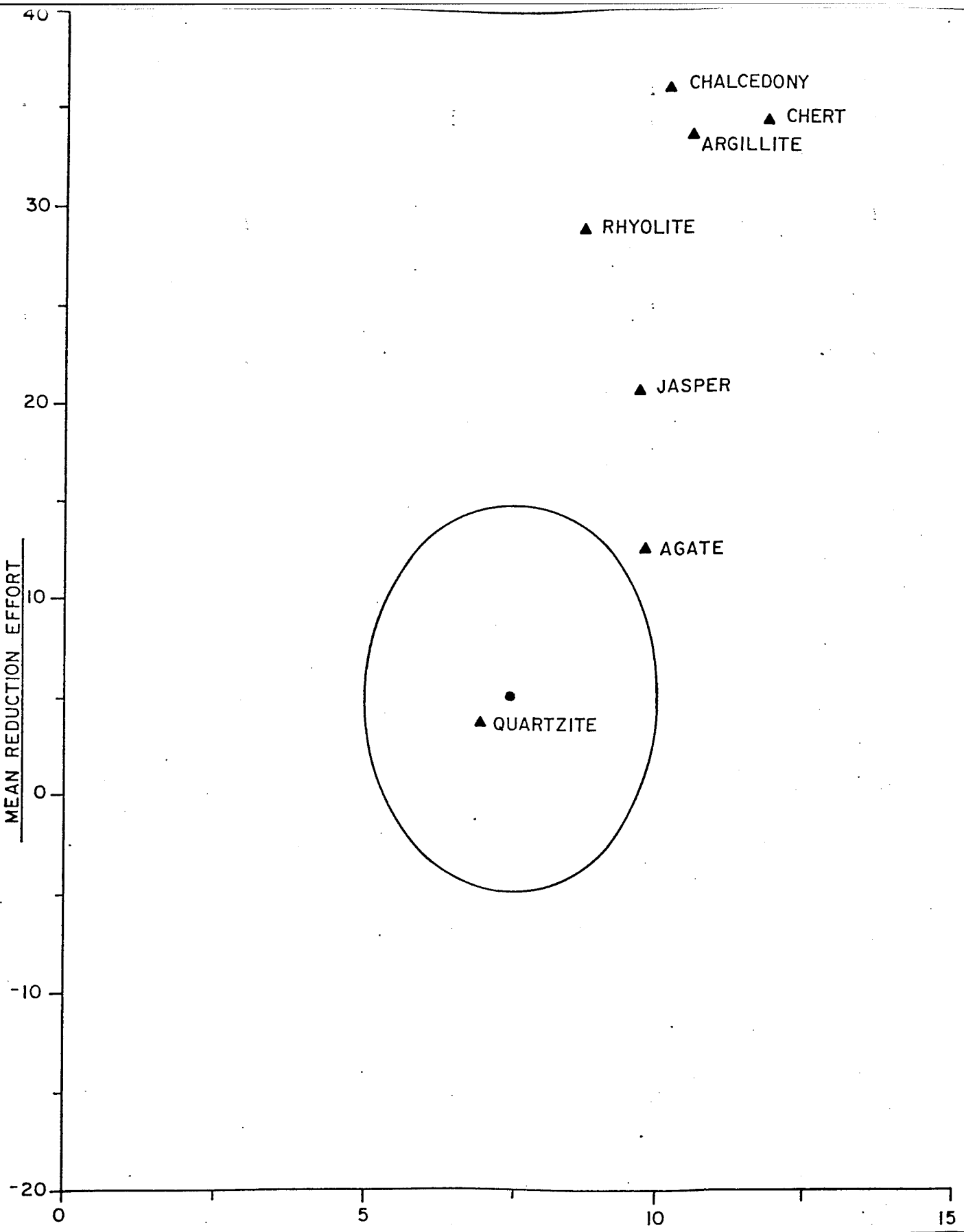

FIGURE 100  
PLOT OF VALUES FOR RAW MAT'L  
TYPES IN PHASE SPACE FOR THE  
LATE LAURENTIAN COMPONENT

Table 221. Neville Component Scale Values for Raw Material by Locality.

Locality	Raw Material	Thinning	Reduction Effort	
			Total	Mean
Local	Agates	6.0	-1	-0.5
	Chalcedonies	8.6	646	8.7
	Combined Cherts	9.3	3613	19.4
	Argillite	6.7	65	5.3
Nonlocal	Caramel/Yellow Jasper	7.1	170	8.0
	Burgundy/Red Jasper	8.1	401	11.5
	All Jasper	8.4	520	9.3
	Rhyolite	6.1	29	5.1

*Temporal Patterning and Late Woodland Evolutionary Change.* The last dimension of variability considered here, with regard to technology and raw material management, is the temporal dimension. Late Woodland technological practices at the Memorial Park site underwent a transformation over the period represented by the dated features (961 A.D.-1380 A.D.), but these changes require a particular way of looking at the data. The first step is to make the comparisons meaningful across dated features. The total reduction effort is strongly tied to the total amount of material represented, whereas the mean reduction effort is an adjusted value unaffected by various lengths of depositional and use time. Therefore we will consider two general measures, thinning and mean reduction effort, as the primary variables of interest in the subsequent analysis.

Tables 222 through 227 summarize the raw data, and two observations may be made regarding trends. For example, if one examines the data for argillite, there is a general decline in thinning from a mean of 8.6 to a mean of 6.25. Given that the dividing line between a thinning trajectory and a thickening trajectory is approximately 6.18, one is seeing a basic change in trajectory forms. The mean reduction effort also declines, from a mean of 6.9 to a mean of -7.0. However, the trends are not quite this simple when examining the data for the other raw material classes. Neither of these comparisons adequately represents the dynamic changes which occurred. Simple tests of equality of the means, whether univariate or multivariate, are not capable of distinguishing meaningful dynamical changes in these reduction systems. Consequently, a different analytical approach is required.

Table 222. Late Woodland Dated Feature Groups and Scale Values for Argillite.

Dated Feature Group	Feature	Thinning	Total Reduction Effort	Mean Reduction Effort
961	63	10.1	2479.0	9.3
	78	7.8	155.0	5.5
	92	7.9	150.0	5.8
	172	-	-	-
1162	29	8.3	231.0	5.7
	80	8.0	243.0	6.9
	107	6.6	5.4	1.0
	152	6.4	28.0	3.9
1380	144	6.9	-4.9	-12.3
	233	5.6	-3.2	-1.7

GAI CONSULTANTS, INC. DWN. REM APPROVED MGS DWG. NO. 89-412-A99

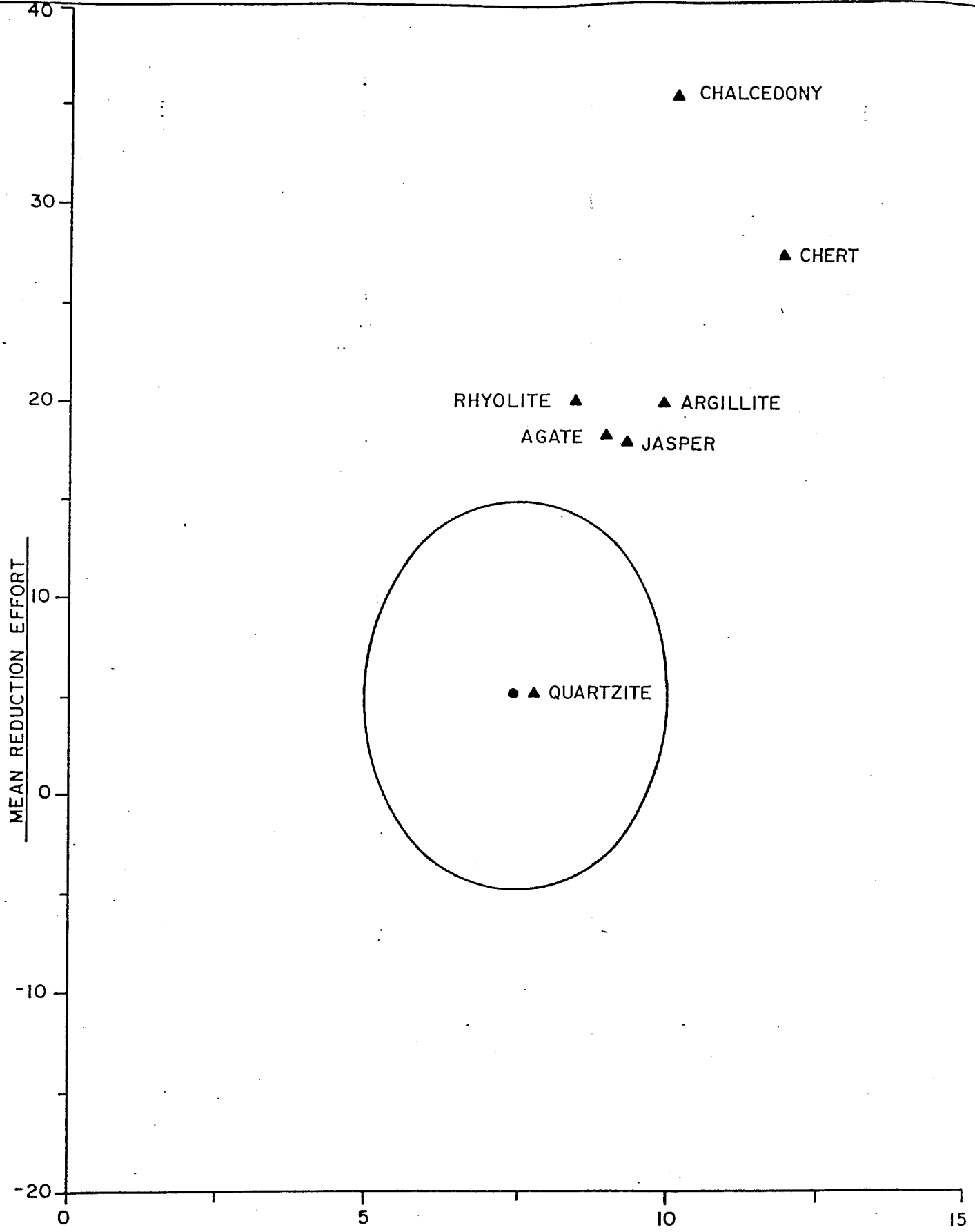

FIGURE 101  
PLOT OF VALUES FOR RAW MAT'L TYPES IN PHASE SPACE FOR THE EARLY LAURENTIAN COMPONENT



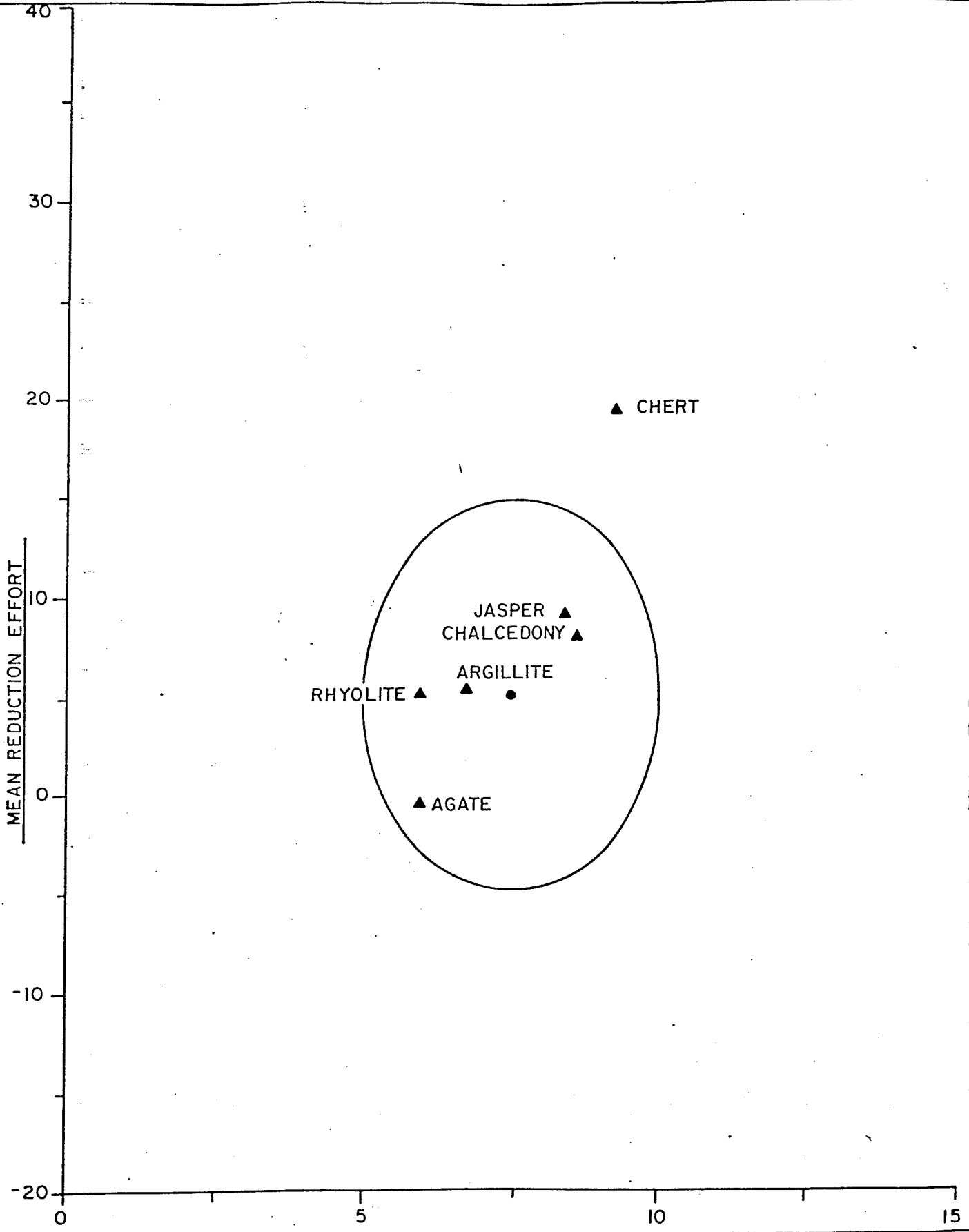

FIGURE 102  
PLOT OF VALUES FOR RAW MAT'L  
TYPES IN PHASE SPACE FOR THE  
NEVILLE COMPONENT

Table 223. Late Woodland Dated Feature Groups and Scale Values for Black Agate.

Dated Feature Group	Feature Number	Thinning	Total Reduction Effort	Mean Reduction Effort
961	63	9.7	456.4	3.0
	78	8.5	329.2	7.3
	92	7.8	74.3	3.2
	172	-	-	-
1162	29	8.9	576.1	7.2
	80	9.1	447.1	5.6
	107	12.2	4.3	0.5
	152	5.2	-4.4	-6.3
1380	144	-	-	-
	233	9.3	43.1	1.1

Table 224. Late Woodland Dated Feature Groups and Scale Values for Dark Gray Chert.

Dated Feature Group	Feature	Thinning	Total Reduction Effort	Mean Reduction Effort
961	63	9.2	1343.7	13.9
	78	8.3	541.6	13.5
	92	9.4	1477.4	11.5
	172	-	-	-
1162	29	8.1	316.5	8.0
	80	9.8	422.5	10.2
	107	4.2	-7.3	-10.4
	152	8.5	114.8	5.7
1380	144	3.8	-8.2	-9.1
	233	5.8	4.9	1.5

Table 225. Dated Feature Groups and Scale Values for Gray Chalcedony.

Dated Feature Group	Feature	Thinning	Total Reduction Effort	Mean Reduction Effort
961	63	10.1	3133.4	13.6
	78	10.1	2575.5	10.1
	92	8.5	610.7	16.5
	172	4.6	-4.1	-20.5
1162	29	9.7	1834.2	11.1
	80	10.9	10202.8	17.4
	107	8.1	124.0	8.0
	152	7.7	2290.7	10.3
1380	144	7.4	52.2	3.1
	233	8.2	193.8	9.2

Table 226. Late Woodland Dated Feature Groups and Scale Values for Gray Chert.

Dated Feature Group	Feature	Thinning	Total Reduction Effort	Mean Reduction Effort
961	63	10.1	3133.4	13.6
	78	10.1	2575.5	10.1
	92	8.5	610.7	16.5
	172	4.6	-4.1	-20.5
1162	29	9.7	1834.2	11.1
	80	10.9	10202.8	17.4
	107	8.1	124.0	8.0
	152	7.7	2290.7	10.3
1380	144	7.4	52.2	3.1
	233	8.2	193.8	9.2

Table 227. Late Woodland Dated Feature Groups and Scale Values for Rhyolite.

Dated Feature Group	Feature Number	Thinning	Total Reduction Effort	Mean Reduction Effort
961	63	6.1	94.0	10.2
	78	6.7	37.1	5.7
	92	6.4	2.3	0.8
	172	-	-	-
1162	29	6.4	12.8	2.6
	80	7.9	51.6	5.3
	107	4.6	-2.1	-3.0
	152	8.1	93.3	2.7
1380	144	-	-	-
	233	8.8	492.6	8.0

The trajectory subspaces, introduced above and in Figure 77, are the basis for a more sensitive analysis of temporal differences in technology than any simple comparison of the scale values presented in Tables 222 through 227. These graphs are called phase portraits, and the space represented in these graphs is termed phase space. Subspaces in phase space signify the presence of different factors which act on the dimensions of thinning and mean reduction effort. These factors predispose the system to behave dynamically within a particular subspace.

The ellipse, in figures 103 through 108, are subspaces in which thinning and mean reduction efforts tend to be stable. This may result from the subsequent reduction and resharping of tools which have been largely reduced elsewhere or by the limited, expedient use of readily-obtained material. Reduction which dominantly occurs within this space does not produce artifacts with the greatest potential for further reduction and reliable, long-term use. Either these tools have already seen significant usage, or they are destined for limited subsequent reduction. Hence, some relative balance between reduction risk and potential invested in the resulting artifacts, is implied.

These subspaces outside of the circle represent different, less stable dynamics. They are less stable in the sense that a high risk is present for an error which would terminate further reduction. More order is possible in the development of artifact form, and greater use-life is possible on certain trajectories.

These subspaces were identified using dynamical analyses of the result of a process given the initial conditions for the reduction represented (i.e., where in phase space tool reduction begins). The boundaries have been on the basis of simple graphical analyses techniques rather than the more accurate, numerical techniques, which are a future task.

Figures 109 through 111 are phase portraits of the locations of all raw materials in phase space for each feature in feature groups 2, 3, and 5, respectively. Group 2 is symbolized by filled squares. Group 3 is symbolized by filled circles. Group 5 is symbolized by filled triangles. As a general observation, the spaces occupied for groups 2 and 3 are larger, with more subspaces represented, than for those in group 5. Two techniques are employed to establish postulated differences in the phase portraits across the three dated feature groups, and to offer an interpretation of what has occurred through time.

The thesis concerning temporal change is that, with the shift to increasing sedentism, the technology was adjusted to emphasize lower risk, more maintainable tools over a more mixed technology, which included high-risk production of larger, more reliable tools with a greater potential for repair and reuse. This would be particularly apparent in subspace 2, which reflects the production and thinning of larger tools, characteristic of past Archaic technology and represented at long-term camps. Further, systemic changes entail the increase of variation on which selection operates to reduce this variation to a more adaptable form. In the context of sedentism, it is hypothesized here that this more adaptable form is that area on the phase plane portrait labeled subspace 1, inside of the circle.

If the phase plane portrait illustrated in Figure 112 is turned on its side, with subspace 3 at the top, the resulting phase portraits appear as in figures 103 through 108. Two techniques are employed in analyzing these graphs, in order to test these ideas regarding structural changes in lithic technology. In this technology, however, a brief examination of the graphs does confirm that the later feature group (5) primarily occupies subspace 1, in contrast to earlier feature groups which also significantly occupy subspace 2. Further, the occupation of subspace 2 by feature group 5 is different and more contracted than that of either feature group 2 or feature group 3.

One technique employed is a single test for independence of dated groups over subspace 1 and subspaces 2 to 5. Three 2 x 2 comparisons were made between each of the dated feature groups, as illustrated in Table 228. Each data point in the contingency table is classified as one of two feature groups and from either subspace 1 or subspaces 2 to 5. The chi-square test for independence was calculated to test the statistical significance of the hypothesized departures from independence.

Table 228. Contingency Table Analysis of Feature Group 2 versus Feature Group 5 over Subsurface.

	Subspace 1	Subspaces 2-5
Feature Group 2	10	12
Feature Group 5	9	1

An associated measure was also used to indicate the degree of segregation of the feature groups, given a postulated theoretical distribution represented in Table 229.

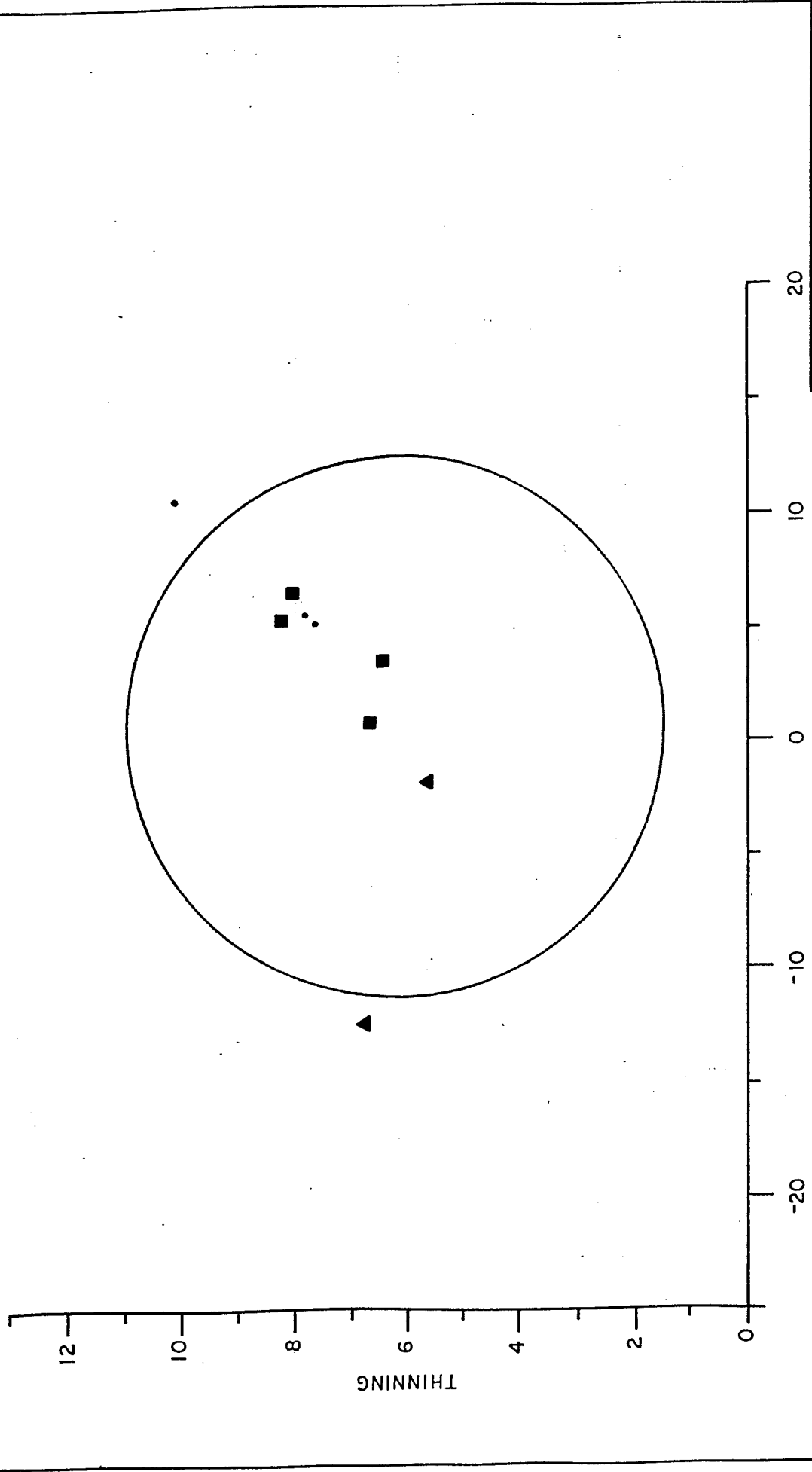

FIGURE 103

LOCATION IN PHASE SPACE  
OF DATED FEATURES FOR  
ARGILLITE

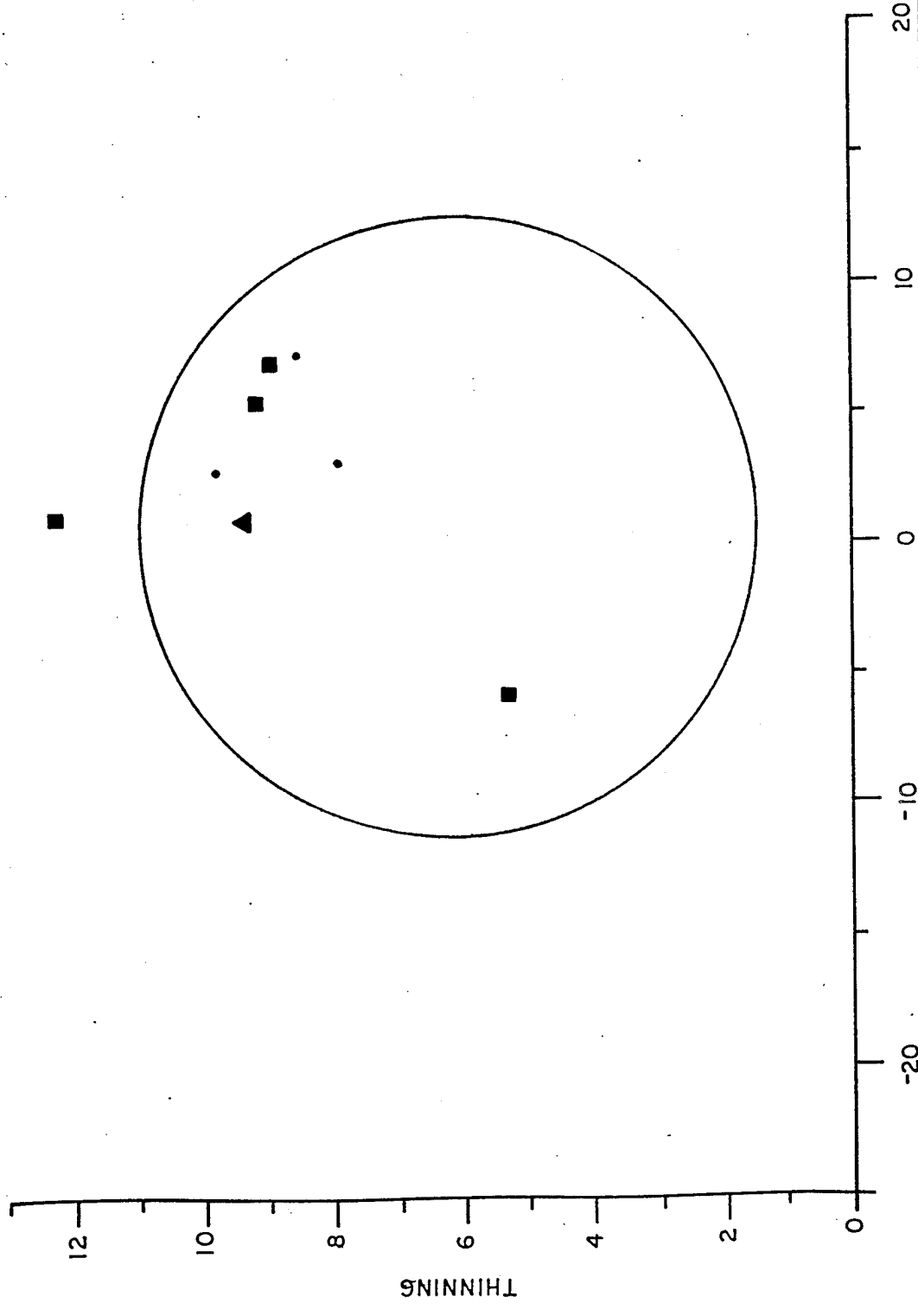

FIGURE 104

LOCATION IN PHASE SPACE  
OF DATED FEATURES FOR  
BLACK AGATE

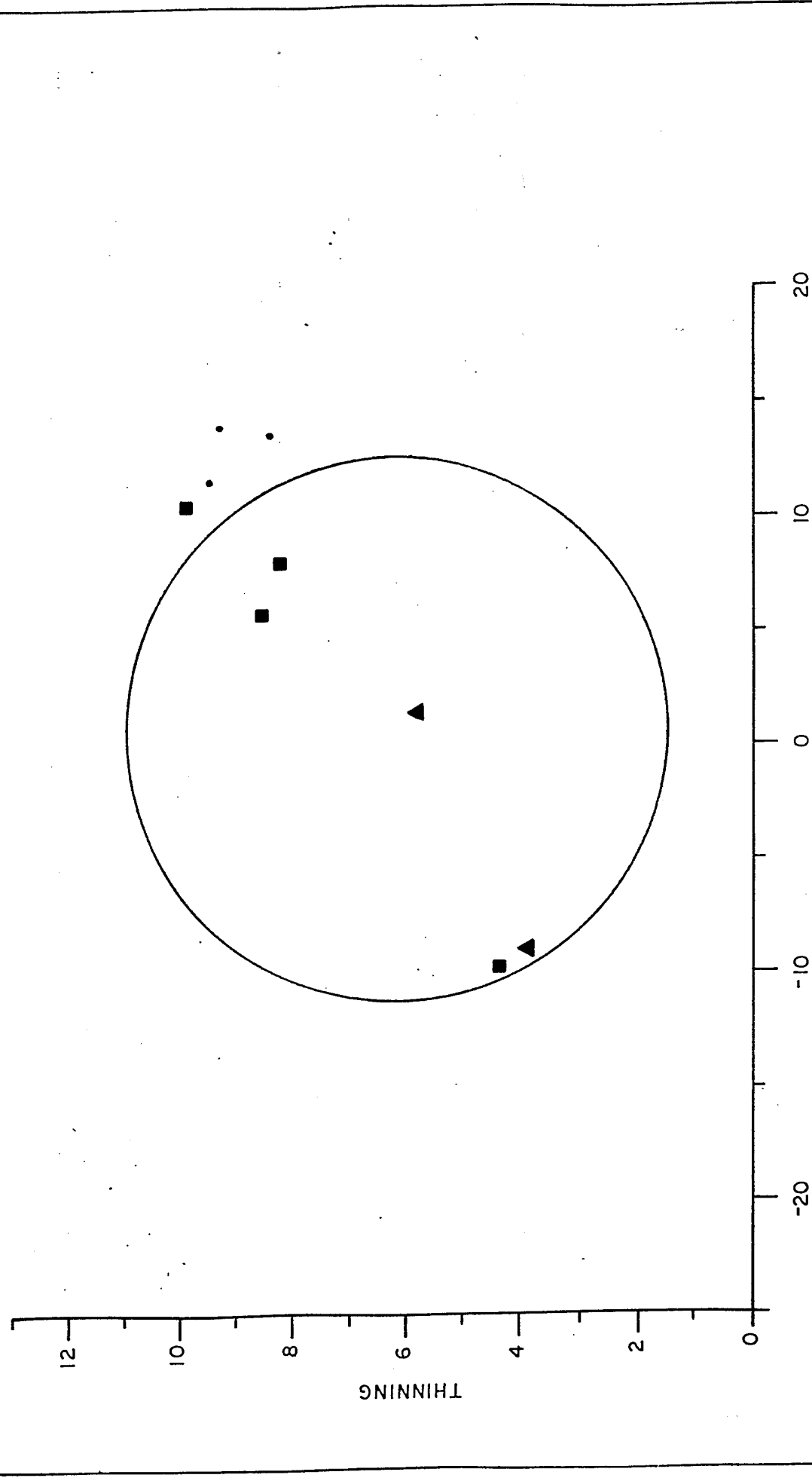

FIGURE 105

LOCATION IN PHASE SPACE  
OF DATED FEATURES FOR  
DARK GRAY CHERT



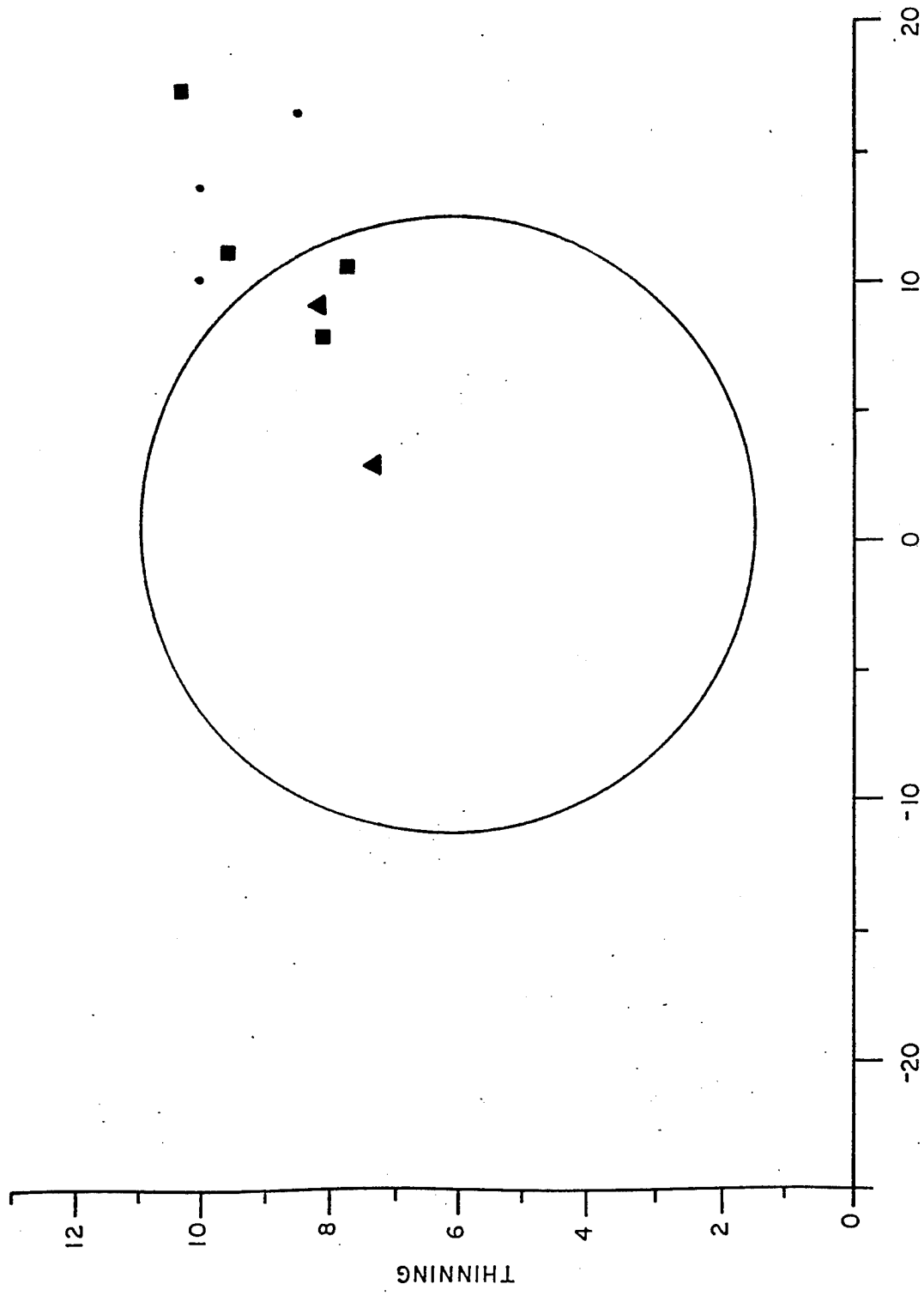

FIGURE 106

LOCATION IN PHASE SPACE  
OF DATED FEATURES FOR  
GRAY CHALCEDONY



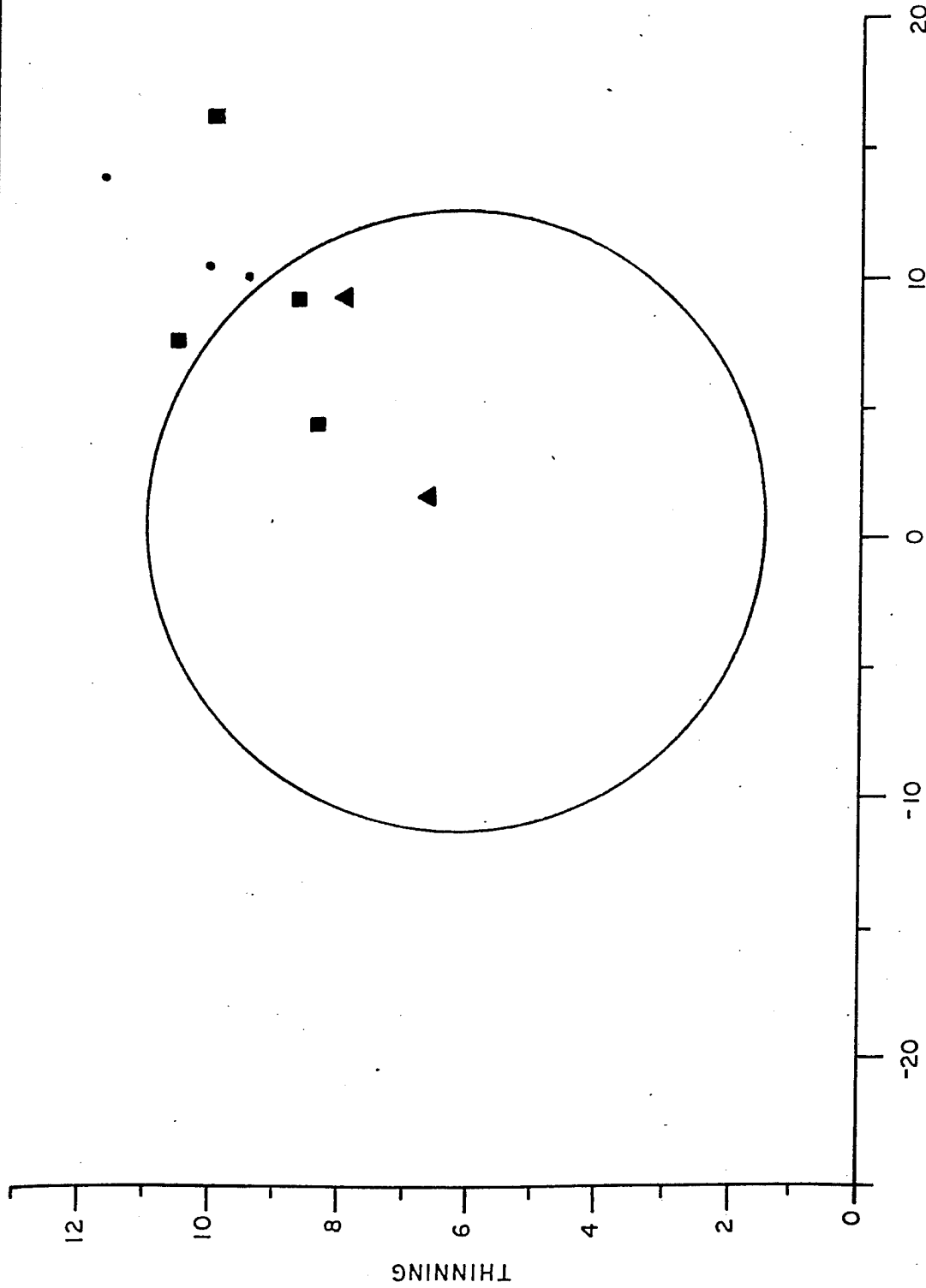

FIGURE 107

LOCATION IN PHASE SPACE  
OF DATED FEATURES FOR  
GRAY CHERT

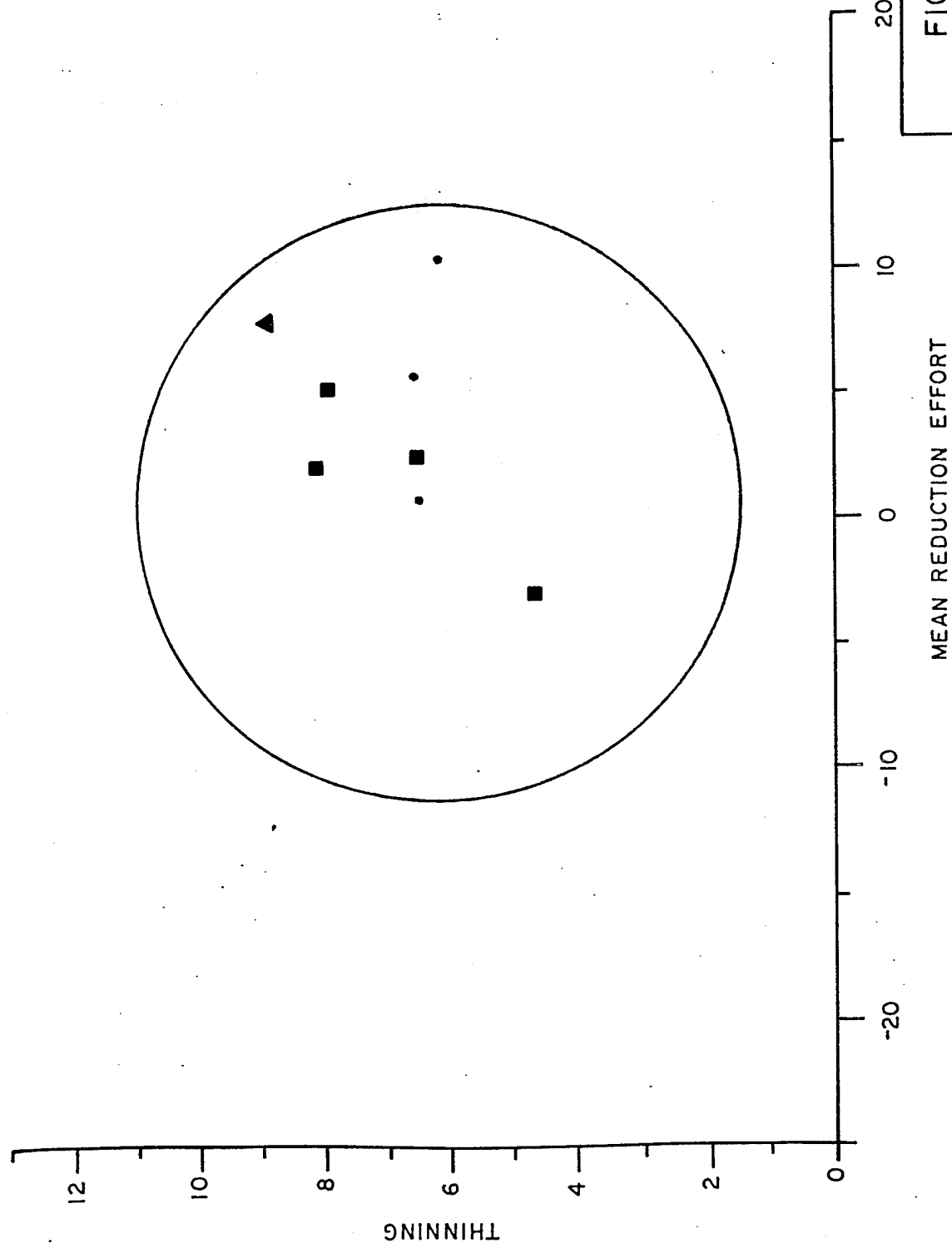

FIGURE 108

LOCATION IN PHASE SPACE  
OF DATED FEATURES FOR  
RHYOLITE

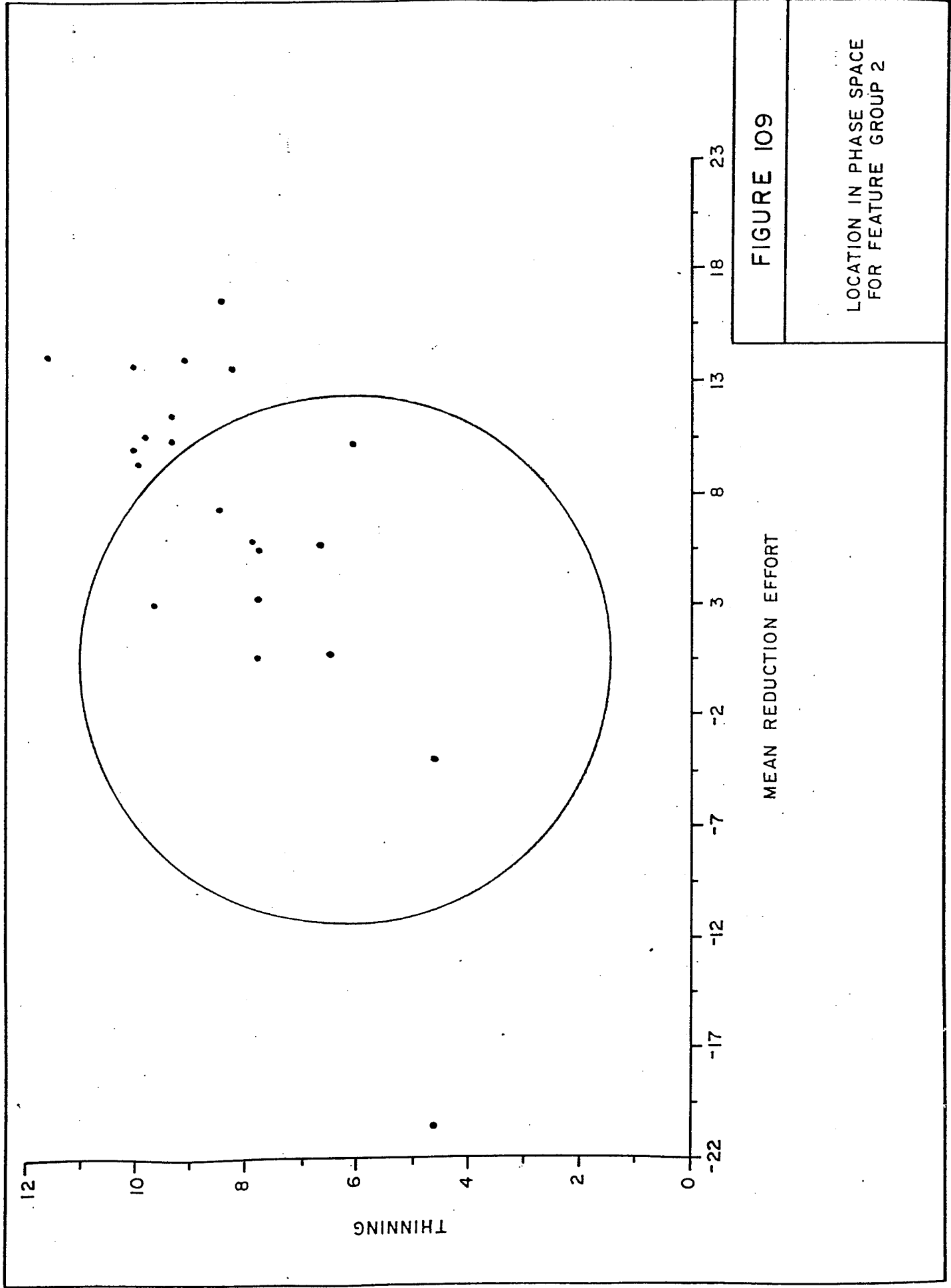

FIGURE 109

LOCATION IN PHASE SPACE  
FOR FEATURE GROUP 2

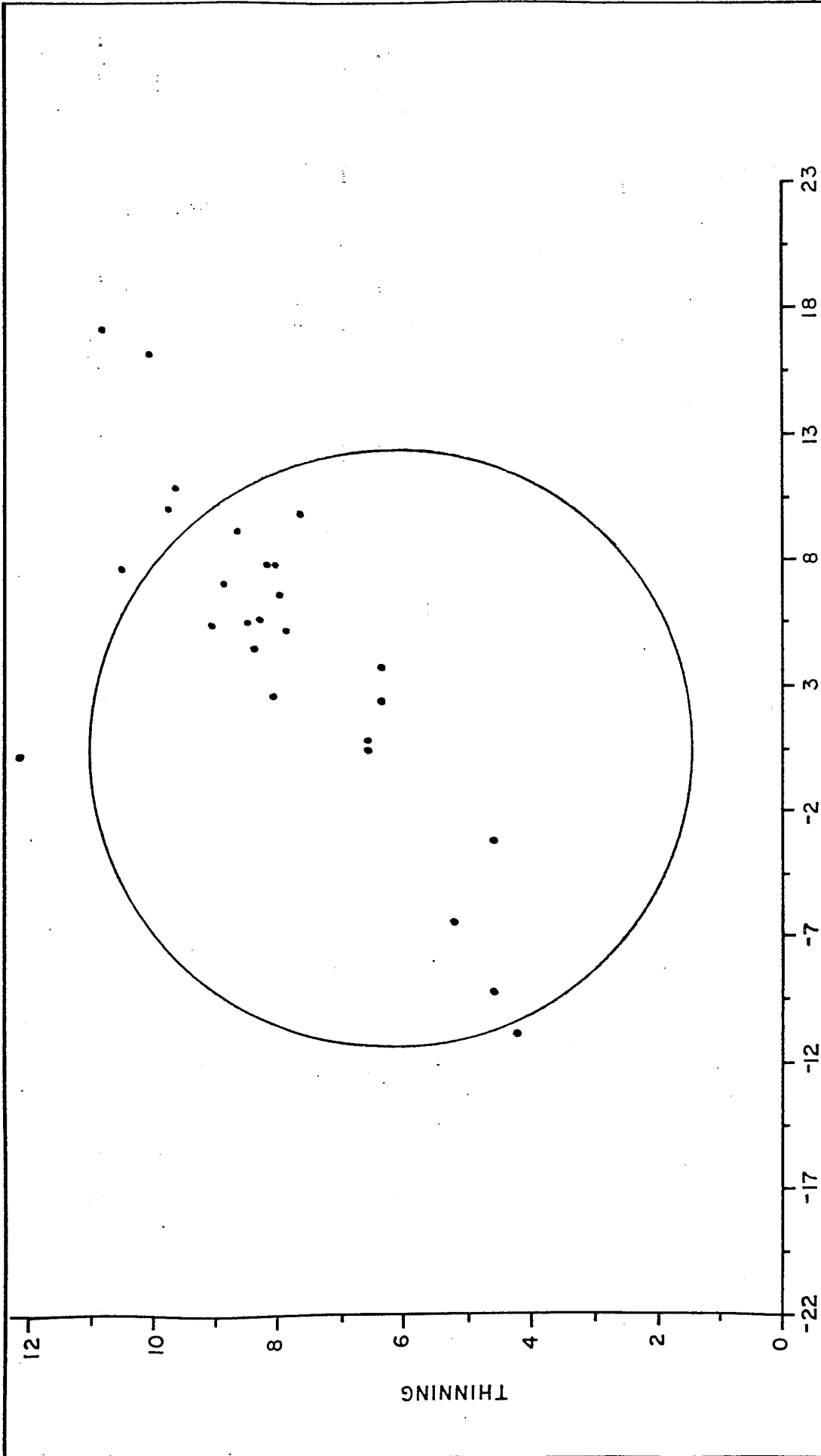

FIGURE 110

LOCATION IN PHASE SPACE FOR FEATURE GROUP 3

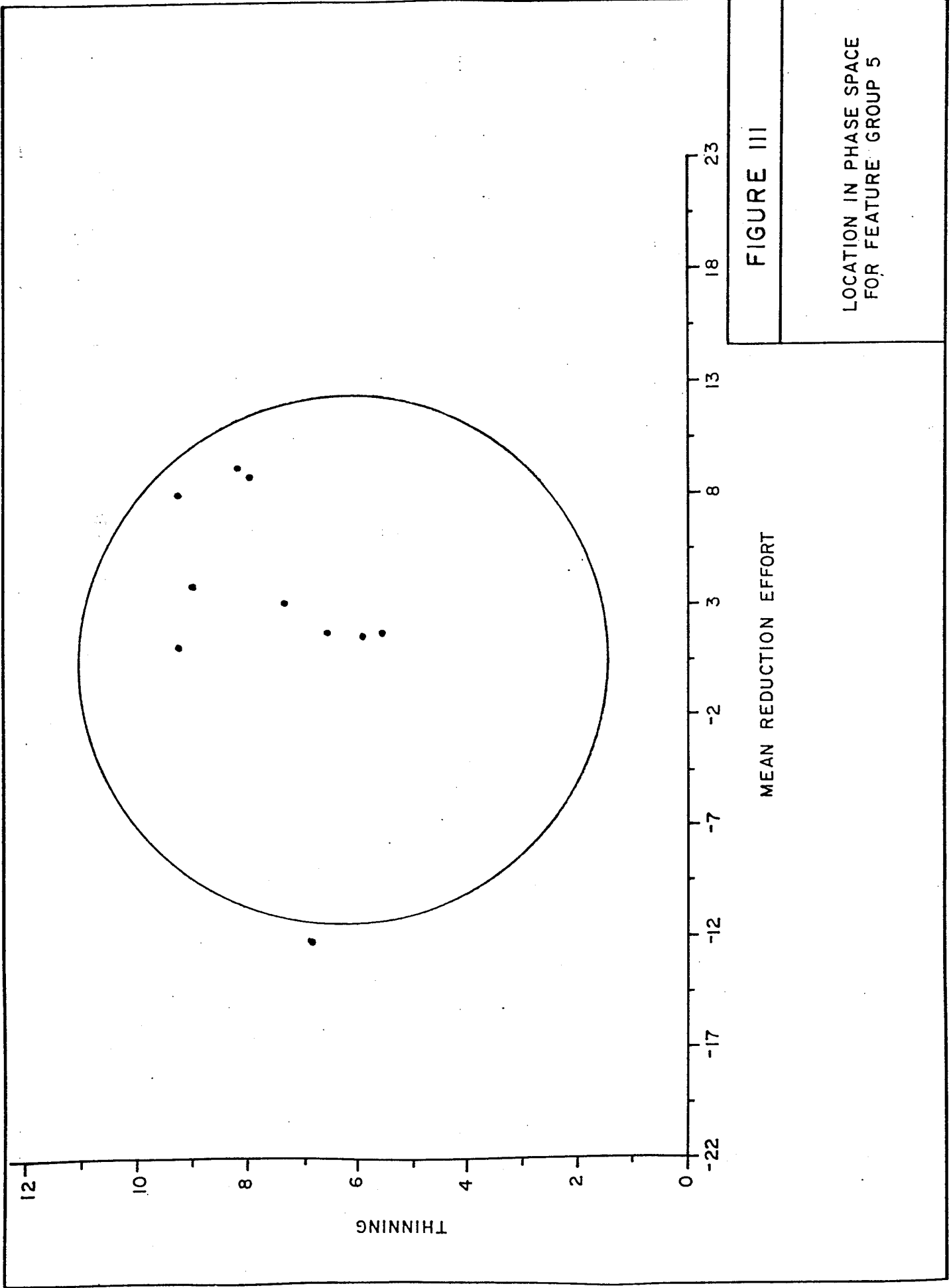

FIGURE III

LOCATION IN PHASE SPACE  
FOR FEATURE GROUP 5

The associational measure (P) has been designed to indicate direction (positive or negative) and degree of association. It has also been scaled to vary from -1 to +1, and is defined as follows:

$$P = 1 - \frac{\sum_{i=1} \sum_{j=1} |O_{ij} - T_{ij}|}{N} \quad (7)$$

- where, i = row
- j = column
- O = observed cell count in cell ij
- T = theoretical cell count in cell ij

P can be interpreted as a measure of the strength of association of the observed distribution relative to a specified theoretical distribution.

The second technique employed was the estimation of the fractal (fractional) dimension of each of the three dated groups over six raw material groups: argillite, black agate, dark gray chert, gray chalcedony, gray chert, and rhyolite. Recent developments in geometry have illustrated that space may be occupied in fractional dimensions rather than integer dimensions, such as 1, 2, or 3 (Mandelbrot 1977). If various factors alter the space occupied in different time periods, then the fractal dimension can be expected to vary. It was postulated that space would expand, then contract, relative to a given initial time period (Feature Group 2). The estimates were based on the minimum circle techniques (Barnsley 1989). The results of these fractal estimates confirm this postulate. Feature Group 2 has a dimensionality of 0.225. Feature Group 3 has a dimensionality of 0.330, an increase. Feature Group 5 has a dimensionality of 0.278, a subsequent decrease. The reduction space represented in the figures is occupied in different locations as well as in different ways.

Table 229. Theoretical Contingency Tables of Observed (a) and Postulated (b) Relations among Contingency Groups from Earlier versus Later Time Periods in Phase Subspace.

a.		
a	b	a+b
c	d	c+d
a+c	b+d	

b.		
$\frac{a+b}{2}$	$\frac{a+b}{2}$	a+b
c+d	0	c+d
$\frac{a+b+c+d}{2}$	$\frac{a+b+0}{2}$	

Table 230 summarizes the results of these tests. All comparisons are significantly different. Note that the ordering of the associational comparisons is consistent with the hypotheses. The direction and degree of difference is greatest between feature groups 2 and 5, with the other values, intermediate.

Table 230. Results of Feature Group Comparisons for Phase Space Subspaces.

	Feature Group 2	Feature Group 3	Feature Group 5
Feature Group 2	—		
Feature Group 3	T=4.4 $\partial < 0.05$ P=0.694	—	
Feature Group 5	T=6.13 $\partial < 0.05$ P=0.875	T=1.7 $\partial > 0.1$ P=0.595	—

The two tests support the hypothesis that the selective pressures associated with a trend to increasing sedentism result in a fundamental structural change in technology. Those dynamic technological processes characteristic of Archaic lifeways are altered from a more diverse system producing more reliable tools at higher risk, to a less diverse system exhibiting lower risk in the production of tools with less potential for repair or resharpening of a given tool.

*Summary.* A theory of lithic reduction was introduced above. This theory is based on modern scientific materialism and was discovered in the author's early work on the problem of lithic reduction. This theory was tested with a wide variety of available data, and the robustness of the test results surpasses those typically achieved in archaeology.

Scales of measurement were developed from this theory and served as the basis for subsequent implications regarding the nature of lithic reduction. From this latter formulation, two fundamental reduction spaces were shown to exist. These roughly correspond to what archaeologists recognize as thinning and thickening trajectories. These scales were then applied to debris from various components at the Memorial Park site for the purpose of ascertaining the nature of the reduction strategies employed by the site's occupants during different time periods.

Since shifts in reductive practices can be identified with the aid of this theory, we are in a position to observe concurring shifts in other subsystems, assuming we can specify the nature of these other subsystems in the way that has been done here for lithic reduction. Understanding the dynamics of intercoupled subsystems of this kind will require imaginative theory building employing modern analytical techniques from studies of nonlinear dynamical processes.

The barest suggestion of the application of this theory at various levels of generality has been presented above. These include the influence of factors such as raw material size, heat treatment, locality of the raw material, and the range of reduction which takes place at a particular location. Further, we can now identify the basic reductive strategy employed in precise quantitative terms for spatial and temporal comparison, and for relating to subsequent theoretical structures regarding other cultural subsystems.

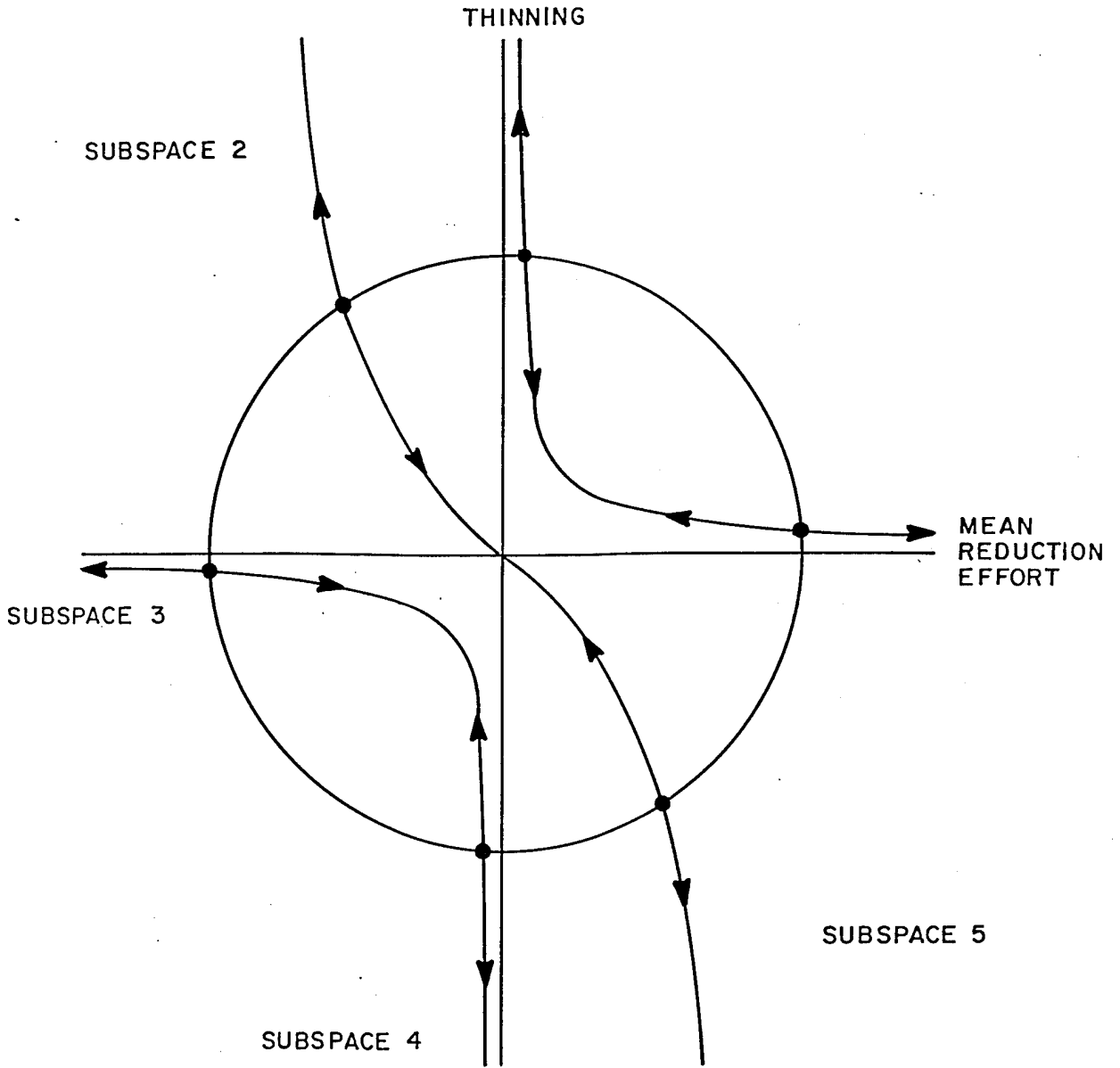

**FIGURE 112**

PLOT ILLUSTRATING DIRECTION OF DYNAMICAL REDUCTION PROCESSES AND THE RESULTING TRAJECTORY SUBSPACES (LABELED). STABLE SUBSPACE (1) WITHIN CIRCLE. UNOCCUPIED SUBSPACES NOT LABELED.



The results of the analysis of lithic debris from the Memorial Park site, using this procedure, indicate that a fundamental shift in lithic reduction strategies occurred from Archaic cultures to the Woodland cultures. This shift is from the employment of thinning trajectories to what has been here termed the thickening trajectories. The thinning trajectory requires high energy input to produce maintainable tools for transport to and use at procurement locations. Resharpener or repair may occur at the procurement site, if necessary, or the tool may be repaired or resharpened at the base camp. This higher input creates greater order in the tool (the tool has more standardized form). To achieve this level of organization, more energy is expended. The thickening trajectory, by contrast, requires less energy input, creating less standardized forms. The resulting expedient tools are used at or near the location of production and typically discarded, rather than resharpened or repaired. A major reason they are discarded is that the potential they possess for resharpening is quite limited since the edge angles become steep so quickly, prohibiting further removals from the edge.

The data recovered at the Memorial Park site clearly illustrate this shift in reduction strategies. All of the Woodland components are characterized by thickening trajectories. In contrast, the Archaic components, specifically the Orient, Terminal Archaic, Piedmont, late Laurentian, and early Laurentian components, demonstrably occupy that part of reduction space which is called thinning space.

The fact that this shift in reductive practices took place has been associated with the shift to a sedentary lifestyle, usually linked with the development of more intensive collecting strategies and the introduction of agriculture. This identification of shifting technological practices, with a shift to sedentism, is a valid observation, but there is no satisfactory, explicit explanation of why and how this occurs. The appropriate linking theories, specifying how the intercoupled subsystems affect one another, are lacking. There is a need to develop this knowledge within a materialist perspective, using our growing knowledge of nonlinear dynamics, energy transformations, and entropic concerns.

### *Tool Analysis*

In the debris analysis two fundamental reduction practices were proposed which not only characterize the archaeological components at the Memorial Park site, but also exhaust the possible types of reduction which may occur. Those practices related to the Archaic components are represented by moderate thinning rates and a high mean reduction effort. This technological system produces tools which are used, resharpened, and repaired (curated tools). The Woodland components are represented by high thinning values and a modest mean reduction effort. These reduction practices are termed thickening trajectories, meaning that thinning occurred rapidly, after which large flakes were modified by retouch or use. These tools are frequently discarded after use, in part, owing to the inability to repair or resharpen the edge due to the resulting high edge angle. These are expedient tools.

In this section, a means of distinguishing these same reduction practices is introduced using tools. It was established in the debris analysis section and Appendix E that certain relationships exist between flakes and workpieces. Also presented in that section were the results of experimental tests of these functional forms relating width and thickness changes of the workpiece to the number of flake removals. The procedures introduced below are based on those relationships.

The results of this development and the subsequent analysis will allow a further test of the nature of the reduction practices discussed in the debris analysis section. This attempted

confirmation can be applied both within and between components, and further support the proposed changes which occurred in lithic technology from Archaic to Woodland times.

### *Analytical Approach*

Tools, in aggregate, provide a different kind of information than debris in aggregate. Whereas debris documents the steps or paths taken in the reduction process, tools represent the end states of the reduction process. If an assemblage of tools is found, can the dominant trajectory employed by the tool makers be inferred?

The basic relation approximating the changes in width and thickness of a workpiece per flake removal is:

$$A = Na + Ca * \exp(-b * F)$$

where A is width or thickness  
Na is the final width or thickness  
Ca is the total change in width or thickness  
b is the rate parameter  
F is the number of flake removals.

This function was tested, and the results were presented above in Table 230. The robust results attest to the validity of this function as an approximation describing the process of width and thickness changes on a workpiece. However, for the purposes of the dynamical analysis which follows, an exact form which includes the influence of width changes on thickness changes, and vice versa, is necessary. That functional form is a differential equation:

$$dW/dF = (r - a * D1 - b * D2) * D1$$

where r is the rate of width or thickness change  
D1 is width or thickness  
D2 is the other dimension (width or thickness)  
a, b are positive constants.

Now the tools are at hand to analyze the consequences of employing a thinning trajectory versus a thickening trajectory. As detailed in Appendix E, beginning with a two-equation system describing width and thickness changes, one can model the results of beginning with multiple initial conditions and plot the end results in the form of widths and thicknesses of tools. If high thinning rates and moderate thinning rates result in different distributions of final widths and thicknesses, then these differences can serve as the basis for distinguishing alternative trajectories. This analysis has been conducted (see Appendix E), and the distinctions are possible. A simplified, nonmathematical approach is presented below.

First, consider an example reduction episode from the Spitzer-Cowan experiments. A biface was knapped, and the width and thickness of the piece was recorded at various intervals. A graph of these recorded values is plotted in Figure 113. Width is represented by the y-axis and thickness is represented by the x-axis. Four straight lines (labeled) represent the locations at which the width-thickness ratios are 1:1, 2:1, 4:1, and 5:1. It should be noted that the piece is thinned

slowly from a width-thickness ratio of less than 2:1 to a width-thickness ratio of greater than 4:1, then thickened to less than 4:1. The thickening corresponds to shaping.

This particular piece was not used and resharpened. Had it been, the width-thickness ratio would have declined even more. The degree to which it can be repaired or resharpened is a measure of potential for future use.

The above is an example trajectory, but what would a sample of end points look like when plotted on the same graph? Figure 114 illustrates a plot of a large sample of ending widths and thicknesses for tools reduced at moderate rates. Most of the resulting tools end up with width-thickness ratios between 2:1 and 4:1. Relative to the total space on the graph, the end states occupy a restricted corridor between these two width-thickness ratios.

The situation associated with expedient tool production should now be considered. The reduction trajectories are conditioned by high rates of thinning. Figure 115 illustrates the two basic consequences of having a much higher rate of thickness removal than width removal. Unlike the case presented above, both the workpiece and product are workable and may be reduced further.

First consider workpiece a. The initial state is 1, and the subsequent states are labeled in numerical order (2a, 3a, etc.). Succeeding states of the workpiece(s) are either relatively thin (> 5:1 ratio) or fall within the width-thickness ranges characteristic of the thinning trajectory. The second case results in one piece which is within the width-thickness ranges of the thinning trajectory or are much thicker, and may or may not be reducible or useable (< 2:1 ratio). Note the wider range of resulting width-thickness ratios that occur (a wider corridor or greater spread of values).

Moving on to Figure 116, one finds end states that have been plotted for a sample of tools produced with high thinning rates. This figure illustrates the wide scatter of width-thickness ratios characteristic of high thinning rates and low mean reduction effort. Less intensive input has resulted in a much wider scatter of values.

There are three ways that comparisons can be made between the width and thickness values of assemblages of tools from archaeological units. First, certain techniques can be employed to compare the results of the two dimensional plots, as illustrated above, with the theoretical possibilities. Second, the comparison of width-thickness ratios from different assemblages can be compared. Third, the relative frequencies of edge-only tools versus bifaces can be compared.

The first technique would entail estimation procedures to determine the fractal dimension of the two trajectory types, given the theoretical model and a comparison of the estimated fractal dimensions of the assemblages with these base values. This could be done using the correlation dimension, a widely used fractal dimension that is appropriate for a scatter of points spread over a region of space. However, as a substitute for this more exacting work, simple examination of the plots for each component will be made to compare to the example figures presented above.

Another way of comparison is possible using width-thickness ratios as the basis. One can produce cumulative frequency diagrams of these ratios and test for differences using Kolmogorov-Smirnov tests. An example plot is presented in Figure 117, where the x-axis is the width-thickness ratio, and the y-axis is the cumulative percentage of tools with ratios less than or equal to the position on the x-axis. In the case of a thinning trajectory, the resulting plot will be steep (1 in plot), while for a thickening trajectory, the plot will be more gradual (2 in plot).

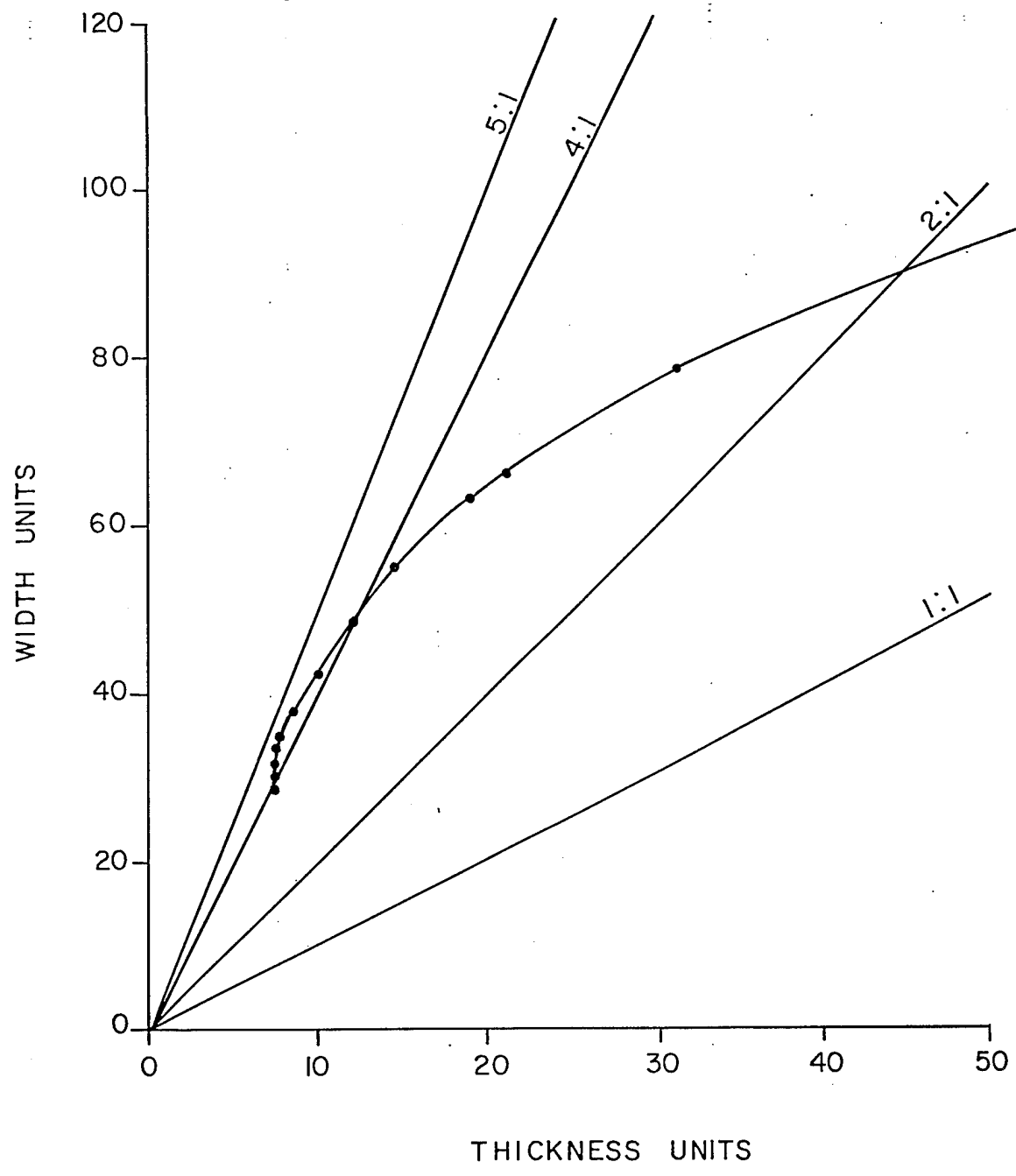

FIGURE 113  
AN EXAMPLE OF  
BIFACE (THINNING) REDUCTION

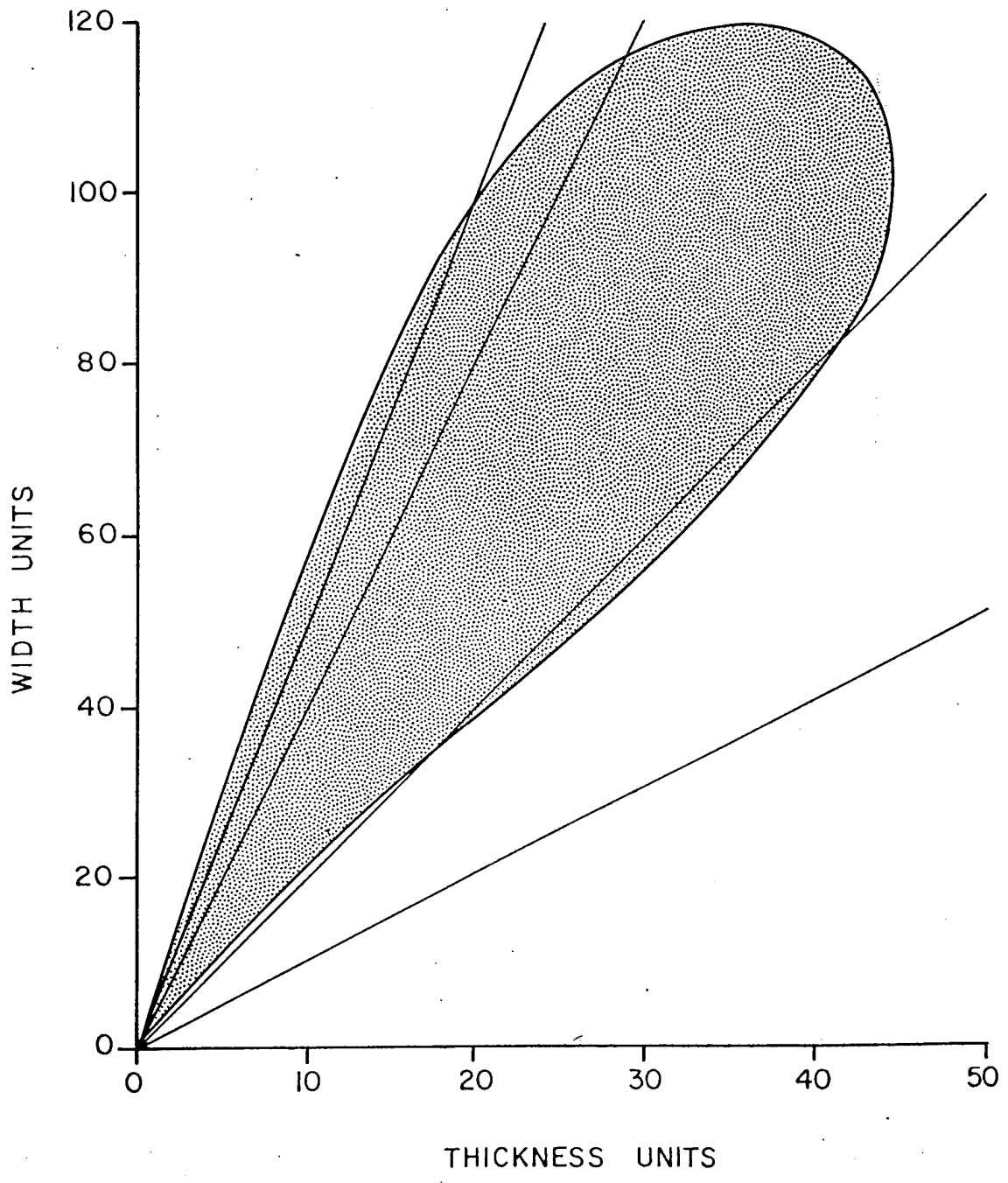

FIGURE 114

THE SPACE OCCUPIED  
BY TOOLS PRODUCED IN A  
THINNING TECHNOLOGY

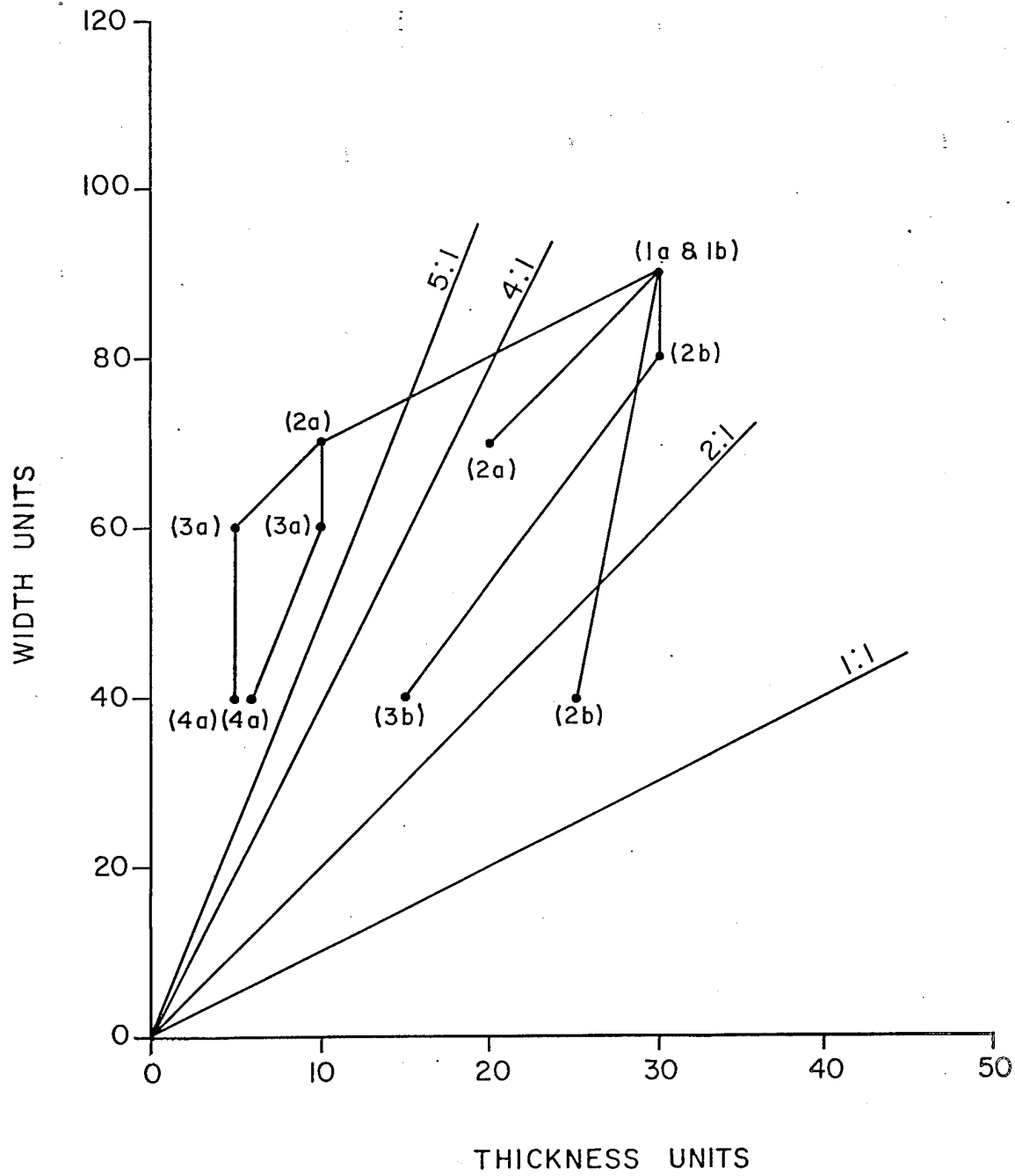

FIGURE 115  
THICKENING TRAJECTORY

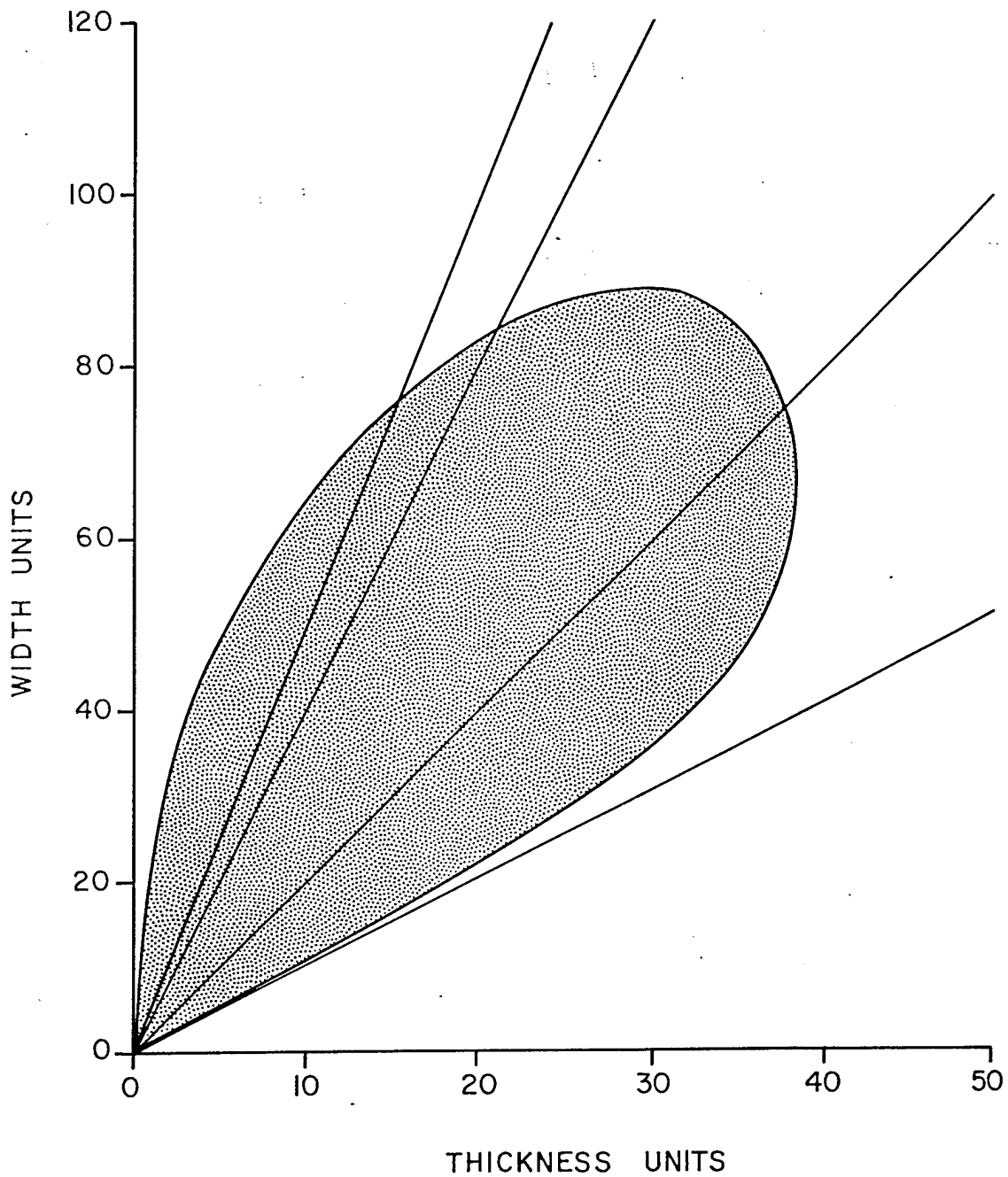

FIGURE 116

THE SPACE OCCUPIED  
BY TOOLS PRODUCED IN A  
THICKENING TECHNOLOGY

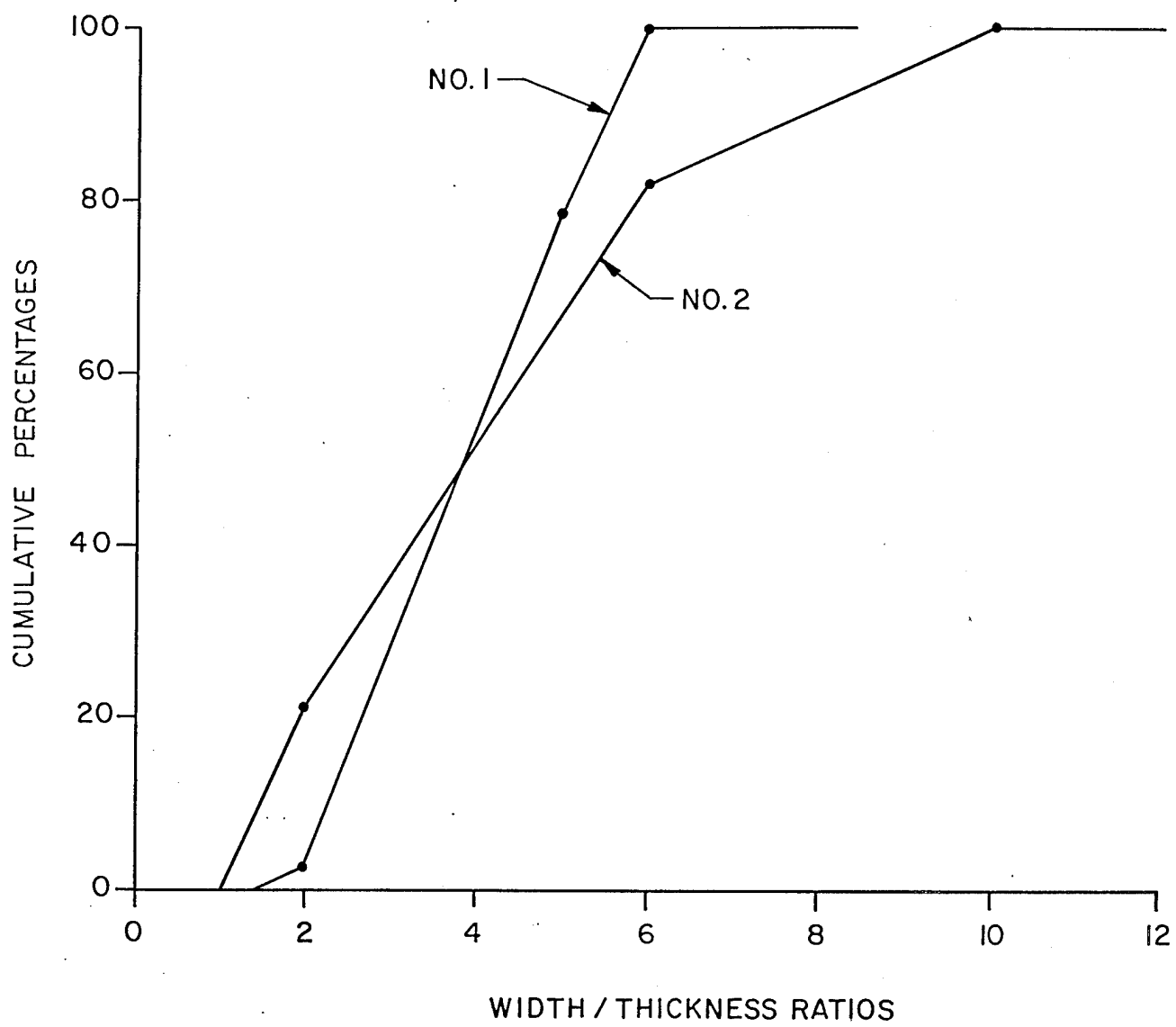

FIGURE I17  
CUMULATIVE PERCENTAGES OF  
WIDTH/THICKNESS RATIOS-ALL TOOLS



Those tools which are produced in a thickening trajectory, frequently as expedient tools, are often edge-only tools. Expedient technologies typically produce a higher proportion of edge-only tools, which is understandable given the restrictions these pieces have for further reduction. If significant shifts do occur in the basic reduction strategies employed, then the frequencies of edge-only tools will increase, and biface forms will decrease in relative frequency. Significant differences in relative frequencies can be confirmed with simple contingency table analysis.

*Results - Individual and Comparative*

Figures 118 and 119 are plots of tool widths and thicknesses for each of the components from the Memorial Park site. The Stewart, Middle Woodland, and Early Woodland components have few representatives and can be considered to be inadequate sample sizes from which to draw a conclusion. The remaining plots are very much like one or the other of those presented above for the two alternative technological approaches. The early/middle and late Clemson Island components have a pattern characteristic of a thickening technology. The Archaic components of Orient, Terminal Archaic, Piedmont, late Laurentian, early Laurentian, and Neville have more restricted patterns of values similar to the thinning trajectory as represented in Figure 113. The patterns illustrated here are completely consistent with the results reported in the debris analysis section.

Table 231 summarizes the results of two-by-two comparisons of distributions of width-thickness ratios between the late Clemson Island, early/middle Clemson Island, Orient, Terminal Archaic, late Laurentian, and early Laurentian. The test statistics are Kolmogorov-Smirnov two-tailed tests for two samples of unequal sizes. The test statistics themselves are presented in the lower diagonal, and the probabilities are presented in the upper diagonal. The Late Clemson Island is significantly different in its distribution of width-thickness ratios from the early Laurentian only. The early/middle Clemson Island is significantly different from all of the Archaic components. The Orient component may be transitional, as it is significantly different from the Early Clemson Island, the Terminal Archaic, and the early Laurentian. The Terminal Archaic is also different from its nearest temporal neighbors and may also indicate transitional changes. Therefore, given the pattern of differences, it is suggested that the change of technology proposed above is confirmed by these test results.

Table 231. Results for the Kolmogorov-Smirnov Test Between Components for Width-Thickness Ratio (see text for explanation).

Component	Late CI	Early CI	Orient	T. Archaic	Late Laur.	Early Laur.
Late CI		.244	.326	.167	.144	.089
Early CI	.194		.007	.049	.001	.001
Orient	.174	.293		.004	.166	.019
T. Archaic	.167	.237	.287		.082	.527
Late Laur.	.194	.313	.168	.188		.373
Early Laur.	.089	.311	.230	.121	.123	

Table 232 summarizes the frequencies of edge-only tools and bifaces for each of the six components for which there is a large enough sample. As argued above, expedient technologies result in higher frequencies of edge-only tools than do curative technologies. If this is the case, then the relative frequencies of edge-only tools should be higher for the Woodland components than the Archaic components. An examination of the table confirms this implication. A chi-square test for independence was performed on this table, yielding a test statistic of 104.3 and a probability much less than 0.001. Hence, the various components have different distributions.

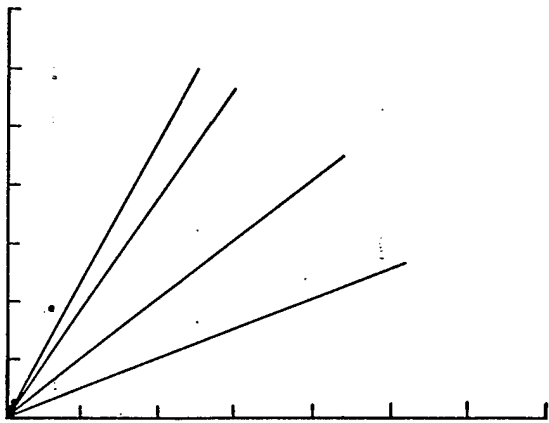

STEWART

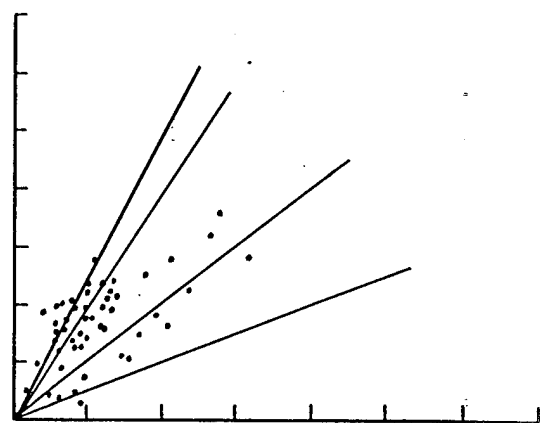

LATE CLEMSON ISLAND

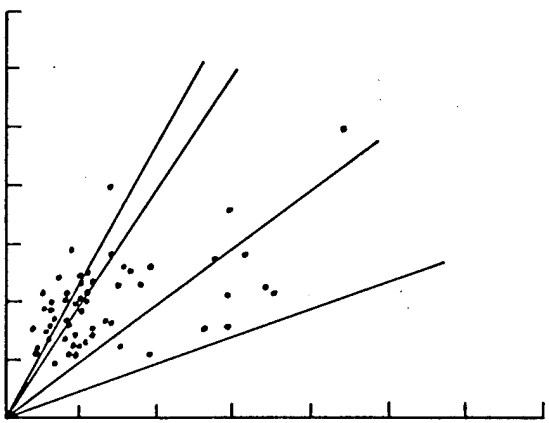

EARLY CLEMSON ISLAND

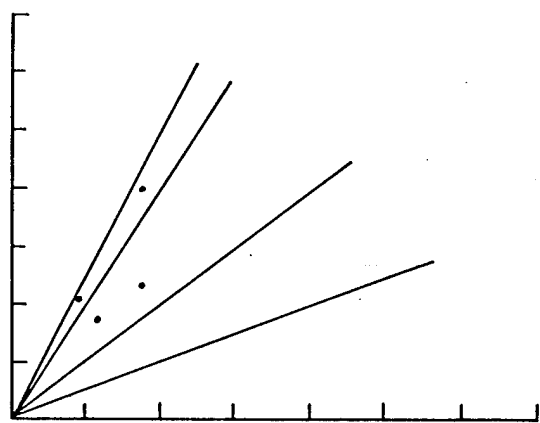

MIDDLE WOODLAND

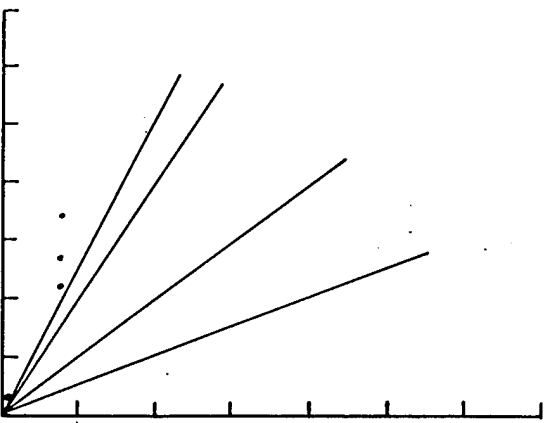

EARLY WOODLAND

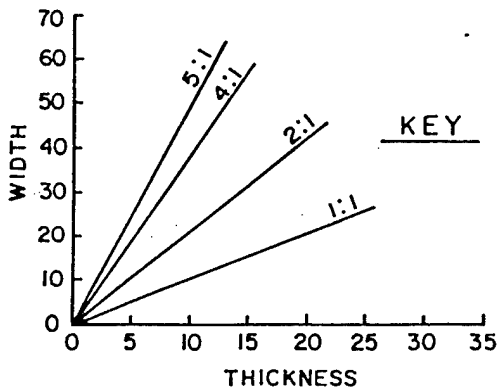

KEY

FIGURE I18

PLOTS OF THICKNESS & WIDTH OF TOOLS. LINES REPRESENT WIDTH-THICKNESS RATIO

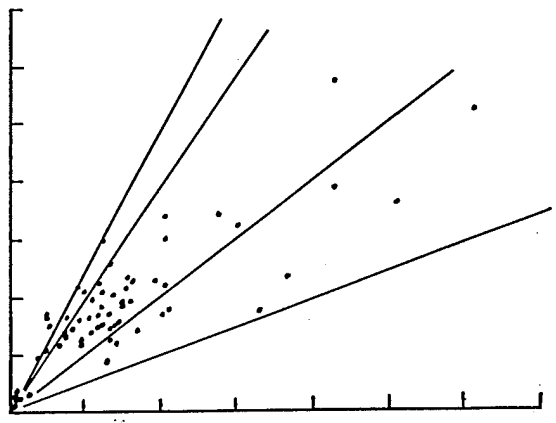

ORIENT

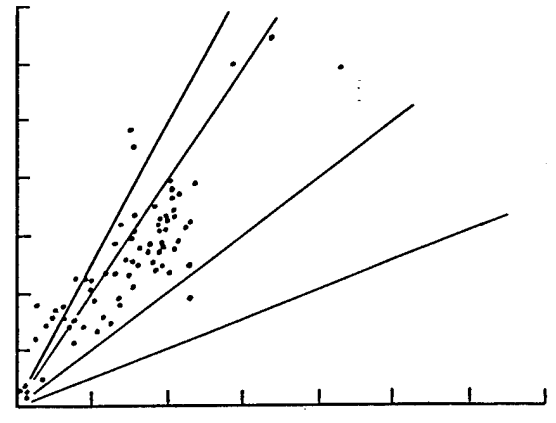

TERMINAL ARCHAIC

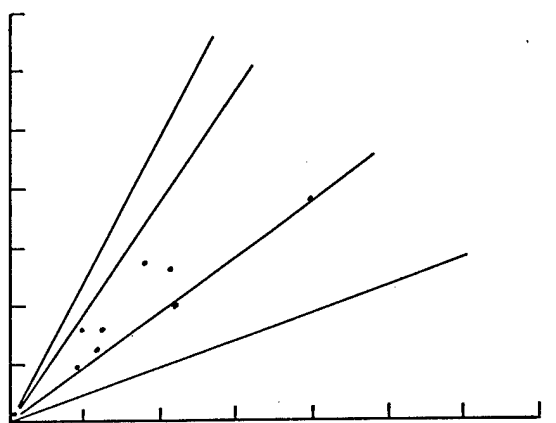

PIEDMONT

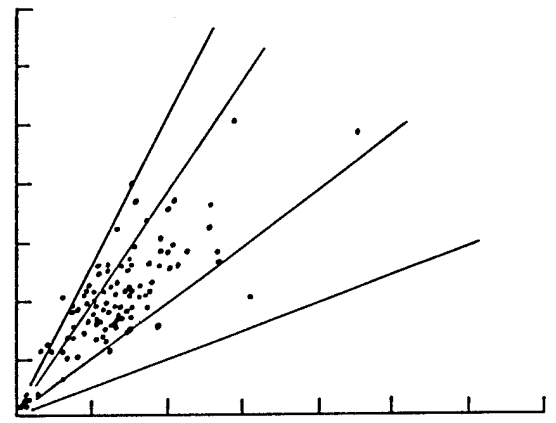

LATE LAURENTIAN

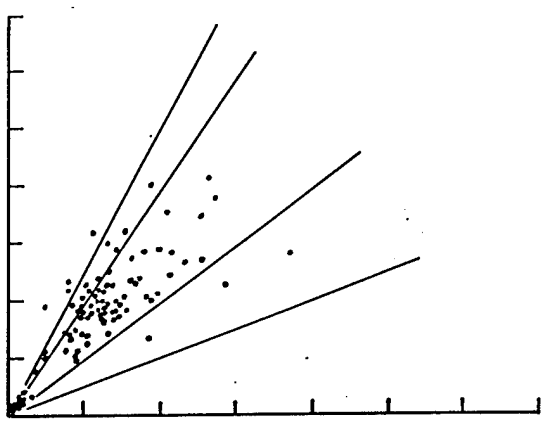

EARLY LAURENTIAN

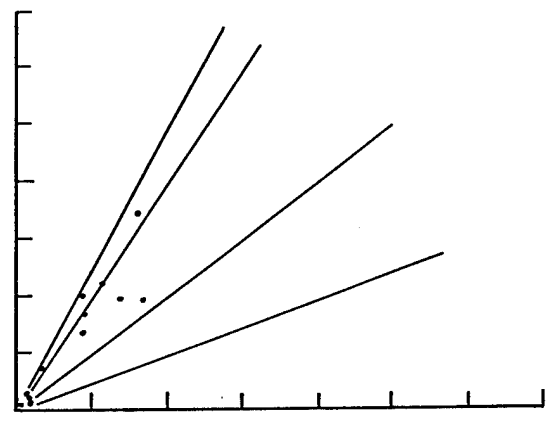

NEVILLE

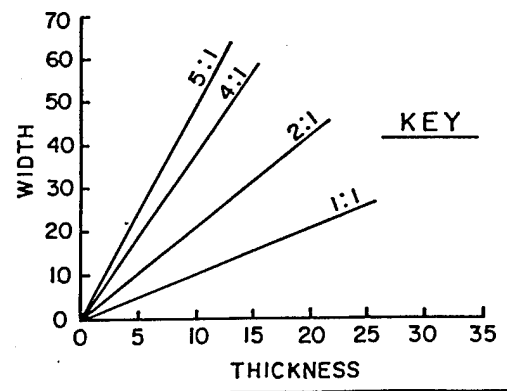

KEY

FIGURE 119

PLOTS OF THICKNESS & WIDTH OF TOOLS. LINES REPRESENT WIDTH-THICKNESS RATIO

Table 232. Frequencies of Edge-only Tools and Bifaces for Six Memorial Park Components.

Component	Edge-only Tools	Bifaces
Late Clemson Island	36	17
Early Clemson Island	41	27
Orient	25	74
Terminal Archaic	17	90
Late Laurentian	26	147
Early Laurentian	34	126

A cross-tabulation of edge-only tools and bifaces versus all Woodland components combined and all Archaic components combined, is presented in Table 233. If there was a major shift in technological practices between Archaic and Woodland times, then the proportions of edge-only tools to bifaces would be expected to shift from more bifaces to more edge-only. An examination of the table confirms this, and a chi-square test for independence yields a test statistic of 948.9 with a probability much smaller than 0.001.

Table 233. Frequencies of Edge-only Tools and Bifaces for Woodland and Archaic Periods.

Components	Edge-only Tools	Bifaces
Woodland	85	53
Archaic	112	463

Two-by-two comparisons among the six components were also made using the chi-square test for each two-by-two table. Table 234 summarizes the results of these comparisons. In this table, a 0 indicates no significant difference, and an asterisk indicates a significant difference at less than the 0.1 level. The two Woodland components are significantly different than any of the Archaic components. Among the Archaic components, the Orient component is significantly different for the Terminal Archaic and late Laurentian, although the remainder of the comparisons are not significant. This may indicate that the Orient is truly a transitional period.

Table 234. Summary of Chi-square Test Results for Two by Two Comparisons\*.

Component	LCI	ECI	ORIENT	TA	LL	EL
LCI						
ECI	0					
ORIENT	*	*				
TA	*	*	*			
LL	*	*	*	0		
EL	*	*	0	0	0	

\* LCI = Late Clemson Island; ECI = Early Clemson Island; TA = Terminal Archaic; LL = Late Laurentian; EL = Early Laurentian.

Three means of examining the tool assemblages from the components at the Memorial Park site have been employed to address questions regarding the nature of the technology in which they were produced. The three different tests are consistent with one another and indicate that the Woodland components represent an expedient technology while the Archaic components represent a curative technology, as the terms are used in this report.

## SUMMARY AND CONCLUSIONS

This chapter has presented the results of the analyses of lithic assemblages from the various prehistoric components identified at the Memorial Park site. The results of the analyses were presented in four major sections, (1) debris assemblage descriptions, (2) tool assemblage descriptions, (3) debris assemblage technological analysis, and (4) tool technology analysis. By component, the debris assemblage description section presented tabulations of debris variables including counts and weights by raw material class for the four size grades, used in the subsequent analytical section. The tool assemblage description presented metric and raw material data for diagnostic and nondiagnostic bifaces, unifaces, multifaces, and edge-only tools. The debris analysis section presented the theoretical and methodological foundations for a form of aggregate analysis developed specifically for this project, as well as the results of this analysis. Finally, the tool analysis section presented analysis of the width-thickness ratios of the tools from each component, using a methodology consistent with the theoretical foundation developed for the debris analysis.

The lithic reduction technological practices represented in the components from the Memorial Park site were investigated relative to raw material management using debris, and temporal changes have been investigated using both debris and tool data. The analyses of debris and technology with respect to raw material management resulted in the following conclusions, which are generalizations independent of time period. First, the size of the raw material chosen for reduction places limitations on the amount of reduction that can occur, and this is reflected in the rate parameters estimated for the sample of debris of the particular raw material type. Second, differences in the amount of reduction that occur at a site for a given raw material is also monitored by the scales employed above. Nonlocal raw materials which are partially reduced near their point of origin can be distinguished from local materials which are acquired and then reduced at the site. Further, if a site is the location of any partial reduction (say, repair and resharpening only), then this can be monitored.

Based upon mathematical criteria, three general reduction trajectories occur that roughly correspond, in a conceptual sense, to what might be called resharpening/repair, a thickening trajectory, and a thinning trajectory. Thinning technologies produce tools that are maintainable and curated; that is, tools that can be transported from location to location and be repaired or resharpened as necessary. Thickening trajectories produce tools that are expediently used and discarded. More effort is required to produce curated tools, but the potential of these tools for future use is greater than expedient tools. Curated tools can be thought of as requiring greater effort for the purpose of generating greater potential for future use. Expedient tools require far less effort to produce than curated tools, and they are designed for immediate use and discard. Analysis of the lithic assemblages from the Memorial Park site produced the following results as summarized by components.

Diagnostic bifaces recovered from Middle Archaic contexts consisted of Neville bifaces and several Eva-like bifaces. All of the Middle Archaic bifaces were manufactured from apparently local cherts, although the recovery of jasper debris (12.3% by count and 11.6% by weight) and a jasper core indicate access to nonlocal raw materials. Aggregate analysis of the debris suggests that the primary lithic reduction activity at the site was resharpening and repair, although chert was used to manufacture bifaces. These results suggest that in general, the nonlocal raw materials arrived on site as finished tools that were subjected to repair and resharpening as necessary, whereas local raw materials were used to manufacture bifaces at the site. The small amount of lithic material recovered from the Middle Archaic time period, and the primary activities of sharpening and repair, suggest use of the site as a short-term camp. The site may have functioned as a logistical forrat camp from a longer-term base camp such as that apparently

represented by the West Water Street site, upstream from the Memorial Park site (Custer, Watson, and Bailey 1994).

Diagnostic bifaces from the early Laurentian component included Otter Creek, Brewerton Eared Triangular, Brewerton Side Notched, Brewerton Eared Notched, Chillequaue Triangle, Stark/Marrow Mountain, and Vosburg. The vast majority of these were manufactured from apparently local raw materials; very little of the debris was of nonlocal raw material. Aggregate analysis of lithic debris and of tool width-thickness ratios indicates a thinning trajectory, suggesting that biface manufacture was the major lithic-reduction activity at the site. The large quantity of lithic debris and the recovery of 27 cores and core fragments also suggest that tool manufacture was an important activity at the site. The early Laurentian lithic assemblage as a whole, therefore, suggests that the site served as a base camp during this time period. Bifaces would have been manufactured at the site for use during procurement forays away from the site, and at logistical camps for the procurement of resources for return to the Memorial Park site.

Diagnostic bifaces from late Laurentian contexts included Beekman Triangles, Brewerton Corner Notched, Brewerton Side Notched, Brewerton Eared Notched, Otter Creek, and Vosburg. The vast majority of tools recovered from early Laurentian contexts were manufactured from apparently local raw materials. Very little of the lithic raw material consists of jasper or rhyolite, and all of the 18 cores and core fragments are of apparently local materials. Aggregate analysis of lithic debris and analysis of width-thickness ratios of the tool assemblage both indicate that thinning was the dominant lithic reduction trajectory for this component, resulting in the production of a primarily curated tool assemblage. The results of this analysis, as well as the recovery of over 140 bifaces and biface fragments, suggests that the site functioned as a base camp during this period of time. This component represents a continuation of the types of activities carried out at the site during the early Laurentian occupations.

Diagnostics associated with the Piedmont component included Bare Island and Lamoka bifaces. Only 15 bifaces and biface fragments were recovered from Piedmont contexts, and of these, four (26.7%) were manufactured from rhyolite. Rhyolite also constituted 10.1 percent of the debris by count and 7.8 percent by weight. Jasper was present in smaller amounts. Aggregate analysis of lithic debris and tool width-thickness ratios indicate primarily thinning reduction trajectories, representing the manufacture of bifaces. However, the patterns are more restricted than during the earlier Late Archaic components, perhaps reflecting shorter-term occupations of the site, congruent with the relatively small chipped-stone assemblage. The presence of relatively large amounts of rhyolite compared to earlier components probably reflects a change in regional trade networks that was enhanced during the subsequent Terminal Archaic period.

Diagnostic bifaces recovered from Terminal Archaic contexts included primarily Canfield Lobate and smaller numbers of Lehigh/Koens-Crispin and Susquehanna broadspears. Several Bare Island bifaces were recovered from a cache in a feature that was comprised mostly of Canfield Lobate bifaces. Of particular note is the large amount of rhyolite associated with the Terminal Archaic component. While rhyolite was present in the debris from all components, and tools for a number of the components, it constitutes 46.4 percent of the Terminal Archaic debris by count and 34.1 percent by weight. Sixty-two percent of the formed tools associated with this component are manufactured from rhyolite, including 85 percent of the diagnostic bifaces. Aggregate debris analysis and tool width-thickness ratios indicate that the primary reduction trajectory associated with this component was thinning for the production of curated tools. This analysis also suggests that rhyolite entered the site as relatively large nodules, blanks, or bifacial cores, and was subsequently reduced into finished, stemmed bifaces. This suggests, perhaps, easy and consistent access to this raw material, whose nearest known source is located in the Susquehanna Valley of far southeastern Pennsylvania. The production of bifaces and the large lithic assemblage suggest

that the site served as a long-term base camp at this time. Tools produced at the site were used both at the site and during logistical forays to procure resources for transport back to the Memorial Park site.

The Orient phase component is represented by Orient Fishtail bifaces. In contrast to the Terminal Archaic assemblage, the Orient phase diagnostics are dominated by apparently local raw materials. Only two of the 15 Orient Fishtail bifaces are manufactured from nonlocal raw material—jasper. Only 10.5 percent of the nondiagnostic bifaces are manufactured from rhyolite, and just over 11 percent of the debris by count and weight is rhyolite. This suggests a major shift in lithic raw material procurement patterns and raw material use. Aggregate analysis of debris, and of tool width-thickness ratios, continues to indicate a thinning trajectory. The relatively large lithic assemblage and the technological analysis both suggest that the site continued to serve as a long-term base camp at this time.

The small Early and Middle Woodland chipped-stone assemblages suggest that the site was not intensively used during this time. Diagnostics associated with the Early Woodland period consist of four Meadowood bifaces and a Rossville-like biface, and the Middle Woodland diagnostics consist of a Fox Creek-like biface manufactured from rhyolite. The small debris collections are dominated by apparently local raw materials; rhyolite constitutes only 2.6 percent of the Early Woodland debris by count and 1.3 percent by weight. Rhyolite constitutes 4 percent of the Middle Woodland debris by count, but 13.5 percent by weight, which, along with the Fox Creek-like biface, suggests increased use of this raw material at this time. Jasper is present in very small amounts for both assemblages.

The Late Woodland occupations at the site were divided into three components for analysis: early/middle Clemson Island, late Clemson Island, and Stewart phase. The early/middle Clemson Island component is represented by Jack's Reef pentagonal, Jack's Reef Corner Notched, and Levanna bifaces, all manufactured from apparently local raw materials. The late Clemson Island diagnostics consist of one Levanna and two Madison bifaces, all manufactured from apparently local raw material. Finally, the Stewart phase diagnostics consists of a single Madison biface manufactured from local raw material. Apparently, local raw materials constitute almost all of the early/middle and late Clemson Island debris and tools. However, rhyolite constitutes 52.7 percent of the Stewart phase debris by count and 30.2 percent by weight, while jasper accounts for 13.6 percent by count and 5.9 percent by weight. These high, nonlocal, raw material totals may suggest changes in lithic procurement activities during this time, but they may also result from sampling error due to the small assemblage size. The dominant lithic trajectory for the Clemson Island components was thickening, representing the production of expedient stone tools, as determined through aggregate analysis of debris and width-thickness ratios of tools. However, aggregate analysis of the Stewart phase materials suggests that the primary trajectory was resharpening/repair, perhaps the result of small sample size. Taken together, the lithic analysis suggests long-term occupation of the site for the Clemson Island components. The results from the Stewart phase suggest a short-term occupation which, again, may be the result of small sample size.

The analysis of the chipped-stone assemblages of the various components, therefore, indicates that there was a basic change in technology from Archaic to Late Woodland times. Archaic components practiced thinning technologies, while the Late Woodland cultures utilized a primarily thickening technology. Results suggest an increase in sedentism through time between the Archaic and Woodland periods and continuing through at least the initial portions of the Late Woodland period. These results are consistent with patterns noted elsewhere in the Eastern Woodlands, where there is a change towards expedient tool production with the development and intensification of agricultural production of tropical cultigens. This probably reflects an increase in

sedentism and less need to expend energy on the production of maintainable tools as the level of risk associated with the use of chipped-stone tools decreased (Torrence 1989b).

The thinning value and mean reduction effort also reveal how nonlocal raw materials were used in different ways. Among the Archaic components, nonlocal materials fall within the resharpening/repair space for the Neville component, thinning for the early and late Laurentian, and Terminal Archaic components. For the Orient and Piedmont components, rhyolite falls within thinning space, while jasper falls within the resharpening/repair space. During the Late Woodland period, nonlocal raw materials fall within the resharpening/repair space. These results indicate that access to nonlocal raw materials changed through time. Those components where nonlocal raw materials fall within the repair/resharpening space probably had limited access to these raw materials, and they arrived on site primarily in the form of finished tools. Those components where nonlocal raw materials fall within the thinning space had ready access to these materials, and arrived on site in the form of partially reduced nodules, or bifacial cores, that were subsequently reduced into bifacial tools. This is most apparent during the Terminal Archaic, where large quantities of rhyolite debris were recovered, suggesting access to the raw material through intensive trade networks, and may represent a hoarding strategy, controlling access to the raw material for the local social network (see Stewart 1989).

In conclusion, the study presented in this chapter was undertaken to specify the nature of the subsystem that operates in controlling technological practices among groups of lithic technologists. The theory presented makes no use of conscious decision-making, and its components are real material items such as rocks, brains, hands, and material processes such as neural processes and fracture. The system has been characterized in terms of the relations among its components, a set of mathematical functions and all of the possible deductions or derivations of these functions. This is one of only a few chipped-stone analyses in Pennsylvania that has applied an aggregate analysis to debris (also see Hart and Cremeens 1990). The theory and methods developed in this chapter and in Appendix E represent provide robust linkages between the archaeological record and human physical behavior. Archaeologists are now in the position to apply these results, develop further applications, and to relate changes that occur in technology to changes in other subsystems, presumably from other systems similarly specified. This is the step that needs to be taken to understand the shift in lithic technology from the Archaic to the Woodland period.





## X. USE-WEAR ANALYSIS OF CHIPPED STONE ARTIFACTS

by

John P. Nass, Jr.  
California University of Pennsylvania

### INTRODUCTION

This portion of the report concentrates on the lithic materials recovered from Late Woodland features and a sample of Archaic period artifacts recovered during block excavations, with particular emphasis on bifaces and retouched and utilized flakes. These artifacts, together with a sample of unmodified debitage, were inspected for traces of use-wear that accrues to the edges and surfaces of stone tools during use (e.g., Keeley 1980; Semenov 1964; Tringham et al. 1974). This damage appears in the form of microscarring, striations, polishes and edge rounding, and forms during a tool's use or motion in chopping, planing, scraping, sawing, boring or drilling, wedging, adzing, and whittling (Figure 120). The activities are also referred to as "actions."

Functional assessments were made with reference to a set of experimental tools made out of flint and chert, and used in the activities listed above. Lithic materials used in the experiments were chosen on the basis of their similarity to those raw materials found at the Memorial Park site. Use-wear traces observed on these tools were then compared with utilization traces found on actual artifacts.

The technique used to observe use-wear on artifacts involves the use of microscopic examination. This was accomplished using an Olympus incident light stereomicroscope with a magnification range of 50x to > 400x. Prior to examination, each specimen was documented on a data recording form.

After documentation, the specimens were cleaned by first soaking them in detergent to remove finger grease, gently scrubbing them and rinsing them in warm water. Next, the specimens were immersed in 10-12 percent solution of HCL to remove lime deposits and any other mineral substances. After rinsing in water, the specimens were immersed in a final bath of 20-30 percent solution of NaOH to remove extraneous organic deposits. The specimens were then rinsed and allowed to air dry.

As each specimen was inspected, observable use-wear traces were recorded on the drawing previously placed on the data recording form. In addition to location of use-wear traces, the direction of use was recorded, as was the type of "action or motion."

### METHODS OF FUNCTIONAL ANALYSIS

Several different methods have been used to assign archaeological remains to functional classes. As pointed out by Dunnell (1978), Keeley (1980), Odell (1981), and Tringham et al. (1974) among others, these methods consisted of 1) morphology 2) ethnographic analogy, 3) tool replication experiments, and 4) use-wear analysis. These methods have been described in detail elsewhere (cf. Odell 1982; Vaughan 1985; Moss 1983), and will be only briefly discussed in order to point out their differences.

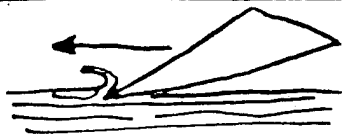

A - WHITTLING



B - PLANING

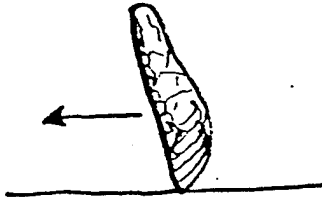

C - SCRAPING

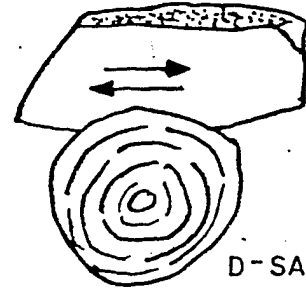

D - SAWING

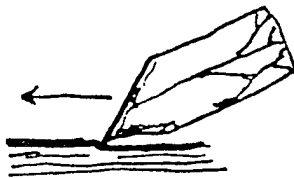

E - GRAVING

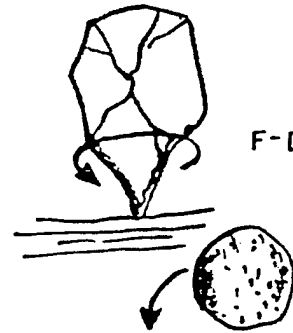

F - DRILLING

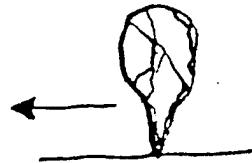

E - GRAVING

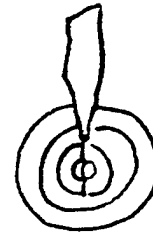

H - WEDGING



I - ADZING

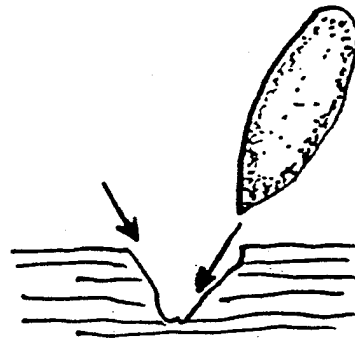

J - CHOPPING

FIGURE 120

TOOL "ACTIONS" (AFTER KEELEY, 1980) RESULTING IN MICROWEAR

Attributes of edge morphology, especially edge shape and spine-plane angle, have attracted particular attention as criteria for differentiating between objects used in cutting tasks and those used in scraping tasks (cf. Crabtree 1973; Gould 1973, et al. 1971; Hayden and Kamminga 1973; Wilmsen 1968, 1970). This kind of typology, however, works best when whole objects are involved and when a few attributes have been used in their formation (White 1969:21-22).

The replication of prehistoric tools (e.g., Crabtree and Davis 1968; Frison and Bradley 1980; Sarayder and Shimada 1971; Sollberger 1969) for testing ideas on tool-task efficiency has played a minor role in artifact classification. As pointed out by Lynott (1975:122), these studies, by themselves, are insufficient for serving as models for the function of prehistoric tools because they are based on modern ideas of tool efficiency.

Ethnographic research has suggested that the morphological attributes of size, edge angle, and mass can play a critical role when objects are selected for particular tasks. Gould's (1971; Gould et al. 1971) research among the aborigines in Australia, and White's (1969) research in New Guinea are examples of this approach. Both studies have shown that overall shape does not play a significant role in tool usage. Rather, the criteria of edge angle and object size were used to differentiate between those flakes suitable for cutting activities, those for adzing-scraping tasks, and those for hafting and use in both sets of activities.

The final method of obtaining data on object function is the systematic recording of use-wear traces on artifact edges, points and surfaces (e.g., Semenov 1964; Sonnenfeld 1962; Tringham et al. 1974). With this analysis has come the realization that the same tool can be used for more than one task (cf. Dunnell 1978; Knudson 1973). Thus, the number of tools within an assemblage can actually exceed the number of objects. The identification of use-wear traces, from Semenov onward, is based on replicative experiments.

The analysis of utilization damage or use-wear has become the dominant theme in functional analysis. Research by Church (1987); Fuller (1981), Hayden (1979), Hester and Heizer (1973), Keeley (1980), Keeley and Newcomer (1977), Lawrence (1979), Moss (1983), Odell (1977, 1980, 1981), Odell and Vereecken (1980), Sabo (1982), Siegel (1984, 1985), Thompson (1978), Tringham et al. (1974), Vaughn (1985), Wylie (1975), and Yerkes (1986, 1987) represent just a few examples of this approach.

Within use-wear analysis, two different scales of identification can be discerned. The first is termed low-power or "macrowear analysis" and uses reflected light and a stereomicroscope with a magnification range of 5x to 70x to identify and assess damage on artifacts (cf. Ahler 1982; Church 1987; Odell 1977, 1981; Odell and Vereecken 1980; Tringham et al. 1974). The second method, termed high-power or incident light "microwear analysis" (Keeley 1980), is a procedure for detecting different types of striations and polishes on artifact surfaces, at magnifications greater than 200x (cf. Moss 1983; Vaughan 1985; Yerkes 1987).

### *The Role of Functional Analysis in Archaeology*

This section will illustrate how use-wear or functional analysis has been employed in advancing archaeological research by grouping examples of functional analysis into categories of research. The categories to be examined are 1) reconstruction of prehistoric activities or site function, and 2) the study of functional variation within and between components at the same site.

The reconstruction of prehistoric activities and/or site function(s) has become the central type of functional analysis. As noted by Parsons (1972:146), "the ability to infer the function of artifacts and artifact classes of all kinds, tools, structures, sites, is perhaps the most fundamental problem with settlement pattern archaeology." And since the function of a site is inferred from an

analysis of the artifacts, functional analysis represents a technique for determining which activities took place at a site. Studies by Odell (1977), Pope (1986), Vaughan (1985), and Yerkes (1983, 1987) will serve as examples.

Odell's (1977) research consisted of the analysis of over 7,000 retouched and unretouched lithic artifacts from Bergumermeer, a Dutch Mesolithic site. The basis of Odell's research was a series of replicative experiments, which would be used for comparison with archaeological examples. Using low-power magnification, Odell was able to identify six functional groups which displayed little internal clustering, but all artifacts were found to aggregate into three distinct clusters, which corresponded with evidence of three structures. Use-wear data from the six functional groups suggested that a vast array of activities were performed by the occupants of each structure, especially hunting, wood working, meat and plant cutting, and hide preparation. Combining these data with site size, site structure, dwelling floor area, population estimates, and faunal remains, Odell concluded that the site served as a large, seasonal base camp, reoccupied most likely in the fall and early winter for a period of perhaps seven years.

Vaughan's (1985) study consisted of analyzing 532 retouched and unretouched artifacts from a lower Magdalenian assemblage excavated from Cassegras Cave in southwestern France. Like Odell, Vaughan conducted a series of experiments to develop a body of experimental use-wear data for comparison with archaeological specimens. High-power analysis of the artifact assemblage revealed that 38 percent of the tools (n=158) exhibited evidence of polish, with 283 discrete activities being represented on the used edges. About 60 percent of the used edges had traces of dry hide polish. The preparation of fresh hide and the working of wood, bone, and antler were also represented. Vaughan believed that the wood, antler, and bone polishes were formed from the manufacture of tools to be used in the preparation of hides. Vaughan concluded that the functional and spatial data on the isolated tool classes suggested that the primary activity carried out at the site was preparing hides for transformation into clothing and/or shelters.

The final examples of identifying activities at prehistoric sites are Yerkes' (1987) research at the Labras Lake site in Illinois, and research on microdrills and shell bead making during the Mississippian Period (Pope 1986; Yerkes 1986). Excavation at the Labras Lake site revealed Archaic, Woodland, and Mississippian occupations, which provided Yerkes with the opportunity to study changing subsistence and site function. Two principal research questions were identified: 1) What activities occurred at the site during each period of occupation, in relation to the available flora and fauna resources, and 2) were those activities of each group different, or were they the same for the entire c 3,000 years that the site was used? An incident light high-power analysis of over 1,000 artifacts, selected from pit features and structure deposits, was completed.

Yerkes' analysis indicated that new types of tools were added to the tool inventory during each successive period, as groups expanded their subsistence base. Yerkes also found no evidence of specialized food production for any of the periods. Specific results were 1) the lack of plant knives during the Late Archaic, 2) the presence of plant knives during the Late Woodland and Mississippian, 3) the presence of ground stone celts, stone hoes, and shell drilling during the Mississippian, and 4) the presence of bone/antler, hide and wood working tools in all periods. Hence, several site activities cross-cut all three periods, while others, such as the plant knives and shell bead drills, were found to be diagnostic in only one or two periods.

Yerkes' (1983, 1986) and Pope's (1986) studies of microlithic tools and shell bead manufacture during the Mississippian period serve as two final examples of identifying site activities—in this instance, craft activities. Yerkes' sample consisted of microcores, microblades, and microdrills from Cahokia and the American Bottom area in Illinois; Pope's data consisted of microlithic tools, reworked triangular "arrow points" and unifacially and bifacially retouched pieces from the Moundville area in Alabama. High-power (incident-light) magnification (50x-500x) was used to analyze the tools.

Analyses by Yerkes and Pope disclosed that several microtools were used to drill shell, but a few other tools were used to work wood, bone, and antler. Both authors concluded that the distribution of shell drills suggests that they were made and used at a variety of site types. The frequency of microtools, however, is variable. Hence, no conclusive evidence of "full-time" shell bead specialists for the Mississippian period could be demonstrated with the data analyzed by Pope and Yerkes. Rather, the evidence suggests that shell bead drilling was probably a part-time household specialization at some Mississippian sites during some time periods.

The last category of functional research to be discussed is synonymous with the research aims of this report; namely, the examination of intrasite variation in household activities. The example to be used is Yerkes' (1985) analysis of the Mississippian component at the Labras Lake site. The distribution of 165 features and eight structures at the site formed four different clusters: a central cluster of five structures, and three surrounding clusters each containing one structure. Yerkes' objective was to ascertain 1) what relationship(s) existed between the structures, and 2) what, if any, was the functional nature of the site structure; i.e., were the structures used differently. Ceramic and lithic refits were confined to the central cluster (only one lithic refit could be established between the central cluster and one of the outlying structures). Still, the homogeneity of the ceramic assemblage and the radiocarbon dates suggest a single component site. The number of features per house, feature shape, feature volume, ceramic vessel morphology, structural dimensions, and the minimum number of vessels (MNV) were tabulated in order to disclose any variation. These measures suggested that the central cluster was somewhat different from the outlying household units. Yet, no functional variation could be inferred from these data.

A microwear analysis of tools from the six household unit assemblages (Yerkes 1985) was then used to detect activity differences that might explain the distribution of the structures and how each was used. Microwear traces disclosed that tools used to cut meat, scrape hide, and work bone, antler, and wood were found in all six assemblages, although the actual number of tools used for each activity may not be a true reflection of the importance of that task. For instance, some activities such as the working of hard materials, may require a higher frequency of tools due to dulling and/or breakage. Shell drills and plant knives, however, were only found in the central cluster. With these data Yerkes suggested that 1) some sort of differential usage of structural space existed at the site, and 2) it appeared to be focused in the central cluster of structures, where the largest house was located along with the greatest storage volume and most of the "exotic goods" (see Lightfoot and Feinman 1982).

Use-wear analysis, however, does have its critics, especially Dunnell (1978), who finds fault with the replication of use-wear on tools which are then used to interpret archaeological specimens. Odell (1982), in a review article of functional analysis, has addressed Dunnell's criticism. Odell states: "...who cares if sites A and B share 13 wear types if we have no idea what those types represent" (1982:27). Odell's comment refers to functional analyses, such as those by Fuller (1981) and Thompson (1978) who devise functional classes or types which are then compared across a group of sites scattered across the environment. Comparison of the functional types results in the identification of different types of archaeological assemblages which can then be used to define different settlement or site types.

### *Summary*

The intent of this review has been twofold: 1) to review how artifact function has been determined, and 2) to provide some examples of functional analysis in the archaeological investigation of site function and settlement analysis. The study of archaeological site function is the most prevalent form of use-wear analysis. The formulation of settlement system models, however, requires large data sets from well-excavated, contemporaneous sites occupied by the same society.

Within the analysis of settlement systems, studies of intrasite variation such as Odell's (1985) and Yerkes' (1985, 1986, 1987) are especially scarce (cf. Ford 1977). As will be shown in this study, the analysis of household units possesses the greatest potential for developing models of social organization which cannot be achieved at coarser scales of research.

## SAMPLES

### *Description of Terms*

Before proceeding with the discussion of the use-wear analysis, it is necessary to define my usage of the terms "retouch" and "utilized" as they will be used in this context. Edge retouch, according to Chapman and Schutt (1977:378), refers to "...removal or detachment of small pieces of debitage from a portion of the perimeter of a given piece of debitage. Retouch modification of an edge can be observed as a series of small flake scars originating from the edge or perimeter and extending over part of either surface." All of the retouch observed on examined specimens would qualify as marginal retouch because the flake scars are small and extend 1-3 mm on either surface and occur in only one direction.

Retouching serves at least three important tasks: 1) strengthening or thickening an otherwise thin or sinuous edge, 2) creating an obtuse or an oblique working angle for facilitating certain types of tool "actions," and 3) for backing and edge. Backing refers to the intentional blunting of a portion of an artifact's edge or perimeter directly opposite an utilized edge, to facilitate "the use of manual force through the utilized edge without causing personal injury" (Chapman and Schutt 1977:92).

Utilized refers to damage caused to the unmodified edge or perimeter of a flake resulting from actions such as cutting, scraping, and sawing. Whereas retouch scars tend to be systematically applied to the edge of a flake and tend to exhibit a uniform size and orientation, the patterning of flake scars obtained from an action, such as sawing, vary in size, shape, orientation, and placement along the edge, and tend to occur on both surfaces. Under magnification, utilized edges also exhibit edge rounding and abrasion.

### *Sample Characteristics*

The percentages of the different artifact classes recovered from Late Woodland contexts at the site are given in Table 235. Using the screening criteria, a total of 206 lithic items (0.75% of the recovered lithic assemblage) were selected by GAI Consultants, Inc. archaeologists for microwear analysis. These represented artifacts from at least three successive Clemson Island components, and a Stewart phase Shenks Ferry component. Of these items, 37.86 percent (n=78; 68 flakes and 10 bifaces) exhibited traces of polish and other use-wear traces (Table 236). An aggregate list of specific activities or tool "actions" from all sampled components is shown in Table 237. Because a tool can be employed in more than one action, the number of actions can actually exceed the number of actual items; i.e., a tool could be used for both butchering and for cutting hide.

A diagram of selected tools, indicating the location of use-wear and the direction of the action, is presented in Figure 121. Photographs of the edges of these same artifacts, showing the polishes or microwear, are provided in Appendix F. The specific location along the edge or perimeter of each flake shown in the photograph is also indicated in Figure 121.

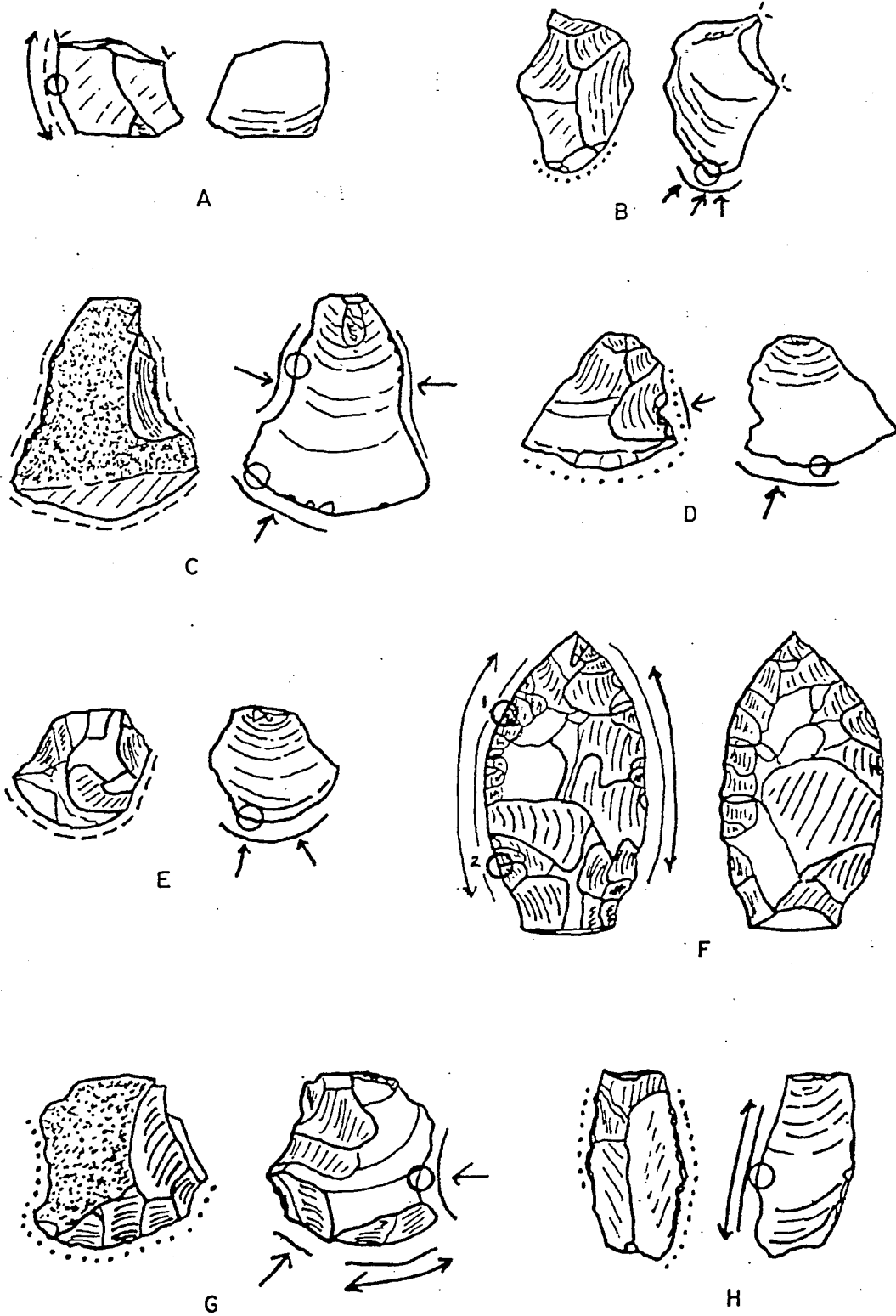

FIGURE 121

SELECTED ARTIFACTS SHOWING AREAS WITH USE-WEAR, DIRECTION OF TOOL MOTION, AND THE AREA(S) ON EACH TOOL THAT WAS PHOTOGRAPHED



Table 235. Chipped Stone Tools from Late Woodland Features.

Artifact Class	Count	Subgroup Percentage	Percentage
Debitage Size Grades	26,845		98.82
1	19	0.07	
2	542	2.02	
3	5,040	18.77	
4	21,244	79.14	
Cores	28		0.10
Bifaces	109	75.23	0.40
	(83 analyzed)		
Unifaces	30	6.66	0.11
	(2 analyzed)		
Retouched	45		0.16
Unretouched	69		0.25
Drills	3		0.01
Bladelets	2		0.01
	(0 analyzed)		
	27,166		99.92

Table 236. Percentage of Used Lithic Items from Late Woodland Features.

Artifact Class	Used	Unused	Total	% Used
Bifaces	8	5	83	9.63
Retouched	29	16	45	64.44
Unretouched	39	30	69	56.52
Drills	2	1	3	66.66
Unifaces	0	2	2	0.00

Table 237. Summary of Tool Actions for Late Woodland Features.

Tool Actions	Bifaces	Drills	Retouched	Unretouched
Butchering	2		2	
Hide working	2		8	11
Wood working			3	11
Bone/Antler Working	1	1	4	5
Soft material	2		4	3
Medium material	1		1	1
Hard material		3	2	
Indeterminate	1	1	4	4
Number of Tools:	78			
Number of Actions:	81			

### Clemson Island Use-Wear Analysis

Three time-successive, Clemson Island occupations have been identified at the site. These have been separated into early, middle, and late components. Twelve of the 15 features containing artifacts with use-wear are associated with these early (n=6), middle (n=2), and late (n=4) components, as shown in Table 238.

Eighty-three (76.15%) of 109 recovered bifaces were chosen for microwear analysis. The remaining 26 specimens (23.85) were analyzed using low-power microscopy (Odell 1980; Odell and Vereecken 1980; Tringham et al. 1974). The 83 bifaces chosen for microwear analysis consist of complete items, basal portions, medial sections, and tips. No evidence of use-wear was found on any of the tip and basal fragments, but wear was present on some medial sections. Similarly, use-wear on complete or nearly complete bifaces, when present, was primarily confined to the medial portions.

Table 238. Tool Actions Associated with Clemson Island Components

Tool Function	Early						Middle		Late			
	26	51	55	57	63	112	78	84	29	52	80	106
Butchering	1	-	1	-	1	-	1	1	1	-	2	-
Hide Working	-	4	6	2	1	-	2	-	-	2	-	3
Wood Working	-	1	1	-	6	-	4	-	2	1	-	-
Bone/Antler Working	-	-	1	-	2	1	1	-	-	-	-	-
Soft Texture	-	1	-	-	2	-	-	-	1	1	2	-
Medium Texture	-	-	1	-	-	-	-	-	-	-	-	-
Hard Texture	-	2	1	-	1	-	-	-	-	-	1	-
Indeterminate	-	1	1	1	2	-	2	-	1	-	2	1
Total	1	10	13	3	15	1	10	1	5	4	7	4

Broken or fragmentary bifaces exhibiting use-wear in the form of polish and/or edge damage (n=7), were thick in cross-section, and some fragments were characterized by having more than a single break. Biface thickness (w/t ratio) and the large number of oblique and transverse fractures suggests that the specimens were not finished tools and broke during the manufacturing process. Once broken, portions of the biface were recycled and used as cutting and scraping tools.

The complete bifaces with microwear (n=3) were used in cutting soft materials such as plant, or meat, or treated hide. None of the bifaces were used for working any type of wood or plant.

The greatest diversity of use-wear and polishes was observed on the retouched and unretouched flakes (Table 238). Several of the flakes with retouch were broken, and their approximate dimensions, especially length, could not be determined. Whether the flakes broke during usage or after discarding also could not be determined. A total of 111 flakes was examined for microwear.

Using the dimension of size, all 111 flake and flake fragments would have been captured within size grades 1 (2.54 cm) and 2 (1.27 cm). In fact, over 90 percent of the unretouched debitage was captured in size grade 1. No complete retouched or unretouched flakes smaller than 1.27 cm were found within the sample. This size bias seems to be intentional and has been found at Late Woodland and Late Prehistoric sites in the Midwest (Yerkes 1987), and the Ohio Valley (Cowan et al. 1990; Nass 1987) where debitage < 1.5 cm was almost never used in domestic activities.

Since retouched and unretouched or utilized flakes are expedient and expendable types of tools, their selection is motivated by the need to complete specific daily activities. Consequently, shape, size and edge angle should figure prominently in the selection process. In addition, retouched and utilized flakes, because they are expedient tools, should be plentiful at sites since their curation rate should be minimal.

Of the two types of debitage, the unretouched flakes seem to manifest the most variation in these three variables. Some of this variation results from the processes creating the debitage, such as core reduction and tool manufacture. Core size also plays a role in the shape and size of the debitage.

Examination of the debitage indicates that cortical, primary and thinning flakes are represented within both the retouched and unretouched debitage classes. Again, this observation fits well with Late Woodland data from the central Ohio Valley (Church 1991; Nass 1990).

In order to ascertain whether there was a bias or preference for using a specific debitage tool class for an activity, items in each tool class were tabulated according to tool action (see Table 237). These data indicate that unretouched debitage exhibits the most use-wear.

#### *Distribution of Artifacts with Use-Wear*

All of the debitage and bifaces exhibiting use-wear were recovered from 12 (43%) of the 28 refuse-filled Late Woodland features (Figure 124). When these are plotted using colors, the ECI component displays two pit clusters, the MCI component a single cluster, and the LCI component one and possibly two clusters. There is overlap between the clusters, but the MCI component displays the tightest spatial arrangement of features.

Table 239 is an expansion of Table 238 so that specific activities within each activity class (i.e., hide-working) can be assessed within each component. The middle Clemson Island occupation is represented by at least five features, two of which contained artifacts with use-wear (Figure 122). Although only ten artifacts manifest use-wear traces, the range of actions is similar to those of the other two components.

Table 239. Microwear Summary of Actions for Clemson Island Artifacts.

Tool Function	Early						Middle		Late			
	26	51	55	57	63	112	78	84	29	52	80	106
Meat Knife	1	-	1	1	-	-	1	1	1	-	2	-
Hide Knife	-	1	2	1	-	-	2	-	-	1	1	2
Hide Scraper	-	3	4	1	1	-	-	-	-	1	1	1
Wood Saw	-	1	1	-	3	-	-	-	1	-	-	-
Wood Scraper	-	-	-	-	2	-	3	-	1	-	-	-
Wood Whittling	-	-	-	-	1	-	1	-	1	-	-	-
Bone/Antler Saw	-	-	-	-	1	-	-	-	-	-	-	-
Bone/Antler Scraper	-	-	1	-	1	-	1	-	-	2	-	-
Bone/Antler Whittling	-	-	-	-	-	-	-	-	1	1	-	-
Bone/Antler Drilling	-	-	-	-	1	-	-	-	-	-	-	-
Bone/Antler Wedging	-	-	-	-	-	-	-	-	2	-	-	-
Soft Texture	-	1	-	-	2	-	-	-	1	1	2	-
Medium Texture	-	1	-	-	-	-	-	-	-	-	-	-
Hard Texture	-	2	1	-	1	-	-	-	-	-	1	-
Indeterminate	-	1	1	1	2	-	2	-	1	-	2	1
Total	1	10	13	3	15	1	10	1	5	4	7	4

By far, the early and the late Clemson Island components are best represented within the use-wear data. Each component's activity structure is basically the same, and the activities suggest a domestic type of context (see Nass 1987, 1989 and Yerkes 1987). The cluster of radiocarbon dates also suggests that a more permanent occupation is represented.

Of the 12 refuse-filled features containing tools with use-wear, three contained only a single tool, while two each contained 12 tools. Except for Feature 29, two or more of the artifact classes were recovered from the remaining seven features. Microscopic examination indicated that the eight utilized flakes from Feature 29 were employed in an array of activities (see Tables 238 and 239).

When the distribution of features containing artifacts with use-wear are compared according to activity class (i.e., antler/bone working), there are no discrete clusters, suggesting that a specific portion of the site was reserved for butchering, hide working, etc. Although tool kits might be more amenable to activity area analysis, the clustering of use-wear types should also be expected if the modification of such items as antler, bone, hide each requires its own tool kit.

### *Summary of Microwear Analysis*

As summarized in the first part of this section, use-wear analysis, especially microwear, has the potential for identifying the true range of activities performed at a site or its activity structure (Nass 1987:6). The "activity structure" concept was found to be a useful analytical device for evaluating use-wear data because it refers to the aggregate of social, domestic, and religious activities carried out at a site. These data can therefore strengthen any argument about the function of a site and its placement within a settlement system.

Because it has not been possible to identify precise household units and clusters as defined by Flannery (1976, 1981), the present discussion will be limited to the components. Given this limitation, what can be said about the "activity structure" of the three occupations? Comments will be limited to two topics: 1) the range of lithic items examined, and 2) component function and the activity structure.

The range of lithic items examined consisted of bifaces, unifaces, and debitage. Within the biface tool class, few complete items were available for examination and of these, only three exhibited evidence of use-wear. One of the bifaces exhibited heavy resharpening, and was most likely a knife. The remaining two complete bifaces also manifested polish and microscarring characteristic of cutting/butchering, and were probably hafted and used as knives, as well.

Noticeably absent were formally shaped end and side scrapers, given the extensiveness of the excavation at the Memorial Park site. Instead, retouched and utilized flakes seem to have been the preferred tools for scraping activities. Those few bifaces that appear to have functioned as side-scraping tools represent technological failures that were apparently recycled for domestic tasks, such as processing hides. These same occurrences have also been documented at the St. Anthony site (Stewart 1988), and at the Fisher Farm site (Hatch 1980).

No bifaces were identified as having evidence of impact fractures or breaks that would suggest their usage as projectile points. The small number of probable projectile points would suggest that they were a highly curated tool form.

Neither of the two morphologically-typed unifaces exhibited any evidence of use-wear. The absence of polish and microscarring suggests that these hypothesized tools were discarded without being used, or else they represented an intermediate stage in a reduction sequence and were never finished.

GAI CONSULTANTS, INC. DWN. REM APPROVED JPH DWG. NO. 89-412-M2

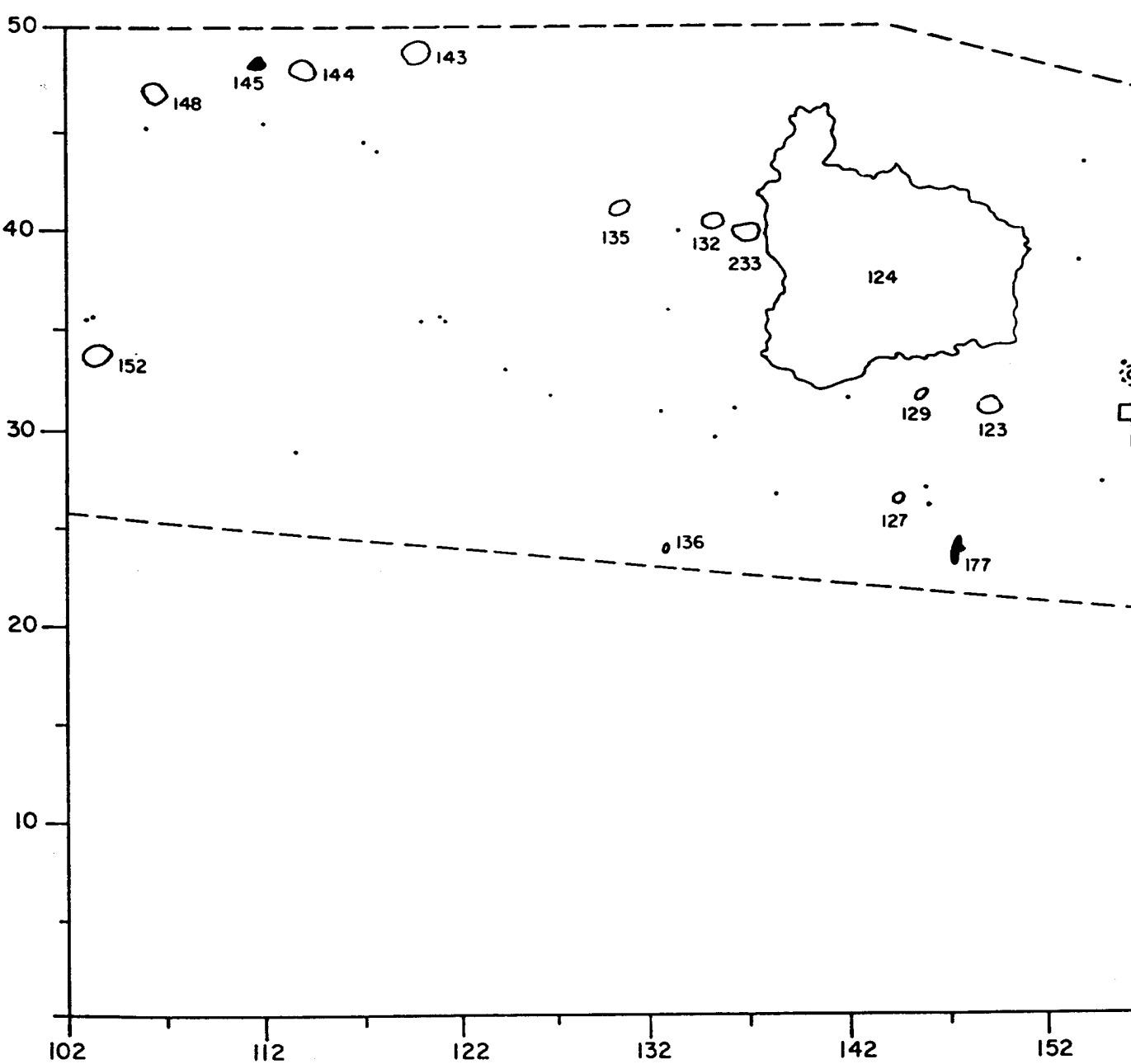

KEY

- POSTMOLD
- ⋯ S2 - STRUCTURE (2)
- 13 ○ - FEATURE (13)
- - PHASE 2 TEST PIT

FEATURES CONTA  
ARTIFACTS W/USE-1

2

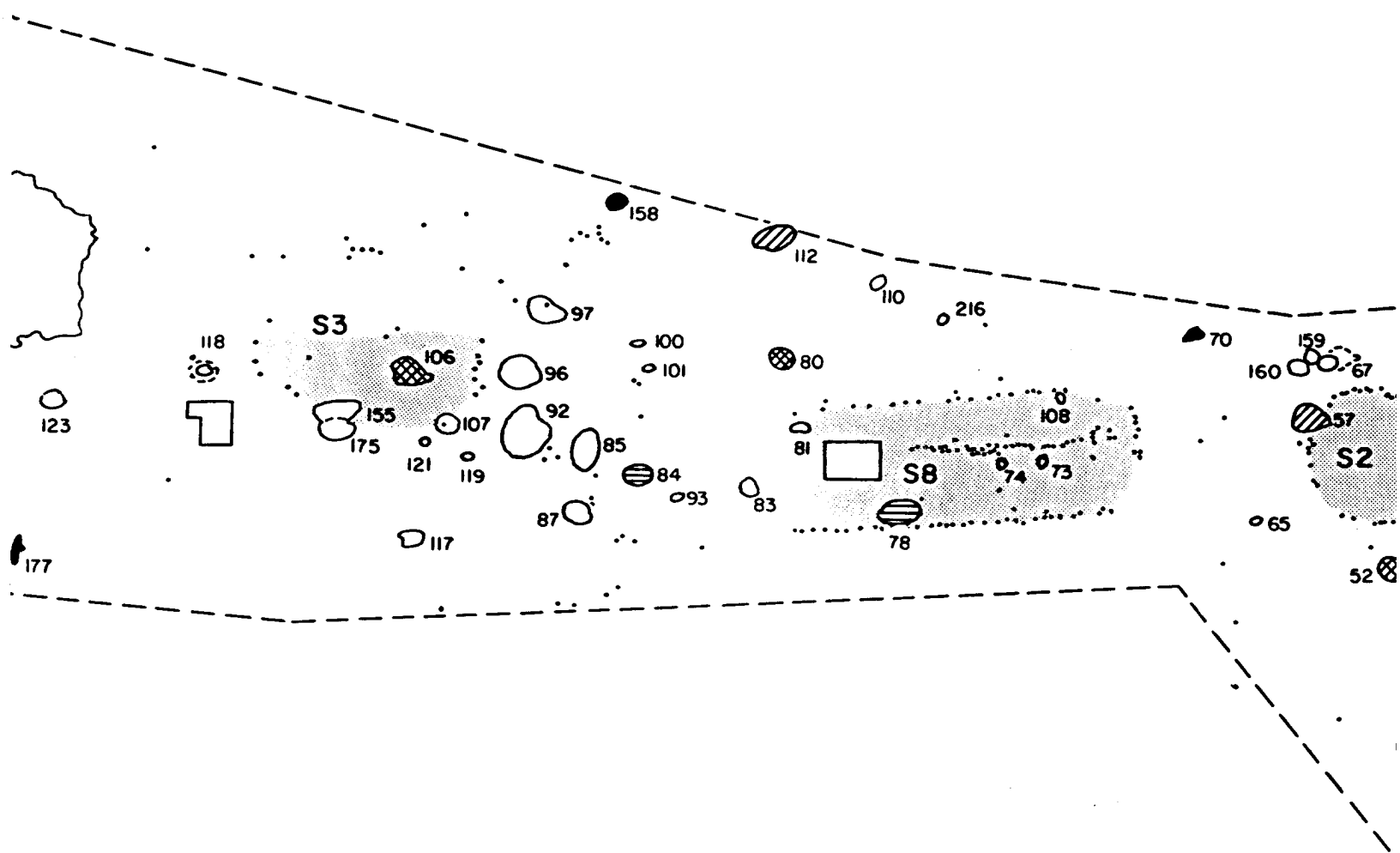

152 162 172 182 192 202 212

FEATURES CONTAINING FACTS W/USE-WEAR

- EARLY CLEMSON ISLAND (A.D. 760-830)
- MIDDLE CLEMSON ISLAND (A.D. 920-930)
- LATE CLEMSON ISLAND (A.D. 1050-1090)
- STEWART PHASE (A.D. 1290-1385)
- UNASSIGNED LATE WOODLAND

3

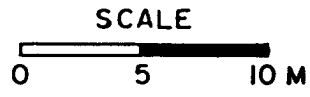
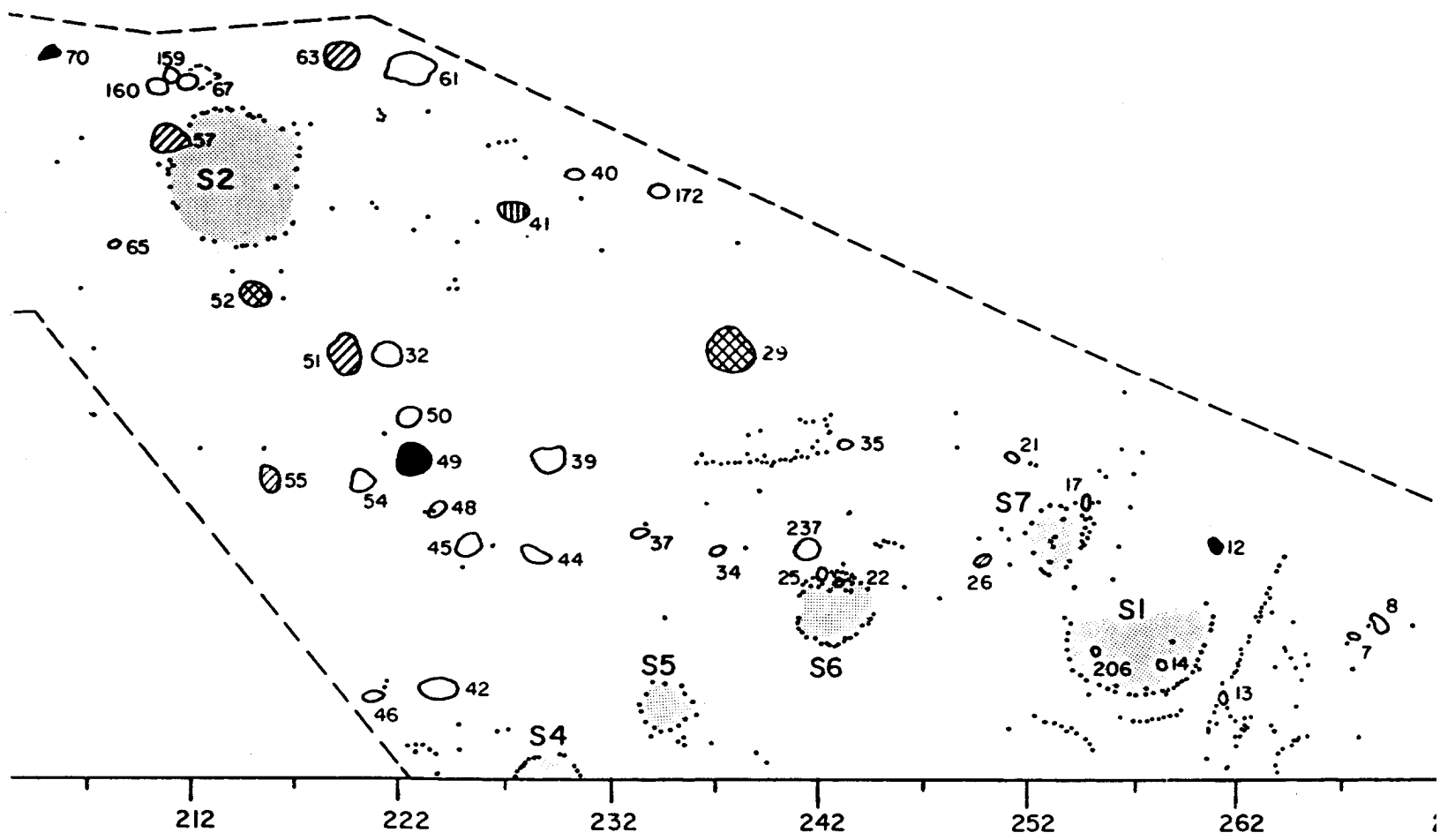

DISTR  
CONTAINING

4

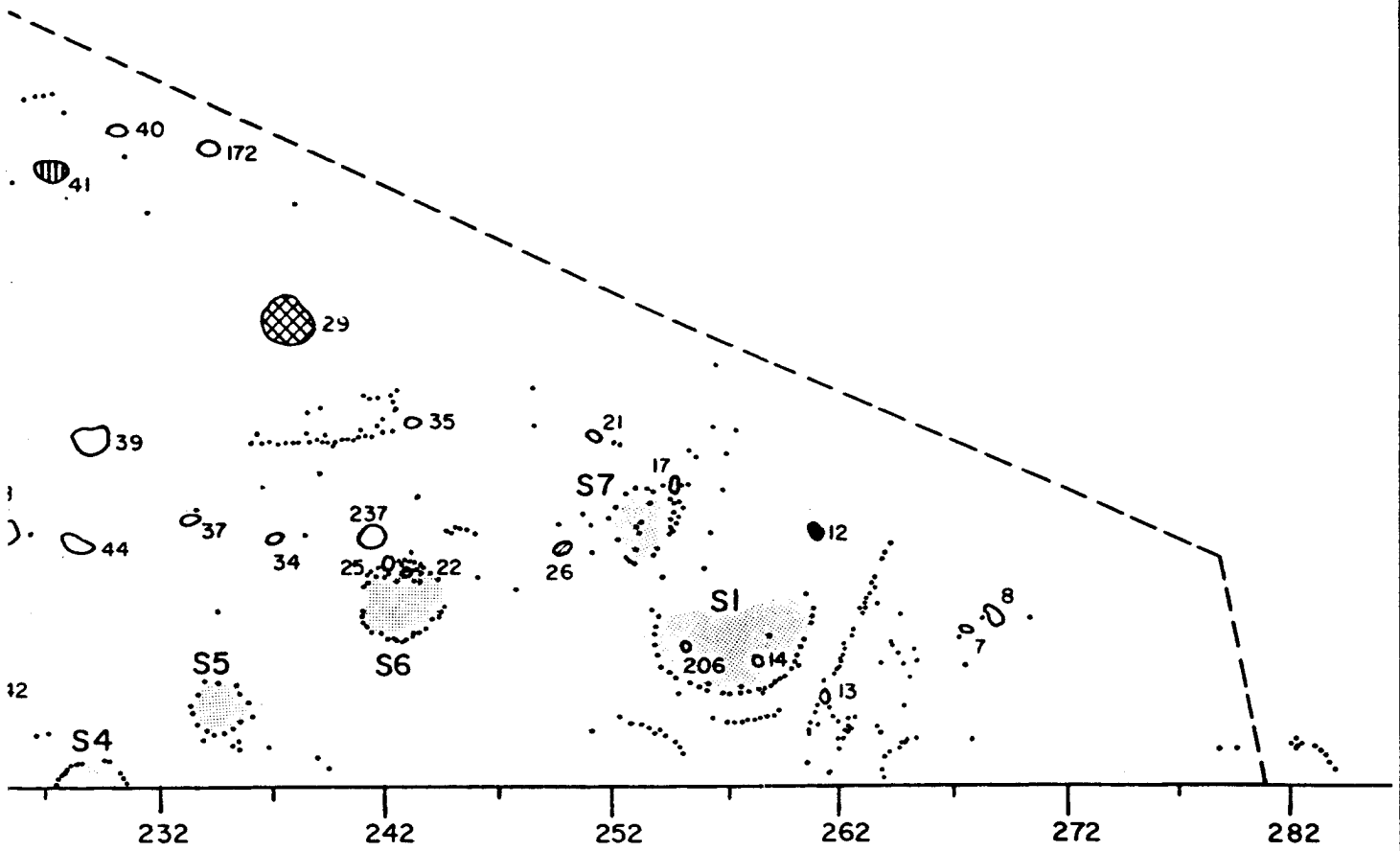

SCALE

5 10 M

FIGURE 122

DISTRIBUTION OF FEATURES  
CONTAINING ARTIFACTS W/USE-WEAR



Debitage from the Memorial Park site consisted predominantly of blue/black to black chert. Cortical, primary, and thinning flakes were either retouched or stylized with no modification. The large number of retouched and utilized flakes, in contrast to formally shaped tools, suggests that flake production, and presumably flake cores, were important activities. This impression has also been expressed about the assemblages at Fisher Farm, St. Anthony, and site 36CN102 (Hay and Hamilton 1984). These same observations have also been described for Late Woodland sites in the Central Ohio Valley.

The corpus of use-wear data from the Memorial Park site provides insights into the activity structure of the site. Since three components have been successfully identified using pottery attributes, radiocarbon dates, and diagnostic artifacts, the following discussion will proceed by examining each component, and then the site, in a general sense.

The early component exhibits the widest spatial distribution across the site. Features contained several artifacts with polish and/or microscarring. Activity-wise, a broad range of domestic and/or maintenance activities was identified. The action least represented is bone/antler working. Taken together, the activity structure suggests that a habitation site is represented. However, the duration of the occupation, as well as season(s), cannot be posited on the basis of either use-wear data or radiocarbon dates.

The middle component is represented by a tight feature cluster, and ten artifacts with use-wear. Although the number of tools is small, a broad range of actions is represented, again suggesting a domestic occupation as opposed to a specialized resource extraction camp.

The late Clemson Island component is distributed over the entire stripped portion of the site. While the sample of stone tools with use-wear is larger than the middle component, it is still smaller than the early component.

Finally, what does a comparison of the activity structure profiles of the components tell us about Clemson Island society? Firstly, the profiles indicate occupations that were identical in purpose. That is, the site occupations were similar if not identical, even with the separation in time by roughly 100 years. While it is not possible to state unequivocally that the same group or its descendants were responsible for the later occupation, the reoccupation of Monongahela, Fort Ancient, and Iroquois village sites during the same phase is well documented (Church 1987; Johnson et al. 1989; Nass 1987).

Second, if the distribution of features and structures and the spatial extent of the site are considered, each occupation represents a "small habitation site" containing one or more household units. The author has purposefully refrained from using the term "hamlet" because of its poor definition by archaeologists north of Mexico (see Pacheco 1989). While its usage might be appropriate for Mississippian and Mesoamerican cultures which have recognized site hierarchies and political economies, its application to other eastern Woodland cultures which qualify as tribal entities is, at best, spurious.

In summary, until large portions of other Clemson Island sites have been exposed, the full range of settlement or site types will continue to be an issue for debate. Suffice to say that if Clemson Island, as currently defined, does not continue beyond A.D. 1200 + years, then nucleated sites (see Fuller 1981 for a definition of nucleated) evincing a circular or zonal arrangement of activity areas may not be present.

### *Stewart Phase Component*

In addition to the Clemson Island component, at least 12 features contained diagnostic artifacts associated with the Stewart phase (Figure 122). Three uncorrected radiocarbon assays place the occupation between A.D. 1290 and 1385. Only a single retouched flake was found to exhibit use-wear (Table 240). The presence of only a single lithic item with use-wear is puzzling. Since Shenks Ferry populations were agriculturists, Stewart Phase households are believed to have spent at least multiple seasons at the same location. The dispersed nature of the features, however, could suggest that the site was used as a resource extraction camp as they exploited the marshy areas around the point bar. Whatever their reason(s) for occupying the site, it is not documented by use-wear.

Table 240. Microwear Summary for Stewart Phase and Unassigned Late Woodland Features.

Tool Function	Stewart Phase	Unassigned Features	
	41	12	49
Hide Scraper	1	-	-
Wood Scraper	-	-	-
Bone/Antler Scraping	-	-	-
Indeterminate	-	-	1
Total	1	1	2

### *Unassigned Features*

Two features (Table 240) containing artifacts with use-wear could not be assigned to any of the known temporal components identified at the site (Figure 122).

### *Archaic Component Use-Wear Analysis*

A random sample of 72 lithic artifacts was chosen for microwear analysis. An inventory of tool classes in this sample is presented in Table 241. The artifacts all were chosen from Archaic components. Seventy percent of the sample consists of complete and broken, or fragmentary, bifaces. Debitage, cores, and tools make up the remainder of the sample. Drawings were made of all used artifacts and photographs were obtained for two lithic tools with microwear (see Appendix F).

Table 241. Lithics Artifacts from all Archaic Period Components.

Artifact Class	Count	Subgroup Percentage	Percentage
Bifaces	51		70.83
Whole	12	23.53	
Broken	39	76.47	
Retouched	9		12.50
Unretouched	9		12.50
Cores	2		2.78
Tools	1		1.39
Total	72		100.00

Of the 51 bifaces, 39 (76.47%) are broken and 13 (23.53%) are complete. Most of the broken items consist of basal medial, and tip fragments, and probably represent technological failures. The remaining items consist of bifaces and possibly projectile points/knives. Only four bifaces (two complete and two broken specimens) exhibited wear (Table 242). One biface was used for scraping both hide and antler bone. Twenty specimens of debitage were also examined, and five items, three retouched and two utilized flakes, exhibited use-wear (Table 242).

Table 242. Frequency of Artifact Types with Use-wear.<sup>a</sup>

Artifact Class	Count	Percentage
Used Bifaces	3	5.55
Used Retouched Flakes	3	33.33
Utilized Flakes	2	18.18

<sup>a</sup>10.39% of examined lithic tools exhibited use wear.

Tables 243 through 245 present the distribution of lithic tools with use-wear among the Archaic components. The Terminal Archaic and late Laurentian artifacts exhibit the most use-wear. However, this observation may be misleading, since these components were the best sampled (see Table 243).

Table 243. Component Distribution of Examined Tools.

Culture/Period	Count	Percentage
Orient	17	23.6
Canfield/Susquehanna	9	12.5
Piedmont	2	2.8
Late Laurentian	16	22.2
Early Laurentian	27	37.5
Neville	1	1.4
Total	71	100.0

Table 244. Microwear Summary of Actions for Archaic Components

Tool Action	Component	Count
Hide Working	Orient	2
	Late Laurentian	1
Bone/Antler Working	Late Laurentian	2
	Early Laurentian	2
Soft Texture	Orient	1
	Piedmont	1
Hard Texture	Early Laurentian	1

Table 245. Archaic Period Microwear According to Tool Class

Tool Class	Bifaces <sup>a</sup>	Retouched	Utilized
Hide Working	1	1	1
Bone/Antler Working	2	1	1
Soft Texture	1		
Hard Texture		1	1

## XI. COBBLE TOOLS, GROUND AND PECKED STONE TOOLS, AND STEATITE

by

John P. Hart, Ph.D.

Analysis of cobble tools and ground and pecked stone tools was focused on description of form attributes. Attributes recorded for these tools include metric data (length, width, thickness, and weight); raw material type; number of prepared surfaces; type and extent of surface modification/preparation (e.g., abrading, pecking, grinding); presence or absence, dimensions, extent and location of pitting, grooving, or drilling; presence or absence and location of breakage; presence or absence of worked edges; edge configuration; and, presence or absence of hafting elements. Results of this analysis are presented below in general descriptive categories by occupational periods.

### LATE WOODLAND

A total of 29 pieces of cobble, ground and pecked tools, weighing 19,019.3 g, was recovered from Clemson Island features exposed during Task 1 investigations and subsequent block excavations.

#### *Hafted Implements*

Four hafted implements were recovered from Clemson Island features. Three of these are hoe-like implements, which were recovered from features 29, 51, and 233 (Figure 123). The implement from late Clemson Island Feature 29 represents a longitudinally split sandstone cobble. All edges of this piece have been modified through flaking of the dorsal side. Flaking of the lateral edges resulted in two opposing notches above the midpoint, apparently for hafting. The distal end of the implement, presumably the used end, is beveled through unifacial flaking on the dorsal side. The proximal end of the piece has also been modified through flaking, presumably to aid hafting. This implement is 20 cm long; it ranges in width from 2.5 to 8.4 cm, and weighs 538.6 g.

The second hoe-like implement, from early Clemson Island Feature 51, is a tear-shaped sandstone cobble, whose edges have been modified through bifacial and unifacial flaking. The distal end of this piece has been modified through unifacial flaking. Two opposing notches were formed through bifacial flaking of the lateral edges above the midpoint of the tool, presumably for hafting. The lateral edges above the notches have been modified through bifacial flaking, presumably to aid in hafting the tool. This implement is 19 cm long; it ranges in width from 3.15 to 10.6 cm, and weighs 6471.4 g.

The third hoe-like implement from Stewart phase Feature 233 consists of a modified sandstone slab whose edges have been modified through a combination of bifacial flaking and battering. This is the largest of the three implements, measuring 22.7 cm long by 10.5 cm wide, and weighs 1352.5 g. The distal end of the piece was originally shaped through bifacial flaking, and was subsequently modified, through use, to almost a rounded state. The proximal end was shaped through bifacial flaking. One lateral edge was modified through bifacial flaking, while the second lateral edge maintains the flat surface of the original slab. Opposing bifacially flaked notches, presumably for hafting, exhibit a great deal of wear. The planar surfaces are unmodified.

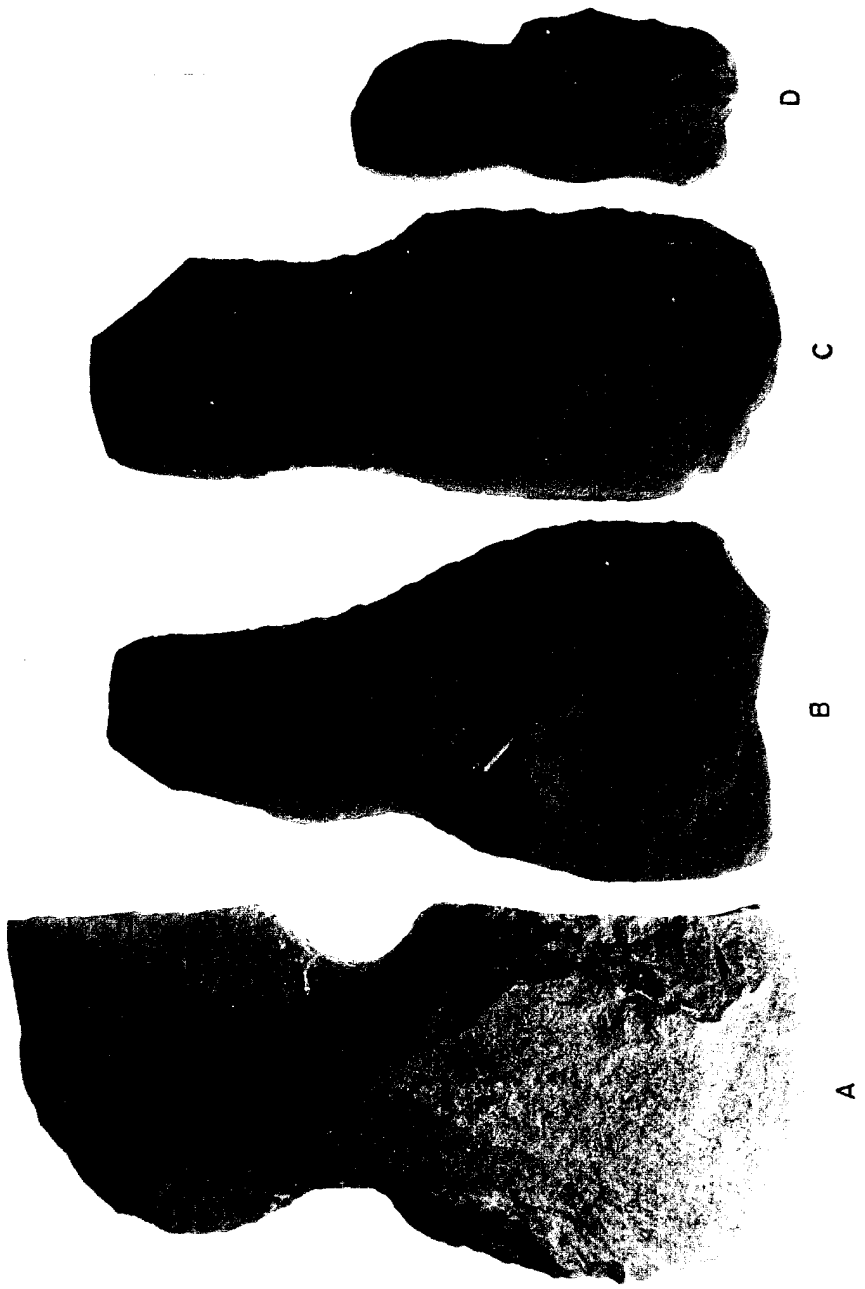

FIGURE 123

PHOTOGRAPHS OF LATE WOODLAND HAFTED IMPLEMENTS



KEY

A, B & C - HOE-LIKE  
 D - OTHER

The fourth hafted implement is a ground-and-flaked sandstone cobble. The presumed hafting end of the piece is, on average, one cm narrower than the opposite end. Distinct shoulders separate the two halves of the piece. The proximal end and one lateral edge have been modified through a combination of bifacial flaking and grinding, while the other lateral edge has been ground flat. The distal end has evidence of battering. This implement is 10.87 cm long, ranges in width from 3.68 to 4.9 cm, and weighs 178.4 g.

### *Notched Cobbles*

One notched sandstone cobble, or netsinker, was recovered from early Clemson Island Feature 57. One shallow notch is present on each edge of the piece; these notches were formed through bifacial flaking. This implement has damage on one end, which may be the result of battering. It measures 10.1 cm long and 1.7 to 6.0 cm wide.

### *Pitted Stones*

Seven pitted stones were recovered from the Clemson Island features. These are sandstone cobbles of very similar size, which are pitted on one, or both, planar surfaces. Metric data are summarized in Table 246. Five of the cobbles have pits on both planar surfaces, while two are pitted on only one surface. The pits on these cobbles are shallow and U-shaped. The deepest pits occur on the largest of the cobbles, and these pits, which occur on either side of the piece, are U-shaped, with extensive shallow pitting spreading out from the margins of the larger pits. Pitting occurs near the center of the whole pieces, and it is assumed that this was also true on the broken pieces. Two of the cobbles are broken, laterally, near the pitting, suggesting that they were fractured during use. The shallow pitting and generally small size of these implements suggest that they were, for the most part, used as hammerstones rather than as anvils.

Table 246. Summary of Metric Data for Pitted Stones

	Weight (cm)	Length (cm)	Width (cm)	Thickness (cm)
Cases	5	5	7	7
Minimum	234.0	9.2	6.6	2.6
Maximum	688.9	12.7	8.8	4.9
Mean	417.5	10.2	7.7	3.9
Std. Deviation	168.5	1.5	0.9	0.8

### *Hammerstones*

Three hammerstones were recovered from the Clemson Island features. These implements are differentiated from the pitted stones in that damage and pitting occurs on their edges, rather than on their faces. Two of these pieces are broken laterally. The third consists of a thin, round sandstone cobble with damage on two opposing margins.

### *Anvil*

A single anvil was recovered from the Clemson Island features, originating from the late Clemson Island Feature 29. This item is a broken sandstone slab, with extensive, shallow pitting on one side. The piece measures 16.7 x 15.8 x 6.0 cm, and weighs 2389.7 g. It is broken laterally near the area of heaviest pitting, suggesting that it was broken during use.

DWG. NO. 89-412-A/2/

APPROVED JPH

REM DWN.

GAI CONSULTANTS, INC.

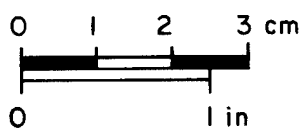
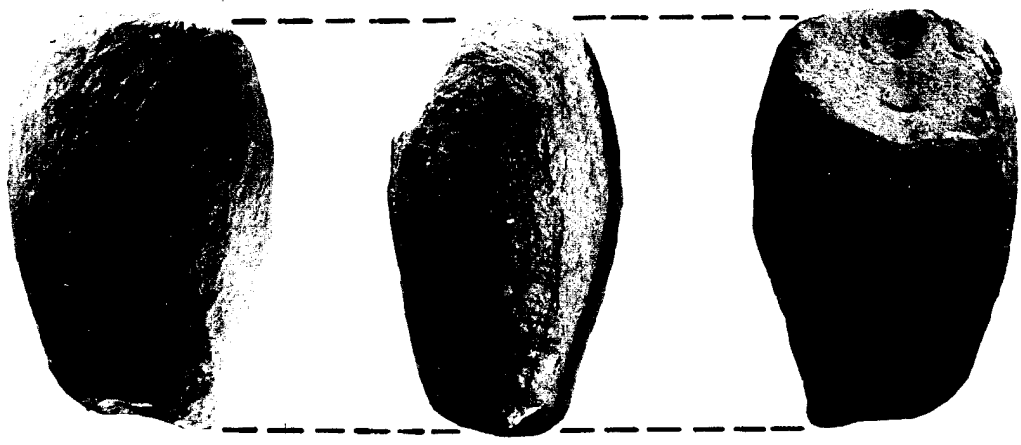

FIGURE 124

PHOTOGRAPH OF LATE  
WOODLAND PENDANT

### *Grinding Slabs*

Two grinding slabs were recovered, one each from from features 8 and 233. The implement from unassigned Feature 8 consists of a broken sandstone slab, which has been ground smooth on both sides. Extensive micro-pitting also occurs on both sides, although it is uncertain whether these pits represent weathering or cultural modification. The grinding of both sides of the slab resulted in a low ridge along its edges. The slab is broken longitudinally, measures 22.34 cm long by 4.69 cm thick, and weighs 2078.3 g.

The piece from Stewart phase Feature 233 consists of a broken sandstone slab with a single modified surface. This surface was modified through a combination of pecking and grinding. The piece measures 23.6 cm long by 16.8 cm wide by 5.5 cm thick, and weighs 3112.0 g.

### *Abraders/Mullers*

Five abraders/mullers were recovered from the Clemson Island features. Three of these implements consist of small, elongated, sandstone river cobbles that appear to have been ground smooth on at least one face or edge. A fourth implement is a laterally-broken sandstone cobble that has extensive grinding on its lateral margins, to the extent that the margins are squared. The fifth piece is a thin, broken, rectangular piece of sandstone whose lateral margins are ground smooth. Both lateral margins on this piece exhibit narrow grooves that presumably formed during use.

### *Pendant*

One possible pendant, manufactured from fireclay, was recovered from the Early Clemson Island Feature 55. This object has an oval cross section with dimensions of 5.5 x 3.5 x 3.0 cm, and was apparently formed through grinding. A hole has been drilled longitudinally through the piece. Damage is evident on both ends. No decoration is present on this object (Figure 124).

### ORIENT

A total of 48 pieces of ground/pecked stone tools manufactured from sandstone and quartzite cobbles, and weighing 12,084.5 g was recovered from the Orient Phase during block excavations. An additional 898 pieces of steatite weighing 505.7 g were recovered. These items are described below.

### *Notched Disks*

Twenty-three notched disks, or netsinkers were recovered from this component, 18 of which were recovered from Feature 182 (Figure 31). Summary statistics for these items are presented in Table 247. While notched-disk caches are frequently reported from Late Woodland contexts in the Delaware Valley, the occurrence of steatite-tempered pottery in Feature 168 suggests an Orient Phase origin for this cache. All of the notched disks were manufactured from locally obtainable sandstone cobbles. Each disk has opposing notches on its lateral edges, formed through bifacial flaking.

### *Cleavers*

Two cleaver-like implements were recovered in Level 3 of Block 11. These represent split, quartzite cobbles, each having one lateral edge modified through flaking; one is flaked bifacially,



the other unifacially. No other modification is evident on these pieces. The implement with the bifacially-flaked lateral edge measures 10.5 x 7.1 x 2.3 cm, while the second measures 9.0 x 6.6 x 7.8 cm.

Table 247. Summary Statistics for Orient Phase Notched Disks.

	Length	Width	Thickness	Weight
N	23	23	23	23
Range	6.0 - 9.0	5.6 - 11.9	1.3 - 2.7	71.0 - 302.1
Mean	7.6	9.4	2.1	215.8
Std. Deviation	0.82	1.4	0.38	59.34

### *Pitted Stones*

Eight pitted sandstone and quartzite cobbles assignable to the Orient component were recovered from the site. These implements consist of locally-available river cobbles that have a pit on one or both faces. Four implements are pitted on a single face, and four are pitted on both faces. The majority of these are small, and probably served as hammerstones. One, large, disk-shaped piece with a broad-pecked area probably served as an anvil. Summary statistics for these pieces is presented in Table 248.

Table 248. Summary Statistics for Orient Phase Pitted Stones

	Length	Width	Thickness	Weight
N	8	8	8	8
Range	5.5 - 10.5	5.5-13.5	2.3 - 5.4	71.2 - 903.7
Mean	7.2	9.3	3.8	381.5
Std. Deviation	1.57	2.77	0.86	256.54

### *Hammerstones*

Eight sandstone river cobbles of varying shape and size exhibited battering on one or more edges, and have been classified as hammerstones. No other modification was noted on these pieces, with the exception of lateral breaks on three. Summary statistics for these tools are presented in Table 249.

Table 249. Summary Statistics for Orient Phase Hammerstones

	Length	Width	Thickness	Weight
N	6	7	8	5
Range	3.8 - 10.5	3.9 - 8.7	1.9 - 4.5	64.7 - 426.8
Mean	6.3	6.1	3.1	228.7
Std. Deviation	2.11	1.87	1.01	141.25

### *Miscellaneous Ground Stone*

This group consists of two implements, one a small, flat slab of sandstone that has been ground on one side, and the second, a sandstone cobble that has been bevelled on one edge through grinding. The latter may represent the initial stages of a celt, although the beveled-end of the piece has been utilized, as evidenced by pitting.

### *Steatite*

A total of 898 pieces of steatite weighing 505.7 g was recovered from Orient contexts. The vast majority consisted of very small pieces weighing 0.1 g or less, which may constitute temper from decomposed Marcey Creek pottery temper or decomposed steatite sherds, and would not have been recovered without the use of 1/8-inch screen. In one instance, 32 pieces of steatite, weighing an average of 0.13 g, were recovered from a single 50 x 50 cm recovery unit, suggesting decomposed pottery.

The larger pieces of steatite were recovered from blocks 3, 4, 5, 6, and 12. The edge of a single steatite sherd from Block 3 has the remnants of a drilled hole. Four large fragments recovered from Block 4 refit to represent a single vessel. The lip of this vessel is decorated by engraved lines perpendicular to the vessel opening. The exterior surface of the rim is decorated with what appear to be random vertical grooves. The interior surface retains fine scratches resulting from the shaping process. This vessel appears to have been a shallow bowl.

A single, large steatite sherd recovered from Block 5 appears to represent another vessel. Two vessels are represented by the steatite sherds recovered from Block 6. One vessel is represented by a single sherd with wide, shallow grooving on the exterior surface. The second vessel is represented by six refitting sherds. Three of the edges of this piece are bevelled and smoothed, and the cross section is flat. Finally, another vessel is represented by sherds recovered from a single 50 x 50 cm recovery unit in Block 12. Wide grooves are present on the exterior surface of the three largest sherds, while the interior surfaces exhibit many thin, parallel striations.

### TERMINAL ARCHAIC

Thirty-eight cobble, ground, or pecked tools were recovered from Terminal Archaic contexts. These generally consisted of modified sandstone and quartzite cobbles. Additionally, 83 pieces of steatite weighing 152.3 g were also recovered. These items are described below.

#### *Notched Disks*

Two notched disks were recovered from Terminal Archaic contexts, both manufactured from relatively thin, sandstone river cobbles (Figure 125). These items have opposing notches formed through bifacial flaking. On one piece, the notches are on the long axis, while on the second, they are on the short axis. These pieces measure 8.7 x 6.5 x 3.7 cm and 7.7 x 5.9 x 1.0 cm, respectively. Their planar surfaces are not modified.

#### *Celt*

A single whole slate celt was recovered from Terminal Archaic contexts from Feature 257 (Figure 126). The bevelled, distal end of the implement was formed through grinding, while the lateral edges were formed through bifacial flaking. The proximal end is unmodified.

#### *Pitted Cobbles/Anvils*

Thirteen pitted cobbles/anvils were recovered from Terminal Archaic contexts. Twelve of the implements consist of sandstone river cobbles, with pits on one or both planar surfaces. Seven of the pieces have pits on both planar surfaces, and five exhibit pitting on only one surface. Two of the implements also exhibit battering on their edges. The pits are generally small and shallow, and round to oval in shape. One bipitted cobble has relatively deep, elongated, opposing pits.

While most of these probably served as hammerstones, the larger pieces may represent anvils. Summary statistics for these implements are provided in Table 250.

Table 250. Summary Statistics for Terminal Archaic Pitted Cobbles/Anvils

	Length	Width	Thickness	Weight
N	7	10	11	5
Range	6.2 - 43.2	6.5 - 15.0	3.5 - 11.4	286.4 - 675.2
Mean	14.2	8.8	5.0	441.3

The thirteenth piece, recovered from Block 8, is a large sandstone slab exhibiting three, broad, shallow pits on one face. It measures 40.6 x 31.8 x 4.5 cm.

### *Hammerstones*

In addition to the pitted cobbles, two cobbles were recovered that exhibit damage on one or more edges and probably functioned as hammerstones. Both of these implements are sandstone river cobbles. The larger of the two, measuring 6.8 x 5.3 x 2.3 cm, exhibits damage on all four edges as a result of battering. The smaller piece, which measures 3.4 x 2.8 x 2.3 cm, has a narrow, shallow-pecked groove on one end. Neither of the implements exhibit damage or modification of the planar surfaces.

### *Grooved Stones*

One tool type that is found primarily in Terminal Archaic contexts is the grooved stone (Figure 125). These implements consist of relatively thin pieces of siltstone that have one or more, narrow, incised grooves on the planar surfaces. The grooves are generally flat-sided with convex to planar bases. The sides often exhibit striations, suggesting that they were formed through lateral grinding. Eight of these implements were recovered from Terminal Archaic contexts, and over half of these were recovered from two features, 257 and 338, containing two and three, respectively.

### *Pestle*

One pestle was recovered from Feature 307 (Figure 126). This implement consists of a large, modified sandstone cobble, measuring 26.7 x 8.1 x 4.9 cm, and weighing 1724.4 g. Both ends of the piece exhibit damage through battering. The faces of the piece have been modified through grinding, as evidenced through long striations running parallel to the long axis. The lateral edges appear to be unmodified.

### *Mullers and Abraders*

Six implements exhibiting heavy grinding on one or more surfaces were recovered from Terminal Archaic contexts. Three of these are sandstone river cobbles of varying size, one is a sandstone cobble fragment, one is a sandstone slab fragment, and one is a granitic cobble. A seventh piece is a small, thin, triangular piece of fine sandstone exhibiting grinding on all three edges. All of these were recovered from nonfeature contexts, with the exception of the granitic cobble which was recovered from Feature 257.

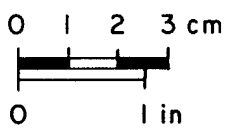
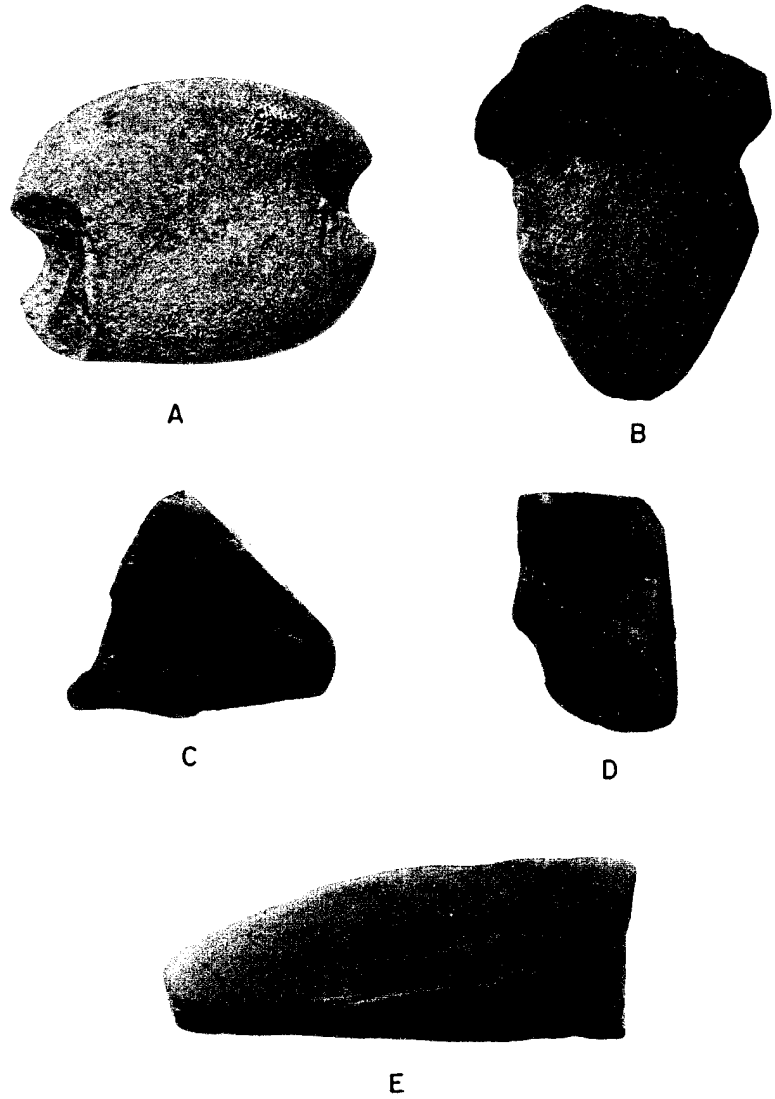

KEY

- A & B - NOTCHED DISCS
- C, D & E - GROOVED STONES

FIGURE 125

PHOTOGRAPHS OF TERMINAL ARCHAIC NOTCHED & GROOVED IMPLEMENTS

### *Groundstone Fragments*

Two groundstone fragments were recovered from Feature 257 (Figure 126). One, a large flake from an unidentifiable tool form, has a large potmark, suggesting that it was subjected to intense heat. The second piece appears to be a celt fragment; it exhibits battering on its proximal end.

### *Steatite*

A total of 83 pieces of steatite, weighing 152.3 g, was recovered from Terminal Archaic contexts. As with the Orient steatite, most pieces were very small, weighing 0.1g or less. Most of the steatite from Terminal Archaic contexts was recovered from the western half of the site in blocks 4, 9, 13, and 14. The only steatite recovered from the eastern half of the site was recovered from Block 1. The larger steatite sherds were recovered from Feature 212 in Block 1 and from general deposits in Block 1 and 14. These appear to represent two distinct vessels. Two large conjoining sherds were recovered from Block 1: one from Feature 212, and one from an adjacent recovery unit in the same level. The exterior surface bears many thin, parallel striations, while the interior surface exhibits thin, apparently random, scratches. Three large steatite sherds were recovered from Level 3 of Block 14. Two appear to be basal sherds, while the third is a body sherd. The exterior surface of the basal sherds is rough, while the interior surface is smooth. The exterior surface of the body sherd exhibits grooves, while the interior surface exhibits many fine striations.

### PIEDMONT

Six pieces of ground/pecked stone were recovered from Piedmont contexts. These consisted of two sandstone slab fragments with ground surfaces, one pitted sandstone cobble, one small sandstone cobble with battering damage on its edges, a grooved stone fragment, and a large anvil. The anvil, recovered from Feature 356, consists of a sandstone slab which measures 10 x 12 cm and exhibits a broad, shallow depression in the center of one face.

### LATE LAURENTIAN

The Late Laurentian assemblage is comprised of 15 implements weighing a total of 11,510.8 g.

### *Celts*

Two slate celts were recovered from late Laurentian contexts, both from roughly the same elevation in Block 14 (Figure 127). One piece measures 10.5 x 6.3 x 1.9 cm and weighs 152.3 g, while the second piece measures 10.0 x 5.1 x 2.2 cm and weighs 142.7 g. Both pieces have ground faces forming a symmetrical bevel on the distal end. The remaining edges of both pieces exhibit partially ground, bifacial flaking; the proximal edges exhibit less modification than the lateral edges. The broader of the two implements exhibits damage to its distal end, presumably as a result of use.

### *Pitted Cobbles and Anvils*

Four implements were recovered that exhibit pitting on their faces. One of these is a large sandstone slab fragment (22.1 x 27.0 x 9.3 cm, weighing 4140.2 g) that has two large, and



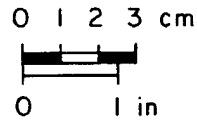
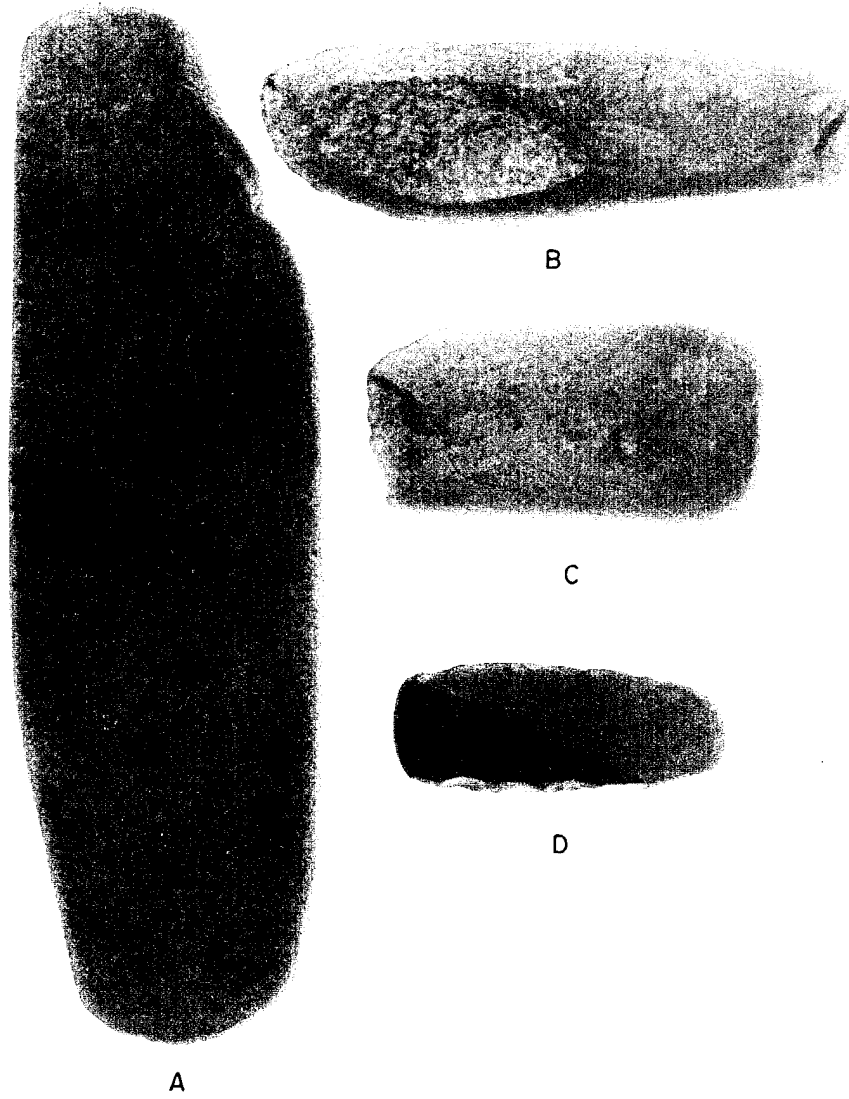

KEY

- A - PESTLE
- B - BURNED GROUNDSTONE FRAGMENT
- C - CELT FRAGMENT
- D - CELT

FIGURE 126

PHOTOGRAPHS OF TERMINAL ARCHAIC  
GROUNDSTONE IMPLEMENTS



A



B

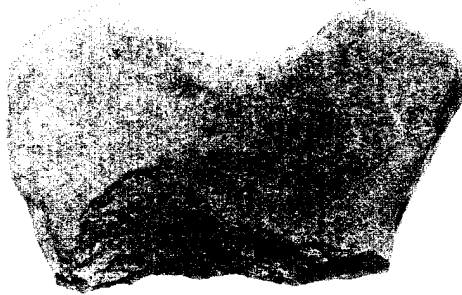

C

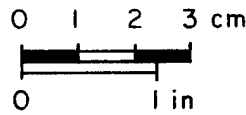

KEY

A & B - CELTS

C - CHOPPING TOOL

FIGURE 127

PHOTOGRAPHS OF LATE LAURENTIAN  
GROUNDSTONE IMPLEMENTS



numerous small, pits on its surface, and presumably served as an anvil. The remaining four pieces are river cobbles: three sandstone, and one quartzite. The three sandstone cobbles, measuring 11.3 x 9.0 x 5.5 cm, 13.5 x 8.6 x 4.5 cm, and 12.3 x 11.0 x 23.0 cm, have broad, shallow pits on their faces and presumably functioned as anvils. The smaller quartzite cobble, measuring 7.7 x 6.6 x 4.3 cm, which has battering damage on one face and one edge, presumably served as a hammerstone.

### *Hammerstones*

Four hammerstones were recovered from late Laurentian contexts. All of these are sandstone cobbles exhibiting damage to one or more edges. Summary statistics for these items are presented in Table 251.

Table 251. Summary Statistics for Late Laurentian Hammerstones

	Length	Width	Thickness	Weight
N	4	4	4	4
Range	3.2 - 8.0	2.1 - 6.3	1.8 - 4.0	16.6 - 230.0
Mean	5.0	3.6	2.8	84.8

### *Grinding Slabs*

Three grinding slabs were recovered from late Laurentian contexts. The largest of these, recovered from Feature 236, consists of a triangular-shaped sandstone slab measuring 29.8 x 14.7 x 4.0 cm, and weighing 3196.0 g. One planar surface and one edge of this piece have been ground smooth. The other two pieces consist of sandstone slab fragments, with ground areas on one planar surface forming a depression.

### *Other Implements*

Two additional implements were recovered from late Laurentian contexts. One is a small, flat, sandstone cobble that exhibits grinding on one edge. The second implement is a reworked, notched, sandstone disk (Figure 127). One lateral edge exhibits a notch formed through bifacial flaking typical for notched disks. The opposing edge is bifacially flaked, forming a straight edge. Presumably, this represents a broken, notched disk reworked into a chopping or cutting tool.

### EARLY LAURENTIAN

Nineteen ground/pecked stone and cobble implements were recovered from early Laurentian contexts, weighing a total of 19,995.6 g.

### *Adzes*

Two adzes and one adze fragment were recovered from early Laurentian contexts (Figure 128). The first, recovered from Feature 349 in Block 13, is manufactured from slate, and measures 11.0 x 5.9 x 2.6 cm. This piece has flake scar remnants on its proximal and lateral edges. The faces and edges of this piece have been ground, leaving an asymmetrical bevelled edge on the distal end. Damage is evident on this edge, apparently as a result of use. The second piece, recovered from Block 8, is manufactured from a sandstone slab fragment. This piece measures 10.0 x 5.8 x 3.0 cm. The distal end is ground into an asymmetrical bevelled edge. The proximal

edge is unmodified. The lateral edges are unground, but each has a notch, formed through pecking, which presumably facilitated hafting.

An adze bit fragment was recovered from Block 13. This piece represents one surface of a sandstone adze. The distal end of the piece retains both surfaces of the implement's bit.

### *Bannerstone*

One contracting-wing, ground-slate bannerstone with a ridged shaft was recovered from early Laurentian contexts. This item measures 6.7 x 5.1 x 2.3 cm and weighs 84.7 g. Surrounding each end of the drilled form are numerous fine striations, presumably left from the manufacture of the piece. The faces of the piece are ground smooth, while one bevelled edge exhibits flake scar remnants.

### *Slate Knives*

One large fragment of a ground-slate knife was recovered from early Laurentian contexts in Block 13. The lateral edge of this fragment was bevelled, through the grinding of one face of the piece. The other face and the ends are unmodified.

### *Pestles*

Three pestles were recovered from early Laurentian contexts: one from Block 5, and two from Block 8 (Figure 128). The implement recovered from Block 5 was formed from a large sandstone cobble. This piece measures 13.7 x 6.3 x 5.3 cm and weighs 749.8 g. The distal end of the piece is irregular, but was apparently ground smooth through use. The proximal end has either been broken, or remains unmodified. The first piece recovered from Block 8 was also formed from a sandstone cobble. This piece measures 15.8 x 4.5 x 4.1 cm and weighs 542.1 g. Both lateral edges of the piece have been ground to a flat surface. The distal end also has been ground smooth, while the proximal end is unmodified. The second piece from Block 8 measures 25.0 x 4.8 x 4.3 cm and weighs 956 g. This tool was fashioned from a sandstone slab fragment. The shaft is rectangular in cross section with each of the four sides having been ground smooth. The distal end is also rectangular in cross section, but is thinner than the shaft as a result of the natural contours of the rock. The proximal end of the piece is either unmodified, or it represents a break in the original piece.

### *Quartz-Crystal Plummet*

A somewhat unusual artifact recovered from early Laurentian contexts was a small tear-drop-shaped quartz crystal, with an encircling groove resembling a plummet. This implement weighs 8.8 g, and measures 3.2 x 1.6 x 1.4 cm. The groove occurs approximately 1.1 cm below the inferred proximal end. At least some portions of it were formed through percussion chipping.

### *Chopping Tool*

One tool recovered from early Laurentian contexts in Block 8 is formed from a longitudinally split sandstone cobble. The distal end of the piece has been bevelled through bifacial flaking. One lateral edge of the piece has been ground smooth. This piece presumably served as a chopping tool.

DWG. NO. 89-412-A/25

APPROVED JPH

DWN. REM

GAI CONSULTANTS, INC.



A



B

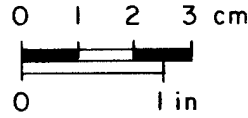

FIGURE 128

PHOTOGRAPHS OF EARLY  
LAURENTIAN ADZES



A



B

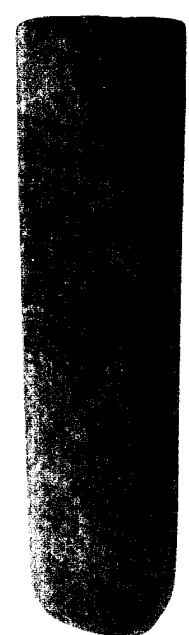

C

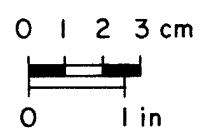

FIGURE 129  
PHOTOGRAPHS OF EARLY  
LAURENTIAN PESTLES

A second item recovered from Block 9 presumably represents a second chopping tool. This piece was formed from a large sandstone cobble tertiary flake. The distal end of the flake has been unifacially flaked. The piece measures 11.3 x 8.4 x 4.5 cm and weighs 415.1 g.

#### *Grooved Cobble/Bollas-Stone*

A grooved sandstone cobble or bollas-stone was recovered from early Laurentian contexts in Block 9. It exhibits shallow grooves on each of its ends. This implement measures 6.9 x 4.5 x 2.9 cm, and weighs 118.7 g.

#### *Pitted Cobbles/Anvils*

One anvil and one pitted sandstone cobble fragment were recovered from early Laurentian contexts. The anvil was recovered from Block 8. It measures 14.3 x 9.0 x 7.5 cm and weighs 1320.4 g. One surface of this piece has two, broad, shallow pits. The second piece, also recovered from Block 8, is a fragment of a large sandstone cobble. This piece exhibits a v-shaped pit on its intact face.

#### *Mullers*

One sandstone-cobble muller was recovered from early Laurentian contexts in Block 8. This piece measures 6.4 x 5.6 x 4.3 cm and weighs 196.0 g. It exhibits a single ground surface. A sandstone cobble fragment recovered from Block 9, and exhibiting a ground surface may represent a muller fragment.

#### *Hammerstone*

One thin, sandstone cobble exhibiting damage to its edges, and apparently representing a hammerstone, was recovered from Block 8. This piece measures 6.0 x 4.9 x 2.0 cm and weighs 83.1 g.

#### NEVILLE

Only one implement, a possible anvil, was recovered from Neville contexts. This is a sandstone slab fragment recovered from Block 5 that exhibits a broad, irregular pit on one side that may be of natural origin. This piece measures 15 x 15 x 7.4 cm and weighs 2189.5 g.

#### SUMMARY

A total of 156 pieces of ground, pecked stone and cobble tools were recovered during the present investigations of the Memorial Park site. Of these, 29 (18.6%) are associated with the Late Woodland occupations, 48 (30.8%) with the Orient phase occupations, 38 (24.4%) with the Terminal Archaic occupations, 6 (3.8%) with the Piedmont occupations, 15 (9.6%) with the late Laurentian occupations, 19 (12.2%) with the early Laurentian, and 1 (0.6%) with the Neville occupations. In addition, 981 pieces of steatite were recovered: 898 pieces from Orient contexts, and 89 from Terminal Archaic contexts.

For the most part, the ground, pecked, and cobble tools, were probably used in resource procurement and processing activities. The large number recovered from early Laurentian contexts, as compared to Neville contexts, probably reflects the first intensive occupation of the

study area. The formally-shaped tools, such as the adzes and the banner stone, represent curated tools that were either brought onto the site in finished form or were made at the site with the anticipation of long-term, multiple uses. The pestles, on the other hand, may have been shaped through use with the anticipation of short-term use. Fewer formally-shaped tools were recovered from late Laurentian contexts, perhaps reflecting the use of more expedient tools during this occupation, and/or the transport of formally shaped tools to other sites during seasonal movements. The small number of tools associated with the Piedmont reflects the less intense occupation of the site during this time. A large anvil recovered from the central of a cluster of features that contained charred acorn meat may reflect a single resource processing event.

The 38 tools recovered from Terminal Archaic contexts represent primarily expedient tools, most representing modified, probably local, sandstone cobbles. This indicates that relatively little time and energy was expended on the manufacture of this class of tools, or that formally-shaped tools were removed to other sites. Portions of two steatite vessels, as well as numerous small pieces of steatite, were recovered from Terminal Archaic contexts. The presence of steatite reflects changes in both technology and, perhaps, regional exchange patterns, which are also evinced by the large number of rhyolite chipped-stone tools and debris as described by Spitzer earlier in this volume. One tool form, flat, siltstone cobble fragments with grooves on the planar surfaces, may have been used for edge grinding during the production of chipped-stone rhyolite tools. That two such tools were recovered from a cache containing rhyolite bifaces supports this interpretation. The largest number of pebble tools was recovered from Orient phase contexts. Almost half of these tools (23) are side-notched, flat sandstone cobbles, or netsinkers, 18 of which were recovered from a cache pit. As discussed in the Field Results section of this report, these objects reflect planned reoccupation of the site as part of the yearly subsistence-settlement cycle. The remainder of the tools represent a variety of expedient tools formed through use of probably local sandstone and quartzite cobbles. The large number of very small steatite fragments recovered from Orient contexts, were probably temper from decomposed Marcey Creek pottery. Steatite sherds recovered from Orient contexts represent a minimum of six vessels.

The 29 tools recovered from Late Woodland contexts include three hoe-like implements formed from large sandstone cobbles recovered from Early Clemson Island, Late Clemson Island, and Stewart phase features. These probably were used in agricultural production near the site, which is suggested by the recovery of maize cob fragments as described by Sidell in the next chapter. The largest of these implements, recovered from Stewart phase contexts, exhibits extensive use wear in the form of pitting and rounding of the blade. Other implements represent primarily expedient tools formed through use of probably local sandstone cobbles.

## XII. ARCHAEOBOTANY

by

Nancy Asch Sidell

The Memorial Park site is located in the floodplain of the West Branch of the Susquehanna River valley, at Lock Haven, Clinton County, in central Pennsylvania. The site was occupied intermittently from the Middle Archaic through the Late Woodland period. This report summarizes results of flotation sample analysis from the following components:

Middle Archaic		
Neville	5140 to 4770 B.C.	(5 dates)
Late Archaic		
Early Laurentian	3840 to 4405 B.C.	(4 dates)
Late Laurentian	3250 to 2950 B.C.	(5 dates)
Piedmont	2460 to 2100 B.C.	(2 dates)
Terminal Archaic		
Canfield/Susquehanna	2100 to 1640 B.C.	(3 dates)
Orient	1145 to 880 B.C.	(2 dates)
Early Woodland		
Meadowood		(no date)
Middle Woodland		
Fox Creek	150 A.D.	(1 date)
Late Woodland		
Early Clemson Island	760 to 830 A.D.	(4 dates)
Middle Clemson Island	920 to 930 A.D.	(2 dates)
Late Clemson Island	1050 to 1090 A.D.	(4 dates)
Stewart Phase	1290 to 1385 A.D.	(3 dates)

Results are compared with the limited information available on prehistoric plant use in Pennsylvania.

This site is important archaeobotanically because it documents that subsistence activities during Late Woodland times in central Pennsylvania involved the growing of two types of domesticated chenopod and little barley in addition to maize, tobacco, and possibly sunflower. The cultivated foods were supplemented with a wide variety of nuts, fruits, berries and wild rice. The site also documents that cultivation began in central Pennsylvania before Late Woodland times with the growing of pepo gourd in the Late Archaic period, squash/pumpkin in the Early Woodland period, and maize in the Middle Woodland period.

### NATURAL ENVIRONMENT

The Memorial Park site lies on a narrow point bar, or natural levee, at the confluence of Bald Eagle Creek with the West Branch of the Susquehanna River. The floodplain in the vicinity of Memorial Park site is 1.6 km broad. The West Branch of the Susquehanna River lies immediately to the north and east, and Bald Eagle Creek 1.3 km to the south. The site is at the

eastern edge of the Allegheny Plateau, along the western edge of the Ridge and Valley Province of the Appalachian Highlands. Eyre (1980) places the Memorial Park Site within the oak-hickory region, based on modern forest cover types. Braun's (1950) reconstruction of the presettlement vegetation of eastern North America positions the Memorial Park site in the oak-chestnut forest region. In Pennsylvania, oaks prevailed on the ridges, sweet birch on rocky upper slopes, and the original forests would have contained chestnut. Mixed mesophytic communities can be found on the lower slopes of narrow valleys created in relatively recent erosion cycles, although this forest type is sporadic in occurrence. Such forests may contain white pine, hemlock, beech, basswood, sugar maple, tuliptree, ash, red maple, black walnut, and red oak. Broader valley floors are dominated by white oak with tuliptree, hickories, red oak, black oak, and white pine (Braun 1950:233-242). It should perhaps be noted that the Memorial Park site is at the northern edge of the distribution of tuliptree (Little 1971) in central Pennsylvania.

Describing the Pennsylvania forest types early in this century, Illick (1928) defined nine major forest types. The oak-hickory type contains the greatest number of species and prevails in agricultural valleys and bordering foothills, including the Susquehanna Valley. The principal members of this forest type are white oak, black oak, red oak, scarlet oak, bur oak, shagbark hickory, mockernut hickory, pignut hickory, black walnut, red mulberry, sassafras, hackberry, and red cedar. (Bur oak and red mulberry do not grow near the Memorial Park Site.) Another type which occurs locally along all of the principal rivers of the state and their main tributaries is the river and swamp hardwood type, composed primarily of silver maple, ash-leaved maple, river birch, walnut, white oak, black ash, swamp hickory, and sycamore (Illick 1928:20).

Given the location of the Memorial Park site in a wide floodplain, firewood would most likely have been collected from the nearby floodplain forest. Plant food resources would have been most abundant along the riverbanks, around cleared or abandoned campsites, and in other openings in the woods. The archaeological record of carbonized plant remains can reveal to us more precisely the nature of the prehistoric forests of the West Branch of the Susquehanna River.

#### METHODS OF RECOVERY AND ANALYSIS

Most plant remains were recovered by flotation of soil samples, although hand-picked charcoal samples were also collected in the field for use as C-14 samples. Each unscreened soil sample collected for flotation processing was measured volumetrically, and then dried prior to automated flotation. The light fraction was collected in a piece of tightly-woven cloth, and the heavy fraction on a 1.18 mm mesh.

In the archaeobotanical laboratory, samples were processed using quantitative methods developed over 20 years by the Center for American Archeology (Asch and Asch 1975, Asch and Sidell 1992). The light and heavy fractions were combined and sieved through 2 mm and 0.5 mm screens. Charcoal larger than 2 mm was sorted using a binocular microscope at 7X magnification and evaluated quantitatively by counting fragments. Large samples were usually divided with a riffle sampler to produce a subsample of 400-600 pieces for quantitative analysis. The remainder >2 mm was scanned to obtain an exact count of rare categories. Charcoal 0.5-2 mm was scanned for presence/absence of all categories; seeds were removed and counted. Charcoal smaller than 0.5 mm was not systematically examined, because it rarely yields identifiable remains. Uncarbonized plant remains, with the exception of some bark, were assumed to be more recent inclusions and were not tabulated.

For most categories of charcoal, the contents of the >2 mm fraction adequately represent the composition of the smaller size fraction. The percentage occurrence of charcoal types by weight can be approximated from counts of fragments larger than 2 mm, and the weight of



particular types in the entire sample can be approximated by multiplying the percentage occurrence by total sample weight. Quantification by sieving and enumeration is faster than complete sorting and weighing of each charcoal type, and identifications of the larger fragments are more reliable. This method may under-represent the percentage of more fragile acorn shell, beechnut shell, chestnut shell and small seeds, but qualitative analysis of all charcoal smaller than 2 mm tends to compensate for this deficiency. When the quantification process is applied consistently, the bias is also consistent so that comparisons among samples and between sites remain meaningful.

For wood charcoal, the objective was to identify 20 fragments larger than 2 mm per sample. When the samples did not yield 20 fragments large enough to identify, usually 0 or 5 or 10 fragments were identified. The transverse section of the wood was examined at 15X-30X magnification after manually breaking the charcoal to obtain a clean section. Specimens were compared with modern carbonized wood samples.

#### SAMPLE COMPOSITION

In all, 211 flotation samples were examined (Appendix G). Time constraints prohibited identifying all recovered plant remains. A summary of sample contents, organized by cultural affiliation is provided in Table 252, excluding the two Neville samples which were too small to provide meaningful statistics. Percentage composition of general categories is presented in Table 253, wood charcoal in Table 254, nutshell in Table 255, seeds in Table 256, and economic categories of seeds in Table 267. Standard flotation sample size was 4 liters but, in practice, the volumes ranged from 0.1 to 4 liters (Appendix G). The results are not standardized for sample volume.

The categories of plant remains that were recovered include wood, bark, twig, pitch, hickory nutshell, bitternut hickory shell, chestnut shell, hazelnut shell, butternut shell, acorn nutshell and nutmeat, grass stem, herbaceous stem, rhizome, tuber, unknown, maize, pepo gourd rind, squash/pumpkin rind, domesticated *Chenopodium* (two types), little barley, tobacco, sunflower and various wild seeds. The grass stem, herbaceous stem, rhizome and tuber fragments were very small and poorly preserved. Little can be said of their significance at this time. The unknown fragments were generally small, poorly preserved fragments, as well. The following is a more detailed discussion of selected categories.

Table 252. Summary of Carbonized Plant Remains.

Cultural Affiliation	Early Lauren- tian	Late Lauren- tian	Pied- mont	Terminal Archaic	Orient	Early Wood- land	Middle Wood- land	Early CI	Mid- dle CI	Late CI	Stewart	Late Wood- land <sup>a</sup>
<b>SAMPLE WEIGHT (g)</b>												
>2 mm	9.3	21.8	49.8	141.5	9.7	7.3	3.1	54.8	4.5	15.4	26.2	97.2
0.5-2mm	9.8	18.3	26.9	96.6	7.8	5.3	2.9	43.9	3.8	12.3	24.5	82.3
Total	19.1	40.1	76.7	238.1	17.5	12.6	6.0	98.7	8.3	28.8	50.7	179.5
<b>SAMPLE COMPOSITION (&gt;2 mm count)<sup>b</sup></b>												
Wood	554	245	983	8871	545	373	268	4034	422	957	2719	7389
Bark	388	817	539	1992	27	68	4	418	102	126	146	559
Twig	-	3	-	2	-	-	-	-	-	-	-	1
Pitch	53	282	29	63	147	4	1	10	11	71	60	112
<b>Nutshell</b>												
<i>Carya</i> spp., hickory	16	507	1	313	41	23	5	216	17	135	54	652
<i>C. cordiformis</i> , bitternut	-	-	-	13	-	1	-	6	-	-	-	21
<i>Carya/C. cordiformis</i>	-	6	-	-	-	-	-	-	-	-	-	-
<i>Castanea dentata</i> , chestnut	-	-	-	-	-	-	-	47	-	-	-	-
<i>Corylus</i> spp., hazelnut	-	-	-	1	-	-	-	2	-	-	-	-

Table 252 (continued)

<i>Juglandaceae</i> , walnut family	1	84	-	74	12	18	-	40	9	1	5	22
<i>Juglans</i> spp., butternut/walnut	7	1	-	11	-	27	-	-	1	-	-	1
<i>J. cinerea</i> , butternut	-	148	-	25	-	13	1	5	-	-	2	-
<i>J. nigra</i> , black walnut	-	-	3	321	17	24	-	5	-	11	12	12
<i>Quercus</i> spp., acorn	-	-	13	55	3	1	1	233	1	18	5	62
Nutmeat	-	-	-	4	-	-	-	-	-	-	-	-
Acorn	5	-	2093	93	-	-	-	-	-	-	-	-
Grass stem	-	-	-	-	-	1	1	1	1	1	1	57
Herbaceous stem	-	-	-	-	-	-	-	1	-	-	-	-
Rhizome	-	-	-	-	-	-	-	4	-	2	8	5
Tuber	-	-	5	-	-	-	-	-	-	-	-	-
Special unknown	-	-	21	-	-	-	-	-	-	-	-	-
Unknown	-	11	63	23	2	-	1	33	9	5	13	87
<i>Zea mays</i> , maize												
Cupule	-	-	(1)	-	-	-	25	57	-	2	11	34
Glume	-	-	-	-	-	-	15	12	-	-	5	8
Kernel	-	-	-	-	-	-	-	48	3	12	13	32
Embryo	-	-	-	-	-	-	-	-	-	1	-	-
<i>Cucurbita</i> , pepo gourd, squash	-	2	-	-	-	10	-	-	-	-	-	10
Seeds	1	1	1	1	-	-	-	4	-	1	3	4
Total	1025	2107	3751	12262	794	563	322	5176	576	1343	3057	9058
SEED IDENTIFICATIONS												
<i>Amaranthus</i> spp., amaranth	-	-	-	-	-	-	-	9	-	-	-	1
<i>Amaranthus/Chenopodium</i>	-	-	-	-	-	-	-	-	-	-	-	1
<i>Chenopodium</i> spp., goosefoot	-	-	-	-	-	-	-	19	-	2	-	-
<i>Cornus</i> spp., dogwood	-	-	-	1	-	-	-	-	-	-	-	-
<i>Echinochloa</i> spp., barnyard grass	-	-	-	-	-	-	-	3	-	-	-	-
Fabaceae, bean family	-	-	-	-	-	-	-	-	-	-	-	2
<i>Galium</i> spp., bedstraw	-	-	1	2	-	-	-	-	-	-	1	2
<i>Helianthus annuus</i> , sunflower	-	-	-	-	-	-	-	1	-	-	-	-
<i>Hordeum pusillum</i> , little barley	-	-	-	-	-	1	1	119	101	70	19	36
<i>Nicotiana rustica</i> , tobacco	-	-	-	-	-	-	-	-	-	-	-	1
<i>Panicum</i> spp., panic grass	-	-	-	-	-	-	-	1	-	-	-	1
Poaceae, grass family	-	-	1	-	-	-	-	7	-	-	3	2
<i>Polygonum</i> spp., smartweed	-	-	-	-	-	-	-	2	1	-	1	3
<i>Prunus pensylvanica</i> , pin cherry	-	-	-	-	-	-	-	-	-	-	-	1
<i>Rhus</i> spp., sumac	-	-	-	-	-	-	-	5	-	-	6	1
<i>Rubus</i> spp., bramble	-	-	-	-	-	-	-	1	1	-	-	4
<i>Sambucus</i> spp., elderberry	-	-	-	1	-	-	-	-	-	-	-	-
<i>Solanum americanum</i> , nightshade	-	-	-	-	-	-	-	20	-	-	1	3
<i>Vaccinium</i> spp., blueberry	-	-	-	-	-	-	-	-	-	-	-	1
<i>Verbena</i> spp., vervain	-	-	-	-	-	-	-	1	-	-	-	-
<i>Vitis</i> spp., grape	-	-	1	1	-	-	-	-	-	1	1	-
<i>Zizania aquatica</i> , wild rice	-	-	-	-	-	-	-	-	-	-	-	1
Type 50	-	-	-	-	-	-	-	5	-	1	27	-
Type 53	-	-	-	-	-	-	-	5	1	-	20	26
Type 54	-	-	-	-	-	-	-	1	-	-	-	1
Unknown/unidentifiable	1	3	-	2	-	-	-	10	4	1	1	12
Total	1	3	3	7	0	1	1	209	108	75	80	99
WOOD IDENTIFICATIONS												
<i>Acer</i> spp., maple	-	-	-	-	-	-	-	-	-	1	-	2
<i>A. saccharum</i> , sugar maple	-	-	-	5	-	-	1	2	-	2	1	33

Table 252 (continued).

<i>Betula</i> spp., birch	-	10	-	-	-	-	-	-	-	-	-	-
<i>Carya</i> spp., hickory	2	17	8	126	10	17	15	66	14	6	22	56
<i>Castanea dentata</i> , chestnut	-	-	-	-	-	-	-	2	-	1	-	-
<i>Fagus grandifolia</i> , beech	-	-	-	1	-	-	-	3	-	-	-	2
<i>Fraxinus</i> spp., ash	1	-	-	-	-	-	-	3	1	-	-	-
<i>Juglans</i> spp., walnut, butternut	-	5	-	146	15	-	19	3	4	-	5	59
<i>Ostrya virginiana</i> , ironwood	-	-	-	4	-	-	-	-	-	-	-	-
<i>Pinus</i> spp., pine	1	15	29	41	-	-	-	6	-	2	10	13
<i>Populus</i> spp., aspen	-	-	-	1	-	-	5	-	-	-	-	0
<i>Prunus serotina</i> , black cherry	-	-	-	-	-	-	-	2	-	1	7	-
<i>Quercus</i> spp., oak	39	10	18	164	10	4	-	62	10	23	30	52
Red oak group	(34)	(9)	(16)	(147)	(9)	(3)	-	(32)	(6)	(10)	(10)	(18)
White oak group	-	-	-	(13)	(1)	-	-	(20)	(1)	(1)	(6)	(18)
<i>Sassafras albidum</i> , sassafras	-	-	15	19	-	-	-	-	-	-	-	-
<i>Tilia americana</i> , basswood	-	-	-	1	-	-	-	-	-	-	-	-
<i>Ulmus</i> spp., elm	11	-	2	38	26	-	-	-	4	1	2	2
Coniferous	1	-	-	2	-	-	-	-	-	-	-	-
Ring porous	8	7	5	19	4	1	-	1	-	1	1	4
Diffuse porous	14	4	6	21	4	2	-	-	2	-	2	13
Unidentifiable	5	-	2	17	-	1	-	-	-	2	-	-
Total	82	68	85	605	69	25	40	150	35	40	80	235

<sup>a</sup>Late Woodland features unassigned to particular component.

<sup>b</sup>Parentheses in Sample Composition section indicate 0.5-2 mm count. Parentheses in Wood Identification section indicate subtotals.

Table 253. Percentage Composition of Carbonized Plant Remains.<sup>a</sup>

Affiliation	Early Lauren- tian	Late Lauren- tian	Pied- mont	Terminal Archaic	Orient	Early Wood- land	Middle Wood- land	Early CI	Middle CI	Late CI	Late Wood- land <sup>b</sup>	
Wood	54.05	11.63	26.21	72.35	68.64	66.25	83.23	77.94	73.26	71.26	88.94	81.576
Bark	37.85	38.78	14.37	16.25	3.40	12.08	1.24	8.08	17.71	9.38	4.78	6.17
Twig	-	0.14	-	0.02	-	-	-	-	-	-	-	0.01
Pitch	5.17	13.38	0.77	3.78	18.51	0.71	0.31	0.19	1.91	5.29	1.96	1.24
Nutshell	2.34	35.41	0.45	6.63	9.19	19.01	2.17	10.70	4.86	12.29	2.55	8.50
Nutmeat	0.49	-	55.80	0.79	-	-	-	-	-	-	-	-
Grass stem	-	-	-	-	-	0.18	0.31	0.02	0.17	0.07	0.03	0.63
Herbaceous stem	-	-	-	-	-	-	-	0.02	-	-	-	-
Rhizome	-	-	-	-	-	-	-	0.08	-	0.15	0.26	0.06
Tuber	-	-	0.13	-	-	-	-	-	-	-	-	-
Special unknown	-	-	0.56	-	-	-	-	-	-	-	-	-
Unknown	-	0.52	1.68	0.19	0.25	-	0.31	0.64	1.56	0.37	0.43	0.96
Maize	-	-	P	-	-	-	12.42	2.26	0.52	1.12	0.95	0.82
Pepo gourd/squash	-	0.09	-	-	-	1.78	-	-	-	-	-	-
Seeds	0.10	0.05	0.03	0.01	-	-	-	0.08	P	0.07	0.10	0.04
Total	100.00	100.00	100.00	100.00	100.00	100.00	100.00	100.00	100.00	100.00	100.00	100.00
Sample Size (g)	19.1	40.1	76.7	238.1	17.5	12.6	6.0	98.7	8.3	27.8	50.7	179.5
No. samples	27	17	6	55	10	2	3	6	5	4	11	52
No. features	26	16	4	46	8	2	3	14	5	4	9	52

<sup>a</sup>P = present in 0.5-2 mm fraction.

<sup>b</sup>Late Woodland features unassigned to particular component.

## WOOD

Wood was the most ubiquitous and abundant category of carbonized plant remains at the Memorial Park site from all components, except late Laurentian and Piedmont (Table 253). The late Laurentian results are skewed by one large sample of nutshell and another large sample of pitch and bark. Similarly, the Piedmont results are skewed by one very large sample of acorn nutmeats. The wood fragments identified were generally quite small. Fragments not identifiable to the family, genus, or species level were classified as coniferous, ring porous, diffuse porous or unidentifiable. Coniferous fragments could be pine or hemlock. Ring porous wood includes red oak group, white oak group, ash, elm, sassafras, and other less common types. The diffuse porous category encompasses a wide variety of types, including tuliptree, birch, maple, aspen, willow, beech, basswood, hawthorn, and dogwood.

Firewood used at archaeological sites can generally be assumed to be collected from the nearest available deadwood (Asch and Sidell 1992). Consequently, the wood types represented are likely to reflect the forest composition near the site. At the Memorial Park site, a wide variety of species was used for firewood, but the assemblage was dominated by oak (particularly red oak group), hickory, pine, walnut, and elm family (both hackberry and elm). Other types identified include maple, sugar maple, birch, chestnut, beech, ash, ironwood, pine, poplar, black cherry, sassafras, and basswood. Many of the features contained a mixture of types, supporting the hypothesis of indiscriminate use of deadwood.

When examining the data for possible changes in forest composition through time, it is important to take into account the various sample sizes for each component (Table 254). For example, although pine and sassafras are prominent in the Piedmont component, the charcoal is from only six samples.

Red oak group (probably pin oak or red oak) dominates in the early Laurentian samples. Is this an indication that the forest was different about 6000 years ago, or was there a preference for red oak group firewood? Another factor that could be important is differential preservation and/or different potential for identification of species from very tiny fragments. For example, the early Laurentian samples contain predominantly oak charcoal, but the charcoal consists of very tiny fragments from very small samples; oak charcoal can be more readily identified from smaller fragments than can most types of diffuse porous charcoal. To answer these questions, it would be useful to examine more firewood from the early Laurentian at this site, and from nearby sites.

The Terminal Archaic sample of 546 fragments identified to family, genus or species level is from 52 flotation samples. The Late Woodland sample is also sizable, especially if the three Clemson Island components and Stewart phase are combined with those designated Late Woodland, giving a sample of 540 fragments from 30 flotation samples. The percentages of the six most common wood types in the Terminal Archaic and combined Late Woodland components (Table 254) indicate that the types of firewood collected, and presumably the forest composition, were generally similar between 2100-1640 B.C. and 760-1385 A.D.

The Terminal Archaic samples contained 30 percent oak (27% red oak group, 2% white oak group), 23 percent hickory, 27 percent walnut/butternut, 8 percent pine, 7 percent elm, and less than 1 percent each sugar maple, beech, aspen and basswood. The combined Clemson Island, Stewart and Late Woodland samples contained 34 percent oak, 31 percent hickory, 14 percent walnut/butternut, 6 percent pine, 2 percent elm, 7 percent sugar maple, 2 percent black cherry, and about 1 percent each maple, chestnut, beech, and ash. This combination of species suggests that the floodplain forest near the site was a rich, well-drained mesic forest.

Table 254. Wood Summary

Affiliation	Early Lauren- tian	Late Lauren- tian	Pied- mont	Terminal Archaic	Orient	Early Wood- land	Middle Wood- land	Early CI	Middle CI	Late CI	Stewart	Late Wood- land <sup>a</sup>
Percentage Composition												
FAMILY, GENUS OR SPECIES												
<i>Acer</i> spp., maple	-	-	-	-	-	-	-	-	-	2.70	-	0.92
<i>A. saccharum</i> , sugar maple	-	-	-	0.92	-	-	2.50	1.34	-	5.41	1.30	14.68
<i>Betula</i> spp., birch	-	17.54	-	-	-	-	-	-	-	-	-	-
<i>Carya</i> spp., hickory	3.70	29.82	11.11	23.08	16.39	80.95	37.50	44.30	42.42	16.22	28.57	25.69
<i>Castanea dentata</i> , chestnut	-	-	-	-	-	-	-	1.34	-	2.70	-	-
<i>Fagus grandifolia</i> , beech	-	-	-	0.18	-	-	-	2.01	-	-	-	0.92
<i>Fraxinus</i> spp., ash	1.85	-	-	-	-	-	-	2.01	3.03	-	-	-
<i>Juglans</i> spp., walnut/butternut	-	8.77	-	26.74	24.59	-	47.50	2.01	12.12	-	6.49	27.06
<i>Ostrya virginiana</i> , ironwood	-	-	-	0.73	-	-	-	-	-	-	-	-
<i>Pinus</i> spp., pine	1.85	26.32	40.28	7.51	-	-	-	4.03	-	5.41	12.99	5.96
<i>Populus</i> spp., aspen	-	-	-	0.18	-	-	12.50	-	-	-	-	-
<i>Prunus serotina</i> , black cherry	-	-	-	-	-	-	-	1.34	-	2.70	9.09	-
<i>Quercus</i> spp., oak	72.22	17.54	25.00	30.04	16.39	19.05	-	41.61	30.30	62.16	38.96	23.85
Red oak group	(62.96)	(15.79)	(22.22)	(26.92)	(14.75)	(14.29)	-	(21.48)	(18.18)	(27.03)	(13.00)	(8.26)
White oak group	-	-	-	(2.38)	(1.64)	-	-	(13.42)	(3.03)	(2.70)	(7.79)	(8.26)
<i>Sassafras albidum</i> , sassafras	-	-	20.83	3.48	-	-	-	-	-	-	-	-
<i>Tilia americana</i> , basswood	-	-	-	0.18	-	-	-	-	-	-	-	-
<i>Ulmus</i> spp., elm	20.37	-	2.78	9.96	42.62	-	-	0.00	12.12	2.70	2.60	0.92
Total	100.00	100.00	100.00	100.00	100.00	100.00	100.00	100.00	100.00	100.00	100.00	100.00
ALL WOOD CATEGORIES												
Family, genus, species	65.85	83.82	84.71	90.25	88.41	84.00	100.00	99.33	94.29	92.50	96.25	92.77
Coniferous	1.22	-	-	0.33	-	-	-	-	-	-	-	-
Ring porous	9.76	10.29	5.88	3.14	5.80	4.00	-	0.67	-	2.50	1.25	1.70
Diffuse porous	17.07	5.88	7.06	3.47	5.80	8.00	-	-	5.71	-	2.50	5.53
Unidentifiable	6.10	-	2.35	2.81	-	4.00	-	-	-	5.00	-	-
Total	100.00	100.00	100.00	100.00	100.00	100.00	100.00	100.00	100.00	100.00	100.00	100.00
Number family, genus, species	54	57	72	546	61	21	40	149	33	37	77	218
Total pieces examined	82	68	85	605	69	25	40	150	35	40	80	235
Number of samples	17	11	6	52	9	2	2	10	3	3	7	17

<sup>a</sup>Late Woodland features unassigned to particular component.

The following descriptions on preferred tree habitat in Pennsylvania are from Illick (1928); plant ranges were verified using detailed distribution maps (Little 1971, 1977). Both black walnut (*Juglans nigra*) and butternut (*J. cinerea*) occur locally in rich bottomlands and on fertile hillsides in Pennsylvania. Several of the hickories grow in rich bottomlands; those extending to Memorial Park Site include *Carya ovata* (shagbark hickory), *C. tomentosa* (mockernut hickory), and *C. cordiformis* (bitternut hickory). *C. glabra* (pignut hickory) is most common on dry ridges and hillsides. Oaks that could grow in the bottomlands near the Memorial Park site include *Quercus alba* (white oak), *Q. palustris* (pin oak), and *Q. rubra* (red oak), although red oak will not grow in wet soils. Other upland oaks that grow in the vicinity include *Q. velutina* (black oak), *Q. prinus* (chestnut oak), *Q. coccinea* (scarlet oak), and *Q. ilicifolia* (scrub oak). Of the pines in central Pennsylvania, probably white pine (*Pinus strobus*) is the only one that prefers fertile, moist, well-drained soil. It is common on banks of streams, river flats, and in hollows and ravines. American elm (*Ulmus americana*), slippery elm (*U. rubra*), basswood (*Tilia americana*), wild black cherry

(*Prunus serotina*), beech (*Fagus grandifolia*), and chestnut (*Castanea dentata*) are all found in bottomlands, although not limited to these areas. Sugar maple (*Acer saccharum*) grows best on rich, well-drained soil and is usually found on low ridges at the base of mountains and along slopes in Pennsylvania. Sassafras (*Sassafras albidum*) and big-toothed aspen (*Populus grandidentata*) both grow in abandoned fields and on abandoned charcoal hearths.

The floodplain forest near Memorial Park site was apparently not the usual white-oak-dominated valley-floor-type forest described for the Ridge and Valley Province in Pennsylvania (Braun 1950:226). Instead, the wood charcoal assemblage more closely resembles the forest which Braun describes as following the margin of the Appalachian Plateau in Pennsylvania—a forest with some features of the mixed mesophytic type, some of the oak-chestnut type, and some of the northern hardwoods type. The wood charcoal from the Terminal Archaic and Late Woodland samples also corresponds well with the oak-hickory type described by Illick (1928) for the major river valleys in Pennsylvania. A larger sample must be examined before any definitive statements can be made about the composition of the Middle Archaic forests.

#### BARK

Since it composes the outer layer of firewood, it is not surprising that bark is identified along with "pitch" from all cultural components at Memorial Park Site. What is surprising, however, is that some Archaic samples contained bark concentrations, but there were no Late Woodland features that contained more bark than wood fragments. Early Laurentian Feature 284, defined as noncultural, contained a concentration of 258 burned-bark fragments larger than 2 mm with only one associated wood fragment and one butternut or black walnut fragment. Seven of 16 late Laurentian features contained more bark than wood. The features with bark concentrations were defined as one smudge pit, two fire-related pits and four burned-wood features. One or two fire-related pits out of four Piedmont features contained more bark than wood. Five of 46 Terminal Archaic features contained more bark than wood. They were defined as one cobble hearth, three fire-related pits and one noncultural. Bark was useful for making shelters, fiber, containers, etc.

#### NUTS

Expressed in terms of percentage of total charcoal recovered, nutshell and nutmeats together varied from 3 percent in early Laurentian, to 35 percent in late Laurentian, to a high of 56 percent in the Piedmont sample (Table 255). The Piedmont sample was perhaps skewed by the recovery of a cache of acorn nutmeats in Feature 359. Then percentages drop to 7 percent in Terminal Archaic, 9 percent in Orient, 19 percent in Early Woodland, 2 percent in Middle Woodland, and 8.3 percent overall during the Late Woodland period.

The most abundant and ubiquitous type of nutshell recovered was thick-shelled hickory nut which was found in all cultural components (Table 255). The thin-shelled bitternut hickory was present in minor amounts in the Terminal Archaic, early Woodland, Early Clemson Island, and Late Woodland samples. Although the bitter nutmeats are not considered edible, they could have been used for extracting oil. Acorn nutshell was found in all occupations except late Laurentian, and black walnut was identified in all except early Laurentian, late Laurentian, and Middle Woodland. Butternut was identified less often, but constituted a high percentage of the late Laurentian, Early Woodland, and Middle Woodland nutshell. early Laurentian, *Juglans* fragments were too small and poorly preserved to distinguish them as butternut or walnut. Chestnut was identified in only three out of fourteen Early Clemson Island features. Hazelnuts were recovered in minuscule amounts: one fragment from Terminal Archaic, and two fragments from Early Clemson

Island samples. Beechnuts were absent, although beech wood was identified in minor amounts from Terminal Archaic and Early Clemson Island features.

Table 255. Nutshell Summary<sup>a</sup>

Affiliation	Early Lauren- tian	Late Lauren- tian	Pied- mont	Terminal Archaic	Orient	Early Wood- land	Middle Wood- land	Early CI	Middle CI	Late CI	Stewart	Late Wood- land <sup>b</sup>
<i>Percentage Composition</i>												
<i>Carya</i> spp., hickory	69.57	77.39	5.88	42.75	67.78	25.94	71.43	45.89	91.07	82.38	74.32	87.48
<i>C. cordiformis</i> , bitternut	-	-	-	1.60	-	0.93	-	1.08	0.00	0.00	0.00	2.73
<i>Castanea dentata</i> , chestnut	-	-	-	-	-	-	-	8.48	-	-	-	-
<i>Corylus</i> spp., hazelnut	-	-	-	0.12	-	-	-	0.36	-	-	-	-
<i>Juglans</i> spp.	30.43 <sup>c</sup>											
<i>Juglans cinerea</i> , butternut	-	22.51	-	3.52	-	25.36	14.29	1.06	-	-	2.75	-
<i>J. nigra</i> , black walnut	-	-	17.65	45.15	28.11	46.82	-	1.06	5.36	6.71	16.52	1.74
<i>Quercus</i> spp., acorn	-	-	76.47	6.77	4.11	0.93	14.29	42.06	3.57	10.91	6.41	8.05
Total	100.0	99.9	100.0	99.9	100.0	100.0	100.0	100.0	100.0	100.0	100.0	100.0
<i>Ubiquity (%)<sup>d</sup></i>												
Hickory	18.5	47.1	16.7	43.6	50.0	100.0	33.3	56.3	80.0	-	90.9	57.7
Bitternut	-	-	-	3.6	-	50.0	-	6.3	-	-	-	3.8
Chestnut	-	5.9	-	-	-	-	-	18.8	-	-	-	-
Hazelnut	-	-	-	1.8	-	-	-	6.3	-	-	-	-
Butternut/walnut	18.5	5.9	-	9.1	10.0	-	-	-	20.0	-	-	1.9
Butternut	-	11.8	-	12.7	-	50.0	33.3	18.8	-	-	9.1	-
Black walnut	-	-	16.7	45.5	30.0	100.0	-	18.8	20.0	25.0	36.4	9.6
Acorn	3.7	-	33.3	36.4	10.0	100.0	66.7	68.8	20.0	100.0	18.2	26.9
No. frags. >2 mm	24	746	17	813	73	107	7	554	28	165	78	770
No. samples <sup>27</sup>	17	6	55	10	16	2	3	5	4	11	57	52
No. with nutshell	9	9	3	42	7	2	3	15	5	4	10	38
Nutshell density (g/10 l)	0.1	6.1	0.2	1.1	0.7	4.0	0.2	2.8	0.2	3.4	0.5	1.6

<sup>a</sup>Nutshell identified to less precise taxonomic levels (Appendix G, Table 252) such as Juglandaceae (walnut family) or *Juglans* (black walnut/butternut) have been allocated to more precise categories in proportion to the relative abundance of more precisely identified specimens in the same sampling context.

<sup>b</sup>Late Woodland features unassigned to particular component.

<sup>c</sup>Fragments too poorly preserved to distinguish between butternut or black walnut.

<sup>d</sup>Percentage of the samples in which nutshell type occurs. For "butternut/walnut" category, it is the percentage of samples without specifically identified butternut or black walnut.

Hazelnuts (*Corylus americana* and *C. cornuta*, the beaked hazel) ripen far earlier than the other nuts. In Pennsylvania, hazelnuts ripen in July and August but must be harvested before fully ripe to avoid competition with squirrels. Hazelnut grows at the borders of woodlands, sometimes in thickets.

#### CUCURBITA RIND

*Cucurbita pepo* (pepo gourd, squash, pumpkin) rind was recovered from late Laurentian (4900-5200 B.P.) and Early Woodland samples at the Memorial Park site. The late Laurentian *Cucurbita* consisted of two thin (0.7 mm) rind fragments from Feature 341, in association with 435 bark fragments (both carbonized and uncarbonized), 10 walnut or butternut wood fragments, and 7 hickory nutshell fragments. The fragments may be from a pepo gourd such as found at Archaic sites in Illinois, Kentucky, and Tennessee (Fritz 1990:392). The earliest occurrence of

pepo gourd in Illinois at 7000 B.P. (Conard et al. 1984) represents the earliest evidence of cultivation by eastern North American Indians (Asch and Asch 1985). Decker and Wilson (1987) have proposed that these occurrences are of a native self-propagating species, *Cucurbita pepo* ssp. *ovifera* var. *texana*, a wild gourd occurring along Texas drainages today. Asch and Sidell (1992) offer arguments and evidence to support the interpretation that *C. pepo* was introduced to the Midwest from Texas or Mexico and that the prehistoric remains in the Midwest are a product of cultivation. Further proof that the Archaic occurrences of pepo gourd at archaeological sites cannot be from a naturally occurring native gourd comes from a 6350-year-old feature at the Sharrow site in Milo, Maine (Petersen 1991) where I identified a single pepo gourd fragment that has recently been accelerator dated to  $5695 \pm 100$  years B.P. The pepo gourd fragments from the late Laurentian at the Memorial Park site are the same thickness as the Maine specimen (0.7 mm) and comparable to the 7000-year-old Illinois specimens which vary from 0.6-0.7 mm thick. The Maine and Pennsylvania specimens, far outside of the range where feral pepo gourds are found today, both lend support to the hypothesis of Asch and Sidell that the midwestern specimens are evidence of the first cultivated plant in eastern North America.

Domesticated *Cucurbita* seeds and rind dating to 4000 B.P. have been recovered from Phillips Spring, Missouri (King 1985; Asch and Sidell 1992:259). The uncarbonized rind at Phillips Spring ranged from 0.6 to 1.8 mm thick. By 2550 B.P. at Salts Cave, Kentucky, warty squashes were used as food and containers, with rind thickness varying from 1.9 to 4.3 mm.

At the Memorial Park site, more than ten Early Woodland specimens of *Cucurbita* were found in Feature 110 in association with 306 wood, 65 bark, and 72 nutshell fragments (black walnut, butternut, hickory, acorn). Two of the ten Late Woodland rind fragments caught in the 2 mm sieve are thin (0.5 mm, 0.7 mm), and may represent pepo gourds or a thicker squash in which only the outer exoderm was preserved. The remaining eight Early Woodland *Cucurbita* fragments are thicker than the Laurentian rinds and are most likely squash or pumpkin rather than pepo gourd. The thicker rinds measure 1.4, 1.6, 1.8, 1.9, 1.9, 2.0, 2.6, and 3.6 mm. The thickest fragment had an irregular surface, possibly that of a "warty" squash.

#### MAIZE

*Zea mays* (maize) was recovered in small quantities from Middle and Late Woodland components at the Memorial Park site. One tiny cupule fragment from a Piedmont feature is assumed to be intrusive from a later occupation.

Two of three Middle Woodland features contained a total of 40 maize cob fragments larger than 2 mm, comprising 1.2 percent of all Middle Woodland charcoal recovered. Feature 143, which has been dated to  $1800 \pm 115$  B.P., yielded 19 cupule and 7 glume fragments larger than 2 mm. Two of the cupules were whole (6.5 mm x 2.8 mm, 6.3 mm x 1.7 mm) and, on the basis of cupule angle appear to be from a 10-rowed cob. Maize of this age is uncommon in eastern North America and its presence in early contexts can often be attributed to post-depositional disturbance. However, direct dating of maize fragments, from the Edwin Harness site in Ohio and Icehouse Bottom in eastern Tennessee, confirm that maize was introduced into eastern North America during the Middle Woodland period, about 1800 B.P. (Fritz 1990).

The Late Woodland components at the Memorial Park site produced 238 fragments of maize larger than 2 mm in size, from 50 features (54 samples), comprising 1.2 percent of all late Woodland charcoal recovered. The maize consisted of 54 percent inedible cupule and glume fragments, and 46 percent kernel fragments. Early Clemson Island Feature 123 yielded one measurable cupule (5.2 mm x 1.9 mm) from an 8-rowed cob. Late Woodland components at other sites have also provided evidence that maize agriculture was important to subsistence at this time (Willey 1980; Hay and Hamilton 1984; King 1988). I use the term "agriculture" in the broad sense



of Fritz (1990) to include "all domesticatory behavior and response," not just the practice of field-scale maize agriculture. In Stewart's (1990) synthesis of the Clemson Island studies in Pennsylvania, he notes that the major Clemson Island sites correlate with highly productive agricultural soils, and that maize remains are consistently found at such sites in small quantities. He mentions *Cucurbita* as another cultivated plant found at Clemson Island sites. Seeds from all other plants are considered to be collected from the wild. Willey's (1980) analysis of the Fisher Farm site documents maize, a possible fragmentary sunflower, a single bean fragment, and a single possible pumpkin/squash seed fragment. *Chenopodium* seeds at Fisher Farm site were not mentioned as being different from the wild type. At the Bald Eagle Township Sewage Project site, maize, beans and *Cucurbita* but no *Chenopodium* were recovered (Hay and Hamilton 1984). At the Catawissa Bridge Replacement Site, maize, one bean, one possible tobacco seed, five *Chenopodium*, and 175 possible little barley were found; it is not clear whether the chenopod was wild or cultivated (King 1988).

## SEEDS

Only fourteen seeds were recovered from all of the Archaic occupations at the Memorial Park site (Table 256). Those of possible economic significance include one grape seed from Piedmont Feature 359, one grape seed from Terminal Archaic Feature 205 and one elderberry seed from Terminal Archaic Feature 199. In contrast, all Late Woodland occupations at the Memorial Park site provided a good sample of economically important seeds for study (Tables 256 and 257).

### *Cultivated Seeds*

Of particular interest, 67 percent of the identifiable Late Woodland seeds, excluding maize, were of cultivated plants. The cultivated plants included *Chenopodium berlandieri* ssp. *jonesianum* (chenopod, goosefoot), *Hordeum pusillum* (little barley), *Nicotiana rustica* (tobacco) and possibly *Helianthus annuus* (sunflower). Beans (*Phaseolus vulgaris*) were not recovered, but this does not mean that they were not used. The following is a brief discussion of each type of cultivated seed.

Twenty-one carbonized *Chenopodium* seeds at Memorial Park Site were recovered from four Early Clemson Island features and one Late Clemson Island feature. Those seeds that were mature and relatively well preserved could be divided into two domesticated types. The first type has a very thin testa (seed coat) and truncate margin, as opposed to the thick seed coat and acute margin of a wild type seed. This thin testa eastern North American type, which resembles the modern chia of Mexico, has been named *Chenopodium berlandieri* ssp. *jonesianum* (Smith and Funk 1985). The second type resembles the Mexican cultigen huauzontle in which the outer epiderm is entirely absent, leaving a thin inner epiderm and resulting in a pale-colored seed. Of course in carbonized specimens, we cannot tell the original color of the seed, but I will refer to these as the pale-seeded type of *Chenopodium berlandieri*. Both the thin-testa and pale-seeded types of domesticated *Chenopodium* are found in Illinois and the Ozarks starting about 1500 B.P. (Fritz 1990:398). The Early Clemson Island samples from Memorial Park Site yielded one definite thin testa type and 6 measurable pale-seeded type (Table 258). The one measurable Late Clemson Island seed (Feature 29) was of the pale-seeded type.

*Chenopodium* seeds recovered from other Clemson Island components in Pennsylvania have not been identified to the species level, so we cannot ascertain whether or not they were part of the agricultural complex.

*Hordeum pusillum* (little barley) is by far the most abundant seed type recovered from the Late Woodland occupations at Memorial Park Site. Altogether, 64 percent of the identifiable seeds were little barley. It occurred in 57 percent of the 46 samples containing seeds. Samples from the

Table 256. Seed Summary.

Affiliation	Early Lauren- tian	Late Lauren- tian	Pied- mont	Terminal Archaic	Early Wood- land	Middle Wood- land	Early CI	Middle CI	Late CI	Stewart	Late Wood- land <sup>a</sup>
<i>Percentage Composition</i>											
<i>Amaranthus</i> spp., amaranth	-	-	-	-	-	-	4.31	-	-	-	1.01
<i>Amaranthus/Chenopodium</i>	-	-	-	-	-	-	-	-	-	-	1.01
<i>Chenopodium</i> spp., chenopod	-	-	-	-	-	-	9.09	-	2.67	-	-
<i>Cornus</i> spp., dogwood	-	-	-	14.29	-	-	-	-	-	-	-
<i>Echinochloa</i> spp., barnyard grass	-	-	-	-	-	-	1.44	-	-	-	-
Fabaceae, bean family	-	-	-	-	-	-	-	-	-	-	2.02
<i>Galium</i> spp., bedstraw	-	-	33.33	28.57	-	-	-	-	-	1.25	2.02
<i>Helianthus annuus</i> , sunflower	-	-	-	-	-	-	0.48	-	-	-	-
<i>Hordeum pusillum</i> , little barley	-	-	-	-	100.00	100.00	56.94	93.52	93.33	23.75	36.36
<i>Nicotiana rustica</i> , tobacco	-	-	-	-	-	-	-	-	-	-	1.01
<i>Panicum</i> spp., panic grass	-	-	-	-	-	-	0.48	-	-	-	1.01
Poaceae, grass family	-	-	33.33	-	-	-	3.35	-	-	3.75	2.02
<i>Polygonum</i> spp., smartweed	-	-	-	-	-	-	0.96	0.93	-	1.25	3.03
<i>Prunus pensylvanica</i> , pin cherry	-	-	-	-	-	-	-	-	-	-	1.01
<i>Rhus</i> spp., sumac	-	-	-	-	-	-	2.39	-	-	7.50	1.01
<i>Rubus</i> spp., raspberry, blackberry	-	-	-	-	-	-	0.48	0.93	-	-	4.04
<i>Sambucus</i> spp., elderberry	-	-	-	14.29	-	-	-	-	-	-	-
<i>Solanum americanum</i> , nightshade	-	-	-	-	-	-	9.57	-	-	1.25	3.03
<i>Vaccinium</i> spp., blueberry	-	-	-	-	-	-	-	-	-	-	1.01
<i>Verbena</i> spp., vervain	-	-	-	-	-	-	0.48	-	-	-	-
<i>Vitis</i> spp., grape	-	-	33.33	14.29	-	-	-	-	1.33	1.25	-
<i>Zizania aquatica</i> , wild rice	-	-	-	-	-	-	-	-	-	-	1.01
Type 50	-	-	-	-	-	-	2.39	-	1.33	33.75	-
Type 53	-	-	-	-	-	-	2.39	0.93	-	25.00	26.26
Type 54	-	-	-	-	-	-	0.48	-	-	-	1.01
Unknown/unidentifiable	100.00	100.00	-	28.57	-	-	4.78	3.70	1.33	1.25	12.12
Total	100.00	100.00	100.00	100.00	100.00	100.00	100.00	100.00	100.00	100.00	100.00
Number of seeds	1	3	3	7	1	1	209	108	75	80	99
Seed density (No. seeds/10 g charcoal)	0.5	0.7	0.4	0.3	0.1	0.2	21	130	27	16	5.5

<sup>a</sup>Late Woodland features unassigned to particular component.

Table 257. Economic Categories of Seeds

Affiliation	Early Clemson Island	Middle Clemson Island	Late Clemson Island	Stewart	Late Woodland <sup>a</sup>	Total
<i>Percentage of Identifiable Seeds</i>						
Starchy cultivated (chenopod, little barley)	69.3	97.1	97.3	24.1	41.4	67.4
Oily cultivated (sunflower)	0.5	-	-	-	-	0.2
Tobacco	-	-	-	-	1.1	0.2
Economic starchy noncultivated (wild rice)	-	-	-	-	1.1	0.2
Sweet/sour fruits & berries (pin cherry, sumac, raspberry/ blackberry, black nightshade, blueberry, grape)	13.1	1.0	1.4	10.1	11.5	8.5
Weed seeds (amaranth, barnyard grass, bedstraw, panic grass, smartweed, vervain)	8.0	1.0	-	2.5	9.2	5.0
Other (bean family, grass family, unknown types)	9.0	1.0	1.4	63.3	35.6	18.6
Total	100.0	100.0	100.0	100.0	100.0	100.0
No. identifiable seeds	199	104	74	79	87	543

<sup>a</sup>Late Woodland features unassigned to particular component.

Table 258. *Chenopodium berlandieri* Measurements<sup>a</sup>

Feature	Thin-testa type	Pale-seeded type
2	-	1.7
63	1.8	1.8
	-	1.5
	-	1.5
83	-	2.1
	-	1.7
	-	1.7
29	-	1.8

<sup>a</sup>Maximum diameter (mm)

Early Woodland and Middle Woodland components each contained one little barley seed. Since the seeds are so tiny, it is uncertain whether the lone seeds are in situ or the result of bioturbation.

Central Pennsylvania is almost certainly outside of the early historic range of little barley. Little barley's prominence in Illinois since Early Woodland times, and at Middle Woodland and later sites, ranging from Arizona to Oklahoma to Wisconsin and to West Virginia, North Carolina and Alabama, provides the best evidence that it was cultivated (Asch and Sidell 1992). Many of these locations are outside of the early nineteenth-century range of little barley. Hundreds of carbonized little barley seeds have been found in association with other seeds known to have been cultivated (chenopod, maygrass, knotweed). Interestingly, at Catawissa Bridge Replacement Site on the Susquehanna River in Columbia County, the Late Woodland components yielded a little barley-like seed comprising 83 percent of 211 identifiable seeds (King 1988). Five *Chenopodium* seeds were also recovered, but not identified to species.

Tobacco seeds are seldom found at archaeological sites because of their very small size. At the Memorial Park site one tobacco seed, presumably *Nicotiana rustica*, was found in a Late Woodland sample, Feature 81, containing only 0.4 g of charcoal recovered from 2 liters of soil. Feature 81 was classified as a charcoal stain.

One *Helianthus annuus* (sunflower) seed kernel was found in Early Clemson Island Feature 172, classified as a "stain." The kernel measured 3.9 mm x 1.7 mm. Correcting for the missing seed coat and for shrinkage due to carbonization using Yarnell's (1978) method, the estimated achene seed size is 5.1 mm x 2.5 mm. This size is generally considered too small to be from a cultivated sunflower. It falls within the size range of a wild or ruderal sunflower.

#### *Economic Starchy Noncultivated Seeds*

Other economically important plants found in the Late Woodland components at the Memorial Park site include one grain of wild rice (*Zizania aquatica*) from Late Woodland Feature 134, a "burned area." Wild rice is a tall grass of marshes, stream borders and shallow water. It will grow in water from one to twelve feet deep but is most productive in water four to five feet deep. In Minnesota, it ripens over a period of 10 to 14 days, from August 18 to September 12 (Vennum 1988:17).

#### *Fruits and Berries*

About 8.5 percent of all Late Woodland seeds were those of fleshy fruits and berries as well as *Rhus* spp. (sumac), a nonfleshy fruit with acidic hairs, used for making beverages and

medicines. The fruits and berries included *Solanum americanum* (black nightshade), *Prunus pennsylvanica* (pin cherry), *Rubus* spp. (raspberry, blackberry, dewberry), *Sambucus* spp. (elderberry), *Vaccinium* spp. (blueberry), and *Vitis* spp. (grape). These fruits were available from late summer through late fall, and could be dried and stored for winter use.

Black nightshade comprised 52 percent of the fruits and berries, with 24 seeds occurring in seven samples. In westcentral Illinois and the American Bottom, the occurrence of black nightshade is associated with the period of intensive horticulture (Asch and Asch 1985:388). Today, black nightshade is widely distributed in open or disturbed habitats. Since it has not been recorded at Archaic sites, it is presumed that disturbances associated with prehistoric agriculture permitted an increase in the plant's abundance. The unripe berries contain a toxic glucoside, but the cooked ripe berries are generally considered edible.

Pin cherry ripens in July and can be found in recent clearings, abandoned fields, and burned areas. Raspberries, blackberries, dewberries and elderberries likewise grow in abandoned fields. Blueberries tend to grow in dry woods, clearings and thickets; they ripen from late July through September. At least three species of grapes grow in bottomlands in central Pennsylvania. The riverbank grape (*Vitis riparia*) ripens in August and September. The other bottomland and two upland species ripen in September and October. Sumac generally grows in dry soil and ripens in June and July. The edible elderberry (*Sambucus canadensis*) prefers damp rich soil and ripens in June and July.

#### *Weed Seeds*

Five percent of the Late Woodland seeds can be considered possible weed seeds, although some of them were occasionally used as food or medicine by some Indian groups. The seeds included in this category are *Amaranthus* spp. (amaranth), *Echinochloa* spp. (barnyard grass), *Galium* spp. (bedstraw), *Panicum* spp. (panic grass), *Polygonum* spp. (smartweed) and *Verbena* spp. (vervain). The weed seeds are most likely a byproduct of agricultural activities.

#### *Other Seeds*

Other seeds identified to family level, or unknown-type status, composed 18.6 percent of the Late Woodland seed sample. Two bean-family seeds may be *Desmodium*, but poor preservation made identification uncertain. Twelve grass-family seeds were very poorly preserved and consisted of more than one type.

Type 50 (33 seeds) may be from a small fruit, like huckleberry, but the tiny (1.6 x 1.3 mm) wedge-shaped seeds remain unidentified at present. This writer has also identified them in sites from Maine and New York state.

Type 53 is a tiny (1.6 x 0.8 mm) rimmed seed, flat on one side, possibly with two seeds per (non-fleshy?) fruit.

#### SUMMARY AND CONCLUSIONS

The Memorial Park site is located in a wide floodplain in a region of oak-hickory forests. Archaeological wood analysis suggests that the prehistoric forests near the site grew on a rich, moist, well-drained soil. Most abundant were oaks, hickories and walnuts, with lesser amounts of pine, elm, sugar maple, black cherry, ash, beech, chestnut and others.

All groups inhabiting the site made use of the wide variety of nuts that would have been available nearby, from Late Archaic through Late Woodland times. Hickory nuts and acorns were most frequently found in the flotation samples, followed by black walnuts. Other nuts utilized at

various times were butternuts, chestnuts, bitternuts and hazelnuts. Many features contained a mixture of nut types and seeds, an indication that nuts and dried fruits may have been stored for later use. This was most evident in the Late Woodland samples but even occurred in the late Laurentian. For example, late Laurentian Feature 35 contained a large amount of hickory and butternut shell with two tiny fragments of hazelnut. The hazelnut would have been collected one to two months earlier than the other nuts.

Two carbonized rind fragments suggest the first plant to be cultivated at the Memorial Park site was *Cucurbita pepo*, most likely a pepo gourd, used for containers during the late Laurentian occupation (4900-5200 B.P.). Several thicker rinds from a pumpkin/squash were recovered from early Woodland contexts.

More than 40 maize cob fragments, recovered from two of three Fox Creek features, signify that maize agriculture was introduced to the site at about 1800 B.P. The presence of inedible cob fragments indicates that maize was probably grown nearby and processed at the site. Maize of this antiquity is uncommon in eastern North America; most maize is recovered from sites dating after about 1000 B.P. Only one seed, that of little barley, was found in the Memorial Park site Middle Woodland features. From the evidence recovered during this project, it appears that the cultivation of native plants did not precede the adoption of maize agriculture in central Pennsylvania, as happens in the Midwest and the central Ohio River valley.

Seed assemblages changed dramatically at about A.D. 760 with the beginning of the Clemson Island occupations at the Memorial Park site. This can be directly attributed to the increased use of agriculture by the Late Woodland cultures. In addition to maize and tobacco, the Clemson Island people grew two types of the native domesticate *Chenopodium berlandieri*, as well as *Hordeum pusillum*, little barley. Although squash/pumpkin rind and beans were not recovered from Late Woodland features at the Memorial Park site, they have been found in small quantities at other Clemson Island sites in Pennsylvania. Pumpkin rind can be uncommon, even at sites where ethnohistoric evidence indicates that pumpkin was an important food source (Asch and Asch 1975). Sunflower may also have been grown, but the single seed recovered appears to be from a wild or ruderal plant.

Little barley is a cool season grass which ripens in late May or early June. Growing little barley extended the harvest season into early June when few fruits and grains are available for consumption in the wild. The most abundant Late Woodland fruit, black nightshade, is from a plant associated with agricultural disturbances at archaeological sites in the Midwest. There was also an increase in types of weed seeds, possibly associated with agricultural activities. The lack of an Early Woodland and Middle Woodland archaeobotanical sample made it impossible to determine if the cultivation of native plants preceded the adoption of maize agriculture in central Pennsylvania.

Although few seeds were preserved in the Archaic samples, this does not mean that fruits and berries were not utilized. They may have been consumed fresh at the site of collection. Another possibility is that more fruits were available during the Late Woodland period due to greater land clearance for agriculture. If fields were abandoned periodically, the old fields would be ideal locations for collecting many fruits and berries. Fire is a factor affecting vegetation in some areas, where land is cleared for agriculture. The recovery of a pin cherry (also known as fire cherry) pit suggests that fire may have been a factor in creating the vegetation found near the site. However, the effect of fire was probably not very extensive since many of the wood species identified (beech, maple, walnut, basswood, etc.) do not tolerate fire.

In the Midwest, it has been demonstrated empirically that successive occupations at a site frequently show differences in archaeobotanical sample composition which are so consistent that plant remains can be used for stratigraphic analysis (Asch and Sidell 1988). Sites in the Northeast

have not undergone the kind of extensive quantitative analysis of plant remains that has been carried out in the Midwest for the past 20 years. Perhaps the greatest value of the present analysis is that it establishes a baseline for comparison with future analyses of plant remains in Pennsylvania.

### XIII. FAUNAL ANALYSIS

by

Cheryl A. Holt

Late Woodland prehistoric sites present diverse and complicated interrelationships between the acquisition, storage, and consumption of food, and the disposal of food byproducts. The Late Woodland period represents the culmination of a dynamic transition throughout much of eastern North America, from primarily hunting and gathering subsistence strategies to subsistence strategies based on agriculture. The current analysis examines the faunal resources that Late Woodland inhabitants of Memorial Park exploited while undergoing these critical changes.

Faunal specimens were examined in order to advance understanding of resource availability, resource selection, and procurement. This research capitalizes on the unique interplay that dietary regimes have with culture and the environment, and examination of faunal resources considering seasonality, diversity, stability, mobility and environmental abundance of the identified species.

The recovery of deer, rabbit, opossum, raccoon, squirrel, turtle, pigeon, bobwhite quail, undetermined sunfish, catfish, perch, shad, shiner, sucker, and mollusk suggests a varied exploitation strategy employed within an eco-zone that appeared to be rich in available wildlife. The abundance of recovered fish and warm-season microfauna suggest that the site area was intensively utilized during the summer months.

#### METHODOLOGY

Bones and bone fragments were identified anatomically, and speciated with the aid of a comparative faunal collection and reference materials (Schmid 1972; Chaplin 1971; Cornwall 1956; Olsen 1964, 1968, 1979; Ryder 1969; Morris 1975; Gilbert 1973). Special thanks are extended to the Department of Archaeological Research at the Colonial Williamsburg Research Foundation in Williamsburg, Virginia. Jo Ann Bowen and Stephen Atkins generously gave of their time and energy in evaluating fish remains from this site. Their contributions greatly promoted accuracy of fish species identification.

Descriptive data were recorded on catalog sheets. Each bone and bone fragment was counted, and weighed to the nearest gram. Some bone was enmeshed in matrix which disallowed accurate weighing. The bone was quite fragile and removal from the matrix, was not practical. Bone contained in matrix is listed as such on catalog sheets. Where possible, each bone was described by taxon, element fragmentation, segment of portion, and side. Bone fragments which crossmended, or articulating bones which fit together, were noted. Bone modification by burning was noted as to whether the specimen was charred to a black, gray or white condition. Bones were measured according to Von den Driesch (1976). Measurements were recorded in millimeters or centimeters.

#### COMPUTER ENTRY OF FAUNAL DATA

The cataloging procedures for faunal data were as follows. The first delineation of data was made at the category "Type." Faunal data was listed as mammal, bird, reptile, fish,

amphibian, or mollusk. The second computer catalog entry was "Name" and Latin species nomenclature for faunal data was entered. This category indicates the level of identification: whether the precise species and family could be ascertained in analysis. "Undet" indicates that the specimen could not be identified to either species or family. The next data entry category was "Common Name," if the name that is recognized as describing a specimen, such as deer or rabbit. Entries listed only as mammal or bird are those that cannot be identified more specifically. The next data entry category is "Element." The range of entries includes the precise skeletal element such as humerus proximal fragment, or a less precise element definition, such as long-bone fragment. Nondiagnostic (ND) appears in this category when the skeletal element cannot be determined.

The data entry "#" is the count number of recovered specimens. The category labeled "Wgt" is a gram weight. The data entry column "X" is used for bones that crossmend. If the specimens do crossmend, the entry will indicate "= the number of recovered fragments." In cases where fragments crossmended, the adjusted figure was listed in data entry # column. This was done so that computerized totals would reflect adjusted totals rather than inflated totals before adjustment. The columns "L" and "R" denote the side from which the skeletal element was recovered and, when that can be determined, it will either be L for left or R for right.

"CB" is the entry column for specimens charred black. "CG" is the entry column for specimens charred grey. "CW" is the entry column for the specimens charred white. "Measure" is the column which includes measurements of bone length in centimeters. The comment column can include the notation SL, which means that the bone is split longitudinally. This column can include data concerning epiphyseal fusion, porous or spalling specimens, and bones that are contained in matrix. This category can also indicate bones that do or do not crossmend with bones in adjacent levels. Notations about tooth wear are in this column.

## RESULTS

The gross total of Late Woodland faunal specimens was 5,610. Table 259 lists the number of fragments recovered for each species, reflecting crossmending. Once fragments of the same bones were matched and mended, the gross totals changed. The total of faunal elements after crossmending was 5,541. For example, from Feature 78, twenty-eight deer molar fragments were recovered. The fragments mended together and were given a count value of one. To facilitate analysis, these adjusted totals were used in the remainder of the text, tables, and analysis. Crossmend calculations are noted in the catalog sheets. Table 260 describes the distribution of faunal specimens by feature.

Spalling or crumbling specimens were noted as such in the catalog sheets. Twenty-five percent of the assemblage was highly diagnostic. The remaining 75 percent of the specimens were small fragile fragments which could not be identified with more specificity than classification to mammal, bird, mollusk or fish status.

### *Variables Affecting Bone Survival*

Bone, horn, teeth, antler, and shell are the most abundant faunal remains recovered in archaeological investigations. Bone is made up of calcium phosphate, lesser quantities of calcium carbonate, and other trace elements and compounds. The mineral salts impart a rigidity and hardness to the bone; the organic compounds give it resilience and toughness (Carbone and Keel 1985:1-19). Because of bones' organic content, they are subject to insect, fungal and rodent attack, both in and out of the soil (Carbone and Keel 1985:1-19). Since microorganisms have been shown to be one of the primary causes of decay, it is reasonable to assume that an analysis of the



environmental tolerance of these organisms will give insight into the kinds of situations that are favorable to preservation of animal remains. The conditions that are favorable to preservation are those that are reflected in our daily kitchen activities: boiling, freezing, pickling, and salting inhibit decay.

Table 259. Late Woodland Faunal Distribution.

Common Name	Count	Weight	CB	CG	CW
bobwhite	5	4.4	0	0	0
catfish	167	15.2	0	0	0
deer	93	263.8	4	3	4
frog	2	0.3	0	0	0
landsnail	2	0.3	0	0	0
large mammal	5	11.3	1	0	0
medium mammal	1	1.3	0	0	0
opossum	1	4.2	0	0	0
perch	85	4.3	0	0	0
pigeon	4	3.1	0	0	0
rabbit	9	11.3	0	0	0
raccoon	1	3.1	0	0	0
shad	6	0.3	0	0	0
small mammal	1	0.7	0	0	0
squirrel	7	4.5	0	0	0
sucker	1,009	67.9	0	0	0
sunfish	6	0.7	0	0	0
turtle	9	17.1	0	0	0
undetermined bird	65	15.8	1	0	18
undetermined fish	1,068	61.4	3	0	0
undetermined mammal	2,959	474.1	387	382	1,023
undetermined mollusk	36	16.0	0	0	0
Total	5,541	981.1	391	385	1,045

Soil acidity has an impact on bone preservation. If the environment is acidic, then the mineral content will be removed. Bone will not survive under conditions where the pH is lower than 6.3; the same holds true for shells. In considering the preservation of bone, the effects of humans must be taken into account because culturally-modified bone, whether boiled or cracked will be more susceptible to environmental forces (Carbone and Keel 1985:14). The effect of the chemical environment on teeth will be somewhat muted since dentine, although chemically similar to bones, contains less organic matter and more phosphate and carbonate. Enamel, which is the hardest, contains the least organic matter and is still more resistant. Teeth will be affected by acidic conditions in the soil but are more likely to be found preserved, although generally they will be somewhat etched (Carbone and Keel 1985:14).

Fire is an agent which can impact faunal material, not only because it can directly cause damage, but because it interacts with other agents to enhance destruction. Fire can alter chemical properties of soils such as pH, and percentage of nitrogen, potassium and sulfur (Wildesen 1982:68). Burning of bones may result as a byproduct of roasting, or from disposal in a hearth. Accidental or purposeful exposure of bone to fire alters the calcium content of bone. If a fresh bone is burned it does not necessarily alter its shape, but it does lose weight and become very friable. The destruction of organic material in bone through burning can shrink it from 5 to 15 percent and reduce its weight by 50 percent (Wing and Brown 1979:109).

Table 260. Distribution of Faunal Specimens by Feature

Taxon	Feature																Total							
	29	51	52	55	57	61	63	73	74	78	80	83	89	92	96	106		107	112	123	152	155	160	
Bobwhite																								5
Catfish				8		43				109							7							167
Deer				10		9			3	25				1	444		1	28						93
Frog										2														2
Landsnail										1				1										2
Large Mammal						2			3															5
Medium Mammal									1															1
Opossum						1																		1
Perch						23				61							1							85
Pigion										4														4
Rabbit						4			3	1										1				4
Raccoon										1														1
Shad																								6
Small Mammal																								6
Squirrel						2			1															1
Sun Fish				3																				3
Sucker						241				735					7									1009
Turtle						2				2								1						7
Undetermined Bird				4		19				3							2							9
Undetermined Fish						207			6	3							8							65
Undeterm. Mammal				1		39				794					1		17	1						1068
Undeterm. Mollusc				2		933		1	12	179	201	7	3	18	4	2	19	139	13	1151	5	13		2959
Total	1	2	1	341	5	1	1513	1	12	202	1947	9	3	20	12	2	47	179	13	1212	5	13		5541

## *Bone Modification*

*Charring.* Of the recovered faunal elements, 1,821, or almost one-third, were charred. Burned bone indicates direct contact with fire or coals. Heat can result in the blackening of bone. Deeply blackened bone may suggest that flesh was still present during the burning (Brothwell 1971:19). Charring of bone during roasting is confined to the exposed ends of the bone not protected from the fire by meat. Burning at high temperatures for prolonged periods can leave the bone pure white, friable, soft and porous, suggesting complete oxidation. Some burned bone that is not completely calcined does not reach the fragile state and, although light in weight, may be quite strong (Carbone and Keel 1985:7).

It is of interest to note that not all of the bone was charred in an even fashion. Burned bone ranges in color from white through grays, and blues to black, depending on the completeness of its combustion (Wing and Brown 1979:109). Some bones of the assemblage were only slightly charred while others, within the same context, were whitened. Table 259 denotes the degree of charring for recovered species. A total of 399 specimens were charred to the black state; 391 specimens were charred grey; and 1,076 were charred white. This suggests uneven exposure of the bone to the fire, which may reflect successive fires. Bones exposed to repeated and prolonged fires would exhibit more modification than bones entering the hearth area at a later time. Bones might be exposed to less prolonged burning, if deposited a short time before the hearth area was cleaned. Debris could have been raked away from the hearth or removed to a trash pit.

Sixty-six percent of the charred material recovered from the hearth (Feature 55) were charred to the white state. The Midden Features (Features 91 and 128) contained very little charred material. All 12 of the recovered faunal elements from the Small Pit Feature 74 were charred to the white state. The single faunal specimen recovered from the Large Post Mold Feature 73 was charred white. Eighty-four percent of the charred specimens from the Shallow Pit (Features 61, 89, 107, and 109) were charred white. In all, 608 charred specimens were recovered from the Pit Features (Features 123, 152, and 155). Sixty-nine percent of the charred specimens from the Pit Features were charred white. A total of 1,003 charred specimens was recovered from the Large Pit Features (Features 51, 57, 63, 78, 80, 83, 92, 96, 112, 126, 160, and 106). Fifty-four percent of the total assemblage of the Large Pit Features was recovered in the charred state. Of those 1,003 charred specimens, 315 (31%) were charred black, 203 (20%) were charred grey, and 488 (49%) were charred to the white state.

*Gnawing.* No bones examined from the samples under study had evidence of gnawing marks. If refuse is left in an open space it is often vulnerable to modification by predation of scavengers. If trash is buried or covered, then scavengers are less likely to gain access to it. Gnawing modification can suggest that the bones were deposited in such a manner which allowed predation to occur.

*Broken Longitudinally.* Previous approaches to understanding the significance of broken and modified bone suggested that 1) humans break bones "longitudinally," whereas animals break them transversely (Breuil 1938:58); 2) the "crack and twist" method of fracturing bones was for tool production rather than marrow extraction (Dart 1959:91); and, 3) midshaft smashing for marrow is indicative of human behavior (Bonnichsen 1979:69).

Binford (1981:41) presents strong arguments that spiral bone fracture is not unique to man; that man does not generally break bones by the "midshaft smash technique" and that spiral fracture, when produced by animals, is not limited to an origin at the distal ends of the bones.

In total, 166 bones and bone fragments were split longitudinally. In light of Binford's arguments it is prudent to assert that this can occur without man being the exclusive causal agent.

Longitudinal breaks can occur as a result of animal chewing, breakage by foot traffic, or deliberate breakage by humans for marrow extraction.

Eleven deer bones, 8 bird bones, 1 large mammal long-bone and 146 mammal long-bone fragments were split longitudinally. The deer bones, which were split longitudinally, included a metatarsal, four phalanges, two radii, a tibia, two metacarpals, and a lower mandible. Feature 152 and Feature 63 contained the highest frequencies of bone which had been split longitudinally.

*Cut Marks.* Five specimens exhibited traces of cut marks. Cutting with stone tools requires a much less continuous action than cutting with a metal knife, and results in a series of short, parallel strokes. Marks from stone tools tend to be short, occurring in groups of parallel marks, and have a more open cross section than metal knives (Binford 1981:105). Cut marks are derived from different stages of processing a carcass. This sequence is usually 1) skinning, 2) dismemberment, 3) filleting for consumption or storage, and 4) marrow consumption (Binford 1981:106).

Binford (1981:106) asserts that there are actually very few places on the anatomy where the manipulation of the skin brings the butcher in direct contact with bone. The two places where this is most likely are the lower legs and the head. Binford states (1981:107) that such cuts have been observed on the lower tibia, the shaft of the metatarsal, and the phalanges. In Feature 92, a distal tibia from a deer exhibited a cut mark. If the head is skinned out, one might expect cut marks around the base of the antlers or horns, around the mouth, particularly in the "chin" area of the mandible. The lower mandible of an opossum with three parallel cut marks was recovered from Feature 63. In keeping with Binford's analysis, the cut marks from the tibia and lower mandible are likely to be result from the skinning process.

Dismemberment consists of disarticulation; therefore, cut marks are associated with points of articulation. Binford (1981:113) states that there are three locations for cut marks inflicted on the ribs and sternum during primary butchering. Transverse marks, derived from the removal of the tenderloin, occur along the dorsal surface of the rib just to the side of the proximal end of the rib. The second most common mark results from cutting off the distal end of a rib during the removal of the sternum from the ribs. Another place where cut marks may occur is across the ventral surface of the rib, close to the proximal rib head. This cut derives from the removal of a rib slab from the spinal column. A midsection of a deer rib, recovered from Feature 152, exhibited a cut mark. This bone specimen was labeled as midsection because neither end was present. While it is likely that this cut was the result of disarticulation, the specimen was not complete enough to evaluate, using Binford's categories.

The distal portion of a deer's left calcaneus was recovered from Feature 55, and it exhibited a butchered surface. Binford classifies a cut at the distal end of the calcaneus as resulting from dismembering or filleting (1981:139).

A long-bone fragment 2 cm long was recovered from Feature 123. The fragment exhibited a cut mark, and was split longitudinally. Binford explains that when bones are prepared for marrow cracking, they are typically cleaned by cutting off adhering sections of meat or tendon that would modify the way the bone would break (1981:134). It is of interest that this specimen exhibited the characteristics described by Binford as "a mark produced during the preparation for consumption."

*Spiral Fracture.* Binford has argued that the "crack and twist" method is not essential to a spiral fracture but, rather, appears to be a product of green bone breakage (1981:148). Binford has further argued that spiral fracture itself is not a characteristic diagnostic of man, but can also occur by animals and other agents (Binford 1981:148). Nevertheless, man does characteristically break

bone for marrow. Marrow cracking can occur during butchering episodes, at hunting stands and camps, at residential camps, and at meals.

The marrow bone to be cracked is generally held by the most robust articulator end, and initial impact is just below the neck of the more compact articulator end. The initial heavy blow normally results in considerable fracture developed through the shaft of the bone, and the resulting splinters are peeled back. The peeling back exposes the cylinder of bone marrow, which can be picked up and either eaten or added to an accumulating pile of marrow (Binford 1981:163).

Three bones from the assemblage exhibited distinctive spiral breaks. A deer metacarpal (Feature 152), a deer humerus (Feature 80), and a long-bone fragment unidentified as to species (Feature 63), were identified as having spiral breaks. Binford explains that metacarpals are sometimes broken for marrow in hunting camps, and humeri are more likely to be broken at a residential camp (1981:158). Binford explains that consumption in hunting camps is done quite expediently and as a partial function of the sociality of the moment. Most of the bones which are marrowed at residential sites are processed during meal preparation. Marrow bones could be collected for several days, and then processed at one session (Binford 1981:158).

### *Species Recovered*

*Deer.* Historically, deer was the most prominent game species in eastern North America, and its importance as the foundation of eastern Archaic economy has been discussed by numerous researchers (Keene 1981:101). Deer have adapted to a wide variety of habitats. Particularly favorable habitats include swamps, forest borders, and cedar glades (Keene 1981:101). Deer density is linked to availability of food and the degree of predation. It is estimated that white-tailed deer densities range from 10-80 per square mile in the Eastern Woodlands (Shelford 1963:26). Intentional burning of forest at regular intervals would have an effect on the composition of plant communities. The burning would increase the carrying capacity of deer in the environment (Day 1953). Paul Mellars suggests that the burning of woodland areas would increase deer productivity by a factor of 10. Mellars further suggests that prehistoric hunters intentionally burned forest areas to increase deer populations (Mellars 1976).

The white-tailed deer is not a colonial animal, although it can be found in small groups. Home range is small, perhaps no greater than 0.12 square km to 2.6 square km (Keene 1981:102). Deer undertake two annual migrations, one in early winter and another in late spring. Their movements are predictable, and they tend to return to the same ranges year after year. In the summer, deer form loose and variable groups of two to four, though the bucks may be solitary. In winter, deer sometimes form bands at favorite feeding grounds; however, aggregations are largest in the fall just prior to rut. "Ethnohistorically, deer were procured throughout the year, though this activity was most intense in the fall" (Keene 1981:104).

Deer are subject to dramatic seasonal weight changes. Males in rut may lose up to 25 percent of their weight in the course of 9 weeks of rut. Females can lose 12-17 percent of their body weight during the breeding season. Deer are at their maximum weight during the late summer and fall and it is at this time that fat content is the highest and hide is in prime condition. Normal deer weights range from 85-96 kilograms for males, and from 57 to 63 kilograms for females (Keene 1981:103-104).

A total of 136 deer elements, with a gram weight of 263.8, were identified. After crossmending adjustments, the total for deer came to 93. The deer elements recovered were: molar, premolar, incisor, mandible, skull, phlange, humerus, pelvis, astragalus, tibia, fibula, cuneiform, metacarpal, metatarsal, and carpal/tarsal.

Table 261 delineates the deer elements recovered from each feature. Elements included in the "head" category include enamel fragments, mandibles, incisor, molars, and skull orbit. Elements included in the "foot" category include metacarpals, metatarsals, phalanges, pisiforms, calcanei, carpals, cuboids, and cuneiforms. Seventy-three percent of the deer assemblage is comprised of head and foot elements. It is interesting to note that no femurs were recovered. Only a section of one humerus was recovered. Numerous skeletal elements are not represented within the deer assemblage. The elements which represent the largest meat values from the animal are not present. The highest percentage of the assemblage is represented by marginal food value elements or waste elements.

An argument could be made that the meatier deer elements were transported elsewhere. However, Binford criticizes the "schlepp effect" as a methodological principle (1981:185), whereby it is thought that faunal parts that yielded low food returns were not transported as far as those of higher value. Binford asserts that this proposition is faulty because it assumes that all sites are either kills or residences, and it also assumes that decisions to transport bones and process meat are always made in the same way (1981:185).

Perhaps this manifestation in the deer assemblage is a function of taphonomy. Densely constructed phalanges and other foot components, as well as enamel, have physical properties which enhance preservation. The recovered deer bone is represented by dense durable bones and enamel, which have a greater chance of survival than do more porous and ultimately more vulnerable bones. While it is possible that this archaeological manifestation of deer remains is the result of taphonomic variables, it seems unlikely that taphonomic variables alone are responsible for such a skewed deer representation.

It is possible that the larger deer elements, such as the femur and humerus, are not highly represented within the assemblage because of bone marrow extraction or rendering of bone grease. In rendering grease and fat, bones are pounded so as to increase the surface area of the bone exposed. These fragments are then boiled, which renders the grease. Splitting and pulverizing the articular ends is an integral part of this processing (Binford 1981:166). Bone marrow extraction does not have the same destructive consequences upon bones. The most likely bone part discarded after marrow extraction is an articular end with very little attached diaphysis. Long-bone articular ends were not recovered in enough abundance to suggest a pattern of marrow extraction. However, an abundance of cylinder fragments was recovered, sufficient to suggest that grease extraction may be responsible for the lack of identifiable femur and humerus elements. Crushing, and further bone degradation by boiling, would likely result in a high frequency of long-bone fragmentation.

The elements recovered from Feature 55 are primarily from the head and foot of the deer. A skull orbit fragment, and mandible fragments, are from the head. The calcaneus, metacarpal, and cuboid represent the foot portion. The thoracic vertebrae fragment and the vertebrae epiphysis represent meatier portions of the deer carcass.

It was from the features defined as storage pits that the most deer elements were recovered. Feature 63 contained phalanges and mandible as well as radii, tibia and vertebrae. From Feature 78, only foot (cuboid, pisiform) and head (molar) elements were recovered. From Feature 107, only one enamel fragment was recovered.

Fifty-six percent of the total deer assemblage was recovered from Features 80 and 112. Feature 112 contained only enamel and mandible fragments. Feature 80 contained incisor, phalange carpal, metacarpal as well as rib, vertebrae, radius and tibia.

Table 261. Late Woodland Deer Element Distribution.

Feature	Element	Count	Left	Right	Weight	X	CB	CG	CW	Measure(cm)	Comments	
55	skull orbit f	2			4.8					4x2, 2x1.5		
	calcaneus	1	1		22.7	=2				4.5x4	cut	
	MC III dist	1			2.6					2x1.8		
	thoracic vert f	1			1.9					3	spine	
	cuboid	1			7.6					3.5x3.5		
	mandible f	2			3.1					4-4.5		
	phalange f	1			2.1		2			2		
	vertebrae epiph	1			0.5					2		
	Totals for Feature 55		10			45.3		2	0	0		
	63	vertebrae epiph	1			4.3						SL
MT f mid		1			2.7		1				SL	
phalange 2		1			2.9					4		
mandible lower		1			2.7					3.5		
radius f mid		1			3.7					2.5	SL	
radius f		2			4.3				2		SL	
tibia		1	1		7.9	=4				2.5-6.5	SL	
phalange		1			4.1		1	1	1	2		SL char 3
Totals for Feature 63		9			32.6		1	2	3			
78		cuboid f	1			1.6					1.5x1	
	pisiform f	1			0.2					.5x.5		
	molar f	1			4.1	=28						
	Totals for Feature 78		3			5.9		0	0	0		
80	radius epiph	1			3.7							
	rib mid	1			0.6					2		
	fibula mid	1			1.2					4		
	incisor	1			4.0							
	carpal	3			6.3							
	lumbar vert f	1			2.7							
	MC 2 prox	1			2.5							
	phalange epiph	1			2.1							
	rib mid	1			1.6							
	thoracic vert f	1			2.1							
	humerus mid	1			13.4	=4						
	radius prox	1			10.2	=2						
	rib mid	1			5.6							

Table 261 (continued)

Feature Element	Count	Left	Right	Weight	X	CB	CG	CW	Measure(cm)	Comments
80 cont.										
tibia distal	1	1		6.9						
vertebrae epiph	1			0.4						
MT prox f	1			8.3						
phalange 3 IV	1			3.2						
phalange 3 V	1			1.9						
phalange f	2			2.9						
rib mid	1			5.7						
rib mid	1			2.4						
vertebrae epiph	1			1.3						
Totals for Feature 80	25			89		0	0	1		
92										
tibia distal	1			8.9		1			2x4.5	cut SL
107										
molar f	1			1.6						
112										
mandible lower	1			7.6	=2				7	
molar f	20			2.2						
molar 1	1			1.7					1.6x1	not worn
mandible lower	1			1.6					4	SL
molar 1	1			1.9	=4					
molar f	4			0.6						
Totals for Feature 112	28			15.6		0	0	0		
152										
phalange 2 dist	1			1.2					2.2x1.1	
phalange 2 prox	2			2.5					1.5x2	
phalange 2 f	1			1.6					2	
molar 3	1			2.8	=2					no wear
cuneiform	1			1.3				1	1x0.7	
phalange 2 prox	1			1.6					2x1.2	SL
cuneiform	1			1.1					1.4x1	
pelvis tuber iscl	1			7.3					4x3	
phalange 1 mid	1			2.7					4x1	
phalange epiph	1			1.6					1.7x1.6	
rib mid	1			1.9					2x2.5	
rib mid	1			2.9					2.8	cut



Table 261 (continued)

Feature Element	Count	Left	Right	Weight	X	CB	CG	CW	Measure(cm)	Comments
152 MC	1			13.7	=4				2-4.9	SL
cont. MC prox	1			6.3					2x2.7	SL
MC distal 1/3	1			16.4					3x5	spiral break
Totals for Feature 152	16			64.9		0	1	0		
TOTALS	93			263.8		4	3	4		

Feature 152 contained metacarpal, phalange, cuneiform, and molar, as well as rib and pelvis.

*Rabbit.* The rabbit has a wide habitat tolerance but prefers areas of dense brush, edges of swamps, and open woods (Keene 1981:108). Rabbits are primarily solitary animals. They have a limited home range; however, their mobility increases during the February to March breeding season. There are erratic population fluctuations. They are quite prolific but are heavily preyed upon. It has been estimated that 75 percent of the population is lost each year (Keene 1981:108).

Rabbits may have been captured by snares; however, Keene reports that the Huron had limited success in trapping rabbits because the animals easily broke or cut through the snares (Keene 1981:108).

Nine rabbit elements were recovered from the site area. A tarsal, an incisor and a vertebrae fragment were recovered from Feature 78. A skull orbit, two phalange IIIs, and a phalange III fragment were recovered from Feature 63. A phalange was recovered from Feature 152, and a molar was recovered from Feature 80.

*Raccoon.* Raccoon were an important game species prehistorically in the eastern United States (Smith 1975:42-52). Raccoon are common to wooded areas especially along streams and lakes. They prefer old hardwood timber, particularly where there are trees with hollows near water (Keene 1981:108). Raccoon are fond of acorn mast when it is available but generally subsist on a diet of fruits, insects, eggs, and frogs. Raccoons may dunk their food into water before eating (Burt and Grossenheider 1976:51).

Raccoons breed in February or March, and their young are born in April and May. A litter is on average comprised of four young; however, many are lost to starvation and predation. Raccoons become dormant in the winter and at this time their locations become somewhat predictable. They den up in hollows of trees, logs, stumps, or animal burrows (Keene 1981:109).

Raccoon weight varies with latitude. In northern states, raccoons undergo extensive weight loss during the winter. Maximum weight is reached in the fall. Raccoon are nocturnal and would have been taken by deadfall trap, or extraction from their denning places (Keene 1981:110). Late fall and early winter would have been the best time to have hunted raccoon, a time when the animal is most easily located but before fat reserves have been depleted. Also raccoon pelts would have been in prime condition at this time.

One raccoon premolar was recovered from Feature 80 which is classified as a storage pit .

*Opossum.* Opossums are the only marsupials in North America. Found in woodlands and along streams, they are usually active only at night. They eat fruits, vegetables, nuts, meat, eggs, insects, and carrion. They seek shelter in old dens and in hollow trees (Burt and Grossenheider 1976:1)

An opossum litter can contain up to 14 young, with gestation being only 13 days. Opossums have one or two litters per year. Their usual home range can be up to 40 acres but they may wander widely. Their weight is roughly comparable to that of raccoons. However, high production capacity is offset by a lack of cunning and an abundance of natural predators with which humans would have had to compete (Styles 1981:88).

Three opossum lower mandible fragments that crossmended were recovered from Feature 63.

*Squirrel.* Squirrels maintain small, somewhat stable, territories. They are prolific breeders, producing two litters a year. Squirrel populations are not stable and tend to fluctuate with mast production (Keene 1981:111). Body weight varies seasonally, and squirrels attain their maximum weight in November and December. Historically squirrels were hunted by means of snares, traps and nets, as well as with bow and arrow (Smith 1975).

Seven squirrel elements were identified. A tarsal and femur were recovered from Feature 63. Two phalange IIIs were recovered from Feature 152. From Feature 55, an incisor was recovered. A radius and an ulna were recovered from Feature 80.

*Turtle.* The species of recovered turtle could not be ascertained; however, it is likely that the recovered specimens are from snapping turtles. Snapping turtles are found in aquatic habitats. They are solitary in the summer but in the winter they aggregate in large numbers to hibernate. A favorite place to hibernate is in abandoned muskrat holes (Keene 1981:119). During hibernation, which occurs from October through March, is the best time to capture the snapping turtle in large quantities. Female snappers could have easily been captured during the June egg-laying season (Smith 1975:102). Turtles are a stable resource in terms of population size and movement.

From Feature 107, 17 plastron fragments were identified. The elements crossmended and were given a count value of one. Five skull fragments were recovered and they also crossmended and were given a count value of one.

Two skull fragments were recovered from Feature 112. One carapace fragment and a scapula were recovered from Feature 63. A humerus fragment, a scapula, and a mid-portion of a humerus were recovered from Feature 80.

It should be recognized that nonfood yields may have encouraged the exploitation of turtle. Turtle shells were of economic importance, beyond dietary contribution.

*Frog.* Frogs inhabit areas close to water. They would have been available around the Susquehanna banks. The small body size of a frog suggests a low meat yield potential. Frogs were most likely not a major food source. Two maxilla fragments, with a gram weight of .3, were recovered from Feature 80.

*Bird.* In total, 74 bird elements, with a gram weight of 23.3, were recovered from the site area. Bobwhite quail and pigeon were identified within the faunal assemblage. Five bobwhite quail elements were recovered from Feature 152, and 4 pigeon elements were recovered from Feature 80. However, 88 percent of the bird assemblage could not be identified to species. The size of the unidentified bird fragments suggests that they were from small birds rather than large waterfowl.

There is extensive ethnographic documentation for utilization and collection methods for pigeons. A good description of gathering passenger pigeons that nested along the Genesee River in New York in 1782 is described by Horatio Jones, who was living among the Senecas.

Word of the annual nesting of pigeons was spread throughout the Seneca territory. The Indians gathered in the locality of the pigeon woods. The Indians cut down the roosting trees to secure the birds and each day thousands were killed. Fires were made and dressed birds were suspended to dry in the heat and smoke. When properly cured they were packed in bags or baskets to the home towns. (Harris 1903:450).

Pigeons were also taken by the Iroquois in the 1600s. Reports are known of more than 1500 being taken at one time with the aid of nets (Keene 1981:114). The Delaware, when hunting pigeons, would chop down the trees in which the pigeons roosted, killing many of the pigeons when the tree toppled (Keene 1981:114).

Mass migrations of pigeons usually appeared in northern states as soon as the ground was bare of snow. Pigeons were colonial animals and remained together during the spring and fall roost. It has been reported that the densities of pigeons in these roosting places was so large that trees were toppled from the sheer weight of the pigeons sitting in them (Keene 1981:112-113).

Squabs were the preferred take. Approximately two weeks after hatching, the young were abandoned by the adults. At this time, the squab was apparently a mass of fat and equaled, if not exceeded the weight of the adult. Within three to four days, it could fly well enough to escape capture (Keene 1981:112). Pigeons were eaten fresh, smoked, or dried by Native American populations, but were particularly favored for their fat, and were frequently boiled down to recover this fat (Keene 1981:114).

North American quails include the bobwhite. The quail (*Colinus virginianus*) was named after its Old World counterpart. When the first Europeans came upon a New World bird for which they had no name, they called it after the Old World bird they thought it most resembled. In Virginia, this was felt to be the partridge, in New England, the quail. The first name remained localized, the second was applied throughout the United States (Root 1980:390). Bobwhite quail have large, white-fleshed muscles which permit rapid flight, but in brief spurts only. They lack the rich blood supply which feeds strong-flying birds, necessary for sustained flight.

Bird specimens account for less than 1 percent of the total faunal assemblage. Given the site's close proximity to water and the attraction of waterfowl to water, it is interesting that bird is so poorly represented at the site.

*Fish.* Fish were certainly an abundant resource along the Susquehanna River. Fish densities in rivers are dependent on a number of conditions, including supply of nutrients, temperature, gradient, discharge, and bottom conditions. Sloughs and backwaters carry a very high density of fish.

Most fish bones are fragile and may tend to flake, or are more easily crushed than those of reptiles, birds, and mammals (Parmalee 1985:80; Singer 1982, 1987). Therefore, it is striking that such a large volume of fish bone was recovered. A total of 2,341 fish elements was recovered from the site area. Forty-two percent of the total faunal assemblage was comprised of fish elements. Undetermined sunfish, catfish, perch, shad, shiner, and sucker were identified within the samples. Table 262 delineates the recovery of fish species and elements from the features under study.

Sucker was the most prominent fish species in the assemblage totaling 1,009 elements. Forty-three percent of the fish assemblage was comprised of Sucker.

Suckers are small to moderately-large, bottom-dwelling, freshwater fishes that inhabit rivers, creeks, and lakes. There are 59 species in North America (Audubon Society 1983:457). Suckers can range from 11 inches to 3-1/2-feet long, and can weigh up to 20 pounds.

A total of 167 channel catfish elements were recovered. Channel catfish inhabit rivers and large creeks in slow to moderate current over sand, gravel or rocks. Channel catfish can weigh up to 58 pounds, with a length of 3 feet, 11 inches (Audubon Society 1983:470-471).

Eighty-five perch specimens were identified from the assemblage. Perch is a freshwater fish found in rivers, lakes and brackish water in bays and estuaries. The average size of a perch is 8 to 10 inches and the average weight is one pound (Audubon Society 1983:533)

Thirty-six species comprise the sunfish family in North America (Audubon Society 1983:548). Bass, flier, warmouth, and crappie, as well as orange-spotted sunfish, green sunfish, redbreast sunfish and spotted sunfish all belong to this family. Six undetermined sunfish elements were recovered. Sunfish are still popular sport fishes and can weigh up to 30 pounds, depending on the species.

Shad is found in bays, estuaries, and fresh water. All shad are schooling species that enter freshwater streams to spawn. None remain long in fresh water, nor do they go far out at sea (Audubon Society 1983:382). Six shad elements were recovered.

Early European observations of coastal Virginia Indians noted the use of nets and labyrinthine weirs, as well as spears and arrows, to catch fish (Whyte 1988:105). Fish preparation methods were probably diverse, and perhaps species- or size-specific. Burned fin spines and rays are not numerous. Only three of the 2,369 fish elements that were recovered were charred. Most small fish bones were found in dense masses and included all elements of the skeleton. This suggests that the fish were probably filleted, or boiled whole and their skeletons or disarticulated bones dumped together.

A full 72 percent of the fish elements were recovered from Feature 80. Twenty-two percent of the fish elements were recovered from Feature 63. Both of these features are storage pits.

*Mollusk.* The mollusk shell was recovered in poor condition. Shell generally preserves well, but the shell assemblage at this site was fragmented, and crumbled when handled. The mollusk specimens were so degraded that identification to species level was not possible. Forty-four small shell fragments were present in the assemblage. Two landsnail shells were also recovered.

#### *Quantification of Faunal Specimens*

There are numerous problems involved in constructing an appropriate measure for determining taxonomic abundance. The number of identified elements can vary from species to species. Numbers of identified specimens can be affected by butchering patterns; differences in specimen counts per taxon may simply reflect the fact that some animals were retrieved from kill sites whole, while others were butchered on the spot with only selected portions retrieved (Binford 1978, 1981). All specimens are not equally affected by preservational variables. Collection techniques can differentially affect the numbers of specimens retrieved, both within and among taxa.

The number of identified specimens cannot, by itself, address questions of biomass and meat weights, which are often of greater importance in examining prehistoric economies. One deer bone can represent a greater dietary input than 200 fish bones. Determination of minimum number of individuals (MNI) has become widely accepted as a measure of taxonomic abundance. However, the determination of MNI is not without methodological problems (Grayson 1984). The definition of the clusters of faunal material by which minimum number of individuals are determined is central to the calculation. Different aggregation techniques applied to the same faunal collection can produce minimum numbers that are very different. If all the faunal material from a site is viewed as a single collection, the MNI will be different from calculations based on features or strata.

Table 262. Late Woodland of Fish Element Distribution.

Feature Name	Common	Element	Count	Weight	CB	CG	CW
29 <i>Catastomidae</i> spp.	sucker	spine	1	0.1			
52 undetermined fish	undetermined	ND	1	0.1			
55 <i>Catastomidae</i> spp.	sucker	rib	8	1.2			
		vertebrae	9	2.1			
		spine	7	0.7			
<i>Centrarchidae</i> spp.	sunfish	scale	1	0.1			
		mandible	2	0.3			
<i>Ictaluridae</i> spp.	catfish	rib	3	0.1			
		scale f	2	0.1			
		quadrate f	1	0.1			
		rib	2	0.1			
undetermined fish	undetermined	ND	39	2.8			
			74	7.6			
Totals for Feature 55							
63 <i>Alosa</i> spp.	shad	preoperculum	1	0.1			
		vertebrae	5	0.2			
<i>Catastomidae</i> spp.	sucker	spine	113	2.7			
		scale f	20	0.3			
		mandible	1	0.2			
		rib	6	0.1			
		operculum	2	0.6			
		preoperculum	6	0.3			
		frontal	3	0.6			
		vertebrae	36	1.5			
		preopercular f	4	0.1			
		quadrate	5	1.3			
		caudal fin f	3	0.4			
		skull f	31	2.1			
		dentary f	3	1.4			
		opercular	5	1.7			
<i>Centrarchidae</i> spp.	sunfish	preopercular	3	0.6			
		dorsal spine	1	0.1			
<i>Ictaluridae</i> spp.	catfish	opercular	2	0.2			
		pelvic girdle	1	0.4			
		quadrate	1	0.3			

Table 262 (continued)

Feature Name	Common	Element	Count	Weight	CB	CG	CW
63 cont. <i>Ictaluridae</i> spp.	catfish	hyomandibular	1	0.2			
		spine	14	0.4			
		rib	5	0.3			
		vertebrae	8	0.3			
		quadrate	1	0.2			
		vertebrate	12	1.1			
	perch	vertebrae	20	0.6			
		scale	2	0.1			
		spine	1	0.1			
	undetermined	ND	206	9.9	3		
		scale f	1	0.1			
Totals for Feature 63			523	28.6	3	0	0
80	<i>Catostomidae</i> spp.	rib	160	8.7			
		vertebrae	225	11.9			
		dentary	16	3.3			
		opercular	3	2.1			
		quadrate	12	4.9			
		preopercular	6	2.4			
		scale	25	0.3			
		operculum	7	1.6			
		caudal fin	3	0.7			
		parasphenoid	1	0.2			
		fin rays	14	3.2			
		spine	235	4.2			
		frontal	1	1.1			
		circumorbital	3	1.4			
		scale f	7	0.1			
		pectoral fin	13	2.1			
		pelvic fin	4	1.2			
		basioccipital	1	0.1			
		fin rays	12	3.2			
		pelvic fin	7	2.1			
		quadrate	14	3.1			
		scale	22	1.1			
		spine	4	0.1			
		vertebrae	31	1.2			
		hyomandibular	1	0.2			
		scale f	17	0.1			
		vertebrae	60	3.2			
	<i>Ictaluridae</i> spp.	catfish					
	<i>Percidae</i> spp.	perch					

Table 262 (continued)

Feature	Name	Common	Element	Count	Weight	CB	CG	CW
83	<i>Percidae</i> spp. undetermined fish	perch undetermined	quadrate	1	0.2			
			ND	583	38.6			
			fin f	12	1.3			
			head f	184	6.4			
			vertebrae	5	0.3			
			spine	3	0.1			
			rib	7	0.2			
Totals for Feature 80				1699	110.9	0	0	0
83	undetermined fish	undetermined	vertebrae f	1	0.1			
			ND	1	0.1			
			Totals for Feature 83				2	0.2
96	<i>Catostomidae</i> spp. undetermined fish	sucker undetermined	spine	6	0.2			
			vertebrae f	1	0.2			
			ND	1	0.3			
			Totals for Feature 96				8	0.7
107	<i>Ictaluridae</i> spp. <i>Percidae</i> spp. undetermined fish	catfish perch undetermined	scale f	3	0.1			
			spine f	4	3.2			
			vertebrae	1	0.1			
			ND	17	0.5			
			Totals for Feature 107				25	0.9
112	<i>Catostomidae</i> spp. undetermined fish	sucker undetermined	scale	1	0.1			
			scale f	1	0.1			
			Totals for Feature 112				2	0.2
152	undetermined fish	undetermined	vertebrae	2	0.2			
			ND	4	0.3			
			Totals for Feature 152				6	0.5
TOTALS				2341	121.2	3	0	0



MNI calculations were performed, using features and levels as the units of aggregation (Grayson 1984). Table 263 gives the results of MNI for deer, rabbit, raccoon, opossum, squirrel, frog, and turtle. When MNI calculations were based on the feature as the unit of aggregation, the recovery of faunal material was such that each feature contained a MNI count of one for each species present. When aggregation units were based on levels the MNI numbers changed. For example, in Feature 78, three rabbit elements were recovered. When viewed as a single unit, the MNI was 1, but when viewed by levels, the number changed to 2. In Table 263 the number in parenthesis is the calculation by level.

Table 263. Minimum Number of Individuals by Late Woodland Feature (Level).

Feature	Deer	Opossum	Raccoon	Rabbit	Squirrel	Turtle	Frog
29	-	-	-	-	-	-	-
51	-	-	-	-	-	-	-
52	-	-	-	-	-	-	-
55	1 (2)	-	-	-	1	-	-
57	-	-	-	-	-	-	-
61	-	-	-	-	-	-	-
63	1 (2)	1	-	1 (2)	1 (2)	1	-
73	-	-	-	-	-	-	-
74	-	-	-	-	-	-	-
78	1	-	-	1 (2)	-	-	-
80	1 (3)	-	1	1	1	1 (2)	1
83	-	-	-	-	-	-	-
89	-	-	-	-	-	-	-
92	-	-	-	-	-	-	-
96	-	-	-	-	-	-	-
107	1	-	-	-	-	1	-
112	1 (3)	-	-	-	-	1	-
123	-	-	-	-	-	-	-
152	1 (2)	-	-	1	1	-	-
155	-	-	-	-	-	-	-
160	-	-	-	-	-	-	-

The problems inherent in these two schemes are that when MNI is calculated for the entire feature the element of deposition over time is ignored; when calculations are done by level, the admixture of levels is ignored.

Table 264 delineates the MNI calculations for fish. The calculations were based on presence in levels. Once again, this calculation assumes no admixture between levels. Because of the high frequency of unidentified and nondiagnostic fish elements which were recovered from the assemblage, it is likely that these calculations under-represent the presence of fish at the site.

### Seasonality

There are four economic seasons, two of which have rather intensive or focal activities and two with a broader base spectrum (Keene 1981:190). In the spring, there would be intensive exploitation of spawning fish. A site which was exploited solely in the spring would, according to the model of seasonality proposed by Keene (1981:190), have a faunal assemblage comprised almost exclusively of fish bones. Although a large percentage (42%) of the total faunal assemblage from the site was comprised of fish elements, they are by no means the exclusive faunal component. It is unlikely that this site was occupied solely in the spring.

Keene's seasonality model predicts summer to be a time of broad-spectrum foraging (1981). Archaeological manifestations of summer sites should be highly variable in response to local variation. There would be continued fishing and turtle capture. Deer hunting would be non-intensive, but continuous, in the summer. In general, the faunal inventory of summer sites should be diverse, and should consist predominantly of deer and fish, with lesser quantities of other resources.

The fall season, particularly the time from September to November, is usually an intensive deer exploitation period (Keene 1981). Some of the deer procured would be dried for winter or spring use. Production of bone grease would tend to degrade certain skeletal elements and skew representation of deer archaeologically. However the general archaeological manifestations of fall occupation should reflect an abundant utilization of deer.

Table 264. Minimum Number of Fish Individuals by Late Woodland Feature Level.

Feature	Sunfish	Catfish	Perch	Shad	Shiner	Sucker
29	-	-	-	-	-	1
51	-	-	-	-	-	-
52	-	-	-	-	-	-
55	1	1	-	-	-	1
57	-	-	-	-	-	-
61	-	-	-	-	-	-
63	2	3	2	1	-	14
73	-	-	-	-	-	-
74	-	-	-	-	-	-
78	-	-	-	-	-	-
80	-	8	3	-	-	24
83	-	-	-	-	-	-
89	-	-	-	-	-	-
92	-	-	-	-	-	-
96	-	-	-	-	-	1
107	-	-	1	-	-	1
112	-	-	-	-	-	1
123	-	-	-	-	-	-
152	-	-	-	-	-	-
155	-	-	-	-	-	-
160	-	-	-	-	-	-

Winter activities are characterized by a broad-spectrum pattern focusing on deer, raccoon, some fish, and any small game that may have been incidentally taken. There would have been a reliance on stored food such as dried meat or fish that would not be perceptible in the archaeological record.

The annual subsistence cycle is therefore characterized by two seasons of relatively focal economic activities: intensive fishing in the spring and deer hunting in the fall, and a more diffuse and variable food procurement pattern for the remainder of the year (Keene 1981). If the faunal assemblage is viewed in its totality, as though it represents a single subsistence pattern, it conforms most closely to a summer season bone-deposition ratio. The model proposed by Keene suggests a deposition ratio of 54 percent fish and 46 percent deer. Forty-two percent of the assemblage is comprised of fish elements. The percentage of identified deer bones does not equal the 46 percent proposed by Keene (1981); however, a large percent of the assemblage was comprised of fragmented, undetermined-to-species mammal bone. Mammal bone comprises 56 percent of the

total assemblage. If the ratio of mammal bone is viewed in juxtaposition to fish bone, then the ratio proposed by Keene is quite close to the ratio observed at the Memorial Park Site.

If storage pits are viewed independently as representing seasonal deposits, the ratios remain fairly constant. The features classified as storage pits comprised a total of 71 percent of the total deer assemblage. A full 72 percent of the fish elements were recovered from Feature 80. Twenty-two percent of the fish elements were recovered from Feature 63. Both of these features are storage pits.

The ratio of fish to mammal in the storage pits is 57 percent fish and 41 percent mammal. The ratio of fish to mammal within the total assemblage is 42 percent fish to 56 percent mammal. It is interesting that the ratios reverse between the total assemblage and the storage pits, but both sets of ratios fall within the summer exploitation ratios established by Keene.

The abundance of fish and warm-season microfauna (landsnail, frog, turtle) strongly suggest that the site was occupied during the summer season. Waterfowl, which probably would have been abundant at the site area in the winter, is virtually absent from the assemblage. The representation of deer elements is highly skewed in favor of marginal food value elements or waste elements. While it is possible that this archaeological manifestation of deer remains is the result of taphonomic variables, it seems unlikely that taphonomic variables alone are responsible for such a skewed deer representation. An argument could be made that the meatier deer elements were transported elsewhere. However, cylinder fragments were recovered with enough abundance to suggest that perhaps grease extraction may be responsible for the lack of identifiable femur and humerus elements. This finding may also suggest the lack of winter occupation at the site.

The marginal food value deer elements, coupled with the lack of migratory fowl and other faunal data, suggest that the site area was not occupied in the late fall and winter seasons.

### *Subsistence Strategy*

Subsistence entails the extraction of matter and energy from the natural environment in order to meet human adaptive requirements. Within environmental, biological, and cultural constraints, subsistence strategies appear to favor risk minimization. However, fauna are not exploited solely in accordance with the criterion of abundance (Binford 1978). Rabbits, squirrels, frogs, turtles, and small birds would have been abundant at the site area. Because of their small body size and low potential meat yield, they would have been exploited under optimal conditions but would not have constituted first-line food resources (Styles 1981). It should be recognized that, in some cases, nonfood yields (e.g. shells of turtles) may have encouraged exploitation despite low meat yield.

Reflecting the criterion of yield, the white-tailed deer is the largest forest species represented in the recovered assemblage. It offers a high meat yield although weight varies by age, sex, season, and quality of habitat. White-tailed deer were abundant; they moved in large groups, occupied small home ranges and were a predictable food source. White-tailed deer certainly qualify as a first-line food source and also rate high for nonfood uses (e.g. pelts, bones for raw material, and sinew).

Water margins in forested areas would have attracted medium-size animals such as opossum and raccoon. They offer high quality pelt and a high meat yield. Raccoons are abundant in wooded areas, with highest densities in river bottoms. They provide a relatively large quantity of meat, have a valuable pelt, occupy relatively small home ranges, and leave ample signs of their presence. Raccoons are available year round and constitute a potential first-line animal food.

Opossum weights are roughly comparable to that of raccoons. However high reproduction capacity in opossums is offset by an abundance of natural predators with which humans would have had to compete (Styles 1981). Smith (1975) suggests that erratic foraging behavior and frequent movement of dens detract from the "huntability" of this species. Opossums probably do not constitute a first-line food but could have been taken in conjunction with other forest species.

The aquatic species available to the site inhabitants undoubtedly played a large role in the diet. The depth of the river in prehistoric times and the available technology would affect the degree to which river species were exploited. The optimal time for exploitation probably was during the spring when the river would flood out of its banks and spawning fish would move into shallow water. However fish are available in rivers all year round. Fish qualify as a first-line food. Procurement probably focuses on a water body rather than on a particular species. The recovery of catfish, perch, shad, shiner, sucker and undetermined sunfish, illustrate the variety of fish available from the Susquehanna River as well as surrounding streams and tributaries.

Only 74 bird elements were identified within the entire faunal assemblage. Therefore, bird comprised only 1 percent of the faunal assemblage. While taphonomic consequences impact all categories of bone, it is noteworthy that fish bone was recovered in significantly greater quantity than bird bone and fish bone is smaller, with some fish elements being more more vulnerable to destruction than bird bone. This data suggests that fish contributed more to the dietary regime than did birds.

The data suggests that the site inhabitants had a rich environment from which to extract resources. Subsistence strategies possibly emphasized exploitation of a combination of small and medium-sized species to add to first-line food species, such as deer. The faunal exploitation strategy probably included a mix of species distributed within the forest, at the forest edge, and the borders of the river, bottomland lakes and streams.

#### ANALYSIS OF ARCHAIC FAUNAL SPECIMENS

A total of 185 small bone fragments, with a total weight of 8.6 gr, was recovered from features and units identified as Late Archaic and Terminal Archaic. A great deal of the recovered bone was encompassed in matrix and therefore could not be weighed or measured with accuracy. The small fragments were very fragile and broke when touched. Removal of the bone fragments from the matrix was not practical and would have resulted in a higher fragmentation rate of nondiagnostic specimens. The specimen counts are approximated when bone is encompassed in matrix because some fragments are obscured by soil. Specimens encountered in matrix are noted as such in the catalog sheets. Table 265 illustrates the recovery by temporal delineation.

The size of the recovered fragments ranged from .1 cm to 1.5 cm. Virtually all of the recovered fragments were nondiagnostic; i.e., neither element nor species could be determined. The fragments are listed as mammal in the catalog sheets. However, due to their non-diagnostic nature, this classification should be viewed with caution. Only one long-bone specimen could be classified with specificity to bird. Of the total number of specimens, 105 were charred: 94 were charred white, and 11 were charred black.

Seventy-nine specimens were recovered from features and units designated as Terminal Archaic. One nondiagnostic fragment was recovered from general excavation contexts. Fourteen nondiagnostic fragments were recovered from the eastern half of Feature 334, and eight were recovered from the western half. Four bone fragments were recovered from Feature 335, and 50 small fragments were recovered from Feature 352.

Table 265. Terminal Archaic and Late Archaic Faunal Specimens.

Time Period	Feature	Block	Level	Type	Name	Element	No.	Wgt.	CB	CW	Measure	Comment
Terminal Archaic		5	5	Mam	undet	ND	1	0.2			.5 cm	
	334	12		Mam	undet	ND	14		4	10		in matrix
		12		Mam	undet	ND	8			8		in matrix
	335		1	Mam	undet	ND	1	0.5		1	1.5 cm	
				1	Mam	undet	ND	3	0.4		3	.5 cm
	352	16		Mam	undet	ND	50	0.5			.1-.5 cm	
						TOTAL	79	2.9	4	22		
Orient		6	3	Mam	undet	ND	2	4.6		2	1.5 cm	
		6	3	Mam	undet	ND	15	1.6		15	.5 cm	
		6	6	Bird	undet	longb frag	1	0.2			1 cm	
		8	3	Mam	undet	ND	1	0.5				
	265	8		Mam	undet	ND	4		1	3		in matrix
	322	15		Mam	undet	ND	27	0.1			.1 cm	
						TOTAL	50	7	1	20		
Early Laurentian		8		Mam	undet	ND	7			7		in matrix
		9	14	Mam	undet	ND	4			4		in matrix
		9	13	Mam	undet	ND	12		6	6		in matrix
	288	8	14	Mam	undet	ND	32			32		in matrix
	302	8		Mam	undet	ND	3			3		in matrix
						TOTAL	58	0	6	52		
TOTAL							187	9.9	11	94		

Fifty specimens were recovered from features and units designated as Orient. Eighteen non-diagnostic fragments were recovered from from general excavation contexts. The single, identified, bird long-bone fragment was also recovered from general excavation contexts. Four nondiagnostic fragments were recovered from Feature 265, and 27 were recovered from Feature 322.

Fifty-eight specimens were recovered from early Laurentian contexts. Seven non-diagnostic specimens were identified from general excavation contexts. Thirty-two non-diagnostic specimens were recovered from Feature 288, and three were recovered from Feature 302.

In the absence of diagnostic faunal material, very little can be said about faunal subsistence from these early contexts. It is unfortunate that these specimens could not advance understanding of faunal procurement for early occupants of the site area.

#### SUMMARY

The analysis of 5,610 pieces of bone, 5,541 after crossmending, associated with the Late Woodland occupations of the site indicated that a number of terrestrial and riverine resources were utilized. These included white-tailed deer, rabbit, raccoon, squirrel, turtle, frog, bobwhite quail, pigeon, sunfish, catfish, perch, shad, shiner, sucker, and mollusk. Bone identifiable to specific taxa constituted only 25% of the assemblage. The remainder of the assemblage consisted of small fragments that could not be classified more specifically than to mammal, bird, mollusk, or fish.

Although almost one-third of the bone was charred, very little of the bone exhibited other modifications. Only 3.0% of the bone exhibited longitudinal fractures, which does not necessarily reflect human behavior. Five pieces of bone exhibited cut marks, and only three bones exhibited spiral fractures, which are indicative of human behavior. A calculation of minimum number of individuals suggests that white-tailed deer was the most frequently exploited mammal in the assemblage, while sucker was the most frequently exploited fish. As a whole, the assemblage suggests that subsistence strategies emphasized the exploitation of small and medium-sized animals to supplement first-line foods such as deer. Faunal exploitation probably included a mix of species dominated by a number of species distributed within the forest, at the forest edge, and the borders of the river, bottomland lakes, and streams. Finally, the faunal assemblage suggests primarily summer procurement.

Poor bone preservation prevented the identification of taxa in the Archaic faunal assemblage.

#### XIV. POLLEN ANALYSIS

by

Grace Brush, Ph.D.  
Johns Hopkins University

One hundred samples from the Memorial Park site were analyzed for pollen content. Samples were processed using standard palynological methods. Each sediment sample was first broken with a mortar and pestle if necessary. It was then treated with diluted hydrochloric acid to remove carbonates. This procedure was followed by treatment with hydrofluoric acid for removal of silica. The samples were then acetylyzed by treatment with a combination of sulfuric acid and acedic anhydride. They were boiled for two minutes in a hot water bath, and the supernant was decanted. Samples were washed first in glacial acetic acid, then in water and ethanol. They were stored in tertiary butyl alcohol. An aliquot of each sample was mounted in silicone oil on a microscope slide for microscopic analysis. Microscopic analysis was performed at 400x magnification. Pollen is present, but extremely scarce, in 45 samples, and is not present in 55 samples. The results are tabulated in tables 266 through 272.

Late Woodland Features (Table 266): Pollen and/or spores occurred in samples from eight of the 10 features examined. Pine and oak are the only tree species recovered from these samples. Oak occurred only in Feature 63, and both pine and oak in the older Feature 152. Herbaceous pollen, including chenopods, composites, and sunflower were found in the younger features. Club moss was found in features 51, 57, 78, 96, and 144. Spikemoss was found only in Feature 144, and cinnamon fern in features 63 and 144.

Table 266. Pollen and Spore Percentages for Late Woodland Features.

Feature	TP	Tree Pollen		Herb Pollen			Fern Spores			C-14 Date
		Pin	Que	Che	Com	Hel	Lyc	Sel	Osm	
51	938	-	-	-	-	-	100	-	-	
57	626	-	-	-	50	-	50	-	-	
63	1284	-	49	24	24.4	-	-	-	24.4	A.D. 830
78	1563	-	-	-	-	-	100	-	-	A.D. 920
92	626	-	-	50	-	50	-	-	-	A.D. 930
96	2188	-	-	-	-	-	100	-	-	
106	0	-	-	-	-	-	-	-	-	
123	0	-	-	-	-	-	-	-	-	
144	1563	-	-	-	-	-	40	40	20	A.D. 1350
152	626	50	50	-	-	-	-	-	-	A.D. 1090

<sup>a</sup>TP-total pollen per cm<sup>3</sup> of sediment; Pin-*Pinus* (pine); Que-*Quercus* (oak); Che-Chenopodiaceae (pigweeds); Com-Compositae (composites); Hel-*Helianthus* (sunflower); Lyc-Lycopodium (club moss); Sel-*Selaginella* (spiek moss); Osm-*Osmunda* (cinnamon fern).

Orient (Table 267): More Orient phase levels yielded pollen than did those any of the other components. Of 26 levels analyzed, 20 contained pollen. There is a greater diversity of taxa in Block 5, where a number of herbaceous pollen are present. Club moss is important throughout. Oak occurs only in Block 6. Other tree pollen present in samples indicate wet environment; i.e., alder, birch, hornbeam, and walnut. Members of the Ericaceae, which include blueberry, huckleberry, cranberry, and various heath species along with laurel are present in Block 5 only.

Terminal Archaic (Table 268): Eight of the 22 features examined contain pollen or spores. Block 1, levels 5 and 7, contain alder and oak pollen, respectively. Levels analyzed from Block 3 contain only fern pollen, including wood fern and cinnamon fern. Levels 3 and 4 in Block 5 contain oak pollen and some herbaceous forms including ragweed, pigweed, swamp dock, and composites. These levels also contain fern spores. The levels that were examined from blocks 2, 4, and 7 contained no pollen.

Piedmont (Table 269). Pollen was extremely scarce in Piedmont levels, being present as only a few grains in three levels. Block 4 Level 7 contains elm pollen and spores of wood fern. Block 5 Level 6 contains grass pollen and Block 5 contains walnut pollen.

Late Laurentian (Table 270). Pollen is present in only two levels. Pine pollen is present in Block 3, Level 18, which is dated  $3,095 \pm 400$  B.P. Birch and pine pollen are present in Block 5, Level 9.

Early Laurentian (Table 271): No pollen was recovered from any of the samples analyzed in early Laurentian contexts.

Neville (Table 272). Oak pollen is present in Block 5, Level 11.

Table 273 lists the pollen types found at the different dated horizons. Environmental interpretations are extremely tentative due to the scarcity of pollen and spores.

Table 273. Pollen Assemblages and Environmental Interpretations of Dated Horizons.

Radiocarbon Date	Culture/Time Period	Pollen/Spore Content	Environmental Interpretation
A.D. 920	Late Woodland	Oak, pigweed, composite, and cinnamon fern	Moderate, open
A.D. 997	Late Woodland	Club moss	wet
A.D. 999	Late Woodland	Pigweed and sunflower	open, dry
A.D. 1191	Late Woodland	Pine and oak	moderate, wooded
A.D. 1363	Late Woodland	Club moss, spike moss, and cinnamon fern	wet
800 BC	Orient	Club moss	Wet
1145 BC	Orient	Grasses	Open
3095 BC	Late Laurentian	Pine	Wooded

Table 274 contains a summary of the pollen assemblages and environmental interpretation for each of the cultures, including all samples. Again the interpretation must be viewed with caution because of the scarcity of data.



Table 267. Pollen and Spore Percentages for the Orient Phase<sup>a</sup>.

Block Level	TP	TREE POLLEN											SHRUB AND HERB POLLEN										FERNS ET AL.			C-14 Date
		Aln	Bet	Car	Cas	Cpr	Fag	Jug	Pin	Que	Amb	Che	Com	Cyp	Eri	Gra	Ros	Rum	Typ	Vio	Dry	Lyc	Sph	?		
1	1																				14	85.7				
	2																					100				
	3																				17	66.6		16.7		
	4	50																					50			
2	1				4.3																8.7	86.9				
	2											11.1									11	66.7		11.1		
	3					20																60		20		
	4									25		25										25		25		
	5											100														
	6	0																						1640±60BP		
3	1																					100				
	2																					75		880±50 BP		
	3	0																								
	4	0																								
	5	0																								
4	1						14.2														14	42.8		14.2		
	2																					100				
	3																				50					
5	1			8	4			4	4			4	16	8	8						4	20	8	8		
	2									10.4		10.4	10.4	5.2	21						10.4	21	5.2	5.2		
6	1													50								50				
	2													33.3									33.3			
	3	0																								
	4													100												
	5	0																								
	6	83																						1145±50 BP		

<sup>a</sup>TP-total pollen per cm<sup>3</sup> of sediment; Aln-*Alnus* (alder); Bet-*Betula* (birch); Car-*Carya* (hickory); Cas-*Casinus* (hornbeam); Fag-*Fagus* (beech); Jug-*Juglans* -*Quercus* (oak); Amb-*Ambrosia* (ragweed); Che-*Chenopodiaceae* (pigweeds); Com-*Compositae* acceae (sedges); Eri-*Ericaceae* (blueberry family); Rosaceae (rose family); Rum-*Rumex* (swamp dock); Typ-*Typha* (cattail); Vio-*Viola* (violet); Dry-*Dryopteris*; Lyc-*Lycopodium* (club moss); Sph-*Sphagnum* (sphagnum moss).

Table 268. Pollen and Spore Percentages for the Terminal Archaic Period<sup>a</sup>.

Block	Level	TP	TREE POLLEN											SHRUB AND HERB POLLEN											FERNS ET AL.		
			Aln	Bet	Car	Cas	Cpr	Fag	Jug	Pin	Que	Amb	Che	Com	Cyp	Eri	Gra	Ros	Rum	Typ	Vio	Dry	Lyc	Sph	?	C-14 Date	
1	5	167	50																								50
	6	0																									
	7	100								100																	
	8	0																									
	9	0																									
	10	0																									
	11	0																									
2	7	0																									
	8	0																									
	9	0																									
	10	0																									
																											2000±60 BP
3	6	83																									
	7	167																									
	8	83																									
	9	83																									
	10	0																									
4	4	0																									
	5	0																									
	6	0																									
5	3	1375									3	12.1	12.1	6													
	4	583										14.2															
	5	83											28.6														
	12	0																									

<sup>a</sup>TP-total pollen per cm<sup>3</sup> of sediment; Aln-*Alnus* (alder); Bet-*Betula* (birch); Car-*Carya* (hickory); Cas-*Casinus* (hornbeam); Fag-*Fagus* (beech); Jug-*Juglans* -*Quercus* (oak); Amb-*Ambrosia* (ragweed); Che-*Chenopodiaceae* (pigweeds); Com-*Compositae* (sedges); Eri-*Ericaceae* (blueberry family); Rosaceae (rose family); Rum-*Rumex* (swamp dock); Typ-*Typha* (cattail); Vio-*Viola* (violet); Dry-*Dryopteris* (wood fern); Lyc-*Lycopodium* (club moss); Sph-*Sphagnum* (sphagnum moss).

Table 269. Pollen and Spore Percentages for the Piedmont Tradition<sup>a</sup>.

Block/Level	TP	TREE POLLEN											SHRUB AND HERB POLLEN											FERNS ET AL.		
		Aln	Bet	Car	Cas	Cpr	Fag	Jug	Pin	Que	Amb	Che	Com	Cyp	Eri	Gra	Ros	Rum	Typ	Vio	Dry	Lyc	Sph			
1	12																									
2	11																									
3	12																									
4	7								50															50		
5	6																									
7	16																									

<sup>a</sup>TP-total pollen per cm<sup>3</sup> of sediment; Aln-*Alnus* (alder); Bet-*Betula* (birch); Car-*Carya* (hickory); Cas-*Casinus* (hornbeam); Fag-*Fagus* (beech); Jug-Juglans -*Quercus* (oak); Amb-*Ambrosia* (ragweed); Che-Chenopodiaceae (pigweeds); Com-Compositae aceae (sedges); Eri-Ericaceae (blueberry family); Ros-Rosaceae (rose family); Rum-*Rumex* (swamp dock); Typ-*Typha* (cattail); Vio-*Viola* (violet); Dry-*Dryopteris* (wood fern); Lyc-*Lycopodium* (club moss); Sph-*Sphagnum* (sphagnum moss).

Table 270. Pollen and Spore Percentages for Late Laurentian<sup>a</sup>.

Block	Level	TP	TREE POLLEN											SHRUB AND HERB POLLEN											FERNS ET AL.			C-14 Date	
			Aln	Bet	Car	Cas	Cpr	Fag	Jug	Pin	Que	Amb	Che	Com	Cyp	Eri	Gra	Ros	Rum	Typ	Vio	Dry	Lyc	Sph					
1	14	0																											
	15	0																											
	16	0																											
	17	0																											
	20	0																											
2	14	0																											
	17	0																											
	20	0																											
3	18	100																											
	21	0								100																			
	9	0																											
5	8	0																											
	9	150									33																		

<sup>a</sup>TP-total pollen per cm<sup>3</sup> of sediment; Aln-*Alnus* (alder); Bet-*Betula* (birch); Car-*Carya* (hickory); Cas-*Casinus* (hornbeam); Fag-*Fagus* (beech); Jug-Juglans -*Quercus* (oak); Amb-*Ambrosia* (ragweed); Che-*Chenopodiaceae* (pigweeds); Com-*Compositae* (daisy family); Eri-Ericaceae (blueberry family); saceae (rose family); Rum-*Rumex* (swamp dock); Typ-*Typcha* (cattail); Vio-*Viola* (violet); Dry-*Dryopteris* (wood fern); Lyc-*Lycopodium* (club moss); Sph-*Sphagnum* (sphagnum moss).

4900±130 BP  
4045±400 BP

5025±60 BP

Table 271. Pollen and Spore Percentages for Early Laurentian<sup>a</sup>.

Block Level	TP	TREE POLLEN											SHRUB AND HERB POLLEN											FERNs ET AL.			C-14 Date
		Aln	Bet	Car	Cas	Cpr	Fag	Jug	Pin	Que	Amb	Che	Com	Cyp	Eri	Gra	Ros	Rum	Typ	Vio	Dry	Lyc	Sph				
2	23																										
3	24																										
4	12																										
	15																										
	18																										
	21																										
5	12																										
6	9																										5830±130 BP
	12																										

<sup>a</sup>TP-total pollen per cm<sup>3</sup> of sediment; *Aln-Alnus* (alder); *Bet-Betula* (birch); *Car-Carya* (hickory); *Cas-Casinus* (hornbeam); *Fag-Fagus* (beech); *Jug-Juglans* -*Quercus* (oak); *Amb-Ambrosia* (ragweed); *Che-Chenopodiaceae* (pigweeds); *Com-Compositae* (sedges); *Eri-Ericaceae* (blueberry family); *sacc* (rose family); *Rum-Rumex* (swamp dock); *Typ-Typha* (cattail); *Vio-Viola* (violet); *Dry-Dryopteris* (wood fern); *Lyc-Lycopodium* (club moss); *Sph-Sphagnum* (sphagnum moss).

Table 272. Pollen and Spore Percentages for Neville<sup>a</sup>.

Block Level	TP	TREE POLLEN											SHRUB AND HERB POLLEN											FERNs ET AL.			C-14 Date
		Aln	Bet	Car	Cas	Cpr	Fag	Jug	Pin	Que	Amb	Che	Com	Cyp	Eri	Gra	Ros	Rum	Typ	Vio	Dry	Lyc	Sph				
4	24																										
5	16												100														
	21																										
	23																										
6	15																										
	18																										7045±210 BP
	20																										

<sup>a</sup>TP-total pollen per cm<sup>3</sup> of sediment; *Aln-Alnus* (alder); *Bet-Betula* (birch); *Car-Carya* (hickory); *Cas-Casinus* (hornbeam); *Fag-Fagus* (beech); *Jug-Juglans* -*Quercus* (oak); *Amb-Ambrosia* (ragweed); *Che-Chenopodiaceae* (pigweeds); *Com-Compositae* (sedges); *Eri-Ericaceae* (blueberry family); *sacc* (rose family); *Rum-Rumex* (swamp dock); *Typ-Typha* (cattail); *Vio-Viola* (violet); *Dry-Dryopteris* (wood fern); *Lyc-Lycopodium* (club moss); *Sph-Sphagnum* (sphagnum moss).

Table 274. Pollen Assemblages and Tentative Environmental Interpretation of Cultures.

Late Woodland	Pine, oak, pigweed, composites, sunflower, ferns and fern allies. <i>A warm to mildly cold open area with some moisture</i>
Orient	Alder, birch, hornbeam, chestnut, beech, walnut, pine and oak; herbaceous taxa including ragweed, pigweed, composites, sedges, members of the blueberry family, grasses, members of the rose family, swamp dock, cattail, and violet. Wood fern and club moss are also present throughout. <i>A moderately open possibly riparian environment.</i>
Canfield/Susquehanna	Pine, oak, ragweed, pigweed, and composites with wood fern and club moss. <i>A generally dry environment.</i>
Piedmont	Walnut and elm with grasses and wood fern. <i>A warm riparian environment.</i>
Late Laurentian	Birch and pine. <i>Cooler climate.</i>
Neville	Oak. <i>Warm and dry.</i>

## XV. SPATIAL ANALYSIS OF FOUR MEMORIAL PARK COMPONENTS

by

Michael G. Spitzer

### INTRODUCTION

Two general sets of procedures are used in this analysis. The first addresses the isolation of activity sets, based on the assumption that the relative spatial association (aggregation, segregation, or independence) of material classes reflects the dynamics of particular activities. The second, introduced here, is an initial attempt to apply measures of the dimensionality of the various material classes to confirm that their distribution results from dynamic processes, that these processes are the result of two or more factors, and to suggest a tentative interpretation of the operative dynamics in energetic and entropic terms, consistent with what was suggested in the Technological Analysis subsection of the Chipped Stone section of this report.

Isolating activity sets is deemed an important and necessary component of archaeological research and studies of behavioral significance. Two primary approaches have been taken to identify activity sets: aspatial methodologies, and spatial methodologies. These two approaches are discussed by Whallon (1973:115-119).

Aspatial procedures can be subdivided further into two types. One relies on the presence and/or absence of specified tool classes which comprise activity sets. The various possibilities are recognized on the basis of ethnoarchaeological studies, ecological considerations, and intuitive impressions developed during fieldwork and laboratory analysis. The second type of procedure examines artifact variability from site to site on the assumption that this variability results from changing ecological parameters. Factor analysis has been employed to quantitatively manipulate the data to isolate activity sets or tool kits (Binford and Binford 1966).

Spatial association procedures have received more recent attention by a number of archaeologists interested in identifying patterns and estimating associations between artifact classes (Clarke 1977; Carr 1984, 1985; Dacey 1973; Hietala and Larson 1980; Hietala and Stevens 1977; Hodder and Orton 1976; Spurling and Hayden 1984; and Whallon 1973a, 1973b, 1974, 1984). Whallon suggests that spatial analysis is an independent test of the necessary differentiation of human activities for the functional argument (1973).

The study of spatial patterns, including the distribution of points in space as representative of dynamic processes, has developed in the last 25 years in the study of nonlinear dynamical systems, chaos, and fractal geometry (Devaney 1989; Feder 1988; Gleick 1987; Mandelbrot 1983, 1991; Schuster 1984; Schroeder 1991). The philosophical thrust of these studies is that complex, even chaotic patterns, can arise from relatively simple dynamical processes, and the genesis of these structures can be understood. However, in the course of the development of this chaos the spontaneous generation of pattern may occur. This is what we strive to understand.

The purpose of this analysis is to determine how space is organized relative to debris, fire-cracked rock (FCR), tools, and features for four Memorial Park components: Orient, Terminal Archaic, late Laurentian, and early Laurentian. The organization of space is addressed in two ways. First, the relative association of the four classes of items is ascertained at a global level and at a local level (relative terms to be defined below). For instance, are any two classes positively

associated (aggregated) in space, negatively associated (segregated) in space, or independently distributed? This information permits the interpretation of the presence of activity sets. Second, the generalized fractal dimensions, specifically the information dimensions, are explored. The information dimension is a measure of the loss of information in the dynamic development of chaotic systems. Are these systems of debris, etc. generated from ordered processes or underlying dynamical processes, and how ordered were they? The information dimension is based on Shannon's entropy measure as part of his information theory, analogous to Boltzman's entropy measure for thermodynamics (Schroeder 1991).

#### DYNAMIC PROCESSES AND FRACTAL GEOMETRY

Dynamic processes leave signatures in the space which the products occupy, whether that space is defined by coefficients (as used in the lithic analysis section) or space in the sense normally employed as distance coordinates. These spaces are defined by the interrelationships of the objects or values among which the relationships obtain.

In archaeology, we are faced with the operation of at least two dynamic processes: cultural-behavioral and post-depositional. These processes leave artifacts and features distributed in Euclidean space. However, these objects do not occupy two- or three-dimensional Euclidean space. Instead, they occupy a dimension smaller than the Euclidean dimension of the embedding space. These are fractional, or fractal, dimensions. Where Euclidean space is characterized by whole numbers (1, 2, 3, or 4 dimensional), fractional dimensions can assume values which are fractions of the embedding space (e.g., 0.9, 1.73, 2.33, or 3.39). These dimensionalities arise as a consequence of dynamic processes. Further, even relatively simple dynamics can give rise to very complex structures.

The question is, can such a space (e.g., distribution of debris) be analyzed in the context of fractal geometry and nonlinear dynamic processes? The answer is that there are techniques which have been developed that can characterize these artifact or feature distributions in terms of relevant dimensions. This is not simple, however, because the fractal nature of these patterns is that they are typically intricate structures with more than one scaling exponent. They are the results of multiple dynamic processes with an underpinning of a primary fractal (produced by one particular dynamic process). Nevertheless, the techniques for characterizing these structures do exist, and one particular technique will be used.

One of the generalized dimensions which describes fractal structures of this sort is the information dimension. The numerator of the information dimension is Shannon's entropy, analogous to Boltzman's entropy in physics (Shannon and Weaver 1963) It measures the relative disorder of the objects of interest in the space they occupy. The information dimension evolved out of Shannon's information theory, where information is a specialized, value-free term, equivalent to unpredictability. This coefficient measures the amount of information produced by the fractal at a given level.

The information dimension will allow the following determinations regarding the spatial organization of artifacts and features at the Memorial Park site. First, by demonstrating that the coefficient can be precisely estimated, the idea that these spatial arrangements are fractal can be confirmed. Second, by recognizing that the estimates of one of the alternative dimensions produce different values than the information dimension, it will be demonstrated that the spatial arrangements are intricate multifractals on a fractal support. I would argue that the fractal support is produced by behavioral processes, whereas the multifractal nature is developed out of post-depositional processes. Third, the reasons for associational relationships can be ascertained. If two material classes have the same fractal (information) dimension, they can be assumed to be produced by the same basic dynamics. If two material classes have significantly different



coefficients for the information dimension, then they have different basic dynamics (behavioral). These factors help us to sort out spurious associational measures from meaningful ones in the search for activity sets.

Additionally, we can go beyond the identification of activity sets to the understanding of the basic organizational concerns of a cultural system. This can be done independently of the identification of these activity sets and can be compared across sites. The subsystems recognized in these analyses may serve as unique signatures for particular cultural situations.

## METHODOLOGY

### *Associational Measures*

One associational measure was chosen for this analysis of how artifacts and features occupy space relative to one another. That measure is the rank correlation coefficient, which is a measure that does not depend on the measurements used as long as they retain their order (invariance property). The rank correlation coefficient is the ordinary sample correlation coefficient for the set of ranks. If two samples (X,Y) of n individuals are ranked so that the ith individual from X has an X-rank  $x_i$  and the ith individual from Y has a Y-rank  $y_i$ , then the rank correlation coefficient is:

$$r_s = 1 - 6 \sum d_i^2 / n(n-1),$$

where  $d_i = x_i - y_i$ .

Tables of probabilities associated with the random variable  $r_s$  are available in most statistical references, and a normal approximation is available for sample sizes in excess of 11.

In this study the values used in the analysis are counts or weights of the material from various size units, all of which are combinations of adjoining 50x50 cm excavation units. Ranks were assigned on the basis of these counts or weights to each of the units employed.

### *Information and Hausdorff Dimensions*

There are an infinite number of dimensions that can be used to describe an intricate fractal structure. All of these dimensions belong to a family of dimensions called the generalized dimensions. The generalized dimension is represented by :

$$D_q := \lim_{r \rightarrow 0} \frac{1}{(q-1)} \log \sum_k p_k^q / \log r$$

where  $r$  is the size of the grid,  $p_k$  is the relative frequency or probability of the material in cell  $k$ , and  $q$  is the dimensional indicator.

The information dimension arises for  $q=1$ , and is written as

$$D_1 = \lim_{r \rightarrow 0} - \sum_k p_k \log p_k / \log(1/r)$$

where the symbols are as above. Here the numerator is Shannon's entropy.

The final dimension used here for testing purposes is the Hausdorff dimension where  $q=0$ .

The information and Hausdorff dimensions are applied to a series of square grid units of successively smaller sizes. In this case, grid sizes of 5 x 5 m, 2.5 x 2.5 m, and 1 x 1 m were used. Each grid corresponds to a cell, and the relative frequency in each cell can be calculated after counting the number of members of a given material class in each cell.

To estimate the size of the dimension, the numerator is regressed against the denominator. The slope of the estimate is an estimate of the given dimension to which the line converges.

## RESULTS

### *Associational Measure (Rank Correlation Coefficient)*

Four groups of contiguous 5 x 5 m blocks are used in this analysis. These groups of blocks constitute the largest possible partitions for an analysis of this type. These groups consist of blocks 6 and 14; blocks 5, 8, and 9; blocks 4 and 13; and blocks 3 and 15. The smallest possible partitioning is into the 50 x 50 cm excavation units.

Two basic partitionings were done for the four components analyzed in this section. Those with fewer partitions, ranging from four to nine, are referred to as global in this section. That is, the contrasts made are relatively large compared to the size of the blocks. Further, they were chosen in such a way that at least five tools were present in each partition, since tools are the next-to-smallest class of material, numerically speaking. Partitioning into smaller units was hindered by the small number of tools and features, since using them results in many empty cells and tied rankings. However, the number of partitions ranges from 27 to 47. These smaller partitions are referred to as local as they represent a test at much smaller levels of spatial contiguity.

Rank correlation results for the varying components and partitions are presented in tables 275 through 282. The lower diagonals of these tables either have a correlation coefficient if it is statistically significant or a 0 if it is not, where a probability of  $\leq 0.1$  is the cutoff. The upper diagonal gives the sign of coefficient if it is significant, and a 0 if it is not. In the ensuing discussion a rank correlation coefficient of  $\leq 0.5$  is referred to as low association, a value of  $> 0.5$  and  $\leq 0.7$  is referred to as a moderate association, and a value  $> 0.7$  is referred to as a high association.

Results for the Orient component are summarized in tables 275 and 276. Of the four significant coefficients in Table 275 summarizing global association, three are in the moderate range, and one (between tools and feature) is in the low range. Tools are aggregating in space with debris and fire-cracked rock. Features are segregating from fire-cracked rock and tools but are independent of debris.

The results are not entirely consistent across the two partitions. In Table 276, summarizing local association, the values are all low. The independent relationship between fire-cracked rock and debris at the global level, is positive at the local level. Further, where fire-cracked rock and features are segregating at the global level, they are independent at the local level.

Table 275. Global Rank Correlation Coefficients for the Orient Component.

Class	Debris	FCR	Tools	Features
Debris		0	+	0
FCR	0		+	-
Tools	.567	.670		-
Features	0	.638	.499	

Table 276. Local Rank Correlation Coefficients for the Orient Component.

Class	Debris	FCR	Tools	Features
Debris		+	+	0
FCR	.385		+	0
Tools	.318	.484		-
Features	0	0	.193	

Results for the Terminal Archaic component are summarized in tables 277 and 278. Rank correlation coefficients are low-to-moderate in both tables. For the summary of global association, Table 277, there are only two significant values. Both indicate aggregation of debris with tools and features, although tools and features are independent of one another.

Table 278, summarizing local association, indicates the positive associations found at the global level, and two additional significant positive (aggregative) associations. One is between features and fire-cracked rock, and the other is between features and tools.

Table 277. Global Rank Correlation Coefficients for the Terminal Archaic Component.

Class	Debris	FCR	Tools	Features
Debris		0	+	+
FCR	0		0	0
Tools	.587	0		0
Features	.460	0	0	

Table 278. Local Rank Correlation Coefficients for the Terminal Archaic Component.

Class	Debris	FCR	Tools	Features
Debris		0	+	+
FCR	0		0	+
Tools	.565	0		+
Features	.442	.324	.215	

The late Laurentian indicates a completely aggregating pattern at both the global and the local levels (tables 279 and 280). All coefficients range from moderate to high. The number of features was too small to include them in the second table. The rank correlation coefficients are particularly high between debris, fire-cracked rock, and tools.

Table 279. Global Rank Correlation Coefficients for the Late Laurentian Component.

Class	Debris	FCR	Tools	Features
Debris		+	+	+
FCR	.952		+	+
Tools	.916	.928		+
Features	.617	.540	.638	

Table 280. Local Rank Correlation Coefficients for the Late Laurentian Component.

Class	Debris	FCR	Tools
Debris		+	+
FCR	.851		+
Tools	.654	.703	

There are few significant associations among the classes of material for the early Laurentian component (tables 281 and 282). At the global level, all classes are independent. At the local level, there are three positive relationships which are statistically significant. They occur between debris and fire-cracked rock, debris and tools, and features and tools.

Table 281. Global Rank Correlation Coefficients for the Early Laurentian Component.

Class	Debris	FCR	Tools	Features
Debris		0	0	0
FCR	0		0	0
Tools	0	0		0
Features	0	0	0	

Table 282. Local Rank Correlation Coefficients for the Early Laurentian Component.

Class	Debris	FCR	Tools	Features
Debris		+	+	0
FCR	.382		0	0
Tools	.377	0		+
Features	0	0	.330	

### *Entropy and the Information Dimension*

The first calculations performed were those for Shannon's entropy for each of the three partitions (grid units). Shannon's Entropy values for each of the four components are presented in tables 283 through 286. In every case, features have the smallest entropy value. As a locus of activity, this would be expected. Further, there is a tendency for the entropy to be largest-to-smallest, from debris to fire-cracked rock, to tools, to features, respectively.

Table 283. Orient Component Shannon's Entropy Values for Three Partition Sizes.

Unit Size	Shannon's Entropy			
	Debris	FCR	Tools	Feature
5X5 meter	1.370	1.231	1.672	1.531
2.5X2.5 meter	2.664	2.363	2.928	2.278
1X1 meter	4.372	3.751	4.118	3.015

Table 284. Terminal Archaic Shannon's Entropy Values for Three Partition Sizes.

Unit Size	Shannon's Entropy			
	Debris	FCR	Tools	Feature
5X5 meter	1.774	1.622	1.183	1.532
2.5X2.5 meter	3.077	2.803	2.335	2.269
1X1 meter	4.724	3.971	3.536	3.206

Table 285. Late Laurentian Shannon's Entropy Values for Three Partition Sizes.

Unit Size	Shannon's Entropy			
	Debris	FCR	Tools	Feature
5X5 meter	1.837	1.478	1.442	1.243
2.5X2.5 meter	2.863	2.716	2.818	1.792
1X1 meter	4.595	4.154	3.967	1.792

Table 286. Early Laurentian Shannon's Entropy Values for Three Partition Sizes.

Unit Size	Shannon's Entropy			
	Debris	FCR	Tools	Feature
5X5 meter	1.279	1.344	1.288	0.968
2.5X2.5 meter	2.540	2.664	2.625	2.029
1X1 meter	4.150	4.277	4.028	2.889

The values of the information dimension are summarized in tables 287 to 290 for each of the four components. These values have the same pattern as the entropy values above, as they are divided by the same scaling value.

Table 287. Orient Component Information Dimension Values for Three Partition Sizes

Unit Size	Information Dimension			
	Debris	FCR	Tools	Feature
5X5 meter	-0.851	-0.765	-1.039	-0.951
2.5X2.5 meter	-2.907	-2.579	-3.195	-2.486
1X1 meter	-439.420	-376.969	-413.830	-303.000

Table 288. Terminal Archaic Information Dimension Values for Three Partition Sizes.

Unit Size	Information Dimension			
	Debris	FCR	Tools	Feature
5X5 meter	-1.102	-1.008	-0.735	-0.948
2.5X2.5 meter	-3.358	-3.059	-2.548	-2.476
1X1 meter	-474.725	-339.082	-355.339	-322.181

Table 289. Late Laurentian Information Dimension Values for Three Partition Sizes.

Unit Size	Information Dimension			
	Debris	FCR	Tools	Feature
5X5 meter	-1.142	-0.918	-0.896	-0.772
2.5X2.5 meter	-3.124	-2.964	-3.075	-1.955
1X1 meter	-461.831	-417.509	-398.645	-180.071

Table 290. Early Laurentian Information Dimension Values for Three Partition Sizes.

Unit Size	Information Dimension			
	Debris	FCR	Tools	Feature
5X5 meter	-0.795	-0.835	-0.801	-0.602
2.5X2.5 meter	-2.772	-2.908	-2.864	-2.215
1X1 meter	-43.543	-429.793	-404.764	-290.367

Linear regression estimates of the slopes of the lines between the entropy values and the denominator were made; these slopes are estimates of the dimension. The median  $R^2$  of these estimates is 0.996. The slopes and standard errors are summarized in Table 291. The larger the value, the larger dimension or space that the material class occupies.

Table 291. Estimates of the Information Dimension.

Material Class	Component			
	Orient	Terminal Archaic	Late Laurentian	Early Laurentian
Debris	1.88+/-0.01	1.84+/-0.02	1.73+/-0.12	1.79+/-0.01
FCR	1.57+/-0.03	1.46+/-0.12	1.67+/-0.06	1.83+/-0.04
Tools	1.51+/-0.14	1.46+/-0.10	1.56+/-0.20	1.70+/-0.11
Features	0.92+/-0.07	1.05+/-0.01	0.79 <sup>a</sup>	1.19+/-0.16

<sup>a</sup>The estimate has no associated standard error since only two points were available over the relevant range of grid sizes.

The high  $R^2$ 's, and statistical significance of the regression estimates, suggest that the distribution in space of each of the four material classes is fractal—a critical point. This indicates that analyses must be instituted that take this factor into consideration. Further, it confirms that the distributions arise from dynamic processes which, in principle, can be studied. In this case, the values tend to decrease from debris to features which might be expected as features are more structured while the byproducts of reduction are less so.

If the distributions were the result of a single dynamic process, then the alternate dimensions would be identical to the information dimension. To test if this is the case, the Hausdorff dimension was calculated using the same procedures used for the information dimension. The results are summarized in Table 292.

Table 292. Estimates of the Hausdorff Dimension.

Material Class	Component			
	Orient	Terminal Archaic	Late Laurentian	Early Laurentian
Debris	1.86	1.99	1.78	1.99
FCR	0.77	1.84	0.92	1.99
Tools	1.40	1.37	1.55	1.70
Features	0.78	0.91	0.59	1.14

The values for the information dimension and the Hausdorff dimension were tested for significant differences, and the results are summarized in Table 293 for Student's t tests of the differences in the means. Notice that a pattern of differences emerges for all classes except tools. Note that both exceptions, late Laurentian debris and early Laurentian features, have high standard errors associated with them. This suggests that the dynamic processes responsible for tool distributions are not only different, but are more basic. A relatively simple set of dynamics is responsible for tool distribution. Perhaps they are discarded at loci of use upon being expended, while the other classes are moved and redeposited in a random pattern relative to their initial use areas. The fractal dimensions for the debris, FCR, and features are more complex.

Table 293. T-Tests Between Information Dimension and the Hausdorff Dimension Estimates.<sup>a</sup>

Material Class	Archaeological Unit			
	Orient	Terminal Archaic	Late Laurentian	Early Laurentian
Debris	*	*		*
FCR	*	*	*	*
Tools				
Features	*	*	*b	

<sup>a</sup>Only values significant at the 0.1 level or less are included in the table. All other values coded 0.

<sup>b</sup>The estimate has no associated standard error since only two points were available over the relevant range of grid sizes. An asterisk here means that the values are presumed to be significantly different.

The next step was a comparison of component dimensions for each material class to determine if the components differ dimensionally for each class. To test this, the Student's t statistic for comparing two means was calculated for each possible comparison across components for each material class. The results are summarized in tables 294 to 297.

With respect to the debris, the early Laurentian is similar to the late Laurentian and Terminal Archaic. The Orient component has a significantly higher information dimension than the other three components. This may be because the reduction activities at this time were more differentiated or individualized.

Table 294. Student's t Values for Comparison of Means for Debris Across Components.

Component	Orient	Terminal Archaic	Late Laurentian	Early Laurentian
Orient		3.27	2.83	11.02
Terminal Archaic	*		1.92	4.08
Late Laurentian	*	*		1.13
Early Laurentian	*	0	0	

For FCR, every component is different from every other except the Orient and Terminal Archaic. The values of the information dimension for these two components are smaller than for the other two components. This may indicate a tighter pattern of disposal of FCR from feature cleaning than in the Early and late Laurentian (FCR tends to be located away from features).

Table 295. Student's t Values for Comparison of the Information Dimension for FCR Across Components.

Component	Orient	Terminal Archaic	Late Laurentian	Early Laurentian
Orient		1.80	2.72	9.10
Terminal Archaic	0		2.86	5.66
Late Laurentian	*	*		3.92
Early Laurentian	*	*	*	

The situation for tools is basically one of uniformity in values of the information dimension across components. The single exception is the significant difference between the early Laurentian and Terminal Archaic. The early Laurentian has the highest value, and the Terminal Archaic has the lowest value among the tools. The general pattern of values does indicate the decrease in this value through time, suggesting greater integration of activities related to tool use and discard.

Table 296. Student's t Values for Comparison of the Information Dimension for Tools Across Components.

Component	Orient	Terminal Archaic	Late Laurentian	Early Laurentian
Orient		0.51	0.36	1.86
Terminal Archaic	0		0.82	2.80
Late Laurentian	0	0		1.11
Early Laurentian	0	*	0	

For the features, the calculation of the information dimension for the late Laurentian posed a special problem in that only two points were available for the estimate. It is possible to estimate a slope to get the value of the information dimension, but it is not possible to obtain an estimate of the standard error. Consequently, statistical tests involving this estimate were not possible. However, given the very low value estimated for the late Laurentian, it is possible to accept the value as significantly lower than those values for the other three components. Based on this assumption, only the Terminal Archaic and early Laurentian are similar. These two values are larger than the others, indicating more clustered and integrated feature placement.



Table 297. Student's t Values for Comparison of the Information Dimension for Features Across Components.

Component	Orient	Terminal Archaic	Late Laurentian	Early Laurentian
Orient		3.98	-.a	2.88
Terminal Archaic	*		-.a	2.02
Late Laurentian	*b	*b		-.a
Early Laurentian	*	0	*b	

<sup>a</sup> The standard error was not estimable since only two points were available for the estimate of the slope.

<sup>b</sup> The features are assumed to be significantly different from all other classes since the value is so much lower.

Intracomponent comparisons are also useful in identifying different processes responsible for the loss, discard, placement or abandonment of the material classes in a given archaeological unit. Tables 298 to 301 are summaries of the Student's t test for differences in the coefficient of the information dimension. The upper diagonal has the values of the test statistic, and the lower diagonal contains asterisks if the significance is  $\leq 0.1$  and 0s if the differences are not significant.

For the Orient component, the dimensionality of tools is not significantly different than that of FCR (Table 298). However, the remaining dimensions are significantly different. This suggests that the processes responsible for the location of FCR and tools are jointly different from debris and features. Since FCR and tools have the same dimensionality, do they also occupy the same space? This question is addressed below.

Table 298. Student's t Values for Comparison of the Information Dimension for Material Classes for the Orient Component.

Material Class	Debris	FCR	Tools	Features
Debris		18.98	6.04	29.39
FCR	*		0.86	15.92
Tools	*	0		6.88
Features	*	*	*	

The Terminal Archaic component appears similar to the Orient component (Table 299). Tools and FCR have the same dimensionality, while jointly they are different from debris and features. Like the Orient component, debris and features are also different. Even the relative ordering of the units of dimensionality are the same. The dynamics responsible for tool and FCR locational patterns would appear to be the same.

Table 299. Student's t Values for Comparison of the Information Dimension for Material Classes for the Terminal Archaic Component.

Material Class	Debris	FCR	Tools	Features
Debris		3.15	16.67	64.50
FCR	*		0	7.73
Tools	*	0		9.13
Features	*	*	*	

The late Laurentian component presents a different picture than the preceding (Table 300). Here the tools, debris, and FCR are not significantly different in terms of their dimensionality. Although the feature estimate is made on only two points and no standard error is available, it appears that the value is significantly smaller than the others. Are the tools, debris, and FCR located by the same underlying process? It would appear so, and it would seem, as well, that the activities responsible for the location of debris, tools, and fire-cracked rock are organized outside of the feature locations.

Table 300. Student's t Values for Comparison of the Information Dimension for Material Classes for the Late Laurentian Component.

Material Class	Debris	FCR	Tools	Features
Debris		0.92	1.30	.a
FCR	0		0.85	.a
Tools	0	0		.a
Features	-	-	-	

<sup>a</sup>The standard error was not estimable since only two points were available for the estimate of the slope.

The early Laurentian component illustrates a similar pattern of dimensionality (Table 301). Features are different from debris, tools and FCR. Debris, FCR, and tools have similar dimensionality. This component seems to suggest the lowest level of differentiation in various processes associated with these material classes.

Table 301. Student's t Values for Comparison of the Information Dimension for Material Classes for the Early Laurentian Component.

Material Class	Debris	FCR	Tools	Features
Debris		1.96	1.84	8.65
FCR	0		2.12	7.84
Tools	0	0		4.63
Features	*	*	*	

#### SUMMARY AND CONCLUSIONS

The analytical results summarized for the associational measures and those of the information dimension are not directly comparable. In fact, many of the associational measures appear to be the result of spurious associations among classes at levels or partitionings where the limits of the information dimension of the classes cross. That is, if one plots Shannon's Entropy against the log of the value of 1/unit size, the resulting straight lines have different slopes, and cross at some point. That point is a particular level of partitioning into cells of size  $r$ . It is near this level of partitioning that positive association occurs solely as the result of the partition. This fact is supported by the relatively inconsistent levels of association at different partitions (see tables 275 through 282).

If two classes of material are aggregating as the result of similar dynamics, which an activity set would imply, then they would have both similar dimensionality over some set of partitions, and associational measures which are positive over the same set of partitions. For which interclass comparisons are these two criteria true?

With respect to the Orient component, only tools and FCR have the same dimensionality. Further, the rank correlation coefficients associated with tools vs. FCR over both partitions are positive. This suggests that the tools and FCR are located where they are, as the result of the same simultaneous dynamic processes. While the tools and FCR are aggregating and have the same dimensionality, these two classes are segregating from features which possess a much lower dimensionality. This would result from the operation of different processes at different locations.

For the Terminal Archaic component, tools and FCR have the same dimensionality, but the rank correlation coefficients indicate that there is no association. In this case, the basic dynamics involved appear to be the same, but they are operating independently in space or time. The remaining classes have different dimensionalities, and features have the smallest value. The rank correlation coefficients are positive for the features and all other classes at 40 partitions, but these are spurious cases.

The late Laurentian component is very different from the previous two. Only the features possess a significantly different dimensionality than the other three classes. In this case, the rank correlations indicate aggregation over all classes and across both partitions. For the tools, debris, and FCR, location in space is the function of simultaneous deposition operating under the same basic dynamic processes. The positive association of features with these other three classes can be regarded as spurious association.

The early Laurentian presents yet another case. Features are different from tools and debris, but tools, debris, and FCR are of the same dimensionality. The early Laurentian appears to be the least differentiated in the pattern of its information values, as well as the rank correlation coefficients, where no association is indicated at the larger partition, and only three low-association measures are present at the greater number of partitions. These latter would appear to be solely a function of this particular partition.

The basic pattern of change from the early Laurentian to the Orient component, as reflected in the intracomponent patterns and the intercomponent differences, is one of increasing differentiation of activities. The primary indicators of this differentiation are the information dimension values which indicate which classes of material, as indicators of various activities, occupy space differently due to alternative dynamic processes. That is, there was a greater structuring of activities through time, which is consistent with other analyses in this volume that suggest longer-term, and more intensive use of the site through time.

The difference between the early Laurentian and the late Laurentian is one of a contraction of the dimensionality of the space associated with features and FCR. This occurs due to more group-effort taking place relative to the features and associated activities, such as cleaning and discard of the FCR. That is, there were more structured activities around features, longer-term use of features, and an attempt to keep the area around the features clear of debris. Activities around the feature from those associated with debris and tools also differentiates; that is, different activities, such as food preparation and tool manufacture and use, were segregated in space during the late Laurentian. A more pronounced change occurs from the late Laurentian to the Terminal Archaic. FCR and tools are the only classes still having similar dimensionality, and second, there is a shift to a smaller dimensionality for FCR. Here, the overall structure has changed in addition to a shrinking of space. In other words, activities at the site became more structured or patterned, and different activities occupied different spaces. From the Terminal Archaic to the Orient, the dimensional pattern is the same, but the associational patterns are different. Tools aggregate with FCR, and segregate from features. This, too, indicates increasing differentiation of certain activities since the segregation of subspaces is occurring, or differentiating certain activities further. This reflects a continuation of trends established earlier; that is, a more structured use of space, probably in response to longer-term and more intensive use of the site.

Hence, the analysis of spatial data presented here indicate that increasing differentiation of activities occurred over the period represented by the early Laurentian through Orient components. If this increasing differentiation is reflected in mobility strategies and procurement, then one would expect that procurement, and mobility strategies would become more specialized across the landscape. In other words, one would expect the development and continued increase in logistical settlement system behaviors. It must be understood, however, that while it is possible to suggest linkages between artifact and feature patterning, there are no clear linkages between current ideas concerning procurement, and mobility and intrasite artifact patterning. Further, while it is possible to suggest reasons for changes in spatial patterning, the precise dynamic processes underlying these changes in spatial arrangement remain obscure. However, the means are now available to identify dynamical changes and to begin to discuss them in terms of energetics and entropy—a desirable goal for a materialist understanding of the dynamics of cultural systems and culture change.

## XVI. SUMMARY AND CONCLUSIONS

by

John P. Hart, Ph.D.

### GENERAL PROJECT SUMMARY

The investigations presented in this report were designed to accomplish two major goals: (1) to mitigate adverse effects to the Late Woodland deposits of the Memorial Park site as a result of levee-floodwall construction, and (2) to test deep, stratified deposits within the three-meter zone of construction impact, in order to determine the temporal span of occupations at the site. These objectives were accomplished through the performance of four tasks: Task 1, the extensive exposure of Late Woodland deposits across a one hectare study area; Task 2, 5 x 5 m block excavations to a depth of 1.5 m below the original ground surface; Task 3, 2 x 2 m block excavations between 1.5 and 3.0 m below original ground surface; and Task 4, expanded excavations to investigate the most promising deposits encountered during tasks 2 and 3. Subsequent investigations by Schuldenrein and Vento (1993) provided information on deeper deposits that confirmed the results presented in the draft version of this report (Hart 1993b).

Despite problems that occurred during the implementation of Task 1 (as described in the Field Methods section of this report) resulting in the over stripping some areas, the fieldwork and subsequent data analyses yielded large data sets of significant information on prehistoric occupations at the Memorial Park site and, by extension, of the West Branch Valley. Thirteen components were identified as a result of these investigations: four Late Woodland, one Middle Woodland, one Early Woodland, three Terminal Archaic, three Late Archaic, and one Middle Archaic. These components encompass a time span of approximately 6500 years, between approximately 5140 B.C. and A.D. 1385, constituting one of the most complete records of prehistoric occupation in the West Branch Valley at a single locus (also see Custer, Watson, and Bailey 1994; Bressler 1989) and at an open-air site in the Mid-Atlantic and Northeast (also see e.g., Dincauze 1976; Kinsey 1975).

In the Research Design section of this report, a number of research topics were identified for the project: Geomorphology and Site Formation, Occupational Sequences and Chronology, Subsistence Strategies, Technology, and Settlement Patterns. Under each of these topics, a theoretical model was developed from which site-specific research questions were derived. Field and laboratory methods were identified that would produce the data needed to address these research questions. Major sections in this report have provided reviews of the analytical methods and their implementation, the resulting descriptive data, and the analytical results for geomorphology and site formation; features; radiocarbon assays; pottery; chipped stone tools and debris; microwear of chipped stone tools; cobble, ground, and pecked stone tools and steatite; botanical remains; faunal remains; pollen; and site structure.

The report was formatted so as to present as much descriptive data as possible for use by future researchers without becoming unwieldy. Each of the analytical chapters presents detailed descriptive statistical summaries for each analytical class. Within each analytical section, these data are then used to address major research questions. The results of the analyses of each analytical class have contributed individually to our understanding of the various occupations at the Memorial

Park site. Additional data are presented in the separate volume of appendices. The artifacts, field records, and all other classes of data generated during this project will be permanently housed at a location to be determined by the U.S. Army Corps of Engineers and the non-federal sponsor. In the following sections, the research topics raised in the Research Design section of this report are revisited, and data from the site are brought to bear on the research questions, drawing upon the results of each of the analytical chapters.

## GEOMORPHOLOGY AND SITE FORMATION

Exhaustive studies of site-specific geomorphology and site formation at Memorial Park were performed during the present investigations (see Hart 1993b) and during subsequent investigations by Schuldenrein and Vento (1993), which allowed the development of a comprehensive model of site formation as presented in the Geomorphology and Site Formation section of this report. Schuldenrein and Vento's (1993) investigations largely supported the original interpretations of site formation presented by Cremeens in the draft version of this report (Hart 1993b). The results of the site formation investigations, coupled with archaeological data, allow a reconstruction of changes in site utilization through time, and provide an excellent case study, demonstrating the contributions that can be made toward site interpretation through pedological analyses.

During the early Holocene (>8000 B.P.), the study area underwent active alluviation as the West Branch channel migrated eastward. The landscape within the study area was immature and apparently did not provide a stable surface for human occupation. Both the current investigations and subsequent investigations by Schuldenrein and Vento (1993) failed to produce evidence of Early Holocene (Paleoindian and Early Archaic) occupations. This contrasts with the nearby West Water Street site in Lock Haven upstream from Memorial Park, where a late Paleoindian/Early Archaic component was dated to 9500 B.P. (Custer, Watson, and Bailey 1994). This site provided a more stable landform, suitable for occupation at this early date. While it is possible that portions of the West Branch flood plain at Memorial Park were used during the Early Holocene, stream migration and episodes of deposition and erosion presented an unstable landscape for extended human occupation, and these processes may have removed evidence of short-term use or occupation.

Sediments deposited during the Early Holocene at Memorial Park were eventually eroded to form a terrace escarpment, the Port Huron terrace, in the western portions of the study area. Brief periods of flood plain stability allowed several immature soils to develop, dating to approximately 7050 B.P. and 6800 B.P. during the Middle Archaic period. These soils were associated with a drier climate as evidenced by pollen data, and they contain the first evidence of human occupation within the study area. Middle Archaic Neville and Eva-like bifaces were recovered from these deposits. Two fire-related pit features and several postmolds were documented in the western-most block excavations on the Port Huron terrace. This landform provided, at least, a briefly stable location for human habitation. The Early Holocene soils were subsequently buried through alluviation; these sediments were subsequently eroded and weathered.

The next occupation of the site is associated with a soil formed in these latter deposits, dated to approximately 6000 B.P. This soil formed on an eroded surface during a period of flood plain stability. By this time, the West Branch channel had continued to migrate eastward and a natural levee had begun to form between the active channel and an abandoned channel east of the Port Huron terrace. This landscape was intensively utilized during the early Late Archaic period; early Laurentian component features were located predominantly on the Port Huron terrace, indicating that it was the most stable landform for human occupation on this portion of the West Branch valley. The intensity of the occupation suggests that the landform was stable for a relatively long period of time. A single feature, and artifacts recovered from the natural levee,

indicate that this landform was used even at this early point of its development. The site probably functioned as a series of base camps at this time, indicating that the location provided ready access to a number of resources at least on a seasonal basis.

The early Late Archaic landscape was subsequently buried through alluviation, and these sediments were, in turn, eroded and weathered. The next period of flood plain stability, at approximately 5000 to 4500 B.P., saw the development of another soil and another intensive Late Archaic occupation. Late Laurentian component features were concentrated on the Port Huron terrace, but were more common on the natural levee than during the early Laurentian occupations. A single feature on the channel remnant indicates that this landform was also being exploited, suggesting that by this time the landscape had accreted to the point where the entire study area was habitable. That the Port Huron terrace was the most intensively occupied suggests that it continued to offer the most stable surface for habitation. The site continued to serve as a base camp during this time, indicating that the location provided easy access to a range of resources.

The landscape continued to upbuild following the late Laurentian occupation. The next period of flood plain stability is associated with the Piedmont component at around 4750 B.P., which is correlated with a drier, warmer climate. With one exception, the Piedmont component features are limited to the Port Huron terrace. The Piedmont component represents a much less intensive occupation than did the two Laurentian components, perhaps as a result of changed environmental conditions, including a less stable landscape to the east of the terrace. The site probably served as a resource extraction camp during this time.

The Piedmont occupations were followed by brief periods of aggregation separated by erosional events and at least two periods of soil formation. The first of these soils formed at around 3500 B.P. and is associated with a generally dry environment. The combined Canfield Island/Susquehanna component represents the most extensive occupation of the site to that time. Features associated with this component are concentrated on both the Port Huron terrace and the natural levee. The occurrence of four features on the channel remnant indicates the first relatively intensive utilization of this landform. The site functioned as a base camp at this time, providing ready access to a variety of resources.

The following episode of landscape evolution consisted of an erosional interval, particularly on the east side of the study area, followed by deposition, flood plain stability, and soil development associated with the Orient phase component dating to approximately 3000 B.P. Like the preceding occupation, Orient phase features were distributed across the study area indicating relatively intensive use of all three landforms. The occurrence of postmold concentrations on the natural levee and Port Huron terrace indicate that the site was probably occupied on a multiseasonal basis and that it served as a base camp.

Periodic alluviation and soil development occurred during the Woodland period. The distribution of Late Woodland features indicates that the entire study was utilized during this time with the probable exception of low-lying portions of the channel remnant. Early Woodland and Middle Woodland features are few in number indicating that the site was not intensively utilized at this time.

In summary, the geomorphological/site formation investigations allowed for the construction of a model of landscape evolution that included three landforms: a terrace, an abandoned channel remnant, and a natural levee. The periodic buildup of these landforms through alluviation, followed by periods of flood plain stability allowing soil development, influenced human occupations of the study area. The Port Huron terrace was the primary focus of occupation, beginning with the Middle Archaic and continuing through Late Archaic. The natural levee and channel remnant, while utilized to some extent during the Late Archaic, were not intensively used until the Terminal Archaic when these landforms afforded elevated, stable loci for

human activity. Periods of extended flood plain stability are associated with intensive utilization of the site, while periods of flood plain instability are associated with less intensive use of the site. The entire West Branch flood plain at this location was probably a highly dynamic landscape, providing various constraints on, and opportunities for, human settlement. As a result, it is likely that the Memorial Park site, as defined in this and previous studies represents only a small portion of complex systems of human subsistence-settlement systems at the confluence of the West Branch and Bald Eagle Creek.

#### OCCUPATIONAL SEQUENCES AND CHRONOLOGY

Earlier archaeological investigations at the Memorial Park site identified components dating from the Late Archaic through Late Woodland periods as reviewed in the introduction to this volume (Hay et al. 1979; Stevenson and Hay 1980; Neumann 1989). The earliest investigations primarily identified Clemson Island material that was the basis for listing of the site on the National Register of Historic Places (Hay et al. 1979; Stevenson and Hay 1980). During the subsequent Phase II investigations, components from all periods from Late Archaic through Late Woodland were documented, and reported to have been vertically distinct (Neumann 1989). No radiocarbon assays were reported; dates for the components in Neumann (1989), were determined by diagnostic artifacts and estimated dates for the five buried soils, based upon the work of Vento et al. (1988). The refinement of the chronological sequence at the Memorial Park site, therefore, was a major focus of the research presented in this volume. During the current investigations, the occupation span was expanded back to the Middle Archaic period and forward to encompass more of the Late Woodland period. Research questions addressed during these investigations included: (1) What was the occupational sequence at the site? (2) What were the absolute dates for each component at the site? (3) Was it possible to aid the development of an absolute chronology for Clemson Island pottery style change? and (4) Was it possible to differentiate multiple components for the various time periods represented at the site, and did these correspond to previously defined phases? The following sections provide a summary of the data recovered from each of the components identified during the current investigations and interpretations of the occupations that address all of these questions.

##### *Paleoindian/Early Archaic*

Investigation of the Memorial Park site presented in this volume failed to produce evidence of Early Holocene occupations that would correspond to the Paleoindian and Early Archaic periods (Hart 1993b). The earliest occupations present within those deposits above 3.0 m below the original ground surface to which the present investigations were limited, are Middle Archaic, dating from 5140 B.C. to 4770 B.C. As described by Cremeens in the draft version of this report (Hart 1993b), the West Branch at this location was migrating eastward during the early Holocene. The site location was undergoing phases of alluviation and erosion (Cremeens 1993:117, 124, 127) which would have either precluded human occupation of the location or removed evidence of such occupations. The lack of Early Holocene occupations at the Memorial Park site locus was confirmed during subsequent investigations by Schuldenrein and Vento (1993) that tested deposits up to 6 m below the original ground surface. Their results indicate that Early Holocene deposits "are strikingly absent, perhaps a function of the relative dynamism of the floodplain at this time; however deposits of this age have been dated on the western site margins in eroded beds of laterally accreted sands. Stabilization of soil environments begins after 7,200 B.P." (Schuldenrein and Vento 1993:6-17). The presence of a late Paleoindian/Early Archaic component at the West Water Street site, upstream from Memorial Park (Custer, Watson, and Bailey 1994), reflects a more stable landform during this period at that location.



### *Middle Archaic*

The first occupation of the study area occurred during the Middle Archaic period; one Middle Archaic component, representing at least two occupations, was identified during the current study. Diagnostic artifacts include Neville bifaces, which are generally dated between 6000 and 5000 B.C. (Justice 1987). Also recovered, in apparent association with the Neville bifaces, were two basal-notched bifaces reminiscent of Eva bifaces. The Eva I type is generally dated between 6000 and 4000 B.C., while the Eva II type is generally dated between 4000 and 2000 B.C. (Justice 1987). The recovery of a triangular biface from Middle Archaic contexts is consistent with the recovery of triangular bifaces from Middle Archaic contexts at the West Water Street site (Custer, Watson, and Bailey 1994), the Abbott Farm site (Stewart and Cavallo 1991), and other sites in the Mid-Atlantic (Cavallo 1981) and Northeast (Snow 1980). Custer, Watson, and Bailey (1994:173) suggest an age range for Middle Archaic triangular bifaces of 6500 B.C. to 5500 B.C. Five radiocarbon assays were obtained that relate to a Neville phase component at Memorial Park. Four of these,  $5095 \pm 210$  B.C.,  $5140 \pm 80$  B.C.,  $4815 \pm 55$  B.C., and  $4770 \pm 225$  B.C., were obtained from bulk soil samples. The final assay,  $4880 \pm 130$  B.C., was obtained from Feature 232, one of two features associated with this component.

The Middle Archaic occupations are contained within two buried soils, Buried soil 7 dated to approximately 7000 B.P., and Buried soil 6 dated to approximately 6800 B.P. At this time, the study area consisted of a terrace escarpment to the west (the Port Huron Terrace), bordered on the east by a channel-remnant flood plain, which in turn was bordered on the east by the active south channel of the West Branch. Between 7000 B.P. and 6800 B.P., the terrace had built to the east, and the active channel had probably migrated somewhat eastward. The relative immaturity of these two soils reflects a relatively brief period of flood plain stability.

Evidence for Middle Archaic occupation was restricted to the western excavations on the Port Huron terrace. Only two features were uncovered in these deposits, both classified as fire-related pits. Neither contained identifiable wood fragments, seeds, or nuts, and no bone was recovered. Scant pollen data suggest a warm-dry environment at this time, represented by oak pollen. This interpretation is consistent with the Hypsithermal Climatic Interval, which has been recognized as a major influence on Middle Archaic subsistence-settlement systems in the Midwest (e.g., papers in Phillips and Brown 1983). The Hypsithermal has been recognized in the Mid-Atlantic and Northeast by a number of authors, based upon the pollen record (e.g., Joyce 1989; Watts 1979).

Lithic analysis suggests that activities were limited primarily to tool maintenance, although some primary reduction of local cherts may also have occurred. Although the number of tools recovered is small, the ratio of formally-shaped tools to retouched and utilized flakes, 2.2, is high suggesting a primarily curated technology. One jasper core indicates the use of nonlocal materials at this time. There was a virtual absence of ground- and pecked-stone and cobble tools.

Hatch et al. (1985) suggest that Middle Archaic subsistence-settlement systems in the Ridge and Valley province were logistically oriented, although it is likely that residentially mobile subsistence-settlement patterns were also used in various areas of the Province. Overall, the data suggest that during the Middle Archaic period, the Memorial Park site was used as either a short-term residential camp or a temporary procurement camp. The landscape at the site was relatively young, and it may have presented limited resource procurement opportunities. This contrasts with the more stable landscape at the West Water Street site, where Custer, Watson, and Bailey (1994:211) documented a relatively intensive Middle Archaic component. They interpret this component as a number of temporally discrete "occupations that were small family units whose settlement locales were not linked into a large based camp with marked spatial differentiation of activity areas." It is probable that the Middle Archaic occupations of Memorial Park were part of the same residential settlement system represented at West Water Street.

### *Late Archaic*

Three Late Archaic components were identified during the current investigations: early Laurentian, dating to between 4405 and 3840 B.C.; late Laurentian, dating between 3250 and 2950 B.C.; and Piedmont, dating between 2460 and 2100 B.C. These components are summarized below.

### *Early Laurentian*

Four radiocarbon assays were obtained for this component, three from bulk soil samples (4405±265 B.C., 3880±130 B.C., and 3840±240 B.C.), and one from a feature (4165±265). These dates are generally consistent with the Vergennes-like complexes in the Hudson, Schoharie, and Susquehanna river basins of New York, which date between 4300 B.C. and 3700 B.C. (Funk 1988). Diagnostic bifaces associated with the Memorial Park component included Otter Creek with straight, ground bases; Brewerton Eared Triangular; Brewerton Side Notched, Brewerton Eared-Notched; Chillesquaque Triangle; Stark/Morrow Mountain; and Vosburg. Radiocarbon dates obtained for all of these types at other sites are generally consistent with the dates obtained at the Memorial Park for this component. For example, George and Davis (1986) report a date of 4140±240 B.C. (MASCA-corrected) at the Brown site in Allegheny County in association with Brewerton Side Notched bifaces. Otter Creek bifaces are found at Vergennes-like complex sites in New York that date between 4300 and 3700 B.C. (Funk 1988). Marrow Mountain bifaces are generally assigned to the Middle Archaic period, but have been dated as late as 4030 B.C. at Russel Cave (Justice 1987). Stark bifaces are considered to be contemporaneous with Marrow Mountain bifaces (Justice 1987) and are found in the Mid-Atlantic region between 6000 and 4000 B.C. (Custer 1989). The triangular biface post-dates Custer, Watson, and Bailey's (1994) estimated date range for Middle Archaic triangulars, but Fogelman (1988) identifies the Chillesqueque type with the Late Archaic period. Other artifacts associated with this component are consistent with early Laurentian occupations in New York (Funk 1988; Ritchie 1965a). These include a contracting-wing, ground-slate bannerstone with a ridged shaft; a quartz-crystal plummet; ground slate semilunar knife fragments; pestles; adzes; chopping tools; hammerstones; and grinding slab fragments.

The landscape at the Memorial Park site during this time continued to upbuild. The active south channel of the West Branch had migrated further to the east, and a natural levee had formed along its western bank. A low channel remnant remained between the levee and Port Huron Terrace. The early Laurentian component is associated with Buried soil 5. Pollen data are missing for this occupation; however, wood charcoal recovered from this component includes hickory, ash, pine, oak, and elm. This assemblage is consistent with Hatch et al.'s (1985:102) assertion that a modern mixed coniferous-northern/deciduous forest was in place by 5000 B.C. Such a setting would have provided opportunities for the exploitation of a large array of plant and animal resources.

Thirty-three features were associated with the early Laurentian component, the majority were classified as fire-related. Thirty-two of these were located on the Port Huron terrace, and one was recorded on the levee. This indicates that the levee was utilized relatively early, but that the terrace was the most stable landform.

Debris analysis resulted in high reduction effort and thinning values, indicating that biface manufacture was performed at the site during this time for both local and nonlocal materials. Nonlocal materials, such as jasper, appear to have been transported to the site in partially reduced form for subsequent biface manufacture. Jasper appears to have been heat treated at the site. This pattern may indicate direct procurement of jasper by the occupants of the site, although like rhyolite, it may have been obtained through a broad-based exchange system (Stewart 1989). The

large amount of lithic debris, and 27 cores recovered from early Laurentian contexts, also suggest that tool manufacture was occurring on the site. The ratio of bifaces to edge-only tools, 3.7, is very high, indicating a curated technology. A relatively large number of cobble tools, groundstone tools, and pecked-stone tools were recovered from early Laurentian contexts, suggesting a wider array of activities at the site than occurred during the Middle Archaic occupations. While Custer (1988) suggests that the occurrence of large groundstone assemblages at Late Archaic sites indicates increased importance of the exploitation of plant resources, in the case of the Memorial Park site, it may simply reflect a change in site function following the Middle Archaic period. However, the large number of tools recovered from the site does indicate that a large range of activities were carried out there. The only direct evidence for subsistence practices for this component consists of a small amount of charred hickory and butternut/walnut shell. Only a small amount of unidentified bone was recovered from early Laurentian contexts.

In general, then, evidence suggests that the site served as a base camp during the early Laurentian occupation. The number of occupations represented by the early Laurentian deposits cannot be ascertained; however, it is likely that a number of temporally distinct occupations are represented. The site was probably occupied in order to exploit seasonally abundant, high-bulk resources, perhaps associated with the river channel or abandoned channel remnant, which may have been flooded periodically. The interpretation of the Memorial Park site as a base camp at this time is compatible with extant models of Late Archaic subsistence-settlement for the Mid-Atlantic region in general (Custer 1989), and the Ridge and Valley Province in Pennsylvania specifically (Hatch et al. 1985). These models suggest that large base camps were situated in major river floodplains so as to provide access to a wide variety of resources. This type of settlement pattern is generally referred to in the literature as logistical (e.g., Binford 1980; Kelly 1983). The Memorial Park site would have served as the primary residence for a group of related individuals for the exploitation of high-bulk resources in the site's general vicinity. Logistical forays would have been mounted for the exploitation of resources away from the base camp. The large number of tools recovered in early Laurentian contexts suggests that a wide variety of activities were occurring at the site, consistent with the base camp interpretation.

Assignment of the early Laurentian component at Memorial Park to an established phase is problematical. Although Turnbaugh (1977:109) suggested a "weak Vergennes infiltration into the Lycoming and West Branch valleys," it would be inappropriate to suggest that the Memorial Park component belonged to this phase, given the great distance between the West Branch valley and the area where this phase was originally defined (Funk 1988; Ritchie 1965a). Rather, it is likely that future investigations in the West Branch valley and its tributaries around Lock Haven, will allow for the definition of a new early Laurentian phase.

#### *Late Laurentian*

Five radiocarbon assays were obtained for the late Laurentian component at Memorial Park: three from bulk soil samples ( $3250 \pm 350$  B.C.,  $3095 \pm 420$  B.C., and  $3075 \pm 60$  B.C.), and two from features ( $2965 \pm 45$  B.C. and  $2950 \pm 45$  B.C.). These dates are contemporaneous with the Brewerton phase in central and northern New York, the Upper Saint Lawrence valley, and the Upper Susquehanna Valley, as well as with Bressler's (1989) date of 3150 B.C. for the Laurentian component at the Canfield Island site downstream from the Memorial Park site.

Diagnostic artifacts for the Brewerton phase include variously notched Brewerton bifaces, short broad gouges, netsinkers, bannerstones, plummets, and ground slate points and ulus (Ritchie 1965; Turnbaugh 1977). Diagnostic bifaces associated with the Memorial Park component include Beekman Triangle, Brewerton Corner Notched, Brewerton Side Notched, Brewerton Eared Notched, Otter Creek (concave, unground bases), and Vosburg. Generally accepted date ranges for these types are consistent with the radiocarbon dates obtained for this component (Justice

1987). Other tools associated with this component include celts, pitted cobbles, anvils, hammerstones, and grinding slabs.

The landscape at Memorial Park continued to upbuild: all three topographic features, terrace, channel remnant, and natural levee, were subject to overbank deposition. The late Laurentian component is contained within Buried soil 4. Limited pollen data suggest cooling conditions, based upon the recovery of birch and pine pollen. Wood charcoal, recovered from late Laurentian contexts, includes a variety of taxa including birch, hickory, walnut/butternut, and red oak.

Subsistence data are limited for this period given the poor bone preservation at the site. Charred hickory nut and butternut shell were recovered from late Laurentian features, indicating the exploitation of terrestrial mast resources. Most significant was the recovery of pepo gourd rind fragments from a late Laurentian feature. This is the second report of early context pepo gourd in the northeastern United States, the other having been recovered from the Sharrow site in Milo, Maine. An accelerated radiocarbon assay of  $5695 \pm 100$  B.P. was obtained from the Sharrow site rind fragments, which is earlier than the context from which the fragments were recovered at Memorial Park. The Sharrow site provides precedence for the early presence of pepo at Memorial Park, which is well east and north of other early reports for this cultigen in the Eastern Woodlands (Fritz 1990; Smith 1989). The late Laurentian pepo gourd from Memorial Park is the first report of cultivated plants in the Susquehanna drainage, and perhaps in Pennsylvania.

Analysis of chipped-stone debris indicates a high level of reduction effort and a high thinning value for this component, representing the production of bifacial tools. These results, along with the recovery of substantial amounts of lithic debris and 18 cores, indicate that both tool manufacture and maintenance were taking place at the site. There is a very high ratio for bifacial tools to edge only tools, 5.7, indicating a curated technology. Rhyolite appears to have been transported to the site in relatively large pieces for subsequent reduction, and jasper was subjected to heat alteration at the site and subsequent bifacial reduction. Although jasper may have been procured directly by the occupants of the site, it is likely that both jasper and rhyolite were obtained through broad-based exchange systems (Stewart 1989). In addition to the chipped-stone tool assemblage, a relatively large number of cobble, groundstone, and pecked-stone tools were recovered from late Laurentian deposits, suggesting a wide range of activities at the site. Twenty-five features were identified in association with this component. Most of these were classified as fire-related. Almost half of the features were located on the levee, suggesting more intensive utilization of this landform during this time.

Memorial Park probably served as a large base camp during this time, situated so as to take advantage of high-bulk resources in the general vicinity of the site, and to provide access to additional resources through logistical forays. Custer (1988:44) describes Late Archaic base camps in the Mid-Atlantic region consistent with data from Memorial Park: "Many of the sites... are quite spectacular. Some such as the Abbott Farm Site Complex, Clyde Farm, and Bare Island, have produced hundreds, if not thousands, of projectile points and bifaces. Many are large and extend over scores of acres. Most likely, these large and dense artifact accumulations are the result of repeated reoccupations and indicate a highly focused settlement system that lasted over many years." The recovery of 147 bifaces and biface fragments from the relatively small area investigated at the Memorial Park site suggests intensive occupation of the site during this period of time. The use of cultivated pepo gourd at the site may indicate that incipient horticultural activities were pursued, again suggesting a base camp.

The results of excavations at Memorial Park, Canfield Island (Bressler 1989), West Water Street (Custer, Watson, and Bailey 1994), and the earlier work of Turnbaugh (1977) in the West Branch valley suggest intensive occupation of the valley during this period of time. Based upon these investigations, it is possible to tentatively define a new Laurentian phase coterminous with

the Brewerton phase in New York. In the West Branch valley, the tentative Piper phase is characterized by primarily Brewerton bifaces including the corner notched, side notched, and eared notched types, as well as Vosburg and perhaps Otter Creek bifaces. Also occurring are a variety of ground, pecked, and cobble stone tools, including notched disks, bannerstones, (Bressler 1989) and celts. During this phase is the first evidence for cultivated plants in the West Branch in the form of pepo gourd from Memorial Park. Additional research is needed in the vicinity of Lock Haven before this proposed phase can be more firmly defined.

### *Piedmont*

The Piedmont component is the lowest-density Late Archaic occupation at the site. Two radiocarbon assays were obtained for this component,  $2460\pm 40$  B.C. from a feature, and  $2100\pm 230$  B.C. from a bulk soil sample. These dates are consistent with dates obtained from other Piedmont tradition sites in other areas of Pennsylvania, New Jersey, and New York (Graybill, Section III, this volume). Diagnostic artifacts recovered from Piedmont contexts at Memorial Park include Bare Island and Lamoka bifaces. Other tools associated with this component include a few cobble tools and a large anvil.

The landscape at Memorial Park was undergoing slow upbuilding through incremental addition of sediments. The sub-Boreal maximum, or xerothermic at approximately 2350 B.C. (Custer 1989, but see Joyce 1988), had some effect on pedological developments at Memorial Park. The development of a fragipan, Buried soil 4, may have resulted from the warm, dry conditions apparently associated with the xerothermic. Drying and cracking of the soil through desiccation and subsequent infilling of these cracks with silt and clay is one method by which fragipans are thought to develop. The increased alluviation on the east side of the site, resulting in Buried soil 3, may be associated with increased moisture following the xerothermic. Limited pollen data from Memorial Park indicate a warm environment, based upon the presence of walnut, elm, and grass pollen. Grass seed was recovered from one Piedmont feature, as was a bedstraw seed. Charred wood fragments from Piedmont features include hickory, pine, oak, sassafras, and elm.

Only 13 features were assigned to this component, all of which were located in the western block excavations on the Port Huron terrace. The lack of features on the eastern end of the site may be related to the more rapid alluviation on this portion of the site, as compared to the terrace. Subsistence remains for this period consist of charred hickory nut and black walnut shell, and a large quantity of acorn meat recovered from a feature cluster in Block 16. One grape seed was also recovered from a Piedmont feature. The recovery of tuber fragments in Piedmont contexts suggests the exploitation of riverine or wetland resources. No identifiable bone was recovered from Piedmont contexts. Analysis of lithic debris indicates a thinning trajectory, but a more restricted distribution of reduction effort and thinning values. This suggests that the primary reduction activity on the site for both local and nonlocal materials, was tool maintenance and/or later stage biface reduction. Fifteen bifaces, five edge-only tools, one core, a small amount of lithic debris, and six ground/pecked stone tools were recovered from Piedmont contexts. Although the numbers are small, the ratio of bifaces to edge-only tools, 3.0, suggests a curated technology.

Taken together, these data suggest that the site served as a resource extraction camp during the latter portions of the Late Archaic period. It is likely that the site was occupied at various times by a small number of individuals exploiting one or a few, low-bulk resources for transport to a base camp (Binford 1980; Kelly 1983). This change in site function may be the result of changing climatic conditions during this period of time with resultant changes in local hydrology and geomorphic processes (see Custer 1989).

### *Terminal Archaic*

Two high-density Terminal Archaic components, Canfield phase and Orient phase, and a possible third low-density component, Susquehanna phase, were identified during the current investigations. The Susquehanna phase component was lightly represented and discontinuous across the site. As a result, it could not be clearly separated from the Canfield component, and the two have been treated together in the site under the rubric Terminal Archaic.

### *Canfield Island/Susquehanna*

Three radiocarbon assays were obtained for this component,  $2000\pm 65$  and  $1640\pm 60$  from features and  $1745\pm 75$  from a bulk soil sample. These dates are somewhat earlier than those obtained by Bressler (1989) for the Canfield phase component at the Canfield Island site, and are too early to be associated with a Susquehanna phase occupation at Memorial Park.

Diagnostic artifacts pertaining to this component consisted primarily of Canfield Lobate, as defined by Bressler (1989), and smaller numbers of Lehigh/Koens-Crispin bifaces. Bressler (1989) reports the recovery of Lehigh bifaces in association with Canfield Lobate bifaces at the Canfield Island site. Several Bare Island bifaces were recovered from a cache containing primarily Canfield Lobate bifaces. A large majority of the bifaces recovered from the Terminal Archaic contexts were manufactured from rhyolite. Other artifacts recovered in association with this component include several notched disks, a pestle, and a small celt. Seventy-nine features were associated with this component. Susquehanna phase diagnostics included two Susquehanna Broadpoints and several steatite sherds. These artifacts were discontinuous across the site, occurring only in blocks 1, 8, and 14.

During this period of time, the landscape continued to change through periodic alluviation by overbank deposition, splay deposition, and lateral accretion, mainly on the eastern portion of the site; site-specific erosion; and the formation of Buried soil 2. The channel remnant was partially filled in during this time and indicates intensive occupation for the first time in the site's history. The pollen record suggests a generally drier local regime. Wood charcoal from Terminal Archaic features includes a wide variety of taxa, including sugar maple, hickory, beech, walnut/butternut, ironwood, pine, aspen, red oak, white oak, sassafras, basswood, and elm.

Subsistence data are limited because of poor bone preservation. Nutshell from Canfield contexts includes hickory, bitternut, hazelnut, butternut, and walnut; acorn meat was also recovered. One grape seed and one elderberry seed indicate exploitation of fruits and berries.

The most striking feature of the Terminal Archaic chipped-stone assemblage is the dominance of rhyolite. Rhyolite accounts for over 40% of chipped-stone debris by count, and 34% by weight. Thirty-four of 40 (85%) diagnostic bifaces were manufactured from rhyolite, while 34% of nondiagnostic bifaces and 60% of the unifaces were manufactured from rhyolite. Analysis of chipped-stone debris indicates a pattern more similar to that noted for the Laurentian components than for the Piedmont component. Relatively high thinning and reduction effort values indicate bifacial tool manufacture. The pattern for rhyolite suggests that the material entered the site in partially-reduced form and was subsequently used for biface manufacture. The high ratio of bifaces to edge-only tools, 5.3, indicates a curated technology. Interestingly, only two cores were recovered from Terminal Archaic contexts, perhaps reflecting the focus on rhyolite and total consumption of this nonlocal raw material.

The high percentage of rhyolite bifaces at the Memorial Park site is similar to patterns noted elsewhere in the Mid-Atlantic during the Terminal Archaic (Custer 1984, 1989; Stewart 1989). However, the percentage of diagnostic bifaces manufactured from rhyolite is much higher than

would be expected at the site given its distance from the rhyolite's point of origin (Stewart 1989). Unlike the broad-based exchange that apparently characterized the earlier portions of the Archaic period, the large proportion of diagnostic bifaces manufactured from rhyolite is perhaps indicative of a hoarding strategy during the Canfield phase/Susquehanna phase occupations. Rhyolite entered the site as relatively large nodules, blanks, or bifacial cores, and was subsequently reduced into finished, stemmed bifaces. This pattern suggests that the Memorial Park site controlled access to rhyolite for the local social network (Stewart 1989).

Seventy-nine features were associated with the Terminal Archaic occupations. These were dispersed across the site, occurring on the terrace, levee, and filled-in channel remnant. Most of these features were classified as fire-related, including five cobble hearths similar to those described by Bressler (1989) for the Canfield phase occupation at the Canfield Island site.

The most interesting feature associated with this occupation was a small pit containing a cache of stemmed, rhyolite bifaces, several quartz crystal fragments, and several pieces of grooved siltstone. Three types are represented by the bifaces: Canfield Lobate, Lehigh/Koens-Crispin, and Bare Island. The recovery of Bare Island bifaces in direct association with the Terminal Archaic types supports Custer's (1989:147) contention that Bare Island bifaces are not good chronological markers. However, their manufacture from rhyolite clearly sets the Bare Island bifaces from the cache apart from those recovered from Piedmont contexts at the site.

The Memorial Park site probably functioned as a base camp at least during the Canfield phase occupation. The small amount of artifacts clearly assignable to the Susquehanna phase occupation suggests that it may have served as a temporary extraction camp during this time.

### *Orient*

Two radiocarbon assays were obtained for the Orient phase component,  $1145 \pm 45$  B.C. from a feature, and  $880 \pm 50$  from an isolated piece of charcoal in Buried soil 1. These dates are consistent with dates reported for the Orient phase elsewhere in the Mid-Atlantic and Northeast, although the 880 B.C. date is also acceptable for the Early Woodland Meadowood phase and may be related to an Early Woodland occupation at the Memorial Park site.

Diagnostic artifacts associated with this phase include Orient Fishtail bifaces and steatite-tempered Marcey Creek pottery. This is the first occurrence of pottery at Memorial Park, although fiber-tempered sherds recovered from Orient phase contexts may predate the steatite-tempered sherds (Custer 1987). Marcey Creek pottery is the first widely occurring pottery in the Mid-Atlantic region, and is generally thought to have replaced steatite bowls by 1200 to 1000 B.C. (Custer 1987:100). Steatite bowl fragments were also recovered from Orient contexts. Other tools associated with this component consist primarily of notched disks, including 18 recovered from a cache pit that also contained a sherd of Marcey Creek pottery.

The landscape during this time underwent an erosional cycle, particularly on the eastern portion of the site, followed by deposition through lateral accretion and the eventual formation of Buried soil 1. Orient materials are associated with both buried soils 1 and 2. Pollen data from Memorial Park suggest a moderately warm, open, riparian environment. The number of taxa represented by wood charcoal is more limited than in the Canfield phase occupation, consisting of hickory, walnut/butternut, red oak, white oak, and elm. This smaller range of taxa may result from sampling error, given the smaller number of features and total number of wood fragments recovered from Orient contexts. Subsistence data are limited because of the poor preservation of bone at the site. Nutshell recovered from Orient phase features includes hickory, black walnut, and acorn. Nineteen features, most classified as fire-related, were associated with this component. Thirty-two postmolds were associated with the Orient phase component, the only substantial



number of postmolds associated with a pre-Late Woodland component at the site. A large midden, exposed during Task 1 stripping was also associated with this component.

Analysis of chipped-stone debris resulted in high total reduction and thinning values for local raw materials, indicating that bifacial tool production occurred on the site. Nonlocal raw materials, on the other hand, generally represent tool maintenance, with the exception of rhyolite, which continued to enter the site in relatively large pieces for subsequent reduction but represents much less of the chipped-stone assemblage than it did for earlier Terminal Archaic components. The nonlocal raw materials were probably obtained through a broad-based exchange system. The hoarding behavior evident during the Canfield phase/Susquehanna phase occupations is no longer evident. The ratio of bifaces to edge-only tools, 3.0, indicates the persistence of a curated technology throughout the Archaic period.

Subsistence data are limited to floral remains recovered from pit features; no identifiable bone was recovered. Charred nutshell recovered from orient features include hickory, walnut, black walnut, and acorn. No seeds were recovered from this component.

In general, the data taken as a whole suggest that the site functioned as a base camp during the Orient phase. The more limited number of features associated with this phase, as compared to the previous Canfield phase, suggests that the number of camps represented may be lower than that for earlier components.

### *Early Woodland*

The primary evidence for Early Woodland occupation at Memorial Park was the recovery of four Meadowood bifaces, two from one feature exposed during Task 1 investigations, and two from upper levels of the block excavations. The 880 B.C. date obtained from the upper levels of Block 3 may relate to this occupation, although it may also be related to the Orient phase occupations. Other artifacts that may be related to this occupation include a number of thin, grit-tempered pottery sherds recovered from the upper levels of several blocks. The recovery of a Rossville-like biface from one feature also suggests an Early Woodland occupation. Subsistence data are limited; however, one feature, containing two Meadowood bifaces, did produce squash rind fragments. These fragments were of a thicker rind variety than those recovered from late Laurentian contexts, and probably represent pumpkin or squash rather than gourd. Also recovered from this feature were charred black walnut, butternut, hickory, and acorn shell. These remains suggest that terrestrial mast was exploited along with domesticated squash. Charred nutshell recovered from another feature assigned to the Early Woodland occupation also contained hickory and bitternut shell. This feature also contained one little barley seed. Both the little barley and squash indicate the use of cultivated plants during the Early Woodland period in addition to the exploitation of terrestrial mast.

### *Middle Woodland*

A Middle Woodland, Fox Creek component was identified on the basis of two and possibly three features exposed during Task 1 operations. A radiocarbon assay of A.D. 150±115 was obtained from Feature 143, which had pottery that refit with pottery from Feature 175. The recovery of a rhyolite Fox Creek-like biface from Feature 32 suggests that this feature may also relate to the Middle Woodland occupation of the site. An additional date of A.D. 470±35, obtained from an unplowed A horizon remnant in at the top of excavations in Block 7, may also reflect a Middle Woodland occupation. It is likely that artifacts contained within the B horizon remnant on top of Buried soil 1 on the eastern end of the stripped area related at least in part to the Middle Woodland occupation of the site, but this could not be clearly separated from the Orient phase



materials contained in the same deposits. Floral remains from the two Middle Woodland features included primarily wood charcoal, although one charred butternut shell fragment was also recovered. The recovery of maize from features 32 and 143 indicates that maize may have been cultivated at a relatively early date. One seed of little barley was also recovered from this pit. The recovery of maize in Middle Woodland contexts is possible, given the controversial presence of maize at Meadowcroft Rockshelter as early as the fourth-century B.C. (Adovasio and Johnson 1981; Cushman 1992). Direct accelerator dating of maize from several Midwestern sites have yielded dates as early as the second century B.C. as well as to the first and second centuries A.D., provide the first convincing evidence for maize in the Eastern Woodlands (Crites 19487; Chapman and Crites 1987; Fritz 1990; Riley et al. 1994). As a result, it is possible that maize initially entered central Pennsylvania by A.D. 150 as represented at Memorial Park.

### *Late Woodland*

The Late Woodland occupations at the site are represented by 80 features, several house patterns, and a large quantity of artifacts. Four Late Woodland components were identified during the current investigations: early Clemson Island, middle Clemson Island, late Clemson Island, and Stewart phase. As is delineated in the following component summaries, it was possible to identify temporal trends in Clemson Island pottery at the Memorial Park site. Whether these trends occur on a regional or local basis can only be determined through additional research.

### *Clemson Island*

*Chronology.* The first Clemson Island component identified during the current investigations is referred to in the report as early Clemson Island. Four radiocarbon assays were obtained from pit features relating to this occupation: A.D. 760±40, A.D. 790±60, A.D. 810±60, and A.D. 830±60. These dates are contemporaneous with what are generally considered to be the earliest expressions of the Clemson Island complex, and coterminous with the end of the traditional date range assigned to the Middle Woodland period (Hay et al. 1987; Stewart 1990). Clemson Island sites with similarly early dates include: Fisher Farm, Kress, Ramm, Bald Eagle, Shermans Creek, Miller, and St. Anthony (Hatch 1980; Hay and Hamilton 1984, Hay et al. 1987; Stewart 1990).

The second Late Woodland component identified during this project has been referred to as middle Clemson Island in this report. Two radiocarbon assays were obtained for this component from pit features: A.D. 920±60, and A.D. 930±50. A relatively large number of dates in the tenth century have been reported from other Clemson Island sites, including Kress, Bald Eagle, Allenwood Bridge, Petersburg Bridge, Nash, Fisher Farm, St. Anthony, and Wells (Hatch 1980; Hay and Hamilton 1984; Hay et al. 1987; Kent et al. 1971; Lucy and McCann; Mitchum 1983; Smith 1976, 1977; Stewart 1990).

The third Clemson Island component identified at Memorial Park has been referred to as late Clemson Island in this report. Four radiocarbon assays were obtained from pit features relating to this component, A.D. 1050±50, A.D. 1050±60, A.D. 1080±50, and A.D. 1090±60. Eleventh-century radiocarbon assays have been reported from a number of Clemson Island sites that include: Bald Eagle, Fisher Farm, Petersburg Bridge, St. Anthony, and, Wells (Hatch 1980; Hay et al. 1987; Kent et al. 1971; Stewart 1990).

*Diagnostic Artifacts.* Several changes in diagnostic artifacts were evident between these three components; the most notable changes occurred with the late Clemson Island component. Jack's Reef bifaces were recovered from both early and middle Clemson Island features. One Jack's Reef Corner Notched biface was recovered from an early Clemson Island feature, while

Jack's Reef Pentagonal bifaces were recovered from both early and middle Clemson Island features. Levanna bifaces were also recovered from features associated with these earlier Clemson Island components. The Jack's Reef types are generally dated between A.D. 500 and A.D. 1000 in the midwestern, mid-Atlantic, and northeastern United States (Justice 1987:215). Jack's Reef bifaces are rarely reported at Clemson Island sites (e.g., Hatch 1980). In New York, these types are associated with Point Peninsula, Kipp Island, Hunters Home, and early Owasco sites (Justice 1987; Ritchie 1961). Justice suggests a terminal date for the Jack's Reef types in the early tenth century based on a date of A.D. 905±250 reported by Crane (1965). The early tenth-century dates associated with the middle Clemson Island component at Memorial Park would be consistent with this proposition. Lantz (1989:33) suggests a date range of A.D. 500 to A.D. 950 for the related Raccoon Notched type in western Pennsylvania and New York. Diagnostic bifaces associated with the late Clemson Island component consist of a few Levanna and Madison bifaces. Levanna bifaces are most prevalent in the mid-Atlantic and northeast between approximately A.D. 700 and A.D. 1200 (Justice 1987). Madison bifaces, while evident as early as A.D. 500, apparently supplant Levanna bifaces after A.D. 1200 (Justice 1987; Fogelman 1988). No Jack's Reef bifaces were recovered from late Clemson Island contexts.

In addition to the apparent changes in diagnostic bifaces from early/middle to late Clemson Island contexts, several changes in pottery stylistic elements were also noted at Memorial Park. Analysis of pottery recovered from Clemson Island features resulted in the definition of 15 descriptive groups. These groups were, in turn, compared to the existing Clemson Island typology scheme (Hay et al. 1987) and other regional typologies (e.g., Ritchie and MacNiesh 1949). The direct assignment of the Memorial Park pottery to established types was avoided because of the apparent difficulties with Hay et al.'s typology (e.g., Johnson 1988; Stewart 1988).

While the earlier components and late component shared the traditional Clemson Island attribute of opposed punctations and nodes on rims, several general trends in pottery stylistic elements were noted from early through late Clemson Island contexts. Early and middle Clemson Island pottery is characterized by several stylistic attributes, including: (1) heavy treatment of lips including cord impressions and cord-wrapped paddle impressions, (2) cordmarked interior rim surfaces, (3) heavily fabric-impressed exterior surfaces, (4) generally coarser treatment of stylistic elements, and (5) a higher percentage of smooth exterior surfaces than is found in later components. While the early and middle Clemson Island components generally share these attributes, the middle Clemson Island pottery is most typified by expanding rim profiles with broad, flat, cordmarked lips. The late Clemson Island pottery is typified by stylistic attributes including: (1) undecorated lips or lips with light treatments, (2) smooth interior rim surfaces that may be overprinted with cord-wrapped dowel impressions, (3) cordmarked as opposed to heavily fabric-impressed, exterior surfaces, and (4) generally finer execution of decorative elements.

Results of the stylistic analysis do not support all of the temporal trends identified earlier in this volume by Graybill for Clemson Island pottery. Specifically, Graybill's suggestions that there was (1) an increase in plain (smooth), decorated rim exteriors at the expense of cordmarked, decorated (i.e., cord-on-cord) rim exteriors; (2) an increase in the use of punctations as a rim decorative technique at the expense of unpunctated rims; and (3) an increase in decorated lips at the expense of undecorated lips are not supported by the pottery recovered from Memorial Park. However, Graybill's suggestions that there was (1) an increase in plain rim interiors at the expense of cordmarked interiors, (2) an increase in neat, fine cordmarked impressions at the expense of sloppy coarse impressions, and (3) an increase in fine, low-density temper at the expense of coarse, high-density temper were supported by the Memorial Park pottery. Stewart's (1990) review of the chronological ambiguities of the current Clemson Island pottery typology (Hay, Hatch, and Sutton 1988), his identification of apparent temporal trends in specific attributes (Stewart 1990:88), and the results of the present analysis, suggest that specific stylistic attributes may be more sensitive to chronological analysis than types. As suggested by Stewart (1990), the continued recovery and analysis of pottery from radiometrically dated features will lead to a

clarification of Clemson Island pottery style chronology. However, it is likely that there was spatial variation in pottery style attributes, through time, in the large area attributed to the Clemson Island taxon that will ultimately preclude the identification of temporally sensitive region-wide types.

Based upon the changes in diagnostic bifaces and pottery stylistic attributes at Memorial Park, as well as the radiocarbon dates, it was possible to assign a number of features to each of the Clemson Island components (Figure 130). Those features not assigned to a particular component contained neither diagnostic bifaces nor a large enough, or distinctive enough, pottery assemblage to warrant assignment to one of the components.

*Subsistence.* The greatest amount of subsistence data for the site was obtained for the Clemson Island components. These data indicate that Clemson Island agriculture involved several domesticated and cultivated plants in addition to maize, and that a variety of wild resources were exploited.

Maize was represented in features from each of the Clemson Island components. The ubiquity of maize varied from component to component but, given the small samples, little significance can be assigned to this fact. Both kernel and cob fragments were recovered, suggesting that maize was grown at or near the site. No evidence was recovered from Clemson Island features for squash or beans, but it is probable that they were in use at the Memorial Park site. The evidence for Clemson Island agricultural production at Memorial Park lends further support to an agricultural system that involved more than maize, bean, squash cultivation. While *Chenopodium* and little barley-like seeds have been reported from other Clemson Island sites (King 1988; Willey 1980), the Memorial Park site has yielded the best data on these plants to date. Two types of domesticated *Chenopodium* were recovered from Clemson Island contexts: thin-testa and pale seeded. The thin-testa type was recovered from early Clemson Island contexts, while the pale-seeded type was recovered from both early and late Clemson Island contexts. Little barley was the most frequently recovered seed from Clemson Island contexts. This cultivated grass has been widely reported at Late Prehistoric sites in the Midwest (e.g., Asch and Asch 1985a; Asch and Sidell 1990); it germinates in winter and would probably have been harvested in early summer (Asch and Asch 1985a). In addition to these cultivated food plants, one tobacco seed was recovered from an unassigned Late Woodland feature, indicating that tobacco may have been cultivated by the Clemson Island occupants of the site. One sunflower kernel was recovered from an early Clemson Island feature, but it appears that it was from a wild or ruderal plant.

A wide variety of wild floral and faunal resources were exploited during the Clemson Island occupations. The early Clemson Island features yielded the largest variety of nut taxa, but this may be a function of sampling error rather than denoting an actual change in the use of mast. Nut shell recovered from Clemson Island features included hickory, bitternut, chestnut, hazelnut, walnut, butternut, black walnut, and acorn. Grape seeds were also recovered. The recovery of wild rice from an unassigned Late Woodland feature suggests that this resource may have been exploited during the Clemson Island occupations.

Faunal remains recovered from Clemson Island features included large and small terrestrial mammals, fish, amphibians, reptiles, and birds. Mammals included deer, opossum, rabbit, raccoon, and squirrel. Birds included bobwhite quail and pigeon. Fish included channel catfish, perch, shad, sunfish, and sucker. Turtle and frog were also recovered. These remains suggest a fairly limited range of faunal resources, concentrated primarily upon the exploitation of deer and fish, with the other resources exploited to supplement the more intensively procured taxa.

The subsistence remains from the Clemson Island features at Memorial Park tend to amplify what little is known about subsistence systems during this time. Based upon the results at Memorial Park, and other Clemson Island sites, it is evident that maize, bean, and squash

agriculture were in place relatively early in the Susquehanna drainage, contemporaneous with early agricultural systems in the lower Upper Ohio River basin (Blake and Cutler 1983). These resources were supplemented through the production of Eastern Agricultural Complex starchy seeds, including goosefoot and little barley. Little barley was probably harvested early in the summer months during a period when other cultigens and domesticates would not have been available. As a result, the use of this seed crop extended the availability of cultivated crops back to the early summer. Terrestrial mast was probably extensively exploited over the course of several months perhaps beginning as early as late summer. Various fruits and berries would have been exploited from late summer through late fall. Fish may have been exploited throughout the year, although it is feasible that much of the harvest would have occurred during the spring spawning season. It is also possible that at least some fish were procured from the temporarily flooded channel remnant on a yearly, or even less-frequent basis (Limp and Reidhead 1979). Deer may have been taken at any time during the year.

*Technology.* The Clemson Island components provided the largest collection of pottery at the site. Changes in stylistic attributes have been reviewed above. In addition to the stylistic changes, it is evident that technological changes also occurred in pottery manufacture. These changes may reflect changes in pottery function.

For the entire Clemson Island collection, pottery wall thickness tends to be correlated with vessel diameter. This indicates that vessel wall thickness was, in part, a function of the manufacturing process: thicker walls were used to support the vessels during construction. Thin-section analysis, however, revealed changes in the body (Stoltman 1991) of the vessels between early/middle and late Clemson Island pottery. In early/middle Clemson Island pottery, there is a positive correlation between wall thickness and temper size: vessels with thicker walls tend to have larger pieces of temper. This correlation may indicate that larger pieces of temper were used to strengthen the walls of larger vessels during manufacture. Alternatively, there may have been a concern with preventing crack propagation: thicker walls and larger pieces of temper would have produced vessels resistant to breakage as a result of impact and load-bearing stress.

Two functional classes of chert-tempered pottery may have been present during the late Clemson Island occupation of the site. In general, thin-walled vessels have relatively high densities of small pieces of chert temper, while thicker-walled vessels tend to have relatively lower densities of larger pieces of chert temper. The body of the thin-walled vessels suggests that there was a concern with flexural strength during the late Clemson Island occupation, which may indicate a concern for thermal shock resistance. The apparent introduction at this time of thin-walled vessels with small pieces of quartz temper may also reflect this concern. The thicker-walled vessels with relatively low densities of large pieces of chert-temper may represent a concern with crack propagation resistance, perhaps representing a class of storage and/or food preparation vessels. Further research on pottery technology and function will be required to determine if these results hold for Clemson Island pottery in general.

Lithic technology during the Clemson Island occupations contrasts markedly with Archaic occupations of the site. Local raw materials occupy thickening space, indicating expedient tool manufacture. Nonlocal raw materials, on the other hand, occupy the resharpening/maintenance ellipse. This indicates a shift from a curated technology, evident throughout the Archaic period, to an expedient technology during the Clemson Island occupations. This is also evinced by the total ratio of bifacial tools to edge-only tools, which is very low (0.22) compared to the Archaic occupations. Resource stress may be evinced by the apparently more intensive use of small, locally obtainable agate cobbles. This is consistent with changes noted in other areas of the eastern United States during the Late Woodland and Late Prehistoric periods. With the onset of agricultural production and more restricted mobility, less energy was expended on the manufacture of lithic tools (Jeske 1989; Torrence 1989b). Interaction with other population is evinced by the use of jasper and small amounts of jasper, perhaps obtained via the Bald Eagle valley.

DWG. NO. 89-412-M3

JPH

APPROVED

REM

GAI CONSULTANTS, INC. DWN.

523  
524

11

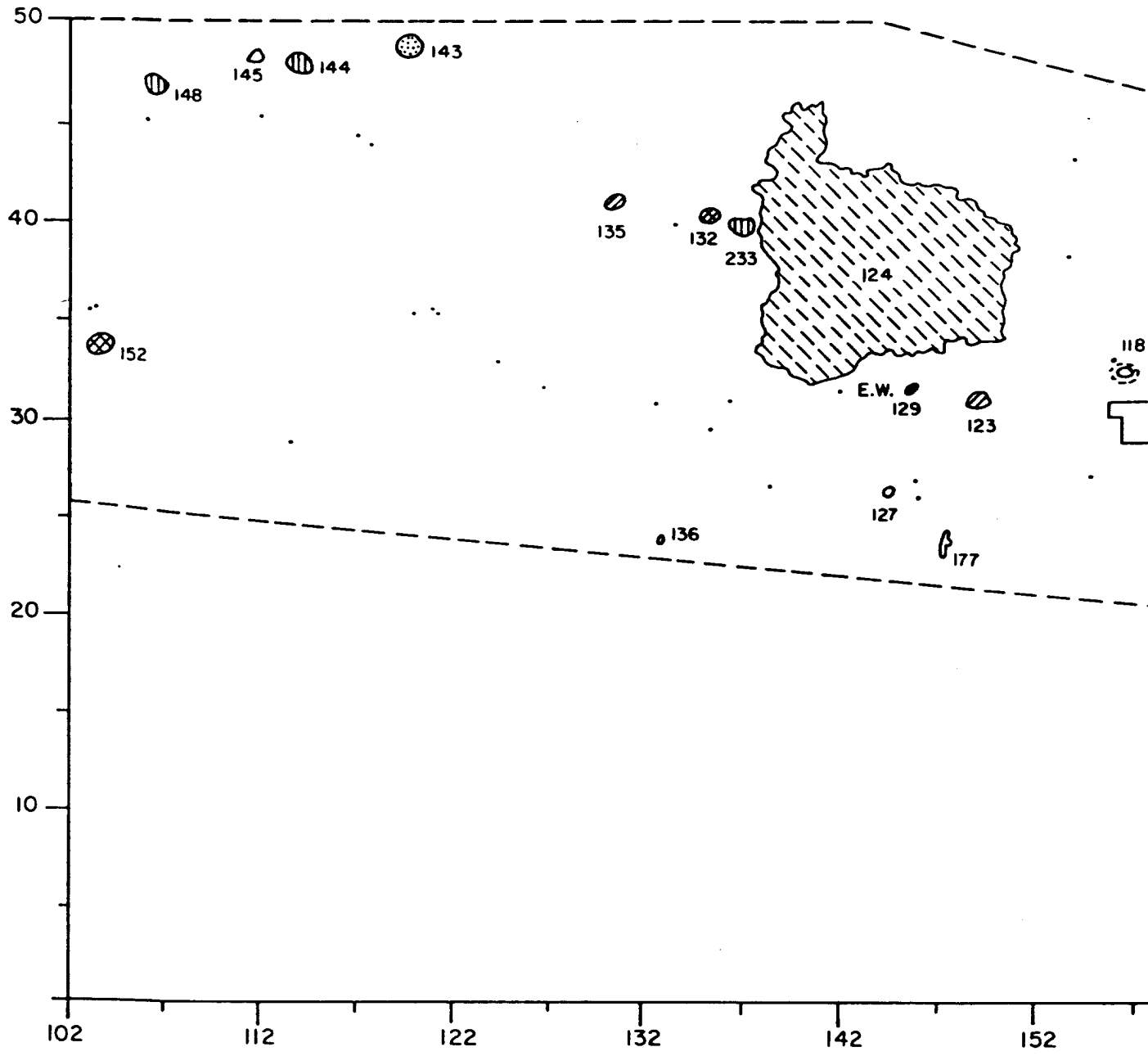

GENERAL KEY

- POSTMOLD
- S2 - STRUCTURE (2)
- PHASE 2 TEST PIT

- ORIENT PHASE MIDDEN
- E.W. - EARLY WOODLAND
- MIDDLE WOODLAND (A.D. 150)
- EARLY CLEMSON ISLAND (A.D. 760-830)
- MIDDLE CLEMSON ISLAND (A.D. 920-9)

FEATUR

2

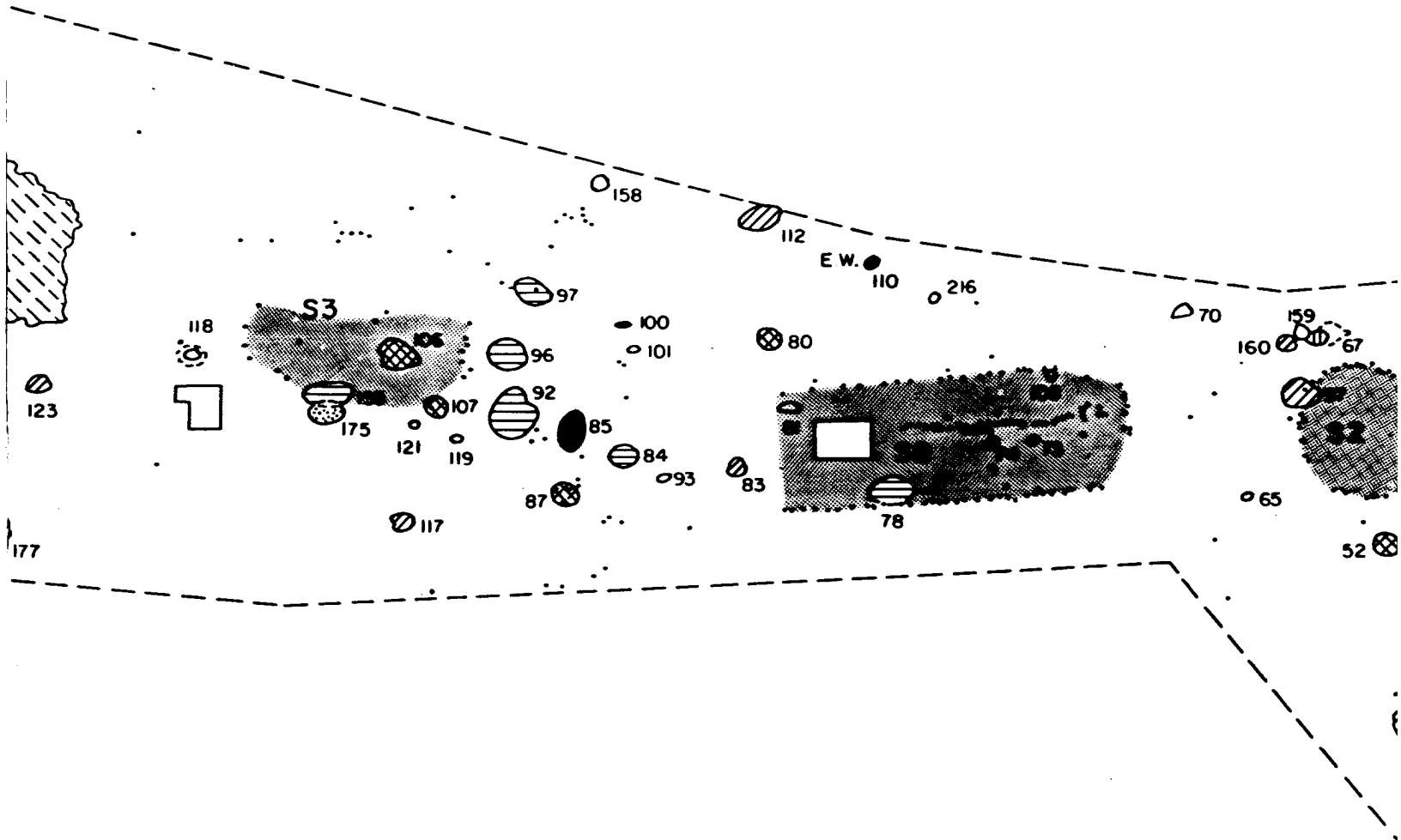

152 162 172 182 192 202 212

FEATURE KEY

- ⊗ - LATE CLEMSON ISLAND (A.D. 1050-1090)
- ▨ - A.D. 150
- ▧ - D (A.D. 760-830)
- ▩ - WIND (A.D. 920-930)
- ▨ - STEWART PHASE (A.D. 1290-1385)
- - NOT SAMPLED
- - UNASSIGNED LATE WOODLAND

3

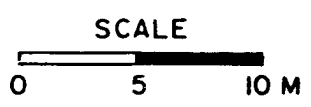
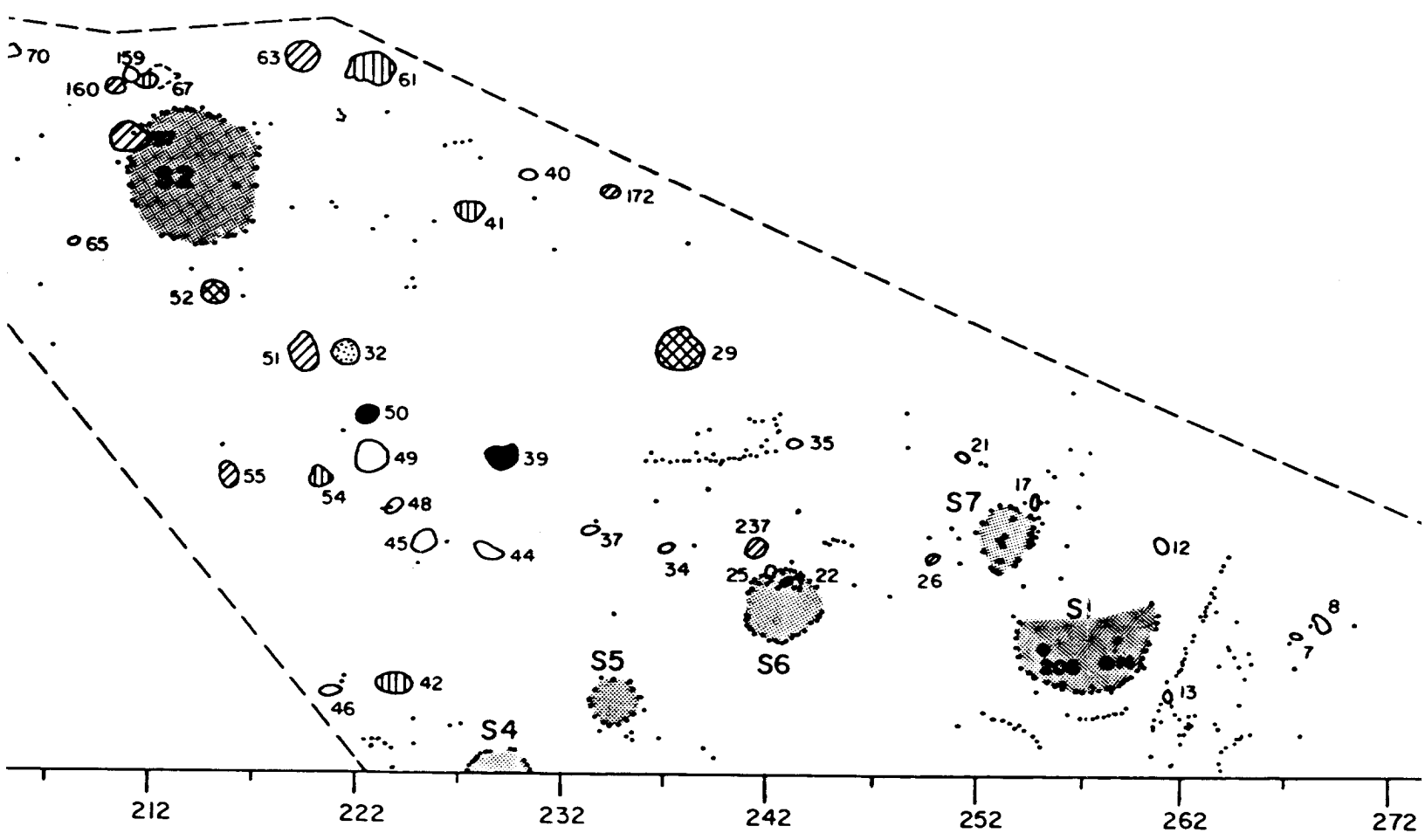
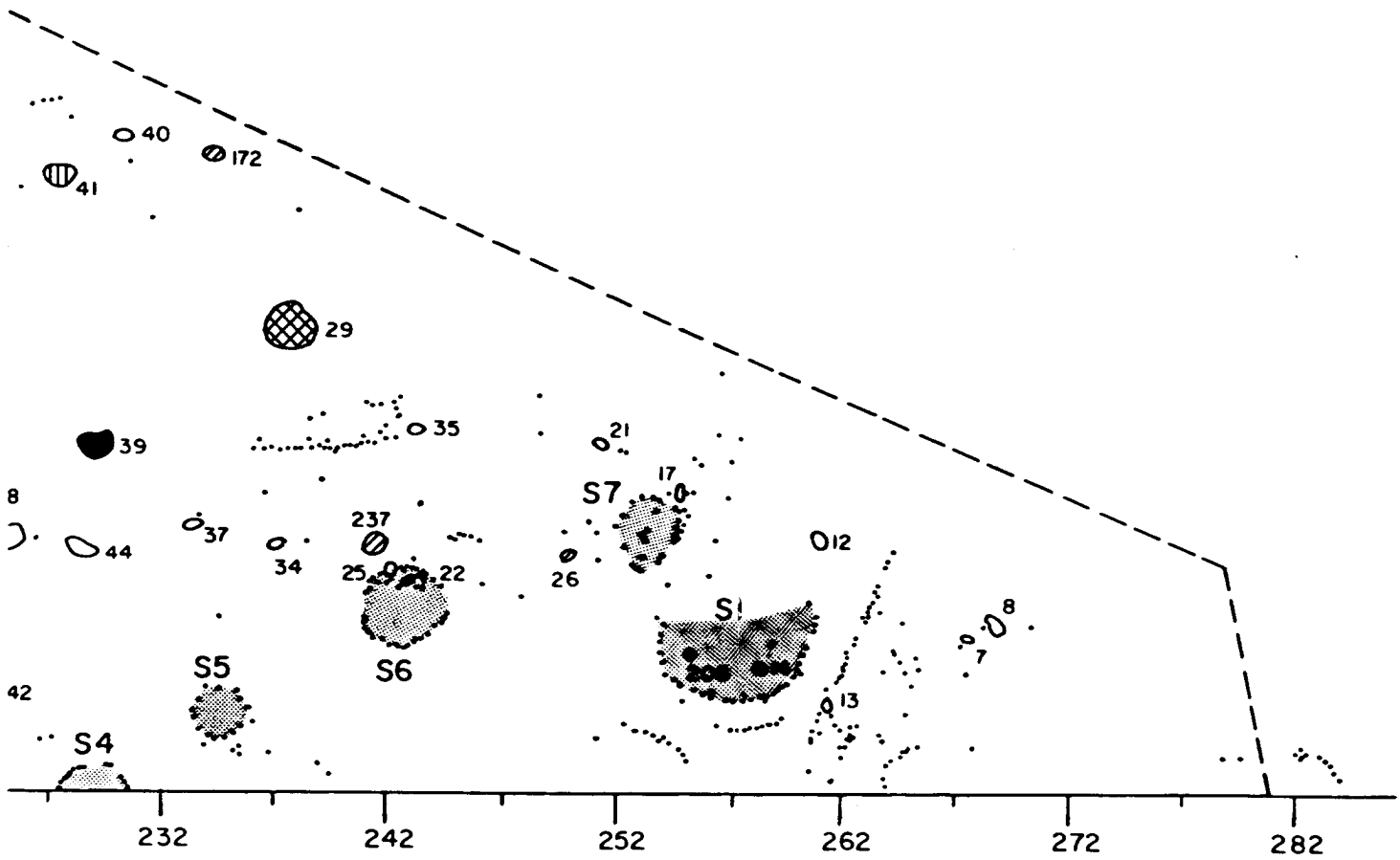

FIG
TEMPORAL FEATURES O

4



SCALE

5 10 M

FIGURE 130

TEMPORAL ASSIGNMENTS OF  
FEATURES ON STRIPPED SURFACE



*Settlement Patterns.* Several changes are evident in site structure with the onset of the Clemson Island occupations of the Memorial Park site, presumably tied to increased importance of agricultural production during the Late Woodland period. First, the only convincing evidence for structures at the site is during this time. While this may be a function of the amount of area exposed, compared to earlier components, it might also represent anticipated, longer-term habitation of the site. Populations are likely to invest a greater amount of energy in the construction and maintenance of houses at sites that they plan to occupy for long periods of time, than those sites where only short-term occupation is anticipated (Kent 1992; Rafferty 1985). Also during the Clemson Island occupation is the first large-scale use of what are apparently storage pits. The use of subterranean storage facilities has several implications. First, they suggest the existence of surplus. Second, subterranean facilities are generally used under conditions where settlements are abandoned periodically each year (DeBoer 1988). This suggests, then that the site may not have been occupied on a year-round basis. Agricultural surplus and other valuables would have been hidden in the subterranean facilities during site abandonment to prevent discovery by competing populations.

Subsistence remains suggest occupations from at least late spring/early summer through autumn. Little barley was harvested during late spring/early summer. The cultivation of little barley indicates the planned use of the site during the late spring to early summer, because it germinates during the winter. This suggests that the crop was sown prior to abandonment in the autumn for a planned harvest during a period when other cultigens would not be available for use except in stored contexts. Maize was sown during the spring, and harvested in ripe form during late summer through early autumn. Green ears may have been consumed earlier in the cycle. Chenopodium, and the inferred squash and beans, would have been harvested during the late summer through early autumn. Terrestrial mast would also have been harvested from early summer-through-autumn. Faunal remains suggest a primarily spring-through-summer procurement.

The distribution of features and structures does not suggest a nucleated village. In fact, the landscape on which the site is located may have precluded such a settlement at this location. The low channel remnant was probably flooded periodically, and was possibly wet through much of the year. This would have precluded all but the smallest of nucleated villages. As a result, it is suggested that the site served as a small habitation site for agricultural production. The relatively short-term nature of the occupations is evidenced by the paucity of cross-feature pottery refits. An intensive effort, performed independently by three individuals including the author of this chapter, was made to refit sherds from different features. This effort resulted in only one refit between Late Woodland features. If the site was subjected to lengthy, intensive settlement, more cross-feature refits would have been identified (Nass 1989). The interpretation of the Memorial Park Clemson Island occupations as relatively short-term occupations is consistent with Stewart's (1990:97) characterization of Clemson Island settlements:

Agriculturally-oriented hamlets or villages are believed to have been occupied from at least summer through fall by some portions of the population...Fishing, hunting, and gathering could have been pursued concurrently from many of these sites.

The Memorial Park site was chosen as a locus for such a settlement for several reasons. First was the availability of tillable floodplain soils for agricultural production. Second was the presence of riverine resources. Third was the availability of local wetland resources in the abandoned channel. And fourth was the presence of terrestrial mast. It is probable that logistical forays were mounted for the exploitation of resources such as deer.

It is possible that the apparent arc of small structures on the east end of the study area represents an organized winter settlement (Graybill, Section VII). However, not enough data are available to determine whether this pattern represents an organized settlement plan or is simply spurious.

### *Stewart Phase*

The final Late Woodland component belongs to the Stewart phase. Three radiocarbon assays were obtained that pertain to this component, A.D. 1290±60, A.D. 1350±45, and A.D. 1385±40. While the thirteenth-century date is at the late end of what has been considered the range for Clemson Island (Hay et al. 1987; Stewart 1990), the date falls within the Stewart phase, based upon the chronology used in this report (Graybill, Section III). The dates obtained for the Stewart phase at Memorial Park are consistent with those reported from sites such as Bull Run, Fisher Farm, and Ramm (Bressler 1980; Hatch 1980; Herbstritt 1988; Stewart 1990).

*Diagnostic Artifacts.* Diagnostic artifacts associated with this component consist of Stewart Incised pottery sherds, Castle Creek Punctate or Brainbridge Incised pottery sherds, and a Madison biface.

*Subsistence.* Subsistence data suggest a pattern very similar to that described above for the Clemson Island components. Nut shells recovered from the features assigned to this phase include hickory, walnut, butternut, walnut, and acorn. Maize and little barley represent the only cultivated plants associated with this component, although it is possible that squash, bean, and *Chenopodium* were also cultivated. Very little bone was recovered from Stewart phase features, and what was recovered could not be identified to specific taxon. However, it is likely that the same range of faunal resources was exploited during this time as during the Clemson Island occupations.

*Technology.* The pottery of this component is generally thinner than that of the Clemson Island components. Quartz temper is apparently more common during this time, as evinced by thin-section analysis. The use of small quantities of small pieces of quartz temper combined with the thin vessel walls may indicate an increased importance placed on flexural strength and thus thermal shock resistance.

Debris analysis indicates that much of the knapping activity occurring at the site was tool maintenance, perhaps indicating a short-term occupation of the site. Alternatively, the results may reflect small sample size. The ratio of bifaces to edge-only tools is 1.0, which is considerably lower than that for the Archaic components, suggesting an expedient technology.

*Settlement Patterns.* Thirteen of the 80 Late Woodland features were assigned to this component. A postmold pattern, presumably representing a longhouse, probably also belongs to this component. Features associated with this component include a number of storage pits, one of which was the largest recorded at the site. As a result, it is likely that Stewart phase occupations were similar to those of the Clemson Island components; that is, occupation of the site primarily during the agricultural season, with subsequent abandonment during the winter and early spring. While it is probable that evidence of the Stewart phase component was removed by the overstripping, as described earlier in this volume, it is perhaps significant that earlier investigations at Memorial Park failed to produce evidence of this component, and that only 20% of the 15 Late Woodland rim sherds recovered from the Block 7 excavations during the current investigations were from Stewart phase vessels. These results suggest that the Stewart phase occupation at Memorial Park was probably not very intense.

## Summary

In summary, the occupational sequence at the Memorial Park site included 13 components dating from the Middle Archaic period through the Late Woodland period. Radiometric dates were obtained for all but the Early Woodland occupation, making the Memorial Park site one of the most extensively dated sites in the Mid-Atlantic region. Schuldenrein and Vento (1993:5-14) report that 16 additional radiocarbon assays were obtained during their investigations that correlated with the dates reported in this volume). Radiocarbon dating, stratigraphic modeling, and diagnostic artifacts all allowed for the identification of multiple components for a number of time periods represented at the site including the Late Archaic, Terminal Archaic, and Late Woodland. While some of these components can be ascribed to established taxon, additional research in the West Branch is needed in order to determine whether additional taxa (phases) can be clearly defined. Stylistic and technological analyses, in conjunction with radiocarbon dating, allowed for the identification of chronological trends in Clemson Island pottery. Whether the trends noted in the Memorial Park assemblage can be generalized to the entire area ascribed to the Clemson Island taxon can only be determined through additional research. The investigations resulted in an extension of known occupations at Memorial Park back to the Middle Archaic period, and forward to the Stewart phase.

## SUBSISTENCE STRATEGIES

In the Research Design section of this report, a review was presented of subsistence trends in the northern Eastern Woodlands, in general, and in the West Branch valley, specifically. In general, subsistence trends in the West Branch valley and in the Mid-Atlantic and Northeast are obscure compared to what is known about these trends in the southwestern, midwestern, and southeastern United States (e.g., Fritz 1990; Smith 1989, 1992). The long temporal sequence at the Memorial Park site provided an opportunity to provide valuable new information on the evolution of subsistence practices in this relatively poorly known region of the Eastern Woodlands. The consistent use of flotation and the analysis of the resulting macrobotanical remains by Nancy Asch Sidell provided a number of new lines of evidence for subsistence practices in this area.

Specific research questions addressed during the current project included those that dealt with the Eastern Agricultural Complex (Ford 1985) and those that dealt with tropical cultigens. Questions concerned with the Eastern Agricultural Complex included: (1) Was the Eastern Horticultural Complex utilized in the West Branch of the Susquehanna River Valley during the Late or Terminal Archaic periods, and if so to what extent? (2) Was the Eastern Horticultural Complex in use during the Early and/or Middle Woodland periods? and (3) Were any local seed-bearing annuals cultivated? Questions dealing with the use of tropical cultigens included: (1) Was maize present in the West Branch of the Susquehanna prior to the early Late Woodland period? (2) To what extent is maize represented in the Clemson Island complex? Nearby work in the Bald Eagle Creek drainage at the Fisher Farm site (Hatch 1980) and to the east at the St. Anthony Bridge site (Stewart 1988) suggest that maize formed part of a mixed agricultural-hunting-gathering economy. Was this substantiated at the Memorial Park site? Could any differences be explained by the various roles these sites played in local Clemson Island settlement systems? and (3) To what, if any, extent are the Eastern Horticultural Complex, or other indigenously domesticated annuals utilized during the Late Woodland period?

Additional questions were raised in the Research Design section, concerned with wild resources. With the introduction of starchy and oily seeds, was there a corresponding decrease in the use of nuts? As more time and energy is devoted to the production of domesticates and cultigens, was there a corresponding change in the exploitation of various animal resources as a result of scheduling conflicts and changes in marginal cost levels (cf. Earle 1980)? To what extent

does the reliance on fishing change as the result of the adoption of agriculture? Changes in climatic and vegetational patterns, such as the proposed xerothermal during the Late Archaic period and the warm-moist climatic episode during the early portions of the Late Woodland period, may have had a substantial influence on subsistence and settlement patterns. How are these changes reflected in the archaeological record at the Memorial Park site?

Not all of the questions posed in the Research Design section could be answered, given the generally poor conditions for the preservation of animal bone, and the almost-exclusive limitation of floral preservation in pre-Woodland features to wood, bark, and nutshell. However, a number of the questions were answered that add to our understanding of prehistoric subsistence systems in the West Branch valley and the Mid-Atlantic and Northeast.

There is no evidence for use of the Eastern Horticultural Complex at the Memorial Park site during the Late or Terminal Archaic periods, nor were any local seed-bearing annuals cultivated. However, of significance is the recovery of pepo gourd rinds from a late Laurentian feature, which indicates that cultivated plants were in use in central Pennsylvania well before the late Woodland period. This finding, along with the Cucurbita rind fragments dated to 6350 B.P. from Maine, suggests that trends noted for the Late Archaic period in the Midwest may also have occurred in the Mid-Atlantic and Northeastern states. The recovery of squash rind and a little barley seed from Early Woodland contexts indicates that agriculture was being pursued to some extent early during the Woodland period in central Pennsylvania. This again reflects trends in the Midwest, where evidence for the use of domesticated and cultivated plants is well documented for this period of time (Fritz 1990; Smith 1989, 1992). The recovery of maize from Middle Woodland contexts dating to A.D. 150 at the Memorial Park site was unexpected. Reports of maize from contexts of this age in the Eastern Woodlands is not unusual, but the number of accepted dates is small (Fritz 1990; Riley et al. 1994). The data associated with maize at the Memorial Park site, however, is within the range of accepted dates in the Midwest for early reports of maize (Crites and Chapman 1987; Fritz 1990; Riley et al. 1994), and later than the earliest reports for Pennsylvania at Meadowcroft Rockshelter (Adovasio and Johnson 1981).

Maize is well represented in the Late Woodland record from the Memorial Park site, beginning with the eighth and ninth centuries, which are generally considered to be the end of the Middle Woodland period in the Mid-Atlantic and Northeast. While the absolute amount of maize recovered from Late Woodland features was small, it occurred in a large percentage of the features. The recovery of both kernels and inedible portions of the cob indicate that production probably occurred near the site. This interpretation is supported by the recovery of black nightshade seeds because this plant is associated with agricultural fields (Sidell, this volume). In addition to maize, seeds from the cultivated grass little barley were recovered from features of all Late Woodland components. Two varieties of domesticated Chenopodium were also recovered from Late Woodland features, and chenopod pollen was recovered from early and middle Clemson Island features. A tobacco seed was recovered from one unassigned Late Woodland feature. One sunflower seed was recovered from an early Clemson Island feature, and sunflower pollen was recovered from a middle Clemson Island feature. These results, along with the reports of squash and bean from other Clemson Island sites (e.g., Custer, Watson, and Bailey 1994; Hatch 1980), suggest a fairly complex agricultural production system, like that reported for the same time in other areas of the Eastern Woodlands (e.g., Asch and Asch 1985; Fritz 1990; Smith 1992). This agricultural system would have included the harvesting of little barley in the late spring or early summer, and the cultivation of mixed agricultural fields that would have included maize, beans, squash, chenopod, sunflower, and tobacco. This complex, Late Woodland, agricultural production system was possibly preceded by thousands of years of agricultural behavior in the West Branch extending back at least to the Late Archaic, as represented by the pepo gourd rind fragments recovered from the late Laurentian component.

Data on wild subsistence resources at the Memorial Park site are scarce for all but the Late Woodland period because of poor bone preservation. Plant remains are limited primarily to nutshell, and fruit and berry seeds. A wide variety of nuts were exploited throughout the site's occupation. It is difficult to determine whether there was a change in the nature of nut exploitation with increased reliance on agricultural production during the Late Woodland. Nutshell and nutmeats constitute varying percentages of total charcoal through time, constituting 3% of the early Laurentian assemblage, 35% of the late Laurentian assemblage, 56% of the Piedmont assemblage, 7% of the combined Canfield Island/Susquehanna assemblage, 9% of the Orient assemblage, 19% of the Early Woodland assemblage, 2% of the Middle Woodland assemblage, and 8.3% of the Late Woodland assemblages. While these changes may reflect differences in nut exploitation through time, they more probably represent sampling error and differential preservation. If one examines the diversity of the nutshell assemblages as reflected by presence/absence of the various taxa (Table 255), then it is apparent that the Terminal Archaic and early Clemson Island assemblages are most diverse. Within the Late Woodland period, there is a considerable drop off in assemblage diversity in the middle Clemson Island compared to the early Clemson Island, a trend which continues during the subsequent late Clemson Island and Stewart Phase components. Assuming that neither preservation nor sampling error account for this difference, it is possible that this drop in diversity reflects either a decrease in the exploitation of nuts with increased reliance on agricultural production or concentrated exploitation of fewer taxa, especially hickory nut. While a few seeds from wild plants are present in the pre-Late Woodland assemblages, they are more abundant during the Late Woodland period, perhaps reflecting expanded habitat in the form of agricultural fields. The recovery of wild rice from one Late Woodland feature indicates that this resource may have supplemented fall agricultural harvests.

Faunal remains from the Late Woodland features indicate the exploitation of riverine and terrestrial resources. Riverine resources include fish, frog, and turtle. Terrestrial resources include white-tailed deer and a variety of small mammals, and some avian taxa. Overall, the taxa recovered suggest procurement from spring through autumn. Bone was not well preserved for earlier components precluding an analysis of changing procurement strategies with increased reliance on agricultural production.

Overall, then, the Late Woodland occupations at the Memorial Park site apparently pursued a mixed subsistence strategy, as was common throughout the northern Eastern Woodlands during this period. It is likely that the contribution of any given wild resource and cultivated plants varied through time during the Late Woodland period in response to local environmental and social factors (Hart 1990b, 1993a), however, such changes could not be tracked with the data available from the site. The results of the current investigations at the Memorial Park site, then, shed new light on prehistoric agriculture in central Pennsylvania specifically, and the Mid-Atlantic region in general. As in the Midwest, cultivated plants apparently were in use as early as the Late Archaic period, and continued to be used through the Early and Middle Woodland period. However, unlike the pattern in the Midwest, cultivation of indigenous seed-bearing annuals did not precede the adoption of domesticated plants. A fairly complex agricultural system was in use during the Late Woodland period, beyond the maize, bean, and squash triad usually suggested for this time period in the Mid-Atlantic region (e.g., Custer 1989).

As stated by Sidell in the Archaeobotany section of this report, the Memorial Park site is important archaeobotanically because it documents that subsistence activities during the Late Woodland in central Pennsylvania involved the growing of two types of domesticated chenopod and little barley in addition to maize, tobacco, and possibly sunflower. The cultivated foods were supplemented with a wide variety of nuts, fruits, berries, and wild rice. The site also documents that cultivation began in central Pennsylvania before the Late Woodland period with the growing of pepo during the Late Archaic and Early Woodland periods and maize during the Middle Woodland period. Also of importance is the consistent association of maize in early Clemson Island features dating to the eighth and ninth centuries. This relatively early date for the consistent association of

maize at what is generally considered the end of the Middle Woodland period in the Mid-Atlantic and Northeast provides support for the probable earlier association of maize with early Middle Woodland features. The eighth and ninth century dates are among the earliest for maize in the northeast (Fritz 1990). If the earlier Middle Woodland dates are substantiated through direct dating, they would represent the earliest maize remains in the northeast, consistent with early dates obtained elsewhere in the Eastern Woodlands (e.g., Chapman and Crites 1987; Riley et al. 1994). Additionally, the presence of pepo gourd rind fragments in late Laurentian contexts if substantiated through direct dating would constitute the second oldest occurrence of this cultigen in the northeast. Clearly, then, results of the archeobotanical investigations at Memorial Park are significant for not only the West Branch but potentially for our understanding of agricultural development in the northern Eastern Woodlands.

## TECHNOLOGY

As reviewed in the Research Design section of this report, tools are designed to cope with specific aspects of the natural and social environments; they are created to cope with one or more problems. These problems are defined by the functional field, the complex of techno-functions, socio-functions, and ideo-functions within particular subsistence-settlement systems (Schiffer and Skibo 1987). Changes in technology are caused, at least in part, by changes in the functional field. As subsistence systems change, for example, there should be corresponding changes in technology. Tools used in food procurement must function adequately so as to ensure an adequate food supply (Torrence 1989a). As a result, although the analysis of stylistic attributes of pottery and lithic tools was important to the current investigations, as reviewed above, the investigation of technological change was also of importance and was applied to the pottery and chipped-stone assemblages. The results of these analyses are reviewed and summarized below.

### *Pottery Technology*

As reviewed in the Research Design section of this report, pots were tools and thus had specific technological requirements that would have changed with changes in the functional field. General trends in Eastern Woodlands prehistory include gradual change to pots with thinner walls and finer rock temper, followed by the adoption of shell or mafic mineral temper with the adoption and intensification of maize-based agriculture (O'Brien et al. 1994). Also, as reviewed earlier, pottery technology in the West Branch valley appears to follow these trends, although these changes have not been rigorously investigated. As a result, a number of research questions were developed for the present investigations concerned with developments in prehistoric pottery technology. These included: (1) Are distinct functional classes present in the Clemson Island pottery assemblage, and are there changes in Clemson Island pottery technology through time? and (2) Are there changes in technological attributes through time that correspond to changes in subsistence? That is, how does pottery technology change from the early Clemson Island to the Stewart phase, as maize presumably became an increasingly important part of the subsistence regime?

Pottery is first evident at the Memorial Park during the Orient phase occupations in the form of steatite-tempered Marcey Creek pottery. Fiber-tempered pottery, recovered from the uppermost portions of the block excavations, also probably relates to the Orient phase component. These results are relatively consistent with the Mid-Atlantic region in general (e.g., Custer 1989). The Memorial Park site, however, appears to be the first site excavated in this portion of the West Branch valley with well-represented Marcey Creek pottery in Orient phase contexts.

While pottery is represented at the Memorial Park site as early as the Terminal Archaic period, the largest collection was recovered from Late Woodland contexts. Functional/

technological analysis of Late Woodland pottery from the Memorial Park site suggests that pottery technology did change through time. This is evident in the general class of chert-tempered pottery and in the introduction of quartz and sandstone-tempered pottery. In general for all Late Woodland components, there is a positive, although weak, correlation between vessel size and wall thickness; larger pots tend to have thicker walls. This can be interpreted as a technological constraint on the construction of larger vessels. Thicker walls were needed to support the weight of the vessels while under construction. This trend was modified during the late Clemson Island occupation.

Examination of the distributions of temper and temper size through thin-section analysis indicates that the bodies (Stoltman 1991) of the vessels underwent change from the early Clemson Island through late Clemson Island occupations. During the early and middle Clemson Island occupations, there is a significant, weak, positive correlation between vessel wall thickness and temper size. In general, thicker-walled vessels contained larger particles of temper. This can be interpreted in several ways. First, larger pieces of temper may have been added to the paste in order to strengthen the walls during construction. Alternatively, if the emphasis was on resistance to crack propagation, larger pieces of temper would have served as a focus for cracks to prevent their growth. This, in conjunction with thicker walls, would have produced pots more resistant to crack propagation.

During the late Clemson Island occupation, there is also a positive correlation between wall thickness and temper size, although the relationship is not significant. There is a negative correlation between temper density and wall thickness. Two groups of sherds were identified through cluster analysis, one with relatively thick walls, relatively larger temper, and relatively lower temper density as compared to the other group. This suggests at least two technological groups within the chert-tempered vessels, perhaps relating to different functions. The first group pertains to larger vessels engineered to withstand crack propagation (larger pieces of temper and lower temper density). The second group consisted of smaller vessels engineered to retard crack initiation (higher temper density with smaller pieces of temper). It is uncertain whether these two groups represent discrete functional classes. However, large vessels engineered to withstand crack propagation may represent storage vessels designed to withstand impact fractures and load-bearing stresses. The second class, engineered to withstand crack initiation, may have been used for cooking purposes, although the higher densities of chert temper are counter-intuitive, given that the expansion rate of this acidic rock is greater than that of clay minerals (Rye 1976).

During the late Clemson Island occupation and continuing into the Stewart phase occupation, there may be the first occurrence of a third technological group, quartz and sandstone-tempered pottery. While the sample size is small, these pots generally had thinner walls, smaller pieces of temper, and lower temper densities. This suggests a concern with thermal stress resistance, perhaps coterminous with an onset of greater dependency on maize in the diet.

In another recent technological/functional analysis of Clemson Island pottery, Custer, Watson, and Bailey (1994:125-128) examined the vessel size distributions between what they consider to be a storage area at the West Water Street site and other, non-storage areas of the site. Measures of vessel size, including vessel volume estimates, indicate that pots recovered from the storage area of the site were larger than those recovered from other areas of the site. This suggests that at least two functional classes of pots were present at the site: storage vessels, and cooking vessels. This interpretation was supported by the presence of sooting on vessels recovered from non-storage contexts, implying that they were used for cooking, while vessels recovered from the storage area were not sooted suggesting that they were not used for cooking. Interestingly, sooting occurred on vessels only with capacities between 2 liters and 28 liters. Custer and associates argue that vessels with less than 2-liter capacities were too small to serve as cooking vessels. Vessels with capacities greater than 28 liters fall within the class of vessels to which they assign a storage function. Thus, while Custer, Watson, and Bailey (1994) were unable to examine technological change at the West Water Street site because of a lack of radiocarbon assays, their



results do suggest the existence of several functionally distinct classes of Clemson Island pottery vessels.

The technological/functional analysis of Late Woodland pottery from the Memorial Park site, then provided answers to the research questions raised earlier in this report. First, there does appear to be distinct functional classes of pottery in the Late Woodland assemblage. These include large pots with relatively small amounts of large pieces of chert temper that probably served a storage function, and thinner-walled vessels with relatively high densities of small chert temper that probably functioned as cooking vessels. The late thin-walled, quartz and/or sandstone-tempered pottery probably also represent cooking vessels. The existence of functionally distinct classes of Clemson Island pottery is supported by the results of Custer, Watson, and Bailey's (1994) analysis of Clemson island pottery from the West Water Street site. Second, there were apparently temporal changes in pottery technology through time. Functionally distinct classes of pottery first become clearly evident in the late Clemson Island assemblage. This lends support to the idea that reliance on agricultural production would have increased through time. Increased reliance on agricultural production may have placed greater emphasis on direct heat cooking, with pots being placed directly on a source of heat for extended periods of time. Interestingly, Custer, Watson, and Bailey (1994) suggest that the Clemson Island component at the West Water Street site dated to between A.D. 1000 to 1200, which would have been contemporaneous with the late Clemson Island occupation at Memorial Park, when the functionally distinct pottery classes first become evident. These two sites, then, have produced the first evidence of distinct Late Woodland pottery function classes at a time when, at least hypothetically, reliance on maize-based agriculture was intensifying.

### *Chipped-stone Technology*

As reviewed in the Research Design section of this report, major advances have been made in theories related to lithic tool technology and raw material management during the past decade. Like pottery vessels, lithic tools were designed to solve problems (Torrence 1983, 1989a, 1989b). Lithic technology responds to changes in the functional field such as subsistence change. General trends in Eastern Woodlands prehistory include a shift towards less-formal chipped-stone tool industries after the adoption and intensification of maize-based agriculture, reflecting changed risk environments for the use of stone tools (Torrence 1989b). Hunter-gatherers relied upon chipped-stone tools, to a large extent to minimize risk of failure during hunting, and therefore expended considerable energy on the production of reliable, well-made bifaces that could be repaired if broken. Agriculturalists who relied less upon hunting and more upon harvesting cultivated plants did not expend as much energy on the production of formally shaped chipped-stone tools, and relied more upon expediently produced flake tools for day to day activities. Similarly, mobile hunter-gatherers had access to wider varieties of lithic raw materials during their annual subsistence cycle than did more sedentary agriculturalists. The theories reviewed earlier in this volume provide an interpretive context for the present investigations, and methodologies were developed specifically for this project to address a series of research questions.

Questions addressed with data generated by the present investigations included: (1) To what extent did lithic technology vary through time as risk factors changed with modifications in subsistence activities? For example, was there a change toward more expediently manufactured tools as maize was adopted? Were there recognizable changes in maintainable and reliable tool design that reflect changes in subsistence risk? Did the incidence of the expedient and curated tools change with changing mobility patterns? Was there less evidence of expedient tool manufacture during the Late Archaic as settlement systems became more logistically organized? (2) What changes occurred in lithic procurement during the time span from Middle Archaic through Late Woodland periods? Was there a trend toward lithic material conservation as mobility decreased, or were locally available materials of high enough quality to preclude such conservation? (3) What



changes occurred in lithic procurement systems at the site through time, and is this reflected in changes in subsistence, trade, etc.? Did amorphous core and bipolar reduction become more common on locally available resources later in the cultural sequence, or is bifacial reduction more common? Was there greater evidence for high-quality lithic resource conservation through time by the production of blades or bladelets, or was there a greater incidence of biface maintenance of tools manufactured from high-quality lithic material?

Spitzer's (this volume) analysis of chipped-stone debris from the Memorial Park site, through a variant of aggregate analysis, provides a clear link between method and theory that is often lacking in individual flake identification analysis. Spitzer's reduction effort and thinning indices allowed for the identification of reduction trajectories for each raw material class. These reduction trajectories included thinning, which corresponds to the production of curated tools, thickening, which corresponds to the production of expedient tools, and resharpening/repair. Spitzer's analysis is one of only a few attempts at aggregate analysis in Pennsylvania (also see Hart and Cromeens 1991), and clearly demonstrates the utility of this approach. His analysis of tools, through width-thickness ratios, allowed direct linkages between the results of tool and debris analyses. In addition to the results of Spitzer's analyses, the detailed presentation of summary statistics for both chipped-stone debris and chipped-stone tools, provides future researchers with data needed for regional and interregional comparisons.

Both chipped-stone tools and debris provided evidence for changing technologies through time at the Memorial Park site. Lithic technology remained relatively consistent throughout the Archaic period, while a major change occurred with the onset of the Late Woodland period. During the Archaic period, lithic technology was geared toward the production of bifaces, constituting a reliable, curated technology. This suggests that chipped-stone tools were designed to exploit resources that were discontinuously but predictably available (Torrence 1989), such as deer and other large game to minimize short-term risks. As a curated technology, the tools were fashioned so that they could be used for a variety of tasks and be transported from site to site. The documentation of a cache pit containing 10 rhyolite bifaces is consistent with expectations for a curated technology. During the Late Woodland period, and perhaps earlier during the Early and Middle Woodland periods, there was a shift to an expedient tool technology. This is represented by a high proportion of edge-only tools to bifaces, and by the results of debris and tool analyses which indicate a primarily thickening technology, producing tools that were used to fulfill immediate needs, after which they were discarded. This change is dramatically evident in figures 90 through 102, which plot the mean reduction effort index against the thinning index. Beginning with the early Laurentian assemblage and continuing through the Orient assemblage, the majority of raw material classes fall well within the thinning space as defined in Figure 77. The Late Woodland component debris classes, however, fall primarily within thickening space, with the exception of the Stewart phase assemblage, which all falls within resharpening/repair space. Spitzer's analysis of tool with thickness ratios, as summarized in figures 118 and 119, also clearly show the shift from a thickening technology to a thinning one with the onset of the Late Woodland period. The change from curated to expedient chipped-stone technologies is noted throughout much of the Eastern Woodlands at this time, and it is explainable within the framework of changing subsistence-settlement systems (Jeske 1987; Torrence 1989b).

Torrence (1989b:64) argues that the shift from curated to expedient chipped-stone technology reflects changes in risk management between subsistence-settlement systems geared primarily to the exploitation of wild resources to one where management of cultivated plants was a major focus.

As a result, the nature of risk altered fundamentally, thereby creating different types of problems requiring alternative solutions. No longer a simple adaptation to natural distribution of resources in the environment, these new subsistence practices involved direct management of resource availability and the short-term risks associated with hunting and, to a lesser extent, with

gathering, were eliminated. Consequently, the need for maintaining a reliable set of subsistence tools disappeared. More important than simply the shift in the function of tools, the amorphous, poorly-made artifacts which characterize these much ignored and unpopular assemblages were adequate for the jobs at hand because the incidence of short-term risk had been eliminated by domestication and management; failure to complete the new tasks quickly and effectively bore few negative consequences. Why invest time and energy in costly equipment if there was no need for it?

The results obtained from the analyses of chipped-stone assemblages from Memorial Park are significant because they provide a positive test of this hypothesis at a single site, where data were collected in a consistent manner for all components from the Middle Archaic through Late Woodland periods. That there was a major shift in lithic technology with an increase in the utilization of agricultural production during the Late Woodland period at the Memorial Park site indicates a substantial degree of agreement for central Pennsylvania with trends noted elsewhere in the Eastern Woodlands. The results of Spitzer's debris analysis provides one of the best examples of this change in Pennsylvania.

In addition to changes in general lithic reduction strategies between the various Archaic components and the Late Woodland components, there are also temporal changes in the level and type of non-local raw material utilization, as represented by argillite, jasper, and rhyolite. As noted by Custer, Watson, and Bailey (1994:164) for the West Water Street site, the nearest rhyolite source is in Adams County, Pennsylvania, some 100 km south of the Memorial Park site (also see Custer 1988; Stewart 1987, 1989). There are a number of jasper sources in Pennsylvania, the nearest of which occurs in the Bald Eagle Valley, in the Huntsville, Pennsylvania area over 21 km from the Memorial Park site (Hatch and Miller 1985; Schindler et al. 1982). Finally, argillite, which Spitzer (this volume) suggests is a possible local material, is most widely recognized as originating from formations in the Delaware and Hudson valleys (Custer 1988; Didier 1975; Stewart 1989).

All of these three raw material types show variation change in the level and intensity of use through time (Figure 131). Rhyolite is present on the site during its earliest occupations, but it does not constitute a major resource until the Piedmont component, after which there is a dramatic increase during the Terminal Archaic. This is followed by a sharp decrease in use during the Orient occupation to virtually no use during the Early Woodland, an increase in use during the Middle Woodland, virtually no use during the Clemson Island occupations, and a final major increase during the Stewart Phase occupation. Rhyolite occupies the resharpening/repair space in the Middle Archaic assemblage, the thickening space for the remainder of the Archaic components, and the resharpening/repair space for Middle the Late Woodland components. This implies that the materials entered the site as finished tools during the Middle Archaic and late Woodland periods and were subjected to repair and resharpening as needed. During the Late and Terminal Archaic periods, the material entered the site in partially reduced form, either as block or bifacial cores, and was reduced to make bifaces at the site. The thinning and mean reduction effort indices vary during the Late and Terminal Archaic periods. The thinning index reaches its highest level, and the mean reduction effort its second highest level during the Terminal Archaic period, reflecting the dominance of the raw material at the site at this time. A high mean reduction effort index for the late Laurentian is somewhat surprising, but indicates that although the amount of material entering the site was small, it was subjected to intensive use.

The intensive use of the material during the Terminal Archaic parallels patterns noted throughout the Mid-Atlantic (Stewart 1989), and in the West Branch Valley (Bressler 1989; Custer, Watson, and Bailey 1994; Turnbaugh 1977) at this time. Fully 87.5% of the diagnostic bifaces associated with this component are manufactured from rhyolite, while 62% of total bifaces are manufactured from rhyolite. The percentage of diagnostic-bifaces manufactured from rhyolite is much higher than that reported by Bressler (1989:44) for the Canfield Island site, where 27% of

the diagnostic bifaces were manufactured from rhyolite. Custer, Watson, and Bailey (1994:157) report that 22 of 24 Susquehanna broadspears recovered from West Water Street were manufactured from rhyolite. Clearly, then, use of rhyolite during the Terminal Archaic in the West Branch valley varied both spatially and temporally. The very high percentage of diagnostic bifaces manufactured from rhyolite at Memorial Park and West Water Street implies either a hoarding strategy as defined by Stewart (1989) or direct procurement as described by Custer and associates (1994). The patterns evident at the site during the Late Archaic and during the Orient phase more closely matches Stewart's (1989) expectations for broad-based exchange. However, as noted by Custer, Watson, and Bailey (1994), the 100 km distance to rhyolite outcrops from Lock Haven would fall within the territory of at least some hunter-gatherers, so direct procurement cannot be discounted.

During the Late Woodland period, rhyolite apparently entered Memorial Park in the form of finished tools, which were subjected to repair and resharpening at the site. This follows trends noted throughout the Middle Atlantic region, where, as noted by Stewart (1989:63), "Frequency distributions of rhyolite and argillite artifacts, among other materials, suggest that broad-based exchange networks were disrupted or severely attenuated, and focused exchange dramatically altered during the Late Woodland period...The volume of intra-regional lithic goods moving through broad-based systems are a fraction of what they were during earlier times and consist largely of triangular projectile points/bifaces that were well-used and discarded in general contexts. Rhyolite and argillite debitage found on distant sites seems to be the exclusive result of maintaining late stage bifaces/projectile points." The high percentage of rhyolite debris recovered from Stewart phase contexts at the Memorial Park site may be a sampling error. Despite the high percentage of debris, rhyolite continues to reflect resharpening/repair at this time, suggesting that if there was an increase in rhyolite availability in the West Branch, it was through the exchange of finished tools (see Stewart 1989).

Argillite exhibits a pattern somewhat different from that of rhyolite. As indicated in Figure 131, argillite use as represented by percent of debris weight, reaches a peak in the late Laurentian and Piedmont component assemblages, falls off during the Terminal Archaic period, when the focus was primarily on rhyolite, then peaks again during the Orient and early Clemson Island period. Argillite occupies the resharpening/repair space during the Middle Archaic, Terminal Archaic, Middle Woodland, late Clemson Island and Stewart phase occupations, when it apparently entered the site as finished tools. Argillite occupies the thinning space in the Late Archaic and the thickening space in the early Clemson Island assemblages, when it apparently entered the site as partially reduced block cores or bifacial cores. Total reduction effort reaches its peak in the late Laurentian component and the thinning index reaches its peak during the early Clemson Island component. While the Archaic period trends match those noted by Stewart (1989) throughout the Mid-Atlantic region, the early Clemson Island pattern is anomalous, perhaps reflecting an exchange system not yet fully documented. Argillite represents a negligible portion of the Clemson Island debris assemblage at the West Water Street site (Custer, Watson, and Bailey 1994).

Use of jasper at the Memorial Park site, as represented by percentage of debris, was most intensive during the Middle Archaic occupations, when it constituted 11.6% of the assemblage. It reaches a second peak during the Stewart phase when it comprises 5.9% of the debris by weight. The highest percentage of diagnostic tools manufactured from jasper occurred during the Orient phase occupation, where 2 of 14 tools were manufactured from jasper. Jasper occupies the resharpening/repair space during all occupations except the early and late Laurentian, where it occupies the thickening space. The highest mean reduction effort occurs during the late Laurentian and the highest thinning index occurs during the late Laurentian and Stewart phase. It appears then, that during most of the occupations, jasper entered the site primarily in the form of finished tools that were subjected to resharpening and repair. During the Laurentian occupations it entered the site as partially reduced block or bifacial cores and was subsequently reduced into bifaces. The

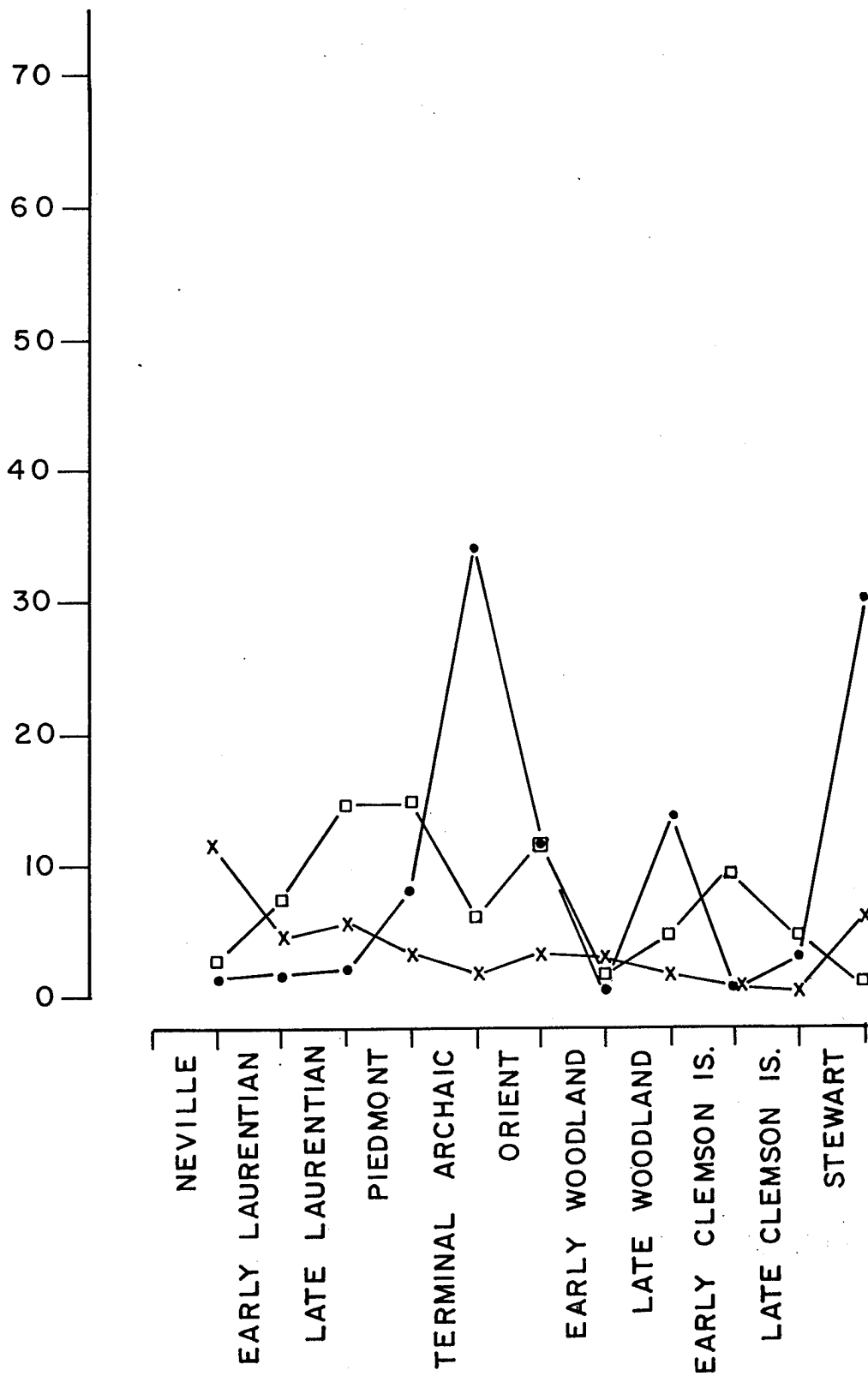

KEY

- - RHYOLITE
- x - JASPER
- - ARGILLITE

FIGURE 131

PERCENT WEIGHT OF NON-LOCAL RAW MATERIAL DEBRIS FOR MEMORIAL PARK COMPONENTS

small percentage of the assemblage represented by jasper in these latter two assemblages suggests that use of jasper was fairly restricted, perhaps representing one or a few procurement episodes for each component. Jasper apparently reached its peak usage at the West Water Street site during the Paleoindian/Early Archaic and Middle Archaic periods (Custer, Watson, and Bailey 1994) indicating that the high percentage of debris at the Memorial Park site during the Middle Archaic is not anomalous. The high percentage of jasper debris represented in the Stewart phase assemblage reflects the continued trade of this material in the Mid-Atlantic during the Late Woodland period (Stewart 1989).

In addition to varied use of non-local raw materials, changes in lithic procurement systems are evident in the diversity of raw material assemblages through time. The Shannon-Weaver information statistic for lithic raw material debris counts for the various components is presented in Figure 132. The Early and Middle Woodland components are excluded from the graph because of small sample size. In Figure 132,  $H'$  is the diversity index and  $J$  is the evenness index (Bobrowsky and Ball 1989; Leonard et al. 1989; Pielou 1975). There is an increase in  $H'$  from the Neville component to the late Laurentian component, a slight decrease for the Piedmont and Terminal Archaic components, followed by an increase for the Orient component, and a major decrease for the early and late Clemson Island components, followed by a sharp rise for the Stewart phase component. The  $J$  index rises from the Neville to the early Laurentian, after which it remains constant until a small rise for the Orient component, followed by a sharp decline for the early and late Clemson Island components and a sharp rise for the Stewart phase.

The decrease in  $H'$  and  $J$  between the Archaic component assemblages and the Clemson Island assemblages indicates that the early Late Woodland inhabitants of the Memorial Park site utilized a less diverse assemblage of raw materials than did the Archaic inhabitants, and that the use of the raw materials was less even than during the Archaic period. This is consistent with the proposal that less mobile populations will have less access to varied raw materials than more mobile populations who encountered a wider variety of raw materials during their annual cycle. If, as Custer, Watson, and Bailey (1994) suggest, the territories of Late Archaic West Branch populations included areas as distant as 100 km south, they would have had direct access to a larger number of raw material classes than the less mobile Late Woodland populations. The fall-off in  $H'$  and  $J$  may also reflect changes in access to non-local raw materials because of changes in interregional exchange patterns. As indicated by Stewart (1989), there was a substantial decrease in interregional exchange during the Late Woodland period. The sharp increase in the indices for the Stewart phase, while possibly a result of sampling error and/or small sample size, may reflect greater access to non-local raw materials through interregional exchange. The fact that all of the non-local raw materials for this component fall within the resharpening/repair space, indicates that interregional exchange probably focused on finished tools at this time in contrast to the movement of cores during the Archaic.

There is no direct evidence for conservation of high quality raw materials with increased sedentism during the Late Woodland period. There is a notably greater reliance on local raw materials, with the exception of the Stewart phase. However, these raw materials generally are of high quality, and they probably would have been obtained on a regular basis. Use of agate during the Late Woodland was higher than during all of the Archaic components with the exception of the late Laurentian. Agate primarily occupies the resharpening/repair space during the Archaic suggesting relatively limited reduction. It occupies the thinning space during the Laurentian components and the thickening space during the Clemson Island occupations. Because agate occurs in small cobbles, and little material can be obtained from a single nucleus, the increased use of agate during the Laurentian and Late Woodland periods may reflect more intensive use of the local area and its available raw materials, but it does not necessarily indicate stress on lithic procurement systems. That chalcedony also reaches its highest level of use during the Late Woodland, representing as much as 39.9% of the debris assemblage for the late Clemson Island occupation, also reflects more intensive use of local, high-quality raw materials.

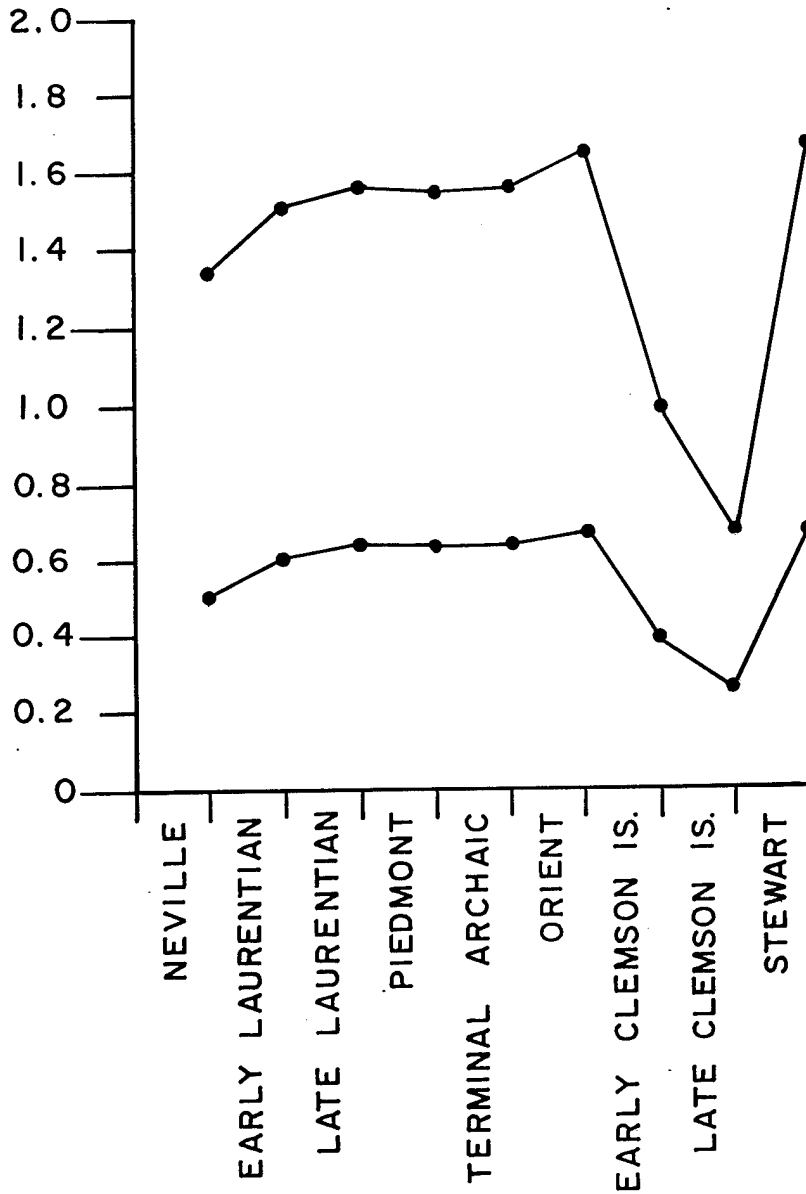

FIGURE 132  
SHANNON-WEAVER INFORMATION  
STATISTIC FOR LITHIC RAW  
MATERIAL DEBRIS COUNTS

In summary, then, the chipped-stone assemblages from the Memorial Park site reflect changes in raw material management and chipped-stone industries evident throughout much of the Eastern Woodlands including the Middle Atlantic and Northeast. The change from largely curated technologies to largely expedient technologies during the Late Woodland period reflects the shift to more intensive reliance on agricultural production. The decreased lithic raw material diversity indices for the early Late Woodland period reflects decreased mobility, also associated with increased reliance on agricultural production. The Memorial Park site, then, provides an important test case for prevailing models of chipped-stone technology and raw material management because the data supporting the models were collected from a single site using standardized recovery, coding, and analysis procedures. The analytical methodology used in this investigation are objective and replicable, and allow for direct linkages between method and theory, which is often lacking in more traditional individual flake identification analyses. Use of these and related methods on other sites in the Mid-Atlantic and Northeast will allow greater understanding temporal and spatial variations in lithic production and raw material management systems.

#### SETTLEMENT PATTERNS

The Memorial Park site represents a locus of prehistoric human activity over a period of approximately 6,500 years, dating from the Middle Archaic through Late Woodland periods. This location is one small segment of a broad flood plain at the confluence of the West Branch with Bald Eagle Creek that was probably exploited to varying degrees of intensity by human populations, beginning in the Late Pleistocene period and extending through the end of the Late Woodland period. Geomorphological and site formation studies indicate that this location was very dynamic and that landforms changed throughout the prehistoric period influencing the nature and intensity of human occupations within the study area. This influence has been delineated in several locations in this volume and will be further summarized below. It is important to note however, that the Memorial Park site, as defined during the present and previous studies, is an artificial construct. The full extent of human occupation in this portion of the West Branch valley can never be known because of the presence of the City of Lock Haven and Piper Airport, which both undoubtedly resulted in the destruction of large portions of the prehistoric archaeological record. It is likely that evidence of human occupation within the study area, and within the area defined as Memorial Park on the National Register, is only one relatively small facet of complex prehistoric human settlements that extend almost continuously across the inhabitable landforms of this broad flood plain.

Settlement pattern analysis serves as the integrating mechanism for the various investigations carried out at the Memorial Park site, and has been addressed to some extent in the component summaries presented earlier in this chapter. Interpretations are presented at two scales: site-specific, and regional. The site-specific interpretations tie together the results of the analysis of all data sets to provide a temporal summary of prehistoric occupations at the Memorial Park site. Questions raised in the Research Design section of this report include: (1) What function(s) did the site play during the Late Woodland period? (2) Was economic or social differentiation represented at the site in the form of distinct artifact and feature patterning? (3) Was the site a base camp during the Late Archaic period, and were there changes in site function through time? Regional settlement pattern interpretation places the Memorial Park site within a broader regional context and provides interpretations of how the Memorial Park site functioned within local and regional subsistence-settlement systems. Questions raised in the Research Design section of this report included: (1) How did the Clemson Island occupations relate to Clemson Island sites within the West Branch Valley? (2) How did this site fit into the subsistence-settlement systems during the Archaic period? Did the site represent a seasonal or multiseasonal base camp as would be expected from its geomorphological setting, or was it a specialized extraction camp? Was the site used for different purposes during different times within the Archaic period, and, if so, would this indicate changes in site usage and regional settlement systems to, for example, more logistically oriented settlement

systems? (3) Was there evidence during the span of the Late Archaic for sedentism, as has been noted in other areas of the Eastern Woodlands? At what date is there evidence for multiple, seasonal, and/or year-round occupations? The framework for these interpretations is created through comparison with other recently excavated and reported investigations at other sites in the West Branch and Bald Eagle Creek valleys (e.g., Bressler 1989; Custer, Watson, and Bailey 1994; Hatch 1980; Hay and Hamilton 1984).

Hatch et al. (1985) suggest that a multiple base-camp radial-settlement pattern became established during the Archaic period in the Ridge and Valley Province and continued through the Woodland period, with the addition of several site types. During the Archaic period, base camps occupied by groups of maximal size were situated in major river valley floodplains, with access to a variety of resources. Specialized resource extraction camps were located away from the valley floors and were used as temporary camps for the extraction of resources. This radial system would have been moved several times during the year to track changes in resource availability. This proposed system follows Binford's (1980) and Kelly's (1983) descriptions of the logistic settlement pattern that has been recognized throughout the eastern United States for the Archaic Period (e.g., papers in Phillips and Brown 1983). Custer and associates (1994) suggest that this pattern did not become established until the Late Archaic period. They believe that during the Middle Archaic subsistence-settlement systems were characterized by foragers organized in residential mobility systems whereby family groups moved between resource patches throughout the yearly cycle without associated macroband camps.

In a number of widely-cited publications, Custer has developed a model of Late Archaic subsistence-settlement systems for the Mid-Atlantic region that may have general applicability to the Memorial Park site (e.g., Custer 1984, 1988, 1989; Custer and Wallace 1982). This model is integrated with models of regional climatic change that produced temporally and spatially varied resource distributions. Changed climatic patterns, including a series of warm-dry climatic episodes between approximately 3050 B.C. and 1050 B.C., resulted in a major differentiation between resource productivity in major river valleys and upland settings. Custer (1988:50) argues that upland settings were productive, but "the nature of productivity changed such that the most effective strategy was to exploit these areas via periodic transient forays from semi-permanent base camps in riverine areas." This pattern resulted in large, riverine, macro-base camps and many smaller, upland procurement camps.

The various Archaic components at the Memorial Park site represent different facets of regional subsistence-settlement systems through time. The settlements at the site were influenced to some extent by the changing landscape at this geomorphologically dynamic location, as reviewed throughout this volume. The components at Memorial Park and other nearby stratified sites, including West Water Street (Custer, Watson, and Bailey 1994) and Canfield Island (Bressler 1989), represent temporally discrete settlement loci of complex subsistence-settlement systems that can only be clarified through additional research. However, through comparison with these sites, it is possible to identify several important aspects of Archaic settlement systems in the West Branch valley.

The Middle Archaic Neville occupations (5140 to 4815 B.C.) at Memorial Park appear to have been resource procurement or short-term residential camps. The Memorial Park landscape was relatively young at this time as a result of the relatively recent migration of the south channel of the West Branch. Occupations are limited to the Port Huron Terrace on the western portion of the study area. Bressler (1989) identified a Middle Archaic component at Canfield Island with a radiocarbon assay of 4855 B.C., and a second component, dating to 4585 B.C. While both of these components lack diagnostics, it is likely that they belong to the same tradition as the Neville phase component at Memorial Park. These occupations were apparently fairly light, and Bressler interprets them as procurement camps. The Middle Archaic component at the West Water Street site (Custer, Wallace, and Bailey 1994), dated to 5440 B.C., produced a large number of Neville



bifaces similar to those recovered from Memorial Park. Custer and associates interpret this component as representing a series of residential camps occupied by individual family units. These three sites, then, provide ample evidence that the West Branch was extensively utilized during the Middle Archaic period (also see Turnbaugh 1977).

Occupations associated with the Laurentian tradition at Memorial Park represent base camps. During the early Laurentian occupations (4405 to 3840 B.C.), the most intensive use of the site occurred on the western half of the study area, on the Port Huron terrace. Utilization of the newly formed levee on the east end of the study area appears to have been light. During the late Laurentian occupations (3250 to 2950 B.C.), both the terrace and levee were intensively utilized. The location of the Memorial Park site at the branching of the West Branch channel and near the confluence of the West Branch and Bald Eagle Creek is the kind of setting where large Late Archaic macroband base camps are most likely to occur (Custer 1988). As described earlier in this chapter, the Laurentian occupations at Memorial Park reflect Custer's (1988) description of Late Archaic riverine base camps. The number of occupations represented by the Laurentian components cannot be determined, but the site was evidently intensively used during this time, and it probably served as a staging area for logistical forays to exploit other areas of the flood plain as well as upland areas. The relatively high percentage of argillite in the late Laurentian debris assemblage suggests that regional exchange networks were beginning to expand at this date following trends noted by Custer (1988) and Stewart (1989). It is conceivable, however, that this raw material was procured within large territories as suggested by Custer, Watson, and Bailey (1994).

Turnbaugh (1977) reported a large number of Laurentian sites in the West Branch valley based upon surface collections. Relatively light Laurentian occupations were present at the West Water Street and Canfield Island sites. Custer and associates were unable to define the nature of Laurentian occupations at West Water Street, although a small number of Brewerton bifaces were recovered from the site. The small number of diagnostic artifacts recovered from this site, suggest that the Laurentian occupations were not extensive. Laurentian occupations at the Canfield Island site produced a single radiocarbon date of 3150 B.C., contemporaneous with the late Laurentian component at Memorial Park site. This component produced a wide array of artifacts including a small number of Brewerton bifaces and 13 fire-related features. Bressler interprets the component as "a seasonal stay of a Brewerton band," which exploited local mast crops, game, and fish. The small area sampled precludes a more comprehensive evaluation of this component. Taken together, then, the three sites indicate that the West Branch was extensively utilized during the earlier portions of the Late Archaic period. Of the three sites, the Memorial Park site was either the most intensively occupied or the most frequently reoccupied area. The setting of the site near the confluence of the West Branch and Bald Eagle Creek would have provided access to a wide number of resource zones. While it is possible that the apparently less extensive settlements at West Water Street and Canfield Island represent procurement camps associated with the Memorial Park site, additional sites must be investigated to provide a more comprehensive analysis of Laurentian subsistence-settlement systems in the West Branch valley.

During the Piedmont (2460 to 2100 B.C.), the site served as a resource procurement site. This change from the Laurentian occupations may be related to changes in resource availability as a result of the xerothermic and subsequent changes in regional hydrology (Custer 1988). No Piedmont occupations were reported by Bressler (1989) at the Canfield Island site, although Graybill (this volume) argues that Bressler's Savannah River component, dated to 1910 B.C. was actually Piedmont. This component was more extensive than the Piedmont component at Memorial Park. A small number of straight-stemmed and contracting stem bifaces were recovered from West Water Street, but like the Laurentian occupations at this site, Custer and associates (1994) were unable to clearly define the nature of the occupations. The apparent shift in occupational intensity at the Memorial Park and Canfield Island sites during this time reflects settlement-subsistence dynamics that can only be fully interpreted through additional research in the valley, although it is

probable that logistically organized systems persisted during this later portion of the late Archaic period.

The site again served as a base camp during the Terminal Archaic period. Features from the Canfield Island component, dated from 2000 B.C. to 1600 B.C., are distributed across the entire study area and on all of the landforms. The site probably served as a base camp during this time. The Susquehanna phase is represented by only a few diagnostic bifaces and steatite bowl fragments. It is possible that the site served as a procurement camp during this time. The large amount of rhyolite associated with these components is reflective of interregional exchange systems noted throughout the Mid-Atlantic and Northeast (Custer 1988; Stewart 1989). There were apparently fairly intensive Susquehanna phase occupations at the West Water Street site, identified on the basis of 24 Susquehanna broadspears, which Custer and associates (1994:156) suggest date from 2000-1000 B.C. As at Memorial Park, a very large percentage of the diagnostics were manufactured from rhyolite. The Canfield Island site (Bressler 1989) is the type site for Canfield Island phase. Bressler identifies an extensive occupation at this time reporting the recovery of over 200 hafted bifaces and 65 features that resemble those documented at Memorial Park including cobble hearths and caches. Bressler also reports the documentation of a number of postmolds, which he believes represent temporary shelters. This component produced radiocarbon dates of 1570 B.C. and 1540 B.C., somewhat later than those at Memorial Park. Interestingly, a much lower percentage of the diagnostic bifaces were manufactured of rhyolite than at Memorial Park. He interprets the occupations as multiseasonal base camps, occupied from spring through fall to exploit riverine resources. Bressler also identifies a Susquehanna component that was less intensive than the Canfield Island phase component, but apparently more intensive than the Susquehanna occupations at Memorial Park. A larger percentage of diagnostic bifaces were manufactured from rhyolite during this time than during the Canfield Island phase occupations.

The site again served as a base camp during the Orient phase (1145 to 880 B.C.). Features from this component are distributed across the entire study area, and several postmold clusters suggest the presence of structures. No Orient phase occupation is reported at Canfield Island (Bressler 1989) and only three fishtail bifaces were recovered from West Water Street (Custer, Watson, and Bailey 1994). Bressler (1980) reports an Orient phase component at the Bull Run site with a date of 1220 B.C.

The Archaic occupations at the Memorial Park, West Water Street, and Canfield Island sites provide a preliminary glimpse of complex, subsistence-settlement systems in the West Branch valley that can only be fully understood through additional research. Clearly, the intensity of occupation at Memorial Park was influenced to some degree by landscape evolution, and this probably influenced the nature of occupations at the other sites as well. As demonstrated by Spitzer's (this volume) spatial analysis of the Archaic components, there was a trend toward more structured activities at the site through time and increased differentiation of activities, that suggest the gradual development of more sedentary settlement systems during the Archaic period. The apparent presence of structures at Memorial Park and at the Canfield Island site during the Terminal Archaic, as well as the use of steatite bowls and pottery, suggest that occupations were more lengthy during the Terminal Archaic period, culminating trends which were begun during the earliest portions of the Late Archaic period. As additional sites in this area are investigated, it may be possible to build models of local and regional subsistence-settlement systems that can more clearly account for the changes noted in this brief. However, it is clear that the valley was extensively and intensively exploited throughout the Archaic period, that logistically oriented systems were established by at least the fifth millennium B.C., and that there were trends toward more sedentary subsistence-settlement systems throughout the Archaic period.

During the Woodland period, Hatch et al. (1985) suggest that the Late Archaic settlement pattern continued with the addition of farming hamlets and villages. A number of models of Late Woodland settlement patterns have been presented that are directly applicable to interpretation of

West Branch occupations, as reviewed in the Research Design section of this report. Hay et al. (1987:57) recognize three Clemson Island types: (1) villages with associated burial mounds, (2) villages and hamlets without associated burial mounds, and (3) special activity, resource-extraction camps. Villages with associated burial mounds tend to be located on major waterways near large expanses of arable soils, and are the least documented because many have been destroyed through urban expansion, looters and early, non-scientific excavations. Early reports describe a burial mound in Lock Haven (Meguinnes 1889) that was destroyed during excavation of the Pennsylvania Canal (Hay et al. 1987).

More data exist for villages and hamlets without associated burial mounds. These sites are smaller than those of villages associated with burial mounds and they have been the focus of recent archaeological research (e.g., Custer, Watson, and Bailey 1994; Hatch 1980; Hay and Hamilton 1984; Graybill 1984; Mitchum 1983; Smith 1976; Stewart 1988). These sites tend to be located on flood plains of major rivers, such as the North, West, and Main branches of the Susquehanna and their major tributaries, on or near arable land (Hay et al. 1987). The number of households represented at the sites varies, but houses are generally associated with food processing and storage features. Hay and associates (1987) presented their third site type, special purpose sites, as hypothetical, since no special activity sites with diagnostic Clemson Island artifacts had been reported. Stewart (1990:95), however, suggests that the Petersburg Bridge and Montgomery Island sites were special purpose sites. These sites would have been used to extract subsistence items and other goods, such as lithic raw materials. Possible special activity sites have been reported in the Bald Eagle Drainage by Hatch (1980), although the lack of diagnostics prevents definite assignment to Clemson Island. Stewart (1988:IV-22) suggests that the term "village" be limited to planned, nucleated settlements. Based upon this definition, he indicates that there have been no Clemson Island villages recorded in association with burial mounds. As a result, he suggests revising Hay et al.'s (1987) model to include four site types: (1) planned villages, (2) hamlets with associated burial mounds, (3) hamlets with no burial mound association, and (4) special purpose camps.

More recently, Custer, Watson, and Bailey (1994: 19-22) provide an evolutionary model of Late Woodland community patterns for Pennsylvania. This model includes six developmental stages, the first three of which, they believe, are applicable to Clemson Island, while the last three are more likely associated with later Late Woodland culture-historical taxa. The first type, Individual Farmsteads/Household Cluster, consists of an isolated household structure and nearby features, associated with a nuclear family. The St. Anthony Bridge site (Stewart 1988) is cited as an example of this type of settlement. The second stage, Hamlets, consists of multiple household clusters, each representing a full suite of household activities; communal activities are limited. The Fisher Farm site (Hatch 1980) is cited as an example of this type of settlement. The third type, Fortified Hamlet, Agglunated Village consists of a hamlet or village surrounded by a stockade with the first evidence of communal activities, although individualized household activities are represented by feature distributions. Communal work areas and middens indicate some integration of community activities. The Airport II (Garraghan 1990) and Ramm (Smith 1976) sites are cited as examples of this type of site.

Custer and associates' (1994) fourth site type, Communal Village, was occupied by hundreds of individuals, housed in up to 60 structures, compared to the first three types, which are limited to no more than 10 houses. Communal activities are common, and specialized central facilities/structures reflect suprahousehold socio-religious activities. Two Shenks Ferry sites, Slackwater (Custer et al. 1993) and Kauffman (Nass and Graybill 1991) are cited as examples of this site type. The fifth site type, Planned Village I, is represented by regular, planned structure placement within the community. Special-purpose structures suggest a continuation of suprahousehold activities initiated in site type 4. The Murry (Kinsey and Graybill 1971) and Mohr (Gruber 1971) sites are cited as examples of this type of site. The final site type, Planned Village II, is the larger site represented in Pennsylvanian prehistory, and was occupied by thousands of

individuals. The presence of outlying cemeteries and lack of household burials, suggests to Custer and associates the presence of community or lineage-based, socio-religious integration. They cite the Strickler (Kent 1984) and Washington Boro Village (Kent 1984) sites as examples of this site type.

Custer and associates (1994) recognize that although there may be general trends in the archaeological record to support this type of developmental model, as suggested by Hart (1993a) and Hart and Nass (1994); it is probable that during any given time, various site types are likely to have existed. While it is likely that there was extensive spatial variation in settlement, at any given period of time during the Late Woodland in the West Branch valley, depending upon local environmental and social factors (Hart 1993a), Custer and associates' community plan typology does provide an interpretive framework for evaluating the function of the four Late Woodland components identified during the current investigations of Memorial Park. Overstripping during Task 1 investigations removed some portions of the Late Woodland record from the site, which prevents an analysis of the complete spatial pattern of the Late Woodland components. The data recovered during these investigations, however, do allow interpretations of site function for each of the components, as outlined below.

Features associated with the earliest Clemson Island component, dating from A.D. 760 to 830, are scattered across the study area (Figure 130). Two possible clusters of features occur: one on the eastern portions of the study area in the area of Structure 2, and one less-convincing cluster on the central portion of the study area. If these apparent clusters represent contemporaneous features, one would expect that pottery sherds from one feature would refit with sherds from other features in the cluster (Nass 1989). In fact, the only Late Woodland cross-feature pottery refit occurred between early Clemson Island features 57 and 160. Given that the early Clemson Island features are so widely scattered, and there were no other cross-feature pottery refits, suggests that the features do not represent a single occupation. This is further suggested by the fact that pottery contained in any given feature generally appears to represent either a single or a small number of vessels, perhaps pots that were used during a single occupation. Additionally, the feature patterns do not clearly associate with any of the structures, although the largest number of early Clemson Island features are located near Structure 2. Microwear analysis of chipped-stone tools indicates that a wide range of domestic behaviors took place during the early Clemson Island occupations, but does not indicate any clustering of these activities. The floral and faunal data both suggest growing season occupations, and the floral assemblage and the recovery of a hoe-like implement suggest that agricultural fields were located near the site. The large storage pits probably indicate seasonal abandonment of the settlement, with food and perhaps seed stock cached in the pits during the winter months to protect them from competing populations (DeBoer 1988; Hart 1995). The recovery of little barley, which germinates during the winter months, indicates that there were planned returns to the site after winter abandonment. The early Clemson Island component is probably representative, then, of a series of individual farmsteads and/or hamlets, as defined by Custer and associates (1994). These were seasonal, agricultural settlements, located so as to provide access to fertile alluvial soils.

This pattern is repeated during the middle Clemson Island component dated to A.D. 920 and 930. Unlike the early Clemson Island features, the middle Clemson Island features were apparently limited to the central portion of the study area. It is possible that these features are associated with Structure 2, which is the nearest structure pattern that does not overlap with one of the middle Clemson Island features. It is also possible that a structure was present in the vicinity of features 100 and 101, which are located at the center of the middle Clemson Island features. The fact that the range of stylistic variation within the middle Clemson Island pottery assemblage was very limited suggests that this component represents a single occupation, perhaps related to one, or a few, agricultural season(s). The floral and faunal assemblages are not obviously different from the early Clemson Island component and microwear analysis of chipped-stone tools continues to suggest a full range of domestic activities. Frankenburg's belief that the middle

Clemson Island burials were interred during the winter months would indicate that these occupations extended through the entire year, at least in some years. The continued use of large storage pits may indicate the periodic abandonment of the site. In general, then, the middle Clemson Island component continues to represent Custer and associate's (1994) individual farmstead and/or hamlet site type.

The late Clemson Island component, dated A.D. 1050 to 1090, continues the trends established during the early and middle Clemson Island components. Features identified with this component are scattered across the study area, with possible clusters occurring on the central portion of the study area where four features occur, and on the eastern portion where two features occur. There is no clear association of any of the late Clemson Island features with a structure pattern. As with the previous two components, the apparent feature clusters may represent individual households, although the lack of pottery refits between the features precludes their identification with a single occupation. The tight radiocarbon dates suggest a limited time span for the component. Floral and faunal assemblages continue to suggest growing season occupations; floral assemblage, and the recovery of a hoe-like implement, suggest the location of agricultural fields near the site. Microwear analysis of the chipped-stone assemblage indicates a full range of domestic activities. The use of deep storage pits continues to suggest periodic abandonment of the site, perhaps on a seasonal basis. As a result, like the early and middle Clemson Island components, the late Clemson Island component apparently represents either Custer and associates' isolated farmstead, or hamlet.

The final Late Woodland component, representing the Stewart phase, is dated from A.D. 1290 to 1385. Features identified with this component are scattered across the study area. No obvious feature clusters are present. An apparent longhouse pattern toward the center of the site, and possible incomplete longhouse patterns on the eastern portion of the study area, indicate that larger household units were occupying the site at this time. Otherwise, in general, the trends established during the earlier portions of the Late Woodland continue. The floral assemblage for the Stewart phase is basically the same as that noted for the Clemson Island components; there is a continued reliance on large storage pits, and a heavy hoe-like implement was recovered from a Stewart phase feature. However, microwear analysis of Stewart phase chipped-stone tools identified only one retouched flake with polish. Additionally, the pottery assemblage is relatively small compared to the Clemson Island assemblages. These factors, coupled with the fact that this component was not identified by earlier investigations of the site suggest that despite the presence of one or more longhouses, the site was not occupied for long periods of time. The continued use of large storage pits suggests periodic abandonment of the site. It is likely that the Stewart phase component continues to represent Custer and associates' isolated farmstead and/or hamlet.

It is unclear which structure patterns are associated with which components, with the exception of the apparent longhouse pattern association with the Stewart phase component. Custer and associates (1994:104) suggest that there was a general trend for larger houses through time during the Late Woodland period, eventually leading to the longhouse. If this is the case, then the smaller house patterns would be associated with the earliest Clemson Island occupations, followed by larger structures associated with the later occupations. Postmolds of Structure 2 overlap one early Clemson Island feature, suggesting that it is associated with the middle or late Clemson Island components. The nearest Clemson Island features to Structure 2 belong to the late Clemson Island component, so it is likely that Structure 2 is associated with that component. Structure 3 overlaps a middle Clemson Island feature, and late Clemson Island features are located within and nearby the structure, so it is possible that this structure is also associated with the late Clemson Island component. If these large structures are associated with the late Clemson Island component, following the trend noted by Custer and associates, Structure 1 may also be associated with this component, given its large size. Under this interpretation, the four small structures located on the eastern end of the project area would be associated with the earlier Clemson Island component. The presence of several early Clemson Island features near Structure 6 may support this

interpretation. The linear pattern of these structures cannot be interpreted, given the lack of larger numbers of temporally assigned features in this area. The arrangement may be spurious, although Graybill (this volume) believes that they represent winter hunting camps. Finally, it is likely that structures associated with the middle Clemson Island component occurred in the vicinity of the feature cluster in the center of the site.

In summary, then, data from the four Late Woodland components suggest that the site functioned as individual farmsteads and/or hamlets throughout the Late Woodland period. The apparent lack of long-term intensive occupations of the site is supported by the virtual lack of overlapping pit features or structure patterns at the site, although it is possible that the overstripping removed evidence of the latter on some portions of the site. There is no evidence of economic or social differentiation in the form of distinct artifact and feature patterning during the Late Woodland period at the Memorial Park site. The probable function of the site throughout this period as isolated farmsteads and/or hamlets, indicates that economic and social stratification are unlikely to have been present at the site. Spitzer interprets non-local raw material distribution in the Stewart assemblage as representative of differential access to non-local raw materials. However, a more likely explanation is that there was simply differential access to the raw materials, through time, as a result of changed interregional exchange networks.

The probable status of the Late Woodland components at the Memorial Park site as individual farmsteads and/or hamlets has several implications for local Late Woodland subsistence-settlement systems. The large flood plain at the confluence of Bald Eagle Creek and the West Branch would have provided large areas of fertile soils for agricultural fields. The occupations at Memorial Park suggest that the area was used as a locus for isolated farmsteads and/or hamlets occupied primarily during the growing season. It is possible that during the earliest occupations at Memorial Park, the local subsistence-settlement system consisted primarily of isolated farmsteads/hamlets dispersed across the West Branch flood plain so as to take advantage of fertile patches of soil for agricultural production and constituting dispersed communities, as defined by Fuller (1981). A number of Clemson Island sites have been subjected to some level of excavation in the nearby region that can be assigned to Custer, Watson, and Bailey's (1994) Fortified Hamlet/Agglunated Village type. These include Bald Eagle (Hay and Hamilton 1984) located in Bald Eagle Creek valley in the town of Mill Valley, Ramm (Smith 1976) located on Great Island, and West Water Street (Custer, Watson, and Bailey 1994) located in the West Branch Valley in Lock Haven upstream from Memorial Park. The chronology of these sites is somewhat uncertain, but it is probable that at least some post date the Memorial Park site. The interpretation of the Bald Eagle site as a village, at a relatively early date (Hay and Hamilton 1984), may reflect initial nucleation. The relatively small size of these sites, however, as compared to later Late Woodland villages, suggests that population densities remained relatively low, and that there was no need for population aggregation into large villages for defense, or for the coordination of communal labor. The apparent continuation of isolated farmsteads/hamlets during the later Late Woodland period as evidenced at the Memorial Park site, is supported by the presence of a recently reported isolated Stewart phase farmstead at Canfield Island (Bressler 1993). It is probable that Late Woodland subsistence-settlement systems in the West Branch valley varied spatially at any given time, with a number of site types and sizes represented, depending upon local environmental and social risks. The apparent presence of isolated farmsteads and/or hamlets at Memorial Park during a 600-year period of time, adds information to our knowledge of regional subsistence-settlements that will allow the development of more comprehensive models of Late Woodland systems. It is likely that these systems were much more complex than traditional interpretations suggest, and that continued research in the West Branch Valley will lead towards revision of extant models.

## CONCLUSION

As documented throughout this report, and as summarized in this chapter, archaeological investigations at the Memorial Park site have added substantially to a growing database of prehistoric settlement in the West Branch valley. Data from the 13 documented components have provided new information on prehistoric settlement in the valley from the Middle Archaic period through the Late Woodland period. While the overstripping during Task I investigations affected the recovery of Late Woodland data, the investigations yielded large data sets on occupations at the site spanning some 6500 years. These data have allowed a number of important interpretations of prehistoric settlement in the West Branch valley, and will aid in the refinement of our knowledge of prehistoric settlement in the Valley as additional sites are investigated.





## XVII. REFERENCES CITED

- Adams, J.  
1971 Intensity Characteristics of the Nactuid Acoustic Receptor. *Journal of General Physiology* 58:562-579.
- Adovasio, J.M., J. Donahue, and R. Stuckenrath  
1990 The Meadowcroft Rockshelter Radiocarbon Chronology 1975-1990. *American Antiquity* 55:348-353.
- Adovasio, J.M., J. Gunn, J. Donahue, and R. Stuckenrath  
1977 Meadowcroft Rockshelter: Retrospect 1976. *Pennsylvania Archaeologist* 47(2-3).  
1978 Meadowcroft Rockshelter, 1977: An Overview. *American Antiquity* 43:632-651.
- Adovasio, J.M., and W.C. Johnson  
1981 The Appearance of Cultigens in the Upper Ohio Valley: A View from Meadowcroft Rockshelter. *Pennsylvania Archaeologist* 51 (1-2): 63-80.
- Adovasio, J.M., A. Quinn, J.G. Donahue, W.C. Johnson, D.C. Dirkmaat, and R.C. Carlisle  
1988 Phase III Data Recovery at the Shermans Creek Site. Paper presented at the annual meeting of the Society for Pennsylvania Archaeology.
- Afifi, A.A., and S.P. Azen  
1972 *Statistical Analysis: A Computer Oriented Approach*. Academic Press, New York.
- Ahler, S.A.  
1971 Projectile Point Form and Function at Rogers Shelter, Missouri. Missouri Archaeological Society Research Series No. 8.  
1979 Functional Analysis of Nonobsidian Chipped Stone Artifacts: Terms, Variables, and Quantification. In *Lithic Use-Wear Analysis*, edited by Brian Hayden, pp.301-328. Academic Press, New York.  
1982 Review of Experimental Determination of Stone Tool Uses, by L.H. Keeley, *American Antiquity* 47(3):688-690.  
1986 *The Knife River Flint Quarries: Excavations at Site 32DU508*. State Historical Society of North Dakota, Bismark.  
1989a Mass Analysis of Flaking Debris: Studying the Forest Rather Than the Trees. In *Alternative Approaches to Lithic Analysis*, edited by D. O. Henry and G. H. Odell, pp. 85-118. Archaeological Papers of the American Anthropological Association, Number 1. Washington, D.C.  
1989b Experimental Knapping with KRF and Midcontinental Cherts: Overview and Applications. In *Experiments in Lithic Technology*, edited by D. S. Amick and R. P. Mauldin, pp. 199-234. BAR International Series 528.

- Ahler, S.A., and R.C. Christenson  
1983 *A Pilot Study of Knife River Flint Procurement and Reduction at Site 32DU508, A Quarry and Workshop Location in Dun County, North Dakota*. Report prepared for the State Historical Society of North Dakota, Bismark by Department of Anthropology and Archaeology, University of North Dakota, Bismark.
- American Commission on Stratigraphic Nomenclature  
1961 Code of Stratigraphic Nomenclature. *American Association of Petroleum Geologists Bulletin* 45 (5):645-665.
- American Geological Institute  
1976 *Dictionary of Geological Terms*. Anchor Books/Doubleday, Garden City, New York.
- Amick, D.S.  
1985 Late Archaic Fort Payne Biface Manufacture at the Topsy Site (40WY204), Buffalo River Basin, Tennessee. *Southeastern Archaeology* 4:134-151.
- Asch, D.L., and N.B. Asch  
1985a Prehistoric Plant Cultivation in West-Central Illinois. In *Prehistoric Food Production in North America*, edited by R. I. Ford, Pp. 149-204. Anthropological Papers, Museum of Anthropology, University of Michigan, No. 75. Ann Arbor.  
1985b Archeobotany. In *Smiling Dan: Structure and Function at a Middle Woodland Settlement in the Illinois Valley*, edited by Barbara D. Stafford and Mark B. Sant, pp. 327-401. Center for American Archeology, Research Series 2.
- Asch, D.L., and N.A. Sidell  
1988 Archaeological Plant Remains: Applications to Stratigraphic Analysis. In *Current Paleoethnobotany: Analytical Methods and Cultural Interpretations of Archaeological Plant Remains*, edited by Christine A. Hastorf and Virginia S. Popper, pp. 86-96. Chicago: The University of Chicago Press.  
1992 Archeobotany. In *Early Woodland Occupations at the Ambrose Flick Site in the Sny Bottom of West-Central Illinois*, edited by C. Russell Stafford, pp. 177-293. Center for American Archeology, Research Series 10.
- Asch, N.B., and D.L. Asch  
1975 Plant Remains from the Zimmerman Site -- Grid A: A Quantitative Perspective. In *The Zimmerman Site: Further Excavations at the Grand Village of Kiskaskia* by M. K. Brown, pp. 116-120. Illinois State Museum, Reports of Investigations 32. Springfield.
- Asch, N.B., R.I. Ford, and D.N. Asch  
1972 *Paleoethnobotony of the Koster Site: The Archaic Horizons*. Illinois State Museum, Report of Investigations 24.
- Audubon Society  
1983 *Field Guide to North American Fishes, Whales, and Dolphins*. Alfred A. Knopf, New York.

- Autin, W.J.  
1992 Use of Alloformations for Definition of Holocene Meander Belts in the Middle Amite River, Southeastern Louisiana. *Geological Society of America Bulletin* 104:233-241.
- Baird, J.C.  
1970a A Cognitive Theory of Psychophysics: II. Fechner's Law and Stevens' Law. *Scandinavian Journal of Psychology* 11:89-102.
- Baird, J.C., and E. Noma  
1978 *Fundamentals of Scaling and Psychophysics*. John Wiley & Sons, New York.
- Baird, J.C., and T. Stein  
1970 When Power Functions Fail: A Theoretical Explanation. *Perceptual and Motor Skills* 30:415-525.
- Barnsley, M.  
1989 *Fractals Everywhere*. Academic Press, Orlando.
- Barry, R.G.  
1983 In S.C. Porter and H.E. Wright Jr. (eds.) Late-quaternary Environments of the United States, Vol. 1, The Late Pleistocene. *Late-Pleistocene Climatology*. pp. 390-407. University of Minnesota Press, Minneapolis.
- Beckerman, I.C  
1980 A Paleoenvironmental Reconstruction of District 9. In *The Fisher Farm Site: A Late Woodland Hamlet in Context*, edited by J. W. Hatch, pp. 12-41. Occasional Papers in Anthropology, Number 12, Department of Anthropology, The Pennsylvania State University, University Park.
- Beynon, D.E., J. Donahue, R.T. Schaub, and R.A. Johnson  
1986 Tempering Types and Sources for Early Bronze Age Ceramics from Bab edh-Dhrá and Numeira, Jordan. *Journal of Field Archaeology* 13:297-305.
- Bilzi, A.F. and E.J. Ciolkosz  
1977 Time as a Factor in the Genesis of Four Soils Developed in Recent Alluvium in Pennsylvania. *Soil Science Society of America Journal* 41:122-127.
- Binford, L.R.  
1962 Archaeology as Anthropology. *American Antiquity* 28:217-225.
- 1977 Forty-Seven Trips: A case Study in the Character of Archaeological Formation Processes. In *Stone Tools as Cultural Markers: Change, Evolution, and Complexity*, edited by R. V. S. Wright, pp. 24-36. Australian Institute of Aboriginal Studies, Canberra.
- 1978a Dimensional Analysis of Behavior and Site Structure: Learning from an Eskimo Hunting Stand. *American Antiquity* 43:330-361.
- 1978b *Nunamiut Ethnoarchaeology*. Academic Press, New York.
- 1979 Organization and Formation Processes: Looking at Curated Technologies. *Journal of Anthropological Research* 35:255-273.

- 1980 Willow Smoke and Dogs Tails: Hunter-Gatherer Settlement Systems and Archaeological Site Formation. *American Antiquity* 45:63-143.
- 1981 *Bones: Ancient Men and Modern Myths*. Academic Press, New York.
- Binford, L.R., and S.R. Binford  
1966 A Preliminary Analysis of Functional Variability in the Mousterian of Lavallois Facies. *American Anthropologist* 68:238-295.
- Birkeland, P.W.  
1974 *Pedology, Weathering, and Geomorphological Research*. Oxford University Press, New York.  
1984 *Soils and Geomorphology*. Oxford University Press, New York.
- Blake, L.W., and H.C. Cutler  
1983 Plant Remains from the Gnagey Site (36SO55). *Pennsylvania Archaeologist* 53 (4): 83-88.
- Blake, G.R., and K.H. Hartge  
1986 Bulk Density. In *Methods of Soil Analysis, Part 1 Physical and Mineralogical Methods*, edited by A. Klute, pp. 363-382. Soil Science Society of America, Madison, Wisconsin.
- Blatt, H., Middleton, G., and Murray, R.  
1980 *Origin of Sedimentary Rocks*. Prentice-Hall, Inc., New Jersey.
- Bleed, P.  
1986 The Optimal Design of Hunting Weapons: Maintainability or Reliability. *American Antiquity* 51:737-747.
- Bobrowsky, P.T., and B.F. Ball  
1989 The Theory and Mechanics of Ecological Diversity in Archaeology. In *Quantifying Diversity in Archaeology*, edited by R.D. Leonard and G.T. Jones, pp. 4-12. Cambridge University Press, Cambridge.
- Bonnichsen, R.  
1977 *Models for Deriving Cultural Information from Stone Tools*. National Museum of Man, Mercury Series, Archaeological Survey of Canada, Paper 60. Edmonton, Alberta.  
  
1979 *Pleistocene Bone Technology in the Beringian Refugium*. Archaeological Survey of Canada Paper, Mercury Series (89). National Museum of Canada, Ottawa.
- Bordes, F.  
1969 Reflections on Typology and Technology in the Paleolithic. *Arctic Anthropology* 6(1):1-21.
- Bradley, R.S.  
1985 *Quaternary Paleoclimatology* p.472. Allen and Unwin, Boston.
- Braker, W.L.  
1981 *Soil Survey of Centre County, Pennsylvania*. USDA Soil Conservation Service, Government Printing Office, Washington D.C.

- Braun, D.B.  
1989 Glacial and Periglacial Erosion of the Appalachians. *Geomorphology* 2:233-256.
- Braun, D.P.  
1983a Pots as Tools. In *Archaeological Hammers and Theories*, edited by J. A. Moore and A. S. Keene, pp. 108-134. Academic Press, New York.  
1983b *Pottery Analysis manual*. Unpublished ms. Center for Archaeological Investigations, Southern Illinois University at Carbondale.  
1987 Coevolution of Sedentism, Pottery, and Horticulture in the Central Midwest, 200 B.C. – A.D. 600. In *Emergent Horticultural Economies of the Eastern Woodlands*, edited by W. F. Keegan, pp. 153-182. Center for Archaeological Investigations, University of Southern Illinois at Carbondale, Occasional Paper No. 7.
- Braun, E.L.  
1950 *Deciduous Forests of Eastern North America*. The Blakiston Company, Philadelphia.
- Brewer, R.  
1976 *Fabric and Mineral Analysis of Soils*. R.E. Krieger Publishing Co., New York.
- Bronitsky, G., and R. Hamer  
1986 Elements in Ceramic Technology: The Effects of Various Tempering Materials on Impact and Thermal Shock Resistance. *American Antiquity* 51:89-101.
- Brothwell, D.R.  
1972 *Digging Up Bones*. British Museum, Publication No. 704. London.
- Broyles, B.J.  
1971 *Second Preliminary Report: The St. Albans Site, Kanawha County, West Virginia*. West Virginia Geological and Economic Survey, Report of Archaeological Investigations 3.
- Bryan, A.L.  
1965 *Paleo-American Prehistory*. Idaho State University Museum, Occasional Papers 3.
- Brennan, L.A.  
1962 A Beginning in Chronology for the Croton River Area. *Pennsylvania Archaeologist* 32(3-4).
- Bressler, J.P.  
1980 Excavation of the Bull Run Site (36LY119). *Pennsylvania Archaeologist* 50(4):31-63.  
1989 *Prehistoric Man on Canfield Island (36LY37), Lycoming County, Pennsylvania*. Lycoming County Historical Society, Williamsport, Pennsylvania.
- Breuil, H.  
1938 The Use of Bone Implements in the Old Paleolithic Period. *Antiquity* 12:56-47.

- Brown, J.A.  
1985 Long-term Trends to Sedentism and the Emergence of Complexity in the American Midwest. In *Prehistoric Hunter-gatherers: The Emergence of Cultural Complexity*, edited by T. D. Price, and J. A. Brown, pp. 201-234. Academic Press, Orlando.
- Bucek, M.F.  
1975 *Pleistocene Geology and History of the West Branch of the Susquehanna River Valley near Williamsport, Pennsylvania*. Unpublished Ph.D. dissertation, Geology Department, The Pennsylvania State University, State College, Pennsylvania.
- Burghes, D.N., and M.S. Barrie  
1982 *Modeling with Differential Equations*. Halstead Press, New York.
- Burt, W., and R. Grossenheider  
1976 *Mammals*. Houghton Mifflin Company, Boston.
- Butts, C, and E. Moore  
1936 *Geology and Mineral Resources of the Belefonte Quadrangle, Pennsylvania*. U.S. Department of the Interior, Bulletin 855.
- Byers, D.S.  
1954 Bull Brook--A Fluted Point Site in Ipswich, Massachusetts. *American Antiquity* 19:343-351.
- Cady, J.G., Wilding, L.P., and Drees, L.R.  
1986 Petrographic Microscope Techniques. In *Methods of Soil Analysis Part 1-Physical and Mineralogical Methods*, edited by A. Klute, pp. 185-218. Soil Science Society of America, Madison, Wisconsin.
- Cahen, D., L.H. Keeley, and F.L. Van Noten  
1979 Stone Tools, Toolkits and Human Behavior in Prehistory. *Current Anthropology* 20:661-683.
- Caldwell, J.R.  
1958 *Trend and Tradition in the Prehistory of the Eastern United States*. American Anthropological Association, Memoir 88.
- Calkin, P.E., and K.E. Miller  
1977 Environment and Man in Western New York. *New York Academy of Sciences, Annals* 288:297-315.
- Callahan, E.C.  
1974 A Guide to Flintworking. *Experimental Archaeology Papers* 3:185-192.
- Cambron, J.W., and D.C. Hulse  
1964 *Handbook of Alabama Archaeology: Part 1, Point Types*. Archaeological Research Association of Alabama, Birmingham, Alabama.

- Camilli, E.  
1989 The Occupational History of Sites and the Interpretation of Prehistoric Technological Systems: An Example from Cedar Mesa, Utah. In *Time, Energy, and Stone Tools*, edited by R. Torrence, pp. 17-26. Cambridge University Press, Cambridge.
- Candland, D. K.  
1968 *Psychology: The Experimental Approach*. John Wiley & Sons, New York.
- Cantwell, A.  
1979 The Functional Analysis of Scrapers: Problems, New Techniques, & Cautions. *Lithic Technology* 8(1):5-9.
- Carbone, V., and B. Keel  
1985 Preservation of Plant and Animal Remains. In *The Analysis of Prehistoric Diets*, edited by R. Gilbert and J. Mielke. Academic Press, New York.
- Carpenter, E.S.  
1949 The Brock Site. *Pennsylvania Archaeologist* 19(3-4):69-77.
- Carr, C.  
1984 The Nature and Organization of Intrasite Archaeological Records and Spatial Analytic Approaches to Their Investigation. In *Advances in Archaeological Method and Theory* 7, edited by M.B. Schiffer, pp 193-122. Academic Press, New York.  
  
1985 Alternative Models, Alternative Techniques: Variable Approaches to Intrasite Spatial Analysis. In *For Concordance in Archaeological Analysis*, edited by C. Carr, pp 302-473. Westport Publishing, Kansas City, Missouri.
- Carr, K.W.  
1989 The Shoop Site: Thirty-Five Years After. In *New Approaches to Other Pasts*, edited by W.F. Kinsey, III and R. W. Moeller, pp. 5-28. Archaeological Services, Inc., Bethlehem, Connecticut.
- Cavallo, J.A.  
1981 *Turkey Swamp: A Late Paleo-Indian Site in New Jersey's Coastal Plain*. Federal Highway Administration and New Jersey Department of Transportation, Trenton.
- Chaplin, R.  
1971 *The Study of Animal Bones from Archaeological Sites*. Seminar Press, London.
- Chapman, J.C.  
1976 The Archaic Period in the Lower Little Tennessee River Valley: The Radiocarbon Dates. *Tennessee Anthropologist* 1(1):1-12.
- Chapman, J., and G. D. Crites  
1987 Evidence for Early Maize (*Zea mays*) from the Icehouse Bottom Site, Tennessee. *American Antiquity* 52:352-355.

- Church, F.  
 1987 *An Inquiry into the Transition from Late Woodland to Late Prehistoric Cultures in the Central Scioto Valley, Ohio Circa A.D. 500 to A.D. 1250*. Unpublished Ph.D. dissertation, Department of Anthropology, The Ohio State University.
- 1991 *The Hunter 1 Site: Mitigation of a Multi-component Late Woodland Site in Blue Rock Township, Muskingum County, Ohio*. Archaeological Services Consultants, Inc. Submitted to Texas Eastern Gas Pipeline Company, Houston.
- Ciolkosz, E.J., Cronce, R.C., and W.D. Sevon  
 1986 *Periglacial Features in Pennsylvania*. Pennsylvania State University, Agronomy Series, 88.
- Ciolkosz, E.J., Waltman, W.J., and N. C. Thurman  
 1992 *Fragipans in Pennsylvania Soils*. Penn State Agronomy Series Number 119, December 1992. The Pennsylvania State University, College of Agriculture.
- Clafin, W.H., Jr.  
 1931 *The Stallings Island Mound, Columbia, Georgia*. Peabody Museum of American Archaeology and Ethnology, Papers 14(1).
- Clark, G.M., and E.J. Ciolkosz  
 1988 Periglacial Geomorphology of the Appalachian Highlands and Interior Highlands South of the Glacial Border-A Review. *Geomorphology* 1:191-220.
- Clarke, D.L.  
 1977 *Spatial Archaeology*. Academic Press, New York.
- Cleland, C.E.  
 1966 *The Prehistoric Animal Ecology and Ethnozoology of the Upper Great Lakes Region*. University of Michigan, Museum of Anthropology, Anthropological Papers 29.
- 1976 The Focal-Diffuse Model: An Evolutionary Perspective on the Prehistoric Cultural Adaptations of the Eastern United States. *Midcontinental Journal of Archaeology* 1:59-75.
- Coe, J.L.  
 1964 The Formative Cultures of the Carolina Piedmont. *American Philosophical Society, Transactions* 54(5).
- Conard, N., D.L. Asch, N.B. Asch, D. Elmore, H. Grove, M Ruben, J.A. Brown, M.D. Wiant, K.B. Farnsworth, and T.G. Cook  
 1984 Accelerator Radiocarbon Dating of Evidence for Prehistoric Horticulture in Illinois. *Nature* 308:443-446.
- Converse, R.N.  
 1963 Ohio Flint Types. *Ohio Archaeologist* 13(4).
- Cook, T.G.  
 1976 Broadpoint: Culture, Phase, Tradition, or Knife? *Journal of Anthropological Research* 32:337-357.



- Cope, F.W.  
1976 Derivation of the Weber-Fechner law and the Lowenstein Equation as the Steady-State Response of an Elovich Solid State Biological System. *Bulletin of Mathematical Biology* 38:111-118.
- Corbalis, M.C., and I.L. Beale  
1976 *The Psychology of Left and Right*. Erlbaum, Hillsdale, New Jersey.
- Cornwal, I.W.  
1956 *Bones for the Archaeologist*. Phoenix House, London.
- Cowan, C.W., Dunavan, S., Nass, J.P., Jr., and Scott, S.  
1990 The Schomaker Site, A Middle Period Fort Ancient Town on the Great Miami River, Hamilton County, Ohio. *West Virginia Archaeologist* 42(1):11-35.
- Crabtree, D.E.  
1966 A Stoneworker's Approach to Analyzing and Replicating the Lindenmeier Folsom. *Tebiwa* 9:3-39.  
  
1973 The Obtuse Angle as a Functional Edge. *Tebiwa* 16(1):46-53.
- Crane, H.R.  
1956 University of Michigan Radiocarbon Dates I. *Science* 124 (3224):644-672.
- Creameens, D.L.  
1993 Geomorphology and Site Formation. In Draft Report *Archaeological Investigations at the Memorial Park Site (36;CN164) Clinton County, Pennsylvania*, edited by J.P. Hart, pp. 87-128. Report prepared for U.S. Army Corps of Engineers, Baltimore, Maryland by GAI Consultants, Inc., Monroeville, Pennsylvania.
- Crites, G.D.  
1987 Human-Plant Mutualism and Niche Expression in the Paleoethnobotanical Record: A Middle Woodland Example. *American Antiquity* 51:826-836.
- Crowl, G.H., and W.D. Sevon  
1980 *Glacial Border Deposits of Late Wisconsinan Age in Northeastern Pennsylvania*. General Geology Report 71, Pennsylvania Geological survey, Harrisburg, Pennsylvania.
- Cushman, K.A.  
1982 Floral Remains from Meadowcroft Rockshelter, Washington County, Southwestern Pennsylvania. In *Meadowcroft: Collected papers on the Archaeology of Meadowcroft Rockshelter and the Cross Creek Drainage*, edited by R.C. Carlisle and J.M. Adovasio, pp. 207-220. University of Pittsburgh, Pittsburgh.
- Custer, J.F.  
1982 Patterns of Resource Distribution and Archaeological Settlement Patterns in the Piedmont of the Middle Atlantic Region. *North American Archaeologist* 3(2): 139-172.  
  
1984 *Prehistoric Delaware Archaeology: An Ecological Approach*. University of Delaware Press, Newark.

- 1986 Late Woodland Cultures of the Lower and Middle Susquehanna Valley. In *Late Woodland Cultures of the Middle Atlantic Region*, edited by J. F. Custer, pp. 116-142. University of Delaware Press, Newark.
- 1987 Problems and Prospects in Northeastern Prehistoric Ceramic Studies. *North American Archaeologist* 8:97-123.
- 1988 Late Archaic Cultural Dynamics in the Central Middle Atlantic Region. *Journal of Middle Atlantic Archaeology* 4:39-59.
- 1989 *Prehistoric Cultures of the Delmarva Peninsula: An Archaeological Study*. University of Delaware Press, Newark.
- Custer, J.F., W.P. Catts, J. Hodny, and C. DeSantis Leithren  
 1993 Data Recovery Excavations at the Slackwater Site (36LA207), Manor Township, Lancaster County, Pennsylvania. Ms. on file, Pennsylvania Historical and Museum Commission, Harrisburg.
- Custer, J.F., and G. Galasso  
 1980 Lithic Resources of the Delmarva Peninsula. *Maryland Archeology* 16(2): 1-13.
- Custer, J.F., and E.B. Wallace  
 1982 Patterns of Resource Distribution and Archaeological Settlement Patterns in the Piedmont Uplands of the Middle Atlantic Region. *North American Archaeologist* 3:139-172.
- Custer, J.F., S.C. Watson, and D.N. Bailey  
 1994 *Data Recovery of the West Water Street Site 36CN175 Lock Haven, Clinton County, Pennsylvania*. Report prepared by KFS Historic Preservation Group, Philadelphia, Pennsylvania for U.S. Army Corps of Engineers, Baltimore District.
- Cutler, H.C., and L.W. Blake  
 1981 Corn Cobs from Meadowcroft Rockshelter. In *The Appearance of Cultigens in the Upper Ohio Valley: A View from Meadowcroft Rockshelter*, by J. Adovasio and W. Johnson. *Pennsylvania Archaeologist* 51(1-2):63-80.
- Dacey, M.F.  
 1973 Statistical Test of Spatial Association in the Locations of Tool Types. *American Antiquity* 38:320-328.
- Dancey, W.S.  
 1976 Riverine Period Settlement and Land Use Pattern in the Priest Rapids Area, Central Washington. *Northwest Archaeological Research Notes* 10(2):147-160.
- Dart, R.  
 1956 Further Light on Australopithecene Humeral and Femoral Weapons. *American Journal of Physical Anthropology* 17:87-94.
- Davidson, D.S.  
 1929 The Lock Haven Expedition. *Museum Journal* 20(3-4): 307-317.

- Davis, M.B.  
1983 Holocene vegetational history of the eastern United States. In *Late-Quaternary Environments of the United States, Vol. 2: The Holocene*, edited by S. C. Porter and H. E. Wright Jr., pp.166-181. University of Minnesota Press, Minneapolis, Minnesota.
- Day, G.M.  
1953 The Indian as an Ecological Factor in the Northeastern Forest. *Ecology* 34(2):329-346.
- DeBoer, W.R.  
1988 Subterranean Storage and the Organization of Surplus: The View From Eastern North America. *Southeastern Archaeology* 7 (1): 1-20.
- Decker, D., and H.D. Wilson  
1987 Allozyme Variation in the *Cucurbita pepo* complex: *C. pepo* var. *ovifera* vs. *C. texana*. *Systematic Botany* 12:263-273.
- Denny, C.S.  
1951 Pleistocene Frost Action Near the Border of the Wisconsin Drift in Pennsylvania. *Ohio Journal of Science* 51:116-125.  
  
1956 *Surficial Geology and Geomorphology of Potter County, Pennsylvania*. U.S. Geological Survey Professional Paper 288. Government Printing Office, Washington D.C.
- Denny, C.S., and W.H. Lyford  
1963 *Surficial Geology and Soils of the Elmira-Williamsport Region, New York and Pennsylvania*. U.S. Geological Survey Professional Paper 379. Government Printing Office, Washington D.C.
- Dibble, H.L., and J.C. Whittaker  
1981 New Experimental Evidence on the Relationship Between Flaking and Flake Variation. *Journal of Archaeological Science* 8:283-296.
- Didier, M.E.  
The Argillite Problem Revisited: An Archaeological and Geological Approach to A Classical Archaeological Problem. *Archaeology of Eastern North America* 3:90-101.
- Dincauze, D.F.  
1968 *Cremation Cemeteries in Eastern Massachusetts*. Harvard University, Peabody Museum of Archaeology and Ethnology, Papers 59(1).  
  
1971 An Archaic Sequence for Southern New England. *American Antiquity* 36(2):194-198.  
  
1976 *The Neville Site, 8,000 Years at Amoskeag, Manchester New Hampshire*. Harvard University, Peabody Museum, Monographs 4.
- Doershuk, J.  
1989 *Hunter-Gatherer Site Structure and Sedentism: The Koster Site Middle Archaic*. Ph.D. dissertation, Northwestern University, University Microfilms, An Arbor.

- Dragoo, D.W.  
 1959 *Archaic Hunters of the Upper Ohio Valley*. Carnegie Museum, Annals 35.
- 1963 *Mounds for the Dead: An Analysis of the Adena Culture*. Carnegie Museum, Annals 37.
- 1976 Some Aspects of Eastern North American Prehistory: A Review 1975. *American Antiquity* 41:3-27.
- Dunnell, R.C.  
 1971 *Systematics in Prehistory*. Free Press, New York.
- 1972 *The Prehistory of Fishtrap, Kentucky*. Yale University, Publications in Anthropology 75.
- 1978 Archaeological Potential of Anthropological and Scientific Models of Function. In *Archaeological Essays in Honor of Irving B. Rous*,; edited by R.C. Dunnell and E.S. Hall, pp. 41-73. Mouton, The Hague.
- 1983 *Aspects of the Spatial Structure of the Mayo Site (15JO14), Johnson County, Kentucky*. University of Michigan, Museum of Anthropology, Anthropological Papers 72:109-165.
- Dunnell, R.C., et al.  
 1971 The Woodside Component of the Slone Site, Pike County, Kentucky. *Southeastern Archaeological Conference, Bulletin* 14.
- Earle, T.K.  
 1980 A Model of Subsistence Change. In *Modeling Change in Subsistence Economies*, edited by T. K. Earle and A. L. Christenson, pp. 1-29. Academic Press, New York.
- East, T.C., J.M. Adovasio, W.C. Johnson, and T. Jorstad  
 1987 *Archaeological Investigations at 36BK549, Berks County, Pennsylvania*. Report prepared for Texas Eastern Gas Pipeline Company, Houston Texas by the Cultural Resource Management Program, Department of Anthropology, University of Pittsburgh.
- East, T.C., J.M. Adovasio, W.C. Johnson, and D.R. Pedler.  
 1988 *The Prehistory of the Catawissa Bridge Replacement Site (36CO9), Columbia County, Pennsylvania*. Interim report prepared for Parsons Brinckerhoff-Quade & Douglas, Inc. and the Pennsylvania Department of Transportation by the Cultural Resource Management Program, Department of Anthropology, University of Pittsburgh..
- Eisler, H.  
 1963 A General Differential Equation in Psychology: Derivation and Empirical Test. *Scandinavian Journal of Psychology* 4:265-277.
- Ekman, G.  
 1959 Weber's Law and Related Functions. *The Journal of Psychology* 47:343-352.
- 1964 Is the Power Law a Special Case of Fechner's Law? *Perceptual and Motor Skills* 19:720.

- Ee, F.H., (editor).  
1980 *Forest Cover Types of the United States and Canada*. Society of American Foresters.
- Falmagne, J.C.  
1971 The Generalized Fechner Problem and Discrimination. *Journal of Mathematical Psychology* 8:22-43.  
  
1974 Foundations of Fechnerian Psychophysics. In *Contemporary Developments in Mathematical Psychology*, Vol. 2, edited by D.H. Krantz, R.C. Atkinson, R.D. Luce, and P. Suppes, pp. 127-159. W.H. Freeman, San Francisco.
- Feder, J.  
1988 *Fractals*. Plenum Press, New York.
- Fitting, J.E.  
1966 *The Paleo-Indian Occupation of the Holcombe Beach*. University of Michigan, Museum of Anthropology, Anthropological Papers 27.  
  
1968 Environmental Potential and Postglacial Readaptation in Eastern North America. *American Antiquity* 33(4):441-445.  
  
1969 Settlement Analysis in the Great Lakes Region. *Southwestern Journal of Anthropology* 25(4):360-377.
- Fitzhugh, W.  
1972 The Eastern Archaic: Commentary and Northern Perspective. *Pennsylvania Archaeologist* 42(4):1-19.
- Fogelman, G.L.  
1988 *Projectile Point Typology for Pennsylvania and the Northeast*. Fogelman Publishing Company, Turbotville, Pennsylvania.
- Follmer, L.R.  
1982 The Geomorphology of the Sangamon Surface: Its Spatial and Temporal Attributes. In *Space and Time in Geomorphology*, pp. 117-146, edited by C.E. Thorn. The Binghampton Symposia in Geomorphology: International Series, no. 12. George Allen and Unwin, London.
- Ford, R.I. (editor)  
1985a *Prehistoric Food Production in North America*. Anthropological Papers, Museum of Anthropology, University of Michigan, No. 75. Ann Arbor, Michigan.
- Ford, R.I.  
1985b Patterns of Prehistoric Food Production. In *Prehistoric Food Production in North America*, edited by R. I. Ford, pp. 341-364. Anthropological Papers, Museum of Anthropology, University of Michigan, No. 75. Ann Arbor, Michigan.
- Foss, J.E., and M.E. Collins  
1987 Future uses of soil genesis and morphology in allied sciences. In *Future Developments in Soil Science Research*, edited by L.L. Boersma, pp.293-300, Soil Science Society of America, Madison, Wisconsin.

- Frison, G.C.  
1968 A Functional Analysis of Certain Chipped Stone Tools. *American Antiquity* 33(2):149-155.
- Fritz, G.J.  
1990 Multiple Pathways to Farming in Precontact Eastern North America. *Journal of World Prehistory* 4(4):387-435.
- Fuller, J.W.  
1981 *Developmental Change in Prehistoric Community Patterns: The Development of Nucleated Village Communities in Northern West Virginia*. Ph.D. dissertation, University of Washington, University Microfilms, Ann Arbor, Michigan.
- Funk, R.E.  
1965 The Archaic of the Hudson Valley--New Evidence and New Interpretations. *Pennsylvania Archaeologist* 35(3-4):139-160.  
  
1968 A New Middle Woodland Complex in Eastern New York. *New York State Archaeological Association, Bulletin* 44(1-7).  
  
1972 Early Man in the Northeast and the Late Glacial Environment. *Man in the Northeast* 4:7-39.  
  
1977 Early and Middle Archaic Occupations in Upstate New York. *New York State Archaeological Association, Researches and Transactions* 17(1):21-29.  
  
1979 The Early and Middle Archaic in New York as Seen from the Upper Susquehanna Valley. *New York State Archaeological Association, Bulletin* 75:23-38.  
  
1988 The Laurentian Concept: A Review. *Archaeology of Eastern North America* 16:1-42.
- Funk, R.E., and P. Lord, Jr.  
1972 Two Stratified Alluvial Sites in the Upper Hudson Valley. *Pennsylvania Archaeologist* 42(1-2):27-61.
- Funk, R.E., and B.E. RippetEAU  
1977 *Adaptation, Continuity, and Change in Upper Susquehanna Prehistory*. Occasional Publications in Northeastern Anthropology 3.
- Funk, R.E., and B. Wellman  
1984 Evidence of Early Holocene Occupations in the Upper Susquehanna Valley, New York State. *Archaeology of Eastern North America* 12:81-109.
- Gallin, D.  
1974 Implications for Psychology of Left and Right Cerebral Specialization. *Archives of General Psychology* 31:572-583.
- Gardner, W.M.  
1974 The Flint Run Complex: Pattern and Process During the Paleo-Indian to Early Archaic. *The Catholic University of America, Department of Anthropology, Occasional Publication* 1:1-47.

- 1981 Paleoindian Settlement Pattern and Site Distribution in the Middle Atlantic. In *Anthropological Careers: Essays Presented to the Anthropological Society of Washington During Its Centennial Year 1979*, edited by R. Landman, pp. 51-73. Anthropological Society of Washington, Washington, D.C.
- Gardner, W.M., and C.W. McNett, Jr.  
 1971 Early Pottery in the Potomac. In *Proceedings of the Middle Atlantic Archaeology Conference*, edited by C.W. McNett, Jr., and W.M. Gardner, pp. 42-52. The Catholic University of America, Washington, D.C.
- Gardner, W.M., and R.A. Verrey  
 1979 Typology and Chronology of Fluted Points from the Flint Run Area. *Pennsylvania Archaeologist* 49(1-2): 13-46.
- Garraghan, F.D.  
 1990 Airport II Site: A Clemson Island/Owasco Settlement on the North Branch of the Susquehanna River. *Pennsylvania Archaeologist* 60(1):1-31.
- Gasche, H., and O. Tunca  
 1983 Guide to Archaeostratigraphic Classification and Terminology: Definitions and Principles. *Journal of Field Archaeology* 10:325-335.
- Gazzinga, M.S.  
 1970 *The Bisected Brain*. Appleton, New York.
- Gee, G.W., and J.W. Bauder  
 1986 Particle-size Analysis. In *Methods of Soil Analysis Part 1-Physical and Mineralogical Methods*, edited by A. Klute, pp. 383-412, Soil Science Society of America, Madison, Wisconsin.
- George, R.L.  
 1983 The Gnagey Site and the Monongahela Occupation of the Somerset Plateau. *Pennsylvania Archaeologist* 53(4).  
 1984 Spruce Run, a Spring-Head Camp Site in Somerset County, Pennsylvania. *Pennsylvania Archaeologist* 54(1-2): 12-25
- George, R.L., and C.E. Davis  
 1986 A Dated Brewerton Component in Armstrong County, Pennsylvania. *Pennsylvania Archaeologist* 56(1-2):12-20.
- Gendel, P.A. and L. Pirnoy  
 1982 Microwear Analysis of Experimental Stone Tools: Further Test Results. *Studia Praehistorica Belgica* 2:251-265.
- Gilbert, B.M.  
 1973 *Mammalian Osteo-Archaeology*. The Missouri Archaeological Society, Columbia.
- Gladfelter, B.G.  
 1983 On the Interpretation of Archaeological Sites in Alluvial Settings. In *Archaeological Sediments in Context*, edited by J. K. Stein and W. R. Farrand, pp. 41-52. Center for the Study of Early man, Institute of Quaternary Studies, University of Maine at Orono.

- Gleick, J.  
1987 *Chaos Making a New Science*. Penguin Books, New York.
- Gould, R.A.  
1973 Use Wear on Western Desert Aborigine Stone Tools: A Reply to Messrs. Hayden and Kamminga. *Newsletter of Lithic Technology* 2(1):9-13.
- Gould, R.A., D.A. Koster, and A.H.L. Sontz  
1971 The Lithic Assemblage of the Western Desert Aborigines of Australia. *American Antiquity* 36(2): 149-169.
- Graham, C.H., and P. Ratoosh  
1962 Notes of Some Interrelations of Sensory Psychology, Perception, and Behavior. In *Psychology: A Study of a Science*, vol. IV, edited by S. Koch. McGraw Hill, New York.
- Gramly, R.M.  
1982 *The Vail Site: A Paleo-Indian Encampment in Maine*. Buffalo Museum of Science, Buffalo.  
  
1988 Conflict and Defense in the Eastern Woodlands. In *Interpretations of Culture Change in the Eastern Woodlands during the Late Woodland Period*, edited by R. W. Yerkes, pp. 85-96. The Ohio State University, Department of Anthropology, Occasional Papers in Anthropology 3.
- Grassberger, P.  
1983 Generalized Dimensions of Strange Attractors. *Phys. Lett.* 97A, 227-230.
- Grassberger, P., and I. Procaccia  
1981 On the Hausdorff Dimension of Fractal Attractors. *Journal of Statistical Physics* 26: 173-179.
- Graybill, J.R.  
1973 Michaels No. 4 Site. In *Archaeological Excavations: Upper Delaware Valley 1972*, edited by W.F Kinsey, pp. 39-52. Franklin and Marshall College, North Museum Publication 1.  
  
1981 *The Eastern Periphery of Fort Ancient (A.D. 1050- 1650): A Diachronic Approach to Settlement Variability*. Ph.D. dissertation, University of Washington, University Microfilms, Ann Arbor, Michigan.  
  
1982 Review of "The Fisher Farm Site: A Late Woodland Hamlet in Context" by J.W. Hatch (ed.). *Pennsylvania Archaeologist* 52(3-4):70-71.  
  
1984a The Eastern Periphery of Fort Ancient. *Pennsylvania Archaeologist* 54(1-2):40-50.  
  
1984b *Phase II Archaeological Investigations, U.S. Rt. 15 Relocation, Lycoming County, Pennsylvania*. Report prepared by GAI Consultants, Inc., for Pennsylvania Department of Transportation.  
  
1984c *Phase III Archaeological Investigations, L.R. 1, Spur A Bridge Replacement, Dauphin County, Pennsylvania*. Report prepared by GAI Consultants, Inc., for Pennsylvania Department of Transportation.



- 1986 Fort Ancient-East: Origins, Change, and External Correlations. Paper presented at the annual meeting of the Midwest Archaeological Conference, Columbus, Ohio.
- 1989 The Shenks Ferry Complex Revisited. In *New Approaches to Other Pasts*, edited by W. F. Kinsey and R. W. Moeller, pp. 51-59. Archaeological Services, Inc., Bethlehem, Connecticut.
- 1989 The Shenks Ferry Tradition. Paper presented at annual meeting of Society for Pennsylvania Archaeology, Edinsboro, Pennsylvania.
- 1992a The Shenks Ferry Tradition: Late Woodland Settlement Change in Southeast Pennsylvania. Paper presented at annual meeting of Society for American Archaeology, Pittsburgh, Pennsylvania.
- 1992b The Shenks Ferry Tradition at the Dawn of History. Paper presented at the annual meeting of the Society for Pennsylvania Archaeology, University Park, Pennsylvania.
- Grayson, D.  
1984 *Quantitative Zooarchaeology*. Academic Press, New York.
- Griffin, J.B.  
1967 Eastern North American Archaeology: A Summary. *Science* 156:175-191.
- Gruber, J.W.  
1971 Patterning in Death in a Late Prehistoric Village in Pennsylvania. *American Antiquity* 36:64-76.
- Handsman, R.G.  
1973 Pre-Late Woodland Occupations: Faucett 1972. In *Archaeological Excavations: Upper Delaware Valley 1972*, edited by W. F. Kinsey, pp. 18-38. *Franklin and Marshall College, North Museum Publication* 1.
- Hannegan, S.B. and J.S. May (editors)  
1989 *Clinton County: A Journey Through Time*. Renovo, Pennsylvania: Dremel Printing and Bindery Services, Inc.
- Harris, G.H.  
1903 *The Life of Horatio Jones*. Buffalo Historical Society, Publication 6.
- Hart, J.P.  
1990 Modeling Oneota Agricultural Intensification: A Cross-cultural Evaluation. *Current Anthropology* 31:569-577.
- 1993 Monongahela Subsistence-settlement Change: The Late Prehistoric Period in the Lower Upper Ohio River Valley. *Journal of World Prehistory* 7(1).
- 1995 Storage and Monongahela Subsistence-Settlement Change. *Archaeology of Eastern North America* 25. In press.

Hart, J.P. (editor)

1990 *Phase II Data Recovery at the Monongahela City Bridge Site (36WH737) L.R. 181, Section 14M, Washington County, Pennsylvania*. Report prepared for Pennsylvania Department of Transportation, Greentree, Pennsylvania by GAI Consultants, Inc., Monroeville, Pennsylvania.

1992 *Phase III Archaeological Data Recovery Investigations at the Parsons Ford Bridge Site (46HY85), Hardy County, West Virginia*. Report prepared for the West Virginia Department of Highways Roadway Design Division, Charleston, West Virginia by GAI Consultants, Inc., Monroeville, Pennsylvania.

1993b Draft Report. *Archaeological Investigations at the Memorial Park Site (36Cn164) Clinton County, Pennsylvania*. Report prepared for U.S. Army Corps of Engineers, Baltimore, Maryland by GAI Consultants, Inc., Monroeville, Pennsylvania.

Hart, J.P., and D.L. Cremeens

1991 *Phase III Data Recovery Investigations at the Piersol II Site (36CH339), Chester County, Pennsylvania*. Report prepared for Texas Eastern Gas Pipeline Company, Houston, Texas by GAI Consultants, Inc., Monroeville, Pennsylvania.

Hart, J.P., and J.P. Nass

1994 *Fracturing the Monongahela Adaptive Type*. Paper presented at the Cultues Before Contact: The Late Prehistory of Ohio, the Third Annual Ohio Archaeological Council Conference. Cincinnati, Ohio. November.

Hassan, F.A.

1979 *Geoarchaeology: The Geologist and Archaeology*. *American Antiquity* 44:267-270.

Hatch, J.W.

1980a *An Analysis of the Ceramics from Stratified Deposits at Fisher Farm*. In *The Fisher Farm Site: A Late Woodland Hamlet in Context*, edited by J. W. Hatch, pp. 266-305. The Pennsylvania State University, Department of Anthropology, Occasional Papers 12.

1980b *Radiocarbon Dates from the Fisher Farm Site*. In *The Fisher Farm Site: A Late Woodland Hamlet in Context*, edited by J. W. Hatch, pp. 267-273. The Pennsylvania State University, Department of Anthropology, Occasional Papers 12.

1983 *A Stratigraphic Analysis of Late Woodland Material Culture Change at Fisher Farm*. *Pennsylvania Archaeologist* 53(1-2):11-27.

Hatch, J.W. (editor)

1980 *The Fisher Farm Site: A Late Woodland Hamlet in Context*. *The Pennsylvania State University, Department of Anthropology, Occasional Papers 12*.

Hatch, J.W., and J. Daugirda

1980 *The Semi-Subterranean Keyhole Structure at Fisher Farm--Feature 28*. In *The Fisher Farm Site: A Late Woodland Hamlet in Context*, edited by J. W. Hatch, pp. 171-190. The Pennsylvania State University, Department of Anthropology, Occasional Papers 12.

- Hatch, J.W., and C.M. Stevenson  
 1980 A Functional Analysis of the Fisher Farm Features. In *The Fisher Farm Site: A Late Woodland Hamlet in Context*, edited by J. W. Hatch, pp. 140-170. The Pennsylvania State University, Department of Anthropology, Occasional Papers 12.
- Hatch, J.W., C. Hamilton, and C. Stevenson  
 1985 The Ridge and Valley Province. In *Comprehensive State Plan for the Conservation of Archaeological Resources*, edited by P. Raber, pp. 83-163. Pennsylvania Historical and Museum Commission, Harrisburg.
- Hawkes, E.W., and R. Linton  
 1916 *A Pre-Lenape Site in New Jersey*. University of Pennsylvania, University Museum, Anthropological Papers 6(3).
- Hay, C.A.  
 1991 *Archaeological Excavations at the Clarks Ferry Bridge Site (36DA126), Dauphin County, Pennsylvania*. Report prepared by Archaeological and Historical Consultants, Inc., for Pennsylvania Department of Transportation.
- Hay, C.A., and M.A. Graetzer  
 1985 *Archaeological Investigations at the Jacks Mill Site (36CE230), Final Mitigation*. Report prepared by Department of Anthropology, Pennsylvania State University, for Boalsburg Limited Partnership, Mifflintown, Pennsylvania.
- Hay, C.A., and C. Hamilton  
 1984 *The Bald Eagle Township Sewage Collection System: Final Mitigation Research*. Report prepared by Department of Anthropology, Pennsylvania State University, for Bald Eagle Township, Clinton County, Pennsylvania.
- 1986 *Archaeological Data Recovery at 36YO240 A Prehistoric Quartz Procurement and Processing Station in Southcentral Pennsylvania*. Report prepared for C.S. Davidson. Inc., and the Eastern York County Sewer Authority by Department of Anthropology, The Pennsylvania State University, State College.
- Hay, C.A., and C.A. Stevenson  
 1982 National Register of Historic Places Nomination Form: 36CN164. Form prepared by Department of Anthropology, Pennsylvania State University, for Bureau of Historic Preservation, Pennsylvania Historical and Museum Commission.
- Hay, C.A., J.W. Hatch, and J. Sutton  
 1987 *A Management Plan for Clemson Island Archaeological Resources in the Commonwealth of Pennsylvania*. Report prepared for Bureau for Historic Preservation, Pennsylvania Historical and Museum Commission.
- Hayden, B.  
 1979 Snap, Shatter, and Superfractures: Use-Wear of Stone Skin Scrapers. In *Lithic Use-Wear Analysis*; edited by Brian Hayden,, pp. 207-229. Academic Press, New York.
- Hayden, B. and J. Kamminga  
 1973 Gould, Koster, and Sontz on "Microwear": A Critical Review. *Newsletter of Lithic Technology* 2(1):3-14.

- Haynes, C.V.  
1967 Carbon-14 Dates and Early Man in the New World. *Proceedings of International Association on Quaternary Research* 6:267-286.
- Heisey, H.  
1971 An Interpretation of Shenks Ferry Ceramics. *Pennsylvania Archaeologist* 41(4):44-70.
- Hemmings, E.T.  
1985 West Virginia Radiocarbon Dates and Prehistory. *West Virginia Archaeologist* 37(2):35-44.
- Henry, D.O., C.V. Haynes, and B. Bradley  
1976 Quantitative Variations in Flaked Stone Debitage. *Plains Anthropologist* 21:57-61.
- Henry, D.O., and G.H. Odell (editors)  
1989 *Alternative Approaches to Lithic Analysis*. Archaeological papers of the American Anthropological Association Number 1. Washington, D.C.
- Henschel, H.G.E., and I. Procaccia  
1986 The Infinite Number of Generalized Dimensions of Fractals and Strange Attractors. *Physica* 8D, 435-444.
- Herbstritt, J.T.  
1988 A Reference for Pennsylvania Radiocarbon Dates. *Pennsylvania Archaeologist* 58(2):1-29.
- Hesse, F.J.  
1968 The Fredenburg Site: A Single Component Site of the Fox Creek Complex. *New York State Archaeological Association, Bulletin* 44:27-32.
- Hester, T.R.  
1970 A Study of Wear Patterns on Hafted and Unhafted Bifaces from Two Nevada Caves. *Contributions, University of California Archaeological Research Facility*, No. 7:44-54.  
  
1973 Arrow Points or Knives? Comments on the Proposed Function of "Stockton Points". *American Antiquity* 38(2):220-221.
- Hietala, H.J. and D. Stevens  
1977 Spatial Analysis: multiple procedures in pattern recognition studies. *American Antiquity* 42: 539-559.
- Hietala, H.J. and R. Larson  
1980 Intrasite and Intersite Spatial Analysis at Bir Tarfawi. In *The Prehistory of the Eastern Sahara: Paleoenvironments and Human Exploitation*, edited by F. Wendorf and R. Schild pp. 379-388.
- Hodder, I.R. and C.R. Horton  
1976 *Spatial Analysis in Archaeology*. Cambridge University Press, Cambridge.

- Hofman, J.L.  
 1981 Refitting of Chipped Stone Artifacts as an Analytical and Interpretive Tool. *Current Anthropology* 22(6):691-693.  
 1986 Vertical Movement of Artifacts in Alluvial and Stratified Deposits. *Current Anthropology* 27 (2):163-171.
- Holliday, V.T.  
 1985 Morphology of Late Holocene Soils at the Lubbock Lake Archaeological Site. *Journal of the Soil Science Society of America* 49:938-946.  
 1990 Pedology in Archaeology. In *Archaeological Geology of North America, Geological Society of America Centennial Special Volume 4*, edited by N.P. Masca and J. Donahue, pp. 525-540. Geology Society of America, Boulder, Colorado.
- Hooton, E.A., and C.C. Willoughby  
 1920 *Indian Village Site and Cemetery near Madisonville, Ohio*. Harvard University, Peabody Museum of American Archaeology and Ethnology, Papers 8(1).
- Illick, J.S.  
 1928 *Pennsylvania Trees*. Pennsylvania Department of Forests and Waters, Bulletin 11. (Reprint of 5th edition of 1925)
- Jeske, R.J.  
 1987 *Efficiency, Economy, and Prehistoric Lithic Assemblages in the American Midwest*. Ph.D. dissertation, Northwestern University, University Microfilms, Ann Arbor, Michigan.  
 1989 Economies in Raw Material Use by Prehistoric Hunter-Gatherers. In *Time, Energy, and Stone Tools*, edited by R. Torrence, pp. 34-45. Cambridge University Press, Cambridge.
- Jeske, R.J., and J.P. Hart  
 1988 *Report on Test Excavations at Four Sites in the Illinois and Michigan Canal national Heritage Corridor La Salle and Grundy Counties, Illinois*. Report prepared for the National park Service, Midwest Archaeological Center, Lincoln, Nebraska by the Northwestern Archaeological Program, Northwestern University, Evanston, Illinois.
- Johnson, D.L., and D. Watson-Stegner  
 1990 The Soil Evolution Model as a Framework for Evaluating Pedoturbation in Archaeological Site Formation. In *Archaeological Geology of North America*, edited by N.P. Lasca and J. Donahue, Centennial Special Volume 4, pp. 541-560 Geological Society of America, Boulder, Colorado.
- Johnson, W.C., W.P. Athens, M.T. Fuess, L.G. Jaramillo, K.R. Bastianini, and E. Ramos  
 1989 *Late Prehistoric Period Monongahela Culture Site and Cultural Resource Inventory*. University of Pittsburgh, Cultural Resource Management Program. Report submitted to the Pennsylvania Historical and Museum Commission, Bureau for Historic Preservation, Harrisburg.

- Jones, R.W.  
1931 Report of Robert W. Jones, Wild Rose, Wisconsin. *Fifth Report of the Pennsylvania Historical Commission*, pp. 97-111.
- Joyce, A.A.  
1988 Early/Middle Holocene Environments in the Middle Atlantic region: A Revised Reconstruction. In *Holocene Human Ecology in Northeastern North America*, edited by G.P. Nicholas, pp. 185-214. Plenum Press, New York.
- Justice, N.D.  
1987 *Stone Age Spear and Arrow Points*. Indiana University Press, Bloomington.
- Kahler, C.B.  
1938 Indian Exploration Work Near Muncy, Pa. *Now and Then* 6(3):69-72.
- Kalin, J.  
1981 Stem Point Manufacture and Debitage Recovery. *Archaeology of Eastern North America* 9:134-175.
- Keegan, W.F.  
1987 *Emergent Horticultural Economies of the Eastern Woodlands*. Southern Illinois University at Carbondale, Center for Archaeological Investigations, Occasional Paper No. 7. Carbondale, Illinois.
- Keeley, L.H.  
1974 Technique and Methodology in Microwear Studies: A Critical Review. *World Archaeology* 5:323-336.  
  
1980 Experimental Determination of Stone Tool Uses: A Microwear Analysis. University of Chicago Press, Chicago.  
  
1982 Hafting and Retooling: Effects on the Archaeological Record. *American Antiquity* 47(4):798-809.
- Keeley, L.H. and M.H. Newcomer  
1977 Microwear Analysis of Experimental Flint Tools: A Test Case. *Journal of Archaeological Science* 4(1): 29-62.
- Keene, A.  
1981 *Prehistoric Foraging in a Temperate Forest*. Academic Press, New York.
- Kelly, R.L.  
1988 The Three Sides of a Biface. *American Antiquity* 53:717-734.
- Kemeny, J.G.  
1959 *A Philosopher Looks at Science*. Van Norstrand Reinhold Company, New York.
- Kent, B.C.  
1970 *Diffusion Spheres and Band Territoriality Among the Archaic Period Cultures of the Northern Piedmont*. Ph.D. dissertation, Pennsylvania State University, University Microfilms, Ann Arbor, Michigan.

- 1984 *Susquehanna's Indians*. Pennsylvania Historical and Museum Commission, Anthropological Series 6.
- Kent, B.C., I.F. Smith III, and C. McCann (editors)  
1971 *Foundations of Pennsylvania Prehistory*. Pennsylvania Historical and Museum Commission, Anthropological Series 1.
- Kent, B. W.  
1981 Patterns of Oyster Utilization in St Mary's City, Maryland 1640 and 1740. Paper presented at the 1981 Middle Atlantic Archaeological Conference, Ocean City, Maryland.  
1988 *Making Dead Oysters Talk: Techniques for Analyzing Oysters from Archaeological Sites*. Maryland Historical Trust, Historic St Mary's City, Jefferson Patterson Park and Museum.
- Kent, S.  
1993 Studying Variability in the Archaeological Record: An Ethnoarchaeological Model for Distinguishing Mobility Patterns. *American Antiquity* 57:635-660.
- King, F.B.  
1985 Early Cultivated Cucurbita in Eastern North America. In *Prehistoric Food Production in North America*, edited by R.I. Ford, pp. 73-91. University of Michigan, Museum of Anthropology, Anthropological Papers 75.  
1988 Floral Remains. In *The Prehistory of the Catawissa Bridge Replacement Site (36CO9), Columbia County, Pennsylvania*, by T.C. East, J.M. Adovasio, W.C. Johnson and D.R. Pedler. A report prepared by the Cultural Resource Management Program, Department of Anthropology, University of Pittsburgh.
- Kinsey, W.F., III  
1958 A Survey of Fluted Points Found in the Susquehanna Basin, Report No. 1. *Pennsylvania Archaeologist* 28(3-4):103-111,126.  
1959 Recent Excavations on Bare Island in Pennsylvania: The Kent-Hally Site. *Pennsylvania Archaeologist* 29(3-4):109-133.  
1971 The Middle Atlantic Culture Province: A Point of View. *Pennsylvania Archaeologist* 41(1-2):1-8.  
1972 *Archaeology in the Upper Delaware Valley: A Study of the Cultural Chronology of the Tocks Island Reservoir*. Pennsylvania Historical and Museum Commission, Anthropological Series 2.  
1975 Faucett and Bam Sites: Chronology and Settlement in the Delaware Valley. *Pennsylvania Archaeologist* 45(1-2):1-103.
- Kinsey, W.F., III, and J.R. Graybill  
1971 Murry Site and Its Role in Lancaster and Funk Phases of Shenks Ferry Culture. *Pennsylvania Archaeologist* 41(4):7-43.

- Klinger, T.K., S.M. Imhoff, and R.P. Kandare  
 1992 *Marie Saline: Data Recovery at 36AS329 Felsenthal National Wildlife Refuge Ashley County, Arkansas*. Historic Preservation Associates Reports 92-25, Fayetteville, Arkansas. Submitted to U.S. Army Corps of Engineers, Vicksburg District, Vicksburg, Mississippi.
- Knox, J.C.  
 1983 Responses of River Systems to Holocene Climates. In *Late Quaternary Environments of the United States, Part 2: The Holocene*, edited by H.E. Wright, pp. 26-41. University of Minnesota Press, Minneapolis, Minnesota.
- Knudson, R.  
 1973 *Organizational Variability in Late Paleo-Indian Assemblages*. Ph.D. dissertation, Washington State University, Pullman. University Microfilms, Ann Arbor.
- Kohler, C.D.  
 1986 *Soil Survey of Lycoming County, Pennsylvania*. USDA Soil Conservation Service, Government Printing Office, Washington D.C.
- Kolb, M.F., N.P. Lasca, and L.G. Goldstein  
 1990 A Soil-geomorphic Analysis of the Midden Deposits at the Aztalan Site, Wisconsin. In *Archaeological Geology of North America, Centennial Special Volume 4*, edited by N.P. Lasca and J. Donahue, pp. 199-218. Geological Society of America, Boulder, Colorado.
- Kooistra, M.J.  
 1990 The Future of Soil Micromorphology. In *Soil Micromorphology: A Basic and Applied Science*, edited by L.A. Douglas, pp. 1-8. Elsevier, New York.
- Kraft, H.C.  
 1975 *The Archaeology of the Tocks Island Area*. Seton Hall University Museum, South Orange, New Jersey.
- Krantz, D.H.  
 1971 Integration of Just-noticeable Differences. *Journal of mathematical Psychology* 8:591-599.
- Krumbein, W.C., and L.L. Sloss  
 1963 *Stratigraphy and Sedimentation*. W.H. Freeman and Company, San Francisco, 660 p.
- Kuhn, T.S.  
 1977 *The Essential Tension*. University of Chicago Press, Chicago.
- Kutzbach, J.E.  
 1983 Modeling of Holocene Climates. In *Late Quaternary Environments of the United States, Vol. 2: The Holocene*, edited by H. E. Wright Jr., pp. 271-277. University of Minnesota Press, Minneapolis, Minnesota.
- Lantz, S.W.  
 1989 *Age, Distribution and Cultural Affiliation of Raccoon Notched Point Varieties in Western Pennsylvania and Western New York*. Bulletin of Carnegie Museum of Natural History, Number 28. Pittsburgh, Pennsylvania.



- Leonard, R.D., F.E. Smiley, and C.M. Cameron  
 1989 Changing Strategies of Anasazi Lithic Procurement on Black Mesa, Arizona. In *Quantifying Diversity in Archaeology*, edited by R.D. Leonard and G.T. Jones, pp. 100-108. Cambridge University Press, Cambridge.
- Lawrence, R.A.  
 1979 Experimental Evidence for the Significance of Attributes Used in Edge-Damage Analysis. In *Lithic Use-Wear Analysis*; edited by Brian Hayden, pp. 113-121. Academic Press, New York.
- Leverett, F.  
 1934 Glacial deposits outside the Wisconsin Terminal Moraine in Pennsylvania. *Pennsylvania Geological Survey Bulletin*, G7.
- Limp, F.W., and V.A. Reidhead  
 1979 An Economic Evaluation of the Potential of Fish Utilization in Riverine Environments. *American Antiquity* 44:70-78.
- Lindbo, D.L., and P.L.M. Veneman  
 1987 Fragipans in the Northeastern United States. In *Fragipans: Their Occurrence, Classification, and Genesis*, edited by N.E. Smeck and E.J. Ciolkosz, Soil Science Society of America special Publication Number 24, Soil Science Society of America, Madison, Wisconsin.
- Lindbo, D.L.; Rhoton, F.E.; Bigham, J.M.; Hudnall, W.H.; Jones, F.S.; Smeck, N.E., and D.D. Tyler  
 1994 *Bulk Density and Fragipan Identification in Loess Soils of the Lower Mississippi River Valley*, Soil Science Society of America Journal, 58:884-891.
- Linn, J.B.  
 1883 *History of Centre and Clinton Counties, Pennsylvania*. Philadelphia: J.B. Lippencott and Company. Reprinted 1975, Centre County Historical Society, Bicentennial Edition. Evansville, Indiana: Unigraphic, Inc.
- Little, E.L., Jr.  
 1971 *Atlas of United States Trees. Volume 1: Conifers and Important Hardwoods*. USDA Forest Service, Miscellaneous Publication 1146.  
 1977 *Atlas of United States Trees. Volume 4: Minor Eastern Hardwoods*. USDA Forest Service, Miscellaneous Publication 1342.
- Lucy, C.  
 1959 Pottery Types in the Upper Susquehanna. *Pennsylvania Archaeologist* 29(1):28-37.
- Lurie, R.  
 1982 *Economic Models of Stone Tool Manufacture and Use: The Koster Site Middle Archaic*. Ph.D. dissertation, Northwestern University, University Microfilms, Ann Arbor, Michigan.  
 1983 A Preliminary Study of Use-Wear of the Artifacts from Some Preceramic Components. In *Prehistory of Ayacucho Basin, Peru*; edited by Richard MacNeish, pp. 22-47. The University of Michigan Press, Ann Arbor.

- 1989 Lithic Technology and Mobility Strategies: The Koster Site Middle Archaic. In *Time, Energy, and Stone Tools*, edited by R. Torrence, pp. 46-56. Cambridge University Press, Cambridge.
- Lynott, M.J.  
1975 Explanation of Microwear Patterns on Gravers. *Plains Anthropologist* 20, No. 68, pp. 121-128.
- MacCord, H.A.  
1971 The Brown Johnson Site, Bland County, Virginia. *Archaeological Society of Virginia, Bulletin* 25(4).  
  
1986 *The Lewis Creek Mound Culture in Virginia*. Privately printed, Richmond, Virginia.
- MacKay, D.M.  
1963 Psychophysics of Perceived Intensity: A Theoretical Basis for Fechner's and Stevens' Laws. *Science* 159:1213-1216.
- MacDonald, G.F.  
1968 *Debert: A Paleo-Indian Site in Central Nova Scotia*. National Museum of Man, Anthropological Papers 16.
- Magne, and Pokotylo  
1981 A Pilot Study in Bifacial Lithic Reduction Sequences. *Lithic Technology* X:34-47.
- Mandel, J.  
1957 Fitting a Straight Line to Certain Types of Cumulative Data. *American Statistical Association Journal* 47:552-566.
- Mandelbrot, B.  
1982 *The Fractal Geometry of Nature*. W.H. Freeman and Company, San Francisco.  
  
1991 *Fractals and Multifractals*. Selecta Vol. 1 Springer, New York.
- Mair, A.P.  
1988 *Cultural Resources Data Recovery, 36NB113, Union- Northumberland Counties, Milton Bridge Replacement*. Report prepared by Wilbur Smith Associates, Inc., for Pennsylvania Department of Transportation.
- Manson, C.  
1948 Marcey Creek Site: An Early Manifestation in the Potomac Valley. *American Antiquity* 13(3):223-227.
- Marchland, D.E.  
1978 Quaternary Deposits and Quaternary History. In *Quaternary Deposits and Soils of the Central Susquehanna Valley of Pennsylvania*, edited by D.E. Marchland, pp. 1-19. Pennsylvania State University, Agronomy Department (Friends of the Pleistocene Guidebook).
- Marks, L.E.  
1974 *Sensory Processes: The New Psychophysics*. Academic Press, New York.

- Marsh, B.  
1987 Pleistocene Pingo Scars in Pennsylvania. *Geology* 15:945-947.
- Mayer-Oakes, W.J.  
1955 *Prehistory of the Upper Ohio Valley*. Carnegie Museum, Annals 34.
- McCann, C.  
1971 Notes on the Pottery of the Clemson Island and Book Mounds. In *Foundations of Pennsylvania Prehistory*, edited by B.C. Kent, and I. F. Smith, pp. 419-423. Pennsylvania Historical and Museum Commission, Harrisburg.
- McLean, E.O.  
1982 Soil pH and Lime Requirement. In *Methods of Soil Analysis, Part 2- Chemical and Microbiological Properties*, edited by A.L. Page, R.H. Miller, and D.R. Keeney, pp. 199-224, Soil Science Society of America, Madison, Wisconsin.
- McNett, C.W., Jr. (editor)  
1985 *Shawnee Minisink: A Stratified Paleoindian-Archaic Site in the Upper Delaware Valley of Pennsylvania*. Academic Press, Orlando.
- Meakin, P.  
1987 Scaling Properties for the Growth Probability Measure and Harmonic Measure of Fractals. *Phys. Rev.* A35, 2234-2128.
- Meginness, J.F.  
1889 *Otzinachson: A History of the West Branch of the Susquehanna*. Gazette Bulletin, Williamson, Pennsylvania.
- Mellars, P.A.  
1976 Fire Ecology, Animal Populations and Man: A Study of Some Ecological Relationships in Prehistory. *Proceedings of the Prehistoric Society* 42:15-46.
- Meltzer, D.J.  
1981 A Study of Style and Function in a Class of Tools. *Journal of Field Archaeology* 8(3):313-326.
- Michaels, J.W.  
1968 Settlement Patterns and Demography at Sheep Rock Shelter: Their Role in Culture Contact. *Southwestern Journal of Anthropology* 24:66-82.
- Michaels, J.W., and J.S. Dutt  
1968 *Archaeological Investigations of the Sheep Rock Shelter, Huntingdon County, Pennsylvania (Vol. 3)*. Department of Sociology and Anthropology, Pennsylvania State University, University Park.
- Michaels, J.W., and J.B. Huner  
1968 *Archaeological Investigations of the Workman Site, Bedford County, Pennsylvania*. Department of Sociology and Anthropology, Pennsylvania State University, University Park.
- Michels, J.W., and I.F. Smith, III  
1967 *Archaeological Investigations of Sheep Rock Shelter, Huntingdon County, Pennsylvania (Vols. 1 and 2)*. Department of Sociology and Anthropology, Pennsylvania State University, University Park.

- Miller, I.W.  
1966 *Old Town: A History of Early Lock Haven 1769-1845*. Lock Haven, Pennsylvania: The Annie Halenbake Ross Library.
- Mitchum, B.  
1983 *Phase II Investigation of the Petersburg Bridge Site, L.R. 352, Section 011, Huntingdon County, Pennsylvania*. Report prepared for Pennsylvania Department of Transportation, Hollidaysburg by GAI Consultants, Inc., Monroeville, Pennsylvania.
- Moeller, R.W.  
1973 Strategies for Study of Late Woodland Occupations. In *Archaeological Excavations: Upper Delaware Valley 1972*, edited by R. W. Moeller, pp. 5-17. Franklin and Marshall College, North Museum Publication 1.
- Morris, P.  
1975 *A Field Guide to Shells*. Houghton Mifflin Company, Boston.
- Morrison, R.B.  
1967 Principles of Quaternary Stratigraphy. In *Quaternary Soils*, edited by R. B. Morrison and H E. Wright, pp. 1-69. International Association of Quaternary Research, VII Congress, Proceedings. Vol. 9.  
  
1978 Quaternary Soil Stratigraphy-Concepts, Methods, and Problems. In *Quaternary Soils*, edited by W.C. Mahaney, pp. 77-108, Geo Abstracts, Norwich, England.
- Moss, E.H.  
1983 *The Functional Analysis of Flint Implements*. BAR International Series 177. England.
- Mounier, R.A.  
1978 Two Radiocarbon Dates for New Jersey. *Pennsylvania Archaeologist* 48(1-2):16-19.
- Muto, G.R.  
1971 A Stage Analysis of the manufacture of Chipped Stone Implements. In *Great basin Anthropological Conference 1970: Selected Papers*, edited by C.M. Aikens. University of Oregon Anthropological Papers 1:109-118.
- Myers, A.  
1989 Reliable and Maintainable Technological Strategies in the Mesolithic of Mainland Britain. In *Time, Energy, and Stone Tools*, edited by R. Torrence, pp. 78-91. Cambridge University Press, Cambridge.
- NACSN (North American Commission on Stratigraphic Nomenclature)  
1983 North American Stratigraphic Code. *American Association of Petroleum Geologists Bulletin* 67:841-875.
- Nance, J.D.  
1971 Functional Interpretation from Microscopic Analysis. *American Antiquity* 36(3):361-366.

Nass, J.

1987 *Use-wear Analysis and Household Archaeology: A Study of the Activity Structure of the Incinerator Site, an Anderson Phase Fort Ancient Community in Southwestern Ohio*. Ph.D. dissertation, Department of Anthropology, The Ohio State University. University Microfilms, Ann Arbor.

1989 Household Archaeology and Functional Analysis as Procedures for Studying Fort Ancient Communities in the Ohio Valley. *Pennsylvania Archaeologist* 59(1):1-13.

1990 *Phase IV Data Recovery at the Sabre Farms Site (33RO385), a Multi-component Prehistoric Site in Ross County, Ohio*. Archaeological Services Consultants, Inc. Submitted to Bucher, Willis, and Ratliff, Columbus, Ohio.

Neumann, T.W.

1989 *Phase II-Intensive Survey, Historic and Prehistoric Archaeological Investigations at Lock Haven, Clinton County, Pennsylvania*. Report prepared by R. Christopher Goodwin and Associates, Inc., for U.S. Army Corps of Engineers, Baltimore District.

Newcomer, M.H.

1971 Some Quantitative Experiments in Hand-axe manufacture. *World Archaeology* 3:85-94.

Newell, A. and H. Simon

1972 *Human Problem Solving*. Prentice-Hall, Englewood Cliffs, New Jersey.

Newmann, T.W. and E. Johnson

1979 Patrow Site Lithic Analysis. *Midcontinental Journal of Archaeology* 4:79-112.

Neusius, S.W. (editor)

1986 *Foraging, Collecting, and Harvesting: Archaic Period Subsistence and Settlement in the Eastern Woodlands*. Southern Illinois University at Carbondale, Center for Archaeological Investigations, Occasional Paper No. 6. Southern Illinois University Press, Carbondale.

Niemczycki, M.P.

1984 *The Origin and Development of the Seneca and Cayuga Tribes of New York State*. Rochester Museum and Science Center, Research Records 17.

Nissen, K., and M. Dittermore

1974 Ethnographic Data and Wear Pattern Analysis: A Study of Socketed Eskimo Scrapers. *Tebiwa* 17(1): 67-88.

Odell, G.H.

1975 Micro-Wear in Perspective: A Sympathetic Response to Lawrence H. Keeley. *World Archaeology* 7:226-240.

1979a A New & Improved System for the Retrieval of Functional Information from Microscopic Observations of Chipped Stone Tools. In *Lithic Use-Wear Analysis*; edited by Brian Hayden, pp. 329-344. Academic Press, New York.

- 1979b Comments on Cohen et al., Stone Tools, Toolkits, and Human Behavior in Prehistory. *Current Anthropology* 20(4):676-677.
- 1981 The Morphological Express at Function Junction: Searching for Meaning in Lithic Tool Types. *Journal of Anthropological Research* 37(4):319-342.
- 1982 Emerging Directions in the Analysis of Prehistoric Stone Tool Use. *Reviews in Anthropology* 9:17-33.
- 1985 Small Sites Archaeology and Use-Wear on Surface- Collected Artifacts. *Midcontinental Journal of Archaeology* 10(1):21-48.
- Odell, G.H. and F. Odell-Vereecken  
 1980 Verifying the Reability of Lithic Use-Wear Assessments by "blind tests": the low-power approach. *Journal of Field Archaeology* 7:87-120.
- Ono, H.  
 1967 Difference Threshold for Stimulus Length Under Simultaneous and Nonsimultaneous Viewing Conditions. *Perception and Psychophysics*.2:201-207.
- Olsen. S.J.  
 1964 *Mammal Remains from Archaeological Sites*. Papers of the Peabody Museum of Archaeology and Ethnology Vol. 56, No. 1. Cambridge.  
 1968 *Fish, Amphibian, and Reptile Remains from Archaeological Sites*. Papers of the Peabody Museum of Archaeology and Ethnology, Vol. 56, No. 2. Cambridge.  
 1979 *Osteology for the Archaeologist*. Papers of the Peabody Museum of Archaeology and Ethnology, Vol. 56, No. 3, 4, and 5. Cambridge.
- Ornstein, R.  
 1978 The Split and Whole Brain. *Human Nature* 1(5):70-83.
- Pacheco, P.J.  
 1989 Ohio Middle Woodland Settlement Variability in the Upper Licking River Drainage. *Journal of the Steward Anthropological Society* 18 (1-2):87-117.
- Parmalee, P.  
 1985 Archaeologically Derived Animal Remains. In *The Analysis of Prehistoric Diets*, edited by R. Gilbert, and J. Mielke, pp. 61-88. Academic Press, New York.
- Parry, W.J.  
 1989 The Relationship Between Lithic Technology and Changing Mobility Strategies in the Middle Atlantic Region. In *New Approaches to Other Pasts*, edited by W. F. Kinsey, and R. W. Moeller, pp. 29-34. Archaeological Services, Inc., Bethlehem, Connecticut.
- Parry, W.J., and R. L. Kelly  
 1987 Expedient Core Technology and Sedentism. in *The Organization of Core Technology*, edited by J. K. Johnson, and C. A. Morrow, pp. 285-304. Westview Press, Boulder, Colorado.

- Patterson, L.W.  
 1977 Comments of Texas Street Lithic Artifacts. *Anthropological Journal of Canada* 15:15-25.
- 1979 Quantitative Characteristics of Debitage from Heat Treated Chert. *Plains Anthropologist* 24:255-260.
- 1982 The Importance of Flake Size Distribution. *Contract Abstracts and CRM Archaeology* 23:103-112.
- 1990 Characteristics of Bifacial Reduction Flake-Size Distribution. *American Antiquity* 55:550-558.
- Patterson, L.W., and J.B. Solberger  
 1978 Replication and Classification of Small Size Lithic Debitage. *Plains Anthropologist* 23:103-112.
- Petersen, J.B.  
 1991 *Archaeological Testing at the Sharrow Site: A Deeply Stratified Early to Late Holocene Cultural Sequence in Central Maine*. Maine Archaeological Society and Maine Historic Preservation Commission, Occasional Publications in Maine Archaeology 8
- Phillips, J.L., and J.A. Brown (editors)  
 1983 *Archaic Hunters and Gatherers in the American Midwest*. Academic Press, New York.
- Pielou, E.C.  
 1975 *Ecological Diversity*. Wiley-Interscience, New York.
- Plog, F.  
 1974 *The Study of Prehistoric Change*. Academic Press, New York.
- Pope, M.K.  
 1986 Microdrills from the Moundville Region: Technology, Function, and Context. Paper presented at the 43rd Annual Southeastern Archaeological Conference, Nashville, Tennessee, November 5-8.
- Pribram, K.H.  
 1971 *Languages of the Brain: Experimental Paradoxes and Principals in Neuropsychology*. Prentice Hall, Englewood Cliffs, New Jersey.
- Price, T.D., (editor)  
 1989 *The Chemistry of Prehistoric Human Bone*. Cambridge University Press, Cambridge.
- Prothero, D.R., and L. Lavin  
 1990 Chert Petrography and its Potential as an Analytical Tool in Archaeology. In *Archaeological Geology of North America*, edited by N. P. Lasca and J. Donahue, pp. 561-584. Geological Society of America, Centennial Special Volume 4, Boulder, Colorado.

- Raab, L.M., R.F. Cande, and D.W. Stahle  
 1979 Debitage Graphs and Archaic Settlement Patterns in the Arkansas Ozarks. *Midcontinental Journal of Archaeology* 4:167-182.
- Rafferty, J.E.  
 1985 The Archaeological Record on Sedentariness: Recognition, Development, and Implications. In *Advances in Archaeological Method and Theory*, No. 8, edited by M.B. Schiffer, pp. 113-155. Academic Press, New York.
- Regensburg, R.A.  
 1970 The Savich Farm Site: A Preliminary Report. *Massachusetts Archaeological Society, Bulletin* 32(1- 2):20-23.
- Rice, P.M.  
 1987 *Pottery Analysis: A Source Book*. University of Chicago Press, Chicago.
- Riley, T.J.  
 1987 Ridged Field Agriculture and the Mississippian Economic Pattern. in *Emergent Horticultural Economies of the Eastern Woodlands*, edited by W. F. Keegan, pp. . Center for Archaeological Investigations, Occasional Paper No. 7. Carbondale, Illinois.
- Riley, T.J., R. Edging, and J. Rossen  
 1989 Cultigens in Prehistoric Eastern North America: Changing Paradigms. *Current Anthropology* 31:525-533, 536-541.
- Riley, T.J., G.R. Waltz, C.J. Baries, A.C. Fortier, and K.E. Parker  
 1994 Accelerator Mass Spectrometry (AMS) Dates Confirm Early *Zea mays* in the Mississippi Valley. *American Antiquity* 59:490-497.
- Ritchie, W.A.  
 1959 The Stony Brook Site and Its Relation to Archaic and Transitional Cultures on Long Island. *New York State Museum and Science Service, Bulletin* 372.  
 1961 A Typology and Nomenclature for New York Projectile Points. *New York State Museum and Science Service, Bulletin* 384.  
 1965a *The Archaeology of New York State*. The Natural History Press, Garden City.  
 1965b The "Small Stemmed Point" in New England. *Pennsylvania Archaeologist* 35(3-4):134-138.  
 1969 *The Archaeology of Martha's Vineyard: A Framework for the Prehistory of Southern New England*. The Natural History Press, Garden City.
- Ritchie, W.A., and D. Dragoo  
 1959 The Eastern Dispersal of Adena. *American Antiquity* 25(1):43-50.  
 1960 The Eastern Dispersal of Adena. *New York State Museum and Science Service, Bulletin* 379.



- Ritchie, W.A., and R.E. Funk  
 1971 Evidence for Early Archaic Occupations on Staten Island. *Pennsylvania Archaeologist* 41(3):45-59.
- 1973 *Aboriginal Settlement Patterns in the Northeast*. New York State Museum, Memoir 20.
- Ritchie, W.A., and R.S. MacNeish  
 1949 The Pre-Iroquoian Pottery of New York State. *American Antiquity* 15(2):97-124.
- Robertson, J.A.  
 1984 Chipped Stone and Functional Interpretations: A Fort Ancient Example. *Midcontinental Journal of Archaeology* 9(2):251-267.
- Rudner, R.  
 1966 *Philosophy of Social Science*. Prentice Hall, Englewood Cliffs, New Jersey.
- Rue, D.J., J. Kreinbrink, C. A. Hay, and P. A. Raber  
 1989 *Archaeological Data Recovery at 36CH374, 36CH161, and 36DE22: Three Sites in the Piedmont Uplands of Chester and Delaware Counties, Pennsylvania*. Report prepared for Columbia Gas Transmission Corporation, Charleston, West Virginia by WAPORA, Inc., Cincinnati, Ohio.
- Ruhe, R.V.  
 1956 Geomorphic Surfaces and the Nature of Soils. *Soil Science* 82:441-455.
- Ryder, M.L.  
 1969 *Animal Bones in Archaeology*. Mammal Society Handbook, Blackwell Scientific Publications, Oxford.
- Rye, O.S.  
 1976 Keeping Your Temper Under Control: Materials and the Manufacture of Papuan Pottery. *Archaeology and Physical Anthropology in Oceania* 11:106-137.
- Sabo, D.R.  
 1982 Preliminary Use-Wear of a Michigan Chert. *The Michigan Archaeologist* 28(1):55-72.
- Sassaman, K.E., and M. J. Brooks  
 1990 Cultural Quarries: Scavaging and Recycling Lithic Refuse in the Southeast. Paper presented at the Southeastern Archaeological Conference.
- Schiffer, M.B.  
 1983 Toward the Identification of Site Formation Processes. *American Antiquity* 48: 675-706.
- 1987 *Formation Processes of the Archaeological Record*
- Schindler, D.L., J.W. Hatch, C.A. Hay, and R.C. Bradt  
 1982 Aboriginal Thermal Alteration of a Central Pennsylvania Jasper: Analytical and Behavioral Implications. *American Antiquity* 47:526-544.

- Schmid, E.  
1972 *Atlas of Animal Bones for Prehistorians, Archaeologists, and Quaternary Geologists*. Elsevier Publishing, Amsterdam.
- Schmitt, K.  
1952 Archaeological Chronology of the Middle Atlantic States. In *Archaeology of Eastern United States*, edited by J. B. Griffin, pp. 59-70. University of Chicago Press, Chicago.
- Schroeder, Manfred  
1991 *Fractals, Chaos, Power Laws*. W.H. Freeman and Company: New York.
- Schuldenrein, J. and F. Vento  
1993 Geoarcheological Investigations at The Memorial Park Site (36CN164), Pennsylvania. Draft report prepared for U.S. Army Corps of Engineers, Baltimore, Maryland.
- Scully, R.W., and R.W. Arnold  
1981 Holocene Alluvial Stratigraphy in the Upper Susquehanna River River Basin, New York. *Quaternary Research* 15: 327-344.
- Schuster, H.G.  
1984 *Deterministic Chaos*. Physik-Verlag, Weinheim.
- Semenov, S.A.  
1964 *Prehistoric Technology* (translated by M.W. Thompson). Cory, Adams, and MacKay, London.
- Sheets, P.D.  
1975 Behavioral Analysis and the Structure of a Prehistoric Industry. *Current Anthropology* 16(3): 367-378.
- Shelford, V.  
1963 *The Ecology of North America*. University of Illinois Press, Urbana.
- Shott, M.J.  
1990 *Childers and Woods: Two Late Woodland Sites in the Upper Ohio Valley, Mason County, West Virginia*. University of Kentucky, Program for Cultural Resource Assessment, Archaeological Report 200.
- Siegel, P.E.  
1984 Functional Variability within an Assemblage of Endscrapers. *Lithic Technology* 13(2):35-51.  
1985 Edge Angle as a Functional Indicator: A Test. *Lithic Technology* 14(2):90-94.
- Singer, D.  
1982 Fish in Foodways Systems-Data Integration and patterning. *Northeast Historical Archaeology* 11:39-47.  
1987 Threshold of Affordability: Assessing Fish for Socioeconomics. In *Consumer Choice in Historical Archaeology*, edited by S. Spencer-Ward, pp. 85-98. Plenum Press, New York.

- Skibo, J.M., and M.B. Schiffer  
1987 The Effects of Water on Processes of Ceramic Abrasion. *Journal of Archaeological Sciences* 14:83-96.
- Skibo, J.M., M.B. Schiffer, and K. C. Reid  
1989 Organic-Tempered Pottery: An Experimental Study. *American Antiquity* 54:122-146.
- Smith, B.D.  
1975 *Middle Mississippian Exploitation of Animal Populations*. University of Michigan, Museum of Anthropology, Anthropological Papers, No. 57. An Arbor.  
1987 The Independent Domestication of Indigenous Seed-Bearing Plants in Eastern North America. In *Emergent Horticultural Economies of the Eastern Woodlands*, edited by W. F. Keegan, pp. 3-48. Center for Archaeological Investigations, Southern Illinois University at Carbondale Occasional paper No. 7.  
1989 Origins of Agriculture in Eastern North America. *Science* 246:1566-1571.  
1992 *Rivers of Change*. Smithsonian Institution Press.
- Smith, B.R. and L.L. Callahan  
1987 *Soils with Bx Horizons in the Upper Coastal Plains of South Carolina*, Soil Science Society of America Journal, 51:158-164.
- Smith, I.F., III  
1971 Early Pottery of the Lower Susquehanna Valley. In *Proceedings of the Middle Atlantic Archaeological Conference*, edited by C.W. McNett, Jr., and W.M. Gardner, pp. 40-41. The Catholic University of America, Washington, D.C.  
1972 Birdstones, Boatstones, and Bar Amulets from the Susquehanna Drainage. *Pennsylvania Archaeologist* 42(1-2): 63-70  
1973 The Parker Site: A Manifestation of the Wyoming Valley Culture. *Pennsylvania Archaeologist* 43(3- 4):1-56.  
1976 A Functional Interpretation of "Keyhole" Structures in the Northeast. *Pennsylvania Archaeologist* 46(1- 2):1-12.  
1977a The Susquehanna River Valley Archaeological Survey. *Pennsylvania Archaeologist* 47(4):27-29.  
1977b *Early and Middle Woodland Campsites on Three Mile Island, Dauphin County, Pennsylvania*. Pennsylvania Historical and Museum Commission, Harrisburg.  
1979 Early Smoking Pipes in the Susquehanna River Valley. *Pennsylvania Archaeologist* 49(4):9-23.  
1984 *A Late Woodland Site in Northcentral Pennsylvania: Its Role in Susquehannock Culture History*. Pennsylvania Historical and Museum Commission, Harrisburg.
- Snow, D.E.  
1980 *The Archaeology of New England*. Academic Press, New York.

- Snyder, K.E., and R.B. Bryant  
1992 Late Pleistocene Surficial Stratigraphy and landscape Development in the Salamanca Re-entrant, Southwestern New York. *Geological Society of America Bulletin* 104:242-251.
- Socolow, A. A.  
1980 *Geologic Map of Pennsylvania*. Commonwealth of Pennsylvania, Department of Environmental Resources, Topographic and Geological Survey, Harrisburg.
- Soil Survey Staff  
1975 *Soil Taxonomy*. USDA Agriculture Handbook 436, USDA Soil Conservation Service, Government Printing Office, Washington D.C.
- Sonnenfeld, J.  
1962 Interpreting the Function of Primitive Implements. *American Antiquity* 28(1):56-65.
- Sperry, R.W.  
1968 Hemisphere Disconnection and Unity in Conscious Awareness. *American Psychologist* 23:723-733.
- Speth, J.D.  
1972 Mechanical Basis for Percussion Flaking. *American Antiquity* 37:34-60.  
1974 Experimental Investigations of Hard-Hammer Percussion Flaking. *Tebiwa*  
1975 Miscellaneous Studies in Hard-Hammer Percussion Flaking: The Effects of Oblique Impact. *American Antiquity* 40:203-207.  
1981 The Role of Platform Angle and Core Size in Hard hammer Percussion Flaking. *Lithic Technology* X:16-21.
- Spitzer, M.G.  
1981 A Study of the Reliability of Measurements of Lithic Artifacts between Trained Observers. Ms. on file, Center for American Archaeology, Contract Archaeology, Kampsville, Illinois.
- Stafford, C.R., and B.D. Stafford  
1983 The Functional Hypothesis: A Formal Approach to Use-Wear Experiments and Settlement-Subsistence. *Journal of Anthropological Research* 39(4):351-375.
- Stahle, D.W., and J.E. Dunn  
1982 An Analysis and Application of the Size Distribution of Waste Flakes from the manufacture of Bifacial Stone Tools. *World Archaeology* 14:84-97.  
1984 *An Experimental Analysis of the Size Distribution of Waste Flakes from Biface Reduction*. Arkansas Archaeological Survey Technology Paper No. 2. Fayetteville.
- Shannon, C.E. and W. Weaver  
1963 *The Mathematical Theory of Communication*. The University of Illinois Press Urbana.

- Spurling, B. and B. Hayden  
 1984 Ethnoarchaeology and Intrasite Spatial Analysis: A Case Study from the Australian Western Desert. In *Intrasite Spatial Analysis in Archaeology*, edited by H. Hietala, pp 226-241. Cambridge University Press.
- Stein, J.K.  
 1987 Deposits for archaeologists. In *Advances in Archaeological Method and Theory*, No. 11, edited by M.B. Schiffer, pp. 337-393. Academic Press, New York.
- 1990 Archaeological Stratigraphy. In *Archaeological Geology of North America*, Geological Society of America Centennial Special Volume 4, edited by N.P. Lasca and J. Donahue, pp. 513-523., Geological Society of America, Boulder, Colorado.
- Steponaitis, V.P.  
 1983 *Ceramics, Chronology, and Community Patterns: An Archaeological Study at Moundsville*. Academic Press, New York.
- Steputis, W.J., R.E. Matticks, R. Zimmerman, and R. Henry.  
 1966 *Soil Survey of Clinton County, Pennsylvania*. United States Department of Agriculture, Soil Conservation Service, In Cooperation with the Pennsylvania State University, College of Agriculture and Agricultural Experimentation Station, and Pennsylvania Department of Agriculture, State Soil and Water Conservation Commission.
- Stevens, J.C., and H.B. Savin  
 1962 On the Form of Learning Curves. *Journal of Experimental Analysis of Behavior* 5:15-18.
- Stevens, J.C. and H.B. Stevens  
 1960 Warmth and Cold: Dynamics of Social Intensity. *Journal of Experimental Psychology* 60:183-192.
- Stevens, S.S.  
 1946 On the Theory of Scales of Measurement. *Science* 103:677-680.
- 1951 Mathematics, Measurement, and Psychophysics. In *Handbook of Experimental Psychology*, edited by S.S. Stevens.
- 1959 Measurement, Psychophysics, and Utility. In *Measurement: Definitions and Theories*, edited by C.W. Churchman and P. Ratoosh. Wiley and Sons, New York.
- 1966 Quantifying the Sensory Experience. In *Mind, Matter, and methods: Essays in Philosophy and Science in Honor of Herbert Feigl*, edited by H. Feyerabend and G. Maxwell, Pp. 215-233. University of Minnesota Press.
- 1971 Issues in Psychophysical Measurement. *Psychological Review* 78:426-450.
- 1975 *Psychophysics: Introduction to its Perceptual, Neural, and Social Prospects*. Wiley & Sons, New York.
- Stevens, S.S., and E.H. Galanter  
 1957 Ratio Scales and Category Scales for a Dozen Perceptual Continua. *Journal of Experimental Psychology* 54:377-411.

- Stevenson, C.M., and C.A. Hay  
1980 United States Department of Interior Heritage Conservation and Recreation Service National Register of Historic Places Inventory — Nomination Form. The Memorial park Site, 36Cn164.
- Stewart, M.C.  
1977 *Pits in the Northeast: A Typological Analysis*. New York State Archaeological Association, Researches and Transactions 17(1).
- Stewart, R.M.  
1980 *Prehistoric Settlement and Subsistence Patterns and the Testing of Predictive Site Location Models in the Great Valley of Maryland*. University Microfilms, Ann Arbor, Michigan.  
  
1987 Rhyolite Quarry and Quarry-Related Sites in Maryland and Pennsylvania. *Archaeology of Eastern North America* 15:47-57.  
  
1988 *Phase II and III Archaeological Investigations, 36UN11, St. Anthony Street Bridge Replacement, L.R. 59024, Section 007, Union County, Lewisburg, Pennsylvania*. Report prepared by Louis Berger & Associates, Inc., for Pennsylvania Department of Transportation.  
  
1990 Clemson's Island Studies in Pennsylvania: A Perspective. *Pennsylvania Archaeologist* 60(1):79- 107.
- Stewart, R.M., and J.A. Cavallo  
1991 Delaware Valley Middle Archaic. *Journal of Middle Atlantic Archaeology* 7:19-42.
- Stewart, T.B.  
1934 Rich Variety of Andaste Indian Material Yielded by Excavating Longhouse Sites in Clinton County, Pennsylvania. *Pennsylvania Archaeologist* 4(3):13-15.
- Stoltman, J.B.  
1989 A Quantitative Approach to the Petrographic Analysis of Ceramic Thin-Sections. *American Antiquity* 54:147-160.
- Stothers, D.M.  
1977 *The Princess Point Complex*. National Museum of Man, Mercury Series 58.
- Struever, S., and K.D. Vickery  
1973 The Beginnings of Cultivation in the Midwest-Riverine Area of the United States. *American Anthropologist* 54:147-160.
- Struiver, M. and G.W. Pearson  
1986 High Precision Calibration of Radiocarbon Time Scale, A.D. 1950-500 B.C. *Radiocarbon* 28(2B):805-838.
- Styles, B.  
1981 *Faunal Exploitation and Resource Selection: Early Late Woodland Subsistence in the Lower Illinois Valley*. Northwestern University Archaeological Program, Evanston, Illinois.

- Sullivan, A.P., III, and K.C. Rozen  
1985 Debitage Analysis and Archaeological Interpretation. *American Antiquity* 50:755-779.
- Taylor, A.R.  
1977 *Geological and Mineral Resources of the Lock Haven 7 1/2-Minute Quadrangle Clinton and Lycoming Counties, Pennsylvania*. U.S. Geological Survey, Somerset, Kentucky.
- Teghtsoonian, R.  
1971 On the Exponents in Steven's law and the Constant in Ekman's law. *Psychological Review* 78:71-80.
- Thompson, G.  
1978 *Prehistoric Settlement Changes in the Southern Northwest Coast: a Functional Approach*. University of Washington, Department of Anthropology. Reports in Archaeology No. 5. Seattle.
- Thornbury, W.D.  
1965 *Regional Geomorphology of the United States*. John Wiley & Sons, Inc., New York.  
1969 *Principles of Geomorphology*. John Wiley and Sons, Inc. New York..
- Thurman, N.C., Ciolkosz, E.J., and R.R. Dobos  
1992 *Soil Characterization Laboratory Methods Manual*. Agronomy Series Number 117, Pennsylvania State University, University Park, 119 p.
- Torrence, R.  
1983 Time Budgeting and Hunter-gatherer Technology. In *Hunter-Gatherer Economy in Prehistory: A European Perspective*, edited by G. Bailey, pp. 11-22. Cambridge University Press, Cambridge.  
1989a Retooling: Towards a Behavioral Theory of Stone Tools. In *Time, Energy, and Stone Tools*, edited by R. Torrence, pp. 57-66. Cambridge University Press, Cambridge.
- Torrence, R. (editor)  
1989b *Time, Energy, and Stone Tools*. Cambridge University Press, Cambridge.
- Treisman, M.  
1964 Sensory Scaling and the Psychophysical Law. *Quarterly Journal of Experimental Psychology* 16:11-22.
- Tringham, R., G. Cooper, G. Odell, B. Voytek, and A. Whitman  
1974 Experiments in the Formation of Edge Damage: A New Approach to Lithic Analysis. *Journal of Field Archaeology* 1:171-196.
- Tsirk, A.  
1974 Mechanical Basis of Percussion Flaking: Some Comments. *American Antiquity* 39:128.

- Tuck, J.A.  
1971 *Onondaga Iroquois Prehistory: A Story in Settlement Archaeology*. Syracuse University Press, Syracuse.
- Turnbaugh, W.A.  
1970 A Study of Argillite Points in Eastern Pennsylvania. *Pennsylvania Archaeologist* 40(1-2):35-42.  
  
1973 Life Zones and Early Man in North-Central Pennsylvania. *Pennsylvania Archaeologist* 43(3-4):61-74.  
  
1975 Toward an Explanation of the Broadpoint Dispersal in Eastern North American Prehistory. *Journal of Anthropological Research* 31:51-68.  
  
1977 *Man, Land, and Time*. Lycoming County Historical Society, Williamsport, Pennsylvania.  
  
1978 Floods and Archaeology. *American Antiquity* 43(4): 593-607.
- U.S. Army Corps of Engineers, Baltimore District  
1989 Statement of Work for the Data Recovery and Additional Testing at the Memorial Park Site (36CN164), Lock Haven, Clinton County, Pennsylvania. In *Solicitation No. DA(W3)-89-R-0099*. U.S. Army Corps of Engineers, Baltimore.  
  
1990 *Archaeological Data Recovery and Mitigation Plan, Memorial Park Site (36CN164), Lock Haven, Pennsylvania*. U.S. Army Corps of Engineers, Baltimore.
- Valter, V.  
1970 Deduction and Verification of Quantum Psychophysical Equation. *Reports from the Institute of Applied Psychology, University of Stockholm* 61:178-184.
- Van Dyke, A.P., and J.A. Behm  
1981 Archaeological Recovery at 11-RI-217, An Early Middle Woodland Site at Milan, Illinois. *The Wisconsin Archaeologist* 62:257-345.
- Vaughn, P.  
1985 *Use-Wear Analysis of Flaked Stone Tools*. University of Arizona Press, Tucson.
- Vento, F.B., P.T. Fitzgibbons, and S.D. Heberling  
1988 *Phase I Cultural Resource Management Investigations for the Lock Haven Flood Protection Project, Clinton County, Pennsylvania*. Report prepared by Vendel Enviro-Industrial Consultants for U.S. Army Corps of Engineers, Baltimore District.
- Vento, F.J., and H.B. Rollins  
1989 *Development of a Late Pleistocene-Holocene Genetic Stratigraphic Framework as It Relates to Atmospheric Circulation and Climate Change in the Upper and Central Susquehanna River Drainage Basin*. Report prepared for Bureau for Historic Preservation, Pennsylvania Historical and Museum Commission.



- Vennum, T., Jr.  
1988 *Wild Rice and the Ojibway People*. St. Paul: Minnesota Historical Society Press.
- von den Driesch, A.  
1976 *A Guide to the Measurement of Animal Bones from Archaeological Sites*. Peabody Museum Bulletin, No. 1. Cambridge.
- Wall, R.D.  
1981 *An Archaeological Study of the Western Maryland Coal Region: The Prehistoric Resources*. Report prepared by Division of Archaeology, Maryland Geological Survey, for Maryland Bureau of Mines.
- Waltman, W.J., Cunningham, R.L., and E.J. Ciolkosz  
1990 Stratigraphy and Parent Material Relationships of Red Substratum Soils on the Allegheny Plateau. *Soil Science Society of America Journal* 54:1049-1057.
- Ward, G.K., and S.R. Wilson  
1978 Procedures for Comparing and Combining Radiocarbon Age Determinations: A Critical Review. *Archaeometry* 20:19-31.
- Watson, P.J.  
1976 In Pursuit of Prehistoric Subsistence: A Comparative Review of Some Contemporary Flotation Techniques. *Midcontinental Journal of Archaeology* 1:77-100.  
  
1985 The Impact of Early Horticulture in Upland Drainages of the Midwest and Midsouth. In *Prehistoric Food Production in North America*, edited by R. I. Ford, pp. 99-148. Anthropological Papers, Museum of Anthropology, University of Michigan, No. 75. Ann Arbor.  
  
1988 Prehistoric Gardening and Agriculture in the Midwest and Midsouth. In *Interpretations of Culture Change in the Eastern Woodlands during the Late Woodland Period*, edited by R. W. Yerkes, pp. 39-67. The Ohio State University, Department of Anthropology, Occasional Papers in Anthropology 3.
- Watts, W.A.  
1979 Late Quaternary Vegetation of Central Appalachia and the New Jersey Coastal Plain. *Ecological Monographs* 49:427-469.  
  
1983 Vegetational history of the eastern United States 15,000 to 10,000 years ago. In *Late-Quaternary Environments of the United States, Vol. 1: The Late Pleistocene*, edited by S. C. Porter and H. E. Wright Jr., pp.166-181. University of Minnesota Press, Minneapolis, Minnesota.
- Webster, D., M. Aldenderfer, J.W. Hatch, and C.A. Hay  
1977 The Milesburg Site: A Hunting Camp in Central Pennsylvania. *Pennsylvania Archaeologist* 47(4):37-47.
- Weed, C., et al.  
1987 *A Cultural Resources Survey of a Portion of the Transcontinental Gas Pipe Line Corporation SS-1 Storage Service Project, Luzerne County, Pennsylvania*. Report prepared by New World Research, Inc., for EMANCO, Inc.

- 1988 *Summary of Phase II Archaeological Investigations and Phase III Data Recovery Plan, 36LU105 (The Gould Island Site), Luzerne County, Pennsylvania*. Report prepared by New World Research, Inc., for EMANCO, Inc.
- Weiser, C.  
1854 Narrative of a Journey from Tulpehocken, Pennsylvania to Onondaga, in 1737. In *Information Respecting the History, Conditions, and Prospects of the Indian Tribes of the United States* by H.R. Schoolcraft. Lippincott, Gambo & Company, Rochester.
- Wendland, W.M., and R.A. Bryson  
1974 *Dating Climatic Episodes of the Holocene*. *Quat. Res.* 12:311-325.
- Whallon, R.  
1973a Spatial Analysis of Occupation Floors I: Applications of Dimensional Analysis of Variance. *American Antiquity* 38:266-278.  
1973b Spatial Analysis of Paleolithic Occupation Areas. In *The Explanation of Culture Change: Models in Prehistory*, edited by Colin Renfrew, pp 115-130. University of Pittsburgh Press, Pittsburgh.  
1974 Spatial Analysis of Occupation Floors, II. Application of Nearest Neighbor Analysis. *American Antiquity* 39:16-34.  
1984 Unconstrained Clustering for the Analysis of Spatial Distributions in Archaeology. In *Intrasite Spatial Analysis in Archaeology*, edited by H. Hietala, pp 242-272.
- White,  
1968 *Introduction to College Physics*. D. Von Nostrand Company.
- White, J.P.  
1969 Typologies for Some Prehistoric Flaked Stone Artifacts of the Australian-New Guinea Highlands. *Archaeology and Physical Anthropology in Oceania* 4: 18-46.
- Wildesen, L.  
1982 The Study of Impacts on Archaeological Sites. In *Advances in Archaeological Method and Theory Vol. 5*, edited by M. B. Schiffer, pp. 51-83. Academic Press, New York.
- Wilk, R.R., and W.L. Rathje (editors)  
1982 Archaeology of the Household: Building a Prehistory of Domestic Life. *American Behavioral Scientist* 25.
- Wilkins, G.R.  
1985 The Hansford Site: An Archaic Site in Kanawha County, West Virginia. *West Virginia Archaeologist* 37(1)21-26.
- Wilkinson, L.  
1989 *SYSTAT: The System for Statistics*. SYSTAT, Inc., Evanston, Illinois.

- Wiley, L.M.  
 1980 The Analysis of Flotation Samples from the Fisher Farm Site. In *The Archaeology of Central Pennsylvania, Volume I. The Fisher Farm Site: A Late Woodland Hamlet in Context*, edited by James W. Hatch. Pennsylvania State University, Department of Anthropology, Occasional Papers in Anthropology 12.
- Williams, E.H.  
 1917 *Pennsylvania Glaciation: First Phase*. Woodstock, VT. 101 p.
- Wilmsen, E. N.  
 1968 Functional Analysis of Flaked Stone Artifacts. *American Antiquity* 33(2):156-161.  
 1970 *Lithic Analysis and Cultural Inferences: A Paleo-Indian Case Study*. Anthropological Papers of the University of Chicago No. 16. Tucson.
- Wing, E., and A. Brown  
 1979 *Paleonutrition*. Academic Press, New York.
- Witthoft, J.  
 1952 A Paleo-Indian Site In Eastern Pennsylvania: An Early Hunting Culture. *American Philosophical Society, Proceedings* 96(4):464-495.  
 1953 Broad Spearpoints and the Transitional Period Cultures in Pennsylvania. *Pennsylvania Archaeologist* 23(1):4-31.  
 1954 *A Brief History of the Indian Hunter*. Pennsylvania Historical and Museum Commission, Reprints in Anthropology 7.  
 1954 Pottery from the Stewart Site, Clinton County, Pennsylvania. *Pennsylvania Archaeologist* 24(1):22- 29.  
 1959 Ancestry of the Susquehannocks. In *Susquehannock Miscellany*, edited by J. Witthoft, and W. F. Kinsey, pp. 19-60. Pennsylvania Historical and Museum Commission, Harrisburg, Pennsylvania.
- Witthoft, J., and S.S. Farver  
 1952 Two Shenks Ferry Sites in Lebanon County, Pennsylvania. *Pennsylvania Archaeologist* 22(1):3-22.
- Wren, C.  
 1914 A Study of North Appalachian Indian Pottery. *Wyoming Historical and Geological Society, Proceedings and Collections* 13:131-221.
- Wright, H.E., Jr.  
 1983 Introduction. In *Late-Quaternary Environments of the United States, Vol. 2, The Holocene*, edited by H. E. Wright Jr., pp. xi-xvii. University of Minnesota Press, Minneapolis, Minnesota.
- Wylie, H.G.  
 1975 Tool Microwear and Functional Types from Hogup Cave, Utah. *Tebiwa* 17(2):1-31.

Yarnell, R.A.

1978 Domestication of Sumpweed and Sunflower in Eastern North America. In *The Nature and Status of Ethnobotany*, edited by R. I. Ford, pp. 289-299. University of Michigan, Museum of Anthropology, Anthropological Papers 67.

Yerkes, R.W.

1983 Microwear, Microdrills, and Mississippian Craft Specialization. *American Antiquity* 48(3):499-518.

1985 Stone Tool Function and Social Differentiation Within the Mississippian Component at the Labras Lake Site, Illinois. Paper presented at the 50th Annual Meeting of the Society for American Archaeology, May, Denver.

1986 Shell Bead Production and Exchange in Prehistoric Mississippian Populations. Paper presented at the Shell Bead Conference organized by the Arthur C. Parker Fund for Iroquois Research and the Rochester Museum and Science Center, November, Rochester, New York.

1987 *Prehistoric Life on the Mississippi Floodplain: Stone Tool Use, Settlement Organization, and Subsistence Practices at the Labras Lake Site, Illinois*. University of Chicago Press.

Youse, H.J.

1985 Comments and Corrections Concerning Amos Points. *West Virginia Archaeologist* 37(2):46.