

DECISION SUPPORT MODEL TO OPTIMIZE SITE
CHARACTERIZATION ACTIVITIES TAKEN IN COMPLIANCE
WITH THE COMPREHENSIVE ENVIRONMENTAL RESPONSE
COMPENSATION AND LIABILITY ACT

THESIS

Daniel J. Clairmont, Captain, USAF

AFIT/GEE/ENS/95D-01

DISTRIBUTION STATEMENT A

Approved for public release;
Distribution Unlimited

19960206 017

DTIC QUALITY INSPECTED 1

The views expressed in this thesis are those of the author and do not reflect the official policy or position of the Department of Defense or the U.S. Government.

AFIT/GEE/ENS/95D-01

DECISION SUPPORT MODEL TO OPTIMIZE SITE CHARACTERIZATION
ACTIVITIES TAKEN IN COMPLIANCE WITH THE COMPREHENSIVE
ENVIRONMENTAL RESPONSE COMPENSATION AND LIABILITY ACT

THESIS

Presented to the Faculty of the School of Engineering
of the Air Force Institute of Technology

Air University

In Partial Fulfillment of the

Requirements for the Degree of

Master of Science in Engineering and Environmental Management

Daniel J. Clairmont, B.S.

Captain, USAF

December 1995

Approved for public release; distribution unlimited

REPORT DOCUMENTATION PAGE			Form Approved OMB No. 0704-0188	
Public reporting burden for this collection of information is estimated to average 1 hour per response, including the time for reviewing instructions, searching existing data sources, gathering and maintaining the data needed, and completing and reviewing the collection of information. Send comments regarding this burden estimate or any other aspect of this collection of information, including suggestions for reducing this burden, to Washington Headquarters Services, Directorate for Information Operations and Reports, 1215 Jefferson Davis Highway, Suite 1204, Arlington, VA 22202-4302, and to the Office of Management and Budget, Paperwork Reduction Project (0704-0188), Washington, DC 20503.				
1. AGENCY USE ONLY (Leave blank)	2. REPORT DATE December 1995	3. REPORT TYPE AND DATES COVERED Master's Thesis		
4. TITLE AND SUBTITLE DECISION SUPPORT MODEL TO OPTIMIZE SITE CHARACTERIZATION ACTIVITIES TAKEN IN COMPLIANCE WITH THE COMPREHENSIVE RESPONSE COMPENSATION AND LIABILITY ACT			5. FUNDING NUMBERS	
6. AUTHOR(S) Daniel J. Clairmont, Capt, USAF				
7. PERFORMING ORGANIZATION NAME(S) AND ADDRESS(ES) Air Force Institute of Technology, WPAFB OH 45433-6583			8. PERFORMING ORGANIZATION REPORT NUMBER AFIT/GEE/ENS/95D-01	
9. SPONSORING/MONITORING AGENCY NAME(S) AND ADDRESS(ES)			10. SPONSORING/MONITORING AGENCY REPORT NUMBER	
11. SUPPLEMENTARY NOTES				
12a. DISTRIBUTION/AVAILABILITY STATEMENT Approved for public release; distribution unlimited			12b. DISTRIBUTION CODE	
13. ABSTRACT (Maximum 200 words) One of the most frequently cited reasons for the slow and costly progress of Superfund cleanups is the remedial investigation and feasibility study process (RI/FS). After each phase of the RI/FS process there are several possible alternatives that may be chosen. This research developed decision support models to help decision makers choose between the feasible alternatives at five different decision points during site characterization activities. The models make recommendations on how to deal with any particular chemical based on the risk posed by that chemical. The models assume that the value of characterizing the site further is a reduction in the uncertainty associated with the chemical concentrations in the contaminated media and a reduction in the probability of errors occurring during and after remedy selection. The models developed in this research were verified and validated using data from a fully characterized hazardous waste site. The site evaluated was the POL Storage Area in operable unit two at Wright-Patterson AFB, Ohio.				
14. SUBJECT TERMS Decision Aids, Decision Making, Decision Support Systems, Hazardous Wastes, Uncertainty, Environmental Management, Risk, Contamination, Site Investigations			15. NUMBER OF PAGES 239	
			16. PRICE CODE	
17. SECURITY CLASSIFICATION OF REPORT Unclassified	18. SECURITY CLASSIFICATION OF THIS PAGE Unclassified	19. SECURITY CLASSIFICATION OF ABSTRACT Unclassified	20. LIMITATION OF ABSTRACT UL	



THESIS APPROVAL

Student: Daniel J. Clairmont, Captain, USAF

Class: GEE-95D

Title: Decision Support Model to Optimize Site Characterization Activities Taken in Compliance with the Comprehensive Environmental Response Compensation and Liability Act

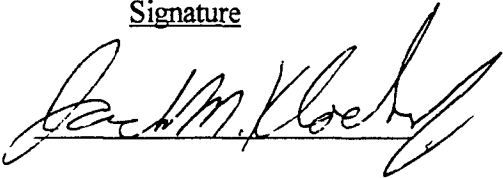
Defense Date: 16 November 1995

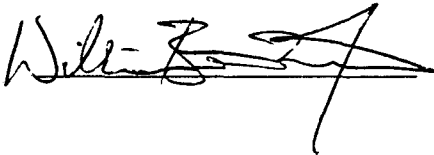
<u>Committee:</u>	<u>Name/Title/Department</u>	<u>Signature</u>
Advisor	Jack M. Kloeber, LTC, USA Assistant Professor Department of Operational Sciences	
Reader	Thomas R. Hauser Distinguished Visiting Professor Department of Engineering and Environmental Management	
Reader	William B. Nixon, Major, USAF Assistant Professor Department of Engineering and Environmental Management	

Preface

The purpose of this research was to use the tools and techniques provided in Decision Analysis to develop a model that could be used by decision makers to select the best hazardous waste site characterization strategy. Five models were actually developed, one for each of the five information gathering phases of site characterization. The models address the preliminary assessment, the site investigation, and the 30, 60, and 100 percent phases of the remedial investigation.

The models select the recommended alternative for a particular chemical based on the risk posed by that chemical. The models assume the benefit to additional site characterization is a reduction in the uncertainty associated with the estimate of the mean chemical concentration and an increase in the probability of selecting an appropriate remediation technology. The models are intended for use by remedial project managers to help them determine the best course of action while reducing the duration and cost of site characterization.

The technical guidance received from my advisor, LTC Jack Kloeber, and the other members of my thesis committee, Maj Brent Nixon and Dr Thomas Hauser, has proven to be extremely valuable throughout this research effort. Also, Ronald Lester and Mary Seitz of the 88 ABW/EM shop were helpful in obtaining the data needed to validate the models. My deepest debt of gratitude, however, goes to my family. They have sacrificed for this research more than anyone else. My wife, Martha, has gone for days without adult conversation and has made sacrifices in her career for the sake of my thesis. My children, Joshua, Audrey, and Elyssa, have given up more horsy rides, batting practice and bike rides to the park than any dad could expect from his children. It is to them that I owe my deepest gratitude, for their patience

and understanding, and it is to them that anyone benefiting from this research is indebted. I can only hope that, when the time comes, I am as forgiving and understanding with them as they have been with me.

Daniel J. Clairmont

Table of Contents

	Page
Preface.....	ii
List of Tables.....	vii
List of Figures.....	viii
Abstract.....	xi
<u>I. Introduction.....</u>	<u>1</u>
Research Objective.....	1
Background.....	1
Superfund Inefficiencies.....	2
Streamlining Approaches.....	3
Goals.....	5
Objectives.....	7
<u>II. Literature Review.....</u>	<u>8</u>
Introduction.....	8
Problem Background.....	8
Congressional Reauthorization Options.....	9
Implementation Initiatives.....	11
The Superfund Accelerated Cleanup Model.....	12
Data Quality Objectives.....	13
The Observational Method.....	14
Presumptive Remedies.....	14
Superfund Innovative Technology Evaluation Program.....	14
Risk Assessment.....	16
Hazard Identification.....	16
Dose-Response Assessment.....	17
Exposure Assessment.....	18
Inhalation Route.....	19
The inhalation route can apply to virtually any media open to the.....	19
Ingestion Route.....	24
Dermal Contact Route.....	25
Risk Characterization.....	27
Statistical Principles.....	28
The Central Limit Theorem.....	29
Linear Combinations.....	31
Decision Analysis.....	34

<u>III. Methodology</u>	36
Introduction.....	36
Model Requirements.....	36
Model Development in DPL.....	40
Identify the Problem.....	40
Identify Objectives and Alternatives.....	40
Preliminary Assessment.....	41
Site Investigation.....	43
Remedial Investigation.....	44
Removal Action.....	46
Feasibility Study.....	47
Decomposition and Modeling of the Problem.....	48
Primary Information Gathering Steps.....	49
Subsequent Information Gathering Steps.....	64
Removal Action.....	65
Feasibility Study.....	67
Model Development in Excel.....	79
Input Variables.....	80
Risk Multipliers.....	84
Probability Calculation.....	85
Cumulative Risk Calculation.....	86
<u>IV. Analysis and Findings</u>	88
Introduction.....	88
Model Verification.....	89
Influence Diagram Verification.....	90
Spreadsheet Model Verification.....	92
Model Validation.....	94
Site Investigation Model Results.....	95
100 Percent Remedial Investigation Model Results.....	96
Preliminary Assessment Model Results.....	96
Decision Policy Interpretation.....	98
The Second Run of the RI100 Model.....	101
Sensitivity Analysis.....	103
Preliminary Assessment Model.....	105
Acceptable Risk.....	106
Cost Weight.....	107
Groundwater Toluene Concentration.....	109
Surface Soil Benzene Concentration.....	110
Surface Soil Removal Action Mean Reduction Factor.....	112
Site Investigation Model.....	114
100 Percent Remedial Investigation Model.....	115
RI100, Run Number One.....	115
RI100, Run Number Two.....	116
Cost and Duration Estimates.....	116

V. <u>Conclusions</u>	119
Assumptions	120
Using the Models	121
Running the Models	122
Recommendations for Future Research	123
Appendix A: Tables of Excel Cell Names and DPL Nodes.....	A-1
Appendix B: List of Acronyms.....	B-1
Appendix C: Molecular Diffusivity Constants.....	C-1
Appendix D: Influence Diagrams for the Five Models Developed	D-1
Appendix E: Summary Results of the Sensitivity Analysis.....	E-1
Appendix F: Input Parameters for the Four Model Runs.....	F-1
Bibliography	Bib-1
Vita.....	Vit-1

List of Tables

	Page
Table 1: Investigation Requirements of the National Contingency Plan.....	10
Table 2: Summary of Inhalation Emission Factors (<i>K</i>) for Equation (1).....	20
Table 3: Table of Typical Upper and Lower Bound Risk Values	54
Table 4: Probabilities of High NFA Costs and Durations for all Risk Level Combinations.....	58
Table 5: Parameters Used in Influence Diagram Verification.....	90
Table 6: Risk Calculation Comparisons	93
Table 7: Summary of Selected Input Parameters	104
Table 8: List of Input Variables	A-2
Table 9: Partial List of Calculated Variables in the Models.....	A-27
Table 10: Table of DPL Nodes Not Linked to Excel.....	A-45
Table 11: Chemical Constants	C-2

List of Figures

Figure 1: EPA's Superfund Management Process.4

Figure 2: The Superfund Accelerated Cleanup Model.....12

Figure 3: Influence Diagram Components35

Figure 4: Strategy Generation Table for the PA Decision.....38

Figure 5: RI/FS Sequence of Decisions and Alternatives41

Figure 6: Preliminary Assessment Decision with Alternatives.....42

Figure 7: Site Investigation Decision with Alternatives43

Figure 8: Remedial Investigation Phases and Alternatives.....45

Figure 9: Removal Action Decision Node with Alternatives46

Figure 10: Feasibility Study Decision Node with Alternatives.....47

Figure 11: Decision Sequence for the 30 Percent Remedial Investigation Model.....49

Figure 12: Conceptual Model for a Primary Information Gathering Step50

Figure 13: Conditioning Nodes Showing Event States52

Figure 14: Effect of the Influence of Media and Type Nodes52

Figure 15: Cancer Risk and Hazard Index Probabilities Nodes with Event States53

Figure 16: NFA Cost and Duration Nodes with States and Values55

Figure 17: Influences from Risk Probability Nodes to NFA Cost and Duration Nodes59

Figure 18: Example of Cost and Duration Value Nodes for Preliminary Assessment

Decision60

Figure 19: Graphic Representation of the Attribute Scoring Function63

Figure 20: Conceptual Model for a Subsequent Information Gathering Step.....64

Figure 21: Conceptual Model for a Removal Action	66
Figure 22: Conceptual Model of the Feasibility Study Decision	68
Figure 23: True Site Similarity Node with Event States	69
Figure 24: Probability of True Site Similarity Determination.....	69
Figure 25: Site Similarity Report Node with Event States and Influences	72
Figure 26: Technically Appropriate Node with Event States and Influences	72
Figure 27: Penalties for the Choosing a Technically Inappropriate Remedy	75
Figure 28: Cleanup Goals Met Node with Probabilities and Influences.....	76
Figure 29: Cleanup Goals Met Node with Values and Influences	78
Figure 30: Risk Probability Distribution Graph	85
Figure 31: Sample Decision Policy Output From DPL.....	91
Figure 32: SI Model Decision Policy Diagram for Benzene in Groundwater	95
Figure 33: 100% Remedial Investigation Decision Policy for Benzene in Groundwater	96
Figure 34: Benzene in Groundwater Decision Policy Diagram.....	97
Figure 35: Benzene in the Surface Soil Decision Policy Diagram	97
Figure 36: Benzene in Surface Soil Expanded Decision Policy	100
Figure 37: Decision Policy Summary for Run 2 of the RI100 Model	102
Figure 38: Strategy Region Graph for Acceptable Risk in PA Model, Run 1	106
Figure 39: Strategy Region Graph for Cost Weight in PA Model, Run 1	108
Figure 40: Strategy Region Graph for Upper Bound Toluene Concentration in Groundwater for PA Model, Run 1	109
Figure 41: Strategy Region Graph for the Upper Bound Concentration Estimate of Benzene in Surface Soil for the PA Model, Run 1	112

Figure 42: Strategy Region Graph of Surface Soil Removal Efficiency for PA Model, Run 1	112
Figure 43: Cumulative Distribution of Cost for the PA Model, Run 1.....	117
Figure 44: Preliminary Assessment Model Influence Diagram.....	D-2
Figure 45: Site Investigation Model Influence Diagram.....	D-3
Figure 46: 30% Remedial Investigation Model Influence Diagram	D-4
Figure 47: 60% Remedial Investigation Model Influence Diagram	D-5
Figure 48: 100% Remedial Investigation Model Influence Diagram	D-6
Figure 49: Complete Decision Tree Starting At the Preliminary Assessment.....	D-7
Figure 50: Preliminary Assessment and Site Investigation Section.....	D-8
Figure 51: 30% Remedial Investigation Section	D-9
Figure 52: 60% Remedial Investigation and Removal Action Section.....	D-10
Figure 53: 100% Remedial Investigation Section	D-11
Figure 54: Preliminary Assessment Run 1 Tornado Diagram.....	E-2
Figure 55: Site Investigation Run 1 Tornado Diagram.....	E-7
Figure 56: 100 Percent Remedial Investigation Run 1 Tornado Diagram.....	E-11
Figure 57: 100 Percent Remedial Investigation Run 2 Tornado Diagram.....	E-14

Abstract

One of the most frequently cited reasons for the slow and costly progress of Superfund cleanups is the remedial investigation and feasibility study process (RI/FS). After each phase of the RI/FS process there are several possible alternatives that may be chosen.

This research developed decision support models to help decision makers choose between the feasible alternatives at five different decision points during site characterization activities. The models make recommendations on how to deal with any particular chemical based on the risk posed by that chemical. The models assume that the value of characterizing the site further is a reduction in the uncertainty associated with the chemical concentrations in the contaminated media and a reduction in the probability of errors occurring during and after remedy selection.

The models developed in this research were verified and validated using data from a fully characterized hazardous waste site. The site evaluated was the POL Storage Area in operable unit two at Wright-Patterson AFB, Ohio.

DECISION SUPPORT MODEL TO OPTIMIZE SITE CHARACTERIZATION
ACTIVITIES TAKEN IN COMPLIANCE WITH THE COMPREHENSIVE
ENVIRONMENTAL RESPONSE COMPENSATION AND LIABILITY ACT

I. Introduction

Research Objective

The objective of this research effort is to develop a decision support model to enable decision makers to better decide the best path through the remedial investigation and feasibility study (RI/FS) process. It enables decision makers to make justifiable decisions about the cleanup of Superfund and Installation Restoration Program (IRP) sites. The model uses site specific information and decision maker preferences to select the course of action with the highest expected value at each step in the planning and investigation phase of site remediation.

Background

The Comprehensive Environmental Response, Compensation, and Liability Act (CERCLA) was first signed into law in 1980. The intent of the law was to provide a vehicle to cleanup hazardous waste sites (LaGrega, 1994:54) at a time when environmental incidents, such as the ones at Love Canal and Times Beach, had caused great concern over environmental issues. It provided the US Environmental Protection Agency (EPA) with the authority to recover cleanup costs from parties shown to have ties to the site. It also provided a fund, known as the Superfund, to be used for site cleanup while the EPA tried to recover the cleanup

costs from the responsible parties. In the first five years of CERCLA, however, only six sites were cleaned (LaGrega, 1994:55).

With the problems of the first five years in mind, Congress needed to revise and reauthorize CERCLA. The Superfund Amendments and Reauthorization Act of 1986 (SARA) was the next effort. SARA increased the authorization given under CERCLA from \$1.6 billion to \$8.5 billion and mandated that the EPA conduct remedial investigations and feasibility studies on 650 sites by 1991 (LaGrega, 1994:55). Even with the added money and the added emphasis, the EPA had removed only 33 of 1200 sites from the National Priorities List (NPL) by mid-1991 (Duplancic, 1993:50).

CERCLA and SARA established hazardous waste site cleanup procedures that are inflexible and are considered unresponsive to the needs of its stakeholders (USEPA, 1992b:1). In 1993 it took an average of 10-12 years to cleanup a site (Duplancic, 1993:50) at an average cost of \$25 million (Ember, 1993:19). These statistics, strong complaints from business about the concept of strict, joint and several liability, and the EPA's redundant management structure (USEPA, 1992b:1) have left little doubt from business, environmental groups, and Congress that the Superfund program must be streamlined.

Superfund Inefficiencies

The process by which hazardous waste sites are remediated under Superfund is detailed, extensive, and written into law. Part 300 of Title 40 of the Code of Federal Regulations (CFR), otherwise known as the National Contingency Plan (NCP), describes the Superfund process. This process is modeled closely by the Air Forces' Installation Restoration Program (IRP), which is divided into three phases: planning and investigation, cleanup, and close-out

(Department of the Air Force, 1992:1-3). The longest and most expensive of these phases is the planning and investigation phase (Duplancic, 1993,53). This portion of the process may take up to 10 years to complete and cost millions of dollars.

The planning and investigation phase consists primarily of a series of data gathering and analysis activities with the goal of determining the appropriate response methodology for the particular site. The four main elements of the planning and investigation phase of site remediation addressed in the NCP are the preliminary assessment, site investigation, remedial investigation, and feasibility study (National Archives and Records Administration, 1993:300.420). The EPA has further added to the extent and confusion of the NCP with its own internal Superfund management practices. They have broken down some of the studies already required in the NCP even further, such as the focused site investigation and the expanded site investigation. See Figure 1 for a flow chart of EPA's Superfund process (USEPA, 1992b:16). A list of acronyms is given in Appendix B.

Streamlining Approaches

The EPA has taken an active role in trying to improve the way Superfund is implemented. The combination of Data Quality Objectives (DQO) (USEPA, 1993a) and the Superfund Accelerated Cleanup Model (SACM), have the potential to "cut years off" the cleanup process (USEPA, 1992b:7). These two initiatives have combined rigorous statistical data analysis techniques (the DQO process) with a complete overhaul of the way the EPA manages the Superfund process (the SACM) within the framework of the current law. SACM emphasizes the reduction of human health risk, as well as the implementation of Total Quality Management initiatives within the organization (Blacker, 1994:466).

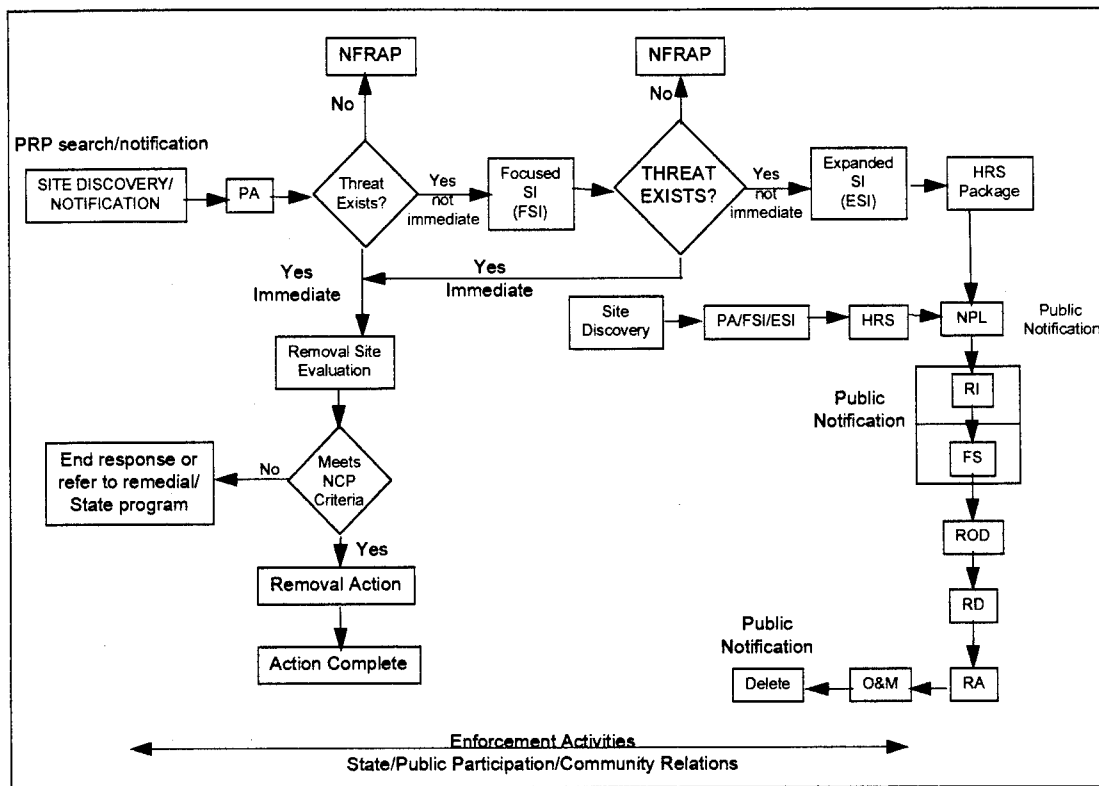

Figure 1: EPA's Superfund Management Process.

Other approaches that attempt to shorten the site characterization phase of the process are the Observational Method and presumptive remedies. The Observational Method attempts to characterize the most likely site conditions instead of performing in-depth investigations of the actual conditions. The most likely conditions are then used to establish a remediation design. The presumptive remedy approach cuts short the feasibility study portion of the planning and investigation phase to choose a remediation technology based on proven results at similar sites. It bypasses the treatability studies required under the NCP (Findall, 1994:2-8-2-9).

The Observational Method and presumptive remedies have the potential to substantially reduce the amount of time and money required to complete Superfund cleanups. However,

they do so by reducing, or eliminating, information that would have otherwise been available to the decision maker. The reduction of information is most generally correlated with an increase in the uncertainty surrounding the particular decision. When dealing with health issues, as is often the case in Superfund cleanups, perceived or actual increases in uncertainty can cause many public relations problems. Additionally, the greater uncertainty may increase the probability that a particular decision is incorrect.

There is a need to develop a decision support model that incorporates the benefits of techniques proven to reduce the cost and duration of site characterization activities such as the SACM, the DQO process, the Observational Method, and presumptive remedies, while considering the increased uncertainty. A model of this type will help decision makers decide when to discontinue site characterization activities and proceed with cleanup or declare that the site poses no significant health risk. Decision Analysis provides the methodology to create such a model. This research effort uses the Decision Analysis methodology and combines it with computer software tools to create a decision support model that can be tailored to specific sites and enables the decision maker to analyze the sensitivity of the decision to specific parameters.

Goals

Given the enormous cost of investigative efforts surrounding a Superfund cleanup and the fact that at the end of fiscal year 1993 the Department of Defense (DOD) had 19,694 sites that required some sort of action, over 9,000 of which had not begun any investigation, with a good many more in the very early stages (DOD, 1994:40), the DOD would benefit from a procedure that could reduce the cost and duration of hazardous waste site characterization. This research

effort proposes the use of a Decision Analysis model to minimize the cost and duration of investigative efforts associated with Superfund or Installation Restoration Program (IRP) sites. The model combines the statistical rigor and risk reduction emphasis of the DQO/SACM initiatives with the abbreviated investigative studies of the Observational Method and presumptive remedies, to determine the need for continued investigation.

That task can be accomplished through the use of Decision Analysis modeling techniques, such as influence diagrams, decision trees, and sensitivity analysis. In doing so, it would minimize the limitations of the other streamlining methods. The model developed in this thesis uses site specific data and characteristics to help a decision maker decide when he or she has enough information to make a decision with some specified degree of uncertainty. At that point the decision maker can choose to forego further studies and proceed directly to the feasibility study. If more information is desired the model will be helpful in identifying the most important media and chemicals of concern. The model incorporates actual site conditions such as the concentration of the chemicals detected, the contaminated media, the potential exposure pathways, the toxicity of the chemicals, and the value of future studies. It approximates the Superfund process using seven sequential decisions with the various uncertainties quantified. The desirability of more information is modeled as a function of both the type and quality of the information.

A decision support tool of this type should significantly shorten the duration and reduce the cost of remedial action. It would have the added benefit of using rigorous statistical techniques, applied to elements of a baseline risk assessment, to assist the decision maker in deciding upon a course of action. Finally, the model could be used to support a course of

action to regulators and to affected communities because it allows the decision maker to place bounds on individual parameters within which the decision will not change.

Objectives

There are three distinct objectives of this research effort. The first is to develop a decision model that contains all the influences that are essential to properly solve the problem, known as a requisite decision model (Clemen, 1991:8).

The second objective is to use the model to evaluate an actual IRP site. The site evaluated is in Operable Unit 2 on Wright-Patterson Air Force Base (WPAFB) in Ohio. WPAFB, as a whole, is listed on the National Priorities List. The RI/FS has already been completed for this site, and its evaluation is meant to validate the model with a well characterized site.

The final objective is to identify the influences and factors that most heavily affect the decision at each decision point. This objective is accomplished through the use of value sensitivity analysis.

The remainder of this thesis consists of four chapters and various appendices. Chapter Two discusses the background requirements of the model. It includes a brief review of current legislative actions to correct the problems with CERCLA as well as a description of risk analysis techniques and relevant statistical principles. It also gives a brief introduction to Decision Analysis. Chapter Three presents the development of the model and describes the influences between the various decisions and uncertain events. Chapter Four uses the model to analyze a specific project site. Three fuel spill sites in operable unit two at Wright-Patterson AFB in Ohio are the subjects of the analysis. Chapter Five gives the conclusions and recommendations drawn from the model as well as follow on research possibilities.

II. Literature Review

Introduction

The following chapter highlights the need for this research as well as the theoretical foundations used in the decision support model developed in Chapter 3. It begins with a discussion of the drivers for the research by highlighting the reasons for the early problems in the Superfund process. It then shows that the model presented here will continue to be useful even after CERCLA is reauthorized by discussing the current legislation before congress which is meant to fix the Superfund process. Next, a review of some current, alternative approaches to streamlining the RI/FS process are reviewed. Then relevant technical aspects are presented to include risk assessment philosophies, statistical principles and basic Decision Analysis background.

Problem Background

Superfund cleanup procedures are cumbersome, time consuming and expensive (Reilly, 1993:57; EPA, 1992b:1; Duplancic, 1993:50). The main reason cited for the excessive cost and duration of Superfund actions is the process itself, with regard to the required site characterization studies prior to beginning cleanup actions (Duplancic, 1993:51). The NCP is the document that governs the Superfund process. It is in the Code of Federal Regulations, Title 40, Part 300.

Federal facilities must comply with the requirements of the NCP, according to section 120 of SARA (Dept. of the Air Force, 1992:3-7). In response to this the Air Force has developed its own hazardous waste site remediation program called the IRP. The IRP consists of three

phases, the planning and investigation phase, the cleanup phase, and the close-out phase (Dept of the Air Force, 1992:1-3). The planning and investigation phase consumes a great deal of the cost and time required for site cleanup. It takes an average of 24 to 36 months (Clean Sites, 1989:21) and can cost millions of dollars (Seitz, 1995). After discovery of a site the planning and investigation phase begins with the preliminary assessment and proceeds to the site investigation, remedial investigation, and feasibility study. Table 1 summarizes the specific requirements of the NCP at each step in the planning and investigation phase (National Archives and Records Administration, 1993:52-59).

The most critical goal of any site cleanup is to protect human health and the environment (Dept of the Air Force, 1992:3-6), ideally, accomplished in a manner that minimizes the cost and duration of the cleanup. The studies done in the planning and investigation phase typically take the longest amount of time, sometimes lasting 10 years or more (Duplancic, 1993:50) and can cost more than the eventual remedy. Many organizations have proposed possible improvements to the Superfund process. One such organization is the U.S. Congress.

Congressional Reauthorization Options

At some point before December 31, 1995, Congress must decide the fate of CERCLA. By law, CERCLA must be reauthorized at the end of every 5 year period. All the funding for Superfund expires and the program will stagnate until the funding is reauthorized (Steinzor, 1995a:10017).

Table 1: Investigation Requirements of the National Contingency Plan

Phase	Requirement	Objectives	Information Needs
Preliminary Assessment	Required	<ol style="list-style-type: none"> 1. Identify sites that pose no threat. 2. Determine need for removal action. 3. Set future priorities. 4. Gather data to ease later evaluation. 	<ol style="list-style-type: none"> 1. Review existing information on exposure scenarios and source and nature of release. 2. Off site inspection as appropriate. 3. On site inspection where appropriate.
Site Investigation	Optional	<ol style="list-style-type: none"> 1. Identify sites that pose no threat. 2. Determine need for removal action. 3. Collect additional data for HRS scoring. 4. Collect additional data for rapid initiation of the RI/FS. 	<ol style="list-style-type: none"> 1. On and off site field investigatory efforts. 2. Sampling
Remedial Investigation	Required only if threat exists	<ol style="list-style-type: none"> 1. Collect data necessary to characterize the site to aid development and evaluation of remedial alternatives. 	As appropriate, conduct: <ol style="list-style-type: none"> 1. Field investigations. 2. Treatability studies. 3. Baseline risk assessment.
Feasibility Study	Required only if threat exists	<ol style="list-style-type: none"> 1. Ensure appropriate remedial alternatives are developed and evaluated by a decision maker. 	<ol style="list-style-type: none"> 1. Remediation goals 2. Detailed analysis of alternatives.

Along with the funding, Congress is trying to rewrite the law to make it less expensive and more responsive. There are at least two distinct, viable proposals on the floor of Congress. The first proposal attempts to streamline the process by eliminating the liability requirements of CERCLA, known as the public works alternative. It is represented as House of Representatives (H.R.) bill number 4161 (Steinzor, 1995b:10078). Although the main focus of this legislation is to reduce the litigation associated with Superfund cleanups, it does propose

risk-based cleanup standards, which is squarely in line with the second major proposal (Steinzor, 1995b:10082).

The second major proposal is the consensus legislation. Consensus legislation refers to H.R. 4916 and Senate bill number 1834. The consensus legislation, like the public works alternative, presents a risk-based decision process. It establishes a national risk protocol. The protocol would function as a tool in determining the cleanup standard at each site. Currently, there is no national standard to which a site must be remediated. The establishment of a risk-based cleanup standard allows the responsible parties to cleanup to a different level as long as the overall cancer risk does not exceed a still unspecified level and the hazard index does not exceed one (Steinzor, 1995a:10026). See the section entitled Risk Characterization on page 27 for a description of the hazard index.

Implementation Initiatives

Recognizing that the EPA's own internal Superfund process is largely to blame for the excessive cost and duration of hazardous waste site investigative efforts, they created the Superfund Accelerated Cleanup Model and the Data Quality Objectives process. The SACM and the DQO process, used in conjunction with each other, can potentially cut years off the time it takes to complete a remedial investigation (EPA, 1992a:7).

Two other common alternative approaches used to shorten the RI/FS process are the Observational Method and the use of presumptive remedies (Findall, 1994:2-7,2-9). These two concepts reduce the amount of information gathered to save time and money in the study phase. However, they have a higher probability of generating an incorrect decision. An incorrect decision would result in increased costs and increased cleanup time.

The Superfund Accelerated Cleanup Model. SACM is a management strategy aimed at speeding up the Superfund process. It eliminated EPA's internal distinction between remedial and removal actions (Lawrence, 1993:2962-2963), and it transformed an existing cumbersome, sequential process (see Figure 1 on page 4) into a more streamlined process, shown here in Figure 2 (EPA, 1992a:5a).

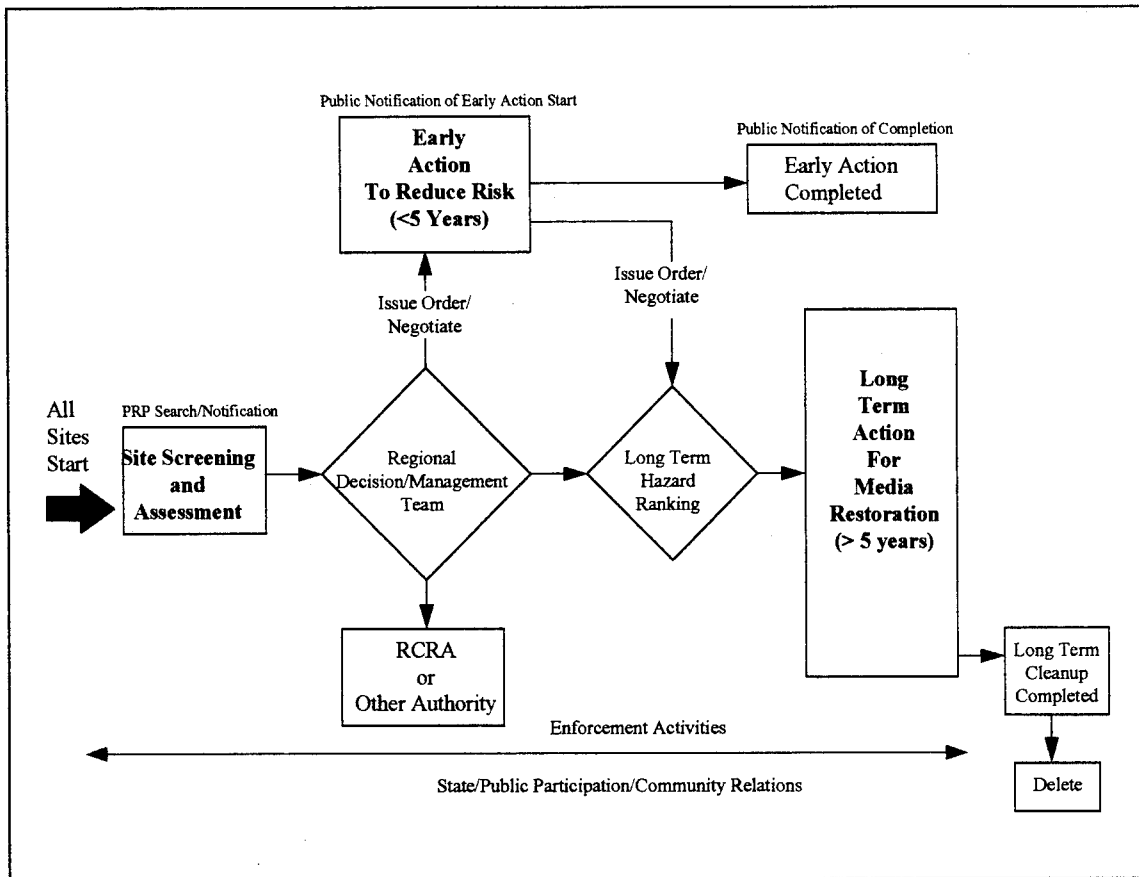

Figure 2: The Superfund Accelerated Cleanup Model

The SACM will help responsible parties in two ways to complete site investigations faster. First it consolidates site assessment activities. Previously, the Superfund process was

separated into sections that performed different studies. The sequential performance of the studies was inefficient. Often the studies did not consider the information gained from previous studies. The biggest obstacle to reducing the number of studies was the requirements of the NCP. However, the EPA believes that it is possible to satisfy the requirements of the NCP with just one study as long as the information is adequate (Lawrence, 1993: 2963-2964).

The second SACM result that helps to speed up site investigations is to turn EPA's focus to risk reduction. It introduced an early action list for sites that pose an immediate threat and will take less than five years to cleanup. The EPA used the number of sites removed from the early action list as the primary metric for program effectiveness. The reason for the change in focus is that sites removed from the early action list represent an immediate reduction in health risk (USEPA, 1992a:9).

Data Quality Objectives. The DQO process is a problem solving heuristic based on the scientific method that emphasizes early planning and the rules of probability to make data gathering as efficient as possible and controls the probability of making an incorrect decision. The DQO process consists of seven sequential problem solving steps that identify quantitative and qualitative information appropriate to the problem at hand (USEPA, 1993a:4).

The main benefit of the DQO process is its statistical procedures. They are especially important when the site contaminant levels are close to an action level or when the variability of the data is so great that the results are inconclusive. The statistical procedures provide a scientific basis for inferences about a site. They provide a basis for defining data quality criteria and supporting site assessment decisions. Additionally, the process provides quantitative criteria for knowing when to stop collecting data. Finally, its basis in the scientific method, helps improve the legal defensibility of site decisions (USEPA, 1993a:4-5).

The Observational Method. The Observational Method is a technique for characterizing subsurface geology, hydrology and the extent of contamination (Peck, 1969:171). These site characteristics are often complex and require extensive testing to describe precisely. The testing is expensive and time consuming. The Observational Method explores only enough to describe the most likely site characteristics. The most probable conditions then form the basis of the remedial design (Peck, 1969:173). The Observational Method has significant possibilities to save time and money (Peck, 1969:186). The cost of the initial savings is increased uncertainty of an accurate site characterization (Dean and Barvenik, 1992:36).

Presumptive Remedies. Presumptive remedies are often used in conjunction with the observational method. A presumptive remedy is a remediation technology that has been proven effective at other sites with similar characteristics (USEPA, 1992b:10). The difficulty arises in knowing how much information to collect to adequately determine site similarity.

Using a presumptive remedy has the potential to save time and money through elimination of the need to perform a feasibility study. Because a remediation technology was successful in the past, at sites with similar characteristics, there is no need to evaluate all the possible treatment technologies. The drawback to this method is the increase in uncertainty surrounding the effectiveness of a presumptive remedy (Findall, 1994:2-10). An unsuccessful remedy requires additional time and money to study and implement other options.

Superfund Innovative Technology Evaluation Program

The Superfund Innovative Technology Evaluation (SITE) program was set up to advance the development, evaluation, and implementation of innovative, alternative technologies for

remediation of contaminated hazardous waste sites. As a consequence, it has also had an impact on reducing the cost and duration of site characterization activities through development of faster and more cost effective monitoring and measurement technologies (USEPA, 1991b:xi).

There are four components of the SITE program, the Demonstration Program, the Emerging Technologies Program, the Monitoring and Measurement Technologies Program, and Technology Information Services. The Demonstration Program field tests innovative technologies and gathers engineering and cost data to evaluate the effectiveness of remediation technologies. The data gathered under this program can be useful in estimating the costs associated with site cleanup (USEPA, 1991b:3).

The Emerging Technologies Program is a precursor to the Demonstration Program. Technologies must first be evaluated under this program using laboratory and pilot scale tests to determine if they are acceptable to proceed on to the demonstration program (USEPA, 1991b:4).

The Monitoring and Measurement Technologies Program explores new technologies to assess the nature and extent of contamination. The technologies can reduce the cost and duration of site characterization (USEPA, 1991b:4).

The final component of the SITE program is the Technology Information Service. This service provides a database of information regarding the progress of the SITE program. The cost and engineering data from the Demonstration Program and the information regarding pending technologies in the Monitoring and Measurement Technologies Program can be obtained through this service (USEPA, 1991b:4).

The four components of the SITE program are another example of how the EPA has recognized the need to reduce the cost and duration of Superfund cleanups. In addition to accelerating characterization through technology, the SITE program can provide information to help decision makers choose the most effective remedial alternative.

Risk Assessment

Risk assessment is the evaluation of information on the hazardous properties of substances, on the extent of human exposure to them, and on the characterization of the resulting risk. It has four steps: hazard identification, dose-response assessment, exposure assessment, and risk characterization (National Research Council (NRC), 1994:4). The chief criticism of the risk assessment process is the uncertainty associated with the development of the relationship between chemical exposure and health risk (NRC, 1994:6). However, it is not the objective of this research to debate the merits of risk assessments. Risk assessment is currently the best method available for quantifying the health threat associated with environmental cleanups and making regulatory decisions (NRC, 1994:3). Throughout this thesis, methods accepted by the EPA and other federal agencies are used to estimate human health risk.

Hazard Identification. Hazard identification is the first step in risk assessment. It involves the identification of the contaminants suspected to pose health hazards. It involves the quantification of the concentrations that may be present in the environment; a description of the specific forms of toxicity, whether it is carcinogenic or not; and how the toxic effects might manifest themselves in humans. Epidemiological studies, animal studies, and other types of experimentation are the source of this information (NRC, 1994:26).

Dose-Response Assessment. Once a chemical has been identified to have some toxic effect, a dose-response assessment is accomplished. A dose-response assessment attempts to quantify the relationship between the dose of a chemical and the toxic response. Data and mathematical models used in this phase of risk assessment help to estimate the toxicity factors for a chemical (NRC, 1994:26). At this point in the risk assessment, the evaluation can take one of two routes depending on the type of toxic effect the chemical triggers.

Dose-response assessment for carcinogens assumes a zero threshold. It assumes that exposure to one molecule of a carcinogen results in a nonzero increased risk of developing cancer. However, in practice, the level of exposure to a carcinogen needed to produce meaningful statistical data in laboratory animals is orders of magnitude higher than one molecule. For this reason it is necessary to extrapolate from actual, high dose animal data to human exposure levels that may be several orders of magnitude lower than the experimental data. The extrapolation is done using mathematical models (NRC, 1983:24). This procedure produces a slope factor for a particular substance from a particular exposure route that quantifies the relationship between the dose and the physiological response (Brothers, 1995:106).

The EPA has determined the slope factors for the oral exposure route and the inhalation exposure route for a large number of potential carcinogens. Slope factors for the dermal absorption exposure route are not available. It is assumed that the dermal absorption slope factor is equivalent to the oral slope factor adjusted so that it is expressed as an absorbed dose (USEPA, 1989b:7-16). This adjustment is made by dividing the oral slope factor by the chemical's ingestion absorption efficiency (USEPA, 1989b:A-3). The Integrated Risk Information System (IRIS) lists the slope factors for various chemicals and the Superfund

Chemical Data Matrix lists toxicity data for chemicals commonly found at hazardous waste cleanup sites (USEPA, 1994).

The second category of toxic effect encompasses all non-cancer effects (NRC, 1994:60). Dose-response assessment for this type of toxic effect involves identifying the highest exposure among all available experimental studies that found a “no-observed-adverse-effect-level” (NOAEL). A NOAEL is the highest exposure where there is no statistically significant increase in the frequency of adverse effects. For noncarcinogenic effects the NOAEL approximates the threshold exposure level below which no adverse effects will occur (NRC, 1994:62). To account for such factors as uncertainty in the experimental data, extrapolation from animals to humans, and sensitive human subpopulations, the NOAEL is divided by a factor of safety between 100 and 10,000. This procedure produces a reference dose (RfD) thought to have a reasonable certainty of no harm (NRC, 1994:62). Reference doses, like slope factors, are for specific exposure routes and published only for oral and inhalation routes. Oral reference doses are adjusted to an absorbed dose RfD for the dermal absorption exposure route. The adjustment is made by multiplying the oral reference dose by the chemical’s ingestion absorption efficiency (USEPA, 1989b:A-2). Reference doses are published in IRIS and listed in the Superfund Chemical Data Matrix (USEPA, 1994).

Exposure Assessment. Exposure assessment is the third step in the risk assessment process. It is the process used to estimate the dose of a substance. Dose refers to the level and duration of exposure. The philosophy that guides the completion of exposure assessments is that they should not underestimate the true risk to the average person. For this reason the EPA has published guidelines to perform exposure assessments (EPA, 1992a:22888) that produce a reasonable maximum exposure (RME) estimate (USEPA, 1989b:6-4). The RME is greater

than the 90th percentile of the population distribution. It is not mandatory that these guidelines be followed explicitly in all cases. There may be reasons to deviate from them at some sites (USEPA, 1989b:6-5). In 1989 the EPA published a technical report called the Exposure Factors Handbook (USEPA, 1989a). It provides probabilities based on population surveys for exposure factors commonly used in risk assessment (EPA, 1989a:1-1).

Exposure can take place via three possible routes, the inhalation route, the oral or ingestion route, and the dermal contact route. Exposure is calculated differently for each of the these three routes. These calculations are explained below.

Inhalation Route. The inhalation route can apply to virtually any media open to the atmosphere if there are volatiles present. Equation (1) calculates the dose for the inhalation route (USEPA, 1991a:51-52; USEPA, 1989b:6-44).

$$Dose = \frac{(C)(IR)(ET)(EF)(ED)}{(K)(BW)(AT)} \quad (1)$$

where

- C = *chemical concentration in the media* (mg/kg in soil, mg/L in water, or mg/m³ in air)
- K = *emission factor* (m³/kg in soil, m³/L in water, or not applicable in air)
- IR = *inhalation rate* (m³/hour)
- ET = *exposure time* (hours/day)
- EF = *exposure frequency* (days/yr)
- ED = *exposure duration* (yr)
- BW = *body weight* (kg)
- AT = *averaging time* (days)

Many of the parameters found in Equation (1) have default values, such as the inhalation rate, body weight, exposure duration and averaging time. The data supporting these default values are in the EPA's Exposure Factors Handbook (USEPA, 1989a). The emission factor, *K*, in Equation (1) varies depending on the type of chemical and the media of concern. It defines the relationship between the concentration of contaminants in the media and the volatile or particulate contaminants in air (USEPA, 1991a:26). If the concentration of the chemical in the air is known then *K* is equal to one. However, use of the appropriate emission factor provides an estimate of risk from inhalation of volatiles contained in water or soil. The same is true for nonvolatiles in soil, inhaled as particulates from fugitive dust emissions. Table 2 gives a summary of appropriate emission factors.

Table 2: Summary of Inhalation Emission Factors (*K*) for Equation (1)

Type of Chemical	Media*	Factor Name	Value of <i>K</i> in Equation (1)
Volatiles	Soil	Soil-Air Volatilization Factor	Chemical Specific, See Equation (2) or (3) (m^3/kg)
	Water	Volatilization Factor	$K = 1/(0.5 L/m^3) = 2 m^3/L$
	Air	None	$K = 1$
Nonvolatiles	Soil	Particulate Emission Factor	$K = 4.63 \times 10^9 m^3/kg$
	Water	None	$K = 1$
	Air	None	$K = 1$

* Refers to the media for which chemical concentration measurements are available.

When water is the media of concern the only way to inhale a contaminant is if that contaminant is volatile because water does not give off fugitive emissions. Assuming the highest dose of a volatile contained in water would result in the home, where an individual is in

an enclosed area for extended periods of time, the default value of the emission factor, K , is one over the volatilization factor or $2.0 \text{ m}^3/\text{L}$. J. B. Andelman developed the volatilization factor in 1990, and it is equal to $0.0005 \times 1000 \text{ L/m}^3$. The value is a unitless number (0.0005) multiplied by the conversion factor of 1000 L/m^3 . The default value assumes the volume of water used in a residence for a family of four is 720 L/day , the volume of the dwelling is $150,000 \text{ L}$, the air exchange rate is $0.25 \text{ m}^3/\text{hr}$, and the average transfer efficiency weighted by water use is 50 percent (USEPA, 1991a:20). Further details on the calculation of the volatilization factor are in Total Exposure to Volatile Organic Chemicals in Potable Water (Andelman, 1994).

When soil is the media of concern it is possible to inhale a contaminant if that contaminant is volatile or if it is a particulate entrained in fugitive dust emissions. The emission factor for volatiles in the soil is known as the soil to air volatilization factor. The principles behind the calculation of the soil-to-air volatilization factor are valid only if the contaminant concentration is below the saturation point of the soil. If there is pure liquid phase product in the soil the mole fraction of the contaminant in the soil is needed to calculate the volatilization factor (USEPA, 1991a:26). The factor is calculated using Equation (2) (USEPA, 1991a:29).

$$K = \left[\frac{(LS)(DH)}{A} \right] \left[\frac{[3.14(D_{ei})(E)(T)]}{\left(E + p_s \frac{(1-E)}{K_{as}} \right)} \right]^{\frac{1}{2}} \left[\frac{V}{2(D_{ei})(E)(K_{as})(10^{-3})} \right] \quad (2)$$

where

K = soil-to-air volatilization factor (m^3/kg)

LS = length of the side of the contaminated area (m), default value is 45 m

- V = wind speed in the mixing zone (m/s), default value is 2.25 m/s
 DH = diffusion height (m), default value is 2 m
 A = area on contamination (cm²), default value is 20,250,000 cm²
 D_{ei} = effective diffusivity (cm²/s), default value is $D_i \times E^{0.33}$
 E = true soil porosity (unitless), default value is 0.35
 K_{as} = soil/air partition coefficient (g soil/cm³ air), default value is $(H/K_d) \times 41$
 T = exposure interval (s), default value is 7.9×10^8 s
 p_s = true soil density or particulate density (g/cm³), default value is 2.65 g/cm³
 D_i = molecular diffusivity (cm²/s), chemical specific
 H = Henry's law constant (atm-m³/mol), chemical specific
 K_d = soil-water partition coefficient (cm³/g), chemical specific or $K_{oc} \times OC$
 K_{oc} = organic carbon partition coefficient (cm³/g), chemical specific
 OC = organic carbon content of soil (fraction), default value is 0.02

Substituting all of the default values given in Equation (2) yields Equation (3). The values for K_d and H are in the Superfund Chemical Data Matrix, (USEPA, 1994) where K_d is the distribution coefficient in ml/g (equivalent to cm³/g). Appendix C lists the molecular diffusivity of some substances. D_i is calculated using Equation (4) for other substances (Pannwitz, 1984:2).

$$K = \frac{1859.13K_d}{D_i \sqrt{5740H^2 + 689K_d}} \quad (3)$$

where

- K = soil to air volatilization factor (m^3/kg)
 D_i = molecular diffusivity (cm^2/s), chemical specific
 H = Henry's law constant ($\text{atm}\cdot\text{m}^3/\text{mol}$), chemical specific
 K_d = soil-water partition coefficient (cm^3/g), chemical specific

Chemicals contained in soil that are not volatile may be inhaled as particulates. If data are available to directly measure the concentration of chemicals in the air use Equation (1) and let K equal one. If the concentration of the chemical in the soil is the only information available use Equation (1) with K equal to the particulate emission factor (PEF). The PEF relates the contaminant concentration in soil with the concentration of respirable particles (PM_{10}) in the air (USEPA, 1991a:29). C. Cowherd developed the PEF as part of a rapid assessment procedure for Superfund sites. It is applicable to a site that presents a relatively constant potential for emission over a number of years. Equation (5) calculates the PEF. The default values given in the list of variables assume a surface with an unlimited erosion potential (USEPA, 1991a:30).

$$D_i = \frac{4.78264\sqrt{0.03453 + 1/M_i}}{W(1.8085 + 0.5d_i)^2} \quad (4)$$

where

- D_i = molecular diffusivity for gases or vapors in air (cm^2/s)
 M_i = molecular mass of substance "i" (g/mol)
 W = correction factor (unitless)
 d_i = molecular diameter of substance "i" (\AA)

$$K = \left[\frac{(LS)(V)(DH)(3600s/hr)}{A} \right] \left[\frac{1000g/kg}{RF(1-G)(F(x))(U_m/U_t)^3} \right] \quad (5)$$

where

- K = particulate emission factor (m^3/kg), default value is $4.63 \times 10^9 m^3/kg$
- LS = width of contaminated area (m), default value is 45 m
- V = wind speed in mixing zone (m/s), default value is 2.25 m/s
- DH = diffusion height (m), default value is 2 m
- A = area of contamination (m^2), default value is $2025 m^2$
- RF = respirable fraction (g/m^2-hr), default value is $.036 g/m^2-hr$
- G = fraction of vegetative cover (unitless), default value is 0.0
- U_m = mean annual wind speed (m/s), default value is 4.5 m/s
- U_t = equivalent threshold value of wind speed at 10 meters (m/s), default value is 12.8 m/s
- $F(x)$ = function dependent on U_m/U_t , unitless, default value is 0.0497

Ingestion Route. The ingestion route is the next major way toxic chemicals infect individuals. Equation (6) estimates the dose of a particular chemical from ingestion (USEPA, 1991a:52).

$$Dose = \frac{(C)(IR)(EF)(ED)(CF)}{(BW)(AT)} \quad (6)$$

where

- C* = concentration of the chemical in the ingested media (mg/kg or mg/L in water)
- IR* = ingestion rate (mg/day or L/day for water)
- EF* = exposure frequency (days/year)
- ED* = exposure duration (yr)
- CF* = conversion factor (10^{-6} kg/mg in soil, 1.0 in water)
- BW* = body weight (kg)
- AT* = averaging time (days)

As with the inhalation route, default values exist for many of the factors used in the calculation of dose for the ingestion route.

Dermal Contact Route. The last major route that a chemical can enter the human body is absorption through the skin from direct contact with the contaminated media. Equation (7) (USEPA, 1989b: 6-37) is used to calculate the absorbed dose of a chemical from dermal contact (USEPA, 1989b: 6-34).

$$Dose = \frac{(C)(SA)(AC)(ET)(AF)(EF)(ED)(CF)}{(BW)(AT)} \quad (7)$$

where

- C* = concentration of the chemical in the contacted media (mg/kg or mg/L in water)
- SA* = skin surface area available for contact (cm²)
- AC* = chemical and media specific absorption constant, in water this is the dermal permeability constant (cm/hr) and in soil this is the absorption factor (fraction/event)

- ET* = exposure time per event used only for water, set equal to 1.0 for other media (hours/event)
- AF* = adherence factor used only for soil, set equal to 1.0 for other media (mg/cm²)
- EF* = exposure frequency (events/year)
- ED* = exposure duration (years)
- CF* = conversion factor (1 liter/1000cm³ for water or 10⁻⁶ kg/mg for soil)
- BW* = body weight (kg)
- AT* = averaging time (days)

Four factors in Equation (7) are media specific, the absorption coefficient, the exposure time, the soil to skin adherence factor and the conversion factor. When the media of concern is water the absorption coefficient, *AC*, is the same as the dermal permeability constant in Exhibit 6-13 of USEPA, 1989b. The units on *AC* when the media is water are centimeters per hour and describe the rate a chemical absorbs into the skin. The absorbed dose is dependent on how long a person is exposed. The exposure time per event applies only when water is the media of concern and is equal to the number of hours per exposure event. The adherence factor is not applicable if the media is water and equals 1.0 (USEPA, 1989b: 6-34).

When the media of concern is soil the absorption coefficient is the same as the absorption factor described in Exhibit 6-15 of USEPA, 1989b. The absorption factor is the percentage of the chemical the skin absorbs per exposure event. This factor is independent of the duration of the exposure event and requires that the exposure time, *ET*, be set equal to 1.0. It is dependent on the actual amount of soil the skin contacts. The soil to skin adherence factor, *AF*, converts the skin surface area to mass of soil. The units for this factor are milligrams per square

centimeter. It defines the mass of the soil remaining on the skin that, when combined with the concentration of the chemical in the soil, gives the quantity of chemical actually in contact with the skin. The absorption factor then estimates the percentage of the chemical absorbed into the skin (USEPA, 1989b: 6-39).

Risk Characterization. Risk characterization is the process of estimating the incidence of a health effect under the various conditions of human exposure described in the exposure assessment phase (NRC, 1983:20). This phase requires no new information or knowledge. It uses the knowledge gained from the previous three phases to determine the magnitude of the health problem and characterizes the uncertainties associated with that estimate.

Computation of the level of hazard is different if the chemical of concern potentially produces cancer in humans or if it has other toxic effects. The general equation used to calculate the carcinogenic risk is Equation (8) (USEPA, 1989b:8-6). Equation (8) produces an incremental probability of an individual developing cancer over a lifetime as a result of exposure to a potential carcinogen (USEPA 1991:vii). For chemicals not believed to produce carcinogenic effects but produce other toxic effects, Equation (9) is the general equation for calculating the level of hazard (USEPA, 1989b:8-11). Equation (9) produces a hazard index that gives the ratio of a single substance exposure level to a reference dose for that substance.

$$ECR = (Dose)(SF) \quad (8)$$

where

ECR = excess cancer risk (unitless probability)

Dose = chemical intake (mg/kg-day)

SF = slope factor (kg-day/mg)

$$HI = \frac{Dose}{RfD} \quad (9)$$

where

HI = *hazard index* (unitless ratio)

Dose = *chemical intake* (mg/kg-day)

RfD = *reference dose* (kg-day/mg)

The slope factor in Equation (8) and the reference dose in Equation (9) are given in IRIS for specific chemicals and exposure routes. The dose refers to the exposure estimate calculated for each exposure pathway. The total risk for each chemical is found by summing the risk, whether carcinogenic or noncarcinogenic, across all exposure pathways. Calculation of the total risk associated with a site is the sum of the risk for each chemical present at the site across each exposure pathway.

The EPA has established guidelines for acceptable levels of risk at a hazardous waste site. The EPA considers an excess lifetime cancer risk less than 10^{-4} acceptable and an adequate margin of safety would dictate that the excess cancer risk should be less than 10^{-6} (NRC, 1994:36). When the noncancer hazard index is less than 1.0, it is unlikely for even sensitive subpopulations to experience adverse health effects. The greater the hazard index above unity, the greater the level of concern (USEPA, 1989b:8-11).

Statistical Principles

Statistics are extremely important in any decision making process that contains uncertainty. In the RI/FS process statistics enable a decision maker to quantitatively estimate the degree of

certainty he has in his decision. They can also help him to quantitatively determine the probability that he made either a correct or incorrect decision. The following section describes the relevant statistical principles used in this thesis.

The RI/FS process gathers site specific information about the scope of contamination. Therefore, this research only addresses ways to evaluate the uncertainty associated with the measurement of the scope of contamination, specifically the concentration of the contaminants in the various media.

The Central Limit Theorem. The primary statistical tool used to quantify the impact of more information on the decisions in the RI/FS process is the Central Limit Theorem (CLT). The CLT says that given a random sample (X_1, X_2, \dots, X_n) with mean μ and variance σ^2 , if n is sufficiently large then \bar{X} , see Equation (11), has approximately a normal distribution with $\mu_{\bar{x}} = \mu$ and $\sigma^2_{\bar{x}} = \sigma^2/n$ (Devore, 1991:220). This theorem is useful because it says that regardless of the underlying distribution the mean value of that distribution, \bar{X} , is itself an approximately normally distributed random variable. It also says that the mean of the distribution of \bar{X} is equal to the mean of the population distribution, and the variance of the distribution of \bar{X} is equal to the variance of the population distribution divided by the number of samples, n (Devore, 1991: 220).

Environmental sampling can be extremely expensive, and it is desirable to keep the number of samples analyzed to a minimum while still providing an acceptable estimate of chemical concentration. The small number of samples makes it difficult to estimate the actual, underlying distribution of the chemical. In the RI/FS for Spill Sites 2, 3, and 10 at Wright-Patterson AFB, for example, the groundwater was analyzed for 36 chemicals. Between eight and 16 analyses were completed for each chemical for a total of 509 samples. Each chemical

was present in measurable concentrations at least one time, but there was a total of only 233 samples that produced meaningful results (Engineering Science, 1995). Because each chemical may have a different distribution and the number of meaningful samples for each chemical is small, it can be difficult to determine the distribution of the chemical in a media. The power of the central limit theorem is that the underlying distribution does not matter. The mean has an approximately normal distribution with expected value equal to \bar{X} and variance equal to s^2 , shown in Equation (10) (Devore, 1991: 220).

$$s^2 = \frac{S^2}{n} \quad (10)$$

where

s^2 = variance of the distribution of \bar{X}

S^2 = sample variance

n = number of samples

\bar{X} and S^2 are themselves estimates of the population parameters. \bar{X} is the unbiased estimator of the population mean, μ (Devore, 1991:236), and is calculated from the sample using Equation (11) (Devore, 1991:15). S^2 is the sample variance and is the unbiased estimator of the population variance, σ^2 . S^2 is calculated using Equation (12) (Devore, 1991:235).

$$\bar{X} = \frac{\sum_{i=1}^n X_i}{n} \quad (11)$$

where

\bar{X} = sample mean

X_1, X_2, \dots, X_n = random sample from a distribution with mean μ and variance σ^2

n = number of samples

$$S^2 = \frac{\sum_{i=1}^n (X_i - \bar{X})^2}{n-1} \quad (12)$$

where

S^2 = sample variance

X_1, X_2, \dots, X_n = random sample from a distribution with mean μ and variance σ^2

\bar{X} = sample mean

n = number of samples

Linear Combinations. The Central Limit Theorem can be used to estimate the mean concentration of the chemical but that distribution must be translated into an estimate of the distribution of the risk posed by that chemical. The rules of linear combinations of random variables are useful to estimate this distribution of risk.

Because exposure parameters and the toxicity values are constants in this model, the distribution of risk posed by a chemical is simply a constant multiplied by the distribution of the concentration. Multiplying a probability distribution by a constant changes the mean and

variance of that distribution but not the shape. Equation (13) shows that the expected value of a constant multiplied by a random variable is equal to the constant multiplied by the expected value of the random variable. Therefore, multiplying a distribution by a constant creates a new distribution with a mean equal to the product of the constant and the original mean (Devore, 1991:212).

$$E(aX) = aE(X) \quad (13)$$

where

$E()$ = *expected value*

a = *constant*

X = *random variable*

The variance of a distribution multiplied by a constant changes in accordance with Equation (14). The original variance multiplied by the square of the constant is the new variance of the random variable multiplied by the constant (Devore, 1991: 218). Multiplying a normal distribution by a constant does not change the general shape of the distribution, however, it does change the parameters of the distribution (Devore, 1991: 218). Therefore, the distribution of the risk posed by a chemical is approximately normally distributed, with mean and variance calculated using Equations (13) and (14).

$$V(aX) = a^2\sigma^2 \quad (14)$$

where

- $V()$ = variance
- a = constant
- X = random variable
- σ^2 = variance of the random variable X

$$\mu_Y = \sum a_i \mu_{X_i} \quad (15)$$

where

- μ_Y = mean of the random variable Y
- a_i = constant
- μ_{X_i} = mean of the random variable X_i

An estimate of the cumulative risk posed by all the chemicals is also possible. Let $Y = a_1 X_1 + a_2 X_2 + \dots + a_n X_n$ where X_i is a normal random variable with mean μ_{X_i} and variance $\sigma_{X_i}^2$ then Y is also a normal random variable with a mean calculated using Equation (15) and variance calculated using Equation (16) (Devore, 1991: 218).

$$\sigma_Y^2 = \sum a_i^2 \sigma_{X_i}^2 \quad (16)$$

where

- σ_Y^2 = variance of the random variable Y
- a_i = constant
- $\sigma_{X_i}^2$ = variance of the random variable X_i

Decision Analysis

Decision Analysis is a prescriptive methodology for making difficult decisions (Clemen, 1991:4). It provides structure and guidance for systematically considering complex situations. Within the field of Decision Analysis there are tools that help to evaluate the expected value of a decision with inherent uncertainties, multiple and conflicting objectives, or that different people view differently (Clemen, 1991:3).

An influence diagram is one such tool. An influence diagram is a graphical representation of a decision problem (Clemen, 1991:34). It consists of a combination of three types of nodes and arcs. Figure 3 describes these components. The nodes represent different events relative to the decision problem. The arcs show the relevance of one event to another. The influence diagram is preferable to other methods of describing a problem because of its usefulness as a communication tool. An influence diagram graphically describes all the relevant relationships between events in a decision problem. That representation can help other stakeholders understand the problem. It can also solve decision problems by identifying the alternative with the expected outcome that optimizes the objective.

Another tool that has similar analytical power, but does not have the communicative benefits of the influence diagram, is the decision tree. Decision trees can be extremely large for problems with a large number of uncertain events. However, where an influence diagram can only show relevance between events, a decision tree can show the chronological order of events. For this reason it is necessary to combine the use of influence diagrams and decision trees to solve complex decision problems.

Influence diagrams and decision trees also have powerful analysis capabilities, the most important of which is sensitivity analysis. The most common form of sensitivity analysis is

value sensitivity analysis. This technique allows the decision maker to vary the values associated with certain events to see the impact that one particular variable has on the expected value and outcome of the decision (ADA, 1995:174).

The Advanced Version 3.11 of DPL (DPL, 1995) is a software package with the ability to perform the required calculations using influence diagrams and decision trees, as well as to perform sensitivity analysis. Supertree, another Decision Analysis software package, is also common, but DPL has the added benefit of allowing the problem to be created by drawing an influence diagram. DPL also has a Dynamic Data Exchange (DDE) feature making it possible to share data with spreadsheet software. Microsoft Excel is the spreadsheet software chosen for this thesis (Excel, 1993). Connection with the spreadsheet allows much more flexibility in formatting and displaying output as well as providing increased mathematical features that are not directly available in DPL.

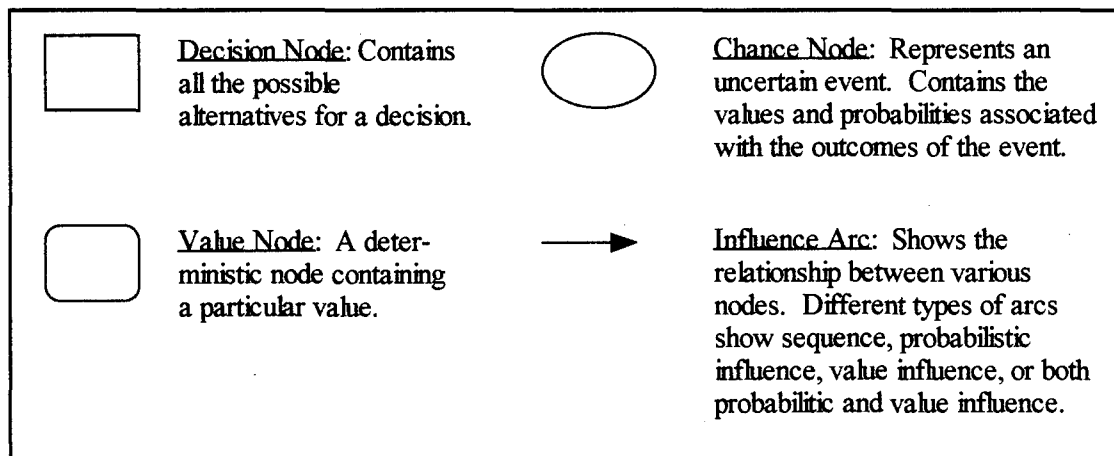

Figure 3: Influence Diagram Components

III. Methodology

Introduction

This chapter explains the development of a decision support model to help decision makers decide when they have enough information to make a cleanup decision about a particular hazardous waste site. It is divided into three main sections. The first section discusses the model requirements. It draws upon the information presented in Chapter Two and explains the thought process behind the model.

The second section presents the development of the model in DPL (DPL, 1995), the Decision Analysis software used to model and analyze the problem. The second section also explains the relationships between the different events in the RI/FS process and how they influence the overall outcome of the decision.

The third section describes how the model works in Excel (Excel, 1993). It explains how the distribution of risk is developed and how more and better information impacts the probabilities associated with the risk calculations.

Model Requirements

Characterizing a site is a complex process containing many steps. Which steps to take and when to take those steps while remain protective of human health and the environment and taking as little time and money as possible are difficult decisions. Figure 4 shows a strategy generation table that can help to illustrate the problem. Figure 4 assumes that the PA has just been completed and the decision maker is trying to decide the next step in the CERCLA process.

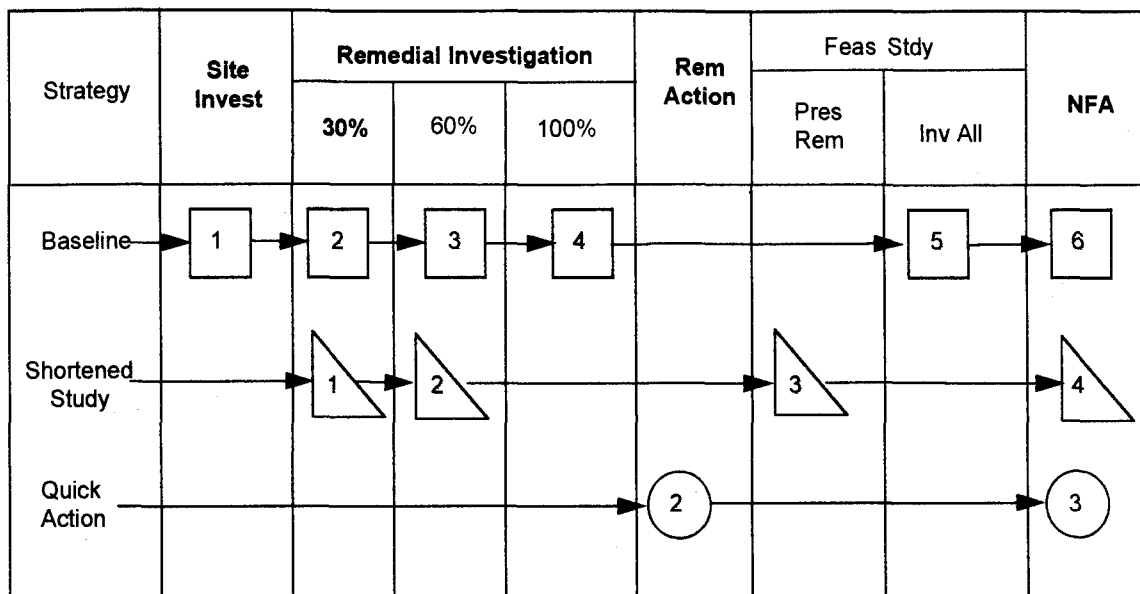

Figure 4: Strategy Generation Table for the PA Decision

Across the top of the strategy generation table are the possible alternatives that can be taken throughout the process. The alternatives shown in bold print are the potential next steps after completion of the PA. The baseline case represents the course of action decision makers choose. All characterization activities are completed, a complete feasibility study is done and then a remedy is selected. The benefit to the baseline strategy is that there is a high probability that, after completion of all activities recommended by the studies, the site will not pose a threat to human health. There is also a high probability that the cleanup goals will be achieved without making any major errors that will cost additional time and money to repair. The drawback to using the baseline strategy is that gathering the information is expensive and time consuming.

Another possible strategy is to shorten the study phase of the process and begin required cleanup actions sooner. This strategy is represented by the shortened study strategy in Figure

4. Using this strategy, time and money are saved by reducing the amount of information gathered before the cleanup decision is made. The drawback to this strategy is a higher probability that errors will be made when cleaning up the site. Errors made at while cleaning up the site will cost additional time and money. There is also a greater uncertainty about the level of contamination that may leave doubt about whether the site needed to be remediated in the first place.

A third possible strategy after a PA is to take quick action. This strategy essentially bypasses all the studies and cleans up the site. The drawback to this is that the site may be cleaned up unnecessarily and, for complex remediation activities such as those required for groundwater, there may be a good chance of not meeting the cleanup goals because there was not enough information to complete a proper design. If the cleanup goals are not met there will be an additional expense incurred to modify the system in the field in order to meet the cleanup goals. However, given the high cost and duration associated with site characterization, the risk of an increased cost resulting from an error may have a higher value to the decision maker than spending the time and money gathering the information.

The decision support model developed in this chapter will help the decision maker evaluate the value of obtaining additional information relative to the higher probability of making an error. The model will then recommend the best strategy to take with each chemical found at a hazardous waste site. The recommendation will help to minimize the cost and duration of investigation activities while quantitatively taking into account the increased uncertainty associated with the elimination of information.

The requirement for such a model is illustrated by the use of the Observational Method to eliminate data gathering steps and by the use of presumptive remedies. The desire to reduce

the cost and duration of the RI/FS process is also apparent in the SACM and DQO processes, with their emphasis on reorganization and planning. The increased utilization of these four methods suggests that there is a need for a tool that helps a decision maker shorten the RI/FS process without sacrificing the health or safety of the affected population.

The need for the tool is established, but it is important to determine the best way for that tool to operate. This model uses the estimate of the actual health risk posed by a chemical to select the course of action with the lowest combination of cost and duration. Health risk is consistently the preferred yardstick for determining the proper course of action. Both pieces of legislation, the public works alternative and the consensus legislation, emphasize the immediate reduction in risk. The Superfund Accelerated Cleanup Model (SACM) made immediate risk reduction the EPA's primary measure of success in the area of Superfund. In some instances an Applicable or Relevant and Appropriate Requirement (ARAR) may drive a cleanup decision. However, risk reduction is now the standard for prioritizing projects (Blacker and Goodman, 1994:466A). Therefore, it is appropriate for a decision support model dealing with the RI/FS process to focus on risk reduction rather than chemical action levels to make a justifiable decision.

Another important criterion of a decision support model is to be able to quantify the uncertainty associated with the decision, which implies statistical rigor. In order to accomplish that, the model must use accepted statistical properties and theorems. The EPA addresses quantification of uncertainty by endorsement of the DQO process, which provides a methodology for collecting the proper quantity and quality of data in order to generate an acceptable probability that the decision is correct.

The use of the Observational Method and presumptive remedies are direct attempts to shorten the RI/FS process through the elimination of information. The eliminated information is not quantified in these two approaches. A decision support model must also account for the value associated with a reduction in information. The techniques of Decision Analysis are ideally suited to accommodate all of the above requirements.

Model Development in DPL

This section presents the development of the model based on the five steps used by Clemen (Clemen, 1991) to model and analyze decision problems.

Identify the Problem. Although this step is not always trivial (Clemen, 1991:5), the problem here, described briefly in Chapter One, is clear. The RI/FS process takes too long and costs too much. The slow pace of Superfund cleanups can increase the chance of adverse health effects. However, shortening the process must be done carefully, because there is a chance that the elimination of information will increase the probability of making an incorrect decision.

Identify Objectives and Alternatives. The objective here is to minimize the cost and duration of the RI/FS process, taking into account the added cost of making the wrong decision. Identifying the alternatives in the problem requires an understanding of the decision, or sequence of decisions. At the end of each phase of the RI/FS process, from the preliminary assessment through the feasibility study and possibly an interim removal action, a decision maker must decide the next appropriate phase. Figure 5 shows a decision tree that represents the sequence of decisions that must be made in the RI/FS process. Each square node represents a decision, and each arrow-shaped node represents an endpoint in the model.

Decision nodes with letters correspond to a sequence of decisions that are made elsewhere in the model. They are shown that way to simplify the presentation. The arcs connecting an earlier decision node with a later one represent the actions that result from the earlier decision until such time as the next decision point is reached. Any path from the beginning of the tree to an endpoint is a feasible course of action.

Preliminary Assessment. The preliminary assessment (PA) decision is the first decision made in the RI/FS process. After discovery of a hazardous waste site the NCP requires that a preliminary assessment be completed to determine if there is sufficient evidence to indicate that contamination exists at the site (USAF, 1992:5-19). The preliminary assessment decision node assumes that a preliminary assessment has already been completed and contains the feasible alternatives for further action.

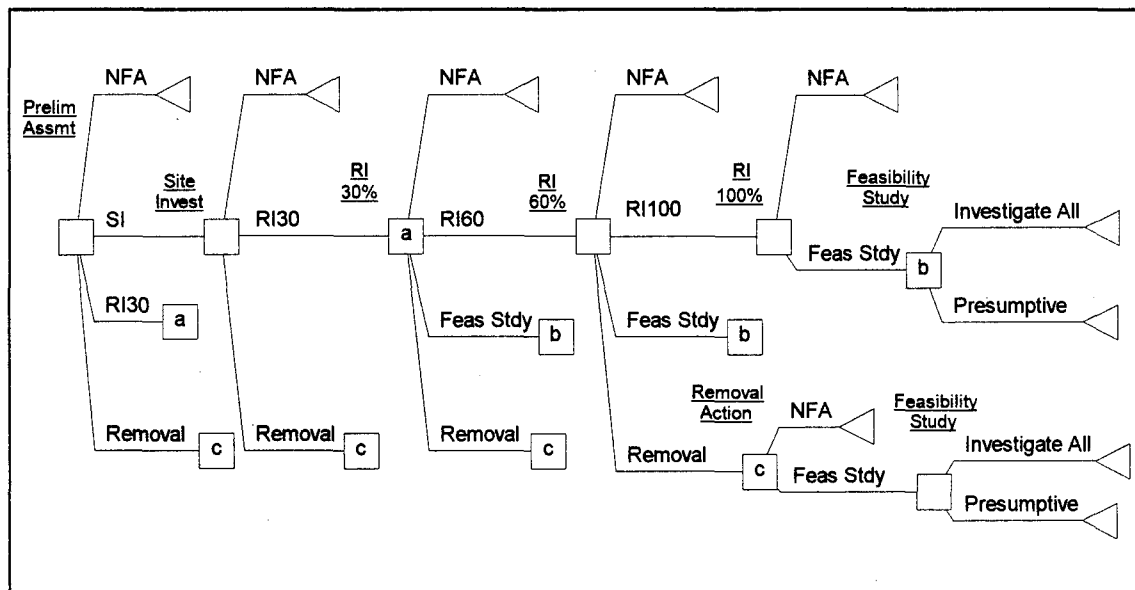

Figure 5: RI/FS Sequence of Decisions and Alternatives

According to the US Air Force Installation Restoration Program Remedial Project Managers Handbook, there are four feasible alternatives after a preliminary assessment (USAF, 1992:5-20). Figure 6 shows the node with its alternatives as it appears in DPL. The first alternative is to take no further action (NFA) at the site. This would occur when there is no evidence that any toxic substances were released at the site or if the site does not pose a health threat, either currently or in the future. Alternative two is to perform a site investigation (SI) and reevaluate the situation with the added information. Alternative three is to begin the remedial investigation process by completing the first round of sampling or the first 30 percent of the remedial investigation (RI30). The fourth alternative is to proceed directly to a removal action (Removal). This would occur whenever there is a reasonable certainty that contamination exists at the site and the risk could be mitigated immediately through some sort of interim action, for example: removal of leaking drums or excavation of obviously contaminated surface soil.

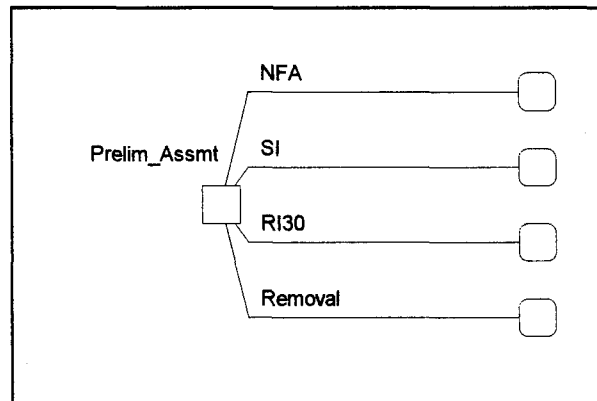

Figure 6: Preliminary Assessment Decision with Alternatives

Site Investigation. A site investigation (SI) is an optional step in the RI/FS process. Its purpose is to eliminate from further consideration a site that poses a minimal risk and to provide information that may support subsequent actions (USAF, 1992:5-24). The SI consists of a visual inspection of the site and usually includes sample collection and analysis (USAF, 1992:2-25).

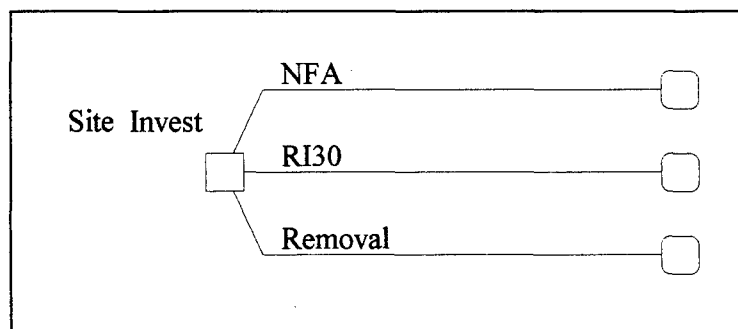

Figure 7: Site Investigation Decision with Alternatives

Figure 7 shows the site investigation decision node with its alternatives as it appears in DPL. In practice there are four feasible alternatives after completing a site investigation (USAF, 1992:5-24). The fourth option, not considered in the model, is long term monitoring. Long term monitoring is not considered because that option provides no measure of risk reduction. Long term monitoring is equivalent to the no further action alternative, except there is a continuous outlay of time and money that provides additional information. In Decision Analysis information has value if it impacts on a decision. There is some nonzero probability that continued monitoring will detect previously unidentified contamination. This possibility conceivably exists at all hazardous waste sites, and there is no way to quantify the likelihood of such an event, given that the best available data indicates a minimal risk. If the uncertainty

associated with the data is large enough to indicate that the risk could increase the best decision would be to reject the no further action decision and continue with the remedial investigation. There may be other reasons not quantified here, such as regulatory requirements, to continue monitoring a site regardless of the likelihood of detecting additional contamination. However, the long term monitoring option is not considered in this model. The long term monitoring alternative provides no method for risk reduction. The only information it provides comes about after the decision has been made not to remediate the site. Information has no value in decision analysis if it is not available before the decision is made. Based on the event relationships and the selection criteria embedded in the model, long term monitoring would never be the preferred alternative to the no further action decision. Long term monitoring provides no risk reduction, it provides no information that can be used to make the cleanup decision, and it costs time and money.

The three alternatives that are considered are the no further action (NFA) option, the 30 percent remedial investigation option (RI30), and the removal option (Removal) that were all described beginning on page 41 as part of the preliminary assessment decision.

Remedial Investigation. A remedial investigation (RI) is designed to determine the nature and extent of site contamination, as well as the threat to human health and the environment, and is the basis for determining response actions. The RI is a complex process that takes longer and costs more than the preliminary assessment or the site investigation.

The remedial investigation is typically one document, although it may be several volumes long, as in the case of the remedial investigation for Operable Unit Two at WPAFB (Engineering Science, 1995). Figure 8 shows that the remedial investigation is broken into three phases. It was modeled this way because the sampling done throughout the course of a

remedial investigation is often done in stages. The stages enable the decision maker to refine the sampling plans developed earlier to fill gaps in information that become apparent (USEPA, 1988:1-6). The first stage usually involves the installation of monitoring wells and includes the majority of soil data. The second stage and any other subsequent stages result in additional groundwater samples (Lester, 1995). By modeling the RI in three phases, it is possible to more precisely estimate how much information is needed. If enough information has been gathered after the first or second sampling round to make a justifiable decision, there may be no need to continue sampling.

The 30, 60, and 100 percent remedial investigation nodes are shown in Figure 8 with their respective alternatives as they appear in DPL. Each node has no further action (NFA) as an alternative in the event that the reduction in uncertainty associated with an increased number of samples lowers the estimate of the risk enough to change the decision. This relationship is shown in Equation (10) on page 30.

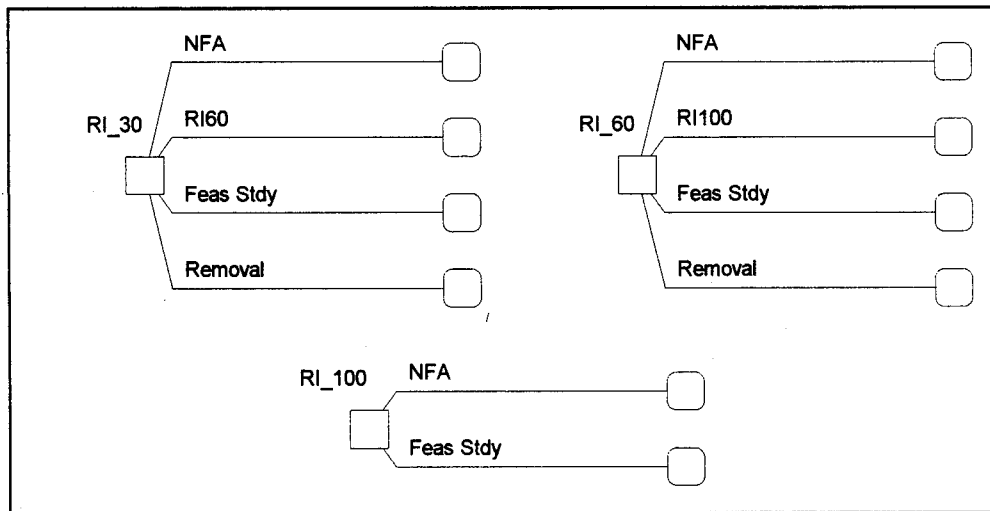

Figure 8: Remedial Investigation Phases and Alternatives

Proceeding to a feasibility study is also an option at each phase of the remedial investigation. Proceeding on with the feasibility study before completion of the RI represents the inclusion of the Observational Method in the model. The assumption is that at any point in the remedial investigation there is enough information to proceed to the feasibility study phase with some probability of success.

The 30 percent and 60 percent phases contain an alternative to proceed to the next level of remedial investigation. The 100 percent RI does not include this option because there is no additional site characterization study that typically takes place after completion of the remedial investigation. The 30 and 60 percent phases also include an option for a removal action. The removal action alternative is not included in the 100 percent phase because it is assumed that after the RI is complete the cleanup technology will be selected from the feasibility study.

Removal Action. A removal action is a short term action that reduces the risk at a site. The term may be misleading because it implies that the contaminant is somehow removed from the site, but one type of action that is considered a removal is the installation of fencing around the site (Lee, 1995: 233). This action minimizes the probability of exposure, thereby removing some of the risk. Figure 9 shows the removal node with its corresponding alternatives.

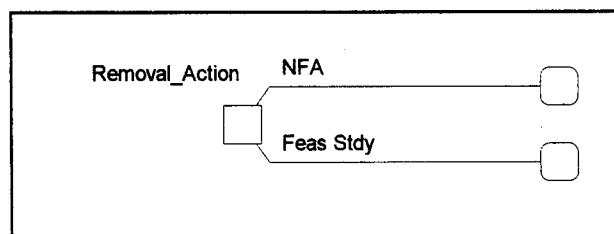

Figure 9: Removal Action Decision Node with Alternatives

The NFA option exists because the removal action may significantly reduce the risk and be the only action required. The feasibility study (*Feas Study*) alternative is there because it is possible that the removal action will not reduce the risk sufficiently to allow no further action but may provide enough information about the site characteristics to proceed with remedy selection.

Feasibility Study. The objective of the feasibility study (FS) is to select the best technology to remediate the site (USAF, 1992:5-51). This model does not select a remediation technology. It indicates the best method to use when selecting a remediation technology. The decision node and alternatives for a feasibility study are shown in Figure 10.

The decision at the feasibility study stage is assumed to be either to investigate all feasible remediation alternatives or to implement a presumptive remedy. The model takes into account the costs, durations and probabilities associated with each course of action based on when in the RI process the decision was made. The value of the FS alternative is also dependent on whether the site conditions are similar to other sites. The influence of the site similarity is explained in more detail below.

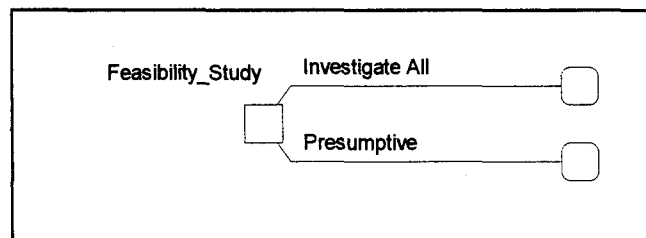

Figure 10: Feasibility Study Decision Node with Alternatives

Decomposition and Modeling of the Problem. The third step in the Decision Analysis process is to break down the problem to determine its structure, the relevant uncertainties, and the decision maker's preferences (Clemen, 1991:6). Figure 5 gives an indication of the structure of the problem by showing the sequence of decisions made during the RI/FS process. However, it does not show any of the uncertainties or relevant information associated with the decisions. This section will discuss these items as well as how the decision maker's preferences are accounted for in the model.

Figure 5 shows all the decisions beginning with the preliminary assessment phase. Because the RI/FS process is iterative (USEPA, 1988:1-6), it is necessary to reevaluate the decision after each phase of the process. To help with this reevaluation, a separate model was developed for each information gathering step in the RI/FS process. Information gathering steps include the preliminary assessment, site investigation, and the three phases of the remedial investigation. Separate models were not developed to reevaluate the decision after a removal action or immediately prior to a feasibility study because the focus of the research is on the evaluation of the information gathering steps. The influence diagrams and decision trees for each of these models is shown in Appendix D.

The structure of all the models is identical. The only changes to later models is that the decisions made earlier are removed. For example, the 30 percent remedial investigation model does not include nodes associated with the preliminary assessment or the site investigation. The decision sequence for the 30 percent remedial investigation model is shown in Figure 11 for illustration. Figure 11 is identical to Figure 5 except the preliminary assessment and site investigation decisions have been removed.

The first decision in each model is known as the primary decision. The primary decision is the decision at hand. The decision nodes following the primary decision are known as subsequent decisions. The *Removal Action* and *Feasibility Study* decisions are always subsequent decisions. The information gathering steps may be either primary or subsequent decisions. The model structure is slightly different between the two. The primary and subsequent information gathering steps, the removal action, and the feasibility study model structures are all detailed below.

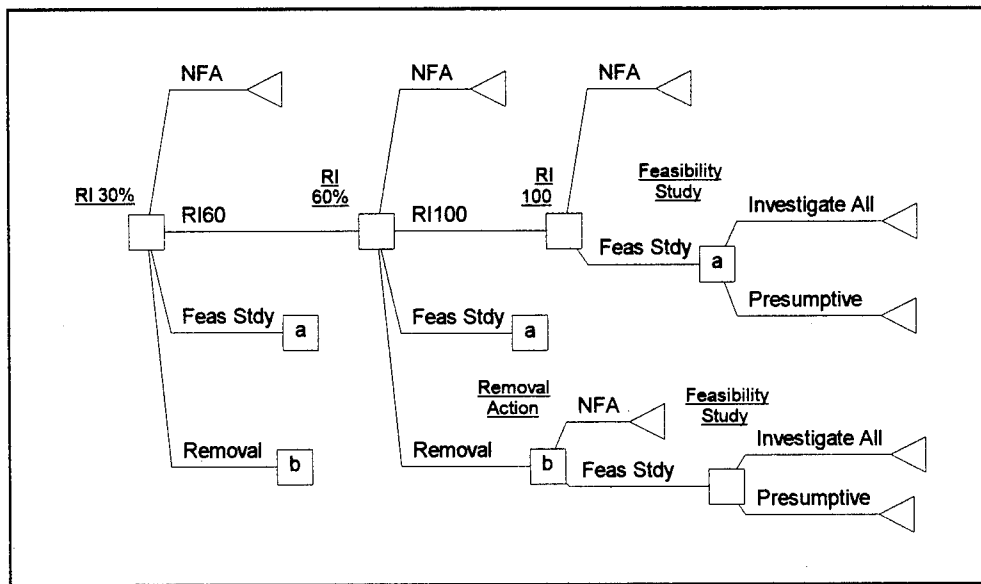

Figure 11: Decision Sequence for the 30 Percent Remedial Investigation Model

Primary Information Gathering Steps. The structure of the model relative to any primary information gathering step is the same (i.e. preliminary assessment, site investigation, 30, 60 and 100 percent remedial investigations). Figure 12 shows a conceptual influence diagram for a generic primary information gathering step. It is important to note that Figure 12

is for illustration purposes and not an exact duplicate of a portion of the working model. Each node and influence is explained in detail below.

Beginning at the far left of Figure 12, the two uncertainty nodes labeled *Media* and *Type* are used to condition any node with chemical or media dependent values. Each node has three states, as shown in Figure 13. The probability associated with each event state is 0.333, indicated in Figure 13 by the 1/3 located on each branch, and there are no values associated with these nodes. The probabilities and values are arranged this way because the sole purpose of the *Type* and *Media* nodes is to simplify the model by reducing the overall number of value nodes required. Weighting a particular chemical would serve no purpose because the model makes an individual recommendation for each chemical. Figure 14 uses the *Sample Mean* to illustrate how this is accomplished.

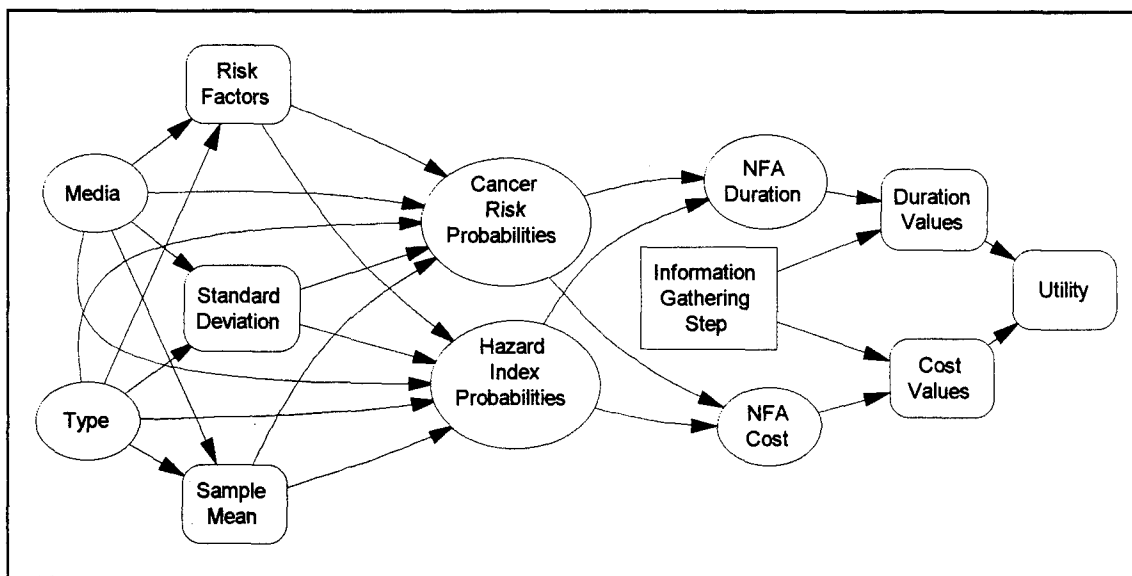

Figure 12: Conceptual Model for a Primary Information Gathering Step

The *Media* and *Type* nodes allow the user to input nine sample means into one node instead of having nine nodes, therefore, up to nine chemicals and three media may be analyzed simultaneously. The *Media* and *Type* nodes influence each of the value nodes associated with chemical specific parameters. They influence the two uncertainty nodes labeled *Cancer Risk Probabilities* and *Hazard Index Probabilities*, so probabilities can be calculated for each chemical of interest.

The value nodes, square nodes with rounded edges, are the chemical specific parameters. The node labeled *Sample Mean* contains the values of the mean concentration for each chemical. The node labeled *Standard Deviation* contains the sample standard deviation for each chemical. The mean and standard deviation are the statistical input parameters required for all models except for the preliminary assessment model. In the preliminary assessment model, because there is frequently no field investigation, the input parameters are the upper and lower bound estimates on the chemical concentrations.

The *Risk Factors* node is symbolic. It represents all of the chemical and medium specific risk factors such as slope factors, hazard indexes, and exposure factors. They are used in the Excel spreadsheet to modify the parameters of the chemical concentration distribution. These calculations are described beginning on page 84.

The arcs from the deterministic nodes in Figure 12 to the *Cancer Risk Probabilities* and the *Hazard Index Probabilities* nodes indicate that those values are used in the calculation of the probabilities.

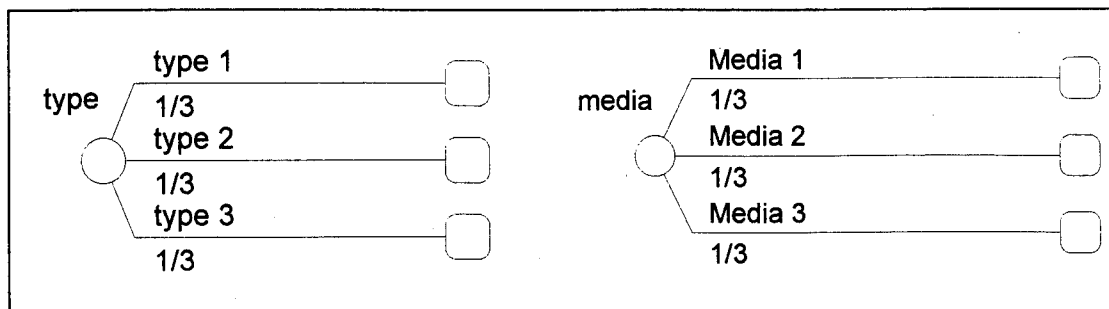

Figure 13: Conditioning Nodes Showing Event States

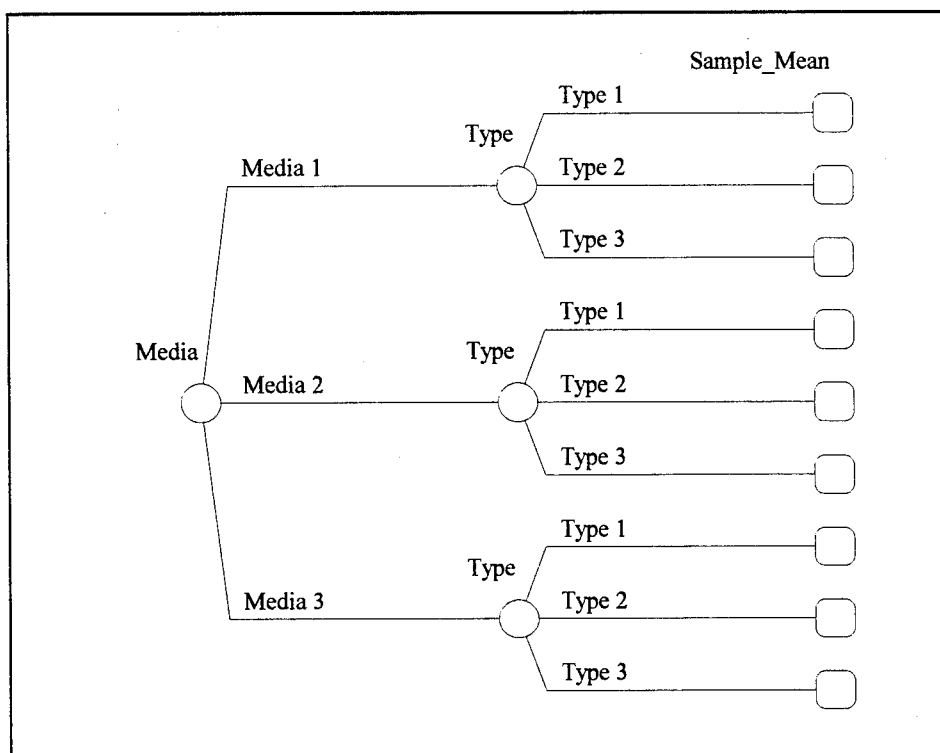

Figure 14: Effect of the Influence of Media and Type Nodes

The *Cancer Risk Probabilities* and *Hazard Index Probabilities* nodes contain the calculated probabilities for the cancer risk and hazard index for each chemical. Figure 15

shows the event states for each node. The calculation of these probabilities is discussed on page 85.

Figure 15 shows the *Cancer Risk Probabilities* and *Hazard Index Probabilities* nodes for the *Media 1, Type 1* chemical at the preliminary assessment with its event states. For simplicity the influence from the *Media* and *Type* nodes is not shown, but the nodes shown in Figure 15 are repeated nine times for each decision. The probabilities associated with each event state change for each chemical and decision. The probabilities are shown as node names in the figure. For example, *P_PA_T1_M1_Can_High* represents the probability (*P*) at the preliminary assessment (*PA*) that the type 1 (*T1*), media 1 (*M1*) chemical cancer risk calculation (*Can*) is higher (*High*) than the clearly unacceptable risk value. See Appendix A for further descriptions of variables. The probability is calculated in Excel and passed to the proper node in DPL.

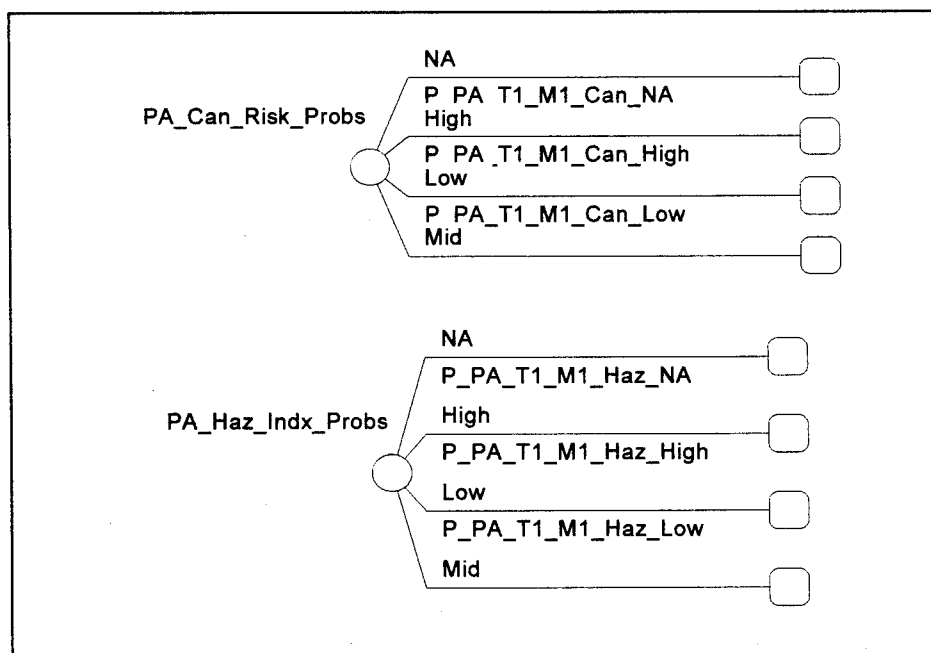

Figure 15: Cancer Risk and Hazard Index Probabilities Nodes with Event States

Each of the nodes in Figure 15 has four event states. The event state labeled *NA* holds the probability that the calculation of cancer risk or hazard index, depending on the node, is not applicable. That probability is either one or zero. A one indicates the calculation is not applicable, meaning there is no published slope factor or reference dose, while zero indicates the calculation is applicable.

The probabilities associated with the remaining three event states, *High*, *Low*, and *Mid*, represent the likelihood that the cancer risk or hazard index, depending on the node, is higher than the clearly unacceptable value (*High*), lower than the clearly acceptable value (*Low*) or between the clearly unacceptable and the clearly acceptable value (*Mid*). *Mid* has no reference to a probability node because DPL calculates its value from the other probabilities, given that the probabilities must sum to one.

Some typical values for the clearly unacceptable value and the clearly acceptable value are given in Table 3. The cancer risk values come from the EPA's published range of acceptable risk (NRC, 1994:3). The acceptable value for the hazard index comes from the fact that the reference dose is derived such that it is unlikely that even sensitive subpopulations will experience adverse health effects. A hazard index less than or equal to one would theoretically produce no adverse health effects (USEPA, 1989b:8-11). Values greater than unity pose a greater risk, but there is no standard value. This value is up to the decision maker's discretion and may be any value greater than or equal to one.

Table 3: Table of Acceptable and Unacceptable Risk Values

	Clearly Unacceptable Value	Clearly Acceptable Value
Cancer Risk	1×10^{-4}	1×10^{-6}
Hazard Index	≥ 1.0	1.0

The *Cancer Risk Probabilities* and the *Hazard Index Probabilities* nodes each influence the *NFA Duration* and *NFA Cost* nodes. These influences relate the level of risk or hazard to the cost of taking no action. Figure 16 shows the *NFA Cost* and *NFA Duration* node with the values associated with each event state. The value nodes referenced in Figure 16 called *NFA Cost Low* and *NFA Dur Low* are input by the user. Those values are the cost and duration of doing nothing assuming the decision to do nothing was the correct one. The values include the time and money required to complete the paperwork to close-out the site with the regulators. The value nodes called *NFA Cost High* and *NFA Dur High* are the cost and duration of doing nothing if doing nothing is the wrong decision. If the risk at the site is high and no action is taken, the cost in time and money could be quite high. Equation (17) shows how the model calculates that cost in dollars. Equation (18) shows how the model calculates the additional time.

With respect to environmental cleanup actions, an incorrect no further action decision can result in exorbitant additional costs. Doing nothing when there is truly a health risk at the site can result in adverse health effects ranging from mild symptoms to cancer and death in exposed individuals. There may be legal action brought against the responsible party. Almost certainly the responsible party would be required to restart the RI/FS process, if not from the beginning, at least from the point where the decision was made.

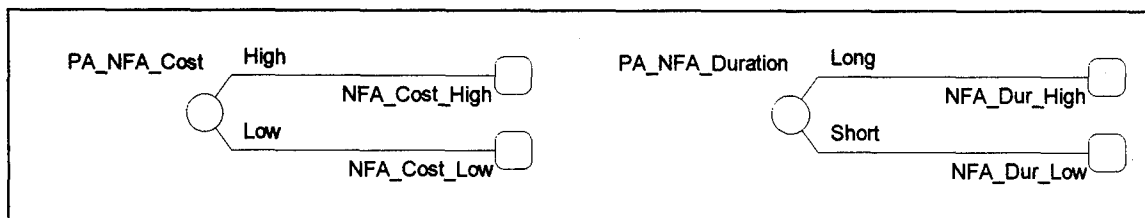

Figure 16: NFA Cost and Duration Nodes with States and Values

There is a great deal of uncertainty associated with these added costs. However, the exact cost is not important to the operation of the model. The important aspect of these costs is that there is a significant penalty for making a mistake. Equations (17) and (18) both arrive at the value of the penalty in the same manner. They sum the upper bound estimate for the cost and duration of the remaining studies and add the maximum value of the upper bound estimate for the cost and duration of remediation, multiplying the sum by the NFA Cost High Multiplier or the NFA Dur High Multiplier. See Appendix Two, Table 8, for a description. This calculation assumes that if a mistake is made the responsible party will be able to reinitiate the RI/FS process where it ended, and cleanup will be required. The calculation uses the upper bound estimates on each of the values to ensure that the cost is not underestimated before multiplying by the factor. The cost and duration multipliers account for the additional cost involved with potential lawsuits, bad public relations, health problems, and other intangible effects of making a bad decision. The multiplication factor assumes that the penalty for an error would be proportional to the size of the site. No information was discovered on penalties for sites that were not cleaned up and should have been. Decisions made during the RI/FS process have typically been extremely conservative. Underestimating the risk at a site and finding out about it later is not a normal occurrence, but the possibility must be accounted for in the model.

Another aspect of the *NFA Cost* and *NFA Duration* nodes is the probability associated with each value described above. The influences from the *Cancer Risk Probabilities* and *Hazard Index Probabilities* nodes in Figure 12 vary the probability of incurring a high cost for deciding to do nothing, based on the calculated risk. Sixteen combinations of risk and hazard are assigned probabilities, shown in Table 4. The *NFA Duration* and *NFA Cost* probability nodes referenced in Table 4 refer to six value nodes in the model. Whether the decision maker is risk

averse or risk seeking is taken into account at this point. The decision maker must input his notional probabilities that the cost and duration of deciding to do nothing will be high when the risk or hazard is high, low or in the middle range.

$$NFA_Cost_High = NFA_Cost_High_Multiplier \left(\frac{(\sum \text{high estimates of remaining study costs}) +}{\max(\text{high estimates of remediation costs})} \right) \quad (17)$$

$$NFA_Dur_High = NFA_Dur_High_Multiplier \left(\frac{(\sum \text{high estimates of future study durations}) +}{\max(\text{high estimates of remediation durations})} \right) \quad (18)$$

The probability that the value of the *NFA Cost* and *NFA Duration* nodes is high given the risk is high ($P\ NFA\ Cost\ High|High$ and $P\ NFA\ Dur\ High|High$) should be close to one. A value somewhat less than one suggests the decision maker feels there is some probability that he can make the decision to do nothing when there is a risk, and the error will not be discovered in the future. When the risk is low the probability that the cost and duration of making the no further action decision is high ($P\ NFA\ Cost\ High|Low$ and $P\ NFA\ Dur\ High|Low$) is close to zero. The decision maker might feel that there is some small probability that, even if the risk is low, the cost of making the decision to do nothing will still be high because of public pressure or other factors. The probability that the cost and duration are high when the risk is in the middle ($P\ NFA\ Cost\ High|Mid$ and $P\ NFA\ Dur\ High|Mid$) is not easy to define. The value depends on how aggressive the decision maker is about site cleanups. This probability could feasibly be zero if the decision maker believes that if the risk is not greater than the unacceptable value the risk is acceptable. The probability the cost or duration is high given the

risk is in the mid range could be one if the decision maker believes that, if the risk is greater than the acceptable value, the risk is unacceptable.

The probabilities in Table 4 are determined based on the highest level of risk or hazard for each combination. For example, if the carcinogenic risk is low but the hazard index is high, the probabilities for the cost and duration are set equal to *P NFA Cost High|High* and *P NFA Dur High|High*.

Table 4: Probabilities of High NFA Costs and Durations for all Risk Level Combinations

Cancer Risk Level	Hazard Index Level	<i>NFA Duration</i> Probability Node	<i>NFA Cost</i> Probability Node
Not Applicable	Not Applicable	0.0	0.0
	High	<i>P NFA Dur High High</i>	<i>P NFA Cost High High</i>
	Low	<i>P NFA Dur High Low</i>	<i>P NFA Cost High Low</i>
	Middle	<i>P NFA Dur High Mid</i>	<i>P NFA Cost High Mid</i>
High	Not Applicable	<i>P NFA Dur High High</i>	<i>P NFA Cost High High</i>
	High	<i>P NFA Dur High High</i>	<i>P NFA Cost High High</i>
	Low	<i>P NFA Dur High High</i>	<i>P NFA Cost High High</i>
	Middle	<i>P NFA Dur High High</i>	<i>P NFA Cost High High</i>
Low	Not Applicable	<i>P NFA Dur High Low</i>	<i>P NFA Cost High Low</i>
	High	<i>P NFA Dur High High</i>	<i>P NFA Cost High High</i>
	Low	<i>P NFA Dur High Low</i>	<i>P NFA Cost High Low</i>
	Middle	<i>P NFA Dur High Mid</i>	<i>P NFA Cost High Mid</i>
Middle	Not Applicable	<i>P NFA Dur High Mid</i>	<i>P NFA Cost High Mid</i>
	High	<i>P NFA Dur High High</i>	<i>P NFA Cost High High</i>
	Low	<i>P NFA Dur High Mid</i>	<i>P NFA Cost High Mid</i>
	Middle	<i>P NFA Dur High Mid</i>	<i>P NFA Cost High Mid</i>

Figure 17 is an example from the preliminary assessment model of how the *Cancer Risk Probability* and *Hazard Index Probability* nodes influence the *NFA Duration* node. DPL determines the best decision based on the expected value of that decision. This sequence of nodes allows DPL to change the expected value of making the no further action decision.

Therefore, the higher the probability the risk or hazard is high, the higher the expected cost and duration of making a no further action decision. A high cost and duration translate into a low utility for that pathway. DPL chooses the decision with the highest expected utility and will therefore not select the no further action decision if there is a significant probability that the risk is high.

The *NFA Cost* and *NFA Duration* nodes from Figure 12 have arrows leading to the *Cost Values* and *Duration Values* nodes. Those arrows indicate only that the expected values of the *NFA Cost* and *NFA Duration* nodes are used in the *Cost Values* and *Duration Values* nodes. The *Cost Values* and *Duration Values* nodes are also influenced by the decision node. Figure 18 uses the preliminary assessment cost and duration value nodes as an example to show the typical values associated with each alternative decision.

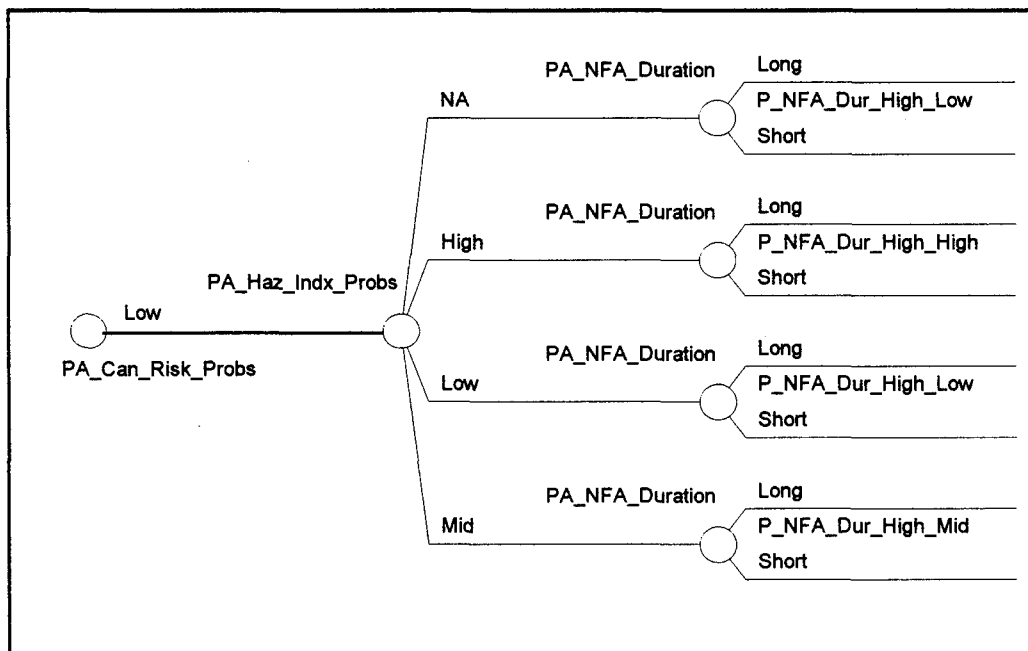

Figure 17: Influences from Risk Probability Nodes to NFA Cost and Duration Nodes

The no further action alternative references the NFA Cost and NFA Duration nodes for the appropriate decision and uses the expected value of those nodes as the cost and duration of that alternative. The estimates of the cost and duration for subsequent information gathering steps (shown in Figure 18 as *SI Cost*, *SI Dur*, *RI30 Cost*, *RI30 Dur*), are value nodes. These value nodes calculate the mean of the cost and duration from the decision maker's estimate of the upper and lower bounds for each alternative. The calculation of the mean assumes that the cost and duration values are uniformly distributed over the range established by the decision maker. An attempt was made to include the cost and duration values as uncertainty nodes to get a better approximation of the cumulative distribution function but the models became too large and were impractical to run.

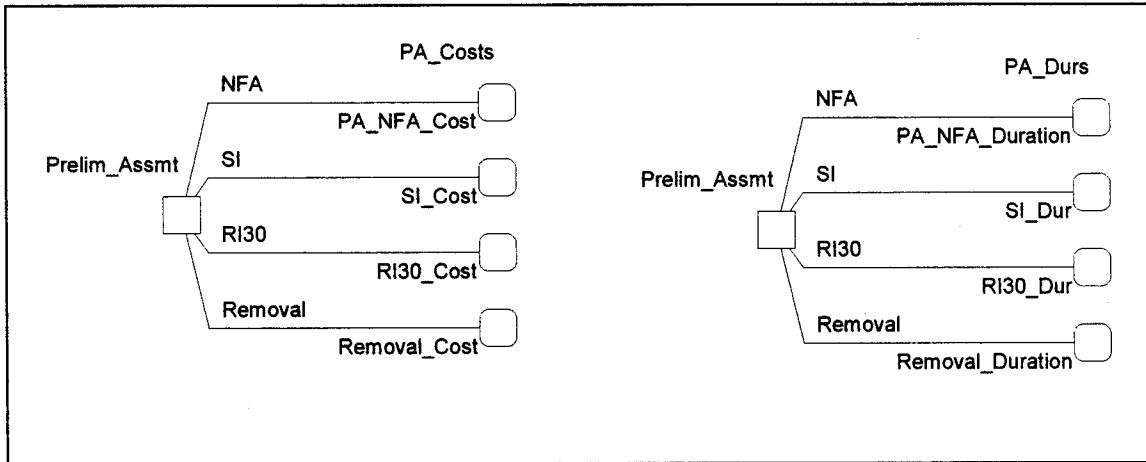

Figure 18: Example of Cost and Duration Value Nodes for Preliminary Assessment Decision

The removal alternative refers to the expected value of the *Removal Cost* node, which is modeled as an uncertainty node influenced by the medium of concern. Modeling removal cost and duration this way allows different cost and duration estimates for each medium, and

accounts for the wide variation between the cost of a removal action for different media. The node still assumes that the cost for each medium is uniformly distributed over the range input by the decision maker.

The *Cost Values* and *Duration Values* nodes in Figure 12 have arrows leading to the value node labeled *Utility*. This value node combines the cost and duration of each alternative into a utility value based on the relative importance of cost over time. The function used to combine the two attributes, cost and duration, is called the utility function. The utility function used in the model is shown in Equation (23). The utility function sums the normalized score for the cost and duration values associated with each possible outcome. The attribute score is derived from Figure 19. The score is assumed to be a continuous linear function between zero and one over the range of attribute values from the minimum to the maximum possible value. The maximum cost and duration are assigned a score of zero, and the minimum cost and duration are assigned a score of one. Equation (19) calculates the score for the cost attribute and Equation (20) calculates the score for the duration attribute.

$$Cost_Score = \frac{(Max_Cost - Cost)}{(Max_Cost - Min_Cost)} \quad (19)$$

where

Max_Cost = highest possible cost for any combination of alternatives

Cost = cost of the particular alternative

Min_Cost = lowest possible cost for any combination of alternatives

$$Duration_Score = \frac{(Max_Duration - Duration)}{(Max_Duration - Min_Duration)} \quad (20)$$

where

Max_Dur = highest possible duration for any combination of alternatives

Duration = duration of the particular alternative

Min_Dur = lowest possible duration for any combination of alternatives

Cost Weight, in Equation (23), is a number between zero and one. The value of the *Cost Weight* node describes the decision maker's attitude about the relative importance of cost versus time. The weight the decision maker places on time is automatically calculated using the fact that the weights must sum to one. The decision maker can determine this value by determining how he feels about the importance of cost compared to time. If he believes that cost and time are of equal importance then the value of *Cost Weight* is 0.5. The value can be found by solving Equations (21) and (22) simultaneously, where α equals 1.0. If he believes that the cost is twice as important as duration then the equations can be solved with α equal to 2.0. In that case *Cost Weight* is 0.667. All combinations of weights are calculated similarly.

$$\alpha(Cost_Weight) = Duration_Weight \quad (21)$$

where

Cost Weight = weight for the cost attribute (unitless)

Duration Weight = weight for the duration attribute (unitless)

α = constant determined by the decision maker

$$\text{Cost_Weight} + \text{Duration_Weight} = 1$$

(22)

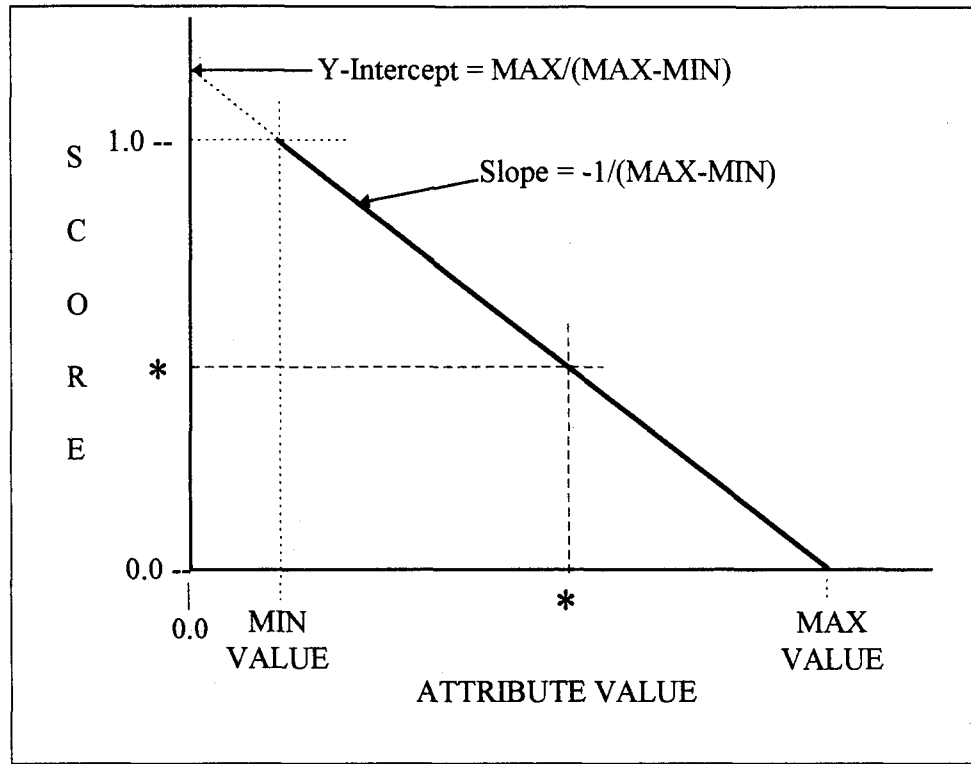

Figure 19: Graphic Representation of the Attribute Scoring Function

The *Max_Cost* and *Max_Dur* variables in Equations (19) and (20) can be determined only after running the model one time for each node with all other values already in place. The *Min Cost* and *Min Dur* nodes are equivalent to the *NFA Cost Low* and *NFA Dur Low* value nodes because the lowest possible cost and duration occurs upon correctly deciding to take no further action with the current information.

$$\text{Utility} = (\text{Cost_Weight})(\text{Cost_Score}) + (1 - \text{Cost_Weight})(\text{Duration_Score}) \quad (23)$$

Subsequent Information Gathering Steps. As discussed earlier, a subsequent information gathering step can be a site investigation or any phase of the remedial investigation as long as it is not the primary decision. Figure 20 shows the conceptual DPL model for a subsequent information gathering step. The logic behind the model is identical to the primary information gathering step. Mechanically, the only difference is that a subsequent information gathering step performs a calculation to update the standard error based on the expected number of samples collected from each medium.

The number of samples for all media types in each information gathering step is represented by the *Number of Samples* node in Figure 20. The *Number of Samples* node is influenced by the *Media* node because each medium may have a different number of samples drawn, depending on the phase of study.

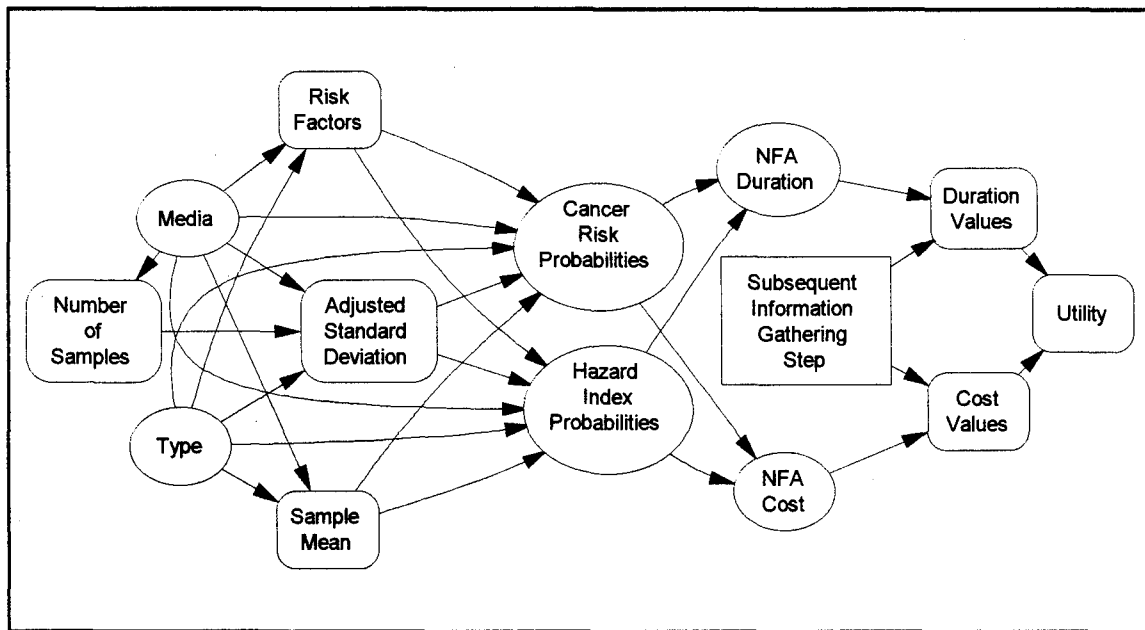

Figure 20: Conceptual Model for a Subsequent Information Gathering Step

The arc from the *Number of Samples* node to the *Adjusted Standard Deviation* node indicates that the information from the *Number of Samples* node is used in the *Adjusted Standard Deviation* node. The calculation estimates the standard error of the distribution of the mean concentration based on Equation (10). The probabilities of the risk or hazard index being high, medium, or low are then recalculated for each chemical based on the new standard error of the mean. The calculation assumes that added information does not change the estimate of the mean, only the standard error of the distribution of the mean.

Using this procedure the cost and duration of the study are compared to the change in expected value if the study is performed. If the cost and duration of the study are more than the expected savings realized from the improved information, the model will not recommend further study. This technique determines whether or not further study is required by directly relating the cost and duration of the study, the number of samples collected, reduction in uncertainty associated with the estimate of the mean, and the probability of making an error.

Removal Action. The removal action portion of the models is similar to an information gathering step, except there are more opportunities for risk reduction. A removal action can reduce the mean concentration as well as the standard error of the estimate of the mean. A removal action can also reduce risk by limiting exposure through installation of barriers or other means. Limiting the exposure may not reduce the concentration or provide more information, but it may reduce the estimate of risk enough to eliminate the need for remediation. Figure 21 shows the conceptual model for a removal action.

The *Adjusted Standard Deviation* node works the same way as it does for subsequent information gathering steps. The standard error for the estimate of the mean concentration is adjusted based on the number of samples collected from each medium over the course of the

removal action. The number of samples is input by the user and is represented by the node entitled *Number of Samples* in Figure 21.

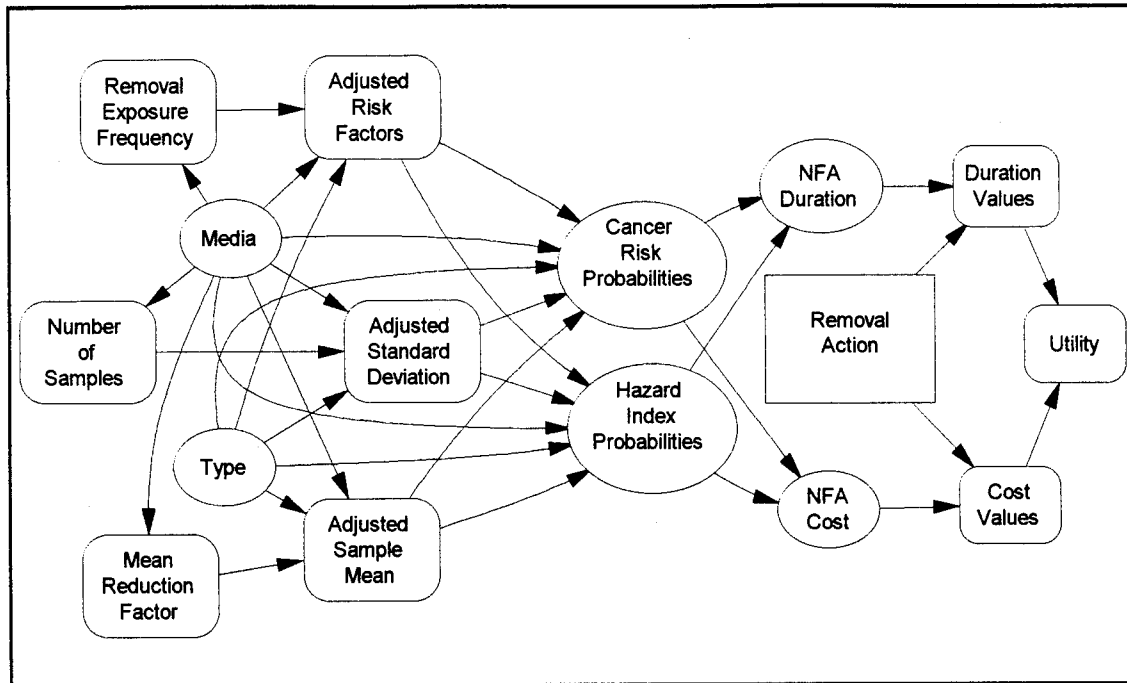

Figure 21: Conceptual Model for a Removal Action

The node entitled *Mean Reduction Factor* is influenced by the *Media* node so that a different factor may be input for each medium. The factor is the decision maker's best estimate of the reduction in the mean concentration as a result of the removal action. For example, if the removal action considered was to pump groundwater through an air stripper to remove volatiles and the air stripper had an average 95% removal efficiency, the mean reduction factor would be equal to 0.95. The factor will modify the estimate of the mean concentration for all chemicals within a medium. It is used in the Excel portion of the model to update the parameters of the distribution of risk.

The final way a removal action reduces the risk is by reducing the estimated exposure frequency. This type of removal action may or may not also reduce the standard error or the mean. The model may select this method if the estimate of risk drops far enough to sufficiently increase the expected utility of the no further action decision.

All the other nodes in the removal action model function as described in the primary information gathering step. The probability that the risk is high is used to modify the expected value of making the no further action decision as shown in Figure 17.

Feasibility Study. The feasibility study portion of the model has a different structure than the other portions. It uses information in the influence diagram in a way that is more typical of decision analysis. The primary and subsequent information steps used the model to evaluate the value of gathering further information over taking immediate action. If the additional information had a lower expected utility than some other alternative, the other alternative was chosen. The feasibility study portion of the model uses expert opinion to determine whether the site is similar to some other site that was successfully remediated. However, experts are not perfect. There is some probability that they evaluate the site similarity incorrectly. The conceptual model, shown in Figure 22, allows for the consideration of imperfect information before selecting the best alternative. It also allows for consideration of when in the remedial investigation the decision to proceed to the feasibility study was made. The function of each of the nodes is described below.

The uncertainty node labeled *True Site Similarity* represents the likelihood that the physical characteristics and conditions of the current site are truly similar to previously, successfully remediated sites (Findall, 1994:3-14). The event states for this node are shown in Figure 23. The *True Site Similarity* node has no values associated with its event states, but it does have a

probability. The true probability that the site is similar, *True Prob Site Sim*, must be input by the decision maker. The determination of this probability requires an estimate of the overall likelihood that any site is similar to another site in order to derive the best estimate that a particular site is similar to another. The recommended value for this probability at Department of Defense sites is 0.56.

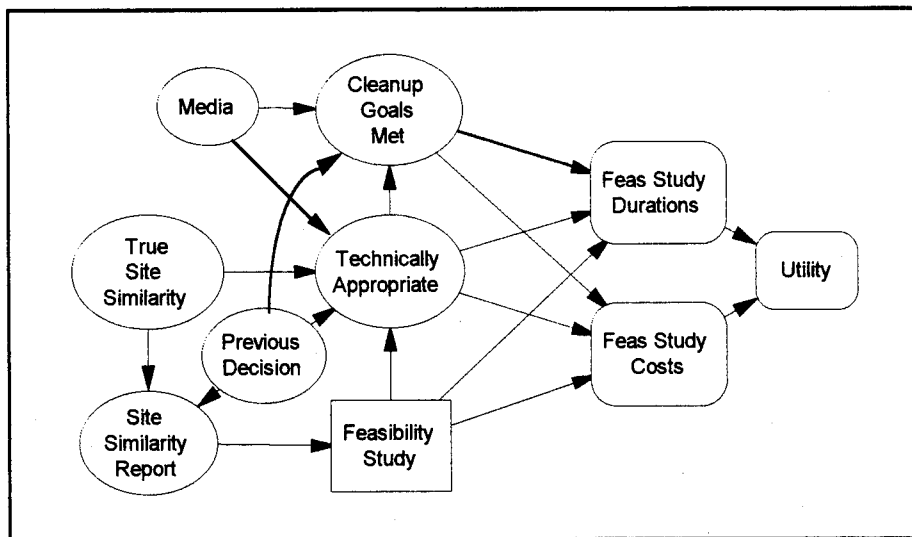

Figure 22: Conceptual Model of the Feasibility Study Decision

Figure 24 provides an illustration of how the 0.56 probability was determined. In order for a site to be similar it must have two similar components. The first component is that the site must be of similar nature when compared with other sites. For example, it must be a common type of site, such as a landfill or groundwater contamination. According to the Defense Environmental Cleanup Program Annual Report to Congress for Fiscal Year 1993, 75 percent of all Department of Defense hazardous sites fit into ten broad categories (DOD, 1994:40), indicating that 75 percent of hazardous waste sites are of similar nature.

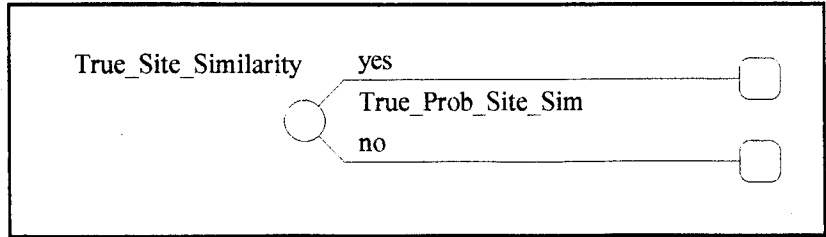

Figure 23: True Site Similarity Node with Event States

The second component is that the site must have similar characteristics in terms of the type of contamination. The site is assumed to have similar characteristics if it can be remediated using an existing technology and no innovative treatment alternative was required. According to the USEPA (USEPA, 1993b:27), from 1988 to 1992 there were 832 records of decision signed and of those approximately 75 percent selected proven treatment technologies, as opposed to innovative technologies, indicating that they are of similar characteristics. From Figure 24, the probability any particular site is considered similar is $(0.75)^2$ or 0.56.

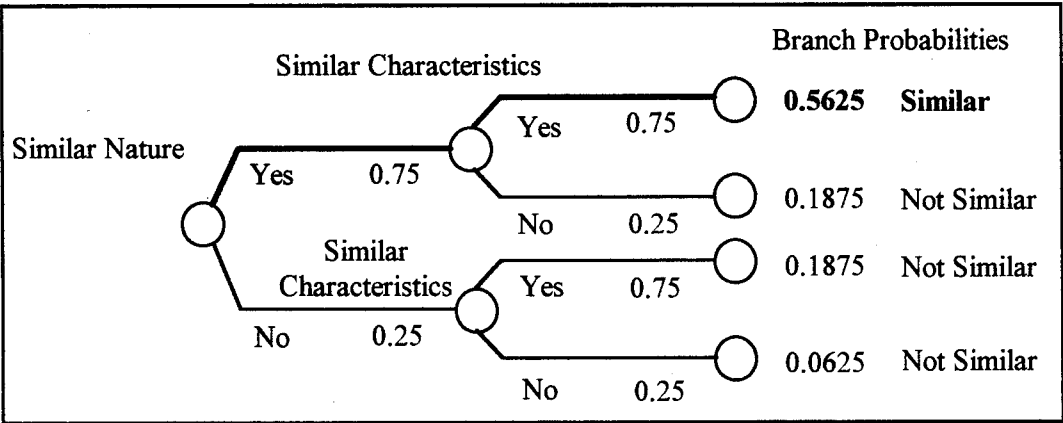

Figure 24: Probability of True Site Similarity Determination

The *Previous Decision* node from Figure 22 is not found in the working model. That node is shown here to simplify the presentation. It influences the *Site Similarity Report* node, the *Technically Appropriate* node and the *Cleanup Goals Met* node because the probabilities associated with those nodes depend on when the decision to proceed to the feasibility study is made. The *Site Similarity Report* node represents the expert's best estimate of the true site similarity. The accuracy of this estimate improves as more information is gathered throughout the remedial investigation.

Similarly, the *Technically Appropriate* node represents the likelihood that an acceptable treatment technology is chosen for the true site conditions. An acceptable treatment technology is one that can, if designed properly, lower the concentration of the contaminants at the site to an acceptable level. The likelihood that the technology is technically appropriate also improves as more information is gathered about the site.

The likelihood that the remedy is designed correctly also improves as more specific information becomes available about the site characteristics. That probability is represented by the *Cleanup Goals Met* node. If the decision to proceed to the feasibility study is made too early, information that directly impacts the design may be missing. Information such as the extent of contamination and even the contaminants themselves may change as more information is obtained.

Because of the dependency on the knowledge of the site characteristics, each decision point with feasibility study as an alternative is associated with a particular *Site Similarity Report* node, *Technically Appropriate* node, and *Cleanup Goals Met* node. The conceptual model in Figure 22 shows this through the use of the *Previous Decision* node for simplicity. The actual working models have individual nodes for each decision point. For example, the *Site Similarity*

Report, Technically Appropriate, and Cleanup Goals Met nodes associated with the 30 percent remedial investigation are called *RI30 Site Sim Report, RI30 Tech Approp, and RI30 Cleanup Goals Met* (See Table 10 in Appendix A).

In addition to the level of site characterization, the likelihoods associated with the *Site Similarity Report* node are also influenced by the true site conditions. Figure 25 uses the 100 percent remedial investigation model to illustrate how the true site conditions influence the *Site Similarity Report* node. Given that the site is truly similar to other sites there is a high probability that, after the 100 percent remedial investigation, the site similarity report predicts that the site is similar. That probability is input by the decision maker in the node labeled *RI100 P SSR Yes g Yes*. Additionally, given that the true site conditions are not similar, there is a lower probability that, after the 100 percent remedial investigation, the site similarity report will predict that the site is similar. That probability is also input by the decision maker in the node labeled *RI100 P SSR Yes g No*. In both cases DPL automatically calculates the probability that the site similarity report says the site is not similar. The *Site Similarity Report* node modifies only the likelihood of the true site conditions and there are no values associated with the node.

The *Technically Appropriate* node is also influenced by more than just when the decision is made to proceed to the feasibility study. That node is also influenced by the extent of the feasibility study, by the true site conditions, and by the medium of concern. These influences are represented in Figure 22 by the arrows from the *True Site Similarity* node, from the *Feasibility Study* decision node, and from the *Media* node. The effect of these influences on whether or not the proper type of remediation technology is selected is shown in Figure 26.

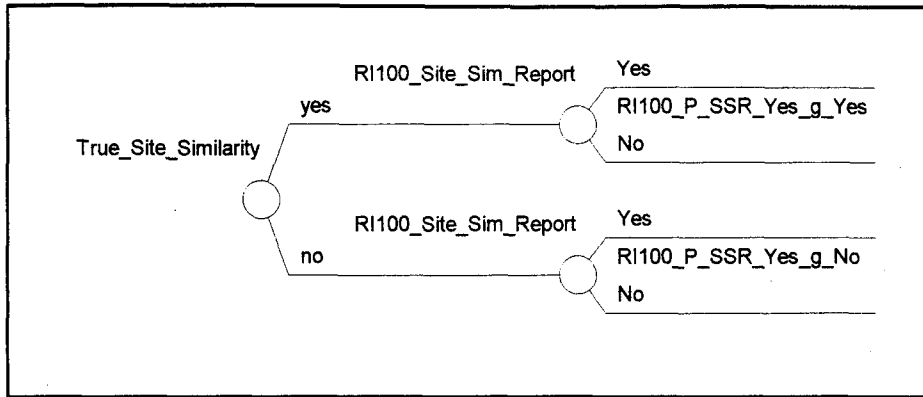

Figure 25: Site Similarity Report Node with Event States and Influences

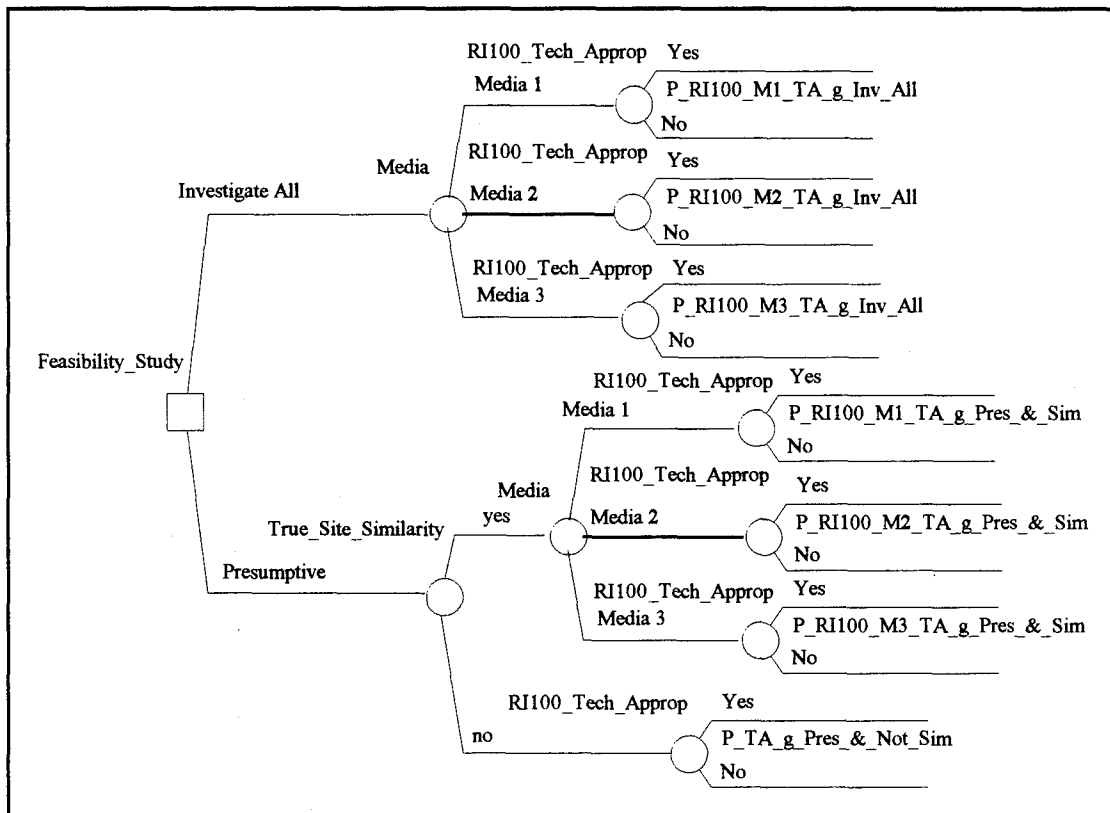

Figure 26: Technically Appropriate Node with Event States and Influences

Figure 26 uses the *Technically Appropriate* node associated with the 100 percent remedial investigation to illustrate the structure of the node. Each decision point with *Feasibility Study* as an alternative is associated with a similar node. The probabilities shown in Figure 26 refer to value nodes in the model. The definition of those probabilities is given in Table 8, Appendix A. If the decision is to investigate all potential remediation technologies, the probability that an appropriate technology is selected is independent of the true site similarity. The probability is independent because complete feasibility studies do not consider the site's similarity before recommending an alternative. However, if all the feasible alternatives are investigated the probability that an appropriate remedy is selected is dependent on the medium of interest. It is not necessary that the probabilities be different across media but the model allows for that possibility.

If the decision is to use a presumptive remedy, the probability that the remedy is successful is dependent on whether the site is similar to other sites and, if the site is similar, on the medium of interest. A condition for a successful presumptive remedy is that the site is similar to another successfully remediated site. If the site is not similar, the remedy could not be expected to be the correct one. Therefore, the node labeled *P TA g Pres & Not Sim* would contain a low probability. It is assumed that this probability is not dependent on when the decision is made, so the *P TA g Pres & Not Sim* node is referenced in all the *Technically Appropriate* nodes. If the true site conditions are similar to other sites and a presumptive remedy is used the probability that the remedy will work should be high. The *P RI100 M1/M2/M3 TA g Pres & Sim* nodes contain these probabilities. The probabilities do not necessarily need to be different across media but the model allows for that option.

The probabilities associated with the *Technically Appropriate* nodes are difficult to evaluate from past data. They are dependent on the true site conditions which makes them site specific. The decision maker must use his best judgment or expert opinion when determining their value. Sensitivity analysis is performed on these probabilities in Chapter 4.

If the remedy selected is not technically appropriate, there is a penalty in terms of cost and duration because it requires a reevaluation of the proper technology. The assumption built into the model is that the penalty is a percentage of the feasibility study cost and duration and is constant regardless of when the decision to proceed to the feasibility study is made. The value of the penalty is calculated in the decision tree portion of the model. Figure 27 shows the *RI100 Tech Approp* node as it is influenced by the alternatives of the *Feasibility Study* decision node. Although the likelihood values associated with the *Technically Appropriate* node are influenced by the *True Site Similarity* node, see Figure 22, the penalty for an error is independent of the *True Site Similarity* node, and so is not shown in Figure 27.

The cost and duration penalties in Figure 27 are separated by a comma. If the decision is to *Investigate All*, the cost factor used is *TA Cost Fac Not TA g Inv All*. The variable name references the *Technically Acceptable* nodes' cost factor (*TA Cost Fac*) for the event state where the technology is not technically acceptable (*Not TA*) given that (*g*) all technologies were investigated (*Inv All*). The other factors are named in a similar manner. If the decision is to use a presumptive remedy, the factors end with *Presmtv*. If the factor deals with duration instead of cost, it begins with *TA Dur Fac* instead of *TA Cost Fac*.

All factors used in this node should be between zero and one. A zero factor indicates that no penalty is charged for selecting an inappropriate technology. A factor of one indicates that, if an inappropriate technology is chosen, the feasibility study will be completely

reaccomplished prior to selecting a new technology. Also, the factors for the *Investigate All* alternative should be smaller than the factors for the *Presumptive* alternative. Once the factor is determined, it is used to multiply the feasibility study cost (*FS Cost*) and duration (*FS Dur*).

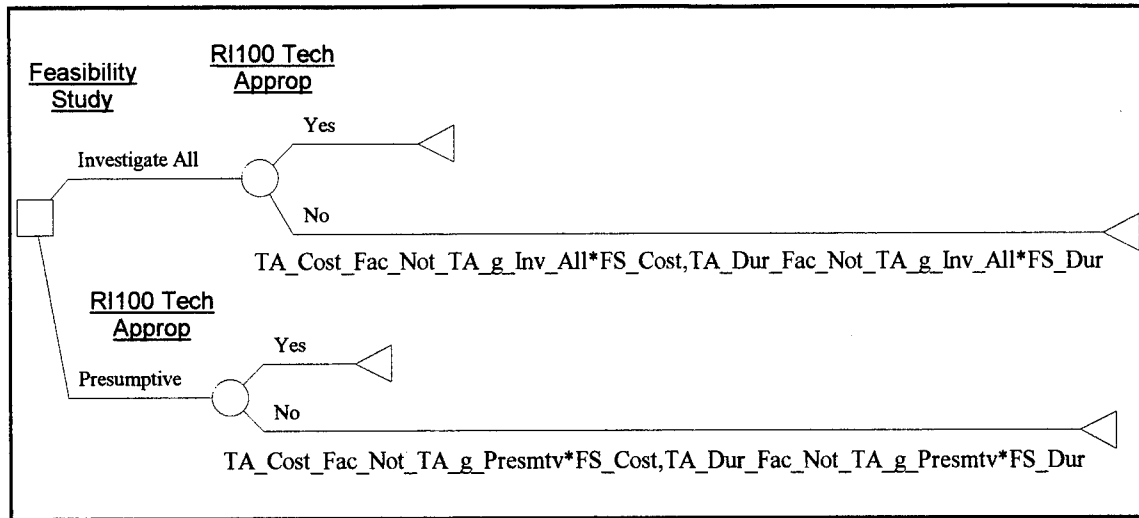

Figure 27: Penalties for the Choosing a Technically Inappropriate Remedy

The *Cleanup Goals Met* node in Figure 22 is influenced by the *Technically Appropriate* node, the *Previous Decision* node and the *Media* node. The *Cleanup Goals Met* node captures the uncertainty associated with the remedial design. Once a remediation technology has been selected, even assuming that it is a technically appropriate technology, there is some probability that the design does not meet the cleanup goals. For example, an appropriate technology may be selected but the equipment may be installed in the wrong location or may be undersized for the actual site conditions. The likelihood of this happening is different depending on how well the site has been characterized. The dependence on how well the site has been characterized leads to the need for an influence from the *Previous Decision* node.

The likelihood associated with the *Cleanup Goals Met* node also varies across media. As an example, it is easy to see that the uncertainty associated with the performance of a complex groundwater treatment process is higher than if soil is being excavated, drummed and shipped off site. Finally, the probability is dependent on whether or not the selected technology is appropriate. If the technology is inappropriate, meeting the cleanup goal is by definition impossible; whereas if the technology is appropriate, the main reason the cleanup goal would not be met is if there was some sort of design error.

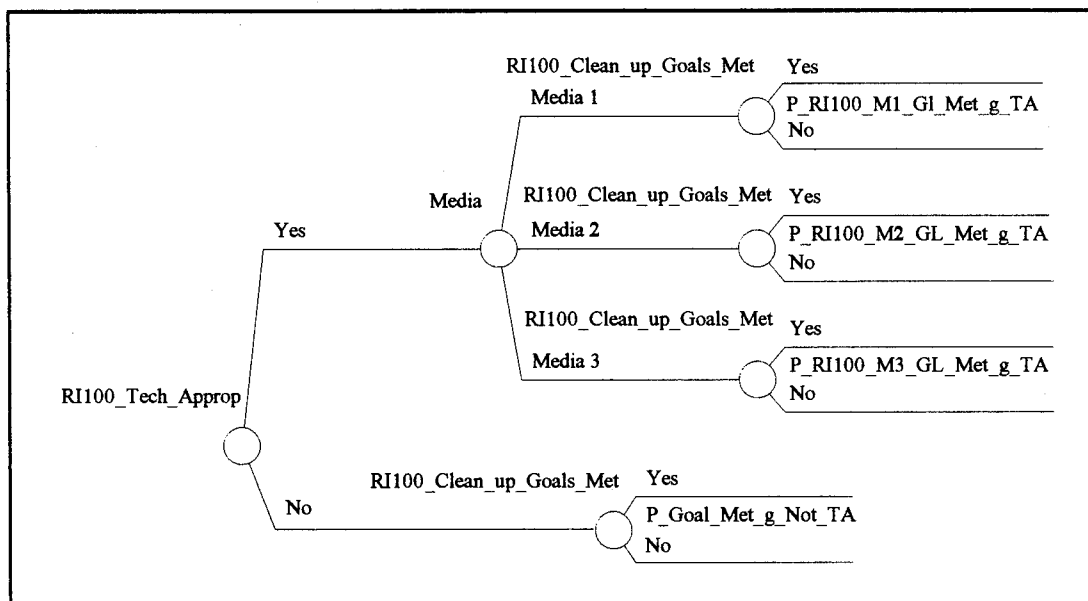

Figure 28: Cleanup Goals Met Node with Probabilities and Influences

The structure of the *Cleanup Goals Met* node is shown in Figure 28, using the RI100 decision point as an example. The figure shows that the likelihood values of the node are dependent on media type only when the technology chosen is technically appropriate. If the

technology is inappropriate, the likelihood that the cleanup goals will be met (*P Goal Met g Not TA*) is zero in all cases.

When the technology is appropriate, the probability that the remedial design is correct and meets the cleanup goals depends on the media type. The nodes referenced in Figure 28 that have names similar to *P RI100 MI GL Met g TA* refer to different decision points such as *RI30*, *RI60* or *Rem* for removal or they may contain different media references such as *M2* or *M3*.

The probabilities are subjective. Possible probabilities range from zero, meaning the technically acceptable remedy will never meet the cleanup goals, to one, where the remedy will certainly meet the cleanup goals. The later the decision to proceed to the feasibility study is made in the site characterization process the higher the probability that a technically appropriate remedy will meet the cleanup goals. The higher probability of success results from the additional information available about the site conditions. Sensitivity analysis is performed on these probabilities in Chapter 4.

The *Cleanup Goals Met* node, like the *Technically Acceptable* node, has cost and duration penalties associated with not meeting the cleanup goals. The penalties in this case are proportional to the remediation cost and duration. If the proper technology was selected and the design did not meet the cleanup goals, then field modifications to the system will be required. These modifications will take time and money. How much time and money they take is assumed to be a function of the original cost and duration of the remediation effort. Figure 29 shows the cost and duration factors for each possible outcome.

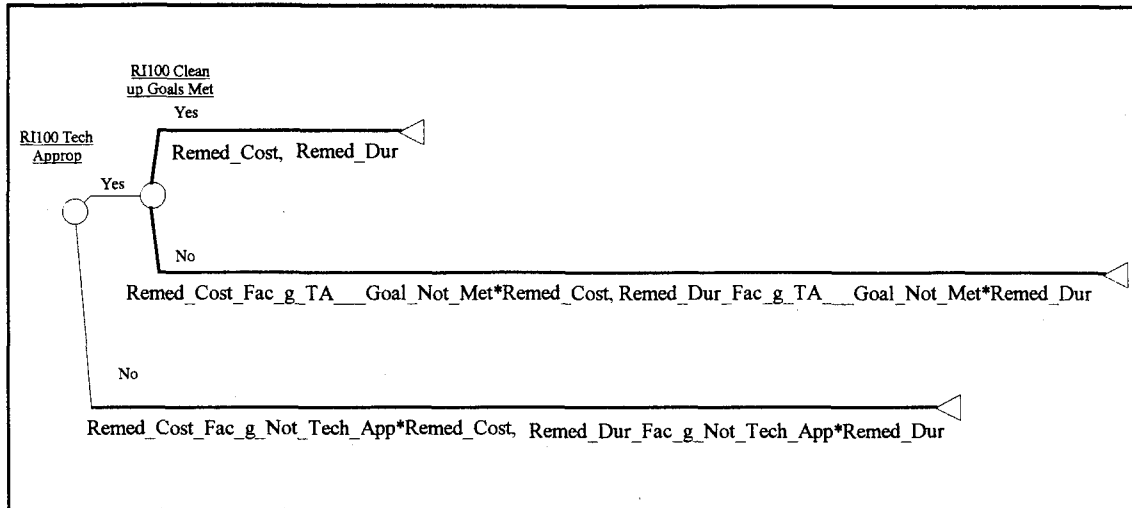

Figure 29: Cleanup Goals Met Node with Values and Influences

Figure 29 shows that when the technology selected is technically appropriate and the cleanup goals are met, the remediation cost and duration are not modified, and there is no penalty. When the technology is appropriate but the cleanup goals are not met, the remediation cost and duration are multiplied by a factor. The factor refers to the node labeled *Remed Cost Fac g TA & Goal Not Met*, which indicates that it is the remediation cost factor given the remedy was technically appropriate and the remediation goal was not met. Factors for cost and duration need not be equal but each must be greater than one. If these factors are equal to one, there is no penalty for a poor remedial design. If they are less than one it is beneficial to have a poor design. Consider that if the technology is appropriate the system will need only modifications to meet the cleanup goals. The possible modification could be minimal or extensive. A factor greater than two indicates that the modifications to the treatment system would more than double the cost of the original system.

If the technology is inappropriate, the cost and duration factors (*Remed Cost Fac g Not Tech App* and *Remed Dur Fac g Not Tech App*) might well be greater than two. If the technology is not appropriate the remediation system probably needs to be completely replaced and a new one installed. This could double the cost and duration of the original remediation effort.

The *Feas Study Costs* and *Feas Study Durations* nodes in Figure 22 represent the total cost and duration of each possible outcome of the *Feasibility Study* decision node. The total cost and duration for each outcome are then scored and converted to a utility value as described on page 61.

Model Development in Excel

The DPL model discussed above shows the relationship between the various parts of the RI/FS process and how the outcome of one event can effect the value or likelihood of another event. In order for the results of the model to be based on the health risk posed by the chemicals of concern, spreadsheet software is required to perform the risk calculations and then automatically linked to DPL. The spreadsheet software used in this model is Excel (Excel, 1993). DPL and Excel have the capability to pass information back and forth while a model is running in DPL. Input variables are put in DPL and passed to Excel. Those variables are used in Excel to calculate the probabilities associated with the risk or hazard posed by a particular chemical and passed back to DPL for use in the model.

The Excel portion of the model is broken down into several sections. The first section includes all the input variables put in DPL in a tabulated format. Because DPL has no capability to display the values in a large number of nodes, it was necessary to send those

values to Excel for presentation. The next portion of the spreadsheet calculates the risk multiplier for each chemical. The risk multiplier combines all the variables associated with the calculation of risk, except the chemical concentration, to derive a constant value. The final risk multiplier is a cumulative value for each chemical across all exposure routes. The risk multiplier is used to modify the parameters of the distribution of the mean chemical concentration. The new distribution parameters are the parameters for the distribution of risk. In the third section the new distribution parameters are compared to the minimum and maximum acceptable values of risk and hazard index. The probability that the measured value of risk is over or under the established standard are calculated, then passed back to DPL. The fourth part of the Excel spreadsheet is the calculation of the probabilities of the cumulative risk at the site. These values are not used in the DPL model, but are calculated for the benefit of the user. Each of these four sections is explained below.

Input Variables. This portion of the spreadsheet is mainly a straightforward presentation of the variables placed in the DPL model with some simple calculations. All input variables must be put in the DPL model initially and not in the Excel spreadsheet. Although inputting and editing the values would be simpler in the spreadsheet, DPL cannot perform sensitivity analysis on values that are input in the spreadsheet. The sensitivity analysis capabilities are one of the major advantages to using the DPL model and that capability should be maintained.

There is a different spreadsheet model for each primary information gathering step. With the exception of the preliminary assessment model, each model is identical. The input variable presentation portion of the models do not display variables that were input in earlier models. This was done in an effort to minimize the input requirements for each model.

Although the primary reason for the input section is to display variables more efficiently, there are some calculations that take place in this section. The first calculation is the expected value of the cost and duration estimates for each of the phases of the RI/FS. The user inputs the upper and lower bounds on the cost and duration estimates. The model assumes that cost and duration are uniformly distributed between these values and uses the mean value of the distribution as the estimate of cost and duration. The assumption of a uniform distribution is generally adequate when the uncertainty is less than a factor of 10 (Hoffman and Hammond, 1992:9). Equation (24) shows the calculation for the mean value of a uniform distribution (Hoffman and Hammond, 1992:32).

The decision maker is allowed to input a range of possible cost and duration values, but the model does not treat them as uncertainties. The model calculates the mean of the input range and uses that value as a point estimate of cost and duration. A point estimate is used instead of a distribution of values in order to keep the model small enough to run quickly. Making the cost and duration values into uncertainty nodes in DPL made the model impractical to run. The system requirements were higher than typical computers could handle and the run time increased to the point where sensitivity analysis would be impractical. Also, DPL bases its recommendations on the expected value of an outcome (ADA Decision Systems, 1995:178), and using the mean of the distribution results in the same answer but reduces the set of possible outcomes shown in the cumulative distribution. The cell names are described in Table 8 for input variables and in Table 9 for calculated variables, both tables are in Appendix A.

$$mean = \frac{(Lower_Bound + Upper_Bound)}{2} \quad (24)$$

Another calculation in the input section is the cumulative number of samples taken at a particular decision point. In the preliminary assessment model the spreadsheet calculates the total number of samples taken assuming a site investigation was completed and assuming it was not completed. The cumulative number of samples for the a removal action assumes that the decision maker proceeds to a removal action immediately after the decision at hand. For example, if the model being run is the site investigation model the cumulative number of samples taken at the removal action only sums the preliminary assessment and site investigation number of samples. This is the case because a removal action is assumed to be required immediately to mitigate a potential hazard.

The cumulative numbers of samples at each decision point are not used in the DPL model and, therefore, are not passed back to DPL. The values are used later in the Excel spreadsheet to calculate the standard error of the distribution of the mean concentration.

The final calculation made in the input section of the spreadsheet deals with the adjusted sampling distribution parameters. The parameters input into DPL are, for the preliminary assessment model, the decision makers best estimate of the upper and lower bound concentrations that will be found. For all other models, the mean and standard deviation of the samples for a particular medium-chemical combination are input. Because determination of the underlying distribution of the chemical concentration is difficult, if not impossible, to determine accurately in most cases, the model uses the Central Limit Theorem and the available data to develop the normal distribution parameters for the estimate of the mean concentration.

These parameters are calculated one of two ways, depending on the model being used. If the preliminary assessment model is used, the decision maker inputs the concentration range of the chemicals. The model assumes that each chemical is uniformly distributed over that range. It then calculates the mean and standard deviation of the range. The mean is calculated using Equation (24) on page 81, and the standard deviation is calculated using Equation (25).

$$S = \left[(High_Contam_Level - Low_Contam_Level)^2 / 12 \right]^{1/2} \quad (25)$$

where

- S* = standard deviation of a uniform distribution
- High_Contam_Level* = upper bound estimate of contaminant concentration (ppm)
- Low_Contam_Level* = lower bound estimate of contaminant concentration (ppm)

Equation (25) calculates the standard deviation of a uniform distribution. That calculation produces an estimate of the standard deviation of the chemical in the particular medium. In order to get the standard error of the estimate of the mean, the standard deviation is divided by the square root of the total number of samples, in accordance with Equation (10) on page 30, taken at the end of each phase of the RI/FS process.

For other than the preliminary assessment model the mean and standard deviation of the samples are input directly into DPL. The spreadsheet then divides the original standard deviation by the square root of the appropriate sample total to calculate the standard error of the

estimate of the mean concentration, which, from the Central Limit Theorem, is approximately normally distributed, assuming the number of samples is large enough.

The calculated standard errors are not sent back to DPL because they are not required in the influence diagram. They are used later in the Excel spreadsheet to estimate the standard deviation of health risk associated with each chemical.

Risk Multipliers. Risk multiplier is the term given to the deterministic calculation of all the risk factors input into the model. The factors include such items as the exposure durations, slope factors, reference doses, exposure times, conversion factors, absorption factors, exposure frequencies, average body weight, averaging time, adherence factors, and exposed dermal surface area. These factors, for the purposes of this model, are assumed to be deterministic. This assumption is valid because the decision maker bases his decision about what to do in the RI/FS process on point estimates of reasonable maximum exposure values published by the EPA. Further site characterization will not change the decision maker's estimate of exposure or the toxicity information used to calculate risk. Further investigation will only serve to decrease the uncertainty associated with the estimate of chemical concentration.

The risk multiplier is calculated for the carcinogenic and noncarcinogenic effects of each chemical in each medium across the three possible exposure routes. The individual values for the exposure routes are then combined into a total carcinogenic and noncarcinogenic effects risk multiplier for each chemical.

That process produces a chemical specific, deterministic value that, when multiplied by the concentration of the specific chemical, will produce a value of risk. However, the chemical concentration is not deterministic. The distribution of the mean concentration for each chemical is approximately normally distributed. Chapter Two explains how a constant can be

used to adjust the mean and variance of a distribution. Equation (15) on page 33 uses the mean concentration and risk multiplier to get the mean value of the distribution of risk. The standard error and the risk multiplier are used in Equation (16) on page 33 to derive the standard deviation of the approximately normally distributed estimate of risk.

Probability Calculation. This portion of the spreadsheet uses the means and standard errors of the distributions of risk that were described above to find the probability that the measured risk is over or under the reference values. Figure 30 gives a graphic display of the distribution of risk with the high and low reference values.

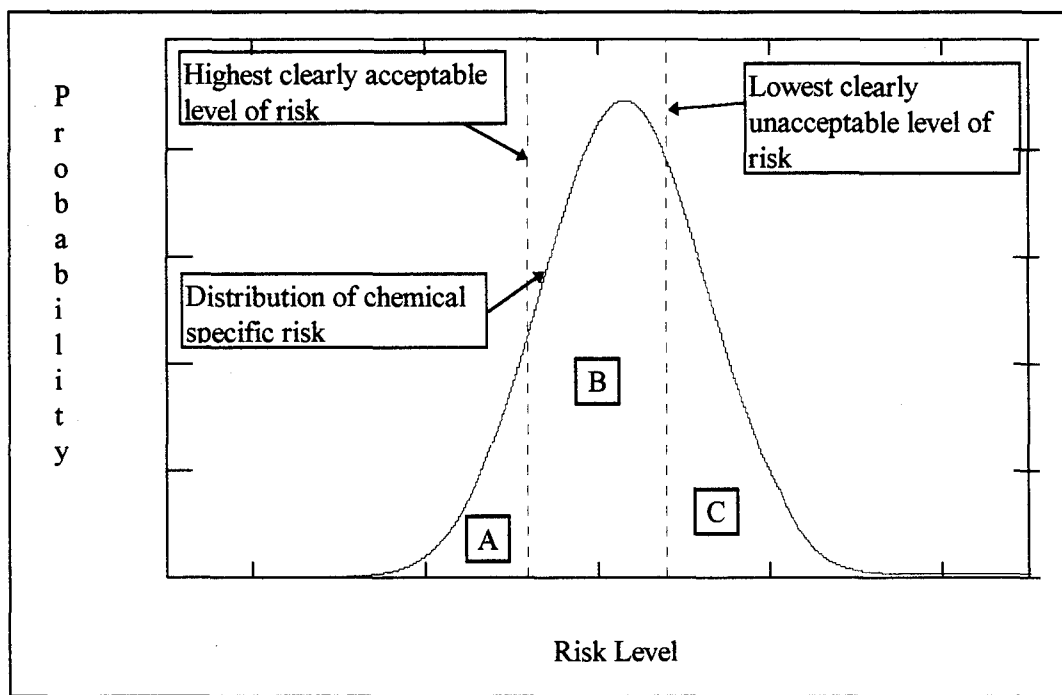

Figure 30: Risk Probability Distribution Graph

Section A in Figure 30 represents the probability that the risk is below the clearly acceptable level. Section B represents the probability that the risk is in the mid range. A

chemical in this section must be given consideration, but it is not clearly a problem. Section C is the probability that the risk posed by the chemical is clearly greater than the accepted standard.

The probabilities are calculated using the NORMDIST function in Excel. The probability associated with area A is equivalent to the cumulative probability up to the maximum clearly acceptable value. The probability that the risk is in area C is equivalent to one minus the cumulative probability up to the clearly unacceptable value. The probability that the risk is in area B is the cumulative probability to the clearly unacceptable value minus the cumulative probability to the clearly acceptable value.

The spreadsheet also tests to ensure that the risk probability calculation is valid. If either the hazard multiplier or the cancer risk multiplier is equal to zero then all the probabilities are set equal to zero and the probability that the calculation is not applicable is set equal to one.

Once the calculations are complete the probabilities that the risk is high, low and not applicable for each chemical at each decision point are passed to DPL. The probability that the risk is in the mid range is automatically calculated by DPL using the fact that the probabilities must sum to one.

Cumulative Risk Calculation. The model determines the best course of action for a particular chemical. The model does not decide the next step based on the cumulative risk at the site because that would mask important information, such as allowing the decision maker to see which chemical or which medium posed the greatest threat. Also, a decision based on the cumulative risk at the site would not indicate on which chemicals or media to focus future efforts. Using the cumulative risk would not evaluate the entire site because the model has the capacity to evaluate only 9 chemicals at a time. However, the drawback to looking at the

chemicals individually is that, in practice, decisions are based on the cumulative site risk which includes all chemicals and all exposure pathways. For this reason the final section of the spreadsheet was added.

The final section uses the rules of linear combinations to determine the overall site cancer risk and the overall site hazard index. It is important to note that these calculations are not used in the model. They are for information and comparison only. The rules of linear combinations of normal random variables require that the variables be independent. Independence is assumed between the nine chemicals in the model. This may or may not be a valid assumption. Finally, the probabilities associated with the site risk assume that the nine chemicals included in the model are the only nine chemicals at the site. If the model is run more than once to accommodate all the chemicals, the user must track the cumulative mean and standard errors and make his own determination of probabilities after all the iterations are complete. This section of the model can be helpful in making a decision but the decision maker must keep in mind the assumptions that go into the calculations.

IV. Analysis and Findings

Introduction

This chapter focuses on the verification and validation of the models developed in Chapter 3 as well as the models' sensitivity to various input parameters. The chapter ends with an example of how the models can be used to develop confidence limits on cleanup costs and durations. Both the verification and validation of the models are done through comparison of the output with results obtained from the remedial investigation and the feasibility study completed for OU2 at WPAFB, Ohio (Engineering Science, 1995). The site, known as the POL Storage Area, consists of three smaller areas, spill sites 1, 2 and 10, where fuel spills are known to have occurred.

A preliminary assessment, consisting primarily of a records search with no actual field investigation; a site investigation; a complete remedial investigation, including a baseline risk assessment; and a feasibility study were completed for this area. The site was also subject to various removal actions in the groundwater medium to extract the free floating fuel on the water table. The data available at the end of the PA, the SI and the 100% remedial investigation (RI100) were entered into the respective models.

The analysis presented in this chapter is based on a total of four separate iterations of the PA, SI, and RI100 models. The first run of each model evaluates benzene, toluene and xylene in three media. The media are groundwater, surface soil, and subsurface soil. The second run of the RI100 model evaluates three different chemicals in each medium that were shown to

pose a health threat greater than the acceptable limit. The input parameters used in each of the four iterations are tabulated in Appendix F.

The remainder of this chapter is separated into four sections. The first section verifies the accuracy of the risk calculations in both the DPL model and the spreadsheet model by comparing them with the results of the risk assessment. The second section compares the results from each of the four iterations discussed above with what is known to be true at this point in time. Keep in mind that the input parameters used in the model are the ones that were available to the decision maker at the end of the study phase the model represents. The third section includes a presentation of the one way sensitivity analysis and discusses the importance of the results. The fourth section shows how to generate confidence limits on the cost and duration of the cleanup. These limits can be used by the decision maker to update cost estimates and schedules at the end of each study phase.

Model Verification.

Verification of the models involves ensuring that the calculations made within the models are accurate. The influence diagram and decision tree in DPL performs a distinctly different function than the spreadsheet portion of the model. The purpose of the influence diagram is to capture the relationships between the uncertain events in the RI/FS process and to calculate the expected utility of each alternative. The function of the spreadsheet model is to calculate the health risk posed by each chemical and determine the likelihood that the health risk is inside or outside of a given range. Verification of the two sections of the models will be handled separately.

Influence Diagram Verification. The calculations in the influence diagram and decision tree involve the summation of the costs and durations of each possible outcome and their conversion to a utility value. The calculations are verified using the results obtained for benzene in the groundwater from the first run of the RI100 model. Figure 31 shows a sample of the decision policy output for this run.

The information contained in a decision policy diagram has a specific format. The recommended alternative is recognized by the bold line leaving the decision node. Numbers in the location labeled "A" in Figure 31 are the cost and duration associated with that event state. If there are no numbers in that location the node has no additional cost or duration associated with it. The number in the position labeled "B" is the likelihood that the event state occurs. The "C" position holds the utility of the particular event state.

Confirmation of the calculations in the models requires the use of Equations (19), (20), and (23) on pages 61 and 63. The equations calculate the cost score, duration score and utility of an outcome, respectively.

Table 5: Parameters Used in Influence Diagram Verification

Parameter	Value
Minimum Duration (months)	0.5
Maximum Duration (months)	213.75
Minimum Cost (dollars)	1500
Maximum Cost (dollars)	2,955,000
Cost Weight (unitless)	0.67

The outcome used to verify the influence diagram calculation is highlighted in Figure 31. Using Equations (19) and (20) to calculate the cost score and the duration score for the highlighted path first involves summing the costs and durations associated with each node

along the path. The total cost for the highlighted outcome is \$808,000, found by summing the cost of the presumptive remedy, \$30,000, and the cost of the event state labeled *Low* on the *Remediation Cost* node, \$778,000. The total duration for that same path is 65.7 months, found by summing the duration associated with the presumptive remedy alternative, 3 months, and the duration for the highlighted event state in the *Remediation Duration* node.

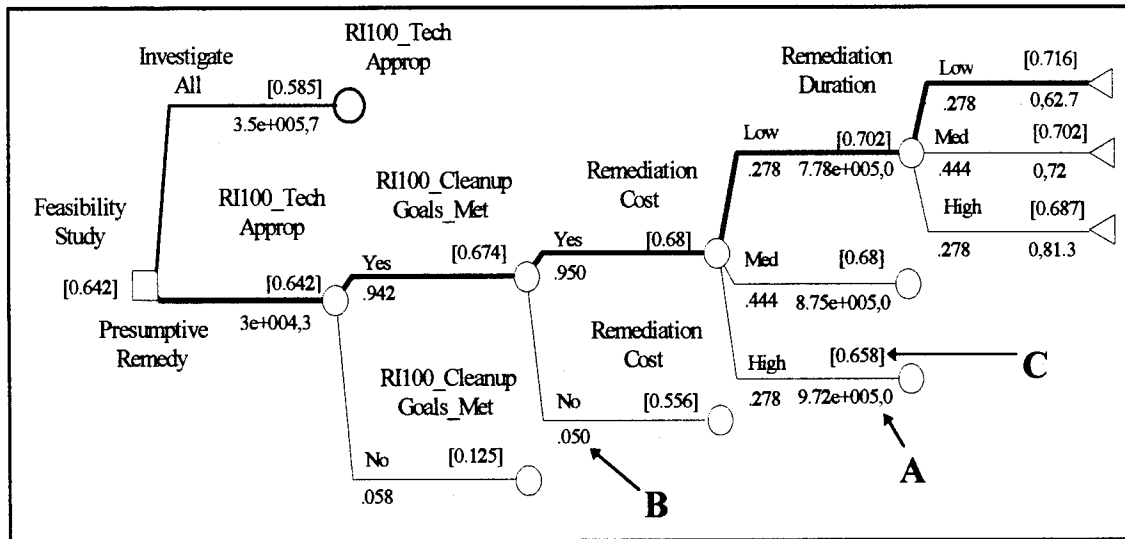

Figure 31: Sample Decision Policy Output From DPL

The cost and duration scores are a measure of how close the actual cost and duration are to the best possible cost and duration. Refer to Figure 19 on page 63 for a graphical description of the scoring functions. Equation (26) shows the calculation of the cost score by substituting the appropriate values into Equation (19).

$$Cost_Score = \frac{(Max_Cost - Cost)}{(Max_Cost - Min_Cost)} = \frac{(2955000 - 808000)}{(2955000 - 1500)} = 0.727 \quad (26)$$

The duration score is calculated in the same manner and is equivalent to 0.694. Once the scores are determined the next step is to verify the utility function. The calculation for the utility of the highlighted path in Figure 31 is shown in Equation (27).

$$\begin{aligned} \text{Utility} &= (\text{Cost_Weight} * \text{Cost_Score}) + [(1 - \text{Cost_Weight}) * \text{Duration_Score}] \\ &= (0.67 * 0.727) + (0.33 * 0.694) = 0.716 \end{aligned} \tag{27}$$

The value arrived at in Equation (27) matches the utility value at the end of the highlighted path in Figure 31. This example shows that the utility for each outcome is calculated properly because all the utility values are found using the same equation in DPL.

The other calculations made as a result of the influence diagram are the expected utility calculations of the nodes. These calculations are done automatically in DPL. The expected utility of an uncertainty node is the sum of the products of the likelihood values and utilities associated with each event state. The expected utility is passed back through the decision tree recalculating the expected utility at each uncertainty node. At a decision node the alternative selected is the one with the highest utility. In Figure 31 the highlighted alternative is the *Presumptive Remedy*, which has a utility of 0.642, compared to the *Investigate All* alternative, which has a utility of 0.585.

Spreadsheet Model Verification. The spreadsheet model is more calculation intensive; however, it is possible to use the final outcome of the risk calculations in the second run of the 100 percent remedial investigation model and compare them with the results of the risk assessment for the POL Storage Area (Engineering Science, 1995:Table 6.5.32 and 6.5.34).

The input parameters used in this run are shown in Appendix F. The model uses the reasonable maximum exposure values for the chemicals and media listed in Table 6.

Table 6: Risk Calculation Comparisons

Media	Chemical	Calculated Risk from the Model	Calculated Risk from the Risk Assessment	Calculated Hazard Index from the Model	Calculated Hazard Index from the Risk Assessment
Groundwater	Benzene	6.47E-05	6.5E-05	0.0	0.0
	Manganese	0.0	0.0	1.56E+00	1.6E+00
	Arsenic	1.77E-04	1.7E-04	9.20E-01	9.1E-01
Surface Soil	Benzo (a) Pyrene	2.53E-04	2.5E-04	0.0	0.0
	Manganese	0.0	0.0	2.75E+00	2.7E+00
	Dibenz (a,h) anthracene	3.44E-04	3.4E-04	0.0	0.0
Subsurface Soil	Antimony	0.0	0.0	1.41E+00	1.4E+00
	Manganese	0.0	0.0	2.50E+00	2.5E+00
	Benz (a) anthracene	1.35E-04	1.3E-05	0.0	0.0

Table 6 shows that the calculations are equivalent within a margin explainable by rounding errors. All of the models use the same equations to calculate risk so, although only the results of the 100 percent remedial investigation model are presented, Table 6 serves to verify the calculations for all the other models.

A final check of the feasibility of the probabilities occurs in DPL. The probabilities must sum to one or the analysis will stop.

Model Validation

It would not be accurate to claim that these models will work for all sites after reviewing the results from only one site. However, this section will show that the models for the different phases of the site characterization process provide consistent results. This section will also show that the results from the models correspond to the current state of knowledge about the site conditions.

The models representing three decision points were used to show the results are consistent over time. The models used are the PA model, the SI model and the RI100 model. These three models were chosen because data were available that clearly showed the current state of knowledge at the end of these phases.

Each model uses the same risk parameters and varies only the estimate of the mean and standard deviation of the chemicals. The risk parameters were taken from the risk assessment for OU2 at Wright-Patterson AFB (Engineering Science, 1995). The underlying assumptions associated with these parameters are that the receptor for the groundwater and surface soil media is a future commercial worker employed in the area for 25 years. The subsurface soil medium assumes that the receptor is a future construction worker employed at the site for a one year period. The exposure routes for the groundwater medium are ingestion, inhalation, and dermal contact. The exposure routes for the soil media are ingestion and dermal contact.

Benzene, toluene and xylene are the three chemicals analyzed in each medium. These chemicals were chosen because they were among the chemicals of concern from the earliest stages of site characterization, and their presence is expected after fuel spills. Also, the sample data was available for these chemicals at each study phase, making it possible to directly compare the results between the PA model, the SI model, and the RI100 model.

In all three models benzene in the groundwater was shown to be the chemical of greatest concern. In the site investigation model and the 100 percent remedial investigation model benzene in the groundwater was the only chemical that indicated any action was required. The results of all three models are discussed below, beginning with the SI model and the RI100 model because the discussion is more straightforward. The PA model is presented last.

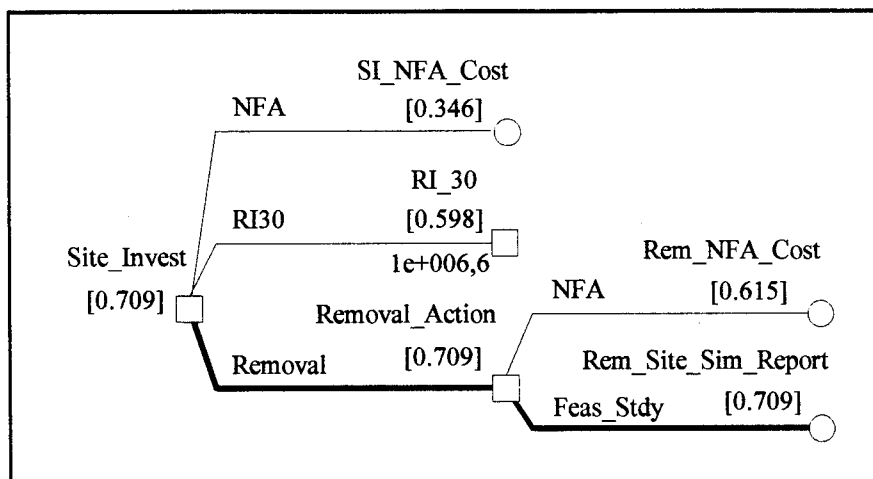

Figure 32: SI Model Decision Policy Diagram for Benzene in Groundwater

Site Investigation Model Results. The site investigation model's decision policy diagram for benzene in the groundwater, shown in Figure 32, indicates that a removal action followed by a feasibility study was the best alternative. The feasibility study decision, not shown in Figure 32, was sensitive to the results of the site similarity report. If the site was declared similar to another site the recommended alternative was to use a presumptive remedy, otherwise investigate all remediation alternatives.

100 Percent Remedial Investigation Model Results. The 100 percent remedial investigation model indicated that the best alternative benzene in the groundwater was to proceed to a feasibility study, shown in Figure 33. All other chemicals were recommended for no further action.

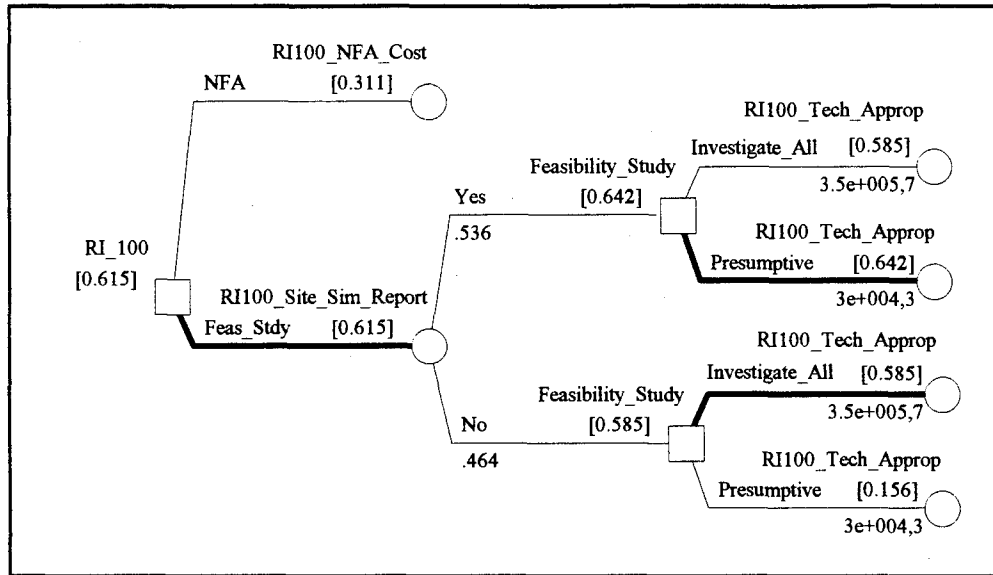

Figure 33: 100% Remedial Investigation Decision Policy for Benzene in Groundwater

Preliminary Assessment Model Results. In the PA model, benzene in the groundwater was selected for a removal action, see Figure 34. Figure 35 shows the decision policy diagram for benzene in the surface soil. Figure 34 indicates that the recommended alternative is to complete a site investigation. Based on the information available after the PA, the model predicts that samples taken at the site investigation should sufficiently reduce the standard error of the mean concentration to assert, with reasonable certainty, that no further action is required for surface soil benzene. All other chemicals evaluated received the NFA recommendation.

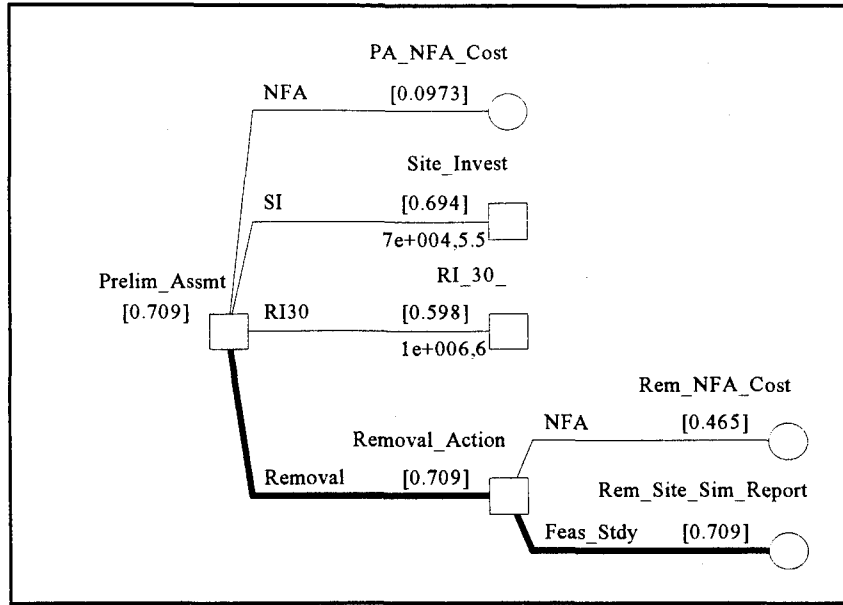

Figure 34: Benzene in Groundwater Decision Policy Diagram

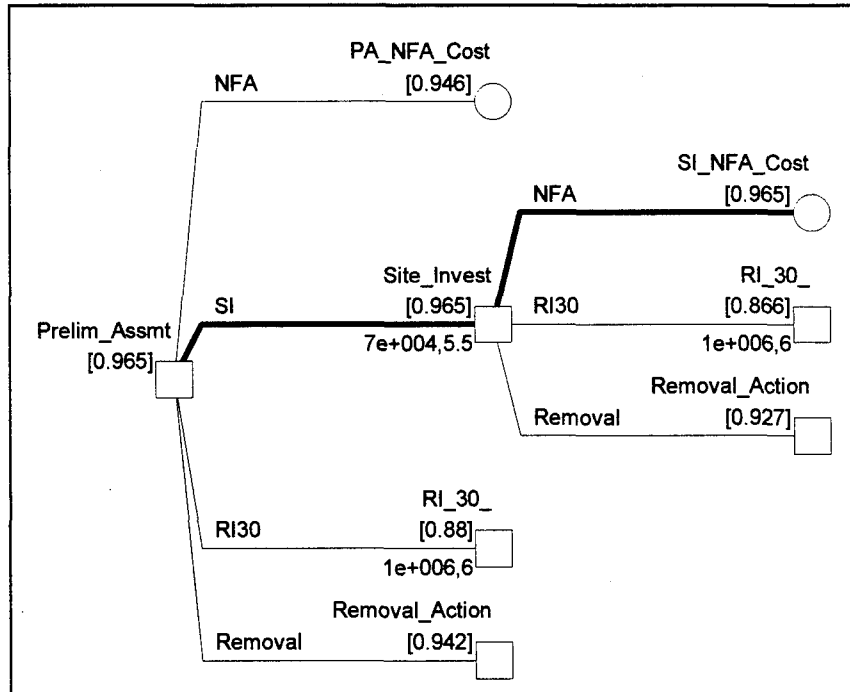

Figure 35: Benzene in the Surface Soil Decision Policy Diagram

The results presented above show that the models' recommendations are consistent from one model to the next, and they are consistent with the known site conditions as well as with the actions taken at the site. Because the results of the models are consistent with existing site conditions and are logical, given the known conditions at the site, the models are assumed to produce valid results.

Decision Policy Interpretation. The results of these models should be interpreted using all the information provided in the decision policy diagrams and the decision maker's understanding of the problem. It is important that the recommendations of the decision policy diagram not be followed without confirming that they are reasonable.

When interpreting the results of the model it is important to remember that it simply selects the pathway with the highest expected utility based on the information provided. The utility for any path is based only on the expected cost and duration of that path. For example, when the model recommends a removal action, it does not necessarily indicate that the removal action is required to protect human health and the environment, only that it possesses the lowest combination of cost and duration. Therefore, other information should be used to help make the final decision.

First, the assumptions incorporated into the model should be considered. One such assumption is that eventually the remediation will be successful. The models account for only one mistake in any given area and assume that the fix for that mistake is correct. Another assumption is that all failures will be discovered and the consequences of that failure can be accounted for in terms of additional time and money.

Along with these assumptions, when analyzing the results of the models, the decision maker should consider all the information available to him in the decision policy diagram. The

expected utility for each alternative is one such piece of information. In Figure 34 on page 97, for example, the expected utility of taking no further action is almost an order of magnitude smaller than any other alternative. The low value of the no further action alternative tells the decision maker that the risk posed by that chemical is quite high. The actual value of the risk and the probability that it is over the acceptable level can be found in the spreadsheet model. Alternatively, Figure 35 on page 97 shows that the expected utility of the NFA alternative and the removal action alternative for benzene in the surface soil is not significantly different than the recommended site investigation alternative. Not only are the utilities of all three alternatives close together, but the magnitudes are large, based on the possible range of utility values being zero to one. This information suggests that none of the three alternatives is much worse than any of the others and the decision maker should consider other factors in the decision.

For example, in this model, the removal action for the soil media is assumed to be the installation of fencing around the site. A fence would not reduce the exposure frequency because the receptors of interest are assumed to be workers at the site. It would neither reduce the chemical concentration, nor provide additional information. Therefore, it should be anticipated that a removal action for surface and subsurface soil has no value in the model.

Figure 36 shows the expanded decision policy diagram from the first run of the preliminary assessment model for benzene in the surface soil. The information from this expanded diagram can help the decision maker get a clearer picture of the model's results. For example, looking at the *Removal Action* decision node shows that the expected utility of the *NFA* alternative is lower than the *NFA* alternative after the preliminary assessment. This is due to the cost and duration associated with the removal action. The probabilities associated with the *Rem NFA Cost* and *Rem NFA Duration* nodes are identical to the *PA NFA Cost* and *PA NFA Duration*

nodes. This shows that the risk was not reduced by completing the removal action but additional cost and duration were added to the project.

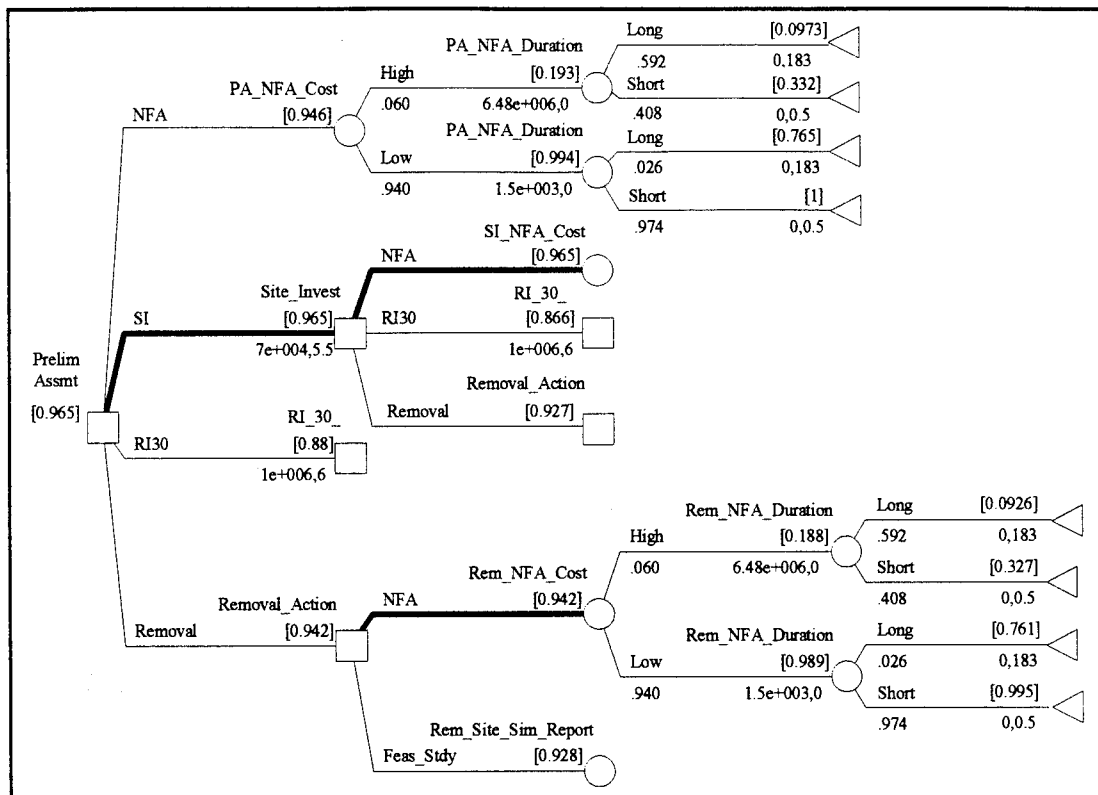

Figure 36: Benzene in Surface Soil Expanded Decision Policy

It is worth noting that Figure 36 shows that the feasibility study alternative is not the best alternative after a removal action. This is further evidence to the decision maker that benzene in the surface soil is probably not a problem. To this end, the model's recommendation is to perform a site investigation in order to gather enough information to declare that the risk from benzene in the surface soil is minimal. The site investigation is the lowest cost and duration alternative that provides enough information to determine the chemical is not a concern.

Performing a 30 percent remedial investigation will bring the same result but the cost and duration is significantly greater.

Of the nine chemicals evaluated in the first runs of the PA, SI and RI100 models the decision maker would have been able to eliminate seven of them from further consideration after the preliminary assessment. The decision maker would have proceeded on with the removal action for the groundwater medium and taken samples of the surface soil medium to get further information regarding benzene. After the site investigation, he would realize that benzene in the surface soil does not pose a significant risk.

If these three chemicals were the only ones at the site, two media would have been eliminated from further consideration after the site investigation. The samples taken during the groundwater removal action would provide enough information to proceed on with the feasibility study.

This example illustrates the benefit of these decision support models. Using these models the decision maker could make the same decisions after the site investigation that he would have made after completion of the 100 percent remedial investigation and a baseline risk assessment. In this case, assuming that these nine chemicals were the only chemicals of concern, use of these models could have eliminated the need for a remedial investigation. Given the cost and duration of the remedial investigation, use of these models might have saved \$2.4 million and 17 months.

The Second Run of the RI100 Model. Unfortunately, contamination at this site extends beyond the three chemicals analyzed above. Across the three media, 59 different chemicals were detected during the remedial investigation (Engineering Science, 1995). The second run of the RI100 model analyzes nine other chemicals that were shown to pose a significant health

risk at the site. The RI100 model was used to analyze these chemicals because the information from earlier phases of the remedial investigation was not available.

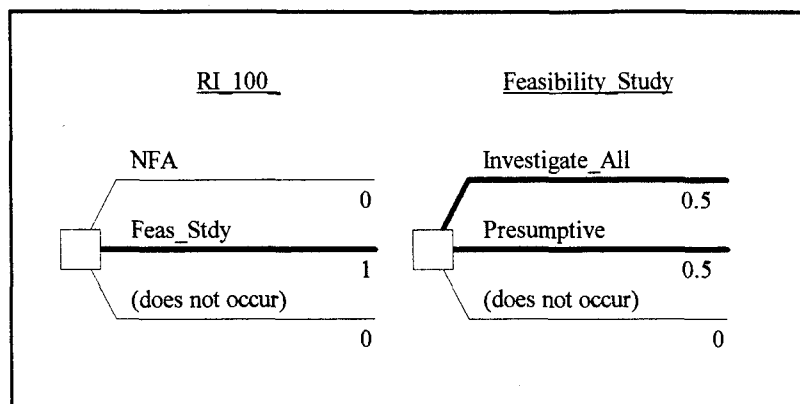

Figure 37: Decision Policy Summary for Run 2 of the RI100 Model

The input parameters for this run are given in Appendix F. The second run of the RI100 model assumes the same risk parameters, receptors, and media as were used in run one of the preliminary assessment, site investigation and 100 percent remedial investigation models. Figure 37 is the decision policy summary showing that in no case did the model choose the no further action alternative. Figure 36 also shows that half of the recommendations for the feasibility study decision were to investigate all the options and the other half were to use a presumptive remedy, depending on the outcome of the site similarity report.

The preceding discussion of the results of the four separate model runs has illustrated the validity of the models, to the extent possible with only one case study. The first run of the PA, SI, and RI100 models have shown that the models are consistent in their recommendation for further action. The discussion of the preliminary assessment model results, beginning on page 96, illustrated that the results of the model were reasonable even with the small amount of

information available at the preliminary assessment. The models generated recommendations consistent with the true site conditions and the actions taken at the site. The models were also shown to produce results consistent with the results of the risk assessment conducted for the site.

Sensitivity Analysis

To assist in making difficult decisions, this model should allow a decision maker to determine how sensitive the models' recommendations are to various input parameters. This type of analysis is called sensitivity analysis.

The sensitivity analysis discussed below is a single variable analysis. This means that only one variable at a time is changed. This analysis is helpful in showing which parameters have the most impact on the decision, but it does not show the results of any interaction between parameters. It is possible to perform a two-way sensitivity analysis which shows the effect that varying two parameters has on the outcome of the model, however, this was not done in this thesis.

The parameters evaluated in the sensitivity analysis include certain probabilities, costs, durations, risk factors, concentrations, and input variables developed specifically for use in the model. The results of the sensitivity analysis for each evaluated variable is given in Appendix E. Many variables had an effect on the expected value of the particular run but there were only a few variables that had an impact on the recommended decision over the reasonable range of possible values. Table 7 summarizes those parameters.

Table 7: Summary of Selected Input Parameters

Variable Name (Baseline Value) (Feasible Range)	PA Model	SI Model	RI100 Model	RI100 Model
	Run 1	Run 1	Run 1	Run 2
	Node(s) where decision change occurs (value(s) at which a change occurs)			
Acceptable Risk (5.0E-07) (1.0E-08 - 1.0E-06)	PA (3.5E-8, 4.8E-7,5.3E-7)	SI (3.5E-8, 1.3E-7)	RI100 (3.5E-8, 1.8E-7)	No Change
Cost Weight (0.67) (0.0 - 1.0)	PA, FS (.02, .07, .17)	Rem, SI (.28, .03)	No Change	FS (0.025)
Groundwater Benzene Mean (0.5) (0.0223 - 0.5)	Not Evaluated	No Change	RI100 (0.034)	RI100 (.034)
Groundwater Manganese Mean (0.67) (0.188 - 0.67)	Not Evaluated	Not Evaluated	Not Evaluated	RI100 (0.441)
Groundwater Toluene Lvl High (10.0) (5.0 - 20.0)	PA (18.9)	Not Evaluated	Not Evaluated	Not Evaluated
Groundwater Toluene Mean (1.937) (0.0 - 13.0)	Not Evaluated	SI (10.724)	No Change	Not Evaluated
Groundwater Xylene Mean (3.884) (0.0 - 36)	Not Evaluated	SI (8.09)	No Change	Not Evaluated
P NFA Cost High Mid (0.7) (0.1 - 0.95)	Rem (0.164)	Rem (0.42)	No Change	No Change
P Rem M1 TA g Pres & Sim (0.95) (0.0 - 1.0)	FS (0.86)	FS (0.86)	Not Evaluated	Not Evaluated
P Rem SSR Yes g No (0.01) (0.0 - 0.5)	FS (0.137)	FS (0.14)	Not Evaluated	Not Evaluated
P RI100 M1 TA g Pres & Sim (0.95) (0.75 - 1.0)	No Change	No Change	FS (0.84)	FS (0.84)
P RI100 SSR Yes g No (0.01) (0.0 - 0.2)	No Change	No Change	FS (0.165)	FS (0.165)
Rem M2 Mean Factor (0.0) (0.0 - 1.0)	PA (0.075)	No Change	Not Evaluated	Not Evaluated
Subsurface Soil Antimony Mean (9.2) (4.04 - 9.2)	Not Evaluated	Not Evaluated	Not Evaluated	RI100 (5.97)
Surface Soil Benzene Lvl High (5.0) (3.0 - 20.0)	PA (4.3, 5.1)	Not Evaluated	Not Evaluated	Not Evaluated
Surface Soil Benzene Mean (0.0) (0.0 - 3.0)	Not Evaluated	SI (2.17)	No Change	Not Evaluated
TA Cost Fac Not TA g Pres (1.0) (0.2 - 1.0)	No Change	No Change	No Change	FS (0.26)

Table 7 lists the parameters responsible for a decision change, the baseline value of that parameter and the range of values considered feasible. The table also shows which model runs were affected by the parameter, the point in the decision sequence that the decision change occurred, and the value of the parameter at which the decision changed. "No Change," indicates that sensitivity analysis was performed on the parameter and it did not change the decision in that particular model. "Not Evaluated," indicates that the parameter was not part of the model.

Preliminary Assessment Model. The first run one of the PA model has eight parameters that can change at least one of the decisions from the baseline. The baseline recommended that benzene in the groundwater undergo a removal action and then to a feasibility study. The baseline also recommended that more information be gathered on benzene in the surface soil by performing a site investigation. All other chemicals were recommended for no further action. Of the eight parameters that change the decisions, two change only the feasibility study decision. One parameter changes only the decision occurring after the removal action for benzene in the groundwater. These three parameters are not critical to the decision at hand, which is selection of the alternative immediately following completion of the preliminary assessment. Although the model forecasts the recommended alternative through the entire process, it is likely that much more information will be obtained before future decisions need to be made. Therefore, analysis of the results of the sensitivity analysis are restricted to the parameters that change the immediate course of action. Those parameters are *Acceptable Risk*, *Cost Weight*, the upper bound of the toluene concentration in groundwater (*T2 M1 Lvl High*), the upper bound of the benzene concentration in the surface

soil (*T1 M2 Lvl High*), and the mean reduction factor of the removal action for surface soil (*Rem M2 Mean Factor*).

Acceptable Risk. The strategy region graph, referred to in DPL as a rainbow diagram (DPL,1995), for the level of acceptable risk is shown in Figure 38. If the acceptable risk is in section one, less than $3.47\text{E-}08$, the recommended decision will change by including a removal action for benzene in the subsurface soil. This range of values, however, is small and represents the most conservative, or health protective, feasible value.

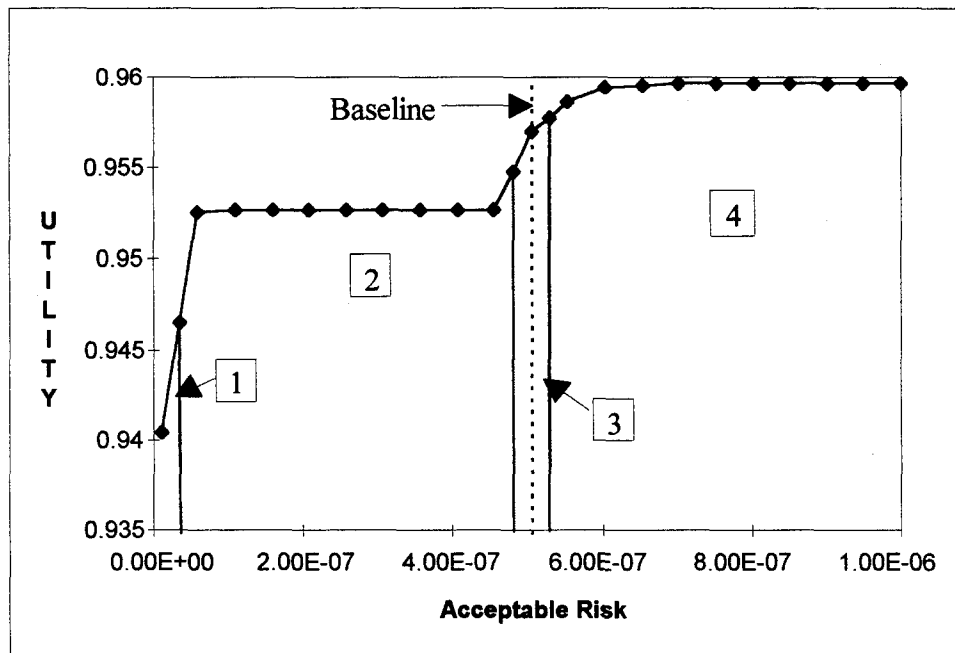

Figure 38: Strategy Region Graph for Acceptable Risk in PA Model, Run 1

Section two, between $3.47\text{E-}08$ and $4.80\text{E-}07$ encompasses a wide range of acceptable risk values that change neither the decision nor the expected utility. *Acceptable Risk* values in this range will result in changing the recommended baseline strategy for benzene in the surface soil

to removal⇒feasibility study. The best method for performing the feasibility study would depend on the results of the site similarity report.

With respect to the *Acceptable Risk* parameter, the location of the baseline case is important. The baseline case is located in section three, which is a narrow region of the graph, indicating that the baseline strategy is preferred only when the level of acceptable risk is between 4.80E-07 and 5.30E-07. If the decision maker is unsure of this parameter he should give consideration to whether he underestimated or overestimated the value of acceptable risk.

The baseline value of acceptable risk is more health protective than the value the EPA has identified as an acceptable level of risk, 1.0E-06. Therefore, the decision maker may feel he has underestimated the value. If acceptable risk was underestimated, the recommended strategy would move to section four of Figure 38. In section four the recommended strategy is the same as the baseline case except that benzene in the surface soil is recommended for no further action instead of a site investigation.

The practical information gained from Figure 38 is that the baseline strategy is preferred over a small range of acceptable risk values. The strategy for the groundwater medium does not change. However, the strategy for the surface soil medium changes to no further action with a small increase in the value, or, with a small decrease in the value, the strategy changes to a removal action⇒feasibility study.

Cost Weight. The decision maker's opinion about the importance of cost over duration, given by the value of *Cost Weight* (see page 62 for a discussion of this parameter), is important to the decision for two reasons. The first reason is because it changes the recommended alternatives. The second reason is because changing the value of *Cost Weight* will change the overall utility of the decision. The second reason is not a primary consideration,

but it should be noted that the more important cost is to the decision maker the higher the utility of the overall decision.

Sensitivity analysis shows that the duration can be more than four times as important as cost, represented by *Cost Weight* equals 0.175, before the recommended strategy will change. The baseline strategy for this case is represented by section four in Figure 39. If the decision maker's opinions change enough so that the value of *Cost Weight* drops into the sensitive range, less than 0.175, the recommendation for benzene in the groundwater changes from the less expensive removal action to a complete remedial investigation and feasibility. Below 0.075, in section two, the recommended strategy for benzene in the surface soil changes to RI30⇒no further action. Section one changes only the feasibility study recommendation for benzene in the groundwater and is not important at this time.

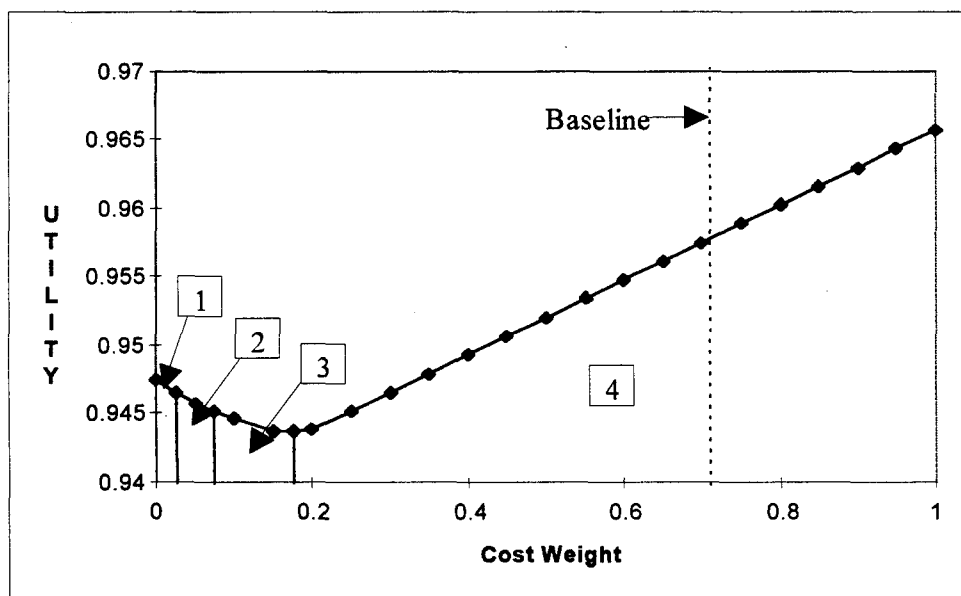

Figure 39: Strategy Region Graph for Cost Weight in PA Model, Run 1

Groundwater Toluene Concentration. After the PA has been completed the best information available about the concentration of contaminants in the soil is likely to be the decision maker's best estimate. The uncertainty associated with these estimates is likely to be large and the confidence the decision maker has in the estimates low. For these reasons it is important to perform sensitivity analysis on the upper bound values of the concentration estimates. The strategy for two chemicals was sensitive to this value. Figure 40 shows the strategy region graph for the upper bound estimate of the toluene concentration found in groundwater.

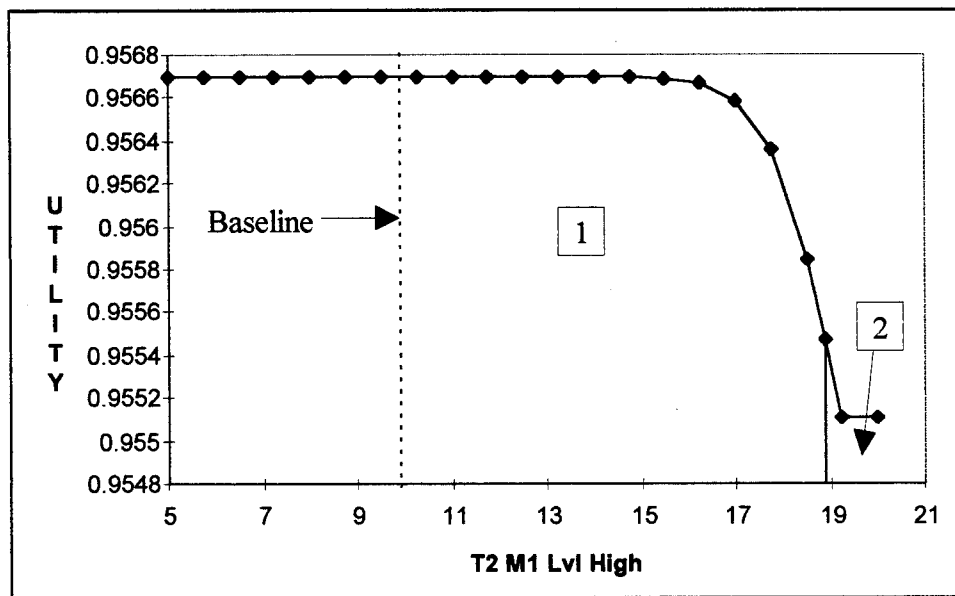

Figure 40: Strategy Region Graph for Upper Bound Toluene Concentration in Groundwater for PA Model, Run 1

Section one of Figure 40 includes the baseline case. The decision and the expected utility remain the same until the upper bound estimate reaches approximately 17 mg/L. At that point the expected utility of the no further action alternative begins to go down. The decrease in utility signifies the risk from toluene in the groundwater is approaching the acceptable level. The recommended alternative does not change, however, until the value of *T2 M1 Lvl High* approaches 19 mg/L. At that point the strategy changes to a site investigation followed by no further action.

Considering that the lower bound estimate remained the same in this analysis, an upper bound value of 19 mg/L corresponds to a mean concentration of 10 mg/L. This value (10 mg/L) is 10,000 times the maximum detected value for toluene in the groundwater, after completion of the remedial investigation (Engineering Science, 1995:Table 6.3.8). This information would not be known to the decision maker, but it illustrates that almost any reasonable estimate of the range of possible concentrations will produce the same recommendation.

Surface Soil Benzene Concentration. *T1 M2 Lvl High* was the only other concentration estimate that changed the recommended strategy. Figure 41 shows the strategy region graph for this parameter. The model's recommended alternative for benzene in the surface soil is sensitive to the estimate of the upper bound. The baseline is in section two of Figure 41. Virtually any increase in the value of this parameter will result in the region three recommendation, which is removal action⇒feasibility study. Alternatively, a small decrease in the value will result in a no further action recommendation.

For this chemical it appears that further study is warranted. The mean concentration resulting from the estimate of the upper and lower bounds is 2.75 mg/kg. This value is more

than 100 times the maximum detected value at the site, however, it would be difficult to justify reduction of this value with the information available after a preliminary assessment. It is reasonable to proceed with the site investigation to eliminate this chemical from consideration.

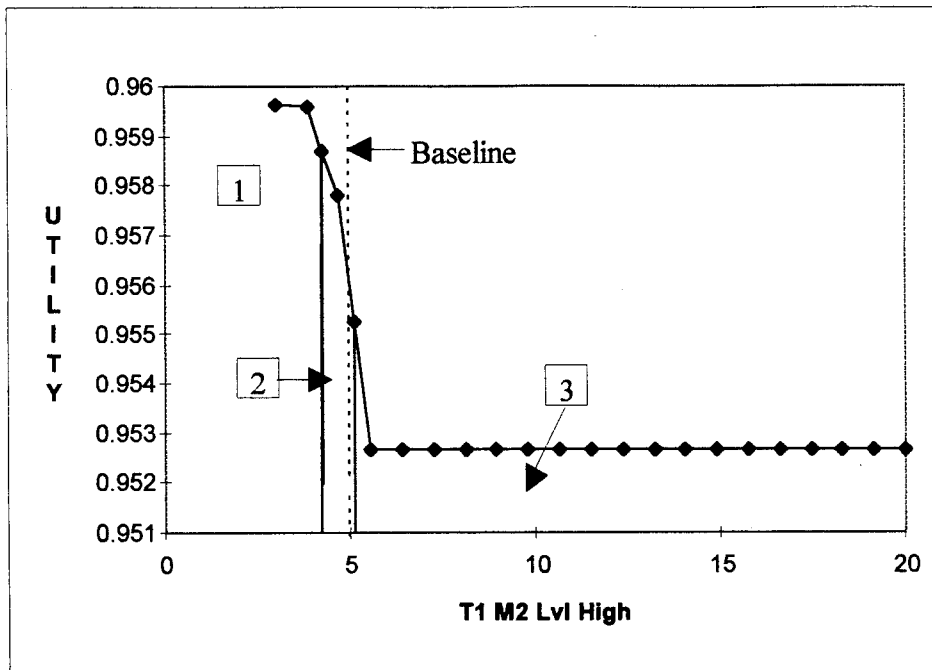

Figure 41: Strategy Region Graph for the Upper Bound Concentration Estimate of Benzene in Surface Soil for the PA Model, Run 1

Surface Soil Removal Action Mean Reduction Factor. This parameter was analyzed not because of the uncertainty associated with its estimate (it is not feasible that a fence could reduce the exposure concentration), but to determine if another technology would result in a different recommendation. It may be expected from the sensitivity of the surface soil strategy, shown in Figure 38 and Figure 41, that an increase in the removal technology's efficiency would impact the recommended alternative for benzene in the surface soil. Figure

42 shows this to be the case. The alternative recommended for all values of *Rem M2 Mean Factor* in section two of Figure 42 is a removal action.

Care must be taken when performing one way sensitivity analysis on parameters such as *Rem M2 Mean Factor*. Figure 42 shows that another technology capable of reducing the concentration of benzene in the surface soil could improve the expected utility of the decision. However, in order to provide such a technology, the cost and duration required to implement the alternative would almost certainly be higher than the baseline case, which is installation of a fence. To find out the recommended strategy, assuming a different removal technology, the model should be run again after changing all the parameters associated with the removal action for surface soil.

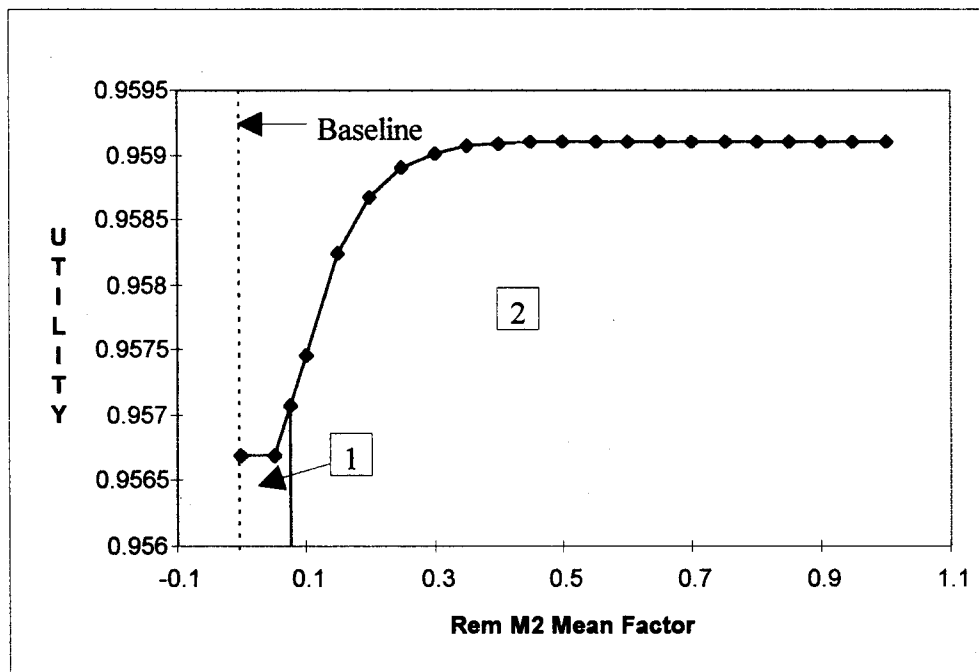

Figure 42: Strategy Region Graph of Surface Soil Removal Efficiency for PA Model, Run 1

This sensitivity analysis has shown that the results of the PA model are stable over a wide range of values for all chemicals, with the exception of benzene in the surface soil. From this analysis, it is reasonable for a decision maker to conclude that the alternatives recommended by the model are insensitive to changes in the parameter estimates. This analysis should increase the level of confidence he has in the model's recommendations. Even the subjective parameters required by the model do not effect the outcome significantly.

The exception to this is benzene in the surface soil. The strategy recommended for this chemical is sensitive to several parameters. A less health protective estimate of one or more parameters would result in a no further action recommendation, while a more conservative estimate would result in a recommendation for a removal action. The analysis has shown that the risk posed by this chemical is fairly low. However, it is not low enough to say, with confidence, that no further action is required. With regard to the removal action, it has been shown that the type of removal action modeled here for the surface soil medium has no value. Also, given that it is unlikely that there is an immediate threat to public health, the most reasonable choice is to proceed with a site investigation, as recommended in the baseline case. The site investigation should provide enough information to eliminate benzene in the surface soil from further consideration.

The methodology used to analyze the results of the decision support models developed in this thesis is given above. The analysis, as described above for the preliminary assessment model, was performed on the other three model runs shown in Table 7. The results of those analyses are briefly described below.

Site Investigation Model. The site investigation model had eight parameters that changed the recommended alternatives. Five of those changed the preferred alternative at the site investigation decision node. The first two were the *Acceptable Risk* and the *Cost Weight*. Both of these parameters were described above on pages 106 and 107 and have similar effects on the site investigation model. The critical points change somewhat, shown in Table 7 on page 104, but in both cases the baseline value of the parameter is inside a wide range of values that do not change the recommended alternative.

The other three parameters that change the site investigation decision are the estimates of the mean concentrations of toluene and xylene in the groundwater and benzene in the surface soil. Although the model takes into account the standard error of the estimate of the population mean, low numbers of samples and sample standard deviations that are, in many cases, greater than the mean, combine to make that estimate questionable. There is also a choice of values to use for the mean concentration, depending on the preferences of the decision maker.

The risk assessment for OU2 (Engineering Science, 1995:Table 6.3.8) used one of three values for the mean in the reasonable maximum exposure estimate. If the detection frequency was greater than 50 percent, the lesser of the 95 percent upper confidence limit of the log-transformed data and the maximum detected value was used. If the detection frequency was between 25 and 50 percent, the maximum value of the 95 percent upper confidence limit of the normally distributed data and the log-transformed data was compared to the maximum detected value and the lesser was used. The maximum detected value was used as the mean for chemicals with less than 25 percent detection frequency.

The mean concentration for the central tendency risk calculations was determined in a similar manner. The difference being that instead of comparing with the 95 percent upper

confidence limit the comparison was between the actual sample mean and the maximum detected value.

Because of the wide variation in the means used to estimate the risk, sensitivity analysis was performed on the mean of each chemical. The reasonable range was assumed to be from the central tendency estimate of the mean to the reasonable maximum exposure estimate of the mean in the case of the 100 percent remedial investigation models. In the case of the site investigation model, because of the much smaller amount of available data, the reasonable range was assumed to be from the minimum detected value, often 0.0, to the maximum detected value.

This evaluation, in the site investigation model, showed that, for each of the three chemicals determined to be sensitive to the estimate of the mean, as the mean increased above the critical values listed in Table 7, the preferred alternative changed from no further action to a removal action.

100 Percent Remedial Investigation Model. The RI100 model was run twice using different chemicals each time. The first run used benzene, toluene and xylene in all three media. The second run evaluated nine chemicals shown to pose a significant threat in the risk assessment. The sensitivity analysis conducted on each of these runs is described below.

RI100, Run Number One. Run one of the RI100 model had four parameters that changed decisions but only two parameters, *Acceptable Risk* and the benzene concentration in the groundwater, changed the preferred alternative of the *RI100* decision node. As the *Acceptable Risk* parameter decreases past its critical points, the model recommends that benzene in the subsurface soil and then benzene in the surface soil be remediated. However, the baseline value is well within the range where there is no decision change.

The benzene concentration in the groundwater is the only chemical concentration that changes the decision within the specified range, from the central tendency exposure point concentration to the reasonable maximum exposure concentration. The critical value, however, is significantly lower than the baseline value. In a case like this it would be helpful to evaluate the major components of the risk to see if some reasonable combination of reduction in mean and reduction in exposure parameters may bring the risk an to acceptable level.

RI100, Run Number Two. The baseline recommendations for run two of the RI100 model were feasibility studies for all nine chemicals analyzed, see Figure 37. The sensitivity analysis on this run showed that the only three parameters that changed the *RI100* decision node's recommended alternative were the mean concentrations for benzene and manganese in the groundwater and antimony in the subsurface soil. In each case, as the mean drops below the critical value, given in Table 7, the recommended alternative changes to no further action.

As in run one of the RI100 model, there may be a reasonable combination of reductions in several parameters that would change these decisions without significantly decreasing the estimate of the mean concentration. However, even if the risk posed by these three chemicals can be reduced sufficiently to recommend no further action, the model suggests that the rest of the chemicals in all three media should be remediated.

Cost and Duration Estimates

In addition to policy diagrams and sensitivity analysis, the models will generate a distribution of possible costs and durations of the recommended alternatives. These

distributions can help decision makers determine confidence limits for the likely cost and duration of the site cleanup.

Using the preliminary assessment model run one as an example, Figure 43 presents the results that can be obtained. The figure shows a histogram of costs that could arise from proceeding through the RI/FS process as recommended by the model. It also shows the cumulative distribution function (CDF) of cost.

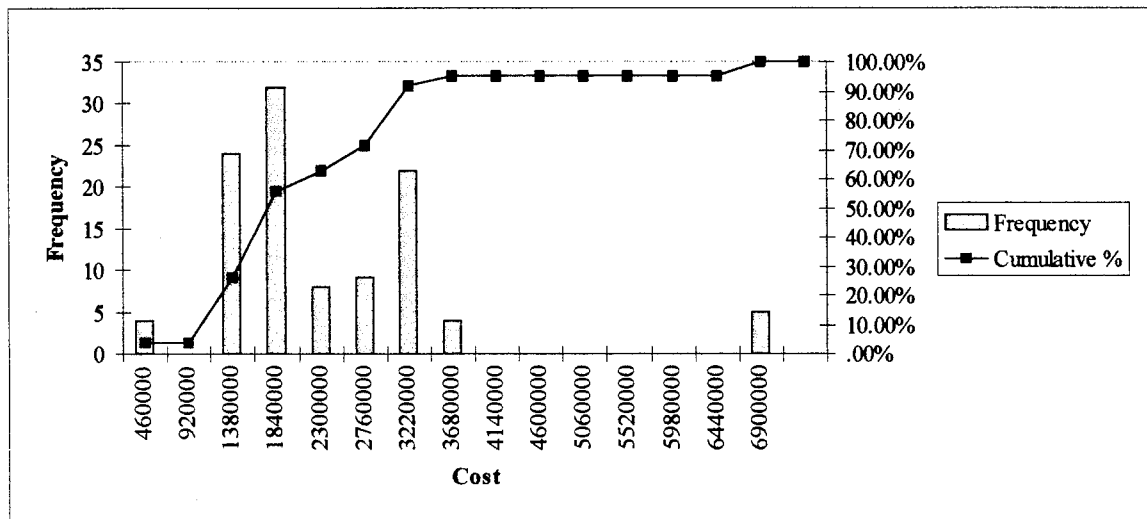

Figure 43: Cumulative Distribution of Cost for the PA Model, Run 1

The CDFs produced by the model can be used by the decision maker to predict confidence limits on cost or duration. These limits can help him to manage his budgeting and scheduling processes. For example, if a decision maker has just completed a site investigation, and he knows that he only has a fixed amount of money left to complete the project, he can use the CDF of cost to find the likelihood that he can finish the project with that amount of money.

It is important to note that the cost and duration CDFs produced by the models include only future values and are based on current information. The models do not require that sunk resources be input, so they do not track the costs and durations from the beginning of the remedial effort. The CDF predicts future costs or durations, depending on the information requested by the model's user.

V. Conclusions

The primary objective of all hazardous waste site cleanups is the protection of human health and the environment (Dept of the Air Force, 1992:3-6). A large portion of the time and money spent on remediating hazardous waste sites under CERCLA and the IRP is spent characterizing the site conditions (Duplancic, 1993,53). The time and money spent characterizing a site provides information about the site that can be used to decide if it needs to be cleaned up or if no further action need be taken. Characterization also provides information that is used to select and design remedial alternatives for cleanup. Although the studies completed provide information, while the studies are being completed the population continues to be exposed to the contaminants at the site, and the money spent gathering the information is not available to clean the site.

There are clearly some tradeoffs that can be made with regard to the quantity of information collected in the Superfund process. This thesis used Decision Analysis to evaluate those tradeoffs. Five decision support models were developed (see Chapter 3 for a discussion of the models' development), one for each phase of the site characterization process (i.e. PA Model, SI Model, RI30 Model, RI60 Model and RI100 Model). These models help decision makers evaluate the value of the information gained from each phase of study and compares that to the value of other alternatives (i.e. a removal action, remediation, or no further action). The other alternatives are evaluated based on their expected cost and duration, taking into account the increased probability of errors given the reduced amount of information.

For each chemical evaluated the models provide a recommended alternative based on that chemical's calculated health risk or hazard index. The risk calculations were verified and the

recommended alternatives were validated in Chapter 4. The validation was done by comparing the results between three different models to ensure the recommended alternatives were consistent. The recommendations from earlier models like the preliminary assessment model and the site investigation model were compared with the known site conditions studies to ensure that the recommendations were appropriate.

Assumptions

The models developed in this thesis are intended to be applicable to any hazardous waste site by simply changing the input parameters to match the site being evaluated. However, some of the model's inherent assumptions need to be considered when using them.

1. The benefits of further information are reduced uncertainty associated with the estimate of the mean concentrations and a reduced probability of error when selecting and designing a remedial alternative. The models assume that the estimate of the mean concentration does not change by taking more information. In order to determine the effect of changing the estimate of the mean the user must perform sensitivity analysis on the parameter.

2. The penalty for making the wrong decision (for example, choosing to take no further action when action was required) is assumed to be accounted for by increased cost and duration. The amount of the increase and the probability of being wrong are combined to determine the expected value of choosing that alternative. The model chooses the alternative with the lowest expected cost and duration combination (see Figure 19 on page 63 for a presentation of utility calculations).

3. The decision to take action is based solely on the health risk posed by the chemical. A chemical with a high risk value will be recommended for remediation regardless of the mean

concentration. Therefore, if the mean does not exceed background levels or other contaminant limits, but the risk is high, the chemical will be recommended for some type of action.

4. The exposure factors and toxicity factors used to calculate the health risk are assumed to be constant.

5. The model assumes that after one wrong decision, such as choosing no further action or choosing a presumptive remedy when the site is truly not similar to any other, the next decision is made correctly.

6. The distribution of the mean concentration is assumed to be approximately normally distributed, in accordance with the Central Limit Theorem, regardless of the number of samples taken.

7. The recommendations made by the models are for a specific chemical. The model does not provide a recommendation for the site as a whole.

Using the Models

Given the assumptions listed above, the results of these models appear to be consistent with the current state of knowledge regarding OU2 at WPAFB. For smaller sites, like the one evaluated in this thesis, it is possible to use these models to determine the best course of action through the various phases of site characterization.

For larger sites it may be difficult to make a specific recommendation about the best course of action because of the number of chemicals and the number of possible receptors that may be involved. However, the models can be used, even on larger sites, as a screening tool to help decision makers determine the chemicals that pose the greatest risk to human health. Even when very little information is available about the level of contamination, the models were

shown in this thesis to successfully determine the chemicals of greatest concern. By reducing the number of chemicals that need to be evaluated the decision maker is in a much better position to determine the best course of action earlier in the Superfund process. There is also a significant potential to save time and money by reducing the number of samples that need to be collected.

The models are also valuable for updating the schedules and cost estimates of the remaining portions of the remedial effort, see page 116. The models are capable of producing a CDF of the remaining costs and durations that the decision maker can use to place confidence limits on his estimates of time and cost.

Another use for these models is the performance of sensitivity analysis on the parameters of concern. A discussion of sensitivity analysis is given beginning on page 103. Sensitivity analysis can be used to determine the impact of specific parameters on the recommended course of action. For example, a decision maker can perform sensitivity analysis on the mean concentration to see how high the concentration must get before the model recommends taking action.

Sensitivity analysis can also be used to evaluate the value of proceeding on with investigation. By analyzing the cost and duration of a remedial investigation, the decision maker can determine how much he should spend on gathering additional information before it is more cost effective to simply remediate the contaminated medium. If the cost is less than the price he will pay for the information then the information is not worth the investment.

Running the Models. In order to run these models the decision maker must have access to an IBM compatible computer. The computer must have Excel (Excel, 1993) and DPL (DPL, 1995) installed on it. The decision maker must also be in possession of the files that

contain the actual models. There is one Excel file and one DPL file required to run each of the five models. Additional files include a spreadsheet for each model to guide the user through collection of the data required for the models.

The values for each input parameter, listed in Table 8 in Appendix A, must be put into the appropriate nodes in DPL. No other modification of the nodes is required. Entering the input parameters will take approximately one hour if the guidance spreadsheet has been completed. Next, the user should open the corresponding model file in Excel. After the Excel file is open run the decision analysis in DPL. All values are calculated automatically. The DPL output includes a decision policy diagram and a CDF of the utility of the decision. The Excel spreadsheet will have been updated with all the values that were just input into DPL and the spreadsheet can be printed out for reference.

Recommendations for Future Research

The models developed in this thesis have been tested on only one site. Further evaluation of how they can be used on IRP sites would be beneficial. If they are to prove valuable they must be shown to be effective at many sites using real data obtained from those sites. Refinement of the models should accompany this effort. The major refinements still necessary include the addition of a feature that allows the comparison of the chemical concentration with other applicable, relevant and appropriate requirements, such as background levels and MCL's. Both DPL and Excel have the capability to perform this comparison and take it into account when recommending the best alternative. Also, the DPL model could be made to automatically import all of the input parameters from the input spreadsheet to make data entry simpler.

There are also ample opportunities for new decision analysis models to help with other significant decisions in the RI/FS process. Some of the problems that would be well suited to other decision analysis models include the selection of the remedial technology, a more focused model to perform risk assessments and a model that makes site or media specific recommendations rather than chemical specific recommendations that must be tracked by the user.

In the models developed here, the feasibility study decision alternatives were assumed to be to investigate all remedial technologies or to use a presumptive remedy. However, the model says nothing about what the remedy should be. A model could be developed that stands alone or that builds on these models to actually select the remedy based on the nine criteria promulgated in the National Contingency Plan.

A model could also be developed that focuses on the calculation of the risk posed by a chemical. The models in this thesis take a simplistic view of the parameters associated with exposure assessments. A model could be developed that considers the parameters of the risk assessment as uncertainties. DPL could then be used to develop a distribution of risk based on the uncertainties in the model similar to the distribution of cost presented in Chapter 4. This type of model would allow the decision maker to get a much better estimate of the actual risk posed by a chemical that could then be used to determine if further action is necessary.

The models developed here could be modified to provide media specific recommendations so the user does not need to track the recommendations for each chemical. This would make it easier to determine the best course of action of chemicals within a media are recommended for different types of action. For example, in these models, it is possible that within on medium a removal action and a site investigation would be recommended. Currently the decision maker

would need to determine which he felt was most appropriate for that medium, or he may proceed with both courses of action. In that case it would be helpful to have a model that considered all the chemicals within the medium and recommended one, most appropriate alternative.

Appendix A: Tables of Excel Cell Names and DPL Nodes

This appendix contains three tables. Table 8 contains a list of the input variables for all five models. The table is arranged alphabetically according to the Excel cell name and gives the corresponding DPL value node name and a description of the variable. Table 9 contains a partial listing of the calculated variables and probabilities in the models with a description of the variable. The listing is partial because it only shows the chemical specific variables as they appear for the type one medium one contaminant. The particular parameter name is identical to the one shown for all other chemicals except the type (T) and medium (M) designator are different. Table 10 contains a listing of the nodes used in DPL that are not directly linked to Excel. It also contains a description of the contents and function of each node.

Table 8: List of Input Variables

Cell Name in Excel	Relevant Models	DPL Value Node Name	Definition
Acceptable Haz_Index	All	Same	Decision maker's clearly acceptable hazard index
Acceptable_Risk	All	Same	Decision maker's clearly acceptable level of carcinogenic risk
ALPHA	All	Cost Weight	Decision maker's level of importance he places on cost over duration
Body_Weight	All	Same	Body weight in of receptor (kg)
FS_COST_High	All	Same	Upper bound on the range of the cost of a feasibility study, not including remediation
FS_COST_Low	All	Same	Lower bound on the range of the cost of a feasibility study, not including remediation
FS_DUR_High	All	Same	Upper bound on the range of the duration of a feasibility study, not including remediation
FS_DUR_Low	All	Same	Lower bound on the range of the duration of a feasibility study, not including remediation
Goal_Met_g_Tech_Not_Acc	All	P Goal Met g Not TA	Probability the remediation goal in met given the technology selected was not technically acceptable, 0.0 is recommended
Lifespan	All	Life Expectancy	Lifetime of the receptor, 25500 is recommended (days)
M1_C_Freq_contacted	All	M1 Derm Contact Exp Freq	Exposure frequency for dermal contact with medium one (days/yr)
M1_C_Surf_Area	All	M1 Surface Area	Exposed skin surface area that medium two comes in contact with (cm ²)
M1_Derm_Conv_Fac	All	Same	Conversion factor used in dermal contact exposure assessment (1.0E-3 L/cm ³ in water or 1.0E-6 kg/mg in soil)
M1_Derm_Exp_Time	All	Same	Duration of dermal contact (hrs/day), applicable only in water, otherwise must be equal to 1.0.

Table 8 Continued

Cell Name in Excel	Relevant Models	DPL Value Node Name	Definition
M1_Dermal_Adherence_Factor	All	Same	Refers to the amount of soil that remains on the skin after contact. Applicable on to soil. Set equal to 1.0 for water. (mg/cm ²)
M1_Exposure_Duration	All	Same	Exposure Duration for medium one (yrs)
M1_I_Freq_contacted	All	M1 Inhal Exp Freq	Exposure frequency for the inhalation exposure route in medium one (days/yr)
M1_I_Vol_contact	All	M1 Inhal Rate	Inhalation rate for medium one. (m ³ /hr)
M1_Ing_Conv_Fac	All	M1 Ingest Conv Fac	Conversion factor for the ingestion route in medium one. Value is 1.0 if the medium is water and 1.0E-6 kg/mg if the medium is soil.
M1_Inhal_Exp_Time	All	Same	Length of time for an exposure incident from the inhalation exposure route in medium one.
M1_O_Freq_contacted	All	M1 Oral Exp Freq	Exposure Frequency for the ingestion route (orally) of medium one (days/yr)
M1_O_Vol_contact	All	M1 Ingestion Rate	Ingestion rate of medium one (mg/day for soil and L/day for water)
M1_Rem_Derm_Exp_Freq	PA, SI, RI30, RI60	Rem M1 Derm Cont Exp Freq	Dermal exposure frequency for medium one after a removal action. May be smaller than the original exposure frequency if the removal action limits exposure (days/yr)
M1_Rem_Ing_Exp_Freq	PA, SI, RI30, RI60	Rem M1 Oral Exp Freq	Ingestion exposure frequency for medium one after a removal action. May be smaller than the original exposure frequency if the removal action limits exposure (days/yr)
M1_Rem_Inh_Exp_Freq	PA, SI, RI30, RI60	Rem M1 Inhal Exp Freq	Inhalation exposure frequency for medium one after a removal action. May be smaller than the original exposure frequency if the removal action limits exposure (days/yr)
M2_C_Freq_Contacted	All	M2 Derm Contact Exp Freq	Exposure frequency for dermal contact with medium two (days/yr)

Table 8 Continued

Cell Name in Excel	Relevant Models	DPL Value Node Name	Definition
M2_C_Surf_Area	All	M2 Surface Area	Exposed skin surface area that medium two comes in contact with (cm ²)
M2_Derm_Conv_Fac	All	Same	Conversion factor used in dermal contact exposure assessment (1.0E-3 L/cm ³ in water or 1.0E-6 kg/mg in soil)
M2_Derm_Exp_Time	All	Same	Duration of dermal contact (hrs/day), applicable only in water, otherwise must be equal to 1.0.
M2_Dermal_Adherence_Factor	All	Same	Refers to the amount of soil that remains on the skin after contact. Applicable on to soil. Set equal to 1.0 for water. (mg/cm ²)
M2_Exposure_Duration	All	Same	Exposure Duration for medium two (yrs)
M2_I_Freq_contacted	All	M2 Inhal Exp Freq	Exposure frequency for the inhalation exposure route in medium two (days/yr)
M2_I_Vol_contact	All	M2 Inhal Rate	Inhalation rate for medium two. (m ³ /hr)
M2_Ing_Conv_Fac	All	M2 Ingest Conv Fac	Conversion factor for the ingestion route in medium two. Value is 1.0 if the medium is water and 1.0E-6 kg/mg if the medium is soil.
M2_Inhal_Exp_Time	All	Same	Length of time for an exposure incident from the inhalation exposure route in medium two.
M2_O_Freq_contacted	All	M2 Oral Exp Freq	Exposure Frequency for the ingestion route (orally) of medium two (days/yr)
M2_O_Vol_contact	All	M2 Ingestion Rate	Ingestion rate of medium two (mg/day for soil and L/day for water)
M2_Rem_Derm_Exp_Freq	PA, SI, RI30, RI60	Rem M2 Derm Cont Exp Freq	Dermal exposure frequency for medium two after a removal action. May be smaller than the original exposure frequency if the removal action limits exposure (days/yr)
M2_Rem_Ing_Exp_Freq	PA, SI, RI30, RI60	Rem M2 Oral Exp Freq	Ingestion exposure frequency for medium two after a removal action. May be smaller than the original exposure frequency if the removal action limits exposure (days/yr)
M2_Rem_Inh_Exp_Freq	PA, SI, RI30, RI60	Rem M2 Inhal Exp Freq	Inhalation exposure frequency for medium two after a removal action. May be smaller than the original exposure frequency if the removal action limits exposure (days/yr)

Table 8 Continued

Cell Name in Excel	Relevant Models	DPL Value Node Name	Definition
M3_C_Freq_contact	All	M3 Derm Contact Exp Freq	Exposure frequency for dermal contact with medium three (days/yr)
M3_C_Surf_Area	All	M3 Surface Area	Exposed skin surface area that medium three comes in contact with (cm ²)
M3_Derm_Conv_Fac	All	Same	Conversion factor used in dermal contact exposure assessment (1.0E-3 L/cm ³ in water or 1.0E-6 kg/mg in soil)
M3_Derm_Exp_Time	All	Same	Duration of dermal contact (hrs/day), applicable only in water, otherwise must be equal to 1.0.
M3_Dermal_Adherence_Factor	All	Same	Refers to the amount of soil that remains on the skin after contact. Applicable on to soil. Set equal to 1.0 for water. (mg/cm ²)
M3_Exposure_Duration	All	Same	Exposure Duration for medium three (yrs)
M3_I_Freq_contact	All	M3 Inhal Exp Freq	Exposure frequency for the inhalation exposure route in medium three (days/yr)
M3_I_Vol_contact	All	M3 Inhal Rate	Inhalation rate for medium three. (m ³ /hr)
M3_Ing_Conv_Fac	All	M3 Ingest Conv Fac	Conversion factor for the ingestion route in medium three. Value is 1.0 if the medium is water and 1.0E-6 kg/mg if the medium is soil.
M3_Inhal_Exp_Time	All	Same	Length of time for an exposure incident from the inhalation exposure route in medium three.
M3_O_Freq_contacted	All	M3 Oral Exp Freq	Exposure Frequency for the ingestion route (orally) of medium three (days/yr)
M3_O_Vol_contact	All	M3 Ingestion Rate	Ingestion rate of medium three (mg/day for soil and L/day for water)
M3_Rem_Derm_Exp_Freq	PA, SI, RI30, RI60	Rem M3 Derm Cont Exp Freq	Dermal exposure frequency for medium three after a removal action. May be smaller than the original exposure frequency if the removal action limits exposure (days/yr)
M3_Rem_Ing_Exp_Freq	PA, SI, RI30, RI60	Rem M3 Oral Exp Freq	Ingestion exposure frequency for medium three after a removal action. May be smaller than the original exposure frequency if the removal action limits exposure (days/yr)

Table 8 Continued

Cell Name in Excel	Relevant Models	DPL Value Node Name	Definition
M3_Rem_Inh_Exp_Freq	PA, SI, RI30, RI60	Rem M3 Inhal Exp Freq	Inhalation exposure frequency for medium three after a removal action. May be smaller than the original exposure frequency if the removal action limits exposure (days/yr)
MAX_COST	All	Same	Maximum possible cost of all possible outcomes. Must be determined by running the model after all other data has been input.
MAX_DUR	All	Same	Maximum possible duration of all possible outcomes. Must be determined by running the model after all other data has been input. (months)
NFA_Cost_High_Multiplier	All	Same	Multiplier used in the calculation of the high cost of choosing to take no further action. Takes into account lawsuits, health effects and public opinion. Recommended value not be less than 1.0 and only in extreme cases should it be greater than 2.0. A value of 1.5 has worked well in the past.
NFA_COST_LOW	All	Same	If taking no further action is the correct decision this is the cost of that decision. It would include preparation of the ROD. This is a low cost.
NFA_Dur_High_Multiplier	All	Same	Multiplier used in the calculation of the high duration of choosing to take no further action. Takes into account lawsuits, health effects and public opinion. Recommend value not be less than 1.0 and only in extreme cases should it be greater than 2.0. A value of 1.5 has worked well in the past.
NFA_DUR_LOW	All	Same	If taking no further action is the correct decision this is the duration of that decision. It would include preparation of the ROD. This is a low duration.
P_NFA_Cost_High_Given_High	All	P NFA Cost High High	Probability that the cost of the no further action alternative is high given the level of risk or hazard index is greater than or equal to the clearly unacceptable level.
P_NFA_Cost_High_Given_Low	All	P NFA Cost High Low	Probability that the cost of the no further action alternative is high given the level of risk or hazard index is greater than or equal to the clearly acceptable level but less than the clearly unacceptable level.

Table 8 Continued

Cell Name in Excel	Relevant Models	DPL Value Node Name	Definition
P_NFA_Cost_High_Given_Mid	All	P NFA Cost High Mid	Probability that the cost of the no further action alternative is high given the level of risk or hazard index is less than or equal to the clearly acceptable level.
P_NFA_Dur_High_Given_High	All	P NFA Dur High High	Probability that the duration of the no further action alternative is high given the level of risk or hazard index is greater than or equal to the clearly unacceptable level.
P_NFA_Dur_High_Given_Low	All	P NFA Dur High Low	Probability that the duration of the no further action alternative is high given the level of risk or hazard index is greater than or equal to the clearly acceptable level but less than the clearly unacceptable level.
P_NFA_Dur_High_Given_Mid	All	P NFA Dur High Mid	Probability that the duration of the no further action alternative is high given the level of risk or hazard index is less than or equal to the clearly acceptable level.
PA_Cost_High	PA	Same	Upper limit of the estimated cost of the preliminary assessment.
PA_Cost_Low	PA	Same	Lower limit of the estimated cost of the preliminary assessment.
PA_Dur_High	PA	Same	Upper limit of the estimated duration of the preliminary assessment.
PA_Dur_Low	PA	Same	Lower limit of the estimated duration of the preliminary assessment.
PA_M1_no_samples	All	PA M1 no smpls	Number of samples taken for the preliminary assessment from medium one.
PA_M2_no_samples	All	PA M2 no smpls	Number of samples taken for the preliminary assessment from medium two.
PA_M3_no_samples	All	PA M3 no smpls	Number of samples taken for the preliminary assessment from medium three.
Pres_Rem_Cost_High	All	Same	Upper bound of the range of estimated cost for determining the appropriate presumptive remedy. This cost does not include remediation, only selection of the technology.
Pres_Rem_Cost_Low	All	Same	Lower bound of the range of estimated cost for determining the appropriate presumptive remedy. This cost does not include remediation, only selection of the technology.

Table 8 Continued

Cell Name in Excel	Relevant Models	DPL Value Node Name	Definition
Pres_Rem_Dur_High	All	Same	Upper bound of the range of estimated duration for determining the appropriate presumptive remedy. This duration does not include remediation, only selection of the technology.
Pres_Rem_Dur_Low	All	Same	Lower bound of the range of estimated duration for determining the appropriate presumptive remedy. This duration does not include remediation, only selection of the technology.
Rem_M1_Goal_Met_g_Tech_Acc	PA, SI, RI30, RI60	P Rem M1 GL Met g TA	Probability that the remediation goal was met given that the technology selected was acceptable after the removal action in medium one.
REM_M1_MEAN_FACTOR	PA, SI, RI30, RI60	Rem M1 Mean Fac	Percent reduction in the mean concentration of chemicals in medium one after a removal action is accomplished. Input as a decimal value.
REM_M1_no_samples	PA, SI, RI30, RI60	Rem M1 no smpls	Number of samples taken in medium one during the removal action.
Rem_M1_Tech_Acc_g_All	PA, SI, RI30, RI60	P Rem M1 TA g Inv All	Probability that if the remedy is selected for medium one by investigating all options after the removal action it will be technically acceptable.
Rem_M1_Tech_Acc_g_Pres_and_Sim	PA, SI, RI30, RI60	P Rem M1 TA g Pres & Sim	Probability that if the remedy is selected for medium one using a presumptive remedy and the site is similar after the removal action it will be technically acceptable.
Rem_M2_Goal_Met_g_Tech_Acc	PA, SI, RI30, RI60	P Rem M2 GL Met g TA	Probability that the remediation goal was met given that the technology selected was acceptable after the removal action in medium two.
REM_M2_MEAN_FACTOR	PA, SI, RI30, RI60	Rem M2 Mean Fac	Percent reduction in the mean concentration of chemicals in medium two after a removal action is accomplished. Input as a decimal value.
REM_M2_no_samples	PA, SI, RI30, RI60	Rem M2 no smpls	Number of samples taken in medium two during the removal action.
Rem_M2_Tech_Acc_g_All	PA, SI, RI30, RI60	P Rem M2 TA g Inv All	Probability that if the remedy is selected for medium two by investigating all options after the removal action it will be technically acceptable.

Table 8 Continued

Cell Name in Excel	Relevant Models	DPL Value Node Name	Definition
Rem_M2_Tech_Acc_g_Pres_and_Sim	PA, SI, RI30, RI60	P Rem M2 TA g Pres & Sim	Probability that if the remedy is selected for medium two using a presumptive remedy and the site is similar after the removal action it will be technically acceptable.
Rem_M3_Goal_Met_g_Tech_Acc	PA, SI, RI30, RI60	P Rem M3 GL Met g TA	Probability that the remediation goal was met given that the technology selected was acceptable after the removal action in medium three.
REM_M3_MEAN_FACTOR	PA, SI, RI30, RI60	Rem M3 Mean Fac	Percent reduction in the mean concentration of chemicals in medium three after a removal action is accomplished. Input as a decimal value.
REM_M3_no_samples	PA, SI, RI30, RI60	Rem M3 no smpls	Number of samples taken in medium three during the removal action.
Rem_M3_Tech_Acc_g_All	PA, SI, RI30, RI60	P Rem M3 TA g Inv All	Probability that if the remedy is selected for medium three by investigating all options after the removal action it will be technically acceptable.
Rem_M3_Tech_Acc_g_Pres and Sim	PA, SI, RI30, RI60	P Rem M3 TA g Pres & Sim	Probability that, after a removal action in medium three, a presumptive remedy will be technically acceptable given the site is similar.
Rem_SSR_Yes_g_No	PA, SI, RI30, RI60	Rem P SSR Yes g No	Probability that the site similarity report conducted after a removal action predicts the site is similar given the site is not similar.
Rem_SSR_Yes_g_Yes	PA, SI, RI30, RI60	Rem P SSR Yes g Yes	Probability that the site similarity report conducted after a removal action predicts the site is similar given the site is similar.
Remed_Cost_Fac_g_Not_TA	All	Remed Cost Fac g Not Tech App	Remediation cost factor given the technology selected is not technically acceptable. Value must be greater than 1.0. Suggested value is 2.5
Remed_Cost_Fac_g_TA_and_Goals_Not_Met	All	Remed Cost Fac g TA & Goal Not Met	Remediation cost factor given the technology selected is technically acceptable but the remediation goals are not met. Value must be greater than 1.0. Suggested value is 1.4.
Remed_Dur_Fac_g_Not_TA	All	Remed Dur Fac g Not Tech App	Remediation duration factor given the technology selected is not technically acceptable. Value must be greater than 1.0. Suggested value is 2.5
Remed_Dur_Fac_g_TA_and_Goals_Not_Met	All	Remed Dur Fac g TA & Goal Not Met	Remediation duration factor given the technology selected is technically acceptable but the remediation goals are not met. Value must be greater than 1.0. Suggested value is 1.4.

Table 8 Continued

Cell Name in Excel	Relevant Models	DPL Value Node Name	Definition
Remed_M1_Cost_High	All	M1 Remov Cost High	Upper bound of the range of costs to remediate medium one.
Remed_M1_Cost_Low	All	M1 Remov Cost Low	Lower bound of the range of costs to remediate medium one.
Remed_M1_Dur_High	All	M1 Remov Dur High	Upper bound of the range of durations to remediate medium one.
Remed_M1_Dur_Low	All	M1 Remov Dur Low	Lower bound of the range of durations to remediate medium one.
Remed_M2_Cost_High	All	M2 Remov Cost High	Upper bound of the range of costs to remediate medium two.
Remed_M2_Cost_Low	All	M2 Remov Cost Low	Lower bound of the range of costs to remediate medium two.
Remed_M2_Dur_High	All	M2 Remov Dur High	Upper bound of the range of durations to remediate medium two.
Remed_M2_Dur_Low	All	M2 Remov Dur Low	Lower bound of the range of durations to remediate medium two.
Remed_M3_Cost_High	All	M3 Remov Cost High	Upper bound of the range of costs to remediate medium three.
Remed_M3_Cost_Low	All	M3 Remov Cost Low	Lower bound of the range of costs to remediate medium three.
Remed_M3_Dur_High	All	M3 Remov Dur High	Upper bound of the range of durations to remediate medium three.
Remed_M3_Dur_Low	All	M3 Remov Dur Low	Lower bound of the range of durations to remediate medium three.
Remov_M1_Cost_High	PA, SI, RI30, RI60	M1 Remov Cost High	Upper bound of the range of costs to perform a removal action on medium one.
Remov_M1_Cost_Low	PA, SI, RI30, RI60	M1 Remov Cost Low	Lower bound of the range of costs to perform a removal action on medium one.

Table 8 Continued

Cell Name in Excel	Relevant Models	DPL Value Node Name	Definition
Remov_M1_Dur_High	PA, SI, RI30, RI60	M1 Remov Dur High	Upper bound of the range of durations to perform a removal action on medium one.
Remov_M1_Dur_Low	PA, SI, RI30, RI60	M1 Remov Dur Low	Lower bound of the range of durations to perform a removal action on medium one.
Remov_M2_Cost_High	PA, SI, RI30, RI60	M2 Remov Cost High	Upper bound of the range of costs to perform a removal action on medium two.
Remov_M2_Cost_Low	PA, SI, RI30, RI60	M2 Remov Cost Low	Lower bound of the range of costs to perform a removal action on medium two.
Remov_M2_Dur_High	PA, SI, RI30, RI60	M2 Remov Dur High	Upper bound of the range of durations to perform a removal action on medium two.
Remov_M2_Dur_Low	PA, SI, RI30, RI60	M2 Remov Dur Low	Lower bound of the range of durations to perform a removal action on medium two.
Remov_M3_Cost_High	PA, SI, RI30, RI60	M3 Remov Cost High	Upper bound of the range of costs to perform a removal action on medium three.
Remov_M3_Cost_Low	PA, SI, RI30, RI60	M3 Remov Cost Low	Lower bound of the range of costs to perform a removal action on medium three.
Remov_M3_Dur_High	PA, SI, RI30, RI60	M3 Remov Dur High	Upper bound of the range of durations to perform a removal action on medium three.
Remov_M3_Dur_Low	PA, SI, RI30, RI60	M3 Remov Dur Low	Lower bound of the range of durations to perform a removal action on medium three.
RI100_COST_High	All	Same	Upper bound of the expected cost range to complete a 100% remedial investigation

Table 8 Continued

Cell Name in Excel	Relevant Models	DPL Value Node Name	Definition
RI100_COST_Low	All	Same	Lower bound of the expected cost range to complete a 100% remedial investigation
RI100_DUR_High	All	Same	Upper bound of the expected duration range to complete a 100% remedial investigation
RI100_DUR_Low	All	Same	Lower bound of the expected duration range to complete a 100% remedial investigation
RI100_M1_Goal_Met_g_Tech_Acc	All	P RI100 M1 GL Met g TA	Probability that the remediation goal was met given that the technology selected was acceptable after the 100% remedial investigation in medium one.
RI100_M1_no_samples	All	RI100 M1 no smpls	Number of samples taken in medium one during the 100% remedial investigation.
RI100_M1_Tech_Acc_g_All	All	P RI100 M1 TA g Inv All	Probability that if the remedy is selected for medium one by investigating all options after the 100% remedial investigation it will be technically acceptable.
RI100_M1_Tech_Acc_g_Pres_and_Sim	All	P RI100 M1 TA g Pres & Sim	Probability that if the remedy is selected for medium one using a presumptive remedy and the site is similar after the 100% remedial investigation it will be technically acceptable.
RI100_M2_Goal_Met_g_Tech_Acc	All	P RI100 M2 GL Met g TA	Probability that the remediation goal was met given that the technology selected was acceptable after the 100% remedial investigation in medium two.
RI100_M2_no_samples	All	RI100 M2 no smpls	Number of samples taken in medium two during the 100% remedial investigation.
RI100_M2_Tech_Acc_g_All	All	P RI100 M2 TA g Inv All	Probability that if the remedy is selected for medium two by investigating all options after the 100% remedial investigation it will be technically acceptable.

Table 8 Continued

Cell Name in Excel	Relevant Models	DPL Value Node Name	Definition
RI100_M2_Tech_Acc_g_Pres_and_Sim	All	P RI100 M2 TA g Pres & Sim	Probability that if the remedy is selected for medium two using a presumptive remedy and the site is similar after the 100% remedial investigation it will be technically acceptable.
RI100_M3_Goal_Met_g_Tech_Acc	All	P RI100 M3 GL Met g TA	Probability that the remediation goal was met given that the technology selected was acceptable after the 100% remedial investigation in medium three.
RI100_M3_no_samples	All	RI100 M3 no smpls	Number of samples taken in medium three during the 100% remedial investigation.
RI100_M3_Tech_Acc_g_All	All	P RI100 M3 TA g Inv All	Probability that if the remedy is selected for medium three by investigating all options after the 100% remedial investigation it will be technically acceptable.
RI100_M3_Tech_Acc_g_Pres_and_Sim	All	P RI100 M3 TA g Pres & Sim	Probability that if the remedy is selected for medium three using a presumptive remedy and the site is similar after the 100% remedial investigation it will be technically acceptable.
RI100_SSR_Yes_g_No	All	RI100 P SSR Yes g No	Probability that the site similarity report conducted after a 100% remedial investigation predicts the site is similar given the site is not similar.
RI100_SSR_Yes_g_Yes	All	RI100 P SSR Yes g Yes	Probability that the site similarity report conducted after a 100% remedial investigation predicts the site is similar given the site is similar.
RI30_COST_High	PA, SI, RI30	Same	Upper bound of the expected cost range to complete a 30% remedial investigation
RI30_COST_Low	PA, SI, RI30	Same	Lower bound of the expected cost range to complete a 30% remedial investigation
RI30_DUR_High	PA, SI, RI30	Same	Upper bound of the expected duration range to complete a 30% remedial investigation
RI30_DUR_Low	PA, SI, RI30	Same	Lower bound of the expected duration range to complete a 30% remedial investigation

Table 8 Continued

Cell Name in Excel	Relevant Models	DPL Value Node Name	Definition
RI30_M1_Goal_Met_g_Tech_Acc	PA, SI, RI30	P RI30 M1 GL Met g TA	Probability that the remediation goal was met given that the technology selected was acceptable after the 30% remedial investigation in medium one.
RI30_M1_no_samples	All	RI30 M1 no smpls	Number of samples taken in medium one during the 30% remedial investigation.
RI30_M1_Tech_Acc_g_All	PA, SI, RI30	P RI30 M1 TA g Inv All	Probability that if the remedy is selected for medium one by investigating all options after the 30% remedial investigation it will be technically acceptable.
RI30_M1_Tech_Acc_g_Pres_and_Sim	PA, SI, RI30	P RI30 M1 TA g Pres & Sim	Probability that if the remedy is selected for medium one using a presumptive remedy and the site is similar after the 30% remedial investigation it will be technically acceptable.
RI30_M2_Goal_Met_g_Tech_Acc	PA, SI, RI30	P RI30 M2 GL Met g TA	Probability that the remediation goal was met given that the technology selected was acceptable after the 30% remedial investigation in medium two.
RI30_M2_no_samples	All	RI30 M2 no smpls	Number of samples taken in medium two during the 30% remedial investigation.
RI30_M2_Tech_Acc_g_All	PA, SI, RI30	P RI30 M2 TA g Inv All	Probability that if the remedy is selected for medium two by investigating all options after the 30% remedial investigation it will be technically acceptable.
RI30_M2_Tech_Acc_g_Pres_and_Sim	PA, SI, RI30	P RI30 M2 TA g Pres & Sim	Probability that if the remedy is selected for medium two using a presumptive remedy and the site is similar after the 30% remedial investigation it will be technically acceptable.
RI30_M3_Goal_Met_g_Tech_Acc	PA, SI, RI30	P RI30 M3 GL Met g TA	Probability that the remediation goal was met given that the technology selected was acceptable after the 30% remedial investigation in medium three.
RI30_M3_no_samples	All	RI30 M3 no smpls	Number of samples taken in medium three during the 30% remedial investigation.

Table 8 Continued

Cell Name in Excel	Relevant Models	DPL Value Node Name	Definition
RI30_M3_Tech_Acc_g_All	PA, SI, RI30	P RI30 M3 TA g Inv All	Probability that if the remedy is selected for medium three by investigating all options after the 30% remedial investigation it will be technically acceptable.
RI30_M3_Tech_Acc_g_Pres_and_Sim	PA, SI, RI30	P RI30 M3 TA g Pres & Sim	Probability that if the remedy is selected for medium three using a presumptive remedy and the site is similar after the 30% remedial investigation it will be technically acceptable.
RI30_SSR_Yes_g_No	PA, SI, RI30	RI30 P SSR Yes g No	Probability that the site similarity report conducted after a 30% remedial investigation predicts the site is similar given the site is not similar.
RI30_SSR_Yes_g_Yes	PA, SI, RI30	RI30 P SSR Yes g Yes	Probability that the site similarity report conducted after a 30% remedial investigation predicts the site is similar given the site is similar.
RI60_COST_High	PA, SI, RI30, RI60	Same	Upper bound of the expected cost range to complete a 60% remedial investigation
RI60_COST_Low	PA, SI, RI30, RI60	Same	Lower bound of the expected cost range to complete a 60% remedial investigation
RI60_DUR_High	PA, SI, RI30, RI60	Same	Upper bound of the expected duration range to complete a 60% remedial investigation
RI60_DUR_Low	PA, SI, RI30, RI60	Same	Lower bound of the expected duration range to complete a 60% remedial investigation
RI60_M1_Goal_Met_g_Tech_Acc	PA, SI, RI30, RI60	P RI60 M1 GL Met g TA	Probability that the remediation goal was met given that the technology selected was acceptable after the 60% remedial investigation in medium one.
RI60_M1_no_samples	All	RI60 M1 no simpls	Number of samples taken in medium one during the 60% remedial investigation.
RI60_M1_Tech_Acc_g_All	PA, SI, RI30, RI60	P RI60 M1 TA g Inv All	Probability that if the remedy is selected for medium one by investigating all options after the 60% remedial investigation it will be technically acceptable.

Table 8 Continued

Cell Name in Excel	Relevant Models	DPL Value Node Name	Definition
RI60_M1_Tech_Acc_g_Pres_and_Sim	PA, SI, RI30, RI60	P RI60 M1 TA g Pres & Sim	Probability that if the remedy is selected for medium one using a presumptive remedy and the site is similar after the 60% remedial investigation it will be technically acceptable.
RI60_M2_Goal_Met_g_Tech_Acc	PA, SI, RI30, RI60	P RI60 M2 GL Met g TA	Probability that the remediation goal was met given that the technology selected was acceptable after the 60% remedial investigation in medium two.
RI60_M2_no_samples	All	RI60 M2 no smpls	Number of samples taken in medium two during the 60% remedial investigation.
RI60_M2_Tech_Acc_g_All	PA, SI, RI30, RI60	P RI60 M2 TA g Inv All	Probability that if the remedy is selected for medium two by investigating all options after the 60% remedial investigation it will be technically acceptable.
RI60_M2_Tech_Acc_g_Pres_and_Sim	PA, SI, RI30, RI60	P RI60 M2 TA g Pres & Sim	Probability that if the remedy is selected for medium two using a presumptive remedy and the site is similar after the 60% remedial investigation it will be technically acceptable.
RI60_M3_Goal_Met_g_Tech_Acc	PA, SI, RI30, RI60	P RI60 M3 GL Met g TA	Probability that the remediation goal was met given that the technology selected was acceptable after the 60% remedial investigation in medium three.
RI60_M3_no_samples	All	RI60 M3 no smpls	Number of samples taken in medium three during the 60% remedial investigation.
RI60_M3_Tech_Acc_g_All	PA, SI, RI30, RI60	P RI60 M3 TA g Inv All	Probability that if the remedy is selected for medium three by investigating all options after the 60% remedial investigation it will be technically acceptable.
RI60_M3_Tech_Acc_g_Pres_and_Sim	PA, SI, RI30, RI60	P RI60 M3 TA g Pres & Sim	Probability that if the remedy is selected for medium three using a presumptive remedy and the site is similar after the 60% remedial investigation it will be technically acceptable.
RI60_SSR_Yes_g_No	PA, SI, RI30, RI60	RI60 P SSR Yes g No	Probability that the site similarity report conducted after a 60% remedial investigation predicts the site is similar given the site is not similar.

Table 8 Continued

Cell Name in Excel	Relevant Models	DPL Value Node Name	Definition
RI60_SSR_Yes_g_Yes	PA, SI, RI30, RI60	RI60 P SSR Yes g Yes	Probability that the site similarity report conducted after a 60% remedial investigation predicts the site is similar given the site is similar.
SI_COST_High	PA, SI	Same	Upper bound of the expected cost range to complete a site investigation
SI_COST_Low	PA, SI	Same	Lower bound of the expected cost range to complete a site investigation
SI_DUR_High	PA, SI	Same	Upper bound of the expected duration range to complete a site investigation
SI_DUR_Low	PA, SI	Same	Lower bound of the expected duration range to complete a site investigation
SI_M1_no_samples	All	SI M1 no smpls	Number of samples taken in medium one during the site investigation.
SI_M2_no_samples	All	SI M2 no smpls	Number of samples taken in medium two during the site investigation.
SI_M3_no_samples	All	SI M3 no smpls	Number of samples taken in medium three during the site investigation.
T1_M1_Contam_Lvl_High	PA	T1 M1 Lvl High	Upper bound estimate of the mean contaminant level for the type one contaminant in medium one (mg/kg in soil or mg/L in water).
T1_M1_Contam_Lvl_Low	PA	T1 M1 Lvl Low	Lower bound estimate of the mean contaminant level for the type one contaminant in medium one (mg/kg in soil or mg/L in water).
T1_M1_Derm_AbF	All	T1 M1 Derm AC	Dermal absorption factor for the type one contaminant in medium one. Unitless for soil. In water it is equivalent to the dermal permeability constant in cm/hr.
T1_M1_Inh_Con	All	Same	Inhalation emission factor for the type one contaminant in medium one. If concentration is given as the airborne concentration this factor is equal to 1.0. See text, Chapter 2 for further information.
T1_M1_MEAN	All	Same	Mean concentration from the type one contaminant in medium one (mg/kg in soil or mg/L in water).
T1_M1_Oral_Abs_Fac	All	T1 M1 Oral Abs Factor	Oral absorption factor for the type one contaminant in medium one. Used to convert the oral slope factor and reference dose to an absorbed toxicity value to be used as the dermal slope factor or reference dose (unitless).

Table 8 Continued

Cell Name in Excel	Relevant Models	DPL Value Node Name	Definition
T1_M1_RfD_Inh	All	Same	Reference dose for the inhalation pathway of the type one contaminant in medium one (mg/kg-day)
T1_M1_RfD_Oral	All	Same	Reference dose for the ingestion pathway of the type one contaminant in medium one (mg/kg-day)
T1_M1_SD	All	Same	Sample standard deviation for the type one contaminant in medium one.
T1_M1_SF_Inh	All	Same	Slope factor for the inhalation pathway of the type one contaminant in medium one (kg-day/mg).
T1_M1_SF_Oral	All	Same	Slope factor for the ingestion pathway of the type one contaminant in medium one (kg-day/mg).
T1_M2_Contam_Lvl_High	PA	T1 M2 Lvl High	Upper bound estimate of the mean contaminant level for the type one contaminant in medium two (mg/kg in soil or mg/L in water).
T1_M2_Contam_Lvl_Low	PA	T1 M2 Lvl Low	Lower bound estimate of the mean contaminant level for the type one contaminant in medium two (mg/kg in soil or mg/L in water).
T1_M2_Derm_AbF	All	T1 M2 Derm AC	Dermal absorption factor for the type one contaminant in medium two. Unitless for soil. In water it is equivalent to the dermal permeability constant in cm/hr.
T1_M2_Inh_Con	All	Same	Inhalation emission factor for the type one contaminant in medium two. If concentration is given as the airborne concentration this factor is equal to 1.0. See text, Chapter 2 for further information.
T1_M2_MEAN	All	Same	Mean concentration from the type one contaminant in medium two (mg/kg in soil or mg/L in water).
T1_M2_Oral_Abs_Fac	All	T1 M2 Oral Abs Factor	Oral absorption factor for the type one contaminant in medium two. Used to convert the oral slope factor and reference dose to an absorbed toxicity value to be used as the dermal slope factor or reference dose (unitless).
T1_M2_RfD_Inh	All	Same	Reference dose for the inhalation pathway of the type one contaminant in medium two (mg/kg-day)

Table 8 Continued

Cell Name in Excel	Relevant Models	DPL Value Node Name	Definition
T1_M2_RfD_Oral	All	Same	Reference dose for the ingestion pathway of the type one contaminant in medium two (mg/kg-day)
T1_M2_SD	All	Same	Sample standard deviation for the type one contaminant in medium two.
T1_M2_SF_Inh	All	Same	Slope factor for the inhalation pathway of the type one contaminant in medium two (kg-day/mg).
T1_M2_SF_Oral	All	Same	Slope factor for the ingestion pathway of the type one contaminant in medium two (kg-day/mg).
T1_M3_Contam_Lvl_High	PA	T1 M3 Lvl High	Upper bound estimate of the mean contaminant level for the type one contaminant in medium three (mg/kg in soil or mg/L in water).
T1_M3_Contam_Lvl_Low	PA	T1 M3 Lvl Low	Lower bound estimate of the mean contaminant level for the type one contaminant in medium three (mg/kg in soil or mg/L in water).
T1_M3_Derm_AbF	All	T1 M3 Derm AC	Dermal absorption factor for the type one contaminant in medium three. Unitless for soil. In water it is equivalent to the dermal permeability constant in cm/hr.
T1_M3_Inh_Con	All	Same	Inhalation emission factor for the type one contaminant in medium three. If concentration is given as the airborne concentration this factor is equal to 1.0. See text, Chapter 2 for further information.
T1_M3_MEAN	All	Same	Mean concentration from the type one contaminant in medium three (mg/kg in soil or mg/L in water).
T1_M3_Oral_Abs_Fac	All	T1 M3 Oral Abs Factor	Oral absorption factor for the type one contaminant in medium three. Used to convert the oral slope factor and reference dose to an absorbed toxicity value to be used as the dermal slope factor or reference dose (unitless).
T1_M3_RfD_Inh	All	Same	Reference dose for the inhalation pathway of the type one contaminant in medium three (mg/kg-day)
T1_M3_RfD_Oral	All	Same	Reference dose for the ingestion pathway of the type one contaminant in medium three (mg/kg-day)
T1_M3_SD	All	Same	Sample standard deviation for the type one contaminant in medium three.

Table 8 Continued

Cell Name in Excel	Relevant Models	DPL Value Node Name	Definition
T1_M3_SF_Inh	All	Same	Slope factor for the inhalation pathway of the type one contaminant in medium three (kg-day/mg).
T1_M3_SF_Oral	All	Same	Slope factor for the ingestion pathway of the type one contaminant in medium three (kg-day/mg).
T2_M1_Contam_Lvl_High	PA	T2 M1 Lvl High	Upper bound estimate of the mean contaminant level for the type two contaminant in medium one (mg/kg in soil or mg/L in water).
T2_M1_Contam_Lvl_Low	PA	T2 M1 Lvl Low	Lower bound estimate of the mean contaminant level for the type two contaminant in medium one (mg/kg in soil or mg/L in water).
T2_M1_Derm_AbF	All	T2 M1 Derm AC	Dermal absorption factor for the type two contaminant in medium one. Unitless for soil. In water it is equivalent to the dermal permeability constant in cm/hr.
T2_M1_Inh_Con	All	Same	Inhalation emission factor for the type two contaminant in medium one. If concentration is given as the airborne concentration this factor is equal to 1.0. See text, Chapter 2 for further information.
T2_M1_MEAN	All	Same	Mean concentration from the type two contaminant in medium one (mg/kg in soil or mg/L in water).
T2_M1_Oral_Abs_Fac	All	T2 M1 Oral Abs Factor	Oral absorption factor for the type two contaminant in medium one. Used to convert the oral slope factor and reference dose to an absorbed toxicity value to be used as the dermal slope factor or reference dose (unitless).
T2_M1_RfD_Inh	All	Same	Reference dose for the inhalation pathway of the type two contaminant in medium one (mg/kg-day)
T2_M1_RfD_Oral	All	Same	Reference dose for the ingestion pathway of the type two contaminant in medium one (mg/kg-day)
T2_M1_SD	All	Same	Sample standard deviation for the type two contaminant in medium one.
T2_M1_SF_Inh	All	Same	Slope factor for the inhalation pathway of the type two contaminant in medium one (kg-day/mg).

Table 8 Continued

Cell Name in Excel	Relevant Models	DPL Value Node Name	Definition
T2_M1_SF_Oral	All	Same	Slope factor for the ingestion pathway of the type two contaminant in medium one (kg-day/mg).
T2_M2_Contam_Lvl_High	PA	T2 M2 Lvl High	Upper bound estimate of the mean contaminant level for the type two contaminant in medium two (mg/kg in soil or mg/L in water).
T2_M2_Contam_Lvl_Low	PA	T2 M2 Lvl Low	Lower bound estimate of the mean contaminant level for the type two contaminant in medium two (mg/kg in soil or mg/L in water).
T2_M2_Derm_AbF	All	T2 M2 Derm AC	Dermal absorption factor for the type two contaminant in medium two. Unitless for soil. In water it is equivalent to the dermal permeability constant in cm/hr.
T2_M2_Inh_Con	All	Same	Inhalation emission factor for the type two contaminant in medium two. If concentration is given as the airborne concentration this factor is equal to 1.0. See text, Chapter 2 for further information.
T2_M2_MEAN	All	Same	Mean concentration from the type two contaminant in medium two (mg/kg in soil or mg/L in water).
T2_M2_Oral_Abs_Fac	All	T2 M2 Oral Abs Factor	Oral absorption factor for the type two contaminant in medium two. Used to convert the oral slope factor and reference dose to an absorbed toxicity value to be used as the dermal slope factor or reference dose (unitless).
T2_M2_RfD_Inh	All	Same	Reference dose for the inhalation pathway of the type two contaminant in medium two (mg/kg-day)
T2_M2_RfD_Oral	All	Same	Reference dose for the ingestion pathway of the type two contaminant in medium two (mg/kg-day)
T2_M2_SD	All	Same	Sample standard deviation for the type two contaminant in medium two.
T2_M2_SF_Inh	All	Same	Slope factor for the inhalation pathway of the type two contaminant in medium two (kg-day/mg).
T2_M2_SF_Oral	All	Same	Slope factor for the ingestion pathway of the type two contaminant in medium two (kg-day/mg).

Table 8 Continued

Cell Name in Excel	Relevant Models	DPL Value Node Name	Definition
T2_M3_Contam_Lvl_High	PA	T2 M3 Lvl High	Upper bound estimate of the mean contaminant level for the type two contaminant in medium three (mg/kg in soil or mg/L in water).
T2_M3_Contam_Lvl_Low	PA	T2 M3 Lvl Low	Lower bound estimate of the mean contaminant level for the type two contaminant in medium three (mg/kg in soil or mg/L in water).
T2_M3_Derm_AbF	All	T2 M3 Derm AC	Dermal absorption factor for the type two contaminant in medium three. Unitless for soil. In water it is equivalent to the dermal permeability constant in cm/hr.
T2_M3_Inh_Con	All	Same	Inhalation emission factor for the type two contaminant in medium three. If concentration is given as the airborne concentration this factor is equal to 1.0. See text, Chapter 2 for further information.
T2_M3_MEAN	All	Same	Mean concentration from the type two contaminant in medium three (mg/kg in soil or mg/L in water).
T2_M3_Oral_Abs_Fac	All	T2 M3 Oral Abs Factor	Oral absorption factor for the type two contaminant in medium three. Used to convert the oral slope factor and reference dose to an absorbed toxicity value to be used as the dermal slope factor or reference dose (unitless).
T2_M3_Rfd_Inh	All	Same	Reference dose for the inhalation pathway of the type two contaminant in medium three (mg/kg-day)
T2_M3_Rfd_Oral	All	Same	Reference dose for the ingestion pathway of the type two contaminant in medium three (mg/kg-day)
T2_M3_SD	All	Same	Sample standard deviation for the type two contaminant in medium three.
T2_M3_SF_Inh	All	Same	Slope factor for the inhalation pathway of the type two contaminant in medium three (kg-day/mg).
T2_M3_SF_Oral	All	Same	Slope factor for the ingestion pathway of the type two contaminant in medium three (kg-day/mg).
T3_M1_Contam_Lvl_High	PA	T3 M1 Lvl High	Upper bound estimate of the mean contaminant level for the type three contaminant in medium one (mg/kg in soil or mg/L in water).

Table 8 Continued

Cell Name in Excel	Relevant Models	DPL Value Node Name	Definition
T3_M1_Contam_Lvl_Low	PA	T3 M1 Lvl Low	Lower bound estimate of the mean contaminant level for the type three contaminant in medium one (mg/kg in soil or mg/L in water).
T3_M1_Derm_AbF	All	T3 M1 Derm AC	Dermal absorption factor for the type three contaminant in medium one. Unitless for soil. In water it is equivalent to the dermal permeability constant in cm/hr.
T3_M1_Inh_Con	All	Same	Inhalation emission factor for the type three contaminant in medium one. If concentration is given as the airborne concentration this factor is equal to 1.0. See text, Chapter 2 for further information.
T3_M1_MEAN	All	Same	Mean concentration from the type three contaminant in medium one (mg/kg in soil or mg/L in water).
T3_M1_Oral_Abs_Fac	All	T3 M1 Oral Abs Factor	Oral absorption factor for the type three contaminant in medium one. Used to convert the oral slope factor and reference dose to an absorbed toxicity value to be used as the dermal slope factor or reference dose (unitless).
T3_M1_RfD_Inh	All	Same	Reference dose for the inhalation pathway of the type three contaminant in medium one (mg/kg-day)
T3_M1_RfD_Oral	All	Same	Reference dose for the ingestion pathway of the type three contaminant in medium one (mg/kg-day)
T3_M1_SD	All	Same	Sample standard deviation for the type three contaminant in medium one.
T3_M1_SF_Inh	All	Same	Slope factor for the inhalation pathway of the type three contaminant in medium one (kg-day/mg).
T3_M1_SF_Oral	All	Same	Slope factor for the ingestion pathway of the type three contaminant in medium one (kg-day/mg).
T3_M2_Contam_Lvl_High	PA	T3 M2 Lvl High	Upper bound estimate of the mean contaminant level for the type three contaminant in medium two (mg/kg in soil or mg/L in water).
T3_M2_Contam_Lvl_Low	PA	T3 M2 Lvl Low	Lower bound estimate of the mean contaminant level for the type three contaminant in medium two (mg/kg in soil or mg/L in water).

Table 8 Continued

Cell Name in Excel	Relevant Models	DPL Value Node Name	Definition
T3_M2_Derm_AbF	All	T3 M2 Derm AC	Dermal absorption factor for the type three contaminant in medium two. Unitless for soil. In water it is equivalent to the dermal permeability constant in cm/hr.
T3_M2_Inh_Con	All	Same	Inhalation emission factor for the type three contaminant in medium two. If concentration is given as the airborne concentration this factor is equal to 1.0. See text, Chapter 2 for further information.
T3_M2_MEAN	All	Same	Mean concentration from the type three contaminant in medium two (mg/kg in soil or mg/L in water).
T3_M2_Oral_Abs_Fac	All	T3 M2 Oral Abs Factor	Oral absorption factor for the type three contaminant in medium two. Used to convert the oral slope factor and reference dose to an absorbed toxicity value to be used as the dermal slope factor or reference dose (unitless).
T3_M2_RfD_Inh	All	Same	Reference dose for the inhalation pathway of the type three contaminant in medium two (mg/kg-day)
T3_M2_RfD_Oral	All	Same	Reference dose for the ingestion pathway of the type three contaminant in medium two (mg/kg-day)
T3_M2_SD	All	Same	Sample standard deviation for the type three contaminant in medium two.
T3_M2_SF_Inh	All	Same	Slope factor for the inhalation pathway of the type three contaminant in medium two (kg-day/mg).
T3_M2_SF_Oral	All	Same	Slope factor for the ingestion pathway of the type three contaminant in medium two (kg-day/mg).
T3_M3_Contam_Lvl_High	PA	T3 M3 Lvl High	Upper bound estimate of the mean contaminant level for the type three contaminant in medium three (mg/kg in soil or mg/L in water).
T3_M3_Contam_Lvl_Low	PA	T3 M3 Lvl Low	Lower bound estimate of the mean contaminant level for the type three contaminant in medium three (mg/kg in soil or mg/L in water).
T3_M3_Derm_AbF	All	T3 M3 Derm AC	Dermal absorption factor for the type three contaminant in medium three. Unitless for soil. In water it is equivalent to the dermal permeability constant in cm/hr.

Table 8 Continued

Cell Name in Excel	Relevant Models	DPL Value Node Name	Definition
T3_M3_Inh_Con	All	Same	Inhalation emission factor for the type three contaminant in medium three. If concentration is given as the airborne concentration this factor is equal to 1.0. See text, Chapter 2 for further information.
T3_M3_MEAN	All	Same	Mean concentration from the type three contaminant in medium three (mg/kg in soil or mg/L in water).
T3_M3_Oral_Abs_Fac	All	T3 M3 Oral Abs Factor	Oral absorption factor for the type three contaminant in medium three. Used to convert the oral slope factor and reference dose to an absorbed toxicity value to be used as the dermal slope factor or reference dose (unitless).
T3_M3_RfD_Inh	All	Same	Reference dose for the inhalation pathway of the type three contaminant in medium three (mg/kg-day)
T3_M3_RfD_Oral	All	Same	Reference dose for the ingestion pathway of the type three contaminant in medium three (mg/kg-day)
T3_M3_SD	All	Same	Sample standard deviation for the type three contaminant in medium three.
T3_M3_SF_Inh	All	Same	Slope factor for the inhalation pathway of the type three contaminant in medium three (kg-day/mg).
T3_M3_SF_Oral	All	Same	Slope factor for the ingestion pathway of the type three contaminant in medium three (kg-day/mg).
TA_Cost_Fac_g_Not_TA_and_Inv_All	All	TA Cost Fac Not TA g Inv All	Cost factor for a technically unacceptable remedy given that all options were investigated. Value represents the percentage of the feasibility study costs required to correct the error in technology selection. Value should be less than one, recommended value is 0.5.
TA_Cost_Fac_g_Not_TA_and_Presumptive	All	TA Cost Fac Not TA g Presmtv	Cost factor for a technically unacceptable remedy given that a presumptive remedy was used. Value represents the percentage of the feasibility study costs required to correct the error in technology selection. Value should be less than or equal to one, recommended value is 1.0.

Table 8 Continued

Cell Name in Excel	Relevant Models	DPL Value Node Name	Definition
TA_Dur_Fac_g_Not_TA_and_Inv_All	All	TA Dur Fac Not TA g Inv All	Duration factor for a technically unacceptable remedy given that all options were investigated. Value represents the percentage of the feasibility study costs required to correct the error in technology selection. Value should be less than one, recommended value is 0.5.
TA_Dur_Fac_g_Not_TA_and_Presumptive	All	TA Dur Fac Not TA g Presmtv	Duration factor for a technically unacceptable remedy given that a presumptive remedy was used. Value represents the percentage of the feasibility study costs required to correct the error in technology selection. Value should be less than or equal to one, recommended value is 1.0.
Tech_Acc_g_Pres_and_NotSim	All	P TA g Pres & Not Sim	Probability that remedy selected is technically acceptable given that a presumptive remedy was used and the site is truly not similar. Recommended value is 0.0.
True_Prob_Site_Similar	All	Same	True probability that the site is similar to another successfully remediated site. Recommended value is 0.56.
Unacceptable_Haz_Index	All	Same	Decision maker's clearly unacceptable hazard index
Unacceptable_Risk	All	Same	Decision maker's clearly unacceptable level of carcinogenic risk

Table 9: Partial List of Calculated Variables in the Models

Cell Name in Excel	Relevant Models	DPL Value Node Name	Definition
Cum_Can_Mean	All	NA	Mean value of the cumulative cancer risk. Used in the calculation of the overall site risk.
Cum_Can_SE	All	NA	Standard error of the mean value of the cumulative cancer risk. Used in the calculation of the overall site risk.
Cum_Haz_Mean	All	NA	Mean value of the cumulative hazard index. Used in the calculation of the overall site hazard index.
Cum_Haz_SE	All	NA	Standard error of the mean value of the cumulative hazard index. Used in the calculation of the overall site hazard index.
NA	All	FS Cost	Mean value of the range of costs input by the decision maker for a feasibility study, assuming cost is distributed uniformly. Value is used when DPL needs the cost of a feasibility study
NA	All	FS Dur	Mean value of the range of durations input by the decision maker for a feasibility study, assuming duration is distributed uniformly. Value is used when DPL needs the duration of a feasibility study
NFA_COST_HIGH	All	Same	Cost associated with taking no further action when that decision has negative impacts in the future. It is the sum of the remaining study costs plus the highest remediation cost multiplied by the NFA Cost Factor.
NFA_DUR_HIGH	All	Same	Duration associated with taking no further action when that decision has negative impacts in the future. It is the sum of the remaining study durations plus the highest remediation duration multiplied by the NFA Dur Factor.

Table 9 Continued

Cell Name in Excel	Relevant Models	DPL Value Node Name	Definition
P_PA_T1_M1_Can_High	PA	Same	Probability the cancer risk for the type one contaminant in medium one is greater than the clearly unacceptable risk value with data available after the preliminary assessment. This value is repeated for all 9 chemicals, not shown in table.
P_PA_T1_M1_Can_Low	PA	Same	Probability the cancer risk for the type one contaminant in medium one is less than the clearly acceptable risk value with data available after the preliminary assessment. This value is repeated for all 9 chemicals, not shown in table.
P_PA_T1_M1_Can_NA	PA	Same	Probability that the type one contaminant in medium one does not have a carcinogenic health effect. This probability is either 0.0 or 1.0 and is repeated for all 9 chemicals, not shown in table.
P_PA_T1_M1_Haz_High	PA	Same	Probability the hazard index for the type one contaminant in medium one is greater than the clearly unacceptable hazard index with data available after the preliminary assessment. This value is repeated for all 9 chemicals, not shown in table.
P_PA_T1_M1_Haz_Low	PA	Same	Probability the hazard index for the type one contaminant in medium one is less than the clearly acceptable hazard index with data available after the preliminary assessment. This value is repeated for all 9 chemicals, not shown in table.
P_PA_T1_M1_Haz_NA	PA	Same	Probability that the type one contaminant in medium one does not have a noncarcinogenic health effect. This probability is either 0.0 or 1.0 and is repeated for all 9 chemicals, not shown in table.
P_REM_T1_M1_Can_High	PA, SI, RI30, RI60	Same	Probability the cancer risk for the type one contaminant in medium one is greater than the clearly unacceptable risk value with data available after the removal action. This value is repeated for all 9 chemicals, not shown in table.

Table 9 Continued

Cell Name in Excel	Relevant Models	DPL Value Node Name	Definition
P_REM_T1_M1_Can_Low	PA, SI, RI30, RI60	Same	Probability the cancer risk for the type one contaminant in medium one is less than the clearly acceptable risk value with data available after the removal action. This value is repeated for all 9 chemicals, not shown in table.
P_REM_T1_M1_Can_NA	PA, SI, RI30, RI60	Same	Probability that the type one contaminant in medium one does not have a carcinogenic health effect. This probability is either 0.0 or 1.0 and is repeated for all 9 chemicals, not shown in table.
P_REM_T1_M1_Haz_High	PA, SI, RI30, RI60	Same	Probability the hazard index for the type one contaminant in medium one is greater than the clearly unacceptable hazard index with data available after the removal action. This value is repeated for all 9 chemicals, not shown in table.
P_REM_T1_M1_Haz_Low	PA, SI, RI30, RI60	Same	Probability the hazard index for the type one contaminant in medium one is less than the clearly acceptable hazard index with data available after the removal action. This value is repeated for all 9 chemicals, not shown in table.
P_REM_T1_M1_Haz_NA	PA, SI, RI30, RI60	Same	Probability that the type one contaminant in medium one does not have a noncarcinogenic health effect. This probability is either 0.0 or 1.0 and is repeated for all 9 chemicals, not shown in table.
P_RI100_T1_M1_Can_High	All	Same	Probability the cancer risk for the type one contaminant in medium one is greater than the clearly unacceptable risk value with data available after the 100% remedial investigation. This value is repeated for all 9 chemicals, not shown in table.
P_RI100_T1_M1_Can_High_woSI	PA	P_RI100_T1_M1_Can_High_wo	Probability the cancer risk for the type one contaminant in medium one is greater than the clearly unacceptable risk value with data available after the 100% remedial investigation assuming the site investigation was skipped. This value is repeated for all 9 chemicals, not shown in table.

Table 9 Continued

Cell Name in Excel	Relevant Models	DPL Value Node Name	Definition
P_RI100_T1_MI_Can_Low	All	Same	Probability the cancer risk for the type one contaminant in medium one is less than the clearly acceptable risk value with data available after the 100% remedial investigation. This value is repeated for all 9 chemicals, not shown in table.
P_RI100_T1_MI_Can_Low_woSI	PA	P_RI100_T1_MI_Can_Low_wo	Probability the cancer risk for the type one contaminant in medium one is less than the clearly acceptable risk value with data available after the 100% remedial investigation assuming the site investigation was skipped. This value is repeated for all 9 chemicals, not shown in table.
P_RI100_T1_MI_Can_NA	All	Same	Probability that the type one contaminant in medium one does not have a carcinogenic health effect. This probability is either 0.0 or 1.0 and is repeated for all 9 chemicals, not shown in table.
P_RI100_T1_MI_Haz_High	All	Same	Probability the hazard index for the type one contaminant in medium one is greater than the clearly unacceptable hazard index with data available after the 100% remedial investigation. This value is repeated for all 9 chemicals, not shown in table.
P_RI100_T1_MI_Haz_High_woSI	PA	P_RI100_T1_MI_Haz_High_wo	Probability the hazard index for the type one contaminant in medium one is greater than the clearly unacceptable hazard index with data available after the 100% remedial investigation assuming the site investigation was skipped. This value is repeated for all 9 chemicals, not shown in table.
P_RI100_T1_MI_Haz_Low	All	Same	Probability the hazard index for the type one contaminant in medium one is less than the clearly acceptable hazard index with data available after the 100% remedial investigation. This value is repeated for all 9 chemicals, not shown in table.

Table 9 Continued

Cell Name in Excel	Relevant Models	DPL Value Node Name	Definition
P_RI100_T1_M1_Haz_Low_woSI	PA	P_RI100_T1_M1_Haz_Low_wo	Probability the hazard index for the type one contaminant in medium one is less than the clearly acceptable hazard index with data available after the 100% remedial investigation assuming the site investigation was skipped. This value is repeated for all 9 chemicals, not shown in table.
P_RI100_T1_M1_Haz_NA	All	Same	Probability that the type one contaminant in medium one does not have a noncarcinogenic health effect. This probability is either 0.0 or 1.0 and is repeated for all 9 chemicals, not shown in table.
P_RI30_T1_M1_Can_High	PA, SI, RI30	Same	Probability the cancer risk for the type one contaminant in medium one is greater than the clearly unacceptable risk value with data available after the 30% remedial investigation. This value is repeated for all 9 chemicals, not shown in table.
P_RI30_T1_M1_Can_High_woSI	PA	P_RI30_T1_M1_Can_High_wo	Probability the cancer risk for the type one contaminant in medium one is greater than the clearly unacceptable risk value with data available after the 30% remedial investigation assuming the site investigation was skipped. This value is repeated for all 9 chemicals, not shown in table.
P_RI30_T1_M1_Can_Low	PA, SI, RI30	Same	Probability the cancer risk for the type one contaminant in medium one is less than the clearly acceptable risk value with data available after the 30% remedial investigation. This value is repeated for all 9 chemicals, not shown in table.
P_RI30_T1_M1_Can_Low_woSI	PA	P_RI30_T1_M1_Can_Low_wo	Probability the cancer risk for the type one contaminant in medium one is less than the clearly acceptable risk value with data available after the 30% remedial investigation assuming the site investigation was skipped. This value is repeated for all 9 chemicals, not shown in table.

Table 9 Continued

Cell Name in Excel	Relevant Models	DPL Value Node Name	Definition
P_RI30_T1_M1_Can_NA	PA, SI, RI30	Same	Probability that the type one contaminant in medium one does not have a carcinogenic health effect. This probability is either 0.0 or 1.0 and is repeated for all 9 chemicals, not shown in table.
P_RI30_T1_M1_Haz_High	PA, SI, RI30	Same	Probability the hazard index for the type one contaminant in medium one is greater than the clearly unacceptable hazard index with data available after the 30% remedial investigation. This value is repeated for all 9 chemicals, not shown in table.
P_RI30_T1_M1_Haz_High_woSI	PA	P_RI30_T1_M1_Haz_High_wo	Probability the hazard index for the type one contaminant in medium one is greater than the clearly unacceptable hazard index with data available after the 30% remedial investigation assuming the site investigation was skipped. This value is repeated for all 9 chemicals, not shown in table.
P_RI30_T1_M1_Haz_Low	PA, SI, RI30	Same	Probability the hazard index for the type one contaminant in medium one is less than the clearly acceptable hazard index with data available after the 30% remedial investigation. This value is repeated for all 9 chemicals, not shown in table.
P_RI30_T1_M1_Haz_Low_woSI	PA	P_RI30_T1_M1_Haz_Low_wo	Probability the hazard index for the type one contaminant in medium one is less than the clearly acceptable hazard index with data available after the 30% remedial investigation assuming the site investigation was skipped. This value is repeated for all 9 chemicals, not shown in table.
P_RI30_T1_M1_Haz_NA	PA, SI, RI30	Same	Probability that the type one contaminant in medium one does not have a noncarcinogenic health effect. This probability is either 0.0 or 1.0 and is repeated for all 9 chemicals, not shown in table.
P_RI60_T1_M1_Can_High	PA, SI, RI30	Same	Probability the cancer risk for the type one contaminant in medium one is greater than the clearly unacceptable risk value with data available after the 60% remedial investigation. This value is repeated for all 9 chemicals, not shown in table.

Table 9 Continued

Cell Name in Excel	Relevant Models	DPL Value Node Name	Definition
P_RI60_T1_M1_Can_High_woSI	PA	P_RI60_T1_M1_Can_High_wo	Probability the cancer risk for the type one contaminant in medium one is greater than the clearly unacceptable risk value with data available after the 60% remedial investigation assuming the site investigation was skipped. This value is repeated for all 9 chemicals, not shown in table.
P_RI60_T1_M1_Can_Low	PA, SI, RI30, RI60	Same	Probability the cancer risk for the type one contaminant in medium one is less than the clearly acceptable risk value with data available after the 60% remedial investigation. This value is repeated for all 9 chemicals, not shown in table.
P_RI60_T1_M1_Can_Low_woSI	PA	P_RI60_T1_M1_Can_Low_wo	Probability the cancer risk for the type one contaminant in medium one is less than the clearly acceptable risk value with data available after the 60% remedial investigation assuming the site investigation was skipped. This value is repeated for all 9 chemicals, not shown in table.
P_RI60_T1_M1_Can_NA	PA, SI, RI30, RI60	Same	Probability that the type one contaminant in medium one does not have a carcinogenic health effect. This probability is either 0.0 or 1.0 and is repeated for all 9 chemicals, not shown in table.
P_RI60_T1_M1_Haz_High	PA, SI, RI30, RI60	Same	Probability the hazard index for the type one contaminant in medium one is greater than the clearly unacceptable hazard index with data available after the 60% remedial investigation. This value is repeated for all 9 chemicals, not shown in table.
P_RI60_T1_M1_Haz_High_woSI	PA	P_RI60_T1_M1_Haz_High_wo	Probability the hazard index for the type one contaminant in medium one is greater than the clearly unacceptable hazard index with data available after the 60% remedial investigation assuming the site investigation was skipped. This value is repeated for all 9 chemicals, not shown in table.

Table 9 Continued

Cell Name in Excel	Relevant Models	DPL Value Node Name	Definition
P_RI60_T1_M1_Haz_Low	PA, SI, RI30, RI60	Same	Probability the hazard index for the type one contaminant in medium one is less than the clearly acceptable hazard index with data available after the 60% remedial investigation. This value is repeated for all 9 chemicals, not shown in table.
P_RI60_T1_M1_Haz_Low_woSI	PA	P_RI60_T1_M1_Haz_Low_wo	Probability the hazard index for the type one contaminant in medium one is less than the clearly acceptable hazard index with data available after the 60% remedial investigation assuming the site investigation was skipped. This value is repeated for all 9 chemicals, not shown in table.
P_RI60_T1_M1_Haz_NA	PA, SI, RI30, RI60	Same	Probability that the type one contaminant in medium one does not have a noncarcinogenic health effect. This probability is either 0.0 or 1.0 and is repeated for all 9 chemicals, not shown in table.
P_SI_T1_M1_Can_High	PA, SI	Same	Probability the cancer risk for the type one contaminant in medium one is greater than the clearly unacceptable risk value with data available after the site investigation. This value is repeated for all 9 chemicals, not shown in table.
P_SI_T1_M1_Can_Low	PA, SI	Same	Probability the cancer risk for the type one contaminant in medium one is less than the clearly acceptable risk value with data available after the site investigation. This value is repeated for all 9 chemicals, not shown in table.
P_SI_T1_M1_Can_NA	PA, SI	Same	Probability that the type one contaminant in medium one does not have a carcinogenic health effect. This probability is either 0.0 or 1.0 and is repeated for all 9 chemicals, not shown in table.
P_SI_T1_M1_Haz_High	PA, SI	Same	Probability the hazard index for the type one contaminant in medium one is greater than the clearly unacceptable hazard index with data available after the site investigation. This value is repeated for all 9 chemicals, not shown in table.

Table 9 Continued

Cell Name in Excel	Relevant Models	DPL Value Node Name	Definition
P_SI_T1_M1_Haz_Low	PA, SI	Same	Probability the hazard index for the type one contaminant in medium one is less than the clearly acceptable hazard index with data available after the site investigation. This value is repeated for all 9 chemicals, not shown in table.
P_SI_T1_M1_Haz_NA	PA, SI	Same	Probability that the type one contaminant in medium one does not have a noncarcinogenic health effect. This probability is either 0.0 or 1.0 and is repeated for all 9 chemicals, not shown in table.
PA_M1_Tot_Samples	PA	NA	The total number of samples taken in medium one at the end of the preliminary assessment.
PA_M2_Tot_Samples	PA	NA	The total number of samples taken in medium two at the end of the preliminary assessment.
PA_M3_Tot_Samples	PA	NA	The total number of samples taken in medium three at the end of the preliminary assessment.
PA_T1_M1_Can_SE	PA	NA	Standard error of the estimate of risk posed by the type one contaminant in medium one using data from the preliminary assessment. Value is repeated for all 9 chemicals, not shown in table.
PA_T1_M1_Haz_SE	PA	NA	Standard error of the estimate of the hazard index from the type one contaminant in medium one using data from the preliminary assessment. Value is repeated for all 9 chemicals, not shown in table.
PA_T1_M1_SE	PA	NA	Standard error of the mean concentration of the type one contaminant in medium one using data from the preliminary assessment. Value is repeated for all 9 chemicals, not shown in table.
NA	All	Pres Rem Cost	Mean value of the range of costs input by the decision maker for a presumptive remedy, assuming cost is distributed uniformly. Value is used when DPL needs the cost to select a presumptive remedy

Table 9 Continued

Cell Name in Excel	Relevant Models	DPL Value Node Name	Definition
NA	All	Pres Rem Dur	Mean value of the range of durations input by the decision maker for a presumptive remedy, assuming duration is distributed uniformly. Value is used when DPL needs the duration to select a presumptive remedy
Rem_M1_Tot_Samples	PA, SI, RI30, RI60	NA	The total number of samples taken in medium one at the end of the removal action.
Rem_M2_Tot_Samples	PA, SI, RI30, RI60	NA	The total number of samples taken in medium two at the end of the removal action.
Rem_M3_Tot_Samples	PA, SI, RI30, RI60	NA	The total number of samples taken in medium three at the end of the removal action.
Rem_T1_M1_Can_Mean	PA, SI, RI30, RI60	NA	Mean of the distribution of cancer risk for the type one contaminant in medium one after the mean reduction factor from the removal action is applied. Value is repeated for all 9 chemicals, not shown in table.
Rem_T1_M1_Can_SE	PA, SI, RI30, RI60	NA	Standard error of the estimate of risk posed by the type one contaminant in medium one using data from the removal action. Value is repeated for all 9 chemicals, not shown in table.
Rem_T1_M1_Haz_Mean	PA, SI, RI30, RI60	NA	Mean of the distribution of hazard index for the type one contaminant in medium one after the mean reduction factor from the removal action is applied. Value is repeated for all 9 chemicals, not shown in table.
Rem_T1_M1_Haz_SE	PA, SI, RI30, RI60	NA	Standard error of the estimate of the hazard index from the type one contaminant in medium one using data from the removal action. Value is repeated for all 9 chemicals, not shown in table.
Rem_T1_M1_Mean	PA, SI, RI30, RI60	NA	Mean of the distribution of chemical concentration for the type one contaminant in medium one after the mean reduction factor from the removal action is applied. Value is repeated for all 9 chemicals, not shown in table.

Table 9 Continued

Cell Name in Excel	Relevant Models	DPL Value Node Name	Definition
Rem_T1_M1_SE	PA, SI, RI30, RI60	NA	Standard error of the mean concentration of the type one contaminant in medium one using data from the removal action. Value is repeated for all 9 chemicals, not shown in table.
NA	All	RI100 Cost	Mean value of the range of costs input by the decision maker for a 100% remedial investigation, assuming cost is distributed uniformly. Value is used when DPL needs the cost of a 100% remedial investigation
NA	All	RI100 Dur	Mean value of the range of durations input by the decision maker for a 100% remedial investigation, assuming duration is distributed uniformly. Value is used when DPL needs the duration of a 100% remedial investigation
RI100_M1_Tot_Samples	All	NA	The total number of samples taken in medium one at the end of the 100% remedial investigation.
RI100_M1_Tot_Samples_woSI	PA	NA	The total number of samples taken in medium one at the end of the 100% remedial investigation, assuming no site investigation was completed.
RI100_M2_Tot_Samples	All	NA	The total number of samples taken in medium two at the end of the 100% remedial investigation.
RI100_M2_Tot_Samples_woSI	PA	NA	The total number of samples taken in medium two at the end of the 100% remedial investigation, assuming no site investigation was completed.
RI100_M3_Tot_Samples	All	NA	The total number of samples taken in medium three at the end of the 100% remedial investigation.
RI100_M3_Tot_Samples_woSI	PA	NA	The total number of samples taken in medium three at the end of the 100% remedial investigation, assuming no site investigation was completed.
RI100_T1_M1_Can_SE	All	NA	Standard error of the estimated risk from the type one contaminant in medium one using data from the 100% remedial investigation. Value is repeated for all 9 chemicals, not shown in table.

Table 9 Continued

Cell Name in Excel	Relevant Models	DPL Value Node Name	Definition
RI100_T1_M1_Can_SE_woSI	PA	NA	Standard error of the estimate of risk posed by the type one contaminant in medium one using data from the 100% remedial investigation, assuming a site investigation was not completed. Value is repeated for all 9 chemicals, not shown in table.
RI100_T1_M1_Haz_SE	All	NA	Standard error of the estimate of the hazard index from the type one contaminant in medium one using data from the 100% remedial investigation. Value is repeated for all 9 chemicals, not shown in table.
RI100_T1_M1_Haz_SE_woSI	PA	NA	Standard error of the estimate of the hazard index from the type one contaminant in medium one using data from the 100% remedial investigation, assuming a site investigation was not completed. Value is repeated for all 9 chemicals, not shown in table.
RI100_T1_M1_SE	All	NA	Standard error of the mean concentration of the type one contaminant in medium one using data from the 100% remedial investigation. Value is repeated for all 9 chemicals, not shown in table.
RI100_T1_M1_SE_woSI	PA	NA	Standard error of the mean concentration of the type one contaminant in medium one using data from the 100% remedial investigation, assuming a site investigation was not completed. Value is repeated for all 9 chemicals, not shown in table.
NA	PA, SI, RI30	RI30 Cost	Mean value of the range of costs input by the decision maker for a 30% remedial investigation, assuming cost is distributed uniformly. Value is used when DPL needs the cost of a 30% remedial investigation
NA	PA, SI, RI30	RI30 Dur	Mean value of the range of durations input by the decision maker for a 30% remedial investigation, assuming duration is distributed uniformly. Value is used when DPL needs the duration of a 30% remedial investigation

Table 9 Continued

Cell Name in Excel	Relevant Models	DPL Value Node Name	Definition
RI30_M1_Tot_Samples	PA, SI, RI30	NA	The total number of samples taken in medium one at the end of the 30% remedial investigation.
RI30_M1_Tot_Samples_woSI	PA	NA	The total number of samples taken in medium one at the end of the 30% remedial investigation, assuming no site investigation was completed.
RI30_M2_Tot_Samples	PA, SI, RI30	NA	The total number of samples taken in medium two at the end of the 30% remedial investigation.
RI30_M2_Tot_Samples_woSI	PA	NA	The total number of samples taken in medium two at the end of the 30% remedial investigation, assuming no site investigation was completed.
RI30_M3_Tot_Samples	PA, SI, RI30	NA	The total number of samples taken in medium three at the end of the 30% remedial investigation.
RI30_M3_Tot_Samples_woSI	PA	NA	The total number of samples taken in medium three at the end of the 30% remedial investigation, assuming no site investigation was completed.
RI30_T1_M1_Can_SE	PA, SI, RI30	NA	Standard error of the estimate of risk posed by the type one contaminant in medium one using data from the 30% remedial investigation. Value is repeated for all 9 chemicals, not shown in table.
RI30_T1_M1_Can_SE_woSI	PA	NA	Standard error of the estimate of risk posed by the type one contaminant in medium one using data from the 30% remedial investigation, assuming a site investigation was not completed. Value is repeated for all 9 chemicals, not shown in table.
RI30_T1_M1_Haz_SE	PA, SI, RI30	NA	Standard error of the estimate of the hazard index from the type one contaminant in medium one using data from the 30% remedial investigation. Value is repeated for all 9 chemicals, not shown in table.

Table 9 Continued

Cell Name in Excel	Relevant Models	DPL Value Node Name	Definition
RI30_T1_M1_Haz_SE_woSI	PA	NA	Standard error of the estimate of the hazard index from the type one contaminant in medium one using data from the 30% remedial investigation, assuming a site investigation was not completed. Value is repeated for all 9 chemicals, not shown in table.
RI30_T1_M1_SE	PA, SI, RI30	NA	Standard error of the mean concentration of the type one contaminant in medium one using data from the 30% remedial investigation. Value repeated for 9 chemicals, not shown in table.
RI30_T1_M1_SE_woSI	PA	NA	Standard error of the mean concentration of the type one contaminant in medium one using data from the 30% remedial investigation, assuming a site investigation was not completed. Value is repeated for all 9 chemicals, not shown in table.
NA	PA, SI, RI30, RI60	RI60 Cost	Mean value of the range of costs input by the decision maker for a 60% remedial investigation, assuming cost is distributed uniformly. Value used when DPL needs cost of a 60% remedial investigation
NA	PA, SI, RI30, RI60	RI60 Dur	Mean value of the range of durations input by the decision maker for a 60% remedial investigation, assuming duration is distributed uniformly. Value is used when DPL needs the duration of a 60% remedial investigation
RI60_M1_Tot_Samples	PA, SI, RI30, RI60	NA	The total number of samples taken in medium one at the end of the 60% remedial investigation.
RI60_M1_Tot_Samples_woSI	PA	NA	Total number of samples taken in medium one at the end of the 60% remedial investigation, assuming no site investigation was completed.
RI60_M2_Tot_Samples	PA, SI, RI30, RI60	NA	The total number of samples taken in medium two at the end of the 60% remedial investigation.
RI60_M2_Tot_Samples_woSI	PA	NA	Total number of samples taken in medium two at the end of the 60% remedial investigation, assuming no site investigation was completed.

Table 9 Continued

Cell Name in Excel	Relevant Models	DPL Value Node Name	Definition
RI60_M3_Tot_Samples	PA, SI, RI30, RI60	NA	The total number of samples taken in medium three at the end of the 60% remedial investigation.
RI60_M3_Tot_Samples_woSI	PA	NA	The total number of samples taken in medium three at the end of the 60% remedial investigation, assuming no site investigation was completed.
RI60_T1_M1_Can_SE	PA, SI, RI30, RI60	NA	Standard error of the estimate of risk posed by the type one contaminant in medium one using data from the 60% remedial investigation. Value is repeated for all 9 chemicals, not shown in table.
RI60_T1_M1_Can_SE_woSI	PA	NA	Standard error of the estimate of risk posed by the type one contaminant in medium one using data from the 60% remedial investigation, assuming a site investigation was not completed. Value is repeated for all 9 chemicals, not shown in table.
RI60_T1_M1_Haz_SE	PA, SI, RI30, RI60	NA	Standard error of the estimate of the hazard index from the type one contaminant in medium one using data from the 60% remedial investigation. Value is repeated for 9 chemicals, not shown in table.
RI60_T1_M1_Haz_SE_woSI	PA	NA	Standard error of the estimate of the hazard index from the type one contaminant in medium one using data from the 60% remedial investigation, assuming a site investigation was not completed. Value is repeated for all 9 chemicals, not shown in table.
RI60_T1_M1_SE	PA, SI, RI30, RI60	NA	Standard error of the mean concentration of the type one contaminant in medium one using data from the 60% remedial investigation. Value is repeated for all 9 chemicals, not shown in table.
RI60_T1_M1_SE_woSI	PA	NA	Standard error of the mean concentration of the type one contaminant in medium one using data from the 60% remedial investigation, assuming a site investigation was not completed. Value is repeated for all 9 chemicals, not shown in table.

Table 9 Continued

Cell Name in Excel	Relevant Models	DPL Value Node Name	Definition
NA	PA, SI	SI Cost	Mean value of the range of costs input by the decision maker for a site investigation, assuming cost is distributed uniformly. Value is used when DPL needs the cost of a site investigation
NA	PA, SI	SI Dur	Mean value of the range of durations input by the decision maker for a site investigation, assuming duration is distributed uniformly. Value is used when DPL needs the duration of a site investigation
SI_M1_Tot_Samples	PA, SI	NA	The total number of samples taken in medium one at the end of the site investigation.
SI_M2_Tot_Samples	PA, SI	NA	The total number of samples taken in medium two at the end of the site investigation.
SI_M3_Tot_samples	PA, SI	NA	The total number of samples taken in medium three at the end of the site investigation.
SI_T1_M1_Can_SE	PA, SI	NA	Standard error of the estimate of risk posed by the type one contaminant in medium one using data from the site investigation. Value is repeated for all 9 chemicals, not shown in table.
SI_T1_M1_Haz_SE	PA, SI	NA	Standard error of the estimate of the hazard index from the type one contaminant in medium one using data from the site investigation. Value is repeated for all 9 chemicals, not shown in table.
SI_T1_M1_SE	PA, SI	NA	Standard error of the mean concentration of the type one contaminant in medium one using data from the site investigation. Value is repeated for all 9 chemicals, not shown in table.
TI_M1_C_Can_Mult	All	NA	Cancer multiplier for the type one contaminant in medium one from the dermal contact exposure route. Includes all exposure and toxicity factors. Used to adjust the mean concentration to provide a value for the mean level of risk. Value is repeated for all 9 chemicals, not shown in table.

Table 9 Continued

Cell Name in Excel	Relevant Models	DPL Value Node Name	Definition
T1_M1_C_Haz_Mult	All	NA	Hazard multiplier for the type one contaminant in medium one from the dermal contact exposure route. Includes all exposure and toxicity factors. Used to adjust the mean concentration to provide a value for the mean hazard index. Value is repeated for all 9 chemicals, not shown in table.
T1_M1_Can_Mean	All	NA	Mean of the distribution of risk for the type one contaminant in medium one. Equivalent to the point estimate of the risk. Value is repeated for all 9 chemicals, not shown in table.
T1_M1_Can_Mult	All	NA	Total cancer multiplier for the type one contaminant in medium one. Sums the cancer multipliers across all three pathways for this chemical. Value is repeated for all 9 chemicals, not shown in table.
T1_M1_Haz_Mean	All	NA	Mean of the distribution of the hazard index for the type one contaminant in medium one. Equivalent to the point estimate of the hazard index. Value is repeated for all 9 chemicals, not shown in table.
T1_M1_Haz_Mult	All	NA	Total hazard multiplier for the type one contaminant in medium one. Sums the hazard multipliers across all three pathways for this chemical. Value is repeated for all 9 chemicals, not shown in table.
T1_M1_I_Can_Mult	All	NA	Cancer multiplier for the type one contaminant in medium one from the inhalation exposure route. Includes all exposure and toxicity factors. Used to adjust the mean concentration to provide a value for the mean level of risk. Value is repeated for all 9 chemicals, not shown in table.
T1_M1_I_Haz_Mult	All	NA	Hazard multiplier for the type one contaminant in medium one from the inhalation exposure route. Includes all exposure and toxicity factors. Used to adjust the mean concentration to provide a value for the mean hazard index. Value is repeated for all 9 chemicals, not shown in table.

Table 9 Continued

Cell Name in Excel	Relevant Models	DPL Value Node Name	Definition
T1_M1_O_Can_Mult	All	NA	Cancer multiplier for the type one contaminant in medium one from the ingestion exposure route. Includes all exposure and toxicity factors. Used to adjust the mean concentration to provide a value for the mean level of risk. Value is repeated for all 9 chemicals, not shown in table.
T1_M1_O_Haz_Mult	All	NA	Hazard multiplier for the type one contaminant in medium one from the ingestion exposure route. Includes all exposure and toxicity factors. Used to adjust the mean concentration to provide a value for the mean hazard index. Value is repeated for all 9 chemicals, not shown in table.
T1_M1_Rem_Can_Mult	All	NA	Total cancer multiplier for the type one contaminant in medium one after a removal action. Sums the cancer multipliers across all three pathways for this chemical. Value is repeated for all 9 chemicals, not shown in table.
T1_M1_Rem_Haz_Mult	All	NA	Mean of the distribution of the hazard index for the type one contaminant in medium one after a removal action. Equivalent to the point estimate of the hazard index. Value is repeated for all 9 chemicals, not shown in table.

NA indicates that the variable is not used in that portion of the model.

Table 10: Table of DPL Nodes Not Linked to Excel

DPL Node Name	Node Type	Relevant Models	Node Description/Function
Adj Exp Freq	Value	PA, SI, RI30, RI60	Dummy node representing the change in exposure frequency resulting from a removal action. Influenced by media node.
Feas Study Costs	Value	All	Contains the costs of the different alternatives from the feasibility study decision. Influenced by Feasibility Study decision node.
Feas Study Durations	Value	All	Contains the durations of the different alternatives from the feasibility study decision. Influenced by Feasibility Study decision node.
Feasibility Study	Decision	All	Contains the alternatives for the feasibility study which are investigate all options or use a presumptive remedy.
Measured Levels	Uncertainty	All	Dummy node representing the input of chemical concentrations. Influenced by media and type nodes.
Media	Uncertainty	All	Influences all media specific variables to reduce the number of nodes
PA Can Risk Probs	Uncertainty	PA	Contains the probabilities calculated in Excel on the magnitude of the cancer risk posed by each chemical using the data available after the preliminary assessment. Influenced by the media and type nodes.
PA Costs	Value	PA	Contains the costs for the alternatives from the preliminary assessment decision.
PA Durs	Value	PA	Contains the costs for the alternatives from the preliminary assessment decision.
PA Haz Indx Probs	Uncertainty	PA	Contains the probabilities calculated in Excel on the magnitude of the hazard index for each chemical using the data available after the preliminary assessment. Influenced by the media and type nodes.
PA NFA Cost	Uncertainty	PA	Contains the high and low values of the cost of taking no further action. Influenced by the PA Can Risk Probs node and the PA Haz Index Probs node.

Table 10 Continued

DPL Node Name	Node Type	Relevant Models	Node Description/Function
PA NFA Duration	Uncertainty	PA	Contains the high and low values of duration for taking no further action. Influenced by the PA Can Risk Probs and the PA Haz Index Probs nodes.
Prelim Assmt	Decision	PA	Contains the alternatives following a preliminary assessment. They include no further action, site investigation, removal action or 30% remedial investigation.
Rem Adj Mean	Value	PA, SI, RI30, RI60	Dummy node showing that the reduction in concentration resulting from a removal action is accounted for.
Rem Adj Std Error	Value	PA, SI, RI30, RI60	Dummy node showing that the additional samples taken as a result of a removal action are accounted for in the reduction of the standard error.
Rem Cleanup Goals Met	Uncertainty	PA, SI, RI30, RI60	Contains the probabilities of the cleanup technology not meeting the cleanup goals after a removal action. Influenced by the media and Rem Tech Approp nodes.
Rem CR Prob	Uncertainty	PA, SI, RI30, RI60	Contains the probabilities calculated in Excel on the magnitude of the cancer risk posed by each chemical using the data available after the removal action. Influenced by the media and type nodes.
Rem HI Prob	Uncertainty	PA, SI, RI30, RI60	Contains the probabilities calculated in Excel on the magnitude of the hazard index for each chemical using the data available after the removal action. Influenced by the media and type nodes.
Rem NFA Cost	Uncertainty	PA, SI, RI30, RI60	Contains the high and low values of the cost of taking no further action. Influenced by the Rem CR Prob node and the Rem HI Prob node.
Rem NFA Duration	Uncertainty	PA, SI, RI30, RI60	Contains the high and low values of duration for taking no further action. Influenced by the Rem CR Prob and the Rem HI Prob nodes.
Rem Site Siim Report	Uncertainty	PA, SI, RI30, RI60	Contains the probabilities associated with the quality of information about the true site similarity after completion of a removal action. Influenced by the True Site Similarity node.

Table 10 Continued

DPL Node Name	Node Type	Relevant Models	Node Description/Function
Rem Tech Approp	Uncertainty	PA, SI, RI30, RI60	Contains the probabilities of the cleanup technology chosen after a removal not being unable to meet the cleanup goals regardless of the system modifications. Influenced by the Feasibility Study decision node, the true site similarity node and the media node.
Remediation Cost	Uncertainty	All	Contains the costs associated with remediation of each medium. Assumes a continuous uniform distribution of cost between the upper and lower limits input by the user. Influenced by the media node.
Remediation Duration	Uncertainty	All	Contains the durations associated with remediation of each medium. Assumes a continuous uniform distribution of duration between the upper and lower limits input by the user. Influenced by the media node.
Removal Action	Decision	PA, SI, RI30, RI60	Contains the alternatives following a removal action, which are taking no further action or proceeding to a feasibility study.
Removal Cost	Uncertainty	PA, SI, RI30, RI60	Contains the costs associated with a removal action in each medium. Assumes a continuous uniform distribution of cost between the upper and lower limits input by the user. Influenced by the media node.
Removal Costs	Value	PA, SI, RI30, RI60	Contains the costs for the alternatives from the removal action decision. Influenced by the Removal Action node.
Removal Duration	Uncertainty	PA, SI, RI30, RI60	Contains the durations associated with a removal action in each medium. Assumes a continuous uniform distribution of duration between the upper and lower limits input by the user. Influenced by the media node.
Removal Durs	Value	PA, SI, RI30, RI60	Contains the durations for the alternatives from the removal action decision. Influenced by the Removal Action node.
RI 100%	Decision	All	Contains the alternatives following a 100% remedial investigation, which are taking no further action or proceeding to a feasibility study.
RI 30%	Decision	PA, SI, RI30	Contains the alternatives following a 30% remedial investigation, which are taking no further action or proceeding to a feasibility study, a removal action or proceeding with a 60% remedial investigation.

Table 10 Continued

DPL Node Name	Node Type	Relevant Models	Node Description/Function
RI 60%	Decision	PA, SI, RI30, RI60	Contains the alternatives following a 60% remedial investigation, which are taking no further action or proceeding to a feasibility study, a removal action or proceeding with a 100% remedial investigation.
RI100 Adj Std Error	Value	All	Dummy node showing that the additional samples taken as a result of a 100% remedial investigation are accounted for in the reduction of the standard error.
RI100 Cleanup Goals Met	Uncertainty	All	Contains the probabilities of the cleanup technology not meeting the cleanup goals after a 100% remedial investigation. Influenced by the media and RI100 Tech Approp nodes.
RI100 Costs	Value	All	Contains the costs for the alternatives from the 100% remedial investigation decision. Influenced by the RI 100% node.
RI100 CR Prob	Uncertainty	All	Contains the probabilities calculated in Excel on the magnitude of the cancer risk posed by each chemical using the data available after the 100% remedial investigation. Influenced by the media and type nodes.
RI100 CR Prob w/o SI	Uncertainty	PA	Contains the probabilities calculated in Excel on the magnitude of the cancer risk posed by each chemical using the data available after the 100% remedial investigation, assuming no site investigation was completed. Influenced by the media and type nodes.
RI100 Durs	Value	All	Contains the durations for the alternatives from the 100% remedial investigation decision. Influenced by the RI 100% node.
RI100 HI Prob	Uncertainty	All	Contains the probabilities calculated in Excel on the magnitude of the hazard index for each chemical using the data available after the 100% remedial investigation. Influenced by the media and type nodes.
RI100 HI Prob w/o SI	Uncertainty	PA	Contains the probabilities calculated in Excel on the magnitude of the hazard index for each chemical using the data available after the 100% remedial investigation, assuming no site investigation was completed. Influenced by the media and type nodes.

Table 10 Continued

DPL Node Name	Node Type	Relevant Models	Node Description/Function
RI100 NFA Cost	Uncertainty	All	Contains the high and low values of the cost of taking no further action. Influenced by the RI100 CR Prob node and the RI100 HI Prob node.
RI100 NFA Cost w/o SI	Uncertainty	PA	Contains the high and low values of the cost of taking no further action. Influenced by the RI100 CR Prob w/o SI node and the RI100 HI Prob w/o SI node.
RI100 NFA Dur w/o SI	Uncertainty	PA	Contains the high and low values of the duration associated with taking no further action. Influenced by the RI100 CR Prob w/o SI node and the RI100 HI Prob w/o SI node.
RI100 NFA Duration	Uncertainty	All	Contains the high and low values of the duration associated with taking no further action. Influenced by the RI100 CR Prob node and the RI100 HI Prob node.
RI100 Site Sim Report	Uncertainty	All	Contains the probabilities associated with the quality of information about the true site similarity after completion of a 100% remedial investigation. Influenced by the True Site Similarity node.
RI100 Tech Approp	Uncertainty	All	Contains the probabilities of the cleanup technology chosen after a 100% remedial investigation not being unable to meet the cleanup goals regardless of the system modifications. Influenced by the Feasibility Study decision node, the true site similarity node and the media node.
RI30 Adj Std Error	Value	PA, SI, RI30	Dummy node showing that the additional samples taken as a result of a 30% remedial investigation are accounted for in the reduction of the standard error.
RI30 Cleanup Goals Met	Uncertainty	PA, SI, RI30	Contains the probabilities of the cleanup technology not meeting the cleanup goals after a 30% remedial investigation. Influenced by the media and RI30 Tech Approp nodes.
RI30 Costs	Value	PA, SI, RI30	Contains the costs for the alternatives from the 30% remedial investigation decision. Influenced by the RI 30% node.

Table 10 Continued

DPL Node Name	Node Type	Relevant Models	Node Description/Function
RI30 CR Prob	Uncertainty	PA, SI, RI30	Contains the probabilities calculated in Excel on the magnitude of the cancer risk posed by each chemical using the data available after the 30% remedial investigation. Influenced by the media and type nodes.
RI30 CR Prob w/o SI	Uncertainty	PA	Contains the probabilities calculated in Excel on the magnitude of the cancer risk posed by each chemical using the data available after the 30% remedial investigation, assuming no site investigation was completed. Influenced by the media and type nodes.
RI30 Durs	Value	PA, SI, RI30	Contains the durations for the alternatives from the 30% remedial investigation decision. Influenced by the RI 30% node.
RI30 HI Prob	Uncertainty	PA, SI, RI30	Contains the probabilities calculated in Excel on the magnitude of the hazard index for each chemical using the data available after the 30% remedial investigation. Influenced by the media and type nodes.
RI30 HI Prob w/o SI	Uncertainty	PA	Contains the probabilities calculated in Excel on the magnitude of the hazard index for each chemical using the data available after the 30% remedial investigation, assuming no site investigation was completed. Influenced by the media and type nodes.
RI30 NFA Cost	Uncertainty	PA, SI, RI30	Contains the high and low values of the cost of taking no further action. Influenced by the RI30 CR Prob node and the RI30 HI Prob node.
RI30 NFA Cost w/o SI	Uncertainty	PA	Contains the high and low values of the cost of taking no further action. Influenced by the RI30 CR Prob w/o SI node and the RI30 HI Prob w/o SI node.
RI30 NFA Dur w/o SI	Uncertainty	PA	Contains the high and low values of the duration associated with taking no further action. Influenced by the RI30 CR Prob w/o SI node and the RI30 HI Prob w/o SI node.
RI30 NFA Duration	Uncertainty	PA, SI, RI30	Contains the high and low values of the duration associated with taking no further action. Influenced by the RI30 CR Prob node and the RI30 HI Prob node.

Table 10 Continued

DPL Node Name	Node Type	Relevant Models	Node Description/Function
RI30 Site Sim Report	Uncertainty	PA, SI, RI30	Contains the probabilities associated with the quality of information about the true site similarity after completion of a 30% remedial investigation. Influenced by the True Site Similarity node.
RI30 Tech Approp	Uncertainty	PA, SI, RI30	Contains the probabilities of the cleanup technology chosen after a 30% remedial investigation not being unable to meet the cleanup goals regardless of the system modifications. Influenced by the Feasibility Study decision node, the true site similarity node and the media node.
RI60 Adj Std Error	Value	PA, SI, RI30, RI60	Dummy node showing that the additional samples taken as a result of a 60% remedial investigation are accounted for in the reduction of the standard error.
RI60 Cleanup Goals Met	Uncertainty	PA, SI, RI30, RI60	Contains the probabilities of the cleanup technology not meeting the cleanup goals after a 60% remedial investigation. Influenced by the media and RI60 Tech Approp nodes.
RI60 Costs	Value	PA, SI, RI30, RI60	Contains the costs for the alternatives from the 60% remedial investigation decision. Influenced by the RI 60% node.
RI60 CR Prob	Uncertainty	PA, SI, RI30, RI60	Contains the probabilities calculated in Excel on the magnitude of the cancer risk posed by each chemical using the data available after the 60% remedial investigation. Influenced by the media and type nodes.
RI60 CR Prob w/o SI	Uncertainty	PA	Contains the probabilities calculated in Excel on the magnitude of the cancer risk posed by each chemical using the data available after the 60% remedial investigation, assuming no site investigation was completed. Influenced by the media and type nodes.
RI60 Durs	Value	PA, SI, RI30, RI60	Contains the durations for the alternatives from the 60% remedial investigation decision. Influenced by the RI 60% node.
RI60 HI Prob	Uncertainty	PA, SI, RI30, RI60	Contains the probabilities calculated in Excel on the magnitude of the hazard index for each chemical using the data available after the 60% remedial investigation. Influenced by the media and type nodes.

Table 10 Continued

DPL Node Name	Node Type	Relevant Models	Node Description/Function
RI60 HI Prob w/o SI	Uncertainty	PA	Contains the probabilities calculated in Excel on the magnitude of the hazard index for each chemical using the data available after the 60% remedial investigation, assuming no site investigation was completed. Influenced by the media and type nodes.
RI60 NFA Cost	Uncertainty	PA, SI, RI30, RI60	Contains the high and low values of the cost of taking no further action. Influenced by the RI60 CR Prob node and the RI60 HI Prob node.
RI60 NFA Cost w/o SI	Uncertainty	PA	Contains the high and low values of the cost of taking no further action. Influenced by the RI60 CR Prob w/o SI node and the RI60 HI Prob w/o SI node.
RI60 NFA Dur w/o SI	Uncertainty	PA	Contains the high and low values of the duration associated with taking no further action. Influenced by the RI60 CR Prob w/o SI node and the RI60 HI Prob w/o SI node.
RI60 NFA Duration	Uncertainty	PA, SI, RI30, RI60	Contains the high and low values of the duration associated with taking no further action. Influenced by the RI60 CR Prob node and the RI60 HI Prob node.
RI60 Site Sim Report	Uncertainty	PA, SI, RI30, RI60	Contains the probabilities associated with the quality of information about the true site similarity after completion of a 60% remedial investigation. Influenced by the True Site Similarity node.
RI60 Tech Approp	Uncertainty	PA, SI, RI30, RI60	Contains the probabilities of the cleanup technology chosen after a 60% remedial investigation not being unable to meet the cleanup goals regardless of the system modifications. Influenced by the Feasibility Study decision node, the true site similarity node and the media node.
SI Adj Std Error	Value	PA, SI	Dummy node showing that the additional samples taken as a result of a site investigation are accounted for in the reduction of the standard error.
SI Costs	Value	PA, SI	Contains the costs for the alternatives from the site investigation decision. Influenced by the Site Invest node.

Table 10 Continued

DPL Node Name	Node Type	Relevant Models	Node Description/Function
SI Durs	Value	PA, SI	Contains the durations for the alternatives from the site investigation decision. Influenced by the Site Invest node.
SI HI Probs	Uncertainty	PA, SI	Contains the probabilities calculated in Excel on the magnitude of the hazard index for each chemical using the data available after the site investigation. Influenced by the media and type nodes.
SI NFA Cost	Uncertainty	PA, SI	Contains the high and low values of the cost of taking no further action. Influenced by the SI CR Prob node and the SI HI Prob node.
SI NFA Duration	Uncertainty	PA, SI	Contains the high and low values of the duration associated with taking no further action. Influenced by the SI CR Prob node and the SI HI Prob node.
Site Investigation	Decision	PA, SI	Contains the alternatives following a site investigation, which are taking no further action or a removal action or proceeding with a 30% remedial investigation.
Total Cost	Value	All	Dummy node representing the total cost of each possible outcome.
Total Dur	Value	All	Dummy node representing the total duration of each possible outcome.
True Site Similarity	Uncertainty	All	Contains the true probabilities that the site is similar to another previously remediated site.
Type	Uncertainty	All	Influences all chemical specific variables to reduce the number of nodes
Value	Value	All	Dummy node representing the combination of the total cost and total duration to arrive at a utility value.

Appendix B: List of Acronyms

Å	angstrom
ARAR	Applicable, Relevant and Appropriate Requirements
atm	atmospheres
Can	Carcinogenic
CDF	Cumulative Distribution Function
CERCLA	Comprehensive Environmental Response Compensation and Liability Act
CFR	Code of Federal Regulations
CLT	Central Limit Theorem
cm ²	square centimeter
cm ² /s	centimeter squared per second
DDE	Dynamic Data Exchange
DOD	Department of Defense
DQO	Data Quality Objectives
Dur	Duration
EPA	United States Environmental Protection Agency
Feas Study	Feasibility Study
FS	Feasibility Study
g	given
Haz	Hazard, refers to noncarcinogenic effects
HR	House of Representatives
HRS	Hazard Ranking System
IRIS	Integrated Risk Information System
IRP	Installation Restoration Program
kg	kilogram
L	liter
m	meter
m/s	meter per second
m ³	cubic meter
Max	Maximum
MCL	Maximum Contaminant Level
mg	milligram
Min	Minimum
mol	mole
NCP	National Contingency Plan
NFA	No Further Action
NFRAP	No Further Response Action Plan
NOAEL	No Observable Adverse Effect Level
NPL	National Priorities List
NRC	National Research Council
O&M	Operations and Maintenance
OU2	Operable Unit Two
P	Probability

PA	Preliminary Assessment
PEF	Particulate Emission Factor
PM ₁₀	Particulate Emission less than or equal to 10 microns in diameter
ppm	part per million
PRP	Principle Responsible Party
RD	Remedial Design
Rem	Removal
Remed	Remediation
RfD	Reference Dose
RI/FS	Remedial Investigation and Feasibility Study
RI100	100 Percent Remedial Investigation
RI30	30 Percent Remedial Investigation
RI60	60 Percent Remedial Investigation
RME	Reasonable Maximum Exposure
ROD	Record of Decision
s	second
SACM	Superfund Accelerated Cleanup Model
SARA	Superfund Amendments and Reauthorization Act
SI	Site Investigation
SITE	Superfund Innovative Technology Evaluation
TA	Technically Acceptable
WPAFB	Wright-Patterson Air Force Base
yr	year

Appendix C: Molecular Diffusivity Constants

Table 11 in this appendix contains chemical specific values for molecular diffusivity, D_i (Pannwitz, 1984:5-7), Henry's law constant, H (USEPA, 1994:Appendix A), and the soil-water partition coefficient, K_d (USEPA, 1994:Appendix A), used in Equation (3).

Table 11: Chemical Constants

Chemical Name	D_i (cm ² /s)	K_d (cm ³ /g)	H (atm-m ³ /mol)
Acetone	0.1049	2.7	3.9E-5
Acetonitrile	0.1181	-	2.0E-5
Acrylonitrile	0.1059	1.4	1.1E-4
Amyl alcohol iso-	0.0728	-	-
Benzene	0.0859	4.7	5.6E-3
Bromoethane	0.0859	-	-
Bromomethane	0.1096	1.6E+1	6.2E-3
butadiene 1,3-	0.1015	-	7.4E-2
butanol n-	0.0861	1.1E+1	8.8E-6
butanol sec-	0.0897	-	-
butanol tert-	0.0873	-	-
butoxyethanol 2-	0.0634	-	-
butyl acetate iso-	0.0690	-	-
butyl acetate n-	0.0672	-	-
butyl formiate iso-	0.0722	-	-
butyl toluene p-tert-	0.0571	-	-
Camphor	0.0547	-	-
Carbon disulphide	0.1013	5.9E+1	3.0E-2
chloro-1,3-butadiene 2-	0.0831	-	-
chloro-2,3-epoxypropane 1-	0.0824	-	-
chloro-ethanol 2-	0.0891	-	-
Chlorobenzene	0.0747	4.2E+1	3.8E-3
Chlorobromomethane	0.0953	-	-
Chloroethane	0.1036	-	-
Chloroform	0.0888	-	-
chloropropene 3-	0.0975	-	-
chlorotoluene α -	0.0713	-	-
Cyclohexane	0.0744	-	2.0E-1
Cyclohexanol	0.0681	-	-
Cyclohexanone	0.0802	-	8.4E-6
Cyclohexene	0.0763	-	-
dibromoethane 1,2-	0.0826	-	7.4E-4
dichloro-1,1,2,2-tetrafluoroethane 1,2-	0.0789	-	-
dichlorobenzene 1,2-	0.0668	4.3E+1	1.9E-3
dichlorobenzene 1,4-	0.0670	9.1E+1	2.4E-3
dichlorodiethyl 2,2'-	0.0694	-	-
Dichlorodifluoromethane	0.0958	3.0E+1	3.4E-1

Table 11: Chemical Constants Continued

Chemical Name	D_i (cm ² /s)	K_d (cm ³ /g)	H (atm-m ³ /mol)
dichloroethane 1,1-	0.0919	6.1	5.6E-3
dichloroethane 1,2-	0.0907	4.9	9.8E-4
dichloroethene 1,1-	0.0918	5.2E+1	2.6E-2
dichloroethene 1,2-	0.0911	-	-
Dichlorofluormethane	0.0972	-	-
dichloropropane 1,2-	0.0765	4.1	2.8E-3
Difluorodibromomethane	0.0840	-	-
Diisopropyl ether	0.0683	-	-
Dimethoxy methane	0.0886	-	-
dimethyl heptane-4-one 2,6-	0.0565	-	-
dioxane 1,4-	0.0922	2.6	4.8E-6
Diphenyl ether	0.0524	-	-
epoxypropane 1,2-	0.0989	-	-
Ethanol	0.1181	-	-
ethoxyethyl acetate 2-	0.0610	-	-
Ethyl acetate	0.0861	1.3	1.4E-4
Ethyl acrylate	0.0736	-	-
Ethyl benzene	0.0693	3.8E+1	8.4E-3
Ethyl ether	0.0918	-	-
Ethyl formiate	0.0976	-	-
Ethyl propionate	0.0722	-	-
Ethylene glycol monoethyl ether	0.0788	3.2	1.2E-7
Ethylene oxide	0.1195	-	-
Glycidol	0.0853	-	-
Halothane	0.0760	-	-
heptane n-	0.0664	-	-
heptanone 2-	0.0643	-	-
heptanone 3-	0.0644	-	-
heptanone 4-	0.0645	-	-
Hexachloroethane	0.0608	3.3E+2	3.9E-3
hexane n-	0.0732	-	1.4E-2
hexanone 2-	0.0946	-	-
Hexone	0.0702	-	-
hydroxy-4-methyl-pentane-2-one 4-	0.0674	-	-
Methacrylic acid methyl ester	0.0741	-	-
methoxy ethanol 2-	0.0845	-	-
methoxy ethyl acetate 2-	0.0686	-	-
Methyl acetate	0.0978	-	-

Table 11: Chemical Constants Continued

Chemical Name	D_i (cm ² /s)	K_d (cm ³ /g)	H (atm-m ³ /mol)
Methyl acrylate	0.0823	-	-
Methyl cyclohexane	0.0679	-	-
Methyl cyclohexanol	0.0845	-	-
Methyl ethyl ketone	0.0903	7.9E-1	5.6E-5
Methyl iodide	0.0965	-	-
Methyl propionate	0.0809	-	-
Methyl styrene	0.0651	-	-
methyl-pent-3-ene-2-one 4-	0.0760	-	-
methyl-pentane-2-ol 4-	0.0672	-	-
Methylene Chloride	0.1037	-	2.2E-3
Naphthaline	0.0650	-	4.8E-4
nitropropane 1-	0.0808	-	-
octane n-	0.0616	-	-
pentane n-	0.0842	-	-
Pentane-2-one	0.0793	-	-
Pentyl acetate	0.0610	-	-
Propyl acetate	0.0768	-	-
propyl alcohol n-	0.0993	-	-
propyl benzene iso-	0.0677	-	-
Propyl formiate	0.0798	-	-
Pyridine	0.0858	7.6E-1	8.9E-6
Styrene	0.0701	1.4E+2	2.8e-3
tetrachloro-1,2-difluoroethane 1,1,2,2-	0.0682	-	-
tetrachloroethane 1,1,2,2-	0.0722	1.2E+1	4.6E-4
Tetrachloroethene	0.0797	3.6E+1	1.8E-2
Tetrachloromethane	0.0828	-	-
Tetrahydrofuran	0.0933	-	2.4E-4
Toluene	0.0763	1.4E+1	6.6E-3
Tribromomethane	0.0767	7.9	5.4E-4
trichloro-1,2,2-trifluoroethane 1,1,2-	0.0730	-	-
trichloroethane 1,1,1-	0.0794	2.7E+1	1.7E-2
trichloroethane 1,1,2-	0.0792	1.2E+1	9.1E-4
Trichloroethylene	0.0875	-	1.0E-2
Trichlorofluoromethane	0.0858	1.4E+1	9.7E-2
Trichloromethane	0.0888	-	-
trichloropropane 1,2,3-	0.0688	1.1E+1	3.4E-4
Trimethyl-2-cyclohexene-1-one 3,5,5-	0.0602	-	-
xylene m-	0.0670	2.5E+1	7.2E-3
xylene o-	0.0727	2.0E+1	5.2E-3
xylene p-	0.0672	4.0E+1	7.6E-3

Appendix D: Influence Diagrams for the Five Models Developed

This appendix contains the influence diagrams for all five models developed in this thesis. It also contains a representative decision tree. The input nodes and the calculated value nodes for the influence diagrams are not shown. Figure 49 contains a reduced version of the preliminary assessment model's decision tree. Figures 47 through 50 contain blow up of the different sections presented in Figure 49. The other models contain identical decision trees except that sections of the tree occurring prior to the decision at hand are deleted.

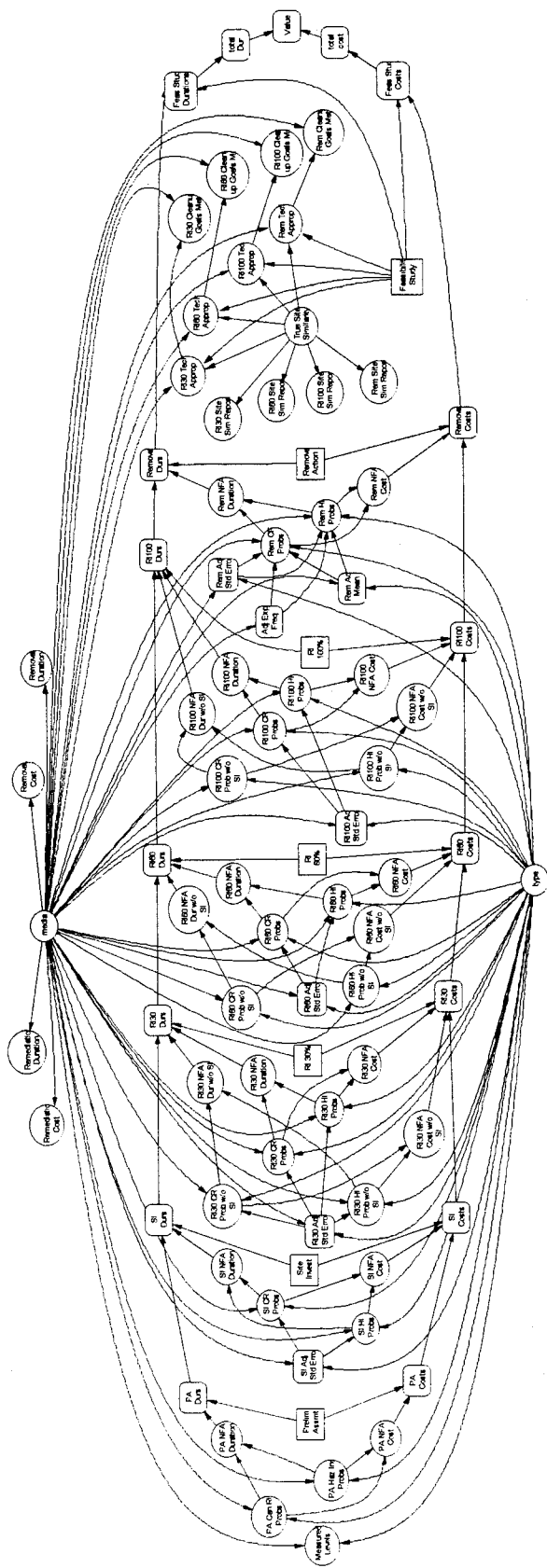

Figure 44: Preliminary Assessment Model Influence Diagram

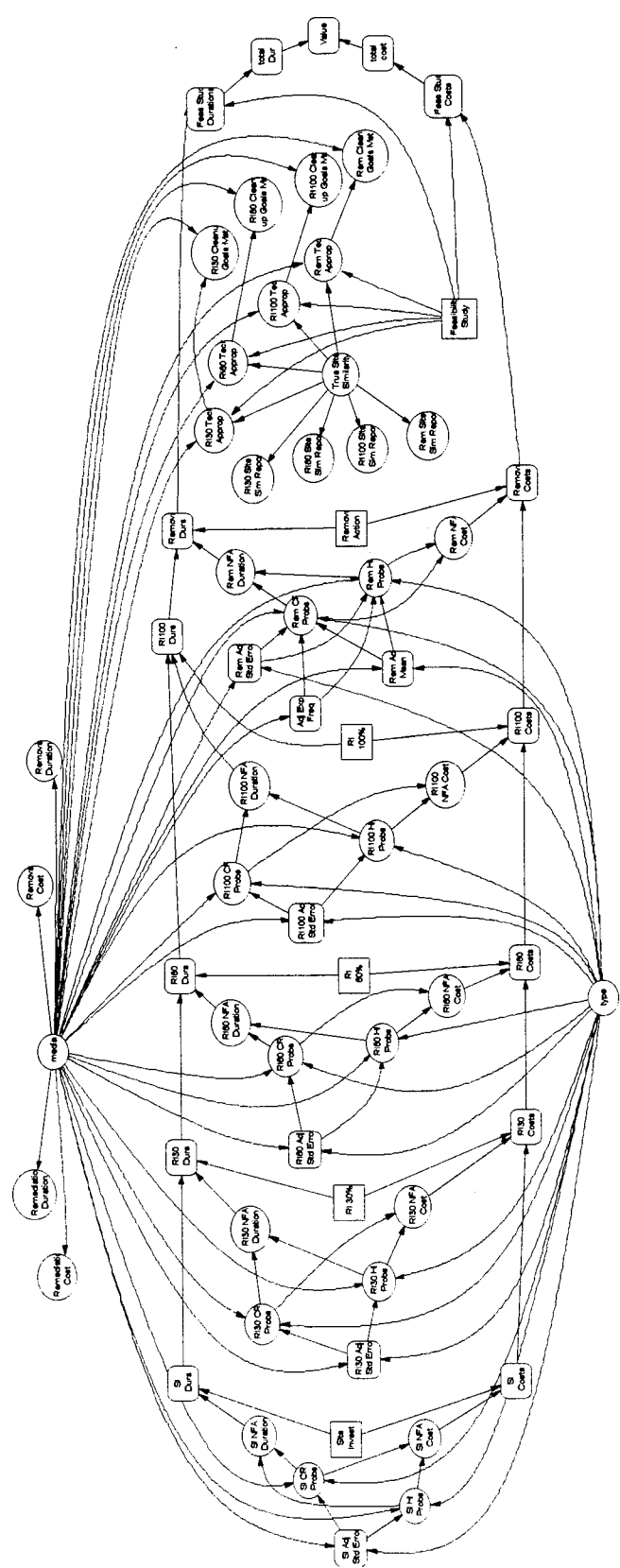

Figure 45: Site Investigation Model Influence Diagram

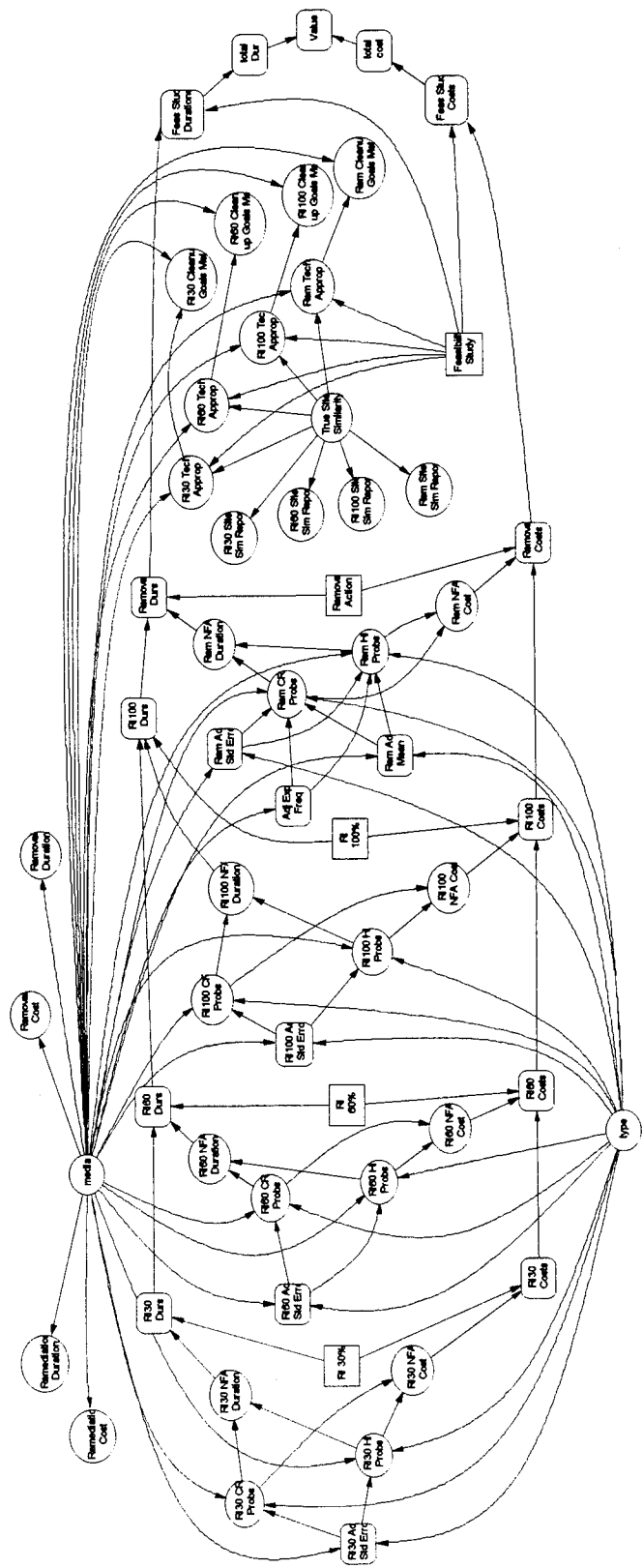

Figure 46: 30% Remedial Investigation Model Influence Diagram

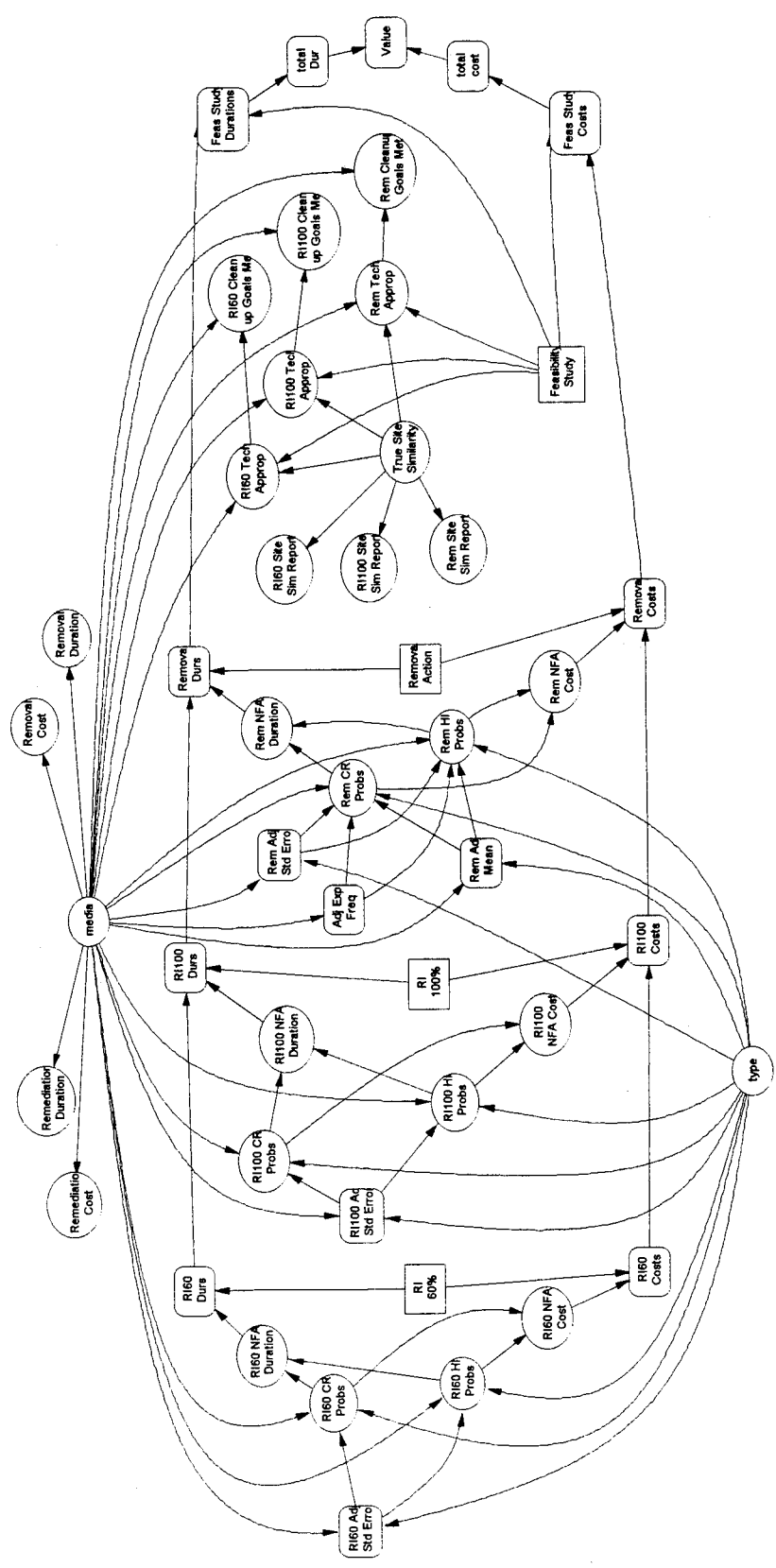

Figure 47: 60% Remedial Investigation Model Influence Diagram

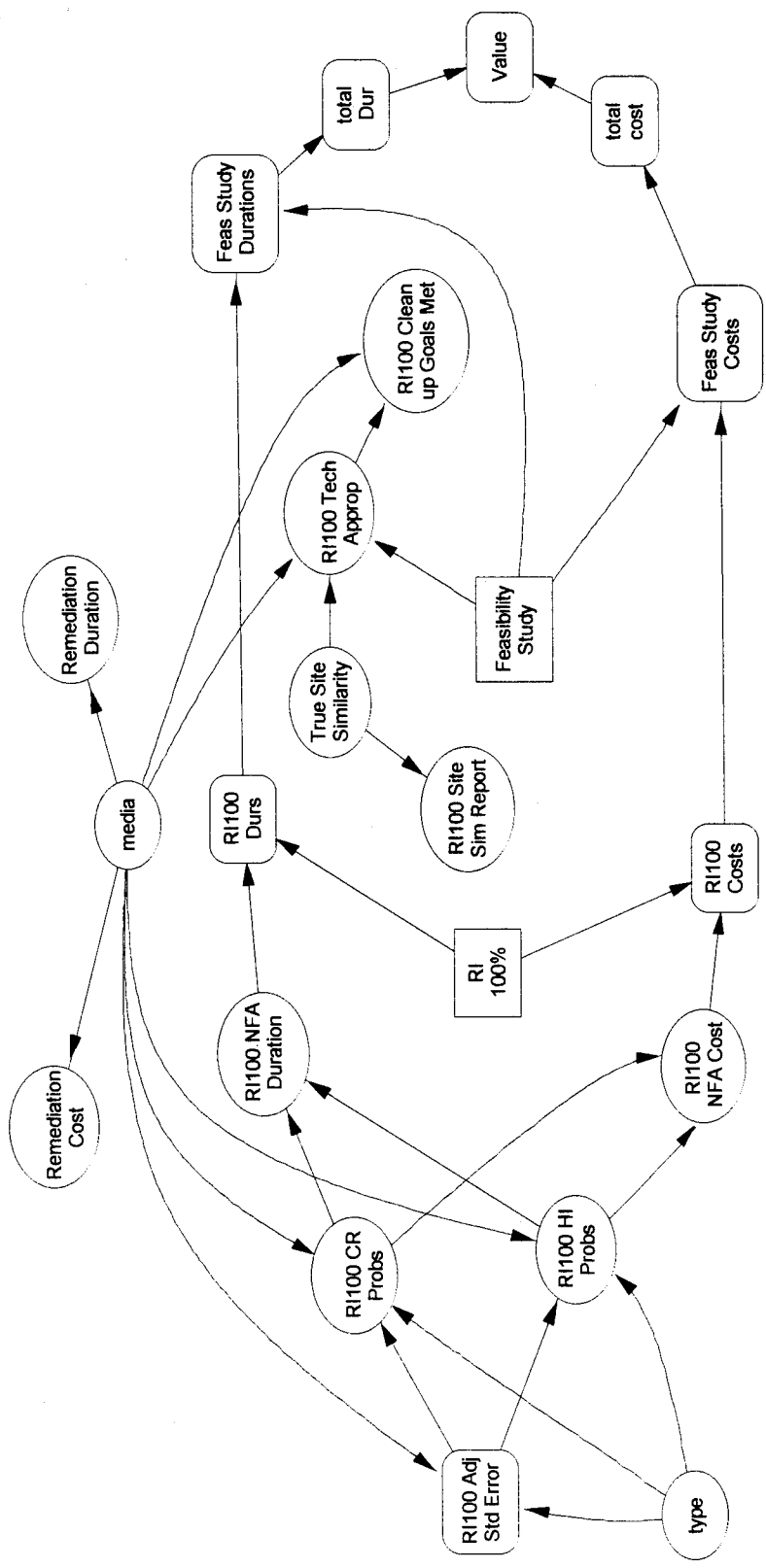

Figure 48: 100% Remedial Investigation Model Influence Diagram

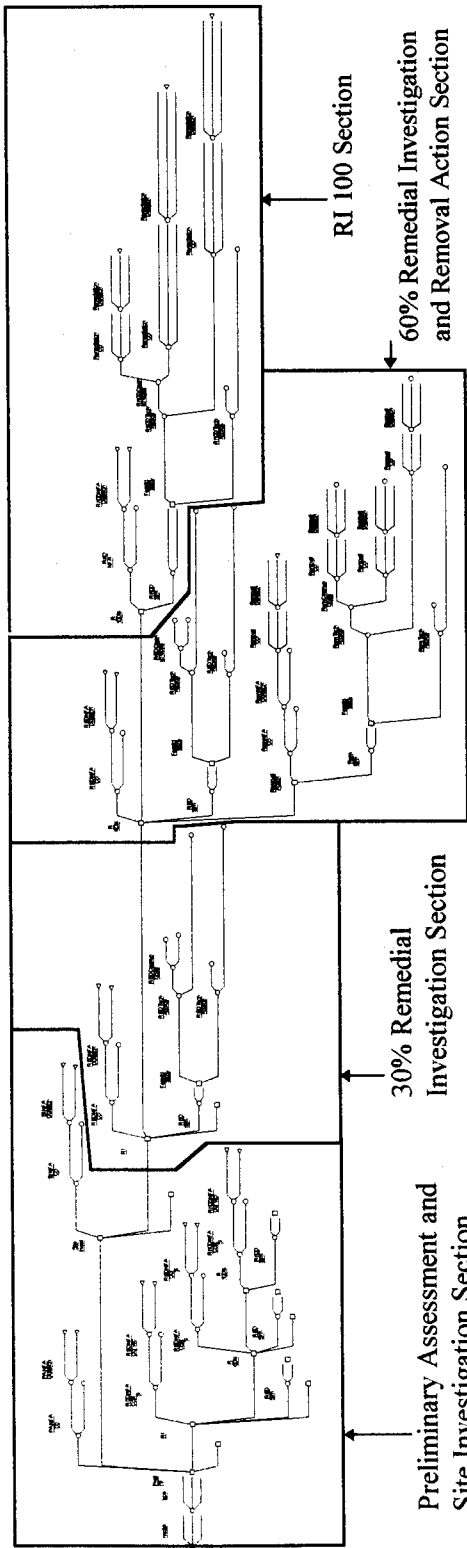

Figure 49: Complete Decision Tree Starting At the Preliminary Assessment

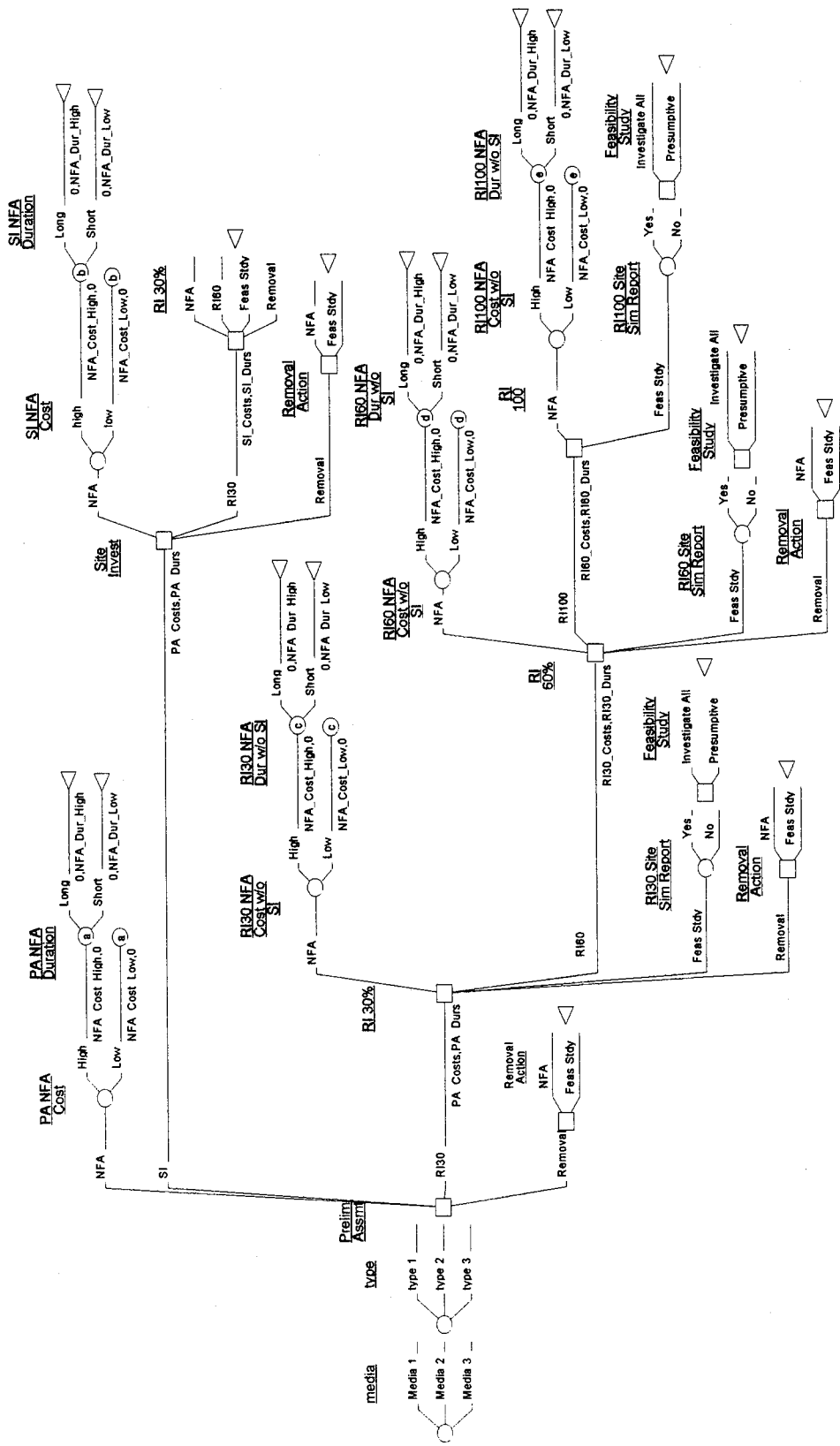

Figure 50: Preliminary Assessment and Site Investigation Section

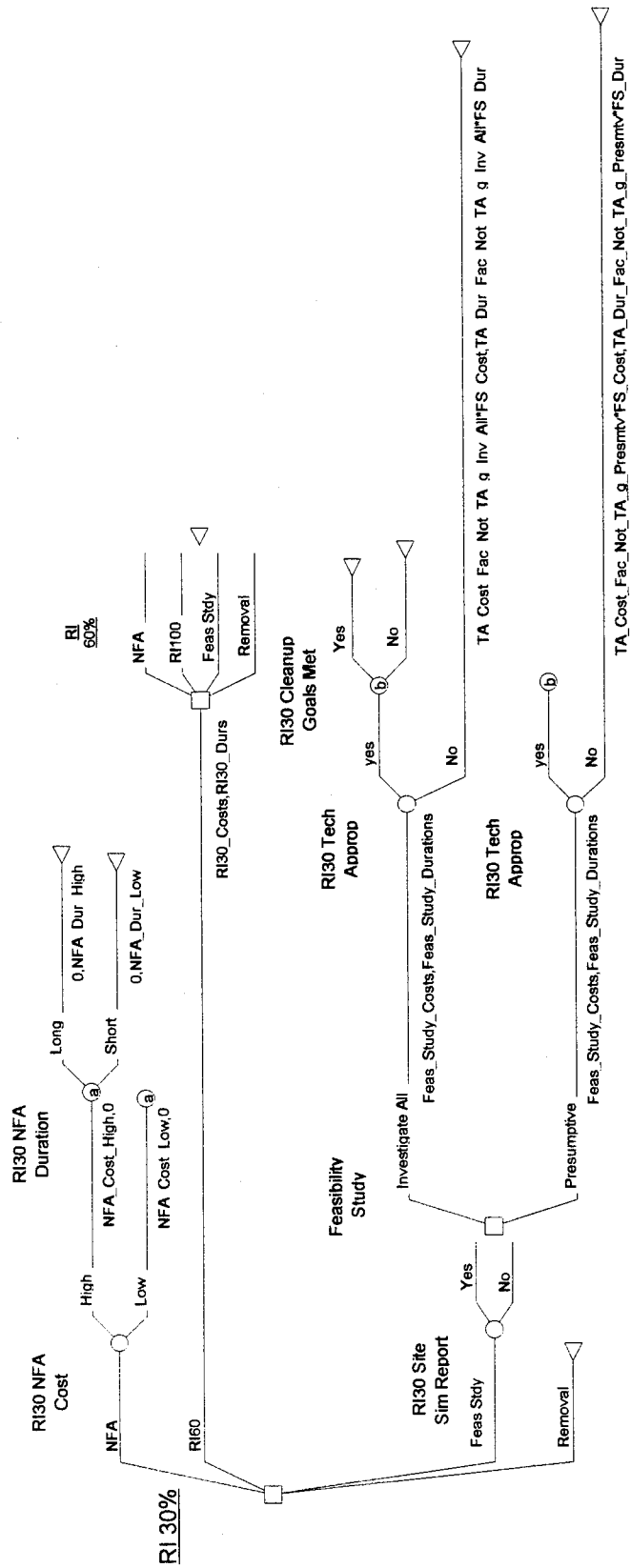

Figure 51: 30% Remedial Investigation Section

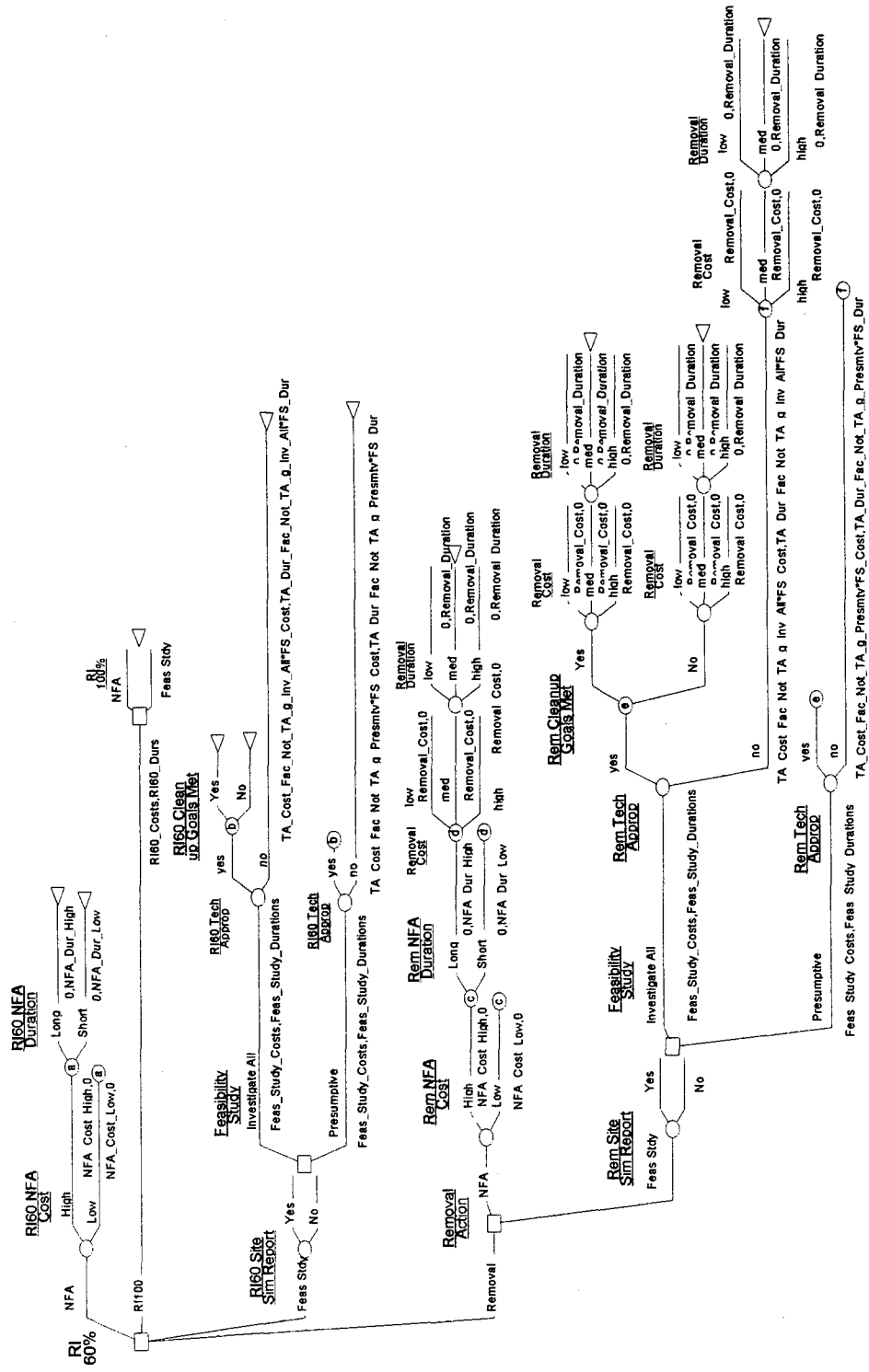

Figure 52: 60% Remedial Investigation and Removal Action Section

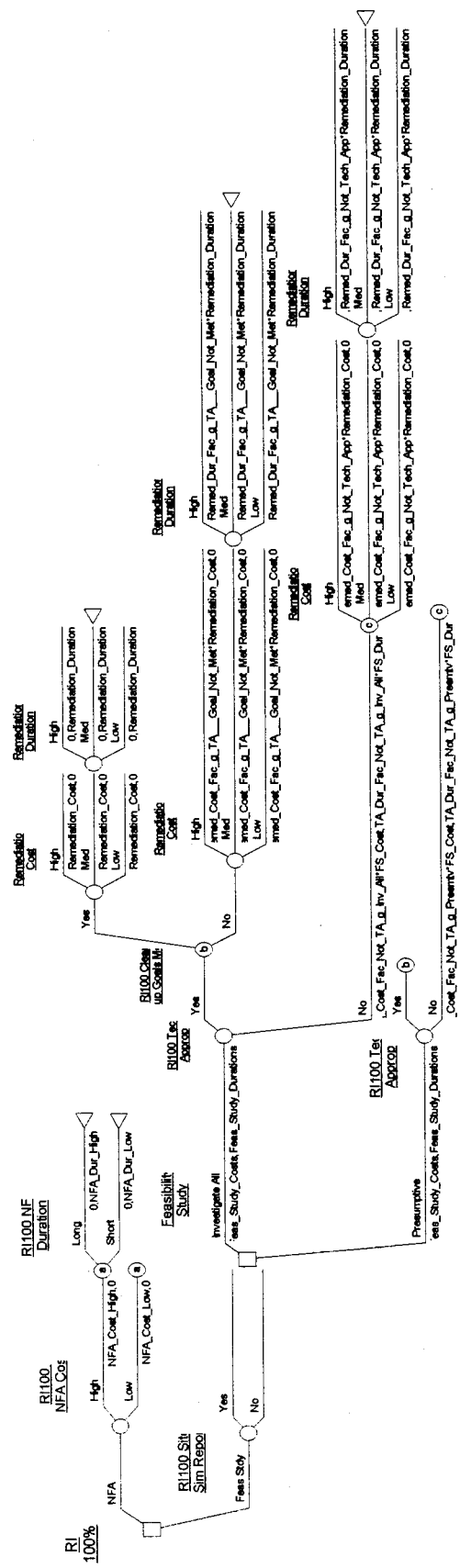

Figure 53: 100% Remedial Investigation Section

Appendix E: Summary Results of the Sensitivity Analysis

This appendix presents the tornado diagrams for each of the four model runs evaluated in the thesis. For each variable evaluated the tornado diagrams show the relative amount each variable changed the expected value of the model by displaying a bar. If the variable changed the decision the bar will have be shaded. If the expected utility changed as a result of varying the value of the parameter the diagram will also show the range over which the variable was evaluated and the expected utility at the end points.

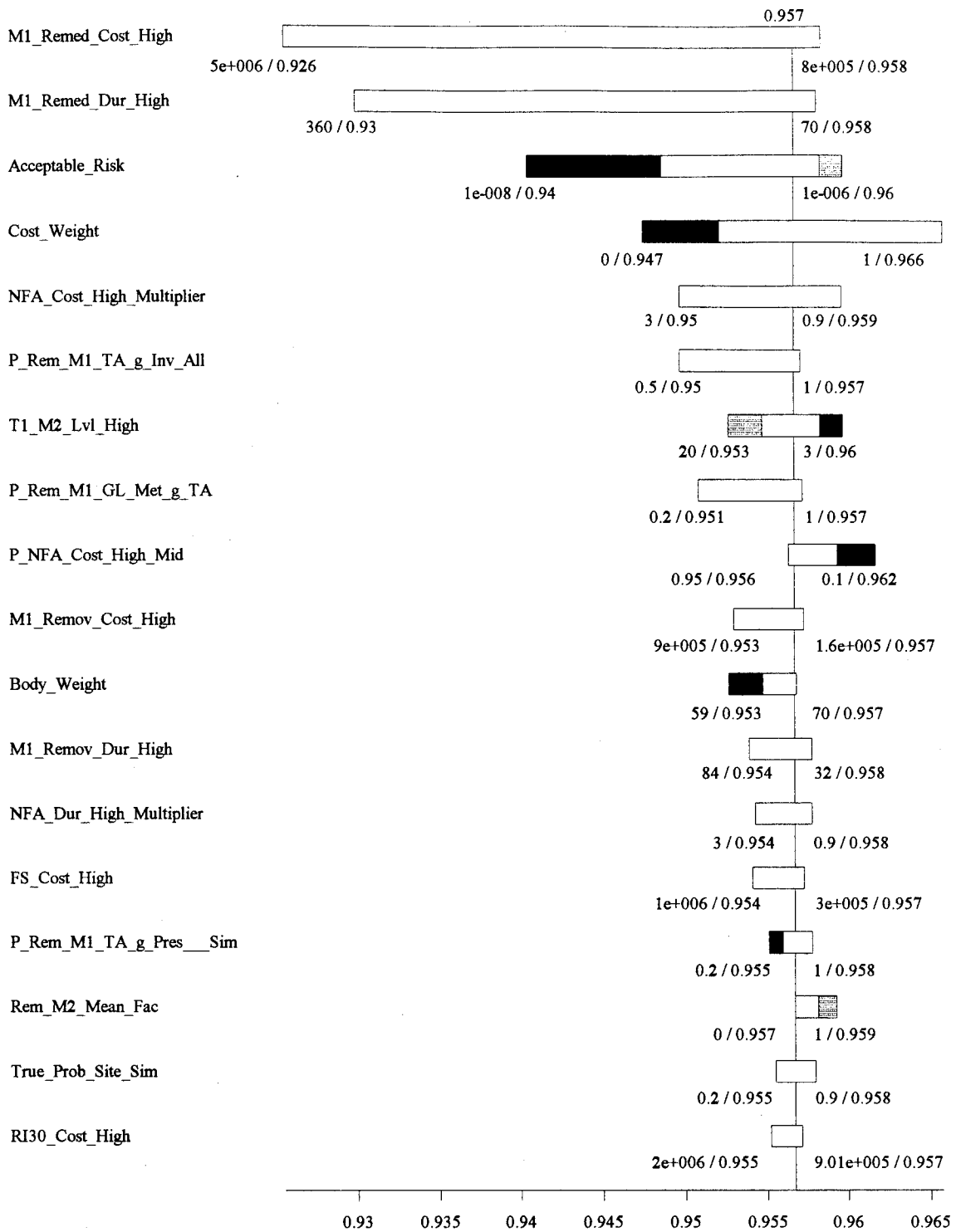

Figure 54: Preliminary Assessment Run 1 Tornado Diagram

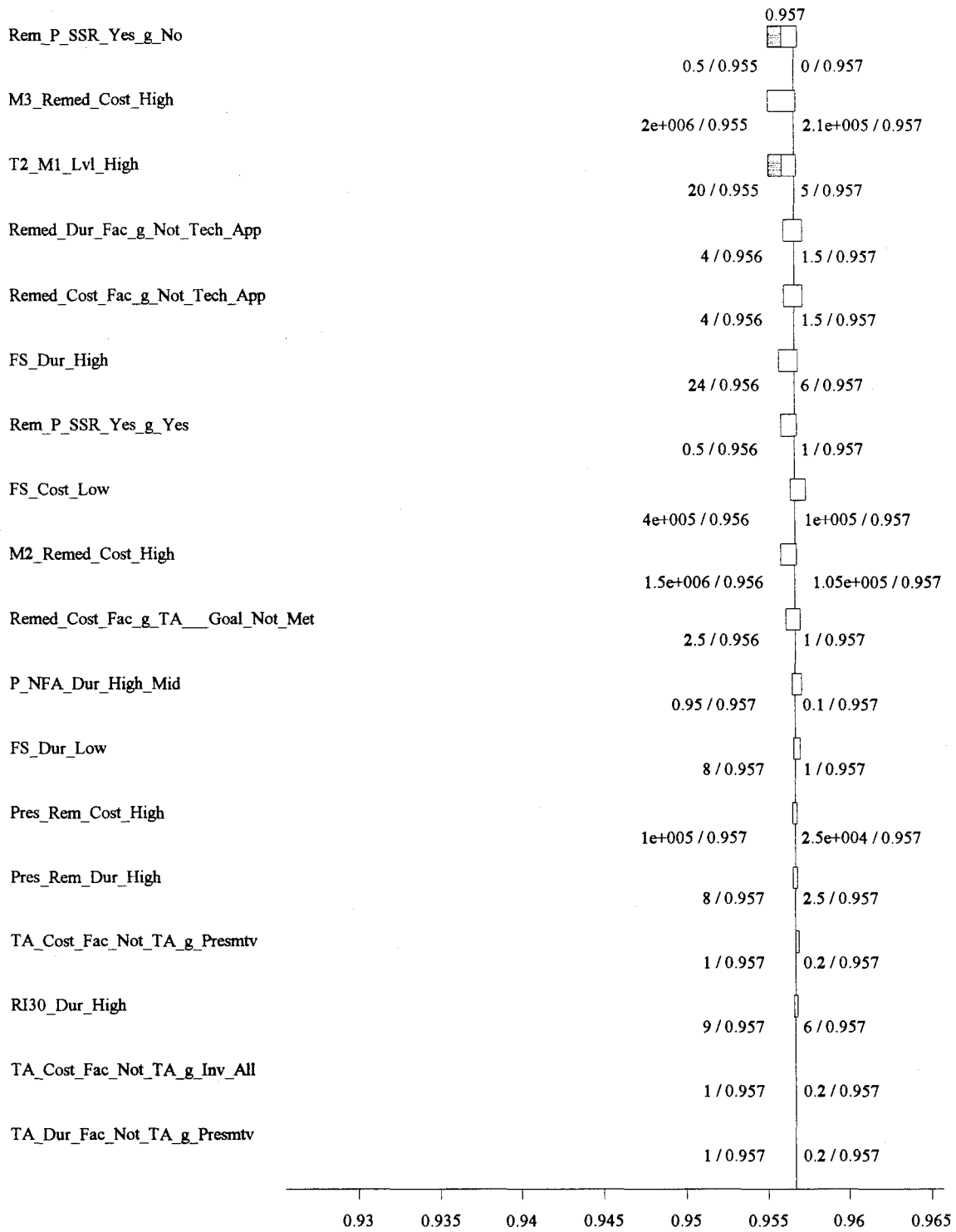

Figure 54: Preliminary Assessment Run 1 Tornado Diagram Continued

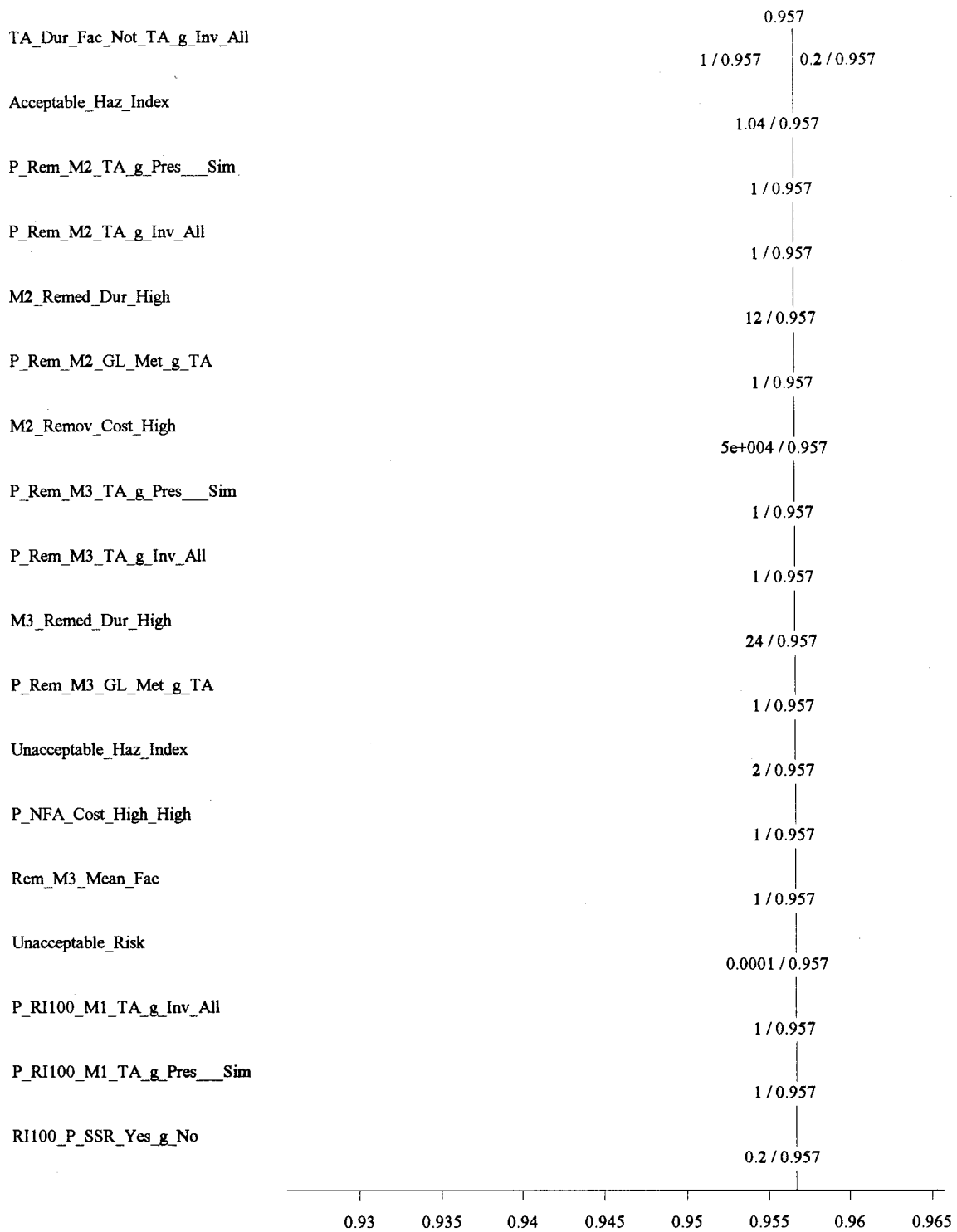

Figure 54: Preliminary Assessment Run 1 Tornado Diagram Continued

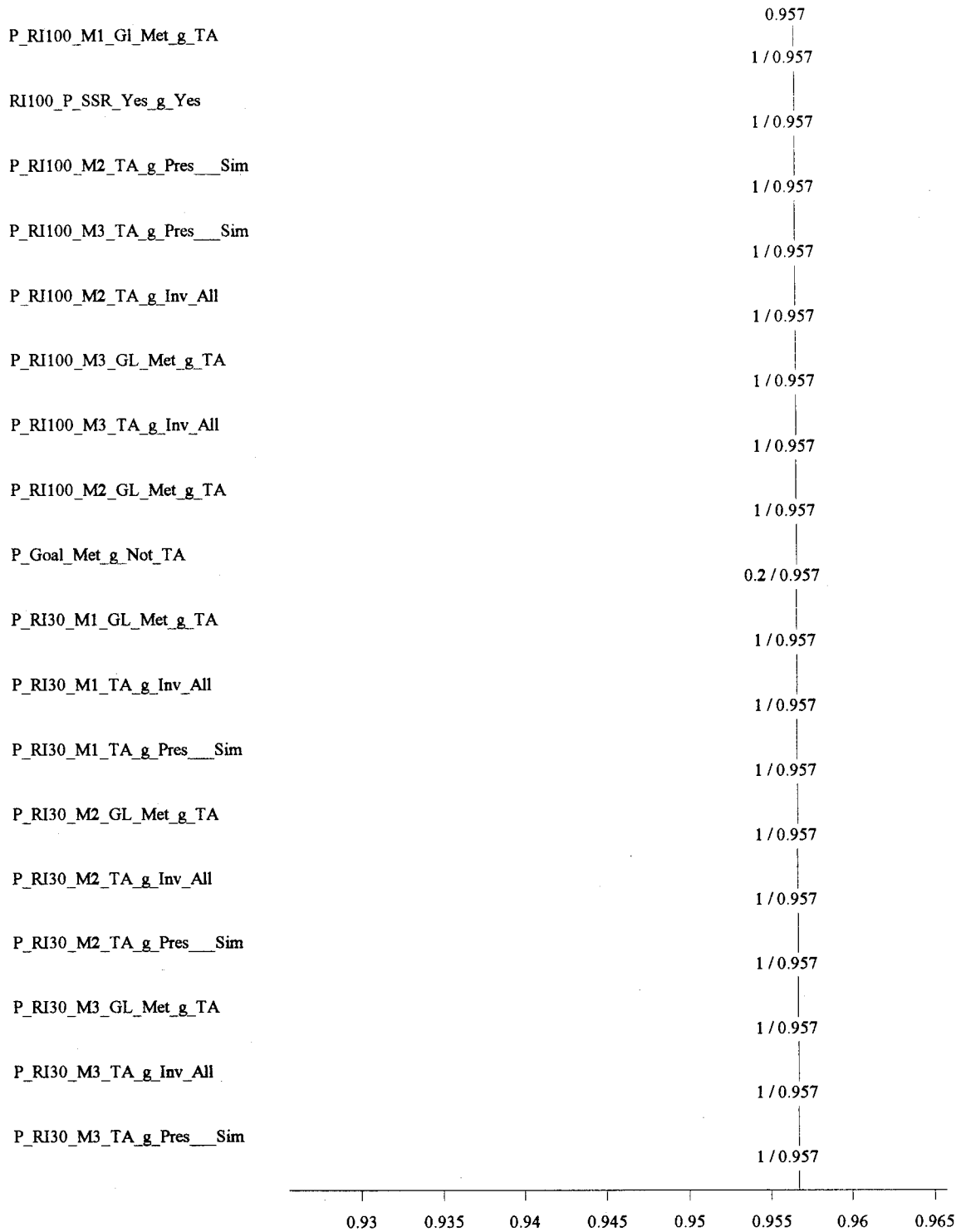

Figure 54: Preliminary Assessment Run 1 Tornado Diagram Continued

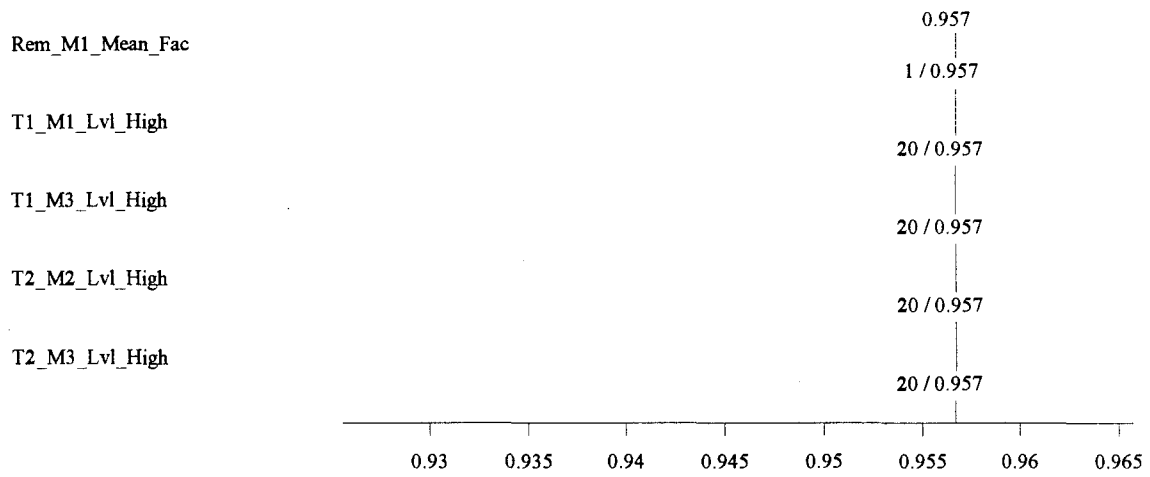

Figure 54: Preliminary Assessment Run 1 Tornado Diagram Continued

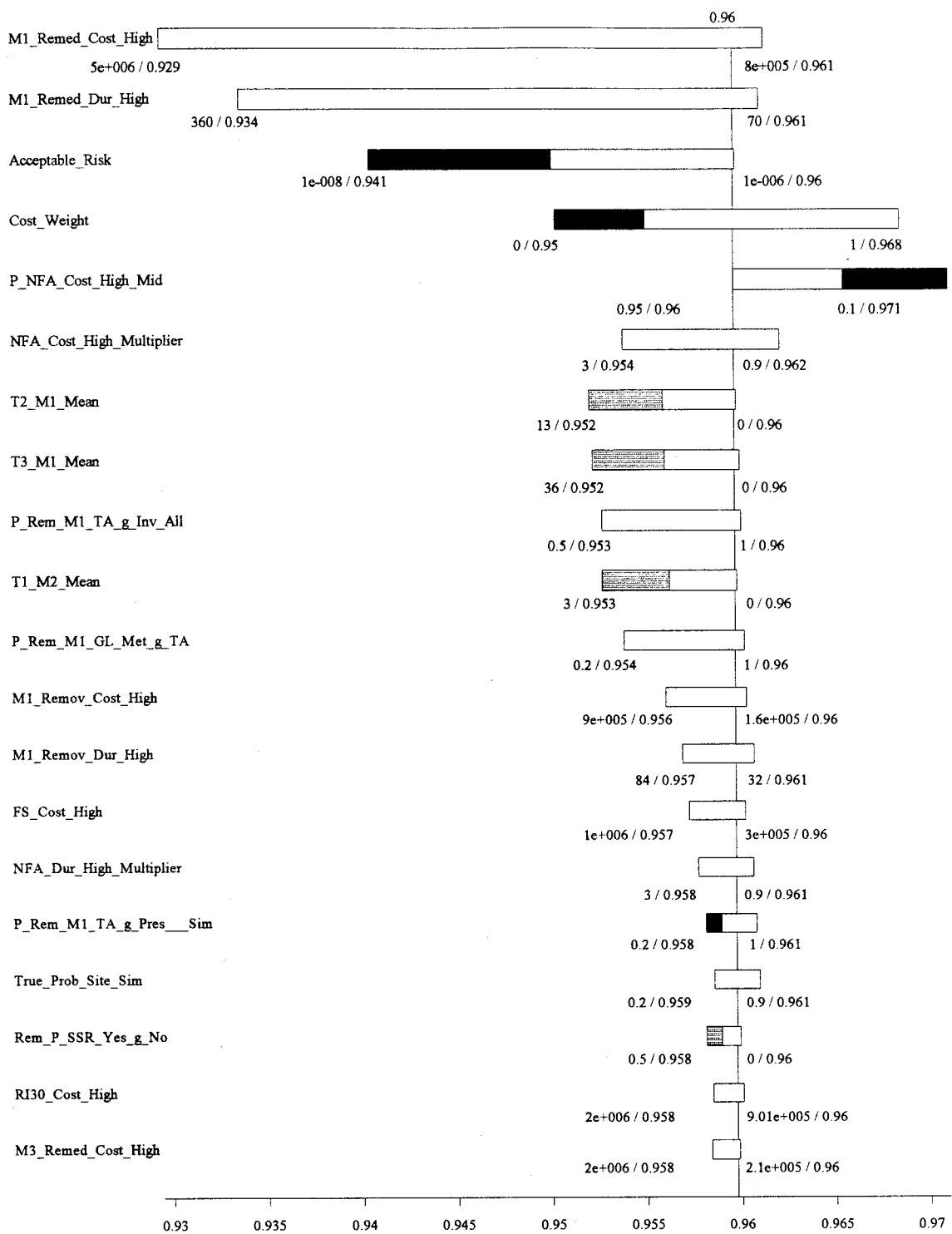

Figure 55: Site Investigation Run 1 Tornado Diagram

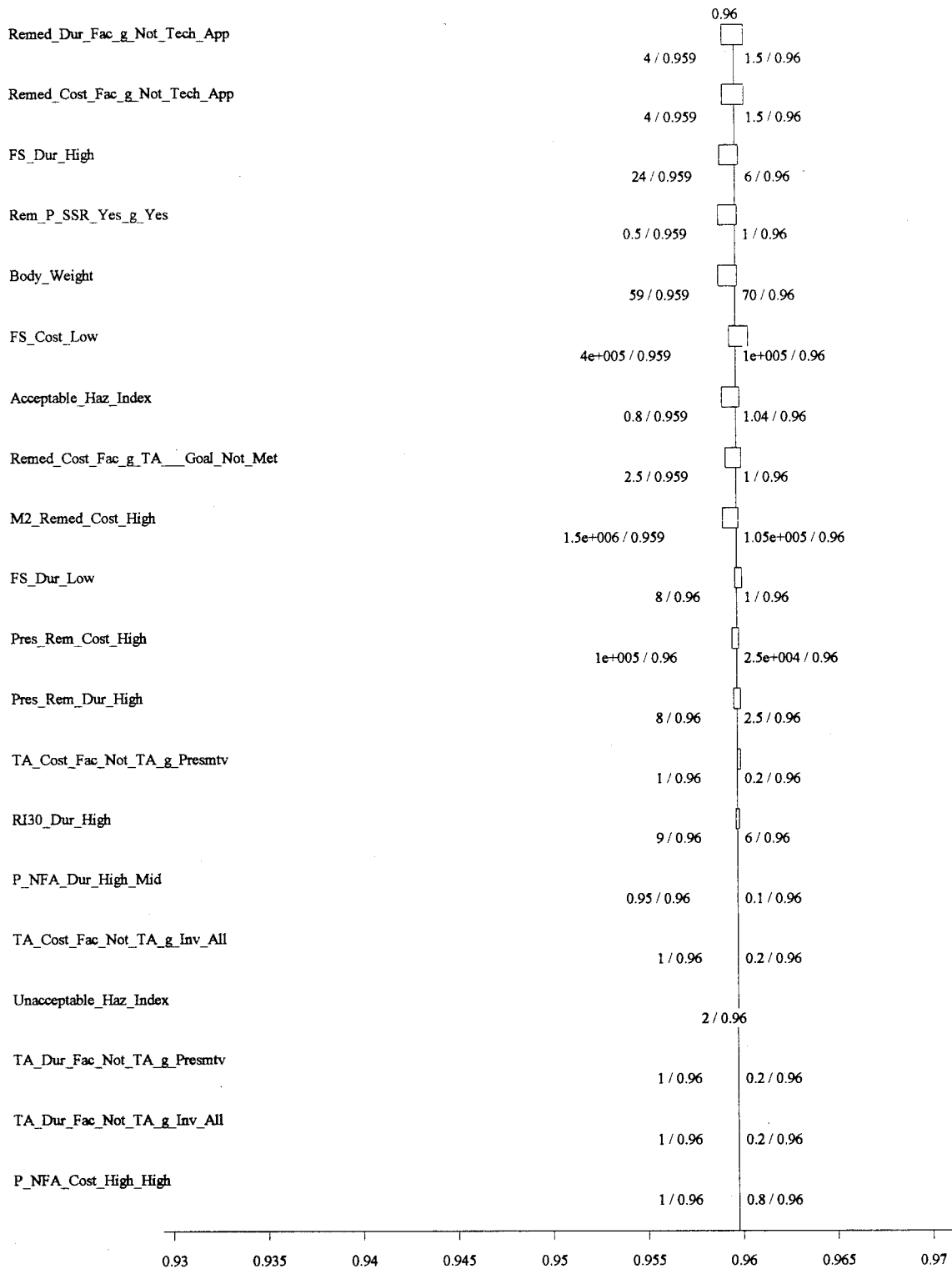

Figure 55: Site Investigation Run 1 Tornado Diagram Continued

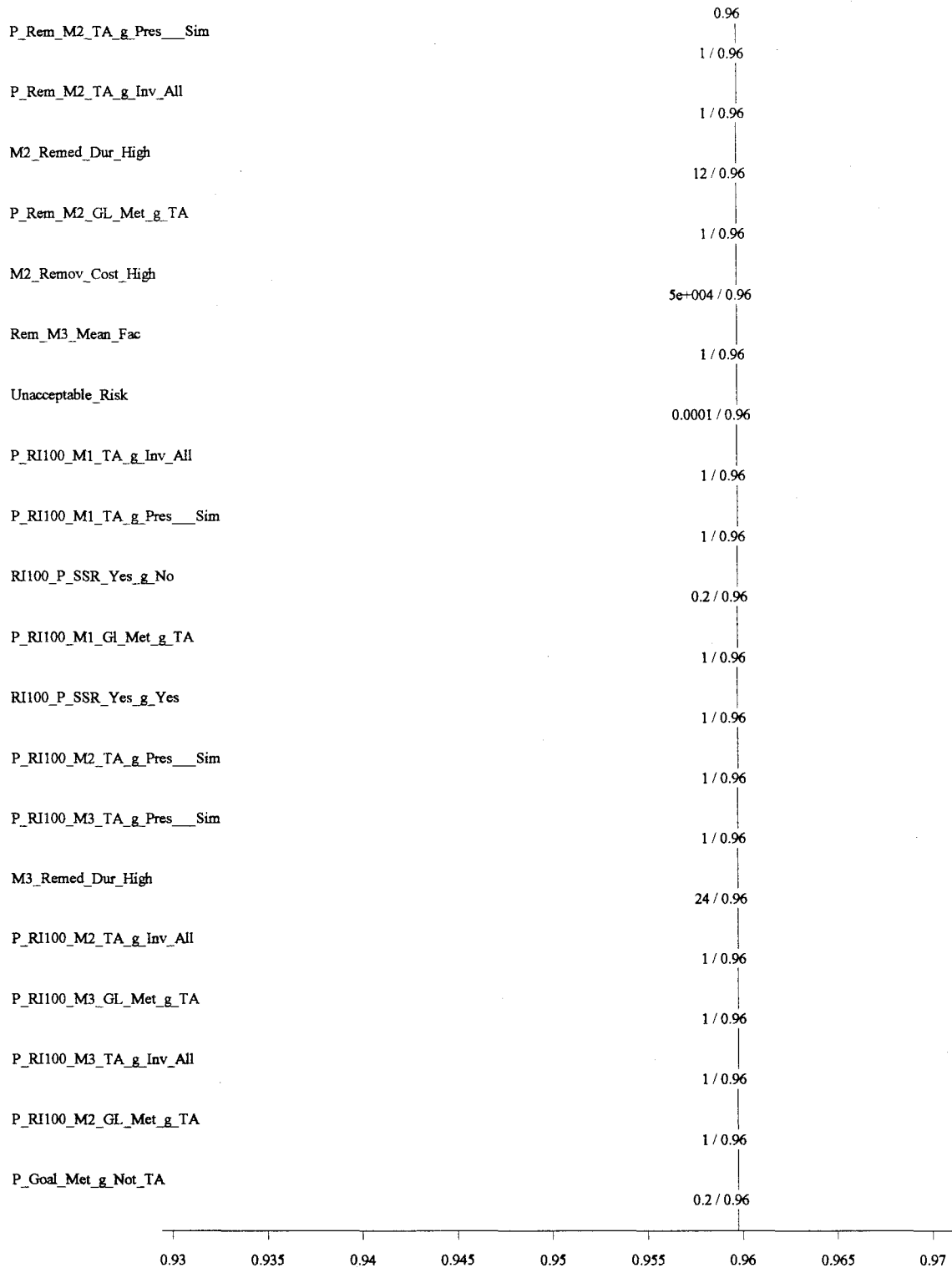

Figure 55: Site Investigation Run 1 Tornado Diagram Continued



Figure 55: Site Investigation Run 1 Tornado Diagram Continued

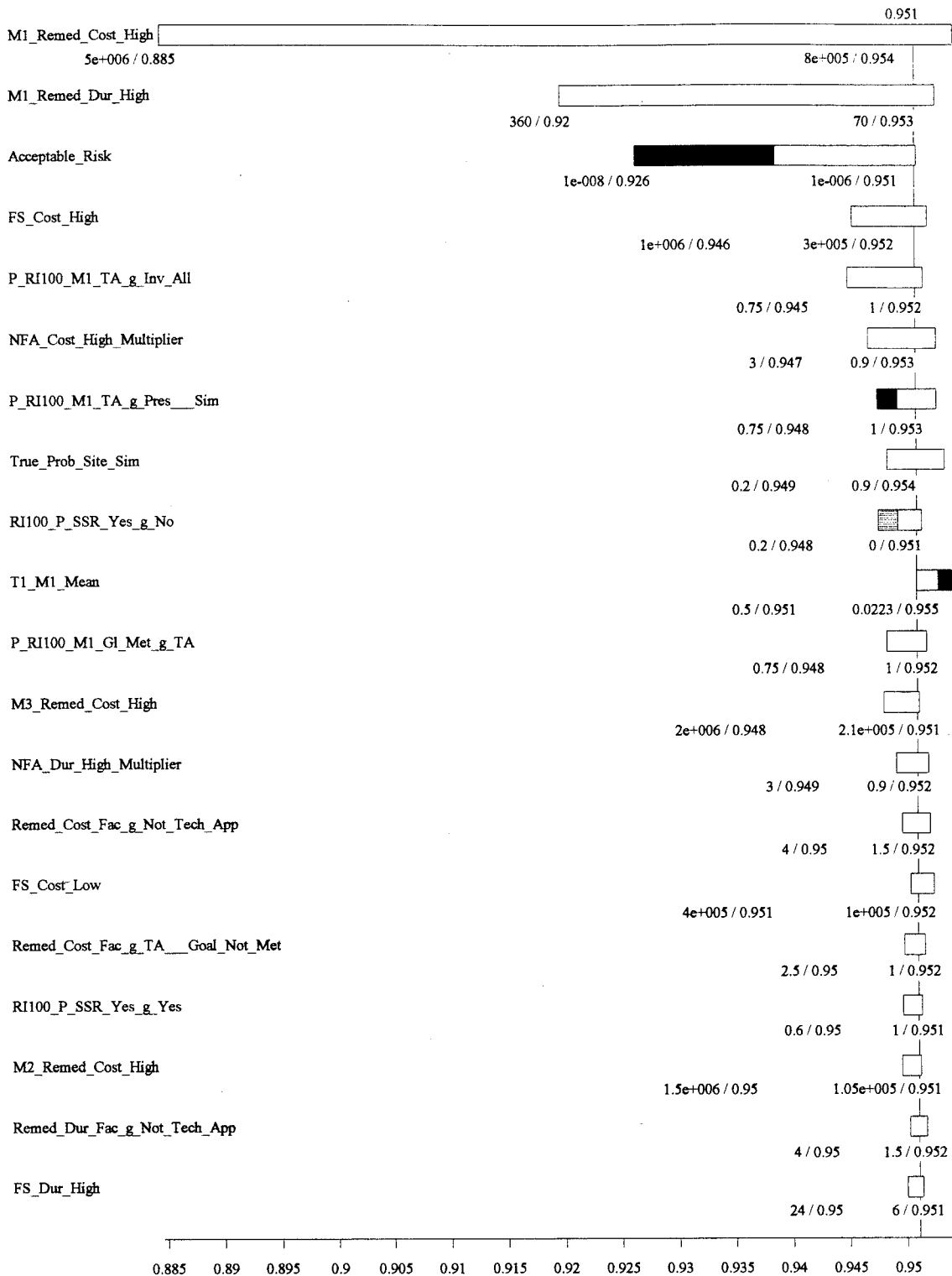

Figure 56: 100 Percent Remedial Investigation Run 1 Tornado Diagram



Figure 56: 100 Percent Remedial Investigation Run 1 Tornado Diagram Continued

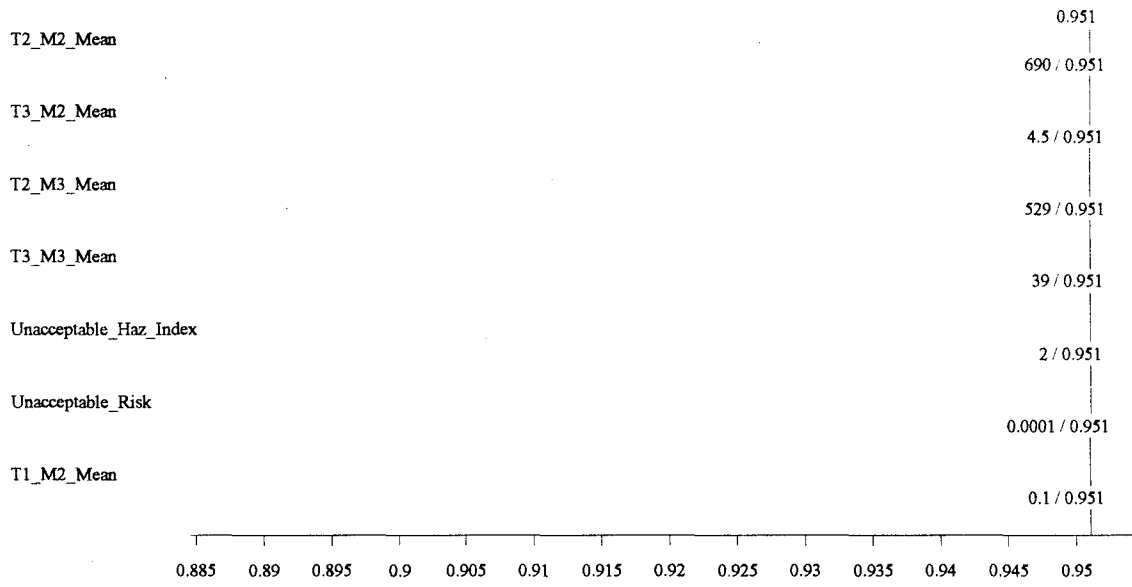

Figure 56: 100 Percent Remedial Investigation Run 1 Tornado Diagram Continued

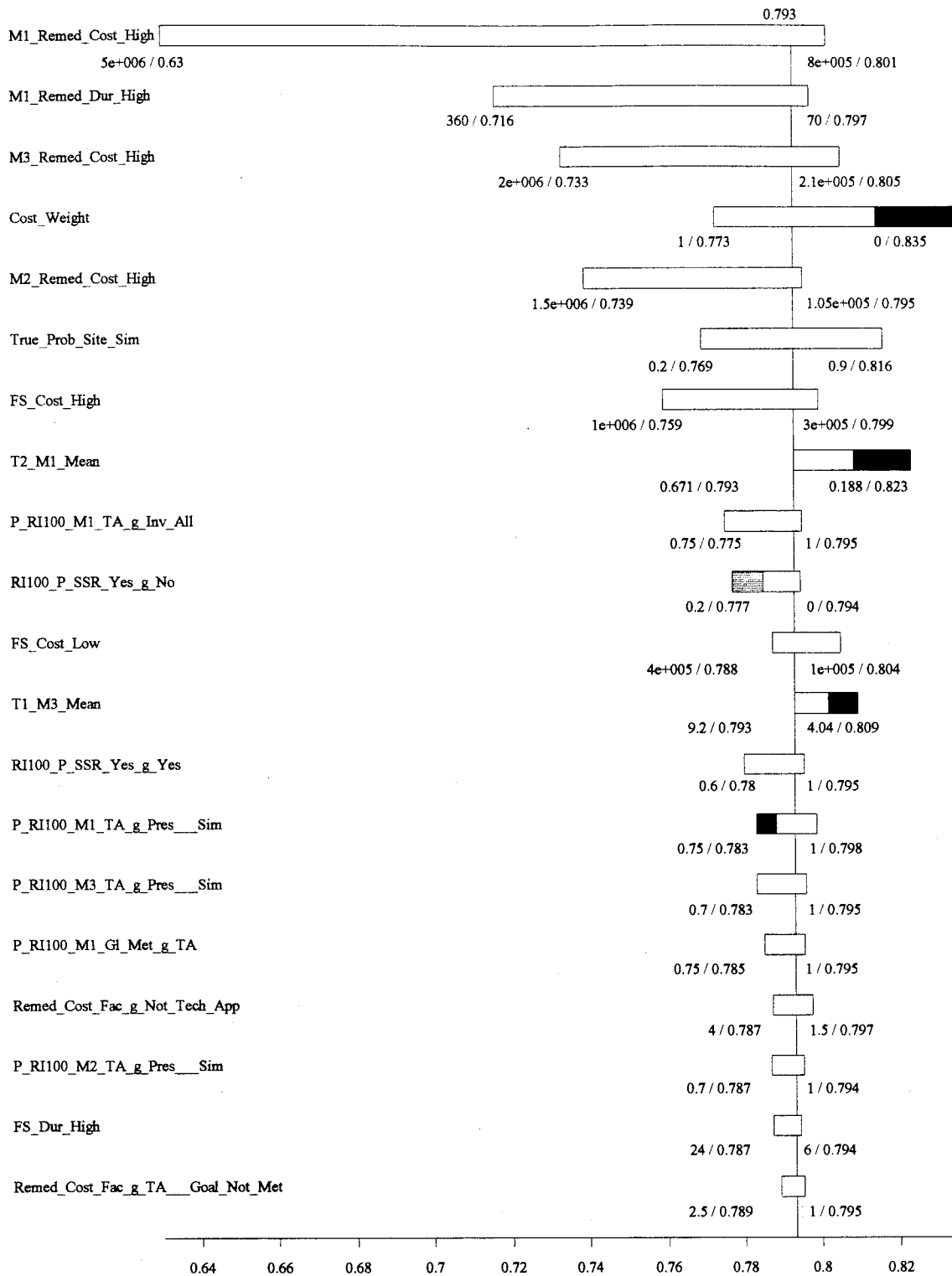

Figure 57: 100 Percent Remedial Investigation Run 2 Tornado Diagram

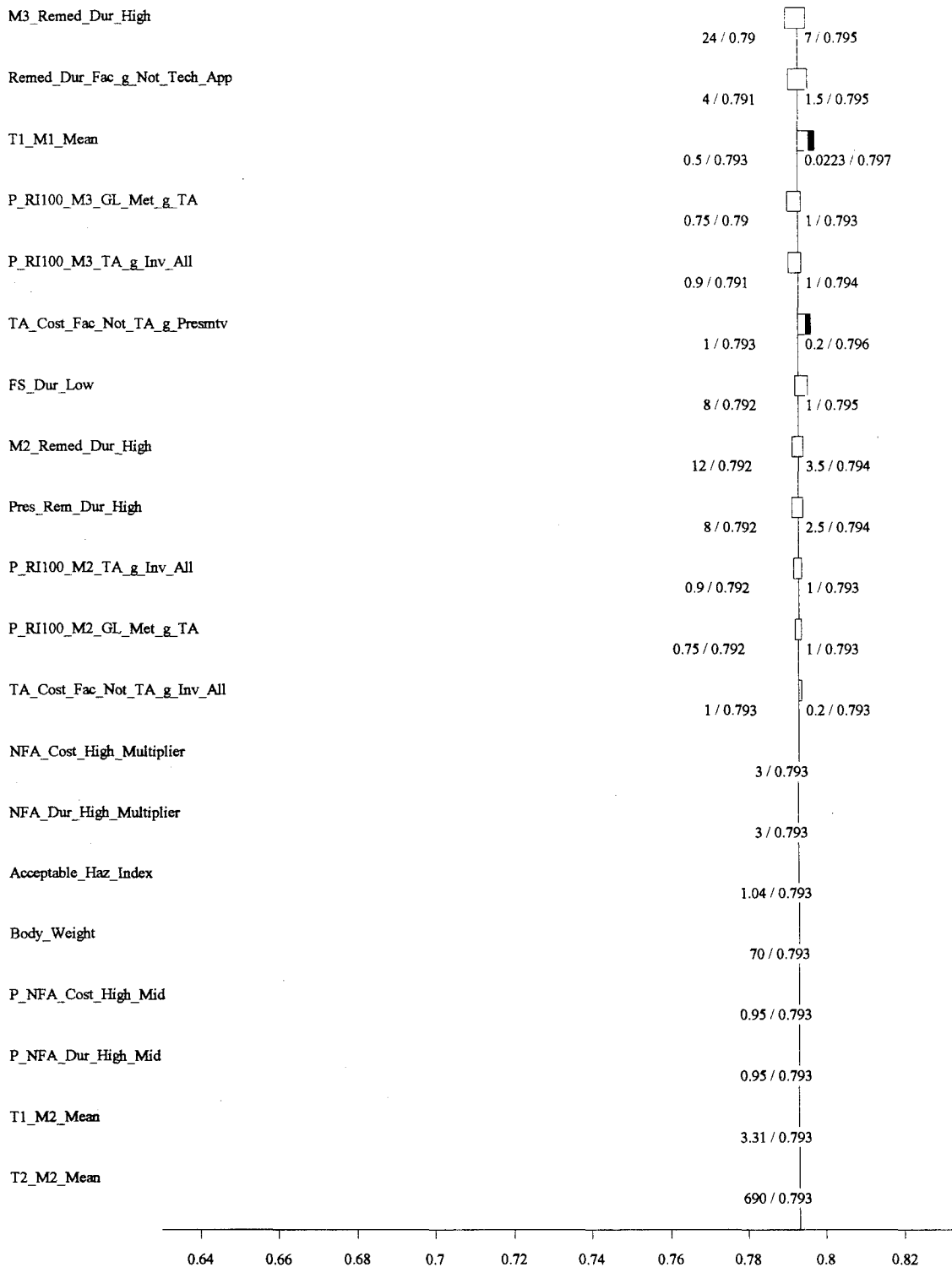

Figure 57: 100 Percent Remedial Investigation Run 2 Tornado Diagram Continued

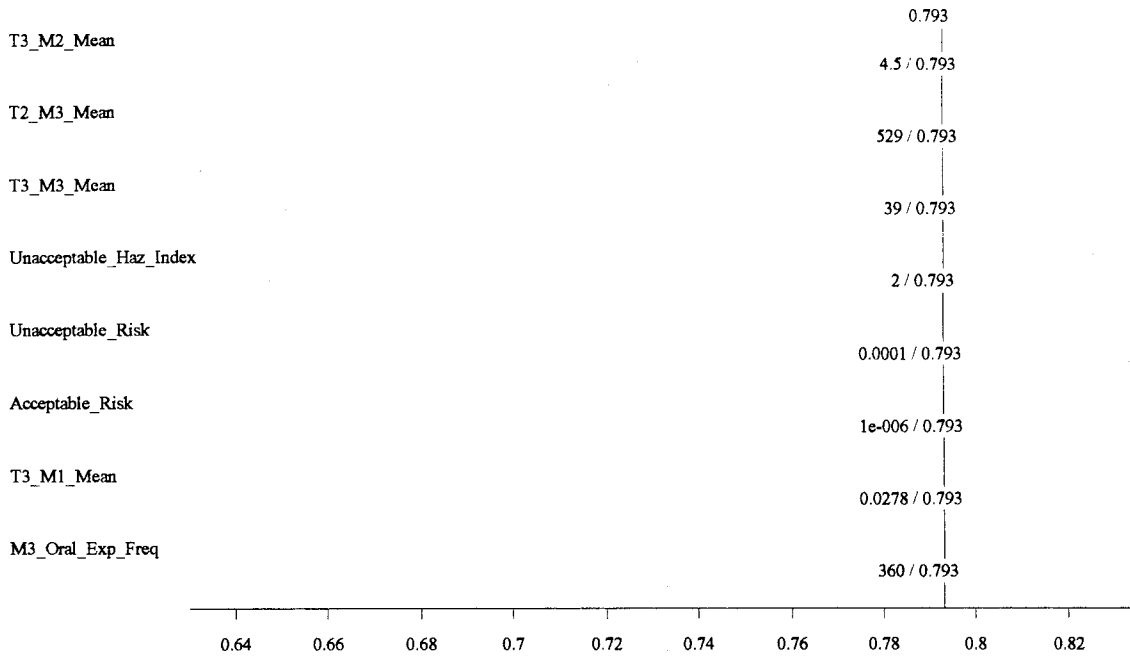

Figure 57: 100 Percent Remedial Investigation Run 2 Tornado Diagram Continued

Appendix F: Input Parameters for the Four Model Runs

This appendix contains a spreadsheet showing the input parameters and guidelines on how to determine the input parameters for the models run in this thesis. All input parameters are shown but not necessarily used in all models. See Table 8 on page A-2 for information on which parameters are used in a particular model. Unless otherwise noted, the parameters are the same for all models.

Model Input Parameters

The following spreadsheet is meant to aid the model user in gathering the required information that needs to be input into the model. Explanations of the variables and how they might be determined can be found in chapters 2 and 3 of the thesis text.

The first step is to clearly identify the media and chemicals of concern. The model allows you to look at a maximum of 3 media types and 3 chemicals for each media type. Although not all 9 values need to be used, data must be input for all values to enable the model to complete its run. It is also important that the chemicals listed under a media be in the same media because some of the risk calculation parameters and other values are media specific. Media refers to soil, water, air, sediment etc. This is also where the concentrations of the chemicals are input. For the preliminary assessment it is likely that no tests have been completed, therefore the concentration estimates are assumed to be uniformly distributed between some reasonable upper and lower bound.

Preliminary Assessment Model, Run 1 Chemicals and Their Concentration Parameters

		Concentrations (mg/kg or mg/L in water)	
		Low	High
Input the name of MEDIA 1:	Groundwater	XXXXXXXX	XXXXXXXX
Input the name of CHEMICAL 1 in MEDIA 1:	Benzene	1.0000	10.0000
Input the name of CHEMICAL 2 in MEDIA 1:	Toluene	1.0000	10.0000
Input the name of CHEMICAL 3 in MEDIA 1:	Xylene	1.0000	10.0000
Input the name of MEDIA 2:	Surface Soil	XXXXXXXX	XXXXXXXX
Input the name of CHEMICAL 1 in MEDIA 2:	Benzene	0.5000	5.0000
Input the name of CHEMICAL 2 in MEDIA 2:	Toluene	0.5000	5.0000
Input the name of CHEMICAL 3 in MEDIA 2:	Xylene	0.5000	5.0000
Input the name of MEDIA 3:	Subsurface Soil	XXXXXXXX	XXXXXXXX
Input the name of CHEMICAL 1 in MEDIA 3:	Benzene	1.0000	10.0000
Input the name of CHEMICAL 2 in MEDIA 3:	Toluene	1.0000	10.0000
Input the name of CHEMICAL 3 in MEDIA 3:	Xylene	1.0000	10.0000

Site Investigation Model, Run 1 Chemicals and Their Concentration Parameters

		Concentrations (mg/kg or mg/L in water)	
		Mean	Std Dev.
Input the name of MEDIA 1:	Groundwater	XXXXXXXX	XXXXXXXXXX
Input the name of CHEMICAL 1 in MEDIA 1:	Benzene	0.5610	0.8820
Input the name of CHEMICAL 2 in MEDIA 1:	Toluene	1.9370	4.5540
Input the name of CHEMICAL 3 in MEDIA 1:	Xylene	3.8840	10.7840
Input the name of MEDIA 2:	Surface Soil	XXXXXXXX	XXXXXXXXXX
Input the name of CHEMICAL 1 in MEDIA 2:	Benzene	0.0000	1.0000
Input the name of CHEMICAL 2 in MEDIA 2:	Toluene	0.0000	1.0000
Input the name of CHEMICAL 3 in MEDIA 2:	Xylene	0.0000	1.0000
Input the name of MEDIA 3:	Subsurface Soil	XXXXXXXX	XXXXXXXXXX
Input the name of CHEMICAL 1 in MEDIA 3:	Benzene	0.8000	1.3850
Input the name of CHEMICAL 2 in MEDIA 3:	Toluene	0.9600	1.3390
Input the name of CHEMICAL 3 in MEDIA 3:	Xylene	18.3330	31.7540

Model Input Parameters

**100% Remedial Investigation Model, Run 1
Chemicals and Their Concentration Parameters**

		Concentrations (mg/kg or mg/L in water)	
		Mean	Std Dev.
Input the name of MEDIA 1:	Groundwater	XXXXXXXX	XXXXXXXX
Input the name of CHEMICAL 1 in MEDIA 1:	Benzene	5.00E-01	1.47E-01
Input the name of CHEMICAL 2 in MEDIA 1:	Toluene	8.83E-04	3.86E-04
Input the name of CHEMICAL 3 in MEDIA 1:	Xylene	7.50E-02	2.39E-02
Input the name of MEDIA 2:	Surface Soil	XXXXXXXX	XXXXXXXX
Input the name of CHEMICAL 1 in MEDIA 2:	Benzene	2.00E-02	5.60E-01
Input the name of CHEMICAL 2 in MEDIA 2:	Toluene	3.40E-02	5.60E-01
Input the name of CHEMICAL 3 in MEDIA 2:	Xylene	2.30E-02	5.60E-01
Input the name of MEDIA 3:	Subsurface Soil	XXXXXXXX	XXXXXXXX
Input the name of CHEMICAL 1 in MEDIA 3:	Benzene	2.15E+01	4.24E+00
Input the name of CHEMICAL 2 in MEDIA 3:	Toluene	9.90E+01	1.61E+01
Input the name of CHEMICAL 3 in MEDIA 3:	Xylene	2.30E+02	4.00E+01

**100% Remedial Investigation Model, Run 2
Chemicals and Their Concentration Parameters**

		Concentrations (mg/kg or mg/L in water)	
		Mean	Std Dev.
Input the name of MEDIA 1:	Groundwater	XXXXXXXX	XXXXXXXX
Input the name of CHEMICAL 1 in MEDIA 1:	Benzene	5.00E-01	1.47E-01
Input the name of CHEMICAL 2 in MEDIA 1:	Manganese	6.70E-01	1.13E+00
Input the name of CHEMICAL 3 in MEDIA 1:	Arsenic	2.80E-02	6.57E-03
Input the name of MEDIA 2:	Surface Soil	XXXXXXXX	XXXXXXXX
Input the name of CHEMICAL 1 in MEDIA 2:	Benzo(a)pyrene	3.31E+00	5.12E+00
Input the name of CHEMICAL 2 in MEDIA 2:	Manganese	6.90E+02	2.89E+02
Input the name of CHEMICAL 3 in MEDIA 2:	Dibenz(a,h)anthracene	4.50E+00	1.37E+00
Input the name of MEDIA 3:	Subsurface Soil	XXXXXXXX	XXXXXXXX
Input the name of CHEMICAL 1 in MEDIA 3:	Antimony	9.20E+00	1.99E+00
Input the name of CHEMICAL 2 in MEDIA 3:	Manganese	5.30E+02	3.07E+02
Input the name of CHEMICAL 3 in MEDIA 3:	Benzo(a)anthracene	3.90E+01	5.66E+00

The costweight is a factor determined by the decision maker. It relates the importance of cost to duration through the equation $\text{costweight} + \text{timeweight} = 1$, where costweight is the importance of cost in the decision and timeweight is the importance of time. For example, if cost and time are considered to be equally important costweight and timeweight are equal therefore costweight is 0.5. If cost is twice as important as time the costweight is twice the size of timeweight or 0.667.

COST WEIGHT = 0.67

Model Input Parameters

The maximum values are determined from the model. To find the maximum cost and duration the model must be run once with all other values in place to find the maximum cost and once to find the maximum duration.

MAX COST = 6500000

MAX DURATION = 257.00

The following probabilities are meant to capture the decision makers attitude about the when it is safe to make a no further action decision. The question to ask that will help to fill in these probabilities is, "If the overall risk at the site is high/mid/low what is the probability that making the decision to do nothing will cost more in the long run?" For example if the risk is high the probability that doing nothing will cost more later is very high, probably 1.0. Whereas if the risk is clearly low the probability that doing nothing will cost more in the long run is also very low.

PROBABILITY NFA COST IS HIGH GIVEN RISK IS HIGH =	1.000
PROBABILITY NFA COST IS HIGH GIVEN RISK IS IN THE MID RANGE =	0.700
PROBABILITY NFA COST IS HIGH GIVEN RISK IS LOW =	0.010

PROBABILITY NFA DURATION IS LONG GIVEN RISK IS HIGH =	1.000
PROBABILITY NFA DURATION IS LONG GIVEN RISK IS IN THE MID RANGE =	0.700
PROBABILITY NFA DURATION IS LONG GIVEN RISK IS LOW =	0.010

This portion of the spreadsheet contains the cost and duration values for the various stages of the characterization process. The costs should all be in dollars at the same point in time, in other words for phases that may take several years the cost used should be present value. The duration is in months. For Removal Action and Remediation Effort the costs and durations can be input separately for each media. If the entire project has one cost then input that cost and duration for all the media. The model does NOT assume that the costs and duration are additive across media.

		COSTS		DURATIONS	
		Low	High	Low	High
Site Investigation		20000	120000	4.0	7.0
30% Remedial Investigation		900000	1100000	5.0	7.0
60% Remedial Investigation		400000	600000	4.0	6.0
100% Remedial Investigation		700000	1100000	5.0	10.0
Removal Action	Media 1	150000	250000	30.0	45.0
	Media 2	10000	30000	1.0	3.0
	Media 3	10000	30000	1.0	3.0
Feasibility Study		300000	400000	6.0	8.0
Presumptive Remedy		20000	40000	2.0	4.0
Recommend No Further Action		1500	Calculated	0.5	Calculated
Remediation Effort	Media 1	750000	1000000	60.0	84.0
	Media 2	100000	150000	3.0	6.0
	Media 3	200000	500000	6.0	12.0

Model Input Parameters

Here the user inputs the estimated or known number of samples taken at each phase of the characterization process. These values can be estimated from experience or obtained from a sampling plan. They are used to estimate the reduction in uncertainty at each study phase. Note that the estimates are media specific. It is assumed that more information only changes the uncertainty associated with the current estimate of the chemical concentration. More information does NOT change the mean with the exception of an interim removal action. If a removal action is accomplished the goal is to reduce the mean value of the chemical concentration. The minimum number of samples for the PA must be 1 in all media, all other phases may have 0 as the minimum number. The mean reduction factor is an estimate of the percent reduction in the current estimate of the mean. This is also media dependent and valid entries range from 0 to 0.999999.

Estimated Number of Samples and Removal Action Mean Reduction Factor

	PA	SI	30% RI	60% RI	100% RI	Removal	
						Mean	Samples
Media 1	1.0	11.0	4.0	4.0	4.0	0.979000	30.00
Media 2	1.0	1.0	24.0	0.0	0.0	0.000000	0.00
Media 3	1.0	3.0	50.0	0.0	0.0	0.000000	0.00

This section is the non-media specific risk values required for the model.

Value below which the cancer risk is CLEARLY ACCEPTABLE (i.e.: 10E-6) =	5.0E-07	
Value below which the hazard index is CLEARLY ACCEPTABLE (i.e.: 0.5) =	0.95	
Value above which the cancer risk is CLEARLY UNACCEPTABLE (i.e.: 10E-4) =	5.0E-05	
Value above which the hazard index is CLEARLY UNACCEPTABLE (i.e.: 1.0) =	1.05	
Body weight for population of interest (kg) =	70.0	
Exposure duration (yrs)	Media 1=	25.0
	Media 2=	25.0
	Media 3=	1.0
Lifespan of affected population (days) =	25550.0	

Dermal Route Exposure Factors: The following values are factors required to calculate the risk posed by dermal contact. The Dermal Adherence factor is used for contact with soil. It represents the mass of soil that sticks to the skin per unit area. The value is specific to soil type. It must be set equal to 1 if the media is not soil. The exposure time for dermal contact with water is used only if the media is water, otherwise it must be set equal to 1. It is the length of time per day that the person is in contact with the contaminated water. The exposure frequency must be input in events/year if the media is soil and in days/year if the media is water. The removal exposure frequencies are the estimated exposure frequencies after a removal action. They may be the same as before the action or they may be lower if the removal action included some sort of fencing or other exposure reduction measure. The conversion factor is 0.001L/cm³ for water and 10⁻⁶ kg/mg for soil.

Model Input Parameters

Dermal Route Exposure Factors

	Adherence Factor for Soil (mg/cm ²)	Exposure Time For Water (Hrs/Day)	Exposed Surface Area (cm ²)	Exposure Frequency Days/yr or Events/yr	Removal Exp Freq Days/yr or Events/yr	Conversion Factor L/cm ³ or kg/mg
Media 1	1.00E+00	0.25	23000.0	250.0	250.0	1.0E-03
Media 2	1.00E+00	1.00	5800.0	250.0	250.0	1.0E-06
Media 3	1.00E+00	1.00	5800.0	250.0	250.0	1.0E-06

The following values are the rates of ingestion or inhalation, exposure frequencies before and after a removal action, ingestion route conversion factor and the inhalation route exposure time. The ingestion rate is the amount ingested per day of the particular media. Soil is given in mg per day and water is given in liters per day. The Exposure Frequencies and Removal Exposure Frequencies are the number of days per year exposure occurs. The Removal Exposure Frequencies are the values after a removal action has been completed. The ingestion conversion factor is 10⁻⁶ kg/mg in soil. It is 1.0 for other media. The inhalation rate is the volume of air inhaled per hour in m³/hour. The inhalation exposure time is the length of time of exposure per day in hours.

Media	Pathway Factors			
	Ingestion			
	Rate mg(L)/day	Exp Freq Days/year	Conv Fac in Soil kg/mg	Removal Exp Freq Days/Yr
Media 1	1.0	250.0	1.0E+00	250
Media 2	100.0	250.0	1.0E-06	250
Media 3	480.0	250.0	1.0E-06	250

Media	Pathway Factors			
	Inhalation			
	Rate m ³ /hour	Exp Freq Days/yr	Exp Times Hours/Day	Removal Exp Freq Days/yr
Media 1	0.6	250.0	0.25	250
Media 2	0.0	0.0	0.0	0.0
Media 3	0.0	0.0	0.0	0.0

The following table shows the **Slope Factors** (for carcinogens), **Reference Doses** (for noncarcinogenic effects), the **Inhalation Emission Factors** and the **Dermal Absorption Factors** for each chemical. The slope factors and reference doses can be obtained from the *Integrated Risk Information System*, updated by the EPA, or from EPA's *Superfund Chemical Data Matrix*. For some chemicals it may be appropriate to have both a slope factor and a reference dose. If a chemical has only one of the two the other should be input as 0.0. The units for the slope factor are kg-day/mg and the units for the reference dose are mg/kg-day. The inhalation emission factor is K in Equation (3) in the thesis text. See the text for information on how to determine K. The dermal absorption factor is unitless for soil, typically assumed to be 1.0. When the media is water the absorption factor is called the dermal permeability constant and is given in cm/hr.

Model Input Parameters

Chemical Specific Risk Factors For All Run 1 Models (PA, SI, RI100)							
	Slope Factor (kg-day/mg)		Reference Dose (mg/kg-day)		Inhal Em. Factor	Dermal Abs Factor	Oral Absorption Factor
	Oral	Inhalation	Oral	Inhalation			
Type 1 Chem							
Media 1	0.0290	0.0290	0.0000	0.0000	1.0000	0.0210	9.5E-01
Media 2	0.0000	0.0000	0.2000	0.1100	1.0000	0.0450	9.0E-01
Media 3	0.0000	0.0000	2.0000	0.0000	1.0000	0.0800	9.0E-01
Type 2 Chem							
Media 1	0.0290	0.0290	0.0000	0.0000	1.0000	0.2500	9.5E-01
Media 2	0.0000	0.0000	0.2000	0.1100	1.0000	0.2500	9.0E-01
Media 3	0.0000	0.0000	2.0000	0.0000	1.0000	0.2500	9.0E-01
Type 3 Chem							
Media 1	0.0290	0.0290	0.0000	0.0000	1.0000	0.2500	9.5E-01
Media 2	0.0000	0.0000	0.2000	0.1100	1.0000	0.2500	9.0E-01
Media 3	0.0000	0.0000	2.0000	0.0000	1.0000	0.2500	9.0E-01

Chemical Specific Risk Factors For RI100 Model, Run 2							
	Slope Factor (kg-day/mg)		Reference Dose (mg/kg-day)		Inhal Em. Factor	Dermal Abs Factor	Oral Absorption Factor
	Oral	Inhalation	Oral	Inhalation			
Type 1 Chem							
Media 1	0.0290	0.0291	0.0000	0.0000	1.0000	0.0210	9.5E-01
Media 2	7.3000	0.0000	0.0000	0.0000	1.0000	0.1000	2.0E-01
Media 3	0.0000	0.0000	0.0004	0.0000	1.0000	0.0100	1.0E-02
Type 2 Chem							
Media 1	0.0000	0.0000	0.0050	0.0000	1.0000	0.0010	3.0E-02
Media 2	0.0000	0.0000	0.0050	0.0000	1.0000	0.0100	3.0E-02
Media 3	0.0000	0.0000	0.0050	0.0000	1.0000	0.0100	3.0E-02
Type 3 Chem							
Media 1	1.8000	0.0000	0.0003	0.0000	1.0000	0.0010	8.0E-01
Media 2	7.3000	0.0000	0.0000	0.0000	1.0000	0.1000	2.0E-01
Media 3	0.7300	0.0000	0.0000	0.0000	1.0000	0.1000	2.0E-01

The following section lists cost and duration factors required to for the model to calculate the penalty associated with incorrect decisions. The feasibility study adjustment factors must be between zero and one. They are used to calculate the portion of the feasibility study that must be repeated if the technology is inappropriate. A one indicates that the entire feasibility study will be done and zero indicates no additional time or money will be spent on further study. The remediation adjustment factors indicate how much would be spent to repair a remediation system during operation that does not meet the cleanup goals. This factor must be greater than one. A one indicates only the original costs will be spent with no additional charges for the error. A two indicates 100% of the original cost/duration will be spent on the repair. The no further action adjustment factors represent the portion of the total costs that would be spent over and above finishing the remedial investigation if no action is taken and it was the wrong decision. This factor accounts for legal fees, medical bills and intangible costs such as bad public relations. It must be greater than one and should be less than 2 in all but the most extreme cases.

Model Input Parameters

Feasibility Study Adjustment Factors

Duration factor for a technically unacceptable remedy given all options were investigated=	0.50
Cost factor for a technically unacceptable remedy given all options were investigated=	0.50
Duration factor for a technically unacceptable remedy given a presumptive remedy was used=	1.00
Cost factor for a technically unacceptable remedy given a presumptive remedy was used=	1.00

Remediation Adjustment Factors

Duration factor given the technology was acceptable but did not meet the cleanup goals=	1.40
Cost factor given the technology was acceptable but did not meet the cleanup goals=	1.40
Duration factor given the technology was not appropriate=	2.50
Cost factor given the technology was not appropriate=	2.50

No Further Action Adjustment Factors

Duration factor for the high duration of the NFA alternative after an improper decision=	1.50
Cost factor for the high cost of the NFA alternative after an improper decision=	1.50

The following section lists the probabilities associated with the feasibility study.

Probability the TRUE SITE CONDITION is SIMILAR to other sites =	0.5600
---	--------

FEASIBILITY STUDY PROBABILITIES				
EVENT STATES	30% RI	60% RI	100% RI	Removal Action
Site Similarity Report predicts similar given the true condition is similar	0.75	0.8000	0.9500	0.9800
Site Similarity Report predicts similar given the true condition is not similar	0.10	0.0500	0.0100	0.0100
Remedy technically acceptable given all remedies are investigated*				
Media 1	0.80	0.9000	0.9800	0.9800
Media 2	0.99	0.9900	0.9900	0.7000
Media 3	0.99	0.9900	0.9900	0.7000
Remedy technically acceptable given presumptive remedy is used and the site is similar				
Media 1	0.70	0.8500	0.9500	0.9500
Media 2	0.95	0.9500	0.9500	0.6000
Media 3	0.95	0.9500	0.9500	0.6000
Remedy technically acceptable given presumptive remedy is used and site is not similar**	0.00	Only one value required		
Cleanup goal is met given the technology is acceptable***				
Media 1	0.50	0.7000	0.9500	0.9500
Media 2	0.95	0.9500	0.9800	0.6000
Media 3	0.95	0.9500	0.9800	0.6000
Cleanup goal is met given the technology is not acceptable****	0.00	Only one value required		

Model Input Parameters

* Technically acceptable refers to the technology being appropriate for the type of contamination.

** The probability that the selected remedy is technically acceptable given that a presumptive remedy is used and the site is not similar is assumed to be 0.0 for all decision points. This is because a presumptive remedy assumes that the site is similar. If the presumptive remedy is technically acceptable when the site is not similar to any other then it would have to be assumed to be a lucky outcome.

*** These probabilities refer to the fact that the correct technology may be chosen but there is not enough information available to do a proper design. If the design is faulty the cleanup goal will not be met.

**** The probability that the cleanup goal is met given that the technology is not acceptable is assumed to be 0.0 in all cases.

Bibliography

- ADA Decision Systems. DPL Advanced Version User Guide. Belmont CA: Duxbury Press, 1995.
- Andelman, J. B. Total Exposure to Volatile Organic Chemicals in Potable Water. Boca Raton, FL: Lewis Publishers, 1994.
- Blacker, Stanley, and Daniel Goodman. "Risk-Based Decision Making: An Integrated Approach for Efficient Site Cleanup," Environmental Science and Technology, 28: 466A-470A (October 1994).
- Brothers, Heidi S. An Alternative Compliance Strategy for Title III of the 1990 Clean Air Act Amendments. PhD dissertation. University of Cincinnati, Cincinnati OH, 1995 (Draft).
- Clean Sites. Making Superfund Work: Recommendations to Improve Program Implementation. Alexandria, VA: Clean Sites, January 1989.
- Clemen, Robert T. Making Hard Decisions, An Introduction to Decision Analysis. Belmont, CA: Wadsworth Publishing Company, 1991.
- Dean, A. and M. Barvenik. "Use of the Observational Method in the Remedial Investigation and Clean-up of Contaminated Land," Geotechnique, 41: 33-36 (March 1992).
- Department of Defense. Defense Environmental Cleanup Program Annual Report to Congress for Fiscal Year 1993. Washington: GPO, March 1994.
- Department of the Air Force. US Air Force Installation Restoration Program Remedial Project Managers Handbook. Washington: HQ USAF, January 1992.
- Devore, Jay L. Probability and Statistics for Engineering and the Sciences (Third Edition). Pacific Grove, CA: Brooks/Cole Publishing Company, 1991.
- DPL. Advanced Version 3.11.02. Computer software. ADA Decision Systems, Menlo Park CA, 1995.

- Duplancic, Neno, and Gregory Buckle. "Hazardous Waste: Quicker Cleanup," Forum for Applied Research and Public Policy, 8: 50-55 (Spring 1993).
- Ember, Lois. "Industry Coalition Slows Superfund," Chemical and Engineering News, 71: 19 (August 1993).
- Engineering Science. Final Remedial Investigation Report for Operable Unit 2 At Wright-Patterson Air Force Base, Ohio. Contract DE-AC05-84OR21400. Oak Ridge TN: August 1995.
- Excel. Version 5.0a. Computer software. Microsoft Corporation, 1993.
- Findall, Christopher E. Decision Support Model to Compare Hazardous Waste Site Remediation Process Alternatives. MS thesis, AFIT/GEE/ENV/94S-09. School of Engineering, Air Force Institute of Technology (AETC), Wright-Patterson Air Force Base OH, September 1994.
- Hoffman, F. O. and J. S. Hammond. An Introductory Guide to uncertainty Analysis in Environmental and Health Risk Assessment. Contract DE-AC05-84OR21400. Oak Ridge TN: Oak Ridge National Laboratory, October 1992.
- LaGrega, Michael D., and others. Hazardous Waste Management. New York: McGraw-Hill, Inc., 1994.
- Lawrence, Barnett. "EPA's Superfund Accelerated Cleanup Model: a Paradigm for CERCLA Reauthorization," Environment Reporter, 23: 2962-2966 (Mar 12, 1993).
- Lee, Robert T. and others. "Comprehensive Environmental Response Compensation and Liability Act," in Environmental Law Handbook (Thirteenth Edition). Ed. Thomas F. P. Sullivan. Rockville MD: Government Institutes, Inc, 1995.
- Lester, Ronald. Chief, Environmental Restoration Flight, 88th Air Base Group, Wright-Patterson AFB OH. Personal interview. 17 April 1995.
- National Archives and Records Administration. Code of Federal Regulations: Protection of Environment. CFR Title 40. Rockville, MD: Government Institutes, Inc., 1 July 1993.

- National Research Council. Risk Assessment in the Federal Government: Managing the Process. Washington DC: National Academy Press, 1983.
- . Science and Judgment in Risk Assessment. Washington DC: National Academy Press, 1994.
- Pannwitz, Karl-Heinz. "Diffusion Coefficients," Dräger Review, 52: 1-8 (January 1984).
- Peck, R. B. "Advantages and Limitations of the Observational Method in Applied Soil Mechanics," Ge'otechnique, 19: 171-187 (June 1969).
- Reilly, Bernard J. "Stop Superfund Waste," Issues in Science and Technology, 9: 57-64 (Spring 1993).
- Seitz, Mary. Remedial Project Manager, 88th ABW Environmental Management, Wright-Patterson AFB OH. Personal Correspondence. 13 September 1995.
- Steinzor, Rena I. "The Reauthorization of Superfund: Can the Deal of the Century be Saved?" The Environmental Reporter, News and Analysis, 25: 10016-10034 (January 1995a).
- . "The Reauthorization of Superfund: The Public Works Alternative," The Environmental Reporter, News and Analysis, 25: 10078-10088 (February 1995b).
- United States Environmental Protection Agency. Data Quality Objectives Process for Superfund. EPA/540/G-93/071. Washington: Office of Emergency and Remedial Response, September 1993a.
- . Exposure Factors Handbook. Report Series EPA/600/8-89/043. Washington: GPO, July 1989a.
- . "Guidelines for Exposure Assessment," Federal Register, 57: 22888-22937 (May 29, 1992a).
- . Interim Final Guidance for Conducting Remedial Investigations and Feasibility Studies Under CERCLA. OSWER Directive 9355.3-01. Washington. GPO, October 1988.

- "Risk Assessment Guidance for Superfund, Vol 1, Human Health Evaluation Manual (Part B), Interim," OSWER publication 9285.7-01B, December 1991a.
- Risk Assessment Guidance for Superfund, Vol 1, Human Health Evaluation Manual (Part A), Interim Final, OSWER pamphlet 540/1-89 002, December 1989b.
- ROD Annual Report. EPA 9355.6-06. Washington: Office of Emergency and Remedial Response, December 1993b.
- Superfund Accelerated Cleanup Model (SACM). OSWER Directive 9203.1-01. Washington: GPO, March 1992b.
- Superfund Chemical Data Matrix. EPA/540/R-94/009. Washington: Office of Solid Waste and Emergency Response, June 1994.
- The Superfund Innovative Technology Evaluation Program, Progress and Accomplishments, Fiscal Year 1990, A Fourth Report to Congress. EPA/540/5-91/004. Washington: Office of Solid Waste and Emergency Response, September 1991b.

Vita

Captain Daniel J. Clairmont [REDACTED]. He graduated from Belmont High School, Belmont, NH in 1985 and entered Western New England College in Springfield Mass. He graduated from Western New England College in 1989 with a Bachelor of Science in Mechanical Engineering and a commission as a Second Lieutenant in the Air Force through the ROTC program. He married Martha Clarke in the summer of 1989 and proceeded to March AFB, CA for his first duty assignment. In 1993 he was reassigned to Eareckson AFS, Alaska where he was the Operations Flight Commander. Leaving Eareckson in 1994 he attended Squadron Officers School in residence on his way to the Air Force Institute of Technology. While at the Institute he received a Masters of Science in Engineering and Environmental Management.

[REDACTED] Address: [REDACTED]

Belmont, NH 03320
[REDACTED]