

NASA
Technical Memorandum 107017

Army Research Laboratory
Technical Report ARL-TR-808

The Surface Fatigue Life of Contour Induction Hardened AISI 1552 Gears

Dennis P. Townsend
*Lewis Research Center
Cleveland, Ohio*

Alan Turza
*Reliance Electric
Greenville, South Carolina*

Mike Chaplin
*Contour Hardening Inc.
Indianapolis, Indiana*

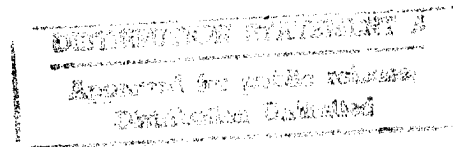

Prepared for the
1995 Fall Technical Meeting
sponsored by the American Gear Manufacturers Association
Charleston, South Carolina, October 16-18, 1995



National Aeronautics and
Space Administration

19960202 032



DTIC QUALITY INSPECTED 1

THE SURFACE FATIGUE LIFE OF CONTOUR INDUCTION HARDENED AISI 1552 GEARS

Dennis P. Townsend
NASA Lewis Research Center
Cleveland, Ohio

Alan Tuzra
Reliance Electric
Greenville SC

and

Mike Chaplin
Contour Hardening Inc.
Indianapolis IN

Introduction:

Induction hardening has been used for several years to harden and improve the strength and durability of gears and other components [1 and 2]. Many applications using induction hardening require a relatively long time to complete the hardening process and control of the case hardness and case depth has often been less than desirable. Other methods of case hardening such as carburizing are very time consuming and tend to induce distortions in the gear which requires additional finishing operations to correct the distortions. Dual frequency induction hardening [3] uses a low frequency to pre-heat the gear and a much higher frequency to very quickly heat the surface of the gear for case hardening. The gear is then immediately quenched resulting in a hard case and good core properties with very little distortion. The dual frequency process also induces some residual compressive stress in the surface being hardened which improves the bending and surface fatigue strength of the material. This process is very attractive to the gear industry because it very dramatically speeds up the production process.

The increased surface compressive residual stress should provide good surface fatigue life and good bending fatigue life for the gears [4 to 7]. If an improvement in the surface and strength properties of gears is obtained by the dual frequency hardening process an increase in the life and reliability of the gear will be realized.

The objectives of the research reported herein were (1) to investigate the effects of dual frequency surface induction hardening of gear teeth on the surface fatigue life of AISI 1552 spur gears, and (2) to compare the life of the induction hardened gears to that of carburized, hardened and ground CEVM AISI 9310 test gears. To accomplish these objectives, one group of gears were manufactured from a single heat of consumable-electrode-vacuum-melted (CEVM) AISI 9310 gear material that was case carburized, hard-

ened and ground. A second group of gears was manufactured from AISI 1552. This group of gears was heat treated to a core hardness of Rc 34-38 after which they were finish ground. After the finishing operation the gears were case hardened by the dual frequency induction method to a case hardness of Rc 60 and a case depth of 0.0635 cm (0.025 in.).

Apparatus, Specimens, and Procedure:

Gear Test Apparatus: The gear fatigue tests were performed in the NASA Lewis Research Center's gear test apparatus (Fig. 1). This test rig used the four-square principle of applying the test gear load so that the input drive only needs to overcome the frictional losses in the system. A schematic of the test rig is shown in Fig. 1(b). Oil pressure and leakage flow are supplied to the load vanes through a shaft seal. As the oil pressure is increased on the load vanes, the slave gear applies the loop torque. This torque is transmitted through the test gears back to the slave gear, where an equal but opposite torque is maintained by the oil pressure. This torque on the test gears, which depends on the hydraulic pressure applied to the load vanes, loads the gear teeth to the desired contact or Hertz stress level. The two identical test gears can be started under no load, and the load can be applied gradually, without changing the running track on the gear teeth.

Separate lubrication systems are provided for the test gears and the main gearbox. The two lubrication systems are separated at the gearbox shafts by pressurized labyrinth seals. Nitrogen is used as the seal gas. The test gear lubricant is filtered through a 5- μ m nominal fiberglass filter. The test lubricant can be heated electrically with an immersion heater. The temperature of the heater is controlled to prevent overheating the test lubricant.

A vibration transducer mounted on the gearbox is used to automatically shut off the test rig when a gear surface fatigue oc-

curls. The gearbox is also automatically shut off if there is a loss of oil flow to either the main gearbox or the test gears, if the test gear oil overheats, or if there is a loss of seal gas pressurization.

The test rig is belt-driven by a variable speed motor. The operating speed for the test reported herein was 10 000 rpm.

Test Materials: One set of test gears was manufactured from a single heat of consumable-electrode vacuum-melted (CEVM) AISI 9310 steel. The AISI 9310 gears were case hardened to a case hardness of Rockwell C 61 and a case depth of 0.97 mm (0.038 in.). The nominal core hardness was Rockwell C 38. The second set of gears were manufactured from AISI 1552 and were case hardened by dual frequency induction system to a case hardness of Rc 60 to a depth of 0.0635 cm (0.025 in.). The core hardness was Rc 34-38. The chemical composition of the AISI 9310 and AISI 1552 materials are given in Table 1. The AISI 9310 test gears were case carburized and heat treated in accordance with the heat treatment schedule of Table 2. The AISI 1552 test gears were heat treated as shown in Table 3 to obtain the core hardness before finish grinding. They were then finish ground and induction hardened by heating the tooth flank surface with the dual frequency system as shown in Table 3 and immediately quenched from the induction hardening process to obtain the case depth and hardness. Figure 2 is a cross section of the AISI 1552 gear showing the case hardened area around the gear teeth. The gears were not finished after the induction hardening process. Figure 3(a) to (c) are photomicrographs of etched and polished gear teeth cross section showing the case, case core interface and core microstructure of the AISI 1552 material which is tempered martensite. Figure 4(a) and (b) are photomicrographs of etched and polished gear teeth cross section showing the case and core microstructure of the AISI 9310 material.

Test Gears: Dimensions of the test gears are given in Table 4. All gears have a nominal surface finish on the tooth face of $0.4 \mu\text{m}$ (16 $\mu\text{in.}$) rms. and a standard 20 degree involute profile with tip relief. The linear tip relief was 0.0013 cm (0.0005 in.), starting at the highest point of single-tooth contact. The AISI 9310 test gears were finish ground after heat treatment. The AISI 1552 test gears were finish ground before contour hardening and were not finished after hardening. Therefore any distortion induced by the induction hardening process would not be removed. Table 5 shows the case and core hardness properties of the AISI 9310 and AISI 1552 gears. Figure 5(a) shows a hardness profile of the hardened case of the AISI 1552 test gear at several locations on the tooth. Figure 5(b) shows the hardness profile of the flank of the AISI 9310 gears. Figure 6(a) shows a typical residual stress curve for the carburized, hardened and ground AISI 9310 test gears. Figure 6(b) shows a typical residual stress curve for a dual frequency hardened AISI 1552 test gear.

Test Lubricant: All the gears were lubricated with a single bath of synthetic paraffinic oil. The physical properties of this lubricant are summarized in Table 6. A five percent by volume extreme-pressure additive, designated Lubrizol 5002 (partial chemical analysis given in Table 6), was added to the lubricant.

Test Procedure: After the test gears were cleaned to remove the preservative, they were assembled on the test rig. The 0.635 cm (0.25-in.) wide test gears were run in an offset condition with a 0.30-cm (0.12-in.) tooth-surface overlap to give a load surface on the gear face of 0.28 cm (0.11 in.), thereby allowing for the

edge radius of the gear teeth. If both faces of the gears were tested, four fatigue tests could be run for each set of gears. All tests were run in at a pitch-line load of 1225 N/cm (700 lb/in.) for 1 hr, which gave a maximum Hertz stress of 0.756 GPa (111 ksi). The load was then increased to 5784 N/cm (3305 lb/in.), which resulted in a pitch-line maximum Hertz stress of 1.71 GPa (248 ksi). At the pitchline load the tooth bending stress was 0.21 GPa (30 ksi) if plain bending is assumed. However, because there was an offset load, an additional stress was imposed on the tooth bending stress. Combining the bending and torsional moments results in a maximum stress of 0.26 GPa (37 ksi). This bending stress does not include the effects of tip relief, which would also increase the bending stress since the tip relief shifts the load to a higher point of single tooth contact.

Operating the test gears at 10 000 rpm results in a pitch-line velocity of 46.55 m/sec (9163 ft/min). Lubricant was supplied to the inlet mesh at $800 \text{ cm}^3/\text{min}$ (0.21 gpm) at $319 \pm 6 \text{ K}$ ($116 \pm 10 \text{ }^\circ\text{F}$). The lubricant outlet temperature was nearly constant at $350 \pm 3 \text{ K}$ ($170 \pm 5 \text{ }^\circ\text{F}$). The tests ran continuously (24 hr/day) until they were automatically shut down by the vibration detection transducer, located on the gearbox adjacent to the test gears or reached a timed out condition of 300×10^6 cycles. The lubricant is circulated through a 5- μm fiberglass filter to remove wear particles. After each test the lubricant and the filter element were discarded. Inlet and outlet oil temperatures were continuously recorded on a strip-chart recorder.

The pitch-line elastohydrodynamic (EHD) film thickness was calculated by the method of Ref. [8]. It was assumed, for this film thickness calculation, that the gear temperature at the pitch line was equal to the outlet oil temperature and that the inlet oil temperature to the contact zone was equal to the gear temperature, even though the inlet oil temperature was considerably lower. It is more likely based on previously measured temperatures [9] that the gear surface temperature was even higher than the outlet oil temperature, especially at the end points of sliding contact. The EHD film thickness for these conditions was computed to be $0.33 \mu\text{m}$ (13 $\mu\text{in.}$), which gave an initial ratio of film thickness to composite surface roughness h/σ of 0.55 at the 1.71 GPa (248 ksi) pitch-line maximum Hertz stress.

Results and Discussion:

One lot of carburized hardened and ground CEVM AISI 9310 gears and one lot of contour induction hardened AISI 1552 gears were tested in pairs until failure or were suspended after 500 hr of testing without failure. Twenty test were conducted with five sets of gears for the AISI 9310 lot of material and only 10 tests were conducted, to save time and money, with four sets of gears for the AISI 1552 gears. Test conditions were a tangential tooth load of 5784 Newton's per centimeter (3305 lb/in.) which produced a maximum Hertz stress of 1.71 GPa (248 ksi) and a speed of 10 000 rpm. The gears failed by classical subsurface pitting fatigue or tooth bending fracture. There were nineteen failures and one suspension for the AISI 9310 gears and five failures and five suspensions for the AISI 1552 gears. Test results were analyzed by considering the life of each pair of gears as a system.

Surface (pitting) fatigue life results for the AISI 9310 gears are shown in Fig. 7(a). These data were analyzed by the method of Ref. [10]. The 10 and 50 percent lives were 20.6×10^6 and 45.4×10^6 stress cycles (34 and 76 hr), respectively. The slope of the Weibul

line was 2.4. The failure index (i.e., the number of fatigue failures out of the number of tests) was 19 out of 20 with one suspension. A typical fatigue spall is shown in Fig. 8. The surface pitting fatigue failure originates below the surface in the region of maximum shear stress.

Pitting fatigue life results of the contour induction hardened AISI 1552 gears are shown in Fig. 7(b). The failure index was 5 out of 10 with five suspensions. The slope of the Weibull line was 1.035. The smaller slope indicates more scatter in the failure data. Increased scatter is usually the results of more variability in the test sample. A typical fatigue spall is shown in Fig. 8(b). The 10 and 50 percent surface pitting fatigue lives were 35.6×10^6 and 220×10^6 stress cycles (59 and 367 hr), respectively. These results are summarized in Table 7. The gears with the contour induction hardening exhibited a 10 percent fatigue life that was 1.7 times that of the AISI 9310 test gears. The confidence number for the difference in life was 75 percent, which indicates that the life difference is statistically significant.

Summary of Result:

Two groups of spur gears manufactured from two different materials and heat treatments were endurance tested for surface pitting fatigue. One group was manufactured from AISI 1552 and was finished ground to a 0.04 μm (16 $\mu\text{in.}$) rms. surface finish and then dual frequency contour induction hardened. The other group was manufactured from CEVMAISI 9310 and was carburized, hardened, and ground to a 16 μm ($\mu\text{in.}$) rms. surface finish. The gear pitch diameter was 8.89 cm (3.5 in.). Test conditions were a maximum Hertz stress of 1.71 GPa (248 ksi), a gear bulk temperature of 350 K (170 °F) and a speed of 10,000 rpm. The lubricant used for the tests was a synthetic paraffinic oil with an additive package. The following results were obtained:

1. The 10 percent surface fatigue (pitting) life of the contour hardened AISI 1552 test gears was 1.7 times that of the carburized and hardened AISI 9310 test gears.
2. There were two early failures of the AISI 1552 gears by bending fatigue.

References:

- [1] Yoshida, A.; Ohue, Y.; and Karasuno, I.: A Study of Fatigue Strength of Induction-Hardened Sintered Powder Metal Gears. Proceedings of JSME MPT'91 International Conference on Motion and Power Transmissions Nov. 23–26, 1991 Hiroshima, Japan pp. 757–762.
- [2] Yoshida, A.; Fujita, K.; Miyanishi, K.; and Ohue, Y.: Estimation of Fatigue Strength for Surface Failure of Surface-Hardened Steel Rollers and Gears. Proceedings of International Conference on Gearing Nov. 5–10 1988 Zhengzhou China Vol. 2, pp. 515–518.
- [3] Storm, J.M.; and Chaplin, M.R.: Dual Frequency Induction Hardening. ASME Proceedings of The 1989 International Power Transmission and Gearing Conference. Vol. 2 Chicago Illinois April 25–28, 1989
- [4] Aida, T.; and Oda, S.: Bending Fatigue Strength of Gears. Bulletin of JSME vol. 9, No. 36, 1966 pp. 793–806.
- [5] Kirk, D.; Nelms, P.R.; and Arnold, B.: Residual Stress and Fatigue Life of Case-Carburized Gears. Metallurgica, Vol. 74, 446, Dec. 1966, p. 255.
- [6] Cretu, S.S.: Influence of Compressive Residual Stresses on Ball Bearing Fatigue Life. Bull. of Iasi Polytech. Inst., Rev. Roum. Sci. Techn.—Mec. Appl., Tome 32, N 5, pp. 547–560, Bucarest, 1987.
- [7] Townsend, Dennis P.: Improvement in The Surface Fatigue Life of Hardened Gears by High Intensity Shot Peening. NASA TM-105678, AVSCOM TR 91-C-042. Presented at the Sixth International Power Transmission and Gearing Conference Sept. 13–16 1992.
- [8] Dowson, D.; and Higginson, G.R.: Elasto-Hydrodynamic Lubrication. Pergamon Press, 1966, p. 96.
- [9] Townsend, D.P. and Akin, L.S., 1981, "Analytical and Experimental Spur Gear Tooth Temperature as Affected by Operating Variables, Journal of Mechanical Design, Vol. 103, pp. 219–226
- [10] Johnson, L.G.: The Statistical Treatment of Fatigue Experiments. Elsevier Pub. Co., 1964.

TABLE 1.—NOMINAL CHEMICAL COMPOSITION OF AISI 9310 & AISI 1552 GEAR MATERIALS

Element (%)	AISI 9310	AISI 1552
Carbon	0.1	0.51
Nickel	3.22	----
Chromium	1.21	----
Molybdenum	0.12	----
Copper	0.13	----
Manganese	0.63	1.35
Silicon	0.27	----
Sulfur	0.005	0.03
Phosphorous	0.005	0.03
Iron	Bal.	Bal.

TABLE 2.—HEAT TREATMENT FOR AISI 9310 GEARS

Step	Process	Temperature		Time, hr
		K	°F	
1	Preheat in air	-----	-----	-----
2	Carburize	1,172	1,650	8
3	Air cool to room temperature	-----	-----	-----
4	Copper plate all over	-----	-----	-----
5	Reheat	922	1,200	2.5
6	Air cool to room temperature	-----	-----	-----
7	Austenitize	1,117	1,550	2.5
8	Oil quench	-----	-----	-----
9	Subzero cool	180	-120	3.5
10	Double temper	450	350	2 each
11	Finish grind	-----	-----	-----
12	Stress relieve	450	350	2

TABLE 3.—HEAT TREATMENT FOR AISI 1552 GEARS

Step	Process	Temperature		Time, hr	
		K	°F		
1	Heat in air	1,117	1,550	2	
2	Oil quench in warm oil	333	140	-----	
3	Temper to Rc 34-38	811	1,000	2	
4	Finish grind	-----	-----	-----	
Dual Frequency Induction Harden					Power
5	Preheat 3-10 k Hertz	686	775	4 sec	120 kW
6	Heat surface 230-270 k Hertz	1,172	1,650	0.357sec	330 kW
7	Water quench immediately	306	92		

TABLE 4.—SPUR GEAR DATA
[Gear Tolerance per Agma Class 12.]

Number of teeth	28
Diametral pitch	8
Circular pitch, cm (in.)	0.9975 (0.3297)
Whole depth, cm (in)	0.762 (0.300)
Addendum, cm (in)	0.318 (0.125)
Chordal tooth thickness (reference), cm (in.)	0.485 (0.191)
Tooth width, cm (in.)	0.635 (0.25)
Pressure angle, deg	20
Pitch diameter, cm (in.)	8.890 (3.500)
Outside diameter, cm (in.)	9.525 (3.750)
Fillet radius, cm (in.)	0.102 to 0.152 (0.04 to 0.06)
Measurement over pins, cm (in.)	9.603 to 9.630 (3.7807 to 3.7915)
Pin diameter, cm (in.)	0.529 (0.216)
Backlash reference, cm (in.)	0.0254 (0.010)
Tip relief, cm (in.)	0.001 to 0.0015 (0.0004 to 0.0006)

TABLE 5.—CASE AND CORE CHARACTERISTICS

Material	Effective case depth to Rc 50 mm (in)	Case hardness Rc	Core hardness Rc
AISI 1552	0.63 (0.025)	60.5	35
AISI 9310	0.81 (0.032)	61	38

TABLE 6.—PROPERTIES OF SYNTHETIC PARAFFINIC LUBRICANT

Additive	Luntizol 5002 ^a
Kinematic viscosity, cm ² /sec (cS) at-	
244 K (-20 °F)	2500×10 ⁻² (2500)
311 K (100 °F)	31.6×10 ⁻² (31.6)
373 K (210 °F)	5.7×10 ⁻² (5.7)
477 K (400 °F)	2.0×10 ⁻² (2.0)
Flash point, K (°F)	508 (455)
Fire point, K (°F)	533 (500)
Pour point, K (°F)	219 (-65)
Specific gravity	0.8285
Vapor pressure at 311 K (100 °F), mm Hg (or torr)	0.1
Specific heat at 311 K (100 °F) J/kg k (Btu/lb °F)	676 (0.523)

^aAdditive, Lubrizol 5002 (5 vol %); content of additive: phosphorus, 0.6 wt %; sulphur, 18.5 wt %.

TABLE 7.—FATIGUE LIFE RESULTS FOR TEST GEARS

Gears	10-percent life, cycles	50- percent life cycles	Slope	Failure index ^a	Confidence number, ^b percent
AISI 9310	21 × 10 ⁶	45 × 10 ⁶	2.4	19/20	--
AISI 1552	36 × 10 ⁶	220 × 10 ⁶	1.04	5/10	75

^aIndicates number of failures out of number of tests

^bProbability, expressed as a percentage, that the 10-percent life with the baseline AISI 9310 gears is either less than, or greater than, that of the particular lot of gears being considered.

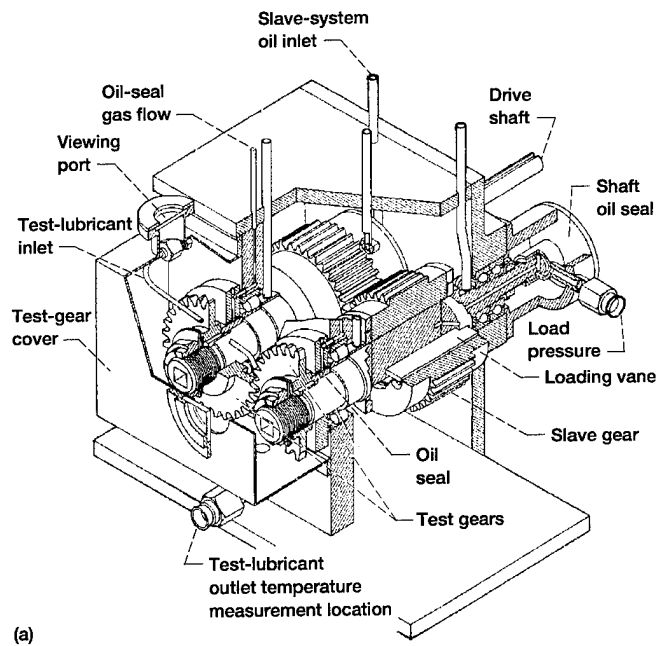

(a)

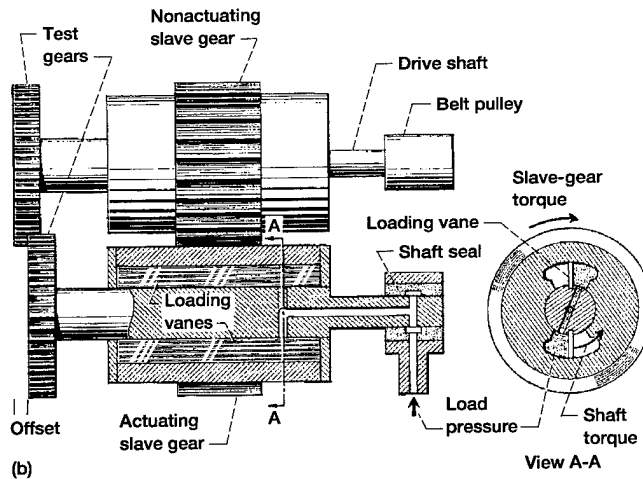

(b)

Figure 1.—NASA Lewis Research Center's gear fatigue test apparatus. (a) Cutaway view. (b) Schematic diagram.

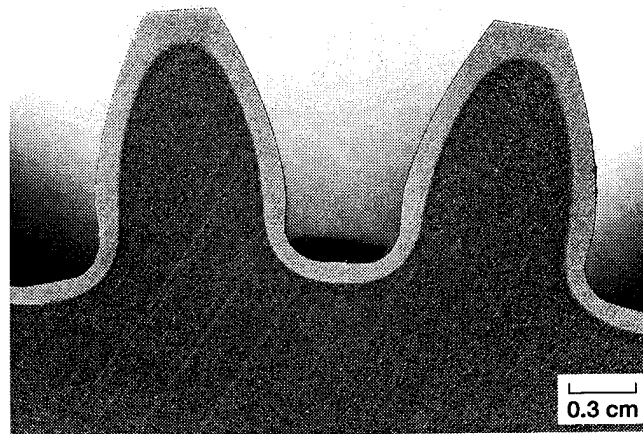

Figure 2.—Cross section of a dual frequency induction case hardened AISI 1552 test gear.

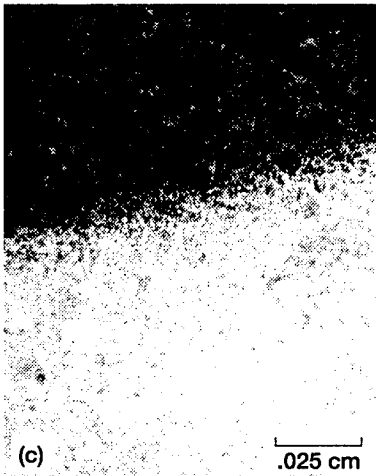
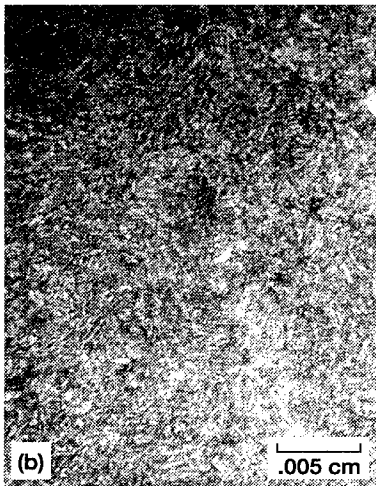
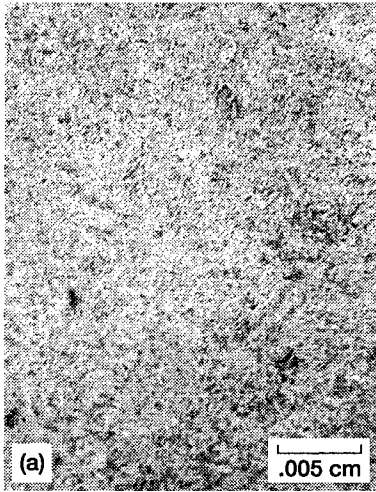

Figure 3.—Photomicrograph of case, core and case-core interface of dual frequency induction hardened AISI 1552 test gear. (a) Case. (b) Core. (c) Case core interface.

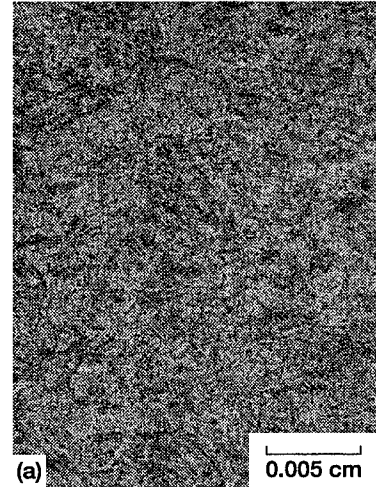

Figure 4.—Photomicrographs of case and core of AISI 9310 test gear. (a) Carburized and hardened case of the CEVM AISI 9310 gear showing high carbon fine grain martensitic structure. (b) Core structure of CEVM AISI 9310 gear showing low carbon refined austenitic grain size.

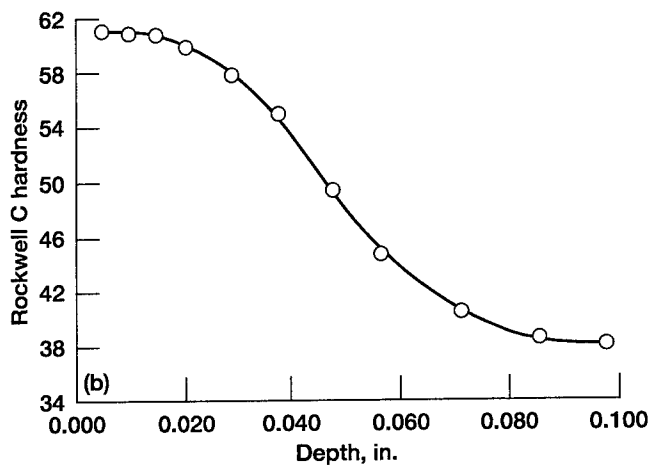
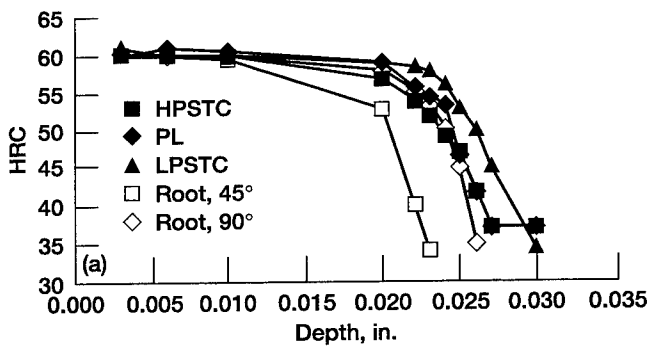

Figure 5.—Hardness profile of AISI 1552 steel test gear contour hardened case and a carburized and hardened AISI 9310 gear. (a) AISI 1552 gear. (b) Carburized and hardened AISI 9310 gear.

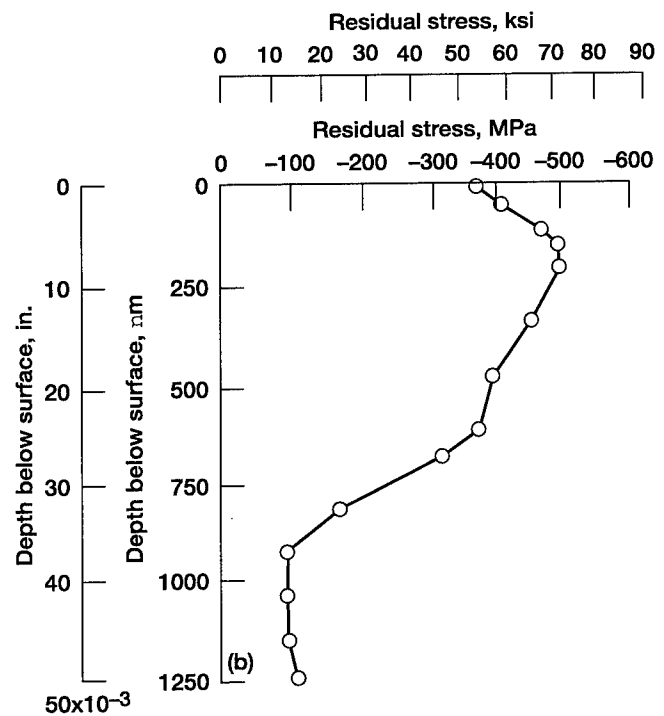
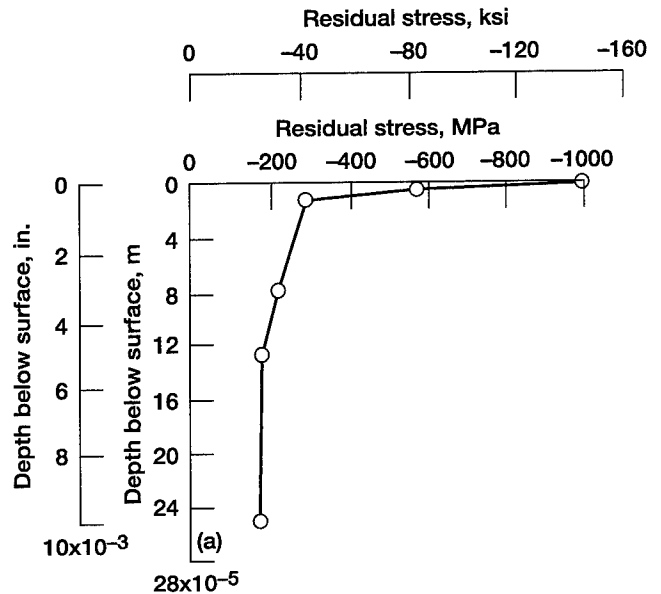

Figure 6.—Residual stress versus depth for carburized, hardened and ground AISI 9310 test gears and dual frequency induction hardened AISI 1552 gears. (a) AISI 9310. (b) AISI 1552.

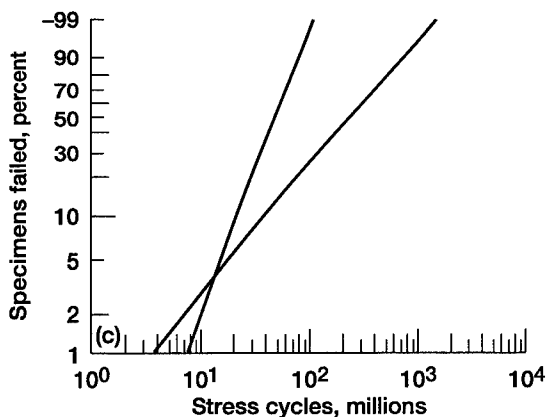
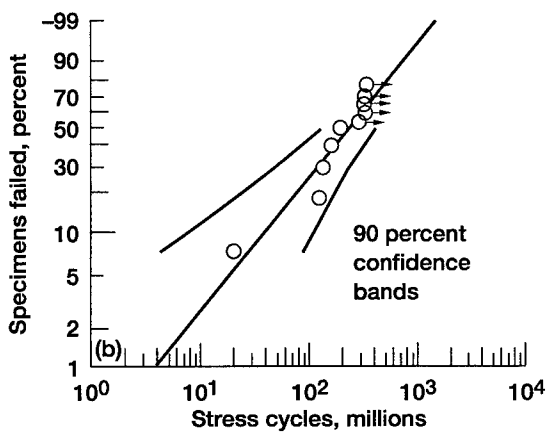
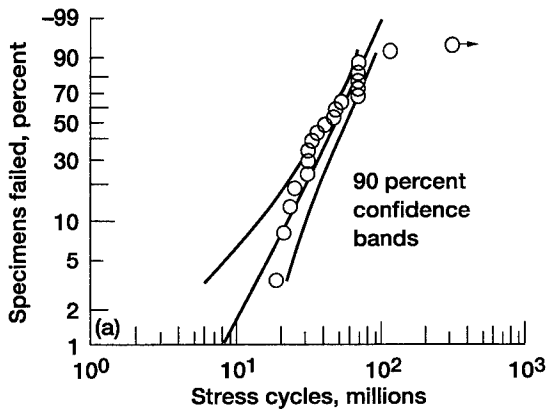

Figure 7.—Surface fatigue lives of surface hardened AISI 9310 and AISI 1552 test gears. Speed 10 000 rpm; maximum Hertz stress, 1.71 GPa (250 ksi); temperature, 350 K (170 °F); lubricant, synthetic paraffinic with 5-percent by volume EP additive. (a) AISI 9310. (b) AISI 1552. (c) Summary.

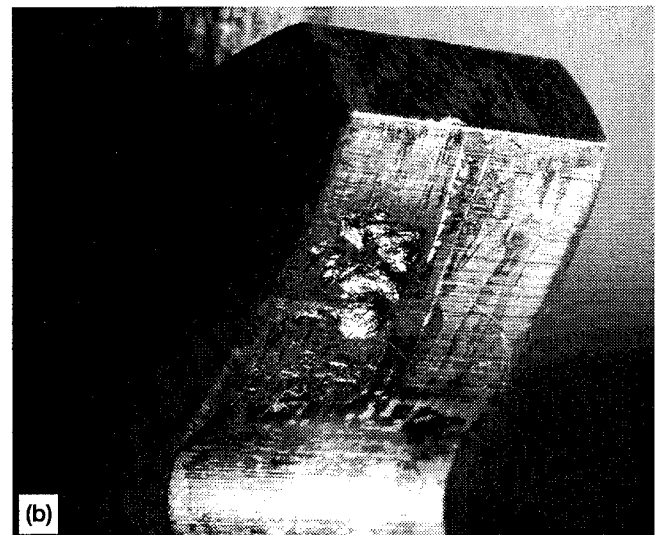
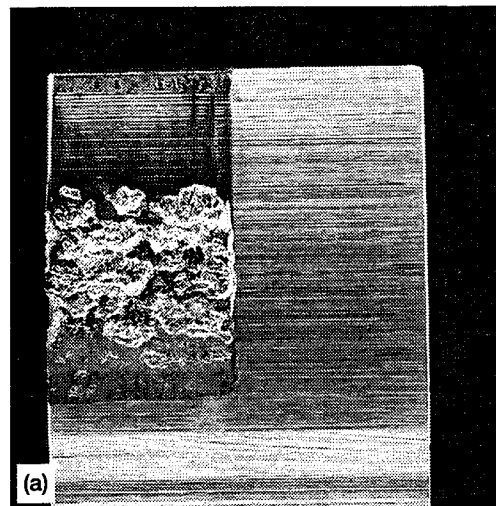

Figure 8.—Typical fatigue spall for test gear. (a) AISI 9310 test gear. (b) AISI 1552 test gear.

REPORT DOCUMENTATION PAGE

Form Approved
OMB No. 0704-0188

Public reporting burden for this collection of information is estimated to average 1 hour per response, including the time for reviewing instructions, searching existing data sources, gathering and maintaining the data needed, and completing and reviewing the collection of information. Send comments regarding this burden estimate or any other aspect of this collection of information, including suggestions for reducing this burden, to Washington Headquarters Services, Directorate for Information Operations and Reports, 1215 Jefferson Davis Highway, Suite 1204, Arlington, VA 22202-4302, and to the Office of Management and Budget, Paperwork Reduction Project (0704-0188), Washington, DC 20503.

1. AGENCY USE ONLY (Leave blank)	2. REPORT DATE July 1995	3. REPORT TYPE AND DATES COVERED Technical Memorandum	
4. TITLE AND SUBTITLE The Surface Fatigue Life of Contour Induction Hardened AISI 1552 Gears		5. FUNDING NUMBERS WU-505-62-36 1L162211A47A	
6. AUTHOR(S) Dennis P. Townsend, Alan Turza, and Mike Chaplin		8. PERFORMING ORGANIZATION REPORT NUMBER E-9808	
7. PERFORMING ORGANIZATION NAME(S) AND ADDRESS(ES) NASA Lewis Research Center Cleveland, Ohio 44135-3191 and Vehicle Propulsion Directorate U.S. Army Research Laboratory Cleveland, Ohio 44135-3191		10. SPONSORING/MONITORING AGENCY REPORT NUMBER NASA TM-107017 ARL-TR-808	
9. SPONSORING/MONITORING AGENCY NAME(S) AND ADDRESS(ES) National Aeronautics and Space Administration Washington, D.C. 20546-0001 and U.S. Army Research Laboratory Adelphi, Maryland 20783-1145		11. SUPPLEMENTARY NOTES Prepared for the 1995 Fall Technical Meeting sponsored by the American Gear Manufacturers Association, Charleston, South Carolina, October 16-18, 1995. Dennis P. Townsend, NASA Lewis Research Center; Alan Tuzra, Reliance Electric, Greenville, South Carolina; and Make Chaplin, Contour Hardening Inc., Indianapolis, Indiana. Responsible person, Dennis P. Townsend, organization code 2730, (216) 433-3955.	
12a. DISTRIBUTION/AVAILABILITY STATEMENT Unclassified - Unlimited Subject Category 37 This publication is available from the NASA Center for Aerospace Information, (301) 621-0390.		12b. DISTRIBUTION CODE	
13. ABSTRACT (Maximum 200 words) Two groups of spur gears manufactured from two different materials and heat treatments were endurance tested for surface fatigue life. One group was manufactured from AISI 1552 and was finished ground to a 0.4 μm (16 $\mu\text{in.}$) rms. surface finish and then dual frequency contour induction hardened. The second group was manufactured from CEVM AISI 9310 and was carburized, hardened, and ground to a 0.4 μm (16 $\mu\text{in.}$) rms. surface finish. The gear pitch diameter was 8.89 cm (3.5 in.). Test conditions were a maximum Hertz stress of 1.71 GPa (248 ksi), a bulk gear temperature of approximately 350 K (170F) and a speed of 10 000 rpm. The lubricant used for the tests was a synthetic paraffinic oil with an additive package. The test results showed that the 10 percent surface fatigue (pitting) life of the contour hardened AISI 1552 test gears was 1.7 times that of the carburized and hardened AISI 9310 test gears. Also there were two early failures of the AISI 1552 gears by bending fatigue.			
14. SUBJECT TERMS Fatigue life; Hertz stress; Induction hardening; AISI 1552; Gears			15. NUMBER OF PAGES 11
17. SECURITY CLASSIFICATION OF REPORT Unclassified			16. PRICE CODE A03
18. SECURITY CLASSIFICATION OF THIS PAGE Unclassified	19. SECURITY CLASSIFICATION OF ABSTRACT Unclassified	20. LIMITATION OF ABSTRACT	

National Aeronautics and
Space Administration

Lewis Research Center
21000 Brookpark Rd.
Cleveland, OH 44135-3191

Official Business
Penalty for Private Use \$300

POSTMASTER: If Undeliverable — Do Not Return